

# MARKS PUBLISHED FOR OPPOSITION

The following marks are published in compliance with section 12(a) of the Trademark Act of 1946. Applications for the registration of marks in more than one class have been filed as provided in section 30 of said act as amended by Public Law 772, 87th Congress, approved Oct. 9, 1962, 76 Stat. 769. Opposition under section 13 may be filed within thirty days of the date of this publication. See rules 2.101 to 2.105.

A separate fee of three hundred dollars (\$300.00) for opposing each mark in each class must accompany the opposition.

## SECTION 1.— INTERNATIONAL CLASSIFICATION

The short titles associated below with the international class numbers are terms designed merely for quick identification and are not an official part of the international classification. The full names of international classes are given in section 6.1 of the trademark rules of practice.

The designation "U.S. Cl." appearing in this section refers to the U.S. class in effect prior to Sep. 1, 1973 rather than the international class which applies to applications filed on or after that date. For adoption of international classification see notice in the OFFICIAL GAZETTE of Jun. 26, 1973 (911 O.G. TM 210).

### Application in more than one class

SN 76-664,020. TRANSPATH INC., EDMONTON, ALBERTA, CANADA, FILED 8-2-2006.

SN 76-699,080. LG-ERICSSON CO., LTD., SEOUL, REPUBLIC OF KOREA, FILED 8-20-2009.

# TRANSPATH

PRIORITY CLAIMED UNDER SEC. 44(D) ON CANADA APPLICATION NO. 1308592, FILED 6-28-2006, REG. NO. TMA692746, DATED 7-24-2007, EXPIRES 7-24-2022.

### CLASS 42—SCIENTIFIC AND COMPUTER SERVICES

FOR CONDUCTING MEDICAL AND SCIENTIFIC RESEARCH IN THE FIELDS OF RENAL TRANSPLANTATION, RENAL BIOPSY PROCESSING AND INTERPRETATION, AND RENAL PATHOLOGY; PROVIDING TEMPORARY USE OF ONLINE NON-DOWNLOADABLE COMPUTER SOFTWARE FOR USE IN IDENTIFICATION AND DIAGNOSIS OF MEDICAL CONDITIONS IN THE FIELDS OF RENAL TRANSPLANTATION, RENAL BIOPSY PROCESSING AND INTERPRETATION, AND RENAL PATHOLOGY (U.S. CLS. 100 AND 101).

FIRST USE 1-1-2007; IN COMMERCE 3-25-2008.

### CLASS 44—MEDICAL, BEAUTY AND AGRICULTURAL SERVICES

FOR PROVIDING AN EDUCATIONAL DATABASE IN THE FIELDS OF RENAL TRANSPLANTATION, RENAL BIOPSY PROCESSING AND INTERPRETATION, AND RENAL PATHOLOGY INFORMATION AND ALSO ALLOWS INPUTTING AND COLLECTION OF DATA AND INFORMATION ALL FOR TREATMENT AND DIAGNOSIS PURPOSES (U.S. CLS. 100 AND 101).

FIRST USE 1-1-2007; IN COMMERCE 3-25-2008.  
WILLIAM ROSSMAN, EXAMINING ATTORNEY



PRIORITY CLAIMED UNDER SEC. 44(D) ON REPUBLIC OF KOREA APPLICATION NO. 40-2009-0029, FILED 6-23-2009.

NO CLAIM IS MADE TO THE EXCLUSIVE RIGHT TO USE "WDM PON", APART FROM THE MARK AS SHOWN.

THE MARK CONSISTS OF THREE PAIRS OF LAMBDA SYMBOLS ARRANGED IN A BACKWARD SLANTING DIAGONAL LINE AND TWO LINES OF TEXT BENEATH, ONE ABOVE THE OTHER. THE TOP LINE CONTAINS THE WORDS "WDM PON" AND THE BOTTOM LINE CONTAINS THE WORD "ECOSYSTEM".

**CLASS 9—ELECTRICAL AND SCIENTIFIC APPARATUS**

FOR FIXED MULTICHANNEL COMMUNICATION APPARATUS; FIXED SINGLE CHANNEL COMMUNICATION APPARATUS; OPEN-WIRE TRANSMISSION MACHINES AND APPARATUS; CARRIER REPEATER MACHINES AND APPARATUS, NAMELY, ETHERNET REPEATERS, WIRELESS NETWORK REPEATERS AND ETHERNET FIBER ACCESS SYSTEM; INTERCOMMUNICATION APPARATUS, NAMELY, COMMUNICATION HUBS AND METRO ETHERNET NETWORK; TELECOMMUNICATION MACHINES AND IMPLEMENTS, NAMELY, AUTOMATIC SWITCHING APPARATUS, CHANGEOVER SWITCHES, COMPUTER HARDWARE FOR TELECOMMUNICATIONS; ELECTRONIC TRANSMITTERS FOR TELECOMMUNICATIONS; TRANSMITTING SETS FOR TELECOMMUNICATIONS, NAMELY, TELEPHONE SETS; POWER LINE TRANSMISSION MACHINES AND APPARATUS; FREQUENCY CONVERTERS; TELECOMMUNICATIONS TRANSMITTERS; APPARATUS FOR TRANSMISSION OF COMMUNICATION (U.S. CLS. 21, 23, 26, 36 AND 38).

**CLASS 35—ADVERTISING AND BUSINESS**

FOR OPERATION OF BROADBAND TELECOMMUNICATION NETWORKS FOR OTHERS (U.S. CLS. 100, 101 AND 102).

**CLASS 38—COMMUNICATION**

FOR COMMUNICATIONS VIA FIBER-OPTIC NETWORKS; TRANSMISSION OF INFORMATION ON OPTICAL TELECOMMUNICATION NETWORKS; TRANSMISSION OF INFORMATION VIA NATIONAL AND INTERNATIONAL NETWORKS; RENTAL OF DATA COMMUNICATIONS INSTALLATIONS; DATA COMMUNICATION BY ELECTRONIC MAIL; RADIO COMMUNICATIONS OF DATA; PROVIDING ACCESS TO WIRELESS INTERNET; WIRELESS TELEPHONE SERVICES; WIRELESS TELEPHONY SERVICES; WIRE COMMUNICATIONS SERVICES, USING, TRANSCIVERS FOR OPTICAL COMMUNICATIONS; MOBILE RADIO COMMUNICATIONS; TELECOMMUNICATIONS BY MOBILE PHONES; PROVIDING VOICE COMMUNICATION SERVICES VIA THE INTERNET; PROVIDING TELECOMMUNICATIONS CONNECTIONS TO A GLOBAL COMPUTER NETWORK; RENTAL OF TELECOMMUNICATION EQUIPMENT; INFORMATION ABOUT TELECOMMUNICATION; RENTAL OF TELECOMMUNICATION EQUIPMENT, NAMELY, TELEPHONE EXCHANGE APPARATUS; COMMUNICATIONS BY TELEPHONE; RENTAL OF TELECOMMUNICATION EQUIPMENT, NAMELY, TELEPHONE, FACSIMILE MACHINES; RENTAL OF VIDEO PHONES; TELECONFERENCING SERVICES (U.S. CLS. 100, 101 AND 104).

PAUL MORENO, EXAMINING ATTORNEY

SN 76-700,595. GMMB, INC, WASHINGTON, DC. FILED 11-27-2009.

cause+gmmmb=effect

OWNER OF U.S. REG. NO. 2,808,589.  
THE COLOR(S) GREY AND ORANGE IS/ARE CLAIMED AS A FEATURE OF THE MARK.

THE MARK CONSISTS OF THE WORD "CAUSE" FOLLOWED BY A PLUS SIGN IN GREY, FOLLOWED BY THE LETTERS "GMMB" IN ORANGE, WITH AN EQUAL SIGN AND THE WORD "EFFECT" IN GREY THEREAFTER.

**CLASS 35—ADVERTISING AND BUSINESS**

FOR CONSULTING SERVICES IN THE FIELDS OF ADVERTISING, PUBLIC RELATIONS, AND POLITICS AND CONSULTATION SERVICES REGARDING DEVELOPMENT OF MARKETING CAMPAIGNS, POLITICAL CAMPAIGNS, AND PUBLIC AWARENESS CAMPAIGNS THROUGH PUBLIC COMMUNICATION MEANS (U.S. CLS. 100, 101 AND 102).

**CLASS 42—SCIENTIFIC AND COMPUTER SERVICES**

FOR CONSULTING SERVICES IN THE FIELD OF WEB SITE DESIGN AND DEVELOPMENT OF WEBSITES (U.S. CLS. 100 AND 101).

TINA L. SNAPP, EXAMINING ATTORNEY

SN 76-702,196. JEWISH EDUCATIONAL MEDIA, INC, BROOKLYN, NY. FILED 3-22-2010.



The Living Archive

NO CLAIM IS MADE TO THE EXCLUSIVE RIGHT TO USE "ARCHIVE", APART FROM THE MARK AS SHOWN.

THE MARK CONSISTS OF THE WORDS "THE LIVING ARCHIVE" FEATURED BENEATH A STYLIZED FLORAL DESIGN WHOSE PETALS ARE ARRANGED IN A CIRCLE, EACH PETAL FORMED BY THREE OVALS THAT ARE OVERLAPPING AND ALTERNATELY COMPLETELY AND PARTIALLY SHADED. IN THE CENTER OF THE CIRCULAR PETAL FORMATION ARE SOLID CIRCLES ARRANGED IN A CIRCLE. WITHIN THIS CIRCLE ARE SMALLER, SOLID CIRCLES ARRANGED IN A CIRCLE. IN THE VERY CENTER IS ONE SOLID CIRCLE.

**CLASS 35—ADVERTISING AND BUSINESS**

FOR ON-LINE RETAIL STORE SERVICE FEATURING AUDIO AND VIDEO DISCS, PHOTOGRAPHS AND MEMORABILIA (U.S. CLS. 100, 101 AND 102).

**CLASS 39—TRANSPORTATION AND STORAGE**

FOR STORAGE SERVICES FOR ARCHIVING DATABASES, IMAGES AND OTHER ELECTRONIC DATA (U.S. CLS. 100 AND 105).

**CLASS 40—MATERIAL TREATMENT**

FOR PHOTO RESTORATION SERVICES (U.S. CLS. 100, 103 AND 106).

CHARISMA HAMPTON, EXAMINING ATTORNEY



SN 76-702,197. JEWISH EDUCATIONAL MEDIA, INC.,  
BROOKLYN, NY. FILED 3-22-2010.



THE MARK CONSISTS OF THE LOWER CASE WORD "JEM" WITHIN A RECTANGLE WITH ROUNDED CORNERS. THE BOTTOM TWO THIRDS OF THE RECTANGLE IS SOLID AND THE TOP THIRD IS WHITE. THE WORD APPEARS HORIZONTALLY WITHIN THE BOTTOM (SOLID) PORTION, EXCEPT THAT THE DOT OVER THE "J" FALLS WITHIN THE WHITE AREA AND IS COMPRISED OF THREE DIAGONALLY PLACED SOLID SQUARES OF DECREASING SIZE, THE LARGEST SQUARE DIRECTLY OVER THE "J" AND THE TWO SMALLER SQUARES ARE EACH ATTACHED TO THE UPPER RIGHT CORNER OF THE PRECEDING LOWER, LARGER SQUARE.

#### CLASS 35—ADVERTISING AND BUSINESS

FOR ON-LINE RETAIL STORE SERVICE FEATURING AUDIO AND VIDEO DISCS, PHOTOGRAPHS AND MEMORABILIA (U.S. CLS. 100, 101 AND 102).

#### CLASS 39—TRANSPORTATION AND STORAGE

FOR STORAGE SERVICES FOR ARCHIVING DATABASES, IMAGES AND OTHER ELECTRONIC DATA (U.S. CLS. 100 AND 105).

#### CLASS 40—MATERIAL TREATMENT

FOR PHOTO RESTORATION SERVICES (U.S. CLS. 100, 103 AND 106).  
CHARISMA HAMPTON, EXAMINING ATTORNEY

SN 76-702,240. DIRECT LINE CORPORATION, DICKSON,  
TN. FILED 3-26-2010.

# DIRECT LINE

THE MARK CONSISTS OF STANDARD CHARACTERS WITHOUT CLAIM TO ANY PARTICULAR FONT, STYLE, SIZE, OR COLOR.

OWNER OF U.S. REG. NO. 1,825,650.  
NO CLAIM IS MADE TO THE EXCLUSIVE RIGHT TO USE "LINE", APART FROM THE MARK AS SHOWN.

#### CLASS 20—FURNITURE AND ARTICLES NOT OTHERWISE CLASSIFIED

FOR FRONT OFFICE AND BACK OFFICE FURNITURE OF METAL OR WOOD, NAMELY, DESKS, CREDENZAS, TABLES, END TABLES, ACCENT TABLES, COFFEE TABLES, DISPLAY CASES, SHELVING, WORK STATIONS, DESK CHAIRS, DINING CHAIRS, OFFICE CHAIRS, OFFICE RECEPTION CHAIRS; METAL CASE GOODS, NAMELY, METAL CABINETS, METAL DESKS, FILE CABINETS AND ACCESSORIES; MOVING-AISLE FILING AND STORAGE SHELVING, NAMELY, HIGH DENSITY MOBILE FILING SYSTEMS, NAMELY, STORAGE AND FILING ORGANIZATION SYSTEMS SOLD AS A UNIT, COMPRISING SHELVES, SHELVING CLOSING ENCLOSURES, BRACKETS, TRACKS, FILE CABINETS AND ACCESSORIES (U.S. CLS. 2, 13, 22, 25, 32 AND 50).

FIRST USE 6-1-1999; IN COMMERCE 6-1-1999.

#### CLASS 37—CONSTRUCTION AND REPAIR

FOR PROVIDING INSTALLATION SERVICES FOR MOVING-AISLE FILING AND STORAGE SHELVING, INCLUDING ROTARY FILES AND HIGH DENSITY MOBILE FILING SYSTEMS EQUIPMENT; PROVIDING MAINTENANCE SERVICES FOR MOVING-AISLE FILING AND STORAGE SHELVING, INCLUDING ROTARY FILES AND HIGH DENSITY MOBILE FILING SYSTEMS EQUIPMENT (U.S. CLS. 100, 103 AND 106).

FIRST USE 6-1-1999; IN COMMERCE 6-1-1999.

#### CLASS 42—SCIENTIFIC AND COMPUTER SERVICES

FOR PROVIDING CONSULTATION SERVICES IN THE FIELDS OF PLANNING AND DESIGN OF ROOM LAYOUT, FLOOR LOAD PLANNING, WORKSPACE AND FILE ROOM EFFICIENCY PLANNING FOR, NAMELY, ALL TYPES OF SHELVING, ROTARY FILES AND HIGH DENSITY MOBILE FILING SYSTEM AND EQUIPMENT; PROVIDING CONVERSION OF DATA OR DOCUMENTS FROM PHYSICAL TO ELECTRONIC MEDIA; COMPUTER SERVICES, NAMELY, DATA CONVERSION OF ELECTRONIC INFORMATION AND DATA CONVERSION FROM PHYSICAL TO ELECTRONIC MEDIA FOR ELECTRONIC MEDICAL RECORDS AND BAR CODE DOCUMENTS; COMPUTER SERVICES, NAMELY, PROVIDING TEMPORARY USE OF NON-DOWNLOADABLE COMPUTER SOFTWARE FOR TRACKING DOCUMENTS VIA A RADIO FREQUENCY IDENTIFICATION (RFID) FILE TRACKING SYSTEM; ELECTRONIC DOCUMENT SCANNING; GRAPHIC ILLUSTRATION AND DRAWING SERVICES, NAMELY, PROVIDING MARKUPS AND GRAPHIC ILLUSTRATIONS AND CAD DRAWINGS OF OFFICE STORAGE AND ORGANIZATIONAL SYSTEMS; CAD CUSTOM DESIGN OF SHELVING SYSTEMS (U.S. CLS. 100 AND 101).

FIRST USE 6-1-1999; IN COMMERCE 6-1-1999.  
HELENE LIWINSKI, EXAMINING ATTORNEY

SN 76-703,468. FAIRFIELD TECHNOLOGIES, INC., CHANTILLY, VA. FILED 6-22-2010.

FAIRFIELD  
TECHNOLOGIES INC.

NO CLAIM IS MADE TO THE EXCLUSIVE RIGHT TO USE "TECHNOLOGIES INC.", APART FROM THE MARK AS SHOWN.

THE COLOR(S) BLACK AND BURGUNDY IS/ARE CLAIMED AS A FEATURE OF THE MARK.

THE MARK CONSISTS OF THE BLACK WORDING "FAIRFIELD TECHNOLOGIES INC." HAVING A BURGUNDY DESIGN IN THE UPPER RIGHT CORNER CONSISTING OF TWO INTERSECTING LINES WITH A BOX IN EACH QUADRANT EXCEPT THE LOWER LEFT QUADRANT.

#### CLASS 35—ADVERTISING AND BUSINESS

FOR BUSINESS MANAGEMENT CONSULTING, BUSINESS OPERATION AND MANAGEMENT ADVISORY SERVICES (U.S. CLS. 100, 101 AND 102).

FIRST USE 7-22-2003; IN COMMERCE 7-22-2003.

#### CLASS 42—SCIENTIFIC AND COMPUTER SERVICES

FOR INFORMATION TECHNOLOGY AND IT MANAGEMENT CONSULTING AND ADVISORY SERVICES, SPECIFICALLY SOFTWARE SPECIFICATION, DESIGN, PROGRAMMING, SUPPORT, OPERATIONS, MAINTENANCE, AND TROUBLESHOOTING OF COMPUTER SOFTWARE PROBLEMS (U.S. CLS. 100 AND 101).

FIRST USE 7-22-2003; IN COMMERCE 7-22-2003.  
DOMINIC FATHY, EXAMINING ATTORNEY

SN 76-704,798. UNIVERSAL IMPORTS INC., GERMANTOWN, MD. FILED 10-6-2010.



THE MARK CONSISTS OF A FANCIFUL DEPICTION OF THE LETTERS "PQ".

#### CLASS 12—VEHICLES

FOR WINDSHIELD WIPER BLADES (U.S. CLS. 19, 21, 23, 31, 35 AND 44).

FIRST USE 1-5-2011; IN COMMERCE 1-5-2011.

#### CLASS 21—HOUSEWARES AND GLASS

FOR DISPOSABLE GLOVES FOR INDUSTRIAL AND GENERAL USE (U.S. CLS. 2, 13, 23, 29, 30, 33, 40 AND 50).

FIRST USE 1-5-2011; IN COMMERCE 1-5-2011.  
DOMINICK J. SALEMI, EXAMINING ATTORNEY

SN 76-704,821. NEFESH INTERNATIONAL, TEANECK, NJ. FILED 10-8-2010.



NO CLAIM IS MADE TO THE EXCLUSIVE RIGHT TO USE "THE INTERNATIONAL NETWORK" AND "OF ORTHODOX MENTAL HEALTH PROFESSIONALS", APART FROM THE MARK AS SHOWN.

THE MARK CONSISTS OF A DESIGN ELEMENT COM-

PRISING STYLIZED DEPICTION OF A GLOBE WITH LONGITUDINAL AND LATITUDINAL LINES SITUATED WITHIN AN OVAL CARRIER WITH TRIANGULAR DECORATIVE BORDER. THE WORDING "THE INTERNATIONAL NETWORK" IS PRESENTED IN STYLIZED FONT AND APPEARS ABOVE THE GLOBE. THE WORDING "OF ORTHODOX MENTAL HEALTH PROFESSIONALS" IS PRESENTED IN STYLIZED FONT BELOW THE GLOBE. THE WORD "NEFESH" AND THREE HEBREW CHARACTERS ARE PRESENTED IN STYLIZED FONT AND SUPERIMPOSED OVER THE GLOBE.

THE ENGLISH TRANSLATION OF "NEFESH" IN THE MARK IS "SOUL".

THE NON-LATIN CHARACTERS IN THE MARK TRANSLITERATE TO "NEFESH" IN HEBREW AND THIS MEANS "SOUL" IN ENGLISH.

#### CLASS 16—PAPER GOODS AND PRINTED MATTER

FOR PRINTED MATTER, NAMELY, BOOKS, NEWSLETTERS, BROCHURES AND GUIDES IN THE FIELD OF MENTAL HEALTH EDUCATION (U.S. CLS. 2, 5, 22, 23, 29, 37, 38 AND 50).

#### CLASS 41—EDUCATION AND ENTERTAINMENT

FOR EDUCATIONAL SERVICES, NAMELY, PROVIDING COURSES OF INSTRUCTION AND SEMINARS IN THE FIELD OF MENTAL HEALTH (U.S. CLS. 100, 101 AND 107).

GRETCHEN ULRICH, EXAMINING ATTORNEY

SN 76-705,046. REPAC, CEDOMIR, D-65611 BRECHEN, FED REP GERMANY, FILED 10-25-2010.

# PASTA CHEF

THE MARK CONSISTS OF STANDARD CHARACTERS WITHOUT CLAIM TO ANY PARTICULAR FONT, STYLE, SIZE, OR COLOR.

NO CLAIM IS MADE TO THE EXCLUSIVE RIGHT TO USE "PASTA", APART FROM THE MARK AS SHOWN.

#### CLASS 8—HAND TOOLS

FOR HAND-OPERATED KITCHEN TOOL FOR CUTTING DOUGH FOR PASTA, PIZZA, CROISSANTS, NAMELY, HAND-OPERATED CUTTERS (U.S. CLS. 23, 28 AND 44).

#### CLASS 21—HOUSEWARES AND GLASS

FOR HAND-OPERATED KITCHEN TOOL FOR CUTTING DOUGH FOR PASTA, PIZZA, CROISSANTS, NAMELY, PASTRY CUTTERS (U.S. CLS. 2, 13, 23, 29, 30, 33, 40 AND 50).

MYRIAH HABEEB, EXAMINING ATTORNEY

SN 76-705,494. BEST BRANDS CONSUMER PRODUCTS, INC., NEW YORK, NY. FILED 11-26-2010.

## GOURMET CLUB

THE MARK CONSISTS OF STANDARD CHARACTERS WITHOUT CLAIM TO ANY PARTICULAR FONT, STYLE, SIZE, OR COLOR.

OWNER OF U.S. REG. NO. 2,160,234.

### CLASS 8—HAND TOOLS

FOR NON-ELECTRIC KITCHEN UTENSILS, NAMELY, NON-ELECTRIC VEGETABLE PEELERS, NON-ELECTRIC CAN OPENERS, COOKIE AND PASTRY NUTCRACKERS, HAND TOOLS, NAMELY, PICKS FOR PICKING NUTS, SEAFOOD SHELL CRACKERS; CHEESE SLICERS, PIZZA CUTTERS, KITCHEN SHEARS, CUTLERY, NAMELY, FORKS, SPOONS AND KNIVES, HAND OPERATED FOOD DICERS, HAND OPERATED VEGETABLE SHREDDERS, KNIFE SHARPENERS, FLATWARE, EGG SLICERS, ICE TONGS AND SUGAR TONGS, CITRUS ZESTERS AND APPLE CORERS (U.S. CLS. 23, 28 AND 44).

FIRST USE 1-20-2006; IN COMMERCE 1-20-2006.

### CLASS 21—HOUSEWARES AND GLASS

FOR BAKEWARE, COOKWARE, NAMELY, POTS, PANS, STEAMERS AND COOKWARE FOR USE IN MICROWAVE OVENS, BOWLS, PLATES, DINNERWARE, COLANDERS, COOKING STRAINERS, STRAINERS FOR HOUSEHOLD PURPOSES, COOKING SKEWERS, WHISKS, BOTTLE OPENERS, ICE CREAM SCOOPS, HOUSEHOLD UTENSILS, NAMELY, SPATULAS, KITCHEN BRUSHES, NAMELY, CLEANING BRUSHES FOR HOUSEHOLD USE, CHEESE GRATERS, CUTTING BOARDS, HOUSEHOLD STORAGE CONTAINERS FOR FOOD, VEGETABLE BRUSHES, BASTING SPOONS, STRAINER SPOONS, MIXING SPOONS, PASTRY BRUSHES, ROLLING PINS, FUNNELS, BAKING CUPS, BASTERS, SERVING UTENSILS FOR HOUSEHOLD USE, NAMELY, POULTRY LIFTERS AND LACERS, CORN HOLDERS, GARLIC PRESSERS, NON-ELECTRIC JUICERS, CORKSCREWS, PAPER TOWEL HOLDERS, SALT AND PEPPER SHAKERS, TOOTHPICK DISPENSERS, SPICE RACKS AND TRIVETS (U.S. CLS. 2, 13, 23, 29, 30, 33, 40 AND 50).

FIRST USE 1-20-2006; IN COMMERCE 1-20-2006.

ADA HAN, EXAMINING ATTORNEY

SN 76-705,845. MALGOR & CO., INC., CATAÑO, PUERTO RICO, FILED 12-29-2010.



THE MARK CONSISTS OF THE WORD "CEDEIRA" IN A STYLIZED FONT ON A SOLID OVAL BACKGROUND WITHIN ANOTHER OVOID SHAPE.

### CLASS 29—MEATS AND PROCESSED FOODS

FOR CANNED SEAFOOD; CORNED BEEF; LUNCHEON MEAT; PROCESSED GREEN OLIVES STUFFED WITH PIMIENTO PASTE; PROCESSED OLIVES; ALCA-PARRADO, NAMELY, OLIVES AND PIMIENTO WITH CAPERS IN VINEGAR; OLIVE OIL; VEGETABLE OIL; AND PROCESSED BEANS (U.S. CL. 46).

FIRST USE 0-0-1960; IN COMMERCE 0-0-1997.

### CLASS 30—STAPLE FOODS

FOR CAPERS AND VINEGAR (U.S. CL. 46).

FIRST USE 0-0-1960; IN COMMERCE 0-0-1997.

JOHN SCHUYLER YARD, EXAMINING ATTORNEY

SN 76-705,846. MALGOR & CO., INC., CATAÑO, PUERTO RICO, FILED 12-29-2010.



THE MARK CONSISTS OF THE WORD "CANARIO" IN A STYLIZED FONT ON A SOLID BANNER, SUPERIMPOSED ON A STRIPED BACKGROUND WITH THE REPRESENTATION OF A CANARY WITHIN A CIRCLE AT THE CENTER BOTTOM PORTION OF THE STRIPED BACKGROUND.

THE ENGLISH TRANSLATION OF THE WORD "CANARIO" IN THE MARK IS "CANARY".

### CLASS 29—MEATS AND PROCESSED FOODS

FOR PROCESSED GREEN OLIVES STUFFED WITH PIMIENTO PASTE; PROCESSED OLIVES; ALCA-PARRADO, NAMELY, OLIVES AND PIMIENTO WITH CAPERS IN VINEGAR; OLIVE OIL; VEGETABLE OIL; PROCESSED BEANS; PROCESSED PIMENTOS; CANNED SEAFOOD SALAD; CANNED GREEN PIGEON PEAS; CANNED VEGETABLES; CANNED CASSAVA; CANNED FRUITS; CORNED BEEF; LUNCHEON MEAT; BEEF BROTH; CHICKEN BROTH AND VEGETABLE BROTH (U.S. CL. 46).

FIRST USE 0-0-1936; IN COMMERCE 0-0-1989.

### CLASS 30—STAPLE FOODS

FOR CAPERS; VINEGAR; SEASONING AND MINCED GARLIC (U.S. CL. 46).

FIRST USE 0-0-1936; IN COMMERCE 0-0-1989.

### CLASS 33—WINES AND SPIRITS

FOR WINE AND LIQUEUR (U.S. CLS. 47 AND 49).

FIRST USE 0-0-1936; IN COMMERCE 0-0-1989.

JOHN SCHUYLER YARD, EXAMINING ATTORNEY

SN 76-705,910. RYLAND ORGANIZATION COMPANY, CALABASAS, CA. FILED 1-5-2011.

## THE TRAILS AT BEECH CREEK

THE MARK CONSISTS OF STANDARD CHARACTERS WITHOUT CLAIM TO ANY PARTICULAR FONT, STYLE, SIZE, OR COLOR.

**CLASS 36—INSURANCE AND FINANCIAL**

FOR REAL ESTATE BROKERAGE SERVICES PROVIDED IN CONNECTION WITH HOMES BUILT AND SOLD BY APPLICANT; PROVIDING INFORMATION VIA THE INTERNET AND THE WORLD WIDE WEB RELATING TO THE PURCHASE AND SALE OF HOMES (U.S. CLS. 100, 101 AND 102).

**CLASS 37—CONSTRUCTION AND REPAIR**

FOR PROVIDING ON-SITE CONSULTATION SERVICE TO HOMEBUYERS REGARDING THE CONSTRUCTION OF NEW HOMES; CONSTRUCTION SERVICES, NAMELY, PLANNING, LAYING OUT AND CONSTRUCTION OF RESIDENTIAL HOUSING AND RESIDENTIAL COMMUNITIES (U.S. CLS. 100, 103 AND 106).

**CLASS 42—SCIENTIFIC AND COMPUTER SERVICES**

FOR PROVIDING ARCHITECTURAL DESIGN CONSULTATION SERVICES, NAMELY, PROVIDING ON SITE CONSULTATION SERVICES TO HOMEBUYERS REGARDING THE STYLING AND PERSONALIZATION OF NEW HOMES (U.S. CLS. 100 AND 101).

DEBRA LEE, EXAMINING ATTORNEY

---

SN 76-705,955. GLOLO, LLC, NEW YORK, NY. FILED 1-10-2011.

# SURVIVE

THE MARK CONSISTS OF STANDARD CHARACTERS WITHOUT CLAIM TO ANY PARTICULAR FONT, STYLE, SIZE, OR COLOR.

**CLASS 3—COSMETICS AND CLEANING PREPARATIONS**

FOR PERFUME (U.S. CLS. 1, 4, 6, 50, 51 AND 52).

**CLASS 5—PHARMACEUTICALS**

FOR MEDICATED SKIN CARE CREAM (U.S. CLS. 6, 18, 44, 46, 51 AND 52).

GINA HAYES, EXAMINING ATTORNEY

---

SN 76-706,950. BRIGADE ELECTRONICS PLC, KENT DA9BD, UNITED KINGDOM, FILED 9-22-2004.

# REVERSE IN SAFETY

OWNER OF U.S. REG. NO. 3,181,200.

**CLASS 9—ELECTRICAL AND SCIENTIFIC APPARATUS**

FOR FIBER OPTIC APPARATUS FOR USE ON ROAD VEHICLES, NAMELY, FIBER OPTIC CABLES FOR CONNECTING REAR AND SIDE VIEW CAMERAS WITH DISPLAY APPARATUS FOR VIEWING BY A VEHICLE OPERATOR; CLOSED CIRCUIT TELEVISION APPARATUS COMPRISING TELEVISION CAMERAS AND TELEVISION MONITORS ALL FOR MOUNTING IN OR ON VEHICLES FOR THE PURPOSE OF INCREASING THE OUTSIDE VEHICLE ZONE OF VISION OF THE DRIVER; ELECTRICAL OR ELECTRONIC SWITCHES, ALL FOR USE IN STOPPING OR REDUCING THE INTAKE OF POLLUTED AIR INTO THE DRIVE AND/OR PASSENGER COMPARTMENTS OF ROAD VEHICLES; REVERSE WARNING ULTRASONIC TRANSMITTERS AND RECEIVERS FOR USE ON VEHICLES; FRESNEL-TYPE LENSES FOR FITTING TO VEHICLE WINDOWS TO INCREASE THE OUTSIDE VEHICLE ZONE OF VISION OF THE DRIVER; SAFETY EQUIPMENT, NAMELY, BLEEPERS AND OTHER ELECTRONIC AUDIO WARNING DEVICES, NAMELY, SIRENS, ALARMS, SIGNALS, HORNS AND COMPUTERIZED SPEAKING VOICES FOR FITTING TO VEHICLES SO AS TO GIVE AUDIBLE WARNING WHILE THE VEHICLE IS BEING REVERSED; ELECTRONIC IN-VEHICLE PARKING METERS; EMERGENCY VEHICLE SIRENS AND HORNS (U.S. CLS. 21, 23, 26, 36 AND 38).

**CLASS 12—VEHICLES**

FOR DIRECTION SIGNALS FOR VEHICLES, TURN SIGNALS FOR VEHICLES, HORNS FOR VEHICLES, HORNS FOR MOTOR CARS, MOTOR VEHICLE ALARM SYSTEMS, MOTOR VEHICLE BACK-UP BEEPERS, MOTOR VEHICLE REVERSING ALARMS (U.S. CLS. 19, 21, 23, 31, 35 AND 44).

ALEXANDER L. POWERS, EXAMINING ATTORNEY

---

SN 77-021,847. ROK-ON LLC, OLYMPIA FIELDS, IL. FILED 10-16-2006.

# ROK-ON

THE MARK CONSISTS OF STANDARD CHARACTERS WITHOUT CLAIM TO ANY PARTICULAR FONT, STYLE, SIZE, OR COLOR.

**CLASS 16—PAPER GOODS AND PRINTED MATTER**

FOR PRINTED MEDIA, NAMELY, BROCHURES AND MAGAZINES IN THE FIELDS OF HEALTH, NUTRITION, FITNESS AND ATHLETICS (U.S. CLS. 2, 5, 22, 23, 29, 37, 38 AND 50).

**CLASS 28—TOYS AND SPORTING GOODS**

FOR SPORTS EQUIPMENT, NAMELY, EXERCISE MACHINES (U.S. CLS. 22, 23, 38 AND 50).

**CLASS 41—EDUCATION AND ENTERTAINMENT**

FOR ATHLETIC EVENTS, NAMELY, ARRANGING AND CONDUCTING ATHLETIC EVENTS, EXHIBITIONS AND COMPETITIONS (U.S. CLS. 100, 101 AND 107).

WILLIAM VERHOSEK, EXAMINING ATTORNEY



SN 77-040,570. FURUKAWA DENKI KOGYO KABUSHIKI KAISHA, DBA THE FURUKAWA ELECTRIC CO., LTD., TOKYO, JAPAN, FILED 11-9-2006.



OWNER OF JAPAN REG. NO. 424327, DATED 5-25-2005, EXPIRES 5-25-2015.

OWNER OF JAPAN REG. NO. 5258653, DATED 8-21-2009, EXPIRES 8-21-2019.

THE MARK CONSISTS OF A TWO-SIDED TRIANGULAR DESIGN ABOVE A BAR OF OVERALL RECTANGULAR SHAPE WITH A CURVED BOTTOM EDGE AND ENLARGED AND ROUNDED SIDE EDGES.

### CLASS 6—METAL GOODS

FOR IRONS AND STEELS; IRONS; SPONGE IRON; ALLOYED IRON; PURE IRON INGOTS; PIG IRON; CAST IRON; PELLETIZED IRON; STEELS; SPECIAL STEELS; ORDINARY STEELS; STEELS IN PRIMARY FORMS; STEEL IN SHEET AND BAR FORM; SLABS, NAMELY, SEMI-WORKED STEEL; TIN BARS; TIN BARS IN COIL; METAL BILLETS; ROLLED STEELS; STEEL PIPES AND TUBES; STEEL PLATES AND SHEETS; REROLLED STEELS; STEEL RAILS; ZINC-COATED STEEL SHEETS; CLAD STEEL PLATES AND SHEETS; HOLLOW STEEL BARS; VINYL COATED STEEL SHEETS AND PLATES; TIN DOOR KICK PLATES; COLD-FINISHED STEEL BARS; IRON OR STEEL SCRAPS; IRON SCRAPS IN THE NATURE OF TURNINGS AND CHIPS; ALLOY STEEL SCRAPS; CARBON STEEL SCRAPS; LOW COPPER CARBON-STEEL SCRAPS; NONFERROUS METAL ALLOYS FOR FURTHER MANUFACTURING; INGOTS OF COPPER AND ITS ALLOYS; COPPER-BASE ALLOY INGOTS; SEMI-FINISHED ARTICLES OF UNREFINED COPPER; COPPER INGOTS; CAST NAGS, FOILS, POWDER, AND ROLLED, DRAWN OR EXTRUDED SEMI-FINISHED ARTICLES OF COPPER OR ITS ALLOYS; LEAD AND ITS ALLOYS; LEAD ALLOY INGOTS; SEMI-FINISHED ARTICLES OF UNREFINED LEAD; LEAD INGOTS; CASTINGS, FOILS, POWDER, AND ROLLED, DRAWN OR EXTRUDED SEMI-FINISHED ARTICLES OF LEAD OR ITS ALLOYS; ZINC AND ITS ALLOYS; ZINC ALLOY INGOTS; SEMI-FINISHED ARTICLES OF UNREFINED ZINC; ZINC INGOTS; CASTINGS, FOILS, POWDER, AND ROLLED, DRAWN OR EXTRUDED SEMI-FINISHED ARTICLES OF ZINC OR ITS ALLOYS; TIN AND ITS ALLOYS; TIN ALLOY INGOTS; SEMI-FINISHED ARTICLES OF UNREFINED TIN; TIN INGOTS; CASTINGS, FOILS, POWDER, AND ROLLED, DRAWN OR EXTRUDED SEMI-FINISHED ARTICLES OF TIN OR ITS ALLOYS; ALUMINUM AND ITS ALLOYS; ALUMINUM ALLOY INGOTS; SEMI-FINISHED ARTICLES OF UNREFINED ALUMINUM; ALUMINUM INGOTS; CASTINGS, FOILS, POWDER, AND ROLLED, DRAWN OR EXTRUDED SEMI-FINISHED ARTICLES OF ALUMINUM OR ITS ALLOYS; MAGNESIUM AND ITS ALLOYS; MAGNESIUM ALLOY INGOTS; SEMI-FINISHED ARTICLES OF UNREFINED MAGNESIUM; MAGNESIUM INGOTS; CASTINGS, FOILS, POWDER, AND ROLLED, DRAWN OR EXTRUDED SEMI-FINISHED ARTICLES OF MAGNESIUM OR ITS ALLOYS; NICKEL AND ITS ALLOYS; NICKEL ALLOY INGOTS; SEMI-FINISHED ARTICLES OF UNREFINED NICKEL; NICKEL INGOTS; CASTINGS, FOILS, POWDER, AND ROLLED, DRAWN OR EXTRUDED SEMI-FINISHED ARTICLES OF NICKEL OR ITS ALLOYS; TITANIUM AND ITS ALLOYS; TITANIUM ALLOY INGOTS; SEMI-FINISHED ARTICLES OF UNREFINED TITANIUM; TITANIUM INGOTS; CASTINGS, FOILS, POWDER, AND ROLLED, DRAWN OR EXTRUDED SEMI-FINISHED ARTICLES OF TITANIUM OR ITS ALLOYS; NONFERROUS COMMON METALS AND THEIR AL-

LOYS, NAMELY, ORES OF INDIUM, CADMIUM, CHROMIUM, GERMANIUM, COBALT, ZIRCONIUM, TUNGSTEN, TANTALUM, NIOBIUM, VANADIUM, HAFNIUM, BERYLLIUM, MANGANESE, MOLYBDENUM; ORES OF METAL, NAMELY, IRON ORES; ZINC ORES; CHROME IRON ORES; COBALT ORES; TIN ORES; TUNGSTEN ORES; IRON ORES; COPPER ORES; LEAD ORES; NICKEL ORES; MANGANESE ORES; MOLYBDENUM ORES; IRON PYRITES; CHIMNEY SHAFTS OF METAL; STAIR TREADS OF METAL; GRATINGS OF METAL; WATER-PIPES OF METAL; TILES OF METAL; STEEL FRAMES FOR BUILDING; HINGES OF METAL; HANDRAILS OF METAL; CEILING BOARDS OF METAL; CEILING DECORATIONS, NAMELY, METAL CEILING PANELS WITH DECORATIVE DESIGNS; POLES OF METAL FOR ELECTRIC POWER LINES; DOOR KNOCKERS OF METAL; GUTTERS OF METAL; GUTTER BRACKETS OF METAL; SLIDING DOOR PULLEYS OR ROLLERS OF METAL; DOORS OF METAL; DOOR HANDLES OF METAL; DOOR STOPS OF METAL; BUILDING MATERIALS, NAMELY, METAL PILLARS; WAINSCOTINGS OF METAL; METAL BEAMS, METAL BUILDING MATERIALS, NAMELY, SOFFITS AND FASCIA; METAL REINFORCEMENT MATERIALS FOR BUILDING; METAL GRATINGS; WIRE FENCES; FIRE RETARDING DOORS OF METAL; FLOOR PAVINGS OF METAL IN THE NATURE OF METAL FLOOR TILES; WINDOWS OF METAL; WINDOW KNOBS OF METAL; WINDOW FRAMES OF METAL; WINDOW PULLEYS OF METAL; MANHOLE COVERS OF METAL; GATES OF METAL; BARBED WIRES; FLOOR BOARDS OF METAL, NAMELY, FLOOR PANELS; LOUVER DOORS OF METAL; ROCK SLIDE RETENTION WIRE NETS; LATHS OF METAL; METAL JOINERY FITTINGS; SLIDING DOORS OF METAL; METAL HARDWARE, NAMELY, SECURITY LOCKS, KEYS FOR LOCKS, RINGS OF METAL FOR KEYS; CUT NAILS; RING SHAPED METAL FITTING; CASTERS OF METAL; NAILS; WEDGES AND PEGS OF METAL; CHAINS OF METAL; METAL HARDWARE, NAMELY, WASHERS; HORSESHOES OF METAL; NUTS OF METAL; METAL PADLOCKS; METAL SCREWS; TACKS OF METAL; METAL PLUGS; BOLTS OF METAL; METAL RIVETS; METAL HARDWARE, NAMELY, WASHERS; PREFABRICATED METAL BUILDINGS; AVIARY ASSEMBLY KITS OF METAL; RESERVOIRS OF METAL; LIQUEFIED GAS STORAGE TANKS OF METAL; LIQUID STORAGE TANKS OR RESERVOIRS OF METAL; GAS STORAGE TANKS OF METAL; INTERNAL FLOATING LIDS OF ALUMINUM FOR USE WITH GAS OR LIQUEFIED GAS STORAGE TANKS; INDUSTRIAL WATER STORAGE TANKS OF METAL; METAL PULLEYS, SPRINGS AND VALVES NOT INCLUDING MACHINE ELEMENTS; PULLEYS OF METAL, NOT MACHINE ELEMENTS; SPRINGS OF METAL, NOT MACHINE ELEMENTS; SPIRAL SPRINGS OF METAL, NOT MACHINE ELEMENTS; LAMINATED LEAF-SPRINGS OF METAL, NOT MACHINE ELEMENTS; COILED SPRINGS OF METAL, NOT MACHINE ELEMENTS; METAL HARDWARE NOT BEING PARTS OF MACHINES, NAMELY, VALVES, ANGLE VALVES, BALL VALVES, BUTTERFLY VALVES; INDUSTRIAL PACKAGING CONTAINERS OF METAL; CANNING TIN CANS SOLD EMPTY; COLLAPSIBLE TUBES OF METAL SOLD EMPTY; HIGH PRESSURE METAL GAS CONTAINERS SOLD EMPTY; STEEL DRUMS SOLD EMPTY; METAL STOPPERS FOR INDUSTRIAL PACKAGING CONTAINERS; METAL LIDS AND CAPS FOR INDUSTRIAL PACKAGING CONTAINERS; LOADING AND UNLOADING PALLETS OF METAL; ARTIFICIAL FISH REEFS OF METAL; METAL MOULDS FOR FORMING CEMENT PRODUCTS; TRANSPORTABLE GREENHOUSES OF METAL FOR HOUSEHOLD USE; PAINT SPRAYING BOOTHS OF METAL; POULTRY CAGES OF METAL; ROAD SIGNS OF METAL NOT LUMINOUS NOR MECHANICAL; METAL RAILWAY CROSSOVERS; METAL DOOR HARDWARE, NAMELY, KEYS AND KEY CYLINDERS; METAL JUNCTIONS FOR PIPES; METAL FLANGES; COTTER PINS; ANCHORS; MOORING BUOYS OF METAL; MOORING BOLLARDS OF METAL; ANVILS; WIRE NETS AND GAUZES; WIRE ROPES; METAL CHAINS FOR DOGS; WATER TANKS OF METAL FOR HOUSEHOLD PURPOSES; TOOL BOXES OF METAL; MONEY BOXES OF METAL; METAL STEPLADDERS AND LADDERS; METAL NAMEPLATES AND DOOR NAMEPLATES; TOWEL DISPENSERS OF METAL; HAT-HANGING HOOKS OF METAL; LETTER BOXES OF METAL; METAL SAFES; UPRIGHT SIGNBOARDS OF METAL; SCULPTURES OF



METAL; METAL TOMBS AND METAL TOMB PLAQUES; FERRULES OF METAL FOR CANES AND WALKING-STICKS; CRAMPONS IN THE NATURE OF CLIMBING IRONS; DIVING PLATFORMS OF METAL; MOUNTAIN-NEERING EQUIPMENT, NAMELY, PITONS OF METAL; STIRRUPS OF METAL; SPURS (U.S. CLS. 2, 12, 13, 14, 23, 25 AND 50).

### CLASS 9—ELECTRICAL AND SCIENTIFIC APPARATUS

FOR SELF-RESCUE APPARATUS, NAMELY, RESPIRATORY GAS CONTAINERS; LABORATORY EQUIPMENT, NAMELY, CONSTANT TEMPERATURE INCUBATORS AND CONSTANT HUMIDITY INCUBATORS; GLASSWARE FOR SCIENTIFIC EXPERIMENTS IN LABORATORIES; GLASSWARE, NAMELY, PORCELAIN WARE FOR SCIENTIFIC EXPERIMENTS IN LABORATORIES; FURNACES FOR LABORATORY EXPERIMENTS; TEMPERATURE INDICATORS; GASOMETERS; THERMOMETERS; WATER METERS; WEIGHING EQUIPMENT, NAMELY, BALANCES; TAPE MEASURES; JAPANESE STYLE BOX-SHAPED VOLUME MEASURE, NAMELY, MASU; PLANIMETERS; MEASURING RULES; DERIVED-UNIT MEASURING MACHINES AND APPARATUS; MANOMETERS IN THE NATURE OF PRESSURE GAUGES; LEVEL INDICATORS, NAMELY, SPIRIT LEVELS; ACOUSTIC METERS; TACHOMETERS; ACCELEROMETERS; REFRACTOMETERS; LUMINOFLUX METERS; PHOTOMETERS; ALTIMETERS; HYGROMETERS; ILLUMINOMETERS; VIBRATION METERS; NOISEMETERS; SPEED INDICATORS; CALORIMETERS; ISOGAMETES; CONCENTRATION METERS; GRAVIMETERS; DYNAMOMETERS; FLOW METERS; ANGEL LEVEL GAUGES; LASER-BEAM-EMITTING DEVICE WHICH PROJECTS RIGHT ANGLES FOR CONSTRUCTION PURPOSES; SPHERIMETERS; INCLINOMETERS; INTERFEROMETERS; STRAIGHTNESS TESTING MACHINES AND INSTRUMENTS, NAMELY, LEVEL GAUGES AND INDICATORS; SLIDE PROJECTORS; GRADUATION CHECKERS, NAMELY, CALIBRATION CHECKERS; LENGTH MEASURING GAUGES; SCREW-THREAD MEASURING MACHINES AND INSTRUMENTS; COMPARATORS; SURFACE ROUGHNESS TESTING MACHINES AND INSTRUMENTS; FLATNESS TESTING MACHINES AND INSTRUMENTS, NAMELY, CARPENTERS' LEVELS, LEVEL GAUGES, AND LIQUID LEVEL SENSORS; AUTOMATIC PRESSURE CONTROL MACHINES AND INSTRUMENTS; AUTOMATIC LIQUID-FLOW CONTROL MACHINES AND INSTRUMENTS; AUTOMATIC FLUID-COMPOSITION CONTROL MACHINES AND INSTRUMENTS; AUTOMATIC LIQUID-LEVEL CONTROL MACHINES AND INSTRUMENTS; AUTOMATIC TEMPERATURE CONTROL MACHINES AND APPARATUS, NAMELY, TEMPERATURE INDICATORS AND SENSORS WHICH AUTOMATICALLY ADJUST TEMPERATURES; AUTOMATIC COMBUSTION CONTROL MACHINES AND INSTRUMENTS; MATERIAL TESTING MACHINES, NAMELY, LUMBER, CONCRETE, CEMENT, PLASTIC AND METAL HARDNESS TESTING MACHINES; METAL COMPRESSION TESTING MACHINES; METAL HARDNESS TESTING MACHINES; METAL STRENGTH TESTING MACHINES; RUBBER TESTING MACHINES; CONCRETE TESTING MACHINES; CEMENT TESTING MACHINES; TEXTILE TESTING MACHINES; PLASTIC TESTING MACHINES; LUMBER TESTING MACHINES; SURVEYING MACHINES AND INSTRUMENTS; ALIDADES; METEOROLOGICAL MACHINES AND APPARATUS, NAMELY, METEOROLOGICAL BALLOONS; DISTANCE MEASURING MACHINES OR APPARATUS, NAMELY, RANGE FINDERS; SALINOMETER; TRIPODS FOR SURVEYING MACHINES; MAGNETIC COMPASSES FOR SURVEYING; SURVEYING COMPASS NEEDLES; GYROCOMPASSES; MAGNETIC GYROCOMPASSES; LEVEL MEASURING MACHINES FOR SURVEYING; PRECISION THEODOLITES; SURVEYING CHAINS; LEVELING RODS WITH VISUAL TARGETS FOR SURVEYING; TRANSITS FOR SURVEYING; LEVELING RODS FOR SURVEYING; SEXTANTS; ASTRONOMETRIC MEASURING MACHINES AND INSTRUMENTS; MERIDIAN TRANSITS FOR SURVEYING; ASTRONOMICAL SPECTROGRAPHS; ZENITH TELESCOPES; THERMO-SENSITIVE TEMPERATURE INDICATOR STRIPS; POWER DISTRIBUTION OR CONTROL MACHINES AND APPARATUS, NAMELY, ELECTRICAL

BUTION BOXES; ELECTRIC SWITCHES; ELECTRIC RELAYS; CIRCUIT BREAKERS; POWER CONTROLLERS; CURRENT RECTIFIERS; ELECTRIC CONNECTORS; ELECTRIC CIRCUIT CLOSERS; ELECTRIC CAPACITORS; ELECTRIC RESISTORS; ELECTRIC LOCAL SWITCHES; POWER DISTRIBUTING BOXES; PLUG ADAPTORS; FUSES FOR ELECTRIC CURRENT; LIGHTNING ARRESTERS; ELECTRIC TRANSFORMERS; INDUCTION VOLTAGE REGULATORS; OPTICAL CABLE CONNECTORS; OPTICAL TRANSMITTERS FOR OPTICAL COMMUNICATIONS DEVICES; OPTICAL AMPLIFIERS; PHOTOELECTRIC CONVERTERS; ELECTRICAL CELLS AND BATTERIES; DRY CELLS; WET CELLS; ACCUMULATORS, NAMELY, BATTERIES; PHOTO VOLTAIC CELLS; ELECTRIC OR MAGNETIC METERS AND TESTERS, NAMELY, CONTINUITY TEST APPARATUS FOR ELECTRIC CIRCUITS; OSCILLOGRAPHS IN THE NATURE OF OSCILLOSCOPES; CIRCUIT TESTERS; ANTENNA PARAMETER MEASURING APPARATUS; DETECTORS, NAMELY, CARBON DIOXIDE DETECTORS; GROUND DETECTORS IN THE NATURE OF ELECTRIC LEAKAGE DETECTORS; MAGNETOMETERS; FREQUENCY METERS; RESISTANCE MEASURING INSTRUMENTS; VOLTMETERS; WAVEMETERS; AMMETERS; WATTMETER; OSCILLATORS; TAPE MEASURES USED FOR MEASURING CAPACITY; ELECTRIC WIRES AND CABLES; ELECTRIC WIRES; RUBBER COVERED AND SPECIAL COVERED ELECTRIC WIRES; BARE AND PLASTIC COVERED ELECTRIC WIRES; ELECTRIC COILS; ELECTRIC CABLES; TERMINAL BOXES, NAMELY, COMPUTER TERMINAL BOXES, TELEPHONE TERMINAL BOXES; JUNCTION BOXES; JUNCTION SLEEVES FOR ELECTRIC CABLES; TELECOMMUNICATION CABLES; POWER CABLES; OPTICAL FIBER CABLES; OPTICAL FIBERS AND OPTICAL FIBER RIBBONS SOLD AS A COMPONENT OF FIBER OPTICAL CABLES; PHOTOGRAPHIC MACHINES AND APPARATUS, NAMELY, PHOTOCOPIERS; TILTING HEADS FOR CAMERAS; CAMERAS; RANGE FINDERS FOR CAMERAS; TRIPODS FOR CAMERAS; SHUTTERS FOR CAMERAS; BELLOWS FOR CAMERAS; SLIDE PROJECTORS; SELF-TIMERS FOR CAMERAS; PHOTOGRAPHIC FLASH UNITS FOR CAMERAS; FLASH LAMPS FOR CAMERAS; VIEWFINDERS FOR CAMERAS; LENS FILTERS FOR CAMERAS; LENS HOODS FOR CAMERAS; FLASH GUNS FOR CAMERAS; SHUTTER RELEASES FOR CAMERAS; CAMERA LENSES FOR PHOTOGRAPHIC APPARATUS; PHOTOGRAPHIC EXPOSURE METERS; CINEMATOGRAPHIC MACHINES AND APPARATUS; MOVIE PROJECTORS; PHOTOGRAPHIC TRANSPARENCIES FOR OVERHEAD PROJECTORS; CINEMATOGRAPHIC CAMERAS; PROJECTION SCREENS FOR MOVIE FILMS; EDITING APPARATUS MACHINES FOR MOVIE FILMS, NAMELY, MOVIE EDITING PROJECTORS; SOUND RECORDING APPARATUS AND INSTRUMENTS FOR CINEMATOGRAPHIC FILMS; OPTICAL APPARATUS AND INSTRUMENTS, NAMELY, OPTICAL CHARACTER RECOGNITION APPARATUS; TELESCOPES; BODY-TUBES FOR TELESCOPES, NAMELY, LENS-BARRELS; TRIPODS FOR TELESCOPES; PERISCOPES; BINOCULARS; REFLECTORS FOR TELESCOPES; PRISMS FOR TELESCOPES; TELESCOPES; LENSES FOR TELESCOPES; MICROSCOPES; MAGNIFYING GLASSES; BODY-TUBES FOR MICROSCOPES, NAMELY, LENS-BARRELS; METALLURGICAL MICROSCOPES; BIOLOGICAL MICROSCOPES; REFLECTORS FOR MICROSCOPES; PRISMS FOR MICROSCOPES; POLARIZING MICROSCOPES; STEREOSCOPES; LENSES FOR MICROSCOPES; SPECTACLES; GOGGLES FOR SPORTS; CONTACT LENSES; SUNGLASSES; SWIMMING FACE MASKS; SWIMMING GOGGLES; PINCER-NEZ; ORDINARY SPECTACLES; DUST PROTECTIVE GOGGLES AND MASKS; PARTS AND ACCESSORIES FOR SPECTACLES, NAMELY, SPECTACLE FRAMES, CASES, CHAINS AND HOLDERS; CONTAINERS FOR CONTACT LENSES; PINCER-NEZ MOUNTINGS; PINCER-NEZ CHAINS; PINCER-NEZ CORDS; SPECTACLE CASES; SPECTACLE GLASSES; SPECTACLE FRAMES; EYEGLASS AND SPECTACLE PARTS, NAMELY, PROCESSED GLASS, ULTRAVIOLET-RAY TRANSMITTING GLASS, AND INFRARED-RAY ABSORBING GLASS ALL FOR USE IN MAKING EYEGLASS LENSES; LIFE NETS; LIFE BELTS; LIFE JACKETS; LIFE-BUOYS; TELECOMMUNICATION MACHINES AND APPARATUS, NAMELY, TELECOMMUNICATIONS TRANSMITTERS; TELEPHONE APPARATUS; INTERCOMS; AUTOMATIC SWITCHING APPARATUS FOR TELECOMMUNICA-

TION; MANUAL SWITCHING APPARATUS FOR TELECOMMUNICATION; TELEPHONE SETS; OPEN-WIRE COMMUNICATION MACHINES AND APPARATUS; TELETYPEWRITERS; AUTOMATIC TELEGRAPH APPARATUS; PHOTO TELEGRAPHY APPARATUS; MANUAL TELEGRAPH APPARATUS; FACSIMILE MACHINES; POWER-LINE TRANSMISSION MACHINES AND APPARATUS; OPEN-WIRE TRANSMISSION MACHINES AND APPARATUS; TRANSMISSION AND RECEIVING APPARATUS FOR RADIO AND TELEVISION BROADCASTING; TELEVISION RECEIVERS, NAMELY, TV SETS; TELEVISION TRANSMITTERS; RADIO RECEIVERS; RADIO TRANSMITTERS; RADIOS, PORTABLE RADIOS, AERONAUTICAL RADIOS, MULTI CHANNEL RADIOS AND SINGLE-CHANNEL RADIOS FOR FIXED STATIONS, VEHICULAR RADIOS, MARINE RADIOS; NAVIGATION APPARATUS FOR VEHICLES, NAMELY, ON-BOARD COMPUTERS; RADIO BEACONS AND DIRECTION FINDERS IN THE NATURE OF RADIO RECEIVERS AND MONITORS FOR REPRODUCTION OF SOUND AND SIGNALS; RADAR; CAR NAVIGATION COMPUTERS; PUBLIC-ADDRESS SYSTEMS AND INSTRUMENTS; COMPACT DISC PLAYERS; JUKE BOXES; TAPE RECORDERS; ELECTRIC PHONOGRAPHS; RECORD PLAYERS; VIDEO FREQUENCY MACHINES AND APPARATUS, NAMELY, VIDEO PHONES; VIDEO CAMERAS, NAMELY, CAMCORDERS; VIDEODISC PLAYERS; VIDEOTAPE RECORDERS; PARTS AND ACCESSORIES FOR TELECOMMUNICATION MACHINES AND APPARATUS, NAMELY, ANTENNAS IN THE NATURE OF AERIAL, CASES FOR ANTENNAS, AND ELECTRIC COILS FOR USE WITH TELECOMMUNICATIONS APPARATUS; MAGNETIC TAPE ERASERS; MAGNETIC TAPE CLEANERS; MAGNETIC HEAD ERASERS; MAGNETIC HEAD CLEANERS APPARATUS; LOUDSPEAKER; ELECTRICAL CONNECTORS FOR TELECOMMUNICATION APPARATUS; STANDS AND RACKS FOR TELECOMMUNICATION MACHINES AND APPARATUS; TIMING DIALS FOR TELECOMMUNICATION APPARATUS; ELECTRIC CAPACITORS FOR TELECOMMUNICATION APPARATUS; FUSES FOR TELECOMMUNICATION APPARATUS; ELECTRIC RESISTORS FOR TELECOMMUNICATION APPARATUS; BLANK MAGNETIC TAPES FOR TAPE RECORDERS; CHANGE-OVER SWITCHES FOR TELECOMMUNICATION APPARATUS; PICKUPS FOR TELECOMMUNICATION APPARATUS; BLANK VIDEO TAPES; INDICATOR LIGHTS FOR TELECOMMUNICATION APPARATUS; ELECTRICAL PHONOMOTORS; HEADPHONES; ELECTRICAL TRANSFORMERS FOR TELECOMMUNICATION APPARATUS; FITTED RADIO COVERS USED TO PROTECT AUTOMOBILE RADIOS; MICROPHONES FOR TELECOMMUNICATION APPARATUS; PHONOGRAPHIC RECORD CLEANING KITS COMPRISED PRIMARILY OF REPLACEMENT STYLUS NEEDLES AND ALSO INCLUDING CLEANING SOLUTION AND BRUSHES; BLANK RECORD DISKS; SOUND RECORDED MAGNETIC CARDS, SHEETS AND TAPES; RECORDED COMPACT DISCS FEATURING MUSICAL PERFORMANCES; METRONOMES; GEIGER COUNTERS; CYCLOTRONS NOT FOR MEDICAL PURPOSES; MAGNETIC OBJECT DETECTORS; SHIELD CASES FOR MAGNETIC DISKS; SEISMIC EXPLORATION MACHINES AND APPARATUS; ECHO SOUNDERS; ULTRASONIC FLAW DETECTORS; ULTRASONIC SENSORS; ELECTROSTATIC COPYING MACHINES; ELECTRONIC DOOR CLOSING SYSTEMS; COMPUTERS; ELECTRON MICROSCOPES; ELECTRONIC DESK CALCULATORS; WORD PROCESSORS; ELECTRON TUBES; RECTIFIER TUBES; CATHODE RAY TUBES; ELECTRIC DISCHARGE TUBES OTHER THAN FOR LIGHTING; SEMI-CONDUCTOR ELEMENTS; THERMISTORS; DIODES; TRANSISTORS; ELECTRONIC CIRCUITS NOT INCLUDING THOSE RECORDED WITH COMPUTER PROGRAMS; INTEGRATED CIRCUITS; LARGE SCALE INTEGRATED CIRCUITS; COMPUTER PROGRAMS FOR USE IN DATABASE MANAGEMENT, USE AS A SPREAD SHEET AND FOR WORD PROCESSING; OZONISERS, NAMELY, OZONATORS; ELECTROLYSERS, ELECTROLYTIC CELLS; ARTIFICIAL SATELLITES; CONSUMER VIDEO GAME SOFTWARE; ELECTRONIC CIRCUITS RECORDING PROGRAMS FOR HANDHELD GAMES WITH LIQUID CRYSTAL DISPLAYS; SLOT MACHINES; VEHICLE DRIVE TRAINING SIMULATORS; ROTARY CONVERTERS; ELECTRIC FLAT IRONS; ELECTRIC HAIR-CURLERS; ELECTRIC BUZZERS; RAILWAY SIGNALS; VEHICLE BREAKDOWN WARNING TRIANGLES; LUMINOUS OR MECHANICAL ROAD SIGNS; FIRE ALARMS; GLOVES

FOR PROTECTION AGAINST ACCIDENTS; FIRE EXTINGUISHERS; FIRE HYDRANTS; FIRE HOSE NOZZLES; FIRE ENGINES; SPRINKLER SYSTEMS FOR FIRE PROTECTION; PROTECTIVE HELMETS; FIRE-PROOF GARMENTS; DUST MASKS; GAS MASKS; MAGNETIC CORES; CIGAR LIGHTERS FOR AUTOMOBILES; RESISTANCE WIRES; ELECTRODES; WELDING MASKS; EXPOSED CINEMATOGRAPHIC FILMS; EXPOSED SLIDE FILMS; SLIDE FILM MOUNTS; VENDING MACHINES; COIN-OPERATED GATES FOR CAR PARKING FACILITIES; CASH REGISTERS; SLIDERULES; COIN COUNTING OR SORTING MACHINES; ELECTRIC SIGN BOARDS FOR DISPLAYING TARGET FIGURES AND CURRENT OUTPUTS; PHOTO-COPYING MACHINES; TIME AND DATE STAMPING MACHINES; TIME CLOCKS IN THE NATURE OF TIME RECORDING DEVICES; PUNCHED CARD OFFICE MACHINES, NAMELY, PUNCH CLOCKS; VOTING MACHINES; POSTAGE STAMP CHECKING APPARATUS, NAMELY, POSTAGE STAMP METERS; WEIGHT BELTS FOR SCUBA DIVING; SURVIVAL SUITS, NAMELY, INSULATED WET SUITS; PROTECTIVE HELMETS FOR SPORTS; AIR TANKS FOR SCUBA DIVING; ELECTRIC ARC WELDERS, LASER WELDING DEVICES, AND WELDING TORCHES, USING GAS OR PLASMA TECHNOLOGY; EGG-CANDLERS; ELECTRIC DOOR OPENERS; EAR PLUGS NOT FOR MEDICAL PURPOSES; EAR PLUGS FOR SWIMMING; EARPLUGS FOR SLEEPING; EAR PLUGS FOR SOUNDPROOFING; FALL PROTECTION EQUIPMENT FOR FALL RESTRAINT AND FALL ARREST, NAMELY, CARABINERS; FIRE BOATS (U.S. CLS. 21, 23, 26, 36 AND 38).

## CLASS 12—VEHICLES

FOR BOATS AND SHIPS AND STRUCTURAL PARTS THEREFOR; VESSELS, NAMELY, BOATS AND SHIPS; AIR-CUSHION VEHICLES; CANOES; CARGO SHIPS AND BOATS; PASSENGER SHIPS AND BOATS; FISHING BOATS; NAVAL VESSELS, NAMELY, WARSHIPS; CABLE SHIPS IN THE NATURE OF CABLE LAYERS; ICEBREAKERS, NAMELY, SHIPS AND BOATS USED FOR BREAKING ICE; DREDGERS IN THE NATURE OF BOATS; WATER BIKES, NAMELY, PERSONAL WATERCRAFTS, NAMELY, WATER SCOOTERS; TANKERS; JAPANESE FLAT-BOTTOMED ROWBOATS, NAMELY, TENMASEN; BARGES; SAILING VESSELS; TUG BOATS; FERRY BOATS; ROWBOATS; MOTORBOATS; YACHTS; LAUNCHES; SCREW PROPELLERS FOR VESSELS; SCREW PROPELLERS FOR VESSELS; STEERING GEARS AND RUDDERS FOR VESSELS; RUDDERS FOR VESSELS; STEAM STEERING GEARS FOR VESSELS; STEERING WHEELS FOR VESSELS; ELECTRIC STEERING GEARS FOR VESSELS; RECREATIONAL VEHICLE ACCESSORIES, NAMELY, AWNINGS FOR VESSELS; OARS; OAR LOCKS, NAMELY, FITTINGS INTO WHICH OARS ARE PLACED WHILE IN USE; CANOE PADDLES; CAPSTANS FOR SHIPS OR BOATS, NAMELY, CYLINDER-SHAPED WINCHES; STEEL HATCH BOARDS, NAMELY, STEEL DOORS; BOAT FENDERS FOR VESSELS, NAMELY, BOAT SIDE PROTECTORS; BOAT HATCH CLEATS; HATCH BATTENS, NAMELY, BOARDS; HATCH BOARDS; FITTED COVERS FOR BOATS; DAVITS FOR BOATS, NAMELY, BOAT DAVITS; BOAT CHOCKS; PORTHOLES FOR VESSELS; MOORING PIPES FOR VESSELS; AIRCRAFT; AUTOGYROS; AIR BALLOONS; GLIDERS; SEAPLANES; AMPHIBIOUS AIRPLANES; TURBO-JET AIRPLANES; TURBO-PROP AIRPLANES; AIRSHIPS, NAMELY, DIRIGIBLE BALLOONS; PROPELLER AIRPLANES; HELICOPTERS; AIRPLANES PARTS, NAMELY, LANDING GEAR; ROTOR BLADES FOR HELICOPTERS; AIRPLANE PARTS, NAMELY, LANDING GEAR; SEATS OF AIRCRAFT; OXYGEN INHALERS OF AIRCRAFT, NAMELY, APPARATUS USED TO PROVIDE OXYGEN TO PASSENGERS AND CREW ON AIRPLANES; STRUCTURAL SUSPENSION STRUTS OF AIRCRAFT; LANDING GEAR WHEELS OF AIRCRAFT; AERODYNAMIC WINGS OF AIRCRAFT; FLIGHT CONTROL GEARS; TIRES FOR LANDING GEAR WHEELS OF AIRCRAFT; INNER TUBES FOR AIRCRAFT WHEEL TIRES; FUSELAGES OF AIRCRAFT; FUEL TANKS FOR AIRCRAFT; AIRPLANE PROPELLERS; AIRCRAFT PARTS, NAMELY, PNEUMATIC DEICERS FOR AIRCRAFT; OIL HYDRAULIC SYSTEM COMPONENTS FOR AIRCRAFT, NAMELY, HYDRAULIC DISC AND RIM BRAKES; RAILWAY ROLLING STOCK; RAILWAY FREIGHT CARS; RAILWAY PASSENGER CARS; CABLE

CARS; STEAM LOCOMOTIVES; STORAGE BATTERY LOCOMOTIVES; ELECTRIC LOCOMOTIVES; ELECTRIC RAILWAY CARS; INTERNAL COMBUSTION LOCOMOTIVES; SELF-GENERATING ELECTRIC LOCOMOTIVES, NAMELY, DIESEL-ELECTRIC LOCOMOTIVES; INTERNAL COMBUSTION RAILCARS; SEATS OF RAILWAY CARS; BODIES OF RAILWAY CARS; WHEELS OF RAILWAY CARS; UNDERCARRIAGES OF RAILWAY CARS; CHASSIS OF RAILWAY CARS; STRUCTURAL PARTS FOR RAILWAY CARS, NAMELY, DOORS; RAILWAY COUPLINGS; SKI LIFTS; AUTOMOBILES; TRUCKS; AMBULANCES; RACING MOTOR CARS; PASSENGER CARS, NAMELY, AUTOMOBILES; AMPHIBIOUS VEHICLES; SNOWMOBILES; ADVERTISING VANS; ARMORED VEHICLES; DUMP TRUCKS; LIBRARY TRUCKS; TRACTORS; TRAILERS; TROLLEY BUSES; BUSES; FORK LIFT TRUCKS; HEARSES; AIR BAGS, NAMELY, SAFETY DEVICES FOR AUTOMOBILES; WINDSCREENS OF AUTOMOBILES; AIR PUMPS OF AUTOMOBILES; CLUTCHES OF AUTOMOBILES; WARNING HORNS OF AUTOMOBILES; SEATS OF AUTOMOBILES; SEAT COVERS OF AUTOMOBILES; CHASSIS OF AUTOMOBILES; BODIES OF AUTOMOBILES; FITTER COVERS FOR AUTOMOBILE BODIES; WHEELS OF AUTOMOBILES; SPOKES OF AUTOMOBILE WHEELS; TIRES FOR AUTOMOBILES; INNER TUBES FOR AUTOMOBILE TIRES; AUTOMOBILE DOOR HANDLES; DOORS OF AUTOMOBILES; MUDGUARDS FOR AUTOMOBILES; LUGGAGE CARRIERS OF AUTOMOBILES; REARVIEW MIRRORS OF AUTOMOBILES; STEERING WHEELS OF AUTOMOBILES; STEERING WHEEL COVERS OF AUTOMOBILES; AUTOMOBILE BUMPERS; AUTOMOBILE WINDSHIELDS, NAMELY, WINDSCREENS; DIRECTION SIGNALS, NAMELY, TURN SIGNALS FOR AUTOMOBILES; HOLDING TOPS OF AUTOMOBILES, NAMELY, LUGGAGE CARRIERS; AUTOMOBILE HOODS; WINDOW CURTAINS OF AUTOMOBILE; AUTOMOBILE SPARE WHEEL HOLDERS; WHEEL RIMS FOR AUTOMOBILES; AUTOMOBILE ROOF RACKS; WINDSCREEN WIPERS FOR AUTOMOBILES; LAND VEHICLE PARTS IN THE NATURE OF WIRE HARNESSSES, NAMELY, WIRES, TERMINALS AND CONNECTORS BUNDLED TOGETHER TO TRANSMIT ELECTRIC POWER AND SIGNALS TO ELECTRIC OR ELECTRONIC EQUIPMENT MOUNTED ON THE BODY PARTS OF AUTOMOBILES; CAR-MOUNTED TERMINALS, NAMELY, CAR-MOUNTED BATTERY TERMINALS; PARTS FOR MOTOR VEHICLES, NAMELY, ROTARY CONNECTORS FOR STEERING WHEELS; CAR-MOUNTED BUSBAR, NAMELY, BUSBARS USED FOR CAR-MOUNTED JUNCTION BOXES; TWO-WHEELED MOTOR VEHICLES; MOTORCYCLES; CHAIN WHEELS OR CRANKS OF TWO-WHEELED MOTOR VEHICLES; AIR PUMPS OF TWO-WHEELED MOTOR VEHICLES; WARNING HORNS OR BELLS OF TWO WHEELED MOTOR VEHICLES; SADDLES OF TWO-WHEELED MOTOR VEHICLES, NAMELY, SEATS; STANDS OF TWO-WHEELED MOTOR VEHICLES, NAMELY, MOTORCYCLE STANDS; SPOKES OF TWO-WHEELED MOTOR VEHICLES; TIRES OF TWO-WHEELED MOTOR VEHICLES; DRIVE CHAINS OF TWO-WHEELED MOTOR VEHICLES; DRIVE-CHAIN GUARDS OF TWO-WHEELED MOTOR VEHICLES; INNER TUBES FOR TWO-WHEELED MOTOR VEHICLES; MUDGUARDS OF TWO-WHEELED MOTOR VEHICLES; HANDLEBAR GRIPS OF TWO-WHEELED MOTOR VEHICLES; LUGGAGE RACKS OF TWO-WHEELED MOTOR VEHICLES; WHEEL HUBS OF TWO-WHEELED MOTOR VEHICLES; HANDLEBARS OF TWO-WHEELED MOTOR VEHICLES; FREEWHEELS OF TWO-WHEELED MOTOR VEHICLES; FRAMES OF TWO-WHEELED MOTOR VEHICLES; PEDALS OF TWO-WHEELED MOTOR VEHICLES; FRONT FORKS OF TWO-WHEELED MOTOR VEHICLES; WHEEL RIMS OF TWO-WHEELED MOTOR VEHICLES; BICYCLES; DELIVERY BICYCLES; COLLAPSIBLE BICYCLES; TOURING BICYCLES; STANDARD BICYCLES; ROAD RACING BICYCLES; TANDEM BICYCLES; CHAIN WHEELS OR CRANKS OF BICYCLES; AIR PUMPS OF BICYCLES; WARNING HORNS OR BELLS OF BICYCLES; SADDLES OF BICYCLES; SPINDLES OF BICYCLES; STANDS OF BICYCLES; SPOKES OF BICYCLES; TIRES OF BICYCLES; DRIVE CHAINS OF BICYCLES; DRIVE-CHAIN GUARDS OF BICYCLES; INNER TUBES OF BICYCLES; MUDGUARDS OF BICYCLES; BASKETS OR PANNIERS ADAPTED FOR BICYCLES; HANDLEBAR GRIPS OF BICYCLES; LUGGAGE RACKS OF BICYCLES; WHEEL HUBS OF BICYCLES; HANDLEBARS OF BICYCLES; FREEWHEELS

OF BICYCLES; FRAMES OF BICYCLES; BICYCLE PEDALS; FRONT FORKS OF BICYCLES; WHEEL RIMS OF BICYCLES; BABY CARRIAGES AND PRAMS; WHEELCHAIRS; RICKSHAWS; SLEIGHS; WHEELBARROWS; CARTS; HORSE DRAWN CARRIAGES; BICYCLE TRAILERS NAMELY RIYAKAHS; MINE-CAR PUSHERS; MINE-CAR PULLERS; TRACTORS; INTERNAL COMBUSTION ENGINES FOR LAND VEHICLES; GASOLINE ENGINES FOR LAND VEHICLES; DIESEL ENGINES FOR LAND VEHICLES; KEROSENE ENGINES FOR LAND VEHICLES; STEAM ENGINES FOR LAND VEHICLES; JET ENGINES FOR LAND VEHICLES; TURBOJET ENGINES FOR LAND VEHICLES; TURBOPROP ENGINES FOR LAND VEHICLES; RAMJET ENGINES FOR LAND VEHICLES; AIR TURBINES FOR LAND VEHICLES; GAS TURBINES FOR LAND VEHICLES; AIR TURBINES FOR LAND VEHICLES; STEAM TURBINES FOR LAND VEHICLES; HYDRAULIC TURBINES FOR LAND VEHICLES; MACHINE ELEMENTS FOR LAND VEHICLES, NAMELY, DRIVE SHAFTS; SHAFTS, AXLES OR SPINDLES FOR LAND VEHICLES; AXLE BEARINGS FOR LAND VEHICLES; SHAFT COUPLINGS OR CONNECTORS FOR LAND VEHICLES; WHEEL BEARINGS FOR LAND VEHICLES; POWER TRANSMISSIONS AND GEARING FOR LAND VEHICLES; POWER TRANSMISSION BELTS FOR LAND VEHICLES; TOOTHED WHEELS OR GEARS FOR LAND VEHICLES; SPEED CHANGE GEARS FOR LAND VEHICLES; HYDRAULIC TORQUE CONVERTERS FOR LAND VEHICLES; SHOCK ABSORBERS FOR LAND VEHICLES; PNEUMATIC SHOCK ABSORBERS AIR SPRINGS FOR LAND VEHICLES; SPRING SHOCK ABSORBERS FOR LAND VEHICLES; SPRING-ASSISTED HYDRAULIC SHOCK ABSORBERS FOR LAND VEHICLES; COIL SUSPENSION SPRINGS FOR LAND VEHICLES; SPIRAL SUSPENSION SPRINGS FOR LAND VEHICLES; LAMINATED LEAF-SUSPENSION-SPRINGS FOR LAND VEHICLES; COILED SUSPENSION SPRINGS FOR LAND VEHICLES; BRAKES FOR LAND VEHICLES; CONE BRAKES FOR LAND VEHICLES; DISC BRAKES FOR LAND VEHICLES; BAND BRAKES FOR LAND VEHICLES; BLOCK BRAKES FOR LAND VEHICLES; AC MOTORS OR DC MOTORS FOR LAND VEHICLES; ADHESIVE RUBBER PATCHES FOR REPAIRING TUBES OR TIRES; ANTI-THEFT ALARMS FOR VEHICLES; PARACHUTES; ANTI-THEFT WARNING APPARATUS FOR MOTOR CARS (U.S. CLS. 19, 21, 23, 31, 35 AND 44).

#### CLASS 17—RUBBER GOODS

FOR RUBBER THAT IS RAW OR SEMI-WORKED; NATURAL RUBBER; GUTTA-PERCHA; RUBBER SHEETS; LIQUID RUBBER; RUBBER TUBES AND PIPES; RUBBER BARS AND RODS; RECLAIMED RUBBER; CRUDE RUBBER; FOAM RUBBER; SYNTHETIC RUBBER; ACRYLIC RUBBER; SILICONE RUBBER; STYRENE-BUTADIENE RUBBER; NITRILE RUBBER; SUBTLENESS-ISOPRENE RUBBER; FLORA RUBBER; RUBBER DERIVATIVES; EBONITE IN THE NATURE OF VULCANITE; CHLORINATED RUBBER; HYDRO-FLUORIC RUBBER; POLYPLIIDY RUBBER; RUBBER THREAD AND COVERED RUBBER YARN NOT FOR TEXTILE USE; WASHERS OF RUBBER OR VULCANIZED FIBER; VALVES OF RUBBER OR VULCANIZED FIBER NOT BEING MACHINE ELEMENTS; RUBBER CORDS AND LACES; ASBESTOS CORDS AND STRINGS; RUBBER STOPPERS FOR INDUSTRIAL PACKAGING CONTAINERS; RUBBER LIDS AND CAPS FOR INDUSTRIAL PACKAGING CONTAINERS; INDUSTRIAL PACKAGING CONTAINERS OF RUBBER; SEMI-WORKED PLASTIC MATERIAL IN EXTRUDED FORM FOR USE IN PRODUCTION; PLASTIC COMPOSITE MATERIAL IN THE FORM OF BOARDS FOR USE IN MANUFACTURING; NEUTRALIZED PLASTIC SHEETS; LAMINATED BOARDS FOR USE IN MANUFACTURING; ADHESIVE-COATED PLASTIC SHEETS; FIBER-REINFORCED PLASTIC BOARDS FOR USE IN MANUFACTURING; REFLECTIVE PLASTIC SHEETS; PLASTIC FILM FOR INDUSTRIAL AND COMMERCIAL PURPOSES; PLASTIC RODS AND BARS; SYNTHETIC STUFFING MATERIALS, NAMELY, FIBROUS PLASTIC WADDING; CHEMICAL FIBER THREAD NOT FOR TEXTILE USE; SYNTHETIC FIBERS NOT FOR TEXTILE USE; REGENERATED FIBERS NOT FOR TEXTILE USE; CHEMICAL FIBER YARN AND THREAD NOT FOR TEXTILE USE; MICA THAT IS RAW OR PARTLY PROCESSED; ROCK WOOL; SLAG WOOL FOR USE AS A BUILDING INSULATOR; ASBESTOS NETS; ASBESTOS



YARN; ASBESTOS FABRICS; ASBESTOS FELT; ASBESTOS BOARDS; ASBESTOS POWDER; ASBESTOS PAPER; VULCANIZED FIBER; ELECTRICAL INSULATING MATERIALS; ELECTRICAL INSULATORS, NAMELY, CERAMIC; ELECTRICAL INSULATING TAPES; ELECTRICAL INSULATING PAINTS; ELECTRICAL INSULATING OILS; ELECTRICAL INSULATING MICA PRODUCTS; ELECTRICAL INSULATING PAPER PRODUCTS, NAMELY, ASBESTOS PAPER; ELECTRICAL INSULATING RUBBER PRODUCTS; ELECTRICAL INSULATING FABRIC PRODUCTS, NAMELY, ASBESTOS FABRIC; FLOATING ANTI-POLLUTION BARRIERS; PIPE GASKETS; JUNCTIONS NOT OF METAL FOR WATER PIPES; FIRE HOSES; ASBESTOS FIRE CURTAINS; INSULATING GLOVES; PLASTIC SHEETING FOR AGRICULTURAL PURPOSES; PACKING FOAM IN SHEET FORM; SOUNDPROOFING MATERIALS OF ROCK WOOL NOT FOR BUILDING PURPOSES (U.S. CLS. 1, 5, 12, 13, 35 AND 50).

WILLIAM ROSSMAN, EXAMINING ATTORNEY

SN 77-043,367. BAKERCORP, SEAL BEACH, CA. FILED 11-14-2006.



OWNER OF U.S. REG. NO. 3,165,824.

#### CLASS 1—CHEMICALS

FOR LIQUID AND VAPOR FILTRATION MEDIA, NOT FOR MEDICAL PURPOSES, NAMELY, ACTIVATED CARBON FOR USE IN CONNECTION WITH THE REMOVAL OF CONTAMINANT FROM VAPOR AND LIQUID STREAMS, ACTIVATED CARBON AND ZEOLITE BASED MEDIA IMPREGNATED WITH CHEMICAL REAGENTS USED FOR THE REMOVAL OF INORGANIC CONTAMINANTS; ION EXCHANGE RESINS USED TO REMOVE PERCHLORATE AND DISSOLVED METALS; METALS REMOVAL MEDIA, NAMELY, ION EXCHANGE RESIN FOR THE REMOVAL OF ARSENIC AND OTHER HEAVY METALS; OIL REMOVAL MEDIA, NAMELY, MODIFIED ZEOLITE BLENDED WITH ACTIVATED CARBON FOR THE REMOVAL OF OIL AND HEAVY ORGANICS FROM WATER; ALL OF THE AFOREMENTIONED GOODS ARE NOT FOR USE AT OR IN WELLBORES OR FOR THE PRODUCTION OF OIL, GAS OR WATER FROM WELLBORES (U.S. CLS. 1, 5, 6, 10, 26 AND 46).

#### CLASS 11—ENVIRONMENTAL CONTROL APPARATUS

FOR LIQUID AND VAPOR FILTRATION SYSTEMS COMPRISED OF A VESSEL WITH AN INTERNAL ASSEMBLY IN THE FORM OF AN INLET AND OUTLET DISTRIBUTOR FOR THE REMOVAL OF INDUSTRIAL LIQUID AND VAPOR CONTAMINANTS, SEDIMENT, AND ODOR CONTROL; LIQUID AND VAPOR POLLUTION CONTROL AND TREATMENT SYSTEM COMPRISED OF A PUMP FOR EITHER WATER OR VAPOR, AN ELECTRICAL CONTROL, AND FILTER VESSELS; CONTAINMENT REMOVAL SYSTEMS COMPRISED OF A VESSEL WITH AN INTERNAL ASSEMBLY IN THE FORM OF AN INLET AND OUTLET DISTRIBUTOR FOR THE REMOVAL OF INDUSTRIAL LIQUID AND VAPOR CONTAMINANTS, SEDIMENT AND ODOR CONTROL; SPECIALTY MEDIA VESSELS AND FILTERS, NAMELY, BAG AND CARTRIDGE FILTERS FOR THE REMOVAL OF INDUSTRIAL LIQUID AND VAPOR CONTAMINANTS, SEDIMENT AND ODOR CONTROL; SAND FILTERS FOR THE REMOVAL OF SEDIMENT FROM TARGET LIQUID STREAMS; DUPLEX CARTRIDGE FILTERS FOR THE REMOVAL OF INDUSTRIAL LIQUID AND VAPOR CONTAMINANTS, SEDIMENT AND ODOR CONTROL; DUPLEX BAG FILTERS FOR THE REMOVAL OF INDUSTRIAL LIQUID AND VAPOR CONTAMINANTS, SEDIMENT AND ODOR CONTROL; MULTI-MEDIA FILTERS FOR USE WITH DIFFERENT TYPES OF MEDIA FILTRATION IN CONNECTION WITH THE REMOVAL OF INDUSTRIAL LIQUID AND VAPOR CONTAMINANTS, SEDIMENT AND ODOR CONTROL; ODOR CONTROL EQUIPMENT, NAMELY, ODOR CONTROL FILTERS USED IN CONNECTION WITH VAPOR PHASE APPLICATIONS; PREFILTER FOR CARBON ABSORBERS, COMPRISED OF, SAND, A BAG, AND CARTRIDGE FILTRATION UNITS TO CAPTURE AND REMOVE FROM WATER OR LIQUIDS SUSPENDED SOLID CONTAMINANTS IN LIQUID PHASE PROCESSES; ALL OF THE AFOREMENTIONED GOODS ARE NOT FOR USE AT OR IN WELLBORES OR FOR THE PRODUCTION OF OIL, GAS OR WATER FROM WELLBORES (U.S. CLS. 13, 21, 23, 31 AND 34).

#### CLASS 37—CONSTRUCTION AND REPAIR

FOR RENTAL OF STEEL EASY ACCESS TANKS TO HOLD EXCESS WATER IN CONSTRUCTION PROJECTS AND TO HOLD SPENT ACIDS, CAUSTICS, AND VISCOUS OR TURBID LIQUIDS; RENTAL OF STEEL OPEN/CLOSED/SAFE TOP TANKS FOR USE IN CONNECTION WITH CONSTRUCTION RUNOFF; RENTAL OF BARREL TANKS USED FOR SEDIMENT SETTLING FOR CONSTRUCTION PROJECTS; RENTAL OF ACCESSORIES, NAMELY, ALUMINUM HYDRAULIC SHORING, HYDRAULIC SHIELDS, ALUMINUM MODULAR SHIELDS, STEEL TRENCH SHIELDS, STEEL AND ALUMINUM SHEETING, SLIDE RAIL SYSTEMS, PIPE PULLERS, STEEL ROAD PLATES, AND BEDDING BOXES; RENTAL OF INDUSTRIAL PUMPS AND PUMP PIPES, NAMELY, TRANSFER PUMPS FOR USE IN CONNECTION WITH THE REMOVAL OF WATER FROM AN EVACUATION AREA; RENTAL OF PRIMING ASSISTED PUMPS USED FOR CONSTRUCTION SITE DEWATERING, SEWER BYPASS, TANK CLEANING, FLOOD MANAGEMENT, AND MUNICIPAL PROJECTS; RENTAL OF HIGH PRESSURE PUMPS USED FOR INDUSTRIAL WATER BLASTING, PIPELINE PIGGING, AND IRRIGATION STANDBY FIRE PROTECTION; RENTAL OF ELECTRIC PUMPS USED FOR CONSTRUCTION AND INDUSTRIAL APPLICATIONS OF ALL TYPES WHERE DIESEL ENGINES ARE NOT ALLOWED OR ARE IMPRACTICAL, NAMELY, FOR THE REMOVAL OF WATER FROM AN EVACUATION AREA, CONSTRUCTION SITE DEWATERING, SEWER BYPASS, TANK CLEANING, FLOOD CONTROL AND MANAGEMENT, MUNICIPAL PROJECTS, INDUSTRIAL WATER BLASTING, PIPELINE PIGGING, AND IRRIGATION STANDBY FIRE PROTECTION; RENTAL OF ELECTRIC SUBMERSIBLE PUMPS FOR THE REMOVAL OF WATER AND HANDLING SOLIDS WHEN ELECTRIC POWER SOURCE IS AVAILABLE; RENTAL OF HYDRAULIC SUBMERSIBLE PUMPS USED FOR HIGH SUCTION LIFT APPLICATIONS, NAMELY, SEWER BYPASS JOBS, AND DEWATERING OF MINES, QUARRIES, AND GRAVEL PITS; RENTAL OF AIR DIAPHRAGM PUMPS FOR USE IN CONNECTION WITH

SLUDGE AND SLURRIES, FLOOD CONTROL; RENTAL OF SOUND ATTENUATED PUMPS FOR USE IN CONNECTION WITH SEWER BYPASS PROJECTS IN RESIDENTIAL AREAS, HOSPITALS OR COMMERCIAL AREAS WHERE SOUND SUPPRESSION IS NECESSARY; RENTAL OF UTILITY PUMPS FOR USE IN CONNECTION WITH CONSTRUCTION SITE DEWATERING, PRODUCT TRANSFER, EMERGENCY STANDBY, SEWAGE TRANSFER, IRRIGATION AND FARM USE, AND ACCESSORIES THEREFOR, NAMELY, PIPE, HOSE, AND FITTINGS, AND SECONDARY CONTAINMENT BERMS, ROAD CROSSINGS, GENERATORS, FUEL TANKS, SPILL GUARDS; RENTAL OF STEEL FIXED AXLE TANKS FOR INDUSTRIAL CONSTRUCTION; RENTAL OF TRENCH SHORING EQUIPMENT FOR EXCAVATION APPLICATIONS FOR USE IN THE CHEMICAL, MANUFACTURING, REFINING, OIL AND GAS, CONSTRUCTION, MUNICIPAL INDUSTRIES; RENTAL OF STEEL MIX TANK SYSTEMS FOR TANK CLEANING AND HEATING THICK MATERIALS FOR CONSTRUCTION APPLICATIONS; RENTAL OF SELF PRIMING PUMPS FOR USE BY REFINERIES AND CHEMICAL FACILITIES; ALL OF THE AFOREMENTIONED GOODS ARE NOT FOR USE AT OR IN WELLBORES OR FOR THE PRODUCTION OF OIL, GAS OR WATER FROM WELLBORES (U.S. CLS. 100, 103 AND 106).

#### **CLASS 39—TRANSPORTATION AND STORAGE**

FOR RENTAL OF INTERMODAL CONTAINERS FOR USE IN TRANSPORT OF SOLID WASTE; RENTAL OF TANKER TRAILERS, NAMELY, POLYETHYLENE TRAILERS FOR USE IN CONNECTION WITH TEMPORARY CHEMICAL STORAGE AND TRANSPORT FOR REFINERIES, CHEMICAL FACILITIES, WASTEWATER TREATMENT PLANTS AND WHEREVER CORROSIVE MATERIALS ARE USED; RENTAL OF SPECIALTY EQUIPMENT, NAMELY, STAINLESS STEEL TANKERS FOR USE IN CONNECTION WITH CHEMICAL STORAGE, TRANSPORT, DISTRIBUTION OF FINISHED, INTERMEDIATE AND WASTE PRODUCTS, STORAGE OF PRODUCT OVERRUNS; RENTAL OF BULK CONTAINERS FOR ACIDIC AND CAUSTIC STORAGE AND TRANSPORT FOR REFINERIES, CHEMICAL FACILITIES, AND WASTEWATER TREATMENT PLANTS; RENTAL OF STEEL FIXED AXLE TANKS FOR DRILLING AND CHEMICAL STORAGE; RENTAL OF BARREL TANKS FOR TEMPORARY STORAGE OF SEDIMENT AND SLUDGE; RENTAL OF BULK CONTAINERS FOR TEMPORARY STORAGE OF CAUSTIC AND ACIDIC MATERIALS FOR TRANSPORT FOR REFINERIES, CHEMICAL FACILITIES, AND WASTEWATER TREATMENT PLANTS; RENTAL OF POLYETHYLENE ADJUSTABLE VALVE TANKS FOR THE STORAGE OF CORROSIVE MATERIALS; RENTAL OF VACUUM AND ROLL-OFF BOXES FOR USE THE TEMPORARY STORAGE OF SLUDGE AND SOLID WASTE; RENTAL OF STEEL DOUBLE WALL TANKS FOR USE FOR STORAGE OF ENVIRONMENTALLY SENSITIVE LIQUID AND VAPOR CONTAINMENTS, INCLUDING CONTAINMENT NEAR RIVERS, LAKES, BAY AND URBAN AREAS; RENTAL OF POLYETHYLENE ADJUSTABLE VALVE TANKS FOR USE BY REFINERIES, CHEMICAL FACILITIES, AND WASTEWATER TREATMENT PLANTS TO STORE ACIDS, CHEMICALS, AND CAUSTICS; RENTAL OF STEEL OPEN/CLOSED/SAFE TOP TANKS USED FOR STORAGE FOR USE IN ENVIRONMENTAL GROUNDWATER PROJECTS; RENTAL OF STEEL SAFETY VAPOR TANKS TO HOLD VOLATILE ORGANIC LIQUIDS, SPENT ACIDS, AND CAUSTICS; ALL OF THE AFOREMENTIONED GOODS ARE NOT FOR USE AT OR IN WELLBORES OR FOR THE PRODUCTION OF OIL, GAS OR WATER FROM WELLBORES (U.S. CLS. 100 AND 105).

#### **CLASS 40—MATERIAL TREATMENT**

FOR RENTAL OF STEEL EASY ACCESS TANKS TO HOLD EXCESS WATER IN ENVIRONMENTAL RUNOFF PROJECTS; RENTAL OF HIGH PRESSURE PUMPS FOR ENVIRONMENTAL CLEANUPS; RENTAL OF AIR DIAPHRAGM PUMPS FOR USE WITH DEWATERING SITUATIONS ASSOCIATED WITH REFINERIES FOR WATER TREATMENT PURPOSES; RENTAL OF LIQUID AND VAPOR FILTRATION SYSTEMS FOR THE REMOVAL OF INDUSTRIAL LIQUID AND VAPOR CONTAMINANTS AND SEDIMENT FROM WATER, LIQUID, OR VAPOR AND ODOR CONTROL; RENTAL OF LIQUID AND VAPOR POLLUTION CONTROL AND TREATMENT EQUIPMENT; RENTAL OF CONTAMINANT REMOVAL SYSTEMS FOR THE REMOVAL OF INDUSTRIAL LIQUID AND VAPOR CONTAMINANTS AND SEDIMENT FROM WATER, LIQUID, OR VAPOR AND FOR ODOR CONTROL; RENTAL OF SPECIALTY MEDIA VESSELS AND FILTERS, NAMELY, BAG AND CARTRIDGE FILTERS FOR USE IN CONNECTION WITH THE REMOVAL OF INDUSTRIAL LIQUID AND VAPOR CONTAMINANTS AND SEDIMENT FROM WATER, LIQUID, OR VAPOR AND ODOR CONTROL; RENTAL OF SAND FILTERS FOR USE IN CONNECTION WITH THE REMOVAL OF SEDIMENT FROM TARGET LIQUID STREAMS FOR WATER TREATMENT PURPOSES; RENTAL OF DUPLEX CARTRIDGE FILTERS FOR USE IN CONNECTION WITH THE REMOVAL OF INDUSTRIAL LIQUID AND VAPOR CONTAMINANTS AND SEDIMENT FROM WATER, LIQUID, OR VAPOR AND ODOR CONTROL; RENTAL OF DUPLEX BAG FILTERS FOR THE REMOVAL OF INDUSTRIAL LIQUID AND VAPOR CONTAMINANTS AND SEDIMENT FROM WATER, LIQUID, OR VAPOR AND ODOR CONTROL; RENTAL OF MULTI-MEDIA FILTERS FOR USE WITH DIFFERENT TYPES OF MEDIA FILTRATION FOR THE REMOVAL OF INDUSTRIAL LIQUID AND VAPOR CONTAMINANTS AND SEDIMENT FROM WATER, LIQUID, OR VAPOR AND ODOR CONTROL; RENTAL OF ODOR CONTROL EQUIPMENT, NAMELY, ODOR CONTROL FILTERS USED TO REMOVE NUISANCE ODORS AND ORGANIC CONTAMINANTS FROM LIQUID, WATER, OR VAPOR; RENTAL OF STEEL OPEN TOP TANKS FOR FILTRATION AND REMOVAL OF SUSPENDED SOLID CONTAMINANTS FROM WATER AND OTHER LIQUIDS; RENTAL OF STEEL SETTLING TANKS FOR FILTRATION AND REMOVAL OF SUSPENDED SOLID CONTAMINANTS FROM WATER AND OTHER LIQUIDS; RENTAL OF STEEL FIXED AXLE TANKS FOR SEWAGE PLANT OUTAGES; RENTAL OF STEEL 10K ROLL-OFF TANKS FOR TANK CLEANING, SLUDGE PROJECTS, AND FOR STORM WATER AND LEACHATES; RENTAL OF POLYETHYLENE TOTAL DRAIN TANKS TO HOLD STORM AND GROUND WATER, ACIDS AND CAUSTICS, FRESH OR SPENT CHEMICALS; RENTAL OF POLYETHYLENE TANKS CAPABLE OF BEING LIFTED BY A FORKLIFT FOR ONSITE MOVEMENT OF WASTEWATER AND VOLATILE LIQUIDS BY WATER TREATMENT FACILITIES, CHEMICAL PLANTS AND REFINERIES; RENTAL OF DEWATERING BOXES FOR FREEING WATER FROM SLUDGE AND SLURRY; RENTAL OF VACUUM AND ROLL-OFF BOXES FOR THE MOVEMENT OF SLUDGE AND SOLID WASTE; RENTAL OF PHASE SEPARATORS FOR USE IN SEPARATING AND DEWATERING SOLID WASTE; RENTAL OF CHEMICAL SLUDGE MIXING AND FEED SYSTEM FOR DEWATERING; RENTAL OF SELF PRIMING PUMPS FOR USE BY WASTE WATER TREATMENT PLANTS; RENTAL OF TRENCH SHORING EQUIPMENT FOR EXCAVATION APPLICATIONS FOR USE IN THE ENVIRONMENTAL REMEDIATION AND WASTEWATER INDUSTRIES ALL OF THE AFOREMENTIONED GOODS ARE NOT FOR USE AT OR IN WELLBORES OR FOR THE PRODUCTION OF OIL, GAS OR WATER FROM WELLBORES (U.S. CLS. 100, 103 AND 106).

CHRISTOPHER BUONGIORNO, EXAMINING ATTORNEY



SN 77-212,255. HALOSOURCE, INC., BOTHELL, WA. FILED 6-21-2007.



OWNER OF U.S. REG. NO. 2,863,154. THE MARK CONSISTS OF AN ARC OVER THE WORD "HALOPURE".

**CLASS 11—ENVIRONMENTAL CONTROL APPARATUS**

FOR WATER FILTERING UNITS FOR KITCHEN SINKS AND ICE-MAKING MACHINES; WATER PURIFICATION CARTRIDGES FOR WATER FOUNTAINS; SWIMMING POOL AND SPA WATER PURIFICATION AND FILTERING UNITS; WATER PURIFYING APPARATUS; NON-ELECTRIC DRINKING WATER DISINFECTION APPARATUS FOR IN-LINE WATER PURIFICATION; GRAVITY DRIP DRINKING WATER DISINFECTION APPARATUS; WATER PURIFIER FILTRATION INSERTS; WATER FILTRATION PITCHERS AND WATER FILTRATION SPORTS BOTTLES SOLD EMPTY (U.S. CLS. 13, 21, 23, 31 AND 34).

**CLASS 20—FURNITURE AND ARTICLES NOT OTHERWISE CLASSIFIED**

FOR NON-METAL PURIFIED WATER STORAGE TANKS (U.S. CLS. 2, 13, 22, 25, 32 AND 50). DANNEAN HETZEL, EXAMINING ATTORNEY

SN 77-212,269. HALOSOURCE, INC., BOTHELL, WA. FILED 6-21-2007.



OWNER OF U.S. REG. NO. 2,863,154. NO CLAIM IS MADE TO THE EXCLUSIVE RIGHT TO USE "POWERED", APART FROM THE MARK AS SHOWN. THE MARK CONSISTS OF AN ARC OVER THE WORDS "HALOPURE POWERED".

**CLASS 11—ENVIRONMENTAL CONTROL APPARATUS**

FOR WATER FILTERING UNITS FOR KITCHEN SINKS AND ICE-MAKING MACHINES; WATER PURIFICATION CARTRIDGES FOR WATER FOUNTAINS; SWIMMING POOL AND SPA WATER PURIFICATION AND FILTERING UNITS; WATER PURIFYING APPARATUS; NON-ELECTRIC DRINKING WATER DISINFECTION APPARATUS FOR IN-LINE WATER PURIFICATION; GRAVITY DRIP DRINKING WATER DISINFECTION APPARATUS; WATER PURIFIER FILTRATION INSERTS; WATER FILTRATION PITCHERS AND WATER FILTRATION SPORTS BOTTLES SOLD EMPTY (U.S. CLS. 13, 21, 23, 31 AND 34).

**CLASS 20—FURNITURE AND ARTICLES NOT OTHERWISE CLASSIFIED**

FOR NON-METAL PURIFIED WATER STORAGE TANKS (U.S. CLS. 2, 13, 22, 25, 32 AND 50). DANNEAN HETZEL, EXAMINING ATTORNEY

SN 77-226,905. PROTALIX LTD., CARMIEL, ISRAEL, FILED 7-11-2007.



THE MARK CONSISTS OF STANDARD CHARACTERS WITHOUT CLAIM TO ANY PARTICULAR FONT, STYLE, SIZE, OR COLOR.

OWNER OF ISRAEL REG. NO. 207457, DATED 5-6-2009, EXPIRES 1-10-2018.

OWNER OF ISRAEL REG. NO. 207456, DATED 5-6-2009, EXPIRES 1-10-2018.

OWNER OF ISRAEL REG. NO. 207455, DATED 5-6-2009, EXPIRES 1-10-2018.

**CLASS 1—CHEMICALS**

FOR CHEMICAL, BIOCHEMICAL, BIOLOGICAL AND BIOTECHNOLOGICAL PREPARATIONS AND SUBSTANCES FOR SCIENTIFIC AND MEDICAL RESEARCH USE, NAMELY, RECOMBINANT VECTORS FOR CLONING; PROTEINS AND REAGENTS FOR SCIENTIFIC AND MEDICAL RESEARCH USE, NAMELY, FOR USE IN RECOMBINANT PROTEIN EXPRESSION IN CELLS; RECOMBINANT VECTORS AND REAGENTS FOR EXPRESSING RECOMBINANT DNA FOR INDUSTRIAL, SCIENTIFIC, AND MEDICAL RESEARCH USE; CHEMICAL, BIOCHEMICAL, BIOLOGICAL AND BIOTECHNOLOGICAL PREPARATIONS AND SUBSTANCES, NAMELY, RECOMBINANT VECTORS FOR INDUSTRIAL, SCIENTIFIC, AND MEDICAL RESEARCH USE IN LABORATORIES, DIAGNOSTICS AND ANALYTICS; CHEMICAL, BIOCHEMICAL, BIOLOGICAL AND BIOTECHNOLOGICAL PREPARATIONS AND SUBSTANCES, NAMELY, CELL GROWTH SUPPORT STRUCTURES MEDIUM AND SUBSTRATES FOR USE IN CELL CULTURES FOR INDUSTRIAL, SCIENTIFIC AND MEDICAL RESEARCH; CHEMICAL, BIOCHEMICAL, BIOLOGICAL AND BIOTECHNOLOGICAL PREPARATIONS AND SUBSTANCES FOR USE IN THE MANUFACTURE OF MEDICINES, PHARMACEUTICALS, DIAGNOSTICS, VACCINES, ANTIBODIES AND BIOLOGICAL MOLECULES FROM RECOMBINANT PROTEINS OR PEPTIDES EXPRESSED IN CELL CULTURES, NAMELY, CELL GROWTH SUPPORT STRUCTURES AND SUBSTRATES FOR USE IN CELL CULTURES, RECOMBINANT VECTORS FOR CLONING AND REAGENTS FOR EXPRESSION OF RECOMBINANT PROTEINS; NONE OF THE FOREGOING BEING DIAGNOSTIC ASSAYS FOR SCIENTIFIC, RESEARCH, CLINICAL, OR MEDICAL LABORATORY USE (U.S. CLS. 1, 5, 6, 10, 26 AND 46).

**CLASS 9—ELECTRICAL AND SCIENTIFIC APPARATUS**

FOR BIOREACTOR FOR CELL CULTURING (U.S. CLS. 21, 23, 26, 36 AND 38).

**CLASS 42—SCIENTIFIC AND COMPUTER SERVICES**

FOR PROVIDING MEDICAL AND SCIENTIFIC RESEARCH EQUIPMENT TO OTHERS FOR CULTURING CELLS USED TO PRODUCE BIOPHARMACEUTICALS, NAMELY, RECOMBINANT PROTEINS; RESEARCH AND DEVELOPMENT FOR OTHERS IN THE FIELD OF GENETICALLY ENGINEERED PLANTS AND PLANT CELLS FOR PRODUCING BIOPHARMACEUTICALS, NAMELY, RECOMBINANT PROTEINS; DEVELOPMENT OF NEW TECHNOLOGY FOR OTHERS IN THE FIELD OF RECOMBINANT BIOTECHNOLOGY; PRODUCT RESEARCH AND DEVELOPMENT; SCIENTIFIC RESEARCH AND INDUSTRIAL RESEARCH FOR OTHERS, NAMELY, DRUG DISCOVERY, CELL DISCOVERY, DISCOVERY OF RECOMBINANT PROTEINS, GENE RESEARCH, ENZYME RESEARCH, MOLECULAR RESEARCH, GENOMICS AND GENE EXPRESSION RESEARCH AND DEVELOPMENT; TECHNICAL CONSULTATION IN THE FIELD OF BIOTECHNOLOGY AND IN THE FIELD OF RECOMBINANT PRODUCTION TECHNOLOGY (U.S. CLS. 100 AND 101).

ALYSSA STEEL, EXAMINING ATTORNEY

**CLASS 41—EDUCATION AND ENTERTAINMENT**

FOR PRODUCTION OF FILM, VIDEO, TELEVISION AND WEBSITE MATERIAL FOR BROADCAST AND INTERNET TELEVISION, BROADBAND TV, CABLE TV, VIDEO PODCAST, VIDEO BLOG; DOMESTIC AND INTERNATIONAL DISTRIBUTION OF VIDEO PROGRAMMING VIA THE INTERNET, TELEVISION, CABLE, BROADBAND; PRODUCTION AND DISTRIBUTION OF VIDEO PROGRAMS VIA THE INTERNET, TELEVISION, BROADBAND, CABLE, VIDEO PODCAST, VIDEO BLOG; ENTERTAINMENT SERVICES, NAMELY, PROVIDING AN ONGOING TELEVISION PROGRAM IN THE FIELDS OF CELEBRITY, MUSIC AND FASHION NEWS (U.S. CLS. 100, 101 AND 107).

FIRST USE 8-31-2007; IN COMMERCE 8-31-2007.  
MIDGE BUTLER, EXAMINING ATTORNEY

SN 77-238,484. HUTCH MEDIA, LLC, SANTA MONICA, CA.  
FILED 7-25-2007.

SN 77-238,471. HUTCH MEDIA, LLC, SANTA MONICA, CA.  
FILED 7-25-2007.

# EGO TV

THE MARK CONSISTS OF STANDARD CHARACTERS WITHOUT CLAIM TO ANY PARTICULAR FONT, STYLE, SIZE, OR COLOR.

NO CLAIM IS MADE TO THE EXCLUSIVE RIGHT TO USE "TV", APART FROM THE MARK AS SHOWN.

**CLASS 35—ADVERTISING AND BUSINESS**

FOR ADVERTISING SERVICES, NAMELY, DISSEMINATION OF VIDEO ADVERTISEMENTS AND VIDEO COMMERCIAL PROMOTIONS VIA THE INTERNET, TELEVISION, BROADBAND TV, CABLE TV, SATELLITE TV, VIDEO PODCAST AND VIDEO BLOG; ADVERTISING THE GOODS AND SERVICES OF OTHERS VIA TELEVISION, CABLE, BROADBAND TV, PODCAST, VIDEO BLOG AND SATELLITE TELEVISION (U.S. CLS. 100, 101 AND 102).

FIRST USE 8-31-2007; IN COMMERCE 8-31-2007.

**CLASS 38—COMMUNICATION**

FOR BROADCASTING AND TRANSMISSION OF TELEVISION, CABLE TV, INTERNET TV, BROADBAND TV, VIDEO PODCAST, VIDEO BLOG, SATELLITE TV, VIDEO WEBCASTING SERVICES; BROADCAST OF TELEVISION PROGRAMS (U.S. CLS. 100, 101 AND 104).

FIRST USE 8-31-2007; IN COMMERCE 8-31-2007.

**EGO ENTERTAINMENT**

THE MARK CONSISTS OF STANDARD CHARACTERS WITHOUT CLAIM TO ANY PARTICULAR FONT, STYLE, SIZE, OR COLOR.

NO CLAIM IS MADE TO THE EXCLUSIVE RIGHT TO USE "ENTERTAINMENT", APART FROM THE MARK AS SHOWN.

**CLASS 35—ADVERTISING AND BUSINESS**

FOR ADVERTISING SERVICES, NAMELY, DISSEMINATION OF VIDEO ADVERTISEMENTS AND VIDEO COMMERCIAL PROMOTIONS VIA THE INTERNET, TELEVISION, BROADBAND TV, CABLE TV, SATELLITE TV, VIDEO PODCAST AND VIDEO BLOG; ADVERTISING THE GOODS AND SERVICES OF OTHERS VIA TELEVISION, CABLE, BROADBAND TV, PODCAST, VIDEO BLOG AND SATELLITE TELEVISION (U.S. CLS. 100, 101 AND 102).

**CLASS 38—COMMUNICATION**

FOR BROADCASTING AND TRANSMISSION OF TELEVISION, CABLE TV, INTERNET TV, BROADBAND TV, VIDEO PODCAST, VIDEO BLOG, SATELLITE TV, VIDEO WEBCASTING SERVICES; BROADCAST OF TELEVISION PROGRAMS (U.S. CLS. 100, 101 AND 104).

**CLASS 41—EDUCATION AND ENTERTAINMENT**

FOR PRODUCTION OF FILM, VIDEO, TELEVISION AND WEBSITE MATERIAL FOR BROADCAST AND INTERNET TELEVISION, BROADBAND TV, CABLE TV, VIDEO PODCAST, VIDEO BLOG; DOMESTIC AND INTERNATIONAL DISTRIBUTION OF VIDEO PROGRAMMING VIA THE INTERNET, TELEVISION, CABLE, BROADBAND; PRODUCTION AND DISTRIBUTION OF VIDEO PROGRAMS VIA THE INTERNET, TELEVISION, BROADBAND, CABLE, VIDEO PODCAST, VIDEO BLOG; ENTERTAINMENT SERVICES, NAMELY, PROVIDING AN ONGOING TELEVISION PROGRAM IN THE FIELDS OF CELEBRITY, MUSIC AND FASHION NEWS (U.S. CLS. 100, 101 AND 107).

MIDGE BUTLER, EXAMINING ATTORNEY

SN 77-238,493. HUTCH MEDIA, LLC, SANTA MONICA, CA. FILED 7-25-2007.

**EGO TV MAKE YOUR MARK**

THE MARK CONSISTS OF STANDARD CHARACTERS WITHOUT CLAIM TO ANY PARTICULAR FONT, STYLE, SIZE, OR COLOR.

NO CLAIM IS MADE TO THE EXCLUSIVE RIGHT TO USE "TV", APART FROM THE MARK AS SHOWN.

**CLASS 35—ADVERTISING AND BUSINESS**

FOR ADVERTISING SERVICES, NAMELY, DISSEMINATION OF VIDEO ADVERTISEMENTS AND VIDEO COMMERCIAL PROMOTIONS VIA THE INTERNET, TELEVISION, BROADBAND TV, CABLE TV, SATELLITE TV, VIDEO PODCAST AND VIDEO BLOG; ADVERTISING THE GOODS AND SERVICES OF OTHERS VIA TELEVISION, CABLE, BROADBAND TV, PODCAST, VIDEO BLOG AND SATELLITE TELEVISION (U.S. CLS. 100, 101 AND 102).

FIRST USE 8-31-2007; IN COMMERCE 8-31-2007.

**CLASS 38—COMMUNICATION**

FOR BROADCASTING AND TRANSMISSION OF TELEVISION, CABLE TV, INTERNET TV, BROADBAND TV, VIDEO PODCAST, VIDEO BLOG, SATELLITE TV, VIDEO WEBCASTING SERVICES; BROADCAST OF TELEVISION PROGRAMS (U.S. CLS. 100, 101 AND 104).

FIRST USE 8-31-2007; IN COMMERCE 8-31-2007.

**CLASS 41—EDUCATION AND ENTERTAINMENT**

FOR PRODUCTION OF FILM, VIDEO, TELEVISION AND WEBSIDE MATERIAL FOR BROADCAST AND INTERNET TELEVISION, BROADBAND TV, CABLE TV, VIDEO PODCAST, VIDEO BLOG; DOMESTIC AND INTERNATIONAL DISTRIBUTION OF VIDEO PROGRAMMING VIA THE INTERNET, TELEVISION, CABLE, BROADBAND; PRODUCTION AND DISTRIBUTION OF VIDEO PROGRAMS VIA THE INTERNET, TELEVISION, BROADBAND, CABLE, VIDEO PODCAST, VIDEO BLOG; ENTERTAINMENT SERVICES, NAMELY, PROVIDING AN ONGOING TELEVISION PROGRAM IN THE FIELDS OF CELEBRITY, MUSIC AND FASHION NEWS (U.S. CLS. 100, 101 AND 107).

FIRST USE 8-31-2007; IN COMMERCE 8-31-2007.

MIDGE BUTLER, EXAMINING ATTORNEY

SN 77-238,525. HUTCH MEDIA, LLC, SANTA MONICA, CA. FILED 7-25-2007.

**EGO**

THE MARK CONSISTS OF STANDARD CHARACTERS WITHOUT CLAIM TO ANY PARTICULAR FONT, STYLE, SIZE, OR COLOR.

**CLASS 35—ADVERTISING AND BUSINESS**

FOR RENTAL OF ADVERTISING SPACE VIA THE INTERNET, TELEVISION, CABLE, PERSONAL MEDIA PLAYER, BROADBAND, TELEPHONE, PODCAST, VIDEO BLOG, SATELLITE, MOBILE DEVICES AND PRIVATE NETWORKS, NAMELY, THOSE FOR RETAIL, AIRLINES, AND HOTELS, FOR ADVERTISING THE GOODS AND SERVICES OF OTHERS; ADVERTISING SERVICES, NAMELY, DISSEMINATION OF ADVERTISEMENTS AND COMMERCIAL PROMOTIONS VIA THE INTERNET, TELEVISION, BROADBAND, CABLE, TELEPHONE, PODCAST, VIDEO BLOG, PERSONAL MEDIA PLAYER, SATELLITE, MOBILE DEVICES AND PRIVATE NETWORKS FOR THOSE IN THE RETAIL, AIRLINE, AND HOTEL INDUSTRY (U.S. CLS. 100, 101 AND 102).

**CLASS 38—COMMUNICATION**

FOR BROADCASTING AND TRANSMISSION OF TELEVISION, CABLE TV, INTERNET TV, BROADBAND TV, VIDEO PODCAST, VIDEO BLOG, SATELLITE TV, VIDEO WEBCASTING SERVICES; ENTERTAINMENT SERVICES, NAMELY, PROVIDING A TELEVISION PROGRAM IN THE FIELDS OF CELEBRITY, MUSIC AND FASHION NEWS, AND BROADCAST OF TELEVISION PROGRAMS (U.S. CLS. 100, 101 AND 104).

**CLASS 41—EDUCATION AND ENTERTAINMENT**

FOR PRODUCTION OF FILM, VIDEO, TELEVISION AND WEBSIDE MATERIAL FOR BROADCAST AND INTERNET TELEVISION, BROADBAND TV, CABLE TV, VIDEO PODCAST, VIDEO BLOG; DOMESTIC AND INTERNATIONAL DISTRIBUTION OF VIDEO PROGRAMMING VIA THE INTERNET, TELEVISION, CABLE, BROADBAND; PRODUCTION AND DISTRIBUTION OF VIDEO PROGRAMS VIA THE INTERNET, TELEVISION, BROADBAND, CABLE, VIDEO PODCAST, VIDEO BLOG (U.S. CLS. 100, 101 AND 107).

MIDGE BUTLER, EXAMINING ATTORNEY

SN 77-276,073. AUTOMOTIVE ENERGY SUPPLY CORPORATION, ZAMA-SHI KANAGAWA 220-0012, JAPAN, FILED 9-10-2007.



PRIORITY CLAIMED UNDER SEC. 44(D) ON JAPAN APPLICATION NO. 2007-063495, FILED 6-20-2007, REG. NO. 5162883, DATED 8-29-2008, EXPIRES 8-29-2018.

THE MARK CONSISTS OF THE STYLIZED LETTERS "AE" AND DESIGN.

**CLASS 9—ELECTRICAL AND SCIENTIFIC APPARATUS**

FOR BATTERIES; LITHIUM ION BATTERIES; ELECTRIC BATTERIES; RECHARGEABLE ACCUMULATOR BATTERIES; WET CELL BATTERIES; DRY CELL BATTERIES; PHOTOVOLTAIC SOLAR BATTERIES; BATTERIES FOR VEHICLES; LITHIUM ION BATTERIES FOR VEHICLES; ELECTRIC BATTERIES FOR VEHICLES; BATTERIES FOR LIGHTING; BATTERIES FOR POCKET LAMPS; BATTERY BOXES; BATTERY CHARGERS; BATTERY JARS (U.S. CLS. 21, 23, 26, 36 AND 38).

**CLASS 12—VEHICLES**

FOR AUTOMOBILES, WAGONS, TRUCKS, VEHICLE VANS, SPORT UTILITY VEHICLES, BUSES, RECREATIONAL VEHICLES, SPORTS CARS, RACING CARS, LORRIES, FORK LIFT TRUCKS, ELECTRIC VEHICLES, NAMELY, AUTOMOBILES, WAGONS, TRUCKS, VANS, SPORT UTILITY VEHICLES, BUSES, RECREATIONAL VEHICLES, SPORTS CARS, RACING CARS, LORRIES, FORKLIFT TRUCKS, TRACTORS, AUTO GUIDED VEHICLES, CARTS AND STRUCTURAL PARTS THEREFOR; FUEL CELL VEHICLES, NAMELY, AUTOMOBILES, WAGONS, TRUCKS, VANS, SPORT UTILITY VEHICLES, BUSES, RECREATIONAL VEHICLES, SPORTS CARS, RACING CARS, LORRIES, FORKLIFT TRUCKS, TRACTORS, AUTO GUIDED VEHICLES, CARTS AND STRUCTURAL PARTS THEREFOR; HYBRID VEHICLES, NAMELY, AUTOMOBILES, WAGONS, TRUCKS, VANS, SPORT UTILITY VEHICLES, BUSES, RECREATIONAL VEHICLES, SPORTS CARS, RACING CARS, LORRIES, FORKLIFT TRUCKS, TRACTORS, AUTO GUIDED VEHICLES, CARTS AND STRUCTURAL PARTS THEREFOR; TOWING TRACTORS, TWO-WHEELED MOTOR VEHICLES, TWO-WHEELED ELECTRIC MOTOR VEHICLES, TWO-WHEELED FUEL CELL MOTOR VEHICLES; BICYCLES AND BICYCLE PARTS, NAMELY, BICYCLE WHEELS, SPROCKETS AND HANDLE BAR ENDS; CARTS; CAR TOWING VEHICLES FOR PUSHING AND PULLING CARS, TRACTORS; MOTORS AND ENGINES FOR LAND VEHICLES; TRACTION ENGINES, HYBRID ENGINES FOR VEHICLES; ALTERNATING CURRENT MOTORS/DIRECT CURRENT MOTORS FOR LAND VEHICLES; LAND VEHICLE PARTS, NAMELY, AXLES, BRAKES, SHOCK ABSORBERS, AND POWER TRANSMISSIONS; ANTI-THEFT ALARMS FOR VEHICLES; ADHESIVE RUBBER PATCHES FOR REPAIRING TUBES OR TIRES (U.S. CLS. 19, 21, 23, 31, 35 AND 44).

**CLASS 37—CONSTRUCTION AND REPAIR**

FOR REPAIR, MAINTENANCE, AND INSTALLATION OF BATTERIES, LITHIUM ION BATTERIES, BATTERY BOXES, BATTERY JARS, MOTORS, AUTOMOBILES AND THEIR PARTS, ELECTRIC VEHICLES, FUEL CELL VEHICLES, HYBRID VEHICLES, TWO-WHEELED MOTOR VEHICLES; RECHARGING BATTERIES (U.S. CLS. 100, 103 AND 106).

WILLIAM P. SHANAHAN, EXAMINING ATTORNEY

SN 77-329,987. SYNnex CORPORATION, FREMONT, CA.  
FILED 11-15-2007.

# CONCENTRIX

THE MARK CONSISTS OF STANDARD CHARACTERS WITHOUT CLAIM TO ANY PARTICULAR FONT, STYLE, SIZE, OR COLOR.

OWNER OF U.S. REG. NO. 2,533,198.

**CLASS 35—ADVERTISING AND BUSINESS**

FOR DESIGN AND DEVELOPMENT OF MARKETING AND ADVERTISING MATERIALS FOR OTHERS; PRE-PRODUCT LAUNCH SALES AND MARKETING SUPPORT SERVICES, NAMELY, PROVIDING MARKETING ANALYTICS AND MARKETING RESEARCH, DEVELOPMENT OF MARKETING STRATEGIES, AND DEVELOPMENT, IMPLEMENTATION AND MANAGEMENT OF MARKETING AND ADVERTISING CAMPAIGNS; MARKETING AND ADVERTISING SERVICES; CONSULTING AND BUSINESS SUPPORT SERVICES IN THE FIELDS OF MARKETING ANALYTICS, MARKETING RESEARCH, DEVELOPMENT OF MARKETING STRATEGIES, AND DEVELOPMENT, IMPLEMENTATION AND MANAGEMENT OF MARKETING AND ADVERTISING CAMPAIGNS; OPERATION AND MANAGEMENT OF TELEPHONE CALL CENTERS FOR OTHERS; BUSINESS CONSULTATION, NAMELY, STRATEGIC MARKETING ANALYSIS, PROMOTING THE GOODS AND SERVICES OF OTHERS THROUGH A GLOBAL COMPUTER NETWORK, COMPUTERIZED DATABASE MANAGEMENT, DIRECT MAIL ADVERTISING, TELEMARKETING, AND DEVELOPING PROMOTIONAL CAMPAIGNS FOR BUSINESSES; DESIGN AND DEVELOPMENT OF ADVERTISING CAMPAIGNS FOR OTHERS IN THE NATURE OF INTERACTIVE DIGITAL MULTIMEDIA PRESENTATIONS AND DEMONSTRATIONS IN THE FIELD OF COMPUTER HARDWARE, COMPUTER SOFTWARE AND INFORMATION TECHNOLOGY (U.S. CLS. 100, 101 AND 102).

**CLASS 42—SCIENTIFIC AND COMPUTER SERVICES**

FOR ASP (APPLICATION SERVICES PROVIDER) SERVICES, NAMELY, HOSTING COMPUTER SOFTWARE APPLICATIONS FOR OTHERS; COMPUTER TECHNOLOGY SUPPORT SERVICES, NAMELY, HELP DESK SERVICES; TECHNICAL SUPPORT SERVICES, NAMELY, TROUBLESHOOTING IN THE NATURE OF DIAGNOSING COMPUTER HARDWARE AND SOFTWARE PROBLEMS; TECHNICAL SUPPORT, NAMELY, MONITORING OF NETWORK SYSTEMS; TECHNOLOGY ADVICE PROVIDED BY MEANS OF A SUPPORT HOTLINE; TECHNICAL SUPPORT SERVICES, NAMELY, INSTALLATION, ADMINISTRATION, AND TROUBLESHOOTING OF WEB AND DATABASE APPLICATIONS; TECHNICAL CONSULTING AND TROUBLESHOOTING SERVICES IN THE FIELDS OF COMPUTER SOFTWARE, AND COMPUTER AND INFORMATION TECHNOLOGY NETWORKS AND INFRASTRUCTURE INSTALLATION, MAINTENANCE, UPDATING AND REPAIR; TECHNICAL CONSULTING AND ASSISTANCE WITH COMPUTER-BASED INFORMATION SYSTEMS AND COMPONENTS, PROVIDED ON BEHALF OF OTHERS; COMPUTER SOFTWARE DESIGN, DEVELOPMENT AND CUSTOMIZATION SERVICES FOR OTHERS; INTEGRATION OF COMPUTER HARDWARE, COMPUTER SOFTWARE AND COMPUTER NETWORKS; GRAPHICS, MULTIMEDIA AND WEBSITE DESIGN AND CONSULTING SERVICES FOR OTHERS; DEVELOPMENT OF CUSTOMIZED MULTIMEDIA APPLICATIONS FOR ONLINE USE; DATABASE DEVELOPMENT AND CUSTOMIZATION SERVICES; TECHNICAL WRITING SERVICES; DESIGN AND DEVELOPMENT OF ONLINE PORTALS AND DIGITAL CONTENT FOR ONLINE PORTALS; COMPUTER SOFTWARE, COMPUTER HARDWARE, AND COMPUTER NETWORK TESTING SERVICES; PROVISION OF HOSTED COMPUTER PROGRAMS ON DATA NETWORKS, IN PARTICULAR ON THE INTERNET AND THE WORLDWIDE WEB, NAMELY, NON-DOWNLOADABLE SOFTWARE FOR USE IN BUSINESS PROCESS OUTSOURCING ("BPO") SERVICES; TECHNICAL SUPPORT SERVICES FOR TROUBLESHOOTING COMPUTER SOFTWARE PROBLEMS PROVIDED BY MEANS OF AN ONLINE COMPUTER DATABASE; PROVISION OF ONLINE COMPUTER DATABASES FEATURING INFORMATION IN THE FIELDS OF COMPUTER SOFTWARE, NAMELY, MAINTENANCE AND UPDATING OF COMPUTER SOFTWARE; PROVISION OF ONLINE COMPUTER DATABASES FEATURING INFORMATION FOR TROUBLESHOOTING PROBLEMS WITH COMPUTER SOFTWARE AND FOR DIAGNOSING PROBLEMS WITH COMPUTER AND TELECOMMUNICATIONS NETWORKS; COMPUTER PROGRAMMING SERVICES; UPDATING OF COMPUTER SOFTWARE SERVICES;



COMPUTER CONSULTANCY SERVICES; RECOVERY OF COMPUTER DATA; ALL OF THE FOREGOING EXCLUDING WEB HOSTING AND TELECOMMUNICATIONS SERVICES (U.S. CLS. 100 AND 101).  
ANDREW LEASER, EXAMINING ATTORNEY

SN 77-357,748. BIODENTIS GMBH, LEIPZIG, FED REP GERMANY, FILED 12-21-2007.

# BIODENTIS

THE MARK CONSISTS OF STANDARD CHARACTERS WITHOUT CLAIM TO ANY PARTICULAR FONT, STYLE, SIZE, OR COLOR.

## CLASS 10—MEDICAL APPARATUS

FOR DENTAL INLAYS, ONLAYS, BRIDGES, IMPLANTS; DENTAL PROSTHESES, NAMELY, CORONAS (U.S. CLS. 26, 39 AND 44).  
FIRST USE 10-29-2007; IN COMMERCE 10-29-2007.

## CLASS 40—MATERIAL TREATMENT

FOR DENTAL TECHNICIAN SERVICES; DENTAL LABOURER SERVICES, NAMELY, DENTAL LABORATORIES OR DENTAL MILLING CENTER; CUSTOM PRODUCTION OF DENTAL PROSTHETICS; PRODUCTION OF ARTIFICIAL DENTURE PARTS AS FOR EXAMPLE INLAYS, ONLAYS, VENEERS, DENTAL CROWNS, PARTIAL-CROWNS, BRIDGES OR IMPLANTS; DENTAL TECHNICIAN AND DENTAL LABOURER SERVICES, NAMELY, MEASUREMENT AND IMAGE ACQUISITION FOR MEDICAL AND DENTAL PURPOSES; PRODUCTION AND PREFABRICATION OF DENTAL CASTING COMPOUND; DENTAL TECHNICIAN AND DENTAL LABOURER SERVICES, NAMELY, ANALYSIS OF MOULDED DENTAL CASTING COMPOUND; CONSULTING SERVICES FOR DENTISTS IN THE FIELD OF MANUFACTURING, USING, PREPARING, FITTING, MEASURING DENTAL PROSTHETICS, NAMELY, INLAYS AND ARTIFICIAL DENTURE PARTS, ESPECIALLY ONLAYS, VENEERS, DENTAL CROWNS, PARTIAL-CROWNS, BRIDGES OR IMPLANTS; CONSULTING SERVICES FOR DENTISTS IN THE FIELD OF MANUFACTURING, USING, PREPARING, FITTING, MEASURING DENTAL PROSTHETICS, NAMELY, IN THE FIELD OF USING DENTAL CASTING COMPOUND (U.S. CLS. 100, 103 AND 106).

FIRST USE 10-29-2007; IN COMMERCE 10-29-2007.  
ALLISON SCHRODY, EXAMINING ATTORNEY

SN 77-357,860. NISSAN JIDOSHA KABUSHIKI KAISHA, DBA NISSAN MOTOR CO., LTD., YOKOHAMA-SHI, JAPAN, FILED 12-21-2007.

# PUREDRIVE

THE MARK CONSISTS OF STANDARD CHARACTERS WITHOUT CLAIM TO ANY PARTICULAR FONT, STYLE, SIZE, OR COLOR.

## CLASS 7—MACHINERY

FOR PARTS FOR NON-ELECTRIC PRIME MOVERS FOR LAND VEHICLES, NAMELY, MUFFLERS FOR MOTORS, ENGINE CAMSHAFTS, VALVES BEING PART OF ENGINES, ENGINE CYLINDERS, SPARK PLUGS, INTERNAL COMBUSTION PARTS, NAMELY, PISTONS; EMISSION REDUCTION UNITS FOR MOTORS AND ENGINES, NAMELY, PUMP CONTROL VALVES; TURBOCHARGERS FOR MACHINES (U.S. CLS. 13, 19, 21, 23, 31, 34 AND 35).

## CLASS 12—VEHICLES

FOR DIESEL ENGINES FOR LAND VEHICLES; AUTOMOBILES, WAGONS, TRUCKS, VEHICLE VANS, SPORT UTILITY VEHICLES, BUSES, RECREATIONAL VEHICLES (RV), NAMELY, CAMPERS, SPORTS CARS, RACING CARS, LORRIES, NAMELY, LIGHT LORRIES, FORK LIFT TRUCKS, TOWING TRACTORS, AND STRUCTURAL PARTS AND FITTINGS THEREFOR; TRACTORS; ANTI-THEFT ALARMS FOR VEHICLES; ADHESIVE RUBBER PATCHES FOR REPAIRING TUBES OR TIRES; NON-ELECTRIC PRIME MOVERS FOR LAND VEHICLES, NAMELY, MOTORS AND ENGINES; DRIVESHAFTS, AXLES, AND SPINDLES, ALL FOR LAND VEHICLES; WHEEL BEARINGS FOR LAND VEHICLES; MACHINE PARTS FOR MOTOR VEHICLES, NAMELY, SHAFT COUPLINGS OR CONNECTORS; POWER TRANSMISSIONS, CONTINUOUSLY VARIABLE TRANSMISSIONS, AND TRANSMISSION GEARBOXES; GEARINGS, NAMELY, REVERSING GEARS FOR LAND VEHICLES, REDUCTION GEARS FOR LAND VEHICLES, TOOTHED GEARS FOR LAND VEHICLES, SPEED CHANGE GEARS FOR LAND VEHICLES; VEHICLE PARTS, NAMELY, SHOCK ABSORBERS; SUSPENSION SPRINGS FOR MOTOR VEHICLES; BRAKES FOR MOTOR CARS; AC MOTORS AND DC ELECTRIC MOTORS FOR LAND VEHICLES; LAND VEHICLE CONSOLE PARTS, NAMELY, WIRING HARNESSES FOR CONTROL, MONITORING AND PROTECTION OF INDUSTRIAL GASOLINE AND DIESEL ENGINES (U.S. CLS. 19, 21, 23, 31, 35 AND 44).

MICHAEL ENGEL, EXAMINING ATTORNEY

SN 77-367,444. PROSLIDE TECHNOLOGY INC., OTTAWA, CANADA, FILED 1-9-2008.

# SPLASHFOREST

THE MARK CONSISTS OF STANDARD CHARACTERS WITHOUT CLAIM TO ANY PARTICULAR FONT, STYLE, SIZE, OR COLOR.

PRIORITY CLAIMED UNDER SEC. 44(D) ON CANADA APPLICATION NO. 1375913, FILED 12-13-2007, REG. NO. TMA787413, DATED 1-17-2011, EXPIRES 1-17-2026.

## CLASS 28—TOYS AND SPORTING GOODS

FOR AMUSEMENT PARK RIDES; AMUSEMENT PARK WATER RIDES; WATER-BASED PLAYGROUND EQUIPMENT, NAMELY, WATER SLIDES AND CLIMBING UNITS CONTAINING WATER FEATURES, AND PARTS AND FITTINGS THEREFOR; WATERSLIDES; INFLATABLE INNER TUBES FOR AQUATIC RECREATIONAL USE, NAMELY, USE ON WATERSLIDES; WATERSLIDE PARTS AND FITTINGS, NAMELY, SPLASHGUARDS (U.S. CLS. 22, 23, 38 AND 50).



**CLASS 37—CONSTRUCTION AND REPAIR**

FOR INSTALLATION AND MAINTENANCE OF AMUSEMENT PARK RIDES, AMUSEMENT PARK WATER-BASED PLAY STATIONS AND WATER-BASED PLAY STRUCTURES AND ACCESSORIES THEREFOR (U.S. CLS. 100, 103 AND 106).

**CLASS 40—MATERIAL TREATMENT**

FOR CUSTOM MANUFACTURE OF AMUSEMENT PARK RIDES, AMUSEMENT PARK WATER-BASED PLAY STATIONS AND WATER-BASED PLAY STRUCTURES AND ACCESSORIES THEREFOR (U.S. CLS. 100, 103 AND 106).

**CLASS 41—EDUCATION AND ENTERTAINMENT**

FOR CHILDREN'S ENTERTAINMENT AND AMUSEMENT CENTERS, NAMELY, INTERACTIVE PLAY AREAS CONTAINING WATER-BASED PLAY STATIONS AND WATER-BASED PLAY STRUCTURES; ENTERTAINMENT IN THE NATURE OF AN AMUSEMENT PARK RIDE, NAMELY, A WATERSLIDE (U.S. CLS. 100, 101 AND 107).

ROBIN MITTLER, EXAMINING ATTORNEY

SN 77-371,046. CABLE ELECTRONICS, INC., GARLAND, TX.  
FILED 1-14-2008.



OWNER OF U.S. REG. NOS. 2,405,323 AND 2,405,324.  
NO CLAIM IS MADE TO THE EXCLUSIVE RIGHT TO USE "LABS", APART FROM THE MARK AS SHOWN.  
THE MARK CONSISTS OF STYLIZED "C", "E" AND "LABS".

**CLASS 38—COMMUNICATION**

FOR DISTRIBUTION OF ELECTRONIC CONTENT, NAMELY, AUDIO AND VIDEO DATA FILES, OVER LOCAL AREA NETWORKS, WIDE AREA NETWORKS AND THE INTERNET (U.S. CLS. 100, 101 AND 104).

**CLASS 42—SCIENTIFIC AND COMPUTER SERVICES**

FOR WEB HOSTING SERVICES (U.S. CLS. 100 AND 101).

KIMBERLY FRYE, EXAMINING ATTORNEY

SN 77-389,403. ORGANICALLY GROWN GROUP, LLC,  
SANTA BARBARA, CA. FILED 2-5-2008.

**ORGANICALLY GROWN KIDS**

THE MARK CONSISTS OF STANDARD CHARACTERS WITHOUT CLAIM TO ANY PARTICULAR FONT, STYLE, SIZE, OR COLOR.

OWNER OF U.S. REG. NO. 2,187,996.

NO CLAIM IS MADE TO THE EXCLUSIVE RIGHT TO USE "KIDS", APART FROM THE MARK AS SHOWN.

**CLASS 3—COSMETICS AND CLEANING PREPARATIONS**

FOR BABY WIPES; DISPOSABLE WIPES IMPREGNATED WITH CHEMICALS OR COMPOUNDS FOR PERSONAL USE ON THE BODY AND FACE, INCLUDING A MOISTURIZER; DISPOSABLE WIPES FOR BABIES AND CHILDREN IMPREGNATED WITH CHEMICALS OR COMPOUNDS FOR PERSONAL USE ON THE BODY AND FACE, INCLUDING A MOISTURIZER; PRE-MOISTENED TOWELETTES FOR USE WITH PREPARATIONS FOR CLEANING, PROTECTING, AND MOISTURIZING THE BODY AND FACE; COSMETIC PADS; PRE-MOISTENED COSMETIC TOWELETTES FOR APPLYING AND REMOVING MAKE-UP; PRE-MOISTENED COSMETIC TOWELETTES; PRE-MOISTENED COSMETIC TOWELETTE STRIPS FOR FACIAL CLEANSING; COTTON SWABS FOR COSMETIC PURPOSES; ALL PURPOSE COTTON SWABS FOR PERSONAL USE; NON-MEDICATED PRE-MOISTENED CLEANSING COSMETIC TOWELETTES; ABSORBENT COTTON SWABS AND BALLS FOR COSMETIC PURPOSES; COTTON BALLS FOR COSMETIC PURPOSES; ABSORBENT ALL-PURPOSE COTTON SWABS FOR PERSONAL USE; COTTON BUDS FOR COSMETIC USE AND COTTON STICKS FOR COSMETIC USE; BLEACHING PREPARATIONS AND OTHER SUBSTANCES, NAMELY, LAUNDRY SOAP AND LAUNDRY DETERGENT FOR LAUNDRY USE; CLEANING, POLISHING, SCOURING AND ABRASIVE PREPARATIONS; SOAPS; PERFUMERY; ESSENTIAL OILS; COSMETICS; HAIR LOTIONS; PREPARATIONS FOR CLEANING THE TEETH; MOUTH WASHES; DENTIFRICES; HOUSE MARK FOR COSMETICS; COSMETICS; BODY AND BEAUTY CARE COSMETICS; BABY AND CHILDREN'S HEALTH AND BEAUTY SKIN CARE PRODUCTS, NAMELY, BODY POWDERS, NON-MEDICATED DIAPER RASH OINTMENTS AND CREAMS; BEDTIME BODY LOTION; NON-MEDICATED BABY DIAPER RASH CREAMS; BABY SKIN CONDITIONERS; BABY POWDERS; BABY SPRITZES, NAMELY, SCENTED BODY SPRAY; BATH AND BODY GELS; BATH BEADS; BUBBLE BATHS; BATH OIL; BATH SALTS; BLUSH; BODY GLITTER; BODY MIST; BODY OIL; BODY SCRUB; BODY WASH; BRONZERS; BODY CREAMS; BODY MISTS; BODY SCRUBS; BODY LOTIONS; BODY OILS; BODY SPRAYS; BATH AND BODY POWDER; BRONZING STICKS; COLD CREAM; COLOGNE; CREAMS; GELS AND SPRAYS FOR THE FACE AND BODY; CONCEALERS; COSMETIC CLEANSING CREAMS; COSMETIC CREAMS FOR SKIN CARE; COSMETIC OILS; COSMETIC PREPARATIONS FOR BODY CARE; COSMETIC PRODUCTS IN THE FORM OF AEROSOLS FOR SKINCARE; CUTICLE CREAMS AND CONDITIONERS; DEODORANTS AND ANTIPERSPIRANTS; EXFOLIATING PREPARATIONS FOR THE SKIN; EYE GELS; EYE MASKS; EYE SHADOW; EYE LINING PENCILS; LIQUID EYE LINERS; EYE MAKEUP; MASCARA; EYEBROW PENCILS; ARTIFICIAL EYELASHES; EYE MAKE-UP REMOVER; ESSENTIAL OILS FOR AROMATHERAPY; ESSENTIAL OILS FOR PERSONAL USE; FACE HIGHLIGHTER; FACE MASKS; FACE MIST; FACE CREAMS FOR COSMETIC USE; FACIAL CLEANSERS; FACIAL CREAMS; FACIAL CLEANSERS; FACIAL MOISTURIZERS; FACIAL SCRUBS FACIAL TONERS, AND ASTRINGENTS FOR COSMETIC USE; FOAMS CONTAINING COSMETICS AND SUNSCREENS; PERFUMERY AND FRAGRANCES FOR PERSONAL USE, NAMELY, PERFUME, COLOGNES, EAU DE COLOGNE, EAU DE PARFUM, EAU DE TOILETTE, AFTER SHAVE GEL AND AFTER SHAVE LOTION; NON-MEDICATED FOOT SOAKS; FRAGRANT BODY SPLASH; FRAGRANT BODY MIST; FOUNDATION MAKEUP FOR THE FACE AND BODY; HAIR GLITTER; HAIR GEL, HAIR SPRAY, HAIR CARE PRODUCTS AND HAIR PREPARATIONS, NAMELY, HAIR SHAMPOOS, SHAMPOOS, SHAMPOO-CONDITIONERS, HAIR CONDITIONERS, HAIR MASKS, GELS, CREAMS, HIGHLIGHTERS, LOTIONS, POMADES AND MOUSSES, HAIR COLOR, HAIR COLOR REMOVERS, HAIR TINTING PREPARATIONS, PRE-SHAMPOO HAIR TREATMENT PREPARATIONS; LIPSTICK; LIP GLOSS; LIP LINERS; LIP BALMS; NON-MEDICATED SKIN CARE PREPARATIONS, NAMELY, MOISTURIZING LOTIONS AND CREAMS; TONERS; ASTRINGENTS FOR COS-

METIC USE; BODY CLEANSERS; SOAPS IN LIQUID, SOLID OR GEL FORM, BODY CREAM SOAP, COSMETIC SOAPS, CREAM SOAPS, HAND SOAPS, LIQUID SOAP, LIQUID SOAPS FOR HANDS, FACE, AND BODY, PERFUMED SOAP, SKIN SOAP, SOAPS FOR BODY CARE, SOAPS FOR PERSONAL USE; FACIAL GELS; FACIAL MOUSSE; NAIL ENAMEL, NAIL POLISH, NAIL HARDENER, NAIL CONDITIONER, NAIL POLISH REMOVER, HAND AND NAIL CARE PREPARATIONS, NAMELY, HAND CREAMS AND LOTIONS, NAIL CREAMS, CUTICLE CREAMS AND CUTICLE CONDITIONERS; NON-MEDICATED FOOT CREAMS AND POWDERS; AGE SPOT REDUCING CREAMS; EYE MAKEUP REMOVER; AROMATHERAPY CREAMS AND OILS; EYE CREAMS; BEAUTY MASKS; SKIN EXFOLIATING CREAM; SALT SCRUBS FOR THE SKIN, SHAVING CREAM, SHAVING GELS, SHOWER CREAM, SHOWER GEL, SKIN BRONZING CREAM, SOAP FOR THE BODY, SOAP FOR THE FACE, SOAP FOR THE HANDS, AND TALCUM POWDER, SKIN EXFOLIANTS; SKIN CLEANSING BARS; LIP CREAMS; MAKE UP REMOVING PREPARATIONS; SUN CARE PRODUCTS, NAMELY, SUN SCREEN, SUN BLOCK, SUN TANNING PREPARATIONS, SUNLESS TANNING LOTION, PRE-SUNTANNING LOTION, POST-SUNTANNING LOTION, AND SELF-TANNING CREAMS, LOTIONS, AND GELS; SHAVING CREAMS; SKIN CLEANSERS; COSMETIC PREPARATIONS FOR BATHS, NAMELY, BATH OILS, BATH GELS, BATH SALTS, BATH PEARLS, BATH LOTIONS, BATH MILK, BATH CRYSTALS, BATH POWDERS, FOAM BATH, MAKE-UP PREPARATIONS, NAMELY, EYE SHADOW, FACE POWDER, COSMETIC PENCILS; DECORATIVE MOTIFS FOR COSMETIC PURPOSES, NAMELY, DECORATIVE TRANSFERS AND SKIN JEWELS FOR COSMETIC PURPOSES AND FACE AND BODY GLITTER; CLEANING, POLISHING, SCOURING AND ABRASIVE PREPARATIONS FOR HOUSEHOLD USE; LAUNDRY POWDERS; SHOE WAXES AND CREAMS; LEATHER CARE PRODUCTS, NAMELY, PREPARATIONS FOR POLISHING, CLEANING, AND CONDITIONING LEATHER GOODS; MAKE-UP KITS COMPRISED OF COSMETICS, ALL OF THE AFOREMENTIONED GOODS ARE ORGANIC OR ARE MADE WHOLLY OR SUBSTANTIALLY FROM ORGANICALLY GROWN MATERIALS AND NOT FROM SYNTHETIC OR MANMADE MATERIALS (U.S. CLS. 1, 4, 6, 50, 51 AND 52).

#### CLASS 28—TOYS AND SPORTING GOODS

FOR STUFFED TOY ANIMALS; BEAN BAGS; PLUSH TOYS; PUPPETS; DOLLS AND DOLL CLOTHING, AND SOFT SCULPTED TOY FIGURES, ALL OF THE AFOREMENTIONED GOODS ARE ORGANIC OR ARE MADE WHOLLY OR SUBSTANTIALLY FROM ORGANICALLY GROWN MATERIALS AND NOT FROM SYNTHETIC OR MANMADE MATERIALS; BALLOONS; BALLS, NAMELY, PLAY BALLS, PLAYGROUND BALLS AND RUBBER BALLS, SPORT BALLS, AND RUBBER ACTION BALLS, BATH TOYS; TOY BUILDING BLOCKS; PLAY WANDS; MUSIC BOX TOYS; BUBBLE MAKING WAND AND SOLUTION SETS; CARD GAMES; CHRISTMAS TREE ORNAMENTS; CHILDREN'S PLAY COSMETICS; MOBILES, NAMELY, TOY AND CRIB MOBILES; FLYING DISCS; PARTY FAVORS IN THE NATURE OF SMALL TOYS; JIGSAW PUZZLES; JUMP ROPES; KITES; MUSICAL TOYS; PLAY SWIMMING POOLS; RIDE-ON TOYS; MANIPULATIVE PUZZLES; WATER-SQUIRTING TOYS; YO-YOS; ADULT AND CHILDREN PARTY GAMES; COLLECTIBLE TOY FIGURES; DOLL HOUSES; DRAWING TOYS; PLAY TENTS; PLAY HOUSES; RADIO CONTROLLED TOY VEHICLES; SAND TOYS; SAND BOX TOYS; TALKING TOYS; SLIDE PUZZLES; PADDLE BALL GAMES; PLAYSETS, NAMELY, DOLL FURNITURE, DOLL FURNITURE ACCESSORIES, DOLL CLOTHES AND DOLL ACCESSORIES; BOARD GAMES; ACCESSORIES FOR DOLL CLOTHES; TOY FURNITURE, SPECIFICALLY BEDS, WARDROBES, VANITIES AND CHESTS; DOLL CASES; TOY VEHICLES; OUTDOOR PLAY EQUIPMENT, NAMELY, BASES, BATS, AND BALLS, PLAY YARDS IN THE NATURE OF OUTDOOR PLAY STRUCTURES, SWINGS, CLIMBING UNITS, SAND BOXES, SWING SETS; ELECTRONIC HAND-HELD GAMES; PLASTIC TOY HOOPS; PINWHEELS; ACTION TARGET GAMES; ROLE-PLAYING GAMES; PARLOR GAMES; MEMORY GAMES; ACTION SKILL GAMES; MANIPULATIVE GAMES; INFLATABLE POOL TOYS; WIND-UP TOYS;

BATTERY-OPERATED ACTION TOYS; BUILDING GAMES; ELECTRONIC EDUCATIONAL GAME MACHINES FOR CHILDREN; LCD GAME MACHINES; HAND PUPPETS; INFANT RATTLES; INFANT ACTION CRIB TOYS; MODEL VEHICLES; TOY MASKS; NOVELTIES FOR PARTIES, NAMELY, PARTY FAVORS IN THE NATURE OF BLOW-OUTS NOISE-MAKING PARTY FAVORS; CRACKERS AND NOISEMAKERS, SMALL TOYS; RIDE-ON TOYS; SANDBOXES; PLAYGROUND EQUIPMENT, NAMELY, SLIDES, INFLATABLE SWIMMING POOLS, WATER SQUIRTING TOYS; TOY BAKE WARE; TOY TOOLS, TOY TOOL BELTS, TOY HARD HATS; TOY TRICYCLES (U.S. CLS. 22, 23, 38 AND 50).  
JENNY PARK, EXAMINING ATTORNEY

SN 77-457,845. DUPREY INVENTIONS, LLC, WATERVLIET, NY. FILED 4-25-2008.

# FOREST

THE MARK CONSISTS OF STANDARD CHARACTERS WITHOUT CLAIM TO ANY PARTICULAR FONT, STYLE, SIZE, OR COLOR.

#### CLASS 9—ELECTRICAL AND SCIENTIFIC APPARATUS

FOR GAMES ADAPTED FOR USE WITH TELEVISION RECEIVERS ONLY, BIKE HELMETS, FLOTATION VESTS, SWIMMING GOGGLES, SNORKELS, SUNGLASSES, CALCULATORS, COMPUTER GAME CASSETTES, VIDEO CARTRIDGES, COMPUTER SOFTWARE PROGRAMS AND PRE-RECORDED AUDIO AND CASSETTE RECORDINGS FEATURING CHILDREN'S PROGRAMS, PERSONAL CASSETTE PLAYERS, SCALES, DECORATIVE MAGNETS AND VIDEO GAME CASSETTES, CARTRIDGES AND SOFTWARE (U.S. CLS. 21, 23, 26, 36 AND 38).

#### CLASS 16—PAPER GOODS AND PRINTED MATTER

FOR CHILDREN'S BOOKS, PAPER NAPKINS, ADHESIVE BANDS FOR STATIONERY OR HOUSEHOLD PURPOSES, DECALS, PAPER TABLECLOTHS, GIFT WRAP PAPER, AUTOGRAPHED PHOTOGRAPHS, PAINT BRUSHES, ERASERS, STAPLERS, CRAYONS, CHALK, BOOK COVERS, ART PRINTS, COLORING BOOKS, STORY BOOKS, TRACING BOOKS, STICKER BOOKS, PUZZLE BOOKS, HIDE AND SEEK BOARD BOOKS, CHILDREN'S LIFT THE FLAP BOOKS, MAGNETIC NOTEPADS, GREETING CARDS, COLLECTIBLE TRADING CARDS, PAPER COASTERS, POSTERS, DISPOSABLE DIAPERS, DISPOSABLE TRAINING PANTS; INK STAMPS (U.S. CLS. 2, 5, 22, 23, 29, 37, 38 AND 50).

**CLASS 28—TOYS AND SPORTING GOODS**

FOR FLYING DISCS, KITES, SNOW SLEDS FOR RECREATIONAL USE, SKATEBOARDS, SURFBOARDS, MULTIPLE ACTIVITY BABY TOYS, INFLATABLE TOYS, TOY STAMPS, TOY INK STAMPS, FINGER DOLLS AND PUPPETS, TOY VEHICLES, TOY ELECTRIC TRAINS AND ACCESSORIES THEREFOR, WATER FLOTATION TOYS FOR RECREATION USE, TOY PAILS, TOY SHOVELS, TOY BEACH BUCKETS; SPORTING EQUIPMENT AND ACCESSORIES FOR SOCCER, NAMELY, SOCCER BALLS; SPORTING EQUIPMENT AND ACCESSORIES FOR GOLF, NAMELY, GOLF BALLS, GOLF TEES, GOLF BALL MARKERS, GOLF PUTTERS, GOLF DIVOT REPAIR TOOLS, GOLF BAGS, GOLF GLOVES; SPORTING EQUIPMENT AND ACCESSORIES FOR FISHING, NAMELY, FISHING LURES, FISHING RODS AND FISHING REELS, TACKLE BOXES; SPORTING EQUIPMENT AND ACCESSORIES FOR SKATING, NAMELY, INLINE SKATES, ROLLER SKATES, ELBOW PADS FOR ATHLETIC USE, KNEE PADS FOR ATHLETIC USE, SHIN PADS FOR ATHLETIC USE, BADMINTON GAME PLAYING EQUIPMENT; HORSE SHOES FOR RECREATIONAL PURPOSES, BILLIARD CUES, BILLIARD GAME PLAYING EQUIPMENT AND ACCESSORIES, NAMELY, BILLIARD BRIDGES, BILLIARD CHALK, BILLIARD BUMPERS, BILLIARD CUE RACKS, BILLIARD CUSHIONS, BILLIARD TABLES, BILLIARD NETS, BILLIARD TALLY BALLS, BILLIARD TIPS, BILLIARD TRIANGLES, CUE STICKS FOR BILLIARDS OR POOL, DART BOARDS AND DART BOARD CASES, CHRISTMAS TREE DECORATIONS AND ACCESSORIES, NAMELY, CHRISTMAS TREE SKIRTS, CHRISTMAS TREE ORNAMENTS, CHRISTMAS STOCKINGS, CHRISTMAS TREE DECORATIONS, SNOW GLOBES, SPORT BALLS, CHILDREN'S DISH SETS, PET TOYS, PLUSH TOYS, BOARD GAMES, DOLLS, STUFFED TOYS, PUZZLES, TOY PLASTIC FIGURINES AND RUBBER FIGURINES, BALLOONS, PLAYING CARDS, HANDHELD UNITS FOR PLAYING ELECTRONIC GAMES, PAPER PARTY HATS (U.S. CLS. 22, 23, 38 AND 50).

SN 77-480,375. OMNI SPORTS TREND AND TECHNOLOGY LTD., WANCHAI, HONG KONG, FILED 5-21-2008.



THE COLOR(S) RED AND GRAY IS/ARE CLAIMED AS A FEATURE OF THE MARK.

THE MARK CONSISTS OF THE STYLIZED LETTER "O" IN RED, ABOVE THE WORD "OMNI" IN GRAY.

**CLASS 28—TOYS AND SPORTING GOODS**

FOR EXERCISE MACHINES (U.S. CLS. 22, 23, 38 AND 50).

FIRST USE 2-8-2010; IN COMMERCE 2-8-2010.

**CLASS 35—ADVERTISING AND BUSINESS**

FOR ON-LINE RETAIL STORE SERVICES FEATURING SPORTING GOODS AND EXERCISE EQUIPMENT; WHOLESALE ORDERING SERVICES IN THE FIELD OF SPORTING GOODS AND EXERCISE EQUIPMENT (U.S. CLS. 100, 101 AND 102).

FIRST USE 2-8-2010; IN COMMERCE 3-6-2010.

STEVEN R. FINE, EXAMINING ATTORNEY

SN 77-484,621. UPMC, PITTSBURGH, PA. FILED 5-28-2008.

**PRIMA Athlete****CLASS 41—EDUCATION AND ENTERTAINMENT**

FOR ENTERTAINMENT SERVICES IN THE FORM OF PROVIDING DISPLAYS OF FILM TRIVIA SLIDES DISPLAYED ON MOVIE THEATER SCREENS; ENTERTAINMENT SERVICES IN THE FORM OF PROVIDING DISPLAYS OF CARTOONS AND COMICS; PROVIDING LIVE ENTERTAINMENT FEATURING MUSICAL AND KARAOKE PERFORMANCES; ENTERTAINMENT SERVICES IN THE FORM OF PRODUCTION OF TV PROGRAMS AND MOTION PICTURES; ENTERTAINMENT SERVICES IN THE FORM OF PRODUCTION OF TELEVISION PROGRAMS AND MOTION PICTURES FEATURING ANIMATION AND/OR LIVE CHARACTERS (U.S. CLS. 100, 101 AND 107).

EDWARD NELSON, EXAMINING ATTORNEY

THE MARK CONSISTS OF STANDARD CHARACTERS WITHOUT CLAIM TO ANY PARTICULAR FONT, STYLE, SIZE, OR COLOR.

NO CLAIM IS MADE TO THE EXCLUSIVE RIGHT TO USE "ATHLETE", APART FROM THE MARK AS SHOWN.

**CLASS 41—EDUCATION AND ENTERTAINMENT**

FOR PROVIDING ASSISTANCE, PERSONAL TRAINING AND PHYSICAL FITNESS CONSULTATION TO PHYSICALLY FIT AND ELITE ATHLETES OVER THE AGE OF 40 IN ORDER TO MAXIMIZE EACH INDIVIDUAL'S PHYSICAL FITNESS PERFORMANCE (U.S. CLS. 100, 101 AND 107).

FIRST USE 12-19-2007; IN COMMERCE 12-19-2007.

**CLASS 44—MEDICAL, BEAUTY AND AGRICULTURAL SERVICES**

FOR PROVIDING COMPREHENSIVE MEDICAL CLINIC CARE SERVICES, NUTRITION COUNSELING, AND MENTAL HEALTH COUNSELING DESIGNED TO MAXIMIZE THE PHYSICAL AND MENTAL PERFORMANCE OF PHYSICALLY FIT AND ELITE ATHLETES OVER THE AGE OF 40 (U.S. CLS. 100 AND 101).

FIRST USE 12-19-2007; IN COMMERCE 12-19-2007.  
ALYSSA STEEL, EXAMINING ATTORNEY

SN 77-500,177. DOTERRA HOLDINGS, LLC, OREM, UT.  
FILED 6-16-2008.

# Microplex VM

THE MARK CONSISTS OF STANDARD CHARACTERS WITHOUT CLAIM TO ANY PARTICULAR FONT, STYLE, SIZE, OR COLOR.

**CLASS 3—COSMETICS AND CLEANING PREPARATIONS**

FOR ESSENTIAL OILS FOR HUMAN USE; ESSENTIAL OILS FOR USE IN MANUFACTURING OF DIETARY SUPPLEMENTS IN GELCAP AND NON-GELCAP FORM FOR HUMAN USE (U.S. CLS. 1, 4, 6, 50, 51 AND 52).

**CLASS 5—PHARMACEUTICALS**

FOR DIETARY AND NUTRITIONAL SUPPLEMENTS FOR HUMAN USE (U.S. CLS. 6, 18, 44, 46, 51 AND 52).  
SARA BENJAMIN, EXAMINING ATTORNEY

SN 77-510,193. THE ORGANIC PHARMACY LIMITED, KENSINGTON, LONDON, UNITED KINGDOM, FILED 6-27-2008.



OWNER OF ERPN CMNTY TM OFC REG. NO. 2922912, DATED 4-1-2004, EXPIRES 1-17-2013.

NO CLAIM IS MADE TO THE EXCLUSIVE RIGHT TO USE "ORGANIC", APART FROM THE MARK AS SHOWN. THE COLOR(S) AQUA AND WHITE IS/ARE CLAIMED AS A FEATURE OF THE MARK.

THE MARK CONSISTS OF THE WORDS "THE ORGANIC PHARMACY" WITH A CROSS DESIGN. THE WORDS APPEAR IN THE COLOR AQUA (PANTONE SYSTEM 306C). THE WORDS ARE SHOWN IN DESCENDING ORDER, WITH THE CROSS DESIGN BETWEEN THE WORDS "THE" AND "ORGANIC". THE CROSS INCLUDES A FLOWER DESIGN IN THE CENTER. THE CROSS APPEARS IN THE COLOR AQUA (PANTONE SYSTEM 306C) AND THE FLOWER DESIGN APPEARS IN THE COLOR WHITE.  
SEC. 2(F).

**CLASS 3—COSMETICS AND CLEANING PREPARATIONS**

FOR COSMETICS MADE SUBSTANTIALLY IN PART OF ORGANIC INGREDIENTS; NATURAL COSMETICS; AROMATHERAPY OILS MADE SUBSTANTIALLY IN PART OF ORGANIC INGREDIENTS; HAIR CARE PRODUCTS, NAMELY, HAIR TREATMENTS, CONDITIONERS AND SHAMPOOS ALL MADE SUBSTANTIALLY IN PART OF ORGANIC INGREDIENTS; DEODORANTS MADE SUBSTANTIALLY IN PART OF ORGANIC INGREDIENTS; BATH PRODUCTS, NAMELY, BATH OILS, BATH MILKS, BATH SALTS AND HERBAL BATH BAGS ALL MADE SUBSTANTIALLY IN PART OF ORGANIC INGREDIENTS; BODY SCRUBS AND SHOWER GELS MADE SUBSTANTIALLY IN PART OF ORGANIC INGREDIENTS; SKIN CARE CREAM MADE SUBSTANTIALLY IN PART OF ORGANIC INGREDIENTS (U.S. CLS. 1, 4, 6, 50, 51 AND 52).

FIRST USE 7-30-2002; IN COMMERCE 7-30-2002.

**CLASS 5—PHARMACEUTICALS**

FOR HOMEOPATHIC SUPPLEMENTS MADE SUBSTANTIALLY IN PART OF ORGANIC INGREDIENTS; HERBAL SUPPLEMENTS AND PREPARATIONS MADE SUBSTANTIALLY IN PART OF ORGANIC INGREDIENTS; HOMEOPATHIC PREPARATIONS MADE SUBSTANTIALLY IN PART OF ORGANIC INGREDIENTS FOR THE TREATMENT OF A WIDE RANGE OF PHYSICAL AND PSYCHOLOGICAL CONDITIONS, NAMELY, BLADDER AND URINARY TRACT INFECTIONS, INSOMNIA, FATIGUE AND SLEEP DISTURBANCE, ANXIETY AND STRESS, NERVOUS SYSTEM COMPLAINTS, HANGOVERS, JET LAG, TRAVEL SICKNESS, NAUSEA, STOMACH COMPLAINTS, GAS AND INDIGESTION, DIARRHEA, COUGHS, COLDS, FLU, CATARRH AND SINUS COMPLAINTS, HAYFEVER AND INSECT BITES, BUMPS, ALLERGIC CONDITIONS, CUTS, AND BRUISES, MUSCLE STIFFNESS, ACHES, PAINS AND CRAMPS, INFANT TEETHING, COLIC, SUNBURN AND SUN SENSITIVITY, SKIN COMPLAINTS, SCARRING, WARTS AND VERRUCAS, AND DETOXIFICATION OF LIVER AND KIDNEYS (U.S. CLS. 6, 18, 44, 46, 51 AND 52).

FIRST USE 7-30-2002; IN COMMERCE 7-30-2002.  
HELENE LIWINSKI, EXAMINING ATTORNEY

SN 77-517,142. SYGNIA INVESTMENT HOLDINGS (PROPRIETARY) LIMITED, CAPE TOWN, SOUTH AFRICA, FILED 7-8-2008.



PRIORITY CLAIMED UNDER SEC. 44(D) ON SOUTH AFRICA APPLICATION NO. 2008/14237, FILED 6-23-2008, REG. NO. 2008/14237, DATED 6-23-2008, EXPIRES 6-23-2018.

PRIORITY CLAIMED UNDER SEC. 44(D) ON SOUTH AFRICA APPLICATION NO. 2008/14236, FILED 6-23-2008, REG. NO. 2008/14236, DATED 6-23-2008, EXPIRES 6-23-2018.

THE MARK CONSISTS OF A STYLIZED DESIGN GENERALLY IN THE SHAPE OF AN E OR SIGMA SYMBOL WITH THE INTERIOR BEING A SILHOUETTE OF THE CONTINENT OF AFRICA; THE WORD "SYGNIA" IS ABOVE THE WORD "PLATINUM" AND THE TWO ARE SEPARATED BY A LINE.



**CLASS 9—ELECTRICAL AND SCIENTIFIC APPARATUS**

FOR COMPUTER SOFTWARE FOR USE IN RELATION TO FINANCIAL SERVICES; COMPUTER SOFTWARE FOR USE IN RELATION TO ASSET MANAGEMENT ADMINISTRATION, RECORD KEEPING, CLIENT ADMINISTRATION, CUSTOMER RELATIONSHIP AND DOCUMENT MANAGEMENT, PROCESSING OF TRADES AND EXECUTION OF AUTOMATED TRADE RECONCILIATIONS, CALCULATION AND TRACKING OF INVESTMENT PERFORMANCES AND PERFORMANCE ATTRIBUTION, CALCULATION OF UNIT PRICES, AUTOMATED UNIT TRADING AND REBALANCING OF POOLED INVESTMENT PORTFOLIOS AND PRODUCTION OF CUSTOMIZED REPORTS FOR FINANCIAL INVESTORS; COMPUTER SOFTWARE TO MONITOR AND ENABLE COMPLIANCE WITH GLOBAL INVESTMENT PERFORMANCE STANDARD AND TO MONITOR REGULATORY AND INVESTMENT MANDATE COMPLIANCE; COMPUTER SOFTWARE FOR USE IN INVESTMENT RESEARCH AND QUANTITATIVE ANALYSIS, FOR PURPOSES OF PORTFOLIO MODELING AND INDEX CONSTRUCTION; COMPUTER OPERATING PROGRAMS FOR USE IN RELATION TO FINANCIAL SERVICES; COMPUTER HARDWARE AND SOFTWARE DESIGNED TO ASSIST FINANCIAL SERVICES MANAGEMENT, FINANCIAL SERVICES PROGRAMS AND THE PROVISION OF FINANCIAL ADVICE; BLANK DISCS, BLANK CARTRIDGES, BLANK MEMORY STICKS AND APPARATUS FOR THE RECORDAL OF DATA, SOUND OR IMAGES FOR USE IN RELATION TO FINANCIAL SERVICES, FINANCIAL SERVICES MANAGEMENT, FINANCIAL SERVICES PROGRAMS AND THE PROVISION OF FINANCIAL ADVICE (U.S. CLS. 21, 23, 26, 36 AND 38).

**CLASS 36—INSURANCE AND FINANCIAL**

FOR FINANCIAL SERVICES, NAMELY, DISCRETIONARY INVESTMENT MANAGEMENT AND MULTI-MANAGER SERVICES IN THE NATURE OF SECURITIES AND OTHER FINANCIAL INSTRUMENT TRADING; INVESTMENT MANAGEMENT OF ABSOLUTE RETURN INVESTMENT PRODUCTS; FINANCIAL MANAGEMENT INCLUDING THAT OF ALTERNATIVE INVESTMENT PRODUCTS, HEDGE FUNDS AND FUNDS OF HEDGE FUNDS; UNDERWRITING OF INSURANCE POLICIES, NAMELY, THOSE OF PURE INVESTMENT POLICIES FOR INDIVIDUALS OR INSTITUTIONS; INVESTMENT ADMINISTRATION AND CLIENT ADMINISTRATION SERVICES IN RESPECT OF UNDERWRITTEN POLICIES; PROVISION OF ADMINISTRATION AND LIFE INSURANCE PRODUCT WRAPPER SERVICES TO THIRD PARTY INVESTMENT MANAGERS AND FINANCIAL SERVICE PROVIDERS (U.S. CLS. 100, 101 AND 102).

JULIE GUTTADAURO, EXAMINING ATTORNEY

SN 77-522,602. INNOVATION VENTURES, LLC, FARMINGTON HILLS, MI. FILED 7-15-2008.

**5-HOUR ENERGY**

THE MARK CONSISTS OF STANDARD CHARACTERS WITHOUT CLAIM TO ANY PARTICULAR FONT, STYLE, SIZE, OR COLOR.

NO CLAIM IS MADE TO THE EXCLUSIVE RIGHT TO USE "ENERGY", APART FROM THE MARK AS SHOWN. SEC. 2(F).

**CLASS 5—PHARMACEUTICALS**

FOR DIETARY SUPPLEMENTS (U.S. CLS. 6, 18, 44, 46, 51 AND 52).  
FIRST USE 9-0-2004; IN COMMERCE 9-0-2004.

**CLASS 32—LIGHT BEVERAGES**

FOR ENERGY SHOTS, NAMELY, ENERGY DRINKS (U.S. CLS. 45, 46 AND 48).  
FIRST USE 9-0-2004; IN COMMERCE 9-0-2004.  
VERNA BETH RIRIE, EXAMINING ATTORNEY

SN 77-543,991. CHORION RIGHTS LIMITED, LONDON, UNITED KINGDOM, FILED 8-11-2008.

**OCTONAUTS**

THE MARK CONSISTS OF STANDARD CHARACTERS WITHOUT CLAIM TO ANY PARTICULAR FONT, STYLE, SIZE, OR COLOR.

OWNER OF ERP CMNTY TM OFC REG. NO. 007174659, DATED 5-20-2009, EXPIRES 8-21-2018.

**CLASS 9—ELECTRICAL AND SCIENTIFIC APPARATUS**

FOR AUDIO CASSETTES FEATURING CHILDREN'S ENTERTAINMENT; COMPUTER GAME DISCS; COMPUTER GAME SOFTWARE; COMPUTER SCREEN SAVER SOFTWARE; DIGITAL MEDIA, NAMELY, PRE-RECORDED VIDEO CASSETTES, DIGITAL VIDEO DISCS, DIGITAL VERSATILE DISCS, DOWNLOADABLE AUDIO AND VIDEO RECORDINGS, DVDS, AND HIGH DEFINITION DIGITAL DISKS FEATURING MUSIC, BOARD GAME INSTRUCTIONS, FILMS FEATURING CHILDREN'S ENTERTAINMENT, LIVE ACTION, ADVENTURE AND ANIMATED PROGRAMS, TELEVISION FILMS FEATURING CHILDREN'S ENTERTAINMENT, LIVE ACTION, ADVENTURE AND ANIMATED PROGRAMS; DIGITAL MUSIC DOWNLOADABLE FROM THE INTERNET; DOWNLOADABLE ELECTRONIC PUBLICATIONS IN THE NATURE OF BOOKS AND MAGAZINES IN THE FIELD OF CHILDREN'S ENTERTAINMENT AND EDUCATION; DOWNLOADABLE MOTION PICTURES AND TELEVISION SHOWS ABOUT CHILDREN'S ENTERTAINMENT AND EDUCATION; DOWNLOADABLE SOFTWARE FOR USE IN INTERACTIVE GAMES; DOWNLOADABLE VIDEO RECORDINGS, RING TONES, MUSIC, ELECTRONIC GAMES AND ARTWORK VIA THE INTERNET AND WIRELESS DEVICES; INTERACTIVE MULTIMEDIA COMPUTER GAME PROGRAM; INTERACTIVE VIDEO GAME PROGRAMS; MOUSEPADS; MUSICAL SOUND RECORDINGS (U.S. CLS. 21, 23, 26, 36 AND 38).



**CLASS 16—PAPER GOODS AND PRINTED MATTER**

FOR ADDRESS BOOKS; ALBUMS FOR STICKERS; APPLIQUES IN THE FORM OF DECALS; AUTOGRAPH BOOKS; BABY BOOKS; BLANK NOTE CARDS; BOOK COVERS; BOOK MARKERS; CALENDARS AND DIARIES; CHALK AND CHALKBOARDS; CHILDREN'S BOOKS; CHILDREN'S INTERACTIVE EDUCATIONAL BOOKS; COLORING BOOKS; COMIC BOOKS; COMIC STRIPS; CRAYONS; DECALS; EDUCATIONAL PUBLICATIONS, NAMELY, EDUCATIONAL LEARNING CARDS, FLASH CARDS, ACTIVITY CARDS, WORKBOOKS, TEXTBOOKS, ACTIVITY BOOKS, STORY BOOKS, PUZZLE BOOKS, PRINTED PUZZLES, TEACHER GUIDES, MANUALS, POSTERS AND EDUCATIONAL BOOKLETS IN THE FIELD OF CHILDREN'S ENTERTAINMENT AND EDUCATION; FLASH CARDS; GIFT CARDS; HEAT TRANSFER PAPER; HOLIDAY CARDS; LITHOGRAPHS; MAGAZINES FEATURING CHILDREN'S ENTERTAINMENT AND EDUCATION; MAPS; NOTE BOOKS; PAINTING SETS FOR CHILDREN; PAPER AND CARDBOARD; PAPER PARTY DECORATIONS; PAPER PARTY FAVORS; PENCILS FOR PAINTING AND DRAWING; PHOTOGRAPH ALBUMS; PHOTOGRAPHS; PICTURE BOOKS; POSTCARDS AND GREETING CARDS; POSTERS; PRINTED INSTRUCTIONAL, EDUCATIONAL, AND TEACHING MATERIALS IN THE FIELD OF CHILDREN'S ENTERTAINMENT AND EDUCATION; SCHOOL SUPPLY KITS CONTAINING VARIOUS COMBINATIONS OF SELECTED SCHOOL SUPPLIES, NAMELY, WRITING INSTRUMENTS, PENS, PENCILS, MECHANICAL PENCILS, ERASERS, MARKERS, CRAYONS, HIGHLIGHTERS, FOLDERS, NOTEBOOKS, PAPER, PROTRACTORS, PAPER CLIPS, PENCIL SHARPENERS, WRITING GRIPS, GLUE AND BOOK MARKS; SELF-ADHESIVE TAPES FOR STATIONERY AND HOUSEHOLD PURPOSES; STATIONERY; STICKERS; TRADING CARDS; TRIVIA CARDS; WRAPPING PAPER (U.S. CLS. 2, 5, 22, 23, 29, 37, 38 AND 50).

**CLASS 25—CLOTHING**

FOR ATHLETIC APPAREL, NAMELY, SHIRTS, PANTS, JACKETS, FOOTWEAR, HATS AND CAPS, ATHLETIC UNIFORMS; BELTS; BLOUSES; CLOTH BIBS; COATS; FOOTWEAR; HEADWEAR; JACKETS; JOGGING SUITS; LINGERIE; MASQUERADE COSTUMES AND MASKS SOLD IN CONNECTION THEREWITH; PAJAMAS; PANTS; RAINWEAR; ROBES; SCARVES; SHIRTS; SHORTS; SKIRTS AND DRESSES; SLEEPWEAR; SNOW SUITS; SUSPENDERS; SWEAT SHIRTS; SWEATERS; SWIM WEAR; T-SHIRTS; TANK-TOPS; TENNIS WEAR; TIES; UNDERWEAR; VISORS (U.S. CLS. 22 AND 39).

**CLASS 28—TOYS AND SPORTING GOODS**

FOR ARCADE GAMES; ARCADE-TYPE ELECTRONIC EDUCATION VIDEO GAMES; BALLOONS; BASEBALL BATS; BASEBALL GLOVES; BASEBALLS; BASKETBALL TABLE TOP GAMES; BASKETBALLS; BATHTUB TOYS; BEAN BAG DOLLS; BOARD GAMES; BOBBLE HEAD DOLLS; CARD GAMES; CHESS SETS; CHRISTMAS TREE ORNAMENTS AND DECORATIONS; DART GAMES; DOLLS; DRAWING TOYS; ELECTRONIC ACTION TOYS; FLYING DISCS; HAND HELD UNIT FOR PLAYING ELECTRONIC GAMES; HAND HELD UNIT FOR PLAYING VIDEO GAMES; HAND-POWERED NON-MECHANICAL FLYING TOY; INFANT TOYS; INFLATABLE BATH TOYS; INFLATABLE TOYS; JIGSAW AND MANIPULATIVE PUZZLES; JUNGLE GYMS; MECHANICAL ACTION TOYS; MEMORY GAMES; MODEL CARS; MODELED PLASTIC TOY FIGURINES; PARTY FAVORS IN THE NATURE OF SMALL TOYS; PARTY GAMES; PINBALL GAMES; PINBALL-TYPE GAMES; PLAY

SWIMMING POOLS; PLAYING CARD CASES; PLUSH TOYS; POP UP TOYS; PUPPETS; REMOTE CONTROL TOYS, NAMELY, VEHICLES AND FIGURES; RUBBER CHARACTER TOYS; SANDBOX TOYS; SNOW BOARDS; SOCCER BALLS; SPORT BALLS; SWIM FINNS; SWIM FLOATS FOR RECREATIONAL USE; TABLE TENNIS RACKETS; TARGET GAMES; TENNIS BALLS; TOY ACTION FIGURES; TOY ANIMALS AND ACCESSORIES THEREFOR; TOY BANKS; TOY CONSTRUCTION SETS; TOY MODEL HOBBYCRAFT KITS; TOY SNOW GLOBES; TOY VEHICLES; WATER SQUIRTING TOYS (U.S. CLS. 22, 23, 38 AND 50).

**CLASS 41—EDUCATION AND ENTERTAINMENT**

FOR BOOK PUBLISHING; ENTERTAINMENT SERVICES IN THE NATURE OF ON-GOING TELEVISION PROGRAMS IN THE FIELD OF CHILDREN'S ENTERTAINMENT; ENTERTAINMENT SERVICES, NAMELY, NON-DOWNLOADABLE RINGTONES, PRE-RECORDED MUSIC, VIDEO AND GRAPHICS PRESENTED TO MOBILE COMMUNICATIONS DEVICES VIA A GLOBAL COMPUTER NETWORK AND WIRELESS NETWORKS; ENTERTAINMENT, NAMELY, PRODUCTION OF TELEVISION PROGRAMS AND FILMS FEATURING CHILDREN'S ENTERTAINMENT AND EDUCATION; MOTION PICTURE FILM PRODUCTION; MULTIMEDIA PUBLISHING OF BOOKS, MAGAZINES, JOURNALS, SOFTWARE, GAMES, MUSIC, AND ELECTRONIC PUBLICATIONS; PRESENTATION OF LIVE SHOW PERFORMANCES; PRODUCTION OF DVDS, VIDEOTAPES AND TELEVISION PROGRAMS FEATURING CHILDREN'S ENTERTAINMENT AND EDUCATION; PRODUCTION OF RADIO AND TELEVISION PROGRAMMES; PRODUCTION OF RADIO AND TELEVISION PROGRAMS; PROVIDING INFORMATION IN THE FIELD OF ENTERTAINMENT, FEATURING ANIMATION RENDERED BY MEANS OF A GLOBAL COMPUTER NETWORK; PROVISION OF NON-DOWNLOADABLE FILMS AND TELEVISION PROGRAMMES VIA A VIDEO-ON-DEMAND SERVICE; VIDEO ARCADE SERVICES (U.S. CLS. 100, 101 AND 107).

RUDY R. SINGLETON, EXAMINING ATTORNEY

---

SN 77-590,173. PARTYGAMING IA LIMITED, HAMILTON, BERMUDA, FILED 10-10-2008.

**PARTYACADEMY**

THE MARK CONSISTS OF STANDARD CHARACTERS WITHOUT CLAIM TO ANY PARTICULAR FONT, STYLE, SIZE, OR COLOR.

**CLASS 9—ELECTRICAL AND SCIENTIFIC APPARATUS**

FOR COMPUTER SOFTWARE FOR USE IN RELATION TO GAMING AND FOR PROVIDING TRAINING, TUTORING AND TEACHING IN THE FIELD OF GAMING; COMPUTER GAME SOFTWARE DISTRIBUTED VIA THE INTERNET, NAMELY, DOWNLOADABLE COMPUTER SOFTWARE FOR USE IN RELATION TO GAMING AND TEACHING THE PLAYING OF GAMING ACTIVITIES; COMPUTER SOFTWARE DISTRIBUTED VIA THE INTERNET, NAMELY, DOWNLOADABLE COMPUTER SOFTWARE FOR PROVIDING TRAINING AND TUTORING IN THE FIELD OF GAMING; DOWNLOADABLE ELECTRONIC PUBLICATIONS, NAMELY, NEWSLETTERS FEATURING INFORMATION IN THE FIELD OF GAMING, AMUSEMENT AND ENTERTAINMENT AND DATABASES FEATURING INFORMATION IN THE FIELD OF GAMING, AMUSEMENT AND ENTERTAINMENT; DOWNLOADABLE ELECTRONIC PUBLICATIONS, NAMELY, NEWSLETTERS PROVIDED BY EMAIL FEATURING INFORMATION IN THE FIELDS OF GAMING, AMUSEMENT AND ENTERTAINMENT (U.S. CLS. 21, 23, 26, 36 AND 38).

**CLASS 38—COMMUNICATION**

FOR TELECOMMUNICATION SERVICES, NAMELY, PROVIDING MULTIPLE USER ACCESS TO THE INTERNET AND TO ELECTRONIC DATABASES FOR USE SPECIFICALLY FOR GAMING, AMUSEMENT AND ENTERTAINMENT SERVICES, FOR PROVIDING ONLINE ENTERTAINMENT IN THE NATURE OF COMPUTER GAMING CONTESTS, GAMES OF CHANCE AND INTERACTIVE GAMES, AND FOR TEACHING THE PLAYING OF GAMING ACTIVITIES (U.S. CLS. 100, 101 AND 104).

**CLASS 41—EDUCATION AND ENTERTAINMENT**

FOR ENTERTAINMENT SERVICES, NAMELY, PROVIDING ONLINE ENTERTAINMENT IN THE NATURE OF COMPUTER GAMING CONTESTS, GAMES OF CHANCE AND INTERACTIVE GAMES; PROVIDING INFORMATION IN THE FIELD OF GAMING, GAMES OF CHANCE AND INTERACTIVE GAMES; EDUCATIONAL SERVICES, NAMELY, PROVIDING TRAINING AND TUTORING IN THE FIELD OF GAMING (U.S. CLS. 100, 101 AND 107).

ALLISON HOLTZ, EXAMINING ATTORNEY

SN 77-595,849. SIGNATURE GAMES PTY LTD, PROSPECT, AUSTRALIA, FILED 10-20-2008.

**FOOTPRINTS**

THE MARK CONSISTS OF STANDARD CHARACTERS WITHOUT CLAIM TO ANY PARTICULAR FONT, STYLE, SIZE, OR COLOR.

**CLASS 9—ELECTRICAL AND SCIENTIFIC APPARATUS**

FOR ELECTRICAL AND ELECTRONIC TOYS AND GAMES OF CHANCE AND/OR SKILL, NAMELY, COMPUTER AND VIDEO GAME SOFTWARE, COMPUTER AND VIDEO GAME PROGRAMS, VIDEO GAME CONSOLES FOR USE WITH AN EXTERNAL DISPLAY SCREEN OR MONITOR, HAND-HELD ELECTRONIC GAMES ADAPTED FOR USE WITH TELEVISION RECEIVERS ONLY; GAMING MACHINES, NAMELY, POKER MACHINES, SLOT MACHINES AND VIDEO GAME MACHINES FOR USE WITH TELEVISIONS AND REPLACEMENT PARTS FOR GAMING MACHINES (U.S. CLS. 21, 23, 26, 36 AND 38).

**CLASS 28—TOYS AND SPORTING GOODS**

FOR TOYS, GAMES AND PLAYTHINGS, NAMELY, BOARD GAMES AND EQUIPMENT SOLD AS A UNIT FOR PLAYING BOARD GAMES; STAND ALONE VIDEO GAME MACHINES; HAND-HELD UNIT FOR PLAYING ELECTRONIC GAMES; REPLACEMENT PARTS FOR THE AFORESAID GOODS (U.S. CLS. 22, 23, 38 AND 50).

**CLASS 41—EDUCATION AND ENTERTAINMENT**

FOR AMUSEMENT AND ENTERTAINMENT SERVICES, NAMELY, PROVIDING AND OPERATING ONLINE ELECTRONIC GAMES OF CHANCE AND/OR SKILL; LEASING EDUCATIONAL BOARD GAMES RELATING TO THE ENVIRONMENT TO EDUCATIONAL INSTITUTIONS; AMUSEMENT AND ENTERTAINMENT SERVICES, NAMELY, PROVIDING ONLINE INFORMATION ABOUT HOW TO PLAY GAMES OF CHANCE (U.S. CLS. 100, 101 AND 107).

GENE MACIOL, EXAMINING ATTORNEY

SN 77-602,402. CONIFER HEALTH SOLUTIONS, INC., FRISCO, TX. FILED 10-28-2008.

**CONIFER**  
HEALTH SOLUTIONS

NO CLAIM IS MADE TO THE EXCLUSIVE RIGHT TO USE "HEALTH SOLUTIONS", APART FROM THE MARK AS SHOWN.

THE COLOR(S) RED IS/ARE CLAIMED AS A FEATURE OF THE MARK.

THE MARK CONSISTS OF THE VERTICAL DISPLAY OF THE MARK "CONIFER HEALTH SOLUTIONS" IN THE COLOR RED.

**CLASS 35—ADVERTISING AND BUSINESS**

FOR BUSINESS CONSULTING, BUSINESS MANAGEMENT AND OUTSOURCING SERVICES IN THE FIELD OF REVENUE CYCLE MANAGEMENT AND SERVICES PROVIDED IN THE FIELD OF HEALTHCARE, PROVIDED BY HOSPITALS, AMBULATORY SERVICE CENTERS, DIAGNOSTIC SERVICE CENTERS, PHYSICIAN PRACTICES AND OTHER HEALTHCARE FACILITIES; PATIENT ACCOUNT MANAGEMENT SERVICES, NAMELY, MEDICAL ACCOUNTS RECEIVABLES SERVICES; COST MANAGEMENT SERVICES FOR HEALTH CARE PROVIDERS AND FACILITIES; REVIEW OF PAYMENT ARRANGEMENTS TO HEALTHCARE PROVIDERS AND HEALTH CARE PROFESSIONAL GROUPS FROM HEALTHCARE AND NON-HEALTHCARE RELATED PAYORS; AND OPERATION OF TELEPHONE CALL CENTERS FOR OTHER HEALTHCARE FACILITIES AND HEALTH CARE PROVIDERS (U.S. CLS. 100, 101 AND 102).

**CLASS 36—INSURANCE AND FINANCIAL**

FOR PATIENT ACCOUNT MANAGEMENT SERVICES, NAMELY, COLLECTION OF DEBTS SERVICES; FINANCIAL CONSULTING SERVICES RELATED TO ENHANCING REVENUE CYCLE SERVICES PROVIDED IN THE FIELD OF HEALTHCARE; CLAIMS ADMINISTRATION SERVICES IN THE FIELD OF HEALTH INSURANCE; ADMINISTRATION OF PATIENT ASSISTANCE ELIGIBILITY PROGRAMS FOR HEALTH CARE BENEFITS AND CLAIMS; PROVIDING PATIENT ELIGIBILITY ASSISTANCE SERVICES, NAMELY, DETERMINING ELIGIBILITY FOR HEALTH BENEFITS AND FUNDING; ENTITLEMENT FUNDING SERVICES, NAMELY, PROVIDING GUIDANCE TO PATIENTS NECESSITATING FUNDING FOR HEALTHCARE (U.S. CLS. 100, 101 AND 102).

**CLASS 38—COMMUNICATION**

FOR MESSAGE MANAGEMENT SERVICES, NAMELY, COLLECTION AND TRANSMISSION OF MESSAGES AND OTHER TELEPHONIC OR ELECTRONIC SERVICES RELATED TO THE PROVISION OF HEALTHCARE SERVICES; AND TELECOMMUNICATION SERVICES, NAMELY, TRANSMISSION OF VOICE, DATA, GRAPHICS, IMAGES, AUDIO AND VIDEO BY MEANS OF TELECOMMUNICATIONS NETWORKS, WIRELESS COMMUNICATION NETWORKS, AND THE INTERNET THAT ENABLES COMMUNICATION SYNCHRONOUSLY AND ASYNCHRONOUSLY AND CONNECTION OF PHYSICIANS WITH THEIR PATIENTS REGARDLESS OF MEDICAL ORGANIZATION OR GEOGRAPHIC LOCATION (U.S. CLS. 100, 101 AND 104).

**CLASS 41—EDUCATION AND ENTERTAINMENT**

FOR ONLINE EDUCATIONAL SERVICES, NAMELY, PROVIDING PROGRAMS, SEMINARS, AND CLASSES IN THE FIELD OF HEALTHCARE OPERATIONS TO HEALTH CARE PROVIDERS AND FACILITIES (U.S. CLS. 100, 101 AND 107).

**CLASS 45—PERSONAL AND LEGAL SERVICES**

FOR REVIEWING STANDARDS AND PRACTICES TO ASSURE COMPLIANCE WITH HEALTH CARE LAWS AND REGULATIONS (U.S. CLS. 100 AND 101).  
ALEXANDER L. POWERS, EXAMINING ATTORNEY

SN 77-604,375. PRACTISING LAW INSTITUTE, NEW YORK, NY. FILED 10-30-2008.



OWNER OF U.S. REG. NOS. 970,425, 988,434 AND OTHERS.

NO CLAIM IS MADE TO THE EXCLUSIVE RIGHT TO USE "INSTITUTE", APART FROM THE MARK AS SHOWN. THE MARK CONSISTS OF THE STYLIZED LETTERS "PLI" WITH AN ARC OF DOTS DESCENDING FROM THE LETTER "I", ABOVE THE WORDS "PRACTISING LAW INSTITUTE".

SEC. 2(F) AS TO "PRACTISING LAW".

**CLASS 9—ELECTRICAL AND SCIENTIFIC APPARATUS**

FOR PRERECORDED CDS AND DVDS, DOWNLOADABLE MP3 FILES, WEBCASTS AND PODCASTS, DOWNLOADABLE ELECTRONIC PUBLICATIONS, NAMELY, BOOKS AND NEWSLETTERS, ALL OF THE ABOVE IN THE FIELDS OF LAW, BUSINESS, ACCOUNTING, LAW PRACTICE MANAGEMENT, MARKETING, BUSINESS DEVELOPMENT AND DIVERSITY AND CONTINUING EDUCATION (U.S. CLS. 21, 23, 26, 36 AND 38).

FIRST USE 2-28-2008; IN COMMERCE 2-28-2008.

**CLASS 16—PAPER GOODS AND PRINTED MATTER**

FOR PUBLICATIONS, NAMELY, TREATISES, COURSE HANDBOOKS, BOOKS, ALL OF THE ABOVE IN THE FIELDS OF LAW, BUSINESS, ACCOUNTING, LAW PRACTICE MANAGEMENT, MARKETING, BUSINESS DEVELOPMENT, DIVERSITY AND CONTINUING EDUCATION; CALENDARS (U.S. CLS. 2, 5, 22, 23, 29, 37, 38 AND 50).

FIRST USE 7-31-2008; IN COMMERCE 7-31-2008.

**CLASS 41—EDUCATION AND ENTERTAINMENT**

FOR EDUCATIONAL SERVICES, NAMELY, PROVIDING LECTURES, SEMINARS, WEBCASTS, AND NON-DOWNLOADABLE EDUCATIONAL PROGRAMS VIA A VIDEO ON-DEMAND SERVICE, ONLINE JOURNALS, NAMELY, BLOGS, ALL OF THE ABOVE IN THE FIELDS OF LAW, BUSINESS, ACCOUNTING, LAW PRACTICE MANAGEMENT, MARKETING, BUSINESS DEVELOPMENT, DIVERSITY AND CONTINUING EDUCATION (U.S. CLS. 100, 101 AND 107).

FIRST USE 5-4-2008; IN COMMERCE 5-4-2008.

**CLASS 42—SCIENTIFIC AND COMPUTER SERVICES**

FOR COMPUTER SERVICES, NAMELY, CREATING AN ONLINE COMMUNITY FOR REGISTERED USERS TO PARTICIPATE IN DISCUSSIONS, GET FEEDBACK FROM THEIR PEERS, FORM VIRTUAL COMMUNITIES AND ENGAGE IN SOCIAL NETWORKING IN THE FIELDS OF LAW, BUSINESS, ACCOUNTING, LAW PRACTICE MANAGEMENT, MARKETING, BUSINESS DEVELOPMENT, DIVERSITY AND CONTINUING EDUCATION (U.S. CLS. 100 AND 101).

FIRST USE 10-29-2008; IN COMMERCE 10-29-2008.  
DOMINIC FATHY, EXAMINING ATTORNEY

SN 77-614,571. AOE CONSULTING, LLC, LITTLETON, CO.  
FILED 11-14-2008.



NO CLAIM IS MADE TO THE EXCLUSIVE RIGHT TO USE "CONSULTING", APART FROM THE MARK AS SHOWN.

**CLASS 41—EDUCATION AND ENTERTAINMENT**

FOR TRAINING SERVICES IN THE FIELDS OF EXAM PREPARATION FOR CONTINUING MEDICAL EDUCATION (CME) PROFESSIONALS AND COMPLIANCE TRAINING FOR CONTINUING MEDICAL EDUCATION (CME)/CONTINUING EDUCATION (CE) PROFESSIONALS; CONSULTING SERVICES IN THE FIELD OF CONTINUING MEDICAL EDUCATION (CME) PROGRAMS (U.S. CLS. 100, 101 AND 107).

FIRST USE 8-11-2008; IN COMMERCE 8-11-2008.

**CLASS 42—SCIENTIFIC AND COMPUTER SERVICES**

FOR CONSULTING SERVICES IN THE FIELD OF ACCREDITATION AND RE-ACCREDITATION FOR CONTINUING MEDICAL EDUCATION (CME) PROFESSIONALS (U.S. CLS. 100 AND 101).

FIRST USE 8-11-2008; IN COMMERCE 8-11-2008.

MARIA-VICTORIA SUAREZ, EXAMINING ATTORNEY

SN 77-628,235. NETAFIM LTD., TEL AVIV, ISRAEL, FILED  
12-8-2008.

GROW MORE WITH LESS

THE MARK CONSISTS OF STANDARD CHARACTERS WITHOUT CLAIM TO ANY PARTICULAR FONT, STYLE, SIZE, OR COLOR.

**CLASS 11—ENVIRONMENTAL CONTROL APPARATUS**

FOR AUTOMATIC EQUIPMENT AND APPARATUS FOR IRRIGATION, NAMELY, IRRIGATION SPRAY NOZZLES, IRRIGATION AND FERTIGATION MIST SPRAYERS, IRRIGATION AND FERTIGATION SPRINKLERS; DRIPPER IRRIGATION SYSTEMS COMPRISED OF VALVES, FILTERS, FERTIGATION DEVICES, NAMELY, FERTIGATION TANKS, VENTURI PUMPS FOR FERTIGATION, HYDRAULIC PUMPS FOR FERTIGATION, ELECTRIC PUMPS FOR FERTIGATION, PIPES, DRIPPER LINES, PARTS AND FITTINGS FOR ALL THE AFOREMENTIONED GOODS, NAMELY, DISTRIBUTION MANIFOLDS; WATER PURIFICATION AND FILTRATION APPARATUS; FERTIGATION SYSTEMS COMPRISED OF FERTIGATION PUMPS, VENTURI PUMPS, FERTIGATION VALVES, PIPES AND ACCESSORIES THEREOF; WASTE WATER PURIFICATION UNITS; WATER RECYCLING CONTROL SYSTEMS COMPRISING MEDIA FILTERS, DISINFECTANT UNITS, PUMPS, CONDUITS, MONITORS AND CONTROL PANELS; WATER PURIFYING APPARATUS; PARTS, FITTINGS AND ACCESSORIES FOR THE ABOVE GOODS, NAMELY, PRESSURE REGULATORS, DISTRIBUTION START AND END LINES; GREENHOUSE STEAM APPARATUS COMPRISING PIPES, PUMPS, WATER BOILERS AND WATER TANKS, GREENHOUSE AIR CONDITIONING AND AIR COOLING APPARATUS COMPRISING VENTILATORS, VENTS, SHADE SCREENS, FOGGERS AND GREENHOUSE VENTILATION APPARATUS COMPRISING AIR CIRCULATORS, VENTILATORS, PRESSURE TANKS, CONTROLLERS AND HUMIDITY SENSORS (U.S. CLS. 13, 21, 23, 31 AND 34).

**CLASS 17—RUBBER GOODS**

FOR IRRIGATION HOSES; DRIPPER LINES FOR IRRIGATION; PARTS AND FITTINGS FOR ALL THE AFOREMENTIONED GOODS; INSULATING GROUND COVERS FROM POLYETHYLENE; INSULATION FILMS MADE OF PLASTIC FOR GREENHOUSES (U.S. CLS. 1, 5, 12, 13, 35 AND 50).

LINDA ORNDORFF, EXAMINING ATTORNEY

SN 77-644,050. SCHRODT, MARZIA, GUTIERREZ, DBA PRINCE, MARZIA, FRISCO, TX. AND SCHRODT, KEITH, ALLEN, FRISCO, TX. FILED 1-6-2009.

The Fit Chic

THE MARK CONSISTS OF STANDARD CHARACTERS WITHOUT CLAIM TO ANY PARTICULAR FONT, STYLE, SIZE, OR COLOR.



**CLASS 16—PAPER GOODS AND PRINTED MATTER**

FOR A SERIES OF NON-FICTION BOOKS AND WRITTEN ARTICLES IN THE FIELD OF FITNESS, EXERCISE, HEALTH AND NUTRITION; A SERIES OF NON-FICTION BOOKS, WRITTEN ARTICLES, HAND-OUTS AND WORKSHEETS IN THE FIELD OF FITNESS, EXERCISE, HEALTH AND NUTRITION; A SERIES OF NON-FICTION CHILDREN'S ACTIVITY BOOKS IN THE FIELD OF FITNESS, EXERCISE, HEALTH AND NUTRITION; COFFEE TABLE BOOKS FEATURING FITNESS, EXERCISE, HEALTH AND NUTRITION; COOK BOOKS; EDUCATIONAL BOOKS FEATURING FITNESS, EXERCISE, HEALTH AND NUTRITION; EDUCATIONAL PUBLICATIONS, NAMELY, EDUCATIONAL LEARNING CARDS, FLASH CARDS, ACTIVITY CARDS, WORKBOOKS, TEXTBOOKS, ACTIVITY BOOKS, STORY BOOKS, PUZZLE BOOKS, PRINTED PUZZLES, TEACHER GUIDES, MANUALS, POSTERS AND EDUCATIONAL BOOKLETS IN THE FIELD OF FITNESS, EXERCISE, HEALTH AND NUTRITION; EDUCATIONAL PUBLICATIONS, NAMELY, TRAINING MANUALS IN THE FIELD OF FITNESS, EXERCISE, HEALTH AND NUTRITION; EDUCATIONAL PUBLICATIONS, NAMELY, BOOKS, MAGAZINES, WEBSITES, CALENDARS, MANUALS IN THE FIELDS OF FITNESS, EXERCISE, HEALTH AND NUTRITION; EXERCISE BOOKS IN THE FIELDS OF FITNESS, EXERCISE, HEALTH AND NUTRITION; EXERCISE-BOOK COVERS; MAGAZINE COLUMNS ABOUT FITNESS, EXERCISE, HEALTH AND NUTRITION; PICTURE BOOKS; PUBLICATIONS, NAMELY, BOOKS, MAGAZINES, MANUALS, WEBSITES, CALENDARS IN THE FIELDS OF FITNESS, EXERCISE, HEALTH AND NUTRITION; REFERENCE BOOKS IN THE FIELD OF FITNESS, EXERCISE, HEALTH AND NUTRITION; RESOURCE BOOKS IN THE FIELD OF FITNESS, EXERCISE, HEALTH AND NUTRITION; SCHOLARLY BOOKS ON VARIOUS TOPICS, NAMELY, FITNESS, EXERCISE, HEALTH AND NUTRITION (U.S. CLS. 2, 5, 22, 23, 29, 37, 38 AND 50).

**CLASS 41—EDUCATION AND ENTERTAINMENT**

FOR ENTERTAINMENT SERVICES, NAMELY, CONTEST AND INCENTIVE AWARD PROGRAMS DESIGNED TO REWARD PROGRAM PARTICIPANTS WHO EXERCISE, MAKE HEALTHY EATING CHOICES, AND ENGAGE IN OTHER HEALTH-PROMOTING ACTIVITIES; HEALTH CLUB SERVICES, NAMELY, PROVIDING INSTRUCTION AND EQUIPMENT IN THE FIELD OF PHYSICAL EXERCISE; PHYSICAL FITNESS CONDITIONING CLASSES; PHYSICAL FITNESS CONSULTATION; PHYSICAL FITNESS INSTRUCTION; PHYSICAL FITNESS TRAINING SERVICES; PROVIDING A WEB SITE FEATURING INFORMATION ON EXERCISE AND FITNESS IN THE AREAS OF FITNESS, EXERCISE; PROVIDING AN ON-LINE COMPUTER DATABASE FEATURING INFORMATION REGARDING EXERCISE AND FITNESS IN THE AREAS OF FITNESS, EXERCISE; PROVIDING AN ON-LINE COMPUTER DATABASE FEATURING INFORMATION REGARDING EXERCISE AND FITNESS BEFORE AND AFTER PREGNANCY IN THE AREAS OF FITNESS, EXERCISE; PROVIDING ASSISTANCE, PERSONAL TRAINING AND PHYSICAL FITNESS CONSULTATION TO CORPORATE CLIENTS TO HELP THEIR EMPLOYEES MAKE PHYSICAL FITNESS, STRENGTH, CONDITIONING, AND EXERCISE ALTERATIONS IN THEIR DAILY LIVING; PROVIDING ASSISTANCE, PERSONAL TRAINING AND PHYSICAL FITNESS CONSULTATION TO INDIVIDUALS TO HELP THEM MAKE PHYSICAL FITNESS, STRENGTH, CONDITIONING, AND EXERCISE IMPROVEMENT IN THEIR DAILY LIVING; PROVIDING FITNESS AND EXERCISE FACILITIES; PROVIDING NON-DOWNLOADABLE ON-LINE PUBLICATIONS IN THE NATURE OF AN E-BOOK IN THE FIELD OF FITNESS, EXERCISE, HEALTH AND NUTRITION; PUBLICATION OF BOOKS IN THE FIELDS OF FITNESS, EXERCISE, HEALTH AND NUTRITION; PUBLICATION OF BOOKS, MAGAZINES, ALMANACS AND JOURNALS IN THE FIELDS OF FITNESS, EXERCISE, HEALTH AND NUTRITION; PUBLICATION OF BOOKS, OF MAGAZINES, OF JOURNALS, OF NEWSPAPERS, OF PERIODICALS, OF CATALOGS, OF BROCHURES IN THE FIELDS OF FITNESS, EXERCISE, HEALTH AND NUTRITION; PUBLICATION OF TEXT BOOKS IN THE FIELDS OF

FITNESS, EXERCISE, HEALTH AND NUTRITION; PUBLICATION OF TEXTS, BOOKS, JOURNALS IN THE FIELDS OF FITNESS, EXERCISE, HEALTH AND NUTRITION; PUBLICATION OF TEXTS, BOOKS, MAGAZINES AND OTHER PRINTED MATTER IN THE FIELDS OF FITNESS, EXERCISE, HEALTH AND NUTRITION; PUBLICATION OF BOOKS, MAGAZINES, CALENDARS, EBOOKS, BOOKS, NEWS LETTERS, ALL WRITTEN PUBLICATIONS IN THE FIELDS OF FITNESS, EXERCISE, HEALTH AND NUTRITION, PROVIDING A WEB SITE IN THE FIELDS OF FITNESS AND EXERCISE; PROVIDING A WEB SITE FEATURING INFORMATION ABOUT FITNESS IN THE FIELD OF FITNESS AND EXERCISE IN INTERNATIONAL CLASS 041 (U.S. CLS. 100, 101 AND 107).

**CLASS 44—MEDICAL, BEAUTY AND AGRICULTURAL SERVICES**

FOR PROVIDING A WEB SITE FEATURING INFORMATION ABOUT HEALTH AND NUTRITION IN THE FIELD OF HEALTH AND NUTRITION; PROVIDING A WEB SITE IN THE FIELD OF HEALTH AND NUTRITION (U.S. CLS. 100 AND 101).

ALLISON HOLTZ, EXAMINING ATTORNEY

SN 77-652,354, SENSOMATIX LTD, RAMAT GAN, ISRAEL, FILED 1-20-2009.



PRIORITY CLAIMED UNDER SEC. 44(D) ON ISRAEL APPLICATION NO. 217846, FILED 1-19-2009, REG. NO. 217846, DATED 3-7-2011, EXPIRES 1-19-2019.

PRIORITY CLAIMED UNDER SEC. 44(D) ON ISRAEL APPLICATION NO. 217841, FILED 1-19-2009, REG. NO. 217841, DATED 3-7-2011, EXPIRES 1-19-2019.

THE MARK CONSISTS OF THREE ROWS OF THREE DOTS EACH, PARTIALLY CONNECTED, PRIOR TO THE LEFT OF THE WORDING OF THE MARK "DRIVING DNA".

**CLASS 9—ELECTRICAL AND SCIENTIFIC APPARATUS**

FOR COMPUTER SOFTWARE AND HARDWARE FOR MANAGING, PROCESSING, ANALYZING AND AGGREGATING DATA FOR INSURANCE UNDERWRITING AND ADMINISTRATION FOR ANALYZING RISKS BASED ON COLLECTED INFORMATION PERTAINING TO THE INSURED ENTITY (U.S. CLS. 21, 23, 26, 36 AND 38).

**CLASS 36—INSURANCE AND FINANCIAL**

FOR INSURANCE UNDERWRITING AND ADMINISTRATION SERVICES, NAMELY, STATISTICS ANALYSIS CONCERNING RISKS ENABLING PREMIUM UNDERWRITING AND PRICING (U.S. CLS. 100, 101 AND 102).

JANICE KIM, EXAMINING ATTORNEY

SN 77-676,578. ZYLOG SYSTEMS (CANADA) LTD., TORONTO, CANADA, FILED 2-23-2009.

## BRAINHUNTER

THE MARK CONSISTS OF STANDARD CHARACTERS WITHOUT CLAIM TO ANY PARTICULAR FONT, STYLE, SIZE, OR COLOR.

PRIORITY CLAIMED UNDER SEC. 44(D) ON CANADA APPLICATION NO. 1408220, FILED 8-21-2008, REG. NO. TMA787975, DATED 1-19-2011, EXPIRES 1-19-2021.

OWNER OF U.S. REG. NO. 2,488,572.

### CLASS 9—ELECTRICAL AND SCIENTIFIC APPARATUS

FOR COMPUTER SOFTWARE AND APPLICATIONS FOR USE BY EMPLOYERS, STAFFING AGENCIES AND JOB SEEKERS, INCLUDING EMPLOYEES AND CONTRACT PERSONNEL, FOR USE IN THE FIELD OF HUMAN CAPITAL MANAGEMENT ENCOMPASSING RECRUITING, MANAGING, ADMINISTRATION, DEVELOPING AND RETAINING AND OUT-PLACING PERSONNEL; COMPUTER SOFTWARE FOR USE BY EMPLOYERS IN THE FIELD OF EMPLOYEE RECRUITMENT AND STAFFING (U.S. CLS. 21, 23, 26, 36 AND 38).

### CLASS 35—ADVERTISING AND BUSINESS

FOR EMPLOYEE AND CONTRACT RECRUITMENT AND PLACEMENT SERVICES, ONLINE JOB SEARCH AND STAFFING SERVICES, CONSULTANCY AND ADVISORY SERVICES IN THE FIELD OF HIRING PERSONNEL, PAYROLLING, ADMINISTRATION AND BUSINESS PROCESS OUTSOURCING; PROVIDING PAYROLLING, ADMINISTRATION, AND BUSINESS PROCESS OUTSOURCING SERVICES (U.S. CLS. 100, 101 AND 102).

KAREN K. BUSH, EXAMINING ATTORNEY

SN 77-687,192. INDUSTRIES SANIMAX INC., MONTREAL, QUEBEC, CANADA, FILED 3-10-2009.

## BIORETURN

THE MARK CONSISTS OF STANDARD CHARACTERS WITHOUT CLAIM TO ANY PARTICULAR FONT, STYLE, SIZE, OR COLOR.

PRIORITY CLAIMED UNDER SEC. 44(D) ON CANADA APPLICATION NO. 1410419, FILED 9-11-2008, REG. NO. TMA787981, DATED 1-19-2011, EXPIRES 1-19-2026.

### CLASS 4—LUBRICANTS AND FUELS

FOR ANIMAL BY-PRODUCTS, NAMELY, GENERAL PURPOSE YELLOW GREASE; ANIMAL FATS AND GREASE FOR USE IN THE MANUFACTURE OF OTHER PRODUCTS; BIODIESEL FUEL (U.S. CLS. 1, 6 AND 15).

### CLASS 18—LEATHER GOODS

FOR ANIMAL BY-PRODUCTS, NAMELY, HIDES AND SKINS (U.S. CLS. 1, 2, 3, 22 AND 41).

### CLASS 29—MEATS AND PROCESSED FOODS

FOR ANIMAL BY-PRODUCTS, NAMELY, ANIMAL FAT AND EDIBLE FAT (U.S. CL. 46).

### CLASS 31—NATURAL AGRICULTURAL PRODUCTS

FOR ANIMAL BY-PRODUCTS, NAMELY, ANIMAL FEED (U.S. CLS. 1 AND 46).

LINDA LAVACHE, EXAMINING ATTORNEY

SN 77-708,692. THE GREENHORIZONS GROUP OF FARMS LTD., MOUNT HOPE, ONTARIO, CANADA, FILED 4-7-2009.

## GREENHORIZONS

THE MARK CONSISTS OF STANDARD CHARACTERS WITHOUT CLAIM TO ANY PARTICULAR FONT, STYLE, SIZE, OR COLOR.

PRIORITY CLAIMED UNDER SEC. 44(D) ON CANADA APPLICATION NO. 1413634, FILED 10-7-2008, REG. NO. TMA774315, DATED 8-12-2010, EXPIRES 8-12-2025.

### CLASS 31—NATURAL AGRICULTURAL PRODUCTS

FOR TOP SOIL; MULCH; GRASS AND LAWN SEED; TURF GRASS SOD (U.S. CLS. 1 AND 46).

### CLASS 35—ADVERTISING AND BUSINESS

FOR RETAIL STORE SERVICES IN THE FIELD OF LAWN AND GARDEN SUPPLIES (U.S. CLS. 100, 101 AND 102).

### CLASS 44—MEDICAL, BEAUTY AND AGRICULTURAL SERVICES

FOR PROVIDING INFORMATION AND ADVICE TO CUSTOMERS IN THE FIELD OF LAWN CARE, LANDSCAPING, AND GARDENING, NAMELY, PROVIDING INFORMATION TO CUSTOMERS ON THE USE OF LAWN AND GARDEN FERTILIZERS, SOIL, GRASS AND LAWN SEED AND TURF GRASS SOD (U.S. CLS. 100 AND 101).

LESLIE RICHARDS, EXAMINING ATTORNEY

SN 77-711,569. DEREK JOHN WEBB AND HANNAH SARAH O'DONNELL IN PARTNERSHIP AS "PRIME TABLE GAMES UK", LITTLEOVER, DERBY, UNITED KINGDOM, FILED 4-10-2009.



PRIORITY CLAIMED UNDER SEC. 44(D) ON UNITED KINGDOM APPLICATION NO. 2,500,808, FILED 10-23-2008, REG. NO. 2,500,808, DATED 4-10-2009, EXPIRES 10-23-2018.

THE MARK CONSISTS OF A CIRCLE AROUND THE WORD "PRIME".

**CLASS 16—PAPER GOODS AND PRINTED MATTER**

FOR PROCEDURE MANUALS FOR PLAYING CASINO CARD GAMES (U.S. CLS. 2, 5, 22, 23, 29, 37, 38 AND 50).

**CLASS 28—TOYS AND SPORTING GOODS**

FOR CASINO CARD GAMES; EQUIPMENT FOR USE IN PLAYING CASINO CARD GAMES, NAMELY, LAYOUT CLOTHS AND DEALER BUTTONS; PLAYER ADVICE CARDS FOR PLAYING CASINO CARD GAMES (U.S. CLS. 22, 23, 38 AND 50).

PAM WILLIS, EXAMINING ATTORNEY

SN 77-741,926. SY ENTERPRISES, LLC, SAN RAFAEL, CA, FILED 5-21-2009.

**PEARL'S DELUXE BURGERS**

THE MARK CONSISTS OF STANDARD CHARACTERS WITHOUT CLAIM TO ANY PARTICULAR FONT, STYLE, SIZE, OR COLOR.

NO CLAIM IS MADE TO THE EXCLUSIVE RIGHT TO USE "DELUXE BURGERS", APART FROM THE MARK AS SHOWN.

**CLASS 30—STAPLE FOODS**

FOR HAMBURGER SANDWICHES (U.S. CL. 46). FIRST USE 4-16-2006; IN COMMERCE 4-16-2006.

**CLASS 43—HOTEL AND RESTAURANT SERVICES**

FOR RESTAURANT SERVICES, INCLUDING SIT-DOWN SERVICE OF FOOD AND TAKE-OUT RESTAURANT SERVICES (U.S. CLS. 100 AND 101).

FIRST USE 4-16-2006; IN COMMERCE 4-16-2006. KATHERINE M. DUBRAY, EXAMINING ATTORNEY

SN 77-771,725. PAGE, CHRISTOPHER, ROGERS, AR. FILED 6-30-2009.

**Toddle Dots**

THE MARK CONSISTS OF STANDARD CHARACTERS WITHOUT CLAIM TO ANY PARTICULAR FONT, STYLE, SIZE, OR COLOR.

**CLASS 16—PAPER GOODS AND PRINTED MATTER**

FOR CHILDREN'S BOOKS; FLASH CARDS (U.S. CLS. 2, 5, 22, 23, 29, 37, 38 AND 50).

**CLASS 28—TOYS AND SPORTING GOODS**

FOR ACTION SKILL GAMES; ARCADE GAMES; BOARD GAMES; CARD GAMES; ELECTRONIC LEARNING TOYS; ELECTRONIC TOY VEHICLES (U.S. CLS. 22, 23, 38 AND 50).

ARETHA SOMERVILLE, EXAMINING ATTORNEY

SN 77-774,639. SALICE PAOLO SRL, CANTU' (CO), ITALY, FILED 7-6-2009.

**SALICE PAOLO**

THE MARK CONSISTS OF STANDARD CHARACTERS WITHOUT CLAIM TO ANY PARTICULAR FONT, STYLE, SIZE, OR COLOR.

PRIORITY CLAIMED UNDER SEC. 44(D) ON ERPNCMNTY TM OFC APPLICATION NO. 008179319, FILED 3-25-2009, REG. NO. 008179319, DATED 10-21-2009, EXPIRES 10-21-2019.

THE NAME(S), PORTRAIT(S), AND/OR SIGNATURE(S) SHOWN IN THE MARK DOES NOT IDENTIFY A PARTICULAR LIVING INDIVIDUAL.

THE ENGLISH TRANSLATION OF "SALICE" IN THE MARK IS "WILLOW".

**CLASS 6—METAL GOODS**

FOR HANDLES AND KNOBS OF METAL AND METAL ALLOYS FOR DOORS, WINDOWS, FURNITURE AND FURNISHINGS IN THE NATURE OF DRAWERS AND CABINET DOORS; METAL KEYS FOR LOCKS; BOWS, NAMELY, METAL ROSES USED FOR HANDLES IN THE NATURE OF BRASS; PLATES, NAMELY, METAL ESCUTCHEONS FOR DOORS AND FURNITURE; METAL HANDLES FOR DOOR FRAMES; METAL MAIL PLATES (U.S. CLS. 2, 12, 13, 14, 23, 25 AND 50).

**CLASS 20—FURNITURE AND ARTICLES NOT OTHERWISE CLASSIFIED**

FOR COAT HANGERS, SHELVES; NON METAL HANDLES FOR FURNITURE; NON METAL KNOBS AND HANDLES FOR FURNITURE; DECORATION FOR FURNITURE, NAMELY, LITTLE KNOBS, LITTLE HANDLES, FURNITURE STUDS, FURNITURE CORNERS, FURNITURE ADORNMENTS, ALL OF BRASS, GLASS, AND CRYSTAL (U.S. CLS. 2, 13, 22, 25, 32 AND 50).

**CLASS 21—HOUSEWARES AND GLASS**

FOR HANDLES OF PORCELAIN, GLASS AND CRYSTAL FOR USE ON DOORS AND FURNITURE; BATHROOM ACCESSORIES, IN PARTICULAR TOWEL RAILS AND RINGS; SOAP HOLDERS, SOAP DISPENSERS, TOOTHBRUSH HOLDERS, TOILET PAPER HOLDERS, SPONGE HOLDERS AND STANDS THEREFORE (U.S. CLS. 2, 13, 23, 29, 30, 33, 40 AND 50).

SUZANNE BLANE, EXAMINING ATTORNEY

SN 77-776,289. NTV BROADCASTING CO., 127427 MOSCOW, RUSSIAN FED., FILED 7-8-2009.

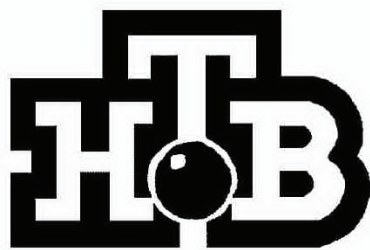

THE MARK CONSISTS OF THE STYLIZED CYRILLIC LETTERS "NTV" IN WHICH THE LETTER "T" IS THE TALLEST LETTER AND A CIRCLE WITH A REFLECTION SPOT SUPERIMPOSED ON THE BOTTOM HALF OF THE LETTER "T".

THE NON-LATIN CHARACTERS IN THE MARK TRANSLITERATE TO "NTV" AND THIS HAS NO MEANING IN A FOREIGN LANGUAGE.

**CLASS 35—ADVERTISING AND BUSINESS**

FOR TELEVISION ADVERTISING, NAMELY, PROVIDING TELEVISION ADVERTISING FOR OTHERS, PRODUCTION OF TELEVISION ADVERTISING, AND RENTAL OF TELEVISION ADVERTISING SPACE (U.S. CLS. 100, 101 AND 102).

FIRST USE 1-17-1994; IN COMMERCE 12-17-2002.

**CLASS 38—COMMUNICATION**

FOR TELECOMMUNICATIONS, NAMELY, TELEVISION BROADCASTING; CABLE TELEVISION BROADCASTING; SUBSCRIPTION TELEVISION BROADCASTING; BROADCASTING SERVICES, NAMELY, PROVIDING INTERACTIVE DELIVERY OF TELEVISION, AUDIO, AND VIDEO OVER DIGITAL NETWORKS; BROADCASTING PROGRAMS AND VIDEO VIA THE INTERNET; STREAMING OF VIDEO MATERIAL ACROSS BROADBAND NETWORKS AND THE INTERNET; TELEVISION, SATELLITE TELEVISION, CABLE TELEVISION, AUDIO AND INTERNET BROADCASTING SERVICES RENDERED THROUGH TERRESTRIAL BROADCASTING SYSTEMS, SATELLITES, AND THE INTERNET; TRANSMISSION OF AUDIO, VIDEO, AND DATA MATERIAL TO WIRELESS COMMUNICATION DEVICES, HANDHELD COMPUTERS, PERSONAL DIGITAL ASSISTANTS, AND MOBILE AND CELLULAR TELEPHONES; ELECTRONIC TRANSMISSION OF DATA, DOCUMENTS, MESSAGES, TEXT, SOUND, IMAGES, GRAPHICS, ENTERTAINMENT MEDIA CONTENT, AND EDUCATIONAL MEDIA CONTENT VIA A GLOBAL COMPUTER NETWORK; VIDEO-ON-DEMAND TRANSMISSION SERVICES; MOBILE MEDIA IN THE NATURE OF ELECTRONIC TRANSMISSION OF ENTERTAINMENT MEDIA CONTENT; AND TELETEXT SERVICES (U.S. CLS. 100, 101 AND 104).

FIRST USE 1-17-1994; IN COMMERCE 9-26-2002.

**CLASS 41—EDUCATION AND ENTERTAINMENT**

FOR ENTERTAINMENT SERVICES, NAMELY, PRODUCTION OF TELEVISION ENTERTAINMENT AND AUDIO AND VIDEO RECORDINGS; PRODUCTION OF MOTION PICTURE FILMS, IMAGES, AND SOUND RECORDINGS, NAMELY, PRODUCTION OF MOVIES AND VIDEO FILMS; PRODUCTION OF ONGOING TELEVISION PROGRAMS; DISTRIBUTION OF TELEVISION PROGRAMMING FOR OTHERS TO CABLE, TERRESTRIAL, OR SATELLITE TELEVISION SYSTEMS; INTERNET PORTAL SERVICES, NAMELY, PROVIDING LINKS TO A WIDE RANGE OF INFORMATION IN THE FIELDS OF CURRENT EVENT NEWS, ENTERTAINMENT, CULTURAL, AND SPORTING EVENTS (U.S. CLS. 100, 101 AND 107).

FIRST USE 1-17-1994; IN COMMERCE 3-17-2003.  
ALYSSA STEEL, EXAMINING ATTORNEY

SN 77-784,800. NATIONAL COUNCIL OF EXAMINERS FOR ENGINEERING AND SURVEYING, CLEMSON, SC. FILED 7-20-2009.



OWNER OF U.S. REG. NOS. 2,325,855, 2,829,164 AND OTHERS.

THE MARK CONSISTS OF A SQUARE CONTAINING A DIAGONAL DASHED LINE FROM THE UPPER LEFT CORNER TO THE LOWER RIGHT CORNER, SUGGESTING AN "N"; PERPENDICULAR BRUSH STROKES WITHIN THE SQUARE, FORMING A BLOCK "C" WITH AN ARROW AND A CIRCLE AT THE OPENING OF THE "C"; A PARALLEL SET OF SMALLER BRUSH STOKES INSIDE THE "C" WITH A DASHED HORIZONTAL LINE IN THE MIDDLE, RUNNING TO THE RIGHT FROM THE MIDPOINT OF THE SPINE OF THE INTERIOR "C" SHAPE, THUS SUGGESTING AN "E"; THE NUMBER "2" AT THE TOP OF THE "E", SUGGESTING 2 "E"'S; AND A SINE WAVE CURVE FORM IN THE CENTER, SUGGESTING AN "S". COLLECTIVELY, THESE DESIGN COMPONENTS SYMBOLIZE IN THE ABSTRACT, "NCEES" IN GRAPHIC FORM WITHIN THE SQUARE. THE LETTERS, "NCEES", APPEAR TO THE RIGHT OF THE DESIGN LOGO.

**CLASS 9—ELECTRICAL AND SCIENTIFIC APPARATUS**

FOR DOWNLOADABLE ELECTRONIC PUBLICATIONS, NAMELY, A DOWNLOADABLE WEB BASED SURVEY DEPICTING LICENSING REQUIREMENTS, AND WEB BASED EXAM INFORMATION MATERIALS IN THE NATURE OF EXAM SPECIFICATIONS AND FORMAT, AND SAMPLE EXAMS USED AS STUDY GUIDES, AND DOWNLOADABLE MODEL LAWS AND MODEL REGULATION STANDARDS (U.S. CLS. 21, 23, 26, 36 AND 38).

**CLASS 16—PAPER GOODS AND PRINTED MATTER**

FOR PUBLICATIONS, NAMELY, A NEWSLETTER PROVIDING INFORMATION, OPINION, AND IDEAS REGARDING THE LICENSURE OF ENGINEERS AND SURVEYORS (U.S. CLS. 2, 5, 22, 23, 29, 37, 38 AND 50).

**CLASS 25—CLOTHING**

FOR CLOTHING, NAMELY, T-SHIRTS, GOLF SHIRTS, FLEECE JACKETS, SWEATER VESTS, AND BASEBALL CAPS (U.S. CLS. 22 AND 39).



**CLASS 35—ADVERTISING AND BUSINESS**

FOR ASSOCIATION SERVICES IN THE NATURE OF PROMOTING THE INTERESTS OF MEMBER ORGANIZATIONS AND INDIVIDUALS IN THE FIELDS OF ENGINEERING AND SURVEYING, AND THE PROMOTION OF AN INTERNATIONAL REGISTRY FOR U.S. REGISTERED PROFESSIONAL ENGINEERS SEEKING TO PRACTICE INTERNATIONALLY; PROMOTING THE SERVICES OF U.S. REGISTERED PROFESSIONAL ENGINEERS BY MAINTAINING A REGISTRY OF LICENSED U.S. REGISTERED PROFESSIONAL ENGINEERS; AND PROVIDING AN ON LINE APPLICATION PROCESS, NAMELY, COLLECTION OF CREDENTIALS AND VERIFICATION OF CREDENTIALS TO DETERMINE PROFESSIONAL COMPETENCY TO ASSIST PROFESSIONAL ENGINEERS AND SURVEYORS SEEKING LICENSURE IN MULTIPLE JURISDICTIONS; BUSINESS SERVICES, NAMELY, DESIGN, DEVELOPMENT AND ANALYSIS OF TESTS TO DETERMINE PROFESSIONAL COMPETENCY FOR TESTING APPLICANTS FOR PROFESSIONAL ENGINEERING AND SURVEYING REGISTRATION; PROVIDING A WEB SITE FEATURING INFORMATION ABOUT TESTING OF PROFESSIONAL QUALIFICATIONS TO DETERMINE JOB COMPETENCY IN THE FIELDS OF ENGINEERING AND SURVEYING (U.S. CLS. 100, 101 AND 102).

**CLASS 41—EDUCATION AND ENTERTAINMENT**

FOR ACTIVITIES RELATED TO PROFESSIONAL LICENSURE, NAMELY, PROVIDING INFORMATION REGARDING EDUCATIONAL EXAMINATION QUALIFICATION REQUIREMENTS TO OBTAIN LICENSURE IN THE FIELD OF ENGINEERING AND SURVEYING; CONTINUING EDUCATION SERVICES, NAMELY, PROVIDING INFORMATION VIA THE INTERNET ABOUT THE CONTINUING EDUCATION REQUIREMENTS APPLICABLE TO PROFESSIONAL ENGINEERING AND SURVEYING LICENSEES IN U.S. JURISDICTIONS RELATED TO MAINTAINING A LICENSE AS A PROFESSIONAL ENGINEER OR SURVEYOR; PREPARING, ADMINISTERING, AND SCORING OF STANDARDIZED EXAMS OF PROFESSIONAL ENGINEER AND SURVEYOR APPLICANTS; CREDENTIAL EVALUATIONS OF NON-U.S. EDUCATED APPLICANTS AS PROFESSIONAL ENGINEER OR SURVEYOR TO DETERMINE SUBSTANTIAL EQUIVALENCY OF EDUCATION WITH U.S. BASED ENGINEERING AND SURVEYING PROGRAMS (U.S. CLS. 100, 101 AND 107).

**CLASS 42—SCIENTIFIC AND COMPUTER SERVICES**

FOR ACCREDITATION SERVICES, NAMELY, DEVELOPING, EVALUATING AND TESTING STANDARDS FOR LICENSURE OF PROFESSIONAL ENGINEERS AND SURVEYORS (U.S. CLS. 100 AND 101).

**CLASS 45—PERSONAL AND LEGAL SERVICES**

FOR PROVIDING A WEB SITE THAT FACILITATES THE VERIFICATION OF A PERSON'S BACKGROUND CREDENTIALS FOR THE NATIONAL COUNCIL OF EXAMINERS FOR ENGINEERING AND SURVEYING (NCEES) MEMBER BOARDS AND CANDIDATES WITH EVALUATIONS OF ACADEMIC CREDENTIALS SUBMITTED BY CANDIDATES FOR LICENSURE WITHIN THE JURISDICTION OF NCEES MEMBER BOARDS, FOR USE IN THE ASSESSMENT OF ENGINEERING AND SURVEYING LICENSURE CANDIDATES WHOSE ACADEMIC DEGREES WERE OBTAINED FROM REGIONALLY-ACCREDITED INSTITUTIONS THAT ARE NOT ACCREDITED BY THE ACCREDITATION BOARD FOR ENGINEERING AND TECHNOLOGY, INC; AND PROVIDING A WEBSITE FEATURING INFORMATION ABOUT ENGINEERING AND SURVEYING LICENSURE (U.S. CLS. 100 AND 101).

THOMAS MANOR, EXAMINING ATTORNEY

SN 77-790,207. WORLDWIDE CLINICAL TRIALS US, INC., BEVERLY HILLS, CA. FILED 7-27-2009.

**WCT PHARMA RESOURCING SOLUTIONS**

THE MARK CONSISTS OF STANDARD CHARACTERS WITHOUT CLAIM TO ANY PARTICULAR FONT, STYLE, SIZE, OR COLOR.

NO CLAIM IS MADE TO THE EXCLUSIVE RIGHT TO USE "PHARMA RESOURCING SOLUTIONS", APART FROM THE MARK AS SHOWN.

**CLASS 35—ADVERTISING AND BUSINESS**

FOR BUSINESS CONSULTING SERVICES, NAMELY, PROVIDING INFORMATION MANAGEMENT DURING CLINICAL TRIALS RELATING TO PHARMACEUTICALS, BIOTECH, AND MEDICAL DEVICES (U.S. CLS. 100, 101 AND 102).

**CLASS 42—SCIENTIFIC AND COMPUTER SERVICES**

FOR MEDICAL AND SCIENTIFIC RESEARCH CONSULTING SERVICES, NAMELY, CONSULTING ON CLINICAL TRIALS IN THE FIELDS OF PHARMACEUTICALS, BIOTECH, AND MEDICAL DEVICES (U.S. CLS. 100 AND 101).

DAVID C. REIHNER, EXAMINING ATTORNEY

SN 77-790,814. GIANT INTERACTIVE LLC, NEW YORK, NY. FILED 7-28-2009.

**BD CONNECT**

THE MARK CONSISTS OF STANDARD CHARACTERS WITHOUT CLAIM TO ANY PARTICULAR FONT, STYLE, SIZE, OR COLOR.

NO CLAIM IS MADE TO THE EXCLUSIVE RIGHT TO USE "BD", APART FROM THE MARK AS SHOWN.

**CLASS 41—EDUCATION AND ENTERTAINMENT**

FOR DIGITAL VIDEO, AUDIO AND MULTIMEDIA PUBLISHING SERVICES (U.S. CLS. 100, 101 AND 107).

**CLASS 42—SCIENTIFIC AND COMPUTER SERVICES**

FOR OPTICAL DISC AUTHORIZING SERVICES (U.S. CLS. 100 AND 101).

ROBERT STRUCK, EXAMINING ATTORNEY

SN 77-804,879. JANDORF LLC, NORTHFIELD, OH. FILED 8-14-2009.

SN 77-805,123. RYDIUM CANADA INC., TORONTO, CANADA, FILED 8-14-2009.

## JANDORF PROJECT CENTER

THE MARK CONSISTS OF STANDARD CHARACTERS WITHOUT CLAIM TO ANY PARTICULAR FONT, STYLE, SIZE, OR COLOR.

OWNER OF U.S. REG. NO. 2,039,819.

### CLASS 6—METAL GOODS

FOR METAL BOXES; METAL SHIMS; METAL KNOBS; METAL LOCKNUTS; WINGNUTS, SCREWS, CLIPS, COTTER PINS, CLEVIS PINS, SHEAR PINS, LYNCH PINS, DETENT RING PINS; METAL CABLE CLIPS SOLD SEPARATELY AND TOGETHER WITH NAILS; BEADED METAL CHAINS; WIRE; METAL FASTENING ANCHORS FOR SECURING PICTURES TO WALLS; METAL WINDOW CRANKS, METAL SASH FASTENERS FOR WINDOWS, METAL HARDWARE FOR MOUNTING WINDOW SHADES ON WINDOW FRAMES; METAL STORM WINDOW CORNER KEYS, METAL DOOR BOLTS, METAL ROLLERS FOR GLASS, SCREEN, AND WOOD SLIDING DOORS AND GARAGE DOORS, METAL HINGES, METAL LATCHES, METAL SPACERS, METAL KEYHOLE PLATES, METAL ESCUTCHEONS FOR KEYHOLES; METAL HOSE FITTINGS; METAL CLAMPS; METAL HOLE PLUGS; METAL SHELF SUPPORTS; METAL KEY BLANKS, METAL KEY RINGS; METAL GASKETS FOR OIL PAN DRAINS; AND METAL SPRINGS (U.S. CLS. 2, 12, 13, 14, 23, 25 AND 50).

### CLASS 8—HAND TOOLS

FOR HAND TOOLS, NAMELY, WRENCHES, SCREWDRIVERS, FILES, CLAMPS, PICKS, UTILITY KNIVES, SAWS, SCISSORS, CABLE CUTTERS AND BITS FOR HAND DRILLS (U.S. CLS. 23, 28 AND 44).

### CLASS 9—ELECTRICAL AND SCIENTIFIC APPARATUS

FOR ELECTRIC SWITCHES FOR LAMPS, FANS, POWER TOOLS, MOTORS, VACUUMS AND REFRIGERATORS; CAPACITORS; ELECTRIC SOCKETS; FUSES, INSULATED ELECTRICAL WIRE TERMINALS; ELECTRICAL CONNECTORS; ELECTRIC PLUGS AND ADAPTERS; ELECTRICAL WIRE; ELECTRICAL COILS; MAGNETS; MAGNIFYING GLASSES; AND ELECTRIC POWER EXTENSION CORDS AND ELECTRICAL POWER CORDS FOR VACUUM CLEANERS (U.S. CLS. 21, 23, 26, 36 AND 38).

### CLASS 11—ENVIRONMENTAL CONTROL APPARATUS

FOR NON-METAL FAUCET HANDLES; METAL FAUCET HANDLES; AND FINIALS FOR LAMPS (U.S. CLS. 13, 21, 23, 31 AND 34).

### CLASS 20—FURNITURE AND ARTICLES NOT OTHERWISE CLASSIFIED

FOR PLASTIC BOXES; PLASTIC KNOBS; NON-METALLIC CABINETS; CORKS; PLASTIC WINDOW CLIPS; NYLON SLIDE BOLTS; PLASTIC SHELF SUPPORTS; PLASTIC AND NYLON ROLLERS FOR GLASS, SCREEN, WOOD AND SHOWER DOORS AND GARAGE DOORS; BUMPER GUARDS FOR FURNITURE; FURNITURE END PIECE AND CHAIR AND TABLE LEG CAPS; NON-METAL LATCHES, HINGES AND SPACERS; NON-METAL PEGS; VINYL CLAMPS; NYLON CONNECTORS; NON-METAL O-RINGS; NON-METAL KEY TAGS AND KEY RINGS (U.S. CLS. 2, 13, 22, 25, 32 AND 50).

ANTHONY RINKER, EXAMINING ATTORNEY

## WHERE YOUR AUDIENCE LIVES

THE MARK CONSISTS OF STANDARD CHARACTERS WITHOUT CLAIM TO ANY PARTICULAR FONT, STYLE, SIZE, OR COLOR.

PRIORITY CLAIMED UNDER SEC. 44(D) ON CANADA APPLICATION NO. 1,428,695, FILED 2-23-2009, REG. NO. TMA793,748, DATED 3-23-2011, EXPIRES 3-23-2021.

### CLASS 35—ADVERTISING AND BUSINESS

FOR ADVERTISING AND PUBLICITY SERVICES, NAMELY, DESIGNING, PREPARING AND PLACING ADVERTISEMENTS FOR THE BENEFIT OF OTHERS, CREATING CORPORATE AND BRAND IDENTITY FOR OTHERS, DISSEMINATION OF ADVERTISEMENTS FOR OTHERS AND CIRCULATION OF ADVERTISING MATTERS FOR OTHERS; THE PROVISION OF ADVERTISING SERVICES FOR OTHERS BY WAY OF ARRANGING ADVERTISING ON THE INTERNET AND OTHER COMMUNICATIONS NETWORKS AND BY ARRANGING FOR SPONSORS TO AFFILIATE SERVICES WITH ADVERTISEMENTS, ADVERTISING FOR OTHERS ON THE INTERNET AND OTHER COMMUNICATIONS NETWORKS, DESIGNING AND DEVELOPING PROMOTIONAL CAMPAIGNS FOR OTHERS; THE DESIGN AND CREATIVE DEVELOPMENT OF ADVERTISEMENTS ON THE INTERNET AND OTHER COMMUNICATIONS NETWORKS, PROMOTING THE BUSINESS OF OTHERS THROUGH CONTESTS AND INFORMATION BULLETINS IN VARIOUS MEDIA; MAILING LIST PREPARATION; ELECTRONIC MAILING LIST PREPARATION; ADVERTISING AGENCY SERVICES, PLANNING, PLACING, COORDINATION AND BUYING OF MEDIA ADVERTISING, ADVERTISING SERVICES IN THE NATURE OF AUDIOVISUAL DISPLAYS; BUSINESS SERVICES, NAMELY, COMPUTERIZED TRACKING AND MONITORING OF RESPONSES TO ADVERTISEMENTS (U.S. CLS. 100, 101 AND 102).

FIRST USE 6-26-2009; IN COMMERCE 7-8-2009.

### CLASS 42—SCIENTIFIC AND COMPUTER SERVICES

FOR DESIGNING AND DEVELOPING INTERNET AND WIRELESS SITES FOR ADVERTISING OR MARKETING PURPOSES FOR OTHERS; PROVIDING AND HOSTING SERVICES FOR OTHERS FOR CREATING, UPLOADING AND PUBLISHING ELECTRONIC MEDIA, TEXT, AUDIO, VIDEO, VISUAL IMAGES, AND DATA ON THE INTERNET AND OTHER COMMUNICATIONS NETWORKS (U.S. CLS. 100 AND 101).

ANDREA HACK, EXAMINING ATTORNEY

SN 77-811,141. ALIBABA GROUP HOLDING LIMITED, GEORGE TOWN, GRAND CAYMAN, CAYMAN ISLANDS, FILED 8-24-2009.

# ALIEXPRESS

THE MARK CONSISTS OF STANDARD CHARACTERS WITHOUT CLAIM TO ANY PARTICULAR FONT, STYLE, SIZE, OR COLOR.

**CLASS 9—ELECTRICAL AND SCIENTIFIC APPARATUS**

FOR SCIENTIFIC, NAUTICAL, SURVEYING, PHOTOGRAPHIC, CINEMATOGRAPHIC, OPTICAL, WEIGHING, MEASURING, SIGNALLING, CHECKING, SUPERVISION, LIFE-SAVING AND TEACHING APPARATUS AND INSTRUMENTS, NAMELY, TELEPHONES, PUNCH CLOCKS, TIME RECORDING DEVICES, NAMELY, TIME CLOCKS, SCALES AND BALANCES, SCALED RULERS, ELECTRONIC POCKET TRANSLATORS, NEON SIGNS, ELECTRONIC NOTICE BOARDS, TRANSPARENCY PROJECTION APPARATUS, KILOMETER RECORDERS FOR VEHICLES, TELESCOPES, MECHANISMS FOR COUNTER-OPERATED APPARATUS, NAMELY, POINT-OF-SALE TERMINALS, FIRE EXTINGUISHERS, ACOUSTIC ALARMS, NAMELY, SMOKE AND FIRE ALARMS, EYEGASSES, BATTERIES, EXPOSED FILMS, NAMELY, EXPOSED CAMERA FILM; APPARATUS AND INSTRUMENTS FOR CONDUCTING, SWITCHING, TRANSFORMING, ACCUMULATING, REGULATING AND CONTROLLING ELECTRICITY, NAMELY, ELECTRIC WIRES; ELECTRIC SWITCHES; ELECTROPLATING APPARATUS, NAMELY, ELECTROPLATING MACHINES, ELECTRIC WELDING APPARATUS, NAMELY, TORCHES, ELECTRIFIED FENCES, NAMELY, ELECTRIC FENCES; APPARATUS FOR RECORDING, TRANSMISSION OR REPRODUCTION OF SOUND AND IMAGES; BLANK MAGNETIC DATA CARRIERS; BLANK RECORDING OPTICAL AND MAGNETIC DISCS; AUTOMATIC VENDING MACHINES AND MECHANISMS FOR COIN-OPERATED APPARATUS; CASH REGISTERS, CALCULATING MACHINES, DATA PROCESSING EQUIPMENT AND COMPUTERS; FIRE-EXTINGUISHING APPARATUS; COMPUTER HARDWARE; COMPUTER SOFTWARE FOR USE IN CONNECTION WITH THE PROVISION OF AN INTERACTIVE WEBSITE FOR THIRD PARTIES FOR POSTING INFORMATION, CREATING ELECTRONIC PRODUCT CATALOGS, RESPONDING TO REQUESTS AND PLACING AND FULFILLING ORDERS FOR PRODUCTS AND SERVICES AND ORGANIZING AND EVALUATING BUSINESS OPPORTUNITIES VIA LOCAL AND GLOBAL COMPUTER NETWORKS, FOR DOCUMENT MANAGEMENT, FOR SEARCHING, BROWSING AND RECEIVING TRANSMISSIONS OF TEXT, ELECTRONIC DOCUMENTS, GRAPHICS AND AUDIOVISUAL INFORMATION ON LOCAL REMOTE AREA NETWORKS, GLOBAL COMPUTER NETWORKS, INTRANETS AND DIRECTORIES OF INFORMATION AVAILABLE ON COMPUTER NETWORKS, FOR USE IN SOFTWARE DEVELOPMENT AND WEB AUTHORING, FOR EXCHANGING INFORMATION VIA GLOBAL COMPUTER NETWORKS AND ONLINE FROM A COMPUTER DATABASE AND THE INTERNET, FOR BUSINESS USE FOR FINANCIAL MANAGEMENT, FINANCIAL PLANNING, BUSINESS MANAGEMENT, CUSTOMER RELATIONSHIP MANAGEMENT (CRM), INVENTORY MANAGEMENT, SALES FORCE MANAGEMENT, PLANNING AND MANAGEMENT OF PERSONAL AND BUSINESS FINANCES, AND MARKETING INFORMATION MANAGEMENT, ALL IN THE FIELD OF E-COMMERCE; COMPACT DISCS FEATURING MUSIC; COMPUTER PROGRAMS AND COMPUTER SOFTWARE FOR BUSINESS FOR FINANCIAL MANAGEMENT, FINANCIAL PLANNING, BUSINESS MANAGEMENT, CUSTOMER RELATIONSHIP MANAGEMENT (CRM), INVENTORY MANAGEMENT, SALES FORCE MANAGEMENT, PLANNING AND MANAGEMENT OF PERSONAL AND BUSINESS FINANCES, AND MARKETING INFORMATION MANAGEMENT, ALL IN THE FIELD OF E-COMMERCE; DIGITAL MUSIC DOWNLOADABLE FROM THE INTERNET; TELECOMMUNICATIONS APPARATUS, NAMELY, NETWORK TELEPHONE, ELECTRONIC FACSIMILE, PORTABLE DEVICE FOR SENDING AND RECEIVING ELECTRONIC MAILS, AND INSTANT MESSAGING COMMUNICATION TOOL IN THE NATURE OF PORTABLE TELECOMMUNICATION INSTANT MESSAGING DEVICES; MOUSE PADS; MOBILE PHONE HEADSETS; MOBILE PHONE ACCESSORIES NAMELY, BATTERY CHARGERS, CASES, COVERS, EAR PHONES AND DEVICES FOR HANDS-FREE USE OF MOBILE PHONES; SPECTACLES AND SUNGLASSES (U.S. CLS. 21, 23, 26, 36 AND 38).

**CLASS 35—ADVERTISING AND BUSINESS**

FOR ADVERTISING; BUSINESS MANAGEMENT; BUSINESS ADMINISTRATION AND OFFICE FUNCTIONS; DATABASE MANAGEMENT; MARKET RESEARCH AND BUSINESS CONSULTING SERVICES; BUSINESS CONSULTANCY SERVICES RELATING TO FACILITATING THE TRANSACTION OF BUSINESS VIA LOCAL AND GLOBAL COMPUTER NETWORKS BY LOCATING AND PROVIDING REFERRALS FOR THE DELIVERY OF A WIDE VARIETY OF BUSINESS AND CONSUMER PRODUCTS AND SERVICES; PROVIDING BUSINESS INFORMATION OF GOODS AND SERVICES OF OTHERS VIA LOCAL AND GLOBAL COMPUTER NETWORKS; BUSINESS CONSULTANCY SERVICES RELATING TO PROVIDING A WEB SITE ON A GLOBAL COMPUTER NETWORK BY WHICH THIRD PARTIES CAN OFFER AND SOURCE GOODS AND SERVICES, PLACE, DETERMINE THE STATUS OF AND FULFILL TRADE LEADS AND ORDERS, ENTER INTO CONTRACTS AND TRANSACT BUSINESS; PROVIDING COMPUTERIZED ONLINE ORDERING SERVICES FEATURING A WIDE VARIETY OF CONSUMER PRODUCTS; ADVERTISING OF GOODS AND SERVICES OF OTHERS VIA LOCAL AND GLOBAL COMPUTER NETWORKS; INTERNATIONAL IMPORT AND EXPORT AGENCY SERVICES; RENTAL OF ADVERTISING SPACE ON COMMUNICATION MEDIA; ONLINE TRADING SERVICES IN WHICH SELLER POSTS PRODUCTS TO BE AUCTIONED AND BIDDING IS DONE VIA THE INTERNET, AND PROVIDING ONLINE BUSINESS EVALUATION RELATING TO THOSE SELLERS; ONLINE RETAIL STORE SERVICES FEATURING A WIDE VARIETY OF CONSUMER GOODS OF OTHERS; PROVIDING DIRECTORY OF THIRD PARTY WEB SITES TO FACILITATE BUSINESS TRANSACTIONS; BUSINESS CONSULTANCY SERVICES RELATING TO OPERATING AN ELECTRONIC MARKETPLACE FOR THE BUYERS AND SELLERS OF GOODS AND/OR SERVICES ON A GLOBAL COMPUTER NETWORK; BUSINESS CONSULTING RELATING TO THE FACILITATION OF BUSINESS TRANSACTIONS VIA LOCAL AND GLOBAL COMPUTER NETWORKS; CORPORATE MANAGEMENT CONSULTANCY SERVICES; ADVERTISING, MARKETING AND PROMOTION SERVICES; PUBLICATION OF PUBLICITY TEXTS; REAL ESTATE MARKETING SERVICES, NAMELY, MARKETING OF VACANT PROPERTY IN THE NATURE OF CONDOMINIUMS, APARTMENTS, HOMES, COMMERCIAL STOREFRONTS, OFFICE BUILDINGS, WAREHOUSES, AND FACTORIES; DISSEMINATION OF ADVERTISING MATERIALS, UPDATING OF ADVERTISING MATERIALS, COMPILATION OF ADVERTISEMENTS FOR USE AS WEB PAGES ON THE INTERNET; RENTAL OF ADVERTISING SPACE; COMPUTER DATA PROCESSING; SALES INFORMATION, NAMELY, PROVIDING INFORMATION ABOUT THE GOODS AND SERVICES OF OTHERS; BUSINESS INFORMATION, NAMELY, PROVIDING A WEBSITE FEATURING INFORMATIONAL, NON-DOWNLOADABLE VIDEO PRESENTATIONS IN THE FIELD OF BUSINESS AND E-COMMERCE; PROMOTIONAL INFORMATION SERVICES, NAMELY, PROMOTING THE GOODS OF OTHER BY PROVIDING INFORMATION REGARDING DISCOUNTS, COUPONS, REBATES, VOUCHERS AND SPECIAL OFFERS FOR THE GOODS OF OTHERS; TELEPHONE ANSWERING; AUCTIONEERING PROVIDED ON THE INTERNET; PERSONNEL MANAGEMENT; PROVISION OF BUSINESS, ADVERTISING AND PROMOTIONAL INFORMATION THROUGH A GLOBAL COMPUTER NETWORK AND VIA THE INTERNET; PRESENTATION OF GOODS ON COMMUNICATION MEDIA FOR RETAIL PURPOSES; THE BRINGING TOGETHER OF A WIDE VARIETY OF CONSUMER GOODS OF OTHERS, ENABLING CUSTOMERS TO CONVENIENTLY VIEW AND PURCHASE THOSE GOODS FROM A GENERAL MERCHANDISE INTERNET WEB SITE AND IN A WHOLESALE OUTLET; THE BRINGING TOGETHER OF A WIDE VARIETY OF CONSUMER GOODS OF OTHERS, ENABLING CUSTOMERS TO CONVENIENTLY VIEW AND PURCHASE THOSE GOODS FROM A GENERAL MERCHANDISE CATALOGUE BY MAIL ORDER OR BY MEANS OF TELECOMMUNICATIONS; THE BRINGING TOGETHER OF A WIDE VARIETY OF CONSUMER GOODS OF OTHERS, ENABLING CUSTOMERS TO CONVENIENTLY VIEW AND PURCHASE THOSE GOODS FROM RETAIL OUTLETS; RETAIL AND WHOLESALE STORE SERVICES FEATURING TELEPHONES, MOBILE PHONE HANDSETS, MOBILE



PHONE ACCESSORIES, ELECTRONIC AND TELECOMMUNICATIONS GOODS, COMPUTER HARDWARE AND COMPUTER SOFTWARE, BATTERIES, BATTERY CHARGERS, APPARATUS AND INSTRUMENTS FOR RECORDING, RECEIVING, TRANSMITTING AND/OR REPRODUCING DATA, INFORMATION, PICTURES, IMAGES AND/OR SOUND, PRECIOUS METALS, JEWELRY, PRECIOUS STONES, PRINTED MATTER, STATIONERY AND MAGNETIC AND NON MAGNETICALLY ENCODED CARDS, FURNITURE, PICTURE FRAMES, HOUSEHOLD AND KITCHEN UTENSILS, GLASSWARE, PORCELAIN AND EARTHENWARE, TEXTILES, CLOTHING, FOOTWEAR, HEADGEAR, LACES AND EMBROIDERY, BUTTONS, RIBBONS, PINS AND NEEDLES, ARTIFICIAL FLOWERS, CARPETS, RUGS, GAMES AND ELECTRONIC TOYS, CHEMICALS USED IN INDUSTRY, SCIENCE, PHOTOGRAPHY AND AGRICULTURE, PAINTS, VARNISHES AND LACQUERS, PERSONAL HYGIENE PRODUCTS, SOAPS, PERFUMERY, COSMETICS, HAIR AND BODY LOTIONS, ESSENTIAL OILS, CLEANING AND BLEACHING PREPARATIONS, LUBRICANTS, FUELS, CANDLES, PHARMACEUTICAL, VETERINARY AND SANITARY PREPARATIONS, IRONMONGERY AND SMALL ITEMS OF METAL HARDWARE, MACHINES AND MACHINE TOOLS, CUTLERY, RAZORS AND HAND TOOLS, COMPUTERS, CALCULATING MACHINES, ELECTRICAL, PHOTOGRAPHIC, CINEMATOGRAPHIC AND OPTICAL APPARATUS AND INSTRUMENTS, SPECTACLES AND SUN GLASSES, SURGICAL AND MEDICAL APPARATUS AND INSTRUMENTS, APPARATUS FOR LIGHTING, HEATING, STEAM GENERATING, COOKING, REFRIGERATING, DRYING, VENTILATING, WATER SUPPLY AND SANITARY PURPOSES, VEHICLES, FIREARMS, FIREWORKS, SILVERWARE, HOROLOGICAL AND CHRONOMETRIC INSTRUMENTS, MUSICAL INSTRUMENTS, MAGAZINE, CARDS, PAPER AND CARDBOARD PRODUCTS, PICTURE, TYPEWRITERS AND OFFICE REQUISITES, PACKAGING MATERIALS, RUBBER AND PLASTICS FOR MANUFACTURE USE, PACKING AND INSULATING MATERIALS, LEATHER AND IMITATIONS OF LEATHER AND GOODS MADE FROM THESE MATERIALS, HANDBAGS, PURSES, WALLETS, LEATHER HOLDERS, BAGS, LUGGAGE, UMBRELLAS, MIRRORS, ROPES, STRING, NETS, TENTS, YARNS AND THREADS FOR TEXTILE USE, COAT HANGERS, PLACE MATS, DRESSMAKER'S ARTICLES, BED AND TABLE COVERS, PLAYTHINGS AND SPORTING ARTICLES, FOODSTUFFS AND BEVERAGES, MEAT, FISH, POULTRY, PRESERVED, DRIED AND COOKED FRUITS AND VEGETABLES, JAMS AND FRUITS SAUCES, EGGS, MILK AND MILK PRODUCTS, EDIBLE OILS AND FATS, COFFEE, TEA, COCOA, SUGAR, RICE, FLOUR, BREAD AND CAKES, CONDIMENTS, FRESH FRUIT AND VEGETABLES, BEER, MINERAL WATER, FRUIT JUICES AND OTHER NON-ALCOHOLIC DRINKS, ALCOHOLIC BEVERAGES, FLORAL PRODUCTS, TOBACCO, SMOKERS' ARTICLES AND MATCHES; DIRECT MAIL ADVERTISING; PROCUREMENT BUYING SERVICES, NAMELY, PURCHASING A WIDE VARIETY OF CONSUMER, BUSINESS AND INDUSTRIAL PRODUCTS AND SERVICES FOR OTHERS; ARRANGING OF BUYING AND SELLING CONTRACTS FOR THIRD PARTIES; SELECTION AND PROCUREMENT OF A WIDE VARIETY OF CONSUMER, BUSINESS AND INDUSTRIAL PRODUCTS AND SERVICES FOR INDIVIDUALS AND BUSINESSES; MAIL ORDER CATALOG, ELECTRONIC CATALOG, AND ONLINE ORDERING SERVICES FEATURING A WIDE VARIETY OF CONSUMER GOODS OF OTHERS; SECRETARIAL SERVICES; PROVIDING STATISTICAL INFORMATION; ORGANIZATION OF EXHIBITIONS FOR COMMERCIAL OR ADVERTISING PURPOSES; BUSINESS SERVICES, NAMELY, THE COMPILATION AND RENTAL OF MARKETING MAILING LISTS; BUSINESS INVESTIGATION; BUSINESS ADMINISTRATION SERVICES FOR THE PROCESSING OF SALES MADE ON THE INTERNET; REFERRAL SERVICES, NAMELY, GENERAL BUSINESS NETWORKING SERVICES IN THE NATURE OF PROMOTING THE GOODS AND SERVICES OF OTHERS BY PASSING BUSINESS LEADS AND REFERRALS AMONG GROUP MEMBERS; PERSONNEL PLACEMENT; IMPORT-EXPORT AGENCIES; ARRANGING OF SUBSCRIPTIONS FOR NEWSPAPERS OF OTHERS; DOCUMENT REPRODUCTION; STENOGRAPHIC TRANSCRIPTION SERVICES; RENTAL OF OFFICE EQUIPMENT; CUSTOMER RELATIONSHIP MANAGEMENT; BUSINESS MANAGEMENT

SERVICES RELATING TO ELECTRONIC COMMERCE; BUSINESS CONSULTANCY, INFORMATION AND ADVISORY SERVICES RELATING TO THE AFORESAID SERVICES; PROVIDING TAX INFORMATION, NAMELY, TAX CONSULTATION; ART GALLERIES; ART GALLERY SERVICES RELATING TO FINE ARTS LEASING; PROMOTING THE GOODS AND SERVICES OF OTHERS BY PROVIDING HYPERTEXT LINKS TO THE WEB SITES OF THIRD PARTY WEB SITES TO FACILITATE E-COMMERCE AND REAL WORLD BUSINESS TRANSACTIONS; RECONCILIATION OF FINANCIAL ACCOUNTS ON BEHALF OF OTHERS (U.S. CLS. 100, 101 AND 102).

### CLASS 36—INSURANCE AND FINANCIAL

FOR INSURANCE AGENCIES; FINANCIAL AFFAIRS AND MONETARY AFFAIRS, NAMELY, FINANCIAL ANALYSIS AND ONLINE ESCROW SERVICE FOR EXCHANGE OF GOODS AND SERVICES; REAL ESTATE AFFAIRS, NAMELY, ASSESSMENT AND MANAGEMENT OF REAL ESTATE, PROVIDING INFORMATION IN THE FIELD OF REAL ESTATE VIA THE INTERNET; REAL ESTATE BROKERAGE; CLEARING FINANCIAL TRANSACTIONS VIA A GLOBAL COMPUTER NETWORK, NAMELY, FINANCIAL CLEARING HOUSES; ONLINE BANKING SERVICES AND FINANCIAL SERVICES, NAMELY, ELECTRONIC FUNDS TRANSFER SERVICES ONLINE FINANCIAL PLANNING SERVICES; CREDIT CARD SERVICES, PROCESSING AND TRANSMISSION OF BILLS AND PAYMENTS THEREOF, AND PROVIDING DEFAULT INSURANCE FOR FINANCIAL TRANSACTIONS; ELECTRONIC FUNDS TRANSFER SERVICES; TRANSMISSION OF FUNDS BY ELECTRONIC MEANS FOR OTHERS; ELECTRONIC PROCESSING OF PAYMENTS FOR OTHERS VIA THE INTERNET; FINANCIAL SERVICES IN THE NATURE OF BILLING AND PAYMENT PROCESSING SERVICES; REAL ESTATE SERVICES, NAMELY, ARRANGEMENT AND MANAGEMENT OF LEASES AND TENANCY; RENTING AND LEASING OF REAL ESTATE; REAL ESTATE APPRAISAL; REAL ESTATE VALUATION, REAL ESTATE FINANCING, REAL ESTATE INVESTMENT; REAL ESTATE BROKERAGE SERVICES; REAL ESTATE AGENCY SERVICES; HOUSING AGENCY SERVICES; ACTUARIAL SERVICES; REAL ESTATE MANAGEMENT AND CONSULTANCY SERVICES; RENT COLLECTION; REAL ESTATE SERVICES, NAMELY, RENTAL OF OFFICES; REAL ESTATE SERVICES, NAMELY, RENTAL OF APARTMENTS AND FLATS; PROVISION OF FINANCIAL INFORMATION VIA THE INTERNET; SAFETY DEPOSIT BOX SERVICES AND ISSUING OF TRAVEL VOUCHERS SERVICES NAMELY, PROVIDING VOUCHERS FOR PAYMENT OF TRANSPORTATION EXPENSES; CAPITAL INVESTMENTS; FINANCIAL INFORMATION AND EVALUATIONS; FINANCIAL ASSET MANAGEMENT SERVICES; INSURANCE AND FINANCIAL INFORMATION AND CONSULTANCY SERVICES; FINANCIAL ANALYSIS SERVICES PROVIDED BY TELECOMMUNICATION MEANS; FINANCIAL CONSULTANCY AND ADVISORY SERVICES; HOME BANKING; BANKING SERVICES PROVIDED ON-LINE FROM A COMPUTER DATABASES OR THE INTERNET; SECURITIES BROKERAGE SERVICES, STOCK EXCHANGE QUOTATION SERVICES; STOCKS AND BONDS BROKERAGE, FINANCIAL ANALYSIS; DEBIT CARD SERVICES, CHARGE CARD SERVICES AND FINANCIAL GUARANTEE OF CHECKS; BANKING, SAVINGS ACCOUNT AND CAPITAL INVESTMENT SERVICES; FINANCIAL CLEARING HOUSE SERVICES; CREDIT CARD VERIFICATION VIA GLOBAL COMPUTER INFORMATION NETWORK; ELECTRONIC CREDIT RISK MANAGEMENT SERVICES; PRE-PAID PURCHASE CARD SERVICES, NAMELY, PROCESSING ELECTRONIC PAYMENTS MADE THROUGH PREPAID CARDS AND ELECTRONIC BILL PAYMENT SERVICES; FINANCIAL SERVICES, NAMELY, DEBT SETTLEMENT AND PROVIDING ELECTRONIC PROCESSING OF CREDIT CARD TRANSACTIONS AND ELECTRONIC PAYMENTS VIA A GLOBAL COMPUTER NETWORK; ELECTRONIC BANKING SERVICES; ISSUANCE OF STORED VALUE CARDS, CHARGE CARDS AND DEBIT CARDS; TELEPHONE CALLING CARDS SERVICES; PROVISION OF FINANCIAL AND INSURANCE INFORMATION SERVICES ONLINE FROM A COMPUTER DATABASE OR INTERNET; DEBT COLLECTION AGENCY FOR COLLECTION OF GAS AND ELECTRICITY FEES; AN-



TIQUE APPRAISAL; ART APPRAISAL; JEWELRY APPRAISAL; USED CAR APPRAISAL; CHARITABLE FUND RAISING; RENTAL OF PAPER MONEY AND COIN COUNTING OR PROCESSING MACHINES; RENTAL OF CASH DISPENSERS OR AUTOMATED-TELLER MACHINES; ONLINE PAYMENT SERVICES, NAMELY, ELECTRONIC PROCESSING OF CREDIT CARD TRANSACTIONS AND ELECTRONIC PAYMENTS VIA A GLOBAL COMPUTER NETWORK; VERIFICATION OF ONLINE PAYMENTS AND TRANSFER OF FUNDS; FINANCIAL CONSULTANCY, INFORMATION AND ADVISORY SERVICES RELATING TO THE AFORESAID SERVICES (U.S. CLS. 100, 101 AND 102).

### **CLASS 38—COMMUNICATION**

FOR TELECOMMUNICATION ACCESS SERVICES; PROVIDING TELECOMMUNICATION CONNECTIONS TO A GLOBAL COMPUTER NETWORK; COMMUNICATION BY ELECTRONIC COMPUTER TERMINALS; PROVIDING TELECOMMUNICATIONS CONNECTIONS TO THE INTERNET OR DATABASES; PROVISION OF TELECOMMUNICATION ACCESS TO THE WORLD-WIDE WEB; COMMUNICATION BY COMPUTER TERMINALS; COMMUNICATION BY FIBRE OPTIC NETWORKS; COMPUTER AIDED TRANSMISSION OF MESSAGES AND IMAGES; FACSIMILE TRANSMISSION; PAGING SERVICES; RENTAL OF MODEMS; DATA COMMUNICATION SERVICES BY ELECTRONIC MAIL; RENTAL OF TELECOMMUNICATION EQUIPMENT; ELECTRONIC MESSAGE SENDING, RECEIVING AND FORWARDING SERVICES; TELECOMMUNICATION SERVICES, NAMELY, COLLECTION, TRANSMISSION AND DELIVERY OF DATA BY ELECTRONIC MEANS; TELECOMMUNICATION SERVICES, NAMELY, COLLECTION, TRANSMISSION AND DELIVERY OF EMAIL MESSAGES, DIGITAL IMAGES, DIGITAL VIDEO, ELECTRONIC MESSAGES, MUSIC, TELEGRAMS AND DATA BY ELECTRONIC, TELEPHONE, CABLE, COMPUTER AND SATELLITE MEANS; ELECTRONIC TRANSMISSION, BROADCAST AND RECEPTION OF AUDIO, VIDEO, STILL AND MOVING IMAGES AND DATA WHETHER IN COMPRESSED OR UNCOMPRESSED FORM AND WHETHER IN REAL OR DELAYED TIME; ELECTRONIC MESSAGING, AUDIO AND VIDEO CONFERENCING AND ORDER-TRANSMISSION FOR E-COMMERCE RETAIL AND WHOLESALE SERVICES; VIDEO CONFERENCING SERVICES; ELECTRONIC BULLETIN BOARD THAT ENABLES USERS TO PERFORM A REAL-TIME INTERACTIVE TALK BETWEEN A COMPUTER TERMINAL AND AN ELECTRONIC BULLETIN BOARD CONTAINING STILL PICTURE AND MOVING PICTURE INFORMATION AND VOICE INFORMATION; PROVIDING ELECTRONIC BULLETIN BOARDS AND MESSAGE BOARDS FOR TRANSMISSION OF MESSAGES; PROVISION OF ON-LINE DISCUSSION FORUMS FOR TRANSMISSION OF MESSAGES AMONG COMPUTER USERS; TELEVISION BROADCASTING SERVICES; BROADCASTING AND TRANSMISSION OF RADIO AND TELEVISION PROGRAMS; MUSIC BROADCASTING; ELECTRONIC DATA TRANSMISSION FEATURING MUSIC, FILMS, INTERACTIVE PROGRAMS, VIDEOS AND ELECTRONIC COMPUTER GAMES; ELECTRONIC TRANSMISSION OF DATA RELATING TO ON-LINE SHOPPING AND GENERAL RETAIL SERVICES; VIDEO-ON-DEMAND TRANSMISSION SERVICES; NEWS AGENCY TRANSMISSION SERVICES FOR ELECTRONIC TRANSMISSION; PROVIDING ACCESS TO COMPUTER DATABASE ON THE GLOBAL COMPUTER NETWORK FOR SEARCHING AND RETRIEVING INFORMATION, DATA, WEB SITES AND RESOURCES AVAILABLE ON COMPUTER NETWORKS; PROVIDING USER ACCESS TO A COMPUTER DATABASE CONTAINING ELECTRONIC PUBLICATIONS, BULLETIN BOARDS, DATABASE AND INFORMATION ACCESSIBLE VIA COMPUTER; PROVIDING INTERNET CHAT ROOMS; PROVIDING MULTIPLE USER ACCESS TO GLOBAL COMPUTER INFORMATION NETWORKS FOR THE TRANSFER AND DISSEMINATION OF A WIDE RANGE OF INFORMATION; PROVIDING ACCESS TO A WEBSITE ON A GLOBAL COMPUTER NETWORK BY WHICH THIRD PARTIES CAN OFFER GOODS AND SERVICES, PLACE AND FULFILL ORDERS, ENTER INTO CONTRACTS AND TRANSACT BUSINESS; PROVIDING ACCESS TO AN INTERACTIVE WEBSITE ON A GLOBAL COMPUTER NETWORK FOR THIRD PARTIES TO POST INFORMATION, RESPOND

TO REQUESTS AND PLACE AND FULFILL ORDERS FOR PRODUCTS, SERVICES AND BUSINESS OPPORTUNITIES; COMMUNICATION SERVICES, NAMELY, TEXT AND NUMERIC WIRELESS DIGITAL MESSAGING SERVICES; TRANSMISSION OF INFORMATION BY DATA COMMUNICATION FOR ASSISTING DECISION MAKING; TRANSMISSION OF INFORMATION THROUGH VIDEO COMMUNICATION SYSTEMS; WEB CONFERENCING SERVICES; ELECTRONIC TRANSMISSION OF DATA FOR ESTABLISHING VIRTUAL CHATROOMS VIA TEXT MESSAGING; PROVIDING ELECTRONIC BULLETIN BOARDS FOR THE POSTING AND TRANSMISSION OF MESSAGES AMONG AND BETWEEN COMPUTER USERS CONCERNING PRODUCTS, SERVICES AND BUSINESS LEADS AND OPPORTUNITIES; PROVIDING AN ONLINE ELECTRONIC INTERACTIVE BULLETIN BOARD FOR THE POSTING, PROMOTION, SALE AND RESALE OF ITEMS VIA A GLOBAL COMPUTER NETWORK; PROVIDING ELECTRONIC MAIL AND ELECTRONIC MAIL FORWARDING SERVICES; TELECOMMUNICATION SERVICES, NAMELY, TRANSMISSION OF AUDIO AND VIDEO DATA VIA COMPUTERS AND COMPUTER NETWORKS, AND VIA A GLOBAL COMMUNICATIONS NETWORK; PROVIDING ACCESS TO ONLINE INTERACTIVE ELECTRONIC BULLETIN BOARDS AND COMPUTER DATABASES; PROVIDING ACCESS TO ELECTRONIC BULLETIN BOARDS FOR THE POSTING AND TRANSMISSION OF MESSAGES AMONG AND BETWEEN COMPUTER USERS CONCERNING PRODUCTS, SERVICES AND BUSINESS OPPORTUNITIES; PROVIDING USER ACCESS TO COMPUTER PROGRAMS THAT CONTAIN ELECTRONIC CALENDARS, ADDRESS BOOKS AND NOTATION FEATURES, VIA LOCAL AND GLOBAL COMPUTER NETWORKS; PROVIDING DIRECT CONNECTION SERVICES, NAMELY, PROVIDING ELECTRONIC TELECOMMUNICATION CONNECTIONS BETWEEN COMPUTER USERS FOR EXCHANGING DATA; TELECOMMUNICATION CONSULTANCY, INFORMATION ABOUT TELECOMMUNICATIONS AND TELECOMMUNICATION ADVISORY SERVICES RELATING TO THE AFORESAID SERVICES (U.S. CLS. 100, 101 AND 104).

### **CLASS 41—EDUCATION AND ENTERTAINMENT**

FOR EDUCATION SERVICES, NAMELY, PROVIDING SEMINARS AND CONFERENCES IN THE FIELD OF BUSINESS AND E-COMMERCE; PROVIDING OF TRAINING SERVICES IN THE FIELD OF BUSINESS AND E-COMMERCE; ORGANIZING COMMUNITY SPORTING AND CULTURAL ACTIVITIES; PUBLICATION OF TEXTS AND BOOKS; ON-LINE JOURNALS, NAMELY, BLOGS ABOUT E-COMMERCE AND BUSINESS; EDUCATION, TRAINING AND INSTRUCTION SERVICES, NAMELY, PROVIDING CLASSES IN THE FIELDS OF TELECOMMUNICATIONS, COMPUTERS, COMPUTER PROGRAMS, WEB SITE DESIGN, E-COMMERCE, BUSINESS MANAGEMENT AND ADVERTISING; DEVELOPMENT OF EDUCATIONAL CURRICULUM AND EDUCATIONAL EXAMINATIONS; ENTERTAINMENT SERVICES, NAMELY, PROVIDING ON-LINE COMPUTER GAME; PROVIDING INFORMATION ABOUT EDUCATION, TRAINING, ENTERTAINMENT, RECREATIONAL ACTIVITIES, SPORTING ACTIVITIES AND SOCIAL AND CULTURAL ACTIVITIES; PROVIDING ON-LINE NON-DOWNLOADABLE PUBLICATIONS IN THE NATURE OF BOOKS, JOURNALS, NEWSLETTERS AND ARTICLES IN THE FIELD OF BUSINESS AND E-COMMERCE; ARRANGING, ORGANIZING, HOSTING AND CONDUCTING SINGING COMPETITIONS; ARRANGING, ORGANIZING, HOSTING AND CONDUCTING CONCERTS; ARRANGING, ORGANIZING, HOSTING AND CONDUCTING SPECIAL EVENTS AND SPORTING COMPETITIONS FOR EDUCATION OR ENTERTAINMENT PURPOSES; ENTERTAINMENT TICKET AGENCY SERVICES; ENTERTAINMENT SERVICES, NAMELY, PROVIDING NON-DOWNLOADABLE PLAYBACK OF DIGITAL MUSIC FROM THE INTERNET; ENTERTAINMENT SERVICES, NAMELY, PROVIDING NON-DOWNLOADABLE PLAYBACK OF DIGITAL MUSIC FROM MP3 FORMATS ON INTERNET WEBSITES; EDUCATIONAL SERVICES, NAMELY, PROVIDING COURSES OF INSTRUCTION ABOUT PLANNING, PRODUCTION AND DISTRIBUTION OF SOUND, IMAGES, DIGITAL MUSIC, MOVIES AND LIVE OR RECORDED AUDIO, VISUAL OR

AUDIOVISUAL MATERIAL FOR BROADCASTING ON TERRESTRIAL CABLE, SATELLITE CHANNELS, THE INTERNET, WIRELESS OR WIRE-LINK SYSTEMS AND OTHER MEANS OF COMMUNICATIONS; ENTERTAINMENT, NAMELY, LIVE MUSIC CONCERTS; RENTAL OF SOUND RECORDINGS; ENTERTAINMENT IN THE NATURE OF ON-GOING TELEVISION PROGRAMS IN THE FIELDS OF BUSINESS AND E-COMMERCE; NEWS REPORTERS' SERVICES; PROVIDING INFORMATION ABOUT SPORTING AND CULTURAL EVENTS, CURRENT ENTERTAINMENT NEWS AND BREAKING NEWS PROVIDED BY SATELLITE TELEVISION TRANSMISSION, THE INTERNET AND OTHER ELECTRONIC MEANS; TELEVISION SHOW, RADIO SHOW AND MOTION PICTURE FILM PRODUCTION; PROVIDING INFORMATION RELATING TO ENTERTAINMENT AND EDUCATION, PROVIDED ON-LINE FROM A COMPUTER DATABASE OR THE INTERNET; ENTERTAINMENT SERVICES, NAMELY, PRODUCTION OF SPECIAL EFFECTS INCLUDING MODEL-MAKING SERVICES, COMPUTER-GENERATED IMAGERY AND COMPUTER-GENERATED GRAPHICS FOR THE PRODUCTION OF MOTION PICTURES, VIDEOS, AND MOVIE TRAILER; ENTERTAINMENT SERVICES, NAMELY, PROVIDING ON-LINE VIDEO GAMES; PROVIDING FACILITIES FOR RECREATION AND SPORTING ACTIVITIES AND GYMNASIUM FACILITIES; ENTERTAINMENT, NAMELY, LIVE PERFORMANCES BY A MUSICAL BAND; DISCOTHEQUES; ORGANIZING FASHION SHOWS FOR ENTERTAINMENT PURPOSES; NIGHT CLUB SERVICES; ARRANGING AND CONDUCTING CONFERENCES, CONVENTIONS, CONGRESSES, SEMINARS AND TRAINING WORKSHOPS IN THE FIELD OF BUSINESS AND E-COMMERCE; ORGANIZING AND CONDUCTING EXHIBITIONS FOR CULTURAL OR EDUCATIONAL PURPOSES; ART EXHIBITION SERVICES; TRAINING SERVICES IN THE FIELDS OF OCCUPATION HEALTH AND SAFETY AND ENVIRONMENTAL CONSERVATION; EDUCATIONAL SERVICES, NAMELY, PROVIDING CLASSES IN THE FIELDS OF CIGAR APPRECIATION AND WINE TASTING; PROVIDING EDUCATIONAL RESEARCH AND INFORMATION ABOUT EDUCATIONAL RESEARCH; ARRANGING, ORGANIZING, AND PLANNING OF SEMINARS IN THE FIELD OF BUSINESS AND E-COMMERCE; ANIMAL TRAINING; DIRECTION OF MAKING RADIO OR TELEVISION PROGRAMS; EDUCATIONAL SERVICES, NAMELY, PROVIDING CLASSES IN THE FIELD OF PRODUCING BROADCASTING PROGRAMS; EDUCATIONAL SERVICES, NAMELY, TRAINING IN THE OPERATION OF AUDIOVISUAL MACHINES AND EQUIPMENT USED FOR THE PRODUCTION OF BROADCASTING PROGRAMS; PROVIDING AUDIO AND VISUAL STUDIOS; PROVIDING SPORTS FACILITIES; PROVIDING FACILITIES FOR MOVIES, SHOWS, PLAYS, MUSIC OR EDUCATIONAL TRAINING; THEATRICAL BOOKING AGENCIES; RENTAL AND LEASING OF MOTION PICTURES; RENTAL AND LEASING OF MUSICAL INSTRUMENTS; RENTAL AND LEASING OF TELEVISION SETS; LENDING LIBRARIES; ARCHIVE LIBRARY SERVICES; PREPARING SUBTITLING FOR MOVIES AND TELEVISION SHOWS; SIGN LANGUAGE INTERPRETATION SERVICES; RENTAL OF ENTERTAINMENT GAME SOFTWARE; ENTERTAINMENT SERVICES, NAMELY, PROVIDING ON-LINE VIDEO GAMES, COMPUTER GAMES AND COMPUTER GAME CONTESTS; RENTAL OF PRE-RECORDED VIDEO TAPES; RENTAL AND LEASING OF GAME MACHINES; LENDING OF ARCADE GAME EQUIPMENT; LENDING OF PHOTOGRAPHS; PHOTOGRAPHY; TRANSLATION; LANGUAGE INTERPRETATION; PROVIDING NEWS IN THE NATURE OF CURRENT EVENT REPORTING (U.S. CLS. 100, 101 AND 107).

#### **CLASS 42—SCIENTIFIC AND COMPUTER SERVICES**

FOR SCIENTIFIC AND TECHNOLOGICAL SERVICES AND RESEARCH AND DESIGN RELATING THERETO, NAMELY, PROVIDING ONLINE NON-DOWNLOADABLE SOFTWARE AND CLOUD COMPUTING FEATURING SOFTWARE FOR PLANNING AND MANAGEMENT OF PERSONAL AND BUSINESS FINANCES, E-COMMERCE DATA MINING, CUSTOMER RELATIONSHIP MANAGEMENT, INVENTORY MANAGEMENT, SALES FORCE MANAGEMENT, AND MARKETING INFORMATION MANAGEMENT; INDUSTRIAL RESEARCH SERVICES IN THE FIELD OF BUSINESS MANAGEMENT, CUSTOMER RELATIONSHIP MANAGEMENT (CRM), INVENTORY MANAGEMENT, SALESFORCE MANAGEMENT, PLANNING AND MANAGEMENT OF PERSONAL AND BUSINESS FINANCES AND MARKETING INFORMATION MANAGEMENT FOR E-COMMERCE; DESIGN AND DEVELOPMENT OF COMPUTER HARDWARE AND SOFTWARE; COMPUTER SERVICES, NAMELY, COMPUTER SYSTEM ADMINISTRATION FOR OTHERS; COMPUTER PROGRAMMING; DESIGN AND DEVELOPMENT OF ON-LINE COMPUTER SOFTWARE SYSTEMS; COMPUTER SOFTWARE DESIGN; COMPUTER SYSTEM DESIGN; DESIGN AND DEVELOPMENT OF WEBPAGES ON THE INTERNET FOR OTHERS; HOSTING THE WEB SITES OF OTHERS; COMPUTER SERVICES, NAMELY, HOSTING COMPUTER APPLICATION SOFTWARE FOR SEARCHING AND RETRIEVING INFORMATION FROM DATABASES AND COMPUTER NETWORKS; PROVIDING TECHNICAL INFORMATION ABOUT COMPUTERS AND COMPUTER SOFTWARE AT THE SPECIFIC REQUEST OF END USERS BY MEANS OF TELEPHONE OR GLOBAL COMPUTER NETWORK; COMPUTER SERVICES, NAMELY, HOSTING SOFTWARE FOR CUSTOMIZED SEARCHING OF COMPUTER DATABASES AND WEBSITES (U.S. CLS. 100 AND 101).

GENE MACIOL, EXAMINING ATTORNEY

---

SN 77-812,183. 2650 VIRGINIA AVE NW LLC, NEW YORK, NY. FILED 8-25-2009.

## **WATERGATE HOTEL**

THE MARK CONSISTS OF STANDARD CHARACTERS WITHOUT CLAIM TO ANY PARTICULAR FONT, STYLE, SIZE, OR COLOR.

OWNER OF U.S. REG. NO. 1,185,142.

NO CLAIM IS MADE TO THE EXCLUSIVE RIGHT TO USE "HOTEL", APART FROM THE MARK AS SHOWN.

#### **CLASS 35—ADVERTISING AND BUSINESS**

FOR HOTEL MANAGEMENT SERVICES FOR OTHERS (U.S. CLS. 100, 101 AND 102).

#### **CLASS 43—HOTEL AND RESTAURANT SERVICES**

FOR HOTEL SERVICES (U.S. CLS. 100 AND 101).  
SALLY SHIH, EXAMINING ATTORNEY

SN 77-818,174. 2077333 ONTARIO INC., AYR, ONTARIO, CANADA, FILED 9-2-2009.

## REVIVE & THRIVE

THE MARK CONSISTS OF STANDARD CHARACTERS WITHOUT CLAIM TO ANY PARTICULAR FONT, STYLE, SIZE, OR COLOR.

PRIORITY CLAIMED UNDER SEC. 44(D) ON CANADA APPLICATION NO. 1449361, FILED 8-25-2009, REG. NO. TMA791713, DATED 2-28-2011, EXPIRES 2-28-2026.

### CLASS 1—CHEMICALS

FOR COMPOST (U.S. CLS. 1, 5, 6, 10, 26 AND 46).

### CLASS 31—NATURAL AGRICULTURAL PRODUCTS

FOR SEEDS FOR HORTICULTURAL PURPOSES (U.S. CLS. 1 AND 46).

ROBERT C. CLARK JR., EXAMINING ATTORNEY

---

SN 77-826,998. REDEEMER CITYNET, NEW YORK, NY. FILED 9-15-2009.



THE COLOR(S) YELLOW, BLACK AND WHITE IS/ARE CLAIMED AS A FEATURE OF THE MARK.

THE MARK CONSISTS OF A YELLOW RECTANGLE WITH A WHITE CROSS IN THE CENTER, THAT ALSO FORMS THE LETTERS "C" "T" AND REVERSE "C", FOLLOWED BY THE WORDS "REDEEMER CITY TO CITY" IN BLACK.

### CLASS 9—ELECTRICAL AND SCIENTIFIC APPARATUS

FOR AUDIO AND VIDEO RECORDINGS FEATURING CONTENT ON CHURCH PLANTING, URBAN RENEWAL AND RELIGIOUS INSTRUCTION; DIGITAL MEDIA, NAMELY, CDS, DVDS, DOWNLOADABLE AUDIO AND VIDEO FILES FEATURING CONTENT ON CHURCH PLANTING, URBAN RENEWAL AND RELIGIOUS INSTRUCTION; DOWNLOADABLE PODCASTS IN THE FIELD OF CHURCH PLANTING, URBAN RENEWAL AND RELIGIOUS INSTRUCTION (U.S. CLS. 21, 23, 26, 36 AND 38).

### CLASS 16—PAPER GOODS AND PRINTED MATTER

FOR A SERIES OF BOOKS, WRITTEN ARTICLES, HANDOUTS AND WORKSHEETS IN THE FIELD OF CHURCH PLANTING, URBAN RENEWAL AND RELIGIOUS INSTRUCTION; BOOKS IN THE FIELD OF CHURCH PLANTING, URBAN RENEWAL AND RELIGIOUS INSTRUCTION; MANUALS IN THE FIELD OF CHURCH PLANTING, URBAN RENEWAL AND RELIGIOUS INSTRUCTION; PRINTED INSTRUCTIONAL, EDUCATIONAL, AND TEACHING MATERIALS IN THE FIELD OF CHURCH PLANTING, URBAN RENEWAL AND RELIGIOUS INSTRUCTION; PRINTED LECTURES; PRINTED MATERIALS, NAMELY, CURRICULA IN THE FIELD OF CHURCH PLANTING, URBAN RENEWAL AND RELIGIOUS INSTRUCTION; PRINTED PERIODICALS IN THE FIELD OF CHURCH PLANTING, URBAN RENEWAL AND RELIGIOUS INSTRUCTION (U.S. CLS. 2, 5, 22, 23, 29, 37, 38 AND 50).

### CLASS 41—EDUCATION AND ENTERTAINMENT

FOR AUDIO RECORDING AND PRODUCTION; DEVELOPMENT AND DISSEMINATION OF EDUCATIONAL MATERIALS OF OTHERS IN THE FIELD OF CHURCH PLANTING, URBAN RENEWAL AND RELIGIOUS INSTRUCTION; EDUCATION SERVICES, NAMELY, PROVIDING CLASSES, SEMINARS, WORKSHOPS, ONLINE NON-DOWNLOADABLE BOOKS, ONLINE PUBLICATIONS IN THE NATURE OF E-BOOKS AND WEB ARTICLES, ALL IN THE FIELD OF CHURCH PLANTING, URBAN RENEWAL AND RELIGIOUS INSTRUCTION; EDUCATIONAL SERVICES, NAMELY, DEVELOPING, ARRANGING, AND CONDUCTING EDUCATIONAL CONFERENCES AND PROGRAMS AND PROVIDING COURSES OF INSTRUCTION IN THE FIELD OF CHURCH PLANTING, URBAN RENEWAL AND RELIGIOUS INSTRUCTION; PROVIDING PODCASTS IN THE FIELD OF CHURCH PLANTING, URBAN RENEWAL AND RELIGIOUS INSTRUCTION; FILM AND VIDEO PRODUCTION; PROVIDING A WEB SITE THAT FEATURES INFORMAL INSTRUCTION ON CHURCH PLANTING, URBAN RENEWAL AND RELIGIOUS INSTRUCTION (U.S. CLS. 100, 101 AND 107).

GISELLE AGOSTO, EXAMINING ATTORNEY

---

SN 77-828,912. BLOGZILLA LLC, SAN FRANCISCO, CA. FILED 9-17-2009.

## DIGITAL SUMMER

THE MARK CONSISTS OF STANDARD CHARACTERS WITHOUT CLAIM TO ANY PARTICULAR FONT, STYLE, SIZE, OR COLOR.

NO CLAIM IS MADE TO THE EXCLUSIVE RIGHT TO USE "DIGITAL", APART FROM THE MARK AS SHOWN.

### CLASS 35—ADVERTISING AND BUSINESS

FOR PROMOTION AND MARKETING FOR OTHERS OF SEASONAL EVENTS IN FIELDS OF TECHNOLOGY, FASHION AND PHOTOGRAPHY (U.S. CLS. 100, 101 AND 102).

FIRST USE 8-19-2009; IN COMMERCE 8-19-2009.

**CLASS 41—EDUCATION AND ENTERTAINMENT**

FOR ARRANGING AND CONDUCTING SEASONAL EVENTS, NAMELY, FASHION AND PHOTOGRAPHY SHOWS THAT FEATURE TECHNOLOGY, FOR ENTERTAINMENT PURPOSES, CONSULTING SERVICES REGARDING SEASONAL EVENTS, NAMELY, FASHION AND PHOTOGRAPHY SHOWS THAT FEATURE TECHNOLOGY, AND PROVIDING A WEBSITE THAT DISPLAYS INFORMATION RELATING TO SEASONAL EVENTS, NAMELY, FASHION AND PHOTOGRAPHY SHOWS THAT FEATURE TECHNOLOGY (U.S. CLS. 100, 101 AND 107).

FIRST USE 8-19-2009; IN COMMERCE 8-19-2009.  
DEZMONA MIZELLE, EXAMINING ATTORNEY

SN 77-835,533. BELARBI, MOHAMED, SAINT TROPEZ, FRANCE, FILED 9-25-2009.

**LES TROPÉZIENNES PAR M. BELARBI**

THE MARK CONSISTS OF STANDARD CHARACTERS WITHOUT CLAIM TO ANY PARTICULAR FONT, STYLE, SIZE, OR COLOR.

OWNER OF ERPN CMNTY TM OFC REG. NO. 6100655, DATED 9-4-2007, EXPIRES 9-4-2017.

THE NAME(S), PORTRAIT(S), AND/OR SIGNATURE(S) SHOWN IN THE MARK IDENTIFIES M. BELARBI, WHOSE CONSENT(S) TO REGISTER IS MADE OF RECORD.

THE ENGLISH TRANSLATION OF "LES TROPÉZIENNES PAR M. BELARBI" IN THE MARK IS "THE TROPÉZIENNES BY M. BELARBI". THE WORDING "TROPÉZIENNES" HAS NO MEANING IN A FOREIGN LANGUAGE.

SN 77-829,469. INTERNATIONAL FINANCIAL REPORTING STANDARDS FOUNDATION, WILMINGTON, DE. FILED 9-18-2009.



OWNER OF U.S. REG. NOS. 3,226,437, 3,871,660 AND OTHERS.

NO CLAIM IS MADE TO THE EXCLUSIVE RIGHT TO USE "IFRS FOR SMES", APART FROM THE MARK AS SHOWN.

THE MARK CONSISTS OF THE LETTERS "IFRS". DIRECTLY BELOW "IFRS", IS THE PHRASE "FOR SMES". TO THE LEFT OF THE LETTERING IS AN INTERLOCKING GEOMETRIC SHAPE, INSIDE OF A RECTANGLE.

**CLASS 9—ELECTRICAL AND SCIENTIFIC APPARATUS**

FOR DOWNLOADABLE ELECTRONIC PUBLICATIONS, NAMELY, GRAPHS, PERIODICAL NEWSLETTERS, PAMPHLETS, AND WRITTEN ARTICLES ALL PERTAINING TO ACCOUNTING STANDARDS (U.S. CLS. 21, 23, 26, 36 AND 38).

FIRST USE 7-9-2009; IN COMMERCE 7-9-2009.

**CLASS 16—PAPER GOODS AND PRINTED MATTER**

FOR BOOKS FEATURING ACCOUNTING STANDARDS AND PRINCIPLES; AND PRINTED FORMS, WRITTEN ARTICLES, GRAPHS, PERIODICAL NEWSLETTERS AND PAMPHLETS ALL PERTAINING TO ACCOUNTING STANDARDS AND PRINCIPLES (U.S. CLS. 2, 5, 22, 23, 29, 37, 38 AND 50).

FIRST USE 7-9-2009; IN COMMERCE 7-9-2009.  
PATRICIA EVANKÓ, EXAMINING ATTORNEY

**CLASS 3—COSMETICS AND CLEANING PREPARATIONS**

FOR BLEACHING PREPARATIONS; CLEANING, POLISHING, SCOURING AND ABRASIVE PREPARATIONS FOR HOUSEHOLD PURPOSES; COSMETIC SOAPS; PERFUMERY, NAMELY, PERFUMES, TOILET WATERS; ESSENTIAL OILS FOR PERSONAL USE AND FOR HOUSEHOLD USE; COSMETICS; HAIR LOTIONS; DENTIFRICES (U.S. CLS. 1, 4, 6, 50, 51 AND 52).

**CLASS 16—PAPER GOODS AND PRINTED MATTER**

FOR ART PAPER, CARDBOARD; PRINTED MATTER, NAMELY, NEWSPAPERS, PHOTOGRAPHS; BOOK BINDING MATERIALS; PHOTOGRAPHS, STATIONERY ADHESIVES FOR STATIONERY OF HOUSEHOLDS PURPOSES; PAINT BRUSHES; TYPE-WRITERS; PLASTIC MATERIALS FOR PACKAGING NOT INCLUDED IN OTHER CLASSES, NAMELY, PLASTIC BAGS FOR MERCHANDISE PACKAGING, ENVELOPES, POUCHES (U.S. CLS. 2, 5, 22, 23, 29, 37, 38 AND 50).

**CLASS 24—FABRICS**

FOR TEXTILES AND TEXTILE GOODS NOT INCLUDED IN OTHER CLASSES, NAMELY, TEXTILE USED AS LINING FOR CLOTHING, NATURAL AND SYNTHETIC FABRICS AND TEXTILES, NAMELY, COTTON, SILK, POLYESTER AND NYLON FABRICS, TEXTILE FABRICS OF ANIMAL SKIN IMITATIONS (U.S. CLS. 42 AND 50).

**CLASS 28—TOYS AND SPORTING GOODS**

FOR GAMES AND PLAYTHINGS, NAMELY, PROMOTIONAL GAME CARDS AND MATERIALS (U.S. CLS. 22, 23, 38 AND 50).

**CLASS 32—LIGHT BEVERAGES**

FOR BEERS, MINERALS AND AERATED WATERS AND OTHER NON-ALCOHOLIC DRINKS, NAMELY, NON-ALCOHOLIC FRUIT COCKTAIL DRINKS; FRUIT JUICES; SYRUPS AND OTHER PREPARATIONS FOR MAKING BEVERAGES, NAMELY, FRUIT-BASED CONCENTRATES AND POWDERS USED IN THE PREPARATION OF BEVERAGES (U.S. CLS. 45, 46 AND 48).

**CLASS 35—ADVERTISING AND BUSINESS**

FOR BUSINESS MANAGEMENT, BUSINESS ADMINISTRATION; OFFICE FUNCTIONS (U.S. CLS. 100, 101 AND 102).



**CLASS 38—COMMUNICATION**

FOR TELECOMMUNICATIONS, NAMELY, DATA TRANSMISSION AND RECEPTION SERVICES VIA TELECOMMUNICATION MEANS (U.S. CLS. 100, 101 AND 104).

**CLASS 39—TRANSPORTATION AND STORAGE**

FOR TRANSPORT, PACKAGING AND STORAGE OF GOODS, NAMELY, TEXTILE, CLOTHING AND FOOTWEAR (U.S. CLS. 100 AND 105).  
EUGENIA MARTIN, EXAMINING ATTORNEY

SN 77-842,672. VELOCITY SOLUTIONS, INC., WILMINGTON, NC. FILED 10-6-2009.

---

# VELOCITY

THE MARK CONSISTS OF STANDARD CHARACTERS WITHOUT CLAIM TO ANY PARTICULAR FONT, STYLE, SIZE, OR COLOR.

**CLASS 35—ADVERTISING AND BUSINESS**

FOR CUSTOMER REFERRAL PROGRAMS IN THE FIELD OF FINANCE; PROVIDING BUSINESS DEVELOPMENT SERVICES TO FINANCIAL INSTITUTIONS, HEALTH INSURANCE COMPANIES AND SELF-INSURED EMPLOYERS; BUSINESS DATA ANALYSIS; PROVIDING BUSINESS SUPPORT SERVICES TO FINANCIAL INSTITUTIONS, HEALTH INSURANCE COMPANIES AND SELF-INSURED EMPLOYERS, NAMELY, BUSINESS CONSULTING SERVICES CONCERNING STRATEGIES TO INCREASE PROFITS (U.S. CLS. 100, 101 AND 102).  
FIRST USE 9-28-2009; IN COMMERCE 9-28-2009.

**CLASS 44—MEDICAL, BEAUTY AND AGRICULTURAL SERVICES**

FOR PROVIDING WELLNESS PROGRAMS FOR HEALTH INSURANCE COMPANIES AND SELF-INSURED EMPLOYERS (U.S. CLS. 100 AND 101).  
FIRST USE 9-29-2009; IN COMMERCE 9-29-2009.  
SANI KHOURI, EXAMINING ATTORNEY

SN 77-842,677. VELOCITY SOLUTIONS, INC., WILMINGTON, NC. FILED 10-6-2009.

---

# VELOCITY SOLUTIONS

THE MARK CONSISTS OF STANDARD CHARACTERS WITHOUT CLAIM TO ANY PARTICULAR FONT, STYLE, SIZE, OR COLOR.

NO CLAIM IS MADE TO THE EXCLUSIVE RIGHT TO USE "SOLUTIONS", APART FROM THE MARK AS SHOWN.

**CLASS 35—ADVERTISING AND BUSINESS**

FOR CUSTOMER REFERRAL PROGRAMS IN THE FIELD OF FINANCE; PROVIDING BUSINESS DEVELOPMENT SERVICES TO FINANCIAL INSTITUTIONS, HEALTH INSURANCE COMPANIES AND SELF-INSURED EMPLOYERS; BUSINESS DATA ANALYSIS; PROVIDING BUSINESS SUPPORT SERVICES TO FINANCIAL INSTITUTIONS, HEALTH INSURANCE COMPANIES AND SELF-INSURED EMPLOYERS, NAMELY, BUSINESS CONSULTING SERVICES CONCERNING STRATEGIES TO INCREASE PROFITS (U.S. CLS. 100, 101 AND 102).  
FIRST USE 9-28-2009; IN COMMERCE 9-28-2009.

**CLASS 44—MEDICAL, BEAUTY AND AGRICULTURAL SERVICES**

FOR PROVIDING WELLNESS PROGRAMS FOR HEALTH INSURANCE COMPANIES AND SELF-INSURED EMPLOYERS (U.S. CLS. 100 AND 101).  
FIRST USE 9-28-2009; IN COMMERCE 9-28-2009.  
SANI KHOURI, EXAMINING ATTORNEY

SN 77-844,373. MULTIBURO, LYON, FRANCE, FILED 10-8-2009.



OWNER OF ERPN CMNTY TM OFC REG. NO. 008468043, DATED 9-6-2010, EXPIRES 8-3-2019.

OWNER OF U.S. REG. NO. 3,643,664.  
THE COLOR(S) BLACK AND ORANGE IS/ARE CLAIMED AS A FEATURE OF THE MARK.

THE MARK CONSISTS OF THE BLACK WORDING "MULTIBURO". ABOVE THE "MULTIBURO" WORDING ARE FIVE ORANGE RECTANGLES OF VARYING LENGTHS.

**CLASS 35—ADVERTISING AND BUSINESS**

FOR BUSINESS PROCUREMENT SERVICES, NAMELY, PURCHASING OFFICE STATIONERY AND OFFICE SUPPLIES FOR OTHERS; OFFICE APPLIANCES AND EQUIPMENT RENTAL; BUSINESS MANAGEMENT OF OFFICES; SECRETARIAL SERVICES; DOCUMENT REPRODUCTION; TYPING, WORD PROCESSING AND BUSINESS DOCUMENT MANAGEMENT SERVICES, NAMELY, BUSINESS DOCUMENT INDEXING FOR OTHERS; PERSONNEL MANAGEMENT, CONSULTANCY AND RECRUITMENT; ADVICE AND ASSISTANCE CONCERNING PAYROLL PROCESSING SERVICES; PREPARATION OF PAYROLLS; PROMOTING THE GOODS AND SERVICES OF OTHERS BY MEANS OF THE ISSUANCE OF LOYALTY REWARD CARDS (U.S. CLS. 100, 101 AND 102).

**CLASS 36—INSURANCE AND FINANCIAL**

FOR LEASING OF REAL ESTATE; LEASING AND RENTAL OF OFFICE SPACE (U.S. CLS. 100, 101 AND 102).

**CLASS 43—HOTEL AND RESTAURANT SERVICES**

FOR PROVIDING OF FOOD AND DRINK; PROVISION OF TEMPORARY ACCOMMODATION; PROVISION OF OVERNIGHT ACCOMMODATION; CATERING SERVICES (U.S. CLS. 100 AND 101).

**CLASS 45—PERSONAL AND LEGAL SERVICES**

FOR LEGAL SERVICES (U.S. CLS. 100 AND 101).  
SIMON TENG, EXAMINING ATTORNEY

SN 77-848,704. I & J FISNAR, INC., FAIR LAWN, NJ. FILED  
10-14-2009.



OWNER OF U.S. REG. NOS. 1,655,230 AND 3,182,899.  
THE MARK CONSISTS OF THE CAPITAL LETTERS "FISNAR" WITH THREE THICK WAVY STYLE LINES DIRECTLY TO THE LEFT OF THE LETTER "F" PORTION OF THE MARK; WITH A STRAIGHT LINE DRAWN THROUGH THE TOP PORTION OF THE LETTERS "ISNAR".

THE WORDING "FISNAR" HAS NO MEANING IN A FOREIGN LANGUAGE.

SN 77-844,589. MULTIBURO, LYON, FRANCE, FILED 10-8-2009.



OWNER OF ERPN CMNTY TM OFC REG. NO. 008468183,  
DATED 9-6-2010, EXPIRES 8-3-2019.

OWNER OF U.S. REG. NO. 3,643,664.

NO CLAIM IS MADE TO THE EXCLUSIVE RIGHT TO USE "WORKSPACES", APART FROM THE MARK AS SHOWN.

THE COLOR(S) BLACK AND ORANGE IS/ARE CLAIMED AS A FEATURE OF THE MARK.

THE MARK CONSISTS OF THE BLACK WORDING "MULTIBURO". BELOW THIS WORDING IS THE ORANGE WORDING "INTELLIGENT WORKSPACES". ABOVE THE "MULTIBURO" WORDING ARE FIVE ORANGE RECTANGLES OF VARYING LENGTHS.

**CLASS 35—ADVERTISING AND BUSINESS**

FOR BUSINESS PROCUREMENT SERVICES, NAMELY, PURCHASING OFFICE STATIONERY AND OFFICE SUPPLIES FOR OTHERS; OFFICE APPLIANCES AND EQUIPMENT RENTAL; BUSINESS MANAGEMENT OF OFFICES; SECRETARIAL SERVICES; DOCUMENT REPRODUCTION; TYPING, WORD PROCESSING AND BUSINESS DOCUMENT MANAGEMENT SERVICES, NAMELY, BUSINESS DOCUMENT INDEXING FOR OTHERS; PERSONNEL MANAGEMENT, CONSULTANCY AND RECRUITMENT; ADVICE AND ASSISTANCE CONCERNING PAYROLL PROCESSING SERVICES; PREPARATION OF PAYROLLS; PROMOTING THE GOODS AND SERVICES OF OTHERS BY MEANS OF THE ISSUANCE OF LOYALTY REWARD CARDS (U.S. CLS. 100, 101 AND 102).

**CLASS 36—INSURANCE AND FINANCIAL**

FOR LEASING OF REAL ESTATE; LEASING AND RENTAL OF OFFICE SPACE (U.S. CLS. 100, 101 AND 102).

**CLASS 43—HOTEL AND RESTAURANT SERVICES**

FOR PROVIDING OF FOOD AND DRINK; PROVISION OF TEMPORARY ACCOMMODATION; PROVISION OF OVERNIGHT ACCOMMODATION; CATERING SERVICES (U.S. CLS. 100 AND 101).

**CLASS 45—PERSONAL AND LEGAL SERVICES**

FOR LEGAL SERVICES (U.S. CLS. 100 AND 101).  
SIMON TENG, EXAMINING ATTORNEY

**CLASS 7—MACHINERY**

FOR DISPENSING VALVES BEING MACHINE PARTS; INDUSTRIAL ROBOTS; PERISTALTIC PUMPS BEING MACHINE PARTS; SPRAY NOZZLES BEING STRUCTURAL PARTS OF POWER-OPERATED SPRAYERS; MACHINE PARTS, NAMELY, SYRINGES AND RELATED CONSUMABLES, NAMELY, NEEDLES, BARRELS AND TIPS ALL BEING STRUCTURAL PARTS OF MACHINES; LIQUID DISPENSING MACHINES COMPRISED OF 4 AXES TABLETOP, GANTRY CRANES, SELECTIVE COMPLIANT ASSEMBLY ROBOT ARM ASSEMBLY AND INDUSTRIAL DISPENSING ROBOTS; TWO PART METER AND MIXING SYSTEMS AND MACHINES, NAMELY, MIXING MACHINES; INDUSTRIAL HOT MELT SYSTEMS AND EQUIPMENT, NAMELY, HOT MELT GLUE APPLICATORS AND DISPENSING UNITS FOR INDUSTRIAL PURPOSES (U.S. CLS. 13, 19, 21, 23, 31, 34 AND 35).

**CLASS 9—ELECTRICAL AND SCIENTIFIC APPARATUS**

FOR AUTOMATIC LIQUID DISPENSING SYSTEMS FOR USE IN INDUSTRIAL APPLICATIONS SUCH AS ADHESIVE, GLUE, CYANOACRYLATES, SILICONE, RTV, ANAEROBIC RESIN, EPOXY, UV CURE FORMULATIONS AND MANY MORE FLUIDS, COMPRISING AUTOMATIC DISPENSING MACHINES AND STRUCTURAL MACHINE PARTS THEREFOR, NAMELY, ARTICULATED ARM GUIDES, VACUUM PICK-UP PENS, STORAGE STRANDS, ADAPTERS, DISPENSING TIPS, CARTRIDGES, BARREL LOADERS, BARREL STORAGE CAPS, BARREL ADAPTERS, BARREL PISTONS, BARREL TIP CAPS, BARREL FINGER SWITCHES, CLEAN ROOM FILTERS AND MUFFLERS (U.S. CLS. 21, 23, 26, 36 AND 38).

MYRIAH HABEEB, EXAMINING ATTORNEY

SN 77-852,990. GRAYCLIFF HOTEL, RESTAURANT & CIGAR COMPANY, NASSAU, BAHAMAS, BAHAMAS, FILED 10-20-2009.



THE MARK CONSISTS OF A STYLIZED LETTER "G", A STYLIZED LETTER "R" CONNECTED TO A STYLIZED

LETTER "A", A STYLIZED LETTER "Y" WHICH CONNECTED TO THE FIRST STYLIZED LETTER "G", A STYLIZED LETTER "C", A STYLIZED LETTER "L", A STYLIZED LETTER "I", A STYLIZED LETTER "F", A STYLIZED LETTER "F". (COLLECTIVELY SPELLING THE WORD "GRAYCLIFF"). ABOVE THE STYLIZED LETTERS ARE FIVE FIVE-POINT SOLID STARS. THE FIRST SOLID FIVE-POINT STAR IS LOCATED ABOVE THE FIRST STYLIZED LETTER "G" WITH THE FIFTH SOLID STAR ABOVE THE SECOND STYLIZED "F".

#### CLASS 14—JEWELRY

FOR CASES FOR WATCHES AND CLOCKS; CLOCKS AND WATCHES; DRESS WATCHES; JEWELRY WATCHES; POCKET WATCHES; STOP WATCHES; WATCH BANDS; WATCH BANDS AND STRAPS; WATCH BOXES; WATCH BRACELETS; WATCH CASES; WATCH CHAINS; WATCH POUCHES; WATCH STRAPS; WATCH STRAPS MADE OF METAL OR LEATHER OR PLASTIC; WATCHES; WRIST WATCHES (U.S. CLS. 2, 27, 28 AND 50).

#### CLASS 18—LEATHER GOODS

FOR HAT BOXES OF LEATHER; LEATHER AND IMITATION LEATHER; LEATHER BOXES FOR STORING GREETING CARDS; LEATHER OR LEATHERBOARD BOXES; LEATHER SOLD IN BULK; PET ACCESSORIES, NAMELY, SPECIALLY DESIGNED CANVAS, VINYL OR LEATHER BAGS ATTACHED TO ANIMAL LEASHES FOR HOLDING SMALL ITEMS SUCH AS KEYS, CREDIT CARDS, MONEY OR DISPOSABLE BAGS FOR DISPOSING OF PET WASTE (U.S. CLS. 1, 2, 3, 22 AND 41).

DOUGLAS LEE, EXAMINING ATTORNEY

SN 77-853,675. SAGE BEARS, LLC, GARDEN CITY, NY. FILED 10-21-2009.

## SAGE SPOONFULS

THE MARK CONSISTS OF STANDARD CHARACTERS WITHOUT CLAIM TO ANY PARTICULAR FONT, STYLE, SIZE, OR COLOR.

#### CLASS 7—MACHINERY

FOR ELECTRIC HANDHELD MIXERS FOR HOUSEHOLD USE (U.S. CLS. 13, 19, 21, 23, 31, 34 AND 35).

#### CLASS 16—PAPER GOODS AND PRINTED MATTER

FOR PRINTED MATERIALS, NAMELY, BOOKS, IN THE NATURE OF COOKBOOKS, BOOKS ON NUTRITION, BOOKS ON FOOD PREPARATION AND FOOD STORAGE; BLANK AND/OR PARTIALLY PRINTED PAPER LABELS (U.S. CLS. 2, 5, 22, 23, 29, 37, 38 AND 50).

#### CLASS 18—LEATHER GOODS

FOR BAGS, NAMELY, TOTE BAGS, TRAVEL BAGS, AND REUSABLE SHOPPING BAGS (U.S. CLS. 1, 2, 3, 22 AND 41).

#### CLASS 21—HOUSEWARES AND GLASS

FOR NON-ELECTRIC HAND-OPERATED FOOD GRINDERS (U.S. CLS. 2, 13, 23, 29, 30, 33, 40 AND 50).

#### CLASS 25—CLOTHING

FOR CLOTHING, NAMELY, CLOTH BIBS, T-SHIRTS; HATS, AND APRONS (U.S. CLS. 22 AND 39).

TRACY WHITTAKER-BROWN, EXAMINING ATTORNEY

SN 77-854,636. OUTTA MY HEAD PRODUCTIONS, INC., MADISON, AL. FILED 10-22-2009.

## CLUB MAGGIE NATION

THE MARK CONSISTS OF STANDARD CHARACTERS WITHOUT CLAIM TO ANY PARTICULAR FONT, STYLE, SIZE, OR COLOR.

#### CLASS 16—PAPER GOODS AND PRINTED MATTER

FOR CHILDREN'S BOOKS, PENS, BINDING MATERIALS FOR PAPERS, NOTEBOOKS, CARTOON PRINTS, CHALKS, BOOK MARKS, BOOKS FEATURING PUZZLES AND GAMES, CALENDARS, COLORING BOOKS, COMIC BOOKS, MAGAZINES IN THE FIELD OF ENTERTAINMENT, PAPER NAPKINS, PAPER PARTY DECORATIONS, PAPER TABLE CLOTHS, PAPER GIFT BAGS, WRAPPING PAPER FOR GIFTS, CRAYONS, DRAWING PADS, PENCILS, ERASERS, MARKERS, NOTE PADS, PAINTING SETS FOR CHILDREN, PENCIL SHARPENERS, STICKERS, CASES FOR WRITING INSTRUMENTS, BUMPER STICKERS, TEMPORARY TATTOOS, COLLECTIBLE TRADING CARDS, AND SCHOOL SUPPLY KITS CONTAINING VARIOUS COMBINATIONS OF SELECTED SCHOOL SUPPLIES, NAMELY, ERASERS, NOTEBOOKS, PAPER, PENCILS, PENS, MARKERS, GLUE, AND CRAYONS (U.S. CLS. 2, 5, 22, 23, 29, 37, 38 AND 50).

#### CLASS 28—TOYS AND SPORTING GOODS

FOR BALLS FOR SPORTS, BATHTUB TOYS, BOARD GAMES, CARD GAMES, CASES FOR PLAY ACCESSORIES, CHILDREN'S PLAY COSMETICS, DOLLS, DOLL ACCESSORIES, DOLL CASES, DOLL CLOTHING, DOLL FURNITURE, DOLL HOUSES, JIGSAW PUZZLES, ROLLER SKATES, RUBBER BALLS, STUFFED TOY ANIMALS, TOY BAKEWARE AND COOKWARE, TOY BOXES, TOY CARS, TOY CLOCKS AND WATCHES, CHILDREN'S DRESS-UP ACCESSORIES, YO-YOS, TOY FLOWER POTS, TOY FLOWERS, NAMELY, DOLLS COMBINED WITH ARTIFICIAL FLOWERS AND SOLD AS A UNIT (U.S. CLS. 22, 23, 38 AND 50).

#### CLASS 41—EDUCATION AND ENTERTAINMENT

FOR ENTERTAINMENT SERVICES, NAMELY, PRODUCTION AND DISTRIBUTION OF MOTION PICTURE FILMS, ANIMATED MOVIES, TELEVISION PROGRAMS, AND ANIMATED VIDEOS; PROVIDING ONLINE COMPUTER GAMES; PROVIDING ONLINE VIDEO GAMES; PROVIDING ON-GOING ANIMATED TELEVISION PROGRAMS; PUBLICATION OF PRINTED MATTER FEATURING CARTOON CHARACTERS FOR CHILDREN; AND PUBLICATION OF BOOKS AND MAGAZINES FOR CHILDREN (U.S. CLS. 100, 101 AND 107).

LESLIE RICHARDS, EXAMINING ATTORNEY

SN 77-854,935. HEMERUS MEDICAL LLC, ST. PAUL, MN.  
FILED 10-22-2009.

SN 77-855,672. MILUX HOLDING S.A., LUXEMBOURG,  
LUXEMBOURG, FILED 10-23-2009.

# HEMERUS

THE MARK CONSISTS OF STANDARD CHARACTERS WITHOUT CLAIM TO ANY PARTICULAR FONT, STYLE, SIZE, OR COLOR.

## CLASS 5—PHARMACEUTICALS

FOR BLOOD THINNERS; BLOOD PRESERVATIVES AND ANTICOAGULANTS (U.S. CLS. 6, 18, 44, 46, 51 AND 52).

## CLASS 9—ELECTRICAL AND SCIENTIFIC APPARATUS

FOR EQUIPMENT FOR PROCESSING AND STORAGE IN A BLOOD BANK; LABORATORY CENTRIFUGES (U.S. CLS. 21, 23, 26, 36 AND 38).

## CLASS 10—MEDICAL APPARATUS

FOR BLOOD BANKING EQUIPMENT AND SUPPLIES FOR BLOOD COLLECTION, NAMELY, APHERESIS DEVICES IN THE NATURE OF TUBING, VALVES, CONTAINERS AND BAGS (U.S. CLS. 26, 39 AND 44).  
LINDA MICKLEBURGH, EXAMINING ATTORNEY

SN 77-855,120. LOYOLA ACADEMY, WILMETTE, IL. FILED  
10-22-2009.

# LOYOLA ACADEMY

THE MARK CONSISTS OF STANDARD CHARACTERS WITHOUT CLAIM TO ANY PARTICULAR FONT, STYLE, SIZE, OR COLOR.

NO CLAIM IS MADE TO THE EXCLUSIVE RIGHT TO USE "ACADEMY" FOR INTERNATIONAL CLASS 41, APART FROM THE MARK AS SHOWN.

## CLASS 25—CLOTHING

FOR CLOTHING, NAMELY, T-SHIRTS, POLO SHIRTS (U.S. CLS. 22 AND 39).  
FIRST USE 0-0-2003; IN COMMERCE 0-0-2003.

## CLASS 41—EDUCATION AND ENTERTAINMENT

FOR EDUCATIONAL SERVICES, NAMELY, CONDUCTING CLASSES, SEMINARS AND LECTURES IN A SECONDARY EDUCATION; ENTERTAINMENT SERVICES IN THE NATURE OF AMATEUR YOUTH SPORTING EVENTS (U.S. CLS. 100, 101 AND 107).  
FIRST USE 0-0-1909; IN COMMERCE 0-0-1909.  
HEATHER BIDDULPH, EXAMINING ATTORNEY

# APPETITEMASTER

THE MARK CONSISTS OF STANDARD CHARACTERS WITHOUT CLAIM TO ANY PARTICULAR FONT, STYLE, SIZE, OR COLOR.

PRIORITY CLAIMED UNDER SEC. 44(D) ON ERPNTY TM OFC APPLICATION NO. 008245466, FILED 4-27-2009, REG. NO. 008245466, DATED 1-27-2010, EXPIRES 4-27-2019.

## CLASS 9—ELECTRICAL AND SCIENTIFIC APPARATUS

FOR APPARATUS, DEVICES AND INSTRUMENTS, ALL NOT USED IN DIRECT ASSOCIATION WITH ACTIVE IMPLANTS, FOR MEASURING, RECEIVING, SENDING, CHECKING, CONTROLLING, DRIVING, TRANSFERRING, TRANSMITTING, PROCESSING, ANALYZING, CONDUCTING, SWITCHING, TRANSFORMING, ACCUMULATING, AND REGULATING ELECTRICITY, ENERGY AND/OR DATA, INCLUDING PHYSICAL PARAMETERS, NAMELY, ELECTRONIC STORAGE DEVICES IN THE NATURE OF BLANK MEMORY DISCS, MEMORY CARDS AND DATA STORAGE MEDIA, NAMELY, PACKAGED SEMICONDUCTORS, ELECTRONIC CONTROL UNIT AND PROGRAMMER WHICH CONTROLS THE WORKING PARAMETERS OF WIRELESS COMMUNICATION SYSTEMS AND WIRELESS POWERING SYSTEMS, CHARGERS IN THE NATURE OF BATTERY CHARGERS, DIGITAL CHARGERS AND ELECTRONIC CHARGERS, ELECTRONIC TRANSMITTERS AND ELECTRONIC RECEIVERS OF ELECTRONIC SIGNALS, AND ELECTRONIC CIRCUITS; REMOTE CONTROLS FOR WIRELESS CONTROLLING, AND PROGRAMMING WIRELESS CHARGER APPARATUS FOR WIRELESS ENERGIZING AND CONTROL STATIONS FOR WIRELESS CONTROLLING, PROGRAMMING AND ENERGIZING OF ACTIVE IMPLANTS; SOFTWARE, IN PARTICULAR FOR ACTIVE MEDICAL IMPLANTS, FOR MEASURING, RECEIVING, SENDING, CHECKING, TRANSFERRING, CALCULATING, PROCESSING, CONTROLLING, PRESENTING AND ANALYZING OF DATA, NAMELY, DATA ABOUT ELECTRICITY, ENERGY, PHYSICAL PARAMETERS, AND COMMUNICATION AND PROGRAMMING DATA IN MEDICAL IMPLANTS; SOFTWARE, IN PARTICULAR FOR MEASURING, RECEIVING, SENDING, CHECKING, TRANSFERRING, CALCULATING, PROCESSING, CONTROLLING, PRESENTING AND ANALYZING OF DATA, NAMELY, DATA ABOUT ELECTRICITY, ENERGY, PHYSICAL PARAMETERS, COMMUNICATION AND PROGRAMMING DATA IN APPARATUS, DEVICES AND INSTRUMENTS FOR COMMUNICATING WITH, ENERGIZING AND PROGRAMMING OF MEDICAL IMPLANTS; AND DATA PROCESSING EQUIPMENT AND COMPUTERS (U.S. CLS. 21, 23, 26, 36 AND 38).

## CLASS 10—MEDICAL APPARATUS

FOR MEDICAL AND SURGICAL APPARATUS, INSTRUMENTS AND DEVICES, INCLUDING ACTIVE AND NON-ACTIVE MEDICAL IMPLANTS, NAMELY, MEDICAL IMPLANTS COMPRISED OF ARTIFICIAL MATERIAL; MEDICAL AND SURGICAL APPARATUS, INSTRUMENTS AND DEVICES INTENDED FOR USE INSIDE THE MAMMAL OR HUMAN BODY, IN PARTICULAR MANUAL, ELECTRICAL OR A COMBINATION OF MANUAL AND ELECTRICAL APPARATUS, DEVICES AND INSTRUMENTS, IN ALL GOODS INCLUDING MEDICAL HYDRAULIC, MECHANICAL, AND PNEUMATIC APPARATUS, DEVICES AND INSTRUMENTS, NAMELY, MEDICAL IMPLANTS COMPRISED OF ARTIFICIAL MATERIAL; MEDICAL AND SURGICAL APPARATUS, INSTRUMENTS AND DEVICES FOR REPLACING AND ADDING ONE OR MORE BODILY



FUNCTIONS AND PARTS INSIDE THE BODY, NAMELY, MEDICAL IMPLANTS COMPRISED OF ARTIFICIAL MATERIAL; MEDICAL AND SURGICAL APPARATUS, INSTRUMENTS AND DEVICES DESIGNED FOR WIRELESS PROGRAMMING, WIRELESS CONTROLLING, WIRELESS COMMUNICATING AND WIRELESS ENERGIZING, NAMELY, ACTIVE IMPLANTS IN THE NATURE OF IMPLANTS CONSISTING OF ARTIFICIAL MATERIALS, AND A WIRELESS TRANSMITTER AND A RECEIVER AS AN INTEGRAL COMPONENT OF A SURGICAL IMPLANT; WIRELESS COMMUNICATION SYSTEMS, APPARATUS, DEVICES, AND INSTRUMENTS AND WIRELESS ENERGIZING SYSTEMS, APPARATUS, DEVICES, AND INSTRUMENTS FOR MEASURING, RECEIVING, SENDING, SWITCHING, TRANSFORMING, ACCUMULATING, REGULATING, STORING, CHECKING, CONTROLLING, DRIVING, TRANSFERRING, TRANSMITTING, PROCESSING AND ANALYZING, IN ALL THE APPLICABLE AFOREMENTIONED GOODS, OF DATA INCLUDING PHYSICAL PARAMETERS, ELECTRICITY, ENERGY AND DATA, NAMELY, ELECTRONIC TRANSMITTERS FOR COMMUNICATING WITH, AND ENERGIZING OF, AND USED IN DIRECT ASSOCIATION WITH, ACTIVE MEDICAL IMPLANTS CONSISTING OF ARTIFICIAL MATERIALS; SURGICAL INSTRUMENTS IN PARTICULAR TO BE USED DURING OPERATIONS OF ACTIVE OR NON-ACTIVE MEDICAL IMPLANTS; VETERINARY MEDICAL AND SURGICAL APPARATUS, INSTRUMENTS AND DEVICES, FOR USE IN IMPLANT SURGERIES; MEDICAL AND SURGICAL APPARATUS, INSTRUMENTS AND DEVICES FOR ORTHOPAEDIC JOINT IMPLANTS; AND MEDICAL IMPLANTS FOR COLLECTING, RECEIVING, SENDING, STORING, PREPARING, CONTROLLING, ANALYZING AND PROCESSING OF DATA AND ENERGY TO AND FROM SAID MEDICAL IMPLANTS (U.S. CLS. 26, 39 AND 44).

#### **CLASS 44—MEDICAL, BEAUTY AND AGRICULTURAL SERVICES**

FOR MEDICAL SERVICES IN RELATION TO MEDICAL IMPLANTS FOR COLLECTING, SENDING, RECEIVING, STORING, PREPARING, CONTROLLING, PRESENTING, CALCULATING, ANALYZING AND PROCESSING OF DATA TO AND FROM PATIENTS AND TO AND FROM MEDICAL IMPLANTS AND TO AND FROM REMOTE CONTROLS, WIRELESS CHARGER APPARATUS AND CONTROL STATIONS FOR ACTIVE IMPLANTS; SURGICAL AND HEALTH SERVICES, NAMELY, IMPLANTATION OF ARTIFICIAL IMPLANTS TO ALLOW THE IMPLANTS TO COLLECT, SEND, RECEIVE, STORE, PREPARE, CONTROL, PRESENT, CALCULATE, ANALYZE, AND PROCESS OF DATA TO AND FROM PATIENTS AND TO AND FROM MEDICAL IMPLANTS AND TO AND FROM MEDICAL IMPLANTS AND TO AND FROM REMOTE CONTROLS, WIRELESS CHARGER APPARATUS AND CONTROL STATIONS FOR ACTIVE IMPLANTS; PROVIDING A MEDICAL, SURGICAL AND HEALTH DATABASE FEATURING MEDICAL, SURGICAL AND HEALTH INFORMATION RELATING TO MEDICAL IMPLANTS THAT HAS BEEN INPUT, COLLECTED, RECEIVED, PREPARED, CONTROLLED, PROGRAMMED, CALCULATED, AND ANALYZED, FROM MEDICAL IMPLANTS, REMOTE CONTROLS OR CONTROL STATIONS FOR USE BY MEDICAL, SURGICAL AND HEALTH PROFESSIONALS FOR THE PURPOSES OF MONITORING AND DIAGNOSING MEDICAL CONDITIONS; MEDICAL AND SURGICAL SERVICES, NAMELY, IMPLANTATION OF ARTIFICIAL IMPLANTS IN RELATION TO MEDICAL IMPLANTS FOR PROGRAMMING, CONTROLLING, COMMUNICATING WITH, AND ENERGIZING OF, ACTIVE IMPLANTS; AND MEDICAL AND SURGICAL SERVICES, NAMELY, ARTIFICIAL IMPLANTATION SERVICES FOR PERSONS HAVING A MEDICAL RELATED CONDITION AND BEING CANDIDATES FOR OR BEING OPERATED ON WITH AN ACTIVE OR A NON-ACTIVE IMPLANT (U.S. CLS. 100 AND 101).

ALEX KEAM, EXAMINING ATTORNEY

SN 77-855,677. MILUX HOLDING S.A., LUXEMBOURG, LUXEMBOURG, FILED 10-23-2009.

# ARTHRITICA

THE MARK CONSISTS OF STANDARD CHARACTERS WITHOUT CLAIM TO ANY PARTICULAR FONT, STYLE, SIZE, OR COLOR.

PRIORITY CLAIMED UNDER SEC. 44(D) ON ERP N CMNTY TM OFC APPLICATION NO. 008245491, FILED 4-27-2009, REG. NO. 008245491, DATED 1-27-2010, EXPIRES 4-27-2019.

#### **CLASS 9—ELECTRICAL AND SCIENTIFIC APPARATUS**

FOR APPARATUS, DEVICES AND INSTRUMENTS, ALL NOT USED IN DIRECT ASSOCIATION WITH ACTIVE IMPLANTS, FOR MEASURING, RECEIVING, SENDING, CHECKING, CONTROLLING, DRIVING, TRANSFERRING, TRANSMITTING, PROCESSING, ANALYZING, CONDUCTING, SWITCHING, TRANSFORMING, ACCUMULATING, AND REGULATING ELECTRICITY, ENERGY AND/OR DATA, INCLUDING PHYSICAL PARAMETERS, NAMELY, ELECTRONIC STORAGE DEVICES IN THE NATURE OF BLANK MEMORY DISCS, MEMORY CARDS AND DATA STORAGE MEDIA, NAMELY, PACKAGED SEMICONDUCTORS, ELECTRONIC CONTROL UNIT AND PROGRAMMER WHICH CONTROLS THE WORKING PARAMETERS OF WIRELESS COMMUNICATION SYSTEMS AND WIRELESS POWERING SYSTEMS, CHARGERS IN THE NATURE OF BATTERY CHARGERS, DIGITAL CHARGERS AND ELECTRONIC CHARGERS, ELECTRONIC TRANSMITTERS AND ELECTRONIC RECEIVERS OF ELECTRONIC SIGNALS, AND ELECTRONIC CIRCUITS; REMOTE CONTROLS FOR WIRELESS CONTROLLING, AND PROGRAMMING WIRELESS CHARGER APPARATUS FOR WIRELESS ENERGIZING AND CONTROL STATIONS FOR WIRELESS CONTROLLING, PROGRAMMING AND ENERGIZING OF ACTIVE IMPLANTS; SOFTWARE, IN PARTICULAR FOR ACTIVE MEDICAL IMPLANTS, FOR MEASURING, RECEIVING, SENDING, CHECKING, TRANSFERRING, CALCULATING, PROCESSING, CONTROLLING, PRESENTING AND ANALYZING OF DATA, NAMELY, DATA ABOUT ELECTRICITY, ENERGY, PHYSICAL PARAMETERS, AND COMMUNICATION AND PROGRAMMING DATA IN MEDICAL IMPLANTS; SOFTWARE, IN PARTICULAR FOR MEASURING, RECEIVING, SENDING, CHECKING, TRANSFERRING, CALCULATING, PROCESSING, CONTROLLING, PRESENTING AND ANALYZING OF DATA, NAMELY, DATA ABOUT ELECTRICITY, ENERGY, PHYSICAL PARAMETERS, COMMUNICATION AND PROGRAMMING DATA IN APPARATUS, DEVICES AND INSTRUMENTS FOR COMMUNICATING WITH, ENERGIZING AND PROGRAMMING OF MEDICAL IMPLANTS; AND DATA PROCESSING EQUIPMENT AND COMPUTERS (U.S. CLS. 21, 23, 26, 36 AND 38).

#### **CLASS 10—MEDICAL APPARATUS**

FOR MEDICAL AND SURGICAL APPARATUS, INSTRUMENTS AND DEVICES, INCLUDING ACTIVE AND NON-ACTIVE MEDICAL IMPLANTS, NAMELY, MEDICAL IMPLANTS COMPRISED OF ARTIFICIAL MATERIAL; MEDICAL AND SURGICAL APPARATUS, INSTRUMENTS AND DEVICES INTENDED FOR USE INSIDE THE MAMMAL OR HUMAN BODY, IN PARTICULAR MANUAL, ELECTRICAL OR A COMBINATION OF MANUAL AND ELECTRICAL APPARATUS, DEVICES AND INSTRUMENTS, IN ALL GOODS INCLUDING MEDICAL HYDRAULIC, MECHANICAL, AND PNEUMATIC APPARATUS, DEVICES AND INSTRUMENTS, NAMELY, MEDICAL IMPLANTS COMPRISED OF ARTIFICIAL MATERIAL; MEDICAL AND SURGICAL APPARATUS, INSTRUMENTS AND DEVICES FOR REPLACING AND ADDING ONE OR MORE BODILY

FUNCTIONS AND PARTS INSIDE THE BODY, NAMELY, MEDICAL IMPLANTS COMPRISED OF ARTIFICIAL MATERIAL; MEDICAL AND SURGICAL APPARATUS, INSTRUMENTS AND DEVICES DESIGNED FOR WIRELESS PROGRAMMING, WIRELESS CONTROLLING, WIRELESS COMMUNICATING AND WIRELESS ENERGIZING, NAMELY, ACTIVE IMPLANTS IN THE NATURE OF IMPLANTS CONSISTING OF ARTIFICIAL MATERIALS, AND A WIRELESS TRANSMITTER AND A RECEIVER AS AN INTEGRAL COMPONENT OF A SURGICAL IMPLANT; WIRELESS COMMUNICATION SYSTEMS, APPARATUS, DEVICES, AND INSTRUMENTS AND WIRELESS ENERGIZING SYSTEMS, APPARATUS, DEVICES, AND INSTRUMENTS FOR MEASURING, RECEIVING, SENDING, SWITCHING, TRANSFORMING, ACCUMULATING, REGULATING, STORING, CHECKING, CONTROLLING, DRIVING, TRANSFERRING, TRANSMITTING, PROCESSING AND ANALYZING, IN ALL THE APPLICABLE AFOREMENTIONED GOODS, OF DATA INCLUDING PHYSICAL PARAMETERS, ELECTRICITY, ENERGY AND DATA, NAMELY, ELECTRONIC TRANSMITTERS FOR COMMUNICATING WITH, AND ENERGIZING OF, AND USED IN DIRECT ASSOCIATION WITH, ACTIVE MEDICAL IMPLANTS CONSISTING OF ARTIFICIAL MATERIALS; SURGICAL INSTRUMENTS IN PARTICULAR TO BE USED DURING OPERATIONS OF ACTIVE OR NON-ACTIVE MEDICAL IMPLANTS; VETERINARY MEDICAL AND SURGICAL APPARATUS, INSTRUMENTS AND DEVICES, FOR USE IN IMPLANT SURGERIES; MEDICAL AND SURGICAL APPARATUS, INSTRUMENTS AND DEVICES FOR ORTHOPAEDIC JOINT IMPLANTS; AND MEDICAL IMPLANTS FOR COLLECTING, RECEIVING, SENDING, STORING, PREPARING, CONTROLLING, ANALYZING AND PROCESSING OF DATA AND ENERGY TO AND FROM SAID MEDICAL IMPLANTS (U.S. CLS. 26, 39 AND 44).

#### **CLASS 44—MEDICAL, BEAUTY AND AGRICULTURAL SERVICES**

FOR MEDICAL SERVICES IN RELATION TO MEDICAL IMPLANTS FOR COLLECTING, SENDING, RECEIVING, STORING, PREPARING, CONTROLLING, PRESENTING, CALCULATING, ANALYZING AND PROCESSING OF DATA TO AND FROM PATIENTS AND TO AND FROM MEDICAL IMPLANTS AND TO AND FROM REMOTE CONTROLS, WIRELESS CHARGER APPARATUS AND CONTROL STATIONS FOR ACTIVE IMPLANTS; SURGICAL AND HEALTH SERVICES, NAMELY, IMPLANTATION OF ARTIFICIAL IMPLANTS TO ALLOW THE IMPLANTS TO COLLECT, SEND, RECEIVE, STORE, PREPARE, CONTROL, PRESENT, CALCULATE, ANALYZE, AND PROCESS OF DATA TO AND FROM PATIENTS AND TO AND FROM MEDICAL IMPLANTS AND TO AND FROM MEDICAL IMPLANTS AND TO AND FROM REMOTE CONTROLS, WIRELESS CHARGER APPARATUS AND CONTROL STATIONS FOR ACTIVE IMPLANTS; PROVIDING A MEDICAL, SURGICAL AND HEALTH DATABASE FEATURING MEDICAL, SURGICAL AND HEALTH INFORMATION RELATING TO MEDICAL IMPLANTS THAT HAS BEEN INPUT, COLLECTED, RECEIVED, PREPARED, CONTROLLED, PROGRAMMED, CALCULATED, AND ANALYZED, FROM MEDICAL IMPLANTS, REMOTE CONTROLS OR CONTROL STATIONS FOR USE BY MEDICAL, SURGICAL AND HEALTH PROFESSIONALS FOR THE PURPOSES OF MONITORING AND DIAGNOSING MEDICAL CONDITIONS; MEDICAL AND SURGICAL SERVICES, NAMELY, IMPLANTATION OF ARTIFICIAL IMPLANTS IN RELATION TO MEDICAL IMPLANTS FOR PROGRAMMING, CONTROLLING, COMMUNICATING WITH, AND ENERGIZING OF, ACTIVE IMPLANTS; AND MEDICAL AND SURGICAL SERVICES, NAMELY, ARTIFICIAL IMPLANTATION SERVICES FOR PERSONS HAVING A MEDICAL RELATED CONDITION AND BEING CANDIDATES FOR OR BEING OPERATED ON WITH AN ACTIVE OR A NON-ACTIVE IMPLANT (U.S. CLS. 100 AND 101).

ALEX KEAM, EXAMINING ATTORNEY

SN 77-855.691. MILUX HOLDING S.A., LUXEMBOURG, LUXEMBOURG, FILED 10-23-2009.

## **AUGMENTICA**

THE MARK CONSISTS OF STANDARD CHARACTERS WITHOUT CLAIM TO ANY PARTICULAR FONT, STYLE, SIZE, OR COLOR.

PRIORITY CLAIMED UNDER SEC. 44(D) ON ERPNCMNTY TM OFC APPLICATION NO. 008245565, FILED 4-27-2009, REG. NO. 008245565, DATED 1-27-2010, EXPIRES 4-27-2019.

#### **CLASS 9—ELECTRICAL AND SCIENTIFIC APPARATUS**

FOR APPARATUS, DEVICES AND INSTRUMENTS, ALL NOT USED IN DIRECT ASSOCIATION WITH ACTIVE IMPLANTS, FOR MEASURING, RECEIVING, SENDING, CHECKING, CONTROLLING, DRIVING, TRANSFERRING, TRANSMITTING, PROCESSING, ANALYZING, CONDUCTING, SWITCHING, TRANSFORMING, ACCUMULATING, AND REGULATING ELECTRICITY, ENERGY AND/OR DATA, INCLUDING PHYSICAL PARAMETERS, NAMELY, ELECTRONIC STORAGE DEVICES IN THE NATURE OF BLANK MEMORY DISCS, MEMORY CARDS AND DATA STORAGE MEDIA, NAMELY, PACKAGED SEMICONDUCTORS, ELECTRONIC CONTROL UNIT AND PROGRAMMER WHICH CONTROLS THE WORKING PARAMETERS OF WIRELESS COMMUNICATION SYSTEMS AND WIRELESS POWERING SYSTEMS, CHARGERS IN THE NATURE OF BATTERY CHARGERS, DIGITAL CHARGERS AND ELECTRONIC CHARGERS, ELECTRONIC TRANSMITTERS AND ELECTRONIC RECEIVERS OF ELECTRONIC SIGNALS, AND ELECTRONIC CIRCUITS; REMOTE CONTROLS FOR WIRELESS CONTROLLING, AND PROGRAMMING WIRELESS CHARGER APPARATUS FOR WIRELESS ENERGIZING AND CONTROL STATIONS FOR WIRELESS CONTROLLING, PROGRAMMING AND ENERGIZING OF ACTIVE IMPLANTS; SOFTWARE, IN PARTICULAR FOR ACTIVE MEDICAL IMPLANTS, FOR MEASURING, RECEIVING, SENDING, CHECKING, TRANSFERRING, CALCULATING, PROCESSING, CONTROLLING, PRESENTING AND ANALYZING OF DATA, NAMELY, DATA ABOUT ELECTRICITY, ENERGY, PHYSICAL PARAMETERS, AND COMMUNICATION AND PROGRAMMING DATA IN MEDICAL IMPLANTS; SOFTWARE, IN PARTICULAR FOR MEASURING, RECEIVING, SENDING, CHECKING, TRANSFERRING, CALCULATING, PROCESSING, CONTROLLING, PRESENTING AND ANALYZING OF DATA, NAMELY, DATA ABOUT ELECTRICITY, ENERGY, PHYSICAL PARAMETERS, COMMUNICATION AND PROGRAMMING DATA IN APPARATUS, DEVICES AND INSTRUMENTS FOR COMMUNICATING WITH, ENERGIZING AND PROGRAMMING OF MEDICAL IMPLANTS; AND DATA PROCESSING EQUIPMENT AND COMPUTERS (U.S. CLS. 21, 23, 26, 36 AND 38).

#### **CLASS 10—MEDICAL APPARATUS**

FOR MEDICAL AND SURGICAL APPARATUS, INSTRUMENTS AND DEVICES, INCLUDING ACTIVE AND NON-ACTIVE MEDICAL IMPLANTS, NAMELY, MEDICAL IMPLANTS COMPRISED OF ARTIFICIAL MATERIAL; MEDICAL AND SURGICAL APPARATUS, INSTRUMENTS AND DEVICES INTENDED FOR USE INSIDE THE MAMMAL OR HUMAN BODY, IN PARTICULAR MANUAL, ELECTRICAL OR A COMBINATION OF MANUAL AND ELECTRICAL APPARATUS, DEVICES AND INSTRUMENTS, IN ALL GOODS INCLUDING MEDICAL HYDRAULIC, MECHANICAL, AND PNEUMATIC APPARATUS, DEVICES AND INSTRUMENTS, NAMELY, MEDICAL IMPLANTS COMPRISED OF ARTIFICIAL MATERIAL; MEDICAL AND SURGICAL APPARATUS, INSTRUMENTS AND DEVICES FOR REPLACING AND ADDING ONE OR MORE BODILY

FUNCTIONS AND PARTS INSIDE THE BODY, NAMELY, MEDICAL IMPLANTS COMPRISED OF ARTIFICIAL MATERIAL; MEDICAL AND SURGICAL APPARATUS, INSTRUMENTS AND DEVICES DESIGNED FOR WIRELESS PROGRAMMING, WIRELESS CONTROLLING, WIRELESS COMMUNICATING AND WIRELESS ENERGIZING, NAMELY, ACTIVE IMPLANTS IN THE NATURE OF IMPLANTS CONSISTING OF ARTIFICIAL MATERIALS, AND A WIRELESS TRANSMITTER AND A RECEIVER AS AN INTEGRAL COMPONENT OF A SURGICAL IMPLANT; WIRELESS COMMUNICATION SYSTEMS, APPARATUS, DEVICES, AND INSTRUMENTS AND WIRELESS ENERGIZING SYSTEMS, APPARATUS, DEVICES, AND INSTRUMENTS FOR MEASURING, RECEIVING, SENDING, SWITCHING, TRANSFORMING, ACCUMULATING, REGULATING, STORING, CHECKING, CONTROLLING, DRIVING, TRANSFERRING, TRANSMITTING, PROCESSING AND ANALYZING, IN ALL THE APPLICABLE AFOREMENTIONED GOODS, OF DATA INCLUDING PHYSICAL PARAMETERS, ELECTRICITY, ENERGY AND DATA, NAMELY, ELECTRONIC TRANSMITTERS FOR COMMUNICATING WITH, AND ENERGIZING OF, AND USED IN DIRECT ASSOCIATION WITH, ACTIVE MEDICAL IMPLANTS CONSISTING OF ARTIFICIAL MATERIALS; SURGICAL INSTRUMENTS IN PARTICULAR TO BE USED DURING OPERATIONS OF ACTIVE OR NON-ACTIVE MEDICAL IMPLANTS; VETERINARY MEDICAL AND SURGICAL APPARATUS, INSTRUMENTS AND DEVICES, FOR USE IN IMPLANT SURGERIES; MEDICAL AND SURGICAL APPARATUS, INSTRUMENTS AND DEVICES FOR ORTHOPAEDIC JOINT IMPLANTS; AND MEDICAL IMPLANTS FOR COLLECTING, RECEIVING, SENDING, STORING, PREPARING, CONTROLLING, ANALYZING AND PROCESSING OF DATA AND ENERGY TO AND FROM SAID MEDICAL IMPLANTS (U.S. CLS. 26, 39 AND 44).

#### **CLASS 44—MEDICAL, BEAUTY AND AGRICULTURAL SERVICES**

FOR MEDICAL SERVICES IN RELATION TO MEDICAL IMPLANTS FOR COLLECTING, SENDING, RECEIVING, STORING, PREPARING, CONTROLLING, PRESENTING, CALCULATING, ANALYZING AND PROCESSING OF DATA TO AND FROM PATIENTS AND TO AND FROM MEDICAL IMPLANTS AND TO AND FROM REMOTE CONTROLS, WIRELESS CHARGER APPARATUS AND CONTROL STATIONS FOR ACTIVE IMPLANTS; SURGICAL AND HEALTH SERVICES, NAMELY, IMPLANTATION OF ARTIFICIAL IMPLANTS TO ALLOW THE IMPLANTS TO COLLECT, SEND, RECEIVE, STORE, PREPARE, CONTROL, PRESENT, CALCULATE, ANALYZE, AND PROCESS OF DATA TO AND FROM PATIENTS AND TO AND FROM MEDICAL IMPLANTS AND TO AND FROM MEDICAL IMPLANTS AND TO AND FROM REMOTE CONTROLS, WIRELESS CHARGER APPARATUS AND CONTROL STATIONS FOR ACTIVE IMPLANTS; PROVIDING A MEDICAL, SURGICAL AND HEALTH DATABASE FEATURING MEDICAL, SURGICAL AND HEALTH INFORMATION RELATING TO MEDICAL IMPLANTS THAT HAS BEEN INPUT, COLLECTED, RECEIVED, PREPARED, CONTROLLED, PROGRAMMED, CALCULATED, AND ANALYZED, FROM MEDICAL IMPLANTS, REMOTE CONTROLS OR CONTROL STATIONS FOR USE BY MEDICAL, SURGICAL AND HEALTH PROFESSIONALS FOR THE PURPOSES OF MONITORING AND DIAGNOSING MEDICAL CONDITIONS; MEDICAL AND SURGICAL SERVICES, NAMELY, IMPLANTATION OF ARTIFICIAL IMPLANTS IN RELATION TO MEDICAL IMPLANTS FOR PROGRAMMING, CONTROLLING, COMMUNICATING WITH, AND ENERGIZING OF, ACTIVE IMPLANTS; AND MEDICAL AND SURGICAL SERVICES, NAMELY, ARTIFICIAL IMPLANTATION SERVICES FOR PERSONS HAVING A MEDICAL RELATED CONDITION AND BEING CANDIDATES FOR OR BEING OPERATED ON WITH AN ACTIVE OR A NON-ACTIVE IMPLANT (U.S. CLS. 100 AND 101).

ALEX KEAM, EXAMINING ATTORNEY

SN 77-855,701. MILUX HOLDING S.A., LUXEMBOURG, LUXEMBOURG, FILED 10-23-2009.

# CARDIUS

THE MARK CONSISTS OF STANDARD CHARACTERS WITHOUT CLAIM TO ANY PARTICULAR FONT, STYLE, SIZE, OR COLOR.

PRIORITY CLAIMED UNDER SEC. 44(D) ON ERP N CMNTY TM OFC APPLICATION NO. 008245623, FILED 4-27-2009, REG. NO. 008245623, DATED 4-26-2010, EXPIRES 4-27-2019.

#### **CLASS 9—ELECTRICAL AND SCIENTIFIC APPARATUS**

FOR APPARATUS, DEVICES AND INSTRUMENTS, ALL NOT USED IN DIRECT ASSOCIATION WITH ACTIVE IMPLANTS, FOR MEASURING, RECEIVING, SENDING, CHECKING, CONTROLLING, DRIVING, TRANSFERRING, TRANSMITTING, PROCESSING, ANALYZING, CONDUCTING, SWITCHING, TRANSFORMING, ACCUMULATING, AND REGULATING ELECTRICITY, ENERGY AND/OR DATA, INCLUDING PHYSICAL PARAMETERS, NAMELY, ELECTRONIC STORAGE DEVICES IN THE NATURE OF BLANK MEMORY DISCS, MEMORY CARDS AND DATA STORAGE MEDIA, NAMELY, PACKAGED SEMICONDUCTORS, ELECTRONIC CONTROL UNIT AND PROGRAMMER WHICH CONTROLS THE WORKING PARAMETERS OF WIRELESS COMMUNICATION SYSTEMS AND WIRELESS POWERING SYSTEMS, CHARGERS IN THE NATURE OF BATTERY CHARGERS, DIGITAL CHARGERS AND ELECTRONIC CHARGERS, ELECTRONIC TRANSMITTERS AND ELECTRONIC RECEIVERS OF ELECTRONIC SIGNALS, AND ELECTRONIC CIRCUITS; REMOTE CONTROLS FOR WIRELESS CONTROLLING, AND PROGRAMMING WIRELESS CHARGER APPARATUS FOR WIRELESS ENERGIZING AND CONTROL STATIONS FOR WIRELESS CONTROLLING, PROGRAMMING AND ENERGIZING OF ACTIVE IMPLANTS; SOFTWARE, IN PARTICULAR FOR ACTIVE MEDICAL IMPLANTS, FOR MEASURING, RECEIVING, SENDING, CHECKING, TRANSFERRING, CALCULATING, PROCESSING, CONTROLLING, PRESENTING AND ANALYZING OF DATA, NAMELY, DATA ABOUT ELECTRICITY, ENERGY, PHYSICAL PARAMETERS, AND COMMUNICATION AND PROGRAMMING DATA IN MEDICAL IMPLANTS; SOFTWARE, IN PARTICULAR FOR MEASURING, RECEIVING, SENDING, CHECKING, TRANSFERRING, CALCULATING, PROCESSING, CONTROLLING, PRESENTING AND ANALYZING OF DATA, NAMELY, DATA ABOUT ELECTRICITY, ENERGY, PHYSICAL PARAMETERS, COMMUNICATION AND PROGRAMMING DATA IN APPARATUS, DEVICES AND INSTRUMENTS FOR COMMUNICATING WITH, ENERGIZING AND PROGRAMMING OF MEDICAL IMPLANTS; AND DATA PROCESSING EQUIPMENT AND COMPUTERS (U.S. CLS. 21, 23, 26, 36 AND 38).

#### **CLASS 10—MEDICAL APPARATUS**

FOR MEDICAL AND SURGICAL APPARATUS, INSTRUMENTS AND DEVICES, INCLUDING ACTIVE AND NON-ACTIVE MEDICAL IMPLANTS, NAMELY, MEDICAL IMPLANTS COMPRISED OF ARTIFICIAL MATERIAL; MEDICAL AND SURGICAL APPARATUS, INSTRUMENTS AND DEVICES INTENDED FOR USE INSIDE THE MAMMAL OR HUMAN BODY, IN PARTICULAR MANUAL, ELECTRICAL OR A COMBINATION OF MANUAL AND ELECTRICAL APPARATUS, DEVICES AND INSTRUMENTS, IN ALL GOODS INCLUDING MEDICAL HYDRAULIC, MECHANICAL, AND PNEUMATIC APPARATUS, DEVICES AND INSTRUMENTS, NAMELY, MEDICAL IMPLANTS COMPRISED OF ARTIFICIAL MATERIAL; MEDICAL AND SURGICAL APPARATUS, INSTRUMENTS AND DEVICES FOR REPLACING AND ADDING ONE OR MORE BODILY



FUNCTIONS AND PARTS INSIDE THE BODY, NAMELY, MEDICAL IMPLANTS COMPRISED OF ARTIFICIAL MATERIAL; MEDICAL AND SURGICAL APPARATUS, INSTRUMENTS AND DEVICES DESIGNED FOR WIRELESS PROGRAMMING, WIRELESS CONTROLLING, WIRELESS COMMUNICATING AND WIRELESS ENERGIZING, NAMELY, ACTIVE IMPLANTS IN THE NATURE OF IMPLANTS CONSISTING OF ARTIFICIAL MATERIALS, AND A WIRELESS TRANSMITTER AND A RECEIVER AS AN INTEGRAL COMPONENT OF A SURGICAL IMPLANT; WIRELESS COMMUNICATION SYSTEMS, APPARATUS, DEVICES, AND INSTRUMENTS AND WIRELESS ENERGIZING SYSTEMS, APPARATUS, DEVICES, AND INSTRUMENTS FOR MEASURING, RECEIVING, SENDING, SWITCHING, TRANSFORMING, ACCUMULATING, REGULATING, STORING, CHECKING, CONTROLLING, DRIVING, TRANSFERRING, TRANSMITTING, PROCESSING AND ANALYZING, IN ALL THE APPLICABLE AFOREMENTIONED GOODS, OF DATA INCLUDING PHYSICAL PARAMETERS, ELECTRICITY, ENERGY AND DATA, NAMELY, ELECTRONIC TRANSMITTERS FOR COMMUNICATING WITH, AND ENERGIZING OF, AND USED IN DIRECT ASSOCIATION WITH, ACTIVE MEDICAL IMPLANTS CONSISTING OF ARTIFICIAL MATERIALS; SURGICAL INSTRUMENTS IN PARTICULAR TO BE USED DURING OPERATIONS OF ACTIVE OR NON-ACTIVE MEDICAL IMPLANTS; VETERINARY MEDICAL AND SURGICAL APPARATUS, INSTRUMENTS AND DEVICES, FOR USE IN IMPLANT SURGERIES; MEDICAL AND SURGICAL APPARATUS, INSTRUMENTS AND DEVICES FOR ORTHOPAEDIC JOINT IMPLANTS; AND MEDICAL IMPLANTS FOR COLLECTING, RECEIVING, SENDING, STORING, PREPARING, CONTROLLING, ANALYZING AND PROCESSING OF DATA AND ENERGY TO AND FROM SAID MEDICAL IMPLANTS (U.S. CLS. 26, 39 AND 44).

#### **CLASS 44—MEDICAL, BEAUTY AND AGRICULTURAL SERVICES**

FOR MEDICAL SERVICES IN RELATION TO MEDICAL IMPLANTS FOR COLLECTING, SENDING, RECEIVING, STORING, PREPARING, CONTROLLING, PRESENTING, CALCULATING, ANALYZING AND PROCESSING OF DATA TO AND FROM PATIENTS AND TO AND FROM MEDICAL IMPLANTS AND TO AND FROM REMOTE CONTROLS, WIRELESS CHARGER APPARATUS AND CONTROL STATIONS FOR ACTIVE IMPLANTS; SURGICAL AND HEALTH SERVICES, NAMELY, IMPLANTATION OF ARTIFICIAL IMPLANTS TO ALLOW THE IMPLANTS TO COLLECT, SEND, RECEIVE, STORE, PREPARE, CONTROL, PRESENT, CALCULATE, ANALYZE, AND PROCESS OF DATA TO AND FROM PATIENTS AND TO AND FROM MEDICAL IMPLANTS AND TO AND FROM MEDICAL IMPLANTS AND TO AND FROM REMOTE CONTROLS, WIRELESS CHARGER APPARATUS AND CONTROL STATIONS FOR ACTIVE IMPLANTS; PROVIDING A MEDICAL, SURGICAL AND HEALTH DATABASE FEATURING MEDICAL, SURGICAL AND HEALTH INFORMATION RELATING TO MEDICAL IMPLANTS THAT HAS BEEN INPUT, COLLECTED, RECEIVED, PREPARED, CONTROLLED, PROGRAMMED, CALCULATED, AND ANALYZED, FROM MEDICAL IMPLANTS, REMOTE CONTROLS OR CONTROL STATIONS FOR USE BY MEDICAL, SURGICAL AND HEALTH PROFESSIONALS FOR THE PURPOSES OF MONITORING AND DIAGNOSING MEDICAL CONDITIONS; MEDICAL AND SURGICAL SERVICES, NAMELY, IMPLANTATION OF ARTIFICIAL IMPLANTS IN RELATION TO MEDICAL IMPLANTS FOR PROGRAMMING, CONTROLLING, COMMUNICATING WITH, AND ENERGIZING OF, ACTIVE IMPLANTS; AND MEDICAL AND SURGICAL SERVICES, NAMELY, ARTIFICIAL IMPLANTATION SERVICES FOR PERSONS HAVING A MEDICAL RELATED CONDITION AND BEING CANDIDATES FOR OR BEING OPERATED ON WITH AN ACTIVE OR A NON-ACTIVE IMPLANT (U.S. CLS. 100 AND 101).

ALEX KEAM, EXAMINING ATTORNEY

SN 77-855.740. MILUX HOLDING S.A., LUXEMBOURG, LUXEMBOURG, FILED 10-23-2009.

# CEPHALICA

THE MARK CONSISTS OF STANDARD CHARACTERS WITHOUT CLAIM TO ANY PARTICULAR FONT, STYLE, SIZE, OR COLOR.

PRIORITY CLAIMED UNDER SEC. 44(D) ON ERPNCMNTY TM OFC APPLICATION NO. 008245656, FILED 4-27-2009, REG. NO. 008245656, DATED 1-27-2010, EXPIRES 4-27-2019.

#### **CLASS 9—ELECTRICAL AND SCIENTIFIC APPARATUS**

FOR APPARATUS, DEVICES AND INSTRUMENTS, ALL NOT USED IN DIRECT ASSOCIATION WITH ACTIVE IMPLANTS, FOR MEASURING, RECEIVING, SENDING, CHECKING, CONTROLLING, DRIVING, TRANSFERRING, TRANSMITTING, PROCESSING, ANALYZING, CONDUCTING, SWITCHING, TRANSFORMING, ACCUMULATING, AND REGULATING ELECTRICITY, ENERGY AND/OR DATA, INCLUDING PHYSICAL PARAMETERS, NAMELY, ELECTRONIC STORAGE DEVICES IN THE NATURE OF BLANK MEMORY DISCS, MEMORY CARDS AND DATA STORAGE MEDIA, NAMELY, PACKAGED SEMICONDUCTORS, ELECTRONIC CONTROL UNIT AND PROGRAMMER WHICH CONTROLS THE WORKING PARAMETERS OF WIRELESS COMMUNICATION SYSTEMS AND WIRELESS POWERING SYSTEMS, CHARGERS IN THE NATURE OF BATTERY CHARGERS, DIGITAL CHARGERS AND ELECTRONIC CHARGERS, ELECTRONIC TRANSMITTERS AND ELECTRONIC RECEIVERS OF ELECTRONIC SIGNALS, AND ELECTRONIC CIRCUITS; REMOTE CONTROLS FOR WIRELESS CONTROLLING, AND PROGRAMMING WIRELESS CHARGER APPARATUS FOR WIRELESS ENERGIZING AND CONTROL STATIONS FOR WIRELESS CONTROLLING, PROGRAMMING AND ENERGIZING OF ACTIVE IMPLANTS; SOFTWARE, IN PARTICULAR FOR ACTIVE MEDICAL IMPLANTS, FOR MEASURING, RECEIVING, SENDING, CHECKING, TRANSFERRING, CALCULATING, PROCESSING, CONTROLLING, PRESENTING AND ANALYZING OF DATA, NAMELY, DATA ABOUT ELECTRICITY, ENERGY, PHYSICAL PARAMETERS, AND COMMUNICATION AND PROGRAMMING DATA IN MEDICAL IMPLANTS; SOFTWARE, IN PARTICULAR FOR MEASURING, RECEIVING, SENDING, CHECKING, TRANSFERRING, CALCULATING, PROCESSING, CONTROLLING, PRESENTING AND ANALYZING OF DATA, NAMELY, DATA ABOUT ELECTRICITY, ENERGY, PHYSICAL PARAMETERS, COMMUNICATION AND PROGRAMMING DATA IN APPARATUS, DEVICES AND INSTRUMENTS FOR COMMUNICATING WITH, ENERGIZING AND PROGRAMMING OF MEDICAL IMPLANTS; AND DATA PROCESSING EQUIPMENT AND COMPUTERS (U.S. CLS. 21, 23, 26, 36 AND 38).

#### **CLASS 10—MEDICAL APPARATUS**

FOR MEDICAL AND SURGICAL APPARATUS, INSTRUMENTS AND DEVICES, INCLUDING ACTIVE AND NON-ACTIVE MEDICAL IMPLANTS, NAMELY, MEDICAL IMPLANTS COMPRISED OF ARTIFICIAL MATERIAL; MEDICAL AND SURGICAL APPARATUS, INSTRUMENTS AND DEVICES INTENDED FOR USE INSIDE THE MAMMAL OR HUMAN BODY, IN PARTICULAR MANUAL, ELECTRICAL OR A COMBINATION OF MANUAL AND ELECTRICAL APPARATUS, DEVICES AND INSTRUMENTS, IN ALL GOODS INCLUDING MEDICAL HYDRAULIC, MECHANICAL, AND PNEUMATIC APPARATUS, DEVICES AND INSTRUMENTS, NAMELY, MEDICAL IMPLANTS COMPRISED OF ARTIFICIAL MATERIAL; MEDICAL AND SURGICAL APPARATUS, INSTRUMENTS AND DEVICES FOR REPLACING AND ADDING ONE OR MORE BODILY



FUNCTIONS AND PARTS INSIDE THE BODY, NAMELY, MEDICAL IMPLANTS COMPRISED OF ARTIFICIAL MATERIAL; MEDICAL AND SURGICAL APPARATUS, INSTRUMENTS AND DEVICES DESIGNED FOR WIRELESS PROGRAMMING, WIRELESS CONTROLLING, WIRELESS COMMUNICATING AND WIRELESS ENERGIZING, NAMELY, ACTIVE IMPLANTS IN THE NATURE OF IMPLANTS CONSISTING OF ARTIFICIAL MATERIALS, AND A WIRELESS TRANSMITTER AND A RECEIVER AS AN INTEGRAL COMPONENT OF A SURGICAL IMPLANT; WIRELESS COMMUNICATION SYSTEMS, APPARATUS, DEVICES, AND INSTRUMENTS AND WIRELESS ENERGIZING SYSTEMS, APPARATUS, DEVICES, AND INSTRUMENTS FOR MEASURING, RECEIVING, SENDING, SWITCHING, TRANSFORMING, ACCUMULATING, REGULATING, STORING, CHECKING, CONTROLLING, DRIVING, TRANSFERRING, TRANSMITTING, PROCESSING AND ANALYZING, IN ALL THE APPLICABLE AFOREMENTIONED GOODS, OF DATA INCLUDING PHYSICAL PARAMETERS, ELECTRICITY, ENERGY AND DATA, NAMELY, ELECTRONIC TRANSMITTERS FOR COMMUNICATING WITH, AND ENERGIZING OF, AND USED IN DIRECT ASSOCIATION WITH, ACTIVE MEDICAL IMPLANTS CONSISTING OF ARTIFICIAL MATERIALS; SURGICAL INSTRUMENTS IN PARTICULAR TO BE USED DURING OPERATIONS OF ACTIVE OR NON-ACTIVE MEDICAL IMPLANTS; VETERINARY MEDICAL AND SURGICAL APPARATUS, INSTRUMENTS AND DEVICES, FOR USE IN IMPLANT SURGERIES; MEDICAL AND SURGICAL APPARATUS, INSTRUMENTS AND DEVICES FOR ORTHOPAEDIC JOINT IMPLANTS; AND MEDICAL IMPLANTS FOR COLLECTING, RECEIVING, SENDING, STORING, PREPARING, CONTROLLING, ANALYZING AND PROCESSING OF DATA AND ENERGY TO AND FROM SAID MEDICAL IMPLANTS (U.S. CLS. 26, 39 AND 44).

#### **CLASS 44—MEDICAL, BEAUTY AND AGRICULTURAL SERVICES**

FOR MEDICAL SERVICES IN RELATION TO MEDICAL IMPLANTS FOR COLLECTING, SENDING, RECEIVING, STORING, PREPARING, CONTROLLING, PRESENTING, CALCULATING, ANALYZING AND PROCESSING OF DATA TO AND FROM PATIENTS AND TO AND FROM MEDICAL IMPLANTS AND TO AND FROM REMOTE CONTROLS, WIRELESS CHARGER APPARATUS AND CONTROL STATIONS FOR ACTIVE IMPLANTS; SURGICAL AND HEALTH SERVICES, NAMELY, IMPLANTATION OF ARTIFICIAL IMPLANTS TO ALLOW THE IMPLANTS TO COLLECT, SEND, RECEIVE, STORE, PREPARE, CONTROL, PRESENT, CALCULATE, ANALYZE, AND PROCESS OF DATA TO AND FROM PATIENTS AND TO AND FROM MEDICAL IMPLANTS AND TO AND FROM MEDICAL IMPLANTS AND TO AND FROM REMOTE CONTROLS, WIRELESS CHARGER APPARATUS AND CONTROL STATIONS FOR ACTIVE IMPLANTS; PROVIDING A MEDICAL, SURGICAL AND HEALTH DATABASE FEATURING MEDICAL, SURGICAL AND HEALTH INFORMATION RELATING TO MEDICAL IMPLANTS THAT HAS BEEN INPUT, COLLECTED, RECEIVED, PREPARED, CONTROLLED, PROGRAMMED, CALCULATED, AND ANALYZED, FROM MEDICAL IMPLANTS, REMOTE CONTROLS OR CONTROL STATIONS FOR USE BY MEDICAL, SURGICAL AND HEALTH PROFESSIONALS FOR THE PURPOSES OF MONITORING AND DIAGNOSING MEDICAL CONDITIONS; MEDICAL AND SURGICAL SERVICES, NAMELY, IMPLANTATION OF ARTIFICIAL IMPLANTS IN RELATION TO MEDICAL IMPLANTS FOR PROGRAMMING, CONTROLLING, COMMUNICATING WITH, AND ENERGIZING OF, ACTIVE IMPLANTS; AND MEDICAL AND SURGICAL SERVICES, NAMELY, ARTIFICIAL IMPLANTATION SERVICES FOR PERSONS HAVING A MEDICAL RELATED CONDITION AND BEING CANDIDATES FOR OR BEING OPERATED ON WITH AN ACTIVE OR A NON-ACTIVE IMPLANT (U.S. CLS. 100 AND 101).

ALEX KEAM, EXAMINING ATTORNEY

SN 77-855,743. MILUX HOLDING S.A., LUXEMBOURG, LUXEMBOURG, FILED 10-23-2009.

# FERTILICA

THE MARK CONSISTS OF STANDARD CHARACTERS WITHOUT CLAIM TO ANY PARTICULAR FONT, STYLE, SIZE, OR COLOR.

PRIORITY CLAIMED UNDER SEC. 44(D) ON ERP N CMNTY TM OFC APPLICATION NO. 008245938, FILED 4-27-2009, REG. NO. 008245938, DATED 1-27-2010, EXPIRES 4-27-2019.

#### **CLASS 9—ELECTRICAL AND SCIENTIFIC APPARATUS**

FOR APPARATUS, DEVICES AND INSTRUMENTS, ALL NOT USED IN DIRECT ASSOCIATION WITH ACTIVE IMPLANTS, FOR MEASURING, RECEIVING, SENDING, CHECKING, CONTROLLING, DRIVING, TRANSFERRING, TRANSMITTING, PROCESSING, ANALYZING, CONDUCTING, SWITCHING, TRANSFORMING, ACCUMULATING, AND REGULATING ELECTRICITY, ENERGY AND/OR DATA, INCLUDING PHYSICAL PARAMETERS, NAMELY, ELECTRONIC STORAGE DEVICES IN THE NATURE OF BLANK MEMORY DISCS, MEMORY CARDS AND DATA STORAGE MEDIA, NAMELY, PACKAGED SEMICONDUCTORS, ELECTRONIC CONTROL UNIT AND PROGRAMMER WHICH CONTROLS THE WORKING PARAMETERS OF WIRELESS COMMUNICATION SYSTEMS AND WIRELESS POWERING SYSTEMS, CHARGERS IN THE NATURE OF BATTERY CHARGERS, DIGITAL CHARGERS AND ELECTRONIC CHARGERS, ELECTRONIC TRANSMITTERS AND ELECTRONIC RECEIVERS OF ELECTRONIC SIGNALS, AND ELECTRONIC CIRCUITS; REMOTE CONTROLS FOR WIRELESS CONTROLLING, AND PROGRAMMING WIRELESS CHARGER APPARATUS FOR WIRELESS ENERGIZING AND CONTROL STATIONS FOR WIRELESS CONTROLLING, PROGRAMMING AND ENERGIZING OF ACTIVE IMPLANTS; SOFTWARE, IN PARTICULAR FOR ACTIVE MEDICAL IMPLANTS, FOR MEASURING, RECEIVING, SENDING, CHECKING, TRANSFERRING, CALCULATING, PROCESSING, CONTROLLING, PRESENTING AND ANALYZING OF DATA, NAMELY, DATA ABOUT ELECTRICITY, ENERGY, PHYSICAL PARAMETERS, AND COMMUNICATION AND PROGRAMMING DATA IN MEDICAL IMPLANTS; SOFTWARE, IN PARTICULAR FOR MEASURING, RECEIVING, SENDING, CHECKING, TRANSFERRING, CALCULATING, PROCESSING, CONTROLLING, PRESENTING AND ANALYZING OF DATA, NAMELY, DATA ABOUT ELECTRICITY, ENERGY, PHYSICAL PARAMETERS, COMMUNICATION AND PROGRAMMING DATA IN APPARATUS, DEVICES AND INSTRUMENTS FOR COMMUNICATING WITH, ENERGIZING AND PROGRAMMING OF MEDICAL IMPLANTS; AND DATA PROCESSING EQUIPMENT AND COMPUTERS (U.S. CLS. 21, 23, 26, 36 AND 38).

#### **CLASS 10—MEDICAL APPARATUS**

FOR MEDICAL AND SURGICAL APPARATUS, INSTRUMENTS AND DEVICES, INCLUDING ACTIVE AND NON-ACTIVE MEDICAL IMPLANTS, NAMELY, MEDICAL IMPLANTS COMPRISED OF ARTIFICIAL MATERIAL; MEDICAL AND SURGICAL APPARATUS, INSTRUMENTS AND DEVICES INTENDED FOR USE INSIDE THE MAMMAL OR HUMAN BODY, IN PARTICULAR MANUAL, ELECTRICAL OR A COMBINATION OF MANUAL AND ELECTRICAL APPARATUS, DEVICES AND INSTRUMENTS, IN ALL GOODS INCLUDING MEDICAL HYDRAULIC, MECHANICAL, AND PNEUMATIC APPARATUS, DEVICES AND INSTRUMENTS, NAMELY, MEDICAL IMPLANTS COMPRISED OF ARTIFICIAL MATERIAL; MEDICAL AND SURGICAL APPARATUS, INSTRUMENTS AND DEVICES FOR REPLACING AND ADDING ONE OR MORE BODILY

FUNCTIONS AND PARTS INSIDE THE BODY, NAMELY, MEDICAL IMPLANTS COMPRISED OF ARTIFICIAL MATERIAL; MEDICAL AND SURGICAL APPARATUS, INSTRUMENTS AND DEVICES DESIGNED FOR WIRELESS PROGRAMMING, WIRELESS CONTROLLING, WIRELESS COMMUNICATING AND WIRELESS ENERGIZING, NAMELY, ACTIVE IMPLANTS IN THE NATURE OF IMPLANTS CONSISTING OF ARTIFICIAL MATERIALS, AND A WIRELESS TRANSMITTER AND A RECEIVER AS AN INTEGRAL COMPONENT OF A SURGICAL IMPLANT; WIRELESS COMMUNICATION SYSTEMS, APPARATUS, DEVICES, AND INSTRUMENTS AND WIRELESS ENERGIZING SYSTEMS, APPARATUS, DEVICES, AND INSTRUMENTS FOR MEASURING, RECEIVING, SENDING, SWITCHING, TRANSFORMING, ACCUMULATING, REGULATING, STORING, CHECKING, CONTROLLING, DRIVING, TRANSFERRING, TRANSMITTING, PROCESSING AND ANALYZING, IN ALL THE APPLICABLE AFOREMENTIONED GOODS, OF DATA INCLUDING PHYSICAL PARAMETERS, ELECTRICITY, ENERGY AND DATA, NAMELY, ELECTRONIC TRANSMITTERS FOR COMMUNICATING WITH, AND ENERGIZING OF, AND USED IN DIRECT ASSOCIATION WITH, ACTIVE MEDICAL IMPLANTS CONSISTING OF ARTIFICIAL MATERIALS; SURGICAL INSTRUMENTS IN PARTICULAR TO BE USED DURING OPERATIONS OF ACTIVE OR NON-ACTIVE MEDICAL IMPLANTS; VETERINARY MEDICAL AND SURGICAL APPARATUS, INSTRUMENTS AND DEVICES, FOR USE IN IMPLANT SURGERIES; MEDICAL AND SURGICAL APPARATUS, INSTRUMENTS AND DEVICES FOR ORTHOPAEDIC JOINT IMPLANTS; AND MEDICAL IMPLANTS FOR COLLECTING, RECEIVING, SENDING, STORING, PREPARING, CONTROLLING, ANALYZING AND PROCESSING OF DATA AND ENERGY TO AND FROM SAID MEDICAL IMPLANTS (U.S. CLS. 26, 39 AND 44).

#### **CLASS 44—MEDICAL, BEAUTY AND AGRICULTURAL SERVICES**

FOR MEDICAL SERVICES IN RELATION TO MEDICAL IMPLANTS FOR COLLECTING, SENDING, RECEIVING, STORING, PREPARING, CONTROLLING, PRESENTING, CALCULATING, ANALYZING AND PROCESSING OF DATA TO AND FROM PATIENTS AND TO AND FROM MEDICAL IMPLANTS AND TO AND FROM REMOTE CONTROLS, WIRELESS CHARGER APPARATUS AND CONTROL STATIONS FOR ACTIVE IMPLANTS; SURGICAL AND HEALTH SERVICES, NAMELY, IMPLANTATION OF ARTIFICIAL IMPLANTS TO ALLOW THE IMPLANTS TO COLLECT, SEND, RECEIVE, STORE, PREPARE, CONTROL, PRESENT, CALCULATE, ANALYZE, AND PROCESS OF DATA TO AND FROM PATIENTS AND TO AND FROM MEDICAL IMPLANTS AND TO AND FROM MEDICAL IMPLANTS AND TO AND FROM REMOTE CONTROLS, WIRELESS CHARGER APPARATUS AND CONTROL STATIONS FOR ACTIVE IMPLANTS; PROVIDING A MEDICAL, SURGICAL AND HEALTH DATABASE FEATURING MEDICAL, SURGICAL AND HEALTH INFORMATION RELATING TO MEDICAL IMPLANTS THAT HAS BEEN INPUT, COLLECTED, RECEIVED, PREPARED, CONTROLLED, PROGRAMMED, CALCULATED, AND ANALYZED, FROM MEDICAL IMPLANTS, REMOTE CONTROLS OR CONTROL STATIONS FOR USE BY MEDICAL, SURGICAL AND HEALTH PROFESSIONALS FOR THE PURPOSES OF MONITORING AND DIAGNOSING MEDICAL CONDITIONS; MEDICAL AND SURGICAL SERVICES, NAMELY, IMPLANTATION OF ARTIFICIAL IMPLANTS IN RELATION TO MEDICAL IMPLANTS FOR PROGRAMMING, CONTROLLING, COMMUNICATING WITH, AND ENERGIZING OF, ACTIVE IMPLANTS; AND MEDICAL AND SURGICAL SERVICES, NAMELY, ARTIFICIAL IMPLANTATION SERVICES FOR PERSONS HAVING A MEDICAL RELATED CONDITION AND BEING CANDIDATES FOR OR BEING OPERATED ON WITH AN ACTIVE OR A NON-ACTIVE IMPLANT (U.S. CLS. 100 AND 101).

ALEX KEAM, EXAMINING ATTORNEY

SN 77-855.813. MILUX HOLDING S.A., LUXEMBOURG, LUXEMBOURG, FILED 10-23-2009.

# OBSICA

THE MARK CONSISTS OF STANDARD CHARACTERS WITHOUT CLAIM TO ANY PARTICULAR FONT, STYLE, SIZE, OR COLOR.

PRIORITY CLAIMED UNDER SEC. 44(D) ON ERPNCMNTY TM OFC APPLICATION NO. 008245649, FILED 4-27-2009, REG. NO. 008245649, DATED 1-27-2010, EXPIRES 4-27-2019.

#### **CLASS 9—ELECTRICAL AND SCIENTIFIC APPARATUS**

FOR APPARATUS, DEVICES AND INSTRUMENTS, ALL NOT USED IN DIRECT ASSOCIATION WITH ACTIVE IMPLANTS, FOR MEASURING, RECEIVING, SENDING, CHECKING, CONTROLLING, DRIVING, TRANSFERRING, TRANSMITTING, PROCESSING, ANALYZING, CONDUCTING, SWITCHING, TRANSFORMING, ACCUMULATING, AND REGULATING ELECTRICITY, ENERGY AND/OR DATA, INCLUDING PHYSICAL PARAMETERS, NAMELY, ELECTRONIC STORAGE DEVICES IN THE NATURE OF BLANK MEMORY DISCS, MEMORY CARDS AND DATA STORAGE MEDIA, NAMELY, PACKAGED SEMICONDUCTORS, ELECTRONIC CONTROL UNIT AND PROGRAMMER WHICH CONTROLS THE WORKING PARAMETERS OF WIRELESS COMMUNICATION SYSTEMS AND WIRELESS POWERING SYSTEMS, CHARGERS IN THE NATURE OF BATTERY CHARGERS, DIGITAL CHARGERS AND ELECTRONIC CHARGERS, ELECTRONIC TRANSMITTERS AND ELECTRONIC RECEIVERS OF ELECTRONIC SIGNALS, AND ELECTRONIC CIRCUITS; REMOTE CONTROLS FOR WIRELESS CONTROLLING, AND PROGRAMMING WIRELESS CHARGER APPARATUS FOR WIRELESS ENERGIZING AND CONTROL STATIONS FOR WIRELESS CONTROLLING, PROGRAMMING AND ENERGIZING OF ACTIVE IMPLANTS; SOFTWARE, IN PARTICULAR FOR ACTIVE MEDICAL IMPLANTS, FOR MEASURING, RECEIVING, SENDING, CHECKING, TRANSFERRING, CALCULATING, PROCESSING, CONTROLLING, PRESENTING AND ANALYZING OF DATA, NAMELY, DATA ABOUT ELECTRICITY, ENERGY, PHYSICAL PARAMETERS, AND COMMUNICATION AND PROGRAMMING DATA IN MEDICAL IMPLANTS; SOFTWARE, IN PARTICULAR FOR MEASURING, RECEIVING, SENDING, CHECKING, TRANSFERRING, CALCULATING, PROCESSING, CONTROLLING, PRESENTING AND ANALYZING OF DATA, NAMELY, DATA ABOUT ELECTRICITY, ENERGY, PHYSICAL PARAMETERS, COMMUNICATION AND PROGRAMMING DATA IN APPARATUS, DEVICES AND INSTRUMENTS FOR COMMUNICATING WITH, ENERGIZING AND PROGRAMMING OF MEDICAL IMPLANTS; AND DATA PROCESSING EQUIPMENT AND COMPUTERS (U.S. CLS. 21, 23, 26, 36 AND 38).

#### **CLASS 10—MEDICAL APPARATUS**

FOR MEDICAL AND SURGICAL APPARATUS, INSTRUMENTS AND DEVICES, INCLUDING ACTIVE AND NON-ACTIVE MEDICAL IMPLANTS, NAMELY, MEDICAL IMPLANTS COMPRISED OF ARTIFICIAL MATERIAL; MEDICAL AND SURGICAL APPARATUS, INSTRUMENTS AND DEVICES INTENDED FOR USE INSIDE THE MAMMAL OR HUMAN BODY, IN PARTICULAR MANUAL, ELECTRICAL OR A COMBINATION OF MANUAL AND ELECTRICAL APPARATUS, DEVICES AND INSTRUMENTS, IN ALL GOODS INCLUDING MEDICAL HYDRAULIC, MECHANICAL, AND PNEUMATIC APPARATUS, DEVICES AND INSTRUMENTS, NAMELY, MEDICAL IMPLANTS COMPRISED OF ARTIFICIAL MATERIAL; MEDICAL AND SURGICAL APPARATUS, INSTRUMENTS AND DEVICES FOR REPLACING AND ADDING ONE OR MORE BODILY

FUNCTIONS AND PARTS INSIDE THE BODY, NAMELY, MEDICAL IMPLANTS COMPRISED OF ARTIFICIAL MATERIAL; MEDICAL AND SURGICAL APPARATUS, INSTRUMENTS AND DEVICES DESIGNED FOR WIRELESS PROGRAMMING, WIRELESS CONTROLLING, WIRELESS COMMUNICATING AND WIRELESS ENERGIZING, NAMELY, ACTIVE IMPLANTS IN THE NATURE OF IMPLANTS CONSISTING OF ARTIFICIAL MATERIALS, AND A WIRELESS TRANSMITTER AND A RECEIVER AS AN INTEGRAL COMPONENT OF A SURGICAL IMPLANT; WIRELESS COMMUNICATION SYSTEMS, APPARATUS, DEVICES, AND INSTRUMENTS AND WIRELESS ENERGIZING SYSTEMS, APPARATUS, DEVICES, AND INSTRUMENTS FOR MEASURING, RECEIVING, SENDING, SWITCHING, TRANSFORMING, ACCUMULATING, REGULATING, STORING, CHECKING, CONTROLLING, DRIVING, TRANSFERRING, TRANSMITTING, PROCESSING AND ANALYZING, IN ALL THE APPLICABLE AFOREMENTIONED GOODS, OF DATA INCLUDING PHYSICAL PARAMETERS, ELECTRICITY, ENERGY AND DATA, NAMELY, ELECTRONIC TRANSMITTERS FOR COMMUNICATING WITH, AND ENERGIZING OF, AND USED IN DIRECT ASSOCIATION WITH, ACTIVE MEDICAL IMPLANTS CONSISTING OF ARTIFICIAL MATERIALS; SURGICAL INSTRUMENTS IN PARTICULAR TO BE USED DURING OPERATIONS OF ACTIVE OR NON-ACTIVE MEDICAL IMPLANTS; VETERINARY MEDICAL AND SURGICAL APPARATUS, INSTRUMENTS AND DEVICES, FOR USE IN IMPLANT SURGERIES; MEDICAL AND SURGICAL APPARATUS, INSTRUMENTS AND DEVICES FOR ORTHOPAEDIC JOINT IMPLANTS; AND MEDICAL IMPLANTS FOR COLLECTING, RECEIVING, SENDING, STORING, PREPARING, CONTROLLING, ANALYZING AND PROCESSING OF DATA AND ENERGY TO AND FROM SAID MEDICAL IMPLANTS (U.S. CLS. 26, 39 AND 44).

#### **CLASS 44—MEDICAL, BEAUTY AND AGRICULTURAL SERVICES**

FOR MEDICAL SERVICES IN RELATION TO MEDICAL IMPLANTS FOR COLLECTING, SENDING, RECEIVING, STORING, PREPARING, CONTROLLING, PRESENTING, CALCULATING, ANALYZING AND PROCESSING OF DATA TO AND FROM PATIENTS AND TO AND FROM MEDICAL IMPLANTS AND TO AND FROM REMOTE CONTROLS, WIRELESS CHARGER APPARATUS AND CONTROL STATIONS FOR ACTIVE IMPLANTS; SURGICAL AND HEALTH SERVICES, NAMELY, IMPLANTATION OF ARTIFICIAL IMPLANTS TO ALLOW THE IMPLANTS TO COLLECT, SEND, RECEIVE, STORE, PREPARE, CONTROL, PRESENT, CALCULATE, ANALYZE, AND PROCESS OF DATA TO AND FROM PATIENTS AND TO AND FROM MEDICAL IMPLANTS AND TO AND FROM MEDICAL IMPLANTS AND TO AND FROM REMOTE CONTROLS, WIRELESS CHARGER APPARATUS AND CONTROL STATIONS FOR ACTIVE IMPLANTS; PROVIDING A MEDICAL, SURGICAL AND HEALTH DATABASE FEATURING MEDICAL, SURGICAL AND HEALTH INFORMATION RELATING TO MEDICAL IMPLANTS THAT HAS BEEN INPUT, COLLECTED, RECEIVED, PREPARED, CONTROLLED, PROGRAMMED, CALCULATED, AND ANALYZED, FROM MEDICAL IMPLANTS, REMOTE CONTROLS OR CONTROL STATIONS FOR USE BY MEDICAL, SURGICAL AND HEALTH PROFESSIONALS FOR THE PURPOSES OF MONITORING AND DIAGNOSING MEDICAL CONDITIONS; MEDICAL AND SURGICAL SERVICES, NAMELY, IMPLANTATION OF ARTIFICIAL IMPLANTS IN RELATION TO MEDICAL IMPLANTS FOR PROGRAMMING, CONTROLLING, COMMUNICATING WITH, AND ENERGIZING OF, ACTIVE IMPLANTS; AND MEDICAL AND SURGICAL SERVICES, NAMELY, ARTIFICIAL IMPLANTATION SERVICES FOR PERSONS HAVING A MEDICAL RELATED CONDITION AND BEING CANDIDATES FOR OR BEING OPERATED ON WITH AN ACTIVE OR A NON-ACTIVE IMPLANT (U.S. CLS. 100 AND 101).

ALEX KEAM, EXAMINING ATTORNEY

SN 77-856,162. MILUX HOLDING S.A., LUXEMBOURG, LUXEMBOURG, FILED 10-23-2009.

## **OSTEOPEDICA**

THE MARK CONSISTS OF STANDARD CHARACTERS WITHOUT CLAIM TO ANY PARTICULAR FONT, STYLE, SIZE, OR COLOR.

PRIORITY CLAIMED UNDER SEC. 44(D) ON ERP N CMNTY TM OFC APPLICATION NO. 008245748, FILED 4-27-2009, REG. NO. 008245748, DATED 1-27-2010, EXPIRES 4-27-2019.

#### **CLASS 9—ELECTRICAL AND SCIENTIFIC APPARATUS**

FOR APPARATUS, DEVICES AND INSTRUMENTS, ALL NOT USED IN DIRECT ASSOCIATION WITH ACTIVE IMPLANTS, FOR MEASURING, RECEIVING, SENDING, CHECKING, CONTROLLING, DRIVING, TRANSFERRING, TRANSMITTING, PROCESSING, ANALYZING, CONDUCTING, SWITCHING, TRANSFORMING, ACCUMULATING, AND REGULATING ELECTRICITY, ENERGY AND/OR DATA, INCLUDING PHYSICAL PARAMETERS, NAMELY, ELECTRONIC STORAGE DEVICES IN THE NATURE OF BLANK MEMORY DISCS, MEMORY CARDS AND DATA STORAGE MEDIA, NAMELY, PACKAGED SEMICONDUCTORS, ELECTRONIC CONTROL UNIT AND PROGRAMMER WHICH CONTROLS THE WORKING PARAMETERS OF WIRELESS COMMUNICATION SYSTEMS AND WIRELESS POWERING SYSTEMS, CHARGERS IN THE NATURE OF BATTERY CHARGERS, DIGITAL CHARGERS AND ELECTRONIC CHARGERS, ELECTRONIC TRANSMITTERS AND ELECTRONIC RECEIVERS OF ELECTRONIC SIGNALS, AND ELECTRONIC CIRCUITS; REMOTE CONTROLS FOR WIRELESS CONTROLLING, AND PROGRAMMING WIRELESS CHARGER APPARATUS FOR WIRELESS ENERGIZING AND CONTROL STATIONS FOR WIRELESS CONTROLLING, PROGRAMMING AND ENERGIZING OF ACTIVE IMPLANTS; SOFTWARE, IN PARTICULAR FOR ACTIVE MEDICAL IMPLANTS, FOR MEASURING, RECEIVING, SENDING, CHECKING, TRANSFERRING, CALCULATING, PROCESSING, CONTROLLING, PRESENTING AND ANALYZING OF DATA, NAMELY, DATA ABOUT ELECTRICITY, ENERGY, PHYSICAL PARAMETERS, AND COMMUNICATION AND PROGRAMMING DATA IN MEDICAL IMPLANTS; SOFTWARE, IN PARTICULAR FOR MEASURING, RECEIVING, SENDING, CHECKING, TRANSFERRING, CALCULATING, PROCESSING, CONTROLLING, PRESENTING AND ANALYZING OF DATA, NAMELY, DATA ABOUT ELECTRICITY, ENERGY, PHYSICAL PARAMETERS, COMMUNICATION AND PROGRAMMING DATA IN APPARATUS, DEVICES AND INSTRUMENTS FOR COMMUNICATING WITH, ENERGIZING AND PROGRAMMING OF MEDICAL IMPLANTS; AND DATA PROCESSING EQUIPMENT AND COMPUTERS (U.S. CLS. 21, 23, 26, 36 AND 38).

#### **CLASS 10—MEDICAL APPARATUS**

FOR MEDICAL AND SURGICAL APPARATUS, INSTRUMENTS AND DEVICES, INCLUDING ACTIVE AND NON-ACTIVE MEDICAL IMPLANTS, NAMELY, MEDICAL IMPLANTS COMPRISED OF ARTIFICIAL MATERIAL; MEDICAL AND SURGICAL APPARATUS, INSTRUMENTS AND DEVICES INTENDED FOR USE INSIDE THE MAMMAL OR HUMAN BODY, IN PARTICULAR MANUAL, ELECTRICAL OR A COMBINATION OF MANUAL AND ELECTRICAL APPARATUS, DEVICES AND INSTRUMENTS, IN ALL GOODS INCLUDING MEDICAL HYDRAULIC, MECHANICAL, AND PNEUMATIC APPARATUS, DEVICES AND INSTRUMENTS, NAMELY, MEDICAL IMPLANTS COMPRISED OF ARTIFICIAL MATERIAL; MEDICAL AND SURGICAL APPARATUS, INSTRUMENTS AND DEVICES FOR REPLACING AND ADDING ONE OR MORE BODILY



FUNCTIONS AND PARTS INSIDE THE BODY, NAMELY, MEDICAL IMPLANTS COMPRISED OF ARTIFICIAL MATERIAL; MEDICAL AND SURGICAL APPARATUS, INSTRUMENTS AND DEVICES DESIGNED FOR WIRELESS PROGRAMMING, WIRELESS CONTROLLING, WIRELESS COMMUNICATING AND WIRELESS ENERGIZING, NAMELY, ACTIVE IMPLANTS IN THE NATURE OF IMPLANTS CONSISTING OF ARTIFICIAL MATERIALS, AND A WIRELESS TRANSMITTER AND A RECEIVER AS AN INTEGRAL COMPONENT OF A SURGICAL IMPLANT; WIRELESS COMMUNICATION SYSTEMS, APPARATUS, DEVICES, AND INSTRUMENTS AND WIRELESS ENERGIZING SYSTEMS, APPARATUS, DEVICES, AND INSTRUMENTS FOR MEASURING, RECEIVING, SENDING, SWITCHING, TRANSFORMING, ACCUMULATING, REGULATING, STORING, CHECKING, CONTROLLING, DRIVING, TRANSFERRING, TRANSMITTING, PROCESSING AND ANALYZING, IN ALL THE APPLICABLE AFOREMENTIONED GOODS, OF DATA INCLUDING PHYSICAL PARAMETERS, ELECTRICITY, ENERGY AND DATA, NAMELY, ELECTRONIC TRANSMITTERS FOR COMMUNICATING WITH, AND ENERGIZING OF, AND USED IN DIRECT ASSOCIATION WITH, ACTIVE MEDICAL IMPLANTS CONSISTING OF ARTIFICIAL MATERIALS; SURGICAL INSTRUMENTS IN PARTICULAR TO BE USED DURING OPERATIONS OF ACTIVE OR NON-ACTIVE MEDICAL IMPLANTS; VETERINARY MEDICAL AND SURGICAL APPARATUS, INSTRUMENTS AND DEVICES, FOR USE IN IMPLANT SURGERIES; MEDICAL AND SURGICAL APPARATUS, INSTRUMENTS AND DEVICES FOR ORTHOPAEDIC JOINT IMPLANTS; AND MEDICAL IMPLANTS FOR COLLECTING, RECEIVING, SENDING, STORING, PREPARING, CONTROLLING, ANALYZING AND PROCESSING OF DATA AND ENERGY TO AND FROM SAID MEDICAL IMPLANTS (U.S. CLS. 26, 39 AND 44).

#### **CLASS 44—MEDICAL, BEAUTY AND AGRICULTURAL SERVICES**

FOR MEDICAL SERVICES IN RELATION TO MEDICAL IMPLANTS FOR COLLECTING, SENDING, RECEIVING, STORING, PREPARING, CONTROLLING, PRESENTING, CALCULATING, ANALYZING AND PROCESSING OF DATA TO AND FROM PATIENTS AND TO AND FROM MEDICAL IMPLANTS AND TO AND FROM REMOTE CONTROLS, WIRELESS CHARGER APPARATUS AND CONTROL STATIONS FOR ACTIVE IMPLANTS; SURGICAL AND HEALTH SERVICES, NAMELY, IMPLANTATION OF ARTIFICIAL IMPLANTS TO ALLOW THE IMPLANTS TO COLLECT, SEND, RECEIVE, STORE, PREPARE, CONTROL, PRESENT, CALCULATE, ANALYZE, AND PROCESS OF DATA TO AND FROM PATIENTS AND TO AND FROM MEDICAL IMPLANTS AND TO AND FROM MEDICAL IMPLANTS AND TO AND FROM REMOTE CONTROLS, WIRELESS CHARGER APPARATUS AND CONTROL STATIONS FOR ACTIVE IMPLANTS; PROVIDING A MEDICAL, SURGICAL AND HEALTH DATABASE FEATURING MEDICAL, SURGICAL AND HEALTH INFORMATION RELATING TO MEDICAL IMPLANTS THAT HAS BEEN INPUT, COLLECTED, RECEIVED, PREPARED, CONTROLLED, PROGRAMMED, CALCULATED, AND ANALYZED, FROM MEDICAL IMPLANTS, REMOTE CONTROLS OR CONTROL STATIONS FOR USE BY MEDICAL, SURGICAL AND HEALTH PROFESSIONALS FOR THE PURPOSES OF MONITORING AND DIAGNOSING MEDICAL CONDITIONS; MEDICAL AND SURGICAL SERVICES, NAMELY, IMPLANTATION OF ARTIFICIAL IMPLANTS IN RELATION TO MEDICAL IMPLANTS FOR PROGRAMMING, CONTROLLING, COMMUNICATING WITH, AND ENERGIZING OF, ACTIVE IMPLANTS; AND MEDICAL AND SURGICAL SERVICES, NAMELY, ARTIFICIAL IMPLANTATION SERVICES FOR PERSONS HAVING A MEDICAL RELATED CONDITION AND BEING CANDIDATES FOR OR BEING OPERATED ON WITH AN ACTIVE OR A NON-ACTIVE IMPLANT (U.S. CLS. 100 AND 101).

ALEX KEAM, EXAMINING ATTORNEY

SN 77-856,195. MILUX HOLDING S.A., LUXEMBOURG, LUXEMBOURG, FILED 10-23-2009.

## **DISTRIBUTICA**

THE MARK CONSISTS OF STANDARD CHARACTERS WITHOUT CLAIM TO ANY PARTICULAR FONT, STYLE, SIZE, OR COLOR.

PRIORITY CLAIMED UNDER SEC. 44(D) ON ERPNCMNTY TM OFC APPLICATION NO. 008245797, FILED 4-27-2009, REG. NO. 008245797, DATED 1-27-2010, EXPIRES 4-27-2019.

#### **CLASS 9—ELECTRICAL AND SCIENTIFIC APPARATUS**

FOR APPARATUS, DEVICES AND INSTRUMENTS, ALL NOT USED IN DIRECT ASSOCIATION WITH ACTIVE IMPLANTS, FOR MEASURING, RECEIVING, SENDING, CHECKING, CONTROLLING, DRIVING, TRANSFERRING, TRANSMITTING, PROCESSING, ANALYZING, CONDUCTING, SWITCHING, TRANSFORMING, ACCUMULATING, AND REGULATING ELECTRICITY, ENERGY AND/OR DATA, INCLUDING PHYSICAL PARAMETERS, NAMELY, ELECTRONIC STORAGE DEVICES IN THE NATURE OF BLANK MEMORY DISCS, MEMORY CARDS AND DATA STORAGE MEDIA, NAMELY, PACKAGED SEMICONDUCTORS, ELECTRONIC CONTROL UNIT AND PROGRAMMER WHICH CONTROLS THE WORKING PARAMETERS OF WIRELESS COMMUNICATION SYSTEMS AND WIRELESS POWERING SYSTEMS, CHARGERS IN THE NATURE OF BATTERY CHARGERS, DIGITAL CHARGERS AND ELECTRONIC CHARGERS, ELECTRONIC TRANSMITTERS AND ELECTRONIC RECEIVERS OF ELECTRONIC SIGNALS, AND ELECTRONIC CIRCUITS; REMOTE CONTROLS FOR WIRELESS CONTROLLING, AND PROGRAMMING WIRELESS CHARGER APPARATUS FOR WIRELESS ENERGIZING AND CONTROL STATIONS FOR WIRELESS CONTROLLING, PROGRAMMING AND ENERGIZING OF ACTIVE IMPLANTS; SOFTWARE, IN PARTICULAR FOR ACTIVE MEDICAL IMPLANTS, FOR MEASURING, RECEIVING, SENDING, CHECKING, TRANSFERRING, CALCULATING, PROCESSING, CONTROLLING, PRESENTING AND ANALYZING OF DATA, NAMELY, DATA ABOUT ELECTRICITY, ENERGY, PHYSICAL PARAMETERS, AND COMMUNICATION AND PROGRAMMING DATA IN MEDICAL IMPLANTS; SOFTWARE, IN PARTICULAR FOR MEASURING, RECEIVING, SENDING, CHECKING, TRANSFERRING, CALCULATING, PROCESSING, CONTROLLING, PRESENTING AND ANALYZING OF DATA, NAMELY, DATA ABOUT ELECTRICITY, ENERGY, PHYSICAL PARAMETERS, COMMUNICATION AND PROGRAMMING DATA IN APPARATUS, DEVICES AND INSTRUMENTS FOR COMMUNICATING WITH, ENERGIZING AND PROGRAMMING OF MEDICAL IMPLANTS; AND DATA PROCESSING EQUIPMENT AND COMPUTERS (U.S. CLS. 21, 23, 26, 36 AND 38).

#### **CLASS 10—MEDICAL APPARATUS**

FOR MEDICAL AND SURGICAL APPARATUS, INSTRUMENTS AND DEVICES, INCLUDING ACTIVE AND NON-ACTIVE MEDICAL IMPLANTS, NAMELY, MEDICAL IMPLANTS COMPRISED OF ARTIFICIAL MATERIAL; MEDICAL AND SURGICAL APPARATUS, INSTRUMENTS AND DEVICES INTENDED FOR USE INSIDE THE MAMMAL OR HUMAN BODY, IN PARTICULAR MANUAL, ELECTRICAL OR A COMBINATION OF MANUAL AND ELECTRICAL APPARATUS, DEVICES AND INSTRUMENTS, IN ALL GOODS INCLUDING MEDICAL HYDRAULIC, MECHANICAL, AND PNEUMATIC APPARATUS, DEVICES AND INSTRUMENTS, NAMELY, MEDICAL IMPLANTS COMPRISED OF ARTIFICIAL MATERIAL; MEDICAL AND SURGICAL APPARATUS, INSTRUMENTS AND DEVICES FOR REPLACING AND ADDING ONE OR MORE BODILY



FUNCTIONS AND PARTS INSIDE THE BODY, NAMELY, MEDICAL IMPLANTS COMPRISED OF ARTIFICIAL MATERIAL; MEDICAL AND SURGICAL APPARATUS, INSTRUMENTS AND DEVICES DESIGNED FOR WIRELESS PROGRAMMING, WIRELESS CONTROLLING, WIRELESS COMMUNICATING AND WIRELESS ENERGIZING, NAMELY, ACTIVE IMPLANTS IN THE NATURE OF IMPLANTS CONSISTING OF ARTIFICIAL MATERIALS, AND A WIRELESS TRANSMITTER AND A RECEIVER AS AN INTEGRAL COMPONENT OF A SURGICAL IMPLANT; WIRELESS COMMUNICATION SYSTEMS, APPARATUS, DEVICES, AND INSTRUMENTS AND WIRELESS ENERGIZING SYSTEMS, APPARATUS, DEVICES, AND INSTRUMENTS FOR MEASURING, RECEIVING, SENDING, SWITCHING, TRANSFORMING, ACCUMULATING, REGULATING, STORING, CHECKING, CONTROLLING, DRIVING, TRANSFERRING, TRANSMITTING, PROCESSING AND ANALYZING, IN ALL THE APPLICABLE AFOREMENTIONED GOODS, OF DATA INCLUDING PHYSICAL PARAMETERS, ELECTRICITY, ENERGY AND DATA, NAMELY, ELECTRONIC TRANSMITTERS FOR COMMUNICATING WITH, AND ENERGIZING OF, AND USED IN DIRECT ASSOCIATION WITH, ACTIVE MEDICAL IMPLANTS CONSISTING OF ARTIFICIAL MATERIALS; SURGICAL INSTRUMENTS IN PARTICULAR TO BE USED DURING OPERATIONS OF ACTIVE OR NON-ACTIVE MEDICAL IMPLANTS; VETERINARY MEDICAL AND SURGICAL APPARATUS, INSTRUMENTS AND DEVICES, FOR USE IN IMPLANT SURGERIES; MEDICAL AND SURGICAL APPARATUS, INSTRUMENTS AND DEVICES FOR ORTHOPAEDIC JOINT IMPLANTS; AND MEDICAL IMPLANTS FOR COLLECTING, RECEIVING, SENDING, STORING, PREPARING, CONTROLLING, ANALYZING AND PROCESSING OF DATA AND ENERGY TO AND FROM SAID MEDICAL IMPLANTS (U.S. CLS. 26, 39 AND 44).

#### **CLASS 44—MEDICAL, BEAUTY AND AGRICULTURAL SERVICES**

FOR MEDICAL SERVICES IN RELATION TO MEDICAL IMPLANTS FOR COLLECTING, SENDING, RECEIVING, STORING, PREPARING, CONTROLLING, PRESENTING, CALCULATING, ANALYZING AND PROCESSING OF DATA TO AND FROM PATIENTS AND TO AND FROM MEDICAL IMPLANTS AND TO AND FROM REMOTE CONTROLS, WIRELESS CHARGER APPARATUS AND CONTROL STATIONS FOR ACTIVE IMPLANTS; SURGICAL AND HEALTH SERVICES, NAMELY, IMPLANTATION OF ARTIFICIAL IMPLANTS TO ALLOW THE IMPLANTS TO COLLECT, SEND, RECEIVE, STORE, PREPARE, CONTROL, PRESENT, CALCULATE, ANALYZE, AND PROCESS OF DATA TO AND FROM PATIENTS AND TO AND FROM MEDICAL IMPLANTS AND TO AND FROM MEDICAL IMPLANTS AND TO AND FROM REMOTE CONTROLS, WIRELESS CHARGER APPARATUS AND CONTROL STATIONS FOR ACTIVE IMPLANTS; PROVIDING A MEDICAL, SURGICAL AND HEALTH DATABASE FEATURING MEDICAL, SURGICAL AND HEALTH INFORMATION RELATING TO MEDICAL IMPLANTS THAT HAS BEEN INPUT, COLLECTED, RECEIVED, PREPARED, CONTROLLED, PROGRAMMED, CALCULATED, AND ANALYZED, FROM MEDICAL IMPLANTS, REMOTE CONTROLS OR CONTROL STATIONS FOR USE BY MEDICAL, SURGICAL AND HEALTH PROFESSIONALS FOR THE PURPOSES OF MONITORING AND DIAGNOSING MEDICAL CONDITIONS; MEDICAL AND SURGICAL SERVICES, NAMELY, IMPLANTATION OF ARTIFICIAL IMPLANTS IN RELATION TO MEDICAL IMPLANTS FOR PROGRAMMING, CONTROLLING, COMMUNICATING WITH, AND ENERGIZING OF, ACTIVE IMPLANTS; AND MEDICAL AND SURGICAL SERVICES, NAMELY, ARTIFICIAL IMPLANTATION SERVICES FOR PERSONS HAVING A MEDICAL RELATED CONDITION AND BEING CANDIDATES FOR OR BEING OPERATED ON WITH AN ACTIVE OR A NON-ACTIVE IMPLANT (U.S. CLS. 100 AND 101).

ALEX KEAM, EXAMINING ATTORNEY

SN 77-856.920. MILUX HOLDING S.A., LUXEMBOURG, LUXEMBOURG, FILED 10-26-2009.

## **IMPLANTICAMEDICAL**

THE MARK CONSISTS OF STANDARD CHARACTERS WITHOUT CLAIM TO ANY PARTICULAR FONT, STYLE, SIZE, OR COLOR.

PRIORITY CLAIMED UNDER SEC. 44(D) ON ERP N CMNTY TM OFC APPLICATION NO. 008245987, FILED 4-27-2009, REG. NO. 008245987, DATED 1-31-2010, EXPIRES 4-27-2019.

#### **CLASS 9—ELECTRICAL AND SCIENTIFIC APPARATUS**

FOR APPARATUS, DEVICES AND INSTRUMENTS, ALL NOT USED IN DIRECT ASSOCIATION WITH ACTIVE IMPLANTS, FOR MEASURING, RECEIVING, SENDING, CHECKING, CONTROLLING, DRIVING, TRANSFERRING, TRANSMITTING, PROCESSING, ANALYZING, CONDUCTING, SWITCHING, TRANSFORMING, ACCUMULATING, AND REGULATING ELECTRICITY, ENERGY AND/OR DATA, INCLUDING PHYSICAL PARAMETERS, NAMELY, ELECTRONIC STORAGE DEVICES IN THE NATURE OF BLANK MEMORY DISCS, MEMORY CARDS AND DATA STORAGE MEDIA, NAMELY, PACKAGED SEMICONDUCTORS, ELECTRONIC CONTROL UNIT AND PROGRAMMER WHICH CONTROLS THE WORKING PARAMETERS OF WIRELESS COMMUNICATION SYSTEMS AND WIRELESS POWERING SYSTEMS, CHARGERS IN THE NATURE OF BATTERY CHARGERS, DIGITAL CHARGERS AND ELECTRONIC CHARGERS, ELECTRONIC TRANSMITTERS AND ELECTRONIC RECEIVERS OF ELECTRONIC SIGNALS, AND ELECTRONIC CIRCUITS; REMOTE CONTROLS FOR WIRELESS CONTROLLING, AND PROGRAMMING WIRELESS CHARGER APPARATUS FOR WIRELESS ENERGIZING AND CONTROL STATIONS FOR WIRELESS CONTROLLING, PROGRAMMING AND ENERGIZING OF ACTIVE IMPLANTS; SOFTWARE, IN PARTICULAR FOR ACTIVE MEDICAL IMPLANTS, FOR MEASURING, RECEIVING, SENDING, CHECKING, TRANSFERRING, CALCULATING, PROCESSING, CONTROLLING, PRESENTING AND ANALYZING OF DATA, NAMELY, DATA ABOUT ELECTRICITY, ENERGY, PHYSICAL PARAMETERS, AND COMMUNICATION AND PROGRAMMING DATA IN MEDICAL IMPLANTS; SOFTWARE, IN PARTICULAR FOR MEASURING, RECEIVING, SENDING, CHECKING, TRANSFERRING, CALCULATING, PROCESSING, CONTROLLING, PRESENTING AND ANALYZING OF DATA, NAMELY, DATA ABOUT ELECTRICITY, ENERGY, PHYSICAL PARAMETERS, COMMUNICATION AND PROGRAMMING DATA IN APPARATUS, DEVICES AND INSTRUMENTS FOR COMMUNICATING WITH, ENERGIZING AND PROGRAMMING OF MEDICAL IMPLANTS; AND DATA PROCESSING EQUIPMENT AND COMPUTERS (U.S. CLS. 21, 23, 26, 36 AND 38).

#### **CLASS 10—MEDICAL APPARATUS**

FOR MEDICAL AND SURGICAL APPARATUS, INSTRUMENTS AND DEVICES, INCLUDING ACTIVE AND NON-ACTIVE MEDICAL IMPLANTS, NAMELY, MEDICAL IMPLANTS COMPRISED OF ARTIFICIAL MATERIAL; MEDICAL AND SURGICAL APPARATUS, INSTRUMENTS AND DEVICES INTENDED FOR USE INSIDE THE MAMMAL OR HUMAN BODY, IN PARTICULAR MANUAL, ELECTRICAL OR A COMBINATION OF MANUAL AND ELECTRICAL APPARATUS, DEVICES AND INSTRUMENTS, IN ALL GOODS INCLUDING MEDICAL HYDRAULIC, MECHANICAL, AND PNEUMATIC APPARATUS, DEVICES AND INSTRUMENTS, NAMELY, MEDICAL IMPLANTS COMPRISED OF ARTIFICIAL MATERIAL; MEDICAL AND SURGICAL APPARATUS, INSTRUMENTS AND DEVICES FOR REPLACING AND ADDING ONE OR MORE BODILY

FUNCTIONS AND PARTS INSIDE THE BODY, NAMELY, MEDICAL IMPLANTS COMPRISED OF ARTIFICIAL MATERIAL; MEDICAL AND SURGICAL APPARATUS, INSTRUMENTS AND DEVICES DESIGNED FOR WIRELESS PROGRAMMING, WIRELESS CONTROLLING, WIRELESS COMMUNICATING AND WIRELESS ENERGIZING, NAMELY, ACTIVE IMPLANTS IN THE NATURE OF IMPLANTS CONSISTING OF ARTIFICIAL MATERIALS, AND A WIRELESS TRANSMITTER AND A RECEIVER AS AN INTEGRAL COMPONENT OF A SURGICAL IMPLANT; WIRELESS COMMUNICATION SYSTEMS, APPARATUS, DEVICES, AND INSTRUMENTS AND WIRELESS ENERGIZING SYSTEMS, APPARATUS, DEVICES, AND INSTRUMENTS FOR MEASURING, RECEIVING, SENDING, SWITCHING, TRANSFORMING, ACCUMULATING, REGULATING, STORING, CHECKING, CONTROLLING, DRIVING, TRANSFERRING, TRANSMITTING, PROCESSING AND ANALYZING, IN ALL THE APPLICABLE AFOREMENTIONED GOODS, OF DATA INCLUDING PHYSICAL PARAMETERS, ELECTRICITY, ENERGY AND DATA, NAMELY, ELECTRONIC TRANSMITTERS FOR COMMUNICATING WITH, AND ENERGIZING OF, AND USED IN DIRECT ASSOCIATION WITH, ACTIVE MEDICAL IMPLANTS CONSISTING OF ARTIFICIAL MATERIALS; SURGICAL INSTRUMENTS IN PARTICULAR TO BE USED DURING OPERATIONS OF ACTIVE OR NON-ACTIVE MEDICAL IMPLANTS; VETERINARY MEDICAL AND SURGICAL APPARATUS, INSTRUMENTS AND DEVICES, FOR USE IN IMPLANT SURGERIES; MEDICAL AND SURGICAL APPARATUS, INSTRUMENTS AND DEVICES FOR ORTHOPAEDIC JOINT IMPLANTS; AND MEDICAL IMPLANTS FOR COLLECTING, RECEIVING, SENDING, STORING, PREPARING, CONTROLLING, ANALYZING AND PROCESSING OF DATA AND ENERGY TO AND FROM SAID MEDICAL IMPLANTS (U.S. CLS. 26, 39 AND 44).

#### **CLASS 44—MEDICAL, BEAUTY AND AGRICULTURAL SERVICES**

FOR MEDICAL SERVICES IN RELATION TO MEDICAL IMPLANTS FOR COLLECTING, SENDING, RECEIVING, STORING, PREPARING, CONTROLLING, PRESENTING, CALCULATING, ANALYZING AND PROCESSING OF DATA TO AND FROM PATIENTS AND TO AND FROM MEDICAL IMPLANTS AND TO AND FROM REMOTE CONTROLS, WIRELESS CHARGER APPARATUS AND CONTROL STATIONS FOR ACTIVE IMPLANTS; SURGICAL AND HEALTH SERVICES, NAMELY, IMPLANTATION OF ARTIFICIAL IMPLANTS TO ALLOW THE IMPLANTS TO COLLECT, SEND, RECEIVE, STORE, PREPARE, CONTROL, PRESENT, CALCULATE, ANALYZE, AND PROCESS OF DATA TO AND FROM PATIENTS AND TO AND FROM MEDICAL IMPLANTS AND TO AND FROM MEDICAL IMPLANTS AND TO AND FROM REMOTE CONTROLS, WIRELESS CHARGER APPARATUS AND CONTROL STATIONS FOR ACTIVE IMPLANTS; PROVIDING A MEDICAL, SURGICAL AND HEALTH DATABASE FEATURING MEDICAL, SURGICAL AND HEALTH INFORMATION RELATING TO MEDICAL IMPLANTS THAT HAS BEEN INPUT, COLLECTED, RECEIVED, PREPARED, CONTROLLED, PROGRAMMED, CALCULATED, AND ANALYZED, FROM MEDICAL IMPLANTS, REMOTE CONTROLS OR CONTROL STATIONS FOR USE BY MEDICAL, SURGICAL AND HEALTH PROFESSIONALS FOR THE PURPOSES OF MONITORING AND DIAGNOSING MEDICAL CONDITIONS; MEDICAL AND SURGICAL SERVICES, NAMELY, IMPLANTATION OF ARTIFICIAL IMPLANTS IN RELATION TO MEDICAL IMPLANTS FOR PROGRAMMING, CONTROLLING, COMMUNICATING WITH, AND ENERGIZING OF, ACTIVE IMPLANTS; AND MEDICAL AND SURGICAL SERVICES, NAMELY, ARTIFICIAL IMPLANTATION SERVICES FOR PERSONS HAVING A MEDICAL RELATED CONDITION AND BEING CANDIDATES FOR OR BEING OPERATED ON WITH AN ACTIVE OR A NON-ACTIVE IMPLANT (U.S. CLS. 100 AND 101).

ALEX KEAM, EXAMINING ATTORNEY

SN 77-856.922. MILUX HOLDING S.A., LUXEMBOURG, LUXEMBOURG, FILED 10-26-2009.

## **CONTRACEPTOR**

THE MARK CONSISTS OF STANDARD CHARACTERS WITHOUT CLAIM TO ANY PARTICULAR FONT, STYLE, SIZE, OR COLOR.

PRIORITY CLAIMED UNDER SEC. 44(D) ON ERP N CMNTY TM OFC APPLICATION NO. 008245714, FILED 4-27-2009, REG. NO. 008245714, DATED 1-31-2010, EXPIRES 4-27-2019.

#### **CLASS 9—ELECTRICAL AND SCIENTIFIC APPARATUS**

FOR APPARATUS, DEVICES AND INSTRUMENTS, ALL NOT USED IN DIRECT ASSOCIATION WITH ACTIVE IMPLANTS, FOR MEASURING, RECEIVING, SENDING, CHECKING, CONTROLLING, DRIVING, TRANSFERRING, TRANSMITTING, PROCESSING, ANALYZING, CONDUCTING, SWITCHING, TRANSFORMING, ACCUMULATING, AND REGULATING ELECTRICITY, ENERGY AND/OR DATA, INCLUDING PHYSICAL PARAMETERS, NAMELY, ELECTRONIC STORAGE DEVICES IN THE NATURE OF BLANK MEMORY DISCS, MEMORY CARDS AND DATA STORAGE MEDIA, NAMELY, PACKAGED SEMICONDUCTORS, ELECTRONIC CONTROL UNIT AND PROGRAMMER WHICH CONTROLS THE WORKING PARAMETERS OF WIRELESS COMMUNICATION SYSTEMS AND WIRELESS POWERING SYSTEMS, CHARGERS IN THE NATURE OF BATTERY CHARGERS, DIGITAL CHARGERS AND ELECTRONIC CHARGERS, ELECTRONIC TRANSMITTERS AND ELECTRONIC RECEIVERS OF ELECTRONIC SIGNALS, AND ELECTRONIC CIRCUITS; REMOTE CONTROLS FOR WIRELESS CONTROLLING, AND PROGRAMMING WIRELESS CHARGER APPARATUS FOR WIRELESS ENERGIZING AND CONTROL STATIONS FOR WIRELESS CONTROLLING, PROGRAMMING AND ENERGIZING OF ACTIVE IMPLANTS; SOFTWARE, IN PARTICULAR FOR ACTIVE MEDICAL IMPLANTS, FOR MEASURING, RECEIVING, SENDING, CHECKING, TRANSFERRING, CALCULATING, PROCESSING, CONTROLLING, PRESENTING AND ANALYZING OF DATA, NAMELY, DATA ABOUT ELECTRICITY, ENERGY, PHYSICAL PARAMETERS, AND COMMUNICATION AND PROGRAMMING DATA IN MEDICAL IMPLANTS; SOFTWARE, IN PARTICULAR FOR MEASURING, RECEIVING, SENDING, CHECKING, TRANSFERRING, CALCULATING, PROCESSING, CONTROLLING, PRESENTING AND ANALYZING OF DATA, NAMELY, DATA ABOUT ELECTRICITY, ENERGY, PHYSICAL PARAMETERS, COMMUNICATION AND PROGRAMMING DATA IN APPARATUS, DEVICES AND INSTRUMENTS FOR COMMUNICATING WITH, ENERGIZING AND PROGRAMMING OF MEDICAL IMPLANTS; AND DATA PROCESSING EQUIPMENT AND COMPUTERS (U.S. CLS. 21, 23, 26, 36 AND 38).

#### **CLASS 10—MEDICAL APPARATUS**

FOR MEDICAL AND SURGICAL APPARATUS, INSTRUMENTS AND DEVICES, INCLUDING ACTIVE AND NON-ACTIVE MEDICAL IMPLANTS, NAMELY, MEDICAL IMPLANTS COMPRISED OF ARTIFICIAL MATERIAL; MEDICAL AND SURGICAL APPARATUS, INSTRUMENTS AND DEVICES INTENDED FOR USE INSIDE THE MAMMAL OR HUMAN BODY, IN PARTICULAR MANUAL, ELECTRICAL OR A COMBINATION OF MANUAL AND ELECTRICAL APPARATUS, DEVICES AND INSTRUMENTS, IN ALL GOODS INCLUDING MEDICAL HYDRAULIC, MECHANICAL, AND PNEUMATIC APPARATUS, DEVICES AND INSTRUMENTS, NAMELY, MEDICAL IMPLANTS COMPRISED OF ARTIFICIAL MATERIAL; MEDICAL AND SURGICAL APPARATUS, INSTRUMENTS AND DEVICES FOR REPLACING AND ADDING ONE OR MORE BODILY

FUNCTIONS AND PARTS INSIDE THE BODY, NAMELY, MEDICAL IMPLANTS COMPRISED OF ARTIFICIAL MATERIAL; MEDICAL AND SURGICAL APPARATUS, INSTRUMENTS AND DEVICES DESIGNED FOR WIRELESS PROGRAMMING, WIRELESS CONTROLLING, WIRELESS COMMUNICATING AND WIRELESS ENERGIZING, NAMELY, ACTIVE IMPLANTS IN THE NATURE OF IMPLANTS CONSISTING OF ARTIFICIAL MATERIALS, AND A WIRELESS TRANSMITTER AND A RECEIVER AS AN INTEGRAL COMPONENT OF A SURGICAL IMPLANT; WIRELESS COMMUNICATION SYSTEMS, APPARATUS, DEVICES, AND INSTRUMENTS AND WIRELESS ENERGIZING SYSTEMS, APPARATUS, DEVICES, AND INSTRUMENTS FOR MEASURING, RECEIVING, SENDING, SWITCHING, TRANSFORMING, ACCUMULATING, REGULATING, STORING, CHECKING, CONTROLLING, DRIVING, TRANSFERRING, TRANSMITTING, PROCESSING AND ANALYZING, IN ALL THE APPLICABLE AFOREMENTIONED GOODS, OF DATA INCLUDING PHYSICAL PARAMETERS, ELECTRICITY, ENERGY AND DATA, NAMELY, ELECTRONIC TRANSMITTERS FOR COMMUNICATING WITH, AND ENERGIZING OF, AND USED IN DIRECT ASSOCIATION WITH, ACTIVE MEDICAL IMPLANTS CONSISTING OF ARTIFICIAL MATERIALS; SURGICAL INSTRUMENTS IN PARTICULAR TO BE USED DURING OPERATIONS OF ACTIVE OR NON-ACTIVE MEDICAL IMPLANTS; VETERINARY MEDICAL AND SURGICAL APPARATUS, INSTRUMENTS AND DEVICES, FOR USE IN IMPLANT SURGERIES; MEDICAL AND SURGICAL APPARATUS, INSTRUMENTS AND DEVICES FOR ORTHOPAEDIC JOINT IMPLANTS; AND MEDICAL IMPLANTS FOR COLLECTING, RECEIVING, SENDING, STORING, PREPARING, CONTROLLING, ANALYZING AND PROCESSING OF DATA AND ENERGY TO AND FROM SAID MEDICAL IMPLANTS (U.S. CLS. 26, 39 AND 44).

#### **CLASS 44—MEDICAL, BEAUTY AND AGRICULTURAL SERVICES**

FOR MEDICAL SERVICES IN RELATION TO MEDICAL IMPLANTS FOR COLLECTING, SENDING, RECEIVING, STORING, PREPARING, CONTROLLING, PRESENTING, CALCULATING, ANALYZING AND PROCESSING OF DATA TO AND FROM PATIENTS AND TO AND FROM MEDICAL IMPLANTS AND TO AND FROM REMOTE CONTROLS, WIRELESS CHARGER APPARATUS AND CONTROL STATIONS FOR ACTIVE IMPLANTS; SURGICAL AND HEALTH SERVICES, NAMELY, IMPLANTATION OF ARTIFICIAL IMPLANTS TO ALLOW THE IMPLANTS TO COLLECT, SEND, RECEIVE, STORE, PREPARE, CONTROL, PRESENT, CALCULATE, ANALYZE, AND PROCESS OF DATA TO AND FROM PATIENTS AND TO AND FROM MEDICAL IMPLANTS AND TO AND FROM MEDICAL IMPLANTS AND TO AND FROM REMOTE CONTROLS, WIRELESS CHARGER APPARATUS AND CONTROL STATIONS FOR ACTIVE IMPLANTS; PROVIDING A MEDICAL, SURGICAL AND HEALTH DATABASE FEATURING MEDICAL, SURGICAL AND HEALTH INFORMATION RELATING TO MEDICAL IMPLANTS THAT HAS BEEN INPUT, COLLECTED, RECEIVED, PREPARED, CONTROLLED, PROGRAMMED, CALCULATED, AND ANALYZED, FROM MEDICAL IMPLANTS, REMOTE CONTROLS OR CONTROL STATIONS FOR USE BY MEDICAL, SURGICAL AND HEALTH PROFESSIONALS FOR THE PURPOSES OF MONITORING AND DIAGNOSING MEDICAL CONDITIONS; MEDICAL AND SURGICAL SERVICES, NAMELY, IMPLANTATION OF ARTIFICIAL IMPLANTS IN RELATION TO MEDICAL IMPLANTS FOR PROGRAMMING, CONTROLLING, COMMUNICATING WITH, AND ENERGIZING OF, ACTIVE IMPLANTS; AND MEDICAL AND SURGICAL SERVICES, NAMELY, ARTIFICIAL IMPLANTATION SERVICES FOR PERSONS HAVING A MEDICAL RELATED CONDITION AND BEING CANDIDATES FOR OR BEING OPERATED ON WITH AN ACTIVE OR A NON-ACTIVE IMPLANT (U.S. CLS. 100 AND 101).

ALEX KEAM, EXAMINING ATTORNEY

SN 77-856,927. MILUX HOLDING S.A., LUXEMBOURG, LUXEMBOURG, FILED 10-26-2009.

# IMPLANTIQ

THE MARK CONSISTS OF STANDARD CHARACTERS WITHOUT CLAIM TO ANY PARTICULAR FONT, STYLE, SIZE, OR COLOR.

PRIORITY CLAIMED UNDER SEC. 44(D) ON ERPNCMNTY TM OFC APPLICATION NO. 008246001, FILED 4-27-2009, REG. NO. 008246001, DATED 1-27-2010, EXPIRES 4-27-2019.

#### **CLASS 9—ELECTRICAL AND SCIENTIFIC APPARATUS**

FOR APPARATUS, DEVICES AND INSTRUMENTS, ALL NOT USED IN DIRECT ASSOCIATION WITH ACTIVE IMPLANTS, FOR MEASURING, RECEIVING, SENDING, CHECKING, CONTROLLING, DRIVING, TRANSFERRING, TRANSMITTING, PROCESSING, ANALYZING, CONDUCTING, SWITCHING, TRANSFORMING, ACCUMULATING, AND REGULATING ELECTRICITY, ENERGY AND/OR DATA, INCLUDING PHYSICAL PARAMETERS, NAMELY, ELECTRONIC STORAGE DEVICES IN THE NATURE OF BLANK MEMORY DISCS, MEMORY CARDS AND DATA STORAGE MEDIA, NAMELY, PACKAGED SEMICONDUCTORS, ELECTRONIC CONTROL UNIT AND PROGRAMMER WHICH CONTROLS THE WORKING PARAMETERS OF WIRELESS COMMUNICATION SYSTEMS AND WIRELESS POWERING SYSTEMS, CHARGERS IN THE NATURE OF BATTERY CHARGERS, DIGITAL CHARGERS AND ELECTRONIC CHARGERS, ELECTRONIC TRANSMITTERS AND ELECTRONIC RECEIVERS OF ELECTRONIC SIGNALS, AND ELECTRONIC CIRCUITS; REMOTE CONTROLS FOR WIRELESS CONTROLLING, AND PROGRAMMING WIRELESS CHARGER APPARATUS FOR WIRELESS ENERGIZING AND CONTROL STATIONS FOR WIRELESS CONTROLLING, PROGRAMMING AND ENERGIZING OF ACTIVE IMPLANTS; SOFTWARE, IN PARTICULAR FOR ACTIVE MEDICAL IMPLANTS, FOR MEASURING, RECEIVING, SENDING, CHECKING, TRANSFERRING, CALCULATING, PROCESSING, CONTROLLING, PRESENTING AND ANALYZING OF DATA, NAMELY, DATA ABOUT ELECTRICITY, ENERGY, PHYSICAL PARAMETERS, AND COMMUNICATION AND PROGRAMMING DATA IN MEDICAL IMPLANTS; SOFTWARE, IN PARTICULAR FOR MEASURING, RECEIVING, SENDING, CHECKING, TRANSFERRING, CALCULATING, PROCESSING, CONTROLLING, PRESENTING AND ANALYZING OF DATA, NAMELY, DATA ABOUT ELECTRICITY, ENERGY, PHYSICAL PARAMETERS, COMMUNICATION AND PROGRAMMING DATA IN APPARATUS, DEVICES AND INSTRUMENTS FOR COMMUNICATING WITH, ENERGIZING AND PROGRAMMING OF MEDICAL IMPLANTS; AND DATA PROCESSING EQUIPMENT AND COMPUTERS (U.S. CLS. 21, 23, 26, 36 AND 38).

#### **CLASS 10—MEDICAL APPARATUS**

FOR MEDICAL AND SURGICAL APPARATUS, INSTRUMENTS AND DEVICES, INCLUDING ACTIVE AND NON-ACTIVE MEDICAL IMPLANTS, NAMELY, MEDICAL IMPLANTS COMPRISED OF ARTIFICIAL MATERIAL; MEDICAL AND SURGICAL APPARATUS, INSTRUMENTS AND DEVICES INTENDED FOR USE INSIDE THE MAMMAL OR HUMAN BODY, IN PARTICULAR MANUAL, ELECTRICAL OR A COMBINATION OF MANUAL AND ELECTRICAL APPARATUS, DEVICES AND INSTRUMENTS, IN ALL GOODS INCLUDING MEDICAL HYDRAULIC, MECHANICAL, AND PNEUMATIC APPARATUS, DEVICES AND INSTRUMENTS, NAMELY, MEDICAL IMPLANTS COMPRISED OF ARTIFICIAL MATERIAL; MEDICAL AND SURGICAL APPARATUS, INSTRUMENTS AND DEVICES FOR REPLACING AND ADDING ONE OR MORE BODILY



FUNCTIONS AND PARTS INSIDE THE BODY, NAMELY, MEDICAL IMPLANTS COMPRISED OF ARTIFICIAL MATERIAL; MEDICAL AND SURGICAL APPARATUS, INSTRUMENTS AND DEVICES DESIGNED FOR WIRELESS PROGRAMMING, WIRELESS CONTROLLING, WIRELESS COMMUNICATING AND WIRELESS ENERGIZING, NAMELY, ACTIVE IMPLANTS IN THE NATURE OF IMPLANTS CONSISTING OF ARTIFICIAL MATERIALS, AND A WIRELESS TRANSMITTER AND A RECEIVER AS AN INTEGRAL COMPONENT OF A SURGICAL IMPLANT; WIRELESS COMMUNICATION SYSTEMS, APPARATUS, DEVICES, AND INSTRUMENTS AND WIRELESS ENERGIZING SYSTEMS, APPARATUS, DEVICES, AND INSTRUMENTS FOR MEASURING, RECEIVING, SENDING, SWITCHING, TRANSFORMING, ACCUMULATING, REGULATING, STORING, CHECKING, CONTROLLING, DRIVING, TRANSFERRING, TRANSMITTING, PROCESSING AND ANALYZING, IN ALL THE APPLICABLE AFOREMENTIONED GOODS, OF DATA INCLUDING PHYSICAL PARAMETERS, ELECTRICITY, ENERGY AND DATA, NAMELY, ELECTRONIC TRANSMITTERS FOR COMMUNICATING WITH, AND ENERGIZING OF, AND USED IN DIRECT ASSOCIATION WITH, ACTIVE MEDICAL IMPLANTS CONSISTING OF ARTIFICIAL MATERIALS; SURGICAL INSTRUMENTS IN PARTICULAR TO BE USED DURING OPERATIONS OF ACTIVE OR NON-ACTIVE MEDICAL IMPLANTS; VETERINARY MEDICAL AND SURGICAL APPARATUS, INSTRUMENTS AND DEVICES, FOR USE IN IMPLANT SURGERIES; MEDICAL AND SURGICAL APPARATUS, INSTRUMENTS AND DEVICES FOR ORTHOPAEDIC JOINT IMPLANTS; AND MEDICAL IMPLANTS FOR COLLECTING, RECEIVING, SENDING, STORING, PREPARING, CONTROLLING, ANALYZING AND PROCESSING OF DATA AND ENERGY TO AND FROM SAID MEDICAL IMPLANTS (U.S. CLS. 26, 39 AND 44).

#### **CLASS 44—MEDICAL, BEAUTY AND AGRICULTURAL SERVICES**

FOR MEDICAL SERVICES IN RELATION TO MEDICAL IMPLANTS FOR COLLECTING, SENDING, RECEIVING, STORING, PREPARING, CONTROLLING, PRESENTING, CALCULATING, ANALYZING AND PROCESSING OF DATA TO AND FROM PATIENTS AND TO AND FROM MEDICAL IMPLANTS AND TO AND FROM REMOTE CONTROLS, WIRELESS CHARGER APPARATUS AND CONTROL STATIONS FOR ACTIVE IMPLANTS; SURGICAL AND HEALTH SERVICES, NAMELY, IMPLANTATION OF ARTIFICIAL IMPLANTS TO ALLOW THE IMPLANTS TO COLLECT, SEND, RECEIVE, STORE, PREPARE, CONTROL, PRESENT, CALCULATE, ANALYZE, AND PROCESS OF DATA TO AND FROM PATIENTS AND TO AND FROM MEDICAL IMPLANTS AND TO AND FROM MEDICAL IMPLANTS AND TO AND FROM REMOTE CONTROLS, WIRELESS CHARGER APPARATUS AND CONTROL STATIONS FOR ACTIVE IMPLANTS; PROVIDING A MEDICAL, SURGICAL AND HEALTH DATABASE FEATURING MEDICAL, SURGICAL AND HEALTH INFORMATION RELATING TO MEDICAL IMPLANTS THAT HAS BEEN INPUT, COLLECTED, RECEIVED, PREPARED, CONTROLLED, PROGRAMMED, CALCULATED, AND ANALYZED, FROM MEDICAL IMPLANTS, REMOTE CONTROLS OR CONTROL STATIONS FOR USE BY MEDICAL, SURGICAL AND HEALTH PROFESSIONALS FOR THE PURPOSES OF MONITORING AND DIAGNOSING MEDICAL CONDITIONS; MEDICAL AND SURGICAL SERVICES, NAMELY, IMPLANTATION OF ARTIFICIAL IMPLANTS IN RELATION TO MEDICAL IMPLANTS FOR PROGRAMMING, CONTROLLING, COMMUNICATING WITH, AND ENERGIZING OF, ACTIVE IMPLANTS; AND MEDICAL AND SURGICAL SERVICES, NAMELY, ARTIFICIAL IMPLANTATION SERVICES FOR PERSONS HAVING A MEDICAL RELATED CONDITION AND BEING CANDIDATES FOR OR BEING OPERATED ON WITH AN ACTIVE OR A NON-ACTIVE IMPLANT (U.S. CLS. 100 AND 101).

ALEX KEAM, EXAMINING ATTORNEY

SN 77-856.940. MILUX HOLDING S.A., LUXEMBOURG, LUXEMBOURG, FILED 10-26-2009.

## **POTENCYMASTER**

THE MARK CONSISTS OF STANDARD CHARACTERS WITHOUT CLAIM TO ANY PARTICULAR FONT, STYLE, SIZE, OR COLOR.

PRIORITY CLAIMED UNDER SEC. 44(D) ON ERP N CMNTY TM OFC APPLICATION NO. 008245862, FILED 4-27-2009, REG. NO. 008245862, DATED 1-27-2010, EXPIRES 4-27-2019.

#### **CLASS 9—ELECTRICAL AND SCIENTIFIC APPARATUS**

FOR APPARATUS, DEVICES AND INSTRUMENTS, ALL NOT USED IN DIRECT ASSOCIATION WITH ACTIVE IMPLANTS, FOR MEASURING, RECEIVING, SENDING, CHECKING, CONTROLLING, DRIVING, TRANSFERRING, TRANSMITTING, PROCESSING, ANALYZING, CONDUCTING, SWITCHING, TRANSFORMING, ACCUMULATING, AND REGULATING ELECTRICITY, ENERGY AND/OR DATA, INCLUDING PHYSICAL PARAMETERS, NAMELY, ELECTRONIC STORAGE DEVICES IN THE NATURE OF BLANK MEMORY DISCS, MEMORY CARDS AND DATA STORAGE MEDIA, NAMELY, PACKAGED SEMICONDUCTORS, ELECTRONIC CONTROL UNIT AND PROGRAMMER WHICH CONTROLS THE WORKING PARAMETERS OF WIRELESS COMMUNICATION SYSTEMS AND WIRELESS POWERING SYSTEMS, CHARGERS IN THE NATURE OF BATTERY CHARGERS, DIGITAL CHARGERS AND ELECTRONIC CHARGERS, ELECTRONIC TRANSMITTERS AND ELECTRONIC RECEIVERS OF ELECTRONIC SIGNALS, AND ELECTRONIC CIRCUITS; REMOTE CONTROLS FOR WIRELESS CONTROLLING, AND PROGRAMMING WIRELESS CHARGER APPARATUS FOR WIRELESS ENERGIZING AND CONTROL STATIONS FOR WIRELESS CONTROLLING, PROGRAMMING AND ENERGIZING OF ACTIVE IMPLANTS; SOFTWARE, IN PARTICULAR FOR ACTIVE MEDICAL IMPLANTS, FOR MEASURING, RECEIVING, SENDING, CHECKING, TRANSFERRING, CALCULATING, PROCESSING, CONTROLLING, PRESENTING AND ANALYZING OF DATA, NAMELY, DATA ABOUT ELECTRICITY, ENERGY, PHYSICAL PARAMETERS, AND COMMUNICATION AND PROGRAMMING DATA IN MEDICAL IMPLANTS; SOFTWARE, IN PARTICULAR FOR MEASURING, RECEIVING, SENDING, CHECKING, TRANSFERRING, CALCULATING, PROCESSING, CONTROLLING, PRESENTING AND ANALYZING OF DATA, NAMELY, DATA ABOUT ELECTRICITY, ENERGY, PHYSICAL PARAMETERS, COMMUNICATION AND PROGRAMMING DATA IN APPARATUS, DEVICES AND INSTRUMENTS FOR COMMUNICATING WITH, ENERGIZING AND PROGRAMMING OF MEDICAL IMPLANTS; AND DATA PROCESSING EQUIPMENT AND COMPUTERS (U.S. CLS. 21, 23, 26, 36 AND 38).

#### **CLASS 10—MEDICAL APPARATUS**

FOR MEDICAL AND SURGICAL APPARATUS, INSTRUMENTS AND DEVICES, INCLUDING ACTIVE AND NON-ACTIVE MEDICAL IMPLANTS, NAMELY, MEDICAL IMPLANTS COMPRISED OF ARTIFICIAL MATERIAL; MEDICAL AND SURGICAL APPARATUS, INSTRUMENTS AND DEVICES INTENDED FOR USE INSIDE THE MAMMAL OR HUMAN BODY, IN PARTICULAR MANUAL, ELECTRICAL OR A COMBINATION OF MANUAL AND ELECTRICAL APPARATUS, DEVICES AND INSTRUMENTS, IN ALL GOODS INCLUDING MEDICAL HYDRAULIC, MECHANICAL, AND PNEUMATIC APPARATUS, DEVICES AND INSTRUMENTS, NAMELY, MEDICAL IMPLANTS COMPRISED OF ARTIFICIAL MATERIAL; MEDICAL AND SURGICAL APPARATUS, INSTRUMENTS AND DEVICES FOR REPLACING AND ADDING ONE OR MORE BODILY



FUNCTIONS AND PARTS INSIDE THE BODY, NAMELY, MEDICAL IMPLANTS COMPRISED OF ARTIFICIAL MATERIAL; MEDICAL AND SURGICAL APPARATUS, INSTRUMENTS AND DEVICES DESIGNED FOR WIRELESS PROGRAMMING, WIRELESS CONTROLLING, WIRELESS COMMUNICATING AND WIRELESS ENERGIZING, NAMELY, ACTIVE IMPLANTS IN THE NATURE OF IMPLANTS CONSISTING OF ARTIFICIAL MATERIALS, AND A WIRELESS TRANSMITTER AND A RECEIVER AS AN INTEGRAL COMPONENT OF A SURGICAL IMPLANT; WIRELESS COMMUNICATION SYSTEMS, APPARATUS, DEVICES, AND INSTRUMENTS AND WIRELESS ENERGIZING SYSTEMS, APPARATUS, DEVICES, AND INSTRUMENTS FOR MEASURING, RECEIVING, SENDING, SWITCHING, TRANSFORMING, ACCUMULATING, REGULATING, STORING, CHECKING, CONTROLLING, DRIVING, TRANSFERRING, TRANSMITTING, PROCESSING AND ANALYZING, IN ALL THE APPLICABLE AFOREMENTIONED GOODS, OF DATA INCLUDING PHYSICAL PARAMETERS, ELECTRICITY, ENERGY AND DATA, NAMELY, ELECTRONIC TRANSMITTERS FOR COMMUNICATING WITH, AND ENERGIZING OF, AND USED IN DIRECT ASSOCIATION WITH, ACTIVE MEDICAL IMPLANTS CONSISTING OF ARTIFICIAL MATERIALS; SURGICAL INSTRUMENTS IN PARTICULAR TO BE USED DURING OPERATIONS OF ACTIVE OR NON-ACTIVE MEDICAL IMPLANTS; VETERINARY MEDICAL AND SURGICAL APPARATUS, INSTRUMENTS AND DEVICES, FOR USE IN IMPLANT SURGERIES; MEDICAL AND SURGICAL APPARATUS, INSTRUMENTS AND DEVICES FOR ORTHOPAEDIC JOINT IMPLANTS; AND MEDICAL IMPLANTS FOR COLLECTING, RECEIVING, SENDING, STORING, PREPARING, CONTROLLING, ANALYZING AND PROCESSING OF DATA AND ENERGY TO AND FROM SAID MEDICAL IMPLANTS (U.S. CLS. 26, 39 AND 44).

#### **CLASS 44—MEDICAL, BEAUTY AND AGRICULTURAL SERVICES**

FOR MEDICAL SERVICES IN RELATION TO MEDICAL IMPLANTS FOR COLLECTING, SENDING, RECEIVING, STORING, PREPARING, CONTROLLING, PRESENTING, CALCULATING, ANALYZING AND PROCESSING OF DATA TO AND FROM PATIENTS AND TO AND FROM MEDICAL IMPLANTS AND TO AND FROM REMOTE CONTROLS, WIRELESS CHARGER APPARATUS AND CONTROL STATIONS FOR ACTIVE IMPLANTS; SURGICAL AND HEALTH SERVICES, NAMELY, IMPLANTATION OF ARTIFICIAL IMPLANTS TO ALLOW THE IMPLANTS TO COLLECT, SEND, RECEIVE, STORE, PREPARE, CONTROL, PRESENT, CALCULATE, ANALYZE, AND PROCESS OF DATA TO AND FROM PATIENTS AND TO AND FROM MEDICAL IMPLANTS AND TO AND FROM MEDICAL IMPLANTS AND TO AND FROM REMOTE CONTROLS, WIRELESS CHARGER APPARATUS AND CONTROL STATIONS FOR ACTIVE IMPLANTS; PROVIDING A MEDICAL, SURGICAL AND HEALTH DATABASE FEATURING MEDICAL, SURGICAL AND HEALTH INFORMATION RELATING TO MEDICAL IMPLANTS THAT HAS BEEN INPUT, COLLECTED, RECEIVED, PREPARED, CONTROLLED, PROGRAMMED, CALCULATED, AND ANALYZED, FROM MEDICAL IMPLANTS, REMOTE CONTROLS OR CONTROL STATIONS FOR USE BY MEDICAL, SURGICAL AND HEALTH PROFESSIONALS FOR THE PURPOSES OF MONITORING AND DIAGNOSING MEDICAL CONDITIONS; MEDICAL AND SURGICAL SERVICES, NAMELY, IMPLANTATION OF ARTIFICIAL IMPLANTS IN RELATION TO MEDICAL IMPLANTS FOR PROGRAMMING, CONTROLLING, COMMUNICATING WITH, AND ENERGIZING OF, ACTIVE IMPLANTS; AND MEDICAL AND SURGICAL SERVICES, NAMELY, ARTIFICIAL IMPLANTATION SERVICES FOR PERSONS HAVING A MEDICAL RELATED CONDITION AND BEING CANDIDATES FOR OR BEING OPERATED ON WITH AN ACTIVE OR A NON-ACTIVE IMPLANT (U.S. CLS. 100 AND 101).

ALEX KEAM, EXAMINING ATTORNEY

SN 77-856.950. MILUX HOLDING S.A., LUXEMBOURG, LUXEMBOURG, FILED 10-26-2009.

# INJECTICA

THE MARK CONSISTS OF STANDARD CHARACTERS WITHOUT CLAIM TO ANY PARTICULAR FONT, STYLE, SIZE, OR COLOR.

PRIORITY CLAIMED UNDER SEC. 44(D) ON ERPNTY TM OFC APPLICATION NO. 008246051, FILED 4-27-2009, REG. NO. 008246051, DATED 1-27-2010, EXPIRES 4-27-2019.

#### **CLASS 9—ELECTRICAL AND SCIENTIFIC APPARATUS**

FOR APPARATUS, DEVICES AND INSTRUMENTS, ALL NOT USED IN DIRECT ASSOCIATION WITH ACTIVE IMPLANTS, FOR MEASURING, RECEIVING, SENDING, CHECKING, CONTROLLING, DRIVING, TRANSFERRING, TRANSMITTING, PROCESSING, ANALYZING, CONDUCTING, SWITCHING, TRANSFORMING, ACCUMULATING, AND REGULATING ELECTRICITY, ENERGY AND/OR DATA, INCLUDING PHYSICAL PARAMETERS, NAMELY, ELECTRONIC STORAGE DEVICES IN THE NATURE OF BLANK MEMORY DISCS, MEMORY CARDS AND DATA STORAGE MEDIA, NAMELY, PACKAGED SEMICONDUCTORS, ELECTRONIC CONTROL UNIT AND PROGRAMMER WHICH CONTROLS THE WORKING PARAMETERS OF WIRELESS COMMUNICATION SYSTEMS AND WIRELESS POWERING SYSTEMS, CHARGERS IN THE NATURE OF BATTERY CHARGERS, DIGITAL CHARGERS AND ELECTRONIC CHARGERS, ELECTRONIC TRANSMITTERS AND ELECTRONIC RECEIVERS OF ELECTRONIC SIGNALS, AND ELECTRONIC CIRCUITS; REMOTE CONTROLS FOR WIRELESS CONTROLLING, AND PROGRAMMING WIRELESS CHARGER APPARATUS FOR WIRELESS ENERGIZING AND CONTROL STATIONS FOR WIRELESS CONTROLLING, PROGRAMMING AND ENERGIZING OF ACTIVE IMPLANTS; SOFTWARE, IN PARTICULAR FOR ACTIVE MEDICAL IMPLANTS, FOR MEASURING, RECEIVING, SENDING, CHECKING, TRANSFERRING, CALCULATING, PROCESSING, CONTROLLING, PRESENTING AND ANALYZING OF DATA, NAMELY, DATA ABOUT ELECTRICITY, ENERGY, PHYSICAL PARAMETERS, AND COMMUNICATION AND PROGRAMMING DATA IN MEDICAL IMPLANTS; SOFTWARE, IN PARTICULAR FOR MEASURING, RECEIVING, SENDING, CHECKING, TRANSFERRING, CALCULATING, PROCESSING, CONTROLLING, PRESENTING AND ANALYZING OF DATA, NAMELY, DATA ABOUT ELECTRICITY, ENERGY, PHYSICAL PARAMETERS, COMMUNICATION AND PROGRAMMING DATA IN APPARATUS, DEVICES AND INSTRUMENTS FOR COMMUNICATING WITH, ENERGIZING AND PROGRAMMING OF MEDICAL IMPLANTS; AND DATA PROCESSING EQUIPMENT AND COMPUTERS (U.S. CLS. 21, 23, 26, 36 AND 38).

#### **CLASS 10—MEDICAL APPARATUS**

FOR MEDICAL AND SURGICAL APPARATUS, INSTRUMENTS AND DEVICES, INCLUDING ACTIVE AND NON-ACTIVE MEDICAL IMPLANTS, NAMELY, MEDICAL IMPLANTS COMPRISED OF ARTIFICIAL MATERIAL; MEDICAL AND SURGICAL APPARATUS, INSTRUMENTS AND DEVICES INTENDED FOR USE INSIDE THE MAMMAL OR HUMAN BODY, IN PARTICULAR MANUAL, ELECTRICAL OR A COMBINATION OF MANUAL AND ELECTRICAL APPARATUS, DEVICES AND INSTRUMENTS, IN ALL GOODS INCLUDING MEDICAL HYDRAULIC, MECHANICAL, AND PNEUMATIC APPARATUS, DEVICES AND INSTRUMENTS, NAMELY, MEDICAL IMPLANTS COMPRISED OF ARTIFICIAL MATERIAL; MEDICAL AND SURGICAL APPARATUS, INSTRUMENTS AND DEVICES FOR REPLACING AND ADDING ONE OR MORE BODILY

FUNCTIONS AND PARTS INSIDE THE BODY, NAMELY, MEDICAL IMPLANTS COMPRISED OF ARTIFICIAL MATERIAL; MEDICAL AND SURGICAL APPARATUS, INSTRUMENTS AND DEVICES DESIGNED FOR WIRELESS PROGRAMMING, WIRELESS CONTROLLING, WIRELESS COMMUNICATING AND WIRELESS ENERGIZING, NAMELY, ACTIVE IMPLANTS IN THE NATURE OF IMPLANTS CONSISTING OF ARTIFICIAL MATERIALS, AND A WIRELESS TRANSMITTER AND A RECEIVER AS AN INTEGRAL COMPONENT OF A SURGICAL IMPLANT; WIRELESS COMMUNICATION SYSTEMS, APPARATUS, DEVICES, AND INSTRUMENTS AND WIRELESS ENERGIZING SYSTEMS, APPARATUS, DEVICES, AND INSTRUMENTS FOR MEASURING, RECEIVING, SENDING, SWITCHING, TRANSFORMING, ACCUMULATING, REGULATING, STORING, CHECKING, CONTROLLING, DRIVING, TRANSFERRING, TRANSMITTING, PROCESSING AND ANALYZING, IN ALL THE APPLICABLE AFOREMENTIONED GOODS, OF DATA INCLUDING PHYSICAL PARAMETERS, ELECTRICITY, ENERGY AND DATA, NAMELY, ELECTRONIC TRANSMITTERS FOR COMMUNICATING WITH, AND ENERGIZING OF, AND USED IN DIRECT ASSOCIATION WITH, ACTIVE MEDICAL IMPLANTS CONSISTING OF ARTIFICIAL MATERIALS; SURGICAL INSTRUMENTS IN PARTICULAR TO BE USED DURING OPERATIONS OF ACTIVE OR NON-ACTIVE MEDICAL IMPLANTS; VETERINARY MEDICAL AND SURGICAL APPARATUS, INSTRUMENTS AND DEVICES, FOR USE IN IMPLANT SURGERIES; MEDICAL AND SURGICAL APPARATUS, INSTRUMENTS AND DEVICES FOR ORTHOPAEDIC JOINT IMPLANTS; AND MEDICAL IMPLANTS FOR COLLECTING, RECEIVING, SENDING, STORING, PREPARING, CONTROLLING, ANALYZING AND PROCESSING OF DATA AND ENERGY TO AND FROM SAID MEDICAL IMPLANTS (U.S. CLS. 26, 39 AND 44).

#### **CLASS 44—MEDICAL, BEAUTY AND AGRICULTURAL SERVICES**

FOR MEDICAL SERVICES IN RELATION TO MEDICAL IMPLANTS FOR COLLECTING, SENDING, RECEIVING, STORING, PREPARING, CONTROLLING, PRESENTING, CALCULATING, ANALYZING AND PROCESSING OF DATA TO AND FROM PATIENTS AND TO AND FROM MEDICAL IMPLANTS AND TO AND FROM REMOTE CONTROLS, WIRELESS CHARGER APPARATUS AND CONTROL STATIONS FOR ACTIVE IMPLANTS; SURGICAL AND HEALTH SERVICES, NAMELY, IMPLANTATION OF ARTIFICIAL IMPLANTS TO ALLOW THE IMPLANTS TO COLLECT, SEND, RECEIVE, STORE, PREPARE, CONTROL, PRESENT, CALCULATE, ANALYZE, AND PROCESS OF DATA TO AND FROM PATIENTS AND TO AND FROM MEDICAL IMPLANTS AND TO AND FROM MEDICAL IMPLANTS AND TO AND FROM REMOTE CONTROLS, WIRELESS CHARGER APPARATUS AND CONTROL STATIONS FOR ACTIVE IMPLANTS; PROVIDING A MEDICAL, SURGICAL AND HEALTH DATABASE FEATURING MEDICAL, SURGICAL AND HEALTH INFORMATION RELATING TO MEDICAL IMPLANTS THAT HAS BEEN INPUT, COLLECTED, RECEIVED, PREPARED, CONTROLLED, PROGRAMMED, CALCULATED, AND ANALYZED, FROM MEDICAL IMPLANTS, REMOTE CONTROLS OR CONTROL STATIONS FOR USE BY MEDICAL, SURGICAL AND HEALTH PROFESSIONALS FOR THE PURPOSES OF MONITORING AND DIAGNOSING MEDICAL CONDITIONS; MEDICAL AND SURGICAL SERVICES, NAMELY, IMPLANTATION OF ARTIFICIAL IMPLANTS IN RELATION TO MEDICAL IMPLANTS FOR PROGRAMMING, CONTROLLING, COMMUNICATING WITH, AND ENERGIZING OF, ACTIVE IMPLANTS; AND MEDICAL AND SURGICAL SERVICES, NAMELY, ARTIFICIAL IMPLANTATION SERVICES FOR PERSONS HAVING A MEDICAL RELATED CONDITION AND BEING CANDIDATES FOR OR BEING OPERATED ON WITH AN ACTIVE OR A NON-ACTIVE IMPLANT (U.S. CLS. 100 AND 101).

ALEX KEAM, EXAMINING ATTORNEY

SN 77-857.300. MILUX HOLDING S.A., LUXEMBOURG, LUXEMBOURG, FILED 10-26-2009.

# RESTORICA

THE MARK CONSISTS OF STANDARD CHARACTERS WITHOUT CLAIM TO ANY PARTICULAR FONT, STYLE, SIZE, OR COLOR.

PRIORITY CLAIMED UNDER SEC. 44(D) ON ERPNCMNTY TM OFC APPLICATION NO. 008245979, FILED 4-27-2009, REG. NO. 008245979, DATED 6-2-2010, EXPIRES 4-27-2019.

#### **CLASS 9—ELECTRICAL AND SCIENTIFIC APPARATUS**

FOR APPARATUS, DEVICES AND INSTRUMENTS, ALL NOT USED IN DIRECT ASSOCIATION WITH ACTIVE IMPLANTS, FOR MEASURING, RECEIVING, SENDING, CHECKING, CONTROLLING, DRIVING, TRANSFERRING, TRANSMITTING, PROCESSING, ANALYZING, CONDUCTING, SWITCHING, TRANSFORMING, ACCUMULATING, AND REGULATING ELECTRICITY, ENERGY AND/OR DATA, INCLUDING PHYSICAL PARAMETERS, NAMELY, ELECTRONIC STORAGE DEVICES IN THE NATURE OF BLANK MEMORY DISCS, MEMORY CARDS AND DATA STORAGE MEDIA, NAMELY, PACKAGED SEMICONDUCTORS, ELECTRONIC CONTROL UNIT AND PROGRAMMER WHICH CONTROLS THE WORKING PARAMETERS OF WIRELESS COMMUNICATION SYSTEMS AND WIRELESS POWERING SYSTEMS, CHARGERS IN THE NATURE OF BATTERY CHARGERS, DIGITAL CHARGERS AND ELECTRONIC CHARGERS, ELECTRONIC TRANSMITTERS AND ELECTRONIC RECEIVERS OF ELECTRONIC SIGNALS, AND ELECTRONIC CIRCUITS; REMOTE CONTROLS FOR WIRELESS CONTROLLING, AND PROGRAMMING WIRELESS CHARGER APPARATUS FOR WIRELESS ENERGIZING AND CONTROL STATIONS FOR WIRELESS CONTROLLING, PROGRAMMING AND ENERGIZING OF ACTIVE IMPLANTS; SOFTWARE, IN PARTICULAR FOR ACTIVE MEDICAL IMPLANTS, FOR MEASURING, RECEIVING, SENDING, CHECKING, TRANSFERRING, CALCULATING, PROCESSING, CONTROLLING, PRESENTING AND ANALYZING OF DATA, NAMELY, DATA ABOUT ELECTRICITY, ENERGY, PHYSICAL PARAMETERS, AND COMMUNICATION AND PROGRAMMING DATA IN MEDICAL IMPLANTS; SOFTWARE, IN PARTICULAR FOR MEASURING, RECEIVING, SENDING, CHECKING, TRANSFERRING, CALCULATING, PROCESSING, CONTROLLING, PRESENTING AND ANALYZING OF DATA, NAMELY, DATA ABOUT ELECTRICITY, ENERGY, PHYSICAL PARAMETERS, COMMUNICATION AND PROGRAMMING DATA IN APPARATUS, DEVICES AND INSTRUMENTS FOR COMMUNICATING WITH, ENERGIZING AND PROGRAMMING OF MEDICAL IMPLANTS; AND DATA PROCESSING EQUIPMENT AND COMPUTERS (U.S. CLS. 21, 23, 26, 36 AND 38).

#### **CLASS 10—MEDICAL APPARATUS**

FOR MEDICAL AND SURGICAL APPARATUS, INSTRUMENTS AND DEVICES, INCLUDING ACTIVE AND NON-ACTIVE MEDICAL IMPLANTS, NAMELY, MEDICAL IMPLANTS COMPRISED OF ARTIFICIAL MATERIAL; MEDICAL AND SURGICAL APPARATUS, INSTRUMENTS AND DEVICES INTENDED FOR USE INSIDE THE MAMMAL OR HUMAN BODY, IN PARTICULAR MANUAL, ELECTRICAL OR A COMBINATION OF MANUAL AND ELECTRICAL APPARATUS, DEVICES AND INSTRUMENTS, IN ALL GOODS INCLUDING MEDICAL HYDRAULIC, MECHANICAL, AND PNEUMATIC APPARATUS, DEVICES AND INSTRUMENTS, NAMELY, MEDICAL IMPLANTS COMPRISED OF ARTIFICIAL MATERIAL; MEDICAL AND SURGICAL APPARATUS, INSTRUMENTS AND DEVICES FOR REPLACING AND ADDING ONE OR MORE BODILY

FUNCTIONS AND PARTS INSIDE THE BODY, NAMELY, MEDICAL IMPLANTS COMPRISED OF ARTIFICIAL MATERIAL; MEDICAL AND SURGICAL APPARATUS, INSTRUMENTS AND DEVICES DESIGNED FOR WIRELESS PROGRAMMING, WIRELESS CONTROLLING, WIRELESS COMMUNICATING AND WIRELESS ENERGIZING, NAMELY, ACTIVE IMPLANTS IN THE NATURE OF IMPLANTS CONSISTING OF ARTIFICIAL MATERIALS, AND A WIRELESS TRANSMITTER AND A RECEIVER AS AN INTEGRAL COMPONENT OF A SURGICAL IMPLANT; WIRELESS COMMUNICATION SYSTEMS, APPARATUS, DEVICES, AND INSTRUMENTS AND WIRELESS ENERGIZING SYSTEMS, APPARATUS, DEVICES, AND INSTRUMENTS FOR MEASURING, RECEIVING, SENDING, SWITCHING, TRANSFORMING, ACCUMULATING, REGULATING, STORING, CHECKING, CONTROLLING, DRIVING, TRANSFERRING, TRANSMITTING, PROCESSING AND ANALYZING, IN ALL THE APPLICABLE AFOREMENTIONED GOODS, OF DATA INCLUDING PHYSICAL PARAMETERS, ELECTRICITY, ENERGY AND DATA, NAMELY, ELECTRONIC TRANSMITTERS FOR COMMUNICATING WITH, AND ENERGIZING OF, AND USED IN DIRECT ASSOCIATION WITH, ACTIVE MEDICAL IMPLANTS CONSISTING OF ARTIFICIAL MATERIALS; SURGICAL INSTRUMENTS IN PARTICULAR TO BE USED DURING OPERATIONS OF ACTIVE OR NON-ACTIVE MEDICAL IMPLANTS; VETERINARY MEDICAL AND SURGICAL APPARATUS, INSTRUMENTS AND DEVICES, FOR USE IN IMPLANT SURGERIES; MEDICAL AND SURGICAL APPARATUS, INSTRUMENTS AND DEVICES FOR ORTHOPAEDIC JOINT IMPLANTS; AND MEDICAL IMPLANTS FOR COLLECTING, RECEIVING, SENDING, STORING, PREPARING, CONTROLLING, ANALYZING AND PROCESSING OF DATA AND ENERGY TO AND FROM SAID MEDICAL IMPLANTS (U.S. CLS. 26, 39 AND 44).

#### **CLASS 44—MEDICAL, BEAUTY AND AGRICULTURAL SERVICES**

FOR MEDICAL SERVICES IN RELATION TO MEDICAL IMPLANTS FOR COLLECTING, SENDING, RECEIVING, STORING, PREPARING, CONTROLLING, PRESENTING, CALCULATING, ANALYZING AND PROCESSING OF DATA TO AND FROM PATIENTS AND TO AND FROM MEDICAL IMPLANTS AND TO AND FROM REMOTE CONTROLS, WIRELESS CHARGER APPARATUS AND CONTROL STATIONS FOR ACTIVE IMPLANTS; SURGICAL AND HEALTH SERVICES, NAMELY, IMPLANTATION OF ARTIFICIAL IMPLANTS TO ALLOW THE IMPLANTS TO COLLECT, SEND, RECEIVE, STORE, PREPARE, CONTROL, PRESENT, CALCULATE, ANALYZE, AND PROCESS OF DATA TO AND FROM PATIENTS AND TO AND FROM MEDICAL IMPLANTS AND TO AND FROM MEDICAL IMPLANTS AND TO AND FROM REMOTE CONTROLS, WIRELESS CHARGER APPARATUS AND CONTROL STATIONS FOR ACTIVE IMPLANTS; PROVIDING A MEDICAL, SURGICAL AND HEALTH DATABASE FEATURING MEDICAL, SURGICAL AND HEALTH INFORMATION RELATING TO MEDICAL IMPLANTS THAT HAS BEEN INPUT, COLLECTED, RECEIVED, PREPARED, CONTROLLED, PROGRAMMED, CALCULATED, AND ANALYZED, FROM MEDICAL IMPLANTS, REMOTE CONTROLS OR CONTROL STATIONS FOR USE BY MEDICAL, SURGICAL AND HEALTH PROFESSIONALS FOR THE PURPOSES OF MONITORING AND DIAGNOSING MEDICAL CONDITIONS; MEDICAL AND SURGICAL SERVICES, NAMELY, IMPLANTATION OF ARTIFICIAL IMPLANTS IN RELATION TO MEDICAL IMPLANTS FOR PROGRAMMING, CONTROLLING, COMMUNICATING WITH, AND ENERGIZING OF, ACTIVE IMPLANTS; AND MEDICAL AND SURGICAL SERVICES, NAMELY, ARTIFICIAL IMPLANTATION SERVICES FOR PERSONS HAVING A MEDICAL RELATED CONDITION AND BEING CANDIDATES FOR OR BEING OPERATED ON WITH AN ACTIVE OR A NON-ACTIVE IMPLANT (U.S. CLS. 100 AND 101).

ALEX KEAM, EXAMINING ATTORNEY

SN 77-857.357. MILUX HOLDING S.A., LUXEMBOURG, LUXEMBOURG, FILED 10-26-2009.

# STENTICA

THE MARK CONSISTS OF STANDARD CHARACTERS WITHOUT CLAIM TO ANY PARTICULAR FONT, STYLE, SIZE, OR COLOR.

PRIORITY CLAIMED UNDER SEC. 44(D) ON ERPNTY TM OFC APPLICATION NO. 008246027, FILED 4-27-2009, REG. NO. 008246027, DATED 1-28-2010, EXPIRES 4-27-2019.

#### **CLASS 9—ELECTRICAL AND SCIENTIFIC APPARATUS**

FOR APPARATUS, DEVICES AND INSTRUMENTS, ALL NOT USED IN DIRECT ASSOCIATION WITH ACTIVE IMPLANTS, FOR MEASURING, RECEIVING, SENDING, CHECKING, CONTROLLING, DRIVING, TRANSFERRING, TRANSMITTING, PROCESSING, ANALYZING, CONDUCTING, SWITCHING, TRANSFORMING, ACCUMULATING, AND REGULATING ELECTRICITY, ENERGY AND/OR DATA, INCLUDING PHYSICAL PARAMETERS, NAMELY, ELECTRONIC STORAGE DEVICES IN THE NATURE OF BLANK MEMORY DISCS, MEMORY CARDS AND DATA STORAGE MEDIA, NAMELY, PACKAGED SEMICONDUCTORS, ELECTRONIC CONTROL UNIT AND PROGRAMMER WHICH CONTROLS THE WORKING PARAMETERS OF WIRELESS COMMUNICATION SYSTEMS AND WIRELESS POWERING SYSTEMS, CHARGERS IN THE NATURE OF BATTERY CHARGERS, DIGITAL CHARGERS AND ELECTRONIC CHARGERS, ELECTRONIC TRANSMITTERS AND ELECTRONIC RECEIVERS OF ELECTRONIC SIGNALS, AND ELECTRONIC CIRCUITS; REMOTE CONTROLS FOR WIRELESS CONTROLLING, AND PROGRAMMING WIRELESS CHARGER APPARATUS FOR WIRELESS ENERGIZING AND CONTROL STATIONS FOR WIRELESS CONTROLLING, PROGRAMMING AND ENERGIZING OF ACTIVE IMPLANTS; SOFTWARE, IN PARTICULAR FOR ACTIVE MEDICAL IMPLANTS, FOR MEASURING, RECEIVING, SENDING, CHECKING, TRANSFERRING, CALCULATING, PROCESSING, CONTROLLING, PRESENTING AND ANALYZING OF DATA, NAMELY, DATA ABOUT ELECTRICITY, ENERGY, PHYSICAL PARAMETERS, AND COMMUNICATION AND PROGRAMMING DATA IN MEDICAL IMPLANTS; SOFTWARE, IN PARTICULAR FOR MEASURING, RECEIVING, SENDING, CHECKING, TRANSFERRING, CALCULATING, PROCESSING, CONTROLLING, PRESENTING AND ANALYZING OF DATA, NAMELY, DATA ABOUT ELECTRICITY, ENERGY, PHYSICAL PARAMETERS, COMMUNICATION AND PROGRAMMING DATA IN APPARATUS, DEVICES AND INSTRUMENTS FOR COMMUNICATING WITH, ENERGIZING AND PROGRAMMING OF MEDICAL IMPLANTS; AND DATA PROCESSING EQUIPMENT AND COMPUTERS (U.S. CLS. 21, 23, 26, 36 AND 38).

#### **CLASS 10—MEDICAL APPARATUS**

FOR MEDICAL AND SURGICAL APPARATUS, INSTRUMENTS AND DEVICES, INCLUDING ACTIVE AND NON-ACTIVE MEDICAL IMPLANTS, NAMELY, MEDICAL IMPLANTS COMPRISED OF ARTIFICIAL MATERIAL; MEDICAL AND SURGICAL APPARATUS, INSTRUMENTS AND DEVICES INTENDED FOR USE INSIDE THE MAMMAL OR HUMAN BODY, IN PARTICULAR MANUAL, ELECTRICAL OR A COMBINATION OF MANUAL AND ELECTRICAL APPARATUS, DEVICES AND INSTRUMENTS, IN ALL GOODS INCLUDING MEDICAL HYDRAULIC, MECHANICAL, AND PNEUMATIC APPARATUS, DEVICES AND INSTRUMENTS, NAMELY, MEDICAL IMPLANTS COMPRISED OF ARTIFICIAL MATERIAL; MEDICAL AND SURGICAL APPARATUS, INSTRUMENTS AND DEVICES FOR REPLACING AND ADDING ONE OR MORE BODILY



FUNCTIONS AND PARTS INSIDE THE BODY, NAMELY, MEDICAL IMPLANTS COMPRISED OF ARTIFICIAL MATERIAL; MEDICAL AND SURGICAL APPARATUS, INSTRUMENTS AND DEVICES DESIGNED FOR WIRELESS PROGRAMMING, WIRELESS CONTROLLING, WIRELESS COMMUNICATING AND WIRELESS ENERGIZING, NAMELY, ACTIVE IMPLANTS IN THE NATURE OF IMPLANTS CONSISTING OF ARTIFICIAL MATERIALS, AND A WIRELESS TRANSMITTER AND A RECEIVER AS AN INTEGRAL COMPONENT OF A SURGICAL IMPLANT; WIRELESS COMMUNICATION SYSTEMS, APPARATUS, DEVICES, AND INSTRUMENTS AND WIRELESS ENERGIZING SYSTEMS, APPARATUS, DEVICES, AND INSTRUMENTS FOR MEASURING, RECEIVING, SENDING, SWITCHING, TRANSFORMING, ACCUMULATING, REGULATING, STORING, CHECKING, CONTROLLING, DRIVING, TRANSFERRING, TRANSMITTING, PROCESSING AND ANALYZING, IN ALL THE APPLICABLE AFOREMENTIONED GOODS, OF DATA INCLUDING PHYSICAL PARAMETERS, ELECTRICITY, ENERGY AND DATA, NAMELY, ELECTRONIC TRANSMITTERS FOR COMMUNICATING WITH, AND ENERGIZING OF, AND USED IN DIRECT ASSOCIATION WITH, ACTIVE MEDICAL IMPLANTS CONSISTING OF ARTIFICIAL MATERIALS; SURGICAL INSTRUMENTS IN PARTICULAR TO BE USED DURING OPERATIONS OF ACTIVE OR NON-ACTIVE MEDICAL IMPLANTS; VETERINARY MEDICAL AND SURGICAL APPARATUS, INSTRUMENTS AND DEVICES, FOR USE IN IMPLANT SURGERIES; MEDICAL AND SURGICAL APPARATUS, INSTRUMENTS AND DEVICES FOR ORTHOPAEDIC JOINT IMPLANTS; AND MEDICAL IMPLANTS FOR COLLECTING, RECEIVING, SENDING, STORING, PREPARING, CONTROLLING, ANALYZING AND PROCESSING OF DATA AND ENERGY TO AND FROM SAID MEDICAL IMPLANTS (U.S. CLS. 26, 39 AND 44).

#### **CLASS 44—MEDICAL, BEAUTY AND AGRICULTURAL SERVICES**

FOR MEDICAL SERVICES IN RELATION TO MEDICAL IMPLANTS FOR COLLECTING, SENDING, RECEIVING, STORING, PREPARING, CONTROLLING, PRESENTING, CALCULATING, ANALYZING AND PROCESSING OF DATA TO AND FROM PATIENTS AND TO AND FROM MEDICAL IMPLANTS AND TO AND FROM REMOTE CONTROLS, WIRELESS CHARGER APPARATUS AND CONTROL STATIONS FOR ACTIVE IMPLANTS; SURGICAL AND HEALTH SERVICES, NAMELY, IMPLANTATION OF ARTIFICIAL IMPLANTS TO ALLOW THE IMPLANTS TO COLLECT, SEND, RECEIVE, STORE, PREPARE, CONTROL, PRESENT, CALCULATE, ANALYZE, AND PROCESS OF DATA TO AND FROM PATIENTS AND TO AND FROM MEDICAL IMPLANTS AND TO AND FROM MEDICAL IMPLANTS AND TO AND FROM REMOTE CONTROLS, WIRELESS CHARGER APPARATUS AND CONTROL STATIONS FOR ACTIVE IMPLANTS; PROVIDING A MEDICAL, SURGICAL AND HEALTH DATABASE FEATURING MEDICAL, SURGICAL AND HEALTH INFORMATION RELATING TO MEDICAL IMPLANTS THAT HAS BEEN INPUT, COLLECTED, RECEIVED, PREPARED, CONTROLLED, PROGRAMMED, CALCULATED, AND ANALYZED, FROM MEDICAL IMPLANTS, REMOTE CONTROLS OR CONTROL STATIONS FOR USE BY MEDICAL, SURGICAL AND HEALTH PROFESSIONALS FOR THE PURPOSES OF MONITORING AND DIAGNOSING MEDICAL CONDITIONS; MEDICAL AND SURGICAL SERVICES, NAMELY, IMPLANTATION OF ARTIFICIAL IMPLANTS IN RELATION TO MEDICAL IMPLANTS FOR PROGRAMMING, CONTROLLING, COMMUNICATING WITH, AND ENERGIZING OF, ACTIVE IMPLANTS; AND MEDICAL AND SURGICAL SERVICES, NAMELY, ARTIFICIAL IMPLANTATION SERVICES FOR PERSONS HAVING A MEDICAL RELATED CONDITION AND BEING CANDIDATES FOR OR BEING OPERATED ON WITH AN ACTIVE OR A NON-ACTIVE IMPLANT (U.S. CLS. 100 AND 101).

ALEX KEAM, EXAMINING ATTORNEY

SN 77-857.373. MILUX HOLDING S.A., LUXEMBOURG, LUXEMBOURG, FILED 10-26-2009.

# VARYSHAPE

THE MARK CONSISTS OF STANDARD CHARACTERS WITHOUT CLAIM TO ANY PARTICULAR FONT, STYLE, SIZE, OR COLOR.

PRIORITY CLAIMED UNDER SEC. 44(D) ON ERP N CMNTY TM OFC APPLICATION NO. 008246142, FILED 4-27-2009, REG. NO. 008246142, DATED 1-28-2010, EXPIRES 4-27-2019.

#### **CLASS 9—ELECTRICAL AND SCIENTIFIC APPARATUS**

FOR APPARATUS, DEVICES AND INSTRUMENTS, ALL NOT USED IN DIRECT ASSOCIATION WITH ACTIVE IMPLANTS, FOR MEASURING, RECEIVING, SENDING, CHECKING, CONTROLLING, DRIVING, TRANSFERRING, TRANSMITTING, PROCESSING, ANALYZING, CONDUCTING, SWITCHING, TRANSFORMING, ACCUMULATING, AND REGULATING ELECTRICITY, ENERGY AND/OR DATA, INCLUDING PHYSICAL PARAMETERS, NAMELY, ELECTRONIC STORAGE DEVICES IN THE NATURE OF BLANK MEMORY DISCS, MEMORY CARDS AND DATA STORAGE MEDIA, NAMELY, PACKAGED SEMICONDUCTORS, ELECTRONIC CONTROL UNIT AND PROGRAMMER WHICH CONTROLS THE WORKING PARAMETERS OF WIRELESS COMMUNICATION SYSTEMS AND WIRELESS POWERING SYSTEMS, CHARGERS IN THE NATURE OF BATTERY CHARGERS, DIGITAL CHARGERS AND ELECTRONIC CHARGERS, ELECTRONIC TRANSMITTERS AND ELECTRONIC RECEIVERS OF ELECTRONIC SIGNALS, AND ELECTRONIC CIRCUITS; REMOTE CONTROLS FOR WIRELESS CONTROLLING, AND PROGRAMMING WIRELESS CHARGER APPARATUS FOR WIRELESS ENERGIZING AND CONTROL STATIONS FOR WIRELESS CONTROLLING, PROGRAMMING AND ENERGIZING OF ACTIVE IMPLANTS; SOFTWARE, IN PARTICULAR FOR ACTIVE MEDICAL IMPLANTS, FOR MEASURING, RECEIVING, SENDING, CHECKING, TRANSFERRING, CALCULATING, PROCESSING, CONTROLLING, PRESENTING AND ANALYZING OF DATA, NAMELY, DATA ABOUT ELECTRICITY, ENERGY, PHYSICAL PARAMETERS, AND COMMUNICATION AND PROGRAMMING DATA IN MEDICAL IMPLANTS; SOFTWARE, IN PARTICULAR FOR MEASURING, RECEIVING, SENDING, CHECKING, TRANSFERRING, CALCULATING, PROCESSING, CONTROLLING, PRESENTING AND ANALYZING OF DATA, NAMELY, DATA ABOUT ELECTRICITY, ENERGY, PHYSICAL PARAMETERS, COMMUNICATION AND PROGRAMMING DATA IN APPARATUS, DEVICES AND INSTRUMENTS FOR COMMUNICATING WITH, ENERGIZING AND PROGRAMMING OF MEDICAL IMPLANTS; AND DATA PROCESSING EQUIPMENT AND COMPUTERS (U.S. CLS. 21, 23, 26, 36 AND 38).

#### **CLASS 10—MEDICAL APPARATUS**

FOR MEDICAL AND SURGICAL APPARATUS, INSTRUMENTS AND DEVICES, INCLUDING ACTIVE AND NON-ACTIVE MEDICAL IMPLANTS, NAMELY, MEDICAL IMPLANTS COMPRISED OF ARTIFICIAL MATERIAL; MEDICAL AND SURGICAL APPARATUS, INSTRUMENTS AND DEVICES INTENDED FOR USE INSIDE THE MAMMAL OR HUMAN BODY, IN PARTICULAR MANUAL, ELECTRICAL OR A COMBINATION OF MANUAL AND ELECTRICAL APPARATUS, DEVICES AND INSTRUMENTS, IN ALL GOODS INCLUDING MEDICAL HYDRAULIC, MECHANICAL, AND PNEUMATIC APPARATUS, DEVICES AND INSTRUMENTS, NAMELY, MEDICAL IMPLANTS COMPRISED OF ARTIFICIAL MATERIAL; MEDICAL AND SURGICAL APPARATUS, INSTRUMENTS AND DEVICES FOR REPLACING AND ADDING ONE OR MORE BODILY



FUNCTIONS AND PARTS INSIDE THE BODY, NAMELY, MEDICAL IMPLANTS COMPRISED OF ARTIFICIAL MATERIAL; MEDICAL AND SURGICAL APPARATUS, INSTRUMENTS AND DEVICES DESIGNED FOR WIRELESS PROGRAMMING, WIRELESS CONTROLLING, WIRELESS COMMUNICATING AND WIRELESS ENERGIZING, NAMELY, ACTIVE IMPLANTS IN THE NATURE OF IMPLANTS CONSISTING OF ARTIFICIAL MATERIALS, AND A WIRELESS TRANSMITTER AND A RECEIVER AS AN INTEGRAL COMPONENT OF A SURGICAL IMPLANT; WIRELESS COMMUNICATION SYSTEMS, APPARATUS, DEVICES, AND INSTRUMENTS AND WIRELESS ENERGIZING SYSTEMS, APPARATUS, DEVICES, AND INSTRUMENTS FOR MEASURING, RECEIVING, SENDING, SWITCHING, TRANSFORMING, ACCUMULATING, REGULATING, STORING, CHECKING, CONTROLLING, DRIVING, TRANSFERRING, TRANSMITTING, PROCESSING AND ANALYZING, IN ALL THE APPLICABLE AFOREMENTIONED GOODS, OF DATA INCLUDING PHYSICAL PARAMETERS, ELECTRICITY, ENERGY AND DATA, NAMELY, ELECTRONIC TRANSMITTERS FOR COMMUNICATING WITH, AND ENERGIZING OF, AND USED IN DIRECT ASSOCIATION WITH, ACTIVE MEDICAL IMPLANTS CONSISTING OF ARTIFICIAL MATERIALS; SURGICAL INSTRUMENTS IN PARTICULAR TO BE USED DURING OPERATIONS OF ACTIVE OR NON-ACTIVE MEDICAL IMPLANTS; VETERINARY MEDICAL AND SURGICAL APPARATUS, INSTRUMENTS AND DEVICES, FOR USE IN IMPLANT SURGERIES; MEDICAL AND SURGICAL APPARATUS, INSTRUMENTS AND DEVICES FOR ORTHOPAEDIC JOINT IMPLANTS; AND MEDICAL IMPLANTS FOR COLLECTING, RECEIVING, SENDING, STORING, PREPARING, CONTROLLING, ANALYZING AND PROCESSING OF DATA AND ENERGY TO AND FROM SAID MEDICAL IMPLANTS (U.S. CLS. 26, 39 AND 44).

#### **CLASS 44—MEDICAL, BEAUTY AND AGRICULTURAL SERVICES**

FOR MEDICAL SERVICES IN RELATION TO MEDICAL IMPLANTS FOR COLLECTING, SENDING, RECEIVING, STORING, PREPARING, CONTROLLING, PRESENTING, CALCULATING, ANALYZING AND PROCESSING OF DATA TO AND FROM PATIENTS AND TO AND FROM MEDICAL IMPLANTS AND TO AND FROM REMOTE CONTROLS, WIRELESS CHARGER APPARATUS AND CONTROL STATIONS FOR ACTIVE IMPLANTS; SURGICAL AND HEALTH SERVICES, NAMELY, IMPLANTATION OF ARTIFICIAL IMPLANTS TO ALLOW THE IMPLANTS TO COLLECT, SEND, RECEIVE, STORE, PREPARE, CONTROL, PRESENT, CALCULATE, ANALYZE, AND PROCESS OF DATA TO AND FROM PATIENTS AND TO AND FROM MEDICAL IMPLANTS AND TO AND FROM MEDICAL IMPLANTS AND TO AND FROM REMOTE CONTROLS, WIRELESS CHARGER APPARATUS AND CONTROL STATIONS FOR ACTIVE IMPLANTS; PROVIDING A MEDICAL, SURGICAL AND HEALTH DATABASE FEATURING MEDICAL, SURGICAL AND HEALTH INFORMATION RELATING TO MEDICAL IMPLANTS THAT HAS BEEN INPUT, COLLECTED, RECEIVED, PREPARED, CONTROLLED, PROGRAMMED, CALCULATED, AND ANALYZED, FROM MEDICAL IMPLANTS, REMOTE CONTROLS OR CONTROL STATIONS FOR USE BY MEDICAL, SURGICAL AND HEALTH PROFESSIONALS FOR THE PURPOSES OF MONITORING AND DIAGNOSING MEDICAL CONDITIONS; MEDICAL AND SURGICAL SERVICES, NAMELY, IMPLANTATION OF ARTIFICIAL IMPLANTS IN RELATION TO MEDICAL IMPLANTS FOR PROGRAMMING, CONTROLLING, COMMUNICATING WITH, AND ENERGIZING OF, ACTIVE IMPLANTS; AND MEDICAL AND SURGICAL SERVICES, NAMELY, ARTIFICIAL IMPLANTATION SERVICES FOR PERSONS HAVING A MEDICAL RELATED CONDITION AND BEING CANDIDATES FOR OR BEING OPERATED ON WITH AN ACTIVE OR A NON-ACTIVE IMPLANT (U.S. CLS. 100 AND 101).

ALEX KEAM, EXAMINING ATTORNEY

SN 77-857.442. MILUX HOLDING S.A., LUXEMBOURG, LUXEMBOURG, FILED 10-26-2009.

# THORAXICA

THE MARK CONSISTS OF STANDARD CHARACTERS WITHOUT CLAIM TO ANY PARTICULAR FONT, STYLE, SIZE, OR COLOR.

PRIORITY CLAIMED UNDER SEC. 44(D) ON ERPNCMNTY TM OFC APPLICATION NO. 008246118, FILED 4-27-2009, REG. NO. 008246118, DATED 1-28-2010, EXPIRES 4-27-2019.

#### **CLASS 9—ELECTRICAL AND SCIENTIFIC APPARATUS**

FOR APPARATUS, DEVICES AND INSTRUMENTS, ALL NOT USED IN DIRECT ASSOCIATION WITH ACTIVE IMPLANTS, FOR MEASURING, RECEIVING, SENDING, CHECKING, CONTROLLING, DRIVING, TRANSFERRING, TRANSMITTING, PROCESSING, ANALYZING, CONDUCTING, SWITCHING, TRANSFORMING, ACCUMULATING, AND REGULATING ELECTRICITY, ENERGY AND/OR DATA, INCLUDING PHYSICAL PARAMETERS, NAMELY, ELECTRONIC STORAGE DEVICES IN THE NATURE OF BLANK MEMORY DISCS, MEMORY CARDS AND DATA STORAGE MEDIA, NAMELY, PACKAGED SEMICONDUCTORS, ELECTRONIC CONTROL UNIT AND PROGRAMMER WHICH CONTROLS THE WORKING PARAMETERS OF WIRELESS COMMUNICATION SYSTEMS AND WIRELESS POWERING SYSTEMS, CHARGERS IN THE NATURE OF BATTERY CHARGERS, DIGITAL CHARGERS AND ELECTRONIC CHARGERS, ELECTRONIC TRANSMITTERS AND ELECTRONIC RECEIVERS OF ELECTRONIC SIGNALS, AND ELECTRONIC CIRCUITS; REMOTE CONTROLS FOR WIRELESS CONTROLLING, AND PROGRAMMING WIRELESS CHARGER APPARATUS FOR WIRELESS ENERGIZING AND CONTROL STATIONS FOR WIRELESS CONTROLLING, PROGRAMMING AND ENERGIZING OF ACTIVE IMPLANTS; SOFTWARE, IN PARTICULAR FOR ACTIVE MEDICAL IMPLANTS, FOR MEASURING, RECEIVING, SENDING, CHECKING, TRANSFERRING, CALCULATING, PROCESSING, CONTROLLING, PRESENTING AND ANALYZING OF DATA, NAMELY, DATA ABOUT ELECTRICITY, ENERGY, PHYSICAL PARAMETERS, AND COMMUNICATION AND PROGRAMMING DATA IN MEDICAL IMPLANTS; SOFTWARE, IN PARTICULAR FOR MEASURING, RECEIVING, SENDING, CHECKING, TRANSFERRING, CALCULATING, PROCESSING, CONTROLLING, PRESENTING AND ANALYZING OF DATA, NAMELY, DATA ABOUT ELECTRICITY, ENERGY, PHYSICAL PARAMETERS, COMMUNICATION AND PROGRAMMING DATA IN APPARATUS, DEVICES AND INSTRUMENTS FOR COMMUNICATING WITH, ENERGIZING AND PROGRAMMING OF MEDICAL IMPLANTS; AND DATA PROCESSING EQUIPMENT AND COMPUTERS (U.S. CLS. 21, 23, 26, 36 AND 38).

#### **CLASS 10—MEDICAL APPARATUS**

FOR MEDICAL AND SURGICAL APPARATUS, INSTRUMENTS AND DEVICES, INCLUDING ACTIVE AND NON-ACTIVE MEDICAL IMPLANTS, NAMELY, MEDICAL IMPLANTS COMPRISED OF ARTIFICIAL MATERIAL; MEDICAL AND SURGICAL APPARATUS, INSTRUMENTS AND DEVICES INTENDED FOR USE INSIDE THE MAMMAL OR HUMAN BODY, IN PARTICULAR MANUAL, ELECTRICAL OR A COMBINATION OF MANUAL AND ELECTRICAL APPARATUS, DEVICES AND INSTRUMENTS, IN ALL GOODS INCLUDING MEDICAL HYDRAULIC, MECHANICAL, AND PNEUMATIC APPARATUS, DEVICES AND INSTRUMENTS, NAMELY, MEDICAL IMPLANTS COMPRISED OF ARTIFICIAL MATERIAL; MEDICAL AND SURGICAL APPARATUS, INSTRUMENTS AND DEVICES FOR REPLACING AND ADDING ONE OR MORE BODILY

FUNCTIONS AND PARTS INSIDE THE BODY, NAMELY, MEDICAL IMPLANTS COMPRISED OF ARTIFICIAL MATERIAL; MEDICAL AND SURGICAL APPARATUS, INSTRUMENTS AND DEVICES DESIGNED FOR WIRELESS PROGRAMMING, WIRELESS CONTROLLING, WIRELESS COMMUNICATING AND WIRELESS ENERGIZING, NAMELY, ACTIVE IMPLANTS IN THE NATURE OF IMPLANTS CONSISTING OF ARTIFICIAL MATERIALS, AND A WIRELESS TRANSMITTER AND A RECEIVER AS AN INTEGRAL COMPONENT OF A SURGICAL IMPLANT; WIRELESS COMMUNICATION SYSTEMS, APPARATUS, DEVICES, AND INSTRUMENTS AND WIRELESS ENERGIZING SYSTEMS, APPARATUS, DEVICES, AND INSTRUMENTS FOR MEASURING, RECEIVING, SENDING, SWITCHING, TRANSFORMING, ACCUMULATING, REGULATING, STORING, CHECKING, CONTROLLING, DRIVING, TRANSFERRING, TRANSMITTING, PROCESSING AND ANALYZING, IN ALL THE APPLICABLE AFOREMENTIONED GOODS, OF DATA INCLUDING PHYSICAL PARAMETERS, ELECTRICITY, ENERGY AND DATA, NAMELY, ELECTRONIC TRANSMITTERS FOR COMMUNICATING WITH, AND ENERGIZING OF, AND USED IN DIRECT ASSOCIATION WITH, ACTIVE MEDICAL IMPLANTS CONSISTING OF ARTIFICIAL MATERIALS; SURGICAL INSTRUMENTS IN PARTICULAR TO BE USED DURING OPERATIONS OF ACTIVE OR NON-ACTIVE MEDICAL IMPLANTS; VETERINARY MEDICAL AND SURGICAL APPARATUS, INSTRUMENTS AND DEVICES, FOR USE IN IMPLANT SURGERIES; MEDICAL AND SURGICAL APPARATUS, INSTRUMENTS AND DEVICES FOR ORTHOPAEDIC JOINT IMPLANTS; AND MEDICAL IMPLANTS FOR COLLECTING, RECEIVING, SENDING, STORING, PREPARING, CONTROLLING, ANALYZING AND PROCESSING OF DATA AND ENERGY TO AND FROM SAID MEDICAL IMPLANTS (U.S. CLS. 26, 39 AND 44).

#### **CLASS 44—MEDICAL, BEAUTY AND AGRICULTURAL SERVICES**

FOR MEDICAL SERVICES IN RELATION TO MEDICAL IMPLANTS FOR COLLECTING, SENDING, RECEIVING, STORING, PREPARING, CONTROLLING, PRESENTING, CALCULATING, ANALYZING AND PROCESSING OF DATA TO AND FROM PATIENTS AND TO AND FROM MEDICAL IMPLANTS AND TO AND FROM REMOTE CONTROLS, WIRELESS CHARGER APPARATUS AND CONTROL STATIONS FOR ACTIVE IMPLANTS; SURGICAL AND HEALTH SERVICES, NAMELY, IMPLANTATION OF ARTIFICIAL IMPLANTS TO ALLOW THE IMPLANTS TO COLLECT, SEND, RECEIVE, STORE, PREPARE, CONTROL, PRESENT, CALCULATE, ANALYZE, AND PROCESS OF DATA TO AND FROM PATIENTS AND TO AND FROM MEDICAL IMPLANTS AND TO AND FROM MEDICAL IMPLANTS AND TO AND FROM REMOTE CONTROLS, WIRELESS CHARGER APPARATUS AND CONTROL STATIONS FOR ACTIVE IMPLANTS; PROVIDING A MEDICAL, SURGICAL AND HEALTH DATABASE FEATURING MEDICAL, SURGICAL AND HEALTH INFORMATION RELATING TO MEDICAL IMPLANTS THAT HAS BEEN INPUT, COLLECTED, RECEIVED, PREPARED, CONTROLLED, PROGRAMMED, CALCULATED, AND ANALYZED, FROM MEDICAL IMPLANTS, REMOTE CONTROLS OR CONTROL STATIONS FOR USE BY MEDICAL, SURGICAL AND HEALTH PROFESSIONALS FOR THE PURPOSES OF MONITORING AND DIAGNOSING MEDICAL CONDITIONS; MEDICAL AND SURGICAL SERVICES, NAMELY, IMPLANTATION OF ARTIFICIAL IMPLANTS IN RELATION TO MEDICAL IMPLANTS FOR PROGRAMMING, CONTROLLING, COMMUNICATING WITH, AND ENERGIZING OF, ACTIVE IMPLANTS; AND MEDICAL AND SURGICAL SERVICES, NAMELY, ARTIFICIAL IMPLANTATION SERVICES FOR PERSONS HAVING A MEDICAL RELATED CONDITION AND BEING CANDIDATES FOR OR BEING OPERATED ON WITH AN ACTIVE OR A NON-ACTIVE IMPLANT (U.S. CLS. 100 AND 101).

ALEX KEAM, EXAMINING ATTORNEY

SN 77-857.456. MILUX HOLDING S.A., LUXEMBOURG, LUXEMBOURG, FILED 10-26-2009.

## **VASCULARICA**

THE MARK CONSISTS OF STANDARD CHARACTERS WITHOUT CLAIM TO ANY PARTICULAR FONT, STYLE, SIZE, OR COLOR.

PRIORITY CLAIMED UNDER SEC. 44(D) ON ERPNCMNTY TM OFC APPLICATION NO. 008246191, FILED 4-27-2009, REG. NO. 008246191, DATED 1-28-2010, EXPIRES 4-27-2019.

#### **CLASS 9—ELECTRICAL AND SCIENTIFIC APPARATUS**

FOR APPARATUS, DEVICES AND INSTRUMENTS, ALL NOT USED IN DIRECT ASSOCIATION WITH ACTIVE IMPLANTS, FOR MEASURING, RECEIVING, SENDING, CHECKING, CONTROLLING, DRIVING, TRANSFERRING, TRANSMITTING, PROCESSING, ANALYZING, CONDUCTING, SWITCHING, TRANSFORMING, ACCUMULATING, AND REGULATING ELECTRICITY, ENERGY AND/OR DATA, INCLUDING PHYSICAL PARAMETERS, NAMELY, ELECTRONIC STORAGE DEVICES IN THE NATURE OF BLANK MEMORY DISCS, MEMORY CARDS AND DATA STORAGE MEDIA, NAMELY, PACKAGED SEMICONDUCTORS, ELECTRONIC CONTROL UNIT AND PROGRAMMER WHICH CONTROLS THE WORKING PARAMETERS OF WIRELESS COMMUNICATION SYSTEMS AND WIRELESS POWERING SYSTEMS, CHARGERS IN THE NATURE OF BATTERY CHARGERS, DIGITAL CHARGERS AND ELECTRONIC CHARGERS, ELECTRONIC TRANSMITTERS AND ELECTRONIC RECEIVERS OF ELECTRONIC SIGNALS, AND ELECTRONIC CIRCUITS; REMOTE CONTROLS FOR WIRELESS CONTROLLING, AND PROGRAMMING WIRELESS CHARGER APPARATUS FOR WIRELESS ENERGIZING AND CONTROL STATIONS FOR WIRELESS CONTROLLING, PROGRAMMING AND ENERGIZING OF ACTIVE IMPLANTS; SOFTWARE, IN PARTICULAR FOR ACTIVE MEDICAL IMPLANTS, FOR MEASURING, RECEIVING, SENDING, CHECKING, TRANSFERRING, CALCULATING, PROCESSING, CONTROLLING, PRESENTING AND ANALYZING OF DATA, NAMELY, DATA ABOUT ELECTRICITY, ENERGY, PHYSICAL PARAMETERS, AND COMMUNICATION AND PROGRAMMING DATA IN MEDICAL IMPLANTS; SOFTWARE, IN PARTICULAR FOR MEASURING, RECEIVING, SENDING, CHECKING, TRANSFERRING, CALCULATING, PROCESSING, CONTROLLING, PRESENTING AND ANALYZING OF DATA, NAMELY, DATA ABOUT ELECTRICITY, ENERGY, PHYSICAL PARAMETERS, COMMUNICATION AND PROGRAMMING DATA IN APPARATUS, DEVICES AND INSTRUMENTS FOR COMMUNICATING WITH, ENERGIZING AND PROGRAMMING OF MEDICAL IMPLANTS; AND DATA PROCESSING EQUIPMENT AND COMPUTERS (U.S. CLS. 21, 23, 26, 36 AND 38).

#### **CLASS 10—MEDICAL APPARATUS**

FOR MEDICAL AND SURGICAL APPARATUS, INSTRUMENTS AND DEVICES, INCLUDING ACTIVE AND NON-ACTIVE MEDICAL IMPLANTS, NAMELY, MEDICAL IMPLANTS COMPRISED OF ARTIFICIAL MATERIAL; MEDICAL AND SURGICAL APPARATUS, INSTRUMENTS AND DEVICES INTENDED FOR USE INSIDE THE MAMMAL OR HUMAN BODY, IN PARTICULAR MANUAL, ELECTRICAL OR A COMBINATION OF MANUAL AND ELECTRICAL APPARATUS, DEVICES AND INSTRUMENTS, IN ALL GOODS INCLUDING MEDICAL HYDRAULIC, MECHANICAL, AND PNEUMATIC APPARATUS, DEVICES AND INSTRUMENTS, NAMELY, MEDICAL IMPLANTS COMPRISED OF ARTIFICIAL MATERIAL; MEDICAL AND SURGICAL APPARATUS, INSTRUMENTS AND DEVICES FOR REPLACING AND ADDING ONE OR MORE BODILY

FUNCTIONS AND PARTS INSIDE THE BODY, NAMELY, MEDICAL IMPLANTS COMPRISED OF ARTIFICIAL MATERIAL; MEDICAL AND SURGICAL APPARATUS, INSTRUMENTS AND DEVICES DESIGNED FOR WIRELESS PROGRAMMING, WIRELESS CONTROLLING, WIRELESS COMMUNICATING AND WIRELESS ENERGIZING, NAMELY, ACTIVE IMPLANTS IN THE NATURE OF IMPLANTS CONSISTING OF ARTIFICIAL MATERIALS, AND A WIRELESS TRANSMITTER AND A RECEIVER AS AN INTEGRAL COMPONENT OF A SURGICAL IMPLANT; WIRELESS COMMUNICATION SYSTEMS, APPARATUS, DEVICES, AND INSTRUMENTS AND WIRELESS ENERGIZING SYSTEMS, APPARATUS, DEVICES, AND INSTRUMENTS FOR MEASURING, RECEIVING, SENDING, SWITCHING, TRANSFORMING, ACCUMULATING, REGULATING, STORING, CHECKING, CONTROLLING, DRIVING, TRANSFERRING, TRANSMITTING, PROCESSING AND ANALYZING, IN ALL THE APPLICABLE AFOREMENTIONED GOODS, OF DATA INCLUDING PHYSICAL PARAMETERS, ELECTRICITY, ENERGY AND DATA, NAMELY, ELECTRONIC TRANSMITTERS FOR COMMUNICATING WITH, AND ENERGIZING OF, AND USED IN DIRECT ASSOCIATION WITH, ACTIVE MEDICAL IMPLANTS CONSISTING OF ARTIFICIAL MATERIALS; SURGICAL INSTRUMENTS IN PARTICULAR TO BE USED DURING OPERATIONS OF ACTIVE OR NON-ACTIVE MEDICAL IMPLANTS; VETERINARY MEDICAL AND SURGICAL APPARATUS, INSTRUMENTS AND DEVICES, FOR USE IN IMPLANT SURGERIES; MEDICAL AND SURGICAL APPARATUS, INSTRUMENTS AND DEVICES FOR ORTHOPAEDIC JOINT IMPLANTS; AND MEDICAL IMPLANTS FOR COLLECTING, RECEIVING, SENDING, STORING, PREPARING, CONTROLLING, ANALYZING AND PROCESSING OF DATA AND ENERGY TO AND FROM SAID MEDICAL IMPLANTS (U.S. CLS. 26, 39 AND 44).

#### **CLASS 44—MEDICAL, BEAUTY AND AGRICULTURAL SERVICES**

FOR MEDICAL SERVICES IN RELATION TO MEDICAL IMPLANTS FOR COLLECTING, SENDING, RECEIVING, STORING, PREPARING, CONTROLLING, PRESENTING, CALCULATING, ANALYZING AND PROCESSING OF DATA TO AND FROM PATIENTS AND TO AND FROM MEDICAL IMPLANTS AND TO AND FROM REMOTE CONTROLS, WIRELESS CHARGER APPARATUS AND CONTROL STATIONS FOR ACTIVE IMPLANTS; SURGICAL AND HEALTH SERVICES, NAMELY, IMPLANTATION OF ARTIFICIAL IMPLANTS TO ALLOW THE IMPLANTS TO COLLECT, SEND, RECEIVE, STORE, PREPARE, CONTROL, PRESENT, CALCULATE, ANALYZE, AND PROCESS OF DATA TO AND FROM PATIENTS AND TO AND FROM MEDICAL IMPLANTS AND TO AND FROM MEDICAL IMPLANTS AND TO AND FROM REMOTE CONTROLS, WIRELESS CHARGER APPARATUS AND CONTROL STATIONS FOR ACTIVE IMPLANTS; PROVIDING A MEDICAL, SURGICAL AND HEALTH DATABASE FEATURING MEDICAL, SURGICAL AND HEALTH INFORMATION RELATING TO MEDICAL IMPLANTS THAT HAS BEEN INPUT, COLLECTED, RECEIVED, PREPARED, CONTROLLED, PROGRAMMED, CALCULATED, AND ANALYZED, FROM MEDICAL IMPLANTS, REMOTE CONTROLS OR CONTROL STATIONS FOR USE BY MEDICAL, SURGICAL AND HEALTH PROFESSIONALS FOR THE PURPOSES OF MONITORING AND DIAGNOSING MEDICAL CONDITIONS; MEDICAL AND SURGICAL SERVICES, NAMELY, IMPLANTATION OF ARTIFICIAL IMPLANTS IN RELATION TO MEDICAL IMPLANTS FOR PROGRAMMING, CONTROLLING, COMMUNICATING WITH, AND ENERGIZING OF, ACTIVE IMPLANTS; AND MEDICAL AND SURGICAL SERVICES, NAMELY, ARTIFICIAL IMPLANTATION SERVICES FOR PERSONS HAVING A MEDICAL RELATED CONDITION AND BEING CANDIDATES FOR OR BEING OPERATED ON WITH AN ACTIVE OR A NON-ACTIVE IMPLANT (U.S. CLS. 100 AND 101).

ALEX KEAM, EXAMINING ATTORNEY

SN 77-857.468. MILUX HOLDING S.A., LUXEMBOURG, LUXEMBOURG, FILED 10-26-2009.

## **TRUEREVERSIBLE**

THE MARK CONSISTS OF STANDARD CHARACTERS WITHOUT CLAIM TO ANY PARTICULAR FONT, STYLE, SIZE, OR COLOR.

PRIORITY CLAIMED UNDER SEC. 44(D) ON ERPNCMNTY TM OFC APPLICATION NO. 008246126, FILED 4-27-2009, REG. NO. 008246126, DATED 3-16-2010, EXPIRES 4-27-2019.

#### **CLASS 9—ELECTRICAL AND SCIENTIFIC APPARATUS**

FOR APPARATUS, DEVICES AND INSTRUMENTS, ALL NOT USED IN DIRECT ASSOCIATION WITH ACTIVE IMPLANTS, FOR MEASURING, RECEIVING, SENDING, CHECKING, CONTROLLING, DRIVING, TRANSFERRING, TRANSMITTING, PROCESSING, ANALYZING, CONDUCTING, SWITCHING, TRANSFORMING, ACCUMULATING, AND REGULATING ELECTRICITY, ENERGY AND/OR DATA, INCLUDING PHYSICAL PARAMETERS, NAMELY, ELECTRONIC STORAGE DEVICES IN THE NATURE OF BLANK MEMORY DISCS, MEMORY CARDS AND DATA STORAGE MEDIA, NAMELY, PACKAGED SEMICONDUCTORS, ELECTRONIC CONTROL UNIT AND PROGRAMMER WHICH CONTROLS THE WORKING PARAMETERS OF WIRELESS COMMUNICATION SYSTEMS AND WIRELESS POWERING SYSTEMS, CHARGERS IN THE NATURE OF BATTERY CHARGERS, DIGITAL CHARGERS AND ELECTRONIC CHARGERS, ELECTRONIC TRANSMITTERS AND ELECTRONIC RECEIVERS OF ELECTRONIC SIGNALS, AND ELECTRONIC CIRCUITS; REMOTE CONTROLS FOR WIRELESS CONTROLLING, AND PROGRAMMING WIRELESS CHARGER APPARATUS FOR WIRELESS ENERGIZING AND CONTROL STATIONS FOR WIRELESS CONTROLLING, PROGRAMMING AND ENERGIZING OF ACTIVE IMPLANTS; SOFTWARE, IN PARTICULAR FOR ACTIVE MEDICAL IMPLANTS, FOR MEASURING, RECEIVING, SENDING, CHECKING, TRANSFERRING, CALCULATING, PROCESSING, CONTROLLING, PRESENTING AND ANALYZING OF DATA, NAMELY, DATA ABOUT ELECTRICITY, ENERGY, PHYSICAL PARAMETERS, AND COMMUNICATION AND PROGRAMMING DATA IN MEDICAL IMPLANTS; SOFTWARE, IN PARTICULAR FOR MEASURING, RECEIVING, SENDING, CHECKING, TRANSFERRING, CALCULATING, PROCESSING, CONTROLLING, PRESENTING AND ANALYZING OF DATA, NAMELY, DATA ABOUT ELECTRICITY, ENERGY, PHYSICAL PARAMETERS, COMMUNICATION AND PROGRAMMING DATA IN APPARATUS, DEVICES AND INSTRUMENTS FOR COMMUNICATING WITH, ENERGIZING AND PROGRAMMING OF MEDICAL IMPLANTS; AND DATA PROCESSING EQUIPMENT AND COMPUTERS (U.S. CLS. 21, 23, 26, 36 AND 38).

#### **CLASS 10—MEDICAL APPARATUS**

FOR MEDICAL AND SURGICAL APPARATUS, INSTRUMENTS AND DEVICES, INCLUDING ACTIVE AND NON-ACTIVE MEDICAL IMPLANTS, NAMELY, MEDICAL IMPLANTS COMPRISED OF ARTIFICIAL MATERIAL; MEDICAL AND SURGICAL APPARATUS, INSTRUMENTS AND DEVICES INTENDED FOR USE INSIDE THE MAMMAL OR HUMAN BODY, IN PARTICULAR MANUAL, ELECTRICAL OR A COMBINATION OF MANUAL AND ELECTRICAL APPARATUS, DEVICES AND INSTRUMENTS, IN ALL GOODS INCLUDING MEDICAL HYDRAULIC, MECHANICAL, AND PNEUMATIC APPARATUS, DEVICES AND INSTRUMENTS, NAMELY, MEDICAL IMPLANTS COMPRISED OF ARTIFICIAL MATERIAL; MEDICAL AND SURGICAL APPARATUS, INSTRUMENTS AND DEVICES FOR REPLACING AND ADDING ONE OR MORE BODILY



FUNCTIONS AND PARTS INSIDE THE BODY, NAMELY, MEDICAL IMPLANTS COMPRISED OF ARTIFICIAL MATERIAL; MEDICAL AND SURGICAL APPARATUS, INSTRUMENTS AND DEVICES DESIGNED FOR WIRELESS PROGRAMMING, WIRELESS CONTROLLING, WIRELESS COMMUNICATING AND WIRELESS ENERGIZING, NAMELY, ACTIVE IMPLANTS IN THE NATURE OF IMPLANTS CONSISTING OF ARTIFICIAL MATERIALS, AND A WIRELESS TRANSMITTER AND A RECEIVER AS AN INTEGRAL COMPONENT OF A SURGICAL IMPLANT; WIRELESS COMMUNICATION SYSTEMS, APPARATUS, DEVICES, AND INSTRUMENTS AND WIRELESS ENERGIZING SYSTEMS, APPARATUS, DEVICES, AND INSTRUMENTS FOR MEASURING, RECEIVING, SENDING, SWITCHING, TRANSFORMING, ACCUMULATING, REGULATING, STORING, CHECKING, CONTROLLING, DRIVING, TRANSFERRING, TRANSMITTING, PROCESSING AND ANALYZING, IN ALL THE APPLICABLE AFOREMENTIONED GOODS, OF DATA INCLUDING PHYSICAL PARAMETERS, ELECTRICITY, ENERGY AND DATA, NAMELY, ELECTRONIC TRANSMITTERS FOR COMMUNICATING WITH, AND ENERGIZING OF, AND USED IN DIRECT ASSOCIATION WITH, ACTIVE MEDICAL IMPLANTS CONSISTING OF ARTIFICIAL MATERIALS; SURGICAL INSTRUMENTS IN PARTICULAR TO BE USED DURING OPERATIONS OF ACTIVE OR NON-ACTIVE MEDICAL IMPLANTS; VETERINARY MEDICAL AND SURGICAL APPARATUS, INSTRUMENTS AND DEVICES, FOR USE IN IMPLANT SURGERIES; MEDICAL AND SURGICAL APPARATUS, INSTRUMENTS AND DEVICES FOR ORTHOPAEDIC JOINT IMPLANTS; AND MEDICAL IMPLANTS FOR COLLECTING, RECEIVING, SENDING, STORING, PREPARING, CONTROLLING, ANALYZING AND PROCESSING OF DATA AND ENERGY TO AND FROM SAID MEDICAL IMPLANTS (U.S. CLS. 26, 39 AND 44).

#### **CLASS 44—MEDICAL, BEAUTY AND AGRICULTURAL SERVICES**

FOR MEDICAL SERVICES IN RELATION TO MEDICAL IMPLANTS FOR COLLECTING, SENDING, RECEIVING, STORING, PREPARING, CONTROLLING, PRESENTING, CALCULATING, ANALYZING AND PROCESSING OF DATA TO AND FROM PATIENTS AND TO AND FROM MEDICAL IMPLANTS AND TO AND FROM REMOTE CONTROLS, WIRELESS CHARGER APPARATUS AND CONTROL STATIONS FOR ACTIVE IMPLANTS; SURGICAL AND HEALTH SERVICES, NAMELY, IMPLANTATION OF ARTIFICIAL IMPLANTS TO ALLOW THE IMPLANTS TO COLLECT, SEND, RECEIVE, STORE, PREPARE, CONTROL, PRESENT, CALCULATE, ANALYZE, AND PROCESS OF DATA TO AND FROM PATIENTS AND TO AND FROM MEDICAL IMPLANTS AND TO AND FROM MEDICAL IMPLANTS AND TO AND FROM REMOTE CONTROLS, WIRELESS CHARGER APPARATUS AND CONTROL STATIONS FOR ACTIVE IMPLANTS; PROVIDING A MEDICAL, SURGICAL AND HEALTH DATABASE FEATURING MEDICAL, SURGICAL AND HEALTH INFORMATION RELATING TO MEDICAL IMPLANTS THAT HAS BEEN INPUT, COLLECTED, RECEIVED, PREPARED, CONTROLLED, PROGRAMMED, CALCULATED, AND ANALYZED, FROM MEDICAL IMPLANTS, REMOTE CONTROLS OR CONTROL STATIONS FOR USE BY MEDICAL, SURGICAL AND HEALTH PROFESSIONALS FOR THE PURPOSES OF MONITORING AND DIAGNOSING MEDICAL CONDITIONS; MEDICAL AND SURGICAL SERVICES, NAMELY, IMPLANTATION OF ARTIFICIAL IMPLANTS IN RELATION TO MEDICAL IMPLANTS FOR PROGRAMMING, CONTROLLING, COMMUNICATING WITH, AND ENERGIZING OF, ACTIVE IMPLANTS; AND MEDICAL AND SURGICAL SERVICES, NAMELY, ARTIFICIAL IMPLANTATION SERVICES FOR PERSONS HAVING A MEDICAL RELATED CONDITION AND BEING CANDIDATES FOR OR BEING OPERATED ON WITH AN ACTIVE OR A NON-ACTIVE IMPLANT (U.S. CLS. 100 AND 101).

ALEX KEAM, EXAMINING ATTORNEY

SN 77-858.091. MILUX HOLDING S.A., LUXEMBOURG, LUXEMBOURG, FILED 10-27-2009.

## **URICONTROL**

THE MARK CONSISTS OF STANDARD CHARACTERS WITHOUT CLAIM TO ANY PARTICULAR FONT, STYLE, SIZE, OR COLOR.

PRIORITY CLAIMED UNDER SEC. 44(D) ON ERP N CMNTY TM OFC APPLICATION NO. 008246183, FILED 4-27-2009, REG. NO. 008246183, DATED 1-28-2010, EXPIRES 4-27-2019.

#### **CLASS 9—ELECTRICAL AND SCIENTIFIC APPARATUS**

FOR APPARATUS, DEVICES AND INSTRUMENTS, ALL NOT USED IN DIRECT ASSOCIATION WITH ACTIVE IMPLANTS, FOR MEASURING, RECEIVING, SENDING, CHECKING, CONTROLLING, DRIVING, TRANSFERRING, TRANSMITTING, PROCESSING, ANALYZING, CONDUCTING, SWITCHING, TRANSFORMING, ACCUMULATING, AND REGULATING ELECTRICITY, ENERGY AND/OR DATA, INCLUDING PHYSICAL PARAMETERS, NAMELY, ELECTRONIC STORAGE DEVICES IN THE NATURE OF BLANK MEMORY DISCS, MEMORY CARDS AND DATA STORAGE MEDIA, NAMELY, PACKAGED SEMICONDUCTORS, ELECTRONIC CONTROL UNIT AND PROGRAMMER WHICH CONTROLS THE WORKING PARAMETERS OF WIRELESS COMMUNICATION SYSTEMS AND WIRELESS POWERING SYSTEMS, CHARGERS IN THE NATURE OF BATTERY CHARGERS, DIGITAL CHARGERS AND ELECTRONIC CHARGERS, ELECTRONIC TRANSMITTERS AND ELECTRONIC RECEIVERS OF ELECTRONIC SIGNALS, AND ELECTRONIC CIRCUITS; REMOTE CONTROLS FOR WIRELESS CONTROLLING, AND PROGRAMMING WIRELESS CHARGER APPARATUS FOR WIRELESS ENERGIZING AND CONTROL STATIONS FOR WIRELESS CONTROLLING, PROGRAMMING AND ENERGIZING OF ACTIVE IMPLANTS; SOFTWARE, IN PARTICULAR FOR ACTIVE MEDICAL IMPLANTS, FOR MEASURING, RECEIVING, SENDING, CHECKING, TRANSFERRING, CALCULATING, PROCESSING, CONTROLLING, PRESENTING AND ANALYZING OF DATA, NAMELY, DATA ABOUT ELECTRICITY, ENERGY, PHYSICAL PARAMETERS, AND COMMUNICATION AND PROGRAMMING DATA IN MEDICAL IMPLANTS; SOFTWARE, IN PARTICULAR FOR MEASURING, RECEIVING, SENDING, CHECKING, TRANSFERRING, CALCULATING, PROCESSING, CONTROLLING, PRESENTING AND ANALYZING OF DATA, NAMELY, DATA ABOUT ELECTRICITY, ENERGY, PHYSICAL PARAMETERS, COMMUNICATION AND PROGRAMMING DATA IN APPARATUS, DEVICES AND INSTRUMENTS FOR COMMUNICATING WITH, ENERGIZING AND PROGRAMMING OF MEDICAL IMPLANTS; AND DATA PROCESSING EQUIPMENT AND COMPUTERS (U.S. CLS. 21, 23, 26, 36 AND 38).

#### **CLASS 10—MEDICAL APPARATUS**

FOR MEDICAL AND SURGICAL APPARATUS, INSTRUMENTS AND DEVICES, INCLUDING ACTIVE AND NON-ACTIVE MEDICAL IMPLANTS, NAMELY, MEDICAL IMPLANTS COMPRISED OF ARTIFICIAL MATERIAL; MEDICAL AND SURGICAL APPARATUS, INSTRUMENTS AND DEVICES INTENDED FOR USE INSIDE THE MAMMAL OR HUMAN BODY, IN PARTICULAR MANUAL, ELECTRICAL OR A COMBINATION OF MANUAL AND ELECTRICAL APPARATUS, DEVICES AND INSTRUMENTS, IN ALL GOODS INCLUDING MEDICAL HYDRAULIC, MECHANICAL, AND PNEUMATIC APPARATUS, DEVICES AND INSTRUMENTS, NAMELY, MEDICAL IMPLANTS COMPRISED OF ARTIFICIAL MATERIAL; MEDICAL AND SURGICAL APPARATUS, INSTRUMENTS AND DEVICES FOR REPLACING AND ADDING ONE OR MORE BODILY



FUNCTIONS AND PARTS INSIDE THE BODY, NAMELY, MEDICAL IMPLANTS COMPRISED OF ARTIFICIAL MATERIAL; MEDICAL AND SURGICAL APPARATUS, INSTRUMENTS AND DEVICES DESIGNED FOR WIRELESS PROGRAMMING, WIRELESS CONTROLLING, WIRELESS COMMUNICATING AND WIRELESS ENERGIZING, NAMELY, ACTIVE IMPLANTS IN THE NATURE OF IMPLANTS CONSISTING OF ARTIFICIAL MATERIALS, AND A WIRELESS TRANSMITTER AND A RECEIVER AS AN INTEGRAL COMPONENT OF A SURGICAL IMPLANT; WIRELESS COMMUNICATION SYSTEMS, APPARATUS, DEVICES, AND INSTRUMENTS AND WIRELESS ENERGIZING SYSTEMS, APPARATUS, DEVICES, AND INSTRUMENTS FOR MEASURING, RECEIVING, SENDING, SWITCHING, TRANSFORMING, ACCUMULATING, REGULATING, STORING, CHECKING, CONTROLLING, DRIVING, TRANSFERRING, TRANSMITTING, PROCESSING AND ANALYZING, IN ALL THE APPLICABLE AFOREMENTIONED GOODS, OF DATA INCLUDING PHYSICAL PARAMETERS, ELECTRICITY, ENERGY AND DATA, NAMELY, ELECTRONIC TRANSMITTERS FOR COMMUNICATING WITH, AND ENERGIZING OF, AND USED IN DIRECT ASSOCIATION WITH, ACTIVE MEDICAL IMPLANTS CONSISTING OF ARTIFICIAL MATERIALS; SURGICAL INSTRUMENTS IN PARTICULAR TO BE USED DURING OPERATIONS OF ACTIVE OR NON-ACTIVE MEDICAL IMPLANTS; VETERINARY MEDICAL AND SURGICAL APPARATUS, INSTRUMENTS AND DEVICES, FOR USE IN IMPLANT SURGERIES; MEDICAL AND SURGICAL APPARATUS, INSTRUMENTS AND DEVICES FOR ORTHOPAEDIC JOINT IMPLANTS; AND MEDICAL IMPLANTS FOR COLLECTING, RECEIVING, SENDING, STORING, PREPARING, CONTROLLING, ANALYZING AND PROCESSING OF DATA AND ENERGY TO AND FROM SAID MEDICAL IMPLANTS (U.S. CLS. 26, 39 AND 44).

#### **CLASS 44—MEDICAL, BEAUTY AND AGRICULTURAL SERVICES**

FOR MEDICAL SERVICES IN RELATION TO MEDICAL IMPLANTS FOR COLLECTING, SENDING, RECEIVING, STORING, PREPARING, CONTROLLING, PRESENTING, CALCULATING, ANALYZING AND PROCESSING OF DATA TO AND FROM PATIENTS AND TO AND FROM MEDICAL IMPLANTS AND TO AND FROM REMOTE CONTROLS, WIRELESS CHARGER APPARATUS AND CONTROL STATIONS FOR ACTIVE IMPLANTS; SURGICAL AND HEALTH SERVICES, NAMELY, IMPLANTATION OF ARTIFICIAL IMPLANTS TO ALLOW THE IMPLANTS TO COLLECT, SEND, RECEIVE, STORE, PREPARE, CONTROL, PRESENT, CALCULATE, ANALYZE, AND PROCESS OF DATA TO AND FROM PATIENTS AND TO AND FROM MEDICAL IMPLANTS AND TO AND FROM MEDICAL IMPLANTS AND TO AND FROM REMOTE CONTROLS, WIRELESS CHARGER APPARATUS AND CONTROL STATIONS FOR ACTIVE IMPLANTS; PROVIDING A MEDICAL, SURGICAL AND HEALTH DATABASE FEATURING MEDICAL, SURGICAL AND HEALTH INFORMATION RELATING TO MEDICAL IMPLANTS THAT HAS BEEN INPUT, COLLECTED, RECEIVED, PREPARED, CONTROLLED, PROGRAMMED, CALCULATED, AND ANALYZED, FROM MEDICAL IMPLANTS, REMOTE CONTROLS OR CONTROL STATIONS FOR USE BY MEDICAL, SURGICAL AND HEALTH PROFESSIONALS FOR THE PURPOSES OF MONITORING AND DIAGNOSING MEDICAL CONDITIONS; MEDICAL AND SURGICAL SERVICES, NAMELY, IMPLANTATION OF ARTIFICIAL IMPLANTS IN RELATION TO MEDICAL IMPLANTS FOR PROGRAMMING, CONTROLLING, COMMUNICATING WITH, AND ENERGIZING OF, ACTIVE IMPLANTS; AND MEDICAL AND SURGICAL SERVICES, NAMELY, ARTIFICIAL IMPLANTATION SERVICES FOR PERSONS HAVING A MEDICAL RELATED CONDITION AND BEING CANDIDATES FOR OR BEING OPERATED ON WITH AN ACTIVE OR A NON-ACTIVE IMPLANT (U.S. CLS. 100 AND 101).

ALEX KEAM, EXAMINING ATTORNEY

SN 77-858,103. MILUX HOLDING S.A., LUXEMBOURG, LUXEMBOURG, FILED 10-27-2009.

# URIMASTER

THE MARK CONSISTS OF STANDARD CHARACTERS WITHOUT CLAIM TO ANY PARTICULAR FONT, STYLE, SIZE, OR COLOR.

PRIORITY CLAIMED UNDER SEC. 44(D) ON ERP N CMNTY TM OFC APPLICATION NO. 008246217, FILED 4-27-2009, REG. NO. 008246217, DATED 1-28-2010, EXPIRES 4-27-2019.

#### **CLASS 9—ELECTRICAL AND SCIENTIFIC APPARATUS**

FOR APPARATUS, DEVICES AND INSTRUMENTS, ALL NOT USED IN DIRECT ASSOCIATION WITH ACTIVE IMPLANTS, FOR MEASURING, RECEIVING, SENDING, CHECKING, CONTROLLING, DRIVING, TRANSFERRING, TRANSMITTING, PROCESSING, ANALYZING, CONDUCTING, SWITCHING, TRANSFORMING, ACCUMULATING, AND REGULATING ELECTRICITY, ENERGY AND/OR DATA, INCLUDING PHYSICAL PARAMETERS, NAMELY, ELECTRONIC STORAGE DEVICES IN THE NATURE OF BLANK MEMORY DISCS, MEMORY CARDS AND DATA STORAGE MEDIA, NAMELY, PACKAGED SEMICONDUCTORS, ELECTRONIC CONTROL UNIT AND PROGRAMMER WHICH CONTROLS THE WORKING PARAMETERS OF WIRELESS COMMUNICATION SYSTEMS AND WIRELESS POWERING SYSTEMS, CHARGERS IN THE NATURE OF BATTERY CHARGERS, DIGITAL CHARGERS AND ELECTRONIC CHARGERS, ELECTRONIC TRANSMITTERS AND ELECTRONIC RECEIVERS OF ELECTRONIC SIGNALS, AND ELECTRONIC CIRCUITS; REMOTE CONTROLS FOR WIRELESS CONTROLLING, AND PROGRAMMING WIRELESS CHARGER APPARATUS FOR WIRELESS ENERGIZING AND CONTROL STATIONS FOR WIRELESS CONTROLLING, PROGRAMMING AND ENERGIZING OF ACTIVE IMPLANTS; SOFTWARE, IN PARTICULAR FOR ACTIVE MEDICAL IMPLANTS, FOR MEASURING, RECEIVING, SENDING, CHECKING, TRANSFERRING, CALCULATING, PROCESSING, CONTROLLING, PRESENTING AND ANALYZING OF DATA, NAMELY, DATA ABOUT ELECTRICITY, ENERGY, PHYSICAL PARAMETERS, AND COMMUNICATION AND PROGRAMMING DATA IN MEDICAL IMPLANTS; SOFTWARE, IN PARTICULAR FOR MEASURING, RECEIVING, SENDING, CHECKING, TRANSFERRING, CALCULATING, PROCESSING, CONTROLLING, PRESENTING AND ANALYZING OF DATA, NAMELY, DATA ABOUT ELECTRICITY, ENERGY, PHYSICAL PARAMETERS, COMMUNICATION AND PROGRAMMING DATA IN APPARATUS, DEVICES AND INSTRUMENTS FOR COMMUNICATING WITH, ENERGIZING AND PROGRAMMING OF MEDICAL IMPLANTS; AND DATA PROCESSING EQUIPMENT AND COMPUTERS (U.S. CLS. 21, 23, 26, 36 AND 38).

#### **CLASS 10—MEDICAL APPARATUS**

FOR MEDICAL AND SURGICAL APPARATUS, INSTRUMENTS AND DEVICES, INCLUDING ACTIVE AND NON-ACTIVE MEDICAL IMPLANTS, NAMELY, MEDICAL IMPLANTS COMPRISED OF ARTIFICIAL MATERIAL; MEDICAL AND SURGICAL APPARATUS, INSTRUMENTS AND DEVICES INTENDED FOR USE INSIDE THE MAMMAL OR HUMAN BODY, IN PARTICULAR MANUAL, ELECTRICAL OR A COMBINATION OF MANUAL AND ELECTRICAL APPARATUS, DEVICES AND INSTRUMENTS, IN ALL GOODS INCLUDING MEDICAL HYDRAULIC, MECHANICAL, AND PNEUMATIC APPARATUS, DEVICES AND INSTRUMENTS, NAMELY, MEDICAL IMPLANTS COMPRISED OF ARTIFICIAL MATERIAL; MEDICAL AND SURGICAL APPARATUS, INSTRUMENTS AND DEVICES FOR REPLACING AND ADDING ONE OR MORE BODILY

FUNCTIONS AND PARTS INSIDE THE BODY, NAMELY, MEDICAL IMPLANTS COMPRISED OF ARTIFICIAL MATERIAL; MEDICAL AND SURGICAL APPARATUS, INSTRUMENTS AND DEVICES DESIGNED FOR WIRELESS PROGRAMMING, WIRELESS CONTROLLING, WIRELESS COMMUNICATING AND WIRELESS ENERGIZING, NAMELY, ACTIVE IMPLANTS IN THE NATURE OF IMPLANTS CONSISTING OF ARTIFICIAL MATERIALS, AND A WIRELESS TRANSMITTER AND A RECEIVER AS AN INTEGRAL COMPONENT OF A SURGICAL IMPLANT; WIRELESS COMMUNICATION SYSTEMS, APPARATUS, DEVICES, AND INSTRUMENTS AND WIRELESS ENERGIZING SYSTEMS, APPARATUS, DEVICES, AND INSTRUMENTS FOR MEASURING, RECEIVING, SENDING, SWITCHING, TRANSFORMING, ACCUMULATING, REGULATING, STORING, CHECKING, CONTROLLING, DRIVING, TRANSFERRING, TRANSMITTING, PROCESSING AND ANALYZING, IN ALL THE APPLICABLE AFOREMENTIONED GOODS, OF DATA INCLUDING PHYSICAL PARAMETERS, ELECTRICITY, ENERGY AND DATA, NAMELY, ELECTRONIC TRANSMITTERS FOR COMMUNICATING WITH, AND ENERGIZING OF, AND USED IN DIRECT ASSOCIATION WITH, ACTIVE MEDICAL IMPLANTS CONSISTING OF ARTIFICIAL MATERIALS; SURGICAL INSTRUMENTS IN PARTICULAR TO BE USED DURING OPERATIONS OF ACTIVE OR NON-ACTIVE MEDICAL IMPLANTS; VETERINARY MEDICAL AND SURGICAL APPARATUS, INSTRUMENTS AND DEVICES, FOR USE IN IMPLANT SURGERIES; MEDICAL AND SURGICAL APPARATUS, INSTRUMENTS AND DEVICES FOR ORTHOPAEDIC JOINT IMPLANTS; AND MEDICAL IMPLANTS FOR COLLECTING, RECEIVING, SENDING, STORING, PREPARING, CONTROLLING, ANALYZING AND PROCESSING OF DATA AND ENERGY TO AND FROM SAID MEDICAL IMPLANTS (U.S. CLS. 26, 39 AND 44).

#### **CLASS 44—MEDICAL, BEAUTY AND AGRICULTURAL SERVICES**

FOR MEDICAL SERVICES IN RELATION TO MEDICAL IMPLANTS FOR COLLECTING, SENDING, RECEIVING, STORING, PREPARING, CONTROLLING, PRESENTING, CALCULATING, ANALYZING AND PROCESSING OF DATA TO AND FROM PATIENTS AND TO AND FROM MEDICAL IMPLANTS AND TO AND FROM REMOTE CONTROLS, WIRELESS CHARGER APPARATUS AND CONTROL STATIONS FOR ACTIVE IMPLANTS; SURGICAL AND HEALTH SERVICES, NAMELY, IMPLANTATION OF ARTIFICIAL IMPLANTS TO ALLOW THE IMPLANTS TO COLLECT, SEND, RECEIVE, STORE, PREPARE, CONTROL, PRESENT, CALCULATE, ANALYZE, AND PROCESS OF DATA TO AND FROM PATIENTS AND TO AND FROM MEDICAL IMPLANTS AND TO AND FROM MEDICAL IMPLANTS AND TO AND FROM REMOTE CONTROLS, WIRELESS CHARGER APPARATUS AND CONTROL STATIONS FOR ACTIVE IMPLANTS; PROVIDING A MEDICAL, SURGICAL AND HEALTH DATABASE FEATURING MEDICAL, SURGICAL AND HEALTH INFORMATION RELATING TO MEDICAL IMPLANTS THAT HAS BEEN INPUT, COLLECTED, RECEIVED, PREPARED, CONTROLLED, PROGRAMMED, CALCULATED, AND ANALYZED, FROM MEDICAL IMPLANTS, REMOTE CONTROLS OR CONTROL STATIONS FOR USE BY MEDICAL, SURGICAL AND HEALTH PROFESSIONALS FOR THE PURPOSES OF MONITORING AND DIAGNOSING MEDICAL CONDITIONS; MEDICAL AND SURGICAL SERVICES, NAMELY, IMPLANTATION OF ARTIFICIAL IMPLANTS IN RELATION TO MEDICAL IMPLANTS FOR PROGRAMMING, CONTROLLING, COMMUNICATING WITH, AND ENERGIZING OF, ACTIVE IMPLANTS; AND MEDICAL AND SURGICAL SERVICES, NAMELY, ARTIFICIAL IMPLANTATION SERVICES FOR PERSONS HAVING A MEDICAL RELATED CONDITION AND BEING CANDIDATES FOR OR BEING OPERATED ON WITH AN ACTIVE OR A NON-ACTIVE IMPLANT (U.S. CLS. 100 AND 101).

ALEX KEAM, EXAMINING ATTORNEY

SN 77-858.200. MILUX HOLDING S.A., LUXEMBOURG, LUXEMBOURG, FILED 10-27-2009.

## **MEDIMASTER**

THE MARK CONSISTS OF STANDARD CHARACTERS WITHOUT CLAIM TO ANY PARTICULAR FONT, STYLE, SIZE, OR COLOR.

PRIORITY CLAIMED UNDER SEC. 44(D) ON ERPNCMNTY TM OFC APPLICATION NO. 008246274, FILED 4-27-2009, REG. NO. 008246274, DATED 1-27-2010, EXPIRES 4-27-2019.

#### **CLASS 9—ELECTRICAL AND SCIENTIFIC APPARATUS**

FOR APPARATUS, DEVICES AND INSTRUMENTS, ALL NOT USED IN DIRECT ASSOCIATION WITH ACTIVE IMPLANTS, FOR MEASURING, RECEIVING, SENDING, CHECKING, CONTROLLING, DRIVING, TRANSFERRING, TRANSMITTING, PROCESSING, ANALYZING, CONDUCTING, SWITCHING, TRANSFORMING, ACCUMULATING, AND REGULATING ELECTRICITY, ENERGY AND/OR DATA, INCLUDING PHYSICAL PARAMETERS, NAMELY, ELECTRONIC STORAGE DEVICES IN THE NATURE OF BLANK MEMORY DISCS, MEMORY CARDS AND DATA STORAGE MEDIA, NAMELY, PACKAGED SEMICONDUCTORS, ELECTRONIC CONTROL UNIT AND PROGRAMMER WHICH CONTROLS THE WORKING PARAMETERS OF WIRELESS COMMUNICATION SYSTEMS AND WIRELESS POWERING SYSTEMS, CHARGERS IN THE NATURE OF BATTERY CHARGERS, DIGITAL CHARGERS AND ELECTRONIC CHARGERS, ELECTRONIC TRANSMITTERS AND ELECTRONIC RECEIVERS OF ELECTRONIC SIGNALS, AND ELECTRONIC CIRCUITS; REMOTE CONTROLS FOR WIRELESS CONTROLLING, AND PROGRAMMING WIRELESS CHARGER APPARATUS FOR WIRELESS ENERGIZING AND CONTROL STATIONS FOR WIRELESS CONTROLLING, PROGRAMMING AND ENERGIZING OF ACTIVE IMPLANTS; SOFTWARE, IN PARTICULAR FOR ACTIVE MEDICAL IMPLANTS, FOR MEASURING, RECEIVING, SENDING, CHECKING, TRANSFERRING, CALCULATING, PROCESSING, CONTROLLING, PRESENTING AND ANALYZING OF DATA, NAMELY, DATA ABOUT ELECTRICITY, ENERGY, PHYSICAL PARAMETERS, AND COMMUNICATION AND PROGRAMMING DATA IN MEDICAL IMPLANTS; SOFTWARE, IN PARTICULAR FOR MEASURING, RECEIVING, SENDING, CHECKING, TRANSFERRING, CALCULATING, PROCESSING, CONTROLLING, PRESENTING AND ANALYZING OF DATA, NAMELY, DATA ABOUT ELECTRICITY, ENERGY, PHYSICAL PARAMETERS, COMMUNICATION AND PROGRAMMING DATA IN APPARATUS, DEVICES AND INSTRUMENTS FOR COMMUNICATING WITH, ENERGIZING AND PROGRAMMING OF MEDICAL IMPLANTS; AND DATA PROCESSING EQUIPMENT AND COMPUTERS (U.S. CLS. 21, 23, 26, 36 AND 38).

#### **CLASS 10—MEDICAL APPARATUS**

FOR MEDICAL AND SURGICAL APPARATUS, INSTRUMENTS AND DEVICES, INCLUDING ACTIVE AND NON-ACTIVE MEDICAL IMPLANTS, NAMELY, MEDICAL IMPLANTS COMPRISED OF ARTIFICIAL MATERIAL; MEDICAL AND SURGICAL APPARATUS, INSTRUMENTS AND DEVICES INTENDED FOR USE INSIDE THE MAMMAL OR HUMAN BODY, IN PARTICULAR MANUAL, ELECTRICAL OR A COMBINATION OF MANUAL AND ELECTRICAL APPARATUS, DEVICES AND INSTRUMENTS, IN ALL GOODS INCLUDING MEDICAL HYDRAULIC, MECHANICAL, AND PNEUMATIC APPARATUS, DEVICES AND INSTRUMENTS, NAMELY, MEDICAL IMPLANTS COMPRISED OF ARTIFICIAL MATERIAL; MEDICAL AND SURGICAL APPARATUS, INSTRUMENTS AND DEVICES FOR REPLACING AND ADDING ONE OR MORE BODILY

FUNCTIONS AND PARTS INSIDE THE BODY, NAMELY, MEDICAL IMPLANTS COMPRISED OF ARTIFICIAL MATERIAL; MEDICAL AND SURGICAL APPARATUS, INSTRUMENTS AND DEVICES DESIGNED FOR WIRELESS PROGRAMMING, WIRELESS CONTROLLING, WIRELESS COMMUNICATING AND WIRELESS ENERGIZING, NAMELY, ACTIVE IMPLANTS IN THE NATURE OF IMPLANTS CONSISTING OF ARTIFICIAL MATERIALS, AND A WIRELESS TRANSMITTER AND A RECEIVER AS AN INTEGRAL COMPONENT OF A SURGICAL IMPLANT; WIRELESS COMMUNICATION SYSTEMS, APPARATUS, DEVICES, AND INSTRUMENTS AND WIRELESS ENERGIZING SYSTEMS, APPARATUS, DEVICES, AND INSTRUMENTS FOR MEASURING, RECEIVING, SENDING, SWITCHING, TRANSFORMING, ACCUMULATING, REGULATING, STORING, CHECKING, CONTROLLING, DRIVING, TRANSFERRING, TRANSMITTING, PROCESSING AND ANALYZING, IN ALL THE APPLICABLE AFOREMENTIONED GOODS, OF DATA INCLUDING PHYSICAL PARAMETERS, ELECTRICITY, ENERGY AND DATA, NAMELY, ELECTRONIC TRANSMITTERS FOR COMMUNICATING WITH, AND ENERGIZING OF, AND USED IN DIRECT ASSOCIATION WITH, ACTIVE MEDICAL IMPLANTS CONSISTING OF ARTIFICIAL MATERIALS; SURGICAL INSTRUMENTS IN PARTICULAR TO BE USED DURING OPERATIONS OF ACTIVE OR NON-ACTIVE MEDICAL IMPLANTS; VETERINARY MEDICAL AND SURGICAL APPARATUS, INSTRUMENTS AND DEVICES, FOR USE IN IMPLANT SURGERIES; MEDICAL AND SURGICAL APPARATUS, INSTRUMENTS AND DEVICES FOR ORTHOPAEDIC JOINT IMPLANTS; AND MEDICAL IMPLANTS FOR COLLECTING, RECEIVING, SENDING, STORING, PREPARING, CONTROLLING, ANALYZING AND PROCESSING OF DATA AND ENERGY TO AND FROM SAID MEDICAL IMPLANTS (U.S. CLS. 26, 39 AND 44).

#### **CLASS 44—MEDICAL, BEAUTY AND AGRICULTURAL SERVICES**

FOR MEDICAL SERVICES IN RELATION TO MEDICAL IMPLANTS FOR COLLECTING, SENDING, RECEIVING, STORING, PREPARING, CONTROLLING, PRESENTING, CALCULATING, ANALYZING AND PROCESSING OF DATA TO AND FROM PATIENTS AND TO AND FROM MEDICAL IMPLANTS AND TO AND FROM REMOTE CONTROLS, WIRELESS CHARGER APPARATUS AND CONTROL STATIONS FOR ACTIVE IMPLANTS; SURGICAL AND HEALTH SERVICES, NAMELY, IMPLANTATION OF ARTIFICIAL IMPLANTS TO ALLOW THE IMPLANTS TO COLLECT, SEND, RECEIVE, STORE, PREPARE, CONTROL, PRESENT, CALCULATE, ANALYZE, AND PROCESS OF DATA TO AND FROM PATIENTS AND TO AND FROM MEDICAL IMPLANTS AND TO AND FROM MEDICAL IMPLANTS AND TO AND FROM REMOTE CONTROLS, WIRELESS CHARGER APPARATUS AND CONTROL STATIONS FOR ACTIVE IMPLANTS; PROVIDING A MEDICAL, SURGICAL AND HEALTH DATABASE FEATURING MEDICAL, SURGICAL AND HEALTH INFORMATION RELATING TO MEDICAL IMPLANTS THAT HAS BEEN INPUT, COLLECTED, RECEIVED, PREPARED, CONTROLLED, PROGRAMMED, CALCULATED, AND ANALYZED, FROM MEDICAL IMPLANTS, REMOTE CONTROLS OR CONTROL STATIONS FOR USE BY MEDICAL, SURGICAL AND HEALTH PROFESSIONALS FOR THE PURPOSES OF MONITORING AND DIAGNOSING MEDICAL CONDITIONS; MEDICAL AND SURGICAL SERVICES, NAMELY, IMPLANTATION OF ARTIFICIAL IMPLANTS IN RELATION TO MEDICAL IMPLANTS FOR PROGRAMMING, CONTROLLING, COMMUNICATING WITH, AND ENERGIZING OF, ACTIVE IMPLANTS; AND MEDICAL AND SURGICAL SERVICES, NAMELY, ARTIFICIAL IMPLANTATION SERVICES FOR PERSONS HAVING A MEDICAL RELATED CONDITION AND BEING CANDIDATES FOR OR BEING OPERATED ON WITH AN ACTIVE OR A NON-ACTIVE IMPLANT (U.S. CLS. 100 AND 101).

ALEX KEAM, EXAMINING ATTORNEY

SN 77-858,349. CODE PROJECT INC., THE, TORONTO, CANADA, FILED 10-27-2009.



PRIORITY CLAIMED UNDER SEC. 44(D) ON CANADA APPLICATION NO. 1455906, FILED 10-19-2009, REG. NO. TMA786,123, DATED 12-30-2010, EXPIRES 12-30-2025.

THE MARK CONSISTS OF A FIGURE OF AN ALIEN WITH TWO ARMS, TWO LEGS AND A CONICAL SHAPED HEAD.

#### **CLASS 9—ELECTRICAL AND SCIENTIFIC APPARATUS**

FOR DOWNLOADABLE ELECTRONIC PUBLICATIONS, NAMELY, WRITTEN ARTICLES AND NEWSLETTERS IN THE FIELD OF USE AND DEVELOPMENT OF SOFTWARE APPLICATIONS; SOFTWARE FOR CREATING DESKTOP WALLPAPERS, ICONS, AND TOOLBARS; MOUSE PADS (U.S. CLS. 21, 23, 26, 36 AND 38).

#### **CLASS 35—ADVERTISING AND BUSINESS**

FOR PROMOTIONAL SERVICES, NAMELY, PROMOTING THE GOODS AND SERVICES OF OTHERS BY PROVIDING ADVERTISING SPACE ON A WEBSITE; PROVIDING AN ON-LINE DIRECTORY OF INDIVIDUALS AND COMPANIES IN THE FIELD OF SOFTWARE DEVELOPMENT; CONDUCTING ON-LINE BUSINESS SURVEYS IN THE FIELD OF USE AND DEVELOPMENT OF SOFTWARE APPLICATIONS; PROVIDING A WEBSITE FEATURING JOB LISTINGS IN THE FIELD OF SOFTWARE DEVELOPMENT (U.S. CLS. 100, 101 AND 102).

FIRST USE 0-0-1999; IN COMMERCE 0-0-1999.

#### **CLASS 38—COMMUNICATION**

FOR COMPUTER SERVICES, NAMELY, PROVIDING ACCESS TO DATABASES FEATURING NEWS AND INFORMATION IN THE FIELD OF USE AND DEVELOPMENT OF SOFTWARE APPLICATIONS; PROVIDING ON-LINE CHAT ROOMS AND BULLETIN BOARDS FOR TRANSMISSION OF MESSAGES AMONG COMPUTER USERS CONCERNING THE USE AND DEVELOPMENT OF SOFTWARE APPLICATIONS (U.S. CLS. 100, 101 AND 104).

FIRST USE 0-0-1999; IN COMMERCE 0-0-1999.

#### **CLASS 41—EDUCATION AND ENTERTAINMENT**

FOR CONDUCTING ON-LINE CONTESTS IN THE FIELD OF USE AND DEVELOPMENT OF SOFTWARE APPLICATIONS; PROVIDING ONLINE PUBLICATIONS, NAMELY, NEWSLETTERS AND ARTICLES IN THE FIELD OF USE AND DEVELOPMENT OF SOFTWARE APPLICATIONS (U.S. CLS. 100, 101 AND 107).

FIRST USE 0-0-1999; IN COMMERCE 0-0-1999.

**CLASS 42—SCIENTIFIC AND COMPUTER SERVICES**

FOR PROVIDING INFORMATION IN THE FIELD OF USE AND DEVELOPMENT OF SOFTWARE APPLICATIONS; PROVIDING SOFTWARE DEVELOPMENT SERVICES, NAMELY, DESIGN AND DEVELOPMENT OF SOFTWARE DEVELOPMENT TOOLS (U.S. CLS. 100 AND 101).

FIRST USE 0-0-1999; IN COMMERCE 0-0-1999.  
GENE MACIOL, EXAMINING ATTORNEY

**CLASS 42—SCIENTIFIC AND COMPUTER SERVICES**

FOR APPLICATION SERVICE PROVIDER, NAMELY, HOSTING, MANAGING, DEVELOPING, AND MAINTAINING APPLICATIONS, SOFTWARE AND WEBSITES IN THE FIELD OF CAREER-BASED HIGH SCHOOL EDUCATIONAL TRAINING AND DIPLOMA PROGRAMS FOR WORKING INDIVIDUALS AND HOME-SCHOOL STUDENTS; PROVIDING TEMPORARY USE OF ON-LINE NON-DOWNLOADABLE SOFTWARE APPLICATIONS THAT ENABLE USERS TO ACCESS TRAINING, EDUCATION, TESTING AND CERTIFICATION MATERIALS IN THE FIELD OF CAREER-BASED HIGH SCHOOL EDUCATIONAL CURRICULUM TRAINING AND DIPLOMA PROGRAMS FOR WORKING INDIVIDUALS AND HOME-SCHOOL STUDENTS; APPLICATION SERVICE PROVIDER FEATURING SOFTWARE FOR PROVIDING AN ON-LINE DATABASE IN THE FIELD OF CAREER-BASED HIGH SCHOOL EDUCATIONAL CURRICULUM TRAINING AND DIPLOMA PROGRAMS FOR WORKING INDIVIDUALS AND HOME-SCHOOL STUDENTS (U.S. CLS. 100 AND 101).

FIRST USE 2-18-2010; IN COMMERCE 2-18-2010.  
STEVEN PEREZ, EXAMINING ATTORNEY

SN 77-858,369. ADVANCED SYSTEMS TECHNOLOGY, INC.,  
LAWTON, OK. FILED 10-27-2009.

SN 77-858,440. NC JAPAN K.K, TOKYO, JAPAN, FILED 10-27-2009.



OWNER OF U.S. REG. NOS. 3,530,145 AND 3,530,146.  
NO CLAIM IS MADE TO THE EXCLUSIVE RIGHT TO USE "CAREER ONLINE HIGH SCHOOL", APART FROM THE MARK AS SHOWN.

THE MARK CONSISTS OF A CIRCLE WITH THE WORDING "SMART HORIZONS CAREER ONLINE HIGH SCHOOL" ON THE EDGE OF THE CIRCLE; THE INSIDE OF THE CIRCLE IS SECTIONED INTO THIRDS; AN OPEN BOOK IS DISPLAYED IN ONE THIRD; A GRADUATION CAP IS DISPLAYED IN ONE THIRD; AND A COMPUTER MONITOR, MOUSE AND KEYBOARD IS DISPLAYED IN ONE THIRD OF THE CIRCLE.

**CLASS 41—EDUCATION AND ENTERTAINMENT**

FOR EDUCATIONAL SERVICES, NAMELY, PROVIDING COURSES OF INSTRUCTION AT THE HIGH SCHOOL LEVEL RENDERED THROUGH ONLINE CORRESPONDENCE COURSES; EDUCATIONAL SERVICES, NAMELY, PROVIDING ON-LINE, WEB-BASED CUSTOMIZABLE SELF-PACED COURSES OF INSTRUCTION AND EDUCATIONAL TRAINING COURSES AT THE HIGH SCHOOL LEVEL; EDUCATIONAL COUNSELING SERVICES PROVIDED ONLINE TO ASSIST STUDENTS IN PLANNING AND PREPARING FOR FURTHER EDUCATION, NAMELY, EDUCATIONAL TRANSCRIPT EVALUATION AND STUDENT COUNSELING AT THE HIGH SCHOOL LEVEL (U.S. CLS. 100, 101 AND 107).

FIRST USE 2-18-2010; IN COMMERCE 2-18-2010.



PRIORITY CLAIMED UNDER SEC. 44(D) ON JAPAN APPLICATION NO. 2009-081092, FILED 10-27-2009, REG. NO. 5320474, DATED 4-30-2010, EXPIRES 4-30-2020.

THE COLOR(S) GREEN, BLUE, PINK, ORANGE, YELLOW AND WHITE IS/ARE CLAIMED AS A FEATURE OF THE MARK.

THE MARK CONSISTS OF THE WORDING "GEN TO KI" IN THE COLOR BLUE WITH BLUE DOTS BETWEEN THE TERMS, ALL APPEARING BELOW A GREEN LEAF/BRANCH DESIGN WITH HIGHLY STYLIZED JAPANESE CHARACTERS APPEARING ABOVE THE LEAF/BRANCH DESIGN IN THE COLORS ORANGE AND PINK WITH WHITE HIGHLIGHTS AND SHADES OF YELLOW APPEARING AROUND THE CHARACTERS IN THE BACKGROUND.

THE NON-LATIN CHARACTERS IN THE MARK TRANSLITERATE TO "GENTOKI" AND THIS MEANS TALE OF THE FANTASY PEACH" IN ENGLISH

**CLASS 9—ELECTRICAL AND SCIENTIFIC APPARATUS**

FOR DOWNLOADABLE COMPUTER GAME PROGRAMS FOR CELLULAR TELEPHONES; DOWNLOADABLE COMPUTER GAME PROGRAMS FOR PORTABLE DIGITAL MUSIC PLAYERS; DOWNLOADABLE COMPUTER GAME PROGRAMS FOR PERSONAL DIGITAL ASSISTANTS; DOWNLOADABLE PERSONAL COMPUTER GAME PROGRAMS; DOWNLOADABLE COMPUTER GAME PROGRAMS FOR HAND-HELD GAMES WITH LIQUID CRYSTAL DISPLAYS; DOWNLOADABLE COMPUTER GAME PROGRAMS FOR HOME VIDEO GAMES; PRERECORDED STORAGE MEDIA, NAMELY, COMPUTER DISCS FEATURING COMPUTER GAME PROGRAMS FOR USE WITH GAME MACHINES WITH LIQUID CRYSTAL SCREENS (U.S. CLS. 21, 23, 26, 36 AND 38).



**CLASS 41—EDUCATION AND ENTERTAINMENT**

FOR ENTERTAINMENT SERVICES, NAMELY, PROVIDING ON-LINE COMPUTER GAMES; PROVIDING INFORMATION WITH RESPECT TO PROVIDING ON-LINE COMPUTER GAMES; PROVIDING INFORMATION ON-LINE RELATING TO COMPUTER GAMES; ENTERTAINMENT INFORMATION (U.S. CLS. 100, 101 AND 107).

GENE MACIOL, EXAMINING ATTORNEY

---

SN 77-859,065. STEVENS, SUSAN HUNT, NEWTON, MA. FILED 10-28-2009.

**TRACK MY GREEN LIFE**

THE MARK CONSISTS OF STANDARD CHARACTERS WITHOUT CLAIM TO ANY PARTICULAR FONT, STYLE, SIZE, OR COLOR.

NO CLAIM IS MADE TO THE EXCLUSIVE RIGHT TO USE "GREEN", APART FROM THE MARK AS SHOWN.

**CLASS 41—EDUCATION AND ENTERTAINMENT**

FOR (BASED ON INTENT TO USE) EDUCATIONAL SERVICES, NAMELY, SEMINARS, WORKSHOPS, WEBINARS, LECTURES, COURSES AND CONFERENCES IN THE FIELDS OF ECOLOGY AND HEALTHY ENVIRONMENTAL LIFESTYLES; ENTERTAINMENT SERVICES, NAMELY, INTERACTIVE AND ONLINE EDUCATIONAL AND INCENTIVE AWARD PROGRAMS AND INTERACTIVE TOOLS, NAMELY, ELECTRONIC QUESTIONNAIRES, SURVEYS AND QUIZZES DESIGNED TO EDUCATE, REWARD AND RECOGNIZE THE EXCELLENCE OF PROGRAM PARTICIPANTS WHO MAKE HEALTHY ENVIRONMENTAL LIFESTYLE CHOICES; ONLINE PUBLICATION OF BOOKS, NEWSLETTERS, BLOGS, WHITE PAPERS AND SURVEYS IN THE FIELDS OF ECOLOGY AND HEALTHY ENVIRONMENTAL LIFESTYLES; (BASED ON USE IN COMMERCE) ONLINE JOURNALS, NAMELY, BLOGS FEATURING CONTENT IN THE FIELD OF HEALTHY AND ECOLOGICALLY RESPONSIBLE LIFESTYLES (U.S. CLS. 100, 101 AND 107).

FIRST USE 5-22-2007; IN COMMERCE 5-22-2007.

**CLASS 45—PERSONAL AND LEGAL SERVICES**

FOR (BASED ON INTENT TO USE) ONLINE SOCIAL NETWORKING SERVICES (U.S. CLS. 100 AND 101).

LEIGH CAROLINE CASE, EXAMINING ATTORNEY

---

SN 77-861,294. HARLOVLEEN, KAUR, DERBY, UNITED KINGDOM, FILED 10-30-2009.

**self address**

THE MARK CONSISTS OF STANDARD CHARACTERS WITHOUT CLAIM TO ANY PARTICULAR FONT, STYLE, SIZE, OR COLOR.

OWNER OF UNITED KINGDOM REG. NO. 2514941, DATED 10-23-2009, EXPIRES 4-30-2019.

**CLASS 9—ELECTRICAL AND SCIENTIFIC APPARATUS**

FOR PRERECORDED INSTRUCTIONAL AND TEACHING DIGITAL MEDIA MATERIALS ON THE SUBJECT OF MENTAL HEALTH (U.S. CLS. 21, 23, 26, 36 AND 38).

**CLASS 16—PAPER GOODS AND PRINTED MATTER**

FOR PRINTED INSTRUCTIONAL AND TEACHING MATERIALS ON THE SUBJECT OF MENTAL HEALTH (U.S. CLS. 2, 5, 22, 23, 29, 37, 38 AND 50).

MIDGE BUTLER, EXAMINING ATTORNEY

---

SN 77-862,420. FISCHER PRODUCTIONS, LLC, PARK CITY, UT. FILED 11-2-2009.

**SHARKMEN**

THE MARK CONSISTS OF STANDARD CHARACTERS WITHOUT CLAIM TO ANY PARTICULAR FONT, STYLE, SIZE, OR COLOR.

**CLASS 25—CLOTHING**

FOR CLOTHING IN THE NATURE OF PANTS, SHORTS, SHIRTS, SKIRTS, HATS, UNDERWEAR, SWEAT SHIRTS AND SWEAT PANTS (U.S. CLS. 22 AND 39).

**CLASS 41—EDUCATION AND ENTERTAINMENT**

FOR ENTERTAINMENT SERVICES, NAMELY, PROVIDING ON GOING TELEVISION PROGRAMS IN THE FIELD OF FISHING, BOATING AND EDUCATION ABOUT OCEANS, SEAS AND MARINE LIFE (U.S. CLS. 100, 101 AND 107).

DAVID COLLIER, EXAMINING ATTORNEY

---

SN 77-865,023. THE TOPPS COMPANY, INC., NEW YORK, NY. FILED 11-4-2009.

**BAZOOKA**

THE MARK CONSISTS OF STANDARD CHARACTERS WITHOUT CLAIM TO ANY PARTICULAR FONT, STYLE, SIZE, OR COLOR.

OWNER OF U.S. REG. NOS. 727,088, 1,896,290 AND OTHERS.

**CLASS 3—COSMETICS AND CLEANING PREPARATIONS**

FOR BODY AND BEAUTY CARE COSMETICS; SHAM-POO, HAIR CONDITIONER, MAKE-UP, TOOTHPASTE AND SOAP (U.S. CLS. 1, 4, 6, 50, 51 AND 52).

**CLASS 5—PHARMACEUTICALS**

FOR MULTI-VITAMIN PREPARATIONS (U.S. CLS. 6, 18, 44, 46, 51 AND 52).

**CLASS 6—METAL GOODS**

FOR STORAGE TINS, NAMELY, STORAGE TINS OF METAL (U.S. CLS. 2, 12, 13, 14, 23, 25 AND 50).

**CLASS 9—ELECTRICAL AND SCIENTIFIC APPARATUS**

FOR SUNGLASSES; VIDEO AND COMPUTER GAME PROGRAMS; GAMING EQUIPMENT, NAMELY, SLOT MACHINES; GRADUATED RULERS (U.S. CLS. 21, 23, 26, 36 AND 38).

**CLASS 14—JEWELRY**

FOR JEWELRY AND WATCHES (U.S. CLS. 2, 27, 28 AND 50).

**CLASS 16—PAPER GOODS AND PRINTED MATTER**

FOR SCHOOL SUPPLY KITS CONTAINING VARIOUS COMBINATIONS OF SCHOOL SUPPLIES, NAMELY, WRITING INSTRUMENTS, PENS, PENCILS, MECHANICAL PENCILS, ERASERS, MARKERS, CRAYONS, HIGHLIGHTER PENS, FOLDERS, NOTEBOOKS, PAPER, PROTRACTORS, PAPER CLIPS, PENCIL SHARPENERS, GLUE AND BOOK MARKS; CALENDARS; SCHOOL SUPPLIES, NAMELY, WRITING INSTRUMENTS, PENS, PENCILS, MECHANICAL PENCILS, ERASERS, MARKERS, CRAYONS, HIGHLIGHTER PENS, FOLDERS, NOTEBOOKS, PAPER, PROTRACTORS, PAPER CLIPS, PENCIL SHARPENERS, GLUE AND BOOK MARKS; STATIONERY; BOOKS, NAMELY, AUTOGRAPH BOOKS, ADDRESS BOOKS, BLANK JOURNAL BOOKS, APPOINTMENT BOOKS, BRAG BOOKS, CHILDREN ACTIVITY BOOKS, COLORING BOOKS, COMIC BOOKS, PICTURE BOOKS, STORY BOOKS; NOTEBOOKS; STICKERS; AND TRADING CARDS (U.S. CLS. 2, 5, 22, 23, 29, 37, 38 AND 50).

**CLASS 18—LEATHER GOODS**

FOR WALLETS, BACKPACKS, TOTE BAGS, BOOK BAGS, GYM BAGS, HANDBAGS, BEACH BAGS, COSMETIC BAGS SOLD EMPTY, DUFFEL BAGS, MESSENGER BAGS (U.S. CLS. 1, 2, 3, 22 AND 41).

**CLASS 21—HOUSEWARES AND GLASS**

FOR BEVERAGE GLASSWARE; TRAYS FOR DOMESTIC PURPOSES (U.S. CLS. 2, 13, 23, 29, 30, 33, 40 AND 50).

**CLASS 25—CLOTHING**

FOR WEARING APPAREL, CLOTHING AND CLOTHING ACCESSORIES, NAMELY, SHIRTS, T-SHIRTS, PANTS, JACKETS, SWEATSHIRTS, LEGGINGS, SHORTS, GLOVES, FOOTWEAR, HEADWEAR, SWIMWEAR, UNDERWEAR, SLEEPWEAR AND HOSIERY (U.S. CLS. 22 AND 39).

**CLASS 26—FANCY GOODS**

FOR BELT BUCKLES AND NOVELTY BUTTONS (U.S. CLS. 37, 39, 40, 42 AND 50).

**CLASS 28—TOYS AND SPORTING GOODS**

FOR SOFT SQUEEZABLE BALLS FOR EXERCISE AND GAMES; BEACH BALLS; PLASTIC VINYL PLAY BALLS; SOFT FLYING DISKS; SQUEEZE TOYS; BUBBLE MAKING WANDS AND SOLUTION SETS; DOLLS; MAGNETIC DOLL SETS CONSISTING OF FLAT MAGNETIC DOLLS WITH FLAT MAGNETIC ARTICLES OF CLOTHING AND ACCESSORIES; TOY CANDY DISPENSERS; ARCADE GAMES; CARD GAMES; TRADING CARD GAMES; BOARD GAMES; PLASTIC MODEL KITS, NAMELY, PLASTIC SCALE MODEL KITS; COSTUME MASKS; TOY FIGURINES, NAMELY, MODELED PLASTIC TOY FIGURES AND ACCESSORIES THEREFOR; POSEABLE FIGURINES, NAMELY, POSITIONABLE TOY FIGURES AND ACCESSORIES THEREFOR; TOY ACTION FIGURES AND ACCESSORIES THEREFOR; TOY VEHICLES; TOY GUMBALL MACHINES; AMUSEMENT PARK RIDES; PINBALL GAMES; ARCADE-TYPE ELECTRONIC VIDEO GAMES (U.S. CLS. 22, 23, 38 AND 50).

**CLASS 30—STAPLE FOODS**

FOR READY-TO-EAT CEREALS; CEREAL-BASED SNACK FOODS; ICE CREAM; FROZEN YOGURT CONFECTIONS; NON-DAIRY FROZEN CONFECTIONS; CAKES AND PASTRIES (U.S. CL. 46).

**CLASS 32—LIGHT BEVERAGES**

FOR SOFT DRINKS, NAMELY, CARBONATED AND NON-CARBONATED SOFT DRINKS; FRUIT JUICES; FLAVORED WATER; SYRUP FOR MAKING BEVERAGES (U.S. CLS. 45, 46 AND 48).

**CLASS 35—ADVERTISING AND BUSINESS**

FOR RETAIL GROCERY STORE SERVICES FEATURING CANDY AND CONFECTIONARY (U.S. CLS. 100, 101 AND 102).

ERIN FALK, EXAMINING ATTORNEY

SN 77-871,496. AHLSTROM CORPORATION, HELSINKI, FINLAND, FILED 11-12-2009.

# HOLLYTEX

THE MARK CONSISTS OF STANDARD CHARACTERS WITHOUT CLAIM TO ANY PARTICULAR FONT, STYLE, SIZE, OR COLOR.

**CLASS 9—ELECTRICAL AND SCIENTIFIC APPARATUS**

FOR POLYESTER FILAMENT SHEET MATERIAL FOR SCIENTIFIC APPLICATIONS AS COMPONENTS OF LATERAL FLOW DIAGNOSTIC TEST KITS AND IN VITRO DIAGNOSTIC DEVICES AND FOR SAMPLE COLLECTION OF CONJUGATE RELEASE PADS (U.S. CLS. 21, 23, 26, 36 AND 38).

FIRST USE 5-1-1967; IN COMMERCE 5-1-1967.

**CLASS 17—RUBBER GOODS**

FOR POLYESTER FILAMENT SHEET MATERIAL FOR INDUSTRIAL AND MANUFACTURING APPLICATIONS, NAMELY, FOR USE IN LIQUID FILTRATION, AS A FILTER MEDIA, AS PLEAT SUPPORT MEDIA IN THE CONSTRUCTION OF FILTER UNITS AND AS MEMBRANE SUPPORT FOR MICROFILTRATION, ULTRAFILTRATION AND REVERSE OSMOSIS MEMBRANE MANUFACTURING (U.S. CLS. 1, 5, 12, 13, 35 AND 50).

FIRST USE 5-1-1967; IN COMMERCE 5-1-1967.

**CLASS 24—FABRICS**

FOR POLYESTER FABRIC FILTERING MATERIALS AND SUPPORT LINING MATERIAL FOR LEATHER OF NONWOVEN POLYMERIC FABRIC, NAMELY, MEMBRANE SUPPORT LINING FOR THE MANUFACTURE OF POLYMERIC MEMBRANES FOR MICROFILTRATION, ULTRAFILTRATION AND REVERSE OSMOSIS, SUPPORTING MEMBRANES USED DURING POLYMERIC MEMBRANE MANUFACTURING, AND PLEAT SUPPORT IN THE MANUFACTURE OF PLEATED CARTRIDGES FOR LIQUID FILTRATION APPLICATIONS (U.S. CLS. 42 AND 50).

FIRST USE 5-1-1967; IN COMMERCE 5-1-1967.

NAAKWAMA ANKRAH, EXAMINING ATTORNEY

**CLASS 9—ELECTRICAL AND SCIENTIFIC APPARATUS**

FOR ACCESSORIES FOR PORTABLE ELECTRONIC EQUIPMENT, NAMELY, EQUIPMENT POSITIONING AND STABILIZATION STANDS, PEDESTALS AND MOUNTS, NAMELY, CAMERA BIPODS AND TRIPODS; ACCESSORIES FOR PORTABLE ELECTRONIC EQUIPMENT, NAMELY, EQUIPMENT ALIGNMENT AND LEVELING MOUNTS, DOCKS AND INTERFACES, NAMELY, TILTING CAMERA HEADS; ACCESSORIES FOR PORTABLE OPTICAL EQUIPMENT, NAMELY, EQUIPMENT POSITIONING AND STABILIZATION STANDS, PEDESTALS, AND MOUNTS, NAMELY, TELESCOPES, BINOCULARS, AND BIPODS AND TRIPODS FOR LASER RANGEFINDERS; ACCESSORIES FOR PORTABLE OPTICAL EQUIPMENT, NAMELY, EQUIPMENT ALIGNMENT AND LEVELING MOUNTS, DOCKS AND INTERFACES ALL IN THE NATURE OF TILTING CAMERA HEADS; ACCESSORIES FOR PORTABLE MECHANICAL EQUIPMENT, NAMELY, EQUIPMENT POSITIONING AND STABILIZATION STANDS, PEDESTALS, AND MOUNTS, NAMELY, PORTABLE STANDS FOR CAMERAS IN THE NATURE OF BIPODS AND TRIPODS FOR SUPPORTING AND STABILIZING WORK SURFACES MOUNTED THEREON (U.S. CLS. 21, 23, 26, 36 AND 38).

**CLASS 12—VEHICLES**

FOR ASSEMBLIES AND COMPONENTS FOR MOVABLY MOUNTING AND CONTROLLABLY MOVING ELECTRONIC EQUIPMENT, NAMELY, CAMERA DOLLIES, RAILS AND SKATES ALL IN THE NATURE OF VEHICLE CAMERA MOUNTS; ASSEMBLIES AND COMPONENTS FOR MOVABLY MOUNTING AND CONTROLLABLY MOVING OPTICAL EQUIPMENT, NAMELY, CAMERA DOLLIES, RAILS AND SKATES ALL IN THE NATURE OF VEHICLE CAMERA MOUNTS (U.S. CLS. 19, 21, 23, 31, 35 AND 44).

MEGHAN REINHART, EXAMINING ATTORNEY

SN 77-871,840. MYT WORKS, INC., NEW YORK, NY. FILED 11-13-2009.

SN 77-872,223. BOHLE AG, HAAN, FED REP GERMANY, FILED 11-13-2009.

MYT WORKS

BOHLE

THE MARK CONSISTS OF STANDARD CHARACTERS WITHOUT CLAIM TO ANY PARTICULAR FONT, STYLE, SIZE, OR COLOR.

**CLASS 7—MACHINERY**

FOR ACCESSORIES FOR PORTABLE MECHANICAL EQUIPMENT, NAMELY, EQUIPMENT POSITIONING AND STABILIZATION STANDS, PEDESTALS, AND MOUNTS, NAMELY, PORTABLE STANDS FOR MACHINES IN THE NATURE OF BIPODS AND TRIPODS FOR SUPPORTING AND STABILIZING WORK SURFACES MOUNTED THEREON (U.S. CLS. 13, 19, 21, 23, 31, 34 AND 35).

THE MARK CONSISTS OF STANDARD CHARACTERS WITHOUT CLAIM TO ANY PARTICULAR FONT, STYLE, SIZE, OR COLOR.

PRIORITY CLAIMED UNDER SEC. 44(D) ON ERPNTY TM OFC APPLICATION NO. 008301434, FILED 5-14-2009, REG. NO. 0083071434, DATED 5-31-2010, EXPIRES 5-14-2019.

OWNER OF U.S. REG. NO. 1,962,798.

THE ENGLISH TRANSLATION OF "BOHLE" IN THE MARK IS "PLANK" OR "BOARD".

**CLASS 1—CHEMICALS**

FOR ADHESIVES USED IN INDUSTRY, IN PARTICULAR ADHESIVES FOR THE GLASS INDUSTRY AND FOR GLUING GLASS; CONTACT CEMENT FOR MENDING BROKEN ARTICLES, IN PARTICULAR ARTICLES OF GLASS; SILICONE RESINS FOR THE GLASS INDUSTRY AND GENERAL INDUSTRY USE; PREPARATIONS FOR PREVENTING THE TARNISHING OF GLASS, NAMELY, ANTI-TARNISHING CHEMICALS FOR GLASS INCLUDING WINDOWS (U.S. CLS. 1, 5, 6, 10, 26 AND 46).

**CLASS 3—COSMETICS AND CLEANING PREPARATIONS**

FOR CLEANING, POLISHING, SCOURING AND ABRASIVE PREPARATIONS; CLEANING PREPARATIONS FOR SURFACE PROTECTION OF GLASS (U.S. CLS. 1, 4, 6, 50, 51 AND 52).

**CLASS 4—LUBRICANTS AND FUELS**

FOR INDUSTRIAL OILS AND GREASES; ALL PURPOSE LUBRICANTS; DUST ABSORBING, WETTING AND BINDING COMPOSITIONS FOR USE IN THE GLASS INDUSTRY AND GENERAL INDUSTRY USE (U.S. CLS. 1, 6 AND 15).

**CLASS 6—METAL GOODS**

FOR METAL HINGES; METAL STRAP HINGES, IN PARTICULAR FOR GLASS DOORS, DOORS FOR SHOWCASES AND SHOWER CUBICLE DOORS; METAL FASTENERS NAMELY, BOLTS, NAILS, RIVETS, SCREWS, AND WASHERS, NAMELY, PINS OF METAL; WALL PLUGS OF METAL, SELF-ADHESIVE METAL SHEETS; METAL MIRROR MOUNTINGS WITH MAGNETIC FASTENINGS; DEVICES FOR ATTACHING OBJECTS TO SURFACES, MAINLY OF METAL, NAMELY, PULLEYS, SPRINGS, CLASPS, METAL LOCKS, METAL CLAMPS; LEAD METAL PROFILES FOR ARRANGING DEVICES ON AND IN WALLS, CEILING AND OTHER SURFACES; METAL BUILDING MATERIALS, NAMELY, SOFFITS, FASCIA, REINFORCEMENT MATERIALS FOR BUILDINGS AND METAL COUNTERTOPS FOR FURTHER INSTALLATION; DOOR AND WINDOW FITTINGS OF METAL FOR BUILDINGS AND FURNITURE (U.S. CLS. 2, 12, 13, 14, 23, 25 AND 50).

**CLASS 7—MACHINERY**

FOR GLASS POLISHING MACHINES; GLASS WASHING MACHINES; GLASS WORKING MACHINES; TABLES SPECIALLY ADAPTED TO HOLD POWERED MACHINERY; LAMINATION MACHINES FOR INDUSTRIAL USE AND/OR HOME AND OFFICE USE; GLASS CUTTING MACHINES; CIRCULAR CUTTING MACHINES, ELLIPTICAL CUTTING MACHINES, STRIP CUTTING AND TRAPEZOIDAL CUTTING MACHINES, SEGMENT POWER DRILLS; EDGE GRINDING MACHINES, GRINDING MACHINES, CUTTING MACHINES, GLASS CUTTERS AND GLASS HAMMERS, BEING PARTS OF MACHINES; MACHINE TOOLS, NAMELY, CLAMPS FOR USE IN PRECISION CLAMPING OF WORK PIECES; PARTS FOR THE AFORESAID GOODS SOLD AS A COMPONENT OF THE AFORESAID MENTIONED GOODS (U.S. CLS. 13, 19, 21, 23, 31, 34 AND 35).

**CLASS 8—HAND TOOLS**

FOR CUTLERY NOT OF PRECIOUS METAL; MANUALLY OPERATED HAND TOOLS AND IMPLEMENTS FOR USE WITH GLASS, FLOOR AND TILE LAYING, NAMELY, NIBBLING BLADES, LEAD KNIVES, DIAMOND DRILLS, GLASS CUTTERS, OIL GLASS CUTTERS, GLASS DRILLS, HANDSPIKES FOR BREAKING GLASS, GLASS PLIERS, GLASS CUTTING BLADES, GLASS SCRAPERS, HAMMERS, CARTRIDGE KNIVES, PUTTY KNIVES, FILM CUTTING BLADES FOR FILM CUTTING KNIVES, BLOCK LEVERS, TRAPEZOIDAL CUTTERS, GLAZIER'S PLIERS, PLASTIC CUTTERS, ROUND CUTTERS, DOUBLE-BLADED PATTERN SHEARS, WHETSTONES, STRIP CUTTERS, DIAMOND CORE DRILLS, GLASS CUTTERS WITH CUTTING WHEELS, CUTTING FRAMES, GLAZERS' ANGLES AND CUTTING RULES BEING CUTTING AIDS, CIRCULAR AND ELLIPTICAL CUTTING INSTRUMENTS, AND PARTS FOR THESE GOODS; HAND OPERATED HAND TOOLS AND IMPLEMENTS FOR THE PROCESSING, TRANSPORT AND MOUNTING OF GLASS AND GLASS PANES, NAMELY, SUCTION HOLDERS, CLAMPS, SUCTION DISCS WITH LEVERS, SUCTION HOLDERS WITH BRACES, POSITIONING DEVICES IN THE NATURE OF ANGLE SUCTION HOLDERS FOR HOLDING GLASS, LOCK POSITIONING DEVICES FOR

MOUNTING A LOCK ONTO GLASS, AND HAND DRILL POSITIONERS, GUIDES, AND DRILL PLATES, ALL FOR TEMPORARY SUCTION ATTACHMENT TO GLASS THAT ALLOW FOR THE PRECISE DRILLING OF GLASS, NIBBLING BLADES, LEAD KNIVES, DIAMOND DRILLS, GLASS CUTTERS, OIL GLASS CUTTERS, GLASS DRILLS, HANDSPIKES FOR BREAKING GLASS, GLASS PLIERS, GLASS CUTTING BLADES, GLASS SCRAPERS, HAMMERS, CARTRIDGE KNIVES, PUTTY KNIVES, FILM CUTTING BLADES, BLOCK LEVERS, TRAPEZOIDAL CUTTERS, GLAZIER'S PLIERS, PLASTIC CUTTERS, ROUND CUTTERS, DOUBLE-BLADED PATTERN SHEARS, WHETSTONES, STRIP CUTTERS, DIAMOND CORE DRILLS, GLASS CUTTERS WITH CUTTING WHEELS, CUTTING FRAMES, GLAZERS' ANGLES AND CUTTING RULES BEING CUTTING AIDS, CIRCULAR AND ELLIPTICAL CUTTING INSTRUMENTS, AND PARTS FOR THESE GOODS; HAND OPERATED HAND TOOLS AND IMPLEMENTS FOR CUTTING GLASS, NAMELY, NIBBLING BLADES, LEAD KNIVES, DIAMOND DRILLS, GLASS CUTTERS, OIL GLASS CUTTERS, GLASS DRILLS, HANDSPIKES FOR BREAKING GLASS, GLASS PLIERS, GLASS CUTTING BLADES, GLASS SCRAPERS, HAMMERS, CARTRIDGE KNIVES, PUTTY KNIVES, FILM CUTTING BLADES, BLOCK LEVERS, TRAPEZOIDAL CUTTERS, GLAZIER'S PLIERS, PLASTIC CUTTERS, ROUND CUTTERS, DOUBLE-BLADED PATTERN SHEARS, WHETSTONES, STRIP CUTTERS, DIAMOND CORE DRILLS, GLASS CUTTERS WITH CUTTING WHEELS, CUTTING FRAMES, GLAZERS' ANGLES AND CUTTING RULES BEING CUTTING AIDS, CIRCULAR AND ELLIPTICAL CUTTING INSTRUMENTS, AND PARTS FOR THESE GOODS; HAND OPERATED HAND TOOLS AND IMPLEMENTS FOR FIXING GLASS PANES BY MEANS OF ADHESION, NAMELY, SUCTION HOLDERS, CLAMPS, SUCTION DISCS WITH LEVERS, SUCTION HOLDERS WITH BRACES, POSITIONING DEVICES IN THE NATURE OF ANGLE SUCTION HOLDERS FOR HOLDING GLASS, LOCK POSITIONING DEVICES FOR MOUNTING A LOCK ONTO GLASS, AND HAND DRILL POSITIONERS, GUIDES, AND DRILL PLATES, ALL FOR TEMPORARY SUCTION ATTACHMENT TO GLASS THAT ALLOW FOR THE PRECISE DRILLING OF GLASS, NIBBLING BLADES, LEAD KNIVES, DIAMOND DRILLS, GLASS CUTTERS, OIL GLASS CUTTERS, GLASS DRILLS, HANDSPIKES FOR BREAKING GLASS, GLASS PLIERS, GLASS CUTTING BLADES, GLASS SCRAPERS, HAMMERS, CARTRIDGE KNIVES, PUTTY KNIVES, FILM CUTTING BLADES, BLOCK LEVERS, TRAPEZOIDAL CUTTERS, GLAZIER'S PLIERS, PLASTIC CUTTERS, ROUND CUTTERS, DOUBLE-BLADED PATTERN SHEARS, WHETSTONES, STRIP CUTTERS, DIAMOND CORE DRILLS, GLASS CUTTERS WITH CUTTING WHEELS, CUTTING FRAMES, GLAZERS' ANGLES AND CUTTING RULES BEING CUTTING AIDS, CIRCULAR AND ELLIPTICAL CUTTING INSTRUMENTS, AND PARTS FOR THESE GOODS; HAND OPERATED HAND TOOLS AND IMPLEMENTS BEING GLASS MOUNTING AIDS, NAMELY, SUCTION HOLDERS, CLAMPS, SUCTION DISCS WITH LEVERS, SUCTION HOLDERS WITH BRACES, POSITIONING DEVICES IN THE NATURE OF ANGLE SUCTION HOLDERS FOR HOLDING GLASS, LOCK POSITIONING DEVICES FOR MOUNTING A LOCK ONTO GLASS, AND HAND DRILL POSITIONERS, GUIDES, AND DRILL PLATES, ALL FOR TEMPORARY SUCTION ATTACHMENT TO GLASS THAT ALLOW FOR THE PRECISE DRILLING OF GLASS, NIBBLING BLADES, LEAD KNIVES, DIAMOND DRILLS, GLASS CUTTERS, OIL GLASS CUTTERS, GLASS DRILLS, HANDSPIKES FOR BREAKING GLASS, GLASS PLIERS, GLASS CUTTING BLADES, GLASS SCRAPERS, HAMMERS, CARTRIDGE KNIVES, PUTTY KNIVES, FILM CUTTING BLADES, BLOCK LEVERS, TRAPEZOIDAL CUTTERS, GLAZIER'S PLIERS, PLASTIC CUTTERS, ROUND CUTTERS, DOUBLE-BLADED PATTERN SHEARS, WHETSTONES, STRIP CUTTERS, DIAMOND CORE DRILLS, GLASS CUTTERS WITH CUTTING WHEELS, CUTTING FRAMES, GLAZERS' ANGLES AND CUTTING RULES BEING CUTTING AIDS, CIRCULAR AND ELLIPTICAL CUTTING INSTRUMENTS, AND PARTS FOR THESE GOODS; HAND OPERATED HAND TOOLS AND IMPLEMENTS IN THE FORM OF MAGNETIC TOOL HOLDERS AND SUCTION HOLDERS; HAND OPERATED HAND IMPLEMENTS FOR THE LIFTING AND TRANSPORTING OF GLASS PANES, PLASTICS, SHEETS, TILES, MARBLE, AND PARTS FOR THESE GOODS, NAMELY, SUCTION HOLDERS, CLAMPS,



SUCTION DISCS WITH LEVERS, SUCTION HOLDERS WITH BRACES, POSITIONING DEVICES IN THE NATURE OF ANGLE SUCTION HOLDERS FOR HOLDING GLASS, LOCK POSITIONING DEVICES FOR MOUNTING A LOCK ONTO GLASS, AND HAND DRILL POSITIONERS, GUIDES, AND DRILL PLATES, ALL FOR TEMPORARY SUCTION ATTACHMENT TO GLASS THAT ALLOW FOR THE PRECISE DRILLING OF GLASS, NIBBLING BLADES, LEAD KNIVES, DIAMOND DRILLS, GLASS CUTTERS, OIL GLASS CUTTERS, GLASS DRILLS, HANDSPIKES FOR BREAKING GLASS, GLASS PLIERS, GLASS CUTTING BLADES, GLASS SCRAPERS, HAMMERS, CARTRIDGE KNIVES, PUTTY KNIVES, FILM CUTTING BLADES, BLOCK LEVERS, TRAPEZOIDAL CUTTERS, GLAZIER'S PLIERS, PLASTIC CUTTERS, ROUND CUTTERS, DOUBLE-BLADED PATTERN SHEARS, WHETSTONES, STRIP CUTTERS, DIAMOND CORE DRILLS, GLASS CUTTERS WITH CUTTING WHEELS, CUTTING FRAMES, GLAZERS' ANGLES AND CUTTING RULES BEING CUTTING AIDS, CIRCULAR AND ELLIPTICAL CUTTING INSTRUMENTS, AND PARTS FOR THESE GOODS (U.S. CLS. 23, 28 AND 44).

#### **CLASS 9—ELECTRICAL AND SCIENTIFIC APPARATUS**

FOR ELECTRONIC APPARATUS AND INSTRUMENTS FOR TESTING GLASS/THICKNESS OF GLASS, NAMELY, GLASS THICKNESS GAUGE, FLAT GLASS ANALYSER; ELECTRONIC MACHINES FOR TESTING GLASS/THICKNESS OF GLASS, NAMELY, GLASS THICKNESS GAUGE, FLAT GLASS ANALYSER; COMPUTER SOFTWARE FOR TESTING GLASS THICKNESS AND MEASURING GLASS; MEASURING INSTRUMENTS, NAMELY, GLASS THICKNESS GAUGE, FLAT GLASS ANALYSER, DIGITIZER; MATERIAL TESTING INSTRUMENTS AND MATERIAL TESTING MACHINES, NAMELY, FOR TESTING AND ANALYZING FLAT GLASS IN PARTICULAR GLASS THICKNESS, CONFIGURATION OF PANES, COATINGS AND PVB FILMS; COMPUTER HARDWARE AND PERIPHERAL DEVICES FOR MEASURING APPARATUS, MEASURING INSTRUMENTS, MATERIAL TESTING INSTRUMENTS AND MATERIAL TESTING MACHINES; INTERFACE APPARATUS IN THE NATURE OF GLASS THICKNESS GAUGES AND FLAT GLASS ANALYSERS AND INTERFACE COMPUTER PROGRAMS FOR MEASURING GOODS MADE OF GLASS, IN PARTICULAR GLASS THICKNESS, CONFIGURATION OF PANES, COATINGS AND PVB FILMS; MEASURING INSTRUMENTS, NAMELY, FLAT GLASS ANALYSERS; MATERIAL TESTING INSTRUMENTS AND MATERIAL TESTING MACHINES FOR TESTING AND ANALYZING GOODS MADE OF GLASS, NAMELY, FLAT GLASS ANALYSERS; ELECTRIC ACCUMULATORS; CHARGERS FOR ELECTRIC BATTERIES; DISPENSERS AND PART OF DISPENSERS THAT COUNT OR MEASURE OUTPUT FOR USE WITH DOSING MACHINES; PROTECTIVE WORK GLOVES; PROTECTIVE GLOVES FOR INDUSTRIAL USE; REFLECTIVE AND ILLUMINATED CLOTHING FOR SAFETY PURPOSES (U.S. CLS. 21, 23, 26, 36 AND 38).

#### **CLASS 11—ENVIRONMENTAL CONTROL APPARATUS**

FOR LIGHTING APPARATUS AND INSTALLATIONS FOR HOUSEHOLD USE, VEHICLES, GENERAL INDUSTRY USE; ULTRAVIOLET RAY LAMPS, NOT FOR MEDICAL PURPOSES; GLASS LAMPS; ELECTRIC LAMPS; LIGHT EMITTING DIODE LIGHT BULBS; RECESSED CEILING LIGHTS; REARVIEW AND VANITY MIRRORS LIGHTS; AQUARIUM LIGHTS; APPARATUS FOR HEATING, STEAM GENERATING, COOKING, REFRIGERATING, DRYING, VENTILATING, WATER SUPPLY AND SANITARY PURPOSES, NAMELY, KILNS FOR AUTOCLAVE-FREE LAMINATION (U.S. CLS. 13, 21, 23, 31 AND 34).

#### **CLASS 20—FURNITURE AND ARTICLES NOT OTHERWISE CLASSIFIED**

FOR FURNITURE, MIRRORS, PICTURE FRAMES; SHOWCASES, IN PARTICULAR SHOWCASES OF GLASS; CURTAIN POLES (U.S. CLS. 2, 13, 22, 25, 32 AND 50).

#### **CLASS 35—ADVERTISING AND BUSINESS**

FOR WHOLESALE AND RETAIL STORE SERVICES, ON-LINE RETAIL STORE SERVICES, MAIL ORDER SERVICES FEATURING TOOLS, MACHINERY AND ACCESSORIES FOR GLASS PROCESSING, GLASS FINISHING AND PICTURE FRAMING; DIRECT MAIL ADVERTISING; RETAIL STORE AND ONLINE ORDERING SERVICES FEATURING TOOLS, MACHINERY AND ACCESSORIES FOR GLASS PROCESSING, GLASS FINISHING AND PICTURE FRAMING; ADVERTISING; AND INFORMATION MANAGEMENT SERVICES, NAMELY, PREPARING SHIPPING INVOICE (U.S. CLS. 100, 101 AND 102).

BRIDGETT SMITH, EXAMINING ATTORNEY

SN 77-872,671. UNDERHILL INTERNATIONAL CORPORATION, LAKE FOREST, CA. FILED 11-13-2009.

# UNDERHILL

THE MARK CONSISTS OF STANDARD CHARACTERS WITHOUT CLAIM TO ANY PARTICULAR FONT, STYLE, SIZE, OR COLOR.

SEC. 2(F).

#### **CLASS 9—ELECTRICAL AND SCIENTIFIC APPARATUS**

FOR IRRIGATION SPRINKLER CONTROLLERS; IRRIGATION SPRINKLER SIGNAL DECODERS; IRRIGATION FLOW METERS; SPECTRAL DETECTION EYEGLASSES (U.S. CLS. 21, 23, 26, 36 AND 38).

FIRST USE 8-24-2005; IN COMMERCE 8-24-2005.

#### **CLASS 11—ENVIRONMENTAL CONTROL APPARATUS**

FOR IRRIGATION SPRINKLERS; IRRIGATION SPRINKLER NOZZLES; VALVES AND FITTINGS FOR IRRIGATION SPRINKLER SYSTEMS; MICRO IRRIGATION KITS COMPRISING TUBING, FITTINGS, EMITTERS, SPIKES (U.S. CLS. 13, 21, 23, 31 AND 34).

FIRST USE 8-24-2005; IN COMMERCE 8-24-2005.

#### **CLASS 35—ADVERTISING AND BUSINESS**

FOR MANUFACTURER REPRESENTATIVE IN THE FIELD OF IRRIGATION EQUIPMENT, WHOLESALE DISTRIBUTORSHIP IN THE FIELD OF IRRIGATION EQUIPMENT, WHOLESALE AND RETAIL DISTRIBUTORSHIP IN THE FIELD OF IRRIGATION EQUIPMENT (U.S. CLS. 100, 101 AND 102).

FIRST USE 8-24-2005; IN COMMERCE 8-24-2005.  
MATTHEW PAPPAS, EXAMINING ATTORNEY

SN 77-873,469. HONDA MOTOR CO., LTD., MINATO-KU, TOKYO, JAPAN, FILED 11-16-2009.

**EXLink**

OWNER OF JAPAN REG. NO. 5312664, DATED 4-2-2010, EXPIRES 4-2-2020.  
THE MARK CONSISTS OF UPPER-CASE LETTERS "EXL" AND LOWER-CASE LETTERS "INK".

#### CLASS 7—MACHINERY

FOR GAS ENGINES NOT FOR LAND VEHICLES; NON-ELECTRIC PRIME MOVERS NOT FOR LAND VEHICLES; PARTS THEREOF, NAMELY, CRANK SHAFTS, CRANKCASES FOR MOTORS AND ENGINES, CRANKS, CYLINDER HEADS, CYLINDERS FOR MOTORS AND ENGINES, PISTONS FOR CYLINDERS, PISTONS, AND PISTON RINGS (U.S. CLS. 13, 19, 21, 23, 31, 34 AND 35).

#### CLASS 12—VEHICLES

FOR GASOLINE ENGINES FOR AUTOMOBILES; NON-ELECTRIC PRIME MOVERS FOR LAND VEHICLES NOT INCLUDING THEIR PARTS (U.S. CLS. 19, 21, 23, 31, 35 AND 44).  
MIDGE BUTLER, EXAMINING ATTORNEY

SN 77-873,975. PROMARK BRANDS, INC., MERIDIAN, ID. FILED 11-17-2009.

**HEINZ**

THE MARK CONSISTS OF STANDARD CHARACTERS WITHOUT CLAIM TO ANY PARTICULAR FONT, STYLE, SIZE, OR COLOR.  
OWNER OF U.S. REG. NOS. 62,182, 2,224,447 AND OTHERS.  
SEC. 2(F).

#### CLASS 6—METAL GOODS

FOR METAL COIN BANKS, METAL KEY CHAINS, AND NON-LUMINOUS AND NON-MECHANICAL METAL SIGNS (U.S. CLS. 2, 12, 13, 14, 23, 25 AND 50).  
FIRST USE 8-31-2005; IN COMMERCE 8-31-2005.

#### CLASS 9—ELECTRICAL AND SCIENTIFIC APPARATUS

FOR COMPUTER BAGS, MAGNETS, MEASURING CUPS, MOUSE PADS, WIRELESS COMPUTER MICE AND COMPUTER STORAGE DEVICES, NAMELY, FLASH DRIVES (U.S. CLS. 21, 23, 26, 36 AND 38).  
FIRST USE 8-31-2005; IN COMMERCE 8-31-2005.

#### CLASS 11—ENVIRONMENTAL CONTROL APPARATUS

FOR ELECTRIC NIGHT LIGHTS AND FLASHLIGHTS (U.S. CLS. 13, 21, 23, 31 AND 34).  
FIRST USE 8-31-2005; IN COMMERCE 8-31-2005.

#### CLASS 14—JEWELRY

FOR CLOCKS, LAPEL PINS AND WATCHES (U.S. CLS. 2, 27, 28 AND 50).  
FIRST USE 5-1-2003; IN COMMERCE 5-1-2003.

#### CLASS 16—PAPER GOODS AND PRINTED MATTER

FOR BLANK JOURNALS, BLANK NOTE CARDS, DESK PADS, DESK SETS, DESKTOP BUSINESS CARD HOLDERS, MEMO PADS, NOTEPAD HOLDERS, PAPERWEIGHTS, PENCIL HOLDERS, PENCILS, PENS, POSTCARDS, AND WRITING PADS (U.S. CLS. 2, 5, 22, 23, 29, 37, 38 AND 50).  
FIRST USE 7-31-2003; IN COMMERCE 7-31-2003.

#### CLASS 18—LEATHER GOODS

FOR BACK PACKS, DRAWSTRING BAGS, GARMENT BAGS FOR TRAVEL, LEATHER BAGS, LEATHER BINDERS FOR TRAVEL PURPOSE, SHOE BAGS FOR TRAVEL, TOTE BAGS, AND UMBRELLAS (U.S. CLS. 1, 2, 3, 22 AND 41).  
FIRST USE 8-31-2005; IN COMMERCE 8-31-2005.

#### CLASS 20—FURNITURE AND ARTICLES NOT OTHERWISE CLASSIFIED

FOR CHAIRS, PLASTIC CLIPS FOR SEALING BAGS, NON-METAL AND NON-LEATHER KEY CHAINS, AND PILLOWS (U.S. CLS. 2, 13, 22, 25, 32 AND 50).  
FIRST USE 12-31-2004; IN COMMERCE 12-31-2004.

#### CLASS 21—HOUSEWARES AND GLASS

FOR BOWLS, CLEANING SPONGES, COOKIE CUTTERS, CUPS, DRINKING GLASSES, JAR OPENERS, MUGS, PLASTIC WATER BOTTLES SOLD EMPTY, SALT AND PEPPER SHAKERS, SAUCERS, SERVING DISHES, SERVING TRAYS, SPOON RESTS, STATUES OF CRYSTAL, THERMAL INSULATED WRAP FOR CANS TO KEEP THE CONTENTS COLD OR HOT, AND GIFTWARE AND HOME DECOR ITEMS MADE OF CERAMIC AND GLASS, NAMELY, FIGURINES AND STATUES IN THE SHAPE OF BUILDINGS AND STRUCTURES (U.S. CLS. 2, 13, 23, 29, 30, 33, 40 AND 50).  
FIRST USE 7-31-2003; IN COMMERCE 7-31-2003.

#### CLASS 24—FABRICS

FOR BLANKET THROWS AND TOWELS (U.S. CLS. 42 AND 50).  
FIRST USE 3-31-2005; IN COMMERCE 3-31-2005.

#### CLASS 25—CLOTHING

FOR APRONS, BABY BIBS NOT OF PAPER, BABY BODYSUITS, BASEBALL CAPS, BOOTIES, HATS, JACKETS, QUILTED VESTS, SCARVES, SHIRTS, SOCKS, SWEAT PANTS, SWEAT SHIRTS, T-SHIRTS, AND TURTLENECKS (U.S. CLS. 22 AND 39).  
FIRST USE 1-1-1984; IN COMMERCE 1-1-1984.

#### CLASS 26—FANCY GOODS

FOR SHOE CHARMS, SHOE LACES, AND THIMBLES (U.S. CLS. 37, 39, 40, 42 AND 50).  
FIRST USE 12-31-2003; IN COMMERCE 12-31-2003.

#### CLASS 28—TOYS AND SPORTING GOODS

FOR BASEBALLS, BOARD GAMES, CHRISTMAS TREE ORNAMENTS, GOLF BAGS, GOLF BALLS, GOLF CLUB COVERS, GOLF PUTTERS, GOLF TEES, JUMP ROPES, PLAYING CARDS, PUZZLES, SOCCER BALLS, STRESS-RELIEF BALLS FOR HAND EXERCISE, STUFFED TOY ANIMALS, TOY TRAINS AND ACCESSORIES, TOY WHISTLES, AND WATER GLOBES (U.S. CLS. 22, 23, 38 AND 50).  
FIRST USE 5-31-2003; IN COMMERCE 5-31-2003.

WON TEAK OH, EXAMINING ATTORNEY

SN 77-881,328. WAL-MART STORES, INC., BENTONVILLE, AR. FILED 11-26-2009.

SN 77-875,241. INSPIRATIONS INK, L.L.C., KANSAS CITY, MO. FILED 11-18-2009.

# ART ALLEY

FIGHT LIKE A WOMAN!

THE MARK CONSISTS OF STANDARD CHARACTERS WITHOUT CLAIM TO ANY PARTICULAR FONT, STYLE, SIZE, OR COLOR.  
NO CLAIM IS MADE TO THE EXCLUSIVE RIGHT TO USE "ART", APART FROM THE MARK AS SHOWN.

THE MARK CONSISTS OF STANDARD CHARACTERS WITHOUT CLAIM TO ANY PARTICULAR FONT, STYLE, SIZE, OR COLOR.  
OWNER OF U.S. REG. NO. 3,345,298.

## CLASS 16—PAPER GOODS AND PRINTED MATTER

FOR CHILDREN'S ACTIVITY KITS PRIMARILY COMPOSED OF COLORING BOOKS, CRAFT PAPER, DRAWING PAPER, CRAYONS, COLOR PENCILS, MARKERS AND STICKERS; CHILDREN'S ACTIVITY KITS PRIMARILY COMPOSED OF MODELING MATERIALS AND COMPOUNDS FOR USE BY CHILDREN; ART AND CRAFT FINGER-PAINTING KITS FOR CHILDREN (U.S. CLS. 2, 5, 22, 23, 29, 37, 38 AND 50).

## CLASS 20—FURNITURE AND ARTICLES NOT OTHERWISE CLASSIFIED

FOR NOVELTY GOODS, NAMELY, BOXING GLOVE KEY CHAIN TAGS (U.S. CLS. 2, 13, 22, 25, 32 AND 50).  
FIRST USE 2-7-2007; IN COMMERCE 2-7-2007.

## CLASS 28—TOYS AND SPORTING GOODS

FOR TOYS AND PLAYTHINGS, NAMELY, CHILDREN'S MULTIPLE ACTIVITY TOYS, DRAWING TOYS, PRINTING TOYS, SKETCHING TOYS, TOY MODELING DOUGH; CHILDREN'S WIRE CONSTRUCTION AND ART ACTIVITY TOYS, CONSTRUCTION TOYS, MECHANICAL TOYS, PLUSH TOYS, PULL TOYS, BOARD GAMES (U.S. CLS. 22, 23, 38 AND 50).  
BERYL GARDNER, EXAMINING ATTORNEY

## CLASS 28—TOYS AND SPORTING GOODS

FOR AUTOGRAPH BOXING GLOVES (U.S. CLS. 22, 23, 38 AND 50).  
FIRST USE 2-7-2007; IN COMMERCE 2-7-2007.  
INGA ERVIN, EXAMINING ATTORNEY

SN 77-882,451. KELLOGG NORTH AMERICA COMPANY, BATTLE CREEK, MI. FILED 11-30-2009.

SN 77-878,197. PCT INTERNATIONAL, INC., MESA, AZ. FILED 11-21-2009.

THEY'RE GR-R-REAT!

# 1PREP

THE MARK CONSISTS OF STANDARD CHARACTERS WITHOUT CLAIM TO ANY PARTICULAR FONT, STYLE, SIZE, OR COLOR.  
OWNER OF U.S. REG. NO. 1,331,096.

THE MARK CONSISTS OF STANDARD CHARACTERS WITHOUT CLAIM TO ANY PARTICULAR FONT, STYLE, SIZE, OR COLOR.

## CLASS 9—ELECTRICAL AND SCIENTIFIC APPARATUS

FOR DECORATIVE MAGNETS (U.S. CLS. 21, 23, 26, 36 AND 38).

## CLASS 9—ELECTRICAL AND SCIENTIFIC APPARATUS

FOR TELECOMMUNICATIONS CABLES; COAXIAL CABLES (U.S. CLS. 21, 23, 26, 36 AND 38).

## CLASS 21—HOUSEWARES AND GLASS

FOR BEVERAGEWARE (U.S. CLS. 2, 13, 23, 29, 30, 33, 40 AND 50).

## CLASS 17—RUBBER GOODS

FOR ADHESIVE TAPE FOR THE TELECOMMUNICATIONS INDUSTRY FOR BONDING CABLE JACKETS TO COAXIAL CABLES (U.S. CLS. 1, 5, 12, 13, 35 AND 50).  
BILL DAWE, EXAMINING ATTORNEY

## CLASS 25—CLOTHING

FOR CAPS; HATS; JACKETS; PANTS; SHIRTS; SHORTS (U.S. CLS. 22 AND 39).  
JILL C. ALT, EXAMINING ATTORNEY

SN 77-882,671. TOWERS PERRIN CAPITAL CORPORATION, WILMINGTON, DE. FILED 11-30-2009.



THE COLOR(S) RED-ORANGE IS/ARE CLAIMED AS A FEATURE OF THE MARK.

THE MARK CONSISTS OF THE LETTERS "TW" IN THE FORM OF A STYLIZED SIGNATURE IN THE COLOR RED-ORANGE.

#### **CLASS 9—ELECTRICAL AND SCIENTIFIC APPARATUS**

FOR COMPUTER SOFTWARE FOR FINANCIAL MODELING AND BENCHMARKING, STOCHASTIC MODELING, EVALUATING JOBS AND BENEFIT PLANS, CREATING AND MAINTAINING EMPLOYEE PAY STRUCTURES, EVALUATING EMPLOYEE PERFORMANCE, ASSET ALLOCATION, CATASTROPHE MODELING, QUALITY ASSURANCE, AND FOR MODELING, RECORDING, ORGANIZING, CALCULATING, REPORTING, DISPLAYING, ANALYZING, EVALUATING, COMPARING, PREDICTING, AND UPDATING ACTUARIAL DATA, FINANCIAL DATA, BUSINESS DATA, AND HUMAN RESOURCES DATA, ALL FOR USE IN THE FIELDS OF HUMAN RESOURCES, EMPLOYEE COMPENSATION AND BENEFITS, RETIREMENT PLANNING, PENSION AND RETIREMENT PLANS, INVESTMENTS, PROFIT-SHARING PLANS, STOCK PURCHASE PLANS, HEALTH CARE, HEALTH CARE PLANS, DENTAL PLANS, PRESCRIPTION PLANS, PERSONNEL MANAGEMENT, WORKFORCE EFFECTIVENESS, REWARDS MANAGEMENT, EMPLOYEE JOB EVALUATION, EMPLOYER-EMPLOYEE COMMUNICATIONS, EMPLOYEE SAFETY, EMPLOYEE RELOCATION, OUTSOURCING, BUSINESS AND ORGANIZATIONAL MANAGEMENT AND OPERATIONS, ORGANIZATIONAL STRUCTURE AND REORGANIZATION, PRODUCT DEVELOPMENT AND MARKETING, MERGERS AND ACQUISITIONS, STRATEGIC PLANNING, CONTINGENCY PLANNING, CHANGE MANAGEMENT, INFORMATION TECHNOLOGY, RISK MANAGEMENT, RISK EVALUATION, ACTUARIAL MATTERS, FINANCIAL SERVICES, INVESTMENTS, FINANCIAL PLANNING, FINANCIAL MODELING, ASSET ALLOCATION, CATASTROPHE MODELING, AND/OR QUALITY ASSURANCE; DOWNLOADABLE ELECTRONIC PUBLICATIONS IN THE NATURE OF PERIODICALS, BOOKS, NEWSLETTERS, REPORTS, SURVEYS, ARTICLE REPRINTS, MEMORANDA, GUIDES, MANUALS, AND DIRECTORIES, DOWNLOADABLE PODCASTS, AND DOWNLOADABLE VIDEO RECORDINGS, ALL IN THE FIELDS OF HUMAN RESOURCES, EMPLOYEE COMPENSATION AND BENEFITS, RETIREMENT PLANNING, PENSION AND RETIREMENT PLANS, INVESTMENTS, PROFIT-SHARING PLANS, STOCK PURCHASE PLANS, HEALTH CARE, HEALTH CARE PLANS, DENTAL PLANS, PRESCRIPTION PLANS, PERSONNEL MANAGEMENT, WORKFORCE EFFECTIVENESS, REWARDS MANAGEMENT, EMPLOYEE JOB EVALUATION, EMPLOYER-EMPLOYEE COMMUNICATIONS, EMPLOYEE SAFETY, EMPLOYEE RELOCATION, OUTSOURCING, BUSINESS AND ORGANIZATIONAL MANAGEMENT AND OPERATIONS, ORGANIZATIONAL STRUCTURE AND REORGANIZATION, PRODUCT DEVELOPMENT AND MARKETING, MERGERS AND ACQUISITIONS, STRATEGIC PLANNING, CONTINGENCY PLANNING, CHANGE MANAGEMENT, INFORMATION TECHNOLOGY, RISK MANAGEMENT, RISK EVALUATION, ACTUARIAL MATTERS, FINANCIAL SERVICES, INVESTMENTS, FINANCIAL PLANNING, FINANCIAL MODELING, ASSET ALLOCATION, CATASTROPHE MODELING, AND/OR QUALITY ASSURANCE; COMPUTER SOFTWARE FOR INTERNAL BUSINESS USE BY INSURERS,

NAMELY, SOFTWARE FOR FINANCIAL MODELING AND BENCHMARKING, STOCHASTIC MODELING, ASSET ALLOCATION, CATASTROPHE MODELING, AND FOR MODELING, RECORDING, ORGANIZING, CALCULATING, REPORTING, DISPLAYING, ANALYZING, EVALUATING, COMPARING, PREDICTING, AND UPDATING ACTUARIAL DATA AND FINANCIAL DATA; DOWNLOADABLE ELECTRONIC PUBLICATIONS, DOWNLOADABLE PODCASTS, AND DOWNLOADABLE VIDEO RECORDINGS FOR USE IN BUSINESS MANAGEMENT BY INSURERS, ALL IN THE FIELDS OF ENTERPRISE RISK MANAGEMENT, FINANCIAL AND REGULATORY REPORTING, MERGERS AND ACQUISITIONS, CORPORATE RESTRUCTURING, MARKETING, FINANCIAL MODELING, PRICING, AND LOSS RESERVE REQUIREMENTS (U.S. CLS. 21, 23, 26, 36 AND 38).

#### **CLASS 16—PAPER GOODS AND PRINTED MATTER**

FOR PRINTED MATTER AND PUBLICATIONS, NAMELY, PERIODICALS, BOOKS, NEWSLETTERS, REPORTS, SURVEYS, ARTICLE REPRINTS, MEMORANDA, GUIDES, MANUALS, AND DIRECTORIES IN THE FIELDS OF HUMAN RESOURCES, EMPLOYEE COMPENSATION AND BENEFITS, RETIREMENT PLANNING, PENSION AND RETIREMENT PLANS, INVESTMENTS, PROFIT-SHARING PLANS, STOCK PURCHASE PLANS, HEALTH CARE, HEALTH CARE PLANS, DENTAL PLANS, PRESCRIPTION PLANS, PERSONNEL MANAGEMENT, WORKFORCE EFFECTIVENESS, REWARDS MANAGEMENT, EMPLOYEE JOB EVALUATION, PERSONNEL POLICIES, EMPLOYER-EMPLOYEE COMMUNICATIONS, EMPLOYEE SAFETY, EMPLOYEE RELOCATION, OUTSOURCING, BUSINESS AND ORGANIZATIONAL MANAGEMENT AND OPERATIONS, ORGANIZATIONAL STRUCTURE AND REORGANIZATION, PRODUCT DEVELOPMENT AND MARKETING, MERGERS AND ACQUISITIONS, STRATEGIC PLANNING, CONTINGENCY PLANNING, CHANGE MANAGEMENT, INFORMATION TECHNOLOGY, RISK MANAGEMENT, RISK EVALUATION, ACTUARIAL MATTERS, FINANCIAL SERVICES, INVESTMENTS, FINANCIAL PLANNING, FINANCIAL MODELING, ASSET ALLOCATION, CATASTROPHE MODELING, AND/OR QUALITY ASSURANCE; PRINTED MATTER AND PUBLICATIONS FOR USE IN BUSINESS MANAGEMENT BY INSURERS, NAMELY, PERIODICALS, BOOKS, NEWSLETTERS, REPORTS, SURVEYS, ARTICLE REPRINTS, MEMORANDA, GUIDE, MANUALS AND DIRECTORIES IN THE FIELDS OF ENTERPRISE RISK MANAGEMENT, FINANCIAL AND REGULATORY REPORTING, MERGERS AND ACQUISITIONS, CORPORATE RESTRUCTURING, MARKETING, FINANCIAL MODELING, PRICING, AND LOSS RESERVE REQUIREMENTS (U.S. CLS. 2, 5, 22, 23, 29, 37, 38 AND 50).

#### **CLASS 35—ADVERTISING AND BUSINESS**

FOR BUSINESS CONSULTATION SERVICES; CONSULTING SERVICES IN THE FIELD OF BUSINESS RISK MANAGEMENT; BUSINESS CONSULTING SERVICES IN THE FIELDS OF PERSONNEL AND HUMAN RESOURCE MANAGEMENT, WORKFORCE EFFECTIVENESS, EMPLOYEE JOB EVALUATION, EMPLOYER-EMPLOYEE COMMUNICATIONS, EMPLOYEE RELOCATION, BUSINESS AND ORGANIZATIONAL MANAGEMENT AND OPERATIONS, CONTINGENCY PLANNING, STRATEGIC PLANNING, OPERATIONS, MERGERS AND ACQUISITIONS, ORGANIZATIONAL STRUCTURE AND REORGANIZATION, AND MARKETING; INFORMATION IN BUSINESS MATTERS; ASSISTANCE IN MANAGEMENT OF BUSINESS ACTIVITIES; OUTSOURCING SERVICES; MANAGEMENT AND COMPILATION OF COMPUTERIZED DATABASES; MARKET ANALYSIS AND RESEARCH SERVICES; MARKET REPORTS AND STUDIES; CONDUCTING BUSINESS RESEARCH AND SURVEYS;



PREPARING BUSINESS REPORTS; CUSTOM PREPARATION OF EMPLOYER-EMPLOYEE COMMUNICATIONS MATERIALS IN THE NATURE OF PRINTED AND ELECTRONIC ANNOUNCEMENTS, MEMORANDA, BOOKS, REPORTS, NEWSLETTERS, GUIDES, MANUALS, PERIODICALS, AND AUDIO-VISUAL PRESENTATIONS FOR OTHERS; BUSINESS CONSULTING SERVICES FOR INSURERS IN THE FIELDS OF BUSINESS RISK MANAGEMENT, REGULATORY REPORTING, MERGERS AND ACQUISITIONS, CORPORATE RESTRUCTURING, AND MARKETING (U.S. CLS. 100, 101 AND 102).

### **CLASS 36—INSURANCE AND FINANCIAL**

FOR FINANCIAL CONSULTING SERVICES IN THE FIELDS OF FINANCIAL RISK MANAGEMENT, FINANCIAL SERVICES, INVESTMENTS, EMPLOYEE COMPENSATION AND BENEFITS, PROFIT-SHARING PLANS, STOCK PURCHASE PLANS, SAVINGS, PENSION AND RETIREMENT PLANS, AND IN THE ADMINISTRATION OF HEALTH CARE, DENTAL, AND PRESCRIPTION DRUG PLANS; ADMINISTRATION OF EMPLOYEE COMPENSATION AND BENEFIT PLANS, PROFIT-SHARING PLANS, STOCK PURCHASE PLANS, SAVINGS, PENSION, AND RETIREMENT PLANS, AND HEALTH CARE, DENTAL, AND PRESCRIPTION PLANS; FINANCIAL RESEARCH AND INFORMATION SERVICES; ACTUARIAL CONSULTING AND SERVICES; REINSURANCE BROKERAGE SERVICES; FINANCIAL CONSULTING SERVICES FOR INSURERS IN THE FIELDS OF FINANCIAL RISK MANAGEMENT, FINANCIAL REPORTING, FINANCIAL MODELING, PRICING, AND LOSS RESERVE REQUIREMENTS (U.S. CLS. 100, 101 AND 102).

### **CLASS 41—EDUCATION AND ENTERTAINMENT**

FOR EDUCATIONAL SERVICES, NAMELY, CONDUCTING WORKSHOPS, SEMINARS, AND EDUCATIONAL PROGRAMS IN THE FIELDS OF HUMAN RESOURCES, EMPLOYEE COMPENSATION AND BENEFITS, RETIREMENT PLANNING, PENSION AND RETIREMENT PLANS, INVESTMENTS, PROFIT-SHARING PLANS, STOCK PURCHASE PLANS, HEALTH CARE, HEALTH CARE PLANS, DENTAL PLANS, PRESCRIPTION PLANS, PERSONNEL MANAGEMENT, WORKFORCE EFFECTIVENESS, REWARDS MANAGEMENT, EMPLOYEE JOB EVALUATION, PERSONNEL POLICIES, EMPLOYER-EMPLOYEE COMMUNICATIONS, EMPLOYEE SAFETY, EMPLOYEE RELOCATION, OUTSOURCING, BUSINESS AND ORGANIZATIONAL MANAGEMENT AND OPERATIONS, ORGANIZATIONAL STRUCTURE AND REORGANIZATION, PRODUCT DEVELOPMENT AND MARKETING, MERGERS AND ACQUISITIONS, STRATEGIC PLANNING, CONTINGENCY PLANNING, CHANGE MANAGEMENT, INFORMATION TECHNOLOGY, RISK MANAGEMENT, RISK EVALUATION, ACTUARIAL MATTERS, FINANCIAL SERVICES, INVESTMENTS, FINANCIAL PLANNING, FINANCIAL MODELING, ASSET ALLOCATION, CATASTROPHE MODELING, AND/OR QUALITY ASSURANCE; ELECTRONIC NON-DOWNLOADABLE PUBLICATIONS, NAMELY, PERIODICALS, BOOKS, NEWSLETTERS, REPORTS, SURVEYS, ARTICLE REPRINTS, MEMORANDA, GUIDES, MANUALS, AND DIRECTORIES, NON-DOWNLOADABLE PODCASTS, AND NON-DOWNLOADABLE VIDEO RECORDINGS, ALL IN THE FIELDS OF HUMAN RESOURCES, EMPLOYEE COMPENSATION AND BENEFITS, RETIREMENT PLANNING, PENSION AND RETIREMENT PLANS, INVESTMENTS, PROFIT-SHARING PLANS, STOCK PURCHASE PLANS, HEALTH CARE, HEALTH CARE PLANS, DENTAL PLANS, PRESCRIPTION PLANS, PERSONNEL MANAGEMENT, WORKFORCE EFFECTIVENESS, REWARDS MANAGEMENT, EMPLOYEE JOB EVALUATION, PERSONNEL POLICIES, EMPLOYER-EMPLOYEE COMMUNICATIONS, EMPLOYEE SAFETY, EMPLOYEE RELOCATION, OUTSOURCING, BUSINESS AND ORGANIZATIONAL MANAGEMENT AND OPERATIONS, ORGANIZATIONAL STRUCTURE AND REORGANIZATION, PRODUCT DEVELOPMENT AND MARKETING, MERGERS AND ACQUISITIONS, STRATEGIC PLANNING, CONTINGENCY PLANNING, CHANGE MANAGEMENT, INFORMATION TECHNOLOGY, RISK MANAGEMENT, RISK EVALUATION, ACTUARIAL MATTERS, FINANCIAL SERVICES, INVESTMENTS, FINANCIAL PLANNING, FINANCIAL MODELING, ASSET ALLOCATION, CATASTROPHE MODELING, AND/OR QUALITY ASSURANCE; PRODUCT DEVELOPMENT CONSULTATION; APPLICATION SERVICE PROVIDER (ASP) SERVICES FOR INTERNAL BUSINESS USE BY INSURERS, NAMELY, PROVIDING, HOSTING, MANAGING, DEVELOPING, AND MAINTAINING APPLICATIONS, SOFTWARE, WEB SITES, AND DATABASES OF OTHERS IN THE FIELDS OF HUMAN RESOURCES, EMPLOYEE COMPENSATION AND BENEFITS, RETIREMENT PLANNING, PENSION AND RETIREMENT PLANS, INVESTMENTS, PROFIT-SHARING PLANS, STOCK PURCHASE PLANS, HEALTH CARE, HEALTH CARE PLANS, DENTAL PLANS, PRESCRIPTION PLANS, PERSONNEL MANAGEMENT, WORKFORCE EFFECTIVENESS, REWARDS MANAGEMENT, EMPLOYEE JOB EVALUATION, PERSONNEL POLICIES, EMPLOYER-EMPLOYEE COMMUNICATIONS, EMPLOYEE SAFETY, EMPLOYEE RELOCATION, OUTSOURCING, BUSINESS AND ORGANIZATIONAL MANAGEMENT AND OPERATIONS, ORGANIZATIONAL STRUCTURE AND REORGANIZATION, PRODUCT DEVELOPMENT AND MARKETING, MERGERS AND ACQUISITIONS, STRATEGIC PLANNING, CONTINGENCY PLANNING, CHANGE MANAGEMENT, INFORMATION TECHNOLOGY, RISK MANAGEMENT, RISK EVALUATION, ACTUARIAL MATTERS, FINANCIAL SERVICES, INVESTMENTS, FINANCIAL PLANNING, FINANCIAL MODELING, ASSET ALLOCATION, CATASTROPHE MODELING, AND/OR QUALITY ASSURANCE; PRODUCT DEVELOPMENT CONSULTATION; APPLICATION SERVICE PROVIDER (ASP) SERVICES FOR INTERNAL BUSINESS USE BY INSURERS, NAMELY, PROVIDING, HOSTING, MANAGING, DEVELOPING, AND MAINTAINING APPLICATIONS, SOFTWARE, WEB SITES, AND DATABASES OF OTHERS IN FIELDS OF ENTERPRISE RISK MANAGEMENT, FINANCIAL AND REGULATORY REPORTING, MERGERS AND ACQUISITIONS, CORPORATE RESTRUCTURING, MARKETING, FINANCIAL MODELING, PRICING, AND LOSS RESERVE REQUIREMENTS (U.S. CLS. 100 AND 101).

MATTERS, FINANCIAL SERVICES, INVESTMENTS, FINANCIAL PLANNING, FINANCIAL MODELING, ASSET ALLOCATION, CATASTROPHE MODELING, AND/OR QUALITY ASSURANCE; EDUCATIONAL SERVICES FOR INSURERS, NAMELY, PROVIDING WORKSHOPS, SEMINARS AND EDUCATIONAL PROGRAMS IN THE FIELDS OF ENTERPRISE RISK MANAGEMENT, FINANCIAL AND REGULATORY REPORTING, MERGERS AND ACQUISITIONS, CORPORATE RESTRUCTURING, MARKETING, FINANCIAL MODELING, PRICING, AND LOSS RESERVE REQUIREMENTS; ELECTRONIC NON-DOWNLOADABLE ELECTRONIC PUBLICATIONS, ELECTRONIC NON-DOWNLOADABLE PODCASTS, AND ELECTRONIC NON-DOWNLOADABLE VIDEO RECORDINGS FOR INSURERS, ALL IN THE FIELDS OF ENTERPRISE RISK MANAGEMENT, FINANCIAL AND REGULATORY REPORTING, MERGERS AND ACQUISITIONS, CORPORATE RESTRUCTURING, MARKETING, FINANCIAL MODELING, PRICING, AND LOSS RESERVE REQUIREMENTS (U.S. CLS. 100, 101 AND 107).

### **CLASS 42—SCIENTIFIC AND COMPUTER SERVICES**

FOR COMPUTER AND INFORMATION TECHNOLOGY CONSULTATION; DESIGN, DEVELOPMENT, AND IMPLEMENTATION OF COMPUTER HARDWARE AND SOFTWARE, DATABASES, WEBSITES, AND INTRANETS; COMPUTER SYSTEMS INTEGRATION SERVICES; COMPUTER PROGRAMMING AND COMPUTER MODELING SERVICES, NAMELY, COMPUTER SIMULATION FROM COMPUTER PROGRAMS FOR OTHERS; COMPUTER PROJECT MANAGEMENT SERVICES; APPLICATION SERVICE PROVIDER (ASP) SERVICES, NAMELY, PROVIDING, HOSTING, MANAGING, DEVELOPING, AND MAINTAINING APPLICATIONS, SOFTWARE, WEB SITES, AND DATABASES OF OTHERS IN THE FIELDS OF HUMAN RESOURCES, EMPLOYEE COMPENSATION AND BENEFITS, RETIREMENT PLANNING, PENSION AND RETIREMENT PLANS, INVESTMENTS, PROFIT-SHARING PLANS, STOCK PURCHASE PLANS, HEALTH CARE, HEALTH CARE PLANS, DENTAL PLANS, PRESCRIPTION PLANS, PERSONNEL MANAGEMENT, WORKFORCE EFFECTIVENESS, REWARDS MANAGEMENT, EMPLOYEE JOB EVALUATION, PERSONNEL POLICIES, EMPLOYER-EMPLOYEE COMMUNICATIONS, EMPLOYEE SAFETY, EMPLOYEE RELOCATION, OUTSOURCING, BUSINESS AND ORGANIZATIONAL MANAGEMENT AND OPERATIONS, ORGANIZATIONAL STRUCTURE AND REORGANIZATION, PRODUCT DEVELOPMENT AND MARKETING, MERGERS AND ACQUISITIONS, STRATEGIC PLANNING, CONTINGENCY PLANNING, CHANGE MANAGEMENT, INFORMATION TECHNOLOGY, RISK MANAGEMENT, RISK EVALUATION, ACTUARIAL MATTERS, FINANCIAL SERVICES, INVESTMENTS, FINANCIAL PLANNING, FINANCIAL MODELING, ASSET ALLOCATION, CATASTROPHE MODELING, AND/OR QUALITY ASSURANCE; PRODUCT DEVELOPMENT CONSULTATION; APPLICATION SERVICE PROVIDER (ASP) SERVICES FOR INTERNAL BUSINESS USE BY INSURERS, NAMELY, PROVIDING, HOSTING, MANAGING, DEVELOPING, AND MAINTAINING APPLICATIONS, SOFTWARE, WEB SITES, AND DATABASES OF OTHERS IN FIELDS OF ENTERPRISE RISK MANAGEMENT, FINANCIAL AND REGULATORY REPORTING, MERGERS AND ACQUISITIONS, CORPORATE RESTRUCTURING, MARKETING, FINANCIAL MODELING, PRICING, AND LOSS RESERVE REQUIREMENTS (U.S. CLS. 100 AND 101).

### **CLASS 45—PERSONAL AND LEGAL SERVICES**

FOR CONSULTING IN THE FIELD OF WORKPLACE SAFETY (U.S. CLS. 100 AND 101).  
ELISSA GARBER KON, EXAMINING ATTORNEY

SN 77-882,675. TOWERS PERRIN CAPITAL CORPORATION,  
WILMINGTON, DE. FILED 11-30-2009.

THE MARK CONSISTS OF THE LETTERS TW IN THE  
FORM OF A STYLIZED SIGNATURE.

### **CLASS 9—ELECTRICAL AND SCIENTIFIC APPARATUS**

FOR COMPUTER SOFTWARE FOR FINANCIAL MODELING AND BENCHMARKING, STOCHASTIC MODELING, EVALUATING JOBS AND BENEFIT PLANS, CREATING AND MAINTAINING EMPLOYEE PAY STRUCTURES, EVALUATING EMPLOYEE PERFORMANCE, ASSET ALLOCATION, CATASTROPHE MODELING, QUALITY ASSURANCE, AND FOR MODELING, RECORDING, ORGANIZING, CALCULATING, REPORTING, DISPLAYING, ANALYZING, EVALUATING, COMPARING, PREDICTING, AND UPDATING ACTUARIAL DATA, FINANCIAL DATA, BUSINESS DATA, AND HUMAN RESOURCES DATA, ALL FOR USE IN THE FIELDS OF HUMAN RESOURCES, EMPLOYEE COMPENSATION AND BENEFITS, RETIREMENT PLANNING, PENSION AND RETIREMENT PLANS, INVESTMENTS, PROFIT-SHARING PLANS, STOCK PURCHASE PLANS, HEALTH CARE, HEALTH CARE PLANS, DENTAL PLANS, PRESCRIPTION PLANS, PERSONNEL MANAGEMENT, WORKFORCE EFFECTIVENESS, REWARDS MANAGEMENT, EMPLOYEE JOB EVALUATION, EMPLOYER-EMPLOYEE COMMUNICATIONS, EMPLOYEE SAFETY, EMPLOYEE RELOCATION, OUTSOURCING, BUSINESS AND ORGANIZATIONAL MANAGEMENT AND OPERATIONS, ORGANIZATIONAL STRUCTURE AND REORGANIZATION, PRODUCT DEVELOPMENT AND MARKETING, MERGERS AND ACQUISITIONS, STRATEGIC PLANNING, CONTINGENCY PLANNING, CHANGE MANAGEMENT, INFORMATION TECHNOLOGY, RISK MANAGEMENT, RISK EVALUATION, ACTUARIAL MATTERS, FINANCIAL SERVICES, INVESTMENTS, FINANCIAL PLANNING, FINANCIAL MODELING, ASSET ALLOCATION, CATASTROPHE MODELING, AND/OR QUALITY ASSURANCE; DOWNLOADABLE ELECTRONIC PUBLICATIONS IN THE NATURE OF PERIODICALS, BOOKS, NEWSLETTERS, REPORTS, SURVEYS, ARTICLE REPRINTS, MEMORANDA, GUIDES, MANUALS, AND DIRECTORIES, DOWNLOADABLE PODCASTS, AND DOWNLOADABLE VIDEO RECORDINGS, ALL IN THE FIELDS OF HUMAN RESOURCES, EMPLOYEE COMPENSATION AND BENEFITS, RETIREMENT PLANNING, PENSION AND RETIREMENT PLANS, INVESTMENTS, PROFIT-SHARING PLANS, STOCK PURCHASE PLANS, HEALTH CARE, HEALTH CARE PLANS, DENTAL PLANS, PRESCRIPTION PLANS, PERSONNEL MANAGEMENT, WORKFORCE EFFECTIVENESS, REWARDS MANAGEMENT, EMPLOYEE JOB EVALUATION, EMPLOYER-EMPLOYEE COMMUNICATIONS, EMPLOYEE SAFETY, EMPLOYEE RELOCATION, OUTSOURCING, BUSINESS AND ORGANIZATIONAL MANAGEMENT AND OPERATIONS, ORGANIZATIONAL STRUCTURE AND REORGANIZATION, PRODUCT DEVELOPMENT AND MARKETING, MERGERS AND ACQUISITIONS, STRATEGIC PLANNING, CONTINGENCY PLANNING, CHANGE MANAGEMENT, INFORMATION TECHNOLOGY, RISK MANAGEMENT, RISK EVALUATION, ACTUARIAL MATTERS, FINANCIAL SERVICES, INVESTMENTS, FINANCIAL PLANNING, FINANCIAL MODELING, ASSET ALLOCATION, CATASTROPHE MODELING, AND/OR QUALITY ASSURANCE; COMPUTER SOFTWARE FOR INTERNAL BUSINESS USE BY INSURERS, NAMELY, SOFTWARE FOR FINANCIAL MODELING AND BENCHMARKING, STOCHASTIC MODELING, ASSET ALLOCATION, CATASTROPHE MODELING,

AND FOR MODELING, RECORDING, ORGANIZING, CALCULATING, REPORTING, DISPLAYING, ANALYZING, EVALUATING, COMPARING, PREDICTING, AND UPDATING ACTUARIAL DATA AND FINANCIAL DATA; DOWNLOADABLE ELECTRONIC PUBLICATIONS, DOWNLOADABLE PODCASTS, AND DOWNLOADABLE VIDEO RECORDINGS FOR USE IN BUSINESS MANAGEMENT BY INSURERS, ALL IN THE FIELDS OF ENTERPRISE RISK MANAGEMENT, FINANCIAL AND REGULATORY REPORTING, MERGERS AND ACQUISITIONS, CORPORATE RESTRUCTURING, MARKETING, FINANCIAL MODELING, PRICING, AND LOSS RESERVE REQUIREMENTS (U.S. CLS. 21, 23, 26, 36 AND 38).

### **CLASS 16—PAPER GOODS AND PRINTED MATTER**

FOR PRINTED MATTER AND PUBLICATIONS, NAMELY, PERIODICALS, BOOKS, NEWSLETTERS, REPORTS, SURVEYS, ARTICLE REPRINTS, MEMORANDA, GUIDES, MANUALS, AND DIRECTORIES IN THE FIELDS OF HUMAN RESOURCES, EMPLOYEE COMPENSATION AND BENEFITS, RETIREMENT PLANNING, PENSION AND RETIREMENT PLANS, INVESTMENTS, PROFIT-SHARING PLANS, STOCK PURCHASE PLANS, HEALTH CARE, HEALTH CARE PLANS, DENTAL PLANS, PRESCRIPTION PLANS, PERSONNEL MANAGEMENT, WORKFORCE EFFECTIVENESS, REWARDS MANAGEMENT, EMPLOYEE JOB EVALUATION, PERSONNEL POLICIES, EMPLOYER-EMPLOYEE COMMUNICATIONS, EMPLOYEE SAFETY, EMPLOYEE RELOCATION, OUTSOURCING, BUSINESS AND ORGANIZATIONAL MANAGEMENT AND OPERATIONS, ORGANIZATIONAL STRUCTURE AND REORGANIZATION, PRODUCT DEVELOPMENT AND MARKETING, MERGERS AND ACQUISITIONS, STRATEGIC PLANNING, CONTINGENCY PLANNING, CHANGE MANAGEMENT, INFORMATION TECHNOLOGY, RISK MANAGEMENT, RISK EVALUATION, ACTUARIAL MATTERS, FINANCIAL SERVICES, INVESTMENTS, FINANCIAL PLANNING, FINANCIAL MODELING, ASSET ALLOCATION, CATASTROPHE MODELING, AND/OR QUALITY ASSURANCE; PRINTED MATTER AND PUBLICATIONS FOR USE IN BUSINESS MANAGEMENT BY INSURERS, NAMELY, PERIODICALS, BOOKS, NEWSLETTERS, REPORTS, SURVEYS, ARTICLE REPRINTS, MEMORANDA, GUIDE, MANUALS AND DIRECTORIES IN THE FIELDS OF ENTERPRISE RISK MANAGEMENT, FINANCIAL AND REGULATORY REPORTING, MERGERS AND ACQUISITIONS, CORPORATE RESTRUCTURING, MARKETING, FINANCIAL MODELING, PRICING, AND LOSS RESERVE REQUIREMENTS (U.S. CLS. 2, 5, 22, 23, 29, 37, 38 AND 50).

### **CLASS 35—ADVERTISING AND BUSINESS**

FOR BUSINESS CONSULTATION SERVICES; CONSULTING SERVICES IN THE FIELD OF BUSINESS RISK MANAGEMENT; BUSINESS CONSULTING SERVICES IN THE FIELDS OF PERSONNEL AND HUMAN RESOURCE MANAGEMENT, WORKFORCE EFFECTIVENESS, EMPLOYEE JOB EVALUATION, EMPLOYER-EMPLOYEE COMMUNICATIONS, EMPLOYEE RELOCATION, BUSINESS AND ORGANIZATIONAL MANAGEMENT AND OPERATIONS, CONTINGENCY PLANNING, STRATEGIC PLANNING, OPERATIONS, MERGERS AND ACQUISITIONS, ORGANIZATIONAL STRUCTURE AND REORGANIZATION, AND MARKETING; INFORMATION IN BUSINESS MATTERS; ASSISTANCE IN MANAGEMENT OF BUSINESS ACTIVITIES; OUTSOURCING SERVICES; MANAGEMENT AND COMPILATION OF COMPUTERIZED DATABASES; MARKET ANALYSIS AND RESEARCH SERVICES; MARKET REPORTS AND STUDIES; CONDUCTING BUSINESS RESEARCH AND SURVEYS;

PREPARING BUSINESS REPORTS; CUSTOM PREPARATION OF EMPLOYER-EMPLOYEE COMMUNICATIONS MATERIALS IN THE NATURE OF PRINTED AND ELECTRONIC ANNOUNCEMENTS, MEMORANDA, BOOKS, REPORTS, NEWSLETTERS, GUIDES, MANUALS, PERIODICALS, AND AUDIO-VISUAL PRESENTATIONS FOR OTHERS; BUSINESS CONSULTING SERVICES FOR INSURERS IN THE FIELDS OF BUSINESS RISK MANAGEMENT, REGULATORY REPORTING, MERGERS AND ACQUISITIONS, CORPORATE RESTRUCTURING, AND MARKETING (U.S. CLS. 100, 101 AND 102).

#### **CLASS 36—INSURANCE AND FINANCIAL**

FOR FINANCIAL CONSULTING SERVICES IN THE FIELDS OF FINANCIAL RISK MANAGEMENT, FINANCIAL SERVICES, INVESTMENTS, EMPLOYEE COMPENSATION AND BENEFITS, PROFIT-SHARING PLANS, STOCK PURCHASE PLANS, SAVINGS, PENSION AND RETIREMENT PLANS, AND IN THE ADMINISTRATION OF HEALTH CARE, DENTAL, AND PRESCRIPTION DRUG PLANS; ADMINISTRATION OF EMPLOYEE COMPENSATION AND BENEFIT PLANS, PROFIT-SHARING PLANS, STOCK PURCHASE PLANS, SAVINGS, PENSION, AND RETIREMENT PLANS, AND HEALTH CARE, DENTAL, AND PRESCRIPTION PLANS; FINANCIAL RESEARCH AND INFORMATION SERVICES; ACTUARIAL CONSULTING AND SERVICES; REINSURANCE BROKERAGE SERVICES; FINANCIAL CONSULTING SERVICES FOR INSURERS IN THE FIELDS OF FINANCIAL RISK MANAGEMENT, FINANCIAL REPORTING, FINANCIAL MODELING, PRICING, AND LOSS RESERVE REQUIREMENTS (U.S. CLS. 100, 101 AND 102).

#### **CLASS 41—EDUCATION AND ENTERTAINMENT**

FOR EDUCATIONAL SERVICES, NAMELY, CONDUCTING WORKSHOPS, SEMINARS, AND EDUCATIONAL PROGRAMS IN THE FIELDS OF HUMAN RESOURCES, EMPLOYEE COMPENSATION AND BENEFITS, RETIREMENT PLANNING, PENSION AND RETIREMENT PLANS, INVESTMENTS, PROFIT-SHARING PLANS, STOCK PURCHASE PLANS, HEALTH CARE, HEALTH CARE PLANS, DENTAL PLANS, PRESCRIPTION PLANS, PERSONNEL MANAGEMENT, WORKFORCE EFFECTIVENESS, REWARDS MANAGEMENT, EMPLOYEE JOB EVALUATION, PERSONNEL POLICIES, EMPLOYER-EMPLOYEE COMMUNICATIONS, EMPLOYEE SAFETY, EMPLOYEE RELOCATION, OUTSOURCING, BUSINESS AND ORGANIZATIONAL MANAGEMENT AND OPERATIONS, ORGANIZATIONAL STRUCTURE AND REORGANIZATION, PRODUCT DEVELOPMENT AND MARKETING, MERGERS AND ACQUISITIONS, STRATEGIC PLANNING, CONTINGENCY PLANNING, CHANGE MANAGEMENT, INFORMATION TECHNOLOGY, RISK MANAGEMENT, RISK EVALUATION, ACTUARIAL MATTERS, FINANCIAL SERVICES, INVESTMENTS, FINANCIAL PLANNING, FINANCIAL MODELING, ASSET ALLOCATION, CATASTROPHE MODELING, AND/OR QUALITY ASSURANCE; ELECTRONIC NON-DOWNLOADABLE PUBLICATIONS, NAMELY, PERIODICALS, BOOKS, NEWSLETTERS, REPORTS, SURVEYS, ARTICLE REPRINTS, MEMORANDA, GUIDES, MANUALS, AND DIRECTORIES, NON-DOWNLOADABLE PODCASTS, AND NON-DOWNLOADABLE VIDEO RECORDINGS, ALL IN THE FIELDS OF HUMAN RESOURCES, EMPLOYEE COMPENSATION AND BENEFITS, RETIREMENT PLANNING, PENSION AND RETIREMENT PLANS, INVESTMENTS, PROFIT-SHARING PLANS, STOCK PURCHASE PLANS, HEALTH CARE, HEALTH CARE PLANS, DENTAL PLANS, PRESCRIPTION PLANS, PERSONNEL MANAGEMENT, WORKFORCE EFFECTIVENESS, REWARDS MANAGEMENT, EMPLOYEE JOB EVALUATION, PERSONNEL POLICIES, EMPLOYER-EMPLOYEE COMMUNICATIONS, EMPLOYEE SAFETY, EMPLOYEE RELOCATION, OUTSOURCING, BUSINESS AND ORGANIZATIONAL MANAGEMENT AND OPERATIONS, ORGANIZATIONAL STRUCTURE AND REORGANIZATION, PRODUCT DEVELOPMENT AND MARKETING, MERGERS AND ACQUISITIONS, STRATEGIC PLANNING, CONTINGENCY PLANNING, CHANGE MANAGEMENT, INFORMATION TECHNOLOGY, RISK MANAGEMENT, RISK EVALUATION, ACTUARIAL MATTERS, FINANCIAL SERVICES, INVESTMENTS, FINANCIAL PLANNING, FINANCIAL MODELING, ASSET ALLOCATION, CATASTROPHE MODELING, AND/OR QUALITY ASSURANCE; PRODUCT DEVELOPMENT CONSULTATION; APPLICATION SERVICE PROVIDER (ASP) SERVICES FOR INTERNAL BUSINESS USE BY INSURERS, NAMELY, PROVIDING, HOSTING, MANAGING, DEVELOPING, AND MAINTAINING APPLICATIONS, SOFTWARE, WEB SITES, AND DATABASES OF OTHERS IN THE FIELDS OF HUMAN RESOURCES, EMPLOYEE COMPENSATION AND BENEFITS, RETIREMENT PLANNING, PENSION AND RETIREMENT PLANS, INVESTMENTS, PROFIT-SHARING PLANS, STOCK PURCHASE PLANS, HEALTH CARE, HEALTH CARE PLANS, DENTAL PLANS, PRESCRIPTION PLANS, PERSONNEL MANAGEMENT, WORKFORCE EFFECTIVENESS, REWARDS MANAGEMENT, EMPLOYEE JOB EVALUATION, PERSONNEL POLICIES, EMPLOYER-EMPLOYEE COMMUNICATIONS, EMPLOYEE SAFETY, EMPLOYEE RELOCATION, OUTSOURCING, BUSINESS AND ORGANIZATIONAL MANAGEMENT AND OPERATIONS, ORGANIZATIONAL STRUCTURE AND REORGANIZATION, PRODUCT DEVELOPMENT AND MARKETING, MERGERS AND ACQUISITIONS, STRATEGIC PLANNING, CONTINGENCY PLANNING, CHANGE MANAGEMENT, INFORMATION TECHNOLOGY, RISK MANAGEMENT, RISK EVALUATION, ACTUARIAL MATTERS, FINANCIAL SERVICES, INVESTMENTS, FINANCIAL PLANNING, FINANCIAL MODELING, ASSET ALLOCATION, CATASTROPHE MODELING, AND/OR QUALITY ASSURANCE; PRODUCT DEVELOPMENT CONSULTATION; APPLICATION SERVICE PROVIDER (ASP) SERVICES FOR INTERNAL BUSINESS USE BY INSURERS, NAMELY, PROVIDING, HOSTING, MANAGING, DEVELOPING, AND MAINTAINING APPLICATIONS, SOFTWARE, WEB SITES, AND DATABASES OF OTHERS IN FIELDS OF ENTERPRISE RISK MANAGEMENT, FINANCIAL AND REGULATORY REPORTING, MERGERS AND ACQUISITIONS, CORPORATE RESTRUCTURING, MARKETING, FINANCIAL MODELING, PRICING, AND LOSS RESERVE REQUIREMENTS (U.S. CLS. 100 AND 101).

MATTERS, FINANCIAL SERVICES, INVESTMENTS, FINANCIAL PLANNING, FINANCIAL MODELING, ASSET ALLOCATION, CATASTROPHE MODELING, AND/OR QUALITY ASSURANCE; EDUCATIONAL SERVICES FOR INSURERS, NAMELY, PROVIDING WORKSHOPS, SEMINARS AND EDUCATIONAL PROGRAMS IN THE FIELDS OF ENTERPRISE RISK MANAGEMENT, FINANCIAL AND REGULATORY REPORTING, MERGERS AND ACQUISITIONS, CORPORATE RESTRUCTURING, MARKETING, FINANCIAL MODELING, PRICING, AND LOSS RESERVE REQUIREMENTS; ELECTRONIC NON-DOWNLOADABLE ELECTRONIC PUBLICATIONS, ELECTRONIC NON-DOWNLOADABLE PODCASTS, AND ELECTRONIC NON-DOWNLOADABLE VIDEO RECORDINGS FOR INSURERS, ALL IN THE FIELDS OF ENTERPRISE RISK MANAGEMENT, FINANCIAL AND REGULATORY REPORTING, MERGERS AND ACQUISITIONS, CORPORATE RESTRUCTURING, MARKETING, FINANCIAL MODELING, PRICING, AND LOSS RESERVE REQUIREMENTS (U.S. CLS. 100, 101 AND 107).

#### **CLASS 42—SCIENTIFIC AND COMPUTER SERVICES**

FOR COMPUTER AND INFORMATION TECHNOLOGY CONSULTATION; DESIGN, DEVELOPMENT, AND IMPLEMENTATION OF COMPUTER HARDWARE AND SOFTWARE, DATABASES, WEBSITES, AND INTRANETS; COMPUTER SYSTEMS INTEGRATION SERVICES; COMPUTER PROGRAMMING AND COMPUTER MODELING SERVICES, NAMELY, COMPUTER SIMULATION FROM COMPUTER PROGRAMS FOR OTHERS; COMPUTER PROJECT MANAGEMENT SERVICES; APPLICATION SERVICE PROVIDER (ASP) SERVICES, NAMELY, PROVIDING, HOSTING, MANAGING, DEVELOPING, AND MAINTAINING APPLICATIONS, SOFTWARE, WEB SITES, AND DATABASES OF OTHERS IN THE FIELDS OF HUMAN RESOURCES, EMPLOYEE COMPENSATION AND BENEFITS, RETIREMENT PLANNING, PENSION AND RETIREMENT PLANS, INVESTMENTS, PROFIT-SHARING PLANS, STOCK PURCHASE PLANS, HEALTH CARE, HEALTH CARE PLANS, DENTAL PLANS, PRESCRIPTION PLANS, PERSONNEL MANAGEMENT, WORKFORCE EFFECTIVENESS, REWARDS MANAGEMENT, EMPLOYEE JOB EVALUATION, PERSONNEL POLICIES, EMPLOYER-EMPLOYEE COMMUNICATIONS, EMPLOYEE SAFETY, EMPLOYEE RELOCATION, OUTSOURCING, BUSINESS AND ORGANIZATIONAL MANAGEMENT AND OPERATIONS, ORGANIZATIONAL STRUCTURE AND REORGANIZATION, PRODUCT DEVELOPMENT AND MARKETING, MERGERS AND ACQUISITIONS, STRATEGIC PLANNING, CONTINGENCY PLANNING, CHANGE MANAGEMENT, INFORMATION TECHNOLOGY, RISK MANAGEMENT, RISK EVALUATION, ACTUARIAL MATTERS, FINANCIAL SERVICES, INVESTMENTS, FINANCIAL PLANNING, FINANCIAL MODELING, ASSET ALLOCATION, CATASTROPHE MODELING, AND/OR QUALITY ASSURANCE; PRODUCT DEVELOPMENT CONSULTATION; APPLICATION SERVICE PROVIDER (ASP) SERVICES FOR INTERNAL BUSINESS USE BY INSURERS, NAMELY, PROVIDING, HOSTING, MANAGING, DEVELOPING, AND MAINTAINING APPLICATIONS, SOFTWARE, WEB SITES, AND DATABASES OF OTHERS IN FIELDS OF ENTERPRISE RISK MANAGEMENT, FINANCIAL AND REGULATORY REPORTING, MERGERS AND ACQUISITIONS, CORPORATE RESTRUCTURING, MARKETING, FINANCIAL MODELING, PRICING, AND LOSS RESERVE REQUIREMENTS (U.S. CLS. 100 AND 101).

#### **CLASS 45—PERSONAL AND LEGAL SERVICES**

FOR CONSULTING IN THE FIELD OF WORKPLACE SAFETY (U.S. CLS. 100 AND 101).  
ELISSA GARBER KON, EXAMINING ATTORNEY

SN 77-884,368. NERDS ON SITE INC., LONDON, ONTARIO, CANADA, FILED 12-2-2009.

## How Nerds Help

THE MARK CONSISTS OF STANDARD CHARACTERS WITHOUT CLAIM TO ANY PARTICULAR FONT, STYLE, SIZE, OR COLOR.

PRIORITY CLAIMED UNDER SEC. 44(D) ON CANADA APPLICATION NO. 1460567, FILED 11-26-2009, REG. NO. TMA779380, DATED 10-7-2010, EXPIRES 10-7-2025.

### CLASS 35—ADVERTISING AND BUSINESS

FOR OPERATING A RETAIL ESTABLISHMENT, NAMELY, RETAIL STORE SERVICES FEATURING COMPUTER HARDWARE AND SOFTWARE (U.S. CLS. 100, 101 AND 102).

### CLASS 37—CONSTRUCTION AND REPAIR

FOR INSTALLATION AND REPAIR OF COMPUTER HARDWARE; TECHNICAL SUPPORT SERVICES, NAMELY, TROUBLESHOOTING IN THE NATURE OF THE REPAIR OF COMPUTER HARDWARE, ALL PROVIDED AT THE APPLICANT'S RETAIL ESTABLISHMENT AND VIA THE MOBILE PERFORMANCE OF THESE SERVICES ON CUSTOMER PREMISES (U.S. CLS. 100, 103 AND 106).

### CLASS 42—SCIENTIFIC AND COMPUTER SERVICES

FOR INSTALLATION AND REPAIR OF COMPUTER SOFTWARE; TECHNICAL SUPPORT SERVICES, NAMELY, TROUBLESHOOTING IN THE NATURE OF DIAGNOSING COMPUTER HARDWARE AND SOFTWARE PROBLEMS, ALL PROVIDED AT THE APPLICANT'S RETAIL ESTABLISHMENT AND VIA THE MOBILE PERFORMANCE OF THESE SERVICES ON CUSTOMER PREMISES (U.S. CLS. 100 AND 101).  
NATALIE POLZER, EXAMINING ATTORNEY

SN 77-884,828. EARTHCHECK PTY LTD, BRISBANE, AUSTRALIA, FILED 12-2-2009.

## Earth Check

THE MARK CONSISTS OF STANDARD CHARACTERS WITHOUT CLAIM TO ANY PARTICULAR FONT, STYLE, SIZE, OR COLOR.

### CLASS 35—ADVERTISING AND BUSINESS

FOR SUSTAINABILITY ASSESSMENT SERVICES FOR BUSINESS, NAMELY, BUSINESS ADVISORY SERVICES, CONSULTANCY AND INFORMATION (U.S. CLS. 100, 101 AND 102).  
FIRST USE 12-20-2000; IN COMMERCE 10-7-2002.

### CLASS 42—SCIENTIFIC AND COMPUTER SERVICES

FOR PROVIDING TEMPORARY USE OF ON-LINE NONDOWNLOADABLE SUSTAINABILITY ASSESSMENT SOFTWARE FOR BENCHMARKING AND ASSESSING THE SUSTAINABILITY PERFORMANCE OF AN OPERATION; SUSTAINABILITY ASSESSMENT SERVICES FOR BUSINESS, NAMELY, CONSULTING SERVICES IN THE FIELD OF ENVIRONMENTAL ASSESSMENT AND PLANNING (U.S. CLS. 100 AND 101).  
FIRST USE 12-20-2000; IN COMMERCE 10-7-2002.  
STEVEN JACKSON, EXAMINING ATTORNEY

SN 77-886,409. BATH & BODY WORKS BRAND MANAGEMENT, INC., REYNOLDSBURG, OH. FILED 12-4-2009.

## WHERE STREET MEETS SWEET

THE MARK CONSISTS OF STANDARD CHARACTERS WITHOUT CLAIM TO ANY PARTICULAR FONT, STYLE, SIZE, OR COLOR.

OWNER OF U.S. REG. NO. 3,593,272.

### CLASS 3—COSMETICS AND CLEANING PREPARATIONS

FOR PERSONAL CARE PRODUCTS AND COSMETICS, NAMELY, LIP BALM, LIP GLOSS, LIP PAINT, LIP SHINE, LIP TINT, NON-MEDICATED LIP TREATMENT PREPARATION, NAIL POLISH, EYE MAKEUP, MAKEUP, EYE CREAM, BLUSH, CREAM BLUSH, EYE LINER, MASCARA, NAIL LACQUER, EYE SHADOW POWDER, CHEEK STAIN, EYE CREAM, BODY BRONZER, FACE BRONZING GEL, LEG BRONZING SPRAY, SKIN CREAM, SKIN LOTION (U.S. CLS. 1, 4, 6, 50, 51 AND 52).

### CLASS 18—LEATHER GOODS

FOR COSMETICS AND TOILETRY BAGS SOLD EMPTY (U.S. CLS. 1, 2, 3, 22 AND 41).  
ALICE BENMAMAN, EXAMINING ATTORNEY

SN 77-887,322. SWANK AUDIO VISUALS, L.L.C., ST. LOUIS, MO. FILED 12-7-2009.

## SWANK AUDIO VISUALS

THE MARK CONSISTS OF STANDARD CHARACTERS WITHOUT CLAIM TO ANY PARTICULAR FONT, STYLE, SIZE, OR COLOR.

OWNER OF U.S. REG. NO. 3,715,920.

NO CLAIM IS MADE TO THE EXCLUSIVE RIGHT TO USE "AUDIO VISUALS", APART FROM THE MARK AS SHOWN.

### CLASS 35—ADVERTISING AND BUSINESS

FOR ASSISTANCE IN MANAGEMENT OF BUSINESS CENTER ACTIVITIES IN THE HOTEL AND CONVENTION INDUSTRY (U.S. CLS. 100, 101 AND 102).  
FIRST USE 0-0-1985; IN COMMERCE 0-0-1985.



**CLASS 41—EDUCATION AND ENTERTAINMENT**

FOR ENTERTAINMENT SERVICES, NAMELY, ARRANGING AND CONDUCTING SPECIAL MULTIMEDIA EVENTS IN THE HOTEL AND CONVENTION INDUSTRY; RENTAL OF AUDIO VISUAL EQUIPMENT, STAGE LIGHTING, AND STAGES FOR OTHERS IN THE HOTEL AND CONVENTION INDUSTRY; SETUP, RIGGING, AND OPERATION OF MULTIMEDIA AUDIO VISUAL EQUIPMENT, STAGE LIGHTING AND EVENT STAGING FOR OTHERS IN THE HOTEL AND CONVENTION INDUSTRY; SPECIAL EVENT PLANNING AND COORDINATION SERVICES IN THE HOTEL AND CONVENTION INDUSTRY (U.S. CLS. 100, 101 AND 107).

FIRST USE 0-0-1980; IN COMMERCE 0-0-1980.  
AMY KERTGATE, EXAMINING ATTORNEY

SN 77-887,503, NEUTEQ EUROPE LIMITED, STAFFORDSHIRE, ENGLAND, FILED 12-7-2009.



PRIORITY CLAIMED UNDER SEC. 44(D) ON ERPNCMNTY TM OFC APPLICATION NO. 8362501, FILED 6-15-2009, REG. NO. 008362501, DATED 10-7-2010, EXPIRES 6-15-2019.

THE MARK CONSISTS OF THE STYLIZED LETTERING "NEUTEQ".

**CLASS 7—MACHINERY**

FOR MACHINES TOOLS, MACHINING CENTERS, METAL FINISHING MACHINES, ABRADING MACHINES, DEBURRING MACHINES, GRINDING MACHINES, AND ALL OF THE FOREGOING RELATING TO THE SURFACE FINISH ENHANCEMENT OF MECHANICAL COMPONENTS, INCLUDING BUT NOT EXCLUSIVELY METAL COMPONENTS; PARTS AND FITTINGS FOR THE AFORESAID GOODS; AERONAUTICAL ENGINE COMPONENTS, AERONAUTICAL TRANSMISSION COMPONENTS, AERONAUTICAL HYDRAULIC AND PUMP PARTS, AERONAUTICAL COMPRESSOR PARTS, AERONAUTICAL STEERING COMPONENTS, MARINE ENGINE COMPONENTS, MARINE ENGINE TRANSMISSION COMPONENTS, MARINE ENGINE HYDRAULIC AND PUMP PARTS, MARINE ENGINE COMPRESSOR PARTS, MARINE ENGINE STEERING COMPONENTS; PARTS AND FITTINGS FOR ALL THE AFORESAID GOODS (U.S. CLS. 13, 19, 21, 23, 31, 34 AND 35).

**CLASS 10—MEDICAL APPARATUS**

FOR PROSTHETIC LIMBS, NAMELY, ARMS, FEET, LEGS; ARTIFICIAL LIMBS, ARTIFICIAL JOINTS, ARTIFICIAL SPINAL DISCS; HIP JOINT IMPLANTS; ARTIFICIAL BONES FOR IMPLANTATION; PROSTHETIC SOCKETS USED TO FASTEN PROSTHETIC LIMBS TO THE BODY; GOODS OF METAL FOR MEDICAL USE, NAMELY, SCREWS, PLATES, PINS, AND PIVOTS (U.S. CLS. 26, 39 AND 44).

**CLASS 12—VEHICLES**

FOR VEHICLE ENGINE COMPONENTS, NAMELY, UNIVERSAL JOINTS, DOUBLE UNIVERSAL JOINTS, CONSTANT VELOCITY JOINTS, HALF SHAFT ASSEMBLIES, CONSTANT VELOCITY UNIVERSAL JOINTS, DRIVE SHAFTS, JOINTS, GEARINGS, COUPLINGS AND CLUTCHES, DRIVE SHAFTS, BEARINGS AND GEAR WHEELS; TRANSMISSION SHAFTS; CONNECTING SHAFTS, VISCOUS COUPLINGS; FLEXIBLE SHAFT COUPLINGS; CARDAN TYPE AND HOOKE'S TYPE JOINTS; TRANSMISSIONS; STEERING MECHANISM JOINTS; WHEEL BEARINGS; GEARS AND GEARBOXES; DIFFERENTIALS; LOCKING DIFFERENTIALS; CROSS PIECES, BEARING CUPS, BEARINGS, YOKES, RUBBER BOOTS, PLASTIC BOOTS, OUTER RACES, CAGES, BALLS AND CONNECTING SHAFTS; AXLES AND STEERING AXLES; BALL GUIDE CONES, DRIVE SHAFT COUPLERS; CHASSIS SYSTEMS, SIDE MEMBERS AND CROSS MEMBERS; VEHICLE TRANSMISSION COMPONENTS, NAMELY, CLUTCHES, GEARS, TRANSMISSION SHAFTS, TRANSMISSION BELTS, FLYWHEELS, PRESSURE PLATES, CLUTCH DISKS, CONNECTING SHAFTS AND CONSTANT VELOCITY SHAFTS, VEHICLE HYDRAULIC AND PUMP PARTS, VEHICLE SHOCK ABSORBER RODS AND STRUTS, VEHICLE COMPRESSOR PARTS, VEHICLE STEERING COMPONENTS; AEROSPACE ENGINE COMPONENTS, NAMELY, UNIVERSAL JOINTS, DOUBLE UNIVERSAL JOINTS, CONSTANT VELOCITY JOINTS, HALF SHAFT ASSEMBLIES, CONSTANT VELOCITY UNIVERSAL JOINTS, DRIVE SHAFTS, JOINTS, GEARINGS, COUPLINGS AND CLUTCHES, DRIVE SHAFTS, BEARINGS AND GEAR WHEELS; TRANSMISSION SHAFTS; CONNECTING SHAFTS, VISCOUS COUPLINGS; FLEXIBLE SHAFT COUPLINGS; CARDAN TYPE AND HOOKE'S TYPE JOINTS; TRANSMISSIONS; STEERING MECHANISM JOINTS; WHEEL BEARINGS; GEARS AND GEARBOXES; DIFFERENTIALS; LOCKING DIFFERENTIALS; CROSS PIECES, BEARING CUPS, BEARINGS, YOKES, RUBBER BOOTS, PLASTIC BOOTS, OUTER RACES, CAGES, BALLS AND CONNECTING SHAFTS; AXLES AND STEERING AXLES; BALL GUIDE CONES, DRIVE SHAFT COUPLERS; CHASSIS SYSTEMS, SIDE MEMBERS AND CROSS MEMBERS, PROPELLER SHAFTS; AEROSPACE LANDING GEAR, AEROSPACE MECHANICAL ACTUATORS; NAUTICAL ENGINE COMPONENTS, NAMELY, UNIVERSAL JOINTS, DOUBLE UNIVERSAL JOINTS, CONSTANT VELOCITY JOINTS, HALF SHAFT ASSEMBLIES, CONSTANT VELOCITY UNIVERSAL JOINTS, DRIVE SHAFTS, JOINTS, GEARINGS, COUPLINGS AND CLUTCHES, DRIVE SHAFTS, BEARINGS AND GEAR WHEELS; TRANSMISSION SHAFTS; CONNECTING SHAFTS, VISCOUS COUPLINGS; FLEXIBLE SHAFT COUPLINGS; CARDAN TYPE AND HOOKE'S TYPE JOINTS; TRANSMISSIONS; STEERING MECHANISM JOINTS; WHEEL BEARINGS; GEARS AND GEARBOXES; DIFFERENTIALS; LOCKING DIFFERENTIALS; CROSS PIECES, BEARING CUPS, BEARINGS, YOKES, RUBBER BOOTS, PLASTIC BOOTS, OUTER RACES, CAGES, BALLS AND CONNECTING SHAFTS; AXLES AND STEERING AXLES; BALL GUIDE CONES, DRIVE SHAFT COUPLERS; CHASSIS SYSTEMS, SIDE MEMBERS AND CROSS MEMBERS, PROPELLER SHAFTS; NAUTICAL TRANSMISSION COMPONENTS, NAMELY, CLUTCHES, GEARS, TRANSMISSION SHAFTS, TRANSMISSION BELTS, FLYWHEELS, PRESSURE PLATES, CLUTCH DISKS, CONNECTING SHAFTS, PROPELLER SHAFTS, CONSTANT VELOCITY SHAFTS, TURBINE BLADES NAUTICAL HYDRAULIC AND PUMP PARTS, NAUTICAL COMPRESSOR PARTS, NAUTICAL STEERING COMPONENTS (U.S. CLS. 19, 21, 23, 31, 35 AND 44).

**CLASS 37—CONSTRUCTION AND REPAIR**

FOR REMANUFACTURE, REFURBISHMENT, MAINTENANCE, AND REPAIR OF MACHINE TOOLS, MACHINING CENTERS, METAL FINISHING MACHINES, ABRADING MACHINES, DEBURRING MACHINES, GRINDING MACHINES, ALL RELATING TO THE SURFACE FINISH ENHANCEMENT OF MECHANICAL COMPONENTS, INCLUDING BUT NOT EXCLUSIVELY METAL COMPONENTS, NONE RELATING TO INDUSTRIAL KILNS, FURNACES, AND OVENS (U.S. CLS. 100, 103 AND 106).

**CLASS 40—MATERIAL TREATMENT**

FOR METAL FINISHING SERVICES, DEBURRING SERVICES, GRINDING SERVICES, POLISHING SERVICES, AND MICROFINISHING SERVICES, ALL RELATING TO THE SURFACE FINISH ENHANCEMENT OF MECHANICAL COMPONENTS INCLUDING BUT NOT EXCLUSIVELY METAL COMPONENTS, NONE RELATING TO INDUSTRIAL KILNS, FURNACES, AND OVENS (U.S. CLS. 100, 103 AND 106).

**CLASS 42—SCIENTIFIC AND COMPUTER SERVICES**

FOR SCIENTIFIC AND TECHNOLOGICAL SERVICES AND RESEARCH AND DESIGN RELATING THERETO, ALL RELATING TO THE SURFACE FINISH ENHANCEMENT OF MECHANICAL COMPONENTS, INCLUDING BUT NOT EXCLUSIVELY METAL COMPONENTS, INDUSTRIAL ANALYSIS SERVICES AND RESEARCH SERVICES, ALL RELATING TO THE SURFACE FINISH ENHANCEMENT OF MECHANICAL COMPONENTS, INCLUDING BUT NOT EXCLUSIVELY METAL COMPONENTS; DESIGN AND DEVELOPMENT OF COMPUTER HARDWARE AND SOFTWARE, ALL RELATING TO THE SURFACE FINISH ENHANCEMENT OF MECHANICAL COMPONENTS, INCLUDING BUT NOT EXCLUSIVELY METAL COMPONENTS; RESEARCH AND DEVELOPMENT SERVICES, ALL RELATING TO THE SURFACE FINISH ENHANCEMENT OF MECHANICAL COMPONENTS, INCLUDING BUT NOT EXCLUSIVELY METAL COMPONENTS; SOFTWARE DESIGN SERVICES, ALL RELATING TO THE SURFACE FINISH ENHANCEMENT OF MECHANICAL COMPONENTS, INCLUDING BUT NOT EXCLUSIVELY METAL COMPONENTS; ENGINEERING AND COMPUTER AIDED ENGINEERING SERVICES, ALL RELATING TO THE SURFACE FINISH ENHANCEMENT OF MECHANICAL COMPONENTS, INCLUDING BUT NOT EXCLUSIVELY METAL COMPONENTS; ENGINEERING SERVICES RELATING TO ROBOTICS, ALL RELATING TO THE SURFACE FINISH ENHANCEMENT OF MECHANICAL COMPONENTS, INCLUDING BUT NOT EXCLUSIVELY METAL COMPONENTS (U.S. CLS. 100 AND 101).

HENRY S. ZAK, EXAMINING ATTORNEY

SN 77-887,648. LONDON & SCANDINAVIAN METALLURGICAL CO. LTD., SOUTH YORKSHIRE, UNITED KINGDOM, FILED 12-7-2009.



THE MARK CONSISTS OF THE LETTERS "LSM" ENCLOSED IN A HEXAGONAL DESIGN.

**CLASS 1—CHEMICALS**

FOR ALUMINUM POWDERS FOR USE IN THE FURTHER MANUFACTURE OF PAINTS, PIGMENTS AND COATINGS, METALLURGICAL, REFRACTORY AND CHEMICAL APPLICATIONS; CHEMICAL PREPARATIONS FOR USE IN INDUSTRY, NAMELY, CASTING POWDER; RAW MATERIALS FOR USE IN POWDER COATING PROCESSES, NAMELY, CHROMIUM POWDER, FERRO TUNGSTEN TITANIUM CARBIDE POWDER AND FERRO TITANIUM CARBIDE POWDER; CHEMICAL PREPARATIONS FOR USE IN INDUSTRY, NAMELY, WELDING POWDER; CHEMICAL PREPARATIONS FOR THE TREATMENT OF GLASS, NAMELY, CHROMIUM POWDER, FERRO TUNGSTEN TITANIUM CARBIDE POWDER, FERRO TITANIUM CARBIDE POWDER, CERIUM OXIDES AND ALUMINAS; CHEMICAL PREPARATIONS FOR USE IN GLASS MANUFACTURE; MATERIALS IN POWDER FORM FOR USE IN FORMING SURFACE COATINGS, NAMELY, CHROMIUM POWDER, FERRO TUNGSTEN TITANIUM CARBIDE POWDER, FERRO TITANIUM CARBIDE POWDER, CERIUM OXIDES AND ALUMINAS (U.S. CLS. 1, 5, 6, 10, 26 AND 46).

**CLASS 2—PAINTS**

FOR RUST PREVENTATIVES IN THE NATURE OF POWDER COATINGS; ALUMINUM POWDERS FOR PAINTING (U.S. CLS. 6, 11 AND 16).

**CLASS 3—COSMETICS AND CLEANING PREPARATIONS**

FOR ABRASIVE POWDER; POLISHING PREPARATIONS; GRINDING PREPARATIONS, NAMELY, METALLIC SCOURING POWDER FOR CLEANING AND SCOURING; PREPARATIONS FOR ABRASIVE CLEANING FOR USE IN POLISHING OR GRINDING IN INDUSTRIAL APPLICATIONS, NAMELY, METALLIC BASED POWDERS OR GRANULES CONSISTING OF CHROMIUM POWDER, FERRO TUNGSTEN TITANIUM CARBIDE POWDER, FERRO TITANIUM CARBIDE POWDER, CERIUM OXIDES AND ALUMINAS (U.S. CLS. 1, 4, 6, 50, 51 AND 52).

**CLASS 6—METAL GOODS**

FOR COMMON METALS AND THEIR ALLOYS, NAMELY, CHROMIUM, FERRO ALLOYS, ALUMINUM, NICKEL AND TITANIUM; FERRO ALLOYS; METAL ALLOYS; METAL IN POWDERED FORM; ALUMINUM; CHROMIUM METAL (U.S. CLS. 2, 12, 13, 14, 23, 25 AND 50).

**CLASS 42—SCIENTIFIC AND COMPUTER SERVICES**

FOR ANALYTICAL SCIENTIFIC RESEARCH SERVICES AND LABORATORY TESTING OF COMMON METALS AND ALLOYS, NAMELY, CHROMIUM, FERRO ALLOYS, ALUMINUM, NICKEL AND TITANIUM (U.S. CLS. 100 AND 101).

COLLEEN DOMBROW, EXAMINING ATTORNEY

SN 77-888,431. BANK OF AMERICA, N.A., AS ADMINISTRATIVE AGENT, CHARLOTTE, NC. FILED 12-8-2009.

**EMPOWERING PEOPLE WHO  
SERVE THE PUBLIC**

THE MARK CONSISTS OF STANDARD CHARACTERS WITHOUT CLAIM TO ANY PARTICULAR FONT, STYLE, SIZE, OR COLOR.

**CLASS 35—ADVERTISING AND BUSINESS**

FOR TAX ASSESSMENT SERVICES; CONSULTING SERVICES IN THE FIELDS OF BUSINESS PROCESS IMPROVEMENT, INTERNAL BUSINESS MANAGEMENT, AND HUMAN RESOURCE MANAGEMENT (U.S. CLS. 100, 101 AND 102).

**CLASS 36—INSURANCE AND FINANCIAL**

FOR REAL ESTATE APPRAISAL SERVICES; CONSULTING SERVICES IN THE FIELD OF REAL ESTATE APPRAISALS AND REAL AND PERSONAL PROPERTY APPRAISALS FOR TAX EQUALIZATION PURPOSES (U.S. CLS. 100, 101 AND 102).

FIRST USE 9-25-2009; IN COMMERCE 9-25-2009.  
CHRISTINE COOPER, EXAMINING ATTORNEY

SN 77-894,036. AMERICAN OSTEOPATHIC ASSOCIATION, CHICAGO, IL. FILED 12-15-2009.

# OMED

THE MARK CONSISTS OF STANDARD CHARACTERS WITHOUT CLAIM TO ANY PARTICULAR FONT, STYLE, SIZE, OR COLOR.

**CLASS 35—ADVERTISING AND BUSINESS**

FOR ORGANIZATION OF BUSINESS CONVENTIONS (U.S. CLS. 100, 101 AND 102).

FIRST USE 8-0-2009; IN COMMERCE 8-0-2009.

**CLASS 41—EDUCATION AND ENTERTAINMENT**

FOR PROVIDING CONTINUED MEDICAL EDUCATION BY CLASSES, SEMINARS AND LECTURES (U.S. CLS. 100, 101 AND 107).

FIRST USE 8-0-2009; IN COMMERCE 8-0-2009.  
SUSAN STIGLITZ, EXAMINING ATTORNEY

SN 77-888,460. BANK OF AMERICA, N.A., AS ADMINISTRATIVE AGENT, CHARLOTTE, NC. FILED 12-8-2009.



THE COLOR(S) BLUE AND GREEN IS/ARE CLAIMED AS A FEATURE OF THE MARK.

THE MARK CONSISTS OF A SERIES OF DOTS IN BLUE IN A T-SHAPED FORMATION INTERLOCKING WITH ANOTHER SERIES OF DOTS IN GREEN, ALSO IN A T-SHAPED FORMATION.

**CLASS 35—ADVERTISING AND BUSINESS**

FOR TAX ASSESSMENT SERVICES; CONSULTING SERVICES IN THE FIELDS OF BUSINESS PROCESS IMPROVEMENT, INTERNAL BUSINESS MANAGEMENT, AND HUMAN RESOURCE MANAGEMENT (U.S. CLS. 100, 101 AND 102).

**CLASS 36—INSURANCE AND FINANCIAL**

FOR REAL ESTATE APPRAISAL SERVICES; CONSULTING SERVICES IN THE FIELD OF REAL ESTATE APPRAISALS AND REAL AND PERSONAL PROPERTY APPRAISALS FOR TAX EQUALIZATION PURPOSES (U.S. CLS. 100, 101 AND 102).

FIRST USE 9-25-2009; IN COMMERCE 9-25-2009.  
CHRISTINE COOPER, EXAMINING ATTORNEY

SN 77-895,059. AVINGTON INTERNATIONAL, GEORGETOWNGRAND CAYMAN, CAYMAN ISLANDS, FILED 12-16-2009.

# AVINGTON<sup>®</sup>

PRIORITY CLAIMED UNDER SEC. 44(D) ON ERPN CMNTY TM OFC APPLICATION NO. 008379885, FILED 6-22-2009, REG. NO. 008379885, DATED 6-22-2009, EXPIRES 6-22-2019.

THE MARK CONSISTS OF THE WORD "AVINGTON" WITH AN "A" INSIDE A CIRCLE LOCATED AT THE END.

**CLASS 9—ELECTRICAL AND SCIENTIFIC APPARATUS**

FOR APPARATUS FOR RECORDING, TRANSMISSION OR REPRODUCTION OF SOUND OR IMAGES; BLANK RECORDABLE DVDS, BLANK VIDEO TAPES, BLANK RECORDABLE CD-RS, BLANK AUDIO AND VIDEO CASSETTES, BLANK MAGNETIC DATA CARRIERS, BLANK RECORDABLE OPTICAL DISCS; PRE-RECORDED DVDS, VIDEO TAPES, CDS, AUDIO AND VIDEO CASSETTES, AND MAGNETIC DATA CARRIERS FEATURING CONTENT RELATING TO FINANCIAL SERVICES AND BANKING; DOWNLOADABLE MP3 FILES AND MP3 RECORDINGS FEATURING CONTENT RELATING TO FINANCIAL SERVICES AND BANKING; DATA PROCESSING EQUIPMENT AND COMPUTERS; COMPUTER SOFTWARE AND HARDWARE FOR USE IN NETWORK MANAGEMENT; APPARATUS AND INSTRUMENTS FOR THE RECORDING, TRANSMISSION OR REPRODUCTION OF SOUND OR IMAGES RELATING TO FINANCIAL SERVICES; ENCODED MAGNETIC CARDS; CARDS, NAMELY, BLANK SMART CARDS, ELECTRONIC KEY CARDS, AND ENCODED SMART CARDS CONTAINING PROGRAMMING USED TO PERFORM FUNCTIONS RELATING TO FINANCIAL SERVICES AND BANKING; MAGNETIC CARDS; MAGNETICALLY ENCODED CREDIT CARDS; MAGNETICALLY ENCODED DEBIT CARDS (U.S. CLS. 21, 23, 26, 36 AND 38).

**CLASS 16—PAPER GOODS AND PRINTED MATTER**

FOR PAPER, CARDBOARD AND GOODS MADE FROM PAPER AND CARDBOARD, NAMELY, PAPER BAGS AND CARDBOARD BOXES; PRINTED MATTER, NAMELY, BOOKS IN THE FIELD OF FINANCIAL SERVICES AND BANKING; BOOK BINDING MATERIAL; PHOTOGRAPHS; STATIONERY; ADHESIVES FOR STATIONERY OR HOUSEHOLD PURPOSES; INSTRUCTIONAL AND TEACHING MATERIALS, NAMELY, BOOKS IN THE FIELD OF FINANCIAL SERVICES AND BANKING; PLASTIC MATERIALS FOR PACKAGING, NAMELY, PLASTIC BAGS AND PLASTIC BUBBLE PACKS; BOOKS IN THE FIELD OF FINANCIAL SERVICES AND BANKING; PRINTED PERIODICALS IN THE FIELD OF FINANCIAL SERVICES AND BANKING; MAGAZINES IN THE FIELD OF FINANCIAL SERVICES AND BANKING; JOURNALS CONCERNING FINANCIAL SERVICES AND BANKING; BOOKS RELATING TO FINANCIAL INVESTMENTS; BOOKS RELATING TO FINANCIAL SERVICES; FINANCIAL DOCUMENTS, NAMELY, BROCHURES AND NEWSLETTERS IN THE FIELD OF FINANCIAL SERVICES; FINANCIAL NEWSLETTERS AND PLANNING GUIDES; PRINTED MATTER AND PRINTED PUBLICATIONS, NAMELY, NEWSPAPERS, PHOTOGRAPHS, MAGAZINES, BOOKS, PRINTED PERIODICALS, NEWSLETTERS, AND BROCHURES ALL IN THE FIELDS OF FINANCIAL SERVICES; STATIONERY FOR USE IN THE CARRYING OUT OF FINANCIAL TRANSACTIONS; CARDS, NAMELY, BLANK CARDS, BLANK NOTE CARDS, BUSINESS CARDS, AND INDEX CARDS; CREDIT CARDS WITHOUT MAGNETIC CODING; DEBIT CARDS WITHOUT MAGNETIC CODING (U.S. CLS. 2, 5, 22, 23, 29, 37, 38 AND 50).

**CLASS 35—ADVERTISING AND BUSINESS**

FOR ADVERTISING; BUSINESS MANAGEMENT; BUSINESS ADMINISTRATION; ADVERTISING SERVICES RELATING TO FINANCIAL INVESTMENT; ADVERTISING SERVICES RELATING TO FINANCIAL SERVICES; EMPLOYMENT RECRUITING CONSULTATION FOR PERSONNEL IN THE FINANCIAL SERVICES FIELD; PROVIDING INFORMATION IN THE FIELD OF PROMOTION OF FINANCIAL SERVICES; PROVIDING INFORMATION IN THE FIELD OF ELECTRONIC SIGNATURE VERIFICATION SERVICES PROVIDED IN CONNECTION WITH BANKING AND FINANCIAL SERVICES (U.S. CLS. 100, 101 AND 102).

**CLASS 36—INSURANCE AND FINANCIAL**

FOR INSURANCE SERVICES, NAMELY, UNDERWRITING, ISSUING AND ADMINISTRATION OF LIFE INSURANCE; FINANCIAL AFFAIRS AND MONETARY AFFAIRS, NAMELY, FINANCIAL INFORMATION, MANAGEMENT AND ANALYSIS SERVICES; REAL ESTATE AFFAIRS, NAMELY, REAL ESTATE APPRAISAL AND VALUATION; ADVISORY SERVICES RELATING TO FINANCIAL RISK MANAGEMENT, FINANCIAL MATTERS AND PLANNING; CARD OPERATED FINANCIAL SERVICES, NAMELY, CREDIT CARD AND DEBIT CARD SERVICES; FINANCIAL INFORMATION SERVICES PROVIDED ON-LINE FROM A COMPUTER DATABASE OR A GLOBAL COMPUTER NETWORK, NAMELY, PROVIDING INFORMATION IN THE FIELD OF FINANCIAL MANAGEMENT AND BUSINESS FINANCIAL PROCUREMENTS; COMPUTERIZED FINANCIAL ADVISORY, DATA AND INFORMATION SERVICES IN THE NATURE OF PROVIDING AN ON-LINE COMPUTER DATABASE IN THE FIELD OF STOCK/SECURITIES MARKET INFORMATION; FINANCIAL CONSULTATION, FINANCIAL CONSULTATION IN THE FIELD OF FINANCIAL INVESTMENTS; FINANCIAL CONSULTATION SERVICES; FINANCIAL MANAGEMENT ADVISORY SERVICES; FINANCIAL PAYMENT SERVICES, NAMELY, CREDIT CARD PAYMENT PROCESSING SERVICES, MONEY ORDER PAYMENT GUARANTEE SERVICES, AND PROVIDING MULTIPLE PAYMENT OPTIONS BY MEANS OF CUSTOMER-OPERATED ELECTRONIC TERMINALS AVAILABLE ON-SITE IN RETAIL STORES; FINANCIAL PLANNING; FINANCIAL SAVINGS SERVICES, NAMELY, ADMINISTRATION OF SAVINGS ACCOUNTS, SAVINGS PROGRAMS FOR YOUTHS, AND

SAVINGS BANK SERVICES; FINANCIAL SERVICES RELATING TO INVESTMENT, NAMELY, CAPITAL INVESTMENT CONSULTING, FINANCIAL INVESTMENT BROKERAGE, AND INVESTMENT MANAGEMENT; FINANCIAL SERVICES RELATING TO INSURANCE, NAMELY, INSURANCE BROKERAGE, INSURANCE CONSULTATION, AND INSURANCE UNDERWRITING IN THE FIELD OF LIFE, HEALTH, ACCIDENT, HOME, MOTOR, TRAVEL, MORTGAGE, CREDIT, PENSION AND TELEPHONE INSURANCE; FINANCIAL SERVICES RELATING TO MORTGAGES, NAMELY, MORTGAGE BANKING, MORTGAGE LENDING, AND MORTGAGE FORECLOSURE SERVICES, FINANCING RELATING TO AUTOMOBILES, AND UNDERWRITING WARRANTY PROGRAMS IN THE FIELD OF AUTOMOBILES; FINANCIAL SERVICES RELATING TO PROPERTY, NAMELY, FINANCIAL VALUATION OF PERSONAL PROPERTY AND REAL ESTATE, FINANCIAL CONSULTING SERVICES, NAMELY, ADVISING OTHERS REGARDING INTELLECTUAL PROPERTY INVESTMENTS; FINANCIAL SERVICES RELATING TO TRAVEL, NAMELY, ESCROW SERVICES FOR THE TRAVEL INDUSTRY, ISSUING OF TRAVELERS' CHECKS, AND ISSUING STORED VALUE CARDS FOR USE AS ELECTRONIC TRAVEL TICKETS; PROVIDING INFORMATION IN THE FIELD OF FINANCING AND LOAN SERVICES; PROVIDING INFORMATION IN THE FIELD OF BANKING; PROVIDING INFORMATION IN THE FIELD OF FUNDS INVESTMENT; BROKERAGE SERVICES RELATING TO FINANCIAL INSTRUMENTS, NAMELY, BROKERAGE OF SHARES OR STOCKS AND OTHER SECURITIES; FINANCIAL ADVISORY SERVICES RELATING TO ASSET MANAGEMENT, LIFE ASSURANCE, RETIREMENT PLANS, SECURITIES AND TAX; FINANCIAL BANKING SERVICES FOR THE DEPOSIT AND WITHDRAWAL OF MONEY; FINANCIAL CREDIT SERVICES, NAMELY, CREDIT AGENCIES, CREDIT UNIONS, CREDIT REPORTING, CREDIT RATING, AND CREDIT CARD SERVICES; PROVIDING FINANCIAL INFORMATION IN THE FIELD OF STOCKS, SHARES, FOREIGN EXCHANGE, COMMODITIES, AND FINANCIAL NEWS IN THE NATURE OF RATES OF EXCHANGE; FINANCIAL INFORMATION SERVICES PROVIDED ON-LINE FROM A COMPUTER DATABASE OR A GLOBAL COMPUTER NETWORK, NAMELY, PROVIDING INFORMATION IN THE FIELD OF STOCK EXCHANGE PRICE QUOTATIONS; BUSINESS ADVICE RELATING TO FINANCIAL RE-ORGANIZATION (U.S. CLS. 100, 101 AND 102).

**CLASS 41—EDUCATION AND ENTERTAINMENT**

FOR EDUCATION SERVICES, NAMELY, PROVIDING CLASSES, SEMINARS, CONFERENCES, WORKSHOPS, LECTURES, TUTORIALS AND SYMPOSIA IN THE FIELD OF FINANCIAL SERVICES; PROVIDING TRAINING IN THE FIELD OF FINANCIAL SERVICES; ENTERTAINMENT IN THE NATURE OF LIVE STAGE PERFORMANCES IN THE NATURE OF MUSICAL PERFORMANCES, PLAYS, CONCERTS; ENTERTAINMENT SERVICES, NAMELY, ORGANIZING COMMUNITY FESTIVALS FEATURING A VARIETY OF ACTIVITIES, NAMELY, ART EXHIBITIONS, HERITAGE MARKETS, ETHNIC DANCES, AND THE LIKE; ENTERTAINMENT SERVICES, NAMELY, PROVIDING ON-LINE COMPUTER GAMES; SPORTING AND CULTURAL ACTIVITIES, NAMELY, ENTERTAINMENT IN THE NATURE OF FOOTBALL, SOCCER, TENNIS, HOCKEY, BADMINTON, VOLLEYBALL AND RUGBY GAMES; ENTERTAINMENT IN THE NATURE OF BALLET PERFORMANCES; ORGANIZING COMMUNITY FESTIVALS FEATURING A VARIETY OF ACTIVITIES, NAMELY, SPORTING EVENTS, ART EXHIBITS, FLEA MARKETS, ETHNIC DANCES AND THE LIKE; LOTTERY SERVICES; ELECTRONIC GAMES SERVICES PROVIDED BY MEANS OF THE INTERNET; PROVIDING NON-DOWNLOADABLE ON-LINE PUBLICATIONS IN THE NATURE OF NEWSPAPERS, MAGAZINES, BOOKLETS, AND JOURNALS IN THE FIELD OF FINANCIAL SERVICES (U.S. CLS. 100, 101 AND 107).

ADA HAN, EXAMINING ATTORNEY



SN 77-897,144. TUV TAAM INC., BROOKLYN, NY. FILED 12-18-2009.

SN 77-898,632. S2ONE, INC., SHERWOOD, OR. FILED 12-21-2009.

# TUV TAAM

THE MARK CONSISTS OF STANDARD CHARACTERS WITHOUT CLAIM TO ANY PARTICULAR FONT, STYLE, SIZE, OR COLOR.

THE ENGLISH TRANSLATION OF "TUV TAAM" IN THE MARK IS "GOOD TASTE".

## CLASS 29—MEATS AND PROCESSED FOODS

FOR CREAM CHEESE; FISH-BASED SALADS AND SPREADS, NAMELY WHITE FISH, LOX, AND SALMON SALADS AND SPREADS; SALADS EXCEPT MACARONI, RICE, AND PASTA SALAD; SOUPS; VEGETABLE SALADS; VEGETABLE-BASED SPREADS; PRE-PREPARED VEGETABLE-BASED ENTREES (U.S. CL. 46).  
FIRST USE 0-0-2004; IN COMMERCE 0-0-2004.

## CLASS 30—STAPLE FOODS

FOR BLINTZES; PUDDINGS; PRE-PREPARED ENTREES CONSISTING PRIMARILY OF PASTA OR RICE (U.S. CL. 46).  
FIRST USE 0-0-2004; IN COMMERCE 0-0-2004.  
CYNTHIA TRIPI, EXAMINING ATTORNEY

# S2ONE

THE MARK CONSISTS OF STANDARD CHARACTERS WITHOUT CLAIM TO ANY PARTICULAR FONT, STYLE, SIZE, OR COLOR.

## CLASS 35—ADVERTISING AND BUSINESS

FOR ONLINE RETAIL STORE SERVICES FEATURING PARTS AND EQUIPMENT FOR TELEVISION BROADCASTING SYSTEMS (U.S. CLS. 100, 101 AND 102).  
FIRST USE 4-0-2000; IN COMMERCE 4-0-2000.

## CLASS 37—CONSTRUCTION AND REPAIR

FOR INSTALLATION, MAINTENANCE, AND REPAIR OF TELEVISION BROADCASTING SYSTEMS; CONSULTING SERVICES IN THE FIELD OF INSTALLING, MAINTAINING AND REPAIRING TELEVISION BROADCAST SYSTEMS (U.S. CLS. 100, 103 AND 106).  
FIRST USE 4-0-2000; IN COMMERCE 4-0-2000.  
CARRIE GENOVESE, EXAMINING ATTORNEY

SN 77-898,555. DESKACTIVE PTY LTD, MELBOURNE, AUSTRALIA, FILED 12-21-2009.

SN 77-899,204. INTEGRATIVE HEALTH CARE, P.C., SCOTTSDALE, AZ. FILED 12-22-2009.

# DeskActive

THE MARK CONSISTS OF STANDARD CHARACTERS WITHOUT CLAIM TO ANY PARTICULAR FONT, STYLE, SIZE, OR COLOR.

OWNER OF AUSTRALIA REG. NO. 1147255, DATED 11-16-2006, EXPIRES 11-16-2016.

## CLASS 9—ELECTRICAL AND SCIENTIFIC APPARATUS

FOR MEDICAL AND EDUCATIONAL SOFTWARE FOR INSTRUCTION IN HEALTH, SAFETY, AND WELL-BEING (U.S. CLS. 21, 23, 26, 36 AND 38).

## CLASS 44—MEDICAL, BEAUTY AND AGRICULTURAL SERVICES

FOR PROVIDING HEALTH CARE INFORMATION VIA THE INTERNET, COMPUTERS, PDAS, MOBILE PHONES, THROUGH TEXT MESSAGING SERVICES AND THROUGH OTHER TELEPHONY SERVICES (U.S. CLS. 100 AND 101).  
ANDREW LEASER, EXAMINING ATTORNEY

# SMALL DOSES

THE MARK CONSISTS OF STANDARD CHARACTERS WITHOUT CLAIM TO ANY PARTICULAR FONT, STYLE, SIZE, OR COLOR.

## CLASS 16—PAPER GOODS AND PRINTED MATTER

FOR PUBLICATIONS, NAMELY, BROCHURES AND BOOKLETS IN THE FIELD HEALTH CARE, NUTRITION AND ALTERNATIVE MEDICINE (U.S. CLS. 2, 5, 22, 23, 29, 37, 38 AND 50).

## CLASS 44—MEDICAL, BEAUTY AND AGRICULTURAL SERVICES

FOR PROVIDING A WEB SITE FEATURING INFORMATION ON HEALTH, NUTRITION AND ALTERNATIVE MEDICINE (U.S. CLS. 100 AND 101).  
C. DIONNE CLYBURN, EXAMINING ATTORNEY

SN 77-903,102. PARADIGM MANAGEMENT SERVICES, LLC, CONCORD, CA. FILED 12-30-2009.

SN 77-906,838. MAJID, INC., NEW YORK, NY. FILED 1-7-2010.



OWNER OF U.S. REG. NO. 2,414,867.  
THE MARK CONSISTS OF THE WORD "PARADIGM" WITHIN A BLACK IMAGE AND THE WORD "OUTCOMES" BELOW.

**CLASS 44—MEDICAL, BEAUTY AND AGRICULTURAL SERVICES**

FOR MANAGED HEALTH CARE SERVICES; MEDICAL CASE MANAGEMENT CONSULTING SERVICES, NAMELY, MEDICAL CONSULTATIONS REGARDING DIAGNOSES AND TREATMENT FOR DISEASES (U.S. CLS. 100 AND 101).

FIRST USE 12-28-2009; IN COMMERCE 12-28-2009.

**CLASS 45—PERSONAL AND LEGAL SERVICES**

FOR CASE MANAGEMENT CONSULTING SERVICES IN THE FIELD OF COORDINATING THE PROCUREMENT AND ADMINISTRATION OF MEDICATION AND COORDINATING PHYSICAL, SOCIAL AND PSYCHOLOGICAL AND MEDICAL SERVICES FOR DISABLED PERSONS (U.S. CLS. 100 AND 101).

FIRST USE 12-28-2009; IN COMMERCE 12-28-2009.  
BRENDAN MCCAULEY, EXAMINING ATTORNEY

SN 77-905,280. MASSACHUSETTS DEPARTMENT OF TRANSPORTATION, BOSTON, MA. FILED 1-5-2010.

**Fast Lane**

THE MARK CONSISTS OF STANDARD CHARACTERS WITHOUT CLAIM TO ANY PARTICULAR FONT, STYLE, SIZE, OR COLOR.

**CLASS 9—ELECTRICAL AND SCIENTIFIC APPARATUS**

FOR ELECTRONIC TRANSPONDERS FOR THE RECORDING AND COLLECTION OF TOLLS AND OTHER FEES TO EXPEDITE PASSAGE OF VEHICLES THROUGH A COLLECTION FACILITY (U.S. CLS. 21, 23, 26, 36 AND 38).

FIRST USE 8-29-1998; IN COMMERCE 8-29-1998.

**CLASS 36—INSURANCE AND FINANCIAL**

FOR HIGHWAY TOLL AND PARKING FEE COLLECTION SERVICES, NAMELY, THE COLLECTION OF TOLLS AND OTHER FEES USING AN ELECTRONIC SYSTEM TO EXPEDITE PASSAGE OF VEHICLES THROUGH A COLLECTION FACILITY (U.S. CLS. 100, 101 AND 102).

FIRST USE 8-29-1998; IN COMMERCE 8-29-1998.  
CHRISTINE COOPER, EXAMINING ATTORNEY

**IMAN HOME**

THE MARK CONSISTS OF STANDARD CHARACTERS WITHOUT CLAIM TO ANY PARTICULAR FONT, STYLE, SIZE, OR COLOR.

OWNER OF U.S. REG. NO. 3,719,993.  
NO CLAIM IS MADE TO THE EXCLUSIVE RIGHT TO USE "HOME", APART FROM THE MARK AS SHOWN.

THE NAME(S), PORTRAIT(S), AND/OR SIGNATURE(S) SHOWN IN THE MARK IDENTIFIES "IMAN", WHOSE CONSENT(S) TO REGISTER IS MADE OF RECORD.

**CLASS 20—FURNITURE AND ARTICLES NOT OTHERWISE CLASSIFIED**

FOR SOFT KITCHEN TABLE TOPS, DECORATIVE PILLOWS AND CHAIR PADS (U.S. CLS. 2, 13, 22, 25, 32 AND 50).

**CLASS 21—HOUSEWARES AND GLASS**

FOR BATH ACCESSORIES, NAMELY, SOAP DISPENSERS, TOOTH BRUSH HOLDERS, SOAP TRAYS AND WASTE BASKETS (U.S. CLS. 2, 13, 23, 29, 30, 33, 40 AND 50).

**CLASS 24—FABRICS**

FOR TEXTILE PLACE MATS; TEXTILE NAPKINS; FABRIC TABLE RUNNERS; TABLE CLOTHS NOT OF PAPER; BEDDING, NAMELY, DUVET COVERS, SHEETS, SHAMS, BED SKIRTS; COMFORTERS; DRAPERIES; FABRIC WINDOW COVERINGS AND TREATMENTS, NAMELY, CURTAINS AND FABRIC VALANCES; SHOWER CURTAINS; FABRICS FOR TEXTILE USE; FABRIC FOR TEXTILE USE IN APPAREL; FABRIC FOR THE MANUFACTURE OF APPAREL; DECORATIVE FABRIC FOR TEXTILE USE ON THE TRIM OF WINDOW, TABLE AND BED COVERINGS (U.S. CLS. 42 AND 50).

**CLASS 26—FANCY GOODS**

FOR FABRIC DECORATIVE TRIM IN THE NATURE OF LACE FOR WINDOW, TABLE AND BED COVERINGS; FABRIC DECORATIVE TRIM IN THE NATURE OF RIBBON FOR WINDOW, TABLE AND BED COVERINGS (U.S. CLS. 37, 39, 40, 42 AND 50).

**CLASS 27—FLOOR COVERINGS**

FOR THROW RUGS; WALLPAPER (U.S. CLS. 19, 20, 37, 42 AND 50).  
LAURA HAMMEL, EXAMINING ATTORNEY

SN 77-907,667. IPSEN PHARMA S.A.S., CEDEX, FRANCE,  
FILED 1-8-2010.



THE MARK CONSISTS OF TWO HANDS WITH THE THUMBS AND FINGERS OF EACH HAND TOUCHING.

**CLASS 16—PAPER GOODS AND PRINTED MATTER**

FOR PRINTED MATTER, NAMELY, INSTRUCTIONAL AND TEACHING MATERIALS IN THE FIELD OF PARKINSONS DISEASE (U.S. CLS. 2, 5, 22, 23, 29, 37, 38 AND 50).

FIRST USE 8-31-2006; IN COMMERCE 8-31-2006.

**CLASS 35—ADVERTISING AND BUSINESS**

FOR ADMINISTRATION OF PATIENT REIMBURSEMENT PROGRAMS (U.S. CLS. 100, 101 AND 102).

FIRST USE 8-31-2006; IN COMMERCE 8-31-2006.

**CLASS 44—MEDICAL, BEAUTY AND AGRICULTURAL SERVICES**

FOR PROVIDING A WEBSITE FEATURING MEDICAL INFORMATION IN THE FIELD OF PARKINSONS DISEASE (U.S. CLS. 100 AND 101).

FIRST USE 8-31-2006; IN COMMERCE 8-31-2006.

ANDREA K. NADELMAN, EXAMINING ATTORNEY

SN 77-907,702. PETCO ANIMAL SUPPLIES STORES, INC.,  
SAN DIEGO, CA. FILED 1-8-2010.

**PLANET PETCO**

THE MARK CONSISTS OF STANDARD CHARACTERS WITHOUT CLAIM TO ANY PARTICULAR FONT, STYLE, SIZE, OR COLOR.

OWNER OF U.S. REG. NOS. 1,695,073, 2,172,931 AND 3,755,215.

**CLASS 5—PHARMACEUTICALS**

FOR MEDICATED PET GROOMING PREPARATIONS AND TREATMENTS FOR HAIR CARE AND SKIN CARE, NAMELY, PET SHAMPOOS, PET CONDITIONERS, PET COLOGNES, PET POWDERS, PET SOAPS, PET SPRAYS, PET WIPES, PET DROPS, AND FLEA, TICK AND MITE TREATMENTS IN THE FORM OF SHAMPOOS, LOTIONS, ANTIBIOTIC OINTMENTS, ANTI-ITCH OINTMENTS AND REPELLANTS; VITAMIN SUPPLEMENTS FOR PETS (U.S. CLS. 6, 18, 44, 46, 51 AND 52).

**CLASS 7—MACHINERY**

FOR AQUARIUM PRODUCTS, NAMELY, PUMPS AND POWERHEADS (U.S. CLS. 13, 19, 21, 23, 31, 34 AND 35).

**CLASS 11—ENVIRONMENTAL CONTROL APPARATUS**

FOR AQUARIUM PRODUCTS, NAMELY, HEATERS AND LIGHTS (U.S. CLS. 13, 21, 23, 31 AND 34).

**CLASS 16—PAPER GOODS AND PRINTED MATTER**

FOR PAPER AND PRINTED MATERIALS, NAMELY, CALENDARS, POSTERS, NOTE CARDS, GREETING CARDS, TRADING CARDS, BUMPER STICKERS, POSTERS, LAMINATED PRINTED SIGNS, BLANK AND PRINTED LABELS, BOOKMARKS, SCORE BOOKS, PRINTED PAPER SIGNS, WRITING PADS, NOTE PAPER, NOTEBOOKS, NOTE PADS, COLORING BOOKS, BOOK COVERS, CALENDARS, GIFT WRAPPING PAPER, PAPER NAPKINS, PAPER TABLECLOTHS, PAPER PLACE MATS, PAPERWEIGHTS, SHOPPING BAGS OF PAPER, DECALS, STICKERS, SOUVENIR PROGRAMS CONCERNING SPORTS AND SPORTING EVENTS, PHOTOGRAPHS, TEMPORARY TATTOOS, SCORE CARDS, BOOKS FEATURING SPORTS AND SPORTING EVENTS, MAGAZINES FEATURING SPORTS AND SPORTING EVENTS, PENS, PENCILS, PENCIL SHARPENERS, ERASERS, PAPER COASTERS, POSTCARDS, AUTOGRAPH BOOKS, BINDERS, SCHOOL AND OFFICE SUPPLIES, NAMELY, NOTEBOOKS, FOLDERS, PENCIL CASES, LUNCH BAGS, CHALKBOARDS AND CLIPBOARDS, PAPER PENNANTS, PAPER BANNERS, AND PAPER FLAGS (U.S. CLS. 2, 5, 22, 23, 29, 37, 38 AND 50).

**CLASS 18—LEATHER GOODS**

FOR BAGS, NAMELY, ALL PURPOSE SPORTS BAGS, DUFFEL BAGS, BACKPACKS, WALLETS, TOTE BAGS, WAIST PACKS; SHOPPING BAGS OF CANVAS, PURSES; UMBRELLAS; PET CLOTHING, HEAD WEAR, FOOTWEAR AND COSTUMES; PET ACCESSORIES, NAMELY, COLLARS, LEASHES, HARNESSSES AND CARRIERS; ANIMAL SKINS AND HIDES (U.S. CLS. 1, 2, 3, 22 AND 41).

**CLASS 21—HOUSEWARES AND GLASS**

FOR HOUSEHOLD ITEMS, NAMELY, BEVERAGE GLASSWARE, CUPS, MUGS; FIGURINES MADE OF GLASS, PORCELAIN, TERRA COTTA; PORTABLE COOLERS, THERMAL INSULATED CONTAINERS FOR FOOD OR BEVERAGES, AND PET FEEDING BOWLS; PET GROOMING PRODUCTS, NAMELY, COMBS AND BRUSHES (U.S. CLS. 2, 13, 23, 29, 30, 33, 40 AND 50).

**CLASS 25—CLOTHING**

FOR CLOTHING, NAMELY, SHIRTS, TOPS, PANTS, JACKETS, JERSEYS, RAINWEAR, PONCHOS, UNDERWEAR, SLEEP WEAR, PAJAMAS, COATS, SCARVES, TIES, BELTS, SOCKS, SWEATSHIRTS, SWEATPANTS, SPORTS SHIRTS, BASEBALL UNIFORMS, BOXER SHORTS, ROBES, WARM-UP SUITS, APRONS, CLOTH BIBS, CHILDREN'S COVERALLS, INFANT ONE PIECE CLOTHING, WRISTBANDS, GLOVES AND MITTENS, SKIRTS AND SHORTS; HEADWEAR, FOOTWEAR, UNIFORMS AND MASQUERADE AND HALLOWEEN COSTUMES (U.S. CLS. 22 AND 39).

**CLASS 28—TOYS AND SPORTING GOODS**

FOR GAMES, TOYS, AND PLAYTHINGS, NAMELY, BOARD GAMES, CARD GAMES, PARTY GAMES, ARCADE GAMES, COIN-OPERATED VIDEO GAMES, PLUSH TOYS, BEAN BAGS, ELECTRIC ACTION TOYS, BATH TOYS, INFANT TOYS, PULL TOYS, SQUEEZE TOYS, FLYING DISCS, KITES, YO-YOS, WIND-UP TOYS, TOY BANKS, MINIATURE BATTING HELMET REPLICAS, MINIATURE BASEBALL BAT REPLICAS, INFLATABLE BASEBALL BATS AND BALLS, DOLLS, STUFFED ANIMALS; PET TOYS; SPORTING GOODS AND EQUIPMENT, NAMELY, BASEBALLS, RECREATIONAL BALLS, GOLF BALLS, BASEBALL GLOVES, BASEBALL BATS, STRIKING BAGS, HAND BALLS, HAND WRAPS, MOUTH GUARDS, EXERCISE EQUIPMENT, NAMELY, PULLEYS, WEIGHT LIFTING MACHINES; BALLOONS AND CHRISTMAS TREE DECORATIONS; PLAYING CARDS (U.S. CLS. 22, 23, 38 AND 50).

**CLASS 35—ADVERTISING AND BUSINESS**

FOR RETAIL AND ON-LINE STORE SERVICES FEATURING PET SUPPLIES, PET TOYS, PET FOOD, AND SPORTS AND SPORTING GOODS; PROMOTING SPORTS COMPETITIONS AND/OR EVENTS OF OTHERS, NAMELY, ENTERTAINMENT IN THE NATURE OF MUSICAL AND THEATRICAL EVENTS, EDUCATIONAL, CULTURAL, AND CIVIC EVENTS AND EXHIBITIONS (U.S. CLS. 100, 101 AND 102).

**CLASS 41—EDUCATION AND ENTERTAINMENT**

FOR ENTERTAINMENT SERVICES, NAMELY, ORGANIZING COMMUNITY SPORTING AND CULTURAL EVENTS; ORGANIZING COMMUNITY FESTIVALS FEATURING A VARIETY OF ACTIVITIES, NAMELY, SPORTING EVENTS, ART EXHIBITIONS, FLEA MARKETS AND THE LIKE; ENTERTAINMENT IN THE NATURE OF LIVE PERFORMANCES BY A MUSICAL BAND, AND THEATRICAL PRODUCTIONS; ORGANIZING CULTURAL AND CIVIC EVENTS AND EXHIBITIONS; PROVIDING ON-LINE INFORMATION ON EDUCATIONAL AND ENTERTAINMENT EVENTS, SPORTING EVENTS, CULTURAL AND CIVIC EVENTS AND EXHIBITIONS AND MUSICAL AND THEATRICAL PERFORMANCES (U.S. CLS. 100, 101 AND 107).

ADA HAN, EXAMINING ATTORNEY

SN 77-911,786. FOUNDING FATHERS PRODUCTS, LLC, ORONO, MN. FILED 1-14-2010.

**FOUNDING FATHERS**

THE MARK CONSISTS OF STANDARD CHARACTERS WITHOUT CLAIM TO ANY PARTICULAR FONT, STYLE, SIZE, OR COLOR.

**CLASS 30—STAPLE FOODS**

FOR FOOD PRODUCTS, NAMELY, PASTA SAUCE, SALAD DRESSING, PIZZA, READY TO EAT CEREAL, MUSTARD, KETCHUP, CEREAL DERIVED NUTRITION BARS, COFFEE (U.S. CL. 46).

**CLASS 32—LIGHT BEVERAGES**

FOR ROOTBEER AND BOTTLED WATER (U.S. CLS. 45, 46 AND 48).

**CLASS 33—WINES AND SPIRITS**

FOR WINE (U.S. CLS. 47 AND 49).  
KAPIL BHANOT, EXAMINING ATTORNEY

SN 77-912,822. IPSEN PHARMA S.A.S., CEDEX, FRANCE, FILED 1-15-2010.



THE MARK CONSISTS OF A MAN IN MOTION WALKING TOGETHER WITH A DIAMOND DESIGN.

**CLASS 5—PHARMACEUTICALS**

FOR PHARMACEUTICAL PREPARATIONS FOR THE TREATMENT OF PARKINSONS DISEASE (U.S. CLS. 6, 18, 44, 46, 51 AND 52).  
FIRST USE 7-8-2009; IN COMMERCE 7-8-2009.

**CLASS 16—PAPER GOODS AND PRINTED MATTER**

FOR PRINTED MATTER, NAMELY, INSTRUCTIONAL AND TEACHING MATERIALS IN THE FIELD OF PARKINSONS DISEASE (U.S. CLS. 2, 5, 22, 23, 29, 37, 38 AND 50).  
FIRST USE 10-31-2006; IN COMMERCE 10-31-2006.

**CLASS 35—ADVERTISING AND BUSINESS**

FOR ADMINISTRATION OF PATIENT REIMBURSEMENT PROGRAMS (U.S. CLS. 100, 101 AND 102).  
FIRST USE 8-31-2006; IN COMMERCE 8-31-2006.

**CLASS 44—MEDICAL, BEAUTY AND AGRICULTURAL SERVICES**

FOR PROVIDING A WEBSITE FEATURING MEDICAL INFORMATION IN THE FIELD OF PARKINSONS DISEASE (U.S. CLS. 100 AND 101).  
FIRST USE 10-31-2006; IN COMMERCE 10-31-2006.  
ANDREA K. NADELMAN, EXAMINING ATTORNEY



SN 77-913,199. SHOW TRANSLATIONS LIMITED, LONDON, UNITED KINGDOM, FILED 1-15-2010.

# AIRSCRIPT

THE MARK CONSISTS OF STANDARD CHARACTERS WITHOUT CLAIM TO ANY PARTICULAR FONT, STYLE, SIZE, OR COLOR.

PRIORITY CLAIMED UNDER SEC. 44(D) ON UNITED KINGDOM APPLICATION NO. 2529397, FILED 10-20-2009, REG. NO. 0088431040, DATED 6-28-2010, EXPIRES 10-20-2019.

## CLASS 9—ELECTRICAL AND SCIENTIFIC APPARATUS

FOR ELECTRONIC SIGNAL PROCESSORS FOR READING, RECORDING, TRANSMISSION AND/OR REPRODUCTION OF WRITTEN MATERIAL AND IMAGES; ELECTRONIC SIGNAL PROCESSORS FOR TRANSCRIPTION OF WRITTEN MATERIAL AND IMAGES FOR WIRELESS TRANSMISSION AND VISUAL ELECTRONIC DISPLAY; PERSONAL ELECTRONIC DISPLAY HAND-SETS; DATA PROCESSORS; COMPUTERS; COMPUTER PROGRAMS; DATA CARRIERS PRE-RECORDED WITH COMPUTER PROGRAMS FOR USE WITH THE AFORESAID GOODS (U.S. CLS. 21, 23, 26, 36 AND 38).

## CLASS 35—ADVERTISING AND BUSINESS

FOR ADVERTISING SERVICES PROVIDED VIA LOCAL-AREA CLOSED-LOOP WIRELESS TRANSMISSION SYSTEMS; ADVERTISING PROVIDED FOR ELECTRONIC DISPLAY VIA LOCAL-AREA CLOSED-LOOP WIRELESS TRANSMISSION SYSTEMS; RENTAL OF ADVERTISING SPACE; DISSEMINATION OF ADVERTISING MATTER (U.S. CLS. 100, 101 AND 102).

## CLASS 41—EDUCATION AND ENTERTAINMENT

FOR RENTAL AND/OR LEASING OF ELECTRONIC SIGNAL PROCESSORS PROVIDING TRANSCRIPTION, RECORDING, TRANSMISSION AND ELECTRONIC DISPLAY OF WRITTEN MATERIAL AND VISUAL IMAGES; LANGUAGE TRANSLATION SERVICES (U.S. CLS. 100, 101 AND 107).

DOMINICK J. SALEMI, EXAMINING ATTORNEY

SN 77-916,054. M-X-SPORT OY, HELSINKI, FINLAND, FILED 1-20-2010.

# YOKO

THE MARK CONSISTS OF STANDARD CHARACTERS WITHOUT CLAIM TO ANY PARTICULAR FONT, STYLE, SIZE, OR COLOR.

PRIORITY CLAIMED UNDER SEC. 44(D) ON ERPN CMNTY TM OFC APPLICATION NO. 8458978, FILED 7-30-2009, REG. NO. 008458978, DATED 1-7-2011, EXPIRES 7-30-2019.

OWNER OF U.S. REG. NO. 1,930,439.

## CLASS 25—CLOTHING

FOR JACKETS FOR CYCLING; JACKETS FOR CROSS COUNTRY SKIING; JACKETS FOR RUNNING; JACKETS FOR NORDIC WALKING; CYCLING PANTS; CROSS COUNTRY SKIING PANTS; CROSS COUNTRY SKIING RACING PANTS; RUNNING PANTS; NORDIC WALKING PANTS; CYCLING SHORTS; RUNNING SHORTS; CYCLING JERSEYS; CROSS COUNTRY SKIING RACING JERSEYS; RUNNING JERSEYS; CYCLING HEADWEAR; CROSS COUNTRY SKIING HEADWEAR; NORDIC WALKING HEADWEAR; RUNNING HEADWEAR; CROSS COUNTRY SKIING VESTS; CYCLING VESTS; NORDIC WALKING VESTS, RUNNING VESTS; CYCLING GLOVES; CROSS COUNTRY SKIING GLOVES; NORDIC WALKING GLOVES (U.S. CLS. 22 AND 39).

FIRST USE 1-1-1991; IN COMMERCE 1-1-1991.

## CLASS 28—TOYS AND SPORTING GOODS

FOR RUNNING GLOVES; CROSS COUNTRY SKIING POLES (U.S. CLS. 22, 23, 38 AND 50).

FIRST USE 1-1-1991; IN COMMERCE 1-1-1991.  
DOMINIC FATHY, EXAMINING ATTORNEY

SN 77-917,783. VISPLAY INTERNATIONAL AG, MUTTENZ, SWITZERLAND, FILED 1-22-2010.

# INVISIBLE DESIGN

THE MARK CONSISTS OF STANDARD CHARACTERS WITHOUT CLAIM TO ANY PARTICULAR FONT, STYLE, SIZE, OR COLOR.

NO CLAIM IS MADE TO THE EXCLUSIVE RIGHT TO USE "DESIGN", APART FROM THE MARK AS SHOWN.

## CLASS 6—METAL GOODS

FOR METAL GOODS, NAMELY, METAL WALL SUPPORTS AND SHELF SUPPORTS WITH ATTACHED HOLDERS, SHELF HOLDERS AND CLOTHES RAILS FOR USE IN FASHION SHOPS; NON-LUMINOUS AND NON-MECHANICAL METAL PRICE AND SIZE SIGNS AND TAGS; METAL FRONT ARM HOLDERS AND PROFILE RAILS FOR USE IN FASHION SHOPS; METAL SHELF BRACKETS; METAL PLACARD WALLS AND PLACARD STANDS FOR USE IN FASHION SHOPS; METAL PLACARD COLUMNS; AND METAL PLACARD BOARDS; TRANSPORTABLE METAL BUILDING ELEMENTS, NAMELY, BACK WALLS AND PARTITION WALLS FOR SHOP INTERIORS (U.S. CLS. 2, 12, 13, 14, 23, 25 AND 50).

## CLASS 19—NON-METALLIC BUILDING MATERIALS

FOR WALL BOARDS NOT OF METAL; NON-LUMINOUS, NON-MECHANICAL AND NON-METAL PRICE AND SIZE SIGNS; NON-METAL RAILS FOR USE IN FASHION SHOPS (U.S. CLS. 1, 12, 33 AND 50).

**CLASS 20—FURNITURE AND ARTICLES NOT OTHERWISE CLASSIFIED**

FOR NON-METAL FURNITURE PARTS, NAMELY, SHELVES, FRONT ARM SUPPORTS, CLOTHES RAILS, PROFILE RAILS, SHELF BRACKETS, SHELF DIVIDERS, RACK SUPPORTS; NON-METAL SHELF DIVIDERS AND SHELF BACK WALLS AND PARTITION WALLS FOR SHELVES AND SHELF SUPPORTS WITH ATTACHED HOLDERS FOR USE IN FASHION SHOPS, SHELVES, NON-METAL SHELF HOLDERS; FURNITURE PARTS, NAMELY, NON-METAL HARDWARE FOR USE IN CONNECTION WITH ADJUSTABLE RACKS, SHELVES AND WALL SUPPORTS, NAMELY, NON-METAL FURNITURE FITTINGS; MOVEABLE ROOM PARTITIONS; SHELVES AND DISPLAY RACKS, NON-METAL DISPLAY STANDS FOR WINDOW DISPLAYS, INFORMATION AND SALES DESK, TABLES, CASH DESKS, CUPBOARDS, DESKS, MIRRORS; CLOTHING RAILS, GONDOLAS, SALES DESK AND STEPPED TABLES FOR USE IN SHOPS, TRADE SHOW BOOTHS, RECEPTION AREAS, OFFICES AND PRIVATE HOUSEHOLDS; ERECTION ELEMENTS FOR WINDOW DISPLAYS, NAMELY, DISPLAY STANDS FOR DECORATION PURPOSES, FOR USE IN SHOPS, TRADE SHOW BOOTHS, RECEPTION AREAS, OFFICES AND PRIVATE HOUSEHOLDS; TRANSPORTABLE NON-METAL BUILDING ELEMENTS, NAMELY, BACK WALLS AND PARTITION WALLS FOR SHOP INTERIORS (U.S. CLS. 2, 13, 22, 25, 32 AND 50).

**CLASS 37—CONSTRUCTION AND REPAIR**

FOR CONSTRUCTION CONSULTANCY; CONSTRUCTION OF FURNITURE AND DISPLAY FIXTURES FOR SHOPS, WINDOWS DISPLAYS, TRADE SHOW BOOTHS, RECEPTION AREAS, OFFICES AND PRIVATE HOUSEHOLDS (U.S. CLS. 100, 103 AND 106).

**CLASS 42—SCIENTIFIC AND COMPUTER SERVICES**

FOR ARCHITECTURAL SERVICES; INDUSTRIAL DESIGN SERVICES; PACKAGING DESIGN SERVICES; INTERIOR ARCHITECTURE SERVICES; INTERIOR DESIGN SERVICES; AND INTERIOR DECORATOR SERVICES (U.S. CLS. 100 AND 101).

**CLASS 43—HOTEL AND RESTAURANT SERVICES**

FOR PROVIDING AN ONLINE DATABASE FEATURING INFORMATION ON RENTAL OF FURNITURE AND DISPLAY FIXTURES FOR RETAIL STORES, WINDOW DISPLAYS, TRADE SHOW BOOTHS, RECEPTION AREAS, OFFICES, AND HOUSEHOLDS (U.S. CLS. 100 AND 101).

CHRISTOPHER BUONGIORNO, EXAMINING ATTORNEY

SN 77-918,358. S2ONE, INC., SHERWOOD, OR. FILED 1-22-2010.

THERE'S A ROADMAP FOR THAT

THE MARK CONSISTS OF STANDARD CHARACTERS WITHOUT CLAIM TO ANY PARTICULAR FONT, STYLE, SIZE, OR COLOR.

**CLASS 35—ADVERTISING AND BUSINESS**

FOR ONLINE RETAIL STORE SERVICES FEATURING PARTS AND EQUIPMENT FOR BROADCAST SYSTEMS (U.S. CLS. 100, 101 AND 102).

**CLASS 42—SCIENTIFIC AND COMPUTER SERVICES**

FOR ENGINEERING SERVICES, NAMELY, IMPROVING AND OPTIMIZING BROADCAST SYSTEMS (U.S. CLS. 100 AND 101).

CARRIE GENOVESE, EXAMINING ATTORNEY

SN 77-922,025. TOEI ANIMATION CO., LTD., NERIMA-KU, TOKYO, JAPAN, FILED 1-28-2010.

GAIKING

THE MARK CONSISTS OF STANDARD CHARACTERS WITHOUT CLAIM TO ANY PARTICULAR FONT, STYLE, SIZE, OR COLOR.

**CLASS 9—ELECTRICAL AND SCIENTIFIC APPARATUS**

FOR COMPUTER SOFTWARE DVDS FEATURING ANIMATION, MUSIC AND GAMES; PRERECORDED VIDEO TAPES FEATURING ANIMATION AND ENTERTAINMENT SHOWS FOR CHILDREN; COMPUTER GAME SOFTWARE; VIDEO GAME SOFTWARE; INTERACTIVE VIDEO GAME SOFTWARE; VISUAL RECORDINGS AND AUDIO VISUAL RECORDINGS FEATURING MUSIC AND/OR ANIMATION; COMPUTER GAME PROGRAMS DOWNLOADABLE FROM THE INTERNET; VIDEO GAME PROGRAMS; VIDEO GAME CARTRIDGES; VIDEO GAME DISCS; VIDEO GAME CD ROMS; VIDEO GAME CASSETTES AND TAPES; PERSONAL COMPUTERS; AND DOWNLOADABLE COMPUTER VIDEO GAME SOFTWARE VIA A GLOBAL COMPUTER NETWORK; HAND-HELD UNITS FOR PLAYING ELECTRONIC GAMES FOR USE WITH EXTERNAL DISPLAY SCREEN OR MONITOR (U.S. CLS. 21, 23, 26, 36 AND 38).

**CLASS 16—PAPER GOODS AND PRINTED MATTER**

FOR TRADING CARDS; POSTERS; STATIONERY; POSTCARDS; AND ADHESIVE STICKERS (U.S. CLS. 2, 5, 22, 23, 29, 37, 38 AND 50).

**CLASS 25—CLOTHING**

FOR SHOES; HEADWEAR; SHIRTS; T-SHIRTS; PANTS; SWEATSHIRTS; COSTUMES FOR USE IN ROLE PLAYING GAMES; HALLOWEEN COSTUMES; MASQUERADE COSTUMES (U.S. CLS. 22 AND 39).

**CLASS 28—TOYS AND SPORTING GOODS**

FOR HAND HELD UNITS FOR PLAYING VIDEO GAMES OTHER THAN THOSE ADAPTED FOR USE WITH AN EXTERNAL DISPLAY SCREEN OR MONITOR; HAND-HELD VIDEO GAMES; COLLECTIBLE TOY FIGURES; ELECTRONIC AND ACTION FIGURES; ACTION FIGURE CLOTHING AND ACCESSORIES; TOY FIGURES; PLUSH TOYS; ROLE PLAYING GAMES; AND PLAYING CARDS (U.S. CLS. 22, 23, 38 AND 50).

**CLASS 38—COMMUNICATION**

FOR BROADCAST OF TELEVISION PROGRAMS; ONLINE BROADCAST OF TELEVISION PROGRAMS; AND MOBILE TELEPHONE COMMUNICATION (U.S. CLS. 100, 101 AND 104).

**CLASS 41—EDUCATION AND ENTERTAINMENT**

FOR ENTERTAINMENT SERVICES, NAMELY, PROVIDING A TELEVISION SERIES FEATURING ANIMATION VIA TERRESTRIAL TELEVISION NETWORK IN THE FIELD OF CHILDREN'S ENTERTAINMENT AND EDUCATION; PROVIDING A TELEVISION SERIES FEATURING ANIMATION VIA CABLE TELEVISION NETWORK IN THE FIELD OF CHILDREN'S ENTERTAINMENT AND EDUCATION; PROVIDING A TELEVISION SERIES FEATURING ANIMATION VIA SATELLITE TELEVISION NETWORK IN THE FIELD OF CHILDREN'S ENTERTAINMENT AND EDUCATION; AND PROVIDING A TELEVISION SERIES FEATURING ANIMATION VIA A GLOBAL COMPUTER NETWORK IN THE FIELD OF CHILDREN'S ENTERTAINMENT AND EDUCATION; ENTERTAINMENT SERVICES, NAMELY, PROVIDING ONLINE VIDEO GAMES (U.S. CLS. 100, 101 AND 107).

\_\_\_\_\_  
 GEOFFREY FOSDICK, EXAMINING ATTORNEY

SN 77-922,046. TOEI ANIMATION CO., LTD., NERIMA-KU, TOKYO, JAPAN, FILED 1-28-2010.

**STARZINGER**

THE MARK CONSISTS OF STANDARD CHARACTERS WITHOUT CLAIM TO ANY PARTICULAR FONT, STYLE, SIZE, OR COLOR.

**CLASS 9—ELECTRICAL AND SCIENTIFIC APPARATUS**

FOR COMPUTER SOFTWARE DVDS FEATURING ANIMATION, MUSIC AND GAMES; PRERECORDED VIDEO TAPES FEATURING ANIMATION AND ENTERTAINMENT SHOWS FOR CHILDREN; COMPUTER GAME SOFTWARE; VIDEO GAME SOFTWARE; INTERACTIVE VIDEO GAME SOFTWARE; VISUAL RECORDINGS AND AUDIO VISUAL RECORDINGS FEATURING MUSIC AND/OR ANIMATION; COMPUTER GAME PROGRAMS DOWNLOADABLE FROM THE INTERNET; VIDEO GAME PROGRAMS; VIDEO GAME CARTRIDGES; VIDEO GAME DISCS; VIDEO GAME CD ROMS; VIDEO GAME CASSETTES AND TAPES; PERSONAL COMPUTERS; AND DOWNLOADABLE COMPUTER VIDEO GAME SOFTWARE VIA A GLOBAL COMPUTER NETWORK; HAND-HELD UNITS FOR PLAYING ELECTRONIC GAMES FOR USE WITH EXTERNAL DISPLAY SCREEN OR MONITOR (U.S. CLS. 21, 23, 26, 36 AND 38).

**CLASS 16—PAPER GOODS AND PRINTED MATTER**

FOR TRADING CARDS; POSTERS; STATIONERY; POSTCARDS; AND ADHESIVE STICKERS (U.S. CLS. 2, 5, 22, 23, 29, 37, 38 AND 50).

**CLASS 25—CLOTHING**

FOR SHOES; HEADWEAR; SHIRTS; T-SHIRTS; PANTS; SWEATSHIRTS; COSTUMES FOR USE IN ROLE PLAYING GAMES; HALLOWEEN COSTUMES; AND MASQUERADE COSTUMES (U.S. CLS. 22 AND 39).

**CLASS 28—TOYS AND SPORTING GOODS**

FOR HAND HELD UNITS FOR PLAYING VIDEO GAMES OTHER THAN THOSE ADAPTED FOR USE WITH AN EXTERNAL DISPLAY SCREEN OR MONITOR; HAND-HELD VIDEO GAMES; COLLECTIBLE TOY FIGURES; ELECTRONIC AND ACTION FIGURES; ACTION FIGURE CLOTHING AND ACCESSORIES; TOY FIGURES; PLUSH TOYS; ROLE PLAYING GAMES; AND PLAYING CARDS (U.S. CLS. 22, 23, 38 AND 50).

**CLASS 38—COMMUNICATION**

FOR BROADCAST OF TELEVISION PROGRAMS; ONLINE BROADCAST OF TELEVISION PROGRAMS; AND MOBILE TELEPHONE COMMUNICATION (U.S. CLS. 100, 101 AND 104).

**CLASS 41—EDUCATION AND ENTERTAINMENT**

FOR ENTERTAINMENT SERVICES, NAMELY, PROVIDING A TELEVISION SERIES FEATURING ANIMATION VIA TERRESTRIAL TELEVISION NETWORK IN THE FIELD OF CHILDREN'S ENTERTAINMENT AND EDUCATION; PROVIDING A TELEVISION SERIES FEATURING ANIMATION VIA CABLE TELEVISION NETWORK IN THE FIELD OF CHILDREN'S ENTERTAINMENT AND EDUCATION; PROVIDING A TELEVISION SERIES FEATURING ANIMATION VIA SATELLITE TELEVISION NETWORK IN THE FIELD OF CHILDREN'S ENTERTAINMENT AND EDUCATION; AND PROVIDING A TELEVISION SERIES FEATURING ANIMATION VIA A GLOBAL COMPUTER NETWORK IN THE FIELD OF CHILDREN'S ENTERTAINMENT AND EDUCATION; ENTERTAINMENT SERVICES, NAMELY, PROVIDING ONLINE VIDEO GAMES (U.S. CLS. 100, 101 AND 107).

\_\_\_\_\_  
 GEOFFREY FOSDICK, EXAMINING ATTORNEY

SN 77-922,078. TOEI ANIMATION CO., LTD., NERIMA-KU, TOKYO, JAPAN, FILED 1-28-2010.

**PLANET ROBOT DANGUARD ACE**

THE MARK CONSISTS OF STANDARD CHARACTERS WITHOUT CLAIM TO ANY PARTICULAR FONT, STYLE, SIZE, OR COLOR.

**CLASS 9—ELECTRICAL AND SCIENTIFIC APPARATUS**

FOR COMPUTER SOFTWARE DVDS FEATURING ANIMATION, MUSIC AND GAMES; PRERECORDED VIDEO TAPES FEATURING ANIMATION AND ENTERTAINMENT SHOWS FOR CHILDREN; COMPUTER GAME SOFTWARE; VIDEO GAME SOFTWARE; INTERACTIVE VIDEO GAME SOFTWARE; VISUAL RECORDINGS AND AUDIO VISUAL RECORDINGS FEATURING MUSIC AND/OR ANIMATION; COMPUTER GAME PROGRAMS DOWNLOADABLE FROM THE INTERNET; VIDEO GAME PROGRAMS; VIDEO GAME CARTRIDGES; VIDEO GAME DISCS; VIDEO GAME CD ROMS; VIDEO GAME CASSETTES AND TAPES; PERSONAL COMPUTERS; AND DOWNLOADABLE COMPUTER VIDEO GAME SOFTWARE VIA A GLOBAL COMPUTER NETWORK; HAND-HELD UNITS FOR PLAYING ELECTRONIC GAMES FOR USE WITH EXTERNAL DISPLAY SCREEN OR MONITOR (U.S. CLS. 21, 23, 26, 36 AND 38).

**CLASS 16—PAPER GOODS AND PRINTED MATTER**

FOR TRADING CARDS; POSTERS; STATIONERY; POSTCARDS; AND ADHESIVE STICKERS (U.S. CLS. 2, 5, 22, 23, 29, 37, 38 AND 50).

**CLASS 25—CLOTHING**

FOR SHOES; HEADWEAR; SHIRTS; T-SHIRTS; PANTS; SWEATSHIRTS; COSTUMES FOR USE IN ROLE PLAYING GAMES; HALLOWEEN COSTUMES; AND MASQUERADE COSTUMES (U.S. CLS. 22 AND 39).

**CLASS 28—TOYS AND SPORTING GOODS**

FOR HAND HELD UNITS FOR PLAYING VIDEO GAMES OTHER THAN THOSE ADAPTED FOR USE WITH AN EXTERNAL DISPLAY SCREEN OR MONITOR; HAND HELD VIDEO GAMES; COLLECTIBLE TOY FIGURES; ELECTRONIC AND ACTION FIGURES; ACTION FIGURE CLOTHING AND ACCESSORIES; TOY FIGURES; PLUSH TOYS; ROLE PLAYING GAMES; AND PLAYING CARDS (U.S. CLS. 22, 23, 38 AND 50).

**CLASS 38—COMMUNICATION**

FOR BROADCAST OF TELEVISION PROGRAMS; ON-LINE BROADCAST OF TELEVISION PROGRAMS; AND MOBILE TELEPHONE COMMUNICATION (U.S. CLS. 100, 101 AND 104).

**CLASS 41—EDUCATION AND ENTERTAINMENT**

FOR ENTERTAINMENT SERVICES, NAMELY, PROVIDING A TELEVISION SERIES FEATURING ANIMATION VIA TERRESTRIAL TELEVISION NETWORK IN THE FIELD OF CHILDREN'S ENTERTAINMENT AND EDUCATION; PROVIDING A TELEVISION SERIES FEATURING ANIMATION VIA CABLE TELEVISION NETWORK IN THE FIELD OF CHILDREN'S ENTERTAINMENT AND EDUCATION; PROVIDING A TELEVISION SERIES FEATURING ANIMATION VIA SATELLITE TELEVISION NETWORK IN THE FIELD OF CHILDREN'S ENTERTAINMENT AND EDUCATION; AND PROVIDING A TELEVISION SERIES FEATURING ANIMATION VIA A GLOBAL COMPUTER NETWORK IN THE FIELD OF CHILDREN'S ENTERTAINMENT AND EDUCATION; ENTERTAINMENT SERVICES, NAMELY, PROVIDING ONLINE VIDEO GAMES (U.S. CLS. 100, 101 AND 107).

GEOFFREY FOSDICK, EXAMINING ATTORNEY

**CLASS 9—ELECTRICAL AND SCIENTIFIC APPARATUS**

FOR COMPUTER SOFTWARE DVDS FEATURING ANIMATION, MUSIC AND GAMES; PRERECORDED VIDEO TAPES FEATURING ANIMATION AND ENTERTAINMENT SHOWS FOR CHILDREN; COMPUTER GAME SOFTWARE; VIDEO GAME SOFTWARE; INTERACTIVE VIDEO GAME SOFTWARE; VISUAL RECORDINGS AND AUDIO VISUAL RECORDINGS FEATURING MUSIC AND/OR ANIMATION; COMPUTER GAME PROGRAMS DOWNLOADABLE FROM THE INTERNET; VIDEO GAME PROGRAMS; VIDEO GAME CARTRIDGES; VIDEO GAME DISCS; VIDEO GAME CD ROMS; VIDEO GAME CASSETTES AND TAPES; PERSONAL COMPUTERS; AND DOWNLOADABLE COMPUTER VIDEO GAME SOFTWARE VIA A GLOBAL COMPUTER NETWORK; HAND-HELD UNITS FOR PLAYING ELECTRONIC GAMES FOR USE WITH EXTERNAL DISPLAY SCREEN OR MONITOR (U.S. CLS. 21, 23, 26, 36 AND 38).

**CLASS 16—PAPER GOODS AND PRINTED MATTER**

FOR TRADING CARDS; POSTERS; STATIONERY; POSTCARDS; AND ADHESIVE STICKERS (U.S. CLS. 2, 5, 22, 23, 29, 37, 38 AND 50).

**CLASS 25—CLOTHING**

FOR SHOES; HEADWEAR; SHIRTS; T-SHIRTS; PANTS; SWEATSHIRTS; COSTUMES FOR USE IN ROLE PLAYING GAMES; HALLOWEEN COSTUMES; AND MASQUERADE COSTUMES (U.S. CLS. 22 AND 39).

**CLASS 28—TOYS AND SPORTING GOODS**

FOR HAND HELD UNITS FOR PLAYING VIDEO GAMES OTHER THAN THOSE ADAPTED FOR USE WITH AN EXTERNAL DISPLAY SCREEN OR MONITOR; HAND-HELD VIDEO GAMES; COLLECTIBLE TOY FIGURES; ELECTRONIC AND ACTION FIGURES; ACTION FIGURE CLOTHING AND ACCESSORIES; TOY FIGURES; PLUSH TOYS; ROLE PLAYING GAMES; AND PLAYING CARDS (U.S. CLS. 22, 23, 38 AND 50).

**CLASS 38—COMMUNICATION**

FOR BROADCAST OF TELEVISION PROGRAMS; ON-LINE BROADCAST OF TELEVISION PROGRAMS; AND MOBILE TELEPHONE COMMUNICATION (U.S. CLS. 100, 101 AND 104).

**CLASS 41—EDUCATION AND ENTERTAINMENT**

FOR ENTERTAINMENT SERVICES, NAMELY, PROVIDING A TELEVISION SERIES FEATURING ANIMATION VIA TERRESTRIAL TELEVISION NETWORK IN THE FIELD OF CHILDREN'S ENTERTAINMENT AND EDUCATION; PROVIDING A TELEVISION SERIES FEATURING ANIMATION VIA CABLE TELEVISION NETWORK IN THE FIELD OF CHILDREN'S ENTERTAINMENT AND EDUCATION; PROVIDING A TELEVISION SERIES FEATURING ANIMATION VIA SATELLITE TELEVISION NETWORK IN THE FIELD OF CHILDREN'S ENTERTAINMENT AND EDUCATION; AND PROVIDING A TELEVISION SERIES FEATURING ANIMATION VIA A GLOBAL COMPUTER NETWORK IN THE FIELD OF CHILDREN'S ENTERTAINMENT AND EDUCATION; ENTERTAINMENT SERVICES, NAMELY, PROVIDING ONLINE VIDEO GAMES (U.S. CLS. 100, 101 AND 107).

GEOFFREY FOSDICK, EXAMINING ATTORNEY

SN 77-922,103. TOEI ANIMATION CO., LTD., NERIMA-KU, TOKYO, JAPAN, FILED 1-28-2010.

UFO ROBOT GRENDIZER RAIDS

THE MARK CONSISTS OF STANDARD CHARACTERS WITHOUT CLAIM TO ANY PARTICULAR FONT, STYLE, SIZE, OR COLOR.



SN 77-922,125. TOEI ANIMATION CO., LTD., NERIMA-KU, TOKYO, JAPAN, FILED 1-28-2010.

## GETTA ROBOT G

THE MARK CONSISTS OF STANDARD CHARACTERS WITHOUT CLAIM TO ANY PARTICULAR FONT, STYLE, SIZE, OR COLOR.

### CLASS 9—ELECTRICAL AND SCIENTIFIC APPARATUS

FOR COMPUTER SOFTWARE DVDS FEATURING ANIMATION, MUSIC AND GAMES; PRERECORDED VIDEO TAPES FEATURING ANIMATION AND ENTERTAINMENT SHOWS FOR CHILDREN; COMPUTER GAME SOFTWARE; VIDEO GAME SOFTWARE; INTERACTIVE VIDEO GAME SOFTWARE; VISUAL RECORDINGS AND AUDIO VISUAL RECORDINGS FEATURING MUSIC AND/OR ANIMATION; COMPUTER GAME PROGRAMS DOWNLOADABLE FROM THE INTERNET; VIDEO GAME PROGRAMS; VIDEO GAME CARTRIDGES; VIDEO GAME DISCS; VIDEO GAME CD ROMS; VIDEO GAME CASSETTES AND TAPES; PERSONAL COMPUTERS; AND DOWNLOADABLE COMPUTER VIDEO GAME SOFTWARE VIA A GLOBAL COMPUTER NETWORK; HAND-HELD UNITS FOR PLAYING ELECTRONIC GAMES FOR USE WITH EXTERNAL DISPLAY SCREEN OR MONITOR (U.S. CLS. 21, 23, 26, 36 AND 38).

### CLASS 16—PAPER GOODS AND PRINTED MATTER

FOR TRADING CARDS; POSTERS; STATIONERY; POSTCARDS; AND ADHESIVE STICKERS (U.S. CLS. 2, 5, 22, 23, 29, 37, 38 AND 50).

### CLASS 25—CLOTHING

FOR SHOES; HEADWEAR; SHIRTS; T-SHIRTS; PANTS; SWEATSHIRTS; COSTUMES FOR USE IN ROLE PLAYING GAMES; HALLOWEEN COSTUMES; AND MASQUERADE COSTUMES (U.S. CLS. 22 AND 39).

### CLASS 28—TOYS AND SPORTING GOODS

FOR HAND HELD UNITS FOR PLAYING VIDEO GAMES OTHER THAN THOSE ADAPTED FOR USE WITH AN EXTERNAL DISPLAY SCREEN OR MONITOR; HAND-HELD VIDEO GAMES; COLLECTIBLE TOY FIGURES; ELECTRONIC AND ACTION FIGURES; ACTION FIGURE CLOTHING AND ACCESSORIES; TOY FIGURES; PLUSH TOYS; ROLE PLAYING GAMES; AND PLAYING CARDS (U.S. CLS. 22, 23, 38 AND 50).

### CLASS 38—COMMUNICATION

FOR BROADCAST OF TELEVISION PROGRAMS; ONLINE BROADCAST OF TELEVISION PROGRAMS; AND MOBILE TELEPHONE COMMUNICATION (U.S. CLS. 100, 101 AND 104).

### CLASS 41—EDUCATION AND ENTERTAINMENT

FOR ENTERTAINMENT SERVICES, NAMELY, PROVIDING A TELEVISION SERIES FEATURING ANIMATION VIA TERRESTRIAL TELEVISION NETWORK IN THE FIELD OF CHILDREN'S ENTERTAINMENT AND EDUCATION; PROVIDING A TELEVISION SERIES FEATURING ANIMATION VIA CABLE TELEVISION NETWORK IN THE FIELD OF CHILDREN'S ENTERTAINMENT AND EDUCATION; PROVIDING A TELEVISION SERIES FEATURING ANIMATION VIA SATELLITE TELEVISION NETWORK IN THE FIELD OF CHILDREN'S ENTERTAINMENT AND EDUCATION; AND PROVIDING A TELEVISION SERIES FEATURING ANIMATION VIA A GLOBAL COMPUTER NETWORK IN THE FIELD OF CHILDREN'S ENTERTAINMENT AND EDUCATION; ENTERTAINMENT SERVICES, NAMELY, PROVIDING ONLINE VIDEO GAMES (U.S. CLS. 100, 101 AND 107).

GEOFFREY FOSDICK, EXAMINING ATTORNEY

SN 77-923,188. ARKTIK GMBH, HAMBURG, FED REP GERMANY, FILED 1-29-2010.

## CO<sub>2</sub>MPENSATE

PRIORITY CLAIMED UNDER SEC. 44(D) ON FED REP GERMANY APPLICATION NO. 302009046404, FILED 8-1-2009, REG. NO. 302009046404, DATED 9-21-2009, EXPIRES 8-31-2019.

THE MARK CONSISTS OF "CO2MPENSATE".

### CLASS 9—ELECTRICAL AND SCIENTIFIC APPARATUS

FOR MULTIMEDIA SOFTWARE RECORDED ON CD-ROMS, DVDS, FLOPPY DISCS, COMPUTER DISCS, DIGITAL TAPES, DIGITAL STORAGE MEDIA, MAGNETIC DISCS, MAGNETIC TAPES FEATURING PROGRAMS FOR DETERMINING EMISSION COMPENSATION IN RELATION TO NOXIOUS EMISSIONS; DATA MEDIUMS, NAMELY, INTEGRATED CIRCUIT CARDS, BLANK SMART CARDS; MAGNETICALLY ENCODED CREDIT CARDS; MAGNETICALLY ENCODED DEBIT CARDS; ELECTRONIC AND MAGNETIC ID CARDS FOR USE IN CONNECTION WITH PAYMENT FOR SERVICES; PRE-PAID TELEPHONE CALLING CARDS, MAGNETICALLY ENCODED; ENCODED MAGNETIC SIGNATURE CARDS, ENCODED MAGNETIC IDENTIFICATION CARDS, ENCODED MAGNETIC MULTIFUNCTION CARDS, ENCODED MAGNETIC SERVICE CARDS WITH PAYMENT FEATURES, ALL AFOREMENTIONED GOODS FOR USAGE FOR EMISSION COMPENSATION (U.S. CLS. 21, 23, 26, 36 AND 38).

**CLASS 35—ADVERTISING AND BUSINESS**

FOR ADVERTISING IN THE FIELD OF EMISSION COMPENSATION; PUBLIC RELATIONS IN THE FIELD OF EMISSION COMPENSATION; MANAGEMENT CONSULTANCY IN THE FIELD OF EMISSION COMPENSATION; BUSINESS ADMINISTRATION IN RELATION TO NOXIOUS EMISSIONS COMPENSATION; ORGANIZATIONAL PROJECT MANAGEMENT FOR OTHERS FOR BUSINESS PURPOSES REGARDING VOLUNTARY EMISSION COMPENSATION; ARRANGING OF CONTRACTUAL SERVICES WITH THIRD PARTIES FOR THE PAYMENT OR PURCHASE AND SALE OF VOLUNTARY POLLUTION TAXES IN PARTICULAR REGARDING NOXIOUS EMISSIONS FOR ROAD TRAFFIC; ACCOUNTING FOR THIRD PARTIES IN THE FIELD OF EMISSION COMPENSATION (U.S. CLS. 100, 101 AND 102).

**CLASS 36—INSURANCE AND FINANCIAL**

FOR FINANCIAL TRANSACTION SERVICES, NAMELY, PROVIDING SECURE COMMERCIAL TRANSACTIONS AND PAYMENT OPTIONS IN THE FIELD OF EMISSION COMPENSATION (U.S. CLS. 100, 101 AND 102).

**CLASS 42—SCIENTIFIC AND COMPUTER SERVICES**

FOR SCIENTIFIC RESEARCH AND TECHNOLOGICAL CONSULTATION IN THE TECHNOLOGY FIELD OF EMISSION COMPENSATION; DESIGN FOR OTHERS IN THE FIELD OF EMISSION COMPENSATION; SCIENTIFIC RESEARCH FOR CREATING STRATEGIES FOR REDUCING NOXIOUS POLLUTION, IN PARTICULAR FOR REDUCING NOXIOUS POLLUTION FOR ROAD TRAFFIC, FOR ASCERTAINMENT OF EMISSIONS, AND FOR REDUCING NOXIOUS EMISSIONS; ENVIRONMENTAL PROTECTION RESEARCH CONSULTANCY SERVICES; DEVELOPMENT, UPDATING AND MAINTENANCE OF SOFTWARE AND DATA BASES IN THE FIELD OF EMISSION COMPENSATION (U.S. CLS. 100 AND 101).

GEOFFREY FOSDICK, EXAMINING ATTORNEY

SN 77-923,962. EVANS, JOY L., NOVATO, CA. AND GOLDBERG, KAYLA, AKA GOLD, KAYLA, NOVATO, CA. FILED 1-29-2010.



THE COLOR(S) BLUE, GREEN, YELLOW, BROWN, BLACK IS/ARE CLAIMED AS A FEATURE OF THE MARK. THE MARK CONSISTS OF A ROUND CUT-OUT EARTH SYMBOL IN BLUE WITH GREEN ACCENTS. A TRIANGULAR SHIELD IS SITUATED WITHIN THIS ROUND CUT-OUT EARTH SYMBOL AND PIERCED BY PARTS OF IT. THE COLOR OF THE SHIELD IS A GRADIENT GREEN WITH BROWN ACCENTS IN THE TRIM NEAR THE OUTER BORDER. THE WORDS ARE A CREATED FONT. THE WORDS "EARTH-GUARDS" ARE YELLOW WITH A BLACK STROKE. THE WORD "ADVENTURE TEAM" ARE BROWN WITH A BLACK STROKE

**CLASS 9—ELECTRICAL AND SCIENTIFIC APPARATUS**

FOR AUDIO AND VIDEO RECORDINGS FEATURING EARTH-GUARDS SONGS, MUSIC, ARTWORK, GAMES AND CONTESTS; CHILDREN'S EDUCATIONAL MUSIC CDS AND DVDS; PRE-RECORDED CDS FEATURING SONGS WITH WORDS, INSTRUMENTAL MUSIC OR AUDIOBOOKS; PRE-RECORDED CDS, VIDEO TAPES, LASER DISKS AND DVDS FEATURING SONGS WITH WORDS, INSTRUMENTAL MUSIC, ARTWORK, GAMES, CONTESTS (U.S. CLS. 21, 23, 26, 36 AND 38).

**CLASS 16—PAPER GOODS AND PRINTED MATTER**

FOR CARTOON PRINTS; CARTOON STRIPS; CHILDREN'S ACTIVITY BOOKS; CHILDREN'S BOOKS; COMIC BOOKS; EDUCATIONAL KITS SOLD AS A UNIT IN THE FIELD OF ENVIRONMENTAL EDUCATION CONSISTING PRIMARILY OF EDUCATIONAL BOOKS, FLASH CARDS AND WORKSHEETS, AND ALSO INCLUDING AN EDUCATIONAL DVD (U.S. CLS. 2, 5, 22, 23, 29, 37, 38 AND 50).

**CLASS 28—TOYS AND SPORTING GOODS**

FOR BOARD GAMES; CARD GAMES; COLLECTABLE TOY FIGURES; COSTUME MASKS; DOLL COSTUMES; DOLLS; DOLLS AND ACCESSORIES THEREFOR; DOLLS AND DOLLS' CLOTHING; DOLLS' CLOTHES; ELECTRIC ACTION TOYS; PAPER DOLLS; TOY ACTION FIGURES; TOY ACTION FIGURES AND ACCESSORIES THEREFOR (U.S. CLS. 22, 23, 38 AND 50).

**CLASS 41—EDUCATION AND ENTERTAINMENT**

FOR ENTERTAINMENT SERVICES, NAMELY, THE PROVISION OF CONTINUING CARTOON, LIVE ACTION, FILMED OR STAGED SHOWS FEATURING THE EARTH-GUARD ADVENTURE TEAM DELIVERED BY RADIO, TV, LIVE ACTION, INTERNET, SATELLITE; ENTERTAINMENT SERVICES, NAMELY, A CONTINUING EARTH-GUARD ADVENTURE CARTOON OR LIVE ACTION SHOW BROADCAST OVER TELEVISION, SATELLITE, AUDIO, AND VIDEO MEDIA; ENTERTAINMENT SERVICES, NAMELY, A CONTINUING EARTH-GUARD ADVENTURE CARTOON OR LIVE ACTION SHOW BROADCAST OVER INTERNET; ENTERTAINMENT SERVICES, NAMELY, PRODUCTION OF STAGE SHOW OR MUSICAL CONCERT; RADIO ENTERTAINMENT SERVICES, NAMELY, RADIO PROGRAMS FEATURING PERFORMANCES BY A THE CHARACTERS WHO COMPRISE THE EARTH-GUARDS ADVENTURE TEAM AND RELATED CHARACTERS (U.S. CLS. 100, 101 AND 107).

NAAKWAMA ANKRAH, EXAMINING ATTORNEY

SN 77-925,069. UNITEDHEALTH GROUP INCORPORATED, MINNETONKA, MN. FILED 2-1-2010.

**LIFEPRINT**

THE MARK CONSISTS OF STANDARD CHARACTERS WITHOUT CLAIM TO ANY PARTICULAR FONT, STYLE, SIZE, OR COLOR.

**CLASS 35—ADVERTISING AND BUSINESS**

FOR HEALTH CARE AND MEDICAL PRACTICE ADMINISTRATION SERVICES, NAMELY, PROVIDING BACK OFFICE SERVICES FOR PHYSICIAN PRACTICES, MEDICAL BILLING SERVICES; MANAGED HEALTH CARE SERVICES, NAMELY, ELECTRONIC PROCESSING OF HEALTH CARE INFORMATION; PROVIDING INFORMATION IN THE FIELD OF BUSINESS ADMINISTRATION OF HEALTH CARE AND MEDICAL PRACTICES; CONSULTATION IN THE FIELD OF MANAGEMENT, OPERATION, AND DEVELOPMENT OF BUSINESS SYSTEMS FOR THE DELIVERY OF HEALTH CARE; HEALTHCARE MANAGEMENT SERVICE ORGANIZATION (MSO) SERVICES, NAMELY, PROVIDING PRACTICE ORGANIZATION, MANAGEMENT AND ADMINISTRATIVE SUPPORT SERVICES TO INDIVIDUAL PHYSICIANS OR SMALL GROUP PRACTICES (U.S. CLS. 100, 101 AND 102).

**CLASS 42—SCIENTIFIC AND COMPUTER SERVICES**

FOR HEALTH CARE AND MEDICAL BUSINESS SERVICES, NAMELY, DEVELOPMENT OF ONLINE COMPUTER SOFTWARE SYSTEMS FOR HEALTH CARE DELIVERY BETWEEN BUSINESSES; INFORMATION TECHNOLOGY SUPPORT SERVICES IN THE NATURE OF PROVIDING SUPPORT TO PHYSICIANS AND PATIENTS BY MEANS OF A WEBSITE FEATURING TEMPORARY USE OF ONLINE NON-DOWNLOADABLE SOFTWARE FOR USE IN ACCESSING ELECTRONIC HEALTH RECORDS, EXCHANGING HEALTH INFORMATION, AND CLAIMS PROCESSING IN THE FIELD OF TELEMEDICINE (U.S. CLS. 100 AND 101).

**CLASS 44—MEDICAL, BEAUTY AND AGRICULTURAL SERVICES**

FOR PROVIDING INFORMATION IN THE FIELD OF HEALTH CARE (U.S. CLS. 100 AND 101).  
LAURA HAMMEL, EXAMINING ATTORNEY

SN 77-925,082. UNITEDHEALTH GROUP INCORPORATED, MINNETONKA, MN. FILED 2-1-2010.

**LIFEPRIINT HEALTH**

THE MARK CONSISTS OF STANDARD CHARACTERS WITHOUT CLAIM TO ANY PARTICULAR FONT, STYLE, SIZE, OR COLOR.

NO CLAIM IS MADE TO THE EXCLUSIVE RIGHT TO USE "HEALTH", APART FROM THE MARK AS SHOWN.

**CLASS 35—ADVERTISING AND BUSINESS**

FOR HEALTH CARE AND MEDICAL PRACTICE ADMINISTRATION SERVICES, NAMELY, PROVIDING BACK OFFICE SERVICES FOR PHYSICIAN PRACTICES, MEDICAL BILLING SERVICES; MANAGED HEALTH CARE SERVICES, NAMELY, ELECTRONIC PROCESSING OF HEALTH CARE INFORMATION; PROVIDING INFORMATION IN THE FIELD OF BUSINESS ADMINISTRATION OF HEALTH CARE AND MEDICAL PRACTICES; CONSULTATION IN THE FIELD OF MANAGEMENT, OPERATION, AND DEVELOPMENT OF BUSINESS SYSTEMS FOR THE DELIVERY OF HEALTH CARE; HEALTHCARE MANAGEMENT SERVICE ORGANIZATION (MSO) SERVICES, NAMELY, PROVIDING PRACTICE ORGANIZATION, MANAGEMENT AND ADMINISTRATIVE SUPPORT SERVICES TO INDIVIDUAL PHYSICIANS OR SMALL GROUP PRACTICES (U.S. CLS. 100, 101 AND 102).

**CLASS 42—SCIENTIFIC AND COMPUTER SERVICES**

FOR HEALTH CARE AND MEDICAL BUSINESS SERVICES, NAMELY, DEVELOPMENT OF ONLINE COMPUTER SOFTWARE SYSTEMS FOR HEALTH CARE DELIVERY BETWEEN BUSINESSES; INFORMATION TECHNOLOGY SUPPORT SERVICES IN THE NATURE OF PROVIDING SUPPORT TO PHYSICIANS AND PATIENTS BY MEANS OF A WEBSITE FEATURING TEMPORARY USE OF ONLINE NON-DOWNLOADABLE SOFTWARE FOR USE IN ACCESSING ELECTRONIC HEALTH RECORDS, EXCHANGING HEALTH INFORMATION, AND CLAIMS PROCESSING IN THE FIELD OF TELEMEDICINE (U.S. CLS. 100 AND 101).

**CLASS 44—MEDICAL, BEAUTY AND AGRICULTURAL SERVICES**

FOR PROVIDING INFORMATION IN THE FIELD OF HEALTH CARE (U.S. CLS. 100 AND 101).  
LAURA HAMMEL, EXAMINING ATTORNEY

SN 77-926,567. ADVANSTAR COMMUNICATIONS INC., DULUTH, MN. FILED 2-3-2010.

**LICENSING INTERNATIONAL EXPO**

THE MARK CONSISTS OF STANDARD CHARACTERS WITHOUT CLAIM TO ANY PARTICULAR FONT, STYLE, SIZE, OR COLOR.

OWNER OF U.S. REG. NO. 2,985,276.  
NO CLAIM IS MADE TO THE EXCLUSIVE RIGHT TO USE "EXPO", APART FROM THE MARK AS SHOWN.  
SEC. 2(F).

**CLASS 35—ADVERTISING AND BUSINESS**

FOR ARRANGING AND CONDUCTING TRADE SHOWS IN THE FIELDS OF MERCHANDISING AND ACQUISITION OF INTELLECTUAL PROPERTY RIGHTS FOR CONSUMER PRODUCT MANUFACTURERS, RETAILERS AND MARKETERS (U.S. CLS. 100, 101 AND 102).

FIRST USE 6-19-2007; IN COMMERCE 6-19-2007.

**CLASS 41—EDUCATION AND ENTERTAINMENT**

FOR ARRANGING AND CONDUCTING EDUCATIONAL CONFERENCES IN THE FIELDS OF MERCHANDISING AND ACQUISITION OF INTELLECTUAL PROPERTY RIGHTS FOR CONSUMER PRODUCT MANUFACTURERS, RETAILERS AND MARKETERS (U.S. CLS. 100, 101 AND 107).

FIRST USE 6-19-2007; IN COMMERCE 6-19-2007.  
INGA ERVIN, EXAMINING ATTORNEY

SN 77-929,140. GUSTAV WIEGARD MASCHINENFABRIK GMBH & CO. KG, WITTEN, FED REP GERMANY, FILED 2-5-2010.



THE MARK CONSISTS OF A STYLIZED LETTER "G" ABOVE A STYLIZED OVERSIZED LETTER "W" INSIDE A CIRCLE.

#### CLASS 6—METAL GOODS

FOR GOODS OF METAL, NAMELY, METAL ROLLERS, NOT BEING MACHINE PARTS, FOR USE WITH CONTINUOUS CASTING INSTALLATIONS (U.S. CLS. 2, 12, 13, 14, 23, 25 AND 50).

#### CLASS 7—MACHINERY

FOR METALWORKING MACHINES, NAMELY, SHROUDING TUBE MANIPULATORS; GEARS, NAMELY, SPECIAL GEARS MACHINES AND REPLACEMENT GEAR COMPONENTS BEING MACHINE PARTS; METAL ROLLERS BEING PARTS OF HOT-ROLLING MILLS; METAL ROLLERS BEING PARTS OF COLD-ROLLING MILLS; METAL MACHINE PARTS, NAMELY, REEL SHAFTS, GRIPPED JAWS, V-LEDGES, TIE RODS, TENSION CROSSES, DRIVE ELEMENTS, PRESSURE SPINDLES, COUPLING HEADS, ARTICULATED SPINDLE HEADS, DRIVE SPINDLES; METAL GEAR PARTS BEING MACHINE PARTS; TOOTHED WHEELS OF METAL BEING MACHINE PARTS; METAL GEAR SHAFTS BEING PARTS OF MACHINES; METAL PINION GEARS BEING PARTS OF MACHINES; METAL TOOTHED SPINDLES BEING PARTS OF MACHINES; METAL TOOTHED COUPLINGS BEING PARTS OF MACHINES; METAL BEVEL WHEELS BEING PARTS OF MACHINES; METAL GEAR RACKS BEING PARTS OF MACHINES; METAL WORM WHEELS BEING MACHINE PARTS; METAL WORM SHAFTS BEING PARTS OF MACHINES; METAL CROWNED TOOTHED HUBS BEING PARTS OF MACHINES; METAL GEAR SLEEVES BEING PARTS OF MACHINES; METAL WOBBLERS BEING PARTS OF MACHINES; METAL HOUSINGS BEING MACHINE PARTS; METAL ROLLERS BEING MACHINE PARTS FOR HOT-ROLLING MILLS AND COLD-ROLLING MILLS; METAL MANDRELS BEING MACHINE PARTS FOR HOT-ROLLING MILLS, COLD-ROLLING MILLS, AND CONTINUOUS CASTING INSTALLATIONS; METAL MANDREL SEGMENTS BEING COMPONENT PARTS OF MANDRELS FOR USE AS PARTS OF HOT-ROLLING MILLS, COLD-ROLLING MILLS, AND CONTINUOUS CASTING INSTALLATIONS; MACHINE PARTS IN THE NATURE OF METAL PINION GEAR PARTS, NAMELY, PINIONS, TOOTHED WHEELS FOR INDUSTRIAL MACHINES; MACHINE PARTS, NAMELY, METAL MANDREL PARTS (U.S. CLS. 13, 19, 21, 23, 31, 34 AND 35).

#### CLASS 37—CONSTRUCTION AND REPAIR

FOR REPAIR, NAMELY, REPAIR OF ROLLERS AND COMPONENTS BEING PARTS OF INDUSTRIAL MACHINES, REFURBISHMENT OF GEARS AND COMPONENTS THEREFOR FOR INDUSTRIAL MACHINES, REPAIR OF COMPLETE MANDRELS AND COMPONENTS THEREFOR, REPAIR OF FITTED PARTS FOR INDUSTRIAL MACHINES AND DRIVE CHAINS FOR INDUSTRIAL MACHINES; DEEP HOLE DRILLING, NAMELY, IN METAL (U.S. CLS. 100, 103 AND 106).

#### CLASS 40—MATERIAL TREATMENT

FOR TREATMENT OF MATERIALS, NAMELY, TURNING FOR CUTTING OF METAL PARTS, MILLING OF METAL PARTS, HOBBING BEING CUTTING OF GEARS, GRINDING, PROFILE GRINDING OF GEAR TEETH, GEAR CUTTING, SLOTTING BEING CUTTING OF GEARS, PROFILE SLOTTING BEING CUTTING OF PROFILES FOR GEARS, HEAT TREATMENT OF METAL PARTS, ANNEALING, NORMALIZING BEING HEAT TREATMENT OF METAL PARTS, HARDENING BEING THE HEAT TREATMENT OF METAL PARTS, WELDING, CONTRACT WELDING, SUBMERGED ARC WELDING, MIG WELDING, MAG WELDING, OPEN ARC PENDULUM WIRE WELDING, POWDER FLAME SPRAYING OF COATINGS TO METAL PARTS, WIRE FLAME SPRAYING OF COATINGS TO METAL PARTS, SINTERING BEING HEAT TREATMENT OF METAL PARTS; CUSTOM CONSTRUCTION OF INDUSTRIAL MACHINES TO THE ORDER AND SPECIFICATION OF OTHERS; APPLICATION OF THERMAL COATINGS (U.S. CLS. 100, 103 AND 106).

#### CLASS 42—SCIENTIFIC AND COMPUTER SERVICES

FOR ENGINEERING, NAMELY, CALCULATION OF GEARING GEOMETRY, GEAR CALCULATION, HOUSING MEASUREMENT, CONSTRUCTION DRAFTING, MATERIAL TESTING, QUALITY CONTROL, TECHNICAL PLANNING, NAMELY, FOR INDUSTRIAL MACHINES, TECHNICAL PROJECT STUDIES IN THE FIELD OF ENGINEERING, AND MATERIAL TESTING (U.S. CLS. 100 AND 101).

DEBRA LEE, EXAMINING ATTORNEY

SN 77-938,139. THE CARNEGIE FOUNDATION FOR THE ADVANCEMENT OF TEACHING, STANFORD, CA. FILED 2-17-2010.

STATWAY

THE MARK CONSISTS OF STANDARD CHARACTERS WITHOUT CLAIM TO ANY PARTICULAR FONT, STYLE, SIZE, OR COLOR.



**CLASS 41—EDUCATION AND ENTERTAINMENT**

FOR EDUCATIONAL SERVICES, NAMELY, DEVELOPING CURRICULA FOR EDUCATORS WHO TEACH STATISTICS AND MATHEMATICS, COLLABORATIVELY DEVELOPING INTRODUCTORY STATISTICS INSTRUCTIONAL SEQUENCES FOR ENABLING COLLEGE AND OTHER STUDENTS AT THE DEVELOPMENTAL MATHEMATICS LEVEL TO OBTAIN COLLEGE CREDIT IN A SINGLE YEAR; PROVIDING EDUCATIONAL INFORMATION ON ACADEMIC SKILLS NEEDED FOR SUCCESS IN COLLEGE AND UNIVERSITY INSTITUTIONS; PROVIDING A DATABASE OF INFORMATION ABOUT STUDENT PERFORMANCE ON THE INSTRUCTIONAL SEQUENCES THAT CAN BE USED FOR IMPROVING TEACHING PRACTICES AND EDUCATION IN THE FIELDS OF STATISTICS AND MATHEMATICS (U.S. CLS. 100, 101 AND 107).

**CLASS 42—SCIENTIFIC AND COMPUTER SERVICES**

FOR RESEARCH AND DEVELOPMENT OF LEARNING TECHNOLOGIES AND TEACHING METHODS IN THE FIELDS OF STATISTICS AND MATHEMATICS (U.S. CLS. 100 AND 101).

**CLASS 45—PERSONAL AND LEGAL SERVICES**

FOR PROVIDING INFORMATION ON MOTIVATIONAL SKILLS NEEDED FOR SUCCESS IN COLLEGE AND UNIVERSITY INSTITUTIONS (U.S. CLS. 100 AND 101).

KELLY CHOE, EXAMINING ATTORNEY

SN 77-947,674. THURMOND, MICHAEL, SANTA MONICA, CA. FILED 3-1-2010.

---

**MICHAEL THURMOND'S  
COSMETIC FITNESS**

THE MARK CONSISTS OF STANDARD CHARACTERS WITHOUT CLAIM TO ANY PARTICULAR FONT, STYLE, SIZE, OR COLOR.

OWNER OF U.S. REG. NO. 3,073,189.

NO CLAIM IS MADE TO THE EXCLUSIVE RIGHT TO USE "COSMETIC FITNESS", APART FROM THE MARK AS SHOWN.

THE NAME(S), PORTRAIT(S), AND/OR SIGNATURE(S) SHOWN IN THE MARK IDENTIFIES "MICHAEL THURMOND", WHOSE CONSENT(S) TO REGISTER IS MADE OF RECORD.

**CLASS 41—EDUCATION AND ENTERTAINMENT**

FOR PHYSICAL FITNESS CONSULTATION SERVICES (U.S. CLS. 100, 101 AND 107).

**CLASS 44—MEDICAL, BEAUTY AND AGRICULTURAL SERVICES**

FOR WEIGHT REDUCTION DIET PLANNING AND SUPERVISION SERVICES (U.S. CLS. 100 AND 101).

SARA BENJAMIN, EXAMINING ATTORNEY

SN 77-948,269. MICHAEL A. ADAMS, TUSCON, AZ. FILED 3-2-2010.

**HEALTH RANGER**

THE MARK CONSISTS OF STANDARD CHARACTERS WITHOUT CLAIM TO ANY PARTICULAR FONT, STYLE, SIZE, OR COLOR.

NO CLAIM IS MADE TO THE EXCLUSIVE RIGHT TO USE "HEALTH", APART FROM THE MARK AS SHOWN.

**CLASS 35—ADVERTISING AND BUSINESS**

FOR PROVIDING CONSUMER INFORMATION AND RELATED NEWS IN THE FIELD OF NATURAL HEALTH AND NATURAL LIVING; PROMOTING HEALTH AND ENVIRONMENTAL AWARENESS WITHIN PEOPLE SO THAT THEY CAN LEAD A HEALTHY LIFE; PROMOTING THE INTERESTS OF PEOPLE CONCERNED WITH HEALTH, COMMUNITY AND ENVIRONMENTAL SUSTAINABILITY ISSUES; PROVIDING CONSUMER PRODUCT REVIEWS, NAMELY, REVIEWING HEALTHY LIVING AND GREEN LIVING PRODUCTS (U.S. CLS. 100, 101 AND 102).

FIRST USE 7-9-2005; IN COMMERCE 7-9-2005.

**CLASS 39—TRANSPORTATION AND STORAGE**

FOR PROVIDING INFORMATION IN THE FIELD OF TRAVEL, NAMELY, REPORTING HEALTH-RELATED TRIPS AND HEALTH-RELATED ADVENTURES (U.S. CLS. 100 AND 105).

FIRST USE 7-9-2005; IN COMMERCE 7-9-2005.

**CLASS 42—SCIENTIFIC AND COMPUTER SERVICES**

FOR PROVIDING A WEBSITE FEATURING INFORMATION ON THE ENVIRONMENT, NAMELY, TECHNOLOGICAL INFORMATION ABOUT ENVIRONMENTALLY-CONSCIOUS AND GREEN INNOVATIONS (U.S. CLS. 100 AND 101).

FIRST USE 7-9-2005; IN COMMERCE 7-9-2005.

**CLASS 44—MEDICAL, BEAUTY AND AGRICULTURAL SERVICES**

FOR PROVIDING A WEBSITE FEATURING INFORMATION ON HEALTH, NUTRITION, ALTERNATIVE HEALTH AND HEALING (U.S. CLS. 100 AND 101).

FIRST USE 7-9-2005; IN COMMERCE 7-9-2005.

KRISTIN DAHLING, EXAMINING ATTORNEY

SN 77-949,781. WEIR MINERALS AUSTRALIA LIMITED, ARTARMON, NSW, AUSTRALIA, FILED 3-3-2010.

---

**HYDRAU-FLO**

THE MARK CONSISTS OF STANDARD CHARACTERS WITHOUT CLAIM TO ANY PARTICULAR FONT, STYLE, SIZE, OR COLOR.

OWNER OF AUSTRALIA REG. NO. 814770, DATED 11-22-1999, EXPIRES 11-22-2019.

**CLASS 6—METAL GOODS**

FOR METAL PIPE COUPLINGS AND CONNECTORS FOR FLUIDS, FOR USE WITH INCORPORATING CONTROL VALVES FOR REGULATING THE FLOW OF GASES AND LIQUID AND FOR PRESSURE RELIEF OR PRESSURE REGULATOR VALVES IN REFUELING DEVICES IN THE MINING AND TRANSPORTATION INDUSTRIES, ALL NOT BEING PARTS OF MACHINES (U.S. CLS. 2, 12, 13, 14, 23, 25 AND 50).

**CLASS 9—ELECTRICAL AND SCIENTIFIC APPARATUS**

FOR CONTROL VALVES FOR REGULATING THE FLOW OF GASES AND LIQUIDS IN REFUELING DEVICES IN THE MINING AND TRANSPORTATION INDUSTRIES, NOT BEING PARTS OF MACHINES; VALVES FOR REGULATING THE FLOW OF GASES OR LIQUIDS IN REFUELING DEVICES IN THE MINING AND TRANSPORTATION INDUSTRIES, NOT BEING PARTS OF MACHINES; PRESSURE RELIEF VALVES AND PRESSURE REGULATING VALVES FOR RELIEVING OR REGULATING THE PRESSURES OF GASES OR FLUIDS IN CONTAINERS IN REFUELING DEVICES IN THE MINING AND TRANSPORTATION INDUSTRIES, NOT BEING PARTS OF MACHINES; FLUID LEVEL SENSORS AND FLUID LEVEL MONITORS FOR DETERMINING THE LEVEL OF FLUID IN A FLUID CONTAINER IN REFUELING DEVICES IN THE MINING AND TRANSPORTATION INDUSTRIES (U.S. CLS. 21, 23, 26, 36 AND 38).

MARY BOAGNI, EXAMINING ATTORNEY

SN 77-949,859. BEAUTISOL, LLC, SAN FRANCISCO, CA. FILED 3-3-2010.



THE MARK CONSISTS OF A FANCIFUL DESIGN OF THE LETTERS "B" AND "S" THAT APPEAR INSIDE A CIRCLE AND THE WORD "BEAUTISOL".

**CLASS 3—COSMETICS AND CLEANING PREPARATIONS**

FOR NON-MEDICATED SKIN CARE PREPARATIONS; SELF-TANNING PREPARATIONS; FACIAL AND BODY SCRUBS; NON-MEDICATED SUN CARE PREPARATIONS; COSMETICS; SKIN BRONZERS; PROTECTIVE LIP GLOSSES AND GELS (U.S. CLS. 1, 4, 6, 50, 51 AND 52).

FIRST USE 4-18-2010; IN COMMERCE 4-18-2010.

**CLASS 9—ELECTRICAL AND SCIENTIFIC APPARATUS**

FOR PRE-RECORDED ELECTRONIC AND DIGITAL MEDIA FEATURING INSTRUCTIONS ON APPLYING SELF-TANNING PREPARATIONS AND MAINTAINING A SUNLESS TAN, CARING FOR SKIN AND APPLYING MAKEUP (U.S. CLS. 21, 23, 26, 36 AND 38).

FIRST USE 4-18-2010; IN COMMERCE 4-18-2010.

**CLASS 21—HOUSEWARES AND GLASS**

FOR EXFOLIATING GLOVES AND MITTS; APPLICATORS, NAMELY, FOLDABLE AND NON-FOLDABLE WANDS FEATURING REMOVABLE AND REPLACEMENT PADS FOR APPLYING SELF-TANNING PREPARATIONS (U.S. CLS. 2, 13, 23, 29, 30, 33, 40 AND 50).

FIRST USE 4-18-2010; IN COMMERCE 4-18-2010.

**CLASS 35—ADVERTISING AND BUSINESS**

FOR RETAIL STORE AND ONLINE RETAIL STORE SERVICES FEATURING SELF-TANNING PREPARATIONS AND RELATED PRODUCTS, NON-MEDICATED SUN CARE PREPARATIONS, NON-MEDICATED SKIN CARE PREPARATIONS AND COSMETICS (U.S. CLS. 100, 101 AND 102).

FIRST USE 4-18-2010; IN COMMERCE 4-18-2010.

**CLASS 44—MEDICAL, BEAUTY AND AGRICULTURAL SERVICES**

FOR PROVIDING ONLINE VIDEOS AND PHOTOS ON SELF-TANNING, SUNLESS TAN MAINTENANCE, APPLYING COSMETICS AND CARING FOR SKIN; PROVIDING INFORMATION IN THE FIELDS OF SUNLESS TANNING, SKIN CARE AND MAKEUP; SELF-TANNING, MAKEUP AND SKIN CARE INSTRUCTION; EDUCATIONAL SERVICES, NAMELY, PROVIDING LIVE DEMONSTRATIONS IN THE FIELDS OF SELF-TANNING, SKIN CARE AND MAKEUP APPLICATION (U.S. CLS. 100 AND 101).

FIRST USE 4-18-2010; IN COMMERCE 4-18-2010.

ALICIA COLLINS, EXAMINING ATTORNEY

SN 77-950,288. SUNGARD HIGHER EDUCATION INC., WILMINGTON, DE. FILED 3-4-2010.

OPEN MYND

THE MARK CONSISTS OF STANDARD CHARACTERS WITHOUT CLAIM TO ANY PARTICULAR FONT, STYLE, SIZE, OR COLOR.

**CLASS 9—ELECTRICAL AND SCIENTIFIC APPARATUS**

FOR COMPUTER SOFTWARE FOR USE BY COLLEGES AND UNIVERSITIES, NAMELY, SOFTWARE USED BY HIGHER EDUCATION ADMINISTRATORS, INSTRUCTORS AND STUDENTS TO ACCESS INSTRUCTIONAL TOOLS, COURSE MATERIALS AND RESOURCE MATERIALS (U.S. CLS. 21, 23, 26, 36 AND 38).

**CLASS 42—SCIENTIFIC AND COMPUTER SERVICES**

FOR APPLICATION SERVICE PROVIDER (ASP) FEATURING COMPUTER SOFTWARE FOR USE BY COLLEGES AND UNIVERSITIES, NAMELY, SOFTWARE USED BY HIGHER EDUCATION ADMINISTRATORS, INSTRUCTORS AND STUDENTS TO ACCESS INSTRUCTIONAL TOOLS, COURSE MATERIALS AND RESOURCE MATERIALS (U.S. CLS. 100 AND 101).

VIVIAN MICZNIK FIRST, EXAMINING ATTORNEY

SN 77-952,113. BBEAUTIFUL LLC, AZUSA, CA. FILED 3-5-2010.

# LASH' EM

THE MARK CONSISTS OF STANDARD CHARACTERS WITHOUT CLAIM TO ANY PARTICULAR FONT, STYLE, SIZE, OR COLOR.

NO CLAIM IS MADE TO THE EXCLUSIVE RIGHT TO USE "LASH", APART FROM THE MARK AS SHOWN.

### CLASS 3—COSMETICS AND CLEANING PREPARATIONS

FOR COSMETICS, NAMELY, NON-MEDICATED EYELASH SERUM, EYE CREAMS, EYE GELS (U.S. CLS. 1, 4, 6, 50, 51 AND 52).

### CLASS 5—PHARMACEUTICALS

FOR MEDICATED EYELASH SERUM (U.S. CLS. 6, 18, 44, 46, 51 AND 52).

STEVEN R. FINE, EXAMINING ATTORNEY

SN 77-954,488. VEDIC BROADCASTING LIMITED, HARDWAR (UTTRAKHAND), INDIA, FILED 3-9-2010.

# AASTHA

THE MARK CONSISTS OF STANDARD CHARACTERS WITHOUT CLAIM TO ANY PARTICULAR FONT, STYLE, SIZE, OR COLOR.

PRIORITY CLAIMED UNDER SEC. 44(D) ON ERPNCMNTY TM OFC APPLICATION NO. 008935868, FILED 3-8-2010, REG. NO. 008935868, DATED 10-22-2010, EXPIRES 3-8-2020.

THE WORD "AASTHA" HAS NO FIXED MEANING IN A FOREIGN LANGUAGE.

### CLASS 9—ELECTRICAL AND SCIENTIFIC APPARATUS

FOR (BASED ON 44(E)) DOWNLOADABLE ELECTRONIC PUBLICATIONS PROVIDED ON-LINE FROM DATABASES OR THE INTERNET IN THE NATURE OF NEWSLETTERS, BOOKS, MANUALS, MAGAZINES AND WORKSHEETS IN THE FIELD OF GUIDES TO SPIRITUALITY, RELIGION AND TELEVISION PROGRAMS; PRE-RECORDED VIDEO CASSETTES, DVDS, VIDEO DISKS FEATURING TELEVISION PROGRAMS AND MOTION PICTURE FILMS FEATURING EDUCATIONAL PROGRAMMING IN THE FIELD OF RELIGION AND SPIRITUALITY; PRE-RECORDED AUDIO CASSETTES, TAPES AND COMPACT DISKS FEATURING YOGA INSTRUCTION IN THE FIELD OF RELIGION AND SPIRITUALITY, MUSIC AND WELL BEING; COMPUTER SOFTWARE FEATURING EDUCATIONAL MATTER IN THE FIELD OF YOGA, RELIGION, SPIRITUALITY AND WELL BEING; PRE-RECORDED CD-ROMS WITH SOFTWARE FOR DEVISING PROGRAMS IN THE FIELD OF SPIRITUALITY, YOGA, RELIGION AND WELL BEING; MOUSEPADS; DOWNLOADABLE DIGITAL MUSIC PROVIDED FROM MP3 INTERNET WEBSITES; DOWNLOADABLE SOFTWARE FOR USE IN VIEWING AND RECORDING TELEVISION PROGRAMS BROADCAST VIA A GLOBAL COMPUTER NETWORK, CABLE, SATELLITE AND OTHER WIRELESS COMMUNICATIONS (U.S. CLS. 21, 23, 26, 36 AND 38).

### CLASS 16—PAPER GOODS AND PRINTED MATTER

FOR (BASED ON 44(E)) PRINTED MATTER, NAMELY, INSTRUCTIONAL AND TEACHING MATERIALS AND MANUALS IN THE FIELD OF YOGA, SPIRITUALITY, RELIGION AND WELL BEING; TELEVISION PROGRAM GUIDES, POSTERS, POSTCARDS, CALENDARS, ADDRESS BOOKS, DIARIES, YOGA CHARTS, WORKSHEETS; PUBLICATIONS, NAMELY, NEWSPAPERS, MAGAZINES IN THE FIELD OF RELIGION, YOGA, SPIRITUALITY AND WELL BEING; BOOKS IN THE FIELD OF RELIGION, YOGA, SPIRITUALITY AND WELL BEING; NEWSLETTERS IN THE FIELD OF RELIGION, YOGA, SPIRITUALITY AND WELL BEING; PERIODICALS IN THE FIELD OF RELIGION, YOGA, SPIRITUALITY AND WELL BEING; PHOTOGRAPHS; STATIONERY; PENS; PENCILS; EDUCATION PACKS COMPRISING PRINTED MATTER IN THE NATURE OF WORKBOOKS, TEACHER GUIDES, MANUALS AND EDUCATIONAL BOOKLETS IN THE FIELD OF RELIGION, YOGA, SPIRITUALITY AND WELL BEING; COASTERS MADE OF PAPER (U.S. CLS. 2, 5, 22, 23, 29, 37, 38 AND 50).

### CLASS 35—ADVERTISING AND BUSINESS

FOR (BASED ON 44(E)) ADVERTISING AND PROMOTIONAL SERVICES; RENTAL OF ADVERTISING SPACE; TELEVISION ADVERTISING; PRODUCTION OF TELEVISION COMMERCIALS; MAGAZINE AND NEWSPAPER SUBSCRIPTIONS; MARKETING SERVICES, NAMELY, PROMOTING THE TELEVISION PROGRAMS AND FILMS OF OTHERS; PREPARATION, DISSEMINATION AND UPDATING OF ADVERTISING MATERIAL FOR USE AS WEB PAGES ON THE INTERNET OR OTHERWISE; ADVERTISING SERVICES BY MEANS OF TELEVISION SCREEN BASED TEXT; PROVIDING INFORMATION, ADVISORY AND CONSULTANCY SERVICES RELATING TO ALL THE AFORESAID SERVICES (U.S. CLS. 100, 101 AND 102).

### CLASS 38—COMMUNICATION

FOR (BASED ON USE IN COMMERCE) (BASED ON 44(E)) TELECOMMUNICATIONS SERVICES, NAMELY, PROVIDING MULTIPLE USER ACCESS TO A GLOBAL COMPUTER NETWORK, GATEWAY SERVICES, TRANSMISSION OF VOICE, DATA, GRAPHICS, SOUND AND VIDEO BY MEANS OF BROADBAND POWER LINE AND WIRELESS NETWORKS; COMMUNICATIONS SERVICES, NAMELY, TRANSMISSION OF VOICE, AUDIO, VISUAL IMAGES AND DATA BY TELECOMMUNICATIONS NETWORKS, WIRELESS COMMUNICATIONS NETWORKS, THE INTERNET, INFORMATION SERVICES AND DATA NETWORKS, SA-

TELLITE COMMUNICATION SERVICES; BROADCASTING AND/OR TRANSMISSION OF NETWORK TELEVISION, CABLE TELEVISION, AND SATELLITE TELEVISION PROGRAMS; BROADCASTING AND/OR TRANSMISSION OF AUDIOVISUAL PROGRAMMING OVER THE INTERNET; BROADCASTING AND/OR TRANSMISSION OF TEXT, MESSAGES, SOUND AND/OR PICTURES; PROVIDING ACCESS TO MOVIES, VIDEOS AND TELEVISION PROGRAMMES TO VIEWERS ON DEMAND OR NEAR ON DEMAND; TELEVISION SCREEN-BASED INFORMATION BROADCASTING AND RETRIEVAL SERVICES; TRANSMISSION OF INFORMATION, COMPUTER PROGRAMS AND OTHER DATA VIA ELECTRONIC COMMUNICATIONS NETWORKS; COMPUTER AIDED TRANSMISSION OF MESSAGES AND/OR IMAGES; ELECTRONIC COMMUNICATION SERVICES, NAMELY, TRANSMISSION OF VOICE, AUDIO, VISUAL IMAGES AND DATA BY TELECOMMUNICATIONS NETWORKS, WIRELESS COMMUNICATIONS NETWORKS, THE INTERNET AND SATELLITE COMMUNICATIONS SERVICES; VIDEO TEXT AND TELETXT SERVICES; NEWS AGENCY SERVICES, NAMELY, THE TRANSMISSION OF NEWS ITEMS TO NEWS REPORTING ORGANISATIONS; INFORMATION AND ADVISORY SERVICES RELATING TO THE AFORESAID; TEXTING SERVICES, NAMELY, TEXT AND NUMERIC WIRELESS DIGITAL MESSAGING SERVICES; PROVIDING SMS, OR SHORT MESSAGE TRANSMISSION SERVICES; AUDIO RELAY SERVICES, NAMELY, PROVIDING RELAY OF SOUND FROM ONE ROOM TO ANOTHER; PROVIDING ONLINE CHAT ROOMS FOR THE TRANSMISSION OF MESSAGES AMONGST COMPUTER USERS CONCERNING RELIGION, SPIRITUALITY, YOGA AND WELL BEING; INFORMATION PROVIDED ON-LINE FROM A COMPUTER DATABASE OR THE INTERNET IN THE FIELDS OF TELECOMMUNICATIONS; STREAMING OF RELIGIOUS, SPIRITUAL, YOGA AND CULTURAL TELEVISION PROGRAMS VIA A WEBSITE (U.S. CLS. 100, 101 AND 104).

FIRST USE 6-18-2000; IN COMMERCE 12-9-2004.

#### **CLASS 41—EDUCATION AND ENTERTAINMENT**

FOR (BASED ON USE IN COMMERCE) (BASED ON 44(E)) ENTERTAINMENT IN THE NATURE OF ONGOING VARIETY, NEWS, MUSIC, RELIGIOUS, SPIRITUAL, EXERCISE AND CULTURAL PROGRAMS BROADCAST OVER NETWORK TELEVISION, CABLE TELEVISION, SATELLITE TELEVISION, THE INTERNET AND RADIO; PROVIDING INFORMATION ABOUT RELIGIOUS, SPIRITUAL, AND CULTURAL TELEVISION PROGRAMS, TELEVISION PROGRAMMING AND TELEVISION PROGRAM SCHEDULING, ALL PROVIDED VIA A WEBSITE; PRODUCTION AND DISTRIBUTION OF TELEVISION PROGRAMMING AND FILMS; DIRECTING AND EDITING OF TELEVISION PROGRAMS; PRODUCTION OF LIVE TELEVISION PROGRAMMES; RENTAL OF FILMS AND TELEVISION PROGRAMMES; EDITING OF TELEVISION PROGRAMMES AND FILMS; PROVIDING AN ONLINE TELEVISION AND FILM VIEWING GUIDE; ORGANIZATION OF EXHIBITIONS FOR CULTURAL, YOGA OR EDUCATIONAL PURPOSES, ORGANIZATION OF EVENTS, FETES, FESTIVALS, PRESENTATIONS, DISPLAYS, AND COMPETITIONS IN THE NATURE OF YOGA, CULTURAL HERITAGE FESTIVALS, PRESENTATION DISPLAYS IN THE FIELD OF RELIGION FOR CULTURAL OR EDUCATIONAL PURPOSES; ARRANGING AND CONDUCTING OF EDUCATIONAL CONFERENCES, CONGRESSES, SEMINARS AND WORKSHOPS; EDUCATION IN THE FIELD OF THE VEDAS, INDIAN CULTURE AND YOGA RENDERED THROUGH CORRESPONDENCE COURSES; PUBLICATION OF ELECTRONIC BOOKS AND JOURNALS ONLINE; PROVIDING NON-DOWNLOADABLE DIGITAL MUSIC FROM THE INTERNET; PROVISION OF NEWS INFORMATION, NAMELY, NEWS SYNDICATION REPORTING, TELEVISION NEWS SHOWS; INFORMATION, ADVISORY AND CONSULTANCY SERVICES RELATING TO ALL THE AFORESAID SERVICES; INFORMATION PROVIDED ON-LINE FROM A COMPUTER DATABASE OR THE INTERNET IN THE FIELD OF CULTURAL EDUCATION (U.S. CLS. 100, 101 AND 107).

FIRST USE 6-18-2000; IN COMMERCE 12-9-2004.

#### **CLASS 42—SCIENTIFIC AND COMPUTER SERVICES**

FOR (BASED ON 44(E)) COMPUTER SERVICES, NAMELY, CREATING AND MAINTAINING WEBSITES FOR OTHERS IN THE NATURE OF CUSTOMISED WEB PAGES FEATURING USER DEFINED INFORMATION, PERSONAL PROFILES AND INFORMATION; COMPUTER SOFTWARE DESIGN AND DEVELOPMENT; WEATHER FORECASTING; CREATING AND MAINTAINING WEBSITES FOR OTHERS; DESIGN SERVICES, NAMELY, COMMERCIAL ART DESIGN; HOSTING SERVICES, NAMELY, HOSTING THE WEBSITES OF OTHERS; PROVIDING INFORMATION AND ADVICE IN THE FIELDS OF COMPUTER SOFTWARE, THE INTERNET AND WEBSITE DEVELOPMENT PROVIDED ONLINE FROM A COMPUTER DATABASE OR FROM THE INTERNET (U.S. CLS. 100 AND 101).

#### **CLASS 45—PERSONAL AND LEGAL SERVICES**

FOR (BASED ON 44(E)) SPIRITUAL ADVICE AND GUIDANCE; COPYRIGHT MANAGEMENT SERVICES RELATING TO FILMS, TELEVISION AND MUSIC; INFORMATION, ADVISORY AND CONSULTANCY SERVICES RELATING TO ALL THE AFORESAID SERVICES; INFORMATION PROVIDED ON-LINE FROM A COMPUTER DATABASE OR THE INTERNET IN THE FIELD OF RELIGION (U.S. CLS. 100 AND 101).

ELLEN BURNS, EXAMINING ATTORNEY

SN 77-954,534. VEDIC BROADCASTING LIMITED, HARDWAR (UTTRAKHAND), INDIA, FILED 3-9-2010.



PRIORITY CLAIMED UNDER SEC. 44(D) ON ERP N CMNTY TM OFC APPLICATION NO. 008935967, FILED 3-8-2010, REG. NO. 008935967, DATED 11-16-2010, EXPIRES 3-8-2020.

THE MARK CONSISTS OF HINDU CHARACTERS FOR THE WORD AASTHA IN THE MIDDLE OF A BROKEN SQUARE DESIGN.

THE NON-LATIN CHARACTERS IN THE MARK TRANSLITERATE TO AASTHA AND THIS HAS NO FIXED MEANING IN A FOREIGN LANGUAGE.



**CLASS 9—ELECTRICAL AND SCIENTIFIC APPARATUS**

FOR (BASED ON 44(E)) DOWNLOADABLE ELECTRONIC PUBLICATIONS PROVIDED ON-LINE FROM DATABASES OR THE INTERNET IN THE NATURE OF NEWSLETTERS, BOOKS, MANUALS, MAGAZINES AND WORKSHEETS IN THE FIELD OF GUIDES TO SPIRITUALITY, RELIGION AND TELEVISION PROGRAMS; PRE-RECORDED VIDEO CASSETTES, DVDS, VIDEO DISKS FEATURING TELEVISION PROGRAMS AND MOTION PICTURE FILMS FEATURING EDUCATIONAL PROGRAMMING IN THE FIELD OF RELIGION AND SPIRITUALITY; PRE-RECORDED AUDIO CASSETTES, TAPES AND COMPACT DISKS FEATURING YOGA INSTRUCTION IN THE FIELD OF RELIGION AND SPIRITUALITY, MUSIC AND WELL BEING; COMPUTER SOFTWARE FEATURING EDUCATIONAL MATTER IN THE FIELD OF YOGA, RELIGION, SPIRITUALITY AND WELL BEING; PRE-RECORDED CDS WITH SOFTWARE FOR DEVISING PROGRAMS IN THE FIELD OF SPIRITUALITY, YOGA, RELIGION AND WELL BEING; MOUSEPADS; DOWNLOADABLE DIGITAL MUSIC PROVIDED FROM MP3 INTERNET WEBSITES; DOWNLOADABLE SOFTWARE FOR USE IN VIEWING AND RECORDING TELEVISION PROGRAMS BROADCAST VIA A GLOBAL COMPUTER NETWORK, CABLE, SATELLITE AND OTHER WIRELESS COMMUNICATIONS (U.S. CLS. 21, 23, 26, 36 AND 38).

**CLASS 16—PAPER GOODS AND PRINTED MATTER**

FOR (BASED ON 44(E)) PRINTED MATTER, NAMELY, INSTRUCTIONAL AND TEACHING MATERIALS AND MANUALS IN THE FIELD OF YOGA, SPIRITUALITY, RELIGION AND WELL BEING; TELEVISION PROGRAM GUIDES, POSTERS, POSTCARDS, CALENDARS, ADDRESS BOOKS, DIARIES, YOGA CHARTS, WORKSHEETS; PUBLICATIONS, NAMELY, NEWSPAPERS, MAGAZINES IN THE FIELD OF RELIGION, YOGA, SPIRITUALITY AND WELL BEING; BOOKS IN THE FIELD OF RELIGION, YOGA, SPIRITUALITY AND WELL BEING; NEWSLETTERS IN THE FIELD OF RELIGION, YOGA, SPIRITUALITY AND WELL BEING; PERIODICALS IN THE FIELD OF RELIGION, YOGA, SPIRITUALITY AND WELL BEING; PHOTOGRAPHS; STATIONERY; PENS; PENCILS; EDUCATION PACKS COMPRISING PRINTED MATTER IN THE NATURE OF WORKBOOKS, TEACHER GUIDES, MANUALS AND EDUCATIONAL BOOKLETS IN THE FIELD OF RELIGION, YOGA, SPIRITUALITY AND WELL BEING; COASTERS MADE OF PAPER (U.S. CLS. 2, 5, 22, 23, 29, 37, 38 AND 50).

**CLASS 35—ADVERTISING AND BUSINESS**

FOR (BASED ON 44(E)) ADVERTISING AND PROMOTIONAL SERVICES; RENTAL OF ADVERTISING SPACE; TELEVISION ADVERTISING; PRODUCTION OF TELEVISION COMMERCIALS; MAGAZINE AND NEWSPAPER SUBSCRIPTIONS; MARKETING SERVICES, NAMELY, PROMOTING THE TELEVISION PROGRAMS AND FILMS OF OTHERS; PREPARATION, DISSEMINATION AND UPDATING OF ADVERTISING MATERIAL FOR USE AS WEB PAGES ON THE INTERNET OR OTHERWISE; ADVERTISING SERVICES BY MEANS OF TELEVISION SCREEN BASED TEXT; PROVIDING INFORMATION, ADVISORY AND CONSULTANCY SERVICES RELATING TO ALL THE AFORESAID SERVICES (U.S. CLS. 100, 101 AND 102).

**CLASS 38—COMMUNICATION**

FOR (BASED ON USE IN COMMERCE) (BASED ON 44(E)) TELECOMMUNICATIONS SERVICES, NAMELY, PROVIDING MULTIPLE USER ACCESS TO A GLOBAL COMPUTER NETWORK, GATEWAY SERVICES, TRANSMISSION OF VOICE, DATA, GRAPHICS, SOUND AND VIDEO BY MEANS OF BROADBAND POWER LINE AND WIRELESS NETWORKS; COMMUNICATIONS SERVICES, NAMELY, TRANSMISSION OF VOICE, AUDIO, VISUAL IMAGES AND DATA BY TELECOMMUNICATIONS NETWORKS, WIRELESS COMMUNICATIONS NETWORKS, THE INTERNET, INFORMATION SERVICES AND DATA NETWORKS, SA-

TELLITE COMMUNICATION SERVICES; BROADCASTING AND/OR TRANSMISSION OF NETWORK TELEVISION, CABLE TELEVISION, AND SATELLITE TELEVISION PROGRAMS; BROADCASTING AND/OR TRANSMISSION OF AUDIOVISUAL PROGRAMMING OVER THE INTERNET; BROADCASTING AND/OR TRANSMISSION OF TEXT, MESSAGES, SOUND AND/OR PICTURES; PROVIDING ACCESS TO MOVIES, VIDEOS AND TELEVISION PROGRAMMES TO VIEWERS ON DEMAND OR NEAR ON DEMAND; TELEVISION SCREEN-BASED INFORMATION BROADCASTING AND RETRIEVAL SERVICES; TRANSMISSION OF INFORMATION, COMPUTER PROGRAMS AND OTHER DATA VIA ELECTRONIC COMMUNICATIONS NETWORKS; COMPUTER AIDED TRANSMISSION OF MESSAGES AND/OR IMAGES; ELECTRONIC COMMUNICATION SERVICES, NAMELY, TRANSMISSION OF VOICE, AUDIO, VISUAL IMAGES AND DATA BY TELECOMMUNICATIONS NETWORKS, WIRELESS COMMUNICATIONS NETWORKS, THE INTERNET AND SATELLITE COMMUNICATIONS SERVICES; VIDEO TEXT AND TELETXT SERVICES; NEWS AGENCY SERVICES, NAMELY, THE TRANSMISSION OF NEWS ITEMS TO NEWS REPORTING ORGANISATIONS; INFORMATION AND ADVISORY SERVICES RELATING TO THE AFORESAID; TEXTING SERVICES, NAMELY, TEXT AND NUMERIC WIRELESS DIGITAL MESSAGING SERVICES; PROVIDING SMS, OR SHORT MESSAGE TRANSMISSION SERVICES; AUDIO RELAY SERVICES, NAMELY, PROVIDING RELAY OF SOUND FROM ONE ROOM TO ANOTHER; PROVIDING ON-LINE CHAT ROOMS FOR THE TRANSMISSION OF MESSAGES AMONGST COMPUTER USERS CONCERNING RELIGION, SPIRITUALITY, YOGA AND WELL BEING; INFORMATION PROVIDED ON-LINE FROM A COMPUTER DATABASE OR THE INTERNET IN THE FIELDS OF TELECOMMUNICATIONS; STREAMING OF RELIGIOUS, SPIRITUAL, YOGA AND CULTURAL TELEVISION PROGRAMS VIA A WEBSITE (U.S. CLS. 100, 101 AND 104).

FIRST USE 6-18-2000; IN COMMERCE 12-9-2004.

**CLASS 41—EDUCATION AND ENTERTAINMENT**

FOR (BASED ON USE IN COMMERCE) (BASED ON 44(E)) ENTERTAINMENT IN THE NATURE OF ONGOING VARIETY, NEWS, MUSIC, RELIGIOUS, SPIRITUAL, EXERCISE AND CULTURAL PROGRAMS BROADCAST OVER NETWORK TELEVISION, CABLE TELEVISION, SATELLITE TELEVISION, THE INTERNET AND RADIO; PROVIDING INFORMATION ABOUT RELIGIOUS, SPIRITUAL, AND CULTURAL TELEVISION PROGRAMS, TELEVISION PROGRAMMING AND TELEVISION PROGRAM SCHEDULING, ALL PROVIDED VIA A WEBSITE; PRODUCTION AND DISTRIBUTION OF TELEVISION PROGRAMMING AND FILMS; DIRECTING AND EDITING OF TELEVISION PROGRAMS; PRODUCTION OF LIVE TELEVISION PROGRAMMES; RENTAL OF FILMS AND TELEVISION PROGRAMMES; EDITING OF TELEVISION PROGRAMMES AND FILMS; PROVIDING AN ONLINE TELEVISION AND FILM VIEWING GUIDE; ORGANIZATION OF EXHIBITIONS FOR CULTURAL, YOGA OR EDUCATIONAL PURPOSES, ORGANIZATION OF EVENTS, FETES, FESTIVALS, PRESENTATIONS, DISPLAYS, AND COMPETITIONS IN THE NATURE OF YOGA, CULTURAL HERITAGE FESTIVALS, PRESENTATION DISPLAYS IN THE FIELD OF RELIGION FOR CULTURAL OR EDUCATIONAL PURPOSES; ARRANGING AND CONDUCTING OF EDUCATIONAL CONFERENCES, CONGRESSES, SEMINARS AND WORKSHOPS; EDUCATION IN THE FIELD OF THE VEDAS, INDIAN CULTURE AND YOGA RENDERED THROUGH CORRESPONDENCE COURSES; PUBLICATION OF ELECTRONIC BOOKS AND JOURNALS ON-LINE; PROVIDING NON-DOWNLOADABLE DIGITAL MUSIC FROM THE INTERNET; PROVISION OF NEWS INFORMATION, NAMELY, NEWS SYNDICATION REPORTING, TELEVISION NEWS SHOWS; INFORMATION, ADVISORY AND CONSULTANCY SERVICES RELATING TO ALL THE AFORESAID SERVICES; INFORMATION PROVIDED ON-LINE FROM A COMPUTER DATABASE OR THE INTERNET IN THE FIELD OF CULTURAL EDUCATION (U.S. CLS. 100, 101 AND 107).

FIRST USE 6-18-2000; IN COMMERCE 12-9-2004.

**CLASS 42—SCIENTIFIC AND COMPUTER SERVICES**

FOR (BASED ON 44(E)) COMPUTER SERVICES, NAMELY, CREATING AND MAINTAINING WEBSITES FOR OTHERS IN THE NATURE OF CUSTOMISED WEB PAGES FEATURING USER DEFINED INFORMATION, PERSONAL PROFILES AND INFORMATION; COMPUTER SOFTWARE DESIGN AND DEVELOPMENT; WEATHER FORECASTING; CREATING AND MAINTAINING WEBSITES FOR OTHERS; DESIGN SERVICES, NAMELY, COMMERCIAL ART DESIGN; HOSTING SERVICES, NAMELY, HOSTING THE WEBSITES OF OTHERS; PROVIDING INFORMATION AND ADVICE IN THE FIELDS OF COMPUTER SOFTWARE, THE INTERNET AND WEBSITE DEVELOPMENT PROVIDED ONLINE FROM A COMPUTER DATABASE OR FROM THE INTERNET (U.S. CLS. 100 AND 101).

**CLASS 45—PERSONAL AND LEGAL SERVICES**

FOR (BASED ON 44(E)) SPIRITUAL ADVICE AND GUIDANCE; COPYRIGHT MANAGEMENT SERVICES RELATING TO FILMS, TELEVISION AND MUSIC; INFORMATION, ADVISORY AND CONSULTANCY SERVICES RELATING TO ALL THE AFORESAID SERVICES; INFORMATION PROVIDED ON-LINE FROM A COMPUTER DATABASE OR THE INTERNET IN THE FIELD OF RELIGION (U.S. CLS. 100 AND 101).

ELLEN BURNS, EXAMINING ATTORNEY

SN 77-956,449. CITIGROUP INC., NEW YORK, NY. FILED 3-11-2010.

CITI INDEPENDENT ADVISOR  
ALLIANCE

THE MARK CONSISTS OF STANDARD CHARACTERS WITHOUT CLAIM TO ANY PARTICULAR FONT, STYLE, SIZE, OR COLOR.

OWNER OF U.S. REG. NOS. 1,181,467, 2,801,076 AND OTHERS.

NO CLAIM IS MADE TO THE EXCLUSIVE RIGHT TO USE "INDEPENDENT ADVISOR ALLIANCE", APART FROM THE MARK AS SHOWN.

**CLASS 35—ADVERTISING AND BUSINESS**

FOR REFERRAL SERVICES IN THE FIELD OF INVESTMENT ADVICE AND FINANCIAL PLANNING (U.S. CLS. 100, 101 AND 102).

**CLASS 36—INSURANCE AND FINANCIAL**

FOR FINANCIAL ADVISORY AND CONSULTANCY SERVICES (U.S. CLS. 100, 101 AND 102).

ALEXANDER L. POWERS, EXAMINING ATTORNEY

SN 77-965,993. SHIELD SECURITY SYSTEMS, L.L.C., DENVER, CO. FILED 3-23-2010.

 **KEYCONTROL**

OWNER OF U.S. REG. NO. 1,836,549.

NO CLAIM IS MADE TO THE EXCLUSIVE RIGHT TO USE "KEY CONTROL", APART FROM THE MARK AS SHOWN.

THE MARK CONSISTS OF A WAFER STACK DESIGN ADJACENT TO THE WORD "KEYCONTROL".

**CLASS 39—TRANSPORTATION AND STORAGE**

FOR DISTRIBUTION SERVICES IN THE NATURE OF DELIVERY TO OTHERS OF ACCESS DEVICES IN THE NATURE OF KEYS, MECHANICAL KEYS, ELECTRONIC KEYS, PIN CODES, SAFE COMBINATIONS, BIOMETRIC IDENTIFICATION SCANNERS, AND FOBS (U.S. CLS. 100 AND 105).

**CLASS 45—PERSONAL AND LEGAL SERVICES**

FOR SECURITY CONSULTANCY SERVICES, NAMELY, CONSULTING SERVICES IN THE FIELD OF ACCESS DEVICES, INCLUDING ACCESS SYSTEMS THAT FEATURE MECHANICAL KEY CONTROLS; DEVELOPMENT, OPERATION, AND ADMINISTRATION OF ACCESS DEVICE SYSTEMS FOR OTHERS, NAMELY, TRACKING AND MONITORING OF ACCESS SYSTEMS FEATURING KEYS, MECHANICAL KEYS, ELECTRONIC KEYS, PIN CODES, SAFE COMBINATION, BIOMETRIC IDENTIFICATION SCANS, OR FOBS, ALL FOR SECURITY PURPOSES (U.S. CLS. 100 AND 101).

KRISTIN DAHLING, EXAMINING ATTORNEY

SN 77-968,101. MICRO CARE CORPORATION, NEW BRITAIN, CT. FILED 3-25-2010.

SPEC CLEAN

THE MARK CONSISTS OF STANDARD CHARACTERS WITHOUT CLAIM TO ANY PARTICULAR FONT, STYLE, SIZE, OR COLOR.

OWNER OF U.S. REG. NO. 2,258,863.

**CLASS 1—CHEMICALS**

FOR DEGREASING PREPARATIONS USED IN MANUFACTURING PROCESSES FOR THE MEDICAL DEVICES, ELECTRONICS, OPTICS AND AEROSPACE INDUSTRIES; CHEMICAL PREPARATIONS, NAMELY, DEGREASING AND CLEANING SOLVENTS FOR THE MEDICAL DEVICES, ELECTRONICS, OPTICS AND AEROSPACE INDUSTRIES (U.S. CLS. 1, 5, 6, 10, 26 AND 46).

FIRST USE 2-9-2010; IN COMMERCE 2-25-2010.

**CLASS 3—COSMETICS AND CLEANING PREPARATIONS**

FOR GENERAL PURPOSE CLEANING LIQUIDS FOR DEGREASING, FLUX REMOVAL AND PRECISION CLEANING IN THE MEDICAL DEVICES, ELECTRONICS, OPTICS AND AEROSPACE INDUSTRIES (U.S. CLS. 1, 4, 6, 50, 51 AND 52).

FIRST USE 2-9-2010; IN COMMERCE 2-25-2010.

BARBARA RUTLAND, EXAMINING ATTORNEY

SN 77-980,479. HERITAGE OPERATING, L.P., TUSLA, OK.  
FILED 11-18-2007.

SN 77-981,623. ROSENBLUM, DANIEL M., BAY SHORE, NY.  
FILED 12-28-2006.



NO CLAIM IS MADE TO THE EXCLUSIVE RIGHT TO USE "PROPANE", APART FROM THE MARK AS SHOWN.  
THE MARK CONSISTS OF THE TERMS "TITAN" AND "PROPANE" WITH AN ARC DESIGN THROUGH THE LETTERS "T", "I", "A" AND "A", ENDING WITH A WHITE CIRCLE IN THE LETTER "N".

#### CLASS 4—LUBRICANTS AND FUELS

FOR ENERGY COMMODITIES, NAMELY, PROPANE GAS (U.S. CLS. 1, 6 AND 15).  
FIRST USE 4-21-2006; IN COMMERCE 4-21-2006.

#### CLASS 35—ADVERTISING AND BUSINESS

FOR RETAIL STORE SERVICES FEATURING FUELS, NAMELY, PROPANE GAS AND FUEL, AND GAS APPLIANCES FOR RESIDENTIAL, COMMERCIAL, INDUSTRIAL AND AGRICULTURAL USES, EXCLUDING GAS OVENS, RANGES AND GRILLS (U.S. CLS. 100, 101 AND 102).  
FIRST USE 4-21-2006; IN COMMERCE 4-21-2006.  
DAVID ELTON, EXAMINING ATTORNEY

SN 77-980,480. HERITAGE OPERATING, L.P., TULSA, OK.  
FILED 11-16-2007.

TITAN

THE MARK CONSISTS OF STANDARD CHARACTERS WITHOUT CLAIM TO ANY PARTICULAR FONT, STYLE, SIZE, OR COLOR.

#### CLASS 4—LUBRICANTS AND FUELS

FOR ENERGY COMMODITIES, NAMELY, PROPANE GAS (U.S. CLS. 1, 6 AND 15).  
FIRST USE 4-21-2006; IN COMMERCE 4-21-2006.

#### CLASS 35—ADVERTISING AND BUSINESS

FOR RETAIL STORE SERVICES FEATURING FUELS, NAMELY, PROPANE GAS AND FUEL, AND GAS APPLIANCES FOR RESIDENTIAL, COMMERCIAL, INDUSTRIAL AND AGRICULTURAL USES, EXCLUDING GAS OVENS, RANGES AND GRILLS (U.S. CLS. 100, 101 AND 102).  
FIRST USE 4-21-2006; IN COMMERCE 4-21-2006.  
DAVID ELTON, EXAMINING ATTORNEY

21st Century Digital

THE MARK CONSISTS OF STANDARD CHARACTERS WITHOUT CLAIM TO ANY PARTICULAR FONT, STYLE, SIZE, OR COLOR.

NO CLAIM IS MADE TO THE EXCLUSIVE RIGHT TO USE "DIGITAL", APART FROM THE MARK AS SHOWN.

#### CLASS 36—INSURANCE AND FINANCIAL

FOR FINANCIAL CONSULTATION; FINANCIAL INFORMATION PROCESSING; FINANCIAL MANAGEMENT; FINANCIAL PLANNING; FINANCIAL PLANNING CONSULTATION; FINANCIAL RESEARCH; FINANCIAL RISK MANAGEMENT; FINANCIAL SERVICES IN THE FIELD OF MONEY LENDING; PROVIDING A WEB SITE WHERE USERS CAN POST RATINGS, REVIEWS AND RECOMMENDATIONS ON STOCKS, BONDS, MUTUAL FUNDS AND OTHER FINANCIAL INSTRUMENTS (U.S. CLS. 100, 101 AND 102).  
FIRST USE 5-1-1996; IN COMMERCE 5-1-1996.

#### CLASS 38—COMMUNICATION

FOR PROVIDING TELECOMMUNICATIONS CONNECTIONS TO A GLOBAL COMPUTER NETWORK; RENTAL OF TELECOMMUNICATION EQUIPMENT; TELECOMMUNICATIONS BY E-MAIL; TELECOMMUNICATIONS CONSULTATION; TELECOMMUNICATIONS SERVICES, NAMELY, PERSONAL COMMUNICATION SERVICES; TRANSFER OF DATA BY TELECOMMUNICATIONS; TRANSMISSION OF DATABASE INFORMATION VIA TELECOMMUNICATIONS NETWORKS; WIRELESS TELEPHONE TELECOMMUNICATIONS SERVICES, NAMELY, WIRELESS MOBILE TELEPHONE CALLING PLANS (U.S. CLS. 100, 101 AND 104).  
FIRST USE 5-1-1996; IN COMMERCE 5-1-1996.  
COLLEEN KEARNEY, EXAMINING ATTORNEY

SN 78-593,833. BOLLYWOOD ON DEMAND, LLC, ORLANDO, FL. FILED 3-23-2005.

BollywoodOnDemand.com

THE MARK CONSISTS OF STANDARD CHARACTERS WITHOUT CLAIM TO ANY PARTICULAR FONT, STYLE, SIZE, OR COLOR.  
SEC. 2(F).

#### CLASS 9—ELECTRICAL AND SCIENTIFIC APPARATUS

FOR DOWNLOADABLE RING TONES, GRAPHICS AND MUSIC VIA A GLOBAL COMPUTER NETWORK AND WIRELESS DEVICES; DOWNLOADABLE FILMS AND TV PROGRAMMES, DOWNLOADABLE AUDIO CONTENTS RELATED TO MUSIC AND FILM FROM INDIA AND THE INDIAN SUB CONTINENT, AND DOWNLOADABLE PRERECORDED MUSIC FROM INDIA AND THE INDIAN SUB CONTINENT (U.S. CLS. 21, 23, 26, 36 AND 38).  
FIRST USE 5-15-2001; IN COMMERCE 5-15-2001.

**CLASS 35—ADVERTISING AND BUSINESS**

FOR ON-LINE RETAIL STORE SERVICES FEATURING DOWNLOADABLE RING TONES (U.S. CLS. 100, 101 AND 102).

FIRST USE 5-15-2001; IN COMMERCE 5-15-2001.

**CLASS 38—COMMUNICATION**

FOR INTERNET BROADCAST OF FILMS, TELEVISION AND OTHER AUDIO AND VIDEO MEDIA PROGRAMS FROM INDIA AND THE INDIAN SUB CONTINENT (U.S. CLS. 100, 101 AND 104).

FIRST USE 5-15-2001; IN COMMERCE 5-15-2001.

**CLASS 41—EDUCATION AND ENTERTAINMENT**

FOR ENTERTAINMENT SERVICES, NAMELY, PROVIDING A WEBSITE FEATURING PROVISION OF NON-DOWNLOADABLE FILMS AND TV PROGRAMMES VIA A VIDEO-ON-DEMAND SERVICE; ENTERTAINMENT SERVICES, NAMELY, PROVIDING A WEBSITE FEATURING NON-DOWNLOADABLE RADIO BROADCAST CONTENTS FROM INDIA AND THE INDIAN SUB CONTINENT; ENTERTAINMENT SERVICES, NAMELY, PROVIDING NON-DOWNLOADABLE PRERECORDED MUSIC, INFORMATION IN THE FIELD OF MUSIC, AND COMMENTARY AND ARTICLES ABOUT MUSIC FROM INDIA AND THE INDIAN SUB CONTINENT, ALL ON-LINE VIA A GLOBAL COMPUTER NETWORK (U.S. CLS. 100, 101 AND 107).

FIRST USE 5-15-2001; IN COMMERCE 5-15-2001.  
ANN E. SAPPENFIELD, EXAMINING ATTORNEY

SN 78-657,195. BIG FISH GAMES, INC., SEATTLE, WA. FILED 6-23-2005.

**BIG FISH GAMES**

THE MARK CONSISTS OF STANDARD CHARACTERS WITHOUT CLAIM TO ANY PARTICULAR FONT, STYLE, SIZE, OR COLOR.

NO CLAIM IS MADE TO THE EXCLUSIVE RIGHT TO USE "GAMES", APART FROM THE MARK AS SHOWN.

**CLASS 9—ELECTRICAL AND SCIENTIFIC APPARATUS**

FOR COMPUTER GAME SOFTWARE; DOWNLOADABLE COMPUTER GAME SOFTWARE (U.S. CLS. 21, 23, 26, 36 AND 38).

FIRST USE 5-9-2002; IN COMMERCE 5-9-2002.

**CLASS 38—COMMUNICATION**

FOR PROVIDING ONLINE CHAT ROOMS FOR TRANSMISSION OF MESSAGES AMONG COMPUTER AND MOBILE COMMUNICATION USERS CONCERNING GAMES (U.S. CLS. 100, 101 AND 104).

FIRST USE 4-1-2005; IN COMMERCE 4-1-2005.

**CLASS 41—EDUCATION AND ENTERTAINMENT**

FOR ENTERTAINMENT SERVICES, NAMELY, PROVIDING ONLINE COMPUTER GAMES (U.S. CLS. 100, 101 AND 107).

FIRST USE 5-9-2002; IN COMMERCE 5-9-2002.

**CLASS 42—SCIENTIFIC AND COMPUTER SERVICES**

FOR DESIGN AND DEVELOPMENT OF COMPUTER GAME SOFTWARE FOR OTHERS (U.S. CLS. 100 AND 101).

FIRST USE 5-9-2002; IN COMMERCE 5-9-2002.  
THEODORE MCBRIDE, EXAMINING ATTORNEY

SN 78-713,289. LRM INDUSTRIES INTERNATIONAL, INC., ROCKLEDGE, FL. FILED 9-15-2005.

**TPF THERMOPLASTIC FLOWFORMING**

THE MARK CONSISTS OF STANDARD CHARACTERS WITHOUT CLAIM TO ANY PARTICULAR FONT, STYLE, SIZE, OR COLOR.

NO CLAIM IS MADE TO THE EXCLUSIVE RIGHT TO USE "THERMOPLASTIC FLOWFORMING", APART FROM THE MARK AS SHOWN.

**CLASS 12—VEHICLES**

FOR APPARATUS FOR LOCOMOTION BY LAND, AIR OR WATER INCLUDING VEHICLES, NAMELY, AUTOMOBILES, TRUCKS, VANS, SPORT UTILITY VEHICLES, TRAILERS, BUSES, CONVERSION VANS, TRAVEL TRAILERS, THEIR STRUCTURAL AND REPLACEMENT PARTS; ENGINES FOR LAND VEHICLES (U.S. CLS. 19, 21, 23, 31, 35 AND 44).

**CLASS 17—RUBBER GOODS**

FOR FINISHED AND SEMI-FINISHED PLASTIC PRODUCTS AND COMPONENT PARTS THEREOF, NAMELY, GLASS FIBER REINFORCED PLASTICS; FINISHED AND SEMI-FINISHED PLASTIC PRODUCTS AND COMPONENT PARTS THEREOF, NAMELY, PLASTICS IN THE FORM OF BARS, BLOCKS, PELLETS, RODS, SHEETS AND TUBES FOR USE IN MANUFACTURING; MOLDED PLASTIC IN THE FORM OF BARS, BLOCKS, PELLETS, RODS, SHEETS AND TUBES FOR USE IN MANUFACTURING; PLASTIC COMPOSITE MATERIAL IN THE FORM OF PROFILES, BOARDS, SHEETS, BLOCKS, RODS, POWDER AND PELLETS FOR USE IN MANUFACTURING (U.S. CLS. 1, 5, 12, 13, 35 AND 50).

**CLASS 19—NON-METALLIC BUILDING MATERIALS**

FOR BUILDING MATERIALS MADE PRINCIPALLY OF PLASTIC, NAMELY, WALL, DECKING, PARTICLE BOARDS AND COMPOSITE BUILDING PANELS, OUTSIDE AND INSIDE COVERING PANELS FOR CONSTRUCTION NOT MADE OF METAL, TUBES AND PIPES MADE OF PLASTIC FOR GENERAL INDUSTRIAL USE, TUBES AND PIPES MADE OF GLASS FIBER REINFORCED PLASTICS FOR GENERAL INDUSTRIAL USE (U.S. CLS. 1, 12, 33 AND 50).

**CLASS 20—FURNITURE AND ARTICLES NOT OTHERWISE CLASSIFIED**

FOR CONTAINERS, NOT OF PRECIOUS METAL FOR INDUSTRIAL AND COMMERCIAL USE; CONTAINERS FOR INDUSTRIAL AND COMMERCIAL LIQUIDS AND CHEMICALS MADE PRIMARILY OF PLASTICS, NOT METAL (U.S. CLS. 2, 13, 22, 25, 32 AND 50).



**CLASS 42—SCIENTIFIC AND COMPUTER SERVICES**

FOR LICENSING OF INTELLECTUAL PROPERTY; DESIGN AND DEVELOPMENT FOR OTHERS OF REINFORCED AND UNREINFORCED PLASTIC PRODUCTS (U.S. CLS. 100 AND 101).

ALEXANDER L. POWERS, EXAMINING ATTORNEY

SN 78-835,180. GAIJIN ENTERTAINMENT CORPORATION, ALEXANDRIA, VA. FILED 3-12-2006.

# Adrenalin

THE MARK CONSISTS OF STANDARD CHARACTERS WITHOUT CLAIM TO ANY PARTICULAR FONT, STYLE, SIZE, OR COLOR.

**CLASS 9—ELECTRICAL AND SCIENTIFIC APPARATUS**

FOR COMPUTER GAME SOFTWARE; ELECTRONIC GAME PROGRAMS; DOWNLOADABLE ELECTRONIC GAME PROGRAMS; ELECTRONIC GAME SOFTWARE; COMPUTER GAME PROGRAMS; DOWNLOADABLE COMPUTER GAME PROGRAMS; INTERACTIVE GAME PROGRAMS; AND INTERACTIVE GAME SOFTWARE (U.S. CLS. 21, 23, 26, 36 AND 38).

**CLASS 41—EDUCATION AND ENTERTAINMENT**

FOR PROVIDING A WEBSITE FEATURING ELECTRONIC GAME CONTENT, INTERACTIVE GAME CONTENT, INFORMATION IN THE FIELD OF COMPUTER GAMES, VIDEO GAMES, COMPUTER GAMES AND ELECTRONIC GAME ENTERTAINMENT; PROVIDING INFORMATION ON-LINE RELATING TO COMPUTER GAMES AND COMPUTER ENHANCEMENTS FOR GAMES; ENTERTAINMENT SERVICES, NAMELY, PROVIDING AN ON-LINE COMPUTER GAME AND ENTERTAINMENT CONTENT IN THE FIELD OF GAMES (U.S. CLS. 100, 101 AND 107).

MICHAEL KEATING, EXAMINING ATTORNEY

SN 78-950,037. AON CAPITAL MARKETS LIMITED, LONDON, UNITED KINGDOM, FILED 8-11-2006.

# RE-EX

THE MARK CONSISTS OF STANDARD CHARACTERS WITHOUT CLAIM TO ANY PARTICULAR FONT, STYLE, SIZE, OR COLOR.

PRIORITY CLAIMED UNDER SEC. 44(D) ON UNITED KINGDOM APPLICATION NO. 2429529, FILED 8-10-2006, REG. NO. 2429529, DATED 3-16-2007, EXPIRES 8-10-2016.

**CLASS 35—ADVERTISING AND BUSINESS**

FOR (BASED SECTION 1(B) AND (BASED ON 44(E) PREPARATION OF TRADING EXCHANGE PRICE INDICES; MAINTAINING RECORDS REGARDING THE TRANSFER OF INDEX FUTURES, STOCK OPTIONS, SECURITIES OPTIONS AND FINANCIAL DERIVATIVES; ALL RELATING TO THE FIELD OF INSURANCE, REINSURANCE AND/OR INSURANCE/REINSURANCE PRODUCTS FOR WEATHER RELATED RISK CONTINGENCIES (U.S. CLS. 100, 101 AND 102).

**CLASS 36—INSURANCE AND FINANCIAL**

FOR (BASED ON SECTION 1(B) FINANCIAL INFORMATION MANAGEMENT AND ANALYSIS SERVICES; TRADING EXCHANGE PRICE QUOTATION AND LISTING SERVICES; SHARE PRICE INFORMATION SERVICES; PROVISIONS OF A FINANCIAL MARKET FOR THE TRADING OF FUTURES, OPTIONS, OVER THE COUNTER CONTRACTS OR OTHER DERIVATIVES IN THE FIELD OF INSURANCE AND RE-INSURANCE; QUOTATION OF TRADING EXCHANGE PRICES AND INDICES, NAMELY, COMMODITY AND STOCK EXCHANGE PRICE QUOTATIONS; AND QUOTATION OF TRADING EXCHANGE PRICES AND INDICES; ALL OF THE AFORESAID SERVICES RELATING TO THE FIELD OF INSURANCE, REINSURANCE, AND/OR INSURANCE/REINSURANCE PRODUCTS FOR WEATHER RELATED RISK CONTINGENCIES (U.S. CLS. 100, 101 AND 102).

ROBIN CHOSID, EXAMINING ATTORNEY

SN 78-958,011. CIPRIANI GROUP INC., NEW YORK, NY. FILED 8-22-2006.



OWNER OF U.S. REG. NOS. 2,330,449, 2,844,146 AND OTHERS.

NO CLAIM IS MADE TO THE EXCLUSIVE RIGHT TO USE "MIAMI", APART FROM THE MARK AS SHOWN.

**CLASS 35—ADVERTISING AND BUSINESS**

FOR APARTMENT, HOME AND CONDOMINIUM SERVICES, NAMELY, PROMOTING THE INTERESTS OF RENTERS AND OWNERS THAT RESIDE IN A COMMUNITY; RESORT HOTEL, CONDOMINIUM AND COOPERATIVE HOUSING SERVICES, NAMELY, PROVIDING FACILITIES FOR BUSINESS MEETINGS (U.S. CLS. 100, 101 AND 102).

**CLASS 36—INSURANCE AND FINANCIAL**

FOR LEASING AND RENTAL OF APARTMENTS, HOMES AND CONDOMINIUMS; REAL ESTATE SERVICES FOR APARTMENTS, HOMES AND CONDOMINIUMS, NAMELY, LISTING, LEASING, FINANCING AND MANAGING COMMERCIAL, RESIDENTIAL AND HOTEL PROPERTIES; REAL ESTATE ACQUISITION, MANAGEMENT, BROKERAGE, APPRAISAL AND CONSULTING SERVICES (U.S. CLS. 100, 101 AND 102).

**CLASS 37—CONSTRUCTION AND REPAIR**

FOR REAL ESTATE DEVELOPMENT SERVICES AND CONSTRUCTION OF COMMERCIAL, RESIDENTIAL AND HOTEL PROPERTIES (U.S. CLS. 100, 103 AND 106).

**CLASS 41—EDUCATION AND ENTERTAINMENT**

FOR HEALTH CLUB SERVICES, NAMELY, PROVIDING INSTRUCTION AND EQUIPMENT IN THE FIELD OF PHYSICAL EXERCISE; ENTERTAINMENT SERVICES, NAMELY, PROVIDING LIVE MUSIC CONCERTS, MUSIC BY DISC JOCKEYS, LIVE PERFORMANCES BY MUSICAL BANDS, PERSONAL APPEARANCES BY PROFESSIONAL ENTERTAINERS, AND ORCHESTRA AND DANCE PERFORMANCES; ART EXHIBITIONS, CONCERT BOOKING; ARRANGING FOR TICKET RESERVATIONS FOR SHOWS AND OTHER ENTERTAINMENT EVENTS; BOOKING OF ENTERTAINMENT HALLS; CASINO AND GAMING SERVICES IN THE NATURE OF GAMBLING SERVICES; GYMNASIUM AND SPORT CENTER SERVICES, NAMELY, PROVIDING SPORTS FACILITIES; RESORT HOTEL, CONDOMINIUM AND COOPERATIVE HOUSING SERVICES, NAMELY, PROVIDING FACILITIES FOR EXERCISE AND RECREATIONAL ACTIVITIES (U.S. CLS. 100, 101 AND 107).

**CLASS 43—HOTEL AND RESTAURANT SERVICES**

FOR RESORT SERVICES, NAMELY, RESORT HOTELS AND RESORT LODGING SERVICES; RESTAURANT, BAR AND COCKTAIL LOUNGE SERVICES; RESTAURANT SERVICES FEATURING MULTIPLE STATIONS FEATURING A VARIETY OF FOOD TYPES; TAKE-OUT RESTAURANT SERVICES; CAFE AND CAFETERIA SERVICES; CATERING SERVICES; PROVIDING FACILITIES FOR EXHIBITIONS; TRAVEL AGENCY SERVICES, NAMELY, MAKING RESERVATIONS AND BOOKINGS FOR TEMPORARY LODGING (U.S. CLS. 100 AND 101).

**CLASS 44—MEDICAL, BEAUTY AND AGRICULTURAL SERVICES**

FOR BEAUTY SALON SERVICES AND HEALTH SPA SERVICES, NAMELY, COSMETIC BODY CARE SERVICES (U.S. CLS. 100 AND 101).

**CLASS 45—PERSONAL AND LEGAL SERVICES**

FOR CONCIERGE SERVICES FOR OTHERS COMPRISING MAKING REQUESTED PERSONAL ARRANGEMENTS AND RESERVATIONS AND PROVIDING CUSTOMER-SPECIFIC INFORMATION TO MEET INDIVIDUAL NEEDS RENDERED TOGETHER IN A RESORT HOTEL AND CONDOMINIUM ENVIRONMENT (U.S. CLS. 100 AND 101).  
JASON LOTT, EXAMINING ATTORNEY

SN 79-029,780. VECTURA DELIVERY DEVICES LIMITED, UNITED KINGDOM, FILED 8-10-2005.

**ASPIRAIR**

THE MARK CONSISTS OF STANDARD CHARACTERS WITHOUT CLAIM TO ANY PARTICULAR FONT, STYLE, SIZE, OR COLOR.  
PRIORITY DATE OF 2-17-2005 IS CLAIMED.

OWNER OF INTERNATIONAL REGISTRATION 0900626 DATED 8-10-2005, EXPIRES 8-10-2015.  
OWNER OF U.S. REG. NO. 2,863,995.

**CLASS 5—PHARMACEUTICALS**

FOR PHARMACEUTICAL PREPARATIONS, SOLD BOTH WITHIN INHALERS AND IN OTHER FORMS, FOR THE PREVENTION OR TREATMENT OF DISEASES OR CONDITIONS OF THE RESPIRATORY AND CARDIOVASCULAR SYSTEMS; PHARMACEUTICAL PREPARATIONS, SOLD BOTH WITHIN INHALERS AND IN OTHER FORMS, FOR THE TREATMENT OF ERECTILE DYSFUNCTION, PREMATURE EJACULATION, CHRONIC OBSTRUCTIVE PULMONARY DISEASE, FEMALE SEXUAL DYSFUNCTION, MIGRAINE, ASTHMA, VIRAL INFECTIONS IN ASTHMA AND CHRONIC OBSTRUCTIVE PULMONARY DISEASE, LUNG TRANSPLANT REJECTION, ASPERGILLOSIS, CYSTIC FIBROSIS, EPILEPSY, RESTLESS LEG SYNDROME, SLEEP DISORDERS AND PARKINSON'S DISEASE; DRUG DELIVERY AGENTS CONSISTING OF COMPOUNDS THAT FACILITATE DELIVERY OF PHARMACEUTICALS, SOLD BOTH WITHIN INHALERS AND IN OTHER FORMS, FORMULATED FOR PULMONARY DELIVERY VIA INHALATION (U.S. CLS. 6, 18, 44, 46, 51 AND 52).

**CLASS 10—MEDICAL APPARATUS**

FOR DRUG DELIVERY SYSTEMS; DRUG DELIVERY DEVICES, NAMELY, INHALERS FOR MEDICAL PURPOSES SOLD EMPTY; METERED DOSE INHALERS FOR MEDICAL PURPOSES SOLD EMPTY; ACTIVE DRY POWDER INHALERS FOR MEDICAL PURPOSES SOLD EMPTY; PASSIVE DRY POWDER INHALERS FOR MEDICAL PURPOSES SOLD EMPTY; NEBULISERS FOR RESPIRATION THERAPY; REPLACEMENT PARTS AND FITTINGS FOR ALL THE AFORESAID GOODS (U.S. CLS. 26, 39 AND 44).

**CLASS 16—PAPER GOODS AND PRINTED MATTER**

FOR PRINTED MATTER, NAMELY, PRINTED PUBLICATIONS IN THE NATURE OF MAGAZINES, NEWSLETTERS, PAMPHLETS, REPORTS, INSTRUCTIONAL AND INFORMATIONAL LEAFLETS, AND POSTERS, IN THE FIELDS OF MEDICINE AND PHARMACEUTICALS; PAPER, CARDBOARD AND GOODS MADE FROM THESE MATERIALS, NAMELY, CARDBOARD PHARMACEUTICAL PACKAGING; BLANK PATIENT RECORD CARDS AND PRESCRIPTION PADS; PHARMACEUTICAL INFORMATION LEAFLETS; BOOKS IN THE FIELDS OF MEDICINE AND PHARMACEUTICALS; PACKAGING PAPER; STATIONERY; PRINTED INSTRUCTIONAL AND TEACHING MATERIALS RELATING TO THE PHARMACEUTICAL, HEALTH CARE AND MEDICAL FIELDS (U.S. CLS. 2, 5, 22, 23, 29, 37, 38 AND 50).

CURTIS FRENCH, EXAMINING ATTORNEY

SN, 79-056,538. LENE OVERGAARD SØRENSEN, DK-8200 ÅRHUS N, DENMARK, FILED 3-6-2008.

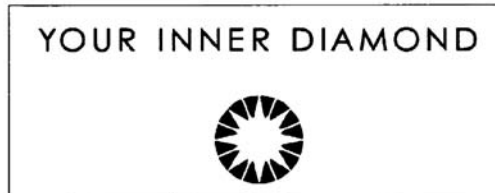

PRIORITY DATE OF 2-1-2008 IS CLAIMED.  
OWNER OF INTERNATIONAL REGISTRATION 0971465 DATED 3-6-2008, EXPIRES 3-6-2018.  
NO CLAIM IS MADE TO THE EXCLUSIVE RIGHT TO USE "DIAMOND", APART FROM THE MARK AS SHOWN.

**CLASS 3—COSMETICS AND CLEANING PREPARATIONS**

FOR SOAPS; PERFUMERY, ESSENTIAL OILS, COSMETICS, HAIR LOTIONS, NON-MEDICATED HAIR CARE PREPARATIONS (U.S. CLS. 1, 4, 6, 50, 51 AND 52).

**CLASS 9—ELECTRICAL AND SCIENTIFIC APPARATUS**

FOR ELECTRONIC MEDIA, NAMELY, PRE-RECORDED CDS, DVDS, DOWNLOADABLE MP3 FILES, MOTION PICTURE FILMS, AND AUDIO TAPES ALL FEATURING MUSIC, SPOKEN WORD IN THE FIELDS OF TRAVEL, COACHING, PSYCHOLOGY, THERAPY, PERSONAL DEVELOPMENT, MEDITATION, SPIRITUALITY, YOGA, BODY KNOWLEDGE, NUTRITION, WELLNESS, SELF AWARENESS, PERSONAL INSIGHT, STRESS MANAGEMENT, TEAMWORK, BUSINESS MANAGEMENT, ORGANIZATION MANAGEMENT; PRERECORDED AUDIO TAPES FEATURING SPOKEN WORD IN THE FIELD OF COACHING, TRAVEL, PSYCHOLOGY, THERAPY, PERSONAL DEVELOPMENT, MEDITATION, SPIRITUALITY, YOGA, BODY KNOWLEDGE, NUTRITION, WELLNESS, SELF AWARENESS, PERSONAL INSIGHT, STRESS MANAGEMENT, TEAMWORK, BUSINESS MANAGEMENT, ORGANIZATION MANAGEMENT; COMPUTER GAMES IN THE NATURE OF DISCS AND PROGRAMMES; CASES FOR SPECTACLES, SPECTACLE LENSES, SPECTACLES, SPECTACLE FRAMES, SUN GLASSES, CHAINS FOR SPECTACLES; NAVIGATION APPARATUS FOR VEHICLES IN THE NATURE OF BUILT-IN COMPUTERS, NAVIGATION INSTRUMENTS AND APPARATUS, NAMELY, CAR NAVIGATION COMPUTERS, NAVIGATION APPARATUS FOR VEHICLES IN THE NATURE OF ON-BOARD COMPUTERS (U.S. CLS. 21, 23, 26, 36 AND 38).

**CLASS 14—JEWELRY**

FOR AGATE AND SARDONYX BEING UNWROUGHT, CUT DIAMONDS, UNWROUGHT DIAMONDS, DIAMOND BELTS, DIAMOND JEWELRY, DIAMONDS, GOLD, GOLD ALLOY INGOTS, GOLD AND ITS ALLOYS, GOLD INGOTS, GOLD UNWORKED OR SEMI-WORKED, IRIIDIUM AND ITS ALLOYS, OLIVINE IN THE NATURE OF PERIDOT, OPAL, OSMIUM AND ITS ALLOYS, PALLADIUM AND ITS ALLOYS, PRECIOUS METAL ALLOYS, PRECIOUS METALS; PRECIOUS METALS AND THEIR ALLOYS, NAMELY, GOLD, SILVER, WHITEGOLD, TITANIUM, PLATINUM, BRONZE AND RHODIUM, PROCESSED OR SEMI-PROCESSED PRECIOUS METALS, RHODIUM AND ITS ALLOYS, RUBY, RUTHENIUM AND ITS ALLOYS, SAPPHIRE, SHEET METAL OF PRECIOUS METAL, SHEETS OF PRECIOUS METAL, SILVER, SILVER ALLOY INGOTS, SILVER AND ITS ALLOYS, SILVER INGOTS, SINTERED DIAMONDS; GOODS CONTAINING OR FEATURING DIAMONDS, NAMELY, ALARM CLOCKS, ANKLE BRACELETS, APPARATUS FOR TIMING SPORTS EVENTS, AUTOMOBILE CLOCKS, BADGES OF PRECIOUS METAL, BANGLE BRACELETS, BODY JEWELRY, BODY-PIERCING RINGS, BODY-PIERCING STUDS, BOLO TIES WITH PRECIOUS METAL TIPS, BRACELETS, BRACELETS OF PRECIOUS METAL, BRONZE JEWELRY, BROOCHES BEING JEWELRY, CHARITY BRACELETS, CHARMS BEING PERSONAL JEWELRY, CHOKERS, CHRONOGRAPHS FOR USE AS WATCHES, CHRONOGRAPHS FOR USE AS TIMEPIECES, CHRONOMETERS, CHRONOMETRIC APPARATUS AND INSTRUMENTS, CHRONOSCOPES, CLIP EARRINGS, CLOCKS AND WATCHES, CLOCKS INCORPORATING RADIOS, CLOISONNE PINS, COMMEMORATIVE STATUARY CUPS MADE OF PRECIOUS METAL, COMPLICATION WATCHES, COSTUME JEWELRY, CUFF LINKS OF PRECIOUS METAL, DIVING WATCHES, DRESS WATCHES, EAR CLIPS, EAR STUDS, EARRINGS, EQUINE NECKLACES, FANCY KEYRINGS OF PRECIOUS METALS, FIGURES OF PRECIOUS METAL, FIGURINES OF PRECIOUS METAL, GEMSTONE JEWELRY, GEMSTONES, GRAVE MARKERS OF PRECIOUS METAL, HAT ORNAMENTS OF PRECIOUS METAL, HOLIDAY ORNAMENTS OF PRECIOUS METAL NOT BEING TREE ORNAMENTS, HOROLOGICAL AND CHRONOMETRIC INSTRUMENTS, IDENTIFICATION BRACELETS BEING JEWELRY, IMITATION JEW-

ELLERY, INSIGNIAS OF PRECIOUS METAL, JADE BEING JEWELLERY, JEWEL CASES OF PRECIOUS METAL, JEWEL CHAINS, JEWEL PENDANTS, JEWELLERY, JEWELLERY AND IMITATION JEWELLERY, JEWELLERY AND PRECIOUS STONES; JEWELLERY AND WATCHES, JEWELLERY CHAINS, JEWELLERY PLATED WITH PRECIOUS METALS, JEWELLERY, CLOCKS AND WATCHES, JEWELRY, JEWELRY AND IMITATION JEWELRY, JEWELRY BOXES OF PRECIOUS METAL, JEWELRY CASES OF PRECIOUS METAL, JEWELRY CASKETS OF PRECIOUS METAL, JEWELRY CHAINS, JEWELRY FOR ATTACHMENT TO CLOTHING, JEWELRY FOR THE HEAD, JEWELRY IN THE NATURE OF ARMBANDS, JEWELRY PINS FOR USE ON HATS, JEWELRY TO BE AFFIXED TO BIKINIS, JEWELRY WATCHES, JEWELRY, NAMELY, AMULETS, JEWELRY, NAMELY, ANKLETS, JEWELRY, NAMELY, CROSSES, JEWELRY, NAMELY, PRECIOUS METAL PLATED REAL LEAVES AND FLOWERS, JEWELRY, NAMELY, STONE PENDANTS, KEY CHAINS OF PRECIOUS METAL, KEY HOLDERS OF PRECIOUS METALS, KEY RINGS OF PRECIOUS METAL, LAPEL PINS BEING JEWELRY, LOCKETS, MECHANICAL AND AUTOMATIC WATCHES, NECK CHAINS, NECKLACES BEING JEWELLERY, NYLON ANKLE BRACELETS, NYLON BRACELETS, ORNAMENTAL LAPEL PINS, ORNAMENTAL PINS, ORNAMENTS OF PRECIOUS METAL, PEARLS BEING JEWELLERY, PENDANTS, PERSONAL ORNAMENTS OF PRECIOUS METAL, PET JEWELRY, PINS BEING JEWELLERY, PLASTIC BRACELETS IN THE NATURE OF JEWELRY, PLATINUM, PLATINUM ALLOY INGOTS, PLATINUM AND ITS ALLOYS, PLATINUM INGOTS, POCKET WATCHES, PRECIOUS AND SEMI-PRECIOUS STONES, PRECIOUS GEMSTONES, PRECIOUS METAL TROPHIES, PRECIOUS METAL TROPHY COLUMNS, REAL AND IMITATION JEWELLERY, RINGS BEING JEWELRY, RUBBER OR SILICON WRISTBANDS IN THE NATURE OF A BRACELET, SCULPTURES MADE OF PRECIOUS METAL, SEMI-PRECIOUS AND PRECIOUS STONES, SEMI-PRECIOUS GEMSTONES, SEMI-PRECIOUS STONES, SEMI-WROUGHT PRECIOUS STONES, SHOE ORNAMENTS OF PRECIOUS METAL, SILVER, SILVER ALLOY INGOTS, SILVER AND ITS ALLOYS, SILVER INGOTS, SINTERED DIAMONDS, SLIDES FOR BOLO TIES, SMALL CLOCKS, SMALL JEWELLERY BOXES OF PRECIOUS METALS, STAINLESS STEEL JEWELRY BRACELETS, STOP WATCHES, SUNDIALS, SYNTHETIC DIAMONDS, TABLE CLOCKS, TIE-PINS OF PRECIOUS METAL, TIMEPIECES AND CHRONOMETRIC INSTRUMENTS, TOMBSTONES OF PRECIOUS METAL, UNWROUGHT AND SEMI-WROUGHT PRECIOUS STONES, UNWROUGHT PRECIOUS STONES, WALL CLOCKS, WATCH BRACELETS, WATCHES AND CLOCKS, WATCHES AND JEWELLERY, WATCHES AND JEWELRY, WATCHES, WATCHES CONTAINING AN ELECTRONIC GAME FUNCTION, WATCHES CONTAINING A GAME FUNCTION, WATCHES FOR OUTDOOR USE, WATCHES, CLOCKS, JEWELLERY AND IMITATION JEWELLERY, WATCHES, CLOCKS, JEWELRY AND IMITATION JEWELRY, WORKS OF ART OF PRECIOUS METAL, WRIST WATCHES, JEWELLERY, PRECIOUS STONES, HOROLOGICAL AND CHRONOMETRIC INSTRUMENTS AND DIADEMS IN THE NATURE OF TIARAS (U.S. CLS. 2, 27, 28 AND 50).

**CLASS 16—PAPER GOODS AND PRINTED MATTER**

FOR PRINTED INSTRUCTIONAL MATERIAL AND TEACHING MATERIAL, NAMELY, PRINTED INSTRUCTIONAL MATERIALS IN THE FIELD OF TRAVEL, COACHING, PSYCHOLOGY, THERAPY, PERSONAL DEVELOPMENT, MEDITATION, SPIRITUALITY, YOGA, BODY KNOWLEDGE, NUTRITION, WELLNESS, SELF AWARENESS, PERSONAL INSIGHT, STRESS MANAGEMENT, TEAMWORK, BUSINESS MANAGEMENT AND ORGANIZATION MANAGEMENT FOR USE IN ORGANIZING PERSONAL FILES, PRINTED INSTRUCTIONAL, EDUCATIONAL, AND TEACHING MATERIALS IN THE FIELDS OF TRAVEL, COACHING, PSYCHOLOGY, THERAPY, PERSONAL DEVELOPMENT, MEDITATION, SPIRITUALITY, YOGA, BODY KNOWLEDGE, NUTRITION, WELLNESS, SELF AWARENESS, PERSONAL INSIGHT, STRESS MANAGEMENT, TEAMWORK, BUSINESS MANAGEMENT, ORGANIZATION MANAGEMENT; MANUALS IN THE FIELDS OF TRAVEL, COACHING, PSYCHOL-

OGY, THERAPY, PERSONAL DEVELOPMENT, MEDITATION, SPIRITUALITY, YOGA, BODY KNOWLEDGE, NUTRITION, WELLNESS, SELF AWARENESS, PERSONAL INSIGHT, STRESS MANAGEMENT, TEAMWORK, BUSINESS MANAGEMENT, ORGANIZATION MANAGEMENT; NEWSPAPERS, BOOKS IN THE FIELDS OF TRAVEL, COACHING, PSYCHOLOGY, THERAPY, PERSONAL DEVELOPMENT, MEDITATION, SPIRITUALITY, YOGA, BODY KNOWLEDGE, NUTRITION, WELLNESS, SELF AWARENESS, PERSONAL INSIGHT, STRESS MANAGEMENT, TEAMWORK, BUSINESS MANAGEMENT, ORGANIZATION MANAGEMENT; WRAPPING PAPER, CALENDARS, CATALOGUES IN THE FIELDS OF TRAVEL, COACHING, PSYCHOLOGY, THERAPY, PERSONAL DEVELOPMENT, MEDITATION, SPIRITUALITY, YOGA, BODY KNOWLEDGE, NUTRITION, WELLNESS, SELF AWARENESS, PERSONAL INSIGHT, STRESS MANAGEMENT, TEAMWORK, BUSINESS MANAGEMENT, ORGANIZATION MANAGEMENT; GREETING CARDS, MAGAZINES FEATURING TRAVELING, COACHING, PSYCHOLOGY, THERAPY, PERSONAL DEVELOPMENT, MEDITATION, SPIRITUALITY, YOGA, BODY KNOWLEDGE, NUTRITION, WELLNESS, SELF AWARENESS, PERSONAL INSIGHT, STRESS MANAGEMENT, TEAMWORK, BUSINESS MANAGEMENT, ORGANIZATION MANAGEMENT; TRAVEL MANUALS IN THE FIELDS OF TRAVELING, COACHING, PSYCHOLOGY, THERAPY, PERSONAL DEVELOPMENT, MEDITATION, SPIRITUALITY, YOGA, BODY KNOWLEDGE, NUTRITION, WELLNESS, SELF AWARENESS, PERSONAL INSIGHT, STRESS MANAGEMENT, TEAMWORK, BUSINESS MANAGEMENT, ORGANIZATION MANAGEMENT; NEWS LETTERS IN THE FIELDS OF TRAVELING, COACHING, PSYCHOLOGY, THERAPY, PERSONAL DEVELOPMENT, MEDITATION, SPIRITUALITY, YOGA, BODY KNOWLEDGE, NUTRITION, WELLNESS, SELF AWARENESS, PERSONAL INSIGHT, STRESS MANAGEMENT, TEAMWORK, BUSINESS MANAGEMENT, ORGANIZATION MANAGEMENT; PENS, PRINTED PAMPHLETS IN THE FIELDS OF TRAVELING, COACHING, PSYCHOLOGY, THERAPY, PERSONAL DEVELOPMENT, MEDITATION, SPIRITUALITY, YOGA, BODY KNOWLEDGE, NUTRITION, WELLNESS, SELF AWARENESS, PERSONAL INSIGHT, STRESS MANAGEMENT, TEAMWORK, BUSINESS MANAGEMENT, ORGANIZATION MANAGEMENT; POST CARDS, PUBLICATIONS, NAMELY, EDUCATIONAL PUBLICATIONS, NAMELY, EDUCATIONAL LEARNING CARDS, FLASH CARDS, ACTIVITY CARDS, WORKBOOKS, TEXTBOOKS, ACTIVITY BOOKS, STORY BOOKS, PUZZLE BOOKS, PRINTED PUZZLES, TEACHER GUIDES, MANUALS, POSTERS AND EDUCATIONAL BOOKLETS, BOOKS, JOURNALS, PLAYBOOKS, WORKSHEETS AND CARDS, AND QUICK REFERENCE POCKET GUIDES, ALL IN THE FIELDS OF TRAVEL, COACHING, PSYCHOLOGY, THERAPY, PERSONAL DEVELOPMENT, MEDITATION, SPIRITUALITY, YOGA, BODY KNOWLEDGE, NUTRITION, WELLNESS, SELF AWARENESS, PERSONAL INSIGHT, STRESS MANAGEMENT, TEAMWORK, BUSINESS MANAGEMENT, ORGANIZATION MANAGEMENT; PUBLICATION PAPER, IN THE FIELDS OF TRAVELING, COACHING, PSYCHOLOGY, THERAPY, PERSONAL DEVELOPMENT, MEDITATION, SPIRITUALITY, YOGA, BODY KNOWLEDGE, NUTRITION, WELLNESS, SELF AWARENESS, PERSONAL INSIGHT, STRESS MANAGEMENT, TEAMWORK, BUSINESS MANAGEMENT, ORGANIZATION MANAGEMENT; SCRAP BOOKS, WRITING UTENSILS, NOTE PADS, PRINTED PERIODICALS IN THE FIELDS OF TRAVELING, COACHING, PSYCHOLOGY, THERAPY, PERSONAL DEVELOPMENT, MEDITATION, SPIRITUALITY, YOGA, BODY KNOWLEDGE, NUTRITION, WELLNESS, SELF AWARENESS, PERSONAL INSIGHT, STRESS MANAGEMENT, TEAMWORK, BUSINESS MANAGEMENT, ORGANIZATION MANAGEMENT; BOXES OF PAPER OR CARDBOARD (U.S. CLS. 2, 5, 22, 23, 29, 37, 38 AND 50).

#### CLASS 18—LEATHER GOODS

FOR LEATHER AND IMITATIONS OF LEATHER, TRUNKS, ALL-PURPOSE CARRYING BAGS, TRAVELING BAGS, RUCKSACKS, TOILETRY BAGS SOLD EMPTY, PURSES (U.S. CLS. 1, 2, 3, 22 AND 41).

#### CLASS 25—CLOTHING

FOR CLOTHING, NAMELY, PANTS, BLOUSES, DRESSES, SKIRTS, SHIRTS, JACKETS, COATS, SCARVES, BELTS, GLOVES; FOOTWEAR, NAMELY, SHOES, BOOTS, SANDALS, HIKING BOOTS, SPORTS SHOES; HEADGEAR, NAMELY, CAPS, HATS, SCARVES (U.S. CLS. 22 AND 39).

#### CLASS 28—TOYS AND SPORTING GOODS

FOR GAMES AND PLAYTHINGS, NAMELY, BOARD GAMES, BUILDING GAMES, CARD GAME FOR BUSINESS TRAINING, CARD GAMES, DICE GAMES, EDUCATIONAL CARD GAMES, ELECTRONIC EDUCATIONAL GAME MACHINES FOR CHILDREN, ELECTRONIC GAMES OTHER THAN THOSE ADAPTED FOR USE WITH TELEVISION RECEIVERS ONLY, ELECTRONIC HUNTING GAME CALL WITH INTERCHANGEABLE SOUND CARTRIDGES, ELECTRONIC TARGETS FOR GAMES AND SPORTS, EQUIPMENT SOLD AS A UNIT FOR PLAYING BOARD GAMES, EQUIPMENT SOLD AS A UNIT FOR PLAYING CARD GAMES, EQUIPMENT SOLD AS A UNIT FOR PLAYING A MEMORY GAME, EQUIPMENT SOLD AS A UNIT FOR PLAYING ACTION TYPE TARGET GAMES, GAME EQUIPMENT SOLD AS A UNIT FOR PLAYING MIND-BODY EMOTIONAL AND PSYCHOLOGICAL GAMES FOR ADULT COUPLES AND INDIVIDUALS, GAME EQUIPMENT, NAMELY, CHIPS, HAND HELD UNIT FOR PLAYING ELECTRONIC GAMES, HAND HELD UNIT FOR PLAYING VIDEO GAMES, HAND-HELD GAMES WITH LIQUID CRYSTAL DISPLAYS, LCD GAME MACHINES, MEMORY GAMES, PLAYING CARDS AND CARD GAMES, POSITIONABLE PRINTED TOY FIGURES FOR USE IN GAMES, POSITIONABLE THREE DIMENSIONAL TOYS FOR USE IN GAMES, POSITIONABLE TWO DIMENSIONAL TOYS FOR USE IN GAMES, PRINTED POSITIONABLE TOYS FOR USE IN CHILDREN'S BOARD GAMES, PROMOTIONAL GAME CARDS, PROMOTIONAL GAME MATERIALS, ROLE PLAYING GAMES, TARGET GAMES, TOY, NAMELY, BATTERY-POWERED COMPUTER GAME WITH LCD SCREEN WHICH FEATURES ANIMATION AND SOUND EFFECTS, TOYS, NAMELY, A DISK TO TOSS IN PLAYING A GAME WHEREIN OTHER DISKS ARE FLIPPED AND COLLECTED, TRADING CARD GAMES; BOARD GAMES, PLAYING CARDS (U.S. CLS. 22, 23, 38 AND 50).

#### CLASS 41—EDUCATION AND ENTERTAINMENT

FOR EDUCATION SERVICES, NAMELY, PROVIDING CLASSES, SEMINARS, WORKSHOPS IN THE FIELD OF TRAVEL, COACHING, PSYCHOLOGY, THERAPY, PERSONAL DEVELOPMENT, MEDITATION, SPIRITUALITY, YOGA, BODY KNOWLEDGE, NUTRITION, WELLNESS, SELF AWARENESS, PERSONAL INSIGHT, STRESS MANAGEMENT, TEAMWORK, BUSINESS MANAGEMENT, ORGANIZATION MANAGEMENT; PROVIDING OF TRAINING IN THE FIELD OF TRAVEL, COACHING, PSYCHOLOGY, THERAPY, PERSONAL DEVELOPMENT, MEDITATION, SPIRITUALITY, YOGA, BODY KNOWLEDGE, NUTRITION, WELLNESS, SELF AWARENESS, PERSONAL INSIGHT, STRESS MANAGEMENT, TEAMWORK, BUSINESS MANAGEMENT, ORGANIZATION MANAGEMENT; PROVIDING EDUCATIONAL SEMINARS IN THE FIELD OF TRAVEL, COACHING, PSYCHOLOGY, THERAPY, PERSONAL DEVELOPMENT, MEDITATION, SPIRITUALITY, YOGA, BODY KNOWLEDGE, NUTRITION, WELLNESS, SELF AWARENESS, PERSONAL INSIGHT, STRESS MANAGEMENT, TEAMWORK, BUSINESS MANAGEMENT, ORGANIZATION MANAGEMENT; PROVIDING EDUCATIONAL WORKSHOPS IN THE FIELD OF TRAVEL, COACHING, PSYCHOLOGY, THERAPY, PERSONAL DEVELOPMENT, MEDITATION, SPIRITUALITY, YOGA, BODY KNOWLEDGE, NUTRITION, WELLNESS,



SELF AWARENESS, PERSONAL INSIGHT, STRESS MANAGEMENT, TEAMWORK, BUSINESS MANAGEMENT, ORGANIZATION MANAGEMENT; EDUCATION IN THE FIELD OF TRAVEL, COACHING, PSYCHOLOGY, THERAPY, PERSONAL DEVELOPMENT, MEDITATION, SPIRITUALITY, YOGA, BODY KNOWLEDGE, NUTRITION, WELLNESS, SELF AWARENESS, PERSONAL INSIGHT, STRESS MANAGEMENT, TEAMWORK, BUSINESS MANAGEMENT AND ORGANIZATION MANAGEMENT RENDERED THROUGH CORRESPONDENCE COURSES, ELECTRONIC DESKTOP PUBLISHING FOR OTHERS RELATING TO BOOKS, VOCATIONAL GUIDANCE, FILM PRODUCTION, PUBLISHING OF BOOKS, MAGAZINES, REVIEWS AND NEWSLETTERS, HEALTH CLUB SERVICES, NAMELY, PROVIDING INSTRUCTION AND EQUIPMENT IN THE FIELD OF PHYSICAL EXERCISE; ARRANGEMENT OF CONCERTS, ARRANGEMENT OF EDUCATIONAL CONFERENCES, ORGANIZING OF SPORTS COMPETITIONS, BOARDING SCHOOLS, SCRIPTWRITING, MOBILE LIBRARIES, PROVIDING MUSEUM FACILITIES, MUSIC COMPOSITION SERVICES FOR OTHERS, NEWS REPORTERS SERVICES; ONLINE PUBLICATION OF ELECTRONIC BOOKS AND PERIODICALS; ORGANIZING OF EXHIBITIONS FOR CULTURAL OR EDUCATIONAL PURPOSES; PRODUCTION OF RADIO AND TELEVISION PROGRAMS, PRODUCTION OF VIDEO FILMS AND SHOWS, REMEDIAL TEACHING IN THE FIELD OF TRAVEL, COACHING, PSYCHOLOGY, THERAPY, PERSONAL DEVELOPMENT, MEDITATION, SPIRITUALITY, YOGA, BODY KNOWLEDGE, NUTRITION, WELLNESS, SELF AWARENESS, PERSONAL INSIGHT, STRESS MANAGEMENT, TEAMWORK, BUSINESS MANAGEMENT, ORGANIZATION MANAGEMENT; EDUCATION SERVICES, NAMELY, PROVIDING CLASSES, SEMINARS, WORKSHOPS IN THE FIELD OF TRAVEL, COACHING, PSYCHOLOGY, THERAPY, PERSONAL DEVELOPMENT, MEDITATION, SPIRITUALITY, YOGA, BODY KNOWLEDGE, NUTRITION, WELLNESS, SELF AWARENESS, PERSONAL INSIGHT, STRESS MANAGEMENT, TEAMWORK, BUSINESS MANAGEMENT, ORGANIZATION MANAGEMENT; ONLINE ELECTRONIC PUBLISHING OF TEXTS IN THE NATURE OF BOOKS ON THE INTERNET IN THE FIELD OF TRAVEL, COACHING, PSYCHOLOGY, THERAPY, PERSONAL DEVELOPMENT, MEDITATION, SPIRITUALITY, YOGA, BODY KNOWLEDGE, NUTRITION, WELLNESS, SELF AWARENESS, PERSONAL INSIGHT, STRESS MANAGEMENT, TEAMWORK, BUSINESS MANAGEMENT, ORGANIZATION MANAGEMENT, EXCLUDING ADVERTISING TEXTS (U.S. CLS. 100, 101 AND 107).

LAURA HAMMEL, EXAMINING ATTORNEY

### CLASS 9—ELECTRICAL AND SCIENTIFIC APPARATUS

FOR MAGNETICALLY ENCODED CREDIT CARDS AND CHEQUE CARDS; MAGNETICALLY ENCODED CASH CARDS; MAGNETICALLY ENCODED DEBIT CARDS; APPARATUS IN THE NATURE OF SECURE TERMINALS FOR ELECTRONIC TRANSACTIONS FOR THE PROCESSING OF MAGNETICALLY ENCODED CARD TRANSACTIONS; APPARATUS IN THE NATURE OF SECURE TERMINALS FOR ELECTRONIC TRANSACTIONS FOR PROCESSING OF DATA RELATING TO MAGNETICALLY ENCODED CARD TRANSACTIONS AND FOR PAYMENT PROCESSING; BLANK CARTRIDGES, DISCS AND TAPES, ALL FOR COLLECTING AND STORING DATA FOR ONLINE PURCHASE TRANSACTIONS, AND ON-LINE BILL PAYMENT AND CREDIT CARD PAYMENT TRANSACTIONS; COMPUTER SOFTWARE FOR RECORDING AND PROCESSING ON-LINE PURCHASE TRANSACTIONS, AND ON-LINE BILL PAYMENT AND CREDIT CARD PAYMENT TRANSACTIONS (U.S. CLS. 21, 23, 26, 36 AND 38).

### CLASS 16—PAPER GOODS AND PRINTED MATTER

FOR ADDRESS STAMPS; ADHESIVE BANDS FOR STATIONERY OR HOUSEHOLD PURPOSES; ADHESIVE TAPES FOR STATIONERY OR HOUSEHOLD PURPOSES; PRINTED ADVERTISEMENT BOARDS OF PAPER OR CARDBOARD; BAGS IN THE NATURE OF ENVELOPES AND POUCHES OF PAPER AND PLASTICS, FOR PACKAGING; BOXES OF CARDBOARD OR PAPER; CARDBOARD; CARDBOARD TUBES; ENVELOPES AS STATIONERY; GREETING CARDS; GUMMED TAPE AS STATIONERY; GUMS IN THE NATURE OF ADHESIVES FOR STATIONERY OR HOUSEHOLD PURPOSES; HOLDERS FOR STAMPS IN THE NATURE OF SLEEVES FOR HOLDING AND PROTECTING STAMPS; PACKAGING MATERIAL IN THE NATURE OF PACKING PAPER; POSTAGE STAMPS; POSTCARDS; SEALING WAX; SEALS AS STAMPS IN THE NATURE OF SEALING STAMPS; SELF-ADHESIVE TAPES FOR STATIONERY AND HOUSEHOLD PURPOSES; CASES FOR STAMPS AS SEALS IN THE NATURE OF SEALING STAMPS; STATIONERY; WRAPPING PAPER (U.S. CLS. 2, 5, 22, 23, 29, 37, 38 AND 50).

### CLASS 35—ADVERTISING AND BUSINESS

FOR RENTAL OF ADVERTISING SPACE; AUCTIONEERING; COMPILATION AND SYSTEMIZATION OF INFORMATION INTO COMPUTER DATABASES; DIRECT MAIL ADVERTISING; DOCUMENT REPRODUCTION; RELOCATION SERVICES FOR BUSINESSES; ADVERTISING AND PROMOTION SERVICES AND PROVIDING INFORMATION IN THE FIELD OF ADVERTISING AND PROMOTION SERVICES; BUSINESS INFORMATION MANAGEMENT; ADVERTISING AGENCIES; COMPILING AND DISSEMINATION OF ADVERTISING MATTER; COMPUTERIZED DATABASE MANAGEMENT; BUSINESS MANAGEMENT CONSULTANCY AND ADVISORY SERVICES; DATA PROCESSING; DATA VERIFICATION, NAMELY, ELECTRONIC SIGNATURE VERIFICATION SERVICES PROVIDED IN CONNECTION WITH BANKING AND FINANCIAL SERVICES, NAMELY, PURCHASE OF ON-LINE GOODS AND SERVICES, AUTOMATED FINANCIAL PAYMENT SERVICES, FINANCIAL PRE-PAYMENT SERVICES, ON-LINE SERVICES RELATING TO PRE-PAYMENT CARDS, DOMESTIC REMITTANCES AND ACCEPTANCE OF BILLS, SERVICES ENABLING PAYMENT FOR USAGE OF UTILITIES INCLUDING GAS, ELECTRICITY, WATER, POSTAL, TELECOMMUNICATION AND ON-LINE COMPUTER SERVICES; RETAIL SALES SERVICES, AND ONLINE RETAIL SALES SERVICES, NAMELY, BY DIRECT SOLICITATION IN THE FIELD OF PHILATELIC PRODUCTS, STAMPS, STAMP ALBUMS; RETAIL SALES SERVICES AND ONLINE RETAIL SALES SERVICES, NAMELY, BY DIRECT SOLICITATION BY SALES AGENTS IN THE FIELD OF WINE, COFFEE, GREETING CARDS, BOOKS, STATIONERY, CLOTHING, GIFT SETS AND OTHER GENERAL

SN 79-064,582, SINGAPORE POST LIMITED, SINGAPORE, FILED 5-14-2008.

Globeshopping. Without Globehopping.

PRIORITY DATE OF 11-14-2007 IS CLAIMED.  
OWNER OF INTERNATIONAL REGISTRATION 0991342  
DATED 5-14-2008, EXPIRES 5-14-2018.

MERCHANDISE; THE BRINGING TOGETHER, FOR THE BENEFIT OF OTHERS, OF A VARIETY OF GOODS AND SERVICES (EXCLUDING THE TRANSPORT THEREOF), IN THE NATURE OF GENERAL MERCHANDISE, ENABLING CUSTOMERS TO CONVENIENTLY VIEW AND PURCHASE THOSE GOODS FROM A GENERAL MERCHANDISE INTERNET WEBSITE AND A GENERAL MERCHANDISE CATALOGUE BY MAIL ORDER; COMPILATION OF MAILING LISTS; COMPILATION OF ADVERTISEMENTS FOR USE AS WEB PAGES ON THE INTERNET (U.S. CLS. 100, 101 AND 102).

#### CLASS 36—INSURANCE AND FINANCIAL

FOR RENT COLLECTION; BILL-POSTING IN THE NATURE OF BILL PAYMENT SERVICES PROVIDED THROUGH A WEBSITE, NAMELY, ON-LINE POSTING OF BILLS TO ENABLE ON-LINE BILL PAYMENT AND CREDIT CARD PAYMENT TRANSACTIONS; ORGANIZATION OF ON-LINE BILL PAYMENT AND CREDIT CARD PAYMENT COLLECTIONS IN THE NATURE OF BILL PAYMENT SERVICES; DEBT COLLECTION AGENCIES; FINANCING SERVICES; INSURANCE INFORMATION; INSTALLMENT LOANS; ISSUING OF TRAVELLERS' CHECKS; RETIREMENT BENEFITS PAYMENT PROCESSING SERVICES; PROVIDING STORED VALUE ELECTRONIC PURSE PAYMENT SERVICES, CASH DISBURSEMENTS, AND TRANSACTION AUTHORIZATION AND SETTLEMENT SERVICES, ALL IN THE NATURE OF STORED VALUE CARD PAYMENT SERVICES; FINANCIAL MANAGEMENT; CREDIT RECOVERY AND COLLECTION; DEBT COLLECTION AND RECOVERY SERVICES; COMPUTERIZED FINANCIAL SERVICES, NAMELY, ON-LINE BILL PAYMENT SERVICES AND CREDIT CARD PAYMENT PROCESSING SERVICES; BANK CARD SERVICES FOR TRANSACTION PAYMENTS, NAMELY, PAYMENT TRANSACTION PROCESSING AND FINANCIAL ADMINISTRATIVE SERVICES FOR CREDIT CARDS, DEBIT CARDS, CHARGE CARDS, BANK CARDS INCORPORATING PERSONAL IDENTIFICATION DATA, PURCHASE AUTHORIZATION CARDS, AND CASH CARDS; PAYMENT PROCESSING SERVICES, NAMELY, CREDIT CARD AND DEBIT CARD TRANSACTION PROCESSING SERVICES, ELECTRONIC FOREIGN EXCHANGE PAYMENT PROCESSING; PAYMENT PROCESSING FOR USAGE OF UTILITIES; FINANCIAL PRE-PAYMENT SERVICES, NAMELY, ON-LINE BILL PAYMENT SERVICES AND CREDIT CARD PAYMENT PROCESSING SERVICES, THROUGH CASH CARDS, DEBIT CARDS AND OTHER PREPAID ENCODED MAGNETIC CARDS; FINANCE AND INSURANCE INFORMATION, PROVIDED ON-LINE FROM A COMPUTER DATABASE AND A GLOBAL COMMUNICATION NETWORK; HOME BANKING; INTERNET BANKING; INFORMATION AND ADVISORY SERVICES RELATING TO THE AFORESAID (U.S. CLS. 100, 101 AND 102).

#### CLASS 38—COMMUNICATION

FOR RENTAL OF ACCESS TIME TO DATABASES; PROVIDING ACCESS TO DATABASES; ADVISORY AND CONSULTANCY SERVICES ALL RELATING TO THE AFOREMENTIONED SERVICES; COMMUNICATIONS BY COMPUTER TERMINALS; ELECTRONIC MAIL; COMPUTER AIDED TRANSMISSION OF MESSAGES AND IMAGES; COMMUNICATION SERVICES, NAMELY, ELECTRONIC TRANSMISSION OF DOCUMENTS, VOICE, DATA, IMAGES, AUDIO, VIDEO, COMPUTER PROGRAMS, WEB PAGES AND MESSAGES VIA COMPUTER TERMINALS, ELECTRONIC MAIL, THE INTERNET, AND MOBILE ELECTRONIC DEVICES; ELECTRONIC DATA INTERCHANGE SERVICES; ELECTRONIC MAIL SERVICES; PROVISION OF ACCESS TO A WEBSITE FOR GENERATION AND COMPLETION OF FORMS, TRANSACTION PROCES-

SING SERVICES, AND INFORMATION COMMUNICATION SERVICES; PROVIDING USER ACCESS TO A GLOBAL COMMUNICATION NETWORK, NAMELY, INTERNET SERVICE PROVIDERS, BEING A TELECOMMUNICATIONS SERVICE; PROVISION OF USER ACCESS TIME TO A GLOBAL COMPUTER NETWORK, BEING A TELECOMMUNICATIONS SERVICE; PROVIDING TELECOMMUNICATIONS CONNECTION TO A GLOBAL COMMUNICATION NETWORK OR DATABASES; PROVISION OF ACCESS TO SEARCH ENGINES AS TELECOMMUNICATIONS SERVICES (U.S. CLS. 100, 101 AND 104).

#### CLASS 39—TRANSPORTATION AND STORAGE

FOR PROVIDING THE PICKING UP, STORAGE AND DELIVERY OF LETTERS, CORRESPONDENCE, MAGAZINES, PACKETS, PARCELS, NEWSPAPERS, FREIGHT AND OF GOODS, ALL BY MESSENGER, ROAD, RAIL, AIR OR WATER, EXCLUDING THE ARRANGEMENT SUCH SERVICES; COURIER SERVICES; FREIGHT FORWARDING; WAREHOUSING SERVICES; GUARDED TRANSPORT OF VALUABLES; MAIL FORWARDING, NAMELY, DELIVERY AND TRANSPORTING OF MAIL; PACKAGING AND PACKING SERVICES FOR DELIVERY AND TRANSPORTATION; RENTAL OF MAILBOXES, RENTAL OF VEHICLES; RENTAL OF WAREHOUSES; TRANSPORT OF GOODS; UNLOADING OF CARGO; ADVISORY AND CONSULTANCY SERVICES ALL RELATING TO THE AFOREMENTIONED SERVICES (U.S. CLS. 100 AND 105).

#### CLASS 42—SCIENTIFIC AND COMPUTER SERVICES

FOR COMMISSIONED WRITING OF COMPUTER PROGRAMS, SOFTWARE AND CODE FOR THE CREATION OF WEB PAGES ON THE INTERNET; DESIGN AND GRAPHIC ARTS DESIGNING, FOR THE CREATION OF WEB PAGES ON THE INTERNET; ELECTRONIC AUTHENTICATION SERVICES, IN THE FIELD OF ELECTRONIC DOCUMENTS; ADVISORY AND CONSULTANCY SERVICES ALL RELATING TO THE AFOREMENTIONED SERVICES; CREATION AND MAINTENANCE OF WEB SITES FOR OTHERS; HOSTING THE WEB SITES OF OTHERS (U.S. CLS. 100 AND 101).

FONG HSU, EXAMINING ATTORNEY

SN 79-064,583. SINGAPORE POST LIMITED, SINGAPORE 408600, SINGAPORE, FILED 5-14-2008.



Globeshopping. Without Globeshopping.

PRIORITY DATE OF 11-14-2007 IS CLAIMED.  
OWNER OF INTERNATIONAL REGISTRATION 0991343  
DATED 5-14-2008, EXPIRES 5-14-2018.

**CLASS 9—ELECTRICAL AND SCIENTIFIC APPARATUS**

FOR MAGNETICALLY ENCODED CREDIT CARDS AND CHEQUE CARDS; MAGNETICALLY ENCODED CASH CARDS; MAGNETICALLY ENCODED DEBIT CARDS; APPARATUS IN THE NATURE OF SECURE TERMINALS FOR ELECTRONIC TRANSACTIONS FOR THE PROCESSING OF MAGNETICALLY ENCODED CARD TRANSACTIONS; APPARATUS IN THE NATURE OF SECURE TERMINALS FOR ELECTRONIC TRANSACTIONS FOR PROCESSING OF DATA RELATING TO MAGNETICALLY ENCODED CARD TRANSACTIONS AND FOR PAYMENT PROCESSING; BLANK CARTRIDGES, DISCS AND TAPES, ALL FOR COLLECTING AND STORING DATA FOR ONLINE PURCHASE TRANSACTIONS, AND ON-LINE BILL PAYMENT AND CREDIT CARD PAYMENT TRANSACTIONS; COMPUTER SOFTWARE FOR RECORDING AND PROCESSING ON-LINE PURCHASE TRANSACTIONS, AND ON-LINE BILL PAYMENT AND CREDIT CARD PAYMENT TRANSACTIONS (U.S. CLS. 21, 23, 26, 36 AND 38).

**CLASS 16—PAPER GOODS AND PRINTED MATTER**

FOR ADDRESS STAMPS; ADHESIVE BANDS FOR STATIONERY OR HOUSEHOLD PURPOSES; ADHESIVE TAPES FOR STATIONERY OR HOUSEHOLD PURPOSES; PRINTED ADVERTISEMENT BOARDS OF PAPER OR CARDBOARD; BAGS IN THE NATURE OF ENVELOPES AND POUCHES OF PAPER AND PLASTICS, FOR PACKAGING; BOXES OF CARDBOARD OR PAPER; CARDBOARD; CARDBOARD TUBES; ENVELOPES AS STATIONERY; GREETING CARDS; GUMMED TAPE AS STATIONERY; GUMS IN THE NATURE OF ADHESIVES FOR STATIONERY OR HOUSEHOLD PURPOSES; HOLDERS FOR STAMPS IN THE NATURE OF SLEEVES FOR HOLDING AND PROTECTING STAMPS; PACKAGING MATERIAL IN THE NATURE OF PACKING PAPER; POSTAGE STAMPS; POSTCARDS; SEALING WAX; SEALS AS STAMPS IN THE NATURE OF SEALING STAMPS; SELF-ADHESIVE TAPES FOR STATIONERY AND HOUSEHOLD PURPOSES; CASES FOR STAMPS AS SEALS IN THE NATURE OF SEALING STAMPS; STATIONERY; WRAPPING PAPER (U.S. CLS. 2, 5, 22, 23, 29, 37, 38 AND 50).

**CLASS 35—ADVERTISING AND BUSINESS**

FOR RENTAL OF ADVERTISING SPACE; AUCTIONEERING; COMPILATION AND SYSTEMIZATION OF INFORMATION INTO COMPUTER DATABASES; DIRECT MAIL ADVERTISING; DOCUMENT REPRODUCTION; RELOCATION SERVICES FOR BUSINESSES; ADVERTISING AND PROMOTION SERVICES AND PROVIDING INFORMATION IN THE FIELD OF ADVERTISING AND PROMOTION SERVICES; BUSINESS INFORMATION MANAGEMENT; ADVERTISING AGENCIES; COMPILING AND DISSEMINATION OF ADVERTISING MATTER; COMPUTERIZED DATABASE MANAGEMENT; BUSINESS MANAGEMENT CONSULTANCY AND ADVISORY SERVICES; DATA PROCESSING; DATA VERIFICATION, NAMELY, ELECTRONIC SIGNATURE VERIFICATION SERVICES PROVIDED IN CONNECTION WITH BANKING AND FINANCIAL SERVICES, NAMELY, PURCHASE OF ON-LINE GOODS AND SERVICES, AUTOMATED FINANCIAL PAYMENT SERVICES, FINANCIAL PRE-PAYMENT SERVICES, ON-LINE SERVICES RELATING TO PRE-PAYMENT CARDS, DOMESTIC REMITTANCES AND ACCEPTANCE OF BILLS, SERVICES ENABLING PAYMENT FOR USAGE OF UTILITIES INCLUDING GAS, ELECTRICITY, WATER, POSTAL, TELECOMMUNICATION AND ON-LINE COMPUTER SERVICES; RETAIL SALES SERVICES, AND ONLINE RETAIL SALES SERVICES, NAMELY, BY DIRECT SOLICITATION IN THE FIELD OF PHILATELIC PRODUCTS, STAMPS, STAMP ALBUMS; RETAIL SALES SERVICES AND ONLINE RETAIL SALES SERVICES, NAMELY, BY DIRECT SOLICITATION BY SALES AGENTS IN THE FIELD OF WINE, COFFEE, GREETING CARDS, BOOKS, STATIONERY, CLOTHING, GIFT SETS AND OTHER GENERAL

MERCHANDISE; THE BRINGING TOGETHER, FOR THE BENEFIT OF OTHERS, OF A VARIETY OF GOODS AND SERVICES (EXCLUDING THE TRANSPORT THEREOF), IN THE NATURE OF GENERAL MERCHANDISE, ENABLING CUSTOMERS TO CONVENIENTLY VIEW AND PURCHASE THOSE GOODS FROM A GENERAL MERCHANDISE INTERNET WEBSITE AND A GENERAL MERCHANDISE CATALOGUE BY MAIL ORDER; COMPILATION OF MAILING LISTS; COMPILATION OF ADVERTISEMENTS FOR USE AS WEB PAGES ON THE INTERNET (U.S. CLS. 100, 101 AND 102).

**CLASS 36—INSURANCE AND FINANCIAL**

FOR RENT COLLECTION; BILL-POSTING IN THE NATURE OF BILL PAYMENT SERVICES PROVIDED THROUGH A WEBSITE, NAMELY, ON-LINE POSTING OF BILLS TO ENABLE ON-LINE BILL PAYMENT AND CREDIT CARD PAYMENT TRANSACTIONS; ORGANIZATION OF ON-LINE BILL PAYMENT AND CREDIT CARD PAYMENT COLLECTIONS IN THE NATURE OF BILL PAYMENT SERVICES; DEBT COLLECTION AGENCIES; FINANCING SERVICES; INSURANCE INFORMATION; INSTALLMENT LOANS; ISSUING OF TRAVELLERS' CHECKS; RETIREMENT BENEFITS PAYMENT PROCESSING SERVICES; PROVIDING STORED VALUE ELECTRONIC PURSE PAYMENT SERVICES, CASH DISBURSEMENTS, AND TRANSACTION AUTHORIZATION AND SETTLEMENT SERVICES, ALL IN THE NATURE OF STORED VALUE CARD PAYMENT SERVICES; FINANCIAL MANAGEMENT; CREDIT RECOVERY AND COLLECTION; DEBT COLLECTION AND RECOVERY SERVICES; COMPUTERIZED FINANCIAL SERVICES, NAMELY, ON-LINE BILL PAYMENT SERVICES AND CREDIT CARD PAYMENT PROCESSING SERVICES; BANK CARD SERVICES FOR TRANSACTION PAYMENTS, NAMELY, PAYMENT TRANSACTION PROCESSING AND FINANCIAL ADMINISTRATIVE SERVICES FOR CREDIT CARDS, DEBIT CARDS, CHARGE CARDS, BANK CARDS INCORPORATING PERSONAL IDENTIFICATION DATA, PURCHASE AUTHORIZATION CARDS, AND CASH CARDS; PAYMENT PROCESSING SERVICES, NAMELY, CREDIT CARD AND DEBIT CARD TRANSACTION PROCESSING SERVICES, ELECTRONIC FOREIGN EXCHANGE PAYMENT PROCESSING; PAYMENT PROCESSING FOR USAGE OF UTILITIES; FINANCIAL PRE-PAYMENT SERVICES, NAMELY, ON-LINE BILL PAYMENT SERVICES AND CREDIT CARD PAYMENT PROCESSING SERVICES, THROUGH CASH CARDS, DEBIT CARDS AND OTHER PREPAID ENCODED MAGNETIC CARDS; FINANCE AND INSURANCE INFORMATION, PROVIDED ON-LINE FROM A COMPUTER DATABASE AND A GLOBAL COMMUNICATION NETWORK; HOME BANKING; INTERNET BANKING; INFORMATION AND ADVISORY SERVICES RELATING TO THE AFORESAID (U.S. CLS. 100, 101 AND 102).

**CLASS 38—COMMUNICATION**

FOR RENTAL OF ACCESS TIME TO DATABASES; PROVIDING ACCESS TO DATABASES; ADVISORY AND CONSULTANCY SERVICES ALL RELATING TO THE AFOREMENTIONED SERVICES; COMMUNICATIONS BY COMPUTER TERMINALS; ELECTRONIC MAIL; COMPUTER AIDED TRANSMISSION OF MESSAGES AND IMAGES; COMMUNICATION SERVICES, NAMELY, ELECTRONIC TRANSMISSION OF DOCUMENTS, VOICE, DATA, IMAGES, AUDIO, VIDEO, COMPUTER PROGRAMS, WEB PAGES AND MESSAGES VIA COMPUTER TERMINALS, ELECTRONIC MAIL, THE INTERNET, AND MOBILE ELECTRONIC DEVICES; ELECTRONIC DATA INTERCHANGE SERVICES; ELECTRONIC MAIL SERVICES; PROVISION OF ACCESS TO A WEBSITE FOR GENERATION AND COMPLETION OF FORMS, TRANSACTION PROCES-

SING SERVICES, AND INFORMATION COMMUNICATION SERVICES; PROVIDING USER ACCESS TO A GLOBAL COMMUNICATION NETWORK, NAMELY, INTERNET SERVICE PROVIDERS, BEING A TELECOMMUNICATIONS SERVICE; PROVISION OF USER ACCESS TIME TO A GLOBAL COMPUTER NETWORK, BEING A TELECOMMUNICATIONS SERVICE; PROVIDING TELECOMMUNICATIONS CONNECTION TO A GLOBAL COMMUNICATION NETWORK OR DATABASES; PROVISION OF ACCESS TO SEARCH ENGINES AS TELECOMMUNICATIONS SERVICES (U.S. CLS. 100, 101 AND 104).

### **CLASS 39—TRANSPORTATION AND STORAGE**

FOR PROVIDING THE PICKING UP, STORAGE AND DELIVERY OF LETTERS, CORRESPONDENCE, MAGAZINES, PACKETS, PARCELS, NEWSPAPERS, FREIGHT AND OF GOODS, ALL BY MESSENGER, ROAD, RAIL, AIR OR WATER, EXCLUDING THE ARRANGEMENT SUCH SERVICES; COURIER SERVICES; FREIGHT FORWARDING; WAREHOUSING SERVICES; GUARDED TRANSPORT OF VALUABLES; MAIL FORWARDING, NAMELY, DELIVERY AND TRANSPORTING OF MAIL; PACKAGING AND PACKING SERVICES FOR DELIVERY AND TRANSPORTATION; RENTAL OF MAILBOXES, RENTAL OF VEHICLES; RENTAL OF WAREHOUSES; TRANSPORT OF GOODS; UNLOADING OF CARGO; ADVISORY AND CONSULTANCY SERVICES ALL RELATING TO THE AFOREMENTIONED SERVICES (U.S. CLS. 100 AND 105).

### **CLASS 42—SCIENTIFIC AND COMPUTER SERVICES**

FOR COMMISSIONED WRITING OF COMPUTER PROGRAMS, SOFTWARE AND CODE FOR THE CREATION OF WEB PAGES ON THE INTERNET; DESIGN AND GRAPHIC ARTS DESIGNING, FOR THE CREATION OF WEB PAGES ON THE INTERNET; ELECTRONIC AUTHENTICATION SERVICES, IN THE FIELD OF ELECTRONIC DOCUMENTS; ADVISORY AND CONSULTANCY SERVICES ALL RELATING TO THE AFOREMENTIONED SERVICES; CREATION AND MAINTENANCE OF WEB SITES FOR OTHERS; HOSTING THE WEB SITES OF OTHERS (U.S. CLS. 100 AND 101).

FONG HSU, EXAMINING ATTORNEY

SN 79-064.637. SINGAPORE POST LIMITED, SINGAPORE, FILED 5-14-2008.



PRIORITY DATE OF 11-14-2007 IS CLAIMED.  
OWNER OF INTERNATIONAL REGISTRATION 0991520 DATED 5-14-2008, EXPIRES 5-14-2018.

THE MARK CONSISTS OF THE WORDING "vPOST" WITHIN A RIMMED RECTANGLE WITH ROUNDED EDGES, AND AN ARROW OVER THE BOTTOM RIGHT CORNER OF THE RECTANGLE.

### **CLASS 9—ELECTRICAL AND SCIENTIFIC APPARATUS**

FOR MAGNETICALLY ENCODED CREDIT CARDS AND CHEQUE CARDS; MAGNETICALLY ENCODED CASH CARDS; MAGNETICALLY ENCODED DEBIT CARDS; APPARATUS IN THE NATURE OF SECURE TERMINALS FOR ELECTRONIC TRANSACTIONS FOR THE PROCESSING OF MAGNETICALLY ENCODED CARD TRANSACTIONS; APPARATUS IN THE NATURE OF SECURE TERMINALS FOR ELECTRONIC TRANSACTIONS FOR PROCESSING OF DATA RELATING TO MAGNETICALLY ENCODED CARD TRANSACTIONS AND FOR PAYMENT PROCESSING; BLANK CARTRIDGES, DISCS AND TAPES, ALL FOR COLLECTING AND STORING DATA FOR ONLINE PURCHASE TRANSACTIONS, AND ON-LINE BILL PAYMENT AND CREDIT CARD PAYMENT TRANSACTIONS; COMPUTER SOFTWARE FOR RECORDING AND PROCESSING ON-LINE PURCHASE TRANSACTIONS, AND ON-LINE BILL PAYMENT AND CREDIT CARD PAYMENT TRANSACTIONS (U.S. CLS. 21, 23, 26, 36 AND 38).

### **CLASS 16—PAPER GOODS AND PRINTED MATTER**

FOR ADDRESS STAMPS; ADHESIVE BANDS FOR STATIONERY OR HOUSEHOLD PURPOSES; ADHESIVE TAPES FOR STATIONERY OR HOUSEHOLD PURPOSES; PRINTED ADVERTISEMENT BOARDS OF PAPER OR CARDBOARD; BAGS IN THE NATURE OF ENVELOPES AND POUCHES OF PAPER AND PLASTICS, FOR PACKAGING; BOXES OF CARDBOARD OR PAPER; CARDBOARD; CARDBOARD TUBES; ENVELOPES AS STATIONERY; GREETING CARDS; GUMMED TAPE AS STATIONERY; GUMS IN THE NATURE OF ADHESIVES FOR STATIONERY OR HOUSEHOLD PURPOSES; HOLDERS FOR STAMPS IN THE NATURE OF SLEEVES FOR HOLDING AND PROTECTING STAMPS; PACKAGING MATERIAL IN THE NATURE OF PACKING PAPER; POSTAGE STAMPS; POSTCARDS; SEALING WAX; SEALS AS STAMPS IN THE NATURE OF SEALING STAMPS; SELF-ADHESIVE TAPES FOR STATIONERY AND HOUSEHOLD PURPOSES; CASES FOR STAMPS AS SEALS IN THE NATURE OF SEALING STAMPS; STATIONERY; WRAPPING PAPER (U.S. CLS. 2, 5, 22, 23, 29, 37, 38 AND 50).

### **CLASS 35—ADVERTISING AND BUSINESS**

FOR RENTAL OF ADVERTISING SPACE; AUCTIONEERING; COMPILATION AND SYSTEMIZATION OF INFORMATION INTO COMPUTER DATABASES; DIRECT MAIL ADVERTISING; DOCUMENT REPRODUCTION; RELOCATION SERVICES FOR BUSINESSES; ADVERTISING AND PROMOTION SERVICES AND PROVIDING INFORMATION IN THE FIELD OF ADVERTISING AND PROMOTION SERVICES; BUSINESS INFORMATION MANAGEMENT; ADVERTISING AGENCIES; COMPILING AND DISSEMINATION OF ADVERTISING MATTER; COMPUTERIZED DATABASE MANAGEMENT; BUSINESS MANAGEMENT CONSULTANCY AND ADVISORY SERVICES; DATA PROCESSING; DATA VERIFICATION, NAMELY, ELECTRONIC SIGNATURE VERIFICATION SERVICES PROVIDED IN CONNECTION WITH BANKING AND FINANCIAL SERVICES, NAMELY, PURCHASE OF ON-LINE GOODS AND SERVICES, AUTOMATED FINANCIAL PAYMENT SERVICES, FINANCIAL PRE-PAYMENT SERVICES, ON-LINE SERVICES RELATING TO PRE-PAYMENT CARDS, DOMESTIC REMITTANCES AND ACCEPTANCE OF BILLS, SERVICES ENABLING PAYMENT FOR USAGE OF UTILITIES INCLUDING GAS, ELECTRICITY, WATER, POSTAL, TELECOMMUNICATION AND ON-LINE COMPUTER SERVICES; RETAIL SALES SERVICES, AND ONLINE RETAIL SALES SERVICES, NAMELY, BY DIRECT SOLICITATION IN THE FIELD OF PHILATELIC PRODUCTS, STAMPS, STAMP ALBUMS; RETAIL SALES SERVICES AND ONLINE RETAIL SALES SERVICES, NAMELY, BY DIRECT SOLICITATION BY SALES AGENTS IN THE FIELD OF WINE, COFFEE, GREETING CARDS, BOOKS, STATIONERY, CLOTHING, GIFT SETS AND OTHER GENERAL



MERCHANDISE; THE BRINGING TOGETHER, FOR THE BENEFIT OF OTHERS, OF A VARIETY OF GOODS AND SERVICES (EXCLUDING THE TRANSPORT THEREOF), IN THE NATURE OF GENERAL MERCHANDISE, ENABLING CUSTOMERS TO CONVENIENTLY VIEW AND PURCHASE THOSE GOODS FROM A GENERAL MERCHANDISE INTERNET WEBSITE AND A GENERAL MERCHANDISE CATALOGUE BY MAIL ORDER; COMPILATION OF MAILING LISTS; COMPILATION OF ADVERTISEMENTS FOR USE AS WEB PAGES ON THE INTERNET (U.S. CLS. 100, 101 AND 102).

#### **CLASS 36—INSURANCE AND FINANCIAL**

FOR RENT COLLECTION; BILL-POSTING IN THE NATURE OF BILL PAYMENT SERVICES PROVIDED THROUGH A WEBSITE, NAMELY, ON-LINE POSTING OF BILLS TO ENABLE ON-LINE BILL PAYMENT AND CREDIT CARD PAYMENT TRANSACTIONS; ORGANIZATION OF ON-LINE BILL PAYMENT AND CREDIT CARD PAYMENT COLLECTIONS IN THE NATURE OF BILL PAYMENT SERVICES; DEBT COLLECTION AGENCIES; FINANCING SERVICES; INSURANCE INFORMATION; INSTALLMENT LOANS; ISSUING OF TRAVELLERS' CHECKS; RETIREMENT BENEFITS PAYMENT PROCESSING SERVICES; PROVIDING STORED VALUE ELECTRONIC PURSE PAYMENT SERVICES, CASH DISBURSEMENTS, AND TRANSACTION AUTHORIZATION AND SETTLEMENT SERVICES, ALL IN THE NATURE OF STORED VALUE CARD PAYMENT SERVICES; FINANCIAL MANAGEMENT; CREDIT RECOVERY AND COLLECTION; DEBT COLLECTION AND RECOVERY SERVICES; COMPUTERIZED FINANCIAL SERVICES, NAMELY, ON-LINE BILL PAYMENT SERVICES AND CREDIT CARD PAYMENT PROCESSING SERVICES; BANK CARD SERVICES FOR TRANSACTION PAYMENTS, NAMELY, PAYMENT TRANSACTION PROCESSING AND FINANCIAL ADMINISTRATIVE SERVICES FOR CREDIT CARDS, DEBIT CARDS, CHARGE CARDS, BANK CARDS INCORPORATING PERSONAL IDENTIFICATION DATA, PURCHASE AUTHORIZATION CARDS, AND CASH CARDS; PAYMENT PROCESSING SERVICES, NAMELY, CREDIT CARD AND DEBIT CARD TRANSACTION PROCESSING SERVICES, ELECTRONIC FOREIGN EXCHANGE PAYMENT PROCESSING; PAYMENT PROCESSING FOR USAGE OF UTILITIES; FINANCIAL PRE-PAYMENT SERVICES, NAMELY, ON-LINE BILL PAYMENT SERVICES AND CREDIT CARD PAYMENT PROCESSING SERVICES, THROUGH CASH CARDS, DEBIT CARDS AND OTHER PREPAID ENCODED MAGNETIC CARDS; FINANCE AND INSURANCE INFORMATION, PROVIDED ON-LINE FROM A COMPUTER DATABASE AND A GLOBAL COMMUNICATION NETWORK; HOME BANKING; INTERNET BANKING; INFORMATION AND ADVISORY SERVICES RELATING TO THE AFORESAID (U.S. CLS. 100, 101 AND 102).

#### **CLASS 38—COMMUNICATION**

FOR RENTAL OF ACCESS TIME TO DATABASES; PROVIDING ACCESS TO DATABASES; ADVISORY AND CONSULTANCY SERVICES ALL RELATING TO THE AFOREMENTIONED SERVICES; COMMUNICATIONS BY COMPUTER TERMINALS; ELECTRONIC MAIL; COMPUTER AIDED TRANSMISSION OF MESSAGES AND IMAGES; COMMUNICATION SERVICES, NAMELY, ELECTRONIC TRANSMISSION OF DOCUMENTS, VOICE, DATA, IMAGES, AUDIO, VIDEO, COMPUTER PROGRAMS, WEB PAGES AND MESSAGES VIA COMPUTER TERMINALS, ELECTRONIC MAIL, THE INTERNET, AND MOBILE ELECTRONIC DEVICES; ELECTRONIC DATA INTERCHANGE SERVICES; ELECTRONIC MAIL SERVICES; PROVISION OF ACCESS TO A WEBSITE FOR GENERATION AND COMPLETION OF FORMS, TRANSACTION PROCES-

SING SERVICES, AND INFORMATION COMMUNICATION SERVICES; PROVIDING USER ACCESS TO A GLOBAL COMMUNICATION NETWORK, NAMELY, INTERNET SERVICE PROVIDERS, BEING A TELECOMMUNICATIONS SERVICE; PROVISION OF USER ACCESS TIME TO A GLOBAL COMPUTER NETWORK, BEING A TELECOMMUNICATIONS SERVICE; PROVIDING TELECOMMUNICATIONS CONNECTION TO A GLOBAL COMMUNICATION NETWORK OR DATABASES; PROVISION OF ACCESS TO SEARCH ENGINES AS TELECOMMUNICATIONS SERVICES (U.S. CLS. 100, 101 AND 104).

#### **CLASS 39—TRANSPORTATION AND STORAGE**

FOR PROVIDING THE PICKING UP, STORAGE AND DELIVERY OF LETTERS, CORRESPONDENCE, MAGAZINES, PACKETS, PARCELS, NEWSPAPERS, FREIGHT AND OF GOODS, ALL BY MESSENGER, ROAD, RAIL, AIR OR WATER, EXCLUDING THE ARRANGEMENT SUCH SERVICES; COURIER SERVICES; FREIGHT FORWARDING; WAREHOUSING SERVICES; GUARDED TRANSPORT OF VALUABLES; MAIL FORWARDING, NAMELY, DELIVERY AND TRANSPORTING OF MAIL; PACKAGING AND PACKING SERVICES FOR DELIVERY AND TRANSPORTATION; RENTAL OF MAILBOXES, RENTAL OF VEHICLES; RENTAL OF WAREHOUSES; TRANSPORT OF GOODS; UNLOADING OF CARGO; ADVISORY AND CONSULTANCY SERVICES ALL RELATING TO THE AFOREMENTIONED SERVICES (U.S. CLS. 100 AND 105).

#### **CLASS 42—SCIENTIFIC AND COMPUTER SERVICES**

FOR COMMISSIONED WRITING OF COMPUTER PROGRAMS, SOFTWARE AND CODE FOR THE CREATION OF WEB PAGES ON THE INTERNET; DESIGN AND GRAPHIC ARTS DESIGNING, FOR THE CREATION OF WEB PAGES ON THE INTERNET; ELECTRONIC AUTHENTICATION SERVICES, IN THE FIELD OF ELECTRONIC DOCUMENTS; ADVISORY AND CONSULTANCY SERVICES ALL RELATING TO THE AFOREMENTIONED SERVICES; CREATION AND MAINTENANCE OF WEB SITES FOR OTHERS; HOSTING THE WEB SITES OF OTHERS (U.S. CLS. 100 AND 101).

FONG HSU, EXAMINING ATTORNEY

SN 79-065,095. EISVOGEL SOLUTIONS GMBH, FED REP GERMANY, FILED 12-22-2008.

**pro green**

THE MARK CONSISTS OF STANDARD CHARACTERS WITHOUT CLAIM TO ANY PARTICULAR FONT, STYLE, SIZE, OR COLOR.

PRIORITY DATE OF 7-1-2008 IS CLAIMED.  
OWNER OF INTERNATIONAL REGISTRATION 0992638 DATED 12-22-2008, EXPIRES 12-22-2018.

NO CLAIM IS MADE TO THE EXCLUSIVE RIGHT TO USE "GREEN", APART FROM THE MARK AS SHOWN.

**CLASS 9—ELECTRICAL AND SCIENTIFIC APPARATUS**

FOR SCIENTIFIC, NAUTICAL, SURVEYING, PHOTOGRAPHIC, CINEMATOGRAPHIC, OPTICAL, WEIGHING, MEASURING, SIGNALING, SUPERVISORY CHECKING, LIFE-SAVING AND TEACHING APPARATUS AND INSTRUMENTS, NAMELY, APPARATUS AND INSTRUMENTS FOR REGULATING LIQUID FLOWS, IN PARTICULAR WATER SAVERS; APPARATUS AND INSTRUMENTS FOR CONDUCTING, SWITCHING, TRANSFORMING, ACCUMULATING, REGULATING OR CONTROLLING ELECTRICITY, NAMELY, APPARATUS AND INSTRUMENTS FOR GENERATING ELECTRICITY FROM LIGHT; IN PARTICULAR SENSOR LAMPS, SOLAR LAMPS; APPARATUS FOR RECORDING, TRANSMISSION OR REPRODUCTION OF SOUND OR IMAGES; MAGNETIC DATA CARRIERS, RECORDING DISCS; AUTOMATIC VENDING MACHINES AND MECHANISMS FOR COIN-OPERATED APPARATUS; CASH REGISTERS, CALCULATING MACHINES, DATA PROCESSING EQUIPMENT AND COMPUTERS; FIRE-EXTINGUISHING APPARATUS, ALL OF THE FOREGOING GOODS MADE FROM ENVIRONMENTALLY FRIENDLY MATERIALS (U.S. CLS. 21, 23, 26, 36 AND 38).

**CLASS 12—VEHICLES**

FOR ENVIRONMENTALLY FRIENDLY VEHICLES, NAMELY, MOTORCYCLES, ELECTRIC BIKES, AND SCOOTERS (U.S. CLS. 19, 21, 23, 31, 35 AND 44).

**CLASS 16—PAPER GOODS AND PRINTED MATTER**

FOR PAPER, CARDBOARD AND GOODS MADE FROM THESE MATERIALS, NAMELY, BABIES' NAPKINS AND PACKAGING MATERIAL; PHOTOGRAPHS; STATIONERY; ADHESIVES FOR STATIONERY OR HOUSEHOLD PURPOSE; PAINT BRUSHES; TYPEWRITERS; PRINTER'S TYPE; PRINTING BLOCKS, ALL OF THE FOREGOING GOODS MADE FROM ENVIRONMENTALLY FRIENDLY MATERIALS (U.S. CLS. 2, 5, 22, 23, 29, 37, 38 AND 50).

**CLASS 20—FURNITURE AND ARTICLES NOT OTHERWISE CLASSIFIED**

FOR FURNITURE, MIRRORS, PICTURE FRAMES, GOODS OF WOOD, CORK, REED, CANE WICKER HORN, BONE, IVORY, WHALEBONE, SHELL, AMBER, MOTHER-OF-PEARL, MEERSCHAUM AND SUBSTITUTES FOR ALL THESE MATERIAL OF PLASTICS, NAMELY, WOOD PRODUCTS AND WATER PRODUCTS, ALL OF THE FOREGOING GOODS MADE FROM ENVIRONMENTALLY FRIENDLY MATERIALS (U.S. CLS. 2, 13, 22, 25, 32 AND 50).

BILL DAWE, EXAMINING ATTORNEY

SN 79-069,453, SUDHEIMER CAR TECHNIK VERTRIEBS GMBH, FED REP GERMANY, FILED 3-27-2009.

# Mannol

THE MARK CONSISTS OF STANDARD CHARACTERS WITHOUT CLAIM TO ANY PARTICULAR FONT, STYLE, SIZE, OR COLOR.

OWNER OF INTERNATIONAL REGISTRATION 0801738 DATED 1-8-2003, EXPIRES 1-8-2013.

**CLASS 1—CHEMICALS**

FOR CHEMICAL PRODUCTS FOR USE IN INDUSTRY, IN PARTICULAR CHEMICALLY ACTIVE ADDITIVES FOR LUBRICANTS, GREASES, INDUSTRIAL OILS AND FOR ENGINE, TRANSMISSION, COMPRESSOR AND HYDRAULIC OILS AND ADDITIVES FOR FUELS, IN PARTICULAR PETROL AND DIESEL FUELS; CHEMICAL ADDITIVES FOR COOLANTS AND FOR FLUIDS OF WINDSCREEN WASHER SYSTEMS; HYDRAULIC FLUIDS; BRAKE FLUIDS; ADHESIVES FOR INDUSTRIAL USE; FILTERING CHARCOAL FOR VEHICLE INTERIOR AIR FILTERING, FUEL FILTERING, AIR INTAKE FILTERING OR OIL FILTERING; CHEMICAL PREPARATIONS IN THE NATURE OF FILTERING MATERIALS FOR VEHICLE INTERIOR AIR FILTERING, FUEL FILTERING, AIR INTAKE FILTERING OR OIL FILTERING; MINERAL SUBSTANCES IN THE NATURE OF FILTERING MATERIALS FOR VEHICLE INTERIOR AIR FILTERING, FUEL FILTERING, AIR INTAKE FILTERING OR OIL FILTERING; CERAMIC PARTICLES FOR USE AS A FILTERING MEDIA FOR VEHICLE INTERIOR AIR FILTERING, FUEL FILTERING, AIR INTAKE FILTERING OR OIL FILTERING (U.S. CLS. 1, 5, 6, 10, 26 AND 46).

**CLASS 2—PAINTS**

FOR ANTI-CORROSIVE PREPARATIONS, NAMELY, COATINGS, ANTI-CORROSIVE PAPERS AND METAL FOILS COMPRISING VOLATILE CORROSION INHIBITORS IN THE NATURE OF A COATING; RUST SOLVENTS, NAMELY, RUST SOLVENTS AND RUST PREVENTATIVES IN THE NATURE OF A COATING, NAMELY, ANTI-RUST OILS AND ANTI-RUST GREASES; ANTI-CORROSIVE CONTACT SPRAYS FOR MAINTAINING CONDUCTIVITY; LACQUERS, IN PARTICULAR ANTI-FRICTION LACQUERS; PAINTS; FIRE RETARDANT COATINGS AND PAINTS (U.S. CLS. 6, 11 AND 16).

**CLASS 3—COSMETICS AND CLEANING PREPARATIONS**

FOR WASHING AND CLEANING PREPARATIONS; CLEANING, POLISHING, SCOURING AND ABRASIVE PREPARATIONS; CLEANING PREPARATIONS FOR OIL-SOILED ENGINES AND OTHER SOILED INDUSTRIAL OBJECTS; CLEANING PREPARATIONS FOR FUEL PIPES AND INJECTION SYSTEMS OF ENGINES, IN PARTICULAR OF MOTOR VEHICLE ENGINES; CAR CARE PRODUCTS, NAMELY, WASH PRESERVATIVE AGENTS IN THE NATURE OF PREPARATIONS FOR PRESERVING VEHICLE SURFACES, PAINT CLEANING PREPARATIONS, PAINT PRESERVATIVE AGENTS IN PASTE FORM AND LIQUID FORM IN THE NATURE OF PREPARATIONS FOR PRESERVING VEHICLE SURFACES; AUTOMOBILE PAINT WAXES; WASHING SHAMPOOS; WASHING PREPARATIONS FOR VEHICLE WASHING EQUIPMENT; POWDER AND LIQUID PRE-WASHING AND WASHING PREPARATIONS FOR STEAM-JET EQUIPMENT AND HIGH PRESSURE CLEANING EQUIPMENT; CHROME CARE PRODUCTS, NAMELY, CHROME POLISH; CLEANING PREPARATIONS FOR CLEANING PLASTIC PRODUCTS; WATER REPELLENT AGENTS FOR VEHICLE WASHING EQUIPMENT IN THE NATURE OF AUTOMOBILE WAX; IMPREGNATING AGENTS IN THE NATURE OF IMPREGNATED CLEANING CLOTHS AND CLEANING PREPARATIONS FOR MOTOR VEHICLE FOLDING ROOFS; PLASTIC CARE PRODUCTS, NAMELY, PREPARATIONS FOR COATING, CLEANING AND SEALING PLASTIC PRODUCTS, NAMELY, PREPARATIONS FOR CLEANING, PROTECTING AND PRESERVING VEHICLE SURFACES; UPHOLSTERY CARE PRODUCTS, NAMELY, UPHOLSTERY CLEANERS; WHEEL RIM CLEANING PREPARATIONS; SOAPS, NAMELY, SOAPS FOR HOUSEHOLD USE AND SOAPS FOR AUTOMOBILE CLEANING (U.S. CLS. 1, 4, 6, 50, 51 AND 52).

**CLASS 4—LUBRICANTS AND FUELS**

FOR INDUSTRIAL LUBRICANTS; DUST ABSORBING, WETTING AND BINDING COMPOSITIONS; FUELS; METHYLATED MOTOR SPIRITS FOR FUEL; MINERAL SPIRITS FOR USE AS AN ACCELERANT; INDUSTRIAL GREASES AND INDUSTRIAL OILS, NAMELY, ENGINE, TRANSMISSION, COMPRESSOR AND HYDRAULIC OILS; CONTACT OILS AND CONTACT GREASES, NAMELY, ENGINE, TRANSMISSION, COMPRESSOR AND HYDRAULIC OILS; NON-CHEMICAL ADDITIVES FOR OIL, FUELS, IN PARTICULAR FOR PETROL AND DIESEL FUELS; NON-CHEMICAL ADDITIVES FOR INDUSTRIAL GREASES, INDUSTRIAL OILS, ENGINE OILS, TRANSMISSION OILS, COMPRESSOR OILS AND HYDRAULIC OILS (U.S. CLS. 1, 6 AND 15).

FONG HSU, EXAMINING ATTORNEY

**CLASS 12—VEHICLES**

FOR LAND VEHICLES; WATER VEHICLES, NAMELY, BOATS; BICYCLES AND STRUCTURAL PARTS THEREFOR (U.S. CLS. 19, 21, 23, 31, 35 AND 44).

FONG HSU, EXAMINING ATTORNEY

SN 79-069,825. BRANDED STOCKS (UK) LIMITED, UNITED KINGDOM, FILED 5-4-2009.

SN 79-069,455. SUDHEIMER CAR TECHNIK VERTRIEBS GMBH, FED REP GERMANY, FILED 3-27-2009.

**SCT**

THE MARK CONSISTS OF STANDARD CHARACTERS WITHOUT CLAIM TO ANY PARTICULAR FONT, STYLE, SIZE, OR COLOR.

OWNER OF INTERNATIONAL REGISTRATION 0812847 DATED 5-21-2003, EXPIRES 5-21-2013.

**CLASS 7—MACHINERY**

FOR ENGINES (EXCEPT FOR LAND VEHICLES); MACHINE COUPLING AND TRANSMISSION COMPONENTS (EXCEPT FOR LAND VEHICLES); BRAKE LININGS, BRAKE DISCS, BRAKE BLOCKS, BRAKE BANDS, BRAKE FRICTION LININGS, ALL FOR MACHINES; HYDRAULIC AND ELECTRIC BRAKES FOR MACHINES; COUPLINGS FOR MACHINES AND GEARS FOR INDUSTRIAL MACHINES; MACHINE PARTS, NAMELY, JOINTS; PROPELLER SHAFTS FOR INDUSTRIAL MACHINES; VIBRATION DAMPERS FOR INDUSTRIAL MACHINES; SILENCERS FOR INDUSTRIAL MACHINES; HYDRAULIC MACHINE COUPLINGS, COMPRESSED-AIR MACHINE COUPLINGS, PLUG-IN MACHINE COUPLINGS, DISCS FOR MACHINE COUPLINGS AND BRAKES, ALL NOT INTENDED FOR OR AS PARTS OF LAND VEHICLES; STRUCTURAL PARTS OF THE AFORESAID GOODS; DRIVE BELTS FOR MACHINES, FAN BELTS OF RUBBER FOR MACHINES, CONVEYOR BELTS FOR MACHINES, (EXCEPT FOR LAND VEHICLES); MACHINE TOOLS AND MACHINERY FOR APPLYING COVERINGS IN THE NATURE OF PAINTS AND COATINGS TO MACHINES AND MACHINE PARTS (U.S. CLS. 13, 19, 21, 23, 31, 34 AND 35).

**CLASS 8—HAND TOOLS**

FOR HAND TOOLS AND HAND OPERATED IMPLEMENTS FOR APPLYING COVERINGS TO MACHINES AND MACHINE PARTS (U.S. CLS. 23, 28 AND 44).

**CLASS 11—ENVIRONMENTAL CONTROL APPARATUS**

FOR AIR FILTERS FOR AIR CONDITIONING UNITS; AIR FILTERING INSTALLATIONS (U.S. CLS. 13, 21, 23, 31 AND 34).



OWNER OF INTERNATIONAL REGISTRATION 1005055 DATED 5-4-2009, EXPIRES 5-4-2019.

NO CLAIM IS MADE TO THE EXCLUSIVE RIGHT TO USE "BRANDED STOCKS", APART FROM THE MARK AS SHOWN.

THE COLOR(S) GREEN IS/ARE CLAIMED AS A FEATURE OF THE MARK.

THE MARK CONSISTS OF A GREEN SQUARE OUTLINED IN DARKER GREEN HOLDING A DEPICTION OF A GLOBE WITH CONTINENTS, MERIDIANS AND PARALLELS IN DARKER GREEN, THIS ABOVE A GREEN RECTANGLE OUTLINED IN DARKER GREEN WITH THE WORDING "BRANDED STOCKS" IN DARKER GREEN THEREIN.

**CLASS 35—ADVERTISING AND BUSINESS**

FOR BUSINESS MANAGEMENT; BUSINESS ADMINISTRATION; THE BRINGING TOGETHER FOR THE BENEFIT OF OTHERS, OF A VARIETY OF GOODS, ENABLING CUSTOMERS TO CONVENIENTLY VIEW AND PURCHASE THOSE GOODS FROM A GENERAL MERCHANDISE INTERNET WEBSITE, A RETAIL CLOTHES STORE, A WHOLESALE OUTLET (U.S. CLS. 100, 101 AND 102).

**CLASS 39—TRANSPORTATION AND STORAGE**

FOR ARRANGING FOR THE COLLECTION, STORING, PACKING, DELIVERING AND TRANSPORTING OF GOODS OF OTHERS BY LAND, RAIL, WATER AND AIR; COLLECTION OF GOODS OF OTHERS FOR STORAGE; STORAGE OF GOODS OF OTHERS; PACKING ARTICLES FOR TRANSPORTATION, AND DELIVERY AND TRANSPORTATION OF GOODS OF OTHERS BY LAND, RAIL, WATER, AND AIR (U.S. CLS. 100 AND 105).

KEVIN DINALLO, EXAMINING ATTORNEY

SN 79-070,635. FUJIAN SIJIA; INDUSTRIAL MATERIAL CO., LTD., 350000 FUJIAN PROVINCE, CHINA, FILED 6-16-2009.

思嘉  
SIJIA

OWNER OF INTERNATIONAL REGISTRATION 1007006 DATED 6-16-2009, EXPIRES 6-16-2019.

THE NON-LATIN CHARACTERS IN THE MARK TRANSLITERATE TO "SIJIA" AND THIS MEANS "THOUGHT" IN ENGLISH.

#### CLASS 17—RUBBER GOODS

FOR GUM, RAW OR PARTLY PROCESSED; SYNTHETIC RUBBER; ACRYLIC RESIN SHEETING FOR USE IN THE MANUFACTURE OF LAMINATED GLASS; RUBBER SLEEVES FOR PROTECTING PARTS OF MACHINES; ARTIFICIAL RESINS IN BARS, BLOCKS, PELLETS, RODS, SHEETS AND TUBES FOR GENERAL INDUSTRIAL USE; SEMI-PROCESSED PLASTICS; PLASTIC FIBERS FOR USE IN THE MANUFACTURE OF TIRE CORD; SEMI-WORKED SYNTHETIC PLASTIC AND SYNTHETIC FILMS AND FOAMS AS SEMI-FINISHED FILTERING SHEETS; PLASTIC AND RUBBER PACKAGING MATERIALS FOR INDUSTRIAL AND COMMERCIAL USE (U.S. CLS. 1, 5, 12, 13, 35 AND 50).

#### CLASS 25—CLOTHING

FOR CLOTHING, NAMELY, JACKETS, PARKAS, DUST COATS, BATHING SUITS, RAINCOAT, RAIN CLOAKS, FOOTBALL SHOES, HOODS AND SHOWER CAPS (U.S. CLS. 22 AND 39).

LAURA KOVALSKY, EXAMINING ATTORNEY

SN 79-071,630. SECURENCY INTERNATIONAL PTY LTD, AUSTRALIA, FILED 3-31-2009.

WinBOSS

THE MARK CONSISTS OF STANDARD CHARACTERS WITHOUT CLAIM TO ANY PARTICULAR FONT, STYLE, SIZE, OR COLOR.

OWNER OF INTERNATIONAL REGISTRATION 1009622 DATED 3-31-2009, EXPIRES 3-31-2019.

#### CLASS 9—ELECTRICAL AND SCIENTIFIC APPARATUS

FOR CURRENCY AUTHENTICATION APPARATUS AND EQUIPMENT, NAMELY, CURRENCY RECOGNITION MACHINES IN THE NATURE OF MACHINES COMPRISING COMPUTER HARDWARE THAT CONTAINS PROGRAMMING FOR AUTHENTICATION OF CURRENCY SOLD AS AN INTEGRAL UNIT; DETECTORS AND SENSING APPARATUS, NAMELY, ELECTRONIC SENSORS AND DETECTORS THAT CONTAIN PROGRAMMING FOR AUTHENTICATION OF CURRENCY, AND OPTICAL READING MACHINES WHICH DETECT SECURITY FEATURES IN BANKNOTES, PASSPORTS AND SECURITY AND IDENTIFICATION DOCUMENTS; CURRENCY RECOGNITION MACHINES AND

OPTICAL CHARACTER RECOGNITION APPARATUS IN THE NATURE OF APPARATUS AND EQUIPMENT FOR DETECTING SECURITY DOCUMENTS, SECURITY FILMS, INKS AND SECURITY FEATURES EMBEDDED IN BANKNOTES, PASSPORTS AND OTHER OFFICIAL PRINTED DOCUMENTS, NAMELY, OPTICAL READERS AND OPTICAL SCANNERS; OPTICAL DETECTION APPARATUS, NAMELY, OPTICAL READERS AND OPTICAL SCANNERS THAT CONTAIN PROGRAMMING FOR THE AUTHENTICATION OF CURRENCY, AND FOR THE DETECTION OF SECURITY FEATURES EMBEDDED IN BANKNOTES, PASSPORTS AND OTHER OFFICIAL PRINTED DOCUMENTS; SECURITY DEVICES INCORPORATING SECURITY FEATURES AND SECURITY DEVICES IN THE NATURE OF SECURITY FEATURES AND OPTICALLY VARIABLE DEVICES USED IN BANKNOTES AND OTHER SECURITY DOCUMENTS, NAMELY, OPTICALLY VARIABLE DEVICES, NAMELY, MICROLENSSES IN THE FORM OF OPTICAL LENSES FOR USE AS SECURITY AND AUTHENTICATION PURPOSES, DIFFRACTIVE OPTICAL ELEMENTS, DIFFRACTION GRATINGS, AND OTHER SURFACE BASED DIFFRACTIVE STRUCTURES, NAMELY, NON-PRINTED HOLOGRAMS, OPTICAL INTERFERENCE FILTERS FOR FILTERING LIGHT, HOLOGRAPHIC OPTICAL FILTERS FOR FILTERING LIGHT, OPTICAL POLARIZATION FILTERS FOR FILTERING LIGHT, HOLOGRAPHIC EMBOSSEMENTS, HOLOGRAPHIC OPTICAL THIN SECURITY FILMS, MULTI LAYER HOLOGRAPHIC FILMS, IRIDESCENT HOLOGRAPHIC SECURITY LAYERS AND REFLECTIVE LAYERS, AND LIQUID CRYSTAL OPTICAL FILTERS FOR FILTERING LIGHT; GOODS IN THIS CLASS INCORPORATING OPTICALLY VARIABLE DEVICES OR OTHER SECURITY DEVICES SOLD AS INTEGRAL COMPONENTS AND SOLD AS SINGLE UNITS, NAMELY, MAGNETICALLY ENCODED CREDIT CARDS AND MAGNETICALLY ENCODED FILMS FOR USE IN THE MANUFACTURE OF SECURITY DOCUMENTS, NAMELY, PASSPORTS, IDENTIFICATION CARDS, DRIVER LICENSE CARDS, TRAVEL DOCUMENTS, AIRLINE TICKETS, TRAIN TICKETS, ENTRANCE CARDS AND TICKETS; MAGNETICALLY ENCODED IDENTIFICATION CARDS, MAGNETIC ENCODED CARDS AND CARDS CONTAINING AN ENCODED INTEGRATED CIRCUIT CHIP FOR USE IN CONNECTION WITH PAYMENT OF SERVICES; MAGNETICALLY ENCODED SMART CARDS CONTAINING PROGRAMMING USED FOR READING, WRITING, CONTROLLING, EXCHANGING AND MODIFICATION OF DATA FOR USE IN THE FIELD OF PAYMENT, FINANCE, ACCESS, CONTROL, TRANSPORT, TICKETING, ELECTRONIC IDENTIFICATION, RETAIL AND GIFT CARD AND MOBILE COMMUNICATION FIELDS; MAGNETICALLY ENCODED CHARGE CARDS; MAGNETICALLY ENCODED BANK CARDS; MAGNETICALLY ENCODED CREDIT CARDS; MAGNETICALLY ENCODED DEBIT CARDS; MAGNETICALLY ENCODED PAYMENT CARDS; MAGNETIC ID CARDS FOR USE IN CONNECTION WITH PAYMENT FOR SERVICES AND GOODS; ELECTRONIC AND MAGNETIC ENCODED CARD READERS; COMPUTER HARDWARE AND SOFTWARE FOR USE IN CURRENCY AUTHENTICATION EQUIPMENT AND APPARATUS; COMPUTER HARDWARE AND SOFTWARE DESIGNED TO ENABLE BANKNOTES AND OTHER SECURITY DOCUMENTS TO INTERACT WITH TERMINALS AND READERS; COMPUTER SOFTWARE FOR IMPLEMENTING ENCRYPTION, AUTHENTICATION, ACCESS CONTROL AND OTHER SECURITY FEATURES IN RELATION TO BANKNOTES, MAGNETIC ENCODED CARDS AND DOCUMENTS CONTAINING AN INTEGRATED CHIP (U.S. CLS. 21, 23, 26, 36 AND 38).



**CLASS 16—PAPER GOODS AND PRINTED MATTER**

FOR PRINTED MATTER, NAMELY, BANKNOTES, BANK CHEQUES, CREDIT CARDS WITHOUT MAGNETIC CODING, PRINTED SECURITY AND IDENTIFICATION DOCUMENTS THAT ARE NOT MAGNETICALLY ENCODED, NAMELY, BLANK PASSPORTS; PRINTED MATTER, NAMELY, IDENTIFICATION DOCUMENTS WITHOUT MAGNETIC CODING HAVING PRINTED OR NON-ELECTRICALLY CONDUCTIVE SECURITY FEATURES, NAMELY, BLANK PASSPORTS, IDENTIFICATION CARDS, BLANK DRIVER LICENSE CARDS, PRINTED SECURITIES AND SHARE CERTIFICATES, PRINTED DEEDS OF TITLE CERTIFICATES, PRINTED TRAVEL DOCUMENTS, PRINTED AIRLINE AND TRAIN TICKETS, PRINTED ENTRANCE CARDS AND TICKETS, PRINTED BIRTH, DEATH AND MARRIAGE CERTIFICATES, PRINTED ACADEMIC TRANSCRIPTS PAPER; PRINTED SECURITY DEVICES, NAMELY, PRINTED HOLOGRAMS FOR SECURITY OR IDENTIFICATION PURPOSES; PRINTED MATTER, NAMELY, PRINTED SECURITY DOCUMENTS THAT ARE NOT MAGNETICALLY ENCODED, NAMELY, BLANK PASSPORTS, IDENTIFICATION CARDS, BLANK DRIVER LICENSE CARDS, PRINTED SECURITIES AND SHARE CERTIFICATES, PRINTED DEEDS OF TITLE CERTIFICATES, PRINTED TRAVEL DOCUMENTS, PRINTED AIRLINE AND TRAIN TICKETS, PRINTED ENTRANCE CARDS AND TICKETS, PRINTED BIRTH, DEATH AND MARRIAGE CERTIFICATES, PRINTED ACADEMIC TRANSCRIPTS PAPER; PRINTED MATTER, NAMELY, PRINTED AND EMBOSSED PLASTIC NON-ELECTRICALLY CONDUCTIVE SECURITY FILM NOT FOR COMMERCIAL OR INDUSTRIAL PURPOSES, AND PRINTED SECURITY DEVICES, NAMELY, INTAGLIO PRINTED IMAGES; PRINTED REFLECTIVE PATCHES; PRINTED SECURITY THREADS; PRINTED IRIDESCENT AND PEARLESCENT IMAGES, VIGNETTES; PAPER OR POLYMER BANK NOTES WITHOUT MAGNETIC CODING; BANK NOTES AND PRINTED SECURITY DOCUMENTS MADE FROM PLASTIC OR POLYMERIC MATERIAL THAT ARE NON-ELECTRICALLY CONDUCTIVE AND NOT MAGNETICALLY ENCODED, EITHER COMBINED OR NOT COMBINED WITH PAPER, NAMELY, BANK CHECKS, BLANK PASSPORTS, IDENTIFICATION CARDS, BLANK DRIVER LICENSE CARDS, PRINTED SECURITIES AND SHARE CERTIFICATES, PRINTED DEEDS OF TITLE CERTIFICATES, PRINTED TRAVEL DOCUMENTS, NAMELY, PRINTED CERTIFICATES AND TICKETS, PRINTED AIRLINE AND TRAIN TICKETS, PRINTED ENTRANCE CARDS AND TICKETS, PRINTED BIRTH, DEATH AND MARRIAGE CERTIFICATES AND PRINTED BLANK ACADEMIC TRANSCRIPTS PAPER; PRESS-READY PAPER SUBSTITUTES, NAMELY, POLYMERIC SUBSTRATES PREPARED READY FOR PRINTING IN THE NATURE OF TRANSPARENT, OPAQUE, AND TRANSLUCENT FILMS FOR USE WITH CURRENCY PRINTERS, INK JET COPIERS OR PRINTERS AND LASER COPIERS OR PRINTERS (U.S. CLS. 2, 5, 22, 23, 29, 37, 38 AND 50).

NAPOLEON SHARMA, EXAMINING ATTORNEY

SN 79-072,441. MILLEFIORI CANDLES DI ROLANDI ALESSANDRO, I-23871 LOMAGNA (LC), ITALY, FILED 5-29-2009.

# MILLEFIORI

THE MARK CONSISTS OF STANDARD CHARACTERS WITHOUT CLAIM TO ANY PARTICULAR FONT, STYLE, SIZE, OR COLOR.

PRIORITY DATE OF 5-20-2009 IS CLAIMED.  
OWNER OF INTERNATIONAL REGISTRATION 1011936 DATED 5-29-2009, EXPIRES 5-29-2019.

**CLASS 3—COSMETICS AND CLEANING PREPARATIONS**

FOR SOAPS FOR PERSONAL USE AND FOR TOILET PURPOSES; PERFUMERY; ESSENTIAL OILS FOR PERSONAL USE AND FOR USE IN THE MANUFACTURE OF SCENTED PRODUCTS; POTPOURRIS; FRAGRANCES (U.S. CLS. 1, 4, 6, 50, 51 AND 52).

**CLASS 5—PHARMACEUTICALS**

FOR AIR DEODORANTS, CAR DEODORANTS, DEODORANTS FOR CLOTHING OR TEXTILES, HOUSEHOLD DEODORANTS (U.S. CLS. 6, 18, 44, 46, 51 AND 52).

**CLASS 21—HOUSEWARES AND GLASS**

FOR NON-ELECTRIC FRAGRANCE DISPENSERS, NAMELY, FRAGRANCE OIL BURNERS (U.S. CLS. 2, 13, 23, 29, 30, 33, 40 AND 50).

SUZANNE BLANE, EXAMINING ATTORNEY

SN 79-075,662. DECATHLON, FRANCE, FILED 4-9-2009.

# NEWFEEL

THE MARK CONSISTS OF STANDARD CHARACTERS WITHOUT CLAIM TO ANY PARTICULAR FONT, STYLE, SIZE, OR COLOR.

PRIORITY DATE OF 10-10-2008 IS CLAIMED.  
OWNER OF INTERNATIONAL REGISTRATION 1020333 DATED 4-9-2009, EXPIRES 4-9-2019.  
OWNER OF U.S. REG. NO. 3,654,882.  
THE WORDING "NEWFEEL" HAS NO MEANING IN A FOREIGN LANGUAGE.

**CLASS 35—ADVERTISING AND BUSINESS**

FOR RETAIL STORES AND ONLINE RETAIL STORES FEATURING FOOTWEAR AND SPORTING FOOTWEAR (U.S. CLS. 100, 101 AND 102).

**CLASS 41—EDUCATION AND ENTERTAINMENT**

FOR PROVIDING INFORMATION AND ADVICE IN THE FIELD OF RECREATIONAL WALKING; ARRANGING, ORGANIZING, CONDUCTING, AND HOSTING RUNNING AND WALKING EVENTS (U.S. CLS. 100, 101 AND 107).

ELISSA GARBER KON, EXAMINING ATTORNEY

SN 79-075,767. MIKE BURTON GROUP LIMITED, UNITED KINGDOM, FILED 10-22-2009.

OWNER OF INTERNATIONAL REGISTRATION 1020667 DATED 10-22-2009, EXPIRES 10-22-2019.

THE MARK CONSISTS OF THE STYLIZED TERM "MB" WHEREIN THE RIGHT SIDE OF THE LETTER "M" FORMS THE STEM OF THE LETTER "B".

#### **CLASS 16—PAPER GOODS AND PRINTED MATTER**

FOR PRINTED MATTER AND PUBLICATIONS, NAMELY, PROGRAMS, BROCHURES, ITINERARIES, PRINTED TICKETS, STATIONERY AND PRINTED GUIDES ALL IN THE FIELDS OF TRAVEL AND TOUR SERVICES AND CELEBRITY AND PLAYER MANAGEMENT; PRINTED MATTER AND PUBLICATIONS, NAMELY, PROGRAMS, BROCHURES, ITINERARIES, PRINTED TICKETS, STATIONERY AND PRINTED GUIDES FOR LECTURES, SEMINARS AND CONFERENCES IN THE FIELDS OF SPORTS, TRAVEL, TOURING, CELEBRITY AND PLAYER MANAGEMENT; PRINTED MATTER AND PUBLICATIONS, NAMELY, PROGRAMS, BROCHURES, ITINERARIES, PRINTED TICKETS, STATIONERY AND PRINTED GUIDES FOR CORPORATE HOSPITALITY RECEPTIONS AT ENTERTAINMENT, CULTURAL AND SPORTING EVENTS; PRINTED TICKETS; STATIONERY; PRINTED GUIDES FOR ENTERTAINMENT OR RECREATIONAL PURPOSES IN THE FIELD OF TRAVEL AND SPORT (U.S. CLS. 2, 5, 22, 23, 29, 37, 38 AND 50).

#### **CLASS 35—ADVERTISING AND BUSINESS**

FOR ADVERTISING; BUSINESS MANAGEMENT AND ORGANIZATION CONSULTANCY; MANAGEMENT OF PERFORMING ARTISTS, SPORTS PEOPLE AND CELEBRITIES; PROVISION OF INFORMATION, CONSULTANCY AND ADVICE, NAMELY, PROVIDING BUSINESS INFORMATION, BUSINESS ADVICE AND INFORMATION (U.S. CLS. 100, 101 AND 102).

#### **CLASS 39—TRANSPORTATION AND STORAGE**

FOR BOOKING OF SEATS FOR TRAVEL; CHAUFFEUR SERVICES; ARRANGING OF TOURS; TRANSPORT BY AIR; TRANSPORT BY LAND AND SEA, NAMELY, BUS, AUTOMOBILE, TRAIN AND BOAT TRANSPORT; TRAVEL AGENCY SERVICES FOR TRAVEL, NAMELY, ORGANIZATION AND RESERVATION OF SEATS FOR TRAVEL IN THE FIELD OF SPORTS; AND MAKING RESERVATIONS AND BOOKINGS FOR SEATS FOR TRANSPORTATION; PROVISION OF INFORMATION, CONSULTANCY AND ADVICE, NAMELY, TRANSPORTATION INFORMATION, TRANSPORTATION CONSULTING (U.S. CLS. 100 AND 105).

#### **CLASS 41—EDUCATION AND ENTERTAINMENT**

FOR BOOKING AGENCY SERVICES FOR THEATRE TICKETS, ENTERTAINMENT AND SPORTING EVENTS; BOOKING OF SEATS FOR CONCERTS AND SHOWS; ENTERTAINMENT SERVICES, NAMELY, PROVISION OF AMUSEMENT ARCADES, CASINO FACILITIES; ARRANGING AND CONDUCTING ATHLETIC COMPETITIONS AND EXHIBITIONS, ALL BEING FOR ENTERTAINMENT PURPOSES, AND PROVISION OF LIVE MUSIC CONCERTS AND LIVE PERFORMERS, NAMELY, COMEDIANS, EDUCATIONAL SPEAKERS, BANDS, MUSICAL GROUPS, VOCALISTS, RAPPERS AND ORCHESTRAS, PROVIDING FACILITIES FOR SPORTS TOURNAMENTS, NAMELY, AMERICAN FOOTBALL, ANGLING, ARCHERY, TRACK AND FIELD, BADMINTON, BASEBALL, BASKETBALL, BILLIARDS, BOXING, CANOEING, CRICKET, CYCLING, DARTS, EQUESTRIAN SPORTS, FENCING, SOCCER, GOLF, GREYHOUND RACING, GYMNASTICS, HANDBALL, HOCKEY, HORSE RACING, ICE HOCKEY, LACROSSE, MARATHONS, MARTIAL ARTS, MOTOR SPORTS, NET BALL, POLO, POWERBOAT RACING, ROWING, RUGBY, RUNNING, SAILING, SHOOTING,

SKATING, SNOW SKIING, SNOOKER, SOFTBALL, SQUASH, SURFING, SWIMMING, TABLE TENNIS, VOLLEYBALL, WATER SKIING, WEIGHT LIFTING, WRESTLING AND YACHTING; ARRANGING AND CONDUCTING EDUCATIONAL COLLOQUIUMS, EDUCATIONAL CONFERENCES, EDUCATIONAL CONGRESSES, SEMINARS, EDUCATIONAL SYMPOSIUMS AND WORKSHOPS IN THE FIELD OF SPORTS, TRAVEL, TOURS, MANAGEMENT OF CELEBRITIES AND SPORTS PLAYERS; PROVIDING ENTERTAINMENT INFORMATION IN THE FIELD OF SPORTS (U.S. CLS. 100, 101 AND 107).

#### **CLASS 43—HOTEL AND RESTAURANT SERVICES**

FOR MAKING TEMPORARY ACCOMMODATION RESERVATIONS AND HOTEL RESERVATIONS FOR OTHERS; CATERING SERVICES; PROVISION OF FOOD AND DRINK; PROVISION OF FACILITIES FOR EXHIBITIONS; PROVISION OF INFORMATION, CONSULTANCY AND ADVICE, NAMELY, CONSULTING SERVICES IN THE FIELD OF HOSPITALITY (U.S. CLS. 100 AND 101).

MYRIAH HABEEB, EXAMINING ATTORNEY

SN 79-077,422. PAUL BASTIANEN, NETHERLANDS, FILED 10-6-2009.

# VINDICO

THE MARK CONSISTS OF STANDARD CHARACTERS WITHOUT CLAIM TO ANY PARTICULAR FONT, STYLE, SIZE, OR COLOR.

OWNER OF INTERNATIONAL REGISTRATION 1025185 DATED 10-6-2009, EXPIRES 10-6-2019.

#### **CLASS 2—PAINTS**

FOR PAINTS, VARNISHES AND LACQUERS, INCLUDING, COATINGS ALSO FOR USE FOR THE PROTECTION OF GLASS; PRESERVATIVES AGAINST RUST IN THE NATURE OF A COATING AND PRESERVATIVES AGAINST DETERIORATION OF WOOD; COLORANTS; MORDANTS FOR USE WITH GLASS; RAW NATURAL RESINS; METALS IN FOIL AND POWDER FORM FOR PAINTERS, DECORATORS, PRINTERS AND ARTISTS (U.S. CLS. 6, 11 AND 16).

#### **CLASS 3—COSMETICS AND CLEANING PREPARATIONS**

FOR CLEANING, POLISHING, SCOURING AND ABRASIVE PREPARATIONS FOR GLASS (U.S. CLS. 1, 4, 6, 50, 51 AND 52).

RON FAIRBANKS, EXAMINING ATTORNEY

SN 79-077,790. SCHNEIDER ELECTRIC INDUSTRIES SAS, FRANCE, FILED 11-6-2009.

# EASYPLUG

PRIORITY DATE OF 6-18-2009 IS CLAIMED.  
OWNER OF INTERNATIONAL REGISTRATION 1026128 DATED 11-6-2009, EXPIRES 11-6-2019.

**CLASS 9—ELECTRICAL AND SCIENTIFIC APPARATUS**

FOR ELECTRONIC COMPONENTS FOR COMMUNICATION VIA ELECTRICAL LINES, NAMELY, ELECTRICAL CONNECTORS, ELECTRICAL POWER CONNECTORS, COMMUNICATION HUBS, OPTICAL RECEIVERS, AND ELECTRONIC TRANSMITTERS FOR JAMMING SIGNALS; CALCULATING MACHINES AND DATA PROCESSING EQUIPMENT; PLUG ADAPTORS, ADAPTORS; ELECTRONIC COMPONENTS FOR COMMUNICATION VIA ELECTRICAL LINES, NAMELY, BRANCH BOXES, SPLICING BOXES, JUNCTION BOXES, ELECTRICAL TERMINALS, COMPUTER NETWORK SIGNALS SPLITTERS, NETWORK BRIDGES, GATEWAY ROUTERS IN THE NATURE OF PROCESSING CONTROL HARDWARE AND NETWORK ROUTERS FOR COMPUTING; PRINTED CIRCUITS, INTEGRATED CIRCUITS, ELECTRICAL AUDIO VIDEO CONNECTORS, ELECTRIC PLUGS USING CARRIER CURRENTS, SATELLITE RECEIVERS USING CARRIER CURRENTS, CAMERAS FOR RECORDING USING CARRIERS, AUDIO-VISUAL RECEIVERS, DIGITAL MEDIA RECEIVERS, AND TRANSMITTERS AND RECEIVERS FOR AUDIO, VIDEO, AND DATA SIGNALS FOR TRANSMISSION OVER TWISTED PAIR CABLES OR POWERLINES USING CARRIER CURRENTS, ELECTRIC CONTROL PANELS, ELECTRIC INSTALLATIONS FOR THE REMOTE CONTROL OF INDUSTRIAL OPERATIONS, ELECTRICAL CONNECTORS, ELECTRICAL CONNECTION BOXES AND CIRCUIT BOARDS, CONNECTIONS FOR ELECTRIC LINES, ELECTRICAL OUTLETS, CIRCUIT BREAKERS, ELECTRIC SWITCHES, ELECTRICAL DISTRIBUTION BOXES, ELECTRIC DISTRIBUTION CONSOLES, ELECTRIC DISTRIBUTION BOARDS, TRANSMITTERS OF ELECTRONIC SIGNALS; ELECTRICAL CONTROLLING DEVICES; ELECTRICAL CONTROL DEVICES, NAMELY, PUSH-BUTTON SWITCHES FOR CONTROLLING ELECTRICAL CIRCUITS, ELECTRIC OR ELECTRONIC SENSORS FOR PROVIDING ELECTRICAL CONTROL SIGNALS, ELECTRIC RELAYS, ELECTRIC CONTACTORS; ELECTRICAL DEVICES FOR MEASURING ELECTRICAL ENERGY, NAMELY, ELECTRIC METERS; INTERCOMMUNICATION APPARATUS, NAMELY, APPARATUS FOR TRANSMISSION OF COMMUNICATION; COMPUTER SOFTWARE, NAMELY, COMMUNICATION SOFTWARE FOR CONNECTING APPARATUS TO A NETWORK (U.S. CLS. 21, 23, 26, 36 AND 38).

**CLASS 38—COMMUNICATION**

FOR PAGING SERVICES; RADIO PAGING SERVICES; TELEPHONE PAGING SERVICES; TELEVISION PROGRAMME BROADCASTING; RADIO PROGRAMME BROADCASTING; ELECTRONIC MESSAGE TRANSMISSION; COMPUTER AIDED TRANSMISSION OF INFORMATION AND IMAGES (U.S. CLS. 100, 101 AND 104).

**CLASS 42—SCIENTIFIC AND COMPUTER SERVICES**

FOR TECHNICAL CONSULTATION AND RESEARCH IN THE FIELD OF TELECOMMUNICATION, NAMELY, TECHNICAL CONSULTATION AND RESEARCH FOR THE USE OF TELECOMMUNICATION DEVICES, APPARATUS, EQUIPMENT AND TELECOMMUNICATION INSTALLATIONS; TECHNICAL CONSULTATION AND RESEARCH IN THE FIELD OF COMPUTER SOFTWARE, NAMELY, COMMUNICATION SOFTWARE (U.S. CLS. 100 AND 101).

JANICE KIM, EXAMINING ATTORNEY

SN 79-078,275. PDA GROUP GMBH, AUSTRIA, FILED 11-2-2009.



PRIORITY DATE OF 5-8-2009 IS CLAIMED.

OWNER OF INTERNATIONAL REGISTRATION 1027293 DATED 11-2-2009, EXPIRES 11-2-2019.

NO CLAIM IS MADE TO THE EXCLUSIVE RIGHT TO USE "GROUP", APART FROM THE MARK AS SHOWN.

THE COLOR(S) WHITE, DARK BLUE AND LIGHT BLUE IS/ARE CLAIMED AS A FEATURE OF THE MARK.

THE MARK CONSISTS OF THE WORDING "PDA GROUP" IN DARK BLUE, WITH A LIGHT BLUE AND WHITE TRIANGLE APPEARING BETWEEN THE WORDS.

**CLASS 9—ELECTRICAL AND SCIENTIFIC APPARATUS**

FOR DATA PROCESSING EQUIPMENT AND COMPUTERS (U.S. CLS. 21, 23, 26, 36 AND 38).

**CLASS 35—ADVERTISING AND BUSINESS**

FOR ADVERTISING; BUSINESS MANAGEMENT; BUSINESS ADMINISTRATION; OFFICE FUNCTIONS; PROVIDING OFFICE FUNCTIONS (U.S. CLS. 100, 101 AND 102).

**CLASS 38—COMMUNICATION**

FOR TELECOMMUNICATIONS IN THE NATURE OF TRANSMISSION OF INFORMATION AND DATA FILES BY ELECTRONIC COMMUNICATION NETWORKS; ONLINE SERVICES, NAMELY, ELECTRONIC TRANSMISSION OF DATA AND DOCUMENTS VIA COMPUTER TERMINALS (U.S. CLS. 100, 101 AND 104).

**CLASS 41—EDUCATION AND ENTERTAINMENT**

FOR EDUCATION SERVICES IN THE NATURE OF PROVIDING CLASSES AND SEMINARS IN THE FIELD OF SOFTWARE, SELLING, KNOWLEDGE MANAGEMENT, ECONOMY; PROVIDING OF TRAINING IN THE FIELD OF SOFTWARE EDUCATION, SALES TRAINING, ECONOMIC EDUCATION AND KNOWLEDGE MANAGEMENT EDUCATION; ORGANIZING SPORTING AND CULTURAL ACTIVITIES (U.S. CLS. 100, 101 AND 107).

**CLASS 42—SCIENTIFIC AND COMPUTER SERVICES**

FOR SCIENTIFIC AND TECHNOLOGICAL SERVICES AND RESEARCH AND DESIGN RELATING THERETO IN THE FIELD OF DATA PROCESSING, DATA ANALYZING, SOFTWARE SOLUTION, KNOWLEDGE MANAGEMENT, RECRUITMENT OF HUMAN RESOURCES; INDUSTRIAL ANALYSIS AND RESEARCH SERVICES IN THE FIELD OF DATA PROCESSING, DATA ANALYZING, SOFTWARE SOLUTION, KNOWLEDGE MANAGEMENT, RECRUITMENT OF HUMAN RESOURCES; DESIGN AND DEVELOPMENT OF COMPUTER HARDWARE AND SOFTWARE (U.S. CLS. 100 AND 101).

JULIE VEPPUMTHARA, EXAMINING ATTORNEY

SN 79-078,830. FASTWEB S.P.A., ITALY, FILED 9-2-2009.



PRIORITY DATE OF 7-8-2009 IS CLAIMED.  
OWNER OF INTERNATIONAL REGISTRATION 1028619  
DATED 9-2-2009, EXPIRES 9-2-2019.

NO CLAIM IS MADE TO THE EXCLUSIVE RIGHT TO  
USE "FASTWEB", APART FROM THE MARK AS SHOWN.

THE MARK CONSISTS OF THE WORD "FASTWEB" IN  
CAPITAL LETTERS; THE LETTERS ARE IN RELIEF WITH  
A THREE DIMENSIONAL EFFECT; THE LETTER "W" IS  
STYLIZED, AND CONSISTING OF THREE BENT STRIPS  
INTERRUPTED IN THE MEDIAN SIDE, THE STRIPS ARE  
NARROWING DOWNWARD AND EXTENDING TO A  
COMMON VERTEX.

#### **CLASS 9—ELECTRICAL AND SCIENTIFIC APPARATUS**

FOR SOFTWARE FOR USE IN SUPPORT OF COMPU-  
TER RESOURCE MANAGEMENT AND PROGRAM EXE-  
CUTION, NAMELY, OPERATION SYSTEM  
SOFTWARE, NETWORK SOFTWARE, DATABASE  
SOFTWARE, SOFTWARE UTILITIES FOR DEVELOPING  
AND RUNNING PROGRAMS, SOFTWARE DRIVES FOR  
MANAGING INTERNAL AND EXTERNAL DEVICES;  
SOFTWARE USED FOR SUPPORTING BUSINESS  
NEEDS, NAMELY, PROGRAMS FOR INCREASING  
PRODUCTIVITY AND EFFICIENCY IN CORPORATE  
DEPARTMENTS IN THE FIELDS OF SALES, ACCOUNT-  
ING AND HUMAN RESOURCES; SOFTWARE USED  
FOR PERSONAL NEEDS, NAMELY, SOFTWARE USED  
FOR CONTROLLING HOME APPLIANCES AND HOME  
ENTERTAINMENT APPLIANCES; ELECTRONIC PUS-  
HISHING PRODUCTS, NAMELY, COMPUTER SOFT-  
WARE FOR USE IN ELECTRONIC PUBLISHING,  
NAMELY, EDITING SOFTWARE; BLANK CD-ROMS,  
FLOPPY-DISKS AND OTHER MAGNETIC SUPPORTS  
FOR RECORDING, TELEPHONY PRODUCTS,  
NAMELY, PHONES AND MOBILE PHONES (U.S. CLS.  
21, 23, 26, 36 AND 38).

#### **CLASS 25—CLOTHING**

FOR CLOTHING, NAMELY, T-SHIRTS; HATS; CA-  
SUAL SHOES (U.S. CLS. 22 AND 39).

#### **CLASS 28—TOYS AND SPORTING GOODS**

FOR GAMES AND PLAYTHINGS, NAMELY, BALLS,  
FOOTBALLS, BOARD GAMES, JIGSAW PUZZLES,  
BRAIN TEASER GAMES (U.S. CLS. 22, 23, 38 AND 50).

#### **CLASS 37—CONSTRUCTION AND REPAIR**

FOR MAINTENANCE AND INSTALLATION OF TEL-  
ECOMMUNICATION SYSTEMS, NAMELY, BROAD-  
BAND TELECOMMUNICATION SYSTEMS, DATA,  
VIDEO AND TELEPHONIC TRANSMISSION SYSTEMS  
(U.S. CLS. 100, 103 AND 106).

#### **CLASS 38—COMMUNICATION**

FOR TELECOMMUNICATION SERVICES, NAMELY,  
TELECOMMUNICATION SERVICES THROUGH  
BROADBAND TELECOMMUNICATION SYSTEMS,  
DATA VIDEO AND TELEPHONIC TRANSMISSION SYS-  
TEMS, TELECOMMUNICATION BY CABLE AND WIRE-  
LESS TELEPHONE TRANSMISSION SERVICES, MOBILE  
AND FIXED TELECOMMUNICATION SERVICES, TEL-  
EPHONE, SATELLITE TELECOMMUNICATION, CEL-  
LULAR TELECOMMUNICATION, RADIO  
COMMUNICATION SYSTEMS, TRANSMISSION OF  
DATA BY RADIO, SATELLITE, ONLINE AND INTER-  
NET; TELEPHONE AND MOBILE TELEPHONE MES-  
SAGE COLLECTION AND TRANSMISSION, CALL  
DIVERSION, ANSWERING-PHONE AND ELECTRONIC  
MAILING SERVICES (U.S. CLS. 100, 101 AND 104).

#### **CLASS 41—EDUCATION AND ENTERTAIN- MENT**

FOR ORGANIZING EXHIBITIONS AND EVENTS FOR  
CULTURAL AND SPORTING PURPOSES, ORGANIZA-  
TION OF SPORT EVENTS, SERVICES PROVIDING  
INFORMATION ON ENTERTAINMENT AND EDUCA-  
TION, AND ELECTRONIC LIBRARY SERVICES SUP-  
PLYING ELECTRONIC AND ELECTRONIC ARCHIVE  
DATA IN THE FORM OF TEXT, AUDIO AND/OR  
VIDEO; PUBLICATION OF BOOKS AND JOURNALS  
ON-LINE (U.S. CLS. 100, 101 AND 107).

#### **CLASS 42—SCIENTIFIC AND COMPUTER SERVICES**

FOR PLANNING AND DEVELOPMENT OF TELE-  
COMMUNICATION SYSTEMS, NAMELY, BROADBAND  
TELECOMMUNICATION SYSTEMS, DATA, VIDEO AND  
TELEPHONIC TRANSMISSION SYSTEMS (U.S. CLS. 100  
AND 101).

JANICE L. MCMORROW, EXAMINING ATTORNEY

---

SN 79-078,834. MATURITY GMBH, MÜNCHEN, FED REP  
GERMANY, FILED 11-24-2009.



OWNER OF INTERNATIONAL REGISTRATION 1028629  
DATED 11-24-2009, EXPIRES 11-24-2019.

THE MARK CONSISTS OF THE TERM "MATURITY"  
WITH PART OF THE LETTERS "R" AND "Y" CURVING  
AROUND THE LETTERS "IT".

#### **CLASS 9—ELECTRICAL AND SCIENTIFIC APPARATUS**

FOR COMPUTER SOFTWARE FOR ANALYSING THE  
ECONOMIC VIABILITY OF UNDERTAKINGS (U.S. CLS.  
21, 23, 26, 36 AND 38).



**CLASS 35—ADVERTISING AND BUSINESS**

FOR ORGANISATIONAL, BUSINESS, PERSONNEL AND PROFESSIONAL BUSINESS CONSULTANCY, INCLUDING OPERATIONAL ANALYSES AND BUSINESS COMPARISONS; BUSINESS MARKETING; SALES PROMOTION; BUSINESS ADMINISTRATION; PROFESSIONAL BUSINESS AND BUSINESS ORGANISATIONAL CONSULTANCY DURING BUSINESS START-UPS FOR OTHERS, COMPANY MANAGEMENT FOR OTHERS; ADVERTISING SERVICES FOR PROMOTING THE BROKERAGE OF INVESTMENTS IN OTHER COMPANIES; ARRANGING AND CONCLUDING CONTRACTUAL SERVICES WITH THIRD PARTIES; BUSINESS MANAGEMENT; MARKET RESEARCH AND ANALYSIS, COMPILATION OF STATISTICS; ADVERTISING, DISSEMINATION OF ADVERTISING MATTER AND ADVERTISING CONSULTANCY; PUBLIC RELATIONS, INCLUDED IN THIS CLASS; PUBLIC RELATIONS, NAMELY, PRESS LIAISON SERVICES, IN PARTICULAR PREPARING PRESS RELEASES, FEATURES, ADVERTISING DESIGN AND DISSEMINATION OF ADVERTISING MATTER; PROMOTIONAL SERVICES, NAMELY, DISTRIBUTION OF PROMOTIONAL ITEMS OF OTHERS; PLANNING, ARRANGING AND CONDUCTING OF PRESENTATIONS, EXHIBITIONS, TRADE FAIRS AND EVENTS FOR COMMERCIAL AND ADVERTISING PURPOSES; OFFICE FUNCTIONS; PREPARING BUSINESS REPORTS FOR REAL ESTATE PROJECTS; BUSINESS DEVELOPMENT CONSULTING SERVICES, NAMELY, DEVELOPMENT OF BUSINESS USE CONCEPTS AND RISK STUDIES FOR REAL ESTATE; BUSINESS ORGANISATION AND MANAGEMENT CONSULTANCY; BUSINESS AND PERSONNEL MANAGEMENT CONSULTANCY, BUSINESS AND BUSINESS ORGANISATIONAL CONSULTANCY; BUSINESS MANAGEMENT CONSULTANCY; CONSULTING SERVICES IN THE FIELDS OF BUSINESS ORGANISATIONAL DESIGN IN THE FIELD OF ELECTRONIC DATA PROCESSING; BUSINESS RESEARCH, IN PARTICULAR RESEARCH WITH REGARD TO ECONOMIC DATA AND INFORMATION; BUSINESS CONSULTANCY WITH REGARD TO PR MATTERS OF ALL KINDS; PUBLIC RELATIONS SERVICES, NAMELY, PRESS LIAISON AND PUBLIC RELATIONS, IN PARTICULAR IN PARTICULAR PREPARING PRESS RELEASES, FEATURES, PLANNING, ARRANGING AND CONDUCTING OF PRESS CONFERENCES AND OTHER PR EVENTS (U.S. CLS. 100, 101 AND 102).

**CLASS 36—INSURANCE AND FINANCIAL**

FOR FINANCIAL AND MONETARY AFFAIRS, NAMELY, FINANCIAL INFORMATION, MANAGEMENT AND ANALYSIS SERVICES; FINANCIAL CONSULTANCY; REAL ESTATE AGENCIES; INSURANCE AGENCIES; FINANCIAL MANAGEMENT; PREPARING FINANCIAL REPORTS FOR OTHERS FOR REAL ESTATE PROJECTS; FINANCIAL CONSULTING SERVICES, NAMELY, DEVELOPMENT OF FINANCIAL USE CONCEPTS AND RISK STUDIES FOR REAL ESTATE; REAL ESTATE VALUATIONS, NAMELY, DRAWING UP OF REAL ESTATE INVENTORY ANALYSES AND ANALYSES OF ANALYSIS OF PROPERTY INVENTORIES FROM THE POINT OF VIEW OF ECONOMIC VIABILITY AND DEGREE OF USE (U.S. CLS. 100, 101 AND 102).

**CLASS 41—EDUCATION AND ENTERTAINMENT**

FOR PROVIDING OF TRAINING IN THE FIELD OF BUSINESS, FINANCE, REAL ESTATE; EDUCATION SERVICES, NAMELY, PROVIDING CLASSES, SEMINARS, WORKSHOPS IN THE FIELDS OF EDUCATIONAL ACTIVITY; INSTRUCTIONS IN THE FIELD OF EDUCATIONAL ACTIVITIES; PUBLICATION OF BOOKS, NEWSPAPERS AND PERIODICALS; PREPARING STANDARDIZED TESTS (U.S. CLS. 100, 101 AND 107).

**CLASS 42—SCIENTIFIC AND COMPUTER SERVICES**

FOR COMPUTER PROGRAMMING, IN PARTICULAR COMPUTER PROGRAMS FOR CHECKING BUSINESS EFFICIENCY; COMPUTER CONSULTANCY; COMPUTER PROJECT MANAGEMENT IN THE FIELD OF ELECTRONIC DATA PROCESSING AND TELECOMMUNICATIONS (U.S. CLS. 100 AND 101).

**CLASS 45—PERSONAL AND LEGAL SERVICES**

FOR LEGAL CONSULTANCY FOR FOUNDING COMPANIES (U.S. CLS. 100 AND 101).  
DEIRDRE ROBERTSON, EXAMINING ATTORNEY

SN 79-078,876. TNP.CO.,LTD., TOKYO153-0042, JAPAN,  
FILED 11-10-2009.

**nonnative**

PRIORITY DATE OF 6-9-2009 IS CLAIMED.  
OWNER OF INTERNATIONAL REGISTRATION 1028725  
DATED 11-10-2009, EXPIRES 11-10-2019.

**CLASS 14—JEWELRY**

FOR KEY RINGS TRINKETS OR FOBS OF PRECIOUS METAL; JEWELRY ORNAMENTS OF PRECIOUS METAL; BRACELETS; JEWELRY; RINGS; PENDANTS; NECKLACES; JEWELRY ANKLETS; PERSONAL JEWELRY; CHARMS; BADGES OF PRECIOUS METAL; WATCHES; CLOCKS; WRISTWATCHES; WATCH CHAINS; BUCKLES FOR WATCHES; SHOE ORNAMENTS OF PRECIOUS METAL (U.S. CLS. 2, 27, 28 AND 50).

**CLASS 18—LEATHER GOODS**

FOR LEATHER THONGS; TOTE BAGS; BRIEFCASES; ATTACHE CASES; SUITCASES; TRAVELING BAGS; BACKPACKS; RUCKSACKS; "BOSTON" BAGS; SHOULDER BAGS; WAIST BAGS; LEATHER SHOPPING BAGS; LEATHER BAGS FOR CLIMBERS; LEATHER CARD CASES; LEATHER NOTECASES; LEATHER KEY CASES; WALLETS; PURSES; COIN PURSES; LEATHER POUCHES (U.S. CLS. 1, 2, 3, 22 AND 41).

**CLASS 25—CLOTHING**

FOR CLOTHING, NAMELY, COATS; OVERCOATS; JACKETS; JUMPERS; BLOUSONS; ANORAKS; SLACKS; SUITS; WAISTCOATS; OVERALLS; VESTS; SWEATERS; SHIRTS; BUTTON FRONT ALOHA SHIRTS; POLO SHIRTS; SWEAT SHIRTS; NIGHTWEAR; UNDERWEAR; BATHING SUITS; SPORTS SHIRTS; PULLOVERS; PARKAS; CARDIGANS; SWEAT PANTS; TEE-SHIRTS; TANK TOPS; CLOTHING OF LEATHER, NAMELY, LEATHER JACKETS; LEATHER WAISTCOATS; CLOTHING OF IMITATIONS OF LEATHER, NAMELY, JACKETS; WAISTCOATS; COLLAR PROTECTORS; BANDANAS; STOLE; FUR STOLE; SHAWLS; SCARVES; MUFFLERS; EAR MUFFS; GLOVES; MITTENS; NECKTIES; HOODS; SOCKS; STOCKINGS; HEADGEAR FOR WEAR, NAMELY, HATS; FUR HATS; CAPS; KNIT HAT; SUN VISORS; WAISTBANDS; SUSPENDERS; BELTS FOR CLOTHING; FOOTWEAR; SHOES; BOOTS; LEATHER SHOES; CANVAS SHOES; HALF-BOOTS; BEACH SHOES; SANDALS; SLIPPERS; INNER SOLES FOR SHOES AND BOOTS; SPORTS SHOES (U.S. CLS. 22 AND 39).

JOHN WILKE, EXAMINING ATTORNEY

SN 79-079,364. HANS HEIDOLPH GMBH & CO. KG, FED REP GERMANY, FILED 1-19-2009.

# HEIMOTION

THE MARK CONSISTS OF STANDARD CHARACTERS WITHOUT CLAIM TO ANY PARTICULAR FONT, STYLE, SIZE, OR COLOR.

OWNER OF INTERNATIONAL REGISTRATION 1029996 DATED 1-19-2009, EXPIRES 1-19-2019.

## CLASS 7—MACHINERY

FOR MACHINES AND MACHINE TOOLS AND EQUIPMENT, INCLUDED IN THIS CLASS, NAMELY, FANS FOR MACHINE ENGINES, SHAKING AND MIXER EQUIPMENT, NAMELY, CONCRETE MIXERS, INCUBATORS FOR EGGS, ELECTRICAL METAL SHEATH DISPERSION MACHINERY USING ELECTRICAL DISCHARGE TO REMOVE THE METAL SHEATH FROM MINERAL INSULATED WIRE AND STAINLESS STEEL OVER BRAID WIRE, AGITATORS FOR CIRCULATING LIQUID MEDIA, MOTORS AND ENGINES, NAMELY, GEAR MOTORS, SPUR WHEEL BACK-GEARED MOTORS, WORM GEAR MOTORS, FRICTION GEAR MOTORS, BEVEL GEAR MOTORS, PLANETARY BACK-GEARED MOTORS, GEAR MOTORS WITH ELECTRONIC SPEED REGULATORS, SHADE-POLE MOTORS, CAPACITOR MOTORS, COMPOSITE ROTARY MOTORS, SERVOMOTORS, PUMP, FAN, BLOWER AND STIRRER MOTORS; MOTORS AND ENGINES, EXCEPT FOR LAND VEHICLES, NAMELY, SPUR WHEEL BACK-GEARED MOTORS AND PLANETARY BACK-GEARED MOTORS, FOR PHOTOCOPYING EQUIPMENT, FOR OFFICE MACHINES, FOR MECHANICAL ENGINEERING, FOR THE APPARATUS CONSTRUCTION INDUSTRY, FOR ELECTRONIC EQUIPMENT, FOR THE AUTOMATIC MACHINES CONSTRUCTION INDUSTRY, FOR GALVANIZING APPARATUS, FOR CAPSTAN DRIVES, FOR AUTOMATIC DATA PROCESSING MACHINES, FOR ADVERTISING EQUIPMENT, FOR DENTAL EQUIPMENT, FOR ROLLER DRIVES, FOR FEEDING AND ADJUSTING DRIVES, FOR TEXTILE MACHINES; MOTORS AND ENGINES, EXCEPT FOR LAND VEHICLES, NAMELY, BEVEL GEAR MOTORS, WORM GEAR MOTORS AND OTHER ANGULAR GEAR MOTORS, FOR THE AUTOMATIC MACHINE CONSTRUCTION INDUSTRY, FOR SWITCHING APPARATUS, FOR THE CONSTRUCTION INDUSTRY, FOR PRECISION MECHANICAL APPARATUS, FOR THE ELECTRIC EQUIPMENT AND APPARATUS CONSTRUCTION INDUSTRY, FOR ELECTRO-MEDICAL PURPOSES, FOR CHEMICAL EQUIPMENT, FOR LABORATORY EQUIPMENT; MOTORS AND ENGINES, EXCEPT FOR LAND VEHICLES, NAMELY, SHADE-POLE MOTORS, FOR FAN HEATERS, FOR VENTILATORS, FOR PROJECTORS, FOR PHOTOCOPYING EQUIPMENT, FOR PRINTING MACHINES, PROGRAMMABLE SWITCH SYSTEMS, AUTOMATIC MACHINES, FOR MEDICAL EQUIPMENT, FOR PHOTOGRAPHIC AND PHONOGRAPH EQUIPMENT, FOR MACHINE TOOLS; BRAKES FOR MACHINES; MACHINE COUPLING AND TRANSMISSION COMPONENTS, EXCEPT FOR LAND VEHICLES, NAMELY, QUICK-STOP DEVICES, STOP BRAKES, MAGNETIC BRAKES, ELECTRONIC MOTOR BRAKES, CHUCKS, FLEXIBLE STIRRER COUPLINGS, STIRRER SEALS, FLEXIBLE SHAFTS, CLAMPS, SLEEVES; ACCESSORIES AND PARTS FOR MACHINES, EQUIPMENT, MOTORS AND ENGINES, INCLUDED IN THIS CLASS, NAMELY, BEARING HOUSINGS, FLUID DRIVE COUPLINGS, STANDS FOR MACHINES, ROTARY PISTONS, PISTONS FOR INTERNAL COMBUSTION ENGINES, OIL COOLERS, RECEIVING PISTONS FOR INTERNAL COMBUSTION ENGINES, CONTROL AND REGULATING ELEMENTS, SPEED GOVERNORS AND PRESSURE REGULATORS (U.S. CLS. 13, 19, 21, 23, 31, 34 AND 35).

## CLASS 9—ELECTRICAL AND SCIENTIFIC APPARATUS

FOR SCIENTIFIC, NAUTICAL, SURVEYING, ELECTRIC, ELECTRONIC, PHOTOGRAPHIC, CINEMATOGRAPHIC, OPTICAL, WEIGHING, MEASURING, SIGNALING, CHECKING, SUPERVISION, LIFE-SAVING AND TEACHING APPARATUS AND INSTRUMENTS, NAMELY, CENTRAL PROCESSING UNIT FANS, GAS MIXERS FOR LABORATORY USE, LABORATORY EQUIPMENT AND SUPPLIES, NAMELY, INCUBATORS, LABORATORY EQUIPMENT, NAMELY, ELECTRIC BATH HEATERS, HIGH PRESSURE PUMPS FOR PROPORTIONING AND TESTING PURPOSE; ACCESSORIES AND PARTS FOR SCIENTIFIC, NAUTICAL, SURVEYING, ELECTRIC, ELECTRONIC, PHOTOGRAPHIC, CINEMATOGRAPHIC, OPTICAL, WEIGHING, MEASURING, SIGNALING, CHECKING, SUPERVISION, LIFE-SAVING AND TEACHING APPARATUS AND INSTRUMENTS, INCLUDED IN THIS CLASS, NAMELY, ELECTRIC SWITCH HOUSINGS, FRAMES FOR ATTACHMENT TO COMPUTER MONITORS, DRIVE INVERTERS, CENTRAL PROCESSING UNIT COOLERS, BOILING TEMPERATURE PROBES, THERMOSTATS, APPARATUS AND INSTRUMENTS FOR CONVEYING, DISTRIBUTING, TRANSFORMING, STORING, REGULATING OR CONTROLLING ELECTRIC CURRENT, SPEED INDICATORS, DATA PROCESSING EQUIPMENT AND COMPUTERS, DATA CARRIERS CONTAINING STORE TYPOGRAPHIC TYPEFACES; BLANK MAGNETIC DATA CARRIERS; ACCELERATION SENSORS (U.S. CLS. 21, 23, 26, 36 AND 38).

LINDA ORNDORFF, EXAMINING ATTORNEY

SN 79-079,610. DIANA NATURALS SAS, FRANCE, FILED 8-28-2009.

# SAV'UP

THE MARK CONSISTS OF STANDARD CHARACTERS WITHOUT CLAIM TO ANY PARTICULAR FONT, STYLE, SIZE, OR COLOR.

OWNER OF INTERNATIONAL REGISTRATION 1030647 DATED 8-28-2009, EXPIRES 8-28-2019.

## CLASS 29—MEATS AND PROCESSED FOODS

FOR INGREDIENTS DERIVED FROM NATURAL, PLANT, MINERAL, ANIMAL, MARINE OR LAND-BASED RAW MATERIALS, NAMELY, LIQUID PLANT, MEAT OR MARINE-ORGANISM EXTRACTS, NAMELY, BOUILLON, BOUILLON CONCENTRATES, PREPARATIONS FOR MAKING BOUILLON, BROTH, BROTH CONCENTRATES, EDIBLE FATS, FOOD ADDITIVES, NAMELY, NATURAL FOOD EXTRACTS DERIVED FROM FISH, PRESERVED FRUITS, MEAT EXTRACTS, PROTEIN BEING FOODSTUFFS FOR HUMAN CONSUMPTION, PREPARATIONS FOR MAKING SOUP, VEGETABLE SOUP PREPARATIONS, VEGETABLE JUICES FOR COOKING, DRIED VEGETABLES; FRUIT AND VEGETABLE POWDERS, PIECES AND FLAKES, NAMELY, PRESERVED, PROCESSED, DRIED, OR CRYSTALLIZED FRUIT AND VEGETABLE EXTRACTS FOR USE IN PREPARED MEALS, FOOD OR DIPS FOR SNACKS; DRIED MEATS AND SEAFOOD, POULTRY FATS AND STOCK IN LIQUID AND POWDER FORM, COOKED MEAT MORSELS, ALL THESE GOODS INTENDED FOR THE AGRI-FOOD INDUSTRIES (U.S. CL. 46).

**CLASS 30—STAPLE FOODS**

FOR PLANT EXTRACTS FOR USE IN THE AGRI-FOOD INDUSTRIES, NAMELY, FOOD FLAVORINGS; CONDIMENTS, NAMELY, KETCHUP, MUSTARD, MAYONNAISE, MARINADES, CHUTNEY, SALSA DIP; ESSENCES FOR FOODSTUFFS, NAMELY, FLAVORINGS, OTHER THAN ESSENTIAL OILS, FOR BEVERAGES, CAKES; NON-MEDICINAL INFUSIONS, NAMELY, HERBAL INFUSIONS; SPICES (U.S. CL. 46).

**CLASS 32—LIGHT BEVERAGES**

FOR INGREDIENTS DERIVED FROM NATURAL, PLANT, MINERAL, ANIMAL, MARINE OR LAND-BASED RAW MATERIALS, NAMELY, PREPARATIONS FOR MAKING BEVERAGES, NAMELY, FRUIT DRINKS; NON-ALCOHOLIC FRUIT EXTRACTS USED IN THE PREPARATION OF BEVERAGES, NAMELY, LIQUID GRAPE AND GRAPE BY-PRODUCT EXTRACTS AND POWDERS, ALL THESE GOODS FOR USE IN THE AGRI-FOOD INDUSTRIES; FRUIT AND VEGETABLE JUICE IN CONCENTRATE OR DEHYDRATED FORM FOR THE AGRI-FOOD INDUSTRIES, NAMELY, CONCENTRATES AND POWDERS USED IN THE PREPARATION OF FRUIT AND VEGETABLE JUICE BEVERAGES (U.S. CLS. 45, 46 AND 48).

HELENE LIWINSKI, EXAMINING ATTORNEY

SN 79-079,701. ANRITSU A/S, DENMARK, FILED 9-7-2009.

# EOPATH

THE MARK CONSISTS OF STANDARD CHARACTERS WITHOUT CLAIM TO ANY PARTICULAR FONT, STYLE, SIZE, OR COLOR.

PRIORITY DATE OF 3-11-2009 IS CLAIMED.

OWNER OF INTERNATIONAL REGISTRATION 1030899 DATED 9-7-2009, EXPIRES 9-7-2019.

**CLASS 9—ELECTRICAL AND SCIENTIFIC APPARATUS**

FOR COMPUTER EQUIPMENT, NAMELY, DEDICATED HARDWARE, BUILT AROUND AN EMBEDDED COMPUTER PLATFORM THAT CAN RUN GENERAL PURPOSE OPERATING SYSTEMS, FOR NETWORK TAPPING AND NETWORK DATA COMPUTING AND STORAGE FOR MONITORING, OPTIMIZATION, QUALITY ASSURANCE, TROUBLE-SHOOTING, CHECKING, MEASURING, SURVEILLANCE AND TESTING COMMUNICATIONS NETWORKS, AND COMPUTER PERIPHERALS; RECORDED COMPUTER PROGRAMS FOR OPERATIONAL PROCESS OPTIMIZATION (OSS) FOR PROVIDING CROSS-ORGANIZATIONAL BUSINESS INTELLIGENCE (U.S. CLS. 21, 23, 26, 36 AND 38).

**CLASS 37—CONSTRUCTION AND REPAIR**

FOR INSTALLATION, REPAIR, AND MAINTENANCE OF COMMUNICATION NETWORKS HARDWARE (U.S. CLS. 100, 103 AND 106).

**CLASS 42—SCIENTIFIC AND COMPUTER SERVICES**

FOR PROVIDING QUALITY ASSURANCE SERVICES IN THE FIELD OF COMMUNICATIONS NETWORKS; TECHNICAL SUPPORT SERVICES, NAMELY, TROUBLESHOOTING OF COMMUNICATIONS NETWORK AND COMPUTER SOFTWARE PROBLEMS; MONITORING, ANALYSIS OF TRAFFIC CAPTURED FROM COMMUNICATIONS NETWORKS FOR SUBSCRIBER EXPERIENCE AND SUBSCRIBER BEHAVIOUR ANALYSIS FOR THE BENEFIT OF OTHERS AND TESTING OF COMMUNICATIONS NETWORKS FOR OTHERS; MANAGED COMPUTER OPERATION SERVICES, NAMELY, CAPACITY PLANNING AND FORECASTING OF COMMUNICATION NETWORKS FOR OTHERS; TECHNICAL CONSULTANCY IN THE FIELD OF COMMUNICATION NETWORKS (U.S. CLS. 100 AND 101).

GISELLE AGOSTO, EXAMINING ATTORNEY

SN 79-080,846. TETHIS S.P.A., ITALY, FILED 1-28-2010.

# microFIND

PRIORITY DATE OF 10-29-2009 IS CLAIMED.

OWNER OF INTERNATIONAL REGISTRATION 1034024 DATED 1-28-2010, EXPIRES 1-28-2020.

THE COLOR(S) BLACK AND BLUE IS/ARE CLAIMED AS A FEATURE OF THE MARK.

THE MARK CONSISTS OF THE WORD "MICROFIND" IN BLACK LETTERS AND A BLUE BAR UNDERLINING THE "MICRO" PORTION OF SAID WORD".

**CLASS 9—ELECTRICAL AND SCIENTIFIC APPARATUS**

FOR DIAGNOSTIC APPARATUS AND INSTRUMENTS FOR USE IN HIGH-THROUGHPUT TESTING OF CHEMICAL COMPOUNDS AND BIOLOGICAL ENTITIES FOR LABORATORY OR RESEARCH USE; SCIENTIFIC APPARATUS AND INSTRUMENTS FOR USE IN HIGH-THROUGHPUT TESTING OF CHEMICAL COMPOUNDS AND BIOLOGICAL ENTITIES FOR LABORATORY OR RESEARCH USE (U.S. CLS. 21, 23, 26, 36 AND 38).

**CLASS 10—MEDICAL APPARATUS**

FOR MEDICAL DIAGNOSTIC APPARATUS IN THE NATURE OF A KIT COMPOSED OF NANO-TECH COATED MICROSCOPE SLIDES, MICRO-FLUIDIC POLYMERIC PADS AND ASSEMBLERS WITH REAGENTS FOR MEDICAL DIAGNOSTIC PURPOSES, NAMELY, INVITRO DIAGNOSTICS (U.S. CLS. 26, 39 AND 44).

MARK T. MULLEN, EXAMINING ATTORNEY

SN 79-082,299. DITERRA - COMÉRCIO; AGRO-INDUSTRIAL, LDA., PORTUGAL, FILED 3-26-2010.

# FADISTA

THE MARK CONSISTS OF STANDARD CHARACTERS WITHOUT CLAIM TO ANY PARTICULAR FONT, STYLE, SIZE, OR COLOR.

OWNER OF INTERNATIONAL REGISTRATION 1037918 DATED 3-26-2010, EXPIRES 3-26-2020.

THE ENGLISH TRANSLATION OF "FADISTA" IN THE MARK IS "FADO'S SINGER".

**CLASS 29—MEATS AND PROCESSED FOODS**

FOR MEAT, FISH, POULTRY AND GAME; MEAT EXTRACTS; PRESERVED, FROZEN, DRIED AND COOKED FRUITS AND VEGETABLES; JELLIES, JAMS, COMPOTES; EGGS, MILK AND MILK PRODUCTS EXCLUDING ICE CREAM, ICE MILK AND FROZEN YOGURT; EDIBLE OILS AND FATS (U.S. CL. 46).

**CLASS 30—STAPLE FOODS**

FOR COFFEE, TEA, COCOA, SUGAR, RICE, TAPIOCA, SAGO, ARTIFICIAL COFFEE; FLOUR AND PREPARATIONS MADE FROM CEREALS, NAMELY, BISCUIT, CAKE AND COOKIES, BREAD, PASTRY AND CONFECTIONERY, NAMELY, FRUIT JELLIES, FONDANT, LIQUORICE AND LOZENGES, FLAVORED ICES; HONEY, TREACLE; YEAST, BAKING-POWDER; SALT, MUSTARD; VINEGAR, SAUCES; CONDIMENTS, NAMELY, SAUCES AND CHŪTNEYS; SPICES (U.S. CL. 46).

CAROLYN CATALDO, EXAMINING ATTORNEY

SN 79-082,530. PURAC BIOCHEM B.V., NETHERLANDS, FILED 2-15-2010.



PRIORITY DATE OF 10-1-2009 IS CLAIMED.  
OWNER OF INTERNATIONAL REGISTRATION 1038600 DATED 2-15-2010, EXPIRES 2-15-2020.  
OWNER OF U.S. REG. NOS. 1,232,414, 1,782,305 AND 1,952,261.

THE COLOR(S) BLUE, BLACK IS/ARE CLAIMED AS A FEATURE OF THE MARK.

THE MARK CONSISTS OF THE TERM "PURAC" IN THE COLOR BLACK BELOW A CIRCLE IN THE COLOR BLUE.

**CLASS 1—CHEMICALS**

FOR CHEMICALS USED IN INDUSTRY, INCLUDING CHEMICALS FOR USE IN FOOD, COSMETICS, PHARMACEUTICAL, CHEMICAL AND TECHNICAL INDUSTRIES; CHEMICAL ADDITIVES FOR USE IN THE MANUFACTURE OF FOOD PRODUCTS; CHEMICALS AND SEMI-FINISHED CHEMICAL PRODUCTS FOR PRESERVING FOODSTUFFS; NATURAL PRESERVATIVES, NAMELY, ORGANIC ACIDS AND THEIR SALTS, PROTEINS, AMINO ACIDS, ACIDULANTS, LACTID ACID, LACTATES, NAMELY, SODIUM LACTATE, POTASSIUM LACTATE, CALCIUM LACTATE, METHYL LACTATE, N-BUTYL LACTATE, 2-ETHYLHEXYL LACTATE, ALUMINUM LACTATE, MAGNESIUM LACTATE AND FERROUS LACTATE, GLUCONATES, LACTIDES, NAMELY, LACTID ACID BASED ON DIMERS AND POLYMERS, ALL FOR USE IN THE PRESERVATION OF FOODSTUFFS (U.S. CLS. 1, 5, 6, 10, 26 AND 46).

**CLASS 30—STAPLE FOODS**

FOR FOOD SUPPLEMENTS, NOT FOR MEDICAL USE, NOT INCLUDED IN OTHER CLASSES; AROMATIC PREPARATIONS FOR FOOD, NAMELY, PREPARATIONS OTHER THAN CHEMICAL SUBSTANCES OBTAINED FROM VEGETABLE, ANIMAL OR MICROBIOLOGICAL MATERIAL IN THE NATURE OF FOOD SEASONINGS AND FOOD FLAVORINGS (U.S. CL. 46).

MICHAEL WIENER, EXAMINING ATTORNEY

SN 79-083,154. DEGREMONT, FRANCE, FILED 4-28-2010.

# AZURAIR

THE MARK CONSISTS OF STANDARD CHARACTERS WITHOUT CLAIM TO ANY PARTICULAR FONT, STYLE, SIZE, OR COLOR.

OWNER OF INTERNATIONAL REGISTRATION 1040380 DATED 4-28-2010, EXPIRES 4-28-2020.

**CLASS 11—ENVIRONMENTAL CONTROL APPARATUS**

FOR EQUIPMENT AND INSTALLATIONS FOR VENTILATION AND TREATMENT OF GASES, PARTICULARLY AIR, NAMELY, BIOLOGICAL DEODORIZERS, VENTILATORS, PHYSICOCHEMICAL DEODORIZERS, BIOLOGICAL FILTERS, PHYSICOCHEMICAL FILTERS; EQUIPMENT AND INSTALLATIONS FOR DEODORIZING GASES PRODUCED BY STATIONS FOR THE BIOLOGICAL PURIFICATION OF URBAN AND INDUSTRIAL WASTEWATER, THE AGRICULTURE AND FOOD INDUSTRIES, ANIMAL HUSBANDRY, WASTE AND RESIDUE FROM HUMAN AND ANIMAL ACTIVITIES AND ANY OTHER SOURCE OF OLFACTORY POLLUTION, NAMELY, BIOLOGICAL DEODORIZERS, PHYSICOCHEMICAL DEODORIZERS; EQUIPMENT AND INSTALLATIONS FOR PHYSICAL, PHYSICO-CHEMICAL AND/OR BIOLOGICAL DEODORIZATION USING CULTURES ATTACHED TO NATURAL OR ARTIFICIAL SUBSTRATES, NAMELY, PHYSICO-CHEMICAL DEODORIZERS, BIOLOGICAL DEODORIZERS; EQUIPMENT AND INSTALLATIONS FOR THE ELIMINATION OF OLFACTORY POLLUTION BY PERCOLATING GASES THROUGH A BED OF FILTERING MATERIALS WITH GRANULAR OR FIBROUS STRUCTURES OF ORGANIC, VEGETAL OR MINERAL ORIGIN, NAMELY, BIOLOGICAL FILTERS, PHYSICO-CHEMICAL FILTERS (U.S. CLS. 13, 21, 23, 31 AND 34).

**CLASS 40—MATERIAL TREATMENT**

FOR DEODORIZATION OF GASEOUS FLUIDS, PARTICULARLY AIR; PURIFICATION AND REGENERATION OF GASEOUS FLUIDS, NAMELY, THE CONDITIONING AND TREATMENT OF AIR; GAS TREATMENT SERVICES, NAMELY, INDUSTRIAL OR DOMESTIC APPLICATION OF DEODORIZING AND CONDITIONING TREATMENTS FOR GASEOUS FLUIDS (U.S. CLS. 100, 103 AND 106).

**CLASS 42—SCIENTIFIC AND COMPUTER SERVICES**

FOR RESEARCH SERVICES CONCERNING TREATMENTS FOR THE DEODORIZATION OF GASEOUS FLUIDS, PARTICULARLY AIR; RESEARCH SERVICES CONCERNING THE OPERATION OF PHYSICAL, PHYSICO-CHEMICAL AND BIOLOGICAL DEODORIZATION INSTALLATIONS; TECHNICAL RESEARCH, LABORATORY RESEARCH STUDIES; CONSULTING AND ENGINEERING RELATING TO THESE PROCESSES AND EQUIPMENT (U.S. CLS. 100 AND 101).

ARETHA SOMERVILLE, EXAMINING ATTORNEY



SN 79-083,155. DEGREMONT, FRANCE, FILED 4-28-2010.

SN 79-083,310. ABC DESIGN GMBH, FED REP GERMANY, FILED 5-7-2010.

# ULTRAFOR

THE MARK CONSISTS OF STANDARD CHARACTERS WITHOUT CLAIM TO ANY PARTICULAR FONT, STYLE, SIZE, OR COLOR.

OWNER OF INTERNATIONAL REGISTRATION 1040388 DATED 4-28-2010, EXPIRES 4-28-2020.

## CLASS 11—ENVIRONMENTAL CONTROL APPARATUS

FOR MODULAR UNITS FOR TREATING, CLARIFYING, PHYSICAL OR PHYSICAL-CHEMICAL FILTERING, DISINFECTING AND STERILISING WATER AND ALL AQUEOUS SOLUTIONS, MODULAR TREATMENT UNITS AND THE VARIOUS ASSEMBLIES THEREOF ON SKIDS FOR THE DELIVERY AND DISTRIBUTION OF WATER AND AQUEOUS SOLUTIONS; PERMEABLE AND SEMI-PERMEABLE MEMBRANES FOR APPARATUS AND EQUIPMENT FOR TREATING WATER AND AQUEOUS SOLUTIONS; SKIDS AND MODULAR TREATMENT UNITS USING MEMBRANES FOR ULTRAFILTRATION, NANOFILTRATION AND/OR HYPERFILTRATION OR INVERSE OSMOSIS; BIOLOGICAL MEMBRANE REACTORS FOR USE IN THE FIELD OF TREATMENT OF WATER AND AQUEOUS OR HYDRO-ORGANIC SOLUTIONS; MODULAR MEMBRANE UNITS FOR THE ELIMINATION OF ORGANIC COMPOUNDS, BACTERIA, PARASITES AND VIRUSES IN THE FIELD OF DRINKING WATER (U.S. CLS. 13, 21, 23, 31 AND 34).

## CLASS 40—MATERIAL TREATMENT

FOR WATER TREATMENT SERVICES, NAMELY, INDUSTRIAL, MUNICIPAL AND DOMESTIC WASTEWATERS; DESIGN AND PLANNING OF TREATMENT INSTALLATIONS AND PROCESSES USING FILTRATION VIA MEMBRANES, PARTICULARLY DESIGN OF MODULAR MEMBRANE FILTRATION UNITS; WATER TREATMENT SERVICES, NAMELY, PURIFYING AND FILTERING FLUIDS USING ORGANIC OR MINERAL MEMBRANES, MEMBRANE REGENERATION AND REACTIVATION; RESEARCH, EXPERIMENTATION AND INDUSTRIAL AND DOMESTIC APPLICATION OF PURIFICATION, CLARIFICATION, FILTRATION AND DISINFECTION TREATMENTS USING ORGANIC OR MINERAL MEMBRANES (U.S. CLS. 100, 103 AND 106).

## CLASS 42—SCIENTIFIC AND COMPUTER SERVICES

FOR RESEARCH SERVICES FOR WATER TREATMENT USING MEMBRANE INSTALLATIONS; INSTALLATIONS FOR TREATING WATER USING MEMBRANES; TECHNICAL AUDITS, NAMELY, EXPERT REPORTS OF ENGINEERS; TECHNICAL STUDIES IN LABORATORIES, NAMELY, TECHNICAL RESEARCH, TECHNICAL CONSULTANCY SERVICES, SCIENTIFIC AND TECHNICAL WORK BY ENGINEERS IN CONNECTION WITH THESE PROCESSES AND PLANTS AND WITH FLUID TREATMENTS, IN THE FIELD OF URBAN AND INDUSTRIAL WASTEWATER (U.S. CLS. 100 AND 101).

ARETHA SOMERVILLE, EXAMINING ATTORNEY

# ABC Design

THE MARK CONSISTS OF STANDARD CHARACTERS WITHOUT CLAIM TO ANY PARTICULAR FONT, STYLE, SIZE, OR COLOR.

PRIORITY DATE OF 3-2-2010 IS CLAIMED.

OWNER OF INTERNATIONAL REGISTRATION 1040790 DATED 5-7-2010, EXPIRES 5-7-2020.

NO CLAIM IS MADE TO THE EXCLUSIVE RIGHT TO USE "DESIGN", APART FROM THE MARK AS SHOWN.

## CLASS 12—VEHICLES

FOR BABY CARRIAGES, ACCESSORIES FOR BABY CARRIAGES, NAMELY, HOODS FOR BABY CARRIAGES, SAFETY SEATS FOR CHILDREN FOR VEHICLES (U.S. CLS. 19, 21, 23, 31, 35 AND 44).

## CLASS 18—LEATHER GOODS

FOR SLING BAGS FOR CARRYING INFANTS (U.S. CLS. 1, 2, 3, 22 AND 41).

## CLASS 20—FURNITURE AND ARTICLES NOT OTHERWISE CLASSIFIED

FOR TRAVEL BEDS FOR CHILDREN, WALKERS AIDS FOR BABIES AND SMALL CHILDREN, HIGH CHAIRS FOR CHILDREN, ROCKING CHAIRS FOR BABIES (U.S. CLS. 2, 13, 22, 25, 32 AND 50).

DOMINIC FATHY, EXAMINING ATTORNEY

SN 79-083,325. SAMENEED, FRANCE, FILED 5-17-2010.

# sameneed

THE MARK CONSISTS OF STANDARD CHARACTERS WITHOUT CLAIM TO ANY PARTICULAR FONT, STYLE, SIZE, OR COLOR.

PRIORITY DATE OF 11-20-2009 IS CLAIMED.

OWNER OF INTERNATIONAL REGISTRATION 1040825 DATED 5-17-2010, EXPIRES 5-17-2020.

## CLASS 35—ADVERTISING AND BUSINESS

FOR ADVERTISING; COMPUTER FILE MANAGEMENT; ONLINE ADVERTISING ON A COMPUTER NETWORK; RENTAL OF ADVERTISING SPACE; DISSEMINATION OF ADVERTISEMENTS (U.S. CLS. 100, 101 AND 102).

## CLASS 38—COMMUNICATION

FOR COMMUNICATIONS BY COMPUTER TERMINALS OR VIA FIBER-OPTIC NETWORKS; RADIO OR TELEPHONE COMMUNICATIONS; MOBILE RADIOTELEPHONY SERVICES; PROVIDING ACCESS TO A GLOBAL COMPUTER NETWORK; ELECTRONIC BULLETIN BOARD SERVICES AS TELECOMMUNICATION SERVICES; PROVIDING TELECOMMUNICATION CONNECTIONS TO A GLOBAL COMPUTER NETWORK; RENTAL OF TELECOMMUNICATION EQUIPMENT; TELECONFERENCING SERVICES; ELECTRONIC MAIL SERVICES; RENTAL OF ACCESS TIME TO GLOBAL COMPUTER NETWORKS (U.S. CLS. 100, 101 AND 104).

**CLASS 42—SCIENTIFIC AND COMPUTER SERVICES**

FOR DESIGN AND DEVELOPMENT OF COMPUTERS AND SOFTWARE; RESEARCH AND DEVELOPMENT OF NEW PRODUCTS FOR OTHERS; DEVELOPMENT AS DESIGN, INSTALLATION, MAINTENANCE, UPDATING OR RENTAL OF SOFTWARE; COMPUTER PROGRAMMING; CONVERSION OF COMPUTER PROGRAMS AND DATA OTHER THAN PHYSICAL CONVERSION; CONVERSION OF DATA OR DOCUMENTS FROM PHYSICAL TO ELECTRONIC MEDIA (U.S. CLS. 100 AND 101).

TASNEEM HUSSAIN, EXAMINING ATTORNEY

SN 79-083,650. AUTOMATED RETAIL CONCEPTS B.V., NETHERLANDS, FILED 3-4-2010.



OWNER OF INTERNATIONAL REGISTRATION 1041698 DATED 3-4-2010, EXPIRES 3-4-2020.

NO CLAIM IS MADE TO THE EXCLUSIVE RIGHT TO USE "SHOPPING", APART FROM THE MARK AS SHOWN. THE COLOR(S) WHITE, GREY, ORANGE AND BLACK IS/ARE CLAIMED AS A FEATURE OF THE MARK.

THE MARK CONSISTS OF A GRAY RECTANGULAR OUTLINE WITH ROUNDED CORNERS WITHIN WHICH APPEARS THREE HORIZONTAL BANDS, THE TOP ONE IN WHITE, THE MIDDLE ONE IN ORANGE, AND THE BOTTOM ONE IN GRAY. WITHIN THE WHITE BAND APPEARS THE WORD "THE" IN GRAY. WITHIN THE ORANGE BAND APPEARS THE WORD "SHOPPING" IN WHITE FOLLOWED BY FIVE VERTICAL BARS, THE FIRST THREE AND LAST ONE IN WHITE, AND THE FOURTH ONE IN BLACK. WITHIN THE GRAY BAND AT THE BOTTOM APPEARS THE WORD "WALL" IN WHITE.

SN 79-083,535. DIRECT DIGITAL GROUP PTY LTD, AUSTRALIA, FILED 5-5-2010.



PRIORITY DATE OF 3-10-2010 IS CLAIMED.

OWNER OF INTERNATIONAL REGISTRATION 1041393 DATED 5-5-2010, EXPIRES 5-5-2020.

THE MARK CONSISTS OF THE WORD "IPOSTCARDS" IN BUBBLE FONT TO THE RIGHT SIDE OF RECTANGLE COMPRISING THREE STRAIGHT SIDES AND AN ARROW SHAPE FORMING THE RIGHT HAND SIDE, INSIDE WHICH IS THE LETTER "I" IN BUBBLE FONT INSIDE A GRAPHIC IMAGE OF A POSTCARD WITH A STAMP.

**CLASS 16—PAPER GOODS AND PRINTED MATTER**

FOR ADVERTISEMENT BOARDS OF PAPER; ADVERTISEMENT BOARDS OF PAPER OR CARDBOARD; ADVERTISING MATERIAL EXPRESSED IN PAPER FORM, NAMELY, ADVERTISING SIGNS OF PAPER; ADVERTISING MATERIAL OF PAPER; ADVERTISING MATERIALS, NAMELY, BROCHURES, LEAFLETS, AND INFORMATION SHEETS ABOUT PROMOTING GOODS AND SERVICES OF OTHERS IN THE FIELD OF TRAVEL AND PHOTOGRAPHIC REPRODUCTION, PROCESSING AND RETOUCHING, FOR DISSEMINATION IN PAPER FORM; ADVERTISING SIGNS OF PAPER; ARTICLES OF PAPER STATIONERY; BUSINESS CARDS OF PAPER; BUSINESS PAPER, NAMELY, BUSINESS CARD PAPER; COATED PAPER FOR PRINTING; COATED PRINTING PAPER; COPYING PAPER (U.S. CLS. 2, 5, 22, 23, 29, 37, 38 AND 50).

**CLASS 40—MATERIAL TREATMENT**

FOR ALTERATION AND RETOUCHING OF PHOTOGRAPHIC IMAGES; PRINTING OF PHOTOGRAPHIC IMAGES FROM DIGITAL MEDIA; PHOTOGRAPHIC PRINTING; PHOTOGRAPHIC PROCESSING; PHOTOGRAPHIC REPRODUCTION; PHOTOGRAPHIC RETOUCHING; PHOTOGRAPHIC REPRODUCTION (U.S. CLS. 100, 103 AND 106).

PAUL MORENO, EXAMINING ATTORNEY

**CLASS 9—ELECTRICAL AND SCIENTIFIC APPARATUS**

FOR AUTOMATIC VENDING MACHINES AND MECHANISMS FOR COIN-OPERATED APPARATUS AND MULTI-FUNCTIONAL ELECTRONIC PAYMENT TERMINALS; AUTOMATIC DISPENSERS FOR THE PARTITIONING OF PRODUCTS, NAMELY, AUTOMATIC VENDING MACHINES; SOFTWARE USED FOR WEBSITE DEVELOPMENT; SOFTWARE FOR CONTROLLING AND OPERATING VENDING MACHINES (U.S. CLS. 21, 23, 26, 36 AND 38).

**CLASS 35—ADVERTISING AND BUSINESS**

FOR COMMERCIAL BUSINESS MEDIATION AND CONSULTANCY IN THE BUYING AND SELLING OF ALL SORTS OF PRODUCTS, INCLUDING CONSUMER ELECTRONICS, PHARMACY ARTICLES, PERFUME, COSMETICS, TOYS AND SPORTS ARTICLES; BUSINESS CONSULTATION IN THE FIELD OF RETAIL AND WHOLESALE TRADING; MEDIATION OF TRADE BUSINESS FOR THIRD PARTIES, NAMELY, COMMERCIAL BUSINESS MEDIATION IN THE COMMERCIALIZATION FOR ALL SORTS OF PRODUCTS INCLUDING CONSUMER ELECTRONICS, PHARMACY ARTICLES, PERFUME, COSMETICS, TOYS AND SPORTS ARTICLES BY MEANS OF VENDING MACHINES; THE BRINGING TOGETHER, FOR THE BENEFIT OF OTHERS, OF A VARIETY OF GOODS ENABLING CUSTOMERS TO CONVENIENTLY VIEW AND PURCHASE THOSE GOODS IN THE FIELD OF CONSUMER ELECTRONICS, PHARMACY ARTICLES, PERFUME, COSMETICS, TOYS AND SPORTS ARTICLES, FOR THE PURPOSE OF ENABLING THIRD PARTIES TO VIEW AND BUY SUCH ARTICLES; PROVIDING COMMERCIAL BUSINESS INFORMATION REGARDING ALL SORTS OF PRODUCTS OF THIRD PARTIES INCLUDING CONSUMER ELECTRONICS, PHARMACY ARTICLES, PERFUME, COSMETICS, TOYS AND SPORTS ARTICLES; OFFICE FUNCTIONS WITHIN THE FRAMEWORK OF FRANCHISE SERVICES; BUSINESS MEDIATION IN THE COMMERCIALIZATION OF VENDING MACHINES AND OF SOFTWARE FOR VENDING MACHINES; BUSINESS AND ADMINISTRATIVE SUPERVISION AND CONSULTANCY IN THE FIELD OF THE EXPLOITATION OF VENDING MACHINES; SALES PROMOTION FOR OTHERS; ADVERTISING SERVICES; RENTAL OF ADVERTISING SPACE AND MAKING ADVERTISING SPACE AVAILABLE FOR OTHERS; DISSEMINATION OF ADVERTISEMENT (U.S. CLS. 100, 101 AND 102).

ANDREA HACK, EXAMINING ATTORNEY

SN 79-083,740. DEUTSCHE PFANDBRIEFBANK AG, FED REP GERMANY, FILED 3-30-2010.

SN 79-083,959. COMPOSITI & CO. S.R.L., ITALY, FILED 5-19-2010.



PRIORITY DATE OF 10-1-2009 IS CLAIMED.  
OWNER OF INTERNATIONAL REGISTRATION 1042004 DATED 3-30-2010, EXPIRES 3-30-2020.

OWNER OF U.S. REG. NOS. 2,635,162 AND 2,645,712.  
NO CLAIM IS MADE TO THE EXCLUSIVE RIGHT TO USE "PUBLIC SECTOR FINANCE", "REAL ESTATE FINANCE" AND "DEUTSCHE PFANDBRIEFBANK", APART FROM THE MARK AS SHOWN.

THE COLOR(S) GREEN, GRAY, WHITE AND BLACK IS/ARE CLAIMED AS A FEATURE OF THE MARK.

THE MARK CONSISTS OF THE WORDING "PUBLIC SECTOR FINANCE" AND "REAL ESTATE FINANCE" IN THE COLOR GREEN, ABOVE THE WORDING "PBB DEUTSCHE PFANDBRIEFBANK" IN WHITE AND GRAY, ALL ON A BLACK BACKGROUND.

THE MARK "DEUTSCHE" MEANS "GERMAN"; THE MARK ELEMENT "PFANDBRIEFBANK" MEANS "COVERED BOND BANK".

#### CLASS 35—ADVERTISING AND BUSINESS

FOR ADVERTISING SERVICES; BUSINESS MANAGEMENT; BUSINESS ADMINISTRATION; PROVIDING OFFICE FUNCTIONS (U.S. CLS. 100, 101 AND 102).

#### CLASS 36—INSURANCE AND FINANCIAL

FOR FINANCIAL AFFAIRS, NAMELY, PROVIDING LENDING SERVICES AND FINANCIAL CONSULTING SERVICES IN THE FIELDS OF PUBLIC SECTOR FINANCE, INFRASTRUCTURE, REAL ESTATE AND ASSET BASED FINANCE AND MORTGAGING; MONETARY AFFAIRS, NAMELY, MONEY LENDING, ASSET BASED FINANCE MANAGEMENT, CAPITAL MARKETS MANAGEMENT AND ASSET MANAGEMENT; REAL ESTATE AFFAIRS, NAMELY, APPRAISAL OF REAL ESTATE, LEASING OF REAL ESTATE, REAL ESTATE BROKERAGE, PROVIDING FINANCIAL CONSULTING SERVICES WITH RESPECT TO REAL ESTATE; INSURANCE, NAMELY, INSURANCE BROKERAGE, INSURANCE CONSULTANCY, INSURANCE INFORMATION, INSURANCE UNDERWRITING SERVICES FOR ALL TYPES OF INSURANCE; FINANCIAL ADVICE; MONETARY STRATEGY CONSULTATION AND RESEARCH; FINANCIAL ANALYSIS; BANKING; FINANCIAL CONSULTANCY; ARRANGING OF LOANS, FINANCIAL LOAN CONSULTING, LOAN FINANCING; SECURITIES BROKERAGE; FINANCING SERVICES; MUTUAL FUND BROKERAGE, DISTRIBUTION AND INVESTMENT; APARTMENT HOUSE MANAGEMENT; REAL ESTATE MANAGEMENT SERVICES; CAPITAL INVESTMENT SERVICES; CREDIT BUREAUX (U.S. CLS. 100, 101 AND 102).

#### CLASS 37—CONSTRUCTION AND REPAIR

FOR BUILDING CONSTRUCTION; REPAIR AND RENOVATION OF BUILDINGS, APARTMENTS AND ROOMS AND OF PARTS OF BUILDINGS, APARTMENTS AND ROOMS; INSTALLATION OF FIXTURES AND FITTINGS IN BUILDINGS (U.S. CLS. 100, 103 AND 106).

DAVID HOFFMAN, EXAMINING ATTORNEY

# AUREAN

THE MARK CONSISTS OF STANDARD CHARACTERS WITHOUT CLAIM TO ANY PARTICULAR FONT, STYLE, SIZE, OR COLOR.

PRIORITY DATE OF 12-21-2009 IS CLAIMED.

OWNER OF INTERNATIONAL REGISTRATION 1042646 DATED 5-19-2010, EXPIRES 5-19-2020.

#### CLASS 1—CHEMICALS

FOR CHEMICALS USED IN INDUSTRY, SCIENCE AND PHOTOGRAPHY, UNPROCESSED ARTIFICIAL RESINS, UNPROCESSED PLASTICS; MANURES; FIRE EXTINGUISHING COMPOSITIONS; TEMPERING PREPARATIONS (U.S. CLS. 1, 5, 6, 10, 26 AND 46).

#### CLASS 17—RUBBER GOODS

FOR RUBBER, GUTTA-PERCHA, GUM, ASBESTOS, MICA, PLASTICS IN EXTRUDED FORM FOR USE IN MANUFACTURE; PACKING AND INSULATING MATERIALS; FLEXIBLE PIPES, NOT OF METAL (U.S. CLS. 1, 5, 12, 13, 35 AND 50).

#### CLASS 19—NON-METALLIC BUILDING MATERIALS

FOR NON-METALLIC RIGID PIPES FOR BUILDING; ASPHALT, PITCH AND BITUMEN; NON-METALLIC TRANSPORTABLE BUILDINGS; MONUMENTS, NOT OF METAL (U.S. CLS. 1, 12, 33 AND 50).

#### CLASS 20—FURNITURE AND ARTICLES NOT OTHERWISE CLASSIFIED

FOR FURNITURE, MIRRORS, PICTURE FRAMES (U.S. CLS. 2, 13, 22, 25, 32 AND 50).  
TARAH HARDY, EXAMINING ATTORNEY

SN 79-084,137. TECHNIKUS AG, LIECHTENSTEIN, FILED 4-26-2010.

# AVIS

THE MARK CONSISTS OF STANDARD CHARACTERS WITHOUT CLAIM TO ANY PARTICULAR FONT, STYLE, SIZE, OR COLOR.

PRIORITY DATE OF 2-4-2010 IS CLAIMED.

OWNER OF INTERNATIONAL REGISTRATION 1042972 DATED 4-26-2010, EXPIRES 4-26-2020.

THE ENGLISH TRANSLATION OF THE FOREIGN WORD(S) IN THE MARK IS: "NOTIFICATION".

#### CLASS 35—ADVERTISING AND BUSINESS

FOR ADVICE ON THE ORGANIZATION AND MANAGEMENT OF BUSINESSES; ACCOUNTING; ORGANIZATIONAL CONSULTING IN BUSINESS MATTERS; PREPARATION OF TAX RETURNS; BUSINESS ADVICE; HUMAN RESOURCES CONSULTANCY; ADVERTISING; BUSINESS ADMINISTRATION AND OFFICE WORK (U.S. CLS. 100, 101 AND 102).

**CLASS 36—INSURANCE AND FINANCIAL**

FOR RAISING CAPITAL FOR CHARITABLE FOUNDATIONS; BILL PAYMENT (U.S. CLS. 100, 101 AND 102). STEVEN R. FINE, EXAMINING ATTORNEY

SN 79-084,178. YORKTEST LABORATORIES LIMITED, UNITED KINGDOM, FILED 3-8-2010.

# YORKTEST

THE MARK CONSISTS OF STANDARD CHARACTERS WITHOUT CLAIM TO ANY PARTICULAR FONT, STYLE, SIZE, OR COLOR.

OWNER OF INTERNATIONAL REGISTRATION 1043079 DATED 3-8-2010, EXPIRES 3-8-2020.  
OWNER OF U.S. REG. NO. 2,749,382.

**CLASS 5—PHARMACEUTICALS**

FOR REAGENTS AND MATERIALS FOR USE IN ASSAYS OF PERSONAL SAMPLES, PARTICULARLY BLOOD, NAMELY, MEDICAL DIAGNOSTIC REAGENTS; PREPARATIONS AND MATERIALS FOR USE IN RELATION TO FOOD INTOLERANCE TESTING, NAMELY, MEDICAL DIAGNOSTIC REAGENTS AND ASSAYS FOR TESTING OF BODY FLUIDS FOR TESTING FOOD INTOLERANCE; DIAGNOSTIC AGENTS FOR MEDICAL PURPOSES, NAMELY, ANTIGENS; PREPARATIONS CONTAINING ANTIGENS, NAMELY, MEDICAL DIAGNOSTIC AGENTS; DIAGNOSTIC ANTIBODIES FOR USE IN DISEASE TESTING; PREPARATIONS CONTAINING ANTIBODIES, NAMELY, MEDICAL DIAGNOSTIC AGENTS; WOUND DRESSINGS; MEDICAL PLASTERS; ANTISEPTIC WIPES; APPARATUS, PREPARATIONS AND MATERIALS SOLD IN KIT FORM FOR USE IN TAKING AND/OR TESTING PERSONAL SAMPLES, PARTICULARLY BLOOD, NAMELY, TEST STRIPS FOR MEASURING BLOOD GLUCOSE LEVELS, HOMOCYSTEINE LEVELS, GLYCOSYLATED HEMOGLOBIN LEVELS, ALANINE AND ASPARTATE AMINOTRANSFERASE LEVELS; FOOD INTOLERANCE TEST KITS, NAMELY, TEST KITS COMPRISED OF MEDICAL DIAGNOSTIC TEST STRIPS FOR USE IN TESTING FOOD INTOLERANCES; ALONG WITH PARTS AND FITTINGS FOR ALL THE AFORESAID GOODS IN THIS CLASS (U.S. CLS. 6, 18, 44, 46, 51 AND 52).

**CLASS 10—MEDICAL APPARATUS**

FOR APPARATUS FOR USE IN TAKING AND/OR COLLECTING PERSONAL SAMPLES, PARTICULARLY BLOOD SAMPLES, NAMELY, DISPOSABLE HYPODERMICS AND MEDICAL SYRINGES, FINGER PRICK NEEDLES, PLASTIC CONTAINERS FOR STORING URINE OR STOOL SAMPLES, BLOOD COLLECTION TUBES, MEDICAL PIPETTES FOR COLLECTING BLOOD, SURGICAL GLOVES; LANCETS; ABSORBENT DEVICES FOR COLLECTING BLOOD, NAMELY, MEDICAL COTTON SWABS AND STICKS CONTAINING ABSORBABLE COTTON PARTS FOR ABSORBING BLOOD; CONTAINERS ESPECIALLY ADAPTED FOR THE AFORESAID DEVICES; KITS COMPRISED OF DISPOSABLE HYPODERMICS AND MEDICAL SYRINGES, FINGER PRICK NEEDLES, PLASTIC CONTAINERS FOR STORING URINE OR STOOL SAMPLES, BLOOD COLLECTION TUBES, MEDICAL PIPETTES FOR COLLECTING BLOOD, SURGICAL GLOVES, MEDICAL COTTON SWABS, STICKS CONTAINING ABSORBABLE COTTON PARTS FOR ABSORBING BLOOD AND CONTAINERS ESPECIALLY ADAPTED FOR THE AFORESAID DEVICES; TOGETHER WITH PARTS AND FITTINGS FOR ALL THE AFORESAID GOODS IN THIS CLASS (U.S. CLS. 26, 39 AND 44).

**CLASS 16—PAPER GOODS AND PRINTED MATTER**

FOR PRINTED MATTER, NAMELY, LEAFLETS AND BROCHURES, MAGAZINES, INSTRUCTION BOOKLETS, PRINTED FORMS, ALL RELATING TO HEALTH, MEDICAL CONDITIONS, HEALTH AND WELLBEING, DIET, FOOD, FOOD INTOLERANCE AND/OR FOOD ALLERGY; PRINTED MATTER, NAMELY, LEAFLETS AND BROCHURES, MAGAZINES, INSTRUCTION BOOKLETS, PRINTED FORMS, ALL RELATING TO SERVICES FOR DETECTING OR MEASURING FACTORS INDICATIVE OF HEALTH CONDITIONS OR DISORDERS (U.S. CLS. 2, 5, 22, 23, 29, 37, 38 AND 50).

**CLASS 42—SCIENTIFIC AND COMPUTER SERVICES**

FOR MEDICAL LABORATORY SERVICES AND LABORATORY TESTING SERVICES, ALL RELATING TO THE EXAMINATION, ANALYSIS OR ASSAYING OF PERSONAL SAMPLES; BLOOD ANALYSIS; FOOD INTOLERANCE TESTING AND ALLERGY TESTING, THROUGH BLOOD AND PERSONAL SAMPLE ANALYSIS SERVICES; MEDICAL LABORATORY SERVICES FOR INFECTIONS; MEDICAL LABORATORY SERVICES FOR DETECTING OR MEASURING FACTORS INDICATIVE OF HEALTH CONDITIONS OR DISORDERS; MEDICAL LABORATORY SERVICES FOR DETECTING OR MEASURING SELECTED ANTIBODIES IN PERSONAL SAMPLES; PROVIDING LABORATORY CONSULTATION REGARDING MEDICAL LABORATORY RESEARCH AND TESTING REGARDING THE ANALYSIS OR ASSAYING OF PERSONAL SAMPLES, ANTIBODY SCREENING, BLOOD ANALYSIS AND BLOOD INFECTIONS (U.S. CLS. 100 AND 101).

**CLASS 44—MEDICAL, BEAUTY AND AGRICULTURAL SERVICES**

FOR PROVIDING MEDICAL HEALTH CONSULTING AND PROVISION OF INFORMATION ABOUT ALLERGIES, FOOD INTOLERANCES, OBESITY, DIET, FOODS, DIETARY FOOD SUPPLEMENTS, HEALTH, HEALTH CARE, MEDICAL PROBLEMS, MEDICAL PRODUCTS AND PREPARATIONS, NUTRITION, SLIMMING, AND/OR POISONS; PROFESSIONAL MEDICAL CONSULTATION REGARDING FOOD INTOLERANCES AND ALLERGIES; MEDICAL SERVICES FOR THE TESTING OF BLOOD, SERA AND/OR URINE; MEDICAL HEALTH ASSESSMENT SERVICES AND MEDICAL ANALYSIS SERVICES, NAMELY, COLLECTING PERSONAL SAMPLES INCLUDING BLOOD, URINE, SALIVA OR FECES AND BASED ON THE RESULT OF THE ANALYSIS OF SUCH SAMPLES, PROVIDING MEDICAL REPORTS AS TO THE HEALTH AND WELLBEING OF THE PROVIDER OF THOSE SAMPLES, MEDICAL SERVICES SPECIALIZING IN THE COMPILATION OF MEDICAL REPORTS AND CONDUCTING OF MEDICAL TESTS AND EXAMINATIONS IN THE FIELD OF FOOD INTOLERANCES AND ALLERGIES; MEDICAL SERVICES FOR THE TREATMENT OF ALLERGIES; ALL OF THE AFORESAID SERVICES BEING PROVIDED OVER THE INTERNET, BY POST, BY FAX, BY EMAIL AND/OR IN PERSON; INFORMATION, ADVICE AND CONSULTANCY RELATING TO ALL THE AFORESAID (U.S. CLS. 100 AND 101).

INGRID C. EULIN, EXAMINING ATTORNEY

SN 79-084,224. TRIANGLE RESOURCE HOLDING (SWITZERLAND) AG, SWITZERLAND, FILED 5-21-2010.

# ECONIMO

THE MARK CONSISTS OF STANDARD CHARACTERS WITHOUT CLAIM TO ANY PARTICULAR FONT, STYLE, SIZE, OR COLOR.

PRIORITY DATE OF 11-25-2009 IS CLAIMED.



OWNER OF INTERNATIONAL REGISTRATION 1043238 DATED 5-21-2010, EXPIRES 5-21-2020.  
THE WORDING "ECONIMO" HAS NO MEANING IN A FOREIGN LANGUAGE.

### CLASS 7—MACHINERY

FOR COMBINED HEAT AND POWER UNITS FOR ELECTRICITY GENERATION, NAMELY, ELECTRICITY GENERATORS WHICH ALSO GENERATE HEAT; MACHINES FOR GENERATING ELECTRICITY AND HEAT, NAMELY, ELECTRICITY GENERATORS WHICH ALSO GENERATE HEAT; MACHINES FOR GENERATING ELECTRICITY AND COLD, NAMELY, ELECTRICITY GENERATORS WHICH ALSO GENERATE COLD; MACHINES FOR GENERATING ELECTRICITY AND HEAT AND COLD, NAMELY, ELECTRICITY GENERATORS WHICH ALSO GENERATE HEAT AND COLD (U.S. CLS. 13, 19, 21, 23, 31, 34 AND 35).

### CLASS 11—ENVIRONMENTAL CONTROL APPARATUS

FOR COMBINED HEAT AND POWER UNITS FOR ELECTRICITY GENERATION, NAMELY, HEAT GENERATORS WHICH ALSO GENERATE ELECTRICITY (U.S. CLS. 13, 21, 23, 31 AND 34).  
CARRIE GENOVESE, EXAMINING ATTORNEY

SN 79-084,389. MOLESKINE S.R.L., ITALY, FILED 2-25-2010.

# MOLESKINE

THE MARK CONSISTS OF STANDARD CHARACTERS WITHOUT CLAIM TO ANY PARTICULAR FONT, STYLE, SIZE, OR COLOR.

OWNER OF INTERNATIONAL REGISTRATION 1043501 DATED 2-25-2010, EXPIRES 2-25-2020.  
OWNER OF U.S. REG. NOS. 2,453,716 AND 3,220,691.

### CLASS 9—ELECTRICAL AND SCIENTIFIC APPARATUS

FOR OPTICAL APPARATUS AND INSTRUMENTS, NAMELY, SPECTACLES, SUNGLASSES, PROTECTIVE EYEGLASSES, FRAMES, CASES AND CHAINS FOR SPECTACLES AND GLASSES; LIFE-SAVING APPARATUS AND INSTRUMENTS, NAMELY, PROTECTIVE HELMETS, PROTECTIVE HELMETS FOR SPORTS; PHOTOGRAPHIC AND CINEMATOGRAPHIC APPARATUS AND INSTRUMENTS, NAMELY, CAMERAS, CAMCORDERS; APPARATUS FOR RECORDING, TRANSMISSION OR REPRODUCTION OF SOUND AND/OR IMAGES, NAMELY, DIGITAL PHOTO FRAMES FOR DISPLAYING DIGITAL PICTURES, DIGITAL PICTURE ALBUMS IN THE NATURE OF PORTABLE LCD PANELS FOR DISPLAYING DIGITAL PICTURES, PORTABLE DIGITAL AUDIO PLAYERS, ELECTRONIC PUBLICATIONS, NAMELY, BOOKS FEATURING TRAVEL INFORMATION RECORDED ON COMPUTER MEDIA; STEREO EQUIPMENT, NAMELY, STEREO RECEIVERS, STEREO AMPLIFIERS, PERSONAL STEREOS AND AUDIO SPEAKERS; BLANK RECORDABLE OPTICAL DISCS; CALCULATING MACHINES, DATA PROCESSING AND DATA STORAGE EQUIPMENT, NAMELY, COMPUTERS, DATA PROCESSORS, CDS AND DVDS FEATURING TRAVEL INFORMATION AND REPRODUCTIONS OF WORKS OF ART, BLANK USB FLASH DRIVES; BLANK OPTICAL AND MAGNETIC DATA CARRIERS; COMPUTER SOFTWARE FOR THE COLLECTION, EDITING, ORGANIZING, MODIFYING, BOOK MARKING, TRANSMISSION, STORAGE, AND SHARING OF DATA AND INFORMATION; COMPUTER SOFTWARE FOR PROCESSING DIGITAL IMAGES AND CREATING, EDITING AND SHARING DIGITAL CONTENT, NAMELY, CONTACT INFORMATION, CALENDAR EVENT ENTRIES AND FILES COMBINING IMAGES AND TEXT; DOWNLOADABLE PRODUCTS, NAMELY, DOWNLOADABLE PAGE FORMAT TEMPLATES FOR NOTEBOOKS; RECORDED CD-ROMS CONTAINING DIGITAL NATURE PHOTOGRAPHS AND REPRODUCTIONS OF WORKS OF ART; AUDIO AND VIDEO MUSICAL RECORDINGS; MOBILE PHONES; HAND HELD COMMUNICATION DEVICES IN THE NATURE OF WALKIE-TALKIES; GLOBAL POSITIONING SYSTEM (GPS); ACCESSORIES SPECIALLY ADAPTED FOR THE ABOVE MENTIONED GOODS, NAMELY, PROTECTIVE CASES, CARRYING CASES, COVERS, EARPHONES, HEADPHONES, CLIPS SPECIALLY ADAPTED FOR ATTACHING MOBILE PHONES TO CLOTHING, ELECTRIC POWER STRIPS, CORD MANAGEMENT SYSTEMS IN THE NATURE OF EARPHONE ACCESSORIES, COMPUTER MOUSE; MOUSE-PADS (U.S. CLS. 21, 23, 26, 36 AND 38).

### CLASS 11—ENVIRONMENTAL CONTROL APPARATUS

FOR APPARATUS FOR LIGHTING, NAMELY, LAMPS, LAMP HOLDERS IN THE NATURE OF READING LAMP HOLDERS AND USB-POWERED LAMP HOLDERS; PARTS AND ACCESSORIES THEREFOR, NAMELY, LAMP BASES, LAMP SHADES, LIGHT BULBS; ELECTRIC TORCHES FOR LIGHTING, SEARCHLIGHTS, OUTDOOR PORTABLE LIGHTING PRODUCTS IN THE NATURE OF HEADLAMPS; LIGHT REFLECTORS (U.S. CLS. 13, 21, 23, 31 AND 34).

STEVEN PEREZ, EXAMINING ATTORNEY

SN 79-084,465. YORKTEST LABORATORIES LIMITED, UNITED KINGDOM, FILED 3-8-2010.

# FOODSCAN

THE MARK CONSISTS OF STANDARD CHARACTERS WITHOUT CLAIM TO ANY PARTICULAR FONT, STYLE, SIZE, OR COLOR.

OWNER OF INTERNATIONAL REGISTRATION 1043697 DATED 3-8-2010, EXPIRES 3-8-2020.  
OWNER OF U.S. REG. NOS. 3,018,897 AND 3,102,527.

**CLASS 5—PHARMACEUTICALS**

FOR REAGENTS AND MATERIALS FOR USE IN ASSAYS OF PERSONAL SAMPLES, PARTICULARLY BLOOD, NAMELY, MEDICAL DIAGNOSTIC REAGENTS; PREPARATIONS AND MATERIALS FOR USE IN RELATION TO FOOD INTOLERANCE TESTING, NAMELY, MEDICAL DIAGNOSTIC REAGENTS AND ASSAYS FOR TESTING OF BODY FLUIDS FOR TESTING FOOD INTOLERANCE; DIAGNOSTIC AGENTS FOR MEDICAL PURPOSES, NAMELY, ANTIGENS; PREPARATIONS CONTAINING ANTIGENS, NAMELY, MEDICAL DIAGNOSTIC AGENTS; DIAGNOSTIC ANTIBODIES FOR USE IN DISEASE TESTING; PREPARATIONS CONTAINING ANTIBODIES, NAMELY, MEDICAL DIAGNOSTIC AGENTS; WOUND DRESSINGS; MEDICAL PLASTERS; ANTISEPTIC WIPES; APPARATUS, PREPARATIONS AND MATERIALS SOLD IN KIT FORM FOR USE IN TAKING AND/OR TESTING PERSONAL SAMPLES, PARTICULARLY BLOOD, NAMELY, TEST STRIPS FOR MEASURING BLOOD GLUCOSE LEVELS, HOMOCYSTEINE LEVELS, GLYCOSYLATED HAEMOGLOBIN LEVELS, ALANINE AND ASPARTATE AMINOTRANSFERASE LEVELS; FOOD INTOLERANCE TEST KITS, NAMELY, TEST KITS COMPRISED OF MEDICAL DIAGNOSTIC TEST STRIPS FOR USE IN TESTING FOOD INTOLERANCE; ALONG WITH PARTS, FITTINGS AND ACCESSORIES FOR ALL THE AFORESAID GOODS IN THIS CLASS (U.S. CLS. 6, 18, 44, 46, 51 AND 52).

**CLASS 10—MEDICAL APPARATUS**

FOR APPARATUS FOR USE IN TAKING AND/OR COLLECTING PERSONAL SAMPLES, PARTICULARLY BLOOD SAMPLES, NAMELY, DISPOSABLE HYPODERMICS AND MEDICAL SYRINGES, FINGER PRICK NEEDLES, MEDICAL SPECIMEN CUPS IN THE NATURE OF PLASTIC CONTAINERS FOR STORING URINE OR STOOL SAMPLES, BLOOD COLLECTION TUBES, MEDICAL PIPETTES FOR COLLECTING BLOOD, SURGICAL GLOVES; LANCETS; KITS COMPRISED OF DISPOSABLE HYPODERMICS AND MEDICAL SYRINGES, FINGER PRICK NEEDLES, PLASTIC CONTAINERS FOR STORING URINE OR STOOL SAMPLES, BLOOD COLLECTION TUBES, MEDICAL PIPETTES FOR COLLECTING BLOOD, SURGICAL GLOVES, MEDICAL COTTON SWABS, STICKS CONTAINING ABSORBABLE COTTON PARTS FOR ABSORBING BLOOD AND CONTAINERS ESPECIALLY ADAPTED FOR THE AFORESAID DEVICES; ALONG WITH PARTS AND FITTINGS FOR ALL THE AFORESAID GOODS IN THIS CLASS (U.S. CLS. 26, 39 AND 44).

**CLASS 16—PAPER GOODS AND PRINTED MATTER**

FOR PRINTED MATTER, NAMELY, LEAFLETS AND BROCHURES, MAGAZINES, INSTRUCTION BOOKLETS, PRINTED FORMS, ALL RELATING TO HEALTH, MEDICAL CONDITIONS, HEALTH AND WELLBEING, DIET, FOOD, FOOD INTOLERANCE AND/OR FOOD ALLERGY; PRINTED MATTER, NAMELY, LEAFLETS AND BROCHURES, MAGAZINES, INSTRUCTION BOOKLETS, PRINTED FORMS, ALL RELATING TO SERVICES FOR DETECTING OR MEASURING FACTORS INDICATIVE OF HEALTH CONDITIONS OR DISORDERS (U.S. CLS. 2, 5, 22, 23, 29, 37, 38 AND 50).

**CLASS 42—SCIENTIFIC AND COMPUTER SERVICES**

FOR MEDICAL LABORATORY SERVICES AND LABORATORY TESTING SERVICES, ALL RELATING TO THE EXAMINATION, ANALYSIS OR ASSAYING OF PERSONAL SAMPLES; BLOOD ANALYSIS; FOOD INTOLERANCE TESTING AND ALLERGY TESTING, THROUGH BLOOD AND PERSONAL SAMPLE ANALYSIS SERVICES; MEDICAL LABORATORY SERVICES FOR INFECTIONS; MEDICAL LABORATORY SERVICES FOR DETECTING OR MEASURING FACTORS INDICATIVE OF HEALTH CONDITIONS OR DISORDERS; MEDICAL LABORATORY SERVICES FOR DETECTING OR MEASURING SELECTED ANTIBODIES IN PERSONAL SAMPLES; PROVIDING LABORATORY CONSULTATION REGARDING MEDICAL LABORATORY RESEARCH AND TESTING REGARDING THE ANALYSIS OR ASSAYING OF PERSONAL SAMPLES, ANTIBODY SCREENING, BLOOD ANALYSIS AND BLOOD INFECTIONS (U.S. CLS. 100 AND 101).

**CLASS 44—MEDICAL, BEAUTY AND AGRICULTURAL SERVICES**

FOR PROVIDING MEDICAL HEALTH CONSULTING AND PROVISION OF MEDICAL ADVICE ABOUT ALLERGIES, FOOD INTOLERANCE, OBESITY, DIET, FOODS, DIETARY FOOD SUPPLEMENTS, HEALTH, HEALTH CARE, MEDICAL PROBLEMS, MEDICAL PRODUCTS AND PREPARATIONS, NUTRITION, SLIMMING, AND/OR POISONS; PROFESSIONAL MEDICAL CONSULTATION REGARDING FOOD INTOLERANCE AND ALLERGIES; MEDICAL SERVICES FOR THE TESTING OF BLOOD, SERA AND/OR URINE; MEDICAL HEALTH ASSESSMENT SERVICES AND MEDICAL ANALYSIS SERVICES, NAMELY, COLLECTING PERSONAL SAMPLES INCLUDING BLOOD, URINE, SALIVA OR FECES AND BASED ON THE RESULT OF THE ANALYSIS OF SUCH SAMPLES, PROVIDING A MEDICAL PROFILE AND MEDICAL RECORD ANALYSIS AS TO THE HEALTH AND WELLBEING OF THE PROVIDER OF THOSE SAMPLES, MEDICAL SERVICES SPECIALIZING IN THE COMPILATION OF MEDICAL REPORTS AND CONDUCTING OF MEDICAL TESTS AND EXAMINATIONS IN THE FIELD OF FOOD INTOLERANCE AND ALLERGIES; MEDICAL SERVICES FOR THE TREATMENT OF ALLERGIES; ALL OF THE AFORESAID SERVICES BEING PROVIDED OVER THE INTERNET, BY POST, BY FAX, BY E-MAIL AND/OR IN PERSON; INFORMATION, ADVICE AND CONSULTANCY RELATING TO ALL THE AFORESAID (U.S. CLS. 100 AND 101).

CARYN GLASSER, EXAMINING ATTORNEY

SN 79-084,806. DEGREMONT, FRANCE, FILED 4-28-2010.

# ULTRAZUR

THE MARK CONSISTS OF STANDARD CHARACTERS WITHOUT CLAIM TO ANY PARTICULAR FONT, STYLE, SIZE, OR COLOR.

OWNER OF INTERNATIONAL REGISTRATION 1044530 DATED 4-28-2010, EXPIRES 4-28-2020.

**CLASS 11—ENVIRONMENTAL CONTROL APPARATUS**

FOR WATER TREATMENT PLANT AND SYSTEMS, NAMELY, DISINFECTION EQUIPMENT, BIOLOGICAL PROCESS EQUIPMENT, STERILIZATION EQUIPMENT, CLARIFIERS, FLOTATORS, SETTLERS; FILTRATION APPARATUS AND EQUIPMENT, NAMELY, GRAVITY SEPARATOR EQUIPMENT, CENTRIFUGAL SEPARATOR EQUIPMENT, DISINFECTION EQUIPMENT; FILTRATION EQUIPMENT MOUNTED ON MODULES AND MEMBRANES EITHER ORGANIC OR MINERAL MICROFILTRATION, ULTRAFILTRATION, NANOFILTRATION AND HYPERFILTRATION OR REVERSE OSMOSIS, NAMELY, SAND AND MEMBRANE FILTERS, CARTRIDGE FILTRATION UNITS, PERMEABLE AND SEMI-PERMEABLE MEMBRANES; PARTS OF THE ABOVE-MENTIONED SYSTEMS, ALSO SOLD AS A UNIT, NAMELY, PIPE WORKS AND ELECTROMECHANICAL EQUIPMENT REQUIRED FOR FILTRATION, NAMELY, PIPES, FILTER (U.S. CLS. 13, 21, 23, 31 AND 34).

**CLASS 40—MATERIAL TREATMENT**

FOR MAINTENANCE, RECONDITIONING AND REPAIR OF WATER TREATMENT, FILTRATION, FILTRATION ON MODULES AND MEMBRANES INTENDED FOR PRODUCTION OF DRINKING WATER, INDUSTRIAL, MUNICIPAL OR DOMESTIC WATER SUPPLIES (U.S. CLS. 100, 103 AND 106).

**CLASS 42—SCIENTIFIC AND COMPUTER SERVICES**

FOR SCIENTIFIC STUDIES AND RESEARCH SERVICES IN THE TREATMENT AND FILTRATION OF WATER; SCIENTIFIC STUDIES AND RESEARCH SERVICES RELATING TO OPERATION OF WATER TREATMENT AND FILTRATION INSTALLATIONS; TECHNICAL AUDITING, LABORATORY RESEARCH STUDIES, ENGINEERING CONSULTANCY AND ENGINEERING SERVICES IN RELATION TO METHODS FOR SETTING UP EQUIPMENT FOR WATER TREATMENT AND FILTRATION (U.S. CLS. 100 AND 101).

ARETHA SOMERVILLE, EXAMINING ATTORNEY

SN 79-084,821. IMPOSSIBLE B.V., NETHERLANDS, FILED 5-25-2010.

# IMPOSSIBLE

PRIORITY DATE OF 3-31-2010 IS CLAIMED.  
OWNER OF INTERNATIONAL REGISTRATION 1044561  
DATED 5-25-2010, EXPIRES 5-25-2020.

**CLASS 1—CHEMICALS**

FOR CHEMICAL PREPARATIONS FOR PHOTOGRAPHY; PHOTOGRAPHIC EMULSIONS; PHOTOGRAPHIC PAPER; PHOTOGRAPHIC SENSITIZERS; GELATINE FOR PHOTOGRAPHIC PURPOSES; SENSITIZED PHOTOGRAPHIC DRY PLATES; CINEMATOGRAPHIC FILM, SENSITIZED BUT NOT EXPOSED; SENSITIZED FILMS, UNEXPOSED; PHOTOGRAPHIC DEVELOPERS; FERROTYPED PHOTOGRAPHIC DRY PLATES; SELF-TONING PHOTOGRAPHIC PAPER (U.S. CLS. 1, 5, 6, 10, 26 AND 46).

**CLASS 9—ELECTRICAL AND SCIENTIFIC APPARATUS**

FOR CAMERA FILMS, EXPOSED; CINEMATOGRAPHIC FILM, EXPOSED; EDITING APPLIANCES FOR CINEMATOGRAPHIC FILMS; SHUTTER RELEASES FOR PHOTOGRAPHY; DIAPHRAGMS FOR PHOTOGRAPHY; FLASHLIGHTS FOR PHOTOGRAPHY; FLASH-BULBS FOR PHOTOGRAPHY; DARKROOM LAMPS FOR PHOTOGRAPHY; CINEMATOGRAPHIC CAMERAS; TRIPODS FOR CAMERAS; CAMCORDERS; FILTERS FOR PHOTOGRAPHY; SPEED MEASURING APPARATUS FOR PHOTOGRAPHY; CAMERAS FOR PHOTOGRAPHY; SCREENS FOR PHOTOENGRAVING; SCREENS FOR PHOTOGRAPHY; CASES ESPECIALLY MADE FOR PHOTOGRAPHIC APPARATUS AND INSTRUMENTS; STANDS FOR PHOTOGRAPHIC APPARATUS; VIEWFINDERS, PHOTOGRAPHIC; DRYING APPARATUS FOR PHOTOGRAPHIC PRINTS; DRYING RACKS FOR PHOTOGRAPHY; FILTERS FOR ULTRAVIOLET RAYS, FOR PHOTOGRAPHY; SHUTTERS FOR PHOTOGRAPHY; ENLARGING APPARATUS FOR PHOTOGRAPHY; WASHING TRAYS FOR PHOTOGRAPHY; FILM CUTTING APPARATUS FOR PHOTOGRAPHY; PHOTOGRAPHIC SLIDE TRANSPARENCIES; SLIDE PROJECTORS; FRAMES FOR PHOTOGRAPHIC TRANSPARENCIES; BAGS FOR MOBILE TELEPHONES; SUNGLASSES; DIGITAL PICTURE FRAMES (U.S. CLS. 21, 23, 26, 36 AND 38).

**CLASS 16—PAPER GOODS AND PRINTED MATTER**

FOR TRANSFERS, NAMELY, TRANSFERS OF DEVELOPED PHOTOGRAPHIC DEPICTIONS FROM ORIGINAL EXPOSURE TO OTHER MATERIALS; ALBUMS, NAMELY, PHOTOGRAPHIC ALBUMS; PHOTOGRAPHS; PHOTO-ENGRAVINGS; PHOTOGRAPH STANDS; GRAPHIC REPRODUCTIONS (U.S. CLS. 2, 5, 22, 23, 29, 37, 38 AND 50).

**CLASS 20—FURNITURE AND ARTICLES NOT OTHERWISE CLASSIFIED**

FOR PICTURE FRAMES (U.S. CLS. 2, 13, 22, 25, 32 AND 50).

**CLASS 40—MATERIAL TREATMENT**

FOR PHOTOGRAPHIC FILM DEVELOPMENT; PHOTOGRAVURE; PHOTOGRAPHIC PRINTING; PHOTOCOMPOSING SERVICES; PROCESSING OF CINEMATOGRAPHIC FILMS (U.S. CLS. 100, 103 AND 106).

JESSICA FATHY, EXAMINING ATTORNEY

SN 79-084,918. TAICA CORPORATION, JAPAN, FILED 6-24-2010.

# OPTALGEL

OWNER OF INTERNATIONAL REGISTRATION 1044721  
DATED 6-24-2010, EXPIRES 6-24-2020.

NO CLAIM IS MADE TO THE EXCLUSIVE RIGHT TO USE "GEL.", APART FROM THE MARK AS SHOWN.

**CLASS 9—ELECTRICAL AND SCIENTIFIC APPARATUS**

FOR OPTICAL APPARATUS, NAMELY, LIQUID CRYSTAL DISPLAYS, PARTS AND ACCESSORIES OF LIQUID CRYSTAL DISPLAYS, PARTS AND ACCESSORIES OF LIGHT-EMITTING DIODES; ELECTRONIC MACHINES, APPARATUS AND THEIR PARTS, NAMELY, TOUCH PANELS, PARTS AND ACCESSORIES OF TOUCH PANELS (U.S. CLS. 21, 23, 26, 36 AND 38).

**CLASS 17—RUBBER GOODS**

FOR PLASTICS, SEMI-WORK PRODUCTS FOR USE AS MATERIAL, NAMELY, SILICON RUBBER AND OTHER RAW OR SEMI-WORKED RUBBERS; PLASTIC SEMI-WORKED PRODUCTS FOR USE AS MATERIAL, NAMELY, SYNTHETIC PLASTIC, SYNTHETIC RESINS IN THE FORM OF BLOCKS, PANELS, SHEETS, TAPES OR STRIPS; PACKING, NAMELY, ELECTRICAL INSULATING MATERIALS, SEALING MATERIALS AND CAULKING MATERIALS (U.S. CLS. 1, 5, 12, 13, 35 AND 50).

AISHA CLARKE, EXAMINING ATTORNEY

SN 79-084,973. DANIEL RECAYTE, FRANCE, AND JEAN JOËL MARCEL BERGER, FRANCE, FILED 4-12-2010.

# AQUASOPHIA

THE MARK CONSISTS OF STANDARD CHARACTERS WITHOUT CLAIM TO ANY PARTICULAR FONT, STYLE, SIZE, OR COLOR.

PRIORITY DATE OF 10-20-2009 IS CLAIMED.  
OWNER OF INTERNATIONAL REGISTRATION 1044899 DATED 4-12-2010, EXPIRES 4-12-2020.

**CLASS 32—LIGHT BEVERAGES**

FOR MINERAL AND AERATED WATERS (U.S. CLS. 45, 46 AND 48).

**CLASS 35—ADVERTISING AND BUSINESS**

FOR ADVERTISING; BUSINESS MANAGEMENT; DIRECT MAIL ADVERTISING; ORGANIZATION OF EXHIBITIONS FOR COMMERCIAL OR ADVERTISING PURPOSES; ON-LINE ADVERTISING ON A COMPUTER NETWORK; RENTAL OF ADVERTISING TIME ON COMMUNICATION MEDIA; PUBLICATION OF ADVERTISING TEXTS; RENTAL OF ADVERTISING SPACE; DISSEMINATION OF ADVERTISING MATTER; PUBLIC RELATIONS (U.S. CLS. 100, 101 AND 102).

**CLASS 41—EDUCATION AND ENTERTAINMENT**

FOR PROVIDING RECREATION FACILITIES; PUBLICATION OF BOOKS; LENDING LIBRARIES; VIDEO-TAPE FILM PRODUCTION; RENTAL OF MOTION PICTURES; RENTAL OF SOUND RECORDINGS; PHOTOGRAPHY SERVICES (U.S. CLS. 100, 101 AND 107).

LEIGH LOWRY, EXAMINING ATTORNEY

SN 79-084,977. UCURE PHARMA, SOCIÉTÉ À RESPONSABILITÉ LIMITÉE, LUXEMBOURG, FILED 6-22-2010.



PRIORITY DATE OF 2-5-2010 IS CLAIMED.  
OWNER OF INTERNATIONAL REGISTRATION 1044913 DATED 6-22-2010, EXPIRES 6-22-2020.

**CLASS 3—COSMETICS AND CLEANING PREPARATIONS**

FOR COSMETICS; DENTIFRICES; CARE PRODUCTS FOR THE MOUTH, NOT FOR MEDICAL PURPOSES, NAMELY, MOUTH RINSES; CARE PRODUCTS FOR THE TREATMENT OF A DRY MOUTH, NOT FOR MEDICAL PURPOSES, NAMELY MOUTH RINSES (U.S. CLS. 1, 4, 6, 50, 51 AND 52).

**CLASS 5—PHARMACEUTICALS**

FOR SANITARY PREPARATIONS FOR MEDICAL PURPOSES; DISINFECTANTS FOR THE MOUTH; CARE PRODUCTS FOR THE MOUTH FOR MEDICAL PURPOSES, NAMELY, MEDICATED MOUTH RINSES; MEDICAL PREPARATIONS FOR THE TREATMENT OF A DRY MOUTH FOR MEDICAL PURPOSES; CHEWING GUM FOR MEDICAL PURPOSES (U.S. CLS. 6, 18, 44, 46, 51 AND 52).

CHRIS DONINGER, EXAMINING ATTORNEY

SN 79-085,014. BELLA BULGARIA AD, BULGARIA, FILED 6-25-2010.



PRIORITY DATE OF 12-30-2009 IS CLAIMED.  
OWNER OF INTERNATIONAL REGISTRATION 1045028 DATED 6-25-2010, EXPIRES 6-25-2020.

THE COLOR(S) LIGHT BLUE, DARK BLUE, RED AND WHITE IS/ARE CLAIMED AS A FEATURE OF THE MARK.  
THE MARK CONSISTS OF THE TERM "BELLA" IN RED WITH WHITE OUTLINE, OVER A CURVED UNDERLINE CONSISTING OF THE COLORS RED, WHITE, AND BLUE. THE WORDING IS SUPERIMPOSED OVER A FLAG LIKE DESIGN COMPRISED OF THE COLORS DARK BLUE AND LIGHT BLUE.

THE ENGLISH TRANSLATION OF THE WORD "BELLA" IN THE MARK IS "BEAUTIFUL".



**CLASS 16—PAPER GOODS AND PRINTED MATTER**

FOR ARTIST'S PAPER; BOOKBINDING MATERIAL; ADHESIVES FOR HOUSEHOLD PURPOSES; PAINT BRUSHES; TYPEWRITERS; PLASTIC MATERIALS FOR PACKAGING; PRINTERS' TYPE; PRINTING BLOCKS; PACKING PAPER FOR FOOD PRODUCTS; PACKING PLASTIC FOR FOOD PRODUCTS (U.S. CLS. 2, 5, 22, 23, 29, 37, 38 AND 50).

**CLASS 29—MEATS AND PROCESSED FOODS**

FOR PRESERVED, FROZEN, DRIED AND COOKED FRUITS AND VEGETABLES; JELLIES, JAMS, COMPOSTES; EGGS, MILK AND MILK PRODUCTS; VEGETABLE BASED EDIBLE OILS; FROZEN HALF COOKED MEALS MADE OF VEGETABLES (U.S. CL. 46).

**CLASS 30—STAPLE FOODS**

FOR COFFEE, TEA, COCOA, SUGAR, RICE, TAPIOCA, SAGO, ARTIFICIAL COFFEE; FLOUR AND PREPARATIONS MADE FROM CEREALS, PASTRY AND CONFECTIONERY, ICES; HONEY, TREACLE; YEAST, BAKING-POWDER; SALT, MUSTARD; VINEGAR, SAUCES; CONDIMENTS; SPICES; ICE; FROZEN FERMENTED FOOD PASTES; CAKE PASTE; BANITSI, A TRADITIONAL BULGARIAN FLOUR PRODUCT-PIE; PUFF PASTRIES (U.S. CL. 46).

**CLASS 35—ADVERTISING AND BUSINESS**

FOR ADVERTISING SERVICES; BUSINESS MANAGEMENT; BUSINESS ADMINISTRATION CONSULTANCY; OFFICE FUNCTIONS; THE BRINGING TOGETHER, FOR THE BENEFIT OF OTHERS, OF VARIETY OF GOODS, ENABLING CUSTOMERS TO CONVENIENTLY VIEW AND PURCHASE THOSE GOODS IN THE FIELD OF FOOD ITEMS; RETAIL AND WHOLESALE STORES FEATURING FOOD PRODUCTS (U.S. CLS. 100, 101 AND 102).

CURTIS FRENCH, EXAMINING ATTORNEY

**CLASS 35—ADVERTISING AND BUSINESS**

FOR ADVERTISING SERVICES; MARKETING AND COMMUNICATION SERVICES, NAMELY, PROMOTING AND MARKETING THE GOODS AND SERVICES OF OTHERS THROUGH ALL PUBLIC COMMUNICATION MEANS; BUSINESS MANAGEMENT; BUSINESS ADMINISTRATION; PROVIDING OFFICE FUNCTIONS; ADVERTISING AND PROMOTIONAL SERVICES RELATING TO TRIPS AND ACCOMMODATION; MARKET CANVASSING, NAMELY, RESEARCHING CUSTOMER REQUIREMENTS AND OPINIONS, AND MARKET ANALYSIS; COMPUTER FILE MANAGEMENT OF DATABASES REGARDING TRIPS AND ACCOMMODATION; FILE MANAGEMENT OF DATABASES REGARDING CONGRESSES, SEMINARS, EXHIBITIONS, WORKSHOPS, COURSES AND CONFERENCES; ORGANIZATION OF BUSINESS CONFERENCES FOR COMMERCIAL OR PROMOTIONAL PURPOSES; PROVIDING INFORMATION ABOUT ALL THE AFOREMENTIONED SERVICES (U.S. CLS. 100, 101 AND 102).

**CLASS 39—TRANSPORTATION AND STORAGE**

FOR TRANSPORT BY AIR, RAIL, BOAT, BUS AND CAR; TRAVEL ARRANGEMENT AND ORGANIZATION OF SIGHTSEEING TOURS; ESCORTING OF TRAVELLERS; INTERMEDIARY SERVICES RELATED TO THE SALE OF TOURS, NAMELY, ORGANIZING TRAVEL ARRANGEMENT AND SIGHTSEEING TOURS ON BEHALF OF THIRD PARTIES; PROVIDING TRAVEL INFORMATION; RESERVATION OF TRANSPORT TICKETS, AND INTERMEDIARY SERVICES IN THIS FIELD, BEING SERVICES OF A TRAVEL AGENCY, NAMELY, TRAVEL AGENCY SERVICES, NAMELY, MAKING RESERVATIONS AND BOOKINGS FOR TRANSPORTATION AND TRAVEL; TRANSPORT OF PERSONS; ORGANIZING BUSINESS TOURS, GROUP TRAVEL AND HOLIDAY TRIPS; RENTAL OF VEHICLES; SERVICES OF A TOUR OPERATOR, NAMELY, THE TRANSPORT OF TRAVELLERS; ARRANGING FOR TRAVEL VISAS, PASSPORTS AND TRAVEL DOCUMENTS FOR PERSONS TRAVELLING ABROAD; PROVIDING INFORMATION ABOUT ALL THE AFOREMENTIONED SERVICES (U.S. CLS. 100 AND 105).

**CLASS 41—EDUCATION AND ENTERTAINMENT**

FOR ORGANIZATION OF RECREATIONAL EVENTS AND ACTIVITIES, NAMELY, FOOTBALL GAMES AND TOURNAMENTS, SOCCER GAMES AND TOURNAMENTS, BASKETBALL GAMES, GOLFING TOURNAMENTS, TENNIS GAMES AND TOURNAMENTS, ATHLETICS EVENTS, POLO EVENTS AND TOURNAMENTS, MOTORSPORT EVENTS AND ACTIVITIES, HORSE-RACING EVENTS, HORSE-RIDING, SAILING, DIVING, CLIMBING, HIKING, CYCLING, AND GOLFING ACTIVITIES; ORGANIZATION OF CULTURAL EVENTS; ORGANIZATION OF ENTERTAINMENT EVENTS AND ACTIVITIES, NAMELY, MUSEUM VISITS, ART GALLERY VISITS, CONCERTS, PLAYS, MUSICAL SHOWS, AND COMEDY SHOWS (U.S. CLS. 100, 101 AND 107).

**CLASS 43—HOTEL AND RESTAURANT SERVICES**

FOR SERVICES FOR PROVIDING FOOD AND DRINK; PROVIDING TEMPORARY ACCOMMODATION; RENTAL OF ROOMS AS TEMPORARY LIVING ACCOMMODATIONS; INTERMEDIARY SERVICES IN THE FIELD OF THE RENTAL OF HOTEL ROOMS, NAMELY, BOOKING AND RESERVING HOTEL ROOMS AND TEMPORARY ACCOMMODATION ON BEHALF OF THIRD PARTIES; SERVICES OF A HOTEL, RESTAURANT AND CAFE; AGENCY SERVICES FOR THE RESERVATION OF TEMPORARY ACCOMMODATION; PROVIDING INFORMATION ABOUT ALL THE AFOREMENTIONED SERVICES (U.S. CLS. 100 AND 101).

SCOTT BIBB, EXAMINING ATTORNEY

SN 79-085,101. ATPI LIMITED, UNITED KINGDOM, FILED 5-28-2010.



PRIORITY DATE OF 2-25-2010 IS CLAIMED.  
OWNER OF INTERNATIONAL REGISTRATION 1045317  
DATED 5-28-2010, EXPIRES 5-28-2020.

THE COLOR(S) BLUE IS/ARE CLAIMED AS A FEATURE OF THE MARK.

THE MARK CONSISTS OF THE STYLIZED LETTERING "ATPI" IN BLUE, COMPRISED WITHIN TWO CRESCENTS ALSO IN BLUE.

SN 79-085,119. Y24 YACHTING 24 GMBH, FED REP GERMANY, FILED 6-16-2010.



**YACHTING24**  
online insurance

OWNER OF INTERNATIONAL REGISTRATION 1045363 DATED 6-16-2010, EXPIRES 6-16-2020.

NO CLAIM IS MADE TO THE EXCLUSIVE RIGHT TO USE "YACHTING" OR "ONLINE INSURANCE", APART FROM THE MARK AS SHOWN.

THE COLOR(S) BLACK, WHITE, AND GRAY IS/ARE CLAIMED AS A FEATURE OF THE MARK.

THE MARK CONSISTS OF THE WORDING "YACHTING 24 ONLINE INSURANCE" IN STYLIZED FONT. THE WORD "YACHTING" APPEARS IN BLACK TYPE, WITH THE LETTER "I" CONSISTING OF A BLACK LIGHTHOUSE WITH A WHITE STRIPE AT THE SIDE AND A WHITE LANTERN AT THE TOP, WITH GRAY LIGHT RAYS EXTENDING HORIZONTALLY FROM THE TOP. THE NUMBER "24" APPEARS IN WHITE TYPE WITH A BLACK OUTLINE. THE WORDS "ONLINE INSURANCE" APPEAR IN GRAY TYPE.

#### CLASS 36—INSURANCE AND FINANCIAL

FOR INSURANCE, NAMELY, MARINE INSURANCE UNDERWRITING; INSURANCE CONSULTANCY, INCLUDING ON THE INTERNET (U.S. CLS. 100, 101 AND 102).

#### CLASS 38—COMMUNICATION

FOR PROVIDING ACCESS TO INFORMATION ON THE INTERNET, NAMELY, THE SERVICES OF AN INTERNET SERVICE PROVIDER (U.S. CLS. 100, 101 AND 104).

#### CLASS 42—SCIENTIFIC AND COMPUTER SERVICES

FOR DRAWING UP TECHNICAL EVALUATIONS, TECHNICAL APPRAISALS, TECHNICAL EXAMINATIONS AND TECHNICAL REPORTS, THE FOREGOING BEING ENGINEERING SERVICES IN THE FIELD OF DAMAGE APPRAISALS, BOAT EVALUATION (U.S. CLS. 100 AND 101).

LIEF MARTIN, EXAMINING ATTORNEY

SN 79-085,144. CUALITAS INDUSTRIAL S.A., SPAIN, FILED 6-4-2010.



**TAVER**

OWNER OF INTERNATIONAL REGISTRATION 0419561 DATED 12-31-1975, EXPIRES 12-31-2015.

THE WORDING "TAVER" HAS NO MEANING IN A FOREIGN LANGUAGE.

#### CLASS 11—ENVIRONMENTAL CONTROL APPARATUS

FOR REFRIGERATING APPARATUS, NAMELY, REFRIGERATORS; REFRIGERATING INSTALLATIONS, REFRIGERATING CABINETS, WALK-IN REFRIGERATORS, ICE BOXES (U.S. CLS. 13, 21, 23, 31 AND 34).

#### CLASS 19—NON-METALLIC BUILDING MATERIALS

FOR FIBERBOARDS; NON-METALLIC BUILDING MATERIALS, NAMELY, PLASTIC BONDED BOARDS NOT OF METAL FOR CONSTRUCTION AND BUILDING (U.S. CLS. 1, 12, 33 AND 50).

COLLEEN DOMBROW, EXAMINING ATTORNEY

SN 79-085,222. VIVABOXES INTERNATIONAL, NAAMLOZE VENNOOTSCHAP, BELGIUM, FILED 5-19-2010.



**TRYFIRST**

THE MARK CONSISTS OF STANDARD CHARACTERS WITHOUT CLAIM TO ANY PARTICULAR FONT, STYLE, SIZE, OR COLOR.

PRIORITY DATE OF 5-12-2010 IS CLAIMED.

OWNER OF INTERNATIONAL REGISTRATION 1045480 DATED 5-19-2010, EXPIRES 5-19-2020.

#### CLASS 9—ELECTRICAL AND SCIENTIFIC APPARATUS

FOR MAGNETIC CARDS; MEMORY CARDS; PRE-RECORDED VIDEO CASSETTES CONTAINING FILMS, TV SERIES, CARTOONS, VIDEO GAMES; PRE-RECORDED AUDIO-VIDEO COMPACT DISCS CONTAINING FILMS, TV SERIES, CARTOONS, VIDEO GAMES; EXPOSED CINEMATOGRAPHIC FILMS; PRE-RECORDED OPTICAL DISCS CONTAINING FILMS, TV SERIES, CARTOONS, VIDEO GAMES; PRE-RECORDED COMPACT OPTICAL DISCS CONTAINING FILMS, TV SERIES, CARTOONS, VIDEO GAMES; VIDEO GAME CONSOLES ADAPTED FOR USE WITH AN EXTERNAL DISPLAY SCREEN OR MONITOR; COMPUTER GAME PROGRAMS; VIDEO GAME CARTRIDGES; VIDEO GAMES SOFTWARE; COMPUTER GAMES PROGRAMS; TELEPHONE APPARATUS; MOBILE TELEPHONES (U.S. CLS. 21, 23, 26, 36 AND 38).

#### CLASS 16—PAPER GOODS AND PRINTED MATTER

FOR PRINTED MATTER, NAMELY, PHOTOGRAPHS; CARDBOARD BOXES FOR USE AS GIFT SETS; PRINTED TICKETS; PRINTED DISCOUNT VOUCHERS FOR THE PURCHASE OF GOODS AND/OR SERVICES; PRINTED PROMOTIONAL VOUCHERS AND/OR PRINTED ADVERTISING VOUCHERS INTENDED TO BE EXCHANGED FOR GOODS AND/OR SERVICES; PAPER AND CARDBOARD CARDS IN THE NATURE OF PROMOTIONAL AND ADVERTISING PRINTED VOUCHERS FOR EXCHANGE OF GOODS AND SERVICES; POSTCARDS; CATALOGS IN THE FIELD OF SPORT ACTIVITIES, RESTAURANTS, DECORATION, PRESENTING MUSEUMS, SHOWS, BOOKS, DVD, PERFUMES, COSMETICS; SERIES OF FICTION BOOKS; CHILDREN'S BOOKS; COMICS STRIPS; BOOKS IN THE FIELDS OF COOKING, TRAVEL, COMICS, HISTORY, POLITICS, ART, MUSIC, SCIENCE, COSMETICS, PERFUMES, SPORTS; BOOKMARKS (U.S. CLS. 2, 5, 22, 23, 29, 37, 38 AND 50).

**CLASS 35—ADVERTISING AND BUSINESS**

FOR DIRECT MAIL ADVERTISING SERVICES; PRESENTATION OF GOODS ON COMMUNICATION MEDIA, FOR RETAIL PURPOSES; ADVERTISING AGENCIES, NAMELY, PROMOTING THE GOODS AND SERVICES OF OTHERS; DATABASE MANAGEMENT; ISSUING GIFT CERTIFICATES WHICH MAY THEN BE REDEEMED FOR GOODS AND SERVICES FOR COMMERCIAL OR ADVERTISING PURPOSES; PROMOTING THE GOODS AND SERVICES OF OTHERS, NAMELY, PROVIDING OF PROMOTIONAL TOKENS OR ADVERTISING VOUCHERS INTENDED TO BE EXCHANGED FOR ANY KIND OF GOODS AND/OR SERVICES OF OTHERS; PROMOTING THE GOODS AND SERVICES OF OTHERS, NAMELY, PROVIDING OF TOKENS INTENDED TO BE EXCHANGED FOR PROMOTIONAL AND/OR PUBLICITY GOODS OF OTHERS; WHOLESALE STORES, SEMI WHOLESALE AND RETAIL STORES FEATURING GIFT SETS; WHOLESALE STORES, SEMI WHOLESALE AND RETAIL STORES FEATURING GIFT SETS CONTAINING CDS OR DVDS, BOOKS, INTERIOR DECORATIVE ARTICLES, FOODSTUFFS, ALCOHOLIC AND NON-ALCOHOLIC BEVERAGES, SPICES, PERFUMES, FOODSTUFFS, BEVERAGES AND HANDICRAFTS FROM FAIR TRADE, GAMES FOR BABIES AND INFANTS, VIDEO GAMES, COMPUTER GAMES, BABY CARE PRODUCT, COSMETICS, OR CONTAINING VOUCHERS FOR SERVICES IN BEAUTY SALONS, VOUCHERS FOR ADMISSION TO SHOWS, VOUCHERS FOR ENTRY INTO LEISURE PARKS OR FAIRGROUNDS, VOUCHERS FOR ADMISSION TO SPORTS EVENTS, VOUCHERS FOR MEALS IN RESTAURANTS, VOUCHERS FOR MEALS AND/OR OVERNIGHT STAYS IN HOTELS (U.S. CLS. 100, 101 AND 102).

**CLASS 36—INSURANCE AND FINANCIAL**

FOR ISSUING OF TRAVELLERS' CHECKS; ISSUE OF TOKENS OF VALUE INTENDED TO BE EXCHANGED FOR ANY KIND OF GOODS AND/OR SERVICES; ISSUE OF TOKENS OF VALUE INTENDED TO BE EXCHANGED FOR CDS, DVDS, BOOKS, INTERIOR DECORATION ARTICLES, FOODSTUFFS, ALCOHOLIC AND NON-ALCOHOLIC BEVERAGES, SPICES, PERFUMES, FOODSTUFFS, BEVERAGES AND HANDICRAFTS FROM FAIR TRADE, GAMES FOR BABIES AND INFANTS, VIDEO GAMES, COMPUTER GAMES, BABY CARE PRODUCT, COSMETICS, CARE IN BEAUTY SALONS, PLACES IN SHOWS, ADMISSION TO LEISURE PARKS OR FAIRGROUNDS, ADMISSION TO SPORTS EVENTS, MEALS IN RESTAURANTS OR OVERNIGHT STAYS IN HOTELS (U.S. CLS. 100, 101 AND 102).

**CLASS 39—TRANSPORTATION AND STORAGE**

FOR ARRANGING OF TOURS; ESCORTING OF TRAVELERS; ARRANGING OF CRUISES; ARRANGING OF SIGHTSEEING TOURS; FLOWER DELIVERY; BOOKING OF SEATS FOR TRAVEL (U.S. CLS. 100 AND 105).

**CLASS 41—EDUCATION AND ENTERTAINMENT**

FOR EDUCATION AND TRAINING IN THE NATURE OF SEMINARS AND WORKSHOPS IN THE FIELD OF COOKING, PAINTING, LITERATURE; ORGANIZING SPORTING AND CULTURAL EVENTS; AMUSEMENT PARKS; ENTERTAINMENT TICKET AGENCY SERVICES; ARRANGING AND CONDUCTING OF COLLOQUIUMS, CONFERENCES, CONGRESSES, COMPETITIONS FOR EDUCATIONAL OR ENTERTAINMENT PURPOSES; ORGANIZATION OF EXHIBITIONS FOR CULTURAL OR EDUCATIONAL PURPOSES; ARRANGING AND CONDUCTING OF CONCERTS; ORGANIZATION OF SPORTS COMPETITIONS; HEALTH CLUB SERVICES, NAMELY, PROVIDING INSTRUCTION AND EQUIPMENT IN THE FIELD OF PHYSICAL EXERCISE; PROVIDING SPORTS FACILITIES; OPERATING LOTTERIES; MUSEUM SERVICES, NAMELY, PROVIDING MUSEUM FACILITIES, MUSEUM PRESENTATIONS, AND MUSEUM EXHIBITIONS; MUSIC-HALLS; PARTY PLANNING; CIRCUSES; CINEMA THEATRES; THEATRE PRODUCTIONS, NAMELY, PRESENTATION OF LIVE SHOW PERFORMANCES; BOOKING OF SEATS FOR SHOWS; PRESENTATION OF LIVE PERFORMANCES (U.S. CLS. 100, 101 AND 107).

KATHERINE E. HALMEN, EXAMINING ATTORNEY

SN 79-085,226. ENSITECH PTY LTD, AUSTRALIA, AND CLIVE WHITE, AUSTRALIA, FILED 6-4-2010.



OWNER OF INTERNATIONAL REGISTRATION 1045494 DATED 6-4-2010, EXPIRES 6-4-2020.

THE MARK CONSISTS OF THE STYLIZED WORDING "ENSITECH" BENEATH A ROUNDED, SEMI-CIRCULAR GEOMETRIC DESIGN FORMING A STYLIZED LETTER "E".

**CLASS 1—CHEMICALS**

FOR CHEMICAL SUBSTANCES FOR USE IN METAL FINISHING AND METAL TREATMENT; CHEMICAL COMPOSITIONS FOR USE IN METAL FINISHING; CHEMICAL PRODUCTS FOR USE IN THE MANUFACTURE OF POLISHING PREPARATIONS; CHEMICAL PRODUCTS FOR USE IN INDUSTRIAL CLEANING PROCESSES; METAL PLATING CHEMICAL COMPOSITIONS; CHEMICALS FOR USE IN METAL PLATING (U.S. CLS. 1, 5, 6, 10, 26 AND 46).

**CLASS 7—MACHINERY**

FOR METAL FINISHING MACHINES; METAL FINISHING PLANT MACHINES; ELECTRIC POLISHING MACHINES; ELECTRIC HAND HELD POLISHING MACHINES; TUBE CLEANING MACHINES; TANK CLEANING MACHINES; CLEANING MACHINES FOR INDUSTRIAL PURPOSES; MACHINES INCORPORATING ROTARY BRUSHES FOR CLEANING METAL SURFACES; ELECTRIC CLEANING MACHINES FOR CLEANING METAL SURFACES; WORK STATION MACHINES FOR METAL PLATING; BRUSHES BEING PARTS OF MACHINES; CLEANING BRUSHES BEING PARTS OF MACHINES (U.S. CLS. 13, 19, 21, 23, 31, 34 AND 35).

NICHOLAS ALTREE, EXAMINING ATTORNEY

SN 79-085,260. LOUIS POULSEN LIGHTING A/S, DK-1202 KØBENHAVN K., DENMARK, FILED 6-4-2010.

**LP NEST**

THE MARK CONSISTS OF STANDARD CHARACTERS WITHOUT CLAIM TO ANY PARTICULAR FONT, STYLE, SIZE, OR COLOR.

PRIORITY DATE OF 12-4-2009 IS CLAIMED.

OWNER OF INTERNATIONAL REGISTRATION 1045573 DATED 6-4-2010, EXPIRES 6-4-2020.

OWNER OF U.S. REG. NOS. 3,423,182, 3,436,315 AND 3,512,784.

**CLASS 11—ENVIRONMENTAL CONTROL APPARATUS**

FOR LIGHTING APPARATUS, NAMELY, APPARATUS FOR STREET LIGHTING IN THE NATURE OF STREET LAMPS (U.S. CLS. 13, 21, 23, 31 AND 34).

**CLASS 35—ADVERTISING AND BUSINESS**

FOR WHOLESALE STORE SERVICES AND WHOLESALE ORDERING SERVICES IN THE FIELD OF LIGHTING APPARATUS, INCLUDING WHOLESALE STORE SERVICES AND WHOLESALE ORDERING SERVICES IN THE FIELD OF LIGHTING APPARATUS THAT ARE AVAILABLE VIA GLOBAL NETWORKS (U.S. CLS. 100, 101 AND 102).

**CLASS 42—SCIENTIFIC AND COMPUTER SERVICES**

FOR INDUSTRIAL DESIGN, IN PARTICULAR INDUSTRIAL DESIGN OF LIGHTING APPARATUS, INCLUDING APPARATUS FOR STREET LIGHTING (U.S. CLS. 100 AND 101).

COLLEEN DOMBROW, EXAMINING ATTORNEY

SN 79-085,267. COPLAX AG, SWITZERLAND, FILED 7-9-2010.

**STYLIES**

THE MARK CONSISTS OF STANDARD CHARACTERS WITHOUT CLAIM TO ANY PARTICULAR FONT, STYLE, SIZE, OR COLOR.

PRIORITY DATE OF 1-19-2010 IS CLAIMED.

OWNER OF INTERNATIONAL REGISTRATION 1045598 DATED 7-9-2010, EXPIRES 7-9-2020.

**CLASS 11—ENVIRONMENTAL CONTROL APPARATUS**

FOR LIGHTING APPARATUS, NAMELY, LIGHT INSTALLATIONS, HEATING APPARATUS, NAMELY, ELECTRIC FAN HEATERS, STEAM GENERATORS, COOLING APPARATUS, NAMELY, AIR HUMIDIFIERS, AIR PURIFIERS, ELECTRIC FANS, AIR CONDITIONING UNITS, DRYING APPARATUS, NAMELY, CLOTHES DRYERS AND AIR CONDITIONING APPARATUS (U.S. CLS. 13, 21, 23, 31 AND 34).

**CLASS 21—HOUSEWARES AND GLASS**

FOR HOUSEHOLD OR KITCHEN UTENSILS AND CONTAINERS NOT OF PRECIOUS METAL OR COATED THEREWITH, NAMELY, LADLES AND NON-ELECTRIC KITCHEN CONTAINERS; COMBS AND CLEANING SPONGES; BRUSHES EXCEPT PAINT BRUSHES, NAMELY, BATH BRUSHES; ARTICLES FOR CLEANING PURPOSES, NAMELY, MICROFIBER CLOTHS (U.S. CLS. 2, 13, 23, 29, 30, 33, 40 AND 50).

JENNIFER VASQUEZ, EXAMINING ATTORNEY

SN 79-085,302. MIWIM, FRANCE, FILED 6-21-2010.

**OLIMEO**

THE MARK CONSISTS OF STANDARD CHARACTERS WITHOUT CLAIM TO ANY PARTICULAR FONT, STYLE, SIZE, OR COLOR.

PRIORITY DATE OF 4-29-2010 IS CLAIMED.

OWNER OF INTERNATIONAL REGISTRATION 1045680 DATED 6-21-2010, EXPIRES 6-21-2020.

THE WORDING "OLIMEO" HAS NO MEANING IN A FOREIGN LANGUAGE.

**CLASS 35—ADVERTISING AND BUSINESS**

FOR ADVERTISING; BUSINESS MANAGEMENT; BUSINESS ADMINISTRATION; PROVIDING OFFICE FUNCTIONS; DIRECT MAIL ADVERTISING; ARRANGING NEWSPAPER SUBSCRIPTIONS FOR OTHERS; BUSINESS MANAGEMENT AND ORGANIZATION CONSULTANCY; BOOKKEEPING; DOCUMENT REPRODUCTION; EMPLOYMENT AGENCIES; COMPUTERIZED FILE MANAGEMENT; ORGANIZATION OF EXHIBITIONS FOR COMMERCIAL OR ADVERTISING PURPOSES; ONLINE ADVERTISING ON A COMPUTER NETWORK; RENTAL OF ADVERTISING TIME ON COMMUNICATION MEDIA; PUBLICATION OF PUBLICITY TEXTS; RENTAL OF ADVERTISING SPACE; DISSEMINATION OF ADVERTISING MATTER; PUBLIC RELATIONS (U.S. CLS. 100, 101 AND 102).

**CLASS 38—COMMUNICATION**

FOR TELECOMMUNICATIONS SERVICES, NAMELY, TELECOMMUNICATIONS GATEWAY SERVICES; INFORMATION ABOUT TELECOMMUNICATION; COMMUNICATIONS VIA COMPUTER TERMINALS AND VIA FIBER-OPTIC NETWORKS; RADIO AND TELEPHONE COMMUNICATION; MOBILE RADIO TELEPHONE SERVICES; PROVIDING USER ACCESS TO A GLOBAL COMPUTER NETWORK; ELECTRONIC BULLETIN BOARD SERVICES; PROVIDING TELECOMMUNICATIONS CONNECTIONS TO A GLOBAL COMPUTER NETWORK; NEWS AGENCIES, NAMELY, THE TRANSMISSION OF NEWS ITEMS TO NEWS REPORTING ORGANIZATIONS; RENTAL OF TELECOMMUNICATION EQUIPMENT; RADIO AND TELEVISION BROADCASTING; TELECONFERENCING SERVICES; ELECTRONIC MAIL SERVICES; RENTAL OF ACCESS TIME TO GLOBAL COMPUTER NETWORKS (U.S. CLS. 100, 101 AND 104).



**CLASS 42—SCIENTIFIC AND COMPUTER SERVICES**

FOR ENGINEERING SERVICES IN THE NATURE OF EVALUATIONS, ASSESSMENTS AND RESEARCH IN THE FIELDS OF SCIENCE AND TECHNOLOGY PROVIDED BY ENGINEERS; DESIGN AND DEVELOPMENT OF COMPUTER HARDWARE AND SOFTWARE; NEW PRODUCT RESEARCH AND DEVELOPMENT FOR OTHERS; TECHNICAL PROJECT STUDIES, NAMELY, RESEARCH RELATING TO MECHANICAL ENGINEERING; ARCHITECTURAL DESIGN SERVICES; DESIGN OF INTERIOR DECOR; DEVELOPMENT, DESIGN, INSTALLATION, MAINTENANCE, UPDATING AND RENTAL OF SOFTWARE; COMPUTER PROGRAMMING; CONSULTANCY IN THE FIELD OF COMPUTER HARDWARE; DATA CONVERSION OF COMPUTER PROGRAMS AND DATA, NOT PHYSICAL CONVERSION; CONVERSION OF DATA OR DOCUMENTS FROM PHYSICAL TO ELECTRONIC MEDIA; VEHICLE ROAD-WORTHINESS TESTING, NAMELY, AUTOMOTIVE SAFETY TESTING AND CONSULTATION IN THE NATURE OF CONDUCTING CRASH TESTS AND PROVIDING ADVICE, INFORMATION AND REPORTS; GRAPHIC ARTS DESIGNING; STYLING IN THE NATURE OF INDUSTRIAL DESIGN; AUTHENTICATING WORKS OF ART (U.S. CLS. 100 AND 101).  
LEIGH LOWRY, EXAMINING ATTORNEY

---

SN 79-085,323. MECALUX, S.A., SPAIN, FILED 5-27-2010.



PRIORITY DATE OF 12-15-2009 IS CLAIMED.  
OWNER OF INTERNATIONAL REGISTRATION 1045726 DATED 5-27-2010, EXPIRES 5-27-2020.

NO CLAIM IS MADE TO THE EXCLUSIVE RIGHT TO USE "MONITOR", APART FROM THE MARK AS SHOWN.  
THE COLOR(S) BLUE AND ORANGE IS/ARE CLAIMED AS A FEATURE OF THE MARK.

THE MARK CONSISTS OF THE STYLIZED WORDS "EASY M MONITOR"; THE WORD "EASY" IS IN ORANGE; THE STYLIZED LETTER "M" IN WHITE IS TRANSPARENT AND POSITIONED IN A BLUE CIRCLE WITH THE WORDING "MONITOR" ALSO IN BLUE; THE COLOR WHITE IS TRANSPARENT AND NOT CLAIMED AS A FEATURE OF THE MARK.

**CLASS 9—ELECTRICAL AND SCIENTIFIC APPARATUS**

FOR DOWNLOADABLE AND PRE-RECORDED COMPUTER APPLICATION AND DATABASE SOFTWARE DISSEMINATED IN ANY MEDIA, USED FOR WAREHOUSE AND STORAGE MANAGEMENT (U.S. CLS. 21, 23, 26, 36 AND 38).

**CLASS 42—SCIENTIFIC AND COMPUTER SERVICES**

FOR DESIGN OF COMPUTER SOFTWARE; INSTALLATION, UPGRADING, MAINTENANCE, AND REPAIR OF COMPUTER SOFTWARE; SOFTWARE AND HARDWARE CONSULTATION; TECHNICAL SUPPORT SERVICES, NAMELY, TROUBLESHOOTING OF COMPUTER SOFTWARE PROBLEMS AND PREVENTIVE, CORRECTIVE AND EVOLVED MAINTENANCE AND SUPPORT FOR COMPUTER SOFTWARE PROGRAMS (U.S. CLS. 100 AND 101).  
LEIGH LOWRY, EXAMINING ATTORNEY

SN 79-085,441. BRIAN O'MALLEY, AUSTRALIA, AND NIGEL M CATT, AUSTRALIA, FILED 6-10-2010.

# OCLOC

THE MARK CONSISTS OF STANDARD CHARACTERS WITHOUT CLAIM TO ANY PARTICULAR FONT, STYLE, SIZE, OR COLOR.

PRIORITY DATE OF 12-11-2009 IS CLAIMED.  
OWNER OF INTERNATIONAL REGISTRATION 1046014 DATED 6-10-2010, EXPIRES 6-10-2020.

**CLASS 19—NON-METALLIC BUILDING MATERIALS**

FOR PLASTIC BUILDING MATERIALS, NAMELY, POST SUPPORTS, FENCES, FENCE POSTS, AGRICULTURAL BARRIER PANELS AND PLASTIC COLLARS FOR REPAIR OF POSTS IN AGRICULTURE; CONSTRUCTION MATERIAL, NAMELY, EXPANDED AND FOAM PLASTIC FOR USE IN THE CONSTRUCTION OF FENCE AND POST SUPPORTS (U.S. CLS. 1, 12, 33 AND 50).

**CLASS 37—CONSTRUCTION AND REPAIR**

FOR BUILDING CONSTRUCTION; REPAIR AND INSTALLATION OF FENCE POSTS, FENCES AND AGRICULTURAL BARRIER PANELS (U.S. CLS. 100, 103 AND 106).

SUSAN LESLIE DUBOIS, EXAMINING ATTORNEY

---

SN 79-085,479. RICCI FASHION GROUP SRL, ITALY, FILED 5-14-2010.

# BURGLAR

THE MARK CONSISTS OF STANDARD CHARACTERS WITHOUT CLAIM TO ANY PARTICULAR FONT, STYLE, SIZE, OR COLOR.

PRIORITY DATE OF 4-7-2010 IS CLAIMED.  
OWNER OF INTERNATIONAL REGISTRATION 1046118 DATED 5-14-2010, EXPIRES 5-14-2020.

**CLASS 18—LEATHER GOODS**

FOR LEATHER AND IMITATIONS OF LEATHER, TRUNKS AND SUITCASES, UMBRELLAS, PARASOLS, WALKING STICKS, RUCKSACKS, ALL-PURPOSE SPORT BAGS, TRAVELLING BAGS, DUFFEL BAGS, BRIEFCASES, PURSES, WALLETS, CLUTCH BAGS, WHEELED CARRIER BAGS, TOTE BAGS, BOOK BAGS, SPORT BAGS, BEACH BAGS, SHOULDER BAGS, WAIST BAGS, EMPTY COSMETIC BAGS (U.S. CLS. 1, 2, 3, 22 AND 41).

**CLASS 25—CLOTHING**

FOR CLOTHING ITEMS, NAMELY, SWEATERS, CARDIGANS, WAISTCOATS, SUITS, TROUSERS, SHORTS, JUMPERS, RAINCOATS, STOCKINGS AND SOCKS, STOCKING SUSPENDERS, SOCK SUSPENDERS, WIND-RESISTANT JACKETS, SKI TROUSERS, FUR COATS, OVERCOATS, SKIRTS, DRESSES, JACKETS, UNDERSHIRTS, T-SHIRTS, BLOUSES, SHIRT COLLARS, SHIRTS, FOULARDS, BEACHWEAR, SWIMSUITS, BIKINI, TRACKSUITS; WEDDING DRESSES; UNDERWEAR, BRAS, BRASSIERE, CORSETS, UNDERPANTS, BRIEFS, VESTS, NIGHTGOWNS, NEGLIGES, PYJAMAS, GLOVES, SHAWLS, SCARVES, NECKTIES, BOW TIES, SUSPENDERS, HATS, CAPS; SHOES, BOOTS, HALF BOOTS, LEATHER SHOES, GALOSHES, RAIN BOOTS, SPORTS FOOTWEAR, SANDALS, SLIPPERS, SHOE SOLES, SHOE HEELS, FOOTWEAR UPPERS (U.S. CLS. 22 AND 39).

SARA BENJAMIN, EXAMINING ATTORNEY

SN 79-085,568. DSM IP ASSETS B.V., NETHERLANDS, FILED 7-21-2010.

# DEFIBRASE

THE MARK CONSISTS OF STANDARD CHARACTERS WITHOUT CLAIM TO ANY PARTICULAR FONT, STYLE, SIZE, OR COLOR.

PRIORITY DATE OF 2-11-2010 IS CLAIMED.

OWNER OF INTERNATIONAL REGISTRATION 1046358 DATED 7-21-2010, EXPIRES 7-21-2020.

THE WORDING "DEFIBRASE" HAS NO MEANING IN A FOREIGN LANGUAGE.

**CLASS 1—CHEMICALS**

FOR CHEMICAL PREPARATIONS FOR INDUSTRIAL AND SCIENTIFIC PURPOSES, IN PARTICULAR FOR USE IN THE MANUFACTURE OF PHARMACEUTICAL AGENTS (U.S. CLS. 1, 5, 6, 10, 26 AND 46).

**CLASS 5—PHARMACEUTICALS**

FOR PHARMACEUTICAL PREPARATIONS, NAMELY, ANTI-THROMBOTIC DRUGS (U.S. CLS. 6, 18, 44, 46, 51 AND 52).

AISHA SALEM, EXAMINING ATTORNEY

SN 79-085,590. KENNETH HORSCH T.H.O.D.N. 4 EYE PRINCIPLE, NETHERLANDS, FILED 4-21-2010.

# 4 EYE PRINCIPLE

THE MARK CONSISTS OF STANDARD CHARACTERS WITHOUT CLAIM TO ANY PARTICULAR FONT, STYLE, SIZE, OR COLOR.

PRIORITY DATE OF 10-22-2009 IS CLAIMED.

OWNER OF INTERNATIONAL REGISTRATION 1046419 DATED 4-21-2010, EXPIRES 4-21-2020.

**CLASS 35—ADVERTISING AND BUSINESS**

FOR PLACEMENT AND HIRING OF PERSONNEL; SECONDMENT OF PERSONNEL, NAMELY, ASSIGNING EMPLOYEES FROM ONE COUNTRY TO ANOTHER COUNTRY; SELECTION OF PERSONNEL, ESPECIALLY USING PSYCHOLOGICAL AND/OR PSYCHOTECHNICAL TESTS; COMPILATION OF STATISTICS; DEVELOPMENT OF CUSTOMIZED PERSONNEL MANAGEMENT MATERIALS FOR OTHERS, NAMELY, DEVELOPMENT OF CUSTOMIZED EMPLOYEE MANUALS AND HANDBOOKS IN THE FIELDS OF WORKING CONDITIONS AND REWARDS FRAMEWORKS; HUMAN RESOURCE CONSULTING, NAMELY, DEVELOPMENT OF CUSTOMIZED EMPLOYEE MANUALS AND HANDBOOKS IN CONNECTION WITH PERSONNEL PLACEMENT AND ABSENTEEISM; BUSINESS ORGANIZATION AND MANAGEMENT CONSULTING FOR FIRMS IN CONNECTION WITH CHANGES IN THE CULTURE AND STRUCTURE THEREOF, WITH RESTRUCTURING AND REORGANIZATION, WITH BUSINESS OPERATION AND BUSINESS EVALUATION, WITH BUSINESS PERFORMANCE MANAGEMENT; INTERNAL BUSINESS COMMUNICATION, NAMELY, CONSULTING IN THE FIELD OF CROSS-CULTURAL COMMUNICATION; BUSINESS ORGANIZATION CONSULTING; COMPILATION AND MANAGEMENT OF A DATABASE CONTAINING RESUMES AND CURRICULUM VITAE; MANAGEMENT OF HUMAN RESOURCES AND PERSONNEL MATTERS IN CONNECTION WITH BUSINESS STRATEGY, POLICY AND OPERATIONS; EMPLOYMENT OUTPLACEMENT OF PERSONNEL; DUE DILIGENCE BUSINESS AUDITS IN CONNECTION WITH THE MANAGEMENT OF HUMAN RESOURCES AND PERSONNEL MATTERS, AS WELL AS IN CONNECTION WITH FINANCIAL MATTERS; THE AFOREMENTIONED SERVICES ALSO PROVIDED VIA ELECTRONIC NETWORKS, INCLUDING THE INTERNET (U.S. CLS. 100, 101 AND 102).

**CLASS 45—PERSONAL AND LEGAL SERVICES**

FOR LEGAL SERVICES, NAMELY, COUNSELING, NEGOTIATION, MEDIATION SERVICES AND LEGAL DOCUMENT PREPARATION IN THE NATURE OF CONTRACTS AND MODEL CONTRACTS; LEGAL CONSULTING SERVICES, NAMELY, LEGAL DUE DILIGENCE AUDITS PREPARED BY LAWYERS; CONSULTING IN THE FIELD OF PROCEDURAL LEGAL SERVICES IN CONNECTION WITH LABOR LAW, PARTICIPATION LAW, SOCIAL SECURITY LAW, PENSION LAW, IMMIGRATION LAW AND TAX LAW; THE AFOREMENTIONED SERVICES ALSO PROVIDED VIA ELECTRONIC NETWORKS, SUCH AS THE INTERNET (U.S. CLS. 100 AND 101).

CAROLINE WOOD, EXAMINING ATTORNEY

SN 79-085,640. QVSIP PTY LTD, AUSTRALIA, FILED 7-8-2010.

# Browtician

THE MARK CONSISTS OF STANDARD CHARACTERS WITHOUT CLAIM TO ANY PARTICULAR FONT, STYLE, SIZE, OR COLOR.

OWNER OF INTERNATIONAL REGISTRATION 1046588 DATED 7-8-2010, EXPIRES 7-8-2020.

**CLASS 3—COSMETICS AND CLEANING PREPARATIONS**

FOR COSMETIC PRODUCTS FOR EYEBROWS, NAMELY, EYEBROW COLOURS, EYEBROW COSMETICS; EYEBROW PENCILS; FALSE EYEBROWS; ADHESIVES FOR AFFIXING FALSE EYELASHES; FALSE EYELASHES; IN INTERNATIONAL CLASS 3 (U.S. CLS. 1, 4, 6, 50, 51 AND 52).

**CLASS 8—HAND TOOLS**

FOR TWEEZERS; EYELASH CURLERS (U.S. CLS. 23, 28 AND 44).

SN 79-085,706. DR. PATERNA, MISCHA, FED REP GERMANY, FILED 3-22-2010.

**CLASS 21—HOUSEWARES AND GLASS**

FOR EYEBROW BRUSHES; COSMETIC BRUSHES; COMBS (U.S. CLS. 2, 13, 23, 29, 30, 33, 40 AND 50).  
MARY CRAWFORD, EXAMINING ATTORNEY

# SUNCYCLE

SN 79-085,661. STIA - HOLZINDUSTRIE GESELLSCHAFT M.B.H., AUSTRIA, FILED 3-5-2010.



## Admonter

OWNER OF INTERNATIONAL REGISTRATION 0723067 DATED 10-11-1999, EXPIRES 10-11-2019.

THE MARK CONSISTS OF THREE TREES WITHIN A CIRCLE NEXT TO THE WORDING "ADMONTER".

**CLASS 19—NON-METALLIC BUILDING MATERIALS**

FOR NON-METALLIC BUILDING MATERIALS, PARTICULARLY SHAPED, COMPRESSIBLE AND SEMI-WORKED WOOD, BUILDING TIMBER, LUMBER, SAWN TIMBER, PLYWOOD, WOOD VENEERS, FURINGS OF WOOD, WOOD PULP BOARD FOR BUILDING, WOOD PAVING TILES, WOOD PANELING BOARDS; NON-METALLIC BUILDING PANEL BOARDS, PLANKS, NON-METALLIC ROOF COVERINGS, NAMELY, ENGINEERED 3-LAYER WOOD PANELS; NON-METALLIC ROOFING, SCANTLINGS AND WINDOW FRAMES; NON-METALLIC WALL TILES FOR BUILDING, NON-METALLIC LATHS, NON-METALLIC WINDOW FRAMES; NON-METALLIC COVERINGS FOR BUILDING, NAMELY, ENGINEERED 3-LAYER WOOD PANELS; NON-METALLIC WALL COVERINGS FOR BUILDING, NAMELY, ENGINEERED 3-LAYER WOOD PANELS; PANELS OF NATURAL WOOD FOR PARTS OF FURNITURE (U.S. CLS. 1, 12, 33 AND 50).

**CLASS 27—FLOOR COVERINGS**

FOR FLOOR COVERINGS, PARTICULARLY FLOORING COVERINGS, INSULATING FLOOR COVERINGS, WALL COVERINGS NOT OF TEXTILE (U.S. CLS. 19, 20, 37, 42 AND 50).

**CLASS 37—CONSTRUCTION AND REPAIR**

FOR CONSTRUCTION SERVICES, PARTICULARLY CONSTRUCTION OF WOODEN FLOORS AND OF WALL COVERINGS; REPAIR SERVICES, PARTICULARLY OF WOODEN FLOORS, OF WALL BOARDING AND OF USED, DAMAGED, DILAPIDATED OR PARTIALLY DESTROYED WOODEN FURNITURE; REPAIR OF FURNITURE (U.S. CLS. 100, 103 AND 106).

MARIAM MAHMOUDI, EXAMINING ATTORNEY

THE MARK CONSISTS OF STANDARD CHARACTERS WITHOUT CLAIM TO ANY PARTICULAR FONT, STYLE, SIZE, OR COLOR.

OWNER OF INTERNATIONAL REGISTRATION 1046621 DATED 3-22-2010, EXPIRES 3-22-2020.

**CLASS 9—ELECTRICAL AND SCIENTIFIC APPARATUS**

FOR COMPUTER SOFTWARE FOR COORDINATING FIELD SUPPORT FOR SOLAR PLANTS AND FOR TRACKING AND REPORTING OF SERVICE INCIDENTS FOR SOLAR PLANTS; DOWNLOADABLE SOFTWARE FOR MANAGEMENT AND ANALYSIS OF TECHNICAL INFORMATION ON REGENERATIVE ENERGY GENERATION PLANTS; RECEIVERS AND CONVERTERS OF DIRECT AND INDIRECT RADIANT AND ENVIRONMENTAL ENERGY, NAMELY, ELECTRIC SOLAR CELLS TO GENERATE ELECTRIC ENERGY; ELECTRIC APPARATUS FOR POWER SUPPLY, POWER CONTROL, POWER TRANSMISSION, POWER STEERING, POWER STORAGE AND POWER DISTRIBUTION; SOLAR GENERATOR UNITS; ELECTRIC SOLAR CELLS; PHOTOVOLTAIC CELLS; SOLAR AND SUN COLLECTORS AND TO GENERATE ELECTRIC ENERGY INCLUDED IN THIS CLASS; SOLAR PANELS TO GENERATE ELECTRICITY INCLUDED IN THIS CLASS; SOLAR MODULES TO GENERATE ELECTRIC ENERGY; SOLAR PANELS TO GENERATE ELECTRIC ENERGY AND PHOTOVOLTAIC PLANTS TO GENERATE ELECTRIC ENERGY FORMED THEREFROM; SOLAR BATTERIES; ELECTRIC DEVICES AND PLANTS TO GENERATE ELECTRICITY FORMED THEREFROM INCLUDED IN THIS CLASS, NAMELY, SOLAR MODULES, INVERTERS AND TRANSFORMERS; ELECTRIC POWER TRANSFORMERS; ELECTRICAL CONNECTORS; ELECTRIC CABLES AND WIRES, BATTERIES, BATTERY CHARGERS, SWITCHES, ELECTRIC POWER CONTROLLERS; ELECTRIC WIRES FED BY SOLAR ENERGY FOR ELECTRIC FENCES; VOLTAGE SURGE PROTECTION DEVICES INCLUDED IN THIS CLASS; ELECTRONIC ENERGY MANAGEMENT SYSTEMS CONSISTING OF HARDWARE AND SOFTWARE FOR THE CONTROL AND REGULATION OF PHOTOVOLTAIC ENERGY; PHOTOVOLTAIC EQUIPMENT AND PLANTS, NAMELY, CELLS, MODULES AND ARRAYS FOR THE PRODUCTION OF ELECTRIC ENERGY THEREFROM; ELECTRICAL SENSORS AS WELL AS ELECTRONIC APPARATUS AND INSTRUMENTS FOR STEERING, CONTROLLING AND MONITORING OF THE TRACKING OF SOLAR PANELS; ELECTRONIC COMPONENTS AS PARTS OF SOLAR PLANTS; ELECTRONIC CABLING INCLUDED IN THIS CLASS FOR PHOTOVOLTAIC PLANTS; SOLAR INVERTERS FOR GRID FEEDING OF SOLAR ELECTRICITY AND FOR ISOLATED OPERATION OF PHOTOVOLTAIC PLANTS; ELECTRICAL AND ELECTRONIC CONTROL DEVICES, NAMELY, SOLAR CHARGE CONTROLLERS; ELECTRIC ACCUMULATORS TO STORE SOLAR ENERGY; PARTS AND ACCESSORIES FOR ALL AFOREMENTIONED GOODS INCLUDED IN THIS CLASS SOLD AS A UNIT THEREWITH (U.S. CLS. 21, 23, 26, 36 AND 38).

**CLASS 11—ENVIRONMENTAL CONTROL APPARATUS**

FOR SOLAR THERMAL PLANTS FOR HEAT GENERATION; HEAT PUMPS; SOLAR COLLECTORS AND SOLAR COLLECTORS FOR HEATING INCLUDED IN THIS CLASS; SOLAR COLLECTORS FOR HOT WATER PRODUCTION; SOLAR PANELS FOR HEAT GENERATION; HEAT ACCUMULATORS; HEAT RECOVERY UNITS; SOLAR FURNACES; PHOTOVOLTAIC PANELS TO GENERATE HEAT; SOLAR-POWERED LAMPS; HEAT EXCHANGERS, IN PARTICULAR SOLAR HEAT EXCHANGERS NOT BEING PARTS OF MACHINES; HEATING RECOVERY PLANTS, CLIMATE RECOVERY PLANTS AND HEAT RECOVERY PLANTS, ALL COMPRISING OF VENTILATION APPARATUS WITH AN EXHAUST HEAT EXCHANGER; CHEMICAL AND PHYSICAL PLANTS FOR THE CONVERSION, STORAGE AND UTILISATION OF ENERGY, CONSISTING OF ACCUMULATORS FOR THE SHORT AND LONG TERM AS WELL AS LATENT HEAT STORAGE; CHEMICAL AND PHYSICAL PLANTS FOR THE CONVERSION, STORAGE AND UTILIZATION OF ENERGY, BASICALLY CONSISTING OF ACCUMULATORS FOR THE SHORT AND LONG TERM AS WELL AS LATENT HEAT STORAGE (U.S. CLS. 13, 21, 23, 31 AND 34).

**CLASS 37—CONSTRUCTION AND REPAIR**

FOR INSTALLATION, MAINTENANCE AND REPAIR OF APPARATUS AND PLANTS FOR ENERGY GENERATION, ENERGY SUPPLY, ENERGY CONTROL, ENERGY TRANSMISSION, ENERGY STEERING, ENERGY STORAGE AND ENERGY DISTRIBUTION; INSTALLATION, MAINTENANCE AND REPAIR OF SOLAR ENERGY PLANTS AND SOLAR GENERATOR EQUIPMENT; INSTALLATION MAINTENANCE AND REPAIR OF SOLAR ROOFS AND SOLAR PANELS; CONSTRUCTION SUPERVISION; CONSTRUCTION REPAIR AND INFORMATION (U.S. CLS. 100, 103 AND 106).

**CLASS 40—MATERIAL TREATMENT**

FOR GENERATION OF ELECTRICITY; GENERATION OF RENEWABLE ENERGY, IN PARTICULAR SOLAR ENERGY; CONTRACT PRODUCTION FOR THIRD PARTIES OF APPARATUS AND PLANTS FOR ENERGY GENERATION, ENERGY SUPPLY, ENERGY CONTROL, TRANSMISSION, ENERGY STEERING, ENERGY STORAGE AND ENERGY DISTRIBUTION; CONTRACT MANUFACTURING FOR THIRD PARTIES OF SOLAR ROOFS AND SOLAR PANELS; CONTRACT MANUFACTURING FOR THIRD PARTIES OF SOLAR PLANTS; INFORMATION ON MATERIAL PROCESSING; GENERATION OF ELECTRIC ENERGY (U.S. CLS. 100, 103 AND 106).

**CLASS 42—SCIENTIFIC AND COMPUTER SERVICES**

FOR TECHNICAL ADVICE FOR COMPANIES RELATING TO THE DESIGN OF SOLAR ENERGY AND RENEWABLE ENERGY; ELABORATION OF TECHNICAL EXPERTISE IN RELATION TO SOLAR ENERGY AND RENEWABLE ENERGY; DESIGN OF SOLAR ENERGY EQUIPMENT; TECHNICAL CONSULTING IN THE FIELD OF SOLAR ENERGY AND RENEWABLE ENERGY; IT CONSULTANCY AND CREATION OF DATA PROCESSING PROGRAMS, BOTH SERVICES PARTICULARLY IN CONNECTION WITH SALES, PRODUCTION, INSTALLATION AND MAINTENANCE OF SOLAR PLANTS, SOLAR THERMAL PLANTS, PHOTOVOLTAIC PLANTS AND PHOTOVOLTAIC MODULES; UPDATING OF SOFTWARE (U.S. CLS. 100 AND 101).  
RON FAIRBANKS, EXAMINING ATTORNEY

SN 79-085,918. JULIEN MACDONALD LIMITED, UNITED KINGDOM, FILED 4-1-2010.

**JULIEN MACDONALD**

PRIORITY DATE OF 10-19-2009 IS CLAIMED.  
OWNER OF INTERNATIONAL REGISTRATION 1047251 DATED 4-1-2010, EXPIRES 4-1-2020.

THE NAME(S), PORTRAIT(S), AND/OR SIGNATURE(S) SHOWN IN THE MARK IDENTIFIES "JULIEN MACDONALD", WHOSE CONSENT(S) TO REGISTER IS MADE OF RECORD.

THE MARK CONSISTS OF THE WORDING "JULIEN MACDONALD" IN STYLIZED FONT.

**CLASS 14—JEWELRY**

FOR KEY FOBS OF LEATHER (U.S. CLS. 2, 27, 28 AND 50).

**CLASS 18—LEATHER GOODS**

FOR LEATHER AND IMITATIONS OF LEATHER; ANIMAL SKINS, HIDES; TRUNKS AND TRAVELLING BAGS; HANDBAGS, RUCKSACKS, PURSES; UMBRELLAS, PARASOLS AND WALKING STICKS; WHIPS, HARNESS AND SADDLERY; CLOTHING FOR ANIMALS; UNFITTED BOOT BAGS FOR TRAVEL; HOLLERS; CREDIT CARD HOLDERS; ALL PURPOSE CARRYING BAGS WHICH INCLUDE A COLD STORAGE FUNCTION; WASH BAGS FOR CARRYING TOILETRIES; DOG LEADS AND DOG COLLARS; LEATHER BAGS; LEATHER SHOULDER BELTS; AT-TACHE CASES; BRIEFCASES; KEY CASES; SUITCASES; VALISES; VANITY CASES SOLD EMPTY; WALLETS (U.S. CLS. 1, 2, 3, 22 AND 41).

**CLASS 25—CLOTHING**

FOR CLOTHING, NAMELY, SUITS, DRESSES, JACKETS, BLAZERS, COATS, RAINCOATS, SKIRTS, PETTI-COATS, TROUSERS, PANTS, JEANS, SHORTS, SWEATERS, SHIRTS, BLOUSES, VESTS, BRIEFS, BRAS, CAMISOLES, SOCKS, T-SHIRTS, WAISTCOATS, JUMPERS, CARDIGANS, GILETS, LEGGINGS, PAJAMAS, ROBES, TIES, BELTS; FOOTWEAR AND HEADWEAR; CRAVATS; CASUAL WEAR, NAMELY, JOGGING PANTS, TRACKSUIT TOPS, SWEATSHIRTS, TRACK-SUITS; ITEMS OF DENIM CLOTHING, NAMELY, DENIM JEANS, DENIM SHORTS, DENIM SKIRTS, DENIM DUNGAREES, DENIM JACKETS, DENIM WAISTCOATS, DENIM SHIRTS; GLOVES; BELTS; HOSIERY; NIGHTWEAR; LINGERIE; CORSETRY AND CONTROL UNDERWEAR; UNDERWEAR; SWIMWEAR; BRIDAL WEAR, NAMELY, WEDDING GOWNS, VEILS, PETTI-COATS, SHRUGS, CHEMISES, UNDERWEAR, STOCKINGS, TIGHTS, SUSPENDERS, CORSETS, SHAWLS; VEILS; SCARVES (U.S. CLS. 22 AND 39).

DANIEL CAPSHAW, EXAMINING ATTORNEY

SN 79-085,965. DEUTSCHE TELEKOM AG, 53113 BONN, FED REP GERMANY, FILED 2-24-2010.

**Ne(x)t Generation Workpower**

THE MARK CONSISTS OF STANDARD CHARACTERS WITHOUT CLAIM TO ANY PARTICULAR FONT, STYLE, SIZE, OR COLOR.

PRIORITY DATE OF 8-27-2009 IS CLAIMED.  
OWNER OF INTERNATIONAL REGISTRATION 1047421 DATED 2-24-2010, EXPIRES 2-24-2020.



**CLASS 16—PAPER GOODS AND PRINTED MATTER**

FOR PAPER AND CARDBOARD; PUBLICATIONS AND PRINTED MATTER, NAMELY, BOOKS, BOOKLETS AND MAGAZINES ABOUT COMPUTERS, COMPUTER NETWORKS, COMPUTER DATABASES, COMPUTER SERVICES AND INTERNET SERVICES; PRINTED INSTRUCTIONAL AND TEACHING MATERIAL IN THE FIELD OF TELECOMMUNICATIONS, INFORMATION TECHNOLOGY, SAFETY, NEWS, SPORTS, ENTERTAINMENT, CULTURE, BUSINESS AND FINANCE, WEATHER AND TRAVEL; PRINTING TYPE; PRINTING BLOCKS (U.S. CLS. 2, 5, 22, 23, 29, 37, 38 AND 50).

**CLASS 35—ADVERTISING AND BUSINESS**

FOR PROCUREMENT OF TRADE CONTACTS FOR OTHERS AND PROCUREMENT OF BUSINESS CONTACTS FOR OTHERS, ALSO VIA THE INTERNET; MEDIATION AND CONCLUSION OF COMMERCIAL TRANSACTIONS FOR OTHERS; ARRANGING CONTRACTS FOR THIRD PARTIES ON THE BUYING AND SELLING OF GOODS, ARRANGING SERVICE CONTRACTS FOR THIRD PARTIES; ADVERTISING; EMPLOYEE LEASING; PERSONNEL MANAGEMENT CONSULTATION; SERVICES OF AN EMPLOYMENT AGENCY; SERVICES OF A HUMAN RESOURCES AGENCY; UPDATING AND MAINTENANCE OF DATA IN COMPUTER DATABASES; SYSTEMIZATION OF DATA INTO COMPUTER DATABASES; COMPILATION OF DATA IN COMPUTER DATABASES; PRESENTATION OF COMPANIES AND INDIVIDUALS IN COMMUNICATIONS MEDIA; PRESENTATION OF GOODS ON COMMUNICATION MEDIA FOR RETAIL PURPOSES, ARRANGING OF GOODS AND SERVICES FOR THIRD PARTIES, FOR PRESENTATION AND MARKETING PURPOSES; PROVIDING OFFICE FUNCTIONS; ARRANGING AND CONDUCTION OF AUCTION SALES; COMPUTERIZED FILE MANAGEMENT; UPDATING ADVERTISING MATERIAL; PREPARATION OF COST PRICE ANALYSIS; BUSINESS INFORMATION MANAGEMENT, NAMELY, ELECTRONIC REPORTING OF BUSINESS INFORMATION; BUSINESS ANALYTICS, NAMELY, BUSINESS INVESTIGATIONS, EVALUATIONS, EXPERT APPRAISALS, INFORMATION AND RESEARCH, TRADE SPEND BUSINESS MANAGEMENT; ADVICE RELATING TO THE ORGANIZATION AND MANAGEMENT OF BUSINESS; BUSINESS MANAGEMENT CONSULTANCY SERVICES; PROCUREMENT SERVICES, NAMELY, PROCURING OF CONTRACTS FOR OTHERS FOR THE PURCHASE OF GOODS; BUSINESS CONSULTANCY; ACCOUNTING SERVICES; BUSINESS AUDITING; SERVICES OF AN ADVERTISING AGENCY; BUSINESS ENQUIRIES AND INVESTIGATIONS; BUSINESS MONITORING AND CONSULTING SERVICES, NAMELY, TRACKING WEB SITES AND APPLICATIONS OF OTHERS TO PROVIDE STRATEGY, INSIGHT, MARKETING, SALES, OPERATION, PRODUCT DESIGN, PARTICULARLY SPECIALIZING IN THE USE OF ANALYTIC AND STATISTIC MODELS FOR THE UNDERSTANDING AND PREDICTING OF CONSUMERS, BUSINESSES, AND MARKET TRENDS AND ACTIONS; PROVIDING BUSINESS EXPERTISES; HELIOGRAPHIC DOCUMENT REPRODUCTIONS; PUBLISHING OF ADVERTISING TEXTS; INFORMATION IN BUSINESS MATTERS; COMMERCIAL ADMINISTRATION OF THE LICENSING OF THE GOODS AND SERVICES OF OTHERS; CUSTOMER ACQUISITION AND CUSTOMER TIE BY MAIL ORDER ADVERTISING; PAYROLL PROCESSING SERVICES; MARKET RESEARCH; OPINION RESEARCH; ORGANIZATIONAL SERVICES FOR BUSINESS PURPOSES; ORGANIZATIONAL PROJECT MANAGEMENT SERVICES FOR OTHERS IN THE FIELDS OF INFORMATION TECHNOLOGY; OUTSOURCING SERVICES (BUSINESS ASSISTANCE); WORD PROCESSING; SECRETARIAL AND CLERICAL SERVICES, DISTRIBUTION; DISSEMINATION OF ADVERTISEMENTS; ADVERTISING COPY; SALES PROMOTION SERVICES FOR THIRD PARTIES; DISTRIBUTION OF ADVERTISING MATERIALS; DOCUMENT REPRODUCTION; ADMINISTRATIVE PROCESSING OF PURCHASE ORDERS; DEMONSTRATION OF GOODS FOR ADVERTISING PURPOSES; ORGANIZATION AND CONDUCTING OF PRODUCT PRESENTATIONS (U.S. CLS. 100, 101 AND 102).

**CLASS 36—INSURANCE AND FINANCIAL**

FOR ONLINE BANKING; ELECTRONIC PAYMENT, NAMELY, ELECTRONIC PROCESSING AND TRANSMISSION OF BILL PAYMENT DATA; ELECTRONIC COMMERCE PAYMENT SERVICES, NAMELY, ESTABLISHING FUNDED ACCOUNTS USED TO PURCHASE GOODS AND SERVICES ON THE INTERNET; PROVIDING ELECTRONIC PROCESSING OF CREDIT CARD TRANSACTIONS AND ELECTRONIC PAYMENTS VIA A GLOBAL COMPUTER NETWORK; CREDIT INQUIRY AND CONSULTATION; SERVICES OF AN ELECTRONIC STOCK EXCHANGE, NAMELY, ORGANIZATION OF STOCK EXCHANGES FOR THE BENEFIT OF THE TRADE OF STOCKS AND OTHER FINANCIAL VALUES, STOCK EXCHANGE PRICE QUOTATIONS, PROVIDING STOCK MARKET INFORMATION (U.S. CLS. 100, 101 AND 102).

**CLASS 37—CONSTRUCTION AND REPAIR**

FOR INSTALLATION OF HARDWARE FOR ACCESS TO THE INTERNET; INSTALLATION OF WIRES FOR ACCESS TO THE INTERNET; COMPUTER INSTALLATION, MAINTENANCE AND SERVICING OF VIRTUAL NETWORKS; INSTALLATION OF COMPUTER NETWORKS; MAINTENANCE OF COMPUTER HARDWARE (U.S. CLS. 100, 103 AND 106).

**CLASS 38—COMMUNICATION**

FOR TELECOMMUNICATIONS SERVICES, NAMELY, ELECTRIC, DIGITAL, CELLULAR AND WIRELESS TRANSMISSION OF VOICE, DATA, INFORMATION, IMAGES, SIGNALS AND MESSAGES AND TRANSMISSION OF VOICE, DATA, IMAGES, AUDIO, VIDEO AND INFORMATION VIA TELEPHONE, TELEVISION AND GLOBAL COMMUNICATION NETWORKS; TRANSMISSION OF INFORMATION BY ELECTRONIC COMMUNICATIONS NETWORKS; INTERNET SERVICE PROVIDER (ISP), NAMELY, COLLECTING, PROVIDING, SUPPLYING, TRANSMITTING OF TEXT, AUDIO AND VISUAL INFORMATION, ELECTRONIC TRANSMISSION OF NEWS; RENTAL OF TELECOMMUNICATIONS EQUIPMENT; TELETXT SERVICE; E-MAIL SERVICES; ELECTRONIC TRANSMISSION OF SHORT TEXT MESSAGES; TELECOMMUNICATIONS SERVICES VIA FIBRE OPTIC AND RADIO BASED NETWORKS AND CABLE NETWORKS, NAMELY, TRANSMISSION OF VOICE, DATA, INFORMATION, IMAGES, SIGNALS AND MESSAGES AND TRANSMISSION; RENTAL OF TELECOMMUNICATIONS LINES; RADIO BROADCASTING; TRANSMISSION OF NEWS, NAMELY, THE COLLECTION AND SUPPLY OF NEWS AND IMAGES ON THE INTERNET; ELECTRONIC TRANSMISSION OF MESSAGES AND IMAGES; TRANSMISSION OF INFORMATION BY ELECTRONIC COMMUNICATIONS NETWORKS; COMPUTER-AIDED TRANSMISSION OF MESSAGES AND IMAGES; PERSONAL PAGING SERVICES; TRANSMISSION OF INFORMATION ON OPTICAL TELECOMMUNICATION NETWORKS; PROVIDING ON-LINE CHAT ROOMS AND ELECTRONIC BULLETIN BOARDS FOR TRANSMISSION OF MESSAGES AMONG USERS IN THE FIELD OF GENERAL INTEREST; COMPUTER AND SATELLITE AIDED TRANSMISSION OF NEWS, INFORMATION, DATA, IMAGES; TELEPHONE COMMUNICATION SERVICES, NAMELY, EXCHANGE OF INFORMATION VIA TELEPHONE CHANNELS; WEB MESSAGING, NAMELY, FORWARDING OF MESSAGES OF ALL TYPES TO INTERNET ADDRESSES; MOBILE TELEPHONY SERVICES, NAMELY, PROVIDING UNIVERSAL SYSTEMS FOR MOBILE TELECOMMUNICATIONS; PROVISION OF INTERNET ACCESS VIA INTERNET DIAL-UP POINTS; SERVICES OF AN INTERNET PROVIDER, NAMELY, PROVIDING ACCESS TO INFORMATION AND ENTERTAINMENT PROGRAMS ON THE INTERNET, RADIO AND TELEVISION BROADCASTING, NAMELY, PROVISION OF TELECOMMUNICATION ACCESS TO VIDEO AND AUDIO CONTENT FROM A RADIO STATION AND TELEVISION STATION VIA VIDEO-ON-DEMAND SERVICES VIA THE INTERNET; TELEVISION BROADCASTING, NAMELY, PROVISION OF A TELEVISION STATION VIA THE INTERNET; TELEPHONE COMMUNICATION SERVICES; FACSIMILE TRANSMISSION SERVICES; ELECTRONIC DATA TRANSMISSION, NAMELY, PLACEMENT OF DATA INTO DIGITAL NETWORKS; PROVIDING ACCESS TO

TELECOMMUNICATION NETWORKS, NAMELY, ACCESS TO THE INTERNET AND ACCESS TO TEXTS, GRAPHICS, AUDIO-VISUAL AND MULTIMEDIA INFORMATION, DOCUMENTS AND COMPUTER PROGRAMS; RENTAL OF TELECOMMUNICATION EQUIPMENT FOR ACCESS TO THE INTERNET; ELECTRONIC DATA TRANSMISSION, NAMELY, ENCODED TRANSMISSION OF DATA; VIDEO ON DEMAND TRANSMISSION AND BROADCASTING SERVICES; PROVIDING DEDICATED MULTIPLE-USER INTERNET ACCESS VIA INTERNET DIAL-UP POINTS; NEWS AGENCIES, NAMELY, GATHERING AND DISSEMINATION OF NEWS (U.S. CLS. 100, 101 AND 104).

#### **CLASS 41—EDUCATION AND ENTERTAINMENT**

FOR EDUCATION AND TRAINING SERVICES, NAMELY, COURSES, SEMINARS, WORKSHOPS AND PROGRAMS IN THE FIELD OF HUMAN RESOURCES DEVELOPMENT; EDUCATIONAL SERVICES, NAMELY, TEACHING, INSTRUCTION, TRAINING IN THE FIELD OF INFORMATION TECHNOLOGY, EDUCATION IN THE FIELD OF INFORMATION TECHNOLOGY RENDERED THROUGH CORRESPONDENCE COURSES; EDUCATION INFORMATION, EDUCATIONAL EXAMINATION ACCREDITATION SERVICES, NAMELY, DEVELOPING AND ADMINISTERING STANDARDS AND PROCEDURES FOR CERTIFYING PROFESSIONALS IN THE FIELD OF INFORMATION TECHNOLOGY; VOCATIONAL GUIDANCE (U.S. CLS. 100, 101 AND 107).

#### **CLASS 42—SCIENTIFIC AND COMPUTER SERVICES**

FOR INVESTIGATION SERVICES IN THE FIELD OF BUSINESS MANAGEMENT, PROVISION OF INTERNET SEARCH ENGINES FOR OTHERS, PROVIDING OF ACCESS TO DATA BASES, RENTAL OF DATABASE SERVER, UPDATING OF COMPUTER SOFTWARE FOR DATABASES, COMPUTER PROGRAMMING, DATA PROCESSING, WEBSITE DEVELOPMENT FOR OTHERS; DESIGN AND DEVELOPMENT OF NETWORKS FOR OTHERS; UPDATING OF COMPUTER SOFTWARE, COMPUTER HARDWARE CONSULTING, COMPUTER SOFTWARE CONSULTING, DESIGN OF COMPUTER SOFTWARE; UPDATING WEBSITES FOR OTHERS, PROVIDING AN ON-LINE NETWORK ENVIRONMENT THAT FEATURES TECHNOLOGY THAT ENABLES USERS TO SHARE DATA, COMPUTER SYSTEMS ANALYSIS, CREATING AND DESIGNING WEBSITES AND WEB PAGES FOR OTHERS, DESIGN OF COMPUTER SOFTWARE, DESIGN OF COMPUTER SYSTEMS; GRAPHIC DESIGN SERVICES, MATERIALS TESTING AND ANALYZING, SCIENTIFIC RESEARCH, BACK-UP SERVICES FOR COMPUTER HARD DRIVE DATA, COMPUTER PROGRAMMING, DEVELOPMENT AND CREATION OF COMPUTER PROGRAMMES FOR DATA PROCESSING, CONFIGURATION OF COMPUTER NETWORKS THROUGH SOFTWARE, DATA CONVERSION OF COMPUTER PROGRAMS AND DATA, NOT PHYSICAL CONVERSION, CONVERSION OF DATA OR DOCUMENTS FROM PHYSICAL TO ELECTRONIC MEDIA, QUALITY CONTROL FOR OTHERS, RESEARCH AND DEVELOPMENT OF NEW PRODUCTS FOR THIRD PARTIES, TECHNICAL SUPPORT SERVICES, NAMELY, TECHNICAL ADMINISTRATION OF SERVERS FOR OTHERS AND TROUBLESHOOTING IN THE NATURE OF DIAGNOSING SERVER PROBLEMS, COMPUTER SECURITY SERVICE, NAMELY, RESTRICTING ACCESS TO AND BY COMPUTER NETWORKS TO AND OF UNDESIRE WEB SITES, MEDIA AND INDIVIDUALS AND FACILITIES, RECOVERY OF COMPUTER DATA (U.S. CLS. 100 AND 101).

LINDA M. KING, EXAMINING ATTORNEY

SN 79-086,012. ARNOLD MÜLLER GMBH & CO KG, FED REP GERMANY, FILED 7-14-2010.

# AMKASYN

OWNER OF INTERNATIONAL REGISTRATION 0560605 DATED 6-26-1990, EXPIRES 6-26-2020.  
OWNER OF U.S. REG. NO. 1,873,600.

#### **CLASS 7—MACHINERY**

FOR ELECTRIC MOTORS FOR MACHINES; SERVO MOTORS, ELECTRIC MOTORS, NOT FOR LAND VEHICLES FOR DRIVE AND CONTROL SYSTEMS (U.S. CLS. 13, 19, 21, 23, 31, 34 AND 35).

#### **CLASS 9—ELECTRICAL AND SCIENTIFIC APPARATUS**

FOR ELECTRIC AND ELECTRONIC REGULATING COMPONENTS FOR THE OPERATION OF ELECTRIC MOTOR LINEAR DRIVES AND ELECTRIC MOTOR SWIVEL DRIVES; ELECTRICALLY DRIVEN MACHINE TOOLS FOR REGULATING CURRENT, VOLTAGE, SPEED, ACCELERATION AND TORQUE AND ELECTRONIC CONTROL DEVICES THEREFORE (U.S. CLS. 21, 23, 26, 36 AND 38).

KRISTINA MORRIS, EXAMINING ATTORNEY

SN 79-086,046. SEIBEL, MARTINA, FED REP GERMANY, FILED 6-21-2010.

# Mitogenomix

THE MARK CONSISTS OF STANDARD CHARACTERS WITHOUT CLAIM TO ANY PARTICULAR FONT, STYLE, SIZE, OR COLOR.

PRIORITY DATE OF 12-22-2009 IS CLAIMED.

OWNER OF INTERNATIONAL REGISTRATION 1047568 DATED 6-21-2010, EXPIRES 6-21-2020.

#### **CLASS 1—CHEMICALS**

FOR CELLS FOR SCIENTIFIC, LABORATORY OR MEDICAL RESEARCH (U.S. CLS. 1, 5, 6, 10, 26 AND 46).

#### **CLASS 5—PHARMACEUTICALS**

FOR SURGICAL TISSUES; SURGICAL IMPLANTS COMPRISING LIVING TISSUE; CHEMICAL REAGENTS FOR MEDICAL OR VETERINARY USE; CHEMICAL-BASED PHARMACEUTICAL PREPARATIONS FOR USE IN TREATING ACQUIRED OR HEREDITARY GENETIC DISEASES, INFECTIOUS DISEASES, MITOCHONDRIAL DISEASES, DEGENERATIVE DISEASES, CANCER, DRUG RESISTANCE, AIDS; NUTRITIONAL SUPPLEMENTS; MEDICATED FOODSTUFFS ADDITIVES; BLOOD AND BLOOD PRODUCTS, NAMELY, BLOOD PLASMA, HUMAN ALBUMIN, BLOOD CLOTTING FACTORS AND IMMUNOGLOBULINS FOR MEDICAL PURPOSES; PHARMACEUTICAL AND MEDICINAL PREPARATIONS FOR CANCER; PHARMACEUTICAL AND MEDICINAL PREPARATIONS FOR DRUG RESISTANCE (U.S. CLS. 6, 18, 44, 46, 51 AND 52).

#### **CLASS 40—MATERIAL TREATMENT**

FOR BATCH BIOLOGICAL TREATMENT SERVICES, NAMELY, MODIFICATION OF BIOLOGICAL SAMPLES (U.S. CLS. 100, 103 AND 106).

**CLASS 41—EDUCATION AND ENTERTAINMENT**

FOR PROVIDING OF TRAINING IN THE FIELD OF BIOMEDICINE, CELL CULTURE ENGINEERING, GENETIC ENGINEERING, BIOCHEMISTRY RESEARCH, BIOLOGICAL RESEARCH, PHARMACEUTICAL RESEARCH (U.S. CLS. 100, 101 AND 107).

**CLASS 42—SCIENTIFIC AND COMPUTER SERVICES**

FOR RESEARCH, DEVELOPMENT AND CONSULTANCY IN THE FIELD OF BIOMEDICINE AND CELL CULTURE ENGINEERING; GENETIC ENGINEERING AND BIOCHEMISTRY RESEARCH AND CONSULTING SERVICES; BIOLOGICAL RESEARCH; PHARMACEUTICAL RESEARCH AND DEVELOPMENT SERVICES (U.S. CLS. 100 AND 101).

DAVID ELTON, EXAMINING ATTORNEY

SN 79-086,188. LUPI MODA D.O.O. ZA TRGOVINU I USLUGE, CROATIA, FILED 4-13-2010.



PRIORITY DATE OF 3-17-2010 IS CLAIMED.  
OWNER OF INTERNATIONAL REGISTRATION 1047967 DATED 4-13-2010, EXPIRES 4-13-2020.

THE NAME(S), PORTRAIT(S), AND/OR SIGNATURE(S) SHOWN IN THE MARK IDENTIFIES "LJUJUPKA GOJIC", WHOSE CONSENT(S) TO REGISTER IS MADE OF RECORD.

THE MARK CONSISTS OF THE WORDING "JOLIE PETITE BY LJUPKA GOJIC" AND A DESIGN OF A DOLL.

THE ENGLISH TRANSLATION OF "JOLIE PETITE" IN THE MARK IS "LITTLE CUTIE".

SN 79-086,111. PARKEON, FRANCE, FILED 6-30-2010.

# ARCHIPEL

THE MARK CONSISTS OF STANDARD CHARACTERS WITHOUT CLAIM TO ANY PARTICULAR FONT, STYLE, SIZE, OR COLOR.

PRIORITY DATE OF 1-4-2010 IS CLAIMED.

OWNER OF INTERNATIONAL REGISTRATION 1047766 DATED 6-30-2010, EXPIRES 6-30-2020.

**CLASS 9—ELECTRICAL AND SCIENTIFIC APPARATUS**

FOR COMPUTER PROGRAMS FOR THE SECUREMENT OF PAYMENT TRANSACTIONS AND ESPECIALLY PAYMENT TRANSACTIONS OVER THE INTERNET, ALL THESE GOODS INTENDED FOR OPERATING OR CONTROLLING APPARATUS FOR VEHICLE PARKING MANAGEMENT, APPARATUS FOR ISSUANCE OF PUBLIC TRANSPORT TICKETS (U.S. CLS. 21, 23, 26, 36 AND 38).

**CLASS 36—INSURANCE AND FINANCIAL**

FOR FINANCIAL SERVICES, NAMELY, PROVIDING SECURE COMMERCIAL TRANSACTIONS AND PAYMENT OPTIONS, ALL THESE SERVICES INTENDED FOR OPERATING OR CONTROLLING APPARATUS FOR VEHICLE PARKING MANAGEMENT, APPARATUS FOR ISSUANCE OF PUBLIC TRANSPORT TICKETS (U.S. CLS. 100, 101 AND 102).

**CLASS 42—SCIENTIFIC AND COMPUTER SERVICES**

FOR COMPUTER PROGRAMMING FOR THE SECUREMENT OF PAYMENT TRANSACTIONS AND ESPECIALLY PAYMENT TRANSACTIONS OVER THE INTERNET, ALL THESE SERVICES INTENDED FOR OPERATING OR CONTROLLING APPARATUS FOR VEHICLE PARKING MANAGEMENT, APPARATUS FOR ISSUANCE OF PUBLIC TRANSPORT TICKETS (U.S. CLS. 100 AND 101).

DAVID HOFFMAN, EXAMINING ATTORNEY

**CLASS 14—JEWELRY**

FOR PRECIOUS METALS AND THEIR ALLOYS AND GOODS IN PRECIOUS METALS OR COATED THEREWITH, NAMELY, JEWELRY, PRECIOUS STONES; HOROLOGICAL AND CHRONOMETRIC INSTRUMENTS (U.S. CLS. 2, 27, 28 AND 50).

**CLASS 16—PAPER GOODS AND PRINTED MATTER**

FOR PAPER, CARDBOARD AND GOODS MADE FROM THESE MATERIALS, NAMELY, PRINTED MATTER IN THE FORM OF PAMPHLETS, BROCHURES, MANUALS, BOOKS, BOOKLETS, LEAFLETS, FLYERS, INFORMATIONAL SHEETS AND NEWSLETTERS IN THE FIELD OF FASHION AND CLOTHING DESIGN, ADHESIVE BACKED STICKERS, NOTE CARDS, POSTCARDS AND GREETING CARDS, DISPLAY CARDS PRIMARILY COMPOSED OF CARDBOARD; BOOK-BINDING MATERIAL; PHOTOGRAPHS; STATIONERY; ADHESIVES FOR STATIONERY OR HOUSEHOLD PURPOSES; ARTISTS' MATERIALS, NAMELY, BRUSHES, PENS, PASTELS, MARKERS, PENCILS, CANVAS PANELS FOR ARTISTS, ART AND CRAFT PAINT KITS; PAINT BRUSHES; TYPEWRITERS AND OFFICE REQUISITES, NAMELY, WRITING PAPER, ENVELOPES, NOTE PADS, PAPER STAPLERS, STAPLES, CORRECTING FLUID FOR TYPE, ADHESIVE TAPE FOR STATIONERY AND HOUSEHOLD PURPOSE, ADHESIVE TAPE DISPENSERS, PUNCHES, RUBBER BANDS AND PAPER CLIPS; PRINTED INSTRUCTIONAL, EDUCATIONAL AND TEACHING MATERIAL IN THE FIELD OF FASHION AND CLOTHING DESIGN; PLASTIC BAGS, ENVELOPES OR POUCHES FOR PACKAGING; PRINTERS' TYPE; PRINTING BLOCKS (U.S. CLS. 2, 5, 22, 23, 29, 37, 38 AND 50).

**CLASS 18—LEATHER GOODS**

FOR LEATHER AND IMITATIONS OF LEATHER, AND GOODS MADE OF THESE MATERIALS, NAMELY, ANIMAL SKINS AND HIDES; TRAVELLING TRUNKS AND TRAVELLING BAGS; UMBRELLAS, PARASOLS AND WALKING STICKS; WHIPS, HARNESS AND SADDLERY (U.S. CLS. 1, 2, 3, 22 AND 41).

**CLASS 24—FABRICS**

FOR TEXTILES AND TEXTILE GOODS, NAMELY, FABRIC BED AND TABLE COVERS, FABRIC TABLE LINENS AND NAPKINS, CURTAINS, FABRICS FOR TEXTILE USE, FABRIC TOWELS, TEXTILE FABRICS FOR MANUFACTURING OF CLOTHING, FOOTWEAR AND HEADWEAR (U.S. CLS. 42 AND 50).

**CLASS 25—CLOTHING**

FOR CLOTHING, NAMELY, SHIRTS, TOPS, DRESSES, T-SHIRTS, SWEATERS, SWEATSHIRTS, HOODED SWEATSHIRTS, JACKETS, UNDERSHIRTS, SWEAT SUITS, PANTS, SHORTS, FOOTWEAR, HEADWEAR (U.S. CLS. 22 AND 39).

**CLASS 28—TOYS AND SPORTING GOODS**

FOR GAMES AND PLAYTHINGS, NAMELY, BOARD AND CARD GAMES, DOLLS, STUFFED ANIMALS; GYMNASIAC AND SPORTING ARTICLES, NAMELY, SPORTS BALLS, BATS FOR GAMES AND NETS FOR SPORTS; DECORATIONS FOR CHRISTMAS TREES (U.S. CLS. 22, 23, 38 AND 50).

**CLASS 35—ADVERTISING AND BUSINESS**

FOR ADVERTISING SERVICES; BUSINESS MANAGEMENT SERVICES; BUSINESS ADMINISTRATION SERVICES; PROVIDING OFFICE FUNCTIONS (U.S. CLS. 100, 101 AND 102).

KATHERINE STOIDES, EXAMINING ATTORNEY

SN 79-086,223. KRIEF FRÉDÉRIC, FRANCE, FILED 6-22-2010.

# BERENICE

PRIORITY DATE OF 12-22-2009 IS CLAIMED.  
OWNER OF INTERNATIONAL REGISTRATION 1048071  
DATED 6-22-2010, EXPIRES 6-22-2020.

**CLASS 9—ELECTRICAL AND SCIENTIFIC APPARATUS**

FOR APPARATUS FOR RECORDING, TRANSMITTING, REPRODUCING OR PROCESSING SOUND OR IMAGES; AUTOMATIC VENDING MACHINES AND MECHANISMS FOR COIN-OPERATED APPARATUS; CASH REGISTERS; CALCULATING MACHINES; DATA PROCESSING EQUIPMENT AND COMPUTERS; COMPUTER GAME PROGRAMS; COMPUTER PERIPHERAL DEVICES; BATTERIES, ELECTRIC; DIVING SUITS, GLOVES OR MASKS; CLOTHING FOR PROTECTION AGAINST ACCIDENTS, IRRADIATION AND FIRE; SPECTACLES; OPTICAL GOODS, NAMELY, CONTACT LENSES, SUNGLASSES; SPECTACLE CASES; INTEGRATED CIRCUIT CARDS; SAFETY TARPAULINS (U.S. CLS. 21, 23, 26, 36 AND 38).

**CLASS 14—JEWELRY**

FOR JEWELRY; JEWELRY, PRECIOUS STONES; HOROLOGICAL AND CHRONOMETRIC INSTRUMENTS; PRECIOUS METALS AND THEIR ALLOYS; WORKS OF ART OF PRECIOUS METAL; JEWELRY CASES; BOXES OF PRECIOUS METAL; WATCH CASES, BANDS, CHAINS, SPRINGS OR GLASSES; KEY RINGS, TRINKETS, OR FOBS OF PRECIOUS METAL; CASES AND PRESENTATION CASES FOR TIMEPIECES; MEDALS (U.S. CLS. 2, 27, 28 AND 50).

**CLASS 24—FABRICS**

FOR NON WOVEN, WOVEN AND KNITTED FABRIC, WOOLLEN, SILK, POLYESTER, NYLON, CASHMERE, JERSEY AND COTTON FABRICS, WATER RESISTANT FABRICS; BED AND TABLE COVERS; FABRICS FOR TEXTILE USE; VELVET; BED LINEN; HOUSEHOLD LINEN; TABLE LINEN, NOT OF PAPER; BATH LINEN, EXCEPT CLOTHING (U.S. CLS. 42 AND 50).

**CLASS 25—CLOTHING**

FOR CLOTHING FOR WOMEN, MEN AND CHILDREN, NAMELY, SHIRTS, TEE-SHIRTS, SLEEVELESS TEE-SHIRTS, BLOUSES, PULLOVERS, TANK TOPS, SWEATERS, DRESSES, VESTS, TROUSERS, SHORTS, SKIRTS, CARDIGANS, COATS, RAINCOATS, GABARDINES, ANORAKS, PARKAS, BLOUSONS, PADDED JACKETS, REEFER JACKETS, UNDERCLOTHING, SWIMWEAR, SCARVES, FOULARDS, SOCKS, GLOVES, BELT; FOOTWEAR EXCEPT ORTHOPEDIC FOOTWEAR, NAMELY, FOOTWEAR FOR WOMEN, FOOTWEAR FOR MEN, FOOTWEAR FOR CHILDREN AND BALLERINAS, BOOTS; HEADGEAR, NAMELY, HATS, CAPS (U.S. CLS. 22 AND 39).

PAM WILLIS, EXAMINING ATTORNEY

SN 79-086,234. BIGA ANGELA, ITALY, FILED 6-30-2010.



OWNER OF INTERNATIONAL REGISTRATION 1048101  
DATED 6-30-2010, EXPIRES 6-30-2020.

NO CLAIM IS MADE TO THE EXCLUSIVE RIGHT TO USE "PRIMO PAN SPECIALITÀ ALIMENTARI", APART FROM THE MARK AS SHOWN.

THE MARK CONSISTS OF A DESIGN OF A SMALLER OVAL INSIDE A LARGER OVAL. IN BETWEEN THE TWO OVALS AT THE TOP APPEARS THE WORDING "PRIMO PAN" WHILE IN BETWEEN THE TWO OVALS AT THE BOTTOM APPEARS THE WORDING "SPECIALITÀ ALIMENTARI". THE WORDS ARE SEPARATED BY A DESIGN OF A PIECE OF GRAIN ON EACH SIDE. IN THE MIDDLE OF THE SMALLER OVAL THERE IS THE IMAGE OF A GREEK WOMAN WITH A FLOWING DRESS LYING DOWN ON WHEAT-STRAW WHILE SHE IS CARESSING SOME EAR OF WHEAT.

THE ENGLISH TRANSLATION OF "PRIMO PAN SPECIALITÀ ALIMENTARI" IS "FIRST BREAD FOOD SPECIALITIES".

**CLASS 29—MEATS AND PROCESSED FOODS**

FOR MEAT, FISH, POULTRY AND GAME; MEAT EXTRACTS; PRESERVED, FROZEN, DRIED AND COOKED FRUITS AND VEGETABLES; JELLIES, JAMS, COMPOTES; EGGS, MILK AND MILK PRODUCTS, NAMELY, BUTTER (U.S. CL. 46).

**CLASS 30—STAPLE FOODS**

FOR COFFEE, TEA, COCOA, SUGAR; FLOUR AND PREPARATIONS MADE OF CEREALS, NAMELY, COOKIES COMPRISED OF WHEAT, MAIZE, SPELT, BUCKWHEAT AND MIX OF OAT, RICE, BARLEY, RYE; BREAD, PASTRY AND CONFECTIONERY, NAMELY, CHOCOLATE CHIPS; EDIBLE ICES; HONEY, TREACLE; YEAST, BAKING-POWDER, SPICES (U.S. CL. 46).

COURTNEY ALVAREZ, EXAMINING ATTORNEY



SN 79-086,312. NGK INSULATORS, LTD., JAPAN, FILED 6-30-2010.

# NGK

PRIORITY DATE OF 6-22-2010 IS CLAIMED.  
OWNER OF INTERNATIONAL REGISTRATION 1048318  
DATED 6-30-2010, EXPIRES 6-30-2020.  
OWNER OF U.S. REG. NOS. 1,734,341, 3,293,949 AND  
OTHERS.

THE MARK CONSISTS OF THE WORDING "NGK" IN A  
STYLIZED FONT.

## CLASS 7—MACHINERY

FOR CHEMICAL PROCESSING MACHINES AND APPARATUSES, NAMELY, CERAMIC FILTERS FOR DUST COLLECTING MACHINES AND FILTERING MACHINES, MIST ELIMINATORS, CORROSION-RESISTANT PUMPS FOR MACHINES, PRESSES, AGITATING MACHINES, DRYING MACHINES, MIXING OR BLENDING MACHINES, CLEANING APPARATUS, GRANULATING MACHINES, REACTION VESSELS BEING MACHINES, SEPARATING MACHINES, DISSOLVING MACHINES AND STRUCTURAL PARTS THEREFOR; PLASTIC PROCESSING MACHINES AND APPARATUSES, NAMELY, MOLDS BEING MACHINE PARTS FOR INJECTION FORMING; CERAMIC COMPONENTS FOR SEMICONDUCTOR MANUFACTURING MACHINES AND SEMICONDUCTOR MANUFACTURING SYSTEMS, NAMELY, HEATERS BEING MACHINE PARTS, ELECTROSTATIC CHUCKS, WALLS BEING MACHINE PARTS, SHOWER PLATES BEING MACHINE PARTS, GAS INLETS BEING MACHINE PARTS, WAFER PLATES BEING MACHINE PARTS, SHAFTS BEING MACHINE PARTS, TUBES BEING MACHINE PARTS, SUSCEPTOR RINGS BEING MACHINE PARTS, DUMMY WAFERS BEING MACHINE PARTS, DOMES BEING MACHINE PARTS, RINGS BEING MACHINE PARTS, ARMS BEING MACHINE PARTS, AND ANTI-STATIC APPARATUSES FOR ULTRA PURE WATER FOR SEMICONDUCTOR MANUFACTURING PROCESSES BEING MACHINE PARTS; MACHINES AND APPARATUSES FOR MANUFACTURING RUBBER GOODS, NAMELY, MOLDS FOR TIRES BEING MACHINE PARTS (U.S. CLS. 13, 19, 21, 23, 31, 34 AND 35).

## CLASS 9—ELECTRICAL AND SCIENTIFIC APPARATUS

FOR LABORATORY APPARATUSES AND INSTRUMENTS, NAMELY, FURNACES, ANTI-STATIC APPARATUSES FOR ULTRA PURE WATER; MEASURING OR TESTING MACHINES AND INSTRUMENTS, NAMELY, EXHAUST GAS TEMPERATURE SENSORS FOR INDUSTRIAL FURNACES; NITRIC OXIDE SENSORS; EXHAUST GAS TEMPERATURE SENSORS FOR AUTOMOBILES; POWER DISTRIBUTION OR CONTROL MACHINES AND APPARATUSES, NAMELY, BUSHINGS; BATTERIES AND ELECTRICAL CELLS; TELECOMMUNICATION DEVICES AND APPARATUSES, NAMELY, REPEATER HOUSINGS FOR UNDERSEA OPTICAL FIBER COMMUNICATION CABLES AND HIGH-FREQUENCY FILTERS FOR MOBILE PHONES; ELECTRONIC MACHINES, APPARATUSES AND THEIR PARTS, NAMELY, HIGH-FREQUENCY FILTERS AND RESONATORS (U.S. CLS. 21, 23, 26, 36 AND 38).

## CLASS 11—ENVIRONMENTAL CONTROL APPARATUS

FOR DRYING APPARATUSES FOR CHEMICAL PROCESSING, NAMELY, EVAPORATORS; HEAT EXCHANGERS FOR CHEMICAL PROCESSING; INDUSTRIAL FURNACES INCLUDING FAR INFRARED RAY HEATERS AND HEATING ELEMENTS; WATER PURIFYING APPARATUSES; ELECTRIC LAMPS AND OTHER ELECTRICAL LIGHTING FIXTURES; AND HOUSEHOLD TAP-WATER FILTERS (U.S. CLS. 13, 21, 23, 31 AND 34).

## CLASS 12—VEHICLES

FOR VESSELS AND STRUCTURAL PARTS THEREFOR NOT BEING AIR CUSHION VEHICLES; AIRCRAFT AND STRUCTURAL PARTS THEREFOR; RAILWAY ROLLING STOCK AND STRUCTURAL PARTS THEREFOR; AUTOMOBILES AND STRUCTURAL PARTS THEREFOR; AND TWO-WHEELED MOTOR VEHICLES AND STRUCTURAL PARTS THEREFOR (U.S. CLS. 19, 21, 23, 31, 35 AND 44).

## CLASS 19—NON-METALLIC BUILDING MATERIALS

FOR CERAMIC BUILDING MATERIALS, NAMELY, CERAMIC TILES, MORTARS; CERAMIC BRICKS FOR USE IN REFRACTORY FURNACES; AND CERAMIC REFRACTORY PRODUCTS, NAMELY, REFRACTORY BLOCKS, REFRACTORY SHAPES, AND REFRACTORY SHAPES FOR USE IN REFRACTORY FURNACES (U.S. CLS. 1, 12, 33 AND 50).

RENEE MCCRAY, EXAMINING ATTORNEY

SN 79-086,409. INDIBA, S.A., SPAIN, FILED 6-29-2010.



The logo for INDIBA DEEP BEAUTY PROIONIC BODY CARE SYSTEM features the brand name "INDIBA" in a large, bold, sans-serif font. Below it, "DEEP BEAUTY" is written in a smaller, all-caps, sans-serif font, and "PROIONIC BODY CARE SYSTEM" is written in an even smaller, all-caps, sans-serif font. To the right of the text is a graphic consisting of three overlapping circles of varying shades of gray, arranged in a vertical line.

PRIORITY DATE OF 2-23-2010 IS CLAIMED.  
OWNER OF INTERNATIONAL REGISTRATION 1048554  
DATED 6-29-2010, EXPIRES 6-29-2020.

NO CLAIM IS MADE TO THE EXCLUSIVE RIGHT TO USE "BEAUTY PROIONIC BODY CARE SYSTEM", APART FROM THE MARK AS SHOWN.

THE MARK CONSISTS OF THE STYLIZED WORDS "INDIBA DEEP BEAUTY PROIONIC BODY CARE SYSTEM", TO THE RIGHT OF THE WORDING ARE THREE OVERLAPPING CIRCLES THAT ARE VERTICALLY ORIENTED.

THE WORDING "INDIBA" HAS NO MEANING IN A FOREIGN LANGUAGE.

## CLASS 3—COSMETICS AND CLEANING PREPARATIONS

FOR SOAPS; PERFUMERY, ESSENTIAL OILS, COSMETICS, HAIR LOTIONS; DENTIFRICES (U.S. CLS. 1, 4, 6, 50, 51 AND 52).

## CLASS 9—ELECTRICAL AND SCIENTIFIC APPARATUS

FOR LASER EQUIPMENT FOR NON MEDICAL PURPOSES, NAMELY, APPARATUS FOR APPLYING LASER RADIATION; LASER EQUIPMENT FOR NON-MEDICAL PURPOSES, NAMELY, LASER LIGHT TRANSMITTING APPARATUS; LASER EQUIPMENT FOR NON-MEDICAL PURPOSES, NAMELY, LASER LIGHT TREATMENT APPARATUS, INSTRUMENTS AND MACHINING TOOLS; LASERS NOT FOR MEDICAL USE; HIGH FREQUENCY GENERATORS FOR NON-MEDICAL USE, NAMELY, ELECTRONIC MAGNETOSTRICTIVE EQUIPMENT, NAMELY, A WAVE GENERATOR (U.S. CLS. 21, 23, 26, 36 AND 38).

**CLASS 10—MEDICAL APPARATUS**

FOR ELECTRO-MEDICAL EQUIPMENT, APPARATUS OR INSTRUMENTS, NAMELY, EQUIPMENT FOR PROFESSIONAL BEAUTY TREATMENTS IN THE NATURE OF ELECTRONIC STIMULATOR FOR SKIN; ESTHETIC MASSAGE APPARATUS; APPARATUS FOR THE THERAPEUTIC STIMULATION OF THE BODY, NAMELY, ELECTROTHERAPY DEVICE FOR PROVIDING TRANSCUTANEOUS ELECTRICAL NERVE STIMULATION, INFRARED HEAT AND COMPRESSION (U.S. CLS. 26, 39 AND 44).

**CLASS 44—MEDICAL, BEAUTY AND AGRICULTURAL SERVICES**

FOR MEDICAL SERVICES; HYGIENIC AND BEAUTY CARE FOR HUMAN BEINGS; COSMETIC BODY CARE SERVICES, NAMELY, CELLULITE TREATMENT SERVICES; COSMETIC BODY CARE SERVICES, COSMETIC FACE AND HAIR CARE SERVICES; BEAUTY SPA SERVICES, NAMELY, COSMETIC BODY CARE SERVICES (U.S. CLS. 100 AND 101).

CHRISTINA SOBRAL, EXAMINING ATTORNEY

**CLASS 35—ADVERTISING AND BUSINESS**

FOR ADVERTISING; COMPILING OF STATISTICS; COMMERCIAL INFORMATION, MARKET RESEARCH AND MARKET ANALYSIS; PROMOTIONAL SERVICES TO PROMOTE TRADING IN SHARES AND OTHER FINANCIAL SECURITIES; PROMOTIONAL SERVICES; ORGANIZATION OF EVENTS FOR PROMOTIONAL AND COMMERCIAL PURPOSES; ADVISORY SERVICES IN THE FIELD OF BUSINESS ECONOMICS; LOBBYING SERVICES FOR COMMERCIAL PURPOSES, NAMELY, REPRESENTING THE REAL ESTATE SECTOR AND LOOKING AFTER THE INTEREST OF THE REAL ESTATE SECTOR TOWARDS GOVERNMENTS, GOVERNMENTAL BODIES AND OTHER PARTIES (U.S. CLS. 100, 101 AND 102).

**CLASS 36—INSURANCE AND FINANCIAL**

FOR INSURANCE AND FINANCIAL BROKERAGE; STOCK EXCHANGE QUOTATIONS, NAMELY, COMPILING, UPDATING AND FINANCIAL MANAGEMENT OF A STOCK EXCHANGE INDEX; SECURITIES BROKERAGE NEGOTIATION REGARDING THE PURCHASE AND SALE OF SHARES AND OTHER FINANCIAL SECURITIES; PROVISION OF A FINANCIAL EXCHANGE FOR THE TRADING OF SECURITIES, SHARES AND OPTIONS AND OTHER DERIVATIVE PRODUCTS; REAL ESTATE AFFAIRS (U.S. CLS. 100, 101 AND 102).

**CLASS 41—EDUCATION AND ENTERTAINMENT**

FOR PUBLICATION OF PRINTED MATTER IN THE NATURE OF STATISTICS, COMMERCIAL INFORMATION, MARKET RESEARCH AND MARKET ANALYSES FOR OTHERS; EDUCATION IN THE FIELD OF PUBLIC REAL ESTATE MATTERS RENDERED THROUGH CORRESPONDENCE COURSES AND BUSINESS TRAINING IN THE FORM OF WORKSHOPS; ORGANIZATION OF SEMINARS AND CONFERENCES IN THE FIELD OF PUBLIC REAL ESTATE AFFAIRS; PUBLICATION OF PRINTED MATTER (U.S. CLS. 100, 101 AND 107).

WILLIAM ROSSMAN, EXAMINING ATTORNEY

SN 79-086,428. TICAPEX AB, SWEDEN, FILED 6-7-2010.

**BIOCHAMBER**

THE MARK CONSISTS OF STANDARD CHARACTERS WITHOUT CLAIM TO ANY PARTICULAR FONT, STYLE, SIZE, OR COLOR.

OWNER OF INTERNATIONAL REGISTRATION 1048592 DATED 6-7-2010, EXPIRES 6-7-2020.

THE WORDING "BIOCHAMBER" HAS NO MEANING IN A FOREIGN LANGUAGE.

**CLASS 5—PHARMACEUTICALS**

FOR SURGICAL IMPLANTS COMPRISING LIVING TISSUE (U.S. CLS. 6, 18, 44, 46, 51 AND 52).

**CLASS 10—MEDICAL APPARATUS**

FOR SURGICAL IMPLANTS COMPRISING ARTIFICIAL MATERIAL (U.S. CLS. 26, 39 AND 44).

ELISSA GARBER KON, EXAMINING ATTORNEY

SN 79-086,613. JACOB JOHAN ROOSJEN, NETHERLANDS, FILED 4-15-2010.

**SRI**

THE MARK CONSISTS OF STANDARD CHARACTERS WITHOUT CLAIM TO ANY PARTICULAR FONT, STYLE, SIZE, OR COLOR.

OWNER OF INTERNATIONAL REGISTRATION 1049071 DATED 4-15-2010, EXPIRES 4-15-2020.

**CLASS 14—JEWELRY**

FOR PRECIOUS METALS AND THEIR ALLOYS AND GOODS IN PRECIOUS METALS OR COATED THEREWITH, NOT INCLUDED IN OTHER CLASSES, NAMELY, SILVER, GOLD, PLATINUM; JEWELRY; PRECIOUS STONES (U.S. CLS. 2, 27, 28 AND 50).

SN 79-086,521. EUROPEAN PUBLIC REAL ESTATE ASSOCIATION, B-1200 BRUSSEL, BELGIUM, FILED 6-16-2010.

**EPRA**

THE MARK CONSISTS OF STANDARD CHARACTERS WITHOUT CLAIM TO ANY PARTICULAR FONT, STYLE, SIZE, OR COLOR.

PRIORITY DATE OF 2-16-2010 IS CLAIMED. OWNER OF INTERNATIONAL REGISTRATION 1048863 DATED 6-16-2010, EXPIRES 6-16-2020.

THE WORDING "EPRA" HAS NO MEANING IN A FOREIGN LANGUAGE.

**CLASS 42—SCIENTIFIC AND COMPUTER SERVICES**

FOR MATERIAL TESTING; QUALITY CONTROL FOR OTHERS; TESTING, ANALYSIS AND EVALUATION OF THE GOODS OF OTHERS FOR CERTIFICATION PURPOSES; ISSUING OF EXPERT REPORTS REGARDING QUALITY AND ORIGIN OF PRECIOUS METALS AND JEWELRY (U.S. CLS. 100 AND 101).

MATTHEW EINSTEIN, EXAMINING ATTORNEY

**CLASS 42—SCIENTIFIC AND COMPUTER SERVICES**

FOR CONTRACT RESEARCH AND CONTRACT DEVELOPMENT, FOR OTHERS, IN PARTICULAR IN THE FIELDS OF MICRO-SYSTEMS ENGINEERING, MICRO-MECHANICS, SENSOR TECHNOLOGY, DOSING TECHNOLOGY, AUTOMATION ENGINEERING, FUNCTION AND RELIABILITY TESTING, WAFER TECHNOLOGY, MEDICAL TECHNOLOGY, TIME MEASURING TECHNOLOGY AND SOFTWARE; SCIENTIFIC RESEARCH AND CUSTOM DESIGN FOR OTHERS IN THE FIELD OF SEMICONDUCTORS, SEMICONDUCTOR SYSTEMS, SEMICONDUCTOR CELL LIBRARIES, WAFERS AND INTEGRATED CIRCUITS, SEMICONDUCTOR PACKAGES, SEMICONDUCTOR TESTING DEVICES, SEMICONDUCTOR HANDLING AND STORAGE DEVICES (U.S. CLS. 100 AND 101).

MATTHEW EINSTEIN, EXAMINING ATTORNEY

SN 79-086,637. IBG IMMOBILIEN UND BETEILIGUNGS GMBH, AUSTRIA, FILED 7-28-2010.

SN 79-086,661. AGRO TERRA LIMITED LIABILITY COMPANY, RUSSIAN FED., FILED 7-5-2010.

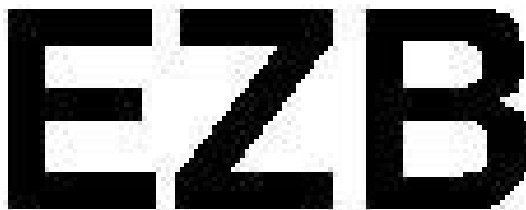

THE MARK CONSISTS OF STANDARD CHARACTERS WITHOUT CLAIM TO ANY PARTICULAR FONT, STYLE, SIZE, OR COLOR.

PRIORITY DATE OF 2-19-2010 IS CLAIMED.

OWNER OF INTERNATIONAL REGISTRATION 1049155 DATED 7-28-2010, EXPIRES 7-28-2020.

**CLASS 7—MACHINERY**

FOR MACHINES AND APPARATUS FOR THE PRODUCTION, ALIGNMENT, ADJUSTMENT, LINKING, COATING, DEVELOPMENT, CLEANING, PRINTING AND LITHOGRAPHIC TREATMENT, NAMELY, NANOSTRUCTURE IMPRINTING, HOT STAMPING, MICRO-CONTACT PRINTING, TESTING AND MANUFACTURING OF ELECTRONIC CIRCUITS OR SEMICONDUCTORS, TRANSISTORS OR WAFERS; STRUCTURAL PARTS AND EQUIPMENT FOR THE AFORESAID MACHINES AND APPARATUS, INCLUDED IN THIS CLASS; SEMICONDUCTOR WAFER PROCESSING MACHINES FOR PROCESSING SEMICONDUCTORS UNDER VACUUM; CONVEYORS FOR CONVEYING SEMICONDUCTORS; MACHINES FOR THE SURFACE TREATMENT OF SEMICONDUCTORS; MACHINES FOR ETCHING SEMICONDUCTOR SURFACES; MACHINES FOR VAPORISING SEMICONDUCTOR SURFACES IN PARTICULAR UNDER VACUUM (CVD PROCESSES); INSTALLATIONS FOR CONVEYING AND PROVIDING AND PROCESSING SEMICONDUCTORS, NAMELY, CONVEYORS AND SEMICONDUCTOR WAFER PROCESSING MACHINES; INSTALLATIONS FOR CONVEYING AND PROCESSING AND PROVIDING FLAT SCREENS, NAMELY, MACHINES FOR MANUFACTURING LCD- OR LED-SCREENS; MACHINES AND TURNKEY PRODUCTION INSTALLATIONS FOR MANUFACTURING SEMICONDUCTOR COMPONENTS FROM THE SEMICONDUCTOR BACKEND SECTOR INCLUDING LIGHT DIODES, NAMELY, MACHINES FOR MANUFACTURING SEMICONDUCTORS; MACHINES FOR SEMICONDUCTOR MANUFACTURING; MACHINES FOR CHIP MANUFACTURING AND CHIP ASSEMBLY (U.S. CLS. 13, 19, 21, 23, 31, 34 AND 35).

# AGROTERRA

THE MARK CONSISTS OF STANDARD CHARACTERS WITHOUT CLAIM TO ANY PARTICULAR FONT, STYLE, SIZE, OR COLOR.

PRIORITY DATE OF 2-12-2010 IS CLAIMED.

OWNER OF INTERNATIONAL REGISTRATION 1049236 DATED 7-5-2010, EXPIRES 7-5-2020.

**CLASS 1—CHEMICALS**

FOR CHEMICALS USED IN AGRICULTURE, HORTICULTURE AND FORESTRY; MANURES (U.S. CLS. 1, 5, 6, 10, 26 AND 46).

**CLASS 5—PHARMACEUTICALS**

FOR VETERINARY PREPARATIONS FOR CATTLE FOR THE TREATMENT OF PAIN AND INTESTINAL INFECTIONS AND FOR DISEASES AND DISORDERS OF HOOVES, SKIN AND FUR; PREPARATIONS FOR DESTROYING NOXIOUS ANIMALS; HERBICIDES; FUNGICIDES (U.S. CLS. 6, 18, 44, 46, 51 AND 52).

**CLASS 7—MACHINERY**

FOR AGRICULTURAL IMPLEMENTS, NAMELY, SEED DRILLS, HAY BALERS, COULTERS; INCUBATORS FOR EGGS; INCUBATORS FOR BACTERIA CULTURES (U.S. CLS. 13, 19, 21, 23, 31, 34 AND 35).

**CLASS 29—MEATS AND PROCESSED FOODS**

FOR MEAT, POULTRY; PRESERVED, FROZEN, DRIED AND COOKED FRUITS AND VEGETABLES; EGGS, MILK AND MILK PRODUCTS EXCLUDING ICE CREAM, ICE MILK AND FROZEN YOGURT; EDIBLE OILS AND FATS (U.S. CL. 46).

**CLASS 30—STAPLE FOODS**

FOR FLOUR AND PREPARATIONS MADE FROM CEREAL, NAMELY, BARLEY FLOUR, BUCKWHEAT FLOUR, CORN FLOUR, RICE FLOUR, EDIBLE FLOUR, WHEAT FLOUR, POTATO FLOUR, FLOUR-BASED CHIPS, PANCAKES, CREPES, SANDWICH WRAPS, MUFFINS AND FROZEN FLOUR-FREE FOODS, NAMELY, GRIDDLE CAKE SANDWICHES WHICH ARE PROTEIN ENRICHED, WAFFLES, BREAD, BISCUITS, TARTS, CAKES MADE WITH CEREALS, BREAKFAST CEREALS, CEREAL BASED SNACK FOOD, CEREAL BASED ENERGY BARS, READY TO EAT, CEREAL DERIVED FOOD BARS; BREAD (U.S. CL. 46).

**CLASS 31—NATURAL AGRICULTURAL PRODUCTS**

FOR AGRICULTURAL, HORTICULTURAL AND FORESTRY PRODUCTS, NAMELY, AGRICULTURAL GRAINS FOR PLANTING, AGRICULTURAL SEEDS, SEEDS FOR FRUIT AND VEGETABLES, SEEDS FOR FLOWERS, SEEDS FOR AGRICULTURAL PURPOSES, BULBS FOR AGRICULTURAL PURPOSES, PLANTABLE SEED PAPER COMPRISED PRIMARILY OF SEEDS FOR AGRICULTURAL PURPOSES, SPORES AND SPAWN FOR AGRICULTURAL PURPOSES, BULBS FOR HORTICULTURAL PURPOSES, SEEDS FOR HORTICULTURAL PURPOSES; MALT FOR BREWING AND DISTILLING; LIVE ANIMALS; FRESH FRUITS AND VEGETABLES (U.S. CLS. 1 AND 46).

**CLASS 36—INSURANCE AND FINANCIAL**

FOR FINANCIAL AFFAIRES AND MONETARY AFFAIRS, NAMELY, FINANCIAL INFORMATION, MANAGEMENT AND ANALYSIS SERVICES; REAL ESTATE SERVICES, NAMELY, REAL ESTATE ACQUISITION SERVICES, REAL ESTATE CONSULTATION, REAL ESTATE CONSULTANCY, LAND ACQUISITION SERVICES (U.S. CLS. 100, 101 AND 102).

**CLASS 44—MEDICAL, BEAUTY AND AGRICULTURAL SERVICES**

FOR AGRICULTURE, HORTICULTURE AND FORESTRY SERVICES, NAMELY, AGRICULTURAL ADVICE, HORTICULTURAL SERVICES, AGRICULTURAL ADVICE, NAMELY, PROVIDING RECOMMENDATIONS FOR PLANT AND SOIL NUTRITION SUPPLEMENTS (U.S. CLS. 100 AND 101).

DOMINICK J. SALEMI, EXAMINING ATTORNEY

SN 79-086,670. KEEBUNGA COMPANY LIMITED, UNITED KINGDOM, FILED 7-23-2010.



OWNER OF INTERNATIONAL REGISTRATION 1049266 DATED 7-23-2010, EXPIRES 7-23-2020.

THE MARK CONSISTS OF AN ARROW INSIDE A RECTANGLE AND THE WORD "KEEBUNGA".

THE MARK DOES NOT HAVE ANY FOREIGN SIGNIFICANCE.

**CLASS 18—LEATHER GOODS**

FOR RUCKSACKS (U.S. CLS. 1, 2, 3, 22 AND 41).

**CLASS 25—CLOTHING**

FOR CLOTHING, NAMELY, SKIWEAR, SNOWBOARD GLOVES, WET SUITS, T-SHIRTS, JEANS, JACKETS, BOARD SHORTS, SANDALS, AND SWEAT SHIRTS (U.S. CLS. 22 AND 39).

**CLASS 28—TOYS AND SPORTING GOODS**

FOR SPORTING ARTICLES, NAMELY, SURFBOARDS, LEASHES USED IN CONJUNCTION WITH SURFING; SNOW BOARDS; MOUNTAINEERING AND ROCK CLIMBING EQUIPMENT, NAMELY, CLIMBING CAMS AND ANCHORS MADE OF METAL; FLIPPERS FOR USE IN SCUBA DIVING; WINDSURFING GLOVES (U.S. CLS. 22, 23, 38 AND 50).

PAUL F. GAST, EXAMINING ATTORNEY

SN 79-086,730. SIEMENS AKTIENGESELLSCHAFT, FED REP GERMANY, FILED 6-28-2010.

# Siemens IT Care Plan

THE MARK CONSISTS OF STANDARD CHARACTERS WITHOUT CLAIM TO ANY PARTICULAR FONT, STYLE, SIZE, OR COLOR.

PRIORITY DATE OF 4-20-2010 IS CLAIMED.

OWNER OF INTERNATIONAL REGISTRATION 1049452 DATED 6-28-2010, EXPIRES 6-28-2020.

OWNER OF U.S. REG. NOS. 2,392,496, 3,022,523 AND OTHERS.

NO CLAIM IS MADE TO THE EXCLUSIVE RIGHT TO USE "IT CARE PLAN", APART FROM THE MARK AS SHOWN.

**CLASS 9—ELECTRICAL AND SCIENTIFIC APPARATUS**

FOR DOWNLOADABLE COMPUTER SOFTWARE PROGRAMS FOR PROVIDING EDUCATIONAL INFORMATION AND ADVANCED TRAINING IN THE FIELD OF MEDICINE AND HEALTH CARE TO TRAINEES IN HOSPITALS (U.S. CLS. 21, 23, 26, 36 AND 38).

**CLASS 42—SCIENTIFIC AND COMPUTER SERVICES**

FOR DESIGN, CREATION, INSTALLATION, DATA RECOVERY, COPYING, UPDATING, RENTING AND MAINTENANCE OF COMPUTER PROGRAMS; COMPUTER SOFTWARE CONSULTANCY SERVICES; COMPUTER SYSTEM ANALYSES; COMPUTER ANTIVIRUS PROTECTION SERVICES (U.S. CLS. 100 AND 101).

COURTNEY ALVAREZ, EXAMINING ATTORNEY

SN 79-086,877. KLINGENBURG GMBH, FED REP GERMANY, FILED 6-25-2010.



THE MARK CONSISTS OF STANDARD CHARACTERS WITHOUT CLAIM TO ANY PARTICULAR FONT, STYLE, SIZE, OR COLOR.

PRIORITY DATE OF 2-26-2010 IS CLAIMED.

OWNER OF INTERNATIONAL REGISTRATION 1049754 DATED 6-25-2010, EXPIRES 6-25-2020.

NO CLAIM IS MADE TO THE EXCLUSIVE RIGHT TO USE "TUBE" FOR INTERNATIONAL CLASS 11, APART FROM THE MARK AS SHOWN.



**CLASS 11—ENVIRONMENTAL CONTROL APPARATUS**

FOR AIR CONDITIONING PLANTS, AIR-CONDITIONING, AIR COOLING AND VENTILATION APPARATUS AND INSTRUMENTS, ENERGY REGENERATION PLANTS AND PARTS OF THE AFOREMENTIONED GOODS, INCLUDED IN THIS CLASS, NAMELY, VENTILATION HOODS; REGENERATIVE AND RECUPERATIVE ENERGY REGENERATION PLANTS; AIR HUMIDIFIERS FOR AIR CONDITIONING PLANTS; AIR HEATERS, AIR FILTERS FOR AIR CONDITIONING, AIR FILTERING PLANTS, AIR COOLING DEVICES, NAMELY, EVAPORATIVE AIR COOLERS, AIR PURIFYING APPLIANCES AND MACHINES, AIR DRIERS IN THE NATURE OF DEHUMIDIFIERS; HEAT EXCHANGERS, IN PARTICULAR ROTARY HEAT EXCHANGERS, PLATE HEAT EXCHANGERS AND HEAT WHEELS, NAMELY, ENERGY RECOVERY ROTORS FOR RECOVERING WASTED ENERGY FROM THE AIR EXHAUSTED FROM AIR-CONDITIONED SPACES; HEAT PUMPS, HEAT RECOVERY DEVICES, NAMELY, HEAT EXCHANGERS NOT BEING PARTS OF MACHINES, HEAT ACCUMULATORS, WATER HEATERS AND WATER HEATER DEVICES, HOT-WATER HEATING SYSTEMS FOR RESIDENTIAL AND COMMERCIAL BUILDINGS COMPRISED OF BOILERS, VALVES, PIPES, MANIFOLDS, SOLAR PANELS, CONTROL PANEL, SWITCHES AND ELECTRICAL WIRE, ALL SOLD AS A UNIT; STEAM GENERATORS, GAS GENERATORS, NAMELY, ELECTROCHEMICAL AND HYDROGEN GAS GENERATORS, AND EVAPORATION GENERATORS, NAMELY, STEAM GENERATORS; FANS FOR AIR-CONDITIONING AND AS PIECE PARTS OF AIR CONDITIONING PLANTS, VENTILATING SYSTEMS AND ENERGY REGENERATION PLANTS (U.S. CLS. 13, 21, 23, 31 AND 34).

**CLASS 37—CONSTRUCTION AND REPAIR**

FOR INSTALLATION OF AIR CONDITIONING PLANTS, VENTILATING SYSTEMS AND ENERGY REGENERATION PLANTS (U.S. CLS. 100, 103 AND 106).  
DOUGLAS LEE, EXAMINING ATTORNEY

---

SN 79-086,880. IBG IMMOBILIEN UND BETEILIGUNGS GMBH, AUSTRIA, FILED 7-28-2010.

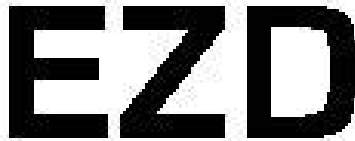

THE MARK CONSISTS OF STANDARD CHARACTERS WITHOUT CLAIM TO ANY PARTICULAR FONT, STYLE, SIZE, OR COLOR.

PRIORITY DATE OF 2-19-2010 IS CLAIMED.  
OWNER OF INTERNATIONAL REGISTRATION 1049758 DATED 7-28-2010, EXPIRES 7-28-2020.

**CLASS 7—MACHINERY**

FOR MACHINES AND APPARATUS FOR THE PRODUCTION, ALIGNMENT, ADJUSTMENT, LINKING, COATING, DEVELOPMENT, CLEANING, PRINTING AND LITHOGRAPHIC TREATMENT, NAMELY, NANOSTRUCTURE IMPRINTING, HOT STAMPING, MICRO-CONTACT PRINTING, TESTING AND MANUFACTURING OF ELECTRONIC CIRCUITS OR SEMICONDUCTORS, TRANSISTORS OR WAFERS; STRUCTURAL PARTS AND EQUIPMENT FOR THE AFORESAID MACHINES AND APPARATUS, INCLUDED IN THIS CLASS; SEMICONDUCTOR WAFER PROCESSING MACHINES FOR PROCESSING SEMICONDUCTORS UNDER VACUUM; CONVEYORS FOR CONVEYING SEMICONDUCTORS; MACHINES FOR THE SURFACE TREATMENT OF SEMICONDUCTORS; MACHINES FOR ETCHING SEMICONDUCTOR SURFACES, MACHINES FOR VAPORISING SEMICONDUCTOR SURFACES IN PARTICULAR UNDER VACUUM (CVD PROCESSES); INSTALLATIONS FOR CONVEYING AND PROVIDING AND PROCESSING SEMICONDUCTORS, NAMELY, CONVEYORS AND SEMICONDUCTOR WAFER PROCESSING MACHINES; INSTALLATIONS FOR CONVEYING AND PROCESSING AND PROVIDING FLAT SCREENS, NAMELY, MACHINES FOR MANUFACTURING LCD- OR LED-SCREENS; MACHINES AND TURNKEY PRODUCTION INSTALLATIONS FOR MANUFACTURING SEMICONDUCTOR COMPONENTS FROM THE SEMICONDUCTOR BACKEND SECTOR INCLUDING LIGHT DIODES, NAMELY, MACHINES FOR MANUFACTURING SEMICONDUCTORS; MACHINES FOR SEMICONDUCTOR MANUFACTURING, MACHINES FOR CHIP MANUFACTURING AND CHIP ASSEMBLY (U.S. CLS. 13, 19, 21, 23, 31, 34 AND 35).

**CLASS 42—SCIENTIFIC AND COMPUTER SERVICES**

FOR CONTRACT RESEARCH AND CONTRACT DEVELOPMENT, FOR OTHERS, IN PARTICULAR IN THE FIELDS OF MICRO-SYSTEMS ENGINEERING, MICRO-MECHANICS, SENSOR TECHNOLOGY, DOSING TECHNOLOGY, AUTOMATION ENGINEERING, FUNCTION AND RELIABILITY TESTING, WAFER TECHNOLOGY, MEDICAL TECHNOLOGY, TIME MEASURING TECHNOLOGY AND SOFTWARE; SCIENTIFIC RESEARCH AND CUSTOM DESIGN FOR OTHERS IN THE FIELD OF SEMICONDUCTORS, SEMICONDUCTOR SYSTEMS, SEMICONDUCTOR CELL LIBRARIES, WAFERS AND INTEGRATED CIRCUITS, SEMICONDUCTOR PACKAGES, SEMICONDUCTOR TESTING DEVICES, SEMICONDUCTOR HANDLING AND STORAGE DEVICES (U.S. CLS. 100 AND 101).

MATTHEW EINSTEIN, EXAMINING ATTORNEY

---

SN 79-086,926. ACRODEA, INC., TOKYO 153-0051, JAPAN, FILED 4-23-2010.



THE MARK CONSISTS OF STANDARD CHARACTERS WITHOUT CLAIM TO ANY PARTICULAR FONT, STYLE, SIZE, OR COLOR.

OWNER OF INTERNATIONAL REGISTRATION 1049918 DATED 4-23-2010, EXPIRES 4-23-2020.

### CLASS 9—ELECTRICAL AND SCIENTIFIC APPARATUS

FOR TELECOMMUNICATION DEVICES AND APPARATUS, NAMELY, INTERCOMS, CELLULAR OR MOBILE PHONES, DOWNLOADABLE ELECTRONIC MANUALS IN THE FIELD OF CELLULAR OR MOBILE PHONES, CELLULAR OR MOBILE PHONES FEATURING THE CAPACITY TO FUNCTION IN ANY NUMBER OF EXTRA WAYS BEYOND JUST AS A PHONE, NAMELY, TO FUNCTION AS A CAMERA, TO PERFORM INSTANT MESSAGING, TO CONDUCT MULTIMEDIA MESSAGING, TO ACCESS AND COMMUNICATE WITH E-MAIL, TO ACCESS AND COMMUNICATE WITH INTERNET, TO ACCESS AND COMMUNICATE WITH INTRANETS OR PRIVATE COMPUTER NETWORKS, TO ACCESS AND COMMUNICATE DATA, TO FUNCTION AS A RADIO, TO RECORD, PLAY, TRANSMIT, RECEIVE, AND/OR MANAGE MUSIC, TO RECORD, PLAY, TRANSMIT, RECEIVE, EDIT, AND/OR MANAGE AUDIO OR VOICE, TO RECORD, PLAY, TRANSMIT, RECEIVE, EDIT, AND/OR MANAGE VIDEO, TO CREATE, VIEW, TRANSMIT, RECEIVE, EDIT, AND/OR MANAGE PHOTOGRAPHS OR PICTURES, TO UPLOAD, VIEW, TRANSMIT, RECEIVE, EDIT, AND/OR MANAGE GRAPHICS OR IMAGES, TO PLAY ELECTRONIC GAMES, TO UPLOAD PHOTOGRAPHS AND TEXT ONTO ONLINE JOURNALS OR WEB LOGS ALSO KNOWN AS BLOGS, TO MANAGE A CALENDAR AND CONTACT INFORMATION AND OTHERWISE FUNCTION AS A PERSONAL DIGITAL ASSISTANT (PDA), TO FUNCTION AS WALKIE-TALKIES, TO EFFECTUATE MOBILE PRINTING, TO PERFORM SATELLITE NAVIGATION, TO VIEW ELECTRONIC CITY GUIDES, TO FUNCTION AS A REMOTE CONTROL FOR COMPUTERS AND RUN MULTIMEDIA PRESENTATIONS, AND/OR TO TRANSMIT VIDEO, SOUND, AND/OR DATA TO WEBSITES AND SOFTWARE USED TO ACCESS, OPERATE, AND COMMUNICATE WITH SUCH PHONES, REPEATING EXCHANGE MACHINES, NAMELY, PRIVATE BRANCH EXCHANGE (PBX) MACHINES, FACSIMILE MACHINES, AUDIO FREQUENCY MACHINES AND APPARATUS, TRANSMISSION AND REPEATING MACHINES AND APPARATUS, NAMELY, ROUTERS, TV SETS, TELEVISION TRANSMITTERS, RADIO RECEIVERS, RADIO TRANSMITTERS, RADIO COMMUNICATION MACHINES AND APPARATUS, NAVIGATION INSTRUMENTS, REMOTE CONTROL TELEMETERING MACHINES AND INSTRUMENTS, DIGITAL CAMERAS AND SOFTWARE USED TO ACCESS, OPERATE, AND COMMUNICATE WITH SUCH CAMERAS, DIGITAL AUDIO PLAYERS INCLUDING DIGITAL MUSIC PLAYERS AND SOFTWARE USED TO ACCESS, OPERATE, AND COMMUNICATE WITH SUCH PLAYERS, DIGITAL VIDEO PLAYERS AND SOFTWARE USED TO ACCESS, OPERATE, AND COMMUNICATE WITH SUCH PLAYERS, STRAP FOR MOBILE PHONES; ELECTRONIC MACHINES, APPARATUS AND THEIR PARTS, NAMELY, COMPUTERS INCLUDING HANDHELD COMPUTERS, PERSONAL DIGITAL ASSISTANTS, ELECTRONIC ORGANIZERS AND ELECTRONIC NOTEPADS, COMPUTER MEMORIES, COMPUTER PERIPHERAL DEVICES, PROCESSORS (CENTRAL PROCESSING UNITS), INTEGRATED CIRCUITS, LARGE SCALE INTEGRATED CIRCUITS, PRINTED CIRCUITS, COMPUTER APPLICATION SOFTWARE FOR CELLULAR OR MOBILE PHONES, DOWNLOADABLE COMPUTER APPLICATION SOFTWARE IN THE FIELD OF CELLULAR OR MOBILE PHONES, DOWNLOADABLE RING TONES, GRAPHICS, GAMES, AUDIO AND VIDEO CLIPS TO COMPUTERS AND CELLULAR OR MOBILE PHONES VIA COMPUTERIZED GLOBAL INFORMATION NETWORKS INCLUDING INTERNET, COMPUTER HARDWARE AND SOFTWARE FOR PROVIDING INTEGRATED TELEPHONE COMMUNICATION WITH COMPUTERIZED GLOBAL INFORMATION NETWORKS INCLUDING INTERNET, COMPUTER SOFTWARE FOR USE IN DATABASE MANAGEMENT, CHARACTER RECOGNITION SOFTWARE, ELECTRONIC MAIL AND MESSAGING SOFTWARE, PAGING SOFTWARE, DATABASE SYNCHRONIZATION SOFTWARE, COMPUTER PROGRAMS FOR ACCESSING, BROWSING AND SEARCHING ONLINE DATABASES, COMPUTER OPERATING SYSTEM SOFTWARE, APPLICATION DEVELOPMENT TOOL PROGRAMS FOR PERSONAL AND HANDHELD COMPUTERS, COMPUTER SOFTWARE FOR USE IN HOME ENTERTAINMENT AND TELECOMMUNICA-

TIONS APPLICATION DEVELOPMENTS, COMPUTER GAME PROGRAMS, COMPUTER GAME PROGRAMS FOR USE IN MOBILE DEVICES, COMPUTER GAME PROGRAMS EMBEDDED IN MOBILE DEVICES; CONSUMER GAMES APPARATUS FOR-ADOPTED FOR USE WITH AN EXTERNAL DISPLAY SCREEN OR MONITOR; ELECTRONIC CIRCUITS AND CD-ROMS RECORDED WITH PROGRAMS FOR HAND-HELD GAMES WITH LIQUID CRYSTAL DISPLAYS; ELECTRONIC CIRCUITS AND CD-ROMS RECORDED WITH AUTOMATIC PERFORMANCE PROGRAMS FOR ELECTRONIC MUSICAL INSTRUMENTS; DOWNLOADABLE MUSIC FILES; DOWNLOADABLE IMAGE FILES CONTAINING ARTWORK, TEXT, AUDIO, VIDEO, GAMES AND INTERNET WEB LINKS RELATING TO SPORTING AND CULTURAL ACTIVITIES; PRERECORDED VIDEO DISCS AND VIDEO TAPES FEATURING CINEMA MOVIES AND MOVIES WITH MUSIC; ELECTRONIC PUBLICATIONS, NAMELY, BOOKS AND MAGAZINES FEATURING CARTOONS, COMICS, GRAPHIC NOVELS AND GAMES RECORDED ON COMPUTER MEDIA (U.S. CLS. 21, 23, 26, 36 AND 38).

### CLASS 42—SCIENTIFIC AND COMPUTER SERVICES

FOR COMPUTER SOFTWARE DESIGN, COMPUTER PROGRAMMING, OR MAINTENANCE OF COMPUTER SOFTWARE INCLUDING WEBSITE DESIGN, CREATION, AND HOSTING SERVICES FOR OTHERS, DEVELOPMENT, DESIGN AND CONSULTANCY OF SOFTWARE USED TO ACCESS, OPERATE, AND COMMUNICATE WITH CELLULAR OR MOBILE PHONES FEATURING THE CAPACITY TO FUNCTION IN ANY NUMBER OF EXTRA WAYS BEYOND JUST AS A PHONE, NAMELY, TO FUNCTION AS A CAMERA, TO PERFORM INSTANT MESSAGING, TO CONDUCT MULTIMEDIA MESSAGING, TO ACCESS AND COMMUNICATE WITH E-MAIL, TO ACCESS AND COMMUNICATE WITH INTERNET, TO ACCESS AND COMMUNICATE WITH INTRANETS OR PRIVATE COMPUTER NETWORKS, TO ACCESS AND COMMUNICATE DATA, TO FUNCTION AS A RADIO, TO RECORD, PLAY, TRANSMIT, RECEIVE, AND/OR MANAGE MUSIC, TO RECORD, PLAY, TRANSMIT, RECEIVE, EDIT, AND/OR MANAGE AUDIO OR VOICE, TO RECORD, PLAY, TRANSMIT, RECEIVE, EDIT, AND/OR MANAGE VIDEO, TO CREATE, VIEW, TRANSMIT, RECEIVE, EDIT, AND/OR MANAGE PHOTOGRAPHS OR PICTURES, TO UPLOAD, VIEW, TRANSMIT, RECEIVE, EDIT, AND/OR MANAGE GRAPHICS OR IMAGES, TO PLAY ELECTRONIC GAMES, TO UPLOAD PHOTOGRAPHS AND TEXT ONTO ONLINE JOURNALS OR WEB LOGS ALSO KNOWN AS BLOGS, TO MANAGE A CALENDAR AND CONTACT INFORMATION AND OTHERWISE FUNCTION AS A PERSONAL DIGITAL ASSISTANT (PDA), TO FUNCTION AS WALKIE-TALKIES, TO EFFECTUATE MOBILE PRINTING, TO PERFORM SATELLITE NAVIGATION, TO VIEW ELECTRONIC CITY GUIDES, TO FUNCTION AS A REMOTE CONTROL FOR COMPUTERS AND RUN MULTIMEDIA PRESENTATIONS, AND/OR TO TRANSMIT VIDEO, SOUND, AND/OR DATA TO WEBSITE, COMPUTER PROGRAMMING FOR MOBILE ENTERTAINMENT, COMPUTER GAME PROGRAMMING, DEVELOPMENT, DESIGN AND UPDATING OF COMPUTER GAME PROGRAMS; RENTAL OF COMPUTER SOFTWARE AND HARDWARE; PROVIDING COMPUTER PROGRAMS INCLUDING PROVIDING USE OF ON-LINE, AND/OR NON-DOWNLOADABLE SOFTWARE, NAMELY, SOFTWARE USED TO ACCESS, OPERATE, AND COMMUNICATE WITH DIGITAL AUDIO, DIGITAL VIDEO, AND MP3 PLAYERS, SOFTWARE FOR PERSONAL INFORMATION MANAGEMENT, DATABASE MANAGEMENT SOFTWARE, CHARACTER RECOGNITION SOFTWARE, TELEPHONY MANAGEMENT SOFTWARE, ELECTRONIC MAIL AND MESSAGING SOFTWARE, PAGING SOFTWARE, DATABASE SYNCHRONIZATION SOFTWARE, COMPUTER SOFTWARE FOR ACCESSING, BROWSING AND SEARCHING ONLINE DATABASES, COMPUTER OPERATING SYSTEM SOFTWARE, SOFTWARE FOR THE REDIRECTION OF MESSAGES, E-MAIL, AND/OR OTHER DATA TO ONE OR MORE HANDHELD ELECTRONIC DEVICES, SOFTWARE FOR COMMUNICATIONS VIA LOCAL OR GLOBAL COMMUNICATIONS NETWORKS INCLUDING INTERNET, INTRANETS, EXTRANETS, TELEVISION, MOBILE COMMUNICATION,

CELLULAR, AND SATELLITE NETWORKS; TECHNICAL ADVICE RELATING TO THE OPERATION OF COMPUTERS; DESIGNING OF MACHINES, APPARATUS, INSTRUMENTS (INCLUDING THEIR PARTS) OR SYSTEMS COMPOSED OF SUCH MACHINES, APPARATUS AND INSTRUMENTS (U.S. CLS. 100 AND 101).

JOHN WILKE, EXAMINING ATTORNEY

#### CLASS 42—SCIENTIFIC AND COMPUTER SERVICES

FOR CONTRACT RESEARCH AND CONTRACT DEVELOPMENT, FOR OTHERS, IN PARTICULAR IN THE FIELDS OF MICRO-SYSTEMS ENGINEERING, MICRO-MECHANICS, SENSOR TECHNOLOGY, DOSING TECHNOLOGY, AUTOMATION ENGINEERING, FUNCTION AND RELIABILITY TESTING, WAFER TECHNOLOGY, MEDICAL TECHNOLOGY, TIME MEASURING TECHNOLOGY AND SOFTWARE; SCIENTIFIC RESEARCH AND CUSTOM DESIGN FOR OTHERS IN THE FIELD OF SEMICONDUCTORS, SEMICONDUCTOR SYSTEMS, SEMICONDUCTOR CELL LIBRARIES, WAFERS AND INTEGRATED CIRCUITS, SEMICONDUCTOR PACKAGES, SEMICONDUCTOR TESTING DEVICES, SEMICONDUCTOR HANDLING AND STORAGE DEVICES (U.S. CLS. 100 AND 101).

MATTHEW EINSTEIN, EXAMINING ATTORNEY

SN 79-086,932. IBG IMMOBILIEN UND BETEILIGUNGS GMBH, AUSTRIA, FILED 7-28-2010.

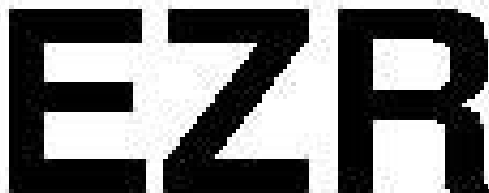

THE MARK CONSISTS OF STANDARD CHARACTERS WITHOUT CLAIM TO ANY PARTICULAR FONT, STYLE, SIZE, OR COLOR.

PRIORITY DATE OF 4-14-2010 IS CLAIMED.

OWNER OF INTERNATIONAL REGISTRATION 1049946 DATED 7-28-2010, EXPIRES 7-28-2020.

#### CLASS 7—MACHINERY

FOR MACHINES AND APPARATUS FOR THE PRODUCTION, ALIGNMENT, ADJUSTMENT, LINKING, COATING, DEVELOPMENT, CLEANING, PRINTING AND LITHOGRAPHIC TREATMENT, NAMELY, NANOSTRUCTURE IMPRINTING, HOT STAMPING, MICRO-CONTACT PRINTING, TESTING AND MANUFACTURING OF ELECTRONIC CIRCUITS OR SEMICONDUCTORS, TRANSISTORS OR WAFERS; STRUCTURAL PARTS AND EQUIPMENT FOR THE AFORESAID MACHINES AND APPARATUS, INCLUDED IN THIS CLASS; SEMICONDUCTOR WAFER PROCESSING MACHINES FOR PROCESSING SEMICONDUCTORS UNDER VACUUM; CONVEYORS FOR CONVEYING SEMICONDUCTORS; MACHINES FOR THE SURFACE TREATMENT OF SEMICONDUCTORS; MACHINES FOR ETCHING SEMICONDUCTOR SURFACES, MACHINES FOR VAPORISING SEMICONDUCTOR SURFACES IN PARTICULAR UNDER VACUUM (CVD PROCESSES); INSTALLATIONS FOR CONVEYING AND PROVIDING AND PROCESSING SEMICONDUCTORS, NAMELY, CONVEYORS AND SEMICONDUCTOR WAFER PROCESSING MACHINES; INSTALLATIONS FOR CONVEYING AND PROCESSING AND PROVIDING FLAT SCREENS, NAMELY, MACHINES FOR MANUFACTURING LCD- OR LED-SCREENS; MACHINES AND TURNKEY PRODUCTION INSTALLATIONS FOR MANUFACTURING SEMICONDUCTOR COMPONENTS FROM THE SEMICONDUCTOR BACKEND SECTOR INCLUDING LIGHT DIODES, NAMELY, MACHINES FOR MANUFACTURING SEMICONDUCTORS; MACHINES FOR SEMICONDUCTOR MANUFACTURING, MACHINES FOR CHIP MANUFACTURING AND CHIP ASSEMBLY (U.S. CLS. 13, 19, 21, 23, 31, 34 AND 35).

SN 79-087,014. WIN WIN PRECISION TECHNOLOGY CO., LTD., CHINA, FILED 5-5-2010.



THE MARK CONSISTS OF STANDARD CHARACTERS WITHOUT CLAIM TO ANY PARTICULAR FONT, STYLE, SIZE, OR COLOR.

PRIORITY DATE OF 12-22-2009 IS CLAIMED.

OWNER OF INTERNATIONAL REGISTRATION 1050191 DATED 5-5-2010, EXPIRES 5-5-2020.

THE WORDING "WINAICO" HAS NO MEANING IN A FOREIGN LANGUAGE.

#### CLASS 6—METAL GOODS

FOR COMMON METALS AND THEIR ALLOYS; METAL BUILDING MATERIALS, NAMELY, METAL BUILDING FLASHING, SOFFITS, FASCIA; TRANSPORTABLE BUILDINGS OF METAL; MATERIALS OF METAL NOT INCLUDED IN OTHER CLASSES, NAMELY, MATERIALS OF METAL FOR SCAFFOLDS, STEEL PLATES AND SHEETS; NON-ELECTRIC CABLES AND WIRES OF COMMON METAL; NON-ELECTRIC CONNECTING MEANS, NOT INCLUDED IN OTHER CLASSES, NAMELY, METAL CONNECTORS FOR PHOTOVOLTAIC SYSTEMS; AND FASTENING MATERIALS MADE OUT OF METAL, NAMELY, CLAMPS, BOLTS, NAILS AND RIVETS, ALL FOR THE MOUNTING OF PHOTOVOLTAIC SYSTEMS (U.S. CLS. 2, 12, 13, 14, 23, 25 AND 50).

**CLASS 9—ELECTRICAL AND SCIENTIFIC APPARATUS**

FOR SCIENTIFIC, NAUTICAL, SURVEYING, PHOTOGRAPHIC, CINEMATOGRAPHIC, OPTICAL, WEIGHING, MEASURING, SIGNALING, CHECKING, SUPERVISION, LIFE-SAVING AND TEACHING APPARATUS AND INSTRUMENTS, NAMELY, MICROSCOPES AND CAMERAS; APPARATUS AND INSTRUMENTS FOR CONDUCTING, SWITCHING, TRANSFORMING, ACCUMULATING, REGULATING OR CONTROLLING ELECTRICITY, NAMELY, ELECTRICAL CONTROLLERS; SOLAR COLLECTORS FOR POWER GENERATION; SOLAR MODULES FOR POWER GENERATION; SOLAR BATTERIES; DEVICES FOR THE CONVERSION OF SOLAR RADIATION INTO ELECTRICAL ENERGY, NAMELY, PHOTOVOLTAIC SOLAR MODULES; SOLAR CELL SYSTEMS COMPRISING SOLAR CELLS FOR SOLAR POWER SYSTEMS; SOLAR CELLS; SOLAR PANELS FOR PRODUCTION OF ELECTRICITY; ELECTRONIC CONTROLS FOR SOLAR POWER SYSTEMS; PHOTOVOLTAIC CELLS AND MODULES; PHOTOVOLTAIC SYSTEMS, CONSISTING OF SOLAR CELLS AND ELECTRICAL CONNECTIONS AS WELL AS ELECTRICAL INSTRUMENTS FOR THE CONTROL AND/OR MODIFICATION OF THE ELECTRICAL POWER; ELECTRIC TERMINALS; DATA PROCESSORS AND COMPUTERS; ELECTRICAL SENSORS (U.S. CLS. 21, 23, 26, 36 AND 38).

**CLASS 11—ENVIRONMENTAL CONTROL APPARATUS**

FOR SOLAR COLLECTORS FOR HEATING; SOLAR MODULES FOR HEAT GENERATION; SOLAR STOVES; LIGHTING DEVICES FOR SHOWCASES, LIGHTING DEVICES FOR THEATRICAL PRODUCTIONS; LIGHT FIXTURES; STREET LIGHTS; FLOOR LAMPS; LED (LIGHT EMITTING DIODE) LIGHTING SYSTEMS, NAMELY, LED (LIGHT EMITTING DIODE) MODULES, POWER SUPPLIES AND WIRING; STREET LIGHTS EQUIPPED WITH LEDS (LIGHT EMITTING DIODES); LED (LIGHT EMITTING DIODE) LIGHTING FIXTURES; VEHICLE LIGHTING, NAMELY, HEADLIGHTS, FOG LAMPS, REAR LIGHTS AND BRAKE LIGHTS FOR VEHICLES; DEVICES FOR HEATING, STEAM GENERATION, COOKING, COOLING, DRYING, VENTILATING AND FOR WATER PIPES AS WELL AS SANITARY FACILITIES, NAMELY, FURNACES, AIR CONDITIONERS (U.S. CLS. 13, 21, 23, 31 AND 34).

**CLASS 35—ADVERTISING AND BUSINESS**

FOR PROCURING OF CONTRACTS FOR OTHERS WITH POWER PROVIDERS; PROVISION OF COMMERCIAL INFORMATION AND BUSINESS AND COMMERCIAL CONSULTING FOR CONSUMERS IN COMMERCIAL MATTERS; BUSINESS MANAGEMENT CONSULTANCY; BUSINESS ORGANIZATIONAL COUNSELING; ORGANIZATION OF EXPOSITIONS AND TRADE FAIRS FOR COMMERCIAL AND ADVERTISING PURPOSES; PROCURING CONTRACTS FOR THIRD PARTIES CONCERNING THE PROVISION OF ENERGY PRODUCTION SERVICES (U.S. CLS. 100, 101 AND 102).

**CLASS 37—CONSTRUCTION AND REPAIR**

FOR BUILDING CONSTRUCTION; INSTALLATION OF SOLAR POWER SYSTEMS; INSTALLATION AND REPAIR OF RAILS, NAMELY, CHAIR RAILS AND RAILROAD TRACKS; INSTALLATION AND REPAIR OF ELECTRICAL DEVICES, OVENS, HEATING, AIR CONDITIONING SYSTEMS, MACHINES; INSTALLATION, MAINTENANCE AND REPAIR OF SOLAR PLANTS (U.S. CLS. 100, 103 AND 106).

**CLASS 39—TRANSPORTATION AND STORAGE**

FOR DISTRIBUTION AND TRANSMISSION OF ELECTRICITY; HEAT SUPPLYING; GAS SUPPLYING; WATER SUPPLYING; CONSUMER SUPPLY BY DELIVERY OF ELECTRICAL POWER, THERMAL HEAT, GAS OR WATER; DISTRIBUTION OF POWER IN THE NATURE OF ELECTRICITY (U.S. CLS. 100 AND 105).

**CLASS 40—MATERIAL TREATMENT**

FOR GENERATION OF POWER; MATERIAL PROCESSING, NAMELY, OBTAINING METALS FROM NATIVE EARTH MATERIALS; GENERATION OF THERMAL HEAT, POWER GENERATION; RENTING OF ELECTRICAL POWER GENERATORS; RENTING OF AIR CONDITIONING DEVICES; RENTING OF SPACE HEATING DEVICES (U.S. CLS. 100, 103 AND 106).

**CLASS 42—SCIENTIFIC AND COMPUTER SERVICES**

FOR SCIENTIFIC AND TECHNOLOGICAL SERVICES AND RESEARCH AND DESIGN RELATING THERETO, NAMELY, RESEARCH AND DEVELOPMENT OF TECHNOLOGY IN THE FIELD OF SOLAR TECHNOLOGY, SCIENTIFIC RESEARCH AND DEVELOPMENT, DESIGN AND TESTING OF NEW PRODUCTS FOR OTHERS; INDUSTRIAL ANALYSIS AND RESEARCH SERVICES, NAMELY, INDUSTRIAL RESEARCH IN THE FIELD OF SOLAR TECHNOLOGY; DESIGN AND DEVELOPMENT OF COMPUTER HARDWARE AND SOFTWARE; COUNSELING IN THE SUBJECT MATTER OF ENERGY SAVINGS, NAMELY, CONSULTING SERVICES IN THE FIELD OF ENERGY MEASUREMENT TO IMPROVE ENERGY EFFICIENCY; IMPLEMENTATION OF TECHNICAL CONTROLS, NAMELY, TECHNICAL ADVICE RELATING TO THE GENERATION OF SOLAR POWER; IMPLEMENTATION OF SCIENTIFIC INVESTIGATIONS, NAMELY, SCIENTIFIC RESEARCH; RESEARCH IN THE FIELD OF SOLAR POWER AND ELECTRICITY GENERATION TECHNOLOGY; IMPLEMENTATION OF TECHNICAL REAL CONTROL, NAMELY, TECHNICAL ADVICE RELATING TO THE GENERATION OF SOLAR POWER; QUALITY CONTROL FOR OTHERS; ENVIRONMENTAL IMPACT ASSESSMENT, NAMELY, ENVIRONMENTAL TESTING AND INSPECTION SERVICES (U.S. CLS. 100 AND 101).

JAMES MACFARLANE, EXAMINING ATTORNEY

SN 79-087,034. TRI-ON GMBH, AUSTRIA, FILED 7-29-2010.



PRIORITY DATE OF 1-29-2010 IS CLAIMED.  
OWNER OF INTERNATIONAL REGISTRATION 1050268  
DATED 7-29-2010, EXPIRES 7-29-2020.

THE MARK CONSISTS OF THE DESIGN ELEMENT OF A SQUARE WITH ROUNDED CORNERS, SERVING AS A CARRIER; A TRIANGLE DESIGN, CANTED AT AN ANGLE IS PLACED IN THE SQUARE. TO THE RIGHT OF THE DESIGN ELEMENT, THE WORD "TRI" APPEARS OVER A SOLID HORIZONTAL LINE, THE WORD "ON" APPEARS BELOW THIS LINE.

**CLASS 6—METAL GOODS**

FOR METAL ADVERTISING HOARDING SIGNS FITTED WITH SEATS (U.S. CLS. 2, 12, 13, 14, 23, 25 AND 50).



**CLASS 20—FURNITURE AND ARTICLES NOT OTHERWISE CLASSIFIED**

FOR FOLDING CHAIRS WITH ADVERTISING ON THE UNDERSIDE AND/OR UPPER SIDE OF THE CHAIR; SEATS OF METAL (U.S. CLS. 2, 13, 22, 25, 32 AND 50).

HENRY S. ZAK, EXAMINING ATTORNEY

SN 79-087,060. PALADINI S.R.L., ITALY, FILED 6-17-2010.



OWNER OF INTERNATIONAL REGISTRATION 1050347 DATED 6-17-2010, EXPIRES 6-17-2020.

NO CLAIM IS MADE TO THE EXCLUSIVE RIGHT TO USE "CAFFE", APART FROM THE MARK AS SHOWN.

THE COLOR(S) ORANGE AND WHITE IS/ARE CLAIMED AS A FEATURE OF THE MARK.

THE MARK CONSIST OF THE COMPOSITION, ON AN ORANGE BACKGROUND, FORMED BY THE WORD "MOKARICO" IN THICK BIG CAPITAL LETTERS - IN WHITE - SURMOUNTED IN ITS TERMINAL PART BY THE WORD "CAFFE" IN WHITE THIN SMALL CAPITAL LETTERS, AND BY A DRAWING FORMED BY TWO CURVILINEAR LINES OF DIFFERENT LENGTH WHICH SKETCH THE HEAD OF A PERSON AND BY THREE CURVILINEAR LINES SUITABLY ARRANGED TO SKETCH A WIDE-BRIMMED HAT, ALL THESE LINES BEING OF WHITE COLOR.

THE ENGLISH TRANSLATION OF "CAFFE" IN THE MARK IS "COFFEE". THE WORDING "MOKARICO" HAS NO MEANING IN A FOREIGN LANGUAGE.

**CLASS 30—STAPLE FOODS**

FOR COFFEE (U.S. CL. 46).

**CLASS 43—HOTEL AND RESTAURANT SERVICES**

FOR BAR SERVICES AND SERVICES FOR PROVIDING FOOD AND DRINK (U.S. CLS. 100 AND 101).

RICHARD WHITE, EXAMINING ATTORNEY

SN 79-087,113. HOERBIGER KOMPRESSORTECHNIK HOLDING GMBH, AUSTRIA, FILED 7-22-2010.

# RECIPCOM

THE MARK CONSISTS OF STANDARD CHARACTERS WITHOUT CLAIM TO ANY PARTICULAR FONT, STYLE, SIZE, OR COLOR.

PRIORITY DATE OF 2-10-2010 IS CLAIMED.

OWNER OF INTERNATIONAL REGISTRATION 1050479 DATED 7-22-2010, EXPIRES 7-22-2020.

**CLASS 9—ELECTRICAL AND SCIENTIFIC APPARATUS**

FOR ELECTRICAL AND ELECTRONIC APPARATUS, EQUIPMENT AND INSTRUMENTS FOR CONTROLLING, MONITORING AND DIAGNOSIS OF COMPRESSORS, NAMELY, ELECTRICAL CONTROLLERS, COMPUTERS; ANALOG, DIGITAL, ELECTRICAL AND ELECTRONIC OPERATING, ACTIVATING, DIAGNOSING AND CONNECTING APPARATUS AND INSTRUMENTS, NAMELY, ELECTRICAL CONTROL SYSTEMS FOR MACHINES; ELECTRIC ACTUATORS; ELECTRIC CONNECTORS; COMMUNICATION NETWORKS COMPRISING COMMUNICATION BUSES, DATA ACQUISITION MODULES, COMPUTER SERVER, COMPUTER NETWORK BRIDGES, ADAPTERS AND HUBS, ACTUATORS, COMMUNICATION NETWORK INTERFACES; ELECTRICAL AND ELECTRONIC SENSORS; COMPUTER SOFTWARE FOR CONTROLLING, MONITORING AND DIAGNOSIS OF COMPRESSORS (U.S. CLS. 21, 23, 26, 36 AND 38).

**CLASS 37—CONSTRUCTION AND REPAIR**

FOR REPAIR, IN PARTICULAR MAINTENANCE, SERVICING AND REPAIR OF COMPRESSORS AND COMPONENTS THEREFOR, INCLUDING VALVES AND REGULATING DEVICES FOR COMPRESSORS (U.S. CLS. 100, 103 AND 106).

**CLASS 42—SCIENTIFIC AND COMPUTER SERVICES**

FOR COMPUTER BASED SYSTEM ANALYSIS AND MAINTENANCE ASSESSMENT IN THE FIELD OF COMPRESSORS AND COMPRESSOR INSTALLATIONS, INCLUDING EQUIPMENT TO CONTROL, MONITORING, AND DIAGNOSIS OF COMPRESSORS AND COMPRESSORS INSTALLATIONS (U.S. CLS. 100 AND 101).

JOSETTE BEVERLY, EXAMINING ATTORNEY

SN 79-087,285. CRAZY INVEST SA, BELGIUM, FILED 8-5-2010.

# LE CRAZY

THE MARK CONSISTS OF STANDARD CHARACTERS WITHOUT CLAIM TO ANY PARTICULAR FONT, STYLE, SIZE, OR COLOR.

PRIORITY DATE OF 2-8-2010 IS CLAIMED.

OWNER OF INTERNATIONAL REGISTRATION 1050904 DATED 8-5-2010, EXPIRES 8-5-2020.

THE ENGLISH TRANSLATION OF "LE" IN THE MARK IS "THE".

**CLASS 3—COSMETICS AND CLEANING PREPARATIONS**

FOR SOAP; PERFUMERY, ESSENTIAL OILS, COSMETICS, HAIR LOTIONS (U.S. CLS. 1, 4, 6, 50, 51 AND 52).

**CLASS 14—JEWELRY**

FOR PRECIOUS METALS AND THEIR ALLOYS AND GOODS MADE OF OR COATED WITH THESE MATERIALS, NAMELY, NECKLACES; JEWELRY; PRECIOUS STONES; TIMEPIECES AND CHRONOMETRIC INSTRUMENTS (U.S. CLS. 2, 27, 28 AND 50).

**CLASS 18—LEATHER GOODS**

FOR LEATHER AND IMITATIONS OF LEATHER, AND GOODS MADE OF THESE MATERIALS, NAMELY, WALLETS; ANIMAL SKINS; TRUNKS AND TRAVELING BAGS; UMBRELLAS, PARASOLS (U.S. CLS. 1, 2, 3, 22 AND 41).

**CLASS 25—CLOTHING**

FOR CLOTHING, NAMELY, PANTS, SHIRTS, SKIRTS, BRAS, UNDERPANTS, CORSETS, BODY SUITS, UNDERWEAR; FOOTWEAR; HEADGEAR, NAMELY, HATS (U.S. CLS. 22 AND 39).

**CLASS 41—EDUCATION AND ENTERTAINMENT**

FOR ENTERTAINMENT, NAMELY, ENTERTAINMENT IN THE NATURE OF DANCE PERFORMANCES; CULTURAL ACTIVITIES, NAMELY, CULTURAL SHOWS; SHOW AND FILM PRODUCTION; ORGANIZATION OF EXHIBITIONS FOR CULTURAL OR EDUCATIONAL PURPOSES; BOOKING OF SEATS FOR SHOWS; IMPRESARIO SERVICES, NAMELY, ORGANIZATION OF THEATRICAL SHOWS; ENTERTAINER SERVICES, NAMELY, LIVE APPEARANCES BY A PROFESSIONAL ENTERTAINER; MODELING FOR ARTISTS (U.S. CLS. 100, 101 AND 107).

FLORENTINA BLANDU, EXAMINING ATTORNEY

SN 79-087,352. TENUTA MONTECATONE DI BENEDETTI GIULIANA & C., ITALY, FILED 6-24-2010.

# COSTA DI ROSE

THE MARK CONSISTS OF STANDARD CHARACTERS WITHOUT CLAIM TO ANY PARTICULAR FONT, STYLE, SIZE, OR COLOR.

PRIORITY DATE OF 6-8-2010 IS CLAIMED.

OWNER OF INTERNATIONAL REGISTRATION 1051066 DATED 6-24-2010, EXPIRES 6-24-2020.

THE ENGLISH TRANSLATION OF "COSTA DI ROSE" IN THE MARK IS "COAST OF ROSES".

**CLASS 32—LIGHT BEVERAGES**

FOR BEER; FRUIT DRINKS; FRUIT NECTARS; MINERAL AND AERATED WATERS; MIXED FRUIT JUICE; NON-ALCOHOLIC BEER; NON-ALCOHOLIC FRUIT JUICE BEVERAGES; SYRUPS FOR MAKING BEVERAGES (U.S. CLS. 45, 46 AND 48).

**CLASS 33—WINES AND SPIRITS**

FOR ALCOHOLIC FRUIT BEVERAGES; DISTILLED SPIRITS; GRAPPAS; SCHNAPPS; WINES AND SPARKLING WINES (U.S. CLS. 47 AND 49).

EVELYN BRADLEY, EXAMINING ATTORNEY

SN 79-087,389. DIETER DALLMEIER, FED REP GERMANY, FILED 2-12-2010.

# davidiT

THE MARK CONSISTS OF STANDARD CHARACTERS WITHOUT CLAIM TO ANY PARTICULAR FONT, STYLE, SIZE, OR COLOR.

PRIORITY DATE OF 9-23-2009 IS CLAIMED.

OWNER OF INTERNATIONAL REGISTRATION 1051212 DATED 2-12-2010, EXPIRES 2-12-2020.

**CLASS 9—ELECTRICAL AND SCIENTIFIC APPARATUS**

FOR ELECTRIC AND ELECTRONIC APPARATUS FOR THE TRANSMISSION OF INFORMATION, DATA AND IMAGES, NAMELY, COMPUTER HARDWARE; ELECTRIC AND ELECTRONIC APPARATUS FOR COMPUTER AND CONTROL ENGINEERING, NAMELY, A VIDEO MONITORING SYSTEM COMPRISED OF SIGNAL PICKUPS, EVENT RECORDERS AND DIGITAL SIGNAL PROCESSORS AND ELECTRONIC CONTROL PANELS; APPARATUS FOR RECORDING AND REPRODUCING DATA, SOUND AND IMAGES, NAMELY, VIDEO CAMERAS, VIDEO MONITORS, VIDEO RECORDERS; CAMERAS FOR BOTH MOVING IMAGES AND STILL IMAGES, NAMELY, VIDEO CAMERAS, ELECTRONIC CAMERAS, DIGITAL CAMERAS, MOVIE CAMERAS AND PHOTOGRAPHIC CAMERAS; THEFT, ROBBERY, VANDALISM, FIRE AND CHEMICAL DISASTER ALARM DEVICES AND INSTALLATIONS FOR OBJECT PROTECTION, IN PARTICULAR FOR BUILDINGS AND VEHICLES, EXCLUDING VEHICLE ANTI-THEFT ALARMS, NAMELY, SECURITY AND FIRE ALARMS; ELECTRIC SURVEILLANCE DEVICES FOR OBJECT PROTECTION, NAMELY, VIDEO RECORDER, OPTICAL SCANNER FOR IMAGE PROCESSING AND IMAGE RECOGNITION AND IMAGE EVALUATION, VIDEO CAMERAS; ELECTRIC AND ELECTRONIC LOCKS FOR BUILDINGS; COMPUTERS, PERSONAL COMPUTERS, PRINTERS, SCANNERS, VIDEO SCREENS, COMPUTER HARD DISK DRIVES, DRIVES FOR DATA CARRIERS, NAMELY, CD DRIVES FOR COMPUTERS, CD-ROM WRITERS, COMPUTER DISK DRIVES, KEYBOARDS, COMPUTER MOUSE, COMPUTER CARDS, NAMELY, GRAPHICS CARDS; INTERFACE CARDS FOR DATA PROCESSING EQUIPMENT IN THE FORM OF PRINTED CIRCUITS, MEMORY CARDS, MODEMS; COMPUTER SOFTWARE, NAMELY, COMPUTER PROGRAMS STORED ON DATA CARRIERS FOR CONTROLLING AND MONITORING ALARM AND SURVEILLANCE APPARATUS AND INSTALLATIONS; COMPUTER SOFTWARE DEVELOPMENT TOOLS; DATA COMMUNICATIONS SOFTWARE FOR ELECTRONIC EXCHANGE OF DATA BETWEEN COMPUTERS, COMPUTER SYSTEMS AND INTERNET OR INTRANET NETWORK INTERFACES (U.S. CLS. 21, 23, 26, 36 AND 38).

**CLASS 41—EDUCATION AND ENTERTAINMENT**

FOR TRAINING IN THE FIELD OF SURVEILLANCE AND SECURITY TECHNOLOGY; EDUCATIONAL SERVICES RENDERED THROUGH CORRESPONDENCE COURSES IN THE FIELD OF SURVEILLANCE AND SECURITY TECHNOLOGY; ORGANIZATION OF WORKSHOPS IN THE FIELD OF SURVEILLANCE AND SECURITY TECHNOLOGY, TRAINING SERVICES IN THE FIELDS OF SURVEILLANCE AND SECURITY TECHNOLOGY FOR PURPOSES OF PERSONNEL DEVELOPMENT (U.S. CLS. 100, 101 AND 107).

**CLASS 42—SCIENTIFIC AND COMPUTER SERVICES**

FOR SERVICES OF AN ELECTRONIC DATA PROCESSING PROGRAMMER, NAMELY, CREATION, MAINTENANCE, REPAIR AND UPDATING OF DATA PROCESSING COMPUTER PROGRAMS FOR ALARM, LOCKING AND SURVEILLANCE SYSTEMS FOR BUILDINGS AND VEHICLES; COMPUTER HARDWARE AND SOFTWARE CONSULTATION IN THE FIELD OF ELECTRONIC DATA PROCESSING; INSTALLATION OF COMPUTER PROGRAMS; CONFIGURATION OF COMPUTER NETWORKS BY MEANS OF SOFTWARE, NAMELY, COMPUTER MANAGEMENT SOFTWARE FOR CONVERGING VARIOUS DATA ON ONE COMPUTER; IMPLEMENTATION OF ELECTRONIC DATA PROCESSING PROGRAMS IN NETWORKS, DESIGN OF COMPUTER ANIMATION FOR OTHERS; DATA CONVERSION OF COMPUTER PROGRAMS AND DATA, NOT PHYSICAL CONVERSION; SOFTWARE LICENSING (U.S. CLS. 100 AND 101).

ROBERT STRUCK, EXAMINING ATTORNEY

SN 79-087,430. APU JOINT STOCK COMPANY, MONGOLIA,  
FILED 7-21-2010.



OWNER OF INTERNATIONAL REGISTRATION 1051329  
DATED 7-21-2010, EXPIRES 7-21-2020.

THE COLOR(S) BLUE, RED, SILVER AND WHITE IS/ARE  
CLAIMED AS A FEATURE OF THE MARK.

THE MARK CONSISTS OF THE FOLLOWING: A WHITE  
STYLIZED IMAGE OF THE TOP PORTION OF A MONGOLIAN  
HORSE FIDDLE OR MORIN KHUUR WITHIN A RED  
SQUARE WITH IRREGULAR SIDES, BORDERED BY A  
WHITE SQUARE, A SILVER SQUARE AND A BLUE OUTER  
SQUARE.

#### CLASS 29—MEATS AND PROCESSED FOODS

FOR MILK, DAIRY PRODUCTS EXCLUDING ICE  
CREAM, ICE MILK AND FROZEN YOGURT (U.S. CL.  
46).

#### CLASS 32—LIGHT BEVERAGES

FOR FRUIT JUICE; BEER; BEVERAGES, NAMELY,  
FRUIT-BASED BEVERAGES, SOFT DRINKS, NAMELY,  
SODAS, FRUIT-FLAVOURED BEVERAGES, NON-AL-  
COHOLIC BEVERAGES CONTAINING FRUIT JUICES,  
NON-ALCOHOLIC BEVERAGES WITH TEA FLAVOR,  
NON-ALCOHOLIC FRUIT JUICE BEVERAGES, NON-  
ALCOHOLIC MALT BEVERAGES, FROZEN CARBO-  
NATED BEVERAGES, NON-ALCOHOLIC RICE-BASED  
BEVERAGES NOT BEING MILK SUBSTITUTES, VEGE-  
TABLE JUICES, WATER BEVERAGES, BOTTLED  
DRINKING WATER (U.S. CLS. 45, 46 AND 48).

#### CLASS 33—WINES AND SPIRITS

FOR VODKA AND OTHER ALCOHOLIC BEVERAGES,  
EXCLUDING BEER (U.S. CLS. 47 AND 49).  
HENRY S. ZAK, EXAMINING ATTORNEY

SN 79-087,585. MAGE, FRANCE, FILED 7-6-2010.

**PIERRE CORTHAY**

THE MARK CONSISTS OF STANDARD CHARACTERS  
WITHOUT CLAIM TO ANY PARTICULAR FONT, STYLE,  
SIZE, OR COLOR.

OWNER OF INTERNATIONAL REGISTRATION 1051787  
DATED 7-6-2010, EXPIRES 7-6-2020.

OWNER OF U.S. REG. NO. 3,021,184.

THE NAME(S), PORTRAIT(S), AND/OR SIGNATURE(S)  
SHOWN IN THE MARK IDENTIFIES "PIERRE CORTHAY",  
WHOSE CONSENT(S) TO REGISTER IS MADE OF RE-  
CORD.

#### CLASS 3—COSMETICS AND CLEANING PRE- PARATIONS

FOR TOILET SOAPS; PERFUMES; TOILET WATER  
AND EAU-DE-COLOGNE; ESSENTIAL OILS FOR PER-  
SONAL USE; FACE MILKS AND LOTIONS, SKIN  
CREAMS AND LOTIONS, FACE AND BODY EMUL-  
SIONS; MAKE-UP REMOVING PREPARATIONS IN THE  
FORM OF LOTIONS, MILKS, CREAMS, GELS; NON-  
MEDICATED BATH SALTS, CREAMS, GELS, AND OILS;  
TALCUM POWDER FOR TOILET USE, DEODORANTS  
FOR PERSONAL USE; PRE-SHAVING LOTIONS,  
AFTER-SHAVE LOTIONS; SHAVING CREAMS, GELS  
AND MOUSSES; NON-MEDICATED HAIR CARE PRE-  
PARATIONS, NAMELY, SPRAYS, GELS, CREAMS AND  
BALMS; HAIR MOUSSES AND SHAMPOOS; LEATHER  
POLISHING, PRESERVING, AND POLISHING PRE-  
PARATIONS IN THE NATURE OF SOAPS, LOTIONS,  
OILS, CREAMS AND GELS; LEATHER PERFUMING  
PREPARATIONS IN THE NATURE OF SOAPS, OILS,  
LOTIONS, CREAMS AND GELS; EAU DE PARFUM AND  
SCENTED WATER FOR PERFUMING LEATHER; POL-  
ISH AND PERFUMED CREAMS FOR LEATHER (U.S.  
CLS. 1, 4, 6, 50, 51 AND 52).

#### CLASS 18—LEATHER GOODS

FOR LEATHER AND IMITATIONS OF LEATHER,  
ANIMAL SKINS; TRUNKS AND TRAVELLING BAGS;  
BAGS, NAMELY, HANDBAGS, TRAVELLING BAGS,  
RUCKSACKS, BEACH BAGS, WHEELED SHOPPING  
BAGS, SCHOOL BAGS; POCKET WALLETS, PURSES,  
CARD CASES, KEY RING CASES, UMBRELLAS, PARA-  
SOLS AND WALKING STICKS; WHIPS, HARNESS AND  
SADDLERY (U.S. CLS. 1, 2, 3, 22 AND 41).

#### CLASS 25—CLOTHING

FOR FOOTWEAR, BOOTS, HALF-BOOTS, ESPARTO  
SHOES OR SANDALS, SLIPPERS, SANDALS AND  
PUMPS (U.S. CLS. 22 AND 39).

ELI HELLMAN, EXAMINING ATTORNEY

SN 79-087,847. FRAUNHOFER-GESELLSCHAFT ZUR FÖR-  
DERUNG DER ANGEWANDTEN FORSCHUNG E.V.,  
FED REP GERMANY, FILED 7-29-2010.

**EDDYcus**

THE MARK CONSISTS OF STANDARD CHARACTERS  
WITHOUT CLAIM TO ANY PARTICULAR FONT, STYLE,  
SIZE, OR COLOR.

PRIORITY DATE OF 2-20-2010 IS CLAIMED.

OWNER OF INTERNATIONAL REGISTRATION 1052486  
DATED 7-29-2010, EXPIRES 7-29-2020.

**CLASS 9—ELECTRICAL AND SCIENTIFIC APPARATUS**

FOR SCIENTIFIC, NAUTICAL-, SURVEYING-, PHOTOGRAPHIC, CINEMATOGRAPHIC, OPTICAL, WEIGHING, MEASURING, SIGNALLING, CHECKING (SUPERVISION) LIVE-SAVING AND TEACHING APPARATUS AND INSTRUMENTS, NAMELY, SURVEYING MACHINES, OPTICAL INSPECTION APPARATUS FOR INDUSTRIAL USE, ULTRASONIC SENSORS, ULTRASONIC INSPECTION APPARATUS FOR INDUSTRIAL USE, PRESSURE SENSORS, TEMPERATURE SENSORS, PROXIMITY SENSORS, PHOTOELECTRIC SENSORS, SENSOR CHIPS FOR SCIENTIFIC USE, ELECTRICAL EDDY CURRENT TEST EQUIPMENT, INSTRUMENTS FOR DETECTING AND MEASURING TWO- AND THREE-DIMENSIONAL DISTRIBUTION OF FORCE; APPARATUS AND INSTRUMENTS FOR CONVEYING, DISTRIBUTING, TRANSFORMING, STORING, REGULATING OR CONTROLLING ELECTRIC CURRENT; APPARATUS FOR RECORDING, TRANSMISSION OR REPRODUCTION OF SOUND OR IMAGES; MATERIAL TESTING INSTRUMENTS AND MACHINES, NAMELY, ELECTRONIC APPARATUS FOR TESTING COMPRESSION, STRENGTH, HARDNESS AND TENSILE CHARACTERISTICS OF INDUSTRIAL MATERIALS, ULTRASOUND INSPECTION DEVICES FOR NON-MEDICAL NON-DESTRUCTIVE TESTING; DATA PROCESSING EQUIPMENT AND COMPUTERS; COMPUTER OPERATING PROGRAMS, RECORDED; COMPUTER PROGRAMS FOR CONTROLLING ULTRASOUND INSPECTION APPARATUS FOR INDUSTRIAL USE; DOWNLOADABLE ELECTRONIC PUBLICATIONS IN THE NATURE OF BOOKS, MAGAZINES, BROCHURES, NEWSLETTERS, AND MANUALS IN THE FIELD OF NON-DESTRUCTIVE TESTING; COMPACT DISCS FEATURING COMPUTER PROGRAMS FOR CONTROLLING ULTRASOUND INSPECTION APPARATUS FOR INDUSTRIAL USE; INTERFACES FOR COMPUTERS (U.S. CLS. 21, 23, 26, 36 AND 38).

**CLASS 37—CONSTRUCTION AND REPAIR**

FOR INSTALLATION SERVICES, NAMELY, INSTALLATION OF ELECTRICAL SYSTEMS AND OF ULTRASOUND INSPECTION DEVICES FOR NON-MEDICAL NON-DESTRUCTIVE TESTING; MACHINERY INSTALLATION, MAINTENANCE AND REPAIR; PIPELINE MAINTENANCE AND REPAIR; MAINTENANCE AND REPAIR OF VEHICLES AND OF APPARATUS FOR LOCOMOTION BY LAND, AIR OR WATER; INSTALLATION, MAINTENANCE AND REPAIR OF COMPUTER HARDWARE; CONSTRUCTION AND MAINTENANCE OF OIL PIPELINE, GAS PIPELINE AND WATER PIPE (U.S. CLS. 100, 103 AND 106).

**CLASS 42—SCIENTIFIC AND COMPUTER SERVICES**

FOR SCIENTIFIC AND TECHNOLOGICAL SERVICES AND RESEARCH AND DESIGN SERVICES RELATING THERETO, NAMELY, SCIENTIFIC RESEARCH AND DEVELOPMENT, INDUSTRIAL DESIGN SERVICES, DESIGN OF OPTICAL, MECHANICAL, ACOUSTICAL, ELECTRICAL, ELECTROMECHANICAL AND OPTOELECTRONIC APPARATUS AND INSTRUMENTS; INDUSTRIAL RESEARCH IN THE FIELD OF PHYSICS, WELDING, NON-DESTRUCTIVE TESTING, ENGINEERING, AND COMPUTER HARDWARE SYSTEMS; SCIENTIFIC AND TECHNICAL CONSULTANCY, NAMELY, SCIENTIFIC CONSULTATION IN THE FIELD OF NON-DESTRUCTIVE TESTING; SURVEYING; MATERIAL TESTING; QUALITY CONTROL FOR OTHERS; RESEARCH AND DEVELOPMENT FOR NEW PRODUCTS FOR OTHERS; ENGINEERING; RESEARCH IN THE FIELD OF PHYSICS; COMPUTER PROGRAMMING; DESIGN AND DEVELOPMENT OF COMPUTER HARDWARE AND SOFTWARE; MAINTENANCE AND INSTALLATION OF COMPUTER SOFTWARE (U.S. CLS. 100 AND 101).

JANICE KIM, EXAMINING ATTORNEY

SN 79-088,072. CEVA SANTE ANIMALE, F-33500 LIBOURNE, FRANCE, FILED 9-21-2010.

# ADAPTIL

THE MARK CONSISTS OF STANDARD CHARACTERS WITHOUT CLAIM TO ANY PARTICULAR FONT, STYLE, SIZE, OR COLOR.

PRIORITY DATE OF 8-19-2010 IS CLAIMED.

OWNER OF INTERNATIONAL REGISTRATION 1053082 DATED 9-21-2010, EXPIRES 9-21-2020.

**CLASS 5—PHARMACEUTICALS**

FOR PHEROMONES FOR PETS FOR VETERINARY USE (U.S. CLS. 6, 18, 44, 46, 51 AND 52).

**CLASS 18—LEATHER GOODS**

FOR COLLARS FOR PETS (U.S. CLS. 1, 2, 3, 22 AND 41).

MAUREEN DALL, EXAMINING ATTORNEY

SN 79-088,224. SCHULZ GROUP GMBH, FED REP GERMANY, FILED 8-18-2010.

# Lang Tube-Tec

THE MARK CONSISTS OF STANDARD CHARACTERS WITHOUT CLAIM TO ANY PARTICULAR FONT, STYLE, SIZE, OR COLOR.

OWNER OF INTERNATIONAL REGISTRATION 1053546 DATED 8-18-2010, EXPIRES 8-18-2020.

**CLASS 7—MACHINERY**

FOR MACHINES FOR METAL PROCESSING AND MACHINING AND METAL WORKING, IN PARTICULAR METAL WORKING MACHINES AND MACHINING CENTERS FOR MACHINING AND PROCESSING OF TUBES AS WELL AS PARTS THEREOF; TOOLS AS MACHINE COMPONENTS, NAMELY, MACHINE TOOLS FOR THE CUTTING AND FORMING OF MATERIALS FOR AUTOMATED TUBE PROCESSING MACHINES (U.S. CLS. 13, 19, 21, 23, 31, 34 AND 35).

**CLASS 9—ELECTRICAL AND SCIENTIFIC APPARATUS**

FOR COMPUTER SOFTWARE FOR THE AUTOMATIC OR AUTOMATED CONTROL OF MACHINES FOR METAL PROCESSING AND METAL WORKING, IN PARTICULAR OF TUBE PROCESSING MACHINES; COMPUTER SOFTWARE FOR USE AS COMPUTER CONTROLS FOR MACHINE TOOLS FOR THE MACHINING AND PROCESSING OF TUBES (U.S. CLS. 21, 23, 26, 36 AND 38).

**CLASS 42—SCIENTIFIC AND COMPUTER SERVICES**

FOR DESIGN, DEVELOPMENT, INSTALLATION AND MAINTENANCE OF COMPUTER SOFTWARE FOR THE AUTOMATED OPERATION OF MACHINES, IN PARTICULAR OF TUBE PROCESSING MACHINES; DESIGN, DEVELOPMENT, INSTALLATION AND MAINTENANCE OF COMPUTER SIMULATION SOFTWARE FOR THE MACHINING AND PROCESSING OF TUBES; DEVELOPMENT, TECHNICAL PLANNING AND CONSTRUCTION DRAFTING OF AUTOMATED TUBE PROCESSING MACHINES (U.S. CLS. 100 AND 101).

ERNEST SHOSHO, EXAMINING ATTORNEY



SN 79-088,294. PLUM & CO. APS, DENMARK, FILED 6-22-2010.

## VITAL DIFFERENCES

THE MARK CONSISTS OF STANDARD CHARACTERS WITHOUT CLAIM TO ANY PARTICULAR FONT, STYLE, SIZE, OR COLOR.

PRIORITY DATE OF 2-16-2010 IS CLAIMED.  
OWNER OF INTERNATIONAL REGISTRATION 1053759 DATED 6-22-2010, EXPIRES 6-22-2020.

### CLASS 16—PAPER GOODS AND PRINTED MATTER

FOR INSTRUCTIONAL AND TEACHING MATERIAL EXCEPT APPARATUS, NAMELY, WORKBOOKS IN THE FIELD OF CULTURAL INTELLIGENCE AND CULTURAL COMPLEXITY, BOOKS CONTAINING ARTICULATED SEGMENTS OF LOOSE LEAVES WHICH FLIP TO PRESENT ILLUSTRATIONS, SCENARIOS, SITUATIONS, VOCABULARY, SOLUTIONS AND BEHAVIORAL SUGGESTIONS CONCERNING THE FIELDS OF CULTURE INTELLIGENCE AND CULTURAL COMPLEXITY WHICH ALLOW USERS TO FIGURE OUT, DETERMINE AND LEARN APPROPRIATE RESPONSES TO SAME, AND PARTICIPANT MATERIALS, NAMELY, EXERCISE BOOKS AND PENS (U.S. CLS. 2, 5, 22, 23, 29, 37, 38 AND 50).

### CLASS 28—TOYS AND SPORTING GOODS

FOR BOARD GAMES, CARD GAMES, DIALOG GAMES IN THE NATURE OF BOARD GAMES WHEREIN PARTICIPANTS INTERACT THROUGH DIALOG, CULTURAL GAMES IN THE NATURE OF BOARD GAMES ABOUT DIFFERENT CULTURES, DEVICE GAMES IN THE NATURE OF ELECTRONIC GAMES FOR THE TEACHING OF CHILDREN AND ADULTS, ROLE PLAYING GAMES, PICTURE LOTTERY IN THE NATURE OF LOTTERY CARDS FEATURING PICTURES, PUZZLES (U.S. CLS. 22, 23, 38 AND 50).

### CLASS 41—EDUCATION AND ENTERTAINMENT

FOR EDUCATION, NAMELY, CLASSES IN THE FIELD OF CULTURAL INTELLIGENCE AND CULTURAL COMPLEXITY; PROVIDING OF TRAINING, NAMELY, COURSES, CONSULTANCY COURSES, CONFERENCES, SEMINARS AND WORKSHOPS IN THE FIELD OF CULTURAL INTELLIGENCE AND CULTURAL COMPLEXITY, TRAINING IN THE FIELD OF MANAGING AND USING BOARD GAMES (U.S. CLS. 100, 101 AND 107).

MELISSA VALLILLO, EXAMINING ATTORNEY

SN 79-088,496. NOVARTIS AG, SWITZERLAND, FILED 9-13-2010.

## ULTRIO ELITE

THE MARK CONSISTS OF STANDARD CHARACTERS WITHOUT CLAIM TO ANY PARTICULAR FONT, STYLE, SIZE, OR COLOR.

PRIORITY DATE OF 3-16-2010 IS CLAIMED.  
OWNER OF INTERNATIONAL REGISTRATION 1054374 DATED 9-13-2010, EXPIRES 9-13-2020.  
OWNER OF U.S. REG. NO. 3,612,719.

### CLASS 1—CHEMICALS

FOR DIAGNOSTIC REAGENTS AND NUCLEIC ACIDS INTENDED FOR SCIENTIFIC AND RESEARCH USE (U.S. CLS. 1, 5, 6, 10, 26 AND 46).

### CLASS 5—PHARMACEUTICALS

FOR DIAGNOSTIC REAGENTS AND NUCLEIC ACIDS FOR MEDICAL AND MEDICAL DIAGNOSTIC PURPOSES (U.S. CLS. 6, 18, 44, 46, 51 AND 52).  
COURTNEY ALVAREZ, EXAMINING ATTORNEY

SN 79-088,510. MEISTERWERKE SCHULTE GMBH, FED REP GERMANY, FILED 2-4-2010.

## MASTERCLIC

THE MARK CONSISTS OF STANDARD CHARACTERS WITHOUT CLAIM TO ANY PARTICULAR FONT, STYLE, SIZE, OR COLOR.

OWNER OF INTERNATIONAL REGISTRATION 1054405 DATED 2-4-2010, EXPIRES 2-4-2020.

### CLASS 19—NON-METALLIC BUILDING MATERIALS

FOR PARQUET AND LAMINATE FLOORING; WALL COVERINGS BEING PANELS, PLATES IN THE NATURE OF PANELS, AND BOARDS, NOT OF METAL; CEILING COVERINGS BEING PANELS, PLATES AND BOARDS, NOT OF METAL; FLOOR COVERINGS BEING PANELS, PLATES IN THE NATURE OF PANELS, AND BOARDS, NOT OF METAL; CONSTRUCTION MATERIALS IN THE NATURE OF PARTITIONS, DOORS, PROFILE STRIPS, FLOOR EDGING STRIPS, SKIRTING BOARDS, CEILING EDGING STRIPS, CORNER PROFILES, JUNCTION AND CONNECTING PROFILES, MATCHING PROFILES, EDGING PROFILES, STEP EDGING PROFILES, END CAPPING, AND STAY BOLTS SPECIALLY ADAPTED FOR SKIRTING BOARDS, THE AFORESAID GOODS NOT OF METAL, IN PARTICULAR OF IMITATION WOOD, FOR BUILDING; NON-METAL FLOORS; TIMBER FLOORING; STEPS AND STRINGERS AS STRUCTURAL PARTS OF STAIRCASES, NOT OF METAL (U.S. CLS. 1, 12, 33 AND 50).

### CLASS 27—FLOOR COVERINGS

FOR FLOOR COVERINGS (U.S. CLS. 19, 20, 37, 42 AND 50).

MARGERY A. TIERNEY, EXAMINING ATTORNEY

SN 79-088,609. CORETRANSFORM GMBH, FED REP GERMANY, FILED 5-26-2010.

## COREtransform

THE MARK CONSISTS OF STANDARD CHARACTERS WITHOUT CLAIM TO ANY PARTICULAR FONT, STYLE, SIZE, OR COLOR.

PRIORITY DATE OF 11-30-2009 IS CLAIMED.  
OWNER OF INTERNATIONAL REGISTRATION 1054620 DATED 5-26-2010, EXPIRES 5-26-2020.

### CLASS 35—ADVERTISING AND BUSINESS

FOR ADVERTISING SERVICES, BUSINESS MANAGEMENT SERVICES, BUSINESS CONSULTATION IN THE FIELD OF ENTERPRISE ADMINISTRATION, PROVIDING OFFICE FUNCTIONS (U.S. CLS. 100, 101 AND 102).

### CLASS 36—INSURANCE AND FINANCIAL

FOR FINANCIAL ANALYSIS, ELECTRONIC CASH TRANSACTION, REAL ESTATE AGENCIES, FINANCIAL ADVICE AND CONSULTANCY (U.S. CLS. 100, 101 AND 102).

**CLASS 42—SCIENTIFIC AND COMPUTER SERVICES**

FOR SCIENTIFIC AND TECHNOLOGICAL SERVICES, NAMELY, SCIENTIFIC RESEARCH, ANALYSIS, TESTING IN THE FIELD OF ELECTRONIC DATA SECURITY SYSTEMS, COMPUTER PROGRAMMES FOR DATA PROCESSING, DATA CONVERSION OF ELECTRONIC INFORMATION AND DATA MIGRATION; INDUSTRIAL RESEARCH AND ANALYSIS IN THE FIELD OF ELECTRONIC DATA SECURITY SYSTEMS, COMPUTER PROGRAMMES FOR DATA PROCESSING, DATA CONVERSION OF ELECTRONIC INFORMATION AND DATA MIGRATION; DESIGN AND DEVELOPMENT OF COMPUTER SOFTWARE AND COMPUTER HARDWARE; INFORMATION TECHNOLOGY CONSULTATION (U.S. CLS. 100 AND 101).

KAREN SEVERSON, EXAMINING ATTORNEY

**CLASS 35—ADVERTISING AND BUSINESS**

FOR COMPUTERIZED DATABASE MANAGEMENT SERVICES FOR DATABASES ENABLING THE IDENTIFICATION AND FOLLOW-UP OF PROSTHESES, SURGICAL IMPLANTS, MEDICAL PRODUCTS AND MEDICINES; COMPUTERIZED DATABASE MANAGEMENT SERVICES FOR DATABASES ENABLING THE STOCK MANAGEMENT FOR PROSTHETICS, SURGICAL IMPLANTS, MEDICAL PRODUCTS, MEDICINES; COMPUTERIZED FILE MANAGEMENT; AUTOMATED STORAGE AND COMPILATION AND SYSTEMIZATION OF DIGITAL DATA INTO A CENTRAL FILE AND COMPILATION AND SYSTEMIZATION OF INFORMATION INTO COMPUTER DATABASES (U.S. CLS. 100, 101 AND 102).

**CLASS 42—SCIENTIFIC AND COMPUTER SERVICES**

FOR TRACEABILITY SERVICES, NAMELY, COMPUTER SERVICES FOR OTHERS ENABLING THE MONITORING, IDENTIFICATION AND QUALITY CONTROL OF PROSTHESES, SURGICAL IMPLANTS, MEDICAL PRODUCTS AND MEDICINES VIA A SYSTEM COMPRISED OF AN ELECTRONIC CHIP OR A BARCODE WHICH ALLOWS CUSTOMERS TO PERMANENTLY MONITOR PHYSICAL PRODUCT FLOWS, AND BARCODE AND CHIP CARD READERS THEREFOR; COMPUTER PROGRAMMING THAT ALLOWS THE IDENTIFICATION, TRACKING AND FOLLOW-UP OF PROSTHESES, SURGICAL IMPLANTS, MEDICAL PRODUCTS AND MEDICINES, VIA A SYSTEM USING ELECTRONIC CHIPS OR BARCODES; DESIGN OF COMPUTER SYSTEMS AND SOFTWARE ENABLING THE READING, RECORDING AND TRANSMITTING OF COMPUTER DATA, FROM SIGNALS HELD IN AN ELECTRONIC CHIP OR ON A BARCODE (U.S. CLS. 100 AND 101).

MARLENE BELL, EXAMINING ATTORNEY

SN 79-088,659. IMPLANET, FRANCE, FILED 5-21-2010.

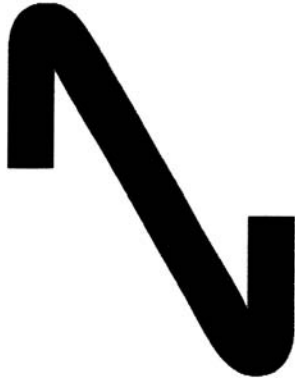

SN 79-088,660. IMPLANET, FRANCE, FILED 5-21-2010.

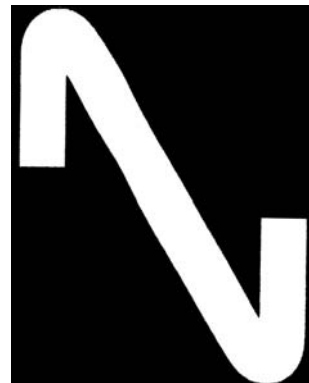

PRIORITY DATE OF 11-25-2009 IS CLAIMED.  
OWNER OF INTERNATIONAL REGISTRATION 1054747  
DATED 5-21-2010, EXPIRES 5-21-2020.  
THE MARK CONSISTS OF A STYLIZED LETTER "N".

**CLASS 9—ELECTRICAL AND SCIENTIFIC APPARATUS**

FOR APPARATUS AND INSTRUMENTS FOR SIGNALING, CHECKING AND IDENTIFYING PROSTHESES, SURGICAL IMPLANTS, MEDICAL PRODUCTS AND MEDICINES, NAMELY, COMPUTER HARDWARE, BARCODE AND CHIP CARD READERS, AND COMPUTER PERIPHERALS; COMPUTER SOFTWARE FOR USE BY MEDICAL PROFESSIONALS IN IDENTIFYING AND TRACKING PROSTHESES, SURGICAL IMPLANTS, MEDICAL PRODUCTS AND MEDICINES; PROGRAMMED MODULES FOR READING, RECORDING AND TRANSMITTING COMPUTER DATA FROM SIGNALS HELD IN AN ELECTRONIC CHIP OR ON A BARCODE, NAMELY, MICROPROCESSORS, ELECTRONIC SIGNAL TRANSMITTERS, BARCODE AND CHIP CARD READERS, ENCODED ELECTRONIC CHIP CARDS CONTAINING PROGRAMMING USED TO IDENTIFY PROSTHESES, SURGICAL IMPLANTS, MEDICAL PRODUCTS AND MEDICINES; PERSONAL DIGITAL ASSISTANTS FOR READING COMPUTER DATA CONTAINED IN A CHIP OR ON A BARCODE (U.S. CLS. 21, 23, 26, 36 AND 38).

PRIORITY DATE OF 11-25-2009 IS CLAIMED.  
OWNER OF INTERNATIONAL REGISTRATION 1054748  
DATED 5-21-2010, EXPIRES 5-21-2020.  
THE MARK CONSISTS OF A STYLIZED LETTER "N" WITHIN A RECTANGLE, BUT THE RECTANGLE IS INTENDED TO SIGNIFY THAT THE MARK APPEARS ON A BACKGROUND, AND IS NOT INTENDED TO FORM PART OF THE MARK.

**CLASS 9—ELECTRICAL AND SCIENTIFIC APPARATUS**

FOR APPARATUS AND INSTRUMENTS FOR SIGNALING, CHECKING AND IDENTIFYING PROSTHESES, SURGICAL IMPLANTS, MEDICAL PRODUCTS AND MEDICINES, NAMELY, COMPUTER HARDWARE, BARCODE AND CHIP CARD READERS, AND COMPUTER PERIPHERALS; COMPUTER SOFTWARE FOR USE BY MEDICAL PROFESSIONALS IN IDENTIFYING AND TRACKING PROSTHESES, SURGICAL IMPLANTS, MEDICAL PRODUCTS AND MEDICINES; PROGRAMMED MODULES FOR READING, RECORDING AND TRANSMITTING COMPUTER DATA FROM SIGNALS HELD IN AN ELECTRONIC CHIP OR ON A BARCODE, NAMELY, MICROPROCESSORS, ELECTRONIC SIGNAL TRANSMITTERS, BARCODE AND CHIP CARD READERS, ENCODED ELECTRONIC CHIP CARDS CONTAINING PROGRAMMING USED TO IDENTIFY PROSTHESES, SURGICAL IMPLANTS, MEDICAL PRODUCTS AND MEDICINES; PERSONAL DIGITAL ASSISTANTS FOR READING COMPUTER DATA CONTAINED IN A CHIP OR ON A BARCODE (U.S. CLS. 21, 23, 26, 36 AND 38).

SN 79-088,661. IMPLANET, FRANCE, FILED 5-21-2010.

**CLASS 35—ADVERTISING AND BUSINESS**

FOR COMPUTERIZED DATABASE MANAGEMENT SERVICES FOR DATABASES ENABLING THE IDENTIFICATION AND FOLLOW-UP OF PROSTHESES, SURGICAL IMPLANTS, MEDICAL PRODUCTS AND MEDICINES; COMPUTERIZED DATABASE MANAGEMENT SERVICES FOR DATABASES ENABLING THE STOCK MANAGEMENT FOR PROSTHETICS, SURGICAL IMPLANTS, MEDICAL PRODUCTS, MEDICINES; COMPUTERIZED FILE MANAGEMENT; AUTOMATED STORAGE AND COMPILATION AND SYSTEMIZATION OF DIGITAL DATA INTO A CENTRAL FILE AND COMPILATION AND SYSTEMIZATION OF INFORMATION INTO COMPUTER DATABASES (U.S. CLS. 100, 101 AND 102).

**CLASS 42—SCIENTIFIC AND COMPUTER SERVICES**

FOR TRACEABILITY SERVICES, NAMELY, COMPUTER SERVICES FOR OTHERS ENABLING THE MONITORING, IDENTIFICATION AND QUALITY CONTROL OF PROSTHESES, SURGICAL IMPLANTS, MEDICAL PRODUCTS AND MEDICINES VIA A SYSTEM COMPRISED OF AN ELECTRONIC CHIP OR A BARCODE WHICH ALLOWS CUSTOMERS TO PERMANENTLY MONITOR PHYSICAL PRODUCT FLOWS, AND BARCODE AND CHIP CARD READERS THEREFOR; COMPUTER PROGRAMMING THAT ALLOWS THE IDENTIFICATION, TRACKING AND FOLLOW-UP OF PROSTHESES, SURGICAL IMPLANTS, MEDICAL PRODUCTS AND MEDICINES, VIA A SYSTEM USING ELECTRONIC CHIPS OR BARCODES; DESIGN OF COMPUTER SYSTEMS AND SOFTWARE ENABLING THE READING, RECORDING AND TRANSMITTING OF COMPUTER DATA, FROM SIGNALS HELD IN AN ELECTRONIC CHIP OR ON A BARCODE (U.S. CLS. 100 AND 101).

MARLENE BELL, EXAMINING ATTORNEY

PRIORITY DATE OF 11-25-2009 IS CLAIMED.  
OWNER OF INTERNATIONAL REGISTRATION 1054749  
DATED 5-21-2010, EXPIRES 5-21-2020.

NO CLAIM IS MADE TO THE EXCLUSIVE RIGHT TO USE "MEDICAL DEVICE TRACEABILITY ENGINE", APART FROM THE MARK AS SHOWN.

THE COLOR(S) BLACK, WHITE AND PURPLE IS/ARE CLAIMED AS A FEATURE OF THE MARK.

THE MARK CONSISTS OF STYLIZED LETTERS AND WORDING "N BEEPTRACK THE MEDICAL DEVICE TRACEABILITY ENGINE" WITHIN A RECTANGLE THAT IS INTENDED TO SIGNIFY THAT THE MARK APPEARS ON A BACKGROUND, BUT THE RECTANGLE DOES NOT FORM PART OF THE MARK. THE BACKGROUND, SIGNIFIED BY THE RECTANGLE IN THIS CASE, IS BLACK AND THE LETTERS AND WORDING "N BEEP TRACK THE MEDICAL DEVICE TRACEABILITY ENGINE" ARE WHITE, THE LETTER "N" BETWEEN THE TERMS "BEEP" AND "TRACK" IS PURPLE. THE WORDING "BEEPTRACK" APPEARS ABOVE THE WORDING "THE MEDICAL DEVICE TRACEABILITY ENGINE". THE LETTER "N" BETWEEN THE TERMS "BEEP" AND "TRACK" IS STYLIZED, WITH THE LEFT STEM OF THE LETTER "N" CONNECTING TO THE TOP OF THE LETTER "P" IN "BEEP" AND THE RIGHT STEM OF THE LETTER "N" CONNECTING TO THE BASE OF THE LETTER "T" IN "TRACK". TO THE LEFT AND BELOW THE WORDING IS A STYLIZED LETTER "N".

**CLASS 9—ELECTRICAL AND SCIENTIFIC APPARATUS**

FOR APPARATUS AND INSTRUMENTS FOR SIGNALING, CHECKING AND IDENTIFYING PROSTHESES, SURGICAL IMPLANTS, MEDICAL PRODUCTS AND MEDICINES, NAMELY, COMPUTER HARDWARE, BARCODE AND CHIP CARD READERS, AND COMPUTER PERIPHERALS; COMPUTER SOFTWARE FOR USE BY MEDICAL PROFESSIONALS IN IDENTIFYING AND TRACKING PROSTHESES, SURGICAL IMPLANTS, MEDICAL PRODUCTS AND MEDICINES; PROGRAMMED MODULES FOR READING, RECORDING AND TRANSMITTING COMPUTER DATA FROM SIGNALS HELD IN AN ELECTRONIC CHIP OR ON A BARCODE, NAMELY, MICROPROCESSORS, ELECTRONIC SIGNAL TRANSMITTERS, BARCODE AND CHIP CARD READERS, ENCODED ELECTRONIC CHIP CARDS CONTAINING PROGRAMMING USED TO IDENTIFY PROSTHESES, SURGICAL IMPLANTS, MEDICAL PRODUCTS AND MEDICINES; PERSONAL DIGITAL ASSISTANTS FOR READING COMPUTER DATA CONTAINED IN A CHIP OR ON A BARCODE (U.S. CLS. 21, 23, 26, 36 AND 38).

**CLASS 35—ADVERTISING AND BUSINESS**

FOR COMPUTERIZED DATABASE MANAGEMENT SERVICES FOR DATABASES ENABLING THE IDENTIFICATION AND FOLLOW-UP OF PROSTHESES, SURGICAL IMPLANTS, MEDICAL PRODUCTS AND MEDICINES; COMPUTERIZED DATABASE MANAGEMENT SERVICES FOR DATABASES ENABLING THE STOCK MANAGEMENT FOR PROSTHETICS, SURGICAL IMPLANTS, MEDICAL PRODUCTS, MEDICINES; COMPUTERIZED FILE MANAGEMENT; AUTOMATED STORAGE AND COMPILATION AND SYSTEMIZATION OF DIGITAL DATA INTO A CENTRAL FILE AND COMPILATION AND SYSTEMIZATION OF INFORMATION INTO COMPUTER DATABASES (U.S. CLS. 100, 101 AND 102).

**CLASS 42—SCIENTIFIC AND COMPUTER SERVICES**

FOR TRACEABILITY SERVICES, NAMELY, COMPUTER SERVICES FOR OTHERS ENABLING THE MONITORING, IDENTIFICATION AND QUALITY CONTROL OF PROSTHESES, SURGICAL IMPLANTS, MEDICAL PRODUCTS AND MEDICINES VIA A SYSTEM COMPRISED OF AN ELECTRONIC CHIP OR A BARCODE WHICH ALLOWS CUSTOMERS TO PERMANENTLY MONITOR PHYSICAL PRODUCT FLOWS, AND BARCODE AND CHIP CARD READERS THEREFOR; COMPUTER PROGRAMMING THAT ALLOWS THE IDENTIFICATION, TRACKING AND FOLLOW-UP OF PROSTHESES, SURGICAL IMPLANTS, MEDICAL PRODUCTS AND MEDICINES, VIA A SYSTEM USING ELECTRONIC CHIPS OR BARCODES; DESIGN OF COMPUTER SYSTEMS AND SOFTWARE ENABLING THE READING, RECORDING AND TRANSMITTING OF COMPUTER DATA, FROM SIGNALS HELD IN AN ELECTRONIC CHIP OR ON A BARCODE (U.S. CLS. 100 AND 101).

MARLENE BELL, EXAMINING ATTORNEY

SN 79-088,667, PHARMA DIAGNOSTICS NV, BELGIUM, FILED 6-25-2010.

# SOPRANO

THE MARK CONSISTS OF STANDARD CHARACTERS WITHOUT CLAIM TO ANY PARTICULAR FONT, STYLE, SIZE, OR COLOR.

PRIORITY DATE OF 1-13-2010 IS CLAIMED.  
OWNER OF INTERNATIONAL REGISTRATION 1054767 DATED 6-25-2010, EXPIRES 6-25-2020.

**CLASS 1—CHEMICALS**

FOR CHEMICALS FOR USE IN LABORATORIES, NAMELY, COLLOIDAL NOBLE METALS AND CONJUGATES THEREOF USED FOR SCREENING IN PRECLINICAL RESEARCH AND DEVELOPMENT LABORATORIES; KITS COMPRISED OF CHEMICALS FOR USE IN LABORATORIES, NAMELY, COMPRISED OF COLLOIDAL NOBLE METALS, CONJUGATES THEREOF AND PROTOCOL, NAMELY, INSTRUCTIONAL MANUAL SOLD TOGETHER WITH THE KIT FOR SCREENING IN PRECLINICAL RESEARCH AND DEVELOPMENT LABORATORIES; CHEMICAL LABORATORY REAGENTS OTHER THAN FOR MEDICAL OR VETERINARY USE; CHEMICAL SOLUTIONS AND PREPARATIONS FOR LABEL FREE USE IN SCIENTIFIC APPARATUS FOR PRECLINICAL RESEARCH PURPOSES, NAMELY, COLLOIDAL NOBLE METALS AND CONJUGATES THEREOF USED FOR SCREENING IN PRECLINICAL RESEARCH AND DEVELOPMENT LABORATORIES; KITS OF SUBSTRATES AND REAGENTS AND PROTOCOL, NAMELY, INSTRUCTIONAL MANUAL FOR SURFACE PLASMON RESONANCE (SPR) MEASUREMENTS FOR LABORATORY OR RESEARCH AND DEVELOPMENT USE (U.S. CLS. 1, 5, 6, 10, 26 AND 46).

**CLASS 42—SCIENTIFIC AND COMPUTER SERVICES**

FOR CHEMICAL, BIOCHEMICAL, BIOLOGICAL, BACTERIOLOGICAL, PHARMACEUTICAL RESEARCH AND DEVELOPMENT; CHEMICAL, BIOCHEMICAL, BIOLOGICAL, BACTERIOLOGICAL AND PHARMACEUTICAL TESTING, INSPECTION AND ANALYSES; PRODUCT DEVELOPMENT OF CHEMICALS, COMPOUNDS AND INGREDIENTS FOR USE IN PHARMACEUTICALS, FOR RESEARCH AND FOR SCIENTIFIC PURPOSES; ANALYSIS OF THE MODE OF ACTION OF CHEMICAL COMBINATIONS ON ANIMALS AND ON HUMANS; CONDUCTING EARLY EVALUATIONS IN THE FIELD OF NEW PHARMACEUTICALS; CONSULTANCY PERTAINING TO PHARMACOLOGY; DESIGN AND DEVELOPMENT OF NANOPARTICLES; DESIGN AND DEVELOPMENT OF SOFTWARE FOR ALL THE AFORESAID SERVICES (U.S. CLS. 100 AND 101).

LAURIE MAYES, EXAMINING ATTORNEY

SN 79-088,682, R82 A/S, DENMARK, FILED 9-22-2010.

# KUDU

THE MARK CONSISTS OF STANDARD CHARACTERS WITHOUT CLAIM TO ANY PARTICULAR FONT, STYLE, SIZE, OR COLOR.

PRIORITY DATE OF 5-18-2010 IS CLAIMED.  
OWNER OF INTERNATIONAL REGISTRATION 1054824 DATED 9-22-2010, EXPIRES 9-22-2020.

**CLASS 10—MEDICAL APPARATUS**

FOR EQUIPMENT AND ACCESSORIES FOR DISABLED PERSONS, NAMELY, ADAPTED CHAIR SEATS, STANDING FRAMES, ADAPTED TOILET CHAIRS AND PARTS THEREOF (U.S. CLS. 26, 39 AND 44).

**CLASS 12—VEHICLES**

FOR MANUAL WHEELCHAIRS AND PARTS AND FITTINGS THEREFORE, NAMELY, FRAMES, BACKRESTS, FOOTRESTS, PUSH HANDLES, WHEELS, HUBS, TIRES, HAND RIMS, WHEEL LOCKS, FITTED BACK UPHOLSTERY, FITTED SEAT UPHOLSTERY, FITTED SEAT CUSHIONS, SIDE GUARDS, ANTI-TIP MECHANISMS FOR PREVENTING THE WHEELCHAIR FROM TIPPING OVER, CAMBERS MECHANISMS FOR ADJUSTING ACCESS TO THE WHEELCHAIR, AXELS, STEMS, ARMRESTS, SEAT BELTS, FRAME PROTECTORS, CALF STRAPS, FITTED BACK PACKS, FITTED SEAT POUCHES, SPOKE GUARDS, CASTER PIN LOCKS, STROLLER HANDLES, LUGGAGE CARRIERS, HEADRESTS, AND FITTED TRAYS (U.S. CLS. 19, 21, 23, 31, 35 AND 44).

SCOTT BIBB, EXAMINING ATTORNEY

SN 79-088,902, KNAPP AG, A-8075 HART BEI GRAZ, AUSTRIA, FILED 8-9-2010.

# OSR Shuttle

THE MARK CONSISTS OF STANDARD CHARACTERS WITHOUT CLAIM TO ANY PARTICULAR FONT, STYLE, SIZE, OR COLOR.

PRIORITY DATE OF 5-5-2010 IS CLAIMED.  
OWNER OF INTERNATIONAL REGISTRATION 1055434 DATED 8-9-2010, EXPIRES 8-9-2020.



**CLASS 7—MACHINERY**

FOR STORAGE SYSTEMS COMPRISED OF CONVEYORS AND CARTONING MACHINES, NAMELY, CONVEYORS IN THE FORM OF CONVEYOR BELTS, MODULAR PLASTIC CONVEYOR, TOOTH BELT CONVEYOR, V-BELT CONVEYOR, DRAG CHAIN CONVEYOR, ROLLER CONVEYOR, BELT DRIVEN LIVE ROLLER CONVEYOR, ROLLER ACCUMULATION CONVEYOR, MULTIPLE BELT CONVEYOR, EMPTY CARTON CONVEYOR, TAPERED ROLLER CURVE CONVEYOR, TURNING BELTS FOR MACHINES, AND COMPONENT REPLACEMENT PARTS FOR THE AFORESAID GOODS, ALL FOR USE IN COMMISSIONING PLANTS; SORTING MACHINES WITH PRODUCTION LINE LANE COMBINER; CONVEYOR INSTALLATIONS COMPRISED OF BELT CONVEYOR, CONVEYOR BELT, MODULAR PLASTIC CONVEYOR, TOOTH BELT CONVEYOR, V-BELT CONVEYOR, DRAG CHAIN CONVEYOR, ROLLER CONVEYOR, BELT DRIVEN LIVE ROLLER CONVEYOR, ROLLER ACCUMULATION CONVEYOR, SHOE SORTER, LANE COMBINER, MULTIPLE BELT CONVEYOR, EMPTY CARTON CONVEYOR, TAPERED ROLLER CURVE, BELT TURN, DIVERTERS, ALL FOR USE IN COMMISSIONING PLANTS, AND COMPONENT PARTS FOR USE THEREIN; MACHINES IN COMMISSIONING INSTALLATIONS, NAMELY, MACHINES FOR AUTOMATIC PICKING SYSTEMS, NAMELY, FAST MOVER AUTOPICKER WITH ADJUSTABLE CHANNELS OR RACKS FOR PRODUCTS AND INTELLIGENT, MOVABLE EJECTORS AND CENTRAL BELT TECHNOLOGY, MACHINES FOR SEMI AUTOMATIC PICKING SYSTEMS WITH PAPERLESS USER GUIDANCE VIA RF TERMINALS ADJUSTABLE WITH FLEXIBLE PICKING ZONES AND CENTRAL BELT TECHNOLOGY, AND MACHINES FOR PAPERLESS PICKING SYSTEMS WITH PAPERLESS USER GUIDANCE VIA DISPLAYS ON RACKS, ALL FOR USE IN AUTOMATIC PICKING SYSTEMS; COMPONENTS FOR THE AFORESAID SYSTEMS AND INSTALLATIONS (U.S. CLS. 13, 19, 21, 23, 31, 34 AND 35).

**CLASS 9—ELECTRICAL AND SCIENTIFIC APPARATUS**

FOR COMPUTER HARDWARE, DATA PROCESSORS, INDUSTRIAL PROCESS CONTROL SOFTWARE FOR USE IN THE FIELDS OF STORAGE ENGINEERING, CONVEYING AND COMMISSIONING TECHNOLOGY, NAMELY, WAREHOUSE MANAGEMENT SYSTEMS, CONTROL-SYSTEMS FOR CONVEYOR SYSTEM, CONTROL-SYSTEMS FOR PICKING SYSTEM, ELECTRONIC MEASURING, REGULATING, CONTROL AND SECURITY DEVICES FOR USE IN CONVEYING UNITS AND MACHINES IN COMMISSIONING PLANTS, NAMELY, BELT CONVEYOR, CONVEYOR BELT, MODULAR PLASTIC CONVEYOR, TOOTH BELT CONVEYOR, V-BELT CONVEYOR, DRAG CHAIN CONVEYOR, ROLLER CONVEYOR, BELT DRIVEN LIVE ROLLER CONVEYOR, ROLLER ACCUMULATION CONVEYOR, SHOE SORTER, LANE COMBINER, MULTIPLE BELT CONVEYOR, EMPTY CARTON CONVEYOR, TAPERED ROLLER CURVE, BELT TURN, DIVERTERS; ELECTRONIC SENSORS FOR USE IN MEASURING, REGULATING AND CONTROLLING TEMPERATURES AND SECURITY BURGLAR ALARMS FOR USE IN STORAGE SYSTEMS, CONVEYING UNITS AND MACHINES IN COMMISSIONING PLANTS (U.S. CLS. 21, 23, 26, 36 AND 38).

**CLASS 42—SCIENTIFIC AND COMPUTER SERVICES**

FOR CREATION, DEVELOPMENT, FURTHER DEVELOPMENT, CARE, UPDATING, DESIGN AND INSTALLATION OF SOFTWARE FOR USE IN STORAGE SYSTEMS, CONVEYORS AND COMMISSIONING INSTALLATIONS, TECHNICAL CONSULTANCY WITH REGARD TO THE APPLICATION OF THE AFORESAID SOFTWARE, TECHNICAL PROJECT STUDIES AND DEVELOPMENT OF COMPUTERS AND COMPUTER HARDWARE FOR USE IN STORAGE SYSTEMS, CONVEYORS AND COMMISSIONING INSTALLATIONS (U.S. CLS. 100 AND 101).

KATHLEEN LORENZO, EXAMINING ATTORNEY

SN 79-088,903. SMS SANAYI MALZEMELERI URETIM VE SATISI ANONIM SIRKETI, KARAKÖY BEYOGLU ISTANBUL, TURKEY, FILED 10-12-2010.



OWNER OF INTERNATIONAL REGISTRATION 1055436 DATED 10-12-2010, EXPIRES 10-12-2020.

THE MARK CONSISTS OF THE DESIGN OF AN ELF DRESSED IN A CHEF'S HAT, A JACKET, PANTS AND BOOTS. THE TERM "TORK" APPEARS AFTER THE DESIGN OF THE ELF.

**CLASS 6—METAL GOODS**

FOR VALVES OF METAL OTHER THAN PARTS OF MACHINES (U.S. CLS. 2, 12, 13, 14, 23, 25 AND 50).

**CLASS 7—MACHINERY**

FOR CLACK VALVES, VALVES, PNEUMATIC VALVES, PNEUMATIC PISTON VALVES, PNEUMATIC ACTUATORS, ALL BEING PARTS OF MACHINES, PNEUMATIC CONTROLS FOR MACHINES, MOTORS, ENGINES (U.S. CLS. 13, 19, 21, 23, 31, 34 AND 35).

**CLASS 9—ELECTRICAL AND SCIENTIFIC APPARATUS**

FOR THERMOMETERS, NOT FOR MEDICAL PURPOSES, MANOMETERS, FLOW METERS, LEVELING INSTRUMENTS, NAMELY, SURVEYORS' LEVELS, LEVELING SWITCHES FOR MEASURING AND CONTROLLING LIQUIDS IN CONTAINERS, LEVEL INDICATORS, LEVELING INFORMATION TRANSMITTER, CARPENTERS' LEVELS, GAUGES, LEVELING STAFFS FOR SURVEYING, HYGROMETERS, SOLENOID VALVES (U.S. CLS. 21, 23, 26, 36 AND 38).

**CLASS 11—ENVIRONMENTAL CONTROL APPARATUS**

FOR PLUMBING FITTINGS, NAMELY, LEVEL CONTROLLING VALVES FOR TANKS (U.S. CLS. 13, 21, 23, 31 AND 34).

CAROLINE WOOD, EXAMINING ATTORNEY

SN 79-089,252. NANO-X GMBH, FED REP GERMANY, FILED 10-7-2010.

THE MARK CONSISTS OF STANDARD CHARACTERS WITHOUT CLAIM TO ANY PARTICULAR FONT, STYLE, SIZE, OR COLOR.

OWNER OF INTERNATIONAL REGISTRATION 1056409 DATED 10-7-2010, EXPIRES 10-7-2020.

**CLASS 1—CHEMICALS**

FOR CHEMICALS USED IN INDUSTRY AND SCIENCE; CHEMICALS USED IN PHOTOGRAPHY, NAMELY, PHOTOGRAPHIC DEVELOPERS; CHEMICALS USED IN AGRICULTURE, HORTICULTURE AND FORESTRY, NAMELY, CHEMICAL FERTILIZERS; UNPROCESSED ARTIFICIAL RESINS, UNPROCESSED PLASTICS; FERTILIZERS; FIRE EXTINGUISHING COMPOSITIONS; TEMPERING AND SOLDERING PREPARATIONS; FOOD PRESERVING CHEMICALS; TANNING SUBSTANCES, NAMELY, TANNING AGENTS FOR USE IN THE MANUFACTURE OF LEATHER; ADHESIVES FOR INDUSTRIAL PURPOSES (U.S. CLS. 1, 5, 6, 10, 26 AND 46).

**CLASS 2—PAINTS**

FOR PAINTS, VARNISHES, LACQUERS; PRESERVATIVE COATINGS USED TO PREVENT RUST AND DETERIORATION OF WOOD; COLORANTS; MORDANTS FOR USE IN THE FIELD OF MECHANICAL CONSTRUCTION; RAW NATURAL RESINS; METALS IN FOIL AND POWDER FORM FOR PAINTERS, DECORATORS, PRINTERS AND ARTISTS (U.S. CLS. 6, 11 AND 16).

**CLASS 42—SCIENTIFIC AND COMPUTER SERVICES**

FOR SCIENTIFIC AND TECHNOLOGICAL SERVICES AND RESEARCH AND DESIGN FOR OTHERS, NAMELY, PRODUCT RESEARCH, PRODUCT DESIGN, PRODUCT DEVELOPMENT, INDUSTRIAL RESEARCH, INDUSTRIAL ANALYSIS, AND TECHNOLOGICAL CONSULTATION FOR PRODUCT DESIGN AND DEVELOPMENT IN THE FIELDS OF CHEMICAL PRODUCT MANUFACTURE AND SURFACE COATING DEVELOPMENT AND MANUFACTURE; DESIGN AND DEVELOPMENT OF COMPUTERS AND SOFTWARE (U.S. CLS. 100 AND 101).

MICHELE SWAIN, EXAMINING ATTORNEY

SN 79-089,315. KABUSHIKI KAISHA YASKAWA DENKI, FUKUOKA, JAPAN, FILED 7-23-2010.

**Q M E T**

THE MARK CONSISTS OF STANDARD CHARACTERS WITHOUT CLAIM TO ANY PARTICULAR FONT, STYLE, SIZE, OR COLOR.

PRIORITY DATE OF 5-19-2010 IS CLAIMED.  
OWNER OF INTERNATIONAL REGISTRATION 1056582 DATED 7-23-2010, EXPIRES 7-23-2020.

**CLASS 7—MACHINERY**

FOR METALWORKING MACHINES AND MACHINE TOOLS; LOADING-UNLOADING MACHINES AND APPARATUS; PAINTING MACHINES AND APPARATUS; PLASTIC PROCESSING MACHINES AND APPARATUS; SEMICONDUCTOR MANUFACTURING MACHINES AND SYSTEMS; NON-ELECTRIC PRIME MOVERS, NAMELY, ENGINES OTHER THAN FOR LAND VEHICLES, WATER MILLS AND WIND MILLS; PARTS FOR NON-ELECTRIC PRIME MOVERS FOR LAND VEHICLES, NAMELY, MECHANICAL ENGINE PARTS FOR LAND VEHICLES; STARTERS FOR MOTORS AND ENGINES; AC MOTORS AND DC MOTORS OTHER THAN FOR LAND VEHICLES; ALTERNATORS; DC GENERATORS; INDUSTRIAL WELDING ROBOTS; INDUSTRIAL PAINTING ROBOTS; INDUSTRIAL TRANSFER ROBOTS; INDUSTRIAL MACHINE ASSEMBLY ROBOTS; INDUSTRIAL ELECTRONIC COMPONENT ASSEMBLY ROBOTS; INDUSTRIAL METAL PROCESSING ROBOTS; ELECTRIC ARC WELDING MACHINES (U.S. CLS. 13, 19, 21, 23, 31, 34 AND 35).

**CLASS 9—ELECTRICAL AND SCIENTIFIC APPARATUS**

FOR ELECTRIC WELDING APPARATUS, NAMELY, ELECTRIC ARC WELDERS, WELDING TORCHES, WELDING TRANSFORMERS; MEASURING OR TESTING MACHINES AND INSTRUMENTS, NAMELY, INSTRUMENTS FOR MEASURING LENGTH, DISTANCE MEASURING APPARATUS, BRAKE FLUID TESTERS, POSITION DETECTORS, ENCODERS, SPEED INDICATORS, ACCELEROMETERS, ANEMOMETERS, ANEMOSCOPIES, WATER FLOW INDICATORS, WATER GAUGE METERS, PRESSURE GAUGES, TEMPERATURE INDICATORS, VOLTMETERS, AMMETERS, POWER MEASUREMENT APPARATUS; POWER DISTRIBUTION OR CONTROL MACHINES AND APPARATUS, NAMELY, ELECTRIC SWITCHES, CIRCUIT BREAKERS, POWER CONTROLLERS; ROTARY CONVERTERS; PHASE MODIFIERS, BATTERIES AND ELECTRICAL CELLS; TELECOMMUNICATION DEVICES AND APPARATUS, NAMELY, MOBILE PHONES, ELECTRICAL TRANSFORMERS, TELECOMMUNICATIONS CABLES; ELECTRONIC MACHINES, APPARATUS AND THEIR PARTS, NAMELY, COMPUTER HARDWARE, CALCULATING MACHINES, ELECTRONIC CONTROL SYSTEMS FOR MACHINES (U.S. CLS. 21, 23, 26, 36 AND 38).

**CLASS 12—VEHICLES**

FOR NON-ELECTRIC PRIME MOVERS FOR LAND VEHICLES, NAMELY, MOTORS, ENGINES, NOT INCLUDING THEIR PARTS; AC MOTORS AND DC MOTORS FOR LAND VEHICLES, NOT INCLUDING THEIR PARTS; RAILWAY ROLLING STOCK AND THEIR PARTS AND FITTINGS, NAMELY, RAILWAY ROLLING STOCK, RAILWAY COUPLINGS, RAILWAY CAR UNDERCARRIAGES (U.S. CLS. 19, 21, 23, 31, 35 AND 44).

KRISTIN CARLSON, EXAMINING ATTORNEY

SN 79-089,477. LEONHARD FEYER, FED REP GERMANY, FILED 9-7-2010.

**Contao**

THE MARK CONSISTS OF STANDARD CHARACTERS WITHOUT CLAIM TO ANY PARTICULAR FONT, STYLE, SIZE, OR COLOR.

PRIORITY DATE OF 3-17-2010 IS CLAIMED.  
OWNER OF INTERNATIONAL REGISTRATION 1056949 DATED 9-7-2010, EXPIRES 9-7-2020.

THE WORDING "CONTAO" HAS NO MEANING IN A FOREIGN LANGUAGE.

**CLASS 9—ELECTRICAL AND SCIENTIFIC APPARATUS**

FOR DOWNLOADABLE COMPUTER SOFTWARE FOR DEVELOPING WEBSITES, FOR DESIGNING WEBSITES, FOR MANAGING THE CONTENT OF WEBSITES, AND FOR UPDATING WEBSITES; COMPUTER SOFTWARE FOR DEVELOPING WEBSITES, FOR DESIGNING WEBSITES, FOR MANAGING THE CONTENT OF WEBSITES, AND FOR UPDATING WEBSITES; COMPUTERS; NONE OF THE AFORE-MENTIONED IN THE FIELD OF OR IN CONNECTION WITH ORGANISING, ARRANGING AND CONDUCTING OF EXHIBITIONS, TRADE FAIRS, CONFERENCES, SEMINARS, CONVENTIONS, SYMPOSIA, COLLOQUIA, WORKSHOPS, TRAINING COURSES (U.S. CLS. 21, 23, 26, 36 AND 38).

**CLASS 42—SCIENTIFIC AND COMPUTER SERVICES**

FOR DESIGN AND DEVELOPMENT OF COMPUTER SOFTWARE, ENGINEERING; UPDATING OF COMPUTER SOFTWARE; COMPUTER HARDWARE AND SOFTWARE CONSULTANCY; INSTALLATION AND MAINTENANCE OF SOFTWARE; COMPUTER PROGRAMMING; SOFTWARE DESIGN SERVICES; DRAFTSMAN'S SERVICES, NAMELY, DRAFTING; COMPUTER CONSULTATION IN THE FIELD OF ELECTRONIC DATA PROCESSING; DESIGN AND MAINTENANCE OF WEBSITES, NAMELY HTML PAGES, FOR OTHERS; CONSULTANCY WITH REGARD TO THE DESIGN OF HOMEPAGES AND WEBSITES; HOSTING THE WEBSITES OF OTHERS; NONE OF THE FOREMENTIONED IN THE FIELD OF OR IN CONNECTION WITH ORGANISING, ARRANGING AND CONDUCTING OF EXHIBITIONS, TRADE FAIRS, CONFERENCES, SEMINARS, CONVENTIONS, SYMPOSIA, COLLOQUIA, WORKSHOPS, TRAINING COURSES (U.S. CLS. 100 AND 101).

LAURA HAMMEL, EXAMINING ATTORNEY

SN 79-090,210. SCHULZ GROUP GMBH, FED REP GERMANY, FILED 8-18-2010.



OWNER OF INTERNATIONAL REGISTRATION 1058937 DATED 8-18-2010, EXPIRES 8-18-2020.

**CLASS 7—MACHINERY**

FOR MACHINES FOR METAL PROCESSING AND MACHINING AND METAL WORKING, IN PARTICULAR METAL WORKING MACHINES AND MACHINING CENTERS FOR MACHINING AND PROCESSING OF TUBES AS WELL AS PARTS THEREOF; TOOLS AS MACHINE COMPONENTS, NAMELY, MACHINE TOOLS FOR THE CUTTING AND FORMING OF MATERIALS FOR AUTOMATED TUBE PROCESSING MACHINES (U.S. CLS. 13, 19, 21, 23, 31, 34 AND 35).

**CLASS 9—ELECTRICAL AND SCIENTIFIC APPARATUS**

FOR COMPUTER SOFTWARE FOR THE AUTOMATIC OR AUTOMATED CONTROL OF MACHINES FOR METAL PROCESSING AND METAL WORKING, IN PARTICULAR OF TUBE PROCESSING MACHINES; COMPUTER SOFTWARE FOR USE AS COMPUTER CONTROLS FOR MACHINE TOOLS FOR THE MACHINING AND PROCESSING OF TUBES (U.S. CLS. 21, 23, 26, 36 AND 38).

**CLASS 42—SCIENTIFIC AND COMPUTER SERVICES**

FOR DESIGN, DEVELOPMENT, INSTALLATION AND MAINTENANCE OF COMPUTER SOFTWARE FOR THE AUTOMATED OPERATION OF MACHINES, IN PARTICULAR OF TUBE PROCESSING MACHINES; DESIGN, DEVELOPMENT, INSTALLATION AND MAINTENANCE OF COMPUTER SIMULATION SOFTWARE FOR THE MACHINING AND PROCESSING OF TUBES; DEVELOPMENT, TECHNICAL PLANNING AND CONSTRUCTION DRAFTING OF AUTOMATED TUBE PROCESSING MACHINES (U.S. CLS. 100 AND 101).

AISHA SALEM, EXAMINING ATTORNEY

SN 79-090,325. 180° VISUAL SYSTEMS GMBH, HAMBURG, FED REP GERMANY, FILED 9-28-2010.



PRIORITY DATE OF 4-6-2010 IS CLAIMED.  
OWNER OF INTERNATIONAL REGISTRATION 1059384 DATED 9-28-2010, EXPIRES 9-28-2020.

NO CLAIM IS MADE TO THE EXCLUSIVE RIGHT TO USE "PERSONALITY SYSTEM", APART FROM THE MARK AS SHOWN.

**CLASS 16—PAPER GOODS AND PRINTED MATTER**

FOR PRINTED PAMPHLETS, BROCHURES, MANUALS, BOOKS, BOOKLETS, LEAFLETS, FLYERS, INFORMATIONAL SHEETS AND NEWSLETTERS, ADHESIVE BACKED STICKERS, AND KITS COMPRISING ONE OR MORE OF THE FOREGOING MATERIALS IN THE FIELD OF PSYCHOLOGY, MARKETING OR NEUROMARKETING; NEWSPAPERS; PRINTED PERIODICALS IN THE FIELD OF PSYCHOLOGY, MARKETING OR NEUROMARKETING (U.S. CLS. 2, 5, 22, 23, 29, 37, 38 AND 50).

**CLASS 35—ADVERTISING AND BUSINESS**

FOR SERVICES OF AN ADVERTISING AGENCY; DIRECT MARKETING; CREATION AND ANALYSIS OF CONSUMER PERSONALITY PROFILES FOR DIRECT MARKETING PURPOSES VIA ONLINE TESTING; PRESENTATIONS OF ADVERTISING LOGOS FOR COMPANIES AND INDIVIDUALS ON THE INTERNET AND IN OTHER MEDIA; MARKET RESEARCH SERVICES; MARKET RESEARCH IN THE AREA OF CONSUMABLES; PUBLIC RELATIONS SERVICES; BUSINESS CONSULTING IN THE CONSUMER PRODUCTS INDUSTRY; BRAND IMAGERY CONSULTING SERVICES; BRANDING SERVICES, NAMELY, CONSULTING, DEVELOPMENT, MANAGEMENT AND MARKETING OF BRANDS FOR BUSINESSES; BUSINESS CONSULTING SERVICES, NAMELY, PROVIDING ASSISTANCE IN DEVELOPMENT OF BUSINESS STRATEGIES AND CREATIVE IDEATION (U.S. CLS. 100, 101 AND 102).

**CLASS 42—SCIENTIFIC AND COMPUTER SERVICES**

FOR SCIENTIFIC RESEARCH IN THE AREAS OF PERSONALITY ANALYSIS AND PERSONALITY CONSULTANCY; DESIGN OF COMPANY LOGOS (U.S. CLS. 100 AND 101).

DOMINICK J. SALEMI, EXAMINING ATTORNEY

SN 79-090,445. ALDI GMBH & CO. KG, 45476 MÜLHEIM, FED REP GERMANY, FILED 10-16-2010.



OWNER OF INTERNATIONAL REGISTRATION 0899309 DATED 5-26-2006, EXPIRES 5-26-2016.

THE MARK CONSISTS OF THE WORDING "LIGHTWAY" WITH A STYLIZED LIGHT BULB APPEARING TO THE LEFT OF THE WORDING, ALL ENCLOSED IN A RECTANGULAR OVAL.

**CLASS 9—ELECTRICAL AND SCIENTIFIC APPARATUS**

FOR APPARATUS FOR RECORDING, TRANSMITTING AND REPRODUCING SOUND OR IMAGES; AUTOMATIC VENDING MACHINES AND MECHANISMS FOR COIN-OPERATED APPARATUS; CASH REGISTERS, CALCULATING MACHINES, DATA PROCESSING EQUIPMENT AND COMPUTERS; FIRE EXTINGUISHERS (U.S. CLS. 21, 23, 26, 36 AND 38).

**CLASS 10—MEDICAL APPARATUS**

FOR ULTRAVIOLET RAY LAMPS FOR MEDICAL PURPOSES; RADIOTHERAPY APPARATUS (U.S. CLS. 26, 39 AND 44).

**CLASS 11—ENVIRONMENTAL CONTROL APPARATUS**

FOR LIGHTING APPARATUS, NAMELY, ELECTRIC TORCHES FOR LIGHTING; INCANDESCENT LAMPS, HALOGEN LAMPS, FLUORESCENT LAMP TUBES, ELECTRIC DISCHARGE LAMPS, SPECIAL REFLECTOR LAMPS, IN PARTICULAR INFRARED RAY RADIATORS NOT FOR MOTORS AND ENGINES, LAMPS FOR SOLARIUMS, ULTRAVIOLET RADIATION METAL HALIDE LAMPS, ULTRA-VIOLET LAMPS FOR TECHNICAL USE, INCANDESCENT LIGHTS; LED LIGHT BULBS; HALOGEN LAMPS; SPARE APPLIANCE LIGHT BULBS FOR COOKERS, COOKER HOODS, OVENS, MICROWAVES, REFRIGERATORS, FREEZERS AND ICE AND WATER DISPENSERS (U.S. CLS. 13, 21, 23, 31 AND 34).

JAY FLOWERS, EXAMINING ATTORNEY

SN 79-090,702. CHAS. A. BLATCHFORD & SONS LIMITED, UNITED KINGDOM, FILED 11-17-2010.

# ENDOLITE

THE MARK CONSISTS OF STANDARD CHARACTERS WITHOUT CLAIM TO ANY PARTICULAR FONT, STYLE, SIZE, OR COLOR.

OWNER OF INTERNATIONAL REGISTRATION 1060341 DATED 11-17-2010, EXPIRES 11-2020.

OWNER OF U.S. REG. NOS. 1,439,068 AND 3,862,711.

**CLASS 10—MEDICAL APPARATUS**

FOR PROSTHESES FOR LIMBS, HANDS, AND FEET; ORTHOSES FOR LIMBS, HANDS, FEET, TRUNK, AND NECK; ARTIFICIAL LIMBS; ARTIFICIAL KNEES AND ANKLES; PARTS AND FITTINGS FOR ALL THE AFORESAID GOODS (U.S. CLS. 26, 39 AND 44).

**CLASS 40—MATERIAL TREATMENT**

FOR CUSTOM MANUFACTURE OF PROSTHESES AND ORTHOSES; INFORMATION AND ADVISORY SERVICES RELATING TO THE AFOREMENTIONED SERVICES (U.S. CLS. 100, 103 AND 106).

**CLASS 44—MEDICAL, BEAUTY AND AGRICULTURAL SERVICES**

FOR FITTING OF PROSTHESES AND ORTHOSES; INFORMATION AND ADVISORY SERVICES RELATING TO ALL THE AFOREMENTIONED SERVICES (U.S. CLS. 100 AND 101).

LINDA E. BLOHM, EXAMINING ATTORNEY

SN 79-090,503. BERRY BROS. & RUDD LIMITED, UNITED KINGDOM, FILED 11-15-2010.

# BBR.COM

THE MARK CONSISTS OF STANDARD CHARACTERS WITHOUT CLAIM TO ANY PARTICULAR FONT, STYLE, SIZE, OR COLOR.

OWNER OF INTERNATIONAL REGISTRATION 1059850 DATED 11-15-2010, EXPIRES 11-15-2020.

OWNER OF U.S. REG. NO. 3,612,691.

**CLASS 33—WINES AND SPIRITS**

FOR WINES, SPIRITS AND LIQUEURS (U.S. CLS. 47 AND 49).

**CLASS 35—ADVERTISING AND BUSINESS**

FOR THE BRINGING TOGETHER, FOR THE BENEFIT OF OTHERS, WINES, SPIRITS, COFFEES, TEAS AND CIGARS, ENABLING CUSTOMERS TO CONVENIENTLY VIEW AND PURCHASE THOSE GOODS IN A RETAIL WINE MERCHANT'S STORE; BUSINESS INFORMATION AND BUSINESS ADVISORY SERVICES RELATING TO KEEPING, STORING, MAKING OF WINE AND SPIRITS (U.S. CLS. 100, 101 AND 102).

GILBERT SWIFT, EXAMINING ATTORNEY

SN 79-090,873. ZHANG, YONGYU, MANCHESTER M88BJ, UNITED KINGDOM, FILED 11-2-2010.



OWNER OF INTERNATIONAL REGISTRATION 1060734 DATED 11-2-2010, EXPIRES 11-2-2020.

NO CLAIM IS MADE TO THE EXCLUSIVE RIGHT TO USE "UK" AND "1943", APART FROM THE MARK AS SHOWN.

THE MARK CONSISTS OF THE WORDING "DS 1943 UK" IN A BANNER AND ABOVE IS A DESIGN OF A LION ON THE LEFT, UNICORN ON THE RIGHT, DIAMOND IN THE MIDDLE, CROWN ON THE TOP, FLOWERS AND SWORDS UNDERNEATH ALL IN STYLIZED FONT.

**CLASS 14—JEWELRY**

FOR JEWELRY, PRECIOUS STONES; HOROLOGICAL AND CHRONOMETRIC INSTRUMENTS (U.S. CLS. 2, 27, 28 AND 50).



**CLASS 18—LEATHER GOODS**

FOR HANDBAGS; EVENING HANDBAGS; LADIES' HANDBAGS; TRAVELING HANDBAGS; LEATHER HANDBAGS; HANDBAGS FOR MEN; HANDBAG FRAMES; HANDBAGS MADE OF IMITATION LEATHER; GENT'S HANDBAGS; GENTLEMEN'S HANDBAGS; HANDBAGS MADE OF LEATHER (U.S. CLS. 1, 2, 3, 22 AND 41).

**CLASS 25—CLOTHING**

FOR CLOTHING, NAMELY, SHIRTS, PANTS, DRESSES, SKIRTS, BLOUSES, SHORTS, JACKETS, COATS, SOCKS, UNDERGARMENTS, BELTS, TIES, AND GLOVES; FOOTWEAR; HEADGEAR, NAMELY, HATS, CAPS, AND HEAD SCARVES (U.S. CLS. 22 AND 39).

WILLIAM ROSSMAN, EXAMINING ATTORNEY

---

SN 79-091,083. MARTIN MOLL, BAD BOLL, FED REP GERMANY, FILED 10-5-2010.

**cool tools**

OWNER OF INTERNATIONAL REGISTRATION 0855993 DATED 8-11-2004, EXPIRES 8-11-2014.

**CLASS 18—LEATHER GOODS**

FOR BEACH BAGS, MESH SHOPPING BAGS, ANIMAL GAME BAGS, SPORTS BAGS, BUSINESS CARD CASES, TRAVELING BAGS, TOOL BAGS SOLD EMPTY, SCHOOL BAGS, SACHELS, RUCKSACKS, UMBRELLAS (U.S. CLS. 1, 2, 3, 22 AND 41).

**CLASS 20—FURNITURE AND ARTICLES NOT OTHERWISE CLASSIFIED**

FOR FURNITURE, SLEEPING BAGS FOR CAMPING, PACKAGING CONTAINERS OF PLASTIC (U.S. CLS. 2, 13, 22, 25, 32 AND 50).

RENEE MCCRAY, EXAMINING ATTORNEY

---

SN 79-091,188. ALSTOM POWER SYSTEMS SA, FRANCE, FILED 11-8-2010.

**MTA Material Tracking Application**

THE MARK CONSISTS OF STANDARD CHARACTERS WITHOUT CLAIM TO ANY PARTICULAR FONT, STYLE, SIZE, OR COLOR.

PRIORITY DATE OF 5-11-2010 IS CLAIMED.

OWNER OF INTERNATIONAL REGISTRATION 1061473 DATED 11-8-2010, EXPIRES 11-8-2020.

NO CLAIM IS MADE TO THE EXCLUSIVE RIGHT TO USE "MATERIAL TRACKING APPLICATION", APART FROM THE MARK AS SHOWN.

**CLASS 9—ELECTRICAL AND SCIENTIFIC APPARATUS**

FOR COMPUTER PROGRAMS FOR MANAGING MATERIAL USED IN THE CONSTRUCTION OF UNITS OF PRODUCTION IN STUDIES, NAMELY, MANAGEMENT OF MATERIALS FOR PIPING, VALVES AND SUPPORTS, PURCHASE REQUISITIONS, ORDERS, THE ITEMIZED LIST OF COMPONENTS TO BE DELIVERED WITH AN INTERNAL VALIDATION MODULE, IN THE LIST OF BOXES AND THE ITEMIZED CONTENT THEREOF AND MANAGEMENT OF THE STATUS "GOOD FOR SHIPPING", TRANSPORT DATA, ON-SITE RECEIVING AND CONFIRMATION OF THE STATED QUANTITIES AND THE MANAGEMENT OF WAREHOUSE OUTPUT (U.S. CLS. 21, 23, 26, 36 AND 38).

**CLASS 35—ADVERTISING AND BUSINESS**

FOR BUSINESS SERVICES, NAMELY, ON-LINE TRACKING AND MANAGEMENT OF ACCESS CONTROL FOR LOADING MATERIALS USED IN THE CONSTRUCTION OF UNITS OF PRODUCTION IN STUDIES, MANAGEMENT OF MATERIALS FOR PIPING, VALVES AND SUPPORTS, PURCHASE REQUISITIONS, ORDERS, THE ITEMIZED LIST OF COMPONENTS TO BE DELIVERED WITH AN INTERNAL VALIDATION MODULE, IN THE LIST OF BOXES AND THE ITEMIZED CONTENT THEREOF AND MANAGEMENT OF THE STATUS "GOOD FOR SHIPPING", TRANSPORT DATA, ON-SITE RECEIVING AND CONFIRMATION OF THE STATED QUANTITIES AND THE MANAGEMENT OF WAREHOUSE OUTPUT (U.S. CLS. 100, 101 AND 102).

JOHN WILKE, EXAMINING ATTORNEY

---

SN 79-091,317. SYNBRA TECHNOLOGY B.V., NETHERLANDS, FILED 11-11-2010.

**SYNTERRA**

THE MARK CONSISTS OF STANDARD CHARACTERS WITHOUT CLAIM TO ANY PARTICULAR FONT, STYLE, SIZE, OR COLOR.

PRIORITY DATE OF 10-15-2010 IS CLAIMED.

OWNER OF INTERNATIONAL REGISTRATION 1061860 DATED 11-11-2010, EXPIRES 11-11-2020.

THE WORDING "SYNTERRA" HAS NO MEANING IN A FOREIGN LANGUAGE.

**CLASS 1—CHEMICALS**

FOR CHEMICALS FOR INDUSTRIAL AND SCIENTIFIC PURPOSES; UNPROCESSED PLASTICS; POLYLACTIC ACID GRANULES (U.S. CLS. 1, 5, 6, 10, 26 AND 46).

**CLASS 17—RUBBER GOODS**

FOR RUBBER AND GOODS MADE THEREFROM, NAMELY, FILM, FOIL OR FOAM FOR COMMERCIAL OR INDUSTRIAL PACKAGING; SEMI-PROCESSED PLASTIC PRODUCTS, NAMELY, PLASTIC FILM, FOIL OR FOAM FOR COMMERCIAL OR INDUSTRIAL PACKAGING; STOPPING MATERIALS, NAMELY, PACKING MATERIAL FOR FORMING SEALS FOR YOGHURT CUPS (U.S. CLS. 1, 5, 12, 13, 35 AND 50).

KRISTIN DAHLING, EXAMINING ATTORNEY

SN 79-091,455. WINTERSTEIGER AG, RIED IM INNKREIS, AUSTRIA, FILED 10-14-2010.

# WINTERSTEIGER

THE MARK CONSISTS OF STANDARD CHARACTERS WITHOUT CLAIM TO ANY PARTICULAR FONT, STYLE, SIZE, OR COLOR.

PRIORITY DATE OF 8-6-2010 IS CLAIMED.  
OWNER OF INTERNATIONAL REGISTRATION 1062225 DATED 10-14-2010, EXPIRES 10-14-2020.  
OWNER OF U.S. REG. NO. 3,899,289.

## CLASS 6—METAL GOODS

FOR GOODS OF METAL, NAMELY, GENERAL PURPOSE METAL STORAGE UNITS AND METAL SKI STORAGE RACKS (U.S. CLS. 2, 12, 13, 14, 23, 25 AND 50).

## CLASS 7—MACHINERY

FOR MACHINES FOR AGRICULTURAL PURPOSES, NAMELY, HARVESTER-THRESHERS, SOWERS, SELF-PROPELLED SOWERS AND SELF-PROPELLED SOWERS COMBINED WITH EARTH MOVING EQUIPMENT; MACHINES FOR WOODWORKING PURPOSES, NAMELY, BAND SAWS, CIRCULAR SAWS AND GANG SAWS; SHARPENING MACHINES FOR SAW BLADES; MACHINE TOOLS, NAMELY, SAW BLADES, SANDING BELTS AND GRINDSTONES; TOOLS FOR AUTOMATING OF PROCESSES IN MANUFACTURING OF WOODEN FLOORS AND MULTI-LAYER-PANELS, NAMELY, CONVEYORS AND GLUING AND GROUTING FACILITIES, NAMELY, ELECTROMECHANICAL PRESSES; ELECTRIC MACHINES FOR BELT GRINDING AND ROTARY GRINDING, WAXING AND POLISHING SKI AND SNOWBOARD BASES AND EDGES, NAMELY, BELT SANDING MACHINES, STONE GRINDING MACHINES AND WAXING AND POLISHING MACHINES; MACHINES FOR REPAIRING SKI BASES AND MELTING COATINGS ONTO SKIS AND SNOWBOARDS; SKI BINDING ADJUSTMENT MACHINES; MACHINE TOOLS, NAMELY, SKI CLAMPING IMPLEMENTS (U.S. CLS. 13, 19, 21, 23, 31, 34 AND 35).

## CLASS 8—HAND TOOLS

FOR HAND-OPERATED TOOLS FOR GRINDING SKI AND SNOWBOARD BASES AND EDGES, NAMELY, ABRADING TOOLS, ADJUSTABLE SPANNERS; HAND-OPERATED TOOLS FOR REPAIRING SKI AND SNOWBOARD BASES AND MELTING COATINGS ONTO SKIS AND SNOWBOARDS, NAMELY, FUSING-GUNS; HAND TOOLS, NAMELY, FILES, SANDING SPONGES, SANDING BLOCKS, SANDING PADS FOR NON-ELECTRIC, HAND-OPERATED SANDERS, AND SCREWDRIVERS; HAND-OPERATED SKI CLAMPS (U.S. CLS. 23, 28 AND 44).

## CLASS 9—ELECTRICAL AND SCIENTIFIC APPARATUS

FOR MACHINE FOR WEIGHING AND RECORDING WEIGHT OF HARVESTS TO BE USED WITH COMBINES, HARVESTERS AND THRESHERS; DATA PROCESSORS AND COMPUTERS; COMPUTER PROGRAMS FOR OPERATING DATA PROCESSORS FOR RENTAL SKIS, SNOWBOARDS AND SKIING AND SNOWBOARDING EQUIPMENT; TOOLS FOR AUTOMATING PROCESSES IN MANUFACTURING OF WOODEN FLOORS AND MULTI-LAYER-PANELS, NAMELY, MEASURING DEVICES FOR MEASURING LENGTH, WIDTH AND THICKNESS (U.S. CLS. 21, 23, 26, 36 AND 38).

## CLASS 11—ENVIRONMENTAL CONTROL APPARATUS

FOR APPARATUS FOR HEATING, DRYING, VENTILATING AND STERILIZING PURPOSES, NAMELY, CLOTHES AND SKI-BOOT DRYERS, HOT AIR BLOWERS; INDUSTRIAL DRYERS FOR HEATING AND DEHUMIDIFYING; STERILIZERS FOR STERILIZING AND DRYING SKIING EQUIPMENT (U.S. CLS. 13, 21, 23, 31 AND 34).

## CLASS 12—VEHICLES

FOR LAND VEHICLES, NAMELY, PLOT TRACTORS; SKI CARRIERS FOR VEHICLES (U.S. CLS. 19, 21, 23, 31, 35 AND 44).

## CLASS 20—FURNITURE AND ARTICLES NOT OTHERWISE CLASSIFIED

FOR STORAGE RACKS MADE OF WOOD AND PLASTIC FOR SKIS (U.S. CLS. 2, 13, 22, 25, 32 AND 50).

## CLASS 28—TOYS AND SPORTING GOODS

FOR SCRAPERS FOR SKIS AND SNOWBOARDS; SKI BINDINGS AND PARTS OF SKI BINDINGS; SKI WAX; SNOWBOARD WAX (U.S. CLS. 22, 23, 38 AND 50).

## CLASS 37—CONSTRUCTION AND REPAIR

FOR REPAIR AND MAINTENANCE OF SKI COATINGS AND SKI EDGES, MACHINES AND MACHINE TOOLS, AGRICULTURAL DEVICES, MACHINES FOR GRINDING SKI BASES AND EDGES, GRINDING MACHINES, MACHINES FOR REPAIRING SKI BASES, SKI CLAMPING IMPLEMENTS, MACHINES FOR MELTING COATINGS ON SKIS, WAXING MACHINES, BINDING ADJUSTMENT MACHINES, SKI STORAGE AND TRANSPORT FACILITIES, WOODWORKING AND PROCESSING MACHINES, WOOD SAWING MACHINES AND ACCESSORIES OF WOOD SAWING MACHINES, HAND TOOLS, HAND-OPERATED IMPLEMENTS; REPAIR AND MAINTENANCE OF AGRICULTURAL MACHINES; CUSTOM CONSTRUCTION OF AGRICULTURAL INSTALLATIONS (U.S. CLS. 100, 103 AND 106).

## CLASS 40—MATERIAL TREATMENT

FOR THRESHING OF CEREALS (U.S. CLS. 100, 103 AND 106).

## CLASS 42—SCIENTIFIC AND COMPUTER SERVICES

FOR COMPUTER PROGRAMMING AND DESIGN OF DATA PROCESSING SOFTWARE, AND CONSULTANCY SERVICES IN THE FIELD OF DATA PROCESSING SOFTWARE DESIGN; TECHNICAL PLANNING OF AGRICULTURAL INSTALLATIONS (U.S. CLS. 100 AND 101).

CHRISTOPHER BUONGIORNO, EXAMINING ATTORNEY

SN 79-091,462. MATERIALISE N.V., BELGIUM, FILED 11-17-2010.

# SURGICASE

THE MARK CONSISTS OF STANDARD CHARACTERS WITHOUT CLAIM TO ANY PARTICULAR FONT, STYLE, SIZE, OR COLOR.

OWNER OF INTERNATIONAL REGISTRATION 1062238 DATED 11-17-2010, EXPIRES 11-17-2020.  
OWNER OF U.S. REG. NO. 3,608,979.

**CLASS 9—ELECTRICAL AND SCIENTIFIC APPARATUS**

FOR SOFTWARE PROGRAMS FOR PROCESSING AND EDITING IMAGES FOR MEDICAL AND SURGICAL APPLICATIONS (U.S. CLS. 21, 23, 26, 36 AND 38).

**CLASS 10—MEDICAL APPARATUS**

FOR MEDICAL AND DENTAL INSTRUMENTS FOR USE IN PRE-OPERATIVE PLANNING AND DIAGNOSTICS, NAMELY, DEVICES FOR CUTTING, DRILLING AND REPOSITIONING OF IMPLANTS (U.S. CLS. 26, 39 AND 44).

MATTHEW EINSTEIN, EXAMINING ATTORNEY

SN 79-091,863. FOSHAN RIFENG ENTERPRISE CO.,LTD, GUANGDONG, CHINA, FILED 10-7-2010.

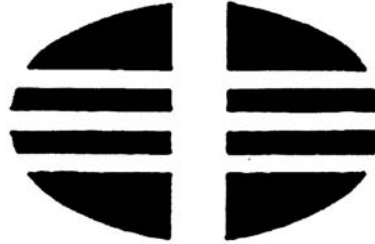

SN 79-091,570. SCHOELLER ARCA SYSTEMS GMBH, FED REP GERMANY, FILED 7-14-2010.



PRIORITY DATE OF 3-3-2010 IS CLAIMED.  
OWNER OF INTERNATIONAL REGISTRATION 1062366 DATED 7-14-2010, EXPIRES 7-14-2020.  
THE MARK CONSISTS OF THE STYLIZED LETTERS "SC".

**CLASS 20—FURNITURE AND ARTICLES NOT OTHERWISE CLASSIFIED**

FOR PLASTIC CONTAINERS, NAMELY, PLASTIC CONTAINERS FOR COMMERCIAL USE, PLASTIC BULK CONTAINERS FOR COMMERCIAL USE, PACKAGING CONTAINERS OF PLASTIC, PLASTIC CONTAINERS FOR STORAGE OR TRANSPORT AND PLASTIC STORAGE CONTAINERS FOR COMMERCIAL OR INDUSTRIAL USE; PLASTIC BOXES, NAMELY, PLASTIC SHIPPING AND STORAGE BOXES; NON-METAL PALLETS, NAMELY, PLASTIC PALLETS, PLASTIC PALLETS FOR LOADING AND PLASTIC PALLETS FOR TRANSPORT (U.S. CLS. 2, 13, 22, 25, 32 AND 50).

**CLASS 37—CONSTRUCTION AND REPAIR**

FOR CLEANING SERVICES, NAMELY, CLEANING OF REUSABLE PACKAGING, REUSABLE CONTAINERS AND REUSABLE PALLETS (U.S. CLS. 100, 103 AND 106).

**CLASS 39—TRANSPORTATION AND STORAGE**

FOR LOGISTIC SERVICES FOR TRANSPORT OF SYSTEMS, NAMELY, PICKUP, TRANSPORT AND DELIVERY OF REUSABLE PRODUCTS, NAMELY, REUSABLE PACKAGING, REUSABLE CONTAINERS AND REUSABLE PALLETS BETWEEN PRODUCERS AND RETAILERS; RENTAL SERVICES, NAMELY, RENTAL OF REUSABLE TRANSPORT PACKAGING, REUSABLE CONTAINERS AND REUSABLE PALLETS (U.S. CLS. 100 AND 105).

NAPOLÉON SHARMA, EXAMINING ATTORNEY

OWNER OF INTERNATIONAL REGISTRATION 1063205 DATED 10-7-2010, EXPIRES 10-7-2020.

OWNER OF U.S. REG. NO. 3,479,814.  
THE MARK CONSISTS OF A OVAL WITH A BREAK IN THE MIDDLE AND FEATURING BARS, BANDS, AND LINES.

**CLASS 1—CHEMICALS**

FOR OIL CEMENT BEING PUTTY; ADHESIVES FOR INDUSTRIAL PURPOSES; VISCOSE FOR MANUFACTURING AND INDUSTRIAL PURPOSES; CONTACT CEMENTS; MASTIC FOR LEATHER; ADHESIVES FOR PAPERHANGING; PLASTISOLS; STARCH PASTE BEING ADHESIVE, OTHER THAN FOR STATIONERY OR HOUSEHOLD PURPOSES; ADHESIVES FOR WALL TILES; GLUE FOR INDUSTRIAL PURPOSES; GUMS BEING ADHESIVES FOR INDUSTRIAL AND COMMERCIAL USE, OTHER THAN FOR STATIONERY OR HOUSEHOLD PURPOSES; CHEMICAL CURING AGENTS (U.S. CLS. 1, 5, 6, 10, 26 AND 46).

**CLASS 2—PAINTS**

FOR WOOD COATINGS BEING PAINTS; VARNISHES; LIME WASH PAINT; THINNERS FOR LACQUERS; DISTEMPERS; SICCATIVES BEING DRYING AGENTS FOR PAINTS; COATINGS BEING PAINTS; FIXATIVES BEING VARNISHES; AGGLUTINANTS FOR PAINTS; PRIMERS; LACQUERS; THINNER FOR PAINTS; NON-STICKY CHEMICAL COATING FOR NON-STICK PANS; WATER-REPELLENT COATING; PAINTS (U.S. CLS. 6, 11 AND 16).

**CLASS 11—ENVIRONMENTAL CONTROL APPARATUS**

FOR REGULATING ACCESSORIES FOR WATER OR GAS APPARATUS AND PIPES; HEAT PUMPS; HYDRANTS; HOT WATER HEATING INSTALLATIONS; ANTI-SPLASH TAP NOZZLES; WATER-PIPES FOR SANITARY INSTALLATIONS, NAMELY, PIPES BEING PART OF SANITARY FACILITIES; WATER DISTRIBUTION INSTALLATIONS, NAMELY, IRRIGATION SPRINKLERS, PIPES BEING PARTS OF PLUMBING INSTALLATIONS, SPOUTS FOR AFFIXING ON WALLS FOR BATHS, BASINS, AND SHOWERS; PRESSURE WATER TREATMENT TANKS; FLOOR DRAINS; PIPE ACCESSORY FOR HOT-WATER HEATING DEVICE, NAMELY, PIPE HEATING TAPE, PIPE REGULATORS FOR HOT WATER HEATING INSTALLATIONS, FLEXIBLE PIPES BEING PARTS OF HOT WATER HEATING INSTALLATIONS; AUTOMATIC WATERING INSTALLATIONS, NAMELY, IRRIGATIONS SPRINKLERS; BATH FITTINGS, NAMELY, COUPLERS, DRAINS, FAUCET FILTERS, SPOUTS, TRAPS, VALVES, BAFFLES; BATH TUBS; WASH-HAND BASINS BEING PARTS OF SANITARY INSTALLATIONS; SHOWER CUBICLE ENCLOSURES; SANITARY APPARATUS AND INSTALLATIONS, NAMELY, SINKS, BASINS, TOILETS, HOT TUBS; URINALS BEING SANITARY FIXTURES; TOILET SEATS; TOILET BOWLS; WATER PURIFICATION INSTALLATIONS; WATER FILTERING APPARATUS; DEVICE FOR DRINKING WATER, NAMELY, DRINKING FOUNTAINS (U.S. CLS. 13, 21, 23, 31 AND 34).

**CLASS 20—FURNITURE AND ARTICLES NOT OTHERWISE CLASSIFIED**

FOR SIDEBARDS; OFFICE FURNITURE; FURNITURE; FURNITURE OF METAL; STORAGE AND DISPLAY RACKS; WASHSTANDS; DRESSING TABLES; TOWEL CLOSETS; BATHROOM CABINETS; CUPBOARDS (U.S. CLS. 2, 13, 22, 25, 32 AND 50).

JACLYN KIDWELL WALKER, EXAMINING ATTORNEY

SN 79-091,875. BYK-CHEMIE GMBH, FED REP GERMANY, FILED 10-21-2010.

# BYKJET

THE MARK CONSISTS OF STANDARD CHARACTERS WITHOUT CLAIM TO ANY PARTICULAR FONT, STYLE, SIZE, OR COLOR.

PRIORITY DATE OF 9-29-2010 IS CLAIMED.

OWNER OF INTERNATIONAL REGISTRATION 1063237 DATED 10-21-2010, EXPIRES 10-21-2020.

OWNER OF U.S. REG. NOS. 3,554,205, 3,619,448 AND 3,619,450.

**CLASS 1—CHEMICALS**

FOR CHEMICAL PREPARATIONS FOR INDUSTRIAL AND SCIENTIFIC PURPOSES; UNPROCESSED SYNTHETIC RESINS AND PLASTICS; ADHESIVES FOR INDUSTRIAL USE; SURFACE ACTIVE COMPOUNDS FOR THE MANUFACTURE OF PAINTS AND LACQUERS FOR INFLUENCING THE SURFACE TENSION, NAMELY, EMULSIFYING AGENTS, DISPERSING AGENTS, WETTING AGENTS, HARDENERS AND SOLVENTS; SILICONES; CHEMICAL ADDITIVES FOR THE PRODUCTION OF INK, PRINTING INK AND TONER; PHOTOGRAPHIC CHEMICALS, NAMELY, TONING SALTS; CHEMICALS FOR USE IN INDUSTRY AND SCIENCE, NAMELY, CARBON BLACK; PROCESS AGENTS, NAMELY, CHEMICAL AGENTS FOR MANUFACTURING DYESTUFFS (U.S. CLS. 1, 5, 6, 10, 26 AND 46).

**CLASS 2—PAINTS**

FOR PAINTS, VARNISHES, LACQUERS; PIGMENTS, IN PARTICULAR CARBON BLACK AND ORGANIC PIGMENTS, NAMELY, IRON PIGMENTS, PEARL GLOSS PIGMENTS, METAL EFFECT PIGMENTS, INTERFERENCE PIGMENTS; POWDER COATINGS, NAMELY, ANTI-CORROSIVE POWDER COATINGS, ANTI-RUST POWDER COATINGS; DYES FOR GENERAL INDUSTRIAL USE, UNPROCESSED NATURAL RESINS; ADDITIVES FOR PAINTS AND LACQUERS, NAMELY, PROCESS AGENTS, NAMELY, FLUORESCENT BRIGHTENING AGENTS, DYES, DRYING AGENTS, BINDING AGENTS, THICKENERS FIXING AGENTS AND MATERIAL TO DISPERSE PAINTS AND LACQUERS; PRINTING INK; PRINTING PASTES, PRINTING LACQUERS; TONER AND TONER CARTRIDGES FOR PRINTERS AND COPIERS; PAINTS, LACQUERS, PIGMENTS FOR THE PRODUCTION OF PRINTING INK (U.S. CLS. 6, 11 AND 16).

**CLASS 4—LUBRICANTS AND FUELS**

FOR WAXES; WAXES FOR GENERAL INDUSTRIAL USE; INDUSTRIAL OILS AND GREASES (U.S. CLS. 1, 6 AND 15).

**CLASS 42—SCIENTIFIC AND COMPUTER SERVICES**

FOR CHEMIST SERVICES; ENGINEERING SERVICES; CHEMICAL ANALYSES; SCIENTIFIC RESEARCHES; CHEMICAL RESEARCH; INDUSTRIAL ANALYSES AND RESEARCH SERVICES IN THE FIELD OF CHEMICAL PREPARATIONS; CALIBRATION AND FUNCTIONAL TESTING OF MEASURING DEVICES; MATERIAL TESTING; TECHNICAL ADVICE RELATING TO THE APPLICATION OF CHEMICAL PREPARATIONS; TECHNICAL PROJECT STUDIES, NAMELY, CONDUCTING FEASIBILITY STUDIES; DESIGN AND DEVELOPMENT OF COMPUTER HARDWARE AND SOFTWARE; TECHNICAL ADVICE RELATING TO COMPUTER HARDWARE AND SOFTWARE (U.S. CLS. 100 AND 101).

DANIEL CAPSHAW, EXAMINING ATTORNEY

SN 79-091,886. NOVO NORDISK A/S, DK-2880 BAGSVAERD, DENMARK, FILED 10-25-2010.

# insulinnovations

THE MARK CONSISTS OF STANDARD CHARACTERS WITHOUT CLAIM TO ANY PARTICULAR FONT, STYLE, SIZE, OR COLOR.

PRIORITY DATE OF 10-20-2010 IS CLAIMED.

OWNER OF INTERNATIONAL REGISTRATION 1063266 DATED 10-25-2010, EXPIRES 10-25-2020.

**CLASS 5—PHARMACEUTICALS**

FOR PHARMACEUTICAL PREPARATION CONTAINING INSULIN FOR THE TREATMENT OF DIABETES (U.S. CLS. 6, 18, 44, 46, 51 AND 52).

**CLASS 10—MEDICAL APPARATUS**

FOR MEDICAL APPARATUS AND INSTRUMENTS, NAMELY, HYPODERMIC SYRINGES (U.S. CLS. 26, 39 AND 44).

**CLASS 44—MEDICAL, BEAUTY AND AGRICULTURAL SERVICES**

FOR PROVIDING A WEBSITE THAT FEATURES INFORMATION IN THE FIELD OF DIABETES TREATMENT (U.S. CLS. 100 AND 101).

DEIRDRE ROBERTSON, EXAMINING ATTORNEY

SN 79-091,924. RAMIRO SEGRELLES MOLMENEU, SPAIN, FILED 9-28-2010.

# QCUMB TONIC

OWNER OF INTERNATIONAL REGISTRATION 1063360 DATED 9-28-2010, EXPIRES 9-28-2020.

NO CLAIM IS MADE TO THE EXCLUSIVE RIGHT TO USE "TONIC", APART FROM THE MARK AS SHOWN.

THE MARK CONSISTS OF THE WORDING "QCUMB TONIC" IN STYLIZED FONT.

THE WORDING "QCUMB" HAS NO MEANING IN A FOREIGN LANGUAGE.

**CLASS 32—LIGHT BEVERAGES**

FOR REFRESHING BEVERAGES IN THE NATURE OF SOFT DRINKS (U.S. CLS. 45, 46 AND 48).



**CLASS 33—WINES AND SPIRITS**

FOR ALCOHOLIC BEVERAGES EXCEPT BEER (U.S. CLS. 47 AND 49).  
KAREN SEVERSON, EXAMINING ATTORNEY

SN 79-092,021. BSG AUTO GLASS CO., LTD., GUANGDONG PROVINCE, CHINA, FILED 5-24-2010.



OWNER OF INTERNATIONAL REGISTRATION 1063620 DATED 5-24-2010, EXPIRES 5-24-2020.  
OWNER OF U.S. REG. NO. 3,588,564.  
THE MARK CONSISTS OF THE LETTERS "B","S","G" SURROUNDED BY AN OVAL.

**CLASS 19—NON-METALLIC BUILDING MATERIALS**

FOR SAFETY GLASS FOR BUILDING PURPOSES; MEMBRANE-PLATING GLASS FOR BUILDING; WINDOW GLASS, FOR BUILDING; WINDOW GLASS NOT FOR VEHICLES; INSULATING GLASS FOR WINDOWS FOR BUILDING PURPOSES; BUILDING GLASS; ALABASTER GLASS; GLASS GRANULES FOR ROAD MARKING; STAINED-GLASS WINDOWS; GLASS DOORS AND WINDOWS WITH STEEL COMPONENTS (U.S. CLS. 1, 12, 33 AND 50).

**CLASS 37—CONSTRUCTION AND REPAIR**

FOR INSTALLATION OF WINDSHIELDS FOR VEHICLES; INSTALLATION OF ANTI-DAZZLE DEVICES FOR VEHICLES; INSTALLATION OF SUN-BLINDS ADAPTED FOR AUTOMOBILES; MAINTENANCE, REPAIR AND REPLACEMENT OF WINDSHIELDS FOR VEHICLE; MOTOR VEHICLE MAINTENANCE AND REPAIR; REFUELING AND MAINTENANCE VEHICLE SERVICE STATIONS (U.S. CLS. 100, 103 AND 106).  
THEODORE MCBRIDE, EXAMINING ATTORNEY

SN 79-092,650. SOCIÉTÉ MOBILE'S REPUBLIC, FRANCE, FILED 11-2-2010.

# NEWS REPUBLIC

THE MARK CONSISTS OF STANDARD CHARACTERS WITHOUT CLAIM TO ANY PARTICULAR FONT, STYLE, SIZE, OR COLOR.  
PRIORITY DATE OF 6-10-2010 IS CLAIMED.  
OWNER OF INTERNATIONAL REGISTRATION 1065355 DATED 11-2-2010, EXPIRES 11-2-2020.  
NO CLAIM IS MADE TO THE EXCLUSIVE RIGHT TO USE "NEWS", APART FROM THE MARK AS SHOWN.

**CLASS 9—ELECTRICAL AND SCIENTIFIC APPARATUS**

FOR COMPUTER SOFTWARE ENABLING THE DEVELOPMENT, MODIFICATION AND MAINTENANCE OF THE DELIVERY AND MANAGEMENT OF IMAGES, SOUND AND DATA VIA MOBILE TELEPHONY OR VIA COMPUTERS AND TELEPHONES; SOFTWARE EMBEDDED ON OR DOWNLOADABLE ONTO MOBILE TERMINALS FOR THE COMMUNICATION OF NEWS TO THE USER; SOFTWARE FOR MANAGING COMMUNITIES OF MOBILE TERMINAL USERS; TELECOMMUNICATION SOFTWARE FOR THE COMMUNICATION OF NEWS TO THE USE (U.S. CLS. 21, 23, 26, 36 AND 38).

**CLASS 38—COMMUNICATION**

FOR TRANSMISSION AND BROADCASTING OF INFORMATION VIA GLOBAL COMMUNICATION NETWORKS SUCH AS THE INTERNET, VIA MOBILE TELEPHONE NETWORKS AND TELECOMMUNICATIONS NETWORKS; TELECOMMUNICATIONS VIA COMPUTER TERMINALS OR MOBILE TERMINALS; INTERACTIVE AND MULTIMEDIA TELECOMMUNICATIONS, NAMELY, TRANSMISSION OF SOUND AND VISION VIA SATELLITE OR INTERACTIVE MULTIMEDIA NETWORKS; TELECOMMUNICATIONS VIA COMPUTER NETWORKS AND GLOBAL TELECOMMUNICATION NETWORKS; ELECTRONIC DATA INTERCHANGE SERVICES; PROVIDING ACCESS TO A GLOBAL COMPUTER NETWORK; TELEVISION PROGRAM BROADCASTING; TELEVISION AND RADIO BROADCASTING; ELECTRONIC MAIL; TRANSMISSION OF MESSAGES, IMAGES, SOUNDS AND DATA AIDED BY COMPUTERS OR BY MOBILE TELEPHONES OR TERMINALS; TRANSMISSION OF INFORMATION HELD IN DATA BANKS; ON-SCREEN CONSULTING OF INFORMATION CONTAINED IN A DATA BANK STORED ON A COMPUTER OR ON A MOBILE TELEPHONE OR TERMINAL, NAMELY, TELEPHONE RELAY SERVICES USING ON-SCREEN VIDEO; ELECTRONIC COMMUNICATION SERVICES BY COMPUTER AND BY MOBILE TELEPHONE OR TERMINAL (U.S. CLS. 100, 101 AND 104).

**CLASS 41—EDUCATION AND ENTERTAINMENT**

FOR ENTERTAINMENT SERVICES, NAMELY, THE PROVISION OF CONTINUING AUDIOVISUAL PROGRAMS FEATURING NEWS, COMEDY, COMMENTARY, VIA THE INTERNET OR PRIVATE OR RESTRICTED-ACCESS SUCH AS AN INTRANET COMMUNICATION NETWORK, OR CABLE, OR SATELLITE, OR RADIO WAVES; PROVIDING ONLINE NON-DOWNLOADABLE ELECTRONIC PUBLICATIONS IN THE NATURE OF MAGAZINES, NEWSPAPERS, FEATURING CURRENT EVENT NEWS; PUBLICATION OF ELECTRONIC BOOKS AND JOURNALS ON-LINE; PRODUCTION AND RECORDING OF AUDIO AND VIDEO MEDIA; ARRANGING AND CONDUCTING EDUCATIONAL CONFERENCES, SEMINARS, SYMPOSIUMS, COURSES AND WORKSHOPS IN THE FIELD OF CURRENT EVENT NEWS REPORTING AND PUBLICATION; ON-LINE ELECTRONIC LIBRARY SERVICES FOR SUPPLYING ELECTRONIC INFORMATION INCLUDING INFORMATION FROM ARCHIVE IN THE FORM OF ELECTRONIC TEXTS, INFORMATION AND AUDIO AND VIDEO DATA, GAMES AND ENTERTAINMENT; PROVIDING WEBSITES AND DATABASES FEATURING PHOTOGRAPHS, IMAGES, GRAPHICS, SOUNDS, FILMS, VIDEOS AND AUDIOVISUAL PROGRAMS IN THE FIELD OF CURRENT EVENT NEWS; PROVIDING INFORMATION AND ADVICE CONCERNING ALL THE AFORESAID SERVICES (U.S. CLS. 100, 101 AND 107).  
KRISTINA MORRIS, EXAMINING ATTORNEY

SN 79-092,705. JOHN FINLAN, UNITED KINGDOM, FILED 9-23-2010.



PRIORITY DATE OF 3-31-2010 IS CLAIMED.  
OWNER OF INTERNATIONAL REGISTRATION 1065554  
DATED 9-23-2010, EXPIRES 9-23-2020.  
NO CLAIM IS MADE TO THE EXCLUSIVE RIGHT TO  
USE "DOG", APART FROM THE MARK AS SHOWN.  
THE MARK CONSISTS OF THE WORDING "COOL DOG"  
IN STYLIZED FONT, TO THE RIGHT OF A DOG'S HEAD.

#### CLASS 18—LEATHER GOODS

FOR ANIMAL LEASHES; PET RESTRAINING DEVICES, NAMELY, LEASHES, COLLARS, MUZZLES AND HARNESSSES; CLOTHING FOR ANIMALS AND PETS (U.S. CLS. 1, 2, 3, 22 AND 41).

#### CLASS 21—HOUSEWARES AND GLASS

FOR GROOMING TOOLS FOR ANIMALS, NAMELY, COMBS, BRUSHES AND SPONGES; NON-MECHANIZED ANIMAL FEEDERS AND ANIMAL FEEDING BOWLS; ANIMAL LITTER SCOOPS; ANIMAL LITTER BOXES; CAT FOOD SCOOPS (U.S. CLS. 2, 13, 23, 29, 30, 33, 40 AND 50).

#### CLASS 28—TOYS AND SPORTING GOODS

FOR PET TOYS, DOG TOYS, CAT TOYS (U.S. CLS. 22, 23, 38 AND 50).  
LIEF MARTIN, EXAMINING ATTORNEY

SN 79-092,712. BEPERFECT CLINICS BV, NETHERLANDS, FILED 10-13-2010.

## CLEAR CORRECT

THE MARK CONSISTS OF STANDARD CHARACTERS WITHOUT CLAIM TO ANY PARTICULAR FONT, STYLE, SIZE, OR COLOR.  
OWNER OF INTERNATIONAL REGISTRATION 1065583  
DATED 10-13-2010, EXPIRES 10-13-2020.

#### CLASS 10—MEDICAL APPARATUS

FOR SURGICAL INSTRUMENTS AND APPARATUS, MEDICAL INSTRUMENTS AND APPARATUS FOR TREATING MALOCCLUSION AND/OR OTHER ORTHODONTIC TREATMENTS, DENTAL APPARATUS AND INSTRUMENTS, NAMELY, ORTHODONTIC MACHINES AND INSTRUMENTS, ARTIFICIAL LIMBS, EYES AND TEETH (U.S. CLS. 26, 39 AND 44).

#### CLASS 41—EDUCATION AND ENTERTAINMENT

FOR EDUCATIONAL SERVICES, NAMELY, PROVIDING WORKSHOPS, SEMINARS AND CLASSES IN THE FIELD OF ORTHODONTICS; PROVIDING OF TRAINING IN THE FIELD OF ORTHODONTICS; ENTERTAINMENT, NAMELY, LIVE PERFORMANCES BY A MUSICAL GROUP; ORGANIZING COMMUNITY SPORTING AND CULTURAL EVENTS (U.S. CLS. 100, 101 AND 107).

#### CLASS 44—MEDICAL, BEAUTY AND AGRICULTURAL SERVICES

FOR MEDICAL SERVICES; VETERINARY ASSISTANCE, NAMELY, VETERINARY SURGERY AND DENTISTRY; HYGIENIC AND BEAUTY CARE FOR HUMAN BEINGS OR ANIMALS (U.S. CLS. 100 AND 101).

ERNEST SHOSHO, EXAMINING ATTORNEY

SN 79-092,846. INDENA SPA, I-20139 MILANO, ITALY, FILED 12-15-2010.

## INDENASELECT

THE MARK CONSISTS OF STANDARD CHARACTERS WITHOUT CLAIM TO ANY PARTICULAR FONT, STYLE, SIZE, OR COLOR.

PRIORITY DATE OF 12-2-2010 IS CLAIMED.  
OWNER OF INTERNATIONAL REGISTRATION 1065877  
DATED 12-15-2010, EXPIRES 12-15-2020.  
OWNER OF U.S. REG. NOS. 2,175,911, 2,495,569 AND OTHERS.

#### CLASS 1—CHEMICALS

FOR CHEMICAL EXTRACTS AND ACTIVE PRINCIPLES EXTRACTED FROM MEDICINAL PLANTS FOR USE IN THE MANUFACTURE OF PHARMACEUTICALS, COSMETICS AND FOODS (U.S. CLS. 1, 5, 6, 10, 26 AND 46).

#### CLASS 42—SCIENTIFIC AND COMPUTER SERVICES

FOR SCIENTIFIC RESEARCH IN THE FIELD OF CHEMICALS, PHARMACEUTICALS, HYGIENIC AND BEAUTY CARE (U.S. CLS. 100 AND 101).  
DANIEL CAPSHAW, EXAMINING ATTORNEY

SN 79-092,915. NOVO NORDISK A/S, DENMARK, FILED 12-1-2010.

## Full STEP

THE MARK CONSISTS OF STANDARD CHARACTERS WITHOUT CLAIM TO ANY PARTICULAR FONT, STYLE, SIZE, OR COLOR.

OWNER OF INTERNATIONAL REGISTRATION 1066056  
DATED 12-1-2010, EXPIRES 12-1-2020.

#### CLASS 16—PAPER GOODS AND PRINTED MATTER

FOR PRINTED PUBLICATIONS, NAMELY, MAGAZINES, JOURNALS, PAMPHLETS, BOOKS, BOOKLETS AND NEWS LETTERS RELATED TO MEDICAL STUDIES AND RESEARCH REGARDING PHARMACEUTICAL PREPARATIONS FOR THE TREATMENT OF DIABETES (U.S. CLS. 2, 5, 22, 23, 29, 37, 38 AND 50).

#### CLASS 42—SCIENTIFIC AND COMPUTER SERVICES

FOR MEDICAL AND SCIENTIFIC RESEARCH, NAMELY, CONDUCTING CLINICAL TRIALS AND STUDIES FOR PHARMACEUTICAL PREPARATIONS RELATED TO THE TREATMENT OF DIABETES AND PROVIDING SCIENTIFIC INFORMATION ON THE EFFICACY OF PHARMACEUTICAL PREPARATIONS FOR THE TREATMENT OF DIABETES (U.S. CLS. 100 AND 101).

**CLASS 44—MEDICAL, BEAUTY AND AGRICULTURAL SERVICES**

FOR PROVIDING MEDICAL INFORMATION ON THE EFFICACY OF PHARMACEUTICAL PREPARATIONS FOR THE TREATMENT OF DIABETES (U.S. CLS. 100 AND 101).

HOWARD B. LEVINE, EXAMINING ATTORNEY

SN 79-093,007. MAREALIS AS, NORWAY, FILED 9-2-2010.

# MAREALIS

THE MARK CONSISTS OF STANDARD CHARACTERS WITHOUT CLAIM TO ANY PARTICULAR FONT, STYLE, SIZE, OR COLOR.

OWNER OF INTERNATIONAL REGISTRATION 1066348 DATED 9-2-2010, EXPIRES 9-2-2020.

**CLASS 1—CHEMICALS**

FOR FERTILIZERS FOR SOIL; FERTILIZERS; CHEMICALS, NAMELY, CHITIN AS A RAW MATERIAL; CHEMICALS, NAMELY, CHITOSAN AS A RAW MATERIAL; FATTY ACIDS FOR USE IN DIETARY SUPPLEMENTS (U.S. CLS. 1, 5, 6, 10, 26 AND 46).

**CLASS 5—PHARMACEUTICALS**

FOR FOODS FOR MEDICAL USE, NAMELY, DIETARY AND NUTRITIONALLY FORTIFIED FOOD PRODUCTS ADAPTED FOR MEDICAL USE, DIETIC FOODS ADAPTED FOR MEDICAL USE; AMINO ACIDS FOR MEDICAL AND VETERINARY PURPOSES, VITAMIN PREPARATIONS; SYNTHETIC PEPTIDES FOR THE TREATMENT OF HYPERTENSION AND METABOLIC SYNDROME (U.S. CLS. 6, 18, 44, 46, 51 AND 52).

**CLASS 29—MEATS AND PROCESSED FOODS**

FOR PROTEIN FOR USE AS A FOOD FILLER; PROTEIN FOR USE AS A FOOD ADDITIVE; HYDROLYZED MARINE PROTEIN (U.S. CL. 46).

ANDREA HACK, EXAMINING ATTORNEY

SN 79-093,076. LABCOSMETICS GMBH & CO. KG, 22761 HAMBURG, FED REP GERMANY, FILED 12-1-2010.

# Rewimol

THE MARK CONSISTS OF STANDARD CHARACTERS WITHOUT CLAIM TO ANY PARTICULAR FONT, STYLE, SIZE, OR COLOR.

OWNER OF INTERNATIONAL REGISTRATION 1066573 DATED 12-1-2010, EXPIRES 12-1-2020.

**CLASS 5—PHARMACEUTICALS**

FOR PHARMACEUTICAL PREPARATIONS FOR TREATING DIABETES; PREPARATIONS FOR MEDICAL PURPOSES, NAMELY, PHARMACEUTICAL PREPARATIONS CONTAINING MINERALS, TRACE ELEMENTS, AND VITAMINS FOR USE IN TREATING DIABETES AND CANCER; DIETETIC FOODS ADAPTED FOR MEDICAL USE (U.S. CLS. 6, 18, 44, 46, 51 AND 52).

**CLASS 29—MEATS AND PROCESSED FOODS**

FOR FOOD SUPPLEMENTS NOT ADAPTED FOR MEDICAL USE, WITH A BASE OF PROTEINS, FATS, FATTY ACIDS, WITH ADDED VITAMINS, MINERALS AND TRACE ELEMENTS, INCLUDED IN THIS CLASS (U.S. CL. 46).

**CLASS 30—STAPLE FOODS**

FOR FOOD SUPPLEMENTS NOT ADAPTED FOR MEDICAL USE, WITH A BASE OF CARBOHYDRATES, ROUGHAGE, WITH ADDED VITAMINS, MINERALS, TRACE ELEMENTS, EITHER SINGLY OR IN COMBINATION, INCLUDED IN THIS CLASS (U.S. CL. 46).

MAUREEN DALL, EXAMINING ATTORNEY

SN 79-094,263. UZIN UTZ AKTIENGESELLSCHAFT, FED REP GERMANY, FILED 10-29-2010.

# Steptec

THE MARK CONSISTS OF STANDARD CHARACTERS WITHOUT CLAIM TO ANY PARTICULAR FONT, STYLE, SIZE, OR COLOR.

PRIORITY DATE OF 5-3-2010 IS CLAIMED.  
OWNER OF INTERNATIONAL REGISTRATION 1068902 DATED 10-29-2010, EXPIRES 10-29-2020.

**CLASS 1—CHEMICALS**

FOR ADHESIVES FOR INDUSTRIAL PURPOSES, NAMELY, DRY ADHESIVES FOR INDUSTRIAL PURPOSES (U.S. CLS. 1, 5, 6, 10, 26 AND 46).

**CLASS 17—RUBBER GOODS**

FOR ADHESIVE PLASTIC FILMS AND ADHESIVE TAPES FOR INDUSTRIAL PURPOSES; CARRIER MATERIALS, NAMELY, FIBRE WEB COATED WITH ADHESIVES FOR LAYING FLOOR COVERINGS (U.S. CLS. 1, 5, 12, 13, 35 AND 50).

KRISTIN CARLSON, EXAMINING ATTORNEY

SN 85-000,226. PROVIDENT BANK, MONTEBELLO, NY, FILED 3-28-2010.

# PBNY Connect

THE MARK CONSISTS OF STANDARD CHARACTERS WITHOUT CLAIM TO ANY PARTICULAR FONT, STYLE, SIZE, OR COLOR.

**CLASS 16—PAPER GOODS AND PRINTED MATTER**

FOR PRINTED QUARTERLY MAGAZINE FOR BUSINESSES FEATURING BUSINESS NEWS, BUSINESS MANAGEMENT SKILLS AND PROFILES OF BUSINESS ENTREPRENEURS (U.S. CLS. 2, 5, 22, 23, 29, 37, 38 AND 50).

FIRST USE 2-1-2010; IN COMMERCE 2-1-2010.

**CLASS 35—ADVERTISING AND BUSINESS**

FOR PROVIDING A WEBSITE FEATURING INFORMATION IN THE FIELD OF BUSINESS MANAGEMENT SKILLS, BUSINESS NEWS AND PROFILES OF BUSINESS ENTREPRENEURS (U.S. CLS. 100, 101 AND 102).  
FIRST USE 2-1-2010; IN COMMERCE 2-1-2010.

**CLASS 41—EDUCATION AND ENTERTAINMENT**

FOR PROVIDING ONLINE ELECTRONIC NEWSLETTERS FOR BUSINESSES FEATURING BUSINESS MANAGEMENT SKILLS, BUSINESS NEWS, AND PROFILES OF BUSINESS ENTREPRENEURS (U.S. CLS. 100, 101 AND 107).  
FIRST USE 2-1-2010; IN COMMERCE 2-1-2010.  
SUSAN STIGLITZ, EXAMINING ATTORNEY

**CLASS 24—FABRICS**

FOR HAND TOWELS OF TEXTILE; INDIVIDUAL PLACE MATS MADE OF TEXTILE; OVEN MITTS; PLACE MATS OF TEXTILE MATERIAL; POT HOLDERS; TABLE CLOTH OF TEXTILE; TABLE LINEN OF TEXTILE; TABLE NAPKINS OF TEXTILE; TABLECLOTHS OF TEXTILES; TOWELS MADE OF TEXTILE MATERIALS (U.S. CLS. 42 AND 50).

**CLASS 25—CLOTHING**

FOR APRONS; CLOGS; GOLF SHIRTS; KNIT SHIRTS; LONG-SLEEVED SHIRTS; PANTS; SHIRTS; SHOES; SMOCKS; SPORT SHIRTS; SPORTS SHIRTS WITH SHORT SLEEVES; SWEAT SHIRTS; T-SHIRTS; TEE SHIRTS (U.S. CLS. 22 AND 39).  
JILL C. ALT, EXAMINING ATTORNEY

---

SN 85-001,639. BLUE JEAN CHEF INC., PHILADELPHIA, PA.  
FILED 3-30-2010.



---

SN 85-006,797. BOURNS, INC., RIVERSIDE, CA. FILED 4-5-2010.

**PORTNOTE**

NO CLAIM IS MADE TO THE EXCLUSIVE RIGHT TO USE "BLUE JEAN CHEF", APART FROM THE MARK AS SHOWN.

THE MARK CONSISTS OF FOUR CONCENTRIC CIRCLES, AN OUTER CIRCLE OF A SINGLE DARK LINE, A LIGHT CIRCLE JUST INWARD TOWARD THE CENTER, ABOUT ONE QUARTER INCH THICK AND INWARD FROM THAT, A DARK CIRCLE, ALSO ABOUT ONE QUARTER INCH THICK. IN THE CENTER OF THE CIRCLE IS YET ANOTHER DARK CIRCLE, SMALLER, AND WITH A THICKNESS OF ONE-EIGHTH OF AN INCH. AT THE 6 O'CLOCK PLACE ON THE CIRCLE IS A SHADED DOT WITH TWO OTHER SHADED DOTS ON EITHER SIDE. IN THE SPACE ABOVE, THE WORDING "BLUE JEAN" IS BENT AROUND THE INNER CIRCLE IN STYLIZED CAPITAL LETTERS, WHILE THE WORD "CHEF" APPEARS IN THE LOWER PART OF THE INNER CIRCLE AND TO THE RIGHT IN STYLIZED CURSIVE SCRIPT.

**CLASS 8—HAND TOOLS**

FOR CUTLERY; CUTLERY, NAMELY, SCALERS; CUTLERY, NAMELY, FORKS, SPOONS AND KNIVES; FORKS (U.S. CLS. 23, 28 AND 44).

**CLASS 21—HOUSEWARES AND GLASS**

FOR COOKWARE FOR USE IN MICROWAVE OVENS; COOKWARE, NAMELY, POTS AND PANS; COOKWARE, NAMELY, ROASTING PANS; COOKWARE, NAMELY, STEAMERS; COOKWARE, NAMELY, WOKS; DUTCH OVENS; OVEN TO TABLE RACKS (U.S. CLS. 2, 13, 23, 29, 30, 33, 40 AND 50).

THE MARK CONSISTS OF STANDARD CHARACTERS WITHOUT CLAIM TO ANY PARTICULAR FONT, STYLE, SIZE, OR COLOR.

**CLASS 16—PAPER GOODS AND PRINTED MATTER**

FOR PRINTED MATTER, NAMELY, DATA SHEETS AND TECHNICAL JOURNALS FEATURING INFORMATION IN THE FIELD OF ELECTRONICS, NAMELY, ELECTROSTATIC DISCHARGE, ELECTRIC LIGHTING, ELECTRIC POWER INDUCTION, GROUND POTENTIAL RISE, SHORT CIRCUITS AND ELECTRIC SURGE ENCOUNTERED IN PLUG-IN CONNECTIONS TO ELECTRONIC INTERFACES, NAMELY, PORTS AND INTERFACES FOR ETHERNETS, MODEMS, SATELLITE ANTENNAS, LIQUID CRYSTAL DISPLAYS, CONTROLLER AREA NETWORK BUSES, LIGHT EMITTING DIODE DRIVERS, AC/DC CONVERTERS, DIRECT CURRENT POWERED DEVICES, INVERTER MOTOR DRIVES, KEYPAD PUSH BUTTONS, BATTERY CHARGERS, TOUCH PANELS, SERIAL ADVANCED TECHNOLOGY ATTACHMENTS, S-VIDEO INPUTS, VIDEO GRAPHIC ARRAYS, HIGH-DEFINITION MULTIMEDIA INTERFACES, AND USB PORTS (U.S. CLS. 2, 5, 22, 23, 29, 37, 38 AND 50).

FIRST USE 3-26-2010; IN COMMERCE 3-26-2010.



**CLASS 41—EDUCATION AND ENTERTAINMENT**

FOR PROVISION OF ON-LINE, NON-DOWNLOADABLE PUBLICATIONS, NAMELY, DATA SHEETS AND TECHNICAL JOURNALS FEATURING INFORMATION IN THE FIELD OF ELECTRONICS, NAMELY, ELECTROSTATIC DISCHARGE, ELECTRIC LIGHTING, ELECTRIC POWER INDUCTION, GROUND POTENTIAL RISE, SHORT CIRCUITS AND ELECTRIC SURGE ENCOUNTERED IN PLUG-IN CONNECTIONS TO ELECTRONIC INTERFACES, NAMELY, PORTS AND INTERFACES FOR ETHERNETS, MODEMS, SATELLITE ANTENNAS, LIQUID CRYSTAL DISPLAYS, CONTROLLER AREA NETWORK BUSES, LIGHT EMITTING DIODE DRIVERS, AC/DC CONVERTERS, DIRECT CURRENT POWERED DEVICES, INVERTER MOTOR DRIVES, KEYPAD PUSH BUTTONS, BATTERY CHARGERS, TOUCH PANELS, SERIAL ADVANCED TECHNOLOGY ATTACHMENTS, S-VIDEO INPUTS, VIDEO GRAPHIC ARRAYS, HIGH-DEFINITION MULTIMEDIA INTERFACES, AND USB PORTS (U.S. CLS. 100, 101 AND 107).

FIRST USE 3-26-2010; IN COMMERCE 3-26-2010.  
JIM RINGLE, EXAMINING ATTORNEY

---

SN 85-007,082. SPARKPEOPLE, INC., CINCINNATI, OH. FILED 4-6-2010.

**SPARKSAVINGS**

THE MARK CONSISTS OF STANDARD CHARACTERS WITHOUT CLAIM TO ANY PARTICULAR FONT, STYLE, SIZE, OR COLOR.

OWNER OF U.S. REG. NOS. 3,227,568, 3,495,125 AND OTHERS.

**CLASS 36—INSURANCE AND FINANCIAL**

FOR ON-LINE FINANCIAL PLANNING AND MANAGEMENT SERVICES; ON-LINE FINANCIAL INFORMATION SERVICES; PROVIDING ONLINE INFORMATION SERVICES IN THE FIELD OF BUDGETING AND PERSONAL FINANCES; PROVIDING ON-LINE FINANCIAL CALCULATORS; PROVIDING ON-LINE INFORMATION IN THE FIELD OF PERSONAL FINANCE AND SAVINGS; PROVIDING A WEBSITE WHERE USERS CAN POST COMMENTS, REVIEWS, TIPS, SUGGESTIONS, AND RECOMMENDATIONS ON PERSONAL FINANCE AND SAVINGS ISSUES (U.S. CLS. 100, 101 AND 102).

FIRST USE 3-22-2010; IN COMMERCE 3-22-2010.

**CLASS 38—COMMUNICATION**

FOR PROVIDING ON-LINE ELECTRONIC BULLETIN BOARDS FOR TRANSMISSION OF MESSAGES AMONG COMPUTER USERS CONCERNING FINANCIAL INFORMATION, BUDGETING, SAVINGS, AND DEBT REDUCTION (U.S. CLS. 100, 101 AND 104).

FIRST USE 3-22-2010; IN COMMERCE 3-22-2010.

**CLASS 42—SCIENTIFIC AND COMPUTER SERVICES**

FOR PROVIDING USE OF ON-LINE NON-DOWNLOADABLE SOFTWARE TO STORE, MANAGE, TRACK, ANALYZE AND REPORT DATA IN THE FIELDS OF FINANCE, CHECKING AND SAVINGS, AND MANAGEMENT OF PERSONAL FINANCES (U.S. CLS. 100 AND 101).

FIRST USE 3-22-2010; IN COMMERCE 3-22-2010.  
RON FAIRBANKS, EXAMINING ATTORNEY

SN 85-007,201. MAGNUM INTEGRATED TECHNOLOGIES INC., BRAMPTON, ONTARIO, CANADA, FILED 4-6-2010.

**AIRCAST**

THE MARK CONSISTS OF STANDARD CHARACTERS WITHOUT CLAIM TO ANY PARTICULAR FONT, STYLE, SIZE, OR COLOR.

PRIORITY CLAIMED UNDER SEC. 44(D) ON CANADA APPLICATION NO. 1473745, FILED 3-18-2010, REG. NO. TMA791374, DATED 2-23-2011, EXPIRES 2-23-2026.

**CLASS 6—METAL GOODS**

FOR ALUMINUM INGOT AND METAL BILLET MOLDS (U.S. CLS. 2, 12, 13, 14, 23, 25 AND 50).

**CLASS 7—MACHINERY**

FOR CASTING MACHINES FOR CASTING ALUMINUM INGOTS AND BILLETS; METAL CASTING MACHINES (U.S. CLS. 13, 19, 21, 23, 31, 34 AND 35).

JULIE VEPPUMTHARA, EXAMINING ATTORNEY

---

SN 85-009,264. APEX TECHNOLOGY GROUP, INC., LAKEWOOD, CO. FILED 4-8-2010.

**NAUGHTYALLIE**

THE MARK CONSISTS OF STANDARD CHARACTERS WITHOUT CLAIM TO ANY PARTICULAR FONT, STYLE, SIZE, OR COLOR.

**CLASS 9—ELECTRICAL AND SCIENTIFIC APPARATUS**

FOR DIGITAL MEDIA, NAMELY, DVDS, AND DOWNLOADABLE VIDEO RECORDINGS, RELATED FILM CLIPS AND IMAGES FEATURING ADULT ENTERTAINMENT (U.S. CLS. 21, 23, 26, 36 AND 38).

FIRST USE 3-6-2005; IN COMMERCE 3-6-2005.

**CLASS 41—EDUCATION AND ENTERTAINMENT**

FOR ENTERTAINMENT SERVICES, NAMELY, PROVIDING A WEB SITE FEATURING NON-DOWNLOADABLE PHOTOGRAPHS, VIDEOS, RELATED FILM CLIPS, LIVE STREAMING SHOWS, SEGMENTS AND EVENTS FEATURING ADULT ENTERTAINMENT; PROVIDING INFORMATION IN THE FIELD OF ADULT ENTERTAINMENT VIA A GLOBAL COMPUTER NETWORK (U.S. CLS. 100, 101 AND 107).

FIRST USE 11-27-2002; IN COMMERCE 4-0-2003.  
TINA L. SNAPP, EXAMINING ATTORNEY

SN 85-010,135. L&P PROPERTY MANAGEMENT COMPANY, SOUTH GATE, CA. FILED 4-9-2010.

## SILVERSHELL

THE MARK CONSISTS OF STANDARD CHARACTERS WITHOUT CLAIM TO ANY PARTICULAR FONT, STYLE, SIZE, OR COLOR.

### CLASS 5—PHARMACEUTICALS

FOR ANTIMICROBIAL ADDITIVES CONTAINING SILVER POWDER FOR USE IN THE MANUFACTURE OF PLASTICS, POLYMERS AND PLASTIC COATINGS ON STORAGE PRODUCTS, WIRE PRODUCTS, FURNITURE, BEDDING AND MATTRESSES (U.S. CLS. 6, 18, 44, 46, 51 AND 52).

### CLASS 20—FURNITURE AND ARTICLES NOT OTHERWISE CLASSIFIED

FOR ANTIMICROBIAL TREATMENT CONTAINING SILVER POWDER SOLD AS AN INTEGRAL PART OF FURNITURE, AND BEDDING, NAMELY, MATTRESSES AND BOX SPRINGS; FABRIC FINISH OR SURFACE ANTIMICROBIAL TREATMENT COMPOSITION CONTAINING SILVER POWDER SOLD AS AN INTEGRAL COMPONENT OF FURNITURE; FABRIC FINISH OR SURFACE ANTIMICROBIAL TREATMENT COMPOSITION CONTAINING SILVER POWDER SOLD AS AN INTEGRAL COMPONENT OF MATTRESSES (U.S. CLS. 2, 13, 22, 25, 32 AND 50).

### CLASS 24—FABRICS

FOR FABRIC FINISH OR SURFACE ANTIMICROBIAL TREATMENT COMPOSITION CONTAINING SILVER POWDER SOLD AS A COMPONENT OF TEXTILES AND TEXTILE GOODS; FABRIC FINISH OR SURFACE ANTIMICROBIAL TREATMENT COMPOSITION CONTAINING SILVER POWDER SOLD AS A COMPONENT OF BEDDING, NAMELY, MATTRESSES, BOX SPRINGS AND MATTRESS, BOX SPRING AND PILLOW COVERS (U.S. CLS. 42 AND 50).

THOMAS MANOR, EXAMINING ATTORNEY

SN 85-010,357. FIRST STEPS IN WORSHIP, LLC, YUKON, OK. FILED 4-9-2010.



NO CLAIM IS MADE TO THE EXCLUSIVE RIGHT TO USE "BABY'S", APART FROM THE MARK AS SHOWN.

THE MARK CONSISTS OF A STYLIZED DESIGN OF AN OVAL WITH A BABY LAYING IN A BLANKET AND HANGING ON A CRESCENT MOON, AND THE TEXT "BABY'S BEDTIME BLESSINGS".

### CLASS 9—ELECTRICAL AND SCIENTIFIC APPARATUS

FOR FAITH BASED-PARENT/CHILD TEACHING CURRICULUM KIT, PRIMARILY COMPRISED OF CHILDREN'S EDUCATIONAL MUSIC CDS AND DVDS, BIBLE BOOK, SONG BOOK, CHILDREN'S BLANKET, BABY RATTLE, PLUSH TOYS, SQUEEZE TOYS AND TOTE BAG SOLD AS A UNIT (U.S. CLS. 21, 23, 26, 36 AND 38).

FIRST USE 3-1-2005; IN COMMERCE 5-1-2005.

### CLASS 16—PAPER GOODS AND PRINTED MATTER

FOR FAITH BASED-PARENT/CHILD TEACHING CURRICULUM KIT, PRIMARILY COMPRISED OF BIBLE BOOK, SONG BOOK, CHILDREN'S EDUCATIONAL MUSIC CDS AND DVDS, CHILDREN'S BLANKET, BABY RATTLE, PLUSH TOYS, SQUEEZE TOYS AND TOTE BAG SOLD AS A UNIT (U.S. CLS. 2, 5, 22, 23, 29, 37, 38 AND 50).

FIRST USE 3-1-2005; IN COMMERCE 5-1-2005.

JENNIFER MARTIN, EXAMINING ATTORNEY

SN 85-010,954. SINCLAIR FINANCE COMPANY, SALT LAKE CITY, UT. FILED 4-9-2010.



OWNER OF U.S. REG. NOS. 929,749, 929,750 AND 2,978,288.

NO CLAIM IS MADE TO THE EXCLUSIVE RIGHT TO USE "75", APART FROM THE MARK AS SHOWN.

THE MARK CONSISTS OF THE STYLIZED NUMBER "75" WITH A DESIGN INSIDE THE CIRCULAR BOTTOM PORTION OF THE "75" CONSISTING OF A SUN WITH A HUMAN FACE.

### CLASS 21—HOUSEWARES AND GLASS

FOR CUPS, MUGS AND GLASSWARE, NAMELY, BEVERAGE GLASSES AND PLATES (U.S. CLS. 2, 13, 23, 29, 30, 33, 40 AND 50).

### CLASS 25—CLOTHING

FOR CLOTHING, NAMELY, T-SHIRTS, SHIRTS, GOLF SHIRTS, POLO SHIRTS, HATS, BASEBALL CAPS, GOLF CAPS, SWEATSHIRTS, SWEATERS, COATS, JACKETS, VESTS, GLOVES, SCARVES (U.S. CLS. 22 AND 39).

**CLASS 41—EDUCATION AND ENTERTAINMENT**

FOR PROVIDING RECREATIONAL, SPORTS AND ENTERTAINMENT FACILITIES FOR SKIING, SNOWBOARDING, SNOWSHOEING, GOLFING, TENNIS, ICE SKATING, HORSEBACK RIDING, MOUNTAIN BIKING, TRAP SHOOTING; PROVIDING INSTRUCTION IN VARIOUS OUTDOOR SPORTS, NAMELY, SKIING, SNOWBOARDING, SNOWSHOEING, GOLFING, TENNIS, ICE SKATING, SWIMMING, TRAP SHOOTING; ARRANGING AND CONDUCTING SPORTING CONTESTS AND EXHIBITIONS, NAMELY, SKI RACES AND EXHIBITIONS, ICE SKATING SHOWS AND EXHIBITIONS; ENTERTAINMENT SERVICES, NAMELY, PROVIDING FACILITIES FOR HAYRIDES, SLEIGH RIDES, MOVIE THEATERS, ICE RINKS, BOWLING ALLEYS, SWIMMING POOLS AND PLAYGROUND FACILITIES; RENTAL OF SPORTING EQUIPMENT, NAMELY, SKIS, SNOWBOARDS, SNOWSHOES, ICE SKATES, TENNIS RACKETS, GOLF CLUBS AND RELATED ACCESSORIES; SKI RESORTS; NIGHT CLUBS (U.S. CLS. 100, 101 AND 107).

**CLASS 43—HOTEL AND RESTAURANT SERVICES**

FOR HOTEL AND RESORT LODGING SERVICES; RESTAURANT SERVICES; CATERING SERVICES; PROVIDING BANQUET AND SOCIAL FUNCTION FACILITIES FOR SPECIAL OCCASSIONS; TRAVEL AGENCY SERVICES, NAMELY, MAKING RESERVATIONS AND BOOKINGS FOR TEMPORARY LODGING (U.S. CLS. 100 AND 101).

JENNIFER DIXON, EXAMINING ATTORNEY

**CLASS 6—METAL GOODS**

FOR METAL CABLE LADDER PARTS, NAMELY, PRE-PUNCHED ANGLE RAIL AND CHANNEL RUNG LADDER SECTIONS FOR THE PURPOSE OF SUPPORTING COAXIAL CABLES; METAL BRACKETS FOR USE IN SUPPORTING COAXIAL CABLES AND FOR STABILIZING ANTENNA MOUNTS; METAL CLAMPS FOR ADAPTING COAX HANGERS TO ANGLE MEMBERS, FOR USE IN STANDING CABLE HANGERS AWAY FROM ROUND STRUCTURES AND FOR USE IN ATTACHING PIPES; METAL CONNECTORS IN THE NATURE OF GROUND LUGS USED TO SECURE GROUND WIRE TO GROUND BUS BARS OR CONNECT SIMILAR GAUGE WIRE END TO END; METAL HARDWARE AND METAL HANGERS, NAMELY, SNAP-IN HANGERS, BUTTERFLY HANGERS, CLIP HANGERS, BLOCK HANGERS, THREADED ROD, WASHERS, BOLTS, HEX NUTS, ANGLE ADAPTERS, CLAMPS, HOISTING GRIPS AND ICE BRIDGE KITS COMPRISING METAL ICE BRIDGES, BURIAL POSTS AND TRAPEZES, ALL FOR THE PURPOSE OF SUPPORTING COAXIAL CABLE; METAL EQUIPMENT RACKS FOR SUPPORTING POWER AND TELECOMMUNICATIONS BOXES AT THE BASE OF STRUCTURES; EXOTHERMIC WELDING APPARATUS COMPRISED PRIMARILY OF WELD METAL IN THE NATURE OF WELD METAL SHOTS AND WELD METAL DISCS AND ALSO COMPRISED OF FLINT IGNITORS, ELECTRONIC IGNITORS, METAL MOLD FASTENERS, NAMELY, MECHANICAL HANDLE CLAMPS TO PHYSICALLY SECURE GRAPHITE MOLDS DURING THE EXOTHERMIC WELDING PROCESS, METAL MOUNTINGS AND METAL CLAMPS, NON-METAL WELDING MOLDS, ALL SOLD AS A UNIT FOR USE IN WELDING APPLICATIONS WHICH EMPLOY EXOTHERMIC ENERGY (U.S. CLS. 2, 12, 13, 14, 23, 25 AND 50).

FIRST USE 9-0-2002; IN COMMERCE 9-0-2002.

**CLASS 9—ELECTRICAL AND SCIENTIFIC APPARATUS**

FOR ANTENNA MOUNTS; GROUNDING KITS FOR PROTECTING COAXIAL CABLES COMPRISING GROUND WIRE IN THE NATURE OF ELECTRICAL WIRES, WEATHERPROOFING TAPE AND METAL HARDWARE; SAFETY HELMETS; FALL PROTECTION EQUIPMENT FOR FALL RESTRAINT AND FALL ARREST IN THE NATURE OF HARNESSSES, LANYARDS, RETRACTING LIFELINES, SAFETY ROPE AND SAFETY ROPE AND CABLE GRABS; METAL CONNECTORS IN THE NATURE OF SPLICES FOR ELECTRICAL TRANSMISSION LINES TO SECURE GROUND WIRE TO GROUND BUS BARS OR CONNECT SIMILAR GAUGE WIRE END TO END; SURGE PROTECTORS; METAL CABLE TRAYS USED TO FORM A RIGID STRUCTURAL SYSTEM SPECIALLY ADAPTED FOR SECURELY FASTENING AND SUPPORTING ELECTRICAL CABLES AND RACEWAYS (U.S. CLS. 21, 23, 26, 36 AND 38).

FIRST USE 9-0-2002; IN COMMERCE 9-0-2002.

**CLASS 35—ADVERTISING AND BUSINESS**

FOR WHOLESALE DISTRIBUTORSHIPS FEATURING SITE INFRASTRUCTURE PRODUCTS FOR THE COMMUNICATIONS INDUSTRY IN THE NATURE OF METAL HARDWARE, COMMUNICATION TOWER AND ANTENNA MOUNTING PRODUCTS, CABLE LADDER, ICE BRIDGE, GROUNDING PRODUCTS, WEATHER PROOFING PRODUCTS, COAXIAL CABLE ACCESSORIES AND EXOTHERMIC WELDING APPARATUS (U.S. CLS. 100, 101 AND 102).

FIRST USE 9-0-2002; IN COMMERCE 9-0-2002.

KATHERINE CONNOLLY, EXAMINING ATTORNEY

SN 85-014,738. BETTER METAL, LLC, LA VERGNE, TN.  
FILED 4-15-2010.

**BETTER METAL**

THE MARK CONSISTS OF STANDARD CHARACTERS WITHOUT CLAIM TO ANY PARTICULAR FONT, STYLE, SIZE, OR COLOR.  
SEC. 2(F).

SN 85-016,876. NEW ENGLAND CHOWDAH COMPANY, LLC, STRAFFORD, NH. FILED 4-19-2010.

SN 85-018,280. CALHOUN SUPER STRUCTURES LTD., TARA, ONTARIO, CANADA, FILED 4-20-2010.

## CHOWDAH

THE MARK CONSISTS OF STANDARD CHARACTERS WITHOUT CLAIM TO ANY PARTICULAR FONT, STYLE, SIZE, OR COLOR.

### CLASS 21—HOUSEWARES AND GLASS

FOR BEER MUGS, COFFEE CUPS, TEA CUPS AND MUGS, CUPS AND EARTHENWARE MUGS, GLASS MUGS, MUG TREES, MUGS, BEVERAGE GLASSWARE, NAMELY, PINT GLASSES AND SHOT GLASSES, DRINKING GLASSES, BOWLS, BOWLS MADE OF PRECIOUS METAL, FINGER BOWLS, FRUIT BOWLS, GLASS BOWLS, JAPANESE RICE BOWLS, MIXING BOWLS, PET FEEDING AND DRINKING BOWLS, SALAD BOWLS, SERVING BOWLS (U.S. CLS. 2, 13, 23, 29, 30, 33, 40 AND 50).

### CLASS 24—FABRICS

FOR BEACH TOWELS; BED BLANKETS; BLANKETS FOR OUTDOOR USE (U.S. CLS. 42 AND 50).  
ESTHER A. BORSUK, EXAMINING ATTORNEY

---

SN 85-017,159. IMS SOFTWARE SERVICES LTD., WILMINGTON, DE. FILED 4-19-2010.

## INTELLIGENCE.APPLIED

THE MARK CONSISTS OF STANDARD CHARACTERS WITHOUT CLAIM TO ANY PARTICULAR FONT, STYLE, SIZE, OR COLOR.

OWNER OF U.S. REG. NO. 3,274,421.

### CLASS 9—ELECTRICAL AND SCIENTIFIC APPARATUS

FOR COMPUTER SOFTWARE AND ACCOMPANYING ELECTRONIC USER MANUALS, BOTH ON CDROM AND DOWNLOADABLE ON-LINE VIA THE INTERNET, AND USED TO PROVIDE, MANIPULATE AND EXTRAPOLATE DATA AND INFORMATION PERTAINING TO THE PHARMACEUTICAL, MEDICAL AND HEALTHCARE INDUSTRIES; ELECTRONIC PUBLICATIONS RECORDED ON COMPUTER MEDIA AND DOWNLOADABLE VIA THE INTERNET, NAMELY, MARKET RESEARCH REPORTS RELATING TO THE PHARMACEUTICAL, MEDICAL AND HEALTHCARE FIELDS (U.S. CLS. 21, 23, 26, 36 AND 38).

### CLASS 35—ADVERTISING AND BUSINESS

FOR MARKET RESEARCH AND BUSINESS CONSULTATION SERVICES, NAMELY, CONDUCTING BUSINESS AND MARKET RESEARCH SURVEYS OVER A GLOBAL COMMUNICATION NETWORK, ALL PERTAINING TO THE PHARMACEUTICAL, MEDICAL OR HEALTHCARE FIELDS (U.S. CLS. 100, 101 AND 102).  
DAWN FELDMAN, EXAMINING ATTORNEY



PRIORITY CLAIMED UNDER SEC. 44(D) ON CANADA APPLICATION NO. 1477204, FILED 4-16-2010, REG. NO. TMA792449, DATED 3-9-2011, EXPIRES 3-9-2026.

OWNER OF U.S. REG. NO. 3,260,254.

NO CLAIM IS MADE TO THE EXCLUSIVE RIGHT TO USE "SUPERSTRUCTURE", APART FROM THE MARK AS SHOWN.

THE MARK CONSISTS OF A CURVED DESIGN ELEMENT ABOVE WITH THE WORD "CALHOUN", ABOVE THE WORD "SUPERSTRUCTURE".

### CLASS 37—CONSTRUCTION AND REPAIR

FOR INSTALLATION OF FABRIC-COVERED SHELTERS (U.S. CLS. 100, 103 AND 106).

### CLASS 40—MATERIAL TREATMENT

FOR MANUFACTURE OF FABRIC-COVERED SHELTERS TO ORDER AND/OR SPECIFICATION OF OTHERS (U.S. CLS. 100, 103 AND 106).

RONALD MCMORROW, EXAMINING ATTORNEY

---

SN 85-019,659. FUNZIO, INC., DBA FUNZIO, SAN FRANCISCO, CA. FILED 4-21-2010.

## CRIME CITY BY FUNZIO

THE MARK CONSISTS OF STANDARD CHARACTERS WITHOUT CLAIM TO ANY PARTICULAR FONT, STYLE, SIZE, OR COLOR.

### CLASS 9—ELECTRICAL AND SCIENTIFIC APPARATUS

FOR DOWNLOADABLE COMPUTER GAME PROGRAMS (U.S. CLS. 21, 23, 26, 36 AND 38).

### CLASS 41—EDUCATION AND ENTERTAINMENT

FOR ENTERTAINMENT SERVICES, NAMELY, PROVIDING ON-LINE COMPUTER GAMES (U.S. CLS. 100, 101 AND 107).

ROBERT STRUCK, EXAMINING ATTORNEY



SN 85-020,624. MARIAMEDIA, LLC, BATH, OH. FILED 4-22-2010.



THE COLOR(S) BLACK, RED, GREEN AND WHITE IS/ARE CLAIMED AS A FEATURE OF THE MARK.

THE MARK CONSISTS OF THE WORDS "CODE CHERRY" IN BLACK WITH THE LETTER "O" REPLACED BY A CHERRY DESIGN, NAMELY, A RED CHERRY WITH A GREEN STEM AND WHITE HIGHLIGHTS ON THE STEM AND CHERRY.

#### CLASS 25—CLOTHING

FOR SHORT-SLEEVED OR LONG-SLEEVED T-SHIRTS (U.S. CLS. 22 AND 39).

FIRST USE 2-16-2010; IN COMMERCE 2-16-2010.

#### CLASS 35—ADVERTISING AND BUSINESS

FOR ON-LINE RETAIL STORE SERVICES FEATURING PHYSICAL AND VIRTUAL MERCHANDISE FOR USE BY MEMBERS OF AN ONLINE COMMUNITY IN CONNECTION WITH A DESIGNATED WEBSITE FEATURING FICTIONAL CHARACTERS (U.S. CLS. 100, 101 AND 102).

FIRST USE 2-16-2010; IN COMMERCE 2-16-2010.

BRENDAN MCCAULEY, EXAMINING ATTORNEY

SN 85-022,249. INTUIT INC., MOUNTAIN VIEW, CA. FILED 4-23-2010.

#### INTUIT FINANCIAL SERVICES

THE MARK CONSISTS OF STANDARD CHARACTERS WITHOUT CLAIM TO ANY PARTICULAR FONT, STYLE, SIZE, OR COLOR.

OWNER OF U.S. REG. NOS. 2,729,119, 2,729,360 AND OTHERS.

NO CLAIM IS MADE TO THE EXCLUSIVE RIGHT TO USE "FINANCIAL SERVICES", APART FROM THE MARK AS SHOWN.

#### CLASS 35—ADVERTISING AND BUSINESS

FOR PROVIDING ONLINE BUSINESS MANAGEMENT AND MARKETING SERVICES TO FINANCIAL INSTITUTIONS; ADVERTISING, PROMOTION, AND MARKETING SERVICES, NAMELY, PROVIDING ONLINE DEPLOYMENT, MANAGEMENT, AND ANALYSIS OF MARKETING CAMPAIGNS; ADVERTISING, PROMOTION, AND MARKETING SERVICES, NAMELY, PROVIDING ONLINE CUSTOMIZING AND SENDING OF MARKETING EMAILS FOR OTHERS; CONDUCTING BUSINESS AND MARKET RESEARCH SURVEYS, NAMELY, DESIGNING, LAUNCHING, AND REPORTING OF CUSTOMER SURVEYS; OUTSOURCING SERVICES IN THE FIELD OF CONSUMER LOANS; PROVIDING ONLINE BILL PRESENTMENT SERVICES; COMPUTERIZED ON-LINE ORDERING SERVICES FEATURING CHECKS; MANAGEMENT OF COMPUTERIZED FORMATTED FILES FOR OTHERS; PREPARING FINANCIAL REPORTS FOR OTHERS (U.S. CLS. 100, 101 AND 102).

FIRST USE 3-16-2010; IN COMMERCE 3-16-2010.

#### CLASS 36—INSURANCE AND FINANCIAL

FOR PROVIDING ONLINE FINANCIAL MANAGEMENT SERVICES FOR USE BY FINANCIAL INSTITUTIONS; PROVIDING ONLINE PERSONAL AND BUSINESS FINANCIAL MANAGEMENT SERVICES; ONLINE BANKING SERVICES; PROVIDING BANKING SERVICES PROVIDED BY MOBILE TELEPHONE CONNECTIONS; PROVIDING ONLINE BILL PAYMENT, AND REMOTE CHECK DEPOSIT SERVICES; PROVIDING A SECURED ACCESS DATABASE VIA THE INTERNET THROUGH WHICH CHECK IMAGES CAN BE VIEWED, COPIED, AND PRINTED FOR PURPOSES OF CONDUCTING FINANCIAL TRANSACTIONS; ELECTRONIC INTER-INSTITUTION FUND TRANSFER SERVICES; PROVIDING ONLINE FINANCIAL SERVICES, NAMELY, PROVIDING FINANCIAL FORECASTING, ANALYSIS OF FINANCIAL DATA, FINANCIAL DATA AGGREGATION FUND TRANSFERS, PAYMENT STOPS, AUTOMATED FINANCIAL ACCOUNT SWEEPS, AND DOMESTIC AND FOREIGN CURRENCY WIRE TRANSFERS; ONLINE PROCESSING OF COMPLIANT TAX PAYMENTS; FINANCIAL SERVICES, NAMELY, PROVIDING ONLINE LOAN APPLICATION, PROCESSING, AND MANAGEMENT SERVICES; PROVIDING ONLINE FINANCIAL MANAGEMENT SERVICES, NAMELY, CATEGORIZING FINANCIAL TRANSACTIONS, TRACKING INCOME, TRACKING EXPENSES, TRACKING TAX DEDUCTIBLE EXPENSES; FINANCIAL SERVICES, NAMELY, PROVIDING FINANCIAL ACCOUNT INFORMATION, MANAGING FINANCIAL BUDGETS, ANALYZING SPENDING BEHAVIOR OF OTHERS, PROVIDING FINANCIAL ACCOUNT BALANCE INFORMATION, AND PROVIDING BILL PAYMENT REMINDERS (U.S. CLS. 100, 101 AND 102).

FIRST USE 3-16-2010; IN COMMERCE 3-16-2010.

#### CLASS 42—SCIENTIFIC AND COMPUTER SERVICES

FOR PROVIDING TEMPORARY USE OF NON-DOWNLOADABLE COMPUTER SOFTWARE FOR USE BY FINANCIAL INSTITUTIONS TO PROVIDE ONLINE FINANCIAL MANAGEMENT AND BANKING SERVICES TO CUSTOMERS; PROVIDING TEMPORARY USE OF NON-DOWNLOADABLE PERSONAL AND BUSINESS FINANCIAL MANAGEMENT SOFTWARE; PROVIDING TEMPORARY USE OF NON-DOWNLOADABLE COMPUTER SOFTWARE FOR USE IN ONLINE BANKING; PROVIDING TEMPORARY USE OF NON-DOWNLOADABLE COMPUTER SOFTWARE FOR MOBILE WEB BANKING SERVICES; PROVIDING TEMPORARY USE OF NON-DOWNLOADABLE COMPUTER SOFTWARE FOR USE IN BILL PAYMENT, BILL PRESENTMENT, AND DEPOSITING CHECKS; PROVIDING TEMPORARY USE OF NON-DOWNLOADABLE COMPUTER SOFTWARE FOR USE IN CHECK IMAGE STORAGE AND CHECK IMAGE ACCESS; PROVIDING TEMPORARY USE OF NON-DOWNLOADABLE COMPUTER SOFTWARE FOR USE IN REORDERING CHECKS; PROVIDING TEMPORARY USE OF NON-DOWNLOADABLE COMPUTER SOFTWARE FOR USE IN INTER-INSTITUTION FUND TRANSFERS AND TO GENERATE ONLINE FINANCIAL STATEMENTS; PRO-

VIDING TEMPORARY USE OF NON-DOWNLOADABLE COMPUTER SOFTWARE FOR USE IN CATEGORIZING FINANCIAL TRANSACTIONS, TRACKING INCOME, EXPENSES, AND TAX DEDUCTIBLE EXPENSES, VIEWING FINANCIAL ACCOUNTS, MANAGING BUDGETS, ANALYZING SPENDING BEHAVIOR, PROVIDING ACCOUNT BALANCE AND BILL PAYMENT ALERTS, AND CREATING REPORTS; PROVIDING TEMPORARY USE OF ONLINE NON-DOWNLOADABLE COMPUTER SOFTWARE FOR DEPLOYING, MANAGING, AND ANALYZING MARKETING CAMPAIGNS; PROVIDING TEMPORARY USE OF ONLINE NON-DOWNLOADABLE COMPUTER SOFTWARE FOR CUSTOMIZING AND SENDING MARKETING EMAILS; PROVIDING TEMPORARY USE OF ONLINE NON-DOWNLOADABLE COMPUTER SOFTWARE FOR USE IN DESIGNING, LAUNCHING, AND REPORTING OF CUSTOMER SURVEYS; PROVIDING TEMPORARY USE OF NON-DOWNLOADABLE SOFTWARE TO CREATE, MANAGE, TRANSMIT, AND STORE FORMATTED COMPUTER FILES; PROVIDING TEMPORARY USE OF NON-DOWNLOADABLE SOFTWARE FOR USE IN FINANCIAL FORECASTING, ANALYSIS OF FINANCIAL DATA, FINANCIAL DATA AGGREGATION, TRANSFERRING FUNDS, STOPPING PAYMENTS, AUTOMATING SWEEPS ON FINANCIAL ACCOUNTS, AND ORIGINATING DOMESTIC AND FOREIGN CURRENCY WIRE TRANSFERS; PROVIDING TEMPORARY USE OF NON-DOWNLOADABLE SOFTWARE FOR USE IN PROCESSING COMPLIANT TAX PAYMENTS; PROVIDING TEMPORARY USE OF NON-DOWNLOADABLE SOFTWARE FOR SECURITY OF PERSONAL OR CONFIDENTIAL INFORMATION, NAMELY, MULTIFACTOR AUTHENTICATION, TRANSACTION MONITORING, AND FRAUD SHUTDOWN SERVICES IN THE FIELDS OF ONLINE BANKING AND FINANCIAL MANAGEMENT; PROVIDING TEMPORARY USE OF NON-DOWNLOADABLE IDENTITY THEFT RESOLUTION SOFTWARE; PROVIDING TEMPORARY USE OF NON-DOWNLOADABLE ANTI-PHISHING AND ANTI-EMAIL FRAUD SOFTWARE; PROVIDING TEMPORARY USE OF NON-DOWNLOADABLE SOFTWARE FOR REAL-TIME FRAUD ALERT AND FRAUD DETECTION IN THE FIELDS OF ONLINE BANKING AND FINANCIAL MANAGEMENT; PROVIDING TEMPORARY USE OF ONLINE NON-DOWNLOADABLE COMPUTER SOFTWARE FOR USE BY CONSUMERS TO APPLY FOR LOANS AND RECEIVE LOAN DECISIONS IN REAL-TIME; PROVIDING TEMPORARY USE OF ONLINE NON-DOWNLOADABLE COMPUTER SOFTWARE FOR USE BY BANKS TO PROCESS AND MANAGE CONSUMER LOANS; COMPUTER SERVICES IN THE NATURE OF FORMATTING ELECTRONIC FILES FOR OTHERS, NAMELY, TRANSFERRING DOCUMENT DATA FROM ONE COMPUTER FORMAT TO ANOTHER; APPLICATION SERVICE PROVIDER (ASP), NAMELY, HOSTING COMPUTER SOFTWARE APPLICATIONS AND ASSOCIATED DATA FOR OTHERS; COMPUTER SERVICES, NAMELY, TECHNICAL CONSULTATION IN THE FIELD OF APPLICATION SERVICE PROVIDER (ASP) SERVICES AND HOSTED COMPUTER SOFTWARE; COMPUTER SERVICES, NAMELY, DESIGNING, CUSTOMIZING, IMPLEMENTING, INTEGRATING AND MAINTAINING NETWORK-BASED COMPUTER SOFTWARE APPLICATIONS FOR OTHERS; TECHNICAL SUPPORT SERVICES, NAMELY, ONLINE TROUBLESHOOTING OF COMPUTER HARDWARE, SOFTWARE, AND NETWORK PROBLEMS; COMPUTER SERVICES, NAMELY, MAINTAINING, DESIGNING, AND IMPLEMENTING WEB SITES FOR OTHERS; COMPUTER SERVICES, NAMELY, HOSTING OF WEB SITES ON A COMPUTER SERVER FOR A GLOBAL COMPUTER NETWORK; PROVIDING TEMPORARY USE OF NON-DOWNLOADABLE SOFTWARE FOR VIEWING FINANCIAL STATEMENTS; PROVIDING ONLINE SALES TRAINING TOOLS, NAMELY, PROVIDING TEMPORARY USE OF NON-DOWNLOADABLE SOFTWARE FOR TRAINING SALES PROFESSIONALS (U.S. CLS. 100 AND 101).

FIRST USE 3-16-2010; IN COMMERCE 3-16-2010.

#### **CLASS 45—PERSONAL AND LEGAL SERVICES**

FOR ONLINE SECURITY SERVICES, NAMELY, MULTIFACTOR AUTHENTICATION OF PERSONAL OR CONFIDENTIAL INFORMATION, TRANSACTION MONITORING, AND FRAUD SHUTDOWN SERVICES IN THE FIELDS OF ONLINE BANKING AND FINANCIAL MANAGEMENT; IDENTITY THEFT RESOLUTION SERVICES, NAMELY, PROVIDING ASSISTANCE IN RESOLVING OCCURRENCES OF IDENTITY THEFT; FRAUD PROTECTION SERVICES, NAMELY, PROVIDING ANTI-PHISHING AND ANTI-EMAIL FRAUD SERVICES; PROVIDING REAL-TIME FRAUD ALERT AND FRAUD DETECTION SERVICES IN THE FIELDS OF ONLINE BANKING AND FINANCIAL MANAGEMENT (U.S. CLS. 100 AND 101).

FIRST USE 3-16-2010; IN COMMERCE 3-16-2010.

ALYSSA STEEL, EXAMINING ATTORNEY

---

SN 85-023,042. HANS HELLNER WORKS UG, HAMBURG, FED REP GERMANY, FILED 4-26-2010.

***RICKSHAW DOLLY***

NO CLAIM IS MADE TO THE EXCLUSIVE RIGHT TO USE "DOLLY", APART FROM THE MARK AS SHOWN.

THE MARK CONSISTS OF THE WORDS "RICKSHAW DOLLY" WHICH IS INTERSECTED BY TWO STRAIGHT LINES.

#### **CLASS 12—VEHICLES**

FOR VEHICLES, NAMELY, DOLLIES, TROLLEYS, CARRIAGES, WAGONS FOR MOVING PERSONS HOLDING FILM EQUIPMENT, ESPECIALLY CAMERAS; DOLLIES ESPECIALLY WALKER GUIDED VEHICLES FOR PERSONS HOLDING FILM EQUIPMENT, ESPECIALLY CAMERAS (U.S. CLS. 19, 21, 23, 31, 35 AND 44).

#### **CLASS 39—TRANSPORTATION AND STORAGE**

FOR RENTAL OF VEHICLES IN THE NATURE OF DOLLIES TROLLEYS, CARRIAGES, WAGONS FOR MOVING PERSONS HOLDING FILM EQUIPMENT, ESPECIALLY CAMERAS; RENTAL OF DOLLIES ESPECIALLY WALKER GUIDED VEHICLES FOR PERSONS HOLDING FILM EQUIPMENT ESPECIALLY CAMERAS (U.S. CLS. 100 AND 105).

ALLISON HOLTZ, EXAMINING ATTORNEY

SN 85-027,091. ALCOHOL COUNTERMEASURE SYSTEMS (INTERNATIONAL) INC., TORONTO, ONTARIO, CANADA, FILED 4-30-2010.



OWNER OF CANADA REG. NO. TMA791,768, DATED 2-28-2011, EXPIRES 2-28-2026.

THE COLOR(S) ORANGE IS/ARE CLAIMED AS A FEATURE OF THE MARK.

THE MARK CONSISTS OF A REPRESENTATION OF AN ATOMIC OR MOLECULAR MODEL, THE ENTIRE MARK BEING COLORED ORANGE.

**CLASS 9—ELECTRICAL AND SCIENTIFIC APPARATUS**

FOR VENDING MACHINES FEATURING BREATH ALCOHOL TESTING; ALCOHOL IGNITION INTER-LOCK DEVICES AND PARTS THEREFOR (U.S. CLS. 21, 23, 26, 36 AND 38).

**CLASS 10—MEDICAL APPARATUS**

FOR ALCOHOL BREATH TESTING UNITS AND PARTS THEREFOR (U.S. CLS. 26, 39 AND 44).  
MARY ROSSMAN, EXAMINING ATTORNEY

SN 85-027,917. BRIDGEPOINT EDUCATION, INC., SAN DIEGO, CA. FILED 4-30-2010.

**CONSTELLATION**

THE MARK CONSISTS OF STANDARD CHARACTERS WITHOUT CLAIM TO ANY PARTICULAR FONT, STYLE, SIZE, OR COLOR.

**CLASS 9—ELECTRICAL AND SCIENTIFIC APPARATUS**

FOR EDUCATIONAL PUBLICATIONS, NAMELY, ELECTRONIC DOWNLOADABLE TEXT BOOKS, WORKBOOKS AND WRITTEN COURSE MATERIALS FOR USE WITH COURSES OF INSTRUCTION IN THE FIELDS OF BUSINESS, MANAGEMENT, EDUCATION, PSYCHOLOGY, SOCIAL SCIENCES AND HEALTH SCIENCES AT THE POST-SECONDARY, UNDERGRADUATE AND GRADUATE LEVEL FOR DOWNLOAD TO WEB-ENABLED CELL PHONES AND OTHER PORTABLE ELECTRONIC DEVICES AS WELL AS COMPUTER HARD DRIVES (U.S. CLS. 21, 23, 26, 36 AND 38).

**CLASS 41—EDUCATION AND ENTERTAINMENT**

FOR EDUCATIONAL SERVICES IN THE NATURE OF PROVIDING ELECTRONIC NON-DOWNLOADABLE TEXT BOOKS, WORKBOOKS AND WRITTEN COURSE MATERIALS FOR USE WITH COURSES OF INSTRUCTIONS IN THE FIELDS OF BUSINESS, MANAGEMENT, EDUCATION, PSYCHOLOGY, SOCIAL SCIENCES AND HEALTH SCIENCES AT THE POST-SECONDARY, UNDERGRADUATE AND GRADUATE LEVEL (U.S. CLS. 100, 101 AND 107).

**CLASS 42—SCIENTIFIC AND COMPUTER SERVICES**

FOR PROVIDING TEMPORARY USE OF ONLINE NON-DOWNLOADABLE SOFTWARE IN THE NATURE OF A BROWSER-BASED NON-DOWNLOADABLE READER WHICH DISPLAYS, AND ALLOWS THE DOWNLOAD OF, WEB-BASED TEXTBOOKS AND WORKBOOKS AT THE POST-SECONDARY, UNDERGRADUATE AND GRADUATE LEVELS (U.S. CLS. 100 AND 101).

BARBARA BROWN, EXAMINING ATTORNEY

SN 85-029,426. DLORAH, INC., RAPID CITY, SD. FILED 5-4-2010.

**THE INSTITUTE OF EXCELLENCE AND SUCCESS**

THE MARK CONSISTS OF STANDARD CHARACTERS WITHOUT CLAIM TO ANY PARTICULAR FONT, STYLE, SIZE, OR COLOR.

OWNER OF U.S. REG. NO. 2,622,131.

NO CLAIM IS MADE TO THE EXCLUSIVE RIGHT TO USE "INSTITUTE", APART FROM THE MARK AS SHOWN.

**CLASS 41—EDUCATION AND ENTERTAINMENT**

FOR PROVIDING ON-LINE TRAINING COURSES FOR EDUCATORS IN THE FIELD OF TEACHING AND POST-SECONDARY EDUCATION; EDUCATION SERVICES, NAMELY, CONDUCTING DISTANCE LEARNING AT THE UNIVERSITY LEVEL FOR STUDENTS AND BUSINESSES SEEKING TO OFFER EDUCATIONAL SERVICES, BENEFITS AND OPPORTUNITIES TO EMPLOYEES AND COMMUNITY MEMBERS (U.S. CLS. 100, 101 AND 107).

**CLASS 42—SCIENTIFIC AND COMPUTER SERVICES**

FOR COMPUTER SERVICES, NAMELY, CREATING AN ON-LINE COMMUNITY FOR REGISTERED USERS FEATURING FORUMS FOR DEVELOPMENT OF DISCUSSIONS ABOUT EDUCATION AMONG EDUCATORS (U.S. CLS. 100 AND 101).

ANTHONY RINKER, EXAMINING ATTORNEY

SN 85-032,090. GREGG RITZ IP, LLC, STRATHAM, NH. FILED 5-6-2010.

## PRIMITIVE INSTINCT

THE MARK CONSISTS OF STANDARD CHARACTERS WITHOUT CLAIM TO ANY PARTICULAR FONT, STYLE, SIZE, OR COLOR.

### CLASS 9—ELECTRICAL AND SCIENTIFIC APPARATUS

FOR DOWNLOADABLE TELEVISION SHOWS AND PROGRAMS ABOUT HUNTING; VIDEO RECORDINGS MEDIA, NAMELY, DVDS AND DOWNLOADABLE VIDEO FILES IN THE FIELD OF HUNTING (U.S. CLS. 21, 23, 26, 36 AND 38).

### CLASS 25—CLOTHING

FOR CLOTHING, NAMELY, HUNTING APPAREL, NAMELY, HUNTING JACKETS, BIB OVERALLS, HATS, CAPS, SHIRTS, SWEATSHIRTS, PANTS, VESTS, PARKAS, RAINWEAR AND BOOTS; CLOTHING, NAMELY, HATS, CAPS, SHIRTS, SWEATSHIRTS, PANTS, JACKETS, VESTS, PARKAS, RAINWEAR AND BOOTS (U.S. CLS. 22 AND 39).

### CLASS 41—EDUCATION AND ENTERTAINMENT

FOR ENTERTAINMENT SERVICES IN THE NATURE OF ONGOING TELEVISION SHOWS, PROGRAMS AND SERIES ABOUT HUNTING; ENTERTAINMENT SERVICES, NAMELY, PROVIDING ONGOING VIDEO SHOWS, PROGRAMS AND SERIES ABOUT HUNTING VIA SATELLITE TELEVISION, TELEVISION BROADCAST, AND CABLE TELEVISION; ENTERTAINMENT SERVICES, NAMELY, PROVIDING NON-DOWNLOADABLE VIDEOS ABOUT HUNTING VIA THE INTERNET; ENTERTAINMENT SERVICES, NAMELY, PROVIDING A WEB SITE FEATURING PHOTOGRAPHIC, AUDIO AND VIDEO PRESENTATIONS FEATURING HUNTING (U.S. CLS. 100, 101 AND 107).

LINDA LAVACHE, EXAMINING ATTORNEY

SN 85-032,215. BSK ASSOCIATES, FRESNO, CA. FILED 5-6-2010.

# BSK

THE MARK CONSISTS OF STANDARD CHARACTERS WITHOUT CLAIM TO ANY PARTICULAR FONT, STYLE, SIZE, OR COLOR.

### CLASS 37—CONSTRUCTION AND REPAIR

FOR CONSTRUCTION INSPECTION, NAMELY, OBSERVATION OF CONSTRUCTION FOR GENERAL CONFORMANCE WITH DRAWINGS AND SPECIFICATIONS AND TESTING OF CONSTRUCTION MATERIALS (U.S. CLS. 100, 103 AND 106).

FIRST USE 1-1-1980; IN COMMERCE 1-1-1980.

### CLASS 40—MATERIAL TREATMENT

FOR ECOLOGICAL SERVICES, NAMELY, TERRESTRIAL, WETLAND, AND AQUATIC HABITAT CREATION, RESTORATION, AND MAINTENANCE (U.S. CLS. 100, 103 AND 106).

FIRST USE 2-28-2010; IN COMMERCE 2-28-2010.

### CLASS 42—SCIENTIFIC AND COMPUTER SERVICES

FOR GEOLOGICAL, GEOTECHNICAL, CIVIL, WATER, AND WASTEWATER ENGINEERING; TECHNICAL CONSULTING SERVICES IN THE FIELDS OF GEOLOGICAL, GEOTECHNICAL, CIVIL, WATER, AND WASTEWATER ENGINEERING; TECHNICAL SERVICES, NAMELY, ANALYSIS, VERIFICATION, AND VALIDATION OF NOTES, PLANS, SPECIFICATIONS, CODES, AND LABORATORY TESTING TECHNIQUE AND RESULTS, EACH IN THE FIELD OF CONSTRUCTION INSPECTION; SOIL, GROUNDWATER, DRINKING WATER, MICROBIOLOGY, AND MATERIAL TESTING; HYDROGEOLOGICAL INVESTIGATION; ENVIRONMENTAL ENGINEERING; TECHNICAL CONSULTING SERVICES IN THE FIELD OF ENVIRONMENTAL ENGINEERING; FORENSIC INVESTIGATION, NAMELY, TESTING, ANALYSIS, AND ASSESSMENT OF CONSTRUCTION FAILURES AND DAMAGE; ECOLOGICAL SERVICES, NAMELY, HABITAT AND SPECIES IDENTIFICATION AND MONITORING (U.S. CLS. 100 AND 101).

FIRST USE 2-28-2010; IN COMMERCE 2-28-2010.

### CLASS 45—PERSONAL AND LEGAL SERVICES

FOR PROVIDING ASSISTANCE TO OTHERS IN THE OBTAINING OF ENVIRONMENTAL, ZONING, AND OTHER GOVERNMENTAL PERMITS (U.S. CLS. 100 AND 101).

FIRST USE 2-28-2010; IN COMMERCE 2-28-2010.

LINDA E. BLOHM, EXAMINING ATTORNEY

SN 85-033,127. BRAINPOP ESL LLC, NEW YORK, NY. FILED 5-7-2010.



THE MARK CONSISTS OF A CURVED LINE WITHIN A CIRCLE WITH AN IMAGE OF HEADPHONES SURROUNDING THE TOP HALF OF IT. BENEATH THE FIGURE IS THE TEXT "HEAR IT, SAY IT!". THESE ELEMENTS ARE LAYERED ON TOP OF A RECTANGULAR SHAPED FIGURE WITH CURVED CORNERS, CONTAINING A CURVED LINE, ONE ON THE TOP AND ONE ON THE BOTTOM OF THE RECTANGLE.



**CLASS 16—PAPER GOODS AND PRINTED MATTER**

FOR PRINTED INSTRUCTIONAL, TEACHING AND EDUCATIONAL MATERIALS, IN FIELD OF LANGUAGE INSTRUCTION; PRINTED COURSE MATERIALS IN THE FIELD OF LANGUAGE INSTRUCTION; EXERCISE WORKSHEETS AND HANDOUTS, GRAMMAR GUIDES, REFERENCE BOOKS, ALL IN THE FIELD OF LANGUAGE INSTRUCTION; NEWSLETTERS IN THE FIELD OF LANGUAGE INSTRUCTION (U.S. CLS. 2, 5, 22, 23, 29, 37, 38 AND 50).

**CLASS 41—EDUCATION AND ENTERTAINMENT**

FOR EDUCATIONAL INTERACTIVE SERVICES, NAMELY, LANGUAGE INSTRUCTION TRAINING OF ENGLISH AS A SECOND LANGUAGE, BY PROVIDING LIVE, WEBSITE AND ONLINE CLASSES, WORKSHOP, AND INTERACTIVE LESSONS; PROVIDING AN ONLINE COMPUTER WEBSITE IN THE FIELD OF LANGUAGE INSTRUCTION; ONLINE INTERACTIVE LANGUAGE INSTRUCTION WEBSITE (U.S. CLS. 100, 101 AND 107).

FIRST USE 9-8-2009; IN COMMERCE 9-8-2009.

**CLASS 42—SCIENTIFIC AND COMPUTER SERVICES**

FOR PROVIDING SUBSCRIPTION BASED USE OF ON-LINE NON-DOWNLOADABLE EDUCATIONAL CONTENT FOR TEACHING ENGLISH AS A SECOND LANGUAGE OVER A GLOBAL COMPUTER NETWORK (U.S. CLS. 100 AND 101).

FIRST USE 9-8-2009; IN COMMERCE 9-8-2009.

AISHA CLARKE, EXAMINING ATTORNEY

**CLASS 16—PAPER GOODS AND PRINTED MATTER**

FOR PRINTED INSTRUCTIONAL, TEACHING AND EDUCATIONAL MATERIALS, IN FIELD OF LANGUAGE INSTRUCTION; PRINTED COURSE MATERIALS IN THE FIELD OF LANGUAGE INSTRUCTION; EXERCISE WORKSHEETS AND HANDOUTS, GRAMMAR GUIDES, REFERENCE BOOKS, ALL IN THE FIELD OF LANGUAGE INSTRUCTION; NEWSLETTERS IN THE FIELD OF LANGUAGE INSTRUCTION (U.S. CLS. 2, 5, 22, 23, 29, 37, 38 AND 50).

**CLASS 41—EDUCATION AND ENTERTAINMENT**

FOR EDUCATIONAL INTERACTIVE SERVICES, NAMELY, LANGUAGE INSTRUCTION TRAINING OF ENGLISH AS A SECOND LANGUAGE, BY PROVIDING LIVE, WEBSITE AND ONLINE CLASSES, WORKSHOP, AND INTERACTIVE LESSONS; PROVIDING AN ONLINE COMPUTER WEBSITE IN THE FIELD OF LANGUAGE INSTRUCTION; ONLINE INTERACTIVE LANGUAGE INSTRUCTION WEBSITE (U.S. CLS. 100, 101 AND 107).

**CLASS 42—SCIENTIFIC AND COMPUTER SERVICES**

FOR PROVIDING SUBSCRIPTION BASED USE OF ON-LINE NON-DOWNLOADABLE EDUCATIONAL CONTENT FOR TEACHING ENGLISH AS A SECOND LANGUAGE OVER A GLOBAL COMPUTER NETWORK (U.S. CLS. 100 AND 101).

AISHA CLARKE, EXAMINING ATTORNEY

SN 85-033,143. BRAINPOP ESL LLC, NEW YORK, NY. FILED 5-7-2010.



THE MARK CONSISTS OF A SMALL CIRCLE ABOVE A VERTICAL RECTANGLE, BOTH WITHIN A CIRCLE. UNDERNEATH THE CIRCLE APPEARS THE TEXT "KNOW" AND BENEATH IT THE TEXT "MORE!". THESE ARE LOCATED WITHIN A RECTANGLE WITH CURVED CORNERS WITH A CURVED LINE ON THE TOP OF THE RECTANGLE AND ANOTHER CURVED LINE ON THE BOTTOM OF THE RECTANGLE.

SN 85-033,808. GROSH GUITARS, INC., BROOMFIELD, CO. FILED 5-9-2010.

*Grosh*  
GUITARS

NO CLAIM IS MADE TO THE EXCLUSIVE RIGHT TO USE "GUITARS", APART FROM THE MARK AS SHOWN. THE MARK CONSISTS OF A STYLIZED VERSION OF THE WORDS "GROSH GUITARS".  
SEC. 2(F) "GROSH".

**CLASS 9—ELECTRICAL AND SCIENTIFIC APPARATUS**

FOR ELECTRICAL PICKUPS FOR USE WITH MUSICAL INSTRUMENTS (U.S. CLS. 21, 23, 26, 36 AND 38).

FIRST USE 1-1-1993; IN COMMERCE 1-1-1993.

**CLASS 15—MUSICAL INSTRUMENTS**

FOR MUSICAL INSTRUMENTS, NAMELY, GUITARS AND BASSES (U.S. CLS. 2, 21 AND 36).

FIRST USE 1-1-1993; IN COMMERCE 1-1-1993.

STEPHANIE ALI, EXAMINING ATTORNEY

SN 85-033,955. GASTROKID LTD, CARDIFF, SOUTH WALES, UNITED KINGDOM, FILED 5-10-2010.

# GASTROKID

THE MARK CONSISTS OF STANDARD CHARACTERS WITHOUT CLAIM TO ANY PARTICULAR FONT, STYLE, SIZE, OR COLOR.

PRIORITY CLAIMED UNDER SEC. 44(D) ON UNITED KINGDOM APPLICATION NO. 2533062, FILED 11-30-2009, REG. NO. 2533062, DATED 3-12-2010, EXPIRES 11-30-2019.

## CLASS 9—ELECTRICAL AND SCIENTIFIC APPARATUS

FOR AUDIOVISUAL RECORDINGS, INCLUDING AUDIOVISUAL RECORDINGS OF ANIMATED TELEVISION SHOWS, IN CONNECTION WITH GASTRONOMY, COOKING, RECIPES, FOOD INGREDIENTS, NUTRITION AND THE PROMOTION OF HEALTHY AND FINE EATING; PRE-RECORDED MEDIA, NAMELY, VIDEO TAPES AND CASSETTES, COMPACT DISCS (CDS), AUDIO CASSETTE TAPES, DVDS, VIDEO GAMES CARTRIDGES AND COMPUTER DISCS IN CONNECTION WITH GASTRONOMY, COOKING, RECIPES, FOOD INGREDIENTS, NUTRITION AND THE PROMOTION OF HEALTHY AND FINE EATING; DOWNLOADABLE PODCASTS IN THE FIELD OF GASTRONOMY, COOKING, RECIPES, FOOD INGREDIENTS, NUTRITION AND THE PROMOTION OF HEALTHY AND FINE EATING; DOWNLOADABLE ELECTRONIC PUBLICATIONS, NAMELY, BOOKS, NEWSLETTERS, MAGAZINES AND JOURNALS IN THE FIELD OF GASTRONOMY, COOKING, RECIPES, FOOD INGREDIENTS, NUTRITION AND THE PROMOTION OF HEALTHY AND FINE EATING; DOWNLOADABLE ELECTRONIC ENCYCLOPAEDIAS; DOWNLOADABLE ELECTRONIC COOKBOOKS; DOWNLOADABLE ELECTRONIC PUBLICATIONS FOR EDUCATIONAL AND ENTERTAINMENT PURPOSES, NAMELY, BOOKS, NEWSLETTERS, MAGAZINES AND JOURNALS IN THE FIELD OF GASTRONOMY, COOKING, RECIPES, FOOD INGREDIENTS, NUTRITION AND THE PROMOTION OF HEALTHY AND FINE EATING; COMPUTER SOFTWARE CONCERNED WITH CHILDREN'S EDUCATION AND ENTERTAINMENT, NAMELY, CHILDREN'S EDUCATIONAL SOFTWARE AND SOFTWARE FOR CHILDREN IN THE NATURE OF COMPUTER GAME SOFTWARE; ELECTRONIC COMPUTER GAMES IN THE FORM OF CONSOLES AND DISKS ADAPTED FOR USE WITH VIDEO APPARATUS OR TELEVISION RECEIVERS; HAND HELD UNITS FOR PLAYING ELECTRONIC GAMES FOR USE WITH EXTERNAL DISPLAY SCREEN OR MONITOR AND ELECTRONIC GAME SOFTWARE FOR HANDHELD ELECTRONIC DEVICES; ELECTRONIC INTERACTIVE EDUCATIONAL BOARD GAMES FOR USE WITH EXTERNAL VIDEO APPARATUS OR TELEVISION RECEIVERS; DOWNLOADABLE ELECTRONIC GAME PROGRAMS PROVIDED BY THE INTERNET; DOWNLOADABLE ELECTRONIC COLOURING BOOKS; MOUSE PADS (U.S. CLS. 21, 23, 26, 36 AND 38).

## CLASS 16—PAPER GOODS AND PRINTED MATTER

FOR PRINTED MATTER, NAMELY, PRINTED PUBLICATIONS IN THE FORM OF PERIODICALS, BOOKS, ENCYCLOPAEDIAS, COOKBOOKS, MANUALS, INSTRUCTIONAL AND TEACHING MATERIAL IN THE FIELDS OF GASTRONOMY, COOKING, RECIPES, FOOD INGREDIENTS, NUTRITION AND THE PROMOTION OF HEALTHY AND FINE EATING; ACTIVITY BOOKS IN THE FIELDS OF GASTRONOMY, COOKING, RECIPES, FOOD INGREDIENTS, NUTRITION AND THE PROMOTION OF HEALTHY AND FINE EATING; ADDRESS BOOKS; ALBUMS FOR USE IN THE COLLECTION OF STICKERS, EVENTS AND RECIPES; AUTOGRAPH BOOKS; BINDERS; BOOK MARKERS; CALENDARS; CARTOON STRIPS; NEWSPAPER CARTOONS; PRINTS OF CARTOONS; COMICS; CASES, HOLDERS AND STANDS FOR PENS, PENCILS, PASTELS AND CRAYONS; COLOURING BOOKS; DECALCOMANIA; DIARIES; DOCUMENT FILES AND BOXES FOR STATIONERY AND PAPERS; DRAWING BOOKS, PADS, PENS AND SETS COMPRISED PRIMARILY OF COLOURING PENS AND PENCILS, CRAYONS, PAINTS, TRACING STENCILS AND TRANSFERABLE STICKERS; EASELS; EMBROIDERY, SEWING AND KNITTING DESIGN PATTERNS; FOLDERS FOR STATIONERY AND PAPERS; GREETING CARDS; MAGAZINES FEATURING GASTRONOMY, COOKING, RECIPES, FOOD INGREDIENTS, NUTRITION AND THE PROMOTION OF HEALTHY AND FINE EATING FOR CHILDREN AND PARENTS; MODELLING CLAY; NEWSLETTERS FEATURING GASTRONOMY, COOKING, RECIPES, FOOD INGREDIENTS, NUTRITION AND THE PROMOTION OF HEALTHY AND FINE EATING FOR CHILDREN AND PARENTS; NOTE BOOKS AND PADS; PARTY INVITATIONS; PENCIL SHARPENERS; PAINTS, PAINT BOXES, PAINTBRUSHES, PASTELS, CRAYONS, PENCILS; POST CARDS; PRINTED PICTURES AND POSTERS; RUBBER ERASERS; RULERS; SCRAP BOOKS; STATIONERY; STENCILS; STICKERS AND TRANSFERS; TABLECLOTHS, MATS OF PAPER, NAPKINS OF PAPER; TEACHING MATERIALS, NAMELY, PRINTED WORKBOOKS AND WORKSHEETS IN CONNECTION WITH GASTRONOMY, COOKING, RECIPES, FOOD INGREDIENTS, NUTRITION AND THE PROMOTION OF HEALTHY AND FINE EATING; TRADING CARDS; WRAPPING PAPER; WRITING PADS AND PAPER; PRINTED GREETING CARDS WITH ELECTRONIC INFORMATION STORED THEREIN (U.S. CLS. 2, 5, 22, 23, 29, 37, 38 AND 50).

## CLASS 41—EDUCATION AND ENTERTAINMENT

FOR EDUCATIONAL AND ENTERTAINMENT SERVICES, NAMELY, PROVIDING PODCASTS FEATURING INFORMATION AND ADVICE IN CONNECTION WITH GASTRONOMY, COOKING, RECIPES, FOOD INGREDIENTS, NUTRITION AND THE PROMOTION OF HEALTHY AND FINE EATING; BOOK PUBLISHING; ELECTRONIC PUBLISHING SERVICES, NAMELY, PUBLICATION OF TEXTS AND GRAPHIC WORKS OF OTHERS ONLINE IN CONNECTION WITH GASTRONOMY, COOKING, RECIPES, FOOD INGREDIENTS, NUTRITION AND THE PROMOTION OF HEALTHY AND FINE EATING; PROVISION OF ONLINE ELECTRONIC PUBLICATIONS, NAMELY, BOOKS, NEWSLETTERS, MAGAZINES AND JOURNALS IN THE FIELD OF GASTRONOMY, COOKING, RECIPES, FOOD INGREDIENTS, NUTRITION AND THE PROMOTION OF HEALTHY AND FINE EATING; PROVISION OF ONLINE INFORMATION RELATING TO ENTERTAINMENT AND/OR EDUCATION, NAMELY, INFORMATION REGARDING TELEVISION SHOWS, PODCASTS AND ANIMATIONS OF OTHERS IN CONNECTION WITH GASTRONOMY, COOKING, RECIPES, FOOD

INGREDIENTS, NUTRITION AND THE PROMOTION OF HEALTHY AND FINE EATING; FILM PRODUCTION; ANIMATED FILM PRODUCTION; RADIO PROGRAMME PRODUCTION; TELEVISION AND RADIO ENTERTAINMENT, NAMELY, LIVE RADIO AND TELEVISION SHOWS IN CONNECTION WITH GASTRONOMY, COOKING, RECIPES, FOOD INGREDIENTS, NUTRITION AND THE PROMOTION OF HEALTHY AND FINE EATING; LIVE COOKERY PERFORMANCES AND PERSONAL APPEARANCES BY A COSTUMED CHARACTER; ORGANISATION OF COOKERY-RELATED COMPETITIONS (U.S. CLS. 100, 101 AND 107).  
SUSAN STIGLITZ, EXAMINING ATTORNEY

SN 85-034,524. JAGEX LIMITED, CAMBRIDGE, UNITED KINGDOM, FILED 5-10-2010.

## VOID HUNTERS

THE MARK CONSISTS OF STANDARD CHARACTERS WITHOUT CLAIM TO ANY PARTICULAR FONT, STYLE, SIZE, OR COLOR.

PRIORITY CLAIMED UNDER SEC. 44(D) ON UNITED KINGDOM APPLICATION NO. 2532206, FILED 11-20-2009, REG. NO. 2532206, DATED 2-26-2010, EXPIRES 11-20-2019.

### CLASS 9—ELECTRICAL AND SCIENTIFIC APPARATUS

FOR DOWNLOADABLE MOBILE TELEPHONE RING TONES; DOWNLOADABLE COMPUTER SCREEN-SAVER SOFTWARE; DOWNLOADABLE COMPUTER WALLPAPER SOFTWARE IN THE NATURE OF SCREEN SAVER SOFTWARE; COMPUTER GAME PROGRAMS; VIDEO GAME PROGRAMS; INTERACTIVE ENTERTAINMENT GAME SOFTWARE FOR PLAYING COMPUTER GAMES, VIDEO GAMES AND GAMES VIA THE INTERNET (U.S. CLS. 21, 23, 26, 36 AND 38).

### CLASS 16—PAPER GOODS AND PRINTED MATTER

FOR PRINTED MATTER, NAMELY, BOOKS, LEAFLETS, BROCHURES, PLAYER'S GUIDES, INSTRUCTIONAL AND TEACHING MATERIALS, AND POSTERS, ALL IN THE FIELDS OF ON-LINE COMPUTER GAMES AND MULTI-USER COMPUTER GAMES PROVIDED VIA LOCAL COMPUTER NETWORKS, GLOBAL COMPUTER NETWORKS, AND THE INTERNET (U.S. CLS. 2, 5, 22, 23, 29, 37, 38 AND 50).

### CLASS 25—CLOTHING

FOR ARTICLES OF CLOTHING, NAMELY, T-SHIRTS, HATS, CAPS (U.S. CLS. 22 AND 39).

### CLASS 41—EDUCATION AND ENTERTAINMENT

FOR ENTERTAINMENT SERVICES, NAMELY, PROVIDING ONLINE COMPUTER GAMES; ELECTRONIC GAME ENTERTAINMENT SERVICES, NAMELY, PROVIDING ONLINE COMPUTER GAMES; ENTERTAINMENT SERVICES, NAMELY, PROVISION OF ONLINE COMPUTER, VIDEO, AND ELECTRONIC GAMES BY MEANS OF LOCAL COMPUTER NETWORKS, GLOBAL COMPUTER NETWORKS, THE INTERNET, CABLE OR WIRE COMMUNICATIONS SERVICES, WIRELESS TELECOMMUNICATIONS SERVICES AND BROADBAND TELECOMMUNICATIONS SERVICES (U.S. CLS. 100, 101 AND 107).

TARA PATE, EXAMINING ATTORNEY

SN 85-034,573. HONEYMARK INTERNATIONAL, LLC, EASTPORT, NY. FILED 5-10-2010.



THE MARK CONSISTS OF THE WORD "HONEYMARK" BENEATH AN IMAGE OF A HALF OVAL WITH WAVY LINES RUNNING THERETHROUGH.

### CLASS 3—COSMETICS AND CLEANING PREPARATIONS

FOR NON-MEDICATED ANTI-WRINKLE SERUM; HAND SOAP; LIQUID HAND SOAP; BAR SOAP; SOAP CONTAINING HONEY; FACIAL AND BODY MASK; BATH SALTS; ALL OF THE FOREGOING CONTAINING HONEY (U.S. CLS. 1, 4, 6, 50, 51 AND 52).

FIRST USE 11-1-2008; IN COMMERCE 11-1-2008.

### CLASS 5—PHARMACEUTICALS

FOR ANTISEPTIC SPRAYS; ACNE TREATMENT CREAM PREPARATIONS; ANTI-FUNGAL SOLUTION; PAIN RELIEF CREAM; ANTI-ITCH CREAM; TOPICAL FIRST AID LOTION; WOUND DRESSING; SANITIZING PREPARATIONS, NAMELY, HAND SANITIZERS; ANTI-SEPTIC LOTIONS; ALL OF THE FOREGOING CONTAINING HONEY (U.S. CLS. 6, 18, 44, 46, 51 AND 52).

FIRST USE 6-1-2007; IN COMMERCE 6-1-2007.

### CLASS 30—STAPLE FOODS

FOR HONEY (U.S. CL. 46).

FIRST USE 11-1-2008; IN COMMERCE 11-1-2008.

HAI-LY LAM, EXAMINING ATTORNEY

SN 85-035,270. THE FAIRIES DEVELOPMENT PTY LTD, NORWOOD, SA 5067, AUSTRALIA, FILED 5-11-2010.



OWNER OF AUSTRALIA REG. NO. 916233, DATED 6-13-2002, EXPIRES 6-13-2012.

OWNER OF U.S. REG. NOS. 3,442,156 AND 3,781,288.

THE MARK CONSISTS OF THE STYLIZED WORDING "THE FAIRIES" WITH A SWIRL ABOVE THE FIRST LETTER "T" IN THE WORD "FAIRIES" AND A FIVE-POINTED STAR ABOVE THE SECOND LETTER "I" IN THE WORD "FAIRIES"; THE MARK CONTAINS A SIX-POINTED STAR APPEARING BEHIND THE TERM "FAIRIES" AS WELL AS A LINE UNDER THE TERM "THE FAIRIES" BEGINNING WITH A SWIRL AND ENDING WITH A SIX-POINTED STAR WITH RAYS.

**CLASS 16—PAPER GOODS AND PRINTED MATTER**

FOR BOOKS FOR CHILDREN, NAMELY, ACTIVITY BOOKS, BATH BOOKS, CHUNKY BOARD BOOKS, COLORING BOOKS, GLOW IN THE DARK BOOKS, PICTURE BOOKS, POP UP BOOKS, PULL TAB BOOKS, SCRAP BOOKS, SQUEAKY BOOKS, STICKER BOOKS, STORY BOOKS; COMIC BOOKS; DRAWING BOOKS IN THE NATURE OF BLANK BOOKS FOR USE IN DRAWING; PRINTED MUSIC BOOKS; BOOKS, BROCHURES AND NEWSLETTERS, IN THE FIELD OF CHILDREN'S EDUCATION AND ENTERTAINMENT; MAGAZINES, NAMELY, GENERAL FEATURE MAGAZINES FOR CHILDREN AND MAGAZINES FOR ADULTS DEALING WITH CHILDREN'S ISSUES; TEACHING MATERIALS, NAMELY, TEXTBOOKS FOR TEACHING READING, MUSIC, DRAMA, MATHEMATICS, SPELLING, WRITING, MAGIC TRICKS TO CHILDREN; BIBS OF PAPER; BOARDS, NAMELY, CHALKBOARDS FOR HOME AND SCHOOL USE, CLIP BOARDS, PAPER BOARD, MAGNETIC BOARDS, POSTER BOARD; PRINTED MATTER AND PAPER GOODS IN THIS CLASS, NAMELY, BOOK MARKS, CALENDARS, PAPER PLACEMATS, POSTERS, CARDS, NAMELY, GREETING CARDS, NOTE CARDS, GIFT CARDS, FLASH CARDS; DECORATED MOUNTED AND UNMOUNTED PICTURES, MOUNTED AND UNMOUNTED PHOTOGRAPHS, WRITING PAPER, PAPER COASTERS, PAPER NAPKINS, PAPER, PAPER PARTYWARE IN THE NATURE OF PARTY BAGS, DECORATIONS, PARTY FAVORS, DECORATIVE GARLANDS, TABLE CLOTHS OF PAPER; PEN AND PENCIL CASES; PEN HOLDERS; PENCIL SHARPENERS; PENCILS; PENS; CRAYONS; SHOW BAGS, NAMELY, DECORATED BAGS FOR HOLDING MERCHANDISE; STAMP PADS; RUBBER STAMPS; STATIONERY; STENCILS; STICKERS; WRITING SLATES; DRAWING PADS; ARTISTS' SUPPLIES IN THIS CLASS, NAMELY, ARTISTS' BRUSHES, ARTISTS' PASTELS, ARTISTS' PENS (U.S. CLS. 2, 5, 22, 23, 29, 37, 38 AND 50).

**CLASS 25—CLOTHING**

FOR CLOTHING, NAMELY, SHIRTS, BLOUSES, T-SHIRTS, PANTS, SHORTS, SKIRTS, DRESSES, SWEATSHIRTS, SWEATPANTS, SWEATERS, JUMPERS, VESTS, COATS, JACKETS, OVERALLS, RAIN SLICKERS, WARM UP SUITS, SNOWSUITS, SLEEPWEAR, CLOTH BIBS, UNDERWEAR, MASQUERADE AND HALLOWEEN COSTUMES AND MASKS, SOCKS, BEACHWEAR; FOOTWEAR; HEADWEAR (U.S. CLS. 22 AND 39).

**CLASS 28—TOYS AND SPORTING GOODS**

FOR TOYS AND PLAYTHINGS, NAMELY, JIGSAW PUZZLES, STUFFED TOYS, BALLOONS, NOISE MAKERS IN THE NATURE OF CHRISTMAS CRACKERS, PARTY FAVORS IN THE NATURE OF SMALL TOYS, DOLLS' HOUSES, DOLLS, FINGER PUPPETS, INFLATABLE POOL TOYS, TOY SWIM MASKS AND TOY DIVING MASKS, KALEIDOSCOPIES, KITES, PLAYING CARDS, PLAY SWIMMING POOLS, PLUSH TOYS, PUPPETS, PUZZLES, SOFT SCULPTURE TOYS, SPINNING TOPS, TOY MONEY BANK, CHEERLEADING POM POMS, BALLS, NAMELY, PLAY BALLS, MUSICAL TOYS, NAMELY, TOY MUSICAL INSTRUMENTS, TOY CYMBALS, TOY DRUM KITS, TOY ELECTRONIC KEYBOARDS, TOY ELECTRONIC AND NON-ELECTRONIC GUITARS, TOY TAMBOURINES, TOY MICROPHONES; GYMNASTIC AND SPORTING GOODS NOT INCLUDED IN OTHER CLASSES, NAMELY, FISHING RODS (U.S. CLS. 22, 23, 38 AND 50).

ELLEN BURNS, EXAMINING ATTORNEY

SN 85-035,326. SMOBILE SYSTEMS, INC., COLUMBUS, OH.  
FILED 5-11-2010.

# SMOBILE

THE MARK CONSISTS OF STANDARD CHARACTERS WITHOUT CLAIM TO ANY PARTICULAR FONT, STYLE, SIZE, OR COLOR.

OWNER OF U.S. REG. NOS. 3,229,212 AND 3,280,619.

**CLASS 9—ELECTRICAL AND SCIENTIFIC APPARATUS**

FOR SOFTWARE FOR ALLOWING REMOTE ACCESS, MANAGEMENT, CONTROL, OPERATION, MONITORING, LOCKING, WIPING, BACKING UP, RESTORING, AND LOCATING OF MOBILE AND WIRELESS DEVICES; SOFTWARE FOR ANTIVIRUS AND SECURITY PROTECTION OF MOBILE, WIRELESS, AND EMBEDDED DEVICES; SOFTWARE FOR DETECTING AND PREVENTING INTRUSIONS, VIRUSES, AND OTHER MALICIOUS CODES FROM ATTACKING COMPUTERS, AND MOBILE AND WIRELESS DEVICES; SOFTWARE FOR PROTECTING COMPUTERS, AND MOBILE AND WIRELESS DEVICES AGAINST COMPUTER SECURITY THREATS SOFTWARE FOR PROVIDING SECURED ACCESS AND ENCRYPTION/DECRYPTION CAPACITY FOR USE IN COMPUTERS, AND MOBILE AND WIRELESS DEVICES; AND SOFTWARE FOR USE IN APPLICATION MANAGEMENT IN CONNECTION WITH COMPUTERS, AND MOBILE AND WIRELESS DEVICES (U.S. CLS. 21, 23, 26, 36 AND 38).

FIRST USE 2-5-2003; IN COMMERCE 2-5-2003.

**CLASS 42—SCIENTIFIC AND COMPUTER SERVICES**

FOR PROVIDING A WEB-BASED SYSTEM AND ONLINE PORTAL FOR CUSTOMERS TO REMOTELY ACCESS, MANAGE, CONTROL, OPERATE, MONITOR, LOCK, WIPE, BACK UP, RESTORE, AND LOCATE MOBILE AND WIRELESS DEVICES (U.S. CLS. 100 AND 101).

FIRST USE 1-0-2009; IN COMMERCE 1-0-2009.

PRISCILLA MILTON, EXAMINING ATTORNEY

SN 85-035,329. SMOBILE SYSTEMS, INC., COLUMBUS, OH.  
FILED 5-11-2010.

# PROTECT WHAT'S YOURS

THE MARK CONSISTS OF STANDARD CHARACTERS WITHOUT CLAIM TO ANY PARTICULAR FONT, STYLE, SIZE, OR COLOR.



**CLASS 9—ELECTRICAL AND SCIENTIFIC APPARATUS**

FOR SOFTWARE FOR ALLOWING REMOTE ACCESS, MANAGEMENT, CONTROL, OPERATION, MONITORING, LOCKING, WIPING, BACKING UP, RESTORING, AND LOCATING OF MOBILE AND WIRELESS DEVICES; SOFTWARE FOR ANTIVIRUS AND SECURITY PROTECTION OF MOBILE, WIRELESS, AND EMBEDDED DEVICES; SOFTWARE FOR DETECTING AND PREVENTING INTRUSIONS, VIRUSES, AND OTHER MALICIOUS CODES FROM ATTACKING COMPUTERS, AND MOBILE AND WIRELESS DEVICES; SOFTWARE FOR PROTECTING COMPUTERS, AND MOBILE AND WIRELESS DEVICES AGAINST COMPUTER SECURITY THREATS SOFTWARE FOR PROVIDING SECURED ACCESS AND ENCRYPTION/DECRYPTION CAPACITY FOR USE IN COMPUTERS, AND MOBILE AND WIRELESS DEVICES; AND SOFTWARE FOR USE IN APPLICATION MANAGEMENT IN CONNECTION WITH COMPUTERS, AND MOBILE AND WIRELESS DEVICES (U.S. CLS. 21, 23, 26, 36 AND 38).

FIRST USE 3-1-2010; IN COMMERCE 3-1-2010.

**CLASS 42—SCIENTIFIC AND COMPUTER SERVICES**

FOR PROVIDING A WEB-BASED SYSTEM AND ONLINE PORTAL FOR CUSTOMERS TO REMOTELY ACCESS, MANAGE, CONTROL, OPERATE, MONITOR, LOCK, WIPE, BACK UP, RESTORE, AND LOCATE MOBILE AND WIRELESS DEVICES (U.S. CLS. 100 AND 101).

FIRST USE 3-1-2010; IN COMMERCE 3-1-2010.  
PRISCILLA MILTON, EXAMINING ATTORNEY

SN 85-035,543. PLATFORM DEVELOPMENT ENTERPRISES LIMITED, ST. JOHN'S ANTIGUA, ANTIGUA & BARBUDA, FILED 5-11-2010.



THE MARK CONSISTS OF THE STYLIZED LETTERS "UB", FOLLOWED BY A PERIOD AND THE SMALLER, STYLIZED LETTERS "NET". A TRIANGLE SHAPE APPEARS TO THE UPPER RIGHT OF THE LETTER "B" WHICH, TOGETHER WITH THE "B", FORMS THE SHAPE OF A PLAYING CARD SPADE SYMBOL.

**CLASS 9—ELECTRICAL AND SCIENTIFIC APPARATUS**

FOR ELECTRONIC PUBLICATIONS DOWNLOADABLE FROM THE INTERNET, NAMELY, MAGAZINES, MANUALS, PERIODICALS AND REPORTS, ALL IN THE FIELD OF POKER AND CASINO GAMES AND TOURNAMENTS; INTERACTIVE COMPUTER HARDWARE AND SOFTWARE FOR GAMES, AMUSEMENT AND ENTERTAINMENT, NAMELY, POKER AND CASINO GAMES AND OTHER GAMES OF CHANCE AND OF MIXED CHANCE AND SKILL (U.S. CLS. 21, 23, 26, 36 AND 38).

**CLASS 41—EDUCATION AND ENTERTAINMENT**

FOR ONLINE NON-DOWNLOADABLE ELECTRONIC PUBLICATIONS, NAMELY, MAGAZINES, MANUALS, PERIODICALS AND REPORTS, ALL IN THE FIELD OF POKER AND CASINO GAMES AND TOURNAMENTS; AND ONLINE INFORMATION, ALL IN THE FIELDS OF SPORTS, GAMING AND ENTERTAINMENT, ONLINE COMPUTER GAMES, ONLINE CARD GAMES, AND ONLINE CASINO GAMES ALL OF THE AFOREMENTIONED PUBLICATIONS AND INFORMATION BEING OBTAINED VIA AN ONLINE DATABASE; ONLINE INTERACTIVE COMPUTER GAMES, NAMELY, POKER AND CASINO GAMES AND OTHER GAMES OF CHANCE AND OF MIXED CHANCE AND SKILL (U.S. CLS. 100, 101 AND 107).

**CLASS 42—SCIENTIFIC AND COMPUTER SERVICES**

FOR HOSTING THE WEB SITES OF OTHERS (U.S. CLS. 100 AND 101).

TRACY WHITTAKER-BROWN, EXAMINING ATTORNEY

SN 85-035,557. PLATFORM DEVELOPMENT ENTERPRISES LIMITED, ST. JOHN'S ANTIGUA, ANTIGUA & BARBUDA, FILED 5-11-2010.



PRIORITY CLAIMED UNDER SEC. 44(D) ON CANADA APPLICATION NO. 1459639, FILED 11-19-2009.

THE MARK CONSISTS OF THE STYLIZED LETTERS "UB", FOLLOWED BY A PERIOD AND THE SMALLER, STYLIZED LETTERS "COM". A TRIANGLE SHAPE APPEARS TO THE UPPER RIGHT OF THE LETTER "B" WHICH, TOGETHER WITH THE "B", FORMS THE SHAPE OF A PLAYING CARD SPADE SYMBOL.

**CLASS 9—ELECTRICAL AND SCIENTIFIC APPARATUS**

FOR ELECTRONIC PUBLICATIONS DOWNLOADABLE FROM THE INTERNET, NAMELY, MAGAZINES, MANUALS, PERIODICALS AND REPORTS, ALL IN THE FIELD OF POKER AND CASINO GAMES AND TOURNAMENTS; INTERACTIVE COMPUTER HARDWARE AND SOFTWARE FOR GAMES, AMUSEMENT AND ENTERTAINMENT, NAMELY, POKER AND CASINO GAMES AND OTHER GAMES OF CHANCE AND OF MIXED CHANCE AND SKILL (U.S. CLS. 21, 23, 26, 36 AND 38).

**CLASS 41—EDUCATION AND ENTERTAINMENT**

FOR ONLINE NON-DOWNLOADABLE ELECTRONIC PUBLICATIONS, NAMELY, MAGAZINES, MANUALS, PERIODICALS AND REPORTS, ALL IN THE FIELD OF POKER AND CASINO GAMES AND TOURNAMENTS; AND ONLINE INFORMATION, ALL IN THE FIELDS OF SPORTS, GAMING AND ENTERTAINMENT, ONLINE COMPUTER GAMES, ONLINE CARD GAMES, AND ONLINE CASINO GAMES ALL OF THE AFOREMENTIONED PUBLICATIONS AND INFORMATION BEING OBTAINED VIA AN ONLINE DATABASE; ONLINE INTERACTIVE COMPUTER GAMES, NAMELY, POKER AND CASINO GAMES AND OTHER GAMES OF CHANCE AND OF MIXED CHANCE AND SKILL (U.S. CLS. 100, 101 AND 107).

**CLASS 42—SCIENTIFIC AND COMPUTER SERVICES**

FOR HOSTING THE WEB SITES OF OTHERS (U.S. CLS. 100 AND 101).  
TRACY WHITTAKER-BROWN, EXAMINING ATTORNEY

---

SN 85-035,848. ACTIVISION PUBLISHING, INC., SANTA MONICA, CA. FILED 5-11-2010.

**CALL OF DUTY ADVANCED WARFARE**

THE MARK CONSISTS OF STANDARD CHARACTERS WITHOUT CLAIM TO ANY PARTICULAR FONT, STYLE, SIZE, OR COLOR.  
OWNER OF U.S. REG. NO. 2,925,780.

**CLASS 9—ELECTRICAL AND SCIENTIFIC APPARATUS**

FOR COMPUTER GAME SOFTWARE AND RELATED INSTRUCTION MANUAL SOLD TOGETHER AS A UNIT; INTERACTIVE VIDEO GAME PROGRAMS; COMPUTER GAME CARTRIDGES; COMPUTER GAME DISCS; DOWNLOADABLE COMPUTER GAME SOFTWARE; VIDEO GAME CONTROLLERS; INTERACTIVE VIDEO GAME COMPRISED OF A CARTRIDGE OR DVD SOLD AS A UNIT WITH A VIDEO GAME CONTROLLER (U.S. CLS. 21, 23, 26, 36 AND 38).

**CLASS 41—EDUCATION AND ENTERTAINMENT**

FOR ENTERTAINMENT SERVICES, NAMELY, PROVIDING AN ON-LINE COMPUTER GAME; ONLINE ENTERTAINMENT IN THE NATURE OF COMPUTER GAME TOURNAMENTS; PROVIDING ONLINE NEWS AND INFORMATION IN THE FIELD OF COMPUTER GAMES; ENTERTAINMENT SERVICES, NAMELY, CONDUCTING CONTESTS ONLINE; PROVIDING A WEBSITE FOR ORGANIZING, PLANNING AND CONDUCTING EXHIBITIONS AND SPECIAL EVENTS BETWEEN COMPUTER GAME PLAYERS AND INTEREST GROUPS FOR ENTERTAINMENT PURPOSES (U.S. CLS. 100, 101 AND 107).  
KATHERINE CONNOLLY, EXAMINING ATTORNEY

---

SN 85-035,853. ACTIVISION PUBLISHING, INC., SANTA MONICA, CA. FILED 5-11-2010.

**CALL OF DUTY FUTURE WARFARE**

THE MARK CONSISTS OF STANDARD CHARACTERS WITHOUT CLAIM TO ANY PARTICULAR FONT, STYLE, SIZE, OR COLOR.  
OWNER OF U.S. REG. NO. 2,925,780.

**CLASS 9—ELECTRICAL AND SCIENTIFIC APPARATUS**

FOR COMPUTER GAME SOFTWARE AND RELATED INSTRUCTION MANUAL SOLD TOGETHER AS A UNIT; INTERACTIVE VIDEO GAME PROGRAMS; COMPUTER GAME CARTRIDGES; COMPUTER GAME DISCS; DOWNLOADABLE COMPUTER GAME SOFTWARE; VIDEO GAME CONTROLLERS; INTERACTIVE VIDEO GAME COMPRISED OF A CARTRIDGE OR DVD SOLD AS A UNIT WITH A VIDEO GAME CONTROLLER (U.S. CLS. 21, 23, 26, 36 AND 38).

**CLASS 41—EDUCATION AND ENTERTAINMENT**

FOR ENTERTAINMENT SERVICES, NAMELY, PROVIDING AN ON-LINE COMPUTER GAME; ONLINE ENTERTAINMENT IN THE NATURE OF COMPUTER GAME TOURNAMENTS; PROVIDING ONLINE NEWS AND INFORMATION IN THE FIELD OF COMPUTER GAMES; ENTERTAINMENT SERVICES, NAMELY, CONDUCTING CONTESTS ONLINE; PROVIDING A WEBSITE FOR ORGANIZING, PLANNING AND CONDUCTING EXHIBITIONS AND SPECIAL EVENTS BETWEEN COMPUTER GAME PLAYERS AND INTEREST GROUPS FOR ENTERTAINMENT PURPOSES (U.S. CLS. 100, 101 AND 107).  
KATHERINE CONNOLLY, EXAMINING ATTORNEY

---

SN 85-035,859. ACTIVISION PUBLISHING, INC., SANTA MONICA, CA. FILED 5-11-2010.

**CALL OF DUTY SECRET WARFARE**

THE MARK CONSISTS OF STANDARD CHARACTERS WITHOUT CLAIM TO ANY PARTICULAR FONT, STYLE, SIZE, OR COLOR.  
OWNER OF U.S. REG. NO. 2,925,780.

**CLASS 9—ELECTRICAL AND SCIENTIFIC APPARATUS**

FOR COMPUTER GAME SOFTWARE AND RELATED INSTRUCTION MANUAL SOLD TOGETHER AS A UNIT; INTERACTIVE VIDEO GAME PROGRAMS; COMPUTER GAME CARTRIDGES; COMPUTER GAME DISCS; DOWNLOADABLE COMPUTER GAME SOFTWARE; VIDEO GAME CONTROLLERS; INTERACTIVE VIDEO GAME COMPRISED OF A CARTRIDGE OR DVD SOLD AS A UNIT WITH A VIDEO GAME CONTROLLER (U.S. CLS. 21, 23, 26, 36 AND 38).

**CLASS 41—EDUCATION AND ENTERTAINMENT**

FOR ENTERTAINMENT SERVICES, NAMELY, PROVIDING AN ON-LINE COMPUTER GAME; ONLINE ENTERTAINMENT IN THE NATURE OF COMPUTER GAME TOURNAMENTS; PROVIDING ONLINE NEWS AND INFORMATION IN THE FIELD OF COMPUTER GAMES; ENTERTAINMENT SERVICES, NAMELY, CONDUCTING CONTESTS ONLINE; PROVIDING A WEBSITE FOR ORGANIZING, PLANNING AND CONDUCTING EXHIBITIONS AND SPECIAL EVENTS BETWEEN COMPUTER GAME PLAYERS AND INTEREST GROUPS FOR ENTERTAINMENT PURPOSES (U.S. CLS. 100, 101 AND 107).  
KATHERINE CONNOLLY, EXAMINING ATTORNEY

SN 85-035,865. ACTIVISION PUBLISHING, INC., SANTA MONICA, CA. FILED 5-11-2010.

### CALL OF DUTY SPACE WARFARE

THE MARK CONSISTS OF STANDARD CHARACTERS WITHOUT CLAIM TO ANY PARTICULAR FONT, STYLE, SIZE, OR COLOR.

OWNER OF U.S. REG. NO. 2,925,780.

### CLASS 9—ELECTRICAL AND SCIENTIFIC APPARATUS

FOR COMPUTER GAME SOFTWARE AND RELATED INSTRUCTION MANUAL SOLD TOGETHER AS A UNIT; INTERACTIVE VIDEO GAME PROGRAMS; COMPUTER GAME CARTRIDGES; COMPUTER GAME DISCS; DOWNLOADABLE COMPUTER GAME SOFTWARE; VIDEO GAME CONTROLLERS; INTERACTIVE VIDEO GAME COMPRISED OF A CARTRIDGE OR DVD SOLD AS A UNIT WITH A VIDEO GAME CONTROLLER (U.S. CLS. 21, 23, 26, 36 AND 38).

### CLASS 41—EDUCATION AND ENTERTAINMENT

FOR ENTERTAINMENT SERVICES, NAMELY, PROVIDING AN ON-LINE COMPUTER GAME; ONLINE ENTERTAINMENT IN THE NATURE OF COMPUTER GAME TOURNAMENTS; PROVIDING ONLINE NEWS AND INFORMATION IN THE FIELD OF COMPUTER GAMES; ENTERTAINMENT SERVICES, NAMELY, CONDUCTING CONTESTS ONLINE; PROVIDING A WEBSITE FOR ORGANIZING, PLANNING AND CONDUCTING EXHIBITIONS AND SPECIAL EVENTS BETWEEN COMPUTER GAME PLAYERS AND INTEREST GROUPS FOR ENTERTAINMENT PURPOSES (U.S. CLS. 100, 101 AND 107).

KATHERINE CONNOLLY, EXAMINING ATTORNEY

SN 85-035,869. ACTIVISION PUBLISHING, INC., SANTA MONICA, CA. FILED 5-11-2010.

### FUTURE WARFARE

THE MARK CONSISTS OF STANDARD CHARACTERS WITHOUT CLAIM TO ANY PARTICULAR FONT, STYLE, SIZE, OR COLOR.

### CLASS 9—ELECTRICAL AND SCIENTIFIC APPARATUS

FOR COMPUTER GAME SOFTWARE AND RELATED INSTRUCTION MANUAL SOLD TOGETHER AS A UNIT; INTERACTIVE VIDEO GAME PROGRAMS; COMPUTER GAME CARTRIDGES; COMPUTER GAME DISCS; DOWNLOADABLE COMPUTER GAME SOFTWARE; VIDEO GAME CONTROLLERS; INTERACTIVE VIDEO GAME COMPRISED OF A CARTRIDGE OR DVD SOLD AS A UNIT WITH A VIDEO GAME CONTROLLER (U.S. CLS. 21, 23, 26, 36 AND 38).

### CLASS 41—EDUCATION AND ENTERTAINMENT

FOR ENTERTAINMENT SERVICES, NAMELY, PROVIDING AN ON-LINE COMPUTER GAME; ONLINE ENTERTAINMENT IN THE NATURE OF COMPUTER GAME TOURNAMENTS; PROVIDING ONLINE NEWS AND INFORMATION IN THE FIELD OF COMPUTER GAMES; ENTERTAINMENT SERVICES, NAMELY, CONDUCTING CONTESTS ONLINE; PROVIDING A WEBSITE FOR ORGANIZING, PLANNING AND CONDUCTING EXHIBITIONS AND SPECIAL EVENTS BETWEEN COMPUTER GAME PLAYERS AND INTEREST GROUPS FOR ENTERTAINMENT PURPOSES (U.S. CLS. 100, 101 AND 107).

KATHERINE CONNOLLY, EXAMINING ATTORNEY

SN 85-035,875. ACTIVISION PUBLISHING, INC., SANTA MONICA, CA. FILED 5-11-2010.

### SPACE WARFARE

THE MARK CONSISTS OF STANDARD CHARACTERS WITHOUT CLAIM TO ANY PARTICULAR FONT, STYLE, SIZE, OR COLOR.

### CLASS 9—ELECTRICAL AND SCIENTIFIC APPARATUS

FOR COMPUTER GAME SOFTWARE AND RELATED INSTRUCTION MANUAL SOLD TOGETHER AS A UNIT; INTERACTIVE VIDEO GAME PROGRAMS; COMPUTER GAME CARTRIDGES; COMPUTER GAME DISCS; DOWNLOADABLE COMPUTER GAME SOFTWARE; VIDEO GAME CONTROLLERS; INTERACTIVE VIDEO GAME COMPRISED OF A CARTRIDGE OR DVD SOLD AS A UNIT WITH A VIDEO GAME CONTROLLER (U.S. CLS. 21, 23, 26, 36 AND 38).

### CLASS 41—EDUCATION AND ENTERTAINMENT

FOR ENTERTAINMENT SERVICES, NAMELY, PROVIDING AN ON-LINE COMPUTER GAME; ONLINE ENTERTAINMENT IN THE NATURE OF COMPUTER GAME TOURNAMENTS; PROVIDING ONLINE NEWS AND INFORMATION IN THE FIELD OF COMPUTER GAMES; ENTERTAINMENT SERVICES, NAMELY, CONDUCTING CONTESTS ONLINE; PROVIDING A WEBSITE FOR ORGANIZING, PLANNING AND CONDUCTING EXHIBITIONS AND SPECIAL EVENTS BETWEEN COMPUTER GAME PLAYERS AND INTEREST GROUPS FOR ENTERTAINMENT PURPOSES (U.S. CLS. 100, 101 AND 107).

KATHERINE CONNOLLY, EXAMINING ATTORNEY

SN 85-036,066. MARY KAY INC., ADDISON, TX. FILED 5-12-2010.

### BEAUTY COMES TO YOU

THE MARK CONSISTS OF STANDARD CHARACTERS WITHOUT CLAIM TO ANY PARTICULAR FONT, STYLE, SIZE, OR COLOR.

**CLASS 3—COSMETICS AND CLEANING PREPARATIONS**

FOR COSMETICS; FRAGRANCES FOR PERSONAL USE; NON-MEDICATED SKIN CARE PREPARATIONS; NON-MEDICATED TOILETRIES (U.S. CLS. 1, 4, 6, 50, 51 AND 52).

**CLASS 16—PAPER GOODS AND PRINTED MATTER**

FOR BROCHURES ABOUT COSMETICS AND BEAUTY CARE; CATALOGS IN THE FIELD OF COSMETICS AND BEAUTY CARE; MAGAZINES FEATURING COSMETICS AND BEAUTY CARE; NEWSLETTERS IN THE FIELD OF COSMETICS AND BEAUTY CARE; POSTCARDS; PRINTED ADVERTISING BOARDS OF PAPER OR CARDBOARD; PRINTED INFORMATIONAL CARDS IN THE FIELD OF COSMETICS AND BEAUTY CARE; PRINTED PERIODICALS IN THE FIELD OF COSMETICS AND BEAUTY CARE; PRINTED PRODUCTS, NAMELY, PRODUCT GUIDES FEATURING COSMETICS AND BEAUTY CARE; PRINTED TRAINING MATERIALS IN THE FIELD OF COSMETICS AND BEAUTY CARE; STATIONERY (U.S. CLS. 2, 5, 22, 23, 29, 37, 38 AND 50).

AMY C. KEAN, EXAMINING ATTORNEY

**CLASS 35—ADVERTISING AND BUSINESS**

FOR RETAIL STORE SERVICES IN THE FIELDS OF FURNITURE, UPHOLSTERED FURNITURE, PARTS AND FITTINGS FOR FURNITURE, CUSHIONS, TEXTILES, TEXTILE FABRICS, TEXTILE PIECE GOODS, WOVEN FABRICS IMITATING LEATHER, ACCESSORIES FOR THE HOME, NAMELY, PILLOWS, CUSHIONS, DUVETS AND PICTURE FRAMES NOT INCLUDING BAGS, GOODS RELATED TO BAGS, FOOTWEAR OR CLOTHING; MAIL ORDER SERVICES AND ON-LINE RETAIL STORE SERVICES IN THE FIELDS OF FURNITURE, UPHOLSTERED FURNITURE, PARTS AND FITTINGS FOR FURNITURE, CUSHIONS, TEXTILES, TEXTILE FABRICS, TEXTILE PIECE GOODS, WOVEN FABRICS IMITATING LEATHER, ACCESSORIES FOR THE HOME, NAMELY, PILLOWS, CUSHIONS, DUVETS AND PICTURE FRAMES NOT INCLUDING BAGS, GOODS RELATED TO BAGS, FOOTWEAR OR CLOTHING; PROVIDING INFORMATION, ADVICE OR ASSISTANCE TO CUSTOMERS IN THE SELECTION AND PURCHASE OF FURNITURE, UPHOLSTERED FURNITURE, PARTS AND FITTINGS FOR FURNITURE, CUSHIONS, TEXTILES, TEXTILE FABRICS, TEXTILE PIECE GOODS, WOVEN FABRICS IMITATING LEATHER, ACCESSORIES FOR THE HOME, NAMELY, PILLOWS, CUSHIONS, DUVETS AND PICTURE FRAMES NOT INCLUDING BAGS, GOODS RELATED TO BAGS, FOOTWEAR OR CLOTHING (U.S. CLS. 100, 101 AND 102).

AMY C. KEAN, EXAMINING ATTORNEY

SN 85-036,077. IP HOLDINGS SA, STEINSEL, LUXEMBOURG, FILED 5-12-2010.

SN 85-036,521. RIVIERA DATA CORP, SANTA BARBARA, CA. FILED 5-12-2010.

# TOSCA

THE MARK CONSISTS OF STANDARD CHARACTERS WITHOUT CLAIM TO ANY PARTICULAR FONT, STYLE, SIZE, OR COLOR.

PRIORITY CLAIMED UNDER SEC. 44(D) ON ERPNCMNTY TM OFC APPLICATION NO. 008680721, FILED 11-12-2009, REG. NO. 008680721, DATED 7-13-2010, EXPIRES 11-12-2019.

THE ENGLISH TRANSLATION OF "TOSCA" IN THE MARK IS "ROUGH OR COARSE".

**CLASS 20—FURNITURE AND ARTICLES NOT OTHERWISE CLASSIFIED**

FOR FURNITURE, UPHOLSTERED FURNITURE, MIRRORS, PICTURE FRAMES; PILLOWS AND CUSHIONS (U.S. CLS. 2, 13, 22, 25, 32 AND 50).

**CLASS 24—FABRICS**

FOR TEXTILE AND TEXTILE GOODS, NAMELY, CURTAINS, DUVETS, BATH TOWELS, CURTAINS FOR SHOWERS AND WINDOWS, NOT INCLUDING BAGS AND RELATED GOODS, FOOTWEAR OR CLOTHING; BED COVERS; TABLE LINEN, NAMELY, TABLE COVERS; TEXTILE TABLE COVERS; COVERS FOR PILLOWS, CUSHIONS, OR DUVETS (U.S. CLS. 42 AND 50).

# RIV DATA CORP

THE MARK CONSISTS OF STANDARD CHARACTERS WITHOUT CLAIM TO ANY PARTICULAR FONT, STYLE, SIZE, OR COLOR.

NO CLAIM IS MADE TO THE EXCLUSIVE RIGHT TO USE "DATA CORP", APART FROM THE MARK AS SHOWN.

**CLASS 35—ADVERTISING AND BUSINESS**

FOR EMPLOYEE MONITORING SERVICES, NAMELY, MONITORING EMPLOYEES FOR JOB PERFORMANCE PURPOSES ON USER GENERATED CONTENT MEDIA WEBSITES AND SOCIAL NETWORKING WEBSITES BASED UPON PRE-SET EMPLOYER CRITERIA AND PROVIDING REPORTS TO EMPLOYERS ON EMPLOYEE ACTIVITIES (U.S. CLS. 100, 101 AND 102).

**CLASS 45—PERSONAL AND LEGAL SERVICES**

FOR PROVIDING EMPLOYERS WITH THE TOOLS TO IDENTIFY AND MONITOR APPLICANT AND EMPLOYEE ACTIVITY IN CONNECTION WITH PRE-EMPLOYMENT SCREENING, NAMELY, CONDUCTING PRE-EMPLOYMENT BACKGROUND SCREENING SERVICES; EMPLOYEE MONITORING SERVICES, NAMELY, MONITORING EMPLOYEE ACTIVITIES FOR SECURITY PURPOSES AND FOR ENFORCEMENT OF A COMPANY'S SOCIAL MEDIA POLICY ON USER GENERATED CONTENT MEDIA WEBSITES AND SOCIAL NETWORKING WEBSITES BASED UPON PRE-SET EMPLOYER CRITERIA (U.S. CLS. 100 AND 101).

EMILY CHUO, EXAMINING ATTORNEY



SN 85-038,084. RIHA RICHARD HARTINGER GETRAENKE GMBH & CO. HANDELS-KG, 31737 RINTELN, FED REP GERMANY, FILED 5-13-2010.

# HAZIENDA

THE MARK CONSISTS OF STANDARD CHARACTERS WITHOUT CLAIM TO ANY PARTICULAR FONT, STYLE, SIZE, OR COLOR.

OWNER OF FED REP GERMANY REG. NO. 30757767, DATED 1-28-2008, EXPIRES 9-30-2017.

THE ENGLISH TRANSLATION OF "HAZIENDA" IN THE MARK IS "HOUSE".

## CLASS 29—MEATS AND PROCESSED FOODS

FOR PRESERVED, DRIED AND COOKED FRUITS AND VEGETABLES; JELLIES; JAMS, COMPOTES; MILK PRODUCTS, NAMELY, YOGURT BASED BEVERAGES CONSISTING PRIMARILY OF YOGURT WITH FRUIT JUICES OR VEGETABLE JUICES (U.S. CL. 46).

## CLASS 31—NATURAL AGRICULTURAL PRODUCTS

FOR FRESH FRUITS (U.S. CLS. 1 AND 46).

## CLASS 32—LIGHT BEVERAGES

FOR MINERAL AND ABATED WATERS, OTHER NON-ALCOHOLIC DRINKS, NAMELY, LEMONADES, BITTER LEMON AND COLA DRINKS; FRUIT JUICES, FRUIT DRINKS, VEGETABLE JUICES AND VEGETABLE DRINKS; SYRUPS AND OTHER PREPARATIONS FOR MAKING BEVERAGES (U.S. CLS. 45, 46 AND 48).

PAULA MAHONEY, EXAMINING ATTORNEY

---

SN 85-039,327. INVIVOSCRIBE TECHNOLOGIES, INC., SAN DIEGO, CA. FILED 5-14-2010.

# INVIVOSCRIBE

THE MARK CONSISTS OF STANDARD CHARACTERS WITHOUT CLAIM TO ANY PARTICULAR FONT, STYLE, SIZE, OR COLOR.

## CLASS 1—CHEMICALS

FOR CHEMICAL AND BIOTECHNOLOGICAL PRODUCTS FOR COMMERCIAL AND SCIENTIFIC RESEARCH PURPOSES, NAMELY, REAGENTS FOR SCIENTIFIC AND RESEARCH USE, IN THE NATURE OF BUFFER SOLUTIONS, ENZYMES, MOLECULAR PROBES, DNA AND RNA POLYMERASES, NUCLEIC ACIDS, NUCLEIC ACID DERIVATIVES, PRIMERS FOR USE IN PCR, DNA TEMPLATES, RNA TEMPLATES, DYES AND BIOTECHNOLOGY REAGENTS AND SOLVENTS FOR SAMPLE PREPARATION, PURIFICATION, LYSIS, MODIFICATION AND MANIPULATION OF CELLS; KITS FOR SCIENTIFIC AND RESEARCH USE CONTAINING BUFFER SOLUTIONS, ENZYMES, MOLECULAR PROBES, DNA AND RNA POLYMERASES, NUCLEIC ACIDS, NUCLEIC ACID DERIVATIVES, PRIMERS FOR USE IN PCR, DNA TEMPLATES, RNA TEMPLATES, DYES AND BIOTECHNOLOGY REAGENTS AND SOLVENTS (U.S. CLS. 1, 5, 6, 10, 26 AND 46).

## CLASS 5—PHARMACEUTICALS

FOR MEDICAL DIAGNOSTIC REAGENTS, NAMELY, BUFFER SOLUTIONS, ENZYMES, MOLECULAR PROBES, DNA AND RNA POLYMERASES, NUCLEIC ACIDS, NUCLEIC ACID DERIVATIVES, PRIMERS FOR USE IN PCR, DNA TEMPLATES, RNA TEMPLATES, DYES AND BIOTECHNOLOGY REAGENTS AND SOLVENTS FOR SAMPLE PREPARATION, PURIFICATION, LYSIS, MODIFICATION AND MANIPULATION OF CELLS; MEDICAL DIAGNOSTIC KITS CONTAINING BUFFER SOLUTIONS, ENZYMES, MOLECULAR PROBES, DNA AND RNA POLYMERASES, NUCLEIC ACIDS, NUCLEIC ACID DERIVATIVES, PRIMERS FOR USE IN PCR, DNA TEMPLATES, RNA TEMPLATES, DYES AND BIOTECHNOLOGY REAGENTS AND SOLVENTS; MEDICAL DIAGNOSTIC KITS COMPRISED OF MEDICAL DIAGNOSTIC REAGENTS FOR THE TREATMENT, MONITORING OR DIAGNOSIS OF DISEASE; MEDICAL DIAGNOSTIC KITS FOR CLINICAL OR MEDICAL USE COMPRISED OF MEDICAL DIAGNOSTIC REAGENTS; MEDICAL DIAGNOSTIC REAGENT ASSAYS FOR THE TREATMENT OR DIAGNOSIS OF DISEASE; DIAGNOSTIC ASSAYS FOR CLINICAL AND MEDICAL USE (U.S. CLS. 6, 18, 44, 46, 51 AND 52).

## CLASS 9—ELECTRICAL AND SCIENTIFIC APPARATUS

FOR COMPUTER SOFTWARE FOR USE IN DATABASE MANAGEMENT TO INTEGRATE DATA AND INFORMATION, AS WELL AS PROVIDE REAL-TIME FINANCIALS FOR MULTIPLE INTERDEPENDENT BUT INDEPENDENT COMPANIES, INCLUDING FOREIGN SUBSIDIARIES; COMPUTER SOFTWARE CAPABLE OF MANAGING BUSINESS AND LABORATORY TASKS IN THE NATURE OF SALES, SALES MANAGEMENT, BUSINESS MANAGEMENT, PROJECT MANAGEMENT, SAMPLE CONTROL, SAMPLE SCHEDULING, QUALITY CONTROL, REPORT MANAGEMENT AND INVOICING; COMPUTER SOFTWARE FOR USE IN MANUFACTURING AND TRACKING CLINICAL SAMPLES IN THE FIELDS OF SCIENTIFIC RESEARCH, CLINICAL RESEARCH AND MEDICINE (U.S. CLS. 21, 23, 26, 36 AND 38).

## CLASS 42—SCIENTIFIC AND COMPUTER SERVICES

FOR PROVIDING MEDICAL TESTING AND CONSULTATION SERVICES FOR BOTH CLINICAL RESEARCH AND RESEARCH APPLICATIONS; PERFORMING SCIENTIFIC RESEARCH SERVICES, NAMELY, THE ISOLATION, DETECTION, AND ANALYSIS OF BIOLOGICAL SUBSTANCES FROM CLINICAL SAMPLES FOR OTHERS (U.S. CLS. 100 AND 101).

**CLASS 44—MEDICAL, BEAUTY AND AGRICULTURAL SERVICES**

FOR PROVIDING MEDICAL TESTING AND CONSULTATION SERVICES FOR CLINICAL APPLICATIONS; PERFORMING MEDICAL DIAGNOSTIC SERVICES, NAMELY, THE ISOLATION, DETECTION, AND ANALYSIS OF BIOLOGICAL SUBSTANCES FROM CLINICAL SAMPLES FOR OTHERS, PROVIDING MEDICAL TESTING AND CONSULTATION SERVICES FOR DIAGNOSTIC AND TREATMENT PURPOSES (U.S. CLS. 100 AND 101).

RAMONA ORTIGA, EXAMINING ATTORNEY

SN 85-039,926. RAVAN, GENYA, AKA ZELKOWITZ, GOLDIE, SAUGHERTIES, NY. FILED 5-17-2010.

**GOLDIE AND THE GINGERBREADS**

THE MARK CONSISTS OF STANDARD CHARACTERS WITHOUT CLAIM TO ANY PARTICULAR FONT, STYLE, SIZE, OR COLOR.

THE NAME "GOLDIE" IDENTIFIES THE STAGE NAME OF GENYA RAVAN A/K/A "GOLDIE" ZELKOWITZ A LIVING INDIVIDUAL WHOSE CONSENT IS OF RECORD.

**CLASS 9—ELECTRICAL AND SCIENTIFIC APPARATUS**

FOR SOUND AND VIDEO RECORDINGS FEATURING MUSIC, MUSICAL PERFORMANCES AND MUSIC BASED ENTERTAINMENT (U.S. CLS. 21, 23, 26, 36 AND 38).

FIRST USE 5-1-1962; IN COMMERCE 5-1-1962.

**CLASS 41—EDUCATION AND ENTERTAINMENT**

FOR ENTERTAINMENT SERVICES, NAMELY, LIVE PERFORMANCES BY A MUSICAL ARTIST (U.S. CLS. 100, 101 AND 107).

FIRST USE 5-1-1962; IN COMMERCE 5-1-1962.

TRACY FLETCHER, EXAMINING ATTORNEY

SN 85-040,086. MILUX HOLDING S.A., LUXEMBOURG, LUXEMBOURG, FILED 5-17-2010.

**REFLUXBMI**

THE MARK CONSISTS OF STANDARD CHARACTERS WITHOUT CLAIM TO ANY PARTICULAR FONT, STYLE, SIZE, OR COLOR.

PRIORITY CLAIMED UNDER SEC. 44(D) ON ERPNCMNTY TM OFC APPLICATION NO. 8694879, FILED 11-18-2009, REG. NO. 008694879, DATED 6-2-2010, EXPIRES 11-18-2019.

**CLASS 9—ELECTRICAL AND SCIENTIFIC APPARATUS**

FOR APPARATUS, DEVICES AND INSTRUMENTS, ALL NOT USED IN DIRECT ASSOCIATION WITH ACTIVE IMPLANTS, FOR MEASURING, RECEIVING, SENDING, CHECKING, CONTROLLING, DRIVING, TRANSFERRING, TRANSMITTING, PROCESSING, ANALYZING, CONDUCTING, SWITCHING, TRANSFORMING, ACCUMULATING, AND REGULATING ELECTRICITY, ENERGY AND/OR DATA, INCLUDING PHYSICAL PARAMETERS, NAMELY, ELECTRONIC STORAGE DEVICES IN THE NATURE OF BLANK MEMORY DISCS, MEMORY CARDS AND DATA STORAGE MEDIA, NAMELY, PACKAGED SEMICONDUCTORS, ELECTRONIC CONTROL UNIT AND PROGRAMMER WHICH CONTROLS THE WORKING PARAMETERS OF WIRELESS COMMUNICATION SYSTEMS AND WIRELESS POWERING SYSTEMS, CHARGERS IN THE NATURE OF BATTERY CHARGERS, DIGITAL CHARGERS AND ELECTRONIC CHARGERS, ELECTRONIC TRANSMITTERS AND ELECTRONIC RECEIVERS OF ELECTRONIC SIGNALS, AND ELECTRONIC CIRCUITS; REMOTE CONTROLS FOR WIRELESS CONTROLLING, AND PROGRAMMING WIRELESS CHARGER APPARATUS FOR WIRELESS ENERGIZING AND CONTROL STATIONS FOR WIRELESS CONTROLLING, PROGRAMMING AND ENERGIZING OF ACTIVE IMPLANTS; SOFTWARE, IN PARTICULAR FOR ACTIVE MEDICAL IMPLANTS, FOR MEASURING, RECEIVING, SENDING, CHECKING, TRANSFERRING, CALCULATING, PROCESSING, CONTROLLING, PRESENTING AND ANALYZING OF DATA, NAMELY, DATA ABOUT ELECTRICITY, ENERGY, PHYSICAL PARAMETERS, AND COMMUNICATION AND PROGRAMMING DATA IN MEDICAL IMPLANTS; SOFTWARE, IN PARTICULAR FOR MEASURING, RECEIVING, SENDING, CHECKING, TRANSFERRING, CALCULATING, PROCESSING, CONTROLLING, PRESENTING AND ANALYZING OF DATA, NAMELY, DATA ABOUT ELECTRICITY, ENERGY, PHYSICAL PARAMETERS, COMMUNICATION AND PROGRAMMING DATA IN APPARATUS, DEVICES AND INSTRUMENTS FOR COMMUNICATING WITH, ENERGIZING AND PROGRAMMING OF MEDICAL IMPLANTS; AND DATA PROCESSING EQUIPMENT AND COMPUTERS (U.S. CLS. 21, 23, 26, 36 AND 38).

**CLASS 10—MEDICAL APPARATUS**

FOR MEDICAL AND SURGICAL APPARATUS, INSTRUMENTS AND DEVICES, INCLUDING ACTIVE AND NON-ACTIVE MEDICAL IMPLANTS, NAMELY, MEDICAL IMPLANTS COMPRISED OF ARTIFICIAL MATERIAL; MEDICAL AND SURGICAL APPARATUS, INSTRUMENTS AND DEVICES INTENDED FOR USE INSIDE THE MAMMAL OR HUMAN BODY, IN PARTICULAR MANUAL, ELECTRICAL OR A COMBINATION OF MANUAL AND ELECTRICAL APPARATUS, DEVICES AND INSTRUMENTS, IN ALL GOODS INCLUDING MEDICAL HYDRAULIC, MECHANICAL, AND PNEUMATIC APPARATUS, DEVICES AND INSTRUMENTS, NAMELY, MEDICAL IMPLANTS COMPRISED OF ARTIFICIAL MATERIAL; MEDICAL AND SURGICAL APPARATUS, INSTRUMENTS AND DEVICES FOR REPLACING AND ADDING ONE OR MORE BODILY FUNCTIONS AND PARTS INSIDE THE BODY, NAMELY, MEDICAL IMPLANTS COMPRISED OF ARTIFICIAL MATERIAL; MEDICAL AND SURGICAL APPARATUS, INSTRUMENTS AND DEVICES DESIGNED FOR WIRELESS PROGRAMMING, WIRELESS CONTROLLING, WIRELESS COMMUNICATING AND WIRELESS ENERGIZING, NAMELY, ACTIVE IMPLANTS IN THE NATURE OF IMPLANTS CONSISTING OF ARTIFICIAL MATERIALS, AND A WIRELESS TRANSMITTER AND A RECEIVER AS AN INTEGRAL COMPONENT OF A SURGICAL IMPLANT; WIRELESS COMMUNICATION SYSTEMS, APPARATUS, DEVICES, AND INSTRUMENTS AND WIRELESS ENERGIZING SYSTEMS, APPARATUS, DEVICES, AND INSTRUMENTS FOR MEASURING, RECEIVING, SENDING, SWITCHING, TRANSFORMING, ACCUMULATING, REGULATING, STORING, CHECKING, CONTROLLING, DRIVING, TRANSFERRING, TRANSMITTING, PROCESSING AND ANALYZING, IN ALL THE APPLICABLE AFOREMENTIONED GOODS, OF DATA INCLUDING PHYSICAL PARAMETERS, ELECTRICITY, ENERGY AND DATA, NAMELY, ELECTRONIC TRANS-

MITTERS FOR COMMUNICATING WITH, AND ENERGIZING OF, AND USED IN DIRECT ASSOCIATION WITH, ACTIVE MEDICAL IMPLANTS CONSISTING OF ARTIFICIAL MATERIALS; SURGICAL INSTRUMENTS IN PARTICULAR TO BE USED DURING OPERATIONS OF ACTIVE OR NON-ACTIVE MEDICAL IMPLANTS; VETERINARY MEDICAL AND SURGICAL APPARATUS, INSTRUMENTS AND DEVICES, FOR USE IN IMPLANT SURGERIES; MEDICAL AND SURGICAL APPARATUS, INSTRUMENTS AND DEVICES FOR ORTHOPAEDIC JOINT IMPLANTS; AND MEDICAL IMPLANTS FOR COLLECTING, RECEIVING, SENDING, STORING, PREPARING, CONTROLLING, ANALYZING AND PROCESSING OF DATA AND ENERGY TO AND FROM SAID MEDICAL IMPLANTS (U.S. CLS. 26, 39 AND 44).

#### CLASS 44—MEDICAL, BEAUTY AND AGRICULTURAL SERVICES

FOR MEDICAL SERVICES IN RELATION TO MEDICAL IMPLANTS FOR COLLECTING, SENDING, RECEIVING, STORING, PREPARING, CONTROLLING, PRESENTING, CALCULATING, ANALYZING AND PROCESSING OF DATA TO AND FROM PATIENTS AND TO AND FROM MEDICAL IMPLANTS AND TO AND FROM REMOTE CONTROLS, WIRELESS CHARGER APPARATUS AND CONTROL STATIONS FOR ACTIVE IMPLANTS; SURGICAL AND HEALTH SERVICES, NAMELY, IMPLANTATION OF ARTIFICIAL IMPLANTS TO ALLOW THE IMPLANTS TO COLLECT, SEND, RECEIVE, STORE, PREPARE, CONTROL, PRESENT, CALCULATE, ANALYZE, AND PROCESS OF DATA TO AND FROM PATIENTS AND TO AND FROM MEDICAL IMPLANTS AND TO AND FROM MEDICAL IMPLANTS AND TO AND FROM MEDICAL IMPLANTS AND TO AND FROM REMOTE CONTROLS, WIRELESS CHARGER APPARATUS AND CONTROL STATIONS FOR ACTIVE IMPLANTS; PROVIDING A MEDICAL, SURGICAL AND HEALTH DATABASE FEATURING MEDICAL, SURGICAL AND HEALTH INFORMATION RELATING TO MEDICAL IMPLANTS THAT HAS BEEN INPUT, COLLECTED, RECEIVED, PREPARED, CONTROLLED, PROGRAMMED, CALCULATED, AND ANALYZED, FROM MEDICAL IMPLANTS, REMOTE CONTROLS OR CONTROL STATIONS FOR USE BY MEDICAL, SURGICAL AND HEALTH PROFESSIONALS FOR THE PURPOSES OF MONITORING AND DIAGNOSING MEDICAL CONDITIONS; MEDICAL AND SURGICAL SERVICES, NAMELY, IMPLANTATION OF ARTIFICIAL IMPLANTS IN RELATION TO MEDICAL IMPLANTS FOR PROGRAMMING, CONTROLLING, COMMUNICATING WITH, AND ENERGIZING OF, ACTIVE IMPLANTS; AND MEDICAL AND SURGICAL SERVICES, NAMELY, ARTIFICIAL IMPLANTATION SERVICES FOR PERSONS HAVING A MEDICAL RELATED CONDITION AND BEING CANDIDATES FOR OR BEING OPERATED ON WITH AN ACTIVE OR A NON-ACTIVE IMPLANT (U.S. CLS. 100 AND 101).

ALEX KEAM, EXAMINING ATTORNEY

SN 85-040,187. C2 IMAGING, LLC, ST. PAUL, MN. FILED 5-17-2010.



The logo for C2 IMAGING features the letters "C2" in a stylized, bold font. The "C" is black with a red outline, and the "2" is solid red. To the right of "C2" is the word "IMAGING" in a black, sans-serif font.

NO CLAIM IS MADE TO THE EXCLUSIVE RIGHT TO USE "IMAGING", APART FROM THE MARK AS SHOWN. THE COLOR(S) RED AND BLACK IS/ARE CLAIMED AS A FEATURE OF THE MARK.

THE MARK CONSISTS OF THE STYLIZED DESIGNATION "C2" WHEREIN THE LOWER PORTION OF THE LETTER "C" IS LAID OUT IN BLACK, AND THE UPPER PORTION OF THE LETTER "C" IS SET FORTH IN RED. THE NUMBER "2" IMMEDIATELY FOLLOWS THE STYLIZED "C". THE "C2" PORTION OF THE MARK IS FOLLOWED BY THE WORD "IMAGING".

#### CLASS 40—MATERIAL TREATMENT

FOR CUSTOM PRINTING OF MATERIALS FOR COMMERCIAL MARKETS (U.S. CLS. 100, 103 AND 106). FIRST USE 4-0-2010; IN COMMERCE 4-0-2010.

#### CLASS 42—SCIENTIFIC AND COMPUTER SERVICES

FOR DESIGN SERVICES, NAMELY, GRAPHIC ART DESIGN (U.S. CLS. 100 AND 101). FIRST USE 4-0-2010; IN COMMERCE 4-0-2010. MIDGE BUTLER, EXAMINING ATTORNEY

SN 85-040,205. ATIGEO LLC, BELLEVUE, WA. FILED 5-17-2010.

# ADEVOLVE

THE MARK CONSISTS OF STANDARD CHARACTERS WITHOUT CLAIM TO ANY PARTICULAR FONT, STYLE, SIZE, OR COLOR.

#### CLASS 35—ADVERTISING AND BUSINESS

FOR AD PLACEMENT SERVICES, NAMELY, THE DYNAMIC CREATION OF ONLINE DISPLAY ADVERTISEMENTS AND WEB SITE PLACEMENT SERVICES, NAMELY, PLACING ADVERTISEMENTS ON WEBSITES FOR OTHERS USING PROPRIETARY TECHNOLOGY AND USER AND CUSTOMER DATABASES; MARKET RESEARCH SERVICES REGARDING INTERNET USAGE HABITS AND CUSTOMER LOYALTY; MARKETING SERVICES, NAMELY, COMPILING AND DISTRIBUTING CONSUMER DEMOGRAPHIC, LIFESTYLE AND BEHAVIOR DATA AND INFORMATION, AND PROVIDING RELATED MARKETING RESEARCH, MARKET REPORTS AND ANALYSES FOR OTHERS; TARGETED ADVERTISING AND DISTRIBUTION OF ADVERTISING MATERIALS VIA THE INTERNET AND WIRELESS DEVICES; PROMOTING THE GOODS AND SERVICES OF OTHERS VIA THE INTERNET AND WIRELESS DEVICES; CREATION OF MARKETING TOOLS DESIGNED TO INCREASE A CLIENT COMPANY'S KNOWLEDGE OF CUSTOMER NEEDS AND ITS COMPETITORS' PRODUCTS AND SERVICES, PRICING, ADVERTISING STRATEGY AND SALES STRATEGY; PROVIDING A DATABASE IN THE FIELD OF CONSUMER-TO-BUSINESS COMMERCE FOR CONTAINING REGISTERED USERS' PREFERENCES, DATA, POSSESSIONS, SOCIAL CONNECTIONS, PERMISSIONS, RECOMMENDATIONS, LOCATION, ROLE OR INTENT FOR USE BY MERCHANTS TO CREATE AND MANAGE OFFERS FOR DELIVERY TO CONSUMERS; CUSTOMER RELATIONSHIP MANAGEMENT; DISSEMINATION OF ADVERTISING FOR OTHERS VIA THE INTERNET; MARKETING SERVICES, NAMELY, CONDUCTING CONSUMER TRACKING BEHAVIOR RESEARCH AND CONSUMER TREND ANALYSIS; PROVIDING BUSINESS INTELLIGENCE SERVICES; PROVIDING AN INTERACTIVE WEB SITE FOR USERS TO REVIEW AND RATE INTERNET CONTENT, PEOPLE, COMPANIES, PRODUCTS AND/OR SERVICES WHEREBY THE REVIEWS AND RATING OF CONTENT EXPAND THE USER PROFILE, RESULTING IN THE SELECTION OF APPROPRIATE PROMOTIONAL ITEMS PROVIDED BY WEBSITE SPONSORS; MANAGEMENT AND COMPILATION OF COMPUTERIZED DATABASES (U.S. CLS. 100, 101 AND 102).

FIRST USE 6-22-2009; IN COMMERCE 6-22-2009.

**CLASS 42—SCIENTIFIC AND COMPUTER SERVICES**

FOR CUSTOMIZED SEARCHING SERVICES, NAMELY, PROVIDING SPECIFIC INFORMATION AS REQUESTED BY CUSTOMERS VIA THE INTERNET OR WIRELESS DEVICES FROM SEARCHABLE INDEXES AND DATABASES OF INFORMATION, INCLUDING TEXT, ELECTRONIC DOCUMENTS, THIRD-PARTY WEB SITES, DATABASES, GRAPHICS AND AUDIO-VISUAL INFORMATION; APPLICATION SERVICE PROVIDER FEATURING COMPUTER SOFTWARE TO TRACK, LOG AND ANALYZE INTERNET USAGE HABITS, INTERNET SEARCHING HABITS, CUSTOMER LOYALTY, DEMOGRAPHIC, LIFESTYLE AND BEHAVIORAL DATA AND INFORMATION; APPLICATION SERVICE PROVIDER FEATURING COMPUTER SOFTWARE FOR GENERATING MARKET RESEARCH DATA, REPORTS AND ANALYSES, AND OTHER MARKETING AND ADVERTISING INFORMATION FOR MARKETING AND ADVERTISING PURPOSES; DATA AUTOMATION AND COLLECTION SERVICE USING PROPRIETARY SOFTWARE TO EVALUATE, ANALYZE AND COLLECT SERVICE DATA; COMPUTER SERVICES, NAMELY, PROVIDING SEARCH ENGINES FOR OBTAINING DATA ON A GLOBAL COMPUTER NETWORK (U.S. CLS. 100 AND 101).

FIRST USE 6-22-2009; IN COMMERCE 6-22-2009.  
NAKIA HENRY, EXAMINING ATTORNEY

**CLASS 9—ELECTRICAL AND SCIENTIFIC APPARATUS**

FOR APPARATUS, DEVICES AND INSTRUMENTS, ALL NOT USED IN DIRECT ASSOCIATION WITH ACTIVE IMPLANTS, FOR MEASURING, RECEIVING, SENDING, CHECKING, CONTROLLING, DRIVING, TRANSFERRING, TRANSMITTING, PROCESSING, ANALYZING, CONDUCTING, SWITCHING, TRANSFORMING, ACCUMULATING, AND REGULATING ELECTRICITY, ENERGY AND/OR DATA, INCLUDING PHYSICAL PARAMETERS, NAMELY, ELECTRONIC STORAGE DEVICES IN THE NATURE OF BLANK MEMORY DISCS, MEMORY CARDS AND DATA STORAGE MEDIA, NAMELY, PACKAGED SEMICONDUCTORS, ELECTRONIC CONTROL UNIT AND PROGRAMMER WHICH CONTROLS THE WORKING PARAMETERS OF WIRELESS COMMUNICATION SYSTEMS AND WIRELESS POWERING SYSTEMS, CHARGERS IN THE NATURE OF BATTERY CHARGERS, DIGITAL CHARGERS AND ELECTRONIC CHARGERS, ELECTRONIC TRANSMITTERS AND ELECTRONIC RECEIVERS OF ELECTRONIC SIGNALS, AND ELECTRONIC CIRCUITS; REMOTE CONTROLS FOR WIRELESS CONTROLLING, AND PROGRAMMING WIRELESS CHARGER APPARATUS FOR WIRELESS ENERGIZING AND CONTROL STATIONS FOR WIRELESS CONTROLLING, PROGRAMMING AND ENERGIZING OF ACTIVE IMPLANTS; SOFTWARE, IN PARTICULAR FOR ACTIVE MEDICAL IMPLANTS, FOR MEASURING, RECEIVING, SENDING, CHECKING, TRANSFERRING, CALCULATING, PROCESSING, CONTROLLING, PRESENTING AND ANALYZING OF DATA, NAMELY, DATA ABOUT ELECTRICITY, ENERGY, PHYSICAL PARAMETERS, AND COMMUNICATION AND PROGRAMMING DATA IN MEDICAL IMPLANTS; SOFTWARE, IN PARTICULAR FOR MEASURING, RECEIVING, SENDING, CHECKING, TRANSFERRING, CALCULATING, PROCESSING, CONTROLLING, PRESENTING AND ANALYZING OF DATA, NAMELY, DATA ABOUT ELECTRICITY, ENERGY, PHYSICAL PARAMETERS, COMMUNICATION AND PROGRAMMING DATA IN APPARATUS, DEVICES AND INSTRUMENTS FOR COMMUNICATING WITH, ENERGIZING AND PROGRAMMING OF MEDICAL IMPLANTS; AND DATA PROCESSING EQUIPMENT AND COMPUTERS (U.S. CLS. 21, 23, 26, 36 AND 38).

SN 85-040,353. MILUX HOLDING S.A., LUXEMBOURG, LUXEMBOURG, FILED 5-17-2010.

---

**ENDOSURGICA**

**CLASS 10—MEDICAL APPARATUS**

FOR MEDICAL AND SURGICAL APPARATUS, INSTRUMENTS AND DEVICES, INCLUDING ACTIVE AND NON-ACTIVE MEDICAL IMPLANTS, NAMELY, MEDICAL IMPLANTS COMPRISED OF ARTIFICIAL MATERIAL; MEDICAL AND SURGICAL APPARATUS, INSTRUMENTS AND DEVICES INTENDED FOR USE INSIDE THE MAMMAL OR HUMAN BODY, IN PARTICULAR MANUAL, ELECTRICAL OR A COMBINATION OF MANUAL AND ELECTRICAL APPARATUS, DEVICES AND INSTRUMENTS, IN ALL GOODS INCLUDING MEDICAL HYDRAULIC, MECHANICAL, AND PNEUMATIC APPARATUS, DEVICES AND INSTRUMENTS, NAMELY, MEDICAL IMPLANTS COMPRISED OF ARTIFICIAL MATERIAL; MEDICAL AND SURGICAL APPARATUS, INSTRUMENTS AND DEVICES FOR REPLACING AND ADDING ONE OR MORE BODILY FUNCTIONS AND PARTS INSIDE THE BODY, NAMELY, MEDICAL IMPLANTS COMPRISED OF ARTIFICIAL MATERIAL; MEDICAL AND SURGICAL APPARATUS, INSTRUMENTS AND DEVICES DESIGNED FOR WIRELESS PROGRAMMING, WIRELESS CONTROLLING, WIRELESS COMMUNICATING AND WIRELESS ENERGIZING, NAMELY, ACTIVE IMPLANTS IN THE NATURE OF IMPLANTS CONSISTING OF ARTIFICIAL MATERIALS, AND A WIRELESS TRANSMITTER AND A RECEIVER AS AN INTEGRAL COMPONENT OF A SURGICAL IMPLANT; WIRELESS COMMUNICATION SYSTEMS, APPARATUS, DEVICES, AND INSTRUMENTS AND WIRELESS ENERGIZING SYSTEMS, APPARATUS, DEVICES, AND INSTRUMENTS FOR MEASURING, RECEIVING, SENDING, SWITCHING, TRANSFORMING, ACCUMULATING, REGULATING, STORING, CHECKING, CONTROLLING, DRIVING, TRANSFERRING, TRANSMITTING, PROCESSING AND ANALYZING, IN ALL THE APPLICABLE AFOREMENTIONED GOODS, OF DATA INCLUDING PHYSICAL PARAMETERS, ELECTRICITY, ENERGY AND DATA, NAMELY, ELECTRONIC TRANS-

THE MARK CONSISTS OF STANDARD CHARACTERS WITHOUT CLAIM TO ANY PARTICULAR FONT, STYLE, SIZE, OR COLOR.

PRIORITY CLAIMED UNDER SEC. 44(D) ON ERPN CMNTY TM OFC APPLICATION NO. 008695462, FILED 11-18-2009, REG. NO. 008695462, DATED 6-2-2010, EXPIRES 11-18-2019.



MITTERS FOR COMMUNICATING WITH, AND ENERGIZING OF, AND USED IN DIRECT ASSOCIATION WITH, ACTIVE MEDICAL IMPLANTS CONSISTING OF ARTIFICIAL MATERIALS; SURGICAL INSTRUMENTS IN PARTICULAR TO BE USED DURING OPERATIONS OF ACTIVE OR NON-ACTIVE MEDICAL IMPLANTS; VETERINARY MEDICAL AND SURGICAL APPARATUS, INSTRUMENTS AND DEVICES, FOR USE IN IMPLANT SURGERIES; MEDICAL AND SURGICAL APPARATUS, INSTRUMENTS AND DEVICES FOR ORTHOPAEDIC JOINT IMPLANTS; AND MEDICAL IMPLANTS FOR COLLECTING, RECEIVING, SENDING, STORING, PREPARING, CONTROLLING, ANALYZING AND PROCESSING OF DATA AND ENERGY TO AND FROM SAID MEDICAL IMPLANTS (U.S. CLS. 26, 39 AND 44).

#### **CLASS 44—MEDICAL, BEAUTY AND AGRICULTURAL SERVICES**

FOR MEDICAL SERVICES IN RELATION TO MEDICAL IMPLANTS FOR COLLECTING, SENDING, RECEIVING, STORING, PREPARING, CONTROLLING, PRESENTING, CALCULATING, ANALYZING AND PROCESSING OF DATA TO AND FROM PATIENTS AND TO AND FROM MEDICAL IMPLANTS AND TO AND FROM REMOTE CONTROLS, WIRELESS CHARGER APPARATUS AND CONTROL STATIONS FOR ACTIVE IMPLANTS; SURGICAL AND HEALTH SERVICES, NAMELY, IMPLANTATION OF ARTIFICIAL IMPLANTS TO ALLOW THE IMPLANTS TO COLLECT, SEND, RECEIVE, STORE, PREPARE, CONTROL, PRESENT, CALCULATE, ANALYZE, AND PROCESS OF DATA TO AND FROM PATIENTS AND TO AND FROM MEDICAL IMPLANTS AND TO AND FROM MEDICAL IMPLANTS AND TO AND FROM REMOTE CONTROLS, WIRELESS CHARGER APPARATUS AND CONTROL STATIONS FOR ACTIVE IMPLANTS; PROVIDING A MEDICAL, SURGICAL AND HEALTH DATABASE FEATURING MEDICAL, SURGICAL AND HEALTH INFORMATION RELATING TO MEDICAL IMPLANTS THAT HAS BEEN INPUT, COLLECTED, RECEIVED, PREPARED, CONTROLLED, PROGRAMMED, CALCULATED, AND ANALYZED, FROM MEDICAL IMPLANTS, REMOTE CONTROLS OR CONTROL STATIONS FOR USE BY MEDICAL, SURGICAL AND HEALTH PROFESSIONALS FOR THE PURPOSES OF MONITORING AND DIAGNOSING MEDICAL CONDITIONS; MEDICAL AND SURGICAL SERVICES, NAMELY, IMPLANTATION OF ARTIFICIAL IMPLANTS IN RELATION TO MEDICAL IMPLANTS FOR PROGRAMMING, CONTROLLING, COMMUNICATING WITH, AND ENERGIZING OF, ACTIVE IMPLANTS; AND MEDICAL AND SURGICAL SERVICES, NAMELY, ARTIFICIAL IMPLANTATION SERVICES FOR PERSONS HAVING A MEDICAL RELATED CONDITION AND BEING CANDIDATES FOR OR BEING OPERATED ON WITH AN ACTIVE OR A NON-ACTIVE IMPLANT (U.S. CLS. 100 AND 101).

ALEX KEAM, EXAMINING ATTORNEY

SN 85-040,706. CKM HOLDINGS INC., LAWRENCEVILLE, GA. FILED 5-17-2010.

## **BIOSAN G PLUS**

THE MARK CONSISTS OF STANDARD CHARACTERS WITHOUT CLAIM TO ANY PARTICULAR FONT, STYLE, SIZE, OR COLOR.

#### **CLASS 1—CHEMICALS**

FOR CHEMICALS, CHEMICAL SUBSTANCES AND NATURAL BIOLOGICAL PREPARATIONS AND SUBSTANCES IN THE NATURE OF BIOLOGICALLY ACTIVE ENZYMES AND MICROORGANISMS FOR THE TREATMENT OF WASTE AND FOR USE IN THE MANUFACTURE OF SUBSTANCES FOR THE TREATMENT OF WASTE, INDUSTRIAL, AND INSTITUTIONAL PRODUCTS, BUT NOT FOR THE DETECTION OF MICROORGANISMS; MICROBIAL PREPARATIONS FOR THE TREATMENT OF WASTE; MICROBIAL PREPARATIONS FOR THE TREATMENT OF WASTEWATER PIPES; NATURAL BIOLOGICAL PREPARATIONS AND SUBSTANCES, NAMELY, BIOLOGICALLY ACTIVE ENZYMES AND MICROORGANISMS FOR THE TREATMENT OF WASTE; NATURAL BIOLOGICAL PREPARATIONS AND SUBSTANCES, NAMELY, PLANT EXTRACTS FOR USE IN MANUFACTURE OF PERFUMERY, ESSENTIAL OILS, CHEMICAL PREPARATIONS FOR CLEANING PURPOSES; MICROBIAL PREPARATIONS FOR THE TREATMENT OF WASTE; MICROBIAL PREPARATIONS FOR USE IN PERFUMERY, ESSENTIAL OILS, CHEMICAL PREPARATIONS FOR CLEANING PURPOSES; MICROBIAL PREPARATIONS FOR THE TREATMENT OF WASTEWATER PIPES; NATURAL BIOLOGICAL PREPARATIONS AND SUBSTANCES, NAMELY, PLANT AND HERB EXTRACTS FOR THE TREATMENT OF WASTE AND FOR USE IN THE MANUFACTURE OF CLEANING COMPOUNDS AND INDUSTRIAL AND INSTITUTIONAL PRODUCTS; NATURAL BIOLOGICAL PREPARATIONS AND SUBSTANCES, NAMELY, PLANT AND HERB EXTRACTS FOR THE TREATMENT OF WASTE; MICROBIAL PREPARATIONS FOR THE TREATMENT OF WASTE; CHEMICAL PREPARATIONS FOR THE TREATMENT OF WASTEWATER PIPES; NATURAL BIOLOGICAL PREPARATIONS AND SUBSTANCES, NAMELY, BOTANICAL EXTRACTS FOR THE TREATMENT OF WASTE AND FOR USE IN THE MANUFACTURE OF CLEANING COMPOUNDS AND INDUSTRIAL AND INSTITUTIONAL PRODUCTS (U.S. CLS. 1, 5, 6, 10, 26 AND 46).

#### **CLASS 3—COSMETICS AND CLEANING PREPARATIONS**

FOR CLEANING PREPARATIONS AND AGENTS FOR THE TREATMENT OF SANITARY WASTE; CLEANING PRODUCTS, NAMELY, IMPREGNATED ITEMS, NAMELY, GRANULES, MICRO-GRANULES, POWDERS, NON-WOVEN SHEATHS, CARDS, STRIPS, SACHETS, TOWELETTS, WIPES AND TISSUES FOR THE TREATMENT OF SANITARY WASTE (U.S. CLS. 1, 4, 6, 50, 51 AND 52).

#### **CLASS 5—PHARMACEUTICALS**

FOR BIOCIDAL AND ODOR CONTROL TREATMENTS, NAMELY, DISINFECTANTS FOR SANITARY PURPOSES, ODOR ELIMINATORS NOT FOR PERSONAL USE AND ODOR NEUTRALIZING PREPARATIONS FOR USE ON SANITARY WARE, SANITARY BINS, DIAPER BINS, ADULT DIAPER BINS AND WASTE BINS (U.S. CLS. 6, 18, 44, 46, 51 AND 52).

NATALIE POLZER, EXAMINING ATTORNEY

SN 85-040,722. CKM HOLDINGS INC., LAWRENCEVILLE, GA. FILED 5-17-2010.

## **BIOSAN P PLUS**

THE MARK CONSISTS OF STANDARD CHARACTERS WITHOUT CLAIM TO ANY PARTICULAR FONT, STYLE, SIZE, OR COLOR.

**CLASS 1—CHEMICALS**

FOR CHEMICALS, CHEMICAL SUBSTANCES AND NATURAL BIOLOGICAL PREPARATIONS AND SUBSTANCES IN THE NATURE OF BIOLOGICALLY ACTIVE ENZYMES AND MICROORGANISMS FOR THE TREATMENT OF WASTE AND FOR USE IN THE MANUFACTURE OF SUBSTANCES FOR THE TREATMENT OF WASTE, INDUSTRIAL, AND INSTITUTIONAL PRODUCTS, BUT NOT FOR THE DETECTION OF MICROORGANISMS; MICROBIAL PREPARATIONS FOR THE TREATMENT OF WASTE; MICROBIAL PREPARATIONS FOR THE TREATMENT OF WASTEWATER PIPES; NATURAL BIOLOGICAL PREPARATIONS AND SUBSTANCES, NAMELY, BIOLOGICALLY ACTIVE ENZYMES AND MICROORGANISMS FOR THE TREATMENT OF WASTE; NATURAL BIOLOGICAL PREPARATIONS AND SUBSTANCES, NAMELY, PLANT EXTRACTS FOR USE IN MANUFACTURE OF PERFUMERY, ESSENTIAL OILS, CHEMICAL PREPARATIONS FOR CLEANING PURPOSES; MICROBIAL PREPARATIONS FOR THE TREATMENT OF WASTE; MICROBIAL PREPARATIONS FOR USE IN PERFUMERY, ESSENTIAL OILS, CHEMICAL PREPARATIONS FOR CLEANING PURPOSES; MICROBIAL PREPARATIONS FOR THE TREATMENT OF WASTEWATER PIPES; NATURAL BIOLOGICAL PREPARATIONS AND SUBSTANCES, NAMELY, PLANT AND HERB EXTRACTS FOR THE TREATMENT OF WASTE AND FOR USE IN THE MANUFACTURE OF CLEANING COMPOUNDS AND INDUSTRIAL AND INSTITUTIONAL PRODUCTS; NATURAL BIOLOGICAL PREPARATIONS AND SUBSTANCES, NAMELY, PLANT AND HERB EXTRACTS FOR THE TREATMENT OF WASTE; MICROBIAL PREPARATIONS FOR THE TREATMENT OF WASTE; CHEMICAL PREPARATIONS FOR THE TREATMENT OF WASTEWATER PIPES; NATURAL BIOLOGICAL PREPARATIONS AND SUBSTANCES, NAMELY, BOTANICAL EXTRACTS FOR THE TREATMENT OF WASTE AND FOR USE IN THE MANUFACTURE OF CLEANING COMPOUNDS AND INDUSTRIAL AND INSTITUTIONAL PRODUCTS (U.S. CLS. 1, 5, 6, 10, 26 AND 46).

**CLASS 3—COSMETICS AND CLEANING PREPARATIONS**

FOR CLEANING PREPARATIONS AND AGENTS FOR THE TREATMENT OF SANITARY WASTE; CLEANING PRODUCTS, NAMELY, IMPREGNATED ITEMS, NAMELY, GRANULES, MICRO-GRANULES, POWDERS, NON-WOVEN SHEATHS, CARDS, STRIPS, SACHETS, TOWELETTES, WIPES AND TISSUES FOR THE TREATMENT OF SANITARY WASTE (U.S. CLS. 1, 4, 6, 50, 51 AND 52).

**CLASS 5—PHARMACEUTICALS**

FOR BIOCIDAL AND ODOR CONTROL TREATMENTS, NAMELY, DISINFECTANTS FOR SANITARY PURPOSES, ODOR ELIMINATORS NOT FOR PERSONAL USE AND ODOR NEUTRALIZING PREPARATIONS FOR USE ON SANITARY WARE, SANITARY BINS, DIAPER BINS, ADULT DIAPER BINS AND WASTE BINS (U.S. CLS. 6, 18, 44, 46, 51 AND 52).  
 NATALIE POLZER, EXAMINING ATTORNEY

**CLASS 1—CHEMICALS**

FOR CHEMICALS, CHEMICAL SUBSTANCES AND NATURAL BIOLOGICAL PREPARATIONS AND SUBSTANCES IN THE NATURE OF BIOLOGICALLY ACTIVE ENZYMES AND MICROORGANISMS FOR THE TREATMENT OF WASTE AND FOR USE IN THE MANUFACTURE OF SUBSTANCES FOR THE TREATMENT OF WASTE, INDUSTRIAL, AND INSTITUTIONAL PRODUCTS, BUT NOT FOR THE DETECTION OF MICROORGANISMS; MICROBIAL PREPARATIONS FOR THE TREATMENT OF WASTE; MICROBIAL PREPARATIONS FOR THE TREATMENT OF WASTEWATER PIPES; NATURAL BIOLOGICAL PREPARATIONS AND SUBSTANCES, NAMELY, BIOLOGICALLY ACTIVE ENZYMES AND MICROORGANISMS FOR THE TREATMENT OF WASTE; NATURAL BIOLOGICAL PREPARATIONS AND SUBSTANCES, NAMELY, PLANT EXTRACTS FOR USE IN MANUFACTURE OF PERFUMERY, ESSENTIAL OILS, CHEMICAL PREPARATIONS FOR CLEANING PURPOSES; MICROBIAL PREPARATIONS FOR THE TREATMENT OF WASTE; MICROBIAL PREPARATIONS FOR USE IN PERFUMERY, ESSENTIAL OILS, CHEMICAL PREPARATIONS FOR CLEANING PURPOSES; MICROBIAL PREPARATIONS FOR THE TREATMENT OF WASTEWATER PIPES; NATURAL BIOLOGICAL PREPARATIONS AND SUBSTANCES, NAMELY, PLANT AND HERB EXTRACTS FOR THE TREATMENT OF WASTE AND FOR USE IN THE MANUFACTURE OF CLEANING COMPOUNDS AND INDUSTRIAL AND INSTITUTIONAL PRODUCTS; NATURAL BIOLOGICAL PREPARATIONS AND SUBSTANCES, NAMELY, PLANT AND HERB EXTRACTS FOR THE TREATMENT OF WASTE; MICROBIAL PREPARATIONS FOR THE TREATMENT OF WASTE; CHEMICAL PREPARATIONS FOR THE TREATMENT OF WASTEWATER PIPES; NATURAL BIOLOGICAL PREPARATIONS AND SUBSTANCES, NAMELY, BOTANICAL EXTRACTS FOR THE TREATMENT OF WASTE AND FOR USE IN THE MANUFACTURE OF CLEANING COMPOUNDS AND INDUSTRIAL AND INSTITUTIONAL PRODUCTS (U.S. CLS. 1, 5, 6, 10, 26 AND 46).

**CLASS 3—COSMETICS AND CLEANING PREPARATIONS**

FOR CLEANING PREPARATIONS AND AGENTS FOR THE TREATMENT OF SANITARY WASTE; CLEANING PRODUCTS, NAMELY, IMPREGNATED ITEMS, NAMELY, GRANULES, MICRO-GRANULES, POWDERS, NON-WOVEN SHEATHS, CARDS, STRIPS, SACHETS, TOWELETTES, WIPES AND TISSUES FOR THE TREATMENT OF SANITARY WASTE (U.S. CLS. 1, 4, 6, 50, 51 AND 52).

**CLASS 5—PHARMACEUTICALS**

FOR BIOCIDAL AND ODOR CONTROL TREATMENTS, NAMELY, DISINFECTANTS FOR SANITARY PURPOSES, ODOR ELIMINATORS NOT FOR PERSONAL USE AND ODOR NEUTRALIZING PREPARATIONS FOR USE ON SANITARY WARE, SANITARY BINS, DIAPER BINS, ADULT DIAPER BINS AND WASTE BINS (U.S. CLS. 6, 18, 44, 46, 51 AND 52).  
 NATALIE POLZER, EXAMINING ATTORNEY

SN 85-040,729. CKM HOLDINGS INC., LAWRENCEVILLE, GA. FILED 5-17-2010.

SN 85-040,734. CKM HOLDINGS INC., LAWRENCEVILLE, GA. FILED 5-17-2010.

**BIOSAN P MAX**

**BIOSAN NATURALS**

THE MARK CONSISTS OF STANDARD CHARACTERS WITHOUT CLAIM TO ANY PARTICULAR FONT, STYLE, SIZE, OR COLOR.

THE MARK CONSISTS OF STANDARD CHARACTERS WITHOUT CLAIM TO ANY PARTICULAR FONT, STYLE, SIZE, OR COLOR.

NO CLAIM IS MADE TO THE EXCLUSIVE RIGHT TO USE "NATURALS" AS TO CLASS 1, APART FROM THE MARK AS SHOWN.

SN 85-041,110. RIPPLEPOINT HOLDINGS, LLC, ORLANDO, FL. FILED 5-18-2010.

### CLASS 1—CHEMICALS

FOR CHEMICALS, CHEMICAL SUBSTANCES AND NATURAL BIOLOGICAL PREPARATIONS AND SUBSTANCES IN THE NATURE OF BIOLOGICALLY ACTIVE ENZYMES AND MICROORGANISMS FOR THE TREATMENT OF WASTE AND FOR USE IN THE MANUFACTURE OF SUBSTANCES FOR THE TREATMENT OF WASTE, INDUSTRIAL, AND INSTITUTIONAL PRODUCTS, BUT NOT FOR THE DETECTION OF MICROORGANISMS; MICROBIAL PREPARATIONS FOR THE TREATMENT OF WASTE; MICROBIAL PREPARATIONS FOR THE TREATMENT OF WASTEWATER PIPES; NATURAL BIOLOGICAL PREPARATIONS AND SUBSTANCES, NAMELY, BIOLOGICALLY ACTIVE ENZYMES AND MICROORGANISMS FOR THE TREATMENT OF WASTE; NATURAL BIOLOGICAL PREPARATIONS AND SUBSTANCES, NAMELY, PLANT EXTRACTS FOR USE IN MANUFACTURE OF PERFUMERY, ESSENTIAL OILS, CHEMICAL PREPARATIONS FOR CLEANING PURPOSES; MICROBIAL PREPARATIONS FOR THE TREATMENT OF WASTE; MICROBIAL PREPARATIONS FOR USE IN PERFUMERY, ESSENTIAL OILS, CHEMICAL PREPARATIONS FOR CLEANING PURPOSES; MICROBIAL PREPARATIONS FOR THE TREATMENT OF WASTEWATER PIPES; NATURAL BIOLOGICAL PREPARATIONS AND SUBSTANCES, NAMELY, PLANT AND HERB EXTRACTS FOR THE TREATMENT OF WASTE AND FOR USE IN THE MANUFACTURE OF CLEANING COMPOUNDS AND INDUSTRIAL AND INSTITUTIONAL PRODUCTS; NATURAL BIOLOGICAL PREPARATIONS AND SUBSTANCES, NAMELY, PLANT AND HERB EXTRACTS FOR THE TREATMENT OF WASTE; MICROBIAL PREPARATIONS FOR THE TREATMENT OF WASTE; CHEMICAL PREPARATIONS FOR THE TREATMENT OF WASTEWATER PIPES; NATURAL BIOLOGICAL PREPARATIONS AND SUBSTANCES, NAMELY, BOTANICAL EXTRACTS FOR THE TREATMENT OF WASTE AND FOR USE IN THE MANUFACTURE OF CLEANING COMPOUNDS AND INDUSTRIAL AND INSTITUTIONAL PRODUCTS (U.S. CLS. 1, 5, 6, 10, 26 AND 46).

### CLASS 3—COSMETICS AND CLEANING PREPARATIONS

FOR CLEANING PREPARATIONS AND AGENTS FOR THE TREATMENT OF SANITARY WASTE; CLEANING PRODUCTS, NAMELY, IMPREGNATED ITEMS, NAMELY, GRANULES, MICRO-GRANULES, POWDERS, NON-WOVEN SHEATHS, CARDS, STRIPS, SACHETS, TOWELETTES, WIPES AND TISSUES FOR THE TREATMENT OF SANITARY WASTE (U.S. CLS. 1, 4, 6, 50, 51 AND 52).

### CLASS 5—PHARMACEUTICALS

FOR BIOCIDAL AND ODOR CONTROL TREATMENTS, NAMELY, DISINFECTANTS FOR SANITARY PURPOSES, ODOR ELIMINATORS NOT FOR PERSONAL USE AND ODOR NEUTRALIZING PREPARATIONS FOR USE ON SANITARY WARE, SANITARY BINS, DIAPER BINS, ADULT DIAPER BINS AND WASTE BINS (U.S. CLS. 6, 18, 44, 46, 51 AND 52).  
NATALIE POLZER, EXAMINING ATTORNEY

# RIPPLEPOINT

THE MARK CONSISTS OF STANDARD CHARACTERS WITHOUT CLAIM TO ANY PARTICULAR FONT, STYLE, SIZE, OR COLOR.

### CLASS 9—ELECTRICAL AND SCIENTIFIC APPARATUS

FOR COMPUTER SOFTWARE FOR CUSTOMER SERVICES AND VENDOR RELATIONSHIP MANAGEMENT, COST CONTROL, MAINTAINING INVENTORY, VENDORS, AND SERVICE PROVIDER COMMUNICATION, NAMELY, GATHERING, ANALYZING AND REPORTING DATA FOR USE IN CUSTOMER SERVICE, VENDOR RELATIONSHIP MANAGEMENT, AND COST CONTROL, MAINTAINING UTILITIES, COMPUTERS, AND OTHER ELECTRONIC EQUIPMENT (U.S. CLS. 21, 23, 26, 36 AND 38).

### CLASS 35—ADVERTISING AND BUSINESS

FOR BUSINESS DATA ANALYSIS, NAMELY, GATHERING, ANALYZING, AND REPORTING DATA FOR USE IN CUSTOMER SERVICE AND VENDOR RELATIONSHIP MANAGEMENT, COST CONTROL, MAINTAINING INVENTORY, VENDORS, GATHERING, ANALYZING, AND REPORTING DATA FOR USE IN CUSTOMER SERVICE, VENDOR RELATIONSHIP MANAGEMENT AND COST CONTROL (U.S. CLS. 100, 101 AND 102).

### CLASS 42—SCIENTIFIC AND COMPUTER SERVICES

FOR COMPUTER SERVICES, NAMELY, PROVIDING AN INTERACTIVE WEB SITE THAT ALLOWS USERS TO COLLECT, STORE, MANAGE, DELIVER AND SHOWCASE ELECTRONIC AND PAPER-BASED CONTENT TO BE USED FOR GATHERING, ANALYZING, AND REPORTING DATA IN THE CUSTOMER SERVICE, VENDOR RELATIONSHIP MANAGEMENT, MAINTAINING INVENTORY AND PROVIDING COST CONTROL FIELDS (U.S. CLS. 100 AND 101).

LOURDES AYALA, EXAMINING ATTORNEY

SN 85-041,503. INVIVOSCRIBE TECHNOLOGIES, INC., SAN DIEGO, CA. FILED 5-18-2010.



THE MARK CONSISTS OF A RIBBON FORMED INTO THREE TEAR-DROP SHAPED LOOPS WITH THE WORD "INVIVOSCRIBE" TO THE RIGHT OF THE RIBBON.

**CLASS 1—CHEMICALS**

FOR CHEMICAL AND BIOTECHNOLOGICAL PRODUCTS FOR COMMERCIAL AND SCIENTIFIC RESEARCH PURPOSES, NAMELY, REAGENTS FOR SCIENTIFIC AND RESEARCH USE, IN THE NATURE OF BUFFER SOLUTIONS, ENZYMES, MOLECULAR PROBES, DNA AND RNA POLYMERASES, NUCLEIC ACIDS, NUCLEIC ACID DERIVATIVES, PRIMERS FOR USE IN PCR, DNA TEMPLATES, RNA TEMPLATES, DYES AND BIOTECHNOLOGY REAGENTS AND SOLVENTS FOR SAMPLE PREPARATION, PURIFICATION, LYSIS, MODIFICATION AND MANIPULATION OF CELLS; KITS FOR SCIENTIFIC AND RESEARCH USE CONTAINING BUFFER SOLUTIONS, ENZYMES, MOLECULAR PROBES, DNA AND RNA POLYMERASES, NUCLEIC ACIDS, NUCLEIC ACID DERIVATIVES, PRIMERS FOR USE IN PCR, DNA TEMPLATES, RNA TEMPLATES, DYES AND BIOTECHNOLOGY REAGENTS AND SOLVENTS (U.S. CLS. 1, 5, 6, 10, 26 AND 46).

**CLASS 5—PHARMACEUTICALS**

FOR MEDICAL DIAGNOSTIC REAGENTS, NAMELY, BUFFER SOLUTIONS, ENZYMES, MOLECULAR PROBES, DNA AND RNA POLYMERASES, NUCLEIC ACIDS, NUCLEIC ACID DERIVATIVES, PRIMERS FOR USE IN PCR, DNA TEMPLATES, RNA TEMPLATES, DYES AND BIOTECHNOLOGY REAGENTS AND SOLVENTS FOR SAMPLE PREPARATION, PURIFICATION, LYSIS, MODIFICATION AND MANIPULATION OF CELLS; MEDICAL DIAGNOSTIC KITS CONTAINING BUFFER SOLUTIONS, ENZYMES, MOLECULAR PROBES, DNA AND RNA POLYMERASES, NUCLEIC ACIDS, NUCLEIC ACID DERIVATIVES, PRIMERS FOR USE IN PCR, DNA TEMPLATES, RNA TEMPLATES, DYES AND BIOTECHNOLOGY REAGENTS AND SOLVENTS; MEDICAL DIAGNOSTIC KITS COMPRISED OF MEDICAL DIAGNOSTIC REAGENTS FOR THE TREATMENT, MONITORING OR DIAGNOSIS OF DISEASE; MEDICAL DIAGNOSTIC KITS FOR CLINICAL OR MEDICAL USE COMPRISED OF MEDICAL DIAGNOSTIC REAGENTS; MEDICAL DIAGNOSTIC REAGENT ASSAYS FOR THE TREATMENT OR DIAGNOSIS OF DISEASE; DIAGNOSTIC ASSAYS FOR CLINICAL AND MEDICAL USE (U.S. CLS. 6, 18, 44, 46, 51 AND 52).

**CLASS 9—ELECTRICAL AND SCIENTIFIC APPARATUS**

FOR COMPUTER SOFTWARE FOR USE IN DATABASE MANAGEMENT TO INTEGRATE DATA AND INFORMATION, AS WELL AS PROVIDE REAL-TIME FINANCIALS FOR MULTIPLE INTERDEPENDENT BUT INDEPENDENT COMPANIES, INCLUDING FOREIGN SUBSIDIARIES; COMPUTER SOFTWARE CAPABLE OF MANAGING BUSINESS AND LABORATORY TASKS IN THE NATURE OF SALES, SALES MANAGEMENT, BUSINESS MANAGEMENT, PROJECT MANAGEMENT, SAMPLE CONTROL, SAMPLE SCHEDULING, QUALITY CONTROL, REPORT MANAGEMENT AND INVOICING; COMPUTER SOFTWARE FOR USE IN MANUFACTURING AND TRACKING CLINICAL SAMPLES IN THE FIELDS OF SCIENTIFIC RESEARCH, CLINICAL RESEARCH AND MEDICINE (U.S. CLS. 21, 23, 26, 36 AND 38).

**CLASS 42—SCIENTIFIC AND COMPUTER SERVICES**

FOR PROVIDING MEDICAL TESTING AND CONSULTATION SERVICES FOR BOTH CLINICAL RESEARCH AND RESEARCH APPLICATIONS; PERFORMING SCIENTIFIC RESEARCH SERVICES, NAMELY, THE ISOLATION, DETECTION, AND ANALYSIS OF BIOLOGICAL SUBSTANCES FROM CLINICAL SAMPLES FOR OTHERS (U.S. CLS. 100 AND 101).

**CLASS 44—MEDICAL, BEAUTY AND AGRICULTURAL SERVICES**

FOR PROVIDING MEDICAL TESTING AND CONSULTATION SERVICES FOR CLINICAL APPLICATIONS; PERFORMING MEDICAL DIAGNOSTIC SERVICES, NAMELY, THE ISOLATION, DETECTION, AND ANALYSIS OF BIOLOGICAL SUBSTANCES FROM CLINICAL SAMPLES FOR OTHERS, PROVIDING MEDICAL TESTING AND CONSULTATION SERVICES FOR DIAGNOSTIC AND TREATMENT PURPOSES (U.S. CLS. 100 AND 101).

RAMONA ORTIGA, EXAMINING ATTORNEY

SN 85-041,780. MALOOF SKATEBOARDING, LLC, SACRAMENTO, CA. FILED 5-18-2010.

## MALOOF CUP WORLD CHAMPIONSHIP OF SKATEBOARDING

THE MARK CONSISTS OF STANDARD CHARACTERS WITHOUT CLAIM TO ANY PARTICULAR FONT, STYLE, SIZE, OR COLOR.

NO CLAIM IS MADE TO THE EXCLUSIVE RIGHT TO USE "CUP WORLD CHAMPIONSHIP OF SKATEBOARDING" LIMITED TO CLASS 41, APART FROM THE MARK AS SHOWN.

**CLASS 25—CLOTHING**

FOR CLOTHING, NAMELY, SHIRTS, T-SHIRTS, SPORTS SHIRTS AND SWEATERS; CAPS, HATS, AND SUN VISORS (U.S. CLS. 22 AND 39).

**CLASS 41—EDUCATION AND ENTERTAINMENT**

FOR ENTERTAINMENT SERVICES IN THE NATURE OF LIVE SPORTING EVENTS, NAMELY, ARRANGING AND CONDUCTING COMPETITIONS FOR SKATEBOARDING; ORGANIZING SPORTING EVENTS, NAMELY, SKATEBOARDING COMPETITIONS; ENTERTAINMENT SERVICES IN THE NATURE LIVE MUSIC CONCERTS AND STAGE PERFORMANCES BY SINGERS AND MUSICAL GROUPS (U.S. CLS. 100, 101 AND 107).

SUSAN STIGLITZ, EXAMINING ATTORNEY

SN 85-043,404. ROSENRETER, JENNIFER JAMES, CHEYENNE, WY. FILED 5-20-2010.

## WellNurse

THE MARK CONSISTS OF STANDARD CHARACTERS WITHOUT CLAIM TO ANY PARTICULAR FONT, STYLE, SIZE, OR COLOR.



**CLASS 25—CLOTHING**

FOR SHIRTS, NAMELY, SHORT AND LONG SLEEVE T-SHIRTS, MATERNITY SHIRTS, PLUS SIZE SHIRTS, POLO SHIRTS, ATHLETIC SHIRTS, CAMP SHIRTS, GOLF SHIRTS, KNIT SHIRTS, UNIFORM SHIRTS, TANK TOPS, MUSCLE SHIRTS; HOODED PULLOVERS, FLEECE PULLOVERS, HOODED SWEAT SHIRTS, INFANT AND TODDLER ONE PIECE CLOTHING, BABY BODYSUITS, BABY BIBS, LADIES UNDERWEAR, NAMELY, BRIEFS, PANTIES, THONGS, BOY SHORTS, G-STRINGS, BOXER SHORTS; MEN'S UNDERWEAR, NAMELY, BRIEFS, BOXER BRIEFS, BOXER SHORTS; HATS AND CAPS, NAMELY, BASEBALL CAPS, CAPS WITH VISORS, KNITTED CAPS; APRONS; SCRUB TOPS, SCRUB BOTTOMS, AND SCRUB SETS NOT FOR MEDICAL PURPOSES (U.S. CLS. 22 AND 39).

**CLASS 41—EDUCATION AND ENTERTAINMENT**

FOR PROVIDING A WEBSITE FEATURING INFORMATION ABOUT EXERCISE AND FITNESS; PROVIDING ONLINE JOURNALS, NAMELY, BLOGS ABOUT HEALTH, WELLNESS, NUTRITION, EXERCISE, FITNESS, AND HEALTHCARE (U.S. CLS. 100, 101 AND 107).  
COLLEEN KEARNEY, EXAMINING ATTORNEY

SN 85-044,657. COBHAM PLC, DORSET, UNITED KINGDOM, FILED 5-21-2010.



THE MARK CONSISTS OF THE WORD "COBHAM" IN ALL CAPITALIZED, BLOCK LETTERING.  
SEC. 2(F).

**CLASS 7—MACHINERY**

FOR COUPLINGS FOR MACHINES; ELECTRIC MOTORS, AND THEIR PARTS, NOT FOR LAND VEHICLES; MACHINE COUPLINGS AND TRANSMISSION COMPONENTS EXCEPT FOR LAND VEHICLES (U.S. CLS. 13, 19, 21, 23, 31, 34 AND 35).

FIRST USE 9-15-2008; IN COMMERCE 9-15-2008.

**CLASS 9—ELECTRICAL AND SCIENTIFIC APPARATUS**

FOR ANTENNAS FOR WIRELESS COMMUNICATIONS APPARATUS; APPARATUS FOR RECORDING, TRANSMISSION OR REPRODUCTION OF SOUND; EMERGENCY POSITION-INDICATING RADIO BEACONS; SATELLITE AND MICROWAVE COMMUNICATIONS APPARATUS TO TRANSMIT COMMUNICATIONS FROM A VEHICLE TO ANOTHER VEHICLE, OR FROM A VEHICLE TO A SATELLITE; SATELLITE TRANSMITTERS AND RECEIVERS; VEHICLE LOCATOR AND RECOVERY DEVICE PROGRAMMED TO USE GLOBAL POSITIONING SYSTEMS (GPS) AND CELLULAR TELECOMMUNICATIONS (U.S. CLS. 21, 23, 26, 36 AND 38).

FIRST USE 9-15-2008; IN COMMERCE 9-15-2008.

**CLASS 11—ENVIRONMENTAL CONTROL APPARATUS**

FOR AIR CONDITIONING APPARATUS; AIR CONDITIONING UNITS; LIGHTING APPARATUS FOR VEHICLES; SEARCHLIGHTS (U.S. CLS. 13, 21, 23, 31 AND 34).

FIRST USE 9-15-2008; IN COMMERCE 9-15-2008.

**CLASS 12—VEHICLES**

FOR AIRCRAFT (U.S. CLS. 19, 21, 23, 31, 35 AND 44).  
FIRST USE 9-15-2008; IN COMMERCE 9-15-2008.

**CLASS 37—CONSTRUCTION AND REPAIR**

FOR MAINTENANCE AND REPAIR OF COMPUTER HARDWARE (U.S. CLS. 100, 103 AND 106).  
FIRST USE 9-15-2008; IN COMMERCE 9-15-2008.

**CLASS 39—TRANSPORTATION AND STORAGE**

FOR AIR FREIGHT SHIPPING SERVICES; AIR TRANSPORT SERVICES; AIR TRANSPORTATION OF PASSENGERS AND FREIGHT; COORDINATING TRAVEL ARRANGEMENTS FOR INDIVIDUALS AND FOR GROUPS (U.S. CLS. 100 AND 105).

FIRST USE 9-15-2008; IN COMMERCE 9-15-2008.

**CLASS 42—SCIENTIFIC AND COMPUTER SERVICES**

FOR COMPUTER SOFTWARE CONSULTANCY; CONSUMER PRODUCT SAFETY TESTING CONSULTATION; TECHNOLOGY CONSULTATION AND RESEARCH IN THE FIELD OF AEROSPACE AND GROUND STRUCTURES AND SYSTEMS; TESTING OR RESEARCH ON MACHINES, APPARATUS AND INSTRUMENTS (U.S. CLS. 100 AND 101).

FIRST USE 9-15-2008; IN COMMERCE 9-15-2008.

DOMINIC FATHY, EXAMINING ATTORNEY

SN 85-045,722. DEARBORN GOLDEN BAKERY, DEARBORN, MI. FILED 5-22-2010.



THE MARK CONSISTS OF STANDARD CHARACTERS WITHOUT CLAIM TO ANY PARTICULAR FONT, STYLE, SIZE, OR COLOR.

NO CLAIM IS MADE TO THE EXCLUSIVE RIGHT TO USE "BAKERY", APART FROM THE MARK AS SHOWN.

**CLASS 30—STAPLE FOODS**

FOR BAKERY DESSERTS; BAKERY GOODS; BAKERY GOODS AND DESSERT ITEMS, NAMELY, CHEESECAKES FOR RETAIL AND WHOLESALE DISTRIBUTION AND CONSUMPTION ON OR OFF THE PREMISES; BAKERY PRODUCTS; BAKERY PRODUCTS, NAMELY, SWEET BAKERY GOODS; MIXES FOR BAKERY GOODS; BREAD; BREAD AND BUNS; BREAD AND PASTRY; BREAD ROLLS; BREAD STICKS (U.S. CL. 46).

FIRST USE 3-1-1988; IN COMMERCE 9-1-1988.

**CLASS 43—HOTEL AND RESTAURANT SERVICES**

FOR CAFE AND RESTAURANT SERVICES; CAFE-RESTAURANTS; FAST-FOOD RESTAURANTS; ICE CREAM SHOP SERVICES IN THE NATURE OF A RESTAURANT; RESTAURANT; RESTAURANT AND CAFE SERVICES; RESTAURANT AND CATERING SERVICES; RESTAURANT SERVICES; RESTAURANT SERVICES FEATURING SANDWICHES; RESTAURANT SERVICES FEATURING MIDDLE-EASTERN CUISINE; RESTAURANT SERVICES, INCLUDING SIT-DOWN SERVICE OF FOOD AND TAKE-OUT RESTAURANT SERVICES; RESTAURANT SERVICES, NAMELY, PROVIDING OF FOOD AND BEVERAGES FOR CONSUMPTION ON AND OFF THE PREMISES; RESTAURANTS (U.S. CLS. 100 AND 101).

FIRST USE 3-1-1988; IN COMMERCE 3-1-1988.

SUSAN RICHARDS, EXAMINING ATTORNEY

SN 85-046,080. BIFFS, INC., SHAKOPEE, MN. FILED 5-24-2010.

# BIFFS

THE MARK CONSISTS OF STANDARD CHARACTERS WITHOUT CLAIM TO ANY PARTICULAR FONT, STYLE, SIZE, OR COLOR.

## CLASS 39—TRANSPORTATION AND STORAGE

FOR RENTAL OF STORAGE CONTAINERS; TRASH SERVICES, NAMELY, RENTAL OF DUMPSTERS (U.S. CLS. 100 AND 105).  
FIRST USE 3-1-2000; IN COMMERCE 3-1-2000.

## CLASS 44—MEDICAL, BEAUTY AND AGRICULTURAL SERVICES

FOR RENTAL OF PORTABLE TOILETS; RENTAL OF TEMPORARY REST ROOMS (U.S. CLS. 100 AND 101).  
FIRST USE 10-1-1986; IN COMMERCE 10-1-1986.  
SUSAN STIGLITZ, EXAMINING ATTORNEY

SN 85-046,228. SALESFORCE.COM, INC., SAN FRANCISCO, CA. FILED 5-24-2010.

# CHATTALYTICS

THE MARK CONSISTS OF STANDARD CHARACTERS WITHOUT CLAIM TO ANY PARTICULAR FONT, STYLE, SIZE, OR COLOR.

## CLASS 35—ADVERTISING AND BUSINESS

FOR BUSINESS MANAGEMENT SERVICES, NAMELY, PROVIDING BUSINESS INTELLIGENCE SERVICES AND PERFORMANCE MANAGEMENT SERVICES RELATING TO SOCIAL NETWORKING FOR BUSINESSES; BUSINESS MANAGEMENT CONSULTING SERVICES RELATING TO BUSINESS INTELLIGENCE, PERFORMANCE MANAGEMENT, AND SOCIAL NETWORKING FOR BUSINESSES; PROVIDING A WEBSITE WITH GENERAL INFORMATION OF INTEREST IN THE FIELDS OF BUSINESS INTELLIGENCE AND PERFORMANCE MANAGEMENT (U.S. CLS. 100, 101 AND 102).

## CLASS 42—SCIENTIFIC AND COMPUTER SERVICES

FOR PROVIDING TEMPORARY USE OF ON-LINE NON-DOWNLOADABLE SOFTWARE TO FACILITATE COMMUNICATING AMONG PEER PROFESSIONALS AND TO STORE, MANAGE, TRACK, ANALYZE, AND REPORT DATA RELATED TO BUSINESS INTELLIGENCE, PERFORMANCE MANAGEMENT, AND SOCIAL NETWORKING FOR BUSINESSES (U.S. CLS. 100 AND 101).

## CLASS 45—PERSONAL AND LEGAL SERVICES

FOR ON-LINE SOCIAL NETWORKING SERVICES (U.S. CLS. 100 AND 101).  
GRETTA YAO, EXAMINING ATTORNEY

SN 85-046,524. BR PROJECTS, LLC, ENCINO, CA. FILED 5-24-2010.

# Neon Carnival

THE MARK CONSISTS OF STANDARD CHARACTERS WITHOUT CLAIM TO ANY PARTICULAR FONT, STYLE, SIZE, OR COLOR.

## CLASS 9—ELECTRICAL AND SCIENTIFIC APPARATUS

FOR DOWNLOADABLE SOUND RECORDINGS FEATURING MUSIC IN THE NATURE OF DJ MIXES VIA THE INTERNET AND WIRELESS DEVICES; SOUND RECORDINGS FEATURING MUSIC IN THE NATURE OF DJ MIXES; VIDEO RECORDINGS FEATURING MUSIC IN THE NATURE OF DJ MIXES; PHONOGRAPH RECORDS FEATURING MUSIC IN THE NATURE OF DJ MIXES; PRE-RECORDED CDS, VIDEO TAPES, LASER DISKS AND DVDS FEATURING PERFORMANCES OF DJS; PRE-RECORDED ELECTRONIC AND DIGITAL MEDIA FEATURING PERFORMANCES OF DJS; PRE-RECORDED AUDIO TAPES FEATURING MUSIC IN THE NATURE OF DJ MIXES; PRERECORDED MAGNETIC DATA CARRIERS FEATURING PERFORMANCES OF VARIOUS DJS (U.S. CLS. 21, 23, 26, 36 AND 38).

## CLASS 16—PAPER GOODS AND PRINTED MATTER

FOR BUMPER STICKERS; DECALS; POSTERS; SOUVENIR PROGRAMS CONCERNING LIVE PERFORMANCES AND NIGHTCLUB EVENTS; STICKERS (U.S. CLS. 2, 5, 22, 23, 29, 37, 38 AND 50).

## CLASS 25—CLOTHING

FOR BASEBALL CAPS; CAMISOLES; CAPS; HATS; JACKETS; LADIES' UNDERWEAR; SHIRTS; SHORT-SLEEVED OR LONG-SLEEVED T-SHIRTS; T-SHIRTS; TOPS (U.S. CLS. 22 AND 39).

## CLASS 41—EDUCATION AND ENTERTAINMENT

FOR ARRANGING AND CONDUCTING NIGHTCLUB ENTERTAINMENT EVENTS FEATURING DJS AND DJ MIXES; ARRANGING, ORGANIZING, CONDUCTING, AND HOSTING SOCIAL ENTERTAINMENT EVENTS FEATURING DJS AND DJ MIXES; ENTERTAINMENT IN THE NATURE OF LIVE PERFORMANCES BY DJS; ENTERTAINMENT SERVICES, NAMELY, PROVIDING A WEB SITE FEATURING PHOTOGRAPHIC, AUDIO, VIDEO AND PROSE PRESENTATIONS FEATURING DJS AND ENTERTAINMENT EVENTS WITH DJS AND DJ MIXES (U.S. CLS. 100, 101 AND 107).

GISELLE AGOSTO, EXAMINING ATTORNEY

SN 85-047,288. THE MENON GROUP, INC., MERCER ISLAND, WA. FILED 5-25-2010.



NO CLAIM IS MADE TO THE EXCLUSIVE RIGHT TO USE "GROUP", APART FROM THE MARK AS SHOWN.

THE COLOR(S) WHITE, GOLD, DARK GOLD, AND BLUE IS/ARE CLAIMED AS A FEATURE OF THE MARK.

THE MARK CONSISTS OF BLUE VERTICAL RECTANGLE WITH THE WORDS "MENON" AT THE TOP AND "GROUP" AT THE BOTTOM IN WHITE WITH A SQUARE, GOLD CENTER FIELD. ON TOP OF THAT IS A GOLD SQUARE WITH FOUR BOXES. IN THE FOUR BOXES ARE 2 HALF CIRCLES IN OPPOSITE CORNERS OUTLINED IN BLUE AND FILLED WITH A DARKER GOLD AND OVER THE BOXES IS A BLUE DIAMOND. ON TOP OF THE BLUE DIAMOND IS A BLUE STYLIZED "M".

#### CLASS 9—ELECTRICAL AND SCIENTIFIC APPARATUS

FOR COMPUTER SOFTWARE AND PROGRAMS FOR DATABASE MANAGEMENT FOR CLINICAL, ADMINISTRATIVE AND FINANCIAL ACTIVITIES IN THE HEALTHCARE FIELD (U.S. CLS. 21, 23, 26, 36 AND 38).  
FIRST USE 4-1-2002; IN COMMERCE 5-2-2002.

#### CLASS 42—SCIENTIFIC AND COMPUTER SERVICES

FOR COMPUTER SOFTWARE DESIGN, COMPUTER PROGRAMMING, AND MAINTENANCE OF COMPUTER SOFTWARE FOR USE BY HEALTHCARE ORGANIZATIONS FOR CLINICAL, ADMINISTRATIVE AND FINANCIAL ACTIVITIES (U.S. CLS. 100 AND 101).  
FIRST USE 4-1-2002; IN COMMERCE 5-2-2002.  
DEZMONA MIZELLE, EXAMINING ATTORNEY

SN 85-047,678. VAIN RECORDS, LLC, SEATTLE, WA. FILED 5-25-2010.

UNVAIN

THE MARK CONSISTS OF STANDARD CHARACTERS WITHOUT CLAIM TO ANY PARTICULAR FONT, STYLE, SIZE, OR COLOR.

#### CLASS 35—ADVERTISING AND BUSINESS

FOR ADVERTISING AND PUBLICITY SERVICES FOR MUSICAL PERFORMING ARTISTS; PUBLIC RELATIONS; AND SPECIAL EVENT PLANNING FOR COMMERCIAL, PROMOTIONAL, OR ADVERTISING PURPOSES FOR THE BENEFIT OF MUSICAL PERFORMING ARTISTS (U.S. CLS. 100, 101 AND 102).

#### CLASS 36—INSURANCE AND FINANCIAL

FOR CHARITABLE FUNDRAISING TO ASSIST MUSICAL PERFORMING ARTISTS AND ARTISTS WHOSE WORK RELATES TO THE MUSIC BUSINESS (U.S. CLS. 100, 101 AND 102).

KATHERINE STOIDES, EXAMINING ATTORNEY

SN 85-048,010. VAIN RECORDS, LLC, SEATTLE, WA. FILED 5-26-2010.

VAIN

THE MARK CONSISTS OF STANDARD CHARACTERS WITHOUT CLAIM TO ANY PARTICULAR FONT, STYLE, SIZE, OR COLOR.

#### CLASS 35—ADVERTISING AND BUSINESS

FOR MANAGEMENT OF MUSICAL PERFORMING ARTISTS; AND PROMOTION AND MARKETING SERVICES AND RELATED CONSULTING (U.S. CLS. 100, 101 AND 102).

FIRST USE 5-22-2010; IN COMMERCE 5-22-2010.

#### CLASS 41—EDUCATION AND ENTERTAINMENT

FOR SPECIAL EVENT PLANNING FOR SOCIAL ENTERTAINMENT PURPOSES; ORGANIZING AND PLANNING LIVE ENTERTAINMENT EVENTS IN THE NATURE OF CONCERTS, PRIVATE PARTIES/EVENTS THAT HIGHLIGHT MUSIC; RECORDING PRODUCTION; PUBLISHING OF BOOKS AND MAGAZINES; MUSICAL EVENT BOOKING AGENCIES (U.S. CLS. 100, 101 AND 107).

FIRST USE 5-22-2010; IN COMMERCE 5-22-2010.

KATHERINE STOIDES, EXAMINING ATTORNEY

SN 85-048,163. ECOWORLD MEDIA LLC, NEWPORT BEACH, CA. FILED 5-26-2010.

ECOWORLD

THE MARK CONSISTS OF STANDARD CHARACTERS WITHOUT CLAIM TO ANY PARTICULAR FONT, STYLE, SIZE, OR COLOR.

OWNER OF U.S. REG. NOS. 1,928,548, 1,951,692 AND 2,882,056.  
SEC. 2(F).

**CLASS 35—ADVERTISING AND BUSINESS**

FOR PROVIDING A WEBSITE FEATURING INFORMATION RELATED TO THE ENVIRONMENT, NAMELY, PROMOTING ENVIRONMENTALLY-FRIENDLY GOODS AND SERVICES OF OTHERS (U.S. CLS. 100, 101 AND 102).

FIRST USE 0-0-1995; IN COMMERCE 0-0-1995.

**CLASS 37—CONSTRUCTION AND REPAIR**

FOR PROVIDING A WEBSITE FEATURING INFORMATION RELATED TO THE ENVIRONMENT, NAMELY, INFORMATION ABOUT CONSTRUCTION OF ENVIRONMENTALLY CONSCIOUS BUILDINGS (U.S. CLS. 100, 103 AND 106).

FIRST USE 0-0-1995; IN COMMERCE 0-0-1995.

**CLASS 40—MATERIAL TREATMENT**

FOR PROVIDING A WEBSITE FEATURING INFORMATION RELATED TO THE ENVIRONMENT, NAMELY, INFORMATION ABOUT SOIL AND WATER TREATMENT FOR ENVIRONMENTAL REMEDIATION (U.S. CLS. 100, 103 AND 106).

FIRST USE 0-0-1995; IN COMMERCE 0-0-1995.

**CLASS 41—EDUCATION AND ENTERTAINMENT**

FOR ONLINE NEWSLETTERS FEATURING INFORMATION RELATED TO THE ENVIRONMENT; ONLINE JOURNALS, NAMELY, BLOGS AND ARTICLES FEATURING INFORMATION RELATED TO THE ENVIRONMENT; ONLINE ELECTRONIC PUBLISHING OF BOOKS AND PERIODICALS (U.S. CLS. 100, 101 AND 107).

FIRST USE 0-0-1995; IN COMMERCE 0-0-1995.

**CLASS 42—SCIENTIFIC AND COMPUTER SERVICES**

FOR PROVIDING A WEBSITE FEATURING INFORMATION RELATED TO THE ENVIRONMENT, NAMELY, INFORMATION ABOUT CLIMATE CHANGE, BIODIVERSITY, ENVIRONMENTAL SCIENCE, AND RESEARCH IN THE FIELD OF ENVIRONMENTAL PROTECTION (U.S. CLS. 100 AND 101).

FIRST USE 0-0-1995; IN COMMERCE 0-0-1995.

**CLASS 45—PERSONAL AND LEGAL SERVICES**

FOR PROVIDING A WEBSITE FEATURING INFORMATION RELATED TO THE ENVIRONMENT, NAMELY, INFORMATION ABOUT ENVIRONMENTAL REGULATORY MATTERS AND ENVIRONMENTAL COMPLIANCE REPORTS (U.S. CLS. 100 AND 101).

FIRST USE 0-0-1995; IN COMMERCE 0-0-1995.

APRIL ROACH, EXAMINING ATTORNEY

---

SN 85-048,600, WINNERS INTERNATIONAL RESTAURANTS FRANCHISE SERVICES, INC., ATLANTA, GA. FILED 5-26-2010.

MRS. WINNER'S CHICKEN AND BISCUITS

THE MARK CONSISTS OF STANDARD CHARACTERS WITHOUT CLAIM TO ANY PARTICULAR FONT, STYLE, SIZE, OR COLOR.

OWNER OF U.S. REG. NOS. 1,174,630, 2,854,321 AND OTHERS.

NO CLAIM IS MADE TO THE EXCLUSIVE RIGHT TO USE "CHICKEN AND BISCUITS", APART FROM THE MARK AS SHOWN.

THE NAME(S), PORTRAIT(S), AND/OR SIGNATURE(S) SHOWN IN THE MARK DOES NOT IDENTIFY A PARTICULAR LIVING INDIVIDUAL.

**CLASS 29—MEATS AND PROCESSED FOODS**

FOR PREPARED FOOD PRODUCTS, NAMELY, FRIED CHICKEN, COUNTRY FRIED STEAK, COLE SLAW, MASHED POTATOES, PROCESSED GREEN BEANS, POTATO WEDGES, BAKED BEANS, AND MACARONI AND CHEESE FOR CONSUMPTION ON AND OFF THE PREMISES (U.S. CL. 46).

FIRST USE 6-30-2002; IN COMMERCE 6-30-2002.

**CLASS 30—STAPLE FOODS**

FOR SANDWICHES AND BISCUITS (U.S. CL. 46).

FIRST USE 6-30-2002; IN COMMERCE 6-30-2002.

**CLASS 43—HOTEL AND RESTAURANT SERVICES**

FOR RESTAURANT SERVICES (U.S. CLS. 100 AND 101).

FIRST USE 6-30-2000; IN COMMERCE 6-30-2000.

SUSAN RICHARDS, EXAMINING ATTORNEY

---

SN 85-049,059, PHILLIPS, LINDA, EDMONTON, ALBERTA, CANADA, FILED 5-27-2010.



TEST OF EARLY LANGUAGE AND LITERACY

PRIORITY CLAIMED UNDER SEC. 44(D) ON CANADA APPLICATION NO. 1460787, FILED 11-27-2009, REG. NO. TMA794307, DATED 3-31-2011, EXPIRES 3-31-2026.

NO CLAIM IS MADE TO THE EXCLUSIVE RIGHT TO USE "TEST OF EARLY LANGUAGE AND LITERACY", APART FROM THE MARK AS SHOWN.

THE MARK CONSISTS OF THE LETTERS "T E L L" IN BOXES, WITH THREE KIDS READING A BOOK, WITH THE WORDS "TEST OF EARLY LANGUAGE AND LITERACY" UNDERNEATH.

**CLASS 16—PAPER GOODS AND PRINTED MATTER**

FOR PRINTED MATERIALS, NAMELY, BROCHURES ABOUT LANGUAGE AND LITERACY DEVELOPMENT IN CHILDREN, BOOKS IN THE FIELD OF LANGUAGE AND LITERACY DEVELOPMENT IN CHILDREN, STORY BOOKS, WORK BOOKS DIRECTED TO LANGUAGE AND LITERACY DEVELOPMENT IN CHILDREN, BOOKLETS IN THE FIELD OF LANGUAGE AND LITERACY DEVELOPMENT IN CHILDREN, NEWSLETTERS IN THE FIELD OF LANGUAGE AND LITERACY DEVELOPMENT IN CHILDREN, REPORTS FEATURING LANGUAGE AND LITERACY DEVELOPMENT IN CHILDREN, MANUALS IN THE FIELD OF LANGUAGE AND LITERACY DEVELOPMENT IN CHILDREN, STUDY GUIDES, PAMPHLETS IN THE FIELD OF LANGUAGE AND LITERACY DEVELOPMENT IN CHILDREN; PRINTED INSTRUCTIONAL, EDUCATIONAL AND TEACHING MATERIAL IN THE FIELD OF LANGUAGE AND LITERACY DEVELOPMENT IN CHILDREN, NAMELY, TESTS, TEST BOOKLETS, TEST ANSWER SHEETS, TEST SCORING SHEETS AND CHECKLISTS; EASELS; EASEL BOARDS; BINDERS (U.S. CLS. 2, 5, 22, 23, 29, 37, 38 AND 50).



**CLASS 41—EDUCATION AND ENTERTAINMENT**

FOR EDUCATIONAL TESTING SERVICES, NAMELY, THE PROVISION OF A DIAGNOSTIC TEST TO ASSESS LANGUAGE AND LITERACY DEVELOPMENT IN CHILDREN AND AN ON-LINE DIAGNOSTIC TEST TO ASSESS LANGUAGE AND LITERACY DEVELOPMENT IN CHILDREN, PROVISION OF ASSESSMENT AND TESTING SERVICES IN THE FIELD OF LANGUAGE AND LITERACY DEVELOPMENT IN CHILDREN, ADMINISTRATION OF LANGUAGE AND LITERACY TESTS, TEST SCORING AND TEST SCORE REPORTING SERVICES, DEVELOPING, ADMINISTERING, SCORING AND INTERPRETING EXAMINATIONS FOR THE ASSESSMENT OF LANGUAGE AND LITERACY DEVELOPMENT IN CHILDREN; PROVISION OF SEMINARS AND WORKSHOPS IN THE FIELD OF LANGUAGE AND LITERACY ASSESSMENT AND DEVELOPMENT; EDUCATIONAL INFORMATION SERVICES, NAMELY, THE PROVISION OF RECOMMENDATIONS TO IMPROVE LANGUAGE AND LITERACY ABILITY AND THE PROVISION OF CONSULTING SERVICES IN THE FIELD OF LANGUAGE AND LITERACY DEVELOPMENT IN CHILDREN; EDUCATIONAL RESEARCH, NAMELY, CONDUCTING RESEARCH AND VALIDITY STUDIES IN THE FIELD OF LANGUAGE AND LITERACY DEVELOPMENT IN CHILDREN; TRAINING SERVICES IN THE FIELD OF LANGUAGE AND LITERACY DEVELOPMENT IN CHILDREN; EDUCATIONAL TESTING SERVICES, NAMELY, ADMINISTERING TESTS TO CHILDREN TO DETERMINE STRENGTHS AND WEAKNESSES IN THE AREAS OF PRINT UNDERSTANDING, LETTER KNOWLEDGE AND NAMING, PHONOLOGICAL AWARENESS, ORAL LANGUAGE, ORAL NARRATIVES, WORD READING, READING COMPREHENSION, WRITING AND SPELLING (U.S. CLS. 100, 101 AND 107).

LINDA M. KING, EXAMINING ATTORNEY

SN 85-050,128. CAMP CANINE, INC., BOCA RATON, FL. FILED 5-28-2010.



NO CLAIM IS MADE TO THE EXCLUSIVE RIGHT TO USE THE DEPICTION OF DOGS APPEARING IN THE PHOTOGRAPH, APART FROM THE MARK AS SHOWN.

THE MARK CONSISTS OF FIVE DOGS LOOKING OVER A WOODEN FENCE.

**CLASS 3—COSMETICS AND CLEANING PREPARATIONS**

FOR REGULAR CLEANSING HAIR SHAMPOO FOR PETS; HYPOALLERGENIC, TEARLESS HAIR SHAMPOO FOR PETS; WHITENING AND BRIGHTENING HAIR SHAMPOO FOR PETS; ANTI SHEDDING HAIR SHAMPOO FOR PETS; STAIN REMOVER WITH DEODORIZING PROPERTIES FOR PET STAINS; BREATH FRESHENER FOR PETS; MOUTH WASH AND TEETH CLEANING PREPARATIONS FOR PETS; AND ANTI-CHEWING, BITING AND LICKING PREPARATIONS FOR PETS (U.S. CLS. 1, 4, 6, 50, 51 AND 52).

**CLASS 31—NATURAL AGRICULTURAL PRODUCTS**

FOR ANIMAL TREATS (U.S. CLS. 1 AND 46).

**CLASS 35—ADVERTISING AND BUSINESS**

FOR RETAIL STORE SERVICES AND ON-LINE RETAIL STORE SERVICES IN THE FIELD OF PET SUPPLIES, PET FOOD AND NUTRIENTS, PET CLEANERS AND ACCESSORIES (U.S. CLS. 100, 101 AND 102).

**CLASS 41—EDUCATION AND ENTERTAINMENT**

FOR ANIMAL EXERCISING SERVICES (U.S. CLS. 100, 101 AND 107).

**CLASS 43—HOTEL AND RESTAURANT SERVICES**

FOR PET BOARDING; PET DAY CARE SERVICES; KENNEL SERVICES, NAMELY, BOARDING FOR PETS; OVERNIGHT AND LONG-TERM PET LODGING SERVICES (U.S. CLS. 100 AND 101).

**CLASS 44—MEDICAL, BEAUTY AND AGRICULTURAL SERVICES**

FOR PET GROOMING SERVICES; PET SALON SERVICES; NAIL CLIPPING, NAIL PAINTING, BATHING, HAIR-STYLING, MASSAGE AND TEETH BRUSHING SERVICES FOR PETS; CONSULTATION IN THE FIELD OF PET GROOMING (U.S. CLS. 100 AND 101).

HENRY S. ZAK, EXAMINING ATTORNEY

SN 85-050,630. M SQUARED CONSULTING, INC., SAN FRANCISCO, CA. FILED 5-28-2010.

# M SQUARED

THE MARK CONSISTS OF STANDARD CHARACTERS WITHOUT CLAIM TO ANY PARTICULAR FONT, STYLE, SIZE, OR COLOR.

OWNER OF U.S. REG. NOS. 2,151,899 AND 2,540,129.

**CLASS 35—ADVERTISING AND BUSINESS**

FOR BUSINESS MANAGEMENT CONSULTANCY SERVICES; EMPLOYMENT AGENCY SERVICES, NAMELY, FILLING THE TEMPORARY AND PERMANENT STAFFING NEEDS OF BUSINESSES; EMPLOYMENT STAFFING CONSULTATION SERVICES; EXECUTIVE SEARCH AND PLACEMENT SERVICES; HUMAN RESOURCE ANALYSIS AND CONSULTING SERVICES; WORKFORCE MANAGEMENT, NAMELY, MANAGEMENT OF EMPLOYEE AND NON-EMPLOYEE PERSONNEL; SERVING AS A HUMAN RESOURCE DEPARTMENT FOR OTHERS BY PROVIDING A SET OF EMPLOYMENT-RELATED SERVICES, NAMELY, PERSONNEL MANAGEMENT, PAYROLL PREPARATION SERVICES, PAYROLL PROCESSING SERVICES, PAYROLL ADMINISTRATION SERVICES AND PAYROLL MANAGEMENT SERVICES, AND PROFESSIONAL EMPLOYER ORGANIZATION SERVICES IN THE NATURE OF EMPLOYEE LEASING (U.S. CLS. 100, 101 AND 102).

FIRST USE 5-11-2000; IN COMMERCE 5-11-2000.

**CLASS 45—PERSONAL AND LEGAL SERVICES**

FOR COMPLIANCE SERVICES, NAMELY, REVIEWING STANDARDS AND PRACTICES TO ASSURE COMPLIANCE WITH EMPLOYMENT LAWS AND REGULATIONS (U.S. CLS. 100 AND 101).

FIRST USE 5-11-2000; IN COMMERCE 5-11-2000.

JENNIFER MARTIN, EXAMINING ATTORNEY

---

SN 85-050,653. GRACE CLINIC HOLDINGS, LLC, LUBBOCK, TX. FILED 5-28-2010.

## CLEARCOR

THE MARK CONSISTS OF STANDARD CHARACTERS WITHOUT CLAIM TO ANY PARTICULAR FONT, STYLE, SIZE, OR COLOR.

### CLASS 5—PHARMACEUTICALS

FOR VITAMINS, FOOD SUPPLEMENTS, NUTRITIONAL SUPPLEMENTS, PHARMACEUTICALS, NAMELY, PHARMACEUTICAL PREPARATIONS FOR THE TREATMENT OF ATHEROSCLEROSIS, VITAMIN D DEFICIENCY, OSTEOPOROSIS, OSTEOPENIA, HIGH BLOOD PRESSURE, OBESITY, HYPERCHOLESTEROLEMIA, HYPERTRIGLYCERIDEMIA, AND INSUFFICIENT HDL-CHOLESTEROL (U.S. CLS. 6, 18, 44, 46, 51 AND 52).

### CLASS 44—MEDICAL, BEAUTY AND AGRICULTURAL SERVICES

FOR PROVIDING INFORMATION IN THE FIELD OF HEALTH (U.S. CLS. 100 AND 101).  
ALEX KEAM, EXAMINING ATTORNEY

---

SN 85-050,667. M SQUARED CONSULTING, INC., SAN FRANCISCO, CA. FILED 5-28-2010.

## M SQUARED CONSULTING

THE MARK CONSISTS OF STANDARD CHARACTERS WITHOUT CLAIM TO ANY PARTICULAR FONT, STYLE, SIZE, OR COLOR.

OWNER OF U.S. REG. NOS. 2,151,899 AND 2,540,129.  
NO CLAIM IS MADE TO THE EXCLUSIVE RIGHT TO USE "CONSULTING", APART FROM THE MARK AS SHOWN.

### CLASS 35—ADVERTISING AND BUSINESS

FOR BUSINESS MANAGEMENT CONSULTANCY SERVICES; EMPLOYMENT AGENCY SERVICES, NAMELY, FILLING THE TEMPORARY AND PERMANENT STAFFING NEEDS OF BUSINESSES; EMPLOYMENT STAFFING CONSULTATION SERVICES; EXECUTIVE SEARCH AND PLACEMENT SERVICES; HUMAN RESOURCE ANALYSIS AND CONSULTING SERVICES; WORKFORCE MANAGEMENT, NAMELY, MANAGEMENT OF EMPLOYEE AND NON-EMPLOYEE PERSONNEL; SERVING AS A HUMAN RESOURCE DEPARTMENT FOR OTHERS BY PROVIDING A SET OF EMPLOYMENT-RELATED SERVICES, NAMELY, PERSONNEL MANAGEMENT, PAYROLL PREPARATION SERVICES, PAYROLL PROCESSING SERVICES, PAYROLL ADMINISTRATION SERVICES AND PAYROLL MANAGEMENT SERVICES, AND PROFESSIONAL EMPLOYER ORGANIZATION SERVICES IN THE NATURE OF EMPLOYEE LEASING (U.S. CLS. 100, 101 AND 102).  
FIRST USE 5-11-2000; IN COMMERCE 5-11-2000.

### CLASS 45—PERSONAL AND LEGAL SERVICES

FOR COMPLIANCE SERVICES, NAMELY, REVIEWING STANDARDS AND PRACTICES TO ASSURE COMPLIANCE WITH EMPLOYMENT LAWS AND REGULATIONS (U.S. CLS. 100 AND 101).

FIRST USE 5-11-2000; IN COMMERCE 5-11-2000.  
JENNIFER MARTIN, EXAMINING ATTORNEY

---

SN 85-050,855. ADAO, PEDRO, ANTIOCH, CA. FILED 5-29-2010.

## TOUCH OF BRASIL

THE MARK CONSISTS OF STANDARD CHARACTERS WITHOUT CLAIM TO ANY PARTICULAR FONT, STYLE, SIZE, OR COLOR.

NO CLAIM IS MADE TO THE EXCLUSIVE RIGHT TO USE "BRASIL", APART FROM THE MARK AS SHOWN.

### CLASS 1—CHEMICALS

FOR CHEMICALS, NAMELY, CHEMICALS FOR USE IN THE MANUFACTURE OF TANNING PREPARATIONS (U.S. CLS. 1, 5, 6, 10, 26 AND 46).

### CLASS 3—COSMETICS AND CLEANING PREPARATIONS

FOR COSMETICS, NAMELY, COSMETIC SUN-TANNING PREPARATIONS FOR CONSUMERS (U.S. CLS. 1, 4, 6, 50, 51 AND 52).

### CLASS 11—ENVIRONMENTAL CONTROL APPARATUS

FOR TANNING APPARATUS, NAMELY, TANNING BEDS AND TANNING LAMPS (U.S. CLS. 13, 21, 23, 31 AND 34).

### CLASS 25—CLOTHING

FOR CLOTHING, NAMELY, T-SHIRTS, JACKETS, PANTS, TOPS, BOTTOMS, FOOTWEAR, HEADWEAR (U.S. CLS. 22 AND 39).

### CLASS 40—MATERIAL TREATMENT

FOR TANNING SERVICES (U.S. CLS. 100, 103 AND 106).  
SANJEEV VOHRA, EXAMINING ATTORNEY

---

SN 85-052,503. FOREST FINANCE SERVICE GMBH, BONN, FED REP GERMANY, FILED 6-2-2010.

## Forest Finance

THE MARK CONSISTS OF STANDARD CHARACTERS WITHOUT CLAIM TO ANY PARTICULAR FONT, STYLE, SIZE, OR COLOR.

OWNER OF ERPN CMNTY TM OFC REG. NO. 005600358, DATED 11-30-2007, EXPIRES 1-8-2017.

OWNER OF U.S. REG. NO. 3,625,608.  
NO CLAIM IS MADE TO THE EXCLUSIVE RIGHT TO USE "FOREST" AS TO CLASSES 031 AND 044 AND "FINANCE" AS TO CLASS 036, APART FROM THE MARK AS SHOWN.

#### CLASS 31—NATURAL AGRICULTURAL PRODUCTS

FOR AGRICULTURAL, HORTICULTURAL AND FORESTRY PRODUCTS, NAMELY, WHEAT, MAIZE, BEANS, SEEDLINGS, TREES, UNRESSED TIMBER, GRASSES, TURF, DRIED FLOWERS; LIVE ANIMALS; FRESH FRUITS AND VEGETABLES; SEEDS, NAMELY, UNPROCESSED SEEDS FOR EATING AND PLANTING SEEDS; NATURAL PLANTS AND FLOWERS; FOODSTUFFS FOR ANIMALS; MALT FOR BREWING AND DISTILLING (U.S. CLS. 1 AND 46).

#### CLASS 35—ADVERTISING AND BUSINESS

FOR ADVERTISING SERVICES; BUSINESS MANAGEMENT SERVICES; BUSINESS ADMINISTRATION; PROVIDING OFFICE FUNCTIONS; SUPPLY SERVICES FOR OTHERS, NAMELY, BUSINESS MANAGEMENT SERVICES, NAMELY, SUPPLY CHAIN LOGISTICS, REVERSE LOGISTICS AND LIQUIDATION OF GOODS OF OTHERS; PROFESSIONAL BUSINESS MANAGEMENT CONSULTANCY, PERSONNEL RECRUITMENT; MARKET RESEARCH STUDIES; MARKET RESEARCH; IMPORT AND EXPORT AGENCY SERVICES (U.S. CLS. 100, 101 AND 102).

#### CLASS 36—INSURANCE AND FINANCIAL

FOR INSURANCE AGENCIES; REAL-ESTATE MANAGEMENT SERVICES (U.S. CLS. 100, 101 AND 102).

#### CLASS 44—MEDICAL, BEAUTY AND AGRICULTURAL SERVICES

FOR AGRICULTURAL AND FORESTRY CONSULTING, NAMELY, PROVIDING RECOMMENDATIONS FOR PLANT AND SOIL NUTRITION SUPPLEMENTS AND FOR CROP AND TREE CULTIVATION AND HARVESTING (U.S. CLS. 100 AND 101).

DAVID HOFFMAN, EXAMINING ATTORNEY

SN 85-052,622. NEUBRAF TEXTILES LIMITED, WANCHAI, HONG KONG, FILED 6-2-2010.



THE NAME SHOWN IN THE MARK IDENTIFIES "STÉPHANE CREMIEUX", WHOSE CONSENT IS MADE RECORD.

THE MARK CONSISTS OF THE WORD "CREMIEUX" APPEARING ABOVE A SHIELD DESIGN THAT CONTAINS THE NUMBER "38" IN THE UPPER LEFT-HAND CORNER. THE SHIELD IS SEPARATED INTO THREE SECTIONS WITH A DIVIDING LINE GOING FROM UPPER RIGHT TO LOWER LEFT.

#### CLASS 18—LEATHER GOODS

FOR HANDBAGS, LEATHER BAGS, LEATHER AND IMITATIONS OF LEATHER, TRAVELLING BAGS, RUCKSACKS, LEATHER SHOPPING BAGS, CLUTCH BAGS, SHOULDER BAGS, LEATHER COIN BAGS, PURSES, WALLETS, LEATHER POUCHES, PERFUME POUCHES MADE OF LEATHER SOLD EMPTY, POUCHES MADE OF LEATHER, LEATHER SHOULDER BELTS, GOODS MADE OF LEATHER AND NOT INCLUDED IN OTHER CLASSES, NAMELY, LEATHER BRIEF CASES; ANIMAL SKINS, HIDES; TRUNKS; UMBRELLAS, PARASOLS AND WALKING STICKS; WHIPS, HARNESSES AND SADDLERY (U.S. CLS. 1, 2, 3, 22 AND 41).

#### CLASS 25—CLOTHING

FOR LEATHER BELTS (U.S. CLS. 22 AND 39).  
DAVID MURRAY, EXAMINING ATTORNEY

SN 85-052,665. WINNERS INTERNATIONAL RESTAURANTS FRANCHISE SERVICES, INC., ATLANTA, GA. FILED 6-2-2010.

## WINNER'S

THE MARK CONSISTS OF STANDARD CHARACTERS WITHOUT CLAIM TO ANY PARTICULAR FONT, STYLE, SIZE, OR COLOR.

OWNER OF U.S. REG. NOS. 1,172,464, 2,246,319 AND OTHERS.

#### CLASS 29—MEATS AND PROCESSED FOODS

FOR PREPARED FOOD PRODUCTS, NAMELY, FRIED CHICKEN, COUNTRY FRIED STEAK, COLE SLAW, MASHED POTATOES, PROCESSED GREEN BEANS, POTATO WEDGES, BAKED BEANS, AND MACARONI AND CHEESE FOR CONSUMPTION ON AND OFF THE PREMISES (U.S. CL. 46).

#### CLASS 30—STAPLE FOODS

FOR SANDWICHES AND BISCUITS (U.S. CL. 46).

#### CLASS 43—HOTEL AND RESTAURANT SERVICES

FOR RESTAURANT SERVICES (U.S. CLS. 100 AND 101).

SUSAN RICHARDS, EXAMINING ATTORNEY

SN 85-053,111. CIANNA MEDICAL, INC., ALISO VIEJO, CA. FILED 6-2-2010.

## SAVI SISTERS

THE MARK CONSISTS OF STANDARD CHARACTERS WITHOUT CLAIM TO ANY PARTICULAR FONT, STYLE, SIZE, OR COLOR.

OWNER OF U.S. REG. NO. 3,464,400.

THE WORD(S) "SAVI" HAS NO MEANING IN A FOREIGN LANGUAGE.

#### **CLASS 14—JEWELRY**

FOR LAPEL PINS DISTRIBUTED EXCLUSIVELY TO BREAST CANCER SURVIVORS AND THEIR PHYSICIANS AND HOSPITAL STAFF IN CONNECTION WITH MEDICAL DEVICES AND SERVICES PROVIDED BY APPLICANT (U.S. CLS. 2, 27, 28 AND 50).

FIRST USE 5-26-2010; IN COMMERCE 5-26-2010.

#### **CLASS 41—EDUCATION AND ENTERTAINMENT**

FOR ARRANGING, ORGANIZING AND HOSTING SOCIAL EVENTS FOR BREAST CANCER SURVIVORS CONSISTING OF LECTURES AND PRESENTATIONS IN THE FIELD OF BREAST CANCER TREATMENTS; ARRANGING, ORGANIZING AND HOSTING SOCIAL EVENTS FOR CANCER SURVIVORS FOR THE PURPOSE OF SOCIALIZING AMONG CANCER SURVIVORS AND PHYSICIANS AND HOSPITAL STAFF (U.S. CLS. 100, 101 AND 107).

FIRST USE 5-19-2010; IN COMMERCE 5-19-2010.

#### **CLASS 42—SCIENTIFIC AND COMPUTER SERVICES**

FOR PROVIDING AN ONLINE NETWORK SERVICE THAT ENABLES USERS TO SHARE DATA AND INFORMATION IN THE FIELDS OF BREAST HEALTH, BREAST CANCER, CANCER RECOVERY AND SURVIVAL (U.S. CLS. 100 AND 101).

FIRST USE 5-26-2010; IN COMMERCE 5-26-2010.

#### **CLASS 44—MEDICAL, BEAUTY AND AGRICULTURAL SERVICES**

FOR PROVIDING A WEBSITE VIA A GLOBAL COMPUTER NETWORK FEATURING INFORMATION AND COMPREHENSIVE CONTENT IN THE FIELDS OF BREAST HEALTH, BREAST CANCER, CANCER RECOVERY AND SURVIVAL, AND CANCER RESOURCES (U.S. CLS. 100 AND 101).

FIRST USE 5-26-2010; IN COMMERCE 5-26-2010.  
ANDREW RHIM, EXAMINING ATTORNEY

---

SN 85-053,195. CAO GROUP, INC., WEST JORDAN, UT. FILED 6-2-2010.

# ASCENT

THE MARK CONSISTS OF STANDARD CHARACTERS WITHOUT CLAIM TO ANY PARTICULAR FONT, STYLE, SIZE, OR COLOR.

#### **CLASS 3—COSMETICS AND CLEANING PREPARATIONS**

FOR DENTAL BLEACHING GELS (U.S. CLS. 1, 4, 6, 50, 51 AND 52).

FIRST USE 2-1-2007; IN COMMERCE 7-1-2007.

#### **CLASS 5—PHARMACEUTICALS**

FOR DENTAL MATERIALS, NAMELY, ADHESIVES FOR DENTISTRY AND DENTAL TECHNICAL PURPOSES; BONDING AND PRIMER MATERIALS FOR DENTAL PURPOSES; COMPOSITE MATERIALS FOR DENTAL AND DENTAL TECHNICAL PURPOSES; CONDUCTIVE LACQUER FOR DENTAL PURPOSES; DENTAL ABRASIVES; DENTAL ADHESIVES; DENTAL ALLOYS; DENTAL AMALGAMS; DENTAL CEMENTS; DENTAL CERAMICS; DENTAL COMPOSITE MATERIALS; DENTAL IMPRESSION MATERIALS; DENTAL POLISH; DENTAL RESIN FOR TEMPORARY BRIDGES, CROWNS AND VENEERS; DENTAL RESTORATION COMPOUNDS; DENTAL RINSE; DENTAL VENEERS; FISSURE SEALANT FOR DENTAL AND DENTAL TECHNICAL PURPOSES; FIXING MATERIALS FOR DENTAL PURPOSES; MATERIAL FOR REPAIRING TEETH AND FOR DENTAL CROWNS AND BRIDGES; MATERIALS FOR DENTAL FILLINGS AND FOR SEALING PURPOSES; SEALING AGENTS FOR DENTAL PURPOSES; HEMOSTATIC AGENTS FOR DENTAL PURPOSES, NAMELY, COLLAGEN, GELATIN, BONE WAX, CELLULOSE; DENTAL ETCHING SOLUTION FOR PREPARING DENTAL SURFACE FOR BONDING; AND CARIES DETECTION COMPOUNDS (U.S. CLS. 6, 18, 44, 46, 51 AND 52).

FIRST USE 2-1-2007; IN COMMERCE 7-1-2007.  
FONG HSU, EXAMINING ATTORNEY

---

SN 85-053,600. BENTLEY LEATHERS INC., MONTREAL, QUEBEC, CANADA, FILED 6-3-2010.

# TRACKER

THE MARK CONSISTS OF STANDARD CHARACTERS WITHOUT CLAIM TO ANY PARTICULAR FONT, STYLE, SIZE, OR COLOR.

OWNER OF CANADA REG. NO. TMA654,550, DATED 12-7-2005, EXPIRES 12-7-2020.

#### **CLASS 9—ELECTRICAL AND SCIENTIFIC APPARATUS**

FOR CALCULATORS; TV REMOTE HOLDERS, NAMELY, STANDS SPECIALLY ADAPTED FOR HOLDING TELEVISION REMOTE CONTROLS; CASES SPECIALLY ADAPTED FOR HOLDING STANDS SPECIALLY ADAPTED FOR HOLDING TELEVISION REMOTE CONTROLS; MEASURING TAPES; ADAPTOR PLUG KITS COMPRISED PRIMARILY OF ADAPTOR PLUGS; CAMERA CASES; RADIOS INCORPORATING CLOCKS FOR USE IN THE SHOWER; CD STORAGE WALLET; CASES SPECIALLY ADAPTED FOR HOLDING COMPACT DISC PLAYERS; CD STORAGE WALLETS THAT CAN BE ATTACHED TO A CAR VISOR (U.S. CLS. 21, 23, 26, 36 AND 38).

#### **CLASS 16—PAPER GOODS AND PRINTED MATTER**

FOR PASSPORT HOLDERS; PHOTOGRAPH ALBUM; LUNCH BAGS (U.S. CLS. 2, 5, 22, 23, 29, 37, 38 AND 50).

#### **CLASS 18—LEATHER GOODS**

FOR BACKPACKS, DUFFLE BAGS, LUGGAGE, PURSES, BRIEFCASES, WALLETS AND SPORT BAGS; COSMETIC CASES SOLD EMPTY; SHAVING BAGS SOLD EMPTY FOR USE WITH SHAVING KITS; TOILETRY CASES SOLD EMPTY FOR USE WITH TOILETRY KITS; LUGGAGE TAGS; LUGGAGE STRAPS; LEATHER KEY CHAINS; CREDIT CARD HOLDERS; SCHOOL BAGS; TRAVEL WALLETS; TRAVEL BAGS; WAIST BAGS (U.S. CLS. 1, 2, 3, 22 AND 41).



**CLASS 25—CLOTHING**

SN 85-054,120. VIRIDISTOR, LLC, TUSTIN, CA. FILED 6-3-2010.

FOR MONEY BELTS; GLOVES; MITTENS; WOOLEN CAPS; HATS; SCARVES; SLIPPERS (U.S. CLS. 22 AND 39).  
MICHAEL GAAFAR, EXAMINING ATTORNEY

SN 85-053,750. HAZELTREE FUND SERVICES, INC., NEW YORK, NY. FILED 6-3-2010.

**HAZELTREE FUND SERVICES**

**GREEN BOX**

THE MARK CONSISTS OF STANDARD CHARACTERS WITHOUT CLAIM TO ANY PARTICULAR FONT, STYLE, SIZE, OR COLOR.  
NO CLAIM IS MADE TO THE EXCLUSIVE RIGHT TO USE "FUND SERVICES", APART FROM THE MARK AS SHOWN.

THE MARK CONSISTS OF STANDARD CHARACTERS WITHOUT CLAIM TO ANY PARTICULAR FONT, STYLE, SIZE, OR COLOR.  
NO CLAIM IS MADE TO THE EXCLUSIVE RIGHT TO USE "GREEN", APART FROM THE MARK AS SHOWN.

**CLASS 35—ADVERTISING AND BUSINESS**

FOR BUSINESS CONSULTING AND MANAGEMENT SERVICES FOR FINANCIAL INSTITUTIONS PERTAINING TO WAREHOUSING, SHARING, MANAGING, ANALYSIS AND REPORTING OF FINANCIAL DATA (U.S. CLS. 100, 101 AND 102).

**CLASS 9—ELECTRICAL AND SCIENTIFIC APPARATUS**

FOR STANDALONE AND NETWORKED COMPUTING DEVICES HAVING COMPUTER HARDWARE AND COMPUTER SOFTWARE CONFIGURED FOR SELECTIVE TRANSMISSION OF DATA FROM AN EVENT EXHIBITOR TO A REMOTE OR PORTABLE DIGITAL MEMORY STORAGE DEVICE HELD BY AN EVENT ATTENDEE; STANDALONE AND NETWORKED COMPUTING DEVICES THAT ARE DISTRIBUTED TO EXHIBITORS AT EVENTS INCLUDING TRADE SHOWS AND CONFERENCES, THE COMPUTING DEVICES HAVING COMPUTER HARDWARE AND COMPUTER SOFTWARE THAT STORE INFORMATIONAL DATA FILES THAT THE CORRESPONDING EXHIBITOR WISHES TO DISSEMINATE TO EVENT ATTENDEES, THE COMPUTER HARDWARE AND COMPUTER SOFTWARE CONFIGURED FOR SELECTIVE TRANSMISSION OF THE INFORMATIONAL DATA FILES TO REMOTE OR PORTABLE DIGITAL MEMORY STORAGE DEVICES HELD BY EVENT ATTENDEES THAT WISH TO RECEIVE THE INFORMATIONAL DATA FILES; COMPUTER SOFTWARE FOR SELECTIVE TRANSMISSION OF DATA FROM A COMPUTING DEVICE OF A TRADE SHOW EXHIBITOR TO ANOTHER, AUTHORIZED COMPUTING DEVICE HELD BY A TRADE SHOW ATTENDEE; COMPUTER SYSTEMS FOR SELECTIVELY DISSEMINATING ELECTRONIC DATA FILES FROM EXHIBITORS TO ATTENDEES AT EVENTS AND CONFERENCES, THE COMPUTER SYSTEMS COMPRISING MULTIPLE STANDALONE OR NETWORKED SECURE COMPUTING DEVICES THAT ARE EACH ASSOCIATED WITH AN EXHIBITOR AND WHICH HAVE COMPUTER HARDWARE AND COMPUTER SOFTWARE THAT STORE ELECTRONIC DATA FILES RELEVANT TO THE ASSOCIATED EXHIBITOR AND ARE CONFIGURED TO SELECTIVELY DELIVER DATA TO AUTHORIZED REMOTE OR PORTABLE COMPUTING DEVICES HELD BY ATTENDEES (U.S. CLS. 21, 23, 26, 36 AND 38).

**CLASS 36—INSURANCE AND FINANCIAL**

FOR CONSULTING AND MANAGEMENT SERVICES FOR FINANCIAL INSTITUTIONS PERTAINING TO ANALYSIS OF FINANCIAL DATA, NAMELY, FINANCIAL ANALYSIS AND CONSULTATION (U.S. CLS. 100, 101 AND 102).  
ROBERT STRUCK, EXAMINING ATTORNEY

SN 85-053,902. ATTN:L, LLC, DBA ATTN:L, SARASOTA, FL. FILED 6-3-2010.

**ATTN:L**

THE MARK CONSISTS OF STANDARD CHARACTERS WITHOUT CLAIM TO ANY PARTICULAR FONT, STYLE, SIZE, OR COLOR.

**CLASS 35—ADVERTISING AND BUSINESS**

FOR ASSISTANCE, ADVISORY SERVICES AND CONSULTANCY WITH REGARD TO BUSINESS PLANNING, BUSINESS ANALYSIS, BUSINESS MANAGEMENT, AND BUSINESS ORGANIZATION (U.S. CLS. 100, 101 AND 102).

**CLASS 36—INSURANCE AND FINANCIAL**

FOR CONSULTING AND INFORMATION CONCERNING PROPERTY AND CASUALTY INSURANCE (U.S. CLS. 100, 101 AND 102).  
NAAKWAMA ANKRAH, EXAMINING ATTORNEY

**CLASS 42—SCIENTIFIC AND COMPUTER SERVICES**

FOR TECHNICAL CONSULTING AND ASSISTANCE WITH COMPUTER-BASED INFORMATION SYSTEMS AND COMPONENTS USED IN TRADE SHOWS OR CONFERENCES; COMPUTER HARDWARE AND SOFTWARE CONSULTING SERVICES IN THE FIELD OF DESIGN, SELECTION, IMPLEMENTATION AND USE OF COMPUTER HARDWARE AND SOFTWARE SYSTEMS FOR USE AT EVENTS IN WHICH EVENT EXHIBITORS ELECTRONICALLY DISSEMINATE DATA FILES TO EVENT ATTENDEES; CONSULTING SERVICES IN THE FIELD OF DESIGN, SELECTION AND IMPLEMENTATION OF COMPUTER HARDWARE AND SOFTWARE SYSTEMS FOR EVENTS IN WHICH MULTIPLE STANDALONE OR NETWORKED COMPUTING DEVICES DISTRIBUTED TO EVENT EXHIBITORS ARE CONFIGURED TO SELECTIVELY DELIVER DATA TO AUTHORIZED REMOTE OR PORTABLE COMPUTING DEVICES HELD BY EVENT ATTENDEES; CONSULTING SERVICES IN THE FIELD OF DESIGN, SELECTION, AND IMPLEMENTATION OF COMPUTER SYSTEMS FOR TRADE SHOWS CONFIGURED TO SELECTIVELY DISSEMINATE DATA FROM TRADE SHOW EXHIBITORS TO AUTHORIZED REMOTE OR PORTABLE COMPUTING DEVICES HELD BY TRADE SHOW ATTENDEES (U.S. CLS. 100 AND 101).

DAVID TOOLEY, EXAMINING ATTORNEY

SN 85-054,763. FRATERNITE NOTRE DAME, INC., CHICAGO, IL. FILED 6-4-2010.



OWNER OF U.S. REG. NO. 2,155,053.  
NO CLAIM IS MADE TO THE EXCLUSIVE RIGHT TO USE "FRATERNITE", APART FROM THE MARK AS SHOWN.

THE MARK CONSISTS OF A WORLD GLOBE WITH SHADOWED DESIGNS OF PEOPLE AROUND IT, A CROSS AT THE TOP OF IT, THE SHADOWED WORD "FRATERNITE" ABOVE THE GLOBE AND SHADOWED WORDS "NOTRE DAME" BELOW IT.

THE ENGLISH TRANSLATION OF "FRATERNITE NOTRE DAME" IN THE MARK IS "FRATERNITY OF OUR LADY".

**CLASS 43—HOTEL AND RESTAURANT SERVICES**

FOR RESTAURANT SERVICES IN THE NATURE OF A SOUP-KITCHEN; SUPPLYING MEALS TO THE HOMELESS OR UNDERPRIVILEGED; CHARITABLE SERVICES, NAMELY, PROVIDING FOOD TO NEEDY PERSONS; CHILD CARE (U.S. CLS. 100 AND 101).

FIRST USE 1-31-1991; IN COMMERCE 1-31-1991.

**CLASS 45—PERSONAL AND LEGAL SERVICES**

FOR EVANGELICAL AND MINISTERIAL SERVICES; CHARITABLE SERVICES, NAMELY, PROVIDING CLOTHING TO NEEDY PERSONS; COUNSELING IN THE FIELD OF RELIGION (U.S. CLS. 100 AND 101).

FIRST USE 1-31-1991; IN COMMERCE 1-31-1991.

TARA PATE, EXAMINING ATTORNEY

SN 85-054,878. GORDY MARKETING INCORPORATED, DBA CUBATRavel.COM, CHICAGO, IL. FILED 6-4-2010.

**CubaTravel.com**  
"where to go to experience  
Cuba"

THE MARK CONSISTS OF STANDARD CHARACTERS WITHOUT CLAIM TO ANY PARTICULAR FONT, STYLE, SIZE, OR COLOR.

NO CLAIM IS MADE TO THE EXCLUSIVE RIGHT TO USE "CUBATRavel.COM", APART FROM THE MARK AS SHOWN.

**CLASS 35—ADVERTISING AND BUSINESS**

FOR ADVERTISING AND MARKETING SERVICES FOR OTHERS (U.S. CLS. 100, 101 AND 102).

FIRST USE 1-8-1999; IN COMMERCE 1-8-1999.

**CLASS 39—TRANSPORTATION AND STORAGE**

FOR TRAVEL AGENCY SERVICES, NAMELY, MAKING RESERVATIONS AND BOOKINGS FOR TRANSPORTATION FOR INDIVIDUAL PERSONS, BUSINESSES AND TRAVEL FOR INSTITUTIONAL CLIENTS (U.S. CLS. 100 AND 105).

FIRST USE 1-8-1999; IN COMMERCE 1-8-1999.

**CLASS 43—HOTEL AND RESTAURANT SERVICES**

FOR TRAVEL AGENCY SERVICES, NAMELY, MAKING RESERVATIONS AND BOOKINGS FOR LODGING, RESTAURANTS AND MEALS (U.S. CLS. 100 AND 101).

FIRST USE 1-8-1999; IN COMMERCE 1-8-1999.

LINDA POWELL, EXAMINING ATTORNEY

SN 85-055,261. SANDHILLS PUBLISHING COMPANY, LINCOLN, NE. FILED 6-4-2010.

**MarketBook**

THE MARK CONSISTS OF STANDARD CHARACTERS WITHOUT CLAIM TO ANY PARTICULAR FONT, STYLE, SIZE, OR COLOR.

**CLASS 16—PAPER GOODS AND PRINTED MATTER**

FOR NEWSPAPERS WHICH ADVERTISE AGRICULTURE, HEAVY MACHINERY, AND TRUCK AND TRAILER EQUIPMENT FOR SALE (U.S. CLS. 2, 5, 22, 23, 29, 37, 38 AND 50).

FIRST USE 5-21-2010; IN COMMERCE 5-21-2010.

**CLASS 35—ADVERTISING AND BUSINESS**

FOR PROVIDING AN ONLINE ELECTRONIC DATABASE ON THE INTERNET IN THE FIELD OF ADVERTISING AGRICULTURE, HEAVY MACHINERY, AND TRUCK AND TRAILER EQUIPMENT FOR SALE (U.S. CLS. 100, 101 AND 102).

FIRST USE 5-19-2010; IN COMMERCE 5-19-2010.  
BRIAN CALLAGHAN, EXAMINING ATTORNEY

SN 85-055,276. SANDHILLS PUBLISHING COMPANY, LINCOLN, NE. FILED 6-4-2010.



THE MARK CONSISTS OF THE STYLIZED WORDING "MARKETBOOK" AND A DESIGN OF A MAPLE LEAF.

**CLASS 16—PAPER GOODS AND PRINTED MATTER**

FOR NEWSPAPERS WHICH ADVERTISE AGRICULTURE, HEAVY MACHINERY, AND TRUCK AND TRAILER EQUIPMENT FOR SALE (U.S. CLS. 2, 5, 22, 23, 29, 37, 38 AND 50).

FIRST USE 5-21-2010; IN COMMERCE 5-21-2010.

**CLASS 35—ADVERTISING AND BUSINESS**

FOR PROVIDING AN ONLINE ELECTRONIC DATABASE ON THE INTERNET IN THE FIELD OF ADVERTISING AGRICULTURE, HEAVY MACHINERY, AND TRUCK AND TRAILER EQUIPMENT FOR SALE (U.S. CLS. 100, 101 AND 102).

FIRST USE 5-19-2010; IN COMMERCE 5-19-2010.  
BRIAN CALLAGHAN, EXAMINING ATTORNEY

SN 85-055,304. SANDHILLS PUBLISHING COMPANY, LINCOLN, NE. FILED 6-4-2010.



OWNER OF U.S. REG. NO. 3,035,759.

THE MARK CONSISTS OF THE STYLIZED WORDING "TRACTORHOUSE" AND THE DESIGN OF A TRACTOR.

**CLASS 16—PAPER GOODS AND PRINTED MATTER**

FOR NEWSPAPER WHICH ADVERTISES FARM MACHINERY AND FARM EQUIPMENT FOR SALE (U.S. CLS. 2, 5, 22, 23, 29, 37, 38 AND 50).

FIRST USE 4-0-2005; IN COMMERCE 4-0-2005.

**CLASS 35—ADVERTISING AND BUSINESS**

FOR PROVIDING AN ONLINE ELECTRONIC DATABASE ON THE INTERNET IN THE FIELD OF ADVERTISING FARM MACHINERY AND FARM EQUIPMENT FOR SALE (U.S. CLS. 100, 101 AND 102).

FIRST USE 2-3-2005; IN COMMERCE 2-3-2005.  
BRIAN CALLAGHAN, EXAMINING ATTORNEY

SN 85-055,324. INVIVOSCRIBE TECHNOLOGIES, INC., SAN DIEGO, CA. FILED 6-4-2010.

# LABPMM

THE MARK CONSISTS OF STANDARD CHARACTERS WITHOUT CLAIM TO ANY PARTICULAR FONT, STYLE, SIZE, OR COLOR.

**CLASS 42—SCIENTIFIC AND COMPUTER SERVICES**

FOR PROVIDING MEDICAL TESTING AND CONSULTATION SERVICES FOR BOTH CLINICAL RESEARCH AND RESEARCH APPLICATIONS; PERFORMING SCIENTIFIC RESEARCH SERVICES, NAMELY, THE ISOLATION, DETECTION, AND ANALYSIS OF BIOLOGICAL SUBSTANCES FROM CLINICAL SAMPLES FOR OTHERS (U.S. CLS. 100 AND 101).

**CLASS 44—MEDICAL, BEAUTY AND AGRICULTURAL SERVICES**

FOR PROVIDING MEDICAL TESTING AND CONSULTATION SERVICES FOR CLINICAL APPLICATIONS; PERFORMING MEDICAL DIAGNOSTIC SERVICES, NAMELY, THE ISOLATION, DETECTION, AND ANALYSIS OF BIOLOGICAL SUBSTANCES FROM CLINICAL SAMPLES FOR OTHERS, PROVIDING MEDICAL TESTING AND CONSULTATION SERVICES FOR DIAGNOSTIC AND TREATMENT PURPOSES (U.S. CLS. 100 AND 101).

RAMONA ORTIGA, EXAMINING ATTORNEY

SN 85-055,428. R' SIDE, LLC, LA HABRA, CA. FILED 6-4-2010.

# R'Side

THE MARK CONSISTS OF STANDARD CHARACTERS WITHOUT CLAIM TO ANY PARTICULAR FONT, STYLE, SIZE, OR COLOR.

**CLASS 25—CLOTHING**

FOR BEANIES; HATS; HOODED SWEAT SHIRTS; JACKETS; LADIES' UNDERWEAR; PANTS; SHIRTS; SHORT-SLEEVED OR LONG-SLEEVED T-SHIRTS; SHORTS; SWEAT PANTS; SWEAT SHIRTS; TANK TOPS; THONGS; UNDERWEAR, NAMELY, BOY SHORTS (U.S. CLS. 22 AND 39).

FIRST USE 5-5-2008; IN COMMERCE 5-5-2008.

**CLASS 26—FANCY GOODS**

FOR EMBROIDERED PATCHES FOR CLOTHING (U.S. CLS. 37, 39, 40, 42 AND 50).  
FIRST USE 5-5-2008; IN COMMERCE 5-5-2008.  
SARA BENJAMIN, EXAMINING ATTORNEY

---

SN 85-055,465. INVIVOSCRIBE TECHNOLOGIES, INC., SAN DIEGO, CA. FILED 6-4-2010.



THE MARK CONSISTS OF A HUMAN FIGURE WITH A DNA MOLECULE POSITIONED HORIZONTALLY AT WASTE LEVEL PLUS THE WORDS, AND/OR LETTERS "LAB PMM" TO THE RIGHT OF THE FIGURE.

**CLASS 42—SCIENTIFIC AND COMPUTER SERVICES**

FOR PROVIDING MEDICAL TESTING AND CONSULTATION SERVICES FOR BOTH CLINICAL RESEARCH AND RESEARCH APPLICATIONS; PERFORMING SCIENTIFIC RESEARCH SERVICES, NAMELY, THE ISOLATION, DETECTION, AND ANALYSIS OF BIOLOGICAL SUBSTANCES FROM CLINICAL SAMPLES FOR OTHERS (U.S. CLS. 100 AND 101).

**CLASS 44—MEDICAL, BEAUTY AND AGRICULTURAL SERVICES**

FOR PROVIDING MEDICAL TESTING AND CONSULTATION SERVICES FOR CLINICAL APPLICATIONS; PERFORMING MEDICAL DIAGNOSTIC SERVICES, NAMELY, THE ISOLATION, DETECTION, AND ANALYSIS OF BIOLOGICAL SUBSTANCES FROM CLINICAL SAMPLES FOR OTHERS, PROVIDING MEDICAL TESTING AND CONSULTATION SERVICES FOR DIAGNOSTIC AND TREATMENT PURPOSES (U.S. CLS. 100 AND 101).

RAMONA ORTIGA, EXAMINING ATTORNEY

---

SN 85-055,978. LIFE TIME FITNESS, INC., CHANHASSEN, MN. FILED 6-7-2010.

**MYHEALTHCHECK**

THE MARK CONSISTS OF STANDARD CHARACTERS WITHOUT CLAIM TO ANY PARTICULAR FONT, STYLE, SIZE, OR COLOR.

**CLASS 9—ELECTRICAL AND SCIENTIFIC APPARATUS**

FOR DOWNLOADABLE ELECTRONIC NEWSLETTERS IN THE FIELDS OF HEALTH, FITNESS AND WELLNESS (U.S. CLS. 21, 23, 26, 36 AND 38).

**CLASS 16—PAPER GOODS AND PRINTED MATTER**

FOR NEWSLETTERS IN THE FIELD OF HEALTH, FITNESS AND WELLNESS (U.S. CLS. 2, 5, 22, 23, 29, 37, 38 AND 50).

**CLASS 35—ADVERTISING AND BUSINESS**

FOR PROVIDING ASSISTANCE, FITNESS EVALUATION AND CONSULTATION TO CORPORATE CLIENTS TO HELP THEIR EMPLOYEES MAKE HEALTH, WELLNESS AND NUTRITIONAL CHANGES IN THEIR DAILY LIVING TO INCREASE PRODUCTIVITY, LOWER HEALTH CARE COSTS AND ACHIEVE OVERALL WELLNESS (U.S. CLS. 100, 101 AND 102).

**CLASS 41—EDUCATION AND ENTERTAINMENT**

FOR ON-LINE ELECTRONIC NEWSLETTERS DELIVERED BY EMAIL IN THE FIELDS OF HEALTH, FITNESS AND WELLNESS; PHYSICAL FITNESS INSTRUCTION AND HEALTH CLUB SERVICES, NAMELY, PROVIDING INSTRUCTION AND ACCESS TO EQUIPMENT IN THE FIELD OF PHYSICAL EXERCISE; PROVIDING HEALTH AND WELLNESS SEMINARS (U.S. CLS. 100, 101 AND 107).

**CLASS 44—MEDICAL, BEAUTY AND AGRICULTURAL SERVICES**

FOR MEDICAL DIAGNOSTIC TESTING, MONITORING AND REPORTING SERVICES; HEALTH RISK ASSESSMENT AND SCREENING SERVICES, NAMELY, MEDICAL SCREENING; WELLNESS COACHING, NAMELY, WELLNESS CONSULTING SERVICES (U.S. CLS. 100 AND 101).

JOSETTE BEVERLY, EXAMINING ATTORNEY

---

SN 85-055,986. LIFE TIME FITNESS, INC., CHANHASSEN, MN. FILED 6-7-2010.

**MYHEALTHCHECK BY LIFE TIME  
FITNESS**

THE MARK CONSISTS OF STANDARD CHARACTERS WITHOUT CLAIM TO ANY PARTICULAR FONT, STYLE, SIZE, OR COLOR.

OWNER OF U.S. REG. NOS. 2,140,172, 2,991,412 AND OTHERS.

NO CLAIM IS MADE TO THE EXCLUSIVE RIGHT TO USE "FITNESS", APART FROM THE MARK AS SHOWN.

**CLASS 9—ELECTRICAL AND SCIENTIFIC APPARATUS**

FOR DOWNLOADABLE ELECTRONIC NEWSLETTERS IN THE FIELDS OF HEALTH, FITNESS AND WELLNESS (U.S. CLS. 21, 23, 26, 36 AND 38).

**CLASS 16—PAPER GOODS AND PRINTED MATTER**

FOR NEWSLETTERS IN THE FIELD OF HEALTH, FITNESS AND WELLNESS (U.S. CLS. 2, 5, 22, 23, 29, 37, 38 AND 50).



**CLASS 35—ADVERTISING AND BUSINESS**

FOR PROVIDING ASSISTANCE, FITNESS EVALUATION AND CONSULTATION TO CORPORATE CLIENTS TO HELP THEIR EMPLOYEES MAKE HEALTH, WELLNESS AND NUTRITIONAL CHANGES IN THEIR DAILY LIVING TO INCREASE PRODUCTIVITY, LOWER HEALTH CARE COSTS AND ACHIEVE OVERALL WELLNESS (U.S. CLS. 100, 101 AND 102).

CARRIE GENOVESE, EXAMINING ATTORNEY

**CLASS 41—EDUCATION AND ENTERTAINMENT**

FOR ON-LINE ELECTRONIC NEWSLETTERS DELIVERED BY EMAIL IN THE FIELDS OF HEALTH, FITNESS AND WELLNESS; PHYSICAL FITNESS INSTRUCTION AND HEALTH CLUB SERVICES, NAMELY, PROVIDING INSTRUCTION AND ACCESS TO EQUIPMENT IN THE FIELD OF PHYSICAL EXERCISE; PROVIDING HEALTH AND WELLNESS SEMINARS (U.S. CLS. 100, 101 AND 107).

SN 85-056,255. SIERRA ENERGY, DAVIS, CA. FILED 6-7-2010.

**CLASS 44—MEDICAL, BEAUTY AND AGRICULTURAL SERVICES**

FOR MEDICAL DIAGNOSTIC TESTING, MONITORING AND REPORTING SERVICES; HEALTH RISK ASSESSMENT AND SCREENING SERVICES, NAMELY, MEDICAL SCREENING; WELLNESS COACHING, NAMELY, WELLNESS CONSULTING SERVICES (U.S. CLS. 100 AND 101).

JOSETTE BEVERLY, EXAMINING ATTORNEY

**FASTOX**

THE MARK CONSISTS OF STANDARD CHARACTERS WITHOUT CLAIM TO ANY PARTICULAR FONT, STYLE, SIZE, OR COLOR.

**CLASS 7—MACHINERY**

FOR NOZZLES FOR USE IN GASIFIERS; GASIFIERS (U.S. CLS. 13, 19, 21, 23, 31, 34 AND 35).

**CLASS 42—SCIENTIFIC AND COMPUTER SERVICES**

FOR DESIGN OF EQUIPMENT FOR GASIFICATION OF MATERIALS, NAMELY, BIOMASS, COAL, OIL SHALE, AND SOLID WASTE; DESIGN OF EQUIPMENT FOR CONVERTING METALLIC OXIDE ORES INTO MOLTEN METALS; ENGINEERING SERVICES IN THE TECHNOLOGY FIELD OF GASIFICATION; TECHNOLOGICAL CONSULTATION IN THE TECHNOLOGY FIELD OF CONVERTING METALLIC OXIDE ORES INTO MOLTEN METALS (U.S. CLS. 100 AND 101).

MIDGE BUTLER, EXAMINING ATTORNEY

SN 85-056,178. SELIT DÄMMTECHNIK GMBH, ERBESBÜDESHEIM, FED REP GERMANY, FILED 6-7-2010.



OWNER OF ERPN CMNTY TM OFC REG. NO. 008585192, DATED 4-26-2010, EXPIRES 9-30-2019.

NO CLAIM IS MADE TO THE EXCLUSIVE RIGHT TO USE "LAY", APART FROM THE MARK AS SHOWN.

THE COLOR(S) WHITE AND BLUE IS/ARE CLAIMED AS A FEATURE OF THE MARK.

THE MARK CONSISTS OF THE WORDS "EASY LAY" IN WHITE ON A BLUE BACKGROUND DESIGN WITH WHITE OUTLINING.

**CLASS 17—RUBBER GOODS**

FOR SOUND-DAMPING AND HEAT-INSULATING MATERIALS, IN PARTICULAR IMPACT SOUND-PROOFING AND INSULATING UNDERLAY FOR PARQUET FLOORS AND LAMINATED FLOORS ALL FOR INTERIOR USE (U.S. CLS. 1, 5, 12, 13, 35 AND 50).

**CLASS 19—NON-METALLIC BUILDING MATERIALS**

FOR FLOOR COVERINGS, NAMELY, INTERIOR FLOORING OF HARDWOOD, LAMINATE, PARQUET AND VINYL (U.S. CLS. 1, 12, 33 AND 50).

**CLASS 27—FLOOR COVERINGS**

FOR FLOOR COVERINGS (U.S. CLS. 19, 20, 37, 42 AND 50).

SN 85-056,291. SOKEN CHEMICAL &amp; ENGINEERING CO., LTD., TOKYO, JAPAN, FILED 6-7-2010.



OWNER OF U.S. REG. NOS. 3,651,317, 3,651,322 AND OTHERS.

THE COLOR(S) RED, BLUE AND BLACK IS/ARE CLAIMED AS A FEATURE OF THE MARK.

THE MARK CONSISTS OF A STYLIZED LETTER "S" IN WHICH THE TOP HALF OF THE LETTER "S" IS RED AND THE BOTTOM HALF BLUE FOLLOWED BY THE WORD "SOKEN" IN BLACK.

**CLASS 4—LUBRICANTS AND FUELS**

FOR INDUSTRIAL OIL; INDUSTRIAL GREASE; HEAT TRANSFER OILS FOR INDUSTRIAL USE (U.S. CLS. 1, 6 AND 15).

**CLASS 7—MACHINERY**

FOR CHEMICAL PROCESSING MACHINES AND APPARATUS, NAMELY, AGITATORS, REACTION VESSELS FOR CHEMICAL PROCESSING, MIXING MACHINES, WASHING APPARATUS, FILTERING MACHINES, SEPARATORS, EMULSIFYING MACHINES FOR CHEMICAL PROCESSING, DISSOLVING MACHINES FOR CHEMICAL PROCESSING, KNEADING MACHINES, DRYING MACHINES FOR CHEMICAL PROCESSING; PLASTIC PROCESSING MACHINES; MACHINE PARTS, NAMELY, PLASTIC MOLDS FOR NANOPRINTING OR NANOIMPRINT LITHOGRAPHY (U.S. CLS. 13, 19, 21, 23, 31, 34 AND 35).

**CLASS 11—ENVIRONMENTAL CONTROL APPARATUS**

FOR INDUSTRIAL BOILERS; EVAPORATORS; DISTILLATION APPARATUS; HEAT EXCHANGERS FOR CHEMICAL PROCESSING (U.S. CLS. 13, 21, 23, 31 AND 34).

**CLASS 37—CONSTRUCTION AND REPAIR**

FOR FACTORY CONSTRUCTION; TELECOMMUNICATION WIRING; CONSTRUCTION CONSULTANCY; REPAIR OR MAINTENANCE OF CHEMICAL PLANTS; REPAIR OR MAINTENANCE OF BOILERS; REPAIR OR MAINTENANCE OF CHEMICAL PROCESSING MACHINES AND APPARATUS; BURNER MAINTENANCE OR REPAIR; REPAIR OR MAINTENANCE OF ELECTRONIC MACHINES AND APPARATUS FOR INDUSTRIAL CHEMICAL PROCESSING; REPAIR OR MAINTENANCE OF COMPUTERS; REPAIR OR MAINTENANCE OF STORAGE TANKS; REPAIR OR MAINTENANCE OF INDUSTRIAL FURNACES; REPAIR OR MAINTENANCE OF POWER DISTRIBUTION OR CONTROL MACHINES AND APPARATUS; STORAGE TANK CLEANING; OPERATION, CHECK OR MAINTENANCE OF HEATING INSTALLATION; REPAIR OR MAINTENANCE OF ELECTRIC MOTORS; PUMP REPAIR OR MAINTENANCE; REPAIR OR MAINTENANCE OF FREEZING MACHINES AND APPARATUS; REPAIR OR MAINTENANCE OF TELECOMMUNICATION MACHINES AND APPARATUS; REPAIR OR MAINTENANCE OF ELECTRIC LIGHTING APPARATUS; REPAIR OR MAINTENANCE OF LABORATORY APPARATUS AND INSTRUMENTS; REPAIR OR MAINTENANCE OF MEASURING AND TESTING MACHINES AND INSTRUMENTS; REPAIR OR MAINTENANCE OF LOADING-UNLOADING MACHINES AND APPARATUS; REPAIR OR MAINTENANCE OF MACHINES AND APPARATUS FOR PROCESSING FOODS OR BEVERAGES; REPAIR OR MAINTENANCE OF FIRE ALARMS (U.S. CLS. 100, 103 AND 106).

DOMINIC FATHY, EXAMINING ATTORNEY

SN 85-056,391. GEE, PATRICK, CHINO, CA. FILED 6-7-2010.

**GPS: Wild About Shooting**

THE MARK CONSISTS OF STANDARD CHARACTERS WITHOUT CLAIM TO ANY PARTICULAR FONT, STYLE, SIZE, OR COLOR.

NO CLAIM IS MADE TO THE EXCLUSIVE RIGHT TO USE "SHOOTING", APART FROM THE MARK AS SHOWN.

**CLASS 8—HAND TOOLS**

FOR GUNSMITHING TOOLS AS ACCESSORIES FOR FIREARMS, NAMELY, SCREWDRIVERS, HAMMERS, PUNCHES, CALIPERS, BENCH VISES AND CLAMPS, WRENCHES, DRILL BITS, BOLT TOOLS SUCH AS FIRING PIN REMOVAL TOOLS, TRIGGER SCALES, AND FILES IN A SET OR SEPARATELY (U.S. CLS. 23, 28 AND 44).

**CLASS 13—FIREARMS**

FOR GUN CLEANING PRODUCTS AS ACCESSORIES FOR FIREARMS, NAMELY, CLEANING RODS, CLEANING PATCHES OF COTTON OR OTHER FABRIC, BARREL CLEANING BRUSHES, SOLVENT OR LUBRICANT CONTAINING GUN CLEANING PATCHES, AND GUN CLEANING LUBRICANTS OR SOLVENTS SEPARATELY OR IN A KIT (U.S. CLS. 2 AND 9).

HEATHER SAPP, EXAMINING ATTORNEY

SN 85-056,434. SAINT-GOBAIN ABRASIVES, INC., WORCESTER, MA. FILED 6-7-2010.

**NORTON ONYX**

THE MARK CONSISTS OF STANDARD CHARACTERS WITHOUT CLAIM TO ANY PARTICULAR FONT, STYLE, SIZE, OR COLOR.

OWNER OF U.S. REG. NOS. 969,450, 1,010,924 AND 3,658,513.

**CLASS 3—COSMETICS AND CLEANING PREPARATIONS**

FOR COATED ABRASIVES WITH CERAMIC GRAIN IN THE FORM OF BELTS, FIBER DISCS, AND CLOTH DISCS (U.S. CLS. 1, 4, 6, 50, 51 AND 52).

**CLASS 7—MACHINERY**

FOR COATED ABRASIVES WITH CERAMIC GRAIN IN THE FORM OF BELTS, USED ON STATIONARY AND ROBOTIC POWER-DRIVEN NARROW, BACKSTAND, BENCHSTAND, CENTERLESS, AND WIDE BELT SANDING, GRINDING, AND POLISHING MACHINES AND HAND-HELD, PORTABLE ELECTRIC AND AIR BELT SANDERS, WIDE ORBITAL MACHINES, AND JITTERBUG MACHINES; COATED ABRASIVES WITH CERAMIC GRAIN IN THE FORM OF FIBER DISCS AND CLOTH DISCS USED ON HAND-HELD PORTABLE, POWER-DRIVEN ELECTRIC AND AIR RIGHT ANGLE AND VERTICAL SHAFT GRINDERS (U.S. CLS. 13, 19, 21, 23, 31, 34 AND 35).

CHRISTINE COOPER, EXAMINING ATTORNEY

SN 85-056,498. ELDER RESOURCE CENTER, LLC, HOLLYWOOD, FL. FILED 6-7-2010.

ElderHelper<sup>®</sup>com

THE MARK CONSISTS OF THE WORDS "ELDERHELPER" AND "COM" SEPARATED BY A SMILEY FACE WEARING GLASSES WITHIN A CIRCLE.

#### CLASS 35—ADVERTISING AND BUSINESS

FOR ADVERTISING SERVICES, NAMELY, PROMOTING THE INTERESTS OF SPECIALIZED PROVIDERS OF ELDER CARE GOODS AND SERVICES IN THE FIELDS OF ACCOUNTING, ALZHEIMER'S CARE, ASSISTED LIVING, CANCER CARE, COMPANION CARE, ESTATE PLANNING, ESTATE SALES, FINAL ARRANGEMENTS IN THE NATURE OF FUNERAL, BURIAL AND CREMATION SERVICES, FINANCIAL PLANNING AND MANAGEMENT, GERIATRIC CARE MANAGEMENT, GOVERNMENT INFORMATION SERVICES AND AGENCY LINKS, HOME CUSTODIAL CARE IN THE NATURE OF HOUSE KEEPING AND LAUNDRY SERVICES, HOME-DELIVERED GROCERIES, HOME DELIVERED MEALS, HOME HEALTH CARE, HOSPICE CARE, INSURANCE SERVICES, LEGAL SERVICES, MEDICAL SERVICES, MEDICAL EQUIPMENT, MEDICAL SUPPLIES, MEDICATIONS, NURSING HOME CARE, PLACEMENT SERVICES, REAL ESTATE, RESPITE CARE, TRANSPORTATION, AND TAX SERVICES; PROVIDING A WEBSITE ON THE GLOBAL COMPUTER INFORMATION NETWORK FEATURING INFORMATION OF INTEREST TO SENIOR CITIZENS, THEIR FAMILIES AND THEIR CAREGIVERS IN THE FIELD OF ACCOUNTING; PROVIDING A WEBSITE ON THE GLOBAL COMPUTER INFORMATION NETWORK FEATURING INFORMATION OF INTEREST TO SENIOR CITIZENS, THEIR FAMILIES AND THEIR CAREGIVERS IN THE FIELD OF ESTATE PLANNING AND ESTATE SALES; PROVIDING A WEBSITE ON THE GLOBAL COMPUTER INFORMATION NETWORK FEATURING INFORMATION OF INTEREST TO SENIOR CITIZENS, THEIR FAMILIES AND THEIR CAREGIVERS IN THE FIELD OF TAX SERVICES, NAMELY, TAX ADVISORY SERVICES, TAX PLANNING" ADVICE, INFORMATION AND CONSULTANCY AND TAX FILING SERVICES (U.S. CLS. 100, 101 AND 102).

#### CLASS 44—MEDICAL, BEAUTY AND AGRICULTURAL SERVICES

FOR PROVIDING A WEBSITE ON THE GLOBAL COMPUTER INFORMATION NETWORK FEATURING INFORMATION OF INTEREST TO SENIOR CITIZENS, THEIR FAMILIES AND THEIR CAREGIVERS IN THE FIELD OF MENTAL HEALTH CARE, SPECIALIZING IN ALZHEIMER'S CARE; PROVIDING A WEBSITE ON THE GLOBAL COMPUTER INFORMATION NETWORK FEATURING INFORMATION OF INTEREST TO SENIOR CITIZENS, THEIR FAMILIES AND THEIR CAREGIVERS IN THE FIELD OF CANCER CARE AND GERIATRIC HEALTH CARE MANAGEMENT SERVICES, HOME HEALTH CARE SERVICES, HOSPICE CARE AND MEDICAL SERVICES; PROVIDING A WEBSITE ON THE GLOBAL COMPUTER INFORMATION NETWORK FEATURING INFORMATION OF INTEREST

TO SENIOR CITIZENS, THEIR FAMILIES AND THEIR CAREGIVERS IN THE FIELD OF PHARMACEUTICAL ADVICE AND DISPENSING OF PHARMACEUTICALS; PROVIDING A WEBSITE ON THE GLOBAL COMPUTER INFORMATION NETWORK FEATURING INFORMATION OF INTEREST TO SENIOR CITIZENS, THEIR FAMILIES AND THEIR CAREGIVERS IN THE FIELD OF NURSING HOMES AND HOME NURSING AID SERVICES; PROVIDING A WEBSITE ON THE GLOBAL COMPUTER INFORMATION NETWORK FEATURING INFORMATION OF INTEREST TO SENIOR CITIZENS, THEIR FAMILIES AND THEIR CARE GIVERS IN THE FIELD OF RESPITE CARE, NAMELY, SHORT-TERM, TEMPORARY ASSISTANCE TO THOSE WHO ARE CARING FOR FAMILY MEMBERS WHO MIGHT OTHERWISE REQUIRE PERMANENT PLACEMENT IN A FACILITY OUTSIDE OF THE HOME; PROVIDING A WEBSITE ON THE GLOBAL COMPUTER INFORMATION NETWORK FEATURING INFORMATION OF INTEREST TO SENIOR CITIZENS, THEIR FAMILIES AND THEIR CARE GIVERS IN THE FIELD OF MEDICAL EQUIPMENT AND MEDICAL SUPPLIES, NAMELY, RENTAL AND PURCHASE OF MEDICAL EQUIPMENT AND MEDICAL SUPPLIES (U.S. CLS. 100 AND 101).  
THOMAS MANOR, EXAMINING ATTORNEY

SN 85-056,505. ELDER RESOURCE CENTER, LLC, HOLLYWOOD, FL. FILED 6-7-2010.

## ELDER HELPER

THE MARK CONSISTS OF STANDARD CHARACTERS WITHOUT CLAIM TO ANY PARTICULAR FONT, STYLE, SIZE, OR COLOR.

#### CLASS 35—ADVERTISING AND BUSINESS

FOR ADVERTISING SERVICES, NAMELY, PROMOTING THE INTERESTS OF SPECIALIZED PROVIDERS OF ELDER CARE GOODS AND SERVICES IN THE FIELDS OF ACCOUNTING, ALZHEIMER'S CARE, ASSISTED LIVING, CANCER CARE, COMPANION CARE, ESTATE PLANNING, ESTATE SALES, FINAL ARRANGEMENTS IN THE NATURE OF FUNERAL, BURIAL AND CREMATION SERVICES, FINANCIAL PLANNING AND MANAGEMENT, GERIATRIC CARE MANAGEMENT, GOVERNMENT INFORMATION SERVICES AND AGENCY LINKS, HOME CUSTODIAL CARE IN THE NATURE OF HOUSE KEEPING AND LAUNDRY SERVICES, HOME-DELIVERED GROCERIES, HOME DELIVERED MEALS, HOME HEALTH CARE, HOSPICE CARE, INSURANCE SERVICES, LEGAL SERVICES, MEDICAL SERVICES, MEDICAL EQUIPMENT, MEDICAL SUPPLIES, MEDICATIONS, NURSING HOME CARE, PLACEMENT SERVICES, REAL ESTATE, RESPITE CARE, TRANSPORTATION, AND TAX SERVICES; PROVIDING A WEBSITE ON THE GLOBAL COMPUTER INFORMATION NETWORK FEATURING INFORMATION OF INTEREST TO SENIOR CITIZENS, THEIR FAMILIES AND THEIR CAREGIVERS IN THE FIELD OF ACCOUNTING; PROVIDING A WEBSITE ON THE GLOBAL COMPUTER INFORMATION NETWORK FEATURING INFORMATION OF INTEREST TO SENIOR CITIZENS, THEIR FAMILIES AND THEIR CAREGIVERS IN THE FIELD OF ESTATE PLANNING AND ESTATE SALES; PROVIDING A WEBSITE ON THE GLOBAL COMPUTER INFORMATION NETWORK FEATURING INFORMATION OF INTEREST TO SENIOR CITIZENS, THEIR FAMILIES AND THEIR CAREGIVERS IN THE FIELD OF TAX SERVICES, NAMELY, TAX ADVISORY SERVICES, TAX PLANNING ADVICE, INFORMATION AND CONSULTANCY AND TAX FILING SERVICES (U.S. CLS. 100, 101 AND 102).

**CLASS 44—MEDICAL, BEAUTY AND AGRICULTURAL SERVICES**

FOR PROVIDING A WEBSITE ON THE GLOBAL COMPUTER INFORMATION NETWORK FEATURING INFORMATION OF INTEREST TO SENIOR CITIZENS, THEIR FAMILIES AND THEIR CAREGIVERS IN THE FIELD OF MENTAL HEALTH CARE, SPECIALIZING IN ALZHEIMER'S CARE; PROVIDING A WEBSITE ON THE GLOBAL COMPUTER INFORMATION NETWORK FEATURING INFORMATION OF INTEREST TO SENIOR CITIZENS, THEIR FAMILIES AND THEIR CAREGIVERS IN THE FIELD OF CANCER CARE AND GERIATRIC HEALTH CARE MANAGEMENT SERVICES, HOME HEALTH CARE SERVICES, HOSPICE CARE AND MEDICAL SERVICES; PROVIDING A WEBSITE ON THE GLOBAL COMPUTER INFORMATION NETWORK FEATURING INFORMATION OF INTEREST TO SENIOR CITIZENS, THEIR FAMILIES AND THEIR CAREGIVERS IN THE FIELD OF PHARMACEUTICAL ADVICE AND DISPENSING OF PHARMACEUTICALS; PROVIDING A WEBSITE ON THE GLOBAL COMPUTER INFORMATION NETWORK FEATURING INFORMATION OF INTEREST TO SENIOR CITIZENS, THEIR FAMILIES AND THEIR CAREGIVERS IN THE FIELD OF NURSING HOMES AND HOME NURSING AID SERVICES; PROVIDING A WEBSITE ON THE GLOBAL COMPUTER INFORMATION NETWORK FEATURING INFORMATION OF INTEREST TO SENIOR CITIZENS, THEIR FAMILIES AND THEIR CARE GIVERS IN THE FIELD OF RESPITE CARE, NAMELY, SHORT-TERM, TEMPORARY ASSISTANCE TO THOSE WHO ARE CARING FOR FAMILY MEMBERS WHO MIGHT OTHERWISE REQUIRE PERMANENT PLACEMENT IN A FACILITY OUTSIDE OF THE HOME; PROVIDING A WEBSITE ON THE GLOBAL COMPUTER INFORMATION NETWORK FEATURING INFORMATION OF INTEREST TO SENIOR CITIZENS, THEIR FAMILIES AND THEIR CARE GIVERS IN THE FIELD OF MEDICAL EQUIPMENT AND MEDICAL SUPPLIES, NAMELY, RENTAL AND PURCHASE OF MEDICAL EQUIPMENT AND MEDICAL SUPPLIES (U.S. CLS. 100 AND 101).

THOMAS MANOR, EXAMINING ATTORNEY

**CLASS 35—ADVERTISING AND BUSINESS**

FOR ADVERTISING SERVICES, NAMELY, PROMOTING THE INTERESTS OF SPECIALIZED PROVIDERS OF ELDER CARE GOODS AND SERVICES IN THE FIELDS OF ACCOUNTING, ALZHEIMER'S CARE, ASSISTED LIVING, CANCER CARE, COMPANION CARE, ESTATE PLANNING, ESTATE SALES, FINAL ARRANGEMENTS IN THE NATURE OF FUNERAL, BURIAL AND CREMATION SERVICES, FINANCIAL PLANNING AND MANAGEMENT, GERIATRIC CARE MANAGEMENT, GOVERNMENT INFORMATION SERVICES AND AGENCY LINKS, HOME CUSTODIAL CARE IN THE NATURE OF HOUSE KEEPING AND LAUNDRY SERVICES, HOME-DELIVERED GROCERIES, HOME DELIVERED MEALS, HOME HEALTH CARE, HOSPICE CARE, INSURANCE SERVICES, LEGAL SERVICES, MEDICAL SERVICES, MEDICAL EQUIPMENT, MEDICAL SUPPLIES, MEDICATIONS, NURSING HOME CARE, PLACEMENT SERVICES, REAL ESTATE, RESPITE CARE, TRANSPORTATION, AND TAX SERVICES; PROVIDING A WEBSITE ON THE GLOBAL COMPUTER INFORMATION NETWORK FEATURING INFORMATION OF INTEREST TO SENIOR CITIZENS, THEIR FAMILIES AND THEIR CAREGIVERS IN THE FIELD OF ACCOUNTING; PROVIDING A WEBSITE ON THE GLOBAL COMPUTER INFORMATION NETWORK FEATURING INFORMATION OF INTEREST TO SENIOR CITIZENS, THEIR FAMILIES AND THEIR CAREGIVERS IN THE FIELD OF ESTATE PLANNING AND ESTATE SALES; PROVIDING A WEBSITE ON THE GLOBAL COMPUTER INFORMATION NETWORK FEATURING INFORMATION OF INTEREST TO SENIOR CITIZENS, THEIR FAMILIES AND THEIR CAREGIVERS IN THE FIELD OF TAX SERVICES, NAMELY, TAX ADVISORY SERVICES, TAX PLANNING ADVICE, INFORMATION AND CONSULTANCY AND TAX FILING SERVICES (U.S. CLS. 100, 101 AND 102).

**CLASS 44—MEDICAL, BEAUTY AND AGRICULTURAL SERVICES**

FOR PROVIDING A WEBSITE ON THE GLOBAL COMPUTER INFORMATION NETWORK FEATURING INFORMATION OF INTEREST TO SENIOR CITIZENS, THEIR FAMILIES AND THEIR CAREGIVERS IN THE FIELD OF MENTAL HEALTH CARE, SPECIALIZING IN ALZHEIMER'S CARE; PROVIDING A WEBSITE ON THE GLOBAL COMPUTER INFORMATION NETWORK FEATURING INFORMATION OF INTEREST TO SENIOR CITIZENS, THEIR FAMILIES AND THEIR CAREGIVERS IN THE FIELD OF CANCER CARE AND GERIATRIC HEALTH CARE MANAGEMENT SERVICES, HOME HEALTH CARE SERVICES, HOSPICE CARE AND MEDICAL SERVICES; PROVIDING A WEBSITE ON THE GLOBAL COMPUTER INFORMATION NETWORK FEATURING INFORMATION OF INTEREST TO SENIOR CITIZENS, THEIR FAMILIES AND THEIR CAREGIVERS IN THE FIELD OF PHARMACEUTICAL ADVICE AND DISPENSING OF PHARMACEUTICALS; PROVIDING A WEBSITE ON THE GLOBAL COMPUTER INFORMATION NETWORK FEATURING INFORMATION OF INTEREST TO SENIOR CITIZENS, THEIR FAMILIES AND THEIR CAREGIVERS IN THE FIELD OF NURSING HOMES AND HOME NURSING AID SERVICES; PROVIDING A WEBSITE ON THE GLOBAL COMPUTER INFORMATION NETWORK FEATURING INFORMATION OF INTEREST TO SENIOR CITIZENS, THEIR FAMILIES AND THEIR CARE GIVERS IN THE FIELD OF RESPITE CARE, NAMELY, SHORT-TERM, TEMPORARY ASSISTANCE TO THOSE WHO ARE CARING FOR FAMILY MEMBERS WHO MIGHT OTHERWISE REQUIRE PERMANENT PLACEMENT IN A FACILITY OUTSIDE OF THE HOME; PROVIDING A WEBSITE ON THE GLOBAL COMPUTER INFORMATION NETWORK FEATURING INFORMATION OF INTEREST TO SENIOR CITIZENS, THEIR FAMILIES AND THEIR CARE GIVERS IN THE FIELD OF MEDICAL EQUIPMENT AND MEDICAL SUPPLIES, NAMELY, RENTAL AND PURCHASE OF MEDICAL EQUIPMENT AND MEDICAL SUPPLIES (U.S. CLS. 100 AND 101).

THOMAS MANOR, EXAMINING ATTORNEY

SN 85-056,509. ELDER RESOURCE CENTER, LLC, HOLLYWOOD, FL. FILED 6-7-2010.



THE MARK CONSISTS OF A SMILEY FACE WEARING GLASSES WITHIN A CIRCLE.



SN 85-056,576. VALUE SUISSE INTERNATIONAL INVESTMENTS, INC., WILMINGTON, DE. FILED 6-7-2010.



NO CLAIM IS MADE TO THE EXCLUSIVE RIGHT TO USE "VALUE", APART FROM THE MARK AS SHOWN. THE STIPPLING IS FOR SHADING PURPOSES ONLY.

THE MARK CONSISTS OF A LIGHTHOUSE IMAGE WITH TWO RAYS EMANATING FROM BOTH SIDES OF THE LIGHTHOUSE IMAGE, ALL ABOVE THE WORDS "VALUE SUISSE".

THE ENGLISH TRANSLATION OF THE WORD "SUISSE" IN THE MARK IS "SWITZERLAND".

#### CLASS 35—ADVERTISING AND BUSINESS

FOR ELECTRONIC COMMERCE SERVICES, NAMELY, PROVIDING INFORMATION ABOUT GOODS AND SERVICES VIA TELECOMMUNICATIONS NETWORKS FOR ADVERTISING AND SALES PURPOSES, AND OPERATING AN ONLINE MARKETPLACE FOR CONSUMERS TO SELL AND PURCHASE GOODS AND SERVICES NOT INCLUDING WATCHES, CHRONOMETRIC INSTRUMENTS, CHOCOLATE, CONFECTIONERY, PHARMACEUTICAL PRODUCTS, AND MEDICAL DEVICES (U.S. CLS. 100, 101 AND 102).

#### CLASS 36—INSURANCE AND FINANCIAL

FOR ELECTRONIC COMMERCE SERVICES, NAMELY, ESTABLISHING FUNDED ACCOUNTS USED TO SELL AND PURCHASE GOODS AND SERVICES ON THE INTERNET (U.S. CLS. 100, 101 AND 102).  
CAROL SPILS, EXAMINING ATTORNEY

SN 85-056,586. VALUE SUISSE INTERNATIONAL INVESTMENTS, INC., WILMINGTON, DE. FILED 6-7-2010.

VALUE SUISSE

THE MARK CONSISTS OF STANDARD CHARACTERS WITHOUT CLAIM TO ANY PARTICULAR FONT, STYLE, SIZE, OR COLOR.

NO CLAIM IS MADE TO THE EXCLUSIVE RIGHT TO USE "VALUE", APART FROM THE MARK AS SHOWN.

THE ENGLISH TRANSLATION OF THE WORD "SUISSE" IN THE MARK IS "SWITZERLAND".

#### CLASS 35—ADVERTISING AND BUSINESS

FOR ELECTRONIC COMMERCE SERVICES, NAMELY, PROVIDING INFORMATION ABOUT GOODS AND SERVICES VIA TELECOMMUNICATIONS NETWORKS FOR ADVERTISING AND SALES PURPOSES, AND OPERATING AN ONLINE MARKETPLACE FOR CONSUMERS TO SELL AND PURCHASE GOODS AND SERVICES NOT INCLUDING WATCHES, CHRONOMETRIC INSTRUMENTS, CHOCOLATE, CONFECTIONERY, PHARMACEUTICAL PRODUCTS, AND MEDICAL DEVICES (U.S. CLS. 100, 101 AND 102).

#### CLASS 36—INSURANCE AND FINANCIAL

FOR ELECTRONIC COMMERCE SERVICES, NAMELY, ESTABLISHING FUNDED ACCOUNTS USED TO SELL AND PURCHASE GOODS AND SERVICES ON THE INTERNET (U.S. CLS. 100, 101 AND 102).  
CAROL SPILS, EXAMINING ATTORNEY

SN 85-057,047. FRANZ SACHS GMBH & CO. KG, TETTANG, FED REP GERMANY, FILED 6-8-2010.

PHYSIO ART

THE MARK CONSISTS OF STANDARD CHARACTERS WITHOUT CLAIM TO ANY PARTICULAR FONT, STYLE, SIZE, OR COLOR.

PRIORITY CLAIMED UNDER SEC. 44(D) ON ERPNCMNTY TM OFC APPLICATION NO. 008739708, FILED 12-8-2009, REG. NO. 008739708, DATED 6-11-2010, EXPIRES 12-8-2019.

NO CLAIM IS MADE TO THE EXCLUSIVE RIGHT TO USE "ART", APART FROM THE MARK AS SHOWN.

#### CLASS 5—PHARMACEUTICALS

FOR ABRASIVE TAPE FOR DENTAL USE (U.S. CLS. 6, 18, 44, 46, 51 AND 52).

#### CLASS 10—MEDICAL APPARATUS

FOR INSERTS FOR ORTHOPEDIC SHOES; DENTAL APPARATUS, NAMELY, MODEL HOLDERS AND MODELS OF DENTAL ARCHES FOR UPPER AND LOWER JAWS, FOR DENTAL USE; DENTURES; OCCLUSIONAL SPLINTS; DENTAL CROWNS, DENTAL CAPS, DENTAL RINGS, DENTAL MOULD STRIPS, DENTAL RETRACTION THREAD (U.S. CLS. 26, 39 AND 44).

#### CLASS 16—PAPER GOODS AND PRINTED MATTER

FOR DENTAL MODEL HEADS, INCLUDING SHOULDERS AND FASTENING SYSTEMS, AND DENTAL WORK AND DEMONSTRATION MODELS, ALL FOR DENTAL AND DENTAL TECHNOLOGY TRAINING PURPOSES (U.S. CLS. 2, 5, 22, 23, 29, 37, 38 AND 50).  
NICHOLAS ALTREE, EXAMINING ATTORNEY

SN 85-057,492. FREMAUX - DELORME, PARIS, FRANCE,  
FILED 6-8-2010.

# I FIL HOME

THE MARK CONSISTS OF STANDARD CHARACTERS WITHOUT CLAIM TO ANY PARTICULAR FONT, STYLE, SIZE, OR COLOR.

PRIORITY CLAIMED UNDER SEC. 44(D) ON FRANCE APPLICATION NO. 103742147, FILED 5-31-2010, REG. NO. 103742147, DATED 5-31-2010, EXPIRES 5-31-2020.

THE ENGLISH TRANSLATION OF THE WORD FIL IN THE MARK IS "THREAD".

## CLASS 20—FURNITURE AND ARTICLES NOT OTHERWISE CLASSIFIED

FOR PILLOWS (U.S. CLS. 2, 13, 22, 25, 32 AND 50).

## CLASS 24—FABRICS

FOR FABRIC FOR THE MANUFACTURE OF TEXTILE, NAMELY, FABRICS FOR TEXTILE USE, BED LINEN, BED SHEETS, DUVET COVERS, BOLSTER PILLOW COVERS, PILLOW CASES, BED SKIRTS, THROWS, BLANKET COVERS, CUSHION COVERS, PLAID-BEDSPREADS, EMBROIDERED PILLOW CASES, EMBROIDERED DUVET COVERS, BED CHANGING SHEETS, FLAT BED SHEETS, CONTOUR SHEETS; BATH LINEN, TOWELS, FACE CLOTHS, BEACH TOWELS; TABLE LINEN, TEXTILE TABLECLOTHS, NAPKINS AND PLACEMATS, FABRIC TABLE RUNNERS, TEA TOWELS; TABLE LINEN, TEXTILE TABLECLOTHS, NAPKINS AND PLACEMATS, FABRIC TABLE RUNNERS, TEA TOWELS; DUVETS, DOWN BLANKETS AND DOWN COMFORTERS; BLANKETS, NAMELY, LAP, SILK AND TRAVELING BLANKETS, AND FABRIC BED VALANCES (U.S. CLS. 42 AND 50).

## CLASS 25—CLOTHING

FOR CLOTHING, NAMELY, BATHROBES, PAJAMAS, DRESSING GOWNS; FOOTWEAR, NAMELY, SLIPPERS; CHILDREN CLOTHING, NAMELY, BATHROBES, PAJAMAS, BIBS MADE OF FABRIC, DRESSING GOWNS, DRESSING GOWNS WITH SPONGE-LINED HOODS; CHILDREN'S AND INFANT'S SLEEP APPAREL, NAMELY, JUMPERS, OVERALL SLEEPWEAR INCLUDING WRIGGLERS, NAMELY, BABY SLEEPWEAR, ROMPERS, ONE-PIECE GARMENTS AND BABY BUNTING (U.S. CLS. 22 AND 39).

TRICIA SONNEBORN, EXAMINING ATTORNEY

SN 85-057,672. QUID, INC., SAN FRANCISCO, CA. FILED 6-8-2010.

# QUID

THE MARK CONSISTS OF STANDARD CHARACTERS WITHOUT CLAIM TO ANY PARTICULAR FONT, STYLE, SIZE, OR COLOR.

## CLASS 35—ADVERTISING AND BUSINESS

FOR BUSINESS CONSULTING SERVICES RELATED TO THE ANALYSIS OF BUSINESS PERFORMANCE, NEW BUSINESS FORMATION, AND NEW VENTURE FORMATION; ARRANGING AND CONDUCTING BUSINESS CONFERENCES AND TRADE SHOWS IN THE FIELDS OF FINANCIAL INVESTMENT, NEW VENTURE ACTIVITY, AND BUSINESS MANAGEMENT; PROVIDING BUSINESS INFORMATION AND BUSINESS DATA ANALYSIS RELATED TO THE FIELDS OF NEW VENTURE ACTIVITY AND BUSINESS MANAGEMENT; COMPUTER SERVICES, NAMELY, COMPILING AND ANALYZING BUSINESS DATA RELATED TO NEW BUSINESS FORMATION AND THE INDIVIDUALS INVOLVED IN THOSE BUSINESSES; COMPILING FINANCIAL INFORMATION RELATED TO BUSINESS VALUATION AND BUSINESS PERFORMANCE FOR BUSINESS PURPOSES (U.S. CLS. 100, 101 AND 102).

## CLASS 36—INSURANCE AND FINANCIAL

FOR FINANCIAL CONSULTING SERVICES RELATED TO THE ANALYSIS OF BUSINESS PERFORMANCE, NEW BUSINESS FORMATION, NEW VENTURE ACTIVITY, AND FINANCIAL INVESTMENT; INVESTMENT MANAGEMENT AND RESEARCH SERVICES; COMPUTER SERVICES, NAMELY, PROVIDING ONLINE FINANCIAL INFORMATION AND FINANCIAL DATA ANALYSIS RELATED TO THE FIELDS OF FINANCIAL INVESTMENT, NEW VENTURE ACTIVITY, AND BUSINESS MANAGEMENT; COMPUTER SERVICES, NAMELY, ANALYZING FINANCIAL INFORMATION RELATED TO BUSINESS VALUATION AND BUSINESS PERFORMANCE (U.S. CLS. 100, 101 AND 102).

## CLASS 41—EDUCATION AND ENTERTAINMENT

FOR ARRANGING AND CONDUCTING SEMINARS, WORKSHOPS, WEBINARS, AND EDUCATIONAL CONFERENCES IN THE FIELDS OF FINANCIAL INVESTMENT, NEW VENTURE ACTIVITY, AND BUSINESS MANAGEMENT (U.S. CLS. 100, 101 AND 107).

KRISTINA MORRIS, EXAMINING ATTORNEY

SN 85-057,721. MERCHSOURCE, LLC, FOOTHILL RANCH, CA. FILED 6-8-2010.

# SARAH PEYTON

THE MARK CONSISTS OF STANDARD CHARACTERS WITHOUT CLAIM TO ANY PARTICULAR FONT, STYLE, SIZE, OR COLOR.

OWNER OF U.S. REG. NOS. 3,493,282, 3,603,089 AND 3,732,533.

THE NAME(S), PORTRAIT(S), AND/OR SIGNATURE(S) SHOWN IN THE MARK DOES NOT IDENTIFY A PARTICULAR LIVING INDIVIDUAL.

## CLASS 9—ELECTRICAL AND SCIENTIFIC APPARATUS

FOR BACKLIT SIGNS, NAMELY, BACKLIT ADDRESS SIGNS (U.S. CLS. 21, 23, 26, 36 AND 38).

FIRST USE 2-28-2010; IN COMMERCE 2-28-2010.

## CLASS 14—JEWELRY

FOR JEWELRY STANDS (U.S. CLS. 2, 27, 28 AND 50).  
FIRST USE 3-31-2010; IN COMMERCE 3-31-2010.

**CLASS 21—HOUSEWARES AND GLASS**

FOR LAZY SUSAN (U.S. CLS. 2, 13, 23, 29, 30, 33, 40 AND 50).  
FIRST USE 2-28-2009; IN COMMERCE 2-28-2009.  
KYLE PEETE, EXAMINING ATTORNEY

SN 85-057,724. MERCHSOURCE, LLC, Foothill Ranch, CA. FILED 6-8-2010.

**BLUE HAT TOY COMPANY**

THE MARK CONSISTS OF STANDARD CHARACTERS WITHOUT CLAIM TO ANY PARTICULAR FONT, STYLE, SIZE, OR COLOR.

OWNER OF U.S. REG. NOS. 3,473,563 AND 3,474,154.  
NO CLAIM IS MADE TO THE EXCLUSIVE RIGHT TO USE "TOY COMPANY", APART FROM THE MARK AS SHOWN.

**CLASS 9—ELECTRICAL AND SCIENTIFIC APPARATUS**

FOR METAL DETECTORS; COMPUTERS, NAMELY, LAPTOP COMPUTERS; ELECTRONIC DIARIES (U.S. CLS. 21, 23, 26, 36 AND 38).  
FIRST USE 3-31-2009; IN COMMERCE 3-31-2009.

**CLASS 14—JEWELRY**

FOR CLOCKS (U.S. CLS. 2, 27, 28 AND 50).  
FIRST USE 3-31-2009; IN COMMERCE 3-31-2009.

**CLASS 21—HOUSEWARES AND GLASS**

FOR NON-METAL BANKS, NAMELY, PIGGY BANKS AND COIN BANK JARS (U.S. CLS. 2, 13, 23, 29, 30, 33, 40 AND 50).  
FIRST USE 3-31-2009; IN COMMERCE 3-31-2009.

**CLASS 28—TOYS AND SPORTING GOODS**

FOR ELECTRONICALLY OPERATED TOY HOVERCRAFTS AND TOY VEHICLES WITH TRANSFORMING PARTS, NAMELY, TRANSFORMING ROBOTIC TOY VEHICLES; TOY BANKS IN THE NATURE OF TOY AUTOMATED TELLER MACHINES (U.S. CLS. 22, 23, 38 AND 50).  
FIRST USE 2-28-2009; IN COMMERCE 2-28-2009.  
KYLE PEETE, EXAMINING ATTORNEY

SN 85-057,990. SINGBOX AB, STOCKHOLM, SWEDEN, FILED 6-9-2010.



OWNER OF ERPN CMNTY TM OFC REG. NO. 008284507, DATED 3-30-2010, EXPIRES 6-15-2019.  
THE MARK CONSISTS OF SINGBOX SPELLED OUT IN LOWERCASE LETTERS ALONG WITH A BOX IMMEDIATELY TO THE LEFT OF THE WORD "SINGBOX" AND ON THE BOX THERE APPEARS A MUSICAL NOTE.

**CLASS 9—ELECTRICAL AND SCIENTIFIC APPARATUS**

FOR APPARATUS FOR RECORDING, REPRODUCTION, MODIFICATION, AND/OR TRANSMISSION OF SOUND; DIGITAL MUSIC AND GAMES DOWNLOADABLE VIA THE INTERNET AND WIRELESS DEVICES (U.S. CLS. 21, 23, 26, 36 AND 38).

**CLASS 35—ADVERTISING AND BUSINESS**

FOR ADVERTISING AND BUSINESS ADMINISTRATION AND MANAGEMENT (U.S. CLS. 100, 101 AND 102).

**CLASS 38—COMMUNICATION**

FOR TELECOMMUNICATIONS SERVICES, NAMELY, THE STREAMING OF MUSIC AND GAMES VIA THE INTERNET (U.S. CLS. 100, 101 AND 104).

**CLASS 41—EDUCATION AND ENTERTAINMENT**

FOR ENTERTAINMENT SERVICES, NAMELY, PROVIDING NON-DOWNLOADABLE PLAYBACK OF MUSIC VIA GLOBAL COMMUNICATIONS NETWORKS; AND PROVIDING ONLINE COMPUTER GAMES AND MUSIC PRODUCTION SERVICES (U.S. CLS. 100, 101 AND 107).

**CLASS 42—SCIENTIFIC AND COMPUTER SERVICES**

FOR DESIGN AND DEVELOPMENT OF COMPUTER HARDWARE AND SOFTWARE FOR MUSIC PLAYBACK AND PRODUCTION, MODIFICATION OF SOUND, AND GAMING (U.S. CLS. 100 AND 101).  
JOHN E. MICHOS, EXAMINING ATTORNEY

SN 85-058,015. BAISDEN MEDIA GROUP, LLC, DALLAS, TX. FILED 6-9-2010.

**V-JOBS**

THE MARK CONSISTS OF STANDARD CHARACTERS WITHOUT CLAIM TO ANY PARTICULAR FONT, STYLE, SIZE, OR COLOR.

**CLASS 35—ADVERTISING AND BUSINESS**

FOR PROVIDING CAREER INFORMATION AND JOB LISTINGS VIA A GLOBAL COMPUTER NETWORK; EMPLOYMENT HIRING, RECRUITING, PLACEMENT, AND STAFFING SERVICES; PROVIDING BUSINESS INFORMATION ON EMPLOYMENT AND CAREERS; ONLINE RECRUITING SERVICES, NAMELY, PROVIDING SEARCHABLE JOB POSTINGS AND RESUME POSTINGS; CAREER MANAGEMENT SERVICES; ADVERTISING SERVICES IN THE NATURE OF RECRUITMENT ADVERTISING; BUSINESS CONSULTING, BUSINESS MARKETING CONSULTATION, AND MARKET RESEARCH SERVICES IN THE FIELDS OF EMPLOYMENT RECRUITMENT, EMPLOYER BRANDING, AND EMPLOYEE AND JOB PROFILING; PROVIDING INFORMATION ON EMPLOYMENT OPPORTUNITIES AND UNEMPLOYMENT RATES; ONLINE INTERACTIVE RESUME PREPARATIONS FOR OTHERS; PROVIDING COUPONS AND DISCOUNTS FOR GOODS AND SERVICES OFFERED BY OTHERS; ADVERTISING AND MARKETING SERVICES, NAMELY, PROMOTING THE GOODS AND SERVICES OF OTHERS OVER THE INTERNET; PROVIDING ONLINE DIRECTORY SERVICES ON THE INTERNET FOR EMPLOYERS AND JOB SEEKERS; PROVIDING BUSINESS INFORMATION, NAMELY, PROVIDING ONLINE ARCHIVES FEATURING BUSINESS INFORMATION FOR EMPLOYERS, ENTREPRENEURS, AND JOB SEEKERS; PROVIDING A WEBSITE THAT ALLOWS USERS TO POST CONSUMER PRODUCT INFORMATION, EMPLOYMENT INFORMATION, AND RESUMES FOR EMPLOYMENT (U.S. CLS. 100, 101 AND 102).

**CLASS 38—COMMUNICATION**

FOR INTERACTIVE TRANSMISSION OF INFORMATION BY ELECTRONIC COMMUNICATION NETWORKS, NAMELY, TRANSMISSION OF A VIRTUAL PLATFORM FEATURING STREAMING VIDEO, STREAMING AUDIO, MULTIMEDIA CONTENT, AND ADVERTISING AND PROMOTION OPPORTUNITIES VIA THE INTERNET; PROVIDING ONLINE CHAT ROOMS FOR THE EXCHANGE OF IDEAS, CONCEPTS, INFORMATION, PRODUCTS, JOB ANNOUNCEMENTS, RESUMES, AND SERVICES IN THE FIELDS OF BUSINESS AND EMPLOYMENT OPPORTUNITIES; PROVIDING AN ONLINE INTERACTIVE BULLETIN BOARD FEATURING JOB LISTINGS, EVENT LISTINGS, COMMERCIAL NOTICES, PRESENTATIONS, IDEAS, AND RESUMES; TEXT AND NUMERIC WIRELESS DIGITAL MESSAGING SERVICES; COMMUNICATION SERVICES, NAMELY, TRANSMISSION OF VOICE, AUDIO, VISUAL IMAGES AND DATA BY TELECOMMUNICATIONS NETWORKS, WIRELESS COMMUNICATION NETWORKS, THE INTERNET, INFORMATION SERVICES NETWORKS AND DATA NETWORKS; PROVIDING ONLINE CHAT ROOMS FOR TRANSMISSION OF MESSAGES AND ONLINE DIRECTORY INFORMATION AMONG COMPUTER USERS FEATURING INFORMATION IN THE FIELDS OF EMPLOYMENT, BUSINESS, GENERAL INTEREST, SOCIAL NETWORKING, CLASSIFIEDS, AND VIRTUAL COMMUNITY; ELECTRONIC DATA TRANSMISSION, NAMELY, PROVIDING TRANSMISSION SERVICES VIA MOBILE DEVICES TO LOOK UP USER PROFILE INFORMATION, SEARCH FOR USERS, SEND MESSAGES TO USERS, POST INFORMATION VIEWABLE BY USERS, ADD CONTACTS, AND PROVIDE NOTIFICATIONS (U.S. CLS. 100, 101 AND 104).

**CLASS 41—EDUCATION AND ENTERTAINMENT**

FOR CAREER COUNSELING AND ADVICE; PROVIDING NEWSLETTERS IN THE FIELD OF CAREER COUNSELING AND ADVICE VIA EMAIL; PROVIDING AN ONLINE ELECTRONIC NEWSLETTER DELIVERED BY EMAIL IN THE FIELDS OF EMPLOYMENT, HUMAN RESOURCES, AND BUSINESS TO REGISTERED USERS OF A WEBSITE; ONLINE JOURNALS, NAMELY, BLOGS FEATURING TOPICS OF GENERAL INTEREST (U.S. CLS. 100, 101 AND 107).

WILLIAM P. SHANAHAN, EXAMINING ATTORNEY

SN 85-058,035. BAISDEN MEDIA GROUP, LLC, DALLAS, TX. FILED 6-9-2010.

**V-BUSINESS**

THE MARK CONSISTS OF STANDARD CHARACTERS WITHOUT CLAIM TO ANY PARTICULAR FONT, STYLE, SIZE, OR COLOR.

**CLASS 35—ADVERTISING AND BUSINESS**

FOR PROVIDING CAREER INFORMATION AND JOB LISTINGS VIA A GLOBAL COMPUTER NETWORK; EMPLOYMENT HIRING, RECRUITING, PLACEMENT, AND STAFFING SERVICES; PROVIDING BUSINESS INFORMATION ON EMPLOYMENT AND CAREERS; ONLINE RECRUITING SERVICES, NAMELY, PROVIDING SEARCHABLE JOB POSTINGS AND RESUME POSTINGS; CAREER MANAGEMENT SERVICES; ADVERTISING SERVICES IN THE NATURE OF RECRUITMENT ADVERTISING; BUSINESS CONSULTING, BUSINESS MARKETING CONSULTATION, AND MARKET RESEARCH SERVICES IN THE FIELDS OF EMPLOYMENT RECRUITMENT, EMPLOYER BRANDING, AND EMPLOYEE AND JOB PROFILING; PROVIDING INFORMATION ON EMPLOYMENT OPPORTUNITIES AND UNEMPLOYMENT RATES; ONLINE INTERACTIVE RESUME PREPARATIONS FOR OTHERS; PROVIDING COUPONS AND DISCOUNTS FOR GOODS AND SERVICES OFFERED BY OTHERS; ADVERTISING AND MARKETING SERVICES, NAMELY, PROMOTING THE GOODS AND SERVICES OF OTHERS OVER THE INTERNET; PROVIDING ONLINE DIRECTORY SERVICES ON THE INTERNET FOR EMPLOYERS AND JOB SEEKERS; PROVIDING BUSINESS INFORMATION, NAMELY, PROVIDING ONLINE ARCHIVES FEATURING BUSINESS INFORMATION FOR EMPLOYERS, ENTREPRENEURS, AND JOB SEEKERS; PROVIDING A WEBSITE THAT ALLOWS USERS TO POST CONSUMER PRODUCT INFORMATION, EMPLOYMENT INFORMATION, AND RESUMES FOR EMPLOYMENT (U.S. CLS. 100, 101 AND 102).

**CLASS 38—COMMUNICATION**

FOR INTERACTIVE TRANSMISSION OF INFORMATION BY ELECTRONIC COMMUNICATION NETWORKS, NAMELY, TRANSMISSION OF A VIRTUAL PLATFORM FEATURING STREAMING VIDEO, STREAMING AUDIO, MULTIMEDIA CONTENT, AND ADVERTISING AND PROMOTION OPPORTUNITIES VIA THE INTERNET; PROVIDING ONLINE CHAT ROOMS FOR THE EXCHANGE OF IDEAS, CONCEPTS, INFORMATION, PRODUCTS, JOB ANNOUNCEMENTS, RESUMES, AND SERVICES IN THE FIELDS OF BUSINESS AND EMPLOYMENT OPPORTUNITIES; PROVIDING AN ONLINE INTERACTIVE BULLETIN BOARD FEATURING JOB LISTINGS, EVENT LISTINGS, COMMERCIAL NOTICES, PRESENTATIONS, IDEAS, AND RESUMES; TEXT AND NUMERIC WIRELESS DIGITAL MESSAGING SERVICES; COMMUNICATION SERVICES, NAMELY, TRANSMISSION OF VOICE, AUDIO, VISUAL IMAGES AND DATA BY TELECOMMUNICATIONS NETWORKS, WIRELESS COMMUNICATION NETWORKS, THE INTERNET, INFORMATION SERVICES NETWORKS AND DATA NETWORKS; PROVIDING ONLINE CHAT ROOMS FOR TRANSMISSION OF MESSAGES AND ONLINE DIRECTORY INFORMATION AMONG COMPUTER USERS FEATURING INFORMATION IN THE FIELDS OF EMPLOYMENT, BUSINESS, GENERAL INTEREST, SOCIAL NETWORKING, CLASSIFIEDS, AND VIRTUAL COMMUNITY; ELECTRONIC DATA TRANSMISSION, NAMELY, PROVIDING TRANSMISSION SERVICES VIA MOBILE DEVICES TO LOOK UP USER PROFILE INFORMATION, SEARCH FOR USERS, SEND MESSAGES TO USERS, POST INFORMATION VIEWABLE BY USERS, ADD CONTACTS, AND PROVIDE NOTIFICATIONS (U.S. CLS. 100, 101 AND 104).



**CLASS 41—EDUCATION AND ENTERTAINMENT**

FOR CAREER COUNSELING AND ADVICE; PROVIDING NEWSLETTERS IN THE FIELD OF CAREER COUNSELING AND ADVICE VIA EMAIL; PROVIDING AN ONLINE ELECTRONIC NEWSLETTER DELIVERED BY EMAIL IN THE FIELDS OF EMPLOYMENT, HUMAN RESOURCES, AND BUSINESS TO REGISTERED USERS OF A WEBSITE; ONLINE JOURNALS, NAMELY, BLOGS FEATURING TOPICS OF GENERAL INTEREST (U.S. CLS. 100, 101 AND 107).

WILLIAM P. SHANAHAN, EXAMINING ATTORNEY

SN 85-058,173. SHY HOLDINGS, LLC, TRAVERSE CITY, MI.  
FILED 6-9-2010.

**SPIRITUALITY & HEALTH**

THE MARK CONSISTS OF STANDARD CHARACTERS WITHOUT CLAIM TO ANY PARTICULAR FONT, STYLE, SIZE, OR COLOR.  
SEC. 2(F).

**CLASS 16—PAPER GOODS AND PRINTED MATTER**

FOR PUBLICATIONS, NAMELY, BOOKS, MAGAZINES, AND NEWSLETTERS IN THE FIELDS OF SPIRITUALITY AND WELLNESS (U.S. CLS. 2, 5, 22, 23, 29, 37, 38 AND 50).

FIRST USE 4-1-1997; IN COMMERCE 4-1-1997.

**CLASS 41—EDUCATION AND ENTERTAINMENT**

FOR ON-LINE PUBLICATION OF BOOKS, MAGAZINES, NEWSLETTERS, AND ELECTRONIC PUBLICATIONS IN THE FIELDS OF SPIRITUALITY AND WELLNESS (U.S. CLS. 100, 101 AND 107).

FIRST USE 4-1-1997; IN COMMERCE 4-1-1997.  
CARRIE GENOVESE, EXAMINING ATTORNEY

SN 85-058,364. JAGER DESIGN, INC., BURLINGTON, VT.  
FILED 6-9-2010.

DESIGN  JAGER DI PAOLA KEMP

NO CLAIM IS MADE TO THE EXCLUSIVE RIGHT TO USE "DESIGN", APART FROM THE MARK AS SHOWN.

THE NAME(S), PORTRAIT(S), AND/OR SIGNATURE(S) SHOWN IN THE MARK DOES NOT IDENTIFY A PARTICULAR LIVING INDIVIDUAL.

THE MARK CONSISTS OF THE WORD "DESIGN" IN CAPITAL LETTERS SPELLED BACKWARDS, FOLLOWED BY FIVE VERTICAL LINES, FOLLOWED BY THE WORDS "JAGER DI PAOLA KEMP" IN CAPITAL LETTERS.

**CLASS 35—ADVERTISING AND BUSINESS**

FOR ADVERTISING SERVICES, NAMELY, CREATION OF ADVERTISING FOR OTHERS; MARKET RESEARCH SERVICES, NAMELY, CONDUCTING MARKET SURVEYS, STUDIES AND ANALYSIS FOR OTHERS; CONSULTATION SERVICES, NAMELY, PRODUCT, BRAND AND CORPORATE IDENTITY AND DEVELOPMENT FOR OTHERS (U.S. CLS. 100, 101 AND 102).

FIRST USE 1-1-2002; IN COMMERCE 1-1-2002.

**CLASS 42—SCIENTIFIC AND COMPUTER SERVICES**

FOR DESIGN SERVICES, NAMELY, GRAPHIC ART, COMMERCIAL ART, PRODUCT, INDUSTRIAL AND PACKAGING DESIGN FOR OTHERS (U.S. CLS. 100 AND 101).

FIRST USE 1-1-2002; IN COMMERCE 1-1-2002.  
MICHELE SWAIN, EXAMINING ATTORNEY

SN 85-058,449. SAM GROUP HOLDING AG, CH - 8005  
ZÜRICH, SWITZERLAND, FILED 6-9-2010.



PRIORITY CLAIMED UNDER SEC. 44(D) ON SWITZERLAND APPLICATION NO. 63940/2009, FILED 12-9-2009, REG. NO. 604445, DATED 8-26-2010, EXPIRES 12-9-2019.

THE COLOR(S) DARK BLUE, TEAL, LIGHT GREEN AND WHITE IS/ARE CLAIMED AS A FEATURE OF THE MARK.

THE MARK CONSISTS OF OVERLAPPING CIRCLES, WITH PART OF THE SMALLER CIRCLE IN DARK BLUE AND WHITE AND PART OF THE LARGER CIRCLE IN LIGHT GREEN; THE OVERLAPPING AREA OF THE TWO CIRCLES IS IN THE COLOR TEAL.

**CLASS 9—ELECTRICAL AND SCIENTIFIC APPARATUS**

FOR ELECTRONIC DATABASES IN THE FIELD OF SUSTAINABLE INVESTMENTS AND COMMERCIAL ENTERPRISES WITH SUSTAINABLE BUSINESS MODELS RECORDED ON COMPUTER MEDIA; DOWNLOADABLE ELECTRONIC PUBLICATIONS IN THE NATURE OF BROCHURES AND LEAFLETS IN THE FIELD OF SUSTAINABLE INVESTMENTS AND COMMERCIAL ENTERPRISES WITH SUSTAINABLE BUSINESS MODELS; COMPUTER SOFTWARE FOR USE IN DATABASE MANAGEMENT, USE AS A SPREADSHEET, AND FOR THE ANALYSIS OF BUSINESS MODELS IN RESPECT OF THE SUSTAINABILITY OF INVESTMENTS AND COMMERCIAL ENTERPRISES; COMPUTER APPLICATION SOFTWARE FOR USE IN DATABASE MANAGEMENT, USE AS A SPREADSHEET, AND FOR THE ANALYSIS OF BUSINESS MODELS IN RESPECT OF THE SUSTAINABILITY OF INVESTMENTS AND COMMERCIAL ENTERPRISES (U.S. CLS. 21, 23, 26, 36 AND 38).

**CLASS 16—PAPER GOODS AND PRINTED MATTER**

FOR PRINTED MATTER OF ALL KIND, NAMELY, BOOKS, BROCHURES, MAGAZINES, LEAFLETS, LOOSE-LEAF-COLLECTIONS, ALL IN THE FIELD OF SUSTAINABLE INVESTMENTS AND COMMERCIAL ENTERPRISES WITH SUSTAINABLE BUSINESS MODELS; PRINTED INSTRUCTIONAL AND TEACHING MATERIALS IN THE FIELD OF SUSTAINABLE INVESTMENTS AND COMMERCIAL ENTERPRISES WITH SUSTAINABLE BUSINESS MODELS (U.S. CLS. 2, 5, 22, 23, 29, 37, 38 AND 50).

**CLASS 35—ADVERTISING AND BUSINESS**

FOR ECONOMIC FORECASTING; BUSINESS FAILURE ANALYSIS SERVICES; BUSINESS ORGANIZATION AND MANAGEMENT CONSULTANCY; EVALUATIONS RELATING TO COMMERCIAL MATTERS; BUSINESS APPRAISALS OF COMMERCIAL ENTERPRISES WITH QUALIFICATION AND CERTIFICATION SCHEMES IN THE FIELD OF SUSTAINABLE INVESTMENT POSSIBILITIES; COMPILATION AND SYSTEMIZATION OF INFORMATION INTO COMPUTER DATABASES; DATABASE MANAGEMENT, NAMELY, UPDATING CONTENT; CONSULTING SERVICES IN THE AREA OF SUSTAINABLE BUSINESS SOLUTIONS; ELECTRONIC COMMERCE SERVICES, NAMELY, PROVIDING INFORMATION ABOUT PRODUCTS VIA TELECOMMUNICATION NETWORKS FOR ADVERTISING AND SALES PURPOSES IN THE FIELD OF SUSTAINABLE INVESTMENTS (U.S. CLS. 100, 101 AND 102).

ALEXANDER L. POWERS, EXAMINING ATTORNEY

SN 85-058,734. MDU RESOURCES GROUP, INC., BISMARCK, ND. FILED 6-9-2010.

**BITTER CREEK**

THE MARK CONSISTS OF STANDARD CHARACTERS WITHOUT CLAIM TO ANY PARTICULAR FONT, STYLE, SIZE, OR COLOR.

**CLASS 35—ADVERTISING AND BUSINESS**

FOR MANAGING THE PRODUCTION AND OPERATIONS OF NATURAL GAS PROPERTIES FOR OTHERS; ENERGY MANAGEMENT SERVICES, NAMELY, PROVIDING A SERVICE THAT ALLOWS CUSTOMERS TO PURCHASE ENERGY FROM VARIOUS ENERGY PROVIDERS; BUSINESS SERVICES, NAMELY, OPERATION OF PIPELINES, NATURAL GAS DEHYDRATION SYSTEMS, COMPRESSOR STATIONS, METERING STATIONS, AND ENERGY FACILITIES FOR OTHERS (U.S. CLS. 100, 101 AND 102).

FIRST USE 6-30-1999; IN COMMERCE 6-30-1999.

**CLASS 37—CONSTRUCTION AND REPAIR**

FOR PIPELINE MAINTENANCE SERVICES; CONSTRUCTION PLANNING; CONSTRUCTION OF NATURAL GAS DEHYDRATION SYSTEMS, NATURAL GAS COMPRESSOR STATIONS, METERING STATIONS, AND ENERGY FACILITIES; CONSTRUCTION PROJECT MANAGEMENT SERVICES; PIPELINE LAYING, CONSTRUCTION AND MAINTENANCE (U.S. CLS. 100, 103 AND 106).

FIRST USE 6-30-1999; IN COMMERCE 6-30-1999.

**CLASS 40—MATERIAL TREATMENT**

FOR GENERATION OF POWER THROUGH OPERATION OF PIPELINES, NATURAL GAS DEHYDRATION SYSTEMS, COMPRESSOR STATIONS, METERING STATIONS AND ENERGY FACILITIES FOR OTHERS (U.S. CLS. 100, 103 AND 106).

FIRST USE 6-30-1999; IN COMMERCE 6-30-1999.

**CLASS 42—SCIENTIFIC AND COMPUTER SERVICES**

FOR GAS METER READING AND DATA ANALYSIS; PIPELINE INSPECTION SERVICES; DESIGN OF PIPELINES, NATURAL GAS DEHYDRATION SYSTEMS, NATURAL GAS COMPRESSOR STATIONS, GAS METERING STATIONS, AND ENERGY FACILITIES (U.S. CLS. 100 AND 101).

FIRST USE 6-30-1999; IN COMMERCE 6-30-1999.

KRISTIN DAHLING, EXAMINING ATTORNEY

SN 85-059,368. ADOPT A HIGHWAY MAINTENANCE CORPORATION, SANTA ANA, CA. FILED 6-10-2010.

**SPONSOR A HIGHWAY**

THE MARK CONSISTS OF STANDARD CHARACTERS WITHOUT CLAIM TO ANY PARTICULAR FONT, STYLE, SIZE, OR COLOR.

NO CLAIM IS MADE TO THE EXCLUSIVE RIGHT TO USE "HIGHWAY", APART FROM THE MARK AS SHOWN. SEC. 2(F).

**CLASS 37—CONSTRUCTION AND REPAIR**

FOR HIGHWAY BEAUTIFICATION SERVICES, NAMELY, CLEANING HIGHWAYS AND OBJECTS ALONG HIGHWAYS TO REMOVE GRAFFITI THEREFROM (U.S. CLS. 100, 103 AND 106).

FIRST USE 6-15-1995; IN COMMERCE 7-31-1995.

**CLASS 39—TRANSPORTATION AND STORAGE**

FOR HIGHWAY BEAUTIFICATION SERVICES, NAMELY, TRASH PICK UP (U.S. CLS. 100 AND 105).

FIRST USE 6-15-1995; IN COMMERCE 7-31-1995.

ANNE FARRELL, EXAMINING ATTORNEY

SN 85-059,378. ADOPT A HIGHWAY MAINTENANCE CORPORATION, SANTA ANA, CA. FILED 6-10-2010.

**ADOPT A HIGHWAY**

THE MARK CONSISTS OF STANDARD CHARACTERS WITHOUT CLAIM TO ANY PARTICULAR FONT, STYLE, SIZE, OR COLOR.

NO CLAIM IS MADE TO THE EXCLUSIVE RIGHT TO USE "HIGHWAY", APART FROM THE MARK AS SHOWN. SEC. 2(F).

**CLASS 37—CONSTRUCTION AND REPAIR**

FOR HIGHWAY BEAUTIFICATION SERVICES, NAMELY, CLEANING HIGHWAYS AND OBJECTS ALONG HIGHWAYS TO REMOVE GRAFFITI THEREFROM (U.S. CLS. 100, 103 AND 106).

FIRST USE 6-15-1995; IN COMMERCE 7-31-1995.

**CLASS 39—TRANSPORTATION AND STORAGE**

FOR HIGHWAY BEAUTIFICATION SERVICES, NAMELY, TRASH PICK UP (U.S. CLS. 100 AND 105).

FIRST USE 6-15-1995; IN COMMERCE 7-31-1995.

ANNE FARRELL, EXAMINING ATTORNEY

SN 85-059,423. ADOPT A HIGHWAY MAINTENANCE CORPORATION, SANTA ANA, CA. FILED 6-10-2010.

**ADOPT A HIGHWAY  
MAINTENANCE CORPORATION**

THE MARK CONSISTS OF STANDARD CHARACTERS WITHOUT CLAIM TO ANY PARTICULAR FONT, STYLE, SIZE, OR COLOR.

NO CLAIM IS MADE TO THE EXCLUSIVE RIGHT TO USE "HIGHWAY MAINTENANCE CORPORATION", APART FROM THE MARK AS SHOWN.

SEC. 2(F).

**CLASS 37—CONSTRUCTION AND REPAIR**

FOR HIGHWAY BEAUTIFICATION SERVICES, NAMELY, CLEANING HIGHWAYS AND OBJECTS ALONG HIGHWAYS TO REMOVE GRAFFITI THEREFROM (U.S. CLS. 100, 103 AND 106).

FIRST USE 6-15-1995; IN COMMERCE 7-31-1995.

**CLASS 39—TRANSPORTATION AND STORAGE**

FOR HIGHWAY BEAUTIFICATION SERVICES, NAMELY, TRASH PICK UP (U.S. CLS. 100 AND 105).

FIRST USE 6-15-1995; IN COMMERCE 7-31-1995.

ANNE FARRELL, EXAMINING ATTORNEY

SN 85-059,396. GLOBAL WEST SUSPENSION COMPONENTS, INC., SAN BERNARDINO, CA. FILED 6-10-2010.



NO CLAIM IS MADE TO THE EXCLUSIVE RIGHT TO USE "SUSPENSION", APART FROM THE MARK AS SHOWN.

THE MARK CONSISTS OF THE STACKED WORDS "GLOBAL WEST" AND "SUSPENSION" CENTERED AGAINST A STYLIZED LINED GLOBE.

**CLASS 12—VEHICLES**

FOR LAND VEHICLE SUSPENSION PARTS, NAMELY, TORSION/SWAY BARS, COIL SPRINGS, LEAF SPRINGS, EQUALIZERS; STEERING AND SUSPENSION SYSTEMS AND PARTS FOR STEERING AND SUSPENSION SYSTEMS FOR VEHICLES, NAMELY, UPPER BALL JOINTS, LOWER BALL JOINTS, BALL JOINTS WITH CONTROL ARMS, BUSHING KITS, INNER TIE ROD ENDS, OUTER TIE ROD ENDS, SLEEVES, IDLER ARMS, CENTER LINKS, STABILIZER KITS, INNER SOCKETS AND PITMAN ARMS; SUSPENSION SPRINGS FOR CARS; FRAMES FOR CARS; VEHICLE PARTS, NAMELY, SUSPENSION STRUTS, BRAKE LININGS FOR CARS, BRAKE SEGMENTS FOR CARS, BRAKE SHOES FOR CARS, AND BRAKES FOR CARS (U.S. CLS. 19, 21, 23, 31, 35 AND 44).

FIRST USE 7-1-1994; IN COMMERCE 7-1-1994.

**CLASS 37—CONSTRUCTION AND REPAIR**

FOR CAR REPAIR AND MAINTENANCE AND RACING MODIFICATIONS; RESTORATION IN THE FIELD OF ANTIQUE CARS; REPAIR OF AUTOMOTIVE FRAME STRETCHING MACHINES (U.S. CLS. 100, 103 AND 106).

FIRST USE 7-1-1994; IN COMMERCE 7-1-1994.

PAULA MAHONEY, EXAMINING ATTORNEY

SN 85-059,673. UNITED WHOLESALE, LLC., CHICAGO, IL. FILED 6-10-2010.

**Auto-intelliKey**

THE MARK CONSISTS OF STANDARD CHARACTERS WITHOUT CLAIM TO ANY PARTICULAR FONT, STYLE, SIZE, OR COLOR.

**CLASS 20—FURNITURE AND ARTICLES NOT OTHERWISE CLASSIFIED**

FOR A NON-FUNCTIONING PLASTIC MOLD OF AN AUTOMOBILE KEY THAT IS ATTACHED TO A BROCHURE FOR DIRECT MAIL MARKETING PURPOSES FOR THE BENEFIT OF SPECIAL EVENTS AT CAR DEALERSHIPS AROUND THE COUNTRY (U.S. CLS. 2, 13, 22, 25, 32 AND 50).

**CLASS 35—ADVERTISING AND BUSINESS**

FOR ADVERTISING SERVICES, NAMELY, PROMOTING SPECIAL EVENTS THROUGH MASS DIRECT MAIL BROCHURES FOR THE BENEFIT OF CAR DEALERSHIPS (U.S. CLS. 100, 101 AND 102).

MICHAEL KEATING, EXAMINING ATTORNEY

SN 85-060,086. NEW SEASONS MARKET LLC, PORTLAND, OR. FILED 6-10-2010.

## NEW SEASONS MARKET

THE MARK CONSISTS OF STANDARD CHARACTERS WITHOUT CLAIM TO ANY PARTICULAR FONT, STYLE, SIZE, OR COLOR.

OWNER OF U.S. REG. NOS. 3,112,256 AND 3,112,257.  
NO CLAIM IS MADE TO THE EXCLUSIVE RIGHT TO USE "MARKET", APART FROM THE MARK AS SHOWN.

### CLASS 29—MEATS AND PROCESSED FOODS

FOR BEAN DIP; BUTTER; CHEESE; DAIRY-BASED FOOD BEVERAGES; DIPS; EGGS; FRUIT-BASED SPREADS; HUMMUS; LUNCHEON MEATS; MARI-NATED VEGETABLES; MEAT; MEAT-BASED SPREADS; MILK; PREPARED MEAT; PROCESSED OLIVES; SAL-ADS EXCEPT MACARONI, RICE, AND PASTA SALAD; SEAFOOD; SOUPS; VEGETABLE-BASED SPREADS; PREPARED ENTREES CONSISTING PRIMARILY OF MEAT, FISH, POULTRY OR VEGETABLES; PREPARED MEALS CONSISTING PRIMARILY OF MEAT, FISH, POULTRY OR VEGETABLES; ALL OF THE ABOVE TO BE SOLD AS PRIVATE-LABEL FOOD PRODUCTS IN THE APPLICANT'S OWN STORES OR AS PRIVATE-LABEL FOOD PRODUCTS FOR SALE SOLELY THROUGH RETAIL GROCERY STORES (U.S. CL. 46).

FIRST USE 2-29-2000; IN COMMERCE 10-10-2001.

### CLASS 30—STAPLE FOODS

FOR BAKERY PRODUCTS; COFFEE; COFFEE BEANS; HAMBURGER SANDWICHES; MACARONI SALAD; PASTA SALAD; PESTO; RICE SALAD; SANDWICHES; SAUCES; PREPARED ENTREES CONSISTING PRIMARILY OF PASTA OR RICE; PREPARED MEALS CONSISTING PRIMARILY OF PASTA OR RICE; ALL OF THE ABOVE TO BE SOLD AS PRIVATE-LABEL FOOD PRODUCTS IN THE APPLICANT'S OWN STORES OR AS PRIVATE-LABEL FOOD PRODUCTS FOR SALE SOLELY THROUGH RETAIL GROCERY STORES (U.S. CL. 46).

FIRST USE 2-29-2000; IN COMMERCE 10-10-2001.

### CLASS 31—NATURAL AGRICULTURAL PRODUCTS

FOR FRESH FRUIT AND VEGETABLES; ALL OF THE ABOVE TO BE SOLD AS PRIVATE-LABEL FOOD PRODUCTS IN THE APPLICANT'S OWN STORES OR AS PRIVATE-LABEL FOOD PRODUCTS FOR SALE SOLELY THROUGH RETAIL GROCERY STORES (U.S. CLS. 1 AND 46).

FIRST USE 2-29-2000; IN COMMERCE 10-10-2001.  
CORY BOONE, EXAMINING ATTORNEY

SN 85-060,114. NEW SEASONS MARKET LLC, PORTLAND, OR. FILED 6-10-2010.



OWNER OF U.S. REG. NOS. 3,112,256 AND 3,112,257.  
NO CLAIM IS MADE TO THE EXCLUSIVE RIGHT TO USE "MARKET", APART FROM THE MARK AS SHOWN.

THE COLOR(S) GREEN AND BLACK IS/ARE CLAIMED AS A FEATURE OF THE MARK.

THE MARK CONSISTS OF THE WORDING "NEW

SEASONS MARKET" INSIDE OF A DESIGN FEATURING THREE ADJOINING COLORED RECTANGLES. THE WORD "NEW" APPEARS IN THE TOP LEFT RECTANGLE IN BLACK WRITING ON A GREEN BACKGROUND. ADJACENT TO THIS, THE WORD "SEASONS" APPEARS IN GREEN WRITING ON A BLACK BACKGROUND. THE WORD "MARKET" APPEARS IN BLACK LETTERS ON A GREEN BACKGROUND IN A SMALLER RECTANGLE CENTERED BELOW THE OTHER RECTANGLES. THE RECTANGLES ALL HAVE BLACK BORDERS.

### CLASS 29—MEATS AND PROCESSED FOODS

FOR BEAN DIP; BUTTER; CHEESE; DAIRY-BASED FOOD BEVERAGES; DIPS; EGGS; FRUIT-BASED SPREADS; HUMMUS; LUNCHEON MEATS; MARI-NATED VEGETABLES; MEAT; MEAT-BASED SPREADS; MILK; PREPARED MEAT; PROCESSED OLIVES; SAL-ADS EXCEPT MACARONI, RICE, AND PASTA SALAD; SEAFOOD; SOUPS; VEGETABLE-BASED SPREADS; PREPARED ENTREES CONSISTING PRIMARILY OF MEAT, FISH, POULTRY OR VEGETABLES; PREPARED MEALS CONSISTING PRIMARILY OF MEAT, FISH, POULTRY OR VEGETABLES; ALL OF THE ABOVE TO BE SOLD AS PRIVATE-LABEL FOOD PRODUCTS IN THE APPLICANT'S OWN STORES OR AS PRIVATE-LABEL FOOD PRODUCTS FOR SALE SOLELY THROUGH RETAIL GROCERY STORES (U.S. CL. 46).

FIRST USE 2-29-2000; IN COMMERCE 10-10-2001.

### CLASS 30—STAPLE FOODS

FOR BAKERY PRODUCTS; COFFEE; COFFEE BEANS; HAMBURGER SANDWICHES; MACARONI SALAD; PASTA SALAD; PESTO; RICE SALAD; SANDWICHES; SAUCES; PREPARED ENTREES CONSISTING PRIMARILY OF PASTA OR RICE; PREPARED MEALS CONSISTING PRIMARILY OF PASTA OR RICE; ALL OF THE ABOVE TO BE SOLD AS PRIVATE-LABEL FOOD PRODUCTS IN THE APPLICANT'S OWN STORES OR AS PRIVATE-LABEL FOOD PRODUCTS FOR SALE SOLELY THROUGH RETAIL GROCERY STORES (U.S. CL. 46).

FIRST USE 2-29-2000; IN COMMERCE 10-10-2001.

### CLASS 31—NATURAL AGRICULTURAL PRODUCTS

FOR FRESH FRUIT AND VEGETABLES; ALL OF THE ABOVE TO BE SOLD AS PRIVATE-LABEL FOOD PRODUCTS IN THE APPLICANT'S OWN STORES OR AS PRIVATE-LABEL FOOD PRODUCTS FOR SALE SOLELY THROUGH RETAIL GROCERY STORES (U.S. CLS. 1 AND 46).

FIRST USE 2-29-2000; IN COMMERCE 10-10-2001.

### CLASS 35—ADVERTISING AND BUSINESS

FOR RETAIL GROCERY STORES (U.S. CLS. 100, 101 AND 102).

FIRST USE 2-29-2000; IN COMMERCE 10-10-2001.  
CORY BOONE, EXAMINING ATTORNEY

SN 85-060,155. KERAFAST, LLC, WINSTON-SALEM, NC. FILED 6-10-2010.

# FASTCELL

THE MARK CONSISTS OF STANDARD CHARACTERS WITHOUT CLAIM TO ANY PARTICULAR FONT, STYLE, SIZE, OR COLOR.



**CLASS 1—CHEMICALS**

FOR KERATIN AND KERATIN BASED PRODUCTS FOR SCIENTIFIC PURPOSES, CELL GROWTH, AND CELL CULTURES, NAMELY, DIAGNOSTIC REAGENTS FOR SCIENTIFIC OR RESEARCH USE (U.S. CLS. 1, 5, 6, 10, 26 AND 46).

**CLASS 5—PHARMACEUTICALS**

FOR KERATIN AND KERATIN BASED PRODUCTS FOR MEDICAL PURPOSES, CELL GROWTH, AND CELL CULTURES, NAMELY, REAGENTS FOR MEDICAL USE (U.S. CLS. 6, 18, 44, 46, 51 AND 52).

ROBERT STRUCK, EXAMINING ATTORNEY

**CLASS 43—HOTEL AND RESTAURANT SERVICES**

FOR RENTAL OF ROOMS FOR SOCIAL MEETINGS, BANQUETS AND SOCIAL FUNCTIONS, INCLUDING CORPORATE SOCIAL EVENTS (U.S. CLS. 100 AND 101).  
FIRST USE 5-1-2010; IN COMMERCE 5-1-2010.  
STEVEN PEREZ, EXAMINING ATTORNEY

SN 85-060,249. SOGEVAL LABORATORIES, INC., COPPELL, TX. FILED 6-11-2010.

SN 85-060,395. MYSINGLEBUDDY.COM LLC, WILMINGTON, DE. FILED 6-11-2010.

# AHBS

THE MARK CONSISTS OF STANDARD CHARACTERS WITHOUT CLAIM TO ANY PARTICULAR FONT, STYLE, SIZE, OR COLOR.

**CLASS 35—ADVERTISING AND BUSINESS**

FOR CREATING CORPORATE AND BRAND IDENTITY FOR OTHERS BY FACILITATING PRIVATE LABEL BRANDING AND/OR CO-BRANDING OF ANIMAL HEALTH PRODUCTS; CONSULTATION SERVICES IN THE FIELD OF MARKETING STRATEGY; CONSULTATION SERVICES IN THE FIELD OF PRIVATE LABEL BRANDING AND CO-BRANDING OF ANIMAL HEALTH PRODUCTS FOR OTHERS (U.S. CLS. 100, 101 AND 102).

**CLASS 42—SCIENTIFIC AND COMPUTER SERVICES**

FOR CUSTOM DESIGN OF PACKAGING AND LABELING FOR OTHERS; CONSULTATION SERVICES IN THE FIELD OF PACKAGING AND LABEL DESIGN (U.S. CLS. 100 AND 101).

RUSS HERMAN, EXAMINING ATTORNEY

SN 85-060,386. GARY HANDEL, NEW YORK, NY. FILED 6-11-2010.

# THE EMPIRE LOFTS

THE MARK CONSISTS OF STANDARD CHARACTERS WITHOUT CLAIM TO ANY PARTICULAR FONT, STYLE, SIZE, OR COLOR.

NO CLAIM IS MADE TO THE EXCLUSIVE RIGHT TO USE "LOFTS", APART FROM THE MARK AS SHOWN.

**CLASS 35—ADVERTISING AND BUSINESS**

FOR PROVIDING FACILITIES IN THE NATURE OF ROOMS FOR BUSINESS CONFERENCES AND MEETINGS (U.S. CLS. 100, 101 AND 102).

FIRST USE 5-1-2010; IN COMMERCE 5-1-2010.

# MYSINGLEBUDDY.COM

THE MARK CONSISTS OF STANDARD CHARACTERS WITHOUT CLAIM TO ANY PARTICULAR FONT, STYLE, SIZE, OR COLOR.

**CLASS 38—COMMUNICATION**

FOR TELECOMMUNICATIONS, NAMELY, THE ELECTRONIC TRANSMISSION OF DATA, SOUND, TEXT, IMAGES AND VIDEO BY MEANS OF FIBER OPTIC, COAXIAL CABLE, SATELLITE, BROADCAST AND TRANSMISSION MEDIA, AND VIA WIRELESS DEVICES; TELECOMMUNICATIONS VIA INTERNET NETWORKS, NAMELY, TELECOMMUNICATIONS ACCESS SERVICES, COMMUNICATIONS BY COMPUTER TERMINALS; PROVISION OF ACCESS TO ELECTRONIC MESSAGING SYSTEMS, NAMELY, PROVISION OF ACCESS TO A GLOBAL COMPUTER NETWORK; INSTANT MESSAGING SERVICES; ELECTRONIC ON-LINE SERVICES FOR THE RECEIPT AND DELIVERY OF MESSAGES, DOCUMENTS, IMAGES AND OTHER DATA BY ELECTRONIC TRANSMISSION, NAMELY, THE ELECTRONIC TRANSMISSION OF DATA, SOUND, TEXT, IMAGES AND VIDEO BY MEANS OF FIBER OPTIC, COAXIAL CABLE, SATELLITE, BROADCAST AND TRANSMISSION MEDIA, AND VIA WIRELESS DEVICES; ELECTRONIC MAIL SERVICES; PROVIDING MULTIPLE-USERS ACCESS TO A GLOBAL COMPUTER INFORMATION NETWORK; ELECTRONIC MESSAGING SERVICES; PROVIDING ACCESS VIA A GLOBAL COMPUTER NETWORK TO ELECTRONIC BULLETIN BOARDS; PROVIDING COMMUNICATION SERVICES TO WEB COMMUNITIES; INFORMATION, ADVICE AND CONSULTANCY RELATING TO ALL THE AFORESAID, NAMELY, INFORMATION, ADVICE AND CONSULTATION IN THE FIELD OF TELECOMMUNICATIONS AND ELECTRONIC MESSAGING SERVICES; PROVIDING INTERNET CHAT ROOMS AND CHAT ROOM SERVICES FOR SOCIAL NETWORKING (U.S. CLS. 100, 101 AND 104).

**CLASS 42—SCIENTIFIC AND COMPUTER SERVICES**

FOR COMPUTER SERVICES, NAMELY, PROVIDING SOFTWARE INTERFACES AVAILABLE OVER A NETWORK IN ORDER TO CREATE AN ON-LINE SEARCH AGGREGATION SERVICE; COMPUTER SERVICES, NAMELY, CREATING, MAINTAINING, AND HOSTING CUSTOMIZED WEB SITES AND WEB CONTENT FOR OTHERS; COMPUTER SERVICES, NAMELY, MAINTAINING AND HOSTING CUSTOMIZED LIMITED ACCESS GAMES, VIDEOS, MUSIC, PICTURES, INFORMATION, WEB SITES AND WEB CONTENT FOR OTHERS; DESIGN AND DEVELOPMENT OF WEB SITES; WRITING FOR WEBSITES, NAMELY, WRITING OF FACTUAL VERBAL CONTENT FOR WEB SITES FOR OTHERS; ASSISTING OTHERS IN CREATING WEB COMMUNITIES AND PROVIDING COMPUTER SERVICES TO THOSE COMMUNITIES, NAMELY, CREATING, MAINTAINING AND DESIGNING COMMUNITY WEB SITES FOR OTHERS; INFORMATION, ADVICE AND CONSULTANCY RELATING TO ALL THE AFORESAID, NAMELY, INFORMATION, ADVICE AND CONSULTATION IN THE FIELD OF WEB SITE DESIGN AND CREATION; CREATING AND MAINTAINING BLOGS FOR OTHERS (U.S. CLS. 100 AND 101).

**CLASS 45—PERSONAL AND LEGAL SERVICES**

FOR PROVIDING SOCIAL INTRODUCTION AND DATE-ARRANGING SERVICES; ADMINISTERING PERSONALITY AND PHYSICAL ATTRACTIVENESS TESTING AND CREATING PERSONALITY AND PHYSICAL ATTRACTIVENESS PROFILES OF OTHERS, NAMELY, ATTRACTIVENESS AND PERSONALITY TESTING AND PROFILING FOR SOCIAL PURPOSES; DATING AGENCY SERVICES; MATCH-MAKING SERVICES; COMPUTER DATING SERVICES; PROVISION OF DATING AGENCY SERVICES VIA THE INTERNET; PROVISION OF DATING AGENCY SERVICES VIA TELEVISION, RADIO AND TELEPHONE; AGENCY SERVICES WHICH ARRANGE PERSONAL INTRODUCTIONS, NAMELY, FOR SOCIAL PURPOSES; SOCIAL ESCORTING SERVICES; INFORMATION AND ADVISORY SERVICES RELATING TO THE AFORESAID SERVICES, NAMELY, INFORMATION AND ADVICE IN THE FIELD OF DATING SERVICES; PROVIDING INFORMATION REGARDING AND IN THE NATURE OF, ON-LINE DATING AND SOCIAL INTRODUCTION SERVICES FOR SOCIAL PURPOSES; SOCIAL NETWORKING SERVICES (U.S. CLS. 100 AND 101).

SEAN CROWLEY, EXAMINING ATTORNEY

**CLASS 9—ELECTRICAL AND SCIENTIFIC APPARATUS**

FOR ACCESS CONTROL EQUIPMENT IN THE NATURE OF HIGH RESOLUTION VIDEO INTERCOM SYSTEMS FOR DOORS AND GATES COMPRISING A MONITOR AND CAMERA; DATA PROCESSING APPARATUS TO PROCESS DIGITAL AND ANALOGUE SIGNAL TRANSFORMATIONS; CLOSED CIRCUIT TELEVISION (CCTV) CAMERAS; SURVEILLANCE CAMERAS; WEB CAMERAS; CHARGE COUPLED DEVICE CAMERAS; INFRA-RED CAMERAS; UNDERWATER CAMERAS; WIRELESS CAMERAS; PINHOLE CAMERAS; WIDE ANGLE CAMERA LENSES; TELEPHOTO CAMERA LENSES; MANUAL VARIABLE FOCAL CAMERA LENSES; FISH EYE CAMERA LENSES; AUTOMATIC IRIS CAMERA LENSES; CAMERA HOUSING, NAMELY, A PROTECTIVE STRUCTURE FOR POSITIONING A CAMERA AT A DESIRED LOCATION, AND POWER CABLES FOR CCTV CAMERAS; CCTV CAMERA SYSTEMS COMPRISED OF SECURITY CAMERAS, MONITORS AND OPTICAL SENSORS; CHARGE COUPLED DEVICE CAMERA SYSTEMS COMPRISED OF SECURITY CAMERAS, MONITORS, OPTICAL SENSORS AND MOTION SENSORS; ELECTRONIC SECURITY DEVICES, NAMELY, SECURITY CAMERAS, DOOR AUDIO INTERCOMS, HIGH RESOLUTION VIDEO DOOR INTERCOMS, AND HAND-HELD PORTABLE VIDEO AND AUDIO MONITORS USED TO MONITOR A DESIRED LOCATION; ELECTRONIC SECURITY SYSTEMS, NAMELY, BURGLAR AND THEFT ALARM SYSTEMS COMPRISED OF SECURITY CAMERAS, OPTICAL SENSORS, MOTION SENSORS AND MONITORS; ACCESS CONTROL SYSTEMS COMPRISED OF AUDIO AND VIDEO RECORDERS, AUDIO AND VIDEO INTERCOMS, AND ELECTRONIC DOOR OPENING DEVICES; MONITORING, MEASURING, CONTROL AND SURVEILLANCE EQUIPMENT, NAMELY, MONITORING EQUIPMENT CONSISTING OF LIQUID CRYSTAL DISPLAY MONITORS, HAND-HELD MONITORS, AND INTERCOM MONITORS ALL USED TO MONITOR AND DISPLAY A DESIRED LOCATION UNDER SURVEILLANCE; MOTION SENSORS; ELECTRONIC CONTROL EQUIPMENT, NAMELY, INTERCOM DEVICES CONTROLLING THE ENTERING OF PROPERTY THROUGH GATES AND DOORS, AND ELECTRONIC DOOR LOCKS; SURVEILLANCE EQUIPMENT, NAMELY, SECURITY CAMERAS FOR CARRYING OUT SURVEILLANCE ON INDOOR AND OUTDOOR AREAS; SURVEILLANCE SYSTEMS, NAMELY, HOME AND OFFICE SURVEILLANCE SYSTEMS COMPRISED OF SECURITY CAMERAS AND MONITORS TO CARRY OUT SURVEILLANCE BOTH INSIDE AND OUTSIDE THE PROPERTY TO PREVENT AGAINST UNWANTED INTRUDERS; MONITORING APPARATUS, NAMELY, ELECTRONIC VIDEO CAMERAS FOR MONITORING PREMISES, ELECTRONIC VIDEO CAMERAS WITH MOTION SENSORS TO MONITOR UNWANTED INTRUDERS (U.S. CLS. 21, 23, 26, 36 AND 38).

FIRST USE 9-15-2009; IN COMMERCE 9-15-2009.

SN 85-060.408, SWANN COMMUNICATIONS LTD., CENTRAL HONG KONG, HONG KONG, FILED 6-11-2010.



NO CLAIM IS MADE TO THE EXCLUSIVE RIGHT TO USE "SERIES", APART FROM THE MARK AS SHOWN. THE MARK CONSISTS OF AN UPWARD POINTING ARROW HAVING A HALF CIRCLE EXTENDING ACROSS A LOWER PORTION OF THE ARROW, ALL POSITIONED TO THE LEFT OF THE WORDS "ALPHA SERIES".

**CLASS 35—ADVERTISING AND BUSINESS**

FOR ADVERTISING; BUSINESS MANAGEMENT; BUSINESS ADMINISTRATION; ONLINE ORDERING VIA A GLOBAL COMMUNICATIONS NETWORK, FEATURING ACCESS CONTROL EQUIPMENT IN THE NATURE OF HIGH RESOLUTION VIDEO INTERCOM SYSTEMS FOR DOORS AND GATES, DATA PROCESSING APPARATUS TO PROCESS DIGITAL AND ANALOGUE SIGNAL TRANSFORMATIONS, CLOSED CIRCUIT TELEVISION (CCTV) CAMERAS, SURVEILLANCE CAMERAS, WEB CAMERAS, CHARGE COUPLED DEVICE CAMERAS, INFRA-RED CAMERAS, UNDERWATER CAMERAS, WIRELESS CAMERAS, PINHOLE CAMERAS, WIDE ANGLE CAMERA LENSES, TELEPHOTO CAMERA LENSES, MANUAL VARIABLE FOCAL CAMERA LENSES, FISH EYE CAMERA LENSES, AUTOMATIC IRIS CAMERA LENSES, CAMERA HOUSINGS, PROTECTIVE STRUCTURES FOR POSITIONING A CAMERA AT A DESIRED LOCATION, POWER CABLES FOR CCTV CAMERAS, CCTV CAMERA SYSTEMS, SECURITY CAMERAS, MONITORS AND OPTICAL SENSORS, CHARGE COUPLED DEVICE CAMERA SYSTEMS, ELECTRONIC SECURITY DEVICES, DOOR AUDIO INTERCOMS, HIGH RESOLUTION VIDEO DOOR INTERCOMS, AND HAND-HELD PORTABLE VIDEO AND AUDIO MONITORS USED TO

MONITOR A DESIRED LOCATION, ELECTRONIC SECURITY SYSTEMS, BURGLAR AND THEFT ALARM SYSTEMS COMPRISED OF SECURITY CAMERAS, OPTICAL SENSORS, MOTION SENSORS AND MONITORS, ACCESS CONTROL SYSTEMS COMPRISED OF AUDIO AND VIDEO RECORDERS, AUDIO AND VIDEO INTERCOMS, ELECTRONIC DOOR OPENING DEVICES, MONITORING EQUIPMENT CONSISTING OF LIQUID CRYSTAL DISPLAY MONITORS, HAND-HELD MONITORS, INTERCOM MONITORS USED TO MONITOR AND DISPLAY A DESIRED LOCATION UNDER SURVEILLANCE, MOTION SENSORS, ELECTRONIC CONTROL EQUIPMENT, INTERCOM DEVICES CONTROLLING THE ENTERING OF PROPERTY THROUGH GATES AND DOORS, ELECTRONIC DOOR LOCKS, SECURITY CAMERAS FOR CARRYING OUT SURVEILLANCE ON INDOOR AND OUTDOOR AREAS; ONLINE ORDERING VIA A GLOBAL COMMUNICATIONS NETWORK FEATURING SURVEILLANCE SYSTEMS, HOME AND OFFICE SURVEILLANCE SYSTEMS COMPRISED OF SECURITY CAMERAS AND MONITORS TO CARRY OUT SURVEILLANCE BOTH INSIDE AND OUTSIDE THE PROPERTY TO PREVENT AGAINST UNWANTED INTRUDERS, MONITORING APPARATUS, ELECTRONIC VIDEO CAMERAS FOR MONITORING PREMISES, ELECTRONIC VIDEO CAMERAS WITH MOTION SENSORS TO MONITOR UNWANTED INTRUDERS (U.S. CLS. 100, 101 AND 102).

FIRST USE 9-15-2009; IN COMMERCE 9-15-2009.  
KRISTIN DAHLING, EXAMINING ATTORNEY

SN 85-061,731. SEE JANE RIDE, LLC, BOALSBURG, PA. FILED 6-14-2010.



THE MARK CONSISTS OF THE WORDS "SEE JANE RIDE" BENEATH A STYLIZED WOMAN RIDING A BICYCLE.

#### CLASS 18—LEATHER GOODS

FOR CARRY-ALL BAGS (U.S. CLS. 1, 2, 3, 22 AND 41).  
FIRST USE 9-0-2009; IN COMMERCE 9-0-2009.

#### CLASS 21—HOUSEWARES AND GLASS

FOR EMPTY PLASTIC WATER BOTTLES (U.S. CLS. 2, 13, 23, 29, 30, 33, 40 AND 50).  
FIRST USE 9-0-2009; IN COMMERCE 9-0-2009.

#### CLASS 25—CLOTHING

FOR CLOTHING AND ACCESSORIES FOR CYCLING, NAMELY, SHIRTS, SHORTS, SOCKS, HATS AND GLOVES (U.S. CLS. 22 AND 39).  
FIRST USE 9-0-2009; IN COMMERCE 9-0-2009.

#### CLASS 39—TRANSPORTATION AND STORAGE

FOR ARRANGING, ORGANIZING AND CONDUCTING TOURS BY BICYCLE (U.S. CLS. 100 AND 105).  
FIRST USE 9-0-2009; IN COMMERCE 9-0-2009.

#### CLASS 41—EDUCATION AND ENTERTAINMENT

FOR EDUCATIONAL SERVICES, NAMELY, CONDUCTING CYCLING CLASSES (U.S. CLS. 100, 101 AND 107).  
FIRST USE 9-0-2009; IN COMMERCE 9-0-2009.  
PAULA MAHONEY, EXAMINING ATTORNEY

SN 85-061,640. ENTENTE SPIRITS, LLC, BARODA, MI. FILED 6-14-2010.

## DIVINE BOURBON

THE MARK CONSISTS OF STANDARD CHARACTERS WITHOUT CLAIM TO ANY PARTICULAR FONT, STYLE, SIZE, OR COLOR.

NO CLAIM IS MADE TO THE EXCLUSIVE RIGHT TO USE "BOURBON" AS TO CLASS 033, APART FROM THE MARK AS SHOWN.

#### CLASS 25—CLOTHING

FOR CLOTHING, NAMELY, SHIRTS; FOOTWEAR AND HEADWEAR FOR CONSUMERS (U.S. CLS. 22 AND 39).

#### CLASS 33—WINES AND SPIRITS

FOR WINES AND SPIRITS, NAMELY, ALCOHOLIC BEVERAGES, EXCEPT BEERS, FOR CONSUMERS (U.S. CLS. 47 AND 49).  
NAKIA HENRY, EXAMINING ATTORNEY

SN 85-062,039. TRADOVE, INC., DBA TRADOVE, PALO ALTO, CA. FILED 6-14-2010.



THE COLOR(S) PINK, BROWN, YELLOW, GREEN, LIGHT BLUE, MEDIUM BLUE, AND PURPLE IS/ARE CLAIMED AS A FEATURE OF THE MARK.  
THE MARK CONSISTS OF THE TERM "TRADOVE" IN

THE COLOR MEDIUM BLUE WITH THE LETTER "O" IN "DOVE" HALF MEDIUM BLUE AND HALF PINK. TO THE LEFT OF THE TERM "TRADOVE" APPEARS THE DESIGN OF A STYLIZED INCOMPLETE GLOBE FORMED BY A PINK CIRCLE AT THE TOP AND A PURPLE CURVED LINE AT THE BOTTOM, AND WITH FIVE DOVES IN FLIGHT WITH CURVED FLIGHT LINES EMANATING THEREFROM IN BETWEEN ENCIRCLING AND/OR FORMING THE GLOBE. THE FIRST DOVE AND CURVED LINE IS BROWN. THE SECOND DOVE AND CURVED LINE IS YELLOW. THE THIRD DOVE AND CURVED LINE IS GREEN. THE FOURTH DOVE AND CURVED LINE IS LIGHT BLUE. THE FIFTH DOVE AND CURVED LINE IS MEDIUM BLUE.

#### **CLASS 35—ADVERTISING AND BUSINESS**

FOR ADVERTISEMENT FOR OTHERS ON THE INTERNET; ADVERTISING AND COMMERCIAL INFORMATION SERVICES, VIA THE INTERNET; ADVERTISING ON THE INTERNET FOR OTHERS; ADVERTISING VIA ELECTRONIC MEDIA AND SPECIFICALLY THE INTERNET; DISSEMINATION OF ADVERTISING FOR OTHERS VIA AN ON-LINE COMMUNICATIONS NETWORK ON THE INTERNET; DISSEMINATION OF ADVERTISING FOR OTHERS VIA THE INTERNET; INTERNET ADVERTISING SERVICES; PROMOTING THE GOODS AND SERVICES OF OTHERS BY MEANS OF DISTRIBUTING ADVERTISING ON THE INTERNET; PROVIDING A SEARCHABLE ON-LINE ADVERTISING WEBSITE AND GUIDE FEATURING THE GOODS AND SERVICES OF OTHER VENDORS VIA THE INTERNET; PROVIDING A SECURED ACCESS DATABASE VIA THE INTERNET THROUGH WHICH DOCUMENTS AND IMAGES CAN BE VIEWED, COPIED, AND PRINTED FOR PURPOSES OF CONDUCTING CORPORATE TRANSACTIONS; PROVIDING ADVERTISING SERVICE TO DISTRIBUTE ADVERTISEMENTS FOR DISPLAY ON INTERNET, NAMELY, IN WEBSITES, SOCIAL CONVERSATIONS OVER THE INTERNET, EMAILS, MICROBLOGS, BLOGS, ELECTRONIC MESSAGES, INSTANT MESSAGES, TEXT MESSAGES, MULTIMEDIA MESSAGES, SOCIAL NETWORKS, STATUS UPDATES, FORUMS, ELECTRONIC BULLETIN BOARDS; PROVIDING AN ON-LINE COMMERCIAL INFORMATION DIRECTORY ON THE INTERNET; PROVIDING AND RENTAL OF ADVERTISING SPACE ON THE INTERNET; PROVIDING BUSINESS INFORMATION, NAMELY, COMMERCIAL CORPORATE AND STATISTICAL INFORMATION PROVIDED ON-LINE FROM A COMPUTER DATABASE OR THE INTERNET; PROVIDING INFORMATION PERTAINING TO PROCUREMENT, BUYING, SELLING AND TENDERING INFORMATION AND OPPORTUNITIES RELATING TO GOODS, SERVICES, AND CONSTRUCTION VIA COMPUTER, COMPUTER NETWORKS, TELEPHONE, THE INTERNET OR ELECTRONIC MAIL (U.S. CLS. 100, 101 AND 102).

#### **CLASS 38—COMMUNICATION**

FOR BROADCASTING OF VIDEO AND AUDIO PROGRAMMING OVER THE INTERNET; BROADCASTING SERVICES AND PROVISION OF TELECOMMUNICATION ACCESS TO VIDEO AND AUDIO CONTENT PROVIDED VIA A VIDEO-ON-DEMAND SERVICE VIA THE INTERNET; COMMUNICATION SERVICES, NAMELY, TRANSMISSION OF VOICE, AUDIO, VISUAL IMAGES AND DATA BY TELECOMMUNICATIONS NETWORKS, WIRELESS COMMUNICATION NETWORKS, THE INTERNET, INFORMATION SERVICES NETWORKS AND DATA NETWORKS; COMMUNICATIONS SERVICES, NAMELY, TRANSMITTING STREAMED SOUND AND AUDIOVISUAL RECORDINGS VIA THE INTERNET; INTERNET BROADCASTING SERVICES; PROVIDING INTERNET CHATROOMS; STREAMING OF AUDIO MATERIAL ON THE INTERNET; STREAMING OF VIDEO MATERIAL ON THE INTERNET; VIDEO BROADCASTING SERVICES OVER THE INTERNET OR OTHER COMMUNICATIONS NETWORK FEATURING THE UPLOADED, POSTED AND TAGGED VIDEOS OF OTHERS; VIDEO BROADCASTING SERVICES OVER THE INTERNET OR OTHER COMMUNICATIONS NETWORK, NAMELY, ELECTRONICALLY TRANSMITTING VIDEO CLIPS; VIDEO-ON-DEMAND TRANSMISSION SERVICES VIA THE INTERNET (U.S. CLS. 100, 101 AND 104).

#### **CLASS 42—SCIENTIFIC AND COMPUTER SERVICES**

FOR PROVIDING A WEB SITE FEATURING TECHNOLOGY THAT ENABLES INTERNET USERS TO SHARE DOCUMENTS, IMAGES AND VIDEOS; PROVIDING A WEB SITE FEATURING TECHNOLOGY THAT ENABLES INTERNET USERS TO SUBMIT COMMENTS OF PERSONAL RECOGNITION; PROVIDING A WEBSITE FEATURING A MEDIA AGGREGATOR AND SEARCH ENGINE FOR INTERNET CONTENT; PROVISION OF INTERNET SEARCH ENGINES; PROVISION OF SEARCH ENGINES FOR THE INTERNET (U.S. CLS. 100 AND 101).

#### **CLASS 45—PERSONAL AND LEGAL SERVICES**

FOR INTERNET-BASED SOCIAL NETWORKING SERVICES (U.S. CLS. 100 AND 101).  
ZHALEH DELANEY, EXAMINING ATTORNEY

SN 85-062,249. GLOBAL CASH ACCESS, INC., LAS VEGAS, NV. FILED 6-14-2010.

CSI

THE MARK CONSISTS OF STANDARD CHARACTERS WITHOUT CLAIM TO ANY PARTICULAR FONT, STYLE, SIZE, OR COLOR.

#### **CLASS 35—ADVERTISING AND BUSINESS**

FOR INFORMATION SERVICES, NAMELY, PROVIDING INFORMATION REGARDING THE CASINO AND GAMING MARKET, MARKET RESEARCH AND BUSINESS ANALYSIS, MARKET DATA RELATING TO CASINO USAGE AND MARKET DATA IN THE NATURE OF CASINO PATRON INFORMATION (U.S. CLS. 100, 101 AND 102).

FIRST USE 11-1-2009; IN COMMERCE 11-1-2009.

#### **CLASS 42—SCIENTIFIC AND COMPUTER SERVICES**

FOR SOFTWARE AS A SERVICE (SAAS) SERVICES FEATURING SOFTWARE IN THE FIELD OF CASINO AND GAMING MARKETING, CASINO AND GAMING MARKET RESEARCH AND ANALYSIS, AND CASINO AND GAMING PATRON INFORMATION (U.S. CLS. 100 AND 101).

FIRST USE 11-1-2009; IN COMMERCE 11-1-2009.  
CHRIS WELLS, EXAMINING ATTORNEY

SN 85-062,321. ENDEO LLC, WILMINGTON, DE. FILED 6-14-2010.

ENDEO

THE MARK CONSISTS OF STANDARD CHARACTERS WITHOUT CLAIM TO ANY PARTICULAR FONT, STYLE, SIZE, OR COLOR.



THE WORDING "ENDEO" HAS NO MEANING IN A FOREIGN LANGUAGE.

### CLASS 37—CONSTRUCTION AND REPAIR

FOR CONSTRUCTION OF TELECOMMUNICATION TOWERS; MAINTENANCE AND REPAIR OF TELECOMMUNICATIONS NETWORKING HARDWARE, APPARATUS AND EQUIPMENT (U.S. CLS. 100, 103 AND 106).

### CLASS 38—COMMUNICATION

FOR COMMUNICATION SERVICES, NAMELY, TRANSMISSION OF VOICE, DATA, GRAPHICS, IMAGES, AUDIO AND VIDEO BY MEANS OF TELECOMMUNICATIONS NETWORKS, WIRELESS COMMUNICATION NETWORKS, THE INTERNET, INFORMATION SERVICES NETWORKS AND DATA NETWORKS; TELECOMMUNICATION SERVICES, NAMELY, LOCAL AND LONG DISTANCE TRANSMISSION OF VOICE, DATA, GRAPHICS AND VIDEO BY MEANS OF BROADBAND, COPPER AND OPTICAL OR WIRELESS NETWORKS; TELECOMMUNICATION SERVICES IN THE NATURE OF PROVIDING TELEPHONE FEATURES, NAMELY, VOICEMAIL, CALL WAITING, CALL IDENTIFICATION, CALL FORWARDING AND MESSAGE WAITING; TELECOMMUNICATION SERVICES, NAMELY, PROVIDING ADVANCED CALLING FEATURES, NAMELY, PROVIDING THE ABILITY TO RECORD VOICE MEMOS AFTER A TELEPHONE CALL BY LEAVING A MESSAGE THAT WILL BE RECORDED SEPARATELY AND SAVED ONLINE AS A FILE WHICH CAN THEN BE EMAILED, SHARED OR KEPT PRIVATE BASED ON THE USER SETTINGS; PROVIDING ACCESS TO TELECOMMUNICATION NETWORKS; PROVIDING ELECTRONIC TELECOMMUNICATION CONNECTIONS TO THE INTERNET; TELECOMMUNICATION SERVICES, NAMELY, PROVIDING INTERNET ACCESS VIA BROADBAND OPTICAL AND WIRELESS NETWORKS; LEASING OF TELECOMMUNICATION EQUIPMENT; PROVIDING CO-LOCATION SERVICES FOR VOICE, VIDEO AND DATA COMMUNICATIONS APPLICATIONS; PROVIDING BACKHAUL BANDWIDTH CAPACITY TO WIRELESS SERVICE PROVIDERS, NAMELY, PROVIDING MULTIPLE USER ACCESS TO A GLOBAL COMPUTER NETWORK, AND PROVIDING VOICE AND DATA BACKHAUL TELECOMMUNICATIONS SERVICES FOR WIRELESS PROVIDERS, NAMELY, PROVIDING A HIGH SPEED ACCESS TO AREA NETWORKS AND A GLOBAL COMPUTER INFORMATION NETWORK (U.S. CLS. 100, 101 AND 104).

TARA PATE, EXAMINING ATTORNEY

### CLASS 35—ADVERTISING AND BUSINESS

FOR MARKET ANALYSIS; MARKET DATA, ALSO KNOWN AS, PRICING, ANALYZING AND COMPILING DATA FOR MEASURING THE PERFORMANCE OF COMPLEX FINANCIAL INSTRUMENTS; ANALYTICS AND REEVALUATION SERVICES, ALSO KNOWN AS, BUSINESS MANAGEMENT CONSULTING WITH RELATION TO STRATEGY, MARKETING, SALES, OPERATION, PORTFOLIO VALUATION AND HEDGING PARTICULARLY SPECIALIZING IN THE USE OF ANALYTIC, FINANCIAL AND STATISTIC MODELS FOR THE UNDERSTANDING AND PREDICTING OF FINANCIAL PORTFOLIOS AND THEIR MARKET BEHAVIOR (U.S. CLS. 100, 101 AND 102).

FIRST USE 9-20-2005; IN COMMERCE 9-20-2005.

### CLASS 36—INSURANCE AND FINANCIAL

FOR GLOBAL FINANCIAL SERVICES IN THE NATURE OF FULL SERVICE INTERDEALER-BROKER SERVICES, NAMELY, BROKERAGE IN THE FIELDS OF INTEREST RATE DERIVATIVES, CREDIT DERIVATIVES, RISK RECYCLING, REAL ESTATE DERIVATIVES, STRUCTURED PROJECT FINANCE, CATASTROPHIC MARKETS, AND OVER THE COUNTER (OTC) DERIVATIVE PRODUCTS; OVERSEAS MARKET AND INVESTMENT SERVICES, NAMELY, AGENCIES FOR BROKERAGE OF SECURITIES TRADING IN OVERSEAS SECURITIES MARKETS AND OF TRANSACTIONS ON COMMISSION OF OVERSEAS MARKET SECURITIES FUTURES; PROVIDING ONLINE BROKERAGE SERVICES IN THE FIELD OF DERIVATIVES AND SECURITIES TRANSACTIONS, NAMELY, MANAGEMENT AND BROKERAGE IN THE FIELDS OF STOCKS, BONDS, OPTIONS, COMMODITIES, FUTURES AND OTHER OVER THE COUNTER (OTC) INSTRUMENTS OR SECURITIES, AND THE INVESTMENT OF FUNDS OF OTHERS (U.S. CLS. 100, 101 AND 102).

FIRST USE 9-20-2005; IN COMMERCE 9-20-2005.

### CLASS 38—COMMUNICATION

FOR CONNECTIVITY TO VARIOUS STRAIGHT THROUGH PROCESSING HUBS, ALSO KNOWN AS, PROVIDING ACCESS TO SECURED DATABASES VIA THE INTERNET THROUGH WHICH DOCUMENTS AND IMAGES CAN BE VIEWED, COPIED, AND PRINTED FOR PURPOSES OF CONDUCTING CORPORATE TRANSACTIONS; PROVISION OF SECURE ACCESS TO DATA OR DOCUMENTS STORED ELECTRONICALLY IN CENTRAL FILES FOR REMOTE CONSULTATION FOR PURPOSES OF CONDUCTING CORPORATE TRANSACTIONS (U.S. CLS. 100, 101 AND 104).

FIRST USE 9-20-2005; IN COMMERCE 9-20-2005.

ANDREW LEASER, EXAMINING ATTORNEY

SN 85-063,477. VYAPAR CAPITAL MARKET PARTNERS LLC, NEW YORK, NY. FILED 6-15-2010.

VCM

THE MARK CONSISTS OF STANDARD CHARACTERS WITHOUT CLAIM TO ANY PARTICULAR FONT, STYLE, SIZE, OR COLOR.

SN 85-064,073. BOOYAH INC., SAN FRANCISCO, CA. FILED 6-16-2010.



THE MARK CONSISTS OF A STYLIZED HUMAN FACE.

**CLASS 9—ELECTRICAL AND SCIENTIFIC APPARATUS**

FOR COMPUTER GAME SOFTWARE, VIDEO GAME SOFTWARE; DOWNLOADABLE VIDEO GAME SOFTWARE; VIDEO GAME SOFTWARE FOR USE ON MOBILE TELEPHONES, SMARTPHONES, PAGERS, MOBILE AND HANDHELD COMPUTERS, PDAS, AND OTHER MOBILE AND HANDHELD COMMUNICATIONS DEVICES; DOWNLOADABLE VIDEO GAME SOFTWARE FOR USE ON MOBILE TELEPHONES, SMARTPHONES, PAGERS, MOBILE AND HANDHELD COMPUTERS, PDAS, AND OTHER MOBILE AND HANDHELD COMMUNICATIONS DEVICES; COMPUTER SOFTWARE, NAMELY, SOFTWARE DEVELOPMENT TOOLS FOR THE CREATION OF MOBILE AND INTERNET APPLICATIONS AND CLIENT INTERFACES; TELECOMMUNICATIONS AND SOCIAL NETWORKING SOFTWARE FOR USE IN CONNECTION WITH ONLINE SOCIAL GAMES AND FOR TRANSPORTING AND AGGREGATING VOICE, DATA AND VIDEO COMMUNICATION ACROSS GLOBAL COMPUTER NETWORKS; SOFTWARE FOR USE ON COMPUTERS AND MOBILE DEVICES FOR CREATING VIRTUAL COMMUNITIES AND FOR CREATING AND INTERACTING WITH OTHER METAGAME PLAYERS VIA DIGITAL PERSONAS AND AVATARS; SOFTWARE FOR USE ON COMPUTERS AND MOBILE DEVICES TO ENABLE UPLOADING, POSTING, SHOWING, DISPLAYING, TAGGING, BLOGGING, SHARING OR OTHERWISE PROVIDING ELECTRONIC MEDIA OR INFORMATION REGARDING THE FIELDS OF VIRTUAL COMMUNITIES, ELECTRONIC GAMING, ENTERTAINMENT, AND GENERAL INTEREST VIA THE INTERNET OR OTHER COMMUNICATIONS NETWORKS WITH THIRD PARTIES; DOWNLOADABLE VIRTUAL GOODS, NAMELY, CLOTHING, ACCESSORIES, LAND, BUILDINGS, OBJECTS, TOOLS, CHARACTERS, AND CURRENCY FOR USE IN ONLINE VIRTUAL WORLDS (U.S. CLS. 21, 23, 26, 36 AND 38).

**CLASS 35—ADVERTISING AND BUSINESS**

FOR ADVERTISING SERVICES, NAMELY, PROMOTING THE GOODS AND SERVICES OF OTHERS ONLINE AND VIA MOBILE AND HANDHELD WIRELESS COMMUNICATIONS DEVICES; ARRANGING AND CONDUCTING INCENTIVE REWARD PROGRAMS THAT PROMOTE THE SALE OF GOODS AND SERVICES OF OTHERS; PROMOTING THE EXCHANGE OF INFORMATION AND RESOURCES BETWEEN AND AMONG REGISTERED PARTICIPANTS IN THE FIELD OF SOCIAL GAMING TO ACHIEVE PERSONALLY-DEFINED AND GROUP-DEFINED GOALS, PURSUITS AND CHALLENGES IN THE FIELD OF SOCIAL GAMING AND ONLINE SOCIAL GAMING; RETAIL STORE SERVICES, ACCESSIBLE VIA THE INTERNET OR WIRELESS COMMUNICATIONS NETWORKS, FEATURING DOWNLOADABLE SOUND, MUSIC, IMAGE, VIDEO, AND GAME FILES, BOOKS, MUSIC, TOYS, GAMES, CLOTHING, AND SOUVENIR ITEMS; RETAIL STORE SERVICES, ACCESSIBLE VIA THE INTERNET OR WIRELESS COMMUNICATIONS NETWORKS, FEATURING VIRTUAL GOODS, NAMELY, CLOTHING, ACCESSORIES, LAND, BUILDINGS, OBJECTS, TOOLS, CHARACTERS, AND CURRENCY FOR USE IN ONLINE VIRTUAL WORLDS (U.S. CLS. 100, 101 AND 102).

**CLASS 41—EDUCATION AND ENTERTAINMENT**

FOR ENTERTAINMENT SERVICES, NAMELY, PROVIDING TEMPORARY USE OF NON-DOWNLOADABLE VIDEO GAMES VIA THE INTERNET OR WIRELESS COMMUNICATIONS NETWORKS; ENTERTAINMENT SERVICES, NAMELY, PROVIDING ONLINE, NON-DOWNLOADABLE VIRTUAL CLOTHING, ACCESSORIES, LAND, BUILDINGS, OBJECTS, TOOLS, CHARACTERS, AND CURRENCY, FOR USE IN VIRTUAL ENVIRONMENTS CREATED FOR ENTERTAINMENT PURPOSES; PROVIDING AN INTERNET WEBSITE PORTAL IN THE FIELD OF COMPUTER GAMES AND GAMING; PROVIDING INFORMATION ONLINE RELATING TO COMPUTER GAMES AND COMPUTER ENHANCEMENTS FOR GAMES; ENTERTAINMENT SERVICES, NAMELY, PROVIDING VIRTUAL ENVIRONMENTS IN WHICH USERS CAN INTERACT

THROUGH SOCIAL GAMES FOR RECREATIONAL, LEISURE, OR ENTERTAINMENT PURPOSES; ENTERTAINMENT SERVICES, NAMELY, ORGANIZATION OF SOCIAL GAMING SERVICES; ENTERTAINMENT SERVICES, NAMELY, PROVIDING NON-DOWNLOADABLE AUDIO, VIDEO AND GRAPHICS TO MOBILE COMMUNICATIONS DEVICES VIA WIRELESS NETWORKS AND A GLOBAL COMPUTER NETWORK; ENTERTAINMENT SERVICES, NAMELY, CONDUCTING CONTESTS; ONLINE JOURNALS, NAMELY, BLOGS FEATURING USER-DEFINED CONTENT REGARDING GAMES, GAMING, SOCIAL NETWORKING, AND VIRTUAL COMMUNITIES; PROVIDING AN ONLINE MAGAZINE IN THE FIELDS OF MOBILE AND WIRELESS COMMUNICATIONS, WIRELESS COMMUNICATIONS SOFTWARE, SOCIAL NETWORKING, CREATING DIGITAL PERSONAS AND AVATARS, MOBILE AND ONLINE COMMUNICATION METHODS AND SERVICES, VIDEO GAMES, SOFTWARE, AND ONLINE GAMES; PROVIDING RECOGNITION AND INCENTIVE AWARDS WHEREBY PARTICIPANTS IN AUGMENTED REALITY AND SOCIAL GAMING CAN EARN VIRTUAL REWARDS FOR DEMONSTRATING EXTRAORDINARY SKILL OR EXCELLENCE REGARDING USER-DEFINED GOALS AND GROUP-DEFINED GOALS (U.S. CLS. 100, 101 AND 107).

**CLASS 42—SCIENTIFIC AND COMPUTER SERVICES**

FOR COMPUTER SERVICES, NAMELY, CREATING AN ON-LINE COMMUNITY FOR REGISTERED USERS TO PARTICIPATE IN DISCUSSIONS, COMPETITIONS, AND INDIVIDUAL AND GROUP CHALLENGES, SHOWCASE AND IMPROVE THEIR SKILLS, GET FEEDBACK FROM THEIR PEERS, FORM VIRTUAL COMMUNITIES, AND ENGAGE IN SOCIAL NETWORKING; PROVIDING A WEBSITE FEATURING NON-DOWNLOADABLE SOFTWARE TOOLS FOR USE IN ACCESSING, PLAYING, AND TRACKING PERFORMANCE OF COMPUTER GAMES; APPLICATION SERVICE PROVIDER FEATURING SOFTWARE FOR USE IN CREATING SOCIAL NETWORKING WEB SITES AND DEVELOPING VIDEO GAMES, AND TO ENABLE UPLOADING, POSTING, SHOWING, DISPLAYING, TAGGING, BLOGGING, SHARING OR OTHERWISE PROVIDING ELECTRONIC MEDIA OR INFORMATION VIA THE INTERNET AND WIRELESS COMMUNICATIONS NETWORKS (U.S. CLS. 100 AND 101).

**CLASS 45—PERSONAL AND LEGAL SERVICES**

FOR ONLINE SOCIAL NETWORKING SERVICES; PROVIDING ON-LINE COMPUTER DATABASES AND ON-LINE SEARCHABLE DATABASES IN THE FIELD OF SOCIAL NETWORKING (U.S. CLS. 100 AND 101).

DANIEL CAPSHAW, EXAMINING ATTORNEY

SN 85-065,158. UNDERWRITERS LABORATORIES INC., NORTHBROOK, IL. FILED 6-17-2010.

SQ

THE MARK CONSISTS OF STANDARD CHARACTERS WITHOUT CLAIM TO ANY PARTICULAR FONT, STYLE, SIZE, OR COLOR.

**CLASS 35—ADVERTISING AND BUSINESS**

FOR PROVIDING BUSINESS ADVISORY SERVICES TO COMPANIES AND OTHER INSTITUTIONS, NAMELY, NON-PROFIT INSTITUTIONS, EDUCATIONAL INSTITUTIONS AND GOVERNMENT AGENCIES AND ENTITIES AS TO HOW THEIR SOCIAL RESPONSIBILITY, CORPORATE GOVERNANCE AND ENVIRONMENTAL SUSTAINABILITY PRACTICES MEASURE AGAINST PUBLISHED STANDARDS AND OTHER REQUIREMENTS RELATED THERETO; AUDITING COMPANIES AND OTHER INSTITUTIONS, NAMELY, NON-PROFIT INSTITUTIONS, EDUCATIONAL INSTITUTIONS AND GOVERNMENT AGENCIES AND ENTITIES IN RELATION TO THEIR SOCIAL RESPONSIBILITY, CORPORATE GOVERNANCE AND ENVIRONMENTAL SUSTAINABILITY PRACTICES PURSUANT TO STANDARDS AND OTHER REQUIREMENTS RELATED THERETO, ALL FOR TECHNICAL PURPOSES OF MEASURING THE QUALITY OF SUCH PRACTICES (U.S. CLS. 100, 101 AND 102).

**CLASS 41—EDUCATION AND ENTERTAINMENT**

FOR TRAINING THIRD PARTIES TO PERFORM ACCREDITING, RATING, MEASUREMENT, EVALUATION, VERIFICATION, AUDITING AND TESTING OF COMPANIES AND OTHER INSTITUTIONS, NAMELY, NON-PROFIT INSTITUTIONS, EDUCATIONAL INSTITUTIONS AND GOVERNMENT AGENCIES AND ENTITIES IN RELATION TO THEIR SOCIAL RESPONSIBILITY, CORPORATE GOVERNANCE AND ENVIRONMENTAL SUSTAINABILITY PRACTICES PURSUANT TO STANDARDS AND OTHER REQUIREMENTS RELATED THERETO (U.S. CLS. 100, 101 AND 107).

**CLASS 42—SCIENTIFIC AND COMPUTER SERVICES**

FOR TECHNICAL RATING, MEASURING, EVALUATING, VERIFYING, AND TESTING COMPANIES AND OTHER INSTITUTIONS, NAMELY, NON-PROFIT INSTITUTIONS, EDUCATIONAL INSTITUTIONS AND GOVERNMENT AGENCIES AND ENTITIES IN RELATION TO THEIR SOCIAL RESPONSIBILITY, CORPORATE GOVERNANCE AND ENVIRONMENTAL SUSTAINABILITY PRACTICES PURSUANT TO STANDARDS AND OTHER REQUIREMENTS RELATED THERETO, ALL FOR TECHNICAL PURPOSES OF MEASURING THE QUALITY OF SUCH PRACTICES; ACCREDITATION SERVICES, NAMELY, DEVELOPING AND ADMINISTERING STANDARDS AND PROCEDURES FOR CERTIFYING THIRD PARTY PROFESSIONALS IN THE FIELD OF SOCIAL RESPONSIBILITY, CORPORATE GOVERNANCE AND ENVIRONMENTAL SUSTAINABILITY PRACTICES PURSUANT TO STANDARDS AND OTHER REQUIREMENTS RELATED THERETO (U.S. CLS. 100 AND 101).

FONG HSU, EXAMINING ATTORNEY

SN 85-065,174. GOCLEAR LLC, SAN FRANCISCO, CA. FILED 6-17-2010.



OWNER OF U.S. REG. NOS. 3,363,896 AND 3,402,325.  
THE MARK CONSISTS OF THE LETTERS (WORD) "GO" IN A STYLIZED FORM AND THE LETTERS (WORD) "CLEAR".

**CLASS 3—COSMETICS AND CLEANING PREPARATIONS**

FOR COSMETICS, NAMELY, SKIN CLEANSER (U.S. CLS. 1, 4, 6, 50, 51 AND 52).  
FIRST USE 3-5-2010; IN COMMERCE 3-5-2010.

**CLASS 5—PHARMACEUTICALS**

FOR PHARMACEUTICAL GRADE SKIN CARE PREPARATION, NAMELY, MEDICATED SUNSCREEN (U.S. CLS. 6, 18, 44, 46, 51 AND 52).  
FIRST USE 3-5-2010; IN COMMERCE 3-5-2010.  
ANTHONY RINKER, EXAMINING ATTORNEY

SN 85-065,341. 101COMMUNICATIONS LLC, CHATSWORTH, CA. FILED 6-17-2010.

**FEDERAL EMPLOYEES ALMANAC**

THE MARK CONSISTS OF STANDARD CHARACTERS WITHOUT CLAIM TO ANY PARTICULAR FONT, STYLE, SIZE, OR COLOR.

NO CLAIM IS MADE TO THE EXCLUSIVE RIGHT TO USE "ALMANAC", APART FROM THE MARK AS SHOWN. SEC. 2(F).

**CLASS 9—ELECTRICAL AND SCIENTIFIC APPARATUS**

FOR DOWNLOADABLE ELECTRONIC PUBLICATION, NAMELY, A SERIES OF BOOKS IN THE FIELD OF FEDERAL EMPLOYEE RULES, PROCEDURE AND REGULATIONS (U.S. CLS. 21, 23, 26, 36 AND 38).  
FIRST USE 2-1-2010; IN COMMERCE 2-1-2010.

**CLASS 16—PAPER GOODS AND PRINTED MATTER**

FOR PRINTED PUBLICATIONS, NAMELY, A SERIES OF BOOKS IN THE FORM OF AN ALMANAC IN THE FIELD OF FEDERAL EMPLOYEE RULES, PROCEDURE AND REGULATIONS (U.S. CLS. 2, 5, 22, 23, 29, 37, 38 AND 50).

FIRST USE 2-1-1953; IN COMMERCE 2-1-1953.  
KELLY BOULTON, EXAMINING ATTORNEY

SN 85-065,680. SMARTHEALTH, INC., PHOENIX, AZ. FILED 6-17-2010.



THE MARK CONSISTS OF THE LETTERS "PRACTICE-MOJO" STYLIZED, WITH A SWOOSH UNDERLINE APPEARING UNDER THE "MOJO" PORTION OF THE MARK.

**CLASS 35—ADVERTISING AND BUSINESS**

FOR MARKETING SERVICES FOR MEDICAL AND DENTAL PRACTICES; PROVIDING A WEBSITE FOR PATIENT CUSTOMER SERVICE, NAMELY, FOR PROVIDING CUSTOMER SERVICE AND PRODUCT INQUIRY SERVICES ONLINE; PROVIDING A WEBSITE FOR ONLINE MARKETING OF MEDICAL AND DENTAL PRACTICES (U.S. CLS. 100, 101 AND 102).

**CLASS 38—COMMUNICATION**

FOR PROVIDING AUTOMATED PATIENT MESSAGING SERVICES, NAMELY, PROVIDING E-MAIL AND TEXT MESSAGES TO PATIENTS; AUTOMATED RECURRING AND PERIODIC DENTAL AND MEDICAL PATIENT COMMUNICATIONS VIA EMAIL AND TEXT MESSAGES (U.S. CLS. 100, 101 AND 104).

FIRST USE 6-25-2010; IN COMMERCE 6-25-2010.

**CLASS 42—SCIENTIFIC AND COMPUTER SERVICES**

FOR PROVIDING TEMPORARY USE OF ONLINE-NON-DOWNLOADABLE SOFTWARE FOR DENTAL AND MEDICAL PRACTICE MANAGEMENT; PROVIDING ON-LINE, NON-DOWNLOADABLE, INTERNET-BASED SOFTWARE APPLICATION FOR MEDICAL AND DENTAL BILLING; PROVIDING TEMPORARY USE OF ONLINE, NON-DOWNLOADABLE SOFTWARE FOR SCHEDULING PATIENTS IN MEDICAL AND DENTAL PRACTICES (U.S. CLS. 100 AND 101).

JULIE VEPPIUMTHARA, EXAMINING ATTORNEY

SN 85-065,727. MOCONSO TECHNOLOGIES GMBH, MUNICH, FED REP GERMANY, FILED 6-17-2010.

**QWAZZ**

THE MARK CONSISTS OF STANDARD CHARACTERS WITHOUT CLAIM TO ANY PARTICULAR FONT, STYLE, SIZE, OR COLOR.

**CLASS 9—ELECTRICAL AND SCIENTIFIC APPARATUS**

FOR APPARATUS FOR RECORDING, TRANSMISSION OR REPRODUCTION OF SOUND OR IMAGES; COMPUTER HARDWARE; COMPUTER SOFTWARE AND PROGRAMS FOR USE IN CONNECTION WITH PROCESSING AND MANAGING BILL PAYMENT AND COMPUTER GAME SOFTWARE FOR USE ON MOBILE AND CELLULAR PHONES (U.S. CLS. 21, 23, 26, 36 AND 38).

**CLASS 35—ADVERTISING AND BUSINESS**

FOR BILLING SERVICES, ALSO VIA MOBILE TERMINALS (U.S. CLS. 100, 101 AND 102).

**CLASS 38—COMMUNICATION**

FOR TELECOMMUNICATIONS SERVICES, NAMELY, TRANSMISSION OF GAMES, VOICE, DATA, GRAPHICS, IMAGES, AUDIO AND VIDEO BY MEANS OF TELECOMMUNICATIONS NETWORKS, WIRELESS COMMUNICATION NETWORKS, MOBILE TERMINALS AND THE INTERNET VIA MOBILE AND BROWSER SOFTWARE, ALL OF THE FOREGOING TO WIRELESS, MOBILE AND HANDHELD DEVICES; TRANSMISSION AND RECEIPT OF INFORMATION AND DATA VIA ELECTRONIC COMMUNICATION NETWORKS (U.S. CLS. 100, 101 AND 104).

**CLASS 41—EDUCATION AND ENTERTAINMENT**

FOR ENTERTAINMENT SERVICES, NAMELY, PROVIDING ONLINE ELECTRONIC GAMES VIA THE INTERNET AND MOBILE TERMINALS; ENTERTAINMENT SERVICES, NAMELY, PROVIDING AN ON-LINE COMPUTER GAME (U.S. CLS. 100, 101 AND 107).

ERNEST SHOSHO, EXAMINING ATTORNEY

SN 85-065,928. ND RIGHTS, LLC, LAS VEGAS, NV. FILED 6-17-2010.

The logo for "GLAM COFFEE" features the word "GLAM" in a large, bold, yellow font with a black outline and a coffee cup shape integrated into the letter "G". Below "GLAM" is the word "COFFEE" in a smaller, yellow font with a black outline.

NO CLAIM IS MADE TO THE EXCLUSIVE RIGHT TO USE "COFFEE", APART FROM THE MARK AS SHOWN.

THE COLOR(S) YELLOW, GOLD, WHITE, AND BLACK IS/ARE CLAIMED AS A FEATURE OF THE MARK.

THE MARK CONSISTS OF THE WORDS "GLAM" AND "COFFEE" WRITTEN IN YELLOW AND GOLD AND OUTLINED IN BLACK. THE "G" HAS A COFFEE CUP AND ITS LOOP WITH 5 WHITE DIAMONDS INSIDE AND WHITE DIAMONDS ON THE LEFT OUTER CURVE AND 1 LARGER WHITE DIAMOND ON THE BOTTOM RIGHT CORNER. THE "L" HAS WHITE DIAMONDS ALONG THE TOP RIGHT SIDE. THE LEFT BOTTOM OF THE "A" ANGLES 45 DEGREES. THE "M" HAS WHITE DIAMONDS ON THE TOP, SIDE AND BOTTOM ON THE RIGHT SIDE, WITH 2 LARGER DIAMONDS ON THE UPPER LEFT OF THE "M".

**CLASS 30—STAPLE FOODS**

FOR COFFEE (U.S. CL. 46).

FIRST USE 10-10-2007; IN COMMERCE 4-25-2009.

**CLASS 43—HOTEL AND RESTAURANT SERVICES**

FOR COFFEE SHOPS (U.S. CLS. 100 AND 101).

FIRST USE 10-10-2007; IN COMMERCE 4-25-2009.

INGA ERVIN, EXAMINING ATTORNEY

SN 85-066,037. BROADMAP, LLC, GLEN ALLEN, VA. FILED 6-18-2010.

**MAPCONNECT**

THE MARK CONSISTS OF STANDARD CHARACTERS WITHOUT CLAIM TO ANY PARTICULAR FONT, STYLE, SIZE, OR COLOR.



**CLASS 9—ELECTRICAL AND SCIENTIFIC APPARATUS**

FOR ELECTRONIC DATABASE FEATURING ENCODED GEOGRAPHIC COORDINATE INFORMATION, GEOGRAPHIC POINT ATTRIBUTION, GEOGRAPHIC BOUNDARIES AND TELECOMMUNICATIONS DATA TO SUPPORT LOCATION INTELLIGENCE IN THE FIELDS OF BROADBAND SERVICE MANAGEMENT, RISK MANAGEMENT, REAL ESTATE AND PROPERTY MANAGEMENT, TARGET MARKETING MANAGEMENT, EMERGENCY SERVICES MANAGEMENT, RETAIL SITE SELECTION MANAGEMENT, GEOGRAPHIC INFORMATION SOFTWARE APPLICATION DEVELOPMENT RECORDED ON COMPUTER MEDIA; COMPUTER SOFTWARE FOR USE IN CREATING MAPS IN THE FIELDS OF GEOGRAPHIC INFORMATION SYSTEMS AND TELECOMMUNICATIONS (U.S. CLS. 21, 23, 26, 36 AND 38).

**CLASS 38—COMMUNICATION**

FOR TELECOMMUNICATION CONSULTATION IN THE NATURE OF TECHNICAL CONSULTING IN THE FIELDS OF TELECOMMUNICATION ASSET MANAGEMENT ATTRIBUTION AND VISUAL MAPPING OF DATA TRANSMISSION AND COMMUNICATIONS (U.S. CLS. 100, 101 AND 104).

**CLASS 42—SCIENTIFIC AND COMPUTER SERVICES**

FOR DATA AUTOMATION SERVICES USING PROPRIETARY SOFTWARE TO COMPILE, COLLECT, STANDARDIZE, INTEGRATE, MAINTAIN, AND IMPROVE DATA, NAMELY BASE MAP DATA, BROADBAND SERVICEABILITY DATA, GEOGRAPHIC IMAGES, AND GEOGRAPHIC INFORMATION SYSTEM DATA; APPLICATION SERVICE PROVIDER FEATURING SOFTWARE FOR USE IN CREATING MAP DATABASES, IN THE FIELDS OF GEOGRAPHIC INFORMATION SYSTEMS AND TELECOMMUNICATIONS (U.S. CLS. 100 AND 101).

AISHA CLARKE, EXAMINING ATTORNEY

SN 85-066,093. AUTOMATED MEDIA SERVICES, INC., ALLENDALE, NJ. FILED 6-18-2010.

**CLASS 35—ADVERTISING AND BUSINESS**

FOR MEDIA BUYING ADVICE SERVICES, NAMELY, ADVISING CLIENTS ON THE PURCHASE OF ADVERTISING; MEDIA PLANNING SERVICES, NAMELY, ADVISING CLIENTS ON THE PURCHASE OF ADVERTISING BASED UPON MEDIA AND/OR MARKET ANALYSIS; PROVIDING CONSULTING SERVICES IN THE FIELD OF FACILITATING THE PLANNING, BUYING, AND SELLING OF MEDIA (U.S. CLS. 100, 101 AND 102).

**CLASS 38—COMMUNICATION**

FOR COMMUNICATIONS SERVICES, NAMELY, TRANSMISSION AND BROADCASTING OF VIDEO, IMAGES, AUDIO AND DATA VIA BROADBAND NETWORKS (U.S. CLS. 100, 101 AND 104).

**CLASS 42—SCIENTIFIC AND COMPUTER SERVICES**

FOR SOFTWARE AS A SERVICE (SAAS) SERVICES, NAMELY, HOSTING SOFTWARE FOR USE BY OTHERS FOR USE IN MANAGING, DISTRIBUTING, MONITORING AND BROADCASTING ALL FORMS OF DIGITAL MEDIA CONTENT FOR THE RETAIL PROMOTIONAL ADVERTISING AND OUT-OF-HOME MEDIA INDUSTRIES; RENTAL OF COMPUTER HARDWARE AND COMPUTER PERIPHERALS FOR USE IN MANAGING, DISTRIBUTING, MONITORING AND BROADCASTING ALL FORMS OF DIGITAL MEDIA CONTENT FOR THE RETAIL PROMOTIONAL ADVERTISING AND OUT-OF-HOME INDUSTRIES (U.S. CLS. 100 AND 101).

JOHN KELLY, EXAMINING ATTORNEY

SN 85-066,313. AUTOZONE PARTS, INC., MEMPHIS, TN. FILED 6-18-2010.

# TRUGRADE

THE MARK CONSISTS OF STANDARD CHARACTERS WITHOUT CLAIM TO ANY PARTICULAR FONT, STYLE, SIZE, OR COLOR.

**CLASS 1—CHEMICALS**

FOR AUTOMOTIVE FLUIDS, NAMELY, CHEMICAL TREATMENTS FOR GAS AND OIL, POWER STEERING FLUID, ANTIFREEZE AND BRAKE FLUID; FUEL INJECTION CLEANER CHEMICAL ADDITIVE (U.S. CLS. 1, 5, 6, 10, 26 AND 46).

**CLASS 2—PAINTS**

FOR UNDERCOATING FOR VEHICLES CHASSIS, PAINT PRIMERS AND AUTOMOTIVE PAINT (U.S. CLS. 6, 11 AND 16).

**CLASS 3—COSMETICS AND CLEANING PREPARATIONS**

FOR WINDSHIELD WASHING FLUID, BRAKE CLEANER, CARBURETOR CLEANER AND ENGINE DEGREASER (U.S. CLS. 1, 4, 6, 50, 51 AND 52).

**CLASS 4—LUBRICANTS AND FUELS**

FOR ALL PURPOSE SILICONE SPRAY LUBRICANT AND MOTOR OIL (U.S. CLS. 1, 6 AND 15).

**CLASS 7—MACHINERY**

FOR INTERNAL COMBUSTION ENGINES LAND VEHICLE PARTS, NAMELY, DISTRIBUTOR CAPS, ROTORS, IGNITION WIRES, IGNITION COILS, SENSORS, RELAYS, SWITCHES, MODULES, REGULATORS, SOLENOIDS, POINTS AND CONDENSERS; WATER PUMPS FOR LAND VEHICLES; NON-METAL ENGINE GASKETS FOR VEHICLES; OIL FILTERS; AUTOMOTIVE ALTERNATORS (U.S. CLS. 13, 19, 21, 23, 31, 34 AND 35).

**CLASS 9—ELECTRICAL AND SCIENTIFIC APPARATUS**

FOR AUTOMOTIVE BATTERIES, BATTERY CABLES, THERMOSTATS AND MARINE BATTERIES (U.S. CLS. 21, 23, 26, 36 AND 38).

**CLASS 11—ENVIRONMENTAL CONTROL APPARATUS**

FOR LIGHTS FOR VEHICLES (U.S. CLS. 13, 21, 23, 31 AND 34).

**CLASS 12—VEHICLES**

FOR V-BELTS FOR LAND VEHICLES, AUTOMOBILE CHASSIS, BRAKE DRUMS, BRAKE ROTORS, BRAKE SHOES, BRAKE PADS, FRICTION PARTS, NAMELY, BRAKE PADS; CLUTCHES; FRONT AND REAR WINDSHIELD WIPER BLADES, AUTOMOTIVE MOTOR MOUNTS, WHEEL HUB BEARINGS, CLUTCH DISCS, ALL FOR LAND VEHICLES; AUTOMOTIVE STARTERS (U.S. CLS. 19, 21, 23, 31, 35 AND 44).

**CLASS 27—FLOOR COVERINGS**

FOR FLOOR MATS FOR VEHICLES (U.S. CLS. 19, 20, 37, 42 AND 50).

CHRISIE B. KING, EXAMINING ATTORNEY

---

SN 85-066,366. CAMPBELL-SHAW, INC., WOODLAND HILLS, CA. FILED 6-18-2010.



THE MARK CONSISTS OF A DESIGN OF A RICKSHAW FEATURING THE SILHOUETTE OF ONE FEMALE AND ONE MALE.

**CLASS 35—ADVERTISING AND BUSINESS**

FOR RETAIL STORE SERVICES FEATURING MULTIMEDIA ENTERTAINMENT AND AUDIO-VISUAL SYSTEMS (U.S. CLS. 100, 101 AND 102).

FIRST USE 10-31-1989; IN COMMERCE 10-31-1989.

**CLASS 42—SCIENTIFIC AND COMPUTER SERVICES**

FOR TECHNOLOGICAL CONSULTATION IN THE FIELD OF SELECTING MULTIMEDIA AND AUDIO-VISUAL ENTERTAINMENT SYSTEMS SUITABLE FOR THEIR INTENDED USES (U.S. CLS. 100 AND 101).

FIRST USE 3-31-1989; IN COMMERCE 10-31-1989.  
LANA PHAM, EXAMINING ATTORNEY

SN 85-066,410. AUTOMATED MEDIA SERVICES, INC., ALLENDALE, NJ. FILED 6-18-2010.

**TV IS SO PERSUASIVE, IT DESERVES TO BE SAVED**

THE MARK CONSISTS OF STANDARD CHARACTERS WITHOUT CLAIM TO ANY PARTICULAR FONT, STYLE, SIZE, OR COLOR.

**CLASS 35—ADVERTISING AND BUSINESS**

FOR MEDIA BUYING ADVICE SERVICES, NAMELY, ADVISING CLIENTS ON THE PURCHASE OF ADVERTISING; MEDIA PLANNING SERVICES, NAMELY, ADVISING CLIENTS ON THE PURCHASE OF ADVERTISING BASED UPON MEDIA AND/OR MARKET ANALYSIS; PROVIDING CONSULTING SERVICES IN THE FIELD OF FACILITATING THE PLANNING, BUYING, AND SELLING OF MEDIA (U.S. CLS. 100, 101 AND 102).

**CLASS 38—COMMUNICATION**

FOR COMMUNICATIONS SERVICES, NAMELY, TRANSMISSION AND BROADCASTING OF VIDEO, IMAGES, AUDIO AND DATA VIA BROADBAND NETWORKS (U.S. CLS. 100, 101 AND 104).

**CLASS 42—SCIENTIFIC AND COMPUTER SERVICES**

FOR SOFTWARE AS A SERVICE (SAAS) SERVICES, NAMELY, HOSTING SOFTWARE FOR USE BY OTHERS FOR USE IN MANAGING, DISTRIBUTING, MONITORING AND BROADCASTING ALL FORMS OF DIGITAL MEDIA CONTENT FOR THE RETAIL PROMOTIONAL ADVERTISING AND OUT-OF-HOME MEDIA INDUSTRIES; RENTAL OF COMPUTER HARDWARE AND COMPUTER PERIPHERALS FOR USE IN MANAGING, DISTRIBUTING, MONITORING AND BROADCASTING ALL FORMS OF DIGITAL MEDIA CONTENT FOR THE RETAIL PROMOTIONAL ADVERTISING AND OUT-OF-HOME INDUSTRIES (U.S. CLS. 100 AND 101).

JOHN KELLY, EXAMINING ATTORNEY

---

SN 85-066,557. MILWAUKEE INSTITUTE OF ART AND DESIGN, INC., MILWAUKEE, WI. FILED 6-18-2010.

**MILWAUKEE INSTITUTE OF ART & DESIGN**

THE MARK CONSISTS OF STANDARD CHARACTERS WITHOUT CLAIM TO ANY PARTICULAR FONT, STYLE, SIZE, OR COLOR.

NO CLAIM IS MADE TO THE EXCLUSIVE RIGHT TO USE "INSTITUTE OF ART & DESIGN", APART FROM THE MARK AS SHOWN.

SEC. 2(F).

**CLASS 35—ADVERTISING AND BUSINESS**

FOR ART GALLERIES, ONLINE ART GALLERIES; PREPARING PROMOTIONAL AND ADVERTISING MATERIALS FOR OTHERS (U.S. CLS. 100, 101 AND 102).

FIRST USE 12-31-1980; IN COMMERCE 12-31-1980.

**CLASS 36—INSURANCE AND FINANCIAL**

FOR PROVIDING EDUCATIONAL SCHOLARSHIPS AND GRANTS, ASSISTING STUDENTS IN APPLYING FOR FEDERAL AND STATE FINANCIAL AID PROGRAMS, AND PROVIDING STUDENT LOANS TO STUDENTS; CHARITABLE FUNDRAISING; AND CHARITABLE FUNDRAISING SERVICES BY MEANS OF ORGANIZING AND CONDUCTING EVENTS (U.S. CLS. 100, 101 AND 102).

FIRST USE 12-31-1980; IN COMMERCE 12-31-1980.

**CLASS 41—EDUCATION AND ENTERTAINMENT**

FOR EDUCATIONAL SERVICES, NAMELY, PROVIDING COURSES OF INSTRUCTION TO SECONDARY STUDENTS AND AT THE COLLEGE LEVEL; CONDUCTING CLASSES, SEMINARS AND WORKSHOPS IN THE FIELDS OF ART AND EDUCATOR INSTRUCTION, AND DISTRIBUTING COURSE MATERIAL IN CONNECTION THEREWITH; TRAVELLING ART EXHIBITIONS (U.S. CLS. 100, 101 AND 107).

FIRST USE 12-31-1980; IN COMMERCE 12-31-1980.

JOHN DWYER, EXAMINING ATTORNEY

SN 85-066,593. POP-IN-KINS, LTD., ALLIANCE, OH. FILED 6-18-2010.

**CHRISTINA MARIE POP-N-KINS**

THE MARK CONSISTS OF STANDARD CHARACTERS WITHOUT CLAIM TO ANY PARTICULAR FONT, STYLE, SIZE, OR COLOR.

THE NAME "CHRISTINA MARIE POP-N-KINS" DOES NOT IDENTIFY A LIVING INDIVIDUAL.

**CLASS 16—PAPER GOODS AND PRINTED MATTER**

FOR PRINTED MATERIALS, NAMELY, STORIES IN ILLUSTRATED FORM AND CHILDREN'S STORY BOOKS (U.S. CLS. 2, 5, 22, 23, 29, 37, 38 AND 50).

**CLASS 28—TOYS AND SPORTING GOODS**

FOR PLAYTHINGS, NAMELY, STUFFED DOLLS AND SOFT SCULPTURE DOLLS (U.S. CLS. 22, 23, 38 AND 50).

JOHN KELLY, EXAMINING ATTORNEY

SN 85-067,256. IMPACT PLANNING GROUP, LLC, WILTON, CT. FILED 6-21-2010.

**IMPACT PLANNING GROUP**

THE MARK CONSISTS OF STANDARD CHARACTERS WITHOUT CLAIM TO ANY PARTICULAR FONT, STYLE, SIZE, OR COLOR.

OWNER OF U.S. REG. NO. 2,343,848.

NO CLAIM IS MADE TO THE EXCLUSIVE RIGHT TO USE "GROUP", APART FROM THE MARK AS SHOWN. SEC. 2(F).

**CLASS 35—ADVERTISING AND BUSINESS**

FOR BUSINESS MANAGEMENT CONSULTATION (U.S. CLS. 100, 101 AND 102).

FIRST USE 0-0-1979; IN COMMERCE 0-0-1979.

**CLASS 41—EDUCATION AND ENTERTAINMENT**

FOR EDUCATIONAL SERVICES, NAMELY, CONDUCTING SEMINARS, CLASSES, WEBINARS AND WORKSHOPS IN THE FIELD OF BUSINESS MANAGEMENT AND MARKETING AND DISTRIBUTION OF COURSE MATERIAL IN CONNECTION THEREWITH (U.S. CLS. 100, 101 AND 107).

FIRST USE 0-0-1979; IN COMMERCE 0-0-1979.

SANJEEV VOHRA, EXAMINING ATTORNEY

SN 85-068,076. SEABRIGHT HOLDINGS, INC., SEATTLE, WA. FILED 6-21-2010.

**PALADIN MANAGED CARE SERVICES**

THE MARK CONSISTS OF STANDARD CHARACTERS WITHOUT CLAIM TO ANY PARTICULAR FONT, STYLE, SIZE, OR COLOR.

NO CLAIM IS MADE TO THE EXCLUSIVE RIGHT TO USE "MANAGED CARE SERVICES", APART FROM THE MARK AS SHOWN.

**CLASS 35—ADVERTISING AND BUSINESS**

FOR MANAGEMENT AND BUSINESS CONSULTING SERVICES IN THE FIELD OF MANAGED CARE SERVICES, NAMELY, MEDICAL BILL REVIEW FOR WORKERS' COMPENSATION, LIABILITY AND GROUP HEALTH INSURANCE MEDICAL CLAIMS, CASE MANAGEMENT, UTILIZATION REVIEW, AND RETURN TO WORK SERVICES IN THE NATURE OF PLACING AND MONITORING RECOVERING EMPLOYEES IN TEMPORARY OR VOLUNTEER TRANSITIONAL DUTY POSITIONS TO ASSIST WORKERS NOT FULLY RECOVERED FROM WORK-RELATED ILLNESS AND/OR INJURY IN TRANSITIONING BACK INTO THE EMPLOYER'S WORKFORCE (U.S. CLS. 100, 101 AND 102).

**CLASS 36—INSURANCE AND FINANCIAL**

FOR MEDICAL INSURANCE CASE AND UTILIZATION REVIEW AND INSURANCE CLAIMS ADJUSTMENT SERVICES FOR HEALTHCARE PURCHASERS AND PAYORS AND PROVIDERS AND MEDICARE BENEFICIARIES (U.S. CLS. 100, 101 AND 102).

KELLY BOULTON, EXAMINING ATTORNEY

SN 85-068,319. DONGKWANG INTERNATIONAL CO., LTD., SEOUL, REPUBLIC OF KOREA, FILED 6-22-2010.

**ad hoc**

THE MARK CONSISTS OF STANDARD CHARACTERS WITHOUT CLAIM TO ANY PARTICULAR FONT, STYLE, SIZE, OR COLOR.

OWNER OF REPUBLIC OF KOREA REG. NO. 0175556,  
DATED 10-13-2008, EXPIRES 10-13-2018.

OWNER OF REPUBLIC OF KOREA REG. NO. 0763921,  
DATED 10-7-2008, EXPIRES 10-7-2018.

OWNER OF REPUBLIC OF KOREA REG. NO. 0763920,  
DATED 10-7-2008, EXPIRES 10-7-2018.

#### **CLASS 18—LEATHER GOODS**

FOR COSMETIC BAGS SOLD EMPTY; PURSES;  
PURSES OF PRECIOUS METAL; MEN'S BAGS,  
NAMESLY, MEN'S CLUTCH BAGS, SMALL BAGS FOR  
MEN; BRIEFCASES; SHOPPING BAGS OF CANVAS,  
LEATHER, MESH; SHOULDER BAGS; SUITCASES;  
SPORTS BAGS; TRAVELING BAGS; CARD CASES,  
NAMESLY, CREDIT CARD CASES, NAME CARD CASES;  
SCHOOL BAGS; BACKPACKS; FUR PELTS; LEATHER  
BAGS; IMITATION LEATHER BAGS; BEACH BAGS;  
BUSINESS CARD CASES; HANDBAGS; UMBRELLAS;  
PARASOLS (U.S. CLS. 1, 2, 3, 22 AND 41).

#### **CLASS 25—CLOTHING**

FOR LEATHER SHOES; GOLF SHOES; SANDALS;  
SLIPPERS; BOOTS; SHOES; MEN'S SUITS; WOMEN'S  
SUITS; RAIN COATS; OVERCOATS; JACKETS; HALF  
COATS; SKIRTS; JEANS; JUMPERS; CHILDREN'S  
CLOTHING, NAMESLY, PANTS, SHIRTS, JACKETS,  
SHOES; INFANTS' CLOTHING, NAMESLY, INFANT  
WEAR; PANTS; SHIRTS; BLOUSES; SWEATERS; VESTS;  
T-SHIRTS; PARKAS; GOLF WEAR OTHER THAN  
GLOVES, NAMESLY, GOLF SHIRTS, GOLF PANTS;  
SWIMSUITS; UNDERWEAR; SPORTSWEAR OTHER  
THAN GLOVES OR HELMETS, NAMESLY, JERSEYS,  
LEOTARDS; BRASSIERES; NIGHTWEAR; CARDIGANS;  
MONEY BELTS; BELTS FOR CLOTHING; LEATHER  
BELTS; SUSPENDERS FOR STOCKINGS; SOCK SUS-  
PENDERS; CAPS; SUN VISORS; SOCKS; SCARVES;  
NECKTIES; GLOVES; SHAWLS; MUFFLERS (U.S. CLS.  
22 AND 39).

#### **CLASS 35—ADVERTISING AND BUSINESS**

FOR WHOLESALE AND RETAIL DISTRIBUTORSHIP  
STORE SERVICES IN THE FIELD OF CLOTHING,  
FOOTWEAR, BAGS, PRECIOUS METALS, JEWELRY,  
CLOCKS, WATCHES AND HEADWEAR; ARRANGING  
AND CONDUCTING MARKETING PROMOTIONAL  
EVENTS AND SALES FOR OTHERS IN THE FIELD OF  
CLOTHING, FOOTWEAR, BAGS, PRECIOUS METALS,  
JEWELRY, CLOCKS, WATCHES AND HEADWEAR;  
IMPORT-EXPORT AGENCIES (U.S. CLS. 100, 101 AND  
102).

BARBARA RUTLAND, EXAMINING ATTORNEY

SN 85-068,372. HC BRIDGE COMPANY, LLC, WILMETTE,  
IL. FILED 6-22-2010.

### **HC BRIDGE COMPANY**

THE MARK CONSISTS OF STANDARD CHARACTERS  
WITHOUT CLAIM TO ANY PARTICULAR FONT, STYLE,  
SIZE, OR COLOR.

NO CLAIM IS MADE TO THE EXCLUSIVE RIGHT TO  
USE "BRIDGE COMPANY", APART FROM THE MARK AS  
SHOWN.

#### **CLASS 37—CONSTRUCTION AND REPAIR**

FOR INSTALLATION OF VEHICULAR AND PEDES-  
TRIAN BRIDGES (U.S. CLS. 100, 103 AND 106).  
FIRST USE 11-30-2008; IN COMMERCE 11-30-2008.

#### **CLASS 40—MATERIAL TREATMENT**

FOR MANUFACTURING SERVICES FOR OTHERS IN  
THE FIELD OF BRIDGE BEAMS (U.S. CLS. 100, 103 AND  
106).

FIRST USE 11-30-2008; IN COMMERCE 11-30-2008.  
JULIE VEPPUMTHARA, EXAMINING ATTORNEY

SN 85-068,412. HC BRIDGE COMPANY, LLC, WILMETTE,  
IN. FILED 6-22-2010.

### **BUILD BETTER**

THE MARK CONSISTS OF STANDARD CHARACTERS  
WITHOUT CLAIM TO ANY PARTICULAR FONT, STYLE,  
SIZE, OR COLOR.

#### **CLASS 37—CONSTRUCTION AND REPAIR**

FOR INSTALLATION OF VEHICULAR AND PEDES-  
TRIAN BRIDGES (U.S. CLS. 100, 103 AND 106).

FIRST USE 6-4-2010; IN COMMERCE 6-4-2010.

#### **CLASS 40—MATERIAL TREATMENT**

FOR MANUFACTURING SERVICES FOR OTHERS IN  
THE FIELD OF BRIDGE BEAMS (U.S. CLS. 100, 103 AND  
106).

FIRST USE 6-4-2010; IN COMMERCE 6-4-2010.

JULIE VEPPUMTHARA, EXAMINING ATTORNEY

SN 85-068,792. AFILIAS LIMITED, DUBLIN, IRELAND,  
FILED 6-22-2010.

### **DNS YOUR WAY**

THE MARK CONSISTS OF STANDARD CHARACTERS  
WITHOUT CLAIM TO ANY PARTICULAR FONT, STYLE,  
SIZE, OR COLOR.

NO CLAIM IS MADE TO THE EXCLUSIVE RIGHT TO  
USE "DNS", APART FROM THE MARK AS SHOWN.

#### **CLASS 35—ADVERTISING AND BUSINESS**

FOR DOMAIN NAME DIRECTORY SERVICES (U.S.  
CLS. 100, 101 AND 102).

#### **CLASS 38—COMMUNICATION**

FOR PROVIDING MULTIPLE-USER ACCESS TO A  
GLOBAL COMPUTER INFORMATION NETWORK (U.S.  
CLS. 100, 101 AND 104).



**CLASS 42—SCIENTIFIC AND COMPUTER SERVICES**

FOR PROVIDING ONLINE NON-DOWNLOADABLE COMPUTER SOFTWARE FOR USE IN CONNECTING TO THE INTERNET FOR THE PURPOSE OF PROVIDING A WIDE RANGE OF INTERNET FUNCTIONALITY, NAMELY, PROVIDING CONNECTIVITY IN THE SHORTEST TIME POSSIBLE, DETERMINING THE MOST DIRECT ROUTE OF CONNECTIVITY, ROUTING AROUND INACTIVE MACHINES AND ROUTING AROUND INACTIVE LINES (U.S. CLS. 100 AND 101).

**CLASS 45—PERSONAL AND LEGAL SERVICES**

FOR DOMAIN NAME REGISTRY SERVICES, NAMELY, COORDINATING THE REGISTRATION OF DOMAIN NAMES FOR IDENTIFICATION OF USERS AND INTERNET PROTOCOL ADDRESSES ON THE INTERNET; PROVIDING AN ONLINE COMPUTER DATABASE IN THE FIELD OF DOMAIN NAMES REGISTRATION INFORMATION; PROVIDING AUTHENTICATION SERVICES VIA ONLINE NON-DOWNLOADABLE SOFTWARE FOR ESTABLISHING AND TRANSMITTING SECURITY CREDENTIALS FOR DOMAIN NAME SERVICES (U.S. CLS. 100 AND 101).

ROBIN CHOSID, EXAMINING ATTORNEY

SN 85-068,912. KEN CARMEN, FORMERLY HARBORGATE RECORDS, HAUPPAUGE, NY. FILED 6-22-2010.

# The Mondays

THE MARK CONSISTS OF STANDARD CHARACTERS WITHOUT CLAIM TO ANY PARTICULAR FONT, STYLE, SIZE, OR COLOR.

**CLASS 9—ELECTRICAL AND SCIENTIFIC APPARATUS**

FOR PRERECORDED AUDIO DISCS AND CASSETTES FEATURING MUSIC (U.S. CLS. 21, 23, 26, 36 AND 38).  
FIRST USE 11-0-1997; IN COMMERCE 11-0-1997.

**CLASS 41—EDUCATION AND ENTERTAINMENT**

FOR ENTERTAINMENT SERVICES IN THE NATURE OF LIVE PERFORMANCES BY A MUSICAL GROUP (U.S. CLS. 100, 101 AND 107).

FIRST USE 11-0-1997; IN COMMERCE 11-0-1997.  
ROBERT STRUCK, EXAMINING ATTORNEY

SN 85-068,957. THE URBAN ALTERNATIVE, DALLAS, TX. FILED 6-22-2010.

# Tony Evans Ministries

THE MARK CONSISTS OF STANDARD CHARACTERS WITHOUT CLAIM TO ANY PARTICULAR FONT, STYLE, SIZE, OR COLOR.

NO CLAIM IS MADE TO THE EXCLUSIVE RIGHT TO USE "MINISTRIES", APART FROM THE MARK AS SHOWN.

THE NAME(S), PORTRAIT(S), AND/OR SIGNATURE(S) SHOWN IN THE MARK IDENTIFIES "TONY EVANS", WHOSE CONSENT(S) TO REGISTER IS MADE OF RECORD.

**CLASS 16—PAPER GOODS AND PRINTED MATTER**

FOR PUBLICATIONS, NAMELY, MAGAZINES, BOOKS, WORKBOOKS, BROCHURES, NEWSLETTERS, TRAINING MANUALS AND HANDOUTS IN THE FIELDS OF RELIGION, CHRISTIAN LIVING AND LIFESTYLES, LEADERSHIP TRAINING, YOUTH DEVELOPMENT, ECONOMIC DEVELOPMENT AND COMMUNITY OUTREACH PROGRAMS (U.S. CLS. 2, 5, 22, 23, 29, 37, 38 AND 50).

FIRST USE 9-1-2005; IN COMMERCE 9-1-2005.

**CLASS 41—EDUCATION AND ENTERTAINMENT**

FOR EDUCATIONAL AND ENTERTAINMENT SERVICES, NAMELY, A CONTINUING PROGRAM ABOUT RELIGION, CHRISTIAN LIVING AND LIFESTYLES, LEADERSHIP TRAINING, YOUTH DEVELOPMENT, ECONOMIC DEVELOPMENT, COMMUNITY OUTREACH PROGRAMS, LIFE SKILLS AND MENTORING ACCESSIBLE BY RADIO, TELEVISION, SATELLITE, AUDIO, VIDEO AND COMPUTER NETWORKS; EDUCATIONAL SERVICES, NAMELY, CONDUCTING CLASSES, CONFERENCES, SEMINARS AND WORKSHOPS IN THE FIELD OF RELIGION, CHRISTIAN LIVING AND LIFESTYLES, LEADERSHIP TRAINING, YOUTH DEVELOPMENT, ECONOMIC DEVELOPMENT, COMMUNITY OUTREACH PROGRAMS, LIFE SKILLS AND MENTORING AND DISTRIBUTION OF PRINTED MATERIALS IN CONNECTION THEREWITH IN HARD COPY OR ELECTRONIC FORMAT ON THE SAME TOPICS; PRODUCTION OF RADIO AND TELEVISION PROGRAMS (U.S. CLS. 100, 101 AND 107).

FIRST USE 9-1-2005; IN COMMERCE 9-1-2005.

**CLASS 45—PERSONAL AND LEGAL SERVICES**

FOR EVANGELISTIC AND MINISTERIAL SERVICES (U.S. CLS. 100 AND 101).

FIRST USE 9-1-2005; IN COMMERCE 9-1-2005.

CHRISTINA SOBRAL, EXAMINING ATTORNEY

SN 85-068,962. AFILIAS LIMITED, DUBLIN, IRELAND. FILED 6-22-2010.

# FLEXDNS

THE MARK CONSISTS OF STANDARD CHARACTERS WITHOUT CLAIM TO ANY PARTICULAR FONT, STYLE, SIZE, OR COLOR.

**CLASS 35—ADVERTISING AND BUSINESS**

FOR DOMAIN NAME DIRECTORY SERVICES (U.S. CLS. 100, 101 AND 102).

**CLASS 38—COMMUNICATION**

FOR PROVIDING MULTIPLE-USER ACCESS TO A GLOBAL COMPUTER INFORMATION NETWORK (U.S. CLS. 100, 101 AND 104).

**CLASS 42—SCIENTIFIC AND COMPUTER SERVICES**

FOR PROVIDING ONLINE NON-DOWNLOADABLE COMPUTER SOFTWARE FOR USE IN CONNECTING TO THE INTERNET FOR THE PURPOSE OF PROVIDING A WIDE RANGE OF INTERNET FUNCTIONALITY, NAMELY, PROVIDING CONNECTIVITY IN THE SHORTEST TIME POSSIBLE, DETERMINING THE MOST DIRECT ROUTE OF CONNECTIVITY, ROUTING AROUND INACTIVE MACHINES AND ROUTING AROUND INACTIVE LINES (U.S. CLS. 100 AND 101).

**CLASS 45—PERSONAL AND LEGAL SERVICES**

FOR DOMAIN NAME REGISTRY SERVICES, NAMELY, COORDINATING THE REGISTRATION OF DOMAIN NAMES FOR IDENTIFICATION OF USERS AND INTERNET PROTOCOL ADDRESSES ON THE INTERNET; PROVIDING AN ONLINE COMPUTER DATABASE IN THE FIELD OF DOMAIN NAMES REGISTRATION INFORMATION; PROVIDING AUTHENTICATION SERVICES VIA ONLINE NON-DOWNLOADABLE SOFTWARE FOR ESTABLISHING AND TRANSMITTING SECURITY CREDENTIALS FOR DOMAIN NAME SERVICES (U.S. CLS. 100 AND 101).  
ROBIN CHOSID, EXAMINING ATTORNEY

SN 85-069,007. SUMMER FRESH SALADS INC., WOODBRIDGE, CANADA, FILED 6-22-2010.



OWNER OF U.S. REG. NOS. 3,712,905, 3,716,264 AND OTHERS.

THE MARK CONSISTS OF THE WORDING "I SUMMER FRESH", WITH THE LETTER "I" APPEARING ADJACENT TO A HEART AND ABOVE THE WORD "SUMMER", ALL OF WHICH IS ABOVE THE WORD "FRESH". ALL OF THE ABOVE APPEARS IN A SHADED CIRCLE.

**CLASS 29—MEATS AND PROCESSED FOODS**

FOR DIPS; SALADS, NAMELY, FRUIT SALADS, GARDEN SALADS, POTATO SALADS, COLESLAW, SEAFOOD SALADS; BEAN SALADS; HUMMUS, SOUPS (U.S. CL. 46).  
FIRST USE 2-1-2010; IN COMMERCE 2-1-2010.

**CLASS 30—STAPLE FOODS**

FOR SALADS, NAMELY, PASTA SALADS, RICE SALADS, GRAIN SALADS (U.S. CL. 46).  
FIRST USE 2-1-2010; IN COMMERCE 2-1-2010.  
KAREN SEVERSON, EXAMINING ATTORNEY

SN 85-069,234. PREMIUM KNOWLEDGE GROUP, DALLAS, TX. FILED 6-23-2010.

**PREMIUM LIVE-A-LIKES**

THE MARK CONSISTS OF STANDARD CHARACTERS WITHOUT CLAIM TO ANY PARTICULAR FONT, STYLE, SIZE, OR COLOR.

NO CLAIM IS MADE TO THE EXCLUSIVE RIGHT TO USE "PREMIUM", APART FROM THE MARK AS SHOWN.

**CLASS 35—ADVERTISING AND BUSINESS**

FOR ADVERTISING, BUSINESS AND RETAIL SERVICES, NAMELY, ADVERTISING; DIRECT MARKETING; MARKET SEGMENTATION CONSULTATION; PREDICTIVE MODELING OF CONSUMER BEHAVIOR FOR MARKETING PROFESSIONALS, DATA BASE PROFESSIONALS, DIRECT MARKETERS, ADVERTISERS, BRAND MANAGERS AND GOVERNMENT OFFICIALS; MARKET ANALYSIS; SOCIO-ECONOMIC ANALYSIS AND RESEARCH SERVICES (U.S. CLS. 100, 101 AND 102).

**CLASS 42—SCIENTIFIC AND COMPUTER SERVICES**

FOR RESEARCH AND DESIGN SERVICES IN THE FIELD OF COMPUTER HARDWARE AND SOFTWARE; DESIGN AND DEVELOPMENT OF COMPUTER SOFTWARE FOR APPLICATION TO EXISTING DATABASES COMPILED BY CLIENTS, THE GOVERNMENT AND 3RD PARTY VENDORS FOR MARKETING PROFESSIONALS, DATA BASE PROFESSIONALS, DIRECT MARKETERS, ADVERTISERS, BRAND MANAGERS AND GOVERNMENT OFFICIALS (U.S. CLS. 100 AND 101).

DAVID TOOLEY, EXAMINING ATTORNEY

SN 85-069,240. ARNOLD'S FOOD DISTRIBUTORS CORPORATION, TAMPA, FL. FILED 6-23-2010.



THE MARK CONSISTS OF THE STYLIZED AND UNDERLINED WORDING "LA DOÑA" ENCOMPASSED BY A RECTANGULAR CARRIER.

THE ENGLISH TRANSLATION OF "LA DOÑA" IN THE MARK IS "THE LADY".

**CLASS 29—MEATS AND PROCESSED FOODS**

FOR MEATS AND PROCESSED MEATS, PORK, POULTRY AND FISH FOR HUMAN CONSUMPTION; EGGS, MILK, CHEESE, CANNED VEGETABLES; CANNED FRUITS, PROCESSED OLIVES, JAMS, JELLIES, SOUPS, PROCESSED NUTS, ALMONDS AND BEANS; CHICKEN, MEAT, HAM, FISH, YUCCA CHIPS, COD FISH, CHEESE, POTATO AND JAM CROQUETTES; SEASONING WRAPS MADE OUT OF PLANTAIN LEAVES; FROZEN AND FRIED PLANTAINS; MEAT STUFFED POTATOES; VEGETABLE OIL, CORN OIL, PALM OIL, SUN FLOUR OIL, OLIVE OIL AND OTHER EDIBLE OILS AND FATS; FROZEN FOODS, NAMELY, MEALS CONSISTING PRIMARILY OF MEAT, PORK, CHICKEN AND SEAFOOD; PRESERVED, DRIED, CANNED AND COOKED FRUITS AND VEGETABLES; FRUIT PULPS; PROCESSED, CANNED, DRIED AND PRESERVED YUCCA; TOMATO PASTE, GUAVA PASTE, COOKED FRUIT, NAMELY, GUAVA SHELLS, FRUIT'S MARMALADE, MANGO PASTE, MANGO JELLY, MANGO MARMALADE, PROCESSED PAPAYA, FROZEN PIGEON PEAS, CANNED TOMATOES, PROCESSED ORANGES, NAMELY, SOUR ORANGES AND BITTER ORANGES, LEMON JUICE FOR COOKING PURPOSES, FRUIT PULPS, PROCESSED HEARTS OF PALMS; CANNED SARDINES (U.S. CL. 46).

**CLASS 30—STAPLE FOODS**

FOR RICE; DAIRY PRODUCTS, NAMELY, ICE CREAM, ICE MILK AND FROZEN YOGURT; FLOUR AND CORN FLOUR; BREAD, BUNS AND CRACKERS; CORN MEAL; SEASONINGS, SPICES, SALT, SUGAR, CHOCOLATE, AND COCOA; TAMALES; AREPAS; FROZEN CONFECTIONS, NAMELY, FROZEN POPS; MAYONNAISE, SALAD DRESSINGS AND STEAK SAUCES; SAUCES IN THE NATURE OF MOJO CRIOLLO; TOMATO SAUCE, TOMATO PUREE; AREQUIPE; COFFEE, COFFEE BEANS, COFFEE POWDER, FLAN, CORN FRITTERS, CREAM OF CORN, BREAD FRITTERS, BISCUIT LIKE FLAT BREAD, READY-MADE SAUCES, EMPANADAS, CHEESE BISCUITS, MINCED GARLIC; CORN SYRUPS; WINE VINEGARS FOR COOKING (U.S. CL. 46).

**CLASS 32—LIGHT BEVERAGES**

FOR COCONUT WATER, FRUIT JUICES; LEMON JUICE FOR USE IN THE PREPARATION OF BEVERAGES; SYRUPS FOR MAKING BEVERAGES (U.S. CLS. 45, 46 AND 48).

BRIAN CALLAGHAN, EXAMINING ATTORNEY

SN 85-069,439. PROPRIETECT L.P., MISSISSAUGA, ONTARIO, CANADA, FILED 6-23-2010.

**STRUCTURELITE**

THE MARK CONSISTS OF STANDARD CHARACTERS WITHOUT CLAIM TO ANY PARTICULAR FONT, STYLE, SIZE, OR COLOR.

OWNER OF CANADA REG. NO. TMA589878, DATED 9-15-2003, EXPIRES 9-15-2018.

**CLASS 17—RUBBER GOODS**

FOR CUSTOM-MANUFACTURED POLYURETHANE FOAM COMPONENTS FOR USE IN THE MANUFACTURE OF AUTOMOTIVE PARTS BY OTHERS (U.S. CLS. 1, 5, 12, 13, 35 AND 50).

**CLASS 40—MATERIAL TREATMENT**

FOR CUSTOM MANUFACTURE OF FOAM PRODUCTS FOR USE IN THE AUTOMOTIVE SECTOR (U.S. CLS. 100, 103 AND 106).

RAMONA ORTIGA, EXAMINING ATTORNEY

SN 85-069,530. JSFM CONSULTING LIMITED, TA PLUS SEMI, LINCOLNSHIRE, ENGLAND, FILED 6-23-2010.

**PLESSEY SEMICONDUCTORS**

THE MARK CONSISTS OF STANDARD CHARACTERS WITHOUT CLAIM TO ANY PARTICULAR FONT, STYLE, SIZE, OR COLOR.

PRIORITY CLAIMED UNDER SEC. 44(D) ON ENGLAND APPLICATION NO. 2535179, FILED 12-23-2009, REG. NO. 2535179, DATED 12-23-2009, EXPIRES 12-23-2019.

NO CLAIM IS MADE TO THE EXCLUSIVE RIGHT TO USE "SEMICONDUCTORS", APART FROM THE MARK AS SHOWN.

**CLASS 9—ELECTRICAL AND SCIENTIFIC APPARATUS**

FOR SEMICONDUCTORS; PARTS AND FITTINGS THEREFOR (U.S. CLS. 21, 23, 26, 36 AND 38).

**CLASS 40—MATERIAL TREATMENT**

FOR CUSTOM MANUFACTURE OF SEMICONDUCTORS AND PARTS AND FITTINGS THEREFOR (U.S. CLS. 100, 103 AND 106).

**CLASS 42—SCIENTIFIC AND COMPUTER SERVICES**

FOR DESIGN AND DEVELOPMENT OF SEMICONDUCTORS, AND PARTS AND FITTINGS THEREFOR (U.S. CLS. 100 AND 101).

JOHN KELLY, EXAMINING ATTORNEY

SN 85-069,638. CABLE MANUFACTURING BUSINESS, INC., HUNTINGTON BEACH, CA. FILED 6-23-2010.

**Armored Shield**

THE MARK CONSISTS OF STANDARD CHARACTERS WITHOUT CLAIM TO ANY PARTICULAR FONT, STYLE, SIZE, OR COLOR.

NO CLAIM IS MADE TO THE EXCLUSIVE RIGHT TO USE "SHIELD", APART FROM THE MARK AS SHOWN.

**CLASS 6—METAL GOODS**

FOR CABLE CLAMPS OF METAL; CABLE JUNCTION SLEEVES OF METAL (U.S. CLS. 2, 12, 13, 14, 23, 25 AND 50).

**CLASS 9—ELECTRICAL AND SCIENTIFIC APPARATUS**

FOR CABLES AND FIBRES FOR THE TRANSMISSION OF SOUNDS AND IMAGES; CABLES FOR ELECTRICAL OR OPTICAL SIGNAL TRANSMISSION; COMMUNICATIONS SOFTWARE FOR CONNECTING SECURE NETWORK USERS; COMPUTER CABLES; COMPUTER HARDWARE AND SOFTWARE FOR SETTING UP AND CONFIGURING LOCAL AREA NETWORKS; COMPUTER HARDWARE AND SOFTWARE FOR SETTING UP AND CONFIGURING WIDE AREA NETWORKS; COMPUTER HARDWARE FOR COMMUNICATING AUDIO, VIDEO AND DATA BETWEEN COMPUTERS VIA A GLOBAL COMPUTER NETWORK, WIDE-AREA COMPUTER NETWORKS, AND PEER-TO-PEER COMPUTER NETWORKS; COMPUTER NETWORK INTERFACE DEVICES; COMPUTER NETWORKING HARDWARE; COMPUTER SOFTWARE AND HARDWARE FOR SECURE NETWORK USERS, NAMELY, TAMPER DETECTION HARDWARE AND SOFTWARE TO MONITOR AND DETECT TAMPERING WITH THE HARDWARE AND SECURITY INTRUSIONS; COMPUTER SOFTWARE FOR ADMINISTRATION OF COMPUTER LOCAL AREA NETWORKS; COMPUTER SOFTWARE FOR ADMINISTRATION OF COMPUTER NETWORKS; COMPUTERS FOR NETWORK MANAGEMENT; ELECTRICAL AND OPTICAL CABLES; ELECTRONIC AND OPTICAL COMMUNICATIONS INSTRUMENTS AND COMPONENTS, NAMELY, OPTICAL DATA LINKS; FIBER OPTIC CABLES; FIBER OPTICS; FIBRE OPTIC COUPLINGS; FIBRE-OPTIC CABLES; LAN (LOCAL AREA NETWORK) ACCESS POINTS FOR CONNECTING NETWORK COMPUTER USERS; LAN (LOCAL AREA NETWORK) HARDWARE; LAN (LOCAL AREA NETWORK) OPERATING SOFTWARE; METAL CABINETS SPECIALLY ADAPTED TO PROTECT TELECOMMUNICATIONS EQUIPMENT IN THE NATURE OF FIBER OPTIC CABLES.; OPTICAL CABLES; OPTICAL COMMUNICATIONS SYSTEMS COMPRISED OF OPTICAL AND ELECTRONIC HARDWARE AND COMPUTER SOFTWARE FOR THE TRANSMISSION OF DATA BETWEEN TWO POINTS; OPTICAL FIBER CABLES; OPTICAL FIBERS; OPTICAL FIBERS SOLD AS A COMPONENT OF FIBER OPTICAL CABLES; OPTICAL FIBRES; OPTICAL FIBRES, TELEPHONE RECEIVERS, SWITCHBOARDS, TELEPHONE AND TELEGRAPH WIRES, VIDEO TELEPHONES; PROTECTIVE SHEATHS FOR FIBER OPTICAL CABLES; TELECOMMUNICATION CABLES; TELECOMMUNICATIONS AND DATA NETWORKING HARDWARE, NAMELY, DEVICES FOR TRANSPORTING AND AGGREGATING VOICE, DATA, AND VIDEO COMMUNICATIONS ACROSS MULTIPLE NETWORK INFRASTRUCTURES AND COMMUNICATIONS PROTOCOLS; WAN (WIDE AREA NETWORK) HARDWARE (U.S. CLS. 21, 23, 26, 36 AND 38).

**CLASS 38—COMMUNICATION**

FOR COMMUNICATION VIA FIBRE OPTICAL NETWORKS; COMMUNICATION VIA FIBRE-OPTIC NETWORKS; COMMUNICATION VIA OPTICAL FIBRE NETWORKS; COMMUNICATIONS VIA FIBER-OPTIC NETWORKS; COMMUNICATIONS VIA FIBRE-OPTIC NETWORKS; TELECOMMUNICATION SERVICES, NAMELY, LOCAL AND LONG DISTANCE TRANSMISSION OF VOICE, DATA, GRAPHICS AND VIDEO BY MEANS OF BROADBAND OPTICAL OR WIRELESS NETWORKS; TELECOMMUNICATION SERVICES, NAMELY, LOCAL AND LONG DISTANCE TRANSMISSION OF VOICE, DATA, GRAPHICS AND VIDEO BY MEANS OF BROADBAND, COPPER AND OPTICAL OR WIRELESS NETWORKS; TELECOMMUNICATION SERVICES, NAMELY, PROVIDING INTERNET ACCESS VIA BROADBAND OPTICAL OR WIRELESS NETWORKS; TELECOMMUNICATIONS SERVICES, NAMELY, PROVIDING FIBER OPTIC NETWORK SERVICES; TRANSMISSION OF INFORMATION ON OPTICAL TELECOMMUNICATION NETWORKS; TRANSMISSION OF SDI-FORMATTED TELEVISION AND AUDIO SIGNALS OVER FIBER OPTIC CABLES (U.S. CLS. 100, 101 AND 104).

CURTIS FRENCH, EXAMINING ATTORNEY

SN 85-069,664. DEFYING GRAVITY, INC, BEVERLY HILLS, CA. FILED 6-23-2010.

**HEALTHY HOLLYWOOD**

THE MARK CONSISTS OF STANDARD CHARACTERS WITHOUT CLAIM TO ANY PARTICULAR FONT, STYLE, SIZE, OR COLOR.

NO CLAIM IS MADE TO THE EXCLUSIVE RIGHT TO USE "HOLLYWOOD", APART FROM THE MARK AS SHOWN.

**CLASS 41—EDUCATION AND ENTERTAINMENT**

FOR ENTERTAINMENT SERVICES, NAMELY, PROVIDING INFORMATION BY MEANS OF A GLOBAL COMPUTER NETWORK IN THE FIELDS OF CELEBRITIES, ENTERTAINMENT, AND POPULAR CULTURE; PROVIDING A WEBSITE FEATURING INFORMATION ON EXERCISE AND FITNESS (U.S. CLS. 100, 101 AND 107).

FIRST USE 4-30-2008; IN COMMERCE 4-30-2008.

**CLASS 44—MEDICAL, BEAUTY AND AGRICULTURAL SERVICES**

FOR PROVIDING A WEBSITE FEATURING INFORMATION ABOUT HEALTH, WELLNESS AND NUTRITION (U.S. CLS. 100 AND 101).

FIRST USE 4-30-2008; IN COMMERCE 4-30-2008.  
BARBARA GAYNOR, EXAMINING ATTORNEY

SN 85-070,261. FLORISTS' TRANSWORLD DELIVERY, INC., DOWNERS GROVE, IL. FILED 6-23-2010.

**FTD FLOWERCAM**

THE MARK CONSISTS OF STANDARD CHARACTERS WITHOUT CLAIM TO ANY PARTICULAR FONT, STYLE, SIZE, OR COLOR.

OWNER OF U.S. REG. NOS. 821,318, 3,795,054 AND OTHERS.

**CLASS 9—ELECTRICAL AND SCIENTIFIC APPARATUS**

FOR COMPUTER SOFTWARE FOR CREATING AND SENDING PHOTOGRAPHS AND INFORMATION RELATING TO FLORAL AND GIFT ORDERS; COMPUTER HARDWARE; AND DIGITAL CAMERAS AND CASES AND BLANK OPTICAL DISKS THEREFOR (U.S. CLS. 21, 23, 26, 36 AND 38).

**CLASS 35—ADVERTISING AND BUSINESS**

FOR TRACKING AND MONITORING OF FLORAL AND GIFT ORDERS (U.S. CLS. 100, 101 AND 102).



**CLASS 38—COMMUNICATION**

FOR ELECTRONIC COMMUNICATION SERVICES FOR RETAIL BUSINESSES, NAMELY, ELECTRONIC TRANSMISSION OF DATA, MESSAGES AND PHOTOGRAPHS RELATING TO FLORAL AND GIFT ORDERS (U.S. CLS. 100, 101 AND 104).

SETH A. RAPPAPORT, EXAMINING ATTORNEY

---

SN 85-070,474. APDN (B.V.I.) INC., ROADTOWN, BR. VIRGIN ISLANDS, FILED 6-24-2010.

# RapiDNA

THE MARK CONSISTS OF STANDARD CHARACTERS WITHOUT CLAIM TO ANY PARTICULAR FONT, STYLE, SIZE, OR COLOR.

**CLASS 9—ELECTRICAL AND SCIENTIFIC APPARATUS**

FOR ANTI-COUNTERFEITING SYSTEM COMPRISING DNA-MAGNETO-OPTICAL LABELS IN THE NATURE OF LABELS CARRYING ENCODED INFORMATION FOR AUTHENTICATION OF GOODS (U.S. CLS. 21, 23, 26, 36 AND 38).

**CLASS 16—PAPER GOODS AND PRINTED MATTER**

FOR PAPER LABELS CONTAINING DNA-MAGNETO-OPTICAL MARKER IN THE NATURE OF INK AND COATING CONTAINING DNA INFORMATION FOR LOGISTIC TRACKING OF GOODS (U.S. CLS. 2, 5, 22, 23, 29, 37, 38 AND 50).

SUZANNE BLANE, EXAMINING ATTORNEY

---

SN 85-070,752. EVANTAGE TECHNOLOGIES LLC, WATERTOWN, CT. FILED 6-24-2010.

# EVANTAGE

THE MARK CONSISTS OF THE WORD COMPONENT EVAN IN A DISTINCT FONT FOLLOWED BY THE WORD COMPONENT TAGE IN THE SAME FONT IN A CONTRASTING SHADE.

**CLASS 7—MACHINERY**

FOR CARBONATORS FOR USE WITH BEVERAGE DISPENSING MACHINES, NAMELY, IN-LINE APPARATUS FOR DISSOLVING CARBON DIOXIDE GAS IN SUPPLIED FLUIDS; APPARATUS FOR ADJUSTING FOR CHANGES IN THE TEMPERATURE OF THE SUPPLIED FLUIDS FEATURING REGULATORS BEING PARTS OF MACHINES (U.S. CLS. 13, 19, 21, 23, 31, 34 AND 35).

**CLASS 9—ELECTRICAL AND SCIENTIFIC APPARATUS**

FOR FOOD AND BEVERAGE PROCESSING AND MONITORING EQUIPMENT FOR USE IN RESTAURANTS AND PROCESSING PLANTS, NAMELY, SYSTEMS FOR BEVERAGE DISPENSING EQUIPMENT, CONSISTING PRIMARILY OF COMPUTER SOFTWARE FOR USE IN MONITORING USAGE LEVELS OF CARBON DIOXIDE, SYRUP, DRINK FLAVORINGS AND BEVERAGES AND FOR COLLECTING DATA FOR INVENTORY AND MARKETING PURPOSES, FLUID SENSORS, IN-LINE CARBONATORS, AND REMOTE DATA TRANSMITTERS; FOOD AND BEVERAGE PROCESSING AND MONITORING EQUIPMENT FOR USE IN RESTAURANTS AND PROCESSING PLANTS, NAMELY, SYSTEMS TO MONITOR AND CONTROL FLUID FLOW FOR BEVERAGE DISPENSING MACHINES, CONSISTING PRIMARILY OF COMPUTER HARDWARE, COMPUTER SOFTWARE FOR BEVERAGE INVENTORY MANAGEMENT, FLUID SENSORS, REMOTE DATA TRANSMITTERS, AND AUTOMATIC VALVES (U.S. CLS. 21, 23, 26, 36 AND 38).

**CLASS 35—ADVERTISING AND BUSINESS**

FOR INVENTORY MANAGEMENT AND CONTROL IN THE FIELD OF BEVERAGE DISPENSING (U.S. CLS. 100, 101 AND 102).

**CLASS 42—SCIENTIFIC AND COMPUTER SERVICES**

FOR DESIGN AND DEVELOPMENT OF FOOD AND BEVERAGE PROCESSING AND MONITORING EQUIPMENT; DESIGN AND DEVELOPMENT OF SYSTEMS FOR USE IN THE CHEMICAL PROCESS AND TREATMENT INDUSTRY (U.S. CLS. 100 AND 101).

EMILY CHUO, EXAMINING ATTORNEY

---

SN 85-070,851. VITAL JUICE DAILY LLC, NEW YORK, NY. FILED 6-24-2010.

# VITAL JUICE

THE MARK CONSISTS OF STANDARD CHARACTERS WITHOUT CLAIM TO ANY PARTICULAR FONT, STYLE, SIZE, OR COLOR.

OWNER OF U.S. REG. NO. 3,375,635.

**CLASS 41—EDUCATION AND ENTERTAINMENT**

FOR ENTERTAINMENT SERVICES, NAMELY, PROVIDING NON-DOWNLOADABLE VIDEOS AND MULTIMEDIA PROGRAMS IN THE FIELD OF FITNESS PROVIDED VIA ELECTRONIC MEANS, AND PROVIDING CONTINUING VIDEO AND MULTIMEDIA PROGRAMS ABOUT FITNESS ACCESSIBLE BY ELECTRONIC MEANS; PROVIDING INFORMATION, NEWS AND COMMENTARY ABOUT FITNESS VIA ELECTRONIC MEANS; PROVIDING NON-DOWNLOADABLE ONLINE ELECTRONIC PUBLICATIONS IN THE NATURE OF NEWSLETTERS IN THE FIELD OF FITNESS (U.S. CLS. 100, 101 AND 107).

FIRST USE 4-18-2007; IN COMMERCE 4-18-2007.

**CLASS 44—MEDICAL, BEAUTY AND AGRICULTURAL SERVICES**

FOR PROVIDING INFORMATION AND ADVICE RELATING TO HEALTH, NUTRITION, BEAUTY AND WELLNESS VIA THE INTERNET; PROVIDING A WEBSITE FEATURING CONTENT REGARDING HEALTHY LIVING AND LIFESTYLE WELLNESS, HEALTH CARE, HYGIENIC AND BEAUTY CARE (U.S. CLS. 100 AND 101).

FIRST USE 4-18-2007; IN COMMERCE 4-18-2007.  
NICHOLAS ALTREE, EXAMINING ATTORNEY

SN 85-071,617. KIRCH, CAROL LEE, VAIL, CO. FILED 6-25-2010.

**THE SYMBOL OF VAIL VALLEY**

THE MARK CONSISTS OF STANDARD CHARACTERS WITHOUT CLAIM TO ANY PARTICULAR FONT, STYLE, SIZE, OR COLOR.

OWNER OF U.S. REG. NO. 2,502,911.

NO CLAIM IS MADE TO THE EXCLUSIVE RIGHT TO USE "VAIL VALLEY", APART FROM THE MARK AS SHOWN.

SN 85-070,943. ARIANA NETWORK SERVICE INC., KABUL, AFGHANISTAN, FILED 6-24-2010.

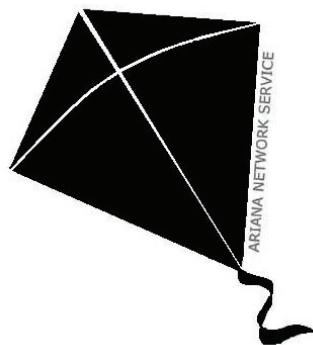

NO CLAIM IS MADE TO THE EXCLUSIVE RIGHT TO USE "NETWORK SERVICE", APART FROM THE MARK AS SHOWN.

THE MARK CONSISTS OF A KITE CONTAINING THE WORDS "ARIANA NETWORK SERVICE" RUNNING ALONGSIDE THE KITE.

**CLASS 38—COMMUNICATION**

FOR VOICE OVER INTERNET PROTOCOL (VOIP) SERVICES; TRANSMISSION OF DATA BY TELECOMMUNICATIONS NETWORKS, WIRELESS COMMUNICATION NETWORKS, AND THE INTERNET; DEDICATED AND SHARED INTERNET BANDWIDTH SERVICES, NAMELY, INTERNET SERVICES PROVIDER (ISP) SERVICES (U.S. CLS. 100, 101 AND 104).

**CLASS 42—SCIENTIFIC AND COMPUTER SERVICES**

FOR HOSTING OF WEB SITES; CUSTOMER PREMISES EQUIPMENT (CPE) MAINTENANCE, NAMELY, WIMAX AND RELATED INTERNET SERVICE, NAMELY, MAINTENANCE OF COMPUTER SOFTWARE USED FOR WORLD WIDE INTEROPERABILITY OF MICROWAVE ACCESS FOR COMPUTER NETWORKS; CO-LOCATION SERVICES, NAMELY, PROVIDING FACILITIES FOR THE LOCATION OF COMPUTER SERVERS WITH THE EQUIPMENT OF OTHERS (U.S. CLS. 100 AND 101).

JAMES STEIN, EXAMINING ATTORNEY

**CLASS 24—FABRICS**

FOR LINENS; SHEETS, NAMELY, BATH SHEETS, BED SHEETS, CONTOUR SHEETS, FITTED BED SHEETS, FLAT BED SHEETS, TOWEL SHEETS AND SHEET SETS; TOWELS; AND BLANKET THROWS (U.S. CLS. 42 AND 50).

**CLASS 25—CLOTHING**

FOR ROBES AND SLIPPERS (U.S. CLS. 22 AND 39).  
AMEEN IMAM, EXAMINING ATTORNEY

SN 85-071,630. KIRCH, CAROL LEE, VAIL, CO. FILED 6-25-2010.

**THE SYMBOL OF VAIL VALLEY**

OWNER OF U.S. REG. NO. 2,502,911.

NO CLAIM IS MADE TO THE EXCLUSIVE RIGHT TO USE "VAIL VALLEY", APART FROM THE MARK AS SHOWN.

THE MARK CONSISTS OF THE WORDS "THE SYMBOL OF VAIL VALLEY" IN SMALLER CAPITAL PRINT RUNNING THROUGH THE MIDDLE OF THE LARGE CAPITAL LETTERS "G" AND "B" SET BEHIND THE WORDS.

**CLASS 14—JEWELRY**

FOR JEWELRY, NAMELY, PENDANTS, BRACELETS, RINGS, EARRINGS, CHARMS, NECKLACES, CUFFLINKS, TIE TACKS, DOG TAGS FOR WEAR BY HUMANS FOR DECORATIVE PURPOSE, LAPEL PINS, BANGLES, CHAINS IN THE NATURE OF NECKLACES, AND WATCHES, ALL MADE WHOLLY OR IN PART OF PRECIOUS METAL, STONE OR LEATHER; KEY RINGS MADE WHOLLY OR IN PART OF PRECIOUS METAL; JEWELRY ITEMS MADE OF PRECIOUS METAL, NAMELY, HAT ORNAMENTS, BELT ORNAMENTS, BOOT ORNAMENTS, AND JEWELRY BOXES MADE OF PRECIOUS METAL (U.S. CLS. 2, 27, 28 AND 50).

**CLASS 16—PAPER GOODS AND PRINTED MATTER**

FOR MONEY CLIPS MADE WHOLLY OR IN PART OF PRECIOUS METAL, STONE OR LEATHER; PADFOLIOS, PASSPORT WALLETS, PHOTO ALBUMS, STATIONERY-TYPE PORTFOLIOS AND DIARIES (U.S. CLS. 2, 5, 22, 23, 29, 37, 38 AND 50).

**CLASS 18—LEATHER GOODS**

FOR LUGGAGE, WALLETS, TRAVEL WALLETS, TRAVEL BAGS, LEATHER BAGS, BRIEFCASE-TYPE PORTFOLIOS, BRIEFCASES, POCKETBOOKS, AT-TACHE CASES, LEATHER BACKPACKS, COIN PURSES, BILLFOLDS, LEATHER JEWELRY BAGS, GARMENT BAGS USED FOR TRAVEL, BUSINESS CARD CASES, CARRY-ON BAGS, CLUTCHES, FANNY PACKS, HANDBAGS, KEY CASES, SUITCASES AND LUGGAGE TAGS (U.S. CLS. 1, 2, 3, 22 AND 41).

**CLASS 21—HOUSEWARES AND GLASS**

FOR GLASSWARE AND EARTHENWARE, NAMELY, PITCHERS, CARAFES, DECANTERS, BEVERAGE GLASSES, CUPS, MUGS, DISHES, BOWLS, ICE BUCKETS, DINNER PLATES AND SALAD PLATES; GLASSWARE, NAMELY, VASES, BEVERAGE GLASSES, MUGS, CHAMPAGNE BUCKETS, CHAMPAGNE GLASSES, DECANTERS, WINE GLASSES, PITCHERS, DISHES, CANDLE HOLDERS, ALL MADE WHOLLY OR IN PART OF GLASS (U.S. CLS. 2, 13, 23, 29, 30, 33, 40 AND 50).

**CLASS 24—FABRICS**

FOR LINENS, BED SHEETS, BED SHEET SETS, TOWELS, AND BLANKET THROWS (U.S. CLS. 42 AND 50).

**CLASS 25—CLOTHING**

FOR ROBES AND SLIPPERS (U.S. CLS. 22 AND 39).

**CLASS 35—ADVERTISING AND BUSINESS**

FOR RETAIL JEWELRY AND CLOTHING STORE SERVICES IN THE FIELDS OF JEWELRY AND CLOTHING AND ACCESSORIES; MAIL ORDER CATALOG SERVICES IN THE FIELDS OF JEWELRY AND CLOTHING AND ACCESSORIES (U.S. CLS. 100, 101 AND 102).  
AMEEN IMAM, EXAMINING ATTORNEY

SN 85-071,715. GILDAN ACTIVEWEAR SRL, ST. MICHAEL, BARBADOS, FILED 6-25-2010.

**GENUINE STEWARDSHIP**

THE MARK CONSISTS OF STANDARD CHARACTERS WITHOUT CLAIM TO ANY PARTICULAR FONT, STYLE, SIZE, OR COLOR.

PRIORITY CLAIMED UNDER SEC. 44(D) ON CANADA APPLICATION NO. 1470489, FILED 2-22-2010.

**CLASS 25—CLOTHING**

FOR MEN, WOMEN, YOUTH AND CHILDREN'S CLOTHING, NAMELY, DRESSES, GOLF SHIRTS, COL-LARED SHIRTS, HOODED SWEAT SHIRTS, HOSIERY, JOGGING SUITS, JOGGING PANTS, JOGGING SHORTS, JOGGING OUTFITS, JUMPSUITS, KNIT SHIRTS, KNIT TOPS, ATHLETIC MUSCLE SHIRTS, ONE AND TWO PIECE PLAY SUITS, OVERALLS, PANTS, SHIRTS, SHORT-RIB COLLARED SHIRTS, SHORTS AND SHORTS SETS, SKIRTS, SLEEPWEAR, NAMELY, INFANT SLEEPERS, PAJAMAS AND NIGHTGOWNS, SOCKS, SPORT SHIRTS, SWEATERS, SWEATPANTS, SWEATSHIRTS, TANK TOPS, T-SHIRTS, TURTLE-NECKS, UNDERSHIRTS, UNDERWEAR, WOMEN'S UNDERGARMENTS (U.S. CLS. 22 AND 39).

FIRST USE 1-12-2010; IN COMMERCE 1-12-2010.

**CLASS 35—ADVERTISING AND BUSINESS**

FOR PROMOTING PUBLIC AWARENESS ON THE IMPACT OF THEIR ACTIVITIES ON THE ENVIRONMENT AND THEIR SURROUNDING COMMUNITIES BY ENCOURAGING COMMUNITY GROWTH AND DEVELOPMENT AND PROMOTING THE ELIMINATION OF PRACTICES THAT HARM THE PUBLIC SPHERE (U.S. CLS. 100, 101 AND 102).

FIRST USE 1-1-2010; IN COMMERCE 1-1-2010.

ROSELLE HERRERA, EXAMINING ATTORNEY

SN 85-072,648. LINCOLN HOLDINGS LLC, DBA MONU-MENTAL SPORTS & ENTERTAINMENT, ARLINGTON, VA. FILED 6-28-2010.

**MONUMENTAL SPORTS\*ENTERTAINMENT**

NO CLAIM IS MADE TO THE EXCLUSIVE RIGHT TO USE "SPORTS" OR "ENTERTAINMENT", APART FROM THE MARK AS SHOWN.

**CLASS 35—ADVERTISING AND BUSINESS**

FOR BUSINESS MANAGEMENT SERVICES, NAMELY, ADMINISTRATION OF COMPETITIONS FOR SPORTING AND ATHLETIC EVENTS; MANAGEMENT OF EVENT TICKETING FOR OTHERS; PROMOTING SPORTS COMPETITIONS AND/OR EVENTS OF OTHERS (U.S. CLS. 100, 101 AND 102).

**CLASS 41—EDUCATION AND ENTERTAINMENT**

FOR ENTERTAINMENT IN THE NATURE OF BASKETBALL GAMES; ENTERTAINMENT IN THE NATURE OF HOCKEY GAMES; PROVIDING SPORTS FACILITIES (U.S. CLS. 100, 101 AND 107).

**CLASS 43—HOTEL AND RESTAURANT SERVICES**

FOR ARENA SERVICES, NAMELY, PROVIDING FACILITIES FOR SPORTS, CONCERTS, CONVENTIONS AND EXHIBITIONS (U.S. CLS. 100 AND 101).

REBECCA POVARCHUK, EXAMINING ATTORNEY

SN 85-072.662. LINCOLN HOLDINGS LLC, DBA MONUMENTAL SPORTS & ENTERTAINMENT, ARLINGTON, VA. FILED 6-28-2010.



NO CLAIM IS MADE TO THE EXCLUSIVE RIGHT TO USE "SPORTS" OR "ENTERTAINMENT", APART FROM THE MARK AS SHOWN.

THE MARK CONSISTS OF THE LETTER "M" AND A STAR DESIGN, AND THE WORDS "MONUMENTAL SPORTS ENTERTAINMENT" AND A STAR DESIGN.

#### CLASS 35—ADVERTISING AND BUSINESS

FOR BUSINESS MANAGEMENT SERVICES, NAMELY, ADMINISTRATION OF COMPETITIONS FOR SPORTING AND ATHLETIC EVENTS; MANAGEMENT OF EVENT TICKETING FOR OTHERS; PROMOTING SPORTS COMPETITIONS AND/OR EVENTS OF OTHERS (U.S. CLS. 100, 101 AND 102).

#### CLASS 41—EDUCATION AND ENTERTAINMENT

FOR ENTERTAINMENT IN THE NATURE OF BASKETBALL GAMES; ENTERTAINMENT IN THE NATURE OF HOCKEY GAMES; PROVIDING SPORTS FACILITIES (U.S. CLS. 100, 101 AND 107).

#### CLASS 43—HOTEL AND RESTAURANT SERVICES

FOR ARENA SERVICES, NAMELY, PROVIDING FACILITIES FOR SPORTS, CONCERTS, CONVENTIONS AND EXHIBITIONS (U.S. CLS. 100 AND 101).

REBECCA POVARCHUK, EXAMINING ATTORNEY

SN 85-073.076. CONTROL POINT ASSOCIATES, INC., WARREN, NJ. FILED 6-28-2010.



NO CLAIM IS MADE TO THE EXCLUSIVE RIGHT TO USE "CONTROL POINT ASSOCIATES, INC.", APART FROM THE MARK AS SHOWN.

THE MARK CONSISTS OF A SYMBOL REPRESENTING A CONTROL POINT, NAMELY, A SPHERE SURROUNDED BY A SQUARE WITH A CIRCULAR HOLE IN THE CENTER AND BROKEN INTO FOUR EQUAL PIECES ALONG EACH DIAGONAL, APPEARING TO THE LEFT OF THE LITERAL ELEMENTS "CONTROL POINT" WHICH APPEARS ABOVE THE LITERAL ELEMENTS "ASSOCIATES, INC."

#### CLASS 37—CONSTRUCTION AND REPAIR

FOR CONSTRUCTION PLANNING IN THE NATURE OF CONSTRUCTION SITE LAYOUT (U.S. CLS. 100, 103 AND 106).

FIRST USE 4-15-1999; IN COMMERCE 4-15-1999.

#### CLASS 42—SCIENTIFIC AND COMPUTER SERVICES

FOR PROFESSIONAL LAND SURVEYING AND CONSULTING SERVICES, NAMELY, BOUNDARY AND TOPOGRAPHICAL SURVEYS AND SUBDIVISION (U.S. CLS. 100 AND 101).

FIRST USE 4-15-1999; IN COMMERCE 4-15-1999.

THOMAS MANOR, EXAMINING ATTORNEY

SN 85-073.623. OPENLANE, INC., REDWOOD CITY, CA. FILED 6-29-2010.

#### CARSARRIVE NETWORK

THE MARK CONSISTS OF STANDARD CHARACTERS WITHOUT CLAIM TO ANY PARTICULAR FONT, STYLE, SIZE, OR COLOR.

NO CLAIM IS MADE TO THE EXCLUSIVE RIGHT TO USE "NETWORK", APART FROM THE MARK AS SHOWN.

#### CLASS 35—ADVERTISING AND BUSINESS

FOR PROVIDING WEB-BASED TRANSPORTATION MANAGEMENT LOGISTICS SERVICES TO FACILITATE SCHEDULING, TRANSPORTING, AND TRACKING OF GOODS, NAMELY, VEHICLES (U.S. CLS. 100, 101 AND 102).

#### CLASS 39—TRANSPORTATION AND STORAGE

FOR PROVIDING SUPPLY CHAIN LOGISTICS SERVICES RELATING TO TRANSPORTATION OF GOODS, NAMELY, VEHICLES, BY AIR, RAIL, LAND AND SEA (U.S. CLS. 100 AND 105).

HANNO RITTNER, EXAMINING ATTORNEY

SN 85-074.237. JOEL M. KIMBALL, TEKOA, WA. FILED 6-29-2010.

#### DRIPPY

THE MARK CONSISTS OF STANDARD CHARACTERS WITHOUT CLAIM TO ANY PARTICULAR FONT, STYLE, SIZE, OR COLOR.



**CLASS 16—PAPER GOODS AND PRINTED MATTER**

FOR EDUCATIONAL PUBLICATION, NAMELY, BOOKS, HANDOUTS, WORKBOOKS AND TRAINING MANUALS IN THE FIELD OF NATURAL SCIENCE; A SERIES OF BOOKS, WRITTEN ARTICLES, HANDOUTS AND WORKSHEETS IN THE FIELD OF NATURAL SCIENCE EDUCATION (U.S. CLS. 2, 5, 22, 23, 29, 37, 38 AND 50).

FIRST USE 6-26-2001; IN COMMERCE 6-26-2001.

**CLASS 35—ADVERTISING AND BUSINESS**

FOR MAIL ORDER SERVICES FEATURING EDUCATIONAL PUBLICATIONS, NAMELY, STORY BOOKS, POSTERS, AND HAND-OUTS, IN THE FIELD OF NATURAL SCIENCE, AUDIO AND VIDEO RECORDINGS FEATURING STORY BOOK NARRATIONS, AND DIGITAL MATERIALS, NAMELY, CDS, FEATURING STORY BOOK NARRATIONS AND EDUCATIONAL PUBLICATIONS IN THE FIELD OF NATURAL SCIENCE; ONLINE RETAIL STORE SERVICES FEATURING EDUCATIONAL PUBLICATIONS, NAMELY, STORY BOOKS, POSTERS, AND HAND-OUTS, IN THE FIELD OF NATURAL SCIENCE; AUDIO AND VIDEO RECORDINGS FEATURING STORY BOOK NARRATIONS, AND DIGITAL MATERIALS, NAMELY, CDS AND DOWNLOADABLE AUDIO, IMAGE, VIDEO, AND DOCUMENT FILES, FEATURING STORY BOOK NARRATIONS AND EDUCATIONAL PUBLICATIONS IN THE FIELD OF NATURAL SCIENCE (U.S. CLS. 100, 101 AND 102).

FIRST USE 6-14-2004; IN COMMERCE 6-14-2004.

JANICE KIM, EXAMINING ATTORNEY

**CLASS 37—CONSTRUCTION AND REPAIR**

FOR MAINTENANCE OF INDUSTRIAL EQUIPMENT, NAMELY, TANK AND VESSEL CLEANING SERVICES; CONSULTANCY REGARDING INDUSTRIAL TANK AND VESSEL CLEANING; CLEANING OF PITS, PONDS, AND CONTAINMENTS (U.S. CLS. 100, 103 AND 106).

**CLASS 40—MATERIAL TREATMENT**

FOR TREATMENT OF MATERIALS, NAMELY, TREATMENT OF SULFIDES, HYDROCARBONS, PYROPHORICS, BENZENE, SLUDGE, CRUDE OIL, FUEL OIL, DECANTED SLURRY OIL, SOUR WATER, SLOP OIL, ASPHALT, GASOLINE, WASTEWATER, AND RESIDUAL OILS; SLUDGE EXTRACTION, NAMELY, ROBOTIC SLUDGE EXTRACTION FOR THE PURPOSE OF TREATING SOIL AND WATER BY REMOVING SLUDGE; WASTE STREAM TREATING, NAMELY, PROCESSING SLUDGE STREAMS FOR COKER INJECTION; TREATING WASTE HYDROCARBONS, NAMELY, PROCESSING WASTE HYDROCARBONS TO BREAK EMULSIONS, PERFORM TWO-PHASE LIQUID AND SOLID SEPARATIONS, AND PERFORM THREE-PHASE OIL, WATER, AND SOLID SEPARATIONS; SLUDGE SEPARATION AND DEWATERING, NAMELY, CENTRIFUGAL SLUDGE SEPARATION AND DEWATERING; CONTROLLING VOLATILE ORGANIC COMPOUNDS AND ODORS IN TANKS AND VESSELS, NAMELY, CHEMICAL PROCESSING AND THERMAL OXIDATION; DECONTAMINATION AND DEGASSING OF INDUSTRIAL EQUIPMENT, NAMELY, DECONTAMINATION AND DEGASSING OF TANKS AND VESSELS; CONSULTANCY REGARDING INDUSTRIAL TANK AND VESSEL DEGASSING AND DECONTAMINATION; ENVIRONMENTAL REMEDIATION SERVICES, NAMELY, DECONTAMINATION OF PITS, PONDS, AND CONTAINMENTS (U.S. CLS. 100, 103 AND 106).

**CLASS 42—SCIENTIFIC AND COMPUTER SERVICES**

FOR ENGINEERING SERVICES REGARDING TANKS, VESSELS, AND CONTAINMENTS; CONSULTANCY AND ADVISORY SERVICES REGARDING ENGINEERING OF TANKS, VESSELS, AND CONTAINMENTS (U.S. CLS. 100 AND 101).

LINDA LAVACHE, EXAMINING ATTORNEY

SN 85-074,437. UNITED LABORATORIES INTERNATIONAL, LLC, HOUSTON, TX. FILED 6-29-2010.

**TriStar PetroServ**

THE MARK CONSISTS OF STANDARD CHARACTERS WITHOUT CLAIM TO ANY PARTICULAR FONT, STYLE, SIZE, OR COLOR.

**CLASS 7—MACHINERY**

FOR CENTRIFUGES FOR REFINERY AND PROCESS INDUSTRY NEEDS, NAMELY, CENTRIFUGES FOR HEAVY SOLIDS, WASTEWATER, AND CRUDE OIL; SEPARATORS FOR REFINERY AND PROCESS INDUSTRY NEEDS, NAMELY, SEPARATORS FOR HEAVY SOLIDS, WASTEWATER, AND CRUDE OIL; MACHINES FOR REFINERY AND PROCESS INDUSTRY USE FOR DIVIDING, CLARIFYING, SEPARATING, MIXING AND CONVEYING OF MIXTURES OF SUBSTANCES, NAMELY, DECANTERS FOR HEAVY SOLIDS, WASTEWATER, AND CRUDE OIL; MACHINES FOR TANK, VESSEL, AND CONTAINMENT CLEANING (U.S. CLS. 13, 19, 21, 23, 31, 34 AND 35).

**CLASS 11—ENVIRONMENTAL CONTROL APPARATUS**

FOR THERMAL OXIDIZERS FOR INDUSTRIAL USE WITH DEGASSING TANKS AND VESSELS, NAMELY, THERMAL OXIDIZERS FOR AIRBORNE VOLATILE ORGANIC COMPOUND CONTROL AND ODOR CONTROL (U.S. CLS. 13, 21, 23, 31 AND 34).

SN 85-074,850. GEOFFREY SELZER, WEST HILLS, CA. FILED 6-30-2010.

**LUMINOUS PUBLISHING**

THE MARK CONSISTS OF STANDARD CHARACTERS WITHOUT CLAIM TO ANY PARTICULAR FONT, STYLE, SIZE, OR COLOR.

NO CLAIM IS MADE TO THE EXCLUSIVE RIGHT TO USE "PUBLISHING", APART FROM THE MARK AS SHOWN.

**CLASS 9—ELECTRICAL AND SCIENTIFIC APPARATUS**

FOR DOWNLOADABLE ELECTRONIC PUBLICATIONS IN THE NATURE OF BOOKS, MAGAZINES AND PERIODICALS ON A WIDE RANGE OF TOPICS OF GENERAL INTEREST, NAMELY, ART, EDUCATION, SPORTS, BEAUTY, RETAIL SALES, PETS, AUTOMOBILES, DO-IT-YOURSELF, HISTORY, TRAVEL, SCIENCE, FASHION, TECHNOLOGY, CHILDREN'S CONTENT, GREEN TOPICS AND SUSTAINABILITY, GARDENING, MUSIC, SCIENCE FICTION, FOOD, WINE, HEALTH AND WELLNESS, FILMS, GAMES, NEWS AND CURRENT EVENTS, ARCHITECTURE AND INTERIOR DESIGN, ALL OF THE FOREGOING NOT IN THE FIELD OF RELIGION; DOWNLOADABLE MULTIMEDIA FILES CONTAINING ARTWORK, TEXT, AUDIO, VIDEO, GAMES, MUSIC, 3-D ANIMATION, AUDIO-VIDEO ENTERTAINMENT, BOOKS, MAGAZINES, PERIODICALS, INTERNET WEB LINKS AND REAL-TIME DATA AND CONTENT RELATING TO A WIDE RANGE OF TOPICS OF GENERAL INTEREST, NAMELY, ART, EDUCATION, SPORTS, BEAUTY, RETAIL SALES, PETS, AUTOMOBILES, DO-IT-YOURSELF, HISTORY, TRAVEL, SCIENCE, FASHION, TECHNOLOGY, CHILDREN'S CONTENT, GREEN TOPICS AND SUSTAINABILITY, GARDENING, MUSIC, SCIENCE FICTION, FOOD, WINE, HEALTH AND WELLNESS, FILMS, GAMES, NEWS AND CURRENT EVENTS, ARCHITECTURE AND INTERIOR DESIGN, ALL OF THE FOREGOING NOT IN THE FIELD OF RELIGION; DOWNLOADABLE SOFTWARE IN THE NATURE OF MOBILE APPLICATIONS ON A WIDE RANGE OF TOPICS OF GENERAL INTEREST FOR USE IN CONNECTION WITH TABLET COMPUTERS AND MOBILE PHONES FOR CONTENT CONSUMPTION, SOCIAL NETWORKING, ECOMMERCE, AND ACCESSING, VIEWING AND READING ELECTRONIC PUBLICATIONS IN THE NATURE OF BOOKS, MAGAZINES AND PERIODICALS, ALL OF THE FOREGOING NOT IN THE FIELD OF RELIGION; SOFTWARE PLUG-IN APPLICATIONS FOR TABLET COMPUTERS AND MOBILE PHONES, NAMELY, FOR CONTENT CONSUMPTION, SOCIAL NETWORKING, ECOMMERCE, AND ACCESSING, VIEWING AND READING ELECTRONIC PUBLICATIONS IN THE NATURE OF BOOKS, MAGAZINES AND PERIODICALS, ALL OF THE FOREGOING NOT IN THE FIELD OF RELIGION (U.S. CLS. 21, 23, 26, 36 AND 38).

**CLASS 41—EDUCATION AND ENTERTAINMENT**

FOR MULTIMEDIA PUBLISHING OF ARTWORK, TEXT, AUDIO, VIDEO, 3-D ANIMATION, AUDIO-VIDEO ENTERTAINMENT, BOOKS, MAGAZINES, PERIODICALS, ELECTRONIC PUBLICATIONS, SOFTWARE, GAMES, MUSIC AND REAL-TIME DATA AND CONTENT, ALL OF THE FOREGOING NOT IN THE FIELD OF RELIGION; PUBLICATION OF ELECTRONIC PUBLICATIONS, ELECTRONIC MAGAZINES, ELECTRONIC PERIODICALS AND ELECTRONIC BOOKS, ALL OF THE FOREGOING NOT IN THE FIELD OF RELIGION; PROVIDING NON-DOWNLOADABLE, ON-LINE PUBLICATIONS IN THE NATURE OF ELECTRONIC MAGAZINES, ELECTRONIC PERIODICALS AND ELECTRONIC BOOKS ON A WIDE RANGE OF TOPICS OF GENERAL INTEREST, NAMELY, ART, EDUCATION, SPORTS, BEAUTY, RETAIL SALES, PETS, AUTOMOBILES, DO-IT-YOURSELF, HISTORY, TRAVEL, SCIENCE, FASHION, TECHNOLOGY, CHILDREN'S CONTENT, GREEN TOPICS AND SUSTAINABILITY, GARDENING, MUSIC, SCIENCE FICTION, FOOD, WINE, HEALTH AND WELLNESS, FILMS, GAMES, NEWS AND CURRENT EVENTS, ARCHITECTURE AND INTERIOR DESIGN, ALL OF THE FOREGOING NOT IN THE FIELD OF RELIGION (U.S. CLS. 100, 101 AND 107).

MARTHA SANTOMARTINO, EXAMINING ATTORNEY

SN 85-075,115. MONSTEROPS LLC, COLORADO SPRINGS, CO. FILED 6-30-2010.

**V DIET**

THE MARK CONSISTS OF STANDARD CHARACTERS WITHOUT CLAIM TO ANY PARTICULAR FONT, STYLE, SIZE, OR COLOR.

NO CLAIM IS MADE TO THE EXCLUSIVE RIGHT TO USE "DIET", APART FROM THE MARK AS SHOWN.

**CLASS 5—PHARMACEUTICALS**

FOR DIETARY SUPPLEMENTS (U.S. CLS. 6, 18, 44, 46, 51 AND 52).

**CLASS 44—MEDICAL, BEAUTY AND AGRICULTURAL SERVICES**

FOR PROVIDING WEIGHT LOSS PROGRAM SERVICES (U.S. CLS. 100 AND 101).

NAPOLEON SHARMA, EXAMINING ATTORNEY

SN 85-075,445. MARKETTEAM, INC., MISSION VIEJO, CA. FILED 6-30-2010.

**MIXLAB**

THE MARK CONSISTS OF STANDARD CHARACTERS WITHOUT CLAIM TO ANY PARTICULAR FONT, STYLE, SIZE, OR COLOR.

**CLASS 35—ADVERTISING AND BUSINESS**

FOR ADVERTISING SERVICES, PROVIDING CONSULTATION SERVICES IN THE FIELD OF ADVERTISING IN THE HOSPITALITY INDUSTRY (U.S. CLS. 100, 101 AND 102).

FIRST USE 7-15-2010; IN COMMERCE 7-15-2010.

**CLASS 42—SCIENTIFIC AND COMPUTER SERVICES**

FOR PROVIDING TEST KITCHEN SERVICES FOR OTHERS, NAMELY, PRODUCT RESEARCH AND DEVELOPMENT; PROVIDING SERVICES TO OTHERS FOR THE DEVELOPMENT, MARKETING AND TESTING OF HOSPITALITY INDUSTRY FOOD AND BEVERAGE PRODUCTS, NAMELY, PRODUCT RESEARCH AND DEVELOPMENT SERVICES FOR OTHERS IN THE FIELD OF FOOD PRODUCTS AND MENUS (U.S. CLS. 100 AND 101).

FIRST USE 7-15-2010; IN COMMERCE 7-15-2010.

INGRID C. EULIN, EXAMINING ATTORNEY

SN 85-075,531. GLOBAL SOLAR ENERGY, INC., TUCSON, AZ. FILED 6-30-2010.

# POWERFLEX

THE MARK CONSISTS OF STANDARD CHARACTERS WITHOUT CLAIM TO ANY PARTICULAR FONT, STYLE, SIZE, OR COLOR.  
OWNER OF U.S. REG. NO. 2,965,897.

## CLASS 9—ELECTRICAL AND SCIENTIFIC APPARATUS

FOR SOLAR CELLS; PHOTOVOLTAIC SOLAR MODULES FOR PRODUCTION OF ENERGY; SOLAR COLLECTOR PANELS; SOLAR CHARGE REGULATORS; SOLAR PANELS FOR ENERGY AND ELECTRICITY GENERATION; PHOTOVOLTAIC CELLS; PHOTOVOLTAIC MODULES; PHOTOVOLTAIC GENERATORS CONSISTING OF SOLAR CELLS, SOLAR MODULES, AND SOLAR PANELS; PHOTOVOLTAIC INSTALLATION APPARATUS, NAMELY, SOLAR MODULES FOR PRODUCTION OF ELECTRICITY; PHOTOVOLTAIC SYSTEMS THAT CONVERT SOLAR ENERGY OR RADIATION INTO OTHER TYPES OF ENERGY, NAMELY, PHOTOVOLTAIC SOLAR MODULES; PHOTOVOLTAIC MODULES IN THE NATURE OF SOLAR PANELS ADAPTED FOR INCORPORATION IN ROOFS, RESIDENTIAL AND COMMERCIAL BUILDINGS, AND BUILDING PRODUCTS FOR PRODUCTION OF ELECTRICITY (U.S. CLS. 21, 23, 26, 36 AND 38).

## CLASS 42—SCIENTIFIC AND COMPUTER SERVICES

FOR DESIGN, DRAFTING, AND DEVELOPMENT OF SOLAR PHOTOVOLTAIC SYSTEMS; ENGINEERING, PHYSICS RESEARCH, AND TECHNICAL CONSULTANCY IN CONNECTION WITH SOLAR ENGINEERING IN THE NATURE OF ENGINEERING, CALCULATION, AND PLANNING OF SOLAR POWER INSTALLATIONS, ELECTRIC INSTALLATIONS, AND ELECTRONIC APPARATUS AND EQUIPMENT; ENERGY METERING AND MONITORING OF THERMAL AND PHOTOVOLTAIC SOLAR INSTALLATIONS; ARCHITECTURAL AND CONSTRUCTION DRAFTING AND TECHNICAL CONSULTANCY WITH REGARD TO THE PLANNING OF SOLAR POWER INSTALLATIONS IN RESIDENTIAL AND COMMERCIAL BUILDINGS (U.S. CLS. 100 AND 101).  
TARAH HARDY, EXAMINING ATTORNEY

SN 85-075,553. STATE BAR OF WISCONSIN, MADISON, WI. FILED 6-30-2010.

# State Bar of Wisconsin

THE MARK CONSISTS OF STANDARD CHARACTERS WITHOUT CLAIM TO ANY PARTICULAR FONT, STYLE, SIZE, OR COLOR.  
OWNER OF U.S. REG. NOS. 2,379,639 AND 3,741,623.  
NO CLAIM IS MADE TO THE EXCLUSIVE RIGHT TO USE "STATE BAR", APART FROM THE MARK AS SHOWN. SEC. 2(F).

## CLASS 16—PAPER GOODS AND PRINTED MATTER

FOR PUBLICATIONS AND PRACTICE MATERIALS, NAMELY, BOOKS, MAGAZINES, NEWSLETTERS, PAMPHLETS, FILL-IN LEGAL FORMS, AND COURSE MATERIALS IN THE FIELD OF LAW (U.S. CLS. 2, 5, 22, 23, 29, 37, 38 AND 50).  
FIRST USE 12-31-1956; IN COMMERCE 12-31-1956.

## CLASS 35—ADVERTISING AND BUSINESS

FOR ASSOCIATION SERVICES, NAMELY, PROMOTING THE INTEREST OF LAWYERS AND IMPROVING THE DELIVERY OF LEGAL SERVICES (U.S. CLS. 100, 101 AND 102).  
FIRST USE 12-31-1956; IN COMMERCE 12-31-1956.

## CLASS 41—EDUCATION AND ENTERTAINMENT

FOR EDUCATIONAL SERVICES AND PROGRAMS FOR LAWYERS, NAMELY, PROVIDING CONTINUING LEGAL EDUCATION COURSES (U.S. CLS. 100, 101 AND 107).  
FIRST USE 12-31-1956; IN COMMERCE 12-31-1956.  
JEFF DEFORD, EXAMINING ATTORNEY

SN 85-075,570. BRIAN E. ROSE, NORTH BRUNSWICK, NJ. AND NELSON C. PAVLOSKY, MORRIS PLAINS, NJ. FILED 7-1-2010.

# Wrong Side of Dawn

THE MARK CONSISTS OF STANDARD CHARACTERS WITHOUT CLAIM TO ANY PARTICULAR FONT, STYLE, SIZE, OR COLOR.

## CLASS 9—ELECTRICAL AND SCIENTIFIC APPARATUS

FOR COMPACT DISCS FEATURING MUSIC; DIGITAL MUSIC DOWNLOADABLE FROM THE INTERNET; DOWNLOADABLE MUSICAL SOUND RECORDINGS; MUSICAL SOUND RECORDINGS; SERIES OF MUSICAL SOUND RECORDINGS (U.S. CLS. 21, 23, 26, 36 AND 38).  
FIRST USE 5-1-2006; IN COMMERCE 12-4-2008.

## CLASS 41—EDUCATION AND ENTERTAINMENT

FOR ENTERTAINMENT SERVICES IN THE NATURE OF LIVE MUSICAL PERFORMANCES; ENTERTAINMENT, NAMELY, LIVE MUSIC CONCERTS; ENTERTAINMENT, NAMELY, LIVE PERFORMANCES BY A MUSICAL BAND; PRODUCTION OF MUSICAL SOUND RECORDING (U.S. CLS. 100, 101 AND 107).  
FIRST USE 5-1-2006; IN COMMERCE 12-16-2009.  
JOHN GARTNER, EXAMINING ATTORNEY

SN 85-076,059. HENSON SLEEP RELIEF, INC., SALTILLO, MS. FILED 7-1-2010.

### TROPICAL HOTEL COLLECTION

THE MARK CONSISTS OF STANDARD CHARACTERS WITHOUT CLAIM TO ANY PARTICULAR FONT, STYLE, SIZE, OR COLOR.

NO CLAIM IS MADE TO THE EXCLUSIVE RIGHT TO USE "HOTEL COLLECTION", APART FROM THE MARK AS SHOWN.

### CLASS 20—FURNITURE AND ARTICLES NOT OTHERWISE CLASSIFIED

FOR PILLOWS (U.S. CLS. 2, 13, 22, 25, 32 AND 50).

### CLASS 24—FABRICS

FOR MATTRESS PADS (U.S. CLS. 42 AND 50).  
ANDREA HACK, EXAMINING ATTORNEY

SN 85-077,011. SATORI SOFTWARE, INC., SEATTLE, WA. FILED 7-2-2010.

## SATORI SOFTWARE

THE MARK CONSISTS OF STANDARD CHARACTERS WITHOUT CLAIM TO ANY PARTICULAR FONT, STYLE, SIZE, OR COLOR.

OWNER OF U.S. REG. NOS. 3,393,861 AND 3,393,862.

NO CLAIM IS MADE TO THE EXCLUSIVE RIGHT TO USE "SOFTWARE", APART FROM THE MARK AS SHOWN.

THE ENGLISH TRANSLATION OF "SATORI" IN THE MARK IS "ENLIGHTENMENT".

### CLASS 9—ELECTRICAL AND SCIENTIFIC APPARATUS

FOR COMPUTER PROGRAMS AND SOFTWARE FOR MAILING LIST PROCESSING AND MANAGEMENT, ADDRESS MANAGEMENT, POSTAL SORTING, DATA PROCESSING, DATA VALIDATION, DATA ENHANCEMENT AND DATA QUALITY, EXCLUDING COMPUTER SOFTWARE FOR USE IN AUTOMATICALLY CONVERTING HANDWRITTEN INFORMATION INTO DIGITAL DATA (U.S. CLS. 21, 23, 26, 36 AND 38).

FIRST USE 5-1-1992; IN COMMERCE 5-1-1992.

### CLASS 42—SCIENTIFIC AND COMPUTER SERVICES

FOR TECHNICAL SUPPORT, NAMELY, TROUBLESHOOTING IN THE NATURE OF DIAGNOSING COMPUTER SOFTWARE PROBLEMS, TECHNICAL CONSULTING AND ASSISTANCE WITH COMPUTER SOFTWARE AND PROGRAMS, COMPUTER SYSTEMS AND COMPUTER SYSTEMS INTEGRATION; TECHNICAL CONSULTING, ANALYSIS, AND ASSISTANCE IN THE FIELD OF MAILING LIST PROCESSING AND MANAGEMENT, ADDRESS MANAGEMENT, POSTAL SORTING; DEVELOPMENT, DESIGN AND CUSTOMIZATION OF COMPUTER SOFTWARE AND PROGRAMS IN THE FIELD OF MAILING LIST PROCESSING AND MANAGEMENT, ADDRESS MANAGEMENT, POSTAL SORTING, DATA PROCESSING, DATA VALIDATION, DATA ENHANCEMENT, AND DATA QUALITY (U.S. CLS. 100 AND 101).

FIRST USE 5-1-1992; IN COMMERCE 5-1-1992.

WILLIAM VERHOSEK, EXAMINING ATTORNEY

SN 85-077,391. PHOTO PACK S.A. DE C.V., ESTADO DE MEXICO, MEXICO, FILED 7-2-2010.

## URBANIA

THE MARK CONSISTS OF STANDARD CHARACTERS WITHOUT CLAIM TO ANY PARTICULAR FONT, STYLE, SIZE, OR COLOR.

THE WORDING "URBANIA" HAS NO MEANING IN A FOREIGN LANGUAGE.

### CLASS 9—ELECTRICAL AND SCIENTIFIC APPARATUS

FOR COMPUTER CARRYING CASES (U.S. CLS. 21, 23, 26, 36 AND 38).

### CLASS 18—LEATHER GOODS

FOR HANDBAGS; BRIEFCASES; BACKPACKS (U.S. CLS. 1, 2, 3, 22 AND 41).

### CLASS 25—CLOTHING

FOR CAPS (U.S. CLS. 22 AND 39).

MICHAEL GAUFAR, EXAMINING ATTORNEY

SN 85-077,397. LICE HAPPENS, LLC, ANNAPOLIS, MD. FILED 7-2-2010.



NO CLAIM IS MADE TO THE EXCLUSIVE RIGHT TO USE "LICE", APART FROM THE MARK AS SHOWN.

THE MARK CONSISTS OF THE WORDS "LICE HAPPENS" WITH DOTS BENEATH IT, FOLLOWED BY THE LOUSE ORIENTED DIAGONALLY AND POINTING UPWARD TO THE RIGHT, FOLLOWED BY THE WORDS "NO SHAME." WITH "NO BLAME." BENEATH IT.



**CLASS 5—PHARMACEUTICALS**

FOR LICE TREATMENT AND REMOVAL PREPARATIONS, INCLUDING TREATMENT FOAM, SHAMPOO, CONDITIONER, REPELLANT SPRAY (U.S. CLS. 6, 18, 44, 46, 51 AND 52).

FIRST USE 2-1-2009; IN COMMERCE 2-1-2009.

**CLASS 10—MEDICAL APPARATUS**

FOR LICE COMBS (U.S. CLS. 26, 39 AND 44).

FIRST USE 2-1-2009; IN COMMERCE 2-1-2009.

**CLASS 44—MEDICAL, BEAUTY AND AGRICULTURAL SERVICES**

FOR MOBILE HEAD LICE REMOVAL AND TREATMENT SERVICES; PROVIDING INFORMATION IN THE FIELDS OF HEAD LICE REMOVAL AND PREVENTION OF HEAD LICE INFESTATION (U.S. CLS. 100 AND 101).

FIRST USE 2-1-2009; IN COMMERCE 2-1-2009.

EMILY CARLSEN, EXAMINING ATTORNEY

SN 85-078,147. DRG TEXAS, LP, BERNE, IN. FILED 7-6-2010.

# ANNIE'S

THE MARK CONSISTS OF STANDARD CHARACTERS WITHOUT CLAIM TO ANY PARTICULAR FONT, STYLE, SIZE, OR COLOR.

OWNER OF U.S. REG. NOS. 1,479,090, 3,649,797 AND OTHERS.

**CLASS 9—ELECTRICAL AND SCIENTIFIC APPARATUS**

FOR ELECTRONIC DOWNLOADABLE PUBLICATIONS RECORDED ON COMPUTER MEDIA AND ELECTRONIC PUBLICATIONS RECORDED ON COMPUTER MEDIA, NAMELY, MAGAZINES, BOOKS ABOUT CRAFT PROJECTS, CROCHET, KNIT, CARD MAKING, CROSS-STITCH, QUILTING, SEWING AND BEADING, CATALOGS, PATTERN BOOKS, NEWSLETTERS AND INSTRUCTION MANUALS IN THE FIELD OF CRAFT PROJECTS, INCLUDING BEADING, CROSS-STITCH, NEEDLECRAFT, CROCHET, KNITTING, PLASTIC CANVAS, PAPER CRAFTS, SEWING, GREETING CARDS, DOLL CLOTHING, ACCESSORIES, CAKE DECORATING, AND CHRISTMAS ORNAMENTS, AND JEWELRY; DOWNLOADABLE VIDEO RECORDINGS FEATURING INSTRUCTION IN THE FIELDS OF BEADED CRAFTS, CROSS-STITCH, NEEDLECRAFT, CROCHET, KNITTING, PLASTIC CANVAS, PAPER CRAFTS, SEWING, GREETING CARDS, DOLL CLOTHING, ACCESSORIES, CAKE DECORATING, CHRISTMAS ORNAMENTS, AND JEWELRY; DOWNLOADABLE ELECTRONIC SOFTWARE, NAMELY, APPLICATIONS FOR SMART PHONES AND PORTABLE COMPUTERS IN THE FIELDS OF BEADED CRAFTS, CROSS-STITCH, NEEDLECRAFT, CROCHET, KNITTING, PLASTIC CANVAS, PAPER CRAFTS, SEWING, GREETING CARDS, DOLL CLOTHING, ACCESSORIES, CAKE DECORATING, CHRISTMAS ORNAMENTS, AND JEWELRY (U.S. CLS. 21, 23, 26, 36 AND 38).

**CLASS 14—JEWELRY**

FOR JEWELRY MAKING KITS COMPRISED PRIMARILY OF BEADS MADE FROM GLASS, WOOD, CERAMIC, CLAY, PEARLS, SEASHELLS, SEMI-PRECIOUS STONES AND METALS, JEWELRY FINDINGS AND METAL WIRE ALONG WITH BEADING STRINGS, THREAD, NEEDLES, FABRIC, ORNAMENTS, RIBBON AND VARIOUS SURFACES THE BEADS WILL ACCENT FROM WOOD, GLASS AND PLASTIC, AND ALSO CONTAINING INSTRUCTIONAL LEAFLETS AND PRINTED PATTERNS FOR BEADING AND MAKING JEWELRY (U.S. CLS. 2, 27, 28 AND 50).

**CLASS 16—PAPER GOODS AND PRINTED MATTER**

FOR PRINT PUBLICATIONS, NAMELY, MAGAZINES, BOOKS ABOUT CRAFT PROJECTS, CROCHET, KNIT, CARD MAKING, CROSS-STITCH, QUILTING, SEWING AND BEADING, CATALOGS, PATTERN BOOKS, NEWSLETTERS AND INSTRUCTION MANUALS IN THE FIELD OF CRAFT PROJECTS, INCLUDING PAINTING, DRAWING, FABRIC CRAFTS, BEADING, CROSS-STITCH, NEEDLECRAFT, CROCHET, KNITTING, PLASTIC CANVAS, PAPER CRAFTS, SEWING, GREETING CARDS, DOLL CLOTHING, ACCESSORIES, CAKE DECORATING, CHRISTMAS ORNAMENTS, AND JEWELRY; A SERIES OF FICTION BOOKS; PATTERNS FOR MAKING PAINTING CRAFTS, DRAWING CRAFTS, FABRIC CRAFTS, BEADED CRAFTS, CROSS-STITCH, NEEDLECRAFT, CROCHET, KNITTING, PLASTIC CANVAS, PAPER CRAFTS, SEWING, GREETING CARDS, DOLL CLOTHING, ACCESSORIES, CAKE DECORATING, CHRISTMAS ORNAMENTS, AND JEWELRY; PACKAGED KITS COMPRISED PRIMARILY OF PRINTED INSTRUCTIONAL, EDUCATIONAL, AND TEACHING MATERIALS FOR EDUCATIONAL ACTIVITIES IN THE FIELDS OF BEADED CRAFTS, CROSS-STITCH, NEEDLECRAFT, CROCHET, KNITTING, PLASTIC CANVAS, PAPER CRAFTS, SEWING, GREETING CARDS, DOLL CLOTHING, ACCESSORIES, CAKE DECORATING, CHRISTMAS ORNAMENTS, AND JEWELRY; AND ALSO CONTAINING PRINTED PATTERNS; PRINTED INSTRUCTION SHEETS IN THE FIELDS OF A WIDE VARIETY OF HOBBY CRAFTS AND BEADING (U.S. CLS. 2, 5, 22, 23, 29, 37, 38 AND 50).

**CLASS 23—YARNS AND THREADS**

FOR KITS FOR CROSS-STITCH, NEEDLECRAFT, CROCHET, KNITTING AND PLASTIC CANVAS, ALL COMPRISED PRIMARILY COMPRISED OF YARN, THREAD, EMBROIDERY FLOSS, AND ALSO CONTAINING INSTRUCTIONAL LEAFLETS WITH PATTERNS (U.S. CL. 43).

**CLASS 26—FANCY GOODS**

FOR CROCHET, KNITTING, CROSS-STITCH, AND PLASTIC CANVAS KITS PRIMARILY COMPRISED OF CROCHET NEEDLES, CROCHET HOOKS, CROCHET HOOK CASES, KNITTING NEEDLES, NEEDLES, NEEDLE THREADERS, NEEDLE CASES, NEEDLE CUSHIONS, STITCH MARKERS, RIBBONS, BRAID, ORNAMENTAL NOVELTY BUTTONS AND BEADS FOR HANDICRAFT WORK OF VARIOUS MATERIALS, NAMELY, METAL, PLASTIC, GLASS, ACRYLIC, BONE, AND WOOD, AND ALSO CONTAINING THREAD, YARN, INSTRUCTIONAL LEAFLETS AND PRINTED PATTERNS (U.S. CLS. 37, 39, 40, 42 AND 50).

**CLASS 28—TOYS AND SPORTING GOODS**

FOR HOBBY CRAFT KITS FOR MAKING BEADED CRAFTS, PAPER CRAFTS, DOLL CLOTHING AND ACCESSORIES, CAKE DECORATIONS, CHRISTMAS ORNAMENTS, JEWELRY, AND KNITTED, CROCHETED, CROSS-STITCHED AND PLASTIC CANVAS CRAFTS, PAINTING CRAFTS, FABRIC CRAFTS AND DRAWING CRAFTS AND ALSO CONTAINING INSTRUCTION LEAFLETS AND PRINTED PATTERNS; HOBBY CRAFT KIT COMPRISED PRIMARILY OF VARIOUS CRAFTING SUPPLIES FOR MAKING CHRISTMAS ORNAMENTS, NAMELY, PAINT, CLAY, PLASTIC MOSAIC PIECES, PAPER, GLITTER, GLUE, WIRE, BEADS, RESIN, WOOD, CERAMIC, GLASS, STICKERS, NEEDLES, YARN, FOAM, SILK FLORALS, DRIED FLORALS, FABRIC AND LACE SOLD AS AN UNIT, AND ALSO CONTAINING INSTRUCTIONAL LEAFLETS AND PRINTED PATTERNS; HOBBY CRAFT KITS COMPRISED PRIMARILY OF BEADS MADE FROM GLASS, WOOD, CERAMIC, CLAY, PEARLS, SEASHELLS, SEMI-PRECIOUS STONES AND METALS, JEWELRY FINDINGS AND METAL WIRE ALONG WITH BEADING STRINGS, THREAD, NEEDLES, FABRIC, ORNAMENTS, RIBBON AND VARIOUS SURFACES THE BEADS WILL ACCENT FROM WOOD, GLASS AND PLASTIC, AND ALSO CONTAINING INSTRUCTION LEAFLETS AND PRINTED PATTERNS; HOBBY CRAFT KITS COMPRISED PRIMARILY OF YARNS, THREADS, RIBBONS, PLASTIC CANVAS, MAGNETIC STRIPS, BUTTONS, BEADS, NEEDLES, MARKING PENS AND TOOLS, FABRIC, FELT, PAPER, PAINTS, PAINT BRUSHES, ADHESIVES, STENCILS, CHARMS, CRAFT FLORAL PRODUCTS, CRAFTING WIRE, CRAFT CUTTING TOOLS, CRAFT STUFFING, BATTING, DOLLS, DOLL PARTS, DOLL HAIR, FEATHERS, LEATHER, WOOD, CROCHET HOOKS, KNITTING NEEDLES, CUTTING TOOLS, QUILTING TOOLS, CROSS-STITCH TOOLS, AND ALSO CONTAINING INSTRUCTIONAL LEAFLETS AND PRINTED PATTERNS (U.S. CLS. 22, 23, 38 AND 50).

MARY ROSSMAN, EXAMINING ATTORNEY

SN 85-078,292. SUNSTAR SUISSE S.A., 1163 ETOY, SWITZERLAND, FILED 7-6-2010.

健康道場  
KENKODOJO

THE MARK CONSISTS OF THE WORDING "KENKODOJO" APPEARING BELOW KANJI CHARACTERS

THE ENGLISH TRANSLATION OF "KENKODOJO" IN THE MARK IS "A PLACE FOR IMPROVING ONE'S HEALTH".

THE NON-LATIN CHARACTERS IN THE MARK TRANSLITERATE TO "KENKODOJO" AND THIS MEANS "A PLACE FOR IMPROVING ONE'S HEALTH" IN ENGLISH.

**CLASS 5—PHARMACEUTICALS**

FOR NUTRITIONAL SUPPLEMENTS; NON-NUTRITIOUS FIBER SUPPLEMENTS; VITAMIN AND MINERAL SUPPLEMENTS; DIABETIC BREAD; MEAL REPLACEMENT DRINKS; HERB TEAS FOR MEDICINAL PURPOSES (U.S. CLS. 6, 18, 44, 46, 51 AND 52).

**CLASS 29—MEATS AND PROCESSED FOODS**

FOR BUTTER; JAMS; SOUP POWDERS; POUCH-PACKED SOUPS (U.S. CL. 46).

**CLASS 30—STAPLE FOODS**

FOR BREAD; NOODLES; PASTRIES; COOKIES; OAT-MEAL; OAT FLAKES; CEREAL BASED SNACK FOODS; RICE; FLOUR; POUCH-PACKED ENTREES CONSISTING PRIMARILY OF PORRIDGE OR RICE AND ALSO CONTAINING VEGETABLES; NON-MEDICATED LOZENGES (U.S. CL. 46).

**CLASS 32—LIGHT BEVERAGES**

FOR VEGETABLE JUICE; NON-ALCOHOLIC FRUIT JUICE BEVERAGES; NON-ALCOHOLIC BEVERAGES, NAMELY, SPORTS DRINKS AND MINERAL WATER DRINKS (U.S. CLS. 45, 46 AND 48).

KATHERINE CHANG, EXAMINING ATTORNEY

SN 85-078,393. SATORI SOFTWARE, INC., SEATTLE, WA. FILED 7-6-2010.

SATORI

THE MARK CONSISTS OF STANDARD CHARACTERS WITHOUT CLAIM TO ANY PARTICULAR FONT, STYLE, SIZE, OR COLOR.

OWNER OF U.S. REG. NOS. 3,393,861 AND 3,393,862.

THE ENGLISH TRANSLATION OF "SATORI" IN THE MARK IS "ENLIGHTENMENT".

**CLASS 9—ELECTRICAL AND SCIENTIFIC APPARATUS**

FOR COMPUTER PROGRAMS AND SOFTWARE FOR MAILING LIST PROCESSING AND MANAGEMENT, ADDRESS MANAGEMENT, POSTAL SORTING, DATA PROCESSING, DATA VALIDATION, DATA ENHANCEMENT AND DATA QUALITY, EXCLUDING COMPUTER SOFTWARE FOR USE IN AUTOMATICALLY CONVERTING HANDWRITTEN INFORMATION INTO DIGITAL DATA (U.S. CLS. 21, 23, 26, 36 AND 38).

FIRST USE 5-1-1992; IN COMMERCE 5-1-1992.

**CLASS 42—SCIENTIFIC AND COMPUTER SERVICES**

FOR TECHNICAL SUPPORT, NAMELY, TROUBLESHOOTING IN THE NATURE OF DIAGNOSING COMPUTER SOFTWARE PROBLEMS, TECHNICAL CONSULTING AND ASSISTANCE WITH COMPUTER SOFTWARE AND PROGRAMS, COMPUTER SYSTEMS AND COMPUTER SYSTEMS INTEGRATION; TECHNICAL CONSULTING, ANALYSIS, AND ASSISTANCE IN THE FIELD OF MAILING LIST PROCESSING AND MANAGEMENT, ADDRESS MANAGEMENT, POSTAL SORTING; DEVELOPMENT, DESIGN AND CUSTOMIZATION OF COMPUTER SOFTWARE AND PROGRAMS IN THE FIELD OF MAILING LIST PROCESSING AND MANAGEMENT, ADDRESS MANAGEMENT, POSTAL SORTING, DATA PROCESSING, DATA VALIDATION, DATA ENHANCEMENT, AND DATA QUALITY (U.S. CLS. 100 AND 101).

FIRST USE 5-1-1992; IN COMMERCE 5-1-1992.

WILLIAM VERHOSEK, EXAMINING ATTORNEY

SN 85-078,421. SMARTHEALTH, INC., PHOENIX, AZ. FILED 7-6-2010.

# SQWIGGLY

THE MARK CONSISTS OF STANDARD CHARACTERS WITHOUT CLAIM TO ANY PARTICULAR FONT, STYLE, SIZE, OR COLOR.

## CLASS 3—COSMETICS AND CLEANING PREPARATIONS

FOR DENTAL CARE AND DENTAL HYGIENE PRODUCTS, NAMELY, TOOTHPASTE (U.S. CLS. 1, 4, 6, 50, 51 AND 52).

## CLASS 16—PAPER GOODS AND PRINTED MATTER

FOR COLORING BOOKS AND PRINTED DENTAL PATIENT COMMUNICATION MATERIALS IN THE NATURE OF ACTIVITY CARDS AND BOOKLETS FEATURING TEETH BRUSHING TECHNIQUES (U.S. CLS. 2, 5, 22, 23, 29, 37, 38 AND 50).

## CLASS 21—HOUSEWARES AND GLASS

FOR DENTAL CARE AND DENTAL HYGIENE PRODUCTS, NAMELY, TOOTHBRUSHES AND DENTAL FLOSS (U.S. CLS. 2, 13, 23, 29, 30, 33, 40 AND 50).  
JULIE VEPPUMTHARA, EXAMINING ATTORNEY

SN 85-078,610. CARS IN BARNS, LLC, RICHARDSON, TX. FILED 7-6-2010.

# Cars in Barns

THE MARK CONSISTS OF STANDARD CHARACTERS WITHOUT CLAIM TO ANY PARTICULAR FONT, STYLE, SIZE, OR COLOR.

NO CLAIM IS MADE TO THE EXCLUSIVE RIGHT TO USE "CARS", APART FROM THE MARK AS SHOWN.

## CLASS 16—PAPER GOODS AND PRINTED MATTER

FOR CALENDARS SOLD ON-LINE AND THROUGH RETAIL OUTLETS (U.S. CLS. 2, 5, 22, 23, 29, 37, 38 AND 50).

FIRST USE 12-14-2000; IN COMMERCE 12-14-2000.

## CLASS 25—CLOTHING

FOR T-SHIRTS AND HATS SOLD ON-LINE AND THROUGH RETAIL OUTLETS (U.S. CLS. 22 AND 39).

## CLASS 35—ADVERTISING AND BUSINESS

FOR PROVIDING ON-LINE ADVERTISING AND DIRECTORY SERVICES TO BUSINESSES TARGETING AUTOMOTIVE ENTHUSIASTS, NAMELY, PROMOTING THE SERVICES OF OTHERS BY PROVIDING A WEB PAGE FEATURING LINKS TO THE WEBSITES OF OTHERS (U.S. CLS. 100, 101 AND 102).

FIRST USE 12-14-2000; IN COMMERCE 12-14-2000.

## CLASS 41—EDUCATION AND ENTERTAINMENT

FOR ENTERTAINMENT SERVICES, NAMELY, PROVIDING A WEB SITE FOR AUTOMOTIVE ENTHUSIASTS FEATURING PHOTOGRAPHS OF CARS, TRUCKS, JUNKYARDS AND OTHER AUTOMOTIVE-RELATED SUBJECTS (U.S. CLS. 100, 101 AND 107).

FIRST USE 12-14-2000; IN COMMERCE 12-14-2000.

RENEE MCCRAY, EXAMINING ATTORNEY

SN 85-079,153. KERAFEST, LLC, WINSTON-SALEM, NC. FILED 7-7-2010.

# MAINESPRING

THE MARK CONSISTS OF STANDARD CHARACTERS WITHOUT CLAIM TO ANY PARTICULAR FONT, STYLE, SIZE, OR COLOR.

## CLASS 1—CHEMICALS

FOR BUFFERS, SOLUTIONS AND RELATED LABORATORY RESEARCH PRODUCTS FOR LIFE SCIENCE RESEARCH, NAMELY, REAGENT KITS COMPRISING GENERIC DNA CIRCLE, DNA PRIMERS, POLYMERASE AND BUFFERS FOR USE IN BIOTECHNOLOGY FIELDS (U.S. CLS. 1, 5, 6, 10, 26 AND 46).

## CLASS 5—PHARMACEUTICALS

FOR BUFFERS, SOLUTIONS AND RELATED LABORATORY RESEARCH PRODUCTS FOR LIFE SCIENCE RESEARCH, NAMELY, DIAGNOSTIC KITS CONSISTING PRIMARILY OF MONOCLONAL ANTIBODIES, BUFFERS, AND REAGENTS FOR USE IN DISEASE TESTING (U.S. CLS. 6, 18, 44, 46, 51 AND 52).

ROBERT STRUCK, EXAMINING ATTORNEY

SN 85-079,169. BIDDINGFORGOOD, INC., CAMBRIDGE, MA. FILED 7-7-2010.

# CHARITY COMMERCE

THE MARK CONSISTS OF STANDARD CHARACTERS WITHOUT CLAIM TO ANY PARTICULAR FONT, STYLE, SIZE, OR COLOR.

OWNER OF U.S. REG. NO. 3,079,144.

NO CLAIM IS MADE TO THE EXCLUSIVE RIGHT TO USE "CHARITY", APART FROM THE MARK AS SHOWN.

**CLASS 36—INSURANCE AND FINANCIAL**

FOR FUND RAISING SERVICES FOR CHARITABLE OR NONPROFIT ENTITIES; ON-LINE FUND RAISING SERVICES FOR CHARITABLE OR NONPROFIT ENTITIES; PROVIDING INFORMATION OVER GLOBAL COMPUTER NETWORKS ABOUT CHARITABLE FUND RAISING CONDUCTED BY CHARITABLE OR NON-PROFIT ENTITIES (U.S. CLS. 100, 101 AND 102).

**CLASS 42—SCIENTIFIC AND COMPUTER SERVICES**

FOR HOSTING OF ON-LINE CHARITABLE FUND RAISING AUCTION WEBSITES OF OTHERS OVER GLOBAL COMPUTER NETWORKS (U.S. CLS. 100 AND 101).

STEVEN R. FINE, EXAMINING ATTORNEY

SN 85-079,638. SAINT-GOBAIN PERFORMANCE PLASTICS CORPORATION, AURORA, OH. FILED 7-7-2010.

WE MEAN CLEAN

THE MARK CONSISTS OF STANDARD CHARACTERS WITHOUT CLAIM TO ANY PARTICULAR FONT, STYLE, SIZE, OR COLOR.

**CLASS 9—ELECTRICAL AND SCIENTIFIC APPARATUS**

FOR LABORATORY EQUIPMENT, NAMELY, PLASTIC, RUBBER AND ELASTOMER CLOSURES, SEALS AND STOPPERS FOR LABORATORY BOTTLES AND VIALS (U.S. CLS. 21, 23, 26, 36 AND 38).

**CLASS 17—RUBBER GOODS**

FOR RUBBER AND ELASTOMER SEALS AND STOPPERS FOR BOTTLES AND VIALS FOR PHARMACEUTICAL, CHROMATOGRAPHY AND ENVIRONMENTAL USE (U.S. CLS. 1, 5, 12, 13, 35 AND 50).

**CLASS 20—FURNITURE AND ARTICLES NOT OTHERWISE CLASSIFIED**

FOR PLASTIC, RUBBER AND ELASTOMER CLOSURES FOR BOTTLES AND VIALS FOR PHARMACEUTICAL, CHROMATOGRAPHY AND ENVIRONMENTAL USE (U.S. CLS. 2, 13, 22, 25, 32 AND 50).

PRISCILLA MILTON, EXAMINING ATTORNEY

SN 85-079,724. ESERVUS.COM ONLINE SERVICES LTD., TORONTO, CANADA, FILED 7-7-2010.



PRIORITY CLAIMED UNDER SEC. 44(D) ON CANADA APPLICATION NO. 1486945, FILED 6-29-2010.

NO CLAIM IS MADE TO THE EXCLUSIVE RIGHT TO USE "ONLINE CONCIERGE SERVICES", APART FROM THE MARK AS SHOWN.

THE MARK CONSISTS OF STYLIZED HAND HOLDING A PLATTER TOPPED WITH A COMPUTER MOUSE AND CORD NEXT TO THE WORDS "ESERVUS ONLINE CONCIERGE SERVICES".

**CLASS 35—ADVERTISING AND BUSINESS**

FOR MANAGEMENT OF EVENT TICKETING FOR OTHERS FOR SHOWS, CONCERTS, ATTRACTIONS, SPORTING EVENTS AND OTHER ENTERTAINMENT EVENTS VIA GLOBAL COMPUTER NETWORK; PROCUREMENT, NAMELY, PURCHASING TICKETS TO ENTERTAINMENT EVENTS FOR OTHERS FOR SHOWS, CONCERTS, ATTRACTIONS, SPORTING EVENTS AND OTHER ENTERTAINMENT EVENTS VIA GLOBAL COMPUTER NETWORK; PROVIDING HOTEL RATE COMPARISON INFORMATION VIA GLOBAL COMPUTER NETWORK (U.S. CLS. 100, 101 AND 102).

**CLASS 41—EDUCATION AND ENTERTAINMENT**

FOR ENTERTAINMENT TICKET AGENCY SERVICES FOR SHOWS, CONCERTS, ATTRACTIONS, SPORTING EVENTS AND OTHER ENTERTAINMENT EVENTS VIA GLOBAL COMPUTER NETWORK; PROVISION OF INFORMATION AND PRICING INFORMATION RELATING TO SHOWS, CONCERTS, TOURIST ATTRACTIONS, SPORTING EVENTS AND OTHER ENTERTAINMENT EVENTS VIA GLOBAL COMPUTER NETWORK; PROVISION OF INFORMATION AND PRICING INFORMATION RELATING TO GOLF COURSES AND FITNESS VIA GLOBAL COMPUTER NETWORK (U.S. CLS. 100, 101 AND 107).

MATTHEW EINSTEIN, EXAMINING ATTORNEY

SN 85-080,640. SIDNEY C. LERFALD, CHARLESTON, WV. FILED 7-8-2010.



NO CLAIM IS MADE TO THE EXCLUSIVE RIGHT TO USE "FULL SERVICE GAS STATIONS NATIONAL DIRECTORY", APART FROM THE MARK AS SHOWN.

THE COLOR(S) RED, WHITE AND BLUE IS/ARE CLAIMED AS A FEATURE OF THE MARK.

THE MARK CONSISTS OF A BLUE HAND HOLDING A RED GAS PUMP, THE HAND AND GAS PUMP ARE BORDERED IN A BLUE FRAME HAVING A WHITE BACKGROUND OVER THE WORDING "FSGSND.COM FULL SERVICE GAS STATIONS NATIONAL DIRECTORY" IN BLUE.

**CLASS 16—PAPER GOODS AND PRINTED MATTER**

FOR QUICK REFERENCE POCKET GUIDES IN THE FIELD OF FULL SERVICE GAS STATIONS (U.S. CLS. 2, 5, 22, 23, 29, 37, 38 AND 50).

**CLASS 25—CLOTHING**

FOR WEARABLE GARMENTS AND CLOTHING, NAMELY, SHIRTS (U.S. CLS. 22 AND 39).



**CLASS 35—ADVERTISING AND BUSINESS**

FOR PROVIDING AN ON-LINE DIRECTORY INFORMATION SERVICE FEATURING INFORMATION REGARDING FULL SERVICE GAS STATIONS (U.S. CLS. 100, 101 AND 102).

LINDA ORNDORFF, EXAMINING ATTORNEY

SN 85-081,195. JFGH CORP., DBA ASTRA INTERNATIONAL, NEW YORK, NY. FILED 7-9-2010.

**KITCHEN-RITE**

THE MARK CONSISTS OF STANDARD CHARACTERS WITHOUT CLAIM TO ANY PARTICULAR FONT, STYLE, SIZE, OR COLOR.

**CLASS 8—HAND TOOLS**

FOR KITCHEN UTENSILS, NAMELY, NON-ELECTRIC FRUIT AND VEGETABLE PEELERS AND CHOPPERS, CHEESE SLICERS, CITRUS ZESTERS, KITCHEN KNIVES AND KNIFE HOLDERS, SOLD IN SETS OR INDIVIDUALLY (U.S. CLS. 23, 28 AND 44).

FIRST USE 6-30-2006; IN COMMERCE 6-30-2006.

**CLASS 21—HOUSEWARES AND GLASS**

FOR NON-ELECTRIC KITCHEN UTENSILS SOLD INDIVIDUALLY OR IN SETS, NAMELY, CHEESE AND VEGETABLE GRATERS, CHOPPING BOARDS, LADLES, JAR OPENERS, BOTTLE OPENERS, COLANDERS, MICROWAVE COOKING AND ROASTING DISHES, DEEP FRY BASKETS, DEEP FRY PANS, EGG POACHERS, SAUTE PAN SETS, COMPRISING A SAUTE PAN, A LID, EGG POACHER, AND EGG CUP STAND, FONDUE POTS WITHOUT HEAT SOURCE, GRID GRILL TOPPERS, EGG SEPARATORS, SPRING-FORM BAKING PANS, VEGETABLE BRUSHES, DUTCH OVEN AND SKILLET SETS COMPRISING A DUTCH OVEN AND A SKILLET, NON-STICK BAKING PANS, EGG POACHER/OMELET MAKERS COMPRISED OF A MICROWAVABLE PAN FOR HOLDING EGGS FOR POACHING AND FOR MAKING AN OMELET, SAUCEPAN SETS COMPRISING AT LEAST TWO SAUCE PANS OF DIFFERENT SIZES, PLASTIC DINNERWARE, MESH SKIMMERS, AND VERTICAL BARBEQUE ROAST PANS (U.S. CLS. 2, 13, 23, 29, 30, 33, 40 AND 50).

FIRST USE 6-30-2006; IN COMMERCE 6-30-2006.

JORDAN BAKER, EXAMINING ATTORNEY

SN 85-081,290. TRUEFLIES, LLC, BILTMORE LAKE, NC. FILED 7-9-2010.



THE MARK CONSISTS OF A STYLIZED DEPICTION OF AN ARTIFICIAL FLY LURE ENCOMPASSED IN WITHIN TWO CONCENTRIC OVALS.

**CLASS 25—CLOTHING**

FOR SPORTING GOODS APPAREL, NAMELY, SHORTS, SHIRTS, HATS, PANTS, JACKETS (U.S. CLS. 22 AND 39).

**CLASS 28—TOYS AND SPORTING GOODS**

FOR FISHING EQUIPMENT, NAMELY, ARTIFICIAL FISHING BAIT, FISH ATTRACTANTS, FISH HOOKS, FISHING FLIES, FISHING LINES, FISHING LURES (U.S. CLS. 22, 23, 38 AND 50).

MYRIAH HABEEB, EXAMINING ATTORNEY

SN 85-081,595. DYNAROLL CORPORATION, SYLMAR, CA. FILED 7-9-2010.

THE MARK CONSISTS OF THE WORD "DYNAROLL" WITH TWO SIDEWAYS TRIANGLES FORMING THE LEFT SIDE OF THE LETTER "D".

**CLASS 6—METAL GOODS**

FOR METAL HARDWARE, NAMELY, PULLEYS (U.S. CLS. 2, 12, 13, 14, 23, 25 AND 50).

FIRST USE 12-0-1987; IN COMMERCE 12-0-1987.

**CLASS 7—MACHINERY**

FOR MOTION CONTROL MACHINE PARTS NOT FOR LAND VEHICLES, NAMELY, POSITIONING SLIDES, BALL SLIDES, CROSSED ROLLER SLIDES, LINEAR ACTUATORS, HYDRAULIC VALVE ACTUATORS, LEADSCREWS, LINEAR GUIDES, NAMELY, ROUND RAIL LINEAR GUIDES FOR SUPPORTING LOAD IN EQUIPMENT WHERE LINEAR MOTION EXISTS, PLAIN BEARING LINEAR GUIDES, NAMELY, NON-RECIRCULATING BALL LINEAR GUIDES THAT SUPPORT LOAD IN APPLICATIONS THAT REQUIRE LINEAR MOTION, RECIRCULATING BALL AND ROLLER GUIDES, PROFILE RAIL LINEAR GUIDES THAT SUPPORT LOAD IN APPLICATIONS, TRACK ROLLERS, CAM FOLLOWERS, PULLEYS, TENSIONERS, AND TENSIONING IDLERS (U.S. CLS. 13, 19, 21, 23, 31, 34 AND 35).

FIRST USE 12-0-1987; IN COMMERCE 12-0-1987.

**CLASS 9—ELECTRICAL AND SCIENTIFIC APPARATUS**

FOR BEARINGS, NAMELY, BALL BEARINGS, MINIATURE BEARINGS, NEEDLE BEARINGS, ROLLER BEARINGS, TAPERED ROLLER BEARINGS, ROD END BEARINGS, SPHERICAL BEARINGS, THRUST BEARINGS, AND SPECIAL BEARINGS, ALL OF THE ABOVE FOR USE IN SEMI-CONDUCTOR FABRICATING EQUIPMENT, SEMI-CONDUCTOR VACUUM DEVICES, PRECISION LASER MIRROR MECHANISMS, SEMI-CONDUCTOR VACUUM BEARING ASSEMBLIES, STORAGE AREA NETWORK ROBOTIC GEAR ASSEMBLIES, COMPUTER PERIPHERAL ELECTRO-MECHANICAL ASSEMBLIES, SEMI-CONDUCTOR MECHANICAL PULLEY ASSEMBLIES, STORAGE AREA NETWORK PRECISION BEARING AND GEAR LEADSCREW ASSEMBLIES (U.S. CLS. 21, 23, 26, 36 AND 38).

FIRST USE 12-0-1987; IN COMMERCE 12-0-1987.

**CLASS 10—MEDICAL APPARATUS**

FOR BEARINGS, NAMELY, BALL BEARINGS, MINIATURE BEARINGS, NEEDLE BEARINGS, ROLLER BEARINGS, TAPERED ROLLER BEARINGS, ROD END BEARINGS, SPHERICAL BEARINGS, THRUST BEARINGS, AND SPECIAL BEARINGS, ALL OF THE ABOVE FOR USE IN MEDICAL DEVICES, NAMELY, MEDICAL ROBOTIC AND SURGICAL DEVICE ASSEMBLIES, MEDICAL ULTRASOUND IMAGING CATHETER DRIVES, MEDICAL ELECTRO-MECHANICAL CATHETER ASSEMBLIES, MEDICAL HIGH-ACCURACY CABLE PULLEY ASSEMBLIES, MEDICAL ELECTRO-MECHANICAL INFUSION PUMPS, MEDICAL HIGH-PRECISION ONE-WAY CLUTCH/BALL BEARING ASSEMBLIES, MEDICAL INFUSION PUMP PRECISION KNOB ASSEMBLIES (U.S. CLS. 26, 39 AND 44).

FIRST USE 12-0-1987; IN COMMERCE 12-0-1987.

**CLASS 40—MATERIAL TREATMENT**

FOR CONTRACT MANUFACTURING, NAMELY, PRECISION MECHANICAL AND ELECTRO-MECHANICAL ASSEMBLIES FOR MEDICAL, AUTOMOTIVE, AEROSPACE, AUTOMATION, SCIENTIFIC, COMPUTER, AND RECREATION INDUSTRIES, AND OTHER GENERAL INDUSTRIAL APPLICATIONS (U.S. CLS. 100, 103 AND 106).

FIRST USE 12-0-1991; IN COMMERCE 12-0-1992.  
TRICIA SONNEBORN, EXAMINING ATTORNEY

SN 85-082,989. TOP FUNCTION LLC, VALENCIA, CA. FILED 7-13-2010.



THE COLOR(S) LIGHT GREEN AND DARK GREEN IS/ ARE CLAIMED AS A FEATURE OF THE MARK.

THE MARK CONSISTS OF AN IMAGE OF A PERSON WITH ARMS RAISED IN AN EXCITED MOVING POSITION; CHEST OUT; LEAPING AND JUMPING IN LIGHT GREEN AND DARK GREEN COLOR. THE WORDS "TOPFUNCTION" IS WRITTEN AT THE RIGHT HAND SIDE OF THE IMAGE WHEREIN THE WORD "TOP" IS WRITTEN IN LIGHT GREEN COLOR AND "FUNCTION" IS WRITTEN IN DARK GREEN COLOR AS SHOWN IN THE MARK.

**CLASS 5—PHARMACEUTICALS**

FOR PHARMACEUTICAL PRODUCTS, NAMELY, DIETARY NUTRITIONAL SUPPLEMENTS FOR CONSUMERS (U.S. CLS. 6, 18, 44, 46, 51 AND 52).

**CLASS 44—MEDICAL, BEAUTY AND AGRICULTURAL SERVICES**

FOR MEDICAL CONSULTATION SERVICES, NAMELY, PROVIDING INFORMATION IN THE FIELD OF HEALTH AND WELLNESS; PROVIDING HEALTHY LIFESTYLE AND NUTRITION SERVICES, NAMELY, PERSONAL ASSESSMENTS, EXPLANATION OF RISKS, COUNSELING FOR RISK REDUCTION AND TRACKING PERSONAL LIFESTYLE CHANGES FOR CONSUMERS (U.S. CLS. 100 AND 101).

RICHARD WHITE, EXAMINING ATTORNEY

SN 85-082,979. TOP FUNCTION LLC, VALENCIA, CA. FILED 7-13-2010.

TOP FUNCTION

THE MARK CONSISTS OF STANDARD CHARACTERS WITHOUT CLAIM TO ANY PARTICULAR FONT, STYLE, SIZE, OR COLOR.

**CLASS 5—PHARMACEUTICALS**

FOR PHARMACEUTICAL PRODUCTS, NAMELY, DIETARY NUTRITIONAL SUPPLEMENTS FOR CONSUMERS (U.S. CLS. 6, 18, 44, 46, 51 AND 52).

**CLASS 44—MEDICAL, BEAUTY AND AGRICULTURAL SERVICES**

FOR MEDICAL CONSULTATION SERVICES, NAMELY, PROVIDING INFORMATION IN THE FIELD OF HEALTH AND WELLNESS; PROVIDING HEALTHY LIFESTYLE AND NUTRITION SERVICES, NAMELY, PERSONAL ASSESSMENTS, EXPLANATION OF RISKS, COUNSELING FOR RISK REDUCTION AND TRACKING PERSONAL LIFESTYLE CHANGES FOR CONSUMERS (U.S. CLS. 100 AND 101).

RICHARD WHITE, EXAMINING ATTORNEY

SN 85-083,408. BYG OUTDOORS, LLC, MARS HILL, NC. FILED 7-13-2010.



THE MARK CONSISTS OF A DEER SKULL, HORNS ATTACHED TO THE DEER SKULL, AND A HUMAN SKULL CENTERED ABOVE THE DEER SKULL AND HAVING EYEBALLS.

**CLASS 25—CLOTHING**

FOR CLOTHING, NAMELY, SHIRTS, HATS, AND OUTERWEAR IN THE NATURE OF COATS, JACKETS AND PARKAS (U.S. CLS. 22 AND 39).

**CLASS 28—TOYS AND SPORTING GOODS**

FOR ARCHERY EQUIPMENT, NAMELY, BOWS, ARROWS, ARROW VANES, ARROW NOCKS, AND ARROW WRAPS (U.S. CLS. 22, 23, 38 AND 50).

**CLASS 41—EDUCATION AND ENTERTAINMENT**

FOR TELEVISION AND MEDIA ENTERTAINMENT, NAMELY, TELEVISION, CABLE TELEVISION AND RADIO SHOWS RELATING TO BOW HUNTING AND PRODUCTION OF DVDS RELATING TO BOW HUNTING (U.S. CLS. 100, 101 AND 107).

MELISSA VALLILLO, EXAMINING ATTORNEY

SN 85-083,850. RELAXED, INC., OAKLAND, CA. FILED 7-13-2010.

**CLASS 42—SCIENTIFIC AND COMPUTER SERVICES**

FOR TECHNICAL SUPPORT SERVICES, NAMELY, TECHNICAL SUPPORT SERVICES FOR USERS OF OPEN SOURCE SOFTWARE AND THIRD-PARTY SOFTWARE, NAMELY, SOFTWARE INSTALLATION, CONFIGURATION AND TROUBLESHOOTING; APPLICATION SERVICE PROVIDER, NAMELY, HOSTING COMPUTER SOFTWARE APPLICATIONS OF OTHERS; APPLICATION SERVICE PROVIDER (ASP), NAMELY, HOSTING COMPUTER SOFTWARE APPLICATIONS OF OTHERS IN THE FIELD OF KNOWLEDGE MANAGEMENT; COMPUTER SERVICE, NAMELY, ACTING AS AN APPLICATION SERVICE PROVIDER IN THE FIELD OF KNOWLEDGE MANAGEMENT TO HOST COMPUTER APPLICATION SOFTWARE FOR THE COLLECTION, EDITING, ORGANIZING, MODIFYING, BOOK MARKING, TRANSMISSION, STORAGE AND SHARING OF DATA AND INFORMATION; INFORMATION TECHNOLOGY CONSULTATION; COMPUTER CONSULTATION SERVICES IN THE FIELDS OF SELECTION, IMPLEMENTATION, INSTALLATION AND USE OF COMPUTER SOFTWARE SYSTEMS FOR OTHERS; COMPUTER CONSULTATION SERVICES IN THE FIELD OF DESIGN, SELECTION, IMPLEMENTATION AND USE OF COMPUTER SOFTWARE SYSTEMS FOR OTHERS; SERVER LEASING SERVICES, NAMELY, RENTAL OF WEB AND COMPUTER SERVERS TO THIRD PARTIES (U.S. CLS. 100 AND 101).

ANNE E. GUSTASON, EXAMINING ATTORNEY

SN 85-084,305. AFFINION PUBLISHING, LLC, LAS VEGAS, NV. FILED 7-14-2010.

COUCHONE

THE MARK CONSISTS OF STANDARD CHARACTERS WITHOUT CLAIM TO ANY PARTICULAR FONT, STYLE, SIZE, OR COLOR.

**CLASS 9—ELECTRICAL AND SCIENTIFIC APPARATUS**

FOR DOWNLOADABLE COMPUTER SOFTWARE FOR USE WITH OPEN SOURCE AND THIRD PARTY SOFTWARE RELATING TO TRAINING AND FUNCTIONALITY (U.S. CLS. 21, 23, 26, 36 AND 38).

**CLASS 41—EDUCATION AND ENTERTAINMENT**

FOR TRAINING SERVICES IN THE FIELD OF OPEN SOURCE AND THIRD-PARTY DATA SOFTWARE RELATING TO INSTALLATION, IMPLEMENTATION, CONFIGURATION, PROCESSING AND ANALYSIS OF SOFTWARE AND SOFTWARE FUNCTIONALITY; EDUCATIONAL SERVICES, NAMELY, DEVELOPING AND CONDUCTING ONLINE TRAINING COURSES AND DISTRIBUTION OF TRAINING MATERIALS IN CONNECTION THEREWITH IN THE FIELD OF OPEN SOURCE AND THIRD-PARTY DATA SOFTWARE INSTALLATION, IMPLEMENTATION, CONFIGURATION, PROCESSING AND ANALYSIS; INFORMATION TECHNOLOGY TRAINING SERVICES; ONLINE BLOGS IN THE FIELD OF SOFTWARE AND SUPPORT SERVICES (U.S. CLS. 100, 101 AND 107).

FindYourID

THE MARK CONSISTS OF STANDARD CHARACTERS WITHOUT CLAIM TO ANY PARTICULAR FONT, STYLE, SIZE, OR COLOR.

**CLASS 35—ADVERTISING AND BUSINESS**

FOR PROVIDING CREDIT CARD REGISTRATION SERVICES IN THE NATURE OF CREDIT CARD CANCELLATION SERVICES FOR LOST OR STOLEN CARDS AND NOTIFICATION SERVICES TO CREDIT CARD ISSUERS; ASSISTANCE IN REMOVAL OF IDENTIFIABLE INFORMATION FROM INTERNET DIRECTORIES, NAMELY, PROVIDING ON-LINE COMMERCIAL DIRECTORY INFORMATION INFORMING CONSUMERS OF PHONE NUMBERS AND ADDRESSES TO REQUEST REMOVAL OF UNWANTED PERSONAL INFORMATION FROM THE WEBSITES OF OTHERS; PROVIDE INFORMATION AND ALERTS TO CONSUMERS IN THE FIELD OF FOOD AND DRUG ADMINISTRATION PRODUCT RECALLS (U.S. CLS. 100, 101 AND 102).

**CLASS 36—INSURANCE AND FINANCIAL**

FOR PROVIDING IDENTITY THEFT INSURANCE UNDERWRITTEN BY OTHER COMPANIES (U.S. CLS. 100, 101 AND 102).

**CLASS 42—SCIENTIFIC AND COMPUTER SERVICES**

FOR PROVIDING TEMPORARY USE OF NON-DOWNLOADABLE SOFTWARE THAT IDENTIFIES SEX OFFENDERS IN A SPECIFIED AREA AND PROVIDES ALERTS TO CONSUMERS WHEN NEW SEX OFFENDERS ARE REGISTERED IN THOSE SPECIFIED AREAS (U.S. CLS. 100 AND 101).

**CLASS 45—PERSONAL AND LEGAL SERVICES**

FOR MONITORING INTERNET WEB SITES, MESSAGE BOARD FORUMS, INTERNET RELAY CHAT ROOMS, BLOGS AND OTHER ONLINE LOCATIONS FOR PERSONAL IDENTITY INFORMATION AND CREDIT AND DEBIT CARD NUMBERS, AND PROVIDING ALERTS AS TO ANY COMPROMISED INFORMATION OR ANY CHANGES THEREIN; CONSULTATION IN THE FIELD OF IDENTITY THEFT PROVIDED BY TELEPHONE, EMAIL, AND ON-LINE VIA THE INTERNET, IN THE FIELD OF DETECTING AND PREVENTING DAMAGE CAUSED BY IDENTITY THEFT AND DAMAGE TO CREDIT HISTORY; MONITORING OF INTERNET WEBSITES AND INDIVIDUAL CONSUMER'S CREDIT REPORTS FOR POTENTIAL THEFT AND MISUSE OF CREDIT CARD OR OTHER PERSONAL INFORMATION FOR FRAUD DETECTION AND PREVENTION PURPOSES; FINANCIAL IDENTITY MONITORING SERVICES, NAMELY, PROVIDING PUBLIC RECORDS MONITORING SERVICES; IDENTITY THEFT CONSULTATION SERVICES PROVIDING ASSISTANCE WITH SETTING FRAUD ALERTS OR SECURITY FREEZES AT CREDIT REPORTING AGENCIES; ELECTRONIC MONITORING SERVICES FOR SECURITY PURPOSES IN THE FIELD OF CREDIT CARDS AND CREDIT CARD INFORMATION; SUPPORT SERVICES PROVIDED BY E-MAIL AND ON-LINE VIA THE INTERNET IN THE FIELD OF IDENTITY THEFT RECOVERY, NAMELY, STEP-BY-STEP INSTRUCTIONS AND GUIDANCE FOR RESOLUTION OF IDENTITY THEFT CLAIMS, NON-DOWNLOADABLE SAMPLE CORRESPONDENCE FOR RESOLUTION OF IDENTITY THEFT CLAIMS; PROVIDING A WEBSITE FEATURING INFORMATION ABOUT IDENTITY THEFT RECOVERY AND RECOVERY FROM IDENTITY FRAUD AND IDENTITY MANIPULATION; CONSULTATION IN THE FIELD OF IDENTITY THEFT, NAMELY, PROVIDING PROTECTION AND ASSISTANCE IN THE EVENT OF A THEFT OF IDENTITY OR IDENTITY MANIPULATION, OR LOST OR STOLEN CREDIT CARD, DRIVERS LICENSES, PASSPORTS, AIRLINE TICKETS AND OTHER PERSONAL IDENTITY DOCUMENTS AND PUBLIC RECORDS (U.S. CLS. 100 AND 101).

VERNA BETH RIRIE, EXAMINING ATTORNEY

**CLASS 36—INSURANCE AND FINANCIAL**

FOR PROVIDING IDENTITY THEFT INSURANCE UNDERWRITTEN BY OTHER COMPANIES (U.S. CLS. 100, 101 AND 102).

**CLASS 42—SCIENTIFIC AND COMPUTER SERVICES**

FOR PROVIDING TEMPORARY USE OF NON-DOWNLOADABLE SOFTWARE THAT IDENTIFIES SEX OFFENDERS IN A SPECIFIED AREA AND PROVIDES ALERTS TO CONSUMERS WHEN NEW SEX OFFENDERS ARE REGISTERED IN THOSE SPECIFIED AREAS (U.S. CLS. 100 AND 101).

**CLASS 45—PERSONAL AND LEGAL SERVICES**

FOR MONITORING INTERNET WEB SITES, MESSAGE BOARD FORUMS, INTERNET RELAY CHAT ROOMS, BLOGS AND OTHER ONLINE LOCATIONS FOR PERSONAL IDENTITY INFORMATION AND CREDIT AND DEBIT CARD NUMBERS, AND PROVIDING ALERTS AS TO ANY COMPROMISED INFORMATION OR ANY CHANGES THEREIN; CONSULTATION IN THE FIELD OF IDENTITY THEFT PROVIDED BY TELEPHONE, EMAIL, AND ON-LINE VIA THE INTERNET, IN THE FIELD OF DETECTING AND PREVENTING DAMAGE CAUSED BY IDENTITY THEFT AND DAMAGE TO CREDIT HISTORY; MONITORING OF INTERNET WEBSITES AND INDIVIDUAL CONSUMER'S CREDIT REPORTS FOR POTENTIAL THEFT AND MISUSE OF CREDIT CARD OR OTHER PERSONAL INFORMATION FOR FRAUD DETECTION AND PREVENTION PURPOSES; FINANCIAL IDENTITY MONITORING SERVICES, NAMELY, PROVIDING PUBLIC RECORDS MONITORING SERVICES; IDENTITY THEFT CONSULTATION SERVICES PROVIDING ASSISTANCE WITH SETTING FRAUD ALERTS OR SECURITY FREEZES AT CREDIT REPORTING AGENCIES; ELECTRONIC MONITORING SERVICES FOR SECURITY PURPOSES IN THE FIELD OF CREDIT CARDS AND CREDIT CARD INFORMATION; SUPPORT SERVICES PROVIDED BY E-MAIL AND ON-LINE VIA THE INTERNET IN THE FIELD OF IDENTITY THEFT RECOVERY, NAMELY, STEP-BY-STEP INSTRUCTIONS AND GUIDANCE FOR RESOLUTION OF IDENTITY THEFT CLAIMS, NON-DOWNLOADABLE SAMPLE CORRESPONDENCE FOR RESOLUTION OF IDENTITY THEFT CLAIMS; PROVIDING A WEBSITE FEATURING INFORMATION ABOUT IDENTITY THEFT RECOVERY AND RECOVERY FROM IDENTITY FRAUD AND IDENTITY MANIPULATION; CONSULTATION IN THE FIELD OF IDENTITY THEFT, NAMELY, PROVIDING PROTECTION AND ASSISTANCE IN THE EVENT OF A THEFT OF IDENTITY OR IDENTITY MANIPULATION, OR LOST OR STOLEN CREDIT CARD, DRIVERS LICENSES, PASSPORTS, AIRLINE TICKETS AND OTHER PERSONAL IDENTITY DOCUMENTS AND PUBLIC RECORDS (U.S. CLS. 100 AND 101).

VERNA BETH RIRIE, EXAMINING ATTORNEY

SN 85-084,353. AFFINION PUBLISHING, LLC, LAS VEGAS, NV. FILED 7-14-2010.

**TraceMYID**

THE MARK CONSISTS OF STANDARD CHARACTERS WITHOUT CLAIM TO ANY PARTICULAR FONT, STYLE, SIZE, OR COLOR.

**CLASS 35—ADVERTISING AND BUSINESS**

FOR PROVIDING CREDIT CARD REGISTRATION SERVICES IN THE NATURE OF CREDIT CARD CANCELLATION SERVICES FOR LOST OR STOLEN CARDS AND NOTIFICATION SERVICES TO CREDIT CARD ISSUERS; ASSISTANCE IN REMOVAL OF IDENTIFIABLE INFORMATION FROM INTERNET DIRECTORIES, NAMELY, PROVIDING ON-LINE COMMERCIAL DIRECTORY INFORMATION INFORMING CONSUMERS OF PHONE NUMBERS AND ADDRESSES TO REQUEST REMOVAL OF UNWANTED PERSONAL INFORMATION FROM THE WEBSITES OF OTHERS; PROVIDE INFORMATION AND ALERTS TO CONSUMERS IN THE FIELD OF FOOD AND DRUG ADMINISTRATION PRODUCT RECALLS (U.S. CLS. 100, 101 AND 102).

SN 85-084,400. SIGMA-ALDRICH BIOTECHNOLOGY L.P., ST. LOUIS, MO. FILED 7-14-2010.

**EQP**

THE MARK CONSISTS OF STANDARD CHARACTERS WITHOUT CLAIM TO ANY PARTICULAR FONT, STYLE, SIZE, OR COLOR.



**CLASS 35—ADVERTISING AND BUSINESS**

FOR CONSULTATION SERVICES IN THE FIELD OF SUPPLY CHAIN MANAGEMENT; SUPPLY CHAIN MANAGEMENT SERVICES (U.S. CLS. 100, 101 AND 102).

**CLASS 42—SCIENTIFIC AND COMPUTER SERVICES**

FOR PROVIDING INFORMATION ABOUT PRODUCT QUALITY AND ANY CHANGES TO PRODUCT COMPOSITIONS AND PRODUCERS OF PRODUCTS (U.S. CLS. 100 AND 101).

KAREN K. BUSH, EXAMINING ATTORNEY

**CLASS 36—INSURANCE AND FINANCIAL**

FOR FINANCIAL AND INVESTMENT SERVICES, NAMELY, MANAGEMENT AND BROKERAGE IN THE FIELDS OF STOCKS, BONDS, OPTIONS, COMMODITIES, FUTURES AND OTHER SECURITIES, AND THE INVESTMENT OF FUNDS OF OTHERS; FINANCIAL CALCULATION SERVICES FOR OTHERS, NAMELY, ROYALTY CALCULATION; FINANCIAL INFORMATION; FINANCIAL INFORMATION PROCESSING; FINANCIAL INVESTMENT SERVICES, NAMELY, ADMINISTERING THE ISSUANCE, UNDERWRITING AND DISTRIBUTION OF SECURITIES; FINANCIAL MANAGEMENT VIA THE INTERNET; FINANCIAL SERVICES IN THE NATURE OF AN INVESTMENT SECURITY; FINANCIAL SERVICES, NAMELY, ASSISTING OTHERS WITH THE COMPLETION OF FINANCIAL TRANSACTIONS FOR STOCKS, BONDS, SECURITIES AND EQUITIES; FINANCIAL SERVICES, NAMELY, BUSINESS FUND RAISING PROVIDED OVER A COMPUTER NETWORK SUCH AS THE INTERNET; FINANCIAL SERVICES, NAMELY, BUSINESS FUNDRAISING FOR OTHERS; PROVIDING FINANCIAL INFORMATION; PROVIDING INVESTORS WITH FINANCIAL INFORMATION (U.S. CLS. 100, 101 AND 102).

FIRST USE 6-14-2010; IN COMMERCE 6-14-2010.  
MYRIAH HABEEB, EXAMINING ATTORNEY

SN 85-085,562. P2P FINANCIAL INC., TORONTO, CANADA, FILED 7-15-2010.

SN 85-085,598. BRUNSWICK SCHOOL, INC., GREENWICH, CT. FILED 7-15-2010.



NO CLAIM IS MADE TO THE EXCLUSIVE RIGHT TO USE "P2P FINANCIAL", APART FROM THE MARK AS SHOWN.

THE COLOR(S) GREEN AND WHITE IS/ARE CLAIMED AS A FEATURE OF THE MARK.

THE MARK CONSISTS OF A GREEN SQUARE WITH ROUNDED CORNERS AND "P2P" WRITTEN INSIDE OF IT IN WHITE COLOR FOLLOWED BY THE WORD "FINANCIAL" WRITTEN IN GREEN CAPITALIZED LETTERS.

**CLASS 35—ADVERTISING AND BUSINESS**

FOR CONNECTING BUYERS AND SELLERS OF FINANCIAL ASSETS; ELECTRONIC SIGNATURE VERIFICATION SERVICES PROVIDED IN CONNECTION WITH BANKING AND FINANCIAL SERVICES; FACILITATING THE EXCHANGE OF NEEDED INFORMATION FOR FINANCIAL COMPENSATION VIA THE INTERNET; FINANCIAL RECORDS MANAGEMENT; FINANCIAL STATEMENT PREPARATION AND ANALYSIS FOR BUSINESSES; PREPARING FINANCIAL REPORTS FOR OTHERS; PROMOTION OF FINANCIAL AND INSURANCE SERVICES, ON BEHALF OF THIRD PARTIES; PROVIDING AN ON-LINE COMPUTER WEB SITE THAT PROVIDES COMMERCIAL FINANCIAL TRANSACTION DATA, ACCOUNT MANAGEMENT, FINANCIAL REPORTING, ACCOUNTING FEATURES AND RELATED REFERENCE INFORMATION (U.S. CLS. 100, 101 AND 102).

FIRST USE 6-14-2010; IN COMMERCE 6-14-2010.



NO CLAIM IS MADE TO THE EXCLUSIVE RIGHT TO USE "SCHOOL" AND "1902", APART FROM THE MARK AS SHOWN.

THE MARK CONSISTS OF THE WORDS "BRUNSWICK SCHOOL COURAGE HONOR TRUTH" IN A CIRCLE AROUND A TREE DESIGN WITH "1902" BENEATH, HAVING A CURVED CIRCULAR BORDER.

**CLASS 35—ADVERTISING AND BUSINESS**

FOR RETAIL STORE SERVICES FEATURING STATIONERY, BAGS, JEWELRY, GIFT ITEMS, CLOTHING AND NOVELTY ITEMS BEARING SCHOOL EMBLEMS OR INSIGNIA; ON-LINE RETAIL STORE SERVICES FEATURING STATIONERY, BAGS, JEWELRY, GIFT ITEMS, CLOTHING AND NOVELTY ITEMS BEARING SCHOOL EMBLEMS OR INSIGNIA (U.S. CLS. 100, 101 AND 102).

**CLASS 36—INSURANCE AND FINANCIAL**

FOR CHARITABLE FUNDRAISING SERVICES (U.S. CLS. 100, 101 AND 102).

**CLASS 41—EDUCATION AND ENTERTAINMENT**

FOR COMPUTER SERVICES, NAMELY, PROVIDING A WEB SITE FEATURING INFORMATION REGARDING SCHOOL ADMISSIONS, ACADEMIC PROGRAMS, ATHLETIC PROGRAMS, EMPLOYMENT OPPORTUNITIES, HOUSING, ADMINISTRATIVE SERVICES, ALUMNI ACTIVITIES AND ORGANIZATIONS, COUNSELING SERVICES, STUDENT ACTIVITIES AND ORGANIZATIONS, PUBLICATIONS, AND INFORMATION TECHNOLOGY SERVICES; EDUCATIONAL SERVICES, NAMELY, PROVIDING COURSES OF INSTRUCTION AT THE PRIMARY AND SECONDARY LEVELS AND DISTRIBUTION OF COURSE MATERIAL IN CONNECTION THEREWITH; PROVIDING COURSES OF INSTRUCTION AT THE ELEMENTARY, JUNIOR HIGH, AND HIGH SCHOOL LEVELS; EDUCATIONAL SERVICES, NAMELY, PROVIDING ACADEMIC COURSES AT THE MIDDLE SCHOOL AND HIGH SCHOOL LEVEL IN THE FIELDS OF MATH, SCIENCE, HISTORY, ENGLISH, FOREIGN LANGUAGE, SOCIAL STUDIES, MUSIC AND TRADITIONAL COLLEGE PREPARATORY CURRICULUM, AND PROVIDING EXTRACURRICULAR ACTIVITIES IN THE NATURE OF CONDUCTING AFTER-SCHOOL TUTORING PROGRAMS AND PROVIDING AFTER SCHOOL EDUCATIONAL AND EXTRACURRICULAR ACADEMIC, SPORTS, AND DRAMATIC ARTS PROGRAMS FOR CHILDREN ENCOURAGING AMATEUR SPORTS AND PHYSICAL EDUCATION BY ORGANIZING, SANCTIONING, AND CONDUCTING AMATEUR ATHLETIC PROGRAMS AND ACTIVITIES; ARRANGING AND CONDUCTING ATHLETIC COMPETITIONS; ADMISSION CONSULTING SERVICES, NAMELY, CONSULTING IN THE FIELD OF COLLEGE ADMISSIONS, SPECIFICALLY, COLLEGE SELECTION, COMPLETING ADMISSIONS APPLICATIONS, AND PREPARATION FOR COLLEGE ADMISSION INTERVIEWS (U.S. CLS. 100, 101 AND 107).

VIVIAN MICZNIK FIRST, EXAMINING ATTORNEY

SN 85-085,837. GDR ACQUISITION COMPANY LLC, COLUMBIA, MO. FILED 7-15-2010.

**GDR**

THE MARK CONSISTS OF STANDARD CHARACTERS WITHOUT CLAIM TO ANY PARTICULAR FONT, STYLE, SIZE, OR COLOR.

**CLASS 35—ADVERTISING AND BUSINESS**

FOR RECORDING AND REGISTERING DEBT OWNERSHIP AND TRANSFERS THEREOF TO OTHERS TO ESTABLISH A RELIABLE CHAIN OF TITLE TO DEBT (U.S. CLS. 100, 101 AND 102).

**CLASS 36—INSURANCE AND FINANCIAL**

FOR DEBT OWNERSHIP VALIDATION SERVICES, NAMELY, DETERMINING THE OWNERSHIP OF DEBT WHICH ENTAILS, DEBT REGISTRY SERVICES, GLOBAL DEBT EXCHANGE MARKETPLACE SERVICES, VALIDATION OF PROOF OF OWNERSHIP OF DEBT SERVICES, PERFORMING DATA INTEGRITY SERVICES TO ELIMINATE ERRORS IN INFORMATION PROVIDED WITH RESPECT TO A GIVEN DEBT, AND DUE DILIGENCE SERVICES TO VALUE PORTFOLIOS OF DEBT FOR BUYERS AND SELLERS (U.S. CLS. 100, 101 AND 102).

**CLASS 38—COMMUNICATION**

FOR ON-LINE DEBT TITLE DOCUMENT DELIVERY SERVICES (U.S. CLS. 100, 101 AND 104).

PAM WILLIS, EXAMINING ATTORNEY

SN 85-085,849. INFINEUM INTERNATIONAL LTD., ABINGDON, OXFORDSHIRE, UNITED KINGDOM, FILED 7-15-2010.

**Infineum** 

THE MARK CONSISTS OF THE TERM "INFINEUM" WITH TWO INTERLOCKING HALF CIRCLE SHAPES.

**CLASS 1—CHEMICALS**

FOR CHEMICAL PRODUCTS FOR USE IN INDUSTRY, NAMELY, CATALYSTS AND CHEMICAL ADDITIVES FOR USE IN THE MANUFACTURE OF CHEMICALS FOR USE IN PETROLEUM PRODUCTS, SUCH AS FUELS AND LUBRICANTS (U.S. CLS. 1, 5, 6, 10, 26 AND 46).

FIRST USE 1-1-1999; IN COMMERCE 1-1-1999.

**CLASS 4—LUBRICANTS AND FUELS**

FOR FUELS, INDUSTRIAL AND MOTOR OILS, AUTOMOTIVE GREASES, ALL PURPOSE LUBRICANTS, AND DIESEL FUELS; GASOLINE (U.S. CLS. 1, 6 AND 15).

FIRST USE 1-1-1999; IN COMMERCE 1-1-1999.

PAM WILLIS, EXAMINING ATTORNEY

SN 85-086,670. ALMO NATURE S.P.A., GENOA, ITALY, FILED 7-16-2010.

**amore...** 

THE MARK CONSISTS OF THE WORD "ALMORE" WHEREIN THE LETTER "L" THEREOF HAS A STYLIZED CURVATURE AND THE LETTER "E" THEREOF IS FOLLOWED BY AN ELLIPSIS.

**CLASS 5—PHARMACEUTICALS**

FOR MEDICAL FOODSTUFF ADDITIVES FOR VETERINARY USE (U.S. CLS. 6, 18, 44, 46, 51 AND 52).

**CLASS 31—NATURAL AGRICULTURAL PRODUCTS**

FOR PET LITTER FOR CATS AND DOGS; FOODSTUFFS FOR CATS AND DOGS (U.S. CLS. 1 AND 46).

**CLASS 41—EDUCATION AND ENTERTAINMENT**

FOR EDUCATIONAL SERVICES, NAMELY, CONDUCTING CLASSES, GIVING SEMINARS AND CONDUCTING WORKSHOPS IN THE FIELD OF ANIMAL WELFARE (U.S. CLS. 100, 101 AND 107).

NICHOLAS ALTREE, EXAMINING ATTORNEY

SN 85-086,936. EUROSTAR BRANDS, INC., LOS ANGELES, CA. FILED 7-16-2010.



OWNER OF U.S. REG. NO. 2,320,586.  
THE MARK CONSISTS OF CONCENTRIC ROUNDED TRIANGLES WITH A WHITE BORDER BETWEEN THE TWO TRIANGLES AND THE LETTERS "WSS" INSIDE THE INNER TRIANGLE.

**CLASS 25—CLOTHING**

FOR FOOTWEAR AND APPAREL, NAMELY, SHORTS, PANTS, SHIRTS, BLOUSES, SKIRTS, DRESSES, TANKS, SOCKS, JACKETS, KNIT TOPS, WOVEN TOPS, SWEATERS, KNIT BOTTOMS, JEANS, UNIFORMS, JACKETS, CASUAL AND DRESS PANTS, HATS, SCARVES, T-SHIRTS, SWEATSHIRTS, PULL-OVERS, HOODED SWEATSHIRTS (U.S. CLS. 22 AND 39).

**CLASS 35—ADVERTISING AND BUSINESS**

FOR RETAIL STORE SERVICES FEATURING FOOTWEAR AND APPAREL (U.S. CLS. 100, 101 AND 102).

JEFFREY LOOK, EXAMINING ATTORNEY

SN 85-088,838. MUELLER INTERNATIONAL, INC., ATLANTA, GA. FILED 7-20-2010.

# SLIDELOK

THE MARK CONSISTS OF STANDARD CHARACTERS WITHOUT CLAIM TO ANY PARTICULAR FONT, STYLE, SIZE, OR COLOR.

**CLASS 6—METAL GOODS**

FOR METAL PIPE FITTINGS, METAL PIPE COUPLINGS, GASKETED METAL PIPE COUPLINGS AND FITTINGS, MANUALLY OPERATED METAL CHECK VALVES AND BUTTERFLY VALVES (U.S. CLS. 2, 12, 13, 14, 23, 25 AND 50).

**CLASS 11—ENVIRONMENTAL CONTROL APPARATUS**

FOR METAL PIPE LINE STRAINERS FOR USE IN PLUMBING WATER LINES FOR USE IN TRAPPING FOREIGN MATERIALS; PUMP INLET SUCTION DIFFUSERS FOR MOUNTING TO PUMP INLET FLANGES TO REDUCE FLUID FLOW TURBULENCE, STREAMLINE FLUID FLOW, AND TRAP FOREIGN MATERIALS, ALL BEING PARTS AND FITTINGS FOR METAL AND PLASTIC TUBES, CONDUITS AND PIPING (U.S. CLS. 13, 21, 23, 31 AND 34).

MARLENE BELL, EXAMINING ATTORNEY

SN 85-089,820. IVERSE MEDIA, LLC, HEWITT, TX. FILED 7-21-2010.

# COMICS PLUS

THE MARK CONSISTS OF STANDARD CHARACTERS WITHOUT CLAIM TO ANY PARTICULAR FONT, STYLE, SIZE, OR COLOR.

NO CLAIM IS MADE TO THE EXCLUSIVE RIGHT TO USE "COMICS", APART FROM THE MARK AS SHOWN.

**CLASS 9—ELECTRICAL AND SCIENTIFIC APPARATUS**

FOR ELECTRONIC DOWNLOADABLE PUBLICATIONS IN THE NATURE OF COMIC BOOKS; ELECTRONIC PUBLICATIONS, NAMELY, COMIC BOOKS RECORDED ON ELECTRONIC MEDIA; DOWNLOADABLE AUDIO FILES, MULTIMEDIA FILES, TEXT FILES, AUDIO MATERIAL, VIDEO MATERIAL AND GAMES FEATURING COMIC BOOK OR COMIC BOOK INDUSTRY RELATED CONTENT, TV EPISODES, MOVIE CLIPS, CARTOONS, AND INTERVIEWS (U.S. CLS. 21, 23, 26, 36 AND 38).

**CLASS 38—COMMUNICATION**

FOR DIGITAL DELIVERY OF PRINT MATERIALS BY ELECTRONIC TRANSMISSION; DIGITAL DELIVERY OF COMIC BOOKS BY ELECTRONIC TRANSMISSION (U.S. CLS. 100, 101 AND 104).

**CLASS 41—EDUCATION AND ENTERTAINMENT**

FOR NON-DOWNLOADABLE ELECTRONIC PUBLICATIONS IN THE NATURE OF COMIC BOOKS; PUBLICATION OF ELECTRONIC COMIC BOOKS; ENTERTAINMENT SERVICES, NAMELY, PROVIDING A WEBSITE FEATURING NON-DOWNLOADABLE AUDIO FILES, MULTIMEDIA FILES, TEXT FILES, AUDIO MATERIAL, VIDEO MATERIAL AND GAMES FEATURING COMIC BOOK OR COMIC BOOK INDUSTRY RELATED CONTENT, TV EPISODES, MOVIE CLIPS, CARTOONS, AND INTERVIEWS (U.S. CLS. 100, 101 AND 107).

SUE LAWRENCE, EXAMINING ATTORNEY

SN 85-090,411. CRYOVAC, INC., ELMWOOD PARK, NJ.  
FILED 7-22-2010.

SUSAN RICHARDS, EXAMINING ATTORNEY

## CRYOVAC MIRABELLA

THE MARK CONSISTS OF STANDARD CHARACTERS WITHOUT CLAIM TO ANY PARTICULAR FONT, STYLE, SIZE, OR COLOR.

OWNER OF U.S. REG. NOS. 384,060, 2,970,887 AND 3,636,243.

### CLASS 20—FURNITURE AND ARTICLES NOT OTHERWISE CLASSIFIED

FOR CONTAINERS COMPRISED OF A COMBINATION OF POLYSTYRENE AND POLYPROPYLENE TRAYS TOGETHER WITH PLASTIC FILM CONTAINING BOTH A PERMEABLE AND BARRIER LAYER USED FOR FOOD PACKAGING IN CONNECTION WITH COMMERCIAL APPLICATIONS (U.S. CLS. 2, 13, 22, 25, 32 AND 50).

### CLASS 21—HOUSEWARES AND GLASS

FOR CONTAINERS COMPRISED OF A COMBINATION OF POLYSTYRENE AND POLYPROPYLENE TRAYS TOGETHER WITH PLASTIC FILM CONTAINING BOTH A PERMEABLE AND BARRIER LAYER FOR FOOD PACKAGING IN CONNECTION WITH HOUSEHOLD APPLICATIONS (U.S. CLS. 2, 13, 23, 29, 30, 33, 40 AND 50).

RUSS HERMAN, EXAMINING ATTORNEY

SN 85-091,425. THE MCGRAW-HILL COMPANIES, INC.,  
NEW YORK, NY. FILED 7-23-2010.

## ABOVE & BEYOND

THE MARK CONSISTS OF STANDARD CHARACTERS WITHOUT CLAIM TO ANY PARTICULAR FONT, STYLE, SIZE, OR COLOR.

### CLASS 9—ELECTRICAL AND SCIENTIFIC APPARATUS

FOR DOWNLOADABLE EDUCATIONAL MATERIALS IN THE NATURE OF MP3 FILES IN THE FIELD OF READING (U.S. CLS. 21, 23, 26, 36 AND 38).

### CLASS 16—PAPER GOODS AND PRINTED MATTER

FOR SERIES OF TEXTBOOKS IN THE FIELD OF READING LESSONS (U.S. CLS. 2, 5, 22, 23, 29, 37, 38 AND 50).

### CLASS 41—EDUCATION AND ENTERTAINMENT

FOR PROVIDING ONLINE PUBLICATIONS IN THE NATURE OF E-BOOKS IN THE FIELD OF READING LESSONS AND IN THE FIELD OF TEACHER SUPPORT MATERIAL IN THE NATURE OF DOWNLOADABLE PDF FILES (U.S. CLS. 100, 101 AND 107).

SN 85-091,853. CATAWBA TREE, LLC, THE, CORNELIUS,  
NC. FILED 7-23-2010.



NO CLAIM IS MADE TO THE EXCLUSIVE RIGHT TO USE "CLUB", APART FROM THE MARK AS SHOWN.

THE COLOR(S) BLACK, PINK, GRAY AND GREEN IS/ARE CLAIMED AS A FEATURE OF THE MARK.

THE MARK CONSISTS OF A STYLIZED OVAL WITH A GREEN BORDER AND GRAY SHADOWING AROUND THE BORDER, CONTAINING THE TEXT "THE GIRLFRIEND CLUB" IN BLACK ON A PINK BACKGROUND CONSISTING OF LIGHTER PINK CIRCLES/RINGS ON VERTICAL LINES.

### CLASS 21—HOUSEWARES AND GLASS

FOR BEVERAGE GLASSWARE (U.S. CLS. 2, 13, 23, 29, 30, 33, 40 AND 50).

### CLASS 25—CLOTHING

FOR T-SHIRTS (U.S. CLS. 22 AND 39).

ELISSA GARBER KON, EXAMINING ATTORNEY

SN 85-092,327. P.U.R.E. PARANORMAL, COLORADO  
SPRINGS, CO. FILED 7-25-2010.

## P.U.R.E. Paranormal

THE MARK CONSISTS OF STANDARD CHARACTERS WITHOUT CLAIM TO ANY PARTICULAR FONT, STYLE, SIZE, OR COLOR.

NO CLAIM IS MADE TO THE EXCLUSIVE RIGHT TO USE "PARANORMAL", APART FROM THE MARK AS SHOWN.

### CLASS 41—EDUCATION AND ENTERTAINMENT

FOR ENTERTAINMENT AND EDUCATIONAL SERVICES, NAMELY, PROVIDING CLASSES FEATURING THE PARANORMAL, THE UNKNOWN, AND GHOST HUNTING (U.S. CLS. 100, 101 AND 107).

FIRST USE 5-1-2008; IN COMMERCE 5-1-2008.

### CLASS 45—PERSONAL AND LEGAL SERVICES

FOR PARANORMAL INVESTIGATION SERVICES (U.S. CLS. 100 AND 101).

FIRST USE 5-1-2008; IN COMMERCE 5-1-2008.  
EMILY CHUO, EXAMINING ATTORNEY



SN 85-093,115. CHARLOTTE RONSON LLC, NEW YORK, NY. FILED 7-26-2010.

SN 85-093,139. CHILDREN'S HOME SOCIETY OF CALIFORNIA, LOS ANGELES, CA. FILED 7-26-2010.

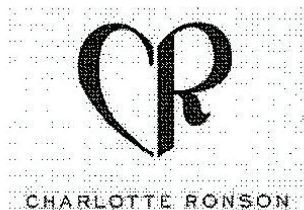

OWNER OF U.S. REG. NOS. 3,614,032, 3,620,635 AND 3,620,843.

THE NAME(S), PORTRAIT(S), AND/OR SIGNATURE(S) SHOWN IN THE MARK IDENTIFIES "CHARLOTTE RONSON", WHOSE CONSENT(S) TO REGISTER IS MADE OF RECORD.

THE MARK CONSISTS OF THE STYLIZED LETTERS "CR" IN A HEART SHAPE ABOVE THE NAME "CHARLOTTE RONSON" IN BLOCK LETTERS.

### CLASS 3—COSMETICS AND CLEANING PREPARATIONS

FOR COMPACTS CONTAINING MAKE-UP; PERFUME, FOUNDATION, FACE POWDER, ROUGE, LIPSTICKS, MASCARAS, LIP GLOSS, LIP LINERS, EYELINERS, EYE SHADOWS, NAIL POLISH, SHAMPOOS, CONDITIONERS, NON-MEDICATED HAIR BALMS, HAIR CREAMS, FACIAL LOTIONS, SKIN MOISTURIZER, MOISTURIZING HAND CREAM, HAIR OILS; FACE CREAMS, SKIN MOISTURIZER MASKS; NON-MEDICATED SKIN CARE PREPARATIONS, NAMELY, FACE GELS, NON-MEDICATED SKIN SERUM; EYE CREAMS, EYE GELS, FACE EXFOLIATORS IN THE NATURE OF AN EXFOLIANT CREAM, FACE CLEANSERS, FACIAL TONERS; BODY GELS, BODY LOTIONS, BODY CREAMS, BODY EXFOLIATORS IN THE NATURE OF AN EXFOLIANT CREAM, BODY SHAMPOOS AND SOAPS, TALCUM POWDERS, HAND CREAMS, HAND LOTIONS, NON-MEDICATED FOOT CREAMS AND LOTIONS, NAIL AND CUTICLE PROTECTOR, NAMELY, SUN BLOCK LOTION, SUN TAN LOTIONS, SELF-TANNING LOTIONS, AFTER-SUN CREAMS, SUN TAN OILS, DEODORANTS FOR PERSONAL USE, ANTIPERSPIRANTS, HAIR REMOVAL LOTION AND WAX, PERMANENT HAIR WAVE PREPARATIONS, NAIL HARDENERS, NAIL STRENGTHENERS, CUTICLE CONDITIONERS AND CUTICLE CREAMS, HAIR DYES, HAIR GELS, HAIR MOUSSE, PERFUMERY, COLOGNES, EAU DE COLOGNE, EAU DE PERFUME, EAU DE TOILETTE (U.S. CLS. 1, 4, 6, 50, 51 AND 52).

### CLASS 21—HOUSEWARES AND GLASS

FOR HAIR BRUSHES, HAIR COMBS, COSMETIC BRUSHES, EYELASH AND EYEBROW COMBS, NAIL BRUSHES, TOOTH BRUSHES, TOOTH BRUSH CASES, BODY SPONGES, LOOFAH SPONGES, BATH SPONGES, FACIAL CLEANSING SPONGES AND FACIAL SPONGES FOR APPLYING MAKEUP, EXFOLIATING MITTS, EXFOLIATING PADS, SOAP DISHES (U.S. CLS. 2, 13, 23, 29, 30, 33, 40 AND 50).  
AISHA SALEM, EXAMINING ATTORNEY



OWNER OF U.S. REG. NOS. 1,637,922 AND 2,338,071.  
THE MARK CONSISTS OF THE SIDE PROFILES OF THREE PEOPLE FACING THE LEFT IN SILHOUETTE, PLACED WITHIN A HOUSE DESIGN. BEHIND THE HOUSE DESIGN ARE TWO PARTIAL STACKED IMAGES OF THE HOUSE DESIGN, SO THAT THE MARK APPEARS TO PROJECT OUTWARDLY TOWARDS THE VIEWER.

### CLASS 35—ADVERTISING AND BUSINESS

FOR PROVIDING REFERRAL SERVICES TO LICENSSED CHILD CARE (U.S. CLS. 100, 101 AND 102).  
FIRST USE 1-2-1989; IN COMMERCE 1-2-1989.

### CLASS 36—INSURANCE AND FINANCIAL

FOR CHARITABLE SERVICES, NAMELY PROVIDING FINANCIAL ASSISTANCE IN THE NATURE OF SUBSIDIES FOR CHILD CARE (U.S. CLS. 100, 101 AND 102).  
FIRST USE 1-2-1989; IN COMMERCE 1-2-1989.

### CLASS 41—EDUCATION AND ENTERTAINMENT

FOR PROVIDING EDUCATIONAL SERVICES, NAMELY, WORKSHOPS, IN THE FIELD OF CHILD CARE AND DEVELOPMENT (U.S. CLS. 100, 101 AND 107).  
FIRST USE 1-2-1989; IN COMMERCE 1-2-1989.

### CLASS 45—PERSONAL AND LEGAL SERVICES

FOR PROVIDING SUPPORT SERVICES FOR ADOPTIVE AND BIRTH FAMILIES, NAMELY PROVIDING PERSONAL BACKGROUND INFORMATION OF ADOPTIVE AND BIRTH FAMILIES IN THE FIELD OF POST ADOPTION (U.S. CLS. 100 AND 101).  
FIRST USE 1-2-1989; IN COMMERCE 1-2-1989.  
REBECCA GILBERT, EXAMINING ATTORNEY

SN 85-094,289. KERAGENETICS, LLC, WINSTON-SALEM, NC. FILED 7-27-2010.

# KERAGENICS

THE MARK CONSISTS OF STANDARD CHARACTERS WITHOUT CLAIM TO ANY PARTICULAR FONT, STYLE, SIZE, OR COLOR.

**CLASS 5—PHARMACEUTICALS**

FOR MEDICAL GELS, DRESSINGS, FILMS, FLUIDS, AND PUTTIES FOR WOUND HEALING AND REGENERATION OF BONES AND NERVES; MEDICAL PUTTIES FOR REPAIR OF BONES, NAMELY, BONE REPAIR PASTE FOR USE IN ORTHOPEDIC SURGERY (U.S. CLS. 6, 18, 44, 46, 51 AND 52).

SN 85-095,715. OLD DUTCH FOODS, INC., ST. PAUL, MN. FILED 7-29-2010.

**CLASS 10—MEDICAL APPARATUS**

FOR MEDICAL PUTTIES FOR REPAIR OF BONES, NAMELY, PROSTHETIC AND FILLING MATERIALS, NAMELY, PUTTY FOR USE IN THE REPLACEMENT OF BONES (U.S. CLS. 26, 39 AND 44).  
ROBERT STRUCK, EXAMINING ATTORNEY

**NORTHERN CHOICE**

THE MARK CONSISTS OF STANDARD CHARACTERS WITHOUT CLAIM TO ANY PARTICULAR FONT, STYLE, SIZE, OR COLOR.

SN 85-095,363. DORMBUNKIE.COM, LLC, FORT WASHINGTON, PA. FILED 7-28-2010.

**CLASS 29—MEATS AND PROCESSED FOODS**

FOR SNACK FOODS, NAMELY, POTATO CHIPS, TORTILLA-LIKE CHIPS MADE FROM CHICK PEAS, AND BAKED VEGETABLE CHIPS (U.S. CL. 46).

**CLASS 30—STAPLE FOODS**

FOR SNACK FOODS, NAMELY, RICE CHIPS, PRETZELS, BAKED CORN CHIPS, TORTILLA CHIPS, AND CHEESE CURLS (U.S. CL. 46).  
TRACY FLETCHER, EXAMINING ATTORNEY

SN 85-096,638. METTLER-TOLEDO AG, GREIFENSEE, SWITZERLAND, FILED 7-30-2010.

THE MARK CONSISTS OF THE WORD "DORM" WHICH APPEARS IN LOWERCASE LETTERS ABOVE THE WORD "BUNKIE", WHICH ALSO APPEARS IN LOWERCASE LETTERS. THE WORD "DORM" IS LINED UP TO APPEAR ABOVE THE "UNKIE" PART OF THE WORD "BUNKIE", SO THAT THE "R" IN "DORM" IS CONNECTED IN A STRAIGHT LINE WITH THE "K" IN "BUNKIE". THE LETTER "E" AT THE END OF THE WORD "BUNKIE" IS ON AN ANGLE.

**CLASS 38—COMMUNICATION**

FOR PROVIDING ONLINE INSTANT MESSAGING SERVICES AND EMAILING SERVICES, NAMELY, FOR STUDENTS TO FIND COLLEGE ROOMMATES AND FRIENDS WITH SIMILAR INTERESTS (U.S. CLS. 100, 101 AND 104).

THE MARK CONSISTS OF STANDARD CHARACTERS WITHOUT CLAIM TO ANY PARTICULAR FONT, STYLE, SIZE, OR COLOR.

**CLASS 42—SCIENTIFIC AND COMPUTER SERVICES**

FOR COMPUTER SERVICES, NAMELY, HOSTING ONLINE WEB FACILITIES FOR FINDING COLLEGE ROOMMATES AND FRIENDS WITH SIMILAR INTERESTS FOR THE PURPOSE OF ORGANIZING AND CONDUCTING ONLINE MEETINGS, GATHERINGS, AND INTERACTIVE DISCUSSIONS; COMPUTER SERVICES IN THE NATURE OF CUSTOMIZED WEB PAGES FEATURING USER-DEFINED INFORMATION, PERSONAL PROFILES, PHOTOS AND INFORMATION (U.S. CLS. 100 AND 101).

PRIORITY CLAIMED UNDER SEC. 44(D) ON SWITZERLAND APPLICATION NO. 51367/2010, FILED 2-11-2010, REG. NO. 601379, DATED 6-8-2010, EXPIRES 2-11-2020.

CHARLES L. JENKINS, EXAMINING ATTORNEY

**CLASS 37—CONSTRUCTION AND REPAIR**

FOR INSTALLATION, SERVICING AND REPAIR OF MEASURING INSTRUMENTS FOR TITRATION, SPECIFICALLY PERFORMANCE OF FUNCTION TESTS ON MEASURING INSTRUMENTS FOR TITRATION; PROVISION OF INFORMATION REGARDING MAINTENANCE OF MEASURING INSTRUMENTS FOR TITRATION (U.S. CLS. 100, 103 AND 106).

FIRST USE 6-30-2009; IN COMMERCE 6-30-2009.

**CLASS 42—SCIENTIFIC AND COMPUTER SERVICES**

FOR CALIBRATION AND CERTIFICATION OF MEASURING INSTRUMENTS FOR TITRATION; CERTIFICATION OF THE MEASUREMENT UNCERTAINTY OF MEASURING INSTRUMENTS FOR TITRATION; QUALIFICATION OF MEASURING INSTRUMENTS FOR TITRATION; RENTAL OF MEASURING INSTRUMENTS FOR TITRATION; PROFESSIONAL CONSULTANCY, NAMELY PROVIDING LABORATORY INFORMATION FOR TITRATION FOR SCIENTIFIC USE; CONSULTING ON TECHNICAL PROCESS OPTIMIZATION FOR TITRATION; CONSULTING ON VALIDATION OF TECHNICAL METHODS AND SYSTEMS FOR TITRATION; CONSULTING ON QUALITY TESTING FOR TITRATION; ADJUSTMENT OF MEASURING INSTRUMENTS FOR TITRATION ACCORDING TO INSTRUCTIONS OF THE MANUFACTURER OR LEGAL INSTRUCTIONS; QUALITY TESTING OF MEASURING INSTRUMENTS FOR TITRATION (U.S. CLS. 100 AND 101).

FIRST USE 6-30-2009; IN COMMERCE 6-30-2009.  
KIMBERLY PERRY, EXAMINING ATTORNEY

SN 85-098,083. ENERGY NOW, WASHINGTON, DC. FILED 8-2-2010.

# Energy Now!

THE MARK CONSISTS OF STANDARD CHARACTERS WITHOUT CLAIM TO ANY PARTICULAR FONT, STYLE, SIZE, OR COLOR.

NO CLAIM IS MADE TO THE EXCLUSIVE RIGHT TO USE "ENERGY", APART FROM THE MARK AS SHOWN.

**CLASS 9—ELECTRICAL AND SCIENTIFIC APPARATUS**

FOR DOWNLOADABLE MOTION PICTURES AND TELEVISION SHOWS ABOUT ENERGY, ENERGY POLICY, AND THE EFFECTS OF ENERGY USE AND PRODUCTION ON THE ENVIRONMENT AND ECONOMY (U.S. CLS. 21, 23, 26, 36 AND 38).

**CLASS 41—EDUCATION AND ENTERTAINMENT**

FOR PRODUCTION AND DISTRIBUTION OF TELEVISION SHOWS AND MOVIES (U.S. CLS. 100, 101 AND 107).

WILLIAM BRECKENFELD, EXAMINING ATTORNEY

SN 85-099,441. GAFFEY AND ASSOCIATES, INC., PLEASANTON, CA. FILED 8-3-2010.

# Revenue as a Service

THE MARK CONSISTS OF STANDARD CHARACTERS WITHOUT CLAIM TO ANY PARTICULAR FONT, STYLE, SIZE, OR COLOR.

**CLASS 9—ELECTRICAL AND SCIENTIFIC APPARATUS**

FOR COMPUTER SOFTWARE FOR CONTROLLING AND MANAGING PATIENT MEDICAL INFORMATION; COMPUTER SOFTWARE THAT PROVIDES WEB-BASED ACCESS TO APPLICATIONS AND SERVICES THROUGH A WEB OPERATING SYSTEM OR PORTAL INTERFACE (U.S. CLS. 21, 23, 26, 36 AND 38).

FIRST USE 1-17-2008; IN COMMERCE 3-1-2009.

**CLASS 35—ADVERTISING AND BUSINESS**

FOR MEDICAL BILLING OUTSOURCING SERVICES; MEDICAL BILLING SUPPORT SERVICES (U.S. CLS. 100, 101 AND 102).

FIRST USE 1-17-2008; IN COMMERCE 3-1-2009.  
CHRISTINA SOBRAL, EXAMINING ATTORNEY

SN 85-100,769. MAUBOUSSIN, PARIS, FRANCE, FILED 8-5-2010.

# MAUBOUSSIN

THE MARK CONSISTS OF STANDARD CHARACTERS WITHOUT CLAIM TO ANY PARTICULAR FONT, STYLE, SIZE, OR COLOR.

**CLASS 3—COSMETICS AND CLEANING PREPARATIONS**

FOR PERFUMES, TOILET WATER AND EAU DE COLOGNE, NON-MEDICATED TOILETRIES (U.S. CLS. 1, 4, 6, 50, 51 AND 52).

FIRST USE 10-13-2008; IN COMMERCE 10-13-2008.

**CLASS 9—ELECTRICAL AND SCIENTIFIC APPARATUS**

FOR OPTICAL GOODS, NAMELY, EYEWEAR, EYEGLASS FRAMES, SUNGLASSES, EYEGLASS CASES (U.S. CLS. 21, 23, 26, 36 AND 38).

FIRST USE 10-13-2008; IN COMMERCE 10-13-2008.

**CLASS 14—JEWELRY**

FOR JEWELRY, PRECIOUS STONES, SEMI-PRECIOUS STONES, PEARLS FOR JEWELRY, WATCHES, WATCH BANDS, WRISTWATCHES, CASES FOR WATCHES, JEWELRY CASES (U.S. CLS. 2, 27, 28 AND 50).

FIRST USE 1-31-1827; IN COMMERCE 10-13-2008.

**CLASS 16—PAPER GOODS AND PRINTED MATTER**

FOR WRITING INSTRUMENTS, NAMELY, FOUNTAIN PENS, PENCIL LEAD HOLDERS, PENHOLDERS; BOXES OF CARDBOARD OR PAPER, CATALOGUES, INVITATION CARDS OF CARDBOARD OR PAPER, BAGS, NAMELY, ENVELOPES, POUCHES OF PAPER OR PLASTICS FOR PACKAGING (U.S. CLS. 2, 5, 22, 23, 29, 37, 38 AND 50).

FIRST USE 10-13-2008; IN COMMERCE 10-13-2008.

**CLASS 35—ADVERTISING AND BUSINESS**

FOR RETAIL STORE SERVICES IN THE FIELDS OF JEWELRY, WATCHES, EYEGLASSES, PERFUMERY AND WRITING INSTRUMENTS (U.S. CLS. 100, 101 AND 102).

FIRST USE 10-13-2008; IN COMMERCE 10-13-2008.

CAROLYN CATALDO, EXAMINING ATTORNEY

SN 85-100,820. DIPROS S.R.L., GENOVA, ITALY, FILED 8-5-2010.

**PLANTS & CO.**

OWNER OF ITALY REG. NO. 1057594, DATED 8-27-2007, EXPIRES 8-27-2017.

NO CLAIM IS MADE TO THE EXCLUSIVE RIGHT TO USE "PLANTS", APART FROM THE MARK AS SHOWN.

THE MARK CONSISTS OF THE STYLIZED WORDING "PLANTS & CO." HAVING LINING ABOVE AND BELOW.

**CLASS 3—COSMETICS AND CLEANING PREPARATIONS**

FOR PERFUMERY, SOAPS, ESSENTIAL OILS, COSMETICS, HAIR LOTIONS, DENTIFRICES (U.S. CLS. 1, 4, 6, 50, 51 AND 52).

**CLASS 5—PHARMACEUTICALS**

FOR PHARMACEUTICAL PREPARATIONS FOR THE TREATMENT OF SKIN AGING AND CHANGES IN SKIN TEXTURE AND FOR TREATING SKIN DISORDERS; PHARMACEUTICAL PREPARATIONS FOR USE IN DERMATOLOGY AND FOR HYDRATING THE SKIN; DIETETIC FOODS AND SUPPLEMENTS FOR ADAPTED FOR MEDICAL PURPOSES; PLASTERS FOR MEDICAL PURPOSES (U.S. CLS. 6, 18, 44, 46, 51 AND 52).  
JULIE GUTTADAURO, EXAMINING ATTORNEY

SN 85-100,942. ACCURACY 1ST, INC., ARTHUR CITY, TX, FILED 8-5-2010.



THE COLOR(S) RED IS/ARE CLAIMED AS A FEATURE OF THE MARK.

THE MARK CONSISTS OF THE WORD "ACCURACY" IMPOSED AS THE HANDLE OF A RIFLE, WITH A CIRCLE SHOWING "1ST" AND A BULLS EYE, AND A RED DOT REPRESENTING THE BULLS EYE. THE COLORS BLACK, WHITE AND/OR GRAY REPRESENT BACKGROUND, OUTLINING, SHADING, AND OR/TRANSPARENT AREAS AND ARE NOT PART OF THE MARK.

**CLASS 41—EDUCATION AND ENTERTAINMENT**

FOR PROVIDING INSTRUCTION AND TRAINING IN THE FIELD OF THE HANDLING, SELECTION, USE, AND OPERATION OF FIREARMS, AND REGARDING SHOOTING AND MARKSMANSHIP; SNIPER AND COUNTER-SNIPER INSTRUCTION (U.S. CLS. 100, 101 AND 107).

FIRST USE 5-15-2005; IN COMMERCE 5-15-2005.

**CLASS 45—PERSONAL AND LEGAL SERVICES**

FOR MILITARY AND LAW ENFORCEMENT CONSULTING IN THE FIELD OF HANDLING, SELECTION, USE, AND OPERATION OF FIREARMS, SHOOTING, MARKSMANSHIP, SNIPING, AND COUNTER-SNIPING; CONSULTING REGARDING THE SAFE HANDLING OF FIREARMS (U.S. CLS. 100 AND 101).

FIRST USE 5-15-2005; IN COMMERCE 5-15-2005.

RUDY R. SINGLETON, EXAMINING ATTORNEY

SN 85-101,233. PENINSULA GAMING, LLC, DUBUQUE, IA, FILED 8-5-2010.

**KANSAS STAR**

NO CLAIM IS MADE TO THE EXCLUSIVE RIGHT TO USE "KANSAS", APART FROM THE MARK AS SHOWN.

THE MARK CONSISTS OF THE WORDS "KANSAS" AND "STAR" SEPARATED BY THE IMAGE OF A STAR ON A CIRCULAR BACKGROUND.

**CLASS 16—PAPER GOODS AND PRINTED MATTER**

FOR PERIODIC PUBLICATIONS, NAMELY, PAMPHLETS, BROCHURES, AND MAGAZINES PROVIDED TO CASINO CUSTOMERS CONCERNING EVENTS AT AND FACILITIES OF A HOTEL, RESORT AND CASINO; WRITING INSTRUMENTS; STATIONERY; POSTCARDS; CALENDARS (U.S. CLS. 2, 5, 22, 23, 29, 37, 38 AND 50).

**CLASS 21—HOUSEWARES AND GLASS**

FOR COFFEE CUPS; MUGS (U.S. CLS. 2, 13, 23, 29, 30, 33, 40 AND 50).

**CLASS 25—CLOTHING**

FOR MEN'S, WOMEN'S AND CHILDREN'S WEARING APPAREL, NAMELY, SHIRTS, T-SHIRTS, HATS, CAPS, SWEATSHIRTS, BATHROBES, JOGGING SUITS, SHORTS, PANTS, SKIRTS, DRESSES, VESTS, SWEATERS, SOCKS, SWIMWEAR, BELTS, TIES, BLOUSES, SCARVES, GLOVES, SHOES, BOOTS AND SLIPPERS (U.S. CLS. 22 AND 39).

**CLASS 28—TOYS AND SPORTING GOODS**

FOR GOLF BALLS; GOLF TEES; GOLF DIVOT REPAIR TOOLS; GOLF BALL MARKERS; CARD GAMES; PARLOR GAMES AND PARTY GAMES (U.S. CLS. 22, 23, 38 AND 50).



**CLASS 35—ADVERTISING AND BUSINESS**

FOR RETAIL STORE SERVICES FEATURING CONVENIENCE STORE ITEMS; RETAIL STORE SERVICES IN THE FIELD OF BUSINESS ACCESSORIES, ELECTRONIC EQUIPMENT, COLLECTABLE ITEMS, HOUSE WARES, PERSONAL-HYGIENE PRODUCTS, HEALTHCARE PRODUCTS, FOOD ITEMS, TRAVEL ACCESSORIES, SEASONAL ITEMS, GIFT-CERTIFICATES AND OTHER GENERAL MERCHANDISE, BATTERIES, PERIODICAL NEWSPAPERS AND MAGAZINES, JEWELRY, COSMETICS, LEATHER GOODS, BEVERAGE WARE, GLASSWARE, CERAMIC WARE, CRYSTAL, DECORATIVE ITEMS MADE OF METALS AND PRECIOUS METALS, PERFUME, STATIONERY ITEMS, FLOWERS, PREPACKAGED FOOD AND BEVERAGES, GAMES, AND TOYS; RETAIL STORE SERVICES IN THE FIELD OF CLOTHING AND GIFT ITEMS; RETAIL GIFT SHOP SERVICES; CONDUCTING BONUS CARD INCENTIVE AWARD PROGRAMS TO PROMOTE HOTEL REPORT AND CASINO SERVICES; DISSEMINATION OF ADVERTISEMENTS FOR THE GOODS AND SERVICES OF OTHERS ON AND THROUGH A GLOBAL COMPUTER NETWORK; AND RETAIL GROCERY STORE SERVICES (U.S. CLS. 100, 101 AND 102).

**CLASS 39—TRANSPORTATION AND STORAGE**

FOR PROVIDING INFORMATION IN THE FIELD OF TRAVEL ON AND THROUGH A GLOBAL COMPUTER NETWORK; TRAVEL SERVICES, NAMELY, RESERVATIONS AND BOOKING SERVICES FOR TRANSPORTATION; CAR PARKING SERVICES (U.S. CLS. 100 AND 105).

**CLASS 41—EDUCATION AND ENTERTAINMENT**

FOR ENTERTAINMENT, NAMELY, CASINO GAMING AND GAMING SERVICES IN THE NATURE OF CASINO GAMING; ENTERTAINMENT SERVICES, NAMELY, ORGANIZING AND CONDUCTING ATHLETIC EVENTS, SPORTING EVENTS, SPORTING COMPETITIONS AND ATHLETIC TOURNAMENTS IN THE FIELDS OF GOLF AND SWIMMING; SPORTS INSTRUCTION; GOLF COURSE SERVICES; GOLF CADDIE SERVICES; ENTERTAINMENT SERVICES IN THE NATURE OF LIVE MUSICAL AND COMEDY PERFORMANCES; HEALTH CLUB, FITNESS CLUB AND ATHLETIC CLUB SERVICES, NAMELY, PROVIDING INSTRUCTION AND EQUIPMENT IN THE FIELD OF PHYSICAL EXERCISE; ENTERTAINMENT IN THE NATURE OF TELEVISION GENERAL LOCAL NEWS SHOWS IN THE FIELD OF SPORTS, PERFORMING ARTS, ENTERTAINMENT LEISURE VIA A GLOBAL COMPUTER NETWORK; ENTERTAINMENT SERVICES, NAMELY, ARRANGING FOR TICKET RESERVATIONS FOR SHOWS AND OTHER ENTERTAINMENT EVENTS (U.S. CLS. 100, 101 AND 107).

**CLASS 43—HOTEL AND RESTAURANT SERVICES**

FOR RESORT SERVICES, NAMELY, RESORT HOTELS; HOTEL SERVICES; BAR SERVICES; PROVIDING TEMPORARY LODGING ACCOMMODATIONS FOR OTHERS IN THE NATURE OF CONDOMINIUM HOTELS; FOOD PREPARATION SERVICES; TRAVEL SERVICES, NAMELY, RESERVATIONS AND BOOKING SERVICES FOR TEMPORARY LODGING AND DINING (U.S. CLS. 100 AND 101).

**CLASS 44—MEDICAL, BEAUTY AND AGRICULTURAL SERVICES**

FOR HEALTH SPA SERVICES, NAMELY, BODY WRAPS, MUD TREATMENTS, SEAWEED TREATMENTS, HYDROTHERAPY BATHS AND BODY SCRUBS; BEAUTY SALON SERVICES (U.S. CLS. 100 AND 101).

AMY C. KEAN, EXAMINING ATTORNEY

SN 85-102,101. NETWORK SERVICES COMPANY, SCHAUMBURG, IL. FILED 8-6-2010.



OWNER OF U.S. REG. NO. 3,810,021.

NO CLAIM IS MADE TO THE EXCLUSIVE RIGHT TO USE "HEALTHY MEASURES", APART FROM THE MARK AS SHOWN.

THE COLOR(S) BLUE AND GREEN IS/ARE CLAIMED AS A FEATURE OF THE MARK.

THE MARK CONSISTS OF THREE GEOMETRIC SHAPES IN THE COLORS GREEN AND BLUE THAT FORM THE LETTERS "H" AND "M". THE WORD "HEALTHY" IS UNDERNEATH THE DESIGN IN BLUE. THE WORD "MEASURES" IS UNDERNEATH THAT IN BLUE.

**CLASS 35—ADVERTISING AND BUSINESS**

FOR BUSINESS MANAGEMENT AND CONSULTATION SERVICES FOR HEALTHCARE FACILITIES, NAMELY, PROVIDING INDUSTRY EXPERTISE AND SUPPLIER PARTNERSHIPS RELATED TO GOODS USED FOR INFECTION PREVENTION, SURFACE SANITATION, AND HAND HYGIENE (U.S. CLS. 100, 101 AND 102).

FIRST USE 6-1-2009; IN COMMERCE 6-1-2009.

**CLASS 41—EDUCATION AND ENTERTAINMENT**

FOR PROVIDING TRAINING AND EDUCATIONAL LECTURES IN THE FIELDS OF SAFETY, INFECTION PREVENTION, SURFACE SANITATION, HAND HYGIENE AND REGULATORY COMPLIANCE; PROVIDING TRAINING AND INSTRUCTION FOR IMPLEMENTATION OF INFECTION PREVENTION ACTION PLANS AND PRODUCT RECOMMENDATIONS DEVELOPED IN CONJUNCTION WITH ANALYTICAL AND CONSULTING SERVICES OF WORKSITE NEEDS (U.S. CLS. 100, 101 AND 107).

FIRST USE 6-1-2009; IN COMMERCE 6-1-2009.

**CLASS 42—SCIENTIFIC AND COMPUTER SERVICES**

FOR WORKSITE SURVEYS AND INSPECTIONS TO DETERMINE THE LEVEL OF WORKSITE CONTAMINANTS AND INFECTIOUS AGENTS (U.S. CLS. 100 AND 101).

FIRST USE 6-1-2009; IN COMMERCE 6-1-2009.

**CLASS 45—PERSONAL AND LEGAL SERVICES**

FOR ANALYSIS AND CONSULTATION PERTAINING TO WORK SITE SAFETY WITH RESPECT TO INFECTION PREVENTION, SURFACE SANITATION, AND HAND HYGIENE; REVIEWING STANDARDS AND PRACTICES TO ASSURE COMPLIANCE WITH INFECTION AND DISEASE PREVENTION LAWS AND REGULATIONS (U.S. CLS. 100 AND 101).

FIRST USE 6-1-2009; IN COMMERCE 6-1-2009.

MARGERY A. TIERNEY, EXAMINING ATTORNEY

SN 85-104,129. DEZER MARKS LLC, SUNNY ISLES BEACH, FL. FILED 8-10-2010.

# DEZER HOTELS

THE MARK CONSISTS OF STANDARD CHARACTERS WITHOUT CLAIM TO ANY PARTICULAR FONT, STYLE, SIZE, OR COLOR.

NO CLAIM IS MADE TO THE EXCLUSIVE RIGHT TO USE "HOTELS", APART FROM THE MARK AS SHOWN. SEC. 2(F) AS TO "DEZER".

## CLASS 37—CONSTRUCTION AND REPAIR

FOR REAL ESTATE DEVELOPMENT AND CONSTRUCTION OF COMMERCIAL, RESIDENTIAL AND HOTEL PROPERTY (U.S. CLS. 100, 103 AND 106). FIRST USE 0-0-1985; IN COMMERCE 0-0-1985.

## CLASS 43—HOTEL AND RESTAURANT SERVICES

FOR EXTENDED-STAY HOTELS; HOTEL ACCOMMODATION SERVICES; HOTEL SERVICES; HOTEL SERVICES FOR PREFERRED CUSTOMERS; HOTEL, BAR AND RESTAURANT SERVICES; HOTEL, RESTAURANT AND CATERING SERVICES; HOTELS; PROVIDING HOTEL ACCOMMODATION; PROVIDING TEMPORARY LODGING SERVICES IN THE NATURE OF A CONDOMINIUM HOTEL; RESORT HOTELS (U.S. CLS. 100 AND 101).

FIRST USE 0-0-1985; IN COMMERCE 0-0-1985. ANNE E. GUSTASON, EXAMINING ATTORNEY

SN 85-104,744. ENTERTAINMENT PUBLICATIONS LLC, TROY, MI. FILED 8-11-2010.

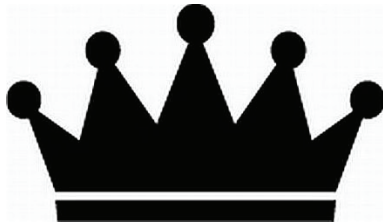

OWNER OF U.S. REG. NOS. 1,718,106, 3,396,008 AND OTHERS. THE MARK CONSISTS OF A CROWN WITH FIVE POINTS.

## CLASS 9—ELECTRICAL AND SCIENTIFIC APPARATUS

FOR DOWNLOADABLE SOFTWARE IN THE NATURE OF A MOBILE APPLICATION FOR MANAGEMENT AND RETRIEVAL OF MERCHANT LISTS AND MERCHANT INFORMATION INCLUDING DISCOUNT OFFERS AND ELECTRONIC CONSUMER COUPONS FOR IMMEDIATE OR FUTURE USE BY CONSUMERS (U.S. CLS. 21, 23, 26, 36 AND 38).

## CLASS 16—PAPER GOODS AND PRINTED MATTER

FOR BOOKS, BOOKLETS, AND NON-MAGNETICALLY ENCODED PRINTED COUPON AND DISCOUNT CARDS ALL WHICH ENTITLE THE HOLDER TO RECEIVE DISCOUNTS ON DINING, HOTEL ACCOMMODATIONS, CONSUMER MERCHANDISE, TRAVEL, MOVIES, SPORTS, THEATER, AND OTHER LEISURE ACTIVITIES SOLD SEPARATELY OR AS PART OF A UNIT (U.S. CLS. 2, 5, 22, 23, 29, 37, 38 AND 50).

## CLASS 35—ADVERTISING AND BUSINESS

FOR ADVERTISING AND PROMOTIONAL SERVICES, NAMELY, PROMOTING THE GOODS AND SERVICES OF OTHERS THROUGH THE DISTRIBUTION OF COUPONS, AND DISCOUNT OFFERS WHICH ENTITLE THE HOLDER TO RECEIVE DISCOUNTS ON DINING, HOTEL ACCOMMODATIONS, CONSUMER MERCHANDISE, TRAVEL, MOVIES, SPORTS, THEATER AND OTHER LEISURE ACTIVITIES; PROVIDING ADVERTISING SERVICE THROUGH THE DISTRIBUTION OF ADVERTISEMENTS, COUPONS AND DISCOUNT OFFERS FOR DISPLAY ON INTERNET, NAMELY, IN WEBSITES, E-MAILS AND MULTIMEDIA MESSAGES; PROVIDING VIA ON-LINE COMPUTER SERVICES A MEMBERSHIP PROGRAM ENTITLING THE PARTICIPANTS TO RECEIVE DISCOUNTS ON DINING, HOTEL ACCOMMODATIONS, CONSUMER MERCHANDISE, TRAVEL, MOVIES, SPORTS, THEATER AND OTHER LEISURE ACTIVITIES, AND PROVIDING IN CONNECTION THEREWITH AN ON-LINE DIRECTORY OF INFORMATION ABOUT THE DISCOUNT PROGRAM AND PARTICIPATING BUSINESSES (U.S. CLS. 100, 101 AND 102).

## CLASS 36—INSURANCE AND FINANCIAL

FOR CHARITABLE FUNDRAISING SERVICES EFFECTED THROUGH A MEMBERSHIP PROGRAM WHICH ENTITLES THE PARTICIPANTS TO DISTRIBUTE COUPONS AND DISCOUNT OFFERS WHICH ALLOWS THE HOLDER TO RECEIVE DISCOUNTS ON DINING, HOTEL ACCOMMODATION, CONSUMER MERCHANDISE, TRAVEL, MOVIES, SPORTS, THEATER AND OTHER LEISURE ACTIVITIES (U.S. CLS. 100, 101 AND 102). CHRISTINE MARTIN, EXAMINING ATTORNEY

SN 85-104,793. ENTERTAINMENT PUBLICATIONS LLC, TROY, MI. FILED 8-11-2010.



OWNER OF U.S. REG. NOS. 1,718,106, 3,396,008 AND OTHERS. THE MARK CONSISTS OF A CROWN WITH 5 POINTS INSIDE A ROUNDED EDGE DIAMOND.

**CLASS 9—ELECTRICAL AND SCIENTIFIC APPARATUS**

FOR DOWNLOADABLE SOFTWARE IN THE NATURE OF A MOBILE APPLICATION FOR MANAGEMENT AND RETRIEVAL OF MERCHANT LISTS AND MERCHANT INFORMATION INCLUDING DISCOUNT OFFERS AND ELECTRONIC CONSUMER COUPONS FOR IMMEDIATE OR FUTURE USE BY CONSUMERS (U.S. CLS. 21, 23, 26, 36 AND 38).

**CLASS 16—PAPER GOODS AND PRINTED MATTER**

FOR BOOKS, BOOKLETS, AND NON-MAGNETICALLY ENCODED PRINTED COUPON AND DISCOUNT CARDS ALL WHICH ENTITLE THE HOLDER TO RECEIVE DISCOUNTS ON DINING, HOTEL ACCOMMODATIONS, CONSUMER MERCHANDISE, TRAVEL, MOVIES, SPORTS, THEATER, AND OTHER LEISURE ACTIVITIES SOLD SEPARATELY OR AS PART OF A UNIT (U.S. CLS. 2, 5, 22, 23, 29, 37, 38 AND 50).

**CLASS 35—ADVERTISING AND BUSINESS**

FOR ADVERTISING AND PROMOTIONAL SERVICES, NAMELY, PROMOTING THE GOODS AND SERVICES OF OTHERS THROUGH THE DISTRIBUTION OF COUPONS, AND DISCOUNT OFFERS WHICH ENTITLE THE HOLDER TO RECEIVE DISCOUNTS ON DINING, HOTEL ACCOMMODATIONS, CONSUMER MERCHANDISE, TRAVEL, MOVIES, SPORTS, THEATER AND OTHER LEISURE ACTIVITIES; PROVIDING ADVERTISING SERVICE THROUGH THE DISTRIBUTION OF ADVERTISEMENTS, COUPONS AND DISCOUNT OFFERS FOR DISPLAY ON INTERNET, NAMELY, IN WEBSITES, E-MAILS AND MULTIMEDIA MESSAGES; PROVIDING VIA ON-LINE COMPUTER SERVICES A MEMBERSHIP PROGRAM ENTITLING THE PARTICIPANTS TO RECEIVE DISCOUNTS ON DINING, HOTEL ACCOMMODATIONS, CONSUMER MERCHANDISE, TRAVEL, MOVIES, SPORTS, THEATER AND OTHER LEISURE ACTIVITIES, AND PROVIDING IN CONNECTION THEREWITH AN ON-LINE DIRECTORY OF INFORMATION ABOUT THE DISCOUNT PROGRAM AND PARTICIPATING BUSINESSES (U.S. CLS. 100, 101 AND 102).

**CLASS 36—INSURANCE AND FINANCIAL**

FOR CHARITABLE FUNDRAISING SERVICES EFFECTED THROUGH A MEMBERSHIP PROGRAM WHICH ENTITLES THE PARTICIPANTS TO DISTRIBUTE COUPONS AND DISCOUNT OFFERS WHICH ALLOWS THE HOLDER TO RECEIVE DISCOUNTS ON DINING, HOTEL ACCOMMODATION, CONSUMER MERCHANDISE, TRAVEL, MOVIES, SPORTS, THEATER AND OTHER LEISURE ACTIVITIES (U.S. CLS. 100, 101 AND 102).

CHRISTINE MARTIN, EXAMINING ATTORNEY

SN 85-104,814. ENTERTAINMENT PUBLICATIONS LLC, TROY, MI. FILED 8-11-2010.



NO CLAIM IS MADE TO THE EXCLUSIVE RIGHT TO USE "DAILY DEAL", APART FROM THE MARK AS SHOWN.

THE MARK CONSISTS OF THE LETTER "U" INSIDE A CURVED EDGE DIAMOND NEXT TO THE WORDS "DAILY DEAL" WITH 15 SMALL DOTS UNDER THE WORDS "DAILY DEAL".

**CLASS 9—ELECTRICAL AND SCIENTIFIC APPARATUS**

FOR DOWNLOADABLE SOFTWARE IN THE NATURE OF A MOBILE APPLICATION FOR MANAGEMENT AND RETRIEVAL OF MERCHANT LISTS AND MERCHANT INFORMATION INCLUDING DISCOUNT OFFERS AND ELECTRONIC CONSUMER COUPONS FOR IMMEDIATE OR FUTURE USE BY CONSUMERS (U.S. CLS. 21, 23, 26, 36 AND 38).

**CLASS 35—ADVERTISING AND BUSINESS**

FOR ADVERTISING AND PROMOTIONAL SERVICES, NAMELY, PROMOTING THE GOODS AND SERVICES OF OTHERS THROUGH THE DISTRIBUTION OF COUPONS, AND DISCOUNT OFFERS WHICH ENTITLE THE HOLDER TO RECEIVE DISCOUNTS ON DINING, HOTEL ACCOMMODATIONS, CONSUMER MERCHANDISE, TRAVEL, MOVIES, SPORTS, THEATER AND OTHER LEISURE ACTIVITIES; PROVIDING ADVERTISING SERVICES THROUGH THE DISTRIBUTION OF ADVERTISEMENTS, COUPONS AND DISCOUNT OFFERS FOR DISPLAY ON INTERNET, NAMELY, IN WEBSITES, E-MAILS AND MULTIMEDIA MESSAGES; PROVIDING VIA ON-LINE COMPUTER SERVICES A MEMBERSHIP PROGRAM ENTITLING THE PARTICIPANTS TO RECEIVE DISCOUNTS ON DINING, HOTEL ACCOMMODATIONS, CONSUMER MERCHANDISE, TRAVEL, MOVIES, SPORTS, THEATER AND OTHER LEISURE ACTIVITIES, AND PROVIDING IN CONNECTION THEREWITH AN ON-LINE DIRECTORY OF INFORMATION ABOUT THE DISCOUNT PROGRAM AND PARTICIPATING BUSINESSES (U.S. CLS. 100, 101 AND 102).

**CLASS 36—INSURANCE AND FINANCIAL**

FOR CHARITABLE FUNDRAISING SERVICES EFFECTED THROUGH A MEMBERSHIP PROGRAM WHICH ENTITLES THE PARTICIPANTS TO DISTRIBUTE COUPONS AND DISCOUNT OFFERS WHICH ALLOWS THE HOLDER TO RECEIVE DISCOUNTS ON DINING, HOTEL ACCOMMODATION, CONSUMER MERCHANDISE, TRAVEL, MOVIES, SPORTS, THEATER AND OTHER LEISURE ACTIVITIES (U.S. CLS. 100, 101 AND 102).

CHRISTINE MARTIN, EXAMINING ATTORNEY

SN 85-105,767. OLYMPIA MEDIA GROUP, INDIANAPOLIS, IN. FILED 8-12-2010.

# The Odyssey

THE MARK CONSISTS OF STANDARD CHARACTERS WITHOUT CLAIM TO ANY PARTICULAR FONT, STYLE, SIZE, OR COLOR.

**CLASS 16—PAPER GOODS AND PRINTED MATTER**

FOR NEWSPAPERS IN THE FIELD OF THE COLLEGE GREEK SYSTEM; SYNDICATED NEWSPAPER COLUMNS DEALING WITH THE COLLEGE GREEK SYSTEM (U.S. CLS. 2, 5, 22, 23, 29, 37, 38 AND 50).  
FIRST USE 9-2-2009; IN COMMERCE 9-2-2009.

**CLASS 35—ADVERTISING AND BUSINESS**

FOR PROVIDING ADVERTISING SPACE IN PERIODICALS, NEWSPAPERS AND MAGAZINES (U.S. CLS. 100, 101 AND 102).

FIRST USE 9-2-2009; IN COMMERCE 9-2-2009.  
DOMINIC J. FERRAIUOLO, EXAMINING ATTORNEY

SN 85-107,982. VANCE PRODUCTS INCORPORATED, DBA  
COOK UROLOGICAL INCORPORATED, SPENCER, IN.  
FILED 8-16-2010.

UVUE

THE MARK CONSISTS OF STANDARD CHARACTERS  
WITHOUT CLAIM TO ANY PARTICULAR FONT, STYLE,  
SIZE, OR COLOR.

#### CLASS 5—PHARMACEUTICALS

FOR CONTRAST AGENT FOR USE WITH ULTRA-  
SOUND PROBES IN GYNECOLOGICAL IMAGING PRO-  
CEDURES (U.S. CLS. 6, 18, 44, 46, 51 AND 52).

#### CLASS 10—MEDICAL APPARATUS

FOR MEDICAL DEVICES, NAMELY, CATHETERS,  
CATHETER TRAYS, NEEDLE GUIDES AND ULTRA-  
SOUND PROBES FOR USE IN GYNECOLOGICAL IMA-  
GING PROCEDURES (U.S. CLS. 26, 39 AND 44).  
BARNEY CHARLON, EXAMINING ATTORNEY

SN 85-110,109. HUMPHREYS, IAN STUART, LONDON,  
UNITED KINGDOM, FILED 8-18-2010.

IAN STUART

PRIORITY CLAIMED UNDER SEC. 44(D) ON UNITED  
KINGDOM APPLICATION NO. 2547381, FILED 5-11-2010,  
REG. NO. 2547381, DATED 5-11-2010, EXPIRES 5-11-2020.  
THE NAME "IAN STUART" IDENTIFIES A LIVING  
INDIVIDUAL WHOSE CONSENT IS OF RECORD.  
THE MARK CONSISTS OF THE WORDS "IAN STUART"  
IN A STYLIZED FORM.

#### CLASS 3—COSMETICS AND CLEANING PRE- PARATIONS

FOR SOAPS, NAMELY, BODY CARE SOAP, SHAVING  
SOAP AND SKIN SOAP; TOILETRIES, NAMELY, FIN-  
GER TOWELS IMPREGNATED WITH CLEANSING PRE-  
PARATIONS; COSMETICS, PERSONAL DEODORANTS,  
SKIN MOISTURIZERS, BATH OILS, BUBBLE BATHS;  
AROMATIC PREPARATIONS, NAMELY, AROMATIC  
CREAMS, AROMATIC OILS, AROMATIC LOTIONS  
AND AROMATIC BODY SPRAYS; BODY POWDER,  
EYEBROW COSMETICS, COSMETIC CREAMS, FACE  
CREAMS, BODY CREAMS; BODY LOTIONS; PERFUM-  
ERY, COLOGNES AND PERFUMES; PERFUME BODY  
SPRAYS; HAIR LOTIONS; ANTIPERSPIRANTS, DEPI-  
LATORY PREPARATIONS; SHAVING SOAPS, COS-  
METIC PREPARATION FOR TANNING THE SKIN;  
COLOGNES, DEODORANT SOAPS, TOILET WATERS;  
SHAVING PREPARATIONS, HAIR WEAVING PRE-  
PARATIONS, NAMELY, BONDING GLUE AND BOND-  
ING GLUE REMOVER, COSMETIC HAIR DRESSING  
PREPARATIONS, HAIR SETTING PREPARATIONS;  
SHOWER PREPARATIONS, NAMELY, GELS; WASHING  
AND BATHROOM PREPARATIONS, NAMELY, BATH  
FOAM, BATH OIL, BATH SALTS, BUBBLE BATH,  
SHAMPOOS, SHOWER GEL, CONDITIONER, HAIR  
GEL, HAIR COLOR, HAIR MOUSSE; BATH SALTS;  
COSMETIC PREPARATIONS FOR BATHS; TALCUM  
POWDER, EMERY BOARDS, EMERY PAPER, EMERY  
CLOTH ALL FOR NAIL GROOMING; CLEANING MILK  
FOR TOILET PURPOSES; ESSENTIAL OILS; LOTIONS  
FOR COSMETIC PURPOSES, NAMELY, PRE SHAVING  
AND AFTER SHAVING LOTIONS; BEAUTY MASKS;  
NAIL CARE PREPARATIONS, NAMELY, NAIL POLISH;  
NAIL VARNISH; NAIL CARE PREPARATIONS; OILS  
FOR COSMETIC PURPOSES, NAMELY, ESSENTIAL  
OILS, OILS FOR PERFUMES AND SCENTS; PERFUMES;  
SUN TANNING PREPARATIONS; TALCUM POWDER;  
TISSUES IMPREGNATED WITH COSMETIC LOTIONS;  
NAIL VARNISH REMOVING PREPARATIONS; MAKE-  
UP, EYE MAKEUP EYEBROW PENCILS, MAKEUP  
POWDER, MAKEUP PREPARATIONS LIPSTICK, LIP  
GLOSS, LIP LINER, LIPSTICKS, NAIL POLISHES; COL-  
ORING MATTERS, NAMELY, TINTS AND LOTIONS,  
ALL FOR THE HAIR AND THE BEARD, HAIR BLEACH-  
ING PREPARATIONS, HAIR COLORANTS, HAIR DYE;  
HAIR CARE PREPARATIONS; HAIR LOTIONS; MAKE-  
UP REMOVING PREPARATIONS; FALSE EYELASHES;  
FALSE NAILS (U.S. CLS. 1, 4, 6, 50, 51 AND 52).

#### CLASS 18—LEATHER GOODS

FOR LEATHER AND IMITATIONS OF LEATHER  
AND GOODS MADE OF THESE MATERIALS, NAMELY,  
TRUNKS, TRAVELLING BAGS, TRAVELLING CASES,  
HANDBAGS, SHOULDER BAGS, DUFFEL BAGS, OVER-  
NIGHT BAGS, CARRIER BAGS, GARMENT BAGS, SUIT  
CARRIERS BEING TRAVELLING BAGS, SHOE BAGS  
FOR TRAVEL, CLUTCH BAGS, TOILET BAGS SOLD  
EMPTY, COSMETIC BAGS SOLD EMPTY, BELT BAGS;  
BELTS; WALLETS, PURSES, LEATHER POUCHES AND  
KEY CASES; KEY FOBS MADE OF LEATHER INCOR-  
PORATING KEY RINGS; KEY CASES; NOTE CASES,  
NAMELY, BILLFOLDS; CREDIT CARD HOLDERS; UM-  
BRELLAS, PARASOLS (U.S. CLS. 1, 2, 3, 22 AND 41).

#### CLASS 25—CLOTHING

FOR CLOTHING, NAMELY, LADIES OUTER CLOTH-  
ING, NAMELY, DRESSES, JACKETS, SKIRTS, GOWNS,  
JUMPERS, SWEATERS, JERSEYS, PULLOVERS, TIES,  
CARDIGANS, TROUSERS, PANTS, SUITS, LADIES SE-  
PARATES, NAMELY, BLOUSES, CAMISOLES, SHIRTS,  
SKIRTS, TROUSERS, PANTS AND JACKETS, SHIRTS,  
DRESS SHIRTS, BLOUSES, GLOVES, SCARVES, COATS,  
WAISTCOATS, FORMAL WEAR, NAMELY, SUITS,  
TAILCOATS, FORMAL TROUSERS, BOW TIES, VESTS,  
BALL GOWNS, EVENING GOWNS, DRESSES AND  
DINNER JACKETS, EVENING WEAR, NAMELY, EVE-  
NING DRESSES, WOMEN'S CEREMONIAL DRESSES,  
CORSETS, PETTICOATS, SHRUGS, BOLEROS, CAPES



AND PROM DRESSES, EVENING DRESSES, PROM DRESSES, PAGEANT DRESSES, COCKTAIL DRESSES; BATH ROBES, BATH SANDALS AND SLIPPERS; BATHING CAPS; UNDERCLOTHING, NAMELY, LINGERIE, FOUNDATION GARMENTS, LADIES UNDERWEAR, BRASSIERES, CAMISOLES, CORSETS, DRESSING GOWNS, BODY LINEN; NIGHTWEAR; PAJAMAS; HOSIERY, NAMELY, STOCKINGS, STOCKINGS SUSPENDERS, LEGGINGS, TIGHTS, PANTIES; BELTS; HEADGEAR, NAMELY, HATS, CAPS, BERETS; FOOTWEAR, NAMELY, SHOES, SLIPPERS, SANDALS, BOOTS (U.S. CLS. 22 AND 39).

#### **CLASS 42—SCIENTIFIC AND COMPUTER SERVICES**

FOR DESIGN SERVICES, NAMELY, FASHION AND CLOTHING DESIGN, DESIGN OF BAGS AND ACCESSORIES; DESIGN OF BRIDAL WEAR, OCCASION WEAR, FORMAL WEAR AND EVENING WEAR (U.S. CLS. 100 AND 101).

KATHERINE STOIDES, EXAMINING ATTORNEY

SN 85-110,128. HUMPHREYS, IAN STUART, LONDON, UNITED KINGDOM, FILED 8-18-2010.

IAN STUART-bride

PRIORITY CLAIMED UNDER SEC. 44(D) ON UNITED KINGDOM APPLICATION NO. 2547383, FILED 5-11-2010, REG. NO. 2547383, DATED 5-11-2010, EXPIRES 5-11-2020.

THE NAME "IAN STUART" IDENTIFIES A LIVING INDIVIDUAL WHOSE CONSENT IS OF RECORD.

THE MARK CONSISTS OF THE WORDS "IAN STUART-BRIDE" IN A STYLIZED FORM.

#### **CLASS 3—COSMETICS AND CLEANING PREPARATIONS**

FOR SOAPS, NAMELY, BODY CARE SOAP, SHAVING SOAP AND SKIN SOAP; TOILETRIES, NAMELY, FINGER TOWELS IMPREGNATED WITH CLEANSING PREPARATIONS; COSMETICS, PERSONAL DEODORANTS, SKIN MOISTURIZERS, BATH OILS, BUBBLE BATHS; AROMATIC PREPARATIONS, NAMELY, AROMATIC CREAMS, AROMATIC OILS, AROMATIC LOTIONS AND AROMATIC BODY SPRAYS; BODY POWDER, EYEBROW COSMETICS, COSMETIC CREAMS, FACE CREAMS, BODY CREAMS; BODY LOTIONS; PERFUMERY, COLOGNES AND PERFUMES; PERFUME BODY SPRAYS; HAIR LOTIONS; ANTIPERSPIRANTS, DEPI-LATORY PREPARATIONS; SHAVING SOAPS, COSMETIC PREPARATION FOR TANNING THE SKIN; COLOGNES, DEODORANT SOAPS, TOILET WATERS; SHAVING PREPARATIONS, HAIR WEAVING PREPARATIONS, NAMELY, BONDING GLUE AND BONDING GLUE REMOVER, COSMETIC HAIR DRESSING PREPARATIONS, HAIR SETTING PREPARATIONS; SHOWER PREPARATIONS, NAMELY, GELS; WASHING AND BATHROOM PREPARATIONS, NAMELY, BATH FOAM, BATH OIL, BATH SALTS, BUBBLE BATH, SHAMPOOS, SHOWER GEL, CONDITIONER, HAIR GEL, HAIR COLOR, HAIR MOUSSE; BATH SALTS; COSMETIC PREPARATIONS FOR BATHS; TALCUM POWDER, EMERY BOARDS, EMERY PAPER, EMERY CLOTH ALL FOR NAIL GROOMING; CLEANING MILK FOR TOILET PURPOSES; ESSENTIAL OILS; LOTIONS FOR COSMETIC PURPOSES, NAMELY, PRE SHAVING AND AFTER SHAVING LOTIONS; BEAUTY MASKS; NAIL CARE PREPARATIONS, NAMELY, NAIL POLISH; NAIL VARNISH; NAIL CARE PREPARATIONS; OILS FOR COSMETIC PURPOSES, NAMELY, ESSENTIAL OILS, OILS FOR PERFUMES AND SCENTS; PERFUMES; SUN TANNING PREPARATIONS; TALCUM POWDER; TISSUES IMPREGNATED WITH COSMETIC LOTIONS; NAIL VARNISH REMOVING PREPARATIONS; MAKE-UP, EYE MAKEUP EYEBROW PENCILS, MAKEUP POWDER, MAKEUP PREPARATIONS LIPSTICK, LIP GLOSS, LIP LINER, LIPSTICKS, NAIL POLISHES; COLORING MATTERS, NAMELY, TINTS AND LOTIONS, ALL FOR THE HAIR AND THE BEARD, HAIR BLEACHING PREPARATIONS, HAIR COLORANTS, HAIR DYE; HAIR CARE PREPARATIONS; HAIR LOTIONS; MAKE-UP REMOVING PREPARATIONS; FALSE EYELASHES; FALSE NAILS (U.S. CLS. 1, 4, 6, 50, 51 AND 52).

#### **CLASS 18—LEATHER GOODS**

FOR LEATHER AND IMITATIONS OF LEATHER AND GOODS MADE OF THESE MATERIALS, NAMELY, TRUNKS, TRAVELLING BAGS, TRAVELLING CASES, HANDBAGS, SHOULDER BAGS, DUFFEL BAGS, OVERNIGHT BAGS, CARRIER BAGS, GARMENT BAGS, SUIT CARRIERS BEING TRAVELLING BAGS, SHOE BAGS FOR TRAVEL, CLUTCH BAGS, TOILET BAGS SOLD EMPTY, COSMETIC BAGS SOLD EMPTY, BELT BAGS; BELTS; WALLETS, PURSES, LEATHER POUCHES AND KEY CASES; KEY FOBS MADE OF LEATHER INCORPORATING KEY RINGS; KEY CASES; NOTE CASES, NAMELY, BILLFOLDS; CREDIT CARD HOLDERS; UMBRELLAS, PARASOLS (U.S. CLS. 1, 2, 3, 22 AND 41).

#### **CLASS 25—CLOTHING**

FOR CLOTHING, NAMELY, LADIES OUTER CLOTHING, NAMELY, DRESSES, JACKETS, SKIRTS, GOWNS, JUMPERS, SWEATERS, JERSEYS, PULLOVERS, TIES, CARDIGANS, TROUSERS, PANTS, SUITS, LADIES SEPARATES, NAMELY, BLOUSES, CAMISOLES, SHIRTS, SKIRTS, TROUSERS, PANTS AND JACKETS, SHIRTS, DRESS SHIRTS, BLOUSES, GLOVES, SCARVES, COATS, WAISTCOATS, FORMAL WEAR, NAMELY, SUITS, TAILCOATS, FORMAL TROUSERS, BOW TIES, VESTS, BALL GOWNS, EVENING GOWNS, DRESSES AND DINNER JACKETS, EVENING WEAR, NAMELY, EVENING DRESSES, WOMEN'S CEREMONIAL DRESSES, CORSETS, PETTICOATS, SHRUGS, BOLEROS, CAPES

AND PROM DRESSES, EVENING DRESSES, PROM DRESSES, PAGEANT DRESSES, COCKTAIL DRESSES; BATH ROBES, BATH SANDALS AND SLIPPERS; BATHING CAPS; UNDERCLOTHING, NAMELY, LINGERIE, FOUNDATION GARMENTS, LADIES UNDERWEAR, BRASSIERES, CAMISOLES, CORSETS, DRESSING GOWNS, BODY LINEN; NIGHTWEAR; PAJAMAS; HOSIERY, NAMELY, STOCKINGS, STOCKINGS SUSPENDERS, LEGGINGS, TIGHTS, PANTIES; BELTS; HEADGEAR, NAMELY, HATS, CAPS, BERETS; FOOTWEAR, NAMELY, SHOES, SLIPPERS, SANDALS, BOOTS (U.S. CLS. 22 AND 39).

#### CLASS 42—SCIENTIFIC AND COMPUTER SERVICES

FOR DESIGN SERVICES, NAMELY, FASHION AND CLOTHING DESIGN, DESIGN OF BAGS AND ACCESSORIES; DESIGN OF BRIDAL WEAR, OCCASION WEAR, FORMAL WEAR AND EVENING WEAR (U.S. CLS. 100 AND 101).

KATHERINE STOIDES, EXAMINING ATTORNEY

SN 85-112,407. HUMANA INC., LOUISVILLE, KY. FILED 8-20-2010.

### MAXIMIZE YOUR BENEFIT

THE MARK CONSISTS OF STANDARD CHARACTERS WITHOUT CLAIM TO ANY PARTICULAR FONT, STYLE, SIZE, OR COLOR.

OWNER OF U.S. REG. NOS. 3,386,959 AND 3,390,267.

#### CLASS 35—ADVERTISING AND BUSINESS

FOR COST CONTAINMENT IN THE FIELD OF CONSUMER PRESCRIPTION MEDICATIONS (U.S. CLS. 100, 101 AND 102).

#### CLASS 36—INSURANCE AND FINANCIAL

FOR UNDERWRITING, ORGANIZING AND ADMINISTRATION OF PRE-PAID AND SELF-FUNDED HEALTH CARE AND PRESCRIPTION DRUG SERVICES AND PLANS; ADMINISTRATION OF PRESCRIPTION DRUG PROGRAMS FOR DRUG COVERAGE INSURERS (U.S. CLS. 100, 101 AND 102).

#### CLASS 41—EDUCATION AND ENTERTAINMENT

FOR EDUCATIONAL SERVICES, NAMELY, PROVIDING CLASSES AND SEMINARS IN THE FIELDS OF COST-EFFECTIVE PHARMACEUTICALS AND PRESCRIPTION DRUG COMPLIANCE (U.S. CLS. 100, 101 AND 107).

STEPHANIE ALI, EXAMINING ATTORNEY

SN 85-112,641. BACKROOM MANAGEMENT SERVICES, LLC, CENTENNIAL, CO. FILED 8-20-2010.



THE COLOR(S) YELLOW, PURPLE, ORANGE, GREEN, BLUE, RED, AND GREY IS/ARE CLAIMED AS A FEATURE OF THE MARK.

THE MARK CONSISTS OF THE WORDING "BACKROOM" NEXT TO A PERSPECTIVE VIEW OF A COLLECTION OF COLORED BLOCKS FORMED INTO A PARTIAL CUBE WITH ONE INVERTED, L SHAPED BLOCK TO THE RIGHT LEAVING AN INVERTED L SHAPED INCOMPLETION IN THE CUBE, THE L SHAPED BLOCK IS RED WITH THE OTHER BLOCKS BEING YELLOW, PURPLE, ORANGE, GREEN AND BLUE AND THE BLOCKS CAST GREY SHADOWS TO THE LEFT WITH THE WORD "BACKROOM", WHICH IS BELOW THE BLOCKS WITH THE LETTERS "BACK" IN BLUE AND THE LETTERS "ROOM" IN GREEN.

#### CLASS 35—ADVERTISING AND BUSINESS

FOR PROVIDING BUSINESS MANAGEMENT AND ACCOUNTING SERVICES (U.S. CLS. 100, 101 AND 102). FIRST USE 5-31-2006; IN COMMERCE 5-31-2006.

#### CLASS 41—EDUCATION AND ENTERTAINMENT

FOR TRAINING SERVICES IN THE FIELDS OF BUSINESS MANAGEMENT AND ACCOUNTING (U.S. CLS. 100, 101 AND 107).

FIRST USE 5-31-2006; IN COMMERCE 5-31-2006.

#### CLASS 42—SCIENTIFIC AND COMPUTER SERVICES

FOR PROVIDING A WEB SITE FEATURING TEMPORARY USE OF NON-DOWNLOADABLE SOFTWARE FOR USE IN DATABASE MANAGEMENT, USE AS A SPREADSHEET, WORD PROCESSING, AND CONTENT MANAGEMENT IN THE FIELDS OF BUSINESS MANAGEMENT AND ACCOUNTING SERVICES (U.S. CLS. 100 AND 101).

FIRST USE 5-31-2006; IN COMMERCE 5-31-2006.

TINA L. SNAPP, EXAMINING ATTORNEY

SN 85-113,269. PEARSON, CHRIS, AUSTIN, TX. FILED 8-23-2010.

## THESIS

THE MARK CONSISTS OF STANDARD CHARACTERS WITHOUT CLAIM TO ANY PARTICULAR FONT, STYLE, SIZE, OR COLOR.

#### CLASS 9—ELECTRICAL AND SCIENTIFIC APPARATUS

FOR WEB SITE DEVELOPMENT SOFTWARE (U.S. CLS. 21, 23, 26, 36 AND 38).

**CLASS 42—SCIENTIFIC AND COMPUTER SERVICES**

FOR COMPUTER SOFTWARE INSTALLATION AND MAINTENANCE; PROVIDING A WEB SITE FEATURING TEMPORARY USE OF NON-DOWNLOADABLE SOFTWARE FOR WEB SITE USERS TO DESIGN AND DEVELOP WEBSITES; TECHNICAL SUPPORT SERVICES, NAMELY, TROUBLESHOOTING OF COMPUTER SOFTWARE PROBLEMS; WEBSITE DESIGN AND DEVELOPMENT FOR OTHERS (U.S. CLS. 100 AND 101).  
DAWN FELDMAN, EXAMINING ATTORNEY

---

SN 85-113,402. AGENT EVOLUTION LLC, RIVERBANK, CA. FILED 8-23-2010.

# Agent Evolution

THE MARK CONSISTS OF STANDARD CHARACTERS WITHOUT CLAIM TO ANY PARTICULAR FONT, STYLE, SIZE, OR COLOR.

NO CLAIM IS MADE TO THE EXCLUSIVE RIGHT TO USE "AGENT", APART FROM THE MARK AS SHOWN.

**CLASS 41—EDUCATION AND ENTERTAINMENT**

FOR TRAINING SERVICES IN THE FIELD OF INTERNET MARKETING (U.S. CLS. 100, 101 AND 107).  
FIRST USE 1-29-2010; IN COMMERCE 1-29-2010.

**CLASS 42—SCIENTIFIC AND COMPUTER SERVICES**

FOR WEB SITE DESIGN (U.S. CLS. 100 AND 101).  
FIRST USE 1-29-2010; IN COMMERCE 1-29-2010.  
WILLIAM BRECKENFELD, EXAMINING ATTORNEY

---

SN 85-114,427. AFFINION PUBLISHING, LLC, LAS VEGAS, NV. FILED 8-24-2010.

# Take Control of Your Identity

THE MARK CONSISTS OF STANDARD CHARACTERS WITHOUT CLAIM TO ANY PARTICULAR FONT, STYLE, SIZE, OR COLOR.

**CLASS 35—ADVERTISING AND BUSINESS**

FOR PROVIDING CREDIT CARD REGISTRATION SERVICES IN THE NATURE OF CREDIT CARD CANCELLATION SERVICES FOR LOST OR STOLEN CARDS AND NOTIFICATION SERVICES TO CREDIT CARD ISSUERS; ASSISTANCE IN REMOVAL OF IDENTIFIABLE INFORMATION FROM INTERNET DIRECTORIES, NAMELY, PROVIDING ON-LINE COMMERCIAL DIRECTORY INFORMATION INFORMING CONSUMERS OF PHONE NUMBERS AND ADDRESSES TO REQUEST REMOVAL OF UNWANTED PERSONAL INFORMATION FROM THE WEBSITES OF OTHERS; PROVIDE INFORMATION AND ALERTS TO CONSUMERS IN THE FIELD OF FOOD AND DRUG ADMINISTRATION PRODUCT RECALLS (U.S. CLS. 100, 101 AND 102).

**CLASS 36—INSURANCE AND FINANCIAL**

FOR PROVIDING IDENTITY THEFT INSURANCE UNDERWRITTEN BY OTHER COMPANIES (U.S. CLS. 100, 101 AND 102).

**CLASS 42—SCIENTIFIC AND COMPUTER SERVICES**

FOR PROVIDING TEMPORARY USE OF NON-DOWNLOADABLE SOFTWARE THAT IDENTIFIES SEX OFFENDERS IN A SPECIFIED AREA AND PROVIDES ALERTS TO CONSUMERS WHEN NEW SEX OFFENDERS ARE REGISTERED IN THOSE SPECIFIED AREAS (U.S. CLS. 100 AND 101).

**CLASS 45—PERSONAL AND LEGAL SERVICES**

FOR MONITORING INTERNET WEB SITES, MESSAGE BOARD FORUMS, INTERNET RELAY CHAT ROOMS, BLOGS AND OTHER ONLINE LOCATIONS FOR PERSONAL IDENTITY INFORMATION AND CREDIT AND DEBIT CARD NUMBERS, AND PROVIDING ALERTS AS TO ANY COMPROMISED INFORMATION OR ANY CHANGES THEREIN; CONSULTATION IN THE FIELD OF IDENTITY THEFT PROVIDED BY TELEPHONE, EMAIL, AND ON-LINE VIA THE INTERNET, IN THE FIELD OF DETECTING AND PREVENTING DAMAGE CAUSED BY IDENTITY THEFT AND DAMAGE TO CREDIT HISTORY; MONITORING OF INTERNET WEBSITES AND INDIVIDUAL CONSUMER'S CREDIT REPORTS FOR POTENTIAL THEFT AND MISUSE OF CREDIT CARD OR OTHER PERSONAL INFORMATION FOR FRAUD DETECTION AND PREVENTION PURPOSES; FINANCIAL IDENTITY MONITORING SERVICES, NAMELY, PROVIDING PUBLIC RECORDS MONITORING SERVICES; IDENTITY THEFT CONSULTATION SERVICES PROVIDING ASSISTANCE WITH SETTING FRAUD ALERTS OR SECURITY FREEZES AT CREDIT REPORTING AGENCIES; ELECTRONIC MONITORING SERVICES FOR SECURITY PURPOSES IN THE FIELD OF CREDIT CARDS AND CREDIT CARD INFORMATION; SUPPORT SERVICES PROVIDED BY E-MAIL AND ON-LINE VIA THE INTERNET IN THE FIELD OF IDENTITY THEFT RECOVERY, NAMELY, STEP-BY-STEP INSTRUCTIONS AND GUIDANCE FOR RESOLUTION OF IDENTITY THEFT CLAIMS, NON-DOWNLOADABLE SAMPLE CORRESPONDENCE FOR RESOLUTION OF IDENTITY THEFT CLAIMS; PROVIDING A WEBSITE FEATURING INFORMATION ABOUT IDENTITY THEFT RECOVERY AND RECOVERY FROM IDENTITY FRAUD AND IDENTITY MANIPULATION; CONSULTATION IN THE FIELD OF IDENTITY THEFT, NAMELY, PROVIDING PROTECTION AND ASSISTANCE IN THE EVENT OF A THEFT OF IDENTITY OR IDENTITY MANIPULATION, OR LOST OR STOLEN CREDIT CARD, DRIVERS LICENSES, PASSPORTS, AIRLINE TICKETS AND OTHER PERSONAL IDENTITY DOCUMENTS AND PUBLIC RECORDS (U.S. CLS. 100 AND 101).  
VERNA BETH RIRIE, EXAMINING ATTORNEY

SN 85-114,439. AFFINION PUBLISHING, LLC, LAS VEGAS, NV. FILED 8-24-2010.



THE MARK CONSISTS OF A LARGE CIRCLE WITH TWO SMALL INNER CIRCLES WITH CURVED LINES OR RINGS THAT EXTEND OUT FROM EITHER SIDE OF BOTH INNER CIRCLES, TO THE LEFT OF THE WORD "TRU-TRACE".

#### CLASS 35—ADVERTISING AND BUSINESS

FOR PROVIDING CREDIT CARD REGISTRATION SERVICES IN THE NATURE OF CREDIT CARD CANCELLATION SERVICES FOR LOST OR STOLEN CARDS AND NOTIFICATION SERVICES TO CREDIT CARD ISSUERS; ASSISTANCE IN REMOVAL OF IDENTIFIABLE INFORMATION FROM INTERNET DIRECTORIES, NAMELY, PROVIDING ON-LINE COMMERCIAL DIRECTORY INFORMATION INFORMING CONSUMERS OF PHONE NUMBERS AND ADDRESSES TO REQUEST REMOVAL OF UNWANTED PERSONAL INFORMATION FROM THE WEBSITES OF OTHERS; PROVIDE INFORMATION AND ALERTS TO CONSUMERS IN THE FIELD OF FOOD AND DRUG ADMINISTRATION PRODUCT RECALLS (U.S. CLS. 100, 101 AND 102).

#### CLASS 36—INSURANCE AND FINANCIAL

FOR PROVIDING IDENTITY THEFT INSURANCE UNDERWRITTEN BY OTHER COMPANIES (U.S. CLS. 100, 101 AND 102).

#### CLASS 42—SCIENTIFIC AND COMPUTER SERVICES

FOR PROVIDING TEMPORARY USE OF NON-DOWNLOADABLE SOFTWARE THAT IDENTIFIES SEX OFFENDERS IN A SPECIFIED AREA AND PROVIDES ALERTS TO CONSUMERS WHEN NEW SEX OFFENDERS ARE REGISTERED IN THOSE SPECIFIED AREAS (U.S. CLS. 100 AND 101).

#### CLASS 45—PERSONAL AND LEGAL SERVICES

FOR MONITORING INTERNET WEB SITES, MESSAGE BOARD FORUMS, INTERNET RELAY CHAT ROOMS, BLOGS AND OTHER ONLINE LOCATIONS FOR PERSONAL IDENTITY INFORMATION AND CREDIT AND DEBIT CARD NUMBERS, AND PROVIDING ALERTS AS TO ANY COMPROMISED INFORMATION OR ANY CHANGES THEREIN; CONSULTATION IN THE FIELD OF IDENTITY THEFT PROVIDED BY TELEPHONE, EMAIL, AND ON-LINE VIA THE INTERNET, IN THE FIELD OF DETECTING AND PREVENTING DAMAGE CAUSED BY IDENTITY THEFT AND DAMAGE TO CREDIT HISTORY; MONITORING OF INTERNET WEBSITES AND INDIVIDUAL CONSUMER'S CREDIT REPORTS FOR POTENTIAL THEFT AND MISUSE OF CREDIT CARD OR OTHER PERSONAL INFORMATION FOR FRAUD DETECTION AND PREVENTION PURPOSES; FINANCIAL IDENTITY MONITORING SERVICES, NAMELY, PROVIDING PUBLIC RECORDS MONITORING SERVICES; IDENTITY THEFT CONSULTATION SERVICES PROVIDING ASSISTANCE WITH SETTING FRAUD ALERTS OR SECURITY FREEZES AT CREDIT REPORTING AGENCIES; ELECTRONIC MONITORING SERVICES FOR SECURITY PURPOSES IN THE FIELD OF CREDIT CARDS AND CREDIT CARD INFORMATION; SUPPORT SERVICES PROVIDED BY E-MAIL AND ON-LINE VIA THE INTERNET IN THE FIELD OF IDENTITY THEFT RECOVERY, NAMELY, STEP-BY-STEP INSTRUCTIONS AND GUIDANCE FOR RESOLUTION OF IDENTITY THEFT CLAIMS, NON-DOWNLOADABLE SAMPLE CORRESPONDENCE FOR RESOLUTION OF IDENTITY THEFT CLAIMS; PROVIDING A WEBSITE FEATURING INFORMATION ABOUT IDENTITY THEFT RECOVERY AND RECOVERY FROM IDENTITY FRAUD AND IDENTITY MANIPULATION; CONSULTATION IN THE FIELD OF IDENTITY THEFT, NAMELY, PROVIDING PROTECTION AND ASSISTANCE IN THE EVENT OF A THEFT OF IDENTITY OR IDENTITY MANIPULATION, OR LOST OR STOLEN CREDIT CARD, DRIVERS LICENSES, PASSPORTS, AIRLINE TICKETS AND OTHER PERSONAL IDENTITY DOCUMENTS AND PUBLIC RECORDS (U.S. CLS. 100 AND 101).

VERNA BETH RIRIE, EXAMINING ATTORNEY

SN 85-114,451. AFFINION PUBLISHING, LLC, LAS VEGAS, NV. FILED 8-24-2010.



THE MARK CONSISTS OF A LARGE CIRCLE WITH TWO SMALL INNER CIRCLES WITH CURVED LINES OR RINGS THAT EXTEND OUT FROM EITHER SIDE OF BOTH INNER CIRCLES, TO THE LEFT OF THE WORDS "TRU-TRACE TAKE CONTROL OF YOUR IDENTITY".

#### CLASS 35—ADVERTISING AND BUSINESS

FOR PROVIDING CREDIT CARD REGISTRATION SERVICES IN THE NATURE OF CREDIT CARD CANCELLATION SERVICES FOR LOST OR STOLEN CARDS AND NOTIFICATION SERVICES TO CREDIT CARD ISSUERS; ASSISTANCE IN REMOVAL OF IDENTIFIABLE INFORMATION FROM INTERNET DIRECTORIES, NAMELY, PROVIDING ON-LINE COMMERCIAL DIRECTORY INFORMATION INFORMING CONSUMERS OF PHONE NUMBERS AND ADDRESSES TO REQUEST REMOVAL OF UNWANTED PERSONAL INFORMATION FROM THE WEBSITES OF OTHERS; PROVIDE INFORMATION AND ALERTS TO CONSUMERS IN THE FIELD OF FOOD AND DRUG ADMINISTRATION PRODUCT RECALLS (U.S. CLS. 100, 101 AND 102).



**CLASS 36—INSURANCE AND FINANCIAL**

FOR PROVIDING IDENTITY THEFT INSURANCE UNDERWRITTEN BY OTHER COMPANIES (U.S. CLS. 100, 101 AND 102).

**CLASS 42—SCIENTIFIC AND COMPUTER SERVICES**

FOR PROVIDING TEMPORARY USE OF NON-DOWNLOADABLE SOFTWARE THAT IDENTIFIES SEX OFFENDERS IN A SPECIFIED AREA AND PROVIDES ALERTS TO CONSUMERS WHEN NEW SEX OFFENDERS ARE REGISTERED IN THOSE SPECIFIED AREAS (U.S. CLS. 100 AND 101).

**CLASS 45—PERSONAL AND LEGAL SERVICES**

FOR MONITORING INTERNET WEB SITES, MESSAGE BOARD FORUMS, INTERNET RELAY CHAT ROOMS, BLOGS AND OTHER ONLINE LOCATIONS FOR PERSONAL IDENTITY INFORMATION AND CREDIT AND DEBIT CARD NUMBERS, AND PROVIDING ALERTS AS TO ANY COMPROMISED INFORMATION OR ANY CHANGES THEREIN; CONSULTATION IN THE FIELD OF IDENTITY THEFT PROVIDED BY TELEPHONE, EMAIL, AND ON-LINE VIA THE INTERNET, IN THE FIELD OF DETECTING AND PREVENTING DAMAGE CAUSED BY IDENTITY THEFT AND DAMAGE TO CREDIT HISTORY; MONITORING OF INTERNET WEBSITES AND INDIVIDUAL CONSUMER'S CREDIT REPORTS FOR POTENTIAL THEFT AND MISUSE OF CREDIT CARD OR OTHER PERSONAL INFORMATION FOR FRAUD DETECTION AND PREVENTION PURPOSES; FINANCIAL IDENTITY MONITORING SERVICES, NAMELY, PROVIDING PUBLIC RECORDS MONITORING SERVICES; IDENTITY THEFT CONSULTATION SERVICES PROVIDING ASSISTANCE WITH SETTING FRAUD ALERTS OR SECURITY FREEZES AT CREDIT REPORTING AGENCIES; ELECTRONIC MONITORING SERVICES FOR SECURITY PURPOSES IN THE FIELD OF CREDIT CARDS AND CREDIT CARD INFORMATION; SUPPORT SERVICES PROVIDED BY E-MAIL AND ON-LINE VIA THE INTERNET IN THE FIELD OF IDENTITY THEFT RECOVERY, NAMELY, STEP-BY-STEP INSTRUCTIONS AND GUIDANCE FOR RESOLUTION OF IDENTITY THEFT CLAIMS, NON-DOWNLOADABLE SAMPLE CORRESPONDENCE FOR RESOLUTION OF IDENTITY THEFT CLAIMS; PROVIDING A WEBSITE FEATURING INFORMATION ABOUT IDENTITY THEFT RECOVERY AND RECOVERY FROM IDENTITY FRAUD AND IDENTITY MANIPULATION; CONSULTATION IN THE FIELD OF IDENTITY THEFT, NAMELY, PROVIDING PROTECTION AND ASSISTANCE IN THE EVENT OF A THEFT OF IDENTITY OR IDENTITY MANIPULATION, OR LOST OR STOLEN CREDIT CARD, DRIVERS LICENSES, PASSPORTS, AIRLINE TICKETS AND OTHER PERSONAL IDENTITY DOCUMENTS AND PUBLIC RECORDS (U.S. CLS. 100 AND 101).

VERNA BETH RIRIE, EXAMINING ATTORNEY

**CLASS 35—ADVERTISING AND BUSINESS**

FOR PROVIDING CREDIT CARD REGISTRATION SERVICES IN THE NATURE OF CREDIT CARD CANCELLATION SERVICES FOR LOST OR STOLEN CARDS AND NOTIFICATION SERVICES TO CREDIT CARD ISSUERS; ASSISTANCE IN REMOVAL OF IDENTIFIABLE INFORMATION FROM INTERNET DIRECTORIES, NAMELY, PROVIDING ON-LINE COMMERCIAL DIRECTORY INFORMATION INFORMING CONSUMERS OF PHONE NUMBERS AND ADDRESSES TO REQUEST REMOVAL OF UNWANTED PERSONAL INFORMATION FROM THE WEBSITES OF OTHERS; PROVIDE INFORMATION AND ALERTS TO CONSUMERS IN THE FIELD OF FOOD AND DRUG ADMINISTRATION PRODUCT RECALLS (U.S. CLS. 100, 101 AND 102).

**CLASS 36—INSURANCE AND FINANCIAL**

FOR PROVIDING IDENTITY THEFT INSURANCE UNDERWRITTEN BY OTHER COMPANIES (U.S. CLS. 100, 101 AND 102).

**CLASS 42—SCIENTIFIC AND COMPUTER SERVICES**

FOR PROVIDING TEMPORARY USE OF NON-DOWNLOADABLE SOFTWARE THAT IDENTIFIES SEX OFFENDERS IN A SPECIFIED AREA AND PROVIDES ALERTS TO CONSUMERS WHEN NEW SEX OFFENDERS ARE REGISTERED IN THOSE SPECIFIED AREAS (U.S. CLS. 100 AND 101).

**CLASS 45—PERSONAL AND LEGAL SERVICES**

FOR MONITORING INTERNET WEB SITES, MESSAGE BOARD FORUMS, INTERNET RELAY CHAT ROOMS, BLOGS AND OTHER ONLINE LOCATIONS FOR PERSONAL IDENTITY INFORMATION AND CREDIT AND DEBIT CARD NUMBERS, AND PROVIDING ALERTS AS TO ANY COMPROMISED INFORMATION OR ANY CHANGES THEREIN; CONSULTATION IN THE FIELD OF IDENTITY THEFT PROVIDED BY TELEPHONE, EMAIL, AND ON-LINE VIA THE INTERNET, IN THE FIELD OF DETECTING AND PREVENTING DAMAGE CAUSED BY IDENTITY THEFT AND DAMAGE TO CREDIT HISTORY; MONITORING OF INTERNET WEBSITES AND INDIVIDUAL CONSUMER'S CREDIT REPORTS FOR POTENTIAL THEFT AND MISUSE OF CREDIT CARD OR OTHER PERSONAL INFORMATION FOR FRAUD DETECTION AND PREVENTION PURPOSES; FINANCIAL IDENTITY MONITORING SERVICES, NAMELY, PROVIDING PUBLIC RECORDS MONITORING SERVICES; IDENTITY THEFT CONSULTATION SERVICES PROVIDING ASSISTANCE WITH SETTING FRAUD ALERTS OR SECURITY FREEZES AT CREDIT REPORTING AGENCIES; ELECTRONIC MONITORING SERVICES FOR SECURITY PURPOSES IN THE FIELD OF CREDIT CARDS AND CREDIT CARD INFORMATION; SUPPORT SERVICES PROVIDED BY E-MAIL AND ON-LINE VIA THE INTERNET IN THE FIELD OF IDENTITY THEFT RECOVERY, NAMELY, STEP-BY-STEP INSTRUCTIONS AND GUIDANCE FOR RESOLUTION OF IDENTITY THEFT CLAIMS, NON-DOWNLOADABLE SAMPLE CORRESPONDENCE FOR RESOLUTION OF IDENTITY THEFT CLAIMS; PROVIDING A WEBSITE FEATURING INFORMATION ABOUT IDENTITY THEFT RECOVERY AND RECOVERY FROM IDENTITY FRAUD AND IDENTITY MANIPULATION; CONSULTATION IN THE FIELD OF IDENTITY THEFT, NAMELY, PROVIDING PROTECTION AND ASSISTANCE IN THE EVENT OF A THEFT OF IDENTITY OR IDENTITY MANIPULATION, OR LOST OR STOLEN CREDIT CARD, DRIVERS LICENSES, PASSPORTS, AIRLINE TICKETS AND OTHER PERSONAL IDENTITY DOCUMENTS AND PUBLIC RECORDS (U.S. CLS. 100 AND 101).

VERNA BETH RIRIE, EXAMINING ATTORNEY

SN 85-114,483. AFFINION PUBLISHING, LLC, LAS VEGAS, NV. FILED 8-24-2010.



THE MARK CONSISTS OF ONE SQUARE MADE UP OF SMALLER SQUARES THAT ARE CONFIGURED TO FORM THE LETTER "T" AND APPEARS TO THE LEFT OF THE WORD "TRUTRACE".

SN 85-114,496. AFFINION PUBLISHING, LLC, LAS VEGAS, NV. FILED 8-24-2010.



THE MARK CONSISTS OF ONE SQUARE MADE UP OF SMALLER SQUARES THAT ARE CONFIGURED TO FORM THE LETTER "T" AND APPEARS TO THE LEFT OF THE WORDS "TRUTRACETAKE CONTROL OF YOUR IDENTITY".

#### CLASS 35—ADVERTISING AND BUSINESS

FOR PROVIDING CREDIT CARD REGISTRATION SERVICES IN THE NATURE OF CREDIT CARD CANCELLATION SERVICES FOR LOST OR STOLEN CARDS AND NOTIFICATION SERVICES TO CREDIT CARD ISSUERS; ASSISTANCE IN REMOVAL OF IDENTIFIABLE INFORMATION FROM INTERNET DIRECTORIES, NAMELY, PROVIDING ON-LINE COMMERCIAL DIRECTORY INFORMATION INFORMING CONSUMERS OF PHONE NUMBERS AND ADDRESSES TO REQUEST REMOVAL OF UNWANTED PERSONAL INFORMATION FROM THE WEBSITES OF OTHERS; PROVIDE INFORMATION AND ALERTS TO CONSUMERS IN THE FIELD OF FOOD AND DRUG ADMINISTRATION PRODUCT RECALLS (U.S. CLS. 100, 101 AND 102).

#### CLASS 36—INSURANCE AND FINANCIAL

FOR PROVIDING IDENTITY THEFT INSURANCE UNDERWRITTEN BY OTHER COMPANIES (U.S. CLS. 100, 101 AND 102).

#### CLASS 42—SCIENTIFIC AND COMPUTER SERVICES

FOR PROVIDING TEMPORARY USE OF NON-DOWNLOADABLE SOFTWARE THAT IDENTIFIES SEX OFFENDERS IN A SPECIFIED AREA AND PROVIDES ALERTS TO CONSUMERS WHEN NEW SEX OFFENDERS ARE REGISTERED IN THOSE SPECIFIED AREAS (U.S. CLS. 100 AND 101).

#### CLASS 45—PERSONAL AND LEGAL SERVICES

FOR MONITORING INTERNET WEB SITES, MESSAGE BOARD FORUMS, INTERNET RELAY CHAT ROOMS, BLOGS AND OTHER ONLINE LOCATIONS FOR PERSONAL IDENTITY INFORMATION AND CREDIT AND DEBIT CARD NUMBERS, AND PROVIDING ALERTS AS TO ANY COMPROMISED INFORMATION OR ANY CHANGES THEREIN; CONSULTATION IN THE FIELD OF IDENTITY THEFT PROVIDED BY TELEPHONE, EMAIL, AND ON-LINE VIA THE INTERNET, IN THE FIELD OF DETECTING AND PREVENTING DAMAGE CAUSED BY IDENTITY THEFT AND DAMAGE TO CREDIT HISTORY; MONITORING OF INTERNET WEBSITES AND INDIVIDUAL CONSUMER'S CREDIT REPORTS FOR POTENTIAL THEFT AND MISUSE OF CREDIT CARD OR OTHER PERSONAL INFORMATION FOR FRAUD DETECTION AND PREVENTION PURPOSES; FINANCIAL IDENTITY MONITORING SERVICES, NAMELY, PROVIDING PUBLIC RECORDS MONITORING SERVICES; IDENTITY THEFT CONSULTATION SERVICES PROVIDING ASSISTANCE WITH SETTING FRAUD ALERTS OR SECURITY FREEZES AT CREDIT REPORTING AGENCIES; ELECTRONIC MONITORING SERVICES FOR SECURITY PURPOSES IN THE FIELD OF CREDIT CARDS AND CREDIT CARD INFORMATION; SUPPORT SERVICES PROVIDED BY E-MAIL AND ON-LINE VIA THE INTERNET IN THE FIELD OF IDENTITY THEFT RECOVERY, NAMELY, STEP-BY-STEP INSTRUCTIONS AND GUIDANCE FOR RESOLUTION OF IDENTITY THEFT CLAIMS, NON-DOWNLOADABLE SAMPLE CORRESPONDENCE FOR RESOLUTION OF IDENTITY THEFT CLAIMS; PROVIDING A WEBSITE FEATURING INFORMATION ABOUT IDENTITY THEFT RECOVERY AND RECOVERY FROM IDENTITY FRAUD AND IDENTITY MANIPULATION; CONSULTATION IN THE FIELD OF IDENTITY THEFT, NAMELY, PROVIDING PROTECTION AND ASSISTANCE IN THE EVENT OF A THEFT OF IDENTITY OR IDENTITY MANIPULATION, OR LOST OR STOLEN CREDIT CARD, DRIVERS LICENSES, PASSPORTS, AIRLINE TICKETS AND OTHER PERSONAL IDENTITY DOCUMENTS AND PUBLIC RECORDS (U.S. CLS. 100 AND 101).

VERNA BETH RIRIE, EXAMINING ATTORNEY

SN 85-114,683. MINDLESS DRIBBLE INC., REDWOOD CITY, CA. FILED 8-24-2010.

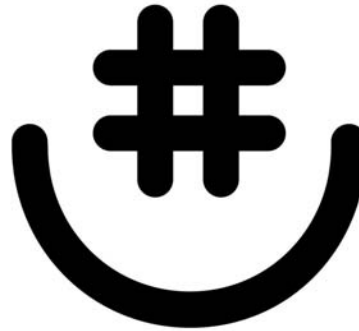

THE MARK CONSISTS OF A NUMBER SIGN AND A PARENTHESIS.

**CLASS 35—ADVERTISING AND BUSINESS**

FOR ADVERTISING SERVICES; ONLINE ADVERTISING ON AN ELECTRONIC OR OPTICAL COMMUNICATIONS NETWORK AND ON WIRELESS AND ELECTRONIC MOBILE DEVICES; PROMOTING THE GOODS AND SERVICES OF OTHERS BY PLACING ADVERTISEMENTS AND PROMOTIONAL DISPLAYS IN AN ELECTRONIC SITE ACCESSED THROUGH ELECTRONIC OR OPTICAL COMMUNICATIONS NETWORKS AND ON WIRELESS AND ELECTRONIC MOBILE DEVICES; ADVERTISING AND PROMOTION OF WEBSITES FOR OTHERS; PROVIDING ON-LINE DIRECTORY INFORMATION SERVICES FEATURING INFORMATION REGARDING THE WIRELESS COMMUNICATIONS AND SOCIAL NETWORKING SERVICES OF OTHERS; COMPUTERIZED DATABASE MANAGEMENT (U.S. CLS. 100, 101 AND 102).

**CLASS 36—INSURANCE AND FINANCIAL**

FOR PROVIDING ELECTRONIC PROCESSING OF ELECTRONIC FUNDS TRANSFER, ACH, CREDIT CARD, DEBIT CARD, ELECTRONIC CHECK AND ELECTRONIC PAYMENTS PROVIDED VIA AN ELECTRONIC OR OPTICAL COMMUNICATIONS NETWORK AND ON WIRELESS AND ELECTRONIC MOBILE DEVICES (U.S. CLS. 100, 101 AND 102).

**CLASS 38—COMMUNICATION**

FOR PROVIDING MULTIPLE-USER ACCESS TO COMPUTER NETWORKS FOR THE TRANSFER AND DISSEMINATION OF A WIDE RANGE OF INFORMATION; ELECTRONIC TRANSMISSION OF DATA, MESSAGES, IMAGES, AND DOCUMENTS; PROVIDING ONLINE CHAT ROOMS AND ELECTRONIC BULLETIN BOARDS FOR TRANSMISSION OF MESSAGES AMONG USERS WITH OTHER ELECTRONIC OR OPTICAL COMMUNICATIONS NETWORK AND WIRELESS AND ELECTRONIC MOBILE DEVICE IN THE FIELD OF GENERAL INTEREST (U.S. CLS. 100, 101 AND 104).

**CLASS 42—SCIENTIFIC AND COMPUTER SERVICES**

FOR COMPUTER SERVICES, NAMELY, COMPUTER SOFTWARE DEVELOPMENT OF WEB APPLICATIONS FOR INTERNET AND WIRELESS AND ELECTRONIC MOBILE DEVICE USERS; PROVIDING TEMPORARY USE OF ON-LINE NON-DOWNLOADABLE SOFTWARE FOR ASSISTING IN WEBSITE DEVELOPMENT; PROVIDING TEMPORARY USE OF NON-DOWNLOADABLE SOFTWARE FOR USE IN SEARCH ENGINE OPTIMIZATION; PROVIDING TEMPORARY USE OF NON-DOWNLOADABLE SOFTWARE FOR USE IN ANALYZING ONLINE AND WIRELESS AND ELECTRONIC MOBILE DEVICE USER BEHAVIOR; SEARCHING AND RETRIEVING INFORMATION, SITES, AND OTHER RESOURCES AVAILABLE ON ELECTRONIC OR OPTICAL COMMUNICATIONS NETWORKS AND VIA WIRELESS AND ELECTRONIC MOBILE DEVICES FOR OTHERS; DESIGNING, CREATING, HOSTING, AND MAINTENANCE OF WEBSITES FOR OTHERS; PROVIDING TEMPORARY USE OF A WEB-BASED SOFTWARE FOR COMMUNICATIONS AMONG USERS VIA A PERSONALIZED WEBPAGE AND WIRELESS AND ELECTRONIC MOBILE DEVICE INTERFACE (U.S. CLS. 100 AND 101).

**CLASS 45—PERSONAL AND LEGAL SERVICES**

FOR ONLINE SOCIAL NETWORKING SERVICES (U.S. CLS. 100 AND 101).  
MICHELE SWAIN, EXAMINING ATTORNEY

SN 85-114,822. SEABRIGHT HOLDINGS, INC., SEATTLE, WA. FILED 8-24-2010.



NO CLAIM IS MADE TO THE EXCLUSIVE RIGHT TO USE "MANAGED CARE SERVICES", APART FROM THE MARK AS SHOWN.

THE MARK CONSISTS OF THE LITERAL ELEMENT "PALADIN MANAGED CARE SERVICES" REPRESENTED IN STYLIZED FONT WHERE THE WORD "PALADIN" APPEARS IN UPPERCASE LETTERS AND IS LOCATED OVER THE WORDS "MANAGED CARE SERVICES" WHICH APPEARS IN TITLE CASE AND WHEREIN THERE IS A STRAIGHT LINE EQUALLY SPACED BETWEEN THE UPPER AND LOWER SET OF WORDS, SPECIFICALLY UNDER "PALADIN" AND OVER "MANAGED CARE SERVICES". A KNIGHT CHESS PIECE OR HORSE HEAD APPEARS ABOVE THE "I" IN "PALADIN".

**CLASS 35—ADVERTISING AND BUSINESS**

FOR MANAGEMENT AND BUSINESS CONSULTING SERVICES IN THE FIELD OF MANAGED CARE SERVICES, NAMELY, MEDICAL BILL REVIEW FOR WORKERS' COMPENSATION, LIABILITY AND GROUP HEALTH INSURANCE MEDICAL CLAIMS, CASE MANAGEMENT, UTILIZATION REVIEW, AND RETURN TO WORK SERVICES IN THE NATURE OF PLACING AND MONITORING RECOVERING EMPLOYEES IN TEMPORARY OR VOLUNTEER TRANSITIONAL DUTY POSITIONS TO ASSIST WORKERS NOT FULLY RECOVERED FROM WORK-RELATED ILLNESS AND/OR INJURY IN TRANSITIONING BACK INTO THE EMPLOYER'S WORKFORCE (U.S. CLS. 100, 101 AND 102).

**CLASS 36—INSURANCE AND FINANCIAL**

FOR MEDICAL INSURANCE CASE AND UTILIZATION REVIEW AND INSURANCE CLAIMS ADJUSTMENT SERVICES FOR HEALTHCARE PURCHASERS AND PAYORS AND PROVIDERS AND MEDICARE BENEFICIARIES (U.S. CLS. 100, 101 AND 102).  
KELLY BOULTON, EXAMINING ATTORNEY

SN 85-114,935. SEABRIGHT HOLDINGS, INC., SEATTLE, WA. FILED 8-24-2010.



NO CLAIM IS MADE TO THE EXCLUSIVE RIGHT TO USE "MANAGED CARE SERVICES", APART FROM THE MARK AS SHOWN.

THE MARK CONSISTS OF THE LITERAL ELEMENT "PALADIN MANAGED CARE SERVICES THE RIGHT MOVE" REPRESENTED IN STYLIZED FONT WHERE THE WORD "PALADIN" APPEARS IN UPPERCASE LETTERS AND IS LOCATED OVER THE WORDS "MANAGED CARE SERVICES" WHICH APPEARS IN TITLE CASE AND WHEREIN THERE IS A STRAIGHT LINE EQUALLY SPACED BETWEEN THE UPPER AND LOWER SET OF WORDS, SPECIFICALLY UNDER "PALADIN" AND OVER "MANAGED CARE SERVICES". "THE RIGHT MOVE" APPEARS IN LOWERCASE, ITALICIZED FONT, CENTERED BENEATH THE WORDS "MANAGED CARE SERVICES". A KNIGHT CHESS PIECE OR HORSE HEAD APPEARS ABOVE THE "I" IN "PALADIN".

SN 85-115,427. PIONEER BRITE, INC., MEMPHIS, TN. FILED 8-25-2010.

## PIONEER BRITE

### CLASS 35—ADVERTISING AND BUSINESS

FOR MANAGEMENT AND BUSINESS CONSULTING SERVICES IN THE FIELD OF MANAGED CARE SERVICES, NAMELY, MEDICAL BILL REVIEW FOR WORKERS' COMPENSATION, LIABILITY AND GROUP HEALTH INSURANCE MEDICAL CLAIMS, CASE MANAGEMENT, UTILIZATION REVIEW, AND RETURN TO WORK SERVICES IN THE NATURE OF PLACING AND MONITORING RECOVERING EMPLOYEES IN TEMPORARY OR VOLUNTEER TRANSITIONAL DUTY POSITIONS TO ASSIST WORKERS NOT FULLY RECOVERED FROM WORK-RELATED ILLNESS AND/OR INJURY IN TRANSITIONING BACK INTO THE EMPLOYER'S WORKFORCE (U.S. CLS. 100, 101 AND 102).

THE MARK CONSISTS OF STANDARD CHARACTERS WITHOUT CLAIM TO ANY PARTICULAR FONT, STYLE, SIZE, OR COLOR.

OWNER OF U.S. REG. NO. 2,436,584.

### CLASS 2—PAINTS

FOR SEALER COATINGS FOR APPLICATION TO TILE, LINOLEUM, WOOD, CONCRETE, MARBLE AND GRANITE SURFACES; COATINGS, NAMELY, CLEAR FINISHES FOR EXTERIOR AND INTERIOR USE ON A VARIETY OF SUBSTRATES; CONCRETE SEALERS IN THE FORM OF A COATING (U.S. CLS. 6, 11 AND 16).

FIRST USE 0-0-1968; IN COMMERCE 0-0-1968.

### CLASS 36—INSURANCE AND FINANCIAL

FOR MEDICAL INSURANCE CASE AND UTILIZATION REVIEW AND INSURANCE CLAIMS ADJUSTMENT SERVICES FOR HEALTHCARE PURCHASERS AND PAYORS AND PROVIDERS AND MEDICARE BENEFICIARIES (U.S. CLS. 100, 101 AND 102).

KELLY BOULTON, EXAMINING ATTORNEY

### CLASS 3—COSMETICS AND CLEANING PREPARATIONS

FOR METAL POLISH; FINISH STRIPPER; FURNITURE POLISH; CARPET CLEANERS; CLEANING, WASHING AND POLISHING PREPARATIONS; CLEANING PREPARATIONS CONTAINING MICROBIAL ENZYMES, USED TO PRESERVE DRAIN SYSTEMS AND WATERWAYS; DRAIN OPENERS; CLEANING PREPARATIONS FOR CLEANING DRAINS; DISPOSABLE WIPES IMPREGNATED WITH CLEANSING CHEMICALS OR COMPOUNDS FOR HOUSEHOLD USE, FOR INDUSTRIAL USE AND FOR COMMERCIAL USE; DISPOSABLE WIPES IMPREGNATED WITH CLEANSING CHEMICALS OR COMPOUNDS FOR PERSONAL HYGIENE; LAUNDRY DETERGENT; DETERGENTS FOR MACHINE DISHWASHING; ALL PURPOSE CLEANERS; CONCRETE CLEANING PREPARATIONS; OVEN CLEANERS; GRILL CLEANING PREPARATIONS; FLOOR CLEANING PREPARATIONS; AUTOMOBILE TIRE CLEANING AND POLISHING PREPARATIONS; AUTOMOTIVE CLEANERS; AUTOMOBILE POLISHES; LAUNDRY BLEACH; FABRIC SOFTENER; ANTIBACTERIAL SOAPS; HAND SOAPS; GENERAL PURPOSE; SCOURING POWDER; GRANULAR ABSORBENT OIL-BASED COMPOSITION FOR ABSORBING SPILLS FROM FLOORS; RUST REMOVING PREPARATIONS; IMPREGNATED CLEANING CLOTHS (U.S. CLS. 1, 4, 6, 50, 51 AND 52).

FIRST USE 0-0-1968; IN COMMERCE 0-0-1968.

SN 85-115,266. PEARSON, CHRIS, AUSTIN, TX. FILED 8-25-2010.

## THESIS THEME

THE MARK CONSISTS OF STANDARD CHARACTERS WITHOUT CLAIM TO ANY PARTICULAR FONT, STYLE, SIZE, OR COLOR.

### CLASS 9—ELECTRICAL AND SCIENTIFIC APPARATUS

FOR WEB SITE DEVELOPMENT SOFTWARE (U.S. CLS. 21, 23, 26, 36 AND 38).

### CLASS 42—SCIENTIFIC AND COMPUTER SERVICES

FOR COMPUTER SOFTWARE INSTALLATION AND MAINTENANCE; PROVIDING A WEB SITE FEATURING TEMPORARY USE OF NON-DOWNLOADABLE SOFTWARE FOR WEB SITE USERS TO DESIGN AND DEVELOP WEB SITES; TECHNICAL SUPPORT SERVICES, NAMELY, TROUBLESHOOTING OF COMPUTER SOFTWARE PROBLEMS; WEBSITE DESIGN AND DEVELOPMENT FOR OTHERS (U.S. CLS. 100 AND 101).

DAWN FELDMAN, EXAMINING ATTORNEY

### CLASS 5—PHARMACEUTICALS

FOR AIR DEODORANT AND DEODORIZER; AIR FRESHENERS; DEODORIZERS FOR AUTOMOBILES; CARPET DEODORIZERS; DEODORIZING PRODUCTS, NAMELY, ALL PURPOSE DEODORIZER PREPARATIONS FOR HOUSEHOLD, COMMERCIAL AND INDUSTRIAL USE; URINAL DEODORIZER BLOCKS; ALL PURPOSE DISINFECTANTS; DISINFECTANTS FOR CHEMICAL TOILETS; DISINFECTANTS FOR MEDICAL INSTRUMENTS; BIOCIDES; GERMICIDES; BACTERICIDES; VIRUCIDES; FUNGICIDES; INSECTICIDES; PESTICIDES; HERBICIDES; DISINFECTANT BATHROOM CLEANERS; REFILLS FOR AIR FRESHENERS; SPRAY SANITIZER FOR PERSONAL USE; ANTI BACTERIAL ALCOHOL SKIN SANITIZER GEL; SANITIZING WIPES; AND DISPOSABLE SANITIZING WIPES (U.S. CLS. 6, 18, 44, 46, 51 AND 52).

FIRST USE 0-0-1982; IN COMMERCE 0-0-1982.



**CLASS 37—CONSTRUCTION AND REPAIR**

FOR MAINTENANCE AND/OR REPAIR OF FLOOR BUFFERS, FLOOR POLISH APPLICATORS, CLEANING MACHINES, PROPANE BUFFERS, SCRUBBERS, CARPET EXTRACTORS, BLOWERS, SWEEPERS, VACUUMS, PRESSURE WASHERS, FOGGERS, SPRAYERS, DISPENSERS, MOP BUCKETS AND WRINGERS, CARTS, DOLLIES, AND TRUCK MOUNTS, COFFEE BREWERS, JANITORIAL EQUIPMENT; TECHNICAL SUPPORT SERVICES, NAMELY, PROVIDING TECHNICAL ADVICE IN THE FIELD OF JANITORIAL SERVICES ABOUT INSTALLATION, MAINTENANCE AND REPAIR OF FLOOR BUFFERS, FLOOR POLISH APPLICATORS, CLEANING MACHINES, PROPANE BUFFERS, SCRUBBERS, CARPET EXTRACTORS, BLOWERS, SWEEPERS, VACUUMS, PRESSURE WASHERS, FOGGERS, SPRAYERS, DISPENSERS, MOP BUCKETS AND WRINGERS, CARTS, DOLLIES, AND TRUCK MOUNTS, COFFEE BREWERS, JANITORIAL EQUIPMENT (U.S. CLS. 100, 103 AND 106).

FIRST USE 0-0-1978; IN COMMERCE 0-0-1978.  
MARY ROSSMAN, EXAMINING ATTORNEY

SN 85-115,544. ROBOSYNTHESIS LIMITED, READING, BERKSHIRE, UNITED KINGDOM, FILED 8-25-2010.

# SCRAM

THE MARK CONSISTS OF STANDARD CHARACTERS WITHOUT CLAIM TO ANY PARTICULAR FONT, STYLE, SIZE, OR COLOR.

**CLASS 9—ELECTRICAL AND SCIENTIFIC APPARATUS**

FOR OPERATING SOFTWARE FOR USE ON MILITARY MACHINES; OPERATING SOFTWARE FOR USE ON REMOTE CONTROL VEHICLES; OPERATING SOFTWARE FOR USE ON AUTONOMOUS VEHICLES; OPERATING SOFTWARE FOR USE ON PARTS OF VEHICLES THAT ARE AUTONOMOUS (U.S. CLS. 21, 23, 26, 36 AND 38).

**CLASS 12—VEHICLES**

FOR REMOTE CONTROL LAND VEHICLES THAT ARE OPERATOR-CONTROLLED; LAND VEHICLES AND STRUCTURAL PARTS OF LAND VEHICLES THAT ARE AUTONOMOUS FOR USE IN MILITARY AND SECURITY APPLICATIONS; AND REMOTE CONTROL LAND VEHICLES AND STRUCTURAL PARTS OF LAND VEHICLES THAT ARE OPERATOR-CONTROLLED; APPARATUS FOR LOCOMOTION BY LAND, AIR OR WATER, NAMELY, LAND VEHICLES, AIRPLANES, FLYING ROBOT AIRCRAFT, HOVERCRAFT, BOATS, SUBMARINES, SHIPS, AND SPACECRAFT; REMOTE CONTROL LAND VEHICLES, MANUALLY-OPERATED LAND VEHICLES AND AUTONOMOUS LAND VEHICLES; REMOTE CONTROL VEHICLES FOR LOCOMOTION BY AIR AND WATER, NAMELY, LAND VEHICLES, AIRPLANES, FLYING ROBOT AIRCRAFT, HOVERCRAFT, BOATS, SUBMARINES, SHIPS AND SPACECRAFT; PARTS OF REMOTE-CONTROLLED LAND VEHICLES THAT ARE OPERATOR-CONTROLLED, NAMELY, WHEELS OF REMOTE-CONTROLLED LAND VEHICLES, AND ELECTRIC MOTORS FOR OPERATING WHEELS OF REMOTE-CONTROLLED LAND VEHICLES (U.S. CLS. 19, 21, 23, 31, 35 AND 44).

**CLASS 40—MATERIAL TREATMENT**

FOR PROVIDING CONSULTANCY ON HOW TO MANUFACTURE ROBOT MACHINES, REMOTE CONTROL VEHICLES, AND AUTONOMOUS VEHICLES OR MANUALLY-OPERATED VEHICLES; PROVIDING CONSULTANCY RELATING TO THE CUSTOM MANUFACTURE OF ROBOTS TO CERTAIN SPECIFICATIONS (U.S. CLS. 100, 103 AND 106).

**CLASS 41—EDUCATION AND ENTERTAINMENT**

FOR PROVIDING TRAINING ON HOW TO OPERATE AND REPAIR ROBOT MACHINES, REMOTE CONTROL VEHICLES, AUTONOMOUS VEHICLES AND MANUALLY-OPERATED VEHICLES; ARRANGING AND CONDUCTING WORKSHOPS ON THE OPERATION OF ROBOT MACHINES, REMOTE CONTROL VEHICLES, AUTONOMOUS VEHICLES, AND MANUALLY-OPERATED VEHICLES; AND PRACTICAL TRAINING ON AND PROVIDING EDUCATIONAL DEMONSTRATIONS ON HOW TO OPERATE AND REPAIR ROBOT MACHINES OR REMOTE CONTROL VEHICLES, AUTONOMOUS VEHICLES AND MANUALLY-OPERATED VEHICLES; AND PRACTICAL TRAINING ON AND PROVIDING EDUCATIONAL DEMONSTRATIONS ON HOW TO ASSEMBLE AND MANUFACTURE PARTS OF ROBOT MACHINES, REMOTE CONTROL VEHICLES, AUTONOMOUS VEHICLES, AND MANUALLY-OPERATED VEHICLES; AND PROVIDING TRAINING ON THE DEVELOPMENT OF ROBOT MACHINES (U.S. CLS. 100, 101 AND 107).

**CLASS 42—SCIENTIFIC AND COMPUTER SERVICES**

FOR PROVIDING CONSULTANCY ON THE DEVELOPMENT OF ROBOT MACHINES, REMOTE CONTROL VEHICLES, AUTONOMOUS VEHICLES AND MANUALLY-OPERATED VEHICLES (U.S. CLS. 100 AND 101).  
LAURIE MAYES, EXAMINING ATTORNEY

SN 85-115,546. IRBSEARCH, LLC, TALLAHASSEE, FL. FILED 8-25-2010.

# IRBmobile

THE MARK CONSISTS OF STANDARD CHARACTERS WITHOUT CLAIM TO ANY PARTICULAR FONT, STYLE, SIZE, OR COLOR.

**CLASS 9—ELECTRICAL AND SCIENTIFIC APPARATUS**

FOR DOWNLOADABLE COMPUTER SOFTWARE FOR PUBLIC RECORDS DATA BASE COMPILATION AND ANALYSIS OF INDIVIDUALS AND BUSINESS ENTITIES IDENTIFICATION INFORMATION; COMPUTER APPLICATION SOFTWARE FOR MOBILE PHONES, PORTABLE MEDIA PLAYERS, HANDHELD COMPUTERS, NAMELY, SOFTWARE FOR PUBLIC RECORDS DATA BASE COMPILATION AND ANALYSIS OF INDIVIDUALS AND BUSINESS ENTITIES IDENTIFICATION INFORMATION (U.S. CLS. 21, 23, 26, 36 AND 38).  
FIRST USE 7-15-2010; IN COMMERCE 7-15-2010.

**CLASS 35—ADVERTISING AND BUSINESS**

FOR PROVIDING ELECTRONIC TRACKING OF INTELLECTUAL AND INDUSTRIAL PROPERTY ASSETS TO OTHERS; PROVIDING TRACKING SERVICES AND INFORMATION CONCERNING TRACKING OF ASSETS IN TRANSIT, NAMELY, VEHICLES, TRAILERS, DRIVERS, CARGO AND DELIVERY CONTAINERS (U.S. CLS. 100, 101 AND 102).

FIRST USE 7-15-2010; IN COMMERCE 7-15-2010.

**CLASS 45—PERSONAL AND LEGAL SERVICES**

FOR INDIVIDUAL OR BUSINESS IDENTIFICATION VERIFICATION SERVICES, NAMELY, PROVIDING AUTHENTICATION OF PERSONAL OR CORPORATE IDENTIFICATION INFORMATION; IDENTIFICATION VERIFICATION SERVICES BY PROVIDING AUTHENTICATION OF PERSONAL IDENTIFICATION INFORMATION VIA SECURE STORAGE AND TRANSMITTING SUCH INFORMATION VIA INTERNET FOR HANDHELD ELECTRONIC DEVICES; INVESTIGATION OF ASSETS FOR SECURITY OR AUTHENTICATION PURPOSES; CONDUCTING PUBLIC RECORDS INVESTIGATION SEARCHES; VALIDATION AND RISK DETECTION PROCESSES, NAMELY, FRAUD AND IDENTITY THEFT PROTECTION SERVICES TO AUTHENTICATE CONSUMER AND BUSINESS IDENTITIES TO SPOT POTENTIAL FRAUD OR IDENTITY THEFT (U.S. CLS. 100 AND 101).

FIRST USE 7-15-2010; IN COMMERCE 7-15-2010.  
ANTHONY RINKER, EXAMINING ATTORNEY

---

SN 85-116,399. FORMULA 43 LLC, LIVONIA, MI. FILED 8-26-2010.



NO CLAIM IS MADE TO THE EXCLUSIVE RIGHT TO USE "FORMULA", APART FROM THE MARK AS SHOWN. THE MARK CONSISTS OF AN ITALICIZED FANCIFUL LETTER "F" WITH "FORMULA" AND "43" ALIGNED BELOW AND TO THE CENTER THEREOF.

**CLASS 12—VEHICLES**

FOR AUTOMOTIVE WHEELS AND WHEEL COMPONENTS, NAMELY, INNER RIM, OUTER RIM, CENTER AND CENTER CAPS FOR MOTOR VEHICLES, INCLUDING HIGH PERFORMANCE RACE AND SPORT VEHICLES (U.S. CLS. 19, 21, 23, 31, 35 AND 44).

FIRST USE 1-0-2010; IN COMMERCE 1-0-2010.

**CLASS 42—SCIENTIFIC AND COMPUTER SERVICES**

FOR RENDERING SERVICES IN THE DESIGN, ANALYSIS AND MANUFACTURE OF WHEELS OF MODULAR TWO AND THREE PIECE AND ALSO ONE PIECE MONO BLOCK WHEELS AND WHEEL RIM ACCESSORIES FOR MOTOR VEHICLES (U.S. CLS. 100 AND 101).

FIRST USE 1-0-2010; IN COMMERCE 1-0-2010.  
FRANK LATTUCA, EXAMINING ATTORNEY

SN 85-116,405. FORMULA 43 LLC, LIVONIA, MI. FILED 8-26-2010.

# Formula 43

THE MARK CONSISTS OF STANDARD CHARACTERS WITHOUT CLAIM TO ANY PARTICULAR FONT, STYLE, SIZE, OR COLOR.

NO CLAIM IS MADE TO THE EXCLUSIVE RIGHT TO USE "FORMULA", APART FROM THE MARK AS SHOWN.

**CLASS 12—VEHICLES**

FOR AUTOMOTIVE WHEELS AND WHEEL COMPONENTS, NAMELY, INNER RIM, OUTER RIM, CENTER AND CENTER CAPS FOR MOTOR VEHICLES, INCLUDING HIGH PERFORMANCE RACE AND SPORT VEHICLES (U.S. CLS. 19, 21, 23, 31, 35 AND 44).

FIRST USE 1-0-2010; IN COMMERCE 1-0-2010.

**CLASS 42—SCIENTIFIC AND COMPUTER SERVICES**

FOR RENDERING SERVICES IN THE DESIGN, ANALYSIS AND MANUFACTURE OF WHEELS OF MODULAR TWO AND THREE PIECE AND ALSO ONE PIECE MONO BLOCK WHEELS AND WHEEL RIM ACCESSORIES FOR MOTOR VEHICLES (U.S. CLS. 100 AND 101).

FIRST USE 1-0-2010; IN COMMERCE 1-0-2010.  
FRANK LATTUCA, EXAMINING ATTORNEY

---

SN 85-116,892. CAMPER, S.L., INCA, BALEARES, SPAIN, FILED 8-26-2010.

**CAMPER EXTRAORDINARY CRAFTS**

THE MARK CONSISTS OF STANDARD CHARACTERS WITHOUT CLAIM TO ANY PARTICULAR FONT, STYLE, SIZE, OR COLOR.

PRIORITY CLAIMED UNDER SEC. 44(D) ON ERPNCMNTY TM OFC APPLICATION NO. 009235391, FILED 7-9-2010, REG. NO. 009235391, DATED 12-10-2010, EXPIRES 7-9-2020.

OWNER OF U.S. REG. NOS. 2,022,753, 2,077,032 AND OTHERS.

NO CLAIM IS MADE TO THE EXCLUSIVE RIGHT TO USE "EXTRAORDINARY CRAFTS", APART FROM THE MARK AS SHOWN.

**CLASS 18—LEATHER GOODS**

FOR (BASED ON 44(E)) ANIMAL SKINS AND HIDES; BRIEFCASES; FUR; HANDBAGS; HARNESSES AND SADDLERY; IMITATION LEATHER; LEATHER; PARASOLS; PURSES; RUCKSACKS; SUITCASES; TANNED LEATHER; TRUNKS; UMBRELLAS AND THEIR PARTS; WALKING STICKS; WALLETS; WHIPS (U.S. CLS. 1, 2, 3, 22 AND 41).

**CLASS 25—CLOTHING**

FOR (BASED ON USE IN COMMERCE) ANORAKS; BEACHWEAR; BELTS; BERMUDA SHORTS; BIKINIS; BLOUSES; BOXER SHORTS; CARDIGANS; COATS; FOOTWEAR; FUR JACKETS; GLOVES; GOLF SHIRTS; HEADWEAR; JACKETS; JEANS; JERSEYS; JUMPSUITS; NECKTIES; POLO SHIRTS; SCARVES; SKIRTS; SOCKS; SPORT COATS; SWEAT SHIRTS; SWIMWEAR; T-SHIRTS; TENNIS WEAR; TROUSERS; UNDERSHIRTS; UNDERWEAR (U.S. CLS. 22 AND 39).

FIRST USE 1-0-2009; IN COMMERCE 9-0-2009.

**CLASS 35—ADVERTISING AND BUSINESS**

FOR (BASED ON USE IN COMMERCE) ADMINISTRATIVE HOTEL MANAGEMENT; ADVERTISING SERVICES; BUSINESS ADMINISTRATION AND MANAGEMENT; BUSINESS MANAGEMENT ASSISTANCE TO INDUSTRIAL OR COMMERCIAL COMPANIES; COMMERCIAL BUSINESS MANAGEMENT; IMPORT AND EXPORT AGENCIES; ON-LINE RETAIL STORE SERVICES FEATURING GOODS MADE OF LEATHER AND IMITATIONS OF LEATHER, ANIMAL SKINS, HIDES, BAGS, TRUNKS, HANDBAGS, BACKPACKS, BRIEFCASES, WALLETS, PURSES NOT MADE OF PRECIOUS METAL, UMBRELLAS AND THEIR PARTS, PARASOLS, WALKING STICKS, WHIPS, HARNESS AND SADDLERY, CLOTHING, FOOTWEAR, HEADGEAR, MAGAZINES, PUBLICATIONS; PUBLIC RELATIONS; RETAIL STORE SERVICES FEATURING GOODS MADE OF LEATHER AND IMITATIONS OF LEATHER, ANIMAL SKINS, HIDES, BAGS, TRUNKS, HANDBAGS, BACKPACKS, BRIEFCASES, WALLETS, PURSES NOT MADE OF PRECIOUS METAL, UMBRELLAS AND THEIR PARTS, PARASOLS, WALKING STICKS, WHIPS, HARNESS AND SADDLERY, CLOTHING, FOOTWEAR, HEADGEAR, MAGAZINES, PUBLICATIONS (U.S. CLS. 100, 101 AND 102).

FIRST USE 1-0-2009; IN COMMERCE 9-0-2009.

JOHN KELLY, EXAMINING ATTORNEY

SN 85-117,140. PERFORMANCE DIESEL INC, ST. GEORGE, UT. FILED 8-27-2010.

# BIG BOSS

THE MARK CONSISTS OF STANDARD CHARACTERS WITHOUT CLAIM TO ANY PARTICULAR FONT, STYLE, SIZE, OR COLOR.

**CLASS 7—MACHINERY**

FOR CAM SHAFT; FUEL INJECTORS; INTERCOOLERS; INTAKE AND EXHAUST MANIFOLDS FOR ENGINES; ENGINE AND MOTOR MUFFLERS; RADIATORS FOR MOTORS AND ENGINES; TURBOCHARGER SYSTEMS FOR VEHICLES (U.S. CLS. 13, 19, 21, 23, 31, 34 AND 35).

FIRST USE 12-1-2007; IN COMMERCE 12-1-2007.

**CLASS 9—ELECTRICAL AND SCIENTIFIC APPARATUS**

FOR ELECTRONIC ENGINE CONTROL MODULES FOR DIESEL ENGINES FOR LAND VEHICLES AND MARINE VEHICLES AND VESSELS; COMPUTER SOFTWARE FOR MODIFYING ENGINE CONTROLS (U.S. CLS. 21, 23, 26, 36 AND 38).

FIRST USE 12-1-2007; IN COMMERCE 12-1-2007.

**CLASS 12—VEHICLES**

FOR RACING AND PERFORMANCE AFTER-MARKET VEHICLE PARTS, NAMELY, DIESEL ENGINES, MOTORS, AND CLUTCHES (U.S. CLS. 19, 21, 23, 31, 35 AND 44).

FIRST USE 12-1-2007; IN COMMERCE 12-1-2007.

NAKIA HENRY, EXAMINING ATTORNEY

SN 85-118,356. KABUSHIKI KAISHA TOSHIBA, TA TOSHIBA CORPORATION, MINATO-KU, TOKYO, JAPAN, FILED 8-30-2010.

# BD6C

THE MARK CONSISTS OF STANDARD CHARACTERS WITHOUT CLAIM TO ANY PARTICULAR FONT, STYLE, SIZE, OR COLOR.

PRIORITY CLAIMED UNDER SEC. 44(D) ON JAPAN APPLICATION NO. 2010-016949, FILED 3-5-2010, REG. NO. 5346961, DATED 8-20-2010, EXPIRES 8-20-2020.

**CLASS 36—INSURANCE AND FINANCIAL**

FOR COLLECTING LICENSE FEES ON BEHALF OF INTELLECTUAL PROPERTY RIGHTS OWNERS (U.S. CLS. 100, 101 AND 102).

**CLASS 45—PERSONAL AND LEGAL SERVICES**

FOR LICENSING OF INTELLECTUAL PROPERTY (U.S. CLS. 100 AND 101).

HOWARD SMIGA, EXAMINING ATTORNEY

SN 85-119,624. ALPHA NATURAL RESOURCES, INC., ABINGDON, VA. FILED 8-31-2010.

# WE POWER THE WORLD THROUGH THE ENERGY OF OUR PEOPLE

THE MARK CONSISTS OF STANDARD CHARACTERS WITHOUT CLAIM TO ANY PARTICULAR FONT, STYLE, SIZE, OR COLOR.

**CLASS 4—LUBRICANTS AND FUELS**

FOR COAL; COAL GAS; COAL BYPRODUCTS, NAMELY, SYN-FUEL, COAL GAS AND COAL ASH (U.S. CLS. 1, 6 AND 15).

FIRST USE 8-31-2010; IN COMMERCE 8-31-2010.

**CLASS 37—CONSTRUCTION AND REPAIR**

FOR MINING EXTRACTION, NAMELY, ENVIRONMENTALLY CONSCIOUS COAL EXTRACTION; ENVIRONMENTALLY CONSCIOUS LAND RECLAMATION (U.S. CLS. 100, 103 AND 106).

FIRST USE 8-31-2010; IN COMMERCE 8-31-2010.

SUSAN RICHARDS, EXAMINING ATTORNEY

SN 85-120,533. BOSTON LOBSTER COMPANY, LLC, DBA BOSTON LOBSTER COMPANY, BOSTON, MA. FILED 9-1-2010.



NO CLAIM IS MADE TO THE EXCLUSIVE RIGHT TO USE "LOBSTER COMPANY" AND "WORLDWIDE SHIPPER", APART FROM THE MARK AS SHOWN.

THE COLOR(S) RED, BLUE, BLACK, AND WHITE IS/ARE CLAIMED AS A FEATURE OF THE MARK.

THE MARK CONSISTS OF A RED LOBSTER, OVER A BLACK LOBSTER TRAP WITH THE WORDS "BOSTON LOBSTER COMPANY" IN BLUE LETTERING UNDER THE LOBSTER, ABOVE A BLUE OVAL WITH TWO SMALL WHITE CIRCLES INSIDE IT, AND THE WORDS "WORLDWIDE SHIPPER" IN WHITE INSIDE THE OVAL. THE MARK IS SET AGAINST A WHITE BACKGROUND.

SEC. 2(F) AS TO "BOSTON LOBSTER COMPANY".

#### CLASS 29—MEATS AND PROCESSED FOODS

FOR LOBSTERS (U.S. CL. 46).  
FIRST USE 1-1-2004; IN COMMERCE 1-1-2004.

#### CLASS 31—NATURAL AGRICULTURAL PRODUCTS

FOR LOBSTERS; LOBSTERS, LIVE (U.S. CLS. 1 AND 46).  
FIRST USE 1-1-1986; IN COMMERCE 1-1-1986.  
ELISSA GARBER KON, EXAMINING ATTORNEY

SN 85-121,755. S. C. JOHNSON & SON, INC., RACINE, WI. FILED 9-2-2010.

# GREENLIST

THE MARK CONSISTS OF STANDARD CHARACTERS WITHOUT CLAIM TO ANY PARTICULAR FONT, STYLE, SIZE, OR COLOR.

OWNER OF U.S. REG. NOS. 3,518,048 AND 3,729,963.

#### CLASS 1—CHEMICALS

FOR CHEMICALLY TREATED SHEETS FOR USE IN WASHING MACHINES FOR ABSORBING DIRT AND DYE DURING A WASH (U.S. CLS. 1, 5, 6, 10, 26 AND 46).

#### CLASS 3—COSMETICS AND CLEANING PREPARATIONS

FOR FURNITURE POLISH, FLOOR WAX, DISPOSABLE WIPES IMPREGNATED WITH CLEANSING CHEMICALS OR COMPOUNDS, DRAIN CLEANERS, CARPET AND UPHOLSTERY CLEANERS (U.S. CLS. 1, 4, 6, 50, 51 AND 52).

#### CLASS 4—LUBRICANTS AND FUELS

FOR CANDLES (U.S. CLS. 1, 6 AND 15).

#### CLASS 5—PHARMACEUTICALS

FOR ALL PURPOSE HOUSEHOLD DISINFECTANTS, AIR FRESHENERS, AIR DEODORIZER, DEODORIZER FOR CARPET, FABRIC AND UPHOLSTERY, INSECTICIDES, INSECT REPELLENTS (U.S. CLS. 6, 18, 44, 46, 51 AND 52).

#### CLASS 11—ENVIRONMENTAL CONTROL APPARATUS

FOR ELECTRICAL FRAGRANCE DISPENSERS (U.S. CLS. 13, 21, 23, 31 AND 34).

#### CLASS 16—PAPER GOODS AND PRINTED MATTER

FOR PLASTIC BAGS FOR HOUSEHOLD USE, PLASTIC WRAP, DISPOSABLE WIPES NOT IMPREGNATED WITH CHEMICALS OR COMPOUNDS FOR HOUSEHOLD USE (U.S. CLS. 2, 5, 22, 23, 29, 37, 38 AND 50).

#### CLASS 21—HOUSEWARES AND GLASS

FOR PLASTIC CONTAINERS FOR HOUSEHOLD USE, MOPS, BROOMS, DUSTING BRUSHES, SCRUBBING BRUSHES, TOILET BRUSHES, MICROFIBER CLEANING CLOTHS (U.S. CLS. 2, 13, 23, 29, 30, 33, 40 AND 50).  
LINDA ESTRADA, EXAMINING ATTORNEY

SN 85-121,870. S. C. JOHNSON & SON, INC., RACINE, WI. FILED 9-2-2010.



OWNER OF U.S. REG. NO. 3,522,370.  
THE MARK CONSISTS OF "GREENLIST" AND TWO LEAVES AND A LINE INSIDE A LARGER LEAF.

#### CLASS 1—CHEMICALS

FOR CHEMICALLY TREATED SHEETS FOR USE IN WASHING MACHINES FOR ABSORBING DIRT AND DYE DURING A WASH (U.S. CLS. 1, 5, 6, 10, 26 AND 46).

#### CLASS 3—COSMETICS AND CLEANING PREPARATIONS

FOR FURNITURE POLISH, FLOOR WAX, DISPOSABLE WIPES IMPREGNATED WITH CLEANSING CHEMICALS OR COMPOUNDS, DRAIN CLEANERS, CARPET AND UPHOLSTERY CLEANERS (U.S. CLS. 1, 4, 6, 50, 51 AND 52).

#### CLASS 4—LUBRICANTS AND FUELS

FOR CANDLES (U.S. CLS. 1, 6 AND 15).



**CLASS 5—PHARMACEUTICALS**

FOR ALL PURPOSE HOUSEHOLD DISINFECTANTS, AIR FRESHENERS, AIR DEODORIZER, DEODORIZER FOR CARPET, FABRIC AND UPHOLSTERY, INSECTICIDES, INSECT REPELLENTS (U.S. CLS. 6, 18, 44, 46, 51 AND 52).

**CLASS 11—ENVIRONMENTAL CONTROL APPARATUS**

FOR ELECTRICAL FRAGRANCE DISPENSERS (U.S. CLS. 13, 21, 23, 31 AND 34).

**CLASS 16—PAPER GOODS AND PRINTED MATTER**

FOR PLASTIC BAGS FOR HOUSEHOLD USE, PLASTIC WRAP, DISPOSABLE WIPES NOT IMPREGNATED WITH CHEMICALS OR COMPOUNDS FOR HOUSEHOLD USE (U.S. CLS. 2, 5, 22, 23, 29, 37, 38 AND 50).

**CLASS 21—HOUSEWARES AND GLASS**

FOR PLASTIC CONTAINERS FOR HOUSEHOLD USE, MOPS, BROOMS, DUSTING BRUSHES, SCRUBBING BRUSHES, TOILET BRUSHES, MICROFIBER CLEANING CLOTHS (U.S. CLS. 2, 13, 23, 29, 30, 33, 40 AND 50).  
LINDA ESTRADA, EXAMINING ATTORNEY

---

SN 85-121,935. PIERRE FABRE S.A., PARIS, FRANCE, FILED 9-2-2010.

# ALPHERIS

THE MARK CONSISTS OF STANDARD CHARACTERS WITHOUT CLAIM TO ANY PARTICULAR FONT, STYLE, SIZE, OR COLOR.

OWNER OF FRANCE REG. NO. 95557392, DATED 2-3-1995, RENEWED AS REG. NO. 95557392, DATED 2-3-2005, EXPIRES 2-3-2015.

**CLASS 3—COSMETICS AND CLEANING PREPARATIONS**

FOR COSMETICS AND CLEANING PREPARATIONS, NAMELY, BODY AND SKIN SOAPS; PERFUME; ESSENTIAL OILS FOR PERSONAL USE; NONMEDICATED SKIN CLEANSING AND HAIR CARE PREPARATIONS; DENTIFRICES; MAKEUP; NON-MEDICATED SKIN CARE PREPARATIONS IN THE FORM OF CREAMS, MILKS, EMULSIONS, GELS AND LOTIONS; NAIL CREAMS AND POLISHES (U.S. CLS. 1, 4, 6, 50, 51 AND 52).

**CLASS 5—PHARMACEUTICALS**

FOR PHARMACEUTICAL PREPARATIONS, NAMELY, MEDICATED PREPARATIONS FOR HYGIENE AND CARE OF SKIN AND HAIR; DIETARY SUPPLEMENTS; BABY FOOD (U.S. CLS. 6, 18, 44, 46, 51 AND 52).

CYNTHIA TRIPI, EXAMINING ATTORNEY

SN 85-122,522. COMPLETE TURBINE SERVICES, LLC, FORT LAUDERDALE, FL. FILED 9-3-2010.

# FOREVER FORWARD

THE MARK CONSISTS OF STANDARD CHARACTERS WITHOUT CLAIM TO ANY PARTICULAR FONT, STYLE, SIZE, OR COLOR.

**CLASS 37—CONSTRUCTION AND REPAIR**

FOR AIRCRAFT ENGINE INSTALLATION, REMOVAL, REPAIR, REPLACEMENT, AND MAINTENANCE SERVICES (U.S. CLS. 100, 103 AND 106).  
FIRST USE 4-0-2003; IN COMMERCE 4-0-2003.

**CLASS 42—SCIENTIFIC AND COMPUTER SERVICES**

FOR AIRCRAFT ENGINE INSPECTION SERVICES (U.S. CLS. 100 AND 101).  
FIRST USE 4-0-2003; IN COMMERCE 4-0-2003.  
RAMONA ORTIGA, EXAMINING ATTORNEY

---

SN 85-122,834. THE ORGANIZED COOK, LLC, LAS VEGAS, NV. FILED 9-3-2010.

# THE ORGANIZED COOK

THE MARK CONSISTS OF STANDARD CHARACTERS WITHOUT CLAIM TO ANY PARTICULAR FONT, STYLE, SIZE, OR COLOR.

NO CLAIM IS MADE TO THE EXCLUSIVE RIGHT TO USE "COOK", APART FROM THE MARK AS SHOWN.

**CLASS 16—PAPER GOODS AND PRINTED MATTER**

FOR PRE-PRINTED FOOD SHOPPING LISTS; WRITING PADS; PRINTED MENU BOARDS (U.S. CLS. 2, 5, 22, 23, 29, 37, 38 AND 50).

**CLASS 21—HOUSEWARES AND GLASS**

FOR PLASTIC STORAGE CONTAINERS FOR HOUSEHOLD OR DOMESTIC USE; COOKWARE AND COOKING UTENSILS, NAMELY, SAUTE PANS, DUTCH OVENS, SOUP PANS, CASSEROLE DISHES AND CUTTING BOARDS (U.S. CLS. 2, 13, 23, 29, 30, 33, 40 AND 50).

**CLASS 25—CLOTHING**

FOR APRONS (U.S. CLS. 22 AND 39).  
ODESSA BIBBINS, EXAMINING ATTORNEY

SN 85-123,044. GFS CHEMICALS, INC., POWELL, OH. FILED 9-3-2010.

## GFS CHEMICALS

THE MARK CONSISTS OF STANDARD CHARACTERS WITHOUT CLAIM TO ANY PARTICULAR FONT, STYLE, SIZE, OR COLOR.

NO CLAIM IS MADE TO THE EXCLUSIVE RIGHT TO USE "CHEMICALS", APART FROM THE MARK AS SHOWN.

### CLASS 1—CHEMICALS

FOR CHEMICALS FOR USE IN INDUSTRY AND SCIENCE (U.S. CLS. 1, 5, 6, 10, 26 AND 46).  
FIRST USE 1-1-1990; IN COMMERCE 1-1-1990.

### CLASS 40—MATERIAL TREATMENT

FOR PROVIDING TECHNICAL INFORMATION IN THE FIELD OF CHEMICAL MANUFACTURING (U.S. CLS. 100, 103 AND 106).  
FIRST USE 1-1-1990; IN COMMERCE 1-1-1990.  
JASON TURNER, EXAMINING ATTORNEY

SN 85-123,417. BDI-BIOENERGY INTERNATIONAL AG, GRAMBACH, AUSTRIA, FILED 9-5-2010.



PRIORITY CLAIMED UNDER SEC. 44(D) ON AUSTRIA APPLICATION NO. AM1644/2010, FILED 3-15-2010, REG. NO. 257563, DATED 6-25-2010, EXPIRES 6-30-2020.

NO CLAIM IS MADE TO THE EXCLUSIVE RIGHT TO USE "OMEGA", APART FROM THE MARK AS SHOWN.

THE MARK CONSISTS OF THE TERM "OMEGA", FOLLOWED BY A DROP SHAPE FEATURING THE TERM "3+".

### CLASS 4—LUBRICANTS AND FUELS

FOR FUELS (U.S. CLS. 1, 6 AND 15).

### CLASS 37—CONSTRUCTION AND REPAIR

FOR CONSTRUCTION OF PROCESS-ENGINEERING PLANTS, IN PARTICULAR PLANTS FOR PROCESSING RENEWABLE RAW MATERIALS SUCH AS VEGETABLE AND ANIMAL FATS, USED EDIBLE OILS OR WASTE FATS; CONSTRUCTION OF PLANTS FOR PRODUCING FATTY ACID ALKYL ESTERS, NAMELY, BIODIESEL; CONSTRUCTION OF PLANTS FOR ENVIRONMENTAL-RELATED TECHNOLOGIES (U.S. CLS. 100, 103 AND 106).

### CLASS 39—TRANSPORTATION AND STORAGE

FOR SUPPLY, NAMELY, SHIPMENT AND DELIVERY OF PREFABRICATED PROCESS-ENGINEERING PLANTS AND COMPONENT PARTS THEREOF, IN PARTICULAR PLANTS FOR PROCESSING RENEWABLE RAW MATERIALS SUCH AS VEGETABLE AND ANIMAL FATS, USED EDIBLE OILS OR WASTE FATS (U.S. CLS. 100 AND 105).

### CLASS 42—SCIENTIFIC AND COMPUTER SERVICES

FOR DEVELOPMENT OF TECHNOLOGIES FOR PROCESSING RENEWABLE RAW MATERIALS (U.S. CLS. 100 AND 101).

SCOTT BIBB, EXAMINING ATTORNEY

SN 85-123,418. BDI-BIOENERGY INTERNATIONAL AG, GRAMBACH, AUSTRIA, FILED 9-5-2010.



PRIORITY CLAIMED UNDER SEC. 44(D) ON AUSTRIA APPLICATION NO. AM1643/2010, FILED 3-15-2010, REG. NO. 257494, DATED 6-24-2010, EXPIRES 6-30-2020.

THE MARK CONSISTS OF THE TERM "BIOCRACK", FOLLOWED BY A LEAF DESIGN, WITH THE STEM OF THE LEAF THROUGH THE "K" IN "CRACK".

### CLASS 4—LUBRICANTS AND FUELS

FOR FUELS (U.S. CLS. 1, 6 AND 15).

### CLASS 37—CONSTRUCTION AND REPAIR

FOR CONSTRUCTION OF PROCESS-ENGINEERING PLANTS, IN PARTICULAR PLANTS FOR PROCESSING RENEWABLE RAW MATERIALS SUCH AS VEGETABLE AND ANIMAL FATS, USED EDIBLE OILS OR WASTE FATS; CONSTRUCTION OF PLANTS FOR PRODUCING FATTY ACID ALKYL ESTERS, NAMELY, BIODIESEL; CONSTRUCTION OF PLANTS FOR ENVIRONMENTAL-RELATED TECHNOLOGIES (U.S. CLS. 100, 103 AND 106).

### CLASS 39—TRANSPORTATION AND STORAGE

FOR SUPPLY, NAMELY, SHIPMENT AND DELIVERY OF PREFABRICATED PROCESS-ENGINEERING PLANTS AND COMPONENT PARTS THEREOF, IN PARTICULAR PLANTS FOR PROCESSING RENEWABLE RAW MATERIALS SUCH AS VEGETABLE AND ANIMAL FATS, USED EDIBLE OILS OR WASTE FATS (U.S. CLS. 100 AND 105).

### CLASS 42—SCIENTIFIC AND COMPUTER SERVICES

FOR DEVELOPMENT OF TECHNOLOGIES FOR PROCESSING RENEWABLE RAW MATERIALS (U.S. CLS. 100 AND 101).

SCOTT BIBB, EXAMINING ATTORNEY

SN 85-123,779. API GROUP, INC., NEW BRIGHTON, MN.  
FILED 9-7-2010.



THE MARK CONSISTS OF THE CAPITAL LETTERS "A" AND "P" FOLLOWED BY A LOWER CASE LETTER "I", FOLLOWED BY A SPROCKET.

#### CLASS 35—ADVERTISING AND BUSINESS

FOR WHOLESALE DISTRIBUTORSHIPS FEATURING INDUSTRIAL AND COMMERCIAL BUILDING MATERIALS; RETAIL STORE SERVICES, FEATURING, AERIAL WORK PLATFORMS, NAMELY, LIFTS, BUILDING SCAFFOLDS, AND PORTABLE HEATING UNITS; RECYCLING OF CHEMICALS, NAMELY, HALON (U.S. CLS. 100, 101 AND 102).

FIRST USE 7-0-1997; IN COMMERCE 7-0-1997.

#### CLASS 37—CONSTRUCTION AND REPAIR

FOR CONSTRUCTION PROJECT MANAGEMENT SERVICES, NAMELY, BUDGETING, CONSTRUCTABILITY REVIEWS, ESTIMATION AND FEASIBILITY STUDIES; BUILDING CONSTRUCTION SERVICES IN THE FIELD OF IN COMMERCIAL, INDUSTRIAL, AND RESIDENTIAL CONSTRUCTION PROJECTS; GENERAL CONSTRUCTION CONTRACTING IN THE FIELD OF THERMAL INSULATION SYSTEMS; INSTALLATION, REPAIR AND MAINTENANCE OF HEATING EQUIPMENT, NAMELY, BOILERS; ELECTRICAL CONTRACTING SERVICES; INSTALLATION AND MAINTENANCE OF HVAC SYSTEMS; REPAIR AND INSTALLATION SERVICES, NAMELY, THE INSTALLATION OF HEATING AND COOLING AIR DUCTS; HEATING EQUIPMENT INSTALLATION AND REPAIR, NAMELY, HEAT RECOVERY STEAM GENERATORS; MECHANICAL CONTRACTING, NAMELY, INSTALLING AND SERVICING HEATING, VENTILATING, AIR CONDITIONING (HVAC) AND AUTOMATION SYSTEMS; INSTALLATION, MAINTENANCE, AND REPAIR OF PIPE SYSTEMS; RENTAL OF AERIAL WORK PLATFORMS, NAMELY, LIFTS, BUILDING SCAFFOLDS, AND PORTABLE HEATING UNITS; MAINTENANCE AND REPAIR OF AERIAL WORK PLATFORMS, NAMELY, LIFTS, BUILDING SCAFFOLDS, AND PORTABLE HEATING UNITS; INSTALLATION OF SILENCERS FOR INDUSTRIAL AND HEAVY EQUIPMENT; GARAGE DOOR INSTALLATION AND REPAIR SERVICES; INSTALLATION, MAINTENANCE AND REPAIR OF AUTOMATIC FIRE SPRINKLER SYSTEMS; INSTALLATION, MAINTENANCE AND REPAIR OF FIRE DETECTION SYSTEMS; INSTALLATION AND MAINTENANCE OF FIRE SUPPRESSION SYSTEMS; INSTALLATION, MAINTENANCE, AND REPAIR OF LOW VOLTAGE SYSTEMS, NAMELY, FIRE ALARM, FIRE DETECTION, CLOSED CIRCUIT TV, NURSE CALL, PUBLIC ADDRESS, PAGING, AND ACCESS CONTROL SYSTEMS (U.S. CLS. 100, 103 AND 106).

FIRST USE 7-0-1997; IN COMMERCE 7-0-1997.

#### CLASS 40—MATERIAL TREATMENT

FOR METAL FABRICATION AND FINISHING SERVICES; CUTTING AND CUSTOM FABRICATION OF DUCT WORK SYSTEMS, DUST COLLECTION SYSTEMS, OEM REPLACEMENTS, TANKS AND PRESSURE VESSELS; CUSTOM CONSTRUCTION OF GARAGE DOORS (U.S. CLS. 100, 103 AND 106).

FIRST USE 7-0-1997; IN COMMERCE 7-0-1997.

#### CLASS 42—SCIENTIFIC AND COMPUTER SERVICES

FOR ENGINEERING SERVICES IN THE FIELD OF PRECONSTRUCTION PLANNING; INSPECTION OF AUTOMATIC FIRE SPRINKLER SYSTEMS; INSPECTION OF FIRE DETECTION SYSTEMS; INSPECTION OF FIRE SUPPRESSION SYSTEMS; INSPECTION OF SPECIAL HAZARD FIRE SUPPRESSION SYSTEMS; INSPECTION OF LOW VOLTAGE SYSTEMS, NAMELY, FIRE ALARM, FIRE DETECTION, CLOSED CIRCUIT TV, NURSE CALL, PUBLIC ADDRESS, PAGING, AND ACCESS CONTROL SYSTEMS; ELECTRICAL SYSTEMS DESIGN SERVICES, ELECTRICAL ENGINEERING SERVICES (U.S. CLS. 100 AND 101).

FIRST USE 7-0-1997; IN COMMERCE 7-0-1997.  
SKYE YOUNG, EXAMINING ATTORNEY

SN 85-124,077. SEGURO SURGICAL, INC., COLUMBIA, MD.  
FILED 9-7-2010.

## SEGURO VENTURES

THE MARK CONSISTS OF STANDARD CHARACTERS WITHOUT CLAIM TO ANY PARTICULAR FONT, STYLE, SIZE, OR COLOR.

NO CLAIM IS MADE TO THE EXCLUSIVE RIGHT TO USE "VENTURES", APART FROM THE MARK AS SHOWN. THE ENGLISH TRANSLATION OF THE WORD "SEGURO" IN THE MARK IS "SAFE".

#### CLASS 10—MEDICAL APPARATUS

FOR SURGICAL INSTRUMENTS AND DEVICES (U.S. CLS. 26, 39 AND 44).

#### CLASS 35—ADVERTISING AND BUSINESS

FOR BUSINESS ORGANIZATIONAL CONSULTATION SERVICES FOR THE SURGICAL INDUSTRY; BUSINESS DEVELOPMENT SERVICES, NAMELY, PROVIDING START-UP ACTIVITIES FOR THE BUSINESS OF OTHERS; BUSINESS CONSULTATION; BUSINESS MARKETING CONSULTATION (U.S. CLS. 100, 101 AND 102).

#### CLASS 36—INSURANCE AND FINANCIAL

FOR VENTURE CAPITAL FUNDING, MANAGEMENT AND CONSULTATION SERVICES TO START-UP, EMERGING AND GROWTH COMPANIES; FACILITATING LIQUIDITY EVENTS FOR START-UP, EMERGING AND GROWTH COMPANIES (U.S. CLS. 100, 101 AND 102).

KAPIL BHANOT, EXAMINING ATTORNEY

SN 85-124,649. NAMEMEDIA, INC., WALTHAM, MA. FILED  
9-8-2010.

LIST ONCE. SELL EVERYWHERE.

THE MARK CONSISTS OF STANDARD CHARACTERS WITHOUT CLAIM TO ANY PARTICULAR FONT, STYLE, SIZE, OR COLOR.

**CLASS 35—ADVERTISING AND BUSINESS**

FOR BUSINESS SERVICE, NAMELY, BRINGING TOGETHER THE BUYERS AND SELLERS OF INTERNET DOMAIN NAMES (U.S. CLS. 100, 101 AND 102).  
FIRST USE 9-30-2010; IN COMMERCE 9-30-2010.

**CLASS 36—INSURANCE AND FINANCIAL**

FOR BROKERAGE IN THE FIELD OF INTERNET DOMAIN NAMES (U.S. CLS. 100, 101 AND 102).  
FIRST USE 9-30-2010; IN COMMERCE 9-30-2010.  
CHRISIE B. KING, EXAMINING ATTORNEY

**CLASS 42—SCIENTIFIC AND COMPUTER SERVICES**

FOR COMPUTER NETWORK CONFIGURATION SERVICES; COMPUTER NETWORK DESIGN FOR OTHERS; TECHNICAL SUPPORT, NAMELY, MONITORING OF NETWORK SYSTEMS; COMPUTER SERVICES, NAMELY, MONITORING, TESTING, ANALYZING, AND REPORTING ON THE INTERNET TRAFFIC CONTROL AND CONTENT CONTROL OF THE WEB SITES OF OTHERS; COMPUTER SECURITY SERVICE, NAMELY, RESTRICTING ACCESS TO AND BY COMPUTER NETWORKS TO AND OF UNDESIRED WEB SITES; COMPUTER VIRUS PROTECTION SERVICES, COMPUTER SERVICES, NAMELY, FILTERING OF UNWANTED E-MAILS (U.S. CLS. 100 AND 101).  
FIRST USE 8-0-2008; IN COMMERCE 8-0-2008.

**CLASS 45—PERSONAL AND LEGAL SERVICES**

FOR COMPUTER NETWORK SECURITY SERVICES, NAMELY, MONITORING OF NETWORK TRAFFIC FOR SECURITY PURPOSES, FOR PURPOSES OF PREVENTING DISTRIBUTED DENIAL OF SERVICE (DDOS) ATTACKS ON COMPUTER SERVERS CONNECTED TO THE INTERNET (U.S. CLS. 100 AND 101).  
FIRST USE 8-0-2008; IN COMMERCE 8-0-2008.  
TINA L. SNAPP, EXAMINING ATTORNEY

SN 85-125,754. LEVEL 3 COMMUNICATIONS, LLC, BROOMFIELD, CO. FILED 9-9-2010.



**Level(3)**  
COMMUNICATIONS

SN 85-126,610. WESTINGHOUSE ELECTRIC COMPANY LC, CRANBERRY TOWNSHIP, PA. FILED 9-10-2010.

OWNER OF U.S. REG. NOS. 2,400,493, 2,586,143 AND OTHERS.

NO CLAIM IS MADE TO THE EXCLUSIVE RIGHT TO USE "COMMUNICATIONS", APART FROM THE MARK AS SHOWN.

THE MARK CONSISTS OF "LEVEL (3)" WITH THE WORD "COMMUNICATIONS" UNDERNEATH.

**CLASS 35—ADVERTISING AND BUSINESS**

FOR TELECOMMUNICATIONS NETWORK MANAGEMENT SERVICES, NAMELY, THE OPERATION AND ADMINISTRATION OF TELECOMMUNICATION SYSTEMS AND NETWORKS FOR OTHERS; MANAGING TELECOMMUNICATION NETWORKS FOR OTHERS, NAMELY, MANAGING TELECOMMUNICATION SERVICES FOR OTHER TELECOMMUNICATION CARRIERS (U.S. CLS. 100, 101 AND 102).  
FIRST USE 3-0-1998; IN COMMERCE 3-0-1998.

**CLASS 37—CONSTRUCTION AND REPAIR**

FOR INSTALLATION, MAINTENANCE AND REPAIR OF TELECOMMUNICATIONS NETWORKING HARDWARE (U.S. CLS. 100, 103 AND 106).  
FIRST USE 5-0-2008; IN COMMERCE 5-0-2008.

**CLASS 38—COMMUNICATION**

FOR PROVIDING COMPUTER NETWORK ACCESS SERVICES BY MEANS OF ETHERNET EQUIPMENT, COMPUTER NETWORK ROUTERS, AND VIRTUAL PRIVATE NETWORK HARDWARE (VPN); PROVIDING ELECTRONIC TRANSMISSION OF VIDEO, VOICE AND DATA USING INTEGRATED ACCESS TELECOMMUNICATIONS HARDWARE AND EQUIPMENT (U.S. CLS. 100, 101 AND 104).  
FIRST USE 3-0-1998; IN COMMERCE 3-0-1998.

THE COLOR(S) BLUE, WHITE AND YELLOW IS/ARE CLAIMED AS A FEATURE OF THE MARK.

THE MARK CONSISTS OF A BLUE RECTANGLE WHERE THE LOWER PORTION OF THE RECTANGLE CONTAINS THE PHRASE "WESTE" IN WHITE FONT AND THE UPPER PORTION DISPLAYS THE TOP OF A CONTAINMENT STRUCTURE IN BLUE WITH YELLOW AND WHITE RAYS EXTENDING THEREFROM.

**CLASS 11—ENVIRONMENTAL CONTROL APPARATUS**

FOR NUCLEAR POWER PLANTS (U.S. CLS. 13, 21, 23, 31 AND 34).

**CLASS 41—EDUCATION AND ENTERTAINMENT**

FOR TRAINING SERVICES IN THE FIELD OF NUCLEAR POWER PLANT INDUSTRY (U.S. CLS. 100, 101 AND 107).  
SUNG IN, EXAMINING ATTORNEY



SN 85-127,344. PRIACTA, INC., POWHATAN, VA. FILED 9-10-2010.

# DONEDESK

THE MARK CONSISTS OF STANDARD CHARACTERS WITHOUT CLAIM TO ANY PARTICULAR FONT, STYLE, SIZE, OR COLOR.

## CLASS 9—ELECTRICAL AND SCIENTIFIC APPARATUS

FOR COMPUTER SOFTWARE FOR TASK AND PROJECT ASSIGNMENT; TRACKING, COORDINATION, AND FOLLOW-UP; COMPUTER SOFTWARE FOR TASK AND APPOINTMENT SCHEDULING; COMPUTER SOFTWARE FOR WORKFLOW COLLABORATION; COMPUTER SOFTWARE FOR WORK PERFORMANCE MONITORING; COMPUTER SOFTWARE FOR TRACKING BUSINESS PERFORMANCE; COMPUTER SOFTWARE FOR CREATING AND DISTRIBUTING MEETING AGENDAS; COMPUTER SOFTWARE FOR USE IN ENGAGING IN SOCIAL NETWORKING (U.S. CLS. 21, 23, 26, 36 AND 38).

## CLASS 42—SCIENTIFIC AND COMPUTER SERVICES

FOR SOFTWARE AS A SERVICE (SAAS) SERVICES FEATURING SOFTWARE FOR TASK AND PROJECT ASSIGNMENT; TRACKING, COORDINATION, AND FOLLOW-UP; SOFTWARE AS A SERVICE (SAAS) SERVICES FEATURING SOFTWARE FOR TASK AND APPOINTMENT SCHEDULING; SOFTWARE AS A SERVICE (SAAS) SERVICES FEATURING SOFTWARE FOR WORKFLOW COLLABORATION; SOFTWARE AS A SERVICE (SAAS) SERVICES FEATURING SOFTWARE FOR WORK PERFORMANCE MONITORING; SOFTWARE AS A SERVICE (SAAS) SERVICES FEATURING SOFTWARE FOR TRACKING BUSINESS PERFORMANCE; SOFTWARE AS A SERVICE (SAAS) SERVICES FEATURING SOFTWARE FOR CREATING AND DISTRIBUTING MEETING AGENDAS; SOFTWARE AS A SERVICE (SAAS) SERVICES FEATURING SOFTWARE FOR USE IN ENGAGING IN SOCIAL NETWORKING (U.S. CLS. 100 AND 101).

ROBERT C. CLARK JR., EXAMINING ATTORNEY

SN 85-128,163. BALOG, DOUGLAS A., DBA BALOG REAL ESTATE SERVICES, PALM DESERT, CA. FILED 9-13-2010.

# Lifestyle Estate Collection

THE MARK CONSISTS OF STANDARD CHARACTERS WITHOUT CLAIM TO ANY PARTICULAR FONT, STYLE, SIZE, OR COLOR.

NO CLAIM IS MADE TO THE EXCLUSIVE RIGHT TO USE "ESTATE COLLECTION", APART FROM THE MARK AS SHOWN.

## CLASS 35—ADVERTISING AND BUSINESS

FOR REAL ESTATE ADVERTISING SERVICES; REAL ESTATE MARKETING SERVICES, NAMELY, ON-LINE SERVICES FEATURING TOURS OF RESIDENTIAL AND COMMERCIAL REAL ESTATE (U.S. CLS. 100, 101 AND 102).

FIRST USE 9-1-2007; IN COMMERCE 9-1-2007.

## CLASS 36—INSURANCE AND FINANCIAL

FOR REAL ESTATE LISTING (U.S. CLS. 100, 101 AND 102).

FIRST USE 9-1-2007; IN COMMERCE 9-1-2007.

SAIMA MAKHDOOM, EXAMINING ATTORNEY

SN 85-129,233. RENEU CONCEPTS CORPORATION, MINNEAPOLIS, MN. FILED 9-14-2010.

# IKAATI

THE MARK CONSISTS OF STANDARD CHARACTERS WITHOUT CLAIM TO ANY PARTICULAR FONT, STYLE, SIZE, OR COLOR.

THE WORDING "IKAATI" HAS NO MEANING IN A FOREIGN LANGUAGE.

## CLASS 5—PHARMACEUTICALS

FOR HERBAL TEAS FOR MEDICINAL PURPOSES (U.S. CLS. 6, 18, 44, 46, 51 AND 52).

## CLASS 30—STAPLE FOODS

FOR TEA; TEA BAGS; HERBAL TEA (U.S. CL. 46).  
PRISCILLA MILTON, EXAMINING ATTORNEY

SN 85-129,263. OCTANE BIOTECH INC., KINGSTON, ONTARIO, CANADA, FILED 9-14-2010.

# OCTANE BIOTECH

THE MARK CONSISTS OF STANDARD CHARACTERS WITHOUT CLAIM TO ANY PARTICULAR FONT, STYLE, SIZE, OR COLOR.

OWNER OF U.S. REG. NO. 3,849,335.

NO CLAIM IS MADE TO THE EXCLUSIVE RIGHT TO USE "BIOTECH", APART FROM THE MARK AS SHOWN.

## CLASS 40—MATERIAL TREATMENT

FOR MANUFACTURING SERVICES OF GOODS IN THE FIELDS OF BIOTECHNOLOGY AND MEDICINE (U.S. CLS. 100, 103 AND 106).

FIRST USE 7-0-2007; IN COMMERCE 7-0-2007.

**CLASS 42—SCIENTIFIC AND COMPUTER SERVICES**

FOR RESEARCH AND DEVELOPMENT IN THE FIELDS OF BIOTECHNOLOGY AND MEDICINE (U.S. CLS. 100 AND 101).

FIRST USE 7-0-2007; IN COMMERCE 7-0-2007.  
APRIL ROACH, EXAMINING ATTORNEY

SN 85-129,287. OCTANE BIOTECH INC., KINGSTON, ONTARIO, CANADA, FILED 9-14-2010.

**OCTANE ORTHOBIOLOGICS**

THE MARK CONSISTS OF STANDARD CHARACTERS WITHOUT CLAIM TO ANY PARTICULAR FONT, STYLE, SIZE, OR COLOR.

OWNER OF U.S. REG. NO. 3,849,335.

NO CLAIM IS MADE TO THE EXCLUSIVE RIGHT TO USE "ORTHOBIOLOGICS", APART FROM THE MARK AS SHOWN.

**CLASS 40—MATERIAL TREATMENT**

FOR MANUFACTURING SERVICES OF GOODS IN THE FIELDS OF BIOTECHNOLOGY AND MEDICINE (U.S. CLS. 100, 103 AND 106).

FIRST USE 7-0-2007; IN COMMERCE 7-0-2007.

**CLASS 42—SCIENTIFIC AND COMPUTER SERVICES**

FOR RESEARCH AND DEVELOPMENT IN THE FIELDS OF BIOTECHNOLOGY AND MEDICINE (U.S. CLS. 100 AND 101).

FIRST USE 7-0-2007; IN COMMERCE 7-0-2007.  
APRIL ROACH, EXAMINING ATTORNEY

SN 85-130,058. ORGANICA BOUTIQUE COMPANY, SAN PEDRO GARZA GARCIA, MEXICO, FILED 9-15-2010.



OWNER OF MEXICO REG. NO. 1107865, DATED 6-23-2009, EXPIRES 6-23-2019.

THE MARK CONSISTS OF THREE STYLIZED CAPITAL LETTERS "OBC" REPRESENTED AS FOLLOWS: THE LEFT SIDE OF THE "O" IS DARKER THAN THE RIGHT AND THE RIGHT SIDE OF THE "C" IS DARKER THAN THE LEFT, AND THE LIGHTER PORTIONS OF BOTH LETTERS COMBINE TO CREATE A LIGHT "B" BETWEEN THE OVERLAP OF THE "O" AND "C". TO THE RIGHT OF AND ABOVE THE "C" IS A SMALL DESIGN CONSISTING OF MULTIPLE INTERSECTING CIRCLES.

**CLASS 33—WINES AND SPIRITS**

FOR ALCOHOLIC BEVERAGES, EXCEPT FOR BEERS (U.S. CLS. 47 AND 49).

**CLASS 38—COMMUNICATION**

FOR PROVIDING AN INTERNET NEWS PORTAL FEATURING LINKS TO NEWS STORIES AND ARTICLES IN THE FIELD OF CURRENT EVENTS; ENTERTAINMENT, NAMELY, A CONTINUING NEWS SHOW BROADCAST OVER THE INTERNET (U.S. CLS. 100, 101 AND 104).

**CLASS 43—HOTEL AND RESTAURANT SERVICES**

FOR PROVIDING FOOD AND BEVERAGES FOR CONSUMPTION ON AND OFF THE PREMISES; CATERING FOR THE PROVISION OF FOOD AND BEVERAGES; PROVIDING BANQUET FACILITIES; ARRANGING TEMPORARY HOUSING ACCOMMODATIONS (U.S. CLS. 100 AND 101).

JILL C. ALT, EXAMINING ATTORNEY

SN 85-131,301. PARK NICOLLET INSTITUTE, ST. LOUIS PARK, MN. FILED 9-16-2010.

**captūrAGP**

THE MARK CONSISTS OF STANDARD CHARACTERS WITHOUT CLAIM TO ANY PARTICULAR FONT, STYLE, SIZE, OR COLOR.

**CLASS 9—ELECTRICAL AND SCIENTIFIC APPARATUS**

FOR COMPUTER SOFTWARE FOR USE BY HEALTH CARE PROVIDERS AND PATIENTS IN PREPARING REPORTS OF STATISTICAL AND VISUAL INFORMATION INTERPRETING GLUCOSE DATA (U.S. CLS. 21, 23, 26, 36 AND 38).

**CLASS 16—PAPER GOODS AND PRINTED MATTER**

FOR PRINTED WRITTEN REPORTS FOR HEALTH CARE PROVIDERS, CONSUMERS AND RESEARCHERS, OF STATISTICAL AND VISUAL INFORMATION INTERPRETING PATIENT GLUCOSE DATA (U.S. CLS. 2, 5, 22, 23, 29, 37, 38 AND 50).

**CLASS 42—SCIENTIFIC AND COMPUTER SERVICES**

FOR DEVELOPING OF VOLUNTARY STANDARDS FOR HEALTH CARE PROFESSIONALS AND INSTITUTIONS FOR USE IN CONNECTION WITH PREPARING REPORTS OF STATISTICAL AND VISUAL INTERPRETATION OF GLUCOSE DATA; PROVIDING MEDICAL AND SCIENTIFIC RESEARCH INFORMATION TO HEALTH CARE PROVIDERS AND PATIENTS OF STATISTICAL AND VISUAL INFORMATION INTERPRETING GLUCOSE DATA; PROVIDING AN INTERACTIVE WEB SITE THAT ENABLES USERS TO ENTER, ACCESS, TRACK, MONITOR AND GENERATE HEALTH AND MEDICAL INFORMATION AND REPORTS (U.S. CLS. 100 AND 101).

**CLASS 44—MEDICAL, BEAUTY AND AGRICULTURAL SERVICES**

FOR MEDICAL SERVICES, NAMELY, PROVIDING ONLINE MEDICAL ANALYSIS SERVICES TO HEALTH CARE PROVIDERS AND PATIENTS OF STATISTICAL AND VISUAL INFORMATION INTERPRETING GLUCOSE DATA (U.S. CLS. 100 AND 101).

SUZANNE BLANE, EXAMINING ATTORNEY

SN 85-133,206. LEFTSNRIGHTS, INC., SALT LAKE CITY, UT. FILED 9-20-2010.

**LIQUID AD TECHNOLOGY**

THE MARK CONSISTS OF STANDARD CHARACTERS WITHOUT CLAIM TO ANY PARTICULAR FONT, STYLE, SIZE, OR COLOR.

NO CLAIM IS MADE TO THE EXCLUSIVE RIGHT TO USE "AD TECHNOLOGY", APART FROM THE MARK AS SHOWN.

**CLASS 35—ADVERTISING AND BUSINESS**

FOR DISSEMINATION OF ADVERTISING FOR OTHERS VIA THE INTERNET; ON-LINE ADVERTISING AND MARKETING SERVICES; PROVIDING ADVERTISING SERVICES TO DISPLAY ADVERTISEMENTS AND PROMOTIONS ON THE INTERNET FOR OTHERS, NAMELY, IN WEBSITES; PROVIDING A DATABASE FEATURING ADVERTISEMENTS (U.S. CLS. 100, 101 AND 102).

**CLASS 42—SCIENTIFIC AND COMPUTER SERVICES**

FOR APPLICATION SERVICE PROVIDER, NAMELY, MANAGING, DEVELOPING AND MAINTAINING APPLICATIONS AND SOFTWARE, OF OTHERS IN THE FIELDS OF ADVERTISING AND MARKETING; PROVIDING ON-LINE NON-DOWNLOADABLE SOFTWARE AND APPLICATIONS FOR USE IN ADVERTISING AND MARKETING (U.S. CLS. 100 AND 101).

DAVID I, EXAMINING ATTORNEY

SN 85-134,135. WORD OF MOUTH PR.NET, LLC. DBA PILATES PLUS NEWPORT BEACH, NEWPORT BEACH, CA. FILED 9-21-2010.

**PEACE. LOVE. PILATES.**

THE MARK CONSISTS OF STANDARD CHARACTERS WITHOUT CLAIM TO ANY PARTICULAR FONT, STYLE, SIZE, OR COLOR.

NO CLAIM IS MADE TO THE EXCLUSIVE RIGHT TO USE "PILATES", APART FROM THE MARK AS SHOWN.

**CLASS 18—LEATHER GOODS**

FOR TOTE BAGS (U.S. CLS. 1, 2, 3, 22 AND 41).  
FIRST USE 7-1-2009; IN COMMERCE 7-1-2009.

**CLASS 21—HOUSEWARES AND GLASS**

FOR BOTTLES, SOLD EMPTY (U.S. CLS. 2, 13, 23, 29, 30, 33, 40 AND 50).

FIRST USE 7-1-2009; IN COMMERCE 7-1-2009.

**CLASS 25—CLOTHING**

FOR ATHLETIC APPAREL, NAMELY, SHIRTS, PANTS, JACKETS, FOOTWEAR, HATS AND CAPS, ATHLETIC UNIFORMS; HOODED SWEAT SHIRTS; SOCKS; SWEAT SHIRTS; T-SHIRTS (U.S. CLS. 22 AND 39).

FIRST USE 9-1-2010; IN COMMERCE 9-1-2010.

**CLASS 41—EDUCATION AND ENTERTAINMENT**

FOR PERSONAL FITNESS TRAINING SERVICES AND CONSULTANCY; PERSONAL FITNESS TRAINING SERVICES FEATURING AEROBIC AND ANAEROBIC ACTIVITIES COMBINED WITH RESISTANCE AND FLEXIBILITY TRAINING; PHYSICAL FITNESS CONDITIONING CLASSES; PHYSICAL FITNESS INSTRUCTION; PHYSICAL FITNESS STUDIO SERVICES, NAMELY, PROVIDING EXERCISE CLASSES, BODY SCULPTING CLASSES, AND GROUP FITNESS CLASSES; PHYSICAL FITNESS STUDIO SERVICES, NAMELY, PROVIDING GROUP EXERCISE INSTRUCTION, EQUIPMENT, AND FACILITIES; PHYSICAL FITNESS TRAINING OF INDIVIDUALS AND GROUPS; PHYSICAL FITNESS TRAINING SERVICES; PROVIDING ASSISTANCE, PERSONAL TRAINING AND PHYSICAL FITNESS CONSULTATION TO INDIVIDUALS TO HELP THEM MAKE PHYSICAL FITNESS, STRENGTH, CONDITIONING, AND EXERCISE IMPROVEMENT IN THEIR DAILY LIVING; PROVIDING FITNESS AND EXERCISE FACILITIES; PROVIDING FITNESS AND EXERCISE STUDIO SERVICES, NAMELY, PILATES INSTRUCTION AND TRAINING (U.S. CLS. 100, 101 AND 107).

FIRST USE 7-1-2009; IN COMMERCE 7-1-2009.

BILL DAWE, EXAMINING ATTORNEY

SN 85-134,191. NIAGARA UNIVERSITY, NIAGARA UNIVERSITY, NY. FILED 9-21-2010.



THE MARK CONSISTS OF A DRAWING OF A PINEAPPLE.

**CLASS 9—ELECTRICAL AND SCIENTIFIC APPARATUS**

FOR DOWNLOADABLE ELECTRONIC JOURNALS VIA THE INTERNET IN THE FIELD OF HOSPITALITY AND HOTEL SERVICES (U.S. CLS. 21, 23, 26, 36 AND 38).  
FIRST USE 12-31-1999; IN COMMERCE 12-31-1999.

**CLASS 16—PAPER GOODS AND PRINTED MATTER**

FOR PRINTED PUBLICATIONS, NAMELY, JOURNALS IN THE FIELD OF HOSPITALITY AND HOTEL SERVICES (U.S. CLS. 2, 5, 22, 23, 29, 37, 38 AND 50).

FIRST USE 8-31-1996; IN COMMERCE 8-31-1996.  
LINDA MICKLEBURGH, EXAMINING ATTORNEY

SN 85-134,923. SEABRIGHT HOLDINGS, INC., SEATTLE, WA. FILED 9-21-2010.



SN 85-134,887. SEABRIGHT HOLDINGS, INC., SEATTLE, WA. FILED 9-21-2010.



NO CLAIM IS MADE TO THE EXCLUSIVE RIGHT TO USE "MANAGED CARE SERVICES", APART FROM THE MARK AS SHOWN.

THE COLOR(S) BLUE AND GOLD IS/ARE CLAIMED AS A FEATURE OF THE MARK.

THE MARK CONSISTS OF THE LITERAL ELEMENT "PALADIN MANAGED CARE SERVICES THE RIGHT MOVE" REPRESENTED IN A STYLIZED FONT WHERE THE WORD "PALADIN" APPEARS IN UPPERCASE LETTERS AND IS LOCATED OVER THE WORDS "MANAGED CARE SERVICES" WHICH APPEAR IN BLUE AND IN TITLE CASE AND WHEREIN THERE IS A STRAIGHT LINE IN GOLD EQUALLY SPACED BETWEEN THE UPPER AND LOWER SET OF WORDS, SPECIFICALLY UNDER "PALADIN" AND OVER "MANAGED CARE SERVICES". THE WORDS "THE RIGHT MOVE" APPEAR IN GOLD, LOWER-CASE, ITALICIZED FONT, CENTERED BENEATH THE WORDS "MANAGED CARE SERVICES". A GOLD COLOR KNIGHT CHESS PIECE OR HORSE HEAD APPEARS ABOVE THE GOLD COLOR "I" IN "PALADIN". ALL OTHER LETTERS IN "PALADIN" ARE IN BLUE.

NO CLAIM IS MADE TO THE EXCLUSIVE RIGHT TO USE "MANAGED CARE SERVICES", APART FROM THE MARK AS SHOWN.

THE COLOR(S) BLUE AND GOLD IS/ARE CLAIMED AS A FEATURE OF THE MARK.

THE MARK CONSISTS OF THE LITERAL ELEMENT "PALADIN MANAGED CARE SERVICES" REPRESENTED IN A STYLIZED FONT WHERE THE WORD "PALADIN" APPEARS IN UPPERCASE LETTERS AND IS LOCATED OVER THE WORDS "MANAGED CARE SERVICES" WHICH APPEAR IN TITLE CASE AND WHEREIN THERE IS A STRAIGHT LINE IN GOLD EQUALLY SPACED BETWEEN THE UPPER AND LOWER SET OF WORDS, SPECIFICALLY UNDER "PALADIN" AND OVER "MANAGED CARE SERVICES". A GOLD COLOR KNIGHT CHESS PIECE OR HORSE HEAD APPEARS ABOVE THE GOLD COLOR "I" IN "PALADIN". ALL OTHER LETTERS ARE IN BLUE.

**CLASS 35—ADVERTISING AND BUSINESS**

FOR MANAGEMENT AND BUSINESS CONSULTING SERVICES IN THE FIELD OF MANAGED CARE SERVICES, NAMELY, MEDICAL BILL REVIEW FOR WORKERS' COMPENSATION, LIABILITY AND GROUP HEALTH INSURANCE MEDICAL CLAIMS, CASE MANAGEMENT, UTILIZATION REVIEW, AND RETURN TO WORK SERVICES IN THE NATURE OF PLACING AND MONITORING RECOVERING EMPLOYEES IN TEMPORARY OR VOLUNTEER TRANSITIONAL DUTY POSITIONS TO ASSIST WORKERS NOT FULLY RECOVERED FROM WORK-RELATED ILLNESS AND/OR INJURY IN TRANSITIONING BACK INTO THE EMPLOYER'S WORKFORCE (U.S. CLS. 100, 101 AND 102).

**CLASS 35—ADVERTISING AND BUSINESS**

FOR MANAGEMENT AND BUSINESS CONSULTING SERVICES IN THE FIELD OF MANAGED CARE SERVICES, NAMELY, MEDICAL BILL REVIEW FOR WORKERS' COMPENSATION, LIABILITY AND GROUP HEALTH INSURANCE MEDICAL CLAIMS, CASE MANAGEMENT, UTILIZATION REVIEW, AND RETURN TO WORK SERVICES IN THE NATURE OF PLACING AND MONITORING RECOVERING EMPLOYEES IN TEMPORARY OR VOLUNTEER TRANSITIONAL DUTY POSITIONS TO ASSIST WORKERS NOT FULLY RECOVERED FROM WORK-RELATED ILLNESS AND/OR INJURY IN TRANSITIONING BACK INTO THE EMPLOYER'S WORKFORCE (U.S. CLS. 100, 101 AND 102).

**CLASS 36—INSURANCE AND FINANCIAL**

FOR MEDICAL INSURANCE CASE AND UTILIZATION REVIEW AND INSURANCE CLAIMS ADJUSTMENT SERVICES FOR HEALTHCARE PURCHASERS AND PAYORS AND PROVIDERS AND MEDICARE BENEFICIARIES (U.S. CLS. 100, 101 AND 102).

KELLY BOULTON, EXAMINING ATTORNEY

SN 85-135,265. HELIAS DOUNDOULAKIS, FREEPORT, NY. FILED 9-22-2010.

**CLASS 36—INSURANCE AND FINANCIAL**

FOR MEDICAL INSURANCE CASE AND UTILIZATION REVIEW AND INSURANCE CLAIMS ADJUSTMENT SERVICES FOR HEALTHCARE PURCHASERS AND PAYORS AND PROVIDERS AND MEDICARE BENEFICIARIES (U.S. CLS. 100, 101 AND 102).

KELLY BOULTON, EXAMINING ATTORNEY

**I WAS TRAINED TO BE A SPY**

THE MARK CONSISTS OF STANDARD CHARACTERS WITHOUT CLAIM TO ANY PARTICULAR FONT, STYLE, SIZE, OR COLOR.



**CLASS 9—ELECTRICAL AND SCIENTIFIC APPARATUS**

FOR PRE-RECORDED AUDIO CASSETTES, TAPES, CDS, CD-ROMS AND DVDS FEATURING DOCUMENTARIES ABOUT ESPIONAGE AND WORLD WAR 2; PRE-RECORDED VIDEO CASSETTES FEATURING DOCUMENTARIES ABOUT ESPIONAGE AND WORLD WAR 2; ELECTRONIC PUBLICATIONS, NAMELY, LEAFLETS, NEWSLETTERS, AND MAGAZINES FEATURING ESPIONAGE AND ACCOUNTS OF WORLD WAR 2 RECORDED ON COMPUTER MEDIA (U.S. CLS. 21, 23, 26, 36 AND 38).

**CLASS 16—PAPER GOODS AND PRINTED MATTER**

FOR PRINTED MATTER, NAMELY, LEAFLETS, NEWSLETTERS, AND MAGAZINES FEATURING DRAMATIZATIONS OF ESPIONAGE AND ACCOUNTS FROM WORLD WAR 2; PRINTED PUBLICATIONS, NAMELY, LEAFLETS, NEWSLETTERS, AND MAGAZINES FEATURING DRAMATIZATIONS OF ESPIONAGE AND ACCOUNTS FROM WORLD WAR 2; BOOKMARKS; PHOTOGRAPHS; STATIONERY; WRITING IMPLEMENTS; BOOKS FEATURING DRAMATIZATIONS OF ESPIONAGE AND ACCOUNTS FROM WORLD WAR 2; POSTERS; STICKERS; DECALCOMANIAS; IRON-ON AND PLASTIC TRANSFERS; CALENDARS; PRINTED INSTRUCTIONAL AND TEACHING MATERIALS ON ESPIONAGE AND DETAILED ACCOUNTS FROM WORLD WAR 2 (U.S. CLS. 2, 5, 22, 23, 29, 37, 38 AND 50).

**CLASS 41—EDUCATION AND ENTERTAINMENT**

FOR ENTERTAINMENT IN THE NATURE OF AN ONGOING TELEVISION DOCUMENTARY SERIES ABOUT ESPIONAGE AND ACCOUNTS FROM WORLD WAR 2; A SERIES OF LIVE THEATRICAL PERFORMANCES BROADCAST ON TELEVISION ABOUT THE ESPIONAGE AND ACCOUNTS FROM WORLD WAR 2; PRESENTATION OF AN ONGOING SERIES OF THEATRICAL DRAMA PERFORMANCES IN THE NATURE OF DOCUMENTARIES BROADCAST ON TELEVISION; LIVE PERFORMANCES OF THEATRICAL DOCUMENTARY PERFORMANCES ABOUT ESPIONAGE AND ACCOUNTS FROM WORLD WAR 2; PRODUCTION OF TELEVISION AND THEATRICAL DOCUMENTARY SERIES ABOUT ESPIONAGE AND ACCOUNTS FROM WORLD WAR 2; PROVIDING ONLINE HISTORICAL INFORMATION ABOUT ESPIONAGE AND ACCOUNTS FROM WORLD WAR 2 (U.S. CLS. 100, 101 AND 107).  
PAULA MAHONEY, EXAMINING ATTORNEY

SN 85-135,993. CHEVRON INTELLECTUAL PROPERTY LLC, SAN RAMON, CA. FILED 9-22-2010.

# DEEPSTAR

THE MARK CONSISTS OF STANDARD CHARACTERS WITHOUT CLAIM TO ANY PARTICULAR FONT, STYLE, SIZE, OR COLOR.

**CLASS 35—ADVERTISING AND BUSINESS**

FOR BUSINESS MANAGEMENT RELATED TO THE FIELD OF DEEPWATER TECHNOLOGY (U.S. CLS. 100, 101 AND 102).  
FIRST USE 12-22-1992; IN COMMERCE 12-22-1992.

**CLASS 42—SCIENTIFIC AND COMPUTER SERVICES**

FOR DEVELOPMENT OF DEEPWATER TECHNOLOGY (U.S. CLS. 100 AND 101).  
FIRST USE 12-22-1992; IN COMMERCE 12-22-1992.  
ANDREA HACK, EXAMINING ATTORNEY

SN 85-137,002. RF SURGICAL SYSTEMS, INC., BELLEVUE, WA. FILED 9-23-2010.

# RF ASSURE

THE MARK CONSISTS OF STANDARD CHARACTERS WITHOUT CLAIM TO ANY PARTICULAR FONT, STYLE, SIZE, OR COLOR.  
OWNER OF U.S. REG. NOS. 3,568,103, 3,884,751 AND OTHERS.  
NO CLAIM IS MADE TO THE EXCLUSIVE RIGHT TO USE "RF", APART FROM THE MARK AS SHOWN.

**CLASS 5—PHARMACEUTICALS**

FOR MEDICAL DISPOSABLE GOODS, NAMELY, SANITARY TOWELS AND GAUZE (U.S. CLS. 6, 18, 44, 46, 51 AND 52).

**CLASS 9—ELECTRICAL AND SCIENTIFIC APPARATUS**

FOR ELECTRONIC DEVICES AND ACCESSORIES, NAMELY, A HANDHELD WAND, A MAT, AND A CONSOLE POWER CONTROLLER, SOLD AS A UNIT, FOR DETECTING TAGGED MEDICAL DISPOSABLE GOODS AND GENERATING AN AUDIBLE SIGNAL WHEN SUCH GOODS ARE DETECTED, AND THE INDIVIDUAL COMPONENTS, NAMELY, HANDHELD WAND, ELECTRONIC MAT, AND A CONSOLE POWER CONTROLLER, AS REPLACEMENT PART (U.S. CLS. 21, 23, 26, 36 AND 38).  
CURTIS FRENCH, EXAMINING ATTORNEY

SN 85-137,448. EVIDON, INC., NEW YORK, NY. FILED 9-24-2010.

# EVIDON

THE MARK CONSISTS OF STANDARD CHARACTERS WITHOUT CLAIM TO ANY PARTICULAR FONT, STYLE, SIZE, OR COLOR.

**CLASS 9—ELECTRICAL AND SCIENTIFIC APPARATUS**

FOR SOFTWARE APPLICATION THAT GATHERS AND REPORTS INFORMATION CONCERNING ONLINE DATA COLLECTION AND USAGE PRACTICES AND PROVIDES INTERNET USERS WITH THE ABILITY TO VIEW, MANAGE AND BLOCK THE TRACKING SETTINGS, WEB BUGS, WIDGETS AND ADVERTISING SERVICES ASSOCIATED WITH WEBSITES VISITED; SOFTWARE APPLICATION FOR USE IN MANAGING ADVERTISING CAMPAIGNS; SOFTWARE FOR USE IN VERIFYING LEGAL COMPLIANCE WITH ONLINE ADVERTISING GUIDELINES; SOFTWARE FOR USE IN MANAGING ONLINE CONSUMER PRIVACY ISSUES (U.S. CLS. 21, 23, 26, 36 AND 38).

**CLASS 35—ADVERTISING AND BUSINESS**

FOR ADVERTISING SERVICES, NAMELY, MANAGING ADVERTISING CAMPAIGNS; BUSINESS CONSULTATION SERVICES, NAMELY, TRACKING AND VERIFYING COMPLIANCE WITH ONLINE ADVERTISING GUIDELINES; BUSINESS CONSULTATION SERVICES IN THE FIELD OF ONLINE CONSUMER PRIVACY ISSUES; PROVIDING INFORMATION REGARDING ONLINE ADVERTISING DATA COLLECTION, USE AND SHARING PRACTICES; PROVIDING INFORMATION REGARDING ONLINE ADVERTISEMENTS, NAMELY, INFORMATION ABOUT THE DATA COLLECTION, USE AND SHARING PRACTICES OF PUBLISHERS, ADVERTISERS, ADVERTISING AGENCIES, AD NETWORKS, DEMAND SIDE PLATFORMS, DATA AGGREGATORS OR OTHER ENTITIES THAT HAVE DELIVERED OR COLLABORATED TO DELIVER, AN ONLINE ADVERTISEMENT BASED ON THE RECIPIENT'S ONLINE BEHAVIOR AND DEMONSTRATED INTEREST (U.S. CLS. 100, 101 AND 102).

**CLASS 42—SCIENTIFIC AND COMPUTER SERVICES**

FOR PROVIDING TEMPORARY USE OF ONLINE NON-DOWNLOADABLE SOFTWARE FOR ONLINE PUBLISHERS TO MONITOR THIRD PARTY DATA COLLECTION AND AD PLACEMENT AND ENSURE COMPLIANCE WITH INDUSTRY GUIDELINES; COMPUTER SERVICES, NAMELY, ACTING AS AN APPLICATION SERVICE PROVIDER TO HOST COMPUTER SOFTWARE FOR THE COLLECTION, USE AND SHARING OF DATA GATHERED IN THE COURSE OF E-COMMERCE TRANSACTIONS, INTERNET WEBSITE USAGE AND ELECTRONIC MAIL USAGE (U.S. CLS. 100 AND 101).

LINDA E. BLOHM, EXAMINING ATTORNEY

SN 85-138,781. ANNE AND MONIQUE APPAREL, LLC, NEW YORK, NY. FILED 9-27-2010.

# MOTT 50

THE MARK CONSISTS OF STANDARD CHARACTERS WITHOUT CLAIM TO ANY PARTICULAR FONT, STYLE, SIZE, OR COLOR.

**CLASS 18—LEATHER GOODS**

FOR HANDBAGS (U.S. CLS. 1, 2, 3, 22 AND 41).

**CLASS 25—CLOTHING**

FOR HATS; CLOTHING, NAMELY, SHIRTS, TUNICS, DRESSES, SKIRTS, PANTS, JACKETS (U.S. CLS. 22 AND 39).

WON TEAK OH, EXAMINING ATTORNEY

SN 85-140,429. BUDDHIST CHURCHES OF AMERICA, AKA BCA, SAN FRANCISCO, CA. FILED 9-28-2010.

## BUDDHIST CHURCHES OF AMERICA

THE MARK CONSISTS OF STANDARD CHARACTERS WITHOUT CLAIM TO ANY PARTICULAR FONT, STYLE, SIZE, OR COLOR.

NO CLAIM IS MADE TO THE EXCLUSIVE RIGHT TO USE "CHURCHES" AS TO CLASS 45, APART FROM THE MARK AS SHOWN.

SEC. 2(F).

**CLASS 16—PAPER GOODS AND PRINTED MATTER**

FOR EDUCATIONAL PUBLICATIONS, NAMELY, NEWSLETTERS, HAND-OUTS, WORKBOOKS, STATIONERY, PRINTED TEACHING MATERIALS, AND BOOKS RELATING TO THE STUDY OF BUDDHISM (U.S. CLS. 2, 5, 22, 23, 29, 37, 38 AND 50).

FIRST USE 0-0-1945; IN COMMERCE 0-0-1945.

**CLASS 41—EDUCATION AND ENTERTAINMENT**

FOR PROVIDING RELIGIOUS INSTRUCTION, TRAINING, AND EDUCATIONAL SERVICES IN THE NATURE OF SEMINARS AND CONFERENCES ABOUT BUDDHISM (U.S. CLS. 100, 101 AND 107).

FIRST USE 0-0-1945; IN COMMERCE 0-0-1945.

**CLASS 45—PERSONAL AND LEGAL SERVICES**

FOR MINISTERIAL SERVICES, AND RELIGIOUS SERVICES, NAMELY, PROVIDING GATHERINGS, AND RETREATS, BOTH CLERGY AND LAY, TO DEVELOP AND ENHANCE THE SPIRITUAL LIVES OF INDIVIDUALS, CONDUCTING CHANTING AND INCENSE OFFERING, MARRIAGE CEREMONIES, BABY DEDICATIONS, BEREAVEMENT CEREMONIES, FUNERALS, PROVIDING A WEB SITE FEATURING INFORMATION ABOUT BUDDHISM, AND PROVIDING INFORMATION ABOUT BUDDHISM (U.S. CLS. 100 AND 101).

FIRST USE 0-0-1945; IN COMMERCE 0-0-1945.

GINA FINK, EXAMINING ATTORNEY

SN 85-140,675. ALI INDUSTRIES, INC., FAIRBORN, OH. FILED 9-29-2010.



THE MARK CONSISTS OF THE LETTER "G" WITH THE NUMBER "2" SUPERPOSED POSITION ADJACENT THERETO IN A DIAMOND BACKGROUND.

**CLASS 3—COSMETICS AND CLEANING PREPARATIONS**

FOR ABRASIVE PRODUCTS FOR SANDING, NAMELY, COATED ABRASIVES AND SANDPAPER IN THE FORM OF SANDING STRIPS, SHEETS, BELTS, SPINDLES, AND DISCS, EMERY CLOTHS, AND SANDING SCREENS IN THE NATURE OF ABRASIVE CLOTH (U.S. CLS. 1, 4, 6, 50, 51 AND 52).

FIRST USE 8-1-2010; IN COMMERCE 8-1-2010.

**CLASS 7—MACHINERY**

FOR SANDING PADS FOR POWER-OPERATED SANDERS; KITS COMPRISED OF SANDPAPER SHEETS CONFIGURED IN DIFFERENT SIZES TO FIT POWER-OPERATED SANDERS (U.S. CLS. 13, 19, 21, 23, 31, 34 AND 35).

FIRST USE 8-1-2010; IN COMMERCE 8-5-2010.  
EMILY CHUO, EXAMINING ATTORNEY

OWNER OF U.S. REG. NO. 3,698,721.

NO CLAIM IS MADE TO THE EXCLUSIVE RIGHT TO USE "INSTITUTE", APART FROM THE MARK AS SHOWN. SEC. 2(F).

**CLASS 9—ELECTRICAL AND SCIENTIFIC APPARATUS**

FOR DOWNLOADABLE ELECTRONIC PUBLICATIONS IN THE NATURE OF PERIODICALS IN THE FIELD OF INVESTOR RELATIONS; DOWNLOADABLE E-MAIL NEWSLETTERS AND ALERTS IN THE FIELD OF INVESTOR RELATIONS; AND DOWNLOADABLE WEBINARS IN THE FIELD OF INVESTOR RELATIONS (U.S. CLS. 21, 23, 26, 36 AND 38).

FIRST USE 9-1-1995; IN COMMERCE 9-1-1995.

SN 85-141,796. SALFEN, GLEN, KEAAU, HI. FILED 9-30-2010.



NO CLAIM IS MADE TO THE EXCLUSIVE RIGHT TO USE "PUNA", APART FROM THE MARK AS SHOWN.

THE MARK CONSISTS OF A BEAR CLAW IN THE SHAPE OF AN ISLAND. BELOW THERE IS THE STYLIZED TEXT "PUNA BEAR".

**CLASS 25—CLOTHING**

FOR HATS; PANTS; SHIRTS; SHORTS; SKIRTS; SWEAT SHIRTS; TANK TOPS (U.S. CLS. 22 AND 39).

FIRST USE 9-1-2010; IN COMMERCE 9-1-2010.

**CLASS 28—TOYS AND SPORTING GOODS**

FOR SURFBOARDS (U.S. CLS. 22, 23, 38 AND 50).

FIRST USE 9-1-2010; IN COMMERCE 9-1-2010.

MICHAEL WEBSTER, EXAMINING ATTORNEY

SN 85-141,844. NATIONAL INVESTOR RELATIONS INSTITUTE, VIENNA, VA. FILED 9-30-2010.

**NATIONAL INVESTOR  
RELATIONS INSTITUTE**

THE MARK CONSISTS OF STANDARD CHARACTERS WITHOUT CLAIM TO ANY PARTICULAR FONT, STYLE, SIZE, OR COLOR.

**CLASS 35—ADVERTISING AND BUSINESS**

FOR LOBBYING SERVICES, NAMELY, PROMOTING THE INTERESTS OF CORPORATE OFFICERS AND INVESTOR RELATIONS CONSULTANTS IN THE FIELDS OF LEGISLATION AND REGULATION; PUBLIC ADVOCACY TO PROMOTE AWARENESS OF THE FIELD OF INVESTOR RELATIONS; PROVIDING AN ON-LINE SEARCHABLE DATABASE FEATURING EMPLOYMENT OPPORTUNITIES THAT ENABLES USERS TO SEARCH AND POST JOBS AND RESUMES RELEVANT TO THE FIELD OF INVESTOR RELATIONS; ONLINE RETAIL STORE SERVICES FEATURING GOODS OF INTEREST TO CORPORATE OFFICERS AND INVESTOR RELATIONS CONSULTANTS RESPONSIBLE FOR COMMUNICATION AMONG CORPORATE MANAGEMENT, THE INVESTING PUBLIC AND THE FINANCIAL COMMUNITY, NAMELY, WRITTEN MATERIALS AND PUBLICATIONS; AND PROVIDING BUSINESS INFORMATION IN THE FIELD OF INVESTOR RELATIONS (U.S. CLS. 100, 101 AND 102).

FIRST USE 11-5-1969; IN COMMERCE 11-5-1969.

**CLASS 41—EDUCATION AND ENTERTAINMENT**

FOR EDUCATIONAL SERVICES, NAMELY, CONTINUING PROFESSIONAL EDUCATION COURSES, PROVIDING COURSES OF INSTRUCTION, SEMINARS, AND LIVE WEBINARS IN THE FIELD OF INVESTOR RELATIONS, AND DISTRIBUTION OF PRINTED MATERIALS IN CONNECTION THEREWITH IN HARD COPY OR ELECTRONIC FORMAT ON THE SAME TOPICS; AND ARRANGING AND CONDUCTING EDUCATIONAL CONFERENCES IN THE FIELD OF INVESTOR RELATIONS (U.S. CLS. 100, 101 AND 107).

FIRST USE 11-5-1969; IN COMMERCE 11-5-1969.

**CLASS 42—SCIENTIFIC AND COMPUTER SERVICES**

FOR COMPUTER SERVICES, NAMELY, CREATING AN ON-LINE COMMUNITY FOR REGISTERED USERS TO PARTICIPATE IN DISCUSSIONS, GET FEEDBACK FROM THEIR PEERS, FORM VIRTUAL COMMUNITIES, AND ENGAGE IN SOCIAL NETWORKING IN THE FIELD OF INVESTOR RELATIONS (U.S. CLS. 100 AND 101).

FIRST USE 9-1-1995; IN COMMERCE 9-1-1995.  
GENE MACIOL, EXAMINING ATTORNEY

SN 85-141,903. NATIONAL INVESTOR RELATIONS INSTITUTE, VIENNA, VA. FILED 9-30-2010.

SN 85-141,929. NATIONAL INVESTOR RELATIONS INSTITUTE, VIENNA, VA. FILED 9-30-2010.

**NIRI**

THE MARK CONSISTS OF STANDARD CHARACTERS WITHOUT CLAIM TO ANY PARTICULAR FONT, STYLE, SIZE, OR COLOR.

OWNER OF U.S. REG. NOS. 2,255,381, 3,698,718 AND 3,698,720.

**CLASS 9—ELECTRICAL AND SCIENTIFIC APPARATUS**

FOR DOWNLOADABLE ELECTRONIC PUBLICATIONS IN THE NATURE OF PERIODICALS IN THE FIELD OF INVESTOR RELATIONS; DOWNLOADABLE E-MAIL NEWSLETTERS AND ALERTS IN THE FIELD OF INVESTOR RELATIONS; AND DOWNLOADABLE WEBINARS IN THE FIELD OF INVESTOR RELATIONS (U.S. CLS. 21, 23, 26, 36 AND 38).

FIRST USE 9-1-1995; IN COMMERCE 9-1-1995.

**CLASS 35—ADVERTISING AND BUSINESS**

FOR LOBBYING SERVICES, NAMELY, PROMOTING THE INTERESTS OF CORPORATE OFFICERS AND INVESTOR RELATIONS CONSULTANTS IN THE FIELDS OF LEGISLATION AND REGULATION; PUBLIC ADVOCACY TO PROMOTE AWARENESS OF THE FIELD OF INVESTOR RELATIONS; PROVIDING AN ON-LINE SEARCHABLE DATABASE FEATURING EMPLOYMENT OPPORTUNITIES THAT ENABLES USERS TO SEARCH AND POST JOBS AND RESUMES RELEVANT TO THE FIELD OF INVESTOR RELATIONS; ONLINE RETAIL STORE SERVICES FEATURING GOODS OF INTEREST TO CORPORATE OFFICERS AND INVESTOR RELATIONS CONSULTANTS RESPONSIBLE FOR COMMUNICATION AMONG CORPORATE MANAGEMENT, THE INVESTING PUBLIC AND THE FINANCIAL COMMUNITY, NAMELY, WRITTEN MATERIALS AND PUBLICATIONS; AND PROVIDING BUSINESS INFORMATION IN THE FIELD OF INVESTOR RELATIONS (U.S. CLS. 100, 101 AND 102).

FIRST USE 11-5-1969; IN COMMERCE 11-5-1969.

**CLASS 41—EDUCATION AND ENTERTAINMENT**

FOR EDUCATIONAL SERVICES, NAMELY, CONTINUING PROFESSIONAL EDUCATION COURSES, PROVIDING COURSES OF INSTRUCTION, SEMINARS, AND LIVE WEBINARS IN THE FIELD OF INVESTOR RELATIONS, AND DISTRIBUTION OF PRINTED MATERIALS IN CONNECTION THEREWITH IN HARD COPY OR ELECTRONIC FORMAT ON THE SAME TOPICS; AND ARRANGING AND CONDUCTING EDUCATIONAL CONFERENCES IN THE FIELD OF INVESTOR RELATIONS (U.S. CLS. 100, 101 AND 107).

FIRST USE 11-5-1969; IN COMMERCE 11-5-1969.

**CLASS 42—SCIENTIFIC AND COMPUTER SERVICES**

FOR COMPUTER SERVICES, NAMELY, CREATING AN ON-LINE COMMUNITY FOR REGISTERED USERS TO PARTICIPATE IN DISCUSSIONS, GET FEEDBACK FROM THEIR PEERS, FORM VIRTUAL COMMUNITIES, AND ENGAGE IN SOCIAL NETWORKING IN THE FIELD OF INVESTOR RELATIONS (U.S. CLS. 100 AND 101).

FIRST USE 9-1-1995; IN COMMERCE 9-1-1995.  
GENE MACIOL, EXAMINING ATTORNEY



OWNER OF U.S. REG. NOS. 2,255,381, 3,698,718 AND 3,698,720.

THE MARK CONSISTS OF THE WORD "NIRI" WITHIN A SQUARE.

**CLASS 9—ELECTRICAL AND SCIENTIFIC APPARATUS**

FOR DOWNLOADABLE ELECTRONIC PUBLICATIONS IN THE NATURE OF PERIODICALS IN THE FIELD OF INVESTOR RELATIONS; DOWNLOADABLE E-MAIL NEWSLETTERS AND ALERTS IN THE FIELD OF INVESTOR RELATIONS; AND DOWNLOADABLE WEBINARS IN THE FIELD OF INVESTOR RELATIONS (U.S. CLS. 21, 23, 26, 36 AND 38).

FIRST USE 9-1-1995; IN COMMERCE 9-1-1995.

**CLASS 35—ADVERTISING AND BUSINESS**

FOR LOBBYING SERVICES, NAMELY, PROMOTING THE INTERESTS OF CORPORATE OFFICERS AND INVESTOR RELATIONS CONSULTANTS IN THE FIELDS OF LEGISLATION AND REGULATION; PUBLIC ADVOCACY TO PROMOTE AWARENESS OF THE FIELD OF INVESTOR RELATIONS; PROVIDING AN ON-LINE SEARCHABLE DATABASE FEATURING EMPLOYMENT OPPORTUNITIES THAT ENABLES USERS TO SEARCH AND POST JOBS AND RESUMES RELEVANT TO THE FIELD OF INVESTOR RELATIONS; ONLINE RETAIL STORE SERVICES FEATURING GOODS OF INTEREST TO CORPORATE OFFICERS AND INVESTOR RELATIONS CONSULTANTS RESPONSIBLE FOR COMMUNICATION AMONG CORPORATE MANAGEMENT, THE INVESTING PUBLIC AND THE FINANCIAL COMMUNITY, NAMELY, WRITTEN MATERIALS AND PUBLICATIONS; AND PROVIDING BUSINESS INFORMATION IN THE FIELD OF INVESTOR RELATIONS (U.S. CLS. 100, 101 AND 102).

FIRST USE 11-5-1969; IN COMMERCE 11-5-1969.

**CLASS 41—EDUCATION AND ENTERTAINMENT**

FOR EDUCATIONAL SERVICES, NAMELY, CONTINUING PROFESSIONAL EDUCATION COURSES, PROVIDING COURSES OF INSTRUCTION, SEMINARS, AND LIVE WEBINARS IN THE FIELD OF INVESTOR RELATIONS, AND DISTRIBUTION OF PRINTED MATERIALS IN CONNECTION THEREWITH IN HARD COPY OR ELECTRONIC FORMAT ON THE SAME TOPICS; AND ARRANGING AND CONDUCTING EDUCATIONAL CONFERENCES IN THE FIELD OF INVESTOR RELATIONS (U.S. CLS. 100, 101 AND 107).

FIRST USE 11-5-1969; IN COMMERCE 11-5-1969.



**CLASS 42—SCIENTIFIC AND COMPUTER SERVICES**

FOR COMPUTER SERVICES, NAMELY, CREATING AN ON-LINE COMMUNITY FOR REGISTERED USERS TO PARTICIPATE IN DISCUSSIONS, GET FEEDBACK FROM THEIR PEERS, FORM VIRTUAL COMMUNITIES, AND ENGAGE IN SOCIAL NETWORKING IN THE FIELD OF INVESTOR RELATIONS (U.S. CLS. 100 AND 101).

FIRST USE 9-1-1995; IN COMMERCE 9-1-1995.  
GENE MACIOL, EXAMINING ATTORNEY

SN 85-145,295. GOLF GALAXY GOLFWORKS, INC., NEWARK, OH. FILED 10-5-2010.



OWNER OF U.S. REG. NOS. 3,135,752, 3,581,838 AND OTHERS.

THE MARK CONSISTS OF A STYLIZED LETTER "M" IN A CIRCLE TO THE LEFT OF THE WORDING "MALTBY PLAY BETTER GOLF" IN STYLIZED LETTERING.

**CLASS 35—ADVERTISING AND BUSINESS**

FOR RETAIL STORE SERVICES, MAIL ORDER CATALOG SERVICES, COMPUTERIZED ON-LINE RETAIL STORE SERVICES, AND TELEPHONE SHOP AT HOME SERVICES, ALL FEATURING GOLF CLUBS AND COMPONENTS THEREOF, GOLF BALLS, GOLF BAGS, GOLF GLOVES, GOLF EQUIPMENT, GOLF CLUB ASSEMBLY KITS, GAUGES FOR USE IN THE MANUFACTURE AND REPAIR OF GOLF CLUBS, HAND TOOLS, MACHINES AND HARDWARE FOR USE IN THE MANUFACTURE AND REPAIR OF GOLF CLUBS, GOLF TRAINING AIDS, GOLF TOWELS, SHOE TREES, BOOKS AND PRE-RECORDED VIDEO TAPES IN THE FIELD OF GOLF, GOLF CLUBS AND GOLF CLUB MAKING (U.S. CLS. 100, 101 AND 102).

FIRST USE 9-0-2010; IN COMMERCE 9-0-2010.

**CLASS 41—EDUCATION AND ENTERTAINMENT**

FOR EDUCATIONAL SERVICES, NAMELY, PROVIDING WORKSHOPS, ON-LINE TRAINING COURSES AND HOME STUDY COURSES ON THE FITTING, ASSEMBLY AND REPAIR OF GOLF CLUBS (U.S. CLS. 100, 101 AND 107).

FIRST USE 9-0-2010; IN COMMERCE 9-0-2010.  
JILL C. ALT, EXAMINING ATTORNEY

SN 85-145,829. SMARTERCOMICS, LLC, SANTA CLARA, CA. FILED 10-5-2010.

**SmarterComics**

THE MARK CONSISTS OF STANDARD CHARACTERS WITHOUT CLAIM TO ANY PARTICULAR FONT, STYLE, SIZE, OR COLOR.

**CLASS 16—PAPER GOODS AND PRINTED MATTER**

FOR COMIC BOOKS (U.S. CLS. 2, 5, 22, 23, 29, 37, 38 AND 50).

FIRST USE 7-1-2010; IN COMMERCE 7-1-2010.

**CLASS 41—EDUCATION AND ENTERTAINMENT**

FOR PUBLISHING OF BOOKS AND E-BOOKS, NAMELY, COMICS BOOKS; ONLINE ELECTRONIC PUBLISHING OF COMIC BOOKS (U.S. CLS. 100, 101 AND 107).

FIRST USE 1-31-2010; IN COMMERCE 1-31-2010.  
JAMES A. RAUEN, EXAMINING ATTORNEY

SN 85-146,066. CONSECRA CORPORATION, AKA CONSECRA HOUSING NETWORK, OAK BROOK, IL. FILED 10-6-2010.

**CONSECRA**

THE MARK CONSISTS OF STANDARD CHARACTERS WITHOUT CLAIM TO ANY PARTICULAR FONT, STYLE, SIZE, OR COLOR.

**CLASS 35—ADVERTISING AND BUSINESS**

FOR PUBLIC ADVOCACY TO PROMOTE AWARENESS OF AFFORDABLE HOUSING ISSUES AS RELATED TO THE SENIORS, THE PHYSICALLY AND MENTALLY DISABLED, AND FAMILIES; CHARITABLE SERVICES, NAMELY, THE COORDINATION OF NON-MONETARY CONTRIBUTIONS TO CHARITIES AND NON-PROFITS WHO SUPPORT AFFORDABLE HOUSING; GOVERNMENT AND COMMUNITY RELATIONS IN THE FIELDS OF LEGISLATION AND REGULATION PROMOTING THE INTERESTS OF PERSONS NEEDING AFFORDABLE HOUSING (U.S. CLS. 100, 101 AND 102).

**CLASS 36—INSURANCE AND FINANCIAL**

FOR HOUSING AND PROPERTY MANAGEMENT SERVICES, NAMELY, RENTAL PROPERTY MANAGEMENT AND PROPERTY MANAGEMENT SERVICES FOR CONDOMINIUM ASSOCIATIONS, HOMEOWNER ASSOCIATIONS AND APARTMENT BUILDINGS; HOUSING AND PROPERTY FINANCING SERVICES (U.S. CLS. 100, 101 AND 102).

**CLASS 37—CONSTRUCTION AND REPAIR**

FOR HOUSING AND PROPERTY DEVELOPMENT SERVICES, NAMELY, DEVELOPMENT OF REAL PROPERTY, NAMELY, REPAIR, IMPROVEMENT, AND NEW CONSTRUCTION (U.S. CLS. 100, 103 AND 106).

**CLASS 41—EDUCATION AND ENTERTAINMENT**

FOR EDUCATION AND TRAINING SERVICES, NAMELY, PROVIDING COURSES AND TRAINING IN THE FIELD OF PROPERTY MANAGEMENT AND MAINTENANCE, INCLUDING ENVIRONMENTALLY CONSCIOUS PRACTICES AND SUSTAINABLE HOUSING (U.S. CLS. 100, 101 AND 107).

**CLASS 45—PERSONAL AND LEGAL SERVICES**

FOR PERSONAL AND SPIRITUAL DEVELOPMENT SERVICES, NAMELY, COUNSELING IN THE FIELD OF PERSONAL DEVELOPMENT, NAMELY, SELF-IMPROVEMENT, SELF-FULFILLMENT, AND INTERPERSONAL COMMUNICATION; AND SPIRITUAL COUNSELING; LEGAL SERVICES (U.S. CLS. 100 AND 101).

ROBIN CHOSID, EXAMINING ATTORNEY

SN 85-147,015. INTERNATIONAL DATA GROUP, INC., FRAMINGHAM, MA. FILED 10-7-2010.



THE MARK CONSISTS OF "MW" OVER "INSIDER" WITHIN A SQUARE HAVING THE UPPER RIGHT BARELY PEELING OVER THE IMAGE.

SN 85-146,711. TVN ENTERTAINMENT CORPORATION, SHERMAN OAKS, CA. FILED 10-6-2010.

**TV Unleashed**

THE MARK CONSISTS OF STANDARD CHARACTERS WITHOUT CLAIM TO ANY PARTICULAR FONT, STYLE, SIZE, OR COLOR.

NO CLAIM IS MADE TO THE EXCLUSIVE RIGHT TO USE "TV", APART FROM THE MARK AS SHOWN.

**CLASS 38—COMMUNICATION**

FOR PAY-PER-VIEW TELEVISION TRANSMISSION SERVICES; VIDEO ON DEMAND TRANSMISSION SERVICES; SATELLITE, CABLE, INTERNET PROTOCOL TELEVISION (INPUT) TRANSMISSION SERVICES; TELECOMMUNICATION SERVICES, NAMELY, TRANSMISSION OF VOICE, DATA, GRAPHICS, SOUND AND VIDEO BY MEANS OF BROADBAND POWER LINE OR WIRELESS NETWORKS; TRANSMISSION OF DATA, SOUND AND IMAGES BY SATELLITE (U.S. CLS. 100, 101 AND 104).

FIRST USE 6-1-2007; IN COMMERCE 6-1-2007.

**CLASS 41—EDUCATION AND ENTERTAINMENT**

FOR PROVISION OF NON-DOWNLOADABLE FILMS AND MOVIES, AND TELEVISION PROGRAMS VIA A VIDEO-ON-DEMAND SERVICE; DISTRIBUTION OF TELEVISION PROGRAMMING TO CABLE TELEVISION SYSTEMS; DISTRIBUTION OF TELEVISION PROGRAMS FOR OTHERS TO CABLE TELEVISION SYSTEMS AND INTERNET PROTOCOL TELEVISION (INPUT) SYSTEMS; CABLE TELEVISION PROGRAMMING; DISTRIBUTION OF TELEVISION PROGRAMS FOR OTHERS TO CABLE TELEVISION SYSTEMS, AND INTERNET PROTOCOL TELEVISION (INPUT) SYSTEMS; DISTRIBUTION OF PAY PER VIEW TELEVISION PROGRAMMING TO CABLE TELEVISION SYSTEMS; DISTRIBUTION OF PAY-PER-VIEW TELEVISION PROGRAMMING TO INTERNET PROTOCOL TELEVISION (INPUT) SYSTEMS; DISTRIBUTION OF MOTION PICTURES (U.S. CLS. 100, 101 AND 107).

FIRST USE 6-1-2007; IN COMMERCE 6-1-2007.  
GEOFFREY FOSDICK, EXAMINING ATTORNEY

**CLASS 9—ELECTRICAL AND SCIENTIFIC APPARATUS**

FOR ELECTRONIC DOWNLOADABLE PUBLICATIONS, NAMELY, MAGAZINES AND NEWSLETTERS IN THE FIELDS OF COMPUTERS, COMPUTER SOFTWARE, HIGH TECHNOLOGY, INFORMATION TECHNOLOGY, ONLINE SERVICES OF OTHERS, TELECOMMUNICATIONS, COMMUNICATIONS, INFORMATION SERVICES OF OTHER AND INTERACTIVE ENTERTAINMENT (U.S. CLS. 21, 23, 26, 36 AND 38).

**CLASS 38—COMMUNICATION**

FOR ON-LINE FORUMS FOR SHARING AND TRANSMISSION OF MESSAGES IN THE FIELDS OF COMPUTERS, COMPUTER SOFTWARE, HIGH TECHNOLOGY, INFORMATION TECHNOLOGY, ONLINE SERVICES OF OTHERS, TELECOMMUNICATIONS, COMMUNICATIONS, INFORMATION SERVICES OF OTHERS AND INTERACTIVE ENTERTAINMENT (U.S. CLS. 100, 101 AND 104).

**CLASS 41—EDUCATION AND ENTERTAINMENT**

FOR PROVIDING A WEBSITE FEATURING NON-DOWNLOADABLE PUBLICATIONS IN THE NATURE OF MAGAZINES AND NEWSLETTERS IN THE FIELDS OF COMPUTERS, COMPUTER SOFTWARE, HIGH TECHNOLOGY, INFORMATION TECHNOLOGY, ONLINE SERVICES OF OTHERS, TELECOMMUNICATIONS, COMMUNICATIONS, INFORMATION SERVICES OF OTHERS AND INTERACTIVE ENTERTAINMENT (U.S. CLS. 100, 101 AND 107).

DANIEL CAPSHAW, EXAMINING ATTORNEY

SN 85-147,153. WALBRIDGE GROUP, INC., DETROIT, MI. FILED 10-7-2010.

**BUILT FOR GOOD**

THE MARK CONSISTS OF STANDARD CHARACTERS WITHOUT CLAIM TO ANY PARTICULAR FONT, STYLE, SIZE, OR COLOR.

**CLASS 37—CONSTRUCTION AND REPAIR**

FOR CONSTRUCTION, CONSTRUCTION PROJECT MANAGEMENT, CONSTRUCTION SUPERVISION AND REPAIR OF FIXED STRUCTURES, NAMELY, BUILDINGS, BRIDGES, ROADWAYS, WAREHOUSES, PLANTS, PORT PASSENGER TERMINALS, INFRASTRUCTURE FOR BUILDINGS AND ROADWAYS, UNDERWATER AND MARINE CONSTRUCTION AND STEEL, CONCRETE AND OTHER STRUCTURES; CONSTRUCTION MANAGEMENT IN THE FIELD OF EQUIPMENT INSTALLATION AND DECOMMISSIONING BUILDINGS AND FACILITIES (U.S. CLS. 100, 103 AND 106).

**CLASS 42—SCIENTIFIC AND COMPUTER SERVICES**

FOR DESIGN AND ENGINEERING SERVICES FOR FIXED STRUCTURES, NAMELY, BUILDINGS, BRIDGES, ROADWAYS, WAREHOUSES, PLANTS, PORT PASSENGER TERMINALS, INFRASTRUCTURE FOR BUILDINGS AND ROADWAYS, UNDERWATER AND MARINE CONSTRUCTION, STEEL, CONCRETE AND OTHER STRUCTURES; ENGINEERING SERVICES FOR PROPERTY CONDITION ASSESSMENT, REPAIR AND RESTORATION, BUILDING INSTRUMENTATION AND MONITORING; ENVIRONMENTAL CONSULTING IN THE FIELD OF ENVIRONMENTAL ASSESSMENT AND PLANNING; FACILITY DECOMMISSIONING, NAMELY, ENGINEERING SERVICES RELATING TO THE CLOSURE OF FACILITIES AND TERMINATION OF OPERATIONS (U.S. CLS. 100 AND 101).

EMILY CHUO, EXAMINING ATTORNEY

SN 85-147,161. NESCHEN AMERICAS CORPORATIN, ELK-RIDGE, MD. FILED 10-7-2010.



THE MARK CONSISTS OF A TRIANGLE DESIGN ABOVE THE WORD "NESCHEN".

THE WORDING "NESCHEN" HAS NO MEANING IN A FOREIGN LANGUAGE.

**CLASS 1—CHEMICALS**

FOR ADHESIVE PREPARATIONS, NAMELY, PLASTIC ADHESIVES TO BE USED ON DRY MOUNTING TISSUE, PAPER, CANVAS, CLOTH AND PAPER BOARDS; LIQUID ADHESIVE FOR USE IN MOUNTING, PRESSURE-SENSITIVE ADHESIVE FOR USE IN MOUNTING, OTHER THAN FOR STATIONERY OR HOUSEHOLD PURPOSES; ADHESIVE RELEASING SOLVENT FOR COMMERCIAL USE; WETTING AGENT FOR USE IN MOUNTING (U.S. CLS. 1, 5, 6, 10, 26 AND 46).

FIRST USE 5-0-1992; IN COMMERCE 5-0-1992.

**CLASS 7—MACHINERY**

FOR MECHANICAL DRY MOUNTING MACHINES AND LAMINATING PRESSES FOR COMMERCIAL AND INDUSTRIAL USE; VACUUM PRESSES FOR LAMINATING; HOT ROLLER LAMINATORS AND PRESSURE-SENSITIVE ROLLER LAMINATORS FOR COMMERCIAL AND INDUSTRIAL USE; COMBINATION HOT/COLD ROLLER LAMINATORS FOR COMMERCIAL AND INDUSTRIAL USE; MACHINES FOR AUTOMATED LACQUER COATING OF PHOTOGRAPHS, BANNERS AND SIGNS FOR COMMERCIAL AND INDUSTRIAL USE (U.S. CLS. 13, 19, 21, 23, 31, 34 AND 35).

FIRST USE 5-0-1992; IN COMMERCE 5-0-1992.

**CLASS 16—PAPER GOODS AND PRINTED MATTER**

FOR POUCH LAMINATORS FOR OFFICE AND HOME USE; MACHINES FOR AUTOMATED LACQUER COATING OF PHOTOGRAPHS FOR OFFICE AND HOME USE; BANNERS AND SIGNS OF PAPER; PAPER PRODUCTS FOR MOUNTING AND LAMINATING, NAMELY, MOUNTING BOARD, RELEASE PAPER AND RELEASE PAPER BOARD; REUSABLE PROTECTIVE COVER SHEETS OF PAPER FOR USE IN DRY MOUNTING; PAPER PRODUCTS FOR USE WITH PRESSES, NAMELY, CUSHION PAPER; ILLUSTRATED SOURCE BOOK FEATURING INFORMATION ON MOUNTING AND LAMINATING METHODS, TECHNIQUES AND APPLICATIONS; GUIDE BOOKS FEATURING SLIDE-RULE FORMAT APPLICATIONS; PRINTED ADHESIVE PLASTIC FILMS USED FOR MOUNTING IMAGES (U.S. CLS. 2, 5, 22, 23, 29, 37, 38 AND 50).

FIRST USE 5-0-1992; IN COMMERCE 5-0-1992.

**CLASS 17—RUBBER GOODS**

FOR HEAT-ACTIVATED AND PRESSURE SENSITIVE LAMINATING PLASTIC FILM, AND PRE-CUT POUCHES OF PLASTIC FILM FOR LAMINATING; ADHESIVE PLASTIC FILMS FOR INDUSTRIAL AND COMMERCIAL USE; PRINTED PLASTIC ADHESIVE FILMS FOR INDUSTRIAL AND COMMERCIAL USE; PLASTIC FILMS WITH ADHESIVE FINISH IN THE FORM OF WEBS, SHEETS, TAPES AND CUTTINGS FOR INDUSTRIAL AND COMMERCIAL USE; TRANSFER ADHESIVE FILMS AND SEALING FILMS OF PLASTIC FOR USE AS ADHESIVE FOR INDUSTRIAL AND COMMERCIAL USE; SYNTHETIC PLASTIC AS SEMI-FINISHED PRODUCTS IN THE FORM OF PLATES WITH AN ADHESIVE FINISH; FLUOROPOLYMER COMPOSITE FILMS OF PRIMARILY PLASTIC WITH METAL, WOOD, PAPER, PVC, POLYPROPYLENE, FABRIC IN THE NATURE OF POLYESTER, COTTON AND/OR FELT EITHER WITH OR WITHOUT AN INKJET TOPCOAT, ALL FOR INDUSTRIAL AND COMMERCIAL USE (U.S. CLS. 1, 5, 12, 13, 35 AND 50).

FIRST USE 5-0-1992; IN COMMERCE 5-0-1992.

EMILY CHUO, EXAMINING ATTORNEY

SN 85-147,740. EDGAR MORENO, CORONA, NY. FILED 10-7-2010.

**MUSCLE MONEY MUSIC**

THE MARK CONSISTS OF STANDARD CHARACTERS WITHOUT CLAIM TO ANY PARTICULAR FONT, STYLE, SIZE, OR COLOR.

NO CLAIM IS MADE TO THE EXCLUSIVE RIGHT TO USE "MUSIC", APART FROM THE MARK AS SHOWN.

**CLASS 9—ELECTRICAL AND SCIENTIFIC APPARATUS**

FOR MUSICAL SOUND RECORDINGS, INCLUDING MUSIC RECORDED ON PHONOGRAPH RECORDS, AUDIO CASSETTES, VIDEO CASSETTES, COMPACT DISCS, MINI-DISCS, DIGITAL COMPACT AUDIO CASSETTES, DIGITAL AUDIO TAPES, DVDS AND CD-ROMS; DOWNLOADABLE MUSICAL SOUND RECORDINGS; MUSICAL VIDEO RECORDINGS; DOWNLOADABLE VIDEO RECORDINGS FEATURING MUSIC AND MUSICAL ENTERTAINMENT (U.S. CLS. 21, 23, 26, 36 AND 38).

**CLASS 35—ADVERTISING AND BUSINESS**

FOR PROMOTING THE AUDIO RECORDINGS AND MUSICAL SERVICES OF OTHERS; ARTIST MANAGEMENT SERVICES, NAMELY, MANAGEMENT SERVICES FOR PERFORMING ARTISTS, MUSICAL GROUPS AND MUSIC ARTISTS; DISTRIBUTORSHIP SERVICES IN THE FIELD OF MUSICAL SOUND RECORDINGS; ARTISTS AND REPERTOIRE SERVICES, NAMELY, TALENT AGENCY AND TALENT RECRUITING SERVICES INCORPORATING THE OVERSEEING OF THE CAREER DEVELOPMENT OF RECORDING ARTISTS ESPECIALLY IN THE FIELD OF MUSICAL ENTERTAINMENT (U.S. CLS. 100, 101 AND 102).

**CLASS 41—EDUCATION AND ENTERTAINMENT**

FOR RECORD LABEL SERVICES, NAMELY, AUDIO AND VIDEO RECORDING AND PRODUCTION; MUSIC PUBLISHING SERVICES; ENTERTAINMENT SERVICES, NAMELY, DEVELOPING, ORGANIZING AND PRODUCING OF RADIO SHOWS; PRODUCTION OF TELEVISION SHOWS, CONCERTS, FILMS, SOUND AND VIDEO RECORDINGS, ESPECIALLY RELATING TO MUSIC; PROVIDING AUDIO OR VIDEO STUDIOS; PUBLICATION OF MUSICAL TEXTS; RECORDING STUDIOS; SOUND RECORDING STUDIOS; ENTERTAINMENT SERVICES, NAMELY, PROVIDING WEBSITES FEATURING PRERECORDED MUSIC, MUSICAL PERFORMANCES AND VIDEO CLIPS, PHOTOGRAPHS, NEWS, REVIEWS AND INFORMATION, ALL IN THE FIELD OF MUSIC, MUSICAL GROUPS AND RECORDING ARTISTS; ENTERTAINMENT MARKETING SERVICES, NAMELY, MARKETING AND ADVERTISING FOR INDEPENDENT ARTISTS (U.S. CLS. 100, 101 AND 107).

KATHLEEN M. VANSTON, EXAMINING ATTORNEY

SN 85-148,476. AVNET, INC., PHOENIX, AZ. FILED 10-8-2010.

**ACCELERATING YOUR SUCCESS**

THE MARK CONSISTS OF STANDARD CHARACTERS WITHOUT CLAIM TO ANY PARTICULAR FONT, STYLE, SIZE, OR COLOR.

**CLASS 9—ELECTRICAL AND SCIENTIFIC APPARATUS**

FOR COMPUTER HARDWARE AND COMPUTER PERIPHERALS; ELECTRICAL, ELECTRONIC AND COMPUTER COMPONENTS AND EQUIPMENT, NAMELY, MICRO-PROCESSORS, SEMICONDUCTORS, INTERCONNECTS, PASSIVES AND ELECTROMECHANICAL SOFTWARE AND HARDWARE FOR LINKING COMMUNICATIONS AND DATA NETWORKS, MICROCHIPS, CIRCUIT BOARDS, SERVERS, DISPLAY PANELS, DATA STORAGE SOFTWARE AND HARDWARE, POINT-OF-SALE SYSTEMS, NAMELY, BAR-CODE SCANNERS, AUTOMATIC IDENTIFICATION SOFTWARE AND HARDWARE, AND WIRELESS COMPUTING SOFTWARE AND HARDWARE, EMBEDDED OPERATING SOFTWARE AND HARDWARE, RADIO FREQUENCY AND MICROWAVE SOFTWARE AND HARDWARE FOR LINKING COMMUNICATIONS AND DATA NETWORKS (U.S. CLS. 21, 23, 26, 36 AND 38).

FIRST USE 10-15-2007; IN COMMERCE 10-15-2007.

**CLASS 35—ADVERTISING AND BUSINESS**

FOR PROVIDING OF INFORMATION REGARDING GOODS AND SERVICES ON THE INTERNET, NAMELY, PROVIDING CONSUMER PRODUCT AND SERVICE INFORMATION VIA THE INTERNET; PROCURING OF CONTRACTS FOR THE PURCHASE AND SALE OF GOODS; WHOLESALE STORE SERVICES AND ONLINE RETAIL AND WHOLESALE STORE SERVICES FEATURING ELECTRICAL, ELECTRONIC AND COMPUTER EQUIPMENT, ELECTRIC MOTORS AND MACHINERY; ELECTROMECHANICAL COMPONENTS AND PRODUCTS, OPTOELECTRONIC DEVICES, PLASTIC INJECTION GOODS, INDUSTRIAL MAINTENANCE SUPPLIES, FACTORY EQUIPMENT FOR INDUSTRIAL, COMMERCIAL, GOVERNMENT, AGRICULTURAL, MINING AND UTILITY MARKETS AND TOOLS; FREIGHT LOGISTICS MANAGEMENT; SUPPLY CHAIN MANAGEMENT SERVICES; DISTRIBUTORSHIP SERVICES IN THE FIELD OF ELECTRICAL, ELECTRONIC AND COMPUTER EQUIPMENT, ELECTRIC MOTORS AND MACHINERY; DISTRIBUTORSHIP SERVICES SPECIALIZING IN ELECTRONIC, ELECTROMECHANICAL COMPONENTS AND PRODUCTS, ELECTRICAL EQUIPMENT, COMPUTERS AND COMPUTER EQUIPMENT, OPTOELECTRONIC DEVICES, PLASTIC INJECTION GOODS, INDUSTRIAL MAINTENANCE SUPPLIES, FACTORY EQUIPMENT FOR INDUSTRIAL, COMMERCIAL, GOVERNMENT, AGRICULTURAL, MINING AND UTILITY MARKETS AND TOOLS, IN PARTICULAR VIA THE INTERNET (U.S. CLS. 100, 101 AND 102).

FIRST USE 10-15-2007; IN COMMERCE 10-15-2007.

**CLASS 39—TRANSPORTATION AND STORAGE**

FOR WAREHOUSE STORAGE OF GOODS AND PACKAGING ARTICLES FOR TRANSPORTATION AND ASSEMBLY; DELIVERY OF COMPUTER PRODUCTS, ELECTRONIC AND ELECTRICAL DEVICES, INSTRUMENTS AND COMPONENTS, AND COMPUTER PRODUCTS; LOGISTICS SERVICES, NAMELY, SUPPLY CHAIN LOGISTICS AND REVERSE LOGISTICS SERVICES, NAMELY, STORAGE, TRANSPORTATION, AND DELIVERY OF DOCUMENTS, PACKAGES, RAW MATERIALS, AND OTHER FREIGHT FOR OTHERS BY AIR, RAIL, SHIP OR TRUCK; ADVISORY AND CONSULTATION SERVICES IN THE FIELD OF WAREHOUSE STORAGE GOODS, PACKAGING ARTICLES FOR TRANSPORTATION (U.S. CLS. 100 AND 105).

FIRST USE 10-15-2007; IN COMMERCE 10-15-2007.

**CLASS 40—MATERIAL TREATMENT**

FOR ASSEMBLY OF COMPUTER PRODUCTS AND COMPONENTS FOR OTHERS (U.S. CLS. 100, 103 AND 106).

FIRST USE 10-15-2007; IN COMMERCE 10-15-2007.

**CLASS 42—SCIENTIFIC AND COMPUTER SERVICES**

FOR COMPUTER PROGRAMMING FOR OTHERS (U.S. CLS. 100 AND 101).

FIRST USE 10-15-2007; IN COMMERCE 10-15-2007.

THEODORE MCBRIDE, EXAMINING ATTORNEY

SN 85-148,598. SECONDMARKET HOLDINGS, INC., NEW YORK, NY. FILED 10-8-2010.

**SIMX**

THE MARK CONSISTS OF STANDARD CHARACTERS WITHOUT CLAIM TO ANY PARTICULAR FONT, STYLE, SIZE, OR COLOR.



OWNER OF U.S. REG. NOS. 3,916,511 AND 3,916,512.

#### **CLASS 9—ELECTRICAL AND SCIENTIFIC APPARATUS**

FOR DOWNLOADABLE SOFTWARE IN THE NATURE OF AN APPLICATION FOR MOBILE DEVICES THAT ENABLES USERS TO CAST VOTES IN VOTING COMPETITIONS RELATING TO PRESENTATIONS, BUSINESS PLANS, BUSINESS VENTURES AND INVESTMENT OPPORTUNITIES; DOWNLOADABLE SOFTWARE IN THE NATURE OF AN APPLICATION FOR MOBILE DEVICES THE ENABLES USERS TO PROVIDE FEEDBACK IN OPINION POLLS RELATING TO PRESENTATIONS, BUSINESS PLANS, BUSINESS VENTURES AND INVESTMENT OPPORTUNITIES (U.S. CLS. 21, 23, 26, 36 AND 38).

#### **CLASS 35—ADVERTISING AND BUSINESS**

FOR VOTING SERVICES, NAMELY, SERVICES ALLOWING USERS TO CAST VOTES IN CONTESTS USING TELEPHONES AND MOBILE DEVICES; ORGANIZING AND CONDUCTING BUSINESS COMPETITIONS RELATING TO PRESENTATIONS, BUSINESS PLANS, BUSINESS VENTURES AND INVESTMENT OPPORTUNITIES; ORGANIZING AND CONDUCTING OPINION POLLS RELATING TO PRESENTATIONS, BUSINESS PLANS, BUSINESS VENTURES AND INVESTMENT OPPORTUNITIES; PROVIDING A WEBSITE THAT ENABLES USERS TO PROVIDE FEEDBACK IN OPINION POLLS RELATING TO PRESENTATIONS, BUSINESS PLANS, BUSINESS VENTURES AND INVESTMENT OPPORTUNITIES (U.S. CLS. 100, 101 AND 102).

#### **CLASS 42—SCIENTIFIC AND COMPUTER SERVICES**

FOR PROVIDING A WEBSITE WITH NON-DOWNLOADABLE SOFTWARE THAT ENABLES USERS TO CAST VOTES IN VOTING COMPETITIONS RELATING TO PRESENTATIONS, BUSINESS PLANS, BUSINESS VENTURES AND INVESTMENT OPPORTUNITIES (U.S. CLS. 100 AND 101).

CAROLINE WOOD, EXAMINING ATTORNEY

#### **CLASS 9—ELECTRICAL AND SCIENTIFIC APPARATUS**

FOR DOWNLOADABLE SOFTWARE IN THE NATURE OF AN APPLICATION FOR MOBILE DEVICES THAT ENABLES USERS TO CAST VOTES IN VOTING COMPETITIONS RELATING TO PRESENTATIONS, BUSINESS PLANS, BUSINESS VENTURES AND INVESTMENT OPPORTUNITIES; DOWNLOADABLE SOFTWARE IN THE NATURE OF AN APPLICATION FOR MOBILE DEVICES THE ENABLES USERS TO PROVIDE FEEDBACK IN OPINION POLLS RELATING TO PRESENTATIONS, BUSINESS PLANS, BUSINESS VENTURES AND INVESTMENT OPPORTUNITIES (U.S. CLS. 21, 23, 26, 36 AND 38).

#### **CLASS 35—ADVERTISING AND BUSINESS**

FOR VOTING SERVICES, NAMELY, SERVICES ALLOWING USERS TO CAST VOTES IN CONTESTS USING TELEPHONES AND MOBILE DEVICES; ORGANIZING AND CONDUCTING BUSINESS COMPETITIONS RELATING TO PRESENTATIONS, BUSINESS PLANS, BUSINESS VENTURES AND INVESTMENT OPPORTUNITIES; ORGANIZING AND CONDUCTING OPINION POLLS RELATING TO PRESENTATIONS, BUSINESS PLANS, BUSINESS VENTURES AND INVESTMENT OPPORTUNITIES; PROVIDING A WEBSITE THAT ENABLES USERS TO PROVIDE FEEDBACK IN OPINION POLLS RELATING TO PRESENTATIONS, BUSINESS PLANS, BUSINESS VENTURES AND INVESTMENT OPPORTUNITIES (U.S. CLS. 100, 101 AND 102).

#### **CLASS 42—SCIENTIFIC AND COMPUTER SERVICES**

FOR PROVIDING A WEBSITE WITH NON-DOWNLOADABLE SOFTWARE THAT ENABLES USERS TO CAST VOTES ON-LINE IN VOTING COMPETITIONS RELATING TO PRESENTATIONS, BUSINESS PLANS, BUSINESS VENTURES AND INVESTMENT OPPORTUNITIES (U.S. CLS. 100 AND 101).

CAROLINE WOOD, EXAMINING ATTORNEY

SN 85-148,606. SECONDMARKET HOLDINGS, INC., NEW YORK, NY. FILED 10-8-2010.



OWNER OF U.S. REG. NOS. 3,900,685, 3,916,511 AND 3,916,512.

THE MARK CONSISTS OF THE TERM "SIMX" WITH THE LETTERS "S", "I" AND "M" APPEARING IN LOWER CASE FOLLOWED BY THE "X" APPEARING CAPITALIZED AND BOLD, WITH THE DESIGN OF THREE TRIANGLES, EACH TRIANGLE INTERSECTING WITH THE OTHER TWO NEAR ITS MOST NARROW VERTEX, TO THE LEFT OF THE UPPER LEFT HAND POINT OF THE "X". THE COLOR GRAY IN THE DRAWING REPRESENTS SHADING AND IS NOT PART OF THE MARK.

SN 85-149,098. BLACK WOMEN'S HEALTH NETWORK, HUNTERSVILLE, NC. FILED 10-9-2010.



THE COLOR(S) BROWN, GREEN, WHITE, BLUE, AND YELLOW IS/ARE CLAIMED AS A FEATURE OF THE MARK.

THE MARK CONSISTS OF THREE CONCENTRIC CIRCLES WITH WORDING AND DESIGNS. THE INNERMOST CIRCLE CONTAINS A STYLIZED LANDSCAPE FEATUR-

ING A WHITE SUN AND YELLOW SKY ABOVE CURVING BANDS OF BLUE WATER AND GREEN EARTH. A LARGE BROWN WHEAT STALK IS PLACED ACROSS THE CENTER OF THE MARK WITH ITS STEM EXTENDING TO JOIN A BROWN OUTER BORDER. BETWEEN THE OUTER BORDER AND INNER CIRCLE IS A DARK GREEN CIRCULAR BAND CONTAINING THE WORDING "A TIME TO HARVEST" AT THE TOP IN STYLIZED WHITE FONT AND "BACK TO BASICS" AT THE BOTTOM IN STYLIZED WHITE FONT.

#### CLASS 29—MEATS AND PROCESSED FOODS

FOR VEGETABLE-BASED FOOD BEVERAGES (U.S. CL. 46).

#### CLASS 35—ADVERTISING AND BUSINESS

FOR CHARITABLE SERVICES, NAMELY, ORGANIZING AND DEVELOPING PROJECTS THAT AIM TO IMPROVE THE LIVES OF UNDERPRIVILEGED AND IMPOVERISHED PEOPLE (U.S. CLS. 100, 101 AND 102). STEVEN PEREZ, EXAMINING ATTORNEY

SN 85-150,428. MOBILEMD, INC., FORMERLY INTRAPRISE SOLUTIONS, INC., WARMINSTER, PA. FILED 10-12-2010.

# MobileMD

THE MARK CONSISTS OF STANDARD CHARACTERS WITHOUT CLAIM TO ANY PARTICULAR FONT, STYLE, SIZE, OR COLOR.

#### CLASS 9—ELECTRICAL AND SCIENTIFIC APPARATUS

FOR COMPUTER PROGRAMS AND SOFTWARE USED TO PROVIDE HEALTH INFORMATION SERVICES, NAMELY, PROVIDING TRANSMISSION, STORAGE AND MANAGEMENT OF HEALTH INFORMATION VIA THE INTERNET AND BETWEEN COMPUTER SYSTEMS, HANDHELD DEVICES AND TELECOMMUNICATION DEVICES OF HEALTH CARE PROVIDERS INCLUDING HEALTH SYSTEMS, HOSPITALS, PHYSICIAN PRACTICES, PRACTICES, TESTING AND LABORATORY COMPANIES, MEDICAL BILLING COMPANIES AND OTHERS AND OTHER HEALTH CARE PROVIDERS AND/OR THEIR RESPECTIVE BUSINESS PARTNERS AND/OR CONTRACTORS (U.S. CLS. 21, 23, 26, 36 AND 38).

FIRST USE 2-5-1999; IN COMMERCE 2-5-1999.

#### CLASS 38—COMMUNICATION

FOR COMMUNICATION SERVICES RELATING TO HEALTH INFORMATION, NAMELY, PROVIDING ELECTRONIC TRANSMISSION OF HEALTH INFORMATION ACCESSED VIA THE INTERNET AND BETWEEN COMPUTER SYSTEMS, HANDHELD DEVICES AND TELECOMMUNICATION DEVICES OF HEALTH CARE PROVIDERS INCLUDING HEALTH SYSTEMS, HOSPITALS, PHYSICIAN PRACTICES, PRACTICES, TESTING AND LABORATORY COMPANIES, MEDICAL BILLING COMPANIES AND OTHERS AND OTHER HEALTH CARE PROVIDERS AND/OR THEIR RESPECTIVE BUSINESS PARTNERS AND/OR CONTRACTORS (U.S. CLS. 100, 101 AND 104).

FIRST USE 2-5-1999; IN COMMERCE 2-5-1999.

#### CLASS 42—SCIENTIFIC AND COMPUTER SERVICES

FOR PROVIDING ONLINE NON-DOWNLOADABLE SOFTWARE FOR THE STORAGE AND MANAGEMENT OF HEALTH CARE INFORMATION VIA THE INTERNET AND BETWEEN COMPUTER SYSTEMS, HANDHELD DEVICES AND TELECOMMUNICATION DEVICES OF HEALTH CARE PROVIDERS INCLUDING HEALTH SYSTEMS, HOSPITALS, PHYSICIAN PRACTICES, PRACTICES, TESTING AND LABORATORY COMPANIES, MEDICAL BILLING COMPANIES AND OTHERS AND OTHER HEALTH CARE PROVIDERS AND/OR THEIR RESPECTIVE BUSINESS PARTNERS AND/OR CONTRACTORS (U.S. CLS. 100 AND 101).

FIRST USE 2-5-1999; IN COMMERCE 2-5-1999.  
MICHAEL WIENER, EXAMINING ATTORNEY

SN 85-151,943. WEST PHARMACEUTICAL SERVICES, INC., LIONVILLE, PA. FILED 10-13-2010.

# WEST PFS SOLUTIONS

THE MARK CONSISTS OF STANDARD CHARACTERS WITHOUT CLAIM TO ANY PARTICULAR FONT, STYLE, SIZE, OR COLOR.

NO CLAIM IS MADE TO THE EXCLUSIVE RIGHT TO USE "PFS", APART FROM THE MARK AS SHOWN.

#### CLASS 10—MEDICAL APPARATUS

FOR MEDICAL SYRINGES; DRUG DELIVERY SYSTEMS (U.S. CLS. 26, 39 AND 44).

#### CLASS 44—MEDICAL, BEAUTY AND AGRICULTURAL SERVICES

FOR PROVIDING A WEBSITE FEATURING MEDICAL AND PHARMACEUTICAL INFORMATION AND LINKS TO THE WEBSITES OF OTHERS REGARDING SYRINGES, SYRINGE PARTS, FILLING SYRINGES, STERILIZATION, AND OTHER SYRINGE-RELATED GOODS AND SERVICES (U.S. CLS. 100 AND 101).

SUSAN STIGLITZ, EXAMINING ATTORNEY

SN 85-152,323. HULU, LLC, LOS ANGELES, CA. FILED 10-14-2010.

# hulu

OWNER OF U.S. REG. NO. 3,878,144.  
THE COLOR(S) GREEN IS/ARE CLAIMED AS A FEATURE OF THE MARK.

THE MARK CONSISTS OF "HULU" IN STYLIZED LETTERING IN THE COLOR GREEN.

**CLASS 9—ELECTRICAL AND SCIENTIFIC APPARATUS**

FOR DOWNLOADABLE AUDIO-VISUAL MEDIA CONTENT IN THE FIELDS OF NEWS, ENTERTAINMENT, SPORTS, COMEDY, DRAMA, MUSIC, AND MUSIC VIDEOS; COMPUTER SOFTWARE, NAMELY, COMPUTER SOFTWARE FOR STREAMING AUDIO-VISUAL MEDIA CONTENT VIA THE INTERNET AND TO MOBILE DIGITAL ELECTRONIC DEVICES, DOWNLOADABLE PLAYERS FOR AUDIO-VISUAL MEDIA CONTENT, SOFTWARE TOOLS FOR EDITING OF AUDIO-VISUAL CONTENT, VIDEO SEARCH AND ANNOTATION SOFTWARE, CONTENT PROTECTION SOFTWARE, AD TRACKING AND OPTIMIZATION SOFTWARE, SOFTWARE PLATFORM FOR PROVIDING PROGRAMMATIC INTERFACES FOR THIRD PARTIES TO ACCESS WEBSITE CONTENT AND DATA FOR WEB DEVELOPMENT AND WEBSITE APPLICATION DEVELOPMENT (U.S. CLS. 21, 23, 26, 36 AND 38).

**CLASS 35—ADVERTISING AND BUSINESS**

FOR BUSINESS-TO-BUSINESS ADVERTISING; ONLINE BANNER ADVERTISING AND MARKETING SERVICES; ONLINE RETAIL SHOPPING SITE SERVICES FEATURING STREAMING OR DOWNLOADABLE AUDIO-VISUAL CONTENT IN THE FIELDS OF NEWS, ENTERTAINMENT, SPORTS, COMEDY, DRAMA, MUSIC, AND MUSIC VIDEOS (U.S. CLS. 100, 101 AND 102).

**CLASS 38—COMMUNICATION**

FOR BROADCASTING AND STREAMING OF AUDIO-VISUAL MEDIA CONTENT IN THE FIELDS OF NEWS, ENTERTAINMENT, SPORTS, COMEDY, DRAMA, MUSIC, AND MUSIC VIDEOS VIA A GLOBAL COMPUTER NETWORK; TRANSMISSION OF DOWNLOADABLE AUDIO-VISUAL MEDIA CONTENT IN THE NATURE OF FULL-LENGTH, PARTIAL-LENGTH, AND CLIPS FROM MOTION PICTURES, TELEVISION PROGRAMMING, VIDEOS, MUSIC VIDEOS, AND MUSIC; PROVIDING ACCESS TO ONLINE FORUMS, CHAT ROOMS, AND BLOGS OVER THE INTERNET; PROVIDING ONLINE ELECTRONIC BULLETIN BOARDS FOR TRANSMISSION OF MESSAGES AMONG USERS IN THE FIELD OF GENERAL INTEREST; WEB MESSAGING SERVICES; VIDEO-ON-DEMAND TRANSMISSION SERVICES; PROVIDING ONLINE FORUMS FOR TRANSMISSION OF MESSAGES FEATURING CURRENT EVENT REPORTING, ENTERTAINMENT, SPORTS, COMEDY, DRAMA, MUSIC, AND MUSIC VIDEOS (U.S. CLS. 100, 101 AND 104).

**CLASS 41—EDUCATION AND ENTERTAINMENT**

FOR EDUCATION AND ENTERTAINMENT SERVICES, NAMELY, ONLINE SERVICES PROVIDING AUDIO-VISUAL CONTENT IN THE FIELDS OF CURRENT EVENT REPORTING, ENTERTAINMENT, SPORTS, COMEDY, DRAMA, MUSIC, AND MUSIC VIDEOS; PROVIDING ONLINE INFORMATION VIA A GLOBAL COMPUTER NETWORK ON THE SUBJECTS OF MOTION PICTURES, TELEVISION PROGRAMMING, VIDEOS, MUSIC VIDEOS, AND MUSIC; PROVIDING ONLINE INTERACTIVE RESOURCE AND PROGRAMMING GUIDES ON THE SUBJECTS OF MOTION PICTURES, TELEVISION PROGRAMMING, VIDEOS, MUSIC VIDEOS, AND MUSIC TAILORED TO VIEWER'S PROGRAMMING PREFERENCES; PRODUCTION AND RENTAL OF AUDIO-VISUAL WORKS, SPECIFICALLY, MOTION PICTURES, TELEVISION PROGRAMMING, VIDEOS, MUSIC VIDEOS, AND MUSIC, FOR STREAMING OR DOWNLOADING IN THE FIELDS OF NEWS, ENTERTAINMENT, SPORTS, COMEDY, DRAMA, MUSIC, AND MUSIC VIDEOS; PROVIDING BLOGS IN THE NATURE OF AN ONLINE

JOURNAL OVER THE INTERNET FEATURING CURRENT EVENT REPORTING, ENTERTAINMENT, SPORTS, COMEDY, DRAMA, MUSIC, AND MUSIC VIDEOS; PROVIDING A WEBSITE FEATURING AUDIO-VISUAL CONTENT, SPECIFICALLY, MOTION PICTURES, TELEVISION PROGRAMMING, VIDEOS, MUSIC VIDEOS, AND MUSIC, AND VIDEO CLIPS, AUDIO CLIPS, MUSIC CLIPS, FILM CLIPS, AND PHOTOGRAPHS, IN THE FIELDS OF CURRENT EVENT REPORTING, ENTERTAINMENT, SPORTS, COMEDY, DRAMA, MUSIC, AND MUSIC VIDEOS (U.S. CLS. 100, 101 AND 107).

**CLASS 42—SCIENTIFIC AND COMPUTER SERVICES**

FOR HOSTING OF DIGITAL CONTENT ON THE INTERNET; HOSTING AND MAINTAINING AN ONLINE COMMUNITY FEATURING AUDIO-VISUAL CONTENT IN THE FIELDS OF NEWS, ENTERTAINMENT, SPORTS, COMEDY, DRAMA, MUSIC, AND MUSIC VIDEOS; PROVIDING PROGRAMMATIC INTERFACES FOR THIRD PARTIES TO ACCESS WEBSITE CONTENT AND DATA FOR WEB DEVELOPMENT AND WEBSITE APPLICATION DEVELOPMENT (U.S. CLS. 100 AND 101).

JOHN DALIER, EXAMINING ATTORNEY

SN 85-152,447. ENVIRONMENTAL FIBERS INTERNATIONAL, INC., PORTLAND, OR. FILED 10-14-2010.

**ENVIRONMENTAL FIBERS INTERNATIONAL**

THE MARK CONSISTS OF STANDARD CHARACTERS WITHOUT CLAIM TO ANY PARTICULAR FONT, STYLE, SIZE, OR COLOR.

NO CLAIM IS MADE TO THE EXCLUSIVE RIGHT TO USE "ENVIRONMENTAL" AND "INTERNATIONAL", APART FROM THE MARK AS SHOWN.

**CLASS 35—ADVERTISING AND BUSINESS**

FOR RESELLER SERVICES IN THE FIELD OF RECYCLED AND WASTE PRODUCTS; AND BROKERAGE SERVICES FOR MATCHING BUYERS AND SELLERS OF RECYCLED AND WASTE PRODUCTS (U.S. CLS. 100, 101 AND 102).

FIRST USE 10-31-2001; IN COMMERCE 11-21-2001.

**CLASS 40—MATERIAL TREATMENT**

FOR WASTE MANAGEMENT AND RECYCLING SERVICES (U.S. CLS. 100, 103 AND 106).

FIRST USE 10-15-2001; IN COMMERCE 10-15-2001.

LESLEY LAMOTHE, EXAMINING ATTORNEY

SN 85-152,451. ENVIRONMENTAL FIBERS INTERNATIONAL, INC., PORTLAND, OR. FILED 10-14-2010.

**EFI**

THE MARK CONSISTS OF STANDARD CHARACTERS WITHOUT CLAIM TO ANY PARTICULAR FONT, STYLE, SIZE, OR COLOR.

**CLASS 35—ADVERTISING AND BUSINESS**

FOR RESELLER SERVICES IN THE FIELD OF RECYCLED AND WASTE PRODUCTS; AND BROKERAGE SERVICES FOR MATCHING BUYERS AND SELLERS OF RECYCLED AND WASTE PRODUCTS (U.S. CLS. 100, 101 AND 102).

FIRST USE 9-13-2001; IN COMMERCE 9-13-2001.

**CLASS 40—MATERIAL TREATMENT**

FOR WASTE MANAGEMENT AND RECYCLING SERVICES (U.S. CLS. 100, 103 AND 106).

FIRST USE 8-10-2001; IN COMMERCE 11-20-2001.

LESLEY LAMOTHE, EXAMINING ATTORNEY

THE MARK CONSISTS OF THE STYLIZED TEXT "W C NUNCHAKU".

**CLASS 25—CLOTHING**

FOR TEE SHIRTS (U.S. CLS. 22 AND 39).

FIRST USE 6-25-2010; IN COMMERCE 8-24-2010.

**CLASS 28—TOYS AND SPORTING GOODS**

FOR MARTIAL ARTS TRAINING EQUIPMENT, NAMELY, NUNCHUCKS (U.S. CLS. 22, 23, 38 AND 50).

FIRST USE 6-25-2010; IN COMMERCE 8-24-2010.

KIM MONINGHOFF, EXAMINING ATTORNEY

SN 85-152,459. ENVIRONMENTAL FIBERS INTERNATIONAL, INC., PORTLAND, OR. FILED 10-14-2010.

**EFI RECYCLING**

THE MARK CONSISTS OF STANDARD CHARACTERS WITHOUT CLAIM TO ANY PARTICULAR FONT, STYLE, SIZE, OR COLOR.

NO CLAIM IS MADE TO THE EXCLUSIVE RIGHT TO USE "RECYCLING", APART FROM THE MARK AS SHOWN.

**CLASS 35—ADVERTISING AND BUSINESS**

FOR RESELLER SERVICES IN THE FIELD OF RECYCLED AND WASTE PRODUCTS; AND BROKERAGE SERVICES FOR MATCHING BUYERS AND SELLERS OF RECYCLED AND WASTE PRODUCTS (U.S. CLS. 100, 101 AND 102).

FIRST USE 8-0-2008; IN COMMERCE 8-0-2008.

**CLASS 40—MATERIAL TREATMENT**

FOR WASTE MANAGEMENT AND RECYCLING SERVICES (U.S. CLS. 100, 103 AND 106).

FIRST USE 8-1-2008; IN COMMERCE 8-6-2008.

LESLEY LAMOTHE, EXAMINING ATTORNEY

SN 85-153,321. ALCAN PRODUCTS CORPORATION, CHICAGO, IL. FILED 10-15-2010.

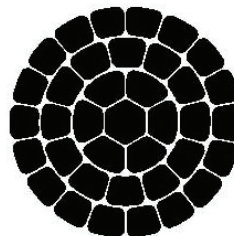

**STABILOY**

SN 85-152,808. CHILDRESS, ANDREW M., TAHLEQUAH, OK. AND WARD, LANCE, TAHLEQUAH, OK. FILED 10-14-2010.



NO CLAIM IS MADE TO THE EXCLUSIVE RIGHT TO USE "NUNCHAKU" FOR INTERNATIONAL CLASS 28, APART FROM THE MARK AS SHOWN.

OWNER OF U.S. REG. NOS. 983,205 AND 1,099,249.  
THE MARK CONSISTS OF UNIQUE CIRCULAR DESIGN COMPRISED GEOMETRIC FIGURES ABOVE THE WORDING "STABILOY".

**CLASS 6—METAL GOODS**

FOR COMMON METALS, UNWROUGHT AND SEMI-WORKED FOR FUTURE MANUFACTURE, NAMELY, ALUMINUM AND ALUMINUM ALLOYS; ROLLED ALUMINUM ALLOYS IN ROD OR BAR FORM (U.S. CLS. 2, 12, 13, 14, 23, 25 AND 50).

**CLASS 9—ELECTRICAL AND SCIENTIFIC APPARATUS**

FOR ELECTRIC WIRE AND CABLE (U.S. CLS. 21, 23, 26, 36 AND 38).

ANGELA DUONG, EXAMINING ATTORNEY



SN 85-154,628. ARRHYTHMIA RESEARCH TECHNOLOGY, INC., FITCHBURG, MA. FILED 10-18-2010.

SN 85-156,077. LA LINS COMPANY LIMITED, KOWLOON, HONG KONG, FILED 10-19-2010.



THE MARK CONSISTS OF THE LETTER "X" WITH A WIRELESS SIGNAL CONSISTING OF A CIRCLE AND THREE SOUND WAVES EMANATING OVER THE "X", CREATING A STICK FIGURE DESIGN OF A PERSON.

#### CLASS 10—MEDICAL APPARATUS

FOR WIRELESS MEDICAL DEVICES FOR MONITORING VITAL SIGNS (U.S. CLS. 26, 39 AND 44).

#### CLASS 44—MEDICAL, BEAUTY AND AGRICULTURAL SERVICES

FOR PROVIDING MEDICAL SERVICES, NAMELY, MONITORING PATIENTS' VITALS USING DATA COLLECTED THROUGH WIRELESS MEDICAL MONITORING DEVICES (U.S. CLS. 100 AND 101).

KRISTIN CARLSON, EXAMINING ATTORNEY

SN 85-155,979. FIRSTCHOICE ADMINISTRATORS, LLC, SPRINGFIELD, MO. FILED 10-19-2010.

# PROMERIS

THE MARK CONSISTS OF STANDARD CHARACTERS WITHOUT CLAIM TO ANY PARTICULAR FONT, STYLE, SIZE, OR COLOR.

#### CLASS 9—ELECTRICAL AND SCIENTIFIC APPARATUS

FOR COMPUTER SOFTWARE FOR MANAGEMENT OF EMPLOYEE BENEFITS (U.S. CLS. 21, 23, 26, 36 AND 38).

#### CLASS 35—ADVERTISING AND BUSINESS

FOR ONLINE MANAGEMENT OF EMPLOYEE BENEFITS CONCERNING INSURANCE (U.S. CLS. 100, 101 AND 102).

DOMINIC FATHY, EXAMINING ATTORNEY

# LALINS

THE MARK CONSISTS OF STANDARD CHARACTERS WITHOUT CLAIM TO ANY PARTICULAR FONT, STYLE, SIZE, OR COLOR.

PRIORITY CLAIMED UNDER SEC. 44(D) ON HONG KONG APPLICATION NO. 301692306, FILED 8-18-2010, REG. NO. 301692306, DATED 8-18-2010, EXPIRES 8-18-2020.

OWNER OF HONG KONG REG. NO. 301124847, DATED 5-26-2008, EXPIRES 5-26-2018.

THE WORDING "LALINS" HAS NO MEANING IN A FOREIGN LANGUAGE.

#### CLASS 18—LEATHER GOODS

FOR UNWORKED OR SEMI-WORKED LEATHER; IMITATION LEATHER SOLD IN BULK; SUITCASES; BAGS, NAMELY, LEATHER SHOPPING BAGS AND SHOPPING BAGS MADE OF SKIN, TRAVELING BAGS, SCHOOL BAGS, ALL PURPOSE SPORTS BAGS, BEACH BAGS, HUNTING BAGS, LEATHER AND IMITATION LEATHER BAGS; HANDBAGS; SADDLE BELTS; KEY CASES; WALLET AND PURSES; FUR (U.S. CLS. 1, 2, 3, 22 AND 41).

#### CLASS 25—CLOTHING

FOR CLOTHING, NAMELY, OVERCOATS, OVERALLS, JUMPERS, TROUSERS, SKIRTS, SWEATERS, PULLOVERS, SUITS, PANTS FOR BABIES, LAYETTES; FUR STOLEES, FUR COATS, FUR JACKETS; FISHING VESTS; WET SUITS FOR WATER-SKIING; GYMNASIATIC SHOES, SPORTSWEAR, NAMELY, SHIRTS, SHORTS, PANTS, COATS, JERSEYS, SWIM WEAR, JACKETS, SWEATS, VESTS, UNDERWEAR, SOCKS, TRACK SUITS, BATHER CAPS; BELTS FOR CLOTHING; FOOTWEAR; HEADGEAR, NAMELY, HATS, CAPS (U.S. CLS. 22 AND 39).

MARK SHINER, EXAMINING ATTORNEY

SN 85-156,259. HART, KRISTINE L., VENTURA, CA. FILED 10-19-2010.



THE MARK CONSISTS OF A CREST LIKE SYMBOL WITH WING LIKE FEATURES. INSIDE SUCH CREST IS A FLEUR DE LIS. TO THE LEFT OF THE FLEUR DE LIS, STILL WITHIN THE CREST, IS ONE "R". DIAGONALLY BELOW SUCH R IS ANOTHER "R". OUTSIDE AND DIRECTLY BELOW THE CREST READS THE TERMS "ROYAL RIDING". THE CREST AND WING DESIGN ARE SURROUNDED BY RAYS OF LIGHT.

**CLASS 12—VEHICLES**

FOR VEHICLE SEAT COVERS AND VEHICLE SEAT CUSHIONS (U.S. CLS. 19, 21, 23, 31, 35 AND 44).  
FIRST USE 12-2-2009; IN COMMERCE 12-2-2009.

**CLASS 20—FURNITURE AND ARTICLES NOT OTHERWISE CLASSIFIED**

FOR SEAT PADS, NAMELY, SEAT CUSHIONS (U.S. CLS. 2, 13, 22, 25, 32 AND 50).  
FIRST USE 12-2-2009; IN COMMERCE 12-2-2009.  
JAMES LOVELACE, EXAMINING ATTORNEY

SN 85-157,902. EARTH TO SKY, LLC, IOWA CITY, IA. FILED 10-21-2010.

**CHAKRABODY FUSION**

THE MARK CONSISTS OF STANDARD CHARACTERS WITHOUT CLAIM TO ANY PARTICULAR FONT, STYLE, SIZE, OR COLOR.

**CLASS 41—EDUCATION AND ENTERTAINMENT**

FOR YOGA INSTRUCTION (U.S. CLS. 100, 101 AND 107).  
FIRST USE 6-1-2010; IN COMMERCE 6-1-2010.

**CLASS 44—MEDICAL, BEAUTY AND AGRICULTURAL SERVICES**

FOR MASSAGE THERAPY WITH MIND-BODY INTEGRATION EXERCISES FOR ENERGY BALANCING (U.S. CLS. 100 AND 101).  
FIRST USE 6-1-2010; IN COMMERCE 6-1-2010.  
JOHN E. MICHOS, EXAMINING ATTORNEY

SN 85-160,092. POWER PRESENTATIONS, INC., BRECKSVILLE, OH. FILED 10-25-2010.

**WEB MEETINGS THAT WOW**

THE MARK CONSISTS OF STANDARD CHARACTERS WITHOUT CLAIM TO ANY PARTICULAR FONT, STYLE, SIZE, OR COLOR.

OWNER OF U.S. REG. NOS. 3,558,934 AND 3,644,200.  
NO CLAIM IS MADE TO THE EXCLUSIVE RIGHT TO USE "WEB MEETINGS", APART FROM THE MARK AS SHOWN.

**CLASS 9—ELECTRICAL AND SCIENTIFIC APPARATUS**

FOR DOWNLOADABLE COMPUTER FILES, NAMELY, ELECTRONIC BOOKS AND DIGITAL VIDEO FILES FEATURING AUDIOVISUAL PRESENTATIONS IN THE FIELD OF PUBLIC SPEAKING AND PRESENTATION SKILLS (U.S. CLS. 21, 23, 26, 36 AND 38).  
FIRST USE 10-21-2010; IN COMMERCE 10-21-2010.

**CLASS 16—PAPER GOODS AND PRINTED MATTER**

FOR BOOKS IN THE FIELD OF PUBLIC SPEAKING AND PRESENTATION SKILLS (U.S. CLS. 2, 5, 22, 23, 29, 37, 38 AND 50).  
FIRST USE 10-21-2010; IN COMMERCE 10-21-2010.

**CLASS 41—EDUCATION AND ENTERTAINMENT**

FOR EDUCATIONAL SERVICES, NAMELY, PRESENTING WORKSHOPS, TRAINING, CLASSES, SEMINARS, AND ONLINE WEBCAST PROGRAMS IN THE FIELD OF PUBLIC SPEAKING AND PRESENTATION SKILLS; PROVIDING NON-DOWNLOADABLE ELECTRONIC BOOKS AND DIGITAL VIDEO FILES FEATURING AUDIOVISUAL PRESENTATIONS IN THE FIELD OF PUBLIC SPEAKING AND PRESENTATION SKILLS (U.S. CLS. 100, 101 AND 107).  
FIRST USE 5-13-2009; IN COMMERCE 5-13-2009.  
CORY BOONE, EXAMINING ATTORNEY

SN 85-160,257. CROSSTEX INTERNATIONAL, INC., HAUPAUGE, NY. FILED 10-25-2010.

**ULTRA PURE**

THE MARK CONSISTS OF STANDARD CHARACTERS WITHOUT CLAIM TO ANY PARTICULAR FONT, STYLE, SIZE, OR COLOR.

**CLASS 5—PHARMACEUTICALS**

FOR BURN DRESSINGS; WOUND DRESSINGS; ADHESIVE BANDAGES; COTTON FOR MEDICAL PURPOSES; MEDICAL PLASTERS; ABSORBENT COTTON FOR MEDICAL USE; SURGICAL GAUZE; SURGICAL DRESSINGS; GAUZE FOR DRESSINGS; STICKING PLASTERS FOR MEDICAL USE; FIRST AID KITS; SANITARY PADS; SANITARY NAPKINS; SURGICAL CLOTH, NAMELY, DRESSINGS AND DRAPES; MEDICATED PRE-MOISTENED TISSUES; BANDAGES FOR DRESSINGS (U.S. CLS. 6, 18, 44, 46, 51 AND 52).

**CLASS 10—MEDICAL APPARATUS**

FOR SPONGES FOR MEDICAL AND DENTAL PLACEMENT ON INCISION AND EXTRACTION SITES (U.S. CLS. 26, 39 AND 44).  
ALICIA COLLINS, EXAMINING ATTORNEY

SN 85-160,737. AUSGAR TECHNOLOGIES, INC., SAN DIEGO, CA. FILED 10-25-2010.



THE COLOR(S) WHITE, BLACK, GREEN AND BLUE IS/ ARE CLAIMED AS A FEATURE OF THE MARK.

THE MARK CONSISTS OF THE WORDING "AUSGAR" IN BLUE TO THE RIGHT OF A LOGO COMPRISED OF CROSSING CURVED LINES IN BLACK, GREEN, AND BLUE, ALL ON A WHITE BACKGROUND.

#### CLASS 35—ADVERTISING AND BUSINESS

FOR BUSINESS CONSULTING SERVICES TO FACILITATE THE DEVELOPMENT AND EXPERIMENTATION CYCLES OF NEWLY DEVELOPED SYSTEMS; BUSINESS CONSULTING SERVICES TO FACILITATE THE DEVELOPMENT OF STREAMLINED ACCREDITATION PROCESSES TO DELIVER REFINED AND CONCISE INFORMATION SYSTEM SECURITY DOCUMENTATION (U.S. CLS. 100, 101 AND 102).

FIRST USE 5-9-2003; IN COMMERCE 5-9-2003.

#### CLASS 42—SCIENTIFIC AND COMPUTER SERVICES

FOR ENGINEERING AND COMPUTER SERVICES, NAMELY, SYSTEMS ENGINEERING AND SOFTWARE DESIGN AND DEVELOPMENT; INFORMATION SECURITY ENGINEERING CONSULTING, TESTING AND EVALUATING THE INFORMATION SECURITY INFRASTRUCTURE OF OTHERS FOR THE PURPOSE OF CERTIFICATION; NETWORK ARCHITECTURE ENGINEERING; INFORMATION SYSTEMS SECURITY ENGINEERING; INFORMATION SYSTEMS MANAGEMENT FOR OTHERS (U.S. CLS. 100 AND 101).

FIRST USE 5-9-2003; IN COMMERCE 5-9-2003.  
KRISTIN DAHLING, EXAMINING ATTORNEY

SN 85-161,159. NISSHINBO TEXTILE INC., TOKYO, JAPAN,  
FILED 10-26-2010.

## DUALCLEAN III

THE MARK CONSISTS OF STANDARD CHARACTERS WITHOUT CLAIM TO ANY PARTICULAR FONT, STYLE, SIZE, OR COLOR.

#### CLASS 24—FABRICS

FOR WOVEN FABRICS (U.S. CLS. 42 AND 50).

#### CLASS 25—CLOTHING

FOR CLOTHING, NAMELY, SHIRTS (U.S. CLS. 22 AND 39).

ROBERT C. CLARK JR., EXAMINING ATTORNEY

SN 85-161,242. SUNGLASS ITALIA LLC, BOCA RATON, FL,  
FILED 10-26-2010.



NO CLAIM IS MADE TO THE EXCLUSIVE RIGHT TO USE "SUNGLASS ITALIA", APART FROM THE MARK AS SHOWN.

THE COLOR(S) BLACK, GOLD, GREEN, WHITE, AND RED IS/ARE CLAIMED AS A FEATURE OF THE MARK.

THE MARK CONSISTS OF THE WORD "SUNGLASS" IN GOLD, CAPITALIZED LETTERING; UNDERNEATH THE WORD "SUNGLASS" IS A HORIZONTAL GREEN LINE ON THE LEFT-HAND SIDE, A HORIZONTAL WHITE LINE IN THE CENTER, AND A HORIZONTAL RED LINE ON THE RIGHT-HAND SIDE; UNDERNEATH THESE THREE LINES IS THE WORD "ITALIA" IN GOLD, CAPITALIZED LETTERING; ALL OF THE FOREGOING IS PLACED AGAINST A BLACK BACKGROUND.

THE ENGLISH TRANSLATION OF "ITALIA" IN THE MARK IS "ITALY".

#### CLASS 9—ELECTRICAL AND SCIENTIFIC APPARATUS

FOR SUNGLASSES, AND SUNGLASS ACCESSORIES AND PARTS, NAMELY, CHAINS, CORDS, CASES, LENSES, AND FRAMES (U.S. CLS. 21, 23, 26, 36 AND 38).

#### CLASS 35—ADVERTISING AND BUSINESS

FOR ON-LINE RETAIL STORE SERVICES AND RETAIL STORE SERVICES FEATURING SUNGLASSES AND SUNGLASS ACCESSORIES AND PARTS (U.S. CLS. 100, 101 AND 102).

JOHN GARTNER, EXAMINING ATTORNEY

SN 85-161,604. UNITEDHEALTH GROUP INCORPORATED,  
MINNETONKA, MN. FILED 10-26-2010.

## INFOPORT

THE MARK CONSISTS OF STANDARD CHARACTERS WITHOUT CLAIM TO ANY PARTICULAR FONT, STYLE, SIZE, OR COLOR.

#### CLASS 9—ELECTRICAL AND SCIENTIFIC APPARATUS

FOR INTERACTIVE WEB-BASED DOWNLOADABLE APPLICATION SOFTWARE FOR USE IN PROVIDING HEALTH BENEFITS ADMINISTRATION AND CLAIMS ADMINISTRATION, FOR ACCESSING AND ASSESSING MEMBER ELIGIBILITY STATUS, FOR ACCESSING AND ASSESSING STATUS AND PAYMENT INFORMATION FOR MEDICAL, DENTAL, PRESCRIPTION AND STOP-LOSS CLAIMS, AND FOR HEALTH CARE UTILIZATION REVIEW AND HEALTH CARE CLAIMS AND COST BENCHMARKING (U.S. CLS. 21, 23, 26, 36 AND 38).

#### CLASS 36—INSURANCE AND FINANCIAL

FOR HEALTH CARE INSURANCE CLAIMS PROCESSING (U.S. CLS. 100, 101 AND 102).

#### CLASS 42—SCIENTIFIC AND COMPUTER SERVICES

FOR PROVIDING ONLINE NON-DOWNLOADABLE SOFTWARE FOR HEALTH BENEFITS ADMINISTRATION, FOR CLAIMS ADMINISTRATION, FOR ACCESSING AND ASSESSING MEMBER ELIGIBILITY STATUS, FOR ACCESSING AND ASSESSING STATUS AND PAYMENT INFORMATION FOR MEDICAL, DENTAL, PRESCRIPTION AND STOP-LOSS CLAIMS, AND FOR HEALTH CARE UTILIZATION REVIEW AND HEALTH CARE CLAIMS AND COST BENCHMARKING (U.S. CLS. 100 AND 101).

**CLASS 44—MEDICAL, BEAUTY AND AGRICULTURAL SERVICES**

FOR MANAGED HEALTH CARE SERVICES (U.S. CLS. 100 AND 101).  
REGINA DRUMMOND, EXAMINING ATTORNEY

---

SN 85-162,246. WEDGE GROUP INCORPORATED, HOUSTON, TX. FILED 10-27-2010.

**WEDGE**

THE MARK CONSISTS OF STANDARD CHARACTERS WITHOUT CLAIM TO ANY PARTICULAR FONT, STYLE, SIZE, OR COLOR.

OWNER OF U.S. REG. NO. 2,367,478.

**CLASS 36—INSURANCE AND FINANCIAL**

FOR LEASING OF OFFICE SPACE (U.S. CLS. 100, 101 AND 102).  
FIRST USE 9-0-1994; IN COMMERCE 9-0-1994.

**CLASS 42—SCIENTIFIC AND COMPUTER SERVICES**

FOR ELECTRICITY AND NATURAL GAS SERVICES, NAMELY, METERING (U.S. CLS. 100 AND 101).  
FIRST USE 7-0-2004; IN COMMERCE 7-0-2004.  
BERYL GARDNER, EXAMINING ATTORNEY

---

SN 85-162,323. WASHINGTON, RONALD, ARLINGTON, TX. FILED 10-27-2010.

**THAT'S THE WAY BASEBALL GO**

THE MARK CONSISTS OF STANDARD CHARACTERS WITHOUT CLAIM TO ANY PARTICULAR FONT, STYLE, SIZE, OR COLOR.

**CLASS 16—PAPER GOODS AND PRINTED MATTER**

FOR PAPER GOODS AND PRINTED MATTER, NAMELY, TRADING CARDS, POSTERS, STICKERS, DECALS, TEMPORARY TATTOOS, BUMPER STICKERS, SCORECARDS, PRINTED BASEBALL GAME PROGRAMS, MAGAZINES AND BOOKS FEATURING BASEBALL, WRITING PADS, NOTE PAPER, NOTEBOOKS, BINDERS, STATIONERY-TYPE PORTFOLIOS, STATIONERY FOLDERS, PREPRINTED AGENDA ORGANIZERS, AUTOGRAPH BOOKS, BASEBALL CARD ALBUMS, BOOK COVERS, CALENDARS, GREETING CARDS, PRINTED BANK CHECKBOOKS, CHECKBOOK COVERS, RUBBER STAMPS, INK STAMPS, PAPER PENNANTS, GIFT WRAPPING PAPER, PAPER GIFT AND PARTY BAGS, PAPER PARTY GOODS IN THE NATURE OF PAPER PARTY DECORATIONS; PAPER NAPKINS, PAPER TABLECLOTHS, MOUNTED AND UN-MOUNTED PHOTOGRAPHS, PHOTOGRAPH ALBUMS, LITHOGRAPHS, PLASTIC BASEBALL CARD HOLDERS AND COLLECTORS CASES, PAPER-WEIGHTS, LETTER OPENERS, PENS, PENCILS, PENCIL TOP ORNAMENTS, CRAYONS, NON-ELECTRIC ERASERS, ART PICTURES, ART PRINTS (U.S. CLS. 2, 5, 22, 23, 29, 37, 38 AND 50).

**CLASS 25—CLOTHING**

FOR CLOTHING, NAMELY, CAPS, HATS, SHIRTS, T-SHIRTS, TANK TOPS, TURTLENECKS, PULLOVERS, SHORTS, PANTS, DRESSES, BASEBALL UNIFORMS, JERSEYS, SWEATSHIRTS, ROBES, JACKETS, CLOTH BIBS, INFANT WEAR, JUMPERS, CREEPERS, TIES, SOCKS, HOSIERY (U.S. CLS. 22 AND 39).

**CLASS 41—EDUCATION AND ENTERTAINMENT**

FOR ENTERTAINMENT SERVICES, NAMELY, BASEBALL GAMES, COMPETITIONS AND EXHIBITIONS RENDERED LIVE AND THROUGH BROADCAST MEDIA INCLUDING TELEVISION AND RADIO, AND VIA A GLOBAL COMPUTER NETWORK OR A COMMERCIAL ON-LINE SERVICE; INFORMATION SERVICES, NAMELY, PROVIDING INFORMATION IN THE FIELD OF SPORTS, ENTERTAINMENT AND RELATED TOPICS, NAMELY, BASEBALL GAMES, COMPETITIONS AND EXHIBITIONS, AND PROVIDING FOR INFORMATIONAL MESSAGES RELATING THERETO, NAMELY, PROVIDING A WEB SITE FEATURING SPORTS AND ENTERTAINMENT INFORMATION RELATED TO BASEBALL GAMES, COMPETITIONS AND EXHIBITIONS; EDUCATIONAL SERVICES IN THE NATURE OF BASEBALL SKILLS PROGRAMS, BASEBALL CAMPS, AND CLINICS OFFERED LIVE; ENTERTAINMENT SERVICES, NAMELY, PRODUCTION OF TELEVISION AND RADIO PROGRAMMING ALSO ACCESSIBLE VIA A GLOBAL COMPUTER NETWORK OR A COMMERCIAL ON-LINE SERVICE; ORGANIZING COMMUNITY SPORTING EVENTS; PROVIDING FACILITIES FOR SPORTS TOURNAMENTS AND COMPETITIONS RELATING TO BASEBALL; ORGANIZING AND CONDUCTING FANTASY SPORTS LEAGUE, SPORTS CONTESTS AND SWEEPSTAKES; FAN CLUBS; PROVIDING ON-LINE NEWSLETTERS IN THE FIELD OF BASEBALL (U.S. CLS. 100, 101 AND 107).

ALEX KEAM, EXAMINING ATTORNEY



SN 85-162,818. EL'S KITCHEN, INC., WESTON, CT. FILED 10-27-2010.

## Medleys, A Zesty Snack Mix

THE MARK CONSISTS OF STANDARD CHARACTERS WITHOUT CLAIM TO ANY PARTICULAR FONT, STYLE, SIZE, OR COLOR.

NO CLAIM IS MADE TO THE EXCLUSIVE RIGHT TO USE "ZESTY SNACK MIX", APART FROM THE MARK AS SHOWN.

### CLASS 5—PHARMACEUTICALS

FOR GLUTEN FREE SNACK MIXES CONSISTING OF PROCESSED CEREALS, GLUTEN FREE POTATO CHIPS, GLUTEN FREE BAGEL CHIPS, GLUTEN FREE CORN CHIPS, GLUTEN FREE PRETZELS, CRACKERS, PROCESSED NUTS, AND SEEDS TO ACCOMMODATE SPECIAL MEDICAL AND HEALTH CONDITIONS (U.S. CLS. 6, 18, 44, 46, 51 AND 52).

### CLASS 29—MEATS AND PROCESSED FOODS

FOR GLUTEN-FREE SNACK MIXES CONSISTING OF GLUTEN FREE POTATO CHIPS, PROCESSED NUTS, AND SEEDS (U.S. CL. 46).

### CLASS 30—STAPLE FOODS

FOR GLUTEN-FREE SNACK MIXES CONSISTING OF PROCESSED CEREALS, GLUTEN FREE BAGEL CHIPS, GLUTEN FREE CORN CHIPS, GLUTEN FREE PRETZELS, CRACKERS (U.S. CL. 46).

ALYSSA STEEL, EXAMINING ATTORNEY

SN 85-163,164. DUNCAN ENTERPRISES, FRESNO, CA. FILED 10-27-2010.

## BEADS IN A BOTTLE

THE MARK CONSISTS OF STANDARD CHARACTERS WITHOUT CLAIM TO ANY PARTICULAR FONT, STYLE, SIZE, OR COLOR.

### CLASS 2—PAINTS

FOR PAINTS FOR ARTS AND CRAFTS (U.S. CLS. 6, 11 AND 16).

### CLASS 16—PAPER GOODS AND PRINTED MATTER

FOR IRON-ON TRANSFERS SPECIFICALLY FOR CRAFT AND HOBBY USE ON FABRICS AND TEXTILES (U.S. CLS. 2, 5, 22, 23, 29, 37, 38 AND 50).

STEVEN PEREZ, EXAMINING ATTORNEY

SN 85-163,583. SUNBEAM PRODUCTS, INC., BOCA RATON, FL. FILED 10-28-2010.



OWNER OF U.S. REG. NOS. 2,751,031, 3,805,807 AND OTHERS.

THE MARK CONSISTS OF THE LITERAL ELEMENT "RIVAL" AND A DESIGN CONSISTING OF AN ARCH EXTENDING, COMPLETELY ACROSS AND CENTERED SYMMETRICALLY DIRECTLY ABOVE THE LITERAL ELEMENT, AND A SOLID CIRCLE POSITIONED DIRECTLY ABOVE THE CENTER OF THE ARCH AND LITERAL ELEMENT.

### CLASS 7—MACHINERY

FOR ELECTRICAL HOUSEHOLD APPLIANCES, NAMELY, JUICE EXTRACTORS, CITRUS JUICERS (U.S. CLS. 13, 19, 21, 23, 31, 34 AND 35).

### CLASS 9—ELECTRICAL AND SCIENTIFIC APPARATUS

FOR ELECTRIC CLOTHING STEAMERS (U.S. CLS. 21, 23, 26, 36 AND 38).

### CLASS 11—ENVIRONMENTAL CONTROL APPARATUS

FOR ELECTRICAL HOUSEHOLD APPLIANCES, NAMELY, POPCORN POPPERS, AND COMPACT REFRIGERATORS (U.S. CLS. 13, 21, 23, 31 AND 34).

MICHAEL WEBSTER, EXAMINING ATTORNEY

SN 85-163,774. L.H. HAYWARD & COMPANY, LLC, HARAHAN, LA. FILED 10-28-2010.



OWNER OF U.S. REG. NO. 1,646,164.

NO CLAIM IS MADE TO THE EXCLUSIVE RIGHT TO USE "BRAND.COM", APART FROM THE MARK AS SHOWN.

THE COLOR(S) RED AND GREEN AND WHITE IS/ARE CLAIMED AS A FEATURE OF THE MARK.

THE MARK CONSISTS OF A RED CAMELLIA FLOWER WITH WHITE TRIM WITH A GREEN LEAF WITH WHITE VEINS ON EITHER SIDE OF THE RED CAMELLIA FLOWER AND THE WORD "CAMELLIA" IN RED BENEATH THE CAMELLIA FLOWER, THE WORD "BRAND" IN RED BENEATH THE WORD "CAMELLIA", AND "COM" IN RED BENEATH THE WORD "CAMELLIA".

#### CLASS 29—MEATS AND PROCESSED FOODS

FOR DRIED PULSES, NAMELY, PROCESSED BEANS (U.S. CL. 46).  
FIRST USE 10-1-2007; IN COMMERCE 10-1-2007.

#### CLASS 31—NATURAL AGRICULTURAL PRODUCTS

FOR UNPROCESSED BEANS, PEAS AND LENTILS, NAMELY, RED KIDNEY BEANS, NAVY BEANS, NAVY PEA BEANS, BLACK EYE PEAS, LARGE LIMA BEANS, BABY LIMA BEANS, PINTO BEANS, GREAT NORTHERN BEANS, GREEN BABY LIMA BEANS, FIELD PEAS, CROWDER PEAS, LADY CREAM PEAS, GREEN SPLIT PEAS, YELLOW SPLIT PEAS, BLACK BEANS, PINK BEANS, LENTILS AND GARBANZO BEANS (U.S. CLS. 1 AND 46).

FIRST USE 10-1-2007; IN COMMERCE 10-1-2007.  
EDWARD FENNESSY, EXAMINING ATTORNEY

SN 85-163,790. L.H. HAYWARD & COMPANY, LLC, HARAHAN, LA. FILED 10-28-2010.



OWNER OF U.S. REG. NO. 1,646,164.  
NO CLAIM IS MADE TO THE EXCLUSIVE RIGHT TO USE "TO GO", APART FROM THE MARK AS SHOWN.

THE COLOR(S) RED, REDDISH, GREEN, WHITE, GRAY-BLACK AND YELLOW IS/ARE CLAIMED AS A FEATURE OF THE MARK.

THE MARK CONSISTS OF A GREEN CAN HAVING AN OVAL WHITE LABEL TRIMMED IN RED WITH A RED CAMELLIA FLOWER HAVING A GREEN LEAF ON EITHER SIDE WITH THE WORD "CAMELLIA" IN RED BENEATH THE FLOWER UNDER WHICH ARE THE WORDS "BEANS.COM" IN RED AND BENEATH ARE THE WORDS "TO GO!" IN YELLOW, THE GREEN CAN HAVING ONE GREEN ARM ON EITHER SIDE AND HAVING TWO GRAY-BLACK TIRES WITH ONE TIRE HAVING A WHITE AND A GREEN HUBCAP IN THE MIDDLE OF THE TIRE AND HAVING BLACK LINES IN PARENTHESIS STYLE BEHIND THE TIRE AND ALSO HAVING BLACK LINES COMING FROM THE SIDES THE GREEN CAN AND HAVING A RED CAN COVER WITH TWO EYES WITH GREEN EYELIDS, BLACK PUPILS ON THE WHITE PARTS OF THE EYES, ALL ON A YELLOW CIRCLE, BELOW WHICH APPEAR THE WORDS "CAMELLIABEANS.COM" IN REDDISH COLOR.

#### CLASS 29—MEATS AND PROCESSED FOODS

FOR DRIED PULSES, NAMELY, PROCESSED BEANS (U.S. CL. 46).

#### CLASS 30—STAPLE FOODS

FOR RICE, SPICES (U.S. CL. 46).

#### CLASS 31—NATURAL AGRICULTURAL PRODUCTS

FOR UNPROCESSED BEANS, PEAS AND LENTILS, NAMELY, RED KIDNEY BEANS, NAVY BEANS, NAVY PEA BEANS, BLACK EYE PEAS, LARGE LIMA BEANS, BABY LIMA BEANS, PINTO BEANS, GREAT NORTHERN BEANS, GREEN BABY LIMA BEANS, FIELD PEAS, CROWDER PEAS, LADY CREAM PEAS, GREEN SPLIT PEAS, YELLOW SPLIT PEAS, BLACK BEANS, PINK BEANS, LENTILS AND GARBANZO BEANS, AND UNPROCESSED RICE (U.S. CLS. 1 AND 46).

EDWARD FENNESSY, EXAMINING ATTORNEY

SN 85-163,892. SKINDER-STRAUSS ASSOCIATES, NEWARK, NJ. FILED 10-28-2010.

#### LAWYERS DIARY AND MANUAL

THE MARK CONSISTS OF STANDARD CHARACTERS WITHOUT CLAIM TO ANY PARTICULAR FONT, STYLE, SIZE, OR COLOR.

OWNER OF U.S. REG. NOS. 1,274,287, 2,731,159 AND OTHERS.  
SEC. 2(F).

#### CLASS 9—ELECTRICAL AND SCIENTIFIC APPARATUS

FOR COMPUTER SOFTWARE FOR THE CREATION AND PUBLICATION OF CALENDARS AND SCHEDULES; COMPUTER SOFTWARE FEATURING LISTINGS OF BUSINESSES SPECIALIZING IN SERVING MEMBERS OF THE LEGAL COMMUNITY; COMPUTER SOFTWARE FEATURING LISTS OF LAWYERS BASED UPON PARTICULAR JURISDICTIONS, STATE AND FEDERAL COURT PROCEDURE, AND OTHER INFORMATION PERTINENT TO A PARTICULAR LOCAL JURISDICTION, NAMELY, FILING FEE SCHEDULES FOR STATE AND FEDERAL COURTS, LISTINGS OF STATE AND FEDERAL DEPARTMENTS AND AGENCIES, DIRECTORIES OF STATE AND FEDERAL COURTS, DIRECTORIES OF STATE AND FEDERAL JUDGES, MUNICIPAL DIRECTORIES, AND DIRECTORIES OF SELECTED ATTORNEYS BY SPECIALTY (U.S. CLS. 21, 23, 26, 36 AND 38).

FIRST USE 12-31-1990; IN COMMERCE 12-31-1990.

#### CLASS 16—PAPER GOODS AND PRINTED MATTER

FOR PRINTED MATTER FOR THE LEGAL COMMUNITY, NAMELY, A DAILY CALENDAR AND ANNUALLY-UPDATED REFERENCE BOOKS CONTAINING LISTS OF LAWYERS BASED UPON PARTICULAR JURISDICTIONS, STATE AND FEDERAL COURT PROCEDURE, AND OTHER INFORMATION PERTINENT TO A PARTICULAR LOCAL JURISDICTION, NAMELY, FILING FEE SCHEDULES FOR STATE AND FEDERAL COURTS, LISTINGS OF STATE AND FEDERAL DEPARTMENTS AND AGENCIES, DIRECTORIES OF STATE AND FEDERAL COURTS, DIRECTORIES OF STATE AND FEDERAL JUDGES, MUNICIPAL DIRECTORIES, AND DIRECTORIES OF SELECTED ATTORNEYS BY SPECIALTY (U.S. CLS. 2, 5, 22, 23, 29, 37, 38 AND 50).

FIRST USE 12-31-1944; IN COMMERCE 12-31-1944.

**CLASS 35—ADVERTISING AND BUSINESS**

FOR RETAIL SERVICES, NAMELY, DIRECT MAIL ORDER SERVICES AND ONLINE RETAIL STORE SERVICES FEATURING LEGAL PUBLICATIONS, TEXTS, AND MATERIALS FOR THE LEGAL PROFESSION (U.S. CLS. 100, 101 AND 102).

FIRST USE 12-31-1990; IN COMMERCE 12-31-1990.  
AISHA SALEM, EXAMINING ATTORNEY

---

SN 85-164,108. THE HANCE FAMILY FOUNDATION, FLORAL PARK, NY. FILED 10-28-2010.

**THE EAK PROJECT**

THE MARK CONSISTS OF STANDARD CHARACTERS WITHOUT CLAIM TO ANY PARTICULAR FONT, STYLE, SIZE, OR COLOR.

NO CLAIM IS MADE TO THE EXCLUSIVE RIGHT TO USE "PROJECT", APART FROM THE MARK AS SHOWN.

**CLASS 35—ADVERTISING AND BUSINESS**

FOR CHARITABLE SERVICES, NAMELY, ORGANIZING AND DEVELOPING PROJECTS THAT AIM TO IMPROVE THE CONFIDENCE AND SELF-ESTEEM OF CHILDREN (U.S. CLS. 100, 101 AND 102).

**CLASS 36—INSURANCE AND FINANCIAL**

FOR CHARITABLE SERVICES, NAMELY, PROVIDING FINANCIAL SUPPORT TO PROGRAMS WHICH ENHANCE AND DEVELOP THE CONFIDENCE AND SELF ESTEEM OF CHILDREN (U.S. CLS. 100, 101 AND 102).

**CLASS 41—EDUCATION AND ENTERTAINMENT**

FOR CONDUCTING EDUCATIONAL PROGRAMS IN THE NATURE OF CLASSES AND WORKSHOPS TO HELP ENHANCE AND DEVELOP CONFIDENCE AND SELF ESTEEM OF CHILDREN (U.S. CLS. 100, 101 AND 107).

KELLEY WELLS, EXAMINING ATTORNEY

---

SN 85-164,114. BRICKELL FINANCIAL SERVICES-MOTOR CLUB, INC., MIAMI, FL. FILED 10-28-2010.

**DRIVER'S SECURITY**

THE MARK CONSISTS OF STANDARD CHARACTERS WITHOUT CLAIM TO ANY PARTICULAR FONT, STYLE, SIZE, OR COLOR.

OWNER OF U.S. REG. NO. 2,911,871.  
SEC. 2(F).

**CLASS 39—TRANSPORTATION AND STORAGE**

FOR EMERGENCY ROADSIDE ASSISTANCE SERVICES, NAMELY, TOWING, WINCH-OUT AND KEY DELIVERY SERVICES (U.S. CLS. 100 AND 105).

FIRST USE 6-1-2002; IN COMMERCE 6-1-2002.

**CLASS 45—PERSONAL AND LEGAL SERVICES**

FOR EMERGENCY ROADSIDE ASSISTANCE SERVICES, NAMELY, OPENING OF LOCKS (U.S. CLS. 100 AND 101).

FIRST USE 6-1-2002; IN COMMERCE 6-1-2002.  
MARILYN IZZI, EXAMINING ATTORNEY

---

SN 85-164,210. ANNETTE I. KAHLER, LOUDONVILLE, NY. FILED 10-28-2010.

**PATENTLICIOUS**

THE MARK CONSISTS OF STANDARD CHARACTERS WITHOUT CLAIM TO ANY PARTICULAR FONT, STYLE, SIZE, OR COLOR.

**CLASS 16—PAPER GOODS AND PRINTED MATTER**

FOR PENS, PENCILS, PAPER, NOTEPADS, CALENDARS, STICKERS, BUMPER STICKERS, NOTE CARDS, POST CARDS, AND PAPER LABELS (U.S. CLS. 2, 5, 22, 23, 29, 37, 38 AND 50).

**CLASS 25—CLOTHING**

FOR CLOTHING, NAMELY, SHIRTS, T-SHIRTS, SWEATSHIRTS, JACKETS, CAPS, AND HATS (U.S. CLS. 22 AND 39).

**CLASS 45—PERSONAL AND LEGAL SERVICES**

FOR LEGAL SERVICES (U.S. CLS. 100 AND 101).  
BRIDGETT SMITH, EXAMINING ATTORNEY

---

SN 85-164,226. ANNETTE I. KAHLER, LOUDONVILLE, NY. FILED 10-28-2010.

**IPLICIOUS**

THE MARK CONSISTS OF STANDARD CHARACTERS WITHOUT CLAIM TO ANY PARTICULAR FONT, STYLE, SIZE, OR COLOR.

**CLASS 16—PAPER GOODS AND PRINTED MATTER**

FOR PENS, PENCILS, PAPER, NOTEPADS, CALENDARS, STICKERS, BUMPER STICKERS, NOTE CARDS, POST CARDS, NOTE BOOKS, BOOK COVERS, AND PAPER LABELS (U.S. CLS. 2, 5, 22, 23, 29, 37, 38 AND 50).

**CLASS 25—CLOTHING**

FOR CLOTHING, NAMELY, SHIRTS, T-SHIRTS, SWEATSHIRTS, JACKETS, CAPS, HATS AND NECKTIES (U.S. CLS. 22 AND 39).

**CLASS 45—PERSONAL AND LEGAL SERVICES**

FOR LEGAL SERVICES (U.S. CLS. 100 AND 101).  
BRIDGETT SMITH, EXAMINING ATTORNEY

**CLASS 4—LUBRICANTS AND FUELS**

FOR CANDLES (U.S. CLS. 1, 6 AND 15).

**CLASS 5—PHARMACEUTICALS**

FOR DEODORIZER FOR FABRIC, CARPET AND UPHOLSTERY (U.S. CLS. 6, 18, 44, 46, 51 AND 52).  
EMILY CARLSEN, EXAMINING ATTORNEY

SN 85-164,407. PEGASUS TRANSTECH CORP., TAMPA, FL.  
FILED 10-29-2010.

**TRANSFLO \$VELOCITY**

THE MARK CONSISTS OF STANDARD CHARACTERS WITHOUT CLAIM TO ANY PARTICULAR FONT, STYLE, SIZE, OR COLOR.  
OWNER OF U.S. REG. NOS. 2,319,213, 2,680,371 AND 2,888,278.

**CLASS 35—ADVERTISING AND BUSINESS**

FOR DOCUMENT MANAGEMENT FOR OTHERS THROUGH USE OF COMPUTER SOFTWARE FOR INDEXING AND TRACKING (U.S. CLS. 100, 101 AND 102).  
FIRST USE 4-0-2010; IN COMMERCE 4-0-2010.

**CLASS 42—SCIENTIFIC AND COMPUTER SERVICES**

FOR COMPUTER SERVICES, NAMELY, APPLICATION SERVICE PROVIDER FEATURING SOFTWARE FOR USE IN BILLING, COLLECTIONS, PAYROLL, SETTLEMENTS, ACCOUNTS PAYABLE, CLAIMS, DRIVER QUALIFICATIONS, DRIVER LOGS, PERMITS, AND ACCOUNTING, ALL IN THE FIELD OF TRANSPORTATION (U.S. CLS. 100 AND 101).  
FIRST USE 4-0-2010; IN COMMERCE 4-0-2010.  
LINDA MICKLEBURGH, EXAMINING ATTORNEY

SN 85-164,991. S. C. JOHNSON & SON, INC., RACINE, WI.  
FILED 10-29-2010.

**REFRESHING SURF**

THE MARK CONSISTS OF STANDARD CHARACTERS WITHOUT CLAIM TO ANY PARTICULAR FONT, STYLE, SIZE, OR COLOR.  
OWNER OF U.S. REG. NO. 3,670,442.

SN 85-166,601. INTERNATIONAL EDUCATION RESEARCH FOUNDATION, INC., CULVER CITY, CA. FILED 11-1-2010.



THE MARK CONSISTS OF THE TERM "IERF" WITH THE LETTERS SEPARATED BY BULLETS. "IERF" IS DISPLAYED AGAINST AN IRREGULAR PENTAGON SHAPED BACKGROUND OF CONTRASTING COLOR. POSITIONED BELOW "IERF" WITHIN THE PENTAGON IS A PARTIAL, STYLIZED GLOBE DESIGN WITH THE LONGITUDINAL AND LATITUDINAL LINES.

**CLASS 41—EDUCATION AND ENTERTAINMENT**

FOR EDUCATIONAL CREDENTIALS EVALUATION SERVICES FOR FOREIGN-EDUCATED INDIVIDUALS SEEKING VISA APPLICATIONS, PROFESSIONAL LICENSURE OR BOARD CERTIFICATIONS, INCLUDING PHYSICAL THERAPY, NURSING, LAW, ACCOUNTING, TEACHING, BARBERING AND COSMETOLOGY, REAL ESTATE, ARCHITECTURE, SPEECH AND LANGUAGE PATHOLOGY, OR SEEKING TO STUDY OR TO SECURE EMPLOYMENT IN THE UNITED STATES (U.S. CLS. 100, 101 AND 107).  
FIRST USE 1-0-1992; IN COMMERCE 1-0-1992.

**CLASS 45—PERSONAL AND LEGAL SERVICES**

FOR CREDENTIALS EVALUATION SERVICES IN THE NATURE OF VERIFYING AND MONITORING THE CREDENTIALS OF FOREIGN-EDUCATED DOCTORS AND OTHER MEDICAL PROFESSIONALS SEEKING LICENSURE OR BOARD CERTIFICATION IN THE MEDICAL FIELD (U.S. CLS. 100 AND 101).  
FIRST USE 1-0-1992; IN COMMERCE 1-0-1992.  
NICHOLAS ALTREE, EXAMINING ATTORNEY



SN 85-166,609. INTERNATIONAL EDUCATION RESEARCH FOUNDATION, INC., CULVER CITY, CA. FILED 11-1-2010.

**IERF**

THE MARK CONSISTS OF STANDARD CHARACTERS WITHOUT CLAIM TO ANY PARTICULAR FONT, STYLE, SIZE, OR COLOR.

**CLASS 41—EDUCATION AND ENTERTAINMENT**

FOR EDUCATIONAL CREDENTIALS EVALUATION SERVICES FOR FOREIGN-EDUCATED INDIVIDUALS SEEKING VISA APPLICATIONS, PROFESSIONAL LICENSURE OR BOARD CERTIFICATIONS, INCLUDING PHYSICAL THERAPY, NURSING, LAW, ACCOUNTING, TEACHING, BARBERING AND COSMETOLOGY, REAL ESTATE, ARCHITECTURE, SPEECH AND LANGUAGE PATHOLOGY, OR SEEKING TO STUDY OR TO SECURE EMPLOYMENT IN THE UNITED STATES (U.S. CLS. 100, 101 AND 107).

FIRST USE 0-0-1970; IN COMMERCE 0-0-1970.

**CLASS 45—PERSONAL AND LEGAL SERVICES**

FOR CREDENTIALS EVALUATION SERVICES IN THE NATURE OF VERIFYING AND MONITORING THE CREDENTIALS OF FOREIGN-EDUCATED DOCTORS AND OTHER MEDICAL PROFESSIONALS SEEKING LICENSURE OR BOARD CERTIFICATION IN THE MEDICAL FIELD (U.S. CLS. 100 AND 101).

FIRST USE 0-0-1970; IN COMMERCE 0-0-1970.

NICHOLAS ALTREE, EXAMINING ATTORNEY

SN 85-166,627. INTERNATIONAL EDUCATION RESEARCH FOUNDATION, INC., CULVER CITY, CA. FILED 11-1-2010.

**INTERNATIONAL EDUCATION  
RESEARCH FOUNDATION**

THE MARK CONSISTS OF STANDARD CHARACTERS WITHOUT CLAIM TO ANY PARTICULAR FONT, STYLE, SIZE, OR COLOR.

NO CLAIM IS MADE TO THE EXCLUSIVE RIGHT TO USE "FOUNDATION", APART FROM THE MARK AS SHOWN.

SEC. 2(F).

**CLASS 41—EDUCATION AND ENTERTAINMENT**

FOR EDUCATIONAL CREDENTIALS EVALUATION SERVICES FOR FOREIGN-EDUCATED INDIVIDUALS SEEKING VISA APPLICATIONS, PROFESSIONAL LICENSURE OR BOARD CERTIFICATIONS, INCLUDING PHYSICAL THERAPY, NURSING, LAW, ACCOUNTING, TEACHING, BARBERING AND COSMETOLOGY, REAL ESTATE, ARCHITECTURE, SPEECH AND LANGUAGE PATHOLOGY, OR SEEKING TO STUDY OR TO SECURE EMPLOYMENT IN THE UNITED STATES (U.S. CLS. 100, 101 AND 107).

FIRST USE 0-0-1970; IN COMMERCE 0-0-1970.

**CLASS 45—PERSONAL AND LEGAL SERVICES**

FOR CREDENTIALS EVALUATION SERVICES IN THE NATURE OF VERIFYING AND MONITORING THE CREDENTIALS OF FOREIGN-EDUCATED DOCTORS AND OTHER MEDICAL PROFESSIONALS SEEKING LICENSURE OR BOARD CERTIFICATION IN THE MEDICAL FIELD (U.S. CLS. 100 AND 101).

FIRST USE 0-0-1970; IN COMMERCE 0-0-1970.

NICHOLAS ALTREE, EXAMINING ATTORNEY

SN 85-166,740. DIGNITY FOR PETS, INC., WALLINGFORD, CT. FILED 11-2-2010.

**DIGNITY FOR PETS**

THE MARK CONSISTS OF STANDARD CHARACTERS WITHOUT CLAIM TO ANY PARTICULAR FONT, STYLE, SIZE, OR COLOR.

**CLASS 35—ADVERTISING AND BUSINESS**

FOR RETAIL STORE SERVICES FEATURING PET CREMATION PRODUCTS, NAMELY, URNS AND JEWELRY CONTAINING CREMATED REMAINS AND OTHER PET MEMORIAL PRODUCTS; MAIL ORDER SERVICES FEATURING PET CREMATION PRODUCTS, NAMELY, URNS AND JEWELRY CONTAINING CREMATED REMAINS AND OTHER PET MEMORIAL PRODUCTS; ON-LINE RETAIL STORE SERVICES FEATURING PET CREMATION PRODUCTS, NAMELY, URNS, JEWELRY CONTAINING CREMATED REMAINS AND OTHER PET MEMORIAL PRODUCTS (U.S. CLS. 100, 101 AND 102).

FIRST USE 10-1-2010; IN COMMERCE 10-15-2010.

**CLASS 39—TRANSPORTATION AND STORAGE**

FOR TRANSPORTATION OF PET FOR OTHERS, NAMELY, THE PICKUP AND DELIVERY OF PETS TO A PET OWNER'S HOME, A CREMATORIUM, PET CEMETERY OR VETERINARIAN OFFICE; STORAGE SERVICES, NAMELY, STORAGE OF PET REMAINS (U.S. CLS. 100 AND 105).

FIRST USE 10-1-2010; IN COMMERCE 10-15-2010.

GRETCHEN ULRICH, EXAMINING ATTORNEY

SN 85-167,298. CORE EDUCATION AND CONSULTING SOLUTIONS, INC., ATLANTA, GA. FILED 11-2-2010.

**AC3**

THE MARK CONSISTS OF STANDARD CHARACTERS WITHOUT CLAIM TO ANY PARTICULAR FONT, STYLE, SIZE, OR COLOR.

**CLASS 41—EDUCATION AND ENTERTAINMENT**

FOR EDUCATIONAL ASSESSMENT; CONSULTING SERVICES IN THE FIELD OF EDUCATION ASSESSMENT AND PLANNING; EDUCATIONAL TESTING EVALUATION (U.S. CLS. 100, 101 AND 107).

**CLASS 42—SCIENTIFIC AND COMPUTER SERVICES**

FOR PROVIDING A WEBSITE FEATURING RESOURCES, NAMELY, A WEBSITE FEATURING PRIMARILY NON-DOWNLOADABLE SOFTWARE FOR ADMINISTERING, COLLECTING AND REVIEWING EDUCATIONAL TESTS AND EDUCATIONAL TEST DATA; PROVIDING A WEBSITE FEATURING RESOURCES, NAMELY, A WEBSITE FEATURING PRIMARILY NON-DOWNLOADABLE SOFTWARE FOR USE IN ANALYZING AND INTERPRETING STUDENT FORMATIVE ASSESSMENT TESTING DATA CONSULTING SERVICES, NAMELY, DESIGN, DEVELOPMENT AND ANALYSIS OF TESTS FOR TESTING STUDENTS; PROVIDING A WEBSITE FEATURING RESOURCES, NAMELY, A WEBSITE FEATURING PRIMARILY NON-DOWNLOADABLE SOFTWARE FOR DESIGNING FORMATIVE EDUCATIONAL ASSESSMENT PROCEDURES (U.S. CLS. 100 AND 101).

RONALD AIKENS, EXAMINING ATTORNEY

**CLASS 41—EDUCATION AND ENTERTAINMENT**

FOR ORGANIZING AND ARRANGING OF COMPETITIONS AND EVENTS FOR PLAYERS OF COMPUTER GAMES PROGRAMS; ORGANIZING AND ARRANGING OF COMPETITIONS AND EVENTS FOR PLAYERS OF VIDEO GAMES PROGRAMS; ORGANIZING AND ARRANGING OF COMPETITIONS AND EVENTS FOR PLAYERS OF INTERACTIVE GAMES SOFTWARE; ORGANIZING AND ARRANGING OF EVENTS FOR PLAYERS OF ENTERTAINMENT SOFTWARE; HOSTING OF EVENTS AWARDING PRIZES TO PLAYERS OF COMPUTER GAMES PROGRAMS AND VIDEO GAMES PROGRAMS AND INTERACTIVE GAMES SOFTWARE AND ENTERTAINMENT SOFTWARE; INFORMATION AND ADVISORY AND CONSULTANCY SERVICES RELATING TO ALL OF THE FOREGOING (U.S. CLS. 100, 101 AND 107).

PAM WILLIS, EXAMINING ATTORNEY

SN 85-167,521. JAGEX LIMITED, CAMBRIDGE, UNITED KINGDOM, FILED 11-2-2010.

SN 85-168,240. ENCOUNTER FOR CULTURE AND EDUCATION, INC., NEW YORK, NY. FILED 11-3-2010.

**GOLDEN GNOMES**

THE MARK CONSISTS OF STANDARD CHARACTERS WITHOUT CLAIM TO ANY PARTICULAR FONT, STYLE, SIZE, OR COLOR.

PRIORITY CLAIMED UNDER SEC. 44(D) ON UNITED KINGDOM APPLICATION NO. 2547235, FILED 5-10-2010, REG. NO. 2547235, DATED 8-27-2010, EXPIRES 5-10-2020.

**CLASS 16—PAPER GOODS AND PRINTED MATTER**

FOR PRINTED PUBLICATIONS, NAMELY, BOOKS, LEAFLETS, BROCHURES, PLAYER'S GUIDES, INSTRUCTIONAL AND TEACHING MATERIALS, ALL IN THE FIELDS OF ON-LINE COMPUTER GAMES AND MULTI-USER COMPUTER GAMES PROVIDED VIA LOCAL COMPUTER NETWORKS, GLOBAL COMPUTER NETWORKS AND THE INTERNET; PRINTED MATTER, NAMELY, POSTCARDS, POSTERS, STATIONERY, STICKERS AND DECALS (U.S. CLS. 2, 5, 22, 23, 29, 37, 38 AND 50).

**CLASS 25—CLOTHING**

FOR ARTICLES OF CLOTHING, NAMELY, HOODED SWEATSHIRTS, T-SHIRTS, HATS, CAPS (U.S. CLS. 22 AND 39).

**ENCOUNTER BROADSIDE**

THE MARK CONSISTS OF STANDARD CHARACTERS WITHOUT CLAIM TO ANY PARTICULAR FONT, STYLE, SIZE, OR COLOR.

OWNER OF U.S. REG. NOS. 2,383,992 AND 2,449,657.

**CLASS 9—ELECTRICAL AND SCIENTIFIC APPARATUS**

FOR DOWNLOADABLE ELECTRONIC PAMPHLETS CONTAINING ESSAYS ON MATTERS OF PUBLIC INTEREST (U.S. CLS. 21, 23, 26, 36 AND 38).

FIRST USE 11-10-2009; IN COMMERCE 11-10-2009.

**CLASS 16—PAPER GOODS AND PRINTED MATTER**

FOR PRINTED PAMPHLETS CONTAINING ESSAYS ON MATTERS OF PUBLIC INTEREST (U.S. CLS. 2, 5, 22, 23, 29, 37, 38 AND 50).

FIRST USE 10-20-2009; IN COMMERCE 10-20-2009.

WARREN L. OLANDRIA, EXAMINING ATTORNEY

SN 85-168,408. ADOLF DARBO AKTIENGESELLSCHAFT,  
TIROL, AUSTRIA, FILED 11-3-2010.



OWNER OF AUSTRIA REG. NO. 118919, DATED 3-2-1988,  
EXPIRES 3-31-2018.

OWNER OF U.S. REG. NOS. 1,598,807, 1,933,476 AND  
1,993,175.

NO CLAIM IS MADE TO THE EXCLUSIVE RIGHT TO  
USE "NATURREIN", APART FROM THE MARK AS  
SHOWN.

THE COLOR(S) RED, GREEN, BLACK IS/ARE CLAIMED  
AS A FEATURE OF THE MARK.

THE MARK CONSISTS OF THE WORD "D'ARBO" IN  
SPECIAL LETTERS IN RED WITH A GREEN LEAF DESIGN  
APPEARING OVER THE LETTER "A" AND THE WORD  
"NATURREIN" IN STYLIZED LETTERS IN BLACK.

THE ENGLISH TRANSLATION OF "NATURREIN" IN  
THE MARK IS "NATURAL".

#### CLASS 29—MEATS AND PROCESSED FOODS

FOR FRUIT PRESERVES, JELLIES, JAM, MARME-  
LADE, COMPOTES, AND FRUIT SPREADS (U.S. CL. 46).

#### CLASS 30—STAPLE FOODS

FOR HONEY (U.S. CL. 46).  
VIVIAN MICZNIK FIRST, EXAMINING ATTORNEY

SN 85-168,943. MOULIN ROUGE SA, BRUSSELS, BELGIUM,  
FILED 11-4-2010.

MOULIN ROUGE

THE MARK CONSISTS OF STANDARD CHARACTERS  
WITHOUT CLAIM TO ANY PARTICULAR FONT, STYLE,  
SIZE, OR COLOR.

OWNER OF U.S. REG. NOS. 2,667,568, 2,783,742 AND  
2,947,197.

THE ENGLISH TRANSLATION OF "MOULIN ROUGE"  
IN THE MARK IS "RED WINDMILL".

#### CLASS 16—PAPER GOODS AND PRINTED MATTER

FOR CALENDARS, COFFEE TABLE BOOKS, COOK  
BOOKS, PAPER STATIONERY, GREETING CARDS,  
POSTCARDS, GIFT WRAP PAPER, PAPER PARTY  
BAGS, PAPER NAPKINS, PAPER TABLECLOTH, PAPER  
INVITATIONS, PAPER ENVELOPES, PAPER PARTY  
INVITATIONS, NOTEBOOK PAPER, PAPER NOTES,  
ADHESIVE-BACKED PAPER, DIARIES, SCRAP BOOKS,  
STICKERS, NOTE PADS, PAPER LABELS, FOLDERS,  
BINDERS, BLANK JOURNALS, MARKING STAMPS,  
STAMP PADS, DECALS, APPLIQUES IN THE FORM  
OF DECALS, WALL STICKERS AND MURALS (U.S.  
CLS. 2, 5, 22, 23, 29, 37, 38 AND 50).

#### CLASS 24—FABRICS

FOR TEXTILES AND TEXTILE GOODS, NAMELY,  
BED AND TABLE COVERS; TEXTILE BACKDROPS FOR  
USE IN PHOTOGRAPHIC, VIDEO, FILM, TELEVISION,  
ART, THEATER PRODUCTION, AND SPECIAL EVENTS  
AND CURTAINS AND STAGE BACKDROPS MADE OF  
TEXTILE FABRICS; TEXTILE WALL HANGINGS; AND  
PILLOW COVERS (U.S. CLS. 42 AND 50).

KIMBERLY PERRY, EXAMINING ATTORNEY

SN 85-168,990. MOULIN ROUGE SA, BRUSSELS, BELGIUM,  
FILED 11-4-2010.



THE COLOR(S) RED AND WHITE IS/ARE CLAIMED AS  
A FEATURE OF THE MARK.

THE MARK CONSISTS OF A RED WINDMILL WITH  
THREE WHITE WINDOWS.

#### CLASS 16—PAPER GOODS AND PRINTED MATTER

FOR CALENDARS, COFFEE TABLE BOOKS, COOK  
BOOKS, PAPER STATIONERY, GREETING CARDS,  
POSTCARDS, GIFT WRAP PAPER, PAPER PARTY  
BAGS, PAPER NAPKINS, PAPER TABLECLOTH, PAPER  
INVITATIONS, PAPER ENVELOPES, PAPER PARTY  
INVITATIONS, NOTEBOOK PAPER, PAPER NOTES,  
ADHESIVE-BACKED PAPER, DIARIES, SCRAP BOOKS,  
STICKERS, NOTE PADS, PAPER LABELS, FOLDERS,  
BINDERS, BLANK JOURNALS, MARKING STAMPS,  
STAMP PADS, DECALS, APPLIQUES IN THE FORM  
OF DECALS, WALL STICKERS AND MURALS (U.S.  
CLS. 2, 5, 22, 23, 29, 37, 38 AND 50).

#### CLASS 24—FABRICS

FOR TEXTILES AND TEXTILE GOODS, NAMELY,  
BED AND TABLE COVERS; TEXTILE BACKDROPS FOR  
USE IN PHOTOGRAPHIC, VIDEO, FILM, TELEVISION,  
ART, THEATER PRODUCTION, AND SPECIAL EVENTS  
AND CURTAINS AND STAGE BACKDROPS MADE OF  
TEXTILE FABRICS; TEXTILE WALL HANGINGS; AND  
PILLOW COVERS (U.S. CLS. 42 AND 50).

KIMBERLY PERRY, EXAMINING ATTORNEY

SN 85-169,016. A & B BUSINESS, INC., SIOUX FALLS, SD.  
FILED 11-4-2010.

SN 85-169,017. A & B BUSINESS, INC., SIOUX FALLS, SD.  
FILED 11-4-2010.



NO CLAIM IS MADE TO THE EXCLUSIVE RIGHT TO USE "PRINTER", APART FROM THE MARK AS SHOWN.

THE MARK CONSISTS OF THE WORD "PRINTERPATROL" WITH PRINTER BEING IN BOLD FONT, WHICH WORD IS PRECEDED BY A STAR INSIDE OF A SHADED CIRCLE.

#### CLASS 35—ADVERTISING AND BUSINESS

FOR IMAGING AND OUTPUT MANAGEMENT SERVICES, NAMELY, BUSINESS MANAGEMENT OF DOCUMENT REPRODUCTION FOR OTHERS; COST ASSESSMENT SERVICES RELATING TO OFFICE DOCUMENT WORKFLOW PROCESSES; BUSINESS ADVISORY SERVICES RELATING TO BUSINESS PRODUCTION OPERATIONS; LEASING, HIRE AND RENTAL OF COPIERS, PRINTERS, SCANNERS, IMAGE AND PHOTO COPYING EQUIPMENT AND OFFICE MACHINES AND APPARATUS; PROVIDING DOCUMENT MANAGEMENT SERVICES FOR OTHERS; DOCUMENT REPRODUCTION; PHOTOCOPYING SERVICES; BUSINESS SERVICES IN THE NATURE OF DOCUMENT REPRODUCTION, DOCUMENT ORGANIZATION AND DOCUMENT MANAGEMENT; BUSINESS CONSULTATION SERVICES DESIGNED TO REDUCE PRINT COSTS (U.S. CLS. 100, 101 AND 102).

#### CLASS 37—CONSTRUCTION AND REPAIR

FOR INSTALLATION, MAINTENANCE AND REPAIR OF OFFICE MACHINES AND APPARATUS, NAMELY, PRINTERS, PHOTOCOPYING MACHINES, PLOTTERS, SCANNERS, FACSIMILE RECEIVING AND TRANSMITTING EQUIPMENT AND MULTIFUNCTIONAL DEVICES WHICH SERVE AS ANY COMBINATION OF A COPIER, FACSIMILE, SCANNER AND PRINTER; INSTALLATION, MAINTENANCE AND REPAIR OF COPYING APPARATUS, NAMELY, PHOTOCOPYING MACHINES, SCANNERS, PLOTTERS, TYPEWRITERS, WORD PROCESSORS, MODEMS, COMPUTER HARDWARE, DISC DRIVES, PRINTERS, FACSIMILE TRANSMITTING AND RECEIVING APPARATUS, CALCULATORS AND OF DOCUMENT HANDLING APPARATUS (U.S. CLS. 100, 103 AND 106).

#### CLASS 42—SCIENTIFIC AND COMPUTER SERVICES

FOR PRINT MANAGEMENT SERVICES, NAMELY, REMOTE MONITORING OF PRINTERS FOR OTHERS; COMPUTER SOFTWARE AND HARDWARE CONSULTING SERVICES IN THE FIELD OF PRINTING; TECHNOLOGICAL ADVISORY AND CONSULTING SERVICES, NAMELY, TROUBLESHOOTING OF COMPUTER PROBLEMS IN THE FIELD OF PRINT MANAGEMENT, FILE CONVERSION, IN DATA STORAGE MANAGEMENT, COMPUTER NETWORK INTEGRATION AND MANAGEMENT; COMPUTER SERVICES NAMELY, PROVIDING SEARCH PLATFORMS TO ALLOW USERS TO REQUEST CONTENT FROM AND RECEIVE CONTENT FROM COMPUTER DATABASES; INSTALLATION, MAINTENANCE AND REPAIR OF COMPUTER SOFTWARE; IMAGE PROCESSING SOFTWARE DESIGN; COMPUTER GRAPHIC IMAGE PRODUCTION (U.S. CLS. 100 AND 101).

NAAKWAMA ANKRAH, EXAMINING ATTORNEY

THE MARK CONSISTS OF THE WORD "WESTREAM" UNDERLINED BY THREE SUCCESSIVELY SHORTER LINES, WITH THE ENTIRE IMAGE BEING SLIGHTLY CURVED UP AND THEN DOWN.

#### CLASS 35—ADVERTISING AND BUSINESS

FOR IMAGING AND OUTPUT MANAGEMENT SERVICES, NAMELY, BUSINESS MANAGEMENT OF DOCUMENT REPRODUCTION FOR OTHERS; COST ASSESSMENT SERVICES RELATING TO OFFICE DOCUMENT WORKFLOW PROCESSES; BUSINESS ADVISORY SERVICES RELATING TO BUSINESS PRODUCTION OPERATIONS; LEASING, HIRE AND RENTAL OF COPIERS, PRINTERS, SCANNERS, IMAGE AND PHOTO COPYING EQUIPMENT AND OFFICE MACHINES AND APPARATUS; PROVIDING DOCUMENT MANAGEMENT SERVICES FOR OTHERS; DOCUMENT REPRODUCTION; PHOTOCOPYING SERVICES; BUSINESS SERVICES IN THE NATURE OF DOCUMENT REPRODUCTION, DOCUMENT ORGANIZATION AND DOCUMENT MANAGEMENT; BUSINESS CONSULTATION SERVICES DESIGNED TO REDUCE PRINT COSTS (U.S. CLS. 100, 101 AND 102).

#### CLASS 37—CONSTRUCTION AND REPAIR

FOR INSTALLATION, MAINTENANCE AND REPAIR OF OFFICE MACHINES AND APPARATUS, NAMELY, PRINTERS, PHOTOCOPYING MACHINES, PLOTTERS, SCANNERS, FACSIMILE RECEIVING AND TRANSMITTING EQUIPMENT AND MULTIFUNCTIONAL DEVICES WHICH SERVE AS ANY COMBINATION OF A COPIER, FACSIMILE, SCANNER AND PRINTER; INSTALLATION, MAINTENANCE AND REPAIR OF COPYING APPARATUS, NAMELY, PHOTOCOPYING MACHINES, SCANNERS, PLOTTERS, TYPEWRITERS, WORD PROCESSORS, MODEMS, COMPUTER HARDWARE, DISC DRIVES, PRINTERS, FACSIMILE TRANSMITTING AND RECEIVING APPARATUS, CALCULATORS AND OF DOCUMENT HANDLING APPARATUS (U.S. CLS. 100, 103 AND 106).

#### CLASS 42—SCIENTIFIC AND COMPUTER SERVICES

FOR PRINT MANAGEMENT SERVICES, NAMELY, REMOTE MONITORING OF PRINTERS FOR OTHERS; COMPUTER SOFTWARE AND HARDWARE CONSULTING SERVICES IN THE FIELD OF PRINTING; TECHNOLOGICAL ADVISORY AND CONSULTING SERVICES, NAMELY, TROUBLESHOOTING OF COMPUTER PROBLEMS IN THE FIELD OF PRINT MANAGEMENT, FILE CONVERSION, DATA STORAGE MANAGEMENT, COMPUTER NETWORK INTEGRATION AND MANAGEMENT; COMPUTER SERVICES NAMELY, PROVIDING SEARCH PLATFORMS TO ALLOW USERS TO REQUEST CONTENT FROM AND RECEIVE CONTENT FROM COMPUTER DATABASES; INSTALLATION, MAINTENANCE AND REPAIR OF COMPUTER SOFTWARE; IMAGE PROCESSING SOFTWARE DESIGN; COMPUTER GRAPHIC IMAGE PRODUCTION (U.S. CLS. 100 AND 101).

NAAKWAMA ANKRAH, EXAMINING ATTORNEY



SN 85-169,480. CHEGG, INC., SANTA CLARA, CA. FILED 11-4-2010.

SN 85-170,226. PALIN, SARAH L., ANCHORAGE, AK. FILED 11-5-2010.



OWNER OF U.S. REG. NO. 3,191,844.  
THE COLOR(S) RED, ORANGE AND WHITE IS/ARE CLAIMED AS A FEATURE OF THE MARK.  
THE MARK CONSISTS OF THE TEXT "CHEGG" IN RED BLOCK LETTERS WITH A WHITE OUTLINE, WITH THE TEXT "POWERED BY" IN SMALL WHITE BLOCK LETTERS ABOVE THE LETTER "C", ALL ON AN ORANGE BACKGROUND.

#### **CLASS 35—ADVERTISING AND BUSINESS**

FOR ADMINISTRATION OF A TEXTBOOK RENTAL PARTNER PROGRAM FOR RETAIL STORES, NAMELY, PROVIDING EXHIBITION STANDS AND BOOTHS, INCLUDING RELATED EQUIPMENT, FOR TEXTBOOK RENTAL IN RETAIL STORES (U.S. CLS. 100, 101 AND 102).  
FIRST USE 1-0-2010; IN COMMERCE 7-29-2010.

#### **CLASS 41—EDUCATION AND ENTERTAINMENT**

FOR RENTAL OF TEXTBOOKS VIA AN ELECTRONIC KIOSK (U.S. CLS. 100, 101 AND 107).  
FIRST USE 1-0-2010; IN COMMERCE 7-29-2010.  
LIEF MARTIN, EXAMINING ATTORNEY

SN 85-170,030. ACALLMI, VINCENNES, FRANCE, FILED 11-5-2010.

# AMI-CAPS

THE MARK CONSISTS OF STANDARD CHARACTERS WITHOUT CLAIM TO ANY PARTICULAR FONT, STYLE, SIZE, OR COLOR.  
THE ENGLISH TRANSLATION OF THE WORD "AMI" IN THE MARK IS "FRIEND".

#### **CLASS 1—CHEMICALS**

FOR PLANT AND HERB EXTRACTS FOR USE IN THE MANUFACTURE OF COSMETICS; BOTANICAL EXTRACTS FOR USE IN MAKING COSMETICS (U.S. CLS. 1, 5, 6, 10, 26 AND 46).

#### **CLASS 3—COSMETICS AND CLEANING PREPARATIONS**

FOR COSMETIC PREPARATIONS FOR SKIN CARE (U.S. CLS. 1, 4, 6, 50, 51 AND 52).  
GILBERT SWIFT, EXAMINING ATTORNEY

# Sarah Palin

THE MARK CONSISTS OF STANDARD CHARACTERS WITHOUT CLAIM TO ANY PARTICULAR FONT, STYLE, SIZE, OR COLOR.

THE NAME(S), PORTRAIT(S), AND/OR SIGNATURE(S) SHOWN IN THE MARK IDENTIFIES "SARAH PALIN", WHOSE CONSENT(S) TO REGISTER IS MADE OF RECORD.

#### **CLASS 35—ADVERTISING AND BUSINESS**

FOR INFORMATION ABOUT POLITICAL ELECTIONS; PROVIDING A WEBSITE FEATURING INFORMATION ABOUT POLITICAL ISSUES (U.S. CLS. 100, 101 AND 102).

FIRST USE 1-1-1996; IN COMMERCE 1-1-1996.

#### **CLASS 41—EDUCATION AND ENTERTAINMENT**

FOR EDUCATIONAL AND ENTERTAINMENT SERVICES, NAMELY, PROVIDING MOTIVATIONAL SPEAKING SERVICES IN THE FIELD OF POLITICS, CULTURE, BUSINESS AND VALUES (U.S. CLS. 100, 101 AND 107).

FIRST USE 1-1-1996; IN COMMERCE 1-1-1996.

KAREN K. BUSH, EXAMINING ATTORNEY

SN 85-170,856. XANTERRA PARKS & RESORTS, INC., GREENWOOD VILLAGE, CO. FILED 11-6-2010.

LEGENDARY HOSPITALITY WITH  
A SOFTER FOOTPRINT

THE MARK CONSISTS OF STANDARD CHARACTERS WITHOUT CLAIM TO ANY PARTICULAR FONT, STYLE, SIZE, OR COLOR.

#### **CLASS 35—ADVERTISING AND BUSINESS**

FOR MANAGEMENT OF PARKS, HOTELS, LODGES, RESORTS, CONCESSIONS AND RESTAURANTS FOR OTHERS; RETAIL GIFT SHOPS; RETAIL SOUVENIR STORES; RETAIL CONVENIENCE STORES; RETAIL SPORTING GOODS STORES; AND PROVIDING CONCESSION STANDS FEATURING FOOD AND SOUVENIRS (U.S. CLS. 100, 101 AND 102).

#### **CLASS 41—EDUCATION AND ENTERTAINMENT**

FOR RECREATIONAL PARK SERVICES; RECREATIONAL SERVICES IN THE NATURE OF GOLF AND TENNIS FACILITIES; PROVIDING FACILITIES FOR RECREATION ACTIVITIES; PROVIDING FITNESS AND EXERCISE FACILITIES (U.S. CLS. 100, 101 AND 107).

**CLASS 43—HOTEL AND RESTAURANT SERVICES**

FOR HOTEL, RESORT LODGING AND RESTAURANT SERVICES; PROVIDING CONVENTION FACILITIES; PROVIDING CAMPGROUND FACILITIES (U.S. CLS. 100 AND 101).

**CLASS 44—MEDICAL, BEAUTY AND AGRICULTURAL SERVICES**

FOR HEALTH SPA SERVICES FOR HEALTH AND WELLNESS OF THE BODY AND SPIRIT; HEALTH SPA SERVICES, NAMELY, COSMETIC BODY CARE SERVICES, AND MASSAGE, FACIAL AND BODY TREATMENT SERVICES (U.S. CLS. 100 AND 101).

DAWN FELDMAN, EXAMINING ATTORNEY

SN 85-171,543. SWOODOO AG, MÜNCHEN, FED REP GERMANY, FILED 11-8-2010.

# SWOODOO

THE MARK CONSISTS OF STANDARD CHARACTERS WITHOUT CLAIM TO ANY PARTICULAR FONT, STYLE, SIZE, OR COLOR.

OWNER OF ERP CMNTY TM OFC REG. NO. 005746359, DATED 7-31-2008, EXPIRES 3-9-2017.

THE WORDING "SWOODOO" HAS NO MEANING IN A FOREIGN LANGUAGE.

SN 85-170,857. XANTERRA PARKS & RESORTS, INC., GREENWOOD VILLAGE, CO. FILED 11-6-2010.

HOSPITALITY WITH A SOFTER  
FOOTPRINT

THE MARK CONSISTS OF STANDARD CHARACTERS WITHOUT CLAIM TO ANY PARTICULAR FONT, STYLE, SIZE, OR COLOR.

**CLASS 35—ADVERTISING AND BUSINESS**

FOR MANAGEMENT OF PARKS, HOTELS, LODGES, RESORTS, CONCESSIONS AND RESTAURANTS FOR OTHERS; RETAIL GIFT SHOPS; RETAIL SOUVENIR STORES; RETAIL CONVENIENCE STORES; RETAIL SPORTING GOODS STORES; AND PROVIDING CONCESSION STANDS FEATURING FOOD AND SOUVENIRS (U.S. CLS. 100, 101 AND 102).

**CLASS 41—EDUCATION AND ENTERTAINMENT**

FOR RECREATIONAL PARK SERVICES; RECREATIONAL SERVICES IN THE NATURE OF GOLF AND TENNIS FACILITIES; PROVIDING FACILITIES FOR RECREATION ACTIVITIES; PROVIDING FITNESS AND EXERCISE FACILITIES (U.S. CLS. 100, 101 AND 107).

**CLASS 43—HOTEL AND RESTAURANT SERVICES**

FOR HOTEL, RESORT LODGING AND RESTAURANT SERVICES; PROVIDING CONVENTION FACILITIES; PROVIDING CAMPGROUND FACILITIES (U.S. CLS. 100 AND 101).

**CLASS 44—MEDICAL, BEAUTY AND AGRICULTURAL SERVICES**

FOR HEALTH SPA SERVICES FOR HEALTH AND WELLNESS OF THE BODY AND SPIRIT; HEALTH SPA SERVICES, NAMELY, COSMETIC BODY CARE SERVICES, AND MASSAGE, FACIAL AND BODY TREATMENT SERVICES (U.S. CLS. 100 AND 101).

DAWN FELDMAN, EXAMINING ATTORNEY

**CLASS 39—TRANSPORTATION AND STORAGE**

FOR TRAVEL AGENCY SERVICES, NAMELY, BOOKING OF SEATS AND TICKET RESERVATIONS FOR TRAVEL; TRAVEL AGENCY SERVICES, NAMELY, MAKING RESERVATIONS AND BOOKINGS FOR TRANSPORTATION; TRAVEL RESERVATION SERVICES; PROVIDING COMPUTERIZED RESERVATION AND TRAVEL TICKET RESERVATION SERVICES; ARRANGING THE BOOKING OF SEATS FOR AIR TRAVEL BY MEANS OF AN ELECTRONIC SEARCH ENGINE; ARRANGING OF FLIGHTS, CRUISES AND TOURS; AUTOMOBILE RENTAL INFORMATION; ADVISORY AND CONSULTANCY SERVICES RELATING TO TRAVEL AND RESERVATION SERVICES; PROVIDING INFORMATION BY MEANS OF GLOBAL COMPUTER NETWORK IN RELATION TO TRIP AND TRAVEL SERVICES (U.S. CLS. 100 AND 105).

**CLASS 43—HOTEL AND RESTAURANT SERVICES**

FOR HOTEL-RESERVATION SERVICES; SERVICES RELATING TO THE PROVISION OF FOOD AND DRINK IN HOTELS, BOARDING HOUSES, TOURIST CAMPS, TOURIST HOUSES, DUDE RANCHES, VILLAS, CHALETS, APARTMENTS, LODGES AND BED AND BREAKFAST ACCOMMODATION; RESTAURANT RESERVATION SERVICES; HOTEL RESTAURANT RESERVATION SERVICES; ON-LINE BOOKING OF RESTAURANT PLACES (SEATS), INCLUDING HOTEL RESTAURANT PLACES (SEATS); INFORMATION ABOUT RESTAURANTS PROVIDED ON-LINE FROM A COMPUTER DATA BASE OR FROM THE INTERNET OR ACCESSIBLE VIA A MOBILE PHONE UTILISING WIRELESS APPLICATION PROTOCOL TECHNOLOGY; RESTAURANT MENUS, INCLUDING HOTEL RESTAURANT MENUS, PROVIDED ON-LINE FROM A COMPUTER DATA BASE OR FROM THE INTERNET OR ACCESSIBLE VIA A MOBILE TELEPHONE UTILISING WIRELESS APPLICATION PROTOCOL TECHNOLOGY; TELEPHONE BOOKING SERVICES IN RESPECT OF RESTAURANTS AND HOTEL RESTAURANTS; INFORMATION AND ADVICE RELATING TO RESTAURANT, HOTEL RESTAURANTS, AND RESTAURANT RESERVATIONS; PROVIDING INFORMATION BY MEANS OF A GLOBAL COMPUTER NETWORK IN RELATION TO RESTAURANTS, HOTEL RESTAURANTS, AND RESTAURANT RESERVATIONS; TRAVEL AGENCY SERVICES, NAMELY, MAKING RESERVATIONS AND BOOKINGS FOR TEMPORARY LODGING, RESTAURANTS, AND MEALS; PROVIDING INFORMATION BY MEANS OF A GLOBAL COMPUTER NETWORK IN RELATION TO HOTEL AND RESTAURANT RESERVATIONS (U.S. CLS. 100 AND 101).

THOMAS MANOR, EXAMINING ATTORNEY

SN 85-171,589. LIBERTY HARDWARE MFG. CORP., WINSTON-SALEM, NC. FILED 11-8-2010.

## HOME GROWN HARDWARE

THE MARK CONSISTS OF STANDARD CHARACTERS WITHOUT CLAIM TO ANY PARTICULAR FONT, STYLE, SIZE, OR COLOR.

NO CLAIM IS MADE TO THE EXCLUSIVE RIGHT TO USE "HARDWARE", APART FROM THE MARK AS SHOWN.

### CLASS 6—METAL GOODS

FOR METAL CABINET HARDWARE, NAMELY, METAL HOOKS AND HOOK RAILS AND METAL WALL PLATES (U.S. CLS. 2, 12, 13, 14, 23, 25 AND 50).

### CLASS 20—FURNITURE AND ARTICLES NOT OTHERWISE CLASSIFIED

FOR NON-METAL CABINET HARDWARE, NAMELY, NON-METAL WALL PLATES, HOOKS AND HOOK RAILS, ROBE HOOKS AND SHELVING (U.S. CLS. 2, 13, 22, 25, 32 AND 50).

### CLASS 21—HOUSEWARES AND GLASS

FOR BATH ACCESSORIES, NAMELY, TOWEL BARS, TOWEL RINGS AND TOILET TISSUE HOLDERS (U.S. CLS. 2, 13, 23, 29, 30, 33, 40 AND 50).

JOHN HWANG, EXAMINING ATTORNEY

SN 85-172,481. ROLAND CORPORATION, SHIZUOKA, JAPAN, FILED 11-9-2010.



OWNER OF U.S. REG. NOS. 1,055,073, 1,150,998 AND OTHERS.

THE NAME SHOWN IN THE MARK DOES NOT IDENTIFY A PARTICULAR LIVING INDIVIDUAL.

THE MARK CONSISTS OF A STYLIZED LETTER "X" WITH THE WORD "PLANET" CENTERED ABOVE THE WORD "EXPRESS" POSITIONED IN THE CENTER OF THE LETTER "X" AND THE WORD "ROLAND" ABOVE THE UPPER LEFT CORNER OF THE LETTER "X".

### CLASS 9—ELECTRICAL AND SCIENTIFIC APPARATUS

FOR GUITAR SOUND PROCESSORS; BASS SOUND PROCESSORS; VOCAL PROCESSORS; GUITAR SYNTHESIZERS, NAMELY, ELECTRONIC SOUND MIXING, PROCESSING AND SYNTHESIZING APPARATUS FOR USE WITH GUITARS; GUITAR EFFECTS PROCESSORS; BASS EFFECTS PROCESSORS; ACOUSTIC INSTRUMENT SOUND PROCESSORS; AUDIO PLAYERS, NAMELY, DIGITAL AUDIO PLAYERS; PORTABLE AMPLIFIERS; KEYBOARD AMPLIFIERS; GUITAR AMPLIFIERS; BASS AMPLIFIERS; DRUM AMPLIFIERS; STAGE AMPLIFIERS; MONITOR AMPLIFIERS; GUITAR PICKUPS; BASS PICKUPS; COMPUTER CONSOLES; COMPUTER SOFTWARE FOR DIGITAL AUDIO WORKSTATIONS FOR COMPOSING AND SYNTHESIZING AUDIO MUSIC TRACKS; USB MIDI INTERFACES; USB AUDIO INTERFACES; KEYBOARD CONTROLLERS FOR COMPUTERS; METRONOMES; PERCUSSION SOUND MODULES, NAMELY, ELECTRONIC APPARATUS FOR REPRODUCING PERCUSSION SOUND; SAMPLERS, NAMELY, APPARATUS FOR RECORDING, TRANSMISSION, PROCESSING, AND REPRODUCTION OF SOUND (U.S. CLS. 21, 23, 26, 36 AND 38).

### CLASS 15—MUSICAL INSTRUMENTS

FOR SYNTHESIZER KEYBOARD INSTRUMENTS; PIANOS; ORGANS; ACCORDIONS; DRUMS; DIGITAL PERCUSSION PADS; TUNERS FOR MUSICAL INSTRUMENTS; RHYTHM MACHINES; GUITAR EFFECTS PEDALS (U.S. CLS. 2, 21 AND 36).

TINA BROWN, EXAMINING ATTORNEY

SN 85-172,859. SPX CORPORATION, CHARLOTTE, NC. FILED 11-9-2010.

## Tech Messaging

THE MARK CONSISTS OF STANDARD CHARACTERS WITHOUT CLAIM TO ANY PARTICULAR FONT, STYLE, SIZE, OR COLOR.

### CLASS 37—CONSTRUCTION AND REPAIR

FOR PROVIDING AN ONLINE COMPUTER DATA BASE FEATURING TECHNICAL INFORMATION ABOUT VEHICLE REPAIR AND MAINTENANCE; TECHNICAL SUPPORT SERVICES, NAMELY, PROVIDING TECHNICAL ADVICE IN THE FIELD OF VEHICLE REPAIR AND MAINTENANCE (U.S. CLS. 100, 103 AND 106).

### CLASS 42—SCIENTIFIC AND COMPUTER SERVICES

FOR VEHICLE SUPPORT SERVICES, NAMELY, AN ONLINE INTERFACE BETWEEN VEHICLE REPAIR AND MAINTENANCE TECHNICIANS AND CUSTOMERS; SUPPORT SERVICES, NAMELY, TROUBLESHOOTING IN THE NATURE OF DIAGNOSING PROBLEMS WITH VEHICLES (U.S. CLS. 100 AND 101).

JOHN GARTNER, EXAMINING ATTORNEY

SN 85-174,518. ARDEO HEALTH, LLC, CUMMING, GA.  
FILED 11-11-2010.

SN 85-174,776. HEAD COUNT, INC., NEW YORK, NY. FILED  
11-11-2010.

## ARDEO HEALTH

THE MARK CONSISTS OF STANDARD CHARACTERS WITHOUT CLAIM TO ANY PARTICULAR FONT, STYLE, SIZE, OR COLOR.

NO CLAIM IS MADE TO THE EXCLUSIVE RIGHT TO USE "HEALTH", APART FROM THE MARK AS SHOWN.

### CLASS 5—PHARMACEUTICALS

FOR PHARMACEUTICALS AND PHARMACEUTICAL PREPARATIONS FOR THE TREATMENT OF OCULAR DISEASE, DERMATOLOGICAL CONDITIONS, AND PEDIATRIC MEDICAL CONDITIONS; PHARMACEUTICAL PREPARATIONS FOR THE TREATMENT OF PARASITES (U.S. CLS. 6, 18, 44, 46, 51 AND 52).

### CLASS 10—MEDICAL APPARATUS

FOR MEDICAL DEVICES, NAMELY, DEVICES FOR THE TREATMENT OF OCULAR DISEASE, DERMATOLOGICAL CONDITIONS, AND PEDIATRIC MEDICAL CONDITIONS (U.S. CLS. 26, 39 AND 44).

### CLASS 42—SCIENTIFIC AND COMPUTER SERVICES

FOR PHARMACEUTICAL RESEARCH RELATING TO AND DRUG AND THERAPEUTICS DEVELOPMENT OF PHARMACEUTICAL PREPARATIONS FOR THE TREATMENT OF OCULAR DISEASE, DERMATOLOGICAL CONDITIONS, AND PEDIATRIC MEDICAL CONDITIONS; RESEARCH AND DEVELOPMENT OF CONSUMER HEALTH PRODUCTS FOR THE TREATMENT OF OCULAR DISEASE, DERMATOLOGICAL CONDITIONS, AND PEDIATRIC MEDICAL CONDITIONS; RESEARCH AND DEVELOPMENT OF PHARMACEUTICAL PREPARATIONS FOR THE TREATMENT OF PARASITES; CONSULTATION IN THE FIELD OF RESEARCH AND DEVELOPMENT OF PHARMACEUTICAL PREPARATIONS AND CONSUMER HEALTH PRODUCTS FOR THE TREATMENT OF OCULAR DISEASE, DERMATOLOGICAL CONDITIONS, AND PEDIATRIC MEDICAL CONDITIONS; CONSULTATION IN THE FIELD OF RESEARCH AND DEVELOPMENT OF PHARMACEUTICAL PREPARATIONS FOR THE TREATMENT OF PARASITES. CONSULTATION PERTAINING TO PHARMACOLOGY, SPECIFICALLY PHARMACEUTICAL PREPARATIONS AND CONSUMER HEALTH PRODUCTS FOR THE TREATMENT OF OCULAR DISEASE, DERMATOLOGICAL CONDITIONS, AND PEDIATRIC MEDICAL CONDITIONS; CONSULTATION PERTAINING TO PHARMACOLOGY, SPECIFICALLY PHARMACEUTICAL PREPARATIONS FOR THE TREATMENT OF PARASITES (U.S. CLS. 100 AND 101).

KEVIN DINALLO, EXAMINING ATTORNEY

## HEADCOUNT

THE MARK CONSISTS OF STANDARD CHARACTERS WITHOUT CLAIM TO ANY PARTICULAR FONT, STYLE, SIZE, OR COLOR.

### CLASS 35—ADVERTISING AND BUSINESS

FOR ORGANIZING AND CONDUCTING VOTER REGISTRATION EVENTS IN ORDER TO REGISTER VOTERS; PROVIDING A WEBSITE FEATURING INFORMATION AND NEWS ABOUT CURRENT POLITICAL ISSUES, PUBLIC POLICY, LEGISLATION, POLITICS, POLITICAL CAMPAIGNS, THE LEGISLATIVE PROCESS, CIVIC ENGAGEMENT AND THE IMPORTANCE OF CIVIC PARTICIPATION; PROMOTING PUBLIC AWARENESS ABOUT CURRENT POLITICAL ISSUES, PUBLIC POLICY, LEGISLATION, POLITICS, POLITICAL CAMPAIGNS, THE LEGISLATIVE PROCESS, CIVIC ENGAGEMENT AND THE IMPORTANCE OF CIVIC PARTICIPATION (U.S. CLS. 100, 101 AND 102).  
FIRST USE 3-1-2004; IN COMMERCE 3-1-2004.

### CLASS 41—EDUCATION AND ENTERTAINMENT

FOR PROVIDING EDUCATIONAL AND ENTERTAINMENT SERVICES IN CONJUNCTION WITH ARTISTS AND MUSICIANS AND THE MUSIC INDUSTRY, NAMELY, LIVE MUSIC CONCERTS AND PROVIDING SPEAKERS ABOUT CURRENT POLITICAL ISSUES, PUBLIC POLICY, LEGISLATION, POLITICS, POLITICAL CAMPAIGNS, THE LEGISLATIVE PROCESS, CIVIC ENGAGEMENT AND THE IMPORTANCE OF CIVIC PARTICIPATION; ONLINE JOURNALS, NAMELY, PROVIDING A BLOG FEATURING INFORMATION AND NEWS ABOUT CURRENT POLITICAL ISSUES, PUBLIC POLICY, LEGISLATION, POLITICS, POLITICAL CAMPAIGNS, THE LEGISLATIVE PROCESS, CIVIC ENGAGEMENT AND THE IMPORTANCE OF CIVIC PARTICIPATION (U.S. CLS. 100, 101 AND 107).

FIRST USE 3-1-2004; IN COMMERCE 3-1-2004.  
JOHN E. MICHOS, EXAMINING ATTORNEY

SN 85-174,781. HEAD COUNT, INC., NEW YORK, NY. FILED  
11-11-2010.



THE MARK CONSISTS OF THE WORD "HEADCOUNT" IN STYLIZED LETTERING AGAINST A SILHOUETTED BACKGROUND OF SEVERAL INDIVIDUALS, THE MOST CENTER AND PROMINENT OF WHICH IS HOLDING UP A GUITAR.



**CLASS 35—ADVERTISING AND BUSINESS**

FOR ORGANIZING AND CONDUCTING VOTER REGISTRATION EVENTS IN ORDER TO REGISTER VOTERS; PROVIDING A WEBSITE FEATURING INFORMATION AND NEWS ABOUT CURRENT POLITICAL ISSUES, PUBLIC POLICY, LEGISLATION, POLITICS, POLITICAL CAMPAIGNS, THE LEGISLATIVE PROCESS, CIVIC ENGAGEMENT AND THE IMPORTANCE OF CIVIC PARTICIPATION; PROMOTING PUBLIC AWARENESS ABOUT CURRENT POLITICAL ISSUES, PUBLIC POLICY, LEGISLATION, POLITICS, POLITICAL CAMPAIGNS, THE LEGISLATIVE PROCESS, CIVIC ENGAGEMENT AND THE IMPORTANCE OF CIVIC PARTICIPATION (U.S. CLS. 100, 101 AND 102).

FIRST USE 3-0-2008; IN COMMERCE 3-0-2008.

**CLASS 41—EDUCATION AND ENTERTAINMENT**

FOR PROVIDING EDUCATIONAL AND ENTERTAINMENT SERVICES IN CONJUNCTION WITH ARTISTS AND MUSICIANS AND THE MUSIC INDUSTRY, NAMELY, LIVE MUSIC CONCERTS AND PROVIDING SPEAKERS ABOUT CURRENT POLITICAL ISSUES, PUBLIC POLICY, LEGISLATION, POLITICS, POLITICAL CAMPAIGNS, THE LEGISLATIVE PROCESS, CIVIC ENGAGEMENT AND THE IMPORTANCE OF CIVIC PARTICIPATION; ONLINE JOURNALS, NAMELY, PROVIDING A BLOG FEATURING INFORMATION AND NEWS ABOUT CURRENT POLITICAL ISSUES, PUBLIC POLICY, LEGISLATION, POLITICS, POLITICAL CAMPAIGNS, THE LEGISLATIVE PROCESS, CIVIC ENGAGEMENT AND THE IMPORTANCE OF CIVIC PARTICIPATION (U.S. CLS. 100, 101 AND 107).

FIRST USE 3-0-2008; IN COMMERCE 3-0-2008.

JOHN E. MICHOS, EXAMINING ATTORNEY

**CLASS 35—ADVERTISING AND BUSINESS**

FOR ADVERTISING AND DIRECTORY SERVICES, NAMELY, PROMOTING THE SERVICES OF OTHERS BY PROVIDING A WEB PAGE FEATURING LINKS TO THE WEBSITES OF OTHERS; ADVERTISING THE SERVICES OF OTHERS VIA WEB PAGES OPTIMIZED FOR ONLINE SEARCH ENGINES; PROMOTING THE GOODS AND SERVICES OF OTHERS BY PROVIDING A COMMUNITY-DRIVEN WEB SITE FEATURING USER-SUBMITTED CONTENT IN THE NATURE OF BOUTIQUE STORE REVIEWS AND LINKS TO THE RETAIL WEB SITES OF OTHERS; PROMOTING THE GOODS AND SERVICES OF OTHERS BY PROVIDING A WEB SITE AT WHICH USERS CAN LINK TO THE WEBSITES OF CLOTHING AND FASHION ACCESSORY BOUTIQUES ORGANIZED BY NEIGHBORHOOD, PRICE, DESIGNER, PRODUCTS AND ACCESSORIES OFFERED, WHETHER THE OFFERED GOODS ARE MADE LOCALLY, VINTAGE OF THE OFFERED GOODS, AND WHETHER OR NOT THE OFFERED GOODS ARE ECO-FRIENDLY; PROMOTING THE GOODS AND SERVICES OF OTHERS BY PROVIDING A WEB SITE FEATURING RETAIL STORE REVIEWS AND LINKS TO THE RETAIL WEB SITES OF OTHERS; PROMOTING THE GOODS AND SERVICES OF OTHERS BY PROVIDING HYPERTEXT LINKS TO THE WEB SITES OF OTHERS; PROVIDING A WEB SITE FEATURING PRODUCT RATINGS OF THE CONSUMER GOODS OF OTHERS IN THE FIELD OF CLOTHING AND FASHION ACCESSORIES; PROVIDING A WEB SITE WHERE USERS CAN POST RATINGS, REVIEWS AND RECOMMENDATIONS ON PRODUCTS AND SERVICES FOR COMMERCIAL PURPOSES (U.S. CLS. 100, 101 AND 102).

FIRST USE 5-0-2009; IN COMMERCE 8-0-2010.

**CLASS 45—PERSONAL AND LEGAL SERVICES**

FOR FASHION INFORMATION; PROVIDING A WEB SITE FEATURING INFORMATION AND CONTENT IN THE FIELD OF FASHION; PROVIDING FASHION INFORMATION; PROVIDING INFORMATION ABOUT FASHION; PROVIDING INFORMATION IN THE FIELD OF FASHION TRENDS; PROVIDING NEWS AND INFORMATION IN THE FIELD OF FASHION; PROVIDING NEWS IN THE FIELD OF FASHION FROM FEATURED BOUTIQUES, CONCEPT STORES, FASHION EVENTS, AND SALE EVENTS (U.S. CLS. 100 AND 101).

FIRST USE 5-0-2009; IN COMMERCE 8-0-2010.

MICHAEL GAAFAR, EXAMINING ATTORNEY

SN 85-175,086. BOUTIIKA LTD, CHEADLE, CHESHIRE, UNITED KINGDOM, FILED 11-11-2010.

SN 85-175,299. MECHOSHADE SYSTEMS, INC., LONG ISLAND CITY, NY. FILED 11-12-2010.

**BoutiiKa**

**MCDONOUGH ICELAND  
COLLECTION**

THE MARK CONSISTS OF STANDARD CHARACTERS WITHOUT CLAIM TO ANY PARTICULAR FONT, STYLE, SIZE, OR COLOR.

NO CLAIM IS MADE TO THE EXCLUSIVE RIGHT TO USE "COLLECTION", APART FROM THE MARK AS SHOWN.

**CLASS 19—NON-METALLIC BUILDING MATERIALS**

FOR NON-METAL EXTERIOR WINDOW COVERINGS IN THE NATURE OF SHADES (U.S. CLS. 1, 12, 33 AND 50).

FIRST USE 11-1-2010; IN COMMERCE 11-1-2010.

THE MARK CONSISTS OF STANDARD CHARACTERS WITHOUT CLAIM TO ANY PARTICULAR FONT, STYLE, SIZE, OR COLOR.

THE WORDING "BOUTIIKA" HAS NO MEANING IN A FOREIGN LANGUAGE.

**CLASS 24—FABRICS**

FOR FABRIC WINDOW COVERINGS, NAMELY, CURTAINS, DRAPERIES, SHEETS, SWAGS AND VALANCES (U.S. CLS. 42 AND 50).

FIRST USE 11-1-2010; IN COMMERCE 11-1-2010.  
TARAH HARDY, EXAMINING ATTORNEY

SN 85-175,819. UNITEDHEALTH GROUP INCORPORATED,  
MINNETONKA, MN. FILED 11-12-2010.

# HELP!CARE

THE MARK CONSISTS OF STANDARD CHARACTERS WITHOUT CLAIM TO ANY PARTICULAR FONT, STYLE, SIZE, OR COLOR.

**CLASS 35—ADVERTISING AND BUSINESS**

FOR SCHEDULING MEDICAL APPOINTMENTS FOR OTHERS; REVIEWING HEALTH CARE CLAIMS (U.S. CLS. 100, 101 AND 102).

**CLASS 44—MEDICAL, BEAUTY AND AGRICULTURAL SERVICES**

FOR PROVIDING HEALTH INFORMATION; PROVIDING HEALTH CARE INFORMATION BY TELEPHONE AND THE INTERNET; PROVIDING HEALTH INFORMATION REGARDING HEALTH AND WELLNESS NEEDS, NAMELY, PROVIDING INFORMATION ABOUT HEALTH CARE PROVIDERS AND PROVIDING INFORMATION REGARDING GUIDANCE TO HELP CONSUMERS NAVIGATE THE HEALTH CARE SYSTEM (U.S. CLS. 100 AND 101).

REGINA DRUMMOND, EXAMINING ATTORNEY

SN 85-175,894. INFORMATION BUILDERS INC., NEW YORK, NY. FILED 11-12-2010.

# HYPER STAGE

THE MARK CONSISTS OF STANDARD CHARACTERS WITHOUT CLAIM TO ANY PARTICULAR FONT, STYLE, SIZE, OR COLOR.

**CLASS 9—ELECTRICAL AND SCIENTIFIC APPARATUS**

FOR DATABASE COMPUTER SOFTWARE FOR STORING, DELIVERING AND ANALYZING INFORMATION (U.S. CLS. 21, 23, 26, 36 AND 38).

**CLASS 38—COMMUNICATION**

FOR PROVIDING ACCESS TO AN ONLINE DATABASE FOR STORING, DELIVERING, AND ANALYZING INFORMATION (U.S. CLS. 100, 101 AND 104).  
MORGAN WYNNE, EXAMINING ATTORNEY

SN 85-176,018. JUST FABULOUS, INC., EL SEGUNDO, CA. FILED 11-12-2010.



# JUSTFABULOUS

THE MARK CONSISTS OF THE LETTER "J" INSIDE A STYLIZED "U" SHAPE WITH THE WORDS "JUSTFABULOUS" UNDERNEATH.

**CLASS 18—LEATHER GOODS**

FOR PURSES, HANDBAGS, LUGGAGE; TRAVEL BACK PACKS, BACKPACKS, DAYPACKS, FANNY PACKS, WAIST PACKS, GARMENT BAGS FOR TRAVEL, DUFFLE BAGS, ALL PURPOSE ATHLETIC BAGS, TRAVEL BAGS, SHOULDER BAGS, BRIEFCASES, ATTACHE CASES (U.S. CLS. 1, 2, 3, 22 AND 41).

**CLASS 25—CLOTHING**

FOR WOMEN'S SHOES, SANDALS, SHOES AND FOOTWEAR; CLOTHING, NAMELY, BANDANAS, BATHING SUITS, BEANIES, BELTS, BLAZERS, BLOUSES, BOOTS, CAPS, COATS, DRESSES, GLOVES, HATS, HEADWEAR, JACKETS, JEANS, JOGGING OUTFITS, NECKTIES, OVERALLS, PAJAMAS, PANTS, PARKAS, PONCHOS, PULLOVERS, RAINWEAR, ROBES, SANDALS, SARONGS, SCARVES, SHIRTS, SHORTS, SKIRTS, SLACKS, SOCKS, SUN VISORS, SUSPENDERS, SWEAT BANDS, SWEAT PANTS, SWEAT SHIRTS, SWEATERS, SWIM WEAR, TANK TOPS, TURTLENECKS, UNDERWEAR, VESTS, WRISTBANDS (U.S. CLS. 22 AND 39).

STEVEN JACKSON, EXAMINING ATTORNEY

SN 85-176,659. REGIONAL AUTO CENTER, INC., GREENSBORO, NC. FILED 11-15-2010.



NO CLAIM IS MADE TO THE EXCLUSIVE RIGHT TO USE "REGIONAL AUTO CENTER COLLISION REPAIR" "AUTO GLASS" "TOWING", APART FROM THE MARK AS SHOWN.

THE MARK CONSISTS OF THE WORD "REGIONAL" WITH THE "R" COMPRISED OF A ROAD DESIGN HAVING A STRIPED CENTER LINE; THE WORD "AUTO" BELOW HAVING THE CURVE OF THE LETTER "R" FROM "REGIONAL" MAKING UP THE HORIZONTAL LINE IN THE "A"; BELOW THE WORD "AUTO" IS THE WORD "CENTER" IN A QUADRILATERAL; BELOW THIS WORD IS THE WORDING "COLLISION REPAIR" FOLLOWED BY A DOT, THE WORD "AUTO GLASS" FOLLOWED BY A DOT AND THE WORD "TOWING".

**CLASS 37—CONSTRUCTION AND REPAIR**

FOR AUTOMOBILE BODY AND COLLISION REPAIR; AUTOMOBILE BODY PAINTING; AUTOMOBILE GLASS REPLACEMENT AND REPAIR (U.S. CLS. 100, 103 AND 106).

FIRST USE 5-1-1997; IN COMMERCE 5-1-1997.

**CLASS 39—TRANSPORTATION AND STORAGE**

FOR VEHICLE TOWING (U.S. CLS. 100 AND 105).  
FIRST USE 5-1-1997; IN COMMERCE 5-1-1997.  
MAYUR VAGHANI, EXAMINING ATTORNEY

---

SN 85-176,765. JOHNSON, KIMBERLEY A., ARLINGTON, VA. FILED 11-15-2010.

**AN INDEPENDENT GUIDE TO  
MOTHERHOOD**

THE MARK CONSISTS OF STANDARD CHARACTERS WITHOUT CLAIM TO ANY PARTICULAR FONT, STYLE, SIZE, OR COLOR.

NO CLAIM IS MADE TO THE EXCLUSIVE RIGHT TO USE "GUIDE TO MOTHERHOOD", APART FROM THE MARK AS SHOWN.

**CLASS 16—PAPER GOODS AND PRINTED MATTER**

FOR PUBLICATIONS, NAMELY, BOOKS, HAND-OUTS, WRITTEN ARTICLES, IN THE FIELDS OF CHILD CARE AND RELATED EDUCATIONAL INFORMATION (U.S. CLS. 2, 5, 22, 23, 29, 37, 38 AND 50).

**CLASS 41—EDUCATION AND ENTERTAINMENT**

FOR ENTERTAINMENT SERVICES, NAMELY, PROVIDING ON-LINE REVIEWS OF CHILD CARE AND RELATED EDUCATIONAL INFORMATION; INFORMATION IN THE FIELD OF PARENTING CONCERNING EDUCATION OF CHILDREN; INFORMATION IN THE FIELD OF PARENTING CONCERNING ENTERTAINMENT OF CHILDREN; ON-LINE JOURNALS, NAMELY, BLOGS FEATURING CHILD CARE AND RELATED EDUCATIONAL INFORMATION; PROVIDING NEWSLETTERS IN THE FIELD OF CHILD CARE AND RELATED EDUCATIONAL INFORMATION VIA E-MAIL (U.S. CLS. 100, 101 AND 107).

FIRST USE 4-21-2010; IN COMMERCE 4-21-2010.  
PAM WILLIS, EXAMINING ATTORNEY

---

SN 85-176,808. ALLEGHENY DIMENSION, LLC, PETERSBURG, WV. FILED 11-15-2010.

**ALLEGHENY DIMENSION**

THE MARK CONSISTS OF STANDARD CHARACTERS WITHOUT CLAIM TO ANY PARTICULAR FONT, STYLE, SIZE, OR COLOR.

NO CLAIM IS MADE TO THE EXCLUSIVE RIGHT TO USE "DIMENSION", APART FROM THE MARK AS SHOWN.

SEC. 2(F).

**CLASS 20—FURNITURE AND ARTICLES NOT OTHERWISE CLASSIFIED**

FOR CABINET DOORS FOR FURNITURE CABINETS; CABINET DRAWERS FOR FURNITURE CABINETS; DOORS FOR FURNITURE; DRAWERS; FURNITURE PARTS (U.S. CLS. 2, 13, 22, 25, 32 AND 50).

FIRST USE 8-0-1995; IN COMMERCE 8-0-1995.

**CLASS 40—MATERIAL TREATMENT**

FOR CONTRACT MANUFACTURING IN THE FIELD OF HARDWOOD COMPONENTS FOR FURNITURE; CUSTOM FABRICATION AND PRODUCTION OF HARDWOOD COMPONENTS FOR FURNITURE; CUSTOM MANUFACTURE OF HARDWOOD COMPONENTS FOR FURNITURE; MANUFACTURE OF GENERAL PRODUCT LINES IN THE FIELD OF FURNITURE TO THE ORDER AND SPECIFICATION OF OTHERS; MANUFACTURE OF FURNITURE COMPONENT PARTS TO ORDER AND/OR SPECIFICATION OF OTHERS (U.S. CLS. 100, 103 AND 106).

FIRST USE 8-0-1995; IN COMMERCE 8-0-1995.  
DANIEL CAPSHAW, EXAMINING ATTORNEY

---

SN 85-176,828. ARIZONA BOARD OF REGENTS, DBA ARIZONA STATE UNIVERSITY, TEMPE, AZ. FILED 11-15-2010.

**KEEPIN' IT REAL REFUSE  
EXPLAIN AVOID LEAVE**

THE MARK CONSISTS OF STANDARD CHARACTERS WITHOUT CLAIM TO ANY PARTICULAR FONT, STYLE, SIZE, OR COLOR.

**CLASS 9—ELECTRICAL AND SCIENTIFIC APPARATUS**

FOR PRE-RECORDED DIGITAL VIDEO DISKS FEATURING LESSONS IN THE FIELD OF DRUG USE PREVENTION (U.S. CLS. 21, 23, 26, 36 AND 38).

FIRST USE 0-0-2005; IN COMMERCE 0-0-2005.

**CLASS 16—PAPER GOODS AND PRINTED MATTER**

FOR PUBLICATIONS, NAMELY, GUIDES AND WORKBOOKS FOR TEACHERS AND STUDENTS IN THE FIELD OF DRUG USE PREVENTION (U.S. CLS. 2, 5, 22, 23, 29, 37, 38 AND 50).

FIRST USE 0-0-2005; IN COMMERCE 0-0-2005.

**CLASS 41—EDUCATION AND ENTERTAINMENT**

FOR PROVIDING ON-LINE VIDEOS AND OTHER MATERIALS, NAMELY, A WEBSITE, FEATURING TRAINING AND EDUCATIONAL INFORMATION IN THE FIELD OF DRUG USE PREVENTION (U.S. CLS. 100, 101 AND 107).

FIRST USE 0-0-2000; IN COMMERCE 0-0-2000.  
KEVON CHISOLM, EXAMINING ATTORNEY

SN 85-177,196. ENVIRO MAIDS LLC, STAMFORD, CT.  
FILED 11-15-2010.

SN 85-177,537. ALLEGHENY DIMENSION, LLC, PETERS-  
BURG, WV. FILED 11-16-2010.



NO CLAIM IS MADE TO THE EXCLUSIVE RIGHT TO USE "MAIDS", APART FROM THE MARK AS SHOWN.

THE COLOR(S) GREEN, BLUE, YELLOW, BLACK, WHITE, AND SILVER IS/ARE CLAIMED AS A FEATURE OF THE MARK.

THE MARK CONSISTS OF THE WORDING "ENVIRO MAIDS" IN BLACK WITH YELLOW OUTLINING TO THE RIGHT OF A HOUSE DESIGN IN WHITE AND OUTLINED IN BLACK WITH A GREEN ROOF, SILVER CHIMNEY, AND WINDOW SHOWING A BLUE SKY REFLECTION. THE HOUSE APPEARS INSIDE A SILVER CIRCLE WITH BLACK OUTLINING AND TWO GREEN LEAVES WITH DEW DROPS, ALL ACCENTED IN WHITE AND BLACK. THE MARK APPEARS ON A WHITE BACKGROUND.

#### CLASS 37—CONSTRUCTION AND REPAIR

FOR HOME CLEANING SERVICES (U.S. CLS. 100, 103 AND 106).

FIRST USE 8-5-2010; IN COMMERCE 8-5-2010.

#### CLASS 44—MEDICAL, BEAUTY AND AGRICULTURAL SERVICES

FOR LANDSCAPE MAINTENANCE SERVICES (U.S. CLS. 100 AND 101).

FIRST USE 8-5-2010; IN COMMERCE 8-5-2010.

CHRISTINE COOPER, EXAMINING ATTORNEY

SN 85-177,243. CLASSIC FOODS INTERNATIONAL CORP.,  
DBA CLASSIC FOODS, INC., IRVINE, CA. FILED 11-15-  
2010.

## BAKED WISDOM

THE MARK CONSISTS OF STANDARD CHARACTERS WITHOUT CLAIM TO ANY PARTICULAR FONT, STYLE, SIZE, OR COLOR.

NO CLAIM IS MADE TO THE EXCLUSIVE RIGHT TO USE "BAKED", APART FROM THE MARK AS SHOWN.

#### CLASS 29—MEATS AND PROCESSED FOODS

FOR POTATO-BASED SNACK FOODS (U.S. CL. 46).

FIRST USE 9-0-2010; IN COMMERCE 9-0-2010.

#### CLASS 30—STAPLE FOODS

FOR WHEAT-BASED SNACK FOODS (U.S. CL. 46).

APRIL ROACH, EXAMINING ATTORNEY

NO CLAIM IS MADE TO THE EXCLUSIVE RIGHT TO USE "ALLEGHENY DIMENSION", APART FROM THE MARK AS SHOWN.

THE MARK CONSISTS OF THE UPPERCASE "A" AND "D", EACH HAVING AN INTERNAL WHITE LINE TRACING ITS PERIMETER, FOLLOWED BY THE WORDS "ALLEGHENY DIMENSION" IN SMALLER UPPERCASE LETTERS, ALL BEING WITHIN A BORDER OPEN ON THE RIGHT END AND FEATURING AN OPEN 4-SIDED LINE IN WHICH THE LETTERS "A" AND "D" ARE LOCATED AND THEN RUNNING ABOVE AND BELOW THE WORDS "ALLEGHENY DIMENSION".

#### CLASS 20—FURNITURE AND ARTICLES NOT OTHERWISE CLASSIFIED

FOR CABINET DOORS FOR FURNITURE CABINETS; CABINET DRAWERS FOR FURNITURE CABINETS; DOORS FOR FURNITURE; DRAWERS; FURNITURE PARTS (U.S. CLS. 2, 13, 22, 25, 32 AND 50).

FIRST USE 8-0-1995; IN COMMERCE 8-0-1995.

#### CLASS 40—MATERIAL TREATMENT

FOR CONTRACT MANUFACTURING IN THE FIELD OF HARDWOOD COMPONENTS FOR FURNITURE; CUSTOM FABRICATION AND PRODUCTION OF HARDWOOD COMPONENTS FOR FURNITURE; CUSTOM MANUFACTURE OF HARDWOOD COMPONENTS FOR FURNITURE; MANUFACTURE OF GENERAL PRODUCT LINES IN THE FIELD OF FURNITURE TO THE ORDER AND SPECIFICATION OF OTHERS; MANUFACTURE OF FURNITURE COMPONENT PARTS TO ORDER AND/OR SPECIFICATION OF OTHERS (U.S. CLS. 100, 103 AND 106).

FIRST USE 8-0-1995; IN COMMERCE 8-0-1995.

DANIEL CAPSHAW, EXAMINING ATTORNEY

SN 85-178,659. TRIPPE MANUFACTURING COMPANY,  
CHICAGO, IL. FILED 11-17-2010.

## TRIPP·LITE

THE MARK CONSISTS OF STANDARD CHARACTERS WITHOUT CLAIM TO ANY PARTICULAR FONT, STYLE, SIZE, OR COLOR.

OWNER OF U.S. REG. NOS. 1,758,013, 2,804,960 AND OTHERS.



**CLASS 9—ELECTRICAL AND SCIENTIFIC APPARATUS**

FOR ELECTRONIC PRODUCTS, NAMELY, POWER INVERTERS; BATTERY CHARGERS; BATTERY CASES; BATTERY CARTRIDGES FOR UNINTERRUPTIBLE POWER SUPPLIES; ELECTRICAL ISOLATION TRANSFORMERS; USB HARDWARE; RACK ENCLOSURES FOR ELECTRONIC EQUIPMENT; CABLES, NAMELY, AUDIO CABLES, AUDIO/VIDEO CABLES, COMPUTER CABLES, COMPUTER NETWORKING CABLES, POWER CABLES, USB CABLES AND VIDEO CABLES; SIGNAL SPLITTERS FOR ELECTRONIC APPARATUS; SWITCHES FOR ELECTRONIC APPARATUS; COOLING DEVICES, NAMELY, A HEAT EXCHANGER, PUMP AND FAN THAT CIRCULATES COOLED AIR FOR ELECTRONIC EQUIPMENT; FANS FOR COOLING COMPUTER HARDWARE CONTAINED IN RACK ENCLOSURES; NOTEBOOK COMPUTER COOLING PADS; NETWORK MANAGEMENT PRODUCTS, NAMELY, SNMP (SIMPLE NETWORK MANAGEMENT PROTOCOL) CARDS; COMPUTER HARDWARE FOR REMOTE MONITORING AND CONTROL OF ENVIRONMENTAL CONDITIONS, SUCH AS TEMPERATURE AND HUMIDITY IN NETWORK ENVIRONMENTS; COMPUTER HARDWARE FOR CONTROLLING AND MONITORING UPS (UNINTERRUPTIBLE POWER SUPPLY) SYSTEMS; COMPUTER SOFTWARE FOR CONTROLLING AND MONITORING UPS (UNINTERRUPTIBLE POWER SUPPLY) SYSTEMS AND COMPUTER NETWORK SYSTEMS; COMPUTER PERIPHERALS; REMOTE CONTROLS FOR PRESENTATION DEVICES; COMPUTER CARRYING CASES AND BAGS; WEBCAMS; AUDIO SPEAKERS (U.S. CLS. 21, 23, 26, 36 AND 38).

FIRST USE 2-0-1961; IN COMMERCE 2-0-1961.

**CLASS 37—CONSTRUCTION AND REPAIR**

FOR PROVIDING ON-SITE START UP, REPAIR AND MAINTENANCE SERVICES FOR POWER SUPPLY PRODUCTS (U.S. CLS. 100, 103 AND 106).

FIRST USE 4-0-1997; IN COMMERCE 4-0-1997.  
KAREN SEVERSON, EXAMINING ATTORNEY

SN 85-180,202. JELD-WEN, INC., KLAMATH FALLS, OR.  
FILED 11-18-2010.



THE MARK CONSISTS OF THE LETTERS "JW" WITH CURVED ARC DESIGN APPEARING BELOW AND TOUCHING THE LETTER "W", ALL INSIDE A RECTANGULAR DESIGN.

**CLASS 6—METAL GOODS**

FOR METAL WINDOWS (U.S. CLS. 2, 12, 13, 14, 23, 25 AND 50).

FIRST USE 10-31-2005; IN COMMERCE 10-31-2005.

**CLASS 19—NON-METALLIC BUILDING MATERIALS**

FOR NON-METAL WINDOWS (U.S. CLS. 1, 12, 33 AND 50).

FIRST USE 10-31-2005; IN COMMERCE 10-31-2005.  
GENE MACIOL, EXAMINING ATTORNEY

SN 85-179,699. SAWYER, MATTHEW, MAMARONECK, NY.  
FILED 11-18-2010.

MOMS WHO ROCK

THE MARK CONSISTS OF STANDARD CHARACTERS WITHOUT CLAIM TO ANY PARTICULAR FONT, STYLE, SIZE, OR COLOR.

NO CLAIM IS MADE TO THE EXCLUSIVE RIGHT TO USE "MOMS", APART FROM THE MARK AS SHOWN.

**CLASS 25—CLOTHING**

FOR HATS; JACKETS; SCARVES; SHIRTS; SWEAT-SHIRTS (U.S. CLS. 22 AND 39).

**CLASS 41—EDUCATION AND ENTERTAINMENT**

FOR ENTERTAINMENT, NAMELY, PRODUCTION OF TELEVISION SHOWS (U.S. CLS. 100, 101 AND 107).  
ROBERT C. CLARK JR., EXAMINING ATTORNEY

SN 85-180,210. JELD-WEN, INC., KLAMATH FALLS, OR.  
FILED 11-18-2010.

JW

THE MARK CONSISTS OF STANDARD CHARACTERS WITHOUT CLAIM TO ANY PARTICULAR FONT, STYLE, SIZE, OR COLOR.

**CLASS 6—METAL GOODS**

FOR METAL WINDOWS (U.S. CLS. 2, 12, 13, 14, 23, 25 AND 50).

FIRST USE 10-31-2005; IN COMMERCE 10-31-2005.

**CLASS 19—NON-METALLIC BUILDING MATERIALS**

FOR NON-METAL WINDOWS (U.S. CLS. 1, 12, 33 AND 50).

FIRST USE 10-31-2005; IN COMMERCE 10-31-2005.  
GENE MACIOL, EXAMINING ATTORNEY

SN 85-180,643. FORALLTIME LLC, SHERBORN, MA. FILED 11-19-2010.

# MEMBLY

THE MARK CONSISTS OF STANDARD CHARACTERS WITHOUT CLAIM TO ANY PARTICULAR FONT, STYLE, SIZE, OR COLOR.

## CLASS 9—ELECTRICAL AND SCIENTIFIC APPARATUS

FOR DOWNLOADABLE SOFTWARE FOR THE PURPOSE OF CAPTURING PHOTOGRAPHIC IMAGES AND VIDEOS DIGITALLY (U.S. CLS. 21, 23, 26, 36 AND 38).

## CLASS 42—SCIENTIFIC AND COMPUTER SERVICES

FOR PROVIDING ONLINE NON-DOWNLOADABLE SOFTWARE FOR THE PURPOSE OF CAPTURING PHOTOGRAPHIC IMAGES AND VIDEOS DIGITALLY (U.S. CLS. 100 AND 101).

ELLEN B. AWRICH, EXAMINING ATTORNEY

SN 85-181,030. GARAGISTRY, LLC, MILTON, GA. FILED 11-19-2010.

# GARAGISTRY

THE MARK CONSISTS OF STANDARD CHARACTERS WITHOUT CLAIM TO ANY PARTICULAR FONT, STYLE, SIZE, OR COLOR.

## CLASS 35—ADVERTISING AND BUSINESS

FOR PROVIDING A WEB SITE WHERE USERS CAN POST ITEMS FOR SALE THROUGH ON-LINE CLASSIFIED ADVERTISEMENTS; PROVIDING ON-LINE SEARCHABLE DATABASES FEATURING CLASSIFIED AD LISTINGS IN THE FIELD OF CLASSIC VEHICLES, NAMELY, MUSCLE CARS, HOT RODS, AUTOMOBILES, TRUCKS, BOATS, PLANES, AND MOTORCYCLES; PROVIDING AN INTERNET WEB SITE TO PROMOTE EVENTS RELATING TO CLASSIC VEHICLES, NAMELY, MUSCLE CARS, HOT RODS, AUTOMOBILES, TRUCKS, BOATS, PLANES, AND MOTORCYCLES, BY MEANS OF AN ONLINE EVENTS CALENDAR; PROVIDING AN ONLINE DIRECTORY INFORMATION SERVICE FEATURING INFORMATION REGARDING CLASSIC VEHICLES, NAMELY, MUSCLE CARS, HOT RODS, AUTOMOBILES, TRUCKS, BOATS, PLANES, AND MOTORCYCLES (U.S. CLS. 100, 101 AND 102).

## CLASS 38—COMMUNICATION

FOR PROVIDING ELECTRONIC BULLETIN BOARDS FOR TRANSMISSION OF MESSAGES AMONG USERS IN THE FIELD OF CLASSIC VEHICLES, NAMELY, MUSCLE CARS, HOT RODS, AUTOMOBILES, TRUCKS, BOATS, PLANES, AND MOTORCYCLES (U.S. CLS. 100, 101 AND 104).

## CLASS 41—EDUCATION AND ENTERTAINMENT

FOR PROVIDING HISTORICAL AND ENTERTAINMENT INFORMATION IN THE FIELD OF CLASSIC VEHICLES, NAMELY, MUSCLE CARS, HOT RODS, AUTOMOBILES, TRUCKS, BOATS, PLANES, AND MOTORCYCLES; PROVIDING ON-LINE ELECTRONIC DATABASES IN THE FIELD OF CLASSIC VEHICLES, NAMELY, MUSCLE CARS, HOT RODS, AUTOMOBILES, TRUCKS, BOATS, PLANES, AND MOTORCYCLES, FEATURING HISTORICAL RECORDS, HISTORICAL PUBLICATIONS, PHOTOGRAPHS, VEHICLE OWNERSHIP RECORDS, VEHICLE OWNERS' NARRATIVES, VEHICLE MAINTENANCE HISTORIES, AND VEHICLE RESTORATION HISTORIES SUBMITTED BY USERS, PROVIDED ON THE GLOBAL COMPUTER NETWORK (U.S. CLS. 100, 101 AND 107).

## CLASS 42—SCIENTIFIC AND COMPUTER SERVICES

FOR COMPUTER SERVICES, NAMELY, CREATING AN ON-LINE COMMUNITY FOR REGISTERED USERS TO PARTICIPATE IN DISCUSSIONS, RECEIVE FEEDBACK FROM THEIR PEERS, SOLICIT ADVICE, FORM VIRTUAL COMMUNITIES, AND ENGAGE IN SOCIAL NETWORKING IN THE FIELD OF CLASSIC VEHICLES, NAMELY, MUSCLE CARS, HOT RODS, AUTOMOBILES, TRUCKS, BOATS, PLANES, AND MOTORCYCLES; COMPUTER SERVICES, NAMELY, CREATING AN ON-LINE COMMUNITY FOR REGISTERED USERS TO PARTICIPATE IN DISCUSSIONS, GET FEEDBACK FROM THEIR PEERS, FORM VIRTUAL COMMUNITIES, AND ENGAGE IN SOCIAL NETWORKING; COMPUTER SERVICES, NAMELY, HOSTING CUSTOMIZED WEB PAGES AND DATA FEEDS FEATURING USER-DEFINED INFORMATION, NAMELY, BLOG POSTS, PERSONAL PROFILES, NEW MEDIA CONTENT, AND ON-LINE CONTENT, ALL IN THE FIELD OF CLASSIC VEHICLES, NAMELY, MUSCLE CARS, HOT RODS, AUTOMOBILES, TRUCKS, BOATS, PLANES, AND MOTORCYCLES; COMPUTER SERVICES, NAMELY, HOSTING AN INTERACTIVE WEB SITE FOR USE IN CREATING, DISPLAYING, SHARING AND STORING MULTIMEDIA PRESENTATIONS THAT INCLUDE TEXT, PHOTOGRAPHS AND SOUND, ALL IN THE FIELD OF CLASSIC VEHICLES, NAMELY, MUSCLE CARS, HOT RODS, AUTOMOBILES, TRUCKS, BOATS, PLANES, AND MOTORCYCLES; HOSTING OF DIGITAL CONTENT ON THE INTERNET, NAMELY, HOSTING OF ON-LINE ARTICLES, JOURNALS, BULLETIN BOARDS, AND BLOGS IN THE FIELD OF CLASSIC VEHICLES, NAMELY, MUSCLE CARS, HOT RODS, AUTOMOBILES, TRUCKS, BOATS, PLANES, AND MOTORCYCLES; COMPUTER SERVICES, NAMELY, HOSTING AND MAINTAINING AN ONLINE WEBSITE FOR OTHERS TO ACCESS PHOTO ALBUMS AND CALENDARS; PROVIDING TEMPORARY USE OF NON-DOWNLOADABLE COMPUTER SOFTWARE FOR USE IN THE CREATION AND PUBLICATION OF ON-LINE JOURNALS, BLOGS, AND MULTI-MEDIA PRESENTATIONS IN THE FIELD OF CLASSIC VEHICLES, NAMELY, MUSCLE CARS, HOT RODS, AUTOMOBILES, TRUCKS, BOATS, PLANES, AND MOTORCYCLES (U.S. CLS. 100 AND 101).

JORDAN BAKER, EXAMINING ATTORNEY

SN 85-181,093. GARAGISTRY, LLC, MILTON, GA. FILED 11-19-2010.

## PRESERVING AUTOMOTIVE HISTORY ... ONE CAR AT A TIME

THE MARK CONSISTS OF STANDARD CHARACTERS WITHOUT CLAIM TO ANY PARTICULAR FONT, STYLE, SIZE, OR COLOR.

**CLASS 35—ADVERTISING AND BUSINESS**

FOR PROVIDING A WEB SITE WHERE USERS CAN POST ITEMS FOR SALE THROUGH ON-LINE CLASSIFIED ADVERTISEMENTS; PROVIDING ON-LINE SEARCHABLE DATABASES FEATURING CLASSIFIED AD LISTINGS IN THE FIELD OF CLASSIC VEHICLES, NAMELY, MUSCLE CARS, HOT RODS, AUTOMOBILES, TRUCKS, BOATS, PLANES, AND MOTORCYCLES; PROVIDING AN INTERNET WEB SITE TO PROMOTE EVENTS RELATING TO CLASSIC VEHICLES, NAMELY, MUSCLE CARS, HOT RODS, AUTOMOBILES, TRUCKS, BOATS, PLANES, AND MOTORCYCLES, BY MEANS OF AN ONLINE EVENTS CALENDAR; PROVIDING AN ON-LINE DIRECTORY INFORMATION SERVICE FEATURING INFORMATION REGARDING CLASSIC VEHICLES, NAMELY, MUSCLE CARS, HOT RODS, AUTOMOBILES, TRUCKS, BOATS, PLANES, AND MOTORCYCLES (U.S. CLS. 100, 101 AND 102).

**CLASS 38—COMMUNICATION**

FOR PROVIDING ELECTRONIC BULLETIN BOARDS FOR TRANSMISSION OF MESSAGES AMONG USERS IN THE FIELD OF CLASSIC VEHICLES, NAMELY, MUSCLE CARS, HOT RODS, AUTOMOBILES, TRUCKS, BOATS, PLANES, AND MOTORCYCLES (U.S. CLS. 100, 101 AND 104).

**CLASS 41—EDUCATION AND ENTERTAINMENT**

FOR PROVIDING HISTORICAL AND ENTERTAINMENT INFORMATION IN THE FIELD OF CLASSIC VEHICLES, NAMELY, MUSCLE CARS, HOT RODS, AUTOMOBILES, TRUCKS, BOATS, PLANES, AND MOTORCYCLES; PROVIDING ON-LINE ELECTRONIC DATABASES IN THE FIELD OF CLASSIC VEHICLES, NAMELY, MUSCLE CARS, HOT RODS, AUTOMOBILES, TRUCKS, BOATS, PLANES, AND MOTORCYCLES, FEATURING HISTORICAL RECORDS, HISTORICAL PUBLICATIONS, PHOTOGRAPHS, VEHICLE OWNERSHIP RECORDS, VEHICLE OWNERS' NARRATIVES, VEHICLE MAINTENANCE HISTORIES, AND VEHICLE RESTORATION HISTORIES SUBMITTED BY USERS, PROVIDED ON THE GLOBAL COMPUTER NETWORK (U.S. CLS. 100, 101 AND 107).

**CLASS 42—SCIENTIFIC AND COMPUTER SERVICES**

FOR COMPUTER SERVICES, NAMELY, CREATING AN ON-LINE COMMUNITY FOR REGISTERED USERS TO PARTICIPATE IN DISCUSSIONS, RECEIVE FEEDBACK FROM THEIR PEERS, SOLICIT ADVICE, FORM VIRTUAL COMMUNITIES, AND ENGAGE IN SOCIAL NETWORKING IN THE FIELD OF CLASSIC VEHICLES, NAMELY, MUSCLE CARS, HOT RODS, AUTOMOBILES, TRUCKS, BOATS, PLANES, AND MOTORCYCLES; COMPUTER SERVICES, NAMELY, CREATING AN ON-LINE COMMUNITY FOR REGISTERED USERS TO PARTICIPATE IN DISCUSSIONS, GET FEEDBACK FROM THEIR PEERS, FORM VIRTUAL COMMUNITIES, AND ENGAGE IN SOCIAL NETWORKING; COMPUTER SERVICES, NAMELY, HOSTING CUSTOMIZED WEB PAGES AND DATA FEEDS FEATURING USER-DEFINED INFORMATION, NAMELY, BLOG POSTS, PERSONAL PROFILES, NEW MEDIA CONTENT, AND ON-LINE CONTENT, ALL IN THE FIELD OF CLASSIC VEHICLES, NAMELY, MUSCLE CARS, HOT RODS, AUTOMOBILES, TRUCKS, BOATS, PLANES, AND MOTORCYCLES; COMPUTER SERVICES, NAMELY, HOSTING AN INTERACTIVE WEB SITE FOR USE IN CREATING, DISPLAYING, SHARING AND STORING MULTIMEDIA PRESENTATIONS THAT INCLUDE TEXT, PHOTOGRAPHS AND SOUND, ALL IN THE FIELD OF CLASSIC VEHICLES, NAMELY, MUSCLE CARS, HOT RODS, AUTOMOBILES, TRUCKS, BOATS, PLANES, AND MOTORCYCLES; HOSTING OF DIGITAL CONTENT ON THE INTERNET, NAMELY, HOSTING OF ON-LINE ARTICLES, JOURNALS, BULLETIN BOARDS, AND BLOGS IN THE FIELD OF CLASSIC VEHICLES, NAMELY, MUSCLE CARS, HOT

RODS, AUTOMOBILES, TRUCKS, BOATS, PLANES, AND MOTORCYCLES; COMPUTER SERVICES, NAMELY, HOSTING AND MAINTAINING AN ONLINE WEBSITE FOR OTHERS TO ACCESS PHOTO ALBUMS AND CALENDARS; PROVIDING TEMPORARY USE OF NON-DOWNLOADABLE COMPUTER SOFTWARE FOR USE IN THE CREATION AND PUBLICATION OF ON-LINE JOURNALS, BLOGS, AND MULTI-MEDIA PRESENTATIONS IN THE FIELD OF CLASSIC VEHICLES, NAMELY, MUSCLE CARS, HOT RODS, AUTOMOBILES, TRUCKS, BOATS, PLANES, AND MOTORCYCLES (U.S. CLS. 100 AND 101).

JORDAN BAKER, EXAMINING ATTORNEY

SN 85-181,785. BRICKELL FINANCIAL SERVICES-MOTOR CLUB, INC., MIAMI, FL. FILED 11-20-2010.

**CYCLE ASSIST**

THE MARK CONSISTS OF STANDARD CHARACTERS WITHOUT CLAIM TO ANY PARTICULAR FONT, STYLE, SIZE, OR COLOR.

OWNER OF U.S. REG. NO. 3,559,913.

NO CLAIM IS MADE TO THE EXCLUSIVE RIGHT TO USE "CYCLE", APART FROM THE MARK AS SHOWN.

**CLASS 37—CONSTRUCTION AND REPAIR**

FOR EMERGENCY ROADSIDE REPAIR SERVICES; AUTOMOTIVE REPAIRS, NAMELY, WINDSHIELD REPAIR AND DENT REMOVAL; EMERGENCY ROADSIDE ASSISTANCE SERVICES, NAMELY, RESPONDING TO CALLS FOR ROADSIDE ASSISTANCE, FLAT TIRE CHANGING, EMERGENCY FUEL SUPPLYING AND BATTERY JUMP STARTING (U.S. CLS. 100, 103 AND 106).

FIRST USE 4-1-1991; IN COMMERCE 4-1-1991.

**CLASS 39—TRANSPORTATION AND STORAGE**

FOR EMERGENCY ROADSIDE ASSISTANCE SERVICES, NAMELY, TOWING, WINCH-OUT AND KEY DELIVERY SERVICES (U.S. CLS. 100 AND 105).

FIRST USE 4-1-1991; IN COMMERCE 4-1-1991.

**CLASS 45—PERSONAL AND LEGAL SERVICES**

FOR EMERGENCY ROADSIDE ASSISTANCE SERVICES, NAMELY, OPENING OF LOCKS (U.S. CLS. 100 AND 101).

FIRST USE 4-1-1991; IN COMMERCE 4-1-1991.

MARILYN IZZI, EXAMINING ATTORNEY

SN 85-181,790. BRICKELL FINANCIAL SERVICES-MOTOR CLUB, INC., MIAMI, FL. FILED 11-20-2010.

**RV ASSIST**

THE MARK CONSISTS OF STANDARD CHARACTERS WITHOUT CLAIM TO ANY PARTICULAR FONT, STYLE, SIZE, OR COLOR.

OWNER OF U.S. REG. NO. 1,737,800.  
NO CLAIM IS MADE TO THE EXCLUSIVE RIGHT TO  
USE "RV", APART FROM THE MARK AS SHOWN.

SN 85-183,548. VIRGINIA INVESTMENT PARTNERSHIP,  
WATERFORD, VA. FILED 11-23-2010.

#### CLASS 37—CONSTRUCTION AND REPAIR

FOR EMERGENCY ROADSIDE REPAIR SERVICES;  
AUTOMOTIVE REPAIRS, NAMELY, WINDSHIELD RE-  
PAIR AND DENT REMOVAL; EMERGENCY ROADSIDE  
ASSISTANCE SERVICES, NAMELY RESPONDING TO  
CALLS FOR ROADSIDE ASSISTANCE, FLAT TIRE  
CHANGING, EMERGENCY FUEL SUPPLYING AND  
BATTERY JUMP STARTING (U.S. CLS. 100, 103 AND  
106).

FIRST USE 3-12-1991; IN COMMERCE 3-12-1991.

#### CLASS 39—TRANSPORTATION AND STO- RAGE

FOR EMERGENCY ROADSIDE ASSISTANCE SER-  
VICES, NAMELY, TOWING, WINCH-OUT AND KEY  
DELIVERY SERVICES (U.S. CLS. 100 AND 105).

FIRST USE 3-12-1991; IN COMMERCE 3-12-1991.

#### CLASS 45—PERSONAL AND LEGAL SER- VICES

FOR EMERGENCY ROADSIDE ASSISTANCE SER-  
VICES, NAMELY, OPENING OF LOCKS (U.S. CLS. 100  
AND 101).

FIRST USE 3-12-1991; IN COMMERCE 3-12-1991.

MARILYN IZZI, EXAMINING ATTORNEY

---

SN 85-181,799. BRICKELL FINANCIAL SERVICES-MOTOR  
CLUB, INC., MIAMI, FL. FILED 11-20-2010.

### SECURITY PLATINUM

THE MARK CONSISTS OF STANDARD CHARACTERS  
WITHOUT CLAIM TO ANY PARTICULAR FONT, STYLE,  
SIZE, OR COLOR.

OWNER OF U.S. REG. NO. 2,920,863.

NO CLAIM IS MADE TO THE EXCLUSIVE RIGHT TO  
USE "SECURITY", APART FROM THE MARK AS SHOWN.

#### CLASS 39—TRANSPORTATION AND STO- RAGE

FOR EMERGENCY ROADSIDE ASSISTANCE SER-  
VICES, NAMELY, TOWING, WINCH-OUT AND KEY  
DELIVERY SERVICES (U.S. CLS. 100 AND 105).

FIRST USE 12-1-2003; IN COMMERCE 12-1-2003.

#### CLASS 45—PERSONAL AND LEGAL SER- VICES

FOR EMERGENCY ROADSIDE ASSISTANCE SER-  
VICES, NAMELY, OPENING OF LOCKS (U.S. CLS. 100  
AND 101).

FIRST USE 12-1-2003; IN COMMERCE 12-1-2003.

MARILYN IZZI, EXAMINING ATTORNEY



NO CLAIM IS MADE TO THE EXCLUSIVE RIGHT TO  
USE "LOUDOUN", APART FROM THE MARK AS SHOWN.

THE MARK CONSISTS OF THE HEAD OF A DOG WHICH  
IS HOLDING A BASEBALL IN ITS MOUTH; ABOVE THE  
HEAD OF THE DOG IS THE WORD "HOUNDS" IN A  
STYLIZED FONT; AND ABOVE THE LETTERS "O", "U",  
"N" AND "D" IN THE WORD "HOUNDS" IS THE WORD  
"LOUDOUN" IN A STYLIZED FONT.

#### CLASS 25—CLOTHING

FOR ATHLETIC APPAREL, NAMELY, SHIRTS,  
PANTS, JACKETS, FOOTWEAR, HATS AND CAPS,  
ATHLETIC UNIFORMS (U.S. CLS. 22 AND 39).

#### CLASS 41—EDUCATION AND ENTERTAIN- MENT

FOR ENTERTAINMENT IN THE NATURE OF BASE-  
BALL GAMES (U.S. CLS. 100, 101 AND 107).

FIRST USE 9-21-2010; IN COMMERCE 9-21-2010.

JIM RINGLE, EXAMINING ATTORNEY

---

SN 85-183,576. VIRGINIA INVESTMENT PARTNERSHIP,  
WATERFORD, VA. FILED 11-23-2010.



THE MARK CONSISTS OF THE LETTER "H" IN A  
STYLIZED FONT PLACED DIRECTLY ON TOP OF THE  
LETTER "L" IN A STYLIZED FONT SET AGAINST A  
RECTANGULAR BACKGROUND CARRIER.

#### CLASS 25—CLOTHING

FOR ATHLETIC APPAREL, NAMELY, SHIRTS,  
PANTS, JACKETS, FOOTWEAR, HATS AND CAPS,  
ATHLETIC UNIFORMS (U.S. CLS. 22 AND 39).



**CLASS 41—EDUCATION AND ENTERTAINMENT**

FOR ENTERTAINMENT IN THE NATURE OF BASEBALL GAMES (U.S. CLS. 100, 101 AND 107).  
JIM RINGLE, EXAMINING ATTORNEY

SN 85-183,591. VIRGINIA INVESTMENT PARTNERSHIP, WATERFORD, VA. FILED 11-23-2010.

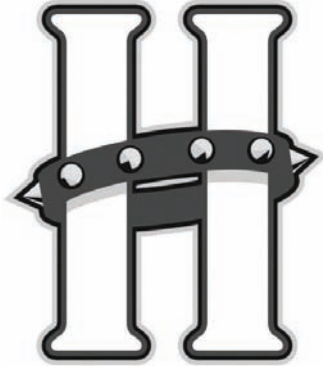

THE MARK CONSISTS OF A STYLIZED LETTER "H" WHEREIN THE CROSSBAR OF THE LETTER "H" IS REPRESENTED BY A SPIKED DOG COLLAR WHICH IS PLACED AROUND THE TWO VERTICAL PORTIONS OF THE LETTER "H".

**CLASS 25—CLOTHING**

FOR ATHLETIC APPAREL, NAMELY, SHIRTS, PANTS, JACKETS, FOOTWEAR, HATS AND CAPS, ATHLETIC UNIFORMS (U.S. CLS. 22 AND 39).

**CLASS 41—EDUCATION AND ENTERTAINMENT**

FOR ENTERTAINMENT IN THE NATURE OF BASEBALL GAMES (U.S. CLS. 100, 101 AND 107).  
JIM RINGLE, EXAMINING ATTORNEY

SN 85-184,374. SALON IAOMO, LLC, PITTSBURGH, PA. FILED 11-24-2010.

# Salon IAOMO

THE MARK CONSISTS OF STANDARD CHARACTERS WITHOUT CLAIM TO ANY PARTICULAR FONT, STYLE, SIZE, OR COLOR.

NO CLAIM IS MADE TO THE EXCLUSIVE RIGHT TO USE "SALON", APART FROM THE MARK AS SHOWN.

**CLASS 26—FANCY GOODS**

FOR HAIR PIECES AND WIGS (U.S. CLS. 37, 39, 40, 42 AND 50).  
FIRST USE 6-0-2008; IN COMMERCE 6-0-2008.

**CLASS 44—MEDICAL, BEAUTY AND AGRICULTURAL SERVICES**

FOR BODY WAXING SERVICES; DAY SPA SERVICES, NAMELY, NAIL CARE, MANICURES, PEDICURES AND NAIL ENHANCEMENTS; EYEBROW THREADING SERVICES; HAIR REPLACEMENT, HAIR ADDITION, AND HAIR EXTENSION SERVICES; HAIR SALON SERVICES; MAKE-UP APPLICATION SERVICES; TANNING SALONS (U.S. CLS. 100 AND 101).

FIRST USE 6-0-2008; IN COMMERCE 6-0-2008.  
GENE MACIOL, EXAMINING ATTORNEY

SN 85-184,464. NATIONAL ASSOCIATION OF SECONDARY SCHOOL PRINCIPALS, INC., RESTON, VA. FILED 11-24-2010.

# STAR LEADERS NATIONAL STUDENT CONFERENCE

THE MARK CONSISTS OF STANDARD CHARACTERS WITHOUT CLAIM TO ANY PARTICULAR FONT, STYLE, SIZE, OR COLOR.

NO CLAIM IS MADE TO THE EXCLUSIVE RIGHT TO USE "LEADERS NATIONAL STUDENT CONFERENCE" IN RELATION TO CLASS 41, APART FROM THE MARK AS SHOWN.

**CLASS 25—CLOTHING**

FOR SHIRTS; T-SHIRTS (U.S. CLS. 22 AND 39).

**CLASS 41—EDUCATION AND ENTERTAINMENT**

FOR EDUCATIONAL SERVICES, NAMELY, CONDUCTING CONFERENCES, CLASSES, SEMINARS, AND WORKSHOPS IN THE FIELD OF STUDENT LEADERSHIP DEVELOPMENT AND CHAPTER AND COUNCIL ADVISER DEVELOPMENT AND DISTRIBUTION OF EDUCATIONAL MATERIALS IN CONNECTION THEREWITH (U.S. CLS. 100, 101 AND 107).

NAPOLEON SHARMA, EXAMINING ATTORNEY

SN 85-184,691. DIOSSY BROTHERS, LLC, VERO BEACH, FL. FILED 11-24-2010.

# AVERNOS

THE MARK CONSISTS OF STANDARD CHARACTERS WITHOUT CLAIM TO ANY PARTICULAR FONT, STYLE, SIZE, OR COLOR.

THE ENGLISH TRANSLATION OF "AVERNOS" IN THE MARK IS "UNDERWORLD".

**CLASS 16—PAPER GOODS AND PRINTED MATTER**

FOR DECALS, DECALS FOR CARS AND BOATS (U.S. CLS. 2, 5, 22, 23, 29, 37, 38 AND 50).

**CLASS 25—CLOTHING**

FOR SHIRTS AND HATS (U.S. CLS. 22 AND 39),  
REGINA DRUMMOND, EXAMINING ATTORNEY

SN 85-185,057. BUMBY WORKS, LLC, CULVER CITY, CA.  
FILED 11-24-2010.

# OODLE

THE MARK CONSISTS OF STANDARD CHARACTERS WITHOUT CLAIM TO ANY PARTICULAR FONT, STYLE, SIZE, OR COLOR.

**CLASS 3—COSMETICS AND CLEANING PREPARATIONS**

FOR BATH SOAPS IN LIQUID, SOLID OR GEL FORM (U.S. CLS. 1, 4, 6, 50, 51 AND 52).

**CLASS 9—ELECTRICAL AND SCIENTIFIC APPARATUS**

FOR NON-REFRIGERATED AND NON-HEATED ELECTRIC-POWERED LIQUID DISPENSER FOR PERSONAL AND HOUSEHOLD USE (U.S. CLS. 21, 23, 26, 36 AND 38).  
KIMBERLY FRYE, EXAMINING ATTORNEY

SN 85-185,707. AW, MALCOLM, BELLEVUE, WA. FILED S.R.  
11-28-2010; AM. P.R. 10-28-2010.



NO CLAIM IS MADE TO THE EXCLUSIVE RIGHT TO USE "POLYGLOT", APART FROM THE MARK AS SHOWN. THE COLOR(S) BLUE, GREEN, RED, WHITE, YELLOW, BLACK, GRAY, PURPLE AND ORANGE IS/ARE CLAIMED AS A FEATURE OF THE MARK.

THE MARK CONSISTS OF A MULTICOLORED PARROT OUTLINED IN BLACK WITH THE LEFT WING STRETCHED OUT. THE PARROT HAS AN ORANGE BEAK, ORANGE FEET, WHITE EYE WITH BLACK PUPIL, AND PURPLE WITH A LITTLE BIT OF BLUE ON THE HEAD AND TAIL FEATHERS. THE BODY OF THE PARROT IS ORANGE, BLUE AND GREEN WITH RED AND GREEN ON THE WINGS. THE WORD, "POLYGLOT" IS TO THE RIGHT OF THE PARROT IN BLACK WITH A GRAY SHADOW AND PARTIALLY UNDERLINED IN BLACK.

**CLASS 9—ELECTRICAL AND SCIENTIFIC APPARATUS**

FOR CHILDREN'S EDUCATIONAL MUSIC CDS AND DVDS; CHILDREN'S EDUCATIONAL SOFTWARE; COMPUTER GAME PROGRAMS; COMPUTER GAME SOFTWARE; COMPUTERIZED VIDEO TABLE GAMES FOR GAMING PURPOSES; DOWNLOADABLE AUDIO FILES, MULTIMEDIA FILES, TEXT FILES, E-MAILS, WRITTEN DOCUMENTS, AUDIO MATERIAL, VIDEO MATERIAL AND GAMES FEATURING INFORMATION IN THE FORM OF DOWNLOADABLE SHORT EDUCATIONAL/TRAINING COMMUNICATIONS IN THE FIELD OF HUMAN RESOURCE DEVELOPMENT FOR THE PROMOTION OF EMPLOYEE RETENTION, CAREER GROWTH AND INCREASED PRODUCTIVITY FOR EMPLOYEES AND EMPLOYERS; DOWNLOADABLE COMPUTER GAME PROGRAMS; DOWNLOADABLE ELECTRONIC GAME PROGRAMS; DOWNLOADABLE IMAGE FILE CONTAINING ARTWORK, TEXT, AUDIO, VIDEO, GAMES AND INTERNET WEB LINKS RELATING TO SPORTING AND CULTURAL ACTIVITIES; ELECTRONIC AND VIDEO GAME CONTROLLERS INCORPORATED INTO EXERCISE MACHINES; ELECTRONIC GAME PROGRAMS; ELECTRONIC GAME SOFTWARE; ELECTRONIC INTERACTIVE BOARD GAMES FOR USE WITH EXTERNAL MONITOR; INTERACTIVE GAME PROGRAMS; INTERACTIVE GAME SOFTWARE; INTERACTIVE VIDEO GAME PROGRAMS (U.S. CLS. 21, 23, 26, 36 AND 38).

**CLASS 16—PAPER GOODS AND PRINTED MATTER**

FOR EDUCATIONAL AND LEARNING PUBLICATIONS, NAMELY, BOOKLETS AND FLASH CARDS ON A VARIETY OF EDUCATIONAL DISCIPLINES IN PRESCHOOL THROUGH EIGHTH GRADE; EDUCATIONAL BOOKS FEATURING LANGUAGES; EDUCATIONAL KITS SOLD AS A UNIT IN THE FIELD OF LANGUAGES CONSISTING PRIMARILY OF EDUCATIONAL BOOKS AND ALSO INCLUDING DVDS AND T-SHIRTS; EDUCATIONAL KITS SOLD AS A UNIT IN THE FIELD OF LANGUAGES CONSISTING PRIMARILY OF EDUCATIONAL BOOKS, FLASH CARDS AND WORKSHEETS, AND ALSO INCLUDING AN EDUCATIONAL DVD; EDUCATIONAL PUBLICATIONS, NAMELY, BOOKS, HAND-OUTS, WORKBOOKS, JOURNALS, PLAYBOOKS, WORKSHEETS AND CARDS IN THE FIELD OF RIGHT-BRAIN FITNESS; EDUCATIONAL PUBLICATIONS, NAMELY, EDUCATIONAL LEARNING CARDS, FLASH CARDS, ACTIVITY CARDS, WORKBOOKS, TEXTBOOKS, ACTIVITY BOOKS, STORY BOOKS, PUZZLE BOOKS, PRINTED PUZZLES, TEACHER GUIDES, MANUALS, POSTERS AND EDUCATIONAL BOOKLETS IN THE FIELD OF LANGUAGES; EDUCATIONAL PUBLICATIONS, NAMELY, TRAINING MANUALS IN THE FIELD OF LANGUAGES; PACKAGED KITS COMPRISING PRINTED INSTRUCTIONAL, EDUCATIONAL, AND TEACHING MATERIALS FOR EDUCATIONAL ACTIVITIES IN THE FIELD OF LANGUAGES; PRINTED MATERIAL, NAMELY, SURVEYS AND ASSESSMENTS IN THE FIELD OF EDUCATOR TRAINING AND PERFORMANCE; ROLE PLAYING GAME EQUIPMENT IN THE NATURE OF GAME BOOK MANUALS (U.S. CLS. 2, 5, 22, 23, 29, 37, 38 AND 50).

**CLASS 18—LEATHER GOODS**

FOR CARRYING BOX WITH GRAPHIC GAMES AND COLORING AREAS PRINTED THEREON FOR USE BY A CHILD TO TRANSPORT PERSONAL ITEMS TO HELP IN THE CHILD'S TRANSITION FROM HOME TO ANOTHER LOCATION (U.S. CLS. 1, 2, 3, 22 AND 41).  
ROBIN CHOSID, EXAMINING ATTORNEY

SN 85-186,043. GOLDEN STAR WHOLESALE, INC., TROY, MI. FILED 11-29-2010.

SN 85-186,232. INFINITY FITNESS AND TRAINING INC., BLACKLICK, OH. FILED 11-29-2010.

## RED KITCHEN

THE MARK CONSISTS OF STANDARD CHARACTERS WITHOUT CLAIM TO ANY PARTICULAR FONT, STYLE, SIZE, OR COLOR.

NO CLAIM IS MADE TO THE EXCLUSIVE RIGHT TO USE "KITCHEN", APART FROM THE MARK AS SHOWN.

### CLASS 4—LUBRICANTS AND FUELS

FOR CHARCOAL (U.S. CLS. 1, 6 AND 15).  
FIRST USE 0-0-2009; IN COMMERCE 0-0-2009.

### CLASS 21—HOUSEWARES AND GLASS

FOR BEVERAGE GLASSWARE; COOKING POTS; COOKING SKEWERS (U.S. CLS. 2, 13, 23, 29, 30, 33, 40 AND 50).

FIRST USE 0-0-2009; IN COMMERCE 0-0-2009.  
BERYL GARDNER, EXAMINING ATTORNEY

SN 85-186,224. HUEN ENERGY SOLUTIONS, LLC, SYRACUSE, NY. FILED 11-29-2010.

## ECONOMIC DISPATCH

THE MARK CONSISTS OF STANDARD CHARACTERS WITHOUT CLAIM TO ANY PARTICULAR FONT, STYLE, SIZE, OR COLOR.

NO CLAIM IS MADE TO THE EXCLUSIVE RIGHT TO USE "ECONOMIC", APART FROM THE MARK AS SHOWN.

### CLASS 9—ELECTRICAL AND SCIENTIFIC APPARATUS

FOR COMPUTER SOFTWARE FOR USE IN OPTIMIZING THE ECONOMIC PERFORMANCE OF COMBINED HEAT AND POWER (CHP) PLANTS BY PROVIDING AN OPERATING SYSTEM FOR RESPONDING TO PRICE SIGNALS PROVIDED BY THE MARKET, WHICH ALSO INCLUDES A REPORTING SYSTEM TO EVALUATE THE RESULTS OF DECISIONS REACHED BY THE SYSTEMS USED BY COMMERCIAL, INDUSTRIAL AND INSTITUTIONAL CUSTOMERS WHO HAVE INSTALLED CHP PLANTS OR WHO PLAN TO INSTALL SUCH PLANTS (U.S. CLS. 21, 23, 26, 36 AND 38).

### CLASS 42—SCIENTIFIC AND COMPUTER SERVICES

FOR PROVIDING ON-LINE NONDOWNLOADABLE COMPUTER SOFTWARE FOR USE IN OPTIMIZING THE ECONOMIC PERFORMANCE OF COMBINED HEAT AND POWER (CHP) PLANTS BY PROVIDING AN OPERATING SYSTEM FOR RESPONDING TO PRICE SIGNALS PROVIDED BY THE MARKET, WHICH ALSO INCLUDES A REPORTING SYSTEM TO EVALUATE THE RESULTS OF DECISIONS REACHED BY THE SYSTEMS USED BY COMMERCIAL, INDUSTRIAL AND INSTITUTIONAL CUSTOMERS WHO HAVE INSTALLED CHP PLANTS OR WHO PLAN TO INSTALL SUCH PLANTS (U.S. CLS. 100 AND 101).

TARAH HARDY, EXAMINING ATTORNEY

## INFINITY FITNESS

THE MARK CONSISTS OF STANDARD CHARACTERS WITHOUT CLAIM TO ANY PARTICULAR FONT, STYLE, SIZE, OR COLOR.

NO CLAIM IS MADE TO THE EXCLUSIVE RIGHT TO USE "FITNESS", APART FROM THE MARK AS SHOWN.

### CLASS 35—ADVERTISING AND BUSINESS

FOR ON-LINE RETAIL STORE SERVICES FEATURING DVDS AND BOOKS IN THE FIELDS OF PHYSICAL TRAINING AND FITNESS; AND ON-LINE RETAIL STORE SERVICES FEATURING NUTRITIONAL SUPPLEMENTS (U.S. CLS. 100, 101 AND 102).

FIRST USE 11-0-1999; IN COMMERCE 11-0-1999.

### CLASS 41—EDUCATION AND ENTERTAINMENT

FOR PROVIDING INFORMATION IN THE FIELD OF PHYSICAL EXERCISE AND FITNESS TRAINING (U.S. CLS. 100, 101 AND 107).

FIRST USE 11-0-1999; IN COMMERCE 11-0-1999.

### CLASS 44—MEDICAL, BEAUTY AND AGRICULTURAL SERVICES

FOR PROVIDING INFORMATION IN THE FIELD OF NUTRITION; AND MEMBERSHIP CLUB SERVICES IN THE FIELD OF PROVIDING INFORMATION IN THE FIELDS OF HEALTH AND NUTRITION (U.S. CLS. 100 AND 101).

FIRST USE 11-0-1999; IN COMMERCE 11-0-1999.

TINA BROWN, EXAMINING ATTORNEY

SN 85-186,250. MERIDIAN HEALTH SYSTEM, INC., NEPTUNE, NJ. FILED 11-29-2010.

## IMPAK HEALTH

THE MARK CONSISTS OF STANDARD CHARACTERS WITHOUT CLAIM TO ANY PARTICULAR FONT, STYLE, SIZE, OR COLOR.

NO CLAIM IS MADE TO THE EXCLUSIVE RIGHT TO USE "HEALTH", APART FROM THE MARK AS SHOWN.

### CLASS 10—MEDICAL APPARATUS

FOR MEDICAL DEVICES, NAMELY, PORTABLE ELECTRONIC PATIENT MONITORS AND PATIENT SENSORS WITH AUTOMATED ALERT AND MONITORING CAPACITY FOR MONITORING AND MEASURING PATIENT REPORTED SYMPTOMS, HEART RATE, BLOOD PRESSURE, BODY TEMPERATURE, PAIN, BLOOD GLUCOSE LEVELS, THE OXYGEN SATURATION OF THE BLOOD AND OTHER VITAL SIGN AND DIAGNOSTIC PARAMETERS (U.S. CLS. 26, 39 AND 44).

**CLASS 44—MEDICAL, BEAUTY AND AGRICULTURAL SERVICES**

FOR MEDICAL DIAGNOSTIC MONITORING AND REPORTING SERVICES FOR MEDICAL PROFESSIONALS AND MEDICAL PATIENTS PROVIDED VIA TELECOMMUNICATION NETWORKS AND/OR GLOBAL COMPUTER NETWORKS FEATURING MEDICAL INFORMATION IN THE NATURE OF PATIENT REPORTED SYMPTOMS, HEART RATE, BLOOD PRESSURE, BODY TEMPERATURE, PAIN, BLOOD GLUCOSE LEVELS, OXYGEN SATURATION OF THE BLOOD AND OTHER VITAL SIGN AND DIAGNOSTIC PARAMETERS, GATHERED FROM ELECTRONIC PATIENT MEDICAL MONITORING DEVICES WHICH FEED INFORMATION TO REMOTE LOCATIONS THAT CAN BE ACCESSED IN REAL-TIME BY MEDICAL PROFESSIONALS FOR PURPOSES OF MONITORING AND DIAGNOSING MEDICAL CONDITIONS FOR INDIVIDUALS WITH HEALTH PROBLEMS (U.S. CLS. 100 AND 101).

WENDY GOODMAN, EXAMINING ATTORNEY

---

SN 85-186,524. MERIDIAN HEALTH SYSTEM, INC., NEPTUNE, NJ. FILED 11-29-2010.



NO CLAIM IS MADE TO THE EXCLUSIVE RIGHT TO USE "HEALTH", APART FROM THE MARK AS SHOWN.

**CLASS 10—MEDICAL APPARATUS**

FOR MEDICAL DEVICES, NAMELY, PORTABLE ELECTRONIC PATIENT MONITORS AND PATIENT SENSORS WITH AUTOMATED ALERT AND MONITORING CAPACITY FOR MONITORING AND MEASURING PATIENT REPORTED SYMPTOMS, HEART RATE, BLOOD PRESSURE, BODY TEMPERATURE, PAIN, BLOOD GLUCOSE LEVELS, THE OXYGEN SATURATION OF THE BLOOD AND OTHER VITAL SIGN AND DIAGNOSTIC PARAMETERS (U.S. CLS. 26, 39 AND 44).

**CLASS 44—MEDICAL, BEAUTY AND AGRICULTURAL SERVICES**

FOR MEDICAL DIAGNOSTIC MONITORING AND REPORTING SERVICES FOR MEDICAL PROFESSIONALS AND MEDICAL PATIENTS PROVIDED VIA TELECOMMUNICATION NETWORKS AND/OR GLOBAL COMPUTER NETWORKS FEATURING MEDICAL INFORMATION IN THE NATURE OF PATIENT REPORTED SYMPTOMS, HEART RATE, BLOOD PRESSURE, BODY TEMPERATURE, PAIN, BLOOD GLUCOSE LEVELS, OXYGEN SATURATION OF THE BLOOD AND OTHER VITAL SIGN AND DIAGNOSTIC PARAMETERS, GATHERED FROM ELECTRONIC PATIENT MEDICAL MONITORING DEVICES WHICH FEED INFORMATION TO REMOTE LOCATIONS THAT CAN BE ACCESSED IN REAL-TIME BY MEDICAL PROFESSIONALS FOR PURPOSES OF MONITORING AND DIAGNOSING MEDICAL CONDITIONS FOR INDIVIDUALS WITH HEALTH PROBLEMS (U.S. CLS. 100 AND 101).

WENDY GOODMAN, EXAMINING ATTORNEY

SN 85-187,173. LAND'S END ACQUISITION CORPORATION, HOMER, AK. FILED 11-30-2010.

**LAND'S END**

THE MARK CONSISTS OF STANDARD CHARACTERS WITHOUT CLAIM TO ANY PARTICULAR FONT, STYLE, SIZE, OR COLOR.

OWNER OF U.S. REG. NOS. 1,672,200 AND 2,301,790.

**CLASS 39—TRANSPORTATION AND STORAGE**

FOR ON-LINE TRIP AND TRAVEL RESERVATION SERVICES; ON-LINE TRANSPORTATION RESERVATION AND TRAVEL TICKET RESERVATION SERVICES; PROVIDING AN ON-LINE COMPUTER DATABASE IN THE FIELD OF TRAVEL INFORMATION SERVICES (U.S. CLS. 100 AND 105).

FIRST USE 6-0-1999; IN COMMERCE 6-0-1999.

**CLASS 42—SCIENTIFIC AND COMPUTER SERVICES**

FOR ON-LINE WEB BASED SOFTWARE SERVICES, NAMELY, HOSTING COMPUTER SOFTWARE APPLICATIONS FOR THE HOSPITALITY, RECREATIONAL AND TRAVEL INDUSTRIES, NAMELY, SOFTWARE FOR TRAVEL RESERVATIONS AND BOOKINGS, MANAGEMENT OF INVENTORY, SALES REPORTING AND PAYMENT TRANSACTIONS (U.S. CLS. 100 AND 101).

FIRST USE 9-0-2009; IN COMMERCE 9-0-2009.

JOHN KELLY, EXAMINING ATTORNEY

---

SN 85-187,219. BLOCHBERGER, CACILIA, VIENNA, AUSTRIA, FILED 11-30-2010.

**JUICE BROTHERS**

THE MARK CONSISTS OF STANDARD CHARACTERS WITHOUT CLAIM TO ANY PARTICULAR FONT, STYLE, SIZE, OR COLOR.

NO CLAIM IS MADE TO THE EXCLUSIVE RIGHT TO USE "JUICE", APART FROM THE MARK AS SHOWN.

**CLASS 30—STAPLE FOODS**

FOR COFFEE AND TEA (U.S. CL. 46).

**CLASS 32—LIGHT BEVERAGES**

FOR FRUIT DRINKS AND FRUIT JUICES (U.S. CLS. 45, 46 AND 48).

MICHAEL WEBSTER, EXAMINING ATTORNEY



SN 85-187,254. OPTICAL AIR DATA SYSTEMS, LLC, MANASSAS, VA. FILED 11-30-2010.

## CATCH THE WIND

THE MARK CONSISTS OF STANDARD CHARACTERS WITHOUT CLAIM TO ANY PARTICULAR FONT, STYLE, SIZE, OR COLOR.

OWNER OF U.S. REG. NO. 3,920,216.

### CLASS 9—ELECTRICAL AND SCIENTIFIC APPARATUS

FOR WIND SPEED MEASURING DEVICES (U.S. CLS. 21, 23, 26, 36 AND 38).

FIRST USE 6-1-2008; IN COMMERCE 6-1-2008.

### CLASS 42—SCIENTIFIC AND COMPUTER SERVICES

FOR LEASING OF WIND SPEED MEASURING DEVICES (U.S. CLS. 100 AND 101).

FIRST USE 11-19-2010; IN COMMERCE 11-19-2010.  
TIMOTHY FINNEGAN, EXAMINING ATTORNEY

SN 85-187,642. NEUBRA S.R.L., I-50134 FIRENZE (FI), ITALY, FILED 11-30-2010.



PRIORITY CLAIMED UNDER SEC. 44(D) ON ERPN CMNTY TM OFC APPLICATION NO. 009160011, FILED 6-8-2010, REG. NO. 009160011, DATED 11-2-2010, EXPIRES 6-8-2020.

NO CLAIM IS MADE TO THE EXCLUSIVE RIGHT TO USE "GELATO & CO.", APART FROM THE MARK AS SHOWN.

THE MARK CONSISTS OF THE WORDING "LOVE GELATO & CO." WITH THE LETTER "LOVE" ENCLOSED IN AN OVAL WITH THE LETTER "V" IN THE SHAPE OF AN ICE CREAM CONE WITH THREE SCOOPS OF ICE CREAM ON TOP, AND THE WORDING "GELATO & CO." INTERRUPTING THE OVAL IN THE LOWER RIGHT HAND SIDE.

THE ENGLISH TRANSLATION OF "GELATO" IN THE MARK IS "ICE CREAM".

### CLASS 29—MEATS AND PROCESSED FOODS

FOR MEAT, FISH, POULTRY AND GAME; MEAT EXTRACTS; PRESERVED, FROZEN, DRIED AND COOKED FRUITS AND VEGETABLES; JELLIES, JAMS, COMPOTES; EGGS, MILK AND MILK PRODUCTS, NAMELY, YOGURT, YOGURT CREAMS AND MILK CREAMS; EDIBLE FATS AND OILS (U.S. CL. 46).

### CLASS 30—STAPLE FOODS

FOR COFFEE, TEA, COCOA, SUGAR, RICE, TAPIOCA, SAGO, ARTIFICIAL COFFEE; FLOURS AND PREPARATIONS MADE FROM CEREALS, NAMELY, BREAD, PASTRY AND CONFECTIONERY MADE OF SUGAR; FLAVORED ICES, SORBETS, FROZEN CONFECTIONS, CHILLED BAKERY DESSERTS, ICE CREAM CAKES, ICE CREAM DESSERTS, FROZEN YOGURT, PUDDINGS; HONEY, TREACLE; YEAST, BAKING-POWDER; SALT, MUSTARD; VINEGAR, SAUCES AS CONDIMENTS; SPICES; ICE (U.S. CL. 46).

### CLASS 43—HOTEL AND RESTAURANT SERVICES

FOR PROVIDING FOOD AND DRINK, NAMELY, ICE CREAM PARLOURS, YOGURT PARLOURS, SNACK-BARS, RESTAURANTS; PROVIDING TEMPORARY ACCOMMODATION (U.S. CLS. 100 AND 101).

MARK T. MULLEN, EXAMINING ATTORNEY

SN 85-187,712. MCGRAW-HILL COMPANIES, INC., THE, NEW YORK, NY. FILED 11-30-2010.



NO CLAIM IS MADE TO THE EXCLUSIVE RIGHT TO USE "PHARMACY", APART FROM THE MARK AS SHOWN.

THE MARK CONSISTS OF THE TERMS "ACCESS PHARMACY" WITH A CENTERED TRIANGLE BETWEEN THE TWO TERMS AND FOUR TRIANGLES BELOW THE CENTER TRIANGLE AND SIX TRIANGLES ABOVE THE CENTER TRIANGLE.

### CLASS 9—ELECTRICAL AND SCIENTIFIC APPARATUS

FOR COMPUTER SOFTWARE THAT CAN BE DOWNLOADED TO A MOBILE DEVICE CONTAINING EDUCATIONAL CONTENT IN THE FIELD OF PHARMACEUTICALS AND CONTINUING MEDICAL EDUCATIONAL MATERIALS (U.S. CLS. 21, 23, 26, 36 AND 38).

FIRST USE 11-0-2009; IN COMMERCE 11-0-2009.

### CLASS 41—EDUCATION AND ENTERTAINMENT

FOR PROVIDING A WEBSITE CONTAINING NON-DOWNLOADABLE EDUCATIONAL CONTENT IN THE FIELD OF PHARMACEUTICALS AND CONTINUING MEDICAL EDUCATIONAL MATERIALS IN THE FIELDS OF MEDICINE, HEALTH CARE, PHARMACEUTICALS, AND PHARMACOLOGY, NAMELY, MEDICAL BOOKS, CASE FILES, CLINICAL CASE STUDIES WITH ACCOMPANYING ASSESSMENTS, AND GLOSSARIES; PROVIDING A WEBSITE FEATURING AN INTERACTIVE SELF-ASSESSMENT FOR MEDICAL STUDENTS THAT ALLOWS STUDENTS TO CONDUCT SELF-DIAGNOSES OF THEIR EDUCATIONAL PROGRESS (U.S. CLS. 100, 101 AND 107).

FIRST USE 11-0-2009; IN COMMERCE 11-0-2009.

**CLASS 44—MEDICAL, BEAUTY AND AGRICULTURAL SERVICES**

FOR PROVIDING A WEBSITE FEATURING INFORMATIONAL, NON-DOWNLOADABLE CONTINUING MEDICAL EDUCATIONAL MATERIALS IN THE NATURE OF VIDEOS, ANIMATIONS, AUDIO LECTURES, PHOTOS, AND ILLUSTRATIONS IN THE FIELDS OF MEDICINE, HEALTH CARE, PHARMACEUTICALS, AND PHARMACOLOGY; PROVIDING AN ONLINE PRESCRIPTION DRUG DATABASE (U.S. CLS. 100 AND 101).

FIRST USE 11-0-2009; IN COMMERCE 11-0-2009.  
KIMBERLY FRYE, EXAMINING ATTORNEY

---

SN 85-187,967. CRESTWOOD TECHNOLOGY GROUP, YONKERS, NY. FILED 12-1-2010.

**THE DISTRIBUTOR THAT BUYERS TRUST**

THE MARK CONSISTS OF STANDARD CHARACTERS WITHOUT CLAIM TO ANY PARTICULAR FONT, STYLE, SIZE, OR COLOR.

**CLASS 35—ADVERTISING AND BUSINESS**

FOR PROVIDING FREE PRICE QUOTE AND AVAILABILITY INFORMATION AS WELL AS DISTRIBUTORSHIP SERVICES, ALL IN THE FIELD OF ELECTRONIC COMPONENTS, ELECTROMECHANICAL PARTS AND MILITARY AND AEROSPACE PARTS, INCLUDING OBSOLETE, DISCONTINUED AND HARD-TO-FIND PARTS (U.S. CLS. 100, 101 AND 102).

FIRST USE 11-30-2010; IN COMMERCE 11-30-2010.

**CLASS 39—TRANSPORTATION AND STORAGE**

FOR DISTRIBUTION SERVICES, NAMELY, DELIVERY OF ELECTRONIC COMPONENTS, ELECTROMECHANICAL PARTS, AND MILITARY AND AEROSPACE PARTS, INCLUDING OBSOLETE, DISCONTINUED AND HARD-TO-FIND PARTS (U.S. CLS. 100 AND 105).

MARK RADEMACHER, EXAMINING ATTORNEY

---

SN 85-188,084. COOKIE JAR ENTERTAINMENT INC., TORONTO, CANADA, FILED 12-1-2010.

**DEBRA!**

THE MARK CONSISTS OF STANDARD CHARACTERS WITHOUT CLAIM TO ANY PARTICULAR FONT, STYLE, SIZE, OR COLOR.

**CLASS 9—ELECTRICAL AND SCIENTIFIC APPARATUS**

FOR DVD'S FEATURING CHILDREN'S ENTERTAINMENT TOPICS AND THEMES; INTERACTIVE VIDEO GAME PROGRAMS AND COMPUTER GAME PROGRAMS FEATURING CHILDREN'S ENTERTAINMENT CHARACTERS AND RELATED STORY LINES FEATURING SUCH CHARACTERS; AUDIO BOOKS RECORDED ON CASSETTES AND COMPACT DISCS FEATURING CHILDREN'S ENTERTAINMENT TOPICS AND THEMES; ELECTRONIC BOOKS RECORDED ON COMPUTER MEDIA FEATURING CHILDREN'S ENTERTAINMENT TOPICS AND THEMES; INTERACTIVE BOOKS RECORDED ON COMPUTER MEDIA FEATURING CHILDREN'S ENTERTAINMENT TOPICS AND THEMES; DOWNLOADABLE COMPUTER GAME PROGRAMS VIA GLOBAL COMPUTER NETWORKS AND WIRELESS DEVICES, NAMELY, PDA'S AND CELL PHONES; DOWNLOADABLE VIDEO CLIPS AND STILL IMAGES VIA GLOBAL COMPUTER NETWORKS AND WIRELESS DEVICES, NAMELY, PDA'S AND CELL PHONES FEATURING CHILDREN'S ENTERTAINMENT; CELLULAR PHONES; CASES FOR CELLULAR PHONES; HOLDERS FOR CELLULAR PHONES AND PDA'S; PROTECTIVE CARRYING CASES SPECIFICALLY ADAPTED FOR PDA'S AND DIGITAL AUDIO PLAYERS (U.S. CLS. 21, 23, 26, 36 AND 38).

**CLASS 41—EDUCATION AND ENTERTAINMENT**

FOR ENTERTAINMENT IN THE NATURE OF ONGOING TELEVISION PROGRAMS IN THE FIELD OF CHILDREN'S EDUCATION AND ENTERTAINMENT; ENTERTAINMENT IN THE NATURE OF LIVE MUSICAL CONCERTS AND THEATRICAL PERFORMANCES; PROVIDING ONLINE ENTERTAINMENT INFORMATION ON A WIDE RANGE OF CHILDREN'S EDUCATION AND ENTERTAINMENT SUBJECTS VIA A COMPUTER NETWORK; PROVISION OF ONGOING CHILDREN'S EDUCATIONAL AND CHILDREN'S ENTERTAINMENT PROGRAMS IN THE FIELD OF CHILDREN'S EDUCATION AND ENTERTAINMENT ACCESSIBLE OVER THE INTERNET AND VIA HANDHELD AND WIRELESS DEVICES VIA A WIRELESS NETWORK; ENTERTAINMENT SERVICES, NAMELY, PROVIDING ONLINE COMPUTER GAMES ACCESSIBLE ON A GLOBAL COMPUTER NETWORK AND VIA HANDHELD AND WIRELESS DEVICES (U.S. CLS. 100, 101 AND 107).

STEVEN PEREZ, EXAMINING ATTORNEY

---

SN 85-188,090. COOKIE JAR ENTERTAINMENT INC., TORONTO, CANADA, FILED 12-1-2010.

**DEBRA!**

THE MARK CONSISTS OF STANDARD CHARACTERS WITHOUT CLAIM TO ANY PARTICULAR FONT, STYLE, SIZE, OR COLOR.

**CLASS 16—PAPER GOODS AND PRINTED MATTER**

FOR PRINTED PUBLICATIONS IN THE FIELD OF CHILDREN'S EDUCATION AND ENTERTAINMENT, NAMELY, BOOKS, WORKBOOKS, COLORING BOOKS, ACTIVITY BOOKS, STORY BOOKS, MANGA COMICS, GRAPHIC NOVELS, COMIC BOOKS, MAGAZINES, JOURNALS, INTERACTIVE BOOKS, BOOKS WITH CD'S SOLD AS A UNIT, BOOKS WITH DVD'S SOLD AS A UNIT; STICKERS; STATIONERY, NAMELY, JOURNALS, DIARIES, NOTE BOOKS; GREETING CARDS, GIFT WRAP STICKERS, TEMPORARY TATTOOS, GIFT BOXES, POSTCARDS, NOTE PAPER, WRITING PAPER, STICKER BOOKS, CALENDARS, POSTERS; PAPER PARTY PRODUCTS, NAMELY, PARTY NAPKINS, BAGS AND ORNAMENTS; SCRAP-BOOKING SUPPLIES IN THE NATURE OF SCRAPBOOK PAGES, ALBUMS, COLORED PAPER AND STICKERS; PAPER PARTY FAVORS; SCHOOL SUPPLIES, NAMELY, PENS, PENCILS, PEN AND PENCIL CASES AND BOXES, PENCIL SHARPENERS AND PAPER FOLDERS; CALENDAR DESK PADS, CALENDAR DESK STANDS, DESK FILE TRAYS, DESK PADS, DESK SETS, DESK STAND AND HOLDERS FOR PENS, PENCILS AND INK, AND HOLDERS FOR DESK ACCESSORIES (U.S. CLS. 2, 5, 22, 23, 29, 37, 38 AND 50).

**CLASS 25—CLOTHING**

FOR APPAREL RELATED TO ONGOING CHILDREN'S TELEVISION PROGRAM, NAMELY, T-SHIRTS, SHIRTS, SWEATSHIRTS, SWEATPANTS, PANTS, SHORTS, JACKETS, SWIMWEAR, SWIMWEAR COVER-UPS, SOCKS, HOSIERY, HATS, CAPS, COATS, GLOVES, MITTENS, SCARVES, BELTS, SLEEPWEAR, UNDERWEAR, FLEECE CLOTHING, NAMELY, PULLOVERS, COATS, VESTS AND PANTS, CLOTHING MADE OF DENIM, NAMELY, JEANS, PANTS, COATS AND VESTS, OUTERWEAR, NAMELY, COATS, RAINWEAR, FOOTWEAR, NAMELY, BOOTS, SHOES, SANDALS AND SLIPPERS (U.S. CLS. 22 AND 39).

**CLASS 28—TOYS AND SPORTING GOODS**

FOR TOYS, NAMELY, DOLLS, PLUSH TOYS, CONSTRUCTION TOYS, ACTION FIGURES, ELECTRONIC TOYS, NAMELY, ELECTRONIC ACTION FIGURES, GAMES, NAMELY, PARTY GAMES, ROLE PLAYING GAMES, ACTION SKILL GAMES, TARGET GAMES, CARD GAMES, BOARD GAMES, PUZZLES, BOARD PUZZLES, FOAM PUZZLES, PLASTIC PUZZLES, HAND HELD UNITS FOR PLAYING VIDEO GAMES OTHER THAN THOSE ADAPTED FOR USE WITH AN EXTERNAL DISPLAY SCREEN OR MONITOR AND BATTERY-POWERED COMPUTER GAMES WITH LCD SCREENS; SKATE BOARDS; IN-LINE SKATES; SWING SETS; SLEDS FOR RECREATIONAL USE; TOBOGGANS; PAPER PARTY PRODUCTS, NAMELY, HATS (U.S. CLS. 22, 23, 38 AND 50).

STEVEN PEREZ, EXAMINING ATTORNEY

SN 85-188,259. BRIGGO, LLC, AUSTIN, TX. FILED 12-1-2010.

**BRIGGO**

THE MARK CONSISTS OF STANDARD CHARACTERS WITHOUT CLAIM TO ANY PARTICULAR FONT, STYLE, SIZE, OR COLOR.

**CLASS 9—ELECTRICAL AND SCIENTIFIC APPARATUS**

FOR KIOSKS AND VENDING MACHINES COMPRISING INTERACTIVE COMPUTERS, COMPUTER HARDWARE, COMPUTER PERIPHERALS, COMPUTER OPERATING SOFTWARE, AND MECHANICAL COMPONENTS AND MECHANISMS FOR USE IN MAKING, FILTERING, PROCESSING, AND DISPENSING BEVERAGES; AUTOMATIC VENDING MACHINES; COIN-OPERATED VENDING MACHINES; VENDING MACHINES (U.S. CLS. 21, 23, 26, 36 AND 38).

**CLASS 25—CLOTHING**

FOR CLOTHING, NAMELY, SHIRTS, HATS, SWEATSHIRTS (U.S. CLS. 22 AND 39).

**CLASS 32—LIGHT BEVERAGES**

FOR BOTTLED WATERS; DRINKING WATER; DRINKING WATER WITH VITAMINS; FLAVORED BOTTLED WATER; FLAVORED WATERS; PURIFIED BOTTLED DRINKING WATER; WATER BEVERAGES; FROZEN FRUIT DRINKS; FRUIT DRINKS; FRUIT DRINKS AND FRUIT JUICES; FRUIT DRINKS AND JUICES; FRUIT FLAVORED DRINKS; SMOOTHIES; FRUIT DRINKS AND FRUIT JUICES; FRUIT JUICE; FRUIT DRINKS AND JUICES; NON-ALCOHOLIC BEVERAGES CONTAINING FRUIT JUICES; NON-ALCOHOLIC FRUIT JUICE BEVERAGES (U.S. CLS. 45, 46 AND 48).

**CLASS 40—MATERIAL TREATMENT**

FOR COFFEE ROASTING AND PROCESSING; TEA PROCESSING (U.S. CLS. 100, 103 AND 106).  
ANNE E. GUSTASON, EXAMINING ATTORNEY

SN 85-188,288. MCGRAW-HILL COMPANIES, INC., THE, NEW YORK, NY. FILED 12-1-2010.

**ACCESSANESTHESIOLOGY**

THE MARK CONSISTS OF STANDARD CHARACTERS WITHOUT CLAIM TO ANY PARTICULAR FONT, STYLE, SIZE, OR COLOR.

**CLASS 9—ELECTRICAL AND SCIENTIFIC APPARATUS**

FOR COMPUTER SOFTWARE THAT CAN BE DOWNLOADED TO A MOBILE DEVICE CONTAINING EDUCATIONAL CONTENT IN THE FIELD OF ANESTHESIOLOGY AND CONTINUING MEDICAL EDUCATIONAL MATERIALS (U.S. CLS. 21, 23, 26, 36 AND 38).

FIRST USE 11-0-2009; IN COMMERCE 11-0-2009.

**CLASS 41—EDUCATION AND ENTERTAINMENT**

FOR PROVIDING A WEBSITE CONTAINING NON-DOWNLOADABLE EDUCATIONAL CONTENT IN THE FIELD OF ANESTHESIOLOGY AND CONTINUING MEDICAL EDUCATIONAL MATERIALS IN THE FIELDS OF MEDICINE, HEALTH CARE, AND ANESTHESIOLOGY, NAMELY, MEDICAL BOOKS, CASE FILES, CLINICAL CASE STUDIES WITH ACCOMPANYING ASSESSMENTS, AND GLOSSARIES; PROVIDING A WEBSITE FEATURING AN INTERACTIVE SELF-ASSESSMENT FOR MEDICAL STUDENTS THAT ALLOWS STUDENTS TO CONDUCT SELF-DIAGNOSES OF THEIR EDUCATIONAL PROGRESS (U.S. CLS. 100, 101 AND 107).

FIRST USE 11-0-2009; IN COMMERCE 11-0-2009.

**CLASS 44—MEDICAL, BEAUTY AND AGRICULTURAL SERVICES**

FOR PROVIDING A WEBSITE FEATURING INFORMATIONAL, NON-DOWNLOADABLE CONTINUING MEDICAL EDUCATIONAL MATERIALS IN THE NATURE OF VIDEOS, ANIMATIONS, AUDIO LECTURES, PHOTOS, AND ILLUSTRATIONS IN THE FIELDS OF MEDICINE, HEALTH CARE, AND ANESTHESIOLOGY; PROVIDING AN ONLINE PRESCRIPTION DRUG DATABASE (U.S. CLS. 100 AND 101).

FIRST USE 11-0-2009; IN COMMERCE 11-0-2009.  
KIMBERLY FRYE, EXAMINING ATTORNEY

SN 85-188,311. SUNEVA MEDICAL, INC., SAN DIEGO, CA. FILED 12-1-2010.

# BELLAFILL

THE MARK CONSISTS OF STANDARD CHARACTERS WITHOUT CLAIM TO ANY PARTICULAR FONT, STYLE, SIZE, OR COLOR.

**CLASS 5—PHARMACEUTICALS**

FOR INJECTABLE DERMAL FILLERS (U.S. CLS. 6, 18, 44, 46, 51 AND 52).

**CLASS 10—MEDICAL APPARATUS**

FOR MEDICAL DEVICES, ACCESSORIES, AND PREPARATIONS, NAMELY, MEDICAL, SURGICAL, AND ORTHOPEDIC IMPLANTS MADE OF ARTIFICIAL MATERIALS (U.S. CLS. 26, 39 AND 44).

DAWN FELDMAN, EXAMINING ATTORNEY

SN 85-188,338. BRIGGO, LLC, AUSTIN, TX. FILED 12-1-2010.

# BRIGGO

THE MARK CONSISTS OF STANDARD CHARACTERS WITHOUT CLAIM TO ANY PARTICULAR FONT, STYLE, SIZE, OR COLOR.

**CLASS 21—HOUSEWARES AND GLASS**

FOR CONTAINERS FOR BEVERAGES, NAMELY, THERMAL INSULATED CONTAINERS, CUPS; THERMAL INSULATED CUPS, BOTTLES FOR BEVERAGES; THERMAL INSULATED BOTTLES, DECANTERS, CUPS, MUGS, FOR BEVERAGES; THERMAL INSULATED MUGS, POTS, CONTAINERS FOR BEVERAGES; BEVERAGE GLASSWARE (U.S. CLS. 2, 13, 23, 29, 30, 33, 40 AND 50).

FIRST USE 5-0-2009; IN COMMERCE 11-0-2010.

**CLASS 30—STAPLE FOODS**

FOR COFFEE; COFFEE BEANS; ROASTED COFFEE; GROUND COFFEE; PREPARED COFFEE AND COFFEE-BASED BEVERAGES; FLAVORING SYRUPS TO ADD TO COFFEES; TEA; BEVERAGES MADE OF TEA; BEVERAGES WITH A TEA BASE; CHAI TEA; ICED TEA; TEA-BASED BEVERAGES; TEA-BASED BEVERAGES WITH FRUIT FLAVORING; HOT CHOCOLATE (U.S. CL. 46).

FIRST USE 5-0-2009; IN COMMERCE 11-0-2010.

ANNE E. GUSTASON, EXAMINING ATTORNEY

SN 85-188,421. TRUE RIVALRY INC., WESTMOUNT, QUEBEC, CANADA, FILED 12-1-2010.

# TRUE RIVALRY

THE MARK CONSISTS OF STANDARD CHARACTERS WITHOUT CLAIM TO ANY PARTICULAR FONT, STYLE, SIZE, OR COLOR.

**CLASS 25—CLOTHING**

FOR CLOTHING, NAMELY, T-SHIRTS, SWEATSHIRTS AND HATS, SWEATPANTS, BLOUSES, TOPS, SHIRTS, SWEATERS, TANK TOPS, JACKETS, COATS, PANTS, JEANS, SHORTS, SKIRTS, DRESSES, UNDERWEAR, SLEEPWEAR, LOUNGEWEAR, BATHING SUITS, COVER-UPS, SOCKS, BELTS, SCARVES AND GLOVES; FOOTWEAR (U.S. CLS. 22 AND 39).

**CLASS 35—ADVERTISING AND BUSINESS**

FOR RETAIL STORES SERVICES, ONLINE RETAIL STORE SERVICES, WHOLESALE AND DISTRIBUTORSHIP SERVICES ALL FEATURING JEWELLRY, HANDBAGS, WALLETS, BACKPACKS, ALL PURPOSE SPORT BAGS, ALL-PURPOSE ATHLETIC BAGS, FOOTWEAR, AND CLOTHING, NAMELY, T-SHIRTS, SWEATSHIRTS, SWEATPANTS, BLOUSES, TOPS, SHIRTS, SWEATERS, TANK TOPS, JACKETS, COATS, PANTS, JEANS, SHORTS, SKIRTS, DRESSES, UNDERWEAR, SLEEPWEAR, LOUNGEWEAR, BATHING SUITS, COVER-UPS, SOCKS, BELTS, SCARVES, GLOVES AND HATS (U.S. CLS. 100, 101 AND 102).

DANIEL CAPSHAW, EXAMINING ATTORNEY



SN 85-188,791. MCGRAW-HILL COMPANIES, INC., THE, NEW YORK, NY. FILED 12-1-2010.

## ACCESSSURGERY

THE MARK CONSISTS OF STANDARD CHARACTERS WITHOUT CLAIM TO ANY PARTICULAR FONT, STYLE, SIZE, OR COLOR.

### CLASS 9—ELECTRICAL AND SCIENTIFIC APPARATUS

FOR COMPUTER SOFTWARE THAT CAN BE DOWNLOADED TO A MOBILE DEVICE CONTAINING EDUCATIONAL CONTENT IN THE FIELD OF SURGERY AND CONTINUING MEDICAL EDUCATIONAL MATERIALS (U.S. CLS. 21, 23, 26, 36 AND 38).

FIRST USE 3-0-2009; IN COMMERCE 3-0-2009.

### CLASS 41—EDUCATION AND ENTERTAINMENT

FOR PROVIDING A WEBSITE CONTAINING NON-DOWNLOADABLE EDUCATIONAL CONTENT IN THE FIELD OF SURGERY AND CONTINUING MEDICAL EDUCATIONAL MATERIALS IN THE FIELDS OF MEDICINE, HEALTH CARE, AND SURGERY, NAMELY: MEDICAL BOOKS, CASE FILES, CLINICAL CASE STUDIES WITH ACCOMPANYING ASSESSMENTS, AND GLOSSARIES; PROVIDING A WEBSITE FEATURING AN INTERACTIVE SELF-ASSESSMENT FOR MEDICAL STUDENTS THAT ALLOWS STUDENTS TO CONDUCT SELF-DIAGNOSES OF THEIR EDUCATIONAL PROGRESS (U.S. CLS. 100, 101 AND 107).

FIRST USE 3-0-2009; IN COMMERCE 3-0-2009.

### CLASS 44—MEDICAL, BEAUTY AND AGRICULTURAL SERVICES

FOR PROVIDING A WEBSITE FEATURING INFORMATIONAL, NON-DOWNLOADABLE CONTINUING MEDICAL EDUCATIONAL MATERIALS IN THE NATURE OF VIDEOS, ANIMATIONS, AUDIO LECTURES, PHOTOS, AND ILLUSTRATIONS IN THE FIELDS OF MEDICINE, HEALTH CARE, AND SURGERY; PROVIDING AN ONLINE PRESCRIPTION DRUG DATABASE (U.S. CLS. 100 AND 101).

FIRST USE 3-0-2009; IN COMMERCE 3-0-2009.  
KIMBERLY FRYE, EXAMINING ATTORNEY

SN 85-188,945. SONY PICTURES TELEVISION INC., CULVER CITY, CA. FILED 12-2-2010.

## DROP DEAD DIVA

THE MARK CONSISTS OF STANDARD CHARACTERS WITHOUT CLAIM TO ANY PARTICULAR FONT, STYLE, SIZE, OR COLOR.

### CLASS 9—ELECTRICAL AND SCIENTIFIC APPARATUS

FOR DOWNLOADABLE DRAMATIC TELEVISION PROGRAMS PROVIDED VIA A VIDEO-ON-DEMAND SERVICE; DIGITAL MEDIA, NAMELY, PRE-RECORDED VIDEO CASSETTES, DIGITAL VIDEO DISCS, DIGITAL VERSATILE DISCS, DOWNLOADABLE AUDIO AND VIDEO RECORDINGS, DVDS, AND HIGH DEFINITION DIGITAL DISCS FEATURING DRAMATIC ENTERTAINMENT PROGRAMMING AND SOUNDTRACKS (U.S. CLS. 21, 23, 26, 36 AND 38).

FIRST USE 6-1-2010; IN COMMERCE 6-1-2010.

### CLASS 41—EDUCATION AND ENTERTAINMENT

FOR ENTERTAINMENT SERVICES IN THE NATURE OF AN ONGOING DRAMATIC TELEVISION SERIES (U.S. CLS. 100, 101 AND 107).

FIRST USE 7-12-2009; IN COMMERCE 7-12-2009.  
MATTHEW PAPPAS, EXAMINING ATTORNEY

SN 85-189,024. KW INTELLECTUAL PROPERTIES, INC., POLK CITY, FL. FILED 12-2-2010.

## ORLAMPA

THE MARK CONSISTS OF STANDARD CHARACTERS WITHOUT CLAIM TO ANY PARTICULAR FONT, STYLE, SIZE, OR COLOR.

OWNER OF U.S. REG. NOS. 3,349,806, 3,448,969 AND 3,449,094.

### CLASS 14—JEWELRY

FOR LAPEL PINS (U.S. CLS. 2, 27, 28 AND 50).

### CLASS 16—PAPER GOODS AND PRINTED MATTER

FOR DECALS, STICKERS, POSTCARDS, WRITING PENS AND WRITING PENCILS (U.S. CLS. 2, 5, 22, 23, 29, 37, 38 AND 50).

### CLASS 20—FURNITURE AND ARTICLES NOT OTHERWISE CLASSIFIED

FOR PLASTIC NOVELTY LICENSE PLATES, NON-METAL NOVELTY LICENSE PLATES (U.S. CLS. 2, 13, 22, 25, 32 AND 50).

### CLASS 21—HOUSEWARES AND GLASS

FOR DRINKING MUGS, GLASSES, CUPS AND INSULATING SLEEVE HOLDERS FOR BEVERAGE CANS (U.S. CLS. 2, 13, 23, 29, 30, 33, 40 AND 50).

### CLASS 35—ADVERTISING AND BUSINESS

FOR RETAIL CLOTHING STORE SERVICES; RETAIL STORES IN THE AREA OF GIFT ITEMS AND SOUVENIRS; PROMOTING THE ORLANDO-TAMPA CORRIDOR, FLORIDA AREA AS A DESTINATION FOR LEISURE AND BUSINESS TRAVELERS (U.S. CLS. 100, 101 AND 102).

SOPHIA S. KIM, EXAMINING ATTORNEY

SN 85-189,076. EXCELERATOR SPORTS, INC, ROCKLEDGE, FL. FILED 12-2-2010.



NO CLAIM IS MADE TO THE EXCLUSIVE RIGHT TO USE "SPORTS", APART FROM THE MARK AS SHOWN.

THE MARK CONSISTS OF AN ABSTRACT DESIGN HAVING AN OVERALL "X" SHAPE AND THE WORDING "EXCELERATOR | SPORTS" IN STYLIZED FORM.

#### CLASS 25—CLOTHING

FOR CLOTHING, NAMELY, SHIRTS, SHORTS, SHOES, TIGHTS, WIND RESISTANT SUITS, WARM UP SUITS (U.S. CLS. 22 AND 39).

FIRST USE 10-1-2010; IN COMMERCE 10-1-2010.

#### CLASS 41—EDUCATION AND ENTERTAINMENT

FOR SPORT CAMPS; SPORTS CLINICS; PERSONAL TRAINING SERVICES, NAMELY, STRENGTH AND CONDITIONING TRAINING; EDUCATION SERVICES, NAMELY, PROVIDING CLASSES, SEMINARS, WORKSHOPS IN THE FIELDS OF EXERCISE AND FITNESS (U.S. CLS. 100, 101 AND 107).

FIRST USE 10-1-2010; IN COMMERCE 10-1-2010.  
ALLISON HOLTZ, EXAMINING ATTORNEY

SN 85-189,253. APPETIZER MOBILE LLC, NEW YORK, NY. FILED 12-2-2010.

## APPETIZER MOBILE

THE MARK CONSISTS OF STANDARD CHARACTERS WITHOUT CLAIM TO ANY PARTICULAR FONT, STYLE, SIZE, OR COLOR.

NO CLAIM IS MADE TO THE EXCLUSIVE RIGHT TO USE "MOBILE", APART FROM THE MARK AS SHOWN.

#### CLASS 35—ADVERTISING AND BUSINESS

FOR MARKETING SERVICES, NAMELY, PROVIDING MOBILE MARKETING STRATEGIES AND CAMPAIGNS; SOCIAL MEDIA STRATEGY AND MARKETING CONSULTANCY FOCUSING ON HELPING CLIENTS CREATE AND EXTEND THEIR PRODUCT AND BRAND STRATEGY; ADVERTISING SERVICES; BRANDING, MARKETING AND CREATIVE SERVICES, NAMELY, MARKET RESEARCH AND ANALYSIS, STRATEGIC PLANNING AND CONSULTING, AND DEVELOPMENT AND MANAGEMENT OF PRINT, TELEVISION, RADIO, ONLINE, MOBILE AND IN-PERSON BRANDING AND MARKETING CAMPAIGNS FOR THE PROMOTION OF THE GOODS AND SERVICES OF OTHERS (U.S. CLS. 100, 101 AND 102).

FIRST USE 1-1-2009; IN COMMERCE 1-1-2009.

#### CLASS 42—SCIENTIFIC AND COMPUTER SERVICES

FOR COMPUTER SOFTWARE DEVELOPMENT, PROGRAMMING AND DESIGN FOR OTHERS, NAMELY, OF MOBILE APPLICATIONS AS WELL AS FOR DIGITAL MEDIA ADAPTATION, FOR RENDERING TEXT, SOUND OR IMAGES AND FOR DELIVERY OF TEXT, SOUND OR IMAGES FOR MOBILE DEVICES AND OF COMPUTER SOFTWARE FOR TRANSCODING AND DELIVERING OF DIGITAL MEDIA AND PORTALS TO MOBILE DEVICES AND OF COMPUTER SOFTWARE FOR WIRELESS TRANSMISSION OF MULTIMEDIA-DATA, VIDEO, AUDIO, IMAGE AND TEXT-DATA AND FOR DELIVERING OF SOFTWARE APPLICATIONS TO MOBILE DEVICES AND OF COMPUTER SOFTWARE FOR MANAGING AND ENCRYPTING DATA AND OF COMPUTER SOFTWARE FOR WIRELESS MESSAGING, ADVERTISING AND BILLING SYSTEMS FOR USE ON MOBILE DEVICES AND OF CUSTOM ANIMATIONS, VOICE-OVERS, 3D/2D MODELS, ENGINES AND SOURCE CODE FOR MOBILE APPLICATIONS; COMPUTER SOFTWARE CONSULTATION SERVICES; COMPUTER-SOFTWARE TECHNICAL SUPPORT IN THE NATURE OF TROUBLESHOOTING PROBLEMS AND MAINTENANCE; AND WEBSITE DESIGN AND DEVELOPMENT FOR OTHERS (U.S. CLS. 100 AND 101).

FIRST USE 1-1-2009; IN COMMERCE 1-1-2009.

TIMOTHY FINNEGAN, EXAMINING ATTORNEY

SN 85-189,333. HANGZHOU ZHELI FORKLIFT GROUP CO., LTD., FUYANG, ZHEJIANG, CHINA, FILED 12-2-2010.



THE MARK CONSISTS OF A WORD AND A DESIGN. THE WORD "UN" CONSISTS OF TWO LETTERS OF "U, N" FROM LEFT TO RIGHT, WITH THE RIGHT PART OF THE LETTER "U" SHARED WITH THE LEFT PART OF THE LETTER "N". THE DESIGN CONSISTS OF FIVE OVALS NESTED ONE AFTER ANOTHER, THREE SHADED, TWO UNSHADED WITH THE MOST INNER SHADED OVAL CONTAINING THE WORD "UN", WITH THE "U" PARTIALLY UNSHADED, AND THE "N" PARTIALLY SHADED.

#### CLASS 7—MACHINERY

FOR ROAD CONSTRUCTION MACHINES, NAMELY, ROAD ROLLERS, STEAMROLLERS; EARTH MOVING MACHINES, NAMELY, EARTH-SCRAPERS, EXCAVATORS; LOADERS; SHOVEL MACHINES; DIGGER MACHINES; BULLDOZERS; ROOTDOZERS; DITCH DIGGERS; PULVERIZER MACHINES, NAMELY, SOIL PULVERIZERS (U.S. CLS. 13, 19, 21, 23, 31, 34 AND 35).

#### CLASS 12—VEHICLES

FOR VEHICLES FOR LIFTING AND TRANSPORTING MATERIALS, NAMELY, FORK LIFT TRUCKS; MOTOR VEHICLES FOR LAND USE, NAMELY, TRUCKS, TRAILER VEHICLES, ELECTRIC VEHICLES, AUTOMOBILES, CYCLE CARS, VAN VEHICLES, MOTOR HOMES, TANK CARS, STORAGE BATTERY CONVEY CARS (U.S. CLS. 19, 21, 23, 31, 35 AND 44).

ODESSA BIBBINS, EXAMINING ATTORNEY

SN 85-190,038. APT IP HOLDINGS, LLC, KANSAS CITY, MO.  
FILED 12-3-2010.

SN 85-191,597. DATASCOPE ANALYTICS LLC, CHICAGO,  
IL. FILED 12-6-2010.

# MOTOVOX

THE MARK CONSISTS OF STANDARD CHARACTERS WITHOUT CLAIM TO ANY PARTICULAR FONT, STYLE, SIZE, OR COLOR.

## CLASS 7—MACHINERY

FOR CARBURETORS; PORTABLE ELECTRIC GENERATORS; SNOWBLOWERS; AIR COMPRESSORS; HAND HELD AND PORTABLE POWER EQUIPMENT, NAMELY, WATER PUMPS FOR USE WITH MOTORS AND ENGINES, WATER PUMPS FOR HOME AND CONSTRUCTION, DEWATERING PUMPS AND SUMP PUMPS, SUBMERSIBLE PUMPS, MULTI-PURPOSE HIGH PRESSURE WASHERS, PRESSURE WASHERS, CHAIN SAWS, LAWN AND WEED TRIMMERS (U.S. CLS. 13, 19, 21, 23, 31, 34 AND 35).

## CLASS 12—VEHICLES

FOR MOTORIZED VEHICLES, NAMELY, GO-CARTS, MINI-BIKES AND DIRT BIKES FOR MOTOCROSS (U.S. CLS. 19, 21, 23, 31, 35 AND 44).  
COLLEEN DOMBROW, EXAMINING ATTORNEY

SN 85-190,246. MOT-LAUR PROPERTIES, LLC, ROCK-AWAY, NJ. FILED 12-3-2010.

# PUSH2O

THE MARK CONSISTS OF STANDARD CHARACTERS WITHOUT CLAIM TO ANY PARTICULAR FONT, STYLE, SIZE, OR COLOR.  
OWNER OF U.S. REG. NO. 3,804,343.

## CLASS 5—PHARMACEUTICALS

FOR VITAMIN ENHANCED WATER (U.S. CLS. 6, 18, 44, 46, 51 AND 52).  
FIRST USE 2-25-2011; IN COMMERCE 2-26-2011.

## CLASS 32—LIGHT BEVERAGES

FOR BOTTLED WATER (U.S. CLS. 45, 46 AND 48).  
FIRST USE 2-25-2011; IN COMMERCE 2-26-2011.  
JOHN GARTNER, EXAMINING ATTORNEY

# ORGANICCHART

THE MARK CONSISTS OF STANDARD CHARACTERS WITHOUT CLAIM TO ANY PARTICULAR FONT, STYLE, SIZE, OR COLOR.

## CLASS 9—ELECTRICAL AND SCIENTIFIC APPARATUS

FOR DOWNLOADABLE DIAGRAMS OF ORGANIZATIONAL STRUCTURE DERIVED FROM DIGITAL TRACES AND ELECTRONIC INFORMATION (U.S. CLS. 21, 23, 26, 36 AND 38).  
FIRST USE 1-1-2010; IN COMMERCE 1-1-2010.

## CLASS 41—EDUCATION AND ENTERTAINMENT

FOR DIAGRAMS OF ORGANIZATIONAL STRUCTURE DERIVED FROM DIGITAL TRACES AND ELECTRONIC INFORMATION, PROVIDED ONLINE (U.S. CLS. 100, 101 AND 107).  
FIRST USE 1-1-2010; IN COMMERCE 1-1-2010.  
JACQUELINE A. LAVINE, EXAMINING ATTORNEY

SN 85-191,669. FEDELTA ENTERPRISES, LLC, SEATTLE, WA. FILED 12-6-2010.

# FEDELTA CARE SOLUTIONS

THE MARK CONSISTS OF STANDARD CHARACTERS WITHOUT CLAIM TO ANY PARTICULAR FONT, STYLE, SIZE, OR COLOR.

OWNER OF U.S. REG. NOS. 3,032,320, 3,144,346 AND 3,328,315.

NO CLAIM IS MADE TO THE EXCLUSIVE RIGHT TO USE "CARE SOLUTIONS", APART FROM THE MARK AS SHOWN.

## CLASS 44—MEDICAL, BEAUTY AND AGRICULTURAL SERVICES

FOR HOME HEALTH CARE SERVICES (U.S. CLS. 100 AND 101).  
FIRST USE 1-0-2010; IN COMMERCE 1-0-2010.

## CLASS 45—PERSONAL AND LEGAL SERVICES

FOR IN-HOME SUPPORT SERVICES TO SENIOR PERSONS, NAMELY, GERIATRIC CARE MANAGEMENT SERVICES IN THE NATURE OF THE COORDINATION OF NECESSARY SERVICES AND PERSONAL CARE FOR OLDER INDIVIDUALS (U.S. CLS. 100 AND 101).  
FIRST USE 1-0-2010; IN COMMERCE 1-0-2010.  
MICHAEL TANNER, EXAMINING ATTORNEY

SN 85-191,829. YOKA INTERNATIONAL INC, BEIJING, CHINA, FILED 12-7-2010.

# YOKA

THE MARK CONSISTS OF STANDARD CHARACTERS WITHOUT CLAIM TO ANY PARTICULAR FONT, STYLE, SIZE, OR COLOR.

## CLASS 35—ADVERTISING AND BUSINESS

FOR ADVERTISING SERVICES, NAMELY, PROMOTING THE GOODS AND SERVICES OF OTHERS; ADVERTISING AND ADVERTISEMENT SERVICES VIA MOBILE PHONE NETWORKS; ADVERTISING AGENCIES, NAMELY, PROMOTING THE GOODS AND SERVICES OF OTHERS; ADVERTISING AND BUSINESS SERVICES, NAMELY, PROVIDING AN ONLINE WEBSITE WHERE ADVERTISERS, MARKETERS, AND CONTENT PROVIDERS CAN INTERACT WITH CONSUMERS FOR ADVERTISING, BRANDING, AND PROMOTING KNOWLEDGE, PRODUCTS, AND SERVICES, AND TRADESHOWS, ON BEHALF OF THEMSELVES AND OTHERS, AND FOR EVALUATING AND RATING THE SAME; ADVERTISING AND MARKETING SERVICES PROVIDED BY MEANS OF INDIRECT METHODS OF MARKETING COMMUNICATIONS, NAMELY, SOCIAL MEDIA, SEARCH ENGINE MARKETING, INQUIRY MARKETING, INTERNET MARKETING, MOBILE MARKETING, BLOGGING AND OTHER FORMS OF PASSIVE, SHARABLE OR VIRAL COMMUNICATIONS CHANNELS; ONLINE MEDIA MONITORING SERVICES USING COMPUTER SOFTWARE TO AUTOMATICALLY MONITOR INTERNET WEBSITES AND ONLINE PUBLICATIONS FOR CUSTOMER-SPECIFIED TOPICS AND TO CAPTURE RELEVANT CONTENT ON THOSE TOPICS, AND PROVIDING DOCUMENTATION AND ANALYSIS OF THAT ONLINE CONTENT TO OTHERS FOR BUSINESS PURPOSES; ONLINE RETAIL SERVICES THROUGH DIRECT SOLICITATION BY SALESPERSONS DIRECTED TO END-USERS FEATURING CLOTHING, COSMETIC CREAMS AND PREPARATIONS, FOOD AND WINE; PROMOTING THE GOODS AND SERVICES OF OTHERS BY PROVIDING A WEBSITE FEATURING COUPONS, REBATES, PRICE-COMPARISON INFORMATION, PRODUCT REVIEWS, LINKS TO THE RETAIL WEBSITES OF OTHERS, AND DISCOUNT INFORMATION; PROVIDING A SEARCHABLE WEBSITE FEATURING THE GOODS AND SERVICES OF OTHER VENDORS (U.S. CLS. 100, 101 AND 102).

FIRST USE 10-1-2006; IN COMMERCE 10-1-2006.

## CLASS 38—COMMUNICATION

FOR PROVIDING INTERNET ACCESS TO DIGITAL ADVERTISEMENT ON A WEBSITE FOR PROMOTING THE GOODS AND SERVICES OF OTHERS; PROVIDING INTERNET ACCESS TO AN ONLINE WEBSITE WHERE ADVERTISERS, MARKETERS, AND CONTENT PROVIDERS CAN INTERACT WITH CONSUMERS FOR ADVERTISING, BRANDING, AND PROMOTING KNOWLEDGE, PRODUCTS, AND SERVICES, AND TRADESHOWS, ON BEHALF OF THEMSELVES AND OTHERS, AND FOR EVALUATING AND RATING THE SAME; PROVIDING INTERNET ACCESS TO MARKETING AND ADVERTISING SERVICES VIA A WEBSITE FEATURING INDIRECT METHODS OF MARKETING COMMUNICATIONS, NAMELY, SOCIAL MEDIA, SEARCH ENGINE MARKETING, INQUIRY MARKETING, INTERNET MARKETING, MOBILE MARKETING, BLOGGING AND OTHER FORMS OF PASSIVE, SHARABLE OR VIRAL COMMUNICATIONS CHANNELS; PROVIDING INTERNET ACCESS TO A WEBSITE FEATURING COUPONS, REBATES, PRICE-COMPARISON INFORMATION, PRODUCT REVIEWS, LINKS TO THE RETAIL WEBSITES OF OTHERS, AND DISCOUNT INFORMATION (U.S. CLS. 100, 101 AND 104).

FIRST USE 10-1-2006; IN COMMERCE 10-1-2006.

ASMAT KHAN, EXAMINING ATTORNEY

SN 85-191,869. REACHLOCAL, INC., WOODLAND HILLS, CA. FILED 12-7-2010.

# TOTALBANNERNOW

THE MARK CONSISTS OF STANDARD CHARACTERS WITHOUT CLAIM TO ANY PARTICULAR FONT, STYLE, SIZE, OR COLOR.

## CLASS 35—ADVERTISING AND BUSINESS

FOR ADVERTISING SERVICES, NAMELY, CREATION OF CONTENT FOR ONLINE ADVERTISING, BANNER ADVERTISING SERVICES, INTERNET ADVERTISING SERVICES, DISSEMINATION OF ADVERTISING FOR OTHERS VIA A GLOBAL COMPUTER NETWORK, DISSEMINATION OF ADVERTISING FOR OTHERS VIA PUBLIC AND PRIVATE WIRELESS NETWORKS FOR DISPLAY ON MOBILE DEVICES; ADVERTISING THE GOODS AND SERVICES OF OTHERS VIA WEB PAGES OPTIMIZED FOR ONLINE SEARCH ENGINES; ADVERTISING ON THE INTERNET FOR OTHERS; ADVERTISING AND MARKETING SERVICES PROVIDED BY MEANS OF INDIRECT METHODS OF MARKETING COMMUNICATIONS, NAMELY, SOCIAL MEDIA, SEARCH ENGINE MARKETING, SEARCH ENGINE OPTIMIZATION, INQUIRY MARKETING, INTERNET MARKETING, MOBILE MARKETING, BLOGGING AND OTHER FORMS OF PASSIVE, SHARABLE, OR VIRAL COMMUNICATIONS CHANNELS; COMPUTER SERVICES, NAMELY, SEARCH ENGINE MARKETING; CONSULTATION SERVICES IN THE FIELDS OF SEARCH ENGINE MARKETING (U.S. CLS. 100, 101 AND 102).

## CLASS 42—SCIENTIFIC AND COMPUTER SERVICES

FOR WEBSITE DESIGN AND DEVELOPMENT SERVICES; COMPUTER SERVICES, NAMELY, SEARCH ENGINE OPTIMIZATION; CONSULTATION SERVICES IN THE FIELDS OF SEARCH ENGINE OPTIMIZATION; COMPUTER SOFTWARE DESIGN AND DEVELOPMENT SERVICES (U.S. CLS. 100 AND 101).

ARETHA SOMERVILLE, EXAMINING ATTORNEY

SN 85-192,251. APOLLO ENDOSURGERY, INC., AUSTIN, TX. FILED 12-7-2010.



OWNER OF U.S. REG. NO. 3,920,115.  
NO CLAIM IS MADE TO THE EXCLUSIVE RIGHT TO USE "ENDOSURGERY", APART FROM THE MARK AS SHOWN.



THE MARK CONSISTS OF A SPHERE ABOVE A WAVY LINE WITH THE TEXT "APOLLO ENDOSURGERY" IN STYLIZED FONT TO THE RIGHT.

SN 85-193,012. 7308574 CANADA INC, DBA BODY GOOD INTERNATIONAL, R.D.P., QUEBEC, CANADA, FILED 12-8-2010.

#### CLASS 10—MEDICAL APPARATUS

FOR MEDICAL DEVICES AND SURGICAL INSTRUMENTS FOR USE IN DIAGNOSIS AND SURGERY OF THE GASTROINTESTINAL TRACT (U.S. CLS. 26, 39 AND 44).

FIRST USE 9-14-2010; IN COMMERCE 9-14-2010.



THE MARK CONSISTS OF THE LETTERS "OD" ON A BACKGROUND WITH TRIBAL DESIGNS.

#### CLASS 41—EDUCATION AND ENTERTAINMENT

FOR TEACHING AND TRAINING IN THE FIELD OF MEDICAL DEVICES, SURGICAL INSTRUMENTS AND PROCEDURES FOR USE IN DIAGNOSIS AND SURGERY OF THE GASTROINTESTINAL TRACT (U.S. CLS. 100, 101 AND 107).

FIRST USE 5-4-2010; IN COMMERCE 5-4-2010.

#### CLASS 5—PHARMACEUTICALS

FOR DIETARY AND NUTRITIONAL SUPPLEMENTS (U.S. CLS. 6, 18, 44, 46, 51 AND 52).

#### CLASS 44—MEDICAL, BEAUTY AND AGRICULTURAL SERVICES

FOR PROVIDING INFORMATION IN THE FIELD OF MEDICAL DEVICES AND SURGICAL INSTRUMENTS FOR USE IN DIAGNOSIS AND SURGERY OF THE GASTROINTESTINAL TRACT (U.S. CLS. 100 AND 101).

FIRST USE 5-4-2010; IN COMMERCE 5-4-2010.  
JOHN KELLY, EXAMINING ATTORNEY

#### CLASS 32—LIGHT BEVERAGES

FOR ENERGY DRINKS (U.S. CLS. 45, 46 AND 48).  
SUSAN RICHARDS, EXAMINING ATTORNEY

SN 85-192,268. ROBISON ENERGY, LLC, ELMSFORD, NY. FILED 12-7-2010.

GREEN IS THE NEW KOSHER

THE MARK CONSISTS OF STANDARD CHARACTERS WITHOUT CLAIM TO ANY PARTICULAR FONT, STYLE, SIZE, OR COLOR.

NO CLAIM IS MADE TO THE EXCLUSIVE RIGHT TO USE "GREEN", APART FROM THE MARK AS SHOWN.

#### CLASS 35—ADVERTISING AND BUSINESS

FOR HOME ENERGY ASSESSMENT, AUDITING, AND CONSULTING SERVICES FOR THE PURPOSE OF DETERMINING ENERGY EFFICIENCY OR USAGE MANAGEMENT (U.S. CLS. 100, 101 AND 102).

#### CLASS 37—CONSTRUCTION AND REPAIR

FOR INSTALLATION, REPAIR AND MAINTENANCE OF AIR CONDITIONING EQUIPMENT AND HEATING EQUIPMENT, ELECTRICAL CONTRACTING, HEATING CONTRACTING, INSTALLATION OF HOME INSULATION, AND PLUMBING SERVICES, FOR ENERGY EFFICIENCY PURPOSES (U.S. CLS. 100, 103 AND 106).

#### CLASS 39—TRANSPORTATION AND STORAGE

FOR DISTRIBUTION OF ENERGY; ELECTRICITY DISTRIBUTION; GAS SUPPLYING; HEAT SUPPLYING (U.S. CLS. 100 AND 105).  
ANNE FARRELL, EXAMINING ATTORNEY

SN 85-193,330. TSUJI RIICHI HONTEN CO., LTD., UJI-CITY, KYOTO, JAPAN, FILED 12-8-2010.

辻利

THE MARK CONSISTS OF THE TERM "TSUJIRI" IN JAPANESE KANJI CHARACTERS.

THE NON-LATIN CHARACTERS IN THE MARK TRANSLITERATE TO "TSUJIRI" AND THIS HAS NO MEANING IN A FOREIGN LANGUAGE.

#### CLASS 30—STAPLE FOODS

FOR TEA; COFFEE; COCOA; ICE; SWEETS; PASTRIES; DESSERT PUDDINGS; FLAN; CREAM PUFFS; CAKES; CHOCOLATE; CHOCOLATE-BASED SNACK FOODS; RICE CAKES FILLED WITH SWEET BEANS (DAIFUKU); SWEET DUMPLINGS (DANGO); SYRUP-COVERED SWEET BEANS AND FRUITS (ANMITSU); CANDIES; ICE CREAM DESSERTS; SWEET BAKERY GOODS; BAKERY DESSERTS; BARS OF SWEET JELLIED BEAN PASTE (YOKAN); RICE CAKE COVERED WITH BEAN JAM (OHAGI); JAPANESE-STYLE PANCAKES FILLED WITH SWEET BEAN PASTE (DORAYAKI); SWEET POUNDED RICE CAKES (MOCHI-GASHI); NON-FROZEN JAPANESE-STYLE DESSERTS CONTAINING SWEET BEAN PASTE; BREAD (U.S. CL. 46).

#### CLASS 32—LIGHT BEVERAGES

FOR SOFT DRINKS; FRUIT DRINKS (U.S. CLS. 45, 46 AND 48).

**CLASS 43—HOTEL AND RESTAURANT SERVICES**

FOR PROVIDING OF FOOD AND DRINK (U.S. CLS. 100 AND 101).  
JERI J. FICKES, EXAMINING ATTORNEY

SN 85-194,301. 8TIMES1 LIMITED, WANCHAI, HONG KONG, FILED 12-9-2010.



SN 85-193,805. MGP & ASSOCIATES, INC., DBA MGP & ASSOCIATES PR, NEW YORK, NY. FILED 12-9-2010.

**The Reputation Doctor**

THE MARK CONSISTS OF STANDARD CHARACTERS WITHOUT CLAIM TO ANY PARTICULAR FONT, STYLE, SIZE, OR COLOR.

NO CLAIM IS MADE TO THE EXCLUSIVE RIGHT TO USE "REPUTATION", APART FROM THE MARK AS SHOWN.

**CLASS 9—ELECTRICAL AND SCIENTIFIC APPARATUS**

FOR MOTION PICTURE FILMS ABOUT PUBLIC RELATIONS OR REPUTATION USED FOR TELEVISION OR OTHER ENTERTAINMENT (U.S. CLS. 21, 23, 26, 36 AND 38).

**CLASS 35—ADVERTISING AND BUSINESS**

FOR ADVERTISING SERVICES, PUBLIC RELATIONS AND MARKETING SERVICES, NAMELY, PROMOTING AND MARKETING THE GOODS AND SERVICES OF OTHERS THROUGH ALL PUBLIC COMMUNICATION MEANS (U.S. CLS. 100, 101 AND 102).  
ERNEST SHOSHO, EXAMINING ATTORNEY

NO CLAIM IS MADE TO THE EXCLUSIVE RIGHT TO USE "LED LIGHTS", APART FROM THE MARK AS SHOWN.

THE MARK CONSISTS OF THE NUMERAL "8" FOLLOWED BY LOWER CASE LETTERS "VO" AND A SERIES OF DOTS FORMING UPPER CASE LETTERS "LED" OVER THE WORDS "LIGHTS OUR GREEN EARTH".

**CLASS 9—ELECTRICAL AND SCIENTIFIC APPARATUS**

FOR COMPUTER CONTROLLERS FOR OPERATING LIGHTING APPARATUS; COMPUTER SOFTWARE FOR CONTROLLING LIGHTING APPARATUS; ELECTRICAL BALLAST FOR LIGHTING; RECTIFIERS; LIGHT EMITTING DIODES (LEDS); LASER DIODES; ZENER DIODES (U.S. CLS. 21, 23, 26, 36 AND 38).

**CLASS 11—ENVIRONMENTAL CONTROL APPARATUS**

FOR ELECTRIC LAMPS; LIGHTING FIXTURES; LED (LIGHT EMITTING DIODE) LIGHTING FIXTURES (U.S. CLS. 13, 21, 23, 31 AND 34).

ELISSA GARBER KON, EXAMINING ATTORNEY

SN 85-194,175. MEISSNER FILTRATION PRODUCTS, INC., CAMARILLO, CA. FILED 12-9-2010.

**SALTUS**

THE MARK CONSISTS OF STANDARD CHARACTERS WITHOUT CLAIM TO ANY PARTICULAR FONT, STYLE, SIZE, OR COLOR.

**CLASS 7—MACHINERY**

FOR INDUSTRIAL MIXERS FOR MIXING LIQUIDS AND/OR COMPOUNDS FOR USE IN THE BIOTECH AND PHARMACEUTICAL INDUSTRIES (U.S. CLS. 13, 19, 21, 23, 31, 34 AND 35).

**CLASS 9—ELECTRICAL AND SCIENTIFIC APPARATUS**

FOR BIOREACTORS FOR GROWING CELLS (U.S. CLS. 21, 23, 26, 36 AND 38).  
JOHN DALIER, EXAMINING ATTORNEY

SN 85-194,446. MERCHSOURCE, LLC, FOOTHILL RANCH, CA. FILED 12-9-2010.



THE MARK CONSISTS OF THE LETTERS "SP" IN LOWERCASE WITH A LEAF INSIDE OF THE LETTER "P".

**CLASS 10—MEDICAL APPARATUS**

FOR ELECTRIC AND NON-ELECTRIC MECHANICAL MASSAGERS, NAMELY, FOOT, NECK, BACK AND SPOT MASSAGERS (U.S. CLS. 26, 39 AND 44).  
FIRST USE 5-31-2010; IN COMMERCE 5-31-2010.

**CLASS 25—CLOTHING**

FOR FOOTWEAR; SLIPPERS, BATH SLIPPERS, PEDICURE SLIPPERS (U.S. CLS. 22 AND 39).  
FIRST USE 5-31-2010; IN COMMERCE 5-31-2010.  
JOHN WILKE, EXAMINING ATTORNEY

SN 85-194,567. MOEN INCORPORATED, NORTH OLMSTED, OH. FILED 12-9-2010.

# WEYMOUTH

THE MARK CONSISTS OF STANDARD CHARACTERS WITHOUT CLAIM TO ANY PARTICULAR FONT, STYLE, SIZE, OR COLOR.

### CLASS 6—METAL GOODS

FOR METAL ROBE HOOKS; METAL BATHROOM OCCUPANCY SIGNS (U.S. CLS. 2, 12, 13, 14, 23, 25 AND 50).

### CLASS 11—ENVIRONMENTAL CONTROL APPARATUS

FOR FAUCETS, NAMELY, LAVATORY FAUCETS, ROMAN TUB FAUCETS; FAUCET HANDLES AND FAUCET VALVES; SHOWER AND TUB FIXTURES, NAMELY, TUB SPOUTS, SHOWER HEADS, HAND HELD SHOWER HEADS, BODY SPRAYERS, SHOWER VALVES, TUB/SHOWER VALVES; FIXTURES FOR BIDETS, NAMELY, FAUCETS, SPRAYERS, FAUCET HANDLES AND DRAINS; TOILET TANK LEVERS; AND ELECTRIC LIGHTING FIXTURES (U.S. CLS. 13, 21, 23, 31 AND 34).

### CLASS 20—FURNITURE AND ARTICLES NOT OTHERWISE CLASSIFIED

FOR GLASS SHELVES (U.S. CLS. 2, 13, 22, 25, 32 AND 50).

### CLASS 21—HOUSEWARES AND GLASS

FOR BATHROOM ACCESSORIES, NAMELY, TOWEL BARS, TOWEL RINGS, TOILET TISSUE HOLDERS (U.S. CLS. 2, 13, 23, 29, 30, 33, 40 AND 50).  
JOHN WILKE, EXAMINING ATTORNEY

SN 85-194,791. MARCO, ZANETTI, TORINO, ITALY, FILED 12-10-2010.



NO CLAIM IS MADE TO THE EXCLUSIVE RIGHT TO USE "NUTRITIONAL COACH", APART FROM THE MARK AS SHOWN.

THE MARK CONSISTS OF THE WORD "NUTRITIONAL" OVERLAPPED TO THE WORD "COACH" AND FLANKED BY A STYLIZED REPRESENTATION OF A SEQUENCE OF DNA.

### CLASS 5—PHARMACEUTICALS

FOR DIETARY AND NUTRITIONAL SUPPLEMENTS (U.S. CLS. 6, 18, 44, 46, 51 AND 52).

### CLASS 41—EDUCATION AND ENTERTAINMENT

FOR EDUCATIONAL SERVICES, NAMELY, CONDUCTING SEMINARS AND COURSES IN THE FIELD OF NUTRITION AND DISTRIBUTION OF COURSE AND EDUCATIONAL MATERIALS IN CONNECTION THEREWITH (U.S. CLS. 100, 101 AND 107).  
AISHA CLARKE, EXAMINING ATTORNEY

SN 85-194,916. WATKINS, MICHAEL G, ROCHESTER, NY. FILED 12-10-2010.

# CAUSE CENT

THE MARK CONSISTS OF STANDARD CHARACTERS WITHOUT CLAIM TO ANY PARTICULAR FONT, STYLE, SIZE, OR COLOR.

NO CLAIM IS MADE TO THE EXCLUSIVE RIGHT TO USE "CENT" FOR CLASS 014 ONLY, APART FROM THE MARK AS SHOWN.

### CLASS 14—JEWELRY

FOR COLLECTIBLE COINS (U.S. CLS. 2, 27, 28 AND 50).

### CLASS 35—ADVERTISING AND BUSINESS

FOR PROMOTING PUBLIC AWARENESS OF POVERTY AND HOMELESSNESS; PROMOTING THE CHARITABLE SERVICES OF OTHERS, NAMELY, PROVIDING INDIVIDUALS WITH INFORMATION FOR THE PURPOSE OF MAKING DONATIONS TO CHARITIES (U.S. CLS. 100, 101 AND 102).

### CLASS 36—INSURANCE AND FINANCIAL

FOR CHARITABLE FUNDRAISING SERVICES BY MEANS OF SELLING GOODS TO RAISE FUNDS; FUNDRAISING SERVICES, NAMELY, SHARING PROFITS FROM THE SALE OF SOCIALLY RESPONSIBLE PRODUCTS WITH NOT-FOR-PROFIT ORGANIZATIONS, SCHOOLS, AND CIVIC GROUPS; ON-LINE BUSINESS FUNDRAISING SERVICES (U.S. CLS. 100, 101 AND 102).  
PAUL MORENO, EXAMINING ATTORNEY

SN 85-195,068. SCOTT A. DERR, DBA BLOWFISH FERTILIZER COMPANY, DILLSBURG, PA. FILED 12-10-2010.

SN 85-195,447. CARMAX BUSINESS SERVICES, LLC, RICHMOND, VA. FILED 12-10-2010.



NO CLAIM IS MADE TO THE EXCLUSIVE RIGHT TO USE "FERTILIZER COMPANY ORGANIC LAWN CARE", APART FROM THE MARK AS SHOWN.

THE COLOR(S) BLACK, WHITE, GRAY, LIGHT GREEN, GREEN, DARK GREEN, LIGHT ORANGE AND ORANGE IS/ARE CLAIMED AS A FEATURE OF THE MARK.

THE MARK CONSISTS OF A BLACK CIRCLE THAT FADES TO GRAY AND THEN TO WHITE ON ITS OUTER RIM; IN THE CENTER OF THE CIRCLE IS A BLOWFISH FACING FORWARD; THE BLOWFISH CONSISTS OF A CIRCLE WHERE THE TOP ONE-THIRD IS LIGHT GREEN AND THE BOTTOM TWO-THIRDS ARE WHITE AND THE CIRCLE HAS GREEN TRIANGULAR SPIKES ON ITS TOP AND GREEN TRIANGULAR SPIKES ON THE BOTTOM THAT HAVE WHITE CENTERS; THE BLOWFISH HAS LIGHT GREEN TRIANGULAR WINGS ON THE LEFT AND RIGHT SIDES; IT HAS A TRIANGULAR TAIL ON THE TOP RIGHT SIDE THAT IS PARTIALLY COVERED BY THE SPIKES; THE TAIL IS LIGHT GREEN OUTLINED IN GREEN, WITH THREE DARK GREEN LINES DOWN THE CENTER OF THE TAIL AND EACH LINE IS HOOKED TO THE RIGHT AT THE TOP AND THE CENTER LINE IS MOSTLY COVERED BY A SPIKE; THE BLOWFISH HAS EYES THAT CONSIST OF A DARK GREEN OVAL WITH A WHITE OVAL IN THE CENTER OF THE DARK GREEN OVAL AND A LIGHT GREEN PUPIL IN THE CENTER OF THE WHITE OVAL; THE BLOWFISH HAS ORANGE LIPS THAT ARE OPEN AND WHITE IN THE CENTER OF THE OPEN MOUTH; THE BLOWFISH HAS LIGHT ORANGE OVALS OF VARIOUS SIZES IN THE BOTTOM WHITE PORTION; ABOVE THE BLOWFISH IS THE WORD "BLOWFISH" IN ORANGE CAPITAL LETTERS AND INSIDE EACH LETTER ARE MULTIPLE BLACK BONES; BELOW THE BLOWFISH ARE THE WORDS "FERTILIZER COMPANY" IN LIGHT GREEN CAPITAL LETTERS AND BELOW THAT ARE THE WORDS "ORGANIC LAWN CARE" IN ORANGE CAPITAL LETTERS; ALL OF THE WORDS ARE CONCAVED TO FIT WITHIN THE BLACK CIRCLE.

#### CLASS 1—CHEMICALS

FOR NON-CHEMICAL BIO-FERTILIZERS (U.S. CLS. 1, 5, 6, 10, 26 AND 46).  
FIRST USE 10-20-2010; IN COMMERCE 10-20-2010.

#### CLASS 44—MEDICAL, BEAUTY AND AGRICULTURAL SERVICES

FOR APPLICATION OF FERTILIZER AND AGRICULTURAL CHEMICALS FOR OTHERS; FERTILIZER SPREADING; HORTICULTURAL PROCESSES AND TURF OR LAWN CARE SERVICES, NAMELY, PROVIDING PREPARATION AND DEVELOPMENT OF TURF-GRASS AND/OR SOIL FOR PROVIDING AN ENVIRONMENT THAT ENCOURAGES IMPROVED GROWTH ATTRIBUTES (U.S. CLS. 100 AND 101).  
FIRST USE 10-20-2010; IN COMMERCE 10-20-2010.  
JASON BLAIR, EXAMINING ATTORNEY

## CarMax EasyShop

THE MARK CONSISTS OF STANDARD CHARACTERS WITHOUT CLAIM TO ANY PARTICULAR FONT, STYLE, SIZE, OR COLOR.

OWNER OF U.S. REG. NOS. 1,947,856, 2,001,858 AND OTHERS.

#### CLASS 35—ADVERTISING AND BUSINESS

FOR RETAIL STORE SERVICES FEATURING AUTOMOBILES AND TRUCKS; CUSTOMER LOYALTY SERVICES AND CUSTOMER CLUB SERVICES; FOR COMMERCIAL, PROMOTIONAL AND/OR ADVERTISING PURPOSES; DIRECT MAIL ADVERTISING; RETAIL OUTLETS FEATURING AUTOMOBILES AND TRUCKS (U.S. CLS. 100, 101 AND 102).

#### CLASS 36—INSURANCE AND FINANCIAL

FOR PROVIDING EXTENDED WARRANTY CONTRACTS FOR AUTOMOBILES AND TRUCKS; AUTOMOBILE APPRAISAL; AUTOMOTIVE FINANCING SERVICES (U.S. CLS. 100, 101 AND 102).

#### CLASS 37—CONSTRUCTION AND REPAIR

FOR REPAIR AND MAINTENANCE OF AUTOMOBILES AND TRUCKS (U.S. CLS. 100, 103 AND 106).

#### CLASS 42—SCIENTIFIC AND COMPUTER SERVICES

FOR AUTOMOTIVE INSPECTION SERVICES (U.S. CLS. 100 AND 101).  
DOMINIC FATHY, EXAMINING ATTORNEY

SN 85-196,117. THE JOHN POWERS MIDDLETON COMPANY LLC, WILMINGTON, DE. FILED 12-13-2010.

## THE COALITION OF REPUBLICAN ENTHUSIASM

THE MARK CONSISTS OF STANDARD CHARACTERS WITHOUT CLAIM TO ANY PARTICULAR FONT, STYLE, SIZE, OR COLOR.

NO CLAIM IS MADE TO THE EXCLUSIVE RIGHT TO USE "COALITION" AND "REPUBLICAN", APART FROM THE MARK AS SHOWN.

#### CLASS 35—ADVERTISING AND BUSINESS

FOR POLITICAL PARTY SERVICES, NAMELY, PROMOTING THE INTERESTS OF A POLITICAL ORGANIZATION; PROMOTING PUBLIC AWARENESS OF POLITICAL ISSUES AND MATTERS (U.S. CLS. 100, 101 AND 102).

#### CLASS 36—INSURANCE AND FINANCIAL

FOR POLITICAL FUNDRAISING SERVICES (U.S. CLS. 100, 101 AND 102).



TARA PATE, EXAMINING ATTORNEY

SN 85-196,123. SEQUENCE, INC., BONITA SPRINGS, FL.  
FILED 12-13-2010.



**BRILLIANCE NEW YORK**

NO CLAIM IS MADE TO THE EXCLUSIVE RIGHT TO USE "NEW YORK", APART FROM THE MARK AS SHOWN.

THE MARK CONSISTS OF A BLACK SQUARE WITH A WHITE "B" REVERSED OUT OF THE BLACK BACKGROUND AND A HORIZONTAL LINE EXTENDING TO THE LEFT FROM THE MIDDLE HORIZONTAL LINE OF THE "B", ALL OF WHICH IS CENTERED OVER THE WORDS "BRILLIANCE NEW YORK".

**CLASS 3—COSMETICS AND CLEANING PREPARATIONS**

FOR COSMETICS; HAIR GEL AND HAIR MOUSSE; HAIR SHAMPOOS AND CONDITIONERS; SKIN CARE PRODUCTS, NAMELY, NON-MEDICATED SKIN SERUM (U.S. CLS. 1, 4, 6, 50, 51 AND 52).

**CLASS 9—ELECTRICAL AND SCIENTIFIC APPARATUS**

FOR ELECTRIC HAIR CURLERS; ELECTRIC HAIR STRAIGHTENER (U.S. CLS. 21, 23, 26, 36 AND 38).

**CLASS 11—ENVIRONMENTAL CONTROL APPARATUS**

FOR HAIR DRYERS (U.S. CLS. 13, 21, 23, 31 AND 34).  
DEIRDRE ROBERTSON, EXAMINING ATTORNEY

SN 85-196,373. POSITIVE ID CORPORATION, DELRAY BEACH, FL. FILED 12-13-2010.

**IGLUCOSE**

THE MARK CONSISTS OF STANDARD CHARACTERS WITHOUT CLAIM TO ANY PARTICULAR FONT, STYLE, SIZE, OR COLOR.

**CLASS 9—ELECTRICAL AND SCIENTIFIC APPARATUS**

FOR COMPUTER HARDWARE AND SOFTWARE FOR USE WITH MEDICAL AND NON-MEDICAL PATIENT MONITORING EQUIPMENT, FOR RECEIVING, PROCESSING, TRANSMITTING AND DISPLAYING DATA (U.S. CLS. 21, 23, 26, 36 AND 38).

**CLASS 44—MEDICAL, BEAUTY AND AGRICULTURAL SERVICES**

FOR REMOTE MONITORING OF DATA INDICATIVE OF THE HEALTH OR CONDITION OF AN INDIVIDUAL OR GROUP OF INDIVIDUALS (U.S. CLS. 100 AND 101).  
ROBIN CHOSID, EXAMINING ATTORNEY

SN 85-196,801. CONOLLY, BRIAN, BROADWAY, NSW, AUSTRALIA, FILED 12-13-2010.

**HyperWarm**

THE MARK CONSISTS OF STANDARD CHARACTERS WITHOUT CLAIM TO ANY PARTICULAR FONT, STYLE, SIZE, OR COLOR.

OWNER OF AUSTRALIA REG. NO. 1330165, DATED 6-21-2010, EXPIRES 11-8-2019.

**CLASS 24—FABRICS**

FOR TEXTILE FABRICS FOR THE MANUFACTURE OF CLOTHING (U.S. CLS. 42 AND 50).

**CLASS 25—CLOTHING**

FOR ATHLETIC APPAREL, NAMELY, SHIRTS, PANTS, JACKETS, FOOTWEAR, HATS AND CAPS, ATHLETIC UNIFORMS (U.S. CLS. 22 AND 39).

WILLIAM VERHOSEK, EXAMINING ATTORNEY

SN 85-197,917. CAPE KINGDOM NUTRACEUTICALS LLC, PARKLAND, FL. FILED 12-14-2010.

**BUCHULIFE**

THE MARK CONSISTS OF STANDARD CHARACTERS WITHOUT CLAIM TO ANY PARTICULAR FONT, STYLE, SIZE, OR COLOR.

**CLASS 5—PHARMACEUTICALS**

FOR MEDICATED DRINKING WATERS FEATURING BUCHU FOR USE AS ANTI-INFLAMMATORIES AND ANTISEPTICS AND FOR USE IN TREATING URINARY TRACT INFECTIONS; MEDICATED HERBAL PREPARATIONS FEATURING BUCHU; PHARMACEUTICAL CAPSULES AND GELS FEATURING BUCHU, NAMELY, PAIN-RELIEF CAPSULES, ANTI-INFLAMMATORY CAPSULES, ANTI-INFLAMMATORY, ANTI-SEPTIC AND ANTI-FUNGAL GELS AND URINARY TRACT INFECTION MEDICATION (U.S. CLS. 6, 18, 44, 46, 51 AND 52).

**CLASS 32—LIGHT BEVERAGES**

FOR BEVERAGES FEATURING BUCHU, NAMELY, DRINKING WATER, MINERAL WATERS, SPRING WATERS, STILL WATERS, FLAVORED WATERS AND HERBAL JUICES (U.S. CLS. 45, 46 AND 48).

MARTHA FROMM, EXAMINING ATTORNEY

SN 85-198,113. NIAGARA COUNTY COMMUNITY COLLEGE, SANBORN, NY. FILED 12-15-2010.

SN 85-198,198. NIAGARA COUNTY COMMUNITY COLLEGE, SANBORN, NY. FILED 12-15-2010.



NO CLAIM IS MADE TO THE EXCLUSIVE RIGHT TO USE "NIAGARA", APART FROM THE MARK AS SHOWN. THE MARK CONSISTS OF A WOLF ABOVE THE WORDS "NIAGARA CCC THUNDER WOLVES".

NO CLAIM IS MADE TO THE EXCLUSIVE RIGHT TO USE "NIAGARA", APART FROM THE MARK AS SHOWN. THE MARK CONSISTS OF A WOLF ABOVE THE WORDS "NIAGARA CCC THUNDER WOLVES" WITH A WATERFALL IN THE BACKGROUND.

#### **CLASS 6—METAL GOODS**

FOR METAL KEY CHAINS (U.S. CLS. 2, 12, 13, 14, 23, 25 AND 50).

#### **CLASS 6—METAL GOODS**

FOR METAL KEY CHAINS (U.S. CLS. 2, 12, 13, 14, 23, 25 AND 50).

#### **CLASS 16—PAPER GOODS AND PRINTED MATTER**

FOR NON-ELECTRONIC DAILY PLANNERS, FOLDERS; DESK ACCESSORIES, NAMELY, DESKTOP ORGANIZERS, DESK PADS, DOCUMENT RACKS, PEN AND PENCIL HOLDERS, PAPER STAPLERS, NOTE PAD HOLDERS, PAPER CLIPS HOLDERS; DECALS (U.S. CLS. 2, 5, 22, 23, 29, 37, 38 AND 50).

#### **CLASS 16—PAPER GOODS AND PRINTED MATTER**

FOR NON-ELECTRONIC DAILY PLANNERS, FOLDERS; DESK ACCESSORIES, NAMELY, DESKTOP ORGANIZERS, DESK PADS, DOCUMENT RACKS, PEN AND PENCIL HOLDERS, PAPER STAPLERS, NOTE PAD HOLDERS, PAPER CLIPS HOLDERS; DECALS (U.S. CLS. 2, 5, 22, 23, 29, 37, 38 AND 50).

#### **CLASS 18—LEATHER GOODS**

FOR UMBRELLAS AND CARRY ALL BAGS, TOTE BAGS, AND BACKPACKS (U.S. CLS. 1, 2, 3, 22 AND 41).

#### **CLASS 18—LEATHER GOODS**

FOR UMBRELLAS AND CARRY ALL BAGS, TOTE BAGS, AND BACKPACKS (U.S. CLS. 1, 2, 3, 22 AND 41).

#### **CLASS 21—HOUSEWARES AND GLASS**

FOR MUGS AND BEVERAGE GLASSWARE (U.S. CLS. 2, 13, 23, 29, 30, 33, 40 AND 50).

#### **CLASS 21—HOUSEWARES AND GLASS**

FOR MUGS AND BEVERAGE GLASSWARE (U.S. CLS. 2, 13, 23, 29, 30, 33, 40 AND 50).

#### **CLASS 22—CORDAGE AND FIBERS**

FOR LANYARDS FOR HOLDING BADGES AND KEYS (U.S. CLS. 1, 2, 7, 19, 22, 42 AND 50).

#### **CLASS 22—CORDAGE AND FIBERS**

FOR LANYARDS FOR HOLDING BADGES AND KEYS (U.S. CLS. 1, 2, 7, 19, 22, 42 AND 50).

#### **CLASS 24—FABRICS**

FOR BED BLANKETS AND BLANKET THROWS (U.S. CLS. 42 AND 50).

#### **CLASS 24—FABRICS**

FOR BED BLANKETS AND BLANKET THROWS (U.S. CLS. 42 AND 50).

#### **CLASS 25—CLOTHING**

FOR BASEBALL CAPS, KNIT HATS, SCARVES, SANDALS, GLOVES FOR APPAREL, T-SHIRTS, SWEATSHIRTS, JACKETS, HOODED SWEATSHIRTS, AND SWEATPANTS (U.S. CLS. 22 AND 39).  
JACLYN KIDWELL WALKER, EXAMINING ATTORNEY

#### **CLASS 25—CLOTHING**

FOR BASEBALL CAPS, KNIT HATS, SCARVES, SANDALS, GLOVES FOR APPAREL, T-SHIRTS, SWEATSHIRTS, JACKETS, HOODED SWEATSHIRTS, AND SWEATPANTS (U.S. CLS. 22 AND 39).  
JACLYN KIDWELL WALKER, EXAMINING ATTORNEY

SN 85-198,206. AUDIOBRAIN, NEW YORK, NY. FILED 12-15-2010.

# Audiobrain

THE MARK CONSISTS OF STANDARD CHARACTERS WITHOUT CLAIM TO ANY PARTICULAR FONT, STYLE, SIZE, OR COLOR.

## CLASS 35—ADVERTISING AND BUSINESS

FOR BRANDING SERVICES, NAMELY, PROVIDING CUSTOMIZED BRAND CONCEPT AND BRAND DEVELOPMENT THROUGH THE USE OF MUSIC STRATEGY TO DEVELOP BRANDS FOR THE PRODUCTS AND SERVICES OF OTHERS (U.S. CLS. 100, 101 AND 102).  
FIRST USE 6-30-2003; IN COMMERCE 6-30-2003.

## CLASS 41—EDUCATION AND ENTERTAINMENT

FOR ORIGINAL MUSIC COMPOSITION FOR OTHERS (U.S. CLS. 100, 101 AND 107).  
FIRST USE 6-30-2003; IN COMMERCE 6-30-2003.  
JACLYN KIDWELL WALKER, EXAMINING ATTORNEY

SN 85-198,256. GUY CARPENTER & COMPANY, LLC, NEW YORK, NY. FILED 12-15-2010.

# GC ANALYTICS

THE MARK CONSISTS OF STANDARD CHARACTERS WITHOUT CLAIM TO ANY PARTICULAR FONT, STYLE, SIZE, OR COLOR.

OWNER OF U.S. REG. NOS. 3,162,434 AND 3,894,269.  
NO CLAIM IS MADE TO THE EXCLUSIVE RIGHT TO USE "ANALYTICS", APART FROM THE MARK AS SHOWN.

## CLASS 35—ADVERTISING AND BUSINESS

FOR BUSINESS PLANNING SERVICES, NAMELY, DESIGNING MODELING DERIVATIVE SYSTEMS; PROVIDING BUSINESS INTELLIGENCE; MARKET RESEARCH AND INTELLIGENCE SERVICES; BUSINESS RISK MANAGEMENT CONSULTATION (U.S. CLS. 100, 101 AND 102).  
FIRST USE 10-31-2010; IN COMMERCE 10-31-2010.

## CLASS 36—INSURANCE AND FINANCIAL

FOR FINANCIAL MANAGEMENT, ANALYSIS AND CONSULTING SERVICES, NAMELY, PREPARATION OF FINANCIAL AND INSURANCE REPORTS, INVESTMENT PERFORMANCE MONITORING, RISK ANALYSIS, INSURANCE AND REINSURANCE STRATEGY SERVICES, CATASTROPHE AND FINANCIAL MODELING; FINANCIAL SERVICES, NAMELY DESIGN AND IMPLEMENTATION OF CAPITAL MARKET RISK HEDGING INSTRUMENTS; INSURANCE CONSULTATION; AND ACTUARIAL SERVICES; CONSULTING IN THE FIELD OF FINANCIAL STRENGTH RATINGS; FINANCIAL SERVICES, NAMELY PROVIDING INFORMATION IN THE FIELDS OF REINSURANCE AND INSURANCE; FINANCIAL RISK MANAGEMENT CONSULTATION (U.S. CLS. 100, 101 AND 102).  
FIRST USE 10-31-2010; IN COMMERCE 10-31-2010.

## CLASS 45—PERSONAL AND LEGAL SERVICES

FOR REGULATORY COMPLIANCE CONSULTING IN THE FIELDS OF INSURANCE AND REINSURANCE (U.S. CLS. 100 AND 101).  
FIRST USE 10-31-2010; IN COMMERCE 10-31-2010.  
REBECCA EISINGER, EXAMINING ATTORNEY

SN 85-198,419. CREATIVE CASINOS, LLC, LAS VEGAS, NV. FILED 12-15-2010.

# CREATIVE CASINOS

THE MARK CONSISTS OF STANDARD CHARACTERS WITHOUT CLAIM TO ANY PARTICULAR FONT, STYLE, SIZE, OR COLOR.

NO CLAIM IS MADE TO THE EXCLUSIVE RIGHT TO USE "CASINOS", APART FROM THE MARK AS SHOWN.

## CLASS 37—CONSTRUCTION AND REPAIR

FOR REAL ESTATE DEVELOPMENT OF CASINOS AND RESORTS FOR THIRD PARTIES (U.S. CLS. 100, 103 AND 106).

## CLASS 42—SCIENTIFIC AND COMPUTER SERVICES

FOR ARCHITECTURAL, INTERIOR AND EXTERIOR DESIGN OF CASINOS AND RESORTS FOR THIRD PARTIES (U.S. CLS. 100 AND 101).  
TINA MAI, EXAMINING ATTORNEY

SN 85-198,521. INNOVID INC., NEW YORK, NY. FILED 12-15-2010.

# INNOVID

THE MARK CONSISTS OF STANDARD CHARACTERS WITHOUT CLAIM TO ANY PARTICULAR FONT, STYLE, SIZE, OR COLOR.

**CLASS 9—ELECTRICAL AND SCIENTIFIC APPARATUS**

FOR COMPUTER SOFTWARE PROGRAMS FOR THE INTEGRATION OF TEXT, AUDIO, GRAPHICS, STILL IMAGES AND MOVING PICTURES INTO AN INTERACTIVE COMMERCIAL VIDEO; INTERACTIVE MULTIMEDIA SOFTWARE FEATURING AUDIO AND VIDEO INFORMATION FOR CREATING, DELIVERING AND MEASURING ON-LINE COMMERCIALS AND ADVERTISEMENTS (U.S. CLS. 21, 23, 26, 36 AND 38).

**CLASS 35—ADVERTISING AND BUSINESS**

FOR ADVERTISING AND PUBLICITY SERVICES, NAMELY, PROMOTING THE GOODS, SERVICES, BRAND IDENTITY, COMMERCIAL INFORMATION AND NEWS OF THIRD PARTIES THROUGH AUDIO, VIDEO, DIGITAL AND ON-LINE MEDIUM; PREPARING ADVERTISEMENTS FOR OTHERS, NAMELY, PREPARING VIDEO ADVERTISING AND PROMOTIONAL VIDEOS FOR COMMERCIAL USE VIA THE INTERNET AND TELEVISION, MOBILE COMMUNICATION, DIGITAL CABLE AND VIDEO-ON-DEMAND OR DOWNLOADS; PROVIDING ADVERTISING SERVICES TO DISTRIBUTE ADVERTISEMENTS FOR DISPLAY ON INTERNET, NAMELY, IN WEBSITES, SOCIAL CONVERSATIONS OVER THE INTERNET, E-MAILS, MICRO-BLOGS, BLOGS, ELECTRONIC MESSAGES, INSTANT MESSAGES, TEXT MESSAGES, MULTIMEDIA MESSAGES, SOCIAL NETWORKS, STATUS UPDATES, FORUMS, ELECTRONIC BULLETIN BOARDS; MARKETING, PROMOTIONAL AND ADVERTISING SERVICES PROVIDED BY MOBILE TELEPHONE CONNECTIONS; PROVIDING TELEVISION ADVERTISING FOR OTHERS; ADVERTISEMENT AND PUBLICITY SERVICES BY TELEVISION; ONLINE ADVERTISING AND PROMOTIONAL SERVICES; ON-LINE ADVERTISING AND MARKETING SERVICES (U.S. CLS. 100, 101 AND 102).

KHANH LE, EXAMINING ATTORNEY

SN 85-198,629. JASPER AND JASPER LIMITED, LONDON, UNITED KINGDOM, FILED 12-15-2010.



PRIORITY CLAIMED UNDER SEC. 44(D) ON ERP CMNTY TM OFC APPLICATION NO. 009043282, FILED 6-18-2010, REG. NO. 009043282, DATED 12-6-2010, EXPIRES 6-18-2020.

THE COLOR(S) GRAY IS/ARE CLAIMED AS A FEATURE OF THE MARK.

THE MARK CONSISTS OF THE WORD "JASPER" FOLLOWED BY A MONOGRAM OF A "J" AND A BACKWARDS "J" WITH A RING AROUND THEM FOLLOWED BY THE WORD "JASPER" AGAIN, ALL IN GRAY COLOR, THE COLOR WHITE REPRESENTS BACKGROUND AND IS NOT CLAIMED AS A FEATURE OF THE MARK.

**CLASS 5—PHARMACEUTICALS**

FOR ELECTRONIC TOBACCO-FREE CIGARETTES FOR MEDICAL PURPOSES; IMITATION CIGARETTES FOR QUITTING SMOKING (U.S. CLS. 6, 18, 44, 46, 51 AND 52).

**CLASS 10—MEDICAL APPARATUS**

FOR PUMPS FOR MEDICAL PURPOSES, NAMELY, INFUSION PUMPS FOR DELIVERING MEASURED AMOUNTS OF SOLUTIONS INTO THE BLOODSTREAM OVER TIME; AEROSOL DISPENSERS FOR MEDICAL PURPOSES (U.S. CLS. 26, 39 AND 44).

**CLASS 34—SMOKERS' ARTICLES**

FOR TOBACCO; CIGARETTES CONTAINING TOBACCO SUBSTITUTES, NOT FOR MEDICAL PURPOSES; SMOKERS' ARTICLES, NAMELY, CIGARETTE CASES AND ASHTRAYS (U.S. CLS. 2, 8, 9 AND 17).

NATALIE POLZER, EXAMINING ATTORNEY

SN 85-198,630. ROEMISCHER, JESSICA, STOCKBRIDGE, MA. FILED 12-15-2010.

**The Piano Duet Paradigm**

THE MARK CONSISTS OF STANDARD CHARACTERS WITHOUT CLAIM TO ANY PARTICULAR FONT, STYLE, SIZE, OR COLOR.

NO CLAIM IS MADE TO THE EXCLUSIVE RIGHT TO USE "PIANO DUET", APART FROM THE MARK AS SHOWN.

**CLASS 9—ELECTRICAL AND SCIENTIFIC APPARATUS**

FOR DOWNLOADABLE MP3 FILES, MP3 RECORDINGS, ON-LINE DISCUSSION BOARDS, WEBCASTS, WEBINARS AND PODCASTS IN THE FIELD OF SELF-AWARENESS, AUDIO BOOKS IN THE FIELD OF SELF-AWARENESS (U.S. CLS. 21, 23, 26, 36 AND 38).

**CLASS 35—ADVERTISING AND BUSINESS**

FOR BUSINESS CONSULTING SERVICE THAT PROVIDES TRANSFORMATIONAL STRATEGIES TO PROFESSIONALS, LEADERS, AND COMPANIES USING MUSIC, NAMELY, TO DEVELOP COMMUNICATION SKILLS, VALUES, CREATIVITY, AND LEADERSHIP DEVELOPMENT (U.S. CLS. 100, 101 AND 102).

**CLASS 41—EDUCATION AND ENTERTAINMENT**

FOR EDUCATION SERVICES, NAMELY, PROVIDING TEACHING, COACHING, SEMINARS, WORKSHOPS, TELESEMINARS AND TELECLASSES IN THE FIELD OF SELF-AWARENESS; DEVELOPING EDUCATIONAL MANUALS, TRAINING SYSTEMS AND METHODOLOGIES FOR OTHERS IN THE FIELD OF SELF-AWARENESS; ON-LINE JOURNALS, NAMELY, BLOGS FEATURING SELF-AWARENESS (U.S. CLS. 100, 101 AND 107).

**CLASS 44—MEDICAL, BEAUTY AND AGRICULTURAL SERVICES**

FOR MUSIC THERAPY FOR PHYSICAL, PSYCHOLOGICAL AND COGNITIVE PURPOSES (U.S. CLS. 100 AND 101).

**CLASS 45—PERSONAL AND LEGAL SERVICES**

FOR COUNSELING USING MUSIC FOR PERSONAL DEVELOPMENT, NAMELY, SELF-IMPROVEMENT, SELF-FULFILLMENT, AND INTERPERSONAL COMMUNICATION; PROVIDING INFORMATION USING MUSIC IN THE FIELD OF PERSONAL DEVELOPMENT; PROVIDING A RESOURCE WEBSITE TO PROVIDE INFORMATION THAT USES MUSIC IN THE FIELD OF PERSONAL DEVELOPMENT (U.S. CLS. 100 AND 101).

NATALIE POLZER, EXAMINING ATTORNEY



SN 85-198,687. BONNIER ACTIVE MEDIA, INC., WINTER PARK, FL. FILED 12-15-2010.

SN 85-199,239. AS OUR OWN, NFP, DBA CHARASIA, NFP, CHICAGO, IL. FILED 12-16-2010.

## The Yachting Life Private Yacht Showcase



THE MARK CONSISTS OF STANDARD CHARACTERS WITHOUT CLAIM TO ANY PARTICULAR FONT, STYLE, SIZE, OR COLOR.

OWNER OF U.S. REG. NOS. 2,286,848, 2,326,200 AND 2,392,709.

NO CLAIM IS MADE TO THE EXCLUSIVE RIGHT TO USE "PRIVATE YACHT SHOWCASE", APART FROM THE MARK AS SHOWN.

THE MARK CONSISTS OF A DESIGN OF THREE HORIZONTALLY INTERCONNECTED AND INCOMPLETE CIRCLES CREATED FROM STYLIZED LINING, WITH THE MIDDLE CIRCLE BEING SLIGHTLY LARGER THAN THE OUTER TWO CIRCLES. TO THE RIGHT OF THE FAR-RIGHT CIRCLE IS THE LOWERCASE PHRASE "AS OUR" ABOVE THE WORD "OWN".

### CLASS 35—ADVERTISING AND BUSINESS

FOR ARRANGING AND CONDUCTING TRADE SHOWS IN THE FIELD OF BOATS; ADVERTISING AND MARKETING SERVICES PROVIDED TO VENDORS AT BOAT SHOWS VIA ALL FORMS OF MEDIA (U.S. CLS. 100, 101 AND 102).

### CLASS 41—EDUCATION AND ENTERTAINMENT

FOR ENTERTAINMENT IN THE NATURE OF BOAT SHOWS (U.S. CLS. 100, 101 AND 107).  
ELLEN BURNS, EXAMINING ATTORNEY

### CLASS 35—ADVERTISING AND BUSINESS

FOR CHARITABLE SERVICES, NAMELY, ORGANIZING AND DEVELOPING PROJECTS THAT AIM TO IMPROVE THE LIVES OF UNDERPRIVILEGED AND IMPOVERISHED PEOPLE; CHARITABLE SERVICES, NAMELY, ORGANIZING AND DEVELOPING PROJECTS THAT AIM TO PROMOTE GLOBAL AWARENESS ABOUT HUMAN TRAFFICKING AND COMMERCIAL SEX INDUSTRY (U.S. CLS. 100, 101 AND 102).

FIRST USE 11-1-2010; IN COMMERCE 12-8-2010.

### CLASS 36—INSURANCE AND FINANCIAL

FOR CHARITABLE FUNDRAISING (U.S. CLS. 100, 101 AND 102).

FIRST USE 11-1-2010; IN COMMERCE 12-8-2010.

PAULA MAHONEY, EXAMINING ATTORNEY

SN 85-198,698. SOCIÉTÉ DES PRODUITS NESTLÉ S.A., 1800 VEVEY, SWITZERLAND, FILED 12-15-2010.

## MUSASHI

THE MARK CONSISTS OF STANDARD CHARACTERS WITHOUT CLAIM TO ANY PARTICULAR FONT, STYLE, SIZE, OR COLOR.

OWNER OF SWITZERLAND REG. NO. 550381, DATED 6-8-2006, EXPIRES 6-8-2016.

THE WORDING "MUSASHI" HAS NO MEANING IN A FOREIGN LANGUAGE.

### CLASS 5—PHARMACEUTICALS

FOR NUTRITIONAL AND DIETARY SUPPLEMENTS; SPECIAL DIETARY FOODS AND BEVERAGES, NAMELY, HIGH PROTEIN AND HIGH ENERGY DIETARY BARS, CAPSULES, DRINKS AND POWDERS; SPECIAL DIETARY FOOD AND BEVERAGE SUPPLEMENTS, NAMELY, HIGH PROTEIN AND HIGH ENERGY DIETARY BARS, CAPSULES, DRINKS AND POWDERS; MEAL REPLACEMENT BARS, CAPSULES, DRINKS AND POWDERS, MINERAL FOOD SUPPLEMENTS, MEDICINAL TONICS, AND MIXES AND POWDERS CONTAINING AMINO ACIDS (U.S. CLS. 6, 18, 44, 46, 51 AND 52).

### CLASS 32—LIGHT BEVERAGES

FOR ENERGY DRINKS; AND ISOTONIC DRINKS (U.S. CLS. 45, 46 AND 48).  
THOMAS MANOR, EXAMINING ATTORNEY

SN 85-199,240. TRIVANI INTERNATIONAL, LLC, SPRINGVILLE, UT. FILED 12-16-2010.

## TrivanThin

THE MARK CONSISTS OF STANDARD CHARACTERS WITHOUT CLAIM TO ANY PARTICULAR FONT, STYLE, SIZE, OR COLOR.

NO CLAIM IS MADE TO THE EXCLUSIVE RIGHT TO USE "THIN", APART FROM THE MARK AS SHOWN.

### CLASS 5—PHARMACEUTICALS

FOR DIETARY AND NUTRITIONAL SUPPLEMENTS USED FOR WEIGHT LOSS; DIETARY SUPPLEMENTAL DRINKS IN THE NATURE OF VITAMIN AND MINERAL BEVERAGES; LIQUID NUTRITIONAL SUPPLEMENT; LIQUID VITAMIN SUPPLEMENTS; VITAMIN AND MINERAL SUPPLEMENTS (U.S. CLS. 6, 18, 44, 46, 51 AND 52).

### CLASS 32—LIGHT BEVERAGES

FOR DRINKING WATER WITH VITAMINS; FLAVORED BOTTLED WATER (U.S. CLS. 45, 46 AND 48).  
JESSICA FATHY, EXAMINING ATTORNEY

SN 85-199,292. SEIDMAN, WILLIAM, DBA SEIDMAN DIGITAL ASSOCIATES (SDA), NEW YORK, NY. FILED 12-16-2010.

### ONLY THE SONG SURVIVES

THE MARK CONSISTS OF STANDARD CHARACTERS WITHOUT CLAIM TO ANY PARTICULAR FONT, STYLE, SIZE, OR COLOR.

#### CLASS 41—EDUCATION AND ENTERTAINMENT

FOR ENTERTAINMENT, NAMELY, AN ON-GOING SERIES FEATURING A SONGWRITING COMPETITION PROVIDED THROUGH TELEVISION, CABLE TELEVISION, SATELLITE TELEVISION, RADIO BROADCASTS, AND INTERNET WEBCASTS; FILM PRODUCTION; RECORD PRODUCTION; BOOK PUBLISHING; MAGAZINE PUBLISHING AND MUSIC PUBLISHING RELATED TO SONGWRITING (U.S. CLS. 100, 101 AND 107).

#### CLASS 42—SCIENTIFIC AND COMPUTER SERVICES

FOR COMPUTER SERVICES, NAMELY, HOSTING ON-LINE WEB FACILITIES FOR OTHERS TO SHOWCASE SONGWRITING AND MUSICAL TALENTS AND FOR FACILITATING AND CONDUCTING ONLINE CONNECTIONS, COLLABORATIONS, AND INTERACTIVE DISCUSSIONS ABOUT SONGWRITING AND MUSIC (U.S. CLS. 100 AND 101).

KATHERINE E. HALMEN, EXAMINING ATTORNEY

SN 85-199,446. AMERICAN REGISTRY, LLC, BOCA RATON, FL. FILED 12-16-2010.



NO CLAIM IS MADE TO THE EXCLUSIVE RIGHT TO USE "AMERICAN", APART FROM THE MARK AS SHOWN. THE MARK CONSISTS OF THE OUTLINE OF A STAR ABOVE THE TERM "AMERICAN REGISTRY".

#### CLASS 20—FURNITURE AND ARTICLES NOT OTHERWISE CLASSIFIED

FOR PLASTIC BANNERS; VINYL BANNERS; WALL PLAQUES MADE OF PLASTIC OR WOOD; WALL PLAQUES MADE OF PLASTIC OR WOOD (U.S. CLS. 2, 13, 22, 25, 32 AND 50).

FIRST USE 7-0-2000; IN COMMERCE 7-0-2000.

#### CLASS 40—MATERIAL TREATMENT

FOR CUSTOM MANUFACTURE OF PLAQUES, MARQUEES, CRYSTALS, COUNTER DISPLAYS, BANNERS; EMBOSSING SERVICES, NAMELY, EMBOSSING WORDS, DESIGNS OR IMAGES ON PLAQUES, MARQUEES, CRYSTALS, COUNTER DISPLAYS, BANNERS; MANUFACTURE OF PLAQUES, MARQUEES, CRYSTALS, COUNTER DISPLAYS, BANNERS TO ORDER AND/OR SPECIFICATION OF OTHERS (U.S. CLS. 100, 103 AND 106).

FIRST USE 7-0-2000; IN COMMERCE 7-0-2000.

FRED CARL, EXAMINING ATTORNEY

SN 85-199,531. INTERCEPT SILVER & JEWELRY CARE COMPANY LLC, WARREN, NJ. FILED 12-16-2010.



THE MARK CONSISTS OF A STAR WITH TWELVE POINTS BETWEEN THE WORDS "TARNISH" AND "TAMER".

#### CLASS 16—PAPER GOODS AND PRINTED MATTER

FOR PAPERBOARD BOXES; PLASTIC BAGS FOR PACKAGING (U.S. CLS. 2, 5, 22, 23, 29, 37, 38 AND 50).

#### CLASS 22—CORDAGE AND FIBERS

FOR FABRIC MAILING POUCHES; JEWELRY ROLLS FOR STORAGE (U.S. CLS. 1, 2, 7, 19, 22, 42 AND 50).

MICHAEL WIENER, EXAMINING ATTORNEY

SN 85-199,543. AMERICAN REGISTRY, LLC, BOCA RATON, FL. FILED 12-16-2010.



NO CLAIM IS MADE TO THE EXCLUSIVE RIGHT TO USE "AMERICAN", APART FROM THE MARK AS SHOWN. THE MARK CONSISTS OF A STAR FLANKED BY THE TERMS "AMERICAN" AND "REGISTRY" ON EITHER SIDE.

#### CLASS 20—FURNITURE AND ARTICLES NOT OTHERWISE CLASSIFIED

FOR PLAQUES OF PLASTIC OR WOOD; PLASTIC BANNERS; VINYL BANNERS; WALL PLAQUES MADE OF PLASTIC OR WOOD (U.S. CLS. 2, 13, 22, 25, 32 AND 50).

FIRST USE 7-0-2000; IN COMMERCE 7-0-2000.

**CLASS 40—MATERIAL TREATMENT**

FOR CUSTOM MANUFACTURE OF PLAQUES, MARQUEES, CRYSTALS, COUNTER DISPLAYS, BANNERS; EMBOSSING SERVICES, NAMELY, EMBOSSING WORDS, DESIGNS OR IMAGES ON PLAQUES, MARQUEES, CRYSTALS, COUNTER DISPLAYS, BANNERS; MANUFACTURE OF PLAQUES, MARQUEES, CRYSTALS, COUNTER DISPLAYS, BANNERS TO ORDER AND/OR SPECIFICATION OF OTHERS (U.S. CLS. 100, 103 AND 106).

FIRST USE 7-0-2000; IN COMMERCE 7-0-2000.  
FRED CARL, EXAMINING ATTORNEY

SN 85-199,578. MAX CURE FOUNDATION, INC., THE, WESTFIELD, NJ. FILED 12-16-2010.

**BE BRAVE ADVENTURES**

THE MARK CONSISTS OF STANDARD CHARACTERS WITHOUT CLAIM TO ANY PARTICULAR FONT, STYLE, SIZE, OR COLOR.

NO CLAIM IS MADE TO THE EXCLUSIVE RIGHT TO USE "ADVENTURES", APART FROM THE MARK AS SHOWN.

**CLASS 35—ADVERTISING AND BUSINESS**

FOR PROMOTING AND ADMINISTERING AMATEUR ATHLETIC PROGRAMS AND ACTIVITIES (U.S. CLS. 100, 101 AND 102).

FIRST USE 11-15-2009; IN COMMERCE 3-1-2010.

**CLASS 41—EDUCATION AND ENTERTAINMENT**

FOR EDUCATIONAL AND ENTERTAINMENT SERVICES, NAMELY, PROVIDING CHILDREN'S PROGRAMS THAT FOCUS ON ATHLETIC EVENTS, RECREATIONAL ACTIVITIES AND SELF-ESTEEM BUILDING EXERCISES (U.S. CLS. 100, 101 AND 107).

FIRST USE 11-15-2009; IN COMMERCE 3-1-2010.  
ANNE E. GUSTASON, EXAMINING ATTORNEY

SN 85-199,597. THE MAX CURE FOUNDATION, WESTFIELD, NJ. FILED 12-16-2010.

**BE BRAVE ATHLETICS**

THE MARK CONSISTS OF STANDARD CHARACTERS WITHOUT CLAIM TO ANY PARTICULAR FONT, STYLE, SIZE, OR COLOR.

NO CLAIM IS MADE TO THE EXCLUSIVE RIGHT TO USE "ATHLETICS", APART FROM THE MARK AS SHOWN.

**CLASS 35—ADVERTISING AND BUSINESS**

FOR PROMOTING AND ADMINISTERING AMATEUR ATHLETIC PROGRAMS AND ACTIVITIES (U.S. CLS. 100, 101 AND 102).

FIRST USE 11-15-2009; IN COMMERCE 3-1-2010.

**CLASS 41—EDUCATION AND ENTERTAINMENT**

FOR EDUCATIONAL AND ENTERTAINMENT SERVICES, NAMELY, PROVIDING CHILDREN'S PROGRAMS THAT FOCUS ON ATHLETIC EVENTS, RECREATIONAL ACTIVITIES AND SELF-ESTEEM BUILDING EXERCISES (U.S. CLS. 100, 101 AND 107).

FIRST USE 11-15-2009; IN COMMERCE 3-1-2010.  
BRIAN CALLAGHAN, EXAMINING ATTORNEY

SN 85-199,870. GRAPHIC CONTROLS ACQUISITION CORP., BUFFALO, NY. FILED 12-16-2010.



THE MARK CONSISTS OF THE LETTER "G" INSIDE A CIRCLE.

**CLASS 2—PAINTS**

FOR INK JET FLUIDS FOR USE IN INK-JET PRINTERS (U.S. CLS. 6, 11 AND 16).

FIRST USE 12-31-1991; IN COMMERCE 12-31-1991.

**CLASS 9—ELECTRICAL AND SCIENTIFIC APPARATUS**

FOR HIGH-RESOLUTION INK JET PRINTERS; COMPONENTS OF PLOTTERS, NAMELY, PEN ARMS; MAGNETICALLY CODED CARDS FOR USE IN LOYALTY REWARDS PROGRAMS; MAGNETICALLY CODED KEY CARDS (U.S. CLS. 21, 23, 26, 36 AND 38).

FIRST USE 12-31-1991; IN COMMERCE 12-31-1991.

**CLASS 16—PAPER GOODS AND PRINTED MATTER**

FOR RECORDING PAPERS, PRINTED CHARTS, PRINT RIBBONS, PRINT WHEELS, INK CARTRIDGES FOR PENS AND INK PENS FOR USE IN RECORDING INSTRUMENTS; PRINTED AND BLANK PAPER FOR USE IN POINT-OF-SALE MARKETING INSTRUMENTS AND SELF SERVE KIOSKS; PRINTED RECORDING CHARTS AND INK PENS FOR USE IN MEDICAL RECORDING INSTRUMENTS; PRINTED ENTERTAINMENT TICKETS (U.S. CLS. 2, 5, 22, 23, 29, 37, 38 AND 50).

FIRST USE 12-31-1991; IN COMMERCE 12-31-1991.

**CLASS 37—CONSTRUCTION AND REPAIR**

FOR CLEANING AND REPAIR OF INK-JET PRINTERS (U.S. CLS. 100, 103 AND 106).

FIRST USE 12-31-1999; IN COMMERCE 12-31-1999.  
BARBARA RUTLAND, EXAMINING ATTORNEY

SN 85-199,993. MR. MARKETING GROUP, INC., BOCA RATON, FL. FILED 12-16-2010.

SN 85-200,006. NEWMAN HAAS RACING, LLC, LINCOLNSHIRE, IL. FILED 12-16-2010.



### CONSUMER NEWS NATION

THE MARK CONSISTS OF STANDARD CHARACTERS WITHOUT CLAIM TO ANY PARTICULAR FONT, STYLE, SIZE, OR COLOR.

NO CLAIM IS MADE TO THE EXCLUSIVE RIGHT TO USE "CONSUMER NEWS", APART FROM THE MARK AS SHOWN.

#### CLASS 16—PAPER GOODS AND PRINTED MATTER

FOR SERIES OF NON-FICTION BOOKS, BOOKLETS, MAGAZINES, PAMPHLETS AND NEWSLETTERS COVERING NEWS, TRENDS, TIPS, EXPERT ADVICE AND KNOW-HOW IN THE FIELDS OF CONSUMER AND BUSINESS INFORMATION, NAMELY, BUSINESS AND MARKETING, CRIMINAL SCIENCE, CURRENT AFFAIRS, COMPUTERS AND TECHNOLOGY, DATING AND RELATIONSHIPS, DECORATING, DIET AND WELLNESS, ENTERTAINMENT, ENVIRONMENTAL, FASHION, FINANCE AND CAREER ADVICE, FILM, FOOD AND COOKING, GARDENING, HEALTH AND FITNESS, HOME AND GARDEN, HISTORY, HUMOR, MEDICINE, MUSIC, POLITICS, PSYCHOLOGY, REAL ESTATE, RELIGION, SELF-HELP, SPIRITUAL PHENOMENA, SPORTS, STRANGE PHENOMENA AND PERSONALITIES, TRAVEL, THEATER, AND PROFILES OF CELEBRITIES, BUSINESS LEADERS, LIFESTYLE LEADERS, INNOVATORS, AND CONSUMER INFORMATION EXPERTS AND ADVOCATES (U.S. CLS. 2, 5, 22, 23, 29, 37, 38 AND 50).

#### CLASS 41—EDUCATION AND ENTERTAINMENT

FOR ENTERTAINMENT SERVICES IN THE NATURE OF ON-GOING TELEVISION PROGRAMS COVERING NEWS, TRENDS, TIPS, EXPERT ADVICE AND KNOW-HOW IN THE FIELDS OF CONSUMER AND BUSINESS INFORMATION, NAMELY, BUSINESS AND MARKETING, CRIMINAL SCIENCE, CURRENT AFFAIRS, COMPUTERS AND TECHNOLOGY, DATING AND RELATIONSHIPS, DECORATING, DIET AND WELLNESS, ENTERTAINMENT, ENVIRONMENTAL, FASHION, FINANCE AND CAREER ADVICE, FILM, FOOD AND COOKING, GARDENING, HEALTH AND FITNESS, HOME AND GARDEN, HISTORY, HUMOR, MEDICINE, MUSIC, POLITICS, PSYCHOLOGY, REAL ESTATE, RELIGION, SELF-HELP, SPIRITUAL PHENOMENA, SPORTS, STRANGE PHENOMENA AND PERSONALITIES, TRAVEL, THEATER, AND PROFILES OF CELEBRITIES, BUSINESS LEADERS, LIFESTYLE LEADERS, INNOVATORS, AND CONSUMER INFORMATION EXPERTS AND ADVOCATES (U.S. CLS. 100, 101 AND 107).

BARBARA BROWN, EXAMINING ATTORNEY

NO CLAIM IS MADE TO THE EXCLUSIVE RIGHT TO USE "RACING", APART FROM THE MARK AS SHOWN.

THE NAME(S), PORTRAIT(S), AND/OR SIGNATURE(S) SHOWN IN THE MARK IDENTIFIES CARL "HAAS", WHOSE CONSENT(S) TO REGISTER IS MADE OF RECORD.

THE MARK CONSISTS OF A DESIGN COMPOSED OF TWO WINGS ABOVE THE WORDING "NEWMAN HAAS" WHICH APPEARS ABOVE THE WORDING "RACING".

#### CLASS 25—CLOTHING

FOR CLOTHING, NAMELY, T-SHIRTS, SWEATSHIRTS, POLO SHIRTS, HATS (U.S. CLS. 22 AND 39).  
FIRST USE 12-31-1991; IN COMMERCE 12-31-1991.

#### CLASS 28—TOYS AND SPORTING GOODS

FOR TOY MODEL CARS; TOY MODEL KIT CARS; TOY MODEL DIE CAST CARS (U.S. CLS. 22, 23, 38 AND 50).  
FIRST USE 12-31-1991; IN COMMERCE 12-31-1991.

#### CLASS 41—EDUCATION AND ENTERTAINMENT

FOR ENTERTAINMENT SERVICES IN THE NATURE OF AUTOMOBILE RACING AND EXHIBITIONS (U.S. CLS. 100, 101 AND 107).  
FIRST USE 12-31-1983; IN COMMERCE 12-31-1983.  
ANGELA DUONG, EXAMINING ATTORNEY

SN 85-200,300. XTREME TOOLS INTERNATIONAL, INC., MIAMI GARDENS, FL. FILED 12-17-2010.



THE MARK CONSISTS OF THE LETTERS "XBI" WITHIN AN OVAL.



**CLASS 3—COSMETICS AND CLEANING PREPARATIONS**

FOR COSMETIC CREAMS FOR SKIN CARE; HAIR CARE LOTIONS; SKIN SOAP (U.S. CLS. 1, 4, 6, 50, 51 AND 52).

FIRST USE 9-5-2006; IN COMMERCE 9-5-2006.

**CLASS 9—ELECTRICAL AND SCIENTIFIC APPARATUS**

FOR ELECTRIC HAIR CRIMPER; ELECTRIC HAIR CURLING IRONS; ELECTRIC HAIR STRAIGHTENER (U.S. CLS. 21, 23, 26, 36 AND 38).

FIRST USE 9-5-2006; IN COMMERCE 9-5-2006.

**CLASS 11—ENVIRONMENTAL CONTROL APPARATUS**

FOR HAIR DRYERS; HAND-HELD ELECTRIC HAIR DRYERS (U.S. CLS. 13, 21, 23, 31 AND 34).

FIRST USE 9-5-2006; IN COMMERCE 9-5-2006.

ARETHA SOMERVILLE, EXAMINING ATTORNEY

SN 85-200,649. GLITTERSLIDE, LLC, BEVERLY HILLS, CA. FILED 12-17-2010.



THE MARK CONSISTS OF A BROKEN LINE SQUARE FRAME WITH ROUNDED CORNERS ENDING WITH AN ARROW LEADING OUTSIDE AND TO THE RIGHT OF THE FRAME WHERE THE FRAME CAPTURES TWO HUMAN FINGERS WITH SMILE FACE MARKS ON THE PAD OF EACH FINGER AND THE TERM "BETTY" PRINTED ABOVE THE ARROW OUTSIDE THE FRAME WHERE A PORTION OF THE "B" FORMS A PART OF THE FRAME.

SN 85-200,426. EQUIBRAND ENTERTAINMENT GROUP, L.P., STEPHENVILLE, TX. FILED 12-17-2010.

USTRC

THE MARK CONSISTS OF STANDARD CHARACTERS WITHOUT CLAIM TO ANY PARTICULAR FONT, STYLE, SIZE, OR COLOR.

OWNER OF U.S. REG. NOS. 1,844,812 AND 2,344,367.

**CLASS 18—LEATHER GOODS**

FOR LEATHER GOODS, NAMELY, SADDLES, BITS FOR ANIMALS, LEATHER SATCHELS, BLANKETS, NAMELY, HORSE BLANKETS AND SADDLE BLANKETS, SADDLE PADS FOR HORSE SADDLES, AND GARMENT BAGS FOR TRAVEL (U.S. CLS. 1, 2, 3, 22 AND 41).

FIRST USE 1-1-1992; IN COMMERCE 1-1-1992.

**CLASS 25—CLOTHING**

FOR CLOTHING, NAMELY, TEE-SHIRTS, COATS AND RELATED OUTERWEAR, NAMELY, JACKETS, VESTS, PARKAS, BLAZERS, SWEATERS AND SWEATSHIRTS, WOVEN SHIRTS, JEANS AND HEADWEAR (U.S. CLS. 22 AND 39).

FIRST USE 1-1-1992; IN COMMERCE 1-1-1992.  
MAUREEN DALL, EXAMINING ATTORNEY

**CLASS 16—PAPER GOODS AND PRINTED MATTER**

FOR STATIC CLING AND ADHESIVE DECALS, TEMPORARY TATTOOS, PAPER HANG-TAGS, PRINTED AND RELATED MATTER, NAMELY, POSTERS, CALENDARS, STICKERS, BUMPER STICKERS, DECALS, POSTCARDS, PLACE CARDS, RECORD CARDS, SCORE CARDS, TRADING CARDS, SCRAPBOOKS, PAPER NOTE TABLETS, WRITING TABLETS AND PAPER, BOOKMARKS, PAPER PENNANTS, BINDERS, APPOINTMENT BOOKS, ADDRESS BOOKS AND DESK PADS; PERSONAL ORGANIZERS, DESK TOP ORGANIZERS, ORGANIZERS FOR STATIONERY USE AND STATIONERY-TYPE PORTFOLIOS, PAPER FLAGS, MOUNTS FOR STAMPS, RUBBER STAMPS, RUBBER DOCUMENT STAMPS, STAMP ALBUMS, STAMP PAD INKS, STAMP PADS, SLEEVES FOR HOLDING AND PROTECTING STAMPS, PAPER BANNERS, HOLDERS FOR DESK ACCESSORIES, LETTER OPENERS, LETTER TRAYS, LETTER RACKS, PEN AND PENCIL HOLDERS, MARKERS, STICK MARKERS, ERASERS, DRAWING AND DRAFTING RULERS, PENCIL SHARPENERS, BOOK ENDS, BOOK COVERS, CHECKBOOK COVERS, BOOK HOLDERS, PHOTOGRAPH AND COIN ALBUMS; PHOTOGRAPHIC AND ART MOUNTS; PHOTOGRAPHIC PRINTS; PHOTOGRAPHS; LITHOGRAPHS; DECORATIVE PAPER CENTERPIECES; DECORATIVE PENCIL-TOP ORNAMENTS; PICTURE BOOKS; PAPER AND CARDBOARD PICTURE MOUNTS; PAPER-WEIGHTS; PAPER CLIP HOLDERS; PAPER SIGN HOLDERS; PRINTED PAPER SIGNS; TABLE CLOTHS OF PAPER; CATALOGS AND BROCHURES FEATURING CLOTHING, BAGS, JEWELRY, COSMETICS AND ACCESSORIES (U.S. CLS. 2, 5, 22, 23, 29, 37, 38 AND 50).

**CLASS 25—CLOTHING**

FOR CLOTHING, NAMELY, FOOTWEAR, HEADWEAR, NECKTIES, SCARVES, BELTS, SHIRTS, BLOUSES, BOARD SHORTS, CAPS, CARDIGANS, SWEATERS, COATS, SUITS, DRESSING GOWNS, HATS, SOCKS, DRESSES, BATHING SUITS; SKIRTS, JACKETS, JOGGING SUITS, SWEATSHIRTS, SWEATPANTS, SHORTS, JEANS, PANTS, SHIRTS, BOWLING SHIRTS, JERSEY SHIRTS, POLO SHIRTS, SPORTS SHIRTS, T-SHIRTS, UNDERWEAR, LINGERIE, SWIMWEAR, VESTS, BLOUSES, OVERALLS, TEE SHIRTS, STOCKINGS, TIGHTS, APRONS, ROBES, PAJAMAS, KNIT TOPS, CAMISOLES, TANK TOPS, GLOVES, UNDERSHIRTS, TROUSERS, BLAZERS, LEGGINGS, PANTIES, BRAS, BUSTIERS, TEDDIES (U.S. CLS. 22 AND 39).

**CLASS 26—FANCY GOODS**

FOR HAIR ACCESSORIES, NAMELY, BOBBY PINS, CURLING PINS, WAVING PINS FOR THE HAIR, HAIR TIES, HAIR ORNAMENTS, HAIR PINS, BARRETTES, HAIR BANDS, HAIR RIBBONS, HAIR BOWS, PONYTAIL HOLDERS, HAIR BOWS WITH CLIPS, HAIR CLIPS, HAIR FASTENERS, HAIR BUCKLES, HAIR ROLLER CLIPS AND PINS, HAIR NETS, HAIR WRAPS, CLAM CLIPS FOR HAIR, CLAW CLIPS, TWISTERS, HAIR SCRUNCHIES, SNAP CLIPS, HAIR CURL CLIPS, SLEEP CLIPS, SALON CLIPS, NON-ELECTRIC HAIR CURLERS AND ROLLERS, BRAIDS, BRAIDING PINS, AND ORNAMENTAL COMBS WORN ON HAIR; ORNAMENTAL NOVELTY BUTTONS AND PINS; CLOTHING AND SHIRT BUTTONS; ZIPPER PULLS AND ZIPPERS; SNAP FASTENERS; CLOTHING BUCKLES; CLASPS FOR CLOTHING; BELT CLASPS; BELT BUCKLES NOT OF PRECIOUS METAL; CLOTH PATCHES FOR CLOTHING; ORNAMENTAL CLOTH PATCHES; EMBROIDERED PATCHES FOR CLOTHING; EMBROIDERED EMBLEMS; PATCHES FOR REPAIRING TEXTILE ARTICLES; HAT PINS; HAT ORNAMENTS NOT OF PRECIOUS METAL; ORNAMENTAL BOWS OF TEXTILE FOR DECORATION; SAFETY PINS; RIBBONS; ORNAMENTAL RIBBONS MADE OF TEXTILES; RIBBONS FOR WRAPPING AND GIFT WRAPPING; ELASTIC RIBBONS; SEWING BOXES (U.S. CLS. 37, 39, 40, 42 AND 50).

**CLASS 35—ADVERTISING AND BUSINESS**

FOR ONLINE RETAIL STORE SERVICES RENDERED THROUGH A GLOBAL COMPUTER NETWORK FEATURING APPAREL, LEATHER GOODS, FASHION ACCESSORIES, SHOES, JEWELRY, LUGGAGE, COSMETICS, HOME PRODUCTS AND PERSONAL CARE PRODUCTS AND FEATURING ADVERTISING AND MARKETING FOR SAME; RETAIL STORE AND MAIL ORDER SERVICES FEATURING APPAREL, LEATHER GOODS, FASHION ACCESSORIES, SHOES, JEWELRY, LUGGAGE, COSMETICS, HOME PRODUCTS AND PERSONAL CARE PRODUCTS AND FEATURING ADVERTISING AND MARKETING FOR SAME; TALENT AGENCIES AND MANAGEMENT SERVICES; PROMOTING CONCERTS, SPORTS AND LIVE ENTERTAINMENT EVENTS OF OTHERS (U.S. CLS. 100, 101 AND 102).

**CLASS 38—COMMUNICATION**

FOR COMMUNICATION SERVICES, NAMELY, TELEVISION, CABLE TELEVISION, SATELLITE TELEVISION AND DIGITAL TELEVISION BROADCASTING AND TRANSMISSION SERVICES; BROADCASTING PROGRAMS VIA GLOBAL COMPUTER NETWORK (U.S. CLS. 100, 101 AND 104).

**CLASS 41—EDUCATION AND ENTERTAINMENT**

FOR MOTION PICTURE FILM, MUSIC AND TELEVISION SHOW PRODUCTION; ENTERTAINMENT IN THE NATURE OF THEATER PRODUCTIONS; ENTERTAINMENT IN THE NATURE OF ONGOING TELEVISION PROGRAMS FEATURING DRAMA, COMEDY, MUSICAL AND THEATRICAL PERFORMANCES; PRODUCTION OF LIVE MUSICAL EVENTS AND TOURS, COMEDY SHOWS, SPORTING EVENTS AND VARIETY SHOWS; PRODUCTION OF TELEVISION PROGRAMS; ENTERTAINMENT IN THE NATURE OF AUDIO, VISUAL AND MUSICAL PERFORMANCES, DANCE PERFORMANCES, VARIETY AND COMEDY SHOWS; CONCERT ENTERTAINMENT, NAMELY, LIVE MUSIC AND MUSICAL PERFORMANCES; ENTERTAINMENT SERVICES, NAMELY, PRODUCING A WIDE RANGE OF THEATRICAL, MUSICAL AND ARTISTIC ACTIVITIES, NAMELY, THEATER PRODUCTIONS, MUSIC AND DANCE PERFORMANCES, AND VARIETY SHOWS; PRODUCTION AND CO-PRODUCTION OF ENTERTAINMENT EVENTS, NAMELY, THEATRICAL PERFORMANCES, LIVE MUSICAL EVENTS, COMEDY SHOWS VARIETY SHOWS, MUSICAL PERFORMANCES, THEATER PRODUCTIONS, MUSIC AND DANCE PERFORMANCES AND SPORTING EVENTS FOR PUBLIC

EXHIBITION, VIEWING AND FOR RADIO, TELEVISION AND PAY-PER-VIEW TELEVISION BROADCAST; ENTERTAINMENT EVENT BOOKING AGENCIES FEATURING ARTISTIC, THEATRICAL, MUSICAL AND OTHER ENTERTAINMENT EVENTS; PROVIDING ENTERTAINMENT INFORMATION RELATING TO MOTION PICTURE FILMS, TELEVISION, CONTESTS AND AMUSEMENT PARKS OFFERED OVER A GLOBAL COMPUTER INFORMATION NETWORK; AND EPISODIC TELEVISION AND INTERNET ENTERTAINMENT CONTENT FEATURING FICTION AND NON-FICTION PROGRAMMING (U.S. CLS. 100, 101 AND 107).

THOMAS MANOR, EXAMINING ATTORNEY

SN 85-201,090. SIATECH, INC., OCEANSIDE, CA. FILED 12-17-2010.

**CONTECH LEARNING STRATEGIES**

THE MARK CONSISTS OF STANDARD CHARACTERS WITHOUT CLAIM TO ANY PARTICULAR FONT, STYLE, SIZE, OR COLOR.

NO CLAIM IS MADE TO THE EXCLUSIVE RIGHT TO USE "LEARNING STRATEGIES", APART FROM THE MARK AS SHOWN.

**CLASS 16—PAPER GOODS AND PRINTED MATTER**

FOR PRINTED WRITTEN MATERIALS IN THE NATURE OF A COURSE OF INSTRUCTION FOR PRIMARY AND SECONDARY SCHOOL GRADE LEVELS (U.S. CLS. 2, 5, 22, 23, 29, 37, 38 AND 50).

FIRST USE 10-21-2010; IN COMMERCE 10-21-2010.

**CLASS 41—EDUCATION AND ENTERTAINMENT**

FOR EDUCATIONAL SERVICES, NAMELY, PROVIDING A COURSE OF INSTRUCTION AT THE PRIMARY AND SECONDARY GRADE LEVELS (U.S. CLS. 100, 101 AND 107).

FIRST USE 10-21-2010; IN COMMERCE 10-21-2010.

RAMONA ORTIGA, EXAMINING ATTORNEY

SN 85-201,280. STUDER, DANIEL, WEST CHESTER, PA. FILED 12-18-2010.

**GO WEST**

THE MARK CONSISTS OF STANDARD CHARACTERS WITHOUT CLAIM TO ANY PARTICULAR FONT, STYLE, SIZE, OR COLOR.

**CLASS 29—MEATS AND PROCESSED FOODS**

FOR CHEESES (U.S. CL. 46).

**CLASS 30—STAPLE FOODS**

FOR SAUCES, SNACK CHIPS, NAMELY, TORTILLA CHIPS (U.S. CL. 46).

JEFFERY COWARD, EXAMINING ATTORNEY

---

SN 85-201,572. FINLEY, JIMMY D., DBA FINLEY GALLERY LLC, HONOLULU, HI. FILED 12-20-2010.

## RAINBOW PEN COMPANY

THE MARK CONSISTS OF STANDARD CHARACTERS WITHOUT CLAIM TO ANY PARTICULAR FONT, STYLE, SIZE, OR COLOR.

NO CLAIM IS MADE TO THE EXCLUSIVE RIGHT TO USE "PEN COMPANY", APART FROM THE MARK AS SHOWN.

### CLASS 16—PAPER GOODS AND PRINTED MATTER

FOR WRITING PEN KITS COMPRISING PARTS FOR MAKING WRITING PENS (U.S. CLS. 2, 5, 22, 23, 29, 37, 38 AND 50).

### CLASS 35—ADVERTISING AND BUSINESS

FOR ONLINE RETAIL STORE SERVICES FEATURING PENS, PEN KITS, PEN SUPPLIES, STATIONARY SUPPLIES AND ACCESSORIES (U.S. CLS. 100, 101 AND 102).

KEVON CHISOLM, EXAMINING ATTORNEY

---

SN 85-201,742. KANTOR, CORINNE, DBA THE FOOD COP, RANCHO SANTA MARGARITA, CA. FILED 12-20-2010.

## The Food Cop

THE MARK CONSISTS OF STANDARD CHARACTERS WITHOUT CLAIM TO ANY PARTICULAR FONT, STYLE, SIZE, OR COLOR.

NO CLAIM IS MADE TO THE EXCLUSIVE RIGHT TO USE "FOOD", APART FROM THE MARK AS SHOWN.

### CLASS 16—PAPER GOODS AND PRINTED MATTER

FOR A SERIES OF BOOKS, WRITTEN ARTICLES, HANDOUTS AND WORKSHEETS IN THE FIELD OF NUTRITION (U.S. CLS. 2, 5, 22, 23, 29, 37, 38 AND 50).

FIRST USE 8-1-2009; IN COMMERCE 8-1-2009.

### CLASS 44—MEDICAL, BEAUTY AND AGRICULTURAL SERVICES

FOR COUNSELING SERVICES IN THE FIELDS OF HEALTH, NUTRITION AND LIFESTYLE WELLNESS; DIETARY AND NUTRITIONAL GUIDANCE; FOOD NUTRITION CONSULTATION; NUTRITION COUNSELING; PROVIDING A WEBSITE FEATURING INFORMATION ABOUT HEALTH, WELLNESS AND NUTRITION; PROVIDING ASSISTANCE, FITNESS EVALUATION AND CONSULTATION TO CORPORATE CLIENTS TO HELP THEIR EMPLOYEES MAKE HEALTH, WELLNESS AND NUTRITIONAL CHANGES IN THEIR DAILY LIVING TO IMPROVE HEALTH; PROVIDING ASSISTANCE, FITNESS EVALUATION AND CONSULTATION TO INDIVIDUALS TO HELP THEM MAKE HEALTH, WELLNESS AND NUTRITIONAL CHANGES IN THEIR DAILY LIVING TO IMPROVE HEALTH; PROVIDING HEALTHY LIFESTYLE AND NUTRITION SERVICES, NAMELY, PERSONAL ASSESSMENTS, PERSONALIZED ROUTINES, MAINTENANCE SCHEDULES, AND COUNSELING; PROVIDING INFORMATION, NEWS AND COMMENTARY IN THE FIELD OF NUTRITION, HEALTH AND WELLNESS (U.S. CLS. 100 AND 101).

FIRST USE 8-1-2009; IN COMMERCE 8-1-2009.

SANJEEV VOHRA, EXAMINING ATTORNEY

---

SN 85-201,819. SEA STAR CONCIERGE, LLC, HILTON HEAD ISLAND, SC. FILED 12-20-2010.



NO CLAIM IS MADE TO THE EXCLUSIVE RIGHT TO USE "CONCIERGE", APART FROM THE MARK AS SHOWN.

THE MARK CONSISTS OF A DESIGN OF A SEA STAR APPEARING TO THE LEFT OF THE WORDING "SEA STAR", WHICH APPEARS ABOVE THE WORDING "CONCIERGE", ALL CONTAINED WITHIN A RECTANGULAR BORDER.

### CLASS 41—EDUCATION AND ENTERTAINMENT

FOR CONSULTATION IN THE FIELD OF SPECIAL EVENT PLANNING FOR SOCIAL ENTERTAINMENT PURPOSES; SPECIAL EVENT PLANNING FOR SOCIAL ENTERTAINMENT PURPOSES (U.S. CLS. 100, 101 AND 107).

### CLASS 45—PERSONAL AND LEGAL SERVICES

FOR PERSONAL CONCIERGE SERVICES FOR OTHERS COMPRISING MAKING REQUESTED PERSONAL ARRANGEMENTS AND RESERVATIONS, RUNNING ERRANDS AND PROVIDING CUSTOMER SPECIFIC INFORMATION TO MEET INDIVIDUAL NEEDS, ALL RENDERED IN BUSINESS ESTABLISHMENTS, OFFICE BUILDINGS, HOTELS, RESIDENTIAL COMPLEXES AND HOMES (U.S. CLS. 100 AND 101).

KAELIE KUNG, EXAMINING ATTORNEY

SN 85-202,003. NISHIDA, YOSHIAKI, TOKYO, JAPAN, FILED 12-20-2010.



THE MARK CONSISTS OF THE WORD "DEICA" IN STYLIZED LETTERING BELOW THE STYLIZED DESIGN OF A FLOWER.  
THE WORDING "DEICA" HAS NO MEANING IN A FOREIGN LANGUAGE.

**CLASS 3—COSMETICS AND CLEANING PREPARATIONS**

FOR ROOM PERFUME SPRAYS; AROMATIC SUBSTANCES AND PREPARATIONS, NAMELY, AROMATIC OILS, ESSENTIAL OILS, MASSAGE OILS, LOTION AND CREAM FOR USE IN THE PERFUME AND COSMETIC INDUSTRIES; AROMATIC OIL; AROMATIC POTPOURRI; SCENTED OILS SOLD AS A UNIT IN ROOM SCENT DIFFUSERS; SOAPS; DETERGENT; DENTIFRICES; COSMETICS; PERFUMES; NATURAL PERFUMERY MADE FROM PLANTS; NATURAL PERFUMERY PREPARED FROM ANIMAL EXTRACTS; SYNTHETIC PERFUMERY; COMPOUND PERFUMERY; FOOD FLAVORINGS PREPARED FROM ESSENTIAL OILS; INCENSES AND FRAGRANCES (U.S. CLS. 1, 4, 6, 50, 51 AND 52).

**CLASS 4—LUBRICANTS AND FUELS**

FOR AROMATHERAPY FRAGRANCE CANDLES; PERFUMED CANDLES; CANDLES; CANDLES FOR LIGHTING; WICKS FOR CANDLES (U.S. CLS. 1, 6 AND 15).  
CIMMERIAN COLEMAN, EXAMINING ATTORNEY

SN 85-202,005. MASTERDUCT HOLDING, INC., HOUSTON, TX. FILED 12-20-2010.

FLEXMASTER U.S.A.

THE MARK CONSISTS OF STANDARD CHARACTERS WITHOUT CLAIM TO ANY PARTICULAR FONT, STYLE, SIZE, OR COLOR.  
NO CLAIM IS MADE TO THE EXCLUSIVE RIGHT TO USE "U.S.A.", APART FROM THE MARK AS SHOWN.

**CLASS 6—METAL GOODS**

FOR METAL JOINERY FITTINGS FOR HVAC DISPERSION DUCTS; METAL ACCESS DOORS FOR VENTILATING DUCTS (U.S. CLS. 2, 12, 13, 14, 23, 25 AND 50).  
FIRST USE 12-31-1979; IN COMMERCE 12-31-1979.

**CLASS 11—ENVIRONMENTAL CONTROL APPARATUS**

FOR FABRIC AIR DISPERSION DUCTS FOR DISTRIBUTING AND DISPENSING AIR AS PART OF A HVAC SYSTEM; METAL DIFFUSER BOXES SOLD AS A COMPONENT PART OF AN HVAC UNIT (U.S. CLS. 13, 21, 23, 31 AND 34).  
FIRST USE 12-31-1979; IN COMMERCE 12-31-1979.

**CLASS 17—RUBBER GOODS**

FOR INSULATING SLEEVES FOR HVAC AIR DISPERSION DUCTS (U.S. CLS. 1, 5, 12, 13, 35 AND 50).  
FIRST USE 12-31-1979; IN COMMERCE 12-31-1979.  
CIMMERIAN COLEMAN, EXAMINING ATTORNEY

SN 85-202,138. PANASONIC CORPORATION OF NORTH AMERICA, SECAUCUS, NJ. FILED 12-20-2010.

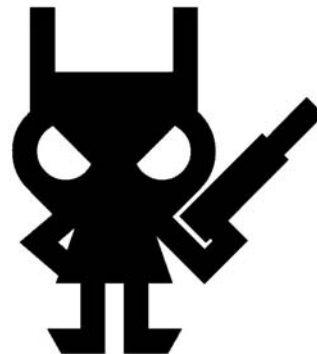

THE MARK CONSISTS OF A STYLIZED, HUMAN-LIKE FIGURE WITH LARGE ANGRY EYES AND EARS EXTENDING ABOVE THE HEAD WEARING A DRESS AND PLACING ONE HAND BEHIND HER BACK AND WIELDING A LARGE GUN IN THE OTHER HAND.



**CLASS 9—ELECTRICAL AND SCIENTIFIC APPARATUS**

FOR PORTABLE AND HAND-HELD DIGITAL ELECTRONIC DEVICES FOR RECORDING, ORGANIZING, TRANSMITTING, MANIPULATING, AND REVIEWING TEXT, DATA, IMAGE, AUDIO AND VIDEO FILES FOR THE PURPOSE OF ELECTRONIC MAIL, INSTANT MESSAGING, SOCIAL NETWORKING, WEB BROWSING, GAMING, MUSIC, VIDEO, AND TEXT; COMPUTER OPERATING SOFTWARE FOR A PORTABLE AND HAND-HELD DIGITAL ELECTRONIC DEVICE USED FOR ELECTRONIC MAIL, INSTANT MESSAGING, SOCIAL NETWORKING, WEB BROWSING, GAMING, MUSIC, VIDEO, AND TEXT; USER INTERFACES FOR ELECTRONIC DEVICES; DIGITAL MATERIALS, NAMELY, OPTICAL DISCS, CD-ROMS, DVD-ROMS, AND MEMORY CARDS FOR DIGITAL ENTERTAINMENT APPLICATIONS FEATURING MUSIC, FILMS, VIDEO CLIPS, AND COMPUTER GAMES; DOWNLOADABLE MULTIMEDIA FILES AND DOWNLOADABLE IMAGE FILES CONTAINING TEXT, DATA, IMAGE, AUDIO AND VIDEO FILES RELATING TO ELECTRONIC MAIL, INSTANT MESSAGING, SOCIAL NETWORKING, WEB BROWSING, GAMING, AND MUSIC; DOWNLOADABLE COMPUTER GAME PROGRAMS; DOWNLOADABLE ELECTRONIC PUBLICATIONS, NAMELY, MAGAZINES, PAMPHLETS, BROCHURES, NEWSLETTERS, AND JOURNALS IN THE FIELDS OF MUSIC, FILMS, TELEVISION, AND COMPUTER GAMES; DIGITAL CAMERAS AND ACCESSORY THEREFOR IN THE NATURE OF A DIGITAL PHOTO VIEWER; VIDEO CAMERAS AND ACCESSORY THEREFOR IN THE NATURE OF A DIGITAL VIDEO PLAYER; MP3 PLAYERS; MICROPHONES; GLOBAL POSITIONING SYSTEM (GPS); AC ADAPTER, POWER CONVERTER, POWER INVERTER; EXTERNAL MOUSE; OPTICAL MOUSE; MOUSEPADS; EXTERNAL KEYBOARD; EXTERNAL COMPUTER SCREEN; VIDEO PROJECTORS; VIDEO GAME INTERACTIVE HAND-HELD REMOTE CONTROLS FOR PLAYING ELECTRONIC GAMES; EARPHONES, HEADPHONES, AND HEADSETS FOR PORTABLE AND HAND-HELD DIGITAL ELECTRONIC DEVICE; STAND FOR HOLDING PORTABLE ELECTRONIC DEVICE AND HANDSET DOCKING STATION; BATTERIES AND BATTERY CHARGER FOR USE IN AUTOMOBILES FOR CHARGING PORTABLE AND HAND-HELD DIGITAL ELECTRONIC DEVICE; STORAGE CASE, PROTECTIVE CARRYING CASE, CARRYING CASE, POUCH, AND BACKPACK, ALL FOR USE WITH PORTABLE AND HAND-HELD DIGITAL ELECTRONIC DEVICE FOR RECORDING, ORGANIZING, TRANSMITTING, MANIPULATING, AND REVIEWING TEXT, DATA, IMAGE, AUDIO AND VIDEO FILES (U.S. CLS. 21, 23, 26, 36 AND 38).

**CLASS 16—PAPER GOODS AND PRINTED MATTER**

FOR FOLDERS; NOTEBOOKS; NOTEPADS; PENS; PENCILS; POSTERS; PRINTED PUBLICATIONS, NAMELY, CATALOGS AND INSTRUCTION BOOKLETS IN THE FIELD OF ELECTRONIC DEVICES AND SOFTWARE THEREFOR; STATIONERY; TRADING CARDS (U.S. CLS. 2, 5, 22, 23, 29, 37, 38 AND 50).

**CLASS 21—HOUSEWARES AND GLASS**

FOR CUPS AND MUGS; DRINKING GLASSES; INSULATED CONTAINERS FOR FOOD OR BEVERAGE FOR DOMESTIC USE; LUNCH BOXES MADE OF METAL AND PLASTIC; PLASTIC AND ALUMINUM WATER BOTTLES SOLD EMPTY; SPORTS BOTTLES SOLD EMPTY (U.S. CLS. 2, 13, 23, 29, 30, 33, 40 AND 50).

**CLASS 25—CLOTHING**

FOR CLOTHING, NAMELY, HATS, T-SHIRTS, JACKETS, SWEATSHIRTS, ATHLETIC APPAREL, NAMELY, CAPS AND SHIRTS, SHORTS, SWEAT PANTS, WRIST BANDS (U.S. CLS. 22 AND 39).

**CLASS 28—TOYS AND SPORTING GOODS**

FOR TOYS, NAMELY, COLLECTIBLE TOY FIGURINES, MODELED PLASTIC TOY FIGURINES, AND PLAY FIGURINES; PLAYING CARDS (U.S. CLS. 22, 23, 38 AND 50).

**CLASS 35—ADVERTISING AND BUSINESS**

FOR ADVERTISING SERVICES; ADVERTISING VIA ELECTRONIC MEDIA AND SPECIFICALLY THE INTERNET; PROVIDING AND RENTAL OF ADVERTISING SPACE ON ELECTRONIC DEVICES AND WEBSITES; ADVERTISING, MARKETING AND PROMOTIONAL SERVICES, NAMELY, ORGANIZING AND CONDUCTING EVENTS FOR THE PURPOSES OF PROMOTING COMPUTER GAMES OF OTHERS (U.S. CLS. 100, 101 AND 102).

**CLASS 38—COMMUNICATION**

FOR TELECOMMUNICATION SERVICES, NAMELY, TRANSMISSION OF VOICE, DATA, DOCUMENTS, GRAPHICS, IMAGES, AUDIO, AND VIDEO FOR ELECTRONIC MAIL, INSTANT MESSAGING, SOCIAL NETWORKING, WEB BROWSING, GAMING, MUSIC, VIDEO, AND TEXT SERVICES; WIRELESS ELECTRONIC TRANSMISSION OF VOICE SIGNALS, DATA, FACSIMILES, IMAGES, COMPUTER AND ELECTRONIC GAMING APPLICATIONS AND CONTENT, MUSIC, CINEMATIC FILMS, TELEVISION PROGRAMS, MULTIMEDIA FILES, AND PUBLICATIONS; WIRELESS BROADBAND COMMUNICATION SERVICES FOR USE WITH THE INTERNET AND CONTENT PROVIDER COMPUTER NETWORKS; ELECTRONIC TRANSMISSION OF HYPERTEXT DOCUMENTS, STREAMING VIDEO WEB HYPERLINKS, MUSIC, DATA, AND DOCUMENTS; PROVIDING ACCESS TO TELECOMMUNICATION NETWORKS; PROVIDING MULTIPLE USE ACCESS TO GLOBAL COMPUTER INFORMATION NETWORKS FOR THE TRANSFER AND DISSEMINATION OF A WIDE RANGE OF INFORMATION; ELECTRONIC MAIL SERVICES; DATA COMMUNICATION BY ELECTRONIC MAIL; PROVIDING ONLINE CHAT ROOMS AND ELECTRONIC BULLETIN BOARDS FOR TRANSMISSION OF MESSAGES AMONG USERS IN THE FIELD OF GENERAL INTEREST, MUSIC, MOVIES, TELEVISION, AND COMPUTER GAMES; PROVIDING CO-LOCATION SERVICES FOR VOICE, VIDEO, AND DATA COMMUNICATIONS APPLICATIONS; STREAMING OF AUDIO, VISUAL, AND AUDIOVISUAL MATERIAL VIA THE INTERNET AND GLOBAL COMPUTER AND WIRELESS NETWORKS; BROADCASTING OF TELEVISION PROGRAMS; BROADCASTING OF VIDEO AND AUDIO PROGRAMMING OVER THE INTERNET; BROADCASTING SERVICES AND PROVISION OF TELECOMMUNICATION ACCESS TO VIDEO, AUDIO, AND AUDIOVISUAL CONTENT PROVIDED VIA A VIDEO-ON-DEMAND SERVICE VIA THE INTERNET (U.S. CLS. 100, 101 AND 104).

**CLASS 41—EDUCATION AND ENTERTAINMENT**

FOR ENTERTAINMENT SERVICES, NAMELY, PROVIDING A WEBSITE FEATURING NON-DOWNLOADABLE MUSIC, VIDEOS, PHOTOGRAPHS, SCREEN SHOTS, ONLINE COMPUTER GAMES, AND NON-DOWNLOADABLE TELEVISION PROGRAMS AND FILMS IN A VARIETY OF GENRES VIA THE INTERNET AND A GLOBAL COMPUTER NETWORK AND WIRELESS NETWORKS; PROVIDING TEMPORARY USE OF NON-DOWNLOADABLE COMPUTER AND ELECTRONIC GAMES VIA COMMUNICATION ON ELECTRONIC DEVICES; PROVIDING ONLINE COMPUTER GAMES; COMPUTERIZED ONLINE RENTAL SERVICES FEATURING INTERACTIVE SOFTWARE IN THE NATURE OF MOVIES, IMAGES, BOOKS, COMPUTER GAMES, MAGAZINES, AND OTHER DIGITAL CONTENT IN A VARIETY OF GENRES; ONLINE DIGITAL VIDEO, AUDIO, AND MULTIMEDIA PUBLISHING SERVICES OF BOOKS, MAGAZINES, AND OTHER DIGITAL CONTENT IN A VARIETY OF GENRES; SWEEPSTAKES SERVICES PROVIDED OVER A GLOBAL COMPUTER NETWORK (U.S. CLS. 100, 101 AND 107).

**CLASS 42—SCIENTIFIC AND COMPUTER SERVICES**

FOR PROVIDING A SECURED-ACCESS WEB SITE THAT GIVES USERS THE ABILITY TO UPLOAD, EXCHANGE, AND SHARE VIDEOS AND OTHER ELECTRONIC DATA, NAMELY, MUSIC, COMPUTER GAMES, STATISTICS AND INFORMATION RELATING TO COMPUTER GAMES, AND PHOTOGRAPHS, ON THE INTERNET (U.S. CLS. 100 AND 101).

PRISCILLA MILTON, EXAMINING ATTORNEY

SN 85-202,162. PANASONIC CORPORATION OF NORTH AMERICA, SECAUCUS, NJ. FILED 12-20-2010.

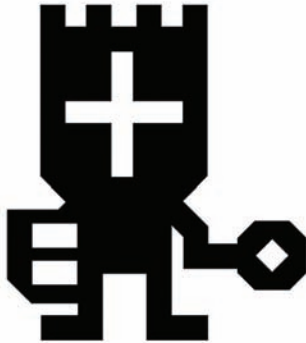

THE MARK CONSISTS OF A STYLIZED KNIGHT WEARING AN ARMORED HELMET WITH A CROSS AND HOLDING A SHIELD AND A MACE.

**CLASS 9—ELECTRICAL AND SCIENTIFIC APPARATUS**

FOR PORTABLE AND HAND-HELD DIGITAL ELECTRONIC DEVICES FOR RECORDING, ORGANIZING, TRANSMITTING, MANIPULATING, AND REVIEWING TEXT, DATA, IMAGE, AUDIO AND VIDEO FILES FOR THE PURPOSE OF ELECTRONIC MAIL, INSTANT MESSAGING, SOCIAL NETWORKING, WEB BROWSING, GAMING, MUSIC, VIDEO, AND TEXT; COMPUTER OPERATING SOFTWARE FOR A PORTABLE AND HAND-HELD DIGITAL ELECTRONIC DEVICE USED FOR ELECTRONIC MAIL, INSTANT MESSAGING, SOCIAL NETWORKING, WEB BROWSING, GAMING, MUSIC, VIDEO, AND TEXT; USER INTERFACES FOR ELECTRONIC DEVICES; DIGITAL MATERIALS, NAMELY, OPTICAL DISCS, CD-ROMS, DVD-ROMS, AND MEMORY CARDS FOR DIGITAL ENTERTAINMENT APPLICATIONS FEATURING MUSIC, FILMS, VIDEO CLIPS, AND COMPUTER GAMES; DOWNLOADABLE MULTIMEDIA FILES AND DOWNLOADABLE IMAGE FILES CONTAINING TEXT, DATA, IMAGE, AUDIO AND VIDEO FILES RELATING TO ELECTRONIC MAIL, INSTANT MESSAGING, SOCIAL NETWORKING, WEB BROWSING, GAMING, AND MUSIC; DOWNLOADABLE COMPUTER GAME PROGRAMS; DOWNLOADABLE ELECTRONIC PUBLICATIONS, NAMELY, MAGAZINES, PAMPHLETS, BROCHURES, NEWSLETTERS, AND JOURNALS IN THE FIELDS OF MUSIC, FILMS, TELEVISION, AND COMPUTER GAMES; DIGITAL CAMERAS AND ACCESSORY THEREFOR IN THE NATURE OF A DIGITAL PHOTO VIEWER; VIDEO CAMERAS AND ACCESSORY THEREFOR IN THE NATURE OF A DIGITAL VIDEO PLAYER; MP3 PLAYERS; MICROPHONES; GLOBAL POSITIONING SYSTEM (GPS); AC ADAPTER, POWER CONVERTER, POWER INVERTER; EXTERNAL MOUSE; OPTICAL MOUSE; MOUSEPADS; EXTERNAL KEYBOARD; EXTERNAL COMPUTER SCREEN; VIDEO PROJECTORS; VIDEO GAME INTERACTIVE HAND-HELD REMOTE CONTROLS FOR PLAYING ELECTRONIC GAMES; EARPHONES, HEADPHONES, AND HEADSETS FOR PORTABLE AND HAND-HELD DIGITAL ELECTRONIC DEVICE; STAND FOR HOLDING

PORTABLE ELECTRONIC DEVICE AND HANDSET DOCKING STATION; BATTERIES AND BATTERY CHARGER FOR USE IN AUTOMOBILES FOR CHARGING PORTABLE AND HAND-HELD DIGITAL ELECTRONIC DEVICE; STORAGE CASE, PROTECTIVE CARRYING CASE, CARRYING CASE, POUCH, AND BACKPACK, ALL FOR USE WITH PORTABLE AND HAND-HELD DIGITAL ELECTRONIC DEVICE FOR RECORDING, ORGANIZING, TRANSMITTING, MANIPULATING, AND REVIEWING TEXT, DATA, IMAGE, AUDIO AND VIDEO FILES (U.S. CLS. 21, 23, 26, 36 AND 38).

**CLASS 16—PAPER GOODS AND PRINTED MATTER**

FOR FOLDERS; NOTEBOOKS; NOTEPADS; PENS; PENCILS; POSTERS; PRINTED PUBLICATIONS, NAMELY, CATALOGS AND INSTRUCTION BOOKLETS IN THE FIELD OF ELECTRONIC DEVICES AND SOFTWARE THEREFOR; STATIONERY; TRADING CARDS (U.S. CLS. 2, 5, 22, 23, 29, 37, 38 AND 50).

**CLASS 21—HOUSEWARES AND GLASS**

FOR CUPS AND MUGS; DRINKING GLASSES; INSULATED CONTAINERS FOR FOOD OR BEVERAGE FOR DOMESTIC USE; LUNCH BOXES MADE OF METAL AND PLASTIC; PLASTIC AND ALUMINUM WATER BOTTLES SOLD EMPTY; SPORTS BOTTLES SOLD EMPTY (U.S. CLS. 2, 13, 23, 29, 30, 33, 40 AND 50).

**CLASS 25—CLOTHING**

FOR CLOTHING, NAMELY, HATS, T-SHIRTS, JACKETS, SWEATSHIRTS, ATHLETIC APPAREL, NAMELY, CAPS AND SHIRTS, SHORTS, SWEAT PANTS, WRIST BANDS (U.S. CLS. 22 AND 39).

**CLASS 28—TOYS AND SPORTING GOODS**

FOR TOYS, NAMELY, COLLECTIBLE TOY FIGURINES, MODELED PLASTIC TOY FIGURINES, AND PLAY FIGURINES; PLAYING CARDS (U.S. CLS. 22, 23, 38 AND 50).

**CLASS 35—ADVERTISING AND BUSINESS**

FOR ADVERTISING SERVICES; ADVERTISING VIA ELECTRONIC MEDIA AND SPECIFICALLY THE INTERNET; PROVIDING AND RENTAL OF ADVERTISING SPACE ON ELECTRONIC DEVICES AND WEBSITES; ADVERTISING, MARKETING AND PROMOTIONAL SERVICES, NAMELY, ORGANIZING AND CONDUCTING EVENTS FOR THE PURPOSES OF PROMOTING COMPUTER GAMES OF OTHERS (U.S. CLS. 100, 101 AND 102).

**CLASS 38—COMMUNICATION**

FOR TELECOMMUNICATION SERVICES, NAMELY, TRANSMISSION OF VOICE, DATA, DOCUMENTS, GRAPHICS, IMAGES, AUDIO, AND VIDEO FOR ELECTRONIC MAIL, INSTANT MESSAGING, SOCIAL NETWORKING, WEB BROWSING, GAMING, MUSIC, VIDEO, AND TEXT SERVICES; WIRELESS ELECTRONIC TRANSMISSION OF VOICE SIGNALS, DATA, FACSIMILES, IMAGES, COMPUTER AND ELECTRONIC GAMING APPLICATIONS AND CONTENT, MUSIC, CINEMATIC FILMS, TELEVISION PROGRAMS, MULTIMEDIA FILES, AND PUBLICATIONS; WIRELESS BROADBAND COMMUNICATION SERVICES FOR USE WITH THE INTERNET AND CONTENT PROVIDER COMPUTER NETWORKS; ELECTRONIC TRANSMISSION OF HYPERTEXT DOCUMENTS, STREAMING VIDEO WEB HYPERLINKS, MUSIC, DATA, AND DOCUMENTS; PROVIDING ACCESS TO TELECOMMUNICATION NETWORKS; PROVIDING MULTIPLE USE ACCESS TO GLOBAL COMPUTER INFORMATION NETWORKS FOR THE TRANSFER AND DISSEMINATION OF A WIDE RANGE OF INFORMATION; ELECTRONIC MAIL SERVICES; DATA COMMUNICATION BY ELECTRONIC MAIL; PROVIDING ONLINE CHAT ROOMS AND ELECTRONIC BULLETIN BOARDS FOR TRANS-

MISSION OF MESSAGES AMONG USERS IN THE FIELD OF GENERAL INTEREST, MUSIC, MOVIES, TELEVISION, AND COMPUTER GAMES; PROVIDING CO-LOCATION SERVICES FOR VOICE, VIDEO, AND DATA COMMUNICATIONS APPLICATIONS; STREAMING OF AUDIO, VISUAL, AND AUDIOVISUAL MATERIAL VIA THE INTERNET AND GLOBAL COMPUTER AND WIRELESS NETWORKS; BROADCASTING OF TELEVISION PROGRAMS; BROADCASTING OF VIDEO AND AUDIO PROGRAMMING OVER THE INTERNET; BROADCASTING SERVICES AND PROVISION OF TELECOMMUNICATION ACCESS TO VIDEO, AUDIO, AND AUDIOVISUAL CONTENT PROVIDED VIA A VIDEO-ON-DEMAND SERVICE VIA THE INTERNET (U.S. CLS. 100, 101 AND 104).

#### **CLASS 41—EDUCATION AND ENTERTAINMENT**

FOR ENTERTAINMENT SERVICES, NAMELY, PROVIDING A WEBSITE FEATURING NON-DOWNLOADABLE MUSIC, VIDEOS, PHOTOGRAPHS, SCREEN SHOTS, ONLINE COMPUTER GAMES, AND NON-DOWNLOADABLE TELEVISION PROGRAMS AND FILMS IN A VARIETY OF GENRES VIA THE INTERNET AND A GLOBAL COMPUTER NETWORK AND WIRELESS NETWORKS; PROVIDING TEMPORARY USE OF NON-DOWNLOADABLE COMPUTER AND ELECTRONIC GAMES VIA COMMUNICATION ON ELECTRONIC DEVICES; PROVIDING ONLINE COMPUTER GAMES; COMPUTERIZED ONLINE RENTAL SERVICES FEATURING INTERACTIVE SOFTWARE IN THE NATURE OF MOVIES, IMAGES, BOOKS, COMPUTER GAMES, MAGAZINES, AND OTHER DIGITAL CONTENT IN A VARIETY OF GENRES; ONLINE DIGITAL VIDEO, AUDIO, AND MULTIMEDIA PUBLISHING SERVICES OF BOOKS, MAGAZINES, AND OTHER DIGITAL CONTENT IN A VARIETY OF GENRES; SWEEPSTAKES SERVICES PROVIDED OVER A GLOBAL COMPUTER NETWORK (U.S. CLS. 100, 101 AND 107).

#### **CLASS 42—SCIENTIFIC AND COMPUTER SERVICES**

FOR PROVIDING A SECURED-ACCESS WEB SITE THAT GIVES USERS THE ABILITY TO UPLOAD, EXCHANGE, AND SHARE VIDEOS AND OTHER ELECTRONIC DATA, NAMELY, MUSIC, COMPUTER GAMES, STATISTICS AND INFORMATION RELATING TO COMPUTER GAMES, AND PHOTOGRAPHS, ON THE INTERNET (U.S. CLS. 100 AND 101).  
PRISCILLA MILTON, EXAMINING ATTORNEY

SN 85-202,176. PANASONIC CORPORATION OF NORTH AMERICA, SECAUCUS, NJ. FILED 12-20-2010.



THE MARK CONSISTS OF A STYLIZED CREATURE WITH HANGING ARMS, LARGE CROSSES FOR EYES, AND EARS STICKING UP HIGH ABOVE THE HEAD, WITH ONE OF THE EARS BEING ASKEW.

#### **CLASS 9—ELECTRICAL AND SCIENTIFIC APPARATUS**

FOR PORTABLE AND HAND-HELD DIGITAL ELECTRONIC DEVICES FOR RECORDING, ORGANIZING, TRANSMITTING, MANIPULATING, AND REVIEWING TEXT, DATA, IMAGE, AUDIO AND VIDEO FILES FOR THE PURPOSE OF ELECTRONIC MAIL, INSTANT MESSAGING, SOCIAL NETWORKING, WEB BROWSING, GAMING, MUSIC, VIDEO, AND TEXT; COMPUTER OPERATING SOFTWARE FOR A PORTABLE AND HAND-HELD DIGITAL ELECTRONIC DEVICE USED FOR ELECTRONIC MAIL, INSTANT MESSAGING, SOCIAL NETWORKING, WEB BROWSING, GAMING, MUSIC, VIDEO, AND TEXT; USER INTERFACES FOR ELECTRONIC DEVICES; DIGITAL MATERIALS, NAMELY, OPTICAL DISCS, CD-ROMS, DVD-ROMS, AND MEMORY CARDS FOR DIGITAL ENTERTAINMENT APPLICATIONS FEATURING MUSIC, FILMS, VIDEO CLIPS, AND COMPUTER GAMES; DOWNLOADABLE MULTIMEDIA FILES AND DOWNLOADABLE IMAGE FILES CONTAINING TEXT, DATA, IMAGE, AUDIO AND VIDEO FILES RELATING TO ELECTRONIC MAIL, INSTANT MESSAGING, SOCIAL NETWORKING, WEB BROWSING, GAMING, AND MUSIC; DOWNLOADABLE COMPUTER GAME PROGRAMS; DOWNLOADABLE ELECTRONIC PUBLICATIONS, NAMELY, MAGAZINES, PAMPHLETS, BROCHURES, NEWSLETTERS, AND JOURNALS IN THE FIELDS OF MUSIC, FILMS, TELEVISION, AND COMPUTER GAMES; DIGITAL CAMERAS AND ACCESSORY THEREFOR IN THE NATURE OF A DIGITAL PHOTO VIEWER; VIDEO CAMERAS AND ACCESSORY THEREFOR IN THE NATURE OF A DIGITAL VIDEO PLAYER; MP3 PLAYERS; MICROPHONES; GLOBAL POSITIONING SYSTEM (GPS); AC ADAPTER, POWER CONVERTER, POWER INVERTER; EXTERNAL MOUSE; OPTICAL MOUSE; MOUSEPADS; EXTERNAL KEYBOARD; EXTERNAL COMPUTER SCREEN; VIDEO PROJECTORS; VIDEO GAME INTERACTIVE HAND-HELD REMOTE CONTROLS FOR PLAYING ELECTRONIC GAMES; EARPHONES, HEADPHONES, AND HEADSETS FOR PORTABLE AND HAND-HELD DIGITAL ELECTRONIC DEVICE; STAND FOR HOLDING PORTABLE ELECTRONIC DEVICE AND HANDSET DOCKING STATION; BATTERIES AND BATTERY CHARGER FOR USE IN AUTOMOBILES FOR CHARGING PORTABLE AND HAND-HELD DIGITAL ELECTRONIC DEVICE; STORAGE CASE, PROTECTIVE CARRYING CASE, CARRYING CASE, POUCH, AND BACKPACK, ALL FOR USE WITH PORTABLE AND HAND-HELD DIGITAL ELECTRONIC DEVICE FOR RECORDING, ORGANIZING, TRANSMITTING, MANIPULATING, AND REVIEWING TEXT, DATA, IMAGE, AUDIO AND VIDEO FILES (U.S. CLS. 21, 23, 26, 36 AND 38).

#### **CLASS 16—PAPER GOODS AND PRINTED MATTER**

FOR FOLDERS; NOTEBOOKS; NOTEPADS; PENS; PENCILS; POSTERS; PRINTED PUBLICATIONS, NAMELY, CATALOGS AND INSTRUCTION BOOKLETS IN THE FIELD OF ELECTRONIC DEVICES AND SOFTWARE THEREFOR; STATIONERY; TRADING CARDS (U.S. CLS. 2, 5, 22, 23, 29, 37, 38 AND 50).

#### **CLASS 21—HOUSEWARES AND GLASS**

FOR CUPS AND MUGS; DRINKING GLASSES; INSULATED CONTAINERS FOR FOOD OR BEVERAGE FOR DOMESTIC USE; LUNCH BOXES MADE OF METAL AND PLASTIC; PLASTIC AND ALUMINUM WATER BOTTLES SOLD EMPTY; SPORTS BOTTLES SOLD EMPTY (U.S. CLS. 2, 13, 23, 29, 30, 33, 40 AND 50).

#### **CLASS 25—CLOTHING**

FOR CLOTHING, NAMELY, HATS, T-SHIRTS, JACKETS, SWEATSHIRTS, ATHLETIC APPAREL, NAMELY, CAPS AND SHIRTS, SHORTS, SWEAT PANTS, WRIST BANDS (U.S. CLS. 22 AND 39).

**CLASS 28—TOYS AND SPORTING GOODS**

FOR TOYS, NAMELY, COLLECTIBLE TOY FIGURINES, MODELED PLASTIC TOY FIGURINES, AND PLAY FIGURINES; PLAYING CARDS (U.S. CLS. 22, 23, 38 AND 50).

**CLASS 35—ADVERTISING AND BUSINESS**

FOR ADVERTISING SERVICES; ADVERTISING VIA ELECTRONIC MEDIA AND SPECIFICALLY THE INTERNET; PROVIDING AND RENTAL OF ADVERTISING SPACE ON ELECTRONIC DEVICES AND WEBSITES; ADVERTISING, MARKETING AND PROMOTIONAL SERVICES, NAMELY, ORGANIZING AND CONDUCTING EVENTS FOR THE PURPOSES OF PROMOTING COMPUTER GAMES OF OTHERS (U.S. CLS. 100, 101 AND 102).

**CLASS 38—COMMUNICATION**

FOR TELECOMMUNICATION SERVICES, NAMELY, TRANSMISSION OF VOICE, DATA, DOCUMENTS, GRAPHICS, IMAGES, AUDIO, AND VIDEO FOR ELECTRONIC MAIL, INSTANT MESSAGING, SOCIAL NETWORKING, WEB BROWSING, GAMING, MUSIC, VIDEO, AND TEXT SERVICES; WIRELESS ELECTRONIC TRANSMISSION OF VOICE SIGNALS, DATA, FACSIMILES, IMAGES, COMPUTER AND ELECTRONIC GAMING APPLICATIONS AND CONTENT, MUSIC, CINEMATIC FILMS, TELEVISION PROGRAMS, MULTIMEDIA FILES, AND PUBLICATIONS; WIRELESS BROADBAND COMMUNICATION SERVICES FOR USE WITH THE INTERNET AND CONTENT PROVIDER COMPUTER NETWORKS; ELECTRONIC TRANSMISSION OF HYPERTEXT DOCUMENTS, STREAMING VIDEO WEB HYPERLINKS, MUSIC, DATA, AND DOCUMENTS; PROVIDING ACCESS TO TELECOMMUNICATION NETWORKS; PROVIDING MULTIPLE USE ACCESS TO GLOBAL COMPUTER INFORMATION NETWORKS FOR THE TRANSFER AND DISSEMINATION OF A WIDE RANGE OF INFORMATION; ELECTRONIC MAIL SERVICES; DATA COMMUNICATION BY ELECTRONIC MAIL; PROVIDING ONLINE CHAT ROOMS AND ELECTRONIC BULLETIN BOARDS FOR TRANSMISSION OF MESSAGES AMONG USERS IN THE FIELD OF GENERAL INTEREST, MUSIC, MOVIES, TELEVISION, AND COMPUTER GAMES; PROVIDING CO-LOCATION SERVICES FOR VOICE, VIDEO, AND DATA COMMUNICATIONS APPLICATIONS; STREAMING OF AUDIO, VISUAL, AND AUDIOVISUAL MATERIAL VIA THE INTERNET AND GLOBAL COMPUTER AND WIRELESS NETWORKS; BROADCASTING OF TELEVISION PROGRAMS; BROADCASTING OF VIDEO AND AUDIO PROGRAMMING OVER THE INTERNET; BROADCASTING SERVICES AND PROVISION OF TELECOMMUNICATION ACCESS TO VIDEO, AUDIO, AND AUDIOVISUAL CONTENT PROVIDED VIA A VIDEO-ON-DEMAND SERVICE VIA THE INTERNET (U.S. CLS. 100, 101 AND 104).

**CLASS 41—EDUCATION AND ENTERTAINMENT**

FOR ENTERTAINMENT SERVICES, NAMELY, PROVIDING A WEBSITE FEATURING NON-DOWNLOADABLE MUSIC, VIDEOS, PHOTOGRAPHS, SCREEN SHOTS, ONLINE COMPUTER GAMES, AND NON-DOWNLOADABLE TELEVISION PROGRAMS AND FILMS IN A VARIETY OF GENRES VIA THE INTERNET AND A GLOBAL COMPUTER NETWORK AND WIRELESS NETWORKS; PROVIDING TEMPORARY USE OF NON-DOWNLOADABLE COMPUTER AND ELECTRONIC GAMES VIA COMMUNICATION ON ELECTRONIC DEVICES; PROVIDING ONLINE COMPUTER GAMES; COMPUTERIZED ONLINE RENTAL SERVICES FEATURING INTERACTIVE SOFTWARE IN THE NATURE OF MOVIES, IMAGES, BOOKS, COMPUTER GAMES, MAGAZINES, AND OTHER DIGITAL CONTENT IN A VARIETY OF GENRES; ONLINE DIGITAL VIDEO, AUDIO, AND MULTIMEDIA PUBLISHING SERVICES OF BOOKS, MAGAZINES, AND OTHER DIGITAL CONTENT IN A VARIETY OF GENRES; SWEEPSTAKES SERVICES PROVIDED OVER A GLOBAL COMPUTER NETWORK (U.S. CLS. 100, 101 AND 107).

**CLASS 42—SCIENTIFIC AND COMPUTER SERVICES**

FOR PROVIDING A SECURED-ACCESS WEB SITE THAT GIVES USERS THE ABILITY TO UPLOAD, EXCHANGE, AND SHARE VIDEOS AND OTHER ELECTRONIC DATA, NAMELY, MUSIC, COMPUTER GAMES, STATISTICS AND INFORMATION RELATING TO COMPUTER GAMES, AND PHOTOGRAPHS, ON THE INTERNET (U.S. CLS. 100 AND 101).

PRISCILLA MILTON, EXAMINING ATTORNEY

SN 85-202,351. G-III LEATHER FASHIONS, INC., NEW YORK, NY. FILED 12-20-2010.

**BENOIT AIR**

THE MARK CONSISTS OF STANDARD CHARACTERS WITHOUT CLAIM TO ANY PARTICULAR FONT, STYLE, SIZE, OR COLOR.

**CLASS 9—ELECTRICAL AND SCIENTIFIC APPARATUS**

FOR COMPUTER BAGS, BRIEFCASES SPECIALLY ADAPTED FOR HOLDING LAPTOP COMPUTERS; AND HOLDERS FOR ELECTRONIC PRODUCTS, NAMELY, CASES FOR CELL PHONES, LAPTOPS AND PORTABLE MEDIA PLAYERS (U.S. CLS. 21, 23, 26, 36 AND 38).

**CLASS 16—PAPER GOODS AND PRINTED MATTER**

FOR PASSPORT HOLDERS AND NOTEPAD COVERS (U.S. CLS. 2, 5, 22, 23, 29, 37, 38 AND 50).

**CLASS 18—LEATHER GOODS**

FOR LUGGAGE, TOTE BAGS, BRIEFCASES, BRIEFCASE-TYPE PORTFOLIOS, LEATHER AGENDA CASES, WALLETS, CREDIT CARD CASES, BUSINESS CARD CASES, TOILETRY CASES SOLD EMPTY, MAKEUP CASES SOLD EMPTY, LUGGAGE TAGS, LEATHER KEY CHAINS, KEY CASES, JEWELRY ORGANIZERS FOR TRAVEL, SHOE BAGS FOR TRAVEL, AND TRAVEL KITS COMPRISING TRAVEL CASES (U.S. CLS. 1, 2, 3, 22 AND 41).

MARK SPARACINO, EXAMINING ATTORNEY

SN 85-202,677. INDEPENDENCE VISITOR CENTER CORPORATION, PHILADELPHIA, PA. FILED 12-21-2010.



OWNER OF U.S. REG. NO. 3,680,911.



NO CLAIM IS MADE TO THE EXCLUSIVE RIGHT TO USE "BALLROOM", APART FROM THE MARK AS SHOWN.

THE MARK CONSISTS OF DESIGN OF A BELL WITH THE WORDING "LIBERTY VIEW BALLROOM" APPEARING BELOW.

#### **CLASS 41—EDUCATION AND ENTERTAINMENT**

FOR ENTERTAINMENT SERVICES, NAMELY, PROVIDING BALLROOM FACILITIES (U.S. CLS. 100, 101 AND 107).

FIRST USE 11-5-2009; IN COMMERCE 12-1-2009.

#### **CLASS 43—HOTEL AND RESTAURANT SERVICES**

FOR PROVIDING OF FOOD AND DRINK SERVICES; PROVIDING FACILITIES FOR EXHIBITIONS AND CONVENTIONS, PROVIDING BANQUET AND SOCIAL FUNCTION FACILITIES FOR SPECIAL OCCASIONS (U.S. CLS. 100 AND 101).

FIRST USE 11-5-2009; IN COMMERCE 12-1-2009.  
SUNG IN, EXAMINING ATTORNEY

---

SN 85-203,467. OZMOTA INC., TA OZMOTA INC, GRAND CAYMAN, CAYMAN ISLANDS, FILED 12-21-2010.

the web made personal

THE MARK CONSISTS OF STANDARD CHARACTERS WITHOUT CLAIM TO ANY PARTICULAR FONT, STYLE, SIZE, OR COLOR.

NO CLAIM IS MADE TO THE EXCLUSIVE RIGHT TO USE "WEB", APART FROM THE MARK AS SHOWN.

#### **CLASS 42—SCIENTIFIC AND COMPUTER SERVICES**

FOR COMPUTER SERVICES, NAMELY, CREATING AN ON-LINE COMMUNITY FOR REGISTERED USERS TO PARTICIPATE IN DISCUSSIONS, GET FEEDBACK FROM THEIR PEERS, FORM VIRTUAL COMMUNITIES, AND ENGAGE IN SOCIAL NETWORKING; COMPUTER SERVICES, NAMELY, CREATING INDEXES OF INFORMATION, SITES AND OTHER RESOURCES AVAILABLE ON COMPUTER NETWORKS (U.S. CLS. 100 AND 101).

FIRST USE 12-15-2010; IN COMMERCE 12-15-2010.

#### **CLASS 45—PERSONAL AND LEGAL SERVICES**

FOR INTERNET-BASED SOCIAL NETWORKING SERVICES; PROVIDING ON-LINE COMPUTER DATABASES AND ON-LINE SEARCHABLE DATABASES IN THE FIELD OF SOCIAL NETWORKING (U.S. CLS. 100 AND 101).

FIRST USE 12-15-2010; IN COMMERCE 12-15-2010.  
CAROLINE WOOD, EXAMINING ATTORNEY

SN 85-203,903. BOSTON FOUNDATION, INC., BOSTON, MA, FILED 12-22-2010.

#### **THE GIVING COMMON**

THE MARK CONSISTS OF STANDARD CHARACTERS WITHOUT CLAIM TO ANY PARTICULAR FONT, STYLE, SIZE, OR COLOR.

NO CLAIM IS MADE TO THE EXCLUSIVE RIGHT TO USE "GIVING", APART FROM THE MARK AS SHOWN.

#### **CLASS 35—ADVERTISING AND BUSINESS**

FOR CHARITABLE SERVICES, NAMELY, COORDINATION OF THE PROCUREMENT AND DISTRIBUTION OF CHARITABLE DONATIONS; MARKETING SERVICES IN THE FIELD OF PLANNED-GIVING FOR NON-PROFIT AND CHARITABLE ORGANIZATIONS; PROMOTING THE CHARITABLE GIVING OF OTHERS, NAMELY, TRACKING AND PUBLICIZING CHARITABLE DONATIONS; PROMOTING THE CHARITABLE SERVICES OF OTHERS, NAMELY, PROVIDING INDIVIDUALS WITH INFORMATION FOR THE PURPOSE OF MAKING DONATIONS TO CHARITIES; PROMOTIONAL SERVICES, NAMELY, PROMOTING THE CHARITIES OF OTHERS (U.S. CLS. 100, 101 AND 102).

#### **CLASS 36—INSURANCE AND FINANCIAL**

FOR CHARITABLE FUNDRAISING SERVICES; PROVIDING ON-LINE PROCESSING OF CREDIT CARD AND GIFT CARD DONATIONS (U.S. CLS. 100, 101 AND 102).

#### **CLASS 42—SCIENTIFIC AND COMPUTER SERVICES**

FOR SOFTWARE AS A SERVICE (SAAS) SERVICES, NAMELY, HOSTING SOFTWARE FOR USE BY OTHERS FOR USE IN PROCESSING PAYMENTS AND DONATIONS FOR CHARITABLE AND NON-PROFIT ORGANIZATIONS; PROVIDING TEMPORARY USE OF NON-DOWNLOADABLE SOFTWARE FOR USE BY CHARITABLE, NONPROFIT AND FUNDRAISING ORGANIZATIONS IN CREATING AND MANAGING RELATIONSHIPS WITH DONORS, PROSPECTIVE DONORS, MEMBERS, AND VOLUNTEERS, AND IN MARKETING, ORGANIZING AND MANAGING FUNDRAISING EVENTS, INFORMATION, AND ACTIVITIES; PROVIDING TEMPORARY USE OF NON-DOWNLOADABLE SOFTWARE IN THE COLLECTION, VERIFICATION, ORGANIZATION, MANAGEMENT AND STORAGE OF DATA ON NON-PROFIT ORGANIZATIONS, CHARITABLE ORGANIZATIONS, COMMUNITY ORGANIZATIONS, CHARITABLE GIVING, PROSPECTIVE DONORS, DONORS, AND DONOR ACTIVITY; PROVIDING TEMPORARY USE OF NON-DOWNLOADABLE SOFTWARE FOR USE BY PROSPECTIVE DONORS AND DONORS TO RESEARCH AND SELECT CHARITABLE ORGANIZATIONS AND NON-PROFIT ORGANIZATIONS FOR DONATIONS, TO CREATE AND MAINTAIN DONOR PROFILES, AND TO RECEIVE DATA ON ACTIVITIES OF CHARITABLE AND NON-PROFIT ORGANIZATIONS; PROVIDING TEMPORARY USE OF NON-DOWNLOADABLE SOFTWARE FOR USE IN GENERATING REPORTS ON CHARITABLE AND NON-PROFIT ORGANIZATIONS, CHARITABLE GIVING, PROSPECTIVE DONORS, DONORS, AND DONOR INFORMATION AND ACTIVITY; TECHNICAL SUPPORT SERVICES, NAMELY, TROUBLESHOOTING OF COMPUTER SOFTWARE PROBLEMS; PROVIDING A WEBSITE THAT GIVES USERS THE ABILITY TO CREATE CUSTOMIZED WEB PAGES FEATURING USER-DEFINED INFORMATION AND PROFILES; CUSTOMIZED SOFTWARE DEVELOPMENT SERVICES; PROVIDING CUSTOMIZED ON-LINE WEB PAGES AND DATA FEEDS FEATURING USER-DEFINED INFORMATION, WHICH INCLUDES BLOG

POSTS, NEW MEDIA CONTENT, OTHER ON-LINE CONTENT, AND ON-LINE WEB LINKS TO OTHER WEBSITES (U.S. CLS. 100 AND 101).

JILL PRATER, EXAMINING ATTORNEY

DEBRA LEE, EXAMINING ATTORNEY

SN 85-203,991. GADEA PHARMACEUTICAL GROUP, S.L., BOECILLO, VALLADOLID, SPAIN, FILED 12-22-2010.



NO CLAIM IS MADE TO THE EXCLUSIVE RIGHT TO USE "PHARMACEUTICAL GROUP", APART FROM THE MARK AS SHOWN.

THE COLOR(S) BLUE, GREEN, AND WHITE IS/ARE CLAIMED AS A FEATURE OF THE MARK.

THE MARK CONSISTS OF A GREEN CIRCLE PARTIALLY OUTLINED IN BLUE WITH A WHITE LOOP DESIGN WITHIN IT, THE STYLIZED WORD "GADEA" APPEARING IN BLUE TO THE RIGHT OF THE CIRCLE DESIGN, THE STYLIZED WORDING "PHARMACEUTICAL GROUP" APPEARING IN GREEN BELOW AND SLIGHTLY TO THE RIGHT OF THE WORD "GADEA". THE COLOR WHITE APPEARING IN THE BACKGROUND OF THE MARK REPRESENTS TRANSPARENT AREAS AND THEREFORE IS NOT PART OF THE MARK.

#### **CLASS 5—PHARMACEUTICALS**

FOR ANTI-INFLAMMATORIES; CONTRACEPTIVES; DERMATOLOGICAL PHARMACEUTICAL PRODUCTS; FUNGICIDES; HORMONES FOR MEDICAL PURPOSES; PHARMACEUTICAL ANTI-ALLERGIC PREPARATIONS AND SUBSTANCES; PHARMACEUTICAL PREPARATIONS FOR SKIN CARE; PHARMACEUTICAL PREPARATIONS FOR THE TREATMENT AND PREVENTION OF DISORDERS OF THE IMMUNE SYSTEM, THE METABOLIC SYSTEM, THE RESPIRATORY SYSTEM, THE MUSCULO-SKELETAL SYSTEM, THE GENITOURINARY SYSTEM; PHARMACEUTICAL PREPARATIONS FOR THE TREATMENT OF DERMATITIS, ECZEMA, RHINITIS AND PRUITIC, RESPIRATORY, HORMONAL, DERMATOLOGICAL AND IMMUNE SYSTEM RELATED DISEASES AND DISORDERS, INFLAMMATORY DISORDERS, FOR USE IN DERMATOLOGY; PHARMACEUTICAL PREPARATIONS FOR TREATING ALLERGIC RHINITIS AND ASTHMA; PHARMACEUTICAL PREPARATIONS FOR USE IN DERMATOLOGY; PHARMACEUTICAL PRODUCTS FOR THE PREVENTION AND TREATMENT OF CANCER; PHARMACEUTICAL PRODUCTS FOR TREATING RESPIRATORY DISEASES AND ASTHMA; STEROIDS (U.S. CLS. 6, 18, 44, 46, 51 AND 52).

#### **CLASS 35—ADVERTISING AND BUSINESS**

FOR IMPORT-EXPORT AGENCIES IN THE FIELD OF PHARMACEUTICS AND MEDICINE; PROVIDING BUSINESS INTELLIGENCE SERVICES IN THE FIELDS OF MEDICAL DEVICES, PHARMACEUTICALS AND THE LIFE SCIENCES (U.S. CLS. 100, 101 AND 102).

#### **CLASS 42—SCIENTIFIC AND COMPUTER SERVICES**

FOR CONSULTING SERVICES IN THE FIELDS OF BIOTECHNOLOGY, PHARMACEUTICAL RESEARCH AND DEVELOPMENT, LABORATORY TESTING, DIAGNOSTICS, AND PHARMACOGENETICS; DEVELOPMENT OF PHARMACEUTICAL PREPARATIONS AND MEDICINES; PHARMACEUTICAL DRUG DEVELOPMENT SERVICES; PHARMACEUTICAL PRODUCT EVALUATION; PHARMACEUTICAL RESEARCH AND DEVELOPMENT; PHARMACEUTICAL RESEARCH SERVICES; RESEARCH ON THE SUBJECT OF PHARMACEUTICALS (U.S. CLS. 100 AND 101).

SN 85-204,110. SKULLCANDY, INC., PARK CITY, UT, FILED 12-22-2010.

#### **EVERY REVOLUTION NEEDS A SOUNDTRACK**

THE MARK CONSISTS OF STANDARD CHARACTERS WITHOUT CLAIM TO ANY PARTICULAR FONT, STYLE, SIZE, OR COLOR.

#### **CLASS 9—ELECTRICAL AND SCIENTIFIC APPARATUS**

FOR HEADPHONES AND EARPHONES; PORTABLE MEDIA PLAYERS; PROTECTIVE HELMETS; SUNGLASSES (U.S. CLS. 21, 23, 26, 36 AND 38).

#### **CLASS 18—LEATHER GOODS**

FOR WALLETS, BACKPACKS, AND ALL PURPOSE SPORTS AND ATHLETIC BAGS (U.S. CLS. 1, 2, 3, 22 AND 41).

#### **CLASS 25—CLOTHING**

FOR CLOTHING AND HEADWEAR, NAMELY, T-SHIRTS, JACKETS, SWEATERS, BEANIES, AND HATS (U.S. CLS. 22 AND 39).

#### **CLASS 35—ADVERTISING AND BUSINESS**

FOR RETAIL KIOSKS, RETAIL STORE SERVICES AND ONLINE RETAIL STORE SERVICES FEATURING EARPHONES, HEADPHONES, MOBILE PHONES AND MOBILE PHONE ACCESSORIES, PORTABLE MEDIA PLAYERS AND PORTABLE MEDIA PLAYER ACCESSORIES, PROTECTIVE HELMETS, WATCHES, SACKS OR BAGS, CLOTHING AND HEADWEAR, AND SUNGLASSES (U.S. CLS. 100, 101 AND 102).

#### **CLASS 41—EDUCATION AND ENTERTAINMENT**

FOR ENTERTAINMENT SERVICES, NAMELY, PROVIDING CONTINUING AUDIO AND VIDEO PROGRAMS IN THE FIELD OF SPORTS, MUSIC, AND POPULAR CULTURE BROADCAST OVER TELEVISION, SATELLITE, AUDIO OR VIDEO BROADCAST MEDIA, AND INTERNET BROADCAST MEDIA; ENTERTAINMENT SERVICES IN THE NATURE OF CREATION, DEVELOPMENT, AND PRODUCTION OF TELEVISION PROGRAMMING; PROVIDING AN INTERNET WEBSITE PORTAL IN THE FIELD OF ENTERTAINMENT, MUSIC, CULTURAL AND SPORTING EVENTS (U.S. CLS. 100, 101 AND 107).

GISELLE AGOSTO, EXAMINING ATTORNEY

SN 85-204,120. CORE PRODUCTS INTERNATIONAL, INC., OSCEOLA, WI. FILED 12-22-2010.

## THERMAL CORE

THE MARK CONSISTS OF STANDARD CHARACTERS WITHOUT CLAIM TO ANY PARTICULAR FONT, STYLE, SIZE, OR COLOR.

NO CLAIM IS MADE TO THE EXCLUSIVE RIGHT TO USE "THERMAL", APART FROM THE MARK AS SHOWN.

### CLASS 10—MEDICAL APPARATUS

FOR THERAPEUTIC HEAT PACKS; THERAPEUTIC STEAM PACKS (U.S. CLS. 26, 39 AND 44).

### CLASS 11—ENVIRONMENTAL CONTROL APPARATUS

FOR HEATING UNITS FOR THERAPEUTIC HEAT PACKS; CABINETS FOR HEATING THERAPEUTIC STEAM PACKS (U.S. CLS. 13, 21, 23, 31 AND 34).

CHRISTINA SOBRAL, EXAMINING ATTORNEY

SN 85-204,123. VOOZ CHARACTER SYSTEM, SEOUL, REPUBLIC OF KOREA, FILED 12-22-2010.

## PUCCA

THE MARK CONSISTS OF STANDARD CHARACTERS WITHOUT CLAIM TO ANY PARTICULAR FONT, STYLE, SIZE, OR COLOR.

OWNER OF U.S. REG. NOS. 3,499,210, 3,807,131 AND 3,916,294.

THE WORDING "PUCCA" HAS NO MEANING IN A FOREIGN LANGUAGE.

### CLASS 3—COSMETICS AND CLEANING PREPARATIONS

FOR COSMETICS, FRAGRANCES, NON-MEDICATED SKIN CARE PREPARATIONS, HAIR CARE PREPARATIONS, COSMETIC SUN-TANNING PREPARATIONS; SUNSCREEN PREPARATIONS; DEODORANTS FOR PERSONAL USE; SKIN WHITENING PREPARATIONS; FALSE EYELASHES; LAUNDRY SOAPS; COSMETIC SOAPS; DENTIFRICES; NON-MEDICATED MOUTH WASHES; NAIL CARE PREPARATIONS; BATH OIL; BABY OIL (U.S. CLS. 1, 4, 6, 50, 51 AND 52).

### CLASS 9—ELECTRICAL AND SCIENTIFIC APPARATUS

FOR COMPUTERS; COMPUTER MONITORS; COMPUTER DISK DRIVES; WRIST RESTS FOR USE WITH COMPUTERS; MAGNETIC TAPE UNITS FOR COMPUTERS; JUKE BOXES FOR COMPUTERS; COMPUTER PRINTERS; COMPUTER GAME CONSOLES FOR USE WITH AN EXTERNAL DISPLAY SCREEN OR MONITOR; COMPUTER KEYBOARDS; CAMERAS; PROTECTIVE HELMETS FOR SPORTS; COMPUTER GAME SOFTWARE THAT MAY BE DOWNLOADED FROM A GLOBAL COMPUTER NETWORK; GAME SOFTWARE FOR VIDEO GAME PLAYERS; VIDEO OUTPUT GAME AMUSEMENT MACHINES FOR USE WITH TELEVISION; VIDEO TAPES WITH RECORDED ANIMATED CARTOONS; BLANK CD-ROMS FOR SOUND OR VIDEO RECORDING; PERSONAL DIGITAL ASSISTANTS (PDA); COMPUTER OPERATING PROGRAMS; COMPUTER SOFTWARE FOR USE IN CREATING DIGITAL ANIMATION AND SPECIAL EFFECTS OF IMAGES; NOTEBOOK COMPUTERS; COMPUTER MOUSE; MOUSE PADS; AUTOMATIC ELECTRONIC VENDING MACHINES; VISUAL RECORDINGS AND AUDIOVISUAL RECORDINGS FEATURING ANIMATION (U.S. CLS. 21, 23, 26, 36 AND 38).

### CLASS 14—JEWELRY

FOR KEY RINGS OF PRECIOUS METALS; CHRONOMETERS; TABLE CLOCKS; WRIST WATCHES; COSTUME JEWELRY; DIAMONDS; PEARLS; EARRINGS; BADGES OF PRECIOUS METAL; BELT ORNAMENTS OF PRECIOUS METALS; PINS BEING JEWELRY; TIE PINS; NECKLACES; RINGS; BROOCHES; ORNAMENTAL PINS; BRACELETS (U.S. CLS. 2, 27, 28 AND 50).

### CLASS 15—MUSICAL INSTRUMENTS

FOR MUSICAL INSTRUMENTS (U.S. CLS. 2, 21 AND 36).

### CLASS 16—PAPER GOODS AND PRINTED MATTER

FOR STICKERS; STATIONERY; CORRUGATED CARDBOARDS; PAPER NAPKINS; LUMINOUS PAPER; WATERPROOF PAPER; FIREPROOF PAPER; WHITE PAPERBOARD; DUPLICATING PAPER; CARDBOARD MADE FROM PAPER MULBERRY; PRINTING PAPER; OIL PAPER FOR USE AS FLOOR MATS; HANDKERCHIEFS OF PAPER; TOWELS OF PAPER; FACE TOWELS OF PAPER; CARBON PAPER; TYPEWRITING PAPER; CARDBOARD; FACSIMILE TRANSMISSION PAPER; POSTCARD PAPER; PACKING PAPER; MILLBOARD; WRITING AND DRAWING PAPER; TISSUES OF PAPER FOR REMOVING MAKE-UP; TAGS FOR INDEX CARDS; CALCULATING TABLES IN THE NATURE OF PRE-PRINTED CARDS WITH MATHEMATICAL FORMULAS ON THEM; NOTE BOOKS; MEMO PAPER; PLOTTING PAPERS; ENVELOPES; POCKET NOTEBOOKS; SKETCH BOOKS; SCRAPBOOKS; ALBUMS FOR PHOTOGRAPHS; FOUNTAIN PENS; BALL POINT PENS; CHALKS; WRITING BRUSHES; FELT PENS FOR WRITING; MECHANICAL PENCILS; SLATE PENCILS; PENCILS; STEEL PENS; PENS; PENHOLDERS; PAINT BOXES FOR USE IN SCHOOLS; CHARCOAL PENCILS; ENGRAVING PLATES; CANVAS FOR PAINTING; CRAYONS; PASTELS; PAINTBRUSHES; PAINTERS' EASELS; PALETTES FOR PAINTERS; RUBBER ERASERS; SEALING STAMPS; LOOSE-LEAF BINDERS; DOCUMENT FILES; GUMMED TAPE FOR STATIONERY; ADHESIVE TAPES FOR STATIONERY; GLUE FOR STATIONERY; CHALK ERASERS; RUBBER BANDS; PUNCHES; CORRECTING FLUID FOR DOCUMENTS; PAPER KNIVES AND STAPLERS; PHOTOGRAPH STANDS; PAPER FOLDERS; STAMP STANDS; STAMP PADS; STAMP CASES; THUMB TACKS; PENCIL SHARPENERS; INK WELLS; INK ERASERS; DRAWING SQUARES; COMPASSES FOR DRAWING; DRAWING T-SQUARES; DRAFTING PAPER; SQUARE RULERS FOR DRAFTING; PRINTED CHARTS; BLACKBOARDS; PAPER CLIPS; PEN AND PENCIL CASES AND BOXES; CORRUGATED CARDBOARD BOXES; PAPER BOXES; PAPER SACKS FOR WRAPPING; FOOD WRAPPING PLASTIC FILM FOR HOUSEHOLD USE; PICTURE POSTCARDS; SONG

BOOKS; CALENDARS; COMIC BOOKS; MUSICAL GREETING CARDS; TELEPHONE CALLING CARDS NOT MAGNETICALLY ENCODED; CREDIT CARDS WITHOUT MAGNETIC CODING; GREETING CARDS; POSTCARDS; PRINTED TEACHING MATERIALS IN THE FIELD OF MUSIC; DIARIES; GEOGRAPHICAL MAPS; CATALOGUES IN THE FIELD OF COMPUTER ANIMATION; PRINTED TICKETS; PAMPHLETS IN THE FIELD OF COMPUTER ANIMATION; POSTERS; PHOTOGRAPHS; BABIES' DIAPERS OF PAPER; PRINT ENGRAVINGS (U.S. CLS. 2, 5, 22, 23, 29, 37, 38 AND 50).

#### **CLASS 18—LEATHER GOODS**

FOR DOG COLLARS; CLOTHING FOR PETS; ARTIFICIAL FUR; RAW SKINS; BACKPACKS IN THE NATURE OF RUCKSACKS; SCHOOLCHILDREN'S BACKPACKS; PURSES NOT OF PRECIOUS METAL; BEACH BAGS; BRIEFCASES; TRAVELING BAGS; TRAVELING TRUNKS; SCHOOL BAGS; HANDBAGS; PARASOLS IN THE NATURE OF SUN UMBRELLAS; UMBRELLAS; WALKING STICKS (U.S. CLS. 1, 2, 3, 22 AND 41).

#### **CLASS 21—HOUSEWARES AND GLASS**

FOR SOAP BOXES; COSMETIC BRUSHES; FITTED VANITY CASES; TOOTHBRUSHES; BROOMS; TRASH CANS; DUST BINS; DUST PANS; CLEANING RAGS; TEMPERED GLASS NOT FOR BUILDING; MOSAICS OF GLASS NOT FOR BUILDING; COMMON SHEET GLASS NOT FOR BUILDING; PANS; PITCHERS NOT OF PRECIOUS METAL; NON-ELECTRIC KETTLES; NON-ELECTRIC FRYING PANS; NON-ELECTRIC COFFEEPOTS NOT OF PRECIOUS METAL; MUGS NOT OF PRECIOUS METAL; DRINKING CUPS NOT OF PRECIOUS METAL; DISHES NOT OF PRECIOUS METAL; TEACUPS NOT OF PRECIOUS METAL; PLASTIC CUPS; DRINKING HORNS; MESS-TINS; CHOPPING BOARDS FOR KITCHEN USE; SPICE RACKS; BUCKETS; INSULATING FLASKS; PORTABLE COOLERS; PIGGY BANKS NOT OF METAL; BIRDCAGES; CAGES FOR HOUSEHOLD PETS; TOILET PAPER HOLDERS; HOLDERS FOR HOUSEHOLD IRONS; BABY BATH TUBS; PAPER CUPS; BOTTLES FOR BEVERAGES SOLD EMPTY; PLASTIC BOTTLES SOLD EMPTY; SHOE BRUSHES; FLOWER VASES NOT OF PRECIOUS METAL; POTTERY, NAMELY, DISHES, JUGS, DRINKING VESSELS; ELECTRIC HAIR COMBS; ELECTRIC TOOTHBRUSHES; SCULPTURES MADE OF GLASS; SCULPTURES MADE OF PORCELAIN (U.S. CLS. 2, 13, 23, 29, 30, 33, 40 AND 50).

#### **CLASS 24—FABRICS**

FOR SHOWER CURTAINS; FITTED TOILET LID COVERS MADE OF FABRIC; UNFITTED FURNITURE COVERINGS OF TEXTILE; TEXTILE TABLECLOTHS; PLACE MATS OF TEXTILE; FABRIC TABLE RUNNERS; UNFITTED TEXTILE PIANO COVERS; QUILTS; MATTRESS COVERS; PILLOWCASES; SLEEPING BAGS AS BED LINENS; PAPER BED COVERS; COVERS FOR CUSHIONS; HANDKERCHIEFS OF TEXTILE; TOWELS OF TEXTILE; SILK FABRICS; COTTON FABRICS; WOOL BASE MIXED FABRICS; COTTON BASE MIXED FABRICS; SEMI-SYNTHETIC FIBER FABRICS (U.S. CLS. 42 AND 50).

#### **CLASS 25—CLOTHING**

FOR LEATHER SHOES; GOLF SHOES; BASKETBALL SHOES; SHOES; MOUNTAINEERING BOOTS; LACE BOOTS; BATH SLIPPERS; ANKLE BOOTS; BATH SANDALS; SANDALS; SKI BOOTS; SLIPPERS; NON-SLIPPING DEVICES FOR BOOTS AND SHOES IN THE NATURE OF SOLES; BASEBALL SHOES; ESPARTO SHOES AND SANDALS; OVERSHOES; RAIN BOOTS; TRAINING SHOES; WORK SHOES AND BOOTS; LONG BOOTS; GYMNASIUM SHOES; FOOTBALL SHOES; BODY SUITS, NAMELY, AEROBICS SUITS; SPORTS ANORAKS; MASQUERADE COSTUMES; SCHOOL UNIFORMS; HALF-LENGTH COATS; BLOUSONS; SARIS; SAFARI SUITS; SUITS; SMOCKS; SKIRTS; SLACKS; ANORAKS; CHILDREN'S SHIRTS; CEREMONIAL DRESSES; OVERALLS; INFANTS' SLEEPERS; EVENING DRESSES; JACKETS; WORK CLOTHING, NAMELY,

SHIRTS, PANTS AND JACKETS; JUMPERS; CHASUBLES; BLUE JEANS; CAPES; TOPCOATS; TOGAS; TUNICS; PARKAS; PELISSES; FROCKS; T-SHIRTS; GIRDLES; NIGHTGOWNS; BUTTON-FRONT ALOHA SHIRTS; NEGLIGES; DRESSING GOWNS; ROMPERS; LEOTARDS; MANTILLAS; BATH ROBES; BODICES; BODY SHIRTS; BRASSIERES; BLOUSES; SHOWER CAPS; SHIRT YOKES; SHIRT FRONTS; UNDERWEAR; UNDERSHIRTS; UNDERPANTS; BATHING CAPS; SWIMSUITS; BATHING TRUNKS; CHEMISETTES; CHEMISES; SWEATERS; SWEAT SHIRTS; SWEAT PANTS; SPORTS SHIRTS; SLIPS FOR USE AS UNDERGARMENTS; EXERCISE CLOTHING, NAMELY, SHIRTS, PANTS AND SWEATBANDS; COLLARS; NIGHTWEAR; JERSEYS; VESTS; CARDIGANS; COLLAR PROTECTORS; COLLAR CUFFS; CAMISOLES; TANK TOPS; TEDDIES IN THE NATURE OF UNDERGARMENTS; TRACKSUITS; PAJAMAS; PETTICOATS; POLO SHIRTS; PULLOVERS; NECKTIES; SWEAT-ABSORBENT STOCKINGS; LEG WARMERS; LEGGINGS; MUFFS; MUFFLERS; BANDANAS; EAR MUFFS; WINTER GLOVES; MITTENS; VEILS; BOAS; FOOT MUFFS NOT ELECTRICALLY HEATED; SHAWLS; SHOULDER WRAPS; SCARVES; STOCKINGS; STOLE; SOCKS; POCKET SQUARES; APRONS; SPORTS SOCKS; INFANT CLOTH DIAPERS; TIGHTS; NIGHTCAPS; CAPS; SUN VISORS; HOODS; WATERPROOF JACKETS; GAITERS; STOCKING SUSPENDERS; SOCK SUSPENDERS; BRACES FOR CLOTHING IN THE NATURE OF SUSPENDERS; LEATHER BELTS (U.S. CLS. 22 AND 39).

#### **CLASS 28—TOYS AND SPORTING GOODS**

FOR TOYS FOR DOMESTIC PETS; TOY MASKS; RUBBER CHARACTER TOYS; METAL CLOCKWORK TOYS; MARIONETTES; BABY RATTLES; REMOTE-CONTROLLED TOY MOTORIZED VEHICLES; MASCOT DOLLS; TOY MOBILES; WOODEN ACTION TOYS; TOY CONSTRUCTION SETS; PUPPETS; SCALE MODEL VEHICLES FOR CHILDREN; TOY TRICYCLES FOR INFANTS; ROCKING HORSES; MUSICAL TOYS; TOY BUILDING BLOCKS; TOY SCOOTERS; TOY FLYING DISCS; DOLLS' ROOMS; DOLLS' FEEDING BOTTLES; CLOTHES FOR DOLLS; DOLLS' HOUSES; DOLLS' BEDS; TOY PISTOLS; PAPER AIRPLANES; PLUSH TOYS; PLASTIC CHARACTER TOYS; KITES; DICE; CHESS BOARDS; CHECKERS; PLAYING CARDS; SPINNING TOPS; JIGSAW PUZZLES; SWING SETS; RACKETS FOR TENNIS; PROTECTIVE COVERS FOR RACKETS; EXERCISE TREADMILLS; ROWING MACHINES FOR PHYSICAL EXERCISE OTHER THAN FOR MEDICAL USE; ROLLER SKATES; KNEE GUARDS FOR SPORTS USE; PLAYGROUND EQUIPMENT IN THE NATURE OF SLIDES; BOWLING BAGS; BOWLING GLOVES; BOWLING BALLS; PAINTBALL GUNS; SURFBOARDS; SNOW GLOBES; SNOWSHOES; SKATEBOARDS; SKIS; SKI BAGS; TOY SLEIGHS; SPRING BOARDS FOR USE AS SPORTING ARTICLES; ICE SKATES; INFLATABLE SWIMMING POOLS; SKIPPING ROPES; PUNCHING BALLS FOR BOXING PRACTICE; RODS FOR FISHING (U.S. CLS. 22, 23, 38 AND 50).

#### **CLASS 35—ADVERTISING AND BUSINESS**

FOR RETAIL STORE AND ON-LINE RETAIL STORE SERVICES IN THE FIELDS OF TOYS, DOLLS, APPAREL, FOOTWEAR, PERSONAL CARE PRODUCTS, BEAUTY PRODUCTS, STATIONARY, CONSUMER ELECTRONICS AND CONSUMER ELECTRONICS ACCESSORIES, JEWELRY, BAGS AND FASHION ACCESSORIES (U.S. CLS. 100, 101 AND 102).

#### **CLASS 38—COMMUNICATION**

FOR COMMUNICATION SERVICES, NAMELY, TRANSMISSION OF VOICE, AUDIO, VISUAL IMAGES AND DATA BY TELECOMMUNICATIONS NETWORKS; ELECTRONIC MAIL SERVICES; CELLULAR TELEPHONE COMMUNICATION; PROVIDING USER ACCESS TO A GLOBAL COMPUTER NETWORK; VIDEO BROADCASTING SERVICES PROVIDED VIA THE INTERNET; TELEVISION BROADCASTING (U.S. CLS. 100, 101 AND 104).



**CLASS 41—EDUCATION AND ENTERTAINMENT**

FOR ANIMATION PRODUCTION SERVICES; PROVIDING TEMPORARY USE OF ONLINE, NON-DOWNLOADABLE ELECTRONIC GAMES FOR USE ON MOBILE DEVICES; PROVIDING TEMPORARY USE OF ONLINE ELECTRONIC GAMES; PROVIDING ONLINE COMPUTER GAMES; PROVIDING TEMPORARY USE OF ONLINE, NON-DOWNLOADABLE COMPUTER GAMES FOR USE VIA MOBILE DEVICES; PROVIDING INFORMATION ABOUT ONLINE COMPUTER GAMES; PROVIDING INFORMATION ABOUT MOBILE COMPUTER GAMES (U.S. CLS. 100, 101 AND 107).  
LAKEISHA LEWIS, EXAMINING ATTORNEY

SN 85-204,131. TWO-CYLINDER, LTD., GRUNDY CENTER, IA. FILED 12-22-2010.

**TWO-CYLINDER**

THE MARK CONSISTS OF STANDARD CHARACTERS WITHOUT CLAIM TO ANY PARTICULAR FONT, STYLE, SIZE, OR COLOR.  
OWNER OF U.S. REG. NO. 2,818,911.  
SEC. 2(F).

**CLASS 16—PAPER GOODS AND PRINTED MATTER**

FOR BOOKS, MAGAZINES, PERIODICALLY ISSUED BOOKLETS DEALING WITH AGRICULTURAL VEHICLES (U.S. CLS. 2, 5, 22, 23, 29, 37, 38 AND 50).  
FIRST USE 9-0-1985; IN COMMERCE 9-0-1985.

**CLASS 35—ADVERTISING AND BUSINESS**

FOR ARRANGING AND CONDUCTING TRADE SHOW EXHIBITIONS IN THE FIELD OF AGRICULTURAL VEHICLES (U.S. CLS. 100, 101 AND 102).  
FIRST USE 5-1-1987; IN COMMERCE 5-1-1987.  
JENNIFER DIXON, EXAMINING ATTORNEY

SN 85-204,321. IDEA NUOVA, INC., NEW YORK, NY. FILED 12-22-2010.

**AMERICAN CAMPUS**

THE MARK CONSISTS OF STANDARD CHARACTERS WITHOUT CLAIM TO ANY PARTICULAR FONT, STYLE, SIZE, OR COLOR.  
NO CLAIM IS MADE TO THE EXCLUSIVE RIGHT TO USE "AMERICAN", APART FROM THE MARK AS SHOWN.

**CLASS 20—FURNITURE AND ARTICLES NOT OTHERWISE CLASSIFIED**

FOR PILLOWS (U.S. CLS. 2, 13, 22, 25, 32 AND 50).

**CLASS 24—FABRICS**

FOR BED BLANKETS; BED SHEETS; BLANKET THROWS; COMFORTERS; PILLOW CASES; PILLOW SHAMS (U.S. CLS. 42 AND 50).  
ODESSA BIBBINS, EXAMINING ATTORNEY

SN 85-204,502. SEMASIO GMBH, HAMBURG, FED REP GERMANY, FILED 12-22-2010.

**SEMASIO**

THE MARK CONSISTS OF STANDARD CHARACTERS WITHOUT CLAIM TO ANY PARTICULAR FONT, STYLE, SIZE, OR COLOR.

**CLASS 35—ADVERTISING AND BUSINESS**

FOR BUSINESS MANAGEMENT SERVICES, NAMELY, PROVIDING BUSINESS DATA ANALYSIS AND BUSINESS INTELLIGENCE SERVICES AND SALES SUPPORT MANAGEMENT SERVICES; BUSINESS MANAGEMENT CONSULTING SERVICES RELATING TO ONLINE ADVERTISING TARGETING, SALES SUPPORT MANAGEMENT, AND MARKETING AUTOMATION; PROVIDING A WEBSITE FEATURING ADVERTISING, MARKETING AND BUSINESS INFORMATION OF INTEREST TO THE FIELDS OF ADVERTISING, MARKETING AND BUSINESS SERVICES (U.S. CLS. 100, 101 AND 102).

**CLASS 42—SCIENTIFIC AND COMPUTER SERVICES**

FOR PROVIDING TEMPORARY USE OF ON-LINE NON-DOWNLOADABLE SOFTWARE TO STORE, MANAGE, TRACK, ANALYZE AND REPORT DATA IN THE FIELD OF MARKETING, PROMOTION, SALES, CUSTOMER INFORMATION, CUSTOMER RELATIONSHIP MANAGEMENT AND SALES SUPPORT (U.S. CLS. 100 AND 101).  
JULIE VEPPUMTHARA, EXAMINING ATTORNEY

SN 85-204,638. EUROPEAN SERVICE AT HOME INC., PALATINE, IL. FILED 12-23-2010.



**European Service at Home**

NO CLAIM IS MADE TO THE EXCLUSIVE RIGHT TO USE "SERVICE AT HOME", APART FROM THE MARK AS SHOWN.

THE COLOR(S) RED, WHITE, AND BLUE IS/ARE CLAIMED AS A FEATURE OF THE MARK.

THE MARK CONSISTS OF A HEART WITH A CROSS AND LITERAL ELEMENT "EUROPEAN SERVICE AT HOME". THE HEART IS PRESENTED IN RED VERTICAL STRIPES WHERE THERE IS THE CROSS ON THE RIGHT SIDE OF THE HEART. ONE PART OF THE CROSS IS ON A TOP OF THE HEART AND IS IN WHITE. THE OTHER PART OF THE CROSS IS OUTSIDE OF THE HEART AND IS IN RED VERTICAL STRIPES. THERE IS ALSO A WORDING "EUROPEAN SERVICE AT HOME" THAT APPEARS TO THE RIGHT OF THE HEART, AND IS WRITTEN IN BLUE.

**CLASS 35—ADVERTISING AND BUSINESS**

FOR TRANSPORTATION LOGISTICS SERVICES, NAMELY, ARRANGING THE TRANSPORTATION OF GOODS FOR OTHERS; TRANSPORTATION MANAGEMENT SERVICES, NAMELY, PLANNING AND COORDINATING TRANSPORTATION OF PEOPLE FOR OTHERS (U.S. CLS. 100, 101 AND 102).

SN 85-204,777. THE AMERICAN TRIAL LAWYERS ASSOCIATION, INC., DOTHAN, AL. FILED 12-23-2010.

**CLASS 39—TRANSPORTATION AND STORAGE**

FOR TRANSPORTATION OF PASSENGERS AND PASSENGERS' LUGGAGE; TRANSPORTATION OF PASSENGERS AND/OR GOODS BY BUS, CAR; TRANSPORTATION SERVICES, NAMELY, PROVIDING SHUTTLE SERVICES BY BUS, CAR (U.S. CLS. 100 AND 105).

**CLASS 45—PERSONAL AND LEGAL SERVICES**

FOR PERSONAL CARE ASSISTANCE OF ACTIVITIES OF DAILY LIVING, SUCH AS BATHING, GROOMING AND PERSONAL MOBILITY FOR MENTALLY OR PHYSICALLY CHALLENGED PEOPLE (U.S. CLS. 100 AND 101).

ANDREA BUTLER, EXAMINING ATTORNEY

NO CLAIM IS MADE TO THE EXCLUSIVE RIGHT TO USE "NATIONAL TRIAL LAWYERS", APART FROM THE MARK AS SHOWN.

THE COLOR(S) BLUE AND GOLD IS/ARE CLAIMED AS A FEATURE OF THE MARK.

THE MARK CONSISTS OF TWO INCOMPLETE CIRCLES AND A SCULPTURE OF A HUMAN BEING WHICH IS LADY JUSTICE HOLDING THE SCALES OF JUSTICE IN HER LEFT HAND AND A SWORD IN HER RIGHT HAND. THE TWO INCOMPLETE CIRCLES ARE BLUE AND THE STATUE OF LADY JUSTICE IS GOLD. THE WORDS "THE NATIONAL TRIAL LAWYERS" ARE BLUE IN A TRAJAN PRO FONT.

SN 85-204,643. PARRY ASHFORD, INC., MIAMI, FL. FILED 12-23-2010.

**CLASS 35—ADVERTISING AND BUSINESS**

FOR ASSOCIATION SERVICES, NAMELY, PROMOTING THE INTERESTS OF LAWYERS (U.S. CLS. 100, 101 AND 102).

## THE PARAGRAPH FOUR REPORT

**CLASS 41—EDUCATION AND ENTERTAINMENT**

FOR ARRANGING AND CONDUCTING EDUCATIONAL CONFERENCES (U.S. CLS. 100, 101 AND 107).

AMY C. KEAN, EXAMINING ATTORNEY

THE MARK CONSISTS OF STANDARD CHARACTERS WITHOUT CLAIM TO ANY PARTICULAR FONT, STYLE, SIZE, OR COLOR.

OWNER OF U.S. REG. NOS. 3,030,837 AND 3,180,511.

NO CLAIM IS MADE TO THE EXCLUSIVE RIGHT TO USE "REPORT", APART FROM THE MARK AS SHOWN. SEC. 2(F).

SN 85-204,892. FROG INDUSTRY LLC, SAN FRANCISCO, CA. FILED 12-23-2010.

**CLASS 16—PAPER GOODS AND PRINTED MATTER**

FOR PRINTED REPORTS REGARDING THE LEGAL AND REGULATORY CHALLENGES MADE BY GENERIC PHARMACEUTICAL COMPANIES AGAINST PHARMACEUTICAL PATENTS OF BRANDED PHARMACEUTICAL PRODUCTS (U.S. CLS. 2, 5, 22, 23, 29, 37, 38 AND 50).

FIRST USE 0-0-2004; IN COMMERCE 0-0-2004.

**CLASS 41—EDUCATION AND ENTERTAINMENT**

FOR PROVIDING ONLINE REPORTS REGARDING THE LEGAL AND REGULATORY CHALLENGES MADE BY GENERIC PHARMACEUTICAL COMPANIES AGAINST PHARMACEUTICAL PATENTS OF BRANDED PHARMACEUTICAL PRODUCTS (U.S. CLS. 100, 101 AND 107).

FIRST USE 0-0-2004; IN COMMERCE 0-0-2004.  
ANDREA BUTLER, EXAMINING ATTORNEY

# ZENLIST

THE MARK CONSISTS OF STANDARD CHARACTERS WITHOUT CLAIM TO ANY PARTICULAR FONT, STYLE, SIZE, OR COLOR.

**CLASS 35—ADVERTISING AND BUSINESS**

FOR ADVERTISING AND INFORMATION DISTRIBUTION SERVICES, NAMELY, PROVIDING CLASSIFIED ADVERTISING SPACE VIA THE GLOBAL COMPUTER NETWORK; PROVIDING CONSUMER PRODUCT AND SERVICE INFORMATION VIA THE INTERNET; PROMOTING THE GOODS AND SERVICES OF OTHERS OVER THE INTERNET; PROVIDING AN ONLINE BUSINESS INFORMATION DIRECTORY ON THE INTERNET; COMPUTERIZED DATABASE MANAGEMENT; PROMOTING AND ADVERTISING INFORMATION ABOUT THE PROFESSIONAL SERVICES OF OTHERS; PROVIDING ON-LINE COMPUTER DATABASES AND ON-LINE SEARCHABLE DATABASES FEATURING CLASSIFIED ADVERTISING LISTINGS AND EMPLOYMENT OPPORTUNITY LISTINGS; PROVIDING ON-LINE COMPUTER DATABASES AND ON-LINE SEARCHABLE DATABASES FEATURING INFORMATION, CLASSIFIED LISTINGS AND ANNOUNCEMENTS ABOUT EMPLOYMENT INFORMATION AND RESUMES, JOB OPENINGS, VOLUNTEER INFORMATION AND VOLUNTEER OPPORTUNITIES THROUGH COMMUNITY AND CHARITABLE ORGANIZATIONS AND BUSINESSES, INFORMATION ABOUT COMMUNITY SERVICE PROGRAMS, INFORMATION ABOUT POLITICS, BUSINESS EVENTS, AND BUSINESS MEETINGS; CLASSIFIED LISTINGS FOR RENTALS OF A WIDE-VARIETY OF CONSUMER AND BUSINESS GOODS; COMPUTER SERVICES, NAMELY, PROVIDING ON-LINE COMPUTER DATABASES AND ON-LINE SEARCHABLE DATABASES FEATURING CONSUMER INFORMATION ON A WIDE VARIETY OF TOPICS OF GENERAL INTEREST TO THE CONSUMING PUBLIC (U.S. CLS. 100, 101 AND 102).

**CLASS 36—INSURANCE AND FINANCIAL**

FOR PROVIDING ON-LINE COMPUTER DATABASES AND ON-LINE SEARCHABLE DATABASES FEATURING INFORMATION, CLASSIFIED LISTINGS AND ANNOUNCEMENTS ABOUT HOUSING, APARTMENTS, CONDOMINIUMS, TOWN HOMES, REAL ESTATE, COMMERCIAL REAL ESTATE, ROOMMATE-WANTED, AND RENTAL AND LEASING AND FOR SALE ADVERTISEMENTS FOR THE FOREGOING (U.S. CLS. 100, 101 AND 102).

**CLASS 38—COMMUNICATION**

FOR PROVIDING AN ONLINE INTERACTIVE BULLETIN BOARD FEATURING JOB LISTINGS, EVENT LISTINGS, COMMERCIAL NOTICES AND RESUME LISTINGS; PROVIDING ONLINE INTERACTIVE BULLETIN BOARDS FOR TRANSMISSION OF MESSAGES AMONG COMPUTER USERS CONCERNING CLASSIFIED LISTINGS AND LISTINGS FOR ANNOUNCEMENTS, EVENTS, CLASSES, MEETINGS, ACTIVITIES, HOUSING, REAL ESTATE, ROOMMATES, RENTALS, FOR SALE ADVERTISEMENTS, WANT ADS, EMPLOYMENT, RESUMES, VOLUNTEERISM, SERVICES, COMMUNITY, PERSONALS, POLITICS, FAMILY, ARTS AND INFORMATION ON A WIDE VARIETY OF TOPICS OF GENERAL INTEREST TO THE PUBLIC; PROVIDING ON-LINE FORUMS AND DISCUSSION GROUPS FOR TRANSMISSION OF MESSAGES AMONG COMPUTER USERS CONCERNING HEALTH, FAMILY, ARTS, POLITICS, LEISURE, ROMANCE, WORK, AND INFORMATION ON A WIDE VARIETY OF TOPICS OF GENERAL INTEREST TO THE PUBLIC; ELECTRONIC MAIL SERVICES; ELECTRONIC MAIL SERVICES OFFERED BY SUBSCRIPTION; AND ELECTRONIC TRANSMISSION OF MESSAGES, DATA AND IMAGES (U.S. CLS. 100, 101 AND 104).

**CLASS 41—EDUCATION AND ENTERTAINMENT**

FOR ON-LINE JOURNALS, NAMELY, BLOGS FEATURING INFORMATION IN THE FIELDS OF NEWS, ENTERTAINMENT, CURRENT EVENTS, LEGAL MATTERS, ONLINE INTERACTIVE BULLETIN BOARDS, DISCUSSION FORUMS, CLASSIFIED ADVERTISING, WANT ADVERTISING, VOLUNTEERING, CHARITY, PERSONALS, FAMILY, ARTS, HEALTH, ACTIVITIES, COMMUNITY AND BUSINESS EVENTS AND MEETINGS, CONSUMER INFORMATION, ROOMMATES, RENTAL AND SALE OF REAL ESTATE, AND TOPICS OF GENERAL INTEREST (U.S. CLS. 100, 101 AND 107).  
REBECCA EISINGER, EXAMINING ATTORNEY

SN 85-205,091. INSPIRED INSTRUMENTS, INC., CHATSWORTH, CA. FILED 12-23-2010.

NO CLAIM IS MADE TO THE EXCLUSIVE RIGHT TO USE "NETWORK", APART FROM THE MARK AS SHOWN. THE COLOR(S) BLUE, BLACK AND WHITE IS/ARE CLAIMED AS A FEATURE OF THE MARK.

THE MARK CONSISTS OF THE WORDING "YOU ROCK NETWORK" WITH THE LETTERS "Y" AND "R" APPEARING IN THE COLOR BLUE, THE LETTERS "OU" AND "OCK" APPEARING IN BLACK AND THE TERM "NETWORK" APPEARING IN BLACK. A HORIZONTAL BLACK LINE APPEARS BENEATH WORDING "YOU ROCK". THE MARK HAS A WHITE BACKGROUND.

**CLASS 9—ELECTRICAL AND SCIENTIFIC APPARATUS**

FOR DOWNLOADABLE RING TONES, GRAPHICS AND MUSIC VIA A GLOBAL COMPUTER NETWORK AND WIRELESS DEVICES (U.S. CLS. 21, 23, 26, 36 AND 38).

**CLASS 42—SCIENTIFIC AND COMPUTER SERVICES**

FOR COMPUTER SERVICES, NAMELY, CREATING AN ON-LINE COMMUNITY FOR REGISTERED USERS TO PARTICIPATE IN COMPETITIONS, SHOWCASE THEIR SKILLS, GET FEEDBACK FROM THEIR PEERS, FORM VIRTUAL COMMUNITIES, ENGAGE IN SOCIAL NETWORKING AND IMPROVE THEIR TALENT; PROVIDING AN ONLINE NETWORK SERVICE THAT ENABLES USERS TO SHARE DATA IN THE FIELD OF MUSIC (U.S. CLS. 100 AND 101).

KAREN BRACEY, EXAMINING ATTORNEY

SN 85-205,166. LOCHENVEST LLC, WILLIAMSBURG, MI. FILED 12-23-2010.

THE MARK CONSISTS OF STANDARD CHARACTERS WITHOUT CLAIM TO ANY PARTICULAR FONT, STYLE, SIZE, OR COLOR.

THE WORDING "LOCHENHEATH" HAS NO MEANING IN A FOREIGN LANGUAGE.

**CLASS 35—ADVERTISING AND BUSINESS**

FOR RETAIL STORE SERVICES AND ONLINE RETAIL STORE SERVICES FEATURING CLOTHING, CLOTHING ACCESSORIES, HATS, FOOTWEAR, TOWELS, SPORTING GOODS, GLASSWARE, DRINKWARE, HOUSEHOLD UTENSILS, GOLF EQUIPMENT AND ACCESSORIES, ORNAMENTS, GAMES, WALLETS, BAGS, LUGGAGE, OFFICE SUPPLIES, BOOKS, POSTCARDS, POSTERS, MUSICAL AND VIDEO RECORDINGS, COMPUTER SOFTWARE, KEY RINGS, JEWELRY, MAGNETS, ART, CANDLES, PERSONAL CARE PRODUCTS, COSMETICS, GIFT BASKETS, TROPHIES AND PLAQUES, RETAIL FOOD AND ALCOHOLIC BEVERAGE CONCESSION STAND AND KIOSK SERVICES; PROVIDING FACILITIES FOR BUSINESS MEETINGS (U.S. CLS. 100, 101 AND 102).

**CLASS 41—EDUCATION AND ENTERTAINMENT**

FOR COUNTRY CLUB SERVICES, NAMELY, PROVIDING GOLF FACILITIES; ENTERTAINMENT SERVICES, NAMELY, ORGANIZING AND CONDUCTING GOLF TOURNAMENTS; EDUCATIONAL SERVICES, NAMELY, INSTRUCTION IN GOLF; RENTAL OF GOLF EQUIPMENT; PROVIDING A WEBSITE THROUGH WHICH GOLFERS RESERVE TEE TIMES AT GOLF COURSES; PROVIDING A WEBSITE THROUGH WHICH GOLFERS LOCATE INFORMATION ABOUT GOLF COURSES AND GOLF TOURNAMENTS; PROVIDING INFORMATION IN THE FIELDS OF GOLF, GOLF RESORTS, GOLF INSTRUCTION, GOLF COURSES, AND GOLF TOURNAMENTS; ENTERTAINMENT IN THE NATURE OF GOLF TOURNAMENTS; AND PROVIDING ONLINE NEWSLETTERS IN THE FIELD OF GOLF; PROVIDING RECREATION MEETING ROOM FACILITIES (U.S. CLS. 100, 101 AND 107).

**CLASS 43—HOTEL AND RESTAURANT SERVICES**

FOR RESTAURANT AND BAR SERVICES (U.S. CLS. 100 AND 101).  
TRICIA SONNEBORN, EXAMINING ATTORNEY

**CLASS 35—ADVERTISING AND BUSINESS**

FOR RETAIL STORE SERVICES AND ONLINE RETAIL STORE SERVICES FEATURING CLOTHING, CLOTHING ACCESSORIES, HATS, FOOTWEAR, TOWELS, SPORTING GOODS, GLASSWARE, DRINKWARE, HOUSEHOLD UTENSILS, GOLF EQUIPMENT AND ACCESSORIES, ORNAMENTS, GAMES, WALLETS, BAGS, LUGGAGE, OFFICE SUPPLIES, BOOKS, POSTCARDS, POSTERS, MUSICAL AND VIDEO RECORDINGS, COMPUTER SOFTWARE, KEY RINGS, JEWELRY, MAGNETS, ART, CANDLES, PERSONAL CARE PRODUCTS, COSMETICS, GIFT BASKETS, TROPHIES AND PLAQUES, RETAIL FOOD AND ALCOHOLIC BEVERAGE CONCESSION STAND AND KIOSK SERVICES; PROVIDING FACILITIES FOR BUSINESS MEETINGS (U.S. CLS. 100, 101 AND 102).

**CLASS 41—EDUCATION AND ENTERTAINMENT**

FOR COUNTRY CLUB SERVICES, NAMELY, PROVIDING GOLF FACILITIES; ENTERTAINMENT SERVICES, NAMELY, ORGANIZING AND CONDUCTING GOLF TOURNAMENTS; EDUCATIONAL SERVICES, NAMELY, INSTRUCTION IN GOLF; RENTAL OF GOLF EQUIPMENT; PROVIDING A WEBSITE THROUGH WHICH GOLFERS RESERVE TEE TIMES AT GOLF COURSES; PROVIDING A WEBSITE THROUGH WHICH GOLFERS LOCATE INFORMATION ABOUT GOLF COURSES AND GOLF TOURNAMENTS; PROVIDING INFORMATION IN THE FIELDS OF GOLF, GOLF RESORTS, GOLF INSTRUCTION, GOLF COURSES, AND GOLF TOURNAMENTS; ENTERTAINMENT IN THE NATURE OF GOLF TOURNAMENTS; AND PROVIDING ONLINE NEWSLETTERS IN THE FIELD OF GOLF; PROVIDING RECREATION MEETING ROOM FACILITIES (U.S. CLS. 100, 101 AND 107).

**CLASS 43—HOTEL AND RESTAURANT SERVICES**

FOR RESTAURANT AND BAR SERVICES (U.S. CLS. 100 AND 101).  
TRICIA SONNEBORN, EXAMINING ATTORNEY

SN 85-205,167. LOCHENVEST LLC, WILLIAMSBURG, MI. FILED 12-23-2010.

SN 85-205,188. SCOSCHE INDUSTRIES, INC, OXNARD, CA. FILED 12-23-2010.



THE MARK CONSISTS OF THE WORD "LOCHENHEATH" IN A STYLIZED FONT APPEARING UNDERNEATH A DESIGN CONSISTING OF THREE WAVING FLAGS.  
THE WORDING "LOCHENHEATH" HAS NO MEANING IN A FOREIGN LANGUAGE.



OWNER OF U.S. REG. NOS. 3,309,408 AND 3,833,515.  
THE MARK CONSISTS OF THE WORDING "SCOSCHE" AND THE WORDING "MYTREK" IN STYLIZED LETTERING.  
THE WORDING "SCOSCHE" HAS NO MEANING IN A FOREIGN LANGUAGE.



**CLASS 9—ELECTRICAL AND SCIENTIFIC APPARATUS**

FOR ELECTRONIC SENSORS AND RECEIVERS FOR SENSING PHYSICAL EXERCISE DATA DURING EXERCISE, NAMELY, ACCELERATION, SPEED, DISTANCE, CALORIES BURNED, WORKOUT TYPE, DURATION OF WORKOUT, STRIDE RATE AND NUMBER OF STEPS; ELECTRONIC PORTABLE DEVICES, NAMELY, DATA RECORDERS FOR STORING, TRANSFERRING AND SYNCHRONIZING PHYSICAL EXERCISE DATA AND STORING, TRANSFERRING, SYNCHRONIZING AND VIEWING TRAINING INSTRUCTIONS DURING EXERCISE; ELECTRONIC TRANSMITTERS AND RECEIVERS, NAMELY, REMOTE DEVICES WORN ON OR ABOUT THE BODY TO TRANSMIT AND RECEIVE DIGITIZED INFORMATION, NAMELY, AUDIBLE TRAINING INSTRUCTIONS AND WORKOUT DATA DURING EXERCISE (U.S. CLS. 21, 23, 26, 36 AND 38).

**CLASS 10—MEDICAL APPARATUS**

FOR HEART RATE MONITORS FOR ATHLETIC AND FITNESS USE (U.S. CLS. 26, 39 AND 44).

**CLASS 14—JEWELRY**

FOR WATCHES; WATCHES INCORPORATING FUNCTIONS FOR MONITORING FITNESS DATA, NAMELY, ACCELERATION, SPEED, DISTANCE, CALORIES BURNED, WORKOUT TYPE, DURATION OF WORKOUT, STRIDE RATE AND NUMBER OF STEPS (U.S. CLS. 2, 27, 28 AND 50).

TRICIA SONNEBORN, EXAMINING ATTORNEY

SN 85-205,372. DEEPA GURNANI LLC, NEW YORK, NY. FILED 12-23-2010.

DEEPA GURNANI

THE MARK CONSISTS OF STANDARD CHARACTERS WITHOUT CLAIM TO ANY PARTICULAR FONT, STYLE, SIZE, OR COLOR.

THE NAME(S), PORTRAIT(S), AND/OR SIGNATURE(S) SHOWN IN THE MARK IDENTIFIES "DEEPA GURNANI", WHOSE CONSENT(S) TO REGISTER IS MADE OF RECORD.

**CLASS 18—LEATHER GOODS**

FOR POCKETBOOKS, HANDBAGS, CLUTCHES AND PURSES (U.S. CLS. 1, 2, 3, 22 AND 41).  
FIRST USE 11-24-2006; IN COMMERCE 11-24-2006.

**CLASS 25—CLOTHING**

FOR APPAREL, NAMELY, BELTS, SCARVES, HEADBANDS AND KAFTANS (U.S. CLS. 22 AND 39).  
FIRST USE 11-24-2006; IN COMMERCE 11-24-2006.

**CLASS 26—FANCY GOODS**

FOR HAIR ACCESSORIES, NAMELY, HAIR BANDS, BARRETTES, PONYTAIL HOLDERS AND HAIR CLIPS (U.S. CLS. 37, 39, 40, 42 AND 50).  
FIRST USE 11-24-2006; IN COMMERCE 11-24-2006.  
MAYUR VAGHANI, EXAMINING ATTORNEY

SN 85-205,570. GUGLIEMELLI, DINO, VALENCIA, CA. FILED 12-24-2010.

COR

THE MARK CONSISTS OF STANDARD CHARACTERS WITHOUT CLAIM TO ANY PARTICULAR FONT, STYLE, SIZE, OR COLOR.

**CLASS 9—ELECTRICAL AND SCIENTIFIC APPARATUS**

FOR PRERECORDED AUDIO DISCS, TAPES AND PHONOGRAPHIC RECORDS FEATURING MUSIC, AND PROVIDING DOWNLOADABLE AUDIO MUSICAL RECORDINGS VIA A GLOBAL COMPUTER NETWORK (U.S. CLS. 21, 23, 26, 36 AND 38).

FIRST USE 6-1-2002; IN COMMERCE 6-1-2002.

**CLASS 41—EDUCATION AND ENTERTAINMENT**

FOR ENTERTAINMENT SERVICES, NAMELY, PERFORMANCES BY A LIVE MUSICAL GROUP AND PROVIDING PRERECORDED NON-DOWNLOADABLE MUSIC ONLINE AND INFORMATION REGARDING A MUSICAL GROUP ONLINE VIA A GLOBAL COMPUTER NETWORK (U.S. CLS. 100, 101 AND 107).

FIRST USE 6-1-2002; IN COMMERCE 6-1-2002.

JANICE L. MCMORROW, EXAMINING ATTORNEY

SN 85-205,703. FRANCHISE TECHNOLOGIES, INC., BOWMANVILLE, NY. FILED 12-26-2010.

STATBRIDGE

THE MARK CONSISTS OF STANDARD CHARACTERS WITHOUT CLAIM TO ANY PARTICULAR FONT, STYLE, SIZE, OR COLOR.

**CLASS 9—ELECTRICAL AND SCIENTIFIC APPARATUS**

FOR COMPUTER SOFTWARE FOR MONITORING, ANALYZING, AND MANAGING QUICK SERVE RESTAURANT OPERATIONS (U.S. CLS. 21, 23, 26, 36 AND 38).

**CLASS 35—ADVERTISING AND BUSINESS**

FOR PROVIDING ON-LINE BUSINESS MANAGEMENT SERVICES TO SUBSCRIBERS TO ANALYZE, MONITOR, AND MANAGE QUICK SERVE RESTAURANT OPERATIONS (U.S. CLS. 100, 101 AND 102).  
MAYUR VAGHANI, EXAMINING ATTORNEY

SN 85-205,744. HACK, KEVIN R., APPLETON, WI. FILED 12-27-2010.

SN 85-206,150. HACK, KEVIN R., APPLETON, WI. FILED 12-27-2010.

## The Pronunciation Of Perfection

THE MARK CONSISTS OF STANDARD CHARACTERS WITHOUT CLAIM TO ANY PARTICULAR FONT, STYLE, SIZE, OR COLOR.

### CLASS 32—LIGHT BEVERAGES

FOR ARTESIAN WATER, AERATED WATER, DRINKING WATER, STILL WATER, TABLE WATER, SPRING WATER, SPARKLING WATER, MINERAL WATER, FLAVORED WATERS, ENERGY DRINKS, ISOTONIC DRINKS, SPORTS DRINKS, NON-ALCOHOLIC BEVERAGES, NAMELY, CARBONATED BEVERAGES AND FRUIT JUICES (U.S. CLS. 45, 46 AND 48).

### CLASS 33—WINES AND SPIRITS

FOR ALCOHOL, NAMELY, DISTILLED SPIRITS (U.S. CLS. 47 AND 49).  
MARILYN IZZI, EXAMINING ATTORNEY

---

SN 85-206,039. HACK, KEVIN R., APPLETON, WI. FILED 12-27-2010.

## VOLUISSE

THE MARK CONSISTS OF STANDARD CHARACTERS WITHOUT CLAIM TO ANY PARTICULAR FONT, STYLE, SIZE, OR COLOR.

THE WORDING "VOLUISSE HAS NO MEANING IN A FOREIGN LANGUAGE.

### CLASS 32—LIGHT BEVERAGES

FOR ARTESIAN WATER, AERATED WATER, DRINKING WATER, STILL WATER, TABLE WATER, SPRING WATER, SPARKLING WATER, MINERAL WATER, SPARKLING MINERAL WATER, FLAVORED WATERS, ENERGY DRINKS, ISOTONIC DRINKS, SPORTS DRINKS, FRUIT DRINKS, NON-ALCOHOLIC BEVERAGES, NAMELY, CARBONATED BEVERAGES AND FRUIT JUICES (U.S. CLS. 45, 46 AND 48).

### CLASS 33—WINES AND SPIRITS

FOR ALCOHOLIC BEVERAGES, NAMELY, DISTILLED SPIRITS (U.S. CLS. 47 AND 49).

### CLASS 43—HOTEL AND RESTAURANT SERVICES

FOR BAR AND RESTAURANT SERVICES (U.S. CLS. 100 AND 101).  
MARILYN IZZI, EXAMINING ATTORNEY

## VOLASAY

THE MARK CONSISTS OF STANDARD CHARACTERS WITHOUT CLAIM TO ANY PARTICULAR FONT, STYLE, SIZE, OR COLOR.

THE WORDING "VOLASAY" HAS NO MEANING IN A FOREIGN LANGUAGE.

### CLASS 32—LIGHT BEVERAGES

FOR ARTESIAN WATER, GLACIAL WATER, AERATED WATER, DRINKING WATER, STILL WATER, TABLE WATER, SPRING WATER, DRINKING WATER WITH VITAMINS, DRINKING WATER WITH NUTRIENTS, SPARKLING WATER, MINERAL WATER, FILTERED WATER, SPARKLING ARTESIAN WATER, SPARKLING GLACIAL WATER, SPARKLING SPRING WATER, SPARKLING WATER WITH VITAMINS, SPARKLING WATER WITH NUTRIENTS, SPARKLING MINERAL WATER, SPARKLING FILTERED WATER, FLAVORED WATERS, ENERGY DRINKS, ISOTONIC DRINKS, SPORTS DRINKS, FRUIT DRINKS, BOTTLED WATER, PREPACKAGED WATER, NON-ALCOHOLIC BEVERAGES, NAMELY, CARBONATED BEVERAGES AND FRUIT JUICES (U.S. CLS. 45, 46 AND 48).

### CLASS 33—WINES AND SPIRITS

FOR ALCOHOLIC BEVERAGES, NAMELY, DISTILLED SPIRITS (U.S. CLS. 47 AND 49).

### CLASS 43—HOTEL AND RESTAURANT SERVICES

FOR BAR AND RESTAURANT SERVICES (U.S. CLS. 100 AND 101).  
MARILYN IZZI, EXAMINING ATTORNEY

---

SN 85-206,209. PROFESSIONAL AMATEUR RECORDS, COCONUT GROVE, FL. FILED 12-27-2010.



**PROFESSIONAL  
AMATEUR  
RECORDS**

NO CLAIM IS MADE TO THE EXCLUSIVE RIGHT TO USE "RECORDS", APART FROM THE MARK AS SHOWN.

THE MARK CONSISTS OF THE SILHOUETTE OF A MAN WITH HIS HANDS BEHIND HIS HEAD AND MUSCLES FLEXED. BELOW THAT IS THE WORDING "PROFESSIONAL AMATEUR RECORDS".

**CLASS 9—ELECTRICAL AND SCIENTIFIC APPARATUS**

FOR COMPACT DISCS FEATURING MUSIC (U.S. CLS. 21, 23, 26, 36 AND 38).

**CLASS 16—PAPER GOODS AND PRINTED MATTER**

FOR PRINTED MATTER, NAMELY, PAPER SIGNS, BOOKS, MANUALS, CURRICULUM, NEWSLETTERS, INFORMATIONAL CARDS AND BROCHURES IN THE FIELD OF MUSIC AND PERFORMANCE ART (U.S. CLS. 2, 5, 22, 23, 29, 37, 38 AND 50).

**CLASS 41—EDUCATION AND ENTERTAINMENT**

FOR ENTERTAINMENT SERVICES IN THE NATURE OF LIVE MUSICAL PERFORMANCES (U.S. CLS. 100, 101 AND 107).

KATHERINE CHANG, EXAMINING ATTORNEY

SN 85-206,368. REPO REMARKETING, INC., CITRUS HEIGHTS, CA. FILED 12-28-2010.



NO CLAIM IS MADE TO THE EXCLUSIVE RIGHT TO USE "REPO REMARKETING", APART FROM THE MARK AS SHOWN.

THE MARK CONSISTS OF THE STYLIZED LETTERS "REPO REMARKETING" ENCIRCLED BY AN OVAL AND A SINGLE STAR.

**CLASS 35—ADVERTISING AND BUSINESS**

FOR ARRANGING AND CONDUCTING AUCTIONS IN THE FIELD OF VEHICLES; STATE VEHICULAR REGISTRATION AND TITLE TRANSFER (U.S. CLS. 100, 101 AND 102).

FIRST USE 12-17-2007; IN COMMERCE 12-17-2007.

**CLASS 39—TRANSPORTATION AND STORAGE**

FOR REPOSSESSION SERVICES, NAMELY, PHYSICAL REMOVAL OF REPOSSESSED ITEMS FROM DEBTORS' POSSESSION (U.S. CLS. 100 AND 105).

FIRST USE 12-17-2007; IN COMMERCE 12-17-2007.

**CLASS 42—SCIENTIFIC AND COMPUTER SERVICES**

FOR INSPECTION SERVICES FOR NEW AND USED VEHICLES FOR PERSONS BUYING OR SELLING THEIR VEHICLES (U.S. CLS. 100 AND 101).

FIRST USE 12-17-2007; IN COMMERCE 12-17-2007.

GISELLE AGOSTO, EXAMINING ATTORNEY

SN 85-206,315. SOZO, LLC, UNIONVILLE, CT. FILED 12-28-2010.

SOZO

THE MARK CONSISTS OF STANDARD CHARACTERS WITHOUT CLAIM TO ANY PARTICULAR FONT, STYLE, SIZE, OR COLOR.

OWNER OF U.S. REG. NOS. 3,009,312, 3,477,078 AND OTHERS.

THE ENGLISH TRANSLATION OF THE WORD "SOZO" IN THE MARK IS "CREATION" OR "IMAGINATION".

**CLASS 21—HOUSEWARES AND GLASS**

FOR BATH SPONGES (U.S. CLS. 2, 13, 23, 29, 30, 33, 40 AND 50).

**CLASS 24—FABRICS**

FOR HOODED TOWELS; BURP CLOTHS (U.S. CLS. 42 AND 50).

**CLASS 25—CLOTHING**

FOR BABY BIBS MADE OF CLOTH; MITTENS; HATS (U.S. CLS. 22 AND 39).

FIRST USE 1-1-2004; IN COMMERCE 1-1-2004.  
BENJAMIN OKEKE, EXAMINING ATTORNEY

SN 85-206,568. ABEYTA, ROBERT, REDONDO BEACH, CA. FILED 12-28-2010.

**Dualforces**  
creative applications group

NO CLAIM IS MADE TO THE EXCLUSIVE RIGHT TO USE "CREATIVE APPLICATIONS GROUP", APART FROM THE MARK AS SHOWN.

THE MARK CONSISTS OF THE STYLIZED TEXT "DUALFORCES CREATIVE APPLICATIONS GROUP".

**CLASS 25—CLOTHING**

FOR HATS; JACKETS; PANTS; SHIRTS; SHOES (U.S. CLS. 22 AND 39).

**CLASS 42—SCIENTIFIC AND COMPUTER SERVICES**

FOR COMPUTER AIDED DESIGN FOR OTHERS; DESIGN FOR OTHERS IN THE FIELD OF CLOTHING (U.S. CLS. 100 AND 101).

SANJEEV VOHRA, EXAMINING ATTORNEY

SN 85-206,745. STEEZ PROMO, LLC, BALTIMORE, MD.  
FILED 12-28-2010.

SN 85-206,619. THE PARENTING GROUP, INC., WINTER  
PARK, FL. FILED 12-28-2010.

## Babyscapes

THE MARK CONSISTS OF STANDARD CHARACTERS WITHOUT CLAIM TO ANY PARTICULAR FONT, STYLE, SIZE, OR COLOR.

### CLASS 16—PAPER GOODS AND PRINTED MATTER

FOR MAGAZINES, FEATURING INFORMATION FOR NEW PARENTS ON WEEKEND GETAWAYS TO TAKE WITH THEIR BABY (U.S. CLS. 2, 5, 22, 23, 29, 37, 38 AND 50).

### CLASS 39—TRANSPORTATION AND STORAGE

FOR PROVIDING AN INTERACTIVE WEBSITE FEATURING TRAVEL INFORMATION, NAMELY, INFORMATION FOR NEW PARENTS ABOUT WEEKEND GETAWAYS TO TAKE WITH THEIR BABY (U.S. CLS. 100 AND 105).

### CLASS 43—HOTEL AND RESTAURANT SERVICES

FOR PROVIDING AN INTERACTIVE WEBSITE FEATURING TRAVEL LODGING INFORMATION AND TRAVEL LODGING BOOKING AGENCY INFORMATION FOR NEW PARENTS IN RELATION TO WEEKEND GETAWAYS TO TAKE WITH THEIR BABY (U.S. CLS. 100 AND 101).

JEAN IM, EXAMINING ATTORNEY

SN 85-206,718. MICHAEL D. SHERLOCK, SAN DIEGO, CA.  
FILED 12-28-2010.

## DREGS

THE MARK CONSISTS OF STANDARD CHARACTERS WITHOUT CLAIM TO ANY PARTICULAR FONT, STYLE, SIZE, OR COLOR.

### CLASS 25—CLOTHING

FOR ATHLETIC APPAREL, NAMELY, SHIRTS, PANTS, JACKETS, FOOTWEAR, HATS AND CAPS, ATHLETIC UNIFORMS (U.S. CLS. 22 AND 39).  
FIRST USE 1-1-1997; IN COMMERCE 1-1-1997.

### CLASS 28—TOYS AND SPORTING GOODS

FOR SKATEBOARD DECKS; SKATEBOARD WHEELS; SKATEBOARDS (U.S. CLS. 22, 23, 38 AND 50).  
FIRST USE 1-1-1997; IN COMMERCE 1-1-1997.  
JUDITH HELFMAN, EXAMINING ATTORNEY

## Dub Nation

THE MARK CONSISTS OF STANDARD CHARACTERS WITHOUT CLAIM TO ANY PARTICULAR FONT, STYLE, SIZE, OR COLOR.

NO CLAIM IS MADE TO THE EXCLUSIVE RIGHT TO USE "DUB" IN CLASS 41, APART FROM THE MARK AS SHOWN.

### CLASS 25—CLOTHING

FOR SHIRTS; SWEAT SHIRTS; T-SHIRTS (U.S. CLS. 22 AND 39).

### CLASS 41—EDUCATION AND ENTERTAINMENT

FOR ARRANGING, ORGANIZING, CONDUCTING, AND HOSTING SOCIAL ENTERTAINMENT EVENTS; ENTERTAINMENT IN THE NATURE OF DANCE PERFORMANCES (U.S. CLS. 100, 101 AND 107).

FIRST USE 12-1-2008; IN COMMERCE 12-1-2008.

DAVID TOOLEY, EXAMINING ATTORNEY

SN 85-206,754. PARK-TOURS, INC., DBA LEFT COAST  
ENGINEERING, SAN DIEGO, CA. FILED 12-28-2010.



OWNER OF U.S. REG. NOS. 3,853,034 AND 3,930,701.

NO CLAIM IS MADE TO THE EXCLUSIVE RIGHT TO USE "ENGINEERING", APART FROM THE MARK AS SHOWN.

THE MARK CONSISTS OF THE LETTERS "L", "C" AND "E" NESTED WITHIN A RECTANGULAR FIELD NEXT TO THE WORDS "LEFT COAST ENGINEERING".

### CLASS 40—MATERIAL TREATMENT

FOR ASSEMBLY OF PRODUCTS FOR OTHERS; PROTOTYPE FABRICATION OF NEW PRODUCTS FOR OTHERS (U.S. CLS. 100, 103 AND 106).

FIRST USE 7-0-2008; IN COMMERCE 7-0-2008.



**CLASS 42—SCIENTIFIC AND COMPUTER SERVICES**

FOR ADVISORY SERVICES IN THE FIELD OF PRODUCT DEVELOPMENT AND QUALITY IMPROVEMENT OF SOFTWARE; COMPUTER HARDWARE AND SOFTWARE CONSULTING SERVICES; COMPUTER HARDWARE AND SOFTWARE DESIGN; COMPUTER SOFTWARE CONSULTING; COMPUTER SOFTWARE DESIGN; COMPUTER SOFTWARE DESIGN AND UPDATING; COMPUTER SOFTWARE DESIGN FOR OTHERS; COMPUTER SOFTWARE DESIGN, COMPUTER PROGRAMMING, OR MAINTENANCE OF COMPUTER SOFTWARE; COMPUTER SOFTWARE DEVELOPMENT; COMPUTER SOFTWARE DEVELOPMENT AND COMPUTER PROGRAMMING DEVELOPMENT FOR OTHERS; COMPUTER SOFTWARE DEVELOPMENT IN THE FIELD OF MOBILE APPLICATIONS; CONSULTANCY IN THE FIELD OF SOFTWARE DESIGN; DESIGN AND TESTING OF NEW PRODUCTS FOR OTHERS; DESIGN OF COMPUTER HARDWARE, CIRCUIT BOARDS, COMMUNICATIONS HARDWARE AND SOFTWARE AND COMPUTER NETWORKS FOR OTHERS; DESIGN AND DEVELOPMENT FOR NEW PRODUCTS FOR OTHERS IN THE FIELD OF ELECTRONICS AND COMPUTER TECHNOLOGY; DESIGN AND DEVELOPMENT OF TECHNOLOGIES FOR THE FABRICATION OF CIRCUITS FOR WIRELESS COMMUNICATION, ELECTRONIC DATA PROCESSING, AND CONSUMER ELECTRONICS (U.S. CLS. 100 AND 101).

FIRST USE 7-0-2008; IN COMMERCE 7-0-2008.  
DORITT L. CARROLL, EXAMINING ATTORNEY

SN 85-207,014. THE NEMOURS FOUNDATION, JACKSONVILLE, FL. FILED 12-29-2010.

**YOUR CHILD. OUR PROMISE.**

THE MARK CONSISTS OF STANDARD CHARACTERS WITHOUT CLAIM TO ANY PARTICULAR FONT, STYLE, SIZE, OR COLOR.

**CLASS 36—INSURANCE AND FINANCIAL**

FOR CHARITABLE FUNDRAISING IN THE FIELDS OF HEALTH, MEDICAL, AND HOSPITAL CARE FOR INFANTS, CHILDREN, ADOLESCENTS, AND THEIR FAMILIES, AND FOR EDUCATION AND RESEARCH IN SUCH FIELDS; FINANCIAL SPONSORSHIP OF EDUCATIONAL CONFERENCES IN THE FIELDS OF HEALTH CARE, MEDICINE, AND HUMAN WELFARE (U.S. CLS. 100, 101 AND 102).

FIRST USE 10-31-2008; IN COMMERCE 10-31-2008.

**CLASS 41—EDUCATION AND ENTERTAINMENT**

FOR EDUCATIONAL SERVICES, NAMELY, ARRANGING AND CONDUCTING EDUCATIONAL CONFERENCES, CLASSES, SEMINARS, WORKSHOPS, AND INDIVIDUALIZED INSTRUCTION IN THE FIELDS OF HEALTH CARE, MEDICINE, AND HUMAN WELFARE; DEVELOPMENT AND DISSEMINATION OF EDUCATIONAL MATERIALS IN THE FIELDS OF HEALTH CARE, MEDICINE, AND HUMAN WELFARE (U.S. CLS. 100, 101 AND 107).

FIRST USE 7-31-2008; IN COMMERCE 7-31-2008.

**CLASS 42—SCIENTIFIC AND COMPUTER SERVICES**

FOR CONDUCTING MEDICAL AND SCIENTIFIC RESEARCH (U.S. CLS. 100 AND 101).

FIRST USE 8-31-2008; IN COMMERCE 8-31-2008.

**CLASS 44—MEDICAL, BEAUTY AND AGRICULTURAL SERVICES**

FOR MEDICAL SERVICES; HEALTH CARE SERVICES; HOSPITAL SERVICES; OPERATION OF MEDICAL CLINICS; MEDICAL TRAUMA CENTER SERVICES (U.S. CLS. 100 AND 101).

FIRST USE 7-31-2008; IN COMMERCE 7-31-2008.  
MATTHEW PAPPAS, EXAMINING ATTORNEY

SN 85-207,034. J2 SOFTWARE SOLUTIONS, LLC, MONKS CORNER, SC. FILED 12-29-2010.

**J2 SOFTWARE**

THE MARK CONSISTS OF STANDARD CHARACTERS WITHOUT CLAIM TO ANY PARTICULAR FONT, STYLE, SIZE, OR COLOR.

NO CLAIM IS MADE TO THE EXCLUSIVE RIGHT TO USE "SOFTWARE", APART FROM THE MARK AS SHOWN.

**CLASS 9—ELECTRICAL AND SCIENTIFIC APPARATUS**

FOR COMPUTER SOFTWARE AND HARDWARE FOR USE IN PUBLIC SAFETY RECORDS DATABASE MANAGEMENT (U.S. CLS. 21, 23, 26, 36 AND 38).

FIRST USE 9-0-2007; IN COMMERCE 9-0-2007.

**CLASS 42—SCIENTIFIC AND COMPUTER SERVICES**

FOR SOFTWARE DEVELOPMENT AND PRODUCT DEVELOPMENT IN THE FIELD OF PUBLIC SAFETY, INCLUDING SOFTWARE DEVELOPMENT AND PRODUCT DEVELOPMENT IN THE FIELD OF PUBLIC SAFETY RECORD DATABASE MANAGEMENT (U.S. CLS. 100 AND 101).

FIRST USE 9-0-2007; IN COMMERCE 9-0-2007.  
KRISTIN CARLSON, EXAMINING ATTORNEY

SN 85-207,064. J2 SOFTWARE SOLUTIONS, LLC, MONKS CORNER, SC. FILED 12-29-2010.



THE COLOR(S) BLUE AND WHITE IS/ARE CLAIMED AS A FEATURE OF THE MARK.

THE MARK CONSISTS OF A BLUE LETTER "J" AND A WHITE NUMBER "2" OUTLINED IN BLUE.

**CLASS 9—ELECTRICAL AND SCIENTIFIC APPARATUS**

FOR COMPUTER SOFTWARE AND HARDWARE FOR USE IN PUBLIC SAFETY RECORDS DATABASE MANAGEMENT (U.S. CLS. 21, 23, 26, 36 AND 38).  
FIRST USE 9-0-2007; IN COMMERCE 9-0-2007.

**CLASS 42—SCIENTIFIC AND COMPUTER SERVICES**

FOR SOFTWARE DEVELOPMENT AND PRODUCT DEVELOPMENT IN THE FIELD OF PUBLIC SAFETY, INCLUDING SOFTWARE DEVELOPMENT AND PRODUCT DEVELOPMENT IN THE FIELD OF PUBLIC SAFETY RECORD DATABASE MANAGEMENT (U.S. CLS. 100 AND 101).  
FIRST USE 9-0-2007; IN COMMERCE 9-0-2007.

KRISTIN CARLSON, EXAMINING ATTORNEY

SN 85-207,099. THE MCCLONE AGENCY, INC., MENASHA, WI. FILED 12-29-2010.

## Results that Earn Relationships, since 1949!

THE MARK CONSISTS OF STANDARD CHARACTERS WITHOUT CLAIM TO ANY PARTICULAR FONT, STYLE, SIZE, OR COLOR.

NO CLAIM IS MADE TO THE EXCLUSIVE RIGHT TO USE "SINCE 1949", APART FROM THE MARK AS SHOWN.

**CLASS 35—ADVERTISING AND BUSINESS**

FOR BUSINESS CONSULTING AND INFORMATION SERVICES; BUSINESS RISK MANAGEMENT CONSULTATION; PROVIDING BUSINESS MANAGEMENT INFORMATION IN CONNECTION WITH CONSULTING AND ADVISORY SERVICES IN THE FIELD OF STRATEGIC PLANNING (U.S. CLS. 100, 101 AND 102).

**CLASS 36—INSURANCE AND FINANCIAL**

FOR CONSULTING AND INFORMATION CONCERNING INSURANCE; FINANCIAL PLANNING; INSURANCE BROKERAGE (U.S. CLS. 100, 101 AND 102).  
CYNTHIA SLOAN, EXAMINING ATTORNEY

SN 85-207,107. THE MCCLONE AGENCY, INC., MENASHA, WI. FILED 12-29-2010.

## D.R.E.A.M. Process

THE MARK CONSISTS OF STANDARD CHARACTERS WITHOUT CLAIM TO ANY PARTICULAR FONT, STYLE, SIZE, OR COLOR.

NO CLAIM IS MADE TO THE EXCLUSIVE RIGHT TO USE "PROCESS", APART FROM THE MARK AS SHOWN.

**CLASS 35—ADVERTISING AND BUSINESS**

FOR BUSINESS CONSULTING AND INFORMATION SERVICES; BUSINESS RISK MANAGEMENT CONSULTATION; PROVIDING BUSINESS MANAGEMENT INFORMATION IN CONNECTION WITH CONSULTING AND ADVISORY SERVICES IN THE FIELD OF STRATEGIC PLANNING (U.S. CLS. 100, 101 AND 102).

**CLASS 36—INSURANCE AND FINANCIAL**

FOR CONSULTING AND INFORMATION CONCERNING INSURANCE; FINANCIAL PLANNING; INSURANCE BROKERAGE (U.S. CLS. 100, 101 AND 102).  
CYNTHIA SLOAN, EXAMINING ATTORNEY

SN 85-207,267. BIENVIVIR SENIOR HEALTH SERVICES, EL PASO, TX. FILED 12-29-2010.

# BIENVIVIR

THE MARK CONSISTS OF STANDARD CHARACTERS WITHOUT CLAIM TO ANY PARTICULAR FONT, STYLE, SIZE, OR COLOR.

OWNER OF U.S. REG. NO. 3,404,700.

THE ENGLISH TRANSLATION OF THE WORD "BIENVIVIR" IN THE MARK IS "LIVING WELL".

**CLASS 39—TRANSPORTATION AND STORAGE**

FOR TRANSPORTATION OF PASSENGERS BY BUS, NAMELY, SHUTTLES AND/OR VANS (U.S. CLS. 100 AND 105).

FIRST USE 1-1-1989; IN COMMERCE 1-1-1989.

**CLASS 43—HOTEL AND RESTAURANT SERVICES**

FOR PROVIDING ASSISTANCE TO SENIOR CITIZENS SEEKING TO DETERMINE ASSISTED LIVING FACILITIES APPROPRIATE FOR THEIR NEEDS (U.S. CLS. 100 AND 101).

FIRST USE 1-1-1989; IN COMMERCE 1-1-1989.

**CLASS 44—MEDICAL, BEAUTY AND AGRICULTURAL SERVICES**

FOR HEALTH CARE SERVICES, NAMELY, WELLNESS PROGRAMS; HEALTH CARE SERVICES; EMERGENCY MEDICAL CARE; MANAGED HEALTH CARE SERVICES; HOSPICES; ALZHEIMER'S CARE; OCCUPATIONAL THERAPY SERVICES; PHYSICAL REHABILITATION; PHYSICAL THERAPY; RECREATIONAL THERAPY; SPEECH AND HEARING THERAPY; NURSING CARE; PROVIDING HEALTHY LIFESTYLE AND NUTRITION SERVICES, NAMELY, PERSONAL ASSESSMENTS, PERSONALIZED ROUTINES, MAINTENANCE SCHEDULES, AND COUNSELING; DIETARY AND NUTRITIONAL GUIDANCE; DISPENSING OF PHARMACEUTICALS (U.S. CLS. 100 AND 101).

FIRST USE 1-1-1989; IN COMMERCE 1-1-1989.

**CLASS 45—PERSONAL AND LEGAL SERVICES**

FOR CASE MANAGEMENT SERVICES, NAMELY, COORDINATION OF LEGAL, SOCIAL AND PSYCHOLOGICAL SERVICES FOR ELDERLY PERSONS (U.S. CLS. 100 AND 101).

FIRST USE 1-1-1989; IN COMMERCE 1-1-1989.  
ANGELA DUONG, EXAMINING ATTORNEY

SN 85-207,418. INTERNATIONAL ASSOCIATION OF MACHINISTS & AEROSPACE WORKERS, UPPER MARLBORO, MD. FILED 12-29-2010.

SN 85-207,488. INTERNATIONAL ASSOCIATION OF MACHINISTS & AEROSPACE WORKERS, UPPER MARLBORO, MD. FILED 12-29-2010.



OWNER OF U.S. REG. NO. 3,930,497.  
THE MARK CONSISTS OF A STYLIZED DESIGN WITH THE LETTER "U"; THE SMALL NUMBER "3" ON THE UPPER RIGHT HAND CORNER OF THE LETTER "U".

#### CLASS 35—ADVERTISING AND BUSINESS

FOR PROVIDING MEMBERSHIP CLUB SERVICES PROVIDING STEEP DISCOUNTS AND PROCESSING REBATES FOR THE SERVICES OF OTHERS FOR JOBS ACTIVISTS; BUSINESS NETWORKING AND REFERRAL SERVICES, NAMELY, PROVIDING REFERRALS IN THE FIELD OF EMPLOYMENT, PERSONNEL RECRUITMENT, AND EMPLOYMENT IN THE NATURE OF CAREERS; PROVIDING ON-LINE EMPLOYMENT DATABASES THAT FEATURE EMPLOYMENT OPPORTUNITIES; PROVIDING ONLINE INFORMATION IN THE FIELD OF EMPLOYMENT, PERSONNEL RECRUITMENT, EMPLOYMENT IN THE NATURE OF CAREERS AND ON-LINE EMPLOYMENT DATABASES THAT FEATURE EMPLOYMENT OPPORTUNITIES, AND PROVIDING EMPLOYMENT COUNSELING BY SHARING SKILLS AND EXPERIENCES THAT WILL ENABLE USERS TO GET BACK TO WORK, PROVIDING NEWS IN THE FIELD OF EMPLOYMENT-RELATED ISSUES AND MATTERS VIA A GLOBAL COMPUTER NETWORK (U.S. CLS. 100, 101 AND 102).

FIRST USE 8-27-2009; IN COMMERCE 12-15-2009.

#### CLASS 38—COMMUNICATION

FOR PROVIDING ON-LINE ELECTRONIC BULLETIN BOARDS FOR TRANSMISSION OF MESSAGES AMONG USERS IN ON LINE COMMUNITIES BASED ON STATE AND ZIP CODE IN THE FIELD OF UNEMPLOYMENT; PROVIDING E-MAIL NOTIFICATION ALERTS THAT ARE LINKED TO LEGISLATIVE ALERT SYSTEMS SO THAT USERS CAN EMAIL PUBLIC OFFICIALS ON ISSUES AFFECTING THE UNEMPLOYED (U.S. CLS. 100, 101 AND 104).

FIRST USE 8-27-2009; IN COMMERCE 12-15-2009.

#### CLASS 41—EDUCATION AND ENTERTAINMENT

FOR PROVIDING NEWS IN THE NATURE OF CURRENT EVENTS REPORTING VIA A GLOBAL COMPUTER NETWORK (U.S. CLS. 100, 101 AND 107).

FIRST USE 8-27-2009; IN COMMERCE 12-15-2009.  
KELLY BOULTON, EXAMINING ATTORNEY



OWNER OF U.S. REG. NO. 3,930,497.  
THE MARK CONSISTS OF A STYLIZED DESIGN WITH THE LETTER "U"; THE SMALL NUMBER "3" ON THE UPPER RIGHT HAND CORNER OF THE LETTER "U"; AND AN EXPLODING BOX DESIGN THAT ARE SHAPED IN SQUARES.

#### CLASS 35—ADVERTISING AND BUSINESS

FOR PROVIDING MEMBERSHIP CLUB SERVICES PROVIDING STEEP DISCOUNTS AND PROCESSING REBATES FOR THE SERVICES OF OTHERS FOR JOBS ACTIVISTS; BUSINESS NETWORKING AND REFERRAL SERVICES, NAMELY, PROVIDING REFERRALS IN THE FIELD OF EMPLOYMENT, PERSONNEL RECRUITMENT, AND EMPLOYMENT IN THE NATURE OF CAREERS; PROVIDING ON-LINE EMPLOYMENT DATABASES THAT FEATURE EMPLOYMENT OPPORTUNITIES; PROVIDING ONLINE INFORMATION IN THE FIELD OF EMPLOYMENT, PERSONNEL RECRUITMENT, EMPLOYMENT IN THE NATURE OF CAREERS AND ON-LINE EMPLOYMENT DATABASES THAT FEATURE EMPLOYMENT OPPORTUNITIES, AND PROVIDING EMPLOYMENT COUNSELING BY SHARING SKILLS AND EXPERIENCES THAT WILL ENABLE USERS TO GET BACK TO WORK, PROVIDING NEWS IN THE FIELD OF EMPLOYMENT-RELATED ISSUES AND MATTERS VIA A GLOBAL COMPUTER NETWORK (U.S. CLS. 100, 101 AND 102).

FIRST USE 8-27-2009; IN COMMERCE 12-15-2009.

#### CLASS 38—COMMUNICATION

FOR PROVIDING ON-LINE ELECTRONIC BULLETIN BOARDS FOR TRANSMISSION OF MESSAGES AMONG USERS IN ON LINE COMMUNITIES BASED ON STATE AND ZIP CODE IN THE FIELD OF UNEMPLOYMENT; PROVIDING E-MAIL NOTIFICATION ALERTS THAT ARE LINKED TO LEGISLATIVE ALERT SYSTEMS SO THAT USERS CAN EMAIL PUBLIC OFFICIALS ON ISSUES AFFECTING THE UNEMPLOYED (U.S. CLS. 100, 101 AND 104).

FIRST USE 8-27-2009; IN COMMERCE 12-15-2009.

#### CLASS 41—EDUCATION AND ENTERTAINMENT

FOR PROVIDING NEWS IN THE NATURE OF CURRENT EVENTS REPORTING VIA A GLOBAL COMPUTER NETWORK (U.S. CLS. 100, 101 AND 107).

FIRST USE 8-27-2009; IN COMMERCE 12-15-2009.  
KELLY BOULTON, EXAMINING ATTORNEY

SN 85-207,550. THE DAILY DOT, INC., AUSTIN, TX. FILED 12-29-2010.

## THE DAILY DOT

THE MARK CONSISTS OF STANDARD CHARACTERS WITHOUT CLAIM TO ANY PARTICULAR FONT, STYLE, SIZE, OR COLOR.

NO CLAIM IS MADE TO THE EXCLUSIVE RIGHT TO USE "DAILY", APART FROM THE MARK AS SHOWN.

### CLASS 9—ELECTRICAL AND SCIENTIFIC APPARATUS

FOR PROVIDING DOWNLOADABLE REPORTS FEATURING INFORMATION CONCERNING ADVERTISING AND MARKETING IN THE FIELDS OF ONLINE COMMUNITIES, SOCIAL NETWORKS AND BLOGS (U.S. CLS. 21, 23, 26, 36 AND 38).

### CLASS 35—ADVERTISING AND BUSINESS

FOR PROVIDING INFORMATION, NEWS AND COMMENTARY IN THE FIELDS OF BUSINESS AND POLITICS; ADVERTISING, MARKETING AND PROMOTION SERVICES; ADVERTISING CONSULTATION AND ANALYSIS IN THE FIELD OF ONLINE COMMUNITIES, SOCIAL NETWORKS AND BLOGS, AND PROVIDING CUSTOM REPORTS IN CONNECTION THEREWITH (U.S. CLS. 100, 101 AND 102).

### CLASS 41—EDUCATION AND ENTERTAINMENT

FOR PROVIDING INFORMATION, NEWS AND COMMENTARY IN THE FIELDS OF ENTERTAINMENT, CURRENT EVENTS, ART, POP CULTURE, BLOGS AND SPORTS (U.S. CLS. 100, 101 AND 107).

### CLASS 45—PERSONAL AND LEGAL SERVICES

FOR PROVIDING INFORMATION, NEWS AND COMMENTARY IN THE FIELDS OF SOCIAL NETWORKING (U.S. CLS. 100 AND 101).

ANDREA K. NADELMAN, EXAMINING ATTORNEY

SN 85-207,591. AUDELO, LARA, SAN DIEGO, CA. FILED 12-29-2010.

## MAMAPEAR DESIGNS

THE MARK CONSISTS OF STANDARD CHARACTERS WITHOUT CLAIM TO ANY PARTICULAR FONT, STYLE, SIZE, OR COLOR.

NO CLAIM IS MADE TO THE EXCLUSIVE RIGHT TO USE "DESIGNS", APART FROM THE MARK AS SHOWN.

### CLASS 25—CLOTHING

FOR BABY BODYSUITS; HATS; HEAD WEAR; SHIRTS; SWEAT SHIRTS; T-SHIRTS; TANK TOPS (U.S. CLS. 22 AND 39).

FIRST USE 6-21-2010; IN COMMERCE 6-21-2010.

### CLASS 35—ADVERTISING AND BUSINESS

FOR RETAIL STORE AND ON-LINE RETAIL STORE SERVICES FEATURING CLOTHING, BAGS, WATER BOTTLES, COFFEE CUPS, COASTERS, STICKERS, MAGNETS, NOTE CARDS, AND MOUSE PADS (U.S. CLS. 100, 101 AND 102).

FIRST USE 6-21-2010; IN COMMERCE 6-21-2010.  
TOBY BULLOFF, EXAMINING ATTORNEY

SN 85-207,595. POLY PAK AMERICA, INC., LOS ANGELES, CA. FILED 12-29-2010.

## Pushing The Envelope For A Better Planet

THE MARK CONSISTS OF STANDARD CHARACTERS WITHOUT CLAIM TO ANY PARTICULAR FONT, STYLE, SIZE, OR COLOR.

### CLASS 16—PAPER GOODS AND PRINTED MATTER

FOR GENERAL PURPOSE PLASTIC BAGS; PLASTIC BAGS FOR PACKAGING (U.S. CLS. 2, 5, 22, 23, 29, 37, 38 AND 50).

### CLASS 36—INSURANCE AND FINANCIAL

FOR CHARITABLE FUNDRAISING SERVICES BY MEANS OF SELLING GENERAL PURPOSE PLASTIC BAGS, PLASTIC BAGS FOR PACKAGING AND PLASTIC POUCHES SOLD EMPTY FOR HOLDING CURRENCY, COIN AND OTHER VALUABLES TO RAISE FUNDS FOR CHARITIES DEDICATED TO TREE PLANTING, CHILDREN'S HEALTH, CARBON NEUTRAL PROJECTS, PROMOTING CLEAN OCEANS AND PROMOTING COMMUNITY AND ECO-SOCIAL PROGRAMS (U.S. CLS. 100, 101 AND 102).

MICHAEL TANNER, EXAMINING ATTORNEY

SN 85-207,782. BERCOM INTERNATIONAL, LLC, CHANHASSEN, MN. FILED 12-30-2010.

## HANDY ROLLER CUP

THE MARK CONSISTS OF STANDARD CHARACTERS WITHOUT CLAIM TO ANY PARTICULAR FONT, STYLE, SIZE, OR COLOR.

OWNER OF U.S. REG. NOS. 2,736,339, 3,802,869 AND OTHERS.

NO CLAIM IS MADE TO THE EXCLUSIVE RIGHT TO USE "ROLLER CUP", APART FROM THE MARK AS SHOWN.

### CLASS 20—FURNITURE AND ARTICLES NOT OTHERWISE CLASSIFIED

FOR PLASTIC INSERTS FOR USE AS CONTAINER LINERS (U.S. CLS. 2, 13, 22, 25, 32 AND 50).



**CLASS 21—HOUSEWARES AND GLASS**

FOR HAND-HELD PAINT CONTAINERS MADE OF PLASTIC (U.S. CLS. 2, 13, 23, 29, 30, 33, 40 AND 50).  
EUGENIA MARTIN, EXAMINING ATTORNEY

SN 85-207,910. Q INTERNATIONAL COURIER, INC., JAMAICA, NY. FILED 12-30-2010.

SN 85-207,866. IPC SYSTEMS, INC., JERSEY CITY, NJ. FILED 12-30-2010.

**QUICKONLINERX****TRANSFORM TRADING WORKFLOW**

THE MARK CONSISTS OF STANDARD CHARACTERS WITHOUT CLAIM TO ANY PARTICULAR FONT, STYLE, SIZE, OR COLOR.

NO CLAIM IS MADE TO THE EXCLUSIVE RIGHT TO USE "TRADING WORKFLOW", APART FROM THE MARK AS SHOWN.

**CLASS 9—ELECTRICAL AND SCIENTIFIC APPARATUS**

FOR VOICE AND DATA COMMUNICATIONS PRODUCTS, NAMELY, INTEGRATED DESKTOP AND SWITCHING TURRETS AND PLATFORMS FOR TRADING ENVIRONMENTS, WHICH SUPPORT VOICE, DATA AND VIDEO APPLICATIONS; ELECTRONIC DESKTOP TRADING CONSOLE THAT PROVIDES COMPUTER, TELECOMMUNICATIONS AND INTERNET CAPABILITY; COMPUTER HARDWARE AND COMPUTER SOFTWARE THAT PROVIDES DESKTOP AND REMOTE COMMUNICATIONS CAPABILITIES FOR USE BY FINANCIAL AND OTHER MARKET TRADERS, AND INSTRUCTION MANUALS, SOLD AS A UNIT; COMPUTER SOFTWARE THAT PROVIDES DESKTOP COMMUNICATIONS CAPABILITIES FOR USE IN THE FINANCIAL INDUSTRY, TRADING FLOOR ENVIRONMENTS, SECURITY AND LAW ENFORCEMENT INDUSTRY, UTILITY INDUSTRY, HEALTHCARE INDUSTRY AND CUSTOMER SUPPORT AND CONTACT CENTER ENVIRONMENTS AND INSTRUCTIONAL MANUALS, SOLD AS A UNIT (U.S. CLS. 21, 23, 26, 36 AND 38).

**CLASS 37—CONSTRUCTION AND REPAIR**

FOR VOICE AND DATA COMMUNICATIONS SYSTEMS INTEGRATION SERVICES, NAMELY, MAINTAINING COMMUNICATIONS INFRASTRUCTURES WHICH INTEGRATE VOICE AND DATA COMMUNICATIONS SYSTEMS USED IN TRADING ROOM ENVIRONMENTS (U.S. CLS. 100, 103 AND 106).

**CLASS 42—SCIENTIFIC AND COMPUTER SERVICES**

FOR VOICE AND DATA COMMUNICATIONS SYSTEMS INTEGRATION SERVICES, NAMELY, DESIGNING AND IMPLEMENTING COMMUNICATIONS INFRASTRUCTURES WHICH INTEGRATE VOICE AND DATA COMMUNICATIONS SYSTEMS USED IN TRADING ROOM ENVIRONMENTS; TECHNICAL CUSTOMER SUPPORT SERVICES, NAMELY, PROACTIVE MONITORING, TROUBLESHOOTING, AND SUPPORTING OF HARDWARE AND SOFTWARE PRODUCTS FOR FINANCIAL AND TELECOMMUNICATIONS SERVICE FIRMS (U.S. CLS. 100 AND 101).

ANNE E. GUSTASON, EXAMINING ATTORNEY

THE MARK CONSISTS OF STANDARD CHARACTERS WITHOUT CLAIM TO ANY PARTICULAR FONT, STYLE, SIZE, OR COLOR.

OWNER OF U.S. REG. NOS. 2,062,773, 2,669,523 AND OTHERS.

**CLASS 35—ADVERTISING AND BUSINESS**

FOR BUSINESS ADVISORY SERVICES RELATING TO BUSINESS MANAGEMENT AND BUSINESS OPERATIONS; COMPUTERIZED TRACKING AND TRACING OF PACKAGES IN TRANSIT AND FLIGHT TRACKING; COMPUTERIZED ONLINE ORDERING SERVICES OF SUPPLIES FOR PACKAGE SHIPMENT, ORDER PLACEMENT, AND GENERATION OF REPORTS; PROVIDING INFORMATION AND TRACKING INFORMATION TO THIRD PARTIES REGARDING PICKUP AND DELIVERY STATUS VIA INTERNET ACCESS AND TELEPHONE; BUSINESS MANAGEMENT CONSULTING SERVICES IN THE FIELD OF TRANSPORTATION AND DELIVERY; BUSINESS MANAGEMENT SERVICES IN THE FIELD OF TRANSPORTATION AND DELIVERY; BUSINESS CONSULTANCY SERVICES IN THE FIELD OF TRANSPORTATION AND DELIVERY; AND BUSINESS ADMINISTRATION SERVICES IN THE FIELD OF TRANSPORTATION AND DELIVERY; PROVIDING A WEB-BASED ON-LINE PORTAL THAT PROVIDES CUSTOMER ACCESS TO THEIR SHIPPING BILL ACCOUNT INFORMATION; ELECTRONIC BILL PRESENTMENT SERVICES; CUSTOMS CLEARANCE SERVICES; BUSINESS SERVICES, NAMELY, FREIGHT INFORMATION MANAGEMENT SERVICES, SHIPMENT PROCESSING, PREPARING SHIPPING DOCUMENTS AND INVOICES, TRACKING DOCUMENTS, PACKAGES AND FREIGHT AND ISSUING CONFIRMATION OF DELIVERY OVER COMPUTER NETWORKS, INTRANETS AND INTERNETS (U.S. CLS. 100, 101 AND 102).

**CLASS 36—INSURANCE AND FINANCIAL**

FOR INSURANCE AND FINANCIAL SERVICES NAMELY, PROVIDING ELECTRONIC BILL PAYMENT SERVICES; ELECTRONIC TRANSFER OF FUNDS IN THE TRANSPORTATION INDUSTRY; CARGO INSURANCE UNDERWRITING SERVICES; CUSTOMS BROKERAGE SERVICES; RECLAMATION OF IMPORT DUTIES FOR OTHERS; BONDING SERVICES IN THE NATURE OF UNDERWRITING CUSTOMS BONDS, PROVISION OF TEMPORARY IMPORT BONDS AND PROVISION OF CUSTOMS BONDS; DUTY DRAWBACK SERVICES; FINANCIAL RISK MANAGEMENT SERVICES (U.S. CLS. 100, 101 AND 102).

**CLASS 39—TRANSPORTATION AND STORAGE**

FOR PACKAGING ARTICLES FOR TRANSPORTATION; PROVIDING INFORMATION ON INTERNATIONAL TRANSPORTATION AND DELIVERY SERVICES; ELECTRONIC STORAGE OF TRACKING, PERFORMANCE, CLAIMS, BILLING AND BROKERAGE SHIPMENT DATA (U.S. CLS. 100 AND 105).

MATTHEW MCDOWELL, EXAMINING ATTORNEY

SN 85-207,985. NEWSPAPERDIRECT INC., RICHMOND, CANADA, FILED 12-30-2010.



THE COLOR(S) BLACK, WHITE AND GREEN IS/ARE CLAIMED AS A FEATURE OF THE MARK.

THE MARK CONSISTS OF TWO WORDS, "PRESS" AND "ON" COMBINED INTO ONE WORD, WITH "PRESS" IN SMALL BLACK ITALIC CHARACTERS, FOLLOWED BY A COMMENT SYMBOL IN GREEN WITH THE WORD "ON" IN SMALL WHITE ITALIC LETTERS INSIDE.

#### CLASS 9—ELECTRICAL AND SCIENTIFIC APPARATUS

FOR ELECTRONIC PUBLICATIONS, NAMELY, NEWSPAPERS AND MAGAZINES FEATURING NEWS, SPORTS, FASHION, ART, ENTERTAINMENT, TRAVEL, HOBBIES, POLITICS, CURRENT AFFAIRS, BUSINESS, TECHNOLOGY, AND EDITORIALS RECORDED ON COMPUTER MEDIA (U.S. CLS. 21, 23, 26, 36 AND 38).

#### CLASS 16—PAPER GOODS AND PRINTED MATTER

FOR DAILY NEWSPAPER; GENERAL FEATURE MAGAZINE IN THE FIELD OF NEWS, SPORTS, FASHION, ART, ENTERTAINMENT, TRAVEL, HOBBIES, POLITICS, CURRENT AFFAIRS, BUSINESS, TECHNOLOGY, EDITORIAL, RELIGION; GENERAL FEATURE MAGAZINES; MAGAZINES FEATURING NEWS, SPORTS, FASHION, ART, ENTERTAINMENT, TRAVEL, HOBBIES, POLITICS, CURRENT AFFAIRS, BUSINESS, TECHNOLOGY, EDITORIAL, RELIGION; MAGAZINES IN THE FIELD OF NEWS, SPORTS, FASHION, ART, ENTERTAINMENT, TRAVEL, HOBBIES, POLITICS, CURRENT AFFAIRS, BUSINESS, TECHNOLOGY, EDITORIAL, RELIGION; NEWSLETTERS, BROCHURES, AND MAGAZINES IN THE FIELDS OF SECURITIES, OPTIONS, BONDS AND OTHER FINANCIAL INSTRUMENTS; NEWSPAPERS; NEWSPAPERS FOR GENERAL CIRCULATION; PRINTED MATTER, NAMELY, NEWSPAPERS, PHOTOGRAPHS, MAGAZINES, BOOKS, PRINTED PERIODICALS, NEWSLETTERS, AND BROCHURES ALL IN THE FIELDS OF SECURITIES, OPTIONS AND OTHER FINANCIAL INSTRUMENTS (U.S. CLS. 2, 5, 22, 23, 29, 37, 38 AND 50).

#### CLASS 35—ADVERTISING AND BUSINESS

FOR ARRANGING NEWSPAPER SUBSCRIPTIONS FOR OTHERS; MAGAZINE SUBSCRIPTION AND FULFILLMENT SERVICES; NEWSPAPER SUBSCRIPTIONS; SUBSCRIPTIONS TO BOOKS, REVIEWS, NEWSPAPERS OR COMIC BOOKS (U.S. CLS. 100, 101 AND 102).

#### CLASS 41—EDUCATION AND ENTERTAINMENT

FOR MAGAZINE PUBLISHING; MULTIMEDIA PUBLISHING OF BOOKS, MAGAZINES, JOURNALS, SOFTWARE, GAMES, MUSIC, AND ELECTRONIC PUBLICATIONS; NEWSPAPER PUBLICATION; NEWSPAPER PUBLISHING; ON-LINE LIBRARY SERVICES, NAMELY, PROVIDING ELECTRONIC LIBRARY SERVICES WHICH FEATURE NEWSPAPERS, MAGAZINES, PHOTOGRAPHS AND PICTURES VIA AN ON-LINE COMPUTER NETWORK; PUBLICATION OF BOOKS, MAGAZINES, ALMANACS AND JOURNALS; PUBLICATION OF BOOKS, OF MAGAZINES, OF JOURNALS, OF NEWSPAPERS, OF PERIODICALS, OF CATALOGS, OF BROCHURES; PUBLICATION OF ELECTRONIC MAGAZINES; PUBLICATION OF ELECTRONIC NEWSPAPERS ACCESSIBLE VIA A GLOBAL COMPUTER NETWORK; PUBLICATION OF MAGAZINES; PUBLICATION OF NEWSPAPERS AND MAGAZINES; PUBLISHING OF BOOKS, MAGAZINES; PUBLISHING OF WEB MAGAZINES (U.S. CLS. 100, 101 AND 107).

JULIE VEPPUMTHARA, EXAMINING ATTORNEY

SN 85-208,026. CHAINTEA (CAYMAN ISLANDS) HOLDING CORP., GRAND CAYMAN, CAYMAN ISLANDS, FILED 12-30-2010.



NO CLAIM IS MADE TO THE EXCLUSIVE RIGHT TO USE THE CHINESE CHARACTER THAT TRANSLITERATES TO CHA, WHICH TRANSLATES IN ENGLISH TO "TEA", AND THE CHINESE CHARACTER JI, WHICH TRANSLATES IN ENGLISH TO "COLLECTION", APART FROM THE MARK AS SHOWN.

THE MARK CONSISTS OF FOUR CHINESE CHARACTERS THAT TRANSLITERATE TO YI CHA YA JI.

THE NON-LATIN CHARACTERS IN THE MARK TRANSLITERATE TO YI CHA YA JI AND THIS MEANS "LEISURE" "TEA" "ELEGANT" AND "COLLECTION" IN ENGLISH.

#### CLASS 21—HOUSEWARES AND GLASS

FOR GLASSWARE, NAMELY, CUPS, DISHES, POTS, TEA POTS, JARS; PORCELAIN AND CERAMIC SCULPTURES, VASES, VESSELS, BOWLS, PLATES; CUPS AND POTS; WORKS OF ART OF CRYSTAL, EARTHENWARE, GLASS, PORCELAIN, TERRA COTTA; TEA CADDIES, NOT OF PRECIOUS METAL; TEA SERVICES, NOT OF PRECIOUS METAL; SAUCERS, NOT OF PRECIOUS METAL; TEAPOTS, NOT OF PRECIOUS METAL; TEA STRAINERS, NOT OF PRECIOUS METAL; TEA INFUSERS, NOT OF PRECIOUS METAL; TEA BALLS, NOT OF PRECIOUS METAL (U.S. CLS. 2, 13, 23, 29, 30, 33, 40 AND 50).

FIRST USE 6-11-2010; IN COMMERCE 6-11-2010.

#### CLASS 30—STAPLE FOODS

FOR TEA; TEA-BASED BEVERAGES; TEA BAGS; TEA SUBSTITUTES (U.S. CL. 46).

FIRST USE 6-11-2010; IN COMMERCE 6-11-2010.  
JUDITH HELFMAN, EXAMINING ATTORNEY

SN 85-208,038. CHAINTEA (CAYMAN ISLANDS) HOLDING CORP., GRAND CAYMAN, CAYMAN ISLANDS, FILED 12-30-2010.

# EASTCHA

THE MARK CONSISTS OF STANDARD CHARACTERS WITHOUT CLAIM TO ANY PARTICULAR FONT, STYLE, SIZE, OR COLOR.

## CLASS 21—HOUSEWARES AND GLASS

FOR GLASSWARE, NAMELY, CUPS, DISHES, POTS, TEA POTS, JARS; PORCELAIN AND CERAMIC SCULPTURES, VASES, VESSELS, BOWLS, PLATES; CUPS AND POTS; WORKS OF ART OF CRYSTAL, EARTHENWARE, GLASS, PORCELAIN, TERRA COTTA; TEA CADDIES, NOT OF PRECIOUS METAL; TEA SERVICES, NOT OF PRECIOUS METAL; SAUCERS, NOT OF PRECIOUS METAL; TEAPOTS, NOT OF PRECIOUS METAL; TEA STRAINERS, NOT OF PRECIOUS METAL; TEA INFUSERS, NOT OF PRECIOUS METAL; TEA BALLS, NOT OF PRECIOUS METAL (U.S. CLS. 2, 13, 23, 29, 30, 33, 40 AND 50).

FIRST USE 6-11-2010; IN COMMERCE 6-11-2010.

## CLASS 30—STAPLE FOODS

FOR TEA; TEA-BASED BEVERAGES; TEA BAGS; TEA SUBSTITUTES (U.S. CL. 46).  
FIRST USE 6-11-2010; IN COMMERCE 6-11-2010.  
JUDITH HELFMAN, EXAMINING ATTORNEY

## CLASS 21—HOUSEWARES AND GLASS

FOR GLASSWARE, NAMELY, CUPS, DISHES, POTS, TEA POTS, JARS; PORCELAIN AND CERAMIC SCULPTURES, VASES, VESSELS, BOWLS, PLATES; CUPS AND POTS; WORKS OF ART OF CRYSTAL, EARTHENWARE, GLASS, PORCELAIN, TERRA COTTA; TEA CADDIES, NOT OF PRECIOUS METAL; TEA SERVICES, NOT OF PRECIOUS METAL; SAUCERS, NOT OF PRECIOUS METAL; TEAPOTS, NOT OF PRECIOUS METAL; TEA STRAINERS, NOT OF PRECIOUS METAL; TEA INFUSERS, NOT OF PRECIOUS METAL; TEA BALLS, NOT OF PRECIOUS METAL (U.S. CLS. 2, 13, 23, 29, 30, 33, 40 AND 50).

FIRST USE 6-11-2010; IN COMMERCE 6-11-2010.

## CLASS 30—STAPLE FOODS

FOR TEA; TEA-BASED BEVERAGES; TEA BAGS; TEA SUBSTITUTES (U.S. CL. 46).

FIRST USE 6-11-2010; IN COMMERCE 6-11-2010.  
JUDITH HELFMAN, EXAMINING ATTORNEY

SN 85-208,066. SPECIALTYCARE, INC., NASHVILLE, TN, FILED 12-30-2010.



OWNER OF U.S. REG. NO. 3,905,642.

NO CLAIM IS MADE TO THE EXCLUSIVE RIGHT TO USE "SPECIALTYCARE UNIVERSITY", "2010" AND "CLINICAL EXCELLENCE", APART FROM THE MARK AS SHOWN.

THE MARK CONSISTS OF A RIBBON-LIKE DESIGN INCORPORATING THE LETTERS "S", "C" ABOVE A DASH, "2010" AND A DASH AND ABOVE TWO BRANCHES WITH LEAVES FRAMING THE BOTTOM, ALL OF WHICH IS SURROUNDED BY A DOTTED CIRCULAR LINE; AND ENCIRCLED WITH THE PHRASE "SPECIALTYCARE UNIVERSITY" AT THE TOP AND THE PHRASES "INTEGRITY", SMALL CIRCLE SHAPE, "RESPECT", SMALL CIRCLE SHAPE, "TEAMWORK"; ABOVE THE PHRASES "CLINICAL EXCELLENCE", SMALL CIRCLE SHAPE, "LEADERSHIP", SMALL CIRCLE SHAPE, "STEWARDSHIP"; ALL OF WHICH IS SURROUNDED BY A DOTTED CIRCULAR LINE.

## CLASS 41—EDUCATION AND ENTERTAINMENT

FOR EDUCATIONAL SERVICES, NAMELY, FIELD TRAINING AND CONDUCTING CLASSES AND DISTANCE LEARNING INSTRUCTION, ALL IN THE FIELD OF HEALTHCARE (U.S. CLS. 100, 101 AND 107).

## CLASS 44—MEDICAL, BEAUTY AND AGRICULTURAL SERVICES

FOR MEDICAL SERVICES PROVIDED ON AN OUTSOURCING BASIS (U.S. CLS. 100 AND 101).  
SANI KHOURI, EXAMINING ATTORNEY

SN 85-208,053. CHAINTEA (CAYMAN ISLANDS) HOLDING CORP., GRAND CAYMAN, CAYMAN ISLANDS, FILED 12-30-2010.



THE MARK CONSISTS OF THE DESIGN ELEMENTS OF A SINGLE LEAF COMPRISED OF A BLADE AND CURVED PETIOLE ON THE LEFT AND A CRESCENT-SHAPED CURVE ON THE RIGHT, WITH ITS CONCAVE SURFACE FACING THE LEAF.

SN 85-208,224. FOX WINK LLC, CHAMPLIN, MN. FILED 12-30-2010.



NO CLAIM IS MADE TO THE EXCLUSIVE RIGHT TO USE "BAR & GRILL", APART FROM THE MARK AS SHOWN.

THE MARK CONSISTS OF A FOX WITH A HAT, SHIRT, AND STYLIZED TEXT "THE WINKIN' FOX BAR & GRILL".

**CLASS 25—CLOTHING**

FOR HATS; SHIRTS; SWEAT SHIRTS (U.S. CLS. 22 AND 39).

**CLASS 43—HOTEL AND RESTAURANT SERVICES**

FOR BAR AND RESTAURANT SERVICES (U.S. CLS. 100 AND 101).  
ANGELA M. MICHELI, EXAMINING ATTORNEY

SN 85-208,306. GRINSTEINER, KAY, BISMARCK, ND. FILED 12-30-2010.



THE MARK CONSISTS OF THE STYLIZED WORD "SCHIZOFANIC". THE LETTER "S" IS IN THE FORM OF A DRAGON AND THE SECOND "I" IS IN THE FORM OF A SWORD.

**CLASS 25—CLOTHING**

FOR T-SHIRTS (U.S. CLS. 22 AND 39).

**CLASS 38—COMMUNICATION**

FOR PROVIDING AN ON-LINE FORUM FOR DISCUSSION OF COMPUTER GAMES (U.S. CLS. 100, 101 AND 104).

**CLASS 41—EDUCATION AND ENTERTAINMENT**

FOR ENTERTAINMENT SERVICES, NAMELY, PROVIDING ON-LINE COMPUTER GAMES (U.S. CLS. 100, 101 AND 107).  
JENNIFER MARTIN, EXAMINING ATTORNEY

SN 85-208,293. SEBAGO USA, LLC, ROCKFORD, MI. FILED 12-30-2010.

**DRYSIDES**

THE MARK CONSISTS OF STANDARD CHARACTERS WITHOUT CLAIM TO ANY PARTICULAR FONT, STYLE, SIZE, OR COLOR.  
OWNER OF U.S. REG. NO. 3,928,803.

**CLASS 14—JEWELRY**

FOR WATCHES (U.S. CLS. 2, 27, 28 AND 50).

**CLASS 18—LEATHER GOODS**

FOR ALL-PURPOSE CARRYING BAGS; BACKPACKS; FANNY PACKS; LEATHER KEY CHAINS; LUGGAGE; PURSES; TRAVEL BAGS; WALLETS (U.S. CLS. 1, 2, 3, 22 AND 41).  
CORY BOONE, EXAMINING ATTORNEY

SN 85-208,354. FIG & OLIVE USA, INC., NEW YORK, NY. FILED 12-30-2010.

**FIG & OLIVE**

THE MARK CONSISTS OF STANDARD CHARACTERS WITHOUT CLAIM TO ANY PARTICULAR FONT, STYLE, SIZE, OR COLOR.  
OWNER OF U.S. REG. NOS. 2,981,952, 3,135,516 AND 3,716,965.

**CLASS 4—LUBRICANTS AND FUELS**

FOR CANDLES (U.S. CLS. 1, 6 AND 15).  
FIRST USE 12-28-2010; IN COMMERCE 12-28-2010.

**CLASS 21—HOUSEWARES AND GLASS**

FOR DISHES; PEPPER MILLS; WINE BOTTLE CRADLES (U.S. CLS. 2, 13, 23, 29, 30, 33, 40 AND 50).  
FIRST USE 12-28-2010; IN COMMERCE 12-28-2010.  
JOHN DWYER, EXAMINING ATTORNEY



SN 85-208,358. ENERGY IQ GROUP, LLC, BOCA RATON, FL. FILED 12-30-2010.

# ENERGY IQ

THE MARK CONSISTS OF STANDARD CHARACTERS WITHOUT CLAIM TO ANY PARTICULAR FONT, STYLE, SIZE, OR COLOR.

OWNER OF U.S. REG. NO. 3,754,241.

NO CLAIM IS MADE TO THE EXCLUSIVE RIGHT TO USE "ENERGY", APART FROM THE MARK AS SHOWN.

## CLASS 35—ADVERTISING AND BUSINESS

FOR MARKETING, NAMELY, PROMOTING THE CONTRACTOR SERVICES OF OTHERS SPECIALIZING IN THE FIELD OF ENERGY EFFICIENT STRUCTURES AND STRUCTURES UTILIZING ALTERNATIVE ENERGY SOLUTIONS (U.S. CLS. 100, 101 AND 102).

FIRST USE 3-1-2008; IN COMMERCE 3-1-2008.

## CLASS 37—CONSTRUCTION AND REPAIR

FOR PROVIDING CONSULTATION, PROJECT MANAGEMENT AND NEGOTIATION SERVICES FOR OTHERS WITH REGARD TO WORKING WITH CONTRACTORS AND SUBCONTRACTORS EXPERIENCED IN BUILDING AND CONSTRUCTION SERVICES IN THE FIELD OF ENERGY EFFICIENCY AND ALTERNATIVE ENERGY SYSTEMS (U.S. CLS. 100, 103 AND 106).

FIRST USE 3-1-2008; IN COMMERCE 3-1-2008.

JOHN DWYER, EXAMINING ATTORNEY

SN 85-208,363. SWAIN CORP., LOS ANGELES, CA. FILED 12-30-2010.

# TALKIE

THE MARK CONSISTS OF STANDARD CHARACTERS WITHOUT CLAIM TO ANY PARTICULAR FONT, STYLE, SIZE, OR COLOR.

## CLASS 9—ELECTRICAL AND SCIENTIFIC APPARATUS

FOR COMPUTER GAME SOFTWARE; VIDEO GAME PROGRAMS; AND COMPUTER SOFTWARE PLATFORMS FOR SOCIAL NETWORKING; INTERACTIVE VIDEO GAME PROGRAMS; DOWNLOADABLE ELECTRONIC GAME PROGRAMS AND COMPUTER SOFTWARE PLATFORMS FOR SOCIAL NETWORKING THAT MAY BE ACCESSED VIA THE INTERNET, COMPUTERS AND WIRELESS DEVICES; COMPUTER SOFTWARE TO ENABLE UPLOADING, POSTING, SHOWING, DISPLAYING, TAGGING, BLOGGING, SHARING OR OTHERWISE PROVIDING ELECTRONIC MEDIA OR INFORMATION IN THE FIELDS OF VIRTUAL COMMUNITIES, ELECTRONIC GAMING, ENTERTAINMENT, AND GENERAL INTEREST VIA THE INTERNET OR OTHER COMMUNICATIONS NETWORKS WITH THIRD PARTIES; DOWNLOADABLE VIRTUAL GOODS, NAMELY, COMPUTER PROGRAMS FEATURING CONSUMER GOODS FOR USE IN ONLINE VIRTUAL WORLDS (U.S. CLS. 21, 23, 26, 36 AND 38).

## CLASS 35—ADVERTISING AND BUSINESS

FOR ADVERTISING SERVICES; ADVERTISING AND MARKETING SERVICES, NAMELY, PROMOTING THE GOODS AND SERVICES OF OTHERS; RETAIL STORE SERVICES FEATURING VIRTUAL GOODS, NAMELY, CONSUMER GOODS FOR USE IN ONLINE VIRTUAL WORLDS (U.S. CLS. 100, 101 AND 102).

## CLASS 41—EDUCATION AND ENTERTAINMENT

FOR ENTERTAINMENT SERVICES, NAMELY, PROVIDING ONLINE COMPUTER AND ELECTRONIC GAMES; PROVIDING ONLINE COMPUTER GAMES, ENHANCEMENTS WITHIN ONLINE COMPUTER GAMES, AND GAME APPLICATIONS WITHIN ONLINE COMPUTER GAMES; PROVIDING ONLINE COMPUTER GAMES VIA THE INTERNET OR OTHER COMMUNICATIONS NETWORKS; PROVIDING VIRTUAL ENVIRONMENTS IN WHICH USERS CAN INTERACT THROUGH SOCIAL GAMES FOR RECREATIONAL, LEISURE OR ENTERTAINMENT PURPOSES (U.S. CLS. 100, 101 AND 107).

## CLASS 42—SCIENTIFIC AND COMPUTER SERVICES

FOR COMPUTER SERVICES, NAMELY, CREATING AN ON-LINE COMMUNITY FOR REGISTERED USERS TO PARTICIPATE IN DISCUSSIONS, GET FEEDBACK FROM THEIR PEERS, FORM VIRTUAL COMMUNITIES, AND ENGAGE IN SOCIAL NETWORKING; CREATING AN ONLINE COMMUNITY FOR REGISTERED USERS TO PARTICIPATE IN COMPUTER GAME COMPETITIONS, SHOWCASE THEIR SKILLS, GET FEEDBACK FROM THEIR PEERS, FORM VIRTUAL COMMUNITIES, AND ENGAGE IN SOCIAL NETWORKING; SOFTWARE DEVELOPMENT AND INTEGRATION SERVICES, COMPUTER PROGRAMMING, DESIGN AND DEVELOPMENT OF COMPUTER GAMES, VIDEO GAMES, ONLINE GAMES, GAME RELATED APPLICATIONS AND DEVELOPMENT TOOLS FOR OTHERS; PROVIDING A WEBSITE FEATURING NON-DOWNLOADABLE SOFTWARE TOOLS FOR USE IN ACCESSING, PLAYING AND TRACKING PERFORMANCE OF COMPUTER GAMES; APPLICATION SERVICE PROVIDER FEATURING SOFTWARE FOR SOCIAL NETWORKING AND GAMES, AND TO ENABLE UPLOADING, POSTING, SHOWING, DISPLAYING, TAGGING, BLOGGING, SHARING OR OTHERWISE PROVIDING ELECTRONIC MEDIA OR INFORMATION VIA THE INTERNET; COMPUTER PROGRAMMING SERVICES, NAMELY, CONTENT CREATION FOR VIRTUAL WORLDS AND THREE DIMENSIONAL PLATFORMS AND HOSTING COMPUTER GAMES OF OTHERS (U.S. CLS. 100 AND 101).

EDWARD NELSON, EXAMINING ATTORNEY

SN 85-208,366. LITTGE, DON, CAMARILLO, CA. FILED 12-30-2010.

# Raincollar

THE MARK CONSISTS OF STANDARD CHARACTERS WITHOUT CLAIM TO ANY PARTICULAR FONT, STYLE, SIZE, OR COLOR.

## CLASS 21—HOUSEWARES AND GLASS

FOR SELF-WATERING PLANTER RINGS FOR SURROUNDING FLOWER POTS AND TREES (U.S. CLS. 2, 13, 23, 29, 30, 33, 40 AND 50).

**CLASS 40—MATERIAL TREATMENT**

FOR MANUFACTURING SERVICES FOR OTHERS IN THE FIELD OF SELF-WATERING OR HIDDEN IRRIGATION DECORATIVE LAWN AND GARDENING PRODUCTS (U.S. CLS. 100, 103 AND 106).  
ROBIN CHOSID, EXAMINING ATTORNEY

SN 85-209,263. FITNESS FINDERS, INC., SPRING ARBOR, MI. FILED 1-3-2011.

SN 85-208,396. MARQUEZ, JUAN ALBERTO, BELL, CA. FILED 12-30-2010.



THE MARK CONSISTS OF THE LETTER "X".

**CLASS 11—ENVIRONMENTAL CONTROL APPARATUS**

FOR AUTOMOTIVE HEADLAMPS; LED LIGHT BULBS; TAILLIGHTS FOR VEHICLES; VEHICLE HEADLIGHTS (U.S. CLS. 13, 21, 23, 31 AND 34).

**CLASS 12—VEHICLES**

FOR ANTI-THEFT AUTOMOTIVE ALARMS; AUTO ACCESSORIES, NAMELY, SIDE MIRROR PROTECTIVE AND VANITY COVERS; AUTOMOBILE ENGINES; AUTOMOBILE SEAT CUSHIONS; AUTOMOTIVE AFTERMARKET PARTS, NAMELY, TRUCK BED EXTENDER AND STORAGE BOX; AUTOMOTIVE BODY KITS COMPRISING EXTERNAL STRUCTURAL PARTS OF AUTOMOBILES; AUTOMOTIVE CARGO RACK; AUTOMOTIVE CONVERSION KITS COMPRISED OF PLASTIC AUTOMOTIVE EXTERIOR AND INTERIOR EXTRUDED DECORATIVE AND PROTECTIVE TRIM TO MAKE STRUCTURAL CHANGES TO AN AUTOMOBILE; AUTOMOTIVE ENGINE MOUNTS; AUTOMOTIVE INTERIOR PANELING; AUTOMOTIVE INTERIOR TRIM; AUTOMOTIVE PARTS, NAMELY, TRANSMISSION SEALS; AUTOMOTIVE STRUCTURAL PARTS, NAMELY, FUEL STORAGE CELLS AND COMPONENT PARTS THEREFOR; AUTOMOTIVE STRUCTURAL PARTS, NAMELY, SELF-SEALING TANKS FOR FUEL STORAGE, COOLANT STORAGE, OIL STORAGE, AND/OR WATER STORAGE; AUTOMOTIVE WINDSHIELD SHADE SCREENS; FITTED AUTOMOTIVE SEAT COVERS; METAL COVERS USED TO COVER AUTOMOTIVE SHOCK PARTS; METAL PARTS FOR VEHICLES, NAMELY, AUTOMOTIVE EXTERIOR AND INTERIOR METAL DECORATIVE AND PROTECTIVE TRIM; PLASTIC PARTS FOR VEHICLES, NAMELY, AUTOMOTIVE EXTERIOR AND INTERIOR PLASTIC EXTRUDED DECORATIVE AND PROTECTIVE TRIM; SECURITY DEVICES IN THE NATURE OF METAL OR STEEL PLATES FOR AUTOMOTIVE AFTERMARKET CAR AND TRUCK APPLICATIONS THAT ARE AFFIXED TO THE VEHICLE TO REINFORCE OR STRENGTHEN DOOR HANDLES, LATCHES AND LOCKS OR LOCK CYLINDERS (U.S. CLS. 19, 21, 23, 31, 35 AND 44).  
WANDA KAY PRICE, EXAMINING ATTORNEY

**MILEAGE CLUB**

THE MARK CONSISTS OF STANDARD CHARACTERS WITHOUT CLAIM TO ANY PARTICULAR FONT, STYLE, SIZE, OR COLOR.

OWNER OF U.S. REG. NO. 3,538,004.

NO CLAIM IS MADE TO THE EXCLUSIVE RIGHT TO USE "CLUB", APART FROM THE MARK AS SHOWN.

**CLASS 16—PAPER GOODS AND PRINTED MATTER**

FOR EDUCATIONAL PUBLICATIONS, NAMELY, MANUALS, TEACHER GUIDES, PRINTED AWARDS, ACTIVITY BOOKS AND POSTERS IN THE FIELD OF EXERCISE FOR YOUTHS (U.S. CLS. 2, 5, 22, 23, 29, 37, 38 AND 50).

FIRST USE 10-26-1988; IN COMMERCE 3-3-1989.

**CLASS 41—EDUCATION AND ENTERTAINMENT**

FOR EDUCATIONAL SERVICES, NAMELY, PROVIDING AND CONDUCTING A HEALTH AND PHYSICAL FITNESS PROGRAM (U.S. CLS. 100, 101 AND 107).

FIRST USE 10-26-1988; IN COMMERCE 3-3-1989.

JERI J. FICKES, EXAMINING ATTORNEY

SN 85-209,298. AGAMATRIX, INC., SALEM, NH. FILED 1-3-2011.

**NUGGET**

THE MARK CONSISTS OF STANDARD CHARACTERS WITHOUT CLAIM TO ANY PARTICULAR FONT, STYLE, SIZE, OR COLOR.

**CLASS 9—ELECTRICAL AND SCIENTIFIC APPARATUS**

FOR DIGITAL SIGNAL PROCESSING APPARATUS, NAMELY, A PROGRAMMED MICROPROCESSOR FOR INCORPORATION INTO ELECTROCHEMICAL METERS FOR THE MEDICAL PURPOSE OF ELECTROCHEMICAL MONITORING OF ANALYTES IN BIOLOGICAL FLUIDS; DIGITAL SIGNAL PROCESSING APPARATUS, NAMELY, A PROGRAMMED MICROPROCESSOR FOR INCORPORATION INTO ELECTROCHEMICAL METERS FOR THE MEDICAL PURPOSE OF ELECTROCHEMICAL MONITORING OF GLUCOSE IN BIOLOGICAL FLUIDS; WIRED OR WIRELESS COMMUNICATION DEVICES FOR COMMUNICATION BETWEEN ANY OF THE DIGITAL SIGNAL PROCESSING APPARATUSES DESCRIBED HEREIN AND DATA TRANSFER OR EXTERNAL OR REMOTE STORAGE DEVICES, FOR EXAMPLE A CONNECTOR FOR CONNECTING A DIGITAL SIGNAL PROCESSING APPARATUS TO A PERSONAL COMPUTER OR WIRELESS COMMUNICATION HARDWARE SUCH AS TRANSMITTERS AND RECEIVERS; SOFTWARE FOR CONTROLLING ELECTROCHEMICAL METERS FOR THE MEDICAL PURPOSE OF ELECTROCHEMICAL MONITORING OF ANALYTES IN BIOLOGICAL FLUIDS; SOFTWARE FOR CONTROLLING ELECTROCHEMICAL METERS FOR THE MEDICAL PURPOSE OF ELECTROCHEMICAL MONITORING OF GLUCOSE IN BIOLOGICAL FLUIDS; SOFTWARE FOR CONTROLLING WIRED OR WIRELESS COMMUNICATION DEVICES FOR COMMUNICATION BETWEEN ANY OF THE DIGITAL SIGNAL PROCESSING APPARATUSES DESCRIBED HEREIN AND A DATA TRANSFER OR EXTERNAL OR REMOTE STORAGE DEVICE; AND COMBINATIONS THEREOF SOLD AS A UNIT (U.S. CLS. 21, 23, 26, 36 AND 38).

**CLASS 10—MEDICAL APPARATUS**

FOR METERS FOR THE MEDICAL PURPOSE OF ELECTROCHEMICAL MONITORING OF ANALYTES IN BIOLOGICAL FLUIDS; METERS FOR THE MEDICAL PURPOSE OF ELECTROCHEMICAL MONITORING OF GLUCOSE IN BIOLOGICAL FLUIDS; DISPOSABLE TEST STRIPS FOR USE IN CONJUNCTION WITH A METER FOR ELECTROCHEMICAL MONITORING OF ANALYTES IN BIOLOGICAL FLUIDS SOLD IN CONNECTION WITH THE METER AS A KIT; DISPOSABLE TEST STRIPS FOR USE IN CONJUNCTION WITH A METER FOR ELECTROCHEMICAL MONITORING OF GLUCOSE IN BIOLOGICAL FLUIDS SOLD IN CONNECTION WITH THE METER AS A KIT (U.S. CLS. 26, 39 AND 44).

MARY ROSSMAN, EXAMINING ATTORNEY

SN 85-209,387. W STERNOFF LLC, BELLEVUE, WA. FILED 1-3-2011.

**FOOT GUARD**

THE MARK CONSISTS OF STANDARD CHARACTERS WITHOUT CLAIM TO ANY PARTICULAR FONT, STYLE, SIZE, OR COLOR.

NO CLAIM IS MADE TO THE EXCLUSIVE RIGHT TO USE "FOOT", APART FROM THE MARK AS SHOWN.

**CLASS 3—COSMETICS AND CLEANING PREPARATIONS**

FOR NON-MEDICATED SKIN CARE PREPARATIONS (U.S. CLS. 1, 4, 6, 50, 51 AND 52).

**CLASS 5—PHARMACEUTICALS**

FOR MEDICATED SKIN CARE PREPARATIONS (U.S. CLS. 6, 18, 44, 46, 51 AND 52).  
JASON TURNER, EXAMINING ATTORNEY

SN 85-209,470. CLEARLEAP, INC., DULUTH, GA. FILED 1-3-2011.

**STREAM BIG BY CLEARLEAP**

THE MARK CONSISTS OF STANDARD CHARACTERS WITHOUT CLAIM TO ANY PARTICULAR FONT, STYLE, SIZE, OR COLOR.

OWNER OF U.S. REG. NO. 3,717,849.  
NO CLAIM IS MADE TO THE EXCLUSIVE RIGHT TO USE "STREAM", APART FROM THE MARK AS SHOWN.

**CLASS 38—COMMUNICATION**

FOR AUDIO AND VIDEO STREAMING SERVICES VIA INTERNET, INTERNET PROTOCOL TELEVISION (IPTV), CABLE, OR SATELLITE, NAMELY, TRANSMISSION OF AUDIO AND VIDEO CONTENT TO OTHERS VIA A GLOBAL COMMUNICATIONS NETWORK; VIDEO ON DEMAND TRANSMISSION SERVICES; TELECOMMUNICATIONS SERVICES, NAMELY, TRANSMISSION OF VIDEO IMAGES COMPATIBLE WITH OPEN NETWORK COMMUNICATION FORMATS VIA A GLOBAL COMMUNICATIONS NETWORK; ON-DEMAND DELIVERY OF MOVIES, TELEVISION PROGRAMMING, AND OTHER VIDEO CONTENT VIA IP-BASED (INTERNET PROTOCOL-BASED) NETWORK DELIVERY (U.S. CLS. 100, 101 AND 104).

**CLASS 41—EDUCATION AND ENTERTAINMENT**

FOR CABLE TELEVISION PROGRAMMING; SYNDICATION OF MOVIES, TELEVISION PROGRAMMING, AND OTHER VIDEO CONTENT FOR OTHERS VIA IP-BASED NETWORK DELIVERY (U.S. CLS. 100, 101 AND 107).

**CLASS 42—SCIENTIFIC AND COMPUTER SERVICES**

FOR COMPUTER NETWORK MANAGEMENT SERVICES, NAMELY, ADMINISTRATION OF A COMPUTER NETWORK DESIGNED TO FACILITATE THE CAPTURE, TRANSMISSION, EDITING, MANAGEMENT AND/OR BROADCAST OF DIGITAL IMAGES, AUDIO AND VIDEO CONTENT; ADMINISTRATION OF A COMPUTER NETWORK DESIGNED TO MONITOR AND MEASURE NETWORK BANDWIDTH DEMANDS, TO ALLOCATE APPROPRIATE POOLS OF BANDWIDTH TO SATISFY NETWORK REQUIREMENTS, AND TO COORDINATE DIGITAL MEDIA CONTENT TRANSMISSION TO AND FROM INDIVIDUAL AND MULTIPLE SITES; TRANSCODING, SEND-FOR-REVIEW, REVIEW-AND-APPROVAL, MARKING AVAILABLE INVENTORY, AND FILE ATTACHMENT OF DIGITAL ADVERTISING ASSETS; ELECTRONIC ENCODING AND TRANSCODING OF VIDEO/AUDIO DATA (U.S. CLS. 100 AND 101).

CHRISTINE COOPER, EXAMINING ATTORNEY

SN 85-209,531. GOODWOOD, INC., EL MONTE, CA. FILED  
1-3-2011.

SN 85-209,541. GOODWOOD, INC., EL MONTE, CA. FILED  
1-3-2011.

# CANA

THE MARK CONSISTS OF STANDARD CHARACTERS WITHOUT CLAIM TO ANY PARTICULAR FONT, STYLE, SIZE, OR COLOR.

THE WORDING "CANA" HAS NO MEANING IN A FOREIGN LANGUAGE.

## CLASS 11—ENVIRONMENTAL CONTROL APPARATUS

FOR BATHTUBS; FAUCETS; HOT TUBS; KITCHEN SINKS; SHOWER AND BATH CUBICLES; SHOWER DOORS; SHOWER ENCLOSURES; SHOWER FAUCET EXTENSIONS; SHOWER PANELS; SHOWER TUBS; SHOWERHEADS AND COMPONENTS THEREOF; SHOWERS; SINKS; TOILET BOWLS; TOILET SEATS; TOILET TANKS; AND TOILETS (U.S. CLS. 13, 21, 23, 31 AND 34).

## CLASS 19—NON-METALLIC BUILDING MATERIALS

FOR BOARDS OF WOOD; CERAMIC TILES FOR FLOORING AND FACING; CHEMICALLY TREATED WOOD, NAMELY, WOOD BEAMS, WOOD BOARDS, WOOD JOISTS, WOOD RAFTERS, WOOD SIDING, WOOD TILE FLOORS AND FLOORING, WOOD TRIM, WOODEN BEAMS, WOODEN FLOORING, WOODEN RAILINGS, AND WOODEN WAINSCOTING, ALL OF THE ABOVE CONTAINING A FIRE RETARDANT CHEMICAL; FIREPROOF TILES; FLOOR BOARDS; FLOOR TILES OF WOOD; FLOORING UNDERLAYMENTS; GLUE-LAMINATED WOOD; LUMBER; MULTI-LAYERED WOOD; NON-METAL FLOOR TILES; NON-METAL FLOORS; PARQUET FLOORING; PLASTIC FLOORBOARDS; PLYWOOD; VINYL FLOORING; VINYL TILES; WOOD MOLDINGS; WOOD DOOR FRAMES; AND WOODEN DOORS (U.S. CLS. 1, 12, 33 AND 50).

## CLASS 20—FURNITURE AND ARTICLES NOT OTHERWISE CLASSIFIED

FOR BEDS; CABINETS; CHAIRS; CHESTS OF DRAWERS; CLOSET ACCESSORIES, NAMELY, SHOE RACKS; CLOSET ACCESSORIES, NAMELY, CLOTHES BARS; CLOSET ACCESSORIES, NAMELY, SLIDING CLOTHES RAILS; CLOSET ACCESSORIES, NAMELY, BELT RACKS; COAT RACKS; COUCHES; CURTAIN RODS; DESKS; DOORS FOR FURNITURE; ENTERTAINMENT CENTERS; FURNITURE; FURNITURE MOLDINGS; HAT RACKS; INDOOR BLINDS; NON-METAL DOOR TRIMS; NON-METAL LADDERS; NON-METAL WINDOW TRIMS; PICTURE FRAME MOLDINGS; SCREENS; SOFAS; TABLES; TOWEL CLOSETS; TOWEL RACKS; WARDROBES; AND WINE RACKS (U.S. CLS. 2, 13, 22, 25, 32 AND 50).

JULIE GUTTADAURO, EXAMINING ATTORNEY

# LICA

THE MARK CONSISTS OF STANDARD CHARACTERS WITHOUT CLAIM TO ANY PARTICULAR FONT, STYLE, SIZE, OR COLOR.

THE WORDING "LICA" HAS NO MEANING IN A FOREIGN LANGUAGE.

## CLASS 11—ENVIRONMENTAL CONTROL APPARATUS

FOR BATHTUBS; FAUCETS; HOT TUBS; KITCHEN SINKS; SHOWER AND BATH CUBICLES; SHOWER DOORS; SHOWER ENCLOSURES; SHOWER FAUCET EXTENSIONS; SHOWER PANELS; SHOWER TUBS; SHOWERHEADS AND COMPONENTS THEREOF; SHOWERS; SINKS; TOILET BOWLS; TOILET SEATS; TOILET TANKS; AND TOILETS (U.S. CLS. 13, 21, 23, 31 AND 34).

## CLASS 19—NON-METALLIC BUILDING MATERIALS

FOR BOARDS OF WOOD; CERAMIC TILES FOR FLOORING AND FACING; CHEMICALLY TREATED WOOD, NAMELY, WOOD BEAMS, WOOD BOARDS, WOOD JOISTS, WOOD RAFTERS, WOOD SIDING, WOOD TILE FLOORS AND FLOORING, WOOD TRIM, WOODEN BEAMS, WOODEN FLOORING, WOODEN RAILINGS, AND WOODEN WAINSCOTING, ALL OF THE ABOVE CONTAINING A FIRE RETARDANT CHEMICAL; FIREPROOF TILES; FLOOR BOARDS; FLOOR TILES OF WOOD; FLOORING UNDERLAYMENTS; GLUE-LAMINATED WOOD; LUMBER; MULTI-LAYERED WOOD; NON-METAL FLOOR TILES; NON-METAL FLOORS; PARQUET FLOORING; PLASTIC FLOORBOARDS; PLYWOOD; VINYL FLOORING; VINYL TILES; WOOD MOLDINGS; WOOD DOOR FRAMES; AND WOODEN DOORS (U.S. CLS. 1, 12, 33 AND 50).

JULIE GUTTADAURO, EXAMINING ATTORNEY

SN 85-209,566. CROMWELL, HAROLD, AUSTIN, TX. FILED  
1-3-2011.

## The Charitable Life Audit

THE MARK CONSISTS OF STANDARD CHARACTERS WITHOUT CLAIM TO ANY PARTICULAR FONT, STYLE, SIZE, OR COLOR.

NO CLAIM IS MADE TO THE EXCLUSIVE RIGHT TO USE "CHARITABLE" OR "AUDIT", APART FROM THE MARK AS SHOWN.

## CLASS 35—ADVERTISING AND BUSINESS

FOR BUSINESS SUCCESSION PLANNING; AUDITING OF EXISTING INSURANCE POLICIES FOR POSSIBLE PREMIUM SAVINGS OR INCREASE IN DEATH BENEFITS, THE SAVINGS OR DEATH BENEFIT INCREASE TO BE APPLIED TOWARD CHARITABLE CAUSES (U.S. CLS. 100, 101 AND 102).



**CLASS 36—INSURANCE AND FINANCIAL**

FOR CHARITABLE FUNDRAISING; INSURANCE CONSULTING SERVICES; CHARITABLE MONEY DONATION AND FUNDRAISING CONSULTING SERVICES; ESTATE PLANNING (U.S. CLS. 100, 101 AND 102).

JAMES GRIFFIN, EXAMINING ATTORNEY

SN 85-209,582. COPPERGATE INVESTMENTS, LLC, DENVER, CO. FILED 1-3-2011.

# uCollect

THE MARK CONSISTS OF STANDARD CHARACTERS WITHOUT CLAIM TO ANY PARTICULAR FONT, STYLE, SIZE, OR COLOR.

SN 85-209,574. DIMIDIA, BETHESDA, MD. FILED 1-3-2011.



NO CLAIM IS MADE TO THE EXCLUSIVE RIGHT TO USE "LLC", APART FROM THE MARK AS SHOWN.

THE MARK CONSISTS OF AN ALCHEMY SYMBOL FOR WATER, AN INVERTED TRIANGLE WITH THE POINT AT THE BOTTOM. A LINE DIVIDES A TOP SECTION FROM A BOTTOM SECTION ABOUT 40% ABOVE THE BASE POINT. THE DIVIDING LINE EXTENDS BEYOND EACH SIDE OF THE TRIANGLE. "DIMIDIA LLC" APPEARS IN STYLIZED LETTERING ACROSS THE TOP OF THE TRIANGLE.

**CLASS 41—EDUCATION AND ENTERTAINMENT**

FOR EDUCATION SERVICES, NAMELY, PROVIDING SEMINARS, COURSES, LECTURES IN THE FIELD OF ENVIRONMENTAL SUSTAINABILITY, NAMELY, AGRICULTURE, GROUNDWATER AND LAND DEGRADATION, AND CLIMATE; ON-LINE JOURNALS, NAMELY, BLOGS FEATURING ENVIRONMENTAL SUSTAINABILITY, NAMELY, AGRICULTURE, GROUNDWATER AND LAND DEGRADATION, AND CLIMATE (U.S. CLS. 100, 101 AND 107).

FIRST USE 4-20-2008; IN COMMERCE 6-0-2009.

**CLASS 44—MEDICAL, BEAUTY AND AGRICULTURAL SERVICES**

FOR CONSULTATION IN THE FIELDS OF AGRICULTURE AND FORESTRY, NAMELY, CONSULTATION REGARDING PROJECTS TO PLANT TREES AND IMPROVE AGRICULTURE IN DEVELOPING COUNTRIES (U.S. CLS. 100 AND 101).

FIRST USE 4-20-2008; IN COMMERCE 6-0-2009.  
JAMES GRIFFIN, EXAMINING ATTORNEY

**CLASS 35—ADVERTISING AND BUSINESS**

FOR ARRANGING AND CONDUCTING AUCTIONS; AUCTION MANAGEMENT SERVICES PROVIDED TO OTHERS OVER AN ON-LINE WEB SITE ACCESSED THROUGH A GLOBAL COMPUTER NETWORK; AUCTIONEERING; BUSINESS MANAGEMENT ASSISTANCE AND PARTICULARLY CARRYING OUT TASKS NECESSARY FOR THE SMOOTH CONDUCT OF SALES BY AUCTION; CARRYING OUT AUCTION SALES; CONDUCTING OF AUCTION SALES; DATA MANAGEMENT SERVICE FOR USE IN REPORTING DEBT COLLECTION ACCOUNTS TO A COLLECTION AGENCY; ON-LINE AUCTION BIDDING FOR OTHERS; ON-LINE AUCTION SERVICES; ON-LINE AUCTIONEERING SERVICES VIA THE INTERNET; ON-LINE CONSIGNMENT SERVICES WHEREBY GOODS ARE RECEIVED ON CONSIGNMENT FOR AUCTION ON AN ONLINE AUCTION SITE; ON-LINE TRADING SERVICES IN WHICH SELLER POSTS PRODUCTS TO BE AUCTIONED AND BIDDING IS DONE VIA THE INTERNET; ORGANIZATION OF INTERNET AUCTIONS; PROVIDING A SEARCHABLE ON-LINE ADVERTISING WEBSITE AND GUIDE FEATURING THE GOODS AND SERVICES OF OTHER VENDORS VIA THE INTERNET; PROVIDING A SEARCHABLE WEBSITE FEATURING THE GOODS AND SERVICES OF OTHER VENDORS; PROVIDING A WEB SITE THAT FEATURES AN ON-LINE MARKET FOR USERS TO LIST OFFERED OR WANTED PERSONAL AND BUSINESS ASSETS AND SKILLS FOR HIRE, RENT, SALE OR AUCTION TRANACTED ON THE BASIS OF PREDEFINED PERFORMANCE AND CLOSING TERMS AND CONDITIONS; PROVIDING A WEBSITE FEATURING AN ONLINE MARKETPLACE FOR EXCHANGING GOODS AND SERVICES WITH OTHER USERS; PROVIDING A WEBSITE FOR CONNECTING SELLERS WITH BUYERS; PROVIDING A WEBSITE WHERE OWNERS CAN POST ITEMS AND SERVICES AVAILABLE FOR RENT BY OTHERS; PROVISION OF SPACE ON WEBSITES FOR ADVERTISING GOODS AND SERVICES (U.S. CLS. 100, 101 AND 102).

**CLASS 36—INSURANCE AND FINANCIAL**

FOR COLLECTION AGENCIES; DEBT COLLECTION AGENCIES; DEBT RECOVERY AND COLLECTION AGENCIES; RENT COLLECTION AGENCIES (U.S. CLS. 100, 101 AND 102).

KRISTIN DAHLING, EXAMINING ATTORNEY

SN 85-209,681. NUTRITIONAL THERAPEUTICS, INC, COM-MACK, NJ. FILED 1-4-2011.

# LRT FACTOR

THE MARK CONSISTS OF STANDARD CHARACTERS WITHOUT CLAIM TO ANY PARTICULAR FONT, STYLE, SIZE, OR COLOR.

OWNER OF U.S. REG. NO. 2,594,754.

**CLASS 1—CHEMICALS**

FOR LIPIDS USED IN THE MANUFACTURE OF COSMETICS, BEVERAGES, FOOD PRODUCTS AND FOOD SUPPLEMENTS (U.S. CLS. 1, 5, 6, 10, 26 AND 46).

**CLASS 5—PHARMACEUTICALS**

FOR DIETARY AND NUTRITIONAL SUPPLEMENTS (U.S. CLS. 6, 18, 44, 46, 51 AND 52).  
JEFFERY COWARD, EXAMINING ATTORNEY

SN 85-209,742. HARVARD MAINTENANCE, INC., NEW YORK, NY. FILED 1-4-2011.



OWNER OF U.S. REG. NOS. 2,825,189 AND 2,825,190.  
THE COLOR(S) DARK BLUE AND GRAY IS/ARE CLAIMED AS A FEATURE OF THE MARK.  
THE MARK CONSISTS OF THE TERM "HARVARD" IN DARK BLUE, WITH THE RIGHT SIDE OF THE "V" EXTENDING ABOVE THE OTHER LETTERS, FOLLOWED BY THE TERM "ACHIEVE" IN GRAY.

**CLASS 35—ADVERTISING AND BUSINESS**

FOR MAIL ROOM AND MESSAGE CENTER SERVICES FOR OTHERS, NAMELY, STAFFING AND RUNNING A MAIL ROOM OR MESSAGE CENTER IN A CORPORATE OFFICE, BUILDING OR FACILITY ENVIRONMENT (U.S. CLS. 100, 101 AND 102).

**CLASS 37—CONSTRUCTION AND REPAIR**

FOR CLEANING OF BUILDINGS AND FACILITIES; MAINTENANCE AND RENOVATION OF BUILDINGS AND FACILITIES; JANITORIAL SERVICES; CARPET AND RUG CLEANING AND SHAMPOOING; WINDOW CLEANING; TRASH COLLECTION; WASTE DISPOSAL FOR OTHERS; CLEANING, BUFFING AND POLISHING OF METAL AND STONE; DOOR MAINTENANCE AND REPAIR SERVICES; FURNITURE RESTORATION, REPAIR AND MAINTENANCE; FLOOR SANDING; PEST CONTROL AND EXTERMINATION OTHER THAN FOR AGRICULTURE (U.S. CLS. 100, 103 AND 106).

**CLASS 45—PERSONAL AND LEGAL SERVICES**

FOR SECURITY GUARD SERVICES; MONITORING SECURITY SYSTEMS (U.S. CLS. 100 AND 101).  
PAUL E. FAHRENKOPF, EXAMINING ATTORNEY

SN 85-209,776. TENDER BELLY, LLC, DENVER, CO. FILED 1-4-2011.



THE MARK CONSISTS OF STANDARD CHARACTERS WITHOUT CLAIM TO ANY PARTICULAR FONT, STYLE, SIZE, OR COLOR.

NO CLAIM IS MADE TO THE EXCLUSIVE RIGHT TO USE "BELLY" IN INTERNATIONAL CLASS 29, APART FROM THE MARK AS SHOWN.

**CLASS 25—CLOTHING**

FOR SHIRTS (U.S. CLS. 22 AND 39).  
FIRST USE 6-1-2010; IN COMMERCE 6-1-2010.

**CLASS 29—MEATS AND PROCESSED FOODS**

FOR BACON; PORK (U.S. CL. 46).  
FIRST USE 6-1-2010; IN COMMERCE 6-1-2010.  
SKYE YOUNG, EXAMINING ATTORNEY

SN 85-209,818. NEW YORK PIZZERIA, INC., DBA NEW YORK PIZZERIA, HOUSTON, TX. FILED 1-4-2011.



OWNER OF U.S. REG. NOS. 3,682,123, 3,682,125 AND OTHERS.

NO CLAIM IS MADE TO THE EXCLUSIVE RIGHT TO USE "NEW YORK PIZZERIA", APART FROM THE MARK AS SHOWN.

THE COLOR(S) RED, WHITE AND YELLOW IS/ARE CLAIMED AS A FEATURE OF THE MARK.

THE MARK CONSISTS OF A CURVED RED RECTANGULAR-SHAPED BACKGROUND WITH A WHITE LINE BORDER. WITHIN APPEARS THE STYLIZED WORDING "RUSSO'S" IN WHITE. DIRECTLY BELOW IS THE WORDING "NEW YORK" WITH TWO DASHES ON EITHER SIDE OF THE WORDING, ALL IN YELLOW. BELOW THAT IS THE WORDING "PIZZERIA" IN THE COLOR WHITE.

**CLASS 35—ADVERTISING AND BUSINESS**

FOR RESTAURANT FRANCHISING, NAMELY, OFFERING BUSINESS MANAGEMENT ASSISTANCE IN THE ESTABLISHMENT AND/OR OPERATION OF RESTAURANTS (U.S. CLS. 100, 101 AND 102).

FIRST USE 12-1-2010; IN COMMERCE 12-1-2010.

**CLASS 43—HOTEL AND RESTAURANT SERVICES**

FOR RESTAURANT SERVICES, INCLUDING SIT-DOWN SERVICE OF FOOD AND TAKE-OUT RESTAURANT SERVICES (U.S. CLS. 100 AND 101).

FIRST USE 12-1-2010; IN COMMERCE 12-1-2010.  
ALLISON SCHRODY, EXAMINING ATTORNEY

SN 85-209,845. NEW YORK PIZZERIA, INC., DBA RUSSO'S COAL FIRED ITALIAN KITCHEN, HOUSTON, TX. FILED 1-4-2011.



OWNER OF U.S. REG. NOS. 3,682,123, 3,682,125 AND OTHERS.

NO CLAIM IS MADE TO THE EXCLUSIVE RIGHT TO USE "COAL FIRED ITALIAN KITCHEN", APART FROM THE MARK AS SHOWN.

THE COLOR(S) BLACK, WHITE AND YELLOW IS/ARE CLAIMED AS A FEATURE OF THE MARK.

THE MARK CONSISTS OF A BLACK RECTANGLE BACKGROUND WITH A WHITE LINE BORDER. WITHIN APPEARS THE STYLIZED WORDING "RUSSO'S" IN WHITE. DIRECTLY BELOW IS THE WORDING "COAL FIRED" WITH TWO DASHES ON EITHER SIDE OF THE WORDING AND A DOT IN BETWEEN THE TWO WORDS, ALL IN YELLOW. BELOW THAT IS THE WORDING "ITALIAN KITCHEN" IN THE COLOR WHITE.

#### CLASS 35—ADVERTISING AND BUSINESS

FOR RESTAURANT FRANCHISING, NAMELY, OFFERING BUSINESS MANAGEMENT ASSISTANCE IN THE ESTABLISHMENT AND/OR OPERATION OF RESTAURANTS (U.S. CLS. 100, 101 AND 102).

FIRST USE 12-1-2010; IN COMMERCE 12-1-2010.

#### CLASS 43—HOTEL AND RESTAURANT SERVICES

FOR RESTAURANT SERVICES, INCLUDING SIT-DOWN SERVICE OF FOOD AND TAKE-OUT RESTAURANT SERVICES (U.S. CLS. 100 AND 101).

FIRST USE 12-1-2010; IN COMMERCE 12-1-2010.

ALLISON SCHRODY, EXAMINING ATTORNEY

---

SN 85-209,849. HARVARD MAINTENANCE, INC., NEW YORK, NY. FILED 1-4-2011.



OWNER OF U.S. REG. NOS. 2,825,189 AND 2,825,190. THE COLOR(S) DARK BLUE AND GRAY IS/ARE CLAIMED AS A FEATURE OF THE MARK.

THE MARK CONSISTS OF THE TERM "HARVARD" IN DARK BLUE, WITH THE RIGHT SIDE OF THE "V" EXTENDING ABOVE THE OTHER LETTERS, FOLLOWED BY THE TERM "PLUS" IN GRAY.

#### CLASS 37—CONSTRUCTION AND REPAIR

FOR CLEANING OF BUILDINGS AND FACILITIES; MAINTENANCE AND RENOVATION OF BUILDINGS AND FACILITIES; JANITORIAL SERVICES; CARPET AND RUG CLEANING AND SHAMPOOING; WINDOW CLEANING; TRASH COLLECTION; WASTE DISPOSAL FOR OTHERS; CLEANING, BUFFING AND POLISHING OF METAL AND STONE; DOOR MAINTENANCE AND REPAIR SERVICES; FURNITURE RESTORATION, REPAIR AND MAINTENANCE; FLOOR SANDING; PEST CONTROL AND EXTERMINATION OTHER THAN FOR AGRICULTURE (U.S. CLS. 100, 103 AND 106).

#### CLASS 45—PERSONAL AND LEGAL SERVICES

FOR SECURITY GUARD SERVICES; MONITORING SECURITY SYSTEMS (U.S. CLS. 100 AND 101).

PAUL E. FAHRENKOPF, EXAMINING ATTORNEY

SN 85-209,951. HARVARD MAINTENANCE, INC., NEW YORK, NY. FILED 1-4-2011.



OWNER OF U.S. REG. NOS. 2,825,189 AND 2,825,190. THE COLOR(S) DARK BLUE AND GRAY IS/ARE CLAIMED AS A FEATURE OF THE MARK.

THE MARK CONSISTS OF THE TERM "HARVARD" IN DARK BLUE, WITH THE RIGHT SIDE OF THE "V" EXTENDING ABOVE THE OTHER LETTERS, FOLLOWED BY THE TERM "SMART" IN GRAY.

#### CLASS 37—CONSTRUCTION AND REPAIR

FOR CLEANING OF BUILDINGS AND FACILITIES; MAINTENANCE AND RENOVATION OF BUILDINGS AND FACILITIES; JANITORIAL SERVICES; WINDOW CLEANING; TRASH COLLECTION; WASTE DISPOSAL FOR OTHERS; CLEANING, BUFFING AND POLISHING OF METAL AND STONE; DOOR MAINTENANCE AND REPAIR SERVICES; FURNITURE RESTORATION, REPAIR AND MAINTENANCE; FLOOR SANDING; PEST CONTROL AND EXTERMINATION OTHER THAN FOR AGRICULTURE (U.S. CLS. 100, 103 AND 106).

#### CLASS 45—PERSONAL AND LEGAL SERVICES

FOR SECURITY GUARD SERVICES; MONITORING SECURITY SYSTEMS (U.S. CLS. 100 AND 101).

PAUL E. FAHRENKOPF, EXAMINING ATTORNEY

---

SN 85-210,083. HAVERFIELD INTERNATIONAL INCORPORATED, DBA HAVERFIELD AVIATION, INC., GETTYSBURG, PA. FILED 1-4-2011.



THE MARK CONSISTS OF STANDARD CHARACTERS WITHOUT CLAIM TO ANY PARTICULAR FONT, STYLE, SIZE, OR COLOR.

OWNER OF U.S. REG. NOS. 1,645,516, 1,682,224 AND 3,140,874.

SEC. 2(F).

#### CLASS 37—CONSTRUCTION AND REPAIR

FOR CONSTRUCTION SERVICES, NAMELY, CONSTRUCTION OF ELECTRICAL POWER TRANSMISSION LINES DONE BY HELICOPTER; CONSTRUCTION SERVICES, NAMELY, INSTALLATION OF FIBER OPTIC GROUND WIRE CABLE DONE BY HELICOPTER; CONSTRUCTION SERVICES, NAMELY, INSTALLATION ON ELECTRIC POWER TRANSMISSION LINES, OF INSULATORS, VIBRATION DAMPERS, BIRD DISCOURAGERS, CONDUCTOR SPACERS, MARKER BALLS, AERIAL NUMBERS, TRANSMISSION LINE WIRE, ALL DONE BY HELICOPTER; INSULATOR WASHING SERVICES, NAMELY, HIGH PRESSURE WATER WASHING OF INSULATORS ON ENERGIZED OR DE-ENERGIZED ELECTRIC POWER TRANSMISSION LINES DONE BY HELICOPTER; INSPECTION OF ELECTRICAL POWER TRANSMISSION LINES IN THE COURSE OF CONSTRUCTION DONE BY HELICOPTER; MAINTENANCE SERVICES, NAMELY, PERFORMING MAINTENANCE ON ELECTRIC POWER TRANSMISSION LINES DONE BY HELICOPTER (U.S. CLS. 100, 103 AND 106).

FIRST USE 0-0-1985; IN COMMERCE 0-0-1985.

**CLASS 41—EDUCATION AND ENTERTAINMENT**

FOR EDUCATIONAL SERVICES, NAMELY, CONDUCTING TRAINING IN THE FIELDS OF INSPECTION, MAINTENANCE AND REPAIR OF ELECTRICAL POWER TRANSMISSION LINES DONE BY HELICOPTER; EDUCATIONAL SERVICES, NAMELY, CONDUCTING TRAINING VIA THE INTERNET IN THE FIELDS OF INSPECTION, MAINTENANCE AND REPAIR OF ELECTRICAL POWER TRANSMISSION LINES DONE BY HELICOPTER (U.S. CLS. 100, 101 AND 107).

FIRST USE 4-0-2007; IN COMMERCE 4-0-2007.

**CLASS 42—SCIENTIFIC AND COMPUTER SERVICES**

FOR INSPECTION SERVICES AND COMPREHENSIVE INSPECTION SERVICES, NAMELY, INSPECTING ELECTRIC POWER TRANSMISSION LINES DONE BY HELICOPTER INCLUDING HIGH SPEED VISUAL OBSERVATION OF ELECTRIC POWER TRANSMISSION LINES, CLOSE VISUAL AND PHOTOGRAPHIC INSPECTION, X-RAY INSPECTIONS OF ELECTRICAL POWER TRANSMISSION LINE HARDWARE, INFRARED INSPECTIONS OF ELECTRICAL POWER TRANSMISSION LINES AND LINE COMPONENTS ALL DONE BY HELICOPTER (U.S. CLS. 100 AND 101).

FIRST USE 0-0-1983; IN COMMERCE 0-0-1983.

**CLASS 44—MEDICAL, BEAUTY AND AGRICULTURAL SERVICES**

FOR AERIAL TREE TRIMMING SERVICES, NAMELY, PROVIDING AERIAL TRIMMING OF TREES ALONG ELECTRICAL TRANSMISSION AND DISTRIBUTION LINE CORRIDORS AND PIPELINE CORRIDORS DONE BY HELICOPTERS (U.S. CLS. 100 AND 101).

FIRST USE 0-0-1983; IN COMMERCE 0-0-1983.

MATTHEW MCDOWELL, EXAMINING ATTORNEY

---

SN 85-210,108. HARVARD MAINTENANCE, INC., NEW YORK, NY. FILED 1-4-2011.



OWNER OF U.S. REG. NOS. 2,825,189 AND 2,825,190. THE COLOR(S) DARK BLUE AND GREEN IS/ARE CLAIMED AS A FEATURE OF THE MARK.

THE MARK CONSISTS OF THE TERM "HARVARD" IN DARK BLUE, WITH THE RIGHT SIDE OF THE "V" EXTENDING ABOVE THE OTHER LETTERS, FOLLOWED BY THE TERM "WORKS" IN GREEN.

**CLASS 37—CONSTRUCTION AND REPAIR**

FOR CLEANING OF BUILDINGS AND FACILITIES; MAINTENANCE AND RENOVATION OF BUILDINGS AND FACILITIES; JANITORIAL SERVICES; CARPET AND RUG CLEANING AND SHAMPOOING; WINDOW CLEANING; TRASH COLLECTION; WASTE DISPOSAL FOR OTHERS; CLEANING, BUFFING AND POLISHING OF METAL AND STONE; DOOR MAINTENANCE AND REPAIR SERVICES; FURNITURE RESTORATION, REPAIR AND MAINTENANCE; FLOOR SANDING; PEST CONTROL AND EXTERMINATION OTHER THAN FOR AGRICULTURE (U.S. CLS. 100, 103 AND 106).

**CLASS 45—PERSONAL AND LEGAL SERVICES**

FOR SECURITY GUARD SERVICES; MONITORING SECURITY SYSTEMS (U.S. CLS. 100 AND 101).  
PAUL E. FAHRENKOPF, EXAMINING ATTORNEY

SN 85-210,165. HARVARD MAINTENANCE, INC., NEW YORK, NY. FILED 1-4-2011.



OWNER OF U.S. REG. NOS. 2,825,189 AND 2,825,190. NO CLAIM IS MADE TO THE EXCLUSIVE RIGHT TO USE "MAINTENANCE", APART FROM THE MARK AS SHOWN.

THE COLOR(S) DARK BLUE AND GRAY IS/ARE CLAIMED AS A FEATURE OF THE MARK.

THE MARK CONSISTS OF THE TERM "HARVARD" IN DARK BLUE, WITH THE RIGHT SIDE OF THE "V" EXTENDING ABOVE THE OTHER LETTERS, FOLLOWED BY THE TERM "MAINTENANCE" IN GRAY.

**CLASS 35—ADVERTISING AND BUSINESS**

FOR MAIL ROOM AND MESSAGE CENTER SERVICES FOR OTHERS, NAMELY, STAFFING AND RUNNING A MAIL ROOM OR MESSAGE CENTER IN A CORPORATE OFFICE, BUILDING OR FACILITY ENVIRONMENT (U.S. CLS. 100, 101 AND 102).

**CLASS 37—CONSTRUCTION AND REPAIR**

FOR CLEANING OF BUILDINGS AND FACILITIES; MAINTENANCE AND RENOVATION OF BUILDINGS AND FACILITIES; JANITORIAL SERVICES; CARPET AND RUG CLEANING AND SHAMPOOING; WINDOW CLEANING; TRASH COLLECTION; WASTE DISPOSAL FOR OTHERS; CLEANING, BUFFING AND POLISHING OF METAL AND STONE; DOOR MAINTENANCE AND REPAIR SERVICES; FURNITURE RESTORATION, REPAIR AND MAINTENANCE; FLOOR SANDING; PEST CONTROL AND EXTERMINATION OTHER THAN FOR AGRICULTURE (U.S. CLS. 100, 103 AND 106).

**CLASS 45—PERSONAL AND LEGAL SERVICES**

FOR SECURITY GUARD SERVICES; MONITORING SECURITY SYSTEMS (U.S. CLS. 100 AND 101).  
PAUL E. FAHRENKOPF, EXAMINING ATTORNEY

---

SN 85-210,197. CMH RECORDS INC., LOS ANGELES, CA. FILED 1-4-2011.

**ROCKABYE BABY!**

THE MARK CONSISTS OF STANDARD CHARACTERS WITHOUT CLAIM TO ANY PARTICULAR FONT, STYLE, SIZE, OR COLOR.

OWNER OF U.S. REG. NOS. 2,925,011 AND 3,339,967.

**CLASS 9—ELECTRICAL AND SCIENTIFIC APPARATUS**

FOR AUDIO-VISUAL RECORDINGS FEATURING MUSICAL ENTERTAINMENT; MUSICAL SOUND RECORDINGS; DOWNLOADABLE MUSICAL SOUND RECORDINGS (U.S. CLS. 21, 23, 26, 36 AND 38).

**CLASS 16—PAPER GOODS AND PRINTED MATTER**

FOR CHILDREN'S BOOKS; BOOKS IN THE FIELD OF MUSIC (U.S. CLS. 2, 5, 22, 23, 29, 37, 38 AND 50).  
ALEXANDER L. POWERS, EXAMINING ATTORNEY



SN 85-210,223. KINKISHARYO INTERNATIONAL, LLC,  
WESTWOOD, MA. FILED 1-4-2011.

# E-BRID

THE MARK CONSISTS OF STANDARD CHARACTERS WITHOUT CLAIM TO ANY PARTICULAR FONT, STYLE, SIZE, OR COLOR.

## CLASS 9—ELECTRICAL AND SCIENTIFIC APPARATUS

FOR PARTS AND ACCESSORIES FOR PASSENGER RAIL VEHICLES AND FOR ELECTRIC AND BATTERY POWERED PROPULSION SYSTEMS FOR SUCH VEHICLES, NAMELY, BATTERIES, ELECTRONIC SPEED CONTROLS FOR ELECTRIC TROLLEYS, TRANSMISSIONS AND ELECTRONIC STEERING CONTROLS (U.S. CLS. 21, 23, 26, 36 AND 38).

## CLASS 12—VEHICLES

FOR PASSENGER RAIL VEHICLES, NAMELY, ELECTRIC POWERED TROLLEYS AND STRUCTURAL PARTS, ACCESSORIES, AND TRIM THEREFOR; ELECTRIC ENGINES FOR TROLLEYS; PARTS AND ACCESSORIES FOR ELECTRIC TROLLEYS, NAMELY, SEATS, COACHWORK, CHASSIS, RAILWAY COUPLINGS, BRAKES, WHEELS, AND PANTOGRAPHS (U.S. CLS. 19, 21, 23, 31, 35 AND 44).

ROBIN CHOSID, EXAMINING ATTORNEY

SN 85-210,409. COLE & ASHCROFT, L.P., HOUSTON, TX.  
FILED 1-4-2011.

# PIC-POD

THE MARK CONSISTS OF STANDARD CHARACTERS WITHOUT CLAIM TO ANY PARTICULAR FONT, STYLE, SIZE, OR COLOR.

## CLASS 9—ELECTRICAL AND SCIENTIFIC APPARATUS

FOR SOFTWARE FOR REMOTELY ACTUATING THE SHUTTER OF A SMART PHONE; SOFTWARE FOR INTEGRATING AND ORGANIZING PHOTOS VIA SMART PHONE APPLICATIONS; CELL PHONE CASES SPECIALLY MODIFIED TO ATTACH SMART PHONES TO TRIPODS (U.S. CLS. 21, 23, 26, 36 AND 38).

## CLASS 16—PAPER GOODS AND PRINTED MATTER

FOR PEEL AND STICK EASELS; EASELS, NAMELY, EASEL BACKS; EASELS FEATURING A PEEL AND STICK ADHESIVE FOR POST CARD DISPLAY; PHOTO STANDS, NAMELY, PHOTO STANDEES AND STAND INS (U.S. CLS. 2, 5, 22, 23, 29, 37, 38 AND 50).

## CLASS 20—FURNITURE AND ARTICLES NOT OTHERWISE CLASSIFIED

FOR ACRYLIC PICTURE FRAMES; PHOTO FRAMES; PHOTO FRAMES, NAMELY, PHOTO CUBES, PHOTO WOBBLERS; KEY CHAINS NOT MADE OF METAL, LEATHER OR PRECIOUS METAL (U.S. CLS. 2, 13, 22, 25, 32 AND 50).

GILBERT SWIFT, EXAMINING ATTORNEY

SN 85-210,568. WESTINGHOUSE ELECTRIC COMPANY  
LLC, CRANBERRY TOWNSHIP, PA. FILED 1-5-2011.



The logo for WESDYNE INTERNATIONAL features a blue square with a white diagonal line on the left, followed by the word "WESDYNE" in a bold, blue, sans-serif font, and the word "INTERNATIONAL" in a smaller, blue, sans-serif font below it.

OWNER OF U.S. REG. NOS. 1,875,855 AND 1,878,285.

NO CLAIM IS MADE TO THE EXCLUSIVE RIGHT TO USE "INTERNATIONAL", APART FROM THE MARK AS SHOWN.

THE COLOR(S) BLACK, BLUE AND WHITE IS/ARE CLAIMED AS A FEATURE OF THE MARK.

THE MARK CONSISTS OF A PARTIALLY SHADED BLUE AND WHITE SQUARE FOLLOWED BY THE WORD "WESDYNE" WITH THE PARTIAL WORD "WES" IN BLACK LETTERING AND THE PARTIAL WORD "DYNE" IN BLUE LETTERING, WITH THE WORD "INTERNATIONAL" IN BLACK LETTERING BENEATH THE WORD "WESDYNE".

## CLASS 9—ELECTRICAL AND SCIENTIFIC APPARATUS

FOR NONDESTRUCTIVE TESTERS, NAMELY, ULTRASONIC TESTERS AND COMPUTER HARDWARE AND PROGRAMS IN SUPPORT THEREOF, ALL FOR USE IN TESTING COMPUTER SOFTWARE DESIGN FOR OTHERS (U.S. CLS. 21, 23, 26, 36 AND 38).

## CLASS 42—SCIENTIFIC AND COMPUTER SERVICES

FOR COMPUTER SOFTWARE DEVELOPMENT IN THE FIELD OF NONDESTRUCTIVE TESTING, AND COMPUTER SOFTWARE DESIGN FOR OTHERS (U.S. CLS. 100 AND 101).

KATHY DE JONGE, EXAMINING ATTORNEY

SN 85-210,584. AMOREPACIFIC CORPORATION, YONG-SAN-KU, SEOUL, REPUBLIC OF KOREA, FILED 1-5-2011.



The logo for ARITAUM features a pink square with rounded corners containing the letters "AR" in black, with "ITUM" in black below it. To the right of the square, the word "ARITAUM" is written in a black, serif font.

OWNER OF U.S. REG. NOS. 3,371,381, 3,387,374 AND 3,518,804.

THE COLOR(S) PINK AND BLACK IS/ARE CLAIMED AS A FEATURE OF THE MARK.

THE MARK CONSISTS OF A PINK SQUARE WITH ROUNDED CORNERS AND OUTLINED IN BLACK, WITH THE WORDING "ARITAUM" APPEARING IN A SCATTERED DESIGN IN BLACK LETTERS. THE WORD "ARITAUM" IN BLACK APPEARS TO THE RIGHT OF THE SQUARE.

**CLASS 3—COSMETICS AND CLEANING PREPARATIONS**

FOR BEAUTY SOAP; COSMETIC PREPARATIONS FOR SKIN CARE; COSMETICS; COSMETICS FOR ANIMALS; CREAMY FOUNDATION; DENTIFRICES; HAIR CONDITIONERS; HAIR SHAMPOO; MAKE-UP POWDER; MASK PACK FOR COSMETIC PURPOSES (U.S. CLS. 1, 4, 6, 50, 51 AND 52).

**CLASS 16—PAPER GOODS AND PRINTED MATTER**

FOR ADVERTISING PAMPHLETS; ADVERTISING SIGNS OF PAPER OR CARDBOARD; BOOKLETS IN THE FIELD OF HEALTH, BEAUTY AND COSMETICS; BOOKS IN THE FIELD OF HEALTH, BEAUTY AND COSMETICS; MAGAZINES IN THE FIELD OF HEALTH, BEAUTY AND COSMETICS; PAPER TISSUES; PHOTOGRAPHS; PLASTIC BAGS FOR PACKAGING; PRINTED PERIODICALS IN THE FIELD OF HEALTH, BEAUTY AND COSMETICS; STATIONERY; TISSUES OF PAPER FOR REMOVING MAKE-UP (U.S. CLS. 2, 5, 22, 23, 29, 37, 38 AND 50).

**CLASS 18—LEATHER GOODS**

FOR BACKPACKS; BANDS OF LEATHER; COSMETIC BAGS SOLD EMPTY; HANDBAGS; LEATHER CASES; LEATHER SHOPPING BAGS; SHOULDER BAGS; TRAVELING BAGS; UMBRELLAS (U.S. CLS. 1, 2, 3, 22 AND 41).

**CLASS 20—FURNITURE AND ARTICLES NOT OTHERWISE CLASSIFIED**

FOR CUSHIONS; DECORATIVE MOBILES; FURNITURE; HAND FANS; MIRRORS; NON-METAL KEY RINGS; NON-METAL TROPHIES; NON-METALLIC BOTTLE STOPPERS; PICTURE FRAMES; PLASTIC BOXES; PLASTIC SIGNBOARDS; WOOD BOXES; WOODEN SIGNBOARDS (U.S. CLS. 2, 13, 22, 25, 32 AND 50).

**CLASS 21—HOUSEWARES AND GLASS**

FOR COMBS; EYEBROW BRUSHES; FITTED VANITY CASES; LIP BRUSHES; MANUAL COSMETIC CLEANERS, NAMELY, NON-WOVEN FABRIC WIPES AND SPONGES; NAIL BRUSHES; PERFUME SPRAYERS SOLD EMPTY; POWDER COMPACTS SOLD EMPTY; POWDER PUFFS (U.S. CLS. 2, 13, 23, 29, 30, 33, 40 AND 50).

**CLASS 25—CLOTHING**

FOR ATHLETIC FOOTWEAR; BELTS MADE OF LEATHER; DRESSES; HEADWEAR; KNIT FACE MASKS; MEN'S SUITS; MONEY BELTS; NECKTIES; SHIRTS; SPORTS OVER UNIFORMS; SPORTS PANTS; SPORTS SHIRTS; SWEAT PANTS; SWEAT SHIRTS; SWEAT SUITS (U.S. CLS. 22 AND 39).

SAMUEL E. SHARPER JR., EXAMINING ATTORNEY

SN 85-210.620. MECHOSHADE SYSTEMS, INC., LONG ISLAND CITY, NY. FILED 1-5-2011.

**MECHOSYSTEMS**

THE MARK CONSISTS OF STANDARD CHARACTERS WITHOUT CLAIM TO ANY PARTICULAR FONT, STYLE, SIZE, OR COLOR.

**CLASS 9—ELECTRICAL AND SCIENTIFIC APPARATUS**

FOR WINDOW SHADE SYSTEMS, NAMELY, ELECTROMECHANICAL CONTROLS, ELECTRIC CONTROL PANELS, COMPUTER HARDWARE AND COMPUTER SOFTWARE FOR ADJUSTING WINDOW COVERINGS; COMPUTERIZED WINDOW SHADING MANAGEMENT AND CONTROL APPARATUSES FOR ELECTRONIC ADJUSTMENT OF WINDOW SHADES BASED ON MONITORING AND ANALYSIS OF SKY CONDITIONS, LIGHT MEASUREMENT, REPORTING SENSORS, DAY LIGHTING PROGRAM AND A BUILDING MANAGEMENT SYSTEM FOR CONTROLLING LIGHT, HEAT GAIN, HEAT LOSS, BRIGHTNESS, GLARE, SOLAR PENETRATION, DAY LIGHTING AND SOLAR GAIN; ELECTRONIC WINDOW SHADING CONTROL APPARATUSES FOR ELECTRONIC TWO WAY COMMUNICATION WITH BUILDING SUBSYSTEMS, BUILDING MANAGEMENT SYSTEMS, LIGHTING CONTROL SYSTEMS, AND DAY LIGHTING CONTROL SYSTEMS; ELECTRONIC COMMUNICATION DEVICES FOR CONTROLLING WINDOW COVERINGS AND MOTORS IN THE NATURE OF WIRED COMPUTER NETWORKING HARDWARE AND WIRELESS COMPUTER NETWORKING HARDWARE (U.S. CLS. 21, 23, 26, 36 AND 38).

**CLASS 40—MATERIAL TREATMENT**

FOR CUSTOM MANUFACTURING OF WINDOW SHADES AND STRUCTURAL PARTS THEREFOR (U.S. CLS. 100, 103 AND 106).

TARAH HARDY, EXAMINING ATTORNEY

SN 85-210.679. SHERIDAN BROADCASTING CORPORATION, PITTSBURGH, PA. FILED 1-5-2011.

**DIGITAL LIFESTYLE**

THE MARK CONSISTS OF STANDARD CHARACTERS WITHOUT CLAIM TO ANY PARTICULAR FONT, STYLE, SIZE, OR COLOR.

NO CLAIM IS MADE TO THE EXCLUSIVE RIGHT TO USE "DIGITAL", APART FROM THE MARK AS SHOWN.

**CLASS 38—COMMUNICATION**

FOR RADIO BROADCASTING SERVICES (U.S. CLS. 100, 101 AND 104).

**CLASS 41—EDUCATION AND ENTERTAINMENT**

FOR ENTERTAINMENT SERVICES IN THE NATURE OF RADIO PROGRAMS IN THE FIELD OF MUSIC, NEWS, SPORTS, BUSINESS, ENTERTAINMENT AND PUBLIC AFFAIRS (U.S. CLS. 100, 101 AND 107).

WILLIAM P. SHANAHAN, EXAMINING ATTORNEY

SN 85-210,729. LEVINE, EDWIN G., EASTON, CT. AND LEVINE, WENDY, EASTON, CT. FILED 1-5-2011.

SN 85-210,924. AMERICAN URBAN RADIO NETWORKS, PITTSBURGH, PA. FILED 1-5-2011.

# GOOD TO GO

THE MARK CONSISTS OF STANDARD CHARACTERS WITHOUT CLAIM TO ANY PARTICULAR FONT, STYLE, SIZE, OR COLOR.

## CLASS 5—PHARMACEUTICALS

FOR LAXATIVES (U.S. CLS. 6, 18, 44, 46, 51 AND 52).

## CLASS 44—MEDICAL, BEAUTY AND AGRICULTURAL SERVICES

FOR PROVIDING HEALTH AND NUTRITION INFORMATION, NAMELY, PROVIDING A REGIMEN TO HELP PREVENT THE CONSTIPATION ASSOCIATED WITH TRAVEL (U.S. CLS. 100 AND 101).  
MARILYN IZZI, EXAMINING ATTORNEY

SN 85-210,923. APR INDUSTRIES INC., BOONTON, NJ. FILED 1-5-2011.



NO CLAIM IS MADE TO THE EXCLUSIVE RIGHT TO USE "USA", APART FROM THE MARK AS SHOWN.

THE MARK CONSISTS OF THE LETTERS "APR" AND "USA" SEPARATED BY A CIRCLE CONTAINING A STAR WITH A PORTION OF A BANNER BENEATH THE WORDING.

## CLASS 6—METAL GOODS

FOR METAL HARDWARE, NAMELY, HINGES, PADLOCKS AND STEEL PARTS THEREFOR, DOORKNOBS AND DOOR PLATES, LOCKS AND PANIC HARDWARE, NAMELY, DOOR LOCKING AND OPENING MECHANISMS IN THE NATURE OF LOCKSETS AND DEADBOLTS (U.S. CLS. 2, 12, 13, 14, 23, 25 AND 50).  
FIRST USE 1-2-1995; IN COMMERCE 1-2-1995.

## CLASS 7—MACHINERY

FOR HYDRAULIC DOOR CLOSERS (U.S. CLS. 13, 19, 21, 23, 31, 34 AND 35).  
FIRST USE 1-2-1995; IN COMMERCE 1-2-1995.  
PAUL F. GAST, EXAMINING ATTORNEY



OWNER OF U.S. REG. NOS. 2,318,314, 3,092,578 AND OTHERS.

NO CLAIM IS MADE TO THE EXCLUSIVE RIGHT TO USE "AMERICAN URBAN" OR "NETWORK", APART FROM THE MARK AS SHOWN.

THE COLOR(S) YELLOW AND BLACK IS/ARE CLAIMED AS A FEATURE OF THE MARK.

THE MARK CONSISTS OF THE WORDS "AMERICAN URBAN ELITE NETWORK" AND AN OVAL HAVING LEFT AND RIGHT HALVES FORMED BY A SERIES OF SPACED APART LINES. THE WORDS "AMERICAN, URBAN" AND "NETWORK" ARE IN BLACK, THE WORD "ELITE" IS IN YELLOW INSIDE A BLACK RECTANGULAR BOX. THE COLOR WHITE REPRESENTS TRANSPARENT AREAS AND IS NOT A PART OF THE MARK.

## CLASS 38—COMMUNICATION

FOR RADIO BROADCASTING SERVICES (U.S. CLS. 100, 101 AND 104).

## CLASS 41—EDUCATION AND ENTERTAINMENT

FOR ENTERTAINMENT SERVICES IN THE NATURE OF RADIO PROGRAMS IN THE FIELD OF MUSIC, NEWS, SPORTS, BUSINESS, ENTERTAINMENT AND PUBLIC AFFAIRS (U.S. CLS. 100, 101 AND 107).

RUDY R. SINGLETON, EXAMINING ATTORNEY

SN 85-210,937. EXACTEARTH LTD., CAMBRIDGE, ONTARIO, CANADA, FILED 1-5-2011.

# EXACTAIS

THE MARK CONSISTS OF STANDARD CHARACTERS WITHOUT CLAIM TO ANY PARTICULAR FONT, STYLE, SIZE, OR COLOR.

## CLASS 9—ELECTRICAL AND SCIENTIFIC APPARATUS

FOR SOFTWARE FOR MONITORING AND TRACKING MARINE VESSELS VIA SATELLITE; SOFTWARE FOR GATHERING, PROCESSING AND TRANSMITTING MARINE VESSEL POSITION DATA; PRE-RECORDED MAGNETIC DATA CARRIERS FEATURING MARINE VESSEL POSITION DATA (U.S. CLS. 21, 23, 26, 36 AND 38).

FIRST USE 6-10-2009; IN COMMERCE 6-10-2009.

**CLASS 35—ADVERTISING AND BUSINESS**

FOR MONITORING AND TRACKING MARINE VESSELS VIA SATELLITE FOR COMMERCIAL PURPOSES, AND PROVIDING CARRIER SIGNALS THAT CONVEY MARINE VESSEL POSITION DATA IN CONNECTION WITH SAID MONITORING AND TRACKING; DATA PROCESSING SERVICES, NAMELY, PROCESSING MARINE VESSEL POSITION DATA (U.S. CLS. 100, 101 AND 102).

FIRST USE 6-10-2009; IN COMMERCE 6-10-2009.

**CLASS 38—COMMUNICATION**

FOR SATELLITE TRANSMISSION OF CARRIER SIGNALS CONVEYING MARINE VESSEL POSITION DATA; ELECTRONIC TRANSMISSION AND SECURE STREAMING OF DIGITAL MEDIA CONTENT FOR OTHERS FEATURING CARRIER SIGNALS THAT CONVEY MARINE VESSEL POSITION DATA VIA THE INTERNET, SECURE FTP, AND TELECOMMUNICATIONS NETWORKS; LEASING OF TELECOMMUNICATIONS EQUIPMENT WHICH ENABLES ACCESS TO A NETWORK OF EARTH BASED SATELLITE STATIONS; RENTAL OF ACCESS TIME TO A COMPUTER NETWORK OF EARTH BASED SATELLITE STATIONS (U.S. CLS. 100, 101 AND 104).

FIRST USE 6-10-2009; IN COMMERCE 6-10-2009.

**CLASS 42—SCIENTIFIC AND COMPUTER SERVICES**

FOR COMPUTER SERVICES, NAMELY, ELECTRONICALLY GATHERING, ANALYZING AND FORMATTING POSITION DATA FOR MARINE VESSELS (U.S. CLS. 100 AND 101).

FIRST USE 6-10-2009; IN COMMERCE 6-10-2009.

ELISSA GARBER KON, EXAMINING ATTORNEY

SN 85-211,005. ARAKAWA, ERIC A, DBA ERIC ARAKAWA DESIGNS, HALEIWA, HI. FILED 1-5-2011.



SN 85-210,956. D'MARIE INC., BEDFORD HEIGHTS, OH. FILED 1-5-2011.

**D'MARIE**

THE MARK CONSISTS OF STANDARD CHARACTERS WITHOUT CLAIM TO ANY PARTICULAR FONT, STYLE, SIZE, OR COLOR.

OWNER OF U.S. REG. NO. 2,993,264.

**CLASS 29—MEATS AND PROCESSED FOODS**

FOR DIP MIXES (U.S. CL. 46).

FIRST USE 2-28-2006; IN COMMERCE 2-28-2006.

**CLASS 30—STAPLE FOODS**

FOR FLOUR-BASED CHIPS (U.S. CL. 46).

FIRST USE 11-1-2004; IN COMMERCE 11-1-2004.

**CLASS 33—WINES AND SPIRITS**

FOR ALCOHOLIC COCKTAIL MIXES (U.S. CLS. 47 AND 49).

FIRST USE 9-1-2006; IN COMMERCE 9-1-2006.  
GISELLE AGOSTO, EXAMINING ATTORNEY

THE MARK CONSISTS OF A FLAME CENTERED ABOVE THE WORD "ARCOMI" IN STYLIZED FONT.

**CLASS 18—LEATHER GOODS**

FOR BAGS, NAMELY, CARRY-ALL BAGS, BEACH BAGS, HANDBAGS, CLUTCH BAGS, SHOULDER BAGS, CANVAS SHOPPING BAGS, WALLETS, WALLETS WITH COMPARTMENTS FOR PASSPORTS, PURSES, ATTACHE CASES, BACKPACKS, SCHOOL BAGS, RUCKSACKS, KNAPSACKS, SACHELS, WAIST PACKS, KEY CASES, BILL FOLDS, COIN PURSES, BUM BAGS, HAVERSACKS; TRAVEL BAGS; GARMENT BAGS FOR TRAVEL; TRUNKS; LUGGAGE; LUGGAGE BAG TAGS; LUGGAGE STRAPS; BRIEFCASES, BRIEFCASE TYPE PORTFOLIO CASES, DOCUMENT CASES, CREDIT CARD CASES, BUSINESS CARD CASES; COSMETIC, TOILETRY, AND VANITY CASES SOLD EMPTY; ROLL BAGS AND TRAVEL BAGS FOR HOLDING JEWELRY, SOLD EMPTY (U.S. CLS. 1, 2, 3, 22 AND 41).

**CLASS 25—CLOTHING**

FOR CLOTHING FOR MEN, WOMEN, AND CHILDREN, NAMELY, T-SHIRTS, SHIRTS AND CASUAL TOPS WITH LONG AND SHORT SLEEVES, SWEATERS, HOODED SWEATERS, SWEAT HOODED PARKAS, JACKETS, RAINCOATS, JUMPERS, SURFING T-SHIRTS, SUN SHIRTS, SHORTS, BOARD SHORTS, WALK SHORTS, VOLLEY SHORTS, LONG PANTS, BEACH PANTS, TROUSERS, JEANS, DRESSES, SKIRTS, SARONGS; SWIMSUITS AND BIKINIS; UNDERCLOTHING; HEADWEAR FOR MEN WOMEN AND CHILDREN, NAMELY, BANDANAS, BEANIES, HEADBANDS, HATS, VISORS, CAPS, HOODS, BERETS, HATS WITH SUNSHIELDS, AND SUN-VISORS; FOOTWEAR FOR MEN, WOMEN, AND CHILDREN, NAMELY, SHOES, SLIPPERS, BEACH SHOES, SANDALS, ATHLETIC SHOES, BOOTS, SPECIAL SPORTING AND GYMNAS TIC FOOTWEAR (U.S. CLS. 22 AND 39).



**CLASS 28—TOYS AND SPORTING GOODS**

FOR SURFBOARDS, BODYBOARDS, KNEEBOARDS, WAKEBOARDS, SAILBOARDS, KITEBOARDS, TOWBOARDS, PADDLEBOARDS, SKIM BOARDS, STAND UP PADDLE BOARDS, WATER SKIS; SPORTING ACCESSORIES, NAMELY, LEASHES FOR SURFBOARDS, BODYBOARDS, KNEEBOARDS, WAKEBOARDS, SAILBOARDS, KITEBOARDS, TOWBOARDS, PADDLEBOARDS, SKIM BOARDS AND STAND UP PADDLE BOARDS, TETHERS FOR SURFBOARDS, BODYBOARDS, KNEEBOARDS, WAKEBOARDS, SAILBOARDS, KITEBOARDS, TOWBOARDS, PADDLEBOARDS, SKIM BOARDS AND STAND UP PADDLE BOARDS; WAX FOR SURFBOARDS AND WATER SKIS; SURFBOARD DECK GRIPS; COVERS AND PROTECTIVE BAGS FOR SPORTING APPARATUS, NAMELY, BAGS ESPECIALLY DESIGNED FOR SURFBOARDS, BODYBOARDS, KNEEBOARDS, WAKEBOARDS, SAILBOARDS, KITEBOARDS, TOWBOARDS, PADDLEBOARDS, SKIM BOARDS, STAND UP PADDLE BOARDS, AND WATER SKIS (U.S. CLS. 22, 23, 38 AND 50).

FIRST USE 10-18-2010; IN COMMERCE 10-18-2010.  
TINA BROWN, EXAMINING ATTORNEY

SN 85-211,244. BROOKS, ROBERT, PHOENIX, AZ. FILED 1-5-2011.

# HECKLERS

THE MARK CONSISTS OF STANDARD CHARACTERS WITHOUT CLAIM TO ANY PARTICULAR FONT, STYLE, SIZE, OR COLOR.

**CLASS 28—TOYS AND SPORTING GOODS**

FOR (BASED ON INTENT TO USE) GOLF CLUBS; GOLF BALLS; GOLF TEES; GOLF BAGS; GOLF BAG PULL CARTS; GOLF GLOVES; GOLF ACCESSORIES, NAMELY, GOLF DIVOT REPAIR TOOLS, GOLF BALL MARKERS, GOLF CLUB GRIPS AND GOLF CLUB COVERS (U.S. CLS. 22, 23, 38 AND 50).

**CLASS 41—EDUCATION AND ENTERTAINMENT**

FOR (BASED ON USE IN COMMERCE) ORGANIZATION OF GOLF TOURNAMENTS (U.S. CLS. 100, 101 AND 107).

FIRST USE 12-14-2010; IN COMMERCE 12-14-2010.  
JOHN GARTNER, EXAMINING ATTORNEY

SN 85-211,258. REACH4SUCCESS, LLC, SAMMAMISH, WA. FILED 1-5-2011.

# NETWORK MARKETING MASTERY

THE MARK CONSISTS OF STANDARD CHARACTERS WITHOUT CLAIM TO ANY PARTICULAR FONT, STYLE, SIZE, OR COLOR.

NO CLAIM IS MADE TO THE EXCLUSIVE RIGHT TO USE "NETWORK MARKETING", APART FROM THE MARK AS SHOWN.

**CLASS 35—ADVERTISING AND BUSINESS**

FOR PROVIDING INFORMATION IN THE FIELD OF THE ONLINE MARKETING INDUSTRY (U.S. CLS. 100, 101 AND 102).

FIRST USE 3-13-2008; IN COMMERCE 6-16-2008.

**CLASS 41—EDUCATION AND ENTERTAINMENT**

FOR EDUCATION SERVICES, NAMELY, PROVIDING LIVE AND ON-LINE PRESENTATIONS IN THE FIELD OF ONLINE MARKETING (U.S. CLS. 100, 101 AND 107).

FIRST USE 3-13-2008; IN COMMERCE 6-16-2008.

NANCY CLARKE, EXAMINING ATTORNEY

SN 85-211,416. PROTOCOL SERVICES ACQUISITION CORP., DBA PROTOCOL GLOBAL SOLUTIONS, SARASOTA, FL. FILED 1-5-2011.

# PROTOCOL

THE MARK CONSISTS OF STANDARD CHARACTERS WITHOUT CLAIM TO ANY PARTICULAR FONT, STYLE, SIZE, OR COLOR.

**CLASS 35—ADVERTISING AND BUSINESS**

FOR BUSINESS MARKETING AND DIRECT MARKETING SERVICES; DIRECT MARKETING ADVERTISING FOR OTHERS; TELEMARKETING; MARKET RESEARCH; ORDER FULFILLMENT SERVICES; OPERATION OF TELEPHONE CALL CENTERS AND CONTACT CENTERS FOR OTHERS; E-MARKETING SERVICES FOR OTHERS, NAMELY, BUSINESS DATA ANALYSIS AND DATABASE MANAGEMENT, MAILING LIST PREPARATION AND MANAGEMENT, PROMOTING GOODS AND SERVICES OF OTHERS VIA CHAT ROOMS, AND EMAIL MARKETING SERVICES FOR OTHERS (U.S. CLS. 100, 101 AND 102).

**CLASS 45—PERSONAL AND LEGAL SERVICES**

FOR PAROLE CASE MANAGEMENT AND MONITORING SERVICES FOR OTHERS (U.S. CLS. 100 AND 101).

PATRICIA EVANKO, EXAMINING ATTORNEY

SN 85-211,419. PROTOCOL SERVICES ACQUISITION CORP., DBA PROTOCOL SERVICES ACQUISITION CORP., SARASOTA, FL. FILED 1-5-2011.

# PROTOCOL GLOBAL SOLUTIONS

THE MARK CONSISTS OF STANDARD CHARACTERS WITHOUT CLAIM TO ANY PARTICULAR FONT, STYLE, SIZE, OR COLOR.

NO CLAIM IS MADE TO THE EXCLUSIVE RIGHT TO USE "GLOBAL SOLUTIONS", APART FROM THE MARK AS SHOWN.

**CLASS 35—ADVERTISING AND BUSINESS**

FOR BUSINESS MARKETING AND DIRECT MARKETING SERVICES; DIRECT MARKETING ADVERTISING FOR OTHERS; TELEMARKETING; MARKET RESEARCH; ORDER FULFILLMENT SERVICES; OPERATION OF TELEPHONE CALL CENTERS AND CONTACT CENTERS FOR OTHERS; E-MARKETING SERVICES FOR OTHERS, NAMELY, BUSINESS DATA ANALYSIS AND DATABASE MANAGEMENT, MAILING LIST PREPARATION AND MANAGEMENT, PROMOTING GOODS AND SERVICES OF OTHERS VIA CHAT ROOMS, AND EMAIL MARKETING SERVICES FOR OTHERS (U.S. CLS. 100, 101 AND 102).

**CLASS 45—PERSONAL AND LEGAL SERVICES**

FOR PAROLE CASE MANAGEMENT AND MONITORING SERVICES FOR OTHERS (U.S. CLS. 100 AND 101).  
PATRICIA EVANKO, EXAMINING ATTORNEY

---

SN 85-211,650. DESIRE SALON SPA, INC., TROPHY CLUB, TX. FILED 1-6-2011.

NO CLAIM IS MADE TO THE EXCLUSIVE RIGHT TO USE "SALON SPA", APART FROM THE MARK AS SHOWN. THE MARK CONSISTS OF STYLIZED LETTERS MAKING UP THE WORDS "DESIRE SALON SPA".

**CLASS 3—COSMETICS AND CLEANING PREPARATIONS**

FOR HAIR CARE CREAMS; HAIR CARE LOTIONS; HAIR CONDITIONERS; HAIR CREAMS; HAIR DRESSINGS FOR MEN; HAIR DRESSINGS FOR WOMEN; HAIR GELS; HAIR GLAZE; HAIR POMADES; HAIR SHAMPOOS AND CONDITIONERS; HAIR SPRAYS AND HAIR GELS; HAIR STYLING FIXATIVE IN THE NATURE OF HAIR WAX (U.S. CLS. 1, 4, 6, 50, 51 AND 52).

FIRST USE 11-15-2010; IN COMMERCE 11-15-2010.

**CLASS 44—MEDICAL, BEAUTY AND AGRICULTURAL SERVICES**

FOR DAY SPA SERVICES, NAMELY, NAIL CARE, MANICURES, PEDICURES AND NAIL ENHANCEMENTS; HAIR SALON SERVICES; MASSAGES (U.S. CLS. 100 AND 101).

FIRST USE 11-15-2010; IN COMMERCE 11-15-2010.  
ROBIN CHOSID, EXAMINING ATTORNEY

SN 85-211,789. MEDTRUST ONLINE, LLC, SCOTTSDALE, AZ. FILED 1-6-2011.

# MEDTRUST

THE MARK CONSISTS OF STANDARD CHARACTERS WITHOUT CLAIM TO ANY PARTICULAR FONT, STYLE, SIZE, OR COLOR.

**CLASS 42—SCIENTIFIC AND COMPUTER SERVICES**

FOR PROVIDING INFORMATION IN THE FIELD OF CANCER RESEARCH (U.S. CLS. 100 AND 101).  
FIRST USE 5-30-2008; IN COMMERCE 5-30-2008.

**CLASS 44—MEDICAL, BEAUTY AND AGRICULTURAL SERVICES**

FOR PROVIDING INFORMATION IN THE FIELD OF MEDICINE, HEALTH, CANCER, CANCER RECOVERY, CANCER SURVIVAL, CANCER TREATMENT, CANCER PREVENTION, CANCER SCREENING, AND CANCER DIAGNOSIS; PROVIDING A WEB SITE FEATURING MEDICAL INFORMATION; PROVIDING AN INTERNET WEB SITE FOR MEDICAL PROFESSIONALS AND MEDICAL PATIENTS THAT ALLOWS FOR THE EXCHANGE OF INFORMATION FROM REMOTE LOCATIONS USING DEVICES THAT FEED INFORMATION TO THE WEB SITE THAT IS THEN PROCESSED AND CAN BE ACCESSED IN REAL-TIME BY USERS; PROVIDING AN ONLINE COMPUTER DATABASE OF MEDICAL INFORMATION (U.S. CLS. 100 AND 101).

FIRST USE 5-30-2008; IN COMMERCE 5-30-2008.  
JEFFERY COWARD, EXAMINING ATTORNEY

---

SN 85-211,806. CHICAGO SPORTS MEDIA, INC., AKA CHICAGO ATHLETE, CHICAGO, IL. FILED 1-6-2011.

# CHICAGO ATHLETE

THE MARK CONSISTS OF STANDARD CHARACTERS WITHOUT CLAIM TO ANY PARTICULAR FONT, STYLE, SIZE, OR COLOR.

OWNER OF U.S. REG. NO. 2,641,316.  
SEC. 2(F).

**CLASS 16—PAPER GOODS AND PRINTED MATTER**

FOR MAGAZINES IN THE FIELD OF SPORTS (U.S. CLS. 2, 5, 22, 23, 29, 37, 38 AND 50).  
FIRST USE 9-1-2001; IN COMMERCE 9-1-2001.

**CLASS 41—EDUCATION AND ENTERTAINMENT**

FOR ENTERTAINMENT SERVICES, NAMELY, PROVIDING A WEB SITE FEATURING PHOTOGRAPHIC, AUDIO, VIDEO AND PROSE PRESENTATIONS FEATURING NEWS AND INFORMATION IN THE FIELD OF SPORTS (U.S. CLS. 100, 101 AND 107).

FIRST USE 9-1-2001; IN COMMERCE 9-1-2001.  
THOMAS MANOR, EXAMINING ATTORNEY

SN 85-211,824. JULINA LLC, DBA JULINA DESIGNS, CEDAR GROVE, NJ. FILED 1-6-2011.

SN 85-211,904. KNORR-NAHRMITTEL AKTIENGESELLSCHAFT, THAYNGEN CH-8240, SWITZERLAND, FILED 1-6-2011.

# Julina Designs

THE HEART OF THE KITCHEN

THE MARK CONSISTS OF STANDARD CHARACTERS WITHOUT CLAIM TO ANY PARTICULAR FONT, STYLE, SIZE, OR COLOR.

NO CLAIM IS MADE TO THE EXCLUSIVE RIGHT TO USE "DESIGNS", APART FROM THE MARK AS SHOWN.

THE MARK CONSISTS OF STANDARD CHARACTERS WITHOUT CLAIM TO ANY PARTICULAR FONT, STYLE, SIZE, OR COLOR.

## CLASS 14—JEWELRY

FOR BODY JEWELRY; DIAMOND JEWELRY; GEMSTONE JEWELRY; JEWELRY; JEWELRY BOXES; JEWELRY CHAINS; RINGS; STAINLESS STEEL JEWELRY BRACELETS (U.S. CLS. 2, 27, 28 AND 50).

## CLASS 29—MEATS AND PROCESSED FOODS

FOR SOUPS AND SOUP MIXES; DIP AND DIP MIXES; BOUILLON; BOUILLON CUBES (U.S. CL. 46).

## CLASS 37—CONSTRUCTION AND REPAIR

FOR GEM AND JEWELRY REPAIR AND CLEANING SERVICES (U.S. CLS. 100, 103 AND 106).  
ALEXANDER L. POWERS, EXAMINING ATTORNEY

## CLASS 30—STAPLE FOODS

FOR PREPARED MEALS CONSISTING PRIMARILY OF PASTA OR RICE; GRAVY AND GRAVY MIXES; SAUCE AND SAUCE MIXES, EXCLUDING APPLE AND CRANBERRY; SEASONINGS AND SEASONED COATING FOR MEAT, FISH AND POULTRY (U.S. CL. 46).  
ALLISON SCHRODY, EXAMINING ATTORNEY

SN 85-211,826. BADGER SPORTSMAN MAGAZINE, LLC, OSHKOSH, WI. FILED 1-6-2011.

SN 85-211,941. XAVIER UNIVERSITY CORPORATION, DBA XAVIER UNIVERSITY, CINCINNATI, OH. FILED 1-6-2011.

# Badger Sportsman Magazine

# Center for the Study of the American Dream

THE MARK CONSISTS OF STANDARD CHARACTERS WITHOUT CLAIM TO ANY PARTICULAR FONT, STYLE, SIZE, OR COLOR.

NO CLAIM IS MADE TO THE EXCLUSIVE RIGHT TO USE "MAGAZINE", APART FROM THE MARK AS SHOWN.

THE MARK CONSISTS OF STANDARD CHARACTERS WITHOUT CLAIM TO ANY PARTICULAR FONT, STYLE, SIZE, OR COLOR.

NO CLAIM IS MADE TO THE EXCLUSIVE RIGHT TO USE "CENTER" AND "STUDY", APART FROM THE MARK AS SHOWN.

## CLASS 16—PAPER GOODS AND PRINTED MATTER

FOR MAGAZINES IN THE FIELD OF WISCONSIN AND MICHIGAN OUTDOORS WITH AN EMPHASIS ON HUNTING AND FISHING (U.S. CLS. 2, 5, 22, 23, 29, 37, 38 AND 50).

FIRST USE 1-1-1944; IN COMMERCE 1-1-1944.

## CLASS 35—ADVERTISING AND BUSINESS

FOR CONDUCTING MARKET SURVEYS; MARKET ANALYSIS AND RESEARCH SERVICES; PUBLIC OPINION SURVEYS (U.S. CLS. 100, 101 AND 102).

FIRST USE 10-14-2010; IN COMMERCE 10-14-2010.

## CLASS 41—EDUCATION AND ENTERTAINMENT

FOR PROVIDING ON-LINE MAGAZINES IN THE FIELD OF WISCONSIN AND MICHIGAN OUTDOORS WITH AN EMPHASIS ON HUNTING AND FISHING (U.S. CLS. 100, 101 AND 107).

FIRST USE 4-19-2002; IN COMMERCE 4-19-2002.

ALEXANDER L. POWERS, EXAMINING ATTORNEY

## CLASS 42—SCIENTIFIC AND COMPUTER SERVICES

FOR SURVEY DESIGN AND RESEARCH (U.S. CLS. 100 AND 101).

FIRST USE 10-14-2010; IN COMMERCE 10-14-2010.

ANGELA M. MICHELI, EXAMINING ATTORNEY

SN 85-211,961. HM3 ENERGY, INC., GRESHAM, OR. FILED 1-6-2011.



THE MARK CONSISTS OF A LEAF DESIGN WITH SERRATED EDGES, ONE SIDE OF THE LEAF BEING LIGHTER IN COLOR THAN THE OTHER SIDE.

#### CLASS 4—LUBRICANTS AND FUELS

FOR TORREFIED BIOMASS PRODUCTS, NAMELY, CELLULOSIC MATERIAL FOR USE AS FUEL PRODUCTS (U.S. CLS. 1, 6 AND 15).

#### CLASS 40—MATERIAL TREATMENT

FOR CUSTOM MANUFACTURE OF TORREFIED BIOMASS PRODUCTS, NAMELY, CELLULOSIC MATERIAL FOR USE AS FUEL PRODUCTS (U.S. CLS. 100, 103 AND 106).

SUSAN RICHARDS, EXAMINING ATTORNEY

SN 85-211,986. SUPER CAKE BAKERY CORP., MIAMI, FL. FILED 1-6-2011.



NO CLAIM IS MADE TO THE EXCLUSIVE RIGHT TO USE "CAKE & BAKERY SHOP", APART FROM THE MARK AS SHOWN.

THE MARK CONSISTS OF THE WORDS "MOULIN ROSE CAKE & BAKERY SHOP" WITH THE WORDS "MOULIN ROSE" IN A STYLIZED SCRIPT FORM. IN BETWEEN THE WORDS "MOULIN ROSE" APPEARS A DESIGN OF A CAKE AND THE WORDS "CAKE & BAKERY SHOP" APPEAR UNDER THE DESIGN OF THE CAKE AND THE WORDS "MOULIN ROSE".

#### CLASS 30—STAPLE FOODS

FOR (BASED ON INTENT TO USE) BAKERY GOODS, NAMELY, CAKES, PASTRIES, BREADS, COFFEE, DESSERTS, SANDWICHES (U.S. CL. 46).

#### CLASS 35—ADVERTISING AND BUSINESS

FOR (BASED ON USE IN COMMERCE) RETAIL BAKERY SHOPS (U.S. CLS. 100, 101 AND 102).

FIRST USE 11-28-2010; IN COMMERCE 11-28-2010.  
KHANH LE, EXAMINING ATTORNEY

SN 85-212,084. ESCALANTE, TERESA, FORT SMITH, AR. FILED 1-6-2011.

## Enduring Traditions

THE MARK CONSISTS OF STANDARD CHARACTERS WITHOUT CLAIM TO ANY PARTICULAR FONT, STYLE, SIZE, OR COLOR.

#### CLASS 16—PAPER GOODS AND PRINTED MATTER

FOR WORKS OF ART OF PAPIER MACHE (U.S. CLS. 2, 5, 22, 23, 29, 37, 38 AND 50).  
FIRST USE 10-20-2010; IN COMMERCE 10-20-2010.

#### CLASS 20—FURNITURE AND ARTICLES NOT OTHERWISE CLASSIFIED

FOR FURNITURE MADE FROM WOOD OR SUBSTITUTES FOR WOOD (U.S. CLS. 2, 13, 22, 25, 32 AND 50).  
FIRST USE 10-20-2010; IN COMMERCE 10-20-2010.  
JACQUELINE A. LAVINE, EXAMINING ATTORNEY

SN 85-212,126. RYAN SCOTT, INC., GREENSBORO, NC. FILED 1-6-2011.



THE MARK CONSISTS OF A SERIES OF OVERLAPPING ARCS IN A TRIANGULAR FORMATION.

#### CLASS 20—FURNITURE AND ARTICLES NOT OTHERWISE CLASSIFIED

FOR FURNITURE, NAMELY, DISPLAY UNITS AND STRUCTURAL PARTS THEREOF (U.S. CLS. 2, 13, 22, 25, 32 AND 50).

#### CLASS 35—ADVERTISING AND BUSINESS

FOR PROVIDING ADVERTISING, MARKETING, AND PROMOTIONAL SERVICES FOR OTHERS, NAMELY, THE DESIGN OF ADVERTISING MATERIALS AND SELECTION OF DISPLAY UNITS FOR USE THEREWITH (U.S. CLS. 100, 101 AND 102).

JEFFERY COWARD, EXAMINING ATTORNEY



SN 85-212,227. TUFF DECKS, INC., ENGLEWOOD, CO.  
FILED 1-6-2011.

SN 85-212,305. EXPEDIA, INC., BELLEVUE, WA. FILED 1-6-2011.



NO CLAIM IS MADE TO THE EXCLUSIVE RIGHT TO USE "DECKS", APART FROM THE MARK AS SHOWN.

THE MARK CONSISTS OF THE WORD "TUFF" WITH THE LETTER "T" IN THE IMAGE OF A PIECE OF WOOD OR LUMBER APPEARING HORIZONTALLY ABOVE THE LETTERS "UFF", THE WORD "DECKS" WRITTEN VERTICALLY FROM THE BOTTOM GOING UP BEHIND THE WORD "TUFF", AND THE WORDS "COAT IT - DON'T REPLACE IT" WRITTEN BELOW THE WORDS "TUFF DECKS".

#### CLASS 2—PAINTS

FOR ARCHITECTURAL PROTECTIVE COATINGS; COATINGS FOR WOOD AS PAINTS; COATINGS IN THE NATURE OF INDUSTRIAL SEALANTS FOR WATERPROOFING AND SURFACE HARDENING; COATINGS, NAMELY, STAINS AND CLEAR FINISHES FOR EXTERIOR AND INTERIOR USE ON A VARIETY OF SUBSTRATES; CONCRETE MOISTURE BARRIER COATING; CONCRETE SEALERS IN THE FORM OF A COATING; CORROSION INHIBITANTS IN THE NATURE OF A COATING; CORROSION INHIBITORS IN THE NATURE OF A COATING; EXTERIOR SURFACE PROTECTIVE COATINGS; PENETRATING SEALER COATINGS FOR USE ON DECKS; POLYMER COATINGS FOR CONCRETE; POLYURETHANE COATINGS FOR EXTERIOR AND INTERIOR USE ON A VARIETY OF SUBSTRATES; POLYURETHANE COATINGS FOR DECKS; PRESERVATIVE COATINGS FOR PAPER AND WOOD SURFACES; SEALER COATINGS FOR USE IN DECKS; STONE SEALER COATINGS; WEATHER-PROOFING COATINGS (U.S. CLS. 6, 11 AND 16).

#### CLASS 17—RUBBER GOODS

FOR POLYMER SEALANT FOR USE IN CONNECTION WITH THE INSTALLATION OF FLOORING; POLYMER-BASED PATCHING AND SEALING COMPOUNDS FOR MASONRY AND WOOD; RAPID CURE, HIGH STRENGTH, POLYMER-BASED CONCRETE PATCHING COMPOUND (U.S. CLS. 1, 5, 12, 13, 35 AND 50).

#### CLASS 35—ADVERTISING AND BUSINESS

FOR ASSISTANCE IN BUSINESS MANAGEMENT AND PRODUCT COMMERCIALIZATION, WITHIN THE FRAMEWORK OF A FRANCHISE CONTRACT; BUSINESS MANAGEMENT ADVISORY SERVICES RELATING TO FRANCHISING; FRANCHISING, NAMELY, CONSULTATION AND ASSISTANCE IN BUSINESS MANAGEMENT, ORGANIZATION AND PROMOTION (U.S. CLS. 100, 101 AND 102).

#### CLASS 37—CONSTRUCTION AND REPAIR

FOR APPLICATION OF COATINGS AND SEALERS; APPLICATION OF COATINGS FOR OTHERS, NAMELY, APPLYING PROTECTIVE COATING; APPLICATION OF PROTECTIVE COATINGS; APPLYING PROTECTIVE COATINGS TO DECKS; INSTALLATION AND MAINTENANCE OF DECKS; INSTALLATION OF DECKS; INSTALLATION, MAINTENANCE AND REPAIR OF DECKS; PAINTING AND APPLYING COATINGS TO BUILDING INTERIORS AND BUILDING EXTERIORS (U.S. CLS. 100, 103 AND 106).

APRIL ROACH, EXAMINING ATTORNEY

The logo for chameleon features the word "chameleon" in a lowercase, sans-serif font. The letter "o" is replaced by a graphic of a chameleon's eye, consisting of several concentric circles.

THE MARK CONSISTS OF THE TERM "CHAMELEON" WITH THE LETTER "O" MADE UP OF A SERIES OF CONCENTRIC OFF-SET CIRCLES.

#### CLASS 35—ADVERTISING AND BUSINESS

FOR CUSTOMER LOYALTY SERVICES AND CUSTOMER CLUB SERVICES FOR COMMERCIAL, PROMOTIONAL AND ADVERTISING PURPOSES; PROMOTING THE USE OF CHARGE AND CREDIT CARD ACCOUNTS OF OTHERS THROUGH THE ADMINISTRATION OF INCENTIVE PROGRAMS; CONDUCTING CUSTOMER LOYALTY, REWARD, AFFINITY AND INCENTIVE PROGRAMS FOR COMMERCIAL PROMOTION AND FOR ADVERTISING PURPOSES; BUSINESS CONSULTING AND MANAGEMENT SERVICES IN THE FIELD OF TRAVEL, TRAVEL PLANNING AND THE OPERATION OF TRAVEL-RELATED BUSINESSES; ADVERTISING SERVICES, NAMELY, PROMOTING AND MARKETING THE GOODS AND SERVICES OF OTHERS VIA ELECTRONIC AND OPTICAL COMMUNICATION NETWORKS; PROVIDING AUTOMOBILE RENTAL, AIRFARE, CRUISE SHIP, AND TEMPORARY LODGING RATE COMPARISON INFORMATION (U.S. CLS. 100, 101 AND 102).

#### CLASS 39—TRANSPORTATION AND STORAGE

FOR TRAVEL AGENCY SERVICES, NAMELY, MAKING RESERVATIONS AND BOOKINGS FOR TRANSPORTATION AND PROVIDING INFORMATION AND REVIEWS CONCERNING TRAVEL BY MEANS OF A TELEPHONE, FACSIMILE AND OVER COMPUTER NETWORKS AND GLOBAL COMMUNICATION NETWORKS; PROVIDING A WEBSITE AND WEBSITE LINKS TO TRAVEL INFORMATION, GEOGRAPHIC INFORMATION, MAPS, MAP IMAGES AND TRIP ROUTING; PROVIDING AN ONLINE COMPUTER DATABASE IN THE FIELD OF TRAVEL INFORMATION; PROVIDING A WEBSITE WHERE USERS CAN POST RATINGS, REVIEWS AND RECOMMENDATIONS ON EVENTS AND ACTIVITIES IN THE FIELD OF TRAVEL (U.S. CLS. 100 AND 105).

#### CLASS 42—SCIENTIFIC AND COMPUTER SERVICES

FOR PROVIDING TEMPORARY USE OF ONLINE NON-DOWNLOADABLE SOFTWARE FOR USE IN THE CREATION OF WEBSITES; PROVIDING TEMPORARY USE OF ONLINE NON-DOWNLOADABLE SOFTWARE FOR USE IN PROVIDING TRAVEL RESERVATION AND BOOKING SERVICES AND IN PROVIDING TRAVEL INFORMATION; PROVIDING TEMPORARY USE OF ONLINE NON-DOWNLOADABLE SOFTWARE FOR USE IN PROVIDING TEMPORARY ACCOMMODATION, HOTEL AND LODGING RESERVATION AND BOOKING SERVICES; PROVIDING TEMPORARY USE OF ONLINE NON-DOWNLOADABLE SOFTWARE FOR USE IN CREATING TEMPLATES AND CUSTOMIZED DISPLAYS IN CONNECTION WITH OFFERING TRAVEL RESERVATION AND BOOKING SERVICES AND PROVIDING TRAVEL INFORMATION (U.S. CLS. 100 AND 101).

**CLASS 43—HOTEL AND RESTAURANT SERVICES**

FOR TRAVEL AGENCY SERVICES, NAMELY, MAKING RESERVATIONS AND BOOKINGS FOR TEMPORARY ACCOMMODATIONS; HOTEL AND LODGING SERVICES, NAMELY, PROVIDING AND RELAYING INFORMATION IN CONNECTION WITH RESERVATIONS AND BOOKINGS FOR TEMPORARY LODGING AND PROVIDING REVIEWS OF HOTELS BY MEANS OF A TELEPHONE, FACSIMILE AND OVER COMPUTER NETWORKS AND GLOBAL COMMUNICATION NETWORKS; MAKING RESERVATIONS AND BOOKINGS FOR TEMPORARY LODGING AND HOTELS FOR OTHERS AND ALSO INCLUDING INFORMATION ON METHODS FOR PAYMENT FOR CONSUMERS WHO ARE BOOKING THE RESERVATIONS; PROVIDING A WEBSITE WHERE USERS CAN POST RATINGS, REVIEWS AND RECOMMENDATIONS ON EVENTS AND ACTIVITIES IN THE FIELD OF TEMPORARY LODGING; PROVIDING ADVICE TO TOURISTS AND BUSINESS TRAVELERS ON TEMPORARY LODGING AND RESTAURANT DESTINATIONS; PROVIDING A WEBSITE FEATURING RATINGS OF CONSUMER SERVICES OF OTHERS IN THE FIELD OF TRAVEL, IN THE NATURE OF TEMPORARY LODGING AND RESORT ACCOMMODATIONS (U.S. CLS. 100 AND 101).  
CHRISIE B. KING, EXAMINING ATTORNEY

---

SN 85-212,310. ECOFRUITS INTERNATIONAL, INC., SOUTH JORDAN, UT. FILED 1-6-2011.



**CLASS 5—PHARMACEUTICALS**

FOR DIETARY SUPPLEMENTAL DRINKS; NUTRACEUTICALS FOR USE AS A DIETARY SUPPLEMENT; NUTRITIONAL SUPPLEMENTS; POWDERED FRUIT-FLAVORED DIETARY SUPPLEMENT DRINK MIX; POWDERED NUTRITIONAL SUPPLEMENT DRINK MIX (U.S. CLS. 6, 18, 44, 46, 51 AND 52).

**CLASS 30—STAPLE FOODS**

FOR EDIBLE FRUIT ICES; FROZEN CONFECTIONS; FROZEN YOGURT; FROZEN YOGURT MIXES; FRUIT ICE; FRUIT ICE BAR (U.S. CL. 46).  
DEBRA LEE, EXAMINING ATTORNEY

---

SN 85-212,388. WILSON, ERIC, LAKE MARY, FL. FILED 1-6-2011.

**Weatherbook**

THE MARK CONSISTS OF STANDARD CHARACTERS WITHOUT CLAIM TO ANY PARTICULAR FONT, STYLE, SIZE, OR COLOR.

**CLASS 9—ELECTRICAL AND SCIENTIFIC APPARATUS**

FOR COMPUTER APPLICATION SOFTWARE FOR MOBILE PHONES, NAMELY, SOFTWARE FOR WEATHER ALERTS (U.S. CLS. 21, 23, 26, 36 AND 38).

**CLASS 35—ADVERTISING AND BUSINESS**

FOR PROVIDING ADVERTISING SERVICE TO DISTRIBUTE ADVERTISEMENTS FOR DISPLAY ON INTERNET, NAMELY, IN WEBSITES, SOCIAL CONVERSATIONS OVER THE INTERNET, E-MAILS, MICROBLOGS, BLOGS, ELECTRONIC MESSAGES, INSTANT MESSAGES, TEXT MESSAGES, MULTIMEDIA MESSAGES, SOCIAL NETWORKS, STATUS UPDATES, FORUMS, ELECTRONIC BULLETIN BOARDS (U.S. CLS. 100, 101 AND 102).  
PAUL F. GAST, EXAMINING ATTORNEY

---

SN 85-212,420. NUTRASOURCE LLC, MIAMI, FL. FILED 1-6-2011.

**NUTRALA**

THE MARK CONSISTS OF STANDARD CHARACTERS WITHOUT CLAIM TO ANY PARTICULAR FONT, STYLE, SIZE, OR COLOR.

**CLASS 5—PHARMACEUTICALS**

FOR DIETARY SUPPLEMENTS CONSISTING OF VITAMINS, MINERALS, HERBS, FIBER, ANTHRACITIC, OR PROTEIN IN TABLET, POWDER, CAPSULE OR LIQUID FORM; NUTRITIONAL DRINK MIXES FOR USE AS A MEAL REPLACEMENT (U.S. CLS. 6, 18, 44, 46, 51 AND 52).

**CLASS 35—ADVERTISING AND BUSINESS**

FOR RETAIL ONLINE STORE SERVICES FEATURING DIETARY SUPPLEMENTS CONSISTING OF VITAMINS, MINERALS, HERBS, FIBER, ANTHRACITIC, OR PROTEIN IN TABLET, POWDER, CAPSULE OR LIQUID FORM, AND NUTRITIONAL DRINK MIXES (U.S. CLS. 100, 101 AND 102).  
JOHN KELLY, EXAMINING ATTORNEY

---

SN 85-212,498. ISAAK, ANDREW JAY, SCARSDALE, NY. FILED 1-7-2011.

**sciencebook**

THE MARK CONSISTS OF STANDARD CHARACTERS WITHOUT CLAIM TO ANY PARTICULAR FONT, STYLE, SIZE, OR COLOR.  
PRIORITY CLAIMED UNDER SEC. 44(D) ON FED REP GERMANY APPLICATION NO. 302010050762, FILED 8-30-2010.

**CLASS 35—ADVERTISING AND BUSINESS**

FOR (BASED ON INTENT TO USE) ADVERTISING AND MARKETING SERVICES, NAMELY, PROMOTING THE GOODS AND SERVICES OF OTHERS; PROVIDING ADVERTISING SERVICE TO DISTRIBUTE ADVERTISEMENTS FOR DISPLAY ON INTERNET, NAMELY, IN WEBSITES, SOCIAL CONVERSATIONS OVER THE INTERNET, E-MAILS, MICROBLOGS, BLOGS, ELECTRONIC MESSAGES, INSTANT MESSAGES, TEXT MESSAGES, MULTIMEDIA MESSAGES, SOCIAL NETWORKS, STATUS UPDATES, FORUMS, ELECTRONIC BULLETIN BOARDS; PROVIDING AN ON-LINE SEARCHABLE DATABASE FEATURING CLASSIFIED AD LISTINGS AND EMPLOYMENT OPPORTUNITIES; PROVISION OF ADVERTISING SPACE BY ELECTRONIC MEANS AND GLOBAL INFORMATION NETWORKS (U.S. CLS. 100, 101 AND 102).

**CLASS 38—COMMUNICATION**

FOR (BASED ON INTENT TO USE) (BASED ON 44(D) PRIORITY APPLICATION) PROVIDING E-MAIL AND INSTANT MESSAGING SERVICES; PROVIDING ON-LINE CHAT ROOMS FOR SOCIAL NETWORKING; VIDEO BROADCASTING SERVICES OVER THE INTERNET OR OTHER COMMUNICATIONS NETWORK, NAMELY, ELECTRONICALLY TRANSMITTING VIDEO CLIPS (U.S. CLS. 100, 101 AND 104).

**CLASS 41—EDUCATION AND ENTERTAINMENT**

FOR (BASED ON INTENT TO USE) (BASED ON 44(D) PRIORITY APPLICATION) ON-LINE JOURNALS, NAMELY, BLOGS FEATURING USER-DEFINED CONTENT (U.S. CLS. 100, 101 AND 107).

**CLASS 42—SCIENTIFIC AND COMPUTER SERVICES**

FOR (BASED ON INTENT TO USE) (BASED ON 44(D) PRIORITY APPLICATION) APPLICATION SERVICE PROVIDER (ASP) FEATURING SOFTWARE FOR USE TO ENABLE UPLOADING, POSTING, DISPLAYING, TAGGING, BLOGGING, SHARING OR OTHERWISE PROVIDING ELECTRONIC MEDIA OR INFORMATION OVER THE INTERNET OR OTHER COMMUNICATIONS NETWORK; COMPUTER SERVICES IN THE NATURE OF CUSTOMIZED WEB PAGES FEATURING USER-DEFINED INFORMATION, PERSONAL PROFILES AND INFORMATION; COMPUTER SERVICES, NAMELY, CREATING AN ON-LINE COMMUNITY FOR REGISTERED USERS TO PARTICIPATE IN DISCUSSIONS, GET FEEDBACK FROM THEIR PEERS, FORM VIRTUAL COMMUNITIES, AND ENGAGE IN SOCIAL NETWORKING; COMPUTER SERVICES, NAMELY, HOSTING ON-LINE WEB FACILITIES FOR OTHERS FOR ORGANIZING AND CONDUCTING ON-LINE MEETINGS, GATHERINGS, AND INTERACTIVE DISCUSSIONS; PEER-TO-BROWSER PHOTO SHARING SERVICES, NAMELY, PROVIDING A WEBSITE FEATURING TECHNOLOGY ENABLING USERS TO UPLOAD, VIEW, AND DOWNLOAD DIGITAL PHOTOS; PROVIDING A WEB SITE FEATURING TEMPORARY USE OF NON-DOWNLOADABLE SOFTWARE ALLOWING WEB SITE USERS TO UPLOAD, POST AND DISPLAY ONLINE VIDEOS FOR SHARING WITH OTHERS FOR ENTERTAINMENT PURPOSES (U.S. CLS. 100 AND 101).

**CLASS 45—PERSONAL AND LEGAL SERVICES**

FOR (BASED ON INTENT TO USE) INTERNET BASED SOCIAL NETWORKING, INTRODUCTION, AND DATING SERVICES; PROVIDING ON-LINE COMPUTER DATABASES AND ON-LINE SEARCHABLE DATABASES IN THE FIELD OF SOCIAL NETWORKING (U.S. CLS. 100 AND 101).

DOMINICK J. SALEMI, EXAMINING ATTORNEY

SN 85-212,542. AMERICAN CHEMICAL SOCIETY, WASHINGTON, DC. FILED 1-7-2011.

**BIOMACROMOLECULES**

THE MARK CONSISTS OF STANDARD CHARACTERS WITHOUT CLAIM TO ANY PARTICULAR FONT, STYLE, SIZE, OR COLOR.

OWNER OF U.S. REG. NO. 2,396,617.  
SEC. 2(F).

**CLASS 9—ELECTRICAL AND SCIENTIFIC APPARATUS**

FOR DOWNLOADABLE PUBLICATIONS, NAMELY, DOWNLOADABLE ARTICLES IN THE FIELD OF BIOLOGICAL CHEMISTRY (U.S. CLS. 21, 23, 26, 36 AND 38).  
FIRST USE 2-0-2000; IN COMMERCE 2-0-2000.

**CLASS 16—PAPER GOODS AND PRINTED MATTER**

FOR PRINTED PUBLICATIONS, NAMELY, SCIENTIFIC RESEARCH JOURNAL CONTAINING ARTICLES AND INFORMATION IN THE FIELD OF BIOLOGICAL CHEMISTRY (U.S. CLS. 2, 5, 22, 23, 29, 37, 38 AND 50).  
FIRST USE 2-0-2000; IN COMMERCE 2-0-2000.

**CLASS 41—EDUCATION AND ENTERTAINMENT**

FOR NON-DOWNLOADABLE PUBLICATIONS, NAMELY, NON-DOWNLOADABLE ARTICLES IN THE FIELD OF BIOLOGICAL CHEMISTRY (U.S. CLS. 100, 101 AND 107).

FIRST USE 2-0-2000; IN COMMERCE 2-0-2000.  
DAWN FELDMAN, EXAMINING ATTORNEY

SN 85-212,562. ASSURANT, INC., NEW YORK, NY. FILED 1-7-2011.

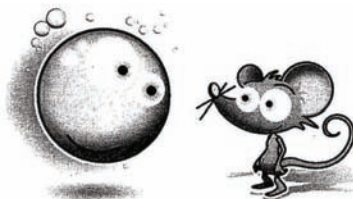

THE MARK CONSISTS OF A CARTOON-LIKE MOUSE FACING A ROUND BUBBLE HAVING TWO EYES AND A SMILE WITH SMALLER BUBBLES FLOATING ABOVE IT.

**CLASS 35—ADVERTISING AND BUSINESS**

FOR ADVERTISING SERVICES; BUSINESS ADMINISTRATION AND MANAGEMENT; PROVIDING OFFICE FUNCTIONS; PROVIDING INCENTIVE AWARD PROGRAMS FOR CUSTOMERS THROUGH THE ISSUANCE AND PROCESSING OF LOYALTY POINTS AND COUPONS FOR THE FREQUENT USE OF PARTICIPATING BUSINESS; PRODUCTION OF TELEVISION AND RADIO ADVERTISEMENTS; DATA PROCESSING SERVICES; PROVISION OF BUSINESS INFORMATION (U.S. CLS. 100, 101 AND 102).

**CLASS 36—INSURANCE AND FINANCIAL**

FOR INSURANCE UNDERWRITING SERVICES IN THE FIELDS OF PROPERTY, TRADITIONAL AND MANUFACTURED HOUSING HOMEOWNER'S, RENTER'S, SINGLE INTEREST, FLOOD, DISASTER AND HAZARD, CREDITOR PLACED INSURANCE, CASUALTY, HEALTH, LIFE, FUNERAL NEEDS COVERAGE, DENTAL, DISABILITY, ACCIDENTAL DEATH, DISMEMBERMENT, INVOLUNTARY UNEMPLOYMENT, CONTRACTUAL LIABILITY, SURETY, CREDIT, MORTGAGE LOAN PROTECTION, AND CREDITOR PAID INSURANCE; FINANCIAL SERVICES, NAMELY, FINANCIAL ADVICE AND CONSULTANCY, FINANCIAL SECURITIES EXCHANGE SERVICES, INVESTMENT SECURITY SERVICES; PROVISION OF FINANCIAL INFORMATION; PROVIDING INSURANCE UNDERWRITING, INCLUDING EXTENDED WARRANTIES AND EXTENDED SERVICE CONTRACTS, AND POST-WARRANTY REPAIR OR REPLACEMENT GUARANTEES INSURANCE, FOR PRODUCTS, NAMELY, TELEPHONES, COMPUTERS, CAMERAS, AND COMPUTER AND VIDEO GAME CONSOLES (U.S. CLS. 100, 101 AND 102).

**CLASS 37—CONSTRUCTION AND REPAIR**

FOR MAINTENANCE AND REPAIR OF COMPUTER HARDWARE (U.S. CLS. 100, 103 AND 106).  
SANDRA BUJA, EXAMINING ATTORNEY

**CLASS 36—INSURANCE AND FINANCIAL**

FOR INSURANCE UNDERWRITING SERVICES IN THE FIELDS OF PROPERTY, TRADITIONAL AND MANUFACTURED HOUSING HOMEOWNER'S, RENTER'S, SINGLE INTEREST, FLOOD, DISASTER AND HAZARD, CREDITOR PLACED INSURANCE, CASUALTY, HEALTH, LIFE, FUNERAL NEEDS COVERAGE, DENTAL, DISABILITY, ACCIDENTAL DEATH, DISMEMBERMENT, INVOLUNTARY UNEMPLOYMENT, CONTRACTUAL LIABILITY, SURETY, CREDIT, MORTGAGE LOAN PROTECTION, AND CREDITOR PAID INSURANCE; FINANCIAL SERVICES, NAMELY, FINANCIAL ADVICE AND CONSULTANCY, FINANCIAL SECURITIES EXCHANGE SERVICES, INVESTMENT SECURITY SERVICES; PROVISION OF FINANCIAL INFORMATION; PROVIDING INSURANCE UNDERWRITING, INCLUDING EXTENDED WARRANTIES AND EXTENDED SERVICE CONTRACTS, AND POST-WARRANTY REPAIR OR REPLACEMENT GUARANTEES INSURANCE, FOR PRODUCTS, NAMELY, TELEPHONES, COMPUTERS, CAMERAS, AND COMPUTER AND VIDEO GAME CONSOLES (U.S. CLS. 100, 101 AND 102).

**CLASS 37—CONSTRUCTION AND REPAIR**

FOR MAINTENANCE AND REPAIR OF COMPUTER HARDWARE (U.S. CLS. 100, 103 AND 106).  
SANDRA BUJA, EXAMINING ATTORNEY

SN 85-212,567. ASSURANT, INC., NEW YORK, NY. FILED 1-7-2011.



THE MARK CONSISTS OF A ROUND BUBBLE HAVING TWO EYES AND A SMILE WITH SMALLER BUBBLES FLOATING ABOVE IT.

**CLASS 35—ADVERTISING AND BUSINESS**

FOR ADVERTISING SERVICES; BUSINESS ADMINISTRATION AND MANAGEMENT; PROVIDING OFFICE FUNCTIONS; PROVIDING INCENTIVE AWARD PROGRAMS FOR CUSTOMERS THROUGH THE ISSUANCE AND PROCESSING OF LOYALTY POINTS AND COUPONS FOR THE FREQUENT USE OF PARTICIPATING BUSINESS; PRODUCTION OF TELEVISION AND RADIO ADVERTISEMENTS; DATA PROCESSING SERVICES; PROVISION OF BUSINESS INFORMATION (U.S. CLS. 100, 101 AND 102).

SN 85-212,600. COACH'S RESTORATION LLC, BIRMINGHAM, MI. FILED 1-7-2011.



OWNER OF U.S. REG. NO. 2,509,780.

NO CLAIM IS MADE TO THE EXCLUSIVE RIGHT TO USE "CATASTROPHE CLEANING & RESTORATION SERVICES", APART FROM THE MARK AS SHOWN.

THE MARK CONSISTS OF THE WORD "COACH'S" WRITTEN IN A RECTANGLE OVER A SEMI-CIRCLE THAT SURROUNDS A DESIGN RESEMBLING A STAR, WITH THE WORDS "CATASTROPHE CLEANING" WRITTEN IN AN ARC ABOVE THE SEMI-CIRCLE AND THE WORDS "& RESTORATION SERVICES" WRITTEN IN AN ARC BELOW THE SEMI-CIRCLE, ALL SURROUNDED BY A SEMI-CIRCULAR OUTLINE.

**CLASS 37—CONSTRUCTION AND REPAIR**

FOR BUILDING RESTORATION; CARPET CLEANING; CLEANING OF BUILDINGS; CLEANING OF COMMERCIAL PREMISES; CLEANING OF INDUSTRIAL PREMISES; CLEANING OF RESIDENTIAL HOUSES; CLEANING OF HVAC AND UPHOLSTERY; RESTORATION SERVICES IN THE FIELD OF WATER, SMOKE AND FIRE DAMAGE (U.S. CLS. 100, 103 AND 106).

FIRST USE 7-3-2002; IN COMMERCE 5-21-2010.



**CLASS 40—MATERIAL TREATMENT**

FOR BACTERIAL REMOVAL TREATMENT OF FURNITURE, FIXTURES, EQUIPMENT AND ANY OTHER ITEMS LOCATED IN A HOME OR WORKPLACE; MOLD REMEDIATION SERVICES; ODOR NEUTRALIZATION SERVICES (U.S. CLS. 100, 103 AND 106).

FIRST USE 7-3-2002; IN COMMERCE 5-21-2010.  
MICHAEL SOUDERS, EXAMINING ATTORNEY

SN 85-212,759. ZALOOM MARKETING CORPORATION, SOUTH HACKENSACK, NJ. FILED 1-7-2011.

**MIX MASTERS**

THE MARK CONSISTS OF STANDARD CHARACTERS WITHOUT CLAIM TO ANY PARTICULAR FONT, STYLE, SIZE, OR COLOR.

NO CLAIM IS MADE TO THE EXCLUSIVE RIGHT TO USE "MIX", APART FROM THE MARK AS SHOWN.

SN 85-212,621. GRAND CANYON PRODUCTS, INC., PHOENIX, AZ. FILED 1-7-2011.

**PWD**

THE MARK CONSISTS OF STANDARD CHARACTERS WITHOUT CLAIM TO ANY PARTICULAR FONT, STYLE, SIZE, OR COLOR.

**CLASS 3—COSMETICS AND CLEANING PREPARATIONS**

FOR AFTER-SHAVE GEL; AROMATIC BODY CARE PRODUCTS, NAMELY, BODY LOTION, SHOWER GEL, CUTICLE CREAM, SHAMPOO, CONDITIONER, NON-MEDICATED LIP BALM, SOAP, BODY POLISH, BODY AND FOOT SCRUB AND NON-MEDICATED FOOT CREAM; BATH AND SHOWER GELS AND SALTS NOT FOR MEDICAL PURPOSES; BODY AND BEAUTY CARE COSMETICS; COSMETIC CREAMS FOR SKIN CARE; COSMETIC PREPARATIONS FOR BODY CARE; COSMETIC PREPARATIONS FOR PROTECTING THE SKIN FROM THE SUN'S RAYS; COSMETIC PREPARATIONS FOR SKIN CARE; COSMETIC PREPARATIONS FOR SKIN RENEWAL; COSMETIC PRODUCTS IN THE FORM OF AEROSOLS FOR SKIN CARE; DEODORANTS FOR BODY CARE; HAIR CARE CREAMS; HAIR CARE LOTIONS; HAIR GEL AND HAIR MOUSSE; MAKE-UP REMOVING MILK, GEL, LOTIONS AND CREAMS; NON-MEDICATED SKIN CARE PREPARATIONS, NAMELY, CREAMS, LOTIONS, GELS, TONERS, CLEANERS AND PEELS; SCULPTING GEL; SHAVING GELS; SHOWER CREAMS; SKIN BRONZER; SKIN CARE PRODUCTS, NAMELY, NON-MEDICATED SKIN SERUM; SKIN CLEANSERS; SKIN CLEANSING CREAM; SKIN CLEANSING LOTION; SKIN LOTION; SKIN MOISTURIZER; SKIN SOAP; SKIN TONERS; SPF SUN BLOCK TOWELETES; SUN CARE LOTIONS; SUN SCREEN; SUN SCREEN PREPARATIONS; SUN TAN LOTION; SUN-BLOCK LOTIONS (U.S. CLS. 1, 4, 6, 50, 51 AND 52).

**CLASS 5—PHARMACEUTICALS**

FOR ROOM DEODORANTS AND FRESHENERS; PERSONAL LUBRICANTS (U.S. CLS. 6, 18, 44, 46, 51 AND 52).  
JANET LEE, EXAMINING ATTORNEY

**CLASS 29—MEATS AND PROCESSED FOODS**

FOR DRIED FRUIT MIXES; DRIED FRUITS; NUTS, NAMELY, DRIED NUTS, ROASTED NUTS AND SHELLED NUTS; DRIED PEAS; SNACK MIXES CONSISTING OF DEHYDRATED FRUIT AND PROCESSED NUTS; SNACK MIX CONSISTING PRIMARILY OF DEHYDRATED FRUITS, PROCESSED NUTS AND ALSO INCLUDING SESAME STICKS (U.S. CL. 46).

**CLASS 30—STAPLE FOODS**

FOR CRACKERS; PRETZELS; RICE CRACKERS; SNACK MIX CONSISTING PRIMARILY OF CRACKERS PRETZELS AND/OR POPPED POPCORN; TOASTED CORN KERNELS; SESAME, CORN, OAT AND RICE STICKS; ORIENTAL CRISPY NOODLES; DRIED BREAD SLICES (U.S. CL. 46).

JANET LEE, EXAMINING ATTORNEY

SN 85-212,940. C-WATER TECHNOLOGIES, INC., EVERGREEN, CO. FILED 1-7-2011.

**AQUASWEEP**

THE MARK CONSISTS OF STANDARD CHARACTERS WITHOUT CLAIM TO ANY PARTICULAR FONT, STYLE, SIZE, OR COLOR.

**CLASS 7—MACHINERY**

FOR INTAKE WATER SEPARATION SYSTEMS, COMPRISED OF LIQUID-MASS SEPARATORS FOR SEPARATING AQUATIC LIFE FROM A WATER STREAM THAT IS USED IN INDUSTRIAL APPLICATIONS INCLUDING WATER USED IN POWER PLANTS, DESALINATION PLANTS, MUNICIPAL WATER PLANTS, FACTORIES, OIL AND GAS FACILITIES, AND OTHER WATER REQUIREMENTS FOR INDUSTRY (U.S. CLS. 13, 19, 21, 23, 31, 34 AND 35).

**CLASS 42—SCIENTIFIC AND COMPUTER SERVICES**

FOR ENGINEERING SERVICES FOR THE CONSTRUCTION OF INTAKE WATER SEPARATION SYSTEMS, NAMELY, LIQUID-MASS SEPARATOR SYSTEMS FOR SEPARATING AQUATIC LIFE FROM A WATER STREAM THAT IS USED IN INDUSTRIAL APPLICATIONS INCLUDING WATER USED IN POWER PLANTS, DESALINATION PLANTS, MUNICIPAL WATER PLANTS, FACTORIES, OIL AND GAS FACILITIES, AND OTHER WATER REQUIREMENTS FOR INDUSTRY; CONSULTING SERVICES IN THE FIELD OF DESIGN AND IMPLEMENTATION OF INTAKE WATER SEPARATION SYSTEMS, NAMELY, LIQUID-MASS SEPARATOR SYSTEMS FOR SEPARATING AQUATIC LIFE FROM A WATER STREAM USED IN INDUSTRIAL APPLICATIONS (U.S. CLS. 100 AND 101).

CAROLINE WOOD, EXAMINING ATTORNEY

SN 85-213,167. TROVIS PHARMACEUTICALS LLC, NEWTON, MA. FILED 1-7-2011.

**TROVIS PHARMACEUTICALS**

THE MARK CONSISTS OF STANDARD CHARACTERS WITHOUT CLAIM TO ANY PARTICULAR FONT, STYLE, SIZE, OR COLOR.

NO CLAIM IS MADE TO THE EXCLUSIVE RIGHT TO USE "PHARMACEUTICALS", APART FROM THE MARK AS SHOWN.

SN 85-213,006. IDEA GIRLS ENTERTAINMENT, LLC, NORTH MIAMI BEACH, FL. FILED 1-7-2011.



NO CLAIM IS MADE TO THE EXCLUSIVE RIGHT TO USE "DIVORCE", APART FROM THE MARK AS SHOWN.

THE MARK CONSISTS OF THE WORDS "DIVORCE" ABOVE THE LETTERS "S.O.S" WITH THE DESIGN OF A BROKEN HEART AS THE LETTER "V".

**CLASS 5—PHARMACEUTICALS**

FOR HOUSE MARK FOR A FULL LINE OF PHARMACEUTICALS AND PHARMACEUTICAL PREPARATIONS (U.S. CLS. 6, 18, 44, 46, 51 AND 52).

**CLASS 42—SCIENTIFIC AND COMPUTER SERVICES**

FOR RESEARCH AND DEVELOPMENT IN THE PHARMACEUTICAL, GENETICS AND BIOTECHNOLOGY FIELDS (U.S. CLS. 100 AND 101).

**CLASS 44—MEDICAL, BEAUTY AND AGRICULTURAL SERVICES**

FOR MEDICAL TESTING FOR DIAGNOSTIC OR TREATMENT PURPOSES; GENETIC TESTING FOR MEDICAL PURPOSES (U.S. CLS. 100 AND 101).

JAY FLOWERS, EXAMINING ATTORNEY

**CLASS 16—PAPER GOODS AND PRINTED MATTER**

FOR BOOKS, MAGAZINES, NEWSLETTERS AND INSTRUCTIONAL TEACHING MATERIALS, ALL ON THE SUBJECT OF DIVORCE, RELATIONSHIPS, CHILDREN AND FAMILIES; COMIC STRIPS (U.S. CLS. 2, 5, 22, 23, 29, 37, 38 AND 50).

SN 85-213,321. QUIET DUKE PRODUCTIONS, VAN NUYS, CA. FILED 1-7-2011.

**CLASS 21—HOUSEWARES AND GLASS**

FOR CUPS, DRINKING GLASSES, TANKARDS NOT OF PRECIOUS METAL, TUMBLERS, DRINKING STEINS, COASTERS NOT OF PAPER AND NOT BEING TABLE LINEN, SALT AND PEPPER SHAKERS, MUGS, THERMAL INSULATED CONTAINERS FOR BEVERAGES (U.S. CLS. 2, 13, 23, 29, 30, 33, 40 AND 50).

**COMEDYMERICALS**

THE MARK CONSISTS OF STANDARD CHARACTERS WITHOUT CLAIM TO ANY PARTICULAR FONT, STYLE, SIZE, OR COLOR.

**CLASS 25—CLOTHING**

FOR CLOTHING, NAMELY, SHIRTS, T-SHIRTS, HATS, HEADWEAR, SWEATSHIRTS, SWEAT PANTS, SWEAT JACKETS, JERSEYS, PULLOVERS, UNDERGARMENTS, SHORTS, TOPS, BOTTOMS (U.S. CLS. 22 AND 39).

**CLASS 35—ADVERTISING AND BUSINESS**

FOR ADVERTISING AND MARKETING SERVICES, NAMELY, PROMOTING THE GOODS AND SERVICES OF OTHERS (U.S. CLS. 100, 101 AND 102).

FIRST USE 8-27-2007; IN COMMERCE 6-7-2010.

**CLASS 41—EDUCATION AND ENTERTAINMENT**

FOR ENTERTAINMENT SERVICES IN THE NATURE OF A VARIETY TELEVISION TALK SHOW ON THE SUBJECT OF DIVORCE, RELATIONSHIP, CHILDREN AND FAMILIES (U.S. CLS. 100, 101 AND 107).

THEODORE MCBRIDE, EXAMINING ATTORNEY

**CLASS 41—EDUCATION AND ENTERTAINMENT**

FOR ENTERTAINMENT SERVICES, NAMELY, MULTIMEDIA PRODUCTION SERVICES (U.S. CLS. 100, 101 AND 107).

FIRST USE 8-27-2007; IN COMMERCE 6-7-2010.

ALEX KEAM, EXAMINING ATTORNEY

SN 85-213,377. GOODWOOD, INC., EL MONTE, CA. FILED 1-7-2011.

# BARACA

THE MARK CONSISTS OF STANDARD CHARACTERS WITHOUT CLAIM TO ANY PARTICULAR FONT, STYLE, SIZE, OR COLOR.

THE ENGLISH TRANSLATION OF "BARACA" IN THE MARK IS "BLESSING".

## CLASS 11—ENVIRONMENTAL CONTROL APPARATUS

FOR BATHTUBS; FAUCETS; HOT TUBS; KITCHEN SINKS; SHOWER AND BATH CUBICLES; SHOWER DOORS; SHOWER ENCLOSURES; SHOWER FAUCET EXTENSIONS; SHOWER PANELS; SHOWER TUBS; SHOWERHEADS AND COMPONENTS THEREOF; SHOWERS; SINKS; TOILET BOWLS; TOILET SEATS; TOILET TANKS; AND TOILETS (U.S. CLS. 13, 21, 23, 31 AND 34).

## CLASS 19—NON-METALLIC BUILDING MATERIALS

FOR BOARDS OF WOOD; CERAMIC TILES FOR FLOORING AND FACING; CHEMICALLY TREATED WOOD, NAMELY, WOOD BEAMS, WOOD BOARDS, WOOD JOISTS, WOOD RAFTERS, WOOD SIDING, WOOD TILE FLOORS AND FLOORING, WOOD TRIM, WOODEN BEAMS, WOODEN FLOORING, WOODEN RAILINGS, AND WOODEN WAINSCOTING, ALL OF THE ABOVE CONTAINING A FIRE RETARDANT CHEMICAL; FIREPROOF TILES; FLOOR BOARDS; FLOOR TILES OF WOOD; FLOORING UNDERLAYMENTS; GLUE-LAMINATED WOOD; LUMBER; MULTI-LAYERED WOOD; NON-METAL FLOOR TILES; NON-METAL FLOORS; PARQUET FLOORING; PLASTIC FLOORBOARDS; PLYWOOD; VINYL FLOORING; VINYL TILES; WOOD MOLDINGS; WOOD DOOR FRAMES; AND WOODEN DOORS (U.S. CLS. 1, 12, 33 AND 50).

## CLASS 20—FURNITURE AND ARTICLES NOT OTHERWISE CLASSIFIED

FOR BEDS; CABINETS; CHAIRS; CHESTS OF DRAWERS; CLOSET ACCESSORIES, NAMELY, SHOE RACKS; CLOSET ACCESSORIES, NAMELY, CLOTHES BARS; CLOSET ACCESSORIES, NAMELY, SLIDING CLOTHES RAILS; CLOSET ACCESSORIES, NAMELY, BELT RACKS; COAT RACKS; COUCHES; CURTAIN RODS; DESKS; DOORS FOR FURNITURE; ENTERTAINMENT CENTERS; FURNITURE; FURNITURE MOLDINGS; HAT RACKS; INDOOR BLINDS; NON-METAL DOOR TRIMS; NON-METAL LADDERS; NON-METAL WINDOW TRIMS; PICTURE FRAME MOLDINGS; SCREENS; SOFAS; TABLES; TOWEL CLOSETS; TOWEL RACKS; WARDROBES; AND WINE RACKS (U.S. CLS. 2, 13, 22, 25, 32 AND 50).

JULIE GUTTADAURO, EXAMINING ATTORNEY

SN 85-213,500. VALENTINE CO., LTD., SEOUL, REPUBLIC OF KOREA, FILED 1-8-2011.

# LOVCAT

THE MARK CONSISTS OF THE WORD "LOVCAT" WHERE THE "O" IS THE HEART SYMBOL.

## CLASS 9—ELECTRICAL AND SCIENTIFIC APPARATUS

FOR SUN GLASSES, EYE GLASSES, EYE GLASS LENSES, EYE GLASS FRAMES, EYE GLASS CHAINS, EYE GLASS CASES, CONTACT LENSES (U.S. CLS. 21, 23, 26, 36 AND 38).

FIRST USE 4-17-2001; IN COMMERCE 4-17-2001.

## CLASS 14—JEWELRY

FOR WRIST WATCHES, WATCH CHAINS, EARRINGS, NECKLACES, RINGS, TIE PINS, BRACELETS, PINS BEING JEWELRY OF PRECIOUS METAL, BROOCHES, BUCKLES FOR WATCH STRAPS OF PRECIOUS METAL (U.S. CLS. 2, 27, 28 AND 50).

FIRST USE 4-17-2001; IN COMMERCE 4-17-2001.

## CLASS 18—LEATHER GOODS

FOR HANDBAGS, BRIEFCASES, SCHOOL SATCHELS, RUCKSACKS, SUITCASES, TRAVELING TRUNKS, VANITY CASES SOLD EMPTY, PURSES NOT OF PRECIOUS METAL, UMBRELLAS, PARASOLS (U.S. CLS. 1, 2, 3, 22 AND 41).

FIRST USE 4-17-2001; IN COMMERCE 4-17-2001.

## CLASS 25—CLOTHING

FOR HALF-COATS, SKIRTS, JACKETS, MANTLES, SHIRTS, NECKTIES, SCARVES, BELTS, HATS, LEATHER SHOES, LOW SHOES, SANDALS, BOOTS, SLIPPERS, OVERSHOES, SOCCER SHOES, GIRDLE, ANORAK FOR SPORTS, SWIMMING SUIT, SWEATERS, OVERCOATS, VESTS, CARDIGANS, SOCKS, STOCKINGS (U.S. CLS. 22 AND 39).

FIRST USE 4-17-2001; IN COMMERCE 4-17-2001.

KAPIL BHANOT, EXAMINING ATTORNEY

SN 85-213,617. RAMIREZ, GUS E, MIRAMAR, FL. FILED 1-9-2011.

# tavo

THE MARK CONSISTS OF STANDARD CHARACTERS WITHOUT CLAIM TO ANY PARTICULAR FONT, STYLE, SIZE, OR COLOR.

## CLASS 14—JEWELRY

FOR BRACELETS; COSTUME JEWELRY; JEWELRY; JEWELRY, NAMELY, CROSSES; NECKLACES (U.S. CLS. 2, 27, 28 AND 50).

## CLASS 16—PAPER GOODS AND PRINTED MATTER

FOR ROSARIES (U.S. CLS. 2, 5, 22, 23, 29, 37, 38 AND 50).

JAMES GRIFFIN, EXAMINING ATTORNEY

SN 85-213,731. ISLE OF CAPRI CASINOS, INC., ST. LOUIS, MO. FILED 1-10-2011.

SN 85-213,801. ADF FOODS LIMITED, MUMBAI, INDIA, FILED 1-10-2011.



OWNER OF U.S. REG. NO. 3,111,626.  
NO CLAIM IS MADE TO THE EXCLUSIVE RIGHT TO USE "JAVA" AND "TRADING CO", APART FROM THE MARK AS SHOWN.

THE MARK CONSISTS OF THE PHRASE "JAVA BAY" OVER A MAP OF THE WORLD, ABOVE THE WORDS "TRADING" AND "CO", WITH A STYLIZED OVAL BACKGROUND.

#### CLASS 35—ADVERTISING AND BUSINESS

FOR GIFT AND SUNDRIES RETAIL STORE SERVICES LOCATED IN CASINOS (U.S. CLS. 100, 101 AND 102).

#### CLASS 43—HOTEL AND RESTAURANT SERVICES

FOR RESTAURANT AND BAR SERVICES (U.S. CLS. 100 AND 101).  
EUGENIA MARTIN, EXAMINING ATTORNEY

SN 85-213,788. PURITAN MEDICAL PRODUCTS COMPANY LLC, GUILFORD, ME. FILED 1-10-2011.

# ULTRAFLOCK

THE MARK CONSISTS OF STANDARD CHARACTERS WITHOUT CLAIM TO ANY PARTICULAR FONT, STYLE, SIZE, OR COLOR.

OWNER OF U.S. REG. NO. 3,562,300.

#### CLASS 9—ELECTRICAL AND SCIENTIFIC APPARATUS

FOR SAMPLE COLLECTION EQUIPMENT FOR COLLECTING AND PRESERVING BLOOD, SALIVA, DNA AND OTHER SPECIMENS COMPRISED OF A DISPOSABLE SWAB APPLICATOR STICK WITH A SANITARY ABSORBENT FLOCKED TIP FOR USE IN LABORATORY AND FORENSIC TESTING (U.S. CLS. 21, 23, 26, 36 AND 38).

#### CLASS 10—MEDICAL APPARATUS

FOR MEDICAL EQUIPMENT FOR COLLECTING AND PRESERVING BLOOD, SALIVA, DNA AND OTHER BIOLOGICAL SPECIMENS COMPRISED OF A DISPOSABLE SWAB APPLICATOR STICK WITH A SANITARY ABSORBENT FLOCKED TIP FOR USE IN MEDICAL TESTING (U.S. CLS. 26, 39 AND 44).

HAI-LY LAM, EXAMINING ATTORNEY



THE MARK CONSISTS OF THE LITERAL ELEMENT "SOUL" IN STYLIZED FONT, AND THE LITERAL ELEMENT "ADF" IN STYLIZED FONT, A DINNER PLATE IS ENCIRCLED BY THE LETTER "O" OF THE LITERAL ELEMENT "SOUL", AND A STEM AND LEAF STRETCH ACROSS THE LITERAL ELEMENT "ADF" FORMING PORTIONS OF THE "A" AND "F".

#### CLASS 29—MEATS AND PROCESSED FOODS

FOR FOOD PRODUCTS, NAMELY, PREPARED AND PACKAGED INDIAN CUISINE IN THE NATURE OF CURRY MEALS CONSISTING PRIMARILY OF VEGETABLES, MILK CREAM, COTTAGE CHEESE, EDIBLE LEGUMES, EDIBLE PULSES, EDIBLE PODS, EDIBLE BULBS, GINGER, FRUITS, NUTS, SEEDS, HERBS, AND SPICES; FOOD PRODUCTS, NAMELY, INDIAN STYLE PREPARED AND PACKAGED ENTREES CONSISTING PRIMARILY OF VEGETABLES IN SHELF STABLE OR FROZEN FORM; PREPARED AND PACKAGED INDIAN VEGETABLE DISHES, NAMELY, READY TO EAT CURRIES; INSTANT OR PRE-COOKED SOUP; INSTANT OR PRE-COOKED STEW; SOUPS; EDIBLE OILS AND FATS, PRESERVES AND PICKLES; PICKLED FRUITS; PICKLED VEGETABLES; PICKLED VEGETABLES IN VINEGAR OR EDIBLE OILS; PRESERVED FRUITS AND VEGETABLES IN VINEGAR OR EDIBLE OILS; PREPARED AND PACKAGED INDIAN VEGETABLE DISHES, NAMELY, EDIBLE LEGUME, PULSE, POD, AND/OR BULB DISHES IN THE NATURE OF BEANS IN SPICED TOMATO SAUCE, SPINACH AND PANEER CHEESE IN CURRIED SAUCE, MASHED VEGETABLES IN SPICED BUTTER AND CHILI SAUCE, CURRIED CHICK PEAS IN SPICED HOT SAUCE, CURRIED GREEN PEAS IN SPICED TOMATO SAUCE, AND CURRIED RED GRAM IN SPICED TOMATO SAUCE; PASTES, NAMELY, SOUP PASTES, VEGETABLE PASTES, MEAT PASTES, VEGETABLE BASED COOKING PASTES AND FRUIT PASTES; FROZEN VEGETABLES, PROCESSED VEGETABLES; LENTILS; PREPARED, PACKAGED AND/OR FROZEN INDIAN VEGETABLE DISHES (U.S. CL. 46).

#### CLASS 30—STAPLE FOODS

FOR CHUTNEYS; PICKLE RELISH; SAUCES; CURRY SAUCE; SPICES; SPICE BLENDS; CURRIES; FROZEN CURRIES; PROCESSED GRAINS; VEGETABLE-BASED COOKING PASTES; RICE; FOOD PRODUCTS, NAMELY, INDIAN STYLE PREPARED AND PACKAGED ENTREES COMPOSED OF PASTA AND RICE IN SHELF STABLE OR FROZEN FORM (U.S. CL. 46).

JACQUELINE A. LAVINE, EXAMINING ATTORNEY



SN 85-213,840. ETAGE SKIN RENEWAL SYSTEMS, INC.,  
EDGEWOOD, KY. FILED 1-10-2011.

# ETAGE

THE MARK CONSISTS OF STANDARD CHARACTERS WITHOUT CLAIM TO ANY PARTICULAR FONT, STYLE, SIZE, OR COLOR.

THE ENGLISH TRANSLATION OF THE WORD "ETAGE" IN THE MARK IS "BUILDING STORY" OR "LEVEL".

## CLASS 5—PHARMACEUTICALS

FOR SKIN CARE PREPARATIONS, NAMELY, MOISTURIZERS, LOTIONS, CLEANSERS, FACIAL CREAMS, TONERS, CLARIFIERS, AND SKIN SOAPS (U.S. CLS. 6, 18, 44, 46, 51 AND 52).

FIRST USE 5-1-1998; IN COMMERCE 5-1-1998.

## CLASS 44—MEDICAL, BEAUTY AND AGRICULTURAL SERVICES

FOR SERVICES IN THE FIELD OF NONINVASIVE SKIN CARE, RENEWAL AND REJUVENATION, NAMELY, FACIALS, MASSAGES AND ACID PEELS; SKIN TREATMENT, NAMELY, THE INJECTION OF DERMAL FILLERS TO REDUCE THE APPEARANCE OF FACIAL FINE LINES; LASER HAIR REMOVAL SERVICES; LASER VEIN REMOVAL SERVICES; LASER AND INTENSE PULSE LIGHT SKIN TREATMENT PROCEDURES (U.S. CLS. 100 AND 101).

FIRST USE 12-0-1996; IN COMMERCE 12-0-1996.  
REBECCA POVARCHUK, EXAMINING ATTORNEY

SN 85-213,918. NATIONAL PARK FOUNDATION, WASHINGTON, DC. FILED 1-10-2011.

# GOPARKS

THE MARK CONSISTS OF STANDARD CHARACTERS WITHOUT CLAIM TO ANY PARTICULAR FONT, STYLE, SIZE, OR COLOR.

## CLASS 35—ADVERTISING AND BUSINESS

FOR PROMOTING PUBLIC AWARENESS OF AND INTEREST IN NATIONAL PARKS, RECREATIONAL FACILITIES AND PUBLIC LANDS AND RESOURCES; DEVELOPING AND COORDINATING PROJECTS FOR NATIONAL PARKS, RECREATIONAL FACILITIES AND PUBLIC LANDS AND RESOURCES (U.S. CLS. 100, 101 AND 102).

FIRST USE 8-0-2005; IN COMMERCE 8-0-2005.

## CLASS 36—INSURANCE AND FINANCIAL

FOR CHARITABLE FUNDRAISING SERVICES (U.S. CLS. 100, 101 AND 102).

FIRST USE 8-0-2005; IN COMMERCE 8-0-2005.

## CLASS 41—EDUCATION AND ENTERTAINMENT

FOR PROVIDING INFORMATION AND NEWS ON-LINE RELATING TO RECREATIONAL FACILITIES AND OPPORTUNITIES, NATIONAL PARKS, PUBLIC LANDS AND RESOURCES, TRIP PLANNING AND TRAVEL TIPS FOR TRAVEL RELATED TO NATIONAL PARKS, GEAR, AND STEWARDSHIP OF PARK RESOURCES; PROVIDING A WEB SITE THROUGH WHICH PEOPLE LOCATE INFORMATION ABOUT RECREATIONAL FACILITIES AND OPPORTUNITIES, NATIONAL PARKS, PUBLIC LANDS AND RESOURCES, TRIP PLANNING AND TRAVEL TIPS FOR TRAVEL RELATED TO NATIONAL PARKS, GEAR, AND STEWARDSHIP OF PARK RESOURCES; ON-LINE ELECTRONIC NEWSLETTERS DELIVERED BY EMAIL RELATING TO RECREATIONAL FACILITIES AND OPPORTUNITIES, NATIONAL PARKS, PUBLIC LANDS AND RESOURCES, TRIP PLANNING AND TRAVEL TIPS FOR TRAVEL RELATED TO NATIONAL PARKS, GEAR, AND STEWARDSHIP OF PARK RESOURCES (U.S. CLS. 100, 101 AND 107).

FIRST USE 8-0-2005; IN COMMERCE 8-0-2005.  
HEATHER SAPP, EXAMINING ATTORNEY

SN 85-213,932. BERRIN, MICHAEL, NEPTUNE, NJ. FILED 1-10-2011.

# Club Triva

THE MARK CONSISTS OF STANDARD CHARACTERS WITHOUT CLAIM TO ANY PARTICULAR FONT, STYLE, SIZE, OR COLOR.

NO CLAIM IS MADE TO THE EXCLUSIVE RIGHT TO USE "TRIVIA", APART FROM THE MARK AS SHOWN.

## CLASS 9—ELECTRICAL AND SCIENTIFIC APPARATUS

FOR COMPUTER APPLICATION SOFTWARE FOR MOBILE PHONES, NAMELY, SOFTWARE FOR BRAIN-TEASING GAMES (U.S. CLS. 21, 23, 26, 36 AND 38).

## CLASS 41—EDUCATION AND ENTERTAINMENT

FOR ENTERTAINMENT SERVICES, NAMELY, AN ON-GOING GAME SHOW BROADCAST OVER THE INTERNET AND TELEVISION (U.S. CLS. 100, 101 AND 107).

MARK SHINER, EXAMINING ATTORNEY

SN 85-214,015. PARIS BROTHERS, INC., KANSAS CITY, MO. FILED 1-10-2011.

# ART FROM THE CUP

THE MARK CONSISTS OF STANDARD CHARACTERS WITHOUT CLAIM TO ANY PARTICULAR FONT, STYLE, SIZE, OR COLOR.

**CLASS 30—STAPLE FOODS**

FOR COFFEE; ROASTED COFFEE BEANS AND TEA (U.S. CL. 46).

**CLASS 43—HOTEL AND RESTAURANT SERVICES**

FOR CAFÉ, RESTAURANT AND COFFEE SHOP SERVICES (U.S. CLS. 100 AND 101).  
PAM WILLIS, EXAMINING ATTORNEY

---

SN 85-214,254. CREABLE, LOS ANGELES, CA. FILED 1-10-2011.

# CREABLE

THE MARK CONSISTS OF STANDARD CHARACTERS WITHOUT CLAIM TO ANY PARTICULAR FONT, STYLE, SIZE, OR COLOR.

**CLASS 35—ADVERTISING AND BUSINESS**

FOR BRANDING SERVICES, NAMELY, CONSULTING, DEVELOPMENT, MANAGEMENT AND MARKETING OF BRANDS FOR BUSINESSES (U.S. CLS. 100, 101 AND 102).

**CLASS 41—EDUCATION AND ENTERTAINMENT**

FOR MULTIMEDIA ENTERTAINMENT SERVICES IN THE NATURE OF DEVELOPMENT, PRODUCTION AND POST-PRODUCTION SERVICES IN THE FIELDS OF VIDEO AND FILMS (U.S. CLS. 100, 101 AND 107).

**CLASS 42—SCIENTIFIC AND COMPUTER SERVICES**

FOR GRAPHIC DESIGN SERVICES; VISUAL DESIGN SERVICES IN THE NATURE OF DESIGNING VISUAL ELEMENTS FOR ON-LINE, BROADCAST, PRINT, OUTDOOR AND OTHER COMMUNICATION MEDIA (U.S. CLS. 100 AND 101).  
C. DIONNE CLYBURN, EXAMINING ATTORNEY

---

SN 85-214,487. CADENCE TRAVEL, INC., LA JOLLA, CA. FILED 1-10-2011.

# Cadence

THE MARK CONSISTS OF STANDARD CHARACTERS WITHOUT CLAIM TO ANY PARTICULAR FONT, STYLE, SIZE, OR COLOR.

**CLASS 35—ADVERTISING AND BUSINESS**

FOR CORPORATE AND BUSINESS TRAVEL MANAGEMENT SERVICES, EMPLOYEE AND CUSTOMER TRAVEL MANAGEMENT SERVICES, PLANNING AND MANAGEMENT OF BUSINESS AND CORPORATE MEETINGS AND EVENTS (U.S. CLS. 100, 101 AND 102).

**CLASS 36—INSURANCE AND FINANCIAL**

FOR INSURANCE BROKERAGE IN THE FIELD OF TRAVEL INSURANCE (U.S. CLS. 100, 101 AND 102).

**CLASS 39—TRANSPORTATION AND STORAGE**

FOR TRAVEL AGENCY SERVICES, NAMELY, MAKING RESERVATIONS AND BOOKING OF TRANSPORTATION; COORDINATING TRAVEL ARRANGEMENTS FOR INDIVIDUALS AND GROUPS (U.S. CLS. 100 AND 105).

**CLASS 43—HOTEL AND RESTAURANT SERVICES**

FOR TRAVEL AGENCY SERVICES, NAMELY, MAKING RESERVATIONS AND BOOKINGS FOR TEMPORARY ACCOMMODATIONS, RESTAURANTS AND MEALS (U.S. CLS. 100 AND 101).  
BARBARA BROWN, EXAMINING ATTORNEY

---

SN 85-214,544. TURKS & FROGS, LLC, NEW YORK, NY. FILED 1-10-2011.

# TURKS & FROGS

THE MARK CONSISTS OF STANDARD CHARACTERS WITHOUT CLAIM TO ANY PARTICULAR FONT, STYLE, SIZE, OR COLOR.

**CLASS 33—WINES AND SPIRITS**

FOR WINE (U.S. CLS. 47 AND 49).

**CLASS 43—HOTEL AND RESTAURANT SERVICES**

FOR BAR AND RESTAURANT SERVICES (U.S. CLS. 100 AND 101).  
FIRST USE 9-1-2004; IN COMMERCE 9-1-2004.  
SHAUNIA CARLYLE, EXAMINING ATTORNEY

SN 85-214,792. ADVANTAGE DENTAL PLAN, INC., REDMOND, OR. FILED 1-11-2011.



OWNER OF U.S. REG. NO. 2,313,021.  
NO CLAIM IS MADE TO THE EXCLUSIVE RIGHT TO USE "DENTAL", APART FROM THE MARK AS SHOWN.  
THE COLOR(S) RED, GREEN, AND WHITE IS/ARE CLAIMED AS A FEATURE OF THE MARK.  
THE MARK CONSISTS OF A WHITE UPPERCASE "A", UNDER WHICH APPEARS A WHOLE, RED APPLE WITH A GREEN STEM AND A GREEN LEAF. THE WORD "ADVANTAGE" APPEARS IN GREEN AND IN AN ARCH ABOVE THE UPPER LEFT SIDE OF THE APPLE. THE WORD "DENTAL" APPEARS IN GREEN IN A RISING DIAGONAL BELOW THE LOWER LEFT SIDE OF THE APPLE.

#### CLASS 35—ADVERTISING AND BUSINESS

FOR CONSULTING SERVICES IN THE FIELD OF DENTAL PRACTICE MANAGEMENT; DENTAL PRACTICE MANAGEMENT FOR OTHERS; PROVIDING A WEBSITE FOR DENTAL PRACTICE MANAGEMENT AND ADMINISTRATIVE SUPPORT SERVICES TO INDIVIDUAL DENTISTS OR GROUP PRACTICES (U.S. CLS. 100, 101 AND 102).  
FIRST USE 0-0-2003; IN COMMERCE 0-0-2003.

#### CLASS 36—INSURANCE AND FINANCIAL

FOR DENTAL HEALTH INSURANCE UNDERWRITING AND ADMINISTRATION (U.S. CLS. 100, 101 AND 102).  
FIRST USE 0-0-2003; IN COMMERCE 0-0-2003.

#### CLASS 44—MEDICAL, BEAUTY AND AGRICULTURAL SERVICES

FOR DENTISTRY (U.S. CLS. 100 AND 101).  
FIRST USE 0-0-2003; IN COMMERCE 0-0-2003.  
PRISCILLA MILTON, EXAMINING ATTORNEY

SN 85-214,958. TREESTAND ASSASSIN, LLC, NEWBURGH, IN. FILED 1-11-2011.

Treestand Assassin

THE MARK CONSISTS OF STANDARD CHARACTERS WITHOUT CLAIM TO ANY PARTICULAR FONT, STYLE, SIZE, OR COLOR.

#### CLASS 21—HOUSEWARES AND GLASS

FOR FOAM DRINK HOLDERS (U.S. CLS. 2, 13, 23, 29, 30, 33, 40 AND 50).  
FIRST USE 12-1-2010; IN COMMERCE 12-1-2010.

#### CLASS 25—CLOTHING

FOR T-SHIRTS (U.S. CLS. 22 AND 39).  
FIRST USE 12-1-2010; IN COMMERCE 12-1-2010.

#### CLASS 28—TOYS AND SPORTING GOODS

FOR ARCHERY EQUIPMENT, NAMELY, ARROW FLETCHING DEVICES AND ARROW NOCKS; HUNTING ARROW POINTS; HUNTING BOWS; HUNTING GAME CALLS; HUNTING STANDS (U.S. CLS. 22, 23, 38 AND 50).  
FIRST USE 12-1-2010; IN COMMERCE 12-1-2010.  
SKYE YOUNG, EXAMINING ATTORNEY

SN 85-215,107. CONTINENTAL EXCHANGE SOLUTIONS, INC., BUENA PARK, CA. FILED 1-11-2011.

RIA

THE MARK CONSISTS OF STANDARD CHARACTERS WITHOUT CLAIM TO ANY PARTICULAR FONT, STYLE, SIZE, OR COLOR.  
OWNER OF U.S. REG. NOS. 1,601,376, 2,113,844 AND 2,706,256.

#### CLASS 9—ELECTRICAL AND SCIENTIFIC APPARATUS

FOR MAGNETICALLY ENCODED STORED VALUE CARDS; MAGNETICALLY ENCODED CARDS USED FOR ELECTRONIC FUNDS TRANSFER SERVICES, ELECTRONIC PAYMENTS, ELECTRONIC PROCESSING AND TRANSMISSION OF BILL PAYMENT DATA, MONEY ORDER SERVICES, CHECK CASHING SERVICES, PAY DAY LOAN SERVICES, DIRECT DEPOSIT OF FUNDS INTO CUSTOMERS BANK ACCOUNTS, CREDIT AND DEBIT CARD SERVICES, PREPAID DEBIT CARDS, DOMESTIC AND INTERNATIONAL TRANSMISSION OF MONEY, TELEPHONE CARD SERVICES AND TRAVELERS' CHEQUES (U.S. CLS. 21, 23, 26, 36 AND 38).

#### CLASS 16—PAPER GOODS AND PRINTED MATTER

FOR NON-MAGNETICALLY ENCODED STORED VALUE CARDS; NON-MAGNETICALLY ENCODED CARDS USED FOR ELECTRONIC FUNDS TRANSFER SERVICES, ELECTRONIC PAYMENTS, ELECTRONIC PROCESSING AND TRANSMISSION OF BILL PAYMENT DATA, MONEY ORDER SERVICES, CHECK CASHING SERVICES, PAY DAY LOAN SERVICES, DIRECT DEPOSIT OF FUNDS INTO CUSTOMERS BANK ACCOUNTS, CREDIT AND DEBIT CARD SERVICES, PREPAID DEBIT CARDS, DOMESTIC AND INTERNATIONAL TRANSMISSION OF MONEY, TELEPHONE CARD SERVICES AND TRAVELERS' CHEQUES (U.S. CLS. 2, 5, 22, 23, 29, 37, 38 AND 50).

**CLASS 36—INSURANCE AND FINANCIAL**

FOR FINANCIAL SERVICES, NAMELY, ELECTRONIC FUNDS TRANSFER SERVICES; MONEY TRANSFER SERVICES, ELECTRONIC BILL PAYMENT SERVICES, ELECTRONIC PROCESSING AND TRANSMISSION OF BILL PAYMENT DATA; MONEY ORDER SERVICES; CHECK CASHING SERVICES, PAY DAY LOAN SERVICES; DIRECT DEPOSIT OF FUNDS INTO CUSTOMERS BANK ACCOUNTS; CREDIT AND DEBIT CARD SERVICES; PREPAID DEBIT CARD SERVICES; STORED VALUE CARD SERVICES; DOMESTIC AND INTERNATIONAL TRANSMISSION OF MONEY; INTERNATIONAL CURRENCY EXCHANGE SERVICES, NAMELY, BUYING AND SELLING OF FOREIGN CURRENCIES; MONEY ORDER SERVICES; TELEPHONE CARD SERVICES; TRADING GOLD AND SILVER; AND TRAVELERS' CHEQUE ISSUANCE (U.S. CLS. 100, 101 AND 102).

FIRST USE 9-9-1987; IN COMMERCE 9-9-1987.

MARK SHINER, EXAMINING ATTORNEY

---

SN 85-215,180. CONTRACTORS REGISTER, INC., JEFFERSON VALLEY, NY. FILED 1-11-2011.

# PROVIEW

THE MARK CONSISTS OF STANDARD CHARACTERS WITHOUT CLAIM TO ANY PARTICULAR FONT, STYLE, SIZE, OR COLOR.

**CLASS 35—ADVERTISING AND BUSINESS**

FOR PROVIDING MARKETING REPORTS TO IDENTIFY BUILDING AND CONSTRUCTION PROJECT AND MATERIALS LEADS; PROVIDING WEBSITES FEATURING MARKETING INFORMATION IN THE FIELD OF BUILDING CONSTRUCTION AND CONSTRUCTION MATERIALS; ADVERTISING, MARKETING AND PROMOTIONAL SERVICES FOR PROVIDERS OF GOODS AND SERVICES IN THE BUILDING AND CONSTRUCTION INDUSTRIES, PROVIDED VIA THE INTERNET (U.S. CLS. 100, 101 AND 102).

FIRST USE 1-3-2011; IN COMMERCE 1-3-2011.

**CLASS 37—CONSTRUCTION AND REPAIR**

FOR PROVIDING SEARCHABLE DATABASES IN THE FIELDS OF BUILDING AND CONSTRUCTION PROJECTS AND MATERIALS REQUIRED THEREFOR (U.S. CLS. 100, 103 AND 106).

FIRST USE 1-3-2011; IN COMMERCE 1-3-2011.

ALLISON HOLTZ, EXAMINING ATTORNEY

---

SN 85-215,188. CONTRACTORS REGISTER, INC., JEFFERSON VALLEY, NY. FILED 1-11-2011.



THE MARK CONSISTS OF THE WORDING "PROVIEW" WITH AN UNDERLINE DESIGN ELEMENT AND A DOUBLE TRIANGLE DESIGN ELEMENT AT THE RIGHT OF THE MARK.

**CLASS 35—ADVERTISING AND BUSINESS**

FOR PROVIDING MARKETING REPORTS TO IDENTIFY BUILDING AND CONSTRUCTION PROJECT AND MATERIALS LEADS; PROVIDING WEBSITES FEATURING MARKETING INFORMATION IN THE FIELD OF BUILDING CONSTRUCTION AND CONSTRUCTION MATERIALS; ADVERTISING, MARKETING AND PROMOTIONAL SERVICES FOR PROVIDERS OF GOODS AND SERVICES IN THE BUILDING AND CONSTRUCTION INDUSTRIES, PROVIDED VIA THE INTERNET (U.S. CLS. 100, 101 AND 102).

FIRST USE 1-3-2011; IN COMMERCE 1-3-2011.

**CLASS 37—CONSTRUCTION AND REPAIR**

FOR PROVIDING SEARCHABLE DATABASES IN THE FIELDS OF BUILDING AND CONSTRUCTION PROJECTS AND MATERIALS REQUIRED THEREFOR (U.S. CLS. 100, 103 AND 106).

FIRST USE 1-3-2011; IN COMMERCE 1-3-2011.

ALLISON HOLTZ, EXAMINING ATTORNEY

---

SN 85-215,189. ESTSOFT, INC., IRVINE, CA. FILED 1-11-2011.

# ESTUS

THE MARK CONSISTS OF STANDARD CHARACTERS WITHOUT CLAIM TO ANY PARTICULAR FONT, STYLE, SIZE, OR COLOR.

**CLASS 9—ELECTRICAL AND SCIENTIFIC APPARATUS**

FOR RECORDED COMPUTER PROGRAMS FOR USE IN DATABASE MANAGEMENT; RECORDED COMPUTER PROGRAMS DESIGNED FOR USE AS A SPREAD SHEET OR WORD PROCESSING PROGRAMS; RECORDED COMPUTER ANTI-VIRUS SOFTWARE; RECORDED COMPUTER SOFTWARE FOR USE IN THE SAFEGUARDING OF DIGITAL FILES, INCLUDING AUDIO, VIDEO, TEXT, BINARY, STILL IMAGES, GRAPHICS AND MULTIMEDIA FILES; RECORDED COMPUTER SOFTWARE FOR USE IN THE ENCRYPTION AND DECRYPTION OF DIGITAL FILES INCLUDING AUDIO, VIDEO, TEXT, BINARY, STILL IMAGES, GRAPHICS AND MULTIMEDIA FILES; COMPUTER PROGRAMS RECORDED ON CD-ROM DESIGNED FOR USE IN FILE COMPRESSION, ARCHIVING, VIRUS SCANNING AND COMPUTER FILE MANAGEMENT; COMPUTER PROGRAMS RECORDED ON CD-ROM DESIGNED FOR VIEWING, PRINTING, ANNOTATING AND MANAGING IMAGE FILES; COMPUTER PROGRAMS RECORDED ON CD-ROM DESIGNED FOR GRAPHICAL APPLICATIONS, NAMELY, FOR THE CREATION, DELIVERY, EDITING AND VIEWING OF DIGITAL MEDIA, SPECIFICALLY VIDEO, SOUND, ANIMATION, GRAPHICS, TEXT, MUSIC AND VIRTUAL REALITY; COMPUTER PROGRAMS RECORDED ON CD-ROM DESIGNED FOR TRANSFERRING FILES BETWEEN COMPUTER SYSTEMS; COMPUTER PROGRAMS RECORDED ON CD-ROM DESIGNED FOR USE IN OPERATING VEHICLE NAVIGATION COMPUTERS, NAMELY, FOR NAVIGATION, ROUTE SEARCHING AND DRAWING MAPS; COMPUTER PROGRAMS RECORDED ON CD-ROM DESIGNED FOR DIGITAL RIGHT MANAGEMENT, NAMELY, TO PREVENT USERS FROM PIRATING DIGITAL CONTENTS, TO PROTECT DIGITAL CONTENTS FROM BEING MODIFIED OR AFFECTED, AND TO PROTECT INTELLECTUAL PROPERTY RIGHTS DERIVED FROM DIGITAL CONTENTS; COMPUTER PROGRAMS FOR PRE-RECORDED GAMES (U.S. CLS. 21, 23, 26, 36 AND 38).



**CLASS 35—ADVERTISING AND BUSINESS**

FOR MANAGEMENT OF COMPUTERIZED FILES; ADVICE IN THE FIELD OF BUSINESS MANAGEMENT AND MARKETING; ON-LINE ADVERTISING ON A COMPUTER COMMUNICATIONS NETWORK. BUSINESS INFORMATION IN THE FIELD OF A COMPUTER COMMUNICATIONS NETWORK (U.S. CLS. 100, 101 AND 102).

ANGELA DUONG, EXAMINING ATTORNEY

SN 85-215,199. JOULE UNLIMITED, INC., CAMBRIDGE, MA. FILED 1-11-2011.

# SUNSPRINGS

SN 85-215,195. ESTSOFT, INC., IRVINE, CA. FILED 1-11-2011.

# ESTGAMES

THE MARK CONSISTS OF STANDARD CHARACTERS WITHOUT CLAIM TO ANY PARTICULAR FONT, STYLE, SIZE, OR COLOR.

**CLASS 9—ELECTRICAL AND SCIENTIFIC APPARATUS**

FOR RECORDED COMPUTER PROGRAMS FOR USE IN DATABASE MANAGEMENT; RECORDED COMPUTER PROGRAMS DESIGNED FOR USE AS A SPREAD SHEET OR WORD PROCESSING PROGRAMS; RECORDED COMPUTER ANTI-VIRUS SOFTWARE; RECORDED COMPUTER SOFTWARE FOR USE IN THE SAFEGUARDING OF DIGITAL FILES, INCLUDING AUDIO, VIDEO, TEXT, BINARY, STILL IMAGES, GRAPHICS AND MULTIMEDIA FILES; RECORDED COMPUTER SOFTWARE FOR USE IN THE ENCRYPTION AND DECRYPTION OF DIGITAL FILES INCLUDING AUDIO, VIDEO, TEXT, BINARY, STILL IMAGES, GRAPHICS AND MULTIMEDIA FILES; COMPUTER PROGRAMS RECORDED ON CD-ROM DESIGNED FOR USE IN FILE COMPRESSION, ARCHIVING, VIRUS SCANNING AND COMPUTER FILE MANAGEMENT; COMPUTER PROGRAMS RECORDED ON CD-ROM DESIGNED FOR VIEWING, PRINTING, ANNOTATING AND MANAGING IMAGE FILES; COMPUTER PROGRAMS RECORDED ON CD-ROM DESIGNED FOR GRAPHICAL APPLICATIONS, NAMELY, FOR THE CREATION, DELIVERY, EDITING AND VIEWING OF DIGITAL MEDIA, SPECIFICALLY VIDEO, SOUND, ANIMATION, GRAPHICS, TEXT, MUSIC AND VIRTUAL REALITY; COMPUTER PROGRAMS RECORDED ON CD-ROM DESIGNED FOR TRANSFERRING FILES BETWEEN COMPUTER SYSTEMS; COMPUTER PROGRAMS RECORDED ON CD-ROM DESIGNED FOR USE IN OPERATING VEHICLE NAVIGATION COMPUTERS, NAMELY, FOR NAVIGATION, ROUTE SEARCHING AND DRAWING MAPS; COMPUTER PROGRAMS RECORDED ON CD-ROM DESIGNED FOR DIGITAL RIGHT MANAGEMENT, NAMELY, TO PREVENT USERS FROM PIRATING DIGITAL CONTENTS, TO PROTECT DIGITAL CONTENTS FROM BEING MODIFIED OR AFFECTED, AND TO PROTECT INTELLECTUAL PROPERTY RIGHTS DERIVED FROM DIGITAL CONTENTS; COMPUTER PROGRAMS FOR PRE-RECORDED GAMES (U.S. CLS. 21, 23, 26, 36 AND 38).

**CLASS 41—EDUCATION AND ENTERTAINMENT**

FOR ENTERTAINMENT SERVICES, NAMELY, PROVIDING AN ON-LINE COMPUTER GAME; CONDUCTING AND PROVIDING FACILITIES FOR SPECIAL EVENTS FEATURING CASINO AND GAMING CONTESTS AND TOURNAMENTS (U.S. CLS. 100, 101 AND 107).

ANGELA DUONG, EXAMINING ATTORNEY

THE MARK CONSISTS OF STANDARD CHARACTERS WITHOUT CLAIM TO ANY PARTICULAR FONT, STYLE, SIZE, OR COLOR.

**CLASS 9—ELECTRICAL AND SCIENTIFIC APPARATUS**

FOR PHOTOBIOREACTORS FOR USE IN CULTURING MICRO-ORGANISMS (U.S. CLS. 21, 23, 26, 36 AND 38).

**CLASS 40—MATERIAL TREATMENT**

FOR PRODUCTION OF FUELS, BIOFUELS, FUEL ADDITIVES, ENZYMES AND CHEMICALS FOR OTHERS (U.S. CLS. 100, 103 AND 106).

ANGELA DUONG, EXAMINING ATTORNEY

SN 85-215,206. LATELY LILY, LLC, HUNTINGTON BEACH, CA. FILED 1-11-2011.



THE MARK CONSISTS OF A STYLIZED DESIGN OF A FEMALE CHILD'S HEAD WITH A RIBBON IN HER HAIR ON THE RIGHT SIDE, AND THE TEXT "LATELY LILY" BELOW.

**CLASS 16—PAPER GOODS AND PRINTED MATTER**

FOR BOOKS IN THE FIELD OF CHILDRENS STORIES (U.S. CLS. 2, 5, 22, 23, 29, 37, 38 AND 50).

**CLASS 25—CLOTHING**

FOR HATS; PAJAMAS; PANTS; SHIRTS; SHOES (U.S. CLS. 22 AND 39).

BARBARA GAYNOR, EXAMINING ATTORNEY

SN 85-215,242. CHRISTIAN ART GIFTS, INC., LOMBARD, IL. FILED 1-11-2011.

## CHRISTIAN ART GIFTS

THE MARK CONSISTS OF STANDARD CHARACTERS WITHOUT CLAIM TO ANY PARTICULAR FONT, STYLE, SIZE, OR COLOR.

OWNER OF U.S. REG. NOS. 2,918,253, 2,974,863 AND 3,007,781.

SEC. 2(F).

### CLASS 6—METAL GOODS

FOR METAL KEY RINGS (U.S. CLS. 2, 12, 13, 14, 23, 25 AND 50).

FIRST USE 5-0-2003; IN COMMERCE 5-0-2003.

### CLASS 20—FURNITURE AND ARTICLES NOT OTHERWISE CLASSIFIED

FOR POLYRESIN WARES, NAMELY, FIGURINES, PICTURE FRAMES, AND WALL PLAQUES (U.S. CLS. 2, 13, 22, 25, 32 AND 50).

FIRST USE 5-0-2003; IN COMMERCE 5-0-2003.

### CLASS 21—HOUSEWARES AND GLASS

FOR CHINA DISHES; GLASS AND CERAMIC CUPS; MUGS FOR BEVERAGES (U.S. CLS. 2, 13, 23, 29, 30, 33, 40 AND 50).

FIRST USE 5-0-2003; IN COMMERCE 5-0-2003.

WILLIAM ROSSMAN, EXAMINING ATTORNEY

SN 85-215,276. ZOMBIE, ROBERT WOLFGANG, LOS ANGELES, CA. FILED 1-11-2011.

## THE LORDS OF SALEM

THE MARK CONSISTS OF STANDARD CHARACTERS WITHOUT CLAIM TO ANY PARTICULAR FONT, STYLE, SIZE, OR COLOR.

### CLASS 9—ELECTRICAL AND SCIENTIFIC APPARATUS

FOR SERIES OF MUSICAL SOUND RECORDINGS, DOWNLOADABLE MUSICAL SOUND RECORDINGS, AUDIOVISUAL RECORDINGS FEATURING MUSIC, DOWNLOADABLE AUDIOVISUAL RECORDINGS FEATURING MUSIC; DOWNLOADABLE RINGTONES AND GRAPHICS VIA A GLOBAL COMPUTER NETWORK (U.S. CLS. 21, 23, 26, 36 AND 38).

### CLASS 25—CLOTHING

FOR CLOTHING, NAMELY, CAPS, T-SHIRTS AND HOODED SWEATSHIRTS; HEADWEAR (U.S. CLS. 22 AND 39).

### CLASS 41—EDUCATION AND ENTERTAINMENT

FOR ENTERTAINMENT SERVICES, NAMELY, LIVE PERFORMANCES BY A MUSICAL GROUP AND INTERNET SERVICES, NAMELY, PROVIDING A WEBSITE WITH INFORMATION ON A MUSICAL GROUP, ITS PERFORMANCES, RECORDINGS, AND BIOGRAPHY (U.S. CLS. 100, 101 AND 107).

KEVIN DINALLO, EXAMINING ATTORNEY

SN 85-215,356. BUSSCHER, SUE, HOLLAND, MI. FILED 1-11-2011.

## Recitrees

THE MARK CONSISTS OF STANDARD CHARACTERS WITHOUT CLAIM TO ANY PARTICULAR FONT, STYLE, SIZE, OR COLOR.

### CLASS 9—ELECTRICAL AND SCIENTIFIC APPARATUS

FOR COMPUTER SOFTWARE FOR CREATING FORMATTED RECIPES (U.S. CLS. 21, 23, 26, 36 AND 38).

### CLASS 16—PAPER GOODS AND PRINTED MATTER

FOR COOK BOOKS; RECIPE BOOKS (U.S. CLS. 2, 5, 22, 23, 29, 37, 38 AND 50).

MAUREEN DALL, EXAMINING ATTORNEY

SN 85-215,384. IDEA LOCO INC., VALPARAISO, IN. FILED 1-11-2011.

## MYREALMD

THE MARK CONSISTS OF STANDARD CHARACTERS WITHOUT CLAIM TO ANY PARTICULAR FONT, STYLE, SIZE, OR COLOR.

### CLASS 35—ADVERTISING AND BUSINESS

FOR ONLINE AND TELEPHONE ORDERING SERVICES IN THE FIELD OF MEDICINES (U.S. CLS. 100, 101 AND 102).

FIRST USE 11-11-2010; IN COMMERCE 11-11-2010.

### CLASS 44—MEDICAL, BEAUTY AND AGRICULTURAL SERVICES

FOR MEDICAL CONSULTATION PROVIDED VIA PHONE, ONLINE CHAT, EMAIL, OR VIDEO CONFERRING; PROVIDING ONLINE MEDICAL HISTORY PROFILES (U.S. CLS. 100 AND 101).

FIRST USE 11-11-2010; IN COMMERCE 11-11-2010.  
ANGELA M. MICHELI, EXAMINING ATTORNEY

SN 85-215,390. IDEA LOCO INC., VALPARAISO, IN. FILED 1-11-2011.

## THE NEW WAY TO SEE THE DOCTOR

THE MARK CONSISTS OF STANDARD CHARACTERS WITHOUT CLAIM TO ANY PARTICULAR FONT, STYLE, SIZE, OR COLOR.

### CLASS 35—ADVERTISING AND BUSINESS

FOR ONLINE AND TELEPHONE ORDERING SERVICES IN THE FIELD OF MEDICINES (U.S. CLS. 100, 101 AND 102).

FIRST USE 11-11-2010; IN COMMERCE 11-11-2010.

### CLASS 44—MEDICAL, BEAUTY AND AGRICULTURAL SERVICES

FOR MEDICAL CONSULTATION PROVIDED VIA PHONE, ONLINE CHAT, EMAIL, OR VIDEO CONFERENCING; PROVIDING ONLINE MEDICAL HISTORY PROFILES (U.S. CLS. 100 AND 101).

FIRST USE 11-11-2010; IN COMMERCE 11-11-2010.  
ANGELA M. MICHELI, EXAMINING ATTORNEY

SN 85-215,399. C.B. FLEET INVESTMENT CORPORATION, WILMINGTON, DE. FILED 1-11-2011.

## HAIL TO THE V

THE MARK CONSISTS OF STANDARD CHARACTERS WITHOUT CLAIM TO ANY PARTICULAR FONT, STYLE, SIZE, OR COLOR.

### CLASS 3—COSMETICS AND CLEANING PREPARATIONS

FOR NON-MEDICATED DOUCHE; FEMININE DEODORANT SPRAY; LIQUID CLEANSING SOLUTION, NAMELY, FEMININE HYGIENE CLEANSING TOWELETES, NON-MEDICATED FEMININE HYGIENE WASH FOR EXTERNAL FEMININE HYGIENE; NON-MEDICATED FOAMING CLEANSING BATH AND SHOWER SOLUTION, NAMELY, BATH FOAM, SHOWER AND BATH GEL, BATH SOAPS IN LIQUID, SOLID OR GEL FORM FOR EXTERNAL FEMININE HYGIENE; NON-MEDICATED BODY WASH; NON-MEDICATED BATH POWDER FOR EXTERNAL COSMETIC USE; NON-MEDICATED BATH AND SHOWER GEL, DEPILATORIES, SHAVING GELS, CREAMS, AND MOUSSE; FEMININE HYGIENE CLEANSING TOWELETES; NON-MEDICATED AFTER SHAVE CREAMS, GELS, LIQUIDS, CLOTHS, NAMELY, CLOTHS OR TISSUES IMPREGNATED WITH A SKIN CLEANSER, AND PRE-MOISTENED COSMETIC TOWELETES (U.S. CLS. 1, 4, 6, 50, 51 AND 52).

### CLASS 5—PHARMACEUTICALS

FOR MEDICATED DOUCHE; MEDICATED SHAVING PREPARATIONS IN THE NATURE OF MEDICATED AFTER SHAVE CREAMS, GELS, LIQUIDS, LOTIONS AND MEDICATED PRE-MOISTENED TOWELETES; VAGINAL MOISTURIZER; PERSONAL LUBRICANT; ANTI ITCH OINTMENT IN THE FORM OF GELS, CREAMS, LIQUIDS AND POWDER; VAGINAL SUPPOSITORIES (U.S. CLS. 6, 18, 44, 46, 51 AND 52).  
EUGENIA MARTIN, EXAMINING ATTORNEY

SN 85-215,426. MY-LOR, INC., DALLAS, GA. FILED 1-11-2011.

## FireTag

THE MARK CONSISTS OF STANDARD CHARACTERS WITHOUT CLAIM TO ANY PARTICULAR FONT, STYLE, SIZE, OR COLOR.

### CLASS 16—PAPER GOODS AND PRINTED MATTER

FOR DRY ERASE WRITING BOARDS AND WRITING SURFACES (U.S. CLS. 2, 5, 22, 23, 29, 37, 38 AND 50).  
FIRST USE 1-11-2011; IN COMMERCE 1-11-2011.

### CLASS 20—FURNITURE AND ARTICLES NOT OTHERWISE CLASSIFIED

FOR PLASTIC NAME BADGES (U.S. CLS. 2, 13, 22, 25, 32 AND 50).  
FIRST USE 1-11-2011; IN COMMERCE 1-11-2011.  
AISHA CLARKE, EXAMINING ATTORNEY

SN 85-215,484. APPINION LLC, ROCHESTER, NY. FILED 1-11-2011.

## Appinion

THE MARK CONSISTS OF STANDARD CHARACTERS WITHOUT CLAIM TO ANY PARTICULAR FONT, STYLE, SIZE, OR COLOR.

### CLASS 9—ELECTRICAL AND SCIENTIFIC APPARATUS

FOR SOFTWARE USED FOR CONDUCTING ADVERTISING, SURVEYS, AND OTHER MARKET RESEARCH ON SMARTPHONES, TABLET COMPUTERS, AND OTHER MOBILE ELECTRONIC DEVICES (U.S. CLS. 21, 23, 26, 36 AND 38).

### CLASS 35—ADVERTISING AND BUSINESS

FOR ADVERTISING, SURVEY, AND MARKET RESEARCH SERVICES VIA SOFTWARE ON SMARTPHONES, TABLET COMPUTERS, AND OTHER MOBILE ELECTRONIC DEVICES; PROVISION OF MARKET RESEARCH INFORMATION TO OTHERS FOR BUSINESS PURPOSES (U.S. CLS. 100, 101 AND 102).

BARBARA BROWN, EXAMINING ATTORNEY

---

SN 85-216,010. HARDEE'S FOOD SYSTEMS, INC., ST. LOUIS, MO. FILED 1-12-2011.

### HOME OF THE BOTTOMLESS CUP

THE MARK CONSISTS OF STANDARD CHARACTERS WITHOUT CLAIM TO ANY PARTICULAR FONT, STYLE, SIZE, OR COLOR.

#### CLASS 30—STAPLE FOODS

FOR COFFEE (U.S. CL. 46).

#### CLASS 43—HOTEL AND RESTAURANT SERVICES

FOR RESTAURANT SERVICES (U.S. CLS. 100 AND 101).  
CAROLINE WOOD, EXAMINING ATTORNEY

---

SN 85-216,137. KIMBERLY KENNEDY LLC, ATLANTA, GA. FILED 1-12-2011.

### PARTY DRESS

THE MARK CONSISTS OF STANDARD CHARACTERS WITHOUT CLAIM TO ANY PARTICULAR FONT, STYLE, SIZE, OR COLOR.

NO CLAIM IS MADE TO THE EXCLUSIVE RIGHT TO USE "PARTY", APART FROM THE MARK AS SHOWN.

#### CLASS 16—PAPER GOODS AND PRINTED MATTER

FOR PAPER PARTY FAVORS; PAPER BOXES; PAPER BOARDS; GIFT BOXES; PAPER PARTY DECORATIONS; PAPER PARTY DECORATIONS, NAMELY, TABLE AND CHAIR DECORATIONS; PARTY ORNAMENTS OF PAPER; PARTY BAGS MADE OF PAPER AND PLASTIC; PAPER CAKE DECORATIONS; DECORATIVE PAPER CENTERPIECES; PACKAGING CONTAINERS OF PAPER; PAPER LABELS; BAGS, NAMELY, PAPER GIFT BAGS; PAPER TABLECLOTHS; PAPER NAPKINS; PAPER RUNNERS; PAPER PICNIC CLOTHS; STATIONERY; INVITATION CARDS; SAVE-THE-DATE CARDS; THANK-YOU CARDS; NOTE CARDS; PLACE CARDS; CALENDARS; GUEST BOOKS; PAPER FOR WRAPPING AND PACKAGING; WRAPPING PAPER SETS COMPRISING GIFT WRAP PAPER AND PAPER GIFT WRAP BOWS; PACKAGE TIES, NAMELY, PAPER GIFT WRAPPING RIBBONS; PAPER TAGS; PRINTED MATTER, NAMELY, BOOKS, NEWSLETTERS, MAGAZINES IN THE FIELD OF ENTERTAINING (U.S. CLS. 2, 5, 22, 23, 29, 37, 38 AND 50).

#### CLASS 21—HOUSEWARES AND GLASS

FOR PLATES; SAUCERS; CUPS; SERVING TRAYS; SERVING PLATTER; VASES; BOWLS; BAKEWARE; COOKWARE; FOOD STORAGE CONTAINERS; AND GLASSWARE, NAMELY, PITCHERS AND BEVERAGEWARE (U.S. CLS. 2, 13, 23, 29, 30, 33, 40 AND 50).

#### CLASS 24—FABRICS

FOR TABLE LINEN, NAMELY, COASTERS, NAPKINS, PLACE MATS; TEXTILE TABLECLOTHS (U.S. CLS. 42 AND 50).

#### CLASS 30—STAPLE FOODS

FOR EDIBLE DECORATIONS FOR BAKERY GOODS (U.S. CL. 46).

#### CLASS 41—EDUCATION AND ENTERTAINMENT

FOR ENTERTAINMENT SERVICES IN THE NATURE OF ONGOING PERSONAL TELEVISION APPEARANCES AND RADIO SPOTS BY AN INDIVIDUAL IN THE FIELDS OF HOMEMAKING, HOMECARE, COOKING, HOUSEKEEPING, DECORATING, ENTERTAINING, WEDDINGS, PARTY PLANNING, MAKING CRAFTS, AND DO-IT-YOURSELF HOME REMODELING PROJECTS (U.S. CLS. 100, 101 AND 107).

REGINA DRUMMOND, EXAMINING ATTORNEY

---

SN 85-216,163. KAUFFMAN, RAY L., TA BONBONNIERE, LANCASTER, PA. AND KAUFFMAN, MARY ELLEN, TA BONBONNIERE, LANCASTER, PA. FILED 1-12-2011.



THE MARK CONSISTS OF A STYLIZED OVAL MEDALLION WITHIN WHICH APPEARS THE OUTLINE OF A BIRD PERCHED ON TOP OF A GIFT BOX WRAPPED WITH A RIBBON.

#### CLASS 30—STAPLE FOODS

FOR CONFECTIONS, NAMELY, CANDY, CHOCOLATE-COVERED PRETZELS, PRETZELS, COOKIES (U.S. CL. 46).

FIRST USE 8-14-2009; IN COMMERCE 8-14-2009.

#### CLASS 35—ADVERTISING AND BUSINESS

FOR RETAIL STORE SERVICES FEATURING CONFECTIONS, NAMELY, CANDY, CHOCOLATE-COVERED PRETZELS, PRETZELS, COOKIES (U.S. CLS. 100, 101 AND 102).

FIRST USE 8-14-2009; IN COMMERCE 8-14-2009.  
DEBRA LEE, EXAMINING ATTORNEY



SN 85-216,244. MAISONETTE INTERNATIONAL, LLC, NEW YORK, NY. FILED 1-12-2011.

SN 85-216,397. CHECKSMART FINANCIAL COMPANY, DUBLIN, OH. FILED 1-13-2011.

# MAISONETTE

THE MARK CONSISTS OF STANDARD CHARACTERS WITHOUT CLAIM TO ANY PARTICULAR FONT, STYLE, SIZE, OR COLOR.

## CLASS 25—CLOTHING

FOR BOTTOMS; MEN'S AND WOMEN'S JACKETS, COATS, TROUSERS, VESTS; SKIRTS AND DRESSES; TOPS (U.S. CLS. 22 AND 39).

FIRST USE 2-15-2010; IN COMMERCE 2-15-2010.

## CLASS 35—ADVERTISING AND BUSINESS

FOR ON-LINE WHOLESALE AND RETAIL STORE SERVICES FEATURING WOMEN'S APPAREL, APPAREL ACCESSORIES, FOOTWEAR; RETAIL APPAREL STORES (U.S. CLS. 100, 101 AND 102).

FIRST USE 2-15-2010; IN COMMERCE 2-15-2010.  
MORGAN WYNNE, EXAMINING ATTORNEY

SN 85-216,396. CHECKSMART FINANCIAL COMPANY, DUBLIN, OH. FILED 1-12-2011.



OWNER OF U.S. REG. NOS. 3,339,073, 3,339,075 AND OTHERS.

THE MARK CONSISTS OF A DOLLAR SIGN TILTED SLIGHTLY TO THE LEFT IN A CIRCLE SURROUNDED BY A STARBURST DESIGN AND TO THE RIGHT OF THE DESIGN IS THE TEXT "CHECKSMART".

## CLASS 35—ADVERTISING AND BUSINESS

FOR RETAIL STORE SERVICES FEATURING STORED VALUE CARDS, TELEPHONE CALLING CARDS AND POSTAGE STAMPS (U.S. CLS. 100, 101 AND 102).

FIRST USE 1-12-2005; IN COMMERCE 1-12-2005.

## CLASS 36—INSURANCE AND FINANCIAL

FOR AUTOMATED TELLER MACHINE SERVICES; BILL PAYMENT SERVICES; CHECK CASHING; ELECTRONIC FUNDS TRANSFER; FINANCIAL SERVICES, NAMELY, VEHICLE TITLE LOANS; ISSUING STORED VALUE CARDS; LOAN FINANCING; MONEY ORDER SERVICES; MONEY WIRING SERVICES; TELEPHONE CALLING CARD SERVICES (U.S. CLS. 100, 101 AND 102).

FIRST USE 1-12-2005; IN COMMERCE 1-12-2005.  
PAULA MAHONEY, EXAMINING ATTORNEY



OWNER OF U.S. REG. NOS. 3,339,073, 3,339,075 AND OTHERS.

NO CLAIM IS MADE TO THE EXCLUSIVE RIGHT TO USE "CONSUMER LOANS" AND "CHECKS CASHED", APART FROM THE MARK AS SHOWN.

THE MARK CONSISTS OF A DOLLAR SIGN TILTED SLIGHTLY TO THE LEFT IN A CIRCLE SURROUNDED BY A STARBURST DESIGN AND TO THE RIGHT OF THE DESIGN IS THE TEXT "CHECKSMART". DIRECTLY BELOW THE TEXT "CHECKSMART" IS THE TEXT "CONSUMER LOANS CHECKS CASHED" WITHIN A RECTANGLE. THE WORDS "CONSUMER LOANS" AND "CHECKS CASHED" ARE SEPARATED BY A BULLET SYMBOL.

## CLASS 35—ADVERTISING AND BUSINESS

FOR RETAIL STORE SERVICES FEATURING STORED VALUE CARDS, TELEPHONE CALLING CARDS AND POSTAGE STAMPS (U.S. CLS. 100, 101 AND 102).

FIRST USE 1-26-2009; IN COMMERCE 1-26-2009.

## CLASS 36—INSURANCE AND FINANCIAL

FOR AUTOMATED TELLER MACHINE SERVICES; BILL PAYMENT SERVICES; CHECK CASHING; ELECTRONIC FUNDS TRANSFER; FINANCIAL SERVICES, NAMELY, VEHICLE TITLE LOANS; ISSUING STORED VALUE CARDS; LOAN FINANCING; MONEY ORDER SERVICES; MONEY WIRING SERVICES; TELEPHONE CALLING CARD SERVICES (U.S. CLS. 100, 101 AND 102).

FIRST USE 1-26-2009; IN COMMERCE 1-26-2009.  
PAULA MAHONEY, EXAMINING ATTORNEY

SN 85-216,450. ALIANO, PATRICK C, LANCASTER, CA. FILED 1-12-2011.

# Complex Creation

THE MARK CONSISTS OF STANDARD CHARACTERS WITHOUT CLAIM TO ANY PARTICULAR FONT, STYLE, SIZE, OR COLOR.

## CLASS 35—ADVERTISING AND BUSINESS

FOR ARRANGING PERSONAL APPEARANCES BY PERSONS WORKING IN THE FIELD OF FILM, MUSIC, TELEVISION, ENTERTAINMENT OR SPORT; BUSINESS CONSULTING, BUSINESS MANAGEMENT AND PROVIDING INFORMATION IN THE MUSIC BUSINESS FIELD; MUSIC SELECTION SERVICES FOR USE IN ADVERTISING; PERSONAL MANAGEMENT SERVICES FOR MUSICAL PERFORMERS (U.S. CLS. 100, 101 AND 102).

**CLASS 41—EDUCATION AND ENTERTAINMENT**

FOR COMPOSITION OF MUSIC FOR OTHERS; CONSULTATION AND ADVICE REGARDING MUSICAL SELECTIONS AND ARRANGEMENTS FOR SOUND RECORDINGS AND LIVE PERFORMANCES; ENTERTAINMENT SERVICES BY A MUSICAL ARTIST AND PRODUCER, NAMELY, MUSICAL COMPOSITION FOR OTHERS AND PRODUCTION OF MUSICAL SOUND RECORDINGS; ENTERTAINMENT SERVICES IN THE NATURE OF LIVE MUSICAL PERFORMANCES; ENTERTAINMENT, NAMELY, LIVE MUSIC CONCERTS; MUSIC COMPOSITION FOR OTHERS; MUSIC PRODUCTION SERVICES (U.S. CLS. 100, 101 AND 107).

LAURA KOVALSKY, EXAMINING ATTORNEY

SN 85-216,600. BBY SOLUTIONS, INC., RICHFIELD, MN. FILED 1-13-2011.



SN 85-216,577. BBY SOLUTIONS, INC., RICHFIELD, MN. FILED 1-13-2011.

HAPPY 24

THE MARK CONSISTS OF STANDARD CHARACTERS WITHOUT CLAIM TO ANY PARTICULAR FONT, STYLE, SIZE, OR COLOR.

**CLASS 35—ADVERTISING AND BUSINESS**

FOR PROVIDING CONSUMER PRODUCT INFORMATION AND ADVICE RELATING TO MOBILE PHONES AND MOBILE PHONE PLANS; PROVIDING INFORMATION REGARDING DISCOUNTS, SPECIAL OFFERS, AND PRODUCT UPGRADES FOR MOBILE PHONES AND MOBILE PHONE PLANS; ADMINISTRATION OF CUSTOMER LOYALTY AND REWARD PROGRAMS OFFERED AND ACCESSED VIA MOBILE PHONES; RETAIL STORE SERVICES IN THE FIELDS OF TELECOMMUNICATION PRODUCTS AND RETAIL STORE SERVICES FEATURING TELECOMMUNICATIONS SERVICE PLANS (U.S. CLS. 100, 101 AND 102).

**CLASS 38—COMMUNICATION**

FOR TRANSMISSION OF NOTIFICATIONS OF PROMOTIONS, SALES, DISCOUNTS, SPECIAL OFFERS, AND PRODUCT UPGRADES, PROGRAM LOYALTY INFORMATION, NEW PRODUCT INFORMATION VIA TELECOMMUNICATIONS NETWORKS; PROVIDING NOTIFICATIONS REGARDING MOBILE PHONES, MOBILE PHONE PLANS, MOBILE PHONE USER TIPS, PRODUCT INFORMATION, AND PROMOTIONAL OFFERS VIA ELECTRONIC MAIL, TEXT MESSAGE, AND MOBILE PHONES (U.S. CLS. 100, 101 AND 104).

LINDA E. BLOHM, EXAMINING ATTORNEY

THE MARK CONSISTS OF A CIRCLE CONTAINING THE NUMBER "24" AND A CURVED LINE REPRESENTING A MOUTH.

**CLASS 35—ADVERTISING AND BUSINESS**

FOR PROVIDING CONSUMER PRODUCT INFORMATION AND ADVICE RELATING TO MOBILE PHONES AND MOBILE PHONE PLANS; PROVIDING INFORMATION REGARDING DISCOUNTS, SPECIAL OFFERS, AND PRODUCT UPGRADES FOR MOBILE PHONES AND MOBILE PHONE PANS; ADMINISTRATION OF CUSTOMER LOYALTY AND REWARD PROGRAMS OFFERED AND ACCESSED VIA MOBILE PHONES; RETAIL STORE SERVICES IN THE FIELDS OF TELECOMMUNICATION PRODUCTS AND RETAIL STORE SERVICES FEATURING TELECOMMUNICATIONS SERVICE PLANS (U.S. CLS. 100, 101 AND 102).

**CLASS 38—COMMUNICATION**

FOR TRANSMISSION OF NOTIFICATIONS OF PROMOTIONS, SALES, DISCOUNTS, SPECIAL OFFERS, AND PRODUCT UPGRADES, PROGRAM LOYALTY INFORMATION, NEW PRODUCT INFORMATION VIA TELECOMMUNICATIONS NETWORKS; PROVIDING NOTIFICATIONS REGARDING MOBILE PHONES, MOBILE PHONE PLANS, MOBILE PHONE USER TIPS, PRODUCT INFORMATION, AND PROMOTIONAL OFFERS VIA ELECTRONIC MAIL, TEXT MESSAGE, AND MOBILE PHONES (U.S. CLS. 100, 101 AND 104).

LINDA E. BLOHM, EXAMINING ATTORNEY

SN 85-216,717. THEORY LLC, NEW YORK, NY. FILED 1-13-2011.

THEORY

THE MARK CONSISTS OF STANDARD CHARACTERS WITHOUT CLAIM TO ANY PARTICULAR FONT, STYLE, SIZE, OR COLOR.

**CLASS 8—HAND TOOLS**

FOR FLATWARE, NAMELY, FORKS, KNIVES AND SPOONS; GRAPEFRUIT TRIMMER, NAMELY, A KITCHEN KNIFE WITH SERRATED EDGES; PARING KNIVES; JAPANESE CHOPPING KITCHEN KNIVES; PRUNING KNIVES; SCALING KNIVES; STERLING SILVER TABLE KNIVES, FORKS AND SPOONS; THIN-BLADED KITCHEN KNIVES (U.S. CLS. 23, 28 AND 44).

SN 85-217,076. RYAN SCOTT, INC., GREENSBORO, NC. FILED 1-13-2011.

**INSPIRATION ON DISPLAY**

THE MARK CONSISTS OF STANDARD CHARACTERS WITHOUT CLAIM TO ANY PARTICULAR FONT, STYLE, SIZE, OR COLOR.

**CLASS 21—HOUSEWARES AND GLASS**

FOR GLASS BEVERAGeware AND STEMWARE, DINNERWARE COMPOSED OF STONWARE, PORCELAIN AND BONE CHINA, COOKING UTENSILS, NAMELY, POTS, PANS, NON-ELECTRIC SKILLETS, CASSEROLES AND KETTLES, THERMAL BEVERAGE CONTAINERS, CARAFES AND SERVERS AND GIFTWARE MADE OF CERAMIC MATERIAL, GLASS OR WOOD, NAMELY, VASES, BOWLS, DECANTERS, PITCHERS AND CANDLESTICKS, BEER MUGS; EARTHENWARE MUGS; GLASS MUGS; MUG TREES; PORCELAIN MUGS (U.S. CLS. 2, 13, 23, 29, 30, 33, 40 AND 50).

REBECCA SMITH, EXAMINING ATTORNEY

**CLASS 20—FURNITURE AND ARTICLES NOT OTHERWISE CLASSIFIED**

FOR FURNITURE, NAMELY, DISPLAY UNITS AND STRUCTURAL PARTS THEREOF (U.S. CLS. 2, 13, 22, 25, 32 AND 50).

**CLASS 35—ADVERTISING AND BUSINESS**

FOR PROVIDING ADVERTISING, MARKETING, AND PROMOTIONAL SERVICES FOR OTHERS, NAMELY, THE DESIGN OF ADVERTISING MATERIALS AND SELECTION OF DISPLAY UNITS FOR USE THEREWITH (U.S. CLS. 100, 101 AND 102).

JEFFERY COWARD, EXAMINING ATTORNEY

SN 85-217,028. DEBORAH L. FINCHER, DBA DEBBIE FINCHER DESIGN, INDIAN TRAIL, NC. FILED 1-13-2011.

SN 85-217,395. SICHUAN HAIDLAO CATERING COMPANY LIMITED, JIANYANG CITY, SICHUAN, CHINA, FILED 1-13-2011.



THE MARK CONSISTS OF THE WORDS "PICTURE THE DREAM" WITH STYLIZED LETTERS "D" AND "F" ABOVE WORDS.

**CLASS 16—PAPER GOODS AND PRINTED MATTER**

FOR POSTERS (U.S. CLS. 2, 5, 22, 23, 29, 37, 38 AND 50).

FIRST USE 5-17-2010; IN COMMERCE 5-17-2010.

**CLASS 42—SCIENTIFIC AND COMPUTER SERVICES**

FOR GRAPHIC ART DESIGN (U.S. CLS. 100 AND 101). FIRST USE 5-14-2010; IN COMMERCE 5-14-2010. TARAH HARDY, EXAMINING ATTORNEY

HDL

THE MARK CONSISTS OF THE LETTERS "HDL" IN A SPECIALIZED FONT.

**CLASS 30—STAPLE FOODS**

FOR FLAVORINGS FOR BEVERAGES; TEA-BASED BEVERAGES; CONDIMENT, NAMELY, PEPPER SAUCE; RELISH; MOLASSES; PASTRIES; SPRING ROLLS; NOODLES; SOYA FLOUR; FARINACEOUS FOOD PASTES FOR HUMAN CONSUMPTION (U.S. CL. 46).

**CLASS 43—HOTEL AND RESTAURANT SERVICES**

FOR CAFES; RESTAURANTS; SNACK-BARS; RENTAL OF ROOMS FOR SOCIAL FUNCTIONS; RETIREMENT HOMES; DAY-CARE CENTERS; BOARDING FOR ANIMALS; RENTAL OF TABLE LINENS (U.S. CLS. 100 AND 101).

JOSETTE BEVERLY, EXAMINING ATTORNEY

SN 85-217,444. ALBERT KILDUFF, EDGEWOOD, MD.  
FILED 1-13-2011.

## Face Dancer

THE MARK CONSISTS OF STANDARD CHARACTERS WITHOUT CLAIM TO ANY PARTICULAR FONT, STYLE, SIZE, OR COLOR.

### CLASS 9—ELECTRICAL AND SCIENTIFIC APPARATUS

FOR SOUND RECORDINGS FEATURING MUSIC (U.S. CLS. 21, 23, 26, 36 AND 38).

### CLASS 41—EDUCATION AND ENTERTAINMENT

FOR ENTERTAINMENT, NAMELY, LIVE MUSIC CONCERTS; ENTERTAINMENT, NAMELY, LIVE PERFORMANCES BY A MUSICAL BAND (U.S. CLS. 100, 101 AND 107).

JOSETTE BEVERLY, EXAMINING ATTORNEY

SN 85-217,555. ABAJIAN, AARON C., DBA CRONOTE, IRVINE, CA. FILED 1-13-2011.

## cronote

THE MARK CONSISTS OF THE WORD "CRONOTE" IN THE FONT ITC AMERICAN TYPEWRITER BOLD.

### CLASS 9—ELECTRICAL AND SCIENTIFIC APPARATUS

FOR COMPUTER SOFTWARE FOR ACCESSING INFORMATION DIRECTORIES THAT MAY BE DOWNLOADED FROM THE GLOBAL COMPUTER NETWORK; COMPUTER SOFTWARE FOR SCHEDULING TIME-BASED REMINDERS IN THE FORM OF TEXT MESSAGES, EMAILS, AND OTHER FORMS OF COMMUNICATION; COMPUTER SOFTWARE FOR CREATING CONTACT GROUPS FROM INFORMATION THAT MAY BE DOWNLOADED FROM A GLOBAL COMPUTER NETWORK; DOWNLOADABLE COMPUTER SOFTWARE FOR SCHEDULING TIME-BASED REMINDERS IN THE FORM OF TIME-BASED TEXT MESSAGES, EMAILS, AND OTHER FORMS OF COMMUNICATION; DOWNLOADABLE SOFTWARE THAT INCORPORATES TIME-BASED ADVERTISING TO CONNECT SOCIAL NETWORK USERS WITH BUSINESSES; DOWNLOADABLE SOFTWARE THAT CAN TRACK THE USAGE OF TIME-BASED MESSAGING TO PREDICT CONSUMER BEHAVIOR; DOWNLOADABLE SOFTWARE IN THE NATURE OF A MOBILE APPLICATION FOR TIME-BASED TEXT MESSAGES, EMAILS, AND OTHER FORMS OF COMMUNICATION (U.S. CLS. 21, 23, 26, 36 AND 38).

FIRST USE 12-3-2010; IN COMMERCE 1-3-2011.

### CLASS 35—ADVERTISING AND BUSINESS

FOR ADVERTISING AND MARKETING; ADVERTISING AND MARKETING SERVICES PROVIDED BY MEANS OF INDIRECT METHODS OF MARKETING COMMUNICATIONS, NAMELY, SOCIAL MEDIA, SEARCH ENGINE MARKETING, INQUIRY MARKETING, INTERNET MARKETING, MOBILE MARKETING, BLOGGING AND OTHER FORMS OF PASSIVE, SHARABLE OR VIRAL COMMUNICATIONS CHANNELS; ADVERTISING AND MARKETING SERVICES, NAMELY, PROMOTING THE GOODS AND SERVICES OF OTHERS; COOPERATIVE ADVERTISING AND MARKETING; ON-LINE ADVERTISING AND MARKETING SERVICES; PROMOTING, ADVERTISING AND MARKETING OF THE BRANDS, PRODUCTS, SERVICES OR ONLINE WEBSITES OF INDIVIDUALS, BUSINESSES AND NONPROFIT ORGANIZATIONS; PROMOTING, ADVERTISING AND MARKETING OF THE ON-LINE WEB SITES OF OTHERS (U.S. CLS. 100, 101 AND 102).

HANNO RITTNER, EXAMINING ATTORNEY

SN 85-217,694. KDH DESIGNS, LLC, LITTLE ROCK, AR.  
FILED 1-14-2011.

## KAY-DEE-H

THE MARK CONSISTS OF STANDARD CHARACTERS WITHOUT CLAIM TO ANY PARTICULAR FONT, STYLE, SIZE, OR COLOR.

### CLASS 14—JEWELRY

FOR JEWELRY (U.S. CLS. 2, 27, 28 AND 50).

### CLASS 18—LEATHER GOODS

FOR HANDBAGS; PURSES (U.S. CLS. 1, 2, 3, 22 AND 41).

### CLASS 25—CLOTHING

FOR WOMEN'S SHOES (U.S. CLS. 22 AND 39).  
TRICIA SONNEBORN, EXAMINING ATTORNEY

SN 85-217,701. CARLSON, INC., MINNEAPOLIS, MN. FILED 1-14-2011.



## CARLSON

OWNER OF U.S. REG. NO. 3,489,275.  
THE COLOR(S) BLACK, RED AND YELLOW IS/ARE CLAIMED AS A FEATURE OF THE MARK.  
THE MARK CONSISTS OF THE WORD "CARLSON" IN BLACK BENEATH A STYLIZED FLOWER DESIGN CONSISTING OF FOUR PETAL SHAPES IN RED WITH FOUR YELLOW OVALS BETWEEN THE PETALS.



**CLASS 35—ADVERTISING AND BUSINESS**

FOR MANAGEMENT OF HOTELS, MOTELS AND RESORTS FOR OTHERS; CUSTOMER LOYALTY SERVICES AND CUSTOMER CLUB SERVICES, FOR COMMERCIAL, PROMOTIONAL AND/OR ADVERTISING PURPOSES; FULFILLMENT OF TRAVEL REWARDS IN CONNECTION WITH LOYALTY PROGRAMS AND INCENTIVE AWARD PROGRAMS; PROVIDING AND MANAGING FREQUENT TRAVELER BENEFIT PROGRAMS FOR OTHERS (U.S. CLS. 100, 101 AND 102).

FIRST USE 1-1-2011, THE MARK WAS FIRST USED ANYWHERE IN A DIFFERENT FORM OTHER THAN THAT SOUGHT TO BE REGISTERED AT LEAST AS EARLY AS 11/00/2006; IN COMMERCE 1-1-2011, THE MARK WAS FIRST USED IN COMMERCE IN A DIFFERENT FORM OTHER THAN THAT SOUGHT TO BE REGISTERED AT LEAST AS EARLY AS 11/00/2006.

**CLASS 39—TRANSPORTATION AND STORAGE**

FOR TRAVEL AGENCY SERVICES, NAMELY, MAKING RESERVATIONS AND BOOKINGS FOR TRANSPORTATION AND PROVIDING INFORMATION THEREON; DESIGNING AND ARRANGING TRAVEL AND VACATION PACKAGES; PROVIDING ONLINE TRAVEL AGENCY SERVICES BY MEANS OF A COMPUTER INFORMATION NETWORK FOR THE PURPOSE OF MAKING RESERVATIONS AND BOOKINGS FOR TRANSPORTATION (U.S. CLS. 100 AND 105).

FIRST USE 1-1-2011, THE MARK WAS FIRST USED ANYWHERE IN A DIFFERENT FORM OTHER THAN THAT SOUGHT TO BE REGISTERED AT LEAST AS EARLY AS 11/00/2006; IN COMMERCE 1-1-2011, THE MARK WAS FIRST USED IN COMMERCE IN A DIFFERENT FORM OTHER THAN THAT SOUGHT TO BE REGISTERED AT LEAST AS EARLY AS 11/00/2006.

**CLASS 43—HOTEL AND RESTAURANT SERVICES**

FOR HOTEL, RESORT AND TEMPORARY LODGING SERVICES; MAKING HOTEL, RESORT AND LODGING RESERVATIONS FOR OTHERS; PROVIDING HOTEL, RESORT AND LODGING INFORMATION AND RESERVATION SERVICES BY MEANS OF A COMPUTER INFORMATION NETWORK; RESTAURANT, CATERING AND BANQUET SERVICES (U.S. CLS. 100 AND 101).

FIRST USE 1-1-2011, THE MARK WAS FIRST USED ANYWHERE IN A DIFFERENT FORM OTHER THAN THAT SOUGHT TO BE REGISTERED AT LEAST AS EARLY AS 11/00/2006; IN COMMERCE 1-1-2011, THE MARK WAS FIRST USED IN COMMERCE IN A DIFFERENT FORM OTHER THAN THAT SOUGHT TO BE REGISTERED AT LEAST AS EARLY AS 11/00/2006.

WON TEAK OH, EXAMINING ATTORNEY

SN 85-217,735. INSITE VISION INCORPORATED, ALAMEDA, CA. FILED 1-14-2011.



THE COLOR(S) GREEN AND BLUE IS/ARE CLAIMED AS A FEATURE OF THE MARK.

THE MARK CONSISTS OF TWO INTERSECTING CIRCULAR DESIGNS, WITH THE LEFT CIRCULAR DESIGN FEATURED IN THE COLOR BLUE AND THE RIGHT CIRCULAR DESIGN FEATURED IN THE COLOR GREEN.

**CLASS 5—PHARMACEUTICALS**

FOR EYE DROPS; PHARMACEUTICAL PREPARATIONS AND SUBSTANCES USED FOR THE TREATMENT OF INFLAMMATION AND PAIN IN THE EYE; AND PHARMACEUTICAL PREPARATIONS AND SUBSTANCES FOR USE IN THE PREVENTION OR TREATMENT OF DISEASES OR DISORDERS OF THE EYE (U.S. CLS. 6, 18, 44, 46, 51 AND 52).

**CLASS 42—SCIENTIFIC AND COMPUTER SERVICES**

FOR RESEARCH AND DEVELOPMENT OF PHARMACEUTICAL PREPARATIONS AND EYE DROPS; MEDICAL AND SCIENTIFIC RESEARCH INFORMATION IN THE FIELDS OF PHARMACEUTICAL PREPARATIONS, EYE DROPS, EYE DISORDERS AND CLINICAL TRIALS; AND PROVIDING A WEBSITE FEATURING MEDICAL AND SCIENTIFIC RESEARCH INFORMATION ABOUT PHARMACEUTICAL PREPARATIONS, EYE DROPS AND EYE DISORDERS (U.S. CLS. 100 AND 101).

REBECCA POVARCHUK, EXAMINING ATTORNEY

SN 85-217,939. LOOSE CUBES, INC., BROOKLYN, NY. FILED 1-14-2011.

# LOOSECUBES

THE MARK CONSISTS OF STANDARD CHARACTERS WITHOUT CLAIM TO ANY PARTICULAR FONT, STYLE, SIZE, OR COLOR.

**CLASS 35—ADVERTISING AND BUSINESS**

FOR PROVIDING AN INTERACTIVE WEBSITE FEATURING AN ONLINE MARKETPLACE FOR OTHERS TO EXCHANGE SERVICES; REAL ESTATE AND WORKSPACE ADVERTISING AND MARKETING SERVICES IN THE FIELD OF SHORT-TERM AND LONG-TERM LEASING AND RENTAL OF REAL ESTATE AND WORKSPACE; ADVERTISING AND MARKETING OF REAL ESTATE AND WORKSPACE (U.S. CLS. 100, 101 AND 102).

FIRST USE 5-9-2010; IN COMMERCE 5-9-2010.

**CLASS 36—INSURANCE AND FINANCIAL**

FOR PROVIDING AN INTERACTIVE REAL ESTATE LISTING WEBSITE WITH IMAGES IN THE FIELD OF REAL ESTATE AND WORKSPACE FOR CONNECTING REAL ESTATE AND WORKSPACE OWNERS AND LESSORS WITH REAL ESTATE AND WORKSPACE RENTERS AND TENANTS (U.S. CLS. 100, 101 AND 102).

FIRST USE 5-9-2010; IN COMMERCE 5-9-2010.

BRIAN PINO, EXAMINING ATTORNEY

SN 85-218,081, JACOBS, MARK B., SPRINGFIELD, VA.  
FILED 1-14-2011.

## TAPESTRY OF WORLDS

THE MARK CONSISTS OF STANDARD CHARACTERS WITHOUT CLAIM TO ANY PARTICULAR FONT, STYLE, SIZE, OR COLOR.

### CLASS 9—ELECTRICAL AND SCIENTIFIC APPARATUS

FOR AUDIO BOOKS IN THE NATURE OF NOVELS; COMPUTER GAME CARTRIDGES AND DISCS; COMPUTER GAME SOFTWARE; COMPUTER GAME SOFTWARE DOWNLOADABLE FROM A GLOBAL COMPUTER NETWORK; COMPUTER GAME SOFTWARE FOR PERSONAL COMPUTERS AND HOME VIDEO GAME CONSOLES; COMPUTER GAME SOFTWARE FOR USE ON MOBILE AND CELLULAR PHONES; COMPUTER GAME SOFTWARE FOR USE WITH PERSONAL COMPUTERS, HOME VIDEO GAME CONSOLES USED WITH TELEVISIONS AND ARCADE-BASED VIDEO GAME CONSOLES; DOWNLOADABLE COMPUTER GAME SOFTWARE VIA A GLOBAL COMPUTER NETWORK AND WIRELESS DEVICES; INTERACTIVE GAME SOFTWARE; VIDEO GAME CARTRIDGES AND DISCS; VIDEO GAME SOFTWARE (U.S. CLS. 21, 23, 26, 36 AND 38).

### CLASS 16—PAPER GOODS AND PRINTED MATTER

FOR COLORING BOOKS; GRAPHIC NOVELS; NOVELS; PRINTED MATERIALS, NAMELY, NOVELS AND SERIES OF FICTION BOOKS AND SHORT STORIES FEATURING SCENES AND CHARACTERS BASED ON VIDEO GAMES; SERIES OF FICTION WORKS, NAMELY, NOVELS AND BOOKS (U.S. CLS. 2, 5, 22, 23, 29, 37, 38 AND 50).

### CLASS 41—EDUCATION AND ENTERTAINMENT

FOR ENTERTAINMENT SERVICES, NAMELY, PROVIDING ON-LINE COMPUTER GAMES; PRODUCTION OF VIDEO AND COMPUTER GAME SOFTWARE (U.S. CLS. 100, 101 AND 107).

DANIEL CAPSHAW, EXAMINING ATTORNEY

SN 85-218,185, TLS IP-HOLDINGS LLC, FREEHOLD, NJ.  
FILED 1-14-2011.

## GETWELLEPHANTS

THE MARK CONSISTS OF STANDARD CHARACTERS WITHOUT CLAIM TO ANY PARTICULAR FONT, STYLE, SIZE, OR COLOR.

### CLASS 9—ELECTRICAL AND SCIENTIFIC APPARATUS

FOR CHILDREN'S EDUCATIONAL SOFTWARE; MOTION PICTURE FILMS AND FILMS FOR TELEVISION FEATURING CHILDREN'S ENTERTAINMENT; MOTION PICTURE FILMS FEATURING CHILDREN'S ENTERTAINMENT; VIDEO DISKS AND VIDEO TAPES WITH RECORDED ANIMATED CARTOONS (U.S. CLS. 21, 23, 26, 36 AND 38).

### CLASS 16—PAPER GOODS AND PRINTED MATTER

FOR CARTOON PRINTS; CARTOON STRIPS; COMIC BOOKS; COMIC MAGAZINES; COMIC STRIPS; COMIC STRIPS APPEARING IN NEWSPAPERS AND MAGAZINES; COMIC STRIPS' COMIC FEATURES; COMICS; NEWSPAPER COMIC STRIPS (U.S. CLS. 2, 5, 22, 23, 29, 37, 38 AND 50).

### CLASS 25—CLOTHING

FOR BATHING SUITS; FOOTWEAR; HATS; JACKETS; PAJAMAS; PANTS; SHIRTS; SOCKS; SWEATSHIRTS; T-SHIRTS; UNDERWEAR (U.S. CLS. 22 AND 39).

### CLASS 28—TOYS AND SPORTING GOODS

FOR PLUSH TOYS; SOFT SCULPTURE PLUSH TOYS; STUFFED AND PLUSH TOYS; TOY ACTION FIGURES; TOY FIGURES (U.S. CLS. 22, 23, 38 AND 50).

ANDREA K. NADELMAN, EXAMINING ATTORNEY

SN 85-218,209, REGENESIS BIOMEDICAL, INC., SCOTTSDALE, AZ. FILED 1-14-2011.



OWNER OF U.S. REG. NO. 2,430,781.

THE MARK CONSISTS OF A STARBURST DESIGN WITH EIGHT POINTS ALTERNATING BETWEEN SHORT AND LONG IN LENGTH, THE STARBURST DESIGN IS TILTED TO THE LEFT AND ENCIRCLED BY A COMPLETE ELLIPSE THAT IS BORDERED BY CRESCENTS ON EACH END.

### CLASS 9—ELECTRICAL AND SCIENTIFIC APPARATUS

FOR (BASED ON INTENT TO USE) LABORATORY ELECTROMAGNETIC RADIATOR DEVICES FOR INDUCING HUMAN, ANIMAL OR PLANT CELL PROLIFERATION FOR USE IN MEDICAL, SCIENTIFIC, PHARMACEUTICAL, DIAGNOSTIC, INDUSTRIAL, AND FOOD INDUSTRIES, NOT FOR MEDICAL DIAGNOSTIC OR CLINICAL PURPOSES (U.S. CLS. 21, 23, 26, 36 AND 38).

**CLASS 10—MEDICAL APPARATUS**

FOR (BASED ON USE IN COMMERCE) MEDICAL ELECTROMAGNETIC RADIATOR DEVICES FOR INDUCING CELL PROLIFERATION, NAMELY, FOR STIMULATING ANGIOGENESIS, SOFT TISSUE REGENERATION, WOUND HEALING, PAIN AND EDEMA ABATEMENT, POST SURGICAL TISSUE REPAIR AND REGENERATION (U.S. CLS. 26, 39 AND 44).

FIRST USE 10-1-2001; IN COMMERCE 10-1-2001.  
ELLEN PERKINS, EXAMINING ATTORNEY

---

SN 85-218,678. THE TYLNEY GROUP, LLC, STUART, FL.  
FILED 1-15-2011.

TECHNEPHOLOGY

THE MARK CONSISTS OF STANDARD CHARACTERS WITHOUT CLAIM TO ANY PARTICULAR FONT, STYLE, SIZE, OR COLOR.

**CLASS 9—ELECTRICAL AND SCIENTIFIC APPARATUS**

FOR AUDIO BOOKS IN THE FIELD OF CLOUD COMPUTING; DOWNLOADABLE MP3 FILES, MP3 RECORDINGS, ON-LINE DISCUSSION BOARDS, WEBCASTS, WEBINARS AND PODCASTS FEATURING MUSIC, AUDIO BOOKS IN THE FIELD OF CLOUD COMPUTING, AND NEWS BROADCASTS; ELECTRONIC PUBLICATIONS, NAMELY, BOOK, MANUAL, PRESENTATIONS FEATURING CLOUD COMPUTING RECORDED ON COMPUTER MEDIA (U.S. CLS. 21, 23, 26, 36 AND 38).

**CLASS 16—PAPER GOODS AND PRINTED MATTER**

FOR A SERIES OF BOOKS AND WRITTEN ARTICLES IN THE FIELD OF CLOUD COMPUTING; A SERIES OF BOOKS, WRITTEN ARTICLES, HANDOUTS AND WORKSHEETS IN THE FIELD OF CLOUD COMPUTING; DATA BOOKS; EDUCATIONAL PUBLICATIONS, NAMELY, BOOKS, HANDOUTS, MANUALS IN THE FIELDS OF CLOUD COMPUTING; PRINTED MATTER, NAMELY, PAPER SIGNS, BOOKS, MANUALS, CURRICULUM, NEWSLETTERS, INFORMATIONAL CARDS AND BROCHURES IN THE FIELD OF CLOUD COMPUTING; PUBLICATIONS, NAMELY, BOOKS, HANDOUTS, PRESENTATIONS IN THE FIELDS OF CLOUD COMPUTING; REFERENCE BOOKS IN THE FIELD OF CLOUD COMPUTING (U.S. CLS. 2, 5, 22, 23, 29, 37, 38 AND 50).

**CLASS 35—ADVERTISING AND BUSINESS**

FOR BUSINESS CONSULTATION IN THE FIELD OF CLOUD COMPUTING; BUSINESS CONSULTATION SERVICES, NAMELY, BUSINESS PROCESS IMPROVEMENT AND ENTERPRISE ARCHITECTURE DESIGN; BUSINESS CONSULTING AND BUSINESS INFORMATION FOR ENTERPRISES; BUSINESS CONSULTING AND INFORMATION SERVICES; BUSINESS CONSULTING SERVICES IN THE FIELD OF INFORMATION ASSURANCE; BUSINESS CONSULTING SERVICES IN THE FIELD OF CLOUD COMPUTING; BUSINESS CONSULTING SERVICES RELATING TO PRODUCT DISTRIBUTION, OPERATIONS MANAGEMENT SERVICES, LOGISTICS, REVERSE LOGISTICS, SUPPLY CHAIN, AND PRODUCTION SYSTEMS AND DISTRIBUTION SOLUTIONS; BUSINESS CONSULTING SERVICES RELATING TO THE INTEGRATION OF THE AREAS OF BUSINESS PROCESS TECHNOLOGY, ORGANIZATIONAL LEARNING, CHANGE MANAGEMENT, AND OPERATIONAL SUSTAINABILITY; BUSINESS CONSULTING SERVICES, NAMELY, PROVIDING ASSISTANCE IN DEVELOPMENT OF BUSINESS STRATEGIES AND CREATIVE IDEATION; BUSINESS CONSULTING, INQUIRIES OR INFORMATION; BUSINESS DEVELOPMENT CONSULTING SERVICES; BUSINESS MANAGEMENT AND CONSULTATION IN THE FIELD OF CLOUD COMPUTING; BUSINESS MANAGEMENT AND ENTERPRISE ORGANIZATION CONSULTANCY; BUSINESS MANAGEMENT CONSULTING AND ADVISORY SERVICES FOR THE CLOUD COMPUTING INDUSTRY; BUSINESS ORGANIZATION AND OPERATION CONSULTANCY; BUSINESS RESEARCH CONSULTATION; CONSULTING REGARDING INTELLECTUAL PROPERTY BUSINESS RISK MITIGATION PROCESSES; INFORMATION, ADVISORY AND CONSULTANCY SERVICES RELATING TO BUSINESS AND MANAGEMENT OR BUSINESS ADMINISTRATION, INCLUDING SUCH SERVICES PROVIDED ON LINE OR VIA THE INTERNET; MANAGEMENT AND BUSINESS CONSULTING SERVICES IN THE FIELD OF CLOUD COMPUTING; MARKETING CONSULTATION IN THE FIELD OF CLOUD COMPUTING; PROVIDING BUSINESS MANAGEMENT INFORMATION IN CONNECTION WITH CONSULTING AND ADVISORY SERVICES IN THE FIELD OF STRATEGIC PLANNING (U.S. CLS. 100, 101 AND 102).

BARBARA BROWN, EXAMINING ATTORNEY

---

SN 85-218,775. TREVINO, LEOBARDO, HIDALGO, TX.  
FILED 1-16-2011.

RICCHI

THE MARK CONSISTS OF STANDARD CHARACTERS WITHOUT CLAIM TO ANY PARTICULAR FONT, STYLE, SIZE, OR COLOR.

OWNER OF U.S. REG. NO. 3,723,761.

THE ENGLISH TRANSLATION OF "RICCHI" IN THE MARK IS RICH.

**CLASS 36—INSURANCE AND FINANCIAL**

FOR REAL ESTATE MANAGEMENT; REAL ESTATE MANAGEMENT IN THE FIELD OF HOTELS, APARTMENTS, AND CONDOMINIUMS (U.S. CLS. 100, 101 AND 102).

**CLASS 43—HOTEL AND RESTAURANT SERVICES**

FOR PROVIDING HOTEL AND MOTEL SERVICES; PROVIDING HOTEL, RESORT HOTEL, AND TEMPORARY ACCOMMODATIONS; PROVIDING TEMPORARY LODGING SERVICES IN THE NATURE OF HOTELS, APARTMENT HOTELS, AND CONDOMINIUM HOTELS; PROVIDING RESIDENTIAL HOTEL SERVICES; ARRANGING TEMPORARY HOUSING ACCOMMODATIONS; TRAVEL AGENCY SERVICES, NAMELY, MAKING RESERVATIONS AND BOOKING FOR TEMPORARY LODGING; RENTAL OF HOTEL, APARTMENT, AND CONDOMINIUM ROOMS; SPA SERVICES, NAMELY, PROVIDING TEMPORARY ACCOMMODATIONS TO CLIENTS OF A HEALTH OR BEAUTY SPA; GUESTHOUSES; HOSTELS; OPERATION OF TOURIST HOMES; PROVIDING ADVICE TO TOURISTS AND BUSINESS TRAVELERS ON HOTEL DESTINATIONS (U.S. CLS. 100 AND 101).

**CLASS 44—MEDICAL, BEAUTY AND AGRICULTURAL SERVICES**

FOR BEAUTY SPA SERVICES, NAMELY, COSMETIC BODY CARE; HEALTH SPA SERVICES, NAMELY, COSMETIC BODY CARE SERVICES (U.S. CLS. 100 AND 101).

DOUGLAS LEE, EXAMINING ATTORNEY

---

SN 85-218,794. OMNILINGUA GERMANY GMBH, REGENSBURG, FED REP GERMANY, FILED 1-16-2011.

NLG

THE MARK CONSISTS OF STANDARD CHARACTERS WITHOUT CLAIM TO ANY PARTICULAR FONT, STYLE, SIZE, OR COLOR.

**CLASS 9—ELECTRICAL AND SCIENTIFIC APPARATUS**

FOR COMPUTER SOFTWARE FOR LANGUAGE TRANSLATION (U.S. CLS. 21, 23, 26, 36 AND 38).

**CLASS 41—EDUCATION AND ENTERTAINMENT**

FOR TRANSLATION SERVICES (U.S. CLS. 100, 101 AND 107).

**CLASS 42—SCIENTIFIC AND COMPUTER SERVICES**

FOR PROVIDING A WEBSITE FEATURING TECHNOLOGY THAT ENABLES USERS TO USE APPLICATION TOOLS FOR LANGUAGE TRANSLATION (U.S. CLS. 100 AND 101).

HAI-LY LAM, EXAMINING ATTORNEY

SN 85-218,829. ROTH, STEPHANIE C., AKA STEPHANIE STEPHENS, LAGUNA NIGUEL, CA. FILED 1-16-2011.

Mind Your Body

THE MARK CONSISTS OF STANDARD CHARACTERS WITHOUT CLAIM TO ANY PARTICULAR FONT, STYLE, SIZE, OR COLOR.

**CLASS 9—ELECTRICAL AND SCIENTIFIC APPARATUS**

FOR (BASED ON INTENT TO USE) DOWNLOADABLE MP3 FILES, MP3 RECORDINGS, ON-LINE DISCUSSION BOARDS, WEBCASTS, WEBINARS AND PODCASTS FEATURING MUSIC, AUDIO BOOKS IN THE FIELD OF PHYSICAL AND MENTAL HEALTH, AND NEWS BROADCASTS (U.S. CLS. 21, 23, 26, 36 AND 38).

**CLASS 41—EDUCATION AND ENTERTAINMENT**

FOR (BASED ON USE IN COMMERCE) ON-LINE JOURNALS, NAMELY, BLOGS FEATURING PHYSICAL AND MENTAL HEALTH (BASED ON INTENT TO USE) ENTERTAINMENT IN THE NATURE OF AN ON-GOING SPECIAL VARIETY, NEWS, MUSIC OR COMEDY SHOW FEATURING PHYSICAL AND MENTAL HEALTH BROADCAST OVER TELEVISION, SATELLITE, AUDIO, AND VIDEO MEDIA; PROVIDING A WEBSITE FEATURING BLOGS AND NON-DOWNLOADABLE PUBLICATIONS IN THE NATURE OF ARTICLES IN THE FIELD OF PHYSICAL AND MENTAL HEALTH (U.S. CLS. 100, 101 AND 107).

FIRST USE 8-11-2010; IN COMMERCE 12-15-2010.

**CLASS 44—MEDICAL, BEAUTY AND AGRICULTURAL SERVICES**

FOR (BASED ON INTENT TO USE) PROVIDING A WEB SITE FEATURING INFORMATION IN THE FIELD OF MENTAL HEALTH AND PHYSICAL HEALTH, INCLUDING LIVING A HEALTHY AND DISEASE FREE LIFE; PROVIDING A WEB SITE FEATURING INFORMATION IN THE FIELD OF MENTAL HEALTH AND WELLNESS; PROVIDING A WEBSITE FEATURING CONTENT REGARDING HEALTHY LIVING AND LIFESTYLE WELLNESS; PROVIDING A WEBSITE FEATURING INFORMATION ABOUT HEALTH, WELLNESS AND NUTRITION; PROVIDING A WEBSITE FEATURING INFORMATION CONCERNING ALTERNATIVE HEALTH AND HEALING (U.S. CLS. 100 AND 101).

JOHN GARTNER, EXAMINING ATTORNEY

---

SN 85-218,842. JAMESDON DESHON STEVENS, NAPLES, FL. FILED 1-16-2011.

Arrow Minded

THE MARK CONSISTS OF STANDARD CHARACTERS WITHOUT CLAIM TO ANY PARTICULAR FONT, STYLE, SIZE, OR COLOR.



**CLASS 16—PAPER GOODS AND PRINTED MATTER**

FOR DECALS; DECORATIVE DECALS FOR VEHICLE WINDOWS; STICKERS (U.S. CLS. 2, 5, 22, 23, 29, 37, 38 AND 50).

FIRST USE 2-16-2009; IN COMMERCE 2-16-2009.

**CLASS 25—CLOTHING**

FOR HATS; SHIRTS; SHORT-SLEEVED OR LONG-SLEEVED T-SHIRTS; SWEAT SHIRTS; TANK TOPS (U.S. CLS. 22 AND 39).

FIRST USE 2-16-2009; IN COMMERCE 2-16-2009.  
DANNEAN HETZEL, EXAMINING ATTORNEY

---

SN 85-218,968. MARKKO GMBH, BERGISCH GLAD-BACH51427, FED REP GERMANY, FILED 1-17-2011.

# YACARANDA

THE MARK CONSISTS OF STANDARD CHARACTERS WITHOUT CLAIM TO ANY PARTICULAR FONT, STYLE, SIZE, OR COLOR.

OWNER OF ERPN CMNTY TM OFC REG. NO. 2730497, DATED 9-10-2003, EXPIRES 6-11-2012.

**CLASS 3—COSMETICS AND CLEANING PREPARATIONS**

FOR LAUNDRY BLEACH; LAUNDRY DETERGENT; GENERAL PURPOSE CLEANING, POLISHING, AND ABRASIVE LIQUIDS AND POWDERS; SKIN SOAPS; PERFUMERY; ESSENTIAL OILS FOR PERSONAL USE, COSMETICS, HAIR LOTIONS; DENTIFRICES (U.S. CLS. 1, 4, 6, 50, 51 AND 52).

**CLASS 24—FABRICS**

FOR TEXTILES FABRICS FOR THE MANUFACTURE OF CLOTHING, MATTRESS COVERS, DUVET COVERS; TABLE LINEN (U.S. CLS. 42 AND 50).

**CLASS 25—CLOTHING**

FOR CLOTHING, NAMELY, FOOTWEAR, HATS, CAPS, SCARVES, SHIRTS, PANTS, SKIRTS, DRESSES, SOCKS (U.S. CLS. 22 AND 39).

RENEE MCCRAY, EXAMINING ATTORNEY

---

SN 85-219,320. DUNCAN, BRUCE, HOBE SOUND, FL. FILED 1-17-2011.

# PICTURE CITY

THE MARK CONSISTS OF STANDARD CHARACTERS WITHOUT CLAIM TO ANY PARTICULAR FONT, STYLE, SIZE, OR COLOR.

**CLASS 35—ADVERTISING AND BUSINESS**

FOR WHOLESALE AND RETAIL STORE SERVICES AND ON-LINE RETAIL AND WHOLESALE SERVICES FEATURING RENEWABLE ENERGY PRODUCTS (U.S. CLS. 100, 101 AND 102).

FIRST USE 12-28-2010; IN COMMERCE 12-28-2010.

**CLASS 36—INSURANCE AND FINANCIAL**

FOR FINANCIAL SERVICES, NAMELY, BROKERING AND MAKING INVESTMENTS IN REAL ESTATE RELATED ASSETS AND MANAGING REAL ESTATE INVESTMENTS FOR INVESTORS, AND REAL ESTATE SERVICES, NAMELY, ACQUIRING AND MANAGING REAL ESTATE ASSETS (U.S. CLS. 100, 101 AND 102).

FIRST USE 12-28-2010; IN COMMERCE 12-28-2010.  
JAY FLOWERS, EXAMINING ATTORNEY

---

SN 85-219,366. MOMENTUM DISTRIBUTION CORP. DBA AIR STRATEGIES, HOUSTON, TX. FILED 1-17-2011.

# APEXAIRE

THE MARK CONSISTS OF STANDARD CHARACTERS WITHOUT CLAIM TO ANY PARTICULAR FONT, STYLE, SIZE, OR COLOR.

**CLASS 11—ENVIRONMENTAL CONTROL APPARATUS**

FOR AIR FILTERS FOR AIR CONDITIONING UNITS (U.S. CLS. 13, 21, 23, 31 AND 34).

**CLASS 12—VEHICLES**

FOR AUTOMOBILES AND STRUCTURAL PARTS THEREFOR; STRUCTURAL PARTS FOR AUTOMOBILES (U.S. CLS. 19, 21, 23, 31, 35 AND 44).

SANJEEV VOHRA, EXAMINING ATTORNEY

---

SN 85-219,387. URBANOG INC., CITY OF INDUSTRY, CA. FILED 1-17-2011.

# UrbanOg

THE MARK CONSISTS OF "URBANOG" IN STYLIZED LETTERING.

**CLASS 25—CLOTHING**

FOR SHOES (U.S. CLS. 22 AND 39).

**CLASS 35—ADVERTISING AND BUSINESS**

FOR ON-LINE RETAIL STORE SERVICES FEATURING CLOTHING, SHOES, JEWELRY, ACCESSORIES, COSTUMES, AND SWIMWEAR (U.S. CLS. 100, 101 AND 102).

FIRST USE 7-1-2007; IN COMMERCE 7-1-2007.  
PATRICIA EVANKO, EXAMINING ATTORNEY

SN 85-219,565. XEROX CORPORATION, NORWALK, CT. FILED 1-18-2011.

ECONCIERGE POWERED BY XEROX

SN 85-219,404. SCHOOL TECHNOLOGY RESOURCES, INC., SCOTTS VALLEY, CA. FILED 1-17-2011.

THE MARK CONSISTS OF STANDARD CHARACTERS WITHOUT CLAIM TO ANY PARTICULAR FONT, STYLE, SIZE, OR COLOR.

OWNER OF U.S. REG. NOS. 2,768,136, 3,764,020 AND OTHERS.

Scopey the Dog

THE MARK CONSISTS OF STANDARD CHARACTERS WITHOUT CLAIM TO ANY PARTICULAR FONT, STYLE, SIZE, OR COLOR.

**CLASS 16—PAPER GOODS AND PRINTED MATTER**

FOR CHILDREN'S BOOKS (U.S. CLS. 2, 5, 22, 23, 29, 37, 38 AND 50).

FIRST USE 5-30-2008; IN COMMERCE 10-30-2008.

**CLASS 28—TOYS AND SPORTING GOODS**

FOR TOY ANIMALS (U.S. CLS. 22, 23, 38 AND 50).  
FIRST USE 5-30-2008; IN COMMERCE 7-16-2010.  
GIANCARLO CASTRO, EXAMINING ATTORNEY

**CLASS 35—ADVERTISING AND BUSINESS**

FOR DATABASE MANAGEMENT SERVICES; COMPILATION OF BUSINESS INFORMATION IN THE NATURE OF REPORTS AND STATISTICS FOR FINANCIAL PURPOSES, SUPPORT PURPOSES, AND MAINTENANCE PURPOSES (U.S. CLS. 100, 101 AND 102).

**CLASS 37—CONSTRUCTION AND REPAIR**

FOR INSTALLATION, MAINTENANCE AND REPAIR OF OFFICE MACHINE AND APPARATUS; INSTALLATION, MAINTENANCE AND REPAIR OF COPYING APPARATUS, PRINTERS, SCANNERS, FACSIMILE TRANSMITTING AND RECEIVING APPARATUS, DOCUMENT HANDLING APPARATUS, AND MULTIFUNCTIONAL DEVICES COMPOSED OF TWO OR MORE OF A COPIER, A PRINTER, A FACSIMILE MACHINE AND A SCANNER (U.S. CLS. 100, 103 AND 106).

JEFFREY LOOK, EXAMINING ATTORNEY

SN 85-219,930. EXPEDIA, INC., BELLEVUE, WA. FILED 1-18-2011.

SN 85-219,444. MOMENTUM DISTRIBUTION CORP, DBA AIR STRATEGIES, HOUSTON, TX. FILED 1-17-2011.

APEXAIRE

ASAP A SUDDEN AMAZING PRICE

THE MARK CONSISTS OF STANDARD CHARACTERS WITHOUT CLAIM TO ANY PARTICULAR FONT, STYLE, SIZE, OR COLOR.

THE MARK CONSISTS OF THE WORD "APEXAIRE" WITH BOTH LETTER "A" IN STYLIZED FORM.

**CLASS 11—ENVIRONMENTAL CONTROL APPARATUS**

FOR AIR FILTERS FOR AIR CONDITIONING UNITS (U.S. CLS. 13, 21, 23, 31 AND 34).

**CLASS 12—VEHICLES**

FOR AUTOMOBILES AND STRUCTURAL PARTS THEREFOR; STRUCTURAL PARTS FOR AUTOMOBILES (U.S. CLS. 19, 21, 23, 31, 35 AND 44).  
SANJEEV VOHRA, EXAMINING ATTORNEY

**CLASS 39—TRANSPORTATION AND STORAGE**

FOR TRAVEL AGENCY SERVICES, NAMELY, MAKING RESERVATIONS AND BOOKINGS FOR TRANSPORTATION AND PROVIDING INFORMATION AND REVIEWS CONCERNING TRAVEL BY MEANS OF A TELEPHONE, FACSIMILE AND OVER COMPUTER NETWORKS AND GLOBAL COMMUNICATION NETWORKS; PROVIDING A WEBSITE AND WEBSITE LINKS TO TRAVEL INFORMATION, GEOGRAPHIC INFORMATION, MAPS, MAP IMAGES AND TRIP ROUTING; PROVIDING AN ONLINE COMPUTER DATABASE IN THE FIELD OF TRAVEL INFORMATION; PROVIDING A WEBSITE WHERE USERS CAN POST RATINGS, REVIEWS AND RECOMMENDATIONS ON EVENTS AND ACTIVITIES IN THE FIELD OF TRAVEL (U.S. CLS. 100 AND 105).

FIRST USE 11-29-2010; IN COMMERCE 11-29-2010.

**CLASS 43—HOTEL AND RESTAURANT SERVICES**

FOR TRAVEL AGENCY SERVICES, NAMELY, MAKING RESERVATIONS AND BOOKINGS FOR TEMPORARY ACCOMMODATIONS; HOTEL AND LODGING SERVICES, NAMELY, PROVIDING AND RELAYING INFORMATION IN CONNECTION WITH RESERVATIONS AND BOOKINGS FOR TEMPORARY LODGING AND PROVIDING REVIEWS OF HOTELS BY MEANS OF A TELEPHONE, FACSIMILE AND OVER COMPUTER NETWORKS AND GLOBAL COMMUNICATION NETWORKS; MAKING RESERVATIONS AND BOOKINGS FOR TEMPORARY LODGING AND HOTELS FOR OTHERS AND ALSO INCLUDING INFORMATION ON METHODS FOR PAYMENT FOR CONSUMERS WHO ARE BOOKING THE RESERVATIONS; PROVIDING A WEBSITE WHERE USERS CAN POST RATINGS, REVIEWS AND RECOMMENDATIONS ON EVENTS AND ACTIVITIES IN THE FIELD OF TEMPORARY LODGING; PROVIDING ADVICE TO TOURISTS AND BUSINESS TRAVELERS ON TEMPORARY LODGING AND RESTAURANT DESTINATIONS; PROVIDING A WEBSITE FEATURING RATINGS OF CONSUMER SERVICES OF OTHERS IN THE FIELD OF TRAVEL, IN THE NATURE OF TEMPORARY LODGING AND RESORT ACCOMMODATIONS (U.S. CLS. 100 AND 101).

FIRST USE 11-29-2010; IN COMMERCE 11-29-2010.  
CHRISIE B. KING, EXAMINING ATTORNEY

SN 85-220,777. GULF INDUSTRIAL SOLUTIONS, WAUKEGAN, IL. FILED 1-19-2011.



THE MARK CONSISTS OF AN OUTLINE SQUARE WITH ROUNDED CORNERS. THE STYLIZED TEXT "PERMA-SAFE" APPEARS INSIDE THE SQUARE AT THE TOP LEFT. A PERSON WEARING FALL ARREST EQUIPMENT APPEARS BELOW THE LITERAL ELEMENT ON THE LEFT SIDE. THE HEAD OF A PERSON WEARING A SAFETY HELMET, SAFETY GLASSES, EAR PROTECTION AND A RESPIRATION MASK APPEARS IN THE BOTTOM RIGHT CORNER OF THE SQUARE.

**CLASS 9—ELECTRICAL AND SCIENTIFIC APPARATUS**

FOR EAR PLUGS NOT FOR MEDICAL PURPOSES; FACE-PROTECTION SHIELDS; HARD HATS; PROTECTION MASKS; PROTECTIVE GLOVES FOR INDUSTRIAL USE; REFLECTIVE AND ILLUMINATED CLOTHING FOR SAFETY PURPOSES; SAFETY GOGGLES (U.S. CLS. 21, 23, 26, 36 AND 38).

FIRST USE 10-1-2009; IN COMMERCE 4-1-2010.

**CLASS 18—LEATHER GOODS**

FOR HARNESES (U.S. CLS. 1, 2, 3, 22 AND 41).

FIRST USE 10-1-2009; IN COMMERCE 4-1-2010.

**CLASS 25—CLOTHING**

FOR EAR MUFFS; FOOTWEAR, NAMELY, WORK BOOTS; SHOE COVERS FOR USE WHEN WEARING SHOES (U.S. CLS. 22 AND 39).

FIRST USE 10-1-2009; IN COMMERCE 4-1-2010.  
LINDA E. BLOHM, EXAMINING ATTORNEY

**FORMULA52**

THE MARK CONSISTS OF STANDARD CHARACTERS WITHOUT CLAIM TO ANY PARTICULAR FONT, STYLE, SIZE, OR COLOR.

**CLASS 5—PHARMACEUTICALS**

FOR DIETARY AND NUTRITIONAL SUPPLEMENTS; DIETARY AND NUTRITIONAL SUPPLEMENTS FOR ENDURANCE SPORTS (U.S. CLS. 6, 18, 44, 46, 51 AND 52).

**CLASS 9—ELECTRICAL AND SCIENTIFIC APPARATUS**

FOR DIGITAL MATERIALS, NAMELY, CDS, DVDS FEATURING FITNESS INSTRUCTION (U.S. CLS. 21, 23, 26, 36 AND 38).

JOHN DALIER, EXAMINING ATTORNEY

SN 85-221,582. EXPEDIA, INC., BELLEVUE, WA. FILED 1-19-2011.

**EXPEDIA ASAP**

THE MARK CONSISTS OF STANDARD CHARACTERS WITHOUT CLAIM TO ANY PARTICULAR FONT, STYLE, SIZE, OR COLOR.

OWNER OF U.S. REG. NOS. 2,220,719, 2,612,384 AND 3,704,230.

**CLASS 39—TRANSPORTATION AND STORAGE**

FOR TRAVEL AGENCY SERVICES, NAMELY, MAKING RESERVATIONS AND BOOKINGS FOR TRANSPORTATION AND PROVIDING INFORMATION AND REVIEWS CONCERNING TRAVEL BY MEANS OF A TELEPHONE, AND OVER COMPUTER NETWORKS AND GLOBAL COMMUNICATION NETWORKS; PROVIDING A WEBSITE AND WEBSITE LINKS TO TRAVEL INFORMATION, GEOGRAPHIC INFORMATION, MAPS, MAP IMAGES AND TRIP ROUTING; PROVIDING AN ONLINE COMPUTER DATABASE IN THE FIELD OF TRAVEL INFORMATION; ORGANIZING AND ARRANGING TRAVEL ACTIVITIES, NAMELY, TOURS, TRAVEL TO EVENTS AND TRAVEL TO ATTRACTIONS; MAKING RESERVATIONS FOR TRAVEL ACTIVITIES, NAMELY, FOR TOURS, TRAVEL TO EVENTS AND TRAVEL TO ATTRACTIONS; PROVIDING INFORMATION ABOUT TOURS AND TRAVEL TO EVENTS AND ATTRACTIONS; ORGANIZING SIGHT-SEEING TOURS; TRAVEL AGENCY SERVICES, NAMELY, MAKING RESERVATIONS AND BOOKINGS FOR TRANSPORTATION; TRAVEL AND TOUR INFORMATION SERVICES; TRAVEL AND TOUR TICKET RESERVATION SERVICES (U.S. CLS. 100 AND 105).

**CLASS 43—HOTEL AND RESTAURANT SERVICES**

FOR TRAVEL AGENCY SERVICES, NAMELY, MAKING RESERVATIONS AND BOOKINGS FOR TEMPORARY ACCOMMODATIONS; HOTEL AND LODGING SERVICES, NAMELY, PROVIDING AND RELAYING INFORMATION IN CONNECTION WITH RESERVATIONS AND BOOKINGS FOR TEMPORARY LODGING AND PROVIDING REVIEWS OF HOTELS BY MEANS OF A TELEPHONE, AND OVER COMPUTER NETWORKS AND GLOBAL COMMUNICATION NETWORKS; MAKING RESERVATIONS AND BOOKINGS FOR TEMPORARY LODGING AND HOTELS FOR OTHERS AND ALSO INCLUDING INFORMATION ON METHODS FOR PAYMENT FOR CONSUMERS WHO ARE BOOKING THE RESERVATIONS; PROVIDING A WEBSITE WHERE USERS CAN POST RATINGS, REVIEWS AND RECOMMENDATIONS ON EVENTS AND ACTIVITIES IN THE FIELD OF TEMPORARY LODGING; PROVIDING ADVICE TO TOURISTS AND BUSINESS TRAVELERS ON TEMPORARY LODGING AND RESTAURANT DESTINATIONS; PROVIDING A WEBSITE FEATURING RATINGS OF CONSUMER SERVICES OF OTHERS IN THE FIELD OF TRAVEL, IN THE NATURE OF TEMPORARY LODGING AND RESORT ACCOMMODATIONS; TRAVEL AGENCY SERVICES, NAMELY, MAKING RESERVATIONS AND BOOKINGS FOR RESTAURANTS AND MEALS (U.S. CLS. 100 AND 101).

CHRISIE B. KING, EXAMINING ATTORNEY

SN 85-221,586. EXPEDIA, INC., BELLEVUE, WA. FILED 1-19-2011.

ASAP A SUDDEN AMAZING PRICE

THE MARK CONSISTS OF STANDARD CHARACTERS WITHOUT CLAIM TO ANY PARTICULAR FONT, STYLE, SIZE, OR COLOR.

**CLASS 39—TRANSPORTATION AND STORAGE**

FOR TRAVEL AGENCY SERVICES, NAMELY, MAKING RESERVATIONS AND BOOKINGS FOR TRANSPORTATION AND PROVIDING INFORMATION AND REVIEWS CONCERNING TRAVEL BY MEANS OF A TELEPHONE, AND OVER COMPUTER NETWORKS AND GLOBAL COMMUNICATION NETWORKS; PROVIDING A WEBSITE AND WEBSITE LINKS TO TRAVEL INFORMATION, GEOGRAPHIC INFORMATION, MAPS, MAP IMAGES AND TRIP ROUTING; PROVIDING AN ONLINE COMPUTER DATABASE IN THE FIELD OF TRAVEL INFORMATION; ORGANIZING AND ARRANGING TRAVEL ACTIVITIES, NAMELY, TOURS, TRAVEL TO EVENTS AND TRAVEL TO ATTRACTIONS; MAKING RESERVATIONS FOR TRAVEL ACTIVITIES, NAMELY, FOR TOURS, TRAVEL TO EVENTS AND TRAVEL TO ATTRACTIONS; PROVIDING INFORMATION ABOUT TOURS AND TRAVEL TO EVENTS AND ATTRACTIONS; ORGANIZING SIGHT-SEEING TOURS; TRAVEL AGENCY SERVICES, NAMELY, MAKING RESERVATIONS AND BOOKINGS FOR TRANSPORTATION; TRAVEL AND TOUR INFORMATION SERVICES; TRAVEL AND TOUR TICKET RESERVATION SERVICES (U.S. CLS. 100 AND 105).

**CLASS 43—HOTEL AND RESTAURANT SERVICES**

FOR TRAVEL AGENCY SERVICES, NAMELY, MAKING RESERVATIONS AND BOOKINGS FOR TEMPORARY ACCOMMODATIONS; HOTEL AND LODGING SERVICES, NAMELY, PROVIDING AND RELAYING INFORMATION IN CONNECTION WITH RESERVATIONS AND BOOKINGS FOR TEMPORARY LODGING AND PROVIDING REVIEWS OF HOTELS BY MEANS OF A TELEPHONE, AND OVER COMPUTER NETWORKS AND GLOBAL COMMUNICATION NETWORKS; MAKING RESERVATIONS AND BOOKINGS FOR TEMPORARY LODGING AND HOTELS FOR OTHERS AND ALSO INCLUDING INFORMATION ON METHODS FOR PAYMENT FOR CONSUMERS WHO ARE BOOKING THE RESERVATIONS; PROVIDING A WEBSITE WHERE USERS CAN POST RATINGS, REVIEWS AND RECOMMENDATIONS ON EVENTS AND ACTIVITIES IN THE FIELD OF TEMPORARY LODGING; PROVIDING ADVICE TO TOURISTS AND BUSINESS TRAVELERS ON TEMPORARY LODGING AND RESTAURANT DESTINATIONS; PROVIDING A WEBSITE FEATURING RATINGS OF CONSUMER SERVICES OF OTHERS IN THE FIELD OF TRAVEL, IN THE NATURE OF TEMPORARY LODGING AND RESORT ACCOMMODATIONS; TRAVEL AGENCY SERVICES, NAMELY, MAKING RESERVATIONS AND BOOKINGS FOR RESTAURANTS AND MEALS (U.S. CLS. 100 AND 101).

CHRISIE B. KING, EXAMINING ATTORNEY

SN 85-222,314. REACH4SUCCESS, LLC, SAMMAMISH, WA. FILED 1-20-2011.

THE FEARLESS NETWORKER

THE MARK CONSISTS OF STANDARD CHARACTERS WITHOUT CLAIM TO ANY PARTICULAR FONT, STYLE, SIZE, OR COLOR.

NO CLAIM IS MADE TO THE EXCLUSIVE RIGHT TO USE "NETWORKER", APART FROM THE MARK AS SHOWN.

**CLASS 35—ADVERTISING AND BUSINESS**

FOR PROVIDING INFORMATION IN THE FIELD OF THE ONLINE MARKETING INDUSTRY (U.S. CLS. 100, 101 AND 102).

FIRST USE 9-24-2003; IN COMMERCE 9-24-2003.



**CLASS 41—EDUCATION AND ENTERTAINMENT**

FOR EDUCATION SERVICES, NAMELY, PROVIDING LIVE AND ON-LINE PRESENTATIONS IN THE FIELD OF ONLINE MARKETING (U.S. CLS. 100, 101 AND 107).  
FIRST USE 9-24-2003; IN COMMERCE 9-24-2003.  
NANCY CLARKE, EXAMINING ATTORNEY

SN 85-226,698. DOW AGROSCIENCES LLC, INDIANAPOLIS, IN. FILED 1-26-2011.

SN 85-223,866. CONOLLY, BRIAN, BROADWAY, NSW, AUSTRALIA, FILED 1-22-2011.



# HydroMerino

THE MARK CONSISTS OF STANDARD CHARACTERS WITHOUT CLAIM TO ANY PARTICULAR FONT, STYLE, SIZE, OR COLOR.

**CLASS 24—FABRICS**

FOR FABRICS OF MERINO WOOL FOR TEXTILE USE (U.S. CLS. 42 AND 50).

**CLASS 25—CLOTHING**

FOR ATHLETIC APPAREL OF MERINO WOOL, NAMELY, SHIRTS, PANTS, JACKETS, FOOTWEAR, HATS AND CAPS, ATHLETIC UNIFORMS (U.S. CLS. 22 AND 39).  
WILLIAM VERHOSEK, EXAMINING ATTORNEY

THE MARK CONSISTS OF THE WORD "ENLIST" WITH HORIZONTAL LINES WITH LEAF DESIGN TO THE LEFT OF THE WORD.

**CLASS 5—PHARMACEUTICALS**

FOR PESTICIDES, NAMELY, HERBICIDES, INSECTICIDES AND FUNGICIDES FOR AGRICULTURE, HORTICULTURE, FORESTRY, TURF AND ORNAMENTAL, COMMERCIAL, INDUSTRIAL AND DOMESTIC USE (U.S. CLS. 6, 18, 44, 46, 51 AND 52).

**CLASS 31—NATURAL AGRICULTURAL PRODUCTS**

FOR AGRICULTURAL SEEDS, NAMELY, CORN, CONTAINING HERBICIDE RESISTANT GENES (U.S. CLS. 1 AND 46).  
ANNE E. GUSTASON, EXAMINING ATTORNEY

SN 85-226,695. DOW AGROSCIENCES LLC, INDIANAPOLIS, IN. FILED 1-26-2011.

SN 85-226,736. CLARICENT, INC., ACTON, MA. FILED 1-26-2011.



# CLARICENT

THE MARK CONSISTS OF THE WORD "ENLIST" AND HORIZONTAL LINES WITH LEAF DESIGN ABOVE.

**CLASS 5—PHARMACEUTICALS**

FOR PESTICIDES, NAMELY, HERBICIDES, INSECTICIDES AND FUNGICIDES FOR AGRICULTURE, HORTICULTURE, FORESTRY, TURF AND ORNAMENTAL, COMMERCIAL, INDUSTRIAL AND DOMESTIC USE (U.S. CLS. 6, 18, 44, 46, 51 AND 52).

**CLASS 31—NATURAL AGRICULTURAL PRODUCTS**

FOR AGRICULTURAL SEEDS, NAMELY CORN, CONTAINING HERBICIDE RESISTANT GENES (U.S. CLS. 1 AND 46).  
ANNE E. GUSTASON, EXAMINING ATTORNEY

THE MARK CONSISTS OF STANDARD CHARACTERS WITHOUT CLAIM TO ANY PARTICULAR FONT, STYLE, SIZE, OR COLOR.

**CLASS 35—ADVERTISING AND BUSINESS**

FOR CONSULTATION SERVICES IN THE FIELD OF BUSINESS INFORMATION MANAGEMENT AND BUSINESS INTELLIGENCE (U.S. CLS. 100, 101 AND 102).  
FIRST USE 3-30-2007; IN COMMERCE 3-30-2007.

**CLASS 42—SCIENTIFIC AND COMPUTER SERVICES**

FOR COMPUTER SOFTWARE CONSULTATION IN THE FIELD OF BUSINESS INTELLIGENCE SOFTWARE (U.S. CLS. 100 AND 101).  
FIRST USE 3-30-2007; IN COMMERCE 3-20-2007.  
DANIEL CAPSHAW, EXAMINING ATTORNEY

SN 85-226,765. CLARICENT, INC., ACTON, MA. FILED 1-26-2011.



THE COLOR(S) LIGHT BLUE, DARK BLUE AND WHITE IS/ARE CLAIMED AS A FEATURE OF THE MARK.

THE MARK CONSISTS OF THE WORD "CLARICENT", IN WHICH "CLAR" AND "CENT" ARE IN DARK BLUE LETTERING, AND THE "I" IS IN WHITE LETTERING WITHIN A LIGHT BLUE RECTANGLE.

#### CLASS 35—ADVERTISING AND BUSINESS

FOR CONSULTATION SERVICES IN THE FIELD OF BUSINESS MANAGEMENT AND BUSINESS INTELLIGENCE (U.S. CLS. 100, 101 AND 102).

FIRST USE 3-30-2007; IN COMMERCE 3-30-2007.

#### CLASS 42—SCIENTIFIC AND COMPUTER SERVICES

FOR COMPUTER SOFTWARE CONSULTATION IN THE FIELD OF BUSINESS INTELLIGENCE SOFTWARE (U.S. CLS. 100 AND 101).

FIRST USE 3-30-2007; IN COMMERCE 3-30-2007.

DANIEL CAPSHAW, EXAMINING ATTORNEY

SN 85-227,304. CLARICENT, INC., ACTON, MA. FILED 1-27-2011.



THE COLOR(S) LIGHT BLUE, DARK BLUE AND WHITE IS/ARE CLAIMED AS A FEATURE OF THE MARK.

THE MARK CONSISTS OF THE WORD "CLARICENT", IN WHICH "CLAR" AND "CENT" ARE IN DARK BLUE LETTERING, AND THE "I" IS IN WHITE LETTERING WITHIN A LIGHT BLUE RECTANGLE, FOLLOWED BY THE PHRASE "SEE MORE. KNOW MORE. DO MORE." IN DARK BLUE LETTERING.

#### CLASS 35—ADVERTISING AND BUSINESS

FOR CONSULTATION SERVICES IN THE FIELD OF BUSINESS MANAGEMENT AND BUSINESS INTELLIGENCE (U.S. CLS. 100, 101 AND 102).

FIRST USE 3-30-2007; IN COMMERCE 3-30-2007.

#### CLASS 42—SCIENTIFIC AND COMPUTER SERVICES

FOR COMPUTER SOFTWARE CONSULTATION IN THE FIELD OF BUSINESS INTELLIGENCE SOFTWARE (U.S. CLS. 100 AND 101).

FIRST USE 3-30-2007; IN COMMERCE 3-30-2007.

DANIEL CAPSHAW, EXAMINING ATTORNEY

SN 85-227,282. VTECH ELECTRONICS NORTH AMERICA, LLC, ARLINGTON HEIGHTS, IL. FILED 1-27-2011.

# INNOPAD

THE MARK CONSISTS OF STANDARD CHARACTERS WITHOUT CLAIM TO ANY PARTICULAR FONT, STYLE, SIZE, OR COLOR.

#### CLASS 9—ELECTRICAL AND SCIENTIFIC APPARATUS

FOR CHILDREN'S EDUCATIONAL SOFTWARE; COMPUTER GAME PROGRAMS; COMPUTER GAME SOFTWARE; COMPUTERS; ELECTRONIC GAME SOFTWARE; NOTEBOOK AND LAPTOP COMPUTERS; TABLET COMPUTER (U.S. CLS. 21, 23, 26, 36 AND 38).

#### CLASS 28—TOYS AND SPORTING GOODS

FOR ELECTRONIC EDUCATIONAL GAME MACHINES FOR CHILDREN; ELECTRONIC GAMES FOR THE TEACHING OF CHILDREN; ELECTRONIC LEARNING TOYS; HAND HELD UNITS FOR PLAYING ELECTRONIC GAMES OTHER THAN THOSE ADAPTED FOR USE WITH AN EXTERNAL DISPLAY SCREEN OR MONITOR (U.S. CLS. 22, 23, 38 AND 50).

JEFF DEFORD, EXAMINING ATTORNEY

SN 85-227,792. VTECH ELECTRONICS NORTH AMERICA, LLC, ARLINGTON HEIGHTS, IL. FILED 1-27-2011.

# INOPAD

THE MARK CONSISTS OF STANDARD CHARACTERS WITHOUT CLAIM TO ANY PARTICULAR FONT, STYLE, SIZE, OR COLOR.

#### CLASS 9—ELECTRICAL AND SCIENTIFIC APPARATUS

FOR CHILDREN'S EDUCATIONAL SOFTWARE; COMPUTER GAME PROGRAMS; COMPUTER GAME SOFTWARE; COMPUTERS; NOTEBOOK AND LAPTOP COMPUTERS; TABLET COMPUTER (U.S. CLS. 21, 23, 26, 36 AND 38).

#### CLASS 28—TOYS AND SPORTING GOODS

FOR ELECTRONIC EDUCATIONAL GAME MACHINES FOR CHILDREN; ELECTRONIC GAMES FOR THE TEACHING OF CHILDREN; ELECTRONIC LEARNING TOYS; HAND HELD UNITS FOR PLAYING ELECTRONIC GAMES OTHER THAN THOSE ADAPTED FOR USE WITH AN EXTERNAL DISPLAY SCREEN OR MONITOR (U.S. CLS. 22, 23, 38 AND 50).

JEFF DEFORD, EXAMINING ATTORNEY

SN 85-228,708. MCGARREY, DAVID B., CODY, WY. FILED 1-28-2011.



OWNER OF U.S. REG. NO. 3,729,721.  
THE COLOR(S) PINK, PURPLE AND BLACK IS/ARE CLAIMED AS A FEATURE OF THE MARK.

THE MARK CONSISTS OF THE TERM "C.A.R.E." IN BLACK EXCEPT THE LETTER "A" WHICH IS DEPICTED AS A STYLIZED RIBBON IN PINK AND PURPLE; BENEATH APPEARS THE WORDING "CONSTRUCTION AND REMODELING EXPERTS" IN BLACK, FOLLOWED BY THE WORDING "FOR A CURE" IN BLACK, WITH THE LETTER "A" BEING DEPICTED AS A PINK AND PURPLE RIBBON DESIGN BETWEEN THE TERMS "FOR" AND "CURE".

#### CLASS 5—PHARMACEUTICALS

FOR AIR FRESHENERS (U.S. CLS. 6, 18, 44, 46, 51 AND 52).

#### CLASS 28—TOYS AND SPORTING GOODS

FOR PLUSH TOYS (U.S. CLS. 22, 23, 38 AND 50).  
LAURA KOVALSKY, EXAMINING ATTORNEY

SN 85-230,539. EDUCATIONAL RECORDS BUREAU, NEW YORK, NY. FILED 1-31-2011.

**ECAA** EARLY CHILDHOOD  
ADMISSIONS ASSESSMENT

NO CLAIM IS MADE TO THE EXCLUSIVE RIGHT TO USE "EARLY CHILDHOOD ADMISSIONS ASSESSMENT", APART FROM THE MARK AS SHOWN.

THE MARK CONSISTS OF THE LETTERS "ECAA" PLACED TO THE LEFT OF THE WORDS "EARLY CHILDHOOD" WHICH APPEAR DIRECTLY ABOVE THE WORDS "ADMISSIONS ASSESSMENT".

#### CLASS 16—PAPER GOODS AND PRINTED MATTER

FOR PRINTED MATTER, NAMELY, MANUALS, GUIDES AND REPORTS RELATING TO STANDARDIZED TESTS OF STUDENT ABILITIES AND ACHIEVEMENTS (U.S. CLS. 2, 5, 22, 23, 29, 37, 38 AND 50).

FIRST USE 2-23-2010, THE MARK WAS FIRST USED ANYWHERE IN A DIFFERENT FORM OTHER THAN THAT SOUGHT TO BE REGISTERED AT LEAST AS EARLY AS 07/00/2008; IN COMMERCE 2-23-2010, THE MARK WAS FIRST USED IN COMMERCE IN A DIFFERENT FORM OTHER THAN THAT SOUGHT TO BE REGISTERED AT LEAST AS EARLY AS 07/00/2008.

#### CLASS 41—EDUCATION AND ENTERTAINMENT

FOR DEVELOPING, ADMINISTERING AND SCORING EDUCATIONAL TESTS OF PRE-SCHOOL AND ELEMENTARY SCHOOL STUDENTS (U.S. CLS. 100, 101 AND 107).

FIRST USE 2-23-2010, THE MARK WAS FIRST USED ANYWHERE IN A DIFFERENT FORM OTHER THAN THAT SOUGHT TO BE REGISTERED AT LEAST AS EARLY AS 07/00/2008; IN COMMERCE 2-23-2010, THE MARK WAS FIRST USED IN COMMERCE IN A DIFFERENT FORM OTHER THAN THAT SOUGHT TO BE REGISTERED AT LEAST AS EARLY AS 07/00/2008.

ARETHA SOMERVILLE, EXAMINING ATTORNEY

SN 85-231,281. ALTEC INDUSTRIES, INC., BIRMINGHAM, AL. FILED 2-1-2011.



OWNER OF U.S. REG. NOS. 849,304, 3,596,633 AND OTHERS.

NO CLAIM IS MADE TO THE EXCLUSIVE RIGHT TO USE "GREEN FLEET", APART FROM THE MARK AS SHOWN.

THE COLOR(S) GOLD, BLACK, LIGHT GREEN, AND DARK GREEN IS/ARE CLAIMED AS A FEATURE OF THE MARK.

THE MARK CONSISTS OF A GOLD COLORED STYLIZED "A" WITH A CLEAR, STYLIZED "A" WITHIN IT, FOLLOWED BY THE WORD "ALTEC" IN BLACK LETTERS ABOVE THE WORDS "GREEN FLEET" IN BLACK LETTERS. THE WORDING IS SUPERIMPOSED OVER A TWO-TONED GREEN LEAF WITH THE DARK GREEN ABOVE AND THE LIGHT GREEN BELOW.

**CLASS 7—MACHINERY**

FOR MACHINES, NAMELY, MOBILE HYDRAULIC EQUIPMENT, AND TRUCK MOUNTED INSULATED AND NON-INSULATED AERIAL DEVICE, NAMELY, ELEVATING WORK PLATFORMS FOR LIFTING PEOPLE AND EQUIPMENT TO WORK POSITIONS; MOTORS, NAMELY, COMBUSTION ENGINE MOTORS AND ENGINES, EXCEPT FOR LAND VEHICLES; AGRICULTURAL IMPLEMENTS OTHER THAN HAND-OPERATED, NAMELY, INCORPORATORS; LIFTS, ELEVATOR LIFTS, AERIAL LIFTS; CRANES, PEDESTAL AND VEHICLE MOUNTED CRANES; AERIAL WORK PLATFORMS ELEVATING WORK PLATFORMS; LOAD CARRYING APPARATUS AND EQUIPMENT, NAMELY, MOBILE HYDRAULIC EQUIPMENT, NAMELY, INSULATING AND NON-INSULATING AERIAL DEVICES FOR PERSONNEL AND MATERIAL HANDLING, NAMELY, TRUCK MOUNTED INSULATED AND NON-INSULATED AERIAL DEVICES ELEVATING WORK PLATFORMS, DIGGER DERRICKS, AND CRANES FOR LIFTING PEOPLE AND EQUIPMENT TO WORK POSITIONS; CABLE REEL LIFTERS, CABLE HANDLERS, AERIAL CABLE PLACERS, NAMELY, AERIAL CABLE CRANES, JIBS, WINCHES, JACKS, NAMELY, HYDRAULIC JACKS; DERRICKS, DIGGER DERRICKS; DIGGERS, NAMELY, EARTH MOVING MACHINES, NAMELY, EXCAVATORS, PRESSURE DIGGERS; HYDRAULIC LEVELING SYSTEM COMPOSED OF HYDRAULIC HOSES, A ROTARY VALVE, METAL LINKS AND A METAL HOUSING THAT SECURELY MAINTAINS THE UPRIGHT POSITION OF PERSONNEL PLATFORMS MOUNTED ON UTILITY VEHICLE AERIAL LIFTS USED IN THE CONSTRUCTION, TELECOMMUNICATIONS AND UTILITY INDUSTRIES (U.S. CLS. 13, 19, 21, 23, 31, 34 AND 35).

FIRST USE 8-1-2009; IN COMMERCE 10-6-2009.

**CLASS 12—VEHICLES**

FOR TRUCKS AND STRUCTURAL PARTS THEREFOR, NAMELY, MOBILE HYDRAULIC EQUIPMENT FOR UTILITY INDUSTRIES THAT IS INSTALLED ON, AND WORK WITH, A HYBRID-ELECTRIC DRIVE-TRAIN CHASSIS FOR TIRE OR TRACK MOUNTED SERVICE TRUCKS AND SPECIAL DUTY TRUCKS, ALL USED IN THE CONSTRUCTION, COMMUNICATIONS, TREE AND UTILITY INDUSTRIES, WITH THE FOLLOWING COMPONENTS BEING SOLD TOGETHER AS COMPONENTS OF THE TRUCKS IN THE NATURE OF AERIAL BUCKETS, NAMELY, BUCKETS ATTACHED AT THE END OF A BOOM ASSEMBLY WHICH IS EXTENDIBLE, ARTICULATING, DESIGNED AND USED TO POSITION AND SUPPORT PERSONNEL AT HIGH ALTITUDES, DERRICKS, WINCHES, HYDRAULIC EARTH AUGERS, PRESSURE DIGGERS, WHICH ARE THE MECHANISMS THAT DRIVE THE AUGERS; TRAILER MOUNTED JACKS, NAMELY, VERTICAL HYDRAULIC JACKS ATTACHED TO THE FRAME OF A SERVICE TRUCK, DESIGNED TO STABILIZE THE VEHICLES AND OR RELIEVE PRESSURE FROM THE VEHICLE'S TIRES; CARGO TRAILERS USED TO TRANSPORT POLES; TRAILERS WITH HOTLINE INSULATOR WASHERS ATTACHED THERETO; SERVICE TRUCK BODY WITH STORAGE BINS, UTILITY BIN METAL LATCHES, AND PEDESTAL MOUNTED STAND-ALONE CRANES, ALL ATTACHED COMPONENTS SOLD AS A UNIT WITH THE TRUCK BODIES; TRUCKS TO TRANSPORT CABLES; AERIAL CABLE PLACERS, NAMELY, TRUCKS FOR USE IN ERECTING OVERHEAD COMMUNICATION CABLE (U.S. CLS. 19, 21, 23, 31, 35 AND 44).

FIRST USE 8-1-2009; IN COMMERCE 10-6-2009.

**CLASS 37—CONSTRUCTION AND REPAIR**

FOR CONSTRUCTION, REPAIR, AND INSTALLATION SERVICES, NAMELY, UTILIZING MACHINES FOR CONSTRUCTION SERVICES IN THE FIELDS OF BUILDING CONSTRUCTION, MINING, DRILLING, DERRICKING, EXCAVATING, CONVEYING, WINCHING, CABLE CONVEYING, CRANE WORK, AERIAL DEVICE WORK, NAMELY, ELEVATING WORK PLATFORMS, LIFTING, AND DIGGING, AND INSTALLATIONS COMPOSED THEREFROM; REPAIR OR MAINTENANCE OF CONSTRUCTION MACHINES AND APPARATUS, NAMELY, REPAIRING OF MACHINES UTILIZED FOR BUILDING CONSTRUCTION, MINING, DRILLING, DERRICKING, EXCAVATING, CONVEYING, WINCHING, CABLE CONVEYING, CRANE WORK, AERIAL DEVICE WORK, LIFTING, AND DIGGING; AND INSTALLATION SERVICES, NAMELY, THE INSTALLATION OF MOTORS, MECHANICAL SYSTEMS, ELECTRICAL SYSTEMS, COMMUNICATIONS SYSTEMS AND WIRES, AND BUILDINGS (U.S. CLS. 100, 103 AND 106).

FIRST USE 8-1-2009; IN COMMERCE 10-6-2009.  
PAULA MAHONEY, EXAMINING ATTORNEY

SN 85-234,554. META PHARMACEUTICAL SERVICES, BLUE BELL, PA. FILED 2-4-2011.

**MOTIONVIEW**

THE MARK CONSISTS OF STANDARD CHARACTERS WITHOUT CLAIM TO ANY PARTICULAR FONT, STYLE, SIZE, OR COLOR.

**CLASS 9—ELECTRICAL AND SCIENTIFIC APPARATUS**

FOR COMPUTER SOFTWARE PLATFORMS FOR TRACKING DATA TO HELP GROW AND MANAGE A PORTFOLIO OF BRANDS AND CONDUCT RELATED BRAND DATA ANALYSIS (U.S. CLS. 21, 23, 26, 36 AND 38).

**CLASS 42—SCIENTIFIC AND COMPUTER SERVICES**

FOR PLATFORM AS A SERVICE (PAAS) FEATURING COMPUTER SOFTWARE PLATFORMS FOR USE IN TRACKING DATA TO HELP GROW AND MANAGE A PORTFOLIO OF BRANDS AND CONDUCT RELATED BRAND DATA ANALYSIS (U.S. CLS. 100 AND 101).

TARA PATE, EXAMINING ATTORNEY

SN 85-235,043. AUDIO RECORD'S, INC., BEVERLY HILLS, CA. FILED 2-5-2011.

**DHAIRMA CARE**

THE MARK CONSISTS OF STANDARD CHARACTERS WITHOUT CLAIM TO ANY PARTICULAR FONT, STYLE, SIZE, OR COLOR.



**CLASS 3—COSMETICS AND CLEANING PREPARATIONS**

FOR 3-IN-1 HAIR CONDITIONERS; 3-IN-1 HAIR SHAMPOOS; AROMATIC BODY CARE PRODUCTS, NAMELY, BODY LOTION, SHOWER GEL, CUTICLE CREAM, SHAMPOO, CONDITIONER, NON-MEDICATED LIP BALM, SOAP, BODY POLISH, BODY AND FOOT SCRUB AND NON-MEDICATED FOOT CREAM; BABY HAIR CONDITIONER; BLEACHING PREPARATIONS FOR THE HAIR; CONDITIONERS; COSMETIC HAIR DRESSING PREPARATIONS; COSMETIC HAIR FILLING POWDERS FOR COVERING BALD AND THINNING SPOTS ON THE SCALP; COSMETIC HAIR REGROWTH INHIBITING PREPARATIONS; COSMETIC PREPARATIONS FOR THE HAIR AND SCALP; GEL FOR HAIR AND SCALP; HAIR BALSAM; HAIR BLEACH; HAIR BLEACHES; HAIR BLEACHING PREPARATIONS; HAIR CARE CREAMS; HAIR CARE KITS COMPRISING NON-MEDICATED HAIR CARE PREPARATIONS, NAMELY, SHAMPOOS AND CONDITIONERS FOR THE HAIR AND SCALP; HAIR CARE LOTIONS; HAIR CARE PREPARATIONS; HAIR CARE PREPARATIONS CONSISTING OF ORGANIC COCONUT VIRGIN OIL AND COCONUT VIRGIN OIL; HAIR CARE PRODUCTS, NAMELY, HEAT PROTECTION SPRAYS; HAIR CLEANING PREPARATIONS; HAIR COLOR; HAIR COLOR REMOVERS; HAIR COLORANTS; HAIR COLORING PREPARATIONS; HAIR COLOURANTS; HAIR COLOURING; HAIR COLOURING AND DYES; HAIR COLOURING PREPARATIONS; HAIR CONDITIONER; HAIR CONDITIONERS; HAIR CONDITIONERS FOR BABIES; HAIR CREAMS; HAIR CURLING PREPARATIONS; HAIR DECOLORANTS; HAIR DRESSINGS FOR MEN; HAIR DRESSINGS FOR WOMEN; HAIR DYE; HAIR DYES; HAIR EMOLLIENTS; HAIR FIXERS; HAIR FROSTS; HAIR GEL; HAIR GEL AND HAIR MOUSSE; HAIR GELS; HAIR GLAZE; HAIR LACQUERS; HAIR LIGHTENERS; HAIR LOTION; HAIR LOTIONS; HAIR MASCARA; HAIR MASKS; HAIR MOUSSE; HAIR MOUSSES; HAIR NOURISHERS; HAIR OILS; HAIR PIECE BONDING GLUE; HAIR POMADES; HAIR PRODUCTS, NAMELY, THICKENING CONTROL CREAMS; HAIR RELAXERS; HAIR RELAXING PREPARATIONS; HAIR RINSES; HAIR RINSES; HAIR SHAMPOO; HAIR SHAMPOOS AND CONDITIONERS; HAIR SHEEN SPRAY; HAIR SPRAY; HAIR SPRAYS; HAIR SPRAYS AND HAIR GELS; HAIR STRAIGHTENING PREPARATIONS; HAIR STYLING FIXATIVE IN THE NATURE OF HAIR WAX; HAIR STYLING GEL; HAIR STYLING PREPARATIONS; HAIR STYLING SPRAY; HAIR TONIC; HAIR TONICS; HAIR WAVING LOTION; HYDROGEN PEROXIDE FOR USE ON THE HAIR; JAPANESE HAIR FIXING OIL (BINTSUKABURA); LOTIONS FOR HAIR AND SCALP; MOUSSE FOR HAIR AND SCALP; NON-MEDICATED BALMS FOR USE ON HAIR AND SCALP; NON-MEDICATED HAIR RESTORATION LOTIONS; NON-MEDICATED HAIR SERUMS; NON-MEDICATED HAIR TREATMENT PREPARATIONS FOR COSMETIC PURPOSES; NON-MEDICATED PREPARATIONS ALL FOR THE CARE OF SKIN, HAIR AND SCALP; NON-MEDICATED SERUMS FOR USE ON HAIR AND SCALP; OIL BATHS FOR HAIR CARE; OILS FOR HAIR CONDITIONING; POMADES FOR HAIR AND SCALP; PREPARATIONS FOR PERMANENT HAIR WAVES; PREPARATIONS FOR SETTING HAIR; STYLING CLAY FOR HAIR; STYLING FOAM FOR HAIR; STYLING PASTE FOR HAIR (U.S. CLS. 1, 4, 6, 50, 51 AND 52).

**CLASS 5—PHARMACEUTICALS**

FOR HAIR GROWTH STIMULANTS; MEDICATED BALMS FOR TREATMENT OF HAIR AND SCALP; MEDICATED HAIR CARE PREPARATIONS; MEDICATED HAIR SERUMS; MEDICATED LOTIONS FOR HAIR AND SCALP; MEDICATED SERUMS FOR TREATMENT OF HAIR AND SCALP; MEDICINAL PREPARATIONS FOR STIMULATING HAIR GROWTH (U.S. CLS. 6, 18, 44, 46, 51 AND 52).

ANDREA K. NADELMAN, EXAMINING ATTORNEY

SN 85-236,625. SALESFORCE.COM, INC., SAN FRANCISCO, CA. FILED 2-8-2011.



THE MARK CONSISTS OF THE STYLIZED WORDING "MANYMOON" WITH A FULL MOON REPLACING THE FIRST "O" AND WITH A CRESCENT MOON APPEARING SLIGHTLY LOWER AND REPLACING THE SECOND "O" IN "MOON".

**CLASS 9—ELECTRICAL AND SCIENTIFIC APPARATUS**

FOR DOWNLOADABLE COMPUTER SOFTWARE FOR USE IN DEVELOPING AND CUSTOMIZING COMPUTER SOFTWARE APPLICATIONS AND COMPUTER SOFTWARE APPLICATION USER INTERFACES; COMPUTER SOFTWARE FOR STORING, MANAGING, TRACKING, ANALYZING, AND REPORTING DATA IN THE FIELD OF MARKETING, PROMOTION, SALES, CUSTOMER INFORMATION, CUSTOMER RELATIONSHIP MANAGEMENT, SALES SUPPORT, AND EMPLOYEE EFFICIENCY; COMPUTER SOFTWARE TO FACILITATE COMMUNICATING AMONG PEER PROFESSIONALS IN THE ADVERTISING, MARKETING, AND BUSINESS SERVICES FIELDS, AND FOR CUSTOMIZING COMPUTER APPLICATION USER INTERFACES (U.S. CLS. 21, 23, 26, 36 AND 38).

**CLASS 35—ADVERTISING AND BUSINESS**

FOR BUSINESS MANAGEMENT SERVICES, NAMELY, PROVIDING INFORMATION, DATA ASSET, AND IDENTITY MANAGEMENT SERVICES; COMPILATION AND MANAGEMENT OF COMPUTERIZED DATABASES AND CONSULTING SERVICES RELATED THERETO; BUSINESS MANAGEMENT SERVICES, NAMELY, PROVIDING CUSTOMER RELATIONSHIP MANAGEMENT SERVICES AND SALES SUPPORT MANAGEMENT SERVICES; BUSINESS MANAGEMENT CONSULTING SERVICES RELATING TO CUSTOMER RELATIONSHIP MANAGEMENT, SALES SUPPORT MANAGEMENT, AND MARKETING AUTOMATION; PROVIDING A WEBSITE FEATURING INFORMATION IN THE FIELDS OF ADVERTISING, MARKETING AND BUSINESS MANAGEMENT, AND CONSULTING SERVICES RELATED THERETO; OPERATING ONLINE MARKETPLACES FOR BUYING AND SELLING, SHARING, AND OFFERING FOR FREE COMPUTER SOFTWARE AND ON-DEMAND APPLICATIONS (U.S. CLS. 100, 101 AND 102).

**CLASS 41—EDUCATION AND ENTERTAINMENT**

FOR EDUCATIONAL SERVICES, NAMELY, CONDUCTING SEMINARS, CONFERENCES, WORKSHOPS, AND COMPUTER APPLICATION TRAINING IN THE FIELDS OF MARKETING, PROMOTION, SALES, CUSTOMER INFORMATION, CUSTOMER RELATIONSHIP MANAGEMENT, SALES SUPPORT AND EMPLOYEE EFFICIENCY, AND DISTRIBUTING COURSE MATERIALS IN CONNECTION THEREWITH (U.S. CLS. 100, 101 AND 107).

**CLASS 42—SCIENTIFIC AND COMPUTER SERVICES**

FOR PROVIDING TEMPORARY USE OF ON-LINE NON-DOWNLOADABLE SOFTWARE TO STORE, MANAGE, TRACK, ANALYZE, AND REPORT DATA IN THE FIELD OF MARKETING, PROMOTION, SALES, CUSTOMER INFORMATION, CUSTOMER RELATIONSHIP MANAGEMENT, SALES SUPPORT AND EMPLOYEE EFFICIENCY; PROVIDING TEMPORARY USE OF ON-LINE NON-DOWNLOADABLE SOFTWARE TO FACILITATE COMMUNICATING AMONG PEER PROFESSIONALS IN THE ADVERTISING, MARKETING AND BUSINESS SERVICES FIELDS, AND FOR CUSTOMIZING COMPUTER APPLICATION USER INTERFACES;

COMPUTER SERVICES, NAMELY, DESIGNING, DEVELOPING, AND MAINTAINING COMPUTER SOFTWARE APPLICATIONS FOR OTHERS AND CONSULTING SERVICES RELATED THERETO; PROVIDING TEMPORARY USE OF ONLINE NON-DOWNLOADABLE COMPUTER SOFTWARE APPLICATION DEVELOPMENT TOOLS AND PROGRAMMING LANGUAGE FOR USE IN DEVELOPING, ANALYZING, CODING, CHECKING, AND CONTROLLING OTHER COMPUTER SOFTWARE; PROVIDING TEMPORARY USE OF ONLINE NON-DOWNLOADABLE COMPUTER SOFTWARE THAT IMPLEMENTS A PROCEDURAL AND OBJECT-ORIENTED PROGRAMMING LANGUAGE; ONLINE HOSTED COMPUTER SERVICES, NAMELY, DESIGNING, DEVELOPING, CUSTOMIZING, AND MAINTAINING COMPUTER SOFTWARE APPLICATIONS FOR OTHERS, AND CONSULTING SERVICES RELATED THERETO (U.S. CLS. 100 AND 101).

**CLASS 45—PERSONAL AND LEGAL SERVICES**

FOR ON-LINE SOCIAL NETWORKING SERVICES (U.S. CLS. 100 AND 101).  
AMY KERTGATE, EXAMINING ATTORNEY

SN 85-236,676. PFIZER INC., NEW YORK, NY. FILED 2-8-2011.

## JOINT STEPS

THE MARK CONSISTS OF STANDARD CHARACTERS WITHOUT CLAIM TO ANY PARTICULAR FONT, STYLE, SIZE, OR COLOR.

NO CLAIM IS MADE TO THE EXCLUSIVE RIGHT TO USE "JOINT", APART FROM THE MARK AS SHOWN.

**CLASS 16—PAPER GOODS AND PRINTED MATTER**

FOR PRINTED PUBLICATIONS, NAMELY, BROCHURES, PAMPHLETS, BOOKLETS, DISPLAYS, POSTERS AND FLYERS IN THE FIELD OF THE TREATMENT AND PREVENTION OF ARTHRITIS (U.S. CLS. 2, 5, 22, 23, 29, 37, 38 AND 50).

**CLASS 41—EDUCATION AND ENTERTAINMENT**

FOR PROVIDING A WEBSITE FEATURING AN ONLINE EDUCATIONAL PROGRAM IN THE FIELD OF THE TREATMENT AND PREVENTION OF ARTHRITIS (U.S. CLS. 100, 101 AND 107).

**CLASS 44—MEDICAL, BEAUTY AND AGRICULTURAL SERVICES**

FOR HEALTHCARE INFORMATION SERVICES, NAMELY, A DISEASE MANAGEMENT AND WELLNESS INFORMATIONAL PROGRAM IN THE FIELD OF THE TREATMENT AND PREVENTION OF ARTHRITIS (U.S. CLS. 100 AND 101).  
SKYE YOUNG, EXAMINING ATTORNEY

SN 85-239,829. FARMERS GROUP, INC., LOS ANGELES, CA. FILED 2-11-2011.

## FARMERS INSURANCE OPEN

THE MARK CONSISTS OF STANDARD CHARACTERS WITHOUT CLAIM TO ANY PARTICULAR FONT, STYLE, SIZE, OR COLOR.

OWNER OF U.S. REG. NOS. 953,862, 1,920,139 AND OTHERS.

NO CLAIM IS MADE TO THE EXCLUSIVE RIGHT TO USE "OPEN" AS TO THE SERVICES LISTED IN CLASS 41, APART FROM THE MARK AS SHOWN.

**CLASS 18—LEATHER GOODS**

FOR GOLF UMBRELLAS (U.S. CLS. 1, 2, 3, 22 AND 41).

**CLASS 24—FABRICS**

FOR GOLF TOWELS (U.S. CLS. 42 AND 50).

**CLASS 25—CLOTHING**

FOR CLOTHING, NAMELY, T-SHIRTS, POLO SHIRTS, SHORT SLEEVED SHIRTS, LONG SLEEVED SHIRTS, GOLF SHIRTS, GLOVES, VEST, SWEATERS, JACKETS, WIND JACKETS, RAIN JACKETS, PANTS, VISORS, GOLF HATS, CAPS, AND SHORTS (U.S. CLS. 22 AND 39).

**CLASS 28—TOYS AND SPORTING GOODS**

FOR GOLF BALLS, GOLF BAGS, PIN FLAGS (U.S. CLS. 22, 23, 38 AND 50).

**CLASS 41—EDUCATION AND ENTERTAINMENT**

FOR ENTERTAINMENT IN THE NATURE OF A GOLF EVENT (U.S. CLS. 100, 101 AND 107).

FIRST USE 1-23-2010; IN COMMERCE 1-28-2010.

THOMAS MANOR, EXAMINING ATTORNEY

SN 85-241,235. ANDREWS MCMEEL PUBLISHING, LLC, KANSAS CITY, MO. FILED 2-14-2011.

## Pocket Posh

THE MARK CONSISTS OF STANDARD CHARACTERS WITHOUT CLAIM TO ANY PARTICULAR FONT, STYLE, SIZE, OR COLOR.

OWNER OF U.S. REG. NO. 3,602,081.

**CLASS 9—ELECTRICAL AND SCIENTIFIC APPARATUS**

FOR DOWNLOADABLE ELECTRONIC PUBLICATIONS AND CONTENT IN THE NATURE OF BOOKS, E-BOOKS, ELECTRONIC BOOKS AND ELECTRONIC TEXT, DATA AND IMAGES IN THE FIELDS OF PUZZLE BOOKS, GAME BOOKS AND NON-FICTION HUMOR, GIFT AND COOKBOOKS (U.S. CLS. 21, 23, 26, 36 AND 38).

**CLASS 41—EDUCATION AND ENTERTAINMENT**

FOR PUBLISHING OF BOOKS, JOURNALS, E-BOOKS AND ELECTRONIC PUBLICATIONS AND TEXT, DATA AND IMAGES; PROVIDING ONLINE NON-DOWNLOADABLE ELECTRONIC PUBLICATIONS AND CONTENT IN THE NATURE OF E-BOOKS, ELECTRONIC BOOKS AND ELECTRONIC TEXT, DATA AND IMAGES IN THE FIELDS OF PUZZLE BOOKS, GAME BOOKS AND NON-FICTION HUMOR, GIFT AND COOKBOOKS (U.S. CLS. 100, 101 AND 107).

**CLASS 42—SCIENTIFIC AND COMPUTER SERVICES**

FOR PROVIDING TEMPORARY USE OF ON-LINE NON-DOWNLOADABLE SOFTWARE TO ENABLE USERS TO ACCESS E-BOOKS, ELECTRONIC BOOKS AND ELECTRONIC TEXT, DATA AND IMAGES IN THE FIELDS OF PUZZLE BOOKS, GAME BOOKS AND NON-FICTION HUMOR, GIFT AND COOKBOOKS (U.S. CLS. 100 AND 101).

DAVID HOFFMAN, EXAMINING ATTORNEY

---

SN 85-241,417. AFFINERGY, INC., RESEARCH TRIANGLE PARK, NC. FILED 2-14-2011.

**AFFINERGY**

THE MARK CONSISTS OF STANDARD CHARACTERS WITHOUT CLAIM TO ANY PARTICULAR FONT, STYLE, SIZE, OR COLOR.

OWNER OF U.S. REG. NOS. 3,151,852 AND 3,281,306.

**CLASS 5—PHARMACEUTICALS**

FOR SURGICAL IMPLANTS COMPRISING COLLAGENOUS TISSUE MATERIALS; PREPARATIONS FOR USE IN RECONSTRUCTIVE SURGERY FORMED OF, OR INCLUDING COLLAGENOUS TISSUE MATERIALS; BONE COMPOSITIONS COMPRISED OF COLLAGENOUS TISSUE MATERIALS AND CALCIUM PHOSPHATE (U.S. CLS. 6, 18, 44, 46, 51 AND 52).

**CLASS 10—MEDICAL APPARATUS**

FOR IMPLANTABLE MEDICAL DEVICES; SYNTHETIC IMPLANTABLE SURGICAL MATERIAL; SURGICAL IMPLANTS COMPRISING NON-LIVING BIOLOGICAL MATERIAL; SYNTHETIC BONE GRAFT IMPLANT MATERIAL; SYNTHETIC BONE GRAFT IMPLANTS; SYNTHETIC BONE FOR IMPLANTS; SYNTHETIC RESORBABLE BONE VOID FILLER (U.S. CLS. 26, 39 AND 44).

SHAUNIA CARLYLE, EXAMINING ATTORNEY

SN 85-249,568. NURISE SALES & MARKETING, OAKVILLE, ONTARIO, CANADA. FILED 2-23-2011.

**Pure Rain, the way nature  
designed it**

THE MARK CONSISTS OF STANDARD CHARACTERS WITHOUT CLAIM TO ANY PARTICULAR FONT, STYLE, SIZE, OR COLOR.

**CLASS 11—ENVIRONMENTAL CONTROL APPARATUS**

FOR FAUCET SPRAYERS; HAND HELD SHOWER HEADS; HAND SHOWERS, HAND HELD SHOWERS; IRRIGATION SPRAY NOZZLES; IRRIGATION SPRINKLERS; KITCHEN SINK SPRAYERS; WATER SPRINKLERS FOR THE IRRIGATION OF LAWNS; OXYGEN GENERATOR FOR PROCESSING WATER BY INCREASING OXYGEN CONTENT IN THE WATER; PLUMBING FITTINGS, NAMELY, AERATORS FOR FAUCETS; PLUMBING FITTINGS, NAMELY, SHOWER CONTROL VALVES; PLUMBING FIXTURES, NAMELY, SHOWER MIXERS; PLUMBING FIXTURES, NAMELY, SHOWER SPRAYERS; PLUMBING FIXTURES, NAMELY, SINK SPRAYERS; SHOWER FAUCET EXTENSIONS; SHOWER HEAD SPRAYERS; TAP WATER FAUCETS; VALVES BEING PARTS OF SPRINKLER SYSTEMS; WATER FAUCET SPOUT (U.S. CLS. 13, 21, 23, 31 AND 34).

**CLASS 21—HOUSEWARES AND GLASS**

FOR GARDEN HOSE SPRAYERS; GRASS SPRINKLERS; LAWN SPRINKLERS; PET GROOMING DEVICE COMPRISING A BUILT IN BRUSH HEAD AND AN ATTACHMENT THAT CONNECTS TO A WATER SOURCE; SHUT-OFF VALVES FOR WATER SPRINKLER NOZZLES; SPRAYER NOZZLES FOR GARDEN HOSES; SPRAYER WANDS FOR GARDEN HOSES; SPRAYERS ATTACHED TO GARDEN HOSES; STREAM DEFLECTOR NOZZLES FOR GARDEN HOSES (U.S. CLS. 2, 13, 23, 29, 30, 33, 40 AND 50).

NANCY CLARKE, EXAMINING ATTORNEY

---

SN 85-251,812. JOHNSON & JOHNSON, NEW BRUNSWICK, NJ. FILED 2-25-2011.

**CAUSES AND YOU**

THE MARK CONSISTS OF STANDARD CHARACTERS WITHOUT CLAIM TO ANY PARTICULAR FONT, STYLE, SIZE, OR COLOR.

**CLASS 16—PAPER GOODS AND PRINTED MATTER**

FOR PRINTED MATERIALS, NAMELY, BROCHURES, PAMPHLETS, NEWSLETTERS, AND PRESS RELEASES IN THE FIELD OF SOCIAL RESPONSIBILITY (U.S. CLS. 2, 5, 22, 23, 29, 37, 38 AND 50).

**CLASS 35—ADVERTISING AND BUSINESS**

FOR PROMOTING PUBLIC AWARENESS OF SOCIAL RESPONSIBILITY; CHARITABLE SERVICES, NAMELY, PROVIDING A FREE ONLINE RESOURCE IN THE NATURE OF A WEBSITE FOR CONNECTING PEOPLE WHO HAVE SERVICE NEEDS WITH PEOPLE WHO ARE WILLING TO PROVIDE VOLUNTEER SERVICES TO PEOPLE AND ORGANIZATIONS ON THE SUBJECT OF SOCIAL RESPONSIBILITY (U.S. CLS. 100, 101 AND 102).

**CLASS 44—MEDICAL, BEAUTY AND AGRICULTURAL SERVICES**

FOR INFORMATION SERVICES, NAMELY, PROVIDING HEALTH INFORMATION TO PEOPLE AND ORGANIZATIONS ON THE SUBJECT OF SOCIAL RESPONSIBILITY THROUGH INTERACTIVE SOCIAL MEDIA WEBSITES (U.S. CLS. 100 AND 101).

CAROL SPILS, EXAMINING ATTORNEY

SN 85-254,886. AGUA CALIENTE BAND OF CAHUILLA INDIANS, PALM SPRINGS, CA. FILED 3-1-2011.



OWNER OF U.S. REG. NO. 2,800,048.

NO CLAIM IS MADE TO THE EXCLUSIVE RIGHT TO USE "SPA RESORT CASINO" AND "DOWNTOWN PALM SPRINGS", APART FROM THE MARK AS SHOWN.

THE COLOR(S) YELLOW, RED, PINK, GREEN, PURPLE, AQUA, BLUE AND WHITE IS/ARE CLAIMED AS A FEATURE OF THE MARK.

THE MARK CONSISTS OF A RED, PINK, GREEN, PURPLE, AQUA AND BLUE WATER JUG WITH YELLOW FLAMES EXTENDING FROM THE MOUTH OF THE JUG AND THE WORDS "SPA RESORT CASINO DOWNTOWN PALM SPRINGS" IN WHITE. THE BLUE BACKGROUND IS TRANSPARENT AREA AND IS NOT PART OF THE MARK.

**CLASS 41—EDUCATION AND ENTERTAINMENT**

FOR CASINOS (U.S. CLS. 100, 101 AND 107).  
FIRST USE 1-21-2009; IN COMMERCE 1-21-2009.

**CLASS 43—HOTEL AND RESTAURANT SERVICES**

FOR HOTEL AND RESTAURANT SERVICES (U.S. CLS. 100 AND 101).  
FIRST USE 1-21-2009; IN COMMERCE 1-21-2009.

**CLASS 44—MEDICAL, BEAUTY AND AGRICULTURAL SERVICES**

FOR HEALTH SPA SERVICES FOR HEALTH AND WELLNESS OF THE BODY AND SPIRIT, NAMELY, PROVIDING MASSAGE, FACIAL AND BODY TREATMENT SERVICES, COSMETIC BODY CARE SERVICES (U.S. CLS. 100 AND 101).

FIRST USE 1-21-2009; IN COMMERCE 1-21-2009.  
KATHLEEN M. VANSTON, EXAMINING ATTORNEY

SN 85-261,818. MERIDIAN HEALTH SYSTEM, INC., NEPTUNE, NJ. FILED 3-9-2011.

**SLEEPTRAK**

THE MARK CONSISTS OF STANDARD CHARACTERS WITHOUT CLAIM TO ANY PARTICULAR FONT, STYLE, SIZE, OR COLOR.

**CLASS 10—MEDICAL APPARATUS**

FOR MEDICAL DEVICES, NAMELY, PORTABLE ELECTRONIC PATIENT MONITORS AND PATIENT SENSORS WITH AUTOMATED ALERT AND MONITORING CAPACITY FOR MONITORING AND MEASURING PATIENT REPORTED SYMPTOMS, HEART RATE, BLOOD PRESSURE, BODY TEMPERATURE, PAIN, BLOOD GLUCOSE LEVELS, THE OXYGEN SATURATION OF THE BLOOD AND OTHER VITAL SIGN AND DIAGNOSTIC PARAMETERS (U.S. CLS. 26, 39 AND 44).

**CLASS 44—MEDICAL, BEAUTY AND AGRICULTURAL SERVICES**

FOR MEDICAL DIAGNOSTIC MONITORING AND REPORTING SERVICES FOR MEDICAL PROFESSIONALS AND MEDICAL PATIENTS PROVIDED VIA TELECOMMUNICATION NETWORKS AND/OR GLOBAL COMPUTER NETWORKS FEATURING MEDICAL INFORMATION IN THE NATURE OF PATIENT REPORTED SYMPTOMS, HEART RATE, BLOOD PRESSURE, BODY TEMPERATURE, PAIN, BLOOD GLUCOSE LEVELS, OXYGEN SATURATION OF THE BLOOD AND OTHER VITAL SIGN AND DIAGNOSTIC PARAMETERS, GATHERED FROM ELECTRONIC PATIENT MEDICAL MONITORING DEVICES WHICH FEED INFORMATION TO REMOTE LOCATIONS THAT CAN BE ACCESSED IN REAL-TIME BY MEDICAL PROFESSIONALS FOR PURPOSES OF MONITORING AND DIAGNOSING MEDICAL CONDITIONS FOR INDIVIDUALS WITH HEALTH PROBLEMS (U.S. CLS. 100 AND 101).

WENDY GOODMAN, EXAMINING ATTORNEY

SN 85-261,908. MERIDIAN HEALTH SYSTEM, INC., NEPTUNE, NJ. FILED 3-9-2011.

**HEALTH PAK**

THE MARK CONSISTS OF STANDARD CHARACTERS WITHOUT CLAIM TO ANY PARTICULAR FONT, STYLE, SIZE, OR COLOR.

NO CLAIM IS MADE TO THE EXCLUSIVE RIGHT TO USE "HEALTH", APART FROM THE MARK AS SHOWN.

**CLASS 10—MEDICAL APPARATUS**

FOR MEDICAL DEVICES, NAMELY, PORTABLE ELECTRONIC PATIENT MONITORS AND PATIENT SENSORS WITH AUTOMATED ALERT AND MONITORING CAPACITY FOR MONITORING AND MEASURING PATIENT REPORTED SYMPTOMS, HEART RATE, BLOOD PRESSURE, BODY TEMPERATURE, PAIN, BLOOD GLUCOSE LEVELS, THE OXYGEN SATURATION OF THE BLOOD AND OTHER VITAL SIGN AND DIAGNOSTIC PARAMETERS (U.S. CLS. 26, 39 AND 44).



**CLASS 44—MEDICAL, BEAUTY AND AGRICULTURAL SERVICES**

WENDY GOODMAN, EXAMINING ATTORNEY

FOR MEDICAL DIAGNOSTIC MONITORING AND REPORTING SERVICES FOR MEDICAL PROFESSIONALS AND MEDICAL PATIENTS PROVIDED VIA TELECOMMUNICATION NETWORKS AND/OR GLOBAL COMPUTER NETWORKS FEATURING MEDICAL INFORMATION IN THE NATURE OF PATIENT REPORTED SYMPTOMS, HEART RATE, BLOOD PRESSURE, BODY TEMPERATURE, PAIN, BLOOD GLUCOSE LEVELS, OXYGEN SATURATION OF THE BLOOD AND OTHER VITAL SIGN AND DIAGNOSTIC PARAMETERS, GATHERED FROM ELECTRONIC PATIENT MEDICAL MONITORING DEVICES WHICH FEED INFORMATION TO REMOTE LOCATIONS THAT CAN BE ACCESSED IN REAL-TIME BY MEDICAL PROFESSIONALS FOR PURPOSES OF MONITORING AND DIAGNOSING MEDICAL CONDITIONS FOR INDIVIDUALS WITH HEALTH PROBLEMS (U.S. CLS. 100 AND 101).

\* \* \* \* \*

## SECTION 2.— INTERNATIONAL CLASSIFICATION

The short titles associated below with the international class numbers are terms designed merely for quick identification and are not an official part of the international classification. The full names of international classes are given in section 6.1 of the trademark rules of practice.

The designation "U.S. Cl." appearing in this section refers to the U.S. class in effect prior to Sep. 1, 1973 rather than the international class which applies to applications filed on or after that date. For adoption of international classification see notice in the OFFICIAL GAZETTE of Jun. 26, 1973 (911 O.G. TM 210).

### Application in one class

#### CLASS 1—CHEMICALS

SN 79-080,748. HANGZHOU JOIN LEADER; ADHESIVE CO., LTD, CHINA, FILED 1-6-2010.

#### CLASS 1—(Continued).

SN 79-083,701. RHODIA OPERATIONS, FRANCE, FILED 5-17-2010.



**JOIN LEADER**

**AUGEO**

OWNER OF INTERNATIONAL REGISTRATION 1033745 DATED 1-6-2010, EXPIRES 1-6-2020.

NO CLAIM IS MADE TO THE EXCLUSIVE RIGHT TO USE "JOIN", APART FROM THE MARK AS SHOWN.

THE MARK CONSISTS OF THE DESIGN OF FIVE OVALS CONNECTED BY BARS AND LINED UP VERTICALLY IN A ZIG-ZAG PATTERN INSIDE A DARK SQUARE ABOVE THE WORDING "JOIN LEADER".

FOR ADHESIVES FOR INDUSTRIAL PURPOSES; GLUE FOR INDUSTRIAL PURPOSES; SILICA GEL; CHLORINE GLUE FOR INDUSTRIAL USE; ADHESIVES FOR WALLPAPER; POLYURETHANE; POLYVINYL ACETATE EMULSION (U.S. CLS. 1, 5, 6, 10, 26 AND 46).  
MARIA-VICTORIA SUAREZ, EXAMINING ATTORNEY

PRIORITY DATE OF 11-24-2009 IS CLAIMED.  
OWNER OF INTERNATIONAL REGISTRATION 1041854 DATED 5-17-2010, EXPIRES 5-17-2020.

THE MARK CONSISTS OF THE WORDING "AUGEO".  
THE ENGLISH TRANSLATION OF "AUGEO" IN THE MARK IS "INCREASE" OR "EXPAND".

FOR CHEMICALS USED IN INDUSTRY, ESPECIALLY CHEMICALS FOR USE IN THE FOLLOWING INDUSTRIES: DETERGENTS AND CLEANING PRODUCTS, COSMETICS, PERSONAL CARE, HOME MAINTENANCE, LATEX, PAPER, ADHESIVES, CONSTRUCTION, FIBERS AND TEXTILES, VARNISHES, LACQUERS, PAINTS AND COATINGS, INKS, METAL DEGREASING, INTERMEDIATE POLYMERS, FOUNDRY, LEATHER, PLASTIC ADDITIVES, SURFACE TREATING, METAL TREATING, GREASES AND LUBRICANTS, AND OIL AND GAS; CHEMICAL SOLVENTS AND ADDITIVES FOR USE IN INDUSTRY, ESPECIALLY SOLVENTS AND ADDITIVES FOR USE IN THE FOLLOWING INDUSTRIES: DETERGENTS AND CLEANING PRODUCTS, COSMETICS, PERSONAL CARE, HOME MAINTENANCE, LATEX, PAPER, ADHESIVES, CONSTRUCTION, FIBERS AND TEXTILES, VARNISHES, LACQUERS, PAINTS AND COATINGS, INKS, METAL DEGREASING, INTERMEDIATE POLYMERS, FOUNDRY, LEATHER, PLASTIC ADDITIVES, SURFACE TREATING, METAL TREATING, GREASES AND LUBRICANTS, AND OIL AND GAS (U.S. CLS. 1, 5, 6, 10, 26 AND 46).  
BRIAN CALLAGHAN, EXAMINING ATTORNEY

**CLASS 1—(Continued).**

SN 79-088,271. ASHLAND-SÜDCHEMIE-KERNFEST GMBH,  
FED REP GERMANY, FILED 6-17-2010.

# MIRATEC

THE MARK CONSISTS OF STANDARD CHARACTERS WITHOUT CLAIM TO ANY PARTICULAR FONT, STYLE, SIZE, OR COLOR.

OWNER OF INTERNATIONAL REGISTRATION 1053688 DATED 6-17-2010, EXPIRES 6-17-2020.

FOR CHEMICAL COATINGS, OTHER THAN FOR THE DENTAL SECTOR, IN PARTICULAR WITH A BASE OF ALUMINUM SILICATES, IN PARTICULAR FOR USE IN THE MANUFACTURE OF FOUNDRY MOULDS AND CORES OF SAND, METAL OR FOAM (U.S. CLS. 1, 5, 6, 10, 26 AND 46).

DOUGLAS LEE, EXAMINING ATTORNEY

---

SN 79-091,320. TAMINCO, NAAMLOZE VENNOOTSCHAP,  
BELGIUM, FILED 11-24-2010.

# TUBA

THE MARK CONSISTS OF STANDARD CHARACTERS WITHOUT CLAIM TO ANY PARTICULAR FONT, STYLE, SIZE, OR COLOR.

OWNER OF INTERNATIONAL REGISTRATION 1061868 DATED 11-24-2010, EXPIRES 11-24-2020.

FOR CHEMICALS FOR USE IN SCIENCE; CHEMICAL PREPARATIONS FOR USE IN AGRICULTURE, HORTICULTURE AND FORESTRY, NAMELY, CHEMICAL PREPARATIONS FOR THE TREATMENT OF SEEDS; FERTILIZERS (U.S. CLS. 1, 5, 6, 10, 26 AND 46).

COLLEEN DOMBROW, EXAMINING ATTORNEY

---

SN 79-091,436. AQUA BIO TECHNOLOGY ASA, NORWAY,  
FILED 7-26-2010.

# Zonase X

THE MARK CONSISTS OF STANDARD CHARACTERS WITHOUT CLAIM TO ANY PARTICULAR FONT, STYLE, SIZE, OR COLOR.

OWNER OF INTERNATIONAL REGISTRATION 1062187 DATED 7-26-2010, EXPIRES 7-26-2020.

THE WORDING "ZONASE" HAS NO MEANING IN A FOREIGN LANGUAGE.

FOR PROTEINS AND ENZYME PREPARATIONS USED IN THE MANUFACTURE OF COSMETICS SUCH AS CREAMS, LOTIONS, GELS, AND SPRAYS (U.S. CLS. 1, 5, 6, 10, 26 AND 46).

JIM RINGLE, EXAMINING ATTORNEY

**CLASS 1—(Continued).**

SN 79-093,003. BASF SE, 67063 LUDWIGSHAFEN AM  
RHEIN, FED REP GERMANY, FILED 1-11-2011.

# LIMUS

THE MARK CONSISTS OF STANDARD CHARACTERS WITHOUT CLAIM TO ANY PARTICULAR FONT, STYLE, SIZE, OR COLOR.

PRIORITY DATE OF 7-12-2010 IS CLAIMED.

OWNER OF INTERNATIONAL REGISTRATION 1066336 DATED 1-11-2011, EXPIRES 1-11-2021.

FOR CHEMICALS FOR THE PRODUCTION AND TREATMENT OF FERTILIZERS; FERTILIZERS (U.S. CLS. 1, 5, 6, 10, 26 AND 46).

MAUREEN DALL, EXAMINING ATTORNEY

---

SN 85-058,634. CHI MEI CORPORATION, TAINAN HSIEN,  
TAIWAN, FILED 6-9-2010.

# WONDERLITE

THE MARK CONSISTS OF STANDARD CHARACTERS WITHOUT CLAIM TO ANY PARTICULAR FONT, STYLE, SIZE, OR COLOR.

OWNER OF TAIWAN REG. NO. 00964666, DATED 10-16-2001, EXPIRES 10-15-2011.

OWNER OF U.S. REG. NO. 2,753,589.

FOR UNPROCESSED ARTIFICIAL RESINS, POLY-CARBONATE RESIN, POLYETHYLENE RESIN, POLY-PROPYLENE RESIN, POLYBUTENE RESIN, METACRYLIC ACID ESTER, POLYSTYRENE RESIN, ACRYLONITRILE-BUTADIENE-STYRENE COPOLYMER FOR USE IN MANUFACTURING, UREA FORMALDEHYDE RESINS, POLYESTER RESIN, UNPROCESSED ACRYLIC RESIN, UNPROCESSED PLASTICS, UNPROCESSED CELLULOSE ACETATE, UNPROCESSED RESIN FOR USE IN FILTERING MATERIALS, BLEND OF POLYCARBONATE/ACRYLONITRILE-BUTADIENE-STYRENE COPOLYMER FOR USE IN MANUFACTURING (U.S. CLS. 1, 5, 6, 10, 26 AND 46).

ARETHA SOMERVILLE, EXAMINING ATTORNEY

---

SN 85-059,291. THE MOSAIC COMPANY, PLYMOUTH, MN,  
FILED 6-10-2010.

# PEGASUS

THE MARK CONSISTS OF STANDARD CHARACTERS WITHOUT CLAIM TO ANY PARTICULAR FONT, STYLE, SIZE, OR COLOR.

FOR FERTILIZER FOR AGRICULTURAL USE SOLD IN BULK NON-PACKAGED FORM (U.S. CLS. 1, 5, 6, 10, 26 AND 46).

BARBARA RUTLAND, EXAMINING ATTORNEY

**CLASS 1—(Continued).**

SN 85-064,574. THE MOSAIC COMPANY, PLYMOUTH, MN. FILED 6-16-2010.



THE MARK CONSISTS OF SHAPE OF A WING IS LATTERLY DISPOSED TO THE LEFT OF THE WORD "PEGASUS".

FOR FERTILIZER FOR AGRICULTURAL USE SOLD IN BULK NON-PACKAGED FORM (U.S. CLS. 1, 5, 6, 10, 26 AND 46).

BARBARA RUTLAND, EXAMINING ATTORNEY

---

SN 85-070,336. OLDCASTLE LAWN & GARDEN, INC., ATLANTA, GA. FILED 6-24-2010.

## SOIL DOCTOR

THE MARK CONSISTS OF STANDARD CHARACTERS WITHOUT CLAIM TO ANY PARTICULAR FONT, STYLE, SIZE, OR COLOR.

OWNER OF U.S. REG. NOS. 2,853,661 AND 2,909,228.

NO CLAIM IS MADE TO THE EXCLUSIVE RIGHT TO USE "SOIL", APART FROM THE MARK AS SHOWN.

FOR POTTING SOIL (U.S. CLS. 1, 5, 6, 10, 26 AND 46).

DAVID ELTON, EXAMINING ATTORNEY

---

SN 85-070,584. BIAGRO WESTERN SALES, INC., VISALIA, CA. FILED 6-24-2010.

## TAKE OFF ST

THE MARK CONSISTS OF STANDARD CHARACTERS WITHOUT CLAIM TO ANY PARTICULAR FONT, STYLE, SIZE, OR COLOR.

NO CLAIM IS MADE TO THE EXCLUSIVE RIGHT TO USE "ST", APART FROM THE MARK AS SHOWN.

FOR CHEMICAL PREPARATIONS FOR USE IN AGRICULTURE, NAMELY, AGRICULTURAL SEED TREATMENTS (U.S. CLS. 1, 5, 6, 10, 26 AND 46).

KATHERINE M. DUBRAY, EXAMINING ATTORNEY

**CLASS 1—(Continued).**

SN 85-124,965. DONGSHENG CHEMPHY INC, WILMINGTON, DE. FILED 9-8-2010.



THE MARK CONSISTS OF STANDARD CHARACTERS WITHOUT CLAIM TO ANY PARTICULAR FONT, STYLE, SIZE, OR COLOR.

FOR POLYMER COMPOSITIONS USED IN THE MANUFACTURE OF PARTS FOR AUTOMOBILES AND AIRCRAFT (U.S. CLS. 1, 5, 6, 10, 26 AND 46).

MICHAEL WIENER, EXAMINING ATTORNEY

---

SN 85-124,966. LEE COUNTY BOARD OF COUNTY COMMISSIONERS, FORT MYERS, FL. FILED 9-8-2010.

## OrganicLee

THE MARK CONSISTS OF STANDARD CHARACTERS WITHOUT CLAIM TO ANY PARTICULAR FONT, STYLE, SIZE, OR COLOR.

FOR ORGANIC COMPOST (U.S. CLS. 1, 5, 6, 10, 26 AND 46).

SUSAN STIGLITZ, EXAMINING ATTORNEY

---

SN 85-152,138. WESTLAKE LONGVIEW CORPORATION, HOUSTON, TX. FILED 10-13-2010.

## ELEVATE

THE MARK CONSISTS OF STANDARD CHARACTERS WITHOUT CLAIM TO ANY PARTICULAR FONT, STYLE, SIZE, OR COLOR.

FOR SOLID ETHYLENE VINYL ACETATE FOR FURTHER PROCESSING IN CONNECTION WITH THE MANUFACTURE OF FINISHED GOODS (U.S. CLS. 1, 5, 6, 10, 26 AND 46).

SALLY SHIH, EXAMINING ATTORNEY



**CLASS 1—(Continued).**

SN 85-179,056. BIOSYSTEM DEVELOPMENT, MADISON, WI. FILED 11-17-2010.



THE COLOR(S) BLUE, BLACK IS/ARE CLAIMED AS A FEATURE OF THE MARK.

THE MARK CONSISTS OF THREE ELEMENTS FORMING AN OVERALL CIRCULAR SHAPE. THE CENTRAL VERTICAL ELEMENT IS BLUE AND BEGINS AS AN ARC AT THE TOP OF THE MARK AND TAPERS DOWNWARD TO CREATE A SHAPE RESEMBLING A PIPETTE. THE COLOR BLUE IN THE VERTICAL ELEMENT ALSO LIGHTENS FROM TOP TO BOTTOM. ON EITHER SIDE OF THE VERTICAL ELEMENT ARE SOLID BLACK CURVING SHAPES RESEMBLING LEAVES OR FLOWER PETALS. THE COLOR WHITE APPEARING IN THE MARK REPRESENTS BACKGROUND OR TRANSPARENT AREAS AND IS NOT CLAIMED AS A FEATURE OF THE MARK.

FOR ASSAYS FOR RESEARCH PURPOSES (U.S. CLS. 1, 5, 6, 10, 26 AND 46).

FIRST USE 11-1-2009; IN COMMERCE 12-9-2009.  
STEVEN PEREZ, EXAMINING ATTORNEY

SN 85-180,161. BAKER HUGHES INCORPORATED, HOUSTON, TX. FILED 11-18-2010.

**STAGE-SWEEP**

THE MARK CONSISTS OF STANDARD CHARACTERS WITHOUT CLAIM TO ANY PARTICULAR FONT, STYLE, SIZE, OR COLOR.

FOR CHEMICAL ADDITIVE FOR OIL WELL DRILLING FLUID, NAMELY, A LIQUID DISPERSION BIOPOLYMER COMPOSITION, FOR INCREASED VISCOSITY AND REDUCED FLUID FRICTION AND PRESSURE LOSSES IN DRILLING OPERATIONS (U.S. CLS. 1, 5, 6, 10, 26 AND 46).

FIRST USE 11-8-2010; IN COMMERCE 11-8-2010.  
KATINA MISTER, EXAMINING ATTORNEY

**CLASS 1—(Continued).**

SN 85-192,615. GLOBAL INFECTION CONTROL CONSULTANTS LLC, BLUFFTON, SC. FILED 12-7-2010.

**Path – Away****Anti-Pathogenic Aerosol Solution**

NO CLAIM IS MADE TO THE EXCLUSIVE RIGHT TO USE "ANTI-PATHOGENIC AEROSOL SOLUTION", APART FROM THE MARK AS SHOWN.

THE MARK CONSISTS OF THE STYLIZED TEXT "PATH-AWAY ANTI-PATHOGENIC AEROSOL SOLUTION".

FOR CHEMICALS USED IN INDUSTRY AND SCIENCE, NAMELY, PRE-MIXED NATURAL BASED REACTANTS AND REAGENTS FOR DETECTING AND ELIMINATING AIRBORNE AND SURFACE PATHOGENS (U.S. CLS. 1, 5, 6, 10, 26 AND 46).

BERYL GARDNER, EXAMINING ATTORNEY

SN 85-192,880. SYNTHONIX INC., WAKE FOREST, NC. FILED 12-8-2010.

**Synthonix  
Elements of Progress**

THE MARK CONSISTS OF STANDARD CHARACTERS WITHOUT CLAIM TO ANY PARTICULAR FONT, STYLE, SIZE, OR COLOR.

OWNER OF U.S. REG. NO. 3,016,301.

FOR CHEMICAL REAGENTS FOR NON-MEDICAL PURPOSES; CHEMICALS FOR USE IN INDUSTRY AND SCIENCE (U.S. CLS. 1, 5, 6, 10, 26 AND 46).

FIRST USE 3-1-2004; IN COMMERCE 5-6-2004.

ELLEN BURNS, EXAMINING ATTORNEY

SN 85-195,010. JAMES BOMBARDO, LAKEVILLE, MN. FILED S.R. 12-10-2010; AM. P.R. 3-18-2011.

**Plasma Defense**

NO CLAIM IS MADE TO THE EXCLUSIVE RIGHT TO USE "PLASMA", APART FROM THE MARK AS SHOWN.

THE COLOR(S) BLUE IS/ARE CLAIMED AS A FEATURE OF THE MARK.

THE MARK CONSISTS OF BLUE TEXT "PLASMA DEFENSE" WITH A BLUE OVERLINE AND BLUE UNDERLINE.

FOR ANTI-RUST AND ANTI-FOULING COOLANT LIQUID FOR THE CAPTURE OF SMOKE GENERATED IN THE PLASMA CUTTING OF METAL (U.S. CLS. 1, 5, 6, 10, 26 AND 46).

FIRST USE 11-1-2010; IN COMMERCE 12-1-2010.  
REBECCA EISINGER, EXAMINING ATTORNEY

**CLASS 1—(Continued).**

SN 85-200,617. CHESTER, BETH, DENNIS PORT, MA. FILED 12-17-2010.

## Spray Away

THE MARK CONSISTS OF STANDARD CHARACTERS WITHOUT CLAIM TO ANY PARTICULAR FONT, STYLE, SIZE, OR COLOR.

NO CLAIM IS MADE TO THE EXCLUSIVE RIGHT TO USE "SPRAY", APART FROM THE MARK AS SHOWN.

FOR CHEMICAL PREPARATIONS, NAMELY, DEGREASING AND CLEANING SOLVENTS FOR CARPETS, CLOTHING, AND OTHER TEXTILE GOODS (U.S. CLS. 1, 5, 6, 10, 26 AND 46).

CAROL SPILS, EXAMINING ATTORNEY

**CLASS 1—(Continued).**

SN 85-201,630. DESERT MOUNTAIN, FARMINGTON, NM. FILED 12-20-2010.

## ROAD LOC

THE MARK CONSISTS OF STANDARD CHARACTERS WITHOUT CLAIM TO ANY PARTICULAR FONT, STYLE, SIZE, OR COLOR.

NO CLAIM IS MADE TO THE EXCLUSIVE RIGHT TO USE "ROAD", APART FROM THE MARK AS SHOWN.

FOR SPRAYABLE LIQUID SOIL ADDITIVES FOR BINDING TOGETHER LOOSE DIRT PARTICLES ON DIRT ROADS, FOR THE PURPOSE OF DUST CONTROL, SOIL STABILIZATION, AND DIRT ROAD STABILIZATION (U.S. CLS. 1, 5, 6, 10, 26 AND 46).

FIRST USE 6-1-2010; IN COMMERCE 10-21-2010.  
BARNEY CHARLON, EXAMINING ATTORNEY

SN 85-201,506. TIGER INDUSTRIES, INC., BRISTOL, RI. FILED 12-20-2010.

## TIGERCAL 30

THE MARK CONSISTS OF STANDARD CHARACTERS WITHOUT CLAIM TO ANY PARTICULAR FONT, STYLE, SIZE, OR COLOR.

NO CLAIM IS MADE TO THE EXCLUSIVE RIGHT TO USE "30", APART FROM THE MARK AS SHOWN.

FOR FERTILIZERS FOR AGRICULTURAL USE (U.S. CLS. 1, 5, 6, 10, 26 AND 46).

FIRST USE 12-3-2007; IN COMMERCE 12-3-2007.  
SANJEEV VOHRA, EXAMINING ATTORNEY

SN 85-204,416. RENNOVIA INC., MENLO PARK, CA. FILED 12-22-2010.

## RENNLON

THE MARK CONSISTS OF STANDARD CHARACTERS WITHOUT CLAIM TO ANY PARTICULAR FONT, STYLE, SIZE, OR COLOR.

THE WORD "RENNLON" HAS NO MEANING IN A FOREIGN LANGUAGE.

FOR CHEMICALS MADE IN WHOLE OR IN PART FROM CARBOHYDRATE-CONTAINING FEEDSTOCKS FOR USE IN INDUSTRY AND SCIENCE; CHEMICALS MADE IN WHOLE OR IN PART FROM CARBOHYDRATE-CONTAINING FEEDSTOCKS FOR USE IN THE MANUFACTURE OF MONOMERIC NYLON TEXTILE FIBERS AND FABRICS; POLYAMIDES, POLYMERS CONTAINING POLYAMIDES AND POLYMERIC ADDITIVES MADE IN WHOLE OR IN PART FROM CARBOHYDRATE-CONTAINING FEEDSTOCKS FOR USE IN THE MANUFACTURE OF FIBER COMPOSITES, PLASTICS, TEXTILES, FABRICS, PLASTIC MOLDING AND EXTRUSION COMPOUNDS, PLASTIC FILMS AND WOVEN AND NON-WOVEN FABRICS; CHEMICALS MADE IN WHOLE OR IN PART FROM CARBOHYDRATE-CONTAINING FEEDSTOCKS FOR USE IN THE MANUFACTURE OF FOOD, MEDICATED AND NON-MEDICATED NUTRITIONAL ADDITIVES FOR ANIMAL FOODSTUFFS AND PHARMACEUTICAL PREPARATIONS; MONOMER CHEMICALS MADE IN WHOLE OR IN PART FROM CARBOHYDRATE-CONTAINING FEEDSTOCKS FOR USE IN THE MANUFACTURE OF NYLON TEXTILE FIBERS AND FABRICS; CARBOXYLIC ACIDS AND DERIVATIVES THEREOF MADE IN WHOLE OR IN PART FROM CARBOHYDRATE-CONTAINING FEEDSTOCKS FOR USE AS CHEMICALS TO MANUFACTURE A WIDE VARIETY OF GOODS; GLUCARIC ACID FOR USE AS CHEMICALS TO MANUFACTURE A WIDE VARIETY OF GOODS; ADIPIC ACID; CHEMICALS MADE IN WHOLE OR IN PART FROM CARBOHYDRATE-CONTAINING FEEDSTOCKS FOR USE IN THE MANUFACTURE OF NYLON TEXTILE FIBERS AND FABRICS AND POLYMERIC POLYAMIDES; CHEMICAL CATALYSTS FOR USE IN THE MANUFACTURE OF INDUSTRIAL CHEMICALS; CHEMICAL CATALYSTS FOR USE IN THE MANUFACTURE OF INDUSTRIAL CHEMICALS MADE IN WHOLE OR IN PART FROM CARBOHYDRATE-CONTAINING FEEDSTOCKS (U.S. CLS. 1, 5, 6, 10, 26 AND 46).

DAVID YONTEF, EXAMINING ATTORNEY

SN 85-201,523. TIGER INDUSTRIES, INC., BRISTOL, RI. FILED 12-20-2010.

## REFLECTIONS

THE MARK CONSISTS OF STANDARD CHARACTERS WITHOUT CLAIM TO ANY PARTICULAR FONT, STYLE, SIZE, OR COLOR.

FOR LIQUID CALCIUM BASED CHEMICAL PREPARATIONS TO TREAT AGAINST EXCESSIVE HEAT AND LIGHT FOR USE WITH GREENHOUSES, MULCH, GROUND COVERS PLACED NEAR PLANTS, PLANTS, OR ANY SURFACE LOCATED BETWEEN A LIGHT OR HEAT SOURCE AND A PLANT (U.S. CLS. 1, 5, 6, 10, 26 AND 46).

FIRST USE 3-26-2010; IN COMMERCE 3-26-2010.  
REBECCA POVARCHUK, EXAMINING ATTORNEY

**CLASS 1—(Continued).**

SN 85-206,477. CULTURES FOR HEALTH, MILWAUKIE, OR. FILED 12-28-2010.



NO CLAIM IS MADE TO THE EXCLUSIVE RIGHT TO USE "CULTURES FOR HEALTH", APART FROM THE MARK AS SHOWN.

THE MARK CONSISTS OF THE LETTER "C" DEPICTED AS A TREE BRANCH WITH LEAVES AND A FLOWER; THE FLOWER INCLUDES A STEM, PEDALS AND LEAVES; THE LETTER "C" DESIGN APPEARS OVER THE WORDS "CULTURES FOR HEALTH".

FOR BACTERIAL CULTURES FOR ADDITION TO FOOD PRODUCTS (U.S. CLS. 1, 5, 6, 10, 26 AND 46).

FIRST USE 10-15-2010; IN COMMERCE 10-15-2010.

ALEXANDER L. POWERS, EXAMINING ATTORNEY

SN 85-206,985. NEW ENERGY TECHNOLOGIES, INC., COLUMBIA, MD. FILED 12-29-2010.

# PowerFilm

THE MARK CONSISTS OF STANDARD CHARACTERS WITHOUT CLAIM TO ANY PARTICULAR FONT, STYLE, SIZE, OR COLOR.

FOR ELECTRICITY GENERATING COATINGS APPLIED TO VARIOUS SUBSTRATE SURFACES FOR USE IN RENEWABLE ENERGY, NAMELY, CHEMICALS FOR USE IN CONNECTION WITH SOLAR CELLS (U.S. CLS. 1, 5, 6, 10, 26 AND 46).

JESSICA A. POWERS, EXAMINING ATTORNEY

**CLASS 1—(Continued).**

SN 85-206,987. NEW ENERGY TECHNOLOGIES, INC., COLUMBIA, MD. FILED 12-29-2010.

# ClearlyElectric

THE MARK CONSISTS OF STANDARD CHARACTERS WITHOUT CLAIM TO ANY PARTICULAR FONT, STYLE, SIZE, OR COLOR.

FOR ELECTRICITY GENERATING COATINGS APPLIED TO VARIOUS SUBSTRATE SURFACES FOR USE IN RENEWABLE ENERGY, NAMELY, CHEMICALS FOR USE IN CONNECTION WITH SOLAR CELLS (U.S. CLS. 1, 5, 6, 10, 26 AND 46).

JESSICA A. POWERS, EXAMINING ATTORNEY

SN 85-206,991. NEW ENERGY TECHNOLOGIES, INC., COLUMBIA, MD. FILED 12-29-2010.

# PowerCoatings

THE MARK CONSISTS OF STANDARD CHARACTERS WITHOUT CLAIM TO ANY PARTICULAR FONT, STYLE, SIZE, OR COLOR.

FOR ELECTRICITY GENERATING COATINGS APPLIED TO VARIOUS SUBSTRATE SURFACES FOR USE IN RENEWABLE ENERGY, NAMELY, CHEMICALS FOR USE IN CONNECTION WITH SOLAR CELLS (U.S. CLS. 1, 5, 6, 10, 26 AND 46).

JESSICA A. POWERS, EXAMINING ATTORNEY

SN 85-208,474. NEW ENERGY TECHNOLOGIES, INC., COLUMBIA, MD. FILED 12-31-2010.

# Clearly Electric

THE MARK CONSISTS OF STANDARD CHARACTERS WITHOUT CLAIM TO ANY PARTICULAR FONT, STYLE, SIZE, OR COLOR.

NO CLAIM IS MADE TO THE EXCLUSIVE RIGHT TO USE "ELECTRIC", APART FROM THE MARK AS SHOWN.

FOR ELECTRICITY GENERATING COATINGS APPLIED TO VARIOUS SUBSTRATE SURFACES FOR USE IN RENEWABLE ENERGY, NAMELY, CHEMICALS FOR USE IN CONNECTION WITH SOLAR CELLS (U.S. CLS. 1, 5, 6, 10, 26 AND 46).

JESSICA A. POWERS, EXAMINING ATTORNEY

**CLASS 1—(Continued).**

SN 85-209,994. ALPHAPET, INC., DECATUR, AL. FILED 1-4-2011.

# FUTURE PET

THE MARK CONSISTS OF STANDARD CHARACTERS WITHOUT CLAIM TO ANY PARTICULAR FONT, STYLE, SIZE, OR COLOR.

NO CLAIM IS MADE TO THE EXCLUSIVE RIGHT TO USE "PET", APART FROM THE MARK AS SHOWN.

FOR POLYESTER RESINS MADE AT LEAST PARTIALLY FROM POST CONSUMER POLYMERIC CONTENT (U.S. CLS. 1, 5, 6, 10, 26 AND 46).

ALICE BENMAMAN, EXAMINING ATTORNEY

**CLASS 1—(Continued).**

SN 85-213,798. CHEMI NUTRA LLC, WHITE BEAR LAKE, MN. FILED 1-10-2011.

# MITOCL

THE MARK CONSISTS OF STANDARD CHARACTERS WITHOUT CLAIM TO ANY PARTICULAR FONT, STYLE, SIZE, OR COLOR.

FOR CHEMICAL ADDITIVES FOR USE IN THE MANUFACTURE OF DIETARY NUTRITIONAL SUPPLEMENTS (U.S. CLS. 1, 5, 6, 10, 26 AND 46).

DAVID TOOLEY, EXAMINING ATTORNEY

SN 85-211,009. MEC COMPANY LTD., HYOGO, JAPAN, FILED 1-5-2011.

# FlatBOND

THE MARK CONSISTS OF STANDARD CHARACTERS WITHOUT CLAIM TO ANY PARTICULAR FONT, STYLE, SIZE, OR COLOR.

OWNER OF U.S. REG. NO. 2,422,669.

FOR CHEMICAL COATINGS USED IN THE MANUFACTURE OF PRINTED CIRCUIT BOARDS (U.S. CLS. 1, 5, 6, 10, 26 AND 46).

GISELLE AGOSTO, EXAMINING ATTORNEY

SN 85-213,820. CHEMI NUTRA LLC, WHITE BEAR LAKE, MN. FILED 1-10-2011.

# CHONDRIAL

THE MARK CONSISTS OF STANDARD CHARACTERS WITHOUT CLAIM TO ANY PARTICULAR FONT, STYLE, SIZE, OR COLOR.

FOR CHEMICAL ADDITIVES FOR USE IN THE MANUFACTURE OF DIETARY NUTRITIONAL SUPPLEMENTS (U.S. CLS. 1, 5, 6, 10, 26 AND 46).

DAVID TOOLEY, EXAMINING ATTORNEY

SN 85-213,772. APPLIED GENETICS INCORPORATED DERMATICS, NEW YORK, NY. FILED 1-10-2011.

# EVODIOX

THE MARK CONSISTS OF STANDARD CHARACTERS WITHOUT CLAIM TO ANY PARTICULAR FONT, STYLE, SIZE, OR COLOR.

OWNER OF U.S. REG. NO. 3,028,469.

FOR CHEMICAL INGREDIENT COMPLEX FOR USE IN THE MANUFACTURE OF COSMETICS AND NON-MEDICATED SKIN CARE PREPARATIONS (U.S. CLS. 1, 5, 6, 10, 26 AND 46).

FIRST USE 7-13-2004; IN COMMERCE 7-13-2004.

JEAN IM, EXAMINING ATTORNEY

SN 85-213,836. PYRAMAX CERAMICS LLC, GREENWICH, CT. FILED 1-10-2011.

# PYRAMAX

THE MARK CONSISTS OF STANDARD CHARACTERS WITHOUT CLAIM TO ANY PARTICULAR FONT, STYLE, SIZE, OR COLOR.

FOR PROPANT FOR USE IN OIL WELL AND GAS WELL HYDRAULIC FRACTURING OPERATIONS (U.S. CLS. 1, 5, 6, 10, 26 AND 46).

PAM WILLIS, EXAMINING ATTORNEY



**CLASS 1—(Continued).**

SN 85-214,420. R.V. CONCEPTS, LLC, DBA HAPPY CAMPERS, MEDFORD, OR. FILED 1-10-2011.

**HAPPY CAMPERS**

THE MARK CONSISTS OF STANDARD CHARACTERS WITHOUT CLAIM TO ANY PARTICULAR FONT, STYLE, SIZE, OR COLOR.

FOR CHEMICALS FOR THE TREATMENT OF WATER AND WASTEWATER (U.S. CLS. 1, 5, 6, 10, 26 AND 46).  
FIRST USE 1-1-2002; IN COMMERCE 1-7-2003.  
SANJEEV VOHRA, EXAMINING ATTORNEY

---

SN 85-217,639. MYTEX POLYMERS US CORP., JEFFERSONVILLE, IN. FILED 1-14-2011.

**METAFORM**

THE MARK CONSISTS OF STANDARD CHARACTERS WITHOUT CLAIM TO ANY PARTICULAR FONT, STYLE, SIZE, OR COLOR.

FOR THERMOPLASTIC COMPOUNDS, NAMELY, POLYOLEFIN RESINS USED IN THE AUTOMOTIVE INDUSTRY, HEAVY TRUCK INDUSTRY, AND TRANSPORTATION MARKETS FOR INTERIOR TRIM, BUMPER FACIA, AUTOMOTIVE LAMP HOUSING, INSTRUMENT PANEL RETAINERS, UNDER HOOD COMPONENTS, AND THE LIKE (U.S. CLS. 1, 5, 6, 10, 26 AND 46).

GIANCARLO CASTRO, EXAMINING ATTORNEY

---

SN 85-217,660. MYTEX POLYMERS US CORP., JEFFERSONVILLE, IN. FILED 1-14-2011.

**DURAFLEX**

THE MARK CONSISTS OF STANDARD CHARACTERS WITHOUT CLAIM TO ANY PARTICULAR FONT, STYLE, SIZE, OR COLOR.

FOR THERMOPLASTIC COMPOUNDS, NAMELY, POLYOLEFIN RESINS USED IN THE AUTOMOTIVE INDUSTRY, HEAVY TRUCK INDUSTRY, AND TRANSPORTATION MARKETS FOR INTERIOR TRIM, BUMPER FACIA, AUTOMOTIVE LAMP HOUSING, INSTRUMENT PANEL RETAINERS, UNDER HOOD COMPONENTS, AND THE LIKE (U.S. CLS. 1, 5, 6, 10, 26 AND 46).

GIANCARLO CASTRO, EXAMINING ATTORNEY

**CLASS 1—(Continued).**

SN 85-217,668. MYTEX POLYMERS US CORP., JEFFERSONVILLE, IN. FILED 1-14-2011.

**DYNAFLOW**

THE MARK CONSISTS OF STANDARD CHARACTERS WITHOUT CLAIM TO ANY PARTICULAR FONT, STYLE, SIZE, OR COLOR.

FOR THERMOPLASTIC COMPOUNDS, NAMELY, POLYOLEFIN RESINS USED IN THE AUTOMOTIVE INDUSTRY, HEAVY TRUCK INDUSTRY, AND TRANSPORTATION MARKETS FOR INTERIOR TRIM, BUMPER FACIA, AUTOMOTIVE LAMP HOUSING, INSTRUMENT PANEL RETAINERS, UNDER HOOD COMPONENTS, AND THE LIKE (U.S. CLS. 1, 5, 6, 10, 26 AND 46).

GIANCARLO CASTRO, EXAMINING ATTORNEY

**CLASS 2—PAINTS**

SN 76-706,026. ENNIS PAINT, INC., DALLAS, TX. FILED 1-18-2011.

**PERVOPLUS**

THE MARK CONSISTS OF STANDARD CHARACTERS WITHOUT CLAIM TO ANY PARTICULAR FONT, STYLE, SIZE, OR COLOR.

FOR PAVEMENT MARKING PAINT (U.S. CLS. 6, 11 AND 16).

DORITT L. CARROLL, EXAMINING ATTORNEY

---

SN 76-706,027. ENNIS PAINT, INC., DALLAS, TX. FILED 1-18-2011.

**PERVOSTRIPE**

THE MARK CONSISTS OF STANDARD CHARACTERS WITHOUT CLAIM TO ANY PARTICULAR FONT, STYLE, SIZE, OR COLOR.

FOR PAVEMENT MARKING PAINT (U.S. CLS. 6, 11 AND 16).

DORITT L. CARROLL, EXAMINING ATTORNEY

**CLASS 2—(Continued).**

SN 76-706,043. ENNIS PAINT, INC., DALLAS, TX. FILED 1-19-2011.

**CHROMAGRIP**

THE MARK CONSISTS OF STANDARD CHARACTERS WITHOUT CLAIM TO ANY PARTICULAR FONT, STYLE, SIZE, OR COLOR.

FOR THERMOPLASTIC PAINT MATERIALS FOR USE ON ROAD SURFACES, SOME WITH ANTI-SKID PROPERTIES (U.S. CLS. 6, 11 AND 16).

FIRST USE 9-0-2010; IN COMMERCE 9-0-2010.

DORITT L. CARROLL, EXAMINING ATTORNEY

SN 76-706,044. ENNIS PAINT, INC., DALLAS, TX. FILED 1-19-2011.

**CYCLEGRIP**

THE MARK CONSISTS OF STANDARD CHARACTERS WITHOUT CLAIM TO ANY PARTICULAR FONT, STYLE, SIZE, OR COLOR.

FOR THERMOPLASTIC PAINT MATERIALS FOR USE ON ROAD SURFACES, SOME WITH ANTI-SKID PROPERTIES (U.S. CLS. 6, 11 AND 16).

FIRST USE 9-0-2010; IN COMMERCE 9-0-2010.

DORITT L. CARROLL, EXAMINING ATTORNEY

SN 76-706,045. ENNIS PAINT, INC., DALLAS, TX. FILED 1-19-2011.

**COLOURBRIGHT**

THE MARK CONSISTS OF STANDARD CHARACTERS WITHOUT CLAIM TO ANY PARTICULAR FONT, STYLE, SIZE, OR COLOR.

FOR THERMOPLASTIC PAINT MATERIALS FOR USE ON ROAD SURFACES, SOME WITH ANTI-SKID PROPERTIES (U.S. CLS. 6, 11 AND 16).

FIRST USE 9-0-2010; IN COMMERCE 9-0-2010.

DORITT L. CARROLL, EXAMINING ATTORNEY

**CLASS 2—(Continued).**

SN 79-091,738. KT.COLOR AG, SWITZERLAND, FILED 11-19-2010.

**KT**

THE MARK CONSISTS OF STANDARD CHARACTERS WITHOUT CLAIM TO ANY PARTICULAR FONT, STYLE, SIZE, OR COLOR.

PRIORITY DATE OF 7-12-2010 IS CLAIMED.

OWNER OF INTERNATIONAL REGISTRATION 1062803 DATED 11-19-2010, EXPIRES 11-19-2020.

OWNER OF U.S. REG. NO. 3,294,214.

FOR PAINTS, COLORANTS, PIGMENTS, NATURAL AND SYNTHETIC DYES, VARNISHES, LACQUERS; DYESTUFFS; RAW NATURAL RESINS; METALS IN FOIL AND POWDER FORM FOR PAINTERS, DECORATORS, PRINTERS AND ARTISTS (U.S. CLS. 6, 11 AND 16).

FRED CARL, EXAMINING ATTORNEY

SN 85-026,932. KLEIN, KEITH, ASHEVILLE, NC. FILED 4-30-2010.

**MIRACLECOLORSEAL**

THE MARK CONSISTS OF STANDARD CHARACTERS WITHOUT CLAIM TO ANY PARTICULAR FONT, STYLE, SIZE, OR COLOR.

FOR PAINTS, NAMELY, COLORANTS (U.S. CLS. 6, 11 AND 16).

SANI KHOURI, EXAMINING ATTORNEY

SN 85-134,823. BECKER-UNDERWOOD, INC., AMES, IA. FILED 9-21-2010.

**CUSHIONFALL SPORT**

THE MARK CONSISTS OF STANDARD CHARACTERS WITHOUT CLAIM TO ANY PARTICULAR FONT, STYLE, SIZE, OR COLOR.

OWNER OF U.S. REG. NO. 3,554,004.

NO CLAIM IS MADE TO THE EXCLUSIVE RIGHT TO USE "SPORT", APART FROM THE MARK AS SHOWN.

FOR COLORANTS (U.S. CLS. 6, 11 AND 16).

JERI J. FICKES, EXAMINING ATTORNEY

**CLASS 2—(Continued).**

SN 85-137,658. ECO WORLD, INC., AKA PRINTPAYLESS, LA PUENTE, CA. FILED 9-24-2010.



NO CLAIM IS MADE TO THE EXCLUSIVE RIGHT TO USE "INK", APART FROM THE MARK AS SHOWN.

THE COLOR(S) RED, BLUE, YELLOW, GREEN IS/ARE CLAIMED AS A FEATURE OF THE MARK.

THE MARK CONSISTS OF THREE SHINING WATER DROPS IN THE UPPER LEFT SIDE OF THE MARK IN, FROM LEFT TO RIGHT, RED, BLUE, AND YELLOW. TO THE RIGHT OF THE DESIGN IS THE STYLIZED WORDING "INK REVOLUTION" IN GREEN. BELOW THE DESIGN IS THE WORDING "PRINT PAY LESS" IN BLUE.

FOR INKS, AND DYES FOR USE WITH OR ON TEXTILES AND FABRICS; METALLIC INKS; PRINTING COMPOSITIONS; THERMOCHROMIC PRINTING INKS; THERMOGRAPHIC INK; FILLED INK CARTRIDGES; INK CARTRIDGES FOR PRINTERS; INK FOR MULTI-FUNCTION ELECTRONIC DEVICES FOR USE IN COPYING, PRINTING, SCANNING, VIDEO CAPTURE OR TRANSMITTING DOCUMENTS AND IMAGES; INK JET CARTRIDGES; INK JET PRINTER INK; PRINTERS' INK; PRINTING INK; PRINTING INKS; PRINTING INKS, COATINGS, PIGMENTS AND DISPERSIONS FOR USE IN THE GRAPHIC ARTS INDUSTRY (U.S. CLS. 6, 11 AND 16).

FIRST USE 4-28-2010; IN COMMERCE 4-28-2010.

JAMES STEIN, EXAMINING ATTORNEY

SN 85-146,335. DYSTAR COLOURS DEUTSCHLAND GMBH, 65926 FRANKFURT, FED REP GERMANY, FILED 10-6-2010.

# PALANIL

THE MARK CONSISTS OF STANDARD CHARACTERS WITHOUT CLAIM TO ANY PARTICULAR FONT, STYLE, SIZE, OR COLOR.

FOR DYES AND COLORANTS FOR USE IN THE MANUFACTURE OF TEXTILES (U.S. CLS. 6, 11 AND 16).

BRIDGETT SMITH, EXAMINING ATTORNEY

**CLASS 2—(Continued).**

SN 85-174,573. HI-TEMP COATINGS TECHNOLOGY COMPANY, INC., BOXBOROUGH, MA. FILED 11-11-2010.

# Hi-Temp 1029

THE MARK CONSISTS OF STANDARD CHARACTERS WITHOUT CLAIM TO ANY PARTICULAR FONT, STYLE, SIZE, OR COLOR.

NO CLAIM IS MADE TO THE EXCLUSIVE RIGHT TO USE "HIGH TEMP", APART FROM THE MARK AS SHOWN.

FOR LIQUID ANTI-CORROSIVE COATINGS IN THE NATURE OF A THICK-FILM COATING FORMULATED FOR INSULATED AND UN-INSULATED SURFACES (U.S. CLS. 6, 11 AND 16).

REBECCA EISINGER, EXAMINING ATTORNEY

SN 85-174,580. HI-TEMP COATINGS TECHNOLOGY COMPANY, INC., BOXBOROUGH, MA. FILED 11-11-2010.

# Hi-Temp 1030

THE MARK CONSISTS OF STANDARD CHARACTERS WITHOUT CLAIM TO ANY PARTICULAR FONT, STYLE, SIZE, OR COLOR.

NO CLAIM IS MADE TO THE EXCLUSIVE RIGHT TO USE "HIGH TEMP", APART FROM THE MARK AS SHOWN.

FOR LIQUID ANTI-CORROSIVE COATINGS IN THE NATURE OF A THICK-FILM COATING FORMULATED FOR INSULATED AND UN-INSULATED SURFACES (U.S. CLS. 6, 11 AND 16).

REBECCA EISINGER, EXAMINING ATTORNEY

SN 85-199,809. DUNCAN ENTERPRISES, FRESNO, CA. FILED 12-16-2010.

# THIN 'N SHADE

THE MARK CONSISTS OF STANDARD CHARACTERS WITHOUT CLAIM TO ANY PARTICULAR FONT, STYLE, SIZE, OR COLOR.

FOR WATER SOLUBLE THINNERS SPECIFICALLY FOR PAINTS AND FIRED AND NON-FIRED CERAMIC COLORS AND STAINS (U.S. CLS. 6, 11 AND 16).

FIRST USE 7-6-1976; IN COMMERCE 7-6-1976.

MARY ROSSMAN, EXAMINING ATTORNEY

**CLASS 2—(Continued).**

SN 85-201,095. CAROMAL COLOURS INC., MECHANICSBURG, PA. FILED 12-17-2010.

# RECLAIM

THE MARK CONSISTS OF STANDARD CHARACTERS WITHOUT CLAIM TO ANY PARTICULAR FONT, STYLE, SIZE, OR COLOR.

FOR COATINGS IN THE NATURE OF PAINTS AND FINISHES FOR CABINETRY AND FURNITURE FINISHING, FOR INTERIOR USE ON A VARIETY OF SUBSTRATES (U.S. CLS. 6, 11 AND 16).

MICHAEL GAAFAR, EXAMINING ATTORNEY

---

SN 85-213,002. GALAXY ASSOCIATES, INC., CINCINNATI, OH. FILED 1-7-2011.

# GALAXY LEAN COAT

THE MARK CONSISTS OF STANDARD CHARACTERS WITHOUT CLAIM TO ANY PARTICULAR FONT, STYLE, SIZE, OR COLOR.

NO CLAIM IS MADE TO THE EXCLUSIVE RIGHT TO USE "COAT", APART FROM THE MARK AS SHOWN.

FOR PHOSPHATE-FREE REACTIVE CONVERSION COATING FORMULATED FOR USE IN THE TREATMENT OF STEEL AND ALUMINUM SURFACES (U.S. CLS. 6, 11 AND 16).

FIRST USE 6-23-2008; IN COMMERCE 6-23-2008.  
JANET LEE, EXAMINING ATTORNEY

**CLASS 3—COSMETICS AND CLEANING PREPARATIONS**

SN 76-703,034. SOCIETE PARISIENNE DE PARFUMS ET COSMETIQUES, PARIS, FRANCE, FILED 5-20-2010.

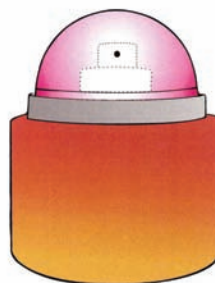

THE COLOR(S) ORANGE, PINK AND SILVER IS/ARE CLAIMED AS A FEATURE OF THE MARK.

THE MARK CONSISTS OF A THREE DIMENSIONAL CONFIGURATION OF A PERFUME BOTTLE AND CAP THEREFORE. THE BOTTLE IS ROUND AND GENERALLY SHORT AND BROAD AND IS COLORED ORANGE. THE CAP HAS A SILVER BASE AND A PINK OVAL TOP. THE BROKEN LINE DEPICTING THE SPRAY NOZZLE INDICATE PLACEMENT OF THE MARK ON THE GOODS AND ARE NOT PART OF THE MARK.

SEC. 2(F).

FOR PERFUMES AND COLOGNES (U.S. CLS. 1, 4, 6, 50, 51 AND 52).

FIRST USE 9-0-2007; IN COMMERCE 10-0-2007.

PRISCILLA MILTON, EXAMINING ATTORNEY

---

SN 77-197,175. NU RADIANCE, INC., GREEN BAY, WI. FILED 6-4-2007.

# Duet

THE MARK CONSISTS OF STANDARD CHARACTERS WITHOUT CLAIM TO ANY PARTICULAR FONT, STYLE, SIZE, OR COLOR.

NO CLAIM IS MADE TO THE EXCLUSIVE RIGHT TO USE "COAT", APART FROM THE MARK AS SHOWN.

FOR PHOSPHATE-FREE REACTIVE CONVERSION COATING FORMULATED FOR USE IN THE TREATMENT OF STEEL AND ALUMINUM SURFACES (U.S. CLS. 6, 11 AND 16).

FIRST USE 6-23-2008; IN COMMERCE 6-23-2008.  
JANET LEE, EXAMINING ATTORNEY

THE MARK CONSISTS OF STANDARD CHARACTERS WITHOUT CLAIM TO ANY PARTICULAR FONT, STYLE, SIZE, OR COLOR.

FOR TOOTH WHITENING GELS (U.S. CLS. 1, 4, 6, 50, 51 AND 52).

FIRST USE 10-2-2001; IN COMMERCE 10-2-2001.  
KAREN K. BUSH, EXAMINING ATTORNEY



**CLASS 3—(Continued).**

SN 77-360,256. C & L TRADING OF MIAMI, INC., MIAMI, FL. FILED 12-27-2007.

FOR COSMETICS, NAMELY, NAIL POLISH, NAIL ART LACQUER, EYE PENCILS, LIP PENCIL, MASCARA, EYE SHADOW, LIP GLOSS, LIQUID EYELINER (U.S. CLS. 1, 4, 6, 50, 51 AND 52).  
THEODORE MCBRIDE, EXAMINING ATTORNEY

**CLASS 3—(Continued).**

SN 77-861,698. AMOREPACIFIC CORPORATION, SEOUL, REPUBLIC OF KOREA, FILED 10-30-2009.

옥용 (玉容) 팩  
**SKIN CLARIFYING MASK**

PRIORITY CLAIMED UNDER SEC. 44(D) ON REPUBLIC OF KOREA APPLICATION NO. 40200938511, FILED 8-12-2009, REG. NO. 400848338, DATED 1-3-2011, EXPIRES 1-3-2021.

NO CLAIM IS MADE TO THE EXCLUSIVE RIGHT TO USE "SKIN CLARIFYING MASK", APART FROM THE MARK AS SHOWN.

THE MARK CONSISTS OF TWO-SYLLABLE KOREAN LETTERS FOLLOWED BY TWO-SYLLABLE CHINESE LETTERS IN PARENTHESIS AND TWO SYLLABLE KOREAN LETTERS IN FIRST LINE, AND "SKIN CLARIFYING MASK" IN SECOND LINE.

THE NON-LATIN CHARACTERS IN THE MARK TRANSLITERATE TO "OK-YONG PACK" AND THIS MEANS "JADE FACE PACK" IN ENGLISH.

FOR COSMETIC MASKS; COSMETICS; MASSAGE CREAMS; MASSAGE OILS; TOILET WATER (U.S. CLS. 1, 4, 6, 50, 51 AND 52).

ELIZABETH KAJUBI, EXAMINING ATTORNEY

SN 77-826,536. COMPASSIONATE CONSULTANT FOR WELLNESS, LLC, VALLEY VILLAGE, CA. FILED 9-15-2009.

**GOD'S GIFT**

THE MARK CONSISTS OF STANDARD CHARACTERS WITHOUT CLAIM TO ANY PARTICULAR FONT, STYLE, SIZE, OR COLOR.

FOR BODY CARE PRODUCTS, NAMELY, BODY LOTION, BODY SPRAY, SHAMPOOS, CONDITIONERS, NON-MEDICATED LIP BALMS, BODY POLISHES, SOAPS, SHOWER GELS, FACE MASKS, MASSAGE OILS (U.S. CLS. 1, 4, 6, 50, 51 AND 52).

JOHN HWANG, EXAMINING ATTORNEY

SN 77-867,879. DR. DERMAL LLC, WILMINGTON, DE. FILED 11-9-2009.

**DR DERMAL**

THE MARK CONSISTS OF STANDARD CHARACTERS WITHOUT CLAIM TO ANY PARTICULAR FONT, STYLE, SIZE, OR COLOR.

THE NAME(S), PORTRAIT(S), AND/OR SIGNATURE(S) SHOWN IN THE MARK DOES NOT IDENTIFY A PARTICULAR LIVING INDIVIDUAL.

FOR NON-MEDICATED SKIN CARE PREPARATIONS, NAMELY, SKIN MOISTURIZERS, SKIN LOTIONS, SKIN EXFOLIATORS, GELS, CLEANSERS, EYE CREAMS, AND DISPOSABLE WIPES AND SKIN PADS IMPREGNATED WITH MAKE-UP REMOVER OR CLEANSING COMPOUNDS (U.S. CLS. 1, 4, 6, 50, 51 AND 52).

FIRST USE 10-20-2009; IN COMMERCE 10-20-2009.

CORY BOONE, EXAMINING ATTORNEY

**CLASS 3—(Continued).**

SN 77-908,632. FOAMIX LTD., NES ZIONA, ISRAEL, FILED 1-11-2010.

# UFOAM

THE MARK CONSISTS OF STANDARD CHARACTERS WITHOUT CLAIM TO ANY PARTICULAR FONT, STYLE, SIZE, OR COLOR.

OWNER OF U.S. REG. NO. 3,555,212.

FOR NON-MEDICATED FOAMABLE, FOAM AND MOUSSE SKIN CARE PREPARATIONS FOR USE BY BABIES, INFANTS, CHILDREN, TEENAGERS AND/OR ADULTS; NON-MEDICATED FOAMABLE, FOAM AND MOUSSE CARE PREPARATIONS, NAMELY, COSMETICS FOR MUCOUS MEMBRANES FOR USE BY BABIES, INFANTS, CHILDREN, TEENAGERS AND/OR ADULTS; NON-MEDICATED FOAMABLE, FOAM AND MOUSSE BODY CAVITY CARE PREPARATIONS, NAMELY, VAGINAL, RECTAL AND EAR CARE PREPARATIONS IN THE NATURE OF COSMETICS FOR USE BY BABIES, INFANTS, CHILDREN, TEENAGERS AND/OR ADULTS; NON-MEDICATED FOAMABLE, FOAM AND MOUSSE SKINCARE PREPARATIONS PRIMARILY COMPOSED OF COSMETICS FOR CLEANSING THE SKIN; NON-MEDICATED FOAMABLE PREPARATIONS, MOUSSES AND FOAMS PRIMARILY CONTAINING COSMETICS, SKIN CONDITIONERS, SKIN MOISTURIZERS, COSMETICS FEATURING PIGMENTS, COSMETICS FEATURING DYES, COSMETICS FEATURING ANTIPIGMENTATION AGENTS, COSMETICS FEATURING ANTI-WRINKLE AGENTS, COSMETICS FEATURING ANTICELLULITE AGENTS, COSMETICS FEATURING ANTI-OXIDANTS, COSMETICS FEATURING LUBRICATING AGENTS, COSMETICS FEATURING WARMING AGENTS, COSMETICS FEATURING COOLING AGENTS, COSMETICS FEATURING FRAGRANCES, COSMETICS FEATURING FREE-RADICAL SCAVENGERS, COSMETICS IN THE NATURE OF FACIAL CLEANSERS (U.S. CLS. 1, 4, 6, 50, 51 AND 52).

MAUREEN DALL, EXAMINING ATTORNEY

**CLASS 3—(Continued).**

SN 77-925,915. ROHTO PHARMACEUTICAL CO., LTD., OSAKA, JAPAN, FILED 2-2-2010.

## ROHTO Hada Labo

THE MARK CONSISTS OF STANDARD CHARACTERS WITHOUT CLAIM TO ANY PARTICULAR FONT, STYLE, SIZE, OR COLOR.

OWNER OF U.S. REG. NOS. 2,633,109, 3,476,759 AND OTHERS.

NO CLAIM IS MADE TO THE EXCLUSIVE RIGHT TO USE "HADA LABO", APART FROM THE MARK AS SHOWN.

THE ENGLISH TRANSLATION OF "HADA" IN THE MARK IS "SKIN". THE ENGLISH TRANSLATION OF "LABO" IN THE MARK IS "LAB". THE WORDING "ROHTO" HAS NO MEANING IN A FOREIGN LANGUAGE.

FOR SOAPS; TOILET SOAPS; COSMETIC PREPARATIONS FOR SKINCARE, NAMELY, CREAMS, LOTIONS, OILS, GEL, FOAM, TONERS, AND SKIN SERUM; HAND AND FACE LOTIONS FOR COSMETIC PURPOSES; MILKS FOR COSMETIC PURPOSES; BEAUTY MASKS; FACIAL WASHES; MAKE-UP REMOVING LOTIONS, OILS, AND MILKS; SUNSCREEN PREPARATIONS; TISSUES IMPREGNATED WITH COSMETIC LOTIONS; SKIN WHITENING CREAM (U.S. CLS. 1, 4, 6, 50, 51 AND 52).

APRIL HESIK, EXAMINING ATTORNEY

SN 79-072,436. PACIFIC CREATION, FRANCE, FILED 4-6-2009.



PRIORITY DATE OF 10-15-2008 IS CLAIMED.  
OWNER OF INTERNATIONAL REGISTRATION 1011920 DATED 4-6-2009, EXPIRES 4-6-2019.

THE COLOR GRAY REPRESENTS OUTLINING AND SHADING AND TRANSPARENT AREAS APPEAR IN WHITE AND ARE NOT PART OF THE MARK

THE COLOR(S) GOLD, WHITE, PURPLE, RED, PINK AND GREEN IS/ARE CLAIMED AS A FEATURE OF THE MARK.

THE MARK CONSISTS OF PRODUCT PACKAGING IN THE FORM OF A CLEAR THREE DIMENSIONAL BOTTLE

**CLASS 3—(Continued).**

WITH MULTIPLE CURVED EDGES RESEMBLING A TREFOIL WITH FOUR LEAVES. THE OUTER EDGES OF THE BOTTLE ARE HIGHLIGHTED IN GOLD. THE CYLINDRICAL SPRAYER CAP IS DEPICTED IN GOLD, AND A WHITE AND PURPLE POLKA DOTTED SCARF PICTURING A RED AND PINK FLOWER ON A GREEN STEM IS TIED TO THE NECK OF THE BOTTLE. THE PUMP STEM IS CLEAR. THE SHAPE OF THE SPRAYER CAP AND PUMP-STEM INSIDE THE BOTTLE ARE NOT CLAIMED AS FEATURES OF THE MARK.

FOR PERFUMERY, ESSENTIAL OILS, DEODORANTS FOR PERSONAL USE (PERFUMERY), PERFUMES, TOILET WATER, SCENTED WATER (U.S. CLS. 1, 4, 6, 50, 51 AND 52).

THOMAS MANOR, EXAMINING ATTORNEY

**CLASS 3—(Continued).**

SN 79-088,348. WANG LIN, CHINA, FILED 9-14-2010.



OWNER OF INTERNATIONAL REGISTRATION 1053903 DATED 9-14-2010, EXPIRES 9-14-2020.

THE MARK CONSISTS OF THE STYLIZED WORDING "FRANDY" WITH A DESIGN OF A HEART SHAPED ANGEL, FORMING A DESIGN AS PART OF THE LETTER "F."

FOR PERFUMES; SHAMPOOS; FACIAL WASHING MILK; BATH LOTION; DENTIFRICES; COSMETICS; HAIR SPRAY; CAKES OF SOAP; HAIR CONDITIONER; ANTIMICROBIAL HAND LOTION (U.S. CLS. 1, 4, 6, 50, 51 AND 52).

REBECCA SMITH, EXAMINING ATTORNEY

SN 79-086,276. CHULEEVANDEVI KFT., HUNGARY, FILED 4-15-2010.



OWNER OF INTERNATIONAL REGISTRATION 1048207 DATED 4-15-2010, EXPIRES 4-15-2020.

THE COLOR(S) GOLD AND DEEP RED IS/ARE CLAIMED AS A FEATURE OF THE MARK.

THE MARK CONSISTS OF THE FOLLOWING: THE DEEP RED WORDING "CHULEEVANDEVI" AND A GOLD DESIGN OF TWO STYLIZED HANDS FORMING A TULIP-LIKE DESIGN.

THE WORDING "CHULEEVANDEVI" HAS NO MEANING IN A FOREIGN LANGUAGE.

FOR BLEACHING PREPARATIONS AND SOAP FOR LAUNDRY USE; CLEANING PREPARATIONS; POLISHING PREPARATIONS; SCOURING AND ABRASIVE PREPARATIONS; SOAP; PERFUMERY; ESSENTIAL OILS; COSMETICS, HAIR LOTIONS; DENTIFRICES (U.S. CLS. 1, 4, 6, 50, 51 AND 52).

LAURA HAMMEL, EXAMINING ATTORNEY

SN 79-088,955. L'OCCITANE, FRANCE, FILED 9-24-2010.

**L'Occitane Mon Huile Nature**

SN 79-087,223. BURBERRY LIMITED, UNITED KINGDOM, FILED 5-20-2010.



THE MARK CONSISTS OF STANDARD CHARACTERS WITHOUT CLAIM TO ANY PARTICULAR FONT, STYLE, SIZE, OR COLOR.

PRIORITY DATE OF 5-4-2010 IS CLAIMED.

OWNER OF INTERNATIONAL REGISTRATION 1050774 DATED 5-20-2010, EXPIRES 5-20-2020.

OWNER OF U.S. REG. NOS. 2,875,336, 3,202,484 AND OTHERS.

FOR COSMETICS; AFTERSHAVE PREPARATIONS; NON-MEDICATED PREPARATIONS FOR THE BATH AND SHOWER; COSMETIC PREPARATIONS FOR BODY CARE; NON-MEDICATED SKIN CARE PREPARATIONS; NAIL CARE PREPARATIONS; FALSE NAILS; ROOM FRAGRANCES, INCENSE; DECORATIVE TRANSFERS FOR COSMETIC PURPOSES; BABY SKIN CREAMS, LOTIONS, SHAMPOOS; CLEANING AND CONDITIONING PREPARATIONS FOR LEATHER AND LEATHER GOODS (U.S. CLS. 1, 4, 6, 50, 51 AND 52).

BARBARA GAYNOR, EXAMINING ATTORNEY

PRIORITY DATE OF 4-28-2010 IS CLAIMED.

OWNER OF INTERNATIONAL REGISTRATION 1055570 DATED 9-24-2010, EXPIRES 9-24-2020.

OWNER OF U.S. REG. NOS. 2,021,793 AND 3,838,040.

NO CLAIM IS MADE TO THE EXCLUSIVE RIGHT TO USE "HUILE NATURE", APART FROM THE MARK AS SHOWN.

THE WORDING "L'OCCITANE" ALONE HAS NO ENGLISH TRANSLATION BUT THE ENGLISH TRANSLATION OF "L'OCCITANE MON HUILE NATURE" IN THE MARK IS "L'OCCITANE MY NATURAL OIL".

FOR ESSENTIAL OILS; COSMETICS; HAIR LOTIONS; OILS FOR COSMETIC USE; OILS FOR PERFUMES AND SCENTS; COSMETIC PREPARATIONS FOR BATHS; SHAMPOOS, SHOWER GEL; COSMETIC PREPARATIONS FOR SKIN CARE; COSMETIC CREAMS; COSMETIC PENCILS; MAKE-UP AND MAKE-UP REMOVING PREPARATIONS; LOTIONS FOR COSMETIC USE; NON-MEDICATED TOILETRIES; COSMETIC PREPARATIONS FOR SLIMMING PURPOSES; COSMETIC SUNSCREEN PREPARATIONS; SUN BLOCK PREPARATIONS (U.S. CLS. 1, 4, 6, 50, 51 AND 52).

DEIRDRE ROBERTSON, EXAMINING ATTORNEY

**CLASS 3—(Continued).**

SN 79-089,481. PARFUMS TED LAPIDUS, FRANCE, FILED 10-11-2010.

# ALCAZAR

THE MARK CONSISTS OF STANDARD CHARACTERS WITHOUT CLAIM TO ANY PARTICULAR FONT, STYLE, SIZE, OR COLOR.

PRIORITY DATE OF 4-15-2010 IS CLAIMED.

OWNER OF INTERNATIONAL REGISTRATION 1056961 DATED 10-11-2010, EXPIRES 10-11-2020.

FOR PERFUMERY, NAMELY, PERFUMES AND EAUX DE TOILETTE; BEAUTY PRODUCTS IN THE NATURE OF COSMETICS, NAMELY, BLUSHER, EYE SHADOW, FOUNDATIONS, FACE AND BEAUTY MASKS, LIPSTICKS, NAIL VARNISH, NAIL VARNISH REMOVING PREPARATIONS; LOTIONS, NAMELY, FACIAL LOTION, EYE LOTIONS, BODY LOTIONS, BATHING LOTIONS, HAND LOTIONS AND AFTER-SHAVE LOTIONS; MAKE-UP REMOVING CREAMS AND OTHER MAKE-UP REMOVING PREPARATIONS, NAMELY, MAKE-UP REMOVING MILKS, GELS, LOTIONS AND CREAMS; TOILETRY PRODUCTS, NAMELY, SHAMPOOS, BATH SALTS, BATH AND SHOWER GELS, FOAM BATHS, ESSENTIAL OILS, COSMETICS, HAIR LOTIONS; SHAVING MOUSSES, CREAMS AND SOAPS; AFTER-SHAVE BALMS AND LOTIONS; DENTIFRICES; COSMETIC SUN PRODUCTS EXCLUDING SUNBURN PREPARATIONS FOR PHARMACEUTICAL PURPOSES, NAMELY, SUN CREAMS, SUN-PROTECTING, SUN-TANNING LOTIONS, SUN-PROTECTING, SUN-TANNING MILKS AND SUN-PROTECTING, SUN-TANNING OILS; SELF-TANNING CREAMS, PRODUCTS FOR TANNING THE SKIN, NAMELY, SUNTAN CREAMS, SUNTAN OILS FOR COSMETIC PURPOSES; NON-MEDICAL COSMETIC PREPARATIONS FOR SKIN, BODY, FACE, EYE, LIP, NECK, BUST, HAND, LEG AND FEET CARE; ANTI-WRINKLE CREAMS; NON-MEDICAL REVITALIZING AND TONING COSMETIC CREAMS AND LOTIONS, HYDRATING COSMETIC CREAMS AND LOTIONS, COSMETIC SCRUBS IN THE FORM OF CREAMS FOR THE BODY, FACE, HANDS, FEET; COSMETIC LOTIONS, CREAMS, SKIN, BODY AND HAIR GELS AND COSMETIC FLUIDS IN THE NATURE OF BODY LOTIONS, MILKS AND SPRAYS FOR SLIMMING PURPOSES; BODY DEODORANTS (U.S. CLS. 1, 4, 6, 50, 51 AND 52).

TINA BROWN, EXAMINING ATTORNEY

**CLASS 3—(Continued).**

SN 79-090,448. HERON COSMETICS PTY LTD, AUSTRALIA, FILED 5-19-2010.



OWNER OF INTERNATIONAL REGISTRATION 0949803 DATED 12-11-2007, EXPIRES 12-11-2017.

THE MARK CONSISTS OF THE WORD "LI'TYA" WITH A SPIRAL CIRCLE DESIGN ABOVE THE WORD.

THE ENGLISH TRANSLATION OF THE FOREIGN WORD(S) IN THE MARK IS: "OF THE EARTH".

FOR SPA PRODUCTS, NAMELY, NON-MEDICATED SKIN CARE PREPARATIONS, SKIN CREAMS AND LOTIONS; COSMETIC CREAMS FOR SKIN CARE; LOTION FOR THE SKIN (U.S. CLS. 1, 4, 6, 50, 51 AND 52).

ARETHA SOMERVILLE, EXAMINING ATTORNEY

SN 79-092,918. TECHNICO-FLOR, FRANCE, FILED 12-27-2010.

# TECHNICO-FLOR

THE MARK CONSISTS OF STANDARD CHARACTERS WITHOUT CLAIM TO ANY PARTICULAR FONT, STYLE, SIZE, OR COLOR.

OWNER OF INTERNATIONAL REGISTRATION 1066069 DATED 12-27-2010, EXPIRES 12-27-2020.

FOR PERFUMERY, COSMETICS (U.S. CLS. 1, 4, 6, 50, 51 AND 52).

MICHAEL TANNER, EXAMINING ATTORNEY

SN 79-093,265. LABORATOIRE DE DERMO-COSMETIQUE ANIMALE, FRANCE, FILED 1-11-2011.

# SPOTDERM

THE MARK CONSISTS OF STANDARD CHARACTERS WITHOUT CLAIM TO ANY PARTICULAR FONT, STYLE, SIZE, OR COLOR.

PRIORITY DATE OF 7-15-2010 IS CLAIMED.

OWNER OF INTERNATIONAL REGISTRATION 1066932 DATED 1-11-2011, EXPIRES 1-11-2021.

FOR SOAP FOR PERSONAL USE, SOAP FOR TOILETRY USE, NAMELY, SOAPS FOR THE SKIN OF ANIMALS; CLEANSING GELS AND LOTIONS FOR THE FACE AND BODY; PERFUMERY; COSMETICS, NAMELY, SKIN CARE PREPARATIONS FOR ANIMALS; ESSENTIAL OILS FOR COSMETIC PURPOSES; LOTIONS FOR ANIMAL HAIR; SHAMPOOS FOR HOUSEHOLD PETS; LOTIONS FOR THE SKIN OF ANIMALS; FOAMS FOR ANIMAL HAIR; EMULSIONS FOR HYDRATING THE SKIN OF ANIMALS; CREAMS FOR HYDRATING THE SKIN OF ANIMALS; CLEANSING COSMETIC PRODUCTS IN THE FORM OF CREAMS, LOTIONS AND EMULSIONS FOR ANIMALS (U.S. CLS. 1, 4, 6, 50, 51 AND 52).

KIM MONINGHOFF, EXAMINING ATTORNEY



**CLASS 3—(Continued).**

SN 79-094,436. HUGO BOSS TRADE MARK MANAGEMENT GMBH & CO. KG, FED REP GERMANY, FILED 12-30-2010.

**CLASS 3—(Continued).**

SN 85-045,287. WONDEUX INTERNATIONAL LIMITED, WANCHAI, HONG KONG, FILED 5-21-2010.

# JUST DIFFERENT

THE MARK CONSISTS OF STANDARD CHARACTERS WITHOUT CLAIM TO ANY PARTICULAR FONT, STYLE, SIZE, OR COLOR.

PRIORITY DATE OF 7-1-2010 IS CLAIMED.

OWNER OF INTERNATIONAL REGISTRATION 1069374 DATED 12-30-2010, EXPIRES 12-30-2020.

FOR EAU DE TOILETTE, AFTERSHAVE LOTIONS, AFTERSHAVE BALMS, SHOWER GELS AND DEODORANTS FOR PERSONAL USE (U.S. CLS. 1, 4, 6, 50, 51 AND 52).

NICHOLAS ALTREE, EXAMINING ATTORNEY



**THEWONDERBAR**

SN 85-034,953. ESTHER HADASSAH, COSMETICS INTERNATIONAL, LLC, LAWRENCE, MA. FILED 5-11-2010.



THE MARK CONSISTS OF A FLOWER WITH THE WORDING "ESTHER HADASSAH" TO THE LEFT.

THE ENGLISH TRANSLATION OF THE WORD "HADASSAH" IN THE MARK IS "ESTHER".

FOR COSMETIC CREAMS FOR SKIN CARE; COSMETIC MASKS; COSMETIC PENCILS; COSMETICS AND MAKE-UP; COSMETICS IN GENERAL, INCLUDING PERFUMES (U.S. CLS. 1, 4, 6, 50, 51 AND 52).

FIRST USE 8-7-2008; IN COMMERCE 8-7-2008.

KAPIL BHANOT, EXAMINING ATTORNEY

THE MARK CONSISTS OF A LOGO WITH A SCRIPT "W" WITH THE WORD "WONDEUX" CENTERED BELOW IT, ALL SURROUNDED BY A CLOVERLEAF DESIGN, ALL FURTHER SURROUNDED BY A CIRCLE DESIGN, ACCOMPANIED BY THE WORDING "THEWONDERBAR".

THE WORDING "WONDEUX" HAS NO MEANING IN A FOREIGN LANGUAGE.

FOR SOAPS; ANTIPERSPIRANT SOAP; DEODORANT SOAP; DISINFECTANT SOAP; MEDICATED SOAP; LOTIONS FOR COSMETIC PURPOSES; MAKE-UP REMOVING PREPARATIONS; PERFUMERY; ESSENTIAL OILS; COSMETICS; HAIR LOTIONS; AFTER SHAVE LOTIONS; COSMETIC PREPARATIONS FOR BATHS; BEAUTY MASKS (U.S. CLS. 1, 4, 6, 50, 51 AND 52).

FIRST USE 5-8-2010; IN COMMERCE 5-8-2010.

RICHARD WHITE, EXAMINING ATTORNEY

**CLASS 3—(Continued).**

SN 85-045,594. COSWAY (M) SDN. BHD. (COMPANY NO. 50118-A), KUALA LUMPUR, MALAYSIA, FILED 5-21-2010.



THE MARK CONSISTS OF THE TERM "PROLIN" UNDERNEATH A FLOWER DESIGN.

FOR AROMATIC PREPARATIONS, NAMELY, CREAM, LOTION; BEAUTY MASKS; COSMETICS; SKIN CREAMS; DEODORANTS FOR PERSONAL USE; DEPI-LATORIES; HAIR COLORANTS; HAIR DYES; HAIR LOTIONS; LAVENDER COLOGNE WATER; LIPSTICKS; LOTIONS FOR SKIN, HAIR WAVING; NAIL POLISH; EYE SHADOWS; BLUSHERS; LIQUID FOUNDATIONS; LOOSE POWDERS; MASCARAS; LIP GLOSS; COMPACT POWDERS; MAKE UP REMOVING PREPARATIONS; CLEANSING MILK; OILS FOR SKIN CARE; PERFUMES AND SCENTS; COSMETIC PENCILS; BODY TALCUM POWDER; SHAMPOOS; SOAPS; NON-MEDICATED TOI-LETRIES; COSMETIC PREPARATIONS IN THE NAT-URE OF GELS FOR SLIMMING PURPOSES; AND BATH SALTS (U.S. CLS. 1, 4, 6, 50, 51 AND 52).

ALLISON HOLTZ, EXAMINING ATTORNEY

**CLASS 3—(Continued).**

SN 85-045,600. COSWAY (M) SDN. BHD. (COMPANY NO. 50118-A), 50200 KUALA LUMPUR, MALAYSIA, FILED 5-21-2010.



THE MARK CONSISTS OF THE STYLIZED LETTERS "DC".

FOR AROMATICS PREPARATIONS, NAMELY, CREAM, LOTION; BEAUTY MASKS; COSMETICS; SKIN CREAMS; DEODORANTS FOR PERSONAL USE; DEPI-LATORIES; HAIR COLORANTS; HAIR DYES; HAIR LOTIONS; LAVENDER COLOGNE WATER; LIPSTICKS; LOTIONS FOR SKIN, HAIR WAVING; NAIL POLISH; EYE SHADOWS; BLUSHERS; LIQUID FOUNDATIONS; LOOSE POWDERS; MASCARAS; LIP GLOSS; COMPACT POWDERS; MAKE UP REMOVING PREPARATIONS; CLEANSING MILK; OILS FOR SKIN CARE; PERFUMES AND SCENTS; COSMETIC PENCILS; BODY TALCUM POWDER; SHAMPOOS; SOAPS; NON-MEDICATED TOI-LETRIES; COSMETICS PREPARATIONS IN THE NAT-URE OF GELS FOR SLIMMING PURPOSES; AND BATH SALTS (U.S. CLS. 1, 4, 6, 50, 51 AND 52).

ALLISON HOLTZ, EXAMINING ATTORNEY

SN 85-045,642. ALVAREZ, NANCY, MIAMI, FL. FILED 5-22-2010.

**CHACA CHACA**

THE MARK CONSISTS OF STANDARD CHARACTERS WITHOUT CLAIM TO ANY PARTICULAR FONT, STYLE, SIZE, OR COLOR.

THE WORDING "CHACA CHACA" HAS NO MEANING IN A FOREIGN LANGUAGE.

FOR COSMETICS AND CLEANING PRODUCTS, NAMELY, WASHING PREPARATIONS AND LAUNDRY BLEACH FOR LAUNDRY USE; CLEANING, POLISH-ING, SCOURING AND ABRASIVE PREPARATIONS; SOAPS; PERFUMERY, ESSENTIAL OILS, COSMETICS, HAIR LOTIONS AND DENTIFRICES FOR CONSUMERS (U.S. CLS. 1, 4, 6, 50, 51 AND 52).

HEATHER THOMPSON, EXAMINING ATTORNEY

**CLASS 3—(Continued).**

SN 85-046,996. COMBE INCORPORATED, WHITE PLAINS, NY. FILED 5-25-2010.

**GRAY TARGET TECHNOLOGY**

THE MARK CONSISTS OF STANDARD CHARACTERS WITHOUT CLAIM TO ANY PARTICULAR FONT, STYLE, SIZE, OR COLOR.

NO CLAIM IS MADE TO THE EXCLUSIVE RIGHT TO USE "GRAY TARGET", APART FROM THE MARK AS SHOWN.

FOR COSMETICS, NAMELY, COLORING PREPARATIONS FOR HAIR (U.S. CLS. 1, 4, 6, 50, 51 AND 52).

FIRST USE 3-12-2010; IN COMMERCE 3-12-2010.

CAROLINE WOOD, EXAMINING ATTORNEY

SN 85-048,701. DUB PUBLISHING, INC., CITY OF INDUSTRY, CA. FILED 5-26-2010.

**DUB**

THE MARK CONSISTS OF STANDARD CHARACTERS WITHOUT CLAIM TO ANY PARTICULAR FONT, STYLE, SIZE, OR COLOR.

FOR SURFACE CARE PRODUCTS FOR LAND VEHICLES AND LAND VEHICLE WHEELS, NAMELY, POLISHES, CLEANING PREPARATIONS, NAMELY, WASHES FOR LAND VEHICLES, WAXES AND CLEANING PREPARATIONS (U.S. CLS. 1, 4, 6, 50, 51 AND 52).

NAKIA HENRY, EXAMINING ATTORNEY

**CLASS 3—(Continued).**

SN 85-050,292. MARK BIRLEY HOLDINGS LIMITED, LONDON, UNITED KINGDOM, FILED 5-28-2010.

**MARK BIRLEY**

THE MARK CONSISTS OF STANDARD CHARACTERS WITHOUT CLAIM TO ANY PARTICULAR FONT, STYLE, SIZE, OR COLOR.

THE NAME(S), PORTRAIT(S), AND/OR SIGNATURE(S) SHOWN IN THE MARK DOES NOT IDENTIFY A PARTICULAR LIVING INDIVIDUAL.

FOR EYE-MASKS FILLED WITH LAVENDER OR OTHER HERBS, FLOWERS OR PLANTS; BEAUTY MASKS; POTPOURRI; SCENTED ESSENTIAL OILS FOR APPLICATION TO POTPOURRI; SACHETS FILLED WITH LAVENDER OR OTHER HERBS, FLOWERS OR PLANTS; PERFUMES; TOILET WATERS; EAU DE COLOGNE; PERFUME OILS; AROMATHERAPY OILS AND PRODUCTS, NAMELY, ESSENTIAL OILS FOR AROMATHERAPY USE; INCENSE; INCENSE STICKS; INCENSE CONES; INCENSE SACHETS; INCENSE SPRAY; MASSAGE OILS; NON-MEDICATED MASSAGE PREPARATIONS, NAMELY, MASSAGE CREAMS, MASSAGE OILS AND MASSAGE LOTIONS; EXTRACTS OF FLOWERS SOLD AS COMPONENTS OF COSMETICS; BREATH FRESHENING PREPARATIONS, NAMELY, BREATH FRESHENER; PERFUMING PREPARATIONS FOR THE ATMOSPHERE, NAMELY, AIR FRESHENERS; SOAPS AS PERSONAL CARE PRODUCTS FOR PERSONAL USE; BODY WASHES; NON-MEDICATED TOILET PREPARATIONS; NON-MEDICATED TOILET PREPARATIONS PRODUCED FROM ESSENTIAL OILS; PREPARATIONS FOR THE CARE OF HAIR, SKIN, SCALP, FACE AND NAILS, NAMELY, LIP BALMS; TONERS; HAIR, SKIN, SCALP, FACE AND NAIL MOISTURIZERS; SHAMPOOS; CONDITIONERS; CREAMS AND LOTIONS FOR REMOVING MAKE-UP; SUN-TANNING PREPARATIONS; SUN-SCREENING PREPARATIONS; DEODORANTS AND ANTIPERSPIRANTS; BODY SPRAYS; BATH AND SHOWER PRODUCTS, NAMELY, FOAM BATH, BATH SALTS, BATH OIL, SHOWER GEL; DEPILATORY PREPARATIONS; SHAVING PREPARATIONS; AFTER-SHAVE PREPARATIONS; COSMETICS; TISSUES AND WIPES IMPREGNATED WITH NON-MEDICATED TOILET PREPARATIONS; COTTON WOOL FOR COSMETIC PURPOSES AND COTTON WOOL BUDS; CLEANING PREPARATIONS FOR HOUSEHOLD USE; MEDICATED BATH AND TOILET PREPARATIONS (U.S. CLS. 1, 4, 6, 50, 51 AND 52).

KRISTIN DAHLING, EXAMINING ATTORNEY

SN 85-050,754. CINE-MAKEUP, INC, CASTAIC, CA. FILED 5-28-2010.

**Digital Capture Inks**

THE MARK CONSISTS OF STANDARD CHARACTERS WITHOUT CLAIM TO ANY PARTICULAR FONT, STYLE, SIZE, OR COLOR.

NO CLAIM IS MADE TO THE EXCLUSIVE RIGHT TO USE "DIGITAL CAPTURE", APART FROM THE MARK AS SHOWN.

FOR MAKE-UP (U.S. CLS. 1, 4, 6, 50, 51 AND 52).

SARA BENJAMIN, EXAMINING ATTORNEY

**CLASS 3—(Continued).**

SN 85-055,893. RECKITT & COLMAN (OVERSEAS) LIMITED, HULL, UNITED KINGDOM, FILED 6-7-2010.

# Woolite

OWNER OF U.S. REG. NOS. 922,525, 1,948,852 AND OTHERS.

THE MARK CONSISTS OF THE STYLIZED LETTERING "WOOLITE".

FOR BLEACHING PREPARATIONS AND SUBSTANCES FOR LAUNDRY USE, NAMELY, LAUNDRY STARCH, LAUNDRY BLEACH, LAUNDRY BLUEING, AND LAUNDRY PRE-SOAK; LAUNDRY DETERGENTS; LAUNDRY PREPARATIONS FOR DRY CLEANERS, NAMELY DRY CLEANING SOLVENTS, DRY CLEANING FLUIDS AND SPOT REMOVERS; CLEANING PREPARATIONS; CARPET CLEANERS; CARPET SHAMPOOS; DETERGENT SOAPS; FABRIC SOFTENERS, LAUNDRY ADDITIVES, NAMELY, STAIN REMOVING PREPARATIONS AND PREPARATIONS FOR THE ABSORPTION OF DYE AND COLOR; LAUNDRY PRODUCT IN THE NATURE OF FABRIC OR SHEET CONTAINING AN ADDITIVE FOR ABSORBING DYE AND COLOUR DURING WASH (U.S. CLS. 1, 4, 6, 50, 51 AND 52).

DAVID TAYLOR, EXAMINING ATTORNEY

SN 85-055,973. RECKITT & COLMAN (OVERSEAS) LIMITED, HULL, UNITED KINGDOM, FILED 6-7-2010.

# WOOLITE

THE MARK CONSISTS OF STANDARD CHARACTERS WITHOUT CLAIM TO ANY PARTICULAR FONT, STYLE, SIZE, OR COLOR.

OWNER OF U.S. REG. NOS. 922,525, 1,948,852 AND OTHERS.

FOR BLEACHING PREPARATIONS AND SUBSTANCES FOR LAUNDRY USE, NAMELY, LAUNDRY STARCH, LAUNDRY BLEACH, LAUNDRY BLUEING, AND LAUNDRY PRE-SOAK; LAUNDRY DETERGENTS; LAUNDRY PREPARATIONS FOR DRY CLEANERS, NAMELY, DRY CLEANING SOLVENTS, DRY CLEANING FLUIDS AND SPOT REMOVERS; CLEANING PREPARATIONS; CARPET CLEANERS; CARPET SHAMPOOS; DETERGENT SOAPS; FABRIC SOFTENERS, LAUNDRY ADDITIVES, NAMELY, STAIN REMOVING PREPARATIONS AND PREPARATIONS FOR THE ABSORPTION OF DYE AND COLOR; LAUNDRY PRODUCT IN THE NATURE OF FABRIC OR SHEET CONTAINING AN ADDITIVE FOR ABSORBING DYE AND COLOUR DURING WASH (U.S. CLS. 1, 4, 6, 50, 51 AND 52).

DAVID TAYLOR, EXAMINING ATTORNEY

**CLASS 3—(Continued).**

SN 85-056,414. HEDAYA HOME FASHIONS, INC., ELIZABETH, NJ. FILED 6-7-2010.

# nature's makeup

NO CLAIM IS MADE TO THE EXCLUSIVE RIGHT TO USE "MAKEUP", APART FROM THE MARK AS SHOWN.

THE MARK CONSISTS OF THE WORDING "NATURE'S MAKEUP" IN STYLIZED FONT.

FOR COSMETICS; COSMETICS AND MAKE-UP (U.S. CLS. 1, 4, 6, 50, 51 AND 52).

HEATHER SAPP, EXAMINING ATTORNEY

SN 85-059,211. ENVIRON SKIN CARE (PROPRIETARY) LIMITED, WESTERN CAPE, SOUTH AFRICA, FILED 6-10-2010.

# DERMA-LAC

THE MARK CONSISTS OF STANDARD CHARACTERS WITHOUT CLAIM TO ANY PARTICULAR FONT, STYLE, SIZE, OR COLOR.

FOR LOTIONS FOR USE ON HUMAN SKIN, ESPECIALLY SUN DAMAGED OR CONGESTED SKIN TO ASSIST IN SOFTENING AND SMOOTHING THE SKIN (U.S. CLS. 1, 4, 6, 50, 51 AND 52).

FIRST USE 9-14-1994; IN COMMERCE 9-14-1994.  
ROSELLE HERRERA, EXAMINING ATTORNEY

SN 85-065,184. HENKEL AG & CO. KGAA, DUESSELDORF, FED REP GERMANY, FILED 6-17-2010.

# STRAIGHT & GLOSSY

THE MARK CONSISTS OF STANDARD CHARACTERS WITHOUT CLAIM TO ANY PARTICULAR FONT, STYLE, SIZE, OR COLOR.

FOR HAIR STYLING PREPARATIONS (U.S. CLS. 1, 4, 6, 50, 51 AND 52).

KATHERINE M. DUBRAY, EXAMINING ATTORNEY



**CLASS 3—(Continued).**

SN 85-072,844. KAO KABUSHIKI KAISHA, TA KAO CORPORATION, CHUO-KU, TOKYO, JAPAN, FILED 6-28-2010.

グラスオール  
GRACEOR

OWNER OF JAPAN REG. NO. 4947779, DATED 4-28-2006, EXPIRES 4-28-2016.

THE MARK CONSISTS OF JAPANESE CHARACTERS OVER THE TERM "GRACEOR".

THE NON-LATIN CHARACTERS IN THE MARK TRANSLITERATE TO "GRACEOR," AND THIS HAS NO MEANING IN A FOREIGN LANGUAGE.

FOR COSMETICS, NAMELY, FACE CREAM, SKIN CREAM, FACIAL MASKS, SKIN LOTION, FACE MILK, FACE LOTIONS, LIP CREAM, MAKE-UP FOUNDATION; SKIN CLEANING PREPARATIONS, NAMELY, COSMETIC SOAPS AND SOAPS FOR PERSONAL USE; SKIN WHITENING PREPARATIONS; FACE POWDER; BATH POWDER; EYE MAKE-UP; EYE LINER; MASCARA; EYE BROW PENCILS; LIPSTICKS; BLUSHER; SUN SCREEN PREPARATIONS, NAMELY, CREAMS AND LOTIONS; NAIL POLISH; CUTICLE CREAM; BATH OILS AND SALTS; BUBBLE BATH; HAIR CARE PREPARATIONS, NAMELY, SHAMPOO, RINSE, CONDITIONER, LOTION, CREAMS, DYE, GEL, MOUSSE AND SPRAY; PERFUMERY, NAMELY, PERFUME, EAU DE COLOGNE; EAU DE TOILETTE; COTTON BALLS FOR COSMETIC PURPOSES (U.S. CLS. 1, 4, 6, 50, 51 AND 52).

IRA J. GOODSaid, EXAMINING ATTORNEY

SN 85-078,886. ARNOLD, MICHAEL, BEVERLY HILLS, CA. FILED 7-6-2010.

WITHOUTWATER

THE MARK CONSISTS OF STANDARD CHARACTERS WITHOUT CLAIM TO ANY PARTICULAR FONT, STYLE, SIZE, OR COLOR.

FOR BREATH FRESHENER; BREATH FRESHENING SPRAYS; COSMETIC PREPARATIONS FOR THE CARE OF MOUTH AND TEETH; NON-MEDICATED MOUTH RINSE; TOOTH POWDER (U.S. CLS. 1, 4, 6, 50, 51 AND 52).

MARY BOAGNI, EXAMINING ATTORNEY

**CLASS 3—(Continued).**

SN 85-085,903. ROUND UP ASSOCIATION, THE, PENDLETON, OR. FILED 7-15-2010.

PENDLETON ROUND-UP

THE MARK CONSISTS OF STANDARD CHARACTERS WITHOUT CLAIM TO ANY PARTICULAR FONT, STYLE, SIZE, OR COLOR.

OWNER OF U.S. REG. NOS. 1,286,511 AND 2,161,540. SEC. 2(F) AS TO "PENDLETON".

FOR FRAGRANCES (U.S. CLS. 1, 4, 6, 50, 51 AND 52). NICHOLAS COLEMAN, EXAMINING ATTORNEY

SN 85-090,756. ARNOLD, MICHAEL, BEVERLY HILLS, CA. FILED 7-22-2010.

WITH OR WITHOUT WATER

THE MARK CONSISTS OF STANDARD CHARACTERS WITHOUT CLAIM TO ANY PARTICULAR FONT, STYLE, SIZE, OR COLOR.

FOR BREATH FRESHENER; COSMETIC PREPARATIONS FOR THE CARE OF MOUTH AND TEETH; NON-MEDICATED MOUTH WASH AND RINSE; TOOTH CLEANING PREPARATIONS; TOOTH WHITENING PREPARATIONS (U.S. CLS. 1, 4, 6, 50, 51 AND 52).

MARY BOAGNI, EXAMINING ATTORNEY

SN 85-109,755. ALCHABAOUN, MOHAMMED, FONTANA, CA. FILED 8-17-2010.



NO CLAIM IS MADE TO THE EXCLUSIVE RIGHT TO USE "SHOE CLEANER", APART FROM THE MARK AS SHOWN.

THE MARK CONSISTS OF THE STYLIZED TEXT "REFRESHED SHOE CLEANER" WITH SIX SHOES.

FOR CLEANER FOR USE ON SHOES (U.S. CLS. 1, 4, 6, 50, 51 AND 52).

KIMBERLY FRYE, EXAMINING ATTORNEY

**CLASS 3—(Continued).**

SN 85-125,950. FUSION BRANDS INTERNATIONAL SRL, CHRIST CHURCH, BARBADOS, FILED 9-9-2010.

**MIRACULES COMPLEX**

THE MARK CONSISTS OF STANDARD CHARACTERS WITHOUT CLAIM TO ANY PARTICULAR FONT, STYLE, SIZE, OR COLOR.

NO CLAIM IS MADE TO THE EXCLUSIVE RIGHT TO USE "COMPLEX", APART FROM THE MARK AS SHOWN. FOR COSMETICS; NON-MEDICATED SKIN CARE PREPARATIONS (U.S. CLS. 1, 4, 6, 50, 51 AND 52). LINDA MICKLEBURGH, EXAMINING ATTORNEY

---

SN 85-127,475. ROSS, TANYA, ATLANTA, GA. FILED 9-10-2010.

**Bazjian Beauty**

THE MARK CONSISTS OF STANDARD CHARACTERS WITHOUT CLAIM TO ANY PARTICULAR FONT, STYLE, SIZE, OR COLOR.

NO CLAIM IS MADE TO THE EXCLUSIVE RIGHT TO USE "BEAUTY", APART FROM THE MARK AS SHOWN.

FOR ANTI-AGING CREAM; AROMATIC ESSENTIAL OILS; BATH OILS AND BATH SALTS; BATH SOAPS IN LIQUID, SOLID OR GEL FORM; BEAUTY CREAMS FOR BODY CARE; BODY BUTTER; BODY LOTION; BODY MASKS; BODY SCRUB; BUBBLE BATH; COSMETIC CREAMS FOR SKIN CARE; FACE AND BODY CREAMS; FACIAL CLEANSERS; HAND CREAMS; NIGHT CREAM; NON-MEDICATED FOOT CREAM; SKIN MASKS; SKIN TONERS (U.S. CLS. 1, 4, 6, 50, 51 AND 52). JEFFERY COWARD, EXAMINING ATTORNEY

---

SN 85-130,312. CHEN, CANDACE, LOS ANGELES, CA. FILED 9-15-2010.

**Ultra Masculine Skincare**

THE MARK CONSISTS OF STANDARD CHARACTERS WITHOUT CLAIM TO ANY PARTICULAR FONT, STYLE, SIZE, OR COLOR.

NO CLAIM IS MADE TO THE EXCLUSIVE RIGHT TO USE "MASCULINE SKINCARE", APART FROM THE MARK AS SHOWN.

FOR AFTER-SHAVE BALMS; BEAUTY SERUMS; SKIN CLEANSERS; SKIN MOISTURIZER; SUN SCREEN (U.S. CLS. 1, 4, 6, 50, 51 AND 52).

ANDREW RHIM, EXAMINING ATTORNEY

**CLASS 3—(Continued).**

SN 85-131,351. BOMBRIL MERCOSUL S.A., SAO BERNARDO DO CAMPO, BRAZIL, FILED 9-16-2010.

**ECOBRIL**

THE MARK CONSISTS OF STANDARD CHARACTERS WITHOUT CLAIM TO ANY PARTICULAR FONT, STYLE, SIZE, OR COLOR.

THE WORD(S) "ECOBRIL" HAS NO MEANING IN A FOREIGN LANGUAGE.

FOR ALL PURPOSE CLEANING PREPARATIONS; DETERGENT SOAP; FABRIC SOFTENERS; SOAPS; ABRASIVE CLEANING PREPARATIONS FOR HOUSEHOLD USE; ALL PURPOSE CLEANING PREPARATIONS FOR CLEANING FLOORS AND SURFACES IN GENERAL; BLEACHING PREPARATIONS FOR LAUNDRY USE; DISINFECTANT SOAPS; POWDER AND LIQUID LAUNDRY SOAP; STAIN REMOVERS; LAUNDRY BLEACH AND LAUNDRY DETERGENT; ALL PURPOSE CLEANING PREPARATIONS FOR CLEANING WINDOWS AND CARPETS; TABLETS IMPREGNATED WITH CLEANING PREPARATIONS FOR CLEANING, DEODORIZING AND CLEARING DRAINS AND PIPES (U.S. CLS. 1, 4, 6, 50, 51 AND 52).

COLLEEN KEARNEY, EXAMINING ATTORNEY

---

SN 85-148,244. HAIR SHOW, LLC, NEW YORK, NY. FILED 10-8-2010.

**FRANCKY L'OFFICIAL HAIR SHOW**

THE MARK CONSISTS OF STANDARD CHARACTERS WITHOUT CLAIM TO ANY PARTICULAR FONT, STYLE, SIZE, OR COLOR.

NO CLAIM IS MADE TO THE EXCLUSIVE RIGHT TO USE "HAIR", APART FROM THE MARK AS SHOWN.

THE NAME(S), PORTRAIT(S), AND/OR SIGNATURE(S) SHOWN IN THE MARK IDENTIFIES "FRANCKY L'OFFICIAL", WHOSE CONSENT(S) TO REGISTER IS MADE OF RECORD.

FOR HAIR CONDITIONERS; HAIR GELS; HAIR MOUSSES; HAIR STYLING SPRAY; NON-MEDICATED HAIR SERUMS; NON-MEDICATED HAIR TREATMENT PREPARATIONS FOR COSMETIC PURPOSES; SHAMPOOS (U.S. CLS. 1, 4, 6, 50, 51 AND 52).

INGA ERVIN, EXAMINING ATTORNEY

**CLASS 3—(Continued).**

SN 85-148,403. GUINOT, PARIS, FRANCE, FILED 10-8-2010.

YOUTH TIME

THE MARK CONSISTS OF STANDARD CHARACTERS WITHOUT CLAIM TO ANY PARTICULAR FONT, STYLE, SIZE, OR COLOR.

PRIORITY CLAIMED UNDER SEC. 44(D) ON FRANCE APPLICATION NO. 10/3770759, FILED 9-30-2010, REG. NO. 10/3770759, DATED 3-3-2011, EXPIRES 9-30-2020.

FOR BEAUTY CREAMS; BODY CREAMS; ESSENTIAL OILS FOR AROMATHERAPY USE; FACE CREAMS; FRAGRANCES; HAIR CARE PREPARATIONS; HAIR LOTIONS; MAKE-UP; PERFUME; SKIN CREAMS; SKIN SOAP; SOAPS FOR BODY CARE (U.S. CLS. 1, 4, 6, 50, 51 AND 52).

REBECCA SMITH, EXAMINING ATTORNEY

---

SN 85-159,389. VALUE MARKETING, INC., CEDARHURST, NY. FILED 10-22-2010.

INSTANTÉ

THE MARK CONSISTS OF STANDARD CHARACTERS WITHOUT CLAIM TO ANY PARTICULAR FONT, STYLE, SIZE, OR COLOR.

THE WORDING "INSTANTÉ" HAS NO MEANING IN A FOREIGN LANGUAGE, "INSTANTE" WITHOUT THE ACCENT MEANS "INSTANT".

FOR ANTI-WRINKLE CREAMS; COSMETICS AND COSMETIC PREPARATIONS; EYE CREAM; MOISTURIZING PREPARATIONS FOR THE SKIN; WRINKLE REMOVING SKIN CARE PREPARATIONS; WRINKLE-MINIMIZING COSMETIC PREPARATIONS FOR TOPICAL FACIAL USE (U.S. CLS. 1, 4, 6, 50, 51 AND 52).

EUGENIA MARTIN, EXAMINING ATTORNEY

**CLASS 3—(Continued).**

SN 85-164,977. DIANE VON FURSTENBERG STUDIO, NEW MILFORD, CT. FILED 10-29-2010.



OWNER OF U.S. REG. NOS. 2,815,344, 3,787,895 AND OTHERS.

THE NAME(S), PORTRAIT(S), AND/OR SIGNATURE(S) SHOWN IN THE MARK IDENTIFIES "DIANE VON FURSTENBERG", WHOSE CONSENT(S) TO REGISTER IS MADE OF RECORD.

THE MARK CONSISTS OF THE STACKED STYLIZED LETTERS "D", "I", "A", "N" AND "E" ABOVE THE STYLIZED WORDS "DIANE VON FURSTENBERG".

FOR PERFUMES, EAU DE PARFUMS, EAU DE TOILETTE, EAU DU COLOGNES, AND COLOGNE (U.S. CLS. 1, 4, 6, 50, 51 AND 52).

ADA HAN, EXAMINING ATTORNEY

---

SN 85-165,916. SIERRA SAGE HERBS LLC, BOISE, ID. FILED 11-1-2010.

SIERRA SAGE

THE MARK CONSISTS OF STANDARD CHARACTERS WITHOUT CLAIM TO ANY PARTICULAR FONT, STYLE, SIZE, OR COLOR.

NO CLAIM IS MADE TO THE EXCLUSIVE RIGHT TO USE "SAGE", APART FROM THE MARK AS SHOWN.

FOR NON-MEDICATED HERBAL BODY CARE PRODUCTS, NAMELY, TOPICAL CREAMS, SALVES, BALMS, AND OINTMENTS (U.S. CLS. 1, 4, 6, 50, 51 AND 52).

FIRST USE 9-0-2007; IN COMMERCE 9-0-2007.

JANICE KIM, EXAMINING ATTORNEY

**CLASS 3—(Continued).**

SN 85-171,830. EZENCIA, LLC, MIAMI, FL. FILED 11-8-2010.

# Ezencia

THE MARK CONSISTS OF STANDARD CHARACTERS WITHOUT CLAIM TO ANY PARTICULAR FONT, STYLE, SIZE, OR COLOR.

THE WORDING "EZENCIA" HAS NO MEANING IN A FOREIGN LANGUAGE.

FOR ESSENTIAL OILS FOR AROMATHERAPY USE; ESSENTIAL OILS FOR USE IN AROMATHERAPY (U.S. CLS. 1, 4, 6, 50, 51 AND 52).

FIRST USE 12-12-2007; IN COMMERCE 2-0-2008.  
KATHLEEN LORENZO, EXAMINING ATTORNEY

SN 85-175,612. CAROLINA HERRERA LTD., NEW YORK, NY. FILED 11-12-2010.



OWNER OF U.S. REG. NO. 3,019,083.  
THE COLOR(S) GOLD IS/ARE CLAIMED AS A FEATURE OF THE MARK.

THE MARK CONSISTS OF PRODUCT PACKAGING IN THE FORM OF A GOLD THREE DIMENSIONAL CAPSULE SHAPED CONTAINER.

FOR PERFUMERY (U.S. CLS. 1, 4, 6, 50, 51 AND 52).  
FIRST USE 9-15-2010; IN COMMERCE 9-15-2010.  
WILLIAM ROSSMAN, EXAMINING ATTORNEY

SN 85-178,126. KLEANENVI, INC., TENAFLY, NJ. FILED 11-16-2010.



NO CLAIM IS MADE TO THE EXCLUSIVE RIGHT TO USE "NATURE", APART FROM THE MARK AS SHOWN.

THE COLOR(S) OFF-WHITE, CREAM, DARK-GREEN IS/ARE CLAIMED AS A FEATURE OF THE MARK.

THE MARK CONSISTS OF A CREAM WOMAN OUTLINED IN DARK-GREEN AND HER HANDS SPREAD OUT ON BOTH SIDES OF HER FACE HOLDING BIRD-LIKE STRUCTURES. HER FACIAL FEATURES ARE DARK-GREEN. THE WOMAN'S HAIR IS DARK GREEN AND

**CLASS 3—(Continued).**

ALSO OUTLINED TO SURROUND HER FACE AND HER HAIR IN A BUN BEHIND HER NECK-LINE. AN OFF WHITE FAN-LIKE BACKGROUND IS BEHIND THE WOMAN BORDERED BY FORTUNE COOKIE SHAPES ALONG THE SEMI-CIRCLE. THE SEMI-CIRCLE CONTAINS DARK GREEN LINES FROM THE CENTER TO THE BORDER THAT DEPICTS LIGHT RAYS. THE WORDING "AVA NATURE" APPEARS IN CREAM AGAINST A DARK GREEN BACKGROUND UNDERNEATH THE DESIGN OF THE WOMAN.

THE WORDING "AVA" HAS NO MEANING IN A FOREIGN LANGUAGE.

FOR FRAGRANCED SKIN CARE PREPARATIONS, NAMELY, SHEA BUTTER AND SHEA BUTTER BASED SKIN CLEANSER; NON-MEDICATED SKIN CARE PREPARATIONS, NAMELY, SHEA BUTTER BASED SKIN CLEANSER; SHEA BUTTER FOR COSMETIC PURPOSES (U.S. CLS. 1, 4, 6, 50, 51 AND 52).

FIRST USE 4-1-2010; IN COMMERCE 4-15-2010.  
JANICE KIM, EXAMINING ATTORNEY

SN 85-179,138. 1156662 FRAGRANCES, INC., NEW YORK, NY. FILED 11-17-2010.

# EAU DE PREP

THE MARK CONSISTS OF STANDARD CHARACTERS WITHOUT CLAIM TO ANY PARTICULAR FONT, STYLE, SIZE, OR COLOR.

THE ENGLISH TRANSLATION OF "EAU DE" IN THE MARK IS WATER OF.

FOR BODY WASH; COLOGNE; EAU DE TOILETTE; FRAGRANCES FOR PERSONAL USE; PERFUMERY; SCENTED BODY SPRAY (U.S. CLS. 1, 4, 6, 50, 51 AND 52).

ALLISON HOLTZ, EXAMINING ATTORNEY

SN 85-180,781. SAN-TEC, INC., LINDEN, NJ. FILED 11-19-2010.

# the color of clean

THE MARK CONSISTS OF STANDARD CHARACTERS WITHOUT CLAIM TO ANY PARTICULAR FONT, STYLE, SIZE, OR COLOR.

FOR ALL PURPOSE CLEANING PREPARATIONS FOR PROFESSIONAL AND GENERAL USE (U.S. CLS. 1, 4, 6, 50, 51 AND 52).

FIRST USE 4-5-2010; IN COMMERCE 4-5-2010.  
SEAN CROWLEY, EXAMINING ATTORNEY



**CLASS 3—(Continued).**

SN 85-180,798. SAN-TEC, INC., LINDEN, NJ. FILED 11-19-2010.

clean by number

THE MARK CONSISTS OF STANDARD CHARACTERS WITHOUT CLAIM TO ANY PARTICULAR FONT, STYLE, SIZE, OR COLOR.

NO CLAIM IS MADE TO THE EXCLUSIVE RIGHT TO USE "CLEAN", APART FROM THE MARK AS SHOWN.

FOR ALL PURPOSE CLEANING PREPARATIONS FOR PROFESSIONAL AND GENERAL USE (U.S. CLS. 1, 4, 6, 50, 51 AND 52).

FIRST USE 4-5-2010; IN COMMERCE 4-5-2010.  
SEAN CROWLEY, EXAMINING ATTORNEY

SN 85-185,547. THE BEOX GROUP, INC., DBA HAIR GO STRAIGHT, HOLLISWOOD, NY. FILED 11-26-2010.

Hair  
GO  
Straight

THE MARK CONSISTS OF THE WORDING "HAIR GO STRAIGHT" IN STYLIZED FORM.

FOR HAIR CONDITIONER; HAIR SHAMPOO; HAIR TONIC (U.S. CLS. 1, 4, 6, 50, 51 AND 52).

FIRST USE 1-1-2008; IN COMMERCE 1-1-2008.  
FRED CARL, EXAMINING ATTORNEY

SN 85-185,725. UNILEVER SUPPLY CHAIN, INC., CLINTON, CT. FILED 11-28-2010.

ANARCHY

THE MARK CONSISTS OF STANDARD CHARACTERS WITHOUT CLAIM TO ANY PARTICULAR FONT, STYLE, SIZE, OR COLOR.

FOR DEODORANTS FOR PERSONAL USE; ANTI-PERSPIRANTS; SHOWER GELS; HAIR CARE PRODUCTS, NAMELY, SHAMPOOS, CONDITIONERS, HAIR CARE PREPARATIONS, HAIR COLOR (U.S. CLS. 1, 4, 6, 50, 51 AND 52).

PRISCILLA MILTON, EXAMINING ATTORNEY

**CLASS 3—(Continued).**

SN 85-189,680. LUSTER CANYON, INC., COTTONWOOD, AZ. FILED 12-2-2010.



NO CLAIM IS MADE TO THE EXCLUSIVE RIGHT TO USE "LUSTER", APART FROM THE MARK AS SHOWN.

THE MARK CONSISTS OF AN OVAL WITH THE WORDS "LUSTER CANYON" WITH SWIRLY SCROLLS ON BOTH SIDES.

FOR 3-IN-1 HAIR SHAMPOOS; AFTER-SHAVE BALMS; ANTI-BACTERIAL SOAP; ANTIBACTERIAL SOAP; AROMATIC BODY CARE PRODUCTS, NAMELY, BODY LOTION, SHOWER GEL, CUTICLE CREAM, SHAMPOO, CONDITIONER, NON-MEDICATED LIP BALM, SOAP, BODY POLISH, BODY AND FOOT SCRUB AND NON-MEDICATED FOOT CREAM; BABY BUBBLE BATH; BABY LOTION; BAR SOAP; BATH AND SHOWER GELS AND SALTS NOT FOR MEDICAL PURPOSES; BATH CREAM; BATH LOTION; BATH SOAPS; BATH SOAPS IN LIQUID, SOLID OR GEL FORM; BATHING LOTIONS; BEAUTY SOAP; BODY BUTTER; BODY CREAM; BODY CREAM SOAP; BODY LOTION; BODY LOTIONS; BODY SCRUB; BODY SPRAYS; BUBBLE BATH; CAKES OF TOILET SOAP; CLEANING, WASHING AND POLISHING PREPARATIONS; COCOA BUTTER FOR COSMETIC PURPOSES; COSMETIC CREAMS; COSMETIC HAND CREAMS; COSMETIC SOAPS; CREAM SOAPS; DEODORANT SOAP; DISINFECTANT SOAPS; DISINFECTING PERFUMED SOAPS; EYE CREAM; FACE AND BODY CREAMS; FACE AND BODY LOTIONS; FACE CREAMS; FACE CREAMS FOR COSMETIC USE; FACIAL CREAM; FACIAL CREAMS; FACIAL SCRUBS; FOOT SCRUBS; HAIR CARE CREAMS; HAIR CARE LOTIONS; HAIR CONDITIONER; HAIR CONDITIONERS; HAIR CREAMS; HAIR GEL; HAIR GEL AND HAIR MOUSSE; HAIR GELS; HAIR LOTIONS; HAIR RINSES; HAIR SHAMPOO; HAIR SHAMPOOS AND CONDITIONERS; HAIR SPRAY; HAIR SPRAYS AND HAIR GELS; HAND CLEANERS; HAND CLEANING GELS; HAND CREAM; HAND CREAMS; HAND LOTIONS; HAND SCRUBS; HAND SOAPS; LAUNDRY SOAP; LIP BALM; LIQUID BATH SOAPS; LIQUID SOAP; LIQUID SOAP USED IN FOOT BATH; LIQUID SOAPS; LIQUID SOAPS FOR HANDS AND FACE; LIQUID SOAPS FOR HANDS, FACE AND BODY; LOOFAH SOAPS; LOTIONS FOR FACE AND BODY CARE; MEDICATED SOAP; MEDICATED SOAPS; NATURAL COCOA BUTTER BASED PERSONAL CARE PRODUCTS, NAMELY, BODY LOTION, SHOWER GEL, SOAP, BODY POLISH, BODY AND FOOT SCRUB AND NON-MEDICATED SKIN CREAMS; NON-MEDICATED BALMS FOR USE ON HAND, FACE, ARNICA SORE MUSCLE, BELLY, BODY, LIP AND FOOT; NON-MEDICATED BUBBLE BATH PREPARATIONS; NON-MEDICATED FEMININE HYGIENE WASH; NON-MEDICATED FOOT CREAM; NON-MEDICATED HERBAL BODY CARE PRODUCTS, NAMELY, BODY OILS, SALVES, AND LIP BALMS; NON-MEDICATED SKIN CARE CREAMS AND LOTIONS; NON-MEDICATED SKIN CARE PREPARATIONS, NAMELY, CREAMS, LOTIONS, GELS, TONERS, CLEANERS AND PEELS; PERFUME; PERFUMED CREAMS; PERFUMED SOAPS; PERFUMES; SHAMPOO-CONDITIONERS; SHAMPOOS; SHAVING BALM; SKIN AND BODY TOPICAL LOTIONS, CREAMS AND OILS FOR COSMETIC USE; SKIN CARE PREPARATIONS, NAMELY, BODY BALM; SKIN CREAM; SKIN CREAMS; SKIN CREAMS IN LIQUID AND IN SOLID FORM; SKIN LOTIONS; SKIN SOAP; SOAPS; SOAPS FOR BODY CARE; SOAPS FOR PERSONAL USE; SPONGES IMPREGNATED WITH MARINE AND AUTOMOTIVE WAXES AND WASHES (U.S. CLS. 1, 4, 6, 50, 51 AND 52).

FIRST USE 7-31-2009; IN COMMERCE 7-31-2009.  
STEVEN JACKSON, EXAMINING ATTORNEY

**CLASS 3—(Continued).**

SN 85-194,737. SOLIYA NATURAL SKINCARE, TA SOLIYA NATURAL SKINCARE PTY LTD, MELBOURNE, VIC 3001, AUSTRALIA, FILED 12-9-2010.



THE COLOR(S) PURPLE IS/ARE CLAIMED AS A FEATURE OF THE MARK.

THE MARK CONSISTS OF THE STYLIZED WORDING "SOLIYA" IN PURPLE.

FOR ANTI-AGING CREAMS; AROMATIC BODY CARE PRODUCTS, NAMELY, BODY LOTION, SHOWER GEL, CUTICLE CREAM, SHAMPOO, CONDITIONER, NON-MEDICATED LIP BALM, SOAP, BODY POLISH, BODY AND FOOT SCRUB AND NON-MEDICATED FOOT CREAM; BEAUTY CREAMS (U.S. CLS. 1, 4, 6, 50, 51 AND 52).

JORDAN BAKER, EXAMINING ATTORNEY

---

SN 85-196,133. ZOTOS INTERNATIONAL, INC., DARIEN, CT. FILED 12-13-2010.

# KeraShield

THE MARK CONSISTS OF STANDARD CHARACTERS WITHOUT CLAIM TO ANY PARTICULAR FONT, STYLE, SIZE, OR COLOR.

FOR HAIR CONDITIONER; HAIR SHAMPOO (U.S. CLS. 1, 4, 6, 50, 51 AND 52).

APRIL HESIK, EXAMINING ATTORNEY

**CLASS 3—(Continued).**

SN 85-196,145. CHOLAYIL PRIVATE LIMITED, CHENNAI, INDIA, FILED 12-13-2010.

# YOGVED

THE MARK CONSISTS OF STANDARD CHARACTERS WITHOUT CLAIM TO ANY PARTICULAR FONT, STYLE, SIZE, OR COLOR.

FOR SOAP; DISINFECTANT SOAP; DEODORANT SOAP; SHAVING SOAP; CAKES OF TOILET SOAP; MEDICATED SOAP; ANTIPERSPIRANT SOAP; SOAP FOR FOOT PERSPIRATION; ALMOND SOAP; HERBAL SOAP; SHAMPOOS; HAIR LOTION; NON-MEDICATED TOILETRIES; CLEANSING MILK FOR TOILET PURPOSES; PERFUMES; PERFUMES FOR USE IN THE MANUFACTURE OF AIR FRESHENERS; EXTRACTS OF FLOWERS SOLD AS COMPONENTS OF PERFUMES; DEODORANTS FOR PERSONAL USE; TALCUM POWDER, FOR TOILET USE; AFTER-SHAVE LOTIONS; DENTIFRICES; COSMETICS; PETROLEUM JELLY FOR COSMETIC PURPOSES; COSMETIC CREAMS; COSMETIC DYES, NAMELY, HAIR DYES; LOTIONS FOR COSMETIC PURPOSES; ALMOND MILK FOR COSMETIC PURPOSES; POMADES FOR COSMETIC PURPOSES; COSMETIC PREPARATIONS FOR BATHS; COSMETIC PREPARATIONS FOR SLIMMING PURPOSES; ASTRINGENTS FOR COSMETIC PURPOSES; COSMETIC PREPARATIONS FOR SKIN CARE; EYEBROW COSMETICS; GREASES FOR COSMETIC PURPOSES; NON-MEDICATED HERBAL COSMETICS AND OTHER NON-MEDICATED HERBAL BODY CARE PRODUCTS, NAMELY BODY OILS, AND SKIN SOAP; ESSENTIAL OILS; OILS FOR COSMETIC PURPOSES; OILS FOR TOILET PURPOSES; ESSENTIAL OILS OF CEDARWOOD; ESSENTIAL OILS OF CITRON; AROMATIC ESSENTIAL OILS; OILS FOR CLEANING PURPOSES; BERGAMOT OIL; GAULTHERIA OIL IN THE NATURE OF ESSENTIAL OILS; JASMINE OIL FOR PERSONAL USE; LAVENDER OIL; ALMOND OIL FOR COSMETIC PURPOSES; ROSE OIL FOR COSMETIC PURPOSES; ESSENTIAL OILS OF MINT ESSENCE; ESSENTIAL OIL OF TERPENES; BLEACHING PREPARATIONS FOR LAUNDRY; CLEANING PREPARATIONS; DRY-CLEANING PREPARATIONS, NAMELY, DRY CLEANING FLUIDS; POLISHING PREPARATIONS; SCOURING SOLUTIONS (U.S. CLS. 1, 4, 6, 50, 51 AND 52).

PRISCILLA MILTON, EXAMINING ATTORNEY

---

SN 85-196,198. ZOTOS INTERNATIONAL, INC., DARIEN, CT. FILED 12-13-2010.

# HYDRAHEAVEN

THE MARK CONSISTS OF STANDARD CHARACTERS WITHOUT CLAIM TO ANY PARTICULAR FONT, STYLE, SIZE, OR COLOR.

OWNER OF U.S. REG. NO. 3,917,916.

FOR HAIR CONDITIONERS (U.S. CLS. 1, 4, 6, 50, 51 AND 52).

APRIL HESIK, EXAMINING ATTORNEY

**CLASS 3—(Continued).**

SN 85-199,693. JOHNSON & JOHNSON, NEW BRUNSWICK, NJ. FILED 12-16-2010.



THE MARK CONSISTS OF A PICTURE OF FINGERS HOLDING A PAD OVER A CLOSED EYE AND DIFFERENT SIZE WATER DROPLETS ON A RECTANGULAR BACKGROUND.

FOR PRE-MOISTENED COSMETIC WIPES (U.S. CLS. 1, 4, 6, 50, 51 AND 52).

KAREN K. BUSH, EXAMINING ATTORNEY

SN 85-200,714. HORNE, SUZAN L., LOS ANGELES, CO. FILED 12-17-2010.

## Polka Dot Dragonfly

THE MARK CONSISTS OF STANDARD CHARACTERS WITHOUT CLAIM TO ANY PARTICULAR FONT, STYLE, SIZE, OR COLOR.

FOR 3-IN-1 HAIR CONDITIONERS; 3-IN-1 HAIR SHAMPOOS; 3-IN-1 ORGANIC SOAP BARS FOR USE AS SOAP, SHAMPOO AND CONDITIONER; ABRASIVE CLOTH; ABRASIVE CLOTH AND PAPER; ABRASIVE PAPER; ABRASIVE PASTE; ABRASIVE ROLLS; ABRASIVE SAND; ABRASIVE SHEETS; ABRASIVE STRIPS; ADHESIVE REMOVERS; ADHESIVES FOR AFFIXING FALSE EYELASHES; ADHESIVES FOR AFFIXING FALSE HAIR; ADHESIVES FOR ARTIFICIAL NAILS; ADHESIVES FOR ATTACHING ARTIFICIAL FINGERNAILS AND/OR EYELASHES; ADHESIVES FOR COSMETIC USE; ADHESIVES FOR FALSE EYELASHES, HAIR AND NAILS; AEROSOL SPRAY FOR CLEANING CONDENSER COILS OF AIR FILTERS FOR AIR CONDITIONING, HEATING AND AIR FILTRATION UNITS; AFTER SHAVE LOTIONS; AFTER SUN CREAMS; AFTER-SHAVE; AFTER-SHAVE BALMS; AFTER-SHAVE CREAMS; AFTER-SHAVE EMULSIONS; AFTER-SHAVE GEL; AFTER-SHAVE LIQUID; AFTER-SHAVE LOTIONS; AFTER-SUN GELS; AFTER-SUN LOTIONS; AFTER-SUN MILKS; AFTER-SUN OILS; AFTERSHAVE; AFTERSHAVE COLOGNE; AFTERSHAVE MOISTURIZING CREAM; AFTERSHAVE PREPARATIONS; AGE RETARDANT GEL; AGE RETARDANT LOTION; AGE SPOT REDUCING CREAMS; ALCOHOL FOR CLEANING PURPOSES; ALL PURPOSE CLEANING PREPARATIONS; ALL PURPOSE COTTON SWABS FOR PERSONAL USE; ALL-PURPOSE CLEANERS; ALMOND SOAPS; ALOE VERA GEL FOR COSMETIC PURPOSES; AMBERGRIS; AMMONIA FOR CLEANING PURPOSES; ANTI-AGING CLEANSER; ANTI-AGING CREAM; ANTI-AGING CREAM CONTAINING A RETINOIC INGREDIENT NOT FOR MEDICAL PURPOSES; ANTI-AGING CREAMS; ANTI-AGING MOISTURIZER; ANTI-AGING TONER; ANTI-BACTERIAL SOAP; ANTI-CAVITY DENTAL RINSES; ANTI-CAVITY MOUTH RINSES; ANTI-CAVITY MOUTHWASHES; ANTI-FRECKLE CREAMS; ANTI-PERSPIRANTS; ANTI-STATIC DRYER SHEETS; ANTI-STATIC PREPARATIONS FOR HOUSEHOLD PURPOSES; ANTI-STATIC SPRAY FOR CLOTHING; ANTI-WRINKLE CREAM; ANTI-WRINKLE CREAMS; ANTIBACTERIAL SKIN SOAPS; ANTIBACTERIAL SOAP; ANTIPERSPIRANTS; ANTIPERSPIRANTS AND DEODORANTS FOR PERSONAL USE; ANTIPERSPIRANTS FOR PERSONAL USE; AROMATIC BODY CARE

**CLASS 3—(Continued).**

PRODUCTS, NAMELY, BODY LOTION, SHOWER GEL, CUTICLE CREAM, SHAMPOO, CONDITIONER, NON-MEDICATED LIP BALM, SOAP, BODY POLISH, BODY AND FOOT SCRUB AND NON-MEDICATED FOOT CREAM; AROMATIC ESSENTIAL OILS; AROMATIC OILS; AROMATIC PILLOWS COMPRISING POTPOURRI IN FABRIC CONTAINERS; AROMATIC POTPOURRIS; AROMATIC PREPARATIONS, NAMELY, BODY LOTION, SKIN LOTIONS, BATH OIL, SHOWER GELS; ARTIFICIAL EYELASHES; ARTIFICIAL FINGERNAILS; ARTIFICIAL FINGERNAILS NOT OF PRECIOUS METAL; ARTIFICIAL FINGERNAILS OF PRECIOUS METAL; ASTRINGENTS FOR COSMETIC PURPOSES; AUTOMATIC DISHWASHING DETERGENTS; AUTOMOBILE AND CAR WAX PREPARATIONS; AUTOMOBILE CARPET AND UPHOLSTERY CLEANING PREPARATIONS; AUTOMOBILE CLEANERS; AUTOMOBILE POLISH; AUTOMOBILE POLISHES; AUTOMOBILE TIRE CLEANING AND POLISHING PREPARATIONS; AUTOMOBILE WAX; AUTOMOBILE, TIRE, GLASS AND WHEEL CLEANING PREPARATIONS; AUTOMOTIVE CLEANING PREPARATIONS; BABY BUBBLE BATH; BABY HAIR CONDITIONER; BABY HAND SOAP; BABY LOTION; BABY OIL; BABY OILS; BABY POWDER; BABY POWDERS; BABY SHAMPOO; BABY WIPES; BAR SOAP; BATH AND SHOWER GELS AND SALTS NOT FOR MEDICAL PURPOSES; BATH BEADS; BATH CREAM; BATH CRYSTALS; BATH FIZZIES; BATH FLAKES; BATH FOAM; BATH FOAMS; BATH GEL; BATH GELS; BATH HERBS; BATH LOTION; BATH MILKS; BATH OIL; BATH OILS; BATH OILS AND BATH SALTS; BATH OILS FOR COSMETIC PURPOSES; BATH PEARLS; BATH POWDER; BATH SALTS; BATH SALTS; BATH SOAPS; BATH SOAPS IN LIQUID, SOLID OR GEL FORM; BATHING LOTIONS; BAY RUMS; BEAUTY CREAMS; BEAUTY CREAMS FOR BODY CARE; BEAUTY GELS; BEAUTY LOTIONS; BEAUTY MASKS; BEAUTY MILKS; BEAUTY SERUMS; BEAUTY SOAP; BERGAMOT OIL; BIOTECHNOLOGICAL CHEMICAL AND SPRAY CLEANERS FOR INDUSTRIAL AND HOUSEHOLD APPLICATIONS SUCH AS STAIN REMOVAL, ODOR ELIMINATION, AND BIOREMEDIATION OF MANY TYPES OF ORGANIC AND HYDROCARBON-BASED MATERIALS; BIOTECHNOLOGICAL CLEANING SOLUTION FOR ELIMINATING ODORS, BREAKING DOWN ORGANICS, AND REMOVING STAINS; BLEACHING PREPARATIONS FOR COSMETIC PURPOSES; BLEACHING PREPARATIONS FOR HOUSEHOLD USE; BLEACHING PREPARATIONS FOR LAUNDRY USE; BLEACHING PREPARATIONS FOR THE HAIR; BLEACHING SALTS; BLUEING FOR LAUNDRY; BLUSH; BLUSH PENCILS; BLUSHER; BODY AND BEAUTY CARE COSMETICS; BODY ART PENS; BODY BUTTER; BODY CRAYONS; BODY CREAM; BODY CREAM SOAP; BODY CREAMS; BODY DEODORANT IN PILL FORM; BODY DEODORANTS; BODY EMULSIONS; BODY GLITTER; BODY LOTION; BODY LOTIONS; BODY MASK CREAM; BODY MASK LOTION; BODY MASK POWDER; BODY MASKS; BODY MILK; BODY MILKS; BODY OIL; BODY OILS; BODY POWDER; BODY SCRUB; BODY SPLASH; BODY SPRAY USED AS A PERSONAL DEODORANT AND AS FRAGRANCE; BODY SPRAYS; BODY SPRAYS, NAMELY, WATER IN ATOMIZED CONTAINERS USED TO PRODUCE A COOLING EFFECT; BODY WASH; BOOT CREAM; BOOT POLISH; BOOT WAX; BREATH FRESHENER; BREATH FRESHENER, NAMELY, BETEL NUT POWDER; BREATH FRESHENER, NAMELY, KATHA; BREATH FRESHENER, NAMELY, MUKHWAS; BREATH FRESHENER, NAMELY, PAN MASALA; BREATH FRESHENER, NAMELY, SCENTED SUPARI; BREATH FRESHENING CONFECTIONARY, NAMELY, DISSOLVABLE BREATH STRIPS, BREATH MINTS, CANDY AND GUM; BREATH FRESHENING SPRAYS; BREATH MINTS FOR USE AS A BREATH FRESHENER; BRILLIANTINE; BUBBLE BATH; BUFFING COMPOUND FOR FEET, HANDS, AND BODY; CAKES OF TOILET SOAP; CANNED PRESSURIZED AIR FOR DUSTING AND CLEANING PURPOSES; CANNED PRESSURIZED GASES FOR DUSTING AND CLEANING PURPOSES; CARBURETOR AND CHOKE CLEANING PREPARATIONS; CARNAUBA WAX FOR AUTOMOTIVE USE; CARPET CLEANERS; CARPET CLEANERS WITH DEODORIZER; CARPET CLEANING PREPARATIONS; CARPET SHAMPOO; CHALK FOR COSMETIC USE; CHALK FOR MAKE-UP; CHEMICAL CLEANERS DIRECTED TO THE PULP AND PAPER INDUSTRIES AND THE METAL

**CLASS 3—(Continued).**

FINISHING INDUSTRIES; CHILDREN'S SCENTED SPRAY FOR USE ON TOYS AND DOLLS; CHROME POLISH; CLEANER FOR COSMETIC BRUSHES; CLEANER FOR USE ON BODY, HANDS, FEET, AND FACE; CLEANING AGENTS AND PREPARATIONS; CLEANING AGENTS FOR CLEANING SURFACES; CLEANING AND POLISHING PAPER; CLEANING AND POLISHING PREPARATIONS; CLEANING AND SHINING PREPARATIONS FOR PLANT LEAVES; CLEANING AND WASHING PREPARATIONS; CLEANING FLUID FOR TYPEWRITER TYPE; CLEANING PREPARATIONS; CLEANING PREPARATIONS CONTAINING MICROBIAL ENZYMES, USED TO PRESERVE DRAIN SYSTEMS AND WATERWAYS; CLEANING PREPARATIONS CONTAINING VITAMINS, MINERALS, PLANT EXTRACTS AND/OR BOTANICALS, USED TO PRESERVE HARD SURFACES BY RENDERING THE SURFACES FREE OF AGING AGENTS; CLEANING PREPARATIONS FOR CLEANING SURFACES; CLEANING PREPARATIONS FOR CLEANSING DRAINS; CLEANING PREPARATIONS FOR HOUSEHOLD PURPOSES; CLEANING PREPARATIONS FOR MEDICAL VENTILATOR EQUIPMENT, TUBING, MASKS; CLEANING PREPARATIONS FOR SKIN, HAIR, BODY, AND HANDS; CLEANING PREPARATIONS THAT ELIMINATE BACTERIA THAT CAUSE PRODUCTS TO AGE OR PRODUCE FOUL ODORS; CLEANING SOLUTIONS FOR DENTAL ULTRASONIC STERILIZATION APPARATUS; CLEANING SWABS FOR HOUSEHOLD PURPOSES; CLEANING, POLISHING AND SCOURING PREPARATIONS; CLEANING, SCOURING AND POLISHING PREPARATIONS AND SUBSTANCES; CLEANING, WASHING AND POLISHING PREPARATIONS; CLEANSING AND POLISHING PREPARATIONS; CLEANSING CREAMS; CLEANSING MILK; CLEANSING MILK FOR TOILET PURPOSES; CLOTHS IMPREGNATED WITH A DETERGENT FOR CLEANING; CLOTHS OR TISSUES IMPREGNATED WITH A SKIN CLEANSER; COATED ABRASIVES AND SANDPAPER IN THE FORM OF BELTS, SHEETS, ROLLS AND DISCS; COBBLERS' WAX; COCOA BUTTER FOR COSMETIC PURPOSES; COLD CREAM; COLD CREAMS; COLD WAVING SOLUTIONS; COLOGNE; COLOGNE WATER; COLOGNES, PERFUMES AND COSMETICS; COLORING PREPARATIONS FOR COSMETIC PURPOSES; COMBINATION CLEANER AND DEODORIZER FOR LITTER BOXES; COMMON TOILET WATER; COMPACTS CONTAINING MAKE-UP; COMPRESSED AIR IN CANS FOR CLEANING AND DUSTING; CONCEALERS; CONCEALERS FOR SKIN, FACE, AND BODY; CONDITIONERS; COSMETIC BALLS; COSMETIC BATH SALTS; COSMETIC COTTON WOOL; COSMETIC CREAMS; COSMETIC CREAMS FOR SKIN CARE; COSMETIC FACIAL BLOTTERING PAPERS; COSMETIC HAIR DRESSING PREPARATIONS; COSMETIC HAIR FILLING POWDERS FOR COVERING BALD AND THINNING SPOTS ON THE SCALP; COSMETIC HAIR REGROWTH INHIBITING PREPARATIONS; COSMETIC HAND CREAMS; COSMETIC MASKS; COSMETIC MASSAGE CREAMS; COSMETIC MILKS; COSMETIC NOURISHING CREAMS; COSMETIC OILS; COSMETIC OILS FOR THE EPIDERMIS; COSMETIC OLIVE OIL FOR THE FACE AND BODY; COSMETIC PADS; COSMETIC PENCILS; COSMETIC PREPARATIONS; COSMETIC PREPARATIONS AGAINST SUNBURN; COSMETIC PREPARATIONS FOR BODY CARE; COSMETIC PREPARATIONS FOR EYE LASHES; COSMETIC PREPARATIONS FOR PROTECTING THE SKIN FROM THE SUN'S RAYS; COSMETIC PREPARATIONS FOR SKIN CARE; COSMETIC PREPARATIONS FOR SKIN RENEWAL; COSMETIC PREPARATIONS FOR SLIMMING PURPOSES; COSMETIC PREPARATIONS FOR THE CARE OF MOUTH AND TEETH; COSMETIC PREPARATIONS FOR THE HAIR AND SCALP; COSMETIC PREPARATIONS, NAMELY, FIRMLING CREAMS; COSMETIC PREPARATIONS, NAMELY, FIRMLING LOTIONS; COSMETIC PREPARATIONS, NAMELY, SKIN BALMS; COSMETIC PRODUCTS IN THE FORM OF AEROSOLS FOR SKIN CARE; COSMETIC PRODUCTS IN THE FORM OF AEROSOLS FOR SKINCARE; COSMETIC PRODUCTS TAKEN ORALLY, NAMELY, PILLS THAT INDUCE BRONZING OF THE SKIN; COSMETIC ROUGES; COSMETIC SKIN FRESHENERS; COSMETIC SOAPS; COSMETIC SUN MILK LOTIONS; COSMETIC SUN OILS; COSMETIC SUN-PROTECTING PREPARATIONS; COSMETIC SUN-TANNING PREPARATIONS; COSMETIC SUNSCREEN PREPARATIONS; COSMETIC

**CLASS 3—(Continued).**

SUNTAN LOTIONS; COSMETIC SUNTAN PREPARATIONS; COSMETIC WHITE FACE POWDER; COSMETICS; COSMETICS AND COSMETIC PREPARATIONS; COSMETICS AND MAKE-UP; COSMETICS FOR ANIMALS; COSMETICS FOR NON-DOMESTIC ANIMALS; COSMETICS IN GENERAL, INCLUDING PERFUMES; COSMETICS IN THE FORM OF MILKS, LOTIONS AND EMULSIONS; COSMETICS, NAMELY, COMPACTS; COSMETICS, NAMELY, LIP PRIMER; COSMETICS, NAMELY, LIP REPAIRERS; COTTON BALLS FOR COSMETIC PURPOSES; COTTON BUDS FOR COSMETIC PURPOSES; COTTON FOR COSMETIC PURPOSES; COTTON PUFFS FOR COSMETIC PURPOSES; COTTON STICKS FOR COSMETIC PURPOSES; COTTON SWABS FOR COSMETIC PURPOSES; COTTON WOOL AND COTTON STICKS FOR COSMETIC PURPOSES; COTTON WOOL BALLS FOR COSMETIC USE; COTTON WOOL BUDS FOR COSMETIC USE; COTTON WOOL FOR COSMETIC PURPOSES; CREAM SOAPS; CREAMS FOR CELLULITE REDUCTION; CREAMS FOR LEATHER; CREAMY FACE POWDER; CREAMY FOUNDATION; CREAMY ROUGES; CUTICLE CONDITIONERS; CUTICLE CREAM; CUTICLE REMOVING PREPARATIONS; DE-GREASING PREPARATIONS FOR HOUSEHOLD PURPOSES; DECALCIFYING AND DESCALING PREPARATIONS FOR CLEANING HOUSEHOLD PRODUCTS; DECORATIVE TRANSFERS AND SKIN JEWELS FOR COSMETIC PURPOSES; DENTAL BLEACHING GEL; DENTAL BLEACHING GELS; DENTIFRICE; DENTIFRICES; DENTIFRICES AND MOUTHWASHES; DENTIFRICES IN THE FORM OF CHEWING GUM; DENTURE CLEANERS; DENTURE CLEANING PREPARATIONS; DEODORANT FOR PERSONAL USE; DEODORANT SOAP; DEODORANTS AND ANTIPERSPIRANTS; DEODORANTS AND ANTIPERSPIRANTS FOR PERSONAL USE; DEODORANTS FOR ANIMALS; DEODORANTS FOR BODY CARE; DEODORANTS FOR PERSONAL USE; DEODORIZERS FOR PETS; DEPILATORIES; DEPILATORY CREAMS; DEPILATORY PREPARATIONS; DEPILATORY PREPARATIONS AND SUBSTANCES; DEPILATORY WAX; DETERGENT SOAP; DETERGENTS FOR AUTOMOBILES; DETERGENTS FOR HOUSEHOLD USE; DETERGENTS FOR MACHINE DISHWASHING; DETERGENTS PREPARED FROM PETROLEUM; DISH DETERGENTS; DISHWASHER DETERGENTS; DISHWASHING DETERGENTS; DISINFECTANT SOAPS; DISINFECTING PERFUMED SOAPS; DISPOSABLE WIPES IMPREGNATED WITH CLEANING CHEMICALS OR COMPOUNDS FOR INDUSTRIAL AND COMMERCIAL USE; DISPOSABLE WIPES IMPREGNATED WITH CLEANSING CHEMICALS OR COMPOUNDS FOR PERSONAL HYGIENE AND HOUSEHOLD USE; DISPOSABLE WIPES IMPREGNATED WITH CLEANSING COMPOUNDS FOR USE ON SKIN, HAIR, HANDS, FACE, COUNTERS, TILES, WALLS, AND FLOORS; DRAIN OPENERS; DRY CLEANING FLUIDS; DRYER SHEETS IMPREGNATED WITH CLEANING GEL AND BAGS FOR USE IN CONNECTION THEREWITH; DUSTING POWDER; EAU DE COLOGNE; EAU DE COLOGNES; EAU DE PARFUM; EAU DE PERFUME; EAU DE TOILETTE; EAU DE TOILETTE AND EAU DE COLOGNE; EAU-DE-COLOGNE; EAU-DE-TOILETTE; EAUX DE COLOGNE; EAUX DE TOILETTE; EMERY BOARDS; EMERY PAPER; EPILATORY STRIPS; ESSENTIAL OILS; ESSENTIAL OILS AS PERFUME FOR LAUNDRY PURPOSES; ESSENTIAL OILS FOR AROMATHERAPY USE; ESSENTIAL OILS FOR FLAVORING BEVERAGES; ESSENTIAL OILS FOR FOOD FLAVORINGS; ESSENTIAL OILS FOR HOUSEHOLD USE; ESSENTIAL OILS FOR INDUSTRIAL USE FOR CLEANERS; ESSENTIAL OILS FOR INDUSTRIAL USE FOR LUBRICANTS; ESSENTIAL OILS FOR PERSONAL USE; ESSENTIAL OILS FOR USE IN AROMATHERAPY; ESSENTIAL OILS FOR USE IN MANUFACTURING OF PERSONAL CARE PRODUCTS, PERFUME, BATH GEL, SHOWER GEL, BODY LOTION, BODY CREAM, SHAMPOO, AND CONDITIONER; ESSENTIAL OILS FOR USE IN THE MANUFACTURE OF SCENTED PRODUCTS; ESSENTIAL OILS OF CITRON; ESSENTIAL OILS, NAMELY, PINE OILS; ESSENTIAL VEGETABLE OILS; ETHEREAL OILS; EXFOLIANT CREAMS; EXFOLIANTS FOR BODY, FEET, HANDS, AND FACE; EXFOLIATING PAD CONTAINING A GLYCOLIC INGREDIENT NOT FOR MEDICAL PURPOSES; EYE COMPRESSES FOR COSMETIC PURPOSES; EYE CREAM; EYE GELS; EYE LINER; EYE LOTIONS; EYE MAKE-UP; EYE MAKE-UP REMOVER; EYE PEN-



**CLASS 3—(Continued).**

CILS; EYE SHADOW; EYE SHADOWS; EYE-SHADOW; EYEBROW COLORS; EYEBROW COSMETICS; EYEBROW PENCILS; EYEGLOSS; EYEGLOSS LENS CLEANING SOLUTIONS; EYELASH TINT; EYELINER; EYELINER PENCILS; EYELINERS; EYES MAKE-UP; EYES PENCILS; EYESHADOW; EYESHADOWS; EYEWEAR CLEANING KITS COMPRISED OF CLEANING FLUID AND A CLEANING CLOTH; FABRIC SOFTENERS; FABRIC SOFTENERS FOR LAUNDRY USE; FACE AND BODY BEAUTY CREAMS; FACE AND BODY CREAMS; FACE AND BODY GLITTER; FACE AND BODY LOTIONS; FACE AND BODY MILK; FACE CREAMS; FACE CREAMS AND CLEANSERS CONTAINING BENZOYL PEROXIDE FOR COSMETIC PURPOSES; FACE CREAMS FOR COSMETIC USE; FACE GLITTER; FACE MILK AND LOTIONS; FACE PAINT; FACE PAINTING KITS; FACE POWDER; FACE POWDER PASTE; FACE-POWDER ON PAPER; FACIAL BEAUTY MASKS; FACIAL CLEANING PREPARATION, NAMELY, SALICYLIC ACNE CLEANSER NOT FOR MEDICAL PURPOSES; FACIAL CLEANSERS; FACIAL CLEANSING GRAINS; FACIAL CLEANSING MILK; FACIAL CONCEALER; FACIAL CREAM; FACIAL CREAMS; FACIAL EMULSIONS; FACIAL LOTION; FACIAL MAKE-UP; FACIAL MASKS; FACIAL MOISTURIZER WITH SPF; FACIAL SCRUBS; FACIAL WASHES; FAIR COMPLEXION CREAM; FAKE BLOOD; FALSE EYELASHES; FALSE NAILS; FEMININE DEODORANT SPRAYS; FEMININE DEODORANT SUPPOSITORIES; FEMININE HYGIENE CLEANSING TOWELETTES; FINGERNAIL DECALS; FINGERNAIL SCULPTING LIQUID; FINGERNAIL SCULPTURING OVERLAYS; FLEXIBLE ABRASIVES; FLOOR BUFFING COMPOUND; FLOOR FINISHING PREPARATION; FLOOR POLISH; FLOOR POLISHES; FLOOR STRIPPING/CLEANING PREPARATION; FLOOR WAX; FLOOR WAX REMOVERS; FOAM BATH; FOAM CLEANING PREPARATIONS; FOAM CLEANSERS FOR PERSONAL USE; FOAMS CONTAINING COSMETICS AND SUNSCREENS; FOOD FLAVORINGS PREPARED FROM ESSENTIAL OILS; FOOT DEODORANT SPRAY; FOOT POWDER; FOOT SCRUBS; FOOT SMOOTHING STONES; FOUNDATION; FOUNDATION MAKE-UP; FOUNDATIONS; FRAGRANCE EMITTING WICKS FOR ROOM FRAGRANCE; FRAGRANCE SACHETS; FRAGRANCED BODY CARE PREPARATIONS, NAMELY, BODY SCRUBS, SHOWER GELS, BODY WASH, SHAMPOO, AND CONDITIONER; FRAGRANCED FACE CARE PREPARATIONS, NAMELY, FACIAL CLEANSERS, FACE SOAPS, FACE LOTIONS, FACE GEL, FASH WASH,FACE CREAMS, AND FACE SERUMS; FRAGRANCED FACIAL MOISTURIZER; FRAGRANCED SKIN CARE PREPARATIONS, NAMELY, SKIN CREAMS, SKIN, CLEANSERS, SKIN LOTIONS, AND SKIN GELS; FRAGRANCES; FRAGRANCES AND PERFUMERY; FRAGRANCES FOR AUTOMOBILES; FRAGRANCES FOR PERSONAL USE; FRUIT AND VEGETABLE WASH; FUMIGATING INCENSES (KUNKO); FURNITURE POLISH; FURNITURE POLISHES; GAUZE FOR COSMETIC PURPOSES; GEL EYE MASKS; GEL FOR HAIR, SKIN, AND BODY; GENERAL PURPOSE CLEANING, POLISHING, AND ABRASIVE LIQUIDS AND POWDERS; GENERAL PURPOSE MENTHOLATED OINTMENT NOT FOR MEDICAL USE; GENERAL PURPOSE SCOURING POWDER; GERMICIDAL DETERGENTS; GIFT BASKETS CONTAINING NON-MEDICATED BATH PREPARATIONS AND COSMETIC PREPARATIONS; GLASS CLEANERS; GLASS CLEANING PREPARATIONS; GLASS CLOTH; GLASS GRANULES USED AS ABRASIVES IN BLASTING SERVICES; GLITTER FOR COSMETIC PURPOSES; GLUE REMOVERS; GRANULATED SOAPS; GRAPE SEED OIL FOR COSMETIC USE; GREASES FOR COSMETIC PURPOSES; GUM REMOVING PREPARATIONS; HAIR BALSAM; HAIR BLEACH; HAIR BLEACHES; HAIR BLEACHING PREPARATIONS; HAIR CARE CREAMS; HAIR CARE KITS COMPRISING NON-MEDICATED HAIR CARE PREPARATIONS, NAMELY, SHAMPOO, CONDITIONER, GEL, LOTION, AND HAIR-SPRAY; HAIR CARE LOTIONS; HAIR CARE PREPARATIONS; HAIR CARE PREPARATIONS CONSISTING OF ORGANIC COCONUT VIRGIN OIL AND COCONUT VIRGIN OIL; HAIR CARE PRODUCTS, NAMELY, HEAT PROTECTION SPRAYS; HAIR CLEANING PREPARATIONS; HAIR COLOR; HAIR COLOR REMOVERS; HAIR COLORANTS; HAIR COLORING PREPARATIONS; HAIR COLOURANTS; HAIR COLOURING; HAIR COLOURING AND DYES; HAIR COLOURING PREPARA-

**CLASS 3—(Continued).**

TIONS; HAIR CONDITIONER; HAIR CONDITIONERS; HAIR CONDITIONERS FOR BABIES; HAIR CREAMS; HAIR CURLING PREPARATIONS; HAIR DECOLORANTS; HAIR DRESSINGS FOR MEN; HAIR DRESSINGS FOR WOMEN; HAIR DYE; HAIR DYES; HAIR EMOLLIENTS; HAIR FIXERS; HAIR FROSTS; HAIR GEL; HAIR GEL AND HAIR MOUSSE; HAIR GELS; HAIR GLAZE; HAIR LACQUERS; HAIR LIGHTENERS; HAIR LOTION; HAIR LOTIONS; HAIR MASCARA; HAIR MASKS; HAIR MOUSSE; HAIR MOUSSES; HAIR NOURISHERS; HAIR OILS; HAIR PIECE BONDING GLUE; HAIR POMADES; HAIR PRODUCTS, NAMELY, THICKENING CONTROL CREAMS; HAIR RELAXERS; HAIR RELAXING PREPARATIONS; HAIR REMOVING CREAM; HAIR RINSES; HAIR RINSES; HAIR SHAMPOO; HAIR SHAMPOOS AND CONDITIONERS; HAIR SHEEN SPRAY; HAIR SPRAY; HAIR SPRAYS; HAIR SPRAYS AND HAIR GELS; HAIR STRAIGHTENING PREPARATIONS; HAIR STYLING FIXATIVE IN THE NATURE OF HAIR WAX; HAIR STYLING GEL; HAIR STYLING PREPARATIONS; HAIR STYLING SPRAY; HAIR TONIC; HAIR TONICS; HAIR WAVING LOTION; HAIR WAVING PREPARATIONS; HAIR WAX; HAIR-WASHING POWDER; HAIRSPRAY; HAND CLEANERS; HAND CLEANING GELS; HAND CLEANING PREPARATIONS; HAND CREAM; HAND CREAMS; HAND LOTIONS; HAND SCRUBS; HAND SOAPS; HANDMADE SOAP BARS; HENNA FOR COSMETIC PURPOSES; HOME DENTAL CARE PRODUCTS FOR DOGS AND CATS, NAMELY, NON-MEDICATED DENTAL SPRAY; HOME DENTAL CARE PRODUCTS FOR DOGS AND CATS, NAMELY, TOOTHPASTE; HOUSEHOLD CLEANING PREPARATIONS; HYDROGEN PEROXIDE FOR USE ON THE HAIR; IMPREGNATED CLEANING CLOTHS; IMPREGNATED CLEANING PADS IMPREGNATED WITH COSMETICS; IMPREGNATED CLEANING PADS IMPREGNATED WITH TOILET PREPARATIONS; IMPREGNATED CLEANING, DUSTING OR POLISHING CLOTHS; IMPREGNATED CLOTHS FOR POLISHING; IMPREGNATED PAPER TISSUES FOR CLEANING DISHWARE; IMPREGNATED STEEL WOOL FOR CLEANING; INCENSE; INCENSE STICKS; INDOOR SUN TANNING PREPARATIONS; INDUSTRIAL SOAP; INHALER SOLD FILLED WITH ESSENTIAL OILS FOR USE IN AROMATHERAPY; JAPANESE HAIR FIXING OIL (BINTSUKU-ABURA); JASMINE OIL FOR PERSONAL USE; JOSS STICKS; KITS FOR REMOVING SCRATCHES FROM AUTOMOTIVE FINISHES AND METAL TRIMS COMPRISED OF BUFFING COMPOUND FOR AUTOMOBILES AND ALSO INCLUDING WOOL BUFFING PADS; LAUNDRY BLEACH; LAUNDRY BLUEING; LAUNDRY DETERGENT; LAUNDRY DETERGENTS; LAUNDRY FABRIC CONDITIONER; LAUNDRY PRE-SOAK; LAUNDRY SIZING; LAUNDRY SOAP; LAUNDRY STARCH; LAVENDER OIL; LEATHER CLEANING PREPARATIONS; LEATHER POLISHES; LEATHER PRESERVATIVES; LIMESTONE REMOVING PREPARATION FOR USE ON HOUSEHOLD APPARATUS; LIP BALM; LIP BALM; LIP CREAM; LIP GLOSS; LIP GLOSS PALATTE; LIP LINER; LIP POLISHER; LIPSTICK; LIPSTICK CASES; LIPSTICK HOLDERS; LIPSTICKS; LIQUID BATH SOAPS; LIQUID FOUNDATION (MIZU-OSHIROI); LIQUID PERFUMES; LIQUID SOAP; LIQUID SOAP USED IN FOOT BATH; LIQUID SOAPS; LIQUID SOAPS FOR HANDS AND FACE; LIQUID SOAPS FOR HANDS, FACE AND BODY; LOOFAH SOAPS; LOOSE FACE POWDER; LOTIONS FOR BEARDS; LOTIONS FOR CELLULITE REDUCTION; LOTIONS FOR COSMETIC PURPOSES; LOTIONS FOR FACE AND BODY CARE; LOTIONS FOR STRENGTHENING THE NAILS; LOTIONS FOR SKIN, HAIR, FACE, BODY, AND HANDS; MAKE UP FOUNDATIONS; MAKE UP REMOVING PREPARATIONS; MAKE-UP; MAKE-UP FOR THE FACE AND BODY; MAKE-UP FOUNDATIONS; MAKE-UP KITS COMPRISED OF LIPSTICK, LIP GLOSS, MASCARA, BLUSH AND POWDER EYESHADOW; MAKE-UP PENCILS; MAKE-UP POWDER; MAKE-UP PREPARATIONS; MAKE-UP PREPARATIONS FOR THE FACE AND BODY; MAKE-UP REMOVER; MAKE-UP REMOVING LOTIONS; MAKE-UP REMOVING MILK, GEL, LOTIONS AND CREAMS; MAKE-UP REMOVING MILKS; MAKE-UP REMOVING PREPARATIONS; MASCARA; MASCARAS; MASK PACK FOR COSMETIC PURPOSES; MASSAGE CREAMS; MASSAGE LOTIONS; MASSAGE OIL; MASSAGE OILS; MASSAGE WAXES; MEDICATED SOAP; MEDICATED SOAPS; METAL POLISHING AND CLEANING PREPARATIONS;

**CLASS 3—(Continued).**

MILK FOR COSMETIC PURPOSES; MINERAL POWDER FOR USE IN COSMETIC BODY WRAP APPLICATIONS; MINERAL SALT IN THE NATURE OF BATH SALTS NOT FOR MEDICAL PURPOSES; MOISTENED TOOTH POWDER; MOISTURIZING CREAMS; MOISTURIZING MILKS; MOISTURIZING PREPARATIONS FOR THE SKIN; MOISTURIZING SOLUTIONS FOR THE SKIN; MOUSSE FOR HAIR AND SKIN; MOUTH WASHES; MOUTHWASH; MOUTHWASHES; MUSK; MUSTACHE WAX; NAIL BUFFING PREPARATIONS; NAIL CARE PREPARATIONS; NAIL CARE PREPARATIONS, NAMELY, NAIL SOFTENERS; NAIL CREAM; NAIL ENAMEL; NAIL ENAMEL REMOVERS; NAIL ENAMELS; NAIL GEL; NAIL GLITTER; NAIL GROOMING PRODUCTS, NAMELY, TIPS, GLUE, LACQUER AND GLITTER; NAIL HARDENERS; NAIL POLISH; NAIL POLISH BASE COAT; NAIL POLISH PROTECTOR IN THE NATURE OF A THIN PLASTIC COVERING APPLIED TO NAILS; NAIL POLISH REMOVER; NAIL POLISH REMOVERS; NAIL POLISH TOP COAT; NAIL REPAIR PRODUCTS, NAMELY, LINEN NAIL WRAPS; NAIL REPAIR PRODUCTS, NAMELY, NAIL WRAPS; NAIL REPAIR PRODUCTS, NAMELY, SILK NAIL WRAPS; NAIL STENCILS; NAIL STRENGTHENERS; NAIL TIPS; NAIL VARNISH; NAIL VARNISH FOR COSMETIC PURPOSES; NAIL VARNISHES; NAIL-POLISH REMOVERS; NATURAL COCOA BUTTER BASED PERSONAL CARE PRODUCTS, NAMELY, BODY LOTION, SHOWER GEL, SOAP, BODY POLISH, BODY AND FOOT SCRUB AND NON-MEDICATED SKIN CREAMS; NATURAL ESSENTIAL OILS; NATURAL MINERAL MAKE-UP; NATURAL SOAP BARS; NATURALLY HANDMADE SOAP BARS; NIGHT CREAM; NON-MEDICATED ACNE TREATMENT PREPARATIONS; NON-MEDICATED ANTI-AGING SERUM; NON-MEDICATED BALMS FOR USE ON HANDS, SKIN, HAIR, BODY AND FEET; NON-MEDICATED BATH PREPARATIONS; NON-MEDICATED BATH SALTS; NON-MEDICATED BODY SOAKS; NON-MEDICATED BREATH FRESHENING STRIPS; NON-MEDICATED BUBBLE BATH PREPARATIONS; NON-MEDICATED CLEANSERS FOR PERSONAL USE, NAMELY, SKIN CLEANSERS, FACIAL CLEANSERS AND BODY CLEANSERS; NON-MEDICATED CLEANSERS, NAMELY, SKIN CLEANSERS, BODY CLEANSERS AND FACIAL CLEANSERS; NON-MEDICATED COSMETIC SKIN CARE PREPARATIONS CONSISTING OF ORGANIC COCONUT VIRGIN OIL AND COCONUT VIRGIN OIL; NON-MEDICATED DENTAL RINSE; NON-MEDICATED DIAPER RASH CREAM; NON-MEDICATED DIAPER RASH OINTMENTS AND LOTIONS; NON-MEDICATED DOUCHES; NON-MEDICATED FACIAL AND EYE SERUM CONTAINING ANTIOXIDANTS; NON-MEDICATED FEMINE HYGIENE WASH; NON-MEDICATED FOOT CREAM; NON-MEDICATED FOOT LOTIONS; NON-MEDICATED FOOT SOAKS; NON-MEDICATED GROOMING PREPARATIONS FOR PETS, DOGS, CATS, LIVESTOCK, NAMELY, SHampoos, CONDITIONERS, FLEA TREATMENTS, BATH GELS, SKIN TREATMENTS; NON-MEDICATED HAIR RESTORATION LOTIONS; NON-MEDICATED HAIR SERUMS; NON-MEDICATED HAIR TREATMENT PREPARATIONS FOR COSMETIC PURPOSES; NON-MEDICATED HERBAL BODY CARE PRODUCTS, NAMELY, BODY OILS, SALVES, AND LIP BALMS; NON-MEDICATED HERBAL BODY CARE PRODUCTS, NAMELY, HAIR CREAMS, LOTIONS, HAIR GELS, HAIR SHAMPOO, HAIR CONDITIONER, FACE CREAM, FACE LOTION BODY LOTION, BODY CREAM, BODY WASH, SHOWER GEL AND BODY SPLASH; NON-MEDICATED LIP BALM THAT DOES NOT CONTAIN BEESWAX; NON-MEDICATED LIP CARE PREPARATIONS; NON-MEDICATED LIP PROTECTORS; NON-MEDICATED MOUTH WASH AND RINSE; NON-MEDICATED MOUTH WASHES; NON-MEDICATED MOUTHWASH AND GARGLE; NON-MEDICATED MOUTHWASHES; NON-MEDICATED OINTMENTS FOR THE PREVENTION AND TREATMENT OF SUNBURN; NON-MEDICATED PREPARATIONS ALL FOR THE CARE OF SKIN, HAIR AND SCALP; NON-MEDICATED SCALP TREATMENT CREAM; NON-MEDICATED SERUMS FOR USE ON HAIR, SKIN AND LIPS; NON-MEDICATED SKIN CARE CREAMS AND LOTIONS; NON-MEDICATED SKIN CARE PREPARATION, NAMELY, BODY MIST; NON-MEDICATED SKIN CARE PREPARATIONS; NON-MEDICATED SKIN CARE PREPARATIONS, NAMELY, CREAMS, LOTIONS, GELS, TONERS, CLEANERS AND PEELS; NON-MEDICATED

**CLASS 3—(Continued).**

SKIN CARE PREPARATIONS, NAMELY, CREAMS, LOTIONS, GELS, TONERS, CLEANSERS AND PEELS; NON-MEDICATED SKIN CREAM FOR GENERAL SKIN RASH AND IRRITATION RESULTING FROM SKIN SHINGLES; NON-MEDICATED SKIN CREAMS; NON-MEDICATED STIMULATING LOTIONS FOR THE SKIN; NON-MEDICATED SUN CARE PREPARATIONS; NON-MEDICATED TOILETRIES; NON-SLIPPING LIQUIDS FOR FLOORS; NON-SLIPPING WAX FOR FLOORS; NUTRITIONAL OILS FOR COSMETIC PURPOSES; OIL BATHS FOR HAIR CARE; OILS FOR CLEANING PURPOSES; OILS FOR COSMETIC PURPOSES; OILS FOR HAIR CONDITIONING; OILS FOR PERFUMES AND SCENTS; OILS FOR TOILETRY PURPOSES; ORGANIC SOAP BARS; OVEN CLEANERS; PAINT AND VARNISH STRIPPING OR REMOVING PREPARATIONS; PAINT REMOVER; PAINT REMOVING COMPOSITIONS; PAINT STRIPPER; PAINT STRIPPING PREPARATIONS; PAINT, LACQUER AND VARNISH REMOVING COMPOSITIONS; PARAFFIN WAX FOR COSMETIC PURPOSES; PATCHES CONTAINING SUN SCREEN AND SUN BLOCK FOR USE ON THE SKIN; PENCILS FOR COSMETIC PURPOSES; PEPPERMINT OIL; PERFUME; PERFUME OILS; PERFUME OILS FOR THE MANUFACTURE OF COSMETIC PREPARATIONS; PERFUMED CREAMS; PERFUMED PASTE; PERFUMED POWDER; PERFUMED POWDERS; PERFUMED SOAP; PERFUMED SOAPS; PERFUMED TALCUM POWDER; PERFUMERIES; PERFUMERY; PERFUMES; PERFUMES AND COGNES; PERFUMES AND TOILET WATERS; PERFUMES FOR INDUSTRIAL PURPOSES; PERFUMES IN SOLID FORM; PERFUMES, AFTERSHAVES AND COGNES; PERFUMES, EAU DE COGNES AND AFTERSHAVES; PERFUMES, EAUX DE COLOGNE AND AFTERSHAVES; PERFUMING SACHETS; PERMANENT WAVE PREPARATIONS; PERMANENT WAVING LOTIONS; PERSONAL DEODORANTS; PET CARE KITS COMPRISING SHAMPOO, CONDITIONER, BODY SPRAY; PET FRAGRANCES; PET ODOR REMOVERS; PET SHAMPOO; PET SHAMPOO AND CONDITIONER; PET STAIN REMOVERS; PETROLEUM JELLY FOR COSMETIC PURPOSES; PLANT AND HERB EXTRACTS SOLD AS COMPONENTS OF COSMETICS; POLISH FOR MUSICAL INSTRUMENTS; POLISHING POWDERS; POLISHING PREPARATIONS; POLISHING STONES; POLISHING WAX; POLISHING, SCOURING AND ABRASIVE PREPARATIONS; POLYMER SEALANT FOR CLEANING, SHINING AND PROTECTING AUTOMOBILE EXTERIOR SURFACES; POMADES; POMADES FOR HAIR, LIP, AND SKIN; POMANDERS; POT POURRI; POTPOURRI; POWDER CLEANERS FOR METALS, CERAMICS AND CARPETS; POWDER FOR MAKE-UP; PRE-MOISTENED COSMETIC TISSUES; PRE-MOISTENED COSMETIC TOWELETTES; PRE-MOISTENED COSMETIC WIPES; PRE-MOISTENED TOWELETTES IMPREGNATED WITH DISHWASHING DETERGENT; PRE-SCENTED STRIPS AND CARDS FOR SAMPLING FRAGRANCES; PRE-SHAVE CREAMS; PRE-SHAVE LIQUID; PREPARATION FOR CLEANING DENTURES; PREPARATIONS FOR CLEANING, PROTECTING AND PRESERVING VEHICLE SURFACES; PREPARATIONS FOR PERMANENT HAIR WAVES; PREPARATIONS FOR SETTING HAIR; PREPARATIONS TO MAKE THE LEAVES OF PLANTS SHINY; PRESERVATIVE CREAMS FOR LEATHER; PRESSED FACE POWDER; PRINTER CLEANING CARD SATURATED WITH A CLEANING SOLVENT; PRIVATE LABEL COSMETICS; PUMICE STONES FOR PERSONAL USE; REEDS AND SCENTED OILS SOLD AS A UNIT FOR USE IN ROOM SCENT DIFFUSERS; REFILLS FOR ELECTRIC ROOM FRAGRANCE DISPENSERS; RETINOL CREAM FOR COSMETIC PURPOSES; ROOM FRAGRANCE REFILLS FOR NON-ELECTRIC ROOM FRAGRANCE DISPENSERS; ROOM FRAGRANCES; ROOM FRAGRANCING PREPARATIONS; ROSE OIL FOR COSMETIC PURPOSES; ROUGE; ROUGES; RUBBER DRESSINGS; RUST REMOVING PREPARATIONS; SACHET-LIKE EYE PILLOWS CONTAINING FRAGRANCES; SACHETS; SACHETS FOR PERFUMING LINEN; SADDLE SOAP; SAND FOR USE AS ABRASIVE IN SANDBLASTING; SANDING APPARATUS IN THE FORM OF A GLOVE; SANDPAPER; SCALE REMOVING PREPARATIONS FOR HOUSEHOLD PURPOSES; SCENT ELIMINATING LAUNDRY DETERGENT FOR USE ASSOCIATED WITH HUNTING AND OUTDOOR RECREATION; SCENT ELIMINATING SHAMPOO AND SOAP FOR USE ASSOCIATED WITH HUNTING AND OUTDOOR RECREA-

**CLASS 3—(Continued).**

TION; SCENTED BODY LOTIONS AND CREAMS; SCENTED BODY SPRAY; SCENTED CERAMIC STONES; SCENTED FABRIC REFRESHER SPRAY; SCENTED LINEN SPRAYS; SCENTED LINEN WATER; SCENTED OILS; SCENTED OILS USED TO PRODUCE AROMAS WHEN HEATED; SCENTED PATCHES THAT MAY BE APPLIED TO VARIOUS SURFACES; SCENTED PINE CONES; SCENTED ROOM SPRAYS; SCENTED STICKS FOR ADDING SCENT TO A FLOWER BOUQUET OR FLOWERING POT PLANT; SCENTED WOOD; SCOURING LIQUIDS; SCOURING POWDERS; SCOURING SOLUTIONS; SCULPTING GEL; SEAWATER-BASED SKIN CARE PREPARATIONS FOR SKIN RENEWAL; SEAWEED FOR COSMETOLOGY; SEAWEED GELATINE FOR LAUNDRY USE (FUNORI); SELF-TANNING PREPARATIONS; SHAMPOO-CONDITIONERS; SHAMPOOS; SHAMPOOS FOR BABIES; SHAVE CREAMS; SHAVING BALM; SHAVING CREAM; SHAVING CREAMS; SHAVING FOAM; SHAVING GEL; SHAVING GELS; SHAVING LOTION; SHAVING LOTIONS; SHAVING MOUSSE; SHAVING PREPARATIONS; SHAVING SOAP; SHAVING SOAPS; SHAVING SPRITZ IN THE NATURE OF A MOISTURIZING SOLUTION FOR SHAVING; SHEA BUTTER FOR COSMETIC PURPOSES; SHINING PREPARATIONS; SHOE AND BOOT CREAM; SHOE AND BOOT POLISH; SHOE BLACK; SHOE CREAM; SHOE CREAMS AND POLISHES; SHOE POLISH; SHOE POLISH AND CREAMS; SHOE POLISH APPLICATORS CONTAINING SHOE POLISH; SHOWER AND BATH FOAM; SHOWER AND BATH GEL; SHOWER CREAMS; SHOWER GEL; SHOWER GELS; SKIN ABRASIVE PREPARATIONS; SKIN AND BODY TOPICAL LOTIONS, CREAMS AND OILS FOR COSMETIC USE; SKIN BRONZER; SKIN BRONZING CREAMS; SKIN CARE PREPARATION, NAMELY, BODY POLISH; SKIN CARE PREPARATIONS, NAMELY, BODY BALM; SKIN CARE PREPARATIONS, NAMELY, CHEMICAL PEELS FOR SKIN; SKIN CARE PREPARATIONS, NAMELY, FRUIT ACID PEELS FOR SKIN; SKIN CARE PREPARATIONS, NAMELY, SKIN PEELS; SKIN CARE PRODUCTS, NAMELY, NON-MEDICATED SKIN SERUM; SKIN CLARIFIERS; SKIN CLEANSER IN LIQUID SPRAY FORM FOR USE AS A BABY WIPE ALTERNATIVE; SKIN CLEANSERS; SKIN CLEANSING CREAM; SKIN CLEANSING LOTION; SKIN CONDITIONERS; SKIN CONDITIONING CREAMS FOR COSMETIC PURPOSES; SKIN CREAM; SKIN CREAMS; SKIN CREAMS IN LIQUID AND IN SOLID FORM; SKIN CREAMS IN LIQUID AND SOLID; SKIN CREAMS IN LIQUID AND SOLID FORM; SKIN EMOLLIENTS; SKIN FRESHENERS; SKIN GELS FOR ACCELERATING, ENHANCING OR EXTENDING TANS; SKIN LIGHTENERS; SKIN LIGHTENING CREAMS; SKIN LOTION; SKIN LOTIONS; SKIN MASKS; SKIN MOISTURIZER; SKIN MOISTURIZER MASKS; SKIN MOISTURIZING GEL; SKIN POLISHING RICE BRAN (ARAI-NUKA); SKIN SOAP; SKIN TEXTURIZERS; SKIN TONERS; SKIN WHITENING CREAMS; SKIN WHITENING PREPARATIONS; SOAP IN THE FORM OF BATH TOYS; SOAP POWDER; SOAPS; SOAPS AND DETERGENTS; SOAPS FOR BODY CARE; SOAPS FOR HOUSEHOLD USE; SOAPS FOR PERSONAL USE; SOAPS FOR TOILET PURPOSES; SOLID POWDER FOR COMPACTS; SPF SUN BLOCK TOWELETTS; SPIRIT GUM FOR COSMETIC USE; SPONGES IMPREGNATED WITH MARINE AND AUTOMOTIVE WAXES AND WASHES; SPOT REMOVER; SPRAY CLEANERS FOR FRESHENING ATHLETIC MOUTH GUARDS; STAIN REMOVERS; STAIN REMOVING PREPARATIONS; STICK POMADE; STONE POLISHERS; STONE POLISHES; STONE POLISHING PREPARATIONS; STRIPPING PREPARATIONS FOR PAINT, FLOOR WAX, BEES WAX, NAIL POLISH; STYLING CLAY FOR HAIR; STYLING FOAM FOR HAIR; STYLING GELS; STYLING LOTIONS; STYLING MOUSSE; STYLING PASTE FOR HAIR; SUN BLOCK; SUN BLOCK PREPARATIONS; SUN CARE LOTIONS; SUN CREAMS; SUN SCREEN; SUN SCREEN PREPARATIONS; SUN TAN GEL; SUN TAN LOTION; SUN TAN OIL; SUN-BLOCK LOTIONS; SUN-TANNING OILS; SUN-TANNING OILS AND LOTIONS; SUN-TANNING PREPARATIONS; SUNSCREEN CREAM; SUNSCREEN CREAMS; SUNTAN CREAMS; SUNTAN OILS FOR COSMETIC PURPOSES; SUNTANNING PREPARATIONS; SYNTHETIC MUSK; SYNTHETIC PERFUMERY; TAILORS' WAX; TALCUM POWDER; TALCUM POWDER; TALCUM POWDERS; TANNING AND AFTER-SUN MILKS, GELS AND OILS; TANNING CREAMS;

**CLASS 3—(Continued).**

TANNING GELS; TANNING MILKS; TANNING OILS; TATTOO REMOVAL PREPARATIONS; TEETH CLEANING LOTIONS; TEETH WHITENING KIT; TEETH WHITENING STRIPS IMPREGNATED WITH TEETH WHITENING PREPARATIONS; TEMPORARY TATTOO SPRAYS AND STENCILS THEREFOR SOLD AS A UNIT; THEATRICAL MAKE-UP; TIRE DRESSINGS; TISSUES IMPREGNATED WITH COSMETIC LOTIONS; TOILET BOWL DETERGENTS; TOILET SOAP; TOILET SOAPS; TOILET WATER; TOILET WATER CONTAINING SNAKE OIL; TOILET WATERS; TONERS; TONING LOTION, FOR THE FACE, BODY AND HANDS; TOOTH BLEACHING PREPARATIONS; TOOTH CLEANING PREPARATIONS; TOOTH GEL; TOOTH PASTE; TOOTH PASTE IN SOFT CAKE; TOOTH POLISHES; TOOTH POWDER; TOOTH POWDERS; TOOTH WHITENERS FOR COSMETIC PURPOSES COMPRISED OF NEUTRAL SODIUM FLUORIDE SUSTAINED RELEASE GEL; TOOTH WHITENING CREAMS; TOOTH WHITENING GELS; TOOTH WHITENING PASTES; TOOTH WHITENING PREPARATIONS; TOOTHPASTE; TOOTHPASTE AND MOUTHWASHES; TOOTHPASTES; TOPICAL HERBAL CREAM FOR FIRING AND ENHANCING BREASTS; TOPICAL SKIN SPRAYS FOR COSMETIC PURPOSES; TREATMENT PREPARATIONS FOR USE ON VEHICLE WHEELS AND WHEEL COVERS; UNDER-EYE ENHANCERS; UPHOLSTERY CLEANERS; VANISHING CREAM; VARNISH REMOVERS; WASHING POWDER; WASHING PREPARATIONS AND LAUNDRY BLEACH; WASHING-UP LIQUIDS; WATERLESS SOAP; WATERLESS SPRAY FOR THE CLEANING AND WAXING OF VEHICLES; WATERPROOF SUNSCREEN; WAX FOR REMOVING BODY HAIR; WAX STRIPPING PREPARATIONS; WAX STRIPS FOR REMOVING BODY HAIR; WHITEWALL CLEANERS; WINDSCREEN CLEANING LIQUIDS; WINDSHIELD CLEANER FLUIDS; WINDSHIELD WASHING FLUID; WIPES IMPREGNATED WITH A SKIN CLEANSER; WOOD CONDITIONER, BRIGHTENER AND RENEWER; WRINKLE REMOVING SKIN CARE PREPARATIONS; WRINKLE RESISTANT CREAM; WRINKLE-MINIMIZING COSMETIC PREPARATIONS FOR TOPICAL FACIAL USE (U.S. CLS. 1, 4, 6, 50, 51 AND 52).

JANICE KIM, EXAMINING ATTORNEY

**CLASS 3—(Continued).**

SN 85-203,613. ESCARCEGA GOMEZ, VICTOR MANUEL, MONTERREY, NUEVO LEON, MEXICO, FILED 12-22-2010.

**FR  
UT  
EN  
D'S**

THE MARK CONSISTS OF THE WORDING "FRUTEND'S" IN STYLIZED FONT, WRITTEN IN TWO VERTICAL LINES WITH THE LETTERS "F", "U", "E", AND "D" ON THE LEFT AND THE LETTERS "R", "T", "N" AND "S" ON THE RIGHT.

FOR HAIR CARE LOTIONS; HAIR CARE PREPARATIONS; HAIR CONDITIONER; HAIR GEL; HAIR GLAZE; HAIR STYLING FIXATIVE IN THE NATURE OF HAIR WAX; HAIR STYLING PREPARATIONS; NON-MEDICATED HAIR TREATMENT PREPARATIONS FOR COSMETIC PURPOSES; SHAMPOOS; STYLING GELS (U.S. CLS. 1, 4, 6, 50, 51 AND 52).

FIRST USE 11-1-2010; IN COMMERCE 11-1-2010.  
JANET LEE, EXAMINING ATTORNEY

SN 85-204,256. THE EVERCARE COMPANY, ALPHARETTA, GA. FILED 12-22-2010.

**ODORLIFT**

THE MARK CONSISTS OF STANDARD CHARACTERS WITHOUT CLAIM TO ANY PARTICULAR FONT, STYLE, SIZE, OR COLOR.

FOR PET ODOR REMOVERS (U.S. CLS. 1, 4, 6, 50, 51 AND 52).

REBECCA SMITH, EXAMINING ATTORNEY

**CLASS 3—(Continued).**

SN 85-205,038. ABERCROMBIE & FITCH TRADING CO., NEW ALBANY, OH. FILED 12-23-2010.

**CLUTCH**

THE MARK CONSISTS OF STANDARD CHARACTERS WITHOUT CLAIM TO ANY PARTICULAR FONT, STYLE, SIZE, OR COLOR.

FOR AFTER-SHAVE; BATH OILS; BEAUTY CREAMS; BEAUTY LOTIONS; BODY AND BEAUTY CARE COSMETICS; BODY CREAMS; BODY LOTIONS; BODY OILS; BODY SCRUB; BODY SPRAY USED AS A PERSONAL DEODORANT AND AS FRAGRANCE; BODY SPRAYS; BODY WASH; DEODORANTS AND ANTIPERSPIRANTS FOR PERSONAL USE; FACIAL SCRUBS; HAIR CARE PREPARATIONS; HAIR STYLING PREPARATIONS; HAND CREAMS; HAND LOTIONS; LIP BALM; LIP GLOSS; MAKE-UP; NON-MEDICATED BATH PREPARATIONS; PERFUME; SHAVING PREPARATIONS; SOAPS FOR PERSONAL USE (U.S. CLS. 1, 4, 6, 50, 51 AND 52).

DOMINICK J. SALEMI, EXAMINING ATTORNEY

SN 85-205,048. ABERCROMBIE & FITCH TRADING CO., NEW ALBANY, OH. FILED 12-23-2010.

**ABERCROMBIE CLUTCH**

THE MARK CONSISTS OF STANDARD CHARACTERS WITHOUT CLAIM TO ANY PARTICULAR FONT, STYLE, SIZE, OR COLOR.

OWNER OF U.S. REG. NOS. 3,343,871, 3,484,812 AND 3,927,048.

FOR AFTER-SHAVE; BATH OILS; BEAUTY CREAMS; BEAUTY LOTIONS; BODY AND BEAUTY CARE COSMETICS; BODY CREAMS; BODY LOTIONS; BODY OILS; BODY SCRUB; BODY SPRAY USED AS A PERSONAL DEODORANT AND AS FRAGRANCE; BODY SPRAYS; BODY WASH; DEODORANTS AND ANTIPERSPIRANTS FOR PERSONAL USE; FACIAL SCRUBS; HAIR CARE PREPARATIONS; HAIR STYLING PREPARATIONS; HAND CREAMS; HAND LOTIONS; LIP BALM; LIP GLOSS; MAKE-UP; NON-MEDICATED BATH PREPARATIONS; PERFUME; SHAVING PREPARATIONS; SOAPS FOR PERSONAL USE (U.S. CLS. 1, 4, 6, 50, 51 AND 52).

DOMINICK J. SALEMI, EXAMINING ATTORNEY



**CLASS 3—(Continued).**

SN 85-205,270. EBEL INTERNATIONAL LIMITED, HAMILTON, BERMUDA, FILED 12-23-2010.

TRADITION DU THÉ

THE MARK CONSISTS OF STANDARD CHARACTERS WITHOUT CLAIM TO ANY PARTICULAR FONT, STYLE, SIZE, OR COLOR.

THE ENGLISH TRANSLATION OF "THÉ" IN THE MARK IS "TEA".

FOR PERFUMES, FRAGRANCES, COLOGNE, EAU DE PARFUM, EAU DE TOILETTE (U.S. CLS. 1, 4, 6, 50, 51 AND 52).

REGINA DRUMMOND, EXAMINING ATTORNEY

**CLASS 3—(Continued).**

SN 85-206,258. LITTLE, LAHRONDA W., ELLENWOOD, GA. FILED 12-27-2010.



NO CLAIM IS MADE TO THE EXCLUSIVE RIGHT TO USE "HIGH QUALITY ORGANICS", APART FROM THE MARK AS SHOWN.

THE COLOR(S) PURPLE AND GREEN IS/ARE CLAIMED AS A FEATURE OF THE MARK.

THE MARK CONSISTS OF THE TERM "HIGH QUALITY" IN PURPLE ABOVE THE TERM "ORGANICS" IN GREEN WITH TWO GREEN LEAVES COMING FROM THE "S" IN "ORGANICS".

FOR AROMATIC BODY CARE PRODUCTS, NAMELY, BODY LOTION, SHOWER GEL, CUTICLE CREAM, SHAMPOO, CONDITIONER, NON-MEDICATED LIP BALM, SOAP, BODY POLISH, BODY AND FOOT SCRUB AND NON-MEDICATED FOOT CREAM; BEAUTY CREAMS FOR BODY CARE; BODY AND BEAUTY CARE COSMETICS; CONDITIONERS; COSMETIC CREAMS FOR SKIN CARE; HAIR CARE CREAMS; HAIR CARE KITS COMPRISING NON-MEDICATED HAIR CARE PREPARATIONS, NAMELY, SHAMPOO, CONDITIONER; HAIR CARE LOTIONS; HAIR CARE PREPARATIONS; HAIR CARE PREPARATIONS CONSISTING OF ORGANIC COCONUT VIRGIN OIL AND COCONUT VIRGIN OIL; LOTIONS FOR FACE AND BODY CARE; LOTIONS FOR SKIN; MOISTURIZING SOLUTIONS FOR THE SKIN; NON-MEDICATED BALMS FOR USE ON LIPS; NON-MEDICATED CLEANSERS FOR PERSONAL USE, NAMELY, SKIN CLEANSERS; NON-MEDICATED CLEANSERS, NAMELY, SKIN CLEANSER; NON-MEDICATED COSMETIC SKIN CARE PREPARATIONS CONSISTING OF ORGANIC COCONUT VIRGIN OIL AND COCONUT VIRGIN OIL; NON-MEDICATED HERBAL BODY CARE PRODUCTS, NAMELY, BODY OILS, SALVES, AND LIP BALMS; NON-MEDICATED HERBAL BODY CARE PRODUCTS, NAMELY, BODY OILS WITH HERBAL ESSENTIAL OILS; NON-MEDICATED LIP CARE PREPARATIONS; NON-MEDICATED PREPARATIONS ALL FOR THE CARE OF SKIN, HAIR AND SCALP; NON-MEDICATED SKIN CARE CREAMS AND LOTIONS; NON-MEDICATED SKIN CREAM FOR GENERAL SKIN RASH AND IRRITATION RESULTING FROM SKIN SHINGLES; NON-MEDICATED SKIN CREAMS; SKIN CLEANSERS; SKIN CLEANSING CREAM; SKIN CONDITIONERS; SKIN CONDITIONING CREAMS FOR COSMETIC PURPOSES; SKIN CREAMS; SKIN CREAMS IN LIQUID AND IN SOLID FORM; SKIN EMOLLIENTS; SKIN LOTION; SKIN LOTIONS; SKIN MOISTURIZER; SOAPS FOR BODY CARE; ALL OF THE AFORESAID PRODUCTS BEING ORGANIC (U.S. CLS. 1, 4, 6, 50, 51 AND 52).

FIRST USE 9-1-2010; IN COMMERCE 11-14-2010.

TARA PATE, EXAMINING ATTORNEY

SN 85-205,316. JACKSON, STEVEN, CHINO, CA. AND JACKSON, GUADALUPE, CHINO, CA. FILED 12-23-2010.



THE MARK CONSISTS OF THE ITALICIZED WORD "CLASSY'S" ABOVE A PAIR OF SCISSORS.

FOR HAIR SHAMPOOS AND CONDITIONERS; HAIR STYLING FIXATIVE IN THE NATURE OF HAIR WAX; HAIR STYLING GEL; HAIR STYLING PREPARATIONS; HAIR STYLING SPRAY; STYLING CLAY FOR HAIR; STYLING FOAM FOR HAIR; STYLING GELS; STYLING LOTIONS; STYLING MOUSSE; STYLING PASTE FOR HAIR (U.S. CLS. 1, 4, 6, 50, 51 AND 52).

H. M. FISHER, EXAMINING ATTORNEY

**CLASS 3—(Continued).**

SN 85-207,368. LARK BEAUTY & WELLNESS, LLC, NASHUA, NH. FILED 12-29-2010.

**LARK BEAUTY & WELLNESS**

THE MARK CONSISTS OF STANDARD CHARACTERS WITHOUT CLAIM TO ANY PARTICULAR FONT, STYLE, SIZE, OR COLOR.

NO CLAIM IS MADE TO THE EXCLUSIVE RIGHT TO USE "BEAUTY & WELLNESS", APART FROM THE MARK AS SHOWN.

FOR AFTER SHAVE LOTIONS; AFTER-SHAVE; AFTER-SHAVE CREAMS; AFTER-SHAVE GEL; AFTER-SHAVE LOTIONS; AFTER-SUN GELS; AFTER-SUN MILKS; AFTER-SUN OILS; ALOE VERA GEL FOR COSMETIC PURPOSES; ASTRINGENTS FOR COSMETIC PURPOSES; BATH GEL; BATH OILS FOR COSMETIC PURPOSES; BATH POWDER; BEAUTY CREAMS; BEAUTY CREAMS FOR BODY CARE; BEAUTY GELS; BEAUTY LOTIONS; BEAUTY SOAP; BODY AND BEAUTY CARE COSMETICS; BODY LOTION; BODY SPRAYS; CLEANSING CREAMS; COLOGNES, PERFUMES AND COSMETICS; COLORING PREPARATIONS FOR COSMETIC PURPOSES; CONCEALERS; COSMETIC BALLS; COSMETIC BATH SALTS; COSMETIC CREAMS; COSMETIC CREAMS FOR SKIN CARE; COSMETIC HAIR REGROWTH INHIBITING PREPARATIONS; COSMETIC HAND CREAMS; COSMETIC MASKS; COSMETIC MASSAGE CREAMS; COSMETIC MILKS; COSMETIC NOURISHING CREAMS; COSMETIC OILS; COSMETIC OILS FOR THE EPIDERMIS; COSMETIC PADS; COSMETIC PREPARATIONS; COSMETIC PREPARATIONS AGAINST SUNBURN; COSMETIC PREPARATIONS FOR BODY CARE; COSMETIC PREPARATIONS FOR EYE LASHES; COSMETIC PREPARATIONS FOR PROTECTING THE SKIN FROM THE SUN'S RAYS; COSMETIC PREPARATIONS FOR SKIN CARE; COSMETIC PREPARATIONS FOR SKIN RENEWAL; COSMETIC PREPARATIONS FOR SLIMMING PURPOSES; COSMETIC PREPARATIONS FOR THE CARE OF MOUTH AND TEETH; COSMETIC PREPARATIONS FOR THE HAIR AND SCALP; COSMETIC PREPARATIONS, NAMELY, FIRMING CREAMS; COSMETIC PREPARATIONS, NAMELY, FIRMING LOTIONS; COSMETIC SUN MILK LOTIONS; COSMETIC SUN-PROTECTING PREPARATIONS; COSMETIC SUN-TANNING PREPARATIONS; COSMETIC SUNSCREEN PREPARATIONS; COSMETIC SUNTAN LOTIONS; COSMETIC SUNTAN PREPARATIONS; COSMETICS; COSMETICS AND COSMETIC PREPARATIONS; COSMETICS AND MAKE-UP; COSMETICS IN GENERAL, INCLUDING PERFUMES; FACE AND BODY BEAUTY CREAMS; FACIAL BEAUTY MASKS; FACIAL WASHES; HAIR GEL AND HAIR MOUSSE; HAIR GELS; MASSAGE CREAMS; MASSAGE LOTIONS; MASSAGE OIL; NON-MEDICATED ACNE TREATMENT PREPARATIONS; NON-MEDICATED HAIR TREATMENT PREPARATIONS FOR COSMETIC PURPOSES; NON-MEDICATED OINTMENTS FOR THE PREVENTION AND TREATMENT OF SUNBURN; SUNSCREEN CREAMS (U.S. CLS. 1, 4, 6, 50, 51 AND 52).  
RICHARD WHITE, EXAMINING ATTORNEY

**CLASS 3—(Continued).**

SN 85-207,435. LA ZAR, COLTON, VALENCIA, CA. FILED 12-29-2010.

**Dream Therapy Diffusers**

THE MARK CONSISTS OF STANDARD CHARACTERS WITHOUT CLAIM TO ANY PARTICULAR FONT, STYLE, SIZE, OR COLOR.

NO CLAIM IS MADE TO THE EXCLUSIVE RIGHT TO USE "DIFFUSERS", APART FROM THE MARK AS SHOWN.

FOR DIFFUSERS, NAMELY, GLASS BOTTLES FILLED WITH SCENTED DIFFUSER OIL OR ELECTRIC WALL PLUG IN DIFFUSERS FILLED WITH SCENTED OIL (U.S. CLS. 1, 4, 6, 50, 51 AND 52).

JANET LEE, EXAMINING ATTORNEY

SN 85-207,465. GENE MIKEL, BOYNTON BEACH, FL. FILED 12-29-2010.

**EARLY SPLENDOR**

THE MARK CONSISTS OF STANDARD CHARACTERS WITHOUT CLAIM TO ANY PARTICULAR FONT, STYLE, SIZE, OR COLOR.

FOR COSMETICS, NAMELY, SKIN CARE LOTIONS, SKIN CREAMS, SKIN EMOLLIENTS AND SKIN MOISTURIZERS; HAIR SHAMPOO; SKIN AND DEODORANT SOAPS ALL OF WHICH CONTAIN PEAT MOSS OR A PEAT MOSS DERIVATIVE AS AN INGREDIENT (U.S. CLS. 1, 4, 6, 50, 51 AND 52).

FIRST USE 3-2-1996; IN COMMERCE 5-24-1996.

MICHAEL TANNER, EXAMINING ATTORNEY

SN 85-207,516. DANIELS, NIKKIE, WESTLAKE VILLAGE, CA. FILED 12-29-2010.

**Bitch Perfumes**

THE MARK CONSISTS OF STANDARD CHARACTERS WITHOUT CLAIM TO ANY PARTICULAR FONT, STYLE, SIZE, OR COLOR.

NO CLAIM IS MADE TO THE EXCLUSIVE RIGHT TO USE "PERFUMES", APART FROM THE MARK AS SHOWN.

FOR FRAGRANT PERFUMES CREATED WITH MULTIPLE SCENTS DERIVED FROM NATURAL SOURCES (U.S. CLS. 1, 4, 6, 50, 51 AND 52).

MICHAEL KEATING, EXAMINING ATTORNEY

**CLASS 3—(Continued).**

SN 85-207,539. PETRILLO, JONATHAN, SACRAMENTO, CA.  
FILED 12-29-2010.



NO CLAIM IS MADE TO THE EXCLUSIVE RIGHT TO USE "COSMETIC SKIN SOLUTIONS", APART FROM THE MARK AS SHOWN.

FOR SKINCARE PRODUCTS, NAMELY, TOPICAL VITAMIN C SERUMS, ANTIOXIDANT SERUMS, FACIAL CREAMS AND MOISTURIZERS (U.S. CLS. 1, 4, 6, 50, 51 AND 52).

FIRST USE 9-1-2010; IN COMMERCE 12-1-2010.  
REBECCA POVARCHUK, EXAMINING ATTORNEY

**CLASS 3—(Continued).**

SN 85-209,707. TODD ELLER, WILTON MANORS, FL.  
FILED 1-4-2011.

## Bubba's Butt Soap

THE MARK CONSISTS OF STANDARD CHARACTERS WITHOUT CLAIM TO ANY PARTICULAR FONT, STYLE, SIZE, OR COLOR.

NO CLAIM IS MADE TO THE EXCLUSIVE RIGHT TO USE "BUTT SOAP", APART FROM THE MARK AS SHOWN.

FOR BATH SOAPS; BATH SOAPS IN LIQUID, SOLID OR GEL FORM; SKIN SOAP; SOAPS FOR BODY CARE; SOAPS FOR PERSONAL USE (U.S. CLS. 1, 4, 6, 50, 51 AND 52).

FIRST USE 3-21-2009; IN COMMERCE 9-1-2010.  
STEPHANIE ALI, EXAMINING ATTORNEY

SN 85-207,934. ATHENA'S HOME NOVELTIES, INC., WOON-SOCKET, RI. FILED 12-30-2010.

## Heavenly Goddess Heavenly Hair

THE MARK CONSISTS OF STANDARD CHARACTERS WITHOUT CLAIM TO ANY PARTICULAR FONT, STYLE, SIZE, OR COLOR.

OWNER OF U.S. REG. NO. 3,291,803.

NO CLAIM IS MADE TO THE EXCLUSIVE RIGHT TO USE "HAIR", APART FROM THE MARK AS SHOWN.

FOR HAIR CONDITIONERS; SHAMPOOS (U.S. CLS. 1, 4, 6, 50, 51 AND 52).

SANDRA BUJA, EXAMINING ATTORNEY

SN 85-210,503. HALFORD, IVY, DALLAS, TX. FILED 1-4-2011.

## Ivy's Skin Luv

THE MARK CONSISTS OF STANDARD CHARACTERS WITHOUT CLAIM TO ANY PARTICULAR FONT, STYLE, SIZE, OR COLOR.

NO CLAIM IS MADE TO THE EXCLUSIVE RIGHT TO USE "SKIN", APART FROM THE MARK AS SHOWN.

FOR COSMETIC CREAMS FOR SKIN CARE; NON-MEDICATED SKIN CARE PREPARATIONS (U.S. CLS. 1, 4, 6, 50, 51 AND 52).

FIRST USE 3-7-1998; IN COMMERCE 3-7-1998.  
CHERYL CLAYTON, EXAMINING ATTORNEY

SN 85-208,811. SKINCERITY, INC., HOUSTON, TX. FILED 1-1-2011.

## NuCerty Resurrection

THE MARK CONSISTS OF STANDARD CHARACTERS WITHOUT CLAIM TO ANY PARTICULAR FONT, STYLE, SIZE, OR COLOR.

OWNER OF U.S. REG. NO. 3,931,580.

FOR COSMETICS (U.S. CLS. 1, 4, 6, 50, 51 AND 52).

MORGAN WYNNE, EXAMINING ATTORNEY

SN 85-210,572. PACIFIC WORLD CORPORATION, LAKE FOREST, CA. FILED 1-5-2011.

## LASH SECRETS

THE MARK CONSISTS OF STANDARD CHARACTERS WITHOUT CLAIM TO ANY PARTICULAR FONT, STYLE, SIZE, OR COLOR.

NO CLAIM IS MADE TO THE EXCLUSIVE RIGHT TO USE "LASH", APART FROM THE MARK AS SHOWN.

FOR ADHESIVES FOR AFFIXING FALSE EYELASHES; ARTIFICIAL EYELASHES (U.S. CLS. 1, 4, 6, 50, 51 AND 52).

HOWARD SMIGA, EXAMINING ATTORNEY

**CLASS 3—(Continued).**

SN 85-210,586. MANA PRODUCTS, INC., LONG ISLAND CITY, NY. FILED 1-5-2011.

# BIOLASHX3

THE MARK CONSISTS OF STANDARD CHARACTERS WITHOUT CLAIM TO ANY PARTICULAR FONT, STYLE, SIZE, OR COLOR.

OWNER OF U.S. REG. NO. 3,674,109,  
FOR COSMETICS (U.S. CLS. 1, 4, 6, 50, 51 AND 52).  
JULIE VEPPUMTHARA, EXAMINING ATTORNEY

SN 85-210,590. MANA PRODUCTS, INC., LONG ISLAND CITY, NY. FILED 1-5-2011.

# BEAUTY EDIT

THE MARK CONSISTS OF STANDARD CHARACTERS WITHOUT CLAIM TO ANY PARTICULAR FONT, STYLE, SIZE, OR COLOR.

NO CLAIM IS MADE TO THE EXCLUSIVE RIGHT TO USE "BEAUTY", APART FROM THE MARK AS SHOWN.  
FOR COSMETICS (U.S. CLS. 1, 4, 6, 50, 51 AND 52).  
JULIE VEPPUMTHARA, EXAMINING ATTORNEY

SN 85-210,591. MANA PRODUCTS, INC., LONG ISLAND CITY, NY. FILED 1-5-2011.

FAST FASHION BEAUTY  
**FFB** ▶▶

NO CLAIM IS MADE TO THE EXCLUSIVE RIGHT TO USE "BEAUTY", APART FROM THE MARK AS SHOWN.

THE MARK CONSISTS OF WORDS "FAST FASHION BEAUTY" AND THE LETTERS "FFB" AND WITH TWO ARROWS POINTING TO THE RIGHT.

FOR COSMETICS (U.S. CLS. 1, 4, 6, 50, 51 AND 52).  
JULIE VEPPUMTHARA, EXAMINING ATTORNEY

**CLASS 3—(Continued).**

SN 85-210,593. MANA PRODUCTS, INC., LONG ISLAND CITY, NY. FILED 1-5-2011.

THE MARK CONSISTS OF THE WORDS "MANE BOOST" IN STYLIZED LETTERING WITH HORIZONTAL LINES AND CURVED DESIGN ELEMENTS IN THE BACKGROUND.

FOR HAIR CARE PREPARATIONS (U.S. CLS. 1, 4, 6, 50, 51 AND 52).  
JULIE VEPPUMTHARA, EXAMINING ATTORNEY

SN 85-210,850. VIBRATIONAL NUTRITION RESEARCH, LLC, BEVERLY HILLS, CA. FILED 1-5-2011.

# VibraEase

THE MARK CONSISTS OF STANDARD CHARACTERS WITHOUT CLAIM TO ANY PARTICULAR FONT, STYLE, SIZE, OR COLOR.

FOR NON-MEDICATED TOPICAL OIL FOR THE RELIEF OF PAIN (U.S. CLS. 1, 4, 6, 50, 51 AND 52).

FIRST USE 6-0-2010; IN COMMERCE 6-0-2010.  
TINA BROWN, EXAMINING ATTORNEY

SN 85-211,081. WINNING BEAUTY SUPPLY (U.S.A.) INC., ALHAMBRA, CA. FILED 1-5-2011.

# VRELAIN

THE MARK CONSISTS OF STANDARD CHARACTERS WITHOUT CLAIM TO ANY PARTICULAR FONT, STYLE, SIZE, OR COLOR.

FOR NON-MEDICATED SKIN CARE PRODUCTS, NAMELY, CREAMS, LOTIONS, GELS, TONERS, CLEANSERS, MASQUES, TONERS, BEAUTY SERUMS, MOISTURIZERS, PEELS, SUNSCREEN OILS AND CREAMS, BODY MASSAGE CREAMS AND GEL, TOPICAL CREAM FOR FIRING AND ENHANCING BREASTS; COSMETICS, NAMELY, FACE POWDER, LIPSTICK, LIP GLOSS, EYEBROW PENCIL, EYE SHADOW, MASCARA, BLUSHER, MAKE UP REMOVER, MAKEUP FOUNDATION, PRIMER, AND CONCEALER (U.S. CLS. 1, 4, 6, 50, 51 AND 52).

FIRST USE 4-1-1993; IN COMMERCE 3-1-1995.  
FRANK LATTUCA, EXAMINING ATTORNEY



**CLASS 3—(Continued).**

SN 85-211,168. COSMETIC DERMATOLOGY, INC., MIAMI, FL. FILED 1-5-2011.

**DR. BRANDT DARK CIRCLES  
AWAY**

THE MARK CONSISTS OF STANDARD CHARACTERS WITHOUT CLAIM TO ANY PARTICULAR FONT, STYLE, SIZE, OR COLOR.

OWNER OF U.S. REG. NOS. 2,913,027, 3,832,920 AND OTHERS.

THE NAME "DR. BRANDT" IDENTIFIES A LIVING INDIVIDUAL WHOSE CONSENT IS OF RECORD.

FOR SKIN MOISTURIZERS, SKIN EMOLLIENTS, EYE CREAMS AND NON-MEDICATED SKIN SERUMS (U.S. CLS. 1, 4, 6, 50, 51 AND 52).

JOHN DALIER, EXAMINING ATTORNEY



SN 85-211,595. THE PROCTER AND GAMBLE COMPANY, CINCINNATI, OH. FILED 1-6-2011.

**CHALLENGE WHAT'S POSSIBLE**

THE MARK CONSISTS OF STANDARD CHARACTERS WITHOUT CLAIM TO ANY PARTICULAR FONT, STYLE, SIZE, OR COLOR.

FOR NON-MEDICATED SKIN CARE PREPARATIONS (U.S. CLS. 1, 4, 6, 50, 51 AND 52).

JENNIFER MARTIN, EXAMINING ATTORNEY



SN 85-211,708. CELLURE, INC., NEW YORK, NY. FILED 1-6-2011.



NO CLAIM IS MADE TO THE EXCLUSIVE RIGHT TO USE "STEM CELL SKIN CARE", APART FROM THE MARK AS SHOWN.

FOR NON-MEDICATED SKIN CARE PREPARATIONS; COSMETIC PREPARATIONS FOR BODY CARE AND FACIAL CARE (U.S. CLS. 1, 4, 6, 50, 51 AND 52).

ELLEN BURNS, EXAMINING ATTORNEY

**CLASS 3—(Continued).**

SN 85-211,822. GUY TROTTER, BONSALE, CA. FILED 1-6-2011.

**SURFACE SUN SYSTEMS**

THE MARK CONSISTS OF STANDARD CHARACTERS WITHOUT CLAIM TO ANY PARTICULAR FONT, STYLE, SIZE, OR COLOR.

NO CLAIM IS MADE TO THE EXCLUSIVE RIGHT TO USE "SUN SYSTEMS", APART FROM THE MARK AS SHOWN.

FOR SUN SCREEN AND LIP BALM (U.S. CLS. 1, 4, 6, 50, 51 AND 52).

ALEXANDER L. POWERS, EXAMINING ATTORNEY



SN 85-211,951. IT COSMETICS, JERSEY CITY, NJ. FILED 1-6-2011.

**Celebration Foundation**

THE MARK CONSISTS OF STANDARD CHARACTERS WITHOUT CLAIM TO ANY PARTICULAR FONT, STYLE, SIZE, OR COLOR.

NO CLAIM IS MADE TO THE EXCLUSIVE RIGHT TO USE "FOUNDATION", APART FROM THE MARK AS SHOWN.

FOR COSMETIC PREPARATIONS; COSMETIC PREPARATIONS AGAINST SUNBURN; COSMETIC PREPARATIONS FOR BODY CARE; COSMETIC PREPARATIONS FOR SKIN CARE; COSMETIC WHITE FACE POWDER; COSMETICS; COSMETICS AND COSMETIC PREPARATIONS; COSMETICS AND MAKE-UP; MINERAL POWDER FOR USE IN COSMETIC BODY WRAP APPLICATIONS; OILS FOR COSMETIC PURPOSES; PRIVATE LABEL COSMETICS; SKIN AND BODY TOPICAL LOTIONS, CREAMS AND OILS FOR COSMETIC USE; SOLID POWDER FOR COMPACTS; WRINKLE-MINIMIZING COSMETIC PREPARATIONS FOR TOPICAL FACIAL USE (U.S. CLS. 1, 4, 6, 50, 51 AND 52).

APRIL HESIK, EXAMINING ATTORNEY



SN 85-212,001. ACI, INC., NEW YORK, NY. FILED 1-6-2011.

**READY TO WEAR LONGEVITY**

THE MARK CONSISTS OF STANDARD CHARACTERS WITHOUT CLAIM TO ANY PARTICULAR FONT, STYLE, SIZE, OR COLOR.

FOR FOUNDATION MAKE-UP; FOUNDATIONS; MAKE UP FOUNDATIONS; MAKE-UP FOUNDATIONS (U.S. CLS. 1, 4, 6, 50, 51 AND 52).

JAMES MACFARLANE, EXAMINING ATTORNEY

**CLASS 3—(Continued).**

SN 85-212,774. COMLOC, CORP., MONTCLAIR, NJ. FILED 1-7-2011.



NO CLAIM IS MADE TO THE EXCLUSIVE RIGHT TO USE "WEAVE RELIEF", APART FROM THE MARK AS SHOWN.

THE COLOR(S) AQUA BLUE, BLACK IS/ARE CLAIMED AS A FEATURE OF THE MARK.

THE MARK CONSISTS OF THE FOLLOWING: A STYLIZED LETTER "W" FOR THE LOWER CASE WORD "WEAVE" WITH A DROP ICON AT THE TOP OF THE LETTER "W", ALL IN AQUA BLUE; THE UPPER CASE WORD "RELIEF" IN BLACK BELOW THAT IN SMALLER FONT; A SINGLE AQUA BLUE LINE SEPARATING THE WORD "RELIEF" AND THE UPPER CASE TAG LINE, "END THE ITCH" ALSO IN BLACK IN SMALLER FONT BELOW THE LINE.

FOR NON-MEDICATED PREPARATIONS ALL FOR THE CARE OF SKIN, HAIR AND SCALP (U.S. CLS. 1, 4, 6, 50, 51 AND 52).

SANDRA BUJA, EXAMINING ATTORNEY

SN 85-212,954. HOBAN, JEFFREY JOHN, DBA MOBEX, INC., BLAINE, WA. FILED S.R. 1-7-2011; AM. P.R. 4-1-2011.

## Boomer Cream

THE MARK CONSISTS OF STANDARD CHARACTERS WITHOUT CLAIM TO ANY PARTICULAR FONT, STYLE, SIZE, OR COLOR.

OWNER OF U.S. REG. NO. 3,772,484.

NO CLAIM IS MADE TO THE EXCLUSIVE RIGHT TO USE "CREAM", APART FROM THE MARK AS SHOWN.

FOR MASSAGE CREAM, MOISTURIZING CREAM, NON-MEDICATED SKIN CREAM (U.S. CLS. 1, 4, 6, 50, 51 AND 52).

FIRST USE 1-10-2006; IN COMMERCE 1-10-2006.

CAROLINE WOOD, EXAMINING ATTORNEY

SN 85-213,365. WARD, ANNE S., CHICAGO, IL. FILED 1-7-2011.

## MYAURA

THE MARK CONSISTS OF STANDARD CHARACTERS WITHOUT CLAIM TO ANY PARTICULAR FONT, STYLE, SIZE, OR COLOR.

THE WORDING "MYAURA" HAS NO MEANING IN A FOREIGN LANGUAGE.

FOR BODY AND BEAUTY CARE COSMETICS; COSMETICS AND MAKE-UP; FRAGRANCES AND PERFUMERY (U.S. CLS. 1, 4, 6, 50, 51 AND 52).

RONALD DELGIZZI, EXAMINING ATTORNEY

**CLASS 3—(Continued).**

SN 85-213,631. VOGEL, KRISTINA, HERMOSA BEACH, CA. FILED 1-9-2011.

## BATH BAR

THE MARK CONSISTS OF STANDARD CHARACTERS WITHOUT CLAIM TO ANY PARTICULAR FONT, STYLE, SIZE, OR COLOR.

NO CLAIM IS MADE TO THE EXCLUSIVE RIGHT TO USE "BATH", APART FROM THE MARK AS SHOWN.

FOR SKIN CLEANSER, SKIN TONER, SKIN LOTIONS, SKIN MOISTURIZER, FACIAL AND BODY MUDS AND MASKS, BATH GELS, BATH CRYSTALS, BATH OILS, BATH SALTS, BUBBLE BATH, BODY WASH, NON-MEDICATED HAIR AND BODY FRAGRANCE MISTS, BATH OILS, BATH SALTS, BATH FIZZIES, ESSENTIAL OILS AND SPRAYS FOR AROMATHERAPY PURPOSES, HAND CREAM, FACIAL CREAM, BODY CREAM, BODY MOISTURIZERS AND LOTIONS, BODY HANDS AND FEET POLISHERS, SHAVING CREAM, SHAVING GELS, AFTERSHAVE LOTION, MASSAGE CREAM, MASSAGE OIL, MASSAGE LOTION, PERFUMERY; ESSENTIAL OILS FOR PERSONAL USE, ESSENTIAL OILS FOR USE IN BURNING WITH CANDLES, PERSONAL CARE PRODUCTS, NAMELY, EAU DE COLOGNE, TOILET WATER, NAMELY, PERFUME, SUN TANNING LOTIONS AND OILS FOR THE FACE, SUN TANNING LOTIONS AND OILS FOR THE BODY; HAIR CARE PREPARATIONS, SHAMPOO, CONDITIONER; COSMETICS, NAMELY, LIPSTICK, LIP GLOSS, LIP MOISTURIZER, NON-MEDICATED TOILETRIES; ALL PURPOSE CLEANING PREPARATIONS; PET SHAMPOO; PET FRAGRANCE; DEODORIZERS FOR PETS; COSMETIC BODY AND FACE CARE FOR MEN, NAMELY, AFTERSHAVE LOTION AND SHAVING CREAM (U.S. CLS. 1, 4, 6, 50, 51 AND 52).

PRISCILLA MILTON, EXAMINING ATTORNEY

SN 85-213,993. POLK, JOHN, HOMESTEAD, FL. FILED 1-10-2011.

## Solar Bare

THE MARK CONSISTS OF STANDARD CHARACTERS WITHOUT CLAIM TO ANY PARTICULAR FONT, STYLE, SIZE, OR COLOR.

FOR BODY LOTION; SUNSCREEN CREAM (U.S. CLS. 1, 4, 6, 50, 51 AND 52).

H. M. FISHER, EXAMINING ATTORNEY

**CLASS 3—(Continued).**

SN 85-214,951. KEITH & JEAN LLC, PEORIA, IL. FILED 1-11-2011.

**Just Bee** 

THE MARK CONSISTS OF AN IMAGE OF A MID FLIGHT BEE.

FOR COSMETIC PRODUCTS, NAMELY, LIP BALMS, BODY AND FACE LOTION, HAIR GELS, HAIR SPRAYS, AND CUTICLE CREAM (U.S. CLS. 1, 4, 6, 50, 51 AND 52).  
SKYE YOUNG, EXAMINING ATTORNEY

---

SN 85-215,492. CONCEPT LABORATORIES, INC., CHICAGO, IL. FILED 1-11-2011.

**BLOOM IT'S A GREAT SKIN DAY!**

THE MARK CONSISTS OF STANDARD CHARACTERS WITHOUT CLAIM TO ANY PARTICULAR FONT, STYLE, SIZE, OR COLOR.

FOR COSMETIC PREPARATIONS FOR SKIN CARE; MOISTURIZING PREPARATIONS FOR THE SKIN (U.S. CLS. 1, 4, 6, 50, 51 AND 52).

FIRST USE 11-12-2010; IN COMMERCE 11-12-2010.  
SANI KHOURI, EXAMINING ATTORNEY

---

SN 85-215,713. DWYER, DOUGLAS, HOLDEN, ME. FILED 1-12-2011.

**Mutt Nose Best**

THE MARK CONSISTS OF STANDARD CHARACTERS WITHOUT CLAIM TO ANY PARTICULAR FONT, STYLE, SIZE, OR COLOR.

FOR NON-MEDICATED DRY NOSE CREAM FOR DOGS (U.S. CLS. 1, 4, 6, 50, 51 AND 52).

FIRST USE 12-17-2010; IN COMMERCE 12-17-2010.  
SUZANNE BLANE, EXAMINING ATTORNEY

**CLASS 3—(Continued).**

SN 85-216,806. REVELATIONS PERFUME AND COSMETICS, INC., HUNTINGTON VALLEY, PA. FILED 1-13-2011.

**Blackjack** 

OWNER OF U.S. REG. NO. 3,932,502.  
THE MARK CONSISTS OF A SCRIPT FORMAT OF THE LETTERS "BLACKJ CK" WITH A REPRESENTATION OF A SPADE BETWEEN THE LETTERS "J" AND "C".

FOR MEN'S COLOGNE, AFTERSHAVE (U.S. CLS. 1, 4, 6, 50, 51 AND 52).

FIRST USE 11-19-2010; IN COMMERCE 11-19-2010.  
BRIDGETT SMITH, EXAMINING ATTORNEY

---

SN 85-216,807. REVELATIONS PERFUME AND COSMETICS, INC., HUNTINGTON VALLEY, PA. FILED 1-13-2011.

**Blackjack** 

OWNER OF U.S. REG. NO. 3,932,502.  
THE MARK CONSISTS OF A SCRIPT FORMAT OF THE LETTERS "BLACKJ CK" WITH A REPRESENTATION OF A HEART BETWEEN THE LETTERS "J" AND "C".

FOR WOMEN'S PERFUME; COLOGNE; BODY SPRAY; SKIN MOISTURIZERS; HAIR CARE PREPARATIONS, NAMELY, SHAMPOO; CONDITIONER, COSMETICS, NAMELY, COMPACTS; NON-MEDICATED LIP CARE PRODUCTS, NAMELY, LIPSTICK; HAIR CARE PRODUCTS, NAMELY, SKIN CARE LOTIONS; SUN TANNING AND SUN CARE PRODUCTS, NAMELY, SUN TAN LOTION; AFTER-SUN LOTION, SUN BLOCK, SUN SCREEN, SUN TAN OIL; BATH CARE PRODUCTS, NAMELY, BATH BEADS, BATH CRYSTALS, BATH FOAM, BATH GEL, SHOWER GEL, BATH LOTION, BATH MILK, BATH OIL, BATH POWDER, BATH SALTS, BUBBLE BATH, SKIN SOAP, BODY SCRUB; BODY POWDER; LIPSTICK CASES AND HOLDERS (U.S. CLS. 1, 4, 6, 50, 51 AND 52).

FIRST USE 11-19-2010; IN COMMERCE 11-19-2010.  
BRIDGETT SMITH, EXAMINING ATTORNEY

**CLASS 3—(Continued).**

SN 85-216,957. AMOREPACIFIC CORPORATION, SEOUL, REPUBLIC OF KOREA, FILED 1-13-2011.

**AMOREPACIFIC**  
MOISTURE BOUND  
REJUVENATING EYE TREATMENT GEL

OWNER OF U.S. REG. NOS. 3,114,690, 3,152,040 AND OTHERS.

NO CLAIM IS MADE TO THE EXCLUSIVE RIGHT TO USE "MOISTURE" AND "REJUVENATING EYE TREATMENT GEL", APART FROM THE MARK AS SHOWN.

THE MARK CONSISTS OF THE STYLIZED WORDS "AMOREPACIFIC MOISTURE BOUND REJUVENATING EYE TREATMENT GEL".

FOR COSMETICS; COSMETIC PREPARATIONS FOR SKIN CARE; COSMETIC GELS, NAMELY, EYE GELS, HAIR GELS AND SCULPTING GELS; COSMETIC NOURISHING CREAMS (U.S. CLS. 1, 4, 6, 50, 51 AND 52).

SAMUEL E. SHARPER JR., EXAMINING ATTORNEY

SN 85-218,349. LIFETECH RESOURCES, LLC, CHATSWORTH, CA. FILED 1-14-2011.

**PROGENATOR**

THE MARK CONSISTS OF STANDARD CHARACTERS WITHOUT CLAIM TO ANY PARTICULAR FONT, STYLE, SIZE, OR COLOR.

FOR COSMETIC HAIR TREATMENTS AND CONDITIONERS (U.S. CLS. 1, 4, 6, 50, 51 AND 52).

GIANCARLO CASTRO, EXAMINING ATTORNEY

SN 85-219,585. HENKEL AG & CO. KGAA, DUESSELDORF, FED REP GERMANY, FILED 1-18-2011.

**OXIGENTA**

THE MARK CONSISTS OF STANDARD CHARACTERS WITHOUT CLAIM TO ANY PARTICULAR FONT, STYLE, SIZE, OR COLOR.

OWNER OF U.S. REG. NO. 701,510.

FOR HAIR CARE PREPARATIONS; HAIR STYLING PREPARATIONS (U.S. CLS. 1, 4, 6, 50, 51 AND 52).

DOMINIC FATHY, EXAMINING ATTORNEY

**CLASS 3—(Continued).**

SN 85-220,262. BBEAUTIFUL LLC, AZUSA, CA. FILED 1-18-2011.

**NAILUV**

THE MARK CONSISTS OF STANDARD CHARACTERS WITHOUT CLAIM TO ANY PARTICULAR FONT, STYLE, SIZE, OR COLOR.

FOR NAIL POLISH AND NAIL GEL (U.S. CLS. 1, 4, 6, 50, 51 AND 52).

RICHARD WHITE, EXAMINING ATTORNEY

SN 85-224,352. L'OREAL USA CREATIVE, INC., NEW YORK, NY. FILED 1-24-2011.

**SURROUND SHINE**

THE MARK CONSISTS OF STANDARD CHARACTERS WITHOUT CLAIM TO ANY PARTICULAR FONT, STYLE, SIZE, OR COLOR.

NO CLAIM IS MADE TO THE EXCLUSIVE RIGHT TO USE "SHINE", APART FROM THE MARK AS SHOWN.

FOR HAIR STYLING PREPARATION (U.S. CLS. 1, 4, 6, 50, 51 AND 52).

ELISSA GARBER KON, EXAMINING ATTORNEY

SN 85-234,385. CALVIN KLEIN TRADEMARK TRUST, NEW YORK, NY. FILED 2-4-2011.

**CK SHOCKED**

THE MARK CONSISTS OF STANDARD CHARACTERS WITHOUT CLAIM TO ANY PARTICULAR FONT, STYLE, SIZE, OR COLOR.

FOR EAU DE TOILETTE, SKIN MOISTURIZER, BODY MASSAGE OIL, BODY WASH, SOAP, PERSONAL DEODORANT, TALC OILS FOR HAIR CONDITIONING, SHAMPOO, HAIR GEL (U.S. CLS. 1, 4, 6, 50, 51 AND 52).

JANICE L. MCMORROW, EXAMINING ATTORNEY



**CLASS 3—(Continued).**

SN 85-241,505. COLGATE-PALMOLIVE COMPANY, NEW YORK, NY. FILED 2-14-2011.

**AJAX SPARKLING CLEAN**

THE MARK CONSISTS OF STANDARD CHARACTERS WITHOUT CLAIM TO ANY PARTICULAR FONT, STYLE, SIZE, OR COLOR.

OWNER OF U.S. REG. NOS. 427,106, 2,425,188 AND OTHERS.

NO CLAIM IS MADE TO THE EXCLUSIVE RIGHT TO USE "SPARKLING CLEAN", APART FROM THE MARK AS SHOWN.

FOR ALL PURPOSE CLEANER (U.S. CLS. 1, 4, 6, 50, 51 AND 52).

MARK SHINER, EXAMINING ATTORNEY

---

SN 85-241,703. L'OREAL USA CREATIVE, INC., NEW YORK, NY. FILED 2-14-2011.

**CLEARLY CORRECTIVE**

THE MARK CONSISTS OF STANDARD CHARACTERS WITHOUT CLAIM TO ANY PARTICULAR FONT, STYLE, SIZE, OR COLOR.

NO CLAIM IS MADE TO THE EXCLUSIVE RIGHT TO USE "CORRECTIVE", APART FROM THE MARK AS SHOWN.

FOR COSMETICS AND NON-MEDICATED SKINCARE PREPARATIONS (U.S. CLS. 1, 4, 6, 50, 51 AND 52).

ELISSA GARBER KON, EXAMINING ATTORNEY

---

SN 85-242,454. L'OREAL, PARIS, FRANCE, FILED 2-15-2011.

**DIARICHESSE**

THE MARK CONSISTS OF STANDARD CHARACTERS WITHOUT CLAIM TO ANY PARTICULAR FONT, STYLE, SIZE, OR COLOR.

PRIORITY CLAIMED UNDER SEC. 44(D) ON FRANCE APPLICATION NO. 103766423, FILED 9-15-2010, REG. NO. 103766423, DATED 9-15-2010, EXPIRES 9-15-2020.

FOR SHAMPOOS; PRODUCTS FOR HAIR STYLING AND HAIR CARE, NAMELY, GELS, MOUSSES, BALMS, CREAM, WAX, SERUMS, LOTIONS AND MASKS; HAIR LACQUERS; HAIR COLORING AND HAIR DECOLORANT PREPARATIONS; PROTECTIVE COLORING PREPARATIONS FOR TREATED HAIR; PERMANENT WAVING AND CURLING PREPARATIONS; ESSENTIAL OILS FOR PERSONAL USE (U.S. CLS. 1, 4, 6, 50, 51 AND 52).

DANNEAN HETZEL, EXAMINING ATTORNEY

**CLASS 3—(Continued).**

SN 85-246,948. JUICY COUTURE, INC., PACOIMA, CA. FILED 2-19-2011.

**JUICY GIRL**

THE MARK CONSISTS OF STANDARD CHARACTERS WITHOUT CLAIM TO ANY PARTICULAR FONT, STYLE, SIZE, OR COLOR.

OWNER OF U.S. REG. NOS. 3,265,587 AND 3,329,779.  
FOR BATH SALTS; BATH SOAPS; BODY CREAM; BODY LOTION; BODY OIL; BODY POWDER; BODY SCRUB; BODY SPRAYS; EAU DE PARFUM; EAU DE TOILETTE; FACE CREAMS; FRAGRANCES; PERFUME; SHOWER GEL (U.S. CLS. 1, 4, 6, 50, 51 AND 52).

REGINA DRUMMOND, EXAMINING ATTORNEY

---

SN 85-249,557. L'OREAL USA CREATIVE, INC., NEW YORK, NY. FILED 2-23-2011.

**DREAM BOUNCY BLUSH**

THE MARK CONSISTS OF STANDARD CHARACTERS WITHOUT CLAIM TO ANY PARTICULAR FONT, STYLE, SIZE, OR COLOR.

OWNER OF U.S. REG. NOS. 2,950,384, 3,696,688 AND OTHERS.

NO CLAIM IS MADE TO THE EXCLUSIVE RIGHT TO USE "BLUSH", APART FROM THE MARK AS SHOWN.

FOR COSMETICS, NAMELY, BLUSH (U.S. CLS. 1, 4, 6, 50, 51 AND 52).

ELISSA GARBER KON, EXAMINING ATTORNEY

---

SN 85-249,709. L'OREAL USA CREATIVE, INC., NEW YORK, NY. FILED 2-23-2011.

**GREEN PULSE**

THE MARK CONSISTS OF STANDARD CHARACTERS WITHOUT CLAIM TO ANY PARTICULAR FONT, STYLE, SIZE, OR COLOR.

OWNER OF U.S. REG. NOS. 3,670,785 AND 3,819,052.  
FOR HAIR STYLING PREPARATIONS (U.S. CLS. 1, 4, 6, 50, 51 AND 52).

ELISSA GARBER KON, EXAMINING ATTORNEY

**CLASS 3—(Continued).**

SN 85-260,631. AHOLD LICENSING SARL, GENEVA, SWITZERLAND, FILED 3-8-2011.



OWNER OF U.S. REG. NOS. 2,871,579, 3,411,740 AND OTHERS.

THE COLOR(S) ORANGE, GRAY AND WHITE IS/ARE CLAIMED AS A FEATURE OF THE MARK.

THE MARK CONSISTS OF THE TRADE DRESS CHARACTERIZING THE FRONT FACE OF THE PACKAGING FOR APPLICANT'S GOODS, NAMELY (1) A WHITE HORIZONTAL BAR SPANNING THE LABEL OR PACKAGE FACE, (2) AN ORANGE BAR BELOW THE WHITE BAR, ALSO SPANNING THE LABEL OR PACKAGE FACE, (3) A DASHED LINE THAT APPEARS GRAY ON THE WHITE BACKGROUND AND WHITE ON THE ORANGE BACKGROUND. THE DASHED LINE EXTENDS HORIZONTALLY ALONG THE WHITE BAR, AND TURNS 90 DEGREES AT EACH END TO EXTEND DOWNWARDS INTO THE ORANGE BAR. THE DESIGN FURTHER COMPRISES (4) A GRAY SCISSORS DESIGN AND (5) THE WORD "GUARANTEED" APPEARING IN ORANGE ABOVE THE GRAY LINE AND THE WORD "VALUE" APPEARING IN ORANGE BELOW THE GRAY LINE.

SEC. 2(F) AS TO "GUARANTEED VALUE".

FOR ALL-PURPOSE CLEANERS; BABY WIPES; BODY WASH; DISH DETERGENTS; FABRIC SOFTENERS; LAUNDRY BLEACH; LAUNDRY DETERGENTS (U.S. CLS. 1, 4, 6, 50, 51 AND 52).

BRIDGETT SMITH, EXAMINING ATTORNEY

SN 85-260,910. AHOLD LICENSING SARL, GENEVA, SWITZERLAND, FILED 3-8-2011.



OWNER OF U.S. REG. NOS. 2,871,579, 3,411,740 AND OTHERS.

THE MARK CONSISTS OF A SCISSORS DESIGN WITH A DASHED LINE EXTENDING TO THE RIGHT OF THE SCISSORS. THE WORD "GUARANTEED" APPEARS ABOVE THE LINE AND THE WORD "VALUE" APPEARS BELOW THE LINE.

SEC. 2(F) AS TO "GUARANTEED VALUE".

FOR ALL-PURPOSE CLEANERS; BABY WIPES; BODY WASH; DISH DETERGENTS; FABRIC SOFTENERS; LAUNDRY BLEACH; LAUNDRY DETERGENTS (U.S. CLS. 1, 4, 6, 50, 51 AND 52).

BRIDGETT SMITH, EXAMINING ATTORNEY

**CLASS 4—LUBRICANTS AND FUELS**

SN 85-087,403. NUCOR CORPORATION, CHARLOTTE, NC. FILED 7-19-2010.

## NU-CARBON

THE MARK CONSISTS OF STANDARD CHARACTERS WITHOUT CLAIM TO ANY PARTICULAR FONT, STYLE, SIZE, OR COLOR.

FOR CARBON PRODUCTS, NAMELY, COAL, CHARCOAL, AND COKE (U.S. CLS. 1, 6 AND 15).

SUSAN RICHARDS, EXAMINING ATTORNEY

SN 85-129,043. ANTHEM PROPANE EXCHANGE, HIGHLAND PARK, IL. FILED 9-14-2010.



NO CLAIM IS MADE TO THE EXCLUSIVE RIGHT TO USE "PROPANE EXCHANGE", APART FROM THE MARK AS SHOWN.

THE COLOR(S) RED, WHITE AND BLUE IS/ARE CLAIMED AS A FEATURE OF THE MARK.

THE MARK CONSISTS OF "ANTHEM PROPANE EXCHANGE" IN BLUE AND LINED IN WHITE WITHIN A RED RECTANGLE. ABOVE THE WORDING IS A STYLIZED PARTIAL AMERICAN FLAG WITH A BLUE BACKGROUND AND WHITE STARS IN THE UPPER LEFT AND RED AND WHITE STRIPES.

FOR FUEL GAS (U.S. CLS. 1, 6 AND 15).

FIRST USE 11-1-2009; IN COMMERCE 11-1-2009.

REBECCA POVARCHUK, EXAMINING ATTORNEY

SN 85-132,710. PETERS, STEVEN C, LAKEVILLE, MN. FILED 9-17-2010.

## Life Cycle Building Group

THE MARK CONSISTS OF STANDARD CHARACTERS WITHOUT CLAIM TO ANY PARTICULAR FONT, STYLE, SIZE, OR COLOR.

NO CLAIM IS MADE TO THE EXCLUSIVE RIGHT TO USE "GROUP", APART FROM THE MARK AS SHOWN.

FOR ELECTRICAL ENERGY; RENEWABLE ENERGY, NAMELY, SOLAR ENERGY, WIND ENERGY AND GEOTHERMAL ENERGY (U.S. CLS. 1, 6 AND 15).

FIRST USE 4-1-2009; IN COMMERCE 6-1-2009.

FLORENTINA BLANDU, EXAMINING ATTORNEY

**CLASS 4—(Continued).**

SN 85-137,006. LAGUNA CANDLES, LAGUNA BEACH, CA. FILED 9-23-2010.

**LAGUNA CANDLES**

THE MARK CONSISTS OF STANDARD CHARACTERS WITHOUT CLAIM TO ANY PARTICULAR FONT, STYLE, SIZE, OR COLOR.

NO CLAIM IS MADE TO THE EXCLUSIVE RIGHT TO USE "CANDLES", APART FROM THE MARK AS SHOWN. FOR CANDLES AND FRAGRANT CANDLES (U.S. CLS. 1, 6 AND 15).

FIRST USE 10-17-2003; IN COMMERCE 10-17-2003. CURTIS FRENCH, EXAMINING ATTORNEY

**CLASS 4—(Continued).**

SN 85-206,294. GAO PO, SHIJIAZHUANG, HEBEI, CHINA, FILED 12-28-2010.

**TOWELL**

SN 85-200,524. JET-LUBE, INC., HOUSTON, TN. FILED 12-17-2010.

**extreme technology under  
extreme conditions**

THE MARK CONSISTS OF STANDARD CHARACTERS WITHOUT CLAIM TO ANY PARTICULAR FONT, STYLE, SIZE, OR COLOR.

NO CLAIM IS MADE TO THE EXCLUSIVE RIGHT TO USE "TECHNOLOGY", APART FROM THE MARK AS SHOWN.

FOR GENERAL PURPOSE GREASES AND LUBRICANTS; LUBRICATING GREASES; ALL PURPOSE LUBRICANTS, NAMELY, TOOL JOINT LUBRICANTS FOR INDUSTRIAL AND OIL FIELD PIPES AND MACHINERY (U.S. CLS. 1, 6 AND 15).

TAMARA FRAZIER, EXAMINING ATTORNEY

THE MARK CONSISTS OF STANDARD CHARACTERS WITHOUT CLAIM TO ANY PARTICULAR FONT, STYLE, SIZE, OR COLOR.

FOR CANDLES; COAL; DIESEL OIL; FUELS; INDUSTRIAL OILS; LUBRICANTS FOR INDUSTRIAL MACHINERY; LUBRICATING GREASES; LUBRICATING OILS; PETROL; PETROLEUM; WAXES (U.S. CLS. 1, 6 AND 15).

FIRST USE 5-7-2009; IN COMMERCE 5-7-2009. BILL DAWE, EXAMINING ATTORNEY

SN 85-202,137. IRISH AMERICAN PEAT INC, DBA SNEAKY PEAT (USA), LOUISBURG, NC. FILED 12-20-2010.

**DRAIOCHT  
MONA**

NO CLAIM IS MADE TO THE EXCLUSIVE RIGHT TO USE "MONA", APART FROM THE MARK AS SHOWN.

THE MARK CONSISTS OF THE STYLIZED WORDING "DRAIOCHT MONA".

THE ENGLISH TRANSLATION OF "DRAIOCHT MONA" IN THE MARK IS "MAGICAL PEAT".

FOR BRIQUETTES OF WOOD; COMBUSTIBLE BRIQUETTES; FIREPLACE LOGS; FIREWOOD; FUEL BRIQUETTES, NAMELY, COMPRESSED CARBON BRIQUETTES; FUEL PELLETS; FUEL PRODUCTS FOR STOVES, NAMELY, WOOD PELLETS, CORN AND GRAINS; FUELS; WOOD CHIPS FOR SMOKING AND GRILLING; WOOD CHIPS FOR SMOKING FOODS; WOOD CHIPS FOR USE AS FUEL; WOOD HEATING PELLETS; WOOD LOGS FOR FUEL (U.S. CLS. 1, 6 AND 15).

FIRST USE 6-0-1999; IN COMMERCE 12-0-1999. TAMARA FRAZIER, EXAMINING ATTORNEY

SN 85-209,853. NATIONAL PERFORMANCE SOLUTIONS, LLC, HOUSTON, TX. FILED 1-4-2011.

**A/C Perform**  
THE SOLUTION FOR AIR CONDITIONING EFFICIENCY

NO CLAIM IS MADE TO THE EXCLUSIVE RIGHT TO USE "A/C", APART FROM THE MARK AS SHOWN.

THE COLOR(S) BLUE AND GREEN IS/ARE CLAIMED AS A FEATURE OF THE MARK.

THE MARK CONSISTS OF TWO RIGHT-ALIGNED HORIZONTAL WAVY LINES, THE TOP LINE BLUE AND THE BOTTOM LINE GREEN AND SLIGHTLY LONGER, ABOVE THE WORDS "A/C PERFORM" IN LARGE BLUE FONT, ABOVE THE WORDS "THE SOLUTION FOR AIR CONDITIONING EFFICIENCY" IN SMALLER BLUE FONT.

FOR SYNTHETIC LUBRICANT FOR ENHANCING THE PERFORMANCE OF AIR CONDITIONING SYSTEMS (U.S. CLS. 1, 6 AND 15).

FIRST USE 10-1-2010; IN COMMERCE 10-1-2010. ALLISON SCHRODY, EXAMINING ATTORNEY

**CLASS 4—(Continued).**

SN 85-209,862. NATIONAL PERFORMANCE SOLUTIONS, LLC, HOUSTON, TX. FILED 1-4-2011.

**A/C Perform**

THE MARK CONSISTS OF STANDARD CHARACTERS WITHOUT CLAIM TO ANY PARTICULAR FONT, STYLE, SIZE, OR COLOR.

NO CLAIM IS MADE TO THE EXCLUSIVE RIGHT TO USE "A/C", APART FROM THE MARK AS SHOWN.

FOR SYNTHETIC LUBRICANT FOR ENHANCING THE PERFORMANCE OF AIR CONDITIONING SYSTEMS (U.S. CLS. 1, 6 AND 15).

FIRST USE 10-1-2010; IN COMMERCE 10-1-2010.  
ALLISON SCHRODY, EXAMINING ATTORNEY

---

SN 85-213,020. THE MISSING LINK TOURS, DBA DOGPATCH BIOFUELS, SAN FRANCISCO, CA. FILED 1-7-2011.



THE COLOR(S) BLACK, GREEN AND YELLOW IS/ARE CLAIMED AS A FEATURE OF THE MARK.

THE MARK CONSISTS OF THE WORD "BIOLIGHTER" IN BLACK TEXTURED TO APPEAR AS THOUGH MADE OF CHARCOAL FOLLOWED BY A FLAME DESIGN WHEN THE CENTER OF THE FLAME IS YELLOW SURROUNDED BY CONCENTRIC SHAPES OF DARKENING SHADES OF GREEN.

FOR LIGHTER FLUID (U.S. CLS. 1, 6 AND 15).  
EUGENIA MARTIN, EXAMINING ATTORNEY

---

SN 85-214,240. GALATA CHEMICALS, LLC, SOUTHURY, CT. FILED 1-10-2011.

**SOYPEX**

THE MARK CONSISTS OF STANDARD CHARACTERS WITHOUT CLAIM TO ANY PARTICULAR FONT, STYLE, SIZE, OR COLOR.

FOR EPOXIDIZED SOYBEAN OIL FOR USE IN THE MANUFACTURE OF CANDLE WAX (U.S. CLS. 1, 6 AND 15).

C. DIONNE CLYBURN, EXAMINING ATTORNEY

**CLASS 5—PHARMACEUTICALS**

SN 77-488,593. ASTRAZENECA AB, SÖDERTÄLJE, SWEDEN, FILED 6-2-2008.

**OMVOCATE**

THE MARK CONSISTS OF STANDARD CHARACTERS WITHOUT CLAIM TO ANY PARTICULAR FONT, STYLE, SIZE, OR COLOR.

OWNER OF ERPN CMNTY TM OFC REG. NO. 006584171, DATED 12-18-2008, EXPIRES 12-18-2018.

THE WORDING "OMVOCATE" HAS NO MEANING IN ENGLISH.

FOR PHARMACEUTICAL PREPARATIONS FOR THE TREATMENT OF DISEASES AND DISORDERS OF THE CARDIOVASCULAR, GASTROINTESTINAL, RESPIRATORY AND NERVOUS SYSTEMS; PHARMACEUTICAL PREPARATIONS FOR THE TREATMENT OF PAIN, INFLAMMATION AND INFECTION; PHARMACEUTICAL PREPARATIONS FOR THE TREATMENT OF CANCER, DIABETES, OBESITY, AND PSYCHIATRIC AND NEUROLOGICAL DISEASES AND DISORDERS (U.S. CLS. 6, 18, 44, 46, 51 AND 52).

PAUL MORENO, EXAMINING ATTORNEY

---

SN 77-591,448. LABOPHARM, INC., LAVAL, QUEBEC, CANADA, FILED 10-13-2008.

**OLEPTRO**

THE MARK CONSISTS OF STANDARD CHARACTERS WITHOUT CLAIM TO ANY PARTICULAR FONT, STYLE, SIZE, OR COLOR.

FOR PHARMACEUTICAL PREPARATIONS, NAMELY, AN ANTIDEPRESSANT (U.S. CLS. 6, 18, 44, 46, 51 AND 52).

FIRST USE 6-4-2010; IN COMMERCE 7-6-2010.  
GENE MACIOL, EXAMINING ATTORNEY

---

SN 77-643,340. BIOTEST LABORATORIES, LLC, COLORADO SPRINGS, CO. FILED 1-5-2009.

**REZ-V**

THE MARK CONSISTS OF STANDARD CHARACTERS WITHOUT CLAIM TO ANY PARTICULAR FONT, STYLE, SIZE, OR COLOR.

FOR NUTRITIONAL SUPPLEMENTS (U.S. CLS. 6, 18, 44, 46, 51 AND 52).

FIRST USE 5-10-2006; IN COMMERCE 5-10-2006.  
SANDRA BUJA, EXAMINING ATTORNEY



**CLASS 5—(Continued).**

SN 77-847,576. JOHNSON & JOHNSON, NEW BRUNSWICK, NJ. FILED 10-13-2009.



OWNER OF U.S. REG. NOS. 2,931,534, 3,746,755 AND OTHERS.

NO CLAIM IS MADE TO THE EXCLUSIVE RIGHT TO USE "PAIN RELIEF", APART FROM THE MARK AS SHOWN.

THE COLOR(S) TEAL GREEN, YELLOW, AQUA BLUE, WHITE AND BROWN IS/ARE CLAIMED AS A FEATURE OF THE MARK.

THE MARK CONSISTS OF THE STYLIZED WORD "NEOSPORIN" IN THE COLOR TEAL GREEN, WITH WHITE AND BROWN BORDERS ON A YELLOW BACKGROUND WITH THE PLUS SIGN AND THE WORDS "PAIN RELIEF" IN THE COLOR AQUA BLUE ON A WHITE RECTANGULAR BACKGROUND IN A LARGER BOX CONTAINING YELLOW ARROW WITH A BLUE GRID WITH AN AQUA BLUE BAND ACROSS THE TOP.

FOR ANTIBIOTICS FOR USE IN THE TREATMENT OF GENERAL AND LOCAL BACTERIAL AND VIRUS INFECTIONS (U.S. CLS. 6, 18, 44, 46, 51 AND 52).

FIRST USE 6-8-2009; IN COMMERCE 6-8-2009.

MARGARET POWER, EXAMINING ATTORNEY

**CLASS 5—(Continued).**

SN 77-848,105. JOHNSON & JOHNSON, NEW BRUNSWICK, NJ. FILED 10-14-2009.



OWNER OF U.S. REG. NOS. 2,931,534, 3,746,755 AND OTHERS.

NO CLAIM IS MADE TO THE EXCLUSIVE RIGHT TO USE "PAIN RELIEF", APART FROM THE MARK AS SHOWN.

THE COLOR(S) TEAL GREEN, YELLOW, AQUA BLUE, WHITE, BROWN AND PURPLE IS/ARE CLAIMED AS A FEATURE OF THE MARK.

THE MARK CONSISTS OF THE STYLIZED WORD "NEOSPORIN" IN THE COLOR TEAL GREEN, WITH WHITE AND BROWN BORDERS ON A YELLOW BACKGROUND WITH THE PLUS SIGN AND THE WORDS "PAIN RELIEF" IN THE COLOR AQUA BLUE ON A WHITE RECTANGULAR BACKGROUND IN A LARGER BOX CONTAINING YELLOW ARROW WITH A BLUE GRID WITH A PURPLE BAND ACROSS THE TOP AND A THIN PURPLE BAND ACROSS THE MIDDLE.

FOR ANTIBIOTICS FOR USE IN THE TREATMENT OF GENERAL AND LOCAL BACTERIAL AND VIRUS INFECTIONS (U.S. CLS. 6, 18, 44, 46, 51 AND 52).

FIRST USE 4-27-2009; IN COMMERCE 4-27-2009.

MARGARET POWER, EXAMINING ATTORNEY

SN 77-859,133. IBITTA ENTERPRISES INC., SHERMAN OAKS, CA. FILED 10-28-2009.

## NOPALINAZA

THE MARK CONSISTS OF STANDARD CHARACTERS WITHOUT CLAIM TO ANY PARTICULAR FONT, STYLE, SIZE, OR COLOR.

OWNER OF U.S. REG. NO. 3,214,233.

THE ENGLISH TRANSLATION OF "NOPALINAZA" IN THE MARK IS "CACTUS LINSEED".

SEC. 2(F).

FOR DIETARY AND NUTRITIONAL SUPPLEMENTS (U.S. CLS. 6, 18, 44, 46, 51 AND 52).

FIRST USE 9-30-2004; IN COMMERCE 9-30-2004.

JANICE KIM, EXAMINING ATTORNEY

**CLASS 5—(Continued).**

SN 77-859,162. IBITTA ENTERPRISES INC., SHERMAN OAKS, CA. FILED 10-28-2009.

**NOPALINAZA PLUS**

THE MARK CONSISTS OF STANDARD CHARACTERS WITHOUT CLAIM TO ANY PARTICULAR FONT, STYLE, SIZE, OR COLOR.

THE ENGLISH TRANSLATION OF "NOPALINAZA" IN THE MARK IS "CACTUS LINSEED".

SEC. 2(F) NOPALINAZA HAS BECOME DISTINCTIVE OF THE GOODS/SERVICES THROUGH THE APPLICANT'S SUBSTANTIALLY EXCLUSIVE AND CONTINUOUS USE IN COMMERCE FOR AT LEAST THE FIVE YEARS IMMEDIATELY BEFORE THE DATE OF THIS STATEMENT.

FOR DIETARY AND NUTRITIONAL SUPPLEMENTS (U.S. CLS. 6, 18, 44, 46, 51 AND 52).

FIRST USE 8-15-2000; IN COMMERCE 8-15-2002.

JANICE KIM, EXAMINING ATTORNEY

SN 77-863,104. SALVADOR ALVAREZ, SAN DIEGO, CA. FILED 11-2-2009.

**AlmaBelleza**

THE MARK CONSISTS OF STANDARD CHARACTERS WITHOUT CLAIM TO ANY PARTICULAR FONT, STYLE, SIZE, OR COLOR.

THE ENGLISH TRANSLATION OF "ALMA BELLEZA" IN THE MARK IS "SOUL BEAUTY".

FOR CALCIUM SUPPLEMENTS; DIETARY AND NUTRITIONAL SUPPLEMENTS; DIETARY BEVERAGE SUPPLEMENTS FOR HUMAN CONSUMPTION IN LIQUID AND DRY MIX FORM FOR THERAPEUTIC PURPOSES; DIETARY FOOD SUPPLEMENTS; DIETARY SUPPLEMENTAL DRINKS; DIETARY SUPPLEMENTAL DRINKS IN THE NATURE OF VITAMIN AND MINERAL BEVERAGES; DIETARY SUPPLEMENTS; DIETARY SUPPLEMENTS FOR CONTROLLING CHOLESTEROL; DIETARY SUPPLEMENTS FOR HUMAN CONSUMPTION; ENZYME FOOD SUPPLEMENTS; FOOD SUPPLEMENTS; FOOD SUPPLEMENTS, NAMELY, ANTI-OXIDANTS; GROUND FLAXSEED FIBER FOR USE AS A DIETARY SUPPLEMENT; HEALTH FOOD SUPPLEMENTS; HERBAL SUPPLEMENTS; HOMEOPATHIC SUPPLEMENTS; LECITHIN FOR USE AS A DIETARY SUPPLEMENT; LIQUID NUTRITIONAL SUPPLEMENT; MEAL REPLACEMENT AND DIETARY SUPPLEMENT DRINK MIXES; MINERAL FOOD SUPPLEMENTS; MINERAL NUTRITIONAL SUPPLEMENTS; MINERAL SUPPLEMENTS; NATURAL HERBAL SUPPLEMENTS; NATURAL SUPPLEMENTS FOR TREATING DEPRESSION AND ANXIETY; NATURAL SUPPLEMENTS FOR TREATING ERECTILE DYSFUNCTION; NUTRACEUTICALS FOR USE AS A DIETARY SUPPLEMENT; NUTRITIONAL ADDITIVES FOR MEDICAL PURPOSES FOR USE IN FOODS AND DIETARY SUPPLEMENTS FOR HUMAN CONSUMPTION; NUTRITIONAL ADDITIVES FOR MEDICAL PURPOSES USED IN FOODS AND DIETARY SUPPLEMENTS FOR HUMAN CONSUMPTION;

**CLASS 5—(Continued).**

TION; NUTRITIONAL SUPPLEMENT FOR ELIMINATING TOXINS FROM THE BODY; NUTRITIONAL SUPPLEMENT FOR ELIMINATING TOXINS FROM THE INTESTINAL TRACT; NUTRITIONAL SUPPLEMENT IN THE NATURE OF A NUTRIENT-DENSE, PROTEIN-BASED DRINK MIX; NUTRITIONAL SUPPLEMENTS; NUTRITIONAL SUPPLEMENTS IN LOTION FORM SOLD AS A COMPONENT OF NUTRITIONAL SKIN CARE PRODUCTS; POWDERED FRUIT-FLAVORED DIETARY SUPPLEMENT DRINK MIX; POWDERED NUTRITIONAL SUPPLEMENT DRINK MIX; PROTEIN SUPPLEMENTS; SOY PROTEIN FOR USE AS A NUTRITIONAL SUPPLEMENT IN VARIOUS POWDERED AND READY-TO-DRINK BEVERAGES; VITAMIN AND MINERAL SUPPLEMENTS; VITAMIN SUPPLEMENT IN TABLET FORM FOR USE IN MAKING AN EFFERVESCENT BEVERAGE WHEN ADDED TO WATER; VITAMIN SUPPLEMENTS; WEIGHT MANAGEMENT SUPPLEMENTS; WHEAT FOR USE AS A DIETARY SUPPLEMENT (U.S. CLS. 6, 18, 44, 46, 51 AND 52).

KIM SAITO, EXAMINING ATTORNEY

SN 77-867,374. LUPIN LTD., MUMBAI, INDIA, FILED 11-6-2009.

**DELBEA**

THE MARK CONSISTS OF STANDARD CHARACTERS WITHOUT CLAIM TO ANY PARTICULAR FONT, STYLE, SIZE, OR COLOR.

THE WORDING "DELBEA" HAS NO MEANING IN A FOREIGN LANGUAGE.

FOR PHARMACEUTICALS, NAMELY, CONTRACEPTIVES; ORAL CONTRACEPTIVES; ORAL HORMONAL CONTRACEPTIVES; CONTRACEPTIVE PREPARATIONS AND SUBSTANCES; HORMONE REPLACEMENT THERAPIES; HORMONAL AGENTS FOR TREATING DISORDERS AND CONDITIONS RELATED TO WOMEN'S HEALTH, NAMELY, SYMPTOMS AND CONDITIONS ASSOCIATED WITH MENOPAUSE, PREMENSTRUATION SYNDROME AND OTHER SYMPTOMS AND CONDITIONS ASSOCIATED WITH MENSTRUATION; TRANSDERMAL PATCHES USED FOR CONTRACEPTIVE PURPOSES (U.S. CLS. 6, 18, 44, 46, 51 AND 52).

NELSON SNYDER, EXAMINING ATTORNEY

SN 77-917,763. HEALTH TO HAPPINES INC., CLEARWATER, FL. FILED 1-22-2010.

**The Swedish Diet**

NO CLAIM IS MADE TO THE EXCLUSIVE RIGHT TO USE "DIET", APART FROM THE MARK AS SHOWN.

THE MARK CONSISTS OF THE STYLIZED TEXT "THE SWEDISH DIET".

FOR LIQUID DIETARY VITAMIN SUPPLEMENT (U.S. CLS. 6, 18, 44, 46, 51 AND 52).

SUE LAWRENCE, EXAMINING ATTORNEY

**CLASS 5—(Continued).**

SN 77-941,607. QUALITY OF LIFE LABS, LLC, PURCHASE, NY. FILED 2-22-2010.

# Metasol

THE MARK CONSISTS OF STANDARD CHARACTERS WITHOUT CLAIM TO ANY PARTICULAR FONT, STYLE, SIZE, OR COLOR.

FOR DIETARY SUPPLEMENTS THAT SUPPORT HEALTHY METABOLIC BIOMARKERS WHICH INCLUDE INSULIN SENSITIVITY, LIPID METABOLISM, GLUCOSE TOLERANCE, AND BLOOD PRESSURE SOLD TO AND THROUGH DOCTORS (U.S. CLS. 6, 18, 44, 46, 51 AND 52).

MARLENE BELL, EXAMINING ATTORNEY

SN 77-954,453. BOGOCH FAMILY LLC, NEW YORK, NY. FILED 3-9-2010.

# TWO-PUNCH

THE MARK CONSISTS OF STANDARD CHARACTERS WITHOUT CLAIM TO ANY PARTICULAR FONT, STYLE, SIZE, OR COLOR.

FOR VACCINES; VETERINARY VACCINES; PHARMACEUTICAL PREPARATIONS FOR USE IN ANTI-BODY THERAPIES AND THE IMMUNIZATION OF HUMANS AND ANIMALS (U.S. CLS. 6, 18, 44, 46, 51 AND 52).

JOSETTE BEVERLY, EXAMINING ATTORNEY

SN 77-966,332. LIL-LETS UK LIMITED, SOLIHULL WEST MIDLANDS, UNITED KINGDOM, FILED 3-23-2010.

# LIL-LETS

THE MARK CONSISTS OF STANDARD CHARACTERS WITHOUT CLAIM TO ANY PARTICULAR FONT, STYLE, SIZE, OR COLOR.

OWNER OF ERPN CMNTY TM OFC REG. NO. 000658187, DATED 7-31-2000, EXPIRES 10-21-2017.

FOR MENSTRUATION APPLIANCES, NAMELY, ABSORBENT SANITARY TOWELS, ABSORBENT SANITARY PANTIES, PANTY LINERS, SANITARY NAPKINS, TAMPONS, FEMININE HYGIENE PADS; SANITARY TAMPONS; SANITARY TOWELS, PANTY LINERS (U.S. CLS. 6, 18, 44, 46, 51 AND 52).

ALYSSA STEEL, EXAMINING ATTORNEY

**CLASS 5—(Continued).**

SN 79-079,727. NOVARTIS AG, SWITZERLAND, FILED 12-29-2009.

# ZYNTEMA

THE MARK CONSISTS OF STANDARD CHARACTERS WITHOUT CLAIM TO ANY PARTICULAR FONT, STYLE, SIZE, OR COLOR.

PRIORITY DATE OF 12-15-2009 IS CLAIMED.

OWNER OF INTERNATIONAL REGISTRATION 1030945 DATED 12-29-2009, EXPIRES 12-29-2019.

FOR ANTI-INFECTIVES; ANTIBIOTICS; ANTIFUNGAL PREPARATIONS; ANTIVIRALS; PHARMACEUTICAL PREPARATIONS FOR THE PREVENTION AND TREATMENT OF DISORDERS OF THE NERVOUS SYSTEM, THE IMMUNE SYSTEM, THE CARDIO-VASCULAR SYSTEM, THE METABOLIC SYSTEM, THE RESPIRATORY SYSTEM, THE MUSCULO-SKELETAL SYSTEM, THE GENITOURINARY SYSTEM; FOR THE TREATMENT OF INFLAMMATORY DISORDERS; FOR USE IN DERMATOLOGY, ONCOLOGY, HEMATOLOGY AND IN TISSUE AND ORGAN TRANSPLANTATION AND FOR GASTROENTEROLOGICAL DISORDERS; PHARMACEUTICAL PREPARATIONS FOR THE PREVENTION AND TREATMENT OF BACTERIA-BASED DISEASES OR DISORDERS, AUTOIMMUNE DISEASES OR DISORDERS, KIDNEY DISEASES OR DISORDERS, AND DIABETES; VACCINES; DIAGNOSTIC PREPARATIONS FOR MEDICAL USE; EXCLUDING OPHTHALMIC PREPARATIONS (U.S. CLS. 6, 18, 44, 46, 51 AND 52).

LAKEISHA LEWIS, EXAMINING ATTORNEY

SN 79-084,416. NEVILLE TREVOR WITTENBAKER, AUSTRALIA, FILED 5-31-2010.

# ARTHRONAT

THE MARK CONSISTS OF STANDARD CHARACTERS WITHOUT CLAIM TO ANY PARTICULAR FONT, STYLE, SIZE, OR COLOR.

OWNER OF INTERNATIONAL REGISTRATION 1043557 DATED 5-31-2010, EXPIRES 5-31-2020.

THE WORDING "ARTHRONAT" HAS NO MEANING IN A FOREIGN LANGUAGE.

FOR NATURAL PHARMACEUTICAL PRODUCTS FOR THE TREATMENT OF JOINT DISEASES, ARTHRITIS, RHEUMATISM, CONDITIONS OF THE KIDNEY, KIDNEY STONES, GOUT, ACNE, HEART DISEASE; PHARMACEUTICAL PREPARATIONS FOR THE TREATMENT OF JOINT DISEASES; PHARMACEUTICAL PREPARATIONS FOR USE IN THE TREATMENT OF ARTHRITIS; PHARMACEUTICAL PREPARATIONS FOR USE IN THE TREATMENT OF RHEUMATISM; PHARMACEUTICAL PRODUCTS DERIVED FROM NATURAL SOURCES FOR THE TREATMENT OF JOINT DISEASES, ARTHRITIS, RHEUMATISM, CONDITIONS OF THE KIDNEY, KIDNEY STONES, GOUT, ACNE, HEART DISEASE; PHARMACEUTICAL TABLETS FOR THE TREATMENT OF JOINT DISEASES, ARTHRITIS, RHEUMATISM, CONDITIONS OF THE KIDNEY, KIDNEY STONES, GOUT, ACNE, HEART DISEASE (U.S. CLS. 6, 18, 44, 46, 51 AND 52).

WENDY JUN, EXAMINING ATTORNEY

**CLASS 5—(Continued).**

SN 79-087,633. MATTHIAS RATH, CAPE TOWN, SOUTH AFRICA, FILED 6-25-2010.

# EpiQuercican

THE MARK CONSISTS OF STANDARD CHARACTERS WITHOUT CLAIM TO ANY PARTICULAR FONT, STYLE, SIZE, OR COLOR.

PRIORITY DATE OF 1-25-2010 IS CLAIMED.  
OWNER OF INTERNATIONAL REGISTRATION 1051910 DATED 6-25-2010, EXPIRES 6-25-2020.

THE WORDING "EPIQUERCICAN" HAS NO MEANING IN A FOREIGN LANGUAGE.

FOR PHARMACEUTICAL PREPARATIONS FOR USE IN THE TREATMENT OF HEART DISEASE AND HEART CONDITIONS, DIABETES, MENSTRUAL DISORDERS, BLOOD PRESSURE PROBLEMS, CARDIOVASCULAR PROBLEMS, LIPID METABOLISM DISORDERS, ASTHMA, ARTHRITIS, ARTHROSIS, TINNITUS, PERIODONTOSIS, ANEMIA, CELL DEFICIENCIES AND CANCER; VITAMIN PREPARATIONS AND FOOD SUPPLEMENTS WITH A BASE OF MINERALS, ALL FOR MEDICAL PURPOSES; DIETETIC SUPPLEMENTS NOT FOR MEDICAL USE WITH A BASE OF VITAMINS, AMINO ACIDS, MINERALS AND TRACE ELEMENTS OF MINERALS; FOOD SUPPLEMENTS NOT FOR MEDICAL PURPOSES, MAINLY CONSISTING OF VITAMINS, AMINO ACIDS, MINERALS AND TRACE ELEMENTS OF MINERALS (U.S. CLS. 6, 18, 44, 46, 51 AND 52).

ELI HELLMAN, EXAMINING ATTORNEY

SN 79-092,365. DIPL.-ING. DDR. WASSYL NOWICKY, AUSTRIA, FILED 11-3-2010.

# ALLEGON

THE MARK CONSISTS OF STANDARD CHARACTERS WITHOUT CLAIM TO ANY PARTICULAR FONT, STYLE, SIZE, OR COLOR.

PRIORITY DATE OF 5-4-2010 IS CLAIMED.  
OWNER OF INTERNATIONAL REGISTRATION 1064525 DATED 11-3-2010, EXPIRES 11-3-2020.

FOR PHARMACEUTICAL PREPARATIONS, NAMELY, PHARMACEUTICAL PREPARATIONS FOR HUMAN APPLICATION COMPRISING MEDICAMENTS FOR THE PROPHYLACTIC OR THERAPEUTIC USE AGAINST DISEASES OR DYSFUNCTIONS OF THE SKIN, OF THE IMMUNE SYSTEM OR OF TISSUES OF THE HUMAN BODY, INCLUDING MEDICAMENTS FOR THE PROPHYLACTIC OR THERAPEUTIC USE AGAINST VIRAL INFECTIONS, CANCER DISEASES, METABOLIC DISEASES, IMMUNOLOGICAL DYSFUNCTIONS, DAMAGES OF THE SKIN OR TISSUE CAUSED BY RADIATION, SKIN TUMORS, ALLERGIES, OSTEOPOROSIS, RHEUMATIC DISEASES, SCARRING, EPILEPSY, MULTIPLE SCLEROSIS; MEDICAMENTS FOR THE TREATMENT OF POSTOPERATIVE WOUNDS; MEDICAMENTS BASED ON ALKALOID COMPOUNDS, FOR ANY OF THE AFOREMENTIONED APPLICATIONS; MEDICAMENTS BASED ON ALKALOID COMPOUNDS HAVING A QUATERNARY NITROGEN, FOR ANY OF THE AFOREMENTIONED APPLICATIONS; MEDICAMENTS BASED ON ALKALOIDS OR MODIFIED ALKALOIDS DERIVED FROM CHELIDONIUM MAJUS L., FOR ANY OF THE AFOREMENTIONED APPLICATIONS; THE AFOREMENTIONED MEDICAMENTS PREFERABLY IN THE FORM OF AQUEOUS SOLUTIONS, OINTMENTS, CREAMS, GELS, TABLETS (U.S. CLS. 6, 18, 44, 46, 51 AND 52).

RAUL CORDOVA, EXAMINING ATTORNEY

**CLASS 5—(Continued).**

SN 79-092,707. PROTRANS MEDIZINISCHE DIAGNOSTISCHE PRODUKTE GMBH, 68766 HOCKENHEIM, FED REP GERMANY, FILED 11-23-2010.

# Domino Stones

THE MARK CONSISTS OF STANDARD CHARACTERS WITHOUT CLAIM TO ANY PARTICULAR FONT, STYLE, SIZE, OR COLOR.

OWNER OF INTERNATIONAL REGISTRATION 1065561 DATED 11-23-2010, EXPIRES 11-23-2020.

FOR DIAGNOSTIC PREPARATIONS FOR MEDICAL PURPOSES (U.S. CLS. 6, 18, 44, 46, 51 AND 52).

ROBERT STRUCK, EXAMINING ATTORNEY

SN 85-022,695. TAIWAN SUNPAN BIOTECHNOLOGY DEVELOPMENT CO., LTD., TAUUYUAN, TAIWAN, FILED 4-26-2010.



THE MARK CONSISTS OF THE LETTERS "TSB" HAVING A BROKEN LINE GOING THROUGH THE BOTTOM OF THE LETTERS AND FIVE CIRCLES WITH LIGHT SPOTS IN THE UPPER LEFT HAND CORNER STARTING NEXT TO THE LETTER "T" AND CONTINUING ABOVE THE LETTERS "TSB" AND GETTING SMALLER IN SIZE AND ENDING TO THE RIGHT OF THE LETTER "B".

FOR MEDICINAL HERBAL PREPARATIONS, NAMELY, GALENICALS; ORAL ANALGESICS; ANTI-INFLAMMATORY DRUGS; PRESCRIPTION SYNTHETIC AND EXTRACTED NARCOTICS; ANTI-CARCINOGEN PREPARATION; ANTI-DIABETES PREPARATION, NAMELY, PHARMACEUTICAL PREPARATIONS FOR TREATING DIABETES; CHOLESTEROL LOWERING DRUGS; ANTIDIARRHEAL PREPARATIONS, NAMELY, DIARRHEA MEDICATION; ANTINEOPLASTIC AGENTS, NAMELY, PHARMACEUTICAL PREPARATIONS FOR USE IN CHEMOTHERAPY AND IN CURING TUMORS AND CANCER; ANTI-HYPERTENSION DRUGS; WESTERN PHARMACEUTICAL PREPARATIONS FOR USE IN OR AS ANTIDEPRESSANTS, ANTICOAGULANTS, ANTI-CANCER DRUGS; CHINESE HERBAL PHARMACEUTICAL PREPARATIONS, NAMELY, MEDICINAL HERBAL PREPARATIONS; MEDICINE AND PHARMACEUTICAL PREPARATIONS FOR CENTRAL NERVOUS SYSTEM; CARDIOVASCULAR AGENTS, NAMELY, CARDIOVASCULAR TREATMENT PREPARATIONS AND CARDIOVASCULAR PHARMACEUTICALS; PHARMACEUTICAL PREPARATIONS FOR PREVENTING AND CURING HYPERTENSION AND CIRCULATORY SYSTEM DISEASES; MEDICINE AND PHARMACEUTICAL PREPARATIONS FOR HUMAN USE, NAMELY, SEDATIVES, ANTIALLERGIC MEDICINES, PHARMACEUTICAL PREPARATIONS, NAMELY, SYNTHETIC OR EXTRACTED PHARMACEUTICAL PREPARATIONS FOR ORAL OR INJECTION ADMINISTRATION TO CURE CANCER, TUMORS, AND DISEASES, ANTI-CONVULSION PREPARATIONS, MEDICINES FOR THE HUMAN BRAIN; ANTIVIRAL AGENTS; ANTISPASMODICS, NAMELY, PHARMACEUTICAL PREPARATIONS TO RELIEVE CRAMPS OR SPASMS OF THE STOMACH, INTESTINES, AND BLADDER (U.S. CLS. 6, 18, 44, 46, 51 AND 52).

LINDSEY RUBIN, EXAMINING ATTORNEY



**CLASS 5—(Continued).**

SN 85-026,688. GUERBET, VILLEPINTE, FRANCE, FILED 4-29-2010.

# LIPIODOL

THE MARK CONSISTS OF STANDARD CHARACTERS WITHOUT CLAIM TO ANY PARTICULAR FONT, STYLE, SIZE, OR COLOR.

FOR CONTRAST MEDIA FOR USE IN MEDICAL IMAGING, NAMELY, A PREPARATION COMPRISED OF AN IODINATED ETHYL ESTER OF THE FATTY ACID OF POPPY SEED OIL FOR USE IN RADIOLOGICAL DIAGNOSIS (U.S. CLS. 6, 18, 44, 46, 51 AND 52).

FIRST USE 0-0-1926; IN COMMERCE 6-1-2010.  
MARTHA FROMM, EXAMINING ATTORNEY

**CLASS 5—(Continued).**

SN 85-054,334. NATIONAL MARKETING, INC., LAGUNA NIGUEL, CA. FILED 6-3-2010.

# CortiKids

THE MARK CONSISTS OF STANDARD CHARACTERS WITHOUT CLAIM TO ANY PARTICULAR FONT, STYLE, SIZE, OR COLOR.

THE WORDING "CORTIKIDS" HAS NO MEANING IN A FOREIGN LANGUAGE.

FOR DIETARY AND NUTRITIONAL SUPPLEMENTS (U.S. CLS. 6, 18, 44, 46, 51 AND 52).

MYRIAH HABEEB, EXAMINING ATTORNEY

SN 85-030,836. APIMEDS, INC., DBA APIMEDS, INC., ZIEGLERVILLE, PA. FILED 5-5-2010.

# APITOX 1.0 mg

THE MARK CONSISTS OF STANDARD CHARACTERS WITHOUT CLAIM TO ANY PARTICULAR FONT, STYLE, SIZE, OR COLOR.

NO CLAIM IS MADE TO THE EXCLUSIVE RIGHT TO USE "1.0 MG", APART FROM THE MARK AS SHOWN.

FOR PHARMACEUTICAL PREPARATIONS AND SUBSTANCES FOR THE TREATMENT OF INFECTIOUS DISEASES, BLOOD DISORDERS, PAIN, INFLAMMATION, SEPSIS, ALOPECIA, OBESITY AND COGNITIVE DISORDERS (U.S. CLS. 6, 18, 44, 46, 51 AND 52).

SUSAN STIGLITZ, EXAMINING ATTORNEY

SN 85-055,809. SOUTHERN CROSS LABORATORIES, KINGWOOD, TX. FILED 6-7-2010.

# PUSH

THE MARK CONSISTS OF STANDARD CHARACTERS WITHOUT CLAIM TO ANY PARTICULAR FONT, STYLE, SIZE, OR COLOR.

FOR WATER BASED AND SILICONE PERSONAL CARE AND PERSONAL LUBRICANTS FOR CONSUMERS (U.S. CLS. 6, 18, 44, 46, 51 AND 52).

FIRST USE 5-1-2010; IN COMMERCE 5-1-2010.

MELISSA VALLILLO, EXAMINING ATTORNEY

SN 85-050,141. TRADITIONAL MEDICINALS, INC., SEBASTOPOL, CA. FILED 5-28-2010.

# JUST FOR KIDS

THE MARK CONSISTS OF STANDARD CHARACTERS WITHOUT CLAIM TO ANY PARTICULAR FONT, STYLE, SIZE, OR COLOR.

SEC. 2(F).

FOR HERBAL PREPARATIONS TO AID IN TREATMENT OF DIGESTION AND UPSET STOMACH AND TO RELIEVE GAS; HERBAL PREPARATIONS TO AID IN SLEEP; HERBAL PREPARATIONS TO RELIEVE SORE THROAT PAIN; HERBAL PREPARATIONS TO TREAT THE SYMPTOMS OF COLDS; HERB TEA FOR MEDICINAL PURPOSES (U.S. CLS. 6, 18, 44, 46, 51 AND 52).

FIRST USE 8-0-2005; IN COMMERCE 8-0-2005.

ROBERT STRUCK, EXAMINING ATTORNEY

SN 85-060,252. HERNANDEZ GUTIERREZ, ALFREDO, UPLAND, CA. FILED 6-11-2010.

# ORIGINAL FIBRA MENONITA

THE MARK CONSISTS OF STANDARD CHARACTERS WITHOUT CLAIM TO ANY PARTICULAR FONT, STYLE, SIZE, OR COLOR.

NO CLAIM IS MADE TO THE EXCLUSIVE RIGHT TO USE "ORIGINAL FIBRA", APART FROM THE MARK AS SHOWN.

THE ENGLISH TRANSLATION OF "FIBRA MENONITA" IN THE MARK IS "MENNONITE FIBER".

FOR VITAMIN AND MINERAL SUPPLEMENTS; DIETARY AND NUTRITIONAL SUPPLEMENTS (U.S. CLS. 6, 18, 44, 46, 51 AND 52).

FIRST USE 1-1-2010; IN COMMERCE 5-1-2010.

RUSS HERMAN, EXAMINING ATTORNEY

**CLASS 5—(Continued).**

SN 85-064,000. EUSA PHARMA (EUROPE) LIMITED, OXFORD, UNITED KINGDOM, FILED 6-16-2010.

# AZINTREL

THE MARK CONSISTS OF STANDARD CHARACTERS WITHOUT CLAIM TO ANY PARTICULAR FONT, STYLE, SIZE, OR COLOR.

FOR PHARMACEUTICAL PREPARATIONS AND SUBSTANCES FOR THE TREATMENT OF CANCER, STROKE, TRAUMATIC BRAIN INJURY, CARDIOVASCULAR DISEASES OR DISORDERS, METABOLIC DISEASES AND DISORDERS; ANTIVIRAL PREPARATIONS, ANTICOAGULANTS AND PLATELET AGGREGATION INHIBITORS, ANTITHROMBOTIC AGENTS; DIAGNOSTIC PREPARATIONS AND REAGENTS FOR MEDICAL USE (U.S. CLS. 6, 18, 44, 46, 51 AND 52).

JEAN IM, EXAMINING ATTORNEY

---

SN 85-065,886. FARR LABORATORIES, LLC, BEVERLY HILLS, CA. FILED 6-17-2010.

# CITUROL PLUS

THE MARK CONSISTS OF STANDARD CHARACTERS WITHOUT CLAIM TO ANY PARTICULAR FONT, STYLE, SIZE, OR COLOR.

FOR DIETARY AND NUTRITIONAL SUPPLEMENTS; VITAMINS AND MINERAL SUPPLEMENTS (U.S. CLS. 6, 18, 44, 46, 51 AND 52).

FIRST USE 4-7-2010; IN COMMERCE 4-7-2010.

RUDY R. SINGLETON, EXAMINING ATTORNEY

---

SN 85-070,911. WEDGEWOOD VILLAGE PHARMACY, INC., SWEDSBORO, NJ. FILED 6-24-2010.

# QUADTAB

THE MARK CONSISTS OF STANDARD CHARACTERS WITHOUT CLAIM TO ANY PARTICULAR FONT, STYLE, SIZE, OR COLOR.

FOR PHARMACEUTICAL PREPARATIONS FOR THE TREATMENT OF HYPERTENSION AND BLADDER CONTROL FOR HUMAN AND VETERINARY USE (U.S. CLS. 6, 18, 44, 46, 51 AND 52).

MICHAEL SOUDERS, EXAMINING ATTORNEY

**CLASS 5—(Continued).**

SN 85-072,579. JOHNSON & JOHNSON, NEW BRUNSWICK, NJ. FILED 6-28-2010.



OWNER OF U.S. REG. NOS. 568,161, 1,671,045 AND OTHERS.

THE COLOR(S) RED, WHITE AND BLUE IS/ARE CLAIMED AS A FEATURE OF THE MARK.

THE MARK CONSISTS OF A THREE DIMENSIONAL IMAGE OF A BOX WITH THE STYLIZED WORDS "JOHNSON & JOHNSON" IN WHITE IN A RED CROSS ON THE FRONT AND CENTER OF THE BOX WITH THE TOP AND SIDE OF THE BOX IN THE COLOR RED, AND THE FRONT OF THE BOX IN WHITE WITH A LIGHT BLUE COLOR AT THE BOTTOM.

FOR WOUND DRESSINGS, NAMELY, ROLLED GAUZE, GAUZE PADS, NON-STICK GAUZE PADS, BANDAGES, AND ADHESIVE PADS (U.S. CLS. 6, 18, 44, 46, 51 AND 52).

BENJAMIN OKEKE, EXAMINING ATTORNEY

---

SN 85-074,039. UROBIOLOGICS, LLC, LIVONIA, MI. FILED 6-29-2010.

# UroGender

THE COLOR(S) BLUE, PURPLE AND BLACK IS/ARE CLAIMED AS A FEATURE OF THE MARK.

THE MARK CONSISTS OF THE WORD "UROGENDER," WITH THE COLORS BLUE AND PURPLE APPEARING IN THE LETTER "O" AND IN THE TWO ARROWS ATTACHED TO THIS LETTER. THE COLOR BLACK APPEARS IN THE REST OF THE LETTERS IN THE WORDING.

FOR IN VITRO GENDER PREDICTION TEST KIT (U.S. CLS. 6, 18, 44, 46, 51 AND 52).

EVELYN BRADLEY, EXAMINING ATTORNEY

---

SN 85-074,185. UROBIOLOGICS, LLC, LIVONIA, MI. FILED 6-29-2010.

# Urobiologics

THE MARK CONSISTS OF STANDARD CHARACTERS WITHOUT CLAIM TO ANY PARTICULAR FONT, STYLE, SIZE, OR COLOR.

FOR IN VITRO GENDER PREDICTION TEST KIT (U.S. CLS. 6, 18, 44, 46, 51 AND 52).

EVELYN BRADLEY, EXAMINING ATTORNEY

**CLASS 5—(Continued).**

SN 85-075,627. SYSTAGENIX WOUND MANAGEMENT (US), INC., QUINCY, MA. FILED 7-1-2010.

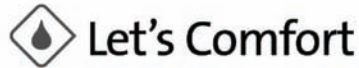

THE MARK CONSISTS OF A SQUARE CONTAINING A TEARDROP WITH THE WORDS "LET'S COMFORT" TO THE RIGHT.

FOR WOUND DRESSINGS (U.S. CLS. 6, 18, 44, 46, 51 AND 52).

ANGELA DUONG, EXAMINING ATTORNEY

**CLASS 5—(Continued).**

SN 85-082,055. EXCLUSIVE SUPPLEMENTS, INC., DBA BIORYTHM - ADVANCED DIETARY SUPPLEMENTS, CORAOPOLIS, PA. FILED 7-11-2010.



NO CLAIM IS MADE TO THE EXCLUSIVE RIGHT TO USE "OLIO", APART FROM THE MARK AS SHOWN.

THE COLOR(S) GREEN, WHITE, BLACK AND RED IS/ARE CLAIMED AS A FEATURE OF THE MARK.

THE MARK CONSISTS OF THE STYLIZED WORD "OLIO" IN WHITE, IN WHICH THE FIRST THREE LETTERS: "O", "L" AND "I" ARE OUTLINED IN THE COLOR GREEN WITH BLACK SHADING; THE "I" IS ALSO DESIGNED WITH THE DOT OF THE "I" BEING A LEAF; AND THE LAST "O" IN OLIO IS ON ITS SIDE, AND OUTLINED IN THE COLOR RED WITH BLACK SHADING. THE BACKGROUND COLOR WHITE WITHIN THE "O" REPRESENTS TRANSPARENT AREAS AND IS NOT PART OF THE MARK.

THE ENGLISH TRANSLATION OF "OLIO" IN THE MARK IS "OIL".

FOR DIETARY SUPPLEMENT CONTAINING, IN WHOLE OR IN PART, OILS, NAMELY, A SOFT-GEL CAPSULE USED TO SUPPORT HEALTHY CHOLESTEROL, WEIGHT MANAGEMENT, AND GENERAL WELL-BEING (U.S. CLS. 6, 18, 44, 46, 51 AND 52).

FIRST USE 2-15-2008; IN COMMERCE 2-15-2008.

DAVID HOFFMAN, EXAMINING ATTORNEY

SN 85-079,610. A.C. GRACE COMPANY, BIG SANDY, TX. FILED 7-7-2010.

**UNIQUE OMEGA E**

THE MARK CONSISTS OF STANDARD CHARACTERS WITHOUT CLAIM TO ANY PARTICULAR FONT, STYLE, SIZE, OR COLOR.

OWNER OF U.S. REG. NO. 2,288,889.

NO CLAIM IS MADE TO THE EXCLUSIVE RIGHT TO USE "OMEGA E", APART FROM THE MARK AS SHOWN.

FOR NUTRITIONAL SUPPLEMENTS, NAMELY, CAPSULES FOR NATURAL VITAMIN E (U.S. CLS. 6, 18, 44, 46, 51 AND 52).

ANTHONY RINKER, EXAMINING ATTORNEY

SN 85-085,436. KEYSTONE FOOD PRODUCTS, INC., EASTON, PA. FILED 7-15-2010.

**The Real Deal All Natural Snacks**

THE MARK CONSISTS OF STANDARD CHARACTERS WITHOUT CLAIM TO ANY PARTICULAR FONT, STYLE, SIZE, OR COLOR.

NO CLAIM IS MADE TO THE EXCLUSIVE RIGHT TO USE "ALL NATURAL SNACKS", APART FROM THE MARK AS SHOWN.

FOR GLUTEN-FREE SNACK FOODS MADE FROM ALL NATURAL INGREDIENTS, EXCLUDING CEREALS AND CEREAL-BASED SNACK FOODS, TO ACCOMMODATE SPECIAL MEDICAL AND HEALTH CONDITIONS (U.S. CLS. 6, 18, 44, 46, 51 AND 52).

KEVIN DINALLO, EXAMINING ATTORNEY

**CLASS 5—(Continued).**

SN 85-090,588. NICHINO AMERICA, INC., WILMINGTON, DE. FILED 7-22-2010.

# Hachi-Hachi

THE MARK CONSISTS OF STANDARD CHARACTERS WITHOUT CLAIM TO ANY PARTICULAR FONT, STYLE, SIZE, OR COLOR.

THE ENGLISH TRANSLATION OF "HACHI-HACHI" IN THE MARK IS EIGHTY-EIGHT.

FOR INSECTICIDES; PESTICIDES (U.S. CLS. 6, 18, 44, 46, 51 AND 52).

FIRST USE 11-23-2010; IN COMMERCE 11-23-2010.  
JOHN GARTNER, EXAMINING ATTORNEY

SN 85-091,429. SYNGENTA PARTICIPATIONS AG, BASEL, SWITZERLAND, FILED 7-23-2010.

# REVIVE

THE MARK CONSISTS OF STANDARD CHARACTERS WITHOUT CLAIM TO ANY PARTICULAR FONT, STYLE, SIZE, OR COLOR.

FOR PREPARATIONS FOR DESTROYING VERMIN, NAMELY, INSECTS AND NEMATODES; FUNGICIDES, HERBICIDES (U.S. CLS. 6, 18, 44, 46, 51 AND 52).

REBECCA EISINGER, EXAMINING ATTORNEY

SN 85-095,290. PURE & NATURAL COMPANY, SCOTSDALE, AZ. FILED 7-28-2010.

# ORCHID BLOSSOMS

THE MARK CONSISTS OF STANDARD CHARACTERS WITHOUT CLAIM TO ANY PARTICULAR FONT, STYLE, SIZE, OR COLOR.

NO CLAIM IS MADE TO THE EXCLUSIVE RIGHT TO USE "ORCHID", APART FROM THE MARK AS SHOWN.

FOR AIR FRESHENERS AND AIR FRESHENING PREPARATIONS (U.S. CLS. 6, 18, 44, 46, 51 AND 52).

VIVIAN MICZNIK FIRST, EXAMINING ATTORNEY

**CLASS 5—(Continued).**

SN 85-098,669. LORNAMEAD, INC., TONAWANDA, NY. FILED 8-3-2010.

# GEAR GUARD

THE MARK CONSISTS OF STANDARD CHARACTERS WITHOUT CLAIM TO ANY PARTICULAR FONT, STYLE, SIZE, OR COLOR.

FOR PHARMACEUTICAL PREPARATIONS FOR THE TREATMENT OF LICE INFESTATION; LICE TREATMENT PREPARATIONS; PREPARATIONS FOR DESTROYING LICE IN THE HAIR; PREPARATIONS FOR DESTROYING INFESTATIONS OF THE HAIR; PREPARATIONS FOR DESTROYING PARASITES IN THE HAIR; MEDICATED PREPARATIONS FOR THE TREATMENT OF THE SCALP (U.S. CLS. 6, 18, 44, 46, 51 AND 52).

LINDA ORNDORFF, EXAMINING ATTORNEY

SN 85-105,848. NUTRAMAX LABORATORIES, INC., EDGEWOOD, MD. FILED 8-12-2010.

# NUTRAMAX PHARMACEUTICALS

THE MARK CONSISTS OF STANDARD CHARACTERS WITHOUT CLAIM TO ANY PARTICULAR FONT, STYLE, SIZE, OR COLOR.

OWNER OF U.S. REG. NOS. 2,231,260 AND 3,292,163.

NO CLAIM IS MADE TO THE EXCLUSIVE RIGHT TO USE "PHARMACEUTICALS", APART FROM THE MARK AS SHOWN.

FOR HOUSEMARK FOR PHARMACEUTICALS FOR VETERINARY USE (U.S. CLS. 6, 18, 44, 46, 51 AND 52).

JOSETTE BEVERLY, EXAMINING ATTORNEY

SN 85-106,561. AMGEN INC., THOUSAND OAKS, CA. FILED 8-12-2010.



THE MARK CONSISTS OF A STYLIZED HUMAN FIGURE IN AN INCOMPLETE SHADED CIRCLE.

FOR PHARMACEUTICAL PREPARATIONS FOR USE IN STIMULATING WHITE BLOOD CELL PRODUCTION (U.S. CLS. 6, 18, 44, 46, 51 AND 52).

RONALD MCMORROW, EXAMINING ATTORNEY



**CLASS 5—(Continued).**

SN 85-143,377. WAMPOLE INC., BOUCHERVILLE, QUEBEC, CANADA, FILED 10-1-2010.

# VALDA

THE MARK CONSISTS OF STANDARD CHARACTERS WITHOUT CLAIM TO ANY PARTICULAR FONT, STYLE, SIZE, OR COLOR.

THE WORDING "VALDA" HAS NO MEANING IN A FOREIGN LANGUAGE.

FOR PHARMACEUTICAL PREPARATIONS FOR THE TREATMENT OF THE RESPIRATORY TRACT (U.S. CLS. 6, 18, 44, 46, 51 AND 52).

JULIE GUTTADAURO, EXAMINING ATTORNEY

---

SN 85-156,719. TETEC TISSUE ENGINEERING TECHNOLOGIES AG, REUTLINGEN, FED REP GERMANY, FILED 10-20-2010.

# NOVOCART

THE MARK CONSISTS OF STANDARD CHARACTERS WITHOUT CLAIM TO ANY PARTICULAR FONT, STYLE, SIZE, OR COLOR.

OWNER OF FED REP GERMANY REG. NO. 30012956, DATED 8-16-2000, RENEWED AS REG. NO. 30012956, DATED 3-1-2010, EXPIRES 2-29-2020.

OWNER OF U.S. REG. NO. 3,093,469.

FOR BIOLOGICAL CELLS FOR MEDICAL PURPOSES, NAMELY, EXPANDED CELLS IN A CELL CULTURE SYSTEM, USED FOR THE REGENERATION OF ARTICULAR CARTILAGE OR COMBINED BONE AND CARTILAGE DEFECTS WITH OR WITHOUT SCAFFOLD (U.S. CLS. 6, 18, 44, 46, 51 AND 52).

NAAKWAMA ANKRAH, EXAMINING ATTORNEY

---

SN 85-162,225. ORIGINS NATURAL RESOURCES INC., NEW YORK, NY. FILED 10-27-2010.

# SUPER SPOT REMOVER

THE MARK CONSISTS OF STANDARD CHARACTERS WITHOUT CLAIM TO ANY PARTICULAR FONT, STYLE, SIZE, OR COLOR.

OWNER OF U.S. REG. NO. 1,987,463.

NO CLAIM IS MADE TO THE EXCLUSIVE RIGHT TO USE "SUPER", APART FROM THE MARK AS SHOWN.

FOR MEDICATED SKIN CARE PREPARATIONS (U.S. CLS. 6, 18, 44, 46, 51 AND 52).

STEVEN R. FINE, EXAMINING ATTORNEY

**CLASS 5—(Continued).**

SN 85-164,957. GLUTEN FREE MAMA KITCHEN LLC, POLSON, MT. FILED 10-29-2010.

# Gluten Free Mama

THE MARK CONSISTS OF STANDARD CHARACTERS WITHOUT CLAIM TO ANY PARTICULAR FONT, STYLE, SIZE, OR COLOR.

NO CLAIM IS MADE TO THE EXCLUSIVE RIGHT TO USE "GLUTEN FREE", APART FROM THE MARK AS SHOWN.

FOR GLUTEN-FREE FOOD TO ACCOMMODATE SPECIAL MEDICAL AND HEALTH CONDITIONS; WHEAT- AND GLUTEN-FREE BREAD MIXES TO ACCOMMODATE SPECIAL MEDICAL AND HEALTH CONDITIONS; WHEAT- AND GLUTEN-FREE PANCAKE MIXES TO ACCOMMODATE SPECIAL MEDICAL AND HEALTH CONDITIONS (U.S. CLS. 6, 18, 44, 46, 51 AND 52).

FIRST USE 10-1-2006; IN COMMERCE 12-7-2006.

EMILY CHUO, EXAMINING ATTORNEY

---

SN 85-166,066. GLAXO GROUP LIMITED, MIDDLESEX, ENGLAND, FILED 11-1-2010.

# KOLBRAFO

THE MARK CONSISTS OF STANDARD CHARACTERS WITHOUT CLAIM TO ANY PARTICULAR FONT, STYLE, SIZE, OR COLOR.

OWNER OF UNITED KINGDOM REG. NO. 2561852, DATED 10-11-2010, EXPIRES 10-11-2020.

FOR PHARMACEUTICAL PREPARATIONS AND SUBSTANCES FOR THE TREATMENT OF DAMAGED SKIN AND TISSUE; PHARMACEUTICAL PREPARATIONS AND SUBSTANCES FOR THE TREATMENT OF INFECTIOUS DISEASES, BLOOD DISORDERS, PAIN, INFLAMMATION, SEPSIS, ALOPECIA, OBESITY AND COGNITIVE DISORDERS; PHARMACEUTICAL PREPARATIONS AND SUBSTANCES FOR THE TREATMENT OF VIRAL, METABOLIC, ENDOCRINE, MUSCULOSKELETAL, CARDIOVASCULAR, CARDIOPULMONARY, GENITOURINARY, SEXUAL DYSFUNCTION, ONCOLOGICAL, HEPATOLOGICAL, OPHTHALMIC, RESPIRATORY, NEUROLOGICAL, GASTROINTESTINAL, HORMONAL, DERMATOLOGICAL, PSYCHIATRIC AND IMMUNE SYSTEM RELATED DISEASES AND DISORDERS; VACCINES (U.S. CLS. 6, 18, 44, 46, 51 AND 52).

RONALD MCMORROW, EXAMINING ATTORNEY

**CLASS 5—(Continued).**

SN 85-167,737. ALTSTATT, TOMMY, BARKER, NY. FILED 11-3-2010.

**WILD GAME CONCEPTS**

THE MARK CONSISTS OF STANDARD CHARACTERS WITHOUT CLAIM TO ANY PARTICULAR FONT, STYLE, SIZE, OR COLOR.

NO CLAIM IS MADE TO THE EXCLUSIVE RIGHT TO USE "WILD GAME", APART FROM THE MARK AS SHOWN.

FOR AGRICULTURAL PRODUCTS; NAMELY, ANIMAL FEED SUPPLEMENTS (U.S. CLS. 6, 18, 44, 46, 51 AND 52).

RUDY R. SINGLETON, EXAMINING ATTORNEY

---

SN 85-170,025. TOKUYAMA CORPORATION, YAMAGUCHI, JAPAN, FILED 11-5-2010.

**CEMFORCE**

THE MARK CONSISTS OF STANDARD CHARACTERS WITHOUT CLAIM TO ANY PARTICULAR FONT, STYLE, SIZE, OR COLOR.

PRIORITY CLAIMED UNDER SEC. 44(D) ON JAPAN APPLICATION NO. 2010-81383, FILED 10-19-2010, REG. NO. 5388855, DATED 2-4-2011, EXPIRES 2-4-2021.

FOR DENTAL MATERIALS, NAMELY, BONDING AND PRIMING MATERIALS FOR DENTAL PURPOSE, DENTAL CEMENTS, ADHESIVES FOR DENTURES, DENTAL ADHESIVES (U.S. CLS. 6, 18, 44, 46, 51 AND 52).

LAKEISHA LEWIS, EXAMINING ATTORNEY

---

SN 85-170,035. TOKUYAMA CORPORATION, YAMAGUCHI, JAPAN, FILED 11-5-2010.

**ESTE-CEM**

THE MARK CONSISTS OF STANDARD CHARACTERS WITHOUT CLAIM TO ANY PARTICULAR FONT, STYLE, SIZE, OR COLOR.

PRIORITY CLAIMED UNDER SEC. 44(D) ON JAPAN APPLICATION NO. 2010-81384, FILED 10-19-2010, REG. NO. 5388856, DATED 2-4-2011, EXPIRES 2-4-2021.

THE WORDING "ESTE-CEM" HAS NO MEANING IN A FOREIGN LANGUAGE.

FOR DENTAL MATERIALS, NAMELY, BONDING AND PRIMING MATERIALS FOR DENTAL PURPOSE, DENTAL CEMENTS, ADHESIVES FOR DENTURES, DENTAL ADHESIVES (U.S. CLS. 6, 18, 44, 46, 51 AND 52).

LAKEISHA LEWIS, EXAMINING ATTORNEY

**CLASS 5—(Continued).**

SN 85-170,557. NAN FOSTER, DBA THE MIGHTY CRUMB, ROSS, CA. FILED 11-5-2010.

**MIGHTY CRUMB BAKING COMPANY  
Food to Live For**

THE MARK CONSISTS OF STANDARD CHARACTERS WITHOUT CLAIM TO ANY PARTICULAR FONT, STYLE, SIZE, OR COLOR.

NO CLAIM IS MADE TO THE EXCLUSIVE RIGHT TO USE "BAKING COMPANY", APART FROM THE MARK AS SHOWN.

FOR GLUTEN-FREE FOOD TO ACCOMMODATE SPECIAL MEDICAL AND HEALTH CONDITIONS; WHEAT- AND GLUTEN-FREE BREAD MIXES TO ACCOMMODATE SPECIAL MEDICAL AND HEALTH CONDITIONS; WHEAT- AND GLUTEN-FREE BREADCRUMBS TO ACCOMMODATE SPECIAL MEDICAL AND HEALTH CONDITIONS; WHEAT- AND GLUTEN-FREE CRUMBLE MIXES TO ACCOMMODATE SPECIAL MEDICAL AND HEALTH CONDITIONS (U.S. CLS. 6, 18, 44, 46, 51 AND 52).

BRIAN PINO, EXAMINING ATTORNEY

---

SN 85-173,562. PLATINUM PERFORMANCE, INC., BUELLTON, CA. FILED 11-10-2010.

**PLATINUM GASTRIC SUPPORT**

THE MARK CONSISTS OF STANDARD CHARACTERS WITHOUT CLAIM TO ANY PARTICULAR FONT, STYLE, SIZE, OR COLOR.

OWNER OF U.S. REG. NOS. 2,132,598, 3,435,403 AND OTHERS.

NO CLAIM IS MADE TO THE EXCLUSIVE RIGHT TO USE "GASTRIC SUPPORT", APART FROM THE MARK AS SHOWN.

FOR NUTRITIONAL SUPPLEMENTS (U.S. CLS. 6, 18, 44, 46, 51 AND 52).

MICHAEL WEBSTER, EXAMINING ATTORNEY

---

SN 85-178,876. POZNER, JASON N., BOCA RATON, FL. FILED 11-17-2010.

**ENVIGOR**

THE MARK CONSISTS OF STANDARD CHARACTERS WITHOUT CLAIM TO ANY PARTICULAR FONT, STYLE, SIZE, OR COLOR.

FOR NUTRITIONAL SUPPLEMENTS FOR HUMANS (U.S. CLS. 6, 18, 44, 46, 51 AND 52).

KIMBERLY PERRY, EXAMINING ATTORNEY

**CLASS 5—(Continued).**

SN 85-182,469. VIRBAC, 06511 CARROS CEDEX, FRANCE, FILED 11-22-2010.

# EFFITIX

THE MARK CONSISTS OF STANDARD CHARACTERS WITHOUT CLAIM TO ANY PARTICULAR FONT, STYLE, SIZE, OR COLOR.

THE WORD(S) "EFFITIX" HAS NO MEANING IN A FOREIGN LANGUAGE.

FOR VETERINARY PREPARATIONS, NAMELY, ANTIBIOTICS FOR VETERINARY USE, DERMATOLOGICAL PREPARATIONS FOR VETERINARY USE AND NUTRITIONAL SUPPLEMENTS FOR VETERINARY USE, FOR THE PREVENTION AND TREATMENT OF OTITIS AND SKIN DISORDERS, IRRITATION AND ITCHING OF THE SKIN AND EARS OF ANIMALS ; ANTIBIOTICS FOR VETERINARY USE AND NUTRITIONAL SUPPLEMENTS FOR VETERINARY USE FOR THE TREATMENT OF BEHAVIOR DISORDERS IN ANIMALS ; INTERNAL AND EXTERNAL ANTIPARASITICS FOR VETERINARY USE FOR ANIMALS (U.S. CLS. 6, 18, 44, 46, 51 AND 52).

MICHAEL SOUDERS, EXAMINING ATTORNEY

SN 85-188,593. SOOK JA CHUNG, LOS ANGELES, CA. FILED 12-1-2010.

익모초 ☆ 육모초 생리대  
G.T. Natural Motherwort

OWNER OF U.S. REG. NOS. 3,368,305 AND 3,548,827.

NO CLAIM IS MADE TO THE EXCLUSIVE RIGHT TO USE "NATURAL MOTHERWORT" AND THE NON-LATIN CHARACTERS IN THE MARK WHICH TRANSLATE INTO "MOTHERWORT" AND "NATURAL MOTHERWORT SANITARY NAPKINS" IN ENGLISH, APART FROM THE MARK AS SHOWN.

THE MARK CONSISTS OF KOREAN CHARACTERS THAT TRANSLITERATES TO "IKMO CHO" WHICH MEANS "MOTHERWORT" ARE FOLLOWED BY THREE DIAMOND DESIGN. KOREAN CHARACTERS WHICH TRANSLITERATES TO "YUKMO CHO SANGLI DAE" WHICH MEANS "NATURAL MOTHERWORT SANITARY NAPKINS" APPEAR ON THE RIGHTHAND SIDE. THE WORDS "G.T. NATURAL MOTHERWORT" APPEAR AT THE BOTTOM.

THE ENGLISH TRANSLATION OF "IKMO CHO" AND "YUKMO CHO SANGLI DAE" IN THE MARK IS "MOTHERWORT" AND "NATURAL MOTHERWORT SANITARY NAPKINS".

THE NON-LATIN CHARACTERS IN THE MARK TRANSLITERATE TO "IKMO CHO" AND "YUKMO CHO SANGLI DAE" AND THIS MEANS "MOTHERWORT" AND "NATURAL MOTHERWORT SANITARY NAPKINS" IN ENGLISH.

FOR FEMININE HYGIENE PADS; SANITARY NAPKINS; SANITARY PADS (U.S. CLS. 6, 18, 44, 46, 51 AND 52).

FIRST USE 5-1-2008; IN COMMERCE 5-1-2008.

JOHN HWANG, EXAMINING ATTORNEY

**CLASS 5—(Continued).**

SN 85-191,990. KEVIN IVES, DBA GREENGO GROWERS, INC, VIRGINIA BEACH, VA. FILED 12-7-2010.

# Greengo Joe's

THE MARK CONSISTS OF STANDARD CHARACTERS WITHOUT CLAIM TO ANY PARTICULAR FONT, STYLE, SIZE, OR COLOR.

FOR BISCUITS, BREAD, BREAD ROLLS, CAKES, CEREAL PRODUCTS, CONFECTIONERY, CRACKERS, NOODLES, FISH SAUCE, RELISH, SAUCES, CEREAL-BASED SNACK-FOODS AND PREPARED DIETARY ITEMS ALL OF WHICH ARE GLUTEN-FREE TO ACCOMMODATE SPECIAL MEDICAL AND HEALTH CONDITIONS (U.S. CLS. 6, 18, 44, 46, 51 AND 52).

FIRST USE 1-1-2007; IN COMMERCE 1-1-2007.

EUGENIA MARTIN, EXAMINING ATTORNEY

SN 85-192,937. SCITECK, INC., ARDEN, NC. FILED 12-8-2010.

# ADULTACHECK

THE MARK CONSISTS OF STANDARD CHARACTERS WITHOUT CLAIM TO ANY PARTICULAR FONT, STYLE, SIZE, OR COLOR.

FOR CHEMICALLY TREATED, MEDICAL DIAGNOSTIC TEST STICKS FOR USE IN TESTING URINE FOR ADULTERATION (U.S. CLS. 6, 18, 44, 46, 51 AND 52).

FIRST USE 8-1-1997; IN COMMERCE 8-1-1997.

MEGHAN REINHART, EXAMINING ATTORNEY

SN 85-195,482. MELALEUCA, INC., IDAHO FALLS, ID. FILED 12-10-2010.

# VITALITY 4

THE MARK CONSISTS OF STANDARD CHARACTERS WITHOUT CLAIM TO ANY PARTICULAR FONT, STYLE, SIZE, OR COLOR.

NO CLAIM IS MADE TO THE EXCLUSIVE RIGHT TO USE "4", APART FROM THE MARK AS SHOWN.

FOR DIETARY AND NUTRITIONAL SUPPLEMENTS (U.S. CLS. 6, 18, 44, 46, 51 AND 52).

FIRST USE 8-27-2008; IN COMMERCE 8-27-2008.

JOHN DALIER, EXAMINING ATTORNEY

**CLASS 5—(Continued).**

SN 85-195,486. MELALEUCA, INC., IDAHO FALLS, ID.  
FILED 12-10-2010.

**VITALITY 6**

THE MARK CONSISTS OF STANDARD CHARACTERS  
WITHOUT CLAIM TO ANY PARTICULAR FONT, STYLE,  
SIZE, OR COLOR.

NO CLAIM IS MADE TO THE EXCLUSIVE RIGHT TO  
USE "6", APART FROM THE MARK AS SHOWN.

FOR DIETARY AND NUTRITIONAL SUPPLEMENTS  
(U.S. CLS. 6, 18, 44, 46, 51 AND 52).

FIRST USE 8-27-2008; IN COMMERCE 8-27-2008.  
JOHN DALIER, EXAMINING ATTORNEY

**CLASS 5—(Continued).**

SN 85-197,186. AVENTIS PHARMACEUTICALS INC.,  
BRIDGEWATER, NJ. FILED 12-14-2010.

**NASACORT AQ**

THE MARK CONSISTS OF STANDARD CHARACTERS  
WITHOUT CLAIM TO ANY PARTICULAR FONT, STYLE,  
SIZE, OR COLOR.

OWNER OF U.S. REG. NO. 1,538,836.

NO CLAIM IS MADE TO THE EXCLUSIVE RIGHT TO  
USE "AQ", APART FROM THE MARK AS SHOWN.

FOR PHARMACEUTICAL PREPARATIONS FOR THE  
TREATMENT OF ALLERGIC RHINITIS (U.S. CLS. 6, 18,  
44, 46, 51 AND 52).

FIRST USE 6-1-1996, THE MARK WAS FIRST USED  
ANYWHERE IN A DIFFERENT FORM OTHER THAN  
THAT SOUGHT TO BE REGISTERED AT LEAST AS EARLY  
AS 08/19/1987; IN COMMERCE 6-1-1996, THE MARK WAS  
FIRST USED IN COMMERCE IN A DIFFERENT FORM  
OTHER THAN THAT SOUGHT TO BE REGISTERED AT  
LEAST AS EARLY AS 08/25/1987.

TAMARA FRAZIER, EXAMINING ATTORNEY

SN 85-198,597. DAVID KIRSCH WELLNESS CO., INC., NEW  
YORK, NY. FILED 12-15-2010.

**KIRSCHBAR**

THE MARK CONSISTS OF STANDARD CHARACTERS  
WITHOUT CLAIM TO ANY PARTICULAR FONT, STYLE,  
SIZE, OR COLOR.

OWNER OF U.S. REG. NOS. 3,504,326, 3,920,116 AND  
OTHERS.

FOR MEAL REPLACEMENT PROTEIN BARS (U.S.  
CLS. 6, 18, 44, 46, 51 AND 52).

JULIE GUTTADAURO, EXAMINING ATTORNEY

SN 85-196,728. SURVIVOR SOLUTIONS, ST. IGNATIUS, MT.  
FILED 12-13-2010.



NO CLAIM IS MADE TO THE EXCLUSIVE RIGHT TO  
USE "SOLUTIONS" AND "THE LEADER IN BREAST  
CANCER NUTRACEUTICALS", APART FROM THE MARK  
AS SHOWN.

THE STIPPLING IS FOR SHADING PURPOSES ONLY.

THE MARK CONSISTS OF A DNA STRAND WITH THE  
STYLIZED TEXT "SURVIVOR SOLUTIONS THE LEADER  
IN BREAST CANCER NUTRACEUTICALS".

FOR NUTRITIONAL SUPPLEMENTS (U.S. CLS. 6, 18,  
44, 46, 51 AND 52).

ROBIN CHOSID, EXAMINING ATTORNEY

SN 85-200,077. PHARMAVITE LLC, MISSION HILLS, CA.  
FILED 12-16-2010.

**NATURE MADE, SAFELY MADE,  
PURELY MADE**

THE MARK CONSISTS OF STANDARD CHARACTERS  
WITHOUT CLAIM TO ANY PARTICULAR FONT, STYLE,  
SIZE, OR COLOR.

OWNER OF U.S. REG. NOS. 1,963,505, 2,592,200 AND  
OTHERS.

FOR VITAMINS, MINERALS AND DIETARY SUPPLE-  
MENTS (U.S. CLS. 6, 18, 44, 46, 51 AND 52).

JESSICA FATHY, EXAMINING ATTORNEY



**CLASS 5—(Continued).**

SN 85-200,269. CENTURY SYSTEMS INC, ATLANTA, GA. FILED 12-17-2010.

**FEMALE DRIVE**

THE MARK CONSISTS OF STANDARD CHARACTERS WITHOUT CLAIM TO ANY PARTICULAR FONT, STYLE, SIZE, OR COLOR.

OWNER OF U.S. REG. NO. 3,484,802.

NO CLAIM IS MADE TO THE EXCLUSIVE RIGHT TO USE "FEMALE", APART FROM THE MARK AS SHOWN.

FOR NUTRITIONAL SUPPLEMENTS (U.S. CLS. 6, 18, 44, 46, 51 AND 52).

FIRST USE 12-17-2010; IN COMMERCE 12-17-2010.

THOMAS MANOR, EXAMINING ATTORNEY

---

SN 85-201,297. MARSHA D WULFF, LLC, AKA AFRICEUTICALS, CARMEL, CA. FILED 12-18-2010.

**AfriCeuticals**

THE MARK CONSISTS OF STANDARD CHARACTERS WITHOUT CLAIM TO ANY PARTICULAR FONT, STYLE, SIZE, OR COLOR.

FOR HEALTH PRODUCTS, NAMELY, PHARMACEUTICAL PREPARATIONS AND SUBSTANCES FOR THE TREATMENT OF INFECTIOUS DISEASES, BLOOD DISORDERS, PAIN, INFLAMMATION, SEPSIS, ALOPECIA, OBESITY AND COGNITIVE DISORDERS; HEALTH PRODUCTS, NAMELY, PHARMACEUTICAL PREPARATIONS AND SUBSTANCES FOR THE TREATMENT OF VIRAL, METABOLIC, ENDOCRINE, MUSCULOSKELETAL, CARDIOVASCULAR, CARDIOPULMONARY, GENITOURINARY, SEXUAL DYSFUNCTION, ONCOLOGICAL, HEPATOLOGICAL, OPHTHALMIC, RESPIRATORY, NEUROLOGICAL, GASTROINTESTINAL, HORMONAL, DERMATOLOGICAL, PSYCHIATRIC AND IMMUNE SYSTEM RELATED DISEASES AND DISORDERS (U.S. CLS. 6, 18, 44, 46, 51 AND 52).

SKYE YOUNG, EXAMINING ATTORNEY

---

SN 85-201,317. ACURA PHARMACEUTICALS, INC., PALATINE, IL. FILED 12-18-2010.

**ACU-FED**

THE MARK CONSISTS OF STANDARD CHARACTERS WITHOUT CLAIM TO ANY PARTICULAR FONT, STYLE, SIZE, OR COLOR.

FOR PHARMACEUTICAL PREPARATIONS, NAMELY, ORAL MEDICATIONS CONTAINING PSEUDOEPHEDRINE HYDROCHLORIDE FOR TREATMENT OF COUGH, COLDS, AND RELATED SYMPTOMS (U.S. CLS. 6, 18, 44, 46, 51 AND 52).

MARLENE BELL, EXAMINING ATTORNEY

**CLASS 5—(Continued).**

SN 85-201,318. ACURA PHARMACEUTICALS, INC., PALATINE, IL. FILED 12-18-2010.

**ACU-PHED**

THE MARK CONSISTS OF STANDARD CHARACTERS WITHOUT CLAIM TO ANY PARTICULAR FONT, STYLE, SIZE, OR COLOR.

FOR PHARMACEUTICAL PREPARATIONS, NAMELY, ORAL MEDICATIONS CONTAINING PSEUDOEPHEDRINE HYDROCHLORIDE FOR TREATMENT OF COUGH, COLDS, AND RELATED SYMPTOMS (U.S. CLS. 6, 18, 44, 46, 51 AND 52).

MARLENE BELL, EXAMINING ATTORNEY

---

SN 85-201,629. SHIRE LLC, FLORENCE, KY. FILED 12-20-2010.

**ADDERALL XR**

THE MARK CONSISTS OF STANDARD CHARACTERS WITHOUT CLAIM TO ANY PARTICULAR FONT, STYLE, SIZE, OR COLOR.

OWNER OF U.S. REG. NO. 1,908,092.

NO CLAIM IS MADE TO THE EXCLUSIVE RIGHT TO USE "XR", APART FROM THE MARK AS SHOWN.

FOR PHARMACEUTICAL PREPARATIONS, NAMELY, AMPHETAMINES, FOR ATTENTION DEFICIT HYPERACTIVITY DISORDER (ADHD) (U.S. CLS. 6, 18, 44, 46, 51 AND 52).

FIRST USE 10-22-2001; IN COMMERCE 10-22-2001.

MARY CRAWFORD, EXAMINING ATTORNEY

**CLASS 5—(Continued).**

SN 85-201,767. PAULINA CRAVIOTO GONZALEZ, MEXICO, D.F., MEXICO, FILED 12-20-2010.



NO CLAIM IS MADE TO THE EXCLUSIVE RIGHT TO USE "MEN & WOMEN" AND "MACA & CITRULLINE", APART FROM THE MARK AS SHOWN.

THE COLOR(S) SILVER, WHITE, RED, YELLOW AND BLACK IS/ARE CLAIMED AS A FEATURE OF THE MARK. THE MARK CONSISTS OF THE WORD "POTTENZA" IN RED ABOVE THE WORDING "MEN & WOMEN" IN SILVER WITH WHITE OUTLINE APPEARING WITHIN A RED OBLONG THAT IS IN TURN LOCATED ABOVE A YELLOW SILHOUETTE OF A MAN AND WOMAN AND THE WORDING "MACA & CITRULLINE" IN WHITE, ALL OF WHICH APPEARS UPON A BLACK BACKGROUND.

FOR PHARMACEUTICAL PREPARATIONS, CONTAINING MACA EXTRACT AND AMINO ACIDS IN THE NATURE OF CITRULLINE, TO BE USED TO INCREASE LIBIDO AND ENERGY (U.S. CLS. 6, 18, 44, 46, 51 AND 52).

MARC LEIPZIG, EXAMINING ATTORNEY

**CLASS 5—(Continued).**

SN 85-202,806. EPIGENESIS PHARMACEUTICALS, LLC, CRANBURY, NJ. FILED 12-21-2010.

**EPIGENE.COM**

SN 85-202,430. PRISTINEHYDRO DEVELOPMENT, INC., LAGUNA WOODS, CA. FILED 12-21-2010.

**Electrolyte Balance**

THE MARK CONSISTS OF STANDARD CHARACTERS WITHOUT CLAIM TO ANY PARTICULAR FONT, STYLE, SIZE, OR COLOR.

NO CLAIM IS MADE TO THE EXCLUSIVE RIGHT TO USE "ELECTROLYTE", APART FROM THE MARK AS SHOWN.

FOR DIETARY SUPPLEMENTAL DRINKS CONTAINING ELECTROLYTES (U.S. CLS. 6, 18, 44, 46, 51 AND 52).

SAMUEL E. SHARPER JR., EXAMINING ATTORNEY

SN 85-202,431. MARKET AMERICA, INC., GREENSBORO, NC. FILED 12-21-2010.

**TotalAloe**

THE MARK CONSISTS OF STANDARD CHARACTERS WITHOUT CLAIM TO ANY PARTICULAR FONT, STYLE, SIZE, OR COLOR.

FOR DIETARY AND NUTRITIONAL SUPPLEMENTS MADE IN WHOLE OR SIGNIFICANT PART OF ALOE VERA (U.S. CLS. 6, 18, 44, 46, 51 AND 52).

STEVEN PEREZ, EXAMINING ATTORNEY

THE MARK CONSISTS OF STANDARD CHARACTERS WITHOUT CLAIM TO ANY PARTICULAR FONT, STYLE, SIZE, OR COLOR.

FOR MEDICAL DIAGNOSTIC AND THERAPEUTIC PREPARATIONS, ALL FOR ADMINISTRATION VIA DIVERSE ROUTES OF ADMINISTRATION INCLUDING THROUGH THE RESPIRATORY AIRWAYS, AND, MEDICAL DEVICES FOR ADMINISTERING THE PHARMACEUTICALS, SOLD FILLED, THE PREPARATIONS INCLUDING NUCLEOTIDES, PROTEINS AND ORGANIC MOLECULES FOR MEDICAL USE, INCLUDING MACROMOLECULES SUCH AS ANTI-SENSE OLIGONUCLEOTIDES AND ENZYMES AND SMALL AND INORGANIC MOLECULES FOR TREATMENT OF HUMAN AND NON-HUMAN ANIMAL RESPIRATORY, CENTRAL NERVOUS SYSTEM, NEOPLASTIC, ENDOCRINE, IMMUNE AND CARDIOVASCULAR AILMENTS, INCLUDING BRONCHOCONSTRICTION, DIFFICULT BREATHING, IMPEDED AND OBSTRUCTED LUNG AIRWAYS, ALLERGY(IES) AND/OR INFLAMMATION, WHICH IN SOME CASES ARE ADENOSINE RECEPTOR ASSOCIATED SYMPTOMS; PHARMACEUTICAL PREPARATIONS FOR TESTING, AND PREVENTING AND THERAPEUTICALLY TREATING RESPIRATORY, AIRWAY AND PULMONARY DISEASES AND CONDITIONS, SUCH AS ASTHMA, PULMONARY VASOCONSTRICTION, INFLAMMATION, ALLERGIES, IMPEDED RESPIRATION, ACUTE RESPIRATORY DISEASE SYNDROME (ARDS), RENAL DAMAGE AND FAILURE, ISCHEMIA RESULTING FROM THE ADMINISTRATION OF CERTAIN DRUGS, INCLUDING ADENOSINE AND OTHER DRUGS FOR, FOR EXAMPLE, TREATING SUPRA VENTRICULAR TACHYCARDIA (SVT), ADENOSINE STRESS TESTS, INFANTILE RESPIRATORY DISTRESS SYNDROME (INFANTILE RDS), PAIN, CYSTIC FIBROSIS, ALLERGIC RHINITIS, ALLERGIC BRONCHITIS, PULMONARY HYPERTENSION, PULMONARY VASOCONSTRICTION, EMPHYSEMA, CHRONIC OBSTRUCTIVE PULMONARY DISEASE (COPD), AS WELL AS CANCERS INCLUDING LEUKEMIAS, LYMPHOMAS, CARCINOMAS, AND THE LIKE, E.G., COLON CANCER, BREAST CANCER, LUNG CANCER, PANCREATIC CANCER, HEPATOCELLULAR CARCINOMA, KIDNEY CANCER, MELANOMA, ETC., AS WELL AS METASTATIC CANCERS, E.G., CANCERS WHICH METASTASIZED TO THE LUNG(S), BREAST, LIVER AND PROSTATE (U.S. CLS. 6, 18, 44, 46, 51 AND 52).

ASMAT KHAN, EXAMINING ATTORNEY

**CLASS 5—(Continued).**

SN 85-203,098. ZACHARY ROSEN, BELLMORE, NY. FILED 12-21-2010.

**Enhanced Body Formulations**

THE MARK CONSISTS OF STANDARD CHARACTERS WITHOUT CLAIM TO ANY PARTICULAR FONT, STYLE, SIZE, OR COLOR.

NO CLAIM IS MADE TO THE EXCLUSIVE RIGHT TO USE "BODY FORMULATIONS", APART FROM THE MARK AS SHOWN.

FOR DIETARY AND NUTRITIONAL SUPPLEMENTS; DIETARY AND NUTRITIONAL SUPPLEMENTS FOR ENDURANCE SPORTS; DIETARY SUPPLEMENTAL DRINKS; DIETARY SUPPLEMENTS FOR ENHANCING EXERCISE PERFORMANCE AND RESULTS; LIQUID NUTRITIONAL SUPPLEMENT; NATURAL HERBAL SUPPLEMENTS; NUTRITIONAL AND DIETARY SUPPLEMENTS FORMED AND PACKAGED AS BARS; NUTRITIONAL SUPPLEMENTS FOR ENHANCING EXERCISE PERFORMANCE AND RESULTS; POWDERED NUTRITIONAL SUPPLEMENT DRINK MIX (U.S. CLS. 6, 18, 44, 46, 51 AND 52).

DAVID HOFFMAN, EXAMINING ATTORNEY

SN 85-204,509. DO YOURSELF A FLAVOR, OGDEN, UT. FILED 12-22-2010.

**Subway Scrub**

THE MARK CONSISTS OF STANDARD CHARACTERS WITHOUT CLAIM TO ANY PARTICULAR FONT, STYLE, SIZE, OR COLOR.

NO CLAIM IS MADE TO THE EXCLUSIVE RIGHT TO USE "SCRUB", APART FROM THE MARK AS SHOWN.

FOR HAND-SANITIZING PREPARATIONS (U.S. CLS. 6, 18, 44, 46, 51 AND 52).

DEBRA LEE, EXAMINING ATTORNEY

SN 85-204,789. NITRO US TRADEMARK LTD., OAKVILLE, ONTARIO, CANADA, FILED 12-23-2010.

**SMART BCAA**

THE MARK CONSISTS OF STANDARD CHARACTERS WITHOUT CLAIM TO ANY PARTICULAR FONT, STYLE, SIZE, OR COLOR.

NO CLAIM IS MADE TO THE EXCLUSIVE RIGHT TO USE "BCAA", APART FROM THE MARK AS SHOWN.

FOR NUTRITIONAL AND DIETARY SUPPLEMENTS CONTAINING BRANCHED CHAIN AMINO ACIDS (U.S. CLS. 6, 18, 44, 46, 51 AND 52).

SCOTT BIBB, EXAMINING ATTORNEY

**CLASS 5—(Continued).**

SN 85-204,793. NITRO US TRADEMARK LTD., OAKVILLE, ONTARIO, CANADA, FILED 12-23-2010.

**SMART LEUCINE**

THE MARK CONSISTS OF STANDARD CHARACTERS WITHOUT CLAIM TO ANY PARTICULAR FONT, STYLE, SIZE, OR COLOR.

NO CLAIM IS MADE TO THE EXCLUSIVE RIGHT TO USE "LEUCINE", APART FROM THE MARK AS SHOWN.

FOR NUTRITIONAL AND DIETARY SUPPLEMENTS CONTAINING LEUCINE (U.S. CLS. 6, 18, 44, 46, 51 AND 52).

SCOTT BIBB, EXAMINING ATTORNEY

SN 85-204,798. NITRO US TRADEMARK LTD., OAKVILLE, ONTARIO, CANADA, FILED 12-23-2010.

**SMART GLUTAMINE**

THE MARK CONSISTS OF STANDARD CHARACTERS WITHOUT CLAIM TO ANY PARTICULAR FONT, STYLE, SIZE, OR COLOR.

NO CLAIM IS MADE TO THE EXCLUSIVE RIGHT TO USE "GLUTAMINE", APART FROM THE MARK AS SHOWN.

FOR NUTRITIONAL AND DIETARY SUPPLEMENTS CONTAINING GLUTAMINE (U.S. CLS. 6, 18, 44, 46, 51 AND 52).

SCOTT BIBB, EXAMINING ATTORNEY

SN 85-204,801. NITRO US TRADEMARK LTD., OAKVILLE, ONTARIO, CANADA, FILED 12-23-2010.

**SMART CREATINE**

THE MARK CONSISTS OF STANDARD CHARACTERS WITHOUT CLAIM TO ANY PARTICULAR FONT, STYLE, SIZE, OR COLOR.

NO CLAIM IS MADE TO THE EXCLUSIVE RIGHT TO USE "CREATINE", APART FROM THE MARK AS SHOWN.

FOR NUTRITIONAL AND DIETARY SUPPLEMENTS CONTAINING CREATINE (U.S. CLS. 6, 18, 44, 46, 51 AND 52).

SCOTT BIBB, EXAMINING ATTORNEY

**CLASS 5—(Continued).**

SN 85-204,804. NITRO US TRADEMARK LTD., OAKVILLE, ONTARIO, CANADA, FILED 12-23-2010.

## SMART N.O.

THE MARK CONSISTS OF STANDARD CHARACTERS WITHOUT CLAIM TO ANY PARTICULAR FONT, STYLE, SIZE, OR COLOR.

NO CLAIM IS MADE TO THE EXCLUSIVE RIGHT TO USE "N.O.", APART FROM THE MARK AS SHOWN.

FOR NUTRITIONAL AND DIETARY SUPPLEMENTS CONTAINING NITRIC OXIDE (U.S. CLS. 6, 18, 44, 46, 51 AND 52).

SCOTT BIBB, EXAMINING ATTORNEY

**CLASS 5—(Continued).**

SN 85-205,860. 7 SISTERS GLUTEN FREE LLC, CITRUS HEIGHTS, CA. FILED 12-27-2010.

## 7 SISTERS Gluten Free

THE MARK CONSISTS OF STANDARD CHARACTERS WITHOUT CLAIM TO ANY PARTICULAR FONT, STYLE, SIZE, OR COLOR.

NO CLAIM IS MADE TO THE EXCLUSIVE RIGHT TO USE "GLUTEN FREE", APART FROM THE MARK AS SHOWN.

FOR GLUTEN-FREE FOOD TO ACCOMMODATE SPECIAL MEDICAL AND HEALTH CONDITIONS (U.S. CLS. 6, 18, 44, 46, 51 AND 52).

ELIZABETH KAJUBI, EXAMINING ATTORNEY

SN 85-205,267. BIG BOOM BRANDS, LLC, WEST PALM BEACH, FL. FILED 12-23-2010.

## COOTIE SHOT

THE MARK CONSISTS OF STANDARD CHARACTERS WITHOUT CLAIM TO ANY PARTICULAR FONT, STYLE, SIZE, OR COLOR.

FOR NUTRITIONAL SUPPLEMENTS, NAMELY, LIQUID AND POWDER PROBIOTICS COMPOSITIONS (U.S. CLS. 6, 18, 44, 46, 51 AND 52).

REGINA DRUMMOND, EXAMINING ATTORNEY

SN 85-206,154. GOWAN COMPANY, L.L.C., YUMA, AZ. FILED 12-27-2010.



OWNER OF U.S. REG. NO. 1,722,902.

THE MARK CONSISTS OF THE LETTER "M" FOLLOWED BY AN OCTOGON AND THE WORD "PEDE", FOR AGRICULTURAL PESTICIDES (U.S. CLS. 6, 18, 44, 46, 51 AND 52).

CORY BOONE, EXAMINING ATTORNEY

SN 85-205,554. ORGANIKA HEALTH PRODUCTS INC., RICHMOND, BC, CANADA, FILED 12-24-2010.

## LIGA-JOINT

THE MARK CONSISTS OF STANDARD CHARACTERS WITHOUT CLAIM TO ANY PARTICULAR FONT, STYLE, SIZE, OR COLOR.

OWNER OF CANADA REG. NO. TMA493,926, DATED 5-5-1998, EXPIRES 5-5-2018.

FOR VITAMINS AND MINERAL SUPPLEMENTS; HERBAL SUPPLEMENTS TO SUPPORT JOINT HEALTH, JOINT CARE AND FLEXIBILITY AND USED FOR THE TREATMENT OF JOINT PAIN (U.S. CLS. 6, 18, 44, 46, 51 AND 52).

TEJBIR SINGH, EXAMINING ATTORNEY

SN 85-206,156. GOWAN COMPANY, L.L.C., YUMA, AZ. FILED 12-27-2010.



OWNER OF U.S. REG. NO. 1,928,282.

NO CLAIM IS MADE TO THE EXCLUSIVE RIGHT TO USE "HERBICIDE", APART FROM THE MARK AS SHOWN. THE MARK CONSISTS OF THE WORDS "SCYTHE" AND "HERBICIDE" OVER A REPRESENTATION OF A SCYTHE BLADE.

FOR AGRICULTURAL PESTICIDES (U.S. CLS. 6, 18, 44, 46, 51 AND 52).

CORY BOONE, EXAMINING ATTORNEY



**CLASS 5—(Continued).**

SN 85-209,022. OPTIMAL MARKETING, LLC, SCOTTSDALE, AZ. FILED 1-3-2011.

# OPTIMAL HCG

THE MARK CONSISTS OF STANDARD CHARACTERS WITHOUT CLAIM TO ANY PARTICULAR FONT, STYLE, SIZE, OR COLOR.

NO CLAIM IS MADE TO THE EXCLUSIVE RIGHT TO USE "HCG", APART FROM THE MARK AS SHOWN.

FOR HOMEOPATHIC SUPPLEMENTS CONTAINING HCG; NUTRITIONAL SUPPLEMENTS CONTAINING HCG; DIETARY SUPPLEMENTS CONTAINING HCG (U.S. CLS. 6, 18, 44, 46, 51 AND 52).

FIRST USE 7-12-2010; IN COMMERCE 7-12-2010.  
HEATHER BIDDULPH, EXAMINING ATTORNEY



SN 85-210,673. FLORA MANUFACTURING & DISTRIBUTING, LTD., BURNABY, B.C., CANADA, FILED 1-5-2011.

# ROYAL IMMUNITY

THE MARK CONSISTS OF STANDARD CHARACTERS WITHOUT CLAIM TO ANY PARTICULAR FONT, STYLE, SIZE, OR COLOR.

NO CLAIM IS MADE TO THE EXCLUSIVE RIGHT TO USE "IMMUNITY", APART FROM THE MARK AS SHOWN.

FOR HERBAL AND ANTI-OXIDENT SUPPLEMENTS IN CAPSULE FORM FOR HUMAN CONSUMPTION (U.S. CLS. 6, 18, 44, 46, 51 AND 52).

TAMARA FRAZIER, EXAMINING ATTORNEY

**CLASS 5—(Continued).**

SN 85-210,961. QUICK-MED TECHNOLOGIES, INC., GAINESVILLE, FL. FILED 1-5-2011.

# NIMBUDERM

THE MARK CONSISTS OF STANDARD CHARACTERS WITHOUT CLAIM TO ANY PARTICULAR FONT, STYLE, SIZE, OR COLOR.

FOR ACNE MEDICATIONS; ANTI-ADHESION GELS FOR USE WITH WOUND DRAINAGE DEVICES; ANTI-INFECTIVES; ANTI-MICROBIAL HANDWASH; ANTI-BACTERIAL ALCOHOL SKIN SANITIZER GEL; ANTI-BACTERIAL CLEANERS; ANTIBACTERIAL HAND LOTIONS; ANTIBACTERIAL HANDWASH; ANTIBACTERIAL SPRAY; ANTIBACTERIAL SUBSTANCES FOR MEDICAL PURPOSES; ANTIMICROBIALS FOR DERMATOLOGIC USE; ANTISEPTIC PREPARATIONS; BACTERICIDES; BACTERIOSTATS FOR MEDICINAL, DENTAL AND VETERINARY USE; BANDAGES FOR SKIN WOUNDS; CLEANSING SOLUTIONS FOR MEDICAL USE; CONTACT LENS CLEANING SOLUTIONS; CONTACT LENS DISINFECTANTS; CONTACT LENS SOLUTIONS; DERMATOLOGICALS; DISINFECTANTS FOR HYGIENIC PURPOSES; DISINFECTING HANDWASH; DRESSINGS FOR WOUNDS, BURNS, AND SURGERY; HAND-SANITIZING PREPARATIONS; MEDICAL CLEANSERS FOR SKIN AND WOUNDS; MEDICATED HAND WASH; MEDICATED LIP BALM; MEDICATED PRE-MOISTENED WIPES; MEDICATED SHAMPOO; MEDICATED SHAVING PREPARATIONS; MEDICATED SKIN CARE PREPARATIONS; PARAPHARMACEUTICAL PRODUCTS FOR USE IN DERMATOLOGY; PHARMACEUTICAL SKIN LOTIONS; PREPARATIONS FOR CLEANSING THE SKIN FOR MEDICAL USE; TOPICAL FIRST AID GEL (U.S. CLS. 6, 18, 44, 46, 51 AND 52).

WILLIAM ROSSMAN, EXAMINING ATTORNEY



SN 85-210,995. PHADIA AB AKTIEBOLAG, UPPSALA, SWEDEN, FILED 1-5-2011.

# UKNOW

THE MARK CONSISTS OF STANDARD CHARACTERS WITHOUT CLAIM TO ANY PARTICULAR FONT, STYLE, SIZE, OR COLOR.

FOR DIAGNOSTIC REAGENTS TO AID IN THE MEDICAL DIAGNOSIS OF ALLERGIC CONDITIONS (U.S. CLS. 6, 18, 44, 46, 51 AND 52).

JOHN KELLY, EXAMINING ATTORNEY

**CLASS 5—(Continued).**

SN 85-211,693. DOUGLAS BIO RESEARCH, SAINT LOUIS, MO. FILED 1-6-2011.



THE COLOR(S) BLACK AND LIGHTER AND DARKER SHADES OF GREEN IS/ARE CLAIMED AS A FEATURE OF THE MARK.

THE MARK CONSISTS OF LIGHTER AND DARKER SHADES OF GREEN HAVING THE APPEARANCE OF PAINT SMEARED ON A CANVAS WITH THE WORD "REJUVENATE" IN BLACK SUPERIMPOSED THEREON.

FOR ANTIBACTERIAL HAND SANITIZER GEL, ANTIBACTERIAL HAND SANITIZER LIQUID, AND ANTIBACTERIAL HAND SANITIZER FOAM (U.S. CLS. 6, 18, 44, 46, 51 AND 52).

MAYUR VAGHANI, EXAMINING ATTORNEY

**CLASS 5—(Continued).**

SN 85-212,069. AMAZING PRECISION, INC. DBA GENDER-MAKER, LOS ANGELES, CA. FILED 1-6-2011.

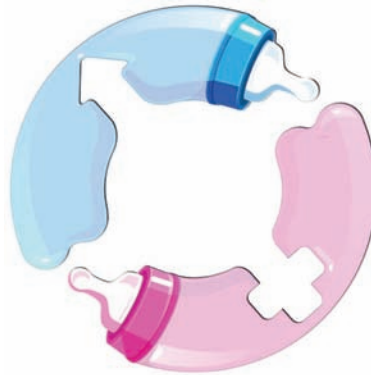

THE COLOR(S) BLUE, PINK, AND WHITE IS/ARE CLAIMED AS A FEATURE OF THE MARK.

THE MARK CONSISTS OF TWO CURVED BABY BOTTLES PLACED TOGETHER TO CREATE A CIRCLE, WITH ONE BOTTLE IN THE COLOR BLUE AND AN ARROW IN THE MIDDLE POINTING UPWARD REPRESENTING A MALE, AND THE OTHER BOTTLE IN THE COLOR PINK WITH A PLUS SIGN IN THE MIDDLE REPRESENTING A FEMALE, EACH BOTTLE HAVING WHITE NIPPLES.

FOR IN VITRO GENDER PREDICTION TEST KIT (U.S. CLS. 6, 18, 44, 46, 51 AND 52).

FIRST USE 8-1-2010; IN COMMERCE 8-1-2010.  
HEATHER SAPP, EXAMINING ATTORNEY

SN 85-212,064. KERNAG, LLC, WALLER, TX. FILED 1-6-2011.

**Chew Armour**

THE MARK CONSISTS OF STANDARD CHARACTERS WITHOUT CLAIM TO ANY PARTICULAR FONT, STYLE, SIZE, OR COLOR.

NO CLAIM IS MADE TO THE EXCLUSIVE RIGHT TO USE "CHEW", APART FROM THE MARK AS SHOWN.

FOR ANIMAL REPELLANTS (U.S. CLS. 6, 18, 44, 46, 51 AND 52).

FIRST USE 12-5-2010; IN COMMERCE 12-6-2010.  
H. M. FISHER, EXAMINING ATTORNEY

SN 85-212,099. PUREFORM 1000 LLC, HENDERSON, NV. FILED 1-6-2011.



NO CLAIM IS MADE TO THE EXCLUSIVE RIGHT TO USE "VITAMIN LIQUID", APART FROM THE MARK AS SHOWN.

THE MARK CONSISTS OF A DESIGN IN THE SHAPE OF A STYLIZED LETTER "V" ALONGSIDE THE WORDS "VITAMIN" AND "LIQUID".

FOR LIQUID VITAMIN SUPPLEMENTS (U.S. CLS. 6, 18, 44, 46, 51 AND 52).

WILLIAM ROSSMAN, EXAMINING ATTORNEY

**CLASS 5—(Continued).**

SN 85-212,375. LABRIOLA, DANIEL J., SEATTLE, WA.  
FILED 1-6-2011.

**SAFE & SOUND**

THE MARK CONSISTS OF STANDARD CHARACTERS  
WITHOUT CLAIM TO ANY PARTICULAR FONT, STYLE,  
SIZE, OR COLOR.

FOR DIETARY FOOD SUPPLEMENTS, NAMELY,  
LOW MICROBIAL FOOD SUPPLEMENTS (U.S. CLS. 6,  
18, 44, 46, 51 AND 52).

FIRST USE 10-9-1998; IN COMMERCE 10-9-1998.  
BENJAMIN OKEKE, EXAMINING ATTORNEY

**CLASS 5—(Continued).**

SN 85-213,004. NATURAL HEALTH NETWORK, LLC, BREA,  
CA. FILED 1-7-2011.

**ACID CALM**

THE MARK CONSISTS OF STANDARD CHARACTERS  
WITHOUT CLAIM TO ANY PARTICULAR FONT, STYLE,  
SIZE, OR COLOR.

NO CLAIM IS MADE TO THE EXCLUSIVE RIGHT TO  
USE "ACID", APART FROM THE MARK AS SHOWN.

FOR DIETARY SUPPLEMENTS (U.S. CLS. 6, 18, 44, 46,  
51 AND 52).  
JEAN IM, EXAMINING ATTORNEY

SN 85-212,674. VITAL PHARMACEUTICALS, INC., WES-  
TON, FL. FILED 1-7-2011.

**AFRITEST**

THE MARK CONSISTS OF STANDARD CHARACTERS  
WITHOUT CLAIM TO ANY PARTICULAR FONT, STYLE,  
SIZE, OR COLOR.

FOR DIETARY AND NUTRITIONAL SUPPLEMENTS  
(U.S. CLS. 6, 18, 44, 46, 51 AND 52).

ANNE MADDEN, EXAMINING ATTORNEY

SN 85-213,595. BIOTANIKA USA, LLC, FT. LAUDERDALE,  
FL. FILED 1-9-2011.

**ARTRIPHEN**

THE MARK CONSISTS OF STANDARD CHARACTERS  
WITHOUT CLAIM TO ANY PARTICULAR FONT, STYLE,  
SIZE, OR COLOR.

FOR DIETARY AND NUTRITIONAL SUPPLEMENTS  
(U.S. CLS. 6, 18, 44, 46, 51 AND 52).

FIRST USE 4-9-2010; IN COMMERCE 4-9-2010.  
TIMOTHY FINNEGAN, EXAMINING ATTORNEY

SN 85-212,947. GC CORPORATION, TOKYO, JAPAN, FILED  
1-7-2011.

**EQUIA**

THE MARK CONSISTS OF STANDARD CHARACTERS  
WITHOUT CLAIM TO ANY PARTICULAR FONT, STYLE,  
SIZE, OR COLOR.

FOR DENTAL GLASS IONOMER CEMENTS (U.S. CLS.  
6, 18, 44, 46, 51 AND 52).

CAROLINE WOOD, EXAMINING ATTORNEY

SN 85-213,763. BRIOSCHI PHARMACEUTICALS INTERNA-  
TIONAL, LLC, SYRACUSE, NY. FILED 1-10-2011.

**BRIO**

THE MARK CONSISTS OF STANDARD CHARACTERS  
WITHOUT CLAIM TO ANY PARTICULAR FONT, STYLE,  
SIZE, OR COLOR.

FOR ANTACIDS (U.S. CLS. 6, 18, 44, 46, 51 AND 52).  
EDWARD FENNESSY, EXAMINING ATTORNEY

**CLASS 5—(Continued).**

SN 85-213,977. USPLABS, LLC, DALLAS, TX. FILED 1-10-2011.

# Yok3d

THE MARK CONSISTS OF STANDARD CHARACTERS WITHOUT CLAIM TO ANY PARTICULAR FONT, STYLE, SIZE, OR COLOR.

FOR DIETARY SUPPLEMENTS (U.S. CLS. 6, 18, 44, 46, 51 AND 52).

AMY HELLA, EXAMINING ATTORNEY

**CLASS 5—(Continued).**

SN 85-215,266. MEDTRONIC, INC., MINNEAPOLIS, MN. FILED 1-11-2011.

# LIORESAL

THE MARK CONSISTS OF STANDARD CHARACTERS WITHOUT CLAIM TO ANY PARTICULAR FONT, STYLE, SIZE, OR COLOR.

FOR PHARMACEUTICAL PREPARATION FOR THE TREATMENT OF SPASTICITY (U.S. CLS. 6, 18, 44, 46, 51 AND 52).

FIRST USE 12-31-2010; IN COMMERCE 12-31-2010.  
SCOTT BIBB, EXAMINING ATTORNEY

SN 85-214,117. NUTRABOLICS, INC., RICHMOND, CANADA, FILED 1-10-2011.

# SWOLLEN

THE MARK CONSISTS OF STANDARD CHARACTERS WITHOUT CLAIM TO ANY PARTICULAR FONT, STYLE, SIZE, OR COLOR.

FOR DIETARY AND NUTRITIONAL SUPPLEMENTS; VITAMIN AND MINERAL SUPPLEMENTS (U.S. CLS. 6, 18, 44, 46, 51 AND 52).

SANI KHOURI, EXAMINING ATTORNEY

SN 85-215,808. GRUPO OMNILIFE, S.A. DE C.V., DBA GOM 940311 LF7, GUADALAJARA, JALISCO, MEXICO, FILED 1-12-2011.

# CAFEZZINO

THE MARK CONSISTS OF STANDARD CHARACTERS WITHOUT CLAIM TO ANY PARTICULAR FONT, STYLE, SIZE, OR COLOR.

THE WORDING "CAFEZZINO" HAS NO MEANING IN A FOREIGN LANGUAGE.

FOR DIETARY SUPPLEMENTS; MINERAL FOOD SUPPLEMENTS; NUTRITIONAL SUPPLEMENTS; VITAMIN PREPARATIONS (U.S. CLS. 6, 18, 44, 46, 51 AND 52).  
SHAUNIA CARLYLE, EXAMINING ATTORNEY

SN 85-214,874. ANDREW M. SAM, ROSEMEAD, CA. FILED 1-11-2011.

# ZI XIU TANG

THE MARK CONSISTS OF STANDARD CHARACTERS WITHOUT CLAIM TO ANY PARTICULAR FONT, STYLE, SIZE, OR COLOR.

THE ENGLISH TRANSLATION OF "ZI XIU TANG" IN THE MARK IS "ELEGANCE HALL".

FOR DIETARY AND NUTRITIONAL SUPPLEMENTS (U.S. CLS. 6, 18, 44, 46, 51 AND 52).

THOMAS MANOR, EXAMINING ATTORNEY

SN 85-217,778. MCDADE, MICHAEL, PHILADELPHIA, PA. FILED 1-14-2011.

# hemphcativa

THE MARK CONSISTS OF STANDARD CHARACTERS WITHOUT CLAIM TO ANY PARTICULAR FONT, STYLE, SIZE, OR COLOR.

FOR MEDICINAL HERBS (U.S. CLS. 6, 18, 44, 46, 51 AND 52).

FIRST USE 11-1-2010; IN COMMERCE 11-1-2010.  
ROBERT STRUCK, EXAMINING ATTORNEY



**CLASS 5—(Continued).**

SN 85-218,835. GUTE BESSERUNG HAUSER LLC, NEW YORK, NY. FILED 1-16-2011.

# Oftalin

THE MARK CONSISTS OF STANDARD CHARACTERS WITHOUT CLAIM TO ANY PARTICULAR FONT, STYLE, SIZE, OR COLOR.

FOR EYE DROPS; EYE WASHES; PHARMACEUTICAL PREPARATIONS FOR THE TREATMENT OF EYE DISEASES AND CONDITIONS (U.S. CLS. 6, 18, 44, 46, 51 AND 52).

DANNEAN HETZEL, EXAMINING ATTORNEY

---

SN 85-219,264. VISPAK INC., MONTREAL, QUEBEC, CANADA, FILED 1-17-2011.

# BACTRA-CLEAN

THE MARK CONSISTS OF STANDARD CHARACTERS WITHOUT CLAIM TO ANY PARTICULAR FONT, STYLE, SIZE, OR COLOR.

FOR ANTIBACTERIAL ALCOHOL SKIN SANITIZER GEL (U.S. CLS. 6, 18, 44, 46, 51 AND 52).

ANTHONY RINKER, EXAMINING ATTORNEY

---

SN 85-219,279. VISPAK INC., MONTREAL, QUEBEC, CANADA, FILED 1-17-2011.



THE COLOR(S) BLUE AND WHITE IS/ARE CLAIMED AS A FEATURE OF THE MARK.

THE MARK CONSISTS OF THE WORDING "BACTRA-CLEAN" IN STYLIZED TEXT IN DARK BLUE ABOVE BLUE AND WHITE WAVES AND BLUE BUBBLES.

FOR ANTIBACTERIAL ALCOHOL SKIN SANITIZER GEL; HAND-SANITIZING PREPARATIONS (U.S. CLS. 6, 18, 44, 46, 51 AND 52).

ANTHONY RINKER, EXAMINING ATTORNEY

**CLASS 5—(Continued).**

SN 85-219,346. PAMLAB, L.L.C., COVINGTON, LA. FILED 1-17-2011.



THE MARK CONSISTS OF A STYLIZED IMAGE OF A PERSON, WHICH IS INTEGRATED WITH AN IMAGE OF A DOUBLE HELIX REPRESENTING DNA, WITH A LEAF EXTENDING ABOVE THE DOUBLE HELIX.

FOR PHARMACEUTICAL PREPARATIONS FOR DEMENTIA, DEPRESSION, DIABETES AND PROBLEM PREGNANCIES (U.S. CLS. 6, 18, 44, 46, 51 AND 52).

BARBARA GAYNOR, EXAMINING ATTORNEY

---

SN 85-219,416. DENMARK, THEODORE C., SCOTTSDALE, AZ. AND DENMARK, KATHLEEN L., SCOTTSDALE, AZ. FILED 1-17-2011.

# ClearFlush

THE MARK CONSISTS OF STANDARD CHARACTERS WITHOUT CLAIM TO ANY PARTICULAR FONT, STYLE, SIZE, OR COLOR.

FOR NUTRITIONAL SUPPLEMENT FOR ELIMINATING TOXINS FROM THE BODY (U.S. CLS. 6, 18, 44, 46, 51 AND 52).

GIANCARLO CASTRO, EXAMINING ATTORNEY

---

SN 85-220,105. ROTAM AGROCHEM INTERNATIONAL CO. LTD, CHAIWAN, HONG KONG, FILED 1-18-2011.

# CHAOS

THE MARK CONSISTS OF STANDARD CHARACTERS WITHOUT CLAIM TO ANY PARTICULAR FONT, STYLE, SIZE, OR COLOR.

FOR AGRICULTURAL HERBICIDES, INSECTICIDES AND FUNGICIDES (U.S. CLS. 6, 18, 44, 46, 51 AND 52).

GEORGE LORENZO, EXAMINING ATTORNEY

**CLASS 5—(Continued).**

SN 85-220,111. ROTAM AGROCHEM INTERNATIONAL CO. LTD, CHAIWAN, HONG KONG, FILED 1-18-2011.

# ICARUS

THE MARK CONSISTS OF STANDARD CHARACTERS WITHOUT CLAIM TO ANY PARTICULAR FONT, STYLE, SIZE, OR COLOR.

FOR AGRICULTURAL HERBICIDES, INSECTICIDES AND FUNGICIDES (U.S. CLS. 6, 18, 44, 46, 51 AND 52).  
GEORGE LORENZO, EXAMINING ATTORNEY

---

SN 85-220,114. ROTAM AGROCHEM INTERNATIONAL CO. LTD, CHAIWAN, HONG KONG, FILED 1-18-2011.

# NEONIC

THE MARK CONSISTS OF STANDARD CHARACTERS WITHOUT CLAIM TO ANY PARTICULAR FONT, STYLE, SIZE, OR COLOR.

FOR AGRICULTURAL HERBICIDES, INSECTICIDES AND FUNGICIDES (U.S. CLS. 6, 18, 44, 46, 51 AND 52).  
GEORGE LORENZO, EXAMINING ATTORNEY

---

SN 85-220,115. ROTAM AGROCHEM INTERNATIONAL CO. LTD, CHAIWAN, HONG KONG, FILED 1-18-2011.

# SKANDIA

THE MARK CONSISTS OF STANDARD CHARACTERS WITHOUT CLAIM TO ANY PARTICULAR FONT, STYLE, SIZE, OR COLOR.

FOR AGRICULTURAL HERBICIDES, INSECTICIDES AND FUNGICIDES (U.S. CLS. 6, 18, 44, 46, 51 AND 52).  
GEORGE LORENZO, EXAMINING ATTORNEY

**CLASS 5—(Continued).**

SN 85-221,351. ACURA PHARMACEUTICALS, INC., PALATINE, IL. FILED 1-19-2011.

# NEXAFED

THE MARK CONSISTS OF STANDARD CHARACTERS WITHOUT CLAIM TO ANY PARTICULAR FONT, STYLE, SIZE, OR COLOR.

FOR PHARMACEUTICAL PREPARATIONS, NAMELY, ORAL MEDICATIONS CONTAINING PSEUDOEPHEDRINE HYDROCHLORIDE FOR TREATMENT OF COUGH, COLDS, AND RELATED SYMPTOMS (U.S. CLS. 6, 18, 44, 46, 51 AND 52).

MARLENE BELL, EXAMINING ATTORNEY

---

SN 85-221,355. ACURA PHARMACEUTICALS, INC., PALATINE, IL. FILED 1-19-2011.

# NEOFED

THE MARK CONSISTS OF STANDARD CHARACTERS WITHOUT CLAIM TO ANY PARTICULAR FONT, STYLE, SIZE, OR COLOR.

FOR PHARMACEUTICAL PREPARATIONS, NAMELY, ORAL MEDICATIONS CONTAINING PSEUDOEPHEDRINE HYDROCHLORIDE FOR TREATMENT OF COUGH, COLDS, AND RELATED SYMPTOMS (U.S. CLS. 6, 18, 44, 46, 51 AND 52).

MARLENE BELL, EXAMINING ATTORNEY

---

SN 85-221,358. ACURA PHARMACEUTICALS, INC., PALATINE, IL. FILED 1-19-2011.

# CLEARFED

THE MARK CONSISTS OF STANDARD CHARACTERS WITHOUT CLAIM TO ANY PARTICULAR FONT, STYLE, SIZE, OR COLOR.

FOR PHARMACEUTICAL PREPARATIONS, NAMELY, ORAL MEDICATIONS CONTAINING PSEUDOEPHEDRINE HYDROCHLORIDE FOR TREATMENT OF COUGH, COLDS, AND RELATED SYMPTOMS (U.S. CLS. 6, 18, 44, 46, 51 AND 52).

MARLENE BELL, EXAMINING ATTORNEY

**CLASS 5—(Continued).**

SN 85-221,360. ACURA PHARMACEUTICALS, INC., PALATINE, IL. FILED 1-19-2011.

# AVERFED

THE MARK CONSISTS OF STANDARD CHARACTERS WITHOUT CLAIM TO ANY PARTICULAR FONT, STYLE, SIZE, OR COLOR.

FOR PHARMACEUTICAL PREPARATIONS, NAMELY, ORAL MEDICATIONS CONTAINING PSEUDOEPHEDRINE HYDROCHLORIDE FOR TREATMENT OF COUGH, COLDS, AND RELATED SYMPTOMS (U.S. CLS. 6, 18, 44, 46, 51 AND 52).

MARLENE BELL, EXAMINING ATTORNEY

**CLASS 5—(Continued).**

SN 85-230,348. IMCLONE LLC, NEW YORK, NY. FILED 1-31-2011.

# IMCLONE SYSTEMS

THE MARK CONSISTS OF STANDARD CHARACTERS WITHOUT CLAIM TO ANY PARTICULAR FONT, STYLE, SIZE, OR COLOR.

NO CLAIM IS MADE TO THE EXCLUSIVE RIGHT TO USE "SYSTEMS", APART FROM THE MARK AS SHOWN.

FOR PHARMACEUTICAL PREPARATIONS FOR TREATMENT OF CANCER (U.S. CLS. 6, 18, 44, 46, 51 AND 52).

CHERYL CLAYTON, EXAMINING ATTORNEY

SN 85-224,137. RAMIREZ MORELES, SELOMITH, IRAPUATO, MEXICO, FILED 1-24-2011.

# PROSVID

THE MARK CONSISTS OF STANDARD CHARACTERS WITHOUT CLAIM TO ANY PARTICULAR FONT, STYLE, SIZE, OR COLOR.

OWNER OF MEXICO REG. NO. 1090721, DATED 3-19-2009, EXPIRES 2-11-2019.

FOR (BASED ON USE IN COMMERCE) DIETARY AND NUTRITIONAL SUPPLEMENTS (BASED ON 44(E)) DIETARY AND NUTRITIONAL SUPPLEMENTS (U.S. CLS. 6, 18, 44, 46, 51 AND 52).

FIRST USE 1-2-2006; IN COMMERCE 10-5-2008.

KAREN K. BUSH, EXAMINING ATTORNEY

SN 85-231,404. SYNGENTA PARTICIPATIONS AG, BASEL, SWITZERLAND, FILED 2-1-2011.

# ARIMA

THE MARK CONSISTS OF STANDARD CHARACTERS WITHOUT CLAIM TO ANY PARTICULAR FONT, STYLE, SIZE, OR COLOR.

THE WORDING "ARIMA" HAS NO MEANING IN A FOREIGN LANGUAGE.

FOR PREPARATIONS FOR DESTROYING VERMIN; FUNGICIDES, HERBICIDES, NEMATICIDES, INSECTICIDES, PESTICIDES FOR COMMERCIAL, DOMESTIC AND AGRICULTURAL USE (U.S. CLS. 6, 18, 44, 46, 51 AND 52).

KELLY CHOE, EXAMINING ATTORNEY

SN 85-229,555. RMK DIVERSIFIED, LLC, CHANDLER, AZ. FILED 1-29-2011.

# "Patch Up"

THE MARK CONSISTS OF STANDARD CHARACTERS WITHOUT CLAIM TO ANY PARTICULAR FONT, STYLE, SIZE, OR COLOR.

NO CLAIM IS MADE TO THE EXCLUSIVE RIGHT TO USE "PATCH", APART FROM THE MARK AS SHOWN.

FOR TRANSDERMAL PATCHES FOR USE IN THE TREATMENT OF HANGOVERS (U.S. CLS. 6, 18, 44, 46, 51 AND 52).

FIRST USE 12-31-2010; IN COMMERCE 12-31-2010.

ANDREA HACK, EXAMINING ATTORNEY

SN 85-234,869. LIFEPEAK LLC, LAKE FOREST, CA. FILED 2-4-2011.

# TRUST YOUR HANDS TO LIFE PEAK

THE MARK CONSISTS OF STANDARD CHARACTERS WITHOUT CLAIM TO ANY PARTICULAR FONT, STYLE, SIZE, OR COLOR.

FOR ANTIBACTERIAL ALCOHOL SKIN SANITIZER GEL; DISPOSABLE SANITIZING WIPES; HAND-SANITIZING PREPARATIONS; SANITIZING PREPARATIONS FOR HOUSEHOLD USE; SPRAY SANITIZER FOR PERSONAL USE (U.S. CLS. 6, 18, 44, 46, 51 AND 52).

GIANCARLO CASTRO, EXAMINING ATTORNEY

**CLASS 5—(Continued).**

SN 85-242,487. MGH HOLDINGS, LLC, HIGHLAND, UT.  
FILED 2-15-2011.

**6° NUTRITION**

THE MARK CONSISTS OF STANDARD CHARACTERS WITHOUT CLAIM TO ANY PARTICULAR FONT, STYLE, SIZE, OR COLOR.

NO CLAIM IS MADE TO THE EXCLUSIVE RIGHT TO USE "NUTRITION", APART FROM THE MARK AS SHOWN.

FOR DIETARY SUPPLEMENTS; ELECTROLYTE REPLACEMENT SOLUTIONS (U.S. CLS. 6, 18, 44, 46, 51 AND 52).

TINA BROWN, EXAMINING ATTORNEY

SN 85-246,609. SANOFI-AVENTIS, 75013 PARIS, FRANCE,  
FILED 2-18-2011.

**SKINSULIN**

THE MARK CONSISTS OF STANDARD CHARACTERS WITHOUT CLAIM TO ANY PARTICULAR FONT, STYLE, SIZE, OR COLOR.

FOR TRANSDERMAL PATCHES FOR USE IN THE PREVENTION AND TREATMENT OF DIABETES (U.S. CLS. 6, 18, 44, 46, 51 AND 52).

SUZANNE BLANE, EXAMINING ATTORNEY

SN 85-247,595. SYNGENTA PARTICIPATIONS AG, BASEL,  
SWITZERLAND, FILED 2-21-2011.

**ARIMA**

THE MARK CONSISTS OF STANDARD CHARACTERS WITHOUT CLAIM TO ANY PARTICULAR FONT, STYLE, SIZE, OR COLOR.

THE WORDING "ARIMA" HAS NO MEANING IN A FOREIGN LANGUAGE.

FOR HERBICIDES, INSECTICIDES, PESTICIDES AND FUNGICIDES FOR HOME, GARDEN AND LAWN USE, FOR TURF AND ORNAMENTAL USE, AND FOR PROFESSIONAL USE (U.S. CLS. 6, 18, 44, 46, 51 AND 52).

KELLY CHOE, EXAMINING ATTORNEY

**CLASS 5—(Continued).**

SN 85-249,381. SMARTBLOCK, INC., MANHASSET, NY.  
FILED 2-23-2011.

**SMART MOMMY**

THE MARK CONSISTS OF STANDARD CHARACTERS WITHOUT CLAIM TO ANY PARTICULAR FONT, STYLE, SIZE, OR COLOR.

NO CLAIM IS MADE TO THE EXCLUSIVE RIGHT TO USE "MOMMY", APART FROM THE MARK AS SHOWN.

FOR PRE-NATAL VITAMINS (U.S. CLS. 6, 18, 44, 46, 51 AND 52).

LINDA M. KING, EXAMINING ATTORNEY

**CLASS 6—METAL GOODS**

SN 77-905,301. KABUSHIKI KAISHA KOBE SEIKO SHO, TA  
KOBE STEEL, LTD., KOBE-SHI, HYOGO, JAPAN, FILED  
1-5-2010.

**DAVINCH**

THE MARK CONSISTS OF STANDARD CHARACTERS WITHOUT CLAIM TO ANY PARTICULAR FONT, STYLE, SIZE, OR COLOR.

OWNER OF JAPAN REG. NO. 4911714, DATED 12-2-2005,  
EXPIRES 12-2-2015.

FOR IRONS AND STEELS; NONFERROUS METALS AND THEIR ALLOYS; METAL MATERIALS FOR BUILDING OR CONSTRUCTION, NAMELY, REINFORCING MATERIALS OF METAL FOR BUILDING PURPOSES; PREFABRICATED BUILDING ASSEMBLY KITS OF METAL COMPRISED OF COMPOSITE PANELS COMPRISED PRIMARILY OF METAL; ARTIFICIAL FISH REEFS OF METAL; POULTRY CAGES OF METAL; METAL MOULDS FOR FORMING CEMENT PRODUCTS; METAL JUNCTIONS FOR PIPES; METAL FLANGES; KEYS, NAMELY, METAL KEYS FOR LOCKS; COTTER PINS; RAILWAY POINTS; ROAD SIGNS OF METAL; INDUSTRIAL PACKAGING CONTAINERS OF METAL, NAMELY, CONTAINERS OF METAL AND PACKAGING CONTAINERS OF METAL (U.S. CLS. 2, 12, 13, 14, 23, 25 AND 50).

ANGELA DUONG, EXAMINING ATTORNEY



**CLASS 6—(Continued).**

SN 77-934,490. ZOMEWORKS CORPORATION, ALBUQUERQUE, NM. FILED 2-12-2010.

**CABLE TRACKER**

THE MARK CONSISTS OF STANDARD CHARACTERS WITHOUT CLAIM TO ANY PARTICULAR FONT, STYLE, SIZE, OR COLOR.

SEC. 2(F).  
FOR METAL STRUCTURES FOR MOUNTING SOLAR PANELS (U.S. CLS. 2, 12, 13, 14, 23, 25 AND 50).  
FIRST USE 11-30-1987; IN COMMERCE 11-30-1987.  
KATHLEEN M. VANSTON, EXAMINING ATTORNEY

SN 77-939,509. ARTFORM LLC, LAS VEGAS, NV. FILED 2-19-2010.

**WORK OF ART.**

THE MARK CONSISTS OF STANDARD CHARACTERS WITHOUT CLAIM TO ANY PARTICULAR FONT, STYLE, SIZE, OR COLOR.

FOR TRINKET BOXES AND KEEPSAKE BOXES OF NON-PRECIOUS METAL (U.S. CLS. 2, 12, 13, 14, 23, 25 AND 50).

FIRST USE 1-22-2008; IN COMMERCE 1-22-2008.  
HEATHER THOMPSON, EXAMINING ATTORNEY

SN 79-077,064. BIOSSUN, FRANCE, FILED 7-29-2009.

**BIOSSUN**

THE MARK CONSISTS OF STANDARD CHARACTERS WITHOUT CLAIM TO ANY PARTICULAR FONT, STYLE, SIZE, OR COLOR.

PRIORITY DATE OF 2-5-2009 IS CLAIMED.  
OWNER OF INTERNATIONAL REGISTRATION 1024205 DATED 7-29-2009, EXPIRES 7-29-2019.

THE WORDING "BIOSSUN" HAS NO MEANING IN A FOREIGN LANGUAGE.

FOR TRANSPORTABLE METAL BUILDINGS; METAL ROOF COVERINGS, NAMELY, METAL ROOFING LOUVRES; METAL PERGOLAS; METAL PERGOLAS WITH TILTABLE METAL SLATS; OUTDOOR METAL BLINDS; METAL SUNSHADES, NAMELY, METAL EXTERIOR WINDOW SHADES; METALLIC COMPONENTS, NAMELY, METAL SCREENS FOR PROTECTION AGAINST RAIN OR SUN DESIGNED FOR FACADES OR ROOFS (U.S. CLS. 2, 12, 13, 14, 23, 25 AND 50).

CHARISMA HAMPTON, EXAMINING ATTORNEY

**CLASS 6—(Continued).**

SN 85-037,575. SAMSUNG HEAVY IND. CO., LTD, SEOUL, REPUBLIC OF KOREA, FILED 5-13-2010.

**FuGaS**

THE MARK CONSISTS OF STANDARD CHARACTERS WITHOUT CLAIM TO ANY PARTICULAR FONT, STYLE, SIZE, OR COLOR.

OWNER OF REPUBLIC OF KOREA REG. NO. 0034028, DATED 3-7-2011, EXPIRES 3-7-2021.

FOR METAL FLUID STORAGE TANKS, METALLIC FUEL STORAGE TANKS (U.S. CLS. 2, 12, 13, 14, 23, 25 AND 50).

JUDITH HELFMAN, EXAMINING ATTORNEY

SN 85-050,371. SANYO SPECIAL STEEL CO., LTD., HIMEJISHI, HYOGO, JAPAN, FILED 5-28-2010.

**SUPERHARDSHOT**

THE MARK CONSISTS OF STANDARD CHARACTERS WITHOUT CLAIM TO ANY PARTICULAR FONT, STYLE, SIZE, OR COLOR.

PRIORITY CLAIMED UNDER SEC. 44(D) ON JAPAN APPLICATION NO. 2010-041231, FILED 5-25-2010, REG. NO. 5379033, DATED 12-24-2010, EXPIRES 12-24-2020.

FOR METAL POWDERS USED IN MANUFACTURING; ALLOYS OF COMMON METAL; COMMON METAL IN SHEET, ROD, BAR AND/OR BILLET FORM; METAL SPATTERING TARGETS; STEEL ALLOYS (U.S. CLS. 2, 12, 13, 14, 23, 25 AND 50).

MARIA-VICTORIA SUAREZ, EXAMINING ATTORNEY

SN 85-050,402. SANYO SPECIAL STEEL CO., LTD., HIMEJISHI, HYOGO, JAPAN, FILED 5-28-2010.

**SUPERSHOT**

THE MARK CONSISTS OF STANDARD CHARACTERS WITHOUT CLAIM TO ANY PARTICULAR FONT, STYLE, SIZE, OR COLOR.

PRIORITY CLAIMED UNDER SEC. 44(D) ON JAPAN APPLICATION NO. 2010-041233, FILED 5-25-2010, REG. NO. 5379035, DATED 12-24-2010, EXPIRES 12-24-2020.

FOR METAL POWDERS USED IN MANUFACTURING; ALLOYS OF COMMON METAL; COMMON METAL IN SHEET, ROD, BAR AND/OR BILLET FORM; METAL SPATTERING TARGETS; STEEL ALLOYS (U.S. CLS. 2, 12, 13, 14, 23, 25 AND 50).

MARIA-VICTORIA SUAREZ, EXAMINING ATTORNEY

**CLASS 6—(Continued).**

SN 85-056,029. GARLAN CHAIN CO., INC., ATTLEBORO, MA. FILED 6-7-2010.

## Whim-Z Wire

THE MARK CONSISTS OF STANDARD CHARACTERS WITHOUT CLAIM TO ANY PARTICULAR FONT, STYLE, SIZE, OR COLOR.

NO CLAIM IS MADE TO THE EXCLUSIVE RIGHT TO USE "WIRE", APART FROM THE MARK AS SHOWN.

FOR COMMON METAL CRAFT WIRE (U.S. CLS. 2, 12, 13, 14, 23, 25 AND 50).

FIRST USE 6-3-2010; IN COMMERCE 6-3-2010.  
TRACY CROSS, EXAMINING ATTORNEY

**CLASS 6—(Continued).**

SN 85-086,320. VAE NORTRAK NORTH AMERICA, INC., CHEYENNE, WY. FILED 7-16-2010.

## HST

THE MARK CONSISTS OF STANDARD CHARACTERS WITHOUT CLAIM TO ANY PARTICULAR FONT, STYLE, SIZE, OR COLOR.

FOR METAL RAILWAY TIES; RAILWAY TURNOUT SYSTEMS, COMPRISING METAL TIES (U.S. CLS. 2, 12, 13, 14, 23, 25 AND 50).

FIRST USE 12-6-2006; IN COMMERCE 12-6-2006.  
STEVEN JACKSON, EXAMINING ATTORNEY

SN 85-117,512. TOWER SOLUTIONS, LLC, PINE CITY, MN. FILED 8-27-2010.

## BABYLON

THE MARK CONSISTS OF STANDARD CHARACTERS WITHOUT CLAIM TO ANY PARTICULAR FONT, STYLE, SIZE, OR COLOR.

FOR METAL MOBILE TOWERS STORED ON REELS AND USED FOR RAISING, LOWERING AND SUPPORTING LOADS (U.S. CLS. 2, 12, 13, 14, 23, 25 AND 50).

REBECCA SMITH, EXAMINING ATTORNEY

SN 85-086,206. KUZU FLEKS METAL HORTUM SANAYKUZU FLEKS METAL HORTUM SANAYI VE TICARET ANONIM SIRKETI, GEMLIK/BURSA, TURKEY, FILED 7-16-2010.



OWNER OF TURKEY REG. NO. 200125450, DATED 12-6-2001, EXPIRES 12-6-2011.

NO CLAIM IS MADE TO THE EXCLUSIVE RIGHT TO USE "FLEX FLEXIBLE METAL HOSES", APART FROM THE MARK AS SHOWN.

THE COLOR(S) GRAY, BLUE WHITE, AND BLACK IS/ARE CLAIMED AS A FEATURE OF THE MARK.

THE MARK CONSISTS OF "KUZU" IN BLUE LETTERING ON TOP OF A WHITE BACKGROUND, SURROUNDED BY A BLUE BORDER; THE TERM "FLEX" IN BLUE LETTERING BELOW THE AFOREMENTIONED BLUE BORDER; "FLEXIBLE METAL HOSES" SHOWN IN THE BLACK; ALL SET ON A GRAY BACKGROUND.

FOR FLEXIBLE METAL HOSES (U.S. CLS. 2, 12, 13, 14, 23, 25 AND 50).

ALLISON HOLTZ, EXAMINING ATTORNEY

SN 85-126,825. MICHAEL J. WALSH & ASSOCIATES, INC., CHILOQUIN, OR. FILED 9-10-2010.

**BIG RED SAFE LOCKS**

"BIG RED, THE SAFE-LOCKS WITH THE RED-WHEELS"



NO CLAIM IS MADE TO THE EXCLUSIVE RIGHT TO USE "SAFE LOCKS" AND "THE SAFE-LOCKS WITH THE RED-WHEELS", APART FROM THE MARK AS SHOWN.

THE COLOR(S) RED, GRAY, WHITE, BLACK, TAN, BROWN, GOLD IS/ARE CLAIMED AS A FEATURE OF THE MARK.

THE MARK CONSISTS OF THE WORDING "BIG RED SAFE LOCKS" ABOVE THE WORDING "BIG RED, THE SAFE-LOCKS WITH THE RED-WHEELS" IN RED WITH GRAY SHADOW EFFECT; WITH A CARTOON CHARACTER IMMEDIATELY TO THE RIGHT OF THE WORDING, WHICH IS A RED CARTOON LOCK WITH A GOLD CENTER WHO IS GIVING A THUMBS UP SIGN WITH IT'S

**CLASS 6—(Continued).**

TAN LEFT HAND AND HAS IT'S TAN RIGHT HAND ON IT'S HIP. IT IS WEARING WHITE ARMS AND WHITE LEGS WITH RED SOCKS AND BROWN SHOES THAT HAVE GRAY SOLES AND THE WORD "BIG RED" APPEAR ON THE LOCK DESIGN IN BLACK. THE COLORS WHITE AND BLACK APPEAR IN THE EYES, MOUTH AND EYEBROWS; THE COLOR WHITE APPEARS INSIDE THE GOLD CENTER; THE ENTIRE DESIGN ELEMENT IS OUTLINED IN BLACK, AND THREE BROWN AND WHITE CIRCLES APPEAR NEXT TO THE RIGHT HAND.

FOR METAL LOCKS FOR SAFES; METAL SAFES (U.S. CLS. 2, 12, 13, 14, 23, 25 AND 50).

FIRST USE 7-1-2010; IN COMMERCE 7-1-2010.

ROBERT C. CLARK JR., EXAMINING ATTORNEY

---

SN 85-140,077. TOWER SOLUTIONS, LLC, PINE CITY, MN. FILED 9-28-2010.

## TOWERPOWER

THE MARK CONSISTS OF STANDARD CHARACTERS WITHOUT CLAIM TO ANY PARTICULAR FONT, STYLE, SIZE, OR COLOR.

FOR METAL MOBILE TOWERS STORED ON REELS AND MOVABLE BETWEEN A RETRACTED STORAGE POSITION AND AN EXTENDED ELEVATED USE POSITION (U.S. CLS. 2, 12, 13, 14, 23, 25 AND 50).

REBECCA SMITH, EXAMINING ATTORNEY

---

SN 85-148,492. CONTINENTAL DISC CORPORATION, LIBERTY, MO. FILED 10-8-2010.

## SANITRX HPX

THE MARK CONSISTS OF STANDARD CHARACTERS WITHOUT CLAIM TO ANY PARTICULAR FONT, STYLE, SIZE, OR COLOR.

OWNER OF U.S. REG. NOS. 1,842,648 AND 2,874,828.

FOR PRESSURE RELIEF DEVICES, NAMELY, RUPTURE DISCS AND RUPTURE DISC HOLDERS MADE OF METAL OR PRIMARILY OF METAL FOR PROTECTING GAS AND LIQUID PIPES FROM OVER PRESSURE (U.S. CLS. 2, 12, 13, 14, 23, 25 AND 50).

FIRST USE 7-6-2010; IN COMMERCE 7-6-2010.

DANIEL CAPSHAW, EXAMINING ATTORNEY

**CLASS 6—(Continued).**

SN 85-148,495. CONTINENTAL DISC CORPORATION, LIBERTY, MO. FILED 10-8-2010.

## HPX

THE MARK CONSISTS OF STANDARD CHARACTERS WITHOUT CLAIM TO ANY PARTICULAR FONT, STYLE, SIZE, OR COLOR.

FOR PRESSURE RELIEF DEVICES, NAMELY, RUPTURE DISCS MADE OF METAL OR PRIMARILY OF METAL FOR PROTECTING GAS AND LIQUID PIPES FROM OVER PRESSURE (U.S. CLS. 2, 12, 13, 14, 23, 25 AND 50).

FIRST USE 6-17-2010; IN COMMERCE 6-17-2010.

DANIEL CAPSHAW, EXAMINING ATTORNEY

---

SN 85-151,470. ATLAS BOLT & SCREW COMPANY LLC, ASHLAND, OH. FILED 10-13-2010.

## WASP

THE MARK CONSISTS OF STANDARD CHARACTERS WITHOUT CLAIM TO ANY PARTICULAR FONT, STYLE, SIZE, OR COLOR.

FOR METAL FASTENERS, NAMELY, THREADED FASTENERS (U.S. CLS. 2, 12, 13, 14, 23, 25 AND 50).

ELIZABETH HUGHITT, EXAMINING ATTORNEY

---

SN 85-171,650. ARMOR MESH LLC, MIAMI, FL. FILED 11-8-2010.

## ARMOR MESH

THE MARK CONSISTS OF STANDARD CHARACTERS WITHOUT CLAIM TO ANY PARTICULAR FONT, STYLE, SIZE, OR COLOR.

NO CLAIM IS MADE TO THE EXCLUSIVE RIGHT TO USE "MESH", APART FROM THE MARK AS SHOWN.

FOR METAL DOORS, DOOR FRAMES, SLIDING DOORS, WINDOWS AND INTERIOR, EXTERIOR AND WINDOW SHUTTERS (U.S. CLS. 2, 12, 13, 14, 23, 25 AND 50).

MARILYN IZZI, EXAMINING ATTORNEY

**CLASS 6—(Continued).**

SN 85-172,325. GEOBRUGG AG, ROMANSHORN, SWITZERLAND, FILED 11-9-2010.

# FOXX

THE MARK CONSISTS OF STANDARD CHARACTERS WITHOUT CLAIM TO ANY PARTICULAR FONT, STYLE, SIZE, OR COLOR.

FOR PROTECTIVE NET SYSTEMS COMPRISING METAL OR WIRE NETS, SUPPORT ELEMENTS AND CABLES AND PROTECTIVE BARRIER SYSTEMS COMPRISING METAL OR WIRE NETS, SUPPORT ELEMENTS AND CABLES FOR USE IN BODIES OF WATER, OR AGAINST ROCKFALLS, AVALANCHES, DEBRIS AVALANCHES; WIRE NETS AND NETTINGS OF METAL; ROCKSLIDE RETENTION WIRE NETS (U.S. CLS. 2, 12, 13, 14, 23, 25 AND 50).

DAVID TAYLOR, EXAMINING ATTORNEY

SN 85-174,461. BELGO BEKAERT ARAMES LTDA, CONTAGEM, MINAS GERAIS, BRAZIL, FILED 11-11-2010.

## Belgo Supremo Arames

THE MARK CONSISTS OF STANDARD CHARACTERS WITHOUT CLAIM TO ANY PARTICULAR FONT, STYLE, SIZE, OR COLOR.

NO CLAIM IS MADE TO THE EXCLUSIVE RIGHT TO USE "SUPREMO ARAMES", APART FROM THE MARK AS SHOWN.

THE ENGLISH TRANSLATION OF THE PORTUGUESE WORDS "SUPREMO" AND "ARAMES" IN THE MARK IS "SUPREME" AND "WIRES", RESPECTIVELY.

FOR BARBED WIRE (U.S. CLS. 2, 12, 13, 14, 23, 25 AND 50).

CURTIS FRENCH, EXAMINING ATTORNEY

SN 85-184,056. PARAGON AIRHEATER TECHNOLOGIES, INC., CORONA, CA, FILED 11-23-2010.

# DURASHIELD

THE MARK CONSISTS OF STANDARD CHARACTERS WITHOUT CLAIM TO ANY PARTICULAR FONT, STYLE, SIZE, OR COLOR.

FOR STAINLESS STEEL SEALS FOR HEAT EXCHANGERS FOR INDUSTRIAL USE IN THE POWER GENERATION, REFINERY, AND ENERGY INDUSTRIES, AND NOT FOR USE IN CONNECTION WITH AIR FILTERS FOR COMMERCIAL AND RESIDENTIAL USE, GAS CONNECTORS, OR MIXING, BLENDING AND CONVEYING MACHINES (U.S. CLS. 2, 12, 13, 14, 23, 25 AND 50).

FIRST USE 4-1-2005; IN COMMERCE 4-1-2005.

CURTIS FRENCH, EXAMINING ATTORNEY

**CLASS 6—(Continued).**

SN 85-187,001. SIRCO, ANTHONY, MELROSE, NY, FILED 11-30-2010.

## Radiant Aqua Structures

THE MARK CONSISTS OF STANDARD CHARACTERS WITHOUT CLAIM TO ANY PARTICULAR FONT, STYLE, SIZE, OR COLOR.

NO CLAIM IS MADE TO THE EXCLUSIVE RIGHT TO USE "AQUA STRUCTURES", APART FROM THE MARK AS SHOWN.

FOR MODULAR METAL STRUCTURES WITH FLEXIBLE COVERS FOR AGRICULTURAL, COMMERCIAL OR INDUSTRIAL STORAGE; PREFABRICATED METAL STRUCTURES WITH FLEXIBLE COVERS FOR AGRICULTURAL, COMMERCIAL OR INDUSTRIAL STORAGE (U.S. CLS. 2, 12, 13, 14, 23, 25 AND 50).

BRIDGETT SMITH, EXAMINING ATTORNEY

SN 85-200,815. FELDMAN, DENISE, ENCINO, CA, FILED 12-17-2010.

# NIDO HOOK

THE MARK CONSISTS OF STANDARD CHARACTERS WITHOUT CLAIM TO ANY PARTICULAR FONT, STYLE, SIZE, OR COLOR.

NO CLAIM IS MADE TO THE EXCLUSIVE RIGHT TO USE "HOOK", APART FROM THE MARK AS SHOWN.

THE ENGLISH TRANSLATION OF THE WORD "NIDO" IN THE MARK IS "NEST".

FOR METAL HOOK FOR THE DISPLAY OF ARTWORK (U.S. CLS. 2, 12, 13, 14, 23, 25 AND 50).

FIRST USE 4-13-2010; IN COMMERCE 4-13-2010.

GINA FINK, EXAMINING ATTORNEY

SN 85-201,268. DUREX PRODUCTS, INC., LUCK, WI, FILED 12-18-2010.

## DUR-X-ACCUSLOT

THE MARK CONSISTS OF STANDARD CHARACTERS WITHOUT CLAIM TO ANY PARTICULAR FONT, STYLE, SIZE, OR COLOR.

OWNER OF U.S. REG. NOS. 843,538, 2,819,357 AND OTHERS.

FOR WIRE SCREENS FOR SORTING FRAGMENTED MATERIAL (U.S. CLS. 2, 12, 13, 14, 23, 25 AND 50).

JERI J. FICKES, EXAMINING ATTORNEY



**CLASS 6—(Continued).**

SN 85-205,027. DIETRICH INDUSTRIES, INC., COLUMBUS, OH. FILED 12-23-2010.

# ProSLOT

FOR FRAMEWORKS OF METAL, NAMELY, SLOTTED TRACKS MADE OF METAL (U.S. CLS. 2, 12, 13, 14, 23, 25 AND 50).  
FIRST USE 11-29-2010; IN COMMERCE 11-29-2010.  
CHRISTINE MARTIN, EXAMINING ATTORNEY

SN 85-205,230. TORNADO TECH, LLC, PONCA CITY, OK. FILED 12-23-2010.



NO CLAIM IS MADE TO THE EXCLUSIVE RIGHT TO USE "TORNADO SHELTERS", APART FROM THE MARK AS SHOWN.

THE COLOR(S) RED, BLACK, GREY AND WHITE IS/ARE CLAIMED AS A FEATURE OF THE MARK.

THE MARK CONSISTS OF A GREY, BLACK AND WHITE CYCLONE BEHIND A LARGE RED "T" OUTLINED IN BLACK, WHICH COMPRISES THE FIRST LETTER IN THE WORDS "TORNADO" ABOVE "TECH", BOTH WORDS COMPRISED OF BLACK LETTERING OUTLINED IN RED OTHER THAN THE LARGE RED "T", AND THE BLACK WORDS "TORNADO SHELTERS" THEREUNDER.

FOR METAL STORM SHELTERS (U.S. CLS. 2, 12, 13, 14, 23, 25 AND 50).

AMY HELLA, EXAMINING ATTORNEY

SN 85-211,483. ILLINOIS TOOL WORKS INC., GLENVIEW, IL. FILED 1-5-2011.

# CREST CUP

THE MARK CONSISTS OF STANDARD CHARACTERS WITHOUT CLAIM TO ANY PARTICULAR FONT, STYLE, SIZE, OR COLOR.

NO CLAIM IS MADE TO THE EXCLUSIVE RIGHT TO USE "CUP", APART FROM THE MARK AS SHOWN.

FOR SAFETY AND SECURING ELEMENTS MADE OF HARDENED SPRING STEEL, NAMELY, LOCKING WASHERS, ALSO IN PRE-MOUNTED COMBINATION WITH SCREWS AND BOLTS (U.S. CLS. 2, 12, 13, 14, 23, 25 AND 50).

MARK PILARO, EXAMINING ATTORNEY

**CLASS 6—(Continued).**

SN 85-213,030. TEKNOR APEX COMPANY, PAWTUCKET, RI. FILED 1-7-2011.

# E-Z TITE

THE MARK CONSISTS OF STANDARD CHARACTERS WITHOUT CLAIM TO ANY PARTICULAR FONT, STYLE, SIZE, OR COLOR.

OWNER OF U.S. REG. NO. 2,358,475.

FOR METAL COUPLINGS FOR USE WITH GARDEN HOSES OR WATERING HOSES (U.S. CLS. 2, 12, 13, 14, 23, 25 AND 50).

PAM WILLIS, EXAMINING ATTORNEY

SN 85-213,778. UNISON HARDWARE, INC., SACRAMENTO, CA. FILED 1-10-2011.

# Brussels

THE MARK CONSISTS OF STANDARD CHARACTERS WITHOUT CLAIM TO ANY PARTICULAR FONT, STYLE, SIZE, OR COLOR.

FOR METAL HANDLES FOR DOORS, NAMELY, DOOR HANDLES (U.S. CLS. 2, 12, 13, 14, 23, 25 AND 50).  
FIRST USE 7-1-2005; IN COMMERCE 7-1-2005.

AMEEN IMAM, EXAMINING ATTORNEY

SN 85-215,504. TAI TONG METAL INDUSTRIAL CO., LTD., PINGTUNG, TAIWAN, FILED 1-11-2011.

# TAITONG

THE MARK CONSISTS OF ENGLISH LETTERS "TAITONG".

FOR METAL KEY BLANKS; METAL KEYS FOR LOCKS; METAL LOCKS; METAL PADLOCKS (U.S. CLS. 2, 12, 13, 14, 23, 25 AND 50).

FIRST USE 11-25-2009; IN COMMERCE 5-27-2010.

GINA HAYES, EXAMINING ATTORNEY

**CLASS 6—(Continued).**

SN 85-260,634. AHOLD LICENSING SARL, GENEVA, SWITZERLAND, FILED 3-8-2011.



OWNER OF U.S. REG. NOS. 2,871,579, 3,411,740 AND OTHERS.

THE COLOR(S) ORANGE, GRAY AND WHITE IS/ARE CLAIMED AS A FEATURE OF THE MARK.

THE MARK CONSISTS OF THE TRADE DRESS CHARACTERIZING THE FRONT FACE OF THE PACKAGING FOR APPLICANT'S GOODS, NAMELY (1) A WHITE HORIZONTAL BAR SPANNING THE LABEL OR PACKAGE FACE, (2) AN ORANGE BAR BELOW THE WHITE BAR, ALSO SPANNING THE LABEL OR PACKAGE FACE, (3) A DASHED LINE THAT APPEARS GRAY ON THE WHITE BACKGROUND AND WHITE ON THE ORANGE BACKGROUND. THE DASHED LINE EXTENDS HORIZONTALLY ALONG THE WHITE BAR, AND TURNS 90 DEGREES AT EACH END TO EXTEND DOWNWARDS INTO THE ORANGE BAR. THE DESIGN FURTHER COMPRISES (4) A GRAY SCISSORS DESIGN AND (5) THE WORD "GUARANTEED" APPEARING IN ORANGE ABOVE THE GRAY LINE AND THE WORD "VALUE" APPEARING IN ORANGE BELOW THE GRAY LINE.

SEC. 2(F) AS TO "GUARANTEED VALUE".

FOR ALUMINUM FOIL (U.S. CLS. 2, 12, 13, 14, 23, 25 AND 50).

BRIDGETT SMITH, EXAMINING ATTORNEY

SN 85-260,914. AHOLD LICENSING SARL, GENEVA, SWITZERLAND, FILED 3-8-2011.



OWNER OF U.S. REG. NOS. 2,871,579, 3,411,740 AND OTHERS.

THE MARK CONSISTS OF A SCISSORS DESIGN WITH A DASHED LINE EXTENDING TO THE RIGHT OF THE SCISSORS. THE WORD "GUARANTEED" APPEARS ABOVE THE LINE AND THE WORD "VALUE" APPEARS BELOW THE LINE.

SEC. 2(F) AS TO "GUARANTEED VALUE".

FOR ALUMINUM FOIL (U.S. CLS. 2, 12, 13, 14, 23, 25 AND 50).

BRIDGETT SMITH, EXAMINING ATTORNEY

**CLASS 7—MACHINERY**

SN 76-697,131. RAM PRODUCTS, INC., EAST BRUNSWICK, NJ. FILED 4-29-2009.

**RAM PRODUCTS, INC.**

THE MARK CONSISTS OF STANDARD CHARACTERS WITHOUT CLAIM TO ANY PARTICULAR FONT, STYLE, SIZE, OR COLOR.

OWNER OF U.S. REG. NO. 2,076,959.

NO CLAIM IS MADE TO THE EXCLUSIVE RIGHT TO USE "PRODUCTS, INC.", APART FROM THE MARK AS SHOWN.

FOR POWER OPERATED HAND-HELD ROTARY GRINDING TOOL FOR PRECISION USE BY DOCTORS, DENTISTS, AND MANICURISTS (U.S. CLS. 13, 19, 21, 23, 31, 34 AND 35).

FIRST USE 0-0-1989; IN COMMERCE 0-0-1989.

KHANH LE, EXAMINING ATTORNEY

SN 76-699,995. GROUPE FORDIA INC./FORDIA GROUP INC., SAINT-LAURENT, QUEBEC, CANADA, FILED 10-22-2009.

# HERO

PRIORITY CLAIMED UNDER SEC. 44(D) ON CANADA APPLICATION NO. 1447447, FILED 8-7-2009, REG. NO. TMA776537, DATED 9-8-2010, EXPIRES 9-8-2025.

FOR DRILLING TOOLS, NAMELY, POWER DRIVEN CORE DRILLING BITS (U.S. CLS. 13, 19, 21, 23, 31, 34 AND 35).

FIRST USE 5-11-2009; IN COMMERCE 5-25-2009.

MYRIAH HABEEB, EXAMINING ATTORNEY

**CLASS 7—(Continued).**

SN 76-704,933. STAIRS INDUSTRIAL CO., LTD., SINJHUANG CITY, TAIPEI COUNTY, TAIWAN, FILED 10-18-2010.



THE MARK CONSISTS OF A COMBINATION OF THE WORD "STAIRS" IN STANDARD LETTER CHARACTERS ADJACENT A PINWHEEL DESIGN.

FOR CENTRIFUGAL PUMPS; ELECTRIC MOTORS FOR MACHINES; ELECTRIC PUMPS; ENGINES AND MOTORS FOR THE GENERATION OF ELECTRICITY; HYDRAULIC CONTROLS FOR MACHINES, MOTORS AND ENGINES; HYDRAULIC PUMPS; MOTORS AND PUMPS FOR REFRIGERATORS AND FREEZERS; MOTORS OTHER THAN FOR LAND VEHICLES; OIL PUMPS FOR USE IN MOTORS AND ENGINES; PNEUMATIC CONTROLS FOR MACHINES, MOTORS AND ENGINES; PNEUMATIC PUMPS; PUMP CONTROL VALVES; PUMPS AS PARTS OF MACHINES, MOTORS AND ENGINES; ROTARY PUMPS; SCREW PUMPS; SERVO MOTORS; SERVO-DRIVES FOR MOTORS; SEWAGE PUMPS; STARTER MOTORS; SUBMERSIBLE PUMPS; SUCTION PUMPS; SUMP PUMPS; VACUUM PUMPS; VARIABLE SPEED DRIVES FOR USE WITH FLUID PUMPING SYSTEMS; VERTICAL TURBINE PUMPS; WATER PUMPS FOR USE IN MOTORS AND ENGINES (U.S. CLS. 13, 19, 21, 23, 31, 34 AND 35).

STEVEN JACKSON, EXAMINING ATTORNEY

SN 77-554,823. ALLIED GATOR, INC., YOUNGSTOWN, OH. FILED 8-25-2008.

**MT**

THE MARK CONSISTS OF STANDARD CHARACTERS WITHOUT CLAIM TO ANY PARTICULAR FONT, STYLE, SIZE, OR COLOR.

FOR HYDRAULICALLY POWERED MATERIAL PROCESSING AND HANDLING ATTACHMENTS IN THE NATURE OF QUICK-CHANGE CRACKER TEETH JAW SETS, QUICK-CHANGE CRUSHER TEETH JAW SETS AND QUICK-CHANGE SHEAR JAW SETS, AND QUICK-CHANGE MAGNETIC EXTENSION HANDLER FOR EXCAVATORS, THE FOREGOING EQUIPMENT TYPICALLY USED IN THE RECYCLING, DEMOLITION AND CONSTRUCTION INDUSTRIES (U.S. CLS. 13, 19, 21, 23, 31, 34 AND 35).

MAYUR VAGHANI, EXAMINING ATTORNEY

**CLASS 7—(Continued).**

SN 77-589,501. IMPACT SELECTOR, INC., ROCKWALL, TX. FILED 10-9-2008.



NO CLAIM IS MADE TO THE EXCLUSIVE RIGHT TO USE "MULTI-CONDUCTOR", APART FROM THE MARK AS SHOWN.

THE MARK CONSISTS OF A LARGE "X" IN STYLIZED FONT WITH THE WORD "MULTI-CONDUCTOR" TO THE RIGHT OF THE "X" AND THE WORD "XTREME" IN STYLIZED FONT BELOW THE WORD "MULTI-CONDUCTOR".

FOR MECHANICAL TOOLS, NAMELY, WIRELINE TOOLS FOR USE IN OIL AND GAS WELLS (U.S. CLS. 13, 19, 21, 23, 31, 34 AND 35).

FIRST USE 10-0-2007; IN COMMERCE 10-0-2007.

JERI J. FICKES, EXAMINING ATTORNEY

SN 77-902,307. JOFEMAR, S.A., 31350 PERALTA, NAVARRA, SPAIN, FILED 12-29-2009.



THE COLOR(S) GREEN AND BLACK IS/ARE CLAIMED AS A FEATURE OF THE MARK.

THE MARK CONSISTS OF EASY IN BLACK FLEX IN GREEN AND A GREEN LINE ENCLOSING THE TEXT IN A HALF CIRCLE.

FOR VENDING MACHINE PARTS, NAMELY, CONVEYORS (U.S. CLS. 13, 19, 21, 23, 31, 34 AND 35).

FIRST USE 0-0-2005; IN COMMERCE 0-0-2005.

JESSICA A. POWERS, EXAMINING ATTORNEY

SN 77-904,964. BLACK & DECKER CORPORATION, THE, TOWSON, MD. FILED 1-5-2010.

**POWERCOMMAND**

THE MARK CONSISTS OF STANDARD CHARACTERS WITHOUT CLAIM TO ANY PARTICULAR FONT, STYLE, SIZE, OR COLOR.

FOR ELECTRONIC CONTROLLERS FOR MAXIMIZING BATTERY POWER AND EXTENDING BATTERY LIFE, SOLD AS FEATURE OF POWER OPERATED LAWN AND GARDEN STRING TRIMMERS (U.S. CLS. 13, 19, 21, 23, 31, 34 AND 35).

FIRST USE 1-4-2010; IN COMMERCE 1-4-2010.

KATHERINE CHANG, EXAMINING ATTORNEY

**CLASS 7—(Continued).**

SN 77-922,209. JUSUNG ENGINEERING CO. LTD., GYEONGGI-DO, REPUBLIC OF KOREA, FILED 1-28-2010.

# EPILUXY

PRIORITY CLAIMED UNDER SEC. 44(D) ON REPUBLIC OF KOREA APPLICATION NO. 2010-0001963, FILED 1-13-2010, REG. NO. 40-0855704, DATED 3-4-2011, EXPIRES 3-4-2021.

THE MARK CONSISTS OF THE WORD "EPILUXY" IN A STYLIZED MANNER.

THE WORDING "EPILUXY" HAS NO MEANING IN A FOREIGN LANGUAGE.

FOR SEMICONDUCTOR PROCESSING MACHINES; SEMICONDUCTOR WAFER PROCESSING MACHINES; LOW PRESSURE CHEMICAL VAPOR DEPOSITION (LPCVD) MACHINES; PLASMA ENHANCED CHEMICAL VAPOR DEPOSITION (PECVD) MACHINES; PLASMA CHEMICAL VAPOR DEPOSITION (PCVD) MACHINES; METAL ORGANIC CHEMICAL VAPOR DEPOSITION (MOCVD) MACHINES; DEPOSITION MACHINES USED FOR MANUFACTURING SEMICONDUCTORS; ETCHING MACHINES USED FOR MANUFACTURING SEMICONDUCTORS; DEPOSITION MACHINES USED FOR MANUFACTURING LIQUID CRYSTAL DISPLAYS (LCD); ETCHING MACHINES USED FOR MANUFACTURING LIQUID CRYSTAL DISPLAYS (LCD); DEPOSITION MACHINES USED FOR MANUFACTURING SOLAR CELLS; ETCHING MACHINES USED FOR MANUFACTURING SOLAR CELLS; DEPOSITION MACHINES USED FOR MANUFACTURING LIGHT EMITTING DIODES (LED); ETCHING MACHINES USED FOR MANUFACTURING LIGHT EMITTING DIODES (LED) (U.S. CLS. 13, 19, 21, 23, 31, 34 AND 35).

KATHLEEN M. VANSTON, EXAMINING ATTORNEY

**CLASS 7—(Continued).**

SN 77-957,457. DOUGLAS MACHINE INC., ALEXANDRIA, MN. FILED 3-12-2010.



NO CLAIM IS MADE TO THE EXCLUSIVE RIGHT TO USE "GUARANTEED BEST PRICING & NEXT DAY DELIVERY", APART FROM THE MARK AS SHOWN.

THE MARK CONSISTS OF THE STYLIZED WORDING "PARTSDIRECT GUARANTEED BEST PRICING & NEXT DAY DELIVERY" WITH A HORIZONTAL LINE ON EITHER SIDE OF THE AMPERSAND, ALL APPEARING ON A SHADED BACKGROUND, IN THE SHAPE OF AN OVAL ON TOP, WITH A RECTANGLE SHAPE BELOW, CONNECTED TO THE OVAL BY AN HOURGLASS SHAPE. FOR PACKAGING MACHINES AND PARTS THEREOF (U.S. CLS. 13, 19, 21, 23, 31, 34 AND 35).

FIRST USE 6-8-2009; IN COMMERCE 6-8-2009.

MARK PILARO, EXAMINING ATTORNEY

SN 77-939,543. FERROTEC (USA) CORPORATION, DBA FERROTEC-TEMESCAL, BEDFORD, NH. FILED 2-19-2010.

# PopTop

THE MARK CONSISTS OF STANDARD CHARACTERS WITHOUT CLAIM TO ANY PARTICULAR FONT, STYLE, SIZE, OR COLOR.

FOR ELECTRON BEAM HEATED DEPOSITION SOURCES, NAMELY, SEMICONDUCTOR SUBSTRATE MANUFACTURING MACHINES (U.S. CLS. 13, 19, 21, 23, 31, 34 AND 35).

FIRST USE 10-31-2000; IN COMMERCE 1-31-2001.

ROBERT STRUCK, EXAMINING ATTORNEY

SN 77-981,753. HUHNSEAL AB, LANDSKRONA, SWEDEN, FILED 12-28-2009.

# EXPELLER

THE MARK CONSISTS OF STANDARD CHARACTERS WITHOUT CLAIM TO ANY PARTICULAR FONT, STYLE, SIZE, OR COLOR.

FOR WATER TURBINES NOT FOR LAND VEHICLES; INDUSTRIAL FOOD PRODUCTION MIXERS, INDUSTRIAL OIL AND GAS MIXERS (U.S. CLS. 13, 19, 21, 23, 31, 34 AND 35).

LAURIE MAYES, EXAMINING ATTORNEY



**CLASS 7—(Continued).**

SN 79-078,701. NINGBO SYBO MACHINERY CO., LTD.; (NINGBO SAIBO JIXIE YOUXIAN GONGSI), ZHEJIANG, CHINA, FILED 1-20-2010.



OWNER OF INTERNATIONAL REGISTRATION 1028258 DATED 1-20-2010, EXPIRES 1-20-2020.

THE MARK CONSISTS OF THE WORD "SYBO", STYLIZED, WITHIN A RECTANGULAR CARRIER.

THE WORDING "SYBO" HAS NO MEANING IN A FOREIGN LANGUAGE.

FOR FOOD PREPARATION MACHINES, ELECTRO-MECHANICAL, NAMELY, ELECTRIC BREAD MAKING AND FLOUR PROCESSING MACHINES, ELECTRIC MEAT PROCESSING MACHINES, ELECTRIC VEGETABLE AND FRUIT PROCESSING MACHINES, HAND-HELD ELECTRIC-POWERED FOOD PROCESSORS, ELECTRIC PLANETARY MIXER, ELECTRIC SPIRAL MIXER, ELECTRIC MEAT MINCER, ELECTRIC MEAT SLICER, ELECTRIC FOOD BLENDERS, ELECTRIC FOOD CHOPPERS, ELECTRIC FOOD PROCESSORS; AGRICULTURAL MACHINES, NAMELY, CULTIVATORS, HARVESTORS, DISK HARROWS, SEEDERS, BRUSH CUTTER, POWER-OPERATED SPRAYER; PRINTING MACHINES; PARTS OF MACHINES, ENGINES OR MOTORS, NAMELY PUMPS; ELECTRIC CARPET SHAMPOOING MACHINES AND APPARATUS; SPRAY GUNS FOR PAINT (U.S. CLS. 13, 19, 21, 23, 31, 34 AND 35).

BARNEY CHARLON, EXAMINING ATTORNEY

SN 79-080,685. WENZHOU ZHENTIAN MACHINERY CO., LTD, ZHEJIANG PROVINCE, CHINA, FILED 2-16-2010.

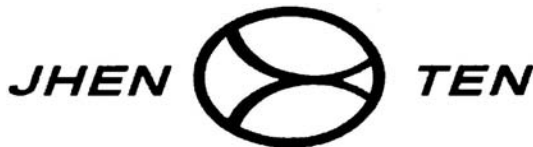

OWNER OF INTERNATIONAL REGISTRATION 1033545 DATED 2-16-2010, EXPIRES 2-16-2020.

THE MARK CONSISTS OF THE WORDING "JHEN TEN" IN STYLIZED FONT WITH THE DESIGN OF A CIRCLE WITH CURVED LINES INSIDE.

THE WORDING "JHEN TEN" HAS NO MEANING IN A FOREIGN LANGUAGE.

FOR CRUSHING MACHINES FOR INDUSTRIAL PURPOSES; ELECTROMECHANICAL FOOD PREPARATION MACHINES, NAMELY, ELECTRIC FOOD BLENDERS; VERMICELLI MAKING MACHINES, NAMELY, ELECTRIC VERMICELLI MAKERS FOR DOMESTIC USE; FOOD PACKING MACHINES; CREAM AND MILK SEPARATORS; BREWING MACHINES, NAMELY, WINE PRESSES; FILTERS FOR MINERAL WATER MAKING MACHINES; FOOD PROCESSORS, ELECTRIC; PROCESSING MACHINERY FOR THE PHARMACEUTICAL INDUSTRY, NAMELY, MACHINES USED FOR PROCESS FILTRATION IN THE PHARMACEUTICAL INDUSTRY (U.S. CLS. 13, 19, 21, 23, 31, 34 AND 35).

WILLIAM ROSSMAN, EXAMINING ATTORNEY

**CLASS 7—(Continued).**

SN 79-084,355. TEHAG AG, SWITZERLAND, FILED 5-17-2010.

# TEHAG

THE MARK CONSISTS OF STANDARD CHARACTERS WITHOUT CLAIM TO ANY PARTICULAR FONT, STYLE, SIZE, OR COLOR.

PRIORITY DATE OF 12-16-2009 IS CLAIMED.

OWNER OF INTERNATIONAL REGISTRATION 1036193 DATED 3-2-2010, EXPIRES 3-2-2020.

THE WORDING "TEHAG" HAS NO MEANING IN A FOREIGN LANGUAGE.

FOR PARTICLE FILTERS FOR MOTORS AND ENGINES, FILTERS FOR MACHINES, MOTORS AND ENGINES, FOR USE IN THE AUTOMOTIVE INDUSTRY OR IN STATIONARY EQUIPMENT, PARTS FOR AFTERTREATMENT OF EXHAUST GAS OF COMBUSTION ENGINES, NAMELY, CATALYSTS FOR EXHAUST GAS, ANTI-POLLUTION DEVICES FOR MOTORS AND ENGINES, CRANKCASES FOR MACHINES, MOTORS AND ENGINES (U.S. CLS. 13, 19, 21, 23, 31, 34 AND 35).

SHAILA SETTLES, EXAMINING ATTORNEY

SN 79-088,018. GUANGZHOU FARET RADIATOR CO., LTD., CHINA, FILED 9-23-2010.



OWNER OF INTERNATIONAL REGISTRATION 1052931 DATED 9-23-2010, EXPIRES 9-23-2020.

THE MARK CONSISTS OF A STYLIZED BEAR AGAINST A GLOBE DESIGN, BENEATH WHICH IS THE WORDING "BAJIXIONG" IN A QUADRILATERAL.

THE ENGLISH TRANSLATION OF "BAJIXIONG" IN THE MARK IS "POLAR BEAR".

FOR FUEL CONVERSION APPARATUS FOR INTERNAL COMBUSTION ENGINES; GASOLINE ECONOMIZERS FOR MOTORS AND ENGINES; COOLING RADIATORS FOR MOTORS AND ENGINES; AUTOMOBILE MOTOR COOLING RADIATORS; AUTOMOBILE MOTOR COOLING WATER TANKS; AUTOMOBILE MOTOR COOLING RADIATOR PIPES; AUTOMOBILE MOTOR COOLING FANS; PUMPS BEING PARTS OF MACHINES, ENGINES OR MOTORS; PARTS FOR INTERNAL COMBUSTION ENGINES, NAMELY, CONDENSERS; WATER HEATERS BEING PARTS OF MACHINES (U.S. CLS. 13, 19, 21, 23, 31, 34 AND 35).

STEVEN R. FINE, EXAMINING ATTORNEY

**CLASS 7—(Continued).**

SN 79-088,259. MAANSHAN MIDDLE ASIA MACHINE TOOLS MANUFACTURE CO., LTD., ANHUI PROVINCE, CHINA, FILED 8-5-2010.



PRIORITY DATE OF 5-24-2010 IS CLAIMED.  
OWNER OF INTERNATIONAL REGISTRATION 1053659  
DATED 8-5-2010, EXPIRES 8-5-2020.

THE MARK CONSISTS OF THE STYLIZED LETTERS "ZYMT" WHERE THE LETTER "Z" EXTENDS BELOW THE WORD AS AN UNDERLINE TO THE LETTER "T".

FOR BENDING MACHINES; MACHINE TOOLS FOR THE CUTTING AND FORMING OF MATERIALS; METAL WORKING MACHINES; MACHINE TOOLS FOR FORMING, RIVETING, SWAGING AND FLARING OF METAL AND PLASTICS; METAL CLAMPS USED FOR HOLDING PIECE PARTS ON MACHINE TOOL TABLES; AUTOMATIC MANIPULATORS FOR FORGING PRESSES AND FOR FORGING MACHINES; INDUSTRIAL ROBOTS (U.S. CLS. 13, 19, 21, 23, 31, 34 AND 35).  
LINDA ORNDORFF, EXAMINING ATTORNEY

SN 79-088,501. TWISTER B.V., NETHERLANDS, FILED 8-16-2010.



PRIORITY DATE OF 2-23-2010 IS CLAIMED.  
OWNER OF INTERNATIONAL REGISTRATION 1054385  
DATED 8-16-2010, EXPIRES 8-16-2020.

THE COLOR(S) BLUE AND GREEN IS/ARE CLAIMED AS A FEATURE OF THE MARK.

THE MARK CONSISTS OF THE WORDING "SWIRL-VALVE" APPEARING IN BLUE WITH A GREEN WATER DROPLET FORMING THE DOT OVER THE LETTER "I".

FOR VALVES BEING PARTS OF MACHINES FOR CONTROLLING PRESSURE, TEMPERATURE AND FLOW OF FLUIDS, LIQUIDS AND GASES (U.S. CLS. 13, 19, 21, 23, 31, 34 AND 35).

ASMAT KHAN, EXAMINING ATTORNEY

SN 79-089,705. OMET S.R.L., ITALY, FILED 9-21-2010.



THE MARK CONSISTS OF STANDARD CHARACTERS WITHOUT CLAIM TO ANY PARTICULAR FONT, STYLE, SIZE, OR COLOR.

PRIORITY DATE OF 9-15-2010 IS CLAIMED.  
OWNER OF INTERNATIONAL REGISTRATION 1057536  
DATED 9-21-2010, EXPIRES 9-21-2020.

FOR PRINTING MACHINES FOR COMMERCIAL AND INDUSTRIAL USE AND ROTATING PUNCHING MACHINES, NAMELY, PRESSES; ELECTRONIC MACHINES FOR SELF-ADHESIVE LABEL PRINTING; MACHINES FOR PLASTICS WORKING, NAMELY, FOR MANUFACTURING PLASTIC FILMS AND PLASTIC MATERIALS FOR FLEXIBLE PACKAGING (U.S. CLS. 13, 19, 21, 23, 31, 34 AND 35).

ANNE FARRELL, EXAMINING ATTORNEY

**CLASS 7—(Continued).**

SN 79-090,841. RUI AN ZHONGBEN AUTO PARTS CO., LTD, CHINA, FILED 11-3-2010.



OWNER OF INTERNATIONAL REGISTRATION 1060674  
DATED 11-3-2010, EXPIRES 11-3-2020.

THE MARK CONSISTS OF THE WORDING "VOOLCO AND STYLIZED LETTER V". THE "V" IS INSIDE OF A CIRCLE DESIGN, THE WORD "VOOLCO" IS IN THE MIDDLE AND THREE CHINESE CHARACTERS ARE THE THIRD LINE.

THE ENGLISH TRANSLATION OF THE FOREIGN WORD(S) IN THE MARK IS: "FERTILE", "YOU" AND "BLOCK". THE WORDING "VOOLCO" HAS NO MEANING IN A FOREIGN LANGUAGE.

THE NON-LATIN CHARACTERS IN THE MARK TRANSLITERATE TO "WO ER KA" AND THIS MEANS "FERTILE", "YOU" AND "BLOCK" IN ENGLISH.

FOR CYLINDER HEADS FOR ENGINES; GENERATORS OF ELECTRICITY; IGNITION MAGNETOS FOR ENGINES; PISTON RINGS; INTERNAL COMBUSTION ENGINE PARTS, NAMELY, PISTONS; MOTORCYCLE ENGINE PARTS, NAMELY, AIR CLEANERS; SUB-MICRON FUEL FILTERS FOR DIESEL EXHAUST FLUID (U.S. CLS. 13, 19, 21, 23, 31, 34 AND 35).

LOURDES AYALA, EXAMINING ATTORNEY

SN 79-091,222. ENGITEC TECHNOLOGIES S.P.A., NOVATE MILANESE (MILANO), ITALY, FILED 10-7-2010.



THE MARK CONSISTS OF STANDARD CHARACTERS WITHOUT CLAIM TO ANY PARTICULAR FONT, STYLE, SIZE, OR COLOR.

PRIORITY DATE OF 5-19-2010 IS CLAIMED.  
OWNER OF INTERNATIONAL REGISTRATION 1061620  
DATED 10-7-2010, EXPIRES 10-7-2020.

FOR MACHINES USED FOR CONVERTING SECONDARY RAW MATERIALS AND WASTE CONTAINING ZINC INTO RAW ZINC OXIDE; WASTE TREATMENT MACHINES (U.S. CLS. 13, 19, 21, 23, 31, 34 AND 35).

SAMUEL E. SHARPER JR., EXAMINING ATTORNEY

**CLASS 7—(Continued).**

SN 79-091,688. MANITOWOC CRANE GROUP FRANCE SAS, FRANCE, FILED 8-10-2010.

# MegaDrive

THE MARK CONSISTS OF STANDARD CHARACTERS WITHOUT CLAIM TO ANY PARTICULAR FONT, STYLE, SIZE, OR COLOR.

PRIORITY DATE OF 3-4-2010 IS CLAIMED. OWNER OF INTERNATIONAL REGISTRATION 1062681 DATED 8-10-2010, EXPIRES 8-10-2020.

FOR FORCE AND TORQUE TRANSMISSION SYSTEMS FOR CRANES, NAMELY, MOBILE CRANES AND VEHICLE CRANES, AND THEIR TRANSPORTATION SYSTEMS SOLD AS A UNIT; DRIVE SYSTEMS FOR CRANES INCLUDED IN THIS CLASS, NAMELY, MOBILE AND VEHICLE CRANES; MECHANICAL, HYDRAULIC AND HYDROSTATIC CRANE DRIVE SYSTEMS AND COMBINATIONS OF THE SAME, NAMELY, HYDRAULIC PUMPS AND MOTORS FOR HYDROSTATIC SYSTEMS, COMPRISED OF PUMPS, MOTORS, VALVES, SWITCHES, SENSORS, AND ELECTRONIC CONTROLS FOR HYDRAULIC DRIVES AND FORCE TRANSMISSIONS IN MOBILE CRANES AND VEHICLE CRANES; GEAR DRIVES FOR MOBILE CRANES AND VEHICLE CRANES (U.S. CLS. 13, 19, 21, 23, 31, 34 AND 35).

LANA PHAM, EXAMINING ATTORNEY

SN 85-007,447. FIRESTONE INDUSTRIAL PRODUCTS COMPANY, LLC, INDIANAPOLIS, IN. FILED 4-6-2010.

**World's Number 1  
Air Spring.**



OWNER OF U.S. REG. NOS. 3,589,604 AND 3,589,605. NO CLAIM IS MADE TO THE EXCLUSIVE RIGHT TO USE "AIR SPRING", APART FROM THE MARK AS SHOWN.

THE MARK CONSISTS OF THE WORDS "WORLD'S NUMBER 1 AIR SPRING.", AN AIR SPRING AND A HORIZONTAL LINE ABOVE AND BELOW THE WORDS AND AIR SPRING.

SEC. 2(F).

FOR PNEUMATIC ACTUATORS FOR USE AS A MOTION CONTROL DEVICE IN MANUFACTURING, MATERIAL HANDLING, ASSEMBLY, FORESTRY, PAPER, HYDRAULICS AND PNEUMATICS, AND RELATED INDUSTRIES; VIBRATION ABSORBING SUSPENSIONS AND VIBRATION ISOLATORS FOR MACHINERY AND PARTS THEREFOR; PNEUMATIC SUSPENSION SPRINGS AND SHOCK ABSORBER UNITS FOR MACHINERY AND EQUIPMENT AND STRUCTURAL AND REPLACEMENT PARTS THEREFOR (U.S. CLS. 13, 19, 21, 23, 31, 34 AND 35).

FIRST USE 4-30-2006; IN COMMERCE 4-30-2006. LINDA ORNDORFF, EXAMINING ATTORNEY

**CLASS 7—(Continued).**

SN 85-032,483. GLOBAL TECH APPLIANCES (HK) LIMITED, KOWLOON, HONG KONG, FILED 5-7-2010.

# LAREDO CHILI'S

THE MARK CONSISTS OF STANDARD CHARACTERS WITHOUT CLAIM TO ANY PARTICULAR FONT, STYLE, SIZE, OR COLOR.

FOR ELECTRIC QUESADILLA MAKERS FOR DOMESTIC USE; ELECTRIC FAJITA MAKERS FOR DOMESTIC USE; ELECTRIC MARGARITA MIXERS FOR HOUSEHOLD PURPOSES (U.S. CLS. 13, 19, 21, 23, 31, 34 AND 35).

TASNEEM HUSSAIN, EXAMINING ATTORNEY

SN 85-040,548. CYPHY WORKS, INC., FRAMINGHAM, MA. FILED 5-17-2010.

# Extreme Access

THE MARK CONSISTS OF STANDARD CHARACTERS WITHOUT CLAIM TO ANY PARTICULAR FONT, STYLE, SIZE, OR COLOR.

NO CLAIM IS MADE TO THE EXCLUSIVE RIGHT TO USE "ACCESS", APART FROM THE MARK AS SHOWN.

FOR ROBOTS AND ROBOTIC SYSTEMS CONSISTING OF AN INDUSTRIAL ROBOT WITH ASSOCIATED COMPUTER HARDWARE AND COMPUTER OPERATING SOFTWARE WHICH PROVIDE ACCESS TO DANGEROUS, DIFFICULT OR HARD TO REACH AREAS (U.S. CLS. 13, 19, 21, 23, 31, 34 AND 35).

JEFFREY LOOK, EXAMINING ATTORNEY

SN 85-046,951. GLOBAL TECH APPLIANCES (HK) LIMITED, KOWLOON, HONG KONG, FILED 5-25-2010.



THE COLOR(S) RED, WINE RED, GREEN, YELLOW, ORANGE AND BLACK IS/ARE CLAIMED AS A FEATURE OF THE MARK.

THE MARK CONSISTS OF THREE CIRCLES WHEREIN THE OUTER MOST CIRCLE HAS A GREEN BORDER OF WHICH HALF OF THE CIRCLE IS DOTTED WITH BLACK COLOR. THE INNER CIRCLE HAS A TRIANGLE DESIGN

**CLASS 7—(Continued).**

ALL OVER ITS CIRCUMFERENCE IN YELLOW COLOR HAVING THE BORDER IN ORANGE COLOR AND THE INNER MOST CIRCLE IS IN RED COLOR WHICH BECOMES DARKER TOWARDS THE END. THE INNER MOST CIRCLE HAS AN IMAGE LIKE RAYS IN WINE COLOR WHICH TOUCHES THE OUTER CIRCLE. THE IMAGE OF THE RED CHILI HAVING GREEN STEM IS BEING DEPICTED IN THE CENTER OF THE CIRCLE AND BELOW THE RED CHILLI THE WORDS "LAREDO CHILI'S" ARE WRITTEN IN RED COLOR ON A BLACK RIBBON OUTLINED WITH YELLOW COLOR.

FOR ELECTRIC QUESADILLA MAKERS FOR DOMESTIC USE; ELECTRIC FAJITA MAKERS FOR DOMESTIC USE; ELECTRIC MARGARITA MIXERS FOR HOUSEHOLD PURPOSES (U.S. CLS. 13, 19, 21, 23, 31, 34 AND 35).

TASNEEM HUSSAIN, EXAMINING ATTORNEY

SN 85-051,059. DYNE SYSTEMS INC., CHEYENNE, WY. FILED 5-30-2010.



NO CLAIM IS MADE TO THE EXCLUSIVE RIGHT TO USE "INC.", APART FROM THE MARK AS SHOWN.

THE COLOR(S) YELLOW, BLUE, AND RED IS/ARE CLAIMED AS A FEATURE OF THE MARK.

THE MARK CONSISTS OF THE WORDS "RACEDYNE INC." IN YELLOW WITH A BLUE ARC DESIGN ON TOP, FLOWING FROM THE FIRST "E" TO THE SECOND "E", AND A RED ARC DESIGN ON THE BOTTOM, FLOWING FROM THE "A" TO THE "Y" (THE BLACK RECTANGULAR BACKGROUND IS BACKGROUND ONLY).

FOR LAND VEHICLE ENGINE PARTS, NAMELY, ROCKER BOX GASKETS, VALVE COVERS, CAM-SHAFTS, CYLINDER HEADS, CYLINDER BLOCKS, ENGINE BLOCKS, TIMING COVERS, FRONT TIMING COVERS, TIMING CHAIN COVERS, FUEL PUMPS AND FUEL SYSTEMS, NAMELY, FUEL DISTRIBUTION BLOCKS (U.S. CLS. 13, 19, 21, 23, 31, 34 AND 35).

FIRST USE 12-31-1998; IN COMMERCE 12-31-1998.

ANGELA M. MICHELI, EXAMINING ATTORNEY

SN 85-053,419. CURTIS INDUSTRIES LLC, WORCESTER, MA. FILED 6-3-2010.

# SNO-PRO

THE MARK CONSISTS OF STANDARD CHARACTERS WITHOUT CLAIM TO ANY PARTICULAR FONT, STYLE, SIZE, OR COLOR.

OWNER OF U.S. REG. NO. 2,113,006.

FOR PLOWS FOR TRACTORS AND UTILITY VEHICLES; MECHANICAL SPREADERS (U.S. CLS. 13, 19, 21, 23, 31, 34 AND 35).

SOPHIA S. KIM, EXAMINING ATTORNEY

**CLASS 7—(Continued).**

SN 85-059,780. LIHOM INC., KANGNAM-GU, SEOUL, REPUBLIC OF KOREA, FILED 6-10-2010.

# LIHOM

OWNER OF U.S. REG. NOS. 3,383,918 AND 3,383,920. THE MARK CONSISTS OF THE LETTERS "LIHOM" IN STYLIZED PRINT; THE LETTER "I" HAS A SMALL CIRCLE OVER IT.

FOR ELECTRIC FOOD BLENDERS FOR HOUSEHOLD PURPOSES; VACUUM CLEANERS; VACUUM CLEANER BAGS; VACUUM CLEANER HOSES; ELECTRIC CLEANERS FOR HOUSEHOLD PURPOSES, NAMELY, FLOOR CLEANING MACHINES AND CARPET CLEANING MACHINES; DISHWASHERS; ELECTRIC WHISKS FOR HOUSEHOLD PURPOSES; ELECTRIC FRUIT PRESSES FOR HOUSEHOLD PURPOSES; ELECTRIC CRUSHERS/GRINDERS FOR HOUSEHOLD PURPOSES; ELECTRIC CAN OPENERS; ELECTRIC MACHINES AND APPARATUS FOR CARPET SHAMPOOING; FOOD MILLS FOR HOUSEHOLD PURPOSES, OTHER THAN HAND-OPERATED; ELECTRIC MIXERS FOR HOUSEHOLD PURPOSES (U.S. CLS. 13, 19, 21, 23, 31, 34 AND 35).

ANN E. SAPPENFIELD, EXAMINING ATTORNEY

SN 85-059,848. LIHOM INC., KANGNAM-GU, SEOUL, REPUBLIC OF KOREA, FILED 6-10-2010.

The logo for CUCHEM features the word "CUCHEM" in a bold, black, sans-serif font. To the right of "CUCHEM" is a small red asterisk symbol.

OWNER OF U.S. REG. NO. 3,256,872.

THE COLOR(S) BLACK, RED AND WHITE IS/ARE CLAIMED AS A FEATURE OF THE MARK.

THE MARK CONSISTS OF THE WORD "CUCHEM" IN BLACK STYLIZED LETTERS AND A DESIGN CONSISTING OF A STYLIZED WHITE ASTERISK ON A BACKGROUND RED CIRCLE WHICH IS RAISED AND PLACED ADJACENT TO THE LETTER "N".

FOR ELECTRIC FOOD BLENDERS FOR HOUSEHOLD PURPOSES; VACUUM CLEANERS; VACUUM CLEANER BAGS; VACUUM CLEANER HOSES; ELECTRIC CLEANERS FOR HOUSEHOLD PURPOSES, NAMELY, FLOOR CLEANING MACHINES AND CARPET CLEANING MACHINES; DISHWASHERS; ELECTRIC WHISKS FOR HOUSEHOLD PURPOSES; ELECTRIC FRUIT PRESSES FOR HOUSEHOLD PURPOSES; ELECTRIC CRUSHERS/GRINDERS FOR HOUSEHOLD PURPOSES; ELECTRIC CAN OPENERS; ELECTRIC MACHINES AND APPARATUS FOR CARPET SHAMPOOING; FOOD MILLS FOR HOUSEHOLD PURPOSES, OTHER THAN HAND-OPERATED; ELECTRIC MIXERS FOR HOUSEHOLD PURPOSES (U.S. CLS. 13, 19, 21, 23, 31, 34 AND 35).

ANN E. SAPPENFIELD, EXAMINING ATTORNEY



**CLASS 7—(Continued).**

SN 85-060,800. USINAGE PRO 24 INC., ASBESTOS, QUEBEC, CANADA, FILED 6-11-2010.

## NORDIK BLADES

THE MARK CONSISTS OF STANDARD CHARACTERS WITHOUT CLAIM TO ANY PARTICULAR FONT, STYLE, SIZE, OR COLOR.

PRIORITY CLAIMED UNDER SEC. 44(D) ON CANADA APPLICATION NO. 1474837, FILED 3-26-2010, REG. NO. TMA794,343, DATED 3-31-2011, EXPIRES 3-31-2026.

NO CLAIM IS MADE TO THE EXCLUSIVE RIGHT TO USE "BLADES", APART FROM THE MARK AS SHOWN.

FOR REPLACEMENT PARTS FOR SNOWPLOWS, SNOWBLOWERS, LOADERS, NAMELY, CARBIDE BLADES, CARBIDE PLOW SHOES AND CARBIDE TIPS (U.S. CLS. 13, 19, 21, 23, 31, 34 AND 35).

FIRST USE 5-0-2005; IN COMMERCE 7-0-2005.  
ROSELLE HERRERA, EXAMINING ATTORNEY

**CLASS 7—(Continued).**

SN 85-062,639. SKYRON SYSTEMS, INC., BEAVERTON, OR, FILED 6-14-2010.



NO CLAIM IS MADE TO THE EXCLUSIVE RIGHT TO USE "SYSTEMS", APART FROM THE MARK AS SHOWN.

THE MARK CONSISTS OF A DESIGN IN THE SHAPE OF A CORNUCOPIA COMPOSED OF FLOWING DOTS AND THE WORDS "SKYRON SYSTEMS".

FOR WIND TURBINES (U.S. CLS. 13, 19, 21, 23, 31, 34 AND 35).

STEVEN PEREZ, EXAMINING ATTORNEY

SN 85-062,628. SKYRON SYSTEMS, INC., BEAVERTON, OR, FILED 6-14-2010.



NO CLAIM IS MADE TO THE EXCLUSIVE RIGHT TO USE "SYSTEMS, INC.", APART FROM THE MARK AS SHOWN.

THE MARK CONSISTS OF A DESIGN IN THE NATURE OF A FLOWING RIBBON FORMING AN OPEN HORIZONTAL LOOP AND THE WORDS "SKYRON SYSTEMS, INC".

FOR WIND TURBINES (U.S. CLS. 13, 19, 21, 23, 31, 34 AND 35).

STEVEN PEREZ, EXAMINING ATTORNEY

SN 85-063,472. TUFTCO CORPORATION, CHATTANOOGA, TN, FILED 6-15-2010.

## iCREEL

THE MARK CONSISTS OF STANDARD CHARACTERS WITHOUT CLAIM TO ANY PARTICULAR FONT, STYLE, SIZE, OR COLOR.

FOR TUFTING MACHINES; PATTERN ATTACHMENTS FOR TUFTING MACHINES FOR THE PURPOSE OF YARN FEED CONTROL; AUTOMATED WRAPPER IN-FEED MACHINES FOR YARN; TUFTING MACHINE PARTS, NAMELY, THREAD TENSIONERS FOR RUNNING LENGTHS OF YARN STRANDS, TENSIONERS FOR RUNNING LENGTHS OF YARN ON YARN CONES AND YARN FEEDERS (U.S. CLS. 13, 19, 21, 23, 31, 34 AND 35).

SAMUEL E. SHARPER JR., EXAMINING ATTORNEY

**CLASS 7—(Continued).**

SN 85-067,698. HONDA MOTOR CO., LTD., MINATO-KU, TOKYO, JAPAN, FILED 6-21-2010.

# HANDI

THE MARK CONSISTS OF STANDARD CHARACTERS WITHOUT CLAIM TO ANY PARTICULAR FONT, STYLE, SIZE, OR COLOR.

OWNER OF U.S. REG. NO. 3,684,089.  
FOR GENERATORS FOR LAND VEHICLES; PORTABLE ELECTRIC GENERATORS; AC GENERATORS; DC GENERATORS; PORTABLE GAS OPERATED POWER GENERATORS, NAMELY, GENERATORS FOR CAMPING, TAILGATING, AND BASIC HOME BACKUP POWER (U.S. CLS. 13, 19, 21, 23, 31, 34 AND 35).  
CYNTHIA TRIPI, EXAMINING ATTORNEY

SN 85-069,726. PANASONIC CORPORATION OF NORTH AMERICA, SECAUCUS, NJ. FILED 6-23-2010.

# TOUGH IP

THE MARK CONSISTS OF STANDARD CHARACTERS WITHOUT CLAIM TO ANY PARTICULAR FONT, STYLE, SIZE, OR COLOR.

NO CLAIM IS MADE TO THE EXCLUSIVE RIGHT TO USE "IP", APART FROM THE MARK AS SHOWN.  
FOR POWER TOOLS, NAMELY, DRILL DRIVERS, HAMMER DRILLS, IMPACT DRIVERS, IMPACT WRENCHES AND JIGSAWS (U.S. CLS. 13, 19, 21, 23, 31, 34 AND 35).

FIRST USE 9-18-2010; IN COMMERCE 9-18-2010.  
DORITT L. CARROLL, EXAMINING ATTORNEY

SN 85-069,848. CORRIHER, TED, NEWTON, NC. FILED 6-23-2010.

# BETTER BY DESIGN

THE MARK CONSISTS OF STANDARD CHARACTERS WITHOUT CLAIM TO ANY PARTICULAR FONT, STYLE, SIZE, OR COLOR.

FOR TRACTOR TOWED OR CARRIED IMPLEMENTS, NAMELY, PLOWS, MOWERS, REAPERS, BLADES, SCRAPERS, RAKES, BUCKETS, TILLERS, DISCS, SWEEPERS, HARROWS, SPREADERS, SPRAYERS, GRADERS, LOADERS, DRAGS, AUGERS, CUTTERS, SPEARS, FORKS, SHEARS, BALERS, CULTIVATORS, SEEDERS, PLUGGERS, GRAPPLERS, TRENCHERS, BACKHOES, BOOM POLES, MIXERS, BEDDERS, POST DRIVERS, ROLLERS, PULVERIZERS, STUMP GRINDERS, CHIPPERS, MULCHERS, SAWS, SNOW BLOWERS, VACUUMS AND GENERATORS (U.S. CLS. 13, 19, 21, 23, 31, 34 AND 35).

MORGAN WYNNE, EXAMINING ATTORNEY

**CLASS 7—(Continued).**

SN 85-080,393. SPECTRUM PLASTICS CORPORATION, CUYAHOGA FALLS, OH. FILED 7-8-2010.



NO CLAIM IS MADE TO THE EXCLUSIVE RIGHT TO USE "OUTDOOR PRODUCTS", APART FROM THE MARK AS SHOWN.

THE MARK CONSISTS OF PARTIAL SUNBURST WITH THE WORDS "SPECTRUM OUTDOOR PRODUCTS" IN ALL CAPITAL LETTERS AND BLADES OF GRASS BENEATH.

FOR PARTS FOR LAWN MOWERS, NAMELY, TRIMMER HEADS, STRING TRIMMER HEADS, TAP AND GO TRIMMER HEADS, AND DECK WHEELS (U.S. CLS. 13, 19, 21, 23, 31, 34 AND 35).

EMILY CARLSEN, EXAMINING ATTORNEY

SN 85-082,045. HAAR, LINDA M, CAMBRIDGE, MA. FILED 7-11-2010.

# Built Tough in America

THE MARK CONSISTS OF STANDARD CHARACTERS WITHOUT CLAIM TO ANY PARTICULAR FONT, STYLE, SIZE, OR COLOR.

FOR GENERATORS FOR WIND TURBINES; PARTS OF WIND TURBINE MOTORS, NAMELY, COMPACT DRIVE SYSTEMS; PROPELLERS FOR WIND-POWERED ELECTRICITY GENERATORS; WIND TURBINES; WIND-POWERED ELECTRICITY GENERATORS (U.S. CLS. 13, 19, 21, 23, 31, 34 AND 35).

FIRST USE 7-1-2010; IN COMMERCE 7-1-2010.  
EDWARD FENNESSY, EXAMINING ATTORNEY

SN 85-096,756. DERRICK CORPORATION, BUFFALO, NY. FILED 7-30-2010.



THE MARK CONSISTS OF THE WORDS "STACK SIZER" WITH THE LETTERS OUTLINED WITH A SMALL SPACE AND LINES. THE WORD "STACK" IS ABOVE "SIZER", AND THE LETTER "A" IN "STACK" AND "R" IN "SIZER" ARE LINED UP; THERE ARE 5 DIAGONAL BAR SHAPES TO THE LEFT OF THE WORDS.

SEC. 2(F) AS TO "STACK SIZER".  
FOR VIBRATORY INDUSTRIAL SCREENING MACHINES FOR SEPARATING WET AND DRY MATERIALS AND PARTS THEREFOR (U.S. CLS. 13, 19, 21, 23, 31, 34 AND 35).

FIRST USE 1-0-2010; IN COMMERCE 1-0-2010.  
LAURIE KAUFMAN, EXAMINING ATTORNEY

**CLASS 7—(Continued).**

SN 85-096,772. DERRICK CORPORATION, BUFFALO, NY. FILED 7-30-2010.



OWNER OF U.S. REG. NOS. 1,361,481 AND 1,365,215. THE MARK CONSISTS OF THE WORDS "DERRICK STACK SIZER" WITH THE LETTERS OF THE WORDS "STACK SIZER" OUTLINED WITH A SMALL SPACE AND LINES; THE WORD "DERRICK" IS SMALLER AND ABOVE THE WORD "STACK"; THE WORD "STACK" IS ABOVE "SIZER", AND THE LETTER "A" IN "STACK" AND "R" IN "SIZER" ARE LINED UP; THERE ARE 5 DIAGONAL BAR SHAPES TO THE LEFT OF THE WORDS "STACK SIZER".

SEC. 2(F) AS TO "STACK SIZER". FOR VIBRATORY INDUSTRIAL SCREENING MACHINES FOR SEPARATING WET AND DRY MATERIALS AND PARTS THEREFOR (U.S. CLS. 13, 19, 21, 23, 31, 34 AND 35).

FIRST USE 1-0-2010; IN COMMERCE 1-0-2010. LAURIE KAUFMAN, EXAMINING ATTORNEY

SN 85-100,631. S&P MULLEN ENTERPRISES, INC., OLDSMAR, FL. FILED 8-5-2010.

**XIED**

THE MARK CONSISTS OF STANDARD CHARACTERS WITHOUT CLAIM TO ANY PARTICULAR FONT, STYLE, SIZE, OR COLOR.

FOR MOTORCYCLE ENGINE PARTS, NAMELY, MODULAR COMPONENT SYSTEMS CONSISTING OF FUEL INJECTION MODULES AND ELECTRONIC FUEL INJECTION MODULES; AUTOMOTIVE PARTS, NAMELY, MODULAR COMPONENT SYSTEMS CONSISTING OF FUEL INJECTION MODULES AND ELECTRONIC FUEL INJECTION MODULES; VEHICLE ENGINE PARTS, NAMELY, MODULAR COMPONENT SYSTEMS CONSISTING OF FUEL INJECTION MODULES AND ELECTRONIC FUEL INJECTION MODULES; ENHANCEMENT PARTS FOR INTERNAL COMBUSTION ENGINES, NAMELY, ELECTRONIC AIR FUEL REGULATING DEVICES THAT ADJUST THE PERFORMANCE OF AN INTERNAL COMBUSTION ENGINE AND FUEL MIXTURE ENRICHMENT DEVICES IN THE NATURE OF FUEL INJECTORS (U.S. CLS. 13, 19, 21, 23, 31, 34 AND 35).

FIRST USE 4-16-2008; IN COMMERCE 4-16-2008. KAREN SEVERSON, EXAMINING ATTORNEY

**CLASS 7—(Continued).**

SN 85-104,821. LB STORAGE SYSTEMS, INC., DBA LOAD-BANK INTERNATIONAL, ORLANDO, FL. FILED 8-11-2010.

**SAFELANE**

THE MARK CONSISTS OF STANDARD CHARACTERS WITHOUT CLAIM TO ANY PARTICULAR FONT, STYLE, SIZE, OR COLOR.

FOR HIGH DENSITY DYNAMIC STORAGE AND PRODUCT HANDLING SYSTEM IN THE NATURE OF AN UPRIGHT FRAMEWORK WHICH STORES AND CONVEYS PRODUCTS TO A DISCHARGE STATION, COMPRISED PRIMARILY OF CONVEYOR ASSEMBLIES IN THE NATURE OF TRACKS WHICH SUPPORT THE PRODUCTS THEREON AND PNEUMATICALLY-ACTUATED ROLLERS WHICH ENGAGE AND DISENGAGE WITH THE PRODUCTS SUPPORTED ON THE TRACKS TO ALLOW OR STOP MOVEMENT OF THE PRODUCTS SUPPORTED ON THE TRACKS, AND SOFTWARE AND COMPUTERIZED CONTROLS TO MOVE THE PRODUCTS THROUGH A STORAGE AREA OR WAREHOUSE (U.S. CLS. 13, 19, 21, 23, 31, 34 AND 35).

FIRST USE 11-17-2008; IN COMMERCE 11-17-2008. AMEEN IMAM, EXAMINING ATTORNEY

SN 85-129,846. H & B BAJA FILTERS, LLC, HERNDON, VA. FILED 9-15-2010.

**BAJA FILTER**

THE MARK CONSISTS OF STANDARD CHARACTERS WITHOUT CLAIM TO ANY PARTICULAR FONT, STYLE, SIZE, OR COLOR.

NO CLAIM IS MADE TO THE EXCLUSIVE RIGHT TO USE "FILTER", APART FROM THE MARK AS SHOWN. FOR FUEL FILTERS (U.S. CLS. 13, 19, 21, 23, 31, 34 AND 35).

FIRST USE 0-0-1978; IN COMMERCE 0-0-1978. LINDA M. KING, EXAMINING ATTORNEY

**CLASS 7—(Continued).**

SN 85-130,254. AGRI-TECH PRODUCERS, LLC, COLUMBIA, SC. FILED 9-15-2010.

**TORRE-TECH**

THE MARK CONSISTS OF STANDARD CHARACTERS WITHOUT CLAIM TO ANY PARTICULAR FONT, STYLE, SIZE, OR COLOR.

THE ENGLISH TRANSLATION OF "TORRE" IN THE MARK IS "TOWER".

FOR MACHINES FOR CONVEYING PLANT, WOODY, AND ANIMAL BIOMASS THROUGH A HEAT CHAMBER TO AFFECT THE PHYSICAL AND CHEMICAL CHARACTER OF SAID BIOMASS AND TO CREATE END PRODUCTS THAT CAN BE USED AS RENEWABLE ALTERNATIVES TO COAL, INTERMEDIARY FEED-STOCK, AND BIOCHARS BY ELECTRIC UTILITIES, INDUSTRIAL FIRMS AND INSTITUTIONS, OTHER BIOMASS PROCESSORS AND AGRICULTURAL PRODUCERS (U.S. CLS. 13, 19, 21, 23, 31, 34 AND 35).

MARLENE BELL, EXAMINING ATTORNEY

---

SN 85-153,280. OPTIMUM ENERGY HOLDINGS LIMITED, AUCKLAND, NEW ZEALAND, FILED 10-15-2010.

**ENVIROPLATE**

THE MARK CONSISTS OF STANDARD CHARACTERS WITHOUT CLAIM TO ANY PARTICULAR FONT, STYLE, SIZE, OR COLOR.

THE WORDING "ENVIROPLATE" HAS NO MEANING IN A FOREIGN LANGUAGE.

FOR LAND VEHICLE ENGINE PARTS, NAMELY, STAINLESS STEEL PLATES THAT CREATE HARMONIC FREQUENCIES USED FOR IMPROVING ENERGY EFFICIENCY AND REDUCTION IN HARMFUL EMISSIONS (U.S. CLS. 13, 19, 21, 23, 31, 34 AND 35).

FIRST USE 10-1-2008; IN COMMERCE 7-14-2010.

MYRIAH HABEEB, EXAMINING ATTORNEY

**CLASS 7—(Continued).**

SN 85-156,131. G.E. LEBLANC INC., SAINT-ANSELME, QUEBEC, CANADA, FILED 10-19-2010.

**MAX YIELD**

THE MARK CONSISTS OF STANDARD CHARACTERS WITHOUT CLAIM TO ANY PARTICULAR FONT, STYLE, SIZE, OR COLOR.

PRIORITY CLAIMED UNDER SEC. 44(D) ON CANADA APPLICATION NO. 1480110, FILED 5-7-2010, REG. NO. TMA791,778, DATED 2-28-2011, EXPIRES 2-28-2026.

FOR BAND SAW BLADES, CIRCULAR BLADES FOR USE WITH POWER SAWS; SKIMMING BLADES FOR USE WITH POWER TOOLS; MACHINE PARTS, NAMELY, KNIVES USED IN AUTOMATIC MACHINES IN THE NATURE OF MEAT SLICERS AND GRINDERS (U.S. CLS. 13, 19, 21, 23, 31, 34 AND 35).

JORDAN BAKER, EXAMINING ATTORNEY

---

SN 85-157,774. H. BARBER & SONS, INC., NAUGATUCK, CT. FILED 10-21-2010.

**BEACH SANITIZER**

THE MARK CONSISTS OF STANDARD CHARACTERS WITHOUT CLAIM TO ANY PARTICULAR FONT, STYLE, SIZE, OR COLOR.

NO CLAIM IS MADE TO THE EXCLUSIVE RIGHT TO USE "BEACH", APART FROM THE MARK AS SHOWN.

FOR A TRACTOR TOWED MACHINE THAT REMOVES SEAWEED, SHELLS, STONES AND OTHER UNWANTED DEBRIS FROM SANDY SURFACES (U.S. CLS. 13, 19, 21, 23, 31, 34 AND 35).

FIRST USE 10-29-2010; IN COMMERCE 10-29-2010.

JEFF DEFORD, EXAMINING ATTORNEY

---

SN 85-161,559. NATIONAL TANK COMPANY, HOUSTON, TX. FILED 10-26-2010.

**MOZLEY**

THE MARK CONSISTS OF STANDARD CHARACTERS WITHOUT CLAIM TO ANY PARTICULAR FONT, STYLE, SIZE, OR COLOR.

SEC. 2(F).

FOR SEPARATION MACHINE USED TO REMOVE SAND AND OTHER SOLID PARTICLES FROM MULTI-PHASE OIL AND GAS WELLSTREAMS; SEPARATION MACHINE USED TO REMOVE SAND AND OTHER SOLID PARTICLES IN MINING AND MINERALS PROCESSING (U.S. CLS. 13, 19, 21, 23, 31, 34 AND 35).

FIRST USE 7-3-1979; IN COMMERCE 7-3-1979.

MELISSA VALLILLO, EXAMINING ATTORNEY



**CLASS 7—(Continued).**

SN 85-165,058. NATEL ENERGY, INC., ALAMEDA, CA.  
FILED 10-29-2010.

**ECOSMARTHYDRO**

THE MARK CONSISTS OF STANDARD CHARACTERS WITHOUT CLAIM TO ANY PARTICULAR FONT, STYLE, SIZE, OR COLOR.

FOR HYDROPOWER SYSTEMS FOR GENERATING HYDRO-ELECTRIC POWER CONSISTING OF AN ENGINE, TURBINE, GENERATOR, SWITCHGEAR, AND CONTROLS (U.S. CLS. 13, 19, 21, 23, 31, 34 AND 35).

DANIEL CAPSHAW, EXAMINING ATTORNEY

SN 85-178,547. SOUCEK, PAUL, GILBERT, AZ. FILED 11-17-2010.

**PUL-N-PAK**

THE MARK CONSISTS OF STANDARD CHARACTERS WITHOUT CLAIM TO ANY PARTICULAR FONT, STYLE, SIZE, OR COLOR.

FOR PACKAGING MACHINE AND PARTS THEREOF, NAMELY, A DISPENSING SYSTEM COMPRISED OF A HOLDER FOR THE PAPER WITH A PASSIVE CUTTING MECHANISM FOR USE WITH A CRUMPLED KRAFT-PAPER BASED VOID FILL MATERIAL (U.S. CLS. 13, 19, 21, 23, 31, 34 AND 35).

KIMBERLY PERRY, EXAMINING ATTORNEY

SN 85-181,425. PRESTOLITE WIRE LLC, SOUTHFIELD, MI.  
FILED 11-19-2010.

**FIRE**  
  
**STORM**

THE MARK CONSISTS OF THE TERMS "FIRE" AND "STORM" AND HAVING A STYLIZED LIGHTNING DESIGN BETWEEN THE TERMS.

FOR MOTOR VEHICLE IGNITION PARTS FOR INTERNAL COMBUSTION ENGINES, NAMELY, IGNITION BOXES (U.S. CLS. 13, 19, 21, 23, 31, 34 AND 35).

MARK SHINER, EXAMINING ATTORNEY

**CLASS 7—(Continued).**

SN 85-181,431. ATCO EQUIPMENT INC., KNOXVILLE, TN.  
FILED 11-19-2010.

**BLUE DIAMOND**

THE MARK CONSISTS OF STANDARD CHARACTERS WITHOUT CLAIM TO ANY PARTICULAR FONT, STYLE, SIZE, OR COLOR.

FOR ATTACHMENTS FOR TRACTORS, WHEEL LOADERS, TELEHANDLERS, BACKHOES, UTILITY LOADERS AND EXCAVATORS, NAMELY, HYDRAULIC HAMMERS, ELECTRIC ROTARY BROOMS, EARTH AUGERS, GRAPPLES, STUMP BUCKETS, BUCKETS, HYDRAULIC TOOLS IN THE NATURE OF THUMBS, POWER-OPERATED STUMP GRINDERS, BRUSH CUTTING MACHINES AND FORKS (U.S. CLS. 13, 19, 21, 23, 31, 34 AND 35).

FIRST USE 0-0-1997; IN COMMERCE 0-0-1997.

KATHERINE CHANG, EXAMINING ATTORNEY

SN 85-196,157. LANKOTA GROUP, INC., HURON, SD.  
FILED 12-13-2010.

**Stalk Stomper**

THE MARK CONSISTS OF STANDARD CHARACTERS WITHOUT CLAIM TO ANY PARTICULAR FONT, STYLE, SIZE, OR COLOR.

NO CLAIM IS MADE TO THE EXCLUSIVE RIGHT TO USE "STALK", APART FROM THE MARK AS SHOWN.

FOR AGRICULTURAL MACHINERY AND ATTACHMENTS THEREFOR, NAMELY, ROTARY MOWERS, BOX SCRAPERS, AND THREE-POINT ATTACHMENTS (U.S. CLS. 13, 19, 21, 23, 31, 34 AND 35).

FIRST USE 1-1-2003; IN COMMERCE 1-1-2003.

MEGHAN REINHART, EXAMINING ATTORNEY

SN 85-197,467. SYNVENTIVE MOLDING SOLUTIONS, INC.,  
PEABODY, MA. FILED 12-14-2010.

**SYNFLOW**

THE MARK CONSISTS OF STANDARD CHARACTERS WITHOUT CLAIM TO ANY PARTICULAR FONT, STYLE, SIZE, OR COLOR.

FOR INJECTION MOLDING MACHINES FEATURING VALVE SYSTEMS COMPRISED OF VALVE PINS, HYDRAULIC ACTUATORS AND ELECTRICAL AND ELECTRONIC CONTROLS FOR CONTROLLING OPENING AND CLOSING SPEEDS, POSITIONS AND FLUID FLOW RATES ASSOCIATED WITH VALVE PINS (U.S. CLS. 13, 19, 21, 23, 31, 34 AND 35).

SIMON TENG, EXAMINING ATTORNEY

**CLASS 7—(Continued).**

SN 85-198,582. INNOVATIVE SALES AND MACHINE SERVICES, LLC, MILFORD, CT. FILED 12-15-2010.

# Swistek

THE MARK CONSISTS OF STANDARD CHARACTERS WITHOUT CLAIM TO ANY PARTICULAR FONT, STYLE, SIZE, OR COLOR.

FOR COMPUTER CONTROLLED LATHES; MILLING MACHINES (U.S. CLS. 13, 19, 21, 23, 31, 34 AND 35).  
FIRST USE 8-19-2009; IN COMMERCE 12-19-2009.  
RICHARD WHITE, EXAMINING ATTORNEY

---

SN 85-199,517. SHING LING SEWING MACHINE CO., LTD., TAIPEI HSIEN, TAIWAN, FILED 12-16-2010.

# accor

THE MARK CONSISTS OF THE WORD "ACCOR" IN STYLIZED FONT.

FOR SEWING MACHINES; INDUSTRIAL SEWING MACHINES; INTERLOCK SEWING MACHINE; INTERLOCK FLAT SEAMING SEWING MACHINES; CHAIN STITCH SEWING MACHINES; ELECTRICALLY POWERED KNITTING MACHINES; ELECTRICALLY POWERED LACE AND ELASTIC BAND ATTACHING MACHINES; PARTS OF SEWING MACHINES (U.S. CLS. 13, 19, 21, 23, 31, 34 AND 35).

FIRST USE 10-18-2010; IN COMMERCE 10-18-2010.  
DAVID HOFFMAN, EXAMINING ATTORNEY

---

SN 85-203,705. ALL-FLO PUMP COMPANY, LTD., MENTOR, OH. FILED 12-22-2010.

# All-Pür

THE MARK CONSISTS OF TYPED LETTERS "ALL-PUR" WITH THE TILDE SYMBOL (˜) OVER THE LETTER "U".

FOR AIR-OPERATED DIAPHRAGM PUMPS MANUFACTURED FROM STAINLESS STEEL FOR USE IN SANITARY FLUID TRANSFER APPLICATIONS (U.S. CLS. 13, 19, 21, 23, 31, 34 AND 35).

FIRST USE 12-15-2008; IN COMMERCE 12-15-2008.  
LAURIE KAUFMAN, EXAMINING ATTORNEY

**CLASS 7—(Continued).**

SN 85-203,721. ALL-FLO PUMP COMPANY, LTD., MENTOR, OH. FILED 12-22-2010.

# All-Pure

THE MARK CONSISTS OF STANDARD CHARACTERS WITHOUT CLAIM TO ANY PARTICULAR FONT, STYLE, SIZE, OR COLOR.

FOR AIR-OPERATED DIAPHRAGM PUMPS MANUFACTURED FROM STAINLESS STEEL FOR USE IN SANITARY FLUID TRANSFER APPLICATIONS (U.S. CLS. 13, 19, 21, 23, 31, 34 AND 35).

FIRST USE 12-15-2008; IN COMMERCE 12-15-2008.  
LAURIE KAUFMAN, EXAMINING ATTORNEY

---

SN 85-204,856. MOLD-MASTERS (2007) LIMITED, GEORGETOWN, ONTARIO, CANADA, FILED 12-23-2010.

# SPRINT

THE MARK CONSISTS OF STANDARD CHARACTERS WITHOUT CLAIM TO ANY PARTICULAR FONT, STYLE, SIZE, OR COLOR.

FOR PLASTICS INJECTION MOLDING EQUIPMENT, NAMELY, HOT RUNNER SYSTEMS, COMPRISED OF NOZZLES, MANIFOLDS, BUSHINGS, HOT VALVES, GATES, CONTROLLERS, INJECTION MOLDING SOLUTIONS AND OPERATION MANUALS SOLD IN CONNECTION THEREWITH (U.S. CLS. 13, 19, 21, 23, 31, 34 AND 35).

FIRST USE 6-23-2009; IN COMMERCE 6-23-2009.  
JOHN E. MICHOS, EXAMINING ATTORNEY

**CLASS 7—(Continued).**

SN 85-205,663. LAMPERTIUS, JOHN ANDREW, DBA PUMPS & CONTROLS, LLC, FARMINGTON HILLS, MI. FILED 12-26-2010.

## Select Clients, Superior Service

THE MARK CONSISTS OF STANDARD CHARACTERS WITHOUT CLAIM TO ANY PARTICULAR FONT, STYLE, SIZE, OR COLOR.

FOR AC VARIABLE FREQUENCY DRIVES THAT ARE USED TO CONTROL SMALL AND MEDIUM-SIZED MOTORS IN APPLICATIONS SUCH AS MANUFACTURING PROCESSES, HVAC AND PUMPS; CENTRIFUGAL PUMPS; COMPONENTS FOR MACHINES AND MACHINE TOOLS, GRINDING MACHINES, MATERIAL HANDLING MACHINES, FOOD PROCESSING MACHINES, CHEMISTRY PROCESSING MACHINES AND TEXTILE INDUSTRY MACHINES, NAMELY, SAND, CHEMICAL AND REVERSE OSMOSIS FILTERS; COMPRESSED AIR PUMPS; ELECTRIC PUMPS; ELECTRIC PUMPS FOR INDUSTRIAL AND COMMERCIAL USE; ELECTRICAL WATER PUMPS FOR INDUSTRIAL AND COMMERCIAL USE; FLUID POWER COMPONENT KIT FOR MACHINE CONTROL COMPRISING PUMPS AND VALVES; HIGH-PRESSURE PUMPS FOR WASHING APPLIANCES AND INSTALLATIONS; HYDRAULIC PUMPS; HYDRAULIC PUMPS AND MOTORS FOR HYDROSTATIC SYSTEMS, COMPRISED OF PUMPS, MOTORS, VALVES, SWITCHES, SENSORS AND ELECTRONIC CONTROLS, FOR HYDRAULIC DRIVES AND FORCE TRANSMISSION IN MACHINES, MACHINE TOOLS, GRINDING AND FOOD PROCESSING MACHINES AND IN OFF-ROAD-VEHICLES; LUBRICATING PUMPS; MACERATOR PUMPS; MULTI-PHASE SCREW PUMPS; OIL DRAIN PUMPS; PARTS OF OIL-FIELD WELLHEAD MACHINES, NAMELY, GATE VALVES, BALL VALVES, CHECK VALVES, PLUG VALVES, GLOBE VALVES, CHOKE AND MANIFOLD INDUSTRIAL PUMPS, PUMP AND VALVE PARTS, PIPE FITTINGS AND FLANGES; PNEUMATIC PUMPS; POND AND WATER GARDEN AERATION SYSTEMS COMPRISING WATER PUMPS, AIR COMPRESSORS, AIR BLOWERS AND A FINNED WHEEL FOR PRESSURIZING AND AERATING PONDS AND AQUARIUMS; POSITIVE DISPLACEMENT PUMPS; PUMP CONTROL VALVES; PUMP DIAPHRAGMS; PUMP IMPELLERS; PUMPS FOR THE BEVERAGE INDUSTRY; PUMPS AND COMPRESSORS AS PARTS OF MACHINES, MOTORS AND ENGINES; PUMPS AS PARTS OF MACHINES, MOTORS AND ENGINES; PUMPS FOR COOLING ENGINES; PUMPS FOR MACHINES; REFRIGERANT RECOVERY PUMPS; REVERSE OSMOSIS PUMPS; ROTARY LOBE PUMPS; ROTARY PUMPS; SCREW PUMPS; SEWAGE PUMPS; SHAFT BEARINGS FOR VACUUM PUMPS; SHAFTS FOR PUMPS; SILT PUMPS; SLUDGE PUMPS; SPRAY PAINT SYSTEMS COMPRISED OF PUMPS, PUMP CONTROLLERS, NOZZLES, TUBING AND VALVES; SUBMERSIBLE PUMPS; SUCTION PUMPS; SUMP PUMPS; VACUUM PUMPS; VACUUM PUMPS; VALVES FOR PUMPS; VARIABLE SPEED DRIVES FOR USE WITH FLUID PUMPING SYSTEMS; VERTICAL TURBINE PUMPS; WATER AERATION SYSTEMS COMPRISING WATER PUMPS, AIR COMPRESSORS AND AIR BLOWERS; WATER PUMPS FOR USE IN MOTORS AND ENGINES; WATER PUMPS FOR INDUSTRIAL AND COMMERCIAL USE; WATER TREATMENT EQUIPMENT, NAMELY, PUMPS FOR USE IN IRRIGATION SYSTEMS; WINDMILL PUMPS (U.S. CLS. 13, 19, 21, 23, 31, 34 AND 35).  
VERNA BETH RIRIE, EXAMINING ATTORNEY

**CLASS 7—(Continued).**

SN 85-206,330. WHIRLPOOL PROPERTIES, INC., ST. JOSEPH, MI. FILED 12-28-2010.

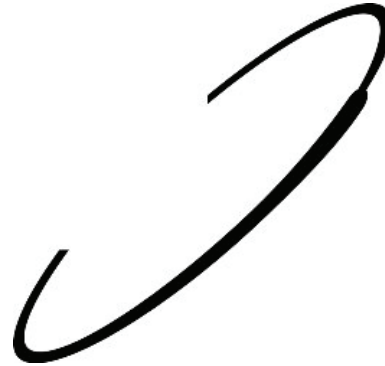

OWNER OF U.S. REG. NOS. 1,832,430, 3,463,701 AND OTHERS.

THE MARK CONSISTS OF A RING.

FOR CLOTHES WASHING MACHINES; DISH WASHING MACHINES; GARBAGE DISPOSALS; TRASH COMPACTORS (U.S. CLS. 13, 19, 21, 23, 31, 34 AND 35).

HELENE LIWINSKI, EXAMINING ATTORNEY

SN 85-206,340. WHIRLPOOL PROPERTIES, INC., ST. JOSEPH, MI. FILED 12-28-2010.



OWNER OF U.S. REG. NOS. 1,137,316, 2,799,094 AND OTHERS.

THE MARK CONSISTS OF A SWIRL.

FOR CLOTHES WASHING MACHINES; DISH WASHING MACHINES; GARBAGE DISPOSALS; TRASH COMPACTORS (U.S. CLS. 13, 19, 21, 23, 31, 34 AND 35).

HELENE LIWINSKI, EXAMINING ATTORNEY

**CLASS 7—(Continued).**

SN 85-206,661. ALCO INDUSTRIES, INC., NORRISTOWN, PA. FILED 12-28-2010.



THE MARK CONSISTS OF THE WORDS "LOOK FOR THE FLAT TOP!" IN A BALLOON AND A BEARING ABOVE THE BALLOON.

FOR MACHINE PARTS, NAMELY, BEARINGS, BALL BEARINGS, WHEEL BEARINGS, ROLLER BEARINGS, BUSHINGS, BALL BUSHINGS, BEARING HOUSINGS, PILLOW BLOCKS, SPLIT BLOCKS, FLANGE BLOCKS, SOLID STEEL BLOCKS, HYDRAULIC ADAPTERS, REMOVAL SLEEVES, BEARING SEALS AND SEALING RINGS; AND PARTS AND FITTINGS FOR ALL THE AFOREMENTIONED MACHINE PARTS (U.S. CLS. 13, 19, 21, 23, 31, 34 AND 35).

KIM SAITO, EXAMINING ATTORNEY

**CLASS 7—(Continued).**

SN 85-208,447. LOFLIN, CHRISTIE, LEXINGTON, NC. FILED 12-31-2010.

**GATOR ATTACHMENTS, LLC**

THE MARK CONSISTS OF STANDARD CHARACTERS WITHOUT CLAIM TO ANY PARTICULAR FONT, STYLE, SIZE, OR COLOR.

NO CLAIM IS MADE TO THE EXCLUSIVE RIGHT TO USE "ATTACHMENTS" AND "LLC", APART FROM THE MARK AS SHOWN.

FOR ATTACHMENTS FOR FARM EQUIPMENT, WALK BEHINDS, MINI EXCAVATORS, AND SKID STEERS, NAMELY, GRAPPLE RAKES, GRAPPLE BUCKETS, STUMP GRAPPLES, TOOTH BARS, TOOTH BUCKETS, SMOOTH BUCKETS, TREE BOOMS, STUMP BUCKETS, QUICK HITCHES, ROOT GRAPPLES, BUCKETS, BACKHOES, 3 POINT HOOKS AND WOOD SPLITTERS (U.S. CLS. 13, 19, 21, 23, 31, 34 AND 35).

FIRST USE 5-1-2009; IN COMMERCE 5-1-2009.

KATINA MISTER, EXAMINING ATTORNEY

SN 85-206,669. ALCO INDUSTRIES, INC., NORRISTOWN, PA. FILED 12-28-2010.

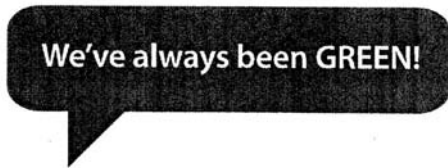

THE MARK CONSISTS OF THE WORDS "WE'VE ALWAYS BEEN GREEN!" IN A BALLOON.

FOR MACHINE PARTS, NAMELY, BEARINGS, BALL BEARINGS, WHEEL BEARINGS, ROLLER BEARINGS, BUSHINGS, BALL BUSHINGS, BEARING HOUSINGS, PILLOW BLOCKS, SPLIT BLOCKS, FLANGE BLOCKS, SOLID STEEL BLOCKS, HYDRAULIC ADAPTERS, REMOVAL SLEEVES, BEARING SEALS AND SEALING RINGS; AND PARTS AND FITTINGS FOR ALL THE AFOREMENTIONED MACHINE PARTS (U.S. CLS. 13, 19, 21, 23, 31, 34 AND 35).

KIM SAITO, EXAMINING ATTORNEY

SN 85-209,330. ALCO INDUSTRIES, INC., NORRISTOWN, PA. FILED 1-3-2011.



NO CLAIM IS MADE TO THE EXCLUSIVE RIGHT TO USE "BEARING PRODUCTS", APART FROM THE MARK AS SHOWN.

THE MARK CONSISTS OF THE WORD "MIETHER" ABOVE THE WORDS "BEARING PRODUCTS" AND A RAINBOW OVER THE SMALL "I" EXTENDING FROM THE "M" TO THE FIRST "E".

FOR MACHINE PARTS, NAMELY, BEARINGS, BALL BEARINGS, WHEEL BEARINGS, ROLLER BEARINGS, BUSHINGS, BALL BUSHINGS, BEARING HOUSINGS, PILLOW BLOCKS, SPLIT BLOCKS, FLANGE BLOCKS, SOLID STEEL BLOCKS, HYDRAULIC ADAPTERS, REMOVAL SLEEVES, BEARING SEALS AND SEALING RINGS; AND PARTS AND FITTINGS FOR ALL THE AFOREMENTIONED MACHINE PARTS (U.S. CLS. 13, 19, 21, 23, 31, 34 AND 35).

FIRST USE 2-24-2011; IN COMMERCE 2-24-2011.

KIM SAITO, EXAMINING ATTORNEY



**CLASS 7—(Continued).**

SN 85-209,667. VITA-MIX CORPORATION, OLMSTED FALLS, OH. FILED 1-4-2011.

# 6000

THE MARK CONSISTS OF STANDARD CHARACTERS WITHOUT CLAIM TO ANY PARTICULAR FONT, STYLE, SIZE, OR COLOR.

FOR ELECTRIC FOOD BLENDERS (U.S. CLS. 13, 19, 21, 23, 31, 34 AND 35).

SUSAN RICHARDS, EXAMINING ATTORNEY

---

SN 85-210,862. ATI STELLRAM SA, FORMERLY STELLRAM SA, GLAND, SWITZERLAND, FILED 1-5-2011.

# UNIDRILL

THE MARK CONSISTS OF STANDARD CHARACTERS WITHOUT CLAIM TO ANY PARTICULAR FONT, STYLE, SIZE, OR COLOR.

OWNER OF U.S. REG. NO. 1,596,095.  
FOR ROTARY CUTTING TOOLS FOR USE IN MACHINES (U.S. CLS. 13, 19, 21, 23, 31, 34 AND 35).  
FIRST USE 2-0-2000; IN COMMERCE 2-0-2000.  
WILLIAM ROSSMAN, EXAMINING ATTORNEY

---

SN 85-211,969. DYNASEP LLC, NEWARK, DE. FILED 1-6-2011.

# ALGAEBINE

THE MARK CONSISTS OF STANDARD CHARACTERS WITHOUT CLAIM TO ANY PARTICULAR FONT, STYLE, SIZE, OR COLOR.

THE WORDING "ALGAEBINE" HAS NO MEANING IN A FOREIGN LANGUAGE.

FOR HARVESTING MACHINE THAT CONVERTS ALGAE CULTURE INTO PRODUCTS (U.S. CLS. 13, 19, 21, 23, 31, 34 AND 35).

LAURA KOVALSKY, EXAMINING ATTORNEY

**CLASS 7—(Continued).**

SN 85-212,578. AMERICA'S BEST COIN LAUNDRY, INC., OAKLAND, MI. FILED 1-7-2011.



NO CLAIM IS MADE TO THE EXCLUSIVE RIGHT TO USE "AMERICA'S BEST COIN LAUNDRY", APART FROM THE MARK AS SHOWN.

THE MARK CONSISTS OF A DESIGN OF A WASHING MACHINE WITH A FACE DEPICTED ON IT, WITH THE WORDING "AMERICA'S BEST COIN LAUNDRY" TO THE RIGHT OF THE DESIGN WITH CURVED LINES OVER THE WORDING AND FIVE STARS UNDERNEATH THE WORDING.

FOR LAUNDRY CENTERS, NAMELY, A CLOTHES WASHER COMBINED WITH A CLOTHES DRYER (U.S. CLS. 13, 19, 21, 23, 31, 34 AND 35).

JANET LEE, EXAMINING ATTORNEY

---

SN 85-213,189. WORLDWIDE ELECTRIC CORPORATION, PITTSFORD, NY. FILED 1-7-2011.

# Competitor Series

THE MARK CONSISTS OF STANDARD CHARACTERS WITHOUT CLAIM TO ANY PARTICULAR FONT, STYLE, SIZE, OR COLOR.

NO CLAIM IS MADE TO THE EXCLUSIVE RIGHT TO USE "SERIES", APART FROM THE MARK AS SHOWN.

FOR ELECTRIC MOTORS, NOT FOR LAND VEHICLES (U.S. CLS. 13, 19, 21, 23, 31, 34 AND 35).

KRISTINA MORRIS, EXAMINING ATTORNEY

---

SN 85-213,279. ORECK HOLDINGS, LLC, NASHVILLE, TN. FILED 1-7-2011.

# ORECK HOTEL VACUUM

THE MARK CONSISTS OF STANDARD CHARACTERS WITHOUT CLAIM TO ANY PARTICULAR FONT, STYLE, SIZE, OR COLOR.

OWNER OF U.S. REG. NOS. 1,454,954, 2,734,838 AND OTHERS.

NO CLAIM IS MADE TO THE EXCLUSIVE RIGHT TO USE "HOTEL VACUUM", APART FROM THE MARK AS SHOWN.

FOR VACUUM CLEANERS (U.S. CLS. 13, 19, 21, 23, 31, 34 AND 35).

FIRST USE 8-31-2007; IN COMMERCE 8-31-2007.

DAVID TAYLOR, EXAMINING ATTORNEY

**CLASS 7—(Continued).**

SN 85-213,368. SRL NANO CORPORATION, CERRITOS, CA. FILED 1-7-2011.

**SRL NANO CORPORATION**

THE MARK CONSISTS OF STANDARD CHARACTERS WITHOUT CLAIM TO ANY PARTICULAR FONT, STYLE, SIZE, OR COLOR.

NO CLAIM IS MADE TO THE EXCLUSIVE RIGHT TO USE "CORPORATION", APART FROM THE MARK AS SHOWN.

FOR CUTTING MACHINES (U.S. CLS. 13, 19, 21, 23, 31, 34 AND 35).

RONALD DELGIZZI, EXAMINING ATTORNEY

---

SN 85-215,376. HARRIMAN, THOMAS, VENICE, FL. FILED 1-11-2011.



NO CLAIM IS MADE TO THE EXCLUSIVE RIGHT TO USE "SOLAR POOL PUMPS", APART FROM THE MARK AS SHOWN.

THE STIPPLING IS FOR SHADING PURPOSES ONLY.

THE MARK CONSISTS OF A SWIRL WITH THE STYLIZED TEXT "SUNFIRE SOLAR POOL PUMPS".

FOR CIRCULATION POOL PUMPS THAT ARE POWERED BY ELECTRICITY GENERATED FROM SOLAR PANELS (U.S. CLS. 13, 19, 21, 23, 31, 34 AND 35).

FIRST USE 8-15-2010; IN COMMERCE 11-1-2010.

HANNO RITTNER, EXAMINING ATTORNEY

---

SN 85-215,580. NORDSON CORPORATION, WESTLAKE, OH. FILED 1-12-2011.

**NexJet**

THE MARK CONSISTS OF STANDARD CHARACTERS WITHOUT CLAIM TO ANY PARTICULAR FONT, STYLE, SIZE, OR COLOR.

FOR VALVES BEING PARTS OF MACHINES FOR DISPENSING AND JETTING LIQUID AND VISCOUS MATERIALS USED IN THE ELECTRONICS INDUSTRY (U.S. CLS. 13, 19, 21, 23, 31, 34 AND 35).

LINDA POWELL, EXAMINING ATTORNEY

**CLASS 7—(Continued).**

SN 85-216,582. HY CITE CORPORATION, MADISON, WI. FILED 1-13-2011.

**MAXTRACTOR**

THE MARK CONSISTS OF STANDARD CHARACTERS WITHOUT CLAIM TO ANY PARTICULAR FONT, STYLE, SIZE, OR COLOR.

FOR ELECTRIC JUICERS (U.S. CLS. 13, 19, 21, 23, 31, 34 AND 35).

JANICE L. MCMORROW, EXAMINING ATTORNEY

---

SN 85-232,966. KABUSHIKI KAISHA TOSHIBA, AKA TOSHIBA CORPORATION, TOKYO, JAPAN, FILED 2-3-2011.

**AT RUNNER**

THE MARK CONSISTS OF STANDARD CHARACTERS WITHOUT CLAIM TO ANY PARTICULAR FONT, STYLE, SIZE, OR COLOR.

NO CLAIM IS MADE TO THE EXCLUSIVE RIGHT TO USE "RUNNER", APART FROM THE MARK AS SHOWN.

FOR HYDRAULIC TURBINES AND COMPONENTS FOR HYDRAULIC TURBINES, NAMELY, TURBINE RUNNERS; PUMP-TURBINES AND COMPONENTS FOR PUMP-TURBINES, NAMELY, PUMP-TURBINE RUNNERS (U.S. CLS. 13, 19, 21, 23, 31, 34 AND 35).

MATTHEW MCDOWELL, EXAMINING ATTORNEY

---

SN 85-232,988. KABUSHIKI KAISHA TOSHIBA, AKA TOSHIBA CORPORATION, TOKYO, JAPAN, FILED 2-3-2011.

**T-BLADE**

THE MARK CONSISTS OF STANDARD CHARACTERS WITHOUT CLAIM TO ANY PARTICULAR FONT, STYLE, SIZE, OR COLOR.

FOR HYDRAULIC TURBINES AND COMPONENTS FOR HYDRAULIC TURBINES, NAMELY, TURBINE RUNNERS; PUMP-TURBINES AND COMPONENTS FOR PUMP-TURBINES, NAMELY, PUMP-TURBINE RUNNERS (U.S. CLS. 13, 19, 21, 23, 31, 34 AND 35).

MATTHEW MCDOWELL, EXAMINING ATTORNEY

**CLASS 7—(Continued).**

SN 85-242,551. ALCO INDUSTRIES, INC., NORRISTOWN, PA. FILED 2-15-2011.

**MMW**

THE MARK CONSISTS OF STANDARD CHARACTERS WITHOUT CLAIM TO ANY PARTICULAR FONT, STYLE, SIZE, OR COLOR.

FOR MACHINE PARTS, NAMELY, BEARINGS, BALL BEARINGS, WHEEL BEARINGS, ROLLER BEARINGS, BUSHINGS, BALL BUSHINGS, BEARING HOUSINGS, PILLOW BLOCKS, SPLIT BLOCKS, FLANGE BLOCKS, SOLID STEEL BLOCKS, HYDRAULIC ADAPTERS, REMOVAL SLEEVES, BEARING SEALS AND SEALING RINGS; AND PARTS AND FITTINGS FOR ALL THE AFOREMENTIONED MACHINE PARTS (U.S. CLS. 13, 19, 21, 23, 31, 34 AND 35).

KIM SAITO, EXAMINING ATTORNEY

**CLASS 7—(Continued).**

SN 85-242,632. ALCO INDUSTRIES, INC., NORRISTOWN, PA. FILED 2-15-2011.

**MBP**

THE MARK CONSISTS OF STANDARD CHARACTERS WITHOUT CLAIM TO ANY PARTICULAR FONT, STYLE, SIZE, OR COLOR.

FOR MACHINE PARTS, NAMELY, BEARINGS, BALL BEARINGS, WHEEL BEARINGS, ROLLER BEARINGS, BUSHINGS, BALL BUSHINGS, BEARING HOUSINGS, PILLOW BLOCKS, SPLIT BLOCKS, FLANGE BLOCKS, SOLID STEEL BLOCKS, HYDRAULIC ADAPTERS, REMOVAL SLEEVES, BEARING SEALS AND SEALING RINGS; AND PARTS AND FITTINGS FOR ALL THE AFOREMENTIONED MACHINE PARTS (U.S. CLS. 13, 19, 21, 23, 31, 34 AND 35).

FIRST USE 0-0-1968; IN COMMERCE 0-0-1968.

KIM SAITO, EXAMINING ATTORNEY

SN 85-242,574. ALCO INDUSTRIES, INC., NORRISTOWN, PA. FILED 2-15-2011.

**MIETHER MACHINE WORKS**

THE MARK CONSISTS OF STANDARD CHARACTERS WITHOUT CLAIM TO ANY PARTICULAR FONT, STYLE, SIZE, OR COLOR.

NO CLAIM IS MADE TO THE EXCLUSIVE RIGHT TO USE "MACHINE WORKS", APART FROM THE MARK AS SHOWN.

FOR MACHINE PARTS, NAMELY, BEARINGS, BALL BEARINGS, WHEEL BEARINGS, ROLLER BEARINGS, BUSHINGS, BALL BUSHINGS, BEARING HOUSINGS, PILLOW BLOCKS, SPLIT BLOCKS, FLANGE BLOCKS, SOLID STEEL BLOCKS, HYDRAULIC ADAPTERS, REMOVAL SLEEVES, BEARING SEALS AND SEALING RINGS; AND PARTS AND FITTINGS FOR ALL THE AFOREMENTIONED MACHINE PARTS (U.S. CLS. 13, 19, 21, 23, 31, 34 AND 35).

FIRST USE 0-0-1968; IN COMMERCE 0-0-1968.

KIM SAITO, EXAMINING ATTORNEY

SN 85-242,642. ALCO INDUSTRIES, INC., NORRISTOWN, PA. FILED 2-15-2011.

**MIETHER**

THE MARK CONSISTS OF STANDARD CHARACTERS WITHOUT CLAIM TO ANY PARTICULAR FONT, STYLE, SIZE, OR COLOR.

FOR MACHINE PARTS, NAMELY, BEARINGS, BALL BEARINGS, WHEEL BEARINGS, ROLLER BEARINGS, BUSHINGS, BALL BUSHINGS, BEARING HOUSINGS, PILLOW BLOCKS, SPLIT BLOCKS, FLANGE BLOCKS, SOLID STEEL BLOCKS, HYDRAULIC ADAPTERS, REMOVAL SLEEVES, BEARING SEALS AND SEALING RINGS; AND PARTS AND FITTINGS FOR ALL THE AFOREMENTIONED MACHINE PARTS (U.S. CLS. 13, 19, 21, 23, 31, 34 AND 35).

FIRST USE 0-0-1968; IN COMMERCE 0-0-1968.

KIM SAITO, EXAMINING ATTORNEY

**CLASS 8—HAND TOOLS**

SN 77-501,756. ALTENLOH, BRINCK & CO. GMBH & CO. KG, 58256 ENNEPETAL, FED REP GERMANY, FILED 6-18-2008.



PRIORITY CLAIMED UNDER SEC. 44(D) ON FED REP GERMANY APPLICATION NO. 307822125, FILED 12-18-2007, REG. NO. 30782212, DATED 5-5-2008, EXPIRES 12-31-2017.

OWNER OF U.S. REG. NO. 2,339,011.

THE MARK CONSISTS OF THE WORD "SPAX" WITH A DESIGN "X".

FOR HAND TOOLS, NAMELY, SCREWDRIVERS, DRILLS, WRENCHES, NUT DRIVERS, MILLING CUTTERS, COUNTERSINKS, ALL NOT FOR USE IN RESCUE WORK AND FIGHTING FIRES; INSERTS AND INSERT TOOLS FOR HAND-OPERATED TOOLS, NAMELY, TOOL BITS, BITS FOR SCREWDRIVERS, BITS FOR DRILLS, ALL NOT FOR USE IN RESCUE WORK AND FIGHTING FIRES; DRIVING AID FOR ROOF TOP INSULATION, NOT FOR USE IN RESCUE WORK AND FIGHTING FIRES; CASES ADAPTED FOR THE AFORESAID GOODS, NOT FOR USE IN RESCUE WORK AND FIGHTING FIRES (U.S. CLS. 23, 28 AND 44).

SANJEEV VOHRA, EXAMINING ATTORNEY

SN 79-089,199. AOKI HAMONO SEISAKUSHO CO., LTD., OSAKA 590-0941, JAPAN, FILED 9-29-2010.

堺  
菊  
孝

OWNER OF INTERNATIONAL REGISTRATION 1056255 DATED 9-29-2010, EXPIRES 9-29-2020.

THE NAME(S), PORTRAIT(S), AND/OR SIGNATURE(S) SHOWN IN THE MARK DOES NOT IDENTIFY A PARTICULAR LIVING INDIVIDUAL.

THE MARK CONSISTS OF CHINESE CHARACTERS.

THE transliteration of the non-Latin characters in the mark is: SAKAIKUTAKA.

FOR KNIVES, NAMELY, CHEF KNIVES; KITCHEN KNIVES; BUTCHER KNIVES; PARING KNIVES; THIN-BLADED KITCHEN KNIVES; SCALING KNIVES; FISH SLICING KITCHEN KNIVES; JAPANESE CHOPPING KITCHEN KNIVES; HAND-OPERATED MEAT CHOPPERS, NAMELY, HAND TOOLS; HAND-OPERATED MINCING KNIVES, NAMELY, HAND TOOLS; CLEAVERS; VEGETABLE KNIVES; TABLE KNIVES; WHET-STONES (SHARPENING STONES) (U.S. CLS. 23, 28 AND 44).

FLORENTINA BLANDU, EXAMINING ATTORNEY

**CLASS 8—(Continued).**

SN 85-054,314. B.H.P. INDUSTRIES CO., LTD., SUITA-SHI, OSAKA, JAPAN, FILED 6-3-2010.



NO CLAIM IS MADE TO THE EXCLUSIVE RIGHT TO USE "BLACK TITANIUM", APART FROM THE MARK AS SHOWN.

THE MARK CONSISTS OF STYLIZED LETTERS "TB" SHOWN IN LARGER FONT AS PART THE STYLIZED WORDING "BLACK TITANIUM" ON A BACKGROUND DESIGN WITH ONE ROUNDED EDGE AND ONE WEDGE-SHAPED EDGE REPRESENTING A CUTTING BLADE EDGE.

FOR SCISSORS AND KNIVES (U.S. CLS. 23, 28 AND 44).

MARLENE BELL, EXAMINING ATTORNEY

SN 85-083,019. ALLIANT TECHSYSTEMS INC., MINNEAPOLIS, MN. FILED 7-13-2010.



OWNER OF U.S. REG. NOS. 3,804,206, 3,804,208 AND OTHERS.

THE COLOR(S) GREEN, WHITE, AND GOLD IS/ARE CLAIMED AS A FEATURE OF THE MARK.

THE MARK CONSISTS OF THE WORD "WEAVER" IN THE COLOR WHITE, WITH THE LETTERS OUTLINED IN GOLD, ON A MOTTLED GREEN BACKGROUND, THE SHADING OF WHICH DEEPENS FROM THE AREA ABOVE THE WORD TO THE AREA BELOW THE WORD, ALL INSIDE A GOLD OVAL OUTLINED IN GREEN.

SEC. 2(F).

FOR FIREARM HANDHELD GUNSMITH TOOLS, NAMELY, TORQUE WRENCH, STEEL PUNCHES, THREAD ADHESIVE FOR MOUNTING OPTICS; MODULAR LEVEL SYSTEM, NAMELY, GUN ATTACHMENT AND LEVEL FOR LEVELING OPTICS ON FIREARM; FIREARM GUNSMITHING TOOL KITS, COMPRISING DRIVER, BITS, LENGTHENING ATTACHMENT, PUNCHES, AND HAMMER; FIREARM GUNSMITH TOOL HOLDER, NAMELY, A MOUNTING CENTER FOR STABILIZING EQUIPMENT AND ORGANIZING TOOLS FOR GUNSMITHING (U.S. CLS. 23, 28 AND 44).

FIRST USE 10-0-2009; IN COMMERCE 10-0-2009.

LOURDES AYALA, EXAMINING ATTORNEY



**CLASS 8—(Continued).**

SN 85-083,022. ALLIANT TECHSYSTEMS INC., MINNEAPOLIS, MN. FILED 7-13-2010.

# WEAVER

THE MARK CONSISTS OF STANDARD CHARACTERS WITHOUT CLAIM TO ANY PARTICULAR FONT, STYLE, SIZE, OR COLOR.

OWNER OF U.S. REG. NOS. 3,804,206, 3,804,207 AND 3,804,208.  
SEC. 2(F).

FOR FIREARM HANDHELD GUNSMITH TOOLS, NAMELY, TORQUE WRENCH, STEEL PUNCHES, THREAD ADHESIVE FOR MOUNTING OPTICS; MODULAR LEVEL SYSTEM, NAMELY, GUN ATTACHMENT AND LEVEL FOR LEVELING OPTICS ON FIREARMS; FIREARM GUNSMITHING TOOL KITS, COMPRISING DRIVER, BITS, LENGTHENING ATTACHMENT, PUNCHES, AND HAMMER; FIREARM GUNSMITH TOOL HOLDER, NAMELY, A MOUNTING CENTER FOR STABILIZING EQUIPMENT AND ORGANIZING TOOLS FOR GUNSMITHING (U.S. CLS. 23, 28 AND 44).  
FIRST USE 10-0-2009; IN COMMERCE 10-0-2009.  
LOURDES AYALA, EXAMINING ATTORNEY

SN 85-088,974. GYOKUCHO TRADING CO., LTD., MIKI-SHI, HYOGO-KEN, JAPAN, FILED 7-20-2010.



# FUGAKU

THE MARK CONSISTS OF STYLIZED WORD "FUGAKU" AND A DESIGN OF A MOUNTAIN WITHIN A SEMICIRCLE WITH A REFLECTION OF THE MOUNTAIN UNDERNEATH. THE STYLIZED LETTER "A" IN "FUGAKU" INCLUDES A WAVY LATERAL LINE INSIDE.

THE ENGLISH TRANSLATION OF "FUGAKU" IN THE MARK IS "MOUNT FUJI".

FOR LAWN AND SHRUB EDGING HAND TOOLS AND HAND OPERATED SAWS (U.S. CLS. 23, 28 AND 44).

LINDA E. BLOHM, EXAMINING ATTORNEY

SN 85-120,742. CLIO DESIGNS INCORPORATED, WATERTOWN, MA. FILED 9-1-2010.

# PIXIE

THE MARK CONSISTS OF STANDARD CHARACTERS WITHOUT CLAIM TO ANY PARTICULAR FONT, STYLE, SIZE, OR COLOR.

FOR ELECTRIC SHAVERS AND HAIR TRIMMERS; BATTERY-OPERATED SHAVERS AND HAIR TRIMMERS (U.S. CLS. 23, 28 AND 44).

REBECCA EISINGER, EXAMINING ATTORNEY

**CLASS 8—(Continued).**

SN 85-125,214. MARIANNA INDUSTRIES, INC., OMAHA, NE. FILED 9-8-2010.

# VIPER

THE MARK CONSISTS OF STANDARD CHARACTERS WITHOUT CLAIM TO ANY PARTICULAR FONT, STYLE, SIZE, OR COLOR.

FOR SCISSORS FOR CUTTING HUMAN HAIR (U.S. CLS. 23, 28 AND 44).

SANI KHOURI, EXAMINING ATTORNEY

SN 85-125,292. BUD K WORLDWIDE, INC., MOULTRIE, GA. FILED 9-8-2010.

# RAMPAGE

THE MARK CONSISTS OF STANDARD CHARACTERS WITHOUT CLAIM TO ANY PARTICULAR FONT, STYLE, SIZE, OR COLOR.

FOR KNIVES (U.S. CLS. 23, 28 AND 44).

COLLEEN DOMBROW, EXAMINING ATTORNEY

SN 85-129,616. LINOVAION CORPORATION, WICKLIFFE, OH. FILED 9-14-2010.

# EZ Twig

THE MARK CONSISTS OF STANDARD CHARACTERS WITHOUT CLAIM TO ANY PARTICULAR FONT, STYLE, SIZE, OR COLOR.

NO CLAIM IS MADE TO THE EXCLUSIVE RIGHT TO USE "TWIG", APART FROM THE MARK AS SHOWN.

FOR MANUALLY OPERATED MASONRY TOOL USED TO HOLD THE MASON'S LINE DURING THE CONSTRUCTION OF BLOCK OR BRICK STRUCTURES (U.S. CLS. 23, 28 AND 44).

FIRST USE 3-1-2010; IN COMMERCE 6-1-2010.

MICHAEL WEBSTER, EXAMINING ATTORNEY

**CLASS 8—(Continued).**

SN 85-157,801. WILD WEST MACHINE, LLC, STEVENS-VILLE, MT. FILED 10-21-2010.



OWNER OF U.S. REG. NOS. 2,456,324 AND 2,458,223.  
THE MARK CONSISTS OF A STYLIZED LETTER "G" RESTING UPON SEVERAL STALKS OF WHEAT; AT THE BOTTOM OF THE DESIGN IS THE WORD "GRAIN-MAKER".  
FOR HAND TOOL, NAMELY, A STEEL GRAIN GRINDER (U.S. CLS. 23, 28 AND 44).  
FIRST USE 11-0-1999; IN COMMERCE 11-0-1999.  
ALICE BENMAMAN, EXAMINING ATTORNEY

SN 85-167,523. SAMUEL P. BRUBAKER, PHOENIX, AZ. FILED 11-2-2010.



NO CLAIM IS MADE TO THE EXCLUSIVE RIGHT TO USE "ORIGINAL", APART FROM THE MARK AS SHOWN.  
THE MARK CONSISTS OF A PARTIALLY SHADED CIRCLE CONTAINING THE WORDS "THE ORIGINAL HULA TOE KICK SOME WEED!" AND INSIDE THE CIRCLE IS A CARTOON IMAGE OF THE LOWER PORTION OF A LEG AND A FOOT WITH A SAW-TOOTHED TOOL ATTACHED TO THE TOE AND THE FOOT IS KICKING A WEED.  
FOR LAWN AND GARDEN TOOL, NAMELY, A WEED REMOVER (U.S. CLS. 23, 28 AND 44).  
FIRST USE 4-12-2010; IN COMMERCE 10-31-2010.  
PAM WILLIS, EXAMINING ATTORNEY

**CLASS 8—(Continued).**

SN 85-173,494. M3G SOLUTIONS, LLC, WEST ISLIP, NY. FILED 11-10-2010.

**BEACH BUDDY**

THE MARK CONSISTS OF STANDARD CHARACTERS WITHOUT CLAIM TO ANY PARTICULAR FONT, STYLE, SIZE, OR COLOR.

NO CLAIM IS MADE TO THE EXCLUSIVE RIGHT TO USE "BEACH", APART FROM THE MARK AS SHOWN.

FOR HAND TOOL, NAMELY, BRUSH COMBINED WITH A DISPENSER AND APPLICATOR FOR APPLYING POWDER AND LOTION (U.S. CLS. 23, 28 AND 44).  
BRENDAN REGAN, EXAMINING ATTORNEY

SN 85-174,185. MORRISON, RICHARD, REYNOLDSBURG, OH. FILED 11-11-2010.

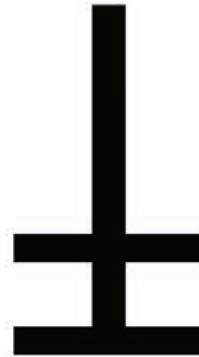

THE MARK CONSISTS OF AN UPSIDE DOWN "T" WITH AN ADDITIONAL HORIZONTAL CROSS BAR ABOVE THE TOP BAR OF THE UPSIDE DOWN "T" WITH THE UPRIGHT PORTION OF THE UPSIDE DOWN "T" BEING SLIGHTLY THICKER THAN THE CROSS BARS.

FOR APPARATUS FOR TATTOOING; TATTOO NEEDLES (U.S. CLS. 23, 28 AND 44).

FIRST USE 12-2-2010; IN COMMERCE 12-2-2010.  
KAREN K. BUSH, EXAMINING ATTORNEY

SN 85-176,835. M3G SOLUTIONS, LLC, WEST ISLIP, NY. FILED 11-15-2010.

**THE BEACH BUDDY**

THE MARK CONSISTS OF STANDARD CHARACTERS WITHOUT CLAIM TO ANY PARTICULAR FONT, STYLE, SIZE, OR COLOR.

NO CLAIM IS MADE TO THE EXCLUSIVE RIGHT TO USE "BEACH", APART FROM THE MARK AS SHOWN.

FOR HAND TOOL, NAMELY, BRUSH COMBINED WITH A DISPENSER AND APPLICATOR FOR APPLYING POWDER AND LOTION (U.S. CLS. 23, 28 AND 44).  
BRENDAN REGAN, EXAMINING ATTORNEY

**CLASS 8—(Continued).**

SN 85-180,984. FREUDENBERG-NOK GENERAL PARTNERSHIP, PLYMOUTH, MI. FILED 11-19-2010.

**LIP WIZARD**

THE MARK CONSISTS OF STANDARD CHARACTERS WITHOUT CLAIM TO ANY PARTICULAR FONT, STYLE, SIZE, OR COLOR.

NO CLAIM IS MADE TO THE EXCLUSIVE RIGHT TO USE "LIP", APART FROM THE MARK AS SHOWN.

FOR AUTOMOTIVE PARTS, NAMELY, FLEXIBLE PLASTIC DISCS USED FOR THE INSTALLATION OF AUTOMATIC TRANSMISSION PISTON SEALS (U.S. CLS. 23, 28 AND 44).

LAURIE MAYES, EXAMINING ATTORNEY

**CLASS 8—(Continued).**

SN 85-210,571. PACIFIC WORLD CORPORATION, LAKE FOREST, CA. FILED 1-5-2011.

**LASH SECRETS**

THE MARK CONSISTS OF STANDARD CHARACTERS WITHOUT CLAIM TO ANY PARTICULAR FONT, STYLE, SIZE, OR COLOR.

NO CLAIM IS MADE TO THE EXCLUSIVE RIGHT TO USE "LASH", APART FROM THE MARK AS SHOWN.

FOR HAND OPERATED APPLICATOR TOOLS FOR USE IN AFFIXING ARTIFICIAL EYELASHES (U.S. CLS. 23, 28 AND 44).

HOWARD SMIGA, EXAMINING ATTORNEY

SN 85-194,723. SHANGHAI DAXON CO., LTD, SHANGHAI, CHINA, FILED 12-9-2010.



OWNER OF CHINA REG. NO. 6428106, DATED 3-28-2010, EXPIRES 3-27-2020.

THE MARK CONSISTS OF A STYLIZED ZEBRA-SHAPED DESIGN.

FOR ELECTRIC MANICURE SETS; KNIVES; MUSTACHE AND BEARD TRIMMERS; NAIL CLIPPERS; NAIL FILES; PEDICURE SETS; SCISSORS (U.S. CLS. 23, 28 AND 44).

MARK PILARO, EXAMINING ATTORNEY

SN 85-212,637. SPINZIT TOOLS LLC, BARNES, WI. FILED 1-7-2011.

**SPINZIT**

THE MARK CONSISTS OF STANDARD CHARACTERS WITHOUT CLAIM TO ANY PARTICULAR FONT, STYLE, SIZE, OR COLOR.

FOR HAND TOOLS AND ACCESSORIES FOR REMOVING FASTENERS, NAMELY, WRENCHES, SOCKETS, SCREW DRIVERS AND HAND TOOL SYSTEMS COMPRISED OF WRENCHES, SOCKETS, AND SCREW DRIVERS (U.S. CLS. 23, 28 AND 44).

NAKIA HENRY, EXAMINING ATTORNEY

SN 85-210,404. KAI U.S.A., LTD., DBA KERSHAW KNIVES, TUALATIN, OR. FILED 1-4-2011.

**BURST**

THE MARK CONSISTS OF STANDARD CHARACTERS WITHOUT CLAIM TO ANY PARTICULAR FONT, STYLE, SIZE, OR COLOR.

FOR FOLDING KNIVES (U.S. CLS. 23, 28 AND 44).

GILBERT SWIFT, EXAMINING ATTORNEY

SN 85-214,875. STUCKEL, CHRISTOPHER JOHN, DBA FIELDTORQ KNIVES, LLC, NEENAH, WI. FILED 1-11-2011.

**FieldTorq Knives**

THE MARK CONSISTS OF STANDARD CHARACTERS WITHOUT CLAIM TO ANY PARTICULAR FONT, STYLE, SIZE, OR COLOR.

NO CLAIM IS MADE TO THE EXCLUSIVE RIGHT TO USE "KNIVES", APART FROM THE MARK AS SHOWN.

FOR HUNTING KNIVES; LEATHER SHEATHS FOR KNIVES (U.S. CLS. 23, 28 AND 44).

THOMAS MANOR, EXAMINING ATTORNEY

**CLASS 8—(Continued).**

SN 85-231,092. JOHNSTON, ANDREW H., KETCHUM, ID.  
FILED 2-1-2011.

# KLHIP

THE MARK CONSISTS OF STANDARD CHARACTERS WITHOUT CLAIM TO ANY PARTICULAR FONT, STYLE, SIZE, OR COLOR.

OWNER OF U.S. REG. NO. 3,926,463.  
NO CLAIM IS MADE TO THE EXCLUSIVE RIGHT TO USE "CLIP", APART FROM THE MARK AS SHOWN.  
FOR MANICURE AND PEDICURE IMPLEMENTS, NAMELY, NAIL CLIPPERS (U.S. CLS. 23, 28 AND 44).  
FIRST USE 5-24-2010; IN COMMERCE 10-29-2010.  
COLLEEN KEARNEY, EXAMINING ATTORNEY

SN 85-238,588. TRACTOR SUPPLY CO. OF TEXAS, LP,  
BRENTWOOD, TN. FILED 2-10-2011.

# REDSTONE

THE MARK CONSISTS OF STANDARD CHARACTERS WITHOUT CLAIM TO ANY PARTICULAR FONT, STYLE, SIZE, OR COLOR.

FOR FIREPLACE TOOL SETS SOLD AS A UNIT; FIREPLACE TOOLS, NAMELY, BELLOWS, POKERS, SHOVELS, BROOMS AND TONGS (U.S. CLS. 23, 28 AND 44).  
ALLISON SCHRODY, EXAMINING ATTORNEY

SN 85-260,637. AHOLD LICENSING SARL, GENEVA, SWITZERLAND, FILED 3-8-2011.



OWNER OF U.S. REG. NOS. 2,871,579, 3,411,740 AND OTHERS.

THE COLOR(S) ORANGE, GRAY AND WHITE IS/ARE CLAIMED AS A FEATURE OF THE MARK.

THE MARK CONSISTS OF THE TRADE DRESS CHARACTERIZING THE FRONT FACE OF THE PACKAGING FOR APPLICANT'S GOODS, NAMELY (1) A WHITE HORIZONTAL BAR SPANNING THE LABEL OR PACKAGE FACE, (2) AN ORANGE BAR BELOW THE WHITE BAR, ALSO SPANNING THE LABEL OR PACKAGE FACE, (3) A

**CLASS 8—(Continued).**

DASHED LINE THAT APPEARS GRAY ON THE WHITE BACKGROUND AND WHITE ON THE ORANGE BACKGROUND. THE DASHED LINE EXTENDS HORIZONTALLY ALONG THE WHITE BAR, AND TURNS 90 DEGREES AT EACH END TO EXTEND DOWNWARDS INTO THE ORANGE BAR. THE DESIGN FURTHER COMPRISES (4) A GRAY SCISSORS DESIGN AND (5) THE WORD "GUARANTEED" APPEARING IN ORANGE ABOVE THE GRAY LINE AND THE WORD "VALUE" APPEARING IN ORANGE BELOW THE GRAY LINE.

SEC. 2(F) AS TO "GUARANTEED VALUE".  
FOR FLATWARE, NAMELY, FORKS, KNIVES, AND SPOONS (U.S. CLS. 23, 28 AND 44).  
BRIDGETT SMITH, EXAMINING ATTORNEY

SN 85-260,918. AHOLD LICENSING SARL, GENEVA, SWITZERLAND, FILED 3-8-2011.



OWNER OF U.S. REG. NOS. 2,871,579, 3,411,740 AND OTHERS.

THE MARK CONSISTS OF A SCISSORS DESIGN WITH A DASHED LINE EXTENDING TO THE RIGHT OF THE SCISSORS. THE WORD "GUARANTEED" APPEARS ABOVE THE LINE AND THE WORD "VALUE" APPEARS BELOW THE LINE.

SEC. 2(F) AS TO "GUARANTEED VALUE".  
FOR FLATWARE, NAMELY, FORKS, KNIVES, AND SPOONS (U.S. CLS. 23, 28 AND 44).  
BRIDGETT SMITH, EXAMINING ATTORNEY

**CLASS 9—ELECTRICAL AND SCIENTIFIC APPARATUS**

SN 76-682,983. TELLIGENT SYSTEMS, INC., DALLAS, TX.  
FILED 10-16-2007.

# GRAFFITI CMS

THE MARK CONSISTS OF STANDARD CHARACTERS WITHOUT CLAIM TO ANY PARTICULAR FONT, STYLE, SIZE, OR COLOR.

NO CLAIM IS MADE TO THE EXCLUSIVE RIGHT TO USE "CMS", APART FROM THE MARK AS SHOWN.

FOR DOWNLOADABLE COMPUTER SOFTWARE FOR THE PURPOSE OF CREATING AND PUBLISHING CUSTOMIZED CONTENT ON THE WORLDWIDE WEB (U.S. CLS. 21, 23, 26, 36 AND 38).

MARLENE BELL, EXAMINING ATTORNEY

**CLASS 9—(Continued).**

SN 76-690,948. DELTA ELECTRONICS (THAILAND) PUBLIC CO., LTD., SAMUTPRAKARN 10280, THAILAND, FILED 6-30-2008.

FOR POWER SUPPLIES; TELECOMMUNICATION POWER SYSTEMS COMPRISED OF UNINTERRUPTIBLE POWER SUPPLIES; RACK POWER SYSTEMS FOR TELECOMMUNICATION COMPRISED OF UNINTERRUPTIBLE POWER SUPPLIES AND SWITCHING POWER SUPPLIES; SWITCHING POWER SUPPLIES; UNINTERRUPTIBLE POWER SUPPLIES (U.S. CLS. 21, 23, 26, 36 AND 38).

WILLIAM VERHOSEK, EXAMINING ATTORNEY

SN 76-703,774. SHARP KABUSHIKI KAISHA, TA SHARP CORPORATION, OSAKA, JAPAN, FILED 7-12-2010.

THE MARK IS PRESENTED IN A STYLIZED FORM OF THE TERM "SAPL-C", WITH THE LETTERS "SAPL" PRESENTED IN UPPER CASE LETTERING, FOLLOWED BY A HYPHEN, FOLLOWED BY THE LETTER "C" IN LOWER CASE.

FOR SOFTWARE FOR USE IN OPERATING PRINTERS; SOFTWARE FOR USE IN OPERATING MULTI-FUNCTION PRINTERS COMBINED WITH COPYING MACHINES, FACSIMILES AND SCANNERS; MULTI-FUNCTION PRINTERS COMBINED WITH COPYING MACHINES, FACSIMILES AND SCANNERS (U.S. CLS. 21, 23, 26, 36 AND 38).

LEIGH LOWRY, EXAMINING ATTORNEY

SN 76-705,063. MUASHER, GHADA, AMMAN 11183, JORDAN, FILED 10-25-2010.

THE MARK CONSISTS OF STANDARD CHARACTERS WITHOUT CLAIM TO ANY PARTICULAR FONT, STYLE, SIZE, OR COLOR.

FOR PRERECORDED VIDEO TAPES, AUDIO TAPES, MAGNETIC DATA CARRIERS, AND RECORDING DISCS FEATURING MUSIC AND ANIMATION (U.S. CLS. 21, 23, 26, 36 AND 38).

FIRST USE 5-11-2010; IN COMMERCE 5-11-2010.  
CARYN GLASSER, EXAMINING ATTORNEY

**CLASS 9—(Continued).**

SN 76-705,581. UTILITY RELAY COMPANY, LTD., AUBURN TOWNSHIP, OH. FILED 12-6-2010.

FOR MICROPROCESSOR-BASED ELECTRONIC SYSTEM HAVING A LIQUID CRYSTAL DISPLAY AND PUSH BUTTONS AND UTILIZED TO COMMUNICATE WITH PROGRAMMABLE, MULTI-FUNCTION PROTECTIVE RELAYS AND TO PROVIDE AN INTERFACE FOR ARC FLASH REDUCTION SWITCHES (U.S. CLS. 21, 23, 26, 36 AND 38).

FIRST USE 5-0-2010; IN COMMERCE 5-0-2010.  
CAROL SPILS, EXAMINING ATTORNEY

SN 76-705,705. UNIVERSAL LIGHTING TECHNOLOGIES, INC., NASHVILLE, TN. FILED 12-17-2010.

THE MARK CONSISTS OF STANDARD CHARACTERS WITHOUT CLAIM TO ANY PARTICULAR FONT, STYLE, SIZE, OR COLOR.

FOR LIGHTING CONTROL SYSTEMS COMPRISED OF LIGHTING CONTROL PANELS, ELECTRIC LIGHT DIMMERS, ELECTRIC LIGHT SWITCHES AND PROXIMITY SENSORS; ELECTRIC LIGHT DIMMERS; SWITCHES, NAMELY, ELECTRONIC RELAY AND DIMMER SWITCHES, ELECTRONIC MOTION SENSOR SWITCHES, LIGHT SWITCHES AND ELECTRICAL CONTACT INPUT SWITCHES; SENSORS, NAMELY, PROXIMITY AND LIGHT SENSORS (U.S. CLS. 21, 23, 26, 36 AND 38).

MARLENE BELL, EXAMINING ATTORNEY

SN 77-319,534. ARISTA NETWORKS, INC., MENLO PARK, CA. FILED 11-1-2007.

THE MARK CONSISTS OF STANDARD CHARACTERS WITHOUT CLAIM TO ANY PARTICULAR FONT, STYLE, SIZE, OR COLOR.

FOR COMPUTER OPERATING PROGRAMS FOR ROUTERS AND SWITCHES (U.S. CLS. 21, 23, 26, 36 AND 38).

LINDSEY RUBIN, EXAMINING ATTORNEY



**CLASS 9—(Continued).**

SN 77-574,413. POLYGRAM HOLDING, INC., SANTA MONICA, CA. FILED 9-19-2008.



THE MARK CONSISTS OF A DESIGN OF A STYLIZED HOUSE WITH A DOOR.

FOR PRE-RECORDED AUDIO TAPES, DISCS, AND CASSETTES, VIDEO TAPES, DISCS, AND CASSETTES, DIGITAL AUDIO AND AUDIO VIDEO TAPES AND DISCS, CDS, DVDS, LASER DISCS, AND PHONOGRAPH RECORDS FEATURING MUSIC, MUSIC SOUNDS AND MUSIC-RELATED ENTERTAINMENT; SOUND RECORDINGS FEATURING THEATRICAL PERFORMANCES; MUSICAL SOUND RECORDINGS; MUSICAL VIDEO RECORDINGS; VIDEO RECORDINGS FEATURING THEATRICAL PERFORMANCES, ARTISTIC PERFORMANCES, AND MUSIC-RELATED ENTERTAINMENT; VIRTUAL REALITY GAME SOFTWARE; DOWNLOADABLE RING TONES, MUSIC, SOUND RECORDINGS, NAMELY, SOUND EFFECTS, GRAPHICS, GAMES AND IMAGES FOR WIRELESS COMMUNICATION DEVICES; DOWNLOADABLE MP3 FILES AND VIDEOS IN THE FIELD OF MUSIC AND MUSIC-RELATED ENTERTAINMENT FOR WIRELESS COMMUNICATION DEVICES; DOWNLOADABLE MUSIC, SOUND RECORDINGS, NAMELY, SOUND EFFECTS, GRAPHICS, COMPUTER GAMES AND IMAGES; DOWNLOADABLE MP3 FILES AND VIDEOS IN THE FIELD OF MUSIC AND MUSIC-RELATED ENTERTAINMENT; COMPUTER GAME SOFTWARE, TAPES, CARTRIDGES, AND CASSETTES; VIDEO GAME SOFTWARE, TAPES, CARTRIDGES, AND CASSETTES; AND MOUSE PADS (U.S. CLS. 21, 23, 26, 36 AND 38).  
RENEE MCCRAY, EXAMINING ATTORNEY

SN 77-609,061. AUDIOKINETIC INC., MONTREAL, CANADA, FILED 11-6-2008.

## SOUNDSEED

THE MARK CONSISTS OF STANDARD CHARACTERS WITHOUT CLAIM TO ANY PARTICULAR FONT, STYLE, SIZE, OR COLOR.

PRIORITY CLAIMED UNDER SEC. 44(D) ON CANADA APPLICATION NO. 1414135, FILED 10-10-2008, REG. NO. TMA757742, DATED 1-25-2010, EXPIRES 1-25-2025.

FOR COMPUTER SOFTWARE WHICH SYNTHETIZES AND/OR GENERATES SOUNDS FOR INTERACTIVE MEDIAS (U.S. CLS. 21, 23, 26, 36 AND 38).

KATHLEEN M. VANSTON, EXAMINING ATTORNEY

**CLASS 9—(Continued).**

SN 77-623,759. AUDIOKINETIC INC., MONTREAL, CANADA, FILED 12-1-2008.



PRIORITY CLAIMED UNDER SEC. 44(D) ON CANADA APPLICATION NO. 1414136, FILED 10-10-2008, REG. NO. TMA792015, DATED 3-2-2011, EXPIRES 3-2-2026.

NO CLAIM IS MADE TO THE EXCLUSIVE RIGHT TO USE "AUDIO", APART FROM THE MARK AS SHOWN.

THE MARK CONSISTS OF THE WORD "SOUNDSEED" WITH A STAR BURST DESIGN OVER THE WORD "SEED" AND THE WORDS "GROWING AUDIO" UNDERNEATH THE WORD "SEED".

FOR COMPUTER SOFTWARE WHICH SYNTHETIZES AND/OR GENERATES SOUND FOR INTERACTIVE MEDIAS (U.S. CLS. 21, 23, 26, 36 AND 38).

KATHLEEN M. VANSTON, EXAMINING ATTORNEY

SN 77-632,363. ANGELO JOHN E., SPOKANE, WA. FILED 12-12-2008.

## A-V-A

THE MARK CONSISTS OF STANDARD CHARACTERS WITHOUT CLAIM TO ANY PARTICULAR FONT, STYLE, SIZE, OR COLOR.

FOR SPECTACLE GLASSES (U.S. CLS. 21, 23, 26, 36 AND 38).

FIRST USE 12-12-2008; IN COMMERCE 12-12-2008.

BARBARA A. GOLD, EXAMINING ATTORNEY

SN 77-697,907. MITSUBISHI RAYON KABUSHIKI KAISHA, TA MITSUBISHI RAYON CO., LTD., TOKYO, JAPAN, FILED 3-24-2009.

## OPTOHOME

THE MARK CONSISTS OF STANDARD CHARACTERS WITHOUT CLAIM TO ANY PARTICULAR FONT, STYLE, SIZE, OR COLOR.

PRIORITY CLAIMED UNDER SEC. 44(D) ON JAPAN APPLICATION NO. 2009-92882, FILED 11-17-2008, REG. NO. 5220682, DATED 4-3-2009, EXPIRES 4-3-2019.

FOR OPTICAL TRANSMISSION CABLES AND OPTICAL COMMUNICATION CABLES, ALL MADE OF PLASTIC OPTICAL FIBERS; PLASTIC OPTICAL FIBERS (U.S. CLS. 21, 23, 26, 36 AND 38).

ALLISON HOLTZ, EXAMINING ATTORNEY

**CLASS 9—(Continued).**

SN 77-740,871. AAMP OF FLORIDA, INC., CLEARWATER, FL. FILED 5-20-2009.

**PAC**

THE MARK CONSISTS OF STANDARD CHARACTERS WITHOUT CLAIM TO ANY PARTICULAR FONT, STYLE, SIZE, OR COLOR.

OWNER OF U.S. REG. NO. 3,411,538.  
FOR MOBILE AUDIO INTERFACING EQUIPMENT, NAMELY, WIRING HARNESES, SWITCHES, AUDIO/VIDEO CABLES, CONNECTORS, CROSSOVERS, BATTERIES, MP3 INTEGRATION, LINE OUTPUT CONVERTERS, DIODES AND ANTENNA ADAPTERS, NOISE FILTERS, ELECTRONIC TESTING EQUIPMENT FOR TESTING THE MOBILE AUDIO INTERFACING EQUIPMENT, TRIGGER MODULES, AND NAVIGATION AND VIDEO INTERFACING EQUIPMENT (U.S. CLS. 21, 23, 26, 36 AND 38).

FIRST USE 0-0-1979; IN COMMERCE 0-0-1979.  
BRENDAN REGAN, EXAMINING ATTORNEY

SN 77-763,707. LG ELECTRONICS INC., SEOUL, REPUBLIC OF KOREA, FILED 6-19-2009.

**Helix**

THE MARK CONSISTS OF STANDARD CHARACTERS WITHOUT CLAIM TO ANY PARTICULAR FONT, STYLE, SIZE, OR COLOR.

FOR MOBILE PHONES (U.S. CLS. 21, 23, 26, 36 AND 38).  
HELENE LIWINSKI, EXAMINING ATTORNEY

**CLASS 9—(Continued).**

SN 77-765,842. UMG RECORDINGS, INC., SANTA MONICA, CA. FILED 6-23-2009.

**TEEN ISLAND**

THE MARK CONSISTS OF STANDARD CHARACTERS WITHOUT CLAIM TO ANY PARTICULAR FONT, STYLE, SIZE, OR COLOR.

NO CLAIM IS MADE TO THE EXCLUSIVE RIGHT TO USE "TEEN", APART FROM THE MARK AS SHOWN.

FOR PRE-RECORDED AUDIO TAPES, DISCS, AND CASSETTES, VIDEO TAPES, DISCS, AND CASSETTES, DIGITAL AUDIO AND AUDIO VIDEO TAPES AND DISCS, CDS, DVDS, LASER DISCS, AND PHONOGRAPH RECORDS FEATURING MUSIC AND MUSIC-RELATED ENTERTAINMENT; SOUND RECORDINGS FEATURING THEATRICAL PERFORMANCES; MUSICAL SOUND RECORDINGS; MUSICAL VIDEO RECORDINGS; VIDEO RECORDINGS FEATURING THEATRICAL PERFORMANCES, ARTISTIC PERFORMANCES, AND MUSIC-RELATED ENTERTAINMENT; VIRTUAL REALITY GAME SOFTWARE; DOWNLOADABLE RING TONES, MUSIC, GRAPHICS, AND GAMES FOR WIRELESS COMMUNICATION DEVICES; DOWNLOADABLE MP3 FILES, IMAGES, AND VIDEOS IN THE FIELD OF MUSIC AND MUSIC-RELATED ENTERTAINMENT FOR WIRELESS COMMUNICATION DEVICES; DOWNLOADABLE MUSIC, GRAPHICS, AND COMPUTER GAMES; DOWNLOADABLE MP3 FILES, IMAGES, AND VIDEOS IN THE FIELD OF MUSIC AND MUSIC-RELATED ENTERTAINMENT; COMPUTER GAME SOFTWARE, TAPES, CARTRIDGES, AND CASSETTES; VIDEO GAME SOFTWARE, TAPES, CARTRIDGES, AND CASSETTES; AND MOUSE PADS (U.S. CLS. 21, 23, 26, 36 AND 38).  
CORY BOONE, EXAMINING ATTORNEY

SN 77-767,086. TOTAL TRANSACTION MANAGEMENT, LLC, SAN MARCOS, CA. FILED 6-24-2009.

**AMON**

THE MARK CONSISTS OF STANDARD CHARACTERS WITHOUT CLAIM TO ANY PARTICULAR FONT, STYLE, SIZE, OR COLOR.

FOR COMPUTER SOFTWARE USED TO MONITOR OPEN SOURCE MESSAGE BROKERS, PROVIDE ALERTS AND TRIGGER RESPONSES (U.S. CLS. 21, 23, 26, 36 AND 38).

FIRST USE 11-1-2008; IN COMMERCE 2-19-2009.  
MARTHA FROMM, EXAMINING ATTORNEY

**CLASS 9—(Continued).**

SN 77-768,986. LG ELECTRONICS INC., SEOUL, REPUBLIC OF KOREA, FILED 6-26-2009.

**CLASS 9—(Continued).**

SN 77-856,313. LG ELECTRONICS INC., SEOUL, REPUBLIC OF KOREA, FILED 10-23-2009.

# Live Infinitely

THE MARK CONSISTS OF STANDARD CHARACTERS WITHOUT CLAIM TO ANY PARTICULAR FONT, STYLE, SIZE, OR COLOR.

PRIORITY CLAIMED UNDER SEC. 44(D) ON REPUBLIC OF KOREA APPLICATION NO. 40-2009-0025, FILED 5-29-2009.

OWNER OF ERPN CMNTY TM OFC REG. NO. 008930221, DATED 7-5-2010, EXPIRES 6-26-2019.

FOR TELEVISIONS RECEIVERS; DIGITAL VERSATILE DISC PLAYERS FOR HOME THEATERS; SPEAKERS FOR HOME THEATERS; AUDIO-VIDEO RECEIVERS FOR HOME THEATERS; PROJECTORS FOR HOME THEATERS (U.S. CLS. 21, 23, 26, 36 AND 38).  
DOMINIC J. FERRAIUOLO, EXAMINING ATTORNEY



SN 77-772,842. LOK-ALERT, LLC, WALLA WALLA, WA. FILED 7-1-2009.



NO CLAIM IS MADE TO THE EXCLUSIVE RIGHT TO USE "WIRELESS LOCKOUT TAGOUT SYSTEMS", APART FROM THE MARK AS SHOWN.

THE MARK CONSISTS OF THE WORDING "LOK-ALERT WIRELESS LOCKOUT TAGOUT SYSTEMS" COMBINED WITH A DESIGN OF A LOCKOUT TAGOUT SYSTEM AND CURVED LINES REPRESENTING A WIRELESS TRANSMISSION, WITH PART OF THE LOCKOUT TAGOUT SYSTEM FORMING THE LETTER "O" IN "LOK".

FOR WIRELESS LOCK-OUT TAG-OUT SYSTEMS AND LOCAL-ALERTING LOCK-OUT TAG-OUT SYSTEMS COMPOSED PRIMARILY OF TRANSPONDERS AND PAGERS (U.S. CLS. 21, 23, 26, 36 AND 38).

FIRST USE 6-1-2007; IN COMMERCE 6-1-2007.  
KIM MONINGHOFF, EXAMINING ATTORNEY

PRIORITY CLAIMED UNDER SEC. 44(D) ON REPUBLIC OF KOREA APPLICATION NO. 402009004051, FILED 8-21-2009, REG. NO. 0842848, DATED 11-12-2010, EXPIRES 11-12-2020.

NO CLAIM IS MADE TO THE EXCLUSIVE RIGHT TO USE "BACKLIGHT CONTROL", APART FROM THE MARK AS SHOWN.

THE MARK CONSISTS OF THE WORDS "BACKLIGHT CONTROL" UNDERNEATH A DESIGN THAT INCLUDES A HALF OF A SPHERE WITH LINES AND OVALS RADIATING OUT OF IT. AN ARROW POINTS OUTWARD FROM THE CENTER OF THE SPHERE.

FOR COMPUTER MONITORS; NOTEBOOK COMPUTERS; TELEVISION RECEIVERS (U.S. CLS. 21, 23, 26, 36 AND 38).

KATHERINE CHANG, EXAMINING ATTORNEY

**CLASS 9—(Continued).**

SN 77-864,607. SAMSUNG ELECTRONICS CO., LTD., SU-WON-SI, GYEONGGI-DO, REPUBLIC OF KOREA, FILED 11-4-2009.

**NcPRAM**

PRIORITY CLAIMED UNDER SEC. 44(D) ON REPUBLIC OF KOREA APPLICATION NO. 40-2009-0053, FILED 11-2-2009, REG. NO. 0849929, DATED 1-14-2011, EXPIRES 1-14-2021.

THE MARK CONSISTS OF THE LETTER "NCPRAM" WITH THE LETTERS "N P R A M" IN CAPITALS AND THE LETTER "C" IN LOWER CASE.

FOR MOBILE PHONES; COMPUTERS; MOBILE PHONE OPERATING SYSTEM SOFTWARE; COMPUTER OPERATING SYSTEM SOFTWARE; SEMICONDUCTORS; UNIVERSAL SERIAL BUS (USB) FLASH MEMORIES; SMART PHONES; WIRELESS HEADSETS FOR USE WITH MOBILE PHONES; ELECTRIC MOBILE PHONE BATTERY CHARGERS; DATA COMMUNICATION CABLES FOR USE WITH MOBILE PHONES; SET-TOP BOXES; HARD DISC DRIVES; OPTICAL DISC DRIVES; NOTEBOOK COMPUTERS; PRINTERS FOR COMPUTERS; MONITORS FOR COMPUTERS; PERSONAL DIGITAL ASSISTANTS (PDA); TELEVISIONS; FACSIMILE MACHINES; BATTERIES FOR USE WITH MOBILE PHONES; OPTICAL FIBER CABLES; DIGITAL VERSATILE DISC (DVD) PLAYERS; MP3 PLAYERS; CAMCORDERS; VIDEO CAMERAS; DIGITAL CAMERAS; VIDEO PROJECTORS; DOWNLOADABLE MUSICAL SOUND RECORDINGS; DOWNLOADABLE COMPUTER GAME SOFTWARE (U.S. CLS. 21, 23, 26, 36 AND 38).

FRED CARL, EXAMINING ATTORNEY

SN 77-872,874. SALLOUM, SAMUEL M., AKA CAPTAIN SAMUEL SALLOUM, DEARBORN HEIGHTS, MI. FILED 11-15-2009.

**GLOBAL SINGLE WINDOW (GSW)**

THE MARK CONSISTS OF STANDARD CHARACTERS WITHOUT CLAIM TO ANY PARTICULAR FONT, STYLE, SIZE, OR COLOR.

NO CLAIM IS MADE TO THE EXCLUSIVE RIGHT TO USE "GLOBAL SINGLE WINDOW", APART FROM THE MARK AS SHOWN.

FOR COMPUTER E-COMMERCE SOFTWARE TO ALLOW USERS TO PERFORM ELECTRONIC BUSINESS TRANSACTIONS VIA A GLOBAL COMPUTER NETWORK (U.S. CLS. 21, 23, 26, 36 AND 38).

LOURDES AYALA, EXAMINING ATTORNEY

**CLASS 9—(Continued).**

SN 77-873,717. J.R. CLANCY, INC., SYRACUSE, NY. FILED 11-16-2009.

**ALTUS**

THE MARK CONSISTS OF STANDARD CHARACTERS WITHOUT CLAIM TO ANY PARTICULAR FONT, STYLE, SIZE, OR COLOR.

THE WORD(S) "ALTUS" HAS NO MEANING IN A FOREIGN LANGUAGE.

FOR ELECTRICAL INTEGRATED SOFTWARE-BASED CONTROL SYSTEMS FOR USE IN THE FIELD OF THEATRICAL RIGGING (U.S. CLS. 21, 23, 26, 36 AND 38).

AMEEN IMAM, EXAMINING ATTORNEY

SN 77-891,870. D.C. THOMSON & CO. LIMITED, DUNDEE, UNITED KINGDOM, FILED 12-11-2009.

**MARVO THE WONDER CHICKEN**

THE MARK CONSISTS OF STANDARD CHARACTERS WITHOUT CLAIM TO ANY PARTICULAR FONT, STYLE, SIZE, OR COLOR.

FOR VIDEO AND SOUND RECORDINGS FEATURING CHILDREN'S CARTOONS; CINEMATOGRAPHIC FILMS FEATURING CHILDREN'S ANIMATED CARTOONS; DVDS AND VIDEO TAPES WITH RECORDED ANIMATED CARTOONS; COMPUTER VIDEO GAMES SOFTWARE; COMPUTER GAME PROGRAMS (U.S. CLS. 21, 23, 26, 36 AND 38).

SUSAN STIGLITZ, EXAMINING ATTORNEY

SN 77-902,599. PRIME SENSE LTD., TEL AVIV, ISRAEL, FILED 12-30-2009.

**NATURAL INTERACTION**

THE MARK CONSISTS OF STANDARD CHARACTERS WITHOUT CLAIM TO ANY PARTICULAR FONT, STYLE, SIZE, OR COLOR.

OWNER OF U.S. REG. NO. 3,247,681.

NO CLAIM IS MADE TO THE EXCLUSIVE RIGHT TO USE "INTERACTION", APART FROM THE MARK AS SHOWN.

FOR ELECTRONIC IMAGING DEVICES AND COMPUTER SOFTWARE FOR THREE-DIMENSIONAL SENSING AND MAPPING; COMPUTER HARDWARE AND SOFTWARE FOR SENSING USER GESTURES OR OTHER THREE-DIMENSIONAL MOTION OF THE USER (U.S. CLS. 21, 23, 26, 36 AND 38).

H. M. FISHER, EXAMINING ATTORNEY

**CLASS 9—(Continued).**

SN 77-905,859. NINTENDO CO., LTD., KYOTO, JAPAN,  
FILED 1-6-2010.

# Wii Relax

THE MARK CONSISTS OF STANDARD CHARACTERS WITHOUT CLAIM TO ANY PARTICULAR FONT, STYLE, SIZE, OR COLOR.

PRIORITY CLAIMED UNDER SEC. 44(D) ON JAPAN APPLICATION NO. 45-2009-0002. FILED 7-7-2009, REG. NO. 5391881, DATED 2-18-2011, EXPIRES 2-18-2021.

FOR CONSUMER VIDEO GAME APPARATUS, ADAPTED FOR USE WITH TV RECEIVERS ONLY; COMPUTER PROGRAMS FOR CONSUMER VIDEO GAME APPARATUS; ELECTRONIC CIRCUITS RECORDED WITH PROGRAMS FOR CONSUMER VIDEO GAME APPARATUS; OPTICAL DISKS RECORDED WITH PROGRAMS FOR CONSUMER VIDEO GAME APPARATUS; CD-ROMS RECORDED WITH PROGRAMS FOR CONSUMER VIDEO GAME APPARATUS; DVD-ROMS RECORDED WITH PROGRAMS FOR CONSUMER VIDEO GAME APPARATUS; STORAGE MEDIA, NAMELY FLASH MEMORY, RECORDED WITH PROGRAMS FOR CONSUMER VIDEO GAME APPARATUS; PRE-RECORDED MEMORY CARDS FEATURING GAMES FOR CONSUMER VIDEO GAME APPARATUS, ADAPTED FOR USE WITH TV RECEIVERS ONLY; MICROPHONES FOR CONSUMER VIDEO GAME APPARATUS, ADAPTED FOR USE WITH TV RECEIVERS ONLY; EARPHONES FOR CONSUMER VIDEO GAME APPARATUS, ADAPTED FOR USE WITH TV RECEIVERS ONLY; CDS FEATURING COMPUTER GAMES; DVDS FEATURING COMPUTER GAMES; SENSORS FOR CONSUMER VIDEO GAME APPARATUS, ADAPTED FOR USE WITH TV RECEIVERS ONLY; PULSE-MEASURING SENSORS FOR CONSUMER VIDEO GAME APPARATUS AND NOT FOR MEDICAL USE; PARTS AND ACCESSORIES FOR CONSUMER VIDEO GAME APPARATUS, NAMELY, JOYSTICKS, CONTROLLERS, POWER SUPPLIES, TRANSFORMERS, CONNECTORS FOR CONNECTING TO OTHER VIDEO GAME MACHINES; PRE-RECORDED COMPACT DISCS AND OPTICAL DISCS FEATURING ENTERTAINMENT, EDUCATIONAL AND INFORMATIONAL CONTENT PERTAINING TO VIDEO AND COMPUTER GAMES, PUZZLES, MUSIC, STORIES AND WELLNESS; COMPUTER GAME DISCS; COMPUTER GAME PROGRAMS; COMPUTER GAME SOFTWARE; ELECTRONIC GAME DISCS; ELECTRONIC GAME PROGRAMS; ELECTRONIC GAME SOFTWARE; INTERACTIVE ELECTRONIC GAME DISCS; INTERACTIVE ELECTRONIC GAME PROGRAMS; INTERACTIVE ELECTRONIC GAME SOFTWARE; INTERACTIVE VIDEO GAME DISCS; INTERACTIVE VIDEO GAME PROGRAMS; INTERACTIVE VIDEO GAME SOFTWARE; VIDEO GAME DISCS; VIDEO GAME PROGRAMS; VIDEO GAME SOFTWARE; DOWNLOADABLE COMPUTER GAME SOFTWARE; DOWNLOADABLE VIDEO GAME SOFTWARE; DOWNLOADABLE COMPUTER GAME PROGRAMS; DOWNLOADABLE VIDEO GAME PROGRAMS (U.S. CLS. 21, 23, 26, 36 AND 38).

ANDREA HACK, EXAMINING ATTORNEY

**CLASS 9—(Continued).**

SN 77-909,387. DIAGEO IRELAND, DUBLIN 8, IRELAND,  
FILED 1-11-2010.

# GUINNESS

THE MARK CONSISTS OF STANDARD CHARACTERS WITHOUT CLAIM TO ANY PARTICULAR FONT, STYLE, SIZE, OR COLOR.

PRIORITY CLAIMED UNDER SEC. 44(D) ON ERP CMNTY TM OFC APPLICATION NO. 008452799, FILED 7-27-2009, REG. NO. 008452799, DATED 2-17-2010, EXPIRES 7-27-2019.

OWNER OF U.S. REG. NOS. 321,014, 1,182,992 AND 3,254,355.

SEC. 2(F).

FOR PRERECORDED COMPUTER PROGRAMS FOR PERSONAL INFORMATION MANAGEMENT; DATABASE MANAGEMENT SOFTWARE; SOFTWARE FOR SENDING AND ORGANIZING ELECTRONIC MAIL AND MESSAGES; DATABASE SYNCHRONIZATION SOFTWARE; COMPUTER PROGRAMS FOR ACCESSING, BROWSING AND SEARCHING ONLINE DATABASES; COMPUTER SOFTWARE FOR PROVIDING INTEGRATED TELEPHONE COMMUNICATION WITH COMPUTERIZED GLOBAL INFORMATION NETWORKS (U.S. CLS. 21, 23, 26, 36 AND 38).

FIRST USE 9-0-2009; IN COMMERCE 9-0-2009.

KELLY CHOE, EXAMINING ATTORNEY

SN 77-910,766. NINTENDO CO., LTD., KYOTO, JAPAN,  
FILED 1-13-2010.

**Nintendo**

# THE LAST STORY

PRIORITY CLAIMED UNDER SEC. 44(D) ON JAPAN APPLICATION NO. 2009-054053, FILED 7-16-2009, REG. NO. 5300613, DATED 2-12-2010, EXPIRES 2-12-2020.

OWNER OF U.S. REG. NOS. 1,213,822, 2,796,527 AND OTHERS.

THE MARK CONSISTS OF THE WORD "NINTENDO" ENCLOSED WITHIN AN OVULAR BORDER. THE WORDS "THE LAST STORY" APPEAR UNDERNEATH THE WORD "NINTENDO".

FOR VIDEO GAME DISCS; PROGRAMS FOR COMPUTER VIDEO GAMES; ELECTRONIC CIRCUITS, PRE-RECORDED OPTICAL DISCS, PRE-RECORDED ROM CARDS, PRE-RECORDED ROM CARTRIDGES, PRE-RECORDED CD-ROMS, PRE-RECORDED DVD-ROMS AND PRE-RECORDED STORAGE MEDIA FEATURING VIDEO GAMES; CONTROLLERS AND JOYSTICKS FOR COMPUTER VIDEO GAMES; PRE-RECORDED MEMORY CARDS FEATURING VIDEO GAMES; REPLACEMENT PARTS AND FITTINGS FOR COMPUTER VIDEO GAMES; COMPUTER PROGRAMS FOR HANDHELD GAMES WITH LIQUID CRYSTAL DISPLAYS; ELECTRONIC CIRCUITS, PRE-RECORDED OPTICAL DISCS, PRE-RECORDED ROM CARDS, PRE-RECORDED ROM CARTRIDGES, PRE-RECORDED CD-ROMS, PRE-RECORDED DVD-ROMS AND PRE-RECORDED STORAGE MEDIA FEATURING COMPUTER PROGRAMS FOR HANDHELD GAMES WITH LIQUID CRYSTAL DISPLAYS; ARCADE VIDEO GAME MACHINES; COMPU-



**CLASS 9—(Continued).**

TER PROGRAMS FOR ARCADE VIDEO GAME MACHINES; ELECTRONIC CIRCUITS, PRE-RECORDED OPTICAL DISCS, PRE-RECORDED ROM CARDS, PRE-RECORDED ROM CARTRIDGES, PRE-RECORDED CD-ROMS, PRE-RECORDED DVD-ROMS AND PRE-RECORDED STORAGE MEDIA FEATURING COMPUTER PROGRAMS FOR ARCADE VIDEO GAMES; REPLACEMENT PARTS AND FITTINGS FOR ARCADE VIDEO GAME MACHINES; COMPUTERS; DOWNLOADABLE VIDEO GAME PROGRAMS FOR COMPUTERS; VIDEO GAME PROGRAMS FOR COMPUTERS; TELECOMMUNICATION MACHINES AND APPARATUS, NAMELY, VIDEO GAME CONSOLES FOR USE WITH EXTERNAL DISPLAY SCREEN OR MONITOR; RECORDED COMPACT DISCS FEATURING MUSIC; DOWNLOADABLE MUSIC FILES; DOWNLOADABLE IMAGE FILES FEATURING ARTWORK; ELECTRONIC PUBLICATIONS, NAMELY, BOOKS, MAGAZINES, MANUALS RECORDED ON COMPUTER MEDIA FEATURING INFORMATION ABOUT VIDEO GAMES (U.S. CLS. 21, 23, 26, 36 AND 38).

ANDREA HACK, EXAMINING ATTORNEY

SN 77-918,796, SUPERCONDUCTOR ENERGY CORPORATION, SOUTH PASADENA, CA. FILED 1-23-2010.



THE COLOR(S) BLUE, LIGHT BLUE, AND BLACK IS/ ARE CLAIMED AS A FEATURE OF THE MARK.

THE MARK CONSISTS OF THE COLOR(S) BLUE, LIGHT BLUE, AND BLACK, WITH THE COLOR BLUE APPEARING IN THE WORDING "ENS" AND "V", THE COLOR LIGHT BLUE APPEARING IN THE DESIGN RESEMBLING THE LETTER "A", AND THE COLOR BLACK APPEARING IN THE WORDING "FREE ENERGY".

FOR POWER TRANSFORMER AND POWER TRANSFORMER CORE (U.S. CLS. 21, 23, 26, 36 AND 38).

TINA MAI, EXAMINING ATTORNEY

**CLASS 9—(Continued).**

SN 77-927,624, ORLIKOFF REINERTSEN BOARDWORKS, LLC, ALTA, WY. FILED 2-4-2010.



THE COLOR(S) BURGUNDY, LIGHT BURGUNDY, GREY, AND BEIGE IS/ARE CLAIMED AS A FEATURE OF THE MARK.

THE MARK CONSISTS OF A BURGUNDY CIRCLE WITH NINE SQUARES OF DIFFERENT SIZES AND SHADINGS. THE BORDERING EIGHT SQUARES ARE LIGHT BURGUNDY IN COLOR. THE CENTER SQUARE IS BEIGE. THE "O", "R", AND "B" OF "ORLIKOFF REINERTSEN BOARDWORKS" ARE BURGUNDY IN COLOR AND POSITIONED IN A VERTICAL LINE. THE REMAINING LETTERS ARE GREY.

FOR ELECTRONIC EDUCATIONAL PUBLICATIONS, NAMELY, DOWNLOADABLE STUDY GUIDE IN THE FIELDS OF HEALTHCARE TRUSTEE, BOARD AND MANAGEMENT EDUCATION (U.S. CLS. 21, 23, 26, 36 AND 38).

FIRST USE 6-1-2009; IN COMMERCE 6-1-2009.

TRACY FLETCHER, EXAMINING ATTORNEY

SN 77-928,282, THE PCRM FOUNDATION, WASHINGTON, DC. FILED 2-4-2010.



NO CLAIM IS MADE TO THE EXCLUSIVE RIGHT TO USE "21-DAY VEGAN KICKSTART", APART FROM THE MARK AS SHOWN.

THE MARK CONSISTS OF THE FIRST LINE CONSISTING OF THE NUMBER "21" FOLLOWED BY A DASH "-" AND THE WORD "DAY". THE BOTTOM OF THE NUMBER "2" IN "21" EXTENDS ACROSS THE LOGO AND ENDS WITH A LEAF. ON THE SECOND LINE, THE WORD "VEGAN" APPEARS. ON THE LAST LINE, THE WORD "KICKSTART" APPEARS.

FOR DIGITAL MATERIALS, NAMELY, CDS, DVDS, AND DOWNLOADABLE AUDIO/VIDEO FILES FEATURING VEGAN DIET AND VEGAN MEAL PLANNING (U.S. CLS. 21, 23, 26, 36 AND 38).

FIRST USE 8-1-2009; IN COMMERCE 8-1-2009.

MARIA-VICTORIA SUAREZ, EXAMINING ATTORNEY

**CLASS 9—(Continued).**

SN 77-938,245. MAD CATZ, INC., SAN DIEGO, CA. FILED 2-17-2010.

 The logo for TRITTON features the word "TRITTON" in a bold, sans-serif font. The letters "T", "R", "I", "O", and "N" are grey, while the letters "T" and "T" in the middle are orange.

THE COLOR(S) GREY AND ORANGE IS/ARE CLAIMED AS A FEATURE OF THE MARK.

THE MARK CONSISTS OF THE WORD "TRITTON" WITH THE SECOND AND THIRD LETTERS "T" IN A STYLIZED DOUBLE "T" DESIGN. THE SECOND AND THIRD LETTERS "T" ARE ORANGE. THE REMAINING LETTERS ARE GREY.

FOR CONSUMER ELECTRONICS DEVICES, NAMELY, GAMING HEADPHONES (U.S. CLS. 21, 23, 26, 36 AND 38).

FIRST USE 1-1-2003; IN COMMERCE 1-1-2003.  
MARK SHINER, EXAMINING ATTORNEY

**CLASS 9—(Continued).**

SN 77-961,745. SUNLUXE ENTERPRISES LIMITED, WAN-CHAI, HONG KONG, FILED 3-17-2010.

 The logo for POWER IN MOTION features the words "POWER IN MOTION" in a stylized, italicized font. The word "IN" is written in a smaller font and is positioned between "POWER" and "MOTION". The letter "I" in "IN" is stylized to resemble a lightning bolt. The entire logo is set against a black rectangular background.

OWNER OF U.S. REG. NOS. 3,690,073, 3,768,376 AND 3,768,377.

THE MARK CONSISTS OF THE WORDS "POWER IN MOTION", WITH THE CHARACTER "I" IN THE WORD "IN" STYLIZED AND THE CHARACTER "N" IN THE WORD "IN" HAVING A LIGHTNING SHAPE, ON A RECTANGULAR BACKGROUND.

FOR ADAPTERS; APPARATUS AND INSTRUMENTS FOR CONVEYING, DISTRIBUTING, TRANSFORMING, STORING, REGULATING OR CONTROLLING ELECTRIC CURRENT; BATTERY CHARGE DEVICES; BATTERY CHARGERS; BATTERY JUMP STARTERS; POWER SUPPLY CONNECTORS AND ADAPTORS FOR USE WITH PORTABLE ELECTRONIC DEVICES (U.S. CLS. 21, 23, 26, 36 AND 38).

FIRST USE 3-26-2008; IN COMMERCE 3-26-2008.  
TRACY CROSS, EXAMINING ATTORNEY

SN 77-946,921. NEXTANT AEROSPACE LLC, CLEVELAND, OH. FILED 3-1-2010.

**NEXTANT 400XT**

THE MARK CONSISTS OF STANDARD CHARACTERS WITHOUT CLAIM TO ANY PARTICULAR FONT, STYLE, SIZE, OR COLOR.

FOR CUSTOMIZED CONVERSION KITS FOR UPGRADING AIRCRAFT ENGINES AND AVIONICS SYSTEMS COMPRISED OF AN ELECTRONIC AVIONICS INSTRUMENT INDICATOR PANEL WITH NEW WIRING, STRUCTURAL MECHANICAL PARTS AND INSTALLATION INSTRUCTIONS (U.S. CLS. 21, 23, 26, 36 AND 38).

JASON TURNER, EXAMINING ATTORNEY

SN 77-964,484. AUDIOVOX CORPORATION, HAUPPAUGE, NY. FILED 3-22-2010.

**PILLOWZ**

THE MARK CONSISTS OF STANDARD CHARACTERS WITHOUT CLAIM TO ANY PARTICULAR FONT, STYLE, SIZE, OR COLOR.

FOR EAR BUDS AND HEADPHONES (U.S. CLS. 21, 23, 26, 36 AND 38).

LOURDES AYALA, EXAMINING ATTORNEY

**CLASS 9—(Continued).**

SN 77-969,166. JONES, JASMINE M, AKA MELONIE MARTELL, SAVANNAH, GA. FILED 3-26-2010.



THE NAME "MELONIE MARTELL" IDENTIFIES A LIVING INDIVIDUAL WHOSE CONSENT IS OF RECORD.

THE MARK CONSISTS OF AN OVERSIZED, SCRIPTED CAPITAL "M" AT THE BEGINNING OF "MELONIE" AND A SCRIPTED CAPITAL "M" AT THE BEGINNING OF "MARTELL".

FOR COMPUTER SOFTWARE AND HARDWARE FOR DISSEMINATING ADVERTISING FOR OTHERS ON EMPLOYEE EARNINGS AND THIRD PARTY PAPER PAYROLL STUBS AND CHECKS AND ON ELECTRONIC PAYROLL PAYMENTS; DOWNLOADABLE MP3 FILES, MP3 RECORDINGS, ON-LINE DISCUSSION BOARDS, WEBCASTS, WEBINARS AND PODCASTS FEATURING MUSIC, AUDIO BOOKS AND NEWS BROADCASTS; DOWNLOADABLE RING TONES, GRAPHICS AND MUSIC VIA A GLOBAL COMPUTER NETWORK AND WIRELESS DEVICES; MUSICAL VIDEO RECORDINGS; PRERECORDED VIDEO CASSETTES FEATURING MUSIC; PRERECORDED VIDEO TAPES FEATURING MUSIC; VISUAL RECORDINGS AND AUDIOVISUAL RECORDINGS FEATURING MUSIC AND ANIMATION (U.S. CLS. 21, 23, 26, 36 AND 38).

NICHOLAS COLEMAN, EXAMINING ATTORNEY

SN 79-074,428. COMPEL ELECTRONICS S.P.A., ITALY, FILED 6-25-2009.



PRIORITY DATE OF 5-5-2009 IS CLAIMED.  
OWNER OF INTERNATIONAL REGISTRATION 1017449 DATED 6-25-2009, EXPIRES 6-25-2019.

OWNER OF U.S. REG. NO. 2,736,050.

NO CLAIM IS MADE TO THE EXCLUSIVE RIGHT TO USE "PHOTOVOLTAIC INTERCONNECTION SYSTEM", APART FROM THE MARK AS SHOWN.

THE COLOR(S) RED, YELLOW AND BLACK IS/ARE CLAIMED AS A FEATURE OF THE MARK.

THE MARK CONSISTS OF THE WORD "COMPEL" APPEARING IN RED ABOVE THE PHRASE "PHOTOVOLTAIC INTERCONNECTION SYSTEM" APPEARING IN BLACK NEXT TO THE DESIGN OF A YELLOW SUN WITH FOUR CONCENTRIC RED OVALS APPEARING IN THE MIDDLE.

FOR SYSTEMS FOR THE CAPTURE AND CONVERSION OF SOLAR ENERGY INTO ELECTRIC POWER, COMPRISED OF PHOTOVOLTAIC CLADDING PANELS, AND APPARATUS, MODULES AND COMPONENTS INTERCONNECTION DEVICES, NAMELY, PHOTOVOLTAIC SOLAR MODULES, PHOTOVOLTAIC ROOFING MEMBERS, INTER PANELS JUNCTION BOX (U.S. CLS. 21, 23, 26, 36 AND 38).

CHRISTINE MARTIN, EXAMINING ATTORNEY

**CLASS 9—(Continued).**

SN 79-074,820. PHM TECHNOLOGY PTY LTD, AUSTRALIA, FILED 8-31-2009.



OWNER OF INTERNATIONAL REGISTRATION 1018504 DATED 8-31-2009, EXPIRES 8-31-2019.

NO CLAIM IS MADE TO THE EXCLUSIVE RIGHT TO USE "DESIGN", APART FROM THE MARK AS SHOWN.

THE MARK CONSISTS OF A THREE DIMENSIONAL RIBBON DESIGN FOLLOWED BY THE WORD "MADE" WITH THE LETTER "E" UNDERSCORED UNDER WHICH IS THE WORDS "MAINTENANCE AWARE DESIGN".

FOR COMPUTER SOFTWARE PROGRAMS USED TO ADDRESS ENGINEERING REQUIREMENTS AND PRACTICES DURING DESIGN, DEVELOPMENT, INTEGRATION, MANUFACTURE, ASSEMBLY AND OPERATION OF SYSTEMS AND PRODUCTS; COMPUTER SOFTWARE PROGRAMS USED TO ASSIST IN THE EVALUATION, MODELING, ASSESSMENT AND MITIGATION OF THE IMPACT OF FAILURES IN SYSTEMS AND PROCESSES THROUGH A SYSTEM OF AUTOMATED DATA PROCESSING AND ANALYSIS; COMPUTER SOFTWARE PROGRAMS USED TO IDENTIFY AND MITIGATE THE RISKS AND EFFECTS OF PRODUCT, SYSTEM OR PROCESS FAILURES INCLUDING SOFTWARE PROGRAMS THAT PLAN, OPTIMIZE AND IMPLEMENT SYSTEM FAILURE IDENTIFICATION, LOCALIZATION, DIAGNOSTICS, PROGNOSTICS AND OTHER MANAGEMENT APPLICATIONS FOR OPERATIONAL AND CONDITION MONITORING (U.S. CLS. 21, 23, 26, 36 AND 38).

REGINA DRUMMOND, EXAMINING ATTORNEY

SN 79-078,452. ANSWERCELL TECHNOLOGIES LIMITED, UNITED KINGDOM, FILED 12-8-2009.

# ANSWERCELL

THE MARK CONSISTS OF STANDARD CHARACTERS WITHOUT CLAIM TO ANY PARTICULAR FONT, STYLE, SIZE, OR COLOR.

OWNER OF INTERNATIONAL REGISTRATION 1027631 DATED 12-8-2009, EXPIRES 12-8-2019.

FOR APPARATUS AND INSTRUMENTS FOR DATA COMMUNICATION, SATELLITE COMMUNICATION AND TELECOMMUNICATION, NAMELY, MOBILE TELEPHONES, ELECTRONIC TELEPHONE HEADSETS, TELECOMMUNICATIONS TRANSMITTERS AND RECEIVERS, AND EARPIECES FOR MOBILE TELEPHONES; MP3 MODULES, NAMELY, MOBILE ELECTRONIC STORAGE DEVICES FOR THE STORAGE, RECEPTION AND TRANSMISSION OF DATA, SOUND AND IMAGES; DATA PROCESSORS; COMPUTERS; COMPUTER PROGRAMS FOR USE IN THE FIELD OF TELECOMMUNICATIONS THAT ORDER, MANAGE, PLAY AND RECORD SOUND AND IMAGES; COMPUTER INTERFACES, MODEMS AND PERIPHERAL EQUIPMENT; OPTICAL APPARATUS AND INSTRUMENTS, NAMELY, CAMERAS, ELECTRONIC IMAGE DISPLAY SCREENS, GLASSES DESIGNED TO BE FITTED WITH MP3 AND ELECTRONIC DATA MODULES, NAMELY, MOBILE ELECTRONIC STORAGE DEVICES ADAPTED TO DISPLAY INFORMATION CONCERNING AUDIO AND VISUAL MESSAGES; APPARATUS AND INSTRUMENTS FOR MONITORING OF TELECOMMUNICATION NETWORKS AND DATA COMMUNICATION NETWORKS, NAMELY, COMPUTER PROGRAMS AND MOBILE COMMUNICATION DEVICES, EARPIECES, MODULES IN THE FORM OF

**CLASS 9—(Continued).**

MOBILE ELECTRONIC STORAGE DEVICES, SPECTACLES AND ELECTRONIC MEDIA STORAGE DEVICES, ALL DESIGNED TO RECORD AND SCREEN TELEPHONE AND VIDEO MESSAGES; BATTERIES; ELECTRICAL AND OPTICAL CABLES; ELECTRICAL WIRES; RADAR; LCD, PLASMA, VIDEO AND DIGITAL DISPLAY SCREENS; SCANNERS; AERIALS; TELEVISIONS; CAMERAS; RECORDING APPARATUS, NAMELY, ELECTRONIC STORAGE MODULES FOR MANAGEMENT AND STORAGE OF MULTIMEDIA AND TELECOMMUNICATIONS MESSAGES; REMOTE CONTROLS FOR ELECTRONIC TELEPHONE HEADSETS, TELECOMMUNICATIONS TRANSMITTERS AND RECEIVERS; MOBILE TELEPHONES; EARPIECES FOR MOBILE TELEPHONES; TELEPHONE ANSWERING MACHINES; LOUDSPEAKERS; RADIOS; TELEPHONE APPARATUS; VIDEO TELEPHONES; PAGING APPARATUS; ELECTRONIC AND DIGITAL DISPLAY SCREENS AND MOBILE COMMUNICATION DEVICES; TELECOMMUNICATIONS, RADIO, VIDEO DIGITAL AND SATELLITE TRANSMITTERS AND RECEIVERS; SWITCHBOARDS; COMPUTER, ELECTRICAL, TELECOMMUNICATIONS AND ETHERNET SWITCHES; TELEPHONE AND RADIOTELEPHONY EQUIPMENT, APPARATUS AND SETS, IN PARTICULAR PUBLIC, PERSONAL, PORTABLE, MOBILE, HANDS-FREE OR VOICE-OPERATED TELEPHONES AND ANSWERING MACHINES; TELEPHONE AND RADIOTELEPHONY RECEIVERS AND TRANSMITTERS; PAGING APPARATUS; VIDEO TELEPHONES; RADIOTELEPHONY TERMINALS; APPARATUS FOR RECORDING, TRANSMISSION, REPRODUCTION AND PROCESSING OF DATA, SOUND AND IMAGES; ANSWERING MACHINES; EARPIECES FOR TELECOMMUNICATIONS SYSTEMS; COMPUTER SOFTWARE, NAMELY, SOFTWARE FOR DATA PROCESSING; COMPUTER SOFTWARE FOR THE CREATION, MANAGEMENT, UPDATING AND OPERATION OF DATABASES; COMPUTER SOFTWARE FOR PROVIDING ELECTRONIC MAIL AND MESSAGE SERVICE ACCESS; APPARATUS FOR DATA, SOUND AND IMAGE CAPTURE, NAMELY, MOBILE TELEPHONES, WIRELESS ELECTRONIC HEADSETS, TELECOMMUNICATIONS TRANSMITTERS AND RECEIVERS AND EARPIECES FOR MOBILE TELEPHONES; COMPUTER TELECOMMUNICATIONS DATA TRANSMISSION TERMINALS; CONNECTORS TO A COMPUTER NETWORK OR TELEPHONE NETWORK; TRANSMITTING AND RECEIVING APPARATUS FOR DATA PROCESSING AND COMMUNICATIONS, NAMELY, MOBILE TELEPHONES, WIRELESS ELECTRONIC HEADSETS, TELECOMMUNICATIONS TRANSMITTERS AND RECEIVERS AND EARPIECES FOR MOBILE TELEPHONES; TELEPHONE SWITCHES; BLANK MEDIA FOR MAGNETIC AND OPTICAL STORAGE; SOUND, IMAGE AND DATA CARRIERS, NAMELY, ELECTRONIC STORAGE MODULES FOR MANAGEMENT AND STORAGE OF MULTIMEDIA AND TELECOMMUNICATIONS MESSAGES; ELECTRONIC MEMORIES; BLANK SMART CARDS; MAGNETIC CARDS AND MICRO CHIP CARDS; SOFTWARE FOR CONTROLLING ACCESS TO AN ELECTRONIC MAIL AND MESSAGING SERVICES; DOWNLOADABLE ELECTRONIC PUBLICATIONS AND PUBLICATIONS RECORDED ON CD, FLASH MEMORY CARDS OR DVD, IN THE NATURE OF INSTRUCTIONAL MANUALS, TECHNICAL INFORMATION LEAFLETS AND USER GUIDES, IN THE FIELD OF TELECOMMUNICATIONS; PARTS AND FITTINGS FOR THE AFORESAID GOODS (U.S. CLS. 21, 23, 26, 36 AND 38).

JAMES GRIFFIN, EXAMINING ATTORNEY

**CLASS 9—(Continued).**

SN 79-083,416. SECTRA COMMUNICATIONS AB, SWEDEN, FILED 4-27-2010.

# PANTHON

THE MARK CONSISTS OF STANDARD CHARACTERS WITHOUT CLAIM TO ANY PARTICULAR FONT, STYLE, SIZE, OR COLOR.

PRIORITY DATE OF 10-27-2009 IS CLAIMED.

OWNER OF INTERNATIONAL REGISTRATION 1041050 DATED 4-27-2010, EXPIRES 4-27-2020.

FOR DEVICES FOR RECEIVING AND TRANSMITTING SOUNDS AND IMAGES; ELECTRONIC ENCRYPTION UNITS FOR RECEIVING AND TRANSMITTING SOUNDS AND IMAGES; ELECTRICAL DEVICES AND INSTRUMENTS FOR PROCESSING AND COMMUNICATING SIGNALS; ELECTRONIC ENCRYPTION UNITS FOR PROCESSING AND COMMUNICATING SIGNALS (U.S. CLS. 21, 23, 26, 36 AND 38).

SANI KHOURI, EXAMINING ATTORNEY

SN 79-083,823. ZHAOQING LEOCH BATTERY; TECHNOLOGY CO., LTD., GUANGDONG, CHINA, FILED 5-10-2010.

# ENERPURE

OWNER OF INTERNATIONAL REGISTRATION 1042226 DATED 5-10-2010, EXPIRES 5-10-2020.

FOR ELECTRIC ACCUMULATORS; BATTERIES; BATTERY CHARGERS; INVERTERS OF ELECTRICITY; ELECTRIC ACCUMULATORS FOR VEHICLES; ACCUMULATOR BOXES; ELECTRIC BATTERIES; BATTERIES FOR LIGHTING; SOLAR BATTERIES; COMPUTER PERIPHERAL DEVICES (U.S. CLS. 21, 23, 26, 36 AND 38).

SHAILA SETTLES, EXAMINING ATTORNEY

**CLASS 9—(Continued).**

SN 79-084,166. ADENE-AGÊNCIA PARA A ENERGIA, P-1495-131ALGES, PORTUGAL, FILED 5-3-2010.



PRIORITY DATE OF 11-3-2009 IS CLAIMED.  
OWNER OF INTERNATIONAL REGISTRATION 1043044 DATED 5-3-2010, EXPIRES 5-3-2020.

NO CLAIM IS MADE TO THE EXCLUSIVE RIGHT TO USE "CASA" AND "SIMULADOR DE EFICIÊNCIA ENERGÉTICA EM EDIFÍCIOS", APART FROM THE MARK AS SHOWN.

THE COLOR(S) RED, ORANGE, YELLOW, GREEN, BLACK AND WHITE IS/ARE CLAIMED AS A FEATURE OF THE MARK.

THE MARK CONSISTS OF A THE WORD "CASA+" WITH THE "C" IN RED, THE FIRST "A" IN ORANGE, THE "S" IN YELLOW, AND THE "A+" IN WHITE ON A GREEN HOUSE, AND THE WORDING "SIMULADOR DE EFICIENCIA ENERGETICA EM EDIFICIOS" IN BLACK.

THE ENGLISH TRANSLATION OF THE FOREIGN WORD(S) IN THE MARK IS "HOME ENERGY EFFICIENCY SIMULATORS FOR BUILDINGS".

FOR COMPUTER SOFTWARE FOR USE IN ASSESSING INFORMATION ABOUT GEOGRAPHICAL LOCATION, SIZE OF DWELLING, MATERIALS USED IN CONSTRUCTION AND OTHER INFORMATION IN ORDER TO SIMULATE AND DETERMINE THE ENERGY EFFICIENCY OF BUILDINGS (U.S. CLS. 21, 23, 26, 36 AND 38).

LAURA HAMMEL, EXAMINING ATTORNEY

SN 79-085,155. COMFACT AB, SWEDEN, FILED 7-5-2010.

# PROSALE

THE MARK CONSISTS OF STANDARD CHARACTERS WITHOUT CLAIM TO ANY PARTICULAR FONT, STYLE, SIZE, OR COLOR.

OWNER OF INTERNATIONAL REGISTRATION 0736003 DATED 7-3-2000, EXPIRES 7-3-2020.

FOR RECORDED COMPUTER PROGRAMS USED FOR DATABASE MANAGEMENT, AS IS RELATES TO THE ADMINISTRATION, TRADE AND TRANSPORT COMPUTERS (U.S. CLS. 21, 23, 26, 36 AND 38).

LINDA E. BLOHM, EXAMINING ATTORNEY

**CLASS 9—(Continued).**

SN 79-085,773. INPECO SA, SWITZERLAND, FILED 2-26-2010.

# NEMO

THE MARK CONSISTS OF STANDARD CHARACTERS WITHOUT CLAIM TO ANY PARTICULAR FONT, STYLE, SIZE, OR COLOR.

PRIORITY DATE OF 2-12-2010 IS CLAIMED.  
OWNER OF INTERNATIONAL REGISTRATION 1046892 DATED 2-26-2010, EXPIRES 2-26-2020.

FOR COMPUTER OPERATING SOFTWARE FOR MANAGING MACHINES THAT CONTROL THE MOVEMENT OF TEST-TUBES FROM ONE LOCATION TO ANOTHER IN CLINICAL LABORATORY TESTING, AND FOR MANAGING DRUG DISTRIBUTION MACHINES; GRAPHICAL USER INTERFACE SOFTWARE TO ENABLE USERS TO MANAGE THE ABOVE MENTIONED SOFTWARE; COMMUNICATION SOFTWARE FOR INTERFACING BETWEEN CORPORATE SOFTWARE AND EXTERNAL IN VITRO (IVD) TEST AUTOMATION SYSTEMS (U.S. CLS. 21, 23, 26, 36 AND 38).

RON FAIRBANKS, EXAMINING ATTORNEY

SN 79-085,982. PRYSMIAN S.P.A., ITALY, FILED 1-27-2010.

# COLDFIT

THE MARK CONSISTS OF STANDARD CHARACTERS WITHOUT CLAIM TO ANY PARTICULAR FONT, STYLE, SIZE, OR COLOR.

PRIORITY DATE OF 12-4-2009 IS CLAIMED.  
OWNER OF INTERNATIONAL REGISTRATION 1047471 DATED 1-27-2010, EXPIRES 1-27-2020.

FOR ELECTRICAL CABLES AND CONDUCTORS; ELECTRICAL JOINTS IN THE NATURE OF CONNECTIONS FOR ELECTRIC LINES, CABLE CONNECTORS, ELECTRIC CONNECTORS AND ELECTRIC CONNECTIONS AND PARTS THEREOF, NAMELY, CONNECTING ELECTRICAL CABLES, CONNECTION CABLES, JOINT ASSEMBLIES IN THE NATURE OF ELECTRIC CONNECTIONS AND CONNECTORS, CABLE CONNECTORS, CONNECTIONS FOR ELECTRIC LINES AND CONNECTORS FOR ELECTRIC CIRCUITS, ELECTRICAL CONNECTION BOXES AND ELECTRICAL CABLES TERMINATORS; ELECTRICAL TERMINATIONS, NAMELY, CONNECTORS, PLUGS AND SOCKETS, AND RECEPTACLES; TELECOMMUNICATION CABLES AND CONDUCTORS; OPTICAL FIBERS; OPTICAL FIBER CABLES (U.S. CLS. 21, 23, 26, 36 AND 38).

MARLENE BELL, EXAMINING ATTORNEY



**CLASS 9—(Continued).**

SN 79-086,225. NGK INSULATORS, LTD., JAPAN, FILED 7-12-2010.



PRIORITY DATE OF 7-6-2010 IS CLAIMED.  
OWNER OF INTERNATIONAL REGISTRATION 1048075  
DATED 7-12-2010, EXPIRES 7-12-2020.

OWNER OF U.S. REG. NOS. 2,488,277 AND 2,942,565.  
THE MARK CONSISTS OF THE WORDING "NAS" IN A  
STYLIZED FONT AND A DESIGN THAT CONSISTS OF  
OBLIQUE LINES THAT APPEAR ON THE LETTER "N".

FOR BATTERIES AND CELLS, ENERGY STORAGE  
EQUIPMENT, ENERGY SUPPLY EQUIPMENT AND  
POWER SUPPLY EQUIPMENT, NAMELY, ELECTRIC  
ACCUMULATORS, ELECTRIC BATTERIES, AND BATTERIES  
FOR LIGHTING; ELECTRICAL POWER DISTRIBUTION  
BLOCKS; ROTARY CONVERTERS (U.S. CLS. 21, 23, 26, 36 AND 38).

RENEE MCCRAY, EXAMINING ATTORNEY

SN 79-087,144. RIMOPTICS PTY LTD, AUSTRALIA, FILED 7-16-2010.



PRIORITY DATE OF 3-29-2010 IS CLAIMED.  
OWNER OF INTERNATIONAL REGISTRATION 1050555  
DATED 7-16-2010, EXPIRES 7-16-2020.

NO CLAIM IS MADE TO THE EXCLUSIVE RIGHT TO  
USE "EYEWEAR", APART FROM THE MARK AS SHOWN.  
THE MARK CONSISTS OF THE WORDING "DVTZ EYEWEAR"  
APPEARING ON A SHADED RECTANGLE DIVIDED INTO  
TWO SECTIONS.

FOR GLASSES FOR OPTICAL USE; OPTICAL SPECTACLES;  
SUNGLASSES BEING OPTICAL APPARATUS (U.S. CLS. 21, 23, 26, 36 AND 38).

KEVIN DINALLO, EXAMINING ATTORNEY

SN 79-087,165. FLEXICON LIMITED, UNITED KINGDOM,  
FILED 8-31-2010.

## FLEXICON ULTRASCREEN

THE MARK CONSISTS OF STANDARD CHARACTERS  
WITHOUT CLAIM TO ANY PARTICULAR FONT, STYLE,  
SIZE, OR COLOR.

PRIORITY DATE OF 3-2-2010 IS CLAIMED.  
OWNER OF INTERNATIONAL REGISTRATION 1050600  
DATED 8-31-2010, EXPIRES 8-31-2020.

OWNER OF U.S. REG. NO. 3,189,800.  
FOR ELECTRICAL CONDUIT, FLEXIBLE ELECTRICAL  
CONDUIT, PLIABLE ELECTRICAL CONDUIT,  
DUCTING FOR ELECTRIC CABLES, PARTS AND FITTINGS  
THEREOF, CONDUITS USED TO PROTECT ELECTRICAL  
CABLES AND PARTS AND FITTINGS THEREFOR IN THE  
NATURE OF CONNECTORS, ELBOWS, CLIPS, SEALS,  
T-PIECES, PLUG ADAPTORS; COMPONENTS FOR  
ELECTRICAL WIRING MANAGEMENT, NAMELY,  
LOCKNUTS, STOP PLUGS, RUBBER END SLEEVES,  
ELBOWS, COUPLERS, SEALING WASHERS,  
EARTHING WASHERS, FIXING CLIPS, CABLE  
GLANDS AND CONVERTORS (U.S. CLS. 21, 23, 26,  
36 AND 38).

MARILYN IZZI, EXAMINING ATTORNEY

**CLASS 9—(Continued).**

SN 79-087,997. ENDRESS + HAUSER WETZER GMBH + CO.  
KG, FED REP GERMANY, FILED 6-29-2010.



THE MARK CONSISTS OF STANDARD CHARACTERS  
WITHOUT CLAIM TO ANY PARTICULAR FONT, STYLE,  
SIZE, OR COLOR.

PRIORITY DATE OF 1-21-2010 IS CLAIMED.  
OWNER OF INTERNATIONAL REGISTRATION 1052869  
DATED 6-29-2010, EXPIRES 6-29-2020.

FOR SCIENTIFIC, MEASURING, SIGNALING AND  
CHECKING APPARATUS AND INSTRUMENTS,  
NAMELY, CUSTODY TRANSFER BTU METERS FOR  
RECORDING AND BILLING THE HEAT/COLD QUANTITY  
GIVEN OFF BY WATER, WATER/GLYCOL MIXTURES  
OR OTHER LIQUIDS; SCIENTIFIC, MEASURING,  
SIGNALING AND CHECKING APPARATUS AND  
INSTRUMENTS, NAMELY, STEAM CALCULATORS  
FOR RECORDING AND BILLING STEAM MASS AND  
ENERGY FLOW FOR APPLICATIONS WITH SATURATED  
OR SUPERHEATED STEAM; APPARATUS FOR  
RECORDING, TRANSMISSION OR REPRODUCTION  
OF SIGNALS AND DATA; MEASURING APPARATUS,  
ESPECIALLY ELECTRIC AND ELECTRONIC  
MEASURING APPARATUS FOR MEASURING PROCESS  
PARAMETERS IN THE FIELDS OF INDUSTRIAL  
PROCESS INSTRUMENTATION AND INDUSTRIAL  
PROCESS AUTOMATION; FLOW-METER, TEMPERATURE  
AND PRESSURE MEASURING APPARATUS,  
ESPECIALLY FLOW-METER, TEMPERATURE AND  
PRESSURE MEASURING APPARATUS FOR MEASURING  
PROCESS PARAMETERS IN THE FIELDS OF  
INDUSTRIAL PROCESS INSTRUMENTATION AND  
INDUSTRIAL PROCESS AUTOMATION; SOFTWARE  
FOR OPERATING, MONITORING, CONTROLLING,  
AND MAINTAINING MEASURING APPARATUS IN THE  
NATURE OF FLOW-METERS AND TEMPERATURE  
AND PRESSURE MEASURING APPARATUS (U.S. CLS.  
21, 23, 26, 36 AND 38).

ANDREW LEASER, EXAMINING ATTORNEY

**CLASS 9—(Continued).**

SN 79-088,427. MOBA-MOBILE AUTOMATION AKTIENGESELLSCHAFT, LIMBURG, FED REP GERMANY, FILED 8-12-2010.

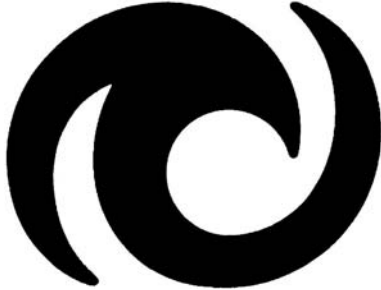

PRIORITY DATE OF 2-15-2010 IS CLAIMED.  
OWNER OF INTERNATIONAL REGISTRATION 1054190 DATED 8-12-2010, EXPIRES 8-12-2020.  
THE MARK CONSISTS OF TWO ADJOINING CURVED BANDS FORMING A STYLIZED CYCLONE.  
FOR ELECTRIC MEASURING DEVICES, NAMELY, PROTRACTORS AND INCLINOMETERS; ELECTRIC REGULATING CIRCUITS AND ELECTRIC CONTROL DEVICES, IN PARTICULAR FOR REGULATING AND CONTROLLING INCLINATION, POSITION AND ROTATIONAL SPEED; ELECTRIC APPARATUS AND INSTRUMENTS FOR WEIGHING; ELECTRONIC APPARATUS AND INSTRUMENTS FOR DOSING; ELECTRIC AND ELECTRONIC SYSTEMS COMPRISING ELECTRIC MEASURING DEVICES, NAMELY, PROTRACTORS AND INCLINOMETERS (U.S. CLS. 21, 23, 26, 36 AND 38).  
SCOTT BIBB, EXAMINING ATTORNEY

SN 79-088,875. PRYSMIAN CAVI E SISTEMI ENERGIA S.R.L., I-20126 MILANO (MI), ITALY, FILED 9-16-2010.



PRIORITY DATE OF 8-3-2010 IS CLAIMED.  
OWNER OF INTERNATIONAL REGISTRATION 1055361 DATED 9-16-2010, EXPIRES 9-16-2020.  
THE COLOR(S) BLACK AND MAGENTA IS/ARE CLAIMED AS A FEATURE OF THE MARK.  
THE TRADEMARK CONSISTS OF THE WORDING "P-SUN" IN FANCY CHARACTERS WITH THE LETTER "P" AND THE HORIZONTAL DASH IN THE COLOR BLACK AND THE REST OF THE WORDING "SUN" IN COLOR MAGENTA.  
FOR ELECTRIC CABLES FOR SOLAR AND PHOTOVOLTAIC USE; SOLAR AND PHOTOVOLTAIC CELLS AND SOLAR AND PHOTOVOLTAIC BATTERIES FOR GENERATING OF ELECTRICITY AND ELECTRICAL ENERGY; APPARATUS AND INSTRUMENTS FOR CONDUCTING, SWITCHING, TRANSFORMING, ACCUMULATING, REGULATING OR CONTROLLING ENERGY, IN PARTICULAR ELECTRICITY, NAMELY, PHOTOVOLTAIC SOLAR MODULES, PHOTOVOLTAIC SOLAR ARRAYS, SOLAR CELLS, SOLAR PANELS AND SOLAR BATTERIES FOR PHOTOVOLTAIC USE AND FOR CONVERSION OF SOLAR AND PHOTONIC POWER INTO OTHER STATES OF ELECTRICAL ENERGY AS WELL AS FOR RENEWABLE ELECTRICAL ENERGIES (U.S. CLS. 21, 23, 26, 36 AND 38).  
DOMINIC FATHY, EXAMINING ATTORNEY

**CLASS 9—(Continued).**

SN 79-089,070. DOWNUNDER GEOSOLUTIONS PTY LTD, AUSTRALIA, FILED 9-20-2010.



PRIORITY DATE OF 4-2-2010 IS CLAIMED.  
OWNER OF INTERNATIONAL REGISTRATION 1055966 DATED 9-20-2010, EXPIRES 9-20-2020.  
THE MARK CONSISTS OF THE WORDING "DUG SPIKE" IN STYLIZED FONT.  
FOR COMPUTER SOFTWARE USED FOR EXPLORATION, ANALYSIS, MODELLING AND EXTRACTION OF NATURAL RESOURCES, BEING OIL, GAS AND MINERAL RESOURCES USED FOR DATABASE MANAGEMENT; COMPUTER SOFTWARE USED FOR GEOTHERMAL ENERGY APPLICATIONS, COAL BED METHANE EXTRACTION AND MANAGEMENT, CARBON DIOXIDE MANAGEMENT, CAPTURE AND STORAGE USED FOR DATABASE MANAGEMENT (U.S. CLS. 21, 23, 26, 36 AND 38).  
TINA BROWN, EXAMINING ATTORNEY

SN 79-089,071. DOWNUNDER GEOSOLUTIONS PTY LTD, AUSTRALIA, FILED 9-20-2010.



PRIORITY DATE OF 4-2-2010 IS CLAIMED.  
OWNER OF INTERNATIONAL REGISTRATION 1055967 DATED 9-20-2010, EXPIRES 9-20-2020.  
THE MARK CONSISTS OF THE WORDING "DUG DISTILL" IN STYLIZED FONT.  
FOR COMPUTER SOFTWARE USED FOR EXPLORATION, ANALYSIS, MODELLING AND EXTRACTION OF NATURAL RESOURCES, BEING OIL, GAS AND MINERAL RESOURCES USED FOR DATABASE MANAGEMENT; COMPUTER SOFTWARE USED FOR GEOTHERMAL ENERGY APPLICATIONS, COAL BED METHANE EXTRACTION AND MANAGEMENT, CARBON DIOXIDE MANAGEMENT, CAPTURE AND STORAGE USED FOR DATABASE MANAGEMENT (U.S. CLS. 21, 23, 26, 36 AND 38).  
TINA BROWN, EXAMINING ATTORNEY

**CLASS 9—(Continued).**

SN 79-089,072. DOWNUNDER GEOSOLUTIONS PTY LTD, AUSTRALIA, FILED 9-20-2010.



PRIORITY DATE OF 4-2-2010 IS CLAIMED.  
OWNER OF INTERNATIONAL REGISTRATION 1055968 DATED 9-20-2010, EXPIRES 9-20-2020.

NO CLAIM IS MADE TO THE EXCLUSIVE RIGHT TO USE "ROCK", APART FROM THE MARK AS SHOWN.  
THE MARK CONSISTS OF THE WORDING "DUG ROCK" IN STYLIZED FONT.

FOR COMPUTER SOFTWARE USED FOR EXPLORATION, ANALYSIS, MODELLING AND EXTRACTION OF NATURAL RESOURCES, BEING OIL, GAS AND MINERAL RESOURCES USED FOR DATABASE MANAGEMENT; COMPUTER SOFTWARE USED FOR GEOTHERMAL ENERGY APPLICATIONS, COAL BED METHANE EXTRACTION AND MANAGEMENT, CARBON DIOXIDE MANAGEMENT, CAPTURE AND STORAGE USED FOR DATABASE MANAGEMENT (U.S. CLS. 21, 23, 26, 36 AND 38).

TINA BROWN, EXAMINING ATTORNEY

**CLASS 9—(Continued).**

SN 79-089,074. DOWNUNDER GEOSOLUTIONS PTY LTD, AUSTRALIA, FILED 9-20-2010.



PRIORITY DATE OF 4-2-2010 IS CLAIMED.  
OWNER OF INTERNATIONAL REGISTRATION 1055970 DATED 9-20-2010, EXPIRES 9-20-2020.

THE MARK CONSISTS OF THE WORDING "DUG" IN STYLIZED FONT.

FOR COMPUTER SOFTWARE USED FOR EXPLORATION, ANALYSIS, MODELLING AND EXTRACTION OF NATURAL RESOURCES, BEING OIL, GAS AND MINERAL RESOURCES USED FOR DATABASE MANAGEMENT; COMPUTER SOFTWARE USED FOR GEOTHERMAL ENERGY APPLICATIONS, COAL BED METHANE EXTRACTION AND MANAGEMENT, CARBON DIOXIDE MANAGEMENT, CAPTURE AND STORAGE USED FOR DATABASE MANAGEMENT (U.S. CLS. 21, 23, 26, 36 AND 38).

TINA BROWN, EXAMINING ATTORNEY

SN 79-089,073. DOWNUNDER GEOSOLUTIONS PTY LTD, AUSTRALIA, FILED 9-20-2010.



PRIORITY DATE OF 4-2-2010 IS CLAIMED.  
OWNER OF INTERNATIONAL REGISTRATION 1055969 DATED 9-20-2010, EXPIRES 9-20-2020.

THE MARK CONSISTS OF THE WORDING "DUG MOD+" IN STYLIZED FONT.

FOR COMPUTER SOFTWARE USED FOR EXPLORATION, ANALYSIS, MODELLING AND EXTRACTION OF NATURAL RESOURCES, BEING OIL, GAS AND MINERAL RESOURCES USED FOR DATABASE MANAGEMENT; COMPUTER SOFTWARE USED FOR GEOTHERMAL ENERGY APPLICATIONS, COAL BED METHANE EXTRACTION AND MANAGEMENT, CARBON DIOXIDE MANAGEMENT, CAPTURE AND STORAGE USED FOR DATABASE MANAGEMENT (U.S. CLS. 21, 23, 26, 36 AND 38).

TINA BROWN, EXAMINING ATTORNEY

SN 79-089,075. DOWNUNDER GEOSOLUTIONS PTY LTD, AUSTRALIA, FILED 9-20-2010.



PRIORITY DATE OF 4-2-2010 IS CLAIMED.  
OWNER OF INTERNATIONAL REGISTRATION 1055971 DATED 9-20-2010, EXPIRES 9-20-2020.

NO CLAIM IS MADE TO THE EXCLUSIVE RIGHT TO USE "REG", APART FROM THE MARK AS SHOWN.

THE MARK CONSISTS OF THE WORD "DUG REG" IN STYLIZED FONT.

FOR COMPUTER SOFTWARE USED FOR EXPLORATION, ANALYSIS, MODELLING AND EXTRACTION OF NATURAL RESOURCES, BEING OIL, GAS AND MINERAL RESOURCES USED FOR DATABASE MANAGEMENT; COMPUTER SOFTWARE USED FOR GEOTHERMAL ENERGY APPLICATIONS, COAL BED METHANE EXTRACTION AND MANAGEMENT, CARBON DIOXIDE MANAGEMENT, CAPTURE AND STORAGE USED FOR DATABASE MANAGEMENT (U.S. CLS. 21, 23, 26, 36 AND 38).

TINA BROWN, EXAMINING ATTORNEY

**CLASS 9—(Continued).**

SN 79-089,352. PROMATICA FAR EAST PTE LTD, SINGAPORE, SINGAPORE, FILED 10-25-2010.

**Anyplan**

PRIORITY DATE OF 10-8-2010 IS CLAIMED.  
OWNER OF INTERNATIONAL REGISTRATION 1056720 DATED 10-25-2010, EXPIRES 10-25-2020.

THE MARK CONSISTS OF A STYLIZED DEPICTION OF THE TERM "ANYPLAN".

FOR COMPUTER PROGRAMS FOR PROJECT MANAGEMENT, PLANNING AND SCHEDULING; DOWNLOADABLE COMPUTER PROGRAMS FOR PROJECT MANAGEMENT, PLANNING AND SCHEDULING; COMPUTER APPLICATION SOFTWARE FOR PERSONAL COMPUTERS, HANDHELD COMPUTERS, WEB APPLICATIONS AND MOBILE DEVICES, NAMELY, FOR PROJECT MANAGEMENT, PLANNING AND SCHEDULING; COMPUTER SOFTWARE THAT ALLOWS USERS TO PERFORM BUSINESS TRANSACTIONS VIA A GLOBAL COMPUTER NETWORK (U.S. CLS. 21, 23, 26, 36 AND 38).

SUSAN LESLIE DUBOIS, EXAMINING ATTORNEY

SN 79-089,832. PROMATICA FAR EAST PTE LTD, SINGAPORE 048424, SINGAPORE, FILED 10-25-2010.

**A**

PRIORITY DATE OF 10-8-2010 IS CLAIMED.  
OWNER OF INTERNATIONAL REGISTRATION 1057909 DATED 10-25-2010, EXPIRES 10-25-2020.

THE MARK CONSISTS OF A STYLIZED DEPICTION OF THE LETTER "A".

FOR COMPUTER PROGRAMS FOR PROJECT MANAGEMENT, PLANNING AND SCHEDULING; DOWNLOADABLE COMPUTER PROGRAMS FOR PROJECT MANAGEMENT, PLANNING AND SCHEDULING; COMPUTER APPLICATION SOFTWARE FOR PERSONAL COMPUTERS, HANDHELD COMPUTERS, WEB APPLICATIONS AND MOBILE DEVICES, NAMELY, FOR PROJECT MANAGEMENT, PLANNING AND SCHEDULING; COMPUTER SOFTWARE THAT ALLOWS USERS TO PERFORM BUSINESS TRANSACTIONS VIA A GLOBAL COMPUTER NETWORK (U.S. CLS. 21, 23, 26, 36 AND 38).

SUSAN LESLIE DUBOIS, EXAMINING ATTORNEY

**CLASS 9—(Continued).**

SN 79-090,121. FUJITSU TECHNOLOGY SOLUTIONS INTELLECTUAL PROPERTY GMBH, FED REP GERMANY, FILED 10-18-2010.

**ServerView**

OWNER OF INTERNATIONAL REGISTRATION 0657158 DATED 12-6-1995, EXPIRES 12-6-2015.

FOR COMPUTER SOFTWARE FOR USE IN COMPUTER SYSTEM MANAGEMENT; COMPUTER SOFTWARE FOR CONTROLLING AND MANAGING ACCESS SERVER APPLICATIONS (U.S. CLS. 21, 23, 26, 36 AND 38).

CURTIS FRENCH, EXAMINING ATTORNEY

SN 79-090,549. ELLEGI SRL, ITALY, FILED 11-5-2010.

**lisamobile**

THE MARK CONSISTS OF STANDARD CHARACTERS WITHOUT CLAIM TO ANY PARTICULAR FONT, STYLE, SIZE, OR COLOR.

PRIORITY DATE OF 5-28-2010 IS CLAIMED.  
OWNER OF INTERNATIONAL REGISTRATION 1059973 DATED 11-5-2010, EXPIRES 11-5-2020.

FOR GROUND BASED SYNTHETIC APERTURE RADARS AND RELATED SOFTWARE USED TO SURVEY, MEASURE, MONITOR AND CHECK THE GROUND AND MANMADE STRUCTURES FOR DISPLACEMENTS INDUCED BY NATURAL HAZARDS OR BY HUMAN ACTIONS, THAT CAN ALSO BE USED IN EMERGENCY SITUATIONS (U.S. CLS. 21, 23, 26, 36 AND 38).

DAVID HOFFMAN, EXAMINING ATTORNEY

SN 79-090,583. M.E.S.A S.R.L., ITALY, FILED 11-11-2010.

**PAG**

THE MARK CONSISTS OF STANDARD CHARACTERS WITHOUT CLAIM TO ANY PARTICULAR FONT, STYLE, SIZE, OR COLOR.

PRIORITY DATE OF 9-13-2010 IS CLAIMED.  
OWNER OF INTERNATIONAL REGISTRATION 1060053 DATED 11-11-2010, EXPIRES 11-11-2020.

THE WORDING "PAG" HAS NO MEANING IN A FOREIGN LANGUAGE.

FOR COORDINATE MEASURING MACHINES (U.S. CLS. 21, 23, 26, 36 AND 38).

TASNEEM HUSSAIN, EXAMINING ATTORNEY

**CLASS 9—(Continued).**

SN 79-091,345. CIGRAPH S.R.L., ITALY, FILED 10-28-2010.

**ARCHISUITE**

THE MARK CONSISTS OF STANDARD CHARACTERS WITHOUT CLAIM TO ANY PARTICULAR FONT, STYLE, SIZE, OR COLOR.

PRIORITY DATE OF 10-21-2010 IS CLAIMED.

OWNER OF INTERNATIONAL REGISTRATION 1061916 DATED 10-28-2010, EXPIRES 10-28-2020.

THE WORD(S) "ARCHISUITE" HAS NO MEANING IN A FOREIGN LANGUAGE.

FOR RECORDED COMPUTER PROGRAMS FOR USE IN CREATING SPREADSHEETS, CAPTIONS AND GRAPHS, MEASURING, SKETCHING AND DRAWING OF FLOOR PLANS (U.S. CLS. 21, 23, 26, 36 AND 38).

DAVID C. REIHNER, EXAMINING ATTORNEY

---

SN 79-091,489. LEICA CAMERA AG, FED REP GERMANY, FILED 11-22-2010.

**Colorplan**

OWNER OF INTERNATIONAL REGISTRATION 0291325 DATED 11-25-1964, EXPIRES 11-25-2014.

OWNER OF U.S. REG. NO. 707,537.

THE MARK CONSISTS OF THE WORDING "COLORPLAN" IN STYLIZED FONT.

FOR LENSES FOR USE IN PHOTOGRAPHY, PROJECTION, MICROSCOPY AND FOR TELESCOPES (U.S. CLS. 21, 23, 26, 36 AND 38).

ROBERT STRUCK, EXAMINING ATTORNEY

---

SN 79-091,557. ANHUI DURALUXE ENERGY CO., LTD., ANHUI PROVINCE, CHINA, FILED 11-3-2010.

**DURALUXE**

OWNER OF INTERNATIONAL REGISTRATION 1062324 DATED 11-3-2010, EXPIRES 11-3-2020.

THE MARK CONSISTS OF THE STYLIZED TERM "DURALUXE", WHERE THE TOP OF THE LETTER "A" IS REPRESENTED BY A GRAPHIC OF A TRIANGLE.

FOR INVERTERS; ELECTRIC CONVERTERS; APPARATUS AND INSTRUMENTS FOR CONVEYING, DISTRIBUTING, TRANSFORMING, STORING, REGULATING OR CONTROLLING ELECTRIC CURRENT; ELECTRIC CONTROL PANELS; COMMUTATORS; TRANSISTORS; SOLAR BATTERIES; ELECTRIC ACCUMULATORS (U.S. CLS. 21, 23, 26, 36 AND 38).

ALYSSA STEEL, EXAMINING ATTORNEY

**CLASS 9—(Continued).**

SN 79-092,501. HALFBRICK STUDIOS PTY LTD, KELVIN GROVE QLD 4059, AUSTRALIA, FILED 11-5-2010.

**Monster Dash**

THE MARK CONSISTS OF STANDARD CHARACTERS WITHOUT CLAIM TO ANY PARTICULAR FONT, STYLE, SIZE, OR COLOR.

PRIORITY DATE OF 8-24-2010 IS CLAIMED.

OWNER OF INTERNATIONAL REGISTRATION 1064922 DATED 11-5-2010, EXPIRES 11-5-2020.

FOR HANDHELD COMPUTER GAMES FOR USE WITH TELEVISION RECEIVERS ONLY; COMPUTER GAME SOFTWARE; COMPUTER GAME DISKS AND CARTRIDGES; COMPUTER GAME SOFTWARE DOWNLOADABLE VIA THE INTERNET; COMPUTER GAME SOFTWARE DOWNLOADABLE VIA MOBILE TELECOMMUNICATIONS DEVICES (U.S. CLS. 21, 23, 26, 36 AND 38).

KIMBERLY FRYE, EXAMINING ATTORNEY

---

SN 79-094,330. GEA PROCESS ENGINEERING A/S, DENMARK, FILED 10-11-2010.

**SPRAYEYE**

THE MARK CONSISTS OF STANDARD CHARACTERS WITHOUT CLAIM TO ANY PARTICULAR FONT, STYLE, SIZE, OR COLOR.

PRIORITY DATE OF 4-21-2010 IS CLAIMED.

OWNER OF INTERNATIONAL REGISTRATION 1069055 DATED 10-11-2010, EXPIRES 10-11-2020.

FOR MONITORING APPARATUS AND INSTRUMENTS FOR MONITORING, CONTROLLING AND FIRE DETECTING, NAMELY, CAMERAS AND INFRARED CAMERAS FOR MONITORING THE TEMPERATURE AND FOR MONITORING THE INSIDE OF PROCESS CHAMBERS FOR USE IN SPRAY DRYERS AND FLUID BED DRYERS, ALL FOR THE FOOD INDUSTRY, THE BEVERAGE INDUSTRY, THE DAIRY INDUSTRY, THE CHEMICAL INDUSTRY, THE ENERGY INDUSTRY AND THE PHARMACEUTICAL INDUSTRY; COMPUTER SOFTWARE FOR USE IN CONNECTION WITH MONITORING THE TEMPERATURE AND MONITORING THE INSIDE OF PROCESS CHAMBERS AS DESCRIBED IN THIS CLASS (U.S. CLS. 21, 23, 26, 36 AND 38).

SUZANNE BLANE, EXAMINING ATTORNEY



**CLASS 9—(Continued).**

SN 79-095,025. CHOI, BYUNGKUK, REPUBLIC OF KOREA, FILED 1-12-2011.

THE MARK CONSISTS OF STANDARD CHARACTERS WITHOUT CLAIM TO ANY PARTICULAR FONT, STYLE, SIZE, OR COLOR.

OWNER OF INTERNATIONAL REGISTRATION 1070895 DATED 1-12-2011, EXPIRES 1-12-2021.

FOR CELLULAR TELEPHONES; PORTABLE TELEPHONES; POCKET COMPUTERS FOR NOTE-TAKING; HANDHELD COMPUTERS; PERSONAL COMPUTERS; NOTEBOOK COMPUTERS; LAPTOP COMPUTERS; MOBILE TELEPHONES; COMPUTERS (U.S. CLS. 21, 23, 26, 36 AND 38).

MICHAEL WIENER, EXAMINING ATTORNEY

SN 85-004,201. ANAND PAG INC, IRVING, TX. FILED 4-1-2010.

THE MARK CONSISTS OF STANDARD CHARACTERS WITHOUT CLAIM TO ANY PARTICULAR FONT, STYLE, SIZE, OR COLOR.

NO CLAIM IS MADE TO THE EXCLUSIVE RIGHT TO USE "MOBILE", APART FROM THE MARK AS SHOWN.

FOR COMPUTER APPLICATION SOFTWARE FOR USE WITH USER INTERFACES AND WORKFLOW FOR BUSINESS APPLICATIONS ASSOCIATED WITH ERP SYSTEMS ON LAPTOPS, DESKTOPS AND MOBILE DEVICES, NAMELY, MOBILE PHONES, PDAS, HANDHELD COMPUTERS, TABLETS AND SMART PHONES; COMPUTER SOFTWARE FOR ENABLING BUSINESS PROCESSES ON MOBILE DEVICES, NAMELY, MOBILE PHONES, PDAS, HANDHELD COMPUTERS AND SMART PHONES BY COMMUNICATING TO BACK END DATABASE SYSTEMS USING WEB SERVICES OR HTTP SERVICE CALLS (U.S. CLS. 21, 23, 26, 36 AND 38).

REGINA DRUMMOND, EXAMINING ATTORNEY

**CLASS 9—(Continued).**

SN 85-015,813. DYNAVOX SYSTEMS, LLC, PITTSBURGH, PA. FILED 4-16-2010.

THE MARK CONSISTS OF STANDARD CHARACTERS WITHOUT CLAIM TO ANY PARTICULAR FONT, STYLE, SIZE, OR COLOR.

FOR SPECIFICALLY PROGRAMMED COMPUTER BASED DEVICE WITH CHANGEABLE TOUCH SCREEN DISPLAY OF MULTIPLE ICONS SELECTABLE BY A SPEECH IMPAIRED USER TO GENERATE SPEAKING VOICE OUTPUT TO ASSIST IN COMMUNICATIONS (U.S. CLS. 21, 23, 26, 36 AND 38).

FIRST USE 10-11-2010; IN COMMERCE 10-11-2010.

LESLEY LAMOTHE, EXAMINING ATTORNEY

SN 85-018,288. HUB TELEVISION NETWORKS, LLC, BURBANK, CA. FILED 4-20-2010.



THE MARK CONSISTS OF AN OVAL SHAPE WITH TWO LEGS AND FEET AND A POINTY TOP AND SHADOW BELOW THE FEET, WITH THE WORD "BUB" PLACED INSIDE OF THE OVAL SHAPE.

FOR PRERECORDED AUDIOVISUAL RECORDINGS, COMPACT DISCS, DVDS, ALL FEATURING SUBJECTS OF GENERAL HUMAN INTEREST; ELECTRONIC LEARNING GAMES IN THE NATURE OF ELECTRONIC GAME SOFTWARE FOR EDUCATIONAL PURPOSES; VIDEO GAME DISCS; COMPUTER GAME DISCS; ELECTRONIC GAME PROGRAMS; DOWNLOADABLE RING TONES, GRAPHICS, RING BACKS, ANIMATED RINGERS, VIDEO RINGERS AND ANIMATED SCREENSAVERS; DOWNLOADABLE PRERECORDED VIDEO CLIPS; PRERECORDED AUDIO CLIPS, TEXT AND GRAPHICS HELD IN ELECTRONIC PERSONAL COMPUTERS AND HANDHELD WIRELESS DEVICES, ALL FEATURING SUBJECTS OF GENERAL HUMAN INTEREST; SUNGLASSES (U.S. CLS. 21, 23, 26, 36 AND 38).

SALLY SHIH, EXAMINING ATTORNEY

**CLASS 9—(Continued).**

SN 85-027,400. AZUL SYSTEMS, INC., MOUNTAIN VIEW, CA. FILED 4-30-2010.

# sMartini

THE MARK CONSISTS OF STANDARD CHARACTERS WITHOUT CLAIM TO ANY PARTICULAR FONT, STYLE, SIZE, OR COLOR.

FOR SOFTWARE, NAMELY, OPEN-SOURCE COMPONENTS FOR DISTRIBUTED APPLICATIONS, TO PROVIDE AN INTEGRATED APPROACH TO ADVANCE THE CAPABILITIES OF MANAGED RUNTIMES ON VARIOUS OPERATING SYSTEMS THROUGH AN OPEN SOURCE DEVELOPMENT MODEL (U.S. CLS. 21, 23, 26, 36 AND 38).

PAM WILLIS, EXAMINING ATTORNEY

SN 85-028,301. PROMISE TECHNOLOGY, INC., MILPITAS, CA. FILED 5-3-2010.

# VFLEX

THE MARK CONSISTS OF STANDARD CHARACTERS WITHOUT CLAIM TO ANY PARTICULAR FONT, STYLE, SIZE, OR COLOR.

THE WORDING "VFLEX" HAS NO MEANING IN A FOREIGN LANGUAGE.

FOR COMPUTER SOFTWARE, FIRMWARE, AND HARDWARE, ALL USED FOR DATA RECOVERY, DATA BACKUP, AND FOR ENABLING HIGH AVAILABILITY OF NETWORK APPLIANCE DATA STORAGE, NAMELY, FOR PROTECTING DATA, PREVENTING DATA LOSS, AND RECOVERING DATA THAT HAS BEEN LOST DUE TO A COMPUTER SYSTEM FAILURE (U.S. CLS. 21, 23, 26, 36 AND 38).

WILLIAM ROSSMAN, EXAMINING ATTORNEY

SN 85-028,304. AINSWORTH GAME TECHNOLOGY LIMITED, NEWINGTON, AUSTRALIA, FILED 5-3-2010.

# Players City

THE MARK CONSISTS OF STANDARD CHARACTERS WITHOUT CLAIM TO ANY PARTICULAR FONT, STYLE, SIZE, OR COLOR.

FOR COMPUTER SOFTWARE AND FIRMWARE FOR GAMES OF CHANCE ON ANY COMPUTERIZED PLATFORM, INCLUDING DEDICATED GAMING CONSOLES, VIDEO BASED SLOT MACHINES, REEL BASED SLOT MACHINES, AND VIDEO LOTTERY TERMINALS (U.S. CLS. 21, 23, 26, 36 AND 38).

TIMOTHY FINNEGAN, EXAMINING ATTORNEY

**CLASS 9—(Continued).**

SN 85-029,018. SPG SOLAR, INC., NOVATO, CA. FILED 5-3-2010.

# FLOATO

THE MARK CONSISTS OF STANDARD CHARACTERS WITHOUT CLAIM TO ANY PARTICULAR FONT, STYLE, SIZE, OR COLOR.

FOR FLOATING PHOTOVOLTAIC SOLAR PANEL ARRAYS AND THE COMPONENTS FOR THE SAME (U.S. CLS. 21, 23, 26, 36 AND 38).

ANGELA DUONG, EXAMINING ATTORNEY

SN 85-035,720. THE MCGRAW-HILL COMPANIES, INC., NEW YORK, NY. FILED 5-11-2010.

# MARKET ANALYZER

THE MARK CONSISTS OF STANDARD CHARACTERS WITHOUT CLAIM TO ANY PARTICULAR FONT, STYLE, SIZE, OR COLOR.

NO CLAIM IS MADE TO THE EXCLUSIVE RIGHT TO USE "ANALYZER", APART FROM THE MARK AS SHOWN. SEC. 2(F).

FOR COMPUTER SOFTWARE THAT CONTAINS DATA ON MARKET TRENDS IN THE CONSTRUCTION INDUSTRY; COMPUTER SOFTWARE THAT CONTAINS FORECASTS FOR CONSTRUCTION PROJECTS; COMPUTER SOFTWARE THAT ANALYZES GEOGRAPHIC TERRITORIES WITH REGARD TO THE CONSTRUCTION INDUSTRY (U.S. CLS. 21, 23, 26, 36 AND 38).

FIRST USE 0-0-1995; IN COMMERCE 0-0-1995.

MARGARET POWER, EXAMINING ATTORNEY

SN 85-037,989. HOGLAND RECORDS, INC., VALLEY STREAM, NY. FILED 5-13-2010.

# PROYECTO UNO

THE MARK CONSISTS OF STANDARD CHARACTERS WITHOUT CLAIM TO ANY PARTICULAR FONT, STYLE, SIZE, OR COLOR.

THE ENGLISH TRANSLATION OF THE WORD "PROYECTO UNO" IN THE MARK IS "PROJECT ONE".

FOR AUDIO AND VIDEO RECORDINGS FEATURING MUSIC AND ARTISTIC PERFORMANCES (U.S. CLS. 21, 23, 26, 36 AND 38).

FIRST USE 1-1-1989; IN COMMERCE 8-30-2009.

ANNE MADDEN, EXAMINING ATTORNEY

**CLASS 9—(Continued).**

SN 85-039,669. DMOL, DBA INDUCOMM, LAS VEGAS, NV. FILED 5-16-2010.

# INDUCOMM

THE MARK CONSISTS OF STANDARD CHARACTERS WITHOUT CLAIM TO ANY PARTICULAR FONT, STYLE, SIZE, OR COLOR.

FOR RUGGEDIZED WIRELESS TELECOMMUNICATIONS HARDWARE AND TELECOMMUNICATIONS SOFTWARE USED FOR AUDIO COMMUNICATIONS, NAMELY, WIRELESS TELEPHONES, BASE STATIONS, REPEATERS, THAT EMPLOY FULL DUPLEX ACOUSTIC ECHO CANCELLATION TECHNOLOGY, AUDIO, GRAPHICS, AND VIDEO (U.S. CLS. 21, 23, 26, 36 AND 38).

FIRST USE 9-1-2008; IN COMMERCE 9-1-2008.  
ARETHA SOMERVILLE, EXAMINING ATTORNEY

SN 85-040,261. KURT KESEDAR, WALDWICK, NJ. FILED 5-17-2010.

# VICI PRODUCTIONS

THE MARK CONSISTS OF STANDARD CHARACTERS WITHOUT CLAIM TO ANY PARTICULAR FONT, STYLE, SIZE, OR COLOR.

NO CLAIM IS MADE TO THE EXCLUSIVE RIGHT TO USE "PRODUCTIONS", APART FROM THE MARK AS SHOWN.

THE ENGLISH TRANSLATION OF "VICI" IN THE MARK IS "TO CONQUER".

FOR AUDIO RECORDINGS FEATURING MUSICAL PERFORMANCES (U.S. CLS. 21, 23, 26, 36 AND 38).

FIRST USE 1-28-2004; IN COMMERCE 1-28-2004.  
WILLIAM ROSSMAN, EXAMINING ATTORNEY

SN 85-043,119. RISBO, JEPPESEN HENRIK, FARUM, DENMARK, FILED 5-19-2010.

# Anitag

THE MARK CONSISTS OF STANDARD CHARACTERS WITHOUT CLAIM TO ANY PARTICULAR FONT, STYLE, SIZE, OR COLOR.

FOR RFID ANIMAL EAR MARK IN THE NATURE OF RADIO FREQUENCY IDENTIFICATION (RFID) TAGS WORN BY ANIMALS FOR USE IN THE TRACKING OF ANIMALS (U.S. CLS. 21, 23, 26, 36 AND 38).

ERIN FALK, EXAMINING ATTORNEY

**CLASS 9—(Continued).**

SN 85-043,835. CATEYE CO., LTD., OSAKA-SHI, OSAKA, JAPAN, FILED 5-20-2010.

# MICRO WIRELESS

OWNER OF U.S. REG. NO. 3,074,835.

THE MARK CONSISTS OF THE TERMS "MICRO WIRELESS" IN A BLOCK STYLE FONT.

SEC. 2(F).

FOR MEASURING APPARATUS FOR BICYCLES, NAMELY, BICYCLE COMPUTERS (U.S. CLS. 21, 23, 26, 36 AND 38).

FIRST USE 1-26-2005; IN COMMERCE 1-26-2005.  
ROBERT STRUCK, EXAMINING ATTORNEY

SN 85-044,618. REMOTE TECHNOLOGIES INCORPORATED, SHAKOPEE, MN. FILED 5-21-2010.

# VIRSA

THE MARK CONSISTS OF STANDARD CHARACTERS WITHOUT CLAIM TO ANY PARTICULAR FONT, STYLE, SIZE, OR COLOR.

FOR ELECTRICAL AND ELECTRONIC DEVICES IN THE FIELD OF REMOTE CONTROL AND AUTOMATION SYSTEMS, NAMELY, INFRARED EMITTERS AND REPLACEMENT PARTS AND STRUCTURAL COMPONENT PARTS USED TO CONTROL SAID INFRARED EMITTERS, SOLD AS SINGLE UNITS (U.S. CLS. 21, 23, 26, 36 AND 38).

NAPOLÉON SHARMA, EXAMINING ATTORNEY

SN 85-046,411. TRY PLAN B, L.L.C., PROVIDENCE, RI. FILED 5-24-2010.

# GLO-ZO

THE MARK CONSISTS OF STANDARD CHARACTERS WITHOUT CLAIM TO ANY PARTICULAR FONT, STYLE, SIZE, OR COLOR.

FOR ENTERTAINMENT SERVICES, NAMELY, A GLOW IN THE DARK MINIATURE GOLF COURSE, VIDEO GAME ARCADE, REDEMPTION GAME ARCADE, NAMELY, AN AMUSEMENT ARCADE FEATURING GAMES THAT DISPENSE TICKETS WHICH MAY BE REDEEMED FOR PRIZES, AND CONDUCTING BIRTHDAY PARTIES (U.S. CLS. 21, 23, 26, 36 AND 38).

DOMINIC FATHY, EXAMINING ATTORNEY

**CLASS 9—(Continued).**

SN 85-047,197. JONES INTERNATIONAL, LTD., CENTENNIAL, CO. FILED 5-25-2010.

**MEDIA TYCOON**

THE MARK CONSISTS OF STANDARD CHARACTERS WITHOUT CLAIM TO ANY PARTICULAR FONT, STYLE, SIZE, OR COLOR.

FOR DOWNLOADABLE COMPUTER SIMULATION GAMES AND SIMULATION GAMES PRE-RECORDED ON CDS, VIDEO TAPES, LASER DISKS AND DVDS, ALL FEATURING BUSINESS PLANNING AND STRATEGIES, NAMELY, HOW TO RUN A PROFITABLE BUSINESS AND HOW TO MARKET A PRODUCT (U.S. CLS. 21, 23, 26, 36 AND 38).

CHRISTOPHER BUONGIORNO, EXAMINING ATTORNEY

---

SN 85-048,156. THIND, KEVIN, CHAMBLY, CANADA, AND THIND, HANSPAL, CHAMBLY, CANADA, FILED 5-26-2010.

**C.I. Analytics**

NO CLAIM IS MADE TO THE EXCLUSIVE RIGHT TO USE "ANALYTICS", APART FROM THE MARK AS SHOWN.

THE MARK CONSISTS OF A LION WITH A GLOBE IN ITS PAW INSIDE A BIG CIRCLE WITH ZIG ZAG LINES ABOVE THE GLOBE.

FOR LABORATORY INSTRUMENTS AND PROCESS ANALYZER THAT DETECT AND MONITOR CHEMICAL IMPURITIES (U.S. CLS. 21, 23, 26, 36 AND 38).

FIRST USE 1-1-1995; IN COMMERCE 1-1-1995.  
REBECCA SMITH, EXAMINING ATTORNEY

---

SN 85-048,182. THIND, KEVIN, CHAMBLY, CANADA, AND THIND, HANSPAL, CHAMBLY, CANADA, FILED 5-26-2010.

**C.I. Analytics**

THE MARK CONSISTS OF STANDARD CHARACTERS WITHOUT CLAIM TO ANY PARTICULAR FONT, STYLE, SIZE, OR COLOR.

NO CLAIM IS MADE TO THE EXCLUSIVE RIGHT TO USE "ANALYTICS", APART FROM THE MARK AS SHOWN.

FOR LABORATORY INSTRUMENTS AND PROCESS ANALYZER THAT DETECT AND MONITOR CHEMICAL IMPURITIES (U.S. CLS. 21, 23, 26, 36 AND 38).

FIRST USE 1-1-1995; IN COMMERCE 1-1-1995.  
REBECCA SMITH, EXAMINING ATTORNEY

**CLASS 9—(Continued).**

SN 85-048,664. GLOBALSCAPE, INC., SAN ANTONIO, TX. FILED 5-26-2010.

**TOTAL RECALL**

THE MARK CONSISTS OF STANDARD CHARACTERS WITHOUT CLAIM TO ANY PARTICULAR FONT, STYLE, SIZE, OR COLOR.

FOR COMPUTER SOFTWARE FOR USE IN THE RECOVERY AND BACKING-UP OF DATA AND PROGRAMS (U.S. CLS. 21, 23, 26, 36 AND 38).

ALYSSA STEEL, EXAMINING ATTORNEY

---

SN 85-049,273. PROJECT MANAGEMENT INSTITUTE, INC., AKA PMI, NEWTOWN SQUARE, PA. FILED 5-27-2010.

**Project Week**

THE MARK CONSISTS OF STANDARD CHARACTERS WITHOUT CLAIM TO ANY PARTICULAR FONT, STYLE, SIZE, OR COLOR.

NO CLAIM IS MADE TO THE EXCLUSIVE RIGHT TO USE "PROJECT", APART FROM THE MARK AS SHOWN.

FOR DOWNLOADABLE ELECTRONIC PUBLICATIONS, NAMELY, NEWSLETTERS IN THE FIELD OF PROJECT MANAGEMENT (U.S. CLS. 21, 23, 26, 36 AND 38).

TRICIA SONNEBORN, EXAMINING ATTORNEY

**CLASS 9—(Continued).**

SN 85-050,943. DYNAMICS INC., PITTSBURGH, PA. FILED 5-29-2010.

# Unlock

THE MARK CONSISTS OF STANDARD CHARACTERS WITHOUT CLAIM TO ANY PARTICULAR FONT, STYLE, SIZE, OR COLOR.

FOR BLANK ELECTRONIC CHIP CARDS; BLANK ELECTRONIC STORAGE MEDIA; BLANK INTEGRATED CIRCUIT CARDS; BLANK MAGNETIC DATA CARRIERS; BLANK SMART CARDS; CARDS AND MICROPROCESSORS FOR COMPUTERS; CARDS WITH INTEGRATED CIRCUITS; CHIPCARDS; ELECTRONIC AND MAGNETIC ID CARDS FOR USE IN CONNECTION WITH PAYMENT FOR SERVICES; ELECTRONIC CIRCUIT CARDS; ELECTRONIC KEY CARDS; ELECTRONICALLY ENCODED BADGES AND SWIPE CARDS FOR USE WITH TIME CLOCKS; ENCODED ELECTRONIC CHIP CARDS CONTAINING PROGRAMMING USED TO PROGRESS A FINANCIAL TRANSACTION; ENCODED ELECTRONIC CHIP CARDS FOR PROGRESSING A FINANCIAL TRANSACTION; ENCODED INTEGRATED CIRCUIT CARDS CONTAINING PROGRAMMING USED TO PROGRESS A FINANCIAL TRANSACTION; ENCODED MAGNETIC CARDS; ENCODED SMART CARDS CONTAINING PROGRAMMING USED TO PROGRESS A FINANCIAL TRANSACTION; INTEGRATED CIRCUIT CARDS AND COMPONENTS; MAGNETIC CARDS; MAGNETIC CODED CARDS FOR PROGRESSING A FINANCIAL TRANSACTION; MAGNETIC CODED GIFT CARDS; MAGNETIC IDENTIFYING CARDS; MAGNETICALLY ENCODED CREDIT CARDS; MAGNETICALLY ENCODED DEBIT CARDS; MAGNETICALLY ENCODED IDENTITY CARDS; MICROCHIP CARDS; PRE-PAID TELEPHONE CALLING CARDS, MAGNETICALLY ENCODED; RADIO FREQUENCY IDENTIFICATION (RFID) CREDENTIALS, NAMELY, CARDS AND TAGS, AND READERS FOR RADIO FREQUENCY IDENTIFICATION CREDENTIALS (U.S. CLS. 21, 23, 26, 36 AND 38).

HELENE LIWINSKI, EXAMINING ATTORNEY

SN 85-051,309. KONAMI GAMING, INC., LAS VEGAS, NV. FILED 5-31-2010.

# FREE REELS

THE MARK CONSISTS OF STANDARD CHARACTERS WITHOUT CLAIM TO ANY PARTICULAR FONT, STYLE, SIZE, OR COLOR.

FOR ELECTRONIC GAME PROGRAMS; GAMING EQUIPMENT, NAMELY, SLOT MACHINES WITH OR WITHOUT VIDEO OUTPUT; GAMING MACHINES; MACHINES FOR PLAYING GAMES OF CHANCE; SLOT MACHINES (U.S. CLS. 21, 23, 26, 36 AND 38).

SANJEEV VOHRA, EXAMINING ATTORNEY

**CLASS 9—(Continued).**

SN 85-053,039. OPTIMUS EMR, INC., IRVINE, CA. FILED 6-2-2010.

# OPTIMUS EMR

THE MARK CONSISTS OF STANDARD CHARACTERS WITHOUT CLAIM TO ANY PARTICULAR FONT, STYLE, SIZE, OR COLOR.

NO CLAIM IS MADE TO THE EXCLUSIVE RIGHT TO USE "EMR", APART FROM THE MARK AS SHOWN.

FOR SOFTWARE FOR USE BY HEALTHCARE PROFESSIONALS FOR TRACKING PATIENT CARE, ADMITTING AND DISCHARGING OF PATIENTS, AND MANAGING PHYSICIAN-ORDERED MEDICATIONS, TREATMENTS, AND TESTS (U.S. CLS. 21, 23, 26, 36 AND 38).

FIRST USE 4-7-2006; IN COMMERCE 4-7-2006.

COLLEEN KEARNEY, EXAMINING ATTORNEY

SN 85-055,010. 4INFO, INC., SAN MATEO, CA. FILED 6-4-2010.

# mHaven

THE MARK CONSISTS OF STANDARD CHARACTERS WITHOUT CLAIM TO ANY PARTICULAR FONT, STYLE, SIZE, OR COLOR.

FOR COMPUTER SOFTWARE PLATFORMS FOR CONTROLLING AND MAINTAINING THE FLOW OF INTERNET TRAFFIC, ADVERTISING, AND NETWORK USER RESPONSE DATA; COMPUTER SOFTWARE PLATFORMS TO PROVIDE APPLICATION PROGRAMMING INTERFACE CONNECTIVITY FOR ADVERTISING NETWORKS; COMPUTER SOFTWARE FOR USE IN DATABASE MANAGEMENT (U.S. CLS. 21, 23, 26, 36 AND 38).

ELIZABETH KAJUBI, EXAMINING ATTORNEY

SN 85-055,510. LOPEZ, R. DAN, WATERVILLE, WA. FILED 6-5-2010.

# MORAL COMPASS

THE MARK CONSISTS OF STANDARD CHARACTERS WITHOUT CLAIM TO ANY PARTICULAR FONT, STYLE, SIZE, OR COLOR.

FOR DIRECTIONAL COMPASSES (U.S. CLS. 21, 23, 26, 36 AND 38).

DAVID H. STINE, EXAMINING ATTORNEY



**CLASS 9—(Continued).**

SN 85-055,877. EVONIK STOCKHAUSEN GMBH, KREFELD, FED REP GERMANY, FILED 6-7-2010.

**CLASS 9—(Continued).**

SN 85-059,510. AMYLIN PHARMACEUTICALS, INC., SAN DIEGO, CA. FILED 6-10-2010.

## STOKO REFRESH

THE MARK CONSISTS OF STANDARD CHARACTERS WITHOUT CLAIM TO ANY PARTICULAR FONT, STYLE, SIZE, OR COLOR.

PRIORITY CLAIMED UNDER SEC. 44(D) ON ERP N CMNTY TM OFC APPLICATION NO. 008753493, FILED 12-14-2009, REG. NO. 008753493, DATED 8-2-2010, EXPIRES 12-14-2019.

OWNER OF U.S. REG. NOS. 1,291,666, 2,958,992 AND 3,334,481.

FOR MECHANICAL DEVICES, NAMELY, DISPENSERS OF PRESET PORTIONS OF RINSING, CLEANING AND DISINFECTANT FLUIDS, SOLID GRANULES AND POWDER FOR DOSING PURPOSES, ALL NOT FOR MEDICAL USE (U.S. CLS. 21, 23, 26, 36 AND 38).

KATHERINE E. HALMEN, EXAMINING ATTORNEY



**T2D Health**

SN 85-057,436. RIMAGE CORPORATION, MINNEAPOLIS, MN. FILED 6-8-2010.

## EVEREST

THE MARK CONSISTS OF STANDARD CHARACTERS WITHOUT CLAIM TO ANY PARTICULAR FONT, STYLE, SIZE, OR COLOR.

FOR PRINTER TO PRODUCE IMAGES DIRECTLY ON OPTICAL DISCS (U.S. CLS. 21, 23, 26, 36 AND 38).

FIRST USE 8-10-2001; IN COMMERCE 8-10-2001.

JUDITH HELFMAN, EXAMINING ATTORNEY

NO CLAIM IS MADE TO THE EXCLUSIVE RIGHT TO USE "DIABETES" AND "T2D HEALTH", APART FROM THE MARK AS SHOWN.

THE COLOR(S) WHITE, BLACK, BLUE, DARK YELLOW, RED, ORANGE, AND GREEN IS/ARE CLAIMED AS A FEATURE OF THE MARK.

THE MARK CONSISTS OF A COLORED BACKGROUND THAT FADES FROM THE COLOR BLUE ON THE TOP TO THE COLOR GREEN ON THE BOTTOM IN THE SHAPE OF A SQUARE. IN THE CENTER OF THE SQUARE IS AN IMAGE OF A HEART IN THE COLOR RED WITH SHADING IN THE COLOR ORANGE ON THE UPPER RIGHT SIDE OF THE HEART. THE HEART IS OUTLINED IN THE COLOR WHITE. AN IMAGE OF A SPHERE-LIKE RING IN THE COLOR BLUE WITH A WHITE OUTLINE ENCIRCLES THE IMAGE OF THE HEART FROM THE BACKSIDE OF THE HEART TO FRONT. BEHIND THE IMAGES OF THE HEART AND THE RING IS A CURVED MUSICAL STAFF IN THE COLOR DARK YELLOW THAT CROSSES FROM LEFT TO RIGHT. THE WORDS "DIABETES LIFE" APPEAR IN THE COLOR WHITE ABOVE THE IMAGES OF THE HEART, RING, AND MUSICAL STAFF. THE WORD "HARMONIZED" APPEARS IN THE COLOR WHITE BELOW THE IMAGES OF THE HEART, RING, AND MUSICAL STAFF. THE WORDS "T2D HEALTH" APPEAR IN THE COLOR BLACK CENTERED BELOW THE COLORED BACKGROUND.

FOR COMPUTER SOFTWARE THAT PROVIDES WEB-BASED ACCESS TO EDUCATIONAL AND INFORMATION SERVICES IN THE FIELDS OF DIABETES, OBESITY, AND CARDIOVASCULAR DISEASE THROUGH A WEB OPERATING SYSTEM PORTAL (U.S. CLS. 21, 23, 26, 36 AND 38).

SCOTT BIBB, EXAMINING ATTORNEY

**CLASS 9—(Continued).**

SN 85-059,570. AMYLIN PHARMACEUTICALS, INC., SAN DIEGO, CA. FILED 6-10-2010.

**CLASS 9—(Continued).**

SN 85-060,882. HARMONIX MUSIC SYSTEMS, INC., NEW YORK, NY. FILED 6-11-2010.

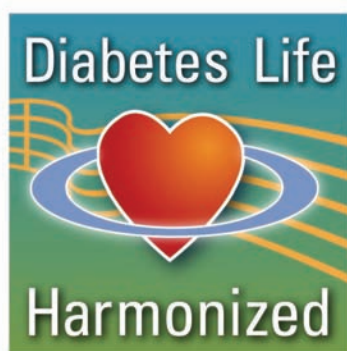
**DANCE CENTRAL**

THE MARK CONSISTS OF STANDARD CHARACTERS WITHOUT CLAIM TO ANY PARTICULAR FONT, STYLE, SIZE, OR COLOR.

FOR COMPUTER GAME SOFTWARE AND ELECTRONIC GAME PROGRAMS, NAMELY, GAME SOFTWARE RECORDED ON CD-ROM AND DIGITAL VIDEO DISCS FOR COMPUTERS; VIDEO GAME SOFTWARE RECORDED ON CD-ROMS, DIGITAL VIDEO DISCS, AND CARTRIDGES FOR CONSOLE AND INDIVIDUAL, PORTABLE GAMING SYSTEMS; VIDEO GAME SOFTWARE THAT IS DOWNLOADABLE FROM A REMOTE COMPUTER SITE AND ELECTRONIC GAME SOFTWARE FOR MOBILE PHONES, PERSONAL DIGITAL ASSISTANTS, AND HANDHELD COMPUTERS (U.S. CLS. 21, 23, 26, 36 AND 38).

RENEE MCCRAY, EXAMINING ATTORNEY

SN 85-060,895. HARMONIX MUSIC SYSTEMS, INC., NEW YORK, NY. FILED 6-11-2010.

NO CLAIM IS MADE TO THE EXCLUSIVE RIGHT TO USE "DIABETES", APART FROM THE MARK AS SHOWN. THE COLOR(S) WHITE, BLUE, GREEN, DARK YELLOW, RED, AND ORANGE IS/ARE CLAIMED AS A FEATURE OF THE MARK.

THE MARK CONSISTS OF A COLORED BACKGROUND THAT FADES FROM THE COLOR BLUE ON THE TOP TO THE COLOR GREEN ON THE BOTTOM IN THE SHAPE OF A SQUARE. IN THE CENTER OF THE SQUARE IS AN IMAGE OF A HEART IN THE COLOR RED WITH SHADING IN THE COLOR ORANGE IN THE UPPER RIGHT SIDE OF THE HEART. THE HEART IS OUTLINED IN THE COLOR WHITE. AN IMAGE OF A SPHERE-LIKE RING IN THE COLOR BLUE WITH A WHITE OUTLINE ENCIRCLES THE IMAGE OF THE HEART FROM THE BACKSIDE OF THE HEART TO THE FRONT. BEHIND THE IMAGES OF THE HEART AND THE RING IS A CURVED MUSICAL STAFF IN THE COLOR DARK YELLOW THAT CROSSES FROM LEFT TO RIGHT. THE WORDS "DIABETES LIFE" APPEAR IN THE COLOR WHITE ABOVE THE IMAGES OF THE HEART, RING, AND MUSICAL STAFF. THE WORD "HARMONIZED" APPEARS IN THE COLOR WHITE BELOW THE IMAGES OF THE HEART, RING, AND MUSICAL STAFF.

FOR COMPUTER SOFTWARE THAT PROVIDES WEB-BASED ACCESS TO EDUCATIONAL AND INFORMATION SERVICES IN THE FIELDS OF DIABETES, OBESITY, AND CARDIOVASCULAR DISEASE THROUGH A WEB OPERATING SYSTEM PORTAL (U.S. CLS. 21, 23, 26, 36 AND 38).

SCOTT BIBB, EXAMINING ATTORNEY



THE MARK CONSISTS OF THE WORDING "DANCE CENTRAL" IN A STYLIZED FONT AND A DESIGN THAT CONSIST OF A SHADED RECTANGLE.

FOR COMPUTER GAME SOFTWARE AND ELECTRONIC GAME PROGRAMS, NAMELY, GAME SOFTWARE RECORDED ON CD-ROM AND DIGITAL VIDEO DISCS FOR COMPUTERS; VIDEO GAME SOFTWARE RECORDED ON CD-ROMS, DIGITAL VIDEO DISCS, AND CARTRIDGES FOR CONSOLE AND INDIVIDUAL, PORTABLE GAMING SYSTEMS; VIDEO GAME SOFTWARE THAT IS DOWNLOADABLE FROM A REMOTE COMPUTER SITE AND ELECTRONIC GAME SOFTWARE FOR MOBILE PHONES, PERSONAL DIGITAL ASSISTANTS, AND HANDHELD COMPUTERS (U.S. CLS. 21, 23, 26, 36 AND 38).

RENEE MCCRAY, EXAMINING ATTORNEY

**CLASS 9—(Continued).**

SN 85-061,155. HOM ESSENCE, INC., LOS ALAMITOS, CA. FILED 6-11-2010.



NO CLAIM IS MADE TO THE EXCLUSIVE RIGHT TO USE "ORGANIZATION", APART FROM THE MARK AS SHOWN.

THE MARK CONSISTS OF THE LETTERS "H", "O" AND "M" IN SIDE-BY-SIDE SQUARE BOXES WITH A HORIZONTAL LINE OVER THE LETTER "O" AND THE WORD "ORGANIZATION" BELOW.

FOR DESK ACCESSORIES, STATIONERY AND ITEMS FOR STORAGE AND ORGANIZATION, NAMELY, LETTER TRAYS, LETTER SORTERS, DESKTOP ORGANIZERS, DOCUMENT BOXES MADE OF PAPERBOARD COVERED WITH EITHER PAPER, FABRIC OR FAUX LEATHER, STORAGE BOXES WITH LIDS MADE OF PAPERBOARD COVERED WITH EITHER PAPER, FABRIC OR FAUX LEATHER, FILE BOXES FOR STORAGE OF BUSINESS AND PERSONAL RECORDS, PENCIL CUPS, PENCIL HOLDERS, DESK BLOTTERS, NEWSPAPER AND MAIL TRAYS, MAGAZINE HOLDERS, TWO-DRAWER LETTER TRAYS, WASTE BASKETS AND DISC STORAGE CONTAINERS FOR CD/DVD STORAGE (U.S. CLS. 21, 23, 26, 36 AND 38).

FIRST USE 5-31-2006; IN COMMERCE 5-31-2006.  
JACQUELINE A. LAVINE, EXAMINING ATTORNEY

SN 85-061,962. ALTAIR ENGINEERING, INC., TROY, MI. FILED 6-14-2010.

**SCICOS PROFESSIONAL**

THE MARK CONSISTS OF STANDARD CHARACTERS WITHOUT CLAIM TO ANY PARTICULAR FONT, STYLE, SIZE, OR COLOR.

NO CLAIM IS MADE TO THE EXCLUSIVE RIGHT TO USE "PROFESSIONAL", APART FROM THE MARK AS SHOWN.

FOR COMPUTER SOFTWARE, NAMELY, SOFTWARE USED FOR GRAPHICAL MODELING AND SIMULATION OF DYNAMIC SYSTEMS IN THE NATURE OF DYNAMIC COMPUTER SYSTEMS (U.S. CLS. 21, 23, 26, 36 AND 38).

ZHALEH DELANEY, EXAMINING ATTORNEY

**CLASS 9—(Continued).**

SN 85-063,119. THEMA OPTICAL S.R.L., DOMEgge DI CADORE (BL), ITALY, FILED 6-15-2010.

**THEMA**

THE MARK CONSISTS OF STANDARD CHARACTERS WITHOUT CLAIM TO ANY PARTICULAR FONT, STYLE, SIZE, OR COLOR.

FOR SPECTACLES, SUNGLASSES, EYEGLASSES, LENSES FOR SPECTACLES, CONTACT LENSES, FRAMES FOR SUNGLASSES AND EYEGLASSES; CASES AND HOLDERS FOR SUNGLASSES AND EYEGLASSES, CONTAINERS FOR CONTACT LENSES; ACCESSORIES FOR SUNGLASSES AND EYEGLASSES, NAMELY, EYEGLASS CHAINS (U.S. CLS. 21, 23, 26, 36 AND 38).

GENE MACIOL, EXAMINING ATTORNEY

SN 85-063,411. AG LEADER TECHNOLOGY, INC., AMES, IA. FILED 6-15-2010.

**AG LEADER**

THE MARK CONSISTS OF STANDARD CHARACTERS WITHOUT CLAIM TO ANY PARTICULAR FONT, STYLE, SIZE, OR COLOR.

OWNER OF U.S. REG. NO. 2,788,717.  
NO CLAIM IS MADE TO THE EXCLUSIVE RIGHT TO USE "AG", APART FROM THE MARK AS SHOWN.

FOR ELECTRICAL MONITORS AND CONTROLS FOR AGRICULTURAL EQUIPMENT, INCLUDING MONITORS AND CONTROLS WHICH USE GLOBAL NAVIGATION SATELLITE SYSTEM (GNSS) RECEIVERS (U.S. CLS. 21, 23, 26, 36 AND 38).

FIRST USE 6-9-2010; IN COMMERCE 6-9-2010.  
JULIE GUTTADAURO, EXAMINING ATTORNEY

SN 85-064,252. IRISH MIKE'S LLC, MEMPHIS, TN. FILED 6-16-2010.

**PARTSFACTSDATA**

THE MARK CONSISTS OF STANDARD CHARACTERS WITHOUT CLAIM TO ANY PARTICULAR FONT, STYLE, SIZE, OR COLOR.

FOR COMPUTER SOFTWARE FOR USE AS AN INTERACTIVE PROGRAM TO PROVIDE PARTS HISTORY USED IN A COLLISION REPAIR FACILITY IN THE AUTOMOTIVE INDUSTRY; COMPUTER SOFTWARE FOR USE AS AN INTERACTIVE PROGRAM TO PROVIDE PARTS HISTORY USED IN A COLLISION REPAIR FACILITY IN THE AUTOMOTIVE INDUSTRY THAT MAY BE DOWNLOADED FROM A GLOBAL COMPUTER NETWORK (U.S. CLS. 21, 23, 26, 36 AND 38).

RONALD MCMORROW, EXAMINING ATTORNEY

**CLASS 9—(Continued).**

SN 85-064,271. FLIR SYSTEMS, INC., WILSONVILLE, OR.  
FILED 6-16-2010.

# MILSIGHT

THE MARK CONSISTS OF STANDARD CHARACTERS WITHOUT CLAIM TO ANY PARTICULAR FONT, STYLE, SIZE, OR COLOR.

FOR MOUNTING NIGHT VISION DEVICES, NAMELY, HIGH-RESOLUTION NIGHT VISION SIGHTS FOR USE WITH WEAPONS (U.S. CLS. 21, 23, 26, 36 AND 38).

REGINA DRUMMOND, EXAMINING ATTORNEY

---

SN 85-065,049. PAIGE ELECTRIC COMPANY, LP, UNION, NJ. FILED 6-17-2010.

# WALL BUSTER

THE MARK CONSISTS OF STANDARD CHARACTERS WITHOUT CLAIM TO ANY PARTICULAR FONT, STYLE, SIZE, OR COLOR.

NO CLAIM IS MADE TO THE EXCLUSIVE RIGHT TO USE "WALL", APART FROM THE MARK AS SHOWN.

FOR THROUGH-WALL WIRING PROTECTION DEVICE IN THE NATURE OF A PROTECTIVE SHEATH FOR ELECTRICAL CABLE AND WIRING (U.S. CLS. 21, 23, 26, 36 AND 38).

LINDA ESTRADA, EXAMINING ATTORNEY

---

SN 85-065,390. 101COMMUNICATIONS LLC, CHATSWORTH, CA. FILED 6-17-2010.

# FEDERAL DAILY

THE MARK CONSISTS OF STANDARD CHARACTERS WITHOUT CLAIM TO ANY PARTICULAR FONT, STYLE, SIZE, OR COLOR.

OWNER OF U.S. REG. NOS. 2,887,999, 2,955,585 AND 2,961,587.

SEC. 2(F).

FOR DOWNLOADABLE ELECTRONIC NEWSLETTERS IN THE FIELD OF GOVERNMENT EMPLOYMENT (U.S. CLS. 21, 23, 26, 36 AND 38).

FIRST USE 2-3-2003; IN COMMERCE 2-3-2003.

KELLY BOULTON, EXAMINING ATTORNEY

**CLASS 9—(Continued).**

SN 85-065,504. GENUS LIMITED, SHEUNG WAN, HONG KONG, FILED 6-17-2010.

# GENUSTECH

THE MARK CONSISTS OF STANDARD CHARACTERS WITHOUT CLAIM TO ANY PARTICULAR FONT, STYLE, SIZE, OR COLOR.

OWNER OF U.S. REG. NO. 3,835,704.

FOR FILM AND VIDEO PRODUCTION PARTS AND FITTINGS AND ACCESSORIES, NAMELY, ADAPTOR RINGS, WIDE ANGLE MATTE BOXES, STANDARD MATTE BOXES, DONUT ADAPTOR RINGS, FRENCH CLIP-ON FLAGS MADE OF METAL, NAMELY, SPECIALITY METAL FLAPS FOR REDUCING LIGHT GLARE AND SHADING, ADVANCED ADAPTOR BARS AND ADAPTOR BAR RODS, FILTER HOLDERS FOR OPTICAL DEVICES, PRODUCTION SUPPORT AND STABILITY ACCESSORIES, NAMELY, SUPPORT BARS ADAPTOR, SUPPORT BRACKET AND SUPPORT BARS, SHOULDER MOUNT SYSTEMS, RAY SHADE, SUNSHADE, FILTER HOLDER, FOLLOW FOCUS UNITS FOR LENS, MOUNTING DEVICES FOR MOTION-PICTURE AND COMMERCIAL VIDEO PRODUCTION EQUIPMENT; ALL THE AFORESAID FUNCTIONING TO ASSIST WITH LIGHTING REQUIREMENTS FOR A PROFESSIONAL USER IN THE FORM OF SPECIALITY ATTACHMENTS FOR PROFESSIONAL MOTION-PICTURE AND COMMERCIAL PRODUCTION EQUIPMENT FOR PROVIDING SHADING AND REDUCING GLARE AND PARTS AND ACCESSORIES THEREFOR (U.S. CLS. 21, 23, 26, 36 AND 38).

EUGENIA MARTIN, EXAMINING ATTORNEY

---

SN 85-067,056. INNOVATIVE PRESSURE TESTING, LLC, KATY, TX. FILED 6-19-2010.

# IPT

THE MARK CONSISTS OF STANDARD CHARACTERS WITHOUT CLAIM TO ANY PARTICULAR FONT, STYLE, SIZE, OR COLOR.

FOR COMPUTER SOFTWARE FOR PROCESSING DATA OBTAINED WHILE PRESSURE TESTING PRESSURE SYSTEMS, NAMELY, PIPELINES, STORAGE TANKS AND CONTAINERS, MANIFOLDS, VALVES, BLOWOUT PREVENTERS, PRODUCTION TREES, WELLS FOR WATER PRODUCTION, WELLS FOR HYDROCARBON PRODUCTION, WELLS FOR GEOTHERMAL ENERGY PRODUCTION, WELL HEADS, PRODUCTION TUBING, CASING, DRILL PIPE, DRILL COLLARS, RISERS, AND FLUID LINES (U.S. CLS. 21, 23, 26, 36 AND 38).

PATRICIA EVANKO, EXAMINING ATTORNEY

**CLASS 9—(Continued).**

SN 85-068,159. SONY CORPORATION, TOKYO, JAPAN, FILED 6-21-2010.



THE COLOR(S) ORANGE AND BLUE IS/ARE CLAIMED AS A FEATURE OF THE MARK.

THE MARK CONSISTS OF THE FOLLOWING: THE STYLIZED WORDING "ECLIPSE" WITH A BLUE CURVED BAND UNDER THE ORANGE LETTERS "E","C","L" AND ABOVE THE LETTERS "P","S","E". THE "I" IN "ECLIPSE" ALSO APPEARS IN BLUE.

FOR CYTOMETERS (U.S. CLS. 21, 23, 26, 36 AND 38).  
INGRID C. EULIN, EXAMINING ATTORNEY

SN 85-068,750. SAMSUNG ELECTRONICS CO., LTD., SUWON-SI, GYEONGGI-DO, REPUBLIC OF KOREA, FILED 6-22-2010.



OWNER OF U.S. REG. NO. 3,559,552.

NO CLAIM IS MADE TO THE EXCLUSIVE RIGHT TO USE "AMOLED", APART FROM THE MARK AS SHOWN.

THE COLOR(S) LIME GREEN, GREEN, BLUE GREEN, BLUE, PURPLE, RED, ORANGE, YELLOW AND BLACK IS/ARE CLAIMED AS A FEATURE OF THE MARK.

THE MARK CONSISTS OF A STYLIZED "C" WITH THE COLORS LIME GREEN, GREEN, BLUE GREEN, BLUE, PURPLE, RED, ORANGE, AND YELLOW MAKING UP THE "C". AND THE STYLIZED COLOR "C" IS ENCOMPASSING THE WORDS "SUPER AMOLED" IN BLACK, AND THE "O" IN "AMOLED" IS IN THE COLORS LIME GREEN, GREEN, BLUE GREEN, BLUE, PURPLE, RED, ORANGE, AND YELLOW.

FOR NOTEBOOK COMPUTERS; DIGITAL CAMERAS; SMARTPHONES; CAMCORDERS; PORTABLE MULTIMEDIA PLAYER; MOBILE TELEPHONES; MP4 PLAYERS; PERSONAL DIGITAL ASSISTANTS; TELEVISION RECEIVERS (U.S. CLS. 21, 23, 26, 36 AND 38).  
WILLIAM ROSSMAN, EXAMINING ATTORNEY

**CLASS 9—(Continued).**

SN 85-069,798. VERANCE CORPORATION, SAN DIEGO, CA. FILED 6-23-2010.



NO CLAIM IS MADE TO THE EXCLUSIVE RIGHT TO USE "PROTECTED", APART FROM THE MARK AS SHOWN.

THE MARK CONSISTS OF A DESIGN OF A STYLIZED LETTER "C" WITH MULTIPLE CURVED LINES ADJACENT TO THE STYLIZED LETTER "C" WITH THE TERMS "PROTECTED" AND "CINAVIA.COM" POSITIONED TO THE SIDE OF THE DESIGN.

THE WORDING "CINAVIA" HAS NO MEANING IN A FOREIGN LANGUAGE.

FOR CDS, DVDS, HIGH DEFINITION DISCS, FLASH MEMORY, COMPUTER DISKS, TAPES, CINEMATOGRAPHIC FILM MEDIA, OPTICAL STORAGE MEDIA, MAGNETIC STORAGE MEDIA AND DIGITAL STORAGE MEDIA, ALL FEATURING MUSIC, VOICE, AUDIOVISUAL, MULTIMEDIA, DIGITAL DATA STREAMS, TOGETHER WITH EMBEDDED INFORMATION; INTERACTIVE COMPUTER GAMES RECORDED ON ELECTRONIC MEDIA AND INTERACTIVE ENTERTAINMENT SOFTWARE PROVIDED TOGETHER WITH INFORMATION EMBEDDED IN AUDIO, VIDEO, AUDIOVISUAL AND MULTIMEDIA PORTIONS THEREOF (U.S. CLS. 21, 23, 26, 36 AND 38).  
ANGELA DUONG, EXAMINING ATTORNEY

SN 85-070,039. VERANCE CORPORATION, SAN DIEGO, CA. FILED 6-23-2010.



NO CLAIM IS MADE TO THE EXCLUSIVE RIGHT TO USE "PROTECTED", APART FROM THE MARK AS SHOWN.

THE MARK CONSISTS OF A DESIGN OF A STYLIZED LETTER "C" WITH MULTIPLE CURVED LINES ADJACENT TO THE STYLIZED LETTER "C" WITH THE TERM "PROTECTED" POSITIONED ABOVE THE DESIGN AND THE TERM "CINAVIA.COM" BENEATH THE DESIGN.

THE WORDING "CINAVIA" HAS NO MEANING IN A FOREIGN LANGUAGE.

FOR CDS, DVDS, HIGH DEFINITION DISCS, FLASH MEMORY, COMPUTER DISKS, TAPES, CINEMATOGRAPHIC FILM MEDIA, OPTICAL STORAGE MEDIA, MAGNETIC STORAGE MEDIA AND DIGITAL STORAGE MEDIA, ALL FEATURING MUSIC, VOICE, AUDIOVISUAL, MULTIMEDIA, DIGITAL DATA STREAMS, TOGETHER WITH EMBEDDED INFORMATION; INTERACTIVE COMPUTER GAMES RECORDED ON ELECTRONIC MEDIA AND INTERACTIVE ENTERTAINMENT SOFTWARE PROVIDED TOGETHER WITH INFORMATION EMBEDDED IN AUDIO, VIDEO, AUDIOVISUAL AND MULTIMEDIA PORTIONS THEREOF (U.S. CLS. 21, 23, 26, 36 AND 38).  
ANGELA DUONG, EXAMINING ATTORNEY



**CLASS 9—(Continued).**

SN 85-070,685. CORONADO, JUAN M., CHULA VISTA, CA.  
FILED 6-24-2010.

**JC POWER Audio Systems**

THE MARK CONSISTS OF STANDARD CHARACTERS WITHOUT CLAIM TO ANY PARTICULAR FONT, STYLE, SIZE, OR COLOR.

NO CLAIM IS MADE TO THE EXCLUSIVE RIGHT TO USE "POWER AUDIO SYSTEMS", APART FROM THE MARK AS SHOWN.

FOR AUDIO EQUIPMENT FOR VEHICLES, NAMELY, STEREOs, SPEAKERS, AMPLIFIERS, EQUALIZERS, CROSSOVERS AND SPEAKER HOUSINGS (U.S. CLS. 21, 23, 26, 36 AND 38).

FIRST USE 0-0-2004; IN COMMERCE 0-0-2004.  
MARY ROSSMAN, EXAMINING ATTORNEY

SN 85-071,760. KONISZCZUK STEVEN JOHN, SARASOTA, FL. FILED 6-25-2010.

**DUDE**

THE MARK CONSISTS OF STANDARD CHARACTERS WITHOUT CLAIM TO ANY PARTICULAR FONT, STYLE, SIZE, OR COLOR.

FOR EYEGLASS CASES; EYEGLASS CHAINS AND CORDS; EYEGLASS FRAMES; EYEWEAR, NAMELY, SUNGLASSES, EYEGLASSES AND OPHTHALMIC FRAMES AND CASES THEREFOR; SPORTS EYEWEAR; SPORTS TRAINING EYEGLASSES (U.S. CLS. 21, 23, 26, 36 AND 38).

CAROLINE WOOD, EXAMINING ATTORNEY

SN 85-071,830. XILINX, INC., SAN JOSE, CA. FILED 6-25-2010.

**ARTIX**

THE MARK CONSISTS OF STANDARD CHARACTERS WITHOUT CLAIM TO ANY PARTICULAR FONT, STYLE, SIZE, OR COLOR.

FOR INTEGRATED CIRCUITS, NAMELY, FIELD PROGRAMMABLE GATE ARRAYS; COMPUTER SOFTWARE FOR DESIGN, PROGRAMMING, AND OPERATION OF PROGRAMMABLE GATE ARRAYS (U.S. CLS. 21, 23, 26, 36 AND 38).

WILLIAM ROSSMAN, EXAMINING ATTORNEY

**CLASS 9—(Continued).**

SN 85-071,836. XILINX, INC., SAN JOSE, CA. FILED 6-25-2010.

**XILINX ARTIX**

THE MARK CONSISTS OF STANDARD CHARACTERS WITHOUT CLAIM TO ANY PARTICULAR FONT, STYLE, SIZE, OR COLOR.

OWNER OF U.S. REG. NOS. 1,713,232, 1,904,283 AND OTHERS.

FOR INTEGRATED CIRCUITS, NAMELY, FIELD PROGRAMMABLE GATE ARRAYS (U.S. CLS. 21, 23, 26, 36 AND 38).

WILLIAM ROSSMAN, EXAMINING ATTORNEY

SN 85-072,233. SIMESCAPE, BATTLE MOUNTAIN, NV. FILED 6-25-2010.

**SimEscape**

THE MARK CONSISTS OF STANDARD CHARACTERS WITHOUT CLAIM TO ANY PARTICULAR FONT, STYLE, SIZE, OR COLOR.

FOR COMPUTER SOFTWARE, NAMELY, VIRTUAL DIPLOMACY SIMULATION AND TRAINING SOFTWARE (U.S. CLS. 21, 23, 26, 36 AND 38).

BARBARA GAYNOR, EXAMINING ATTORNEY

SN 85-073,311. STEREN ELECTRONICS INTERNATIONAL, LLC, SAN DIEGO, CA. FILED 6-28-2010.



THE MARK CONSISTS OF THE WORD "ANACONDA" WITH A STYLIZED ANACONDA IN AN "S" SHAPE WRAPPED AROUND AND GOING THROUGH THE FIRST LETTER "A".

FOR ELECTRICAL CABLES, NAMELY, CABLE ASSEMBLIES FOCUSED ON CONNECTIVITY FOR AUDIO-VIDEO SYSTEMS INTEGRATION, SATELLITE, BROADBAND, AND STRUCTURED WIRING INDUSTRIES (U.S. CLS. 21, 23, 26, 36 AND 38).

FIRST USE 8-0-2009; IN COMMERCE 8-0-2009.

JUSTINE D. PARKER, EXAMINING ATTORNEY

**CLASS 9—(Continued).**

SN 85-073,331. GH RECORDS, INC., GIG HARBOR, WA.  
FILED 6-28-2010.



THE MARK CONSISTS OF A STYLIZED LINE DRAWING OF A HORSE ABOVE THE STYLIZED WORDS "GIFT HORSE", WHICH ARE UNDERLINED.

FOR PHONOGRAPH RECORDS, PRERECORDED TAPE CASSETTES AND COMPACT DISCS FEATURING MUSIC (U.S. CLS. 21, 23, 26, 36 AND 38).

FIRST USE 0-0-1980; IN COMMERCE 0-0-1980.  
ANDREW LEASER, EXAMINING ATTORNEY

SN 85-074,271. ACTIFIO, INC., WALTHAM, MA. FILED 6-29-2010.

# SIMPLI

THE MARK CONSISTS OF STANDARD CHARACTERS WITHOUT CLAIM TO ANY PARTICULAR FONT, STYLE, SIZE, OR COLOR.

FOR COMPUTER SOFTWARE AND HARDWARE FOR MANAGING COMPUTER NETWORK STORAGE (U.S. CLS. 21, 23, 26, 36 AND 38).

REBECCA SMITH, EXAMINING ATTORNEY

SN 85-074,273. ACTIFIO, INC., WALTHAM, MA. FILED 6-29-2010.

# ACTIFIO

THE MARK CONSISTS OF STANDARD CHARACTERS WITHOUT CLAIM TO ANY PARTICULAR FONT, STYLE, SIZE, OR COLOR.

FOR COMPUTER SOFTWARE AND HARDWARE FOR MANAGING COMPUTER NETWORK STORAGE (U.S. CLS. 21, 23, 26, 36 AND 38).

REBECCA SMITH, EXAMINING ATTORNEY

**CLASS 9—(Continued).**

SN 85-074,826. FREMANTLEMEDIA OPERATIONS B.V.,  
HILVERSUM, NETHERLANDS, FILED 6-30-2010.

## PLAY YOUR HUNCH

THE MARK CONSISTS OF STANDARD CHARACTERS WITHOUT CLAIM TO ANY PARTICULAR FONT, STYLE, SIZE, OR COLOR.

OWNER OF U.S. REG. NO. 2,552,894.

FOR CAMERA CASES; CAMERAS; CASES FOR ELECTRONIC DIARIES; CASES FOR MOBILE PHONES; CASES FOR POCKET CALCULATORS; CD CASES; CD PLAYERS; CELLULAR PHONE ACCESSORY CHARMS; COMPUTER GAME SOFTWARE; DECORATIVE MAGNETS; DOWNLOADABLE COMPUTER GAME PROGRAMS; DOWNLOADABLE COMPUTER GRAPHICS; DOWNLOADABLE IMAGE FILE CONTAINING ARTWORK, TEXT, AUDIO, VIDEO, GAMES AND INTERNET WEB LINKS RELATING TO A GAME SHOW; ELECTRONIC DIARIES; ELECTRONIC DAY PLANNERS; ELECTRONIC GAME SOFTWARE FOR CELLULAR TELEPHONES; EYEGLASSES; FITTED PLASTIC FILMS KNOWN AS SKINS FOR COVERING AND PROVIDING A SCRATCH PROOF BARRIER OR PROTECTION FOR ELECTRONIC DEVICES, NAMELY, MP3 PLAYERS, MOBILE TELEPHONES, SMART TELEPHONES, DIGITAL CAMERAS, GLOBAL POSITIONING SYSTEMS AND PERSONAL DIGITAL ASSISTANTS; GAMING MACHINES, NAMELY, SLOT MACHINES AND VIDEO LOTTERY TERMINALS; GAMING MACHINES, NAMELY, DEVICES WHICH ACCEPT A WAGER; HEADSETS FOR MOBILE TELEPHONES; HOLDERS FOR MAGNETICALLY ENCODED GIFT CARDS; MAGNETICALLY ENCODED DEBIT CARDS; INTERACTIVE VIDEO GAME PROGRAMS; MAGNETIC CODED GIFT CARDS; MOBILE TELEPHONES; MP3 PLAYERS; PERSONAL DIGITAL ASSISTANTS (PDA); POCKET CALCULATORS; PRE-PAID TELEPHONE CALLING CARDS, MAGNETICALLY ENCODED; PRE-RECORDED ELECTRONIC AND DIGITAL MEDIA FEATURING A GAME SHOW; RADIOS; SUNGLASSES; VIDEO GAME INTERACTIVE CONTROL FLOOR PADS OR MATS; VIDEO GAME INTERACTIVE HAND HELD REMOTE CONTROLS FOR PLAYING ELECTRONIC GAMES; VIDEO GAME MACHINES FOR USE WITH EXTERNAL DISPLAY SCREEN OR MONITOR; VIDEO GAME SOFTWARE; INTERACTIVE EDUCATIONAL SOFTWARE FEATURING MUSICAL INSTRUMENT INSTRUCTION; ELECTRIC HAIR APPLIANCES, NAMELY, BRAIDERS, WRAPPERS, IRONS, CRIMPERS, CURLERS, CURLING IRONS, ROLLERS, STRAIGHTENERS; BATTERY-OPERATED HAIR APPLIANCES, NAMELY, BRAIDERS, WRAPPERS, IRONS, CRIMPERS, CURLERS, CURLING IRONS, ROLLERS, STRAIGHTENERS; COMPUTER SOFTWARE FOR CREATING, RECORDING, EDITING AND TRANSMITTING MUSIC AND OTHER AUDIO MATERIAL; PRINTERS, PICTURE PROJECTORS; DIGITAL PHOTO FRAMES FOR DISPLAYING DIGITAL PHOTOS; ELECTRONIC AUDIO TAPE RECORDER; DIGITAL AUDIO TAPE PLAYER AND RECORDER; DIGITAL MEDIA, NAMELY, PRE-RECORDED VIDEO CASSETTES, DIGITAL VIDEO DISCS, DIGITAL VERSATILE DISCS, DOWNLOADABLE AUDIO AND VIDEO RECORDINGS, DVDS, AND HIGH DEFINITION DIGITAL DISCS FEATURING GAME SHOWS; INTERACTIVE EDUCATIONAL SOFTWARE FEATURING SINGING INSTRUCTIONS AND KARAOKE MUSIC; KARAOKE PLAYER AND RECORDER; DOWNLOADABLE ELECTRONIC NEWSLETTERS IN THE FIELD OF ENTERTAINMENT; DOWNLOADABLE ELECTRONIC PUBLICATIONS IN THE NATURE OF MAGAZINES OR BOOKS IN THE FIELD OF ENTERTAINMENT (U.S. CLS. 21, 23, 26, 36 AND 38).

REBECCA SMITH, EXAMINING ATTORNEY

**CLASS 9—(Continued).**

SN 85-074,832. GEOFFREY SELZER, WEST HILLS, CA.  
FILED 6-30-2010.

**LUMINOUS BOOKS**

THE MARK CONSISTS OF STANDARD CHARACTERS WITHOUT CLAIM TO ANY PARTICULAR FONT, STYLE, SIZE, OR COLOR.

NO CLAIM IS MADE TO THE EXCLUSIVE RIGHT TO USE "BOOKS", APART FROM THE MARK AS SHOWN.

FOR DOWNLOADABLE ELECTRONIC PUBLICATIONS IN THE NATURE OF BOOKS, MAGAZINES AND PERIODICALS ON A WIDE RANGE OF TOPICS OF GENERAL INTEREST, NAMELY, ART, EDUCATION, SPORTS, BEAUTY, RETAIL SALES, PETS, AUTOMOBILES, DO-IT-YOURSELF, HISTORY, TRAVEL, SCIENCE, FASHION, TECHNOLOGY, CHILDREN'S CONTENT, GREEN TOPICS AND SUSTAINABILITY, GARDENING, MUSIC, SCIENCE FICTION, FOOD, WINE, HEALTH AND WELLNESS, FILMS, GAMES, NEWS AND CURRENT EVENTS, ARCHITECTURE AND INTERIOR DESIGN, ALL OF THE FOREGOING NOT IN THE FIELD OF RELIGION; DOWNLOADABLE MULTIMEDIA FILES CONTAINING ARTWORK, TEXT, AUDIO, VIDEO, GAMES, MUSIC, 3-D ANIMATION, AUDIO-VIDEO ENTERTAINMENT, BOOKS, MAGAZINES, PERIODICALS, INTERNET WEB LINKS AND REAL-TIME DATA AND CONTENT RELATING TO A WIDE RANGE OF TOPICS OF GENERAL INTEREST, NAMELY, ART, EDUCATION, SPORTS, BEAUTY, RETAIL SALES, PETS, AUTOMOBILES, DO-IT-YOURSELF, HISTORY, TRAVEL, SCIENCE, FASHION, TECHNOLOGY, CHILDREN'S CONTENT, GREEN TOPICS AND SUSTAINABILITY, GARDENING, MUSIC, SCIENCE FICTION, FOOD, WINE, HEALTH AND WELLNESS, FILMS, GAMES, NEWS AND CURRENT EVENTS, ARCHITECTURE AND INTERIOR DESIGN, ALL OF THE FOREGOING NOT IN THE FIELD OF RELIGION; DOWNLOADABLE SOFTWARE IN THE NATURE OF MOBILE APPLICATIONS ON A WIDE RANGE OF TOPICS OF GENERAL INTEREST FOR USE IN CONNECTION WITH TABLET COMPUTERS AND MOBILE PHONES FOR CONTENT CONSUMPTION, SOCIAL NETWORKING, ECOMMERCE, AND ACCESSING, VIEWING AND READING ELECTRONIC PUBLICATIONS IN THE NATURE OF BOOKS, MAGAZINES AND PERIODICALS, ALL OF THE FOREGOING NOT IN THE FIELD OF RELIGION; SOFTWARE PLUG-IN APPLICATIONS FOR TABLET COMPUTERS AND MOBILE PHONES, NAMELY, FOR CONTENT CONSUMPTION, SOCIAL NETWORKING, ECOMMERCE, AND ACCESSING, VIEWING AND READING ELECTRONIC PUBLICATIONS IN THE NATURE OF BOOKS, MAGAZINES AND PERIODICALS, ALL OF THE FOREGOING NOT IN THE FIELD OF RELIGION (U.S. CLS. 21, 23, 26, 36 AND 38).

MARTHA SANTOMARTINO, EXAMINING ATTORNEY

**CLASS 9—(Continued).**

SN 85-074,956. CONAIR CORPORATION, STAMFORD, CT.  
FILED 6-30-2010.

**HOT LINX**

THE MARK CONSISTS OF STANDARD CHARACTERS WITHOUT CLAIM TO ANY PARTICULAR FONT, STYLE, SIZE, OR COLOR.

OWNER OF U.S. REG. NO. 1,441,071.

NO CLAIM IS MADE TO THE EXCLUSIVE RIGHT TO USE "HOT", APART FROM THE MARK AS SHOWN.

FOR ELECTRIC HAIR CURLERS; ELECTRIC HAIR ROLLERS; HAIR-CURLERS, ELECTRICALLY HEATED (U.S. CLS. 21, 23, 26, 36 AND 38).

YAT SYE, LEE, EXAMINING ATTORNEY

SN 85-078,439. OLYMPUS CORPORATION, TOKYO, JAPAN,  
FILED 7-6-2010.

**OLYMPUS PENPAL**

THE MARK CONSISTS OF STANDARD CHARACTERS WITHOUT CLAIM TO ANY PARTICULAR FONT, STYLE, SIZE, OR COLOR.

OWNER OF U.S. REG. NOS. 1,240,989 AND 2,365,504.

FOR DIGITAL CAMERA ACCESSORIES, NAMELY, WIRELESS COMMUNICATION DEVICES FOR TRANSMITTING IMAGES TAKEN BY A CAMERA, GPS DEVICES FOR IDENTIFYING THE PRESENT LOCATION, IMAGE AND SOUND PROCESSORS, IMAGE DISPLAYS, NAMELY, LCD DISPLAYS AND DIGITAL PHOTO FRAMES, PROJECTORS, NAMELY, PHOTOGRAPHIC PROJECTORS, MICROPHONES, AUDIO SPEAKERS, BATTERIES, BATTERY CHARGERS, LIGHTINGS, NAMELY, PHOTOGRAPHIC FLASH UNITS AND FLASHLIGHTS WITH LIGHT EMITTING DIODES FOR USE IN PHOTOGRAPHY, CABLES, NAMELY, USB CABLES AND CONNECTING ELECTRICAL CABLES, WATER PROOF PROTECTORS, AND BLANK DIGITAL STORAGE MEDIA (U.S. CLS. 21, 23, 26, 36 AND 38).

RON FAIRBANKS, EXAMINING ATTORNEY

**CLASS 9—(Continued).**

SN 85-080,392. THE CHAMBERLAIN GROUP, INC., ELMHURST, IL. FILED 7-8-2010.

**PTI**

THE MARK CONSISTS OF STANDARD CHARACTERS WITHOUT CLAIM TO ANY PARTICULAR FONT, STYLE, SIZE, OR COLOR.

FOR ELECTRICAL ACCESS SYSTEM CONTROLLERS; ACCESS SYSTEM SOFTWARE; REMOTE CONTROLS FOR DOORS OR GATES; ELECTRONIC SECURITY DEVICES, NAMELY, ELECTRONIC CONTROLS FOR GRANTING ACCESS AND EGRESS THROUGH DOORS OR GATES; ELECTRONIC KEYPADS; ACCESS CONTROL AND DOOR MONITORING SYSTEMS (U.S. CLS. 21, 23, 26, 36 AND 38).

FIRST USE 12-31-1979; IN COMMERCE 12-31-1979.  
LINDSEY RUBIN, EXAMINING ATTORNEY

SN 85-082,197. TELECOMMUNICATION SYSTEMS, INC., ANNAPOLIS, MD. FILED 7-12-2010.



OWNER OF U.S. REG. NOS. 1,679,651, 2,405,074 AND 3,527,898.

NO CLAIM IS MADE TO THE EXCLUSIVE RIGHT TO USE "TELECOMMUNICATION SYSTEMS", APART FROM THE MARK AS SHOWN.

THE COLOR(S) BLUE AND GOLD IS/ARE CLAIMED AS A FEATURE OF THE MARK.

THE MARK CONSISTS OF THE LETTERS "TCS" IN GOLD OVER A GOLD BAR, BOTH ON A BLUE BACKGROUND ON THE LEFT OF THE MARK. ON THE RIGHT OF THE LETTERS "TCS" ON A WHITE BACKGROUND ARE THE WORDS "TELECOMMUNICATION SYSTEMS" IN BLUE OVER A BLUE BAR AND THE WORDS "ENABLING CONVERGENT TECHNOLOGIES" IN BLUE. THE COLOR WHITE REPRESENTS BACKGROUND AND IS NOT PART OF THE MARK.

SEC. 2(F) AS TO "TCS TELECOMMUNICATION SYSTEMS".

FOR TELECOMMUNICATIONS COMPUTER HARDWARE; PORTABLE COMMUNICATIONS TERMINAL COMPRISING COMPUTER HARDWARE AND SOFTWARE FOR USE IN CONNECTING TO THE INTERNET AND SATELLITES AND TRANSMITTING DATA, VOICE AND VIDEO OVER THE INTERNET AND SATELLITES; TELECOMMUNICATIONS SOFTWARE, NAMELY, APPLICATION SOFTWARE FOR ADMINISTRATION OF CELLULAR SERVICES BY WIRELESS SERVICE PROVIDERS, SOFTWARE USED IN THE RETRIEVAL AND DISPLAY OF GEOGRAPHIC DATA AND LOCATION-BASED INFORMATION SUCH AS MAPS, POINTS OF INTEREST, EVENTS, AND TRAFFIC INFORMATION FOR THE PURPOSE OF PROVIDING LOCATIONS AND DIRECTIONS TO USERS FOR USE WITH DESKTOP COMPUTERS, MOBILE COMPUTERS, MOBILE PHONES AND VEHICLES, SOFTWARE USED TO PROVIDE ACCESS TO THE INTERNET, SATELLITES AND TELEPHONE NETWORKS FOR TRANSMITTING DATA, VOICE AND VIDEO OVER THE INTERNET AND SATELLITES AND TEXT MESSAGING, PAGING AND TELEPHONE SERVICE, TEXT MESSAGING, PAGING AND TELEPHONE SERVICE, SOFTWARE USED IN

**CLASS 9—(Continued).**

CONVERTING MARK-UP LANGUAGE OR WEB-ENABLED APPLICATIONS, DATA OR OTHER INFORMATION FOR DISPLAY ON WIRELESS HANDHELD DEVICES, SOFTWARE USED IN CONNECTING WIRELESSLY REMOTE USERS TO A CORPORATE COMPUTER NETWORK, SOFTWARE USED IN CONNECTION WITH WIRELESS TELEPHONE NETWORKS TO PROVIDE ACCESS TO ADVANCED APPLICATIONS, NAMELY, VOICE MESSAGING, PAGING, ELECTRONIC ACTIVATION OF CUSTOMERS, PREPAID WIRELESS, GLOBAL COMPUTER NETWORK MESSAGING, WIRELESS CALENDAR NOTIFICATION AND TELEPHONE SERVICE, SOFTWARE WITH DATA STORAGE CAPABILITIES FOR MANAGEMENT OF DATA, SOFTWARE USED FOR ENHANCED LOCATION IDENTIFICATION, ENHANCED CONNECTIVITY AND POSITIONING IN THE FIELD OF WIRELESS TELECOMMUNICATION AND EMERGENCY COMMUNICATIONS, SOFTWARE, NAMELY, SOFTWARE ALLOWING LOCATION-BASED INFORMATION TO BE TRANSMITTED TO AND FROM MOBILE DEVICES (U.S. CLS. 21, 23, 26, 36 AND 38).

KATHLEEN M. VANSTON, EXAMINING ATTORNEY

SN 85-082,644. APPROVE PRODUCTS CO., LTD., TAI-CHUNG CITY, TAIWAN, FILED 7-12-2010.

**HoloMagic**

PRIORITY CLAIMED UNDER SEC. 44(D) ON TAIWAN APPLICATION NO. 099033174, FILED 7-9-2010.

OWNER OF TAIWAN REG. NO. 01453775, DATED 3-1-2011, EXPIRES 2-28-2021.

THE COLOR(S) BLUE, BLACK, AND WHITE IS/ARE CLAIMED AS A FEATURE OF THE MARK.

THE MARK CONSISTS OF THE WORD "HOLOMAGIC" IN STYLIZED BLUE WORDING AND OUTLINED IN BLACK, WITH WHITE COLOR SPACING BETWEEN THE OUTLINE AND THE LETTERING.

FOR FLASHLIGHTS FOR USE IN PHOTOGRAPHY; CELL PHONE COVERS AND CASES WITH FLASHLIGHTS; PROTECTIVE COVERS AND CASES FOR CELL PHONES; HANDS FREE DEVICES FOR MOBILE PHONES; COMPUTER CURSOR CONTROL DEVICES, NAMELY, COMPUTER MOUSE; USB (UNIVERSAL SERIAL BUS) HARDWARE; COVERS AND CASES FOR LAPTOPS; COVERS AND CASES FOR FLAT PANEL COMPUTERS; AUDIO SPEAKERS; SPEAKERS FOR COMPUTERS; SIGNALING LIGHTS THAT BLINK, NOT INCLUDING VEHICLE SIGNAL LIGHTS; LUMINOUS SIGNS; ELECTRICAL PLUGS; ELECTRICAL SOCKETS; FIRE, BURGLAR, SMOKE, SOUND ALARMS; COMPUTER HARDWARE; LITHIUM ION BATTERIES; BATTERY CHARGERS; CELL PHONE BATTERY CHARGERS (U.S. CLS. 21, 23, 26, 36 AND 38).

ANDREA HACK, EXAMINING ATTORNEY

**CLASS 9—(Continued).**

SN 85-083,712. GRAPECITY INCORPORATED, AKA GRAPECITY, SENDAI, JAPAN, FILED 7-13-2010.



THE MARK CONSISTS OF THE STYLIZED WORD "GRAPESEED" AND A VINE WITH LEAVES ON THE END RUNNING THROUGH THE LETTERS "E", "E" AND "D" IN "SEED".

FOR AUDIO, VISUAL AND AUDIO/VISUAL RECORDINGS FOR USE IN INSTRUCTION IN CONNECTION WITH ENGLISH LANGUAGE AND CULTURE (U.S. CLS. 21, 23, 26, 36 AND 38).

AMY KERTGATE, EXAMINING ATTORNEY

---

SN 85-085,429. ARISTOCRAT TECHNOLOGIES AUSTRALIA PTY LTD., NORTH RYDE, NSW, AUSTRALIA, FILED 7-15-2010.

## WILD ROMANS

THE MARK CONSISTS OF STANDARD CHARACTERS WITHOUT CLAIM TO ANY PARTICULAR FONT, STYLE, SIZE, OR COLOR.

PRIORITY CLAIMED UNDER SEC. 44(D) ON AUSTRALIA APPLICATION NO. 1345614, FILED 2-15-2010, REG. NO. 1345614, DATED 2-15-2010, EXPIRES 2-15-2020.

FOR ELECTRONIC GAMING MACHINES, NAMELY, DEVICES WHICH ACCEPT A WAGER (U.S. CLS. 21, 23, 26, 36 AND 38).

NAAKWAMA ANKRAH, EXAMINING ATTORNEY

**CLASS 9—(Continued).**

SN 85-086,171. METTLER-TOLEDO AG, GREIFENSEE, SWITZERLAND, FILED 7-16-2010.

## UNICOND

THE MARK CONSISTS OF STANDARD CHARACTERS WITHOUT CLAIM TO ANY PARTICULAR FONT, STYLE, SIZE, OR COLOR.

FOR TRANSMITTER OF ELECTRONIC SIGNALS; ELECTRODES; ELECTRONIC CONTROLS, SENSORS, HOLDERS AND HOUSINGS FOR USE IN THE MEASUREMENT OF CONCENTRATION, THE POTENTIOMETRIC MEASUREMENT, THE CONDUCTOMETRY, THE AMPEROMETRIC MEASUREMENT, THE PH MEASUREMENT, THE REDOX MEASUREMENT, THE MEASUREMENT OF IONS, THE ION SELECTIVE MEASUREMENT, THE TURBIDITY MEASUREMENT, THE OXYGEN MEASUREMENT, THE OZONE MEASUREMENT, THE CARBON DIOXIDE MEASUREMENT, THE MEASUREMENT OF DISSOLVED GASES, THE CONDUCTIVITY MEASUREMENT, THE TOTAL-ORGANIC-CONTENT MEASUREMENT, THE TENSIDE MEASUREMENT; DATA STORAGE, COMPUTER SOFTWARE FOR USE IN DATA STORAGE AND DATA PROCESSORS FOR RECORDING, STATISTICAL ANALYSIS AND OUTPUT OF PHYSICAL, CHEMICAL AND ANALYTICAL MEASUREMENT VALUES FOR QUALITY AND CHARGE CONTROL AND FOR FUNCTION CONTROL AND DIAGNOSIS OF DEVICES, SYSTEMS AS WELL AS PARTS THEREOF (U.S. CLS. 21, 23, 26, 36 AND 38).

FIRST USE 2-25-2010; IN COMMERCE 2-25-2010.  
KIMBERLY PERRY, EXAMINING ATTORNEY

---

SN 85-088,523. BANG ZOOM! ENTERTAINMENT, INC., BURBANK, CA. FILED 7-20-2010.

## ADVENTURES IN VOICE ACTING

THE MARK CONSISTS OF STANDARD CHARACTERS WITHOUT CLAIM TO ANY PARTICULAR FONT, STYLE, SIZE, OR COLOR.

NO CLAIM IS MADE TO THE EXCLUSIVE RIGHT TO USE "VOICE ACTING", APART FROM THE MARK AS SHOWN.

FOR DVDS FEATURING PROGRAMS IN THE FIELD OF VOICE ACTING (U.S. CLS. 21, 23, 26, 36 AND 38).

FIRST USE 4-5-2010; IN COMMERCE 4-5-2010.  
JAMES A. RAUEN, EXAMINING ATTORNEY



**CLASS 9—(Continued).**

SN 85-091,452. RODERICK FRAZIER, JACKSONVILLE, FL.  
FILED 7-23-2010.



NO CLAIM IS MADE TO THE EXCLUSIVE RIGHT TO USE "ENTERTAINMENT", APART FROM THE MARK AS SHOWN.

THE MARK CONSISTS OF A STYLIZED DESIGN OF A BRICK HOUSE WITH A CHIMNEY, STYLIZED WINDOWS, A SIDEWALK WITH A CHECKERBOARD PATTERN LEADING FROM THE FRONT DOOR AND A COLUMN ON EACH SIDE OF THE HOUSE. THERE IS A QUARTER ARCH DESIGN EXTENDING FROM EACH SIDE OF THE HOUSE. CENTERED ABOVE THE HOUSE IS THE ARCHED STYLIZED WORDING "BLUE HOUSE". CENTERED AT THE BOTTOM OF THE MARK IS THE STYLIZED WORD "ENTERTAINMENT".

FOR AUDIO AND VIDEO RECORDINGS, NAMELY, A SERIES OF PRE-RECORDED PHONOGRAPH RECORDS, COMPACT DISCS AND AUDIO AND VIDEO CASSETTES FEATURING MUSIC (U.S. CLS. 21, 23, 26, 36 AND 38).

FIRST USE 1-1-2010; IN COMMERCE 6-1-2010.  
PAULA MAHONEY, EXAMINING ATTORNEY

SN 85-093,125. AGILENT TECHNOLOGIES, INC., SANTA CLARA, CA. FILED 7-26-2010.

**BIOANALYZER**

THE MARK CONSISTS OF STANDARD CHARACTERS WITHOUT CLAIM TO ANY PARTICULAR FONT, STYLE, SIZE, OR COLOR.

FOR LIQUID SAMPLE SEPARATION APPARATUS COMPRISED OF MICROCHANNEL-BASED ELECTROPHORETIC CHIPS, ELECTRONIC HARDWARE AND COMPUTER SOFTWARE USED FOR SIZING, QUANTIFICATION AND QUALITY CONTROL OF DNA, RNA, PROTEINS AND CELLS IN PROTEIN AND MOLECULAR BIOLOGY RESEARCH, GENOMICS, THE TESTING OF PROTEIN-BASED DRUGS, GENETICALLY-BASED FOOD IDENTIFICATION AND AUTHENTICITY VERIFICATION, METHOD DEVELOPMENT, QUANTITATIVE ANALYSIS, AND QUALITY CONTROL (U.S. CLS. 21, 23, 26, 36 AND 38).

FIRST USE 11-0-1999; IN COMMERCE 11-0-1999.  
JULIE GUTTADAURO, EXAMINING ATTORNEY

**CLASS 9—(Continued).**

SN 85-096,066. RETAIL MANAGEMENT PRODUCTS, LTD., DELAWARE, OH. FILED 7-29-2010.

**UD CHECK**

THE MARK CONSISTS OF STANDARD CHARACTERS WITHOUT CLAIM TO ANY PARTICULAR FONT, STYLE, SIZE, OR COLOR.

NO CLAIM IS MADE TO THE EXCLUSIVE RIGHT TO USE "UD", APART FROM THE MARK AS SHOWN.

FOR SOFTWARE FOR BAR CODE SCANNERS TO VERIFY UNIT DOSE PACKAGING OF DRUGS (U.S. CLS. 21, 23, 26, 36 AND 38).

FIRST USE 12-0-2006; IN COMMERCE 12-0-2006.  
JOHN DALIER, EXAMINING ATTORNEY

SN 85-097,934. SONY CORPORATION, TOKYO, JAPAN,  
FILED 8-2-2010.

**Intelligent Peak LED**

THE MARK CONSISTS OF STANDARD CHARACTERS WITHOUT CLAIM TO ANY PARTICULAR FONT, STYLE, SIZE, OR COLOR.

NO CLAIM IS MADE TO THE EXCLUSIVE RIGHT TO USE "LED", APART FROM THE MARK AS SHOWN.

FOR TELEVISION SETS; LCD TELEVISION SETS; PDP TELEVISION SETS; PROJECTION TELEVISION SETS; DVD PLAYERS; DVD RECORDERS; HARD DISK VIDEO RECORDERS; VIDEO PROJECTORS; LCD COMPUTER DISPLAYS, INTEGRATED CIRCUITS FOR TELEVISIONS (U.S. CLS. 21, 23, 26, 36 AND 38).

INGRID C. EULIN, EXAMINING ATTORNEY

SN 85-098,319. 21ST CENTURY TECHNOLOGIES, INC., AUSTIN, TX. FILED 8-2-2010.

**LYNXeon**

THE MARK CONSISTS OF THE WORD "LYNXEON" CONSISTING OF CAPITALIZED STYLIZED LETTERS "LYNX" AND LOWERCASE STYLIZED LETTERS "EON" WITH A CIRCLE IN THE CENTER OF THE LOWERCASE LETTER "O".

FOR COMPUTER SOFTWARE, NAMELY, SERVER AND COMPUTER SOFTWARE FOR STORING, MANAGING, QUERYING, SEARCHING, ANALYZING AND REPORTING INTELLIGENCE DATA INCLUDING SOCIAL NETWORK DATA; COMPUTER SOFTWARE FOR PERFORMING INTELLIGENCE ANALYTICS FOR USE BY GOVERNMENT AND BUSINESS INTELLIGENCE ANALYSTS, MANAGERS, STAFF, AND TEAMS; COMPUTER SOFTWARE PLATFORM AND COMPUTER SOFTWARE DEVELOPMENT TOOLS USED FOR DEVELOPING AND MANAGING INTELLIGENCE ANALYTICS APPLICATIONS (U.S. CLS. 21, 23, 26, 36 AND 38).

FIRST USE 6-17-2010; IN COMMERCE 6-17-2010.  
KATHLEEN M. VANSTON, EXAMINING ATTORNEY

**CLASS 9—(Continued).**

SN 85-098,356. 21ST CENTURY TECHNOLOGIES, INC., AUSTIN, TX. FILED 8-2-2010.

# LYNXeon

THE MARK CONSISTS OF THE WORD "LYNXEON" CONSISTING OF CAPITALIZED LETTERS "LYNX" AND LOWERCASE LETTERS "EON".

FOR COMPUTER SOFTWARE, NAMELY, SERVER AND COMPUTER SOFTWARE FOR STORING, MANAGING, QUERYING, SEARCHING, ANALYZING AND REPORTING INTELLIGENCE DATA INCLUDING SOCIAL NETWORK DATA; COMPUTER SOFTWARE FOR PERFORMING INTELLIGENCE ANALYTICS FOR USE BY GOVERNMENT AND BUSINESS INTELLIGENCE ANALYSTS, MANAGERS, STAFF, AND TEAMS; COMPUTER SOFTWARE PLATFORM AND COMPUTER SOFTWARE DEVELOPMENT TOOLS USED FOR DEVELOPING AND MANAGING INTELLIGENCE ANALYTICS APPLICATIONS (U.S. CLS. 21, 23, 26, 36 AND 38).

FIRST USE 5-4-2009; IN COMMERCE 6-17-2010.  
JAY FLOWERS, EXAMINING ATTORNEY

SN 85-101,780. SYMETRICA LIMITED, SOUTHAMPTON, UNITED KINGDOM, FILED 8-6-2010.

# SCINTISPHERE

THE MARK CONSISTS OF STANDARD CHARACTERS WITHOUT CLAIM TO ANY PARTICULAR FONT, STYLE, SIZE, OR COLOR.

PRIORITY CLAIMED UNDER SEC. 44(D) ON ERP N CMNTY TM OFC APPLICATION NO. 9292434, FILED 8-3-2010, REG. NO. 009292434, DATED 1-17-2011, EXPIRES 8-3-2020.

FOR EQUIPMENT AND APPARATUS FOR DETECTING AND IDENTIFYING THE NATURE AND COMPOSITION OF MATERIALS THROUGH THE USE OF SPECTROSCOPY AND IMAGING AND NATURALLY OCCURRING OR SPECIALLY GENERATED SOURCES OF ELECTROMAGNETIC OR IONIZING RADIATION (U.S. CLS. 21, 23, 26, 36 AND 38).

TINA L. SNAPP, EXAMINING ATTORNEY

SN 85-105,917. CORSAIR MEMORY INC., FREEMONT, CA. FILED 8-12-2010.

# GRAPHITE SERIES

THE MARK CONSISTS OF STANDARD CHARACTERS WITHOUT CLAIM TO ANY PARTICULAR FONT, STYLE, SIZE, OR COLOR.

NO CLAIM IS MADE TO THE EXCLUSIVE RIGHT TO USE "SERIES", APART FROM THE MARK AS SHOWN.

FOR COMPUTER COMPONENTS, NAMELY, COMPUTER CASINGS (U.S. CLS. 21, 23, 26, 36 AND 38).

REBECCA SMITH, EXAMINING ATTORNEY

**CLASS 9—(Continued).**

SN 85-106,697. QUEST SOFTWARE, INC., ALISO VIEJO, CA. FILED 8-12-2010.



OWNER OF U.S. REG. NOS. 1,684,124, 3,225,071 AND OTHERS.

THE MARK CONSISTS OF THE WORD "QUEST" ABOVE THE WORK PORTION OF THE UNDERLINED WORD "VWORKSPACE", TO THE LEFT OF THE VERTICALLY ORIENTED WORD "READY", ALL CONTAINED WITHIN A RECTANGLE WITH ROUNDED CORNERS.

FOR COMPUTER HARDWARE; COMPUTER SOFTWARE FOR USE IN ACCESSING COMPUTER APPLICATIONS THAT ARE REMOTELY HOSTED (U.S. CLS. 21, 23, 26, 36 AND 38).

ERNEST SHOSHO, EXAMINING ATTORNEY

SN 85-107,067. RECOMMIND, INC., SAN FRANCISCO, CA. FILED 8-13-2010.

# DECISIV

THE MARK CONSISTS OF STANDARD CHARACTERS WITHOUT CLAIM TO ANY PARTICULAR FONT, STYLE, SIZE, OR COLOR.

OWNER OF U.S. REG. NO. 3,558,536.

FOR COMPUTER SOFTWARE FOR USE IN SEARCHING, MERGING, ORGANIZING, ARCHIVING, MANAGEMENT AND RETRIEVING OF EMAIL AND OTHER ELECTRONIC RECORDS, NOT IN THE TRANSPORTATION AND COMMERCIAL TRUCK INDUSTRY (U.S. CLS. 21, 23, 26, 36 AND 38).

ELLEN BURNS, EXAMINING ATTORNEY

**CLASS 9—(Continued).**

SN 85-109,967. SYMETRICA LIMITED, SOUTHAMPTON, UNITED KINGDOM, FILED 8-18-2010.

**DISCOVERY TECHNOLOGY**

THE MARK CONSISTS OF STANDARD CHARACTERS WITHOUT CLAIM TO ANY PARTICULAR FONT, STYLE, SIZE, OR COLOR.

PRIORITY CLAIMED UNDER SEC. 44(D) ON ERPN CMNTY TM OFC APPLICATION NO. 9292343, FILED 8-3-2010.

NO CLAIM IS MADE TO THE EXCLUSIVE RIGHT TO USE "TECHNOLOGY", APART FROM THE MARK AS SHOWN.

FOR SOFTWARE, EQUIPMENT AND APPARATUS FOR DETECTING AND IDENTIFYING THE NATURE AND COMPOSITION OF MATERIALS THROUGH THE USE OF SPECTROSCOPY AND IMAGING AND NATURALLY OCCURRING OR SPECIALLY GENERATED SOURCES OF ELECTROMAGNETIC OR IONIZING RADIATION (U.S. CLS. 21, 23, 26, 36 AND 38).

TINA L. SNAPP, EXAMINING ATTORNEY

---

SN 85-115,597. RECON INDUSTRIAL CONTROLS CORP., ENGLEWOOD, NJ. FILED 8-25-2010.

**LABRECON**

THE MARK CONSISTS OF STANDARD CHARACTERS WITHOUT CLAIM TO ANY PARTICULAR FONT, STYLE, SIZE, OR COLOR.

FOR COMPUTER SOFTWARE AND COMPUTER HARDWARE FOR USE IN MEASUREMENT OF PHYSICAL QUANTITIES, CONTROL OF MECHANICAL DEVICES, SIMULATION OF PHYSICAL SYSTEMS, AND ROBOTICS DEVELOPMENT (U.S. CLS. 21, 23, 26, 36 AND 38).

FIRST USE 8-1-2010; IN COMMERCE 8-1-2010.  
RENEE SERVANCE, EXAMINING ATTORNEY

**CLASS 9—(Continued).**

SN 85-116,151. JBZ&A, INC., WILLMINGTON, DE. FILED 8-26-2010.

**INSPIRING BUSINESS PERFORMANCE**

THE MARK CONSISTS OF STANDARD CHARACTERS WITHOUT CLAIM TO ANY PARTICULAR FONT, STYLE, SIZE, OR COLOR.

NO CLAIM IS MADE TO THE EXCLUSIVE RIGHT TO USE "BUSINESS PERFORMANCE", APART FROM THE MARK AS SHOWN.

FOR COMPUTER SOFTWARE FOR USE IN THE FIELD OF HUMAN RESOURCES AND EMPLOYEE MANAGEMENT FOR CUSTOMIZED JOB DESCRIPTIONS, CUSTOMIZED PERFORMANCE EVALUATIONS, RECRUITING AND APPLICANT TRACKING, TIME AND ATTENDANCE MANAGEMENT, AND LEARNING MANAGEMENT, AND INSTRUCTIONAL MATERIALS PROVIDED THEREWITH, NAMELY, PRINTED INSTRUCTIONAL MATERIALS PACKAGED WITH THE SOFTWARE AND DOWNLOADABLE ELECTRONIC INSTRUCTIONAL MATERIALS; COMPUTER SOFTWARE FOR SMALL BUSINESS ACCOUNTING APPLICATIONS, EMPLOYEE AND CONTRACTOR EXPENSE MANAGEMENT, AND PAYROLL, AND INSTRUCTIONAL MATERIALS PROVIDED THEREWITH, NAMELY, PRINTED INSTRUCTIONAL MATERIALS PACKAGED WITH THE SOFTWARE AND DOWNLOADABLE ELECTRONIC INSTRUCTIONAL MATERIALS; COMPUTER SOFTWARE FOR DATABASE MANAGEMENT IN THE FIELD OF HUMAN RESOURCES AND EMPLOYEE MANAGEMENT AND INSTRUCTIONAL MATERIALS SOLD THEREWITH, NAMELY, PRINTED INSTRUCTIONAL MATERIALS PACKAGED WITH THE SOFTWARE AND DOWNLOADABLE ELECTRONIC INSTRUCTIONAL MATERIALS (U.S. CLS. 21, 23, 26, 36 AND 38).

JENNIFER DIXON, EXAMINING ATTORNEY

---

SN 85-116,292. SONY CORPORATION, TOKYO, JAPAN, FILED 8-26-2010.

**Bloggie Touch**

THE MARK CONSISTS OF STANDARD CHARACTERS WITHOUT CLAIM TO ANY PARTICULAR FONT, STYLE, SIZE, OR COLOR.

NO CLAIM IS MADE TO THE EXCLUSIVE RIGHT TO USE "TOUCH", APART FROM THE MARK AS SHOWN.

FOR HIGH DEFINITION CAMERAS; VIDEO CAMERAS; DIGITAL STILL CAMERAS; DIGITAL SINGLE-LENS REFLEX CAMERAS; MOBILE PHONES; PERSONAL COMPUTERS; OPTICAL DISC BURNERS (U.S. CLS. 21, 23, 26, 36 AND 38).

INGRID C. EULIN, EXAMINING ATTORNEY



**CLASS 9—(Continued).**

TION, VELOCITY, AND TEMPERATURE AND CONTROL OF CONNECTED DEVICES BY DEVICES ATTACHED TO OR CARRIED ON FULLY OR ASSISTED HUMAN-POWERED VEHICLES AND RELATED ACCESSORIES; SOFTWARE FOR HANDHELD COMPUTERS FOR TRACKING VEHICLE LOCATION, WHEEL ROTATION, CRANK ROTATION, PULSE, HEARTBEAT, WIND SPEED, ALTITUDE, PRESSURE, GEAR RATIO, ASSIST RATIO, BATTERY LEVEL, SPEED, CRANK ROTATIONS PER UNIT OF TIME, DISTANCE, GRADIENT, POWER, CALORIES, EXERTION, ACCELERATION, VELOCITY, AND TEMPERATURE AND CONTROL OF CONNECTED DEVICES BY DEVICES ATTACHED TO OR CARRIED ON FULLY OR ASSISTED HUMAN-POWERED VEHICLES AND RELATED ACCESSORIES; SOFTWARE FOR HANDHELD COMPUTERS FOR SHARING VEHICLE LOCATION, WHEEL ROTATION, CRANK ROTATION, PULSE, HEARTBEAT, WIND SPEED, ALTITUDE, PRESSURE, GEAR RATIO, ASSIST RATIO, BATTERY LEVEL, SPEED, CRANK ROTATIONS PER UNIT OF TIME, DISTANCE, GRADIENT, POWER, CALORIES, EXERTION, ACCELERATION, VELOCITY, AND TEMPERATURE AND CONTROL OF CONNECTED DEVICES BY DEVICES ATTACHED TO OR CARRIED ON FULLY OR ASSISTED HUMAN-POWERED VEHICLES AND RELATED ACCESSORIES; SOFTWARE FOR HANDHELD COMPUTERS PROVIDED VIA COMPUTER AND COMMUNICATION NETWORKS, FOR THE COLLECTION, EDITING, ORGANIZING, MODIFYING, BOOK MARKING, TRANSMISSION, STORAGE AND SHARING OF VEHICLE LOCATION, WHEEL ROTATION, CRANK ROTATION, PULSE, HEARTBEAT, WIND SPEED, ALTITUDE, PRESSURE, GEAR RATIO, ASSIST RATIO, BATTERY LEVEL, SPEED, CRANK ROTATIONS PER UNIT OF TIME, DISTANCE, GRADIENT, POWER, CALORIES, EXERTION, ACCELERATION, VELOCITY, AND TEMPERATURE; SOFTWARE FOR HANDHELD COMPUTERS FOR CREATING SEARCHABLE DATABASES OF INFORMATION AND DATA; SOFTWARE FOR HANDHELD COMPUTERS FOR CALCULATING, MONITORING, MEASURING, SENSING, DISPLAYING, TRACKING, AND SHARING INFORMATION AND DATA OF A FULLY OR ASSISTED HUMAN-POWERED VEHICLE THAT MAY BE DOWNLOADED FROM A GLOBAL COMPUTER NETWORK; ELECTRONIC DEVICES AND SENSORS FOR MEASURING VEHICLE LOCATION, WHEEL ROTATION, CRANK ROTATION, PULSE, HEARTBEAT, WIND SPEED, ALTITUDE, PRESSURE, GEAR RATIO, ASSIST RATIO, BATTERY LEVEL, SPEED, CRANK ROTATIONS PER UNIT OF TIME, DISTANCE, GRADIENT, POWER, CALORIES, EXERTION, ACCELERATION, VELOCITY, AND TEMPERATURE; AND COMPUTERS FOR USE IN THE FIELD OF ATHLETIC TRAINING (U.S. CLS. 21, 23, 26, 36 AND 38).  
JULIE VEPPIUMTHARA, EXAMINING ATTORNEY

**CLASS 9—(Continued).**

SN 85-122,101. FIN SCAN OY, 02200 ESPOO, FINLAND, FILED 9-2-2010.

# ENDSPY

THE MARK CONSISTS OF STANDARD CHARACTERS WITHOUT CLAIM TO ANY PARTICULAR FONT, STYLE, SIZE, OR COLOR.

PRIORITY CLAIMED UNDER SEC. 44(D) ON ERPN CMNTY TM OFC APPLICATION NO. 008996357, FILED 3-31-2010, REG. NO. 08996357, DATED 3-31-2010, EXPIRES 3-31-2020.

FOR AUTOMATIC SYSTEMS FOR MEASURING, CONTROLLING, MONITORING AND SUPERVISING EQUIPMENT FOR THE SAWMILL INDUSTRY, NAMELY, MEASURING FRAMES WITH CCD-CAMERAS, CAMERA STANDS AND FRAMEWORKS, TRANSPUTERS, OPTICAL FIBRE CABLES, KNOT DETECTORS, SPLIT DETECTORS, SAWS, TRIMMERS, GRADERS, SORTING BINS, AND ON LINE REPORTERS, ALL SOLD AS A UNIT; PARTS SOLD SEPARATELY FOR AUTOMATIC SYSTEMS FOR MEASURING, CONTROLLING, MONITORING AND SUPERVISING EQUIPMENT FOR THE SAWMILL INDUSTRY, NAMELY, MEASURING FRAMES WITH CCD-CAMERAS, CAMERA STANDS AND FRAMEWORKS, TRANSPUTERS, OPTICAL FIBRE CABLES, KNOT DETECTORS AND SPLIT DETECTORS; OPTICAL MEASURING AND ANALYZING APPARATUS FOR DETERMINING OR MEASURING THE DIMENSIONS OF WOOD PRODUCTS OR WOOD BLOCKS, NAMELY, CAMERAS, LIGHT SOURCE UNITS, MEASURING FRAMEWORKS AND CONVEYORS, TRANSDUCERS, TRANSMITTERS, PULSE ENCODERS, OPTICAL AND MEASURING SENSORS, ALL SOLD SEPARATELY OR AS A UNIT; DEVICES FOR FORMING AND PROCESSING AN OPTICAL IMAGE OF WOOD PRODUCTS OR WOOD BLOCKS, NAMELY, COMPUTERS, COMPUTER MONITORS, AND COMPUTER SOFTWARE, ALL SOLD SEPARATELY OR AS A UNIT (U.S. CLS. 21, 23, 26, 36 AND 38).

BRENDAN MCCAULEY, EXAMINING ATTORNEY

SN 85-122,517. UNIVERSITY OF PRINCE EDWARD ISLAND, CHARLOTTETOWN, PEI, CANADA, FILED 9-3-2010.

# ISLANDORA

THE MARK CONSISTS OF STANDARD CHARACTERS WITHOUT CLAIM TO ANY PARTICULAR FONT, STYLE, SIZE, OR COLOR.

FOR COMPUTER SOFTWARE FOR DIGITAL ASSET MANAGEMENT AND DIGITAL DATA STEWARDSHIP THAT MAY BE DOWNLOADED FROM A GLOBAL COMPUTER NETWORK (U.S. CLS. 21, 23, 26, 36 AND 38).

FIRST USE 10-16-2007; IN COMMERCE 10-16-2007.  
JANET LEE, EXAMINING ATTORNEY



**CLASS 9—(Continued).**

SN 85-123,742. KABUSHIKI KAISHA TOSHIBA, TA TOSHIBA CORPORATION, MINATO-KU, TOKYO, JAPAN, FILED 9-7-2010.

# AMSO

THE MARK CONSISTS OF STANDARD CHARACTERS WITHOUT CLAIM TO ANY PARTICULAR FONT, STYLE, SIZE, OR COLOR.

OWNER OF JAPAN REG. NO. 5362929, DATED 10-22-2010, EXPIRES 10-22-2020.

THE WORD(S) "AMSO" HAS NO MEANING IN A FOREIGN LANGUAGE.

FOR ENCRYPTION SYSTEM FOR ELECTRIC POWER METERS COMPRISING COMPUTER HARDWARE AND SOFTWARE USED TO PREVENT OTHERS FROM ACCESSING ELECTRIC POWER METERS AND AN ELECTRIC POWER METER CONTAINING THE ENCRYPTION SYSTEM (U.S. CLS. 21, 23, 26, 36 AND 38).  
HOWARD SMIGA, EXAMINING ATTORNEY

**CLASS 9—(Continued).**

SN 85-125,436. TOUCH SUNGLASSES CORP., EL MONTE, CA 91733, CA. FILED 9-8-2010.

# CHRISTINA LUCCI

THE MARK CONSISTS OF STANDARD CHARACTERS WITHOUT CLAIM TO ANY PARTICULAR FONT, STYLE, SIZE, OR COLOR.

THE NAME(S), PORTRAIT(S), AND/OR SIGNATURE(S) SHOWN IN THE MARK DOES NOT IDENTIFY A PARTICULAR LIVING INDIVIDUAL.

FOR EYEWEAR, NAMELY, SUNGLASSES, EYEGLASSES AND OPHTHALMIC FRAMES AND CASES THEREFOR (U.S. CLS. 21, 23, 26, 36 AND 38).

FIRST USE 8-1-2010; IN COMMERCE 9-1-2010.

MATTHEW PAPPAS, EXAMINING ATTORNEY

SN 85-127,084. STEREN ELECTRONICS INTERNATIONAL, LLC, SAN DIEGO, CA. FILED 9-10-2010.

SN 85-125,025. AUTODESK, INC., SAN RAFAEL, CA. FILED 9-8-2010.



# MUDBOX

THE MARK CONSISTS OF STANDARD CHARACTERS WITHOUT CLAIM TO ANY PARTICULAR FONT, STYLE, SIZE, OR COLOR.

OWNER OF U.S. REG. NO. 3,241,391.

FOR COMPUTER SOFTWARE FOR ANIMATION, GRAPHICS, AND DESIGN MODELING APPLICATIONS, NAMELY, ORGANIZING AND VIEWING DIGITAL IMAGES AND PHOTOGRAPHS, DIGITAL ANIMATION AND SPECIAL EFFECTS OF IMAGES, CREATION OF DIGITAL ASSETS, PROCESSING OF IMAGES, GRAPHICS AND TEXT (U.S. CLS. 21, 23, 26, 36 AND 38).

FIRST USE 12-15-2006; IN COMMERCE 12-15-2006.

CHRISTOPHER BUONGIORNO, EXAMINING ATTORNEY

NO CLAIM IS MADE TO THE EXCLUSIVE RIGHT TO USE "HD PICTURE", APART FROM THE MARK AS SHOWN.

THE MARK CONSISTS OF A DRAWING OF A TELEVISION WITH THE WORDS "PROS-CHOICE" TO THE RIGHT IN BOLD TEXT AND ADJACENT TO THE TELEVISION ON THE UPPER PORTION OF THE LOGO AND THE WORDS "HD PICTURE PERFECT" TO THE RIGHT AND ADJACENT TO THE TELEVISION ON THE LOWER PORTION OF THE LOGO AND UNDERNEATH THE WORDS "PROS-CHOICE" AND THESE TWO PHRASES ARE SEPARATED WITH A HORIZONTAL LINE.

FOR INSTALLATION SUPPLIES AND ACCESSORIES, NAMELY, ANTENNA MOUNTS, GROUNDING AND BONDING HARDWARE, WALL PLATES, ACTIVE AND PASSIVE SPLITTERS AND AMPLIFIERS AND INTERCONNECTION CABLES, FOR AUDIO-VIDEO SYSTEMS INTEGRATION, SATELLITE, BROADBAND, COMMERCIAL, AND STRUCTURED WIRING INDUSTRIES (U.S. CLS. 21, 23, 26, 36 AND 38).

FIRST USE 6-17-2008; IN COMMERCE 6-17-2008.

CAROLYN CATALDO, EXAMINING ATTORNEY

**CLASS 9—(Continued).**

SN 85-127,798. CIRCADENCE CORPORATION, BOULDER, CO. FILED 9-13-2010.

**CIRCADENCE**

THE MARK CONSISTS OF STANDARD CHARACTERS WITHOUT CLAIM TO ANY PARTICULAR FONT, STYLE, SIZE, OR COLOR.

OWNER OF U.S. REG. NOS. 2,836,803 AND 2,843,394. FOR COMPUTER HARDWARE AND SOFTWARE FOR SECURITY, SCALABILITY, PRIORITIZATION, EFFICIENCY, PROFITABILITY AND PERFORMANCE ENHANCEMENT OF ELECTRONIC CONTENT DELIVERY (U.S. CLS. 21, 23, 26, 36 AND 38).

FIRST USE 3-0-2001; IN COMMERCE 3-0-2001.  
DAVID HOFFMAN, EXAMINING ATTORNEY

---

SN 85-130,084. LECO CORPORATION, ST. JOSEPH, MI. FILED 9-15-2010.

**CHROMATOF-HRT**

THE MARK CONSISTS OF STANDARD CHARACTERS WITHOUT CLAIM TO ANY PARTICULAR FONT, STYLE, SIZE, OR COLOR.

OWNER OF U.S. REG. NO. 2,644,187. FOR COMPUTER SOFTWARE FOR USE IN COMPUTER CONTROL OF MASS SPECTROMETERS; SCIENTIFIC AND LABORATORY INSTRUMENTS, NAMELY ANALYTICAL INSTRUMENTS FOR DETERMINING CHEMICAL CONSTITUENTS; INSTRUMENTS AND APPARATUS FOR USE IN TESTING, CONTROL, DETECTION, MONITORING AND THE ANALYSIS OF MATERIALS IN THE NATURE OF ELEMENTS, COMBINATIONS OF ELEMENTS FROM THE PERIODIC TABLE, MOLECULAR MATERIALS, AND COMPLEX CHEMISTRIES IN SCIENTIFIC AND INDUSTRIAL OPERATIONS (U.S. CLS. 21, 23, 26, 36 AND 38).

JENNY PARK, EXAMINING ATTORNEY

---

SN 85-131,188. ISAAC S. DANIEL, MIRAMAR, FL. FILED 9-16-2010.

**P240**

THE MARK CONSISTS OF STANDARD CHARACTERS WITHOUT CLAIM TO ANY PARTICULAR FONT, STYLE, SIZE, OR COLOR.

FOR WIRELESS COMMUNICATIONS TRACKING SYSTEM USING A GLOBAL POSITIONING SYSTEM (GPS) TO LOCATE INDIVIDUALS, OBJECTS (U.S. CLS. 21, 23, 26, 36 AND 38).

DAVID C. REIHNER, EXAMINING ATTORNEY

**CLASS 9—(Continued).**

SN 85-131,834. HAMILTON PRODUCTS, INC., LEBANON, OH. FILED 9-17-2010.

**ZUKI BEADS**

THE MARK CONSISTS OF STANDARD CHARACTERS WITHOUT CLAIM TO ANY PARTICULAR FONT, STYLE, SIZE, OR COLOR.

NO CLAIM IS MADE TO THE EXCLUSIVE RIGHT TO USE "BEADS", APART FROM THE MARK AS SHOWN.

FOR EDUCATIONAL DEVICES FOR TEACHING MUSIC PRINCIPLES CONSISTING OF COUNTING BEADS ON A STICK FOR COUNTING MUSICAL EXERCISES (U.S. CLS. 21, 23, 26, 36 AND 38).

FIRST USE 2-28-2010; IN COMMERCE 2-28-2010.  
KATINA MISTER, EXAMINING ATTORNEY

---

SN 85-132,731. DEVON BROOKS, DBA APPLERT, LOS ANGELES, CA. FILED 9-18-2010.

**APPLERT**

THE MARK CONSISTS OF STANDARD CHARACTERS WITHOUT CLAIM TO ANY PARTICULAR FONT, STYLE, SIZE, OR COLOR.

FOR COMPUTER APPLICATION SOFTWARE FOR HANDHELD COMPUTING DEVICES FOR WIRELESS NETWORKING, AND HANDHELD MOBILE DIGITAL ELECTRONIC DEVICE FOR THE SENDING AND RECEIVING OF TELEPHONE CALLS, ELECTRONIC MAIL AND OTHER DIGITAL DATA; COMPUTER APPLICATION SOFTWARE FOR HANDHELD COMPUTING DEVICES FOR WIRELESS NETWORKING, AND HANDHELD MOBILE DIGITAL ELECTRONIC DEVICE FOR THE SENDING AND RECEIVING OF TELEPHONE CALLS, ELECTRONIC MAIL AND OTHER DIGITAL DATA; DOWNLOADABLE SOFTWARE IN THE NATURE OF A MOBILE APPLICATION FOR HANDHELD COMPUTING DEVICES FOR WIRELESS NETWORKING, AND HANDHELD MOBILE DIGITAL ELECTRONIC DEVICE FOR THE SENDING AND RECEIVING OF TELEPHONE CALLS, ELECTRONIC MAIL AND OTHER DIGITAL DATA (U.S. CLS. 21, 23, 26, 36 AND 38).

DOMINICK J. SALEMI, EXAMINING ATTORNEY

**CLASS 9—(Continued).**

SN 85-133,963. PARALLOCTY, INC, SUNNYVALE, CA.  
FILED 9-20-2010.

**Kernel-MD**

THE MARK CONSISTS OF STANDARD CHARACTERS WITHOUT CLAIM TO ANY PARTICULAR FONT, STYLE, SIZE, OR COLOR.

FOR COMPUTER SOFTWARE FOR DEBUGGING OTHER COMPUTER SOFTWARE THAT MAY BE DOWNLOADED FROM A GLOBAL COMPUTER NETWORK (U.S. CLS. 21, 23, 26, 36 AND 38).

FIRST USE 1-7-2010; IN COMMERCE 1-7-2010.  
KATINA MISTER, EXAMINING ATTORNEY

SN 85-134,740. REVELLO MEDIA LLC, LOS ANGELES, CA.  
FILED 9-21-2010.

**BIKINI RIOT**

THE MARK CONSISTS OF STANDARD CHARACTERS WITHOUT CLAIM TO ANY PARTICULAR FONT, STYLE, SIZE, OR COLOR.

OWNER OF U.S. REG. NO. 3,844,411.

NO CLAIM IS MADE TO THE EXCLUSIVE RIGHT TO USE "BIKINI", APART FROM THE MARK AS SHOWN.

FOR DOWNLOADABLE AUDIO AND VIDEO RECORDINGS FEATURING AUDIO AND VISUAL CONTENT OF AN ADULT NATURE AND OF A NON-ADULT NATURE, NAMELY, MODELS FULLY CLOTHED IN BIKINIS; ADULT THEMED DOWNLOADABLE PHOTOGRAPHS; ADULT THEMED VIDEO RECORDINGS; DOWNLOADABLE SOFTWARE IN THE NATURE OF ADULT THEMED MOBILE APPLICATIONS (U.S. CLS. 21, 23, 26, 36 AND 38).

FIRST USE 7-1-2001; IN COMMERCE 7-1-2001.  
GINA FINK, EXAMINING ATTORNEY

SN 85-135,976. CRIST, JASON, MARIETTA, GA. FILED 9-22-2010.



*Virtual Technologies  
Enclosures*

NO CLAIM IS MADE TO THE EXCLUSIVE RIGHT TO USE "VIRTUAL TECHNOLOGIES ENCLOSURES", APART FROM THE MARK AS SHOWN.

THE MARK CONSISTS OF THE STYLIZED WORDING "VT VIRTUAL TECHNOLOGIES ENCLOSURES".

FOR AUDIO SPEAKER ENCLOSURES; SPEAKER ENCLOSURES (U.S. CLS. 21, 23, 26, 36 AND 38).  
STEPHANIE ALI, EXAMINING ATTORNEY

**CLASS 9—(Continued).**

SN 85-139,157. GAS INFORMATICA LTDA., BRASILIA D.F., BRAZIL, FILED 9-27-2010.

**G-LOCK**

THE MARK CONSISTS OF STANDARD CHARACTERS WITHOUT CLAIM TO ANY PARTICULAR FONT, STYLE, SIZE, OR COLOR.

FOR COMPUTER SOFTWARE FOR ENSURING THE SECURITY AND PROTECTION OF DATA IN COMPUTERS (U.S. CLS. 21, 23, 26, 36 AND 38).

DAVID H. STINE, EXAMINING ATTORNEY

SN 85-139,545. SPIELO MANUFACTURING ULC, MONCTON, NEW BRUNSWICK, CANADA, FILED 9-28-2010.

**PICK 'N PLAY CLASSICS**

THE MARK CONSISTS OF STANDARD CHARACTERS WITHOUT CLAIM TO ANY PARTICULAR FONT, STYLE, SIZE, OR COLOR.

OWNER OF CANADA REG. NO. TMA775,866, DATED 8-31-2010, EXPIRES 8-31-2025.

NO CLAIM IS MADE TO THE EXCLUSIVE RIGHT TO USE "CLASSICS", APART FROM THE MARK AS SHOWN.

FOR COMPUTER GAME SOFTWARE FOR GAMING MACHINES, NAMELY, SLOT MACHINES AND VIDEO LOTTERY TERMINALS; GAMING MACHINES, NAMELY, SLOT MACHINES AND VIDEO LOTTERY TERMINALS (U.S. CLS. 21, 23, 26, 36 AND 38).

HEATHER SAPP, EXAMINING ATTORNEY

SN 85-140,763. EKTRON TEK CO., LTD., CHANGHUA COUNTY, TAIWAN, FILED 9-29-2010.



OWNER OF U.S. REG. NO. 2,977,331.

THE MARK CONSISTS OF THE WORD "EKTRON" IN A STYLIZED FONT SET WITHIN 2 STYLIZED SEMI-OVAL STROKES FORMING A STYLIZED OVAL PERIMETER.

FOR MEASURING INSTRUMENTS, NAMELY, RHEOMETER, VISCOMETER, TENSILE TESTER, FLEXOMETER, PLUNGER TESTER, OZONE TEST CHAMBER, VIBRATION SIMULATOR, MIXING GRADER, DEMATTIA FLEXING FATIGUE TESTER, LOW TEMPERATURE RETRACTION TESTER (U.S. CLS. 21, 23, 26, 36 AND 38).

FIRST USE 1-16-2008; IN COMMERCE 1-16-2008.  
GRETTA YAO, EXAMINING ATTORNEY

**CLASS 9—(Continued).**

SN 85-141,454. BROCADE COMMUNICATIONS SYSTEMS, INC., SAN JOSE, CA. FILED 9-29-2010.

# VDX

THE MARK CONSISTS OF STANDARD CHARACTERS WITHOUT CLAIM TO ANY PARTICULAR FONT, STYLE, SIZE, OR COLOR.

FOR COMPUTER SOFTWARE USED TO OPTIMIZE NETWORK CLOUDS AND VIRTUALIZED DATA CENTERS; COMPUTER HARDWARE FOR USE IN COMPUTER NETWORKS, NAMELY, ROUTERS, BACKBONES, SWITCHES, ACCESS POINTS AND CONTROLLERS (U.S. CLS. 21, 23, 26, 36 AND 38).

ERIN FALK, EXAMINING ATTORNEY

---

SN 85-147,115. INTERNATIONAL DATA GROUP, INC., FRAMINGHAM, MA. FILED 10-7-2010.

## MACWORLD DAILY READER

THE MARK CONSISTS OF STANDARD CHARACTERS WITHOUT CLAIM TO ANY PARTICULAR FONT, STYLE, SIZE, OR COLOR.

OWNER OF U.S. REG. NOS. 1,427,411, 1,873,845 AND OTHERS.

NO CLAIM IS MADE TO THE EXCLUSIVE RIGHT TO USE "DAILY READER", APART FROM THE MARK AS SHOWN.

FOR DOWNLOADABLE SOFTWARE THAT ALLOWS USERS TO ACCESS NON-DOWNLOADABLE AND DOWNLOADABLE MAGAZINE ARTICLES AND CONTENT IN THE FIELDS OF COMPUTERS, COMPUTER SOFTWARE, HIGH TECHNOLOGY, INFORMATION TECHNOLOGY, ONLINE SERVICES OF OTHERS, TELECOMMUNICATIONS, COMMUNICATIONS, INFORMATION SERVICES OF OTHERS AND INTERACTIVE ENTERTAINMENT (U.S. CLS. 21, 23, 26, 36 AND 38).

DANIEL CAPSHAW, EXAMINING ATTORNEY

**CLASS 9—(Continued).**

SN 85-147,127. INTERNATIONAL DATA GROUP, INC., FRAMINGHAM, MA. FILED 10-7-2010.



THE MARK CONSISTS OF A SQUARE WITH ROUNDED CORNERS THAT HAS A MOUSE OVER A SHADED "M".

FOR DOWNLOADABLE SOFTWARE THAT ALLOWS USERS TO ACCESS NON-DOWNLOADABLE AND DOWNLOADABLE MAGAZINE ARTICLES AND CONTENT IN THE FIELDS OF COMPUTERS, COMPUTER SOFTWARE, HIGH TECHNOLOGY, INFORMATION TECHNOLOGY, ONLINE SERVICES OF OTHERS, TELECOMMUNICATIONS, COMMUNICATIONS, INFORMATION SERVICES OF OTHERS AND INTERACTIVE ENTERTAINMENT (U.S. CLS. 21, 23, 26, 36 AND 38).

DANIEL CAPSHAW, EXAMINING ATTORNEY

---

SN 85-148,121. WORKSHARE TECHNOLOGY, INC., SAN FRANCISCO, CA. FILED 10-8-2010.

## WORKSHARE VIEW POINT

THE MARK CONSISTS OF STANDARD CHARACTERS WITHOUT CLAIM TO ANY PARTICULAR FONT, STYLE, SIZE, OR COLOR.

OWNER OF U.S. REG. NO. 3,365,516.

FOR COMPUTER SOFTWARE FOR DOCUMENT AND EMAIL MANAGEMENT; COMPUTER SOFTWARE FOR SHARING OF DOCUMENTS AND EMAILS AMONG USERS; COMPUTER SOFTWARE FOR DOCUMENT AND EMAIL VERSION MANAGEMENT, AND PREVENTING VERSION PROLIFERATION OF THE SAME DOCUMENT IN THE DOCUMENT MANAGEMENT STORE; COMPUTER SOFTWARE FOR EXTENDING AND IMPROVING THE CAPABILITIES PROVIDED BY THIRD PARTY DOCUMENT MANAGEMENT SYSTEMS; AND USER MANUALS SUPPLIED AS A UNIT THEREWITH (U.S. CLS. 21, 23, 26, 36 AND 38).

SUSAN RICHARDS, EXAMINING ATTORNEY

**CLASS 9—(Continued).**

SN 85-149,368. T-SYSTEM, INC., DALLAS, TX. FILED 10-11-2010.

# T SYSTEMDS

THE MARK CONSISTS OF STANDARD CHARACTERS WITHOUT CLAIM TO ANY PARTICULAR FONT, STYLE, SIZE, OR COLOR.

OWNER OF U.S. REG. NOS. 2,207,936, 2,552,310 AND 2,569,735.

FOR DIGITAL RECORD KEEPING SYSTEMS COMPRISING DIGITAL PENS COUPLED WITH COMPUTER SOFTWARE THAT PROVIDES WEB-BASED ACCESS TO APPLICATIONS AND ONLINE SERVICES THROUGH A WEB OPERATING SYSTEM OR PORTAL INTERFACE FOR EMERGENCY ROOMS, URGENT CARE CENTERS, AND FIRST RESPONSE UNITS (U.S. CLS. 21, 23, 26, 36 AND 38).

ODESSA BIBBINS, EXAMINING ATTORNEY

SN 85-150,002. STATSOFT, INC., TULSA, OK. FILED 10-11-2010.

# live score

THE MARK CONSISTS OF STANDARD CHARACTERS WITHOUT CLAIM TO ANY PARTICULAR FONT, STYLE, SIZE, OR COLOR.

NO CLAIM IS MADE TO THE EXCLUSIVE RIGHT TO USE "SCORE", APART FROM THE MARK AS SHOWN.

FOR COMPUTER SOFTWARE FOR USE IN DATA MINING, NAMELY, COMPUTER SOFTWARE THAT PROVIDES REAL-TIME, INTEGRATED BUSINESS MANAGEMENT INTELLIGENCE BY COMBINING INFORMATION FROM VARIOUS BUSINESS DATABASES AND PRESENTING IT IN AN EASY-TO-UNDERSTAND USER INTERFACE (U.S. CLS. 21, 23, 26, 36 AND 38).

FIRST USE 9-1-2008; IN COMMERCE 9-1-2008.  
NATALIE POLZER, EXAMINING ATTORNEY

SN 85-150,439. RUNNER TECHNOLOGIES, INC., BOCA RATON, FL. FILED 10-12-2010.

# CLEAN\_Address

THE MARK CONSISTS OF STANDARD CHARACTERS WITHOUT CLAIM TO ANY PARTICULAR FONT, STYLE, SIZE, OR COLOR.

FOR SOFTWARE FOR VERIFYING AND STANDARDIZING GLOBAL ADDRESSES (U.S. CLS. 21, 23, 26, 36 AND 38).

FIRST USE 9-28-2000; IN COMMERCE 9-28-2000.  
LIEF MARTIN, EXAMINING ATTORNEY

**CLASS 9—(Continued).**

SN 85-152,688. XEROX CORPORATION, NORWALK, CT. FILED 10-14-2010.

# BUSINESS OF YOUR BRAIN

THE MARK CONSISTS OF STANDARD CHARACTERS WITHOUT CLAIM TO ANY PARTICULAR FONT, STYLE, SIZE, OR COLOR.

FOR COMPUTER PROGRAMS, NAMELY, SOFTWARE FOR SCANNING IMAGES AND DOCUMENTS, DESKTOP INFORMATION MANAGER PROGRAMS PROVIDING ELECTRONIC MAIL, PERSONAL CALENDAR, GROUP SCHEDULING, PERSONAL INFORMATION MANAGEMENT, TASK MANAGEMENT, AND BROWSING AND SHARING OF DOCUMENTS; COMPUTER PROGRAMS FOR MANAGING, VIEWING, AND EDITING FILES, DOCUMENTS, ELECTRONIC MAIL MESSAGES AND PRIVATE NETWORK AND GLOBAL COMPUTER NETWORK COMMUNICATIONS; COMPUTER PROGRAMS FOR MEETING AND EVENT SCHEDULING, MANAGING GROUP CALENDARS, TASK DELEGATION AND REPORTING, RECORDING NOTES, TRANSFERRING DATA TO AND FROM DATABASES AND TO AND FROM COMPUTER PROGRAMS, AND COMPUTER FILES; ADDRESS BOOK COMPUTER PROGRAMS, TELEPHONE DIALING COMPUTER PROGRAMS, COMPUTER PROGRAMS FOR CORRECTING TYPOGRAPHICAL AND CAPITALIZATION ERRORS, COMPUTER PROGRAMS FOR TALLYING VOTING RESPONSES (U.S. CLS. 21, 23, 26, 36 AND 38).

RAMONA ORTIGA, EXAMINING ATTORNEY

SN 85-153,381. CONTINUANCE HEALTH SOLUTIONS, INC., PEAPACK, NJ. FILED 10-15-2010.

# WellScore

THE MARK CONSISTS OF STANDARD CHARACTERS WITHOUT CLAIM TO ANY PARTICULAR FONT, STYLE, SIZE, OR COLOR.

FOR COMPUTER SOFTWARE FOR ANALYZING HEALTH CARE DATA AND MEASURING MORBIDITY AND RELATED RISK FACTORS (U.S. CLS. 21, 23, 26, 36 AND 38).

FIRST USE 10-6-2010; IN COMMERCE 10-11-2010.  
MARGARET POWER, EXAMINING ATTORNEY



**CLASS 9—(Continued).**

SN 85-155,573. ODELLUS CORPORATION, GLENN DALE, MD. FILED 10-19-2010.

# ComplyFirst

THE MARK CONSISTS OF STANDARD CHARACTERS WITHOUT CLAIM TO ANY PARTICULAR FONT, STYLE, SIZE, OR COLOR.

FOR DOWNLOADABLE COMPUTER SOFTWARE FOR ANALYZING WEBSITES AND WEB APPLICATIONS FOR USABILITY AND FEDERAL GOVERNMENT MANDATED ACCESSIBILITY COMPLIANCE REQUIREMENTS (U.S. CLS. 21, 23, 26, 36 AND 38).

FIRST USE 1-13-2002; IN COMMERCE 1-13-2002.  
ODESSA BIBBINS, EXAMINING ATTORNEY

---

SN 85-155,835. HAWS CORPORATION, SPARKS, NV. FILED 10-19-2010.

# AXION

THE MARK CONSISTS OF STANDARD CHARACTERS WITHOUT CLAIM TO ANY PARTICULAR FONT, STYLE, SIZE, OR COLOR.

FOR SAFETY AND EMERGENCY EQUIPMENT, NAMELY, DRENCH SHOWERS AND DECONTAMINATING EYEWASH AND EYE/FACE WASH STATIONS, REPLACEMENT PARTS THEREOF, AND PARTS AND ACCESSORIES FOR USE THEREWITH SOLD AS A UNIT, ALL MARKETED PRIMARILY FOR USE IN INDUSTRIAL FACILITIES IN CASE OF CONTAMINATION (U.S. CLS. 21, 23, 26, 36 AND 38).

FIRST USE 1-15-2009; IN COMMERCE 1-15-2009.  
JOHN DALIER, EXAMINING ATTORNEY

---

SN 85-158,201. BIO-CHEK LLC, CARMEL, CA. FILED 10-21-2010.



THE COLOR(S) GREEN, BROWN, AND TAN IS/ARE CLAIMED AS A FEATURE OF THE MARK.

THE MARK CONSISTS OF THE WORDING "BIO-CHEK" IN BROWN LETTERS BESIDE A FANCIFUL DESIGN CONSISTING OF A GREEN CIRCLE DIVIDED INTO TWO SPACED APART SECTIONS OF DIFFERENT ARC LENGTH, WITH A TAN SEGMENT OF ANOTHER CIRCLE WITHIN THE SECTION OF GREATER ARC LENGTH. THE WHITE IN THE MARK REPRESENTS BACKGROUND AND IS NOT CLAIMED AS A FEATURE OF THE MARK.

FOR PESTICIDE DETECTORS, NAMELY, INSTRUMENTS FOR DETECTING THE PRESENCE OF PESTICIDES ON FRUITS, VEGETABLES, AND OTHER OBJECTS (U.S. CLS. 21, 23, 26, 36 AND 38).

KIMBERLY FRYE, EXAMINING ATTORNEY

**CLASS 9—(Continued).**

SN 85-160,896. NETSWITCH, INC., DBA NETSWITCH TECHNOLOGY MANAGEMENT, SOUTH SAN FRANCISCO, CA. FILED 10-26-2010.

# Voxbyte

THE MARK CONSISTS OF STANDARD CHARACTERS WITHOUT CLAIM TO ANY PARTICULAR FONT, STYLE, SIZE, OR COLOR.

FOR COMMUNICATION SOFTWARE TO ACCESS DATA STORED ON AN OXIMETER AND TRANSFER DATA TO ANOTHER DEVICE; COMPUTER APPLICATION SOFTWARE FOR MOBILE PHONES, NAMELY, SOFTWARE FOR MULTIMODAL INPUT METHOD; COMPUTER E-COMMERCE SOFTWARE TO ALLOW USERS TO PERFORM ELECTRONIC BUSINESS TRANSACTIONS VIA A GLOBAL COMPUTER NETWORK; COMPUTER HARDWARE AND COMPUTER SOFTWARE PROGRAMS FOR THE INTEGRATION OF TEXT, AUDIO, GRAPHICS, STILL IMAGES AND MOVING PICTURES INTO AN INTERACTIVE DELIVERY FOR MULTIMEDIA APPLICATIONS; COMPUTER HARDWARE AND SOFTWARE USED FOR THE CONTROL OF VOICE CONTROLLED INFORMATION AND COMMUNICATION DEVICES; COMPUTER SOFTWARE DEVELOPMENT TOOLS; COMPUTER SOFTWARE FOR COMMUNICATING WITH USERS OF HAND-HELD COMPUTERS; COMPUTER SOFTWARE FOR CONTROLLING AND MANAGING ACCESS SERVER APPLICATIONS (U.S. CLS. 21, 23, 26, 36 AND 38).

FIRST USE 6-19-2002; IN COMMERCE 6-19-2002.  
AMY C. KEAN, EXAMINING ATTORNEY

---

SN 85-161,131. TOCCATA GAMING INTERNATIONAL, LLC, NEENAH, WI. FILED 10-26-2010.

# COBRA CASH

THE MARK CONSISTS OF STANDARD CHARACTERS WITHOUT CLAIM TO ANY PARTICULAR FONT, STYLE, SIZE, OR COLOR.

NO CLAIM IS MADE TO THE EXCLUSIVE RIGHT TO USE "CASH", APART FROM THE MARK AS SHOWN.

FOR ELECTRONIC AMUSEMENT GAMES, NAMELY, ELECTRONIC WAGERING AND NON-WAGERING MACHINES FOR PLAYING GAMES OF CHANCE; ELECTRONIC GAMES OF SKILL, NAMELY, GAMING MACHINES; AND INTERACTIVE VIDEO GAME PROGRAMS (U.S. CLS. 21, 23, 26, 36 AND 38).

PATRICIA EVANKO, EXAMINING ATTORNEY

**CLASS 9—(Continued).**

SN 85-161,628. NET POWER AND LIGHT, INC., SAN FRANCISCO, CA. FILED 10-26-2010.

net  power & light

NO CLAIM IS MADE TO THE EXCLUSIVE RIGHT TO USE "NET", APART FROM THE MARK AS SHOWN.

THE MARK CONSISTS OF THE WORDS NET POWER & (AMPERSAND CHARACTER) LIGHT WITH A RECTANGLE FORMED BY FOUR CIRCLES BETWEEN THE WORDS NET AND POWER.

FOR MOBILE ELECTRONIC DEVICES, NAMELY, RECEPTORS AND TRANSMITTERS TO PROCESS DATA FOR REMOTE COMPUTING APPLICATIONS; COMPUTER SOFTWARE FOR RECEPTORS AND TRANSMITTERS TO PROCESS DATA FOR REMOTE COMPUTING APPLICATIONS (U.S. CLS. 21, 23, 26, 36 AND 38).

GINA HAYES, EXAMINING ATTORNEY

---

SN 85-162,238. NET POWER AND LIGHT, INC., SAN FRANCISCO, CA. FILED 10-27-2010.

NPL LUX

THE MARK CONSISTS OF STANDARD CHARACTERS WITHOUT CLAIM TO ANY PARTICULAR FONT, STYLE, SIZE, OR COLOR.

FOR COMPUTER SOFTWARE DEVELOPMENT TOOLS; COMPUTER SOFTWARE DEVELOPMENT TOOLS FOR CREATING COMPUTER SOFTWARE TO PROCESS DATA FOR DISTRIBUTED COMPUTING APPLICATIONS; COMPUTER SOFTWARE DEVELOPMENT TOOLS FOR CREATING COMPUTER SOFTWARE FOR STREAMING AUDIO AND VIDEO CONTENT TO A VARIETY OF REMOTE DEVICES, NAMELY, HANDHELD COMPUTERS, LAPTOPS, PERSONAL COMPUTERS, MOBILE PHONES, TV'S, PROJECTORS, STAND-ALONE HARDWARE DECODERS AND MOBILE ELECTRONIC DEVICES; COMPUTER DEVELOPMENT TOOLS FOR CREATING SOFTWARE FOR USE IN PROVIDING, HOSTING, MANAGING, DEVELOPING, AND MAINTAINING APPLICATIONS, SOFTWARE, WEB SITES, AND DATABASES FOR WIRELESS COMMUNICATION, MOBILE INFORMATION ACCESS, AND REMOTE DATA MANAGEMENT FOR WIRELESS DELIVERY OF DATA AND CONTENT TO HANDHELD COMPUTERS, LAPTOPS, PERSONAL COMPUTERS, MOBILE PHONES, TV'S, PROJECTORS, STAND-ALONE HARDWARE DECODERS AND MOBILE ELECTRONIC DEVICES; COMPUTER SOFTWARE DEVELOPMENT TOOLS FOR CREATING SOFTWARE FOR USE IN DISTRIBUTED COMPUTING FEATURING NON-DOWNLOADABLE SOFTWARE ALLOWING USERS TO UPLOAD, POST AND DISPLAY ONLINE DIGITAL CONTENT FOR SHARING WITH OTHERS FOR ENTERTAINMENT PURPOSES; COMPUTER SOFTWARE DEVELOPMENT TOOLS FOR CREATING SOFTWARE WHICH ALLOWS USERS TO COLLABORATE IN THE PREPARATION, UPLOADING, DOWNLOADING, SHARING, PUBLISHING, RECEPTION AND TRANSMISSION OF DIGITAL CONTENT TO REMOTE DEVICES (U.S. CLS. 21, 23, 26, 36 AND 38).

GINA HAYES, EXAMINING ATTORNEY

**CLASS 9—(Continued).**

SN 85-164,179. ENTONE, INC., SAN MATEO, CA. FILED 10-28-2010.

KAMI

THE MARK CONSISTS OF STANDARD CHARACTERS WITHOUT CLAIM TO ANY PARTICULAR FONT, STYLE, SIZE, OR COLOR.

THE TERM "KAMI" IS A TRANSLITERATED JAPANESE WORD FOR THE SPIRITS, NATURAL FORCES OR ESSENCE OF THE SHINTO FAITH.

FOR COMPUTER HARDWARE AND SOFTWARE FOR THE INTEGRATION OF TEXT, AUDIO, GRAPHICS, STILL IMAGES AND MOVING PICTURES INTO AN INTERACTIVE DELIVERY FOR MULTIMEDIA APPLICATIONS OVER DIGITAL BROADBAND NETWORKS FOR INTEGRATION WITH BROADCAST TELEVISION CHANNELS (U.S. CLS. 21, 23, 26, 36 AND 38).

RUSS HERMAN, EXAMINING ATTORNEY

---

SN 85-164,181. ENTONE, INC., SAN MATEO, CA. FILED 10-28-2010.

KAMAI

THE MARK CONSISTS OF STANDARD CHARACTERS WITHOUT CLAIM TO ANY PARTICULAR FONT, STYLE, SIZE, OR COLOR.

THE TERM "KAMAI" REFERS TO HIMALAYAN PEOPLE WHO ARE ARYAN IN ORIGIN

FOR COMPUTER HARDWARE AND SOFTWARE FOR THE INTEGRATION OF TEXT, AUDIO, GRAPHICS, STILL IMAGES AND MOVING PICTURES INTO AN INTERACTIVE DELIVERY FOR MULTIMEDIA APPLICATIONS OVER DIGITAL BROADBAND NETWORKS FOR INTEGRATION WITH BROADCAST TELEVISION CHANNELS (U.S. CLS. 21, 23, 26, 36 AND 38).

RUSS HERMAN, EXAMINING ATTORNEY

**CLASS 9—(Continued).**

SN 85-164,319. DAVIS, VICTORIA, SAN FRANCISCO, CA.  
FILED 10-29-2010.

**SPACE DOG BOOKS**

THE MARK CONSISTS OF STANDARD CHARACTERS WITHOUT CLAIM TO ANY PARTICULAR FONT, STYLE, SIZE, OR COLOR.

NO CLAIM IS MADE TO THE EXCLUSIVE RIGHT TO USE "BOOKS", APART FROM THE MARK AS SHOWN.

FOR DOWNLOADABLE SOFTWARE, NAMELY, SOFTWARE APPLICATIONS FOR CREATING INTERACTIVE MEDIA USED IN MOBILE COMPUTING DEVICES, LAPTOPS, TABLET COMPUTERS, MOBILE TELEPHONES; DOWNLOADABLE SOFTWARE FOR INTERACTIVE PUBLISHING IN THE FIELD OF CHILDREN'S ENTERTAINMENT OR CHILDREN'S EDUCATION; DOWNLOADABLE SOFTWARE FOR CREATING INTERACTIVE MEDIA AND INTERACTIVE PUBLISHING IN THE FIELD OF LITERATURE AND INTERACTIVE BOOKS FOR CONSUMERS OF ALL AGES; ELECTRONIC PUBLICATIONS, NAMELY, ELECTRONIC BOOKS IN THE FIELDS OF CHILDREN'S LITERATURE, CHILDREN'S BOOKS, AND CHILDREN'S EDUCATIONAL BOOKS, ALL RECORDED ON COMPUTER MEDIA (U.S. CLS. 21, 23, 26, 36 AND 38).

BRIAN PINO, EXAMINING ATTORNEY

SN 85-165,752. CHUAH, KHAH GAN, AUSTIN, TX. FILED 11-1-2010.

**SNAPLITE**

THE MARK CONSISTS OF STANDARD CHARACTERS WITHOUT CLAIM TO ANY PARTICULAR FONT, STYLE, SIZE, OR COLOR.

FOR ELECTRIC WARNING LIGHTS, EMERGENCY WARNING LIGHTS, FLASHING SAFETY LIGHTS, LIGHT EMITTING DIODE (LED) DISPLAYS, LUMINOUS BEACONS FOR SAFETY OR WARNING PURPOSES, LUMINOUS SAFETY BEACONS, PORTABLE LED SAFETY LIGHTING DEVICES FOR PERSONAL USE FOR SAFETY PURPOSES, ALL OF THE AFOREMENTIONED GOODS ARE FOR BICYCLES AND JUVENILE PRODUCTS NAMELY, BABY STROLLERS AND RIDE-ON TOYS (U.S. CLS. 21, 23, 26, 36 AND 38).

FIRST USE 10-1-2010; IN COMMERCE 10-1-2010.  
COURTNEY ALVAREZ, EXAMINING ATTORNEY

**CLASS 9—(Continued).**

SN 85-170,869. JOHN NOVAK, THE WOODLANDS, TX.  
FILED 11-6-2010.

**Nexgen Revolution**

THE MARK CONSISTS OF STANDARD CHARACTERS WITHOUT CLAIM TO ANY PARTICULAR FONT, STYLE, SIZE, OR COLOR.

OWNER OF U.S. REG. NO. 3,411,440.  
FOR DOWNLOADABLE COMPUTER SOFTWARE FOR TECHNICAL ANALYSIS OF FINANCIAL MARKETS (U.S. CLS. 21, 23, 26, 36 AND 38).

FIRST USE 10-22-2010; IN COMMERCE 10-22-2010.  
TARAH HARDY, EXAMINING ATTORNEY

SN 85-173,594. NICHOLAS I. SIMONETTE, SMYRNA, GA.  
FILED 11-10-2010.

**ClickerCover!**

NO CLAIM IS MADE TO THE EXCLUSIVE RIGHT TO USE "CLICKER COVER", APART FROM THE MARK AS SHOWN.

THE COLOR(S) RED AND BLACK IS/ARE CLAIMED AS A FEATURE OF THE MARK.

THE MARK CONSISTS OF THE STYLIZED WORDING "CLICKERCOVER!" WITH THE LETTERING IN BLACK AND THE TWO EXCLAMATION POINTS IN RED.

FOR CLEAR PROTECTIVE COVERS, MADE OF PLASTIC OR OTHER SUITABLE MATERIALS, ADAPTED FOR PERSONAL ELECTRONIC DEVICES FOR THE PURPOSE OF PROTECTING PERSONAL HEALTH BY CUTTING THE RISK OF COSS-CONTAMINATION (U.S. CLS. 21, 23, 26, 36 AND 38).

FIRST USE 4-27-2010; IN COMMERCE 4-27-2010.  
JULIE GUTTADAURO, EXAMINING ATTORNEY

SN 85-173,737. SLOVENKO, RICHARD, YONKERS, NY.  
FILED 11-10-2010.

**ALL THE SIGNAL**

THE MARK CONSISTS OF STANDARD CHARACTERS WITHOUT CLAIM TO ANY PARTICULAR FONT, STYLE, SIZE, OR COLOR.

FOR WIRELESS PRODUCTS, NAMELY, RADIOS, RADIO RECEIVERS AND TRANSMITTERS, MODEMS, RADIO FREQUENCY SIGNAL GENERATORS FOR USE IN WIRELESS BROADCASTS AND TESTING, SIGNAL ENCODERS, RADIO FREQUENCY INTEGRATED CIRCUITS, DEVICES FOR WIRELESS RADIO TRANSMISSION, WIRELESS CONTROLLER TO MONITOR AND CONTROL THE FUNCTIONING OF OTHER ELECTRONIC DEVICES, AND ANTENNAS (U.S. CLS. 21, 23, 26, 36 AND 38).

BRIDGETT SMITH, EXAMINING ATTORNEY

**CLASS 9—(Continued).**

SN 85-176,142. ECLIPSE GAMING SYSTEMS, LLC, LAWRENCEVILLE, GA. FILED 11-13-2010.

**PLAYER ADVANTAGE**

THE MARK CONSISTS OF STANDARD CHARACTERS WITHOUT CLAIM TO ANY PARTICULAR FONT, STYLE, SIZE, OR COLOR.

NO CLAIM IS MADE TO THE EXCLUSIVE RIGHT TO USE "PLAYER", APART FROM THE MARK AS SHOWN.

FOR ELECTRIC SIGNS; COMPUTER SOFTWARE FOR USE IN GAMING MACHINES INCLUDING BINGO MACHINES, SLOT MACHINES OR VIDEO LOTTERY TERMINALS (U.S. CLS. 21, 23, 26, 36 AND 38).

JOHN DWYER, EXAMINING ATTORNEY

---

SN 85-177,774. DIGITAL CHAOTICS LLC, SAN JOSE, CA. FILED 11-16-2010.

**Digital Chaotics**

THE MARK CONSISTS OF STANDARD CHARACTERS WITHOUT CLAIM TO ANY PARTICULAR FONT, STYLE, SIZE, OR COLOR.

NO CLAIM IS MADE TO THE EXCLUSIVE RIGHT TO USE "DIGITAL", APART FROM THE MARK AS SHOWN.

FOR MUSIC VIDEO COMPOSITION SOFTWARE (U.S. CLS. 21, 23, 26, 36 AND 38).

MARK SHINER, EXAMINING ATTORNEY

---

SN 85-179,345. MOTOROLA TRADEMARK HOLDINGS, LLC, LIBERTYVILLE, IL. FILED 11-17-2010.

**STADIA**

THE MARK CONSISTS OF STANDARD CHARACTERS WITHOUT CLAIM TO ANY PARTICULAR FONT, STYLE, SIZE, OR COLOR.

FOR SMART PHONES FEATURING FITNESS MONITORS FOR NON-MEDICAL USE; FITNESS MONITORING DEVICES COMPRISING A HANDHELD UNIT FEATURING A CALORIMETER, PEDOMETER AND ACCELEROMETER; ELECTRONIC NON-MEDICAL PORTABLE FITNESS MONITORING DEVICE FOR MEASURING, STORING, TRANSFERRING AND SYNCHRONIZING AN INDIVIDUAL'S PHYSICAL EXERCISE AND ACTIVITY LEVELS INCLUDING DATE, TIME, HEART RATE, GLOBAL POSITIONING, DIRECTION, DISTANCE, ALTITUDE, SPEED, DISTANCE, CALORIES AND TEMPERATURE (U.S. CLS. 21, 23, 26, 36 AND 38).

PATRICIA EVANKO, EXAMINING ATTORNEY

**CLASS 9—(Continued).**

SN 85-179,916. FELDMAN, ALEXANDER N., SAN FRANCISCO, CA. FILED 11-18-2010.

**ALEXANDER DAAS**

THE MARK CONSISTS OF STANDARD CHARACTERS WITHOUT CLAIM TO ANY PARTICULAR FONT, STYLE, SIZE, OR COLOR.

THE NAME "ALEXANDER DAAS" DOES NOT IDENTIFY A LIVING INDIVIDUAL.

FOR ANTI-DAZZLE SPECTACLES; ANTI-GLARE GLASSES; ANTI-GLARE SPECTACLES; ANTIREFLECTION COATED EYEGLASSES; CASES FOR CHILDREN'S EYE GLASSES; CASES FOR EYEGLASSES AND SUNGLASSES; CASES FOR SPECTACLES AND SUNGLASSES; CASES FOR SPECTACLES, FOR PINCE-NEZ AND FOR CONTACT LENSES; CHAINS FOR EYEGLASSES; CHAINS FOR SPECTACLES; CHAINS FOR SPECTACLES AND FOR SUNGLASSES; CHILDREN'S EYE GLASSES; CORRECTIVE GLASSES; EYE GLASS CASES; EYE GLASS CHAINS; EYE GLASS CORDS; EYE GLASSES; EYEGLASS CASES; EYEGLASS CHAINS; EYEGLASS CHAINS AND CORDS; EYEGLASS CORDS; EYEGLASS FRAMES; EYEGLASS RETAINING CORDS; EYEGLASSES; EYEWEAR; EYEWEAR ACCESSORIES, NAMELY, STRAPS, NECK CORDS AND HEAD STRAPS WHICH RESTRAIN EYEWEAR FROM MOVEMENT ON A WEARER; EYEWEAR CASES; EYEWEAR RETAINERS; EYEWEAR, NAMELY, SUNGLASSES, EYEGLASSES AND OPHTHALMIC FRAMES AND CASES THEREFOR; FRAMES FOR EYEGLASSES AND PINCE-NEZ; FRAMES FOR GLASSES AND PINCE-NEZ; FRAMES FOR SPECTACLES; FRAMES FOR SPECTACLES AND PINCE-NEZ; FRAMES FOR SPECTACLES AND SUNGLASSES; GLACIER EYEGLASSES; GLASSES FOR SPORTS; LENSES FOR SUNGLASSES; MAGNIFYING GLASSES THAT FIT ON THE USER'S FACE IN THE MANNER OF EYEGLASSES; MONOCULAR FRAMES; NOSE GUARDS WHICH CAN BE WORN BY ATTACHMENT TO EYEWEAR SUCH AS SUNGLASSES AND SKI GOGGLES; OPERA GLASSES; OPTICAL FRAMES; OPTICAL GLASSES; POLARIZING SPECTACLES; PROTECTIVE EYEGLASSES; PROTECTIVE EYEWEAR; PROTECTIVE EYEWEAR AND COMPONENT PARTS THEREOF; PROTECTIVE GLASSES; PROTECTIVE SPECTACLES; READING EYEGLASSES; READING GLASSES; SAFETY EYEWEAR; SIDE GUARDS FOR EYEGLASSES; SKI GLASSES; SPECTACLE CASES; SPECTACLE FRAMES; SPECTACLE FRAMES MADE OF METAL AND OF SYNTHETIC MATERIAL; SPECTACLE FRAMES MADE OF METAL OR A COMBINATION OF METAL AND PLASTICS; SPECTACLE FRAMES MADE OF METAL OR OF A COMBINATION OF METAL AND PLASTIC; SPECTACLE GLASSES; SPECTACLE HOLDERS; SPECTACLE LENS BLANKS; SPECTACLE LENSES; SPECTACLES AND SUNGLASSES; SPECTACLES, FRAMES AND CASES; SPORTS EYEWEAR; SPORTS GLASSES; SPORTS TRAINING EYEGLASSES; SPORTS' GLASSES; SUN GLASSES; SUNGLASS CHAINS AND CORDS; SUNGLASS LENSES; SUNGLASSES; SUNGLASSES AND SPECTACLES; THEATRE GLASSES; UNMOUNTED SPECTACLE FRAMES; VISUAL TRAINING AID, NAMELY, NON-PRESCRIPTION GLASSES USED FOR VISUAL TRAINING PURPOSES (U.S. CLS. 21, 23, 26, 36 AND 38).

FIRST USE 4-7-2010; IN COMMERCE 11-12-2010.

SUSAN RICHARDS, EXAMINING ATTORNEY

**CLASS 9—(Continued).**

SN 85-181,719. HTC CORPORATION, TAOYUAN CITY, TAIWAN, FILED 11-19-2010.

**FRIENDSTREAM**

THE MARK CONSISTS OF STANDARD CHARACTERS WITHOUT CLAIM TO ANY PARTICULAR FONT, STYLE, SIZE, OR COLOR.

FOR COMPUTER APPLICATION SOFTWARE FOR MOBILE PHONES, NAMELY, SOFTWARE THAT ENABLES TRANSMISSION, RETRIEVAL, SEARCH, SYNCHRONIZATION, ACCESS, ORGANIZATION AND MANAGEMENT OF TEXT MESSAGING, INSTANT MESSAGING, ONLINE BLOG JOURNALS, TEXT, WEB LINKS, WEB MESSAGING, IMAGES, VIDEO, AUDIO, AND DATA CONTENT VIA THE INTERNET, COMPUTER NETWORKS AND OTHER COMMUNICATION NETWORKS; COMPUTER SOFTWARE FOR USE AS AN APPLICATION PROGRAMMING INTERFACE (API); APPLICATION PROGRAMMING INTERFACE (API) COMPUTER SOFTWARE WHICH FACILITATES ONLINE SERVICES FOR SOCIAL NETWORKING, BUILDING SOCIAL NETWORKING APPLICATIONS, BY ALLOWING DATA RETRIEVAL, UPLOAD, DOWNLOAD, ACCESS AND MANAGEMENT BY ENABLING UPLOADING, DOWNLOADING, ACCESSING, POSTING, DISPLAYING, TAGGING, BLOGGING, STREAMING, LINKING, SHARING OR OTHERWISE PROVIDING ELECTRONIC MEDIA OR INFORMATION VIA COMPUTER AND COMMUNICATION NETWORKS; COMPUTER SOFTWARE TO ENABLE UPLOADING, DOWNLOADING, ACCESSING, POSTING, DISPLAYING, TAGGING, BLOGGING, STREAMING, LINKING AND SHARING ELECTRONIC MEDIA AND INFORMATION IN THE FIELD OF EDUCATION, ENTERTAINMENT, SOCIAL MEDIA AND SOCIAL NETWORKING PROVIDED VIA COMPUTER AND COMMUNICATION NETWORKS (U.S. CLS. 21, 23, 26, 36 AND 38).

FIRST USE 2-16-2010; IN COMMERCE 2-16-2010.  
JASON TURNER, EXAMINING ATTORNEY

SN 85-182,528. KANEKA CORPORATION, OSAKA, JAPAN, FILED 11-22-2010.

**KANEKA**

THE MARK CONSISTS OF THE STYLIZED WORD "KANEKA".

FOR LABORATORY APPARATUS AND INSTRUMENTS, NAMELY, PRE-PACKED COLUMNS FOR USE IN CELL SEPARATION AND PURIFICATION (U.S. CLS. 21, 23, 26, 36 AND 38).

LINDA M. KING, EXAMINING ATTORNEY

**CLASS 9—(Continued).**

SN 85-183,313. PARABELLUM COLLECTION, INC., LOS ANGELES, CA. FILED 11-23-2010.

**PARABELLUM**

THE MARK CONSISTS OF STANDARD CHARACTERS WITHOUT CLAIM TO ANY PARTICULAR FONT, STYLE, SIZE, OR COLOR.

OWNER OF U.S. REG. NOS. 3,750,271 AND 3,750,702.  
FOR SUNGLASSES (U.S. CLS. 21, 23, 26, 36 AND 38).  
COURTNEY ALVAREZ, EXAMINING ATTORNEY

SN 85-184,175. OLSEN GAMING, INC., HENDERSON, NV, FILED 11-23-2010.

**TURTLE TROVE BONUS**

THE MARK CONSISTS OF STANDARD CHARACTERS WITHOUT CLAIM TO ANY PARTICULAR FONT, STYLE, SIZE, OR COLOR.

NO CLAIM IS MADE TO THE EXCLUSIVE RIGHT TO USE "BONUS", APART FROM THE MARK AS SHOWN.

FOR GAMING MACHINES THAT GENERATE OR DISPLAY WAGER OUTCOMES (U.S. CLS. 21, 23, 26, 36 AND 38).

LAKEISHA LEWIS, EXAMINING ATTORNEY

SN 85-184,256. ELSA INVESTMENT CORP., LTD., TAIPEI COUNTY, TAIWAN, FILED 11-24-2010.

**ELSA GLORIA**

THE MARK CONSISTS OF STANDARD CHARACTERS WITHOUT CLAIM TO ANY PARTICULAR FONT, STYLE, SIZE, OR COLOR.

FOR COMPUTER GRAPHICS SOFTWARE; COMPUTER PROGRAMS FOR EDITING IMAGES, SOUND AND VIDEO; COMPUTER PROGRAMS FOR USER INTERFACE DESIGN; COMPUTER PROGRAMS RECORDED ON DATA MEDIA (SOFTWARE) DESIGNED FOR USE IN CONSTRUCTION AND AUTOMATED MANUFACTURING (CAD/CAM); GRAPHICS CARDS; VIEWING DEVICES, NAMELY, DIGITAL PHOTOGRAPH VIEWERS, 3D DIGITAL PHOTOGRAPH VIEWERS, UNDERWATER DIGITAL PHOTOGRAPH VIEWERS, UNDERWATER 3D DIGITAL PHOTOGRAPH VIEWERS, UNDERWATER LCD DISPLAYS, UNDERWATER ENCLOSURES FOR LCD DISPLAYS AND UNDERWATER ENCLOSURES FOR VIDEO PLAYERS (U.S. CLS. 21, 23, 26, 36 AND 38).

BARBARA RUTLAND, EXAMINING ATTORNEY



**CLASS 9—(Continued).**

SN 85-184,487. U.S. ROBOTICS CORPORATION, BEVERLY HILLS, CA. FILED 11-24-2010.

**USHARE**

THE MARK CONSISTS OF STANDARD CHARACTERS WITHOUT CLAIM TO ANY PARTICULAR FONT, STYLE, SIZE, OR COLOR.

FOR COMMUNICATION DEVICE FOR DATA OR IMAGE TRANSMISSION, NAMELY, USB (UNIVERSAL SERIAL BUS) DONGLE DEVICE THAT ENABLES USERS TO SHARE DATA OR FILES CONTAINED ON USB DATA STORAGE DEVICES THROUGH A LOCAL AREA NETWORK (LAN) (U.S. CLS. 21, 23, 26, 36 AND 38).

STEVEN PEREZ, EXAMINING ATTORNEY

SN 85-184,901. ORACLE INTERNATIONAL CORPORATION, REDWOOD CITY, CA. FILED 11-24-2010.

**UNBREAKABLE ENTERPRISE  
KERNEL**

THE MARK CONSISTS OF STANDARD CHARACTERS WITHOUT CLAIM TO ANY PARTICULAR FONT, STYLE, SIZE, OR COLOR.

OWNER OF U.S. REG. NOS. 3,406,416 AND 3,406,417. NO CLAIM IS MADE TO THE EXCLUSIVE RIGHT TO USE "ENTERPRISE KERNEL", APART FROM THE MARK AS SHOWN.

FOR COMPUTER OPERATING SYSTEM SOFTWARE; DOWNLOADABLE COMPUTER OPERATING SYSTEM SOFTWARE (U.S. CLS. 21, 23, 26, 36 AND 38).

FIRST USE 9-19-2010; IN COMMERCE 9-19-2010.

KATHLEEN M. VANSTON, EXAMINING ATTORNEY

SN 85-185,885. HGW ACQUISITION COMPANY, LLC, MINNEAPOLIS, MN. FILED 11-29-2010.

**PROXIMITY PLUS**

THE MARK CONSISTS OF STANDARD CHARACTERS WITHOUT CLAIM TO ANY PARTICULAR FONT, STYLE, SIZE, OR COLOR.

NO CLAIM IS MADE TO THE EXCLUSIVE RIGHT TO USE "PLUS", APART FROM THE MARK AS SHOWN.

FOR ELECTRONIC SECURITY ACCESS CARDS (U.S. CLS. 21, 23, 26, 36 AND 38).

FIRST USE 6-0-2002; IN COMMERCE 6-0-2002.

KATHY DE JONGE, EXAMINING ATTORNEY

**CLASS 9—(Continued).**

SN 85-185,889. HGW ACQUISITION COMPANY, LLC, MINNEAPOLIS, MN. FILED 11-29-2010.

**MIRAGE**

THE MARK CONSISTS OF STANDARD CHARACTERS WITHOUT CLAIM TO ANY PARTICULAR FONT, STYLE, SIZE, OR COLOR.

OWNER OF U.S. REG. NO. 1,841,256. FOR ELECTRONIC ACCESS CONTROL EQUIPMENT, NAMELY, ENCODED CARDS AND CARD READERS (U.S. CLS. 21, 23, 26, 36 AND 38).

FIRST USE 4-19-1988; IN COMMERCE 4-19-1988.

KATHY DE JONGE, EXAMINING ATTORNEY

SN 85-187,249. ALTERNATIVES TECHNOLOGIE PHARMA INC., LAVAL, QUEBEC, CANADA, FILED 11-30-2010.

**ATP-Mirador**

THE MARK CONSISTS OF STANDARD CHARACTERS WITHOUT CLAIM TO ANY PARTICULAR FONT, STYLE, SIZE, OR COLOR.

THE ENGLISH TRANSLATION OF "MIRADOR" IN THE MARK IS "SUGGEST AN IMPROVEMENT".

FOR SHIPMENT MONITORING SYSTEM COMPRISED OF METERS AND SENSORS THAT MEASURE TEMPERATURE (U.S. CLS. 21, 23, 26, 36 AND 38).

FIRST USE 6-10-2006; IN COMMERCE 6-10-2006.

LAKEISHA LEWIS, EXAMINING ATTORNEY

SN 85-187,711. GONZALEZ ALLEGRE, LUIS EDGAR, MEXICO CITY, MEXICO, FILED 11-30-2010.



NO CLAIM IS MADE TO THE EXCLUSIVE RIGHT TO USE "SOCCER", APART FROM THE MARK AS SHOWN.

THE MARK CONSISTS OF THE WORDS "SOCCER MAT" WITH A STYLIZED SOCCER BALL.

FOR EDUCATIONAL COMPUTER APPLICATION SOFTWARE FOR MOBILE PHONES, NAMELY, SOFTWARE FEATURING SOCCER TRAINING; EDUCATIONAL COMPUTER APPLICATION SOFTWARE FOR MOBILE PHONES, PORTABLE MEDIA PLAYERS AND HANDHELD COMPUTERS, NAMELY, SOFTWARE FEATURING SOCCER TRAINING (U.S. CLS. 21, 23, 26, 36 AND 38).

FIRST USE 10-31-2005; IN COMMERCE 4-28-2010.

BARNEY CHARLON, EXAMINING ATTORNEY

**CLASS 9—(Continued).**

SN 85-188,219. SPARTAN TOOL, L.L.C., MENDOTA, IL. FILED 12-1-2010.

**PROVISION TOUCH**

THE MARK CONSISTS OF STANDARD CHARACTERS WITHOUT CLAIM TO ANY PARTICULAR FONT, STYLE, SIZE, OR COLOR.

NO CLAIM IS MADE TO THE EXCLUSIVE RIGHT TO USE "TOUCH", APART FROM THE MARK AS SHOWN.

FOR CAMERA SYSTEMS, NAMELY, CAMERAS FOR INSPECTING CONDUITS SUCH AS SEWER CONDUITS, AND PARTS AND ACCESSORIES THEREFOR, NAMELY, AUXILIARY PUSH RODS TO ALLOW INSPECTION OVER LONGER DISTANCES, CAMERA CENTERING GUIDES THAT ARE PLACED OVER A CAMERA HEAD TO KEEP IT CENTERED IN CONDUITS, CAMERA SLEEVES THAT ARE PLACED OVER A CAMERA HEAD TO PROTECT IT FROM SHOCK IN USE, ROLLER CARRIAGES FOR TRANSPORTATION OF THE CAMERAS, AND LOCATORS AND TRANSMITTERS USED WITH THE CAMERAS (U.S. CLS. 21, 23, 26, 36 AND 38).

RAUL CORDOVA, EXAMINING ATTORNEY

**CLASS 9—(Continued).**

SN 85-188,996. RECKITT BENCKISER N.V., 2132 WT HOOFDDORP, NETHERLANDS, FILED 12-2-2010.



PRIORITY CLAIMED UNDER SEC. 44(D) ON ERPNTY TM OFC APPLICATION NO. 009172651, FILED 6-14-2010, REG. NO. 9172651, DATED 11-29-2010, EXPIRES 6-14-2020.

THE COLOR(S) PINK BLUE AND WHITE IS/ARE CLAIMED AS A FEATURE OF THE MARK.

THE MARK CONSISTS OF THE WORD "POWERBRANDS" IN PINK, OUTLINED IN WHITE AND BLUE, SUPERIMPOSED OVER AN ILLUSTRATION OF THREE EXECUTIVES DEPICTED IN SHADOW IN BLUE AND WHITE ALL ON A WHITE BACKGROUND SURROUNDED BY A THIN BLUE LINE.

FOR DOWNLOADABLE ELECTRONIC GAME PROGRAMS; COMPUTER GAME SOFTWARE (U.S. CLS. 21, 23, 26, 36 AND 38).

ERNEST SHOSHO, EXAMINING ATTORNEY

SN 85-188,574. HARRIS, LOGAN CARL, OREM, UT. AND HARRIS, LOGAN CARL, OREM, UT. FILED 12-1-2010.



THE COLOR(S) BLACK AND YELLOW IS/ARE CLAIMED AS A FEATURE OF THE MARK.

THE MARK CONSISTS OF CAPITAL LETTER "S" IN BLACK, LOWERCASE LETTERS "P", "O", "T", "E", AND "R" IN BLACK; CAPITAL LETTERS "R" AND "F" IN YELLOW. THE LETTERS "R" AND "F" ARE ENCLOSED IN A BLACK CIRCLE THAT STARTS ON TOP OF THE LOWERCASE "R" AND FINISHES ON THE BOTTOM ON THE LOWERCASE "R". THE CIRCLE IS INTERCEPTED BY THREE DASHES.

FOR GROUND SURVEILLANCE RADAR (U.S. CLS. 21, 23, 26, 36 AND 38).

FIRST USE 12-1-2007; IN COMMERCE 12-1-2008.  
JOHN E. MICHOS, EXAMINING ATTORNEY

SN 85-189,068. SONY PICTURES HOME ENTERTAINMENT INC., CULVER CITY, CA. FILED 12-2-2010.



THE COLOR(S) BLUE, WHITE AND BLACK IS/ARE CLAIMED AS A FEATURE OF THE MARK.

THE MARK CONSISTS OF THE WORDING "MOVIESNAX" IN BLACK AND OUTLINED IN WHITE, A BLACK AND WHITE CLAP BOARD CONSISTING OF THREE WHITE DOTS ON THE TOP LEFT CORNER, BLACK AND WHITE ALTERNATING DIAGONAL BARS ON THE CLAP PART OF THE CLAP BOARD, AND THREE TRIANGULAR PIECES BITTEN OFF FROM THE CLAP BOARD TO THE RIGHT BOTTOM CORNER IN BLACK AND OUTLINED IN WHITE, THE WORDING "MOVIESNAX" AND THE CLAP BOARD ARE BORDERED IN BLUE, AND THE ENTIRE MARK APPEARS ON A BLACK BACKGROUND.

FOR COMPUTER PROGRAM FOR VIEWING PARTS OF FEATURE MOTION PICTURES AND TELEVISION SHOWS ON MULTIPLE COMPUTER AND NETWORK PLATFORMS (U.S. CLS. 21, 23, 26, 36 AND 38).

JENNY PARK, EXAMINING ATTORNEY

**CLASS 9—(Continued).**

SN 85-189,664. ALL SYSTEMS BROADBAND, INC., LIVERMORE, CA. FILED 12-2-2010.



**ALL SYSTEMS BROADBAND**

NO CLAIM IS MADE TO THE EXCLUSIVE RIGHT TO USE "ALL SYSTEMS BROADBAND", APART FROM THE MARK AS SHOWN.

THE COLOR(S) BLUE AND WHITE IS/ARE CLAIMED AS A FEATURE OF THE MARK.

THE MARK CONSISTS OF THE WORDING "ALL SYSTEMS BROADBAND" APPEARING IN BLUE, BELOW A DESIGN OF TWO OPPOSING CRESCENT CURVES IN BLUE, WITH A HORIZONTAL LINE EXTENDING OUT OF ONE SIDE OF EACH OF THE CURVES, ALL ON A WHITE BACKGROUND.

FOR ELECTRONIC EQUIPMENT, NAMELY, TRANSFORMERS, BALUNS, CABLES USED IN CONNECTION WITH COMPUTERS, COMPUTER PERIPHERAL DEVICES, TELEVISIONS, AUDIO-VIDEO EQUIPMENT, CLOSED-CIRCUIT TV EQUIPMENT AND TELECOMMUNICATION EQUIPMENT (U.S. CLS. 21, 23, 26, 36 AND 38).

FIRST USE 1-0-2008; IN COMMERCE 6-0-2008.  
KAELE KUNG, EXAMINING ATTORNEY

**CLASS 9—(Continued).**

SN 85-190,215. REALTIME MUSIC SOLUTIONS, LLC, NEW YORK, NY. FILED 12-3-2010.

**RMS KEYBOARDS**

THE MARK CONSISTS OF STANDARD CHARACTERS WITHOUT CLAIM TO ANY PARTICULAR FONT, STYLE, SIZE, OR COLOR.

NO CLAIM IS MADE TO THE EXCLUSIVE RIGHT TO USE "KEYBOARDS", APART FROM THE MARK AS SHOWN.

FOR DOWNLOADABLE COMPUTER SOFTWARE THAT PROVIDES ALL MUSICAL SOUNDS REQUIRED TO PERFORM THE PROPER SOUNDS IN PRODUCTION OF MUSICAL PLAY (U.S. CLS. 21, 23, 26, 36 AND 38).

FIRST USE 8-1-2010; IN COMMERCE 8-1-2010.  
STEVEN R. FINE, EXAMINING ATTORNEY

SN 85-189,777. CLEARSTAK, LLC, WILLINGTON, CT. FILED 12-2-2010.

**ClearStak**

THE MARK CONSISTS OF A HORIZONTALLY ALIGNED RECTANGLE, CONTAINING TWO HORIZONTALLY RECTANGLES. THE FIRST RECTANGLE CONTAINS A SHADED BACKGROUND AND THE NON-SHADED LITERAL ELEMENT "CLEAR", THE SECOND RECTANGLE CONTAINS A SHADED BORDER, A CLEAR BACKGROUND AND THE SHADED LITERAL ELEMENT "STAK".

FOR INTEGRATED AND ADD-ON THERMO-CHEMICAL CATALYTIC CONTROL DEVICES AND ELECTRONIC CONTROL MODULES FOR THE CONTROL OF AIR POLLUTION FROM BIOMASS FIRED FURNACES AND BOILERS (U.S. CLS. 21, 23, 26, 36 AND 38).

FIRST USE 9-1-2010; IN COMMERCE 9-1-2010.  
THOMAS MANOR, EXAMINING ATTORNEY

SN 85-191,163. WISEMAN, BRIAN, M., DBA AIRFLOW DIRECTION INCORPORATED, NEWBURY, MA. FILED 12-6-2010.

**BAULIN-TUBE**

THE MARK CONSISTS OF STANDARD CHARACTERS WITHOUT CLAIM TO ANY PARTICULAR FONT, STYLE, SIZE, OR COLOR.

OWNER OF U.S. REG. NO. 2,747,215.  
SEC. 2(F).  
FOR PRESSURE INDICATORS (U.S. CLS. 21, 23, 26, 36 AND 38).

FIRST USE 5-30-2002; IN COMMERCE 5-30-2002.  
STEPHANIE ALI, EXAMINING ATTORNEY

**CLASS 9—(Continued).**

SN 85-191,284. GAMBRO LUNDIA AB, SE - 220 10 LUND, SWEDEN, FILED 12-6-2010.

# ACCESCAN

THE MARK CONSISTS OF STANDARD CHARACTERS WITHOUT CLAIM TO ANY PARTICULAR FONT, STYLE, SIZE, OR COLOR.

PRIORITY CLAIMED UNDER SEC. 44(D) ON FRANCE APPLICATION NO. 103744429, FILED 6-8-2010, REG. NO. 103744429, DATED 6-8-2010, EXPIRES 6-8-2020.

FOR CONTROL, MONITORING AND MANAGEMENT SOFTWARE FOR DIALYSIS SESSIONS; MANAGEMENT SOFTWARE FOR DIALYSIS CENTRES; ASSISTANCE SOFTWARE FOR DIALYSIS MACHINES; ASSISTANCE SOFTWARE FOR CREATING AND UPDATING SPECIFIC OPERATING MODES FOR DIALYSIS MACHINES; SOFTWARE FOR KIDNEY FAILURE TREATMENT AND TO MACHINES FOR KIDNEY TREATMENT; MEMORY CARDS FOR THE STORAGE AND TRANSFER OF INFORMATION REGARDING A PATIENT SUFFERING FROM RENAL INSUFFICIENCY AND/OR A TREATMENT UNDERGONE BY THIS PATIENT; MEMORY CARDS FOR THE STORAGE AND TRANSFER OF INFORMATION REGARDING THE OPERATION OF A DIALYSIS MACHINE; ELECTRONIC/COMPUTER SYSTEMS INTERFACING BETWEEN A DIALYSIS MACHINE AND A COMPUTER AND DEVICE FOR DISPLAYING THE DATA PROVIDED TO THE INTERFACE SYSTEM OR IN TRANSIT THROUGH IT (U.S. CLS. 21, 23, 26, 36 AND 38).

DOMINICK J. SALEMI, EXAMINING ATTORNEY

**CLASS 9—(Continued).**

SN 85-193,015. LA SPORTIVA N.A., INC., BOULDER, CO. FILED 12-8-2010.

# LA SPORTIVA

THE MARK CONSISTS OF STANDARD CHARACTERS WITHOUT CLAIM TO ANY PARTICULAR FONT, STYLE, SIZE, OR COLOR.

OWNER OF U.S. REG. NOS. 1,705,106, 3,485,093 AND OTHERS.

THE ENGLISH TRANSLATION OF "SPORTIVA" IN THE MARK IS "SPORTY" OR "SPORTING".

FOR SUNGLASSES, CASES FOR SUNGLASSES, PROTECTIVE HELMETS, CAMERAS, AND AVALANCHE PROBES, NAMELY, ELONGATED RODS USED TO MANUALLY PROBE FOR PEOPLE OR OBJECTS COVERED BY AN AVALANCHE (U.S. CLS. 21, 23, 26, 36 AND 38).

CAROLINE WOOD, EXAMINING ATTORNEY

SN 85-193,033. LA SPORTIVA N.A., INC., BOULDER, CO. FILED 12-8-2010.

# SPORTIVA

THE MARK CONSISTS OF STANDARD CHARACTERS WITHOUT CLAIM TO ANY PARTICULAR FONT, STYLE, SIZE, OR COLOR.

OWNER OF U.S. REG. NOS. 1,705,106, 3,485,093 AND OTHERS.

THE ENGLISH TRANSLATION OF "SPORTIVA" IN THE MARK IS "SPORTY" OR "SPORTING".

FOR SUNGLASSES, CASES FOR SUNGLASSES, PROTECTIVE HELMETS, CAMERAS, AND AVALANCHE PROBES, NAMELY, ELONGATED RODS USED TO MANUALLY PROBE FOR PEOPLE OR OBJECTS COVERED BY AN AVALANCHE (U.S. CLS. 21, 23, 26, 36 AND 38).

CAROLINE WOOD, EXAMINING ATTORNEY

SN 85-191,975. DONOHOO,RUSTY S, BURLINGTON, KY. FILED 12-7-2010.

# CodeKase

THE MARK CONSISTS OF STANDARD CHARACTERS WITHOUT CLAIM TO ANY PARTICULAR FONT, STYLE, SIZE, OR COLOR.

FOR ELECTRONIC LCD ADVERTISEMENT DISPLAY UNIT USED FOR PROMOTIONS TO AUTO DEALERSHIPS AND CASINOS (U.S. CLS. 21, 23, 26, 36 AND 38).

GRETTA YAO, EXAMINING ATTORNEY

**CLASS 9—(Continued).**

SN 85-193,721. QUEST DIAGNOSTICS INVESTMENTS INCORPORATED, WILMINGTON, DE. FILED 12-8-2010.

# CARE360

THE MARK CONSISTS OF STANDARD CHARACTERS WITHOUT CLAIM TO ANY PARTICULAR FONT, STYLE, SIZE, OR COLOR.

OWNER OF U.S. REG. NO. 3,691,004.

FOR MOBILE DEVICE COMPUTER SOFTWARE APPLICATION FOR PROVIDING, STORING AND TRANSFERRING HEALTH AND HEALTH CARE INFORMATION, EMERGENCY MEDICAL INFORMATION AND BILLING INFORMATION AND FOR FACILITATING THE PAYMENT OF BILLS FOR MEDICAL AND DIAGNOSTIC LABORATORY TESTING VIA A MOBILE DEVICE SOFTWARE APPLICATION (U.S. CLS. 21, 23, 26, 36 AND 38).

FIRST USE 3-30-2009; IN COMMERCE 3-30-2009.  
CAROL SPILS, EXAMINING ATTORNEY

---

SN 85-194,225. SAMSILL CORPORATION, FORT WORTH, TX. FILED 12-9-2010.

# ALTEGO

THE MARK CONSISTS OF STANDARD CHARACTERS WITHOUT CLAIM TO ANY PARTICULAR FONT, STYLE, SIZE, OR COLOR.

FOR CASES, BAGS AND SLEEVES ALL FOR USE WITH THE FOLLOWING ITEMS, NAMELY, LAPTOP COMPUTERS, DIGITAL AND ELECTRONIC BOOK READERS, TABLET COMPUTERS, NOTEBOOK COMPUTERS, NETBOOK COMPUTERS, MOBILE COMPUTERS, HANDHELD COMPUTERS AND COMPUTER PERIPHERAL EQUIPMENT (U.S. CLS. 21, 23, 26, 36 AND 38).

FIRST USE 1-0-2009; IN COMMERCE 1-0-2009.  
JEFFREY LOOK, EXAMINING ATTORNEY

**CLASS 9—(Continued).**

SN 85-194,284. SAMSILL CORPORATION, FORT WORTH, TX. FILED 12-9-2010.



THE MARKS CONSISTS OF A STYLIZED LETTER "A" WITHIN A CIRCULAR FIELD WITH THE LEFT HALF OF THE CIRCLE SHADED AND THE RIGHT HALF UNSHADED. THE LEFT HALF OF THE LETTER "A" IS UNSHADED WHILE THE RIGHT HALF OF THE LETTER "A" IS SHADED.

FOR CASES, BAGS AND SLEEVES ALL FOR USE WITH THE FOLLOWING ITEMS, NAMELY, LAPTOP COMPUTERS, DIGITAL AND ELECTRONIC BOOK READERS, TABLET COMPUTERS, NOTEBOOK COMPUTERS, NETBOOK COMPUTERS, MOBILE COMPUTERS, HANDHELD COMPUTERS AND COMPUTER PERIPHERAL EQUIPMENT (U.S. CLS. 21, 23, 26, 36 AND 38).

FIRST USE 1-0-2009; IN COMMERCE 1-0-2009.  
JEFFREY LOOK, EXAMINING ATTORNEY

---

SN 85-194,741. MERZ, MICHAEL J., BOCA RATON, FL. FILED 12-9-2010.



THE MARK CONSISTS OF A STYLIZED FEATHER WITH THE WORDS "THE COMFORTER" ALONG THE CONTOUR OF THE FEATHER.

FOR A HANDHELD CRADLE THAT IS SPECIALLY ADAPTED TO HOLD CELLULAR PHONES (U.S. CLS. 21, 23, 26, 36 AND 38).

FIRST USE 7-21-2010; IN COMMERCE 11-19-2010.  
MEGHAN REINHART, EXAMINING ATTORNEY



**CLASS 9—(Continued).**

SN 85-195,372. DIRECTV SPORTS NETWORKS, LLC, SEATTLE, WA. FILED 12-10-2010.

**ROOT SPORTS**

THE MARK CONSISTS OF STANDARD CHARACTERS WITHOUT CLAIM TO ANY PARTICULAR FONT, STYLE, SIZE, OR COLOR.

OWNER OF U.S. REG. NO. 3,726,772.

NO CLAIM IS MADE TO THE EXCLUSIVE RIGHT TO USE "SPORTS", APART FROM THE MARK AS SHOWN.

FOR PRE-RECORDED VIDEO CASSETTES, VIDEO DISCS AND DVD'S CONTAINING TELEVISION SHOWS IN THE FIELD OF SPORTS, NEWS AND VARIETY; DOWNLOADABLE TELEVISION SHOWS FEATURING SPORTS, NEWS AND VARIETY; DOWNLOADABLE SOFTWARE IN THE NATURE OF A MOBILE APPLICATION FOR VIEWING TELEVISION PROGRAMMING ON A MOBILE COMMUNICATION DEVICE (U.S. CLS. 21, 23, 26, 36 AND 38).

GISELLE AGOSTO, EXAMINING ATTORNEY

---

SN 85-195,617. DIRECTV SPORTS NETWORKS, LLC, SEATTLE, WA. FILED 12-10-2010.



OWNER OF U.S. REG. NO. 3,726,772.

NO CLAIM IS MADE TO THE EXCLUSIVE RIGHT TO USE "SPORTS", APART FROM THE MARK AS SHOWN.

THE MARK CONSISTS OF THE WORD "ROOT", THE LETTERS "R" AND "T" HAVING TRIANGULAR NOTCHES CUT AT THE TOP, OVER THE WORD "SPORTS", ALL IN SLANTED LETTERS.

FOR PRE-RECORDED VIDEO CASSETTES, VIDEO DISCS AND DVD'S CONTAINING TELEVISION SHOWS IN THE FIELD OF SPORTS, NEWS AND VARIETY; DOWNLOADABLE TELEVISION SHOWS FEATURING SPORTS, NEWS AND VARIETY; DOWNLOADABLE SOFTWARE IN THE NATURE OF A MOBILE APPLICATION FOR VIEWING TELEVISION PROGRAMMING ON A MOBILE COMMUNICATION DEVICE (U.S. CLS. 21, 23, 26, 36 AND 38).

GISELLE AGOSTO, EXAMINING ATTORNEY

**CLASS 9—(Continued).**

SN 85-196,214. RUG DOCTOR, INC., PLANO, TX. FILED 12-13-2010.

**Rug Doctor Rapid Rent**

THE MARK CONSISTS OF STANDARD CHARACTERS WITHOUT CLAIM TO ANY PARTICULAR FONT, STYLE, SIZE, OR COLOR.

OWNER OF U.S. REG. NOS. 973,037, 2,604,818 AND OTHERS.

NO CLAIM IS MADE TO THE EXCLUSIVE RIGHT TO USE "RUG" AND "RAPID RENT", APART FROM THE MARK AS SHOWN.

FOR INTERACTIVE SELF-SERVICE COMPUTER KIOSKS COMPRISING COMPUTERS AND COMPUTER OPERATING SOFTWARE FOR USE IN RENTAL, LEASE OR HIRE OF CLEANING MACHINES, NAMELY, TO CLEAN AND REMOVE ALL FOREIGN MATTER FROM RUGS, CARPETING, UPHOLSTERY, FURNITURE, FLOORS, CEILING, WALLS AND OTHER TEXTILES OR FIBROUS FABRIC OR MATERIALS (U.S. CLS. 21, 23, 26, 36 AND 38).

LAURIE MAYES, EXAMINING ATTORNEY

---

SN 85-196,816. SOLAR JUNCTION CORPORATION, SAN JOSE, CA. FILED 12-13-2010.

**A-SLAM**

THE MARK CONSISTS OF STANDARD CHARACTERS WITHOUT CLAIM TO ANY PARTICULAR FONT, STYLE, SIZE, OR COLOR.

FOR SOLAR CELLS; SOLAR ENERGY SYSTEMS COMPRISED OF SOLAR CELLS, SOLAR RECHARGEABLE BATTERIES, PHOTOVOLTAIC SOLAR MODULES, OPTICAL AND ELECTRONIC SENSORS FOR MEASURING SOLAR RADIATION (U.S. CLS. 21, 23, 26, 36 AND 38).

DANIEL CAPSHAW, EXAMINING ATTORNEY

**CLASS 9—(Continued).**

SN 85-197,475. SECURITY ALARMS CO., INC., DBA SECURITY ALARMS CO., MUSKOGEE, OK. FILED 12-14-2010.



NO CLAIM IS MADE TO THE EXCLUSIVE RIGHT TO USE "SECURITY ALARMS CO.", APART FROM THE MARK AS SHOWN.

THE COLOR(S) RED, BLACK AND WHITE IS/ARE CLAIMED AS A FEATURE OF THE MARK.

THE MARK CONSISTS OF A RED CIRCLE ENCLOSING A BURGLAR IN BLACK SURROUNDED IN WHITE SPACE HOLDING A BLACK BAG AND BLACK CROWBAR WITH A BLACK LINE GOING THROUGH THE BURGLAR, THE CIRCLE IS CONNECTED TO A BAR IN RED WITH THE WORDS "SECURITY ALARMS CO." IN WHITE WITH THE ENTIRE DESIGN OUTLINED IN BLACK.

FOR HOME AND OFFICE AUTOMATION SYSTEMS COMPRISING WIRELESS AND WIRED CONTROLLERS, CONTROLLED DEVICES, AND SOFTWARE FOR LIGHTING, HVAC, SECURITY, SAFETY AND OTHER HOME AND OFFICE MONITORING AND CONTROL APPLICATIONS (U.S. CLS. 21, 23, 26, 36 AND 38).

FIRST USE 1-1-2000; IN COMMERCE 1-1-2000.

SIMON TENG, EXAMINING ATTORNEY

**CLASS 9—(Continued).**

SN 85-198,745. TERRAGO TECHNOLOGIES, INC., ATLANTA, GA. FILED 12-15-2010.

**TERRAGO PUBLISHER**

THE MARK CONSISTS OF STANDARD CHARACTERS WITHOUT CLAIM TO ANY PARTICULAR FONT, STYLE, SIZE, OR COLOR.

OWNER OF U.S. REG. NOS. 3,192,189 AND 3,192,190.

NO CLAIM IS MADE TO THE EXCLUSIVE RIGHT TO USE "PUBLISHER", APART FROM THE MARK AS SHOWN.

FOR COMPUTER SOFTWARE FOR PERFORMING FUNCTIONS RELATING TO GEOSPATIAL MAPS AND IMAGES, NAMELY, RENDERING MAPPING INFORMATION, GEOGRAPHIC INFORMATION SYSTEM (GIS) INFORMATION, AND DATABASE INFORMATION TO GEOSPATIAL MAPS AND IMAGES (U.S. CLS. 21, 23, 26, 36 AND 38).

FIRST USE 8-12-2009; IN COMMERCE 8-12-2009.

MARILYN IZZI, EXAMINING ATTORNEY

SN 85-198,376. VYZION ENTERTAINMENT, RALEIGH, NC. FILED 12-15-2010.

# VYZION

SN 85-198,751. TERRAGO TECHNOLOGIES, INC., ATLANTA, GA. FILED 12-15-2010.

**TERRAGO COMPOSER**

THE MARK CONSISTS OF STANDARD CHARACTERS WITHOUT CLAIM TO ANY PARTICULAR FONT, STYLE, SIZE, OR COLOR.

FOR AUDIO AND VIDEO RECORDINGS FEATURING MUSIC AND ARTISTIC PERFORMANCES; DIGITAL MUSIC DOWNLOADABLE FROM THE INTERNET; DOWNLOADABLE MP3 FILES AND MP3 RECORDINGS FEATURING MUSICAL ENTERTAINMENT; DOWNLOADABLE MP3 FILES, MP3 RECORDINGS, ON-LINE DISCUSSION BOARDS, WEBCASTS, WEBINARS AND PODCASTS FEATURING MUSIC, AUDIO BOOKS IN THE FIELD OF ENTERTAINMENT, AND NEWS BROADCASTS; MUSICAL SOUND RECORDINGS; MUSICAL VIDEO RECORDINGS; PRE-RECORDED DIGITAL MEDIA FEATURING MUSICAL ARTIST AND DJ'S; PRE-RECORDED ELECTRONIC AND DIGITAL MEDIA FEATURING MUSICAL ARTIST AND DJ'S; PRE-RECORDED ELECTRONIC MEDIA FEATURING MUSICAL ARTIST AND DJ'S (U.S. CLS. 21, 23, 26, 36 AND 38).

FIRST USE 10-20-2010; IN COMMERCE 10-20-2010.

LINDA E. BLOHM, EXAMINING ATTORNEY

THE MARK CONSISTS OF STANDARD CHARACTERS WITHOUT CLAIM TO ANY PARTICULAR FONT, STYLE, SIZE, OR COLOR.

OWNER OF U.S. REG. NOS. 3,192,189 AND 3,192,190.

NO CLAIM IS MADE TO THE EXCLUSIVE RIGHT TO USE "COMPOSER", APART FROM THE MARK AS SHOWN.

FOR COMPUTER SOFTWARE FOR PERFORMING FUNCTIONS RELATING TO GEOSPATIAL MAPS AND IMAGES, NAMELY, RENDERING MAPPING INFORMATION, GEOGRAPHIC INFORMATION SYSTEM (GIS) INFORMATION, AND DATABASE INFORMATION TO GEOSPATIAL MAPS AND IMAGES (U.S. CLS. 21, 23, 26, 36 AND 38).

FIRST USE 8-20-2009; IN COMMERCE 8-20-2009.

MARILYN IZZI, EXAMINING ATTORNEY

**CLASS 9—(Continued).**

SN 85-198,761. TERRAGO TECHNOLOGIES, INC., ATLANTA, GA. FILED 12-15-2010.

**TERRAGO TOOLBAR**

THE MARK CONSISTS OF STANDARD CHARACTERS WITHOUT CLAIM TO ANY PARTICULAR FONT, STYLE, SIZE, OR COLOR.

OWNER OF U.S. REG. NOS. 3,192,189 AND 3,192,190.

NO CLAIM IS MADE TO THE EXCLUSIVE RIGHT TO USE "TOOLBAR", APART FROM THE MARK AS SHOWN.

FOR COMPUTER SOFTWARE FOR PERFORMING FUNCTIONS RELATING TO GEOSPATIAL MAPS AND IMAGES, NAMELY, RENDERING GEOSPATIAL MAPS AND IMAGES, FINDING GEOSPATIAL LOCATIONS, MEASURING GEOSPATIAL DISTANCES, VIEWING GEOSPATIAL COORDINATES, EDITING OR REVISING GEOSPATIAL MAPS AND IMAGES, AND IMPORTING AND EXPORTING DATA RELATING TO A GEOSPATIAL MAP OR IMAGE (U.S. CLS. 21, 23, 26, 36 AND 38).

FIRST USE 8-26-2009; IN COMMERCE 8-26-2009.

MARILYN IZZI, EXAMINING ATTORNEY

---

SN 85-198,772. TERRAGO TECHNOLOGIES, INC., ATLANTA, GA. FILED 12-15-2010.

**TERRAGO MOBILE**

THE MARK CONSISTS OF STANDARD CHARACTERS WITHOUT CLAIM TO ANY PARTICULAR FONT, STYLE, SIZE, OR COLOR.

OWNER OF U.S. REG. NOS. 3,192,189 AND 3,192,190.

NO CLAIM IS MADE TO THE EXCLUSIVE RIGHT TO USE "MOBILE", APART FROM THE MARK AS SHOWN.

FOR COMPUTER SOFTWARE FOR PERFORMING FUNCTIONS RELATING TO GEOSPATIAL MAPS AND IMAGES VIA A HANDHELD DEVICE, NAMELY, RENDERING GEOSPATIAL MAPS AND IMAGES, FINDING GEOSPATIAL LOCATIONS, MEASURING GEOSPATIAL DISTANCES, VIEWING GEOSPATIAL COORDINATES, EDITING OR REVISING GEOSPATIAL MAPS AND IMAGES, AND IMPORTING AND EXPORTING DATA RELATING TO A GEOSPATIAL MAP OR IMAGE (U.S. CLS. 21, 23, 26, 36 AND 38).

FIRST USE 10-14-2008; IN COMMERCE 10-14-2008.

MARILYN IZZI, EXAMINING ATTORNEY

**CLASS 9—(Continued).**

SN 85-199,262. DELTA TAO SOFTWARE, INC., CITRUS HEIGHTS, CA. FILED 12-16-2010.

**Eric's Ultimate Solitaire**

THE MARK CONSISTS OF STANDARD CHARACTERS WITHOUT CLAIM TO ANY PARTICULAR FONT, STYLE, SIZE, OR COLOR.

NO CLAIM IS MADE TO THE EXCLUSIVE RIGHT TO USE "ULTIMATE SOLITAIRE", APART FROM THE MARK AS SHOWN.

FOR COMPUTER GAME CARTRIDGES AND DISCS; COMPUTER GAME DISCS; COMPUTER GAME EQUIPMENT, NAMELY, DISCS; COMPUTER GAME PROGRAMMES; COMPUTER GAME PROGRAMMES DOWNLOADABLE VIA THE INTERNET; COMPUTER GAME PROGRAMS; COMPUTER GAME PROGRAMS, CARTRIDGES, AND CASSETTES; COMPUTER GAME SOFTWARE; COMPUTER GAME SOFTWARE DOWNLOADABLE FROM A GLOBAL COMPUTER NETWORK; COMPUTER GAME SOFTWARE FOR PERSONAL COMPUTERS AND HOME VIDEO GAME CONSOLES; COMPUTER GAME SOFTWARE FOR USE ON MOBILE AND CELLULAR PHONES; COMPUTER GAME SOFTWARE FOR USE WITH PERSONAL COMPUTERS, HOME VIDEO GAME CONSOLES USED WITH TELEVISIONS AND ARCADE-BASED VIDEO GAME CONSOLES; COMPUTER PROGRAMS FOR VIDEO AND COMPUTER GAMES; DOWNLOADABLE COMPUTER GAME PROGRAMS; DOWNLOADABLE COMPUTER GAME SOFTWARE VIA A GLOBAL COMPUTER NETWORK AND WIRELESS DEVICES (U.S. CLS. 21, 23, 26, 36 AND 38).

FIRST USE 1-1-1994; IN COMMERCE 1-1-1994.

DAVID HOFFMAN, EXAMINING ATTORNEY

---

SN 85-199,702. LIGHT IRON DIGITAL, LOS ANGELES, CA. FILED 12-16-2010.

**LIVEPLAY**

THE MARK CONSISTS OF STANDARD CHARACTERS WITHOUT CLAIM TO ANY PARTICULAR FONT, STYLE, SIZE, OR COLOR.

FOR SOFTWARE AND HARDWARE FOR THE MANAGEMENT, PRODUCTION, EDITING, AND POST-PRODUCTION OF ANALOG CONTENT AND DIGITAL CONTENT INCLUDING STATIC AND MOVING PICTURES, SOUND, DATA, AND OTHER INFORMATION (U.S. CLS. 21, 23, 26, 36 AND 38).

FIRST USE 9-30-2010; IN COMMERCE 9-30-2010.

CAROL SPILS, EXAMINING ATTORNEY

**CLASS 9—(Continued).**

SN 85-200,055. BALBOA MANUFACTURING COMPANY, LLC, POWAY, CA. FILED S.R. 12-16-2010; AM. P.R. 3-21-2011.



THE MARK CONSISTS OF A STYLIZED LETTER "B" IN A RECTANGULAR CARRIER.

FOR EYEWEAR; EYEWEAR ACCESSORIES, NAMELY, STRAPS, NECK CORDS AND HEAD STRAPS WHICH RESTRAIN EYEWEAR FROM MOVEMENT ON A WEARER; EYEWEAR CASES; MOTORCYCLE GOGGLES; PROTECTIVE FACE MASKS NOT FOR MEDICAL PURPOSES; SUNGLASSES (U.S. CLS. 21, 23, 26, 36 AND 38).

FIRST USE 7-1-2010; IN COMMERCE 7-1-2010.  
LINDA POWELL, EXAMINING ATTORNEY

---

SN 85-200,193. ANGESTI, ANDY, LIPPO KARAWACI, TANGER, INDONESIA, FILED 12-17-2010.

**IOZ**

THE MARK CONSISTS OF STANDARD CHARACTERS WITHOUT CLAIM TO ANY PARTICULAR FONT, STYLE, SIZE, OR COLOR.

THE WORDING "IOZ" HAS NO MEANING IN A FOREIGN LANGUAGE.

FOR MOTORCYCLE HELMETS; PROTECTIVE HELMETS; PROTECTIVE HELMETS FOR SPORTS; RIDING HELMETS (U.S. CLS. 21, 23, 26, 36 AND 38).

MARGERY A. TIERNEY, EXAMINING ATTORNEY

**CLASS 9—(Continued).**

SN 85-200,460. VOCALITY INTERNATIONAL LIMITED, SHACKLEFORD, SURREY., UNITED KINGDOM, FILED 12-17-2010.



THE MARK CONSISTS OF A STYLIZED LETTER "V".  
FOR TELECOMMUNICATIONS EQUIPMENT, NAMELY, TELEPHONES, PERSONAL DIGITAL ASSISTANTS, ELECTRONIC PERSONAL ORGANIZERS, ROUTERS, MULTIPLEXERS, ISDN INTERFACES, GATEWAY ROUTERS IN THE NATURE OF COMPUTER CONTROL HARDWARE, COMPUTER HARDWARE AND SOFTWARE FOR SETTING UP AND CONFIGURING WIDE AREA NETWORKS; SECURE TELECOMMUNICATIONS EQUIPMENT, NAMELY, SECURE TELECOMMUNICATIONS EQUIPMENT, NAMELY, TELEPHONES, PERSONAL DIGITAL ASSISTANTS, ELECTRONIC PERSONAL ORGANIZERS, ROUTERS, MULTIPLEXERS, ISDN INTERFACES, GATEWAY ROUTERS IN THE NATURE OF COMPUTER CONTROL HARDWARE, COMPUTER HARDWARE AND SOFTWARE FOR SETTING UP AND CONFIGURING WIDE AREA NETWORKS; SECURE TELECOMMUNICATIONS EQUIPMENT INCORPORATING DISCRETE COMMUNICATIONS DEVICES, NAMELY, A NETWORK ROUTER AND INTERNET PROTOCOL LINK ENCRYPTOR, NAMELY, ELECTRONIC ENCRYPTION UNITS FOR ENCRYPTING INTERNET PROTOCOL LINK DATA; TELECOMMUNICATIONS EQUIPMENT TO PROVIDE SATELLITE OPTIMIZATION BY MAKING ACCOMMODATION FOR SATELLITE DELAY AND BANDWIDTH RESTRICTIONS, NAMELY, NETWORK ROUTERS AND MULTIPLEXERS; MULTIPLEXERS TO PROVIDE BASE-BAND SERVICES OVER INTERNET PROTOCOLS IN MILITARY AND GOVERNMENT NETWORKS; TELECOMMUNICATIONS INTERFACES, NAMELY, MILITARY PHONES FOR USE OVER INTERNET PROTOCOL-BASED WIDE AREA NETWORKS AND TELECOMMUNICATIONS INTERFACES, NAMELY, TACTICAL SECURE TELEPHONES FOR USE OVER INTERNET PROTOCOL-BASED WIDE AREA NETWORKS; TELECOMMUNICATIONS APPARATUS, NAMELY, ROUTERS, MULTIPLEXERS, ISDN INTERFACES, GATEWAY ROUTERS IN THE NATURE OF COMPUTER CONTROL HARDWARE, COMPUTER HARDWARE AND SOFTWARE FOR SETTING UP AND CONFIGURING WIDE AREA NETWORKS; TELEPHONE APPARATUS; RADIO-TELEPHONE APPARATUS; OPTICAL FIBERS, OPTICAL FIBERS SOLD AS A COMPONENT OF FIBER OPTICAL CABLES; TELECOMMUNICATIONS SOFTWARE FOR SETTING UP AND CONFIGURING WIDE AREA NETWORKS; ELECTRONIC ENCRYPTION UNITS FOR ENCRYPTING VIDEO AND/OR SOUND SIGNALS AND/OR DATA; STRUCTURAL PARTS AND ELECTRIC AND/OR ELECTRONIC CONNECTION FITTINGS FOR ALL THE AFORESAID GOODS (U.S. CLS. 21, 23, 26, 36 AND 38).

WILLIAM BRECKENFELD, EXAMINING ATTORNEY

**CLASS 9—(Continued).**

SN 85-200,917. FACECAKE MARKETING TECHNOLOGIES, INC., CALABASAS, CA. FILED 12-17-2010.

**COLORCLICK**

THE MARK CONSISTS OF STANDARD CHARACTERS WITHOUT CLAIM TO ANY PARTICULAR FONT, STYLE, SIZE, OR COLOR.

FOR COMPUTER SOFTWARE, NAMELY, AN APPLICATION PERMITTING USERS TO OBTAIN ONLINE PRODUCT RECOMMENDATIONS; COMPUTER SOFTWARE, NAMELY, AN APPLICATION PERMITTING USERS TO VISUALIZE USE AND PLACEMENT OF PRODUCTS, EXCLUDING PAINT COLORS, ONLINE THROUGH THE CREATION AND MANIPULATION OF DIGITAL IMAGES (U.S. CLS. 21, 23, 26, 36 AND 38).

PAUL E. FAHRENKOPF, EXAMINING ATTORNEY

SN 85-201,362. MAHONEY, DONALD B, SIDNEY, NY. FILED 12-19-2010.

**Retirement Confidential**

THE MARK CONSISTS OF STANDARD CHARACTERS WITHOUT CLAIM TO ANY PARTICULAR FONT, STYLE, SIZE, OR COLOR.

NO CLAIM IS MADE TO THE EXCLUSIVE RIGHT TO USE "RETIREMENT", APART FROM THE MARK AS SHOWN.

FOR DOWNLOADABLE ELECTRONIC NEWSLETTERS DELIVERED BY E-MAIL IN THE FIELD OF RETIREMENT INVESTING AND RETIREMENT HEALTH AND LIFESTYLE (U.S. CLS. 21, 23, 26, 36 AND 38).

WILLIAM BRECKENFELD, EXAMINING ATTORNEY

SN 85-201,423. MY BILL REGISTRY, LLC., BROOKLYN, NY. FILED 12-19-2010.

**MYBILLREGISTRY**

THE MARK CONSISTS OF STANDARD CHARACTERS WITHOUT CLAIM TO ANY PARTICULAR FONT, STYLE, SIZE, OR COLOR.

FOR COMPUTER SOFTWARE, NAMELY, ELECTRONIC FINANCIAL PLATFORM THAT ACCOMMODATES MULTIPLE TYPES OF PAYMENT AND DEBT TRANSACTIONS IN AN INTEGRATED MOBILE PHONE, PDA, AND WEB BASED ENVIRONMENT (U.S. CLS. 21, 23, 26, 36 AND 38).

KELLY BOULTON, EXAMINING ATTORNEY

**CLASS 9—(Continued).**

SN 85-201,712. MAINSOFT CORPORATION, MILPITAS, CA. FILED 12-20-2010.



THE MARK CONSISTS OF AN IMAGE OF A HEAD WITH A TIE AND GIVING A THUMBS UP.

FOR COMPUTER SOFTWARE THAT INTEGRATES AND UNIFIES DESKTOP, MOBILE, VIRTUAL, CLOUD-BASED, COMMUNICATION-BASED AND OTHER SOFTWARE APPLICATIONS WITH VARIOUS COLLABORATION SYSTEMS, NAMELY, DOCUMENT COLLABORATION SERVERS, SOCIAL NETWORKING SITES, AND MICRO-BLOGGING SITES (U.S. CLS. 21, 23, 26, 36 AND 38).

FIRST USE 11-30-2010; IN COMMERCE 11-30-2010.

PAUL E. FAHRENKOPF, EXAMINING ATTORNEY

SN 85-202,087. PATTERSON, JOHN MARK, TA ORION VISION GROUP, MARIETTA, FL. FILED 12-20-2010.

**Bioperm RGP Contact Lenses**

THE MARK CONSISTS OF STANDARD CHARACTERS WITHOUT CLAIM TO ANY PARTICULAR FONT, STYLE, SIZE, OR COLOR.

NO CLAIM IS MADE TO THE EXCLUSIVE RIGHT TO USE "RGP CONTACT LENSES", APART FROM THE MARK AS SHOWN.

FOR CONTACT LENSES (U.S. CLS. 21, 23, 26, 36 AND 38).

ANGELA M. MICHELI, EXAMINING ATTORNEY



**CLASS 9—(Continued).**

SN 85-202,250. SPINTOP MEDIA INC., VANCOUVER, B.C., CANADA, FILED 12-20-2010.

**AMAZING ADVENTURES THE  
FORGOTTEN DYNASTY**

THE MARK CONSISTS OF STANDARD CHARACTERS WITHOUT CLAIM TO ANY PARTICULAR FONT, STYLE, SIZE, OR COLOR.

OWNER OF U.S. REG. NOS. 3,658,717, 3,911,927 AND OTHERS.

FOR INTERACTIVE GAME SOFTWARE; COMPUTER GAME SOFTWARE; VIDEO GAME PROGRAMS AND CARTRIDGES; ELECTRONIC GAME PROGRAMS; GAME SOFTWARE FOR USE ON ANY COMPUTERIZED PLATFORM, INCLUDING GAME CONSOLES, HANDHELD ELECTRONIC DEVICES, ELECTRONIC ENTERTAINMENT DEVICES, TELECOMMUNICATIONS DEVICES, MOBILE PHONES, AND ELECTRONIC COMMUNICATION DEVICES; DOWNLOADABLE INTERACTIVE, COMPUTER, VIDEO AND ELECTRONIC GAME PROGRAMS (U.S. CLS. 21, 23, 26, 36 AND 38).

ALEXANDER L. POWERS, EXAMINING ATTORNEY

**CLASS 9—(Continued).**

SN 85-202,618. COAL CAR, LLC, PLANO, TX. FILED 12-21-2010.



NO CLAIM IS MADE TO THE EXCLUSIVE RIGHT TO USE "JIGSAWPUZZLE MOBILE", APART FROM THE MARK AS SHOWN.

THE COLOR(S) GRAY, BLUE, BLACK, WHITE, GREEN AND BROWN IS/ARE CLAIMED AS A FEATURE OF THE MARK.

THE MARK CONSISTS OF THE MARK CONSISTS OF THE WORDS "JIGSAWPUZZLE MOBILE" SET ON THE IMAGE OF A WOODEN BOARD IN BROWN AND BLACK WITH THE WORDS "JIGSAWPUZZLE" HAVING THE LETTERS FILLED WITH THE IMAGE OF THE SKY IN GRAY, BLUE AND WHITE. THE IMAGE FURTHER CONSISTS OF THE WORD "MOBILE" HAVING THE TOP 2/3 OF THE LETTER "M" FILLED WITH THE IMAGE OF THE SKY IN BLUE, GRAY AND WHITE AND THE REMAINDER FILLED WITH THE IMAGE OF A MOUNTAIN IN THE COLORS BROWN AND BLACK. THE REST OF THE WORD "MOBILE" IS FILLED WITH THE IMAGE OF A MOUNTAIN WITH BROWN, GREEN AND BLACK COLORING. THE WORD "MOBILE" ALSO HAS PIECES OF A PUZZLE TAKEN OUT OF THE LETTERING AND THERE ARE IMAGES OF THE PUZZLE PIECES ON THE WOODEN BOARD. THE PUZZLE PIECES ON THE WOODEN BOARD ARE IN VARIOUS COMBINATIONS OF THE COLORS GRAY, BROWN, BLACK AND WHITE.

FOR DOWNLOADABLE MULTIMEDIA FILE CONTAINING ARTWORK, TEXT, AUDIO, VIDEO, GAMES, AND INTERNET WEB LINKS RELATING TO VIDEO GAMES; DOWNLOADABLE GAMES VIA THE INTERNET AND WIRELESS DEVICES; DOWNLOADABLE ELECTRONIC GAME PROGRAMS; DOWNLOADABLE ELECTRONIC GAME SOFTWARE; DOWNLOADABLE ELECTRONIC GAME SOFTWARE FOR CELLULAR TELEPHONES; DOWNLOADABLE ELECTRONIC GAME SOFTWARE FOR HANDHELD ELECTRONIC DEVICES; DOWNLOADABLE ELECTRONIC GAME SOFTWARE FOR WIRELESS DEVICES; DOWNLOADABLE GAME SOFTWARE; INTERACTIVE DOWNLOADABLE VIDEO GAME PROGRAMS; DOWNLOADABLE VIDEO AND COMPUTER GAME PROGRAMS; DOWNLOADABLE VIDEO GAME SOFTWARE (U.S. CLS. 21, 23, 26, 36 AND 38).

BARBARA BROWN, EXAMINING ATTORNEY

SN 85-202,546. AMERICAN ALARM & COMMUNICATIONS, INC., ARLINGTON, MA. FILED 12-21-2010.

**American Alarm**

THE MARK CONSISTS OF STANDARD CHARACTERS WITHOUT CLAIM TO ANY PARTICULAR FONT, STYLE, SIZE, OR COLOR.

OWNER OF U.S. REG. NOS. 1,837,460, 3,442,138 AND OTHERS.

NO CLAIM IS MADE TO THE EXCLUSIVE RIGHT TO USE "ALARM", APART FROM THE MARK AS SHOWN. SEC. 2(F).

FOR ELECTRONIC SYSTEM EQUIPMENT, NAMELY, CABINETS FOR ELECTRIC WIRING, ELECTRIC JUNCTION BOXES, PATCH PANELS FOR INTERCONNECTING SYSTEM COMPONENTS, MULTI-FUNCTION CABLE FOR COMPUTER, CATV, AND LOW VOLTAGE ELECTRICAL WIRING, ELECTRICAL OUTLETS AND ELECTRICAL WALL OUTLET PLATES, AUDIO SPEAKERS, VIDEO CAMERAS, FIRE DETECTION SENSORS, INTRUSION DETECTION SENSORS, VOLUME CONTROLS FOR SOUND SYSTEMS, DIGITAL AND ANALOG VIDEO PLAYERS AND RECORDERS, COMPUTERS, CENTRAL PROCESSING UNITS, CONTROL PANELS, PROGRAMMABLE LOGIC CONTROLLERS, TELEPHONE TRANSMITTERS AND RECEIVERS, RADIO FREQUENCY TRANSMITTERS AND RECEIVERS, INTERNET TRANSMITTERS AND RECEIVERS, COMPUTER NETWORK ROUTERS AND HUBS, KEYPADS AND TOUCH SCREENS, PROXIMITY CARD READERS, POWER SUPPLIES, ELECTRICAL TRANSFORMERS, BATTERIES, TELEVISION MONITORS, AND STEREO RECEIVERS (U.S. CLS. 21, 23, 26, 36 AND 38).

FIRST USE 1-1-1974; IN COMMERCE 11-1-1978.

PAUL F. GAST, EXAMINING ATTORNEY

**CLASS 9—(Continued).**

SN 85-202,698. MOCON, INC., MINNEAPOLIS, MN. FILED 12-21-2010.

# LIPPKE

THE MARK CONSISTS OF STANDARD CHARACTERS WITHOUT CLAIM TO ANY PARTICULAR FONT, STYLE, SIZE, OR COLOR.

OWNER OF U.S. REG. NO. 3,420,978.

SEC. 2(F).

FOR LEAKAGE TESTING APPARATUS FOR FLEXIBLE AND SEMI-RIGID PACKAGES; SEAL TESTING APPARATUS FOR FLEXIBLE AND SEMI-RIGID PACKAGES; INSTRUMENT FOR MEASURING WATER VAPOR TRANSMISSION, NAMELY, WATER VAPOR TRANSMISSION RATE ANALYZER; ELECTRONIC AND ELECTROCHEMICAL DEVICES FOR MEASURING CONCENTRATIONS OF GASES IN FLEXIBLE PACKAGES (U.S. CLS. 21, 23, 26, 36 AND 38).

FIRST USE 12-31-1986; IN COMMERCE 11-30-2004.

DAVID ELTON, EXAMINING ATTORNEY

SN 85-202,951. JASON HOWELL COMPANY, ARLINGTON, VA. FILED 12-21-2010.

## PATRIOTIC DEVELOPMENT

THE MARK CONSISTS OF STANDARD CHARACTERS WITHOUT CLAIM TO ANY PARTICULAR FONT, STYLE, SIZE, OR COLOR.

FOR AUDIO BOOKS IN THE FIELD OF PERSONAL GROWTH AND MOTIVATION (U.S. CLS. 21, 23, 26, 36 AND 38).

FIRST USE 10-0-2009; IN COMMERCE 10-0-2009.

COLLEEN KEARNEY, EXAMINING ATTORNEY

SN 85-203,053. GENESIS NETWORKS, INC., SAN ANTONIO, TX. FILED 12-21-2010.

## MOBILE SMART HANDS

THE MARK CONSISTS OF STANDARD CHARACTERS WITHOUT CLAIM TO ANY PARTICULAR FONT, STYLE, SIZE, OR COLOR.

NO CLAIM IS MADE TO THE EXCLUSIVE RIGHT TO USE "MOBILE SMART", APART FROM THE MARK AS SHOWN.

FOR COMPUTER SOFTWARE FOR TRACKING, MANAGING, PROCESSING, AND OPTIMIZING THE ASSIGNMENT OF WORK ORDERS AND INCIDENTS WITH TECHNICIANS OR TRADE PROFESSIONALS, AND FOR PROVIDING ACCESS TO A DATABASE OF TECHNICIANS AND TECHNICAL PROFESSIONALS FOR A VIRTUAL MOBILE AND ON DEMAND WORKFORCE (U.S. CLS. 21, 23, 26, 36 AND 38).

ANNE FARRELL, EXAMINING ATTORNEY

**CLASS 9—(Continued).**

SN 85-203,060. VISUALWARE, INC., TURLOCK, CA. FILED 12-21-2010.

# InboxGuardian

THE MARK CONSISTS OF STANDARD CHARACTERS WITHOUT CLAIM TO ANY PARTICULAR FONT, STYLE, SIZE, OR COLOR.

FOR DOWNLOADABLE COMPUTER SOFTWARE FOR IDENTIFYING AND REMOVING SPAM EMAIL BEFORE IT REACHES AN INBOX OF A PC DESKTOP, SERVER, MOBILE PHONE OR OTHER DEVICE (U.S. CLS. 21, 23, 26, 36 AND 38).

FIRST USE 12-6-2010; IN COMMERCE 12-6-2010.

ANNE FARRELL, EXAMINING ATTORNEY

SN 85-203,402. IQZONE, INC., SCOTTSDALE, AZ. FILED 12-21-2010.

# SAB

THE MARK CONSISTS OF STANDARD CHARACTERS WITHOUT CLAIM TO ANY PARTICULAR FONT, STYLE, SIZE, OR COLOR.

FOR DOWNLOADABLE SOFTWARE FOR MOBILE AND COMPUTER BASED DEVICES TO PROVIDE SYNCHRONIZATION BETWEEN USERS' ELECTRONIC ADDRESS BOOK AND SOCIAL NETWORKING SITE PROFILE PICTURES, DISPLAYS AND DATA ELEMENTS (U.S. CLS. 21, 23, 26, 36 AND 38).

ELLEN PERKINS, EXAMINING ATTORNEY

SN 85-203,553. SYNTHES USA, LLC., WEST CHESTER, PA. FILED 12-22-2010.

# PROPLAN CMF

THE MARK CONSISTS OF STANDARD CHARACTERS WITHOUT CLAIM TO ANY PARTICULAR FONT, STYLE, SIZE, OR COLOR.

NO CLAIM IS MADE TO THE EXCLUSIVE RIGHT TO USE "CMF", APART FROM THE MARK AS SHOWN.

FOR SOFTWARE FOR USE IN THE MEDICAL AND SURGICAL FIELD, NAMELY, FOR PRE-OPERATIVE PLANNING AND FOR IMPLANT AND SURGICAL INSTRUMENT SELECTION, MODIFICATION, AND DESIGN (U.S. CLS. 21, 23, 26, 36 AND 38).

KRISTIN DAHLING, EXAMINING ATTORNEY

**CLASS 9—(Continued).**

SN 85-203,790. CROSSWING INC., MARKHAM, ONTARIO, CANADA, FILED 12-22-2010.

# VIRTUALME

THE MARK CONSISTS OF STANDARD CHARACTERS WITHOUT CLAIM TO ANY PARTICULAR FONT, STYLE, SIZE, OR COLOR.

PRIORITY CLAIMED UNDER SEC. 44(D) ON CANADA APPLICATION NO. 1495690, FILED 9-13-2010.

FOR ROBOTS FOR PERSONAL COMMUNICATION (U.S. CLS. 21, 23, 26, 36 AND 38).

NANCY CLARKE, EXAMINING ATTORNEY

**CLASS 9—(Continued).**

SN 85-203,970. THE TILE SHOP, LLC, PLYMOUTH, MN. FILED 12-22-2010.



SN 85-203,876. MITCHELL, STEVEN, IRVING, TX. FILED 12-22-2010.

# Home Card

THE MARK CONSISTS OF STANDARD CHARACTERS WITHOUT CLAIM TO ANY PARTICULAR FONT, STYLE, SIZE, OR COLOR.

NO CLAIM IS MADE TO THE EXCLUSIVE RIGHT TO USE "CARD", APART FROM THE MARK AS SHOWN.

FOR COMPUTER APPLICATION SOFTWARE FOR HANDHELD COMPUTING DEVICES, NAMELY, SOFTWARE FOR PLAYING A CARD GAME (U.S. CLS. 21, 23, 26, 36 AND 38).

ZHALEH DELANEY, EXAMINING ATTORNEY

OWNER OF U.S. REG. NOS. 2,413,607, 3,108,881 AND 3,290,690.

NO CLAIM IS MADE TO THE EXCLUSIVE RIGHT TO USE "STONE STUDIOS", APART FROM THE MARK AS SHOWN.

THE MARK CONSISTS OF THE WORDS "RUSH RIVER" OVER THE LETTERS "R" AND "R" REVERSED. BELOW THAT IS AN IMAGE OF A RIVER FLOWING FROM THE LETTER "R". ALL OF THE FOREGOING APPEARS ON A RECTANGULAR BACKGROUND. BELOW THE RECTANGLE IS THE WORDING "STONE STUDIOS".

SEC. 2(F) "RUSH RIVER".

FOR DECORATIVE SWITCH PLATE COVERS; ELECTRIC OUTLET COVERS (U.S. CLS. 21, 23, 26, 36 AND 38).

KATHERINE CHANG, EXAMINING ATTORNEY

SN 85-203,914. MODA COLLECTION, NIXA, MO. FILED 12-22-2010.

# DIG

THE MARK CONSISTS OF STANDARD CHARACTERS WITHOUT CLAIM TO ANY PARTICULAR FONT, STYLE, SIZE, OR COLOR.

FOR FRAMES FOR SPECTACLES AND SUNGLASSES; SUNGLASS LENSES; SUNGLASSES (U.S. CLS. 21, 23, 26, 36 AND 38).

FIRST USE 12-20-2010; IN COMMERCE 12-20-2010.

JILL PRATER, EXAMINING ATTORNEY

SN 85-204,272. THE SANDBOX LEARNING COMPANY, CHARLOTTE, NC. FILED 12-22-2010.

## SMALL STEPS. BIG SKILLS.

THE MARK CONSISTS OF STANDARD CHARACTERS WITHOUT CLAIM TO ANY PARTICULAR FONT, STYLE, SIZE, OR COLOR.

FOR DOWNLOADABLE COMPUTER GAME SOFTWARE; VIDEO GAME SOFTWARE; INTERACTIVE GAME SOFTWARE; COMPUTER GAME AND EDUCATIONAL PROGRAMS FOR USE IN DEVELOPING LANGUAGE SKILLS, SOCIAL SKILLS, DAILY LIVING SKILLS, COMMUNITY SKILLS, SAFETY SKILLS, AND INDEPENDENCE SKILLS INSTRUCTION AND REHABILITATION FOR ADULTS AND CHILDREN WITH INTELLECTUAL OR DEVELOPMENTAL DISABILITIES (U.S. CLS. 21, 23, 26, 36 AND 38).

JUDITH HELFMAN, EXAMINING ATTORNEY

**CLASS 9—(Continued).**

SN 85-204,306. PARKER, JOHN, RENO, NV. FILED 12-22-2010.

## Big Bad Mamma

THE MARK CONSISTS OF STANDARD CHARACTERS WITHOUT CLAIM TO ANY PARTICULAR FONT, STYLE, SIZE, OR COLOR.

FOR DOWNLOADABLE COMPUTER SOFTWARE PROGRAM THAT ALLOWS PARENTS TO LIMIT THEIR CHILDREN'S TIME ON THE COMPUTER (U.S. CLS. 21, 23, 26, 36 AND 38).

FIRST USE 11-11-2010; IN COMMERCE 11-11-2010.  
ALYSSA STEEL, EXAMINING ATTORNEY

**CLASS 9—(Continued).**

SN 85-205,543. DEFINIENS AG, MUNICH, FED REP GERMANY, FILED 12-24-2010.

## Tissue Studio

THE MARK CONSISTS OF STANDARD CHARACTERS WITHOUT CLAIM TO ANY PARTICULAR FONT, STYLE, SIZE, OR COLOR.

NO CLAIM IS MADE TO THE EXCLUSIVE RIGHT TO USE "TISSUE", APART FROM THE MARK AS SHOWN.

FOR COMPUTER PROGRAMS FOR USE IN DATABASE MANAGEMENT, KNOWLEDGE MANAGEMENT, DECISION SUPPORT, PATTERN ANALYSIS, AND BIOMEDICAL INFORMATION EXTRACTION, ANALYSIS OF DIGITAL IMAGES ACQUIRED BY OPTICAL, X-RAY, PET AND MR TOMOGRAPHY AND ULTRASOUND, ANALYSIS OF NUMERICAL, TEXTUAL AND IMAGE DATA IN DATABASES AND ELECTRONIC DOCUMENTS; MAGNETIC, OPTICAL, AND ELECTRICAL PROGRAMMABLE MACHINE-READABLE PRERECORDED DATA CARRIERS FEATURING THE AFOREMENTIONED SOFTWARE (U.S. CLS. 21, 23, 26, 36 AND 38).

FIRST USE 1-1-2009; IN COMMERCE 1-1-2009.  
REBECCA POVARCHUK, EXAMINING ATTORNEY

SN 85-205,418. HINESLAB, INC., GLENDALE, CA. FILED 12-23-2010.

## POPIX3D

THE MARK CONSISTS OF STANDARD CHARACTERS WITHOUT CLAIM TO ANY PARTICULAR FONT, STYLE, SIZE, OR COLOR.

FOR COMPUTER APPLICATION SOFTWARE FOR MOBILE PHONES, NAMELY, SOFTWARE FOR VIEWING THREE DIMENSIONAL PICTURES, WITHOUT USING 3-D GLASSES, USING MOTION PARALLAX; COMPUTER APPLICATION SOFTWARE FOR PORTABLE MEDIA PLAYERS, HANDHELD COMPUTERS AND PORTABLE ELECTRONIC DEVICES, NAMELY, SOFTWARE FOR VIEWING THREE DIMENSIONAL PICTURES, WITHOUT 3-D GLASSES, USING MOTION PARALLAX (U.S. CLS. 21, 23, 26, 36 AND 38).

ANGELA M. MICHELI, EXAMINING ATTORNEY

SN 85-205,560. DEFINIENS AG, MUNICH, FED REP GERMANY, FILED 12-24-2010.

## LymphExpert

THE MARK CONSISTS OF STANDARD CHARACTERS WITHOUT CLAIM TO ANY PARTICULAR FONT, STYLE, SIZE, OR COLOR.

FOR COMPUTER PROGRAMS FOR USE IN DATABASE MANAGEMENT, KNOWLEDGE MANAGEMENT, DECISION SUPPORT, PATTERN ANALYSIS, AND BIOMEDICAL INFORMATION EXTRACTION, ANALYSIS OF DIGITAL IMAGES ACQUIRED BY OPTICAL, X-RAY, PET AND MR TOMOGRAPHY AND ULTRASOUND, ANALYSIS OF NUMERICAL, TEXTUAL AND IMAGE DATA IN DATABASES AND ELECTRONIC DOCUMENTS; MAGNETIC, OPTICAL, AND ELECTRICAL PROGRAMMABLE MACHINE-READABLE PRERECORDED DATA CARRIERS FEATURING THE AFOREMENTIONED SOFTWARE (U.S. CLS. 21, 23, 26, 36 AND 38).

REBECCA POVARCHUK, EXAMINING ATTORNEY

**CLASS 9—(Continued).**

SN 85-205,602. AGA IMPORTS, LLC, SOUTHFIELD, MI.  
FILED 12-24-2010.

# VLYNX

THE MARK CONSISTS OF STANDARD CHARACTERS WITHOUT CLAIM TO ANY PARTICULAR FONT, STYLE, SIZE, OR COLOR.

FOR CONSUMER ELECTRONIC PRODUCTS, NAMELY, AUDIO AMPLIFIERS, AUDIO SPEAKERS, AUDIO RECEIVERS, ELECTRICAL AUDIO AND SPEAKER CABLES AND CONNECTORS, HOME THEATER CABLES AND INTERCONNECTS, AUDIO DECODERS, VIDEO DECODERS, SPEAKERS, POWER CONVERSION DEVICES, POWER CONVERTERS, AND POWER INVERTERS (U.S. CLS. 21, 23, 26, 36 AND 38).

FIRST USE 3-6-2009; IN COMMERCE 3-6-2009.  
KELLEY WELLS, EXAMINING ATTORNEY

SN 85-205,608. DEFINIENS AG, MUNICH, FED REP GERMANY, FILED 12-24-2010.

# LungExpert

THE MARK CONSISTS OF STANDARD CHARACTERS WITHOUT CLAIM TO ANY PARTICULAR FONT, STYLE, SIZE, OR COLOR.

FOR COMPUTER PROGRAMS FOR USE IN DATABASE MANAGEMENT, KNOWLEDGE MANAGEMENT, DECISION SUPPORT, PATTERN ANALYSIS, AND BIOMEDICAL INFORMATION EXTRACTION, ANALYSIS OF DIGITAL IMAGES ACQUIRED BY OPTICAL, X-RAY, PET AND MR TOMOGRAPHY AND ULTRASOUND, ANALYSIS OF NUMERICAL, TEXTUAL AND IMAGE DATA IN DATABASES AND ELECTRONIC DOCUMENTS; MAGNETIC, OPTICAL, AND ELECTRICAL PROGRAMMABLE MACHINE-READABLE PRE-RECORDED DATA CARRIERS FEATURING THE AFOREMENTIONED SOFTWARE (U.S. CLS. 21, 23, 26, 36 AND 38).

REBECCA POVARCHUK, EXAMINING ATTORNEY

SN 85-205,672. HTC CORPORATION, TAOYUAN, TAIWAN, FILED 12-26-2010.

# HTC SCRIBE

THE MARK CONSISTS OF STANDARD CHARACTERS WITHOUT CLAIM TO ANY PARTICULAR FONT, STYLE, SIZE, OR COLOR.

OWNER OF U.S. REG. NOS. 3,584,881, 3,919,900 AND OTHERS.

FOR HANDHELD WIRELESS DEVICE, NAMELY, A TABLET COMPUTER (U.S. CLS. 21, 23, 26, 36 AND 38).

DANNEAN HETZEL, EXAMINING ATTORNEY

**CLASS 9—(Continued).**

SN 85-205,863. MOORE, ANNE, REDONDO BEACH, CA.  
FILED 12-27-2010.

The logo features the letters 'EZ' in a large, bold, sans-serif font. Below 'EZ' is the word 'FOCUS' in a smaller, sans-serif font. A curved line underlines the 'O' in 'FOCUS', resembling a smile.

THE MARK CONSISTS OF THE STYLIZED TEXT "EZ FOCUS" WITH A CURVED LINE UNDERNEATH REPRESENTING A STYLIZED FACE.

FOR COMPUTER SOFTWARE FOR HELPING PEOPLE WITH READING AND FOCUSING THEIR ATTENTION; MECHANICAL READING DEVICE IN THE NATURE OF A HANDHELD ADJUSTABLE FRAME CONTAINING A MAGNIFYING LENS THAT ALLOWS USER TO NARROW A PAGE DOWN TO A SMALLER AREA FOR EASIER FOCUS (U.S. CLS. 21, 23, 26, 36 AND 38).

KARANENDRA S. CHHINA, EXAMINING ATTORNEY

SN 85-205,991. COX, DAVID, GREENWOOD VILLAGE, CO.  
FILED 12-27-2010.

# HIGH DEFINITION HANDS-FREE HDHF

THE MARK CONSISTS OF STANDARD CHARACTERS WITHOUT CLAIM TO ANY PARTICULAR FONT, STYLE, SIZE, OR COLOR.

NO CLAIM IS MADE TO THE EXCLUSIVE RIGHT TO USE "HIGH DEFINITION HANDS-FREE", APART FROM THE MARK AS SHOWN.

FOR HIGH DEFINITION, POINT OF VIEW, HANDS FREE DIGITAL VIDEO RECORDING APPARATUS FOR VIDEO AND STILL IMAGE CAPTURE EMBEDDED IN VARIOUS STYLES OF EYEWEAR AND SUNGLASSES FOR PROFESSIONAL USE, RECREATIONAL USE, DRIVING, SPORTS, AND INDOOR USE (U.S. CLS. 21, 23, 26, 36 AND 38).

AMEEN IMAM, EXAMINING ATTORNEY



**CLASS 9—(Continued).**

SN 85-206,331. WHIRLPOOL PROPERTIES, INC., ST. JOSEPH, MI. FILED 12-28-2010.

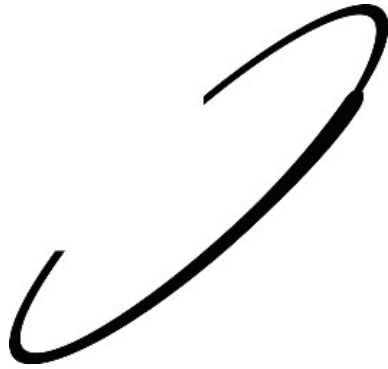

OWNER OF U.S. REG. NOS. 1,832,430, 3,463,701 AND OTHERS.

THE MARK CONSISTS OF A RING.  
FOR CLIMATE CONTROL SYSTEMS CONSISTING OF DIGITAL THERMOSTATS, AIR CONDITIONING, HEATING, VENTILATION AND DRYING CONTROL DEVICES; USB (UNIVERSAL SERIAL BUS) OPERATING SOFTWARE (U.S. CLS. 21, 23, 26, 36 AND 38).  
HELENE LIWINSKI, EXAMINING ATTORNEY

SN 85-206,342. WHIRLPOOL PROPERTIES, INC., ST. JOSEPH, MI. FILED 12-28-2010.



OWNER OF U.S. REG. NOS. 1,137,316, 2,799,094 AND OTHERS.

THE MARK CONSISTS OF A SWIRL.  
FOR CLIMATE CONTROL SYSTEMS CONSISTING OF DIGITAL THERMOSTATS, AIR CONDITIONING, HEATING, VENTILATION AND DRYING CONTROL DEVICES; USB (UNIVERSAL SERIAL BUS) OPERATING SOFTWARE (U.S. CLS. 21, 23, 26, 36 AND 38).  
HELENE LIWINSKI, EXAMINING ATTORNEY

**CLASS 9—(Continued).**

SN 85-206,580. T-MOD ENTERPRISE CO., LTD., TAIPEI HSIEN 234, TAIWAN, FILED 12-28-2010.



THE MARK CONSISTS OF THE STYLIZED WORDING ARCHGON.

FOR BAGS AND CASES SPECIALLY ADAPTED FOR HOLDING OR CARRYING PORTABLE DIGITAL EQUIPMENT AND ACCESSORIES, NAMELY, TELEPHONES AND TABLET COMPUTERS; BLANK HARD DRIVES FOR COMPUTERS; BLANK OPTICAL DATA CARRIERS; BLANK RECORDABLE OPTICAL DISKS; OPTICAL DISK DRIVES FOR COMPUTERS; COMPUTER BAGS; COMPUTER CARRYING CASES; COMPUTER CHASSIS; COMPUTER EXPANSION BOARDS; COMPUTER GAME DISCS; COMPUTER HARD DRIVE ENCLOSURES; COMPUTER HARDWARE AND COMPUTER PERIPHERALS; COMPUTER HARDWARE AND COMPUTER SOFTWARE PROGRAMS FOR THE INTEGRATION OF TEXT, AUDIO, GRAPHICS, STILL IMAGES AND MOVING PICTURES INTO AN INTERACTIVE DELIVERY FOR MULTIMEDIA APPLICATIONS; COMPUTER KEYBOARDS; COMPUTER MONITORS; COMPUTER MOUSE; COMPUTER NETWORKING HARDWARE; COMPUTER OPERATING PROGRAMS; COMPUTER PRINTERS; COMPUTER STORAGE DEVICES, NAMELY, BLANK FLASH DRIVES; COMPUTER STORAGE DEVICES, NAMELY, HIGH-SPEED STORAGE SUBSYSTEMS FOR STORAGE AND BACKUP OF ELECTRONIC DATA EITHER LOCALLY OR VIA A TELECOMMUNICATIONS NETWORK; COMPUTER TERMINALS; FLASH MEMORY CARDS; MOBILE COMPUTERS; NOTEBOOK AND LAPTOP COMPUTERS; RANDOM ACCESS MEMORY CARDS (U.S. CLS. 21, 23, 26, 36 AND 38).

FIRST USE 12-7-2010; IN COMMERCE 12-7-2010.  
LINDSEY RUBIN, EXAMINING ATTORNEY

SN 85-206,681. INTEL CORPORATION, SANTA CLARA, CA. FILED 12-28-2010.



THE MARK CONSISTS OF STANDARD CHARACTERS WITHOUT CLAIM TO ANY PARTICULAR FONT, STYLE, SIZE, OR COLOR.

OWNER OF U.S. REG. NOS. 1,702,463, 2,179,209 AND OTHERS.

FOR DATA PROCESSING HARDWARE; DATA PROCESSORS; COMPUTERS; SEMICONDUCTORS; MICROPROCESSORS AND OTHER SEMICONDUCTOR DEVICES; INTEGRATED CIRCUITS; COMPUTER CHIPS; COMPUTER MOTHERBOARDS; COMPUTER SOFTWARE, NAMELY, COMPUTER OPERATING SYSTEMS, COMPUTER UTILITY SOFTWARE AND OTHER COMPUTER SOFTWARE USED TO MAINTAIN AND OPERATE A COMPUTER SYSTEM; PROGRAMMABLE DATA PROCESSORS; COMPUTER HARDWARE; COMPUTER FIRMWARE (U.S. CLS. 21, 23, 26, 36 AND 38).

SCOTT BIBB, EXAMINING ATTORNEY

**CLASS 9—(Continued).**

SN 85-206,759. ELEMENT CASE INC., SAN CARLOS, CA. FILED 12-28-2010.

**E** ELEMENTCASE

THE MARK CONSISTS OF A HIGHLY STYLIZED GRAPHIC OF THE OVERLAPPING LETTERS "E" AND "C" AND TO THE RIGHT THE WORDING "ELEMENTCASE" IN STYLIZED FONT.

FOR CARRYING CASES, HOLDERS, PROTECTIVE CASES AND STANDS FEATURING POWER SUPPLY CONNECTORS, ADAPTORS, SPEAKERS AND BATTERY CHARGING DEVICES, SPECIALLY ADAPTED FOR USE WITH HANDHELD DIGITAL ELECTRONIC DEVICES; PROTECTIVE COVERS AND CASES FOR CELL PHONES, LAPTOPS AND PORTABLE MEDIA PLAYERS (U.S. CLS. 21, 23, 26, 36 AND 38).

FIRST USE 4-7-2010; IN COMMERCE 4-7-2010.  
ADA HAN, EXAMINING ATTORNEY

SN 85-206,777. ROBALA, LLC, OXNARD, CA. FILED 12-28-2010.

SANARE

THE MARK CONSISTS OF STANDARD CHARACTERS WITHOUT CLAIM TO ANY PARTICULAR FONT, STYLE, SIZE, OR COLOR.

THE ENGLISH TRANSLATION OF THE WORD "SANARE" IN THE MARK IS "TO HEAL".

FOR COMPUTER SOFTWARE THAT PROVIDES WEB-BASED ACCESS TO APPLICATIONS AND SERVICES THROUGH A WEB OPERATING SYSTEM OR PORTAL INTERFACE THAT PROVIDES INFORMATION AND TO HELP DIAGNOSE AND TREAT HEADACHES (U.S. CLS. 21, 23, 26, 36 AND 38).

JANET LEE, EXAMINING ATTORNEY

**CLASS 9—(Continued).**

SN 85-206,826. JC 23 ENTERTAINMENT, INC., BEVERLY HILLS, CA. FILED 12-28-2010.



THE MARK CONSISTS OF A STYLIZED CHARACTER SITTING IN YOGA STYLE.

FOR PRE-RECORDED DIGITAL VERSATILE DISCS, PRE-RECORDED AUDIO VIDEO DISCS, PRE-RECORDED CD'S, PRE-RECORDED AUDIO CASSETTES, PRE-RECORDED VIDEO CASSETTES, ALL FEATURING RECORDINGS OF MUSIC, MOTION PICTURE SOUND TRACKS, MOTION PICTURE FILMS FOR EDUCATION AND ENTERTAINMENT, TELEVISION PROGRAMS, COVERING A WIDE VARIETY OF ENTERTAINMENT THEMES, NAMELY, ANIMATION, COMEDY, DRAMA, ACTION, ADVENTURE, AND VARIETY; STEREO HEADPHONES, BATTERIES, CORDLESS TELEPHONES, HAND-HELD CALCULATORS; CD PLAYERS, CD ROM COMPUTER GAME DISCS, HAND-HELD KARAOKE PLAYERS, TELEPHONE AND/OR RADIO PAGERS; SHORT MOTION PICTURE FILM CASSETTES, FEATURING COMEDY, DRAMA, ACTION, ADVENTURE AND/OR ANIMATION TO BE USED WITH HAND-HELD VIEWERS OR PROJECTORS, VIDEO CASSETTE RECORDERS AND PLAYERS, COMPACT DISC PLAYERS, DIGITAL AUDIO TAPE RECORDERS AND PLAYERS, ELECTRONIC DIARIES; RADIOS; MOUSE PADS, EYEGLASSES, SUNGLASSES, AND CASES THEREFORE; AUDIO TAPES AND BOOKLETS SOLD AS A UNIT FEATURING COMEDY, DRAMA, ACTION, ADVENTURE, ANIMATION AND MUSIC INFORMATION; COMPUTER PROGRAMS, NAMELY, SOFTWARE LINKING DIGITIZED VIDEO AND AUDIO MEDIA TO A GLOBAL COMPUTER INFORMATION NETWORK; COMPUTER GAME EQUIPMENT COMPRISED OF HARDWARE FOR USE WITH AN EXTERNAL MONITOR AND SOFTWARE SOLD AS A UNIT FOR PLAYING A PARLOR-TYPE COMPUTER GAME; VIDEO AND COMPUTER GAME PROGRAMS; VIDEO GAME CARTRIDGES AND CASSETTES; CELLULAR TELEPHONE ACCESSORIES, NAMELY, HANDS-FREE ACCESSORIES IN THE NATURE OF HEADPHONES, EARBUDS, EAR PIECES; CELLULAR TELEPHONE COVERS AND CELLULAR TELEPHONE FACE COVERS; ENCODED MAGNETIC CARDS, NAMELY, PHONE CARDS, CREDIT CARDS, CASH CARDS, DEBIT CARDS AND MAGNETIC KEY CARDS; AND DECORATIVE MAGNETS (U.S. CLS. 21, 23, 26, 36 AND 38).

CYNTHIA SLOAN, EXAMINING ATTORNEY

**CLASS 9—(Continued).**

SN 85-207,059. WHITE OAK RESOURCES, LLC, LAS VEGAS, NV. FILED 12-29-2010.

**CoreState Protection**

THE MARK CONSISTS OF STANDARD CHARACTERS WITHOUT CLAIM TO ANY PARTICULAR FONT, STYLE, SIZE, OR COLOR.

NO CLAIM IS MADE TO THE EXCLUSIVE RIGHT TO USE "PROTECTION", APART FROM THE MARK AS SHOWN.

FOR COMPUTER PROGRAMS FOR DATA BACKUP AND RECOVERY (U.S. CLS. 21, 23, 26, 36 AND 38).

FIRST USE 10-15-2010; IN COMMERCE 10-15-2010.

JERI J. FICKES, EXAMINING ATTORNEY

---

SN 85-207,161. PROMASYS UPBOUND B.V., 2282 AS RIJSWIJK, NETHERLANDS, FILED 12-29-2010.

**PROMASYS**

THE MARK CONSISTS OF STANDARD CHARACTERS WITHOUT CLAIM TO ANY PARTICULAR FONT, STYLE, SIZE, OR COLOR.

OWNER OF ERP N CMNTY TM OFC REG. NO. 001882869, DATED 1-13-2003, EXPIRES 10-3-2020.

FOR SOFTWARE TO COLLECT, PROCESS, ANALYZE AND REPORT PERFORMANCE DATA IN THE FIELD OF BUSINESS ORGANIZATION AND MANAGEMENT AND FOR TECHNICAL APPLICATIONS (U.S. CLS. 21, 23, 26, 36 AND 38).

JOHN KELLY, EXAMINING ATTORNEY

---

SN 85-207,207. ZODIAC POOL SYSTEMS, INC., MOORPARK, CA. FILED 12-29-2010.

**SHADOW MANAGEMENT**

THE MARK CONSISTS OF STANDARD CHARACTERS WITHOUT CLAIM TO ANY PARTICULAR FONT, STYLE, SIZE, OR COLOR.

NO CLAIM IS MADE TO THE EXCLUSIVE RIGHT TO USE "MANAGEMENT", APART FROM THE MARK AS SHOWN.

FOR ELECTRONIC CONTROLLERS FOR SPAS AND SWIMMING POOLS (U.S. CLS. 21, 23, 26, 36 AND 38).

HOWARD SMIGA, EXAMINING ATTORNEY

**CLASS 9—(Continued).**

SN 85-207,268. RADIODETECTION LIMITED, BRISTOL, UNITED KINGDOM, FILED 12-29-2010.

**CLEARTRACK**

THE MARK CONSISTS OF STANDARD CHARACTERS WITHOUT CLAIM TO ANY PARTICULAR FONT, STYLE, SIZE, OR COLOR.

FOR GEOPHYSICAL SURVEYING MACHINES AND INSTRUMENTS, FOR USE IN LOCATING, TRACING, IDENTIFYING AND FAULT-FINDING IN RELATION TO UNDERGROUND CABLES, PIPES AND DRAINS; ELECTROMAGNETIC FIELD DETECTORS; PARTS AND FITTINGS FOR ALL THE AFORESAID GOODS (U.S. CLS. 21, 23, 26, 36 AND 38).

KARANENDRA S. CHHINA, EXAMINING ATTORNEY

---

SN 85-207,451. ART FULLY TAUGHT, LLC, GROSSE POINTE PARK, MI. FILED 12-29-2010.

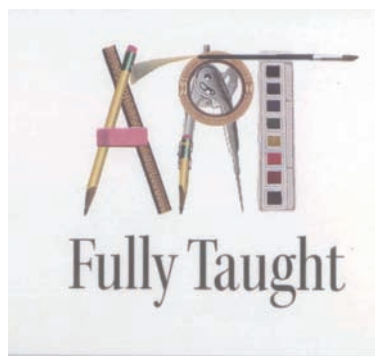

NO CLAIM IS MADE TO THE EXCLUSIVE RIGHT TO USE "ART", APART FROM THE MARK AS SHOWN.

THE COLOR(S) YELLOW, PINK, GREEN, BROWN, BLACK, SILVER, BEIGE, VIOLET, BLUE, ORANGE, RED AND WHITE IS/ARE CLAIMED AS A FEATURE OF THE MARK.

THE MARK CONSISTS OF THE STYLIZED LOGO CONSISTS OF THE WORDS "ART", IN CAPITAL LETTERS FORMED BY A VARIETY OF ART MATERIALS, AND THE WORDS "FULLY" AND "TAUGHT" IN STANDARD CHARACTERS. THE LEFT SIDE OF THE LETTER "A" IS A YELLOW PENCIL WITH A PINK ERASER ATTACHED BY A GREEN METAL SLEEVE. THE RIGHT SIDE OF THE "A" IS A BROWN WOODEN RULER WITH BLACK LINES AND NUMBERS. THE CENTER SECTION OF THE LETTER "A" IS A PINK RECTANGULAR ERASER. THE LETTER "R" IS A SILVER PROTRACTOR HOLDING A YELLOW PENCIL WITH A PINK ERASER ATTACHED BY A GREEN METAL SLEEVE. THE ROUNDED SECTION OF THE "R" IS A ROLL OF BEIGE MASKING TAPE. THE LETTER "T" IS COM-

**CLASS 9—(Continued).**

POSED OF AN EIGHT COLORED WATERCOLOR SET AND PAINT BRUSH. THE PLACEMENT OF THE WATERCOLORS ARE, FROM TOP TO BOTTOM, AS FOLLOWS: BROWN; VIOLET; BLUE; GREEN; YELLOW; ORANGE; RED; AND BLACK. THE CASE HOLDING THE WATERCOLORS IS WHITE. THE TOP SECTION THE "T" IS A BLACK HANDLED PAINT BRUSH WITH A SILVER COLLAR AND BROWN BRUSH BRISTLES. THE WORDS "FULLY" AND "TAUGHT" IN STANDARD BLACK CHARACTERS CREATE THE SECOND LINE OF THE LOGO.

FOR DOWNLOADABLE COMPUTER SOFTWARE FOR ART INSTRUCTION TO ALLOW INSTRUCTORS AND STUDENTS ACCESS TO LESSONS, PRESENTATIONS, AND WORKSHOPS IN THE FIELD OF ART (U.S. CLS. 21, 23, 26, 36 AND 38).

FIRST USE 10-15-2010; IN COMMERCE 10-15-2010.  
KAPIL BHANOT, EXAMINING ATTORNEY

---

SN 85-207,501. ATMA CORE, LLC, HOUSTON, TX. FILED 12-29-2010.

# Ring Runner

THE MARK CONSISTS OF STANDARD CHARACTERS WITHOUT CLAIM TO ANY PARTICULAR FONT, STYLE, SIZE, OR COLOR.

FOR ELECTRONIC VIDEO GAME SOFTWARE (U.S. CLS. 21, 23, 26, 36 AND 38).  
JENNY PARK, EXAMINING ATTORNEY

---

SN 85-207,780. PLURIBUS NETWORKS INC., LOS ALTOS, CA. FILED 12-30-2010.

# VMANAGE

THE MARK CONSISTS OF STANDARD CHARACTERS WITHOUT CLAIM TO ANY PARTICULAR FONT, STYLE, SIZE, OR COLOR.

FOR COMPUTER SOFTWARE, NAMELY, SOFTWARE FOR MANAGING DISTRIBUTED OPERATING SYSTEMS EXECUTING ON SWITCHES AND OTHER NETWORK DEVICES (U.S. CLS. 21, 23, 26, 36 AND 38).  
LINDA MICKLEBURGH, EXAMINING ATTORNEY

**CLASS 9—(Continued).**

SN 85-207,833. MWM MOBILE PRODUCTS, LLC, INDIANAPOLIS, IN. FILED 12-30-2010.

# SPL2

THE MARK CONSISTS OF STANDARD CHARACTERS WITHOUT CLAIM TO ANY PARTICULAR FONT, STYLE, SIZE, OR COLOR.

FOR ACOUSTIC COMPONENTS, NAMELY, HEADPHONES, EARPHONES, SOUND PRESSURE LIMITERS AND SOUND PRESSURE LEVEL METERS (U.S. CLS. 21, 23, 26, 36 AND 38).

RUDY R. SINGLETON, EXAMINING ATTORNEY

---

SN 85-208,149. AKER WADE POWER TECHNOLOGIES, LLC, CHARLOTTESVILLE, VA. FILED 12-30-2010.

# EMAX HF

THE MARK CONSISTS OF STANDARD CHARACTERS WITHOUT CLAIM TO ANY PARTICULAR FONT, STYLE, SIZE, OR COLOR.

NO CLAIM IS MADE TO THE EXCLUSIVE RIGHT TO USE "HF", APART FROM THE MARK AS SHOWN.

FOR BATTERY CHARGERS; CHARGERS FOR ELECTRIC VEHICLE BATTERIES (U.S. CLS. 21, 23, 26, 36 AND 38).

KIM SAITO, EXAMINING ATTORNEY

---

SN 85-208,221. V.J. TECHNOLOGIES, BOHEMIA, NY. FILED 12-30-2010.



# VJ TECHNOLOGIES

NO CLAIM IS MADE TO THE EXCLUSIVE RIGHT TO USE "TECHNOLOGIES", APART FROM THE MARK AS SHOWN.

THE COLOR(S) GREEN, GREY IS/ARE CLAIMED AS A FEATURE OF THE MARK.

THE MARK CONSISTS OF THE LETTER "V" IN GREEN AND THE LETTER "J" IN GREY BOTH IN TOP LEFT HAND CORNER OF THE MARK AND THE LITERAL ELEMENT "VJ TECHNOLOGIES" IN GREY IN THE LOWER PART OF THE MARK.

FOR INDUSTRIAL X-RAY APPARATUS IN THE NATURE OF TESTING EQUIPMENT FOR DETERMINING INDUSTRIAL FLAWS (U.S. CLS. 21, 23, 26, 36 AND 38).

ANGELA M. MICHELI, EXAMINING ATTORNEY

**CLASS 9—(Continued).**

SN 85-208,315. ETYMOTIC RESEARCH, INC., ELK GROVE VILLAGE, IL. FILED 12-30-2010.

**ETY PLUGS**

THE MARK CONSISTS OF STANDARD CHARACTERS WITHOUT CLAIM TO ANY PARTICULAR FONT, STYLE, SIZE, OR COLOR.

NO CLAIM IS MADE TO THE EXCLUSIVE RIGHT TO USE "PLUGS", APART FROM THE MARK AS SHOWN.

FOR EAR PLUGS NOT FOR MEDICAL PURPOSES (U.S. CLS. 21, 23, 26, 36 AND 38).

FIRST USE 11-15-2005; IN COMMERCE 11-15-2005.

SAMUEL E. SHARPER JR., EXAMINING ATTORNEY

SN 85-208,815. TRADE WINDS ADVERTISING INC, FERNANDINA BEACH, FL. FILED 1-2-2011.

**RELIABLE RENTERS**

THE MARK CONSISTS OF STANDARD CHARACTERS WITHOUT CLAIM TO ANY PARTICULAR FONT, STYLE, SIZE, OR COLOR.

NO CLAIM IS MADE TO THE EXCLUSIVE RIGHT TO USE "RENTERS", APART FROM THE MARK AS SHOWN.

FOR COMPUTER SOFTWARE THAT PROVIDES WEB-BASED ACCESS TO APPLICATIONS AND SERVICES THROUGH A WEB OPERATING SYSTEM OR PORTAL INTERFACE (U.S. CLS. 21, 23, 26, 36 AND 38).

FIRST USE 11-1-2010; IN COMMERCE 12-15-2010.

JEFF DEFORD, EXAMINING ATTORNEY

**CLASS 9—(Continued).**

SN 85-208,898. BARBEAU, SEAN J., TAMPA, FL. FILED 1-2-2011.



NO CLAIM IS MADE TO THE EXCLUSIVE RIGHT TO USE "GPS", APART FROM THE MARK AS SHOWN.

THE MARK CONSISTS OF A SOLID SQUARE CONTAINING TWO PERPENDICULAR LINES FORMING A CROSS WITH A CIRCLE SURROUNDING THE INTERSECTION OF THE LINES AND THE WORDING "GPS BENCHMARK".

FOR COMPUTER APPLICATION SOFTWARE FOR MOBILE PHONES, HANDHELD COMPUTERS, PORTABLE MEDIA PLAYERS, EMBEDDED DEVICES, TABLETS, LAPTOPS, NETBOOKS, SET-TOP BOXES, AND SERVERS, NAMELY, SOFTWARE FOR THE COLLECTION AND ANALYSIS OF GEOGRAPHIC LOCATION DATA AND SETTINGS FROM POSITIONING SYSTEMS, NAMELY GLOBAL POSITIONING SYSTEMS, CELLULAR AND WIRELESS NETWORK-BASED POSITIONING SYSTEMS, DEAD-RECKONING POSITIONING SYSTEMS, AND HYBRID POSITIONING SYSTEMS COMBINING ANY AFOREMENTIONED POSITIONING SYSTEMS, TO PRODUCE QUANTITATIVE AND QUALITATIVE SUMMARIES OF THE ACCURACY OF DATA FROM THE POSITIONING SYSTEM, AS WELL AS TO PROVIDE MANUAL OR AUTOMATED GUIDANCE ON HOW SETTINGS OF THE POSITIONING SYSTEM COULD BE ADJUSTED TO IMPROVE ACCURACY PERFORMANCE (U.S. CLS. 21, 23, 26, 36 AND 38).

FIRST USE 11-10-2009; IN COMMERCE 11-10-2009.

PAM WILLIS, EXAMINING ATTORNEY

SN 85-208,923. GNL ENTERTAINMENT, INC., WASHINGTON, DC. FILED 1-3-2011.

**Music-Ebru**

THE MARK CONSISTS OF STANDARD CHARACTERS WITHOUT CLAIM TO ANY PARTICULAR FONT, STYLE, SIZE, OR COLOR.

THE ENGLISH TRANSLATION OF THE TURKISH WORD "EBRU" IN THE MARK IS "TURKISH PAPER MARBLING".

FOR AUDIO AND VIDEO RECORDINGS FEATURING MUSIC AND ARTISTIC PERFORMANCES; COMPACT DISCS FEATURING MUSIC; DIGITAL MUSIC DOWNLOADABLE FROM THE INTERNET; DOWNLOADABLE MUSICAL SOUND RECORDINGS; MUSICAL SOUND RECORDINGS; MUSICAL VIDEO RECORDINGS (U.S. CLS. 21, 23, 26, 36 AND 38).

ANDREA HACK, EXAMINING ATTORNEY



**CLASS 9—(Continued).**

SN 85-209,026. ACCU1ST INC, CERRITOS, CA. FILED 1-3-2011.

# ACCU1ST

THE MARK CONSISTS OF STANDARD CHARACTERS WITHOUT CLAIM TO ANY PARTICULAR FONT, STYLE, SIZE, OR COLOR.

FOR PEDOMETERS; TIMERS (U.S. CLS. 21, 23, 26, 36 AND 38).

SUZANNE BLANE, EXAMINING ATTORNEY

**CLASS 9—(Continued).**

SN 85-209,137. CRANDALL, MARK, OVIEDO, FL. FILED 1-3-2011.

# modern meal

THE MARK CONSISTS OF STANDARD CHARACTERS WITHOUT CLAIM TO ANY PARTICULAR FONT, STYLE, SIZE, OR COLOR.

NO CLAIM IS MADE TO THE EXCLUSIVE RIGHT TO USE "MEAL", APART FROM THE MARK AS SHOWN.

FOR COMPUTER SOFTWARE FOR PROVIDING AN ON-LINE DATABASE IN THE FIELD OF TRANSACTION PROCESSING TO UPLOAD TRANSACTIONAL DATA, PROVIDE STATISTICAL ANALYSIS, AND PRODUCE NOTIFICATIONS AND REPORTS; COMPUTER SOFTWARE FOR RECIPE MANAGEMENT THAT ENABLES STREAMLINED CONNECTION FOR THE CONSUMER FROM RECIPE TO INGREDIENT (U.S. CLS. 21, 23, 26, 36 AND 38).

NAKIA HENRY, EXAMINING ATTORNEY

SN 85-209,043. BENEVA SOLUTIONS, LLC, SARASOTA, FL. FILED 1-3-2011.

# floralapp

THE MARK CONSISTS OF THE WORD "FLORALAPP" IN ALL LOWERCASE LETTERS.

FOR COMPUTER APPLICATION SOFTWARE FOR CELL PHONES, NAMELY, SOFTWARE ENABLING A CUSTOMER TO ORDER FLORAL PRODUCTS USING THE CELL PHONE AND TO ENABLE THE FLORIST TO CONTACT THE CUSTOMER THROUGH THE CUSTOMER'S CELL PHONE (U.S. CLS. 21, 23, 26, 36 AND 38).

FIRST USE 9-1-2010; IN COMMERCE 9-14-2010.  
TAMARA FRAZIER, EXAMINING ATTORNEY

SN 85-209,502. SOCIETY OF COST ESTIMATING AND ANALYSIS, VIENNA, VA. FILED 1-3-2011.

# CEBoK

SN 85-209,087. PRODICO TECHNOLOGIES, LLC., CHICAGO, IL. FILED 1-3-2011.

# CertAlert

THE MARK CONSISTS OF STANDARD CHARACTERS WITHOUT CLAIM TO ANY PARTICULAR FONT, STYLE, SIZE, OR COLOR.

FOR MACHINES FOR DISPENSING PRE-DETERMINED DOSAGES OF MEDICATION WHICH ALSO INCORPORATE TIMERS FOR REMINDING PERSONS TO TAKE MEDICINE (U.S. CLS. 21, 23, 26, 36 AND 38).

STEVEN PEREZ, EXAMINING ATTORNEY

THE MARK CONSISTS OF STANDARD CHARACTERS WITHOUT CLAIM TO ANY PARTICULAR FONT, STYLE, SIZE, OR COLOR.

FOR EDUCATIONAL SOFTWARE FEATURING INSTRUCTION IN COST ESTIMATION AND COST ANALYSIS (U.S. CLS. 21, 23, 26, 36 AND 38).

FIRST USE 1-22-2009; IN COMMERCE 1-22-2009.  
SUSAN RICHARDS, EXAMINING ATTORNEY

**CLASS 9—(Continued).**

SN 85-209,800. SHOCKLEE, JACK, SPRING HILL, TN. FILED 1-4-2011.



THE MARK CONSISTS OF INTERLOCKING "S"'S WITH THREE HORIZONTAL LINES.

FOR AUDIO AND VIDEO RECORDINGS FEATURING MUSIC AND ARTISTIC PERFORMANCES; AUDIO RECORDINGS FEATURING MUSIC; AUDIO TAPES FEATURING MUSIC; COMPACT DISCS FEATURING MUSIC; DIGITAL MUSIC DOWNLOADABLE FROM THE INTERNET; DOWNLOADABLE MUSICAL SOUND RECORDINGS; DOWNLOADABLE RING TONES, GRAPHICS AND MUSIC VIA A GLOBAL COMPUTER NETWORK AND WIRELESS DEVICES; DOWNLOADABLE VIDEO RECORDINGS FEATURING MUSIC; DOWNLOADABLE MUSIC VIA THE INTERNET AND WIRELESS DEVICES; MUSICAL SOUND RECORDINGS; MUSICAL VIDEO RECORDINGS; PHONOGRAPH RECORDS FEATURING MUSIC; PRERECORDED AUDIO TAPES FEATURING MUSIC; PRERECORDED VIDEO CASSETTES FEATURING MUSIC; PRERECORDED VIDEO TAPES FEATURING MUSIC; SOUND RECORDINGS FEATURING MUSIC; VIDEO RECORDINGS FEATURING MUSIC (U.S. CLS. 21, 23, 26, 36 AND 38).  
LANA PHAM, EXAMINING ATTORNEY

SN 85-209,825. SINBI & SUN CO., LTD., INCHEON, REPUBLIC OF KOREA, FILED 1-4-2011.

**SINBI & SUN**

THE MARK CONSISTS OF STANDARD CHARACTERS WITHOUT CLAIM TO ANY PARTICULAR FONT, STYLE, SIZE, OR COLOR.

THE WORD(S) "SINBI" HAS NO MEANING IN A FOREIGN LANGUAGE.

FOR SOLAR PANELS FOR THE PRODUCTION OF ELECTRICITY, SOLAR CELLS (U.S. CLS. 21, 23, 26, 36 AND 38).

FIRST USE 1-1-2011; IN COMMERCE 1-1-2011.  
KYLE PEETE, EXAMINING ATTORNEY

**CLASS 9—(Continued).**

SN 85-209,964. JONA GROUP LTD., HUNTINGTON STATION, NY. FILED 1-4-2011.



NO CLAIM IS MADE TO THE EXCLUSIVE RIGHT TO USE "MOUSE", APART FROM THE MARK AS SHOWN.

FOR ELECTRICAL CONTROLLING DEVICES; REMOTE CONTROLS FOR COMPUTERS; REMOTE CURSOR CONTROLS FOR COMPUTERS (U.S. CLS. 21, 23, 26, 36 AND 38).

MARIA-VICTORIA SUAREZ, EXAMINING ATTORNEY

SN 85-209,972. KISS CATALOG, LTD., PINE BROOK, NJ. FILED 1-4-2011.



OWNER OF U.S. REG. NOS. 1,055,765, 1,894,876 AND OTHERS.

THE MARK CONSISTS OF THE WORD "KISS" IN A STYLIZED FONT.

FOR SOUND RECORDINGS FEATURING MUSIC; SOUND AND VIDEO RECORDINGS FEATURING MUSIC AND MUSICAL PERFORMANCES (U.S. CLS. 21, 23, 26, 36 AND 38).

FIRST USE 2-18-1974; IN COMMERCE 2-18-1974.  
JUSTINE D. PARKER, EXAMINING ATTORNEY

SN 85-210,031. SPECTRUM VISIONS GLOBAL, INC., SAN JOSE, CA. FILED 1-4-2011.

**Voice4u**

THE MARK CONSISTS OF STANDARD CHARACTERS WITHOUT CLAIM TO ANY PARTICULAR FONT, STYLE, SIZE, OR COLOR.

FOR AUGMENTATIVE AND ALTERNATIVE COMMUNICATION SOFTWARE APPLICATION (U.S. CLS. 21, 23, 26, 36 AND 38).

FIRST USE 10-30-2009; IN COMMERCE 12-1-2009.  
MORGAN WYNNE, EXAMINING ATTORNEY

**CLASS 9—(Continued).**

SN 85-210,121. E-BIZSOFT.COM, INC., PEMBROKE PINES, FL. FILED 1-4-2011.



THE MARK CONSISTS OF THE STYLIZED WORD "TRXLINK" WHEREIN THE "X" IS SMALLER THAN THE REST OF THE LETTERS AND APPEARING ABOVE IT IS A GLOBE FIGURE CONTAINING LINES AND CONNECTING DOTS; APPEARING BELOW THE WORD IS AN ARC THAT TRAILS OFF.

FOR COMPUTER SOFTWARE FOR REQUISITIONING, PURCHASING, SALES, APPROVAL FACILITATION, VENDOR MANAGEMENT, AND E-COMMERCE; COMPUTER SOFTWARE THAT PROVIDES WEB-BASED ACCESS TO APPLICATIONS AND SERVICES THROUGH A WEB OPERATING SYSTEM OR PORTAL INTERFACE (U.S. CLS. 21, 23, 26, 36 AND 38).

FIRST USE 0-0-2007; IN COMMERCE 2-29-2008.  
AISHA SALEM, EXAMINING ATTORNEY

**CLASS 9—(Continued).**

SN 85-210,164. POWERMAT USA, LLC, COMMERCE TOWNSHIP, MI. FILED 1-4-2011.

**BLEEP THE CORDS**

THE MARK CONSISTS OF STANDARD CHARACTERS WITHOUT CLAIM TO ANY PARTICULAR FONT, STYLE, SIZE, OR COLOR.

OWNER OF U.S. REG. NO. 3,911,853.

FOR AERIALS; BATTERY CHARGERS; CONSUMER TYPE POWER SUPPLIES; ELECTRICAL POWER SUPPLY APPARATUS, NAMELY, POWER SUPPLY CONNECTORS AND ADAPTORS FOR USE WITH PORTABLE ELECTRONIC DEVICES; ELECTRIC POWER SUPPLY UNITS COMPRISED OF POWER SUPPLY CONNECTORS AND ADAPTORS FOR USE WITH PORTABLE ELECTRONIC DEVICES; ELECTRIC RELAYS; ELECTRONIC TRANSMITTERS FOR WIRELESS TRANSMISSION OF ENERGY FOR INDUCTIVE CHARGING OF PORTABLE ELECTRONIC DEVICES; INDUCTIVE ELECTRIC COUPLINGS; INDUCTIVE ELECTRONIC TRANSMITTERS FOR CHARGING PORTABLE ELECTRONIC DEVICES; MASTS FOR WIRELESS AERIALS; POWER MODULES, NAMELY, APPARATUS FOR SUPPLYING POWER TO PORTABLE ELECTRONIC DEVICES; BATTERY POWER SUPPLIES FOR BATTERY CHARGERS FOR PORTABLE ELECTRONIC DEVICES; RECEIVING ELEMENTS, NAMELY, SOCKETS AND PLUGS FOR INTERFACING WITH AND CHARGING OF PORTABLE ELECTRONIC DEVICES; TRANSFORMERS; TRANSMITTERS OF ELECTRONIC SIGNALS; APPARATUS FOR WIRELESS TRANSMISSION OF ENERGY FOR INDUCTIVE CHARGING OF PORTABLE ELECTRONIC DEVICES (U.S. CLS. 21, 23, 26, 36 AND 38).

MATTHEW MCDOWELL, EXAMINING ATTORNEY

SN 85-210,127. TASTEFUL MARKETING, LLC, CHARLOTTE, NC. FILED 1-4-2011.

**F.A.S.T.**

THE MARK CONSISTS OF STANDARD CHARACTERS WITHOUT CLAIM TO ANY PARTICULAR FONT, STYLE, SIZE, OR COLOR.

FOR COMPUTER SOFTWARE FOR PLANNING, ORGANIZING, TRACKING, AND RECORDING SALES AND MARKETING RESULTS FOR FOOD MANUFACTURERS, BROKERS, DISTRIBUTORS, AND FOOD SERVICE OPERATIONS (U.S. CLS. 21, 23, 26, 36 AND 38).

FIRST USE 5-31-2006; IN COMMERCE 5-31-2006.  
ANGELA DUONG, EXAMINING ATTORNEY

SN 85-210,211. MARKETWATCH, INC., NEW YORK, NY. FILED 1-4-2011.

**MARKETWATCH**

THE MARK CONSISTS OF STANDARD CHARACTERS WITHOUT CLAIM TO ANY PARTICULAR FONT, STYLE, SIZE, OR COLOR.

OWNER OF U.S. REG. NOS. 2,824,080, 2,899,317 AND OTHERS.

FOR DOWNLOADABLE SOFTWARE IN THE NATURE OF AN APPLICATION FOR MOBILE AND STATIONARY ELECTRONIC DEVICES FOR OBTAINING NEWS, INFORMATION, COMMENTARY, AND TEXTUAL, AUDIO, AND VISUAL CONTENT OF THE TYPE FOUND IN GENERAL INTEREST PUBLICATIONS (U.S. CLS. 21, 23, 26, 36 AND 38).

FIRST USE 11-2-2009; IN COMMERCE 11-2-2009.  
ROBIN CHOSID, EXAMINING ATTORNEY

**CLASS 9—(Continued).**

SN 85-210,216. E-BIZSOFT.COM, INC., PEMBROKE PINES, FL. FILED 1-4-2011.

# TRxLink

THE MARK CONSISTS OF STANDARD CHARACTERS WITHOUT CLAIM TO ANY PARTICULAR FONT, STYLE, SIZE, OR COLOR.

FOR COMPUTER SOFTWARE FOR REQUISITIONING, PURCHASING, SALES, APPROVAL FACILITATION, VENDOR MANAGEMENT, AND E-COMMERCE; COMPUTER SOFTWARE THAT PROVIDES WEB-BASED ACCESS TO APPLICATIONS AND SERVICES THROUGH A WEB OPERATING SYSTEM OR PORTAL INTERFACE (U.S. CLS. 21, 23, 26, 36 AND 38).

FIRST USE 0-0-2007; IN COMMERCE 2-29-2008.  
AISHA SALEM, EXAMINING ATTORNEY

SN 85-210,222. MARKETWATCH, INC., NEW YORK, NY. FILED 1-4-2011.



OWNER OF U.S. REG. NO. 2,931,675.  
THE MARK CONSISTS OF THE LETTER "W" REPRESENTED AS A THREE DIMENSIONAL LETTER WITH A BLACK FRONT AND WHITE SIDES WITH BLACK BOUNDARY LINES, WITH THE TOP OF THE NEAR END OF THE LETTER FORMING AN UPWARD POINTING ARROW.

FOR DOWNLOADABLE SOFTWARE IN THE NATURE OF AN APPLICATION FOR MOBILE AND STATIONARY ELECTRONIC DEVICES FOR OBTAINING NEWS, INFORMATION, COMMENTARY, AND TEXTUAL, AUDIO, AND VISUAL CONTENT OF THE TYPE FOUND IN GENERAL INTEREST PUBLICATIONS (U.S. CLS. 21, 23, 26, 36 AND 38).

FIRST USE 11-2-2009; IN COMMERCE 11-2-2009.  
ROBIN CHOSID, EXAMINING ATTORNEY

**CLASS 9—(Continued).**

SN 85-210,600. KLIPSCH GROUP, INC., INDIANAPOLIS, IN. FILED 1-5-2011.

# KLIPSCH GALLERY

THE MARK CONSISTS OF STANDARD CHARACTERS WITHOUT CLAIM TO ANY PARTICULAR FONT, STYLE, SIZE, OR COLOR.

FOR LOUDSPEAKERS, SUBWOOFERS, AND SPEAKER DOCKS (U.S. CLS. 21, 23, 26, 36 AND 38).

DANIEL CAPSHAW, EXAMINING ATTORNEY

SN 85-210,933. AQUA CONSERVE, INC., RIVERSIDE, CA. FILED 1-5-2011.

# ET FREE

THE MARK CONSISTS OF STANDARD CHARACTERS WITHOUT CLAIM TO ANY PARTICULAR FONT, STYLE, SIZE, OR COLOR.

NO CLAIM IS MADE TO THE EXCLUSIVE RIGHT TO USE "ET", APART FROM THE MARK AS SHOWN.

FOR IRRIGATION CONTROLS FOR CONTROLLING IRRIGATION UNITS USED FOR WATER CONSERVATION THAT UTILIZE LOCAL WEATHER INFORMATION GATHERED OVER THE INTERNET (U.S. CLS. 21, 23, 26, 36 AND 38).

PAUL F. GAST, EXAMINING ATTORNEY

SN 85-210,936. AQUA CONSERVE, INC., RIVERSIDE, CA. FILED 1-5-2011.

# ET RELIABLE

THE MARK CONSISTS OF STANDARD CHARACTERS WITHOUT CLAIM TO ANY PARTICULAR FONT, STYLE, SIZE, OR COLOR.

NO CLAIM IS MADE TO THE EXCLUSIVE RIGHT TO USE "ET", APART FROM THE MARK AS SHOWN.

FOR IRRIGATION CONTROLS FOR CONTROLLING IRRIGATION UNITS USED FOR WATER CONSERVATION THAT UTILIZE LOCAL WEATHER INFORMATION GATHERED OVER THE INTERNET (U.S. CLS. 21, 23, 26, 36 AND 38).

PAUL F. GAST, EXAMINING ATTORNEY

**CLASS 9—(Continued).**

SN 85-210,941. AQUA CONSERVE, INC., RIVERSIDE, CA.  
FILED 1-5-2011.

# ET PEAK

THE MARK CONSISTS OF STANDARD CHARACTERS WITHOUT CLAIM TO ANY PARTICULAR FONT, STYLE, SIZE, OR COLOR.

NO CLAIM IS MADE TO THE EXCLUSIVE RIGHT TO USE "ET", APART FROM THE MARK AS SHOWN.

FOR IRRIGATION CONTROLS FOR CONTROLLING IRRIGATION UNITS USED FOR WATER CONSERVATION THAT UTILIZE LOCAL WEATHER INFORMATION GATHERED OVER THE INTERNET (U.S. CLS. 21, 23, 26, 36 AND 38).

PAUL F. GAST, EXAMINING ATTORNEY

---

SN 85-210,946. AQUA CONSERVE, INC., RIVERSIDE, CA.  
FILED 1-5-2011.

## AQUA SMART PROGRAM

THE MARK CONSISTS OF STANDARD CHARACTERS WITHOUT CLAIM TO ANY PARTICULAR FONT, STYLE, SIZE, OR COLOR.

NO CLAIM IS MADE TO THE EXCLUSIVE RIGHT TO USE "AQUA" AND "SMART", APART FROM THE MARK AS SHOWN.

THE TERM "AQUA" TRANSLATES INTO ENGLISH AS "WATER".

FOR IRRIGATION CONTROLS FOR CONTROLLING IRRIGATION UNITS USED FOR WATER CONSERVATION THAT UTILIZE LOCAL WEATHER INFORMATION GATHERED OVER THE INTERNET (U.S. CLS. 21, 23, 26, 36 AND 38).

PAUL F. GAST, EXAMINING ATTORNEY

---

SN 85-211,007. TNT CREATIONS, LLC, ROCKVILLE, MD.  
FILED 1-5-2011.

# TransFire

THE MARK CONSISTS OF STANDARD CHARACTERS WITHOUT CLAIM TO ANY PARTICULAR FONT, STYLE, SIZE, OR COLOR.

FOR COMPUTER APPLICATION SOFTWARE FOR MOBILE PHONES, MOBILE COMPUTING DEVICES AND HAND-HELD COMPUTING DEVICES, NAMELY, SOFTWARE FOR LANGUAGE TRANSLATION AND SENDING TRANSLATED TEXT MESSAGES; COMPUTER SOFTWARE FOR LANGUAGE TRANSLATION AND SENDING TRANSLATED TEXT MESSAGES (U.S. CLS. 21, 23, 26, 36 AND 38).

BARNEY CHARLON, EXAMINING ATTORNEY

**CLASS 9—(Continued).**

SN 85-211,082. RSI RELO, INC, VISTA, CA. FILED 1-5-2011.

# RITA

THE MARK CONSISTS OF STANDARD CHARACTERS WITHOUT CLAIM TO ANY PARTICULAR FONT, STYLE, SIZE, OR COLOR.

FOR COMPUTER APPLICATION SOFTWARE FOR PLANNING AND IMPLEMENTING MOVES OF HOMES AND OFFICES (U.S. CLS. 21, 23, 26, 36 AND 38).

ANGELA DUONG, EXAMINING ATTORNEY

---

SN 85-211,096. THE TILE SHOP, LLC, PLYMOUTH, MN.  
FILED 1-5-2011.



OWNER OF U.S. REG. NOS. 3,442,292 AND 3,661,965.

NO CLAIM IS MADE TO THE EXCLUSIVE RIGHT TO USE "FIRED EARTH CERAMICS" OR "DURABLE HAND-CRAFTED QUALITY PORCELAIN BATHWARE", APART FROM THE MARK AS SHOWN.

THE MARK CONSISTS OF THREE KILNS, BELOW WHICH IS THE WORDING "FIRED EARTH CERAMICS". BELOW THAT IS THE WORDING "DURABLE HAND-CRAFTED QUALITY PORCELAIN BATHWARE" WITH A HORIZONTAL LINE ON EITHER SIDE. ALL OF THE FOREGOING IS SURROUNDED BY A RECTANGLE.

FOR TILE-RELATED PRODUCTS, NAMELY, ELECTRICAL OUTLET COVERS AND DECORATIVE SWITCH PLATE COVERS, ALL MADE OF TILE (U.S. CLS. 21, 23, 26, 36 AND 38).

KATHERINE CHANG, EXAMINING ATTORNEY



**CLASS 9—(Continued).**

SN 85-211,763. WNBA ENTERPRISES, LLC, SECAUCUS, NJ. FILED 1-6-2011.



OWNER OF U.S. REG. NOS. 2,194,220, 2,200,374 AND OTHERS.

NO CLAIM IS MADE TO THE EXCLUSIVE RIGHT TO USE "PHOENIX", APART FROM THE MARK AS SHOWN.

THE MARK CONSISTS OF A STYLIZED DRAWING OF A PLANET APPEARING WITH THREE LINES THAT INDICATE ORBITS OVER THE STYLIZED WORDS "PHOENIX MERCURY".

FOR AUDIO RECORDINGS AND VIDEO RECORDINGS FEATURING ENTERTAINMENT AND INFORMATION IN THE FIELD OF BASKETBALL; AUDIO DISCS, VIDEO DISCS, COMPUTER LASER DISCS, PRE-RECORDED AUDIO AND VIDEO CASSETTES, PRE-RECORDED AUDIO AND VIDEO TAPES, PRE-RECORDED COMPACT DISCS, PRE-RECORDED COMPUTER LASER DISCS, ALL FEATURING ENTERTAINMENT AND INFORMATION RELATED TO BASKETBALL; COMPUTER ACCESSORIES, NAMELY, MOUSE PADS, MICE, COMPACT DISC CASES, COMPUTER CARRY-ON CASES, KEYBOARD WRIST PADS, COMPUTER MONITOR CARDBOARD FRAMES, ALL RELATED TO BASKETBALL; COMPUTER PROGRAMS FOR VIEWING INFORMATION, STATISTICS OR TRIVIA ABOUT BASKETBALL; COMPUTER SOFTWARE, NAMELY, SCREEN SAVERS FEATURING BASKETBALL THEMES; COMPUTER SOFTWARE TO ACCESS AND VIEW COMPUTER WALLPAPER; COMPUTER BROWSER SOFTWARE FOR USE IN VIEWING AND DISPLAYING DATA ON THE INTERNET; COMPUTER SKINS, NAMELY, FITTED PLASTIC FILM FOR COVERING AND PROVIDING A SCRATCH PROOF BARRIER FOR COMPUTER DEVICES; COMPUTER GAME SOFTWARE; VIDEO GAME SOFTWARE, VIDEO GAME CARTRIDGES AND VIDEO GAME MACHINES FOR USE WITH TELEVISION AND VIDEO GAME HAND HELD CONTROLLERS FOR USE WITH TELEVISIONS; WIRELESS OR CELLULAR TELEPHONES; RADIOS, TELEPHONES, AND CELL PHONE ACCESSORIES, NAMELY, FACE PLATES AND CELL PHONE COVERS OR SKINS, NAMELY, FITTED PLASTIC FILM FOR COVERING AND PROVIDING A SCRATCH PROOF BARRIER FOR CELL PHONES; VIDEO MONITORS, COMPUTER MONITORS, BINOCULARS; SUNGLASSES; EYEGLOSS FRAMES; EYEGLOSS AND SUNGLASS STRAPS AND CHAINS; EYEGLOSS AND SUNGLASS CASES; MAGNETS; DISPOSABLE CAMERAS; CREDIT CARDS AND PRE-PAID TELEPHONE CALLING CARDS MAGNETICALLY ENCODED; DOWNLOADABLE VIDEO RECORDINGS, VIDEO STREAM RECORDINGS, AND DOWNLOADABLE AUDIO RECORDINGS IN THE FIELD OF BASKETBALL PROVIDED OVER THE INTERNET; DOWNLOADABLE COMPUTER SOFTWARE FOR VIEWING DATABASES OF INFORMATION, STATISTICAL INFORMATION, TRIVIA, POLLING INFORMATION, AND INTERACTIVE POLLING IN THE FIELD OF BASKETBALL PROVIDED OVER THE INTERNET; DOWNLOADABLE COMPUTER GAME SOFTWARE; DOWNLOADABLE INTERACTIVE VIDEO GAMES AND DOWNLOADABLE TRIVIA GAME SOFTWARE PROVIDED OVER THE INTERNET; DOWNLOADABLE COMPUTER SOFTWARE FOR USE AS SCREENSAVERS AND WALLPAPER, TO ACCESS AND DISPLAY COMPUTER BROWSERS, FOR USE IN VIEWING DATA ON THE INTERNET, FOR USE IN DESIGNING PLASTIC FILM COMPUTER SKINS TO PROTECT COMPUTER MONITORS, FOR USE IN CREATING AVATARS FOR PLAYING GAMES AND FOR USE IN REMOTELY MANIPULATING COMPUTER CURSORS OVER THE

**CLASS 9—(Continued).**

INTERNET; DOWNLOADABLE ELECTRONIC PUBLICATIONS IN THE NATURE OF MAGAZINES, NEWSLETTERS, COLORING BOOKS, GAME SCHEDULES ALL IN THE FIELD OF BASKETBALL PROVIDED OVER THE INTERNET; DOWNLOADABLE CATALOGS PROVIDED OVER THE INTERNET FEATURING AN ARRAY OF BASKETBALL-THEMED PRODUCTS; DOWNLOADABLE GREETING CARDS PROVIDED OVER THE INTERNET; DOWNLOADABLE COMPUTER WALLPAPER, DOWNLOADABLE COMPUTER SCREENSAVERS AND DOWNLOADABLE COMPUTER TOOLBARS PROVIDED OVER THE INTERNET (U.S. CLS. 21, 23, 26, 36 AND 38).

FIRST USE 10-31-1999; IN COMMERCE 10-31-1999.  
MAYUR VAGHANI, EXAMINING ATTORNEY

SN 85-212,050. POINT BEARING CORPORATION, CHICAGO, IL. FILED 1-6-2011.

**TRUSTED EXCHANGE CONTROLLER**

THE MARK CONSISTS OF STANDARD CHARACTERS WITHOUT CLAIM TO ANY PARTICULAR FONT, STYLE, SIZE, OR COLOR.

NO CLAIM IS MADE TO THE EXCLUSIVE RIGHT TO USE "EXCHANGE CONTROLLER", APART FROM THE MARK AS SHOWN.

FOR COMPUTER SOFTWARE FOR INFORMATION SECURITY (U.S. CLS. 21, 23, 26, 36 AND 38).

MATTHEW MCDOWELL, EXAMINING ATTORNEY

SN 85-212,096. POINT BEARING CORPORATION, CHICAGO, IL. FILED 1-6-2011.

**TEC**

THE MARK CONSISTS OF STANDARD CHARACTERS WITHOUT CLAIM TO ANY PARTICULAR FONT, STYLE, SIZE, OR COLOR.

FOR COMPUTER SOFTWARE FOR MANAGING ACCESS TO COMPUTER SYSTEMS, COMPUTER APPLICATIONS AND DATABASES THROUGH BIOMETRIC AND NON-BIOMETRIC AUTHENTICATION (U.S. CLS. 21, 23, 26, 36 AND 38).

MATTHEW MCDOWELL, EXAMINING ATTORNEY

**CLASS 9—(Continued).**

SN 85-212,510. PROTECTIVE SPORTS EQUIPMENT, EDINBORO, PA. FILED 1-7-2011.

# Gladiator PSE

THE MARK CONSISTS OF STANDARD CHARACTERS WITHOUT CLAIM TO ANY PARTICULAR FONT, STYLE, SIZE, OR COLOR.

FOR FOOTBALL HELMETS (U.S. CLS. 21, 23, 26, 36 AND 38).

JESSICA FATHY, EXAMINING ATTORNEY

**CLASS 9—(Continued).**

SN 85-213,441. BORRION ENTERPRISE CO., LTD., TAINAN CITY, TAIWAN, FILED 1-8-2011.



THE MARK CONSISTS OF HIGHLY STYLIZED AND HORIZONTALLY EXTENDED LETTERS "D.C."

FOR SAFETY HELMETS; BICYCLE HELMETS; PROTECTIVE HELMETS FOR SPORTS; GOGGLES FOR SPORTS; SKI GLASSES; SAFETY GOGGLES; EYEGLASSES; SUNGLASSES; SPECTACLE FRAMES; EYEGLASS FRAMES; EYEGLASS CASES (U.S. CLS. 21, 23, 26, 36 AND 38).

FIRST USE 1-13-1995; IN COMMERCE 1-13-1995.

MICHAEL WEBSTER, EXAMINING ATTORNEY

SN 85-212,825. QUANTRIVER SYSTEMS, LLC, WOBURN, MA. FILED 1-7-2011.

# QuantRiver

THE MARK CONSISTS OF STANDARD CHARACTERS WITHOUT CLAIM TO ANY PARTICULAR FONT, STYLE, SIZE, OR COLOR.

FOR COMPUTER SOFTWARE FOR FINANCIAL MANAGEMENT (U.S. CLS. 21, 23, 26, 36 AND 38).

FIRST USE 2-1-2010; IN COMMERCE 2-1-2010.

DOMINIC FATHY, EXAMINING ATTORNEY

SN 85-213,443. BORRION ENTERPRISE CO., LTD., TAINAN CITY, TAIWAN, FILED 1-8-2011.



THE MARK CONSISTS OF HIGHLY STYLIZED LETTERING "D'CURVE".

FOR SAFETY HELMETS; BICYCLE HELMETS; PROTECTIVE HELMETS FOR SPORTS; GOGGLES FOR SPORTS; SKI GLASSES; SAFETY GOGGLES; EYEGLASSES; SUNGLASSES; SPECTACLE FRAMES; EYEGLASS FRAMES; EYEGLASS CASES (U.S. CLS. 21, 23, 26, 36 AND 38).

FIRST USE 1-13-1995; IN COMMERCE 1-13-1995.

MICHAEL WEBSTER, EXAMINING ATTORNEY

SN 85-213,130. HORIZON BUSINESS SERVICES, INC., NAPLES, FL. FILED 1-7-2011.

# CATEREASE

THE MARK CONSISTS OF STANDARD CHARACTERS WITHOUT CLAIM TO ANY PARTICULAR FONT, STYLE, SIZE, OR COLOR.

FOR COMPUTER SOFTWARE ENCOMPASSING THE BUSINESS OF CATERING FOR THE HOSPITALITY INDUSTRY, NAMELY, MARKETING, SALES, SCHEDULING, BOOKING, ACCOUNTING, TRACKING, REPORTING, FUNCTION ROOM LAYOUT DRAWING AND INVOICING (U.S. CLS. 21, 23, 26, 36 AND 38).

FIRST USE 2-28-1997; IN COMMERCE 2-28-1997.

FRANK LATTUCA, EXAMINING ATTORNEY

SN 85-213,480. THREE FERNS FILMS, LLC, ROCKVILLE, MD. FILED 1-8-2011.



THE MARK CONSISTS OF STYLIZED DRAWING OF CAT WITH LONG CURLED TAIL, CURVED BACK, FRONT PAW, POINTY EARS, SIZE PROMINENT WHISKERS AND TRIANGULAR NOSE, IN BLACK OUTLINE.

FOR MOTION PICTURE FILMS ABOUT GENERAL ENTERTAINMENT (U.S. CLS. 21, 23, 26, 36 AND 38).

FIRST USE 12-2-2010; IN COMMERCE 12-2-2010.

ALEXANDER L. POWERS, EXAMINING ATTORNEY

**CLASS 9—(Continued).**

SN 85-213,601. JARED FLYNN, DBA TREE FROG VISUAL MEDIA, OGDEN, UT. FILED 1-9-2011.



NO CLAIM IS MADE TO THE EXCLUSIVE RIGHT TO USE "VISUAL MEDIA", APART FROM THE MARK AS SHOWN.

THE COLOR(S) GREEN, ORANGE, BLACK, AND WHITE IS/ARE CLAIMED AS A FEATURE OF THE MARK.

THE MARK CONSISTS OF A GREEN FROG STANDING ERECT WITH ORANGE HANDS, FEET, SHORTS, AND EYES AND WEARING BLACK GLASSES WITH WHITE TRIM AND HOLDING A BLACK TABLET COMPUTER WITH A WHITE SCREEN SHOWING. THE WORDING "TREE FROG VISUAL MEDIA" IS WRITTEN BELOW THE FROG IN ALTERNATING COLORS ORANGE AND GREEN, WITH EACH WORDING WITH A GREEN LETTER.

FOR ELECTRONIC ADVERTISEMENT AND MESSAGING DISPLAY UNIT WITH MULTI-NETWORKING (TCP/IP) CAPABILITIES AND REMOTE CONNECTIVITY; ELECTRONIC LCD ADVERTISEMENT DISPLAY UNIT WITH MULTI-NETWORKING (TCP/IP) CAPABILITIES; LCD PROJECTORS USED TO DISPLAY ADVERTISEMENTS (U.S. CLS. 21, 23, 26, 36 AND 38).

FIRST USE 12-18-2010; IN COMMERCE 12-18-2010.  
DAVID TAYLOR, EXAMINING ATTORNEY

SN 85-213,639. BRYTUN LIGHTING CORP., CHINO HILLS, CA. FILED 1-9-2011.



THE COLOR(S) DARK BLUE, LIGHT BLUE, WHITE, AND GRAY IS/ARE CLAIMED AS A FEATURE OF THE MARK.

THE MARK CONSISTS OF THE WORDING "PRIMESCALES" WITH "PRIME" IN DARK BLUE AND "SCALES" IN LIGHT BLUE. BELOW THE WORDING IS A BEAM IN GRAY. TO THE LEFT OF "PRIMESCALES" IS THE LETTERING "PS" WITH "P" AND WHITE AND "S" IN LIGHT BLUE ON A DARK BLUE BACKGROUND WITH A WHITE CIRCLE AND GRAY CIRCLE OUTLINE.

FOR WEIGHING EQUIPMENT, NAMELY, SCALES AND BALANCES (U.S. CLS. 21, 23, 26, 36 AND 38).

KAPIL BHANOT, EXAMINING ATTORNEY

**CLASS 9—(Continued).**

SN 85-213,706. GAMEMILL ENTERTAINMENT, LLC, EDINA, MN. FILED 1-10-2011.

**COUNTRY DANCE**

THE MARK CONSISTS OF STANDARD CHARACTERS WITHOUT CLAIM TO ANY PARTICULAR FONT, STYLE, SIZE, OR COLOR.

FOR COMPUTER GAME SOFTWARE (U.S. CLS. 21, 23, 26, 36 AND 38).

GEOFFREY FOSDICK, EXAMINING ATTORNEY

SN 85-213,715. TRANG, BRIAN T., NAPLES, FL. FILED 1-10-2011.

**SMARTER WAY TO WORK OR PLAY**

THE MARK CONSISTS OF STANDARD CHARACTERS WITHOUT CLAIM TO ANY PARTICULAR FONT, STYLE, SIZE, OR COLOR.

FOR ATTACHABLE STANDS FOR ELEVATING LAPTOP COMPUTERS AND OTHER PORTABLE ELECTRONIC DEVICES (U.S. CLS. 21, 23, 26, 36 AND 38).

ANDREA K. NADELMAN, EXAMINING ATTORNEY

SN 85-213,728. WILLIAMS SOUND, LLC, EDEN PRAIRIE, MN. FILED 1-10-2011.

**DIGI-WAVE**

THE MARK CONSISTS OF STANDARD CHARACTERS WITHOUT CLAIM TO ANY PARTICULAR FONT, STYLE, SIZE, OR COLOR.

FOR ASSISTIVE LISTENING DEVICE NOT FOR MEDICAL PURPOSES (U.S. CLS. 21, 23, 26, 36 AND 38).

FIRST USE 6-0-2010; IN COMMERCE 9-0-2010.

MICHAEL KEATING, EXAMINING ATTORNEY

**CLASS 9—(Continued).**

SN 85-213,807. DADDO BOGICH, BROOKLYN, NY. FILED 1-10-2011.

# MyTreat

THE MARK CONSISTS OF STANDARD CHARACTERS WITHOUT CLAIM TO ANY PARTICULAR FONT, STYLE, SIZE, OR COLOR.

FOR COMPUTER APPLICATION SOFTWARE FOR MOBILE PHONES, NAMELY, SOFTWARE FOR CONDUCTING MONETARY TRANSACTIONS; COMPUTER APPLICATION SOFTWARE FOR WEB-SITES, NAMELY, SOFTWARE FOR CONDUCTING MONETARY TRANSACTIONS; COMPUTER COMMUNICATIONS SOFTWARE TO ALLOW CUSTOMERS TO ACCESS BANK ACCOUNT INFORMATION AND TRANSACT BANK BUSINESS; COMPUTER E-COMMERCE SOFTWARE TO ALLOW USERS TO PERFORM ELECTRONIC BUSINESS TRANSACTIONS VIA A GLOBAL COMPUTER NETWORK; COMPUTER SOFTWARE AND HARDWARE FOR CONDUCTING MONETARY TRANSACTIONS; COMPUTER SOFTWARE FOR ACCESSING INFORMATION DIRECTORIES THAT MAY BE DOWNLOADED FROM THE GLOBAL COMPUTER NETWORK; COMPUTER SOFTWARE FOR PROVIDING AN ON-LINE DATABASE IN THE FIELD OF TRANSACTION PROCESSING TO UPLOAD TRANSACTIONAL DATA, PROVIDE STATISTICAL ANALYSIS, AND PRODUCE NOTIFICATIONS AND REPORTS; DOWNLOADABLE COMPUTER SOFTWARE FOR MOBILE PHONES AND SMART PHONES FOR MONETARY TRANSACTIONS; DOWNLOADABLE SOFTWARE FOR POINT OF SALE SYSTEMS AND OTHER COMPUTERS FOR MONETARY TRANSACTIONS DOWNLOADABLE SOFTWARE IN THE NATURE OF A MOBILE APPLICATION FOR CONDUCTING MONETARY TRANSACTIONS (U.S. CLS. 21, 23, 26, 36 AND 38).

REBECCA SMITH, EXAMINING ATTORNEY

SN 85-213,809. KEVIN GROSS, JAMESTOWN, CO. FILED 1-10-2011.

# PANOAGAEA

THE MARK CONSISTS OF STANDARD CHARACTERS WITHOUT CLAIM TO ANY PARTICULAR FONT, STYLE, SIZE, OR COLOR.

THE ENGLISH TRANSLATION OF "PANOAGAEA" IN THE MARK IS "ALL EARTH".

FOR SOFTWARE PROGRAM FOR MANIPULATION OF PANORAMIC IMAGES IN A COMPUTER (U.S. CLS. 21, 23, 26, 36 AND 38).

FIRST USE 12-29-2010; IN COMMERCE 1-6-2011.  
INGRID C. EULIN, EXAMINING ATTORNEY

**CLASS 9—(Continued).**

SN 85-213,816. SNAPLOGIC, INC., SAN MATEO, CA. FILED 1-10-2011.

# SNAPCENTER

THE MARK CONSISTS OF STANDARD CHARACTERS WITHOUT CLAIM TO ANY PARTICULAR FONT, STYLE, SIZE, OR COLOR.

FOR COMPUTER SOFTWARE FOR APPLICATION, DATA, AND DATABASE INTEGRATION; COMPUTER SOFTWARE FOR DATA COMMUNICATIONS BETWEEN APPLICATION PROGRAMS AND NETWORKED DATA SOURCES (U.S. CLS. 21, 23, 26, 36 AND 38).

EVELYN BRADLEY, EXAMINING ATTORNEY

SN 85-213,834. ERGOTRON, INC., EAGAN, MN. FILED 1-10-2011.



THE COLOR(S) BLACK, LIME GREEN IS/ARE CLAIMED AS A FEATURE OF THE MARK.

THE MARK CONSISTS OF A BLACK CIRCLE WITH TWO BLACK LINES EXTENDING FROM THE LEFT AND FIVE BLACK LINES EXTENDING FROM THE RIGHT. THE LETTERS "PS" ARE LIME GREEN AND INSIDE THE BLACK CIRCLE. THE WORD "POWERSHUTTLE" IS UNDERNEATH THE CIRCLE AND "POWER" IS BLACK AND "SHUTTLE" IS LIME GREEN.

FOR ELECTRICAL POWER DEVICES, NAMELY, INTELLIGENT ELECTRICAL SYSTEMS COMPRISED OF SENSING, LOGIC, MATHEMATICAL, CONTROL, AND DISPLAY HARDWARE AND FIRMWARE, THAT SENSE THE POWER NEEDS OF MULTIPLE ATTACHED ELECTRONIC OR ELECTRICAL DEVICES TO SAFELY AND EFFICIENTLY ALLOCATE POWER TO EACH DEVICE WITHOUT EXCEEDING THE TOTAL POWER AVAILABLE, EVEN THOUGH THE TOTAL POWER NEEDED WOULD EASILY EXCEED THE TOTAL POWER AVAILABLE TO THE DEVICES (U.S. CLS. 21, 23, 26, 36 AND 38).

PAM WILLIS, EXAMINING ATTORNEY

**CLASS 9—(Continued).**

SN 85-213,906. SIRRINGHAUS, DENIS F, SAN FRANCISCO, CA. FILED 1-10-2011.

# GootNau

THE MARK CONSISTS OF STANDARD CHARACTERS WITHOUT CLAIM TO ANY PARTICULAR FONT, STYLE, SIZE, OR COLOR.

FOR COMPUTER APPLICATION SOFTWARE FOR MOBILE PHONES, HANDHELD COMPUTERS AND COMPUTERS, NAMELY, SOFTWARE FOR RATING AND REVIEWING OF BUSINESS ORGANIZATIONS, EVENTS, GATHERINGS, PERFORMANCES AND SERVICE PROVIDERS (U.S. CLS. 21, 23, 26, 36 AND 38).  
MAYUR VAGHANI, EXAMINING ATTORNEY

---

SN 85-213,981. LINEAR TECHNOLOGY CORPORATION, MILPITAS, CA. FILED 1-10-2011.

# LTPOWERCAD

THE MARK CONSISTS OF STANDARD CHARACTERS WITHOUT CLAIM TO ANY PARTICULAR FONT, STYLE, SIZE, OR COLOR.

FOR COMPUTER SOFTWARE FOR USE IN DESIGNING AND PRODUCING ELECTRICAL POWER SUPPLIES (U.S. CLS. 21, 23, 26, 36 AND 38).  
RONALD DELGIZZI, EXAMINING ATTORNEY

---

SN 85-213,989. PREMIER 3D ANIMATION LLC, NOVI, MI. FILED 1-10-2011.



THE MARK CONSISTS OF THE STYLIZED WORDS "THE GREAT BIBLE RACE" IN A STACKED FORMATION.

FOR VIDEO GAME SOFTWARE (U.S. CLS. 21, 23, 26, 36 AND 38).

WILLIAM ROSSMAN, EXAMINING ATTORNEY

**CLASS 9—(Continued).**

SN 85-213,996. LINEAR TECHNOLOGY CORPORATION, MILPITAS, CA. FILED 1-10-2011.

# LTPOWERPLAY

THE MARK CONSISTS OF STANDARD CHARACTERS WITHOUT CLAIM TO ANY PARTICULAR FONT, STYLE, SIZE, OR COLOR.

FOR COMPUTER SOFTWARE FOR USE IN DESIGNING AND PRODUCING ELECTRICAL POWER SUPPLIES (U.S. CLS. 21, 23, 26, 36 AND 38).  
RONALD DELGIZZI, EXAMINING ATTORNEY

---

SN 85-214,001. LINEAR TECHNOLOGY CORPORATION, MILPITAS, CA. FILED 1-10-2011.

# LTPOWERPLANNER

THE MARK CONSISTS OF STANDARD CHARACTERS WITHOUT CLAIM TO ANY PARTICULAR FONT, STYLE, SIZE, OR COLOR.

FOR COMPUTER SOFTWARE FOR USE IN DESIGNING AND PRODUCING ELECTRICAL POWER SUPPLIES (U.S. CLS. 21, 23, 26, 36 AND 38).  
RONALD DELGIZZI, EXAMINING ATTORNEY

---

SN 85-214,023. OSS NOKALVA, INC., SOMERSET, NJ. FILED 1-10-2011.

# ASN-1STEP

THE MARK CONSISTS OF STANDARD CHARACTERS WITHOUT CLAIM TO ANY PARTICULAR FONT, STYLE, SIZE, OR COLOR.

FOR DOWNLOADABLE SOFTWARE FOR USE IN CONNECTION WITH MESSAGING FOR NOTATION SYNTAXES (U.S. CLS. 21, 23, 26, 36 AND 38).

FIRST USE 10-0-2000; IN COMMERCE 2-0-2001.

APRIL ROACH, EXAMINING ATTORNEY



**CLASS 9—(Continued).**

SN 85-214,024. CENTER6 INC., DENVER, CO. FILED 1-10-2011.

# InformXL

THE MARK CONSISTS OF STANDARD CHARACTERS WITHOUT CLAIM TO ANY PARTICULAR FONT, STYLE, SIZE, OR COLOR.

FOR COMPUTER SOFTWARE FOR ANALYZING SALES, ACCOUNTING, AND PRODUCTION DATA FOR BUSINESSES (U.S. CLS. 21, 23, 26, 36 AND 38).

FIRST USE 5-1-2009; IN COMMERCE 5-1-2009.

LINDA MICKLEBURGH, EXAMINING ATTORNEY

SN 85-214,260. WINK BACK, INC, SAN FRANCISCO, CA. FILED 1-10-2011.

# Orbiter

THE MARK CONSISTS OF STANDARD CHARACTERS WITHOUT CLAIM TO ANY PARTICULAR FONT, STYLE, SIZE, OR COLOR.

FOR COMPUTER APPLICATION SOFTWARE FOR SMART PHONES AND HAND HELD COMPUTING DEVICES, NAMELY, SOFTWARE FOR PLAYING A LOCATION-BASED GAME FOR ENTERTAINMENT PURPOSES (U.S. CLS. 21, 23, 26, 36 AND 38).

FIRST USE 12-1-2010; IN COMMERCE 12-1-2010.

THOMAS MANOR, EXAMINING ATTORNEY

**CLASS 9—(Continued).**

SN 85-215,203. LANNER ELECTRONICS USA, INC., FREMONT, CA. FILED 1-11-2011.

# Lanner

THE COLOR(S) GREEN IS/ARE CLAIMED AS A FEATURE OF THE MARK.

THE MARK CONSISTS OF STYLIZED WORD "LANNER" IN GREEN.

FOR CARDS AND MICROPROCESSORS FOR COMPUTERS; CARDS WITH INTEGRATED CIRCUITS; CELL PHONE BACKPLATES; COMPUTER CHASSIS; COMPUTER HARDWARE FOR COMMUNICATING AUDIO, VIDEO AND DATA BETWEEN COMPUTERS VIA A GLOBAL COMPUTER NETWORK, WIDE-AREA COMPUTER NETWORKS, AND PEER-TO-PEER COMPUTER NETWORKS; COMPUTER NETWORK INTERFACE DEVICES; COMPUTER NETWORK SERVER; COMPUTER NETWORKING HARDWARE; DIGITAL VIDEO RECORDERS; ELECTRONIC CARDS FOR PROCESSING IMAGES; INTEGRATED CIRCUIT CARDS AND COMPONENTS; INTEGRATED CIRCUIT MODULES; INTEGRATED CIRCUITS, INTEGRATED CIRCUIT CHIPS, AND INTEGRATED CIRCUIT MODULES FOR DIGITAL VIDEO COMPRESSION AND DECOMPRESSION; INTEGRATED CIRCUITS, INTEGRATED CIRCUIT CHIPS, AND INTEGRATED CIRCUIT MODULES FOR ENCODING AND DECODING DIGITAL VIDEO; LAN (LOCAL AREA NETWORK) COMPUTER CARDS FOR CONNECTING PORTABLE COMPUTER DEVICES TO COMPUTER NETWORKS; LAN (LOCAL AREA NETWORK) HARDWARE; MOTHERBOARDS; VIDEO CAPTURE CARDS (U.S. CLS. 21, 23, 26, 36 AND 38).

FIRST USE 6-1-2000; IN COMMERCE 6-1-2000.

ANGELA DUONG, EXAMINING ATTORNEY

SN 85-215,323. SURVEON TECHNOLOGY INC., TAIPEI HSIEN 235, TAIWAN, FILED 1-11-2011.

# Surveon

THE MARK CONSISTS OF STANDARD CHARACTERS WITHOUT CLAIM TO ANY PARTICULAR FONT, STYLE, SIZE, OR COLOR.

FOR ANTI-THEFT WARNING APPARATUS, NAMELY, VIDEO SURVEILLANCE AND PROCESSING UNITS COMPRISED OF CAMERAS, SWITCHERS, MONITORS, MICROPHONES, AND AUDIO-VIDEO RECORDERS; CAMCORDERS; COMPUTER MEMORIES; COMPUTER PERIPHERAL DEVICES; RECORDED COMPUTER PROGRAMS FOR VIDEO MANAGEMENT AND FOR CONNECTING COMPUTER TO A COMPUTER SERVER; DOWNLOADABLE COMPUTER SOFTWARE FOR USE AS A SPREADSHEET AND FOR WORD PROCESSING; RECORDED COMPUTER SOFTWARE FOR CONTROLLING COMPUTER OPERATIONAL FUNCTIONS; COMPUTERS; COMPUTER OPERATING PROGRAMS AND COMPUTER SOFTWARE FOR MONITORING VIDEO SURVEILLANCE SYSTEMS, AND FOR COMPUTER DIAGNOSTICS; DATA PROCESSING APPARATUS; COMPUTER BASED APPARATUS FOR THE REMOTE CONTROL OF INDUSTRIAL SURVEILLANCE OPERATIONS; COMPUTER INTERFACE CIRCUIT BOARDS; COMPUTER MONITORS; OPTICAL INSPECTION APPARATUS FOR INDUSTRIAL AND DOMESTIC USE, NOT FOR MEDICAL USE; AUDIO/VIDEO RECEIVERS; SOUND RECORDING APPARATUS; VIDEO RECORDERS (U.S. CLS. 21, 23, 26, 36 AND 38).

FIRST USE 4-30-2009; IN COMMERCE 4-30-2009.

ANDREA K. NADELMAN, EXAMINING ATTORNEY

**CLASS 9—(Continued).**

SN 85-215,386. RICCOBONI, GENE, BREWSTER, NY. FILED 1-11-2011.

**HOLOGRAMVILLE**

THE MARK CONSISTS OF STANDARD CHARACTERS WITHOUT CLAIM TO ANY PARTICULAR FONT, STYLE, SIZE, OR COLOR.

FOR COMPUTER E-COMMERCE SOFTWARE TO ALLOW USERS TO PERFORM ELECTRONIC BUSINESS TRANSACTIONS VIA A GLOBAL COMPUTER NETWORK; COMPUTER GAME SOFTWARE; COMPUTER GAME SOFTWARE DOWNLOADABLE FROM A GLOBAL COMPUTER NETWORK; COMPUTER GAME SOFTWARE FOR USE ON MOBILE AND CELLULAR PHONES; COMPUTER GAME SOFTWARE FOR USE WITH PERSONAL COMPUTERS, HOME VIDEO GAME CONSOLES USED WITH TELEVISIONS AND ARCADE-BASED VIDEO GAME CONSOLES; DOWNLOADABLE COMPUTER GAME SOFTWARE VIA A GLOBAL COMPUTER NETWORK AND WIRELESS DEVICES; DOWNLOADABLE ELECTRONIC GAME PROGRAMS; ELECTRONIC GAME SOFTWARE FOR HANDHELD ELECTRONIC DEVICES; ELECTRONIC GAME SOFTWARE FOR WIRELESS DEVICES; ELECTRONIC MACHINES USED TO APPLY HOLOGRAPHIC OVERLAY AND TO SET UP AND CONTROL HOLOGRAMS AND VERIFICATION THEREOF; GAMES ADAPTED FOR USE WITH TELEVISION RECEIVERS; HOLOGRAM APPARATUS; INTERACTIVE MULTIMEDIA COMPUTER GAME PROGRAM; VIDEO GAME SOFTWARE; VIRTUAL REALITY GAME SOFTWARE (U.S. CLS. 21, 23, 26, 36 AND 38).

ANGELA M. MICHELI, EXAMINING ATTORNEY

SN 85-215,401. ROOM CANDY GAMES, LLC, SAN MARINO, CA. FILED 1-11-2011.

**PIMPLE POPPER**

THE MARK CONSISTS OF STANDARD CHARACTERS WITHOUT CLAIM TO ANY PARTICULAR FONT, STYLE, SIZE, OR COLOR.

FOR VIDEO GAME SOFTWARE (U.S. CLS. 21, 23, 26, 36 AND 38).

FIRST USE 4-30-2009; IN COMMERCE 4-30-2009.

AISHA CLARKE, EXAMINING ATTORNEY

**CLASS 9—(Continued).**

SN 85-215,407. ZENAPSIS INC., CONCORD, ONTARIO, CANADA, FILED 1-11-2011.

**ZENAPSIS**

THE MARK CONSISTS OF STANDARD CHARACTERS WITHOUT CLAIM TO ANY PARTICULAR FONT, STYLE, SIZE, OR COLOR.

FOR CORPORATE AND COMMUNITY NETWORK MANAGEMENT SOFTWARE FOR LOGISTICS, ACCOUNTING, HUMAN RESOURCES, COMMUNICATIONS, AND RECORD KEEPING (U.S. CLS. 21, 23, 26, 36 AND 38).

AISHA CLARKE, EXAMINING ATTORNEY

SN 85-215,471. TODDWORLD INC., BERKELEY, CA. FILED 1-11-2011.

**MY UNDERWEAR**

THE MARK CONSISTS OF STANDARD CHARACTERS WITHOUT CLAIM TO ANY PARTICULAR FONT, STYLE, SIZE, OR COLOR.

NO CLAIM IS MADE TO THE EXCLUSIVE RIGHT TO USE "UNDERWEAR", APART FROM THE MARK AS SHOWN.

FOR COMPUTER GAME PROGRAMMES DOWNLOADABLE VIA THE INTERNET (U.S. CLS. 21, 23, 26, 36 AND 38).

FIRST USE 1-4-2011; IN COMMERCE 1-4-2011.

LAURIE KAUFMAN, EXAMINING ATTORNEY

SN 85-216,042. FKA DISTRIBUTING CO. D/B/A HOMEDICS, INC., COMMERCE TOWNSHIP, MI. FILED 1-12-2011.



**myCharge**

THE MARK CONSISTS OF A ROUNDED SQUARE CONTAINING A STYLIZED "M" WITH A PLUS SIGN, WITH THE WORD "MYCHARGE" BELOW.

FOR BATTERIES; BATTERY CHARGERS (U.S. CLS. 21, 23, 26, 36 AND 38).

KAPIL BHANOT, EXAMINING ATTORNEY

**CLASS 9—(Continued).**

SN 85-216,414. COX, DAVID, GREENWOOD VILLAGE, CO.  
FILED 1-12-2011.



THE MARK CONSISTS OF A CRESCENT MOON WHICH IS CUT IN HALF AND REATTACHED SO PART OF THE CRESCENT IS POINTED UP AND PART IS POINTED DOWN; IN THE HOLLOW OF THE TOP CRESCENT HALF, OFF TO THE LEFT, IS A LARGE SOLID CIRCLE DOT.

FOR HIGH DEFINITION, POINT OF VIEW, HANDS-FREE VIDEO RECORDING APPARATUS, EMBEDDED IN VARIOUS STYLES OF EYEWEAR AND SUNGLASSES FOR PROFESSIONAL USE, RECREATIONAL USE, DRIVING, SPORTS, AND INDOOR USE (U.S. CLS. 21, 23, 26, 36 AND 38).

AMEEN IMAM, EXAMINING ATTORNEY

---

SN 85-216,545. FRIEDRICH LUTZE GMBH & CO., WEIN-STADT, FED REP GERMANY, FILED 1-13-2011.

## DRIVEFLEX

THE MARK CONSISTS OF STANDARD CHARACTERS WITHOUT CLAIM TO ANY PARTICULAR FONT, STYLE, SIZE, OR COLOR.

FOR ELECTRICAL CABLES FOR MACHINES, ELECTRICAL MOTORS AND ELECTRICAL CONNECTIONS (U.S. CLS. 21, 23, 26, 36 AND 38).

MARK SPARACINO, EXAMINING ATTORNEY

**CLASS 9—(Continued).**

SN 85-216,552. INFOSEC CO., LTD., SEOUL, REPUBLIC OF KOREA, FILED 1-13-2011.

## IMShield

THE MARK CONSISTS OF STANDARD CHARACTERS WITHOUT CLAIM TO ANY PARTICULAR FONT, STYLE, SIZE, OR COLOR.

FOR RECORDED COMPUTER GAME PROGRAM; COMPUTER PROGRAM FOR ENCRYPTION; COMPUTER SOFTWARE FOR ENSURING THE SECURITY AND TRANSMISSION OF ELECTRONIC MAIL; COMPUTER SOFTWARE FOR THE ENABLING OF ACCESS OR ENTRANCE CONTROL FOR A COMPUTER NETWORK; COMPUTER PROGRAM FOR DATA SECURITY; COMPUTER PROGRAM TO FACILITATE COMPUTER NETWORK SECURITY; CENTRAL PROCESSING UNITS; SECURE TERMINALS FOR ELECTRONIC TRANSACTIONS; ENCODED SMART CARDS CONTAINING PROGRAMMING USED FOR AUTHORIZATION OF NETWORK USERS (U.S. CLS. 21, 23, 26, 36 AND 38).

LINDSEY RUBIN, EXAMINING ATTORNEY

---

SN 85-216,584. WINDWARDMARK INTERACTIVE LLC, WALTHAM, MA. FILED 1-13-2011.

## Alliance: The Silent War

THE MARK CONSISTS OF STANDARD CHARACTERS WITHOUT CLAIM TO ANY PARTICULAR FONT, STYLE, SIZE, OR COLOR.

FOR COMPUTER GAME SOFTWARE; COMPUTER GRAPHICS SOFTWARE; COMPUTER SOFTWARE FOR APPLICATION AND DATABASE INTEGRATION (U.S. CLS. 21, 23, 26, 36 AND 38).

JANICE L. MCMORROW, EXAMINING ATTORNEY

---

SN 85-217,104. CLARICENT, INC., ACTON, MA. FILED 1-13-2011.

## BladeRocket

THE MARK CONSISTS OF STANDARD CHARACTERS WITHOUT CLAIM TO ANY PARTICULAR FONT, STYLE, SIZE, OR COLOR.

FOR COMPUTER HARDWARE PERIPHERAL DEVICE FOR USE IN ACCELERATING DATA RETRIEVAL (U.S. CLS. 21, 23, 26, 36 AND 38).

DANIEL CAPSHAW, EXAMINING ATTORNEY

**CLASS 9—(Continued).**

SN 85-217,288. MEMORY EXPERTS INTERNATIONAL (MXI), INC., ST. LAURENT, QUEBEC, CANADA, FILED 1-13-2011.

**MXI STEALTH HD**

THE MARK CONSISTS OF STANDARD CHARACTERS WITHOUT CLAIM TO ANY PARTICULAR FONT, STYLE, SIZE, OR COLOR.

OWNER OF U.S. REG. NOS. 3,294,996, 3,370,652 AND 3,386,715.

NO CLAIM IS MADE TO THE EXCLUSIVE RIGHT TO USE "HD", APART FROM THE MARK AS SHOWN.

FOR FLASH MEMORY CARDS, NAMELY, SECURE PORTABLE MEMORY CARDS AND COMPUTER DRIVES FOR USE IN CONNECTION THEREWITH (U.S. CLS. 21, 23, 26, 36 AND 38).

BRIDGETT SMITH, EXAMINING ATTORNEY

SN 85-217,517. COX, DAVID, GREENWOOD VILLAGE, CO. FILED 1-13-2011.

**The new face of video**

THE MARK CONSISTS OF STANDARD CHARACTERS WITHOUT CLAIM TO ANY PARTICULAR FONT, STYLE, SIZE, OR COLOR.

FOR HIGH DEFINITION, POINT OF VIEW, HANDS FREE DIGITAL IMAGE RECORDING APPARATUS FOR VIDEO AND STILL IMAGE CAPTURE, EMBEDDED IN VARIOUS STYLES OF EYEWEAR AND SUNGLASSES FOR PROFESSIONAL USE, RECREATIONAL USE, DRIVING, SPORTS, AND INDOOR USE (U.S. CLS. 21, 23, 26, 36 AND 38).

AMEEN IMAM, EXAMINING ATTORNEY

SN 85-218,120. SLUTSKY, COREY B, MURRIETA, CA. FILED 1-14-2011.

**Voices Only**

THE MARK CONSISTS OF STANDARD CHARACTERS WITHOUT CLAIM TO ANY PARTICULAR FONT, STYLE, SIZE, OR COLOR.

FOR AUDIO RECORDINGS FEATURING MUSIC (U.S. CLS. 21, 23, 26, 36 AND 38).

FIRST USE 0-0-2004; IN COMMERCE 0-0-2005.  
CAROLINE WOOD, EXAMINING ATTORNEY

**CLASS 9—(Continued).**

SN 85-218,587. CELLPOINT MOBILE INC., CORAL GABLES, FL. FILED 1-15-2011.

**MPAYMENT**

THE MARK CONSISTS OF STANDARD CHARACTERS WITHOUT CLAIM TO ANY PARTICULAR FONT, STYLE, SIZE, OR COLOR.

FOR COMPUTER SOFTWARE APPLICATION FOR MOBILE DEVICES, NAMELY, SOFTWARE FOR MAKING AND PROCESSING PAYMENTS; COMPUTER SOFTWARE, NAMELY, ELECTRONIC FINANCIAL PLATFORM THAT ACCOMMODATES MULTIPLE TYPES OF PAYMENT AND DEBT TRANSACTIONS IN AN INTEGRATED MOBILE DEVICE AND WEB BASED ENVIRONMENT (U.S. CLS. 21, 23, 26, 36 AND 38).

REBECCA SMITH, EXAMINING ATTORNEY

SN 85-218,618. NEUHOLD-TRAXINGER OG, LINZ, 4040, AUSTRIA, FILED 1-15-2011.

**iDestroy**

THE MARK CONSISTS OF STANDARD CHARACTERS WITHOUT CLAIM TO ANY PARTICULAR FONT, STYLE, SIZE, OR COLOR.

FOR COMPUTER GAME PROGRAMS (U.S. CLS. 21, 23, 26, 36 AND 38).

FIRST USE 4-17-2009; IN COMMERCE 4-17-2009.

REBECCA SMITH, EXAMINING ATTORNEY

SN 85-218,627. SAMYA TECHNOLOGY CO., LTD., TAOYUAN COUNTY 33460, TAIWAN, FILED 1-15-2011.

**Samya** 

THE MARK CONSISTS OF THE SCRIPTED WORD "SAMYA" ADJACENT A DIAMOND LIKE CONTOUR HAVING BREAK LINES PASSING THROUGH THE DIAMOND LIKE CONTOUR.

FOR BATTERY CHARGERS; SOLAR BATTERY CHARGERS; AC PLUG ADAPTORS (U.S. CLS. 21, 23, 26, 36 AND 38).

FIRST USE 9-16-2001; IN COMMERCE 6-18-2010.  
DANNEAN HETZEL, EXAMINING ATTORNEY

**CLASS 9—(Continued).**

SN 85-218,668. LINDA SEARLES, ANNADALE, NJ. FILED 1-15-2011.

# Baby Power

THE MARK CONSISTS OF STANDARD CHARACTERS WITHOUT CLAIM TO ANY PARTICULAR FONT, STYLE, SIZE, OR COLOR.

OWNER OF U.S. REG. NOS. 1,631,411 AND 1,634,438.  
FOR COMPACT DISCS FEATURING CHILDREN'S STORIES AND MUSIC (U.S. CLS. 21, 23, 26, 36 AND 38).  
FIRST USE 1-5-2005; IN COMMERCE 1-5-2005.  
SANI KHOURI, EXAMINING ATTORNEY

SN 85-218,854. INDIANA INTEGRATED CIRCUITS, LLC, AKA IIC, SOUTH BEND, IN. FILED 1-16-2011.

# Quilt Packaging

THE MARK CONSISTS OF STANDARD CHARACTERS WITHOUT CLAIM TO ANY PARTICULAR FONT, STYLE, SIZE, OR COLOR.

NO CLAIM IS MADE TO THE EXCLUSIVE RIGHT TO USE "PACKAGING", APART FROM THE MARK AS SHOWN.

FOR AMPLIFIER FOR WIRELESS COMMUNICATIONS; ANTENNAS FOR WIRELESS COMMUNICATIONS APPARATUS; BROADBAND WIRELESS EQUIPMENT, NAMELY, TELECOMMUNICATIONS BASE STATION EQUIPMENT FOR CELLULAR AND FIXED NETWORKING AND COMMUNICATIONS APPLICATIONS; CHIP CARRIERS, NAMELY, SEMICONDUCTOR CHIP HOUSINGS; CIRCUIT TESTERS; COMPUTER CHIPS; COMPUTER HARDWARE FOR WIRELESS CONTENT DELIVERY; COMPUTER HARDWARE, NAMELY, WIRELESS ACCESS POINT (WAP) DEVICES; COMPUTER HARDWARE, NAMELY, WIRELESS NETWORK EXTENDERS; COMPUTER HARDWARE, NAMELY, WIRELESS NETWORK REPEATERS; CONNECTORS FOR ELECTRONIC CIRCUITS; DESIGN LIBRARIES, NAMELY, DOWNLOADABLE ELECTRONIC DATA FILES FOR USE IN INTEGRATED CIRCUIT AND SEMICONDUCTOR DESIGN; DEVICES FOR WIRELESS RADIO TRANSMISSION; ELECTRIC AND ELECTRONIC CIRCUITS; ELECTRICAL CIRCUIT BOARDS; ELECTRONIC CHIPS FOR THE MANUFACTURER OF INTEGRATED CIRCUITS; ELECTRONIC CIRCUITS; ELECTRONIC INTEGRATED CIRCUITS; INTEGRATED CIRCUIT HANDLERS, NAMELY, MA-

**CLASS 9—(Continued).**

CHINES FOR TESTING INTEGRATED CIRCUITS; INTEGRATED CIRCUIT MODULE; INTEGRATED CIRCUIT MODULES; INTEGRATED CIRCUITS; INTEGRATED CIRCUITS AND INTEGRATED CIRCUIT CORES FOR USE IN WIRELESS COMMUNICATIONS AND WIRELESS COMMUNICATION EQUIPMENT AND APPARATUS AND DIGITAL SIGNAL PROCESSORS (DSP); LARGE SCALE INTEGRATED CIRCUITS; PRINTED CIRCUIT BOARDS; PRINTED CIRCUIT BOARDS (PCBS); PROBES FOR TESTING INTEGRATED CIRCUITS; RADAR; RADAR RECEIVERS WITH AMPLIFIERS; SATELLITE AND MICROWAVE COMMUNICATIONS APPARATUS TO TRANSMIT COMMUNICATIONS FROM A VEHICLE TO ANOTHER VEHICLE, OR FROM A VEHICLE TO A SATELLITE; SEMICONDUCTOR CHIPS; SEMICONDUCTOR DEVICES; SEMICONDUCTOR POWER ELEMENTS; SEMICONDUCTORS; SILICON CHIPS; SUPERCOMPUTERS; VERY LARGE SCALE INTEGRATION (VLSI) SEMICONDUCTOR INTEGRATED CIRCUITS; WIRELESS BROADBAND RADIOS (U.S. CLS. 21, 23, 26, 36 AND 38).

KAPIL BHANOT, EXAMINING ATTORNEY

SN 85-219,280. GTFM, INC., NEW YORK, NY. FILED 1-17-2011.

# FB

THE MARK CONSISTS OF STANDARD CHARACTERS WITHOUT CLAIM TO ANY PARTICULAR FONT, STYLE, SIZE, OR COLOR.

OWNER OF U.S. REG. NOS. 2,065,987, 3,165,612 AND OTHERS.

FOR COMPACT DISCS FEATURING MUSIC; DIGITAL MEDIA, NAMELY, PRE-RECORDED VIDEO CASSETTES, DIGITAL VIDEO DISCS, DIGITAL VERSATILE DISCS, DOWNLOADABLE AUDIO AND VIDEO RECORDINGS, DVDS, AND HIGH DEFINITION DIGITAL DISCS FEATURING MUSICAL PERFORMANCES; DVDS FEATURING MUSICAL PERFORMANCES; EYEGLASS FRAMES; MUSICAL SOUND RECORDINGS; SPECTACLES; SUNGLASSES (U.S. CLS. 21, 23, 26, 36 AND 38).

JOSETTE BEVERLY, EXAMINING ATTORNEY

SN 85-220,373. AKEMANN, PETER, MARINA DEL REY, CA. FILED 1-18-2011.

# PWND

THE MARK CONSISTS OF STANDARD CHARACTERS WITHOUT CLAIM TO ANY PARTICULAR FONT, STYLE, SIZE, OR COLOR.

FOR INTERACTIVE VIDEO GAME PROGRAMS; VIDEO GAME SOFTWARE; VIDEO GAME CARTRIDGES AND DISCS; DOWNLOADABLE COMPUTER GAME PROGRAMS (U.S. CLS. 21, 23, 26, 36 AND 38).

KRISTINA MORRIS, EXAMINING ATTORNEY



**CLASS 9—(Continued).**

SN 85-220,419. LANGE, POUL, NEW YORK, NY. FILED 1-18-2011.

**Woody, Clay & Eye**

THE MARK CONSISTS OF STANDARD CHARACTERS WITHOUT CLAIM TO ANY PARTICULAR FONT, STYLE, SIZE, OR COLOR.

FOR COMPUTER APPLICATION SOFTWARE FOR MOBILE PHONES, NAMELY, SOFTWARE FOR PROVIDING PICTURE BOOKS AND STORIES FOR CHILDREN (U.S. CLS. 21, 23, 26, 36 AND 38).

DEIRDRE ROBERTSON, EXAMINING ATTORNEY

---

SN 85-220,483. DEXIM SANTOM USA INC., ONTARIO, CA. FILED 1-18-2011.



THE MARK CONSISTS OF LETTERS "VISIBLE G" IN BLACK AND IN UPPERCASE AND A TORCH ON THE RIGHT SIDE OF THE LETTER "G" IN WHICH THE LETTER "S" IS DESIGNED AS AN EYE.

FOR BATTERY CHARGE DEVICES; BATTERY CHARGERS; CELL PHONE BATTERY CHARGERS; CHARGERS FOR BATTERIES (U.S. CLS. 21, 23, 26, 36 AND 38). FIRST USE 12-31-2010; IN COMMERCE 12-31-2010.

MARK T. MULLEN, EXAMINING ATTORNEY

---

SN 85-221,131. ASICSERVE, LTD., MODIIN, ISRAEL, FILED 1-19-2011.

**BOOSTAR**

THE MARK CONSISTS OF STANDARD CHARACTERS WITHOUT CLAIM TO ANY PARTICULAR FONT, STYLE, SIZE, OR COLOR.

FOR COMPUTER SOFTWARE FOR USE IN DESIGNING SILICONE CHIPS (U.S. CLS. 21, 23, 26, 36 AND 38). AMY HELLA, EXAMINING ATTORNEY

**CLASS 9—(Continued).**

SN 85-221,161. ASICSERVE, LTD., MODIIN, ISRAEL, FILED 1-19-2011.

**WAVSTAR**

THE MARK CONSISTS OF STANDARD CHARACTERS WITHOUT CLAIM TO ANY PARTICULAR FONT, STYLE, SIZE, OR COLOR.

FOR COMPUTER SOFTWARE FOR USE IN DESIGNING SILICONE CHIPS (U.S. CLS. 21, 23, 26, 36 AND 38). AMY HELLA, EXAMINING ATTORNEY

---

SN 85-221,206. KANEKA CORPORATION, OSAKA, JAPAN, FILED 1-19-2011.



THE COLOR(S) BLUE IS/ARE CLAIMED AS A FEATURE OF THE MARK.

THE MARK CONSISTS OF TWO CONCENTRIC CIRCLES IN SHADES OF BLUE.

FOR LABORATORY APPARATUS AND INSTRUMENTS, NAMELY, PRE-PACKED COLUMNS FOR USE IN CELL SEPARATION AND PURIFICATION (U.S. CLS. 21, 23, 26, 36 AND 38).

LINDA M. KING, EXAMINING ATTORNEY

**CLASS 9—(Continued).**

SN 85-224,143. DISCOVERY COMMUNICATIONS, LLC, SILVER SPRING, MD. FILED 1-24-2011.

**FLYING WILD ALASKA**

THE MARK CONSISTS OF STANDARD CHARACTERS WITHOUT CLAIM TO ANY PARTICULAR FONT, STYLE, SIZE, OR COLOR.

NO CLAIM IS MADE TO THE EXCLUSIVE RIGHT TO USE "ALASKA", APART FROM THE MARK AS SHOWN.

FOR PRERECORDED AUDIOVISUAL RECORDINGS, AUDIOTAPES, VIDEO DISCS, COMPACT DISCS, DVDS AND MULTIMEDIA SOFTWARE RECORDED ON CD-ROM, ALL FEATURING SUBJECTS OF GENERAL HUMAN INTEREST; ELECTRONIC LEARNING GAMES IN THE NATURE OF ELECTRONIC GAME SOFTWARE FOR EDUCATIONAL PURPOSES; VIDEO GAME DISCS; COMPUTER GAME DISCS; ELECTRONIC GAME PROGRAMS; DOWNLOADABLE RING TONES, GRAPHICS, RING BACKS, ANIMATED RINGERS, VIDEO RINGERS AND ANIMATED SCREENSAVERS; DOWNLOADABLE PRERECORDED VIDEO CLIPS, PRERECORDED AUDIO CLIPS, TEXT AND GRAPHICS HELD IN ELECTRONIC PERSONAL COMPUTERS AND HANDHELD WIRELESS DEVICES, ALL FEATURING SUBJECTS OF GENERAL HUMAN INTEREST; SUNGLASSES (U.S. CLS. 21, 23, 26, 36 AND 38).

MATTHEW MCDOWELL, EXAMINING ATTORNEY

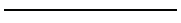

SN 85-226,692. CLARICENT, INC., ACTON, MA. FILED 1-26-2011.



THE COLOR(S) DARK BLUE AND LIGHT BLUE IS/ARE CLAIMED AS A FEATURE OF THE MARK.

THE MARK CONSISTS OF THE WORD "BLADE" IN DARK BLUE LETTERING, THE WORD "ROCKET" IN LIGHT BLUE LETTERING, THE PHRASE "THE POWER TO EXPLORE" IN DARK BLUE LETTERING, AND THE IMAGE OF A ROCKET WITH A CURVED LINE IN LIGHT BLUE.

FOR COMPUTER HARDWARE PERIPHERAL DEVICE FOR USE IN ACCELERATING DATA RETRIEVAL (U.S. CLS. 21, 23, 26, 36 AND 38).

DANIEL CAPSHAW, EXAMINING ATTORNEY

**CLASS 9—(Continued).**

SN 85-228,030. MAD DOGG ATHLETICS, INC., VENICE, CA. FILED 1-27-2011.

**FITCORE**

THE MARK CONSISTS OF STANDARD CHARACTERS WITHOUT CLAIM TO ANY PARTICULAR FONT, STYLE, SIZE, OR COLOR.

FOR PRERECORDED AUDIO AND VIDEO RECORDINGS, NAMELY, CDS, DVDS, AND AUDIO AND VIDEO CASSETTES FEATURING EXERCISE AND GENERAL PHYSICAL FITNESS INSTRUCTION (U.S. CLS. 21, 23, 26, 36 AND 38).

CHERYL CLAYTON, EXAMINING ATTORNEY

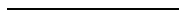

SN 85-230,592. SAMSUNG OPTO-ELECTRONICS AMERICA, INC., DBA SAMSUNG TECHWIN AMERICA, RIDGEFIELD PARK, NJ. FILED 1-31-2011.

**OMNIVIEW**

THE MARK CONSISTS OF STANDARD CHARACTERS WITHOUT CLAIM TO ANY PARTICULAR FONT, STYLE, SIZE, OR COLOR.

FOR BABY MONITORS (U.S. CLS. 21, 23, 26, 36 AND 38).

KIMBERLY PERRY, EXAMINING ATTORNEY

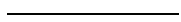

SN 85-231,569. CARTER, SHAWN, NEW YORK, NY. FILED 2-1-2011.

**AKA SHAWN CARTER**

THE MARK CONSISTS OF STANDARD CHARACTERS WITHOUT CLAIM TO ANY PARTICULAR FONT, STYLE, SIZE, OR COLOR.

THE NAME(S), PORTRAIT(S), AND/OR SIGNATURE(S) SHOWN IN THE MARK IDENTIFIES "SHAWN CARTER", WHOSE CONSENT(S) TO REGISTER IS MADE OF RECORD.

FOR EYEWEAR, NAMELY, SUNGLASSES, EYEGLASSES AND THEIR STRUCTURAL PARTS AND CASES (U.S. CLS. 21, 23, 26, 36 AND 38).

MATTHEW EINSTEIN, EXAMINING ATTORNEY

**CLASS 9—(Continued).**

SN 85-232,111. SUMMER INFANT (USA), INC., WOONSOCKET, RI. FILED 2-2-2011.

# PEEK

THE MARK CONSISTS OF STANDARD CHARACTERS WITHOUT CLAIM TO ANY PARTICULAR FONT, STYLE, SIZE, OR COLOR.

FOR BABY MONITORS; ELECTRICAL CONNECTIONS FOR NETWORK ROUTERS USED TO STREAM BABY MONITOR DISPLAYS OVER THE INTERNET AND BABY MONITORS, SOLD AS A UNIT (U.S. CLS. 21, 23, 26, 36 AND 38).

JUDITH HELFMAN, EXAMINING ATTORNEY

SN 85-233,196. LINEAR TECHNOLOGY CORPORATION, MILPITAS, CA. FILED 2-3-2011.

# LTPOE++

THE MARK CONSISTS OF STANDARD CHARACTERS WITHOUT CLAIM TO ANY PARTICULAR FONT, STYLE, SIZE, OR COLOR.

FOR SEMICONDUCTOR CHIPS, NAMELY, POWER-OVER-ETHERNET CHIPS (U.S. CLS. 21, 23, 26, 36 AND 38).

RONALD DELGIZZI, EXAMINING ATTORNEY

SN 85-235,361. KLIPSCH GROUP, INC., INDIANAPOLIS, IN. FILED 2-7-2011.

# ENERGY POWER

THE MARK CONSISTS OF STANDARD CHARACTERS WITHOUT CLAIM TO ANY PARTICULAR FONT, STYLE, SIZE, OR COLOR.

FOR LOUDSPEAKERS, SUBWOOFERS, COMPUTER SPEAKERS, HEADPHONES, SPEAKER DOCKS (U.S. CLS. 21, 23, 26, 36 AND 38).

DANIEL CAPSHAW, EXAMINING ATTORNEY

**CLASS 9—(Continued).**

SN 85-236,970. E2INTERACTIVE, INC., DBA E2INTERACTIVE, INC., ATLANTA, GA. FILED 2-8-2011.

# Global Direct

THE MARK CONSISTS OF STANDARD CHARACTERS WITHOUT CLAIM TO ANY PARTICULAR FONT, STYLE, SIZE, OR COLOR.

NO CLAIM IS MADE TO THE EXCLUSIVE RIGHT TO USE "GLOBAL", APART FROM THE MARK AS SHOWN.

FOR PREPAID PHONE CALLING CARD WITH MAGNETIC ENCODING (U.S. CLS. 21, 23, 26, 36 AND 38).

FIRST USE 10-11-2002; IN COMMERCE 10-11-2002.

SAMUEL E. SHARPER JR., EXAMINING ATTORNEY

SN 85-237,448. DOW AGROSCIENCES LLC, INDIANAPOLIS, IN. FILED 2-9-2011.

# FIELD REF

THE MARK CONSISTS OF STANDARD CHARACTERS WITHOUT CLAIM TO ANY PARTICULAR FONT, STYLE, SIZE, OR COLOR.

FOR COMPUTER APPLICATION SOFTWARE FOR PORTABLE MEDIA PLAYERS OR HANDHELD COMPUTERS, NAMELY, SOFTWARE FOR PRODUCT LABELS, PRODUCT USE GUIDES, AND PEST IDENTIFICATION FOR AGRICULTURAL RICE CONSULTANTS (U.S. CLS. 21, 23, 26, 36 AND 38).

ANNE E. GUSTASON, EXAMINING ATTORNEY

SN 85-238,626. CLARICENT, INC., ACTON, MA. AND NORTH STAR GEOGRAPHICS, LLC, ST. PAUL, MN. FILED 2-10-2011.



NO CLAIM IS MADE TO THE EXCLUSIVE RIGHT TO USE "GEO", APART FROM THE MARK AS SHOWN.

THE COLOR(S) BROWN, BLUE, GREEN AND WHITE IS/ARE CLAIMED AS A FEATURE OF THE MARK.

THE MARK CONSISTS OF THE WORD "GEO" IN BROWN LETTERING AND THE WORD "CRUNCHER" IN BLUE LETTERING, SUPERIMPOSED OVER AN IMAGE OF A GLOBE WITH GREEN OCEANS AND WHITE CONTINENTS, ENCIRCLED BY A BLUE COG.

FOR COMPUTER SOFTWARE FOR PERFORMING GEOSPATIAL ANALYTICS (U.S. CLS. 21, 23, 26, 36 AND 38).

DANIEL CAPSHAW, EXAMINING ATTORNEY

**CLASS 9—(Continued).**

SN 85-238,628. CLARICENT, INC., ACTON, MA. AND NORTH STAR GEOGRAPHICS, LLC, ST. PAUL, MN. FILED 2-10-2011.

Because where matters.

THE MARK CONSISTS OF STANDARD CHARACTERS WITHOUT CLAIM TO ANY PARTICULAR FONT, STYLE, SIZE, OR COLOR.  
FOR COMPUTER SOFTWARE FOR PERFORMING GEOSPATIAL ANALYTICS (U.S. CLS. 21, 23, 26, 36 AND 38).  
DANIEL CAPSHAW, EXAMINING ATTORNEY

SN 85-239,031. NEWPORT CORPORATION, IRVINE, CA. FILED 2-10-2011.

**INSIGHT**

THE MARK CONSISTS OF STANDARD CHARACTERS WITHOUT CLAIM TO ANY PARTICULAR FONT, STYLE, SIZE, OR COLOR.  
FOR LASERS FOR NON-MEDICAL PURPOSES (U.S. CLS. 21, 23, 26, 36 AND 38).  
ROBIN CHOSID, EXAMINING ATTORNEY

SN 85-240,002. ALPINE HOLDING B.V., 3789 AL SOESTERBERG, NETHERLANDS, FILED 2-11-2011.

ALPINE HEARING PROTECTION

THE MARK CONSISTS OF STANDARD CHARACTERS WITHOUT CLAIM TO ANY PARTICULAR FONT, STYLE, SIZE, OR COLOR.  
NO CLAIM IS MADE TO THE EXCLUSIVE RIGHT TO USE "HEARING PROTECTION", APART FROM THE MARK AS SHOWN.  
FOR EAR PLUGS FOR SLEEPING; EAR PLUGS FOR SOUNDPROOFING; EAR PLUGS NOT FOR MEDICAL PURPOSES (U.S. CLS. 21, 23, 26, 36 AND 38).  
FIRST USE 7-0-1994; IN COMMERCE 7-0-2000.  
WENDY GOODMAN, EXAMINING ATTORNEY

**CLASS 9—(Continued).**

SN 85-245,643. GIBSON GUITAR CORP., NASHVILLE, TN. FILED 2-18-2011.

**DV DEMON**

THE MARK CONSISTS OF STANDARD CHARACTERS WITHOUT CLAIM TO ANY PARTICULAR FONT, STYLE, SIZE, OR COLOR.  
FOR LOUD SPEAKER SYSTEMS (U.S. CLS. 21, 23, 26, 36 AND 38).  
FRANK LATTUCA, EXAMINING ATTORNEY

SN 85-252,229. HUNTER ENGINEERING COMPANY, BRIDGETON, MO. FILED 2-25-2011.

**HAWKEYE ELITE**

THE MARK CONSISTS OF STANDARD CHARACTERS WITHOUT CLAIM TO ANY PARTICULAR FONT, STYLE, SIZE, OR COLOR.  
OWNER OF U.S. REG. NO. 3,609,433.  
FOR AUTOMOTIVE WHEEL ALIGNMENT SYSTEMS, NAMELY, WHEEL ALIGNMENT SENSORS AND TARGETS FOR DETERMINING WHEEL POSITION AND ORIENTATION INCLUDING BY WAY OF EXAMPLE CASTER, CAMBER AND TOE OF THE WHEEL (U.S. CLS. 21, 23, 26, 36 AND 38).  
FIRST USE 2-15-2011; IN COMMERCE 2-15-2011.  
TARAH HARDY, EXAMINING ATTORNEY

SN 85-252,323. SKECHERS U.S.A., INC. II, MANHATTAN BEACH, CA. FILED 2-25-2011.

SKECHERS FITNESS TRACKER

THE MARK CONSISTS OF STANDARD CHARACTERS WITHOUT CLAIM TO ANY PARTICULAR FONT, STYLE, SIZE, OR COLOR.  
NO CLAIM IS MADE TO THE EXCLUSIVE RIGHT TO USE "FITNESS TRACKER", APART FROM THE MARK AS SHOWN.  
FOR COMPUTER APPLICATION SOFTWARE FOR MOBILE PHONES AND DEVICES, NAMELY, SOFTWARE FOR TRACKING INFORMATION IN THE FIELD OF FITNESS MANAGEMENT (U.S. CLS. 21, 23, 26, 36 AND 38).  
SKYE YOUNG, EXAMINING ATTORNEY

**CLASS 9—(Continued).**

SN 85-254,635. V-MODA, HOLLYWOD, CA. FILED 3-1-2011.

**VENI**

THE MARK CONSISTS OF STANDARD CHARACTERS WITHOUT CLAIM TO ANY PARTICULAR FONT, STYLE, SIZE, OR COLOR.

THE ENGLISH TRANSLATION OF "VENI" IS "I CAME". FOR PERSONAL HEADPHONES FOR USE WITH SOUND TRANSMITTING SYSTEMS EXCLUDING GAMING SYSTEMS (U.S. CLS. 21, 23, 26, 36 AND 38).

TRACY WHITTAKER-BROWN, EXAMINING ATTORNEY

---

SN 85-254,655. V-MODA, HOLLYWOD, CA. FILED 3-1-2011.

**VIDI**

THE MARK CONSISTS OF STANDARD CHARACTERS WITHOUT CLAIM TO ANY PARTICULAR FONT, STYLE, SIZE, OR COLOR.

THE ENGLISH TRANSLATION OF "VIDI" IS "I SAW". FOR PERSONAL HEADPHONES FOR USE WITH SOUND TRANSMITTING SYSTEMS EXCLUDING GAMING SYSTEMS (U.S. CLS. 21, 23, 26, 36 AND 38).

TRACY WHITTAKER-BROWN, EXAMINING ATTORNEY

---

SN 85-254,725. V-MODA, HOLLYWOD, CA. FILED 3-1-2011.

**VICI**

THE MARK CONSISTS OF STANDARD CHARACTERS WITHOUT CLAIM TO ANY PARTICULAR FONT, STYLE, SIZE, OR COLOR.

THE ENGLISH TRANSLATION OF "VICI" IS "I CONQUERED".

FOR PERSONAL HEADPHONES FOR USE WITH SOUND TRANSMITTING SYSTEMS EXCLUDING GAMING SYSTEMS (U.S. CLS. 21, 23, 26, 36 AND 38).

TRACY WHITTAKER-BROWN, EXAMINING ATTORNEY

**CLASS 9—(Continued).**

SN 85-255,612. V-MODA, HOLLYWOD, CA. FILED 3-2-2011.

**VENI, VIDI, VICI**

THE MARK CONSISTS OF STANDARD CHARACTERS WITHOUT CLAIM TO ANY PARTICULAR FONT, STYLE, SIZE, OR COLOR.

THE ENGLISH TRANSLATION OF "VENI, VIDI, VICI" IS "I CAME, I SAW, I CONQUERED".

FOR PERSONAL HEADPHONES FOR USE WITH SOUND TRANSMITTING SYSTEMS EXCLUDING GAMING SYSTEMS (U.S. CLS. 21, 23, 26, 36 AND 38).

TRACY WHITTAKER-BROWN, EXAMINING ATTORNEY

---

SN 85-259,959. HANDMARK, INC., KANSAS CITY, MO. FILED 3-7-2011.

**FRIENDCASTER**

THE MARK CONSISTS OF STANDARD CHARACTERS WITHOUT CLAIM TO ANY PARTICULAR FONT, STYLE, SIZE, OR COLOR.

FOR DOWNLOADABLE SOFTWARE IN THE NATURE OF MOBILE APPLICATIONS FOR USE WITH SMART PHONES, PDA DEVICES, TABLET COMPUTERS AND OTHER PORTABLE HANDHELD DIGITAL ELECTRONIC COMMUNICATION DEVICES, FEATURING THE ACCESS, DELIVERY AND UTILIZATION OF INFORMATION IN THE FIELD OF SOCIAL MEDIA AND INSTANT MESSAGING SERVICES, INCLUDING REAL-TIME DELIVERY OF SOCIAL MEDIA DATA THROUGH ONLINE AND MOBILE DISTRIBUTION CHANNELS, INCLUDING MESSAGES, IMAGES, PHOTOGRAPHS, DOCUMENTS, TEXT AND OTHER DATA RELATED THERETO; COMPUTER SOFTWARE FOR WIRELESS AGGREGATION AND CONTENT DELIVERY; COMPUTER APPLICATION SOFTWARE FOR USE WITH SMART PHONES, PDA DEVICES, TABLET COMPUTERS AND OTHER PORTABLE HANDHELD DIGITAL ELECTRONIC COMMUNICATION DEVICES, NAMELY, SOFTWARE FOR ACCESSING, VIEWING, INTERACTING WITH AND DOWNLOADING SOCIAL MEDIA AND INSTANT MESSAGING CONTENT FROM WEBSITES, SMART PHONES, PDA DEVICES, TABLET COMPUTERS AND OTHER PORTABLE HANDHELD DIGITAL ELECTRONIC COMMUNICATION DEVICES RELATED TO REAL-TIME DELIVERY OF DATA, MESSAGES, IMAGES, PHOTOGRAPHS, DOCUMENTS, TEXT AND OTHER DATA RELATED THERETO, INCLUDING TRANSMISSION OF ELECTRONIC CONTENT IN THE NATURE OF MESSAGES IMAGES, PHOTOGRAPHS, DOCUMENTS, TEXT AND OTHER DATA; COMPUTER APPLICATION SOFTWARE FOR SMART PHONES, PDA DEVICES, TABLET COMPUTERS AND OTHER PORTABLE HANDHELD DIGITAL ELECTRONIC COMMUNICATION DEVICES, NAMELY, SOFTWARE FOR DELIVERY OF IMMEDIATE MESSAGES, TEXT, DATA AND INFORMATION TO ANY SMART PHONES, PDA DEVICES, TABLET COMPUTERS AND OTHER PORTABLE HANDHELD DIGITAL ELECTRONIC COMMUNICATION DEVICES FROM SOCIAL MEDIA AND INSTANT MESSAGING SERVICES (U.S. CLS. 21, 23, 26 AND 38).

REBECCA SMITH, EXAMINING ATTORNEY



**CLASS 10—MEDICAL APPARATUS**

SN 76-703,086. MEDICOOL, INC., TORRANCE, CA. FILED 5-24-2010.

**VAC FILE**

THE MARK CONSISTS OF STANDARD CHARACTERS WITHOUT CLAIM TO ANY PARTICULAR FONT, STYLE, SIZE, OR COLOR.

SEC. 2(F).  
FOR MEDICAL INSTRUMENTS, NAMELY, PODIATRY DRILLS (U.S. CLS. 26, 39 AND 44).  
FIRST USE 0-0-2003; IN COMMERCE 0-0-2003.  
CHRISTINE COOPER, EXAMINING ATTORNEY

SN 77-832,088. BGS MEDICAL PRODUCTS, INC., VENICE, FL. FILED 9-22-2009.

**SQUEEZE TEST**

The GOLD Standard of Fecal Examination

THE MARK CONSISTS OF STANDARD CHARACTERS WITHOUT CLAIM TO ANY PARTICULAR FONT, STYLE, SIZE, OR COLOR.

NO CLAIM IS MADE TO THE EXCLUSIVE RIGHT TO USE "TEST" AND "FECAL EXAMINATION", APART FROM THE MARK AS SHOWN.

FOR VETERINARY DIAGNOSTIC TEST KITS COMPRISING A COLLECTING AND MIXING CONTAINER FOR FECAL MATTER, A UTENSIL FOR MANIPULATING THE FECAL MATTER AND A STRAINER FOR FILTERING THE MATERIAL (U.S. CLS. 26, 39 AND 44).  
DEZMONA MIZELLE, EXAMINING ATTORNEY

SN 77-875,592. ERBE ELEKTROMEDIZIN GMBH, TÜBINGEN 72072, FED REP GERMANY, FILED 11-18-2009.

**ERBECRYO**

THE MARK CONSISTS OF STANDARD CHARACTERS WITHOUT CLAIM TO ANY PARTICULAR FONT, STYLE, SIZE, OR COLOR.

FOR SURGICAL AND MEDICAL APPARATUS AND INSTRUMENTS, NAMELY, CRYOSURGICAL SYSTEMS COMPRISING CRYOSURGICAL PROBES, AN ENERGY/POWER CONSOLE AND SAFETY CONTROLS IN ORDER TO ACCOMPLISH TISSUE DEVILATIZATION, FOR SURGICAL AND MEDICAL PURPOSES (U.S. CLS. 26, 39 AND 44).

SHAILA SETTLES, EXAMINING ATTORNEY

**CLASS 10—(Continued).**

SN 79-080,131. ANN SUMMERS LIMITED, UNITED KINGDOM, FILED 11-10-2009.

**G-PULSE**

THE MARK CONSISTS OF STANDARD CHARACTERS WITHOUT CLAIM TO ANY PARTICULAR FONT, STYLE, SIZE, OR COLOR.

PRIORITY DATE OF 7-13-2009 IS CLAIMED.

OWNER OF INTERNATIONAL REGISTRATION 1032072 DATED 11-10-2009. EXPIRES 11-10-2019.

FOR MASSAGE DEVICES, NAMELY, DEVICES FOR MASSAGING OR VIBRATING PORTIONS OF THE FACE AND BODY AND PACIFIERS FOR MASSAGING THE LIPS; ADULT SEXUAL AIDS FOR ASSISTING IN COPULATION AND MASTURBATION, NAMELY, VIBRATING AND NON-VIBRATING REPRODUCTIONS OF PARTS OF THE MALE AND FEMALE ANATOMIES, NAMELY, PENISES AND VAGINAS; VAGINA STIMULATORS, DILDOS, DONGS, BUTT PLUGS, PENIS EXTENSIONS, RINGS TO BE WORN ABOUT THE PENIS, SLEEVES SOLD AS A UNIT WITH VIBRATORS THAT ARE USED AS SEXUAL AIDS, SLEEVES USED WITH VIBRATORS FOR USE AS SEXUAL AIDS, PENIS EXTENSIONS SOLD AS A UNIT WITH DEVICES FOR MASSAGING OR VIBRATING PORTIONS OF THE FACE AND BODY; ADULT SEXUAL STIMULATION AIDS, NAMELY, NIPPLE CLAMPS, NIPPLE AROUSERS, BODY PROSTHESES, INFLATABLE LIFE-SIZED DOLLS USED IN SEXUAL ACTIVITY, INFLATABLE REPRODUCTIONS OF BODY PARTS USED IN SEXUAL ACTIVITY, ELECTRICAL APPLIANCES FOR MASSAGING THE BODY; ADULT SEXUAL AID KITS COMPRISED OF DEVICES FOR MASSAGING OR VIBRATING PORTIONS OF THE FACE AND BODY AND PACIFIERS FOR MASSAGING THE LIPS, ADULT SEXUAL AIDS FOR ASSISTING IN COPULATION AND MASTURBATION, NAMELY, VIBRATING AND NON-VIBRATING REPRODUCTIONS OF PARTS OF THE MALE AND FEMALE ANATOMIES, NAMELY, PENISES AND VAGINAS, VAGINA STIMULATORS, DILDOS, DONGS, BUTT PLUGS, PENIS EXTENSIONS, RINGS TO BE WORN ABOUT THE PENIS, SLEEVES SOLD AS A UNIT WITH VIBRATORS THAT ARE USED AS SEXUAL AIDS, SLEEVES USED WITH VIBRATORS FOR USE AS SEXUAL AIDS, PENIS EXTENSIONS SOLD AS A UNIT WITH DEVICES FOR MASSAGING OR VIBRATING PORTIONS OF THE FACE AND BODY, ADULT SEXUAL STIMULATION AIDS, NAMELY, NIPPLE CLAMPS, NIPPLE AROUSERS, BODY PROSTHESES, INFLATABLE LIFE-SIZED DOLLS USED IN SEXUAL ACTIVITY, INFLATABLE REPRODUCTIONS OF BODY PARTS USED IN SEXUAL ACTIVITY, ELECTRICAL APPLIANCES FOR MASSAGING THE BODY (U.S. CLS. 26, 39 AND 44).

CHRISTOPHER BUONGIORNO, EXAMINING ATTORNEY

**CLASS 10—(Continued).**

SN 79-084,634. MEMBRANA GMBH, FED REP GERMANY, FILED 6-2-2010.

# IMMULOC

THE MARK CONSISTS OF STANDARD CHARACTERS WITHOUT CLAIM TO ANY PARTICULAR FONT, STYLE, SIZE, OR COLOR.

PRIORITY DATE OF 2-9-2010 IS CLAIMED.

OWNER OF INTERNATIONAL REGISTRATION 1044162 DATED 6-2-2010, EXPIRES 6-2-2020.

FOR MEMBRANES FOR USE IN MEDICAL APPARATUS MADE OF SYNTHETIC OR REGENERATED POLYMERS IN FORM OF FILMS, HOLLOW FIBERS, TUBINGS AND PIPINGS FOR SEPARATION PROCESSES, AS WELL AS BUNDLES OF THE AFORESAID HOLLOW FIBERS, TUBINGS AND PIPINGS IN COMBINATION WITH TEXTILE THREADS; MEDICAL APPARATUS AND INSTRUMENTS, NAMELY, MODULES FOR USE IN MEDICAL APPARATUS EQUIPPED WITH THE AFORESAID MEMBRANES AND BUNDLES, ESPECIALLY HEMODIALYSERS, HEMOFILTRATION MODULES, HEMODIAFILTRATION MODULES, ENDOTOXIN FILTRATION MODULES, PLASMAPHERESIS MODULES, HEMOCONCENTRATION MODULES, MODULES FOR REMOVAL OF TOXINS FROM BLOOD OR BLOOD PLASMA, MODULES FOR REMOVAL OF BLOOD CONSTITUENTS FROM BLOOD OR BLOOD PLASMA, ALL AFOREMENTIONED GOODS INCLUDED IN THIS CLASS (U.S. CLS. 26, 39 AND 44).

RON FAIRBANKS, EXAMINING ATTORNEY

**CLASS 10—(Continued).**

SN 79-091,770. RESEARCH MEDICAL PTY LTD, SORRENTO WA 6020, AUSTRALIA, FILED 12-14-2010.



OWNER OF INTERNATIONAL REGISTRATION 1062912 DATED 12-14-2010, EXPIRES 12-14-2020.

THE MARK CONSISTS OF THE WORDING "VARIVAC" WITH A DROPLET DESIGN APPEARING AS THE DOT IN THE LETTER "I".

FOR SURGICAL AND MEDICAL EQUIPMENT, NAMELY, WOUND DRAINAGE DEVICES (U.S. CLS. 26, 39 AND 44).

REBECCA POVARCHUK, EXAMINING ATTORNEY

SN 79-089,314. ROCHE DIAGNOSTICS GMBH, FED REP GERMANY, FILED 9-29-2010.

# PERFORMA INSIGHT

THE MARK CONSISTS OF STANDARD CHARACTERS WITHOUT CLAIM TO ANY PARTICULAR FONT, STYLE, SIZE, OR COLOR.

PRIORITY DATE OF 6-21-2010 IS CLAIMED.

OWNER OF INTERNATIONAL REGISTRATION 1056581 DATED 9-29-2010, EXPIRES 9-29-2020.

OWNER OF U.S. REG. NOS. 3,223,375, 3,567,986 AND OTHERS.

FOR INSTRUMENTS, DEVICES AND APPARATUS FOR MEDICAL AND DIAGNOSTIC PURPOSES, NAMELY, BLOOD GLUCOSE METERS; LANCET AND LANCET DEVICES, NAMELY, A BLOOD-LETTING DEVICE FOR OBTAINING A CAPILLARY BLOOD SAMPLE; INSULIN PUMPS AND INFUSION SETS (U.S. CLS. 26, 39 AND 44).

TINA BROWN, EXAMINING ATTORNEY

SN 85-001,712. CODE KIT PRO LLC, ERIE, PA. FILED 3-30-2010.



NO CLAIM IS MADE TO THE EXCLUSIVE RIGHT TO USE "PROFESSIONAL RESUSCITATION ORGANIZERS", APART FROM THE MARK AS SHOWN.

THE MARK CONSISTS OF THE STYLIZED WORDS "PEDI-PRO" ADJACENT TO A DESIGN CONSISTING OF SIX RECTANGLES THAT FORM THE PERIMETER OF A HEXAGON. WITHIN THE HEXAGON IS A BROKEN LINE CIRCLE. BELOW THE WORDING "PEDI-PRO" IS A ROW OF RECTANGLES. BELOW THE ROW OF RECTANGLES IS THE WORDING "PROFESSIONAL RESUSCITATION ORGANIZERS".

FOR KITS FOR AMBULANCE AND HOSPITAL USE, FOR PEDIATRIC RESUSCITATIONS, COMPRISED OF MEDICAL SUPPLY ORGANIZERS SPECIALLY ADAPTED FOR HOLDING MEDICAL INSTRUMENTS AND PHARMACEUTICALS FOR USE IN PEDIATRIC RESUSCITATIONS (U.S. CLS. 26, 39 AND 44).

RUDY R. SINGLETON, EXAMINING ATTORNEY

SN 79-090,582. TICKLER EUROPE AB, SWEDEN, FILED 11-19-2010.

# toyfriend

PRIORITY DATE OF 10-29-2010 IS CLAIMED.

OWNER OF INTERNATIONAL REGISTRATION 1060052 DATED 11-19-2010, EXPIRES 11-19-2020.

FOR HANDHELD MASSAGE APPARATUS (U.S. CLS. 26, 39 AND 44).

KATHERINE E. HALMEN, EXAMINING ATTORNEY

**CLASS 10—(Continued).**

SN 85-019,644. ISONIC MEDICAL, S.A.S., PARIS, FRANCE, FILED 4-21-2010.

## isonic Medical

THE MARK CONSISTS OF STANDARD CHARACTERS WITHOUT CLAIM TO ANY PARTICULAR FONT, STYLE, SIZE, OR COLOR.

OWNER OF FRANCE REG. NO. 093653924, DATED 5-30-2009, EXPIRES 5-30-2019.

NO CLAIM IS MADE TO THE EXCLUSIVE RIGHT TO USE "MEDICAL", APART FROM THE MARK AS SHOWN.

FOR SURGICAL, MEDICAL, DENTAL AND VETERINARY DEVICES, EQUIPMENT AND INSTRUMENTS, NAMELY, DEVICES TO MEASURE PRESSURE OR TISSUE PROPERTIES IN HUMANS AND FOR VETERINARY PURPOSES, TONOMETERS, MEDICAL DEVICES THAT MEASURE HUMAN TISSUE CHARACTERISTICS, AND MEDICAL IMAGING APPARATUS AND DEVICES; ARTIFICIAL LIMBS, EYES AND TEETH; MEDICAL INSTRUMENTS, NAMELY, ORTHOPEDIC APPARATUS AND INSTRUMENTS; SUTURE MATERIALS; COMPRESSION STOCKINGS, FEEDING BOTTLES, PACIFIERS, SPECIAL UNIFORMS FOR SURGERY SUITES, MASSAGE APPARATUS AND INSTRUMENTS; ESTHETIC MASSAGE APPARATUS AND INSTRUMENTS; PROSTHESES, NAMELY, JOINT PROSTHESES, BONE PROSTHESES, BREAST PROSTHESES, HIP PROSTHESES, HAIR PROSTHESES, DENTAL PROSTHESES; IMPLANTS CONSISTING OF ARTIFICIAL MATERIALS; MEDICAL OR DENTAL CHAIRS; BEDPANS OR HYGIENIC BASINS FOR MEDICAL USE; SURGICAL CUTLERY; ORTHOPEDIC SHOES (U.S. CLS. 26, 39 AND 44).  
PAUL F. GAST, EXAMINING ATTORNEY

SN 85-036,749. L.A.D. GLOBAL ENTERPRISES, INC., OLATHE, KS. FILED 5-12-2010.

## SCRUBS YOU'LL LOVE

THE MARK CONSISTS OF STANDARD CHARACTERS WITHOUT CLAIM TO ANY PARTICULAR FONT, STYLE, SIZE, OR COLOR.

NO CLAIM IS MADE TO THE EXCLUSIVE RIGHT TO USE "SCRUBS", APART FROM THE MARK AS SHOWN.

FOR APPAREL FOR PROFESSIONALS IN HOSPITAL AND HEALTHCARE INDUSTRIES IN THE NATURE OF MEDICAL WEARING APPAREL, NAMELY, SCRUB TOPS AND SCRUB PANTS (U.S. CLS. 26, 39 AND 44).  
NAPOLEON SHARMA, EXAMINING ATTORNEY

**CLASS 10—(Continued).**

SN 85-046,493. WEBER ORTHOPEDIC INC., AKA HELY & WEBER, SANTA PAULA, CA. FILED 5-24-2010.

## KUHL-SKN

THE MARK CONSISTS OF STANDARD CHARACTERS WITHOUT CLAIM TO ANY PARTICULAR FONT, STYLE, SIZE, OR COLOR.

FOR BRACES FOR LIMBS AND JOINTS, FOR MEDICAL USE (U.S. CLS. 26, 39 AND 44).  
GEORGE LORENZO, EXAMINING ATTORNEY

SN 85-048,313. PATRICK, JAMES E., DARIEN, IL. FILED 5-26-2010.

## LIFTAEM

THE MARK CONSISTS OF STANDARD CHARACTERS WITHOUT CLAIM TO ANY PARTICULAR FONT, STYLE, SIZE, OR COLOR.

FOR PATIENT MOVING DEVICE, NAMELY, A LOW FRICTION PAD FOR SLIDING PATIENTS TO OR FROM A STRETCHER AND BED (U.S. CLS. 26, 39 AND 44).  
FIRST USE 5-30-2005; IN COMMERCE 1-1-2007.  
ROBERT C. CLARK JR., EXAMINING ATTORNEY

SN 85-053,630. PATIENT TRANSFER SYSTEMS, INC., CENTER VALLEY, PA. FILED 6-3-2010.

## AIRPAL

THE MARK CONSISTS OF STANDARD CHARACTERS WITHOUT CLAIM TO ANY PARTICULAR FONT, STYLE, SIZE, OR COLOR.

FOR MEDICAL DEVICES, NAMELY, INFLATABLE PATIENT TRANSFER AND POSITIONING DEVICE (U.S. CLS. 26, 39 AND 44).

FIRST USE 7-17-1984; IN COMMERCE 7-17-1984.  
CYNTHIA SLOAN, EXAMINING ATTORNEY

**CLASS 10—(Continued).**

SN 85-055,826. LOOKOOL,LLC, PELHAM, NY. FILED 6-7-2010.

**PATIENT PAC**

THE MARK CONSISTS OF STANDARD CHARACTERS WITHOUT CLAIM TO ANY PARTICULAR FONT, STYLE, SIZE, OR COLOR.

NO CLAIM IS MADE TO THE EXCLUSIVE RIGHT TO USE "PATIENT", APART FROM THE MARK AS SHOWN.

FOR PATIENT WEAR, NAMELY, PATIENT EXAMINATION GOWNS (U.S. CLS. 26, 39 AND 44).

SEAN CROWLEY, EXAMINING ATTORNEY

---

SN 85-055,837. CORDIS CORPORATION, MIAMI LAKES, FL. FILED 6-7-2010.

**EXOSEAL**

THE MARK CONSISTS OF STANDARD CHARACTERS WITHOUT CLAIM TO ANY PARTICULAR FONT, STYLE, SIZE, OR COLOR.

FOR VASCULAR CLOSURE DEVICES FOR USE IN PATIENTS WHO HAVE UNDERGONE MEDICAL PROCEDURES (U.S. CLS. 26, 39 AND 44).

MICHAEL WIENER, EXAMINING ATTORNEY

---

SN 85-058,529. HOME ACCESS HEALTH CORPORATION, HOFFMAN ESTATES, IL. FILED 6-9-2010.

**MY LAB TEST**

THE MARK CONSISTS OF STANDARD CHARACTERS WITHOUT CLAIM TO ANY PARTICULAR FONT, STYLE, SIZE, OR COLOR.

NO CLAIM IS MADE TO THE EXCLUSIVE RIGHT TO USE "LAB TEST", APART FROM THE MARK AS SHOWN.

FOR FINGERSTICK BLOOD SAMPLE COLLECTION KIT COMPRISED OF A SAMPLE COLLECTION CASSETTE, LANCETS, BANDAGE, GAUZE PAD, PRINTED PATIENT INFORMATION CARD, SAMPLE RETURN POUCH AND RETURN MAILING ENVELOPE (U.S. CLS. 26, 39 AND 44).

ROBIN CHOSID, EXAMINING ATTORNEY

**CLASS 10—(Continued).**

SN 85-060,294. RSB SPINE LLC, CLEVELAND, OH. FILED 6-11-2010.

**BRIDGING FLUSH-FIT**

THE MARK CONSISTS OF STANDARD CHARACTERS WITHOUT CLAIM TO ANY PARTICULAR FONT, STYLE, SIZE, OR COLOR.

NO CLAIM IS MADE TO THE EXCLUSIVE RIGHT TO USE "FLUSH-FIT", APART FROM THE MARK AS SHOWN.

FOR MEDICAL AND SURGICAL APPARATUS AND INSTRUMENTS, NAMELY, ORTHOPEDIC FIXATION DEVICE USED IN ORTHOPEDIC TRANSPLANT AND/OR IMPLANT SURGERY (U.S. CLS. 26, 39 AND 44).

KEVON CHISOLM, EXAMINING ATTORNEY

---

SN 85-061,824. LRC PRODUCTS LIMITED, SLOUGH, ENGLAND, FILED 6-14-2010.

**DISCOVER**

THE MARK CONSISTS OF STANDARD CHARACTERS WITHOUT CLAIM TO ANY PARTICULAR FONT, STYLE, SIZE, OR COLOR.

PRIORITY CLAIMED UNDER SEC. 44(D) ON UNITED KINGDOM APPLICATION NO. 2535520, FILED 12-23-2009, REG. NO. 2535520, DATED 4-16-2010, EXPIRES 12-23-2019.

FOR CONDOMS; MESSAGE APPARATUS AND INSTRUMENTS; ELECTRIC AND BATTERY-OPERATED MESSAGE APPLIANCES FOR SEXUAL STIMULATION, NAMELY, VIBRATING MASSAGERS, BODY MASSAGERS, AND MASSAGERS FOR INTIMATE AREAS; ADULT SEXUAL STIMULATION AIDS AND MARITAL AIDS, NAMELY, VIBRATORS FOR PERSONAL USE, PENIS RINGS, AND RINGS FOR GENITAL STIMULATION; PARTS AND FITTINGS FOR ALL OF THE AFORESAID GOODS (U.S. CLS. 26, 39 AND 44).

STEVEN R. FINE, EXAMINING ATTORNEY

**CLASS 10—(Continued).**

SN 85-068,558. CURETIS AG, HOLZGERLINGEN, FED REP GERMANY, FILED 6-22-2010.

# UNIVERO

THE MARK CONSISTS OF STANDARD CHARACTERS WITHOUT CLAIM TO ANY PARTICULAR FONT, STYLE, SIZE, OR COLOR.

PRIORITY CLAIMED UNDER SEC. 44(D) ON FED REP GERMANY APPLICATION NO. 302010032714, FILED 5-31-2010, REG. NO. 302010032714, DATED 5-31-2010, EXPIRES 5-31-2020.

THE WORDING "UNIVERO" HAS NO MEANING IN A FOREIGN LANGUAGE.

FOR (BASED ON 44(E)) DIAGNOSTIC APPARATUS FOR NUCLEIC ACID DETECTION FOR IDENTIFYING DISEASES; (BASED ON INTENT TO USE) ACCESSORIES FOR DIAGNOSTIC APPARATUS FOR NUCLEIC ACID DETECTION FOR IDENTIFYING DISEASES, NAMELY, MEASUREMENT CARTRIDGES, REAGENT CONTAINERS, SAMPLE CONTAINERS, SAMPLE HANDLING TOOLS AND LIDS (U.S. CLS. 26, 39 AND 44).

JENNIFER VASQUEZ, EXAMINING ATTORNEY

SN 85-068,577. CURETIS AG, HOLZGERLINGEN, FED REP GERMANY, FILED 6-22-2010.

# UNYVERO

THE MARK CONSISTS OF STANDARD CHARACTERS WITHOUT CLAIM TO ANY PARTICULAR FONT, STYLE, SIZE, OR COLOR.

PRIORITY CLAIMED UNDER SEC. 44(D) ON FED REP GERMANY APPLICATION NO. 302010032715, FILED 5-31-2010, REG. NO. 302010032715, DATED 12-10-2010, EXPIRES 5-31-2020.

THE WORDING "UNYVERO" HAS NO MEANING IN A FOREIGN LANGUAGE.

FOR (BASED ON 44(E)) DIAGNOSTIC APPARATUS FOR NUCLEIC ACID DETECTION FOR IDENTIFYING DISEASES; (BASED ON INTENT TO USE) ACCESSORIES FOR DIAGNOSTIC APPARATUS FOR NUCLEIC ACID DETECTION FOR IDENTIFYING DISEASES, NAMELY, MEASUREMENT CARTRIDGES, REAGENT CONTAINERS, SAMPLE CONTAINERS, SAMPLE HANDLING TOOLS AND LIDS (U.S. CLS. 26, 39 AND 44).

JENNIFER VASQUEZ, EXAMINING ATTORNEY

**CLASS 10—(Continued).**

SN 85-070,357. FORMULAWISE, INC., FRISCO, TX. FILED 6-24-2010.

# FORMULAWISE

THE MARK CONSISTS OF STANDARD CHARACTERS WITHOUT CLAIM TO ANY PARTICULAR FONT, STYLE, SIZE, OR COLOR.

FOR BABY BOTTLE FORMULA ADAPTER, NAMELY, SPECIALLY DESIGNED FORMULA DISPENSERS FOR ATTACHMENT TO BABY BOTTLES (U.S. CLS. 26, 39 AND 44).

FIRST USE 4-17-2009; IN COMMERCE 9-21-2009.

JOHN KELLY, EXAMINING ATTORNEY

SN 85-070,738. ORTHOTICS WEST, INC., SPRINGFIELD, MA. FILED 6-24-2010.



NO CLAIM IS MADE TO THE EXCLUSIVE RIGHT TO USE "BOUTIQUE AND GIFTS", APART FROM THE MARK AS SHOWN.

THE MARK CONSISTS OF THE WORDS "THE PINK PETAL BOUTIQUE AND GIFTS" IN A STYLIZED FONT. TO THE LEFT OF THE WORDING IS A DESIGN OF A RIBBON HAVING A MULTI-PETAL FLOWER SUPERIMPOSED THEREON.

FOR MEDICAL SUPPORT PRODUCTS, NAMELY, BREAST PROSTHESES; MASTECTOMY BRAS FOR MEDICAL AND COSMETIC PURPOSES (U.S. CLS. 26, 39 AND 44).

ERNEST SHOSHO, EXAMINING ATTORNEY

SN 85-070,768. ORTHOTICS WEST, INC., SPRINGFIELD, MA. FILED 6-24-2010.

# THE PINK PETAL BOUTIQUE AND GIFTS

THE MARK CONSISTS OF STANDARD CHARACTERS WITHOUT CLAIM TO ANY PARTICULAR FONT, STYLE, SIZE, OR COLOR.

NO CLAIM IS MADE TO THE EXCLUSIVE RIGHT TO USE "BOUTIQUE AND GIFTS", APART FROM THE MARK AS SHOWN.

FOR MEDICAL SUPPORT PRODUCTS, NAMELY, BREAST PROSTHESES; MASTECTOMY BRAS FOR MEDICAL AND COSMETIC PURPOSES (U.S. CLS. 26, 39 AND 44).

ERNEST SHOSHO, EXAMINING ATTORNEY



**CLASS 10—(Continued).**

SN 85-073,188. RE-OWNED.COM, LLC, OKLAHOMA CITY, OK. FILED 6-28-2010.

**RE-OWNED.COM**

THE MARK CONSISTS OF STANDARD CHARACTERS WITHOUT CLAIM TO ANY PARTICULAR FONT, STYLE, SIZE, OR COLOR.

FOR NEW AND PRE-OWNED MEDICAL INSTRUMENTS AND EQUIPMENT FOR SURGICAL PROCEDURES, NAMELY, SURGICAL INSTRUMENTS IN THE NATURE OF ORTHOPEDIC SETS AND ACCESSORIES COMPRISED OF SURGICAL SAWS AND DRILLS; PODIATRY, NEURO, PLASTICS, GENERAL SURGERY, CARDIOVASCULAR AND ENT INSTRUMENT SETS CONSISTING OF FORCEPS, SCISSORS, RETRACTORS AND ASSORTED SPECIALTY TOOLS FOR ORTHOPEDIC AND OTHER SURGICAL PROCEDURES IN THE NATURE OF SURGICAL SCOPES, OSTEOTOMES AND SCALPELS; X-RAY EQUIPMENT, NAMELY, C-ARMS FOR DIAGNOSTIC AND SURGICAL ASSESSMENT; OPERATING ROOM EQUIPMENT, NAMELY, OPERATING TABLES FOR PATIENT POSITIONING FOR PROCEDURES AND STAINLESS STEEL PRODUCTS FOR USE IN SURGERY IN THE NATURE OF PREP TABLES, BASINS AND MAYO STANDS; MONITORS, NAMELY, ANESTHESIA AND BLOOD PRESSURE MACHINES FOR VITAL SIGNS MEASUREMENT; AND FURNISHINGS IN THE NATURE OF TRANSPORT STRETCHERS TO FACILITATE PATIENT CARE (U.S. CLS. 26, 39 AND 44).

EMILY CARLSEN, EXAMINING ATTORNEY

SN 85-089,271. CURETIS AG, 71088 HOLZGERLINGEN, FED REP GERMANY, FILED 7-21-2010.

**TROVERO**

THE MARK CONSISTS OF STANDARD CHARACTERS WITHOUT CLAIM TO ANY PARTICULAR FONT, STYLE, SIZE, OR COLOR.

PRIORITY CLAIMED UNDER SEC. 44(D) ON FED REP GERMANY APPLICATION NO. 302010034450, FILED 6-9-2010, REG. NO. 302010034450, DATED 6-30-2010, EXPIRES 6-9-2020.

THE WORDING "TROVERO" HAS NO MEANING IN A FOREIGN LANGUAGE.

FOR (BASED ON 44(E)) DIAGNOSTIC APPARATUS FOR NUCLEIC ACID DETECTION FOR IDENTIFYING DISEASES; (BASED ON INTENT TO USE) ACCESSORIES FOR DIAGNOSTIC APPARATUS FOR NUCLEIC ACID DETECTION FOR IDENTIFYING DISEASES, NAMELY, MEASUREMENT CARTRIDGES, REAGENT CONTAINERS, SAMPLE CONTAINERS, SAMPLE HANDLING TOOLS AND LIDS (U.S. CLS. 26, 39 AND 44).

JENNIFER VASQUEZ, EXAMINING ATTORNEY

**CLASS 10—(Continued).**

SN 85-101,298. FISHER & PAYKEL HEALTHCARE LIMITED, AUCKLAND 2013, NEW ZEALAND, FILED 8-5-2010.

**VERSAPUFF**

THE MARK CONSISTS OF STANDARD CHARACTERS WITHOUT CLAIM TO ANY PARTICULAR FONT, STYLE, SIZE, OR COLOR.

PRIORITY CLAIMED UNDER SEC. 44(D) ON NEW ZEALAND APPLICATION NO. 827103, FILED 7-12-2010, REG. NO. 827103, DATED 1-13-2011, EXPIRES 1-13-2021.

FOR HUMIDIFICATION APPARATUS FOR MEDICAL PURPOSES; RESPIRATORY APPARATUS AND INSTRUMENTS FOR MEDICAL USE, NAMELY, RESPIRATORS AND ARTIFICIAL RESPIRATORY APPARATUS; MEDICAL APPARATUS FOR THE TREATMENT OF BREATHING DIFFICULTIES; MEDICAL APPARATUS AND EQUIPMENT FOR THE TREATMENT OF RESPIRATORY DISEASES AND CONDITIONS; RESUSCITATION APPARATUS; MEDICAL EQUIPMENT, NAMELY, VOLUME CONTROL METERS AND PRESSURE CONTROL METERS FOR RESUSCITATION APPARATUS; MEDICAL APPARATUS AND INSTRUMENTS DELIVERING MEDICAL GASES AND HUMIDIFICATION THERAPY TO TREAT RESPIRATORY DISEASES AND CONDITIONS; MEDICAL BREATHING TUBES USED IN THE DELIVERY OF AIR AND GASES TO AND AWAY FROM PATIENTS; FACIAL MASKS, ORAL MASKS, NASAL MASKS, NASAL CANNULA, MOUTHPIECES, HEADGEAR, ALL BEING FOR MEDICAL PURPOSES; MEDICAL APPARATUS, NAMELY, BREATHING CIRCUITS; MEDICAL APPARATUS, NAMELY, BREATHING TUBES; TUBING CONNECTORS FOR MEDICAL USE, TUBING FOR MEDICAL USE, HOSES ADAPTED FOR USE WITH MEDICAL RESUSCITATORS, COMPRESSOR MODULES BEING PARTS OF RESUSCITATORS, ALL BEING FOR MEDICAL PURPOSES; PARTS AND FITTINGS FOR ALL THE AFOREMENTIONED GOODS (U.S. CLS. 26, 39 AND 44).

SUSAN RICHARDS, EXAMINING ATTORNEY

SN 85-103,085. GORHAM ENTERPRISES LLC, WESTPORT, CT. FILED 8-9-2010.

**B-CAPLETS**

THE MARK CONSISTS OF STANDARD CHARACTERS WITHOUT CLAIM TO ANY PARTICULAR FONT, STYLE, SIZE, OR COLOR.

FOR MEDICAL DEVICES FOR CONTROLLING OBESITY, NAMELY, MAGNETIC CUBES IN PILL FORM WHICH AFTER INGESTION, REMAIN IN THE STOMACH (U.S. CLS. 26, 39 AND 44).

JERI J. FICKES, EXAMINING ATTORNEY

**CLASS 10—(Continued).**

SN 85-106,992. INTEGRA LIFESCIENCES CORPORATION, PLAINSBORO, NJ. FILED 8-13-2010.

# INTEGRA

THE MARK CONSISTS OF STANDARD CHARACTERS WITHOUT CLAIM TO ANY PARTICULAR FONT, STYLE, SIZE, OR COLOR.

OWNER OF U.S. REG. NOS. 3,673,792, 3,852,085 AND OTHERS.

FOR SURGICAL IMPLANTS COMPRISING ARTIFICIAL MATERIAL; ARTIFICIAL SKIN FOR SURGICAL PURPOSES, EXCLUDING DENTAL IMPLANTS; DURA MATER, BONE, NERVE AND SKIN REGENERATION MATRICES COMPRISED OF ARTIFICIAL MATERIAL, EXCLUDING DENTAL USE; BONE GRAFT SUBSTITUTE AND BONE VOID FILLER COMPRISING ARTIFICIAL MATERIAL, EXCLUDING DENTAL USE; IMPLANTABLE MEDICAL DEVICES TO REGENERATE, REPAIR OR HEAL SKIN, NERVE, BONE, TENDON OR DURA MATER TISSUE; HEMOSTATS, EXCLUDING DENTAL IMPLANTS; SURGICAL IMPLANTS COMPRISING ARTIFICIAL MATERIAL AND ASSOCIATED SURGICAL INSTRUMENT SETS; ORTHOPEDIC IMPLANTS COMPOSED OF ARTIFICIAL MATERIAL; ORTHOPEDIC JOINT IMPLANTS MADE OF ARTIFICIAL MATERIAL, EXCLUDING DENTAL IMPLANTS; MEDICAL DEVICES, NAMELY, SCREWS, PLATES AND PINS FOR ORTHOPEDIC AND SPINAL APPLICATIONS; MEDICAL AND SURGICAL APPARATUS AND INSTRUMENTS, NAMELY, ORTHOPEDIC FIXATION DEVICE USED IN IMPLANT SURGERY; SPINAL IMPLANTS COMPOSED OF ARTIFICIAL MATERIAL; VALVES FOR THE TREATMENT OF HYDRODCEPHALUS; SHUNTS; CATHETERS; DRAINAGE TUBES FOR MEDICAL PURPOSES; EXTERNAL CEREBROSPINAL FLUID DRAINAGE DEVICES; CRANIAL ACCESS SURGICAL DEVICES AND INSTRUMENTS; CRANIAL CLOSURE DEVICES, NAMELY, SCREWS, PLATES, MESH, AND INSTRUMENTS THEREFOR; MEDICAL DEVICES, NAMELY, PATIENT MONITORS AND SENSORS FOR MONITORING AND MEASURING INTRACRANIAL PRESSURE AND TEMPERATURE AND BRAIN OXYGEN LEVEL; NEUROSURGICAL DEVICES AND INSTRUMENTS, NAMELY, SKULL CLAMPS, SKULL PINS, OPERATING TABLE ATTACHMENTS, AND OPERATING TABLE HEADRESTS; SURGICAL ULTRASOUND APPARATUS; MEDICAL APPARATUS, NAMELY, A LOCALIZING RING FOR STEREOTACTIC PROCEDURES TO PINPOINT THE LOCATION OF TUMORS OR ABSCESSES IN THE BRAIN FOR BIOPSY, REMOVAL, AND/OR RADIATION THERAPY; SURGICAL TREATMENT PLANNING APPARATUS, NAMELY, COMPUTERIZED RADIATION THERAPY MACHINES AND RELATED SOFTWARE, WITH COLLIMATORS AND FILM HOLDERS SOLD AS UNIT; ULTRASONIC SURGICAL ASPIRATOR; ELECTRODES FOR MEDICAL USE ON EPILEPSY PATIENTS; ELECTRONIC STIMULATOR FOR CORTICAL TISSUE; BIPOLAR SURGICAL FORCEPS; SURGICAL LOUPES, NAMELY, MAGNIFYING GLASSES THAT FIT ON THE USER'S FACE IN THE MANNER OF EYEGLASSES; SURGICAL ILLUMINATION DEVICES, NAMELY, SURGICAL HEADLIGHTS AND LIGHT SOURCES COMPRISING XENON AND HALOGEN HEADLIGHTS, FIBER OPTIC SURGICAL HEADLIGHT SYSTEMS COMPRISING HEADBAND, LAMP, CABLE, AND LINKAGE; MEDICAL VIDEO CAMERA FOR SURGERIES; DENTAL INSTRUMENTS FOR USE IN ENDODONTIA, ORTHODONTIA AND PERIODONTIA; DENTAL HANDPIECES; SURGICAL AND MEDICAL APPARATUS AND INSTRUMENTS FOR USE IN GENERAL SURGERY, NEUROSURGERY, ORTHOPEDIC SURGERY, SPINAL SURGERY, MICROSURGERY, THORACIC SURGERY, CARDIOVASCULAR SURGERY, DERMATOLOGICAL SURGERY, ORAL SURGERY, PODIATRIC SURGERY, OBSTETRICAL AND GYNECOLOGICAL SURGERY, PLASTIC SURGERY, GASTROINTESTINAL SURGERY, RECONSTRUCTIVE SURGERY, ENDOSCOPIC SURGERY,

**CLASS 10—(Continued).**

OPHTHALMIC SURGERY, EAR AND NASAL SURGERY, THROAT AND LARYNGEAL SURGERY, AND RECTAL AND GENITOR-URINARY SURGERY; MEDICAL APPARATUS AND INSTRUMENTS, NAMELY, RETRACTORS, CLAMPS, FORCEPS, SCISSORS, CURETTES, PROBES, KNIVES, RONGEURS, KERRISONS, SUCTION TUBES, DISSECTORS, ELEVATORS, BURRS, DRILLS, SAWS, HOOKS, SPATULAS, ENDOSCOPES, TROCARS, LAPAROTOMY RINGS, PROBES, DILATORS, BONE CHISELS, BONE GOUGES, OSTEOTOMES, DERMATOMES, MALLETS, AND RASPATORIES; STERILIZATION UNITS FOR MEDICAL PURPOSES, NAMELY, TRAYS AND CONTAINERS; BIOPSY INSTRUMENTS, NAMELY, CURETTES AND FORCEPS; MEDICAL RETRACTORS; MEDICAL INSTRUMENTS FOR CUTTING, DISSECTING, GRASPING, HOLDING, OR RETRACTING TISSUE; ALL OF THE ABOVE EXCLUDING TISSUE EXPANDERS (U.S. CLS. 26, 39 AND 44).

FIRST USE 3-1-1996; IN COMMERCE 3-1-1996.  
IRA J. GOODSaid, EXAMINING ATTORNEY

SN 85-127,986. BECTON, DICKINSON AND COMPANY, FRANKLIN LAKES, NJ. FILED 9-13-2010.



OWNER OF U.S. REG. NOS. 2,510,232, 3,262,341 AND OTHERS.

THE MARK CONSISTS OF A SHADED CIRCLE CONTAINING A SUNBURST DESIGN AND A PARTIAL ARC DESIGN; NEXT TO THE SHADED CIRCLE ARE THE LETTERS "BD" AND THE WORD "HYPAK".

FOR MEDICAL SYRINGES AND SYRINGE COMPONENTS, NAMELY, NEEDLES, PLUNGER RODS, BARRELS, PLASTIC COMPONENTS AND STOPPERS (U.S. CLS. 26, 39 AND 44).

FIRST USE 9-30-2005; IN COMMERCE 9-30-2005.  
MATTHEW EINSTEIN, EXAMINING ATTORNEY

SN 85-161,315. MICROLINE SURGICAL, INC., BEVERLY, MA. FILED 10-26-2010.



OWNER OF U.S. REG. NO. 3,859,352.

NO CLAIM IS MADE TO THE EXCLUSIVE RIGHT TO USE "SURGICAL", APART FROM THE MARK AS SHOWN.

THE MARK CONSISTS OF THE WORDING "MICROLINE SURGICAL" AND A DESIGN PORTION CONSISTING OF A PORTAL DESIGN FOR THE LETTER "O".

FOR SURGICAL APPARATUS AND INSTRUMENTS (U.S. CLS. 26, 39 AND 44).

FIRST USE 9-1-2009; IN COMMERCE 9-1-2009.  
PAULA MAHONEY, EXAMINING ATTORNEY

**CLASS 10—(Continued).**

SN 85-164,643. ORPYX MEDICAL TECHNOLOGIES INC., CALGARY, ALBERTA, CANADA, FILED 10-29-2010.

# ORPYX

THE MARK CONSISTS OF STANDARD CHARACTERS WITHOUT CLAIM TO ANY PARTICULAR FONT, STYLE, SIZE, OR COLOR.

THE WORDING "ORPYX" HAS NO MEANING IN A FOREIGN LANGUAGE.

FOR SENSORY AUGMENTATION DEVICES FOR MEDICAL PURPOSES, NAMELY, SHOE INSOLES, BELT-TYPE BODILY AFFIXATION DEVICES, WRIST BAND-TYPE BODILY AFFIXATION DEVICES, PRESSURE SENSORS, APPARATUS FOR TRANSMISSION OF PRESSURE DATA, APPARATUS FOR RECEPTION OF PRESSURE DATA, STIMULATOR ARRAYS THAT EMIT ELECTRICAL PULSES, GRAPHICAL AND NUMERICAL DISPLAYS OF PRESSURE DATA, AND APPARATUS TO ALERT THE USER BY MEANS OF VIBRATION OR SOUND (U.S. CLS. 26, 39 AND 44).

WARREN L. OLANDRIA, EXAMINING ATTORNEY

SN 85-170,385. WORLDWIDE INNOVATIONS & TECHNOLOGIES, INC., KANSAS CITY, KS. FILED 11-5-2010.

# THE GOLD STANDARD IN RADIATION PROTECTION

THE MARK CONSISTS OF STANDARD CHARACTERS WITHOUT CLAIM TO ANY PARTICULAR FONT, STYLE, SIZE, OR COLOR.

NO CLAIM IS MADE TO THE EXCLUSIVE RIGHT TO USE "RADIATION PROTECTION", APART FROM THE MARK AS SHOWN.

FOR RADIATION PROTECTIVE SURGICAL SHIELDS, FOR MEDICAL USE (U.S. CLS. 26, 39 AND 44).

FIRST USE 10-27-2010; IN COMMERCE 11-15-2010.

SEAN CROWLEY, EXAMINING ATTORNEY

SN 85-172,135. PATTISON, PETER, LONDON, UNITED KINGDOM, FILED 11-9-2010.

# WMC

THE MARK CONSISTS OF STANDARD CHARACTERS WITHOUT CLAIM TO ANY PARTICULAR FONT, STYLE, SIZE, OR COLOR.

FOR ADULT SEXUAL STIMULATION AIDS, NAMELY, TESTICLE WEIGHTS, TESTICLE STRETCHERS, SCROTUM ENLARGERS (U.S. CLS. 26, 39 AND 44).

FIRST USE 6-9-2008; IN COMMERCE 6-9-2008.

FRANK LATTUCA, EXAMINING ATTORNEY

**CLASS 10—(Continued).**

SN 85-181,552. STEREOTAXIS, INC., ST. LOUIS, MO. FILED 11-19-2010.

# VDRIVE

THE MARK CONSISTS OF STANDARD CHARACTERS WITHOUT CLAIM TO ANY PARTICULAR FONT, STYLE, SIZE, OR COLOR.

FOR SYSTEM FOR REMOTELY OPERATING MEDICAL DEVICES, NAMELY, DEVICES THAT REMOTELY ADVANCE AND RETRACT AND/OR REMOTELY ACTUATE MEDICAL DEVICES (U.S. CLS. 26, 39 AND 44).

ALLISON SCHRODY, EXAMINING ATTORNEY

SN 85-188,599. ACE SURGICAL SUPPLY CO., INC., BROCKTON, MA. FILED 12-1-2010.

# MARK

THE MARK CONSISTS OF STANDARD CHARACTERS WITHOUT CLAIM TO ANY PARTICULAR FONT, STYLE, SIZE, OR COLOR.

FOR DENTAL IMPLANTS (U.S. CLS. 26, 39 AND 44).

JULIE VEPPUMTHARA, EXAMINING ATTORNEY

SN 85-188,610. ACE SURGICAL SUPPLY CO., INC., BROCKTON, MA. FILED 12-1-2010.

# miniMARK

THE MARK CONSISTS OF STANDARD CHARACTERS WITHOUT CLAIM TO ANY PARTICULAR FONT, STYLE, SIZE, OR COLOR.

FOR DENTAL IMPLANTS (U.S. CLS. 26, 39 AND 44).

JULIE VEPPUMTHARA, EXAMINING ATTORNEY

**CLASS 10—(Continued).**

SN 85-188,621. ACE SURGICAL SUPPLY CO., INC., BROCKTON, MA. FILED 12-1-2010.

triMARK

THE MARK CONSISTS OF STANDARD CHARACTERS WITHOUT CLAIM TO ANY PARTICULAR FONT, STYLE, SIZE, OR COLOR.

FOR DENTAL IMPLANTS (U.S. CLS. 26, 39 AND 44).  
JULIE VEPPUMTHARA, EXAMINING ATTORNEY

SN 85-188,633. ACE SURGICAL SUPPLY CO., INC., BROCKTON, MA. FILED 12-1-2010.

xMARK

THE MARK CONSISTS OF STANDARD CHARACTERS WITHOUT CLAIM TO ANY PARTICULAR FONT, STYLE, SIZE, OR COLOR.

FOR DENTAL IMPLANTS (U.S. CLS. 26, 39 AND 44).  
JULIE VEPPUMTHARA, EXAMINING ATTORNEY

SN 85-188,647. ACE SURGICAL SUPPLY CO., INC., BROCKTON, MA. FILED 12-1-2010.

iMARK

THE MARK CONSISTS OF STANDARD CHARACTERS WITHOUT CLAIM TO ANY PARTICULAR FONT, STYLE, SIZE, OR COLOR.

FOR DENTAL IMPLANTS (U.S. CLS. 26, 39 AND 44).  
JULIE VEPPUMTHARA, EXAMINING ATTORNEY

**CLASS 10—(Continued).**

SN 85-188,958. NATIONAL DENTEX CORPORATION, NANTICK, MA. FILED 12-2-2010.

EZ FLEX

THE MARK CONSISTS OF STANDARD CHARACTERS WITHOUT CLAIM TO ANY PARTICULAR FONT, STYLE, SIZE, OR COLOR.

NO CLAIM IS MADE TO THE EXCLUSIVE RIGHT TO USE "FLEX", APART FROM THE MARK AS SHOWN.

FOR DENTAL PROSTHETIC APPLIANCES, DENTURES, PARTIAL DENTURES (U.S. CLS. 26, 39 AND 44).  
EDWARD NELSON, EXAMINING ATTORNEY

SN 85-191,376. ELECTROCHEMICAL OXYGEN CONCEPTS, INC., SAN ANTONIO, TX. FILED 12-6-2010.

TRANSCU O2

THE MARK CONSISTS OF STANDARD CHARACTERS WITHOUT CLAIM TO ANY PARTICULAR FONT, STYLE, SIZE, OR COLOR.

NO CLAIM IS MADE TO THE EXCLUSIVE RIGHT TO USE "O2", APART FROM THE MARK AS SHOWN.

FOR MEDICAL DEVICES, NAMELY, LOW-DOSE TISSUE OXYGENATION PORTABLE UNITS FOR PROMOTING WOUND HEALING, SOLD AS A UNIT WITH MEDICAL TUBING, AND PARTS AND ACCESSORIES THEREOF (U.S. CLS. 26, 39 AND 44).

FIRST USE 10-1-2010; IN COMMERCE 10-1-2010.  
EUGENIA MARTIN, EXAMINING ATTORNEY

SN 85-196,201. HARBOR LINEN, LLC, CHERRY HILL, NJ. FILED 12-13-2010.



SmartShield  
by Harbor Linen

OWNER OF U.S. REG. NO. 1,294,096.

THE MARK CONSISTS OF THE WORDS "SMART-SHIELD" WITH THE WORDS BY "HARBOR LINEN" UNDERNEATH. TO THE LEFT IS THE IMAGE OF A GLOBE SITTING ON TOP OF A SQUARE.

FOR INCONTINENCE BED PADS (U.S. CLS. 26, 39 AND 44).

GRETTA YAO, EXAMINING ATTORNEY

**CLASS 10—(Continued).**

SN 85-202,532. FOUNTAIN HEAD MARKETING, SAN ANTONIO, TX. FILED 12-21-2010.



THE MARK CONSISTS OF AN IMAGE OF A CIRCLE CONTAINING AN A DOT WITH THREE CURVED LINES REPRESENTING AUDIO SOUND WAVES TO THE RIGHT OF THE DOT, WITH THE STYLIZED WORD "ROMET" APPEARING TO THE RIGHT OF THE CIRCLE.

THE WORDING "ROMET" HAS NO MEANING IN A FOREIGN LANGUAGE.

FOR MEDICAL APPARATUS, NAMELY, AN ELECTRONIC LARYNX THAT FUNCTIONS AS A SPEECH AID (U.S. CLS. 26, 39 AND 44).

FIRST USE 0-0-2007; IN COMMERCE 0-0-2007.  
FLORENTINA BLANDU, EXAMINING ATTORNEY

**CLASS 10—(Continued).**

SN 85-208,318. ETYMOTIC RESEARCH, INC., ELK GROVE VILLAGE, IL. FILED 12-30-2010.

# ERO SCAN

THE MARK CONSISTS OF STANDARD CHARACTERS WITHOUT CLAIM TO ANY PARTICULAR FONT, STYLE, SIZE, OR COLOR.

NO CLAIM IS MADE TO THE EXCLUSIVE RIGHT TO USE "SCAN", APART FROM THE MARK AS SHOWN.

FOR MEDICAL TESTING DEVICES FOR MEASURING HEARING LOSS IN PATIENTS, NAMELY, AUDIO-METERS (U.S. CLS. 26, 39 AND 44).

FIRST USE 5-1-1999; IN COMMERCE 5-1-1999.  
SAMUEL E. SHARPER JR., EXAMINING ATTORNEY

SN 85-205,273. PATRICK MALONEY, DBA EHEALTHREWARDS, SACRAMENTO, CA. FILED 12-23-2010.

# ehealthrewards

THE MARK CONSISTS OF STANDARD CHARACTERS WITHOUT CLAIM TO ANY PARTICULAR FONT, STYLE, SIZE, OR COLOR.

FOR EXERCISE MACHINES FOR THERAPEUTIC PURPOSES; HEART MONITORS TO BE WORN DURING EXERCISE; PHYSICAL EXERCISE APPARATUS, FOR MEDICAL PURPOSES (U.S. CLS. 26, 39 AND 44).

REGINA DRUMMOND, EXAMINING ATTORNEY

SN 85-210,714. ICONACY ORTHOPEDIC IMPLANTS LLC, WARSAW, IN. FILED 1-5-2011.

# ICONACY

THE MARK CONSISTS OF STANDARD CHARACTERS WITHOUT CLAIM TO ANY PARTICULAR FONT, STYLE, SIZE, OR COLOR.

FOR ORTHOPEDIC PRODUCTS, NAMELY, ORTHOPEDIC JOINT IMPLANTS AND SURGICAL INSTRUMENTS (U.S. CLS. 26, 39 AND 44).

SIMON TENG, EXAMINING ATTORNEY

SN 85-207,734. 3-POINT PRODUCTS, INC., STEVENSVILLE, MD. FILED 12-30-2010.

# GEL MATE

THE MARK CONSISTS OF STANDARD CHARACTERS WITHOUT CLAIM TO ANY PARTICULAR FONT, STYLE, SIZE, OR COLOR.

NO CLAIM IS MADE TO THE EXCLUSIVE RIGHT TO USE "GEL", APART FROM THE MARK AS SHOWN.

FOR SILICONE GEL SHEETING FOR THE TREATMENT OF SCARS (U.S. CLS. 26, 39 AND 44).

FIRST USE 12-31-2008; IN COMMERCE 12-31-2008.  
MARY ROSSMAN, EXAMINING ATTORNEY

SN 85-211,109. UNOMEDICAL A/S, BIRKEROD, DENMARK, FILED 1-5-2011.

# GENTLECATH

THE MARK CONSISTS OF STANDARD CHARACTERS WITHOUT CLAIM TO ANY PARTICULAR FONT, STYLE, SIZE, OR COLOR.

FOR CATHETERS (U.S. CLS. 26, 39 AND 44).  
KIM MONINGHOFF, EXAMINING ATTORNEY



**CLASS 10—(Continued).**

SN 85-213,818. MEDTRONIC, INC., MINNEAPOLIS, MN. FILED 1-10-2011.

## CARELINK EXPRESS

THE MARK CONSISTS OF STANDARD CHARACTERS WITHOUT CLAIM TO ANY PARTICULAR FONT, STYLE, SIZE, OR COLOR.

OWNER OF U.S. REG. NOS. 2,766,910 AND 3,415,031. NO CLAIM IS MADE TO THE EXCLUSIVE RIGHT TO USE "EXPRESS", APART FROM THE MARK AS SHOWN.

FOR MEDICAL APPARATUS AND EQUIPMENT FOR USE IN ELECTRONIC ACQUISITION, CAPTURE, PROCESSING AND TRANSMISSION OF INFORMATION FROM AN IMPLANTED CARDIAC DEVICE (U.S. CLS. 26, 39 AND 44).

SCOTT BIBB, EXAMINING ATTORNEY



SN 85-214,041. SUTUREPRO TECHNOLOGIES, INC., MENLO PARK, CA. FILED 1-10-2011.

## SALAMANDER

THE MARK CONSISTS OF STANDARD CHARACTERS WITHOUT CLAIM TO ANY PARTICULAR FONT, STYLE, SIZE, OR COLOR.

FOR SURGICAL INSTRUMENTS, NAMELY, SUTURE PASSERS (U.S. CLS. 26, 39 AND 44).

HELENE LIWINSKI, EXAMINING ATTORNEY



SN 85-215,220. LOTUS REVOLUTIONS LLC, DBA LOTUS REVOLUTIONS, LYNNWOOD, WA. FILED 1-11-2011.

## Lotus Revolutions

THE MARK CONSISTS OF STANDARD CHARACTERS WITHOUT CLAIM TO ANY PARTICULAR FONT, STYLE, SIZE, OR COLOR.

FOR ADULT SEXUAL STIMULATION AIDS, NAMELY, CLITORAL STIMULATORS (U.S. CLS. 26, 39 AND 44).

FIRST USE 4-12-2010; IN COMMERCE 1-5-2011. CORY BOONE, EXAMINING ATTORNEY

**CLASS 10—(Continued).**

SN 85-215,400. DMI, INC., EUGENE, OR. FILED 1-11-2011.

## DentureMasters

THE MARK CONSISTS OF STANDARD CHARACTERS WITHOUT CLAIM TO ANY PARTICULAR FONT, STYLE, SIZE, OR COLOR.

OWNER OF U.S. REG. NO. 3,351,340. FOR DENTURES (U.S. CLS. 26, 39 AND 44). FIRST USE 12-1-2005; IN COMMERCE 12-1-2005. AISHA CLARKE, EXAMINING ATTORNEY



SN 85-217,152. CANGEMI, CHARLES FRANK, JR., MOORESVILLE, NC. FILED 1-13-2011.

## THE PROPER LENGTH

THE MARK CONSISTS OF STANDARD CHARACTERS WITHOUT CLAIM TO ANY PARTICULAR FONT, STYLE, SIZE, OR COLOR.

FOR ENDOTRACHEAL TUBES (U.S. CLS. 26, 39 AND 44).

EMILY CHUO, EXAMINING ATTORNEY



SN 85-218,223. COMEDICA INCORPORATED, DALLAS, TX. FILED 1-14-2011.

## METAPAP

THE MARK CONSISTS OF STANDARD CHARACTERS WITHOUT CLAIM TO ANY PARTICULAR FONT, STYLE, SIZE, OR COLOR.

OWNER OF U.S. REG. NOS. 3,314,255, 3,364,777 AND 3,879,967.

FOR RESPIRATORY MEDICAL APPARATUS, NAMELY, NEBULIZERS AND PARTS AND ATTACHMENTS THEREFOR (U.S. CLS. 26, 39 AND 44).

APRIL HESIK, EXAMINING ATTORNEY

**CLASS 10—(Continued).**

SN 85-218,268. CONSTITUTION MEDICAL, INC., BOSTON, MA. FILED 1-14-2011.

# DIGIMAC3

THE MARK CONSISTS OF STANDARD CHARACTERS WITHOUT CLAIM TO ANY PARTICULAR FONT, STYLE, SIZE, OR COLOR.

FOR APPARATUS FOR BLOOD ANALYSIS, AND REPLACEMENT PARTS THEREFOR (U.S. CLS. 26, 39 AND 44).

ANDREA K. NADELMAN, EXAMINING ATTORNEY

---

SN 85-218,276. CONSTITUTION MEDICAL, INC., BOSTON, MA. FILED 1-14-2011.

# DIGIMACCC

THE MARK CONSISTS OF STANDARD CHARACTERS WITHOUT CLAIM TO ANY PARTICULAR FONT, STYLE, SIZE, OR COLOR.

FOR APPARATUS FOR BLOOD ANALYSIS, AND REPLACEMENT PARTS THEREFOR (U.S. CLS. 26, 39 AND 44).

ANDREA K. NADELMAN, EXAMINING ATTORNEY

---

SN 85-218,862. IN HINDSIGHT, SAN DIEGO, CA. FILED 1-16-2011.

# In Hindsight - "It's Your Duty to Check Your Booty"

THE MARK CONSISTS OF STANDARD CHARACTERS WITHOUT CLAIM TO ANY PARTICULAR FONT, STYLE, SIZE, OR COLOR.

FOR MEDICAL DIAGNOSTIC APPARATUS FOR DETECTING CANCER (U.S. CLS. 26, 39 AND 44).

KIMBERLY FRYE, EXAMINING ATTORNEY

**CLASS 10—(Continued).**

SN 85-229,705. IDEAL NETWORK TECHNOLOGY (ZHEJIANG) CO., LTD., ZHEJIANG 313100, CHINA, FILED 1-31-2011.

# Blow Boy

THE MARK CONSISTS OF THE STYLIZED WORDS "BLOW BOY" IN BOLD FONT WITH THE INNER CIRCLES OF THE CHARACTERS "O" BEING REPLACED BY STARS.

FOR ABDOMINAL BELTS; APPARATUS FOR PHYSICAL TRAINING FOR MEDICAL USE; CONDOMS; CONTRACEPTIVES; ELECTRIC MASSAGE APPLIANCES, NAMELY, ELECTRIC VIBRATING MASSAGER; FEEDING BOTTLES; GLOVES FOR MASSAGE; MASSAGE APPARATUS; PHYSICAL EXERCISE APPARATUS, FOR MEDICAL PURPOSES; SURGICAL IMPLANTS COMPRISING ARTIFICIAL MATERIAL (U.S. CLS. 26, 39 AND 44).

MICHAEL WIENER, EXAMINING ATTORNEY

---

SN 85-229,708. IDEAL NETWORK TECHNOLOGY (ZHEJIANG) CO., LTD., ZHEJIANG 313100, CHINA, FILED 1-31-2011.

# BLOWTORCH

THE MARK CONSISTS OF THE WORD "BLOWTORCH" WITH THE CHARACTER "O" REPLACED BY A FLAME DESIGN.

THE WORDING "BLOWTORCH" HAS NO MEANING IN A FOREIGN LANGUAGE.

FOR ABDOMINAL BELTS; APPARATUS FOR PHYSICAL TRAINING FOR MEDICAL USE; CONDOMS; CONTRACEPTIVES; ELECTRIC MASSAGE APPLIANCES, NAMELY, ELECTRIC VIBRATING MASSAGER; FEEDING BOTTLES; GLOVES FOR MASSAGE; MASSAGE APPARATUS; PHYSICAL EXERCISE APPARATUS, FOR MEDICAL PURPOSES; SURGICAL IMPLANTS COMPRISING ARTIFICIAL MATERIAL (U.S. CLS. 26, 39 AND 44).

MICHAEL WIENER, EXAMINING ATTORNEY

**CLASS 10—(Continued).**

SN 85-231,183. MEDTRONIC, INC., MINNEAPOLIS, MN. FILED 2-1-2011.

**RESILIA**

THE MARK CONSISTS OF STANDARD CHARACTERS WITHOUT CLAIM TO ANY PARTICULAR FONT, STYLE, SIZE, OR COLOR.

FOR MEDICAL DEVICES USED IN CARDIAC RE-SYNCHRONIZATION AND THE TREATMENT OF HEART FAILURE, NAMELY, IMPLANTABLE DEFIBRILLATORS AND IMPLANTABLE PULSE GENERATORS, COMPONENT PARTS AND FITTINGS THEREFOR (U.S. CLS. 26, 39 AND 44).  
SCOTT BIBB, EXAMINING ATTORNEY

SN 85-231,198. MEDTRONIC, INC., MINNEAPOLIS, MN. FILED 2-1-2011.

**VIVA**

THE MARK CONSISTS OF STANDARD CHARACTERS WITHOUT CLAIM TO ANY PARTICULAR FONT, STYLE, SIZE, OR COLOR.

FOR MEDICAL DEVICES USED IN CARDIAC RE-SYNCHRONIZATION AND THE TREATMENT OF HEART FAILURE, NAMELY, IMPLANTABLE DEFIBRILLATORS AND IMPLANTABLE PULSE GENERATORS, COMPONENT PARTS AND FITTINGS THEREFOR (U.S. CLS. 26, 39 AND 44).  
SCOTT BIBB, EXAMINING ATTORNEY

**CLASS 10—(Continued).**

SN 85-232,108. AGAMATRIX, INC., SALEM, NH. FILED 2-2-2011.

**LUMISTRIP**

THE MARK CONSISTS OF STANDARD CHARACTERS WITHOUT CLAIM TO ANY PARTICULAR FONT, STYLE, SIZE, OR COLOR.

FOR METERS FOR THE MEDICAL PURPOSE OF ELECTROCHEMICAL MONITORING OF ANALYTES IN BIOLOGICAL FLUIDS; METERS FOR THE MEDICAL PURPOSE OF ELECTROCHEMICAL MONITORING OF ANALYTES IN BIOLOGICAL FLUIDS; METERS FOR THE MEDICAL PURPOSE OF ELECTROCHEMICAL MONITORING OF GLUCOSE IN BIOLOGICAL FLUIDS; METERS FOR THE MEDICAL PURPOSE OF ELECTROCHEMICAL MONITORING OF GLUCOSE IN BLOOD; DISPOSABLE TEST STRIPS FOR USE IN CONJUNCTION WITH A METER FOR ELECTROCHEMICAL MONITORING OF ANALYTES IN BIOLOGICAL FLUIDS SOLD IN CONNECTION WITH THE METER AS A KIT; DISPOSABLE TEST STRIPS FOR USE IN CONJUNCTION WITH A METER FOR ELECTROCHEMICAL MONITORING OF GLUCOSE IN BIOLOGICAL FLUIDS SOLD IN CONNECTION WITH THE METER AS A KIT; DISPOSABLE TEST STRIPS FOR USE IN CONJUNCTION WITH A METER FOR ELECTROCHEMICAL MONITORING OF GLUCOSE IN BLOOD SOLD IN CONNECTION WITH THE METER AS A KIT (U.S. CLS. 26, 39 AND 44).  
MARY ROSSMAN, EXAMINING ATTORNEY

SN 85-240,536. GENERAL ELECTRIC COMPANY, SCHE-NECTADY, NY. FILED 2-11-2011.

**GE**

THE MARK CONSISTS OF STANDARD CHARACTERS WITHOUT CLAIM TO ANY PARTICULAR FONT, STYLE, SIZE, OR COLOR.

OWNER OF U.S. REG. NOS. 2,700,341, 3,363,509 AND OTHERS.  
FOR BLOOD GLUCOSE MONITORS, ANALYZERS, AND METERS; BLOOD GLUCOSE MONITORING COMBINATION KITS COMPRISED OF LANCETS, CONTROL SOLUTION, AND TEST STRIPS ALL SOLD AS A UNIT; MEDICAL LANCETS (U.S. CLS. 26, 39 AND 44).  
PAUL F. GAST, EXAMINING ATTORNEY

**CLASS 10—(Continued).**

SN 85-241,246. GENERAL ELECTRIC COMPANY, SCHE-  
NECTADY, NY. FILED 2-14-2011.



OWNER OF U.S. REG. NOS. 1,790,247, 3,336,279 AND  
OTHERS.

THE MARK CONSISTS OF THE STYLIZED LETTERS  
"GE" INSIDE A CIRCLE WITH FOUR CURLICUES.

FOR BLOOD GLUCOSE MONITORS, ANALYZERS,  
AND METERS; BLOOD GLUCOSE MONITORING COM-  
BINATION KITS COMPRISED OF LANCETS, CONTROL  
SOLUTION, AND TEST STRIPS ALL SOLD AS A UNIT;  
MEDICAL LANCETS (U.S. CLS. 26, 39 AND 44).

PAUL F. GAST, EXAMINING ATTORNEY

SN 85-250,217. CONSTITUTION MEDICAL, INC., BOSTON,  
MA. FILED 2-24-2011.

**COMPLETELY DIFFERENT**

THE MARK CONSISTS OF STANDARD CHARACTERS  
WITHOUT CLAIM TO ANY PARTICULAR FONT, STYLE,  
SIZE, OR COLOR.

FOR APPARATUS FOR BLOOD ANALYSIS, AND  
REPLACEMENT PARTS THEREFOR (U.S. CLS. 26, 39  
AND 44).

ANDREA K. NADELMAN, EXAMINING ATTORNEY

SN 85-253,002. CONSTITUTION MEDICAL, INC., BOSTON,  
MA. FILED 2-28-2011.

THE MARK CONSISTS OF THE WORD "BLOODHOUND"  
WITH AN INFINITY SYMBOL USED FOR THE "OO'S".

FOR APPARATUS FOR BLOOD ANALYSIS, AND  
REPLACEMENT PARTS THEREFOR (U.S. CLS. 26, 39  
AND 44).

ANDREA K. NADELMAN, EXAMINING ATTORNEY

**CLASS 11—ENVIRONMENTAL CONTROL AP-  
PARATUS**

SN 76-705,736. JKL COMPONENTS CORPORATION, PACOI-  
MA, CA. FILED 12-20-2010.

# ALUMILINE

THE MARK CONSISTS OF STANDARD CHARACTERS  
WITHOUT CLAIM TO ANY PARTICULAR FONT, STYLE,  
SIZE, OR COLOR.

FOR ELECTRICAL ILLUMINATION DEVICES,  
NAMELY, LED LIGHT FIXTURES AND ACCESSORIES,  
NAMELY, LED LIGHT BARS AND LIGHT BULBS (U.S.  
CLS. 13, 21, 23, 31 AND 34).

FIRST USE 7-0-2010; IN COMMERCE 7-0-2010.  
LAKEISHA LEWIS, EXAMINING ATTORNEY

SN 77-822,887. MANSFIELD PLUMBING PRODUCTS, LLC,  
PERRYSVILLE, OH. FILED 9-9-2009.

# CASCADE

THE MARK CONSISTS OF STANDARD CHARACTERS  
WITHOUT CLAIM TO ANY PARTICULAR FONT, STYLE,  
SIZE, OR COLOR.

FOR TOILETS; URINALS (U.S. CLS. 13, 21, 23, 31 AND  
34).

KATHRYN COWARD, EXAMINING ATTORNEY

SN 77-834,973. ASIA SALES & MARKETING, LLC, MINNE-  
TONKA, MN. FILED 9-25-2009.

SMART  
WHITE LED



NO CLAIM IS MADE TO THE EXCLUSIVE RIGHT TO  
USE "SMART WHITE LED", APART FROM THE MARK AS  
SHOWN.

THE MARK CONSISTS OF THE WORD "SMART"  
PLACED OVER THE WORD "WHITE", WITH THE WORDS  
"SMART" AND "WHITE" BEING PLACED TO THE LEFT OF  
THE DESIGNATION "LED". TO THE RIGHT OF THE  
WORDING THERE IS A FANCIFUL DEPICTION OF A LIT  
"LED" BULB WITH RAYS OF LIGHT.

FOR LED LIGHT BULBS (U.S. CLS. 13, 21, 23, 31 AND  
34).

SUSAN RICHARDS, EXAMINING ATTORNEY

**CLASS 11—(Continued).**

SN 77-890,457. ACS INDUSTRIES, INC., LINCOLN, RI.  
FILED 12-10-2009.

# MAXCAP

THE MARK CONSISTS OF STANDARD CHARACTERS WITHOUT CLAIM TO ANY PARTICULAR FONT, STYLE, SIZE, OR COLOR.

FOR GAS AND LIQUID ENTRAINMENT SCRUBBERS; CHEMICAL PROCESSING MACHINE PARTS, NAMELY, FRACTIONAL DISTILLATION TOWER INTERNAL PARTS, NAMELY, TRAYS, SUPPORT PLATES, AND PACKING MATERIALS OF METAL, PLASTIC, OR CERAMIC FOR USE AS FILLER BODIES IN FRACTIONAL DISTILLATION COLUMNS AND TOWERS DURING CHEMICAL OR PHYSICAL PROCESSES; AND FRACTIONAL DISTILLATION TOWERS AND COLUMNS OF CERAMIC, BRICK OR OTHER NON-CORRO-SIVE MATERIALS (U.S. CLS. 13, 21, 23, 31 AND 34).

FIRST USE 12-31-2007; IN COMMERCE 12-31-2007.  
BARBARA GAYNOR, EXAMINING ATTORNEY

**CLASS 11—(Continued).**

SN 79-079,854. RASCHIG GMBH, FED REP GERMANY,  
FILED 12-23-2009.

# RSP

THE MARK CONSISTS OF STANDARD CHARACTERS WITHOUT CLAIM TO ANY PARTICULAR FONT, STYLE, SIZE, OR COLOR.

PRIORITY DATE OF 7-10-2009 IS CLAIMED.  
OWNER OF INTERNATIONAL REGISTRATION 1031294 DATED 12-23-2009, EXPIRES 12-23-2019.

FOR APPARATUS FOR EXCHANGING HEAT, ENERGY, AND SUBSTANCES, NAMELY, PACKING ELEMENTS AND MOUNTING ELEMENTS FOR DISTILLATION, ABSORPTION, DESORPTION, EXTRACTION AND HEAT TRANSFER, MADE OF METAL, PLASTICS, GLASS, OR CERAMICS AS CUSTOMIZED PARTS FOR MASS SEPARATION COLUMNS AND TOWERS, AND FOR MASS TRANSFER COLUMNS AND TOWERS, AS WELL AS FOR HEAT EXCHANGE COLUMNS AND TOWERS FOR PROCESS ENGINEERING, NAMELY, FOR DISTILLATION, ABSORPTION, DESORPTION, EXTRACTION AND HEAT TRANSFER OF CHEMICALS; STRUCTURAL PARTS OF AFOREMENTIONED GOODS (U.S. CLS. 13, 21, 23, 31 AND 34).  
FRANK LATTUCA, EXAMINING ATTORNEY

SN 77-964,860. MAAX BATH INC., LACHINE (QUÉBEC),  
CANADA, FILED 3-22-2010.

# MAAX SPAS

THE MARK CONSISTS OF STANDARD CHARACTERS WITHOUT CLAIM TO ANY PARTICULAR FONT, STYLE, SIZE, OR COLOR.

PRIORITY CLAIMED UNDER SEC. 44(D) ON CANADA APPLICATION NO. 1461344, FILED 12-2-2009, REG. NO. TMA788,851, DATED 1-27-2011, EXPIRES 1-27-2026.

NO CLAIM IS MADE TO THE EXCLUSIVE RIGHT TO USE "SPAS", APART FROM THE MARK AS SHOWN.

FOR WHIRLPOOL BATHS AND SPAS (U.S. CLS. 13, 21, 23, 31 AND 34).

FIRST USE 8-0-2009; IN COMMERCE 8-0-2009.  
MICHAEL ENGEL, EXAMINING ATTORNEY

SN 79-085,730. NINGBO DELI SANITARY WARE CO., LTD,  
CHINA, FILED 3-29-2010.

# DEXIN

OWNER OF INTERNATIONAL REGISTRATION 1046683 DATED 3-29-2010, EXPIRES 3-29-2020.

OWNER OF U.S. REG. NO. 3,686,203.

THE ENGLISH TRANSLATION OF THE WORD "DEXIN" IN THE MARK IS NEW AND CLEAN.

FOR WATER HEATING INSTALLATIONS, NAMELY, GAS WATER HEATERS, HOT WATER HEATERS; AUTOMATIC WATERING INSTALLATIONS, NAMELY, WATERING MACHINES FOR AGRICULTURAL PURPOSES; IRRIGATION SPRINKLERS; HYDRANTS; HEATING ELEMENTS; HAIR DRYERS; DISINFECTANT APPARATUS, NAMELY, DISH DISINFECTANT APPARATUS FOR INDUSTRIAL PURPOSES; BATH INSTALLATIONS; POCKET WARMERS, NAMELY, NONELECTRIC POCKET WARMERS IN THE NATURE OF CHEMICALLY-ACTIVATED HEATING PACKETS FOR WARMING HANDS, NOT FOR MEDICAL PURPOSES; LAMPS (U.S. CLS. 13, 21, 23, 31 AND 34).

RON FAIRBANKS, EXAMINING ATTORNEY



**CLASS 11—(Continued).**

SN 79-086,750. ZHENG HAI ZHOU, FUJIAN, CHINA, FILED 6-13-2010.

# FINEWELL

OWNER OF INTERNATIONAL REGISTRATION 1049503 DATED 6-13-2010, EXPIRES 6-13-2020.

THE MARK CONSISTS OF THE WORDING "FINEWELL" WITH AN OVAL OVER THE LETTER "W".

FOR LIGHT BULBS; ELECTRIC LIGHT BULBS; ELECTRIC LAMPS; LIGHTING APPARATUS FOR VEHICLES; INCANDESCENT LAMPS; LAMPS; FLUORESCENT LAMP TUBE; ELECTRIC TORCHES FOR LIGHTING (U.S. CLS. 13, 21, 23, 31 AND 34).

MARIAM MAHMOUDI, EXAMINING ATTORNEY

SN 79-086,890. CINIER RADIATEURS SARL, SETE, FRANCE, FILED 8-2-2010.

# CINIER

THE MARK CONSISTS OF STANDARD CHARACTERS WITHOUT CLAIM TO ANY PARTICULAR FONT, STYLE, SIZE, OR COLOR.

OWNER OF INTERNATIONAL REGISTRATION 1049805 DATED 8-2-2010, EXPIRES 8-2-2020.

THE WORD(S) "CINIER" HAS NO MEANING IN A FOREIGN LANGUAGE.

FOR APPARATUS FOR HEATING, VENTILATING AND AIR CONDITIONING BUILDINGS, NAMELY, RADIATORS, AIR CONDITIONING UNITS, ELECTRIC SPACE HEATERS (U.S. CLS. 13, 21, 23, 31 AND 34).

EVELYN BRADLEY, EXAMINING ATTORNEY

SN 79-087,711. DEKEMA DENTAL-KERAMIKÖFEN GMBH, FED REP GERMANY, FILED 8-16-2010.

# Panamat

THE MARK CONSISTS OF STANDARD CHARACTERS WITHOUT CLAIM TO ANY PARTICULAR FONT, STYLE, SIZE, OR COLOR.

OWNER OF INTERNATIONAL REGISTRATION 1052129 DATED 8-16-2010, EXPIRES 8-16-2020.

FOR FURNACES, INCLUDING DENTAL OVENS, AND STRUCTURAL FITTINGS THEREFOR (U.S. CLS. 13, 21, 23, 31 AND 34).

KARANENDRA S. CHHINA, EXAMINING ATTORNEY

**CLASS 11—(Continued).**

SN 79-091,192. SHENZHEN RIFENG ELECTRONICS CO., LTD., CHINA, FILED 11-25-2010.

# lefons

OWNER OF INTERNATIONAL REGISTRATION 1061481 DATED 11-25-2010, EXPIRES 11-25-2020.

THE MARK CONSISTS OF THE STYLIZED WORDS "LEFONS".

FOR LAMPS; LIGHTERS PRIMARILY FOR LIGHTING GRILLS, FIREPLACES AND CANDLES; LANTERNS FOR LIGHTING; DAYLIGHT FLUORESCENT LAMP TUBE; LUMINOUS TUBES FOR LIGHTING; LIGHTING APPARATUS AND INSTALLATIONS, NAMELY, LIGHTING FIXTURES, LIGHTING TRACKS, LIGHTING TUBES; ELECTRIC DEODORIZING UNITS FOR REFRIGERATOR; VENTILATION EQUIPMENT, NAMELY, AIR-CONDITIONING INSTALLATIONS AND APPARATUS; FAUCETS FOR PIPES; BATH FITTINGS, NAMELY, JET NOZZLES FOR BATHTUBS, SHOWER AND BATH CUBICLES, BATHTUBS, TOILETS, BIDETS, SPOUTS FOR AFFIXING ON WALLS FOR BATHS, BASINS, BIDETS (U.S. CLS. 13, 21, 23, 31 AND 34).

JEAN IM, EXAMINING ATTORNEY

SN 85-032,798. LIGHTAIR HOLDING AB, SOLNA, SWEDEN, FILED 5-7-2010.



THE MARK CONSISTS OF A STYLIZED CLOUD AND MOUNTAIN IMAGE WITH THE WORDS "LIGHTAIR" DIRECTLY TO THE RIGHT OF THE CLOUD AND MOUNTAIN IMAGE.

FOR AIR CONDITIONING APPARATUS; AIR COOLING APPARATUS (U.S. CLS. 13, 21, 23, 31 AND 34).

SIMON TENG, EXAMINING ATTORNEY

SN 85-033,147. SAMSON, MARK, LAS VEGAS, NV. FILED 5-7-2010.

# moda

OWNER OF U.S. REG. NO. 3,371,295.

THE MARK CONSISTS OF STYLIZED WORDING "MODA".

THE ENGLISH TRANSLATION OF "MODA" IN THE MARK IS "FASHION".

FOR LED (LIGHT EMITTING DIODE) LIGHTING FIXTURES (U.S. CLS. 13, 21, 23, 31 AND 34).

FIRST USE 9-9-2009; IN COMMERCE 9-9-2009.

BRIAN CALLAGHAN, EXAMINING ATTORNEY

**CLASS 11—(Continued).**

SN 85-063,559. TUFTCO CORPORATION, CHATTANOOGA, TN. FILED 6-15-2010.

# iFINISH

THE MARK CONSISTS OF STANDARD CHARACTERS WITHOUT CLAIM TO ANY PARTICULAR FONT, STYLE, SIZE, OR COLOR.

FOR ELECTRIC AND GAS COATING AND DYE RANGES; CARPET DRYERS; CARPET OVENS; CARPET DYE DECKS; CARPET STEAM ACCUMULATORS (U.S. CLS. 13, 21, 23, 31 AND 34).

SAMUEL E. SHARPER JR., EXAMINING ATTORNEY

SN 85-083,170. EARL KEISLING, RIDGEFIELD, CT. FILED 7-13-2010.

# EHIVE

THE MARK CONSISTS OF STANDARD CHARACTERS WITHOUT CLAIM TO ANY PARTICULAR FONT, STYLE, SIZE, OR COLOR.

FOR MODULAR AIR HANDLING UNITS FOR USE INSIDE MODULAR DATA CENTERS FOR COOLING COMPUTER EQUIPMENT (U.S. CLS. 13, 21, 23, 31 AND 34).

SETH A. RAPPAPORT, EXAMINING ATTORNEY

SN 85-083,179. EARL KEISLING, RIDGEFIELD, CT. FILED 7-13-2010.

# ECOMB

THE MARK CONSISTS OF STANDARD CHARACTERS WITHOUT CLAIM TO ANY PARTICULAR FONT, STYLE, SIZE, OR COLOR.

FOR MODULAR AIR HANDLING UNIT FOR USE INSIDE MODULAR DATA CENTERS FOR COOLING COMPUTER EQUIPMENT (U.S. CLS. 13, 21, 23, 31 AND 34).

SETH A. RAPPAPORT, EXAMINING ATTORNEY

**CLASS 11—(Continued).**

SN 85-090,946. NUVO RESIDENTIAL, LLC, DBA NUVOH2O, SALT LAKE CITY, UT. FILED 7-22-2010.



THE MARK CONSISTS OF STYLIZED LETTERS AND NUMBER, WHERE THE STYLIZED "H2O" PORTION APPEARS ON THE SURFACE OF THE SPHERE.

FOR WATER SOFTENING PRODUCTS AND SYSTEMS, NAMELY, WATER SOFTENING UNITS; WATER FILTERING PRODUCTS AND SYSTEMS, NAMELY, WATER FILTERING UNITS (U.S. CLS. 13, 21, 23, 31 AND 34).

FIRST USE 4-1-2009; IN COMMERCE 4-1-2009.

JOSETTE BEVERLY, EXAMINING ATTORNEY

SN 85-127,532. RAYDAR ENTERPRISE CO., LTD., KAOHSIUNG HSIEN, TAIWAN, FILED 9-11-2010.

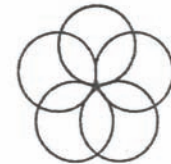

# RAYDAR

THE MARK CONSISTS OF FIVE OVERLAPPING CIRCULAR CONTOURS HAVING A COMMON CENTRAL CONNECTING POINT ALL ABOVE THE WORD "RAYDAR".

FOR LAMPS; LAMP SHADES; LIGHT BULBS; STREET LAMPS (U.S. CLS. 13, 21, 23, 31 AND 34).

FIRST USE 4-2-2007; IN COMMERCE 4-2-2007.

MICHAEL ENGEL, EXAMINING ATTORNEY

SN 85-147,165. SPX CORPORATION, CHARLOTTE, NC. FILED 10-7-2010.



THE MARK CONSISTS OF THE WORDING "COLD-WAVE" WITH A WAVY LINE DESIGN UNDERLINING THE WORDING "COLDWAVE".

FOR COMPRESSED AIR DRYERS AND STRUCTURAL PARTS THEREFOR FOR CONTROLLING THE MOISTURE LEVEL IN INDUSTRIAL AND MANUFACTURING PROCESSES (U.S. CLS. 13, 21, 23, 31 AND 34).

FIRST USE 5-11-2005; IN COMMERCE 5-11-2005.

JOHN GARTNER, EXAMINING ATTORNEY

**CLASS 11—(Continued).**

SN 85-172,889. COMPRESSORWORKS, INC., DALLAS, TX.  
FILED 11-9-2010.

**CLASS 11—(Continued).**

SN 85-182,833. HANSON, MICHAEL BRODY, MINDEN, NV.  
FILED 11-22-2010.

# HeaterWorks

THE MARK CONSISTS OF STANDARD CHARACTERS WITHOUT CLAIM TO ANY PARTICULAR FONT, STYLE, SIZE, OR COLOR.

FOR AUTOMOTIVE HEATERS AND RELATED PARTS, NAMELY, HEATER CORES, WATER OUTLETS WITH AND WITHOUT THERMOSTATS, HEATER VALVES, AND HEATER FITTINGS (U.S. CLS. 13, 21, 23, 31 AND 34).

ANDREA K. NADELMAN, EXAMINING ATTORNEY

# VILLAGER

THE MARK CONSISTS OF STANDARD CHARACTERS WITHOUT CLAIM TO ANY PARTICULAR FONT, STYLE, SIZE, OR COLOR.

FOR WATER FILTERING APPARATUS; WATER FILTERING UNITS FOR DOMESTIC AND COMMERCIAL USE; WATER FILTERS; WATER FILTRATION AND PURIFICATION UNITS AND REPLACEMENT CARTRIDGES AND FILTERS THEREFOR; WATER PURIFICATION AND FILTRATION APPARATUS; WATER PURIFICATION INSTALLATIONS; WATER PURIFICATION MACHINES; WATER PURIFICATION TANKS; WATER PURIFICATION UNITS; WATER PURIFICATION, SEDIMENTATION AND FILTRATION APPARATUS FOR CLARIFICATION, THICKENING AND FILTRATION OF WATER, WASTE WATER AND INDUSTRIAL WATER; WATER PURIFIERS; WATER PURIFYING APPARATUS; WATER PURIFYING UNITS, FOR POTABLE WATER FOR DOMESTIC AND COMMERCIAL USE; WATER STERILISERS; WATER STERILIZERS; WATER TREATMENT APPARATUS, NAMELY, CLARIFICATION AND THICKENING MACHINES FOR USE IN TREATMENT OF LIQUIDS IN THE NATURE OF WATER, WASTE WATER AND INDUSTRIAL WATER; WATER TREATMENT EQUIPMENT, NAMELY, CARTRIDGE FILTRATION UNITS; WATER TREATMENT EQUIPMENT, NAMELY, CHEMICAL STERILIZATION UNITS; WATER TREATMENT EQUIPMENT, NAMELY, REVERSE OSMOSIS FILTRATION UNITS; WATER TREATMENT EQUIPMENT, NAMELY, REVERSE OSMOSIS UNITS; WATER TREATMENT EQUIPMENT, NAMELY, ULTRAVIOLET STERILIZATION UNITS; WATER TREATMENT EQUIPMENT, NAMELY, WATER FILTRATION UNITS; WATER TREATMENT EQUIPMENT, NAMELY, WATER FILTRATION UNITS AND REVERSE OSMOSIS UNITS (U.S. CLS. 13, 21, 23, 31 AND 34).

FIRST USE 1-1-2006; IN COMMERCE 1-1-2006.

ROBERT C. CLARK JR., EXAMINING ATTORNEY

SN 85-181,583. HOTSTART, INC., SPOKANE, WA. FILED 11-19-2010.

# HOTSTART HOTFLOW

THE MARK CONSISTS OF STANDARD CHARACTERS WITHOUT CLAIM TO ANY PARTICULAR FONT, STYLE, SIZE, OR COLOR.

FOR PUMP-DRIVEN ENGINE HEATERS, NAMELY, ELECTRIC HEATERS FOR COMMERCIAL USE (U.S. CLS. 13, 21, 23, 31 AND 34).

SAMUEL E. SHARPER JR., EXAMINING ATTORNEY

**CLASS 11—(Continued).**

SN 85-184,516. ENERSHIELD INDUSTRIES LTD., EDMONTON, ALBERTA, CANADA, FILED 11-24-2010.



NO CLAIM IS MADE TO THE EXCLUSIVE RIGHT TO USE "AIR BARRIERS", APART FROM THE MARK AS SHOWN.

THE MARK CONSISTS OF THE WORDS "ENERSHIELD AIR BARRIERS" WRITTEN ACROSS THE BACKGROUND IMAGE OF A SHIELD.

FOR BLOWER ASSEMBLIES FOR GENERATING AIR CURTAINS AND AIR BARRIERS IN ENTRYWAYS (U.S. CLS. 13, 21, 23, 31 AND 34).

FIRST USE 7-17-2006; IN COMMERCE 8-20-2009.

KATHLEEN LORENZO, EXAMINING ATTORNEY

SN 85-185,917. MASCO BATH CORPORATION, MOORESTOWN, NJ. FILED 11-29-2010.

## ESENCIA

THE MARK CONSISTS OF STANDARD CHARACTERS WITHOUT CLAIM TO ANY PARTICULAR FONT, STYLE, SIZE, OR COLOR.

THE ENGLISH TRANSLATION OF "ESENCIA" IN THE MARK IS AROMA, PERFUME OR DISTINCTIVE ODOR.

FOR BATHTUBS, SOAKING TUBS, SHOWERS, SHOWER ENCLOSURES, SHOWER SURROUNDS, SHOWER BASES, BATHTUB SURROUNDS, AND BATHTUB ENCLOSURES (U.S. CLS. 13, 21, 23, 31 AND 34).

ERIN FALK, EXAMINING ATTORNEY

**CLASS 11—(Continued).**

SN 85-186,761. BEACH 'N OUTBACK LIMITED, MACAU, MACAO, FILED 11-29-2010.

## MARTINI GRILL

THE MARK CONSISTS OF STANDARD CHARACTERS WITHOUT CLAIM TO ANY PARTICULAR FONT, STYLE, SIZE, OR COLOR.

NO CLAIM IS MADE TO THE EXCLUSIVE RIGHT TO USE "GRILL", APART FROM THE MARK AS SHOWN.

FOR ELECTRIC AND/OR FUEL OPERATED COOKING APPARATUS, NAMELY, BARBECUES, GRILLS, AND HIBACHIS (U.S. CLS. 13, 21, 23, 31 AND 34).

TINA MAI, EXAMINING ATTORNEY

SN 85-195,193. HEAT SURGE, LLC, CANTON, OH. FILED 12-10-2010.

## CONVECTA-RED

THE MARK CONSISTS OF STANDARD CHARACTERS WITHOUT CLAIM TO ANY PARTICULAR FONT, STYLE, SIZE, OR COLOR.

FOR ELECTRIC SPACE HEATERS; PORTABLE ELECTRIC HEATERS; ELECTRIC RADIANT HEATERS (U.S. CLS. 13, 21, 23, 31 AND 34).

TRICIA SONNEBORN, EXAMINING ATTORNEY

SN 85-197,596. TACO, INC., CRANSTON, RI. FILED 12-14-2010.

## E-SMART

THE MARK CONSISTS OF STANDARD CHARACTERS WITHOUT CLAIM TO ANY PARTICULAR FONT, STYLE, SIZE, OR COLOR.

FOR HEATING, COOLING AND VENTILATION SYSTEMS AND COMPONENTS COMPRISING WATER PUMPS, CIRCULATORS, AIR ELIMINATION VALVES, THERMOSTATS, ELECTRONIC CONTROLS, ZONE VALVES AND MIXING VALVES (U.S. CLS. 13, 21, 23, 31 AND 34).

FIRST USE 12-1-2010; IN COMMERCE 12-1-2010.

MORGAN WYNNE, EXAMINING ATTORNEY

**CLASS 11—(Continued).**

SN 85-199,950. C2 DEVELOPMENT, INC., AMES, IA. FILED 12-16-2010.

**SOL BLUE**

THE MARK CONSISTS OF STANDARD CHARACTERS WITHOUT CLAIM TO ANY PARTICULAR FONT, STYLE, SIZE, OR COLOR.

NO CLAIM IS MADE TO THE EXCLUSIVE RIGHT TO USE "BLUE", APART FROM THE MARK AS SHOWN.

THE ENGLISH TRANSLATION OF "SOL" IN THE MARK IS SUN.

FOR AQUARIUM LIGHTS (U.S. CLS. 13, 21, 23, 31 AND 34).

FIRST USE 8-2-2010; IN COMMERCE 8-2-2010.  
JOHN KELLY, EXAMINING ATTORNEY

SN 85-201,235. CITY OF GRACE SOLUTIONS LLC, DBA RENOVO DESIGNS, HIGH POINT, NC. FILED 12-18-2010.

**Piedmont Winterfest**

THE MARK CONSISTS OF STANDARD CHARACTERS WITHOUT CLAIM TO ANY PARTICULAR FONT, STYLE, SIZE, OR COLOR.

NO CLAIM IS MADE TO THE EXCLUSIVE RIGHT TO USE "PIEDMONT", APART FROM THE MARK AS SHOWN.

FOR ICE SKATING RINKS (U.S. CLS. 13, 21, 23, 31 AND 34).

FIRST USE 11-17-2010; IN COMMERCE 11-17-2010.  
ASMAT KHAN, EXAMINING ATTORNEY

SN 85-203,441. HOMESELECTS INTERNATIONAL, WINCHESTER, CA. FILED 12-21-2010.

** ENVIROCOOL**

NO CLAIM IS MADE TO THE EXCLUSIVE RIGHT TO USE THE RECYCLING SYMBOL, APART FROM THE MARK AS SHOWN.

THE MARK CONSISTS OF A STYLIZED RECYCLING SYMBOL TO THE LEFT OF THE WORDING "ENVIROCOOL" IN STYLIZED TEXT.

FOR AIR-CONDITIONING, AIR COOLING AND VENTILATION APPARATUS AND INSTRUMENTS, ALL OF THE FOREGOING BEING ENERGY EFFICIENT (U.S. CLS. 13, 21, 23, 31 AND 34).

NANCY CLARKE, EXAMINING ATTORNEY

**CLASS 11—(Continued).**

SN 85-206,194. HUMBAY HEALTH, A DIVISION OF THE NORWEST CO. INC., KIRKLAND, WA. FILED 12-27-2010.

**HumDayHealth**

THE MARK CONSISTS OF THE STYLIZED TEXT "HUMBAY HEALTH"; A HUMMINGBIRD IS PRESENTED AS A DESIGN IN THE LETTER "B".

FOR HUMIDIFIER USED FOR AIRCRAFTS AND IN THE MEDICAL FIELD (U.S. CLS. 13, 21, 23, 31 AND 34).  
NAKIA HENRY, EXAMINING ATTORNEY

SN 85-206,332. WHIRLPOOL PROPERTIES, INC., ST. JOSEPH, MI. FILED 12-28-2010.

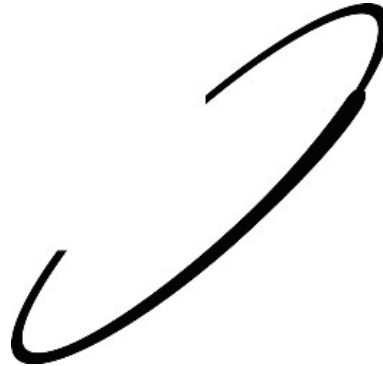

OWNER OF U.S. REG. NOS. 1,832,430, 3,463,701 AND OTHERS.

THE MARK CONSISTS OF A RING.

FOR AIR PURIFIERS; AIR-CONDITIONING APPARATUS; APPARATUS FOR COOKING, NAMELY, COOK-TOPS; BAKING OVENS; CLOTHES DRYERS; DEHUMIDIFIERS FOR HOUSEHOLD USE; ELECTRIC RANGES; ELECTRIC REFRIGERATORS; EXHAUST HOODS FOR KITCHENS; FREEZERS; GAS RANGES; GAS REFRIGERATORS; ICE CHESTS; ICE CUBE MAKING MACHINES; MICROWAVE OVENS; RANGE HOODS; REFRIGERATED BEVERAGE DISPENSING UNITS; WINE COOLERS, NAMELY, REFRIGERATED CABINETS CONTAINING RACKS FOR WINE BOTTLES AND STORAGE SHELVES (U.S. CLS. 13, 21, 23, 31 AND 34).

HELENE LIWINSKI, EXAMINING ATTORNEY



**CLASS 11—(Continued).**

SN 85-206,334. WHIRLPOOL PROPERTIES, INC., ST. JOSEPH, MI. FILED 12-28-2010.

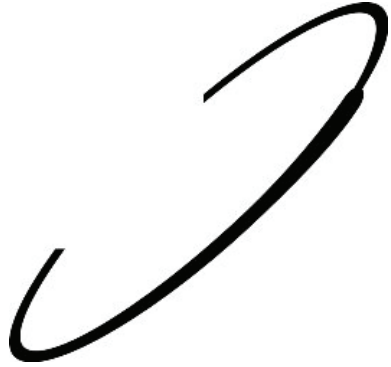

OWNER OF U.S. REG. NOS. 1,832,430, 3,463,701 AND OTHERS.

THE MARK CONSISTS OF A RING.  
FOR ELECTRICALLY OPERATED HOT WATER DISPENSERS, WATER PURIFICATION AND DELIVERY SYSTEMS COMPRISING STAND ALONE WATER CABINETS, BUILT-IN BOTTLED WATER DISPENSING APPARATUS FOR HOT OR CHILLED WATER, DOMESTIC WATER FILTRATION UNITS, REVERSE OSMOSIS UNITS FOR PURIFICATION OF WATER; WATER DISTILLATION UNITS (U.S. CLS. 13, 21, 23, 31 AND 34).  
HELENE LIWINSKI, EXAMINING ATTORNEY

**CLASS 11—(Continued).**

SN 85-206,336. WHIRLPOOL PROPERTIES, INC., ST. JOSEPH, MI. FILED 12-28-2010.

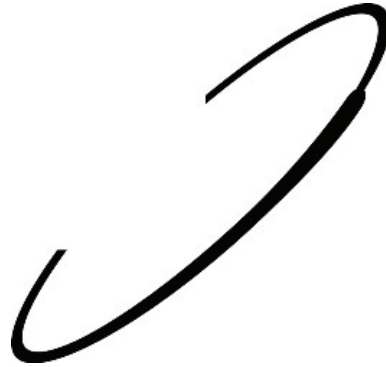

OWNER OF U.S. REG. NOS. 1,832,430, 3,463,701 AND OTHERS.

THE MARK CONSISTS OF A RING.  
FOR WATER CONDITIONING UNITS, WATER SOFTENING DEVICES, WATER COOLERS, WATER CHILLERS, COUNTERTOP WATER FILTRATION DEVICES, HOME WATER FILTRATION DEVICES AND WATER FAUCET FILTERS (U.S. CLS. 13, 21, 23, 31 AND 34).  
HELENE LIWINSKI, EXAMINING ATTORNEY

SN 85-206,335. WHIRLPOOL PROPERTIES, INC., ST. JOSEPH, MI. FILED 12-28-2010.

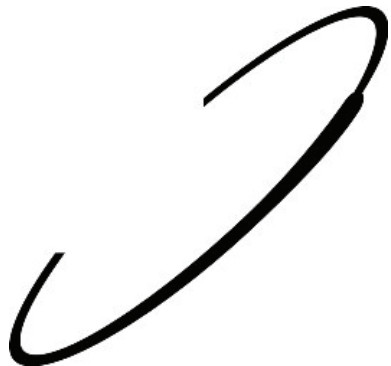

OWNER OF U.S. REG. NOS. 1,832,430, 3,463,701 AND OTHERS.

THE MARK CONSISTS OF A RING.  
FOR GAS WATER HEATERS; WATER HEATERS (U.S. CLS. 13, 21, 23, 31 AND 34).  
HELENE LIWINSKI, EXAMINING ATTORNEY

SN 85-206,417. LUCKY I CREMAS CO., LTD., HYOGO-KEN 658-0023, JAPAN, FILED 12-28-2010.

**HIKARI SIPHON TABLE**

THE MARK CONSISTS OF STANDARD CHARACTERS WITHOUT CLAIM TO ANY PARTICULAR FONT, STYLE, SIZE, OR COLOR.

NO CLAIM IS MADE TO THE EXCLUSIVE RIGHT TO USE "SIPHON TABLE", APART FROM THE MARK AS SHOWN.

THE ENGLISH TRANSLATION OF "HIKARI" IS "LIGHT".

FOR ELECTRIC TABLE TOP COFFEE MAKERS CONTAINING BREWING AND HEATING ELEMENTS FOR USE WITH COFFEE SIPHONS (U.S. CLS. 13, 21, 23, 31 AND 34).

RENEE MCCRAY, EXAMINING ATTORNEY

**CLASS 11—(Continued).**

SN 85-206,555. TAGWIRE SOLUTIONS, INC., CHARLOTTE, NC. FILED 12-28-2010.



THE MARK CONSISTS OF THE STYLIZED TEXT "COLNEK".

FOR WRAP THAT IS USED TO CONTAIN COLD OR HOT PACKS FOR HEATING OR COOLING THE BODY, NOT FOR MEDICAL USE (U.S. CLS. 13, 21, 23, 31 AND 34).

FIRST USE 5-10-2009; IN COMMERCE 5-25-2010.  
KIMBERLY FRYE, EXAMINING ATTORNEY

**CLASS 11—(Continued).**

SN 85-209,739. SOPOGY, INC., HONOLULU, HI. FILED 1-4-2011.



THE MARK CONSISTS OF STANDARD CHARACTERS WITHOUT CLAIM TO ANY PARTICULAR FONT, STYLE, SIZE, OR COLOR.

FOR SOLAR HEAT COLLECTION PANELS (U.S. CLS. 13, 21, 23, 31 AND 34).

GEORGE LORENZO, EXAMINING ATTORNEY

SN 85-206,993. THE MARLEY-WYLAIN COMPANY, MICHIGAN CITY, IN. FILED 12-29-2010.



THE MARK CONSISTS OF STANDARD CHARACTERS WITHOUT CLAIM TO ANY PARTICULAR FONT, STYLE, SIZE, OR COLOR.

FOR HEATING BOILERS (U.S. CLS. 13, 21, 23, 31 AND 34).

LAURIE KAUFMAN, EXAMINING ATTORNEY

SN 85-209,748. SOPOGY, INC., HONOLULU, HI. FILED 1-4-2011.



THE MARK CONSISTS OF STANDARD CHARACTERS WITHOUT CLAIM TO ANY PARTICULAR FONT, STYLE, SIZE, OR COLOR.

FOR SOLAR HEAT COLLECTION PANELS (U.S. CLS. 13, 21, 23, 31 AND 34).

GEORGE LORENZO, EXAMINING ATTORNEY

SN 85-208,617. ALPHA/OMEGA ENVIRONMENTAL, INC., COLORADO SPRINGS, CO. FILED 12-31-2010.



THE MARK CONSISTS OF STANDARD CHARACTERS WITHOUT CLAIM TO ANY PARTICULAR FONT, STYLE, SIZE, OR COLOR.

FOR WATER PURIFICATION AND FILTRATION APPARATUS (U.S. CLS. 13, 21, 23, 31 AND 34).

CARYN GLASSER, EXAMINING ATTORNEY

SN 85-210,148. CHANA, KURT E., ALTAMONTE SPRINGS, FL. FILED 1-4-2011.



THE MARK CONSISTS OF STANDARD CHARACTERS WITHOUT CLAIM TO ANY PARTICULAR FONT, STYLE, SIZE, OR COLOR.

NO CLAIM IS MADE TO THE EXCLUSIVE RIGHT TO USE "PLUMB", APART FROM THE MARK AS SHOWN.

FOR PLUMBING FITTINGS, NAMELY, VALVES (U.S. CLS. 13, 21, 23, 31 AND 34).

DAVID TAYLOR, EXAMINING ATTORNEY

**CLASS 11—(Continued).**

SN 85-210,682. INAX CORPORATION, TOKONAME-SHI, AICHI, JAPAN, FILED 1-5-2011.

# Lafayette

THE MARK CONSISTS OF STANDARD CHARACTERS WITHOUT CLAIM TO ANY PARTICULAR FONT, STYLE, SIZE, OR COLOR.

FOR SHOWER TOILETS AND STRUCTURAL PARTS THEREFOR; TOILET SEATS, INCLUDING TOILET SEATS WITH WASHING WATER SQUIRTER; TOILET BOWLS, INCLUDING TOILET BOWLS EQUIPPED WITH WASHING WATER SQUIRTER; TOILET SEATS FOR HEATING, WASHING AND DRYING BODY PARTS; BIDETS AND REMOTE CONTROLS FOR USE WITH BIDETS, SOLD TOGETHER AS A UNIT; WATER CLOSETS AND REMOTE CONTROLS FOR USE WITH WATER CLOSETS, SOLD TOGETHER AS A UNIT; TOILET TANKS AND STRUCTURAL PARTS THEREFOR; TOILET TANK ASSEMBLIES COMPRISED OF TOILET TANK BOWLS FOR FLUSHING TOILET TANKS; TOILETS AND REMOTE CONTROLS FOR USE WITH TOILETS, SOLD TOGETHER AS A UNIT; TANKS, NAMELY, CISTERN TANKS FOR TOILETS; TOILET TANK BALLS; TAP WATER FAUCETS; FIXED SPOUTS USED DIRECTLY IN BIDETS AND TOILETS; PLUMBING FIXTURES, NAMELY, SHOWER SPRAYERS FOR USE WITH TOILETS AND BIDETS; BIDET NOZZLES; ELECTRIC HAND DRYING APPARATUS FOR WASH-ROOMS, NAMELY, ELECTRIC HAND DRYERS; ELECTRIC WATER WARMER; HOT WATER HEATER USING GAS AND STRUCTURAL PARTS THEREFOR; HOT WATER HEATER USING OIL AND STRUCTURAL PARTS THEREFOR; BASINS AND WASH-HAND BOWLS BEING PARTS OF SANITARY INSTALLATIONS; HANDLES FOR FLUSHING TOILET WATER OPERATED BY REMOTE CONTROL; CONTROL VALVES FOR TOILET FLUSHING WATER; SINKS; BATH FITTINGS, NAMELY, BATH TUBS WITH WASHING PLACE; BATH TUBS WITH BUBBLE GENERATION APPARATUS; SHOWERS; BATH TUBS; BATH UNITS, NAMELY, PREFABRICATED BATH ROOMS CONTAINING A FAUCET, BATH TUB, FLOOR, WALLS, CEILING BOARD AND SHOWER (U.S. CLS. 13, 21, 23, 31 AND 34).

TOBY BULLOFF, EXAMINING ATTORNEY

**CLASS 11—(Continued).**

SN 85-211,862. KEMCO SYSTEMS, INC., CLEARWATER, FL. FILED 1-6-2011.



NO CLAIM IS MADE TO THE EXCLUSIVE RIGHT TO USE "CLEAN WATER", APART FROM THE MARK AS SHOWN.

THE MARK CONSISTS OF A "K" WITH TWO ARROWS AROUND THE "K" FORMING A CIRCLE FOLLOWED BY THE WORD "KLEENWATER".

FOR WATER TREATMENT AND PURIFICATION EQUIPMENT FOR PROCESSING WASTE WATER, IRRIGATION WATER, OR POTABLE WATER, NAMELY, CERAMIC MICROFILTRATION UNITS (U.S. CLS. 13, 21, 23, 31 AND 34).

FIRST USE 1-5-2011; IN COMMERCE 1-5-2011.

BRENDAN MCCAULEY, EXAMINING ATTORNEY

SN 85-213,942. COAST CUTLERY CO., PORTLAND, OR. FILED 1-10-2011.

# BEAM-LOCK

THE MARK CONSISTS OF STANDARD CHARACTERS WITHOUT CLAIM TO ANY PARTICULAR FONT, STYLE, SIZE, OR COLOR.

FOR FLASHLIGHTS, LANTERNS, SPOT LIGHTS, AREA LIGHTS AND HEADLAMPS (U.S. CLS. 13, 21, 23, 31 AND 34).

KATHERINE M. DUBRAY, EXAMINING ATTORNEY

SN 85-213,944. COAST CUTLERY CO., PORTLAND, OR. FILED 1-10-2011.

# PURE-BEAM

THE MARK CONSISTS OF STANDARD CHARACTERS WITHOUT CLAIM TO ANY PARTICULAR FONT, STYLE, SIZE, OR COLOR.

FOR FLASHLIGHTS, LANTERNS, SPOT LIGHTS, AREA LIGHTS AND HEADLAMPS (U.S. CLS. 13, 21, 23, 31 AND 34).

KATHERINE M. DUBRAY, EXAMINING ATTORNEY

**CLASS 11—(Continued).**

SN 85-218,215. EVOLUTION LIGHTING, LLC, MIAMI LAKES, FL. FILED 1-14-2011.

AUDIOBRIGHT

THE MARK CONSISTS OF STANDARD CHARACTERS WITHOUT CLAIM TO ANY PARTICULAR FONT, STYLE, SIZE, OR COLOR.  
FOR ELECTRIC LIGHT BULBS WITH INTEGRATED AUDIO SPEAKERS (U.S. CLS. 13, 21, 23, 31 AND 34).  
DANIEL CAPSHAW, EXAMINING ATTORNEY

SN 85-218,220. EVOLUTION LIGHTING, LLC, MIAMI LAKES, FL. FILED 1-14-2011.

FACEBOX

THE MARK CONSISTS OF STANDARD CHARACTERS WITHOUT CLAIM TO ANY PARTICULAR FONT, STYLE, SIZE, OR COLOR.  
FOR COSMETIC CASES, FEATURING MIRRORS, SOLD EMPTY (U.S. CLS. 13, 21, 23, 31 AND 34).  
DANIEL CAPSHAW, EXAMINING ATTORNEY

**CLASS 11—(Continued).**

SN 85-218,908. CHANGZHOU YUYU ELECTRIC LIGHT APPLIANCE CO., LTD, CHANGZHOU, JIANGSU, CHINA, FILED 1-17-2011.

THE MARK CONSISTS OF ENGLISH LETTERS "YUYU" AND TWO CHINESE CHARACTERS.  
THE WORDING "YUYU" HAS NO MEANING IN A FOREIGN LANGUAGE.

THE NON-LATIN CHARACTERS IN THE MARK TRANSLITERATE TO "YUYU" AND THIS HAS NO MEANING IN A FOREIGN LANGUAGE.

FOR ARC LAMPS; BUNSEN BURNERS FOR LABORATORY USE; DIVING LIGHTS; ELECTRIC LAMPS; FLUORESCENT LAMP TUBES; GAS LAMPS; LAMPS; LIGHT BULBS; LIGHTING APPARATUS FOR VEHICLES; LIGHTING APPARATUS, NAMELY, LIGHTING INSTALLATIONS; LIGHTING TUBES; LIGHTS FOR VEHICLES; LUMINAIRES, USING LIGHT EMITTING DIODES (LEDS) AS A LIGHT SOURCE, FOR STREET OR ROADWAY LIGHTING; PROJECTOR LAMPS; SAFETY LAMPS FOR UNDERGROUND USE; SEARCHLIGHTS (U.S. CLS. 13, 21, 23, 31 AND 34).  
KAREN K. BUSH, EXAMINING ATTORNEY

**CLASS 12—VEHICLES**

SN 76-571,206. HUMBOLDT SPECIALTY MANUFACTURING CO., OMAHA, NE. FILED 1-21-2004.

CARRYALL SLED

THE MARK CONSISTS OF STANDARD CHARACTERS WITHOUT CLAIM TO ANY PARTICULAR FONT, STYLE, SIZE, OR COLOR.  
NO CLAIM IS MADE TO THE EXCLUSIVE RIGHT TO USE SLED, APART FROM THE MARK AS SHOWN.  
FOR UTILITY SLED MADE OF PLASTIC FOR HAULING MATERIAL (U.S. CLS. 19, 21, 23, 31, 35 AND 44).  
PATRICIA EVANKO, EXAMINING ATTORNEY

**CLASS 12—(Continued).**

SN 76-668,019. BTM LLC, GLENDALE, AZ. FILED 10-25-2006.

# CRO/SAL SPECIAL CHEETAH

THE MARK CONSISTS OF STANDARD CHARACTERS WITHOUT CLAIM TO ANY PARTICULAR FONT, STYLE, SIZE, OR COLOR.

FOR VEHICLES, NAMELY, AUTOMOBILES (U.S. CLS. 19, 21, 23, 31, 35 AND 44).

CHRIS WELLS, EXAMINING ATTORNEY

SN 76-698,115. DEJANA TRUCK & UTILITY EQUIPMENT CO., KINGS PARK, NY. FILED 6-26-2009.

# KATERACK

THE MARK CONSISTS OF STANDARD CHARACTERS WITHOUT CLAIM TO ANY PARTICULAR FONT, STYLE, SIZE, OR COLOR.

FOR TRUCK PARTS, NAMELY, TRUCK FLOOR ASSEMBLIES AND CARGO STORAGE RACK AND TRAY ASSEMBLIES FOR TRUCKS (U.S. CLS. 19, 21, 23, 31, 35 AND 44).

FIRST USE 4-0-2009; IN COMMERCE 4-0-2009.  
MARGARET POWER, EXAMINING ATTORNEY

SN 77-547,299. FORD MOTOR COMPANY, DEARBORN, MI. FILED 8-14-2008.

# CONTINENTAL

THE MARK CONSISTS OF STANDARD CHARACTERS WITHOUT CLAIM TO ANY PARTICULAR FONT, STYLE, SIZE, OR COLOR.

OWNER OF U.S. REG. NOS. 591,601, 591,602 AND 2,908,822.

FOR AUTOMOBILES; EXTERIOR AND INTERIOR INSIGNIA BADGES FOR AUTOMOBILES (U.S. CLS. 19, 21, 23, 31, 35 AND 44).

HELENE LIWINSKI, EXAMINING ATTORNEY

**CLASS 12—(Continued).**

SN 77-900,990. TBD PRODUCTS, INC., AKA TUFFRAIL-COM, GERMANTOWN, WI. FILED 12-25-2009.



THE MARK CONSISTS OF THE WORD TOUGH SPELLED PHONETICALLY AS "TUFF" COMBINED WITH THE WORD "RAIL", UNDERLINED THE FULL LENGTH OF THE WORD ALONG WITH THE HORIZONTAL BAR OF THE LETTER "T" EXTENDED AT BEYOND THE LENGTH OF THE ENTIRE WORD COMBINATION.

FOR GENERAL PURPOSE CARGO MANAGEMENT SYSTEM FOR ATTACHMENT TO AUTOMOBILES, TRUCKS, OFF-ROAD VEHICLES, TRAILERS AND BOATS AND FOR GENERAL PURPOSE SECUREMENT COMPRISED PRIMARILY OF SINGULAR OR PLURAL EXTRUDED ALUMINUM ALLOY RAILS AND CARGO-SECURING ACCESSORIES, NAMELY, RATCHET DEVICES, LOCKING PINS, STRAPS, HOOKS AND NETS, NONE OF THE ABOVE BEING USED WITH RAILROAD CARS (U.S. CLS. 19, 21, 23, 31, 35 AND 44).

RUDY R. SINGLETON, EXAMINING ATTORNEY

SN 77-951,229. MOTOCOMPONENTS PTY LTD, AKA GAZI SUSPENSION, MOUNT CROSBY, AUSTRALIA, FILED 3-4-2010.



NO CLAIM IS MADE TO THE EXCLUSIVE RIGHT TO USE "SUSPENSION", APART FROM THE MARK AS SHOWN.

THE COLOR(S) GREEN, BLACK, WHITE AND GRAY IS/ ARE CLAIMED AS A FEATURE OF THE MARK.

THE MARK CONSISTS OF THE STYLIZED WORDING "GAZI SUSPENSION". THE TERM "GAZI" IS GREEN WITH WHITE HIGHLIGHTS AND A GRAY SHADOW. THE TERM "SUSPENSION" IS BLACK WITH A GRAY SHADOW.

THE WORDING "GAZI" HAS NO MEANING IN A FOREIGN LANGUAGE.

FOR MOTORCYCLE SUSPENSION (U.S. CLS. 19, 21, 23, 31, 35 AND 44).

NELSON SNYDER, EXAMINING ATTORNEY



**CLASS 12—(Continued).**

SN 79-088,520. CHINA NATIONAL HEAVY DUTY TRUCK GROUP CO., LTD., CHINA, FILED 4-21-2010.

# SITRAK

THE MARK CONSISTS OF STANDARD CHARACTERS WITHOUT CLAIM TO ANY PARTICULAR FONT, STYLE, SIZE, OR COLOR.

PRIORITY DATE OF 11-2-2009 IS CLAIMED.

OWNER OF INTERNATIONAL REGISTRATION 1054437 DATED 4-21-2010, EXPIRES 4-21-2020.

FOR LAND VEHICLES; AUTOMOBILES; CARTS; BUSES; TRUCKS; COACHES; RECREATIONAL VEHICLES, NAMELY, CAMPERS; WAGONS AND MOTOR CYCLES; FORK LIFT TRUCKS (U.S. CLS. 19, 21, 23, 31, 35 AND 44).

CHRISTOPHER BUONGIORNO, EXAMINING ATTORNEY

SN 79-089,882. KUNSHAN HENRY METAL TECHNOLOGY CO., LTD., JIANGSU PROVINCE, CHINA, FILED 11-3-2010.

# KAHOMOTO

OWNER OF INTERNATIONAL REGISTRATION 1058068 DATED 11-3-2010, EXPIRES 11-3-2020.

THE MARK CONSISTS OF THE TERM "KAHOMOTO" IN A STYLIZED FONT.

FOR VEHICLE WHEELS; HUBS FOR VEHICLE WHEELS; MOTORCYCLE WHEELS; HUBS FOR MOTORCYCLE WHEELS; BICYCLES; BICYCLE RIMS; BICYCLE STANDS; MOTORCYCLES; CYCLE CARS (U.S. CLS. 19, 21, 23, 31, 35 AND 44).

FRANK LATTUCA, EXAMINING ATTORNEY

SN 85-007,595. FIRESTONE INDUSTRIAL PRODUCTS COMPANY, LLC, INDIANAPOLIS, IN. FILED 4-6-2010.

**World's Number 1  
Air Spring.**



OWNER OF U.S. REG. NOS. 3,589,604 AND 3,589,605.  
NO CLAIM IS MADE TO THE EXCLUSIVE RIGHT TO USE "AIR SPRING", APART FROM THE MARK AS SHOWN.

THE MARK CONSISTS OF THE WORDS "WORLD'S NUMBER 1 AIR SPRING.", AN AIR SPRING AND A HORIZONTAL LINE ABOVE AND BELOW THE WORDS AND AIR SPRING.

SEC. 2(F).

FOR COMPONENTS FOR VEHICLES CONSISTING OF AIR SPRINGS; PNEUMATIC SUSPENSION SPRINGS AND SHOCK ABSORBER UNITS FOR VEHICLES AND STRUCTURAL AND REPLACEMENT PARTS THEREFOR; AIR HELPER SPRINGS FOR VEHICLES (U.S. CLS. 19, 21, 23, 31, 35 AND 44).

FIRST USE 4-30-2006; IN COMMERCE 4-30-2006.  
LINDA ORNDORFF, EXAMINING ATTORNEY

**CLASS 12—(Continued).**

SN 85-039,622. T.Y. CUSHION TIRE, LLC, ONTARIO, CA. FILED 5-15-2010.



NO CLAIM IS MADE TO THE EXCLUSIVE RIGHT TO USE "CUSHION TIRE", APART FROM THE MARK AS SHOWN.

THE MARK CONSISTS OF STYLIZED LETTERS "TY CUSHION TIRE" IN STYLIZED FONT IN GREY SCALE IN A BOX WITH FOUR HEXAGONAL DOTS IN THE CORNERS.

FOR TIRES FOR LAND VEHICLES (U.S. CLS. 19, 21, 23, 31, 35 AND 44).

FIRST USE 3-1-2010; IN COMMERCE 3-1-2010.

WILLIAM ROSSMAN, EXAMINING ATTORNEY

SN 85-046,531. RINGBROTHERS LLC, SPRING GREEN, WI. FILED 5-24-2010.



OWNER OF U.S. REG. NOS. 3,878,353, 3,900,611 AND 3,900,612.

THE MARK CONSISTS OF A STYLIZED LETTER "R" IN CONNECTION WITH A STYLIZED BACKWARD LETTER "B".

FOR AUTOMOTIVE BODY KITS COMPRISING EXTERNAL STRUCTURAL PARTS OF AUTOMOBILES; AUTOMOTIVE INTERIOR TRIM, INTERIOR PANELING AND EXTERIOR TRIM, NAMELY, DOOR HANDLES, DOOR STRIKERS, AND HEADLAMP TRIM RINGS; AND VEHICLE PARTS, NAMELY, AUTOMOBILE HOODS, AUTOMOBILE TRUNK LIDS, HOOD PINS, HOOD HINGES, CLUTCH RESERVOIRS, EXPORT BRACE SYSTEMS, NAMELY, A CROSS BRACE IN THE ENGINE COMPARTMENT THAT ADDS RIGIDITY TO THE ENGINE SUSPENSION SYSTEM, HOOD ADJUSTERS, AUTOMOBILE FRONT APRONS, AUTOMOBILE BOLTS, FRONT AND REAR FENDER BOLTS, SHOCK TOWER BOLTS, NAMELY, NUTS AND BOLTS THAT HOLD SHOCK TOWER TOPS TO THE AUTOMOBILE BODY, BATTERY CHARGE PORTS, GAUGE BEZELS; METAL TRUNK HINGES, HOOD HINGES (U.S. CLS. 19, 21, 23, 31, 35 AND 44).

FIRST USE 1-31-2005; IN COMMERCE 1-31-2005.  
KATHRYN COWARD, EXAMINING ATTORNEY

**CLASS 12—(Continued).**

SN 85-055,053. M M ROTORS, INC., DBA M M ROTORS, INC., POMONA, CA. FILED 6-4-2010.



THE COLOR(S) BLUE AND WHITE IS/ARE CLAIMED AS A FEATURE OF THE MARK.

THE MARK CONSISTS OF THE LETTERS "M M" ABOVE THE LETTER "R", ALL OF WHICH ARE IN WHITE AND ALL WITHIN A BLUE CIRCLE THAT IS RINGED BY A WHITE LINE AND ANOTHER THIN BLUE CIRCLE.

FOR AUTOMOBILE BRAKE DRUMS; AUTOMOBILE BRAKE ROTORS FOR LAND VEHICLES; AUTOMOBILE BRAKE SHOES FOR LAND VEHICLES; AUTOMOBILE BRAKES FOR VEHICLES; AUTOMOBILE DISC BRAKE PADS FOR VEHICLES; AUTOMOBILE WHEEL HUBS FOR VEHICLE BRAKES (U.S. CLS. 19, 21, 23, 31, 35 AND 44).

FIRST USE 7-1-1992; IN COMMERCE 6-1-2010.  
CORY BOONE, EXAMINING ATTORNEY

**CLASS 12—(Continued).**

SN 85-059,410. GLOBAL WEST SUSPENSION COMPONENTS, INC., SAN BERNARDINO, CA. FILED 6-10-2010.

## DEL-A-LUM

THE MARK CONSISTS OF STANDARD CHARACTERS WITHOUT CLAIM TO ANY PARTICULAR FONT, STYLE, SIZE, OR COLOR.

FOR STEERING AND SUSPENSION SYSTEMS AND PARTS FOR STEERING AND SUSPENSION SYSTEMS FOR VEHICLES, NAMELY, BUSHINGS, SUSPENSION BUSHINGS, BUSHING KITS; STEERING AND SUSPENSION SYSTEMS AND PARTS FOR STEERING AND SUSPENSION SYSTEMS FOR VEHICLES, NAMELY, UPPER BALL JOINTS, LOWER BALL JOINTS, BALL JOINTS WITH CONTROL ARMS, BUSHING KITS, INNER TIE ROD ENDS, OUTER TIE ROD ENDS, SLEEVES, IDLER ARMS, CENTER LINKS, STABILIZER KITS, INNER SOCKETS AND PITMAN ARMS (U.S. CLS. 19, 21, 23, 31, 35 AND 44).

FIRST USE 1-1-1985; IN COMMERCE 1-1-1985.  
PAULA MAHONEY, EXAMINING ATTORNEY

SN 85-059,428. GLOBAL WEST SUSPENSION COMPONENTS, INC., SAN BERNARDINO, CA. FILED 6-10-2010.

## TRACLINK

THE MARK CONSISTS OF STANDARD CHARACTERS WITHOUT CLAIM TO ANY PARTICULAR FONT, STYLE, SIZE, OR COLOR.

FOR PARTS FOR LAND VEHICLES, NAMELY, TRACTION CONTROL DEVICE, NAMELY, HIGH PERFORMANCE SUSPENSION KITS COMPRISED OF A TORQUE ARM, SPECIAL COLLAR WITH BRONZE SLEEVE, TWO RUBBER BUSHINGS, TUBULAR CENTER SUPPORT, REINFORCEMENT PLATES, ANGLE PLATES, SPHERICAL ROD ENDS AND ASSOCIATED HARDWARE, NAMELY, NUTS AND BOLTS, ALL SOLD AS A UNIT (U.S. CLS. 19, 21, 23, 31, 35 AND 44).

FIRST USE 3-1-1994; IN COMMERCE 3-1-1994.  
PAULA MAHONEY, EXAMINING ATTORNEY

SN 85-057,909. PHILADELPHIA FORD DEALER ASSOCIATION, FT. WASHINGTON, PA. FILED 6-8-2010.

## SIGN AND RIDE EVENT

THE MARK CONSISTS OF STANDARD CHARACTERS WITHOUT CLAIM TO ANY PARTICULAR FONT, STYLE, SIZE, OR COLOR.

FOR AUTOMOTIVE LAND VEHICLES (U.S. CLS. 19, 21, 23, 31, 35 AND 44).

FIRST USE 5-17-2010; IN COMMERCE 5-17-2010.  
AMY C. KEAN, EXAMINING ATTORNEY

**CLASS 12—(Continued).**

SN 85-063,235. MOSS BACK OUTDOOR SYSTEMS, INC.,  
SPRINGDALE, AR. FILED 6-15-2010.



NO CLAIM IS MADE TO THE EXCLUSIVE RIGHT TO USE "MOSS BACK", "FISH RACK" AND "MADE IN THE USA", APART FROM THE MARK AS SHOWN.

THE MARK CONSISTS OF THE WORDS "NO MATTER HOW YOU STACK 'EM, WE ATTRACT 'EM!" THE WORDS "MOSS BACK", "FISH RACK" AND "MADE IN THE USA", A STYLIZED FISH WITH AN OPEN MOUTH ALL APPEARING IN A RECTANGLE WITH CURVED EDGES.

FOR RACKS FOR MOTOR VEHICLES FOR CARRYING FISH (U.S. CLS. 19, 21, 23, 31, 35 AND 44).

EDWARD NELSON, EXAMINING ATTORNEY

---

SN 85-082,336. NHK SPRING CO., LTD., YOKOHAMA-SHI,  
KANAGAWA, JAPAN, FILED 7-12-2010.

**ISP**

THE MARK CONSISTS OF STANDARD CHARACTERS WITHOUT CLAIM TO ANY PARTICULAR FONT, STYLE, SIZE, OR COLOR.

FOR LAND VEHICLE SUSPENSION PARTS, NAMELY, COIL SPRINGS, LEAF SPRINGS; SUSPENSION SPRINGS FOR MOTOR CARS (U.S. CLS. 19, 21, 23, 31, 35 AND 44).

DAVID I, EXAMINING ATTORNEY

---

SN 85-092,075. DARCY MD, SEAN, LONG BEACH, CA.  
FILED 7-23-2010.

**BRIANNA BELT**

THE MARK CONSISTS OF STANDARD CHARACTERS WITHOUT CLAIM TO ANY PARTICULAR FONT, STYLE, SIZE, OR COLOR.

NO CLAIM IS MADE TO THE EXCLUSIVE RIGHT TO USE "BELT", APART FROM THE MARK AS SHOWN.

FOR SAFETY RESTRAINTS FOR VEHICLES; SAFETY RESTRAINTS FOR PREGNANT WOMEN FOR VEHICLES (U.S. CLS. 19, 21, 23, 31, 35 AND 44).

DANNEAN HETZEL, EXAMINING ATTORNEY

**CLASS 12—(Continued).**

SN 85-152,713. THE YOKOHAMA RUBBER CO., LTD.,  
MINATO-KU, TOKYO, JAPAN, FILED 10-14-2010.



PRIORITY CLAIMED UNDER SEC. 44(D) ON JAPAN APPLICATION NO. 2010-074849, FILED 9-24-2010.

OWNER OF JAPAN REG. NO. 5396126, DATED 3-4-2011, EXPIRES 3-4-2021.

NO CLAIM IS MADE TO THE EXCLUSIVE RIGHT TO USE "ORANGE OIL", APART FROM THE MARK AS SHOWN.

THE COLOR(S) ORANGE AND GREEN IS/ARE CLAIMED AS A FEATURE OF THE MARK.

THE MARK CONSISTS OF "ORANGE OIL" IN THE COLOR ORANGE INSIDE AN ORANGE DESIGN WITH A GREEN LEAF DESIGN ON TOP.

FOR TIRES FOR AUTOMOBILES AND COMPONENT PARTS SOLD AS PART OF TIRES (U.S. CLS. 19, 21, 23, 31, 35 AND 44).

ANDREW LEASER, EXAMINING ATTORNEY

---

SN 85-167,979. DBEST PRODUCTS INC., CARSON, CA.  
FILED 11-3-2010.

**SMART CART**

NO CLAIM IS MADE TO THE EXCLUSIVE RIGHT TO USE "CART", APART FROM THE MARK AS SHOWN.

THE MARK CONSISTS OF THE WORDS "SMART CART" IN THE STYLIZED LETTERING AS SHOWN.

FOR CARTS, NAMELY, WHEELED, COLLAPSIBLE, CANVAS CARTS FOR TRANSPORTING AND HAULING GOODS (U.S. CLS. 19, 21, 23, 31, 35 AND 44).

FIRST USE 10-23-2010; IN COMMERCE 10-23-2010.

GRETTA YAO, EXAMINING ATTORNEY

**CLASS 12—(Continued).**

SN 85-168,103. RICKETTS, WAYNE M, DBA WXM WADIFF XTREME MOTORSPORTS, VANCOUVER, BC, CANADA, FILED 11-3-2010.

**Undercover Motorcycle**

THE MARK CONSISTS OF STANDARD CHARACTERS WITHOUT CLAIM TO ANY PARTICULAR FONT, STYLE, SIZE, OR COLOR.

NO CLAIM IS MADE TO THE EXCLUSIVE RIGHT TO USE "MOTORCYCLE", APART FROM THE MARK AS SHOWN.

FOR MOTORCYCLES (U.S. CLS. 19, 21, 23, 31, 35 AND 44).

CHERYL CLAYTON, EXAMINING ATTORNEY

**CLASS 12—(Continued).**

SN 85-196,279. F & F IMPORTS, LLC, TEMPE, AZ. FILED 12-13-2010.

**State Bicycle**

THE MARK CONSISTS OF STANDARD CHARACTERS WITHOUT CLAIM TO ANY PARTICULAR FONT, STYLE, SIZE, OR COLOR.

NO CLAIM IS MADE TO THE EXCLUSIVE RIGHT TO USE "BICYCLE", APART FROM THE MARK AS SHOWN.

FOR BICYCLE FRAMES AND BICYCLE HANDLEBAR GRIPS; BICYCLE GRIP TAPE; BICYCLE SADDLES; BICYCLE WHEELS, RIMS AND STRUCTURAL PARTS THEREFOR; BICYCLES; FRAMES FOR BICYCLES (U.S. CLS. 19, 21, 23, 31, 35 AND 44).

FIRST USE 11-25-2009; IN COMMERCE 11-25-2009.  
AMEEN IMAM, EXAMINING ATTORNEY

SN 85-175,047. CHEER MIRRORS INDUSTRIES, DBA CHEER MIRRORS INDUSTRIES, SEATTLE, WA. FILED 11-11-2010.

**CHEER MIRRORS**

THE MARK CONSISTS OF STANDARD CHARACTERS WITHOUT CLAIM TO ANY PARTICULAR FONT, STYLE, SIZE, OR COLOR.

NO CLAIM IS MADE TO THE EXCLUSIVE RIGHT TO USE "MIRRORS", APART FROM THE MARK AS SHOWN.

FOR AUTO ACCESSORIES, NAMELY, SIDE MIRROR PROTECTIVE AND VANITY COVERS (U.S. CLS. 19, 21, 23, 31, 35 AND 44).

REBECCA SMITH, EXAMINING ATTORNEY

SN 85-200,223. G AND J LEWIS ENTERPRISES PTY LTD, WETHERILL PARK, NSW, AUSTRALIA, FILED 12-17-2010.

**LTSS**

THE MARK CONSISTS OF STANDARD CHARACTERS WITHOUT CLAIM TO ANY PARTICULAR FONT, STYLE, SIZE, OR COLOR.

OWNER OF AUSTRALIA REG. NO. 882732, DATED 7-16-2001, RENEWED AS REG. NO. 882732, DATED 2-7-2011, EXPIRES 7-16-2021.

FOR SEATS FOR VEHICLES; STRUCTURAL PARTS AND FITTINGS RELATING THERETO (U.S. CLS. 19, 21, 23, 31, 35 AND 44).

JUDITH HELFMAN, EXAMINING ATTORNEY

SN 85-181,352. INSECT INFERNO, INC., LEONARD, MN. FILED 11-19-2010.

**INSECT INFERNO**

THE MARK CONSISTS OF STANDARD CHARACTERS WITHOUT CLAIM TO ANY PARTICULAR FONT, STYLE, SIZE, OR COLOR.

NO CLAIM IS MADE TO THE EXCLUSIVE RIGHT TO USE "INSECT", APART FROM THE MARK AS SHOWN.

FOR MOBILE PEST EXTERMINATION TRAILERS (U.S. CLS. 19, 21, 23, 31, 35 AND 44).

FIRST USE 11-18-2010; IN COMMERCE 11-18-2010.  
SUSAN LESLIE DUBOIS, EXAMINING ATTORNEY

SN 85-207,530. CHRISTOPHER D. KING, PORTLAND, OR. FILED 12-29-2010.

**KING**

THE MARK CONSISTS OF STANDARD CHARACTERS WITHOUT CLAIM TO ANY PARTICULAR FONT, STYLE, SIZE, OR COLOR.

OWNER OF U.S. REG. NOS. 3,616,478, 3,839,327 AND OTHERS.

FOR BICYCLE PARTS, NAMELY, SEAT POSTS (U.S. CLS. 19, 21, 23, 31, 35 AND 44).

MARK SHINER, EXAMINING ATTORNEY

**CLASS 12—(Continued).**

SN 85-207,936. CHRYSLER GROUP LLC, AUBURN HILLS, MI. FILED 12-30-2010.

**RED BLOODED AMERICAN**

THE MARK CONSISTS OF STANDARD CHARACTERS WITHOUT CLAIM TO ANY PARTICULAR FONT, STYLE, SIZE, OR COLOR.

FOR MOTOR VEHICLES, NAMELY, PASSENGER AUTOMOBILES, THEIR STRUCTURAL PARTS, TRIM AND BADGES (U.S. CLS. 19, 21, 23, 31, 35 AND 44).

TARA PATE, EXAMINING ATTORNEY

---

SN 85-208,896. VOLAGI, L.L.C., DBA VOLAGI CYCLES, MORGAN HILL, CA. FILED 1-2-2011.

**Liscio**

THE MARK CONSISTS OF STANDARD CHARACTERS WITHOUT CLAIM TO ANY PARTICULAR FONT, STYLE, SIZE, OR COLOR.

THE ENGLISH TRANSLATION OF "LISCIO" IN THE MARK IS "SMOOTH" IN ITALIAN.

FOR BICYCLE FRAMES; BICYCLE FRAMES AND BICYCLE HANDLEBAR GRIPS; BICYCLE PARTS, NAMELY, FORKS; BICYCLE PARTS, NAMELY, TUBES AND CONNECTORS FOR BICYCLE FRAMES; BICYCLE SEAT POSTS; BICYCLES; FRAMES FOR BICYCLES; RACING BICYCLES; ROAD RACING BICYCLES; STRUCTURAL PARTS OF BICYCLES; TANDEM BICYCLES; TOURING BICYCLES (U.S. CLS. 19, 21, 23, 31, 35 AND 44).

PAM WILLIS, EXAMINING ATTORNEY

---

SN 85-208,934. NO CHOKE, LLC, LELAND, NC. FILED 1-3-2011.

**No-Choke**

THE MARK CONSISTS OF STANDARD CHARACTERS WITHOUT CLAIM TO ANY PARTICULAR FONT, STYLE, SIZE, OR COLOR.

FOR FITTED FABRIC COVERS FOR VEHICLE SEAT BELTS FOR USE IN RELOCATING THE SEAT BELT AWAY FROM THE PASSENGER'S NECK AND THROAT AREA (U.S. CLS. 19, 21, 23, 31, 35 AND 44).

JENNIFER MARTIN, EXAMINING ATTORNEY

**CLASS 12—(Continued).**

SN 85-210,134. RADIO FLYER, INC., CHICAGO, IL. FILED 1-4-2011.

**MY 1ST BIG FLYER**

THE MARK CONSISTS OF STANDARD CHARACTERS WITHOUT CLAIM TO ANY PARTICULAR FONT, STYLE, SIZE, OR COLOR.

OWNER OF U.S. REG. NOS. 635,875, 3,373,636 AND OTHERS.

NO CLAIM IS MADE TO THE EXCLUSIVE RIGHT TO USE "BIG", APART FROM THE MARK AS SHOWN.

FOR TRICYCLES (U.S. CLS. 19, 21, 23, 31, 35 AND 44).

JOHN DWYER, EXAMINING ATTORNEY

---

SN 85-213,456. INFLATION SOLUTIONS GROUP, MIAMI, FL. FILED 1-8-2011.

**GATOR**

THE MARK CONSISTS OF STANDARD CHARACTERS WITHOUT CLAIM TO ANY PARTICULAR FONT, STYLE, SIZE, OR COLOR.

FOR TIRE INFLATORS; TIRE VALVES FOR VEHICLE TIRES; VEHICLE TIRE VALVE STEM CAPS (U.S. CLS. 19, 21, 23, 31, 35 AND 44).

MICHAEL WEBSTER, EXAMINING ATTORNEY

---

SN 85-214,900. AIRCRAFT RUBBER MANUFACTURING, INC., REDMOND, OR. FILED 1-11-2011.

**FUEL SAFE**

THE MARK CONSISTS OF STANDARD CHARACTERS WITHOUT CLAIM TO ANY PARTICULAR FONT, STYLE, SIZE, OR COLOR.

OWNER OF U.S. REG. NOS. 3,736,110 AND 3,784,124.

NO CLAIM IS MADE TO THE EXCLUSIVE RIGHT TO USE "FUEL", APART FROM THE MARK AS SHOWN.

FOR VEHICLE PARTS, NAMELY, FUEL STORAGE SYSTEMS AND COMPONENT STRUCTURAL PARTS, NAMELY, ADAPTERS, BLADDERS, BOLTS, CANS, CAPS, CLAMPS, COLLECTORS, ELBOWS, FLANGES, FILTERS, FITTINGS, FOAM, GASKETS, HOSE BARBS, HOSES, PLATES, PICKUPS, PUMPS, RETURNS, RINGS, TANKS, VALVES, VENTS, WASHERS, AND WIRE HARNESSSES (U.S. CLS. 19, 21, 23, 31, 35 AND 44).

FIRST USE 10-1-1986; IN COMMERCE 10-1-1986.

JEFFREY LOOK, EXAMINING ATTORNEY



**CLASS 12—(Continued).**

SN 85-219,323. TREK BICYCLE CORPORATION, WATER-  
LOO, WI. FILED 1-17-2011.

# LUSH

THE MARK CONSISTS OF STANDARD CHARACTERS  
WITHOUT CLAIM TO ANY PARTICULAR FONT, STYLE,  
SIZE, OR COLOR.

FOR BICYCLES AND STRUCTURAL PARTS THERE-  
FOR (U.S. CLS. 19, 21, 23, 31, 35 AND 44).  
BRIDGETT SMITH, EXAMINING ATTORNEY

SN 85-227,986. POLARIS INDUSTRIES INC., MEDINA, MN.  
FILED 1-27-2011.



OWNER OF U.S. REG. NOS. 2,207,376, 2,209,340 AND  
3,389,459.

NO CLAIM IS MADE TO THE EXCLUSIVE RIGHT TO  
USE "MOTORCYCLES", APART FROM THE MARK AS  
SHOWN.

THE MARK CONSISTS OF THE WORDS "VICTORY"  
AND "MOTORCYCLES" OVER AND UNDER THE LETTER  
"V".

FOR MOTORCYCLES AND STRUCTURAL PARTS  
THEREFOR (U.S. CLS. 19, 21, 23, 31, 35 AND 44).

FIRST USE 3-0-2010; IN COMMERCE 3-0-2010.

VIVIAN MICZNIK FIRST, EXAMINING ATTORNEY

SN 85-228,441. CHRYSLER GROUP LLC, AUBURN HILLS,  
MI. FILED 1-28-2011.

# SKYDOME

THE MARK CONSISTS OF STANDARD CHARACTERS  
WITHOUT CLAIM TO ANY PARTICULAR FONT, STYLE,  
SIZE, OR COLOR.

OWNER OF U.S. REG. NO. 3,485,635.

FOR SUNROOFS INCORPORATED AS AN INTEGRAL  
PART OF MOTOR VEHICLES (U.S. CLS. 19, 21, 23, 31, 35  
AND 44).

TARA PATE, EXAMINING ATTORNEY

**CLASS 12—(Continued).**

SN 85-231,353. CHRYSLER GROUP LLC, AUBURN HILLS,  
MI. FILED 2-1-2011.

# TORQUEFLITE

THE MARK CONSISTS OF STANDARD CHARACTERS  
WITHOUT CLAIM TO ANY PARTICULAR FONT, STYLE,  
SIZE, OR COLOR.

OWNER OF U.S. REG. NO. 3,240,307.

FOR TRANSMISSIONS INCORPORATED AS AN IN-  
TEGRAL PART OF MOTOR VEHICLES (U.S. CLS. 19, 21,  
23, 31, 35 AND 44).

TARA PATE, EXAMINING ATTORNEY

SN 85-235,318. CHRYSLER GROUP LLC, AUBURN HILLS,  
MI. FILED 2-7-2011.

# JEEP ARCTIC

THE MARK CONSISTS OF STANDARD CHARACTERS  
WITHOUT CLAIM TO ANY PARTICULAR FONT, STYLE,  
SIZE, OR COLOR.

OWNER OF U.S. REG. NOS. 820,237, 3,382,692 AND  
OTHERS.

FOR MOTOR VEHICLES, NAMELY, PASSENGER  
AUTOMOBILES, THEIR STRUCTURAL PARTS, TRIM  
AND BADGES (U.S. CLS. 19, 21, 23, 31, 35 AND 44).

TARA PATE, EXAMINING ATTORNEY

SN 85-239,258. POLARIS INDUSTRIES INC., MEDINA, MN.  
FILED 2-10-2011.

# CROSS COUNTRY TOUR

THE MARK CONSISTS OF STANDARD CHARACTERS  
WITHOUT CLAIM TO ANY PARTICULAR FONT, STYLE,  
SIZE, OR COLOR.

OWNER OF U.S. REG. NO. 3,765,353.

NO CLAIM IS MADE TO THE EXCLUSIVE RIGHT TO  
USE "TOUR", APART FROM THE MARK AS SHOWN.

FOR MOTORCYCLES AND STRUCTURAL PARTS  
THEREFOR (U.S. CLS. 19, 21, 23, 31, 35 AND 44).

VIVIAN MICZNIK FIRST, EXAMINING ATTORNEY

**CLASS 13—FIREARMS**

SN 77-375,051. AMERICAN PIONEER POWDER, INC., BOCA RATON, FL. FILED 1-18-2008.

**SUPER STICKS**

THE MARK CONSISTS OF STANDARD CHARACTERS WITHOUT CLAIM TO ANY PARTICULAR FONT, STYLE, SIZE, OR COLOR.

OWNER OF U.S. REG. NO. 2,865,486.  
SEC. 2(F) AS TO "STICKS".

FOR COMPRESSED POWDER CHARGES FOR USE IN MODERN AND PRIMITIVE FIREARMS; PRE-MEASURED POWDER CHARGES FOR USE IN MODERN AND PRIMITIVE FIREARMS AND GUNPOWDER FOR USE IN MODERN AND PRIMITIVE FIREARMS, AND FOR USE IN RELATED GOODS (U.S. CLS. 2 AND 9).  
SUE LAWRENCE, EXAMINING ATTORNEY

SN 85-043,225. AVALANCHE MACHINE INC, BELGRADE, MT. FILED 5-19-2010.

**Bad News**

THE MARK CONSISTS OF STANDARD CHARACTERS WITHOUT CLAIM TO ANY PARTICULAR FONT, STYLE, SIZE, OR COLOR.

FOR FIREARMS (U.S. CLS. 2 AND 9).  
FIRST USE 3-1-2010; IN COMMERCE 4-1-2010.  
MARC LEIPZIG, EXAMINING ATTORNEY

SN 85-140,466. GRUPO MERCARI SA DE CV, DBA GRUPO MERCARI AND DECALGRIP, MEXICO DF, MEXICO CITY, MEXICO, FILED 9-28-2010.

**DECAL GRIP**

THE MARK CONSISTS OF STANDARD CHARACTERS WITHOUT CLAIM TO ANY PARTICULAR FONT, STYLE, SIZE, OR COLOR.

NO CLAIM IS MADE TO THE EXCLUSIVE RIGHT TO USE "GRIP", APART FROM THE MARK AS SHOWN.  
SEC. 2(F).

FOR FIREARM ATTACHMENTS, NAMELY, MOUNTS FOR ATTACHING GRIPS TO A FIREARM; GRIPS FOR SMALL ARMS; PISTOL GRIPS; RIFLE HAND GRIPS (U.S. CLS. 2 AND 9).

FIRST USE 1-1-1996; IN COMMERCE 10-1-1997.  
VIVIAN MICZNIK FIRST, EXAMINING ATTORNEY

**CLASS 13—(Continued).**

SN 85-159,793. EDYGEAR INC., PALOS VERDES, CA. FILED 10-24-2010.

**VERSIPACK**

THE MARK CONSISTS OF STANDARD CHARACTERS WITHOUT CLAIM TO ANY PARTICULAR FONT, STYLE, SIZE, OR COLOR.

FOR HOLSTER SYSTEM SPECIFICALLY DESIGNED FOR CARRYING AND CONCEALING FIREARMS, AMMUNITION, AND AMMUNITION MAGAZINES COMPRISING BACKPACKS, WAIST PACKS, BANDOLEERS, CHEST HARNESS PACKS AND CARRY BAGS (U.S. CLS. 2 AND 9).

FIRST USE 5-8-2003; IN COMMERCE 5-8-2003.  
KAREN K. BUSH, EXAMINING ATTORNEY

SN 85-169,294. ATLAS IMPORTERS, INC., MARION, SC. FILED 11-4-2010.

**"QUARTER STICKS" BRAND  
MAGNUM SALUTES**

THE MARK CONSISTS OF STANDARD CHARACTERS WITHOUT CLAIM TO ANY PARTICULAR FONT, STYLE, SIZE, OR COLOR.

NO CLAIM IS MADE TO THE EXCLUSIVE RIGHT TO USE "QUARTER STICKS BRAND" AND "SALUTES", APART FROM THE MARK AS SHOWN.

FOR FIREWORKS (U.S. CLS. 2 AND 9).  
FIRST USE 1-15-1999; IN COMMERCE 1-15-1999.  
MARK SHINER, EXAMINING ATTORNEY

SN 85-173,898. CROSSTAC CORPORATION, BOZEMAN, MT. FILED 11-10-2010.

**CROSS TAC**

THE MARK CONSISTS OF STANDARD CHARACTERS WITHOUT CLAIM TO ANY PARTICULAR FONT, STYLE, SIZE, OR COLOR.

NO CLAIM IS MADE TO THE EXCLUSIVE RIGHT TO USE "TAC", APART FROM THE MARK AS SHOWN.  
FOR GUN BELTS; GUN PARTS; SHOOTING ACCESSORIES, NAMELY, GUN RESTS; SLING STRAPS FOR FIREARMS (U.S. CLS. 2 AND 9).

FIRST USE 3-2-2007; IN COMMERCE 3-2-2007.  
PAUL F. GAST, EXAMINING ATTORNEY

**CLASS 13—(Continued).**

SN 85-196,141. B.J. ALAN COMPANY, YOUNGSTOWN, OH.  
FILED S.R. 12-13-2010; AM. P.R. 3-14-2010.

**PHANTOM PIXIE DUST**

THE MARK CONSISTS OF STANDARD CHARACTERS WITHOUT CLAIM TO ANY PARTICULAR FONT, STYLE, SIZE, OR COLOR.

OWNER OF U.S. REG. NOS. 1,923,559, 3,710,491 AND OTHERS.

FOR FIREWORKS (U.S. CLS. 2 AND 9).  
FIRST USE 1-1-2010; IN COMMERCE 3-26-2010.  
KEVIN CORWIN, EXAMINING ATTORNEY

SN 85-205,668. ALLEM'S GUN CRAFT INC., ZIONSVILLE, PA. FILED 12-26-2010.

**ALLEM ROLLER RELEASE**

THE MARK CONSISTS OF STANDARD CHARACTERS WITHOUT CLAIM TO ANY PARTICULAR FONT, STYLE, SIZE, OR COLOR.

NO CLAIM IS MADE TO THE EXCLUSIVE RIGHT TO USE "ROLLER RELEASE", APART FROM THE MARK AS SHOWN.

FOR GUN CASES; GUN PARTS; GUNS (U.S. CLS. 2 AND 9).

FIRST USE 5-7-2008; IN COMMERCE 5-7-2008.  
MATTHEW EINSTEIN, EXAMINING ATTORNEY

SN 85-213,363. MICOR INDUSTRIES, INC, DECATUR, AL. FILED 1-7-2011.



THE MARK CONSISTS OF A STYLIZED GORILLA HOLDING A RIFLE.

FOR MUZZLE BREAKS THAT SCREW ONTO A RIFLE BARREL (U.S. CLS. 2 AND 9).

FIRST USE 6-29-2010; IN COMMERCE 1-6-2011.  
NANCY CLARKE, EXAMINING ATTORNEY

**CLASS 14—JEWELRY**

SN 76-703,406. OASIS FASHIONS LIMITED, WITNEY OXFORDSHIRE, ENGLAND, FILED 6-16-2010.

**OASIS**

THE MARK CONSISTS OF STANDARD CHARACTERS WITHOUT CLAIM TO ANY PARTICULAR FONT, STYLE, SIZE, OR COLOR.

OWNER OF UNITED KINGDOM REG. NO. 2313153, DATED 2-6-2004, EXPIRES 10-14-2012.

FOR JEWELLERY, CLOCKS, WATCHES, PARTS AND FITTINGS FOR THE AFORESAID GOODS (U.S. CLS. 2, 27, 28 AND 50).

LAURIE KAUFMAN, EXAMINING ATTORNEY

SN 77-215,270. HOPE FAITH MIRACLES, LLC, NORTON, MA. FILED 6-26-2007.

**HOPE FAITH MIRACLES**

THE MARK CONSISTS OF STANDARD CHARACTERS WITHOUT CLAIM TO ANY PARTICULAR FONT, STYLE, SIZE, OR COLOR.

FOR BEADS FOR USE IN THE MANUFACTURE OF JEWELRY; BRACELETS; CHARMS; JEWELRY; JEWELRY BOXES; JEWELRY BOXES NOT OF METAL; JEWELRY BOXES OF METAL; JEWELRY BOXES OF PRECIOUS METAL; JEWELRY CASES; JEWELRY CHAINS; JEWELRY FINDINGS; JEWELRY WATCHES; LAPEL PINS; LEATHER JEWELRY AND ACCESSORY BOXES; PINS BEING JEWELRY; RINGS BEING JEWELRY (U.S. CLS. 2, 27, 28 AND 50).

FIRST USE 11-7-2006; IN COMMERCE 11-7-2006.  
ALEXANDER L. POWERS, EXAMINING ATTORNEY

SN 77-766,401. MONTESINO INTERNATIONAL CORP, FORT LAUDERDALE, FL. FILED 6-23-2009.

**THE ORIGINAL CARIBBEAN BRACELET COMPANY**

THE MARK CONSISTS OF STANDARD CHARACTERS WITHOUT CLAIM TO ANY PARTICULAR FONT, STYLE, SIZE, OR COLOR.

OWNER OF U.S. REG. NOS. 2,819,144, 3,229,194 AND 3,352,255.

NO CLAIM IS MADE TO THE EXCLUSIVE RIGHT TO USE "BRACELET COMPANY", APART FROM THE MARK AS SHOWN.

SEC. 2(F).  
FOR JEWELRY (U.S. CLS. 2, 27, 28 AND 50).  
BARNEY CHARLON, EXAMINING ATTORNEY

**CLASS 14—(Continued).**

SN 77-766,404. MONTESINO INTERNATIONAL CORP.,  
FORT LAUDERDALE, FL. FILED 6-23-2009.

**THE ORIGINAL CARIBBEAN  
BRACELET**

THE MARK CONSISTS OF STANDARD CHARACTERS  
WITHOUT CLAIM TO ANY PARTICULAR FONT, STYLE,  
SIZE, OR COLOR.

OWNER OF U.S. REG. NOS. 2,819,144, 3,229,194 AND  
3,352,255.

NO CLAIM IS MADE TO THE EXCLUSIVE RIGHT TO  
USE "BRACELET", APART FROM THE MARK AS SHOWN.  
SEC. 2(F).

FOR JEWELRY (U.S. CLS. 2, 27, 28 AND 50).  
BARNEY CHARLON, EXAMINING ATTORNEY

SN 77-936,724. MBFTM LTD, ROAD TOWN, TORTOLA,  
BR.VIRGIN ISLANDS, FILED 2-16-2010.

**MECHANICAL ART GALLERY**

THE MARK CONSISTS OF STANDARD CHARACTERS  
WITHOUT CLAIM TO ANY PARTICULAR FONT, STYLE,  
SIZE, OR COLOR.

PRIORITY CLAIMED UNDER SEC. 44(D) ON SWITZER-  
LAND APPLICATION NO. 61991/2009, FILED 10-29-2009.

NO CLAIM IS MADE TO THE EXCLUSIVE RIGHT TO  
USE "MECHANICAL ART", APART FROM THE MARK AS  
SHOWN.

FOR JEWELRY, JEWELS; HOROLOGICAL AND  
CHRONOMETRIC INSTRUMENTS, NAMELY, CLOCKS,  
WATCHES AND CHRONOMETERS (U.S. CLS. 2, 27, 28  
AND 50).

TRACY CROSS, EXAMINING ATTORNEY

SN 77-939,614. GREAT WALL STREET, LLC, WESTON, FL.  
FILED 2-19-2010.



THE NAME(S), PORTRAIT(S), AND/OR SIGNATURE(S)  
SHOWN IN THE MARK DOES NOT IDENTIFY A PARTI-  
CULAR LIVING INDIVIDUAL.

THE MARK CONSISTS OF A STYLIZED REPRESENTA-  
TION OF THE LETTER "M" WITH A 3/4 CIRCLE SUR-  
ROUNDING THE LETTER, AND THE STYLIZED WORD  
"MAURITZ" UNDERNEATH.

FOR WATCHES (U.S. CLS. 2, 27, 28 AND 50).  
PRISCILLA MILTON, EXAMINING ATTORNEY

**CLASS 14—(Continued).**

SN 79-082,669. CARTIER INTERNATIONAL AG, SWITZER-  
LAND, FILED 5-6-2010.

**MERVEILLES DU NIL**

THE MARK CONSISTS OF STANDARD CHARACTERS  
WITHOUT CLAIM TO ANY PARTICULAR FONT, STYLE,  
SIZE, OR COLOR.

PRIORITY DATE OF 12-29-2009 IS CLAIMED.

OWNER OF INTERNATIONAL REGISTRATION 1039040  
DATED 5-6-2010, EXPIRES 5-6-2020.

THE ENGLISH TRANSLATION OF "MERVEILLES DU  
NIL" IN THE MARK IS "WONDERS OF THE NILE".

FOR CUFF LINKS, TIE CLIPS, RINGS, BRACELETS,  
EARRINGS, NECKLACES, BROOCHES, KEY HOLDERS  
OF PRECIOUS METAL, WATCHES, CHRONOMETERS,  
WALL CLOCKS, WATCHBANDS, BOXES OF PRECIOUS  
METAL FOR WATCHES AND JEWELRY (U.S. CLS. 2, 27,  
28 AND 50).

ANDREA HACK, EXAMINING ATTORNEY

SN 79-084,205. SHENZHEN CREATION JEWELRY CO.,  
LTD., CHINA, FILED 6-3-2010.



OWNER OF INTERNATIONAL REGISTRATION 1043167  
DATED 6-3-2010, EXPIRES 6-3-2020.

NO CLAIM IS MADE TO THE EXCLUSIVE RIGHT TO  
USE "JEWELRY" OR NON-LATIN CHARACTERS THAT  
TRANSLITERATE TO "ZHUBAO", APART FROM THE  
MARK AS SHOWN.

THE MARK CONSISTS OF A STYLIZED DESIGN OF A  
SWIRL ABOVE FOUR CHINESE CHARACTERS ABOVE  
THE STYLIZED PHRASE "SHUIBEI JEWELRY".

THE ENGLISH TRANSLATION OF "ZHUBAO" IS "JE-  
WELRY"; THE WORDING "SHUIBEI" HAS NO MEANING  
IN A FOREIGN LANGUAGE.

THE NON-LATIN CHARACTERS IN THE MARK TRANS-  
LITERATE TO "SHUIBEI ZHUBAO".

FOR PLATINUM BEING METAL; ALLOYS OF PRE-  
CIOUS METAL; JEWELRY CASES OF PRECIOUS ME-  
TAL; SILVER ORNAMENTS; PRECIOUS STONES;  
NECKLACES BEING JEWELLERY; JEWELLERY; RINGS  
BEING JEWELLERY; JADE; WRISTWATCHES (U.S. CLS.  
2, 27, 28 AND 50).

MYRIAH HABEEB, EXAMINING ATTORNEY

**CLASS 14—(Continued).**

SN 79-087,426. CHOPARD INTERNATIONAL SA, SWITZERLAND, FILED 8-6-2010.

**CHOPARD ANIMAL WORLD**

THE MARK CONSISTS OF STANDARD CHARACTERS WITHOUT CLAIM TO ANY PARTICULAR FONT, STYLE, SIZE, OR COLOR.

PRIORITY DATE OF 2-9-2010 IS CLAIMED.

OWNER OF INTERNATIONAL REGISTRATION 1051319 DATED 8-6-2010, EXPIRES 8-6-2020.

NO CLAIM IS MADE TO THE EXCLUSIVE RIGHT TO USE "ANIMAL", APART FROM THE MARK AS SHOWN.

FOR PRECIOUS METALS AND THEIR ALLOYS; KEY RINGS OF PRECIOUS METAL OR PLATED THEREWITH; JEWELRY AND PRECIOUS STONES; HOROLOGICAL AND CHRONOMETRIC INSTRUMENTS AND THEIR PARTS INCLUDED IN THIS CLASS (U.S. CLS. 2, 27, 28 AND 50).

ROBIN CHOSID, EXAMINING ATTORNEY

**CLASS 14—(Continued).**

SN 79-089,888. AMOR GMBH, 63179 OBERTSHAUSEN, FED REP GERMANY, FILED 11-2-2010.



OWNER OF INTERNATIONAL REGISTRATION 1058080 DATED 11-2-2010, EXPIRES 11-2-2020.

THE COLOR(S) BLACK, ORANGE IS/ARE CLAIMED AS A FEATURE OF THE MARK.

THE MARK CONSISTS OF THE STYLIZED WORDING "AMOR" IN BLACK WITH A DESIGN OF A FLOWER IN ORANGE.

THE ENGLISH TRANSLATION OF "AMOR" IN THE MARK IS "LOVE".

FOR JEWELLERY; CLOCKS; PASTE JEWELLERY; JEWELLERY BOXES, CUFFLINKS, TIE PINS, KEY RINGS OF PRECIOUS METAL; JEWELLERY FOR ORNAMENTAL USE WITH MOBILE RADIOTELEPHONES (U.S. CLS. 2, 27, 28 AND 50).

ROBERT STRUCK, EXAMINING ATTORNEY

SN 79-087,427. CHOPARD INTERNATIONAL SA, SWITZERLAND, FILED 8-6-2010.



PRIORITY DATE OF 2-9-2010 IS CLAIMED.  
OWNER OF INTERNATIONAL REGISTRATION 1051322 DATED 8-6-2010, EXPIRES 8-6-2020.

NO CLAIM IS MADE TO THE EXCLUSIVE RIGHT TO USE "ANIMAL", APART FROM THE MARK AS SHOWN.

THE MARK CONSISTS OF THE STYLIZED WORD, "CHOPARD", WITH "ANIMAL WORLD" UNDERNEATH.

FOR PRECIOUS METALS AND THEIR ALLOYS; KEY RINGS MADE OF PRECIOUS METALS OR COATED THEREWITH; JEWELRY AND PRECIOUS STONES; TIMEPIECES AND CHRONOMETRIC INSTRUMENTS AND THEIR PARTS INCLUDED IN THIS CLASS (U.S. CLS. 2, 27, 28 AND 50).

ROBIN CHOSID, EXAMINING ATTORNEY

SN 85-025,795. SMITH, WESLEY, R, NORWALK, CT. AND SCHAAF, SUSAN, E, NORWALK, CT. FILED 4-28-2010.

**Diamonever**

THE MARK CONSISTS OF STANDARD CHARACTERS WITHOUT CLAIM TO ANY PARTICULAR FONT, STYLE, SIZE, OR COLOR.

FOR BRACELETS; CHARMS; JEWELRY; JEWELRY BOXES OF PRECIOUS METAL; JEWELRY CASES NOT OF PRECIOUS METAL; JEWELRY CASES OF PRECIOUS METAL; JEWELRY CHAINS; JEWELRY WATCHES; JEWELRY, NAMELY, ANKLETS; JEWELRY, NAMELY, CROSSES; JEWELRY, NAMELY, STONE PENDANTS; PRECIOUS AND SEMI-PRECIOUS CRYSTAL STONES AND BEADS FOR USE IN JEWELRY; RINGS; RINGS BEING JEWELRY; STAINLESS STEEL JEWELRY BRACELETS; WATCHES AND JEWELRY; WATCHES, CLOCKS, JEWELRY AND IMITATION JEWELRY; ALL THE FOREGOING GOODS MADE IN WHOLE OR IN PART OF DIAMONDS (U.S. CLS. 2, 27, 28 AND 50).

FIRST USE 1-15-2010; IN COMMERCE 1-15-2010.

JACLYN KIDWELL WALKER, EXAMINING ATTORNEY



**CLASS 14—(Continued).**

SN 85-041,985. BIJOU MAX LLC, DBA ORO NASSIONALE, LOS ANGELES, CA. FILED 5-18-2010.

**BONNDORF**  
— LABORATORIES —

NO CLAIM IS MADE TO THE EXCLUSIVE RIGHT TO USE "LABORATORIES", APART FROM THE MARK AS SHOWN.

THE MARK CONSISTS OF THE TERM "BONNDORF" WITH THE "F" IS INVERTED, ABOVE THE TERM "LABORATORIES" WITH A LINE ON EITHER END.

FOR (BASED ON USE IN COMMERCE) BRACELETS; JEWELRY, NAMELY, DOG TAGS FOR WEAR BY HUMANS FOR DECORATIVE PURPOSES (BASED ON INTENT TO USE) BEADS FOR USE IN THE MANUFACTURE OF JEWELRY; BRACELETS AND JEWELRY FEATURING ELECTRONIC CHIPS FOR ATTRACTING ENERGY TO THE BODY WHEREIN THE ELECTRONIC CHIPS INCREASE IN POWER IN THE PRESENCE OF ELECTROMAGNETIC FIELDS, FOR THE PURPOSE OF RE-BALANCING THE HUMAN ENERGY FIELD; BROACHES; BROOCHES; CHARMS; CHARMS FOR COLLAR JEWELRY AND BRACELET; COSTUME JEWELRY; DIAMOND JEWELRY; GEMSTONE JEWELRY; GOLD THREAD JEWELRY; IDENTIFICATION BRACELETS; JEWELRY; JEWELRY AND IMITATION JEWELRY; JEWELRY BOXES; JEWELRY BOXES NOT OF METAL; JEWELRY BOXES OF METAL; JEWELRY BOXES OF PRECIOUS METAL; JEWELRY BROOCHES; JEWELRY CASES; JEWELRY CASES NOT OF PRECIOUS METAL; JEWELRY CASES OF PRECIOUS METAL; JEWELRY CASKETS; JEWELRY CASKETS OF PRECIOUS METAL; JEWELRY CHAINS; JEWELRY FINDINGS; JEWELRY FOR ATTACHMENT TO CLOTHING; JEWELRY FOR THE HEAD; JEWELRY IN THE NATURE OF ARMBANDS; JEWELRY ORGANIZERS; JEWELRY PINS FOR USE ON HATS; JEWELRY RING HOLDERS; JEWELRY THAT INCORPORATES TECHNOLOGY FOR REBALANCING THE HUMAN ENERGY FIELD; JEWELRY TO BE AFFIXED TO BIKINIS; JEWELRY WATCHES; JEWELRY, NAMELY, AMULETS; JEWELRY, NAMELY, ANKLETS; JEWELRY, NAMELY, ARM CUFFS; JEWELRY, NAMELY, CROSSES; JEWELRY, NAMELY, MAGNETIC NECKLACES; JEWELRY, NAMELY, MAGNETIC PENDANTS; JEWELRY, NAMELY, PRECIOUS METAL PLATED REAL LEAVES AND FLOWERS; JEWELRY, NAMELY, STONE PENDANTS; LAPEL PINS; LEATHER JEWELRY AND ACCESSORY BOXES; METAL WIRE FOR USE IN THE MAKING OF JEWELRY, NAMELY, JEWELRY CABLE; PET JEWELRY; PINS BEING JEWELRY; PLASTIC BRACELETS IN THE NATURE OF JEWELRY; PRECIOUS AND SEMI-PRECIOUS CRYSTAL STONES AND BEADS FOR USE IN JEWELRY; RINGS; RINGS BEING JEWELRY; STAINLESS STEEL JEWELRY BRACELETS; WATCHES AND JEWELRY (U.S. CLS. 2, 27, 28 AND 50).

FIRST USE 7-15-2009; IN COMMERCE 7-15-2009.

WILLIAM P. SHANAHAN, EXAMINING ATTORNEY

**CLASS 14—(Continued).**

SN 85-043,483. NICE DE MEXICO, S.A. DE C.V., GUADALAJARA, JALISCO, MEXICO, FILED 5-20-2010.

**NICE**

THE MARK CONSISTS OF STANDARD CHARACTERS WITHOUT CLAIM TO ANY PARTICULAR FONT, STYLE, SIZE, OR COLOR.

OWNER OF U.S. REG. NOS. 2,917,857 AND 2,919,315.

FOR BRACELETS; EARRINGS; JEWELRY AND IMITATION JEWELRY; PRECIOUS AND SEMI-PRECIOUS CRYSTAL STONES AND BEADS FOR USE IN JEWELRY; RINGS; WATCHES AND JEWELRY (U.S. CLS. 2, 27, 28 AND 50).

FIRST USE 11-19-1996; IN COMMERCE 3-5-2001.

JOHN KELLY, EXAMINING ATTORNEY

SN 85-054,317. OKO INTERNATIONAL CO., DEERFIELD BEACH, FL. FILED 6-3-2010.

**VIRTUOSO**

THE MARK CONSISTS OF STANDARD CHARACTERS WITHOUT CLAIM TO ANY PARTICULAR FONT, STYLE, SIZE, OR COLOR.

FOR TIMEPIECES; WATCHES (U.S. CLS. 2, 27, 28 AND 50).

SARA BENJAMIN, EXAMINING ATTORNEY

SN 85-054,590. FRIENDS OF THE HUNLEY, INC., CHARLESTON, SC. FILED 6-4-2010.



OWNER OF U.S. REG. NOS. 2,848,092, 2,848,093 AND 2,953,776.

THE MARK CONSISTS OF THE CONFIGURATION OF A THREE DIMENSIONAL REPLICA OF A BENT, TWO-SIDED US \$20 COIN. THE FIRST SIDE CONSISTS OF THE BUST OF A WOMAN WEARING A CROWN WITH THE LETTERING

**CLASS 14—(Continued).**

"ERTY" WITH THE YEAR "1860" BELOW. THE BUST IS SURROUNDED BY STARS AND A REEDED OUTER EDGE OF THE COIN. THE SECOND SIDE CONSISTS OF AN EAGLE HOLDING A STRIPED SHIELD, HOLDING ARROWS WITH SCROLL WORK BEHIND THE EAGLE AND THE WORDING "TES OF AMERICA AND "WENTY D." SURROUNDED BY A REEDED EDGE. THE WORDING "SHILOH APRIL 6TH 1862 MY LIFE PRESERVER G.E.D." IS SUPER IMPOSED OVER THE LEFT SIDE OF THE COIN COVERING PART OF THE WORDING AND DESIGN.

SEC. 2(F).  
FOR COMMEMORATIVE COINS (U.S. CLS. 2, 27, 28 AND 50).  
FIRST USE 4-6-2000; IN COMMERCE 4-6-2000.  
KELLY BOULTON, EXAMINING ATTORNEY

---

SN 85-055,637. NADJIBI, FARID, GREENBRAE, CA. FILED 6-5-2010.

**LOCAL BEADS**

THE MARK CONSISTS OF STANDARD CHARACTERS WITHOUT CLAIM TO ANY PARTICULAR FONT, STYLE, SIZE, OR COLOR.

NO CLAIM IS MADE TO THE EXCLUSIVE RIGHT TO USE "BEADS", APART FROM THE MARK AS SHOWN.

FOR BEADS TO EVOKE VARIOUS TRAVEL DESTINATIONS FOR USE IN THE MANUFACTURE OF JEWELRY; PRECIOUS AND SEMI-PRECIOUS CRYSTAL STONES AND BEADS TO EVOKE VARIOUS TRAVEL DESTINATIONS FOR USE IN JEWELRY (U.S. CLS. 2, 27, 28 AND 50).

FIRST USE 11-15-2009; IN COMMERCE 11-15-2009.  
CAROLINE WOOD, EXAMINING ATTORNEY

---

SN 85-059,078. TIZON, RUBEN, NEW YORK, NY. FILED 6-10-2010.

**- ION POWER**

THE MARK CONSISTS OF STANDARD CHARACTERS WITHOUT CLAIM TO ANY PARTICULAR FONT, STYLE, SIZE, OR COLOR.

NO CLAIM IS MADE TO THE EXCLUSIVE RIGHT TO USE "-ION", APART FROM THE MARK AS SHOWN.

FOR JEWELRY PRODUCTS, NAMELY, PRECIOUS METALS AND THEIR ALLOYS AND GOODS IN PRECIOUS METALS OR COATED THEREWITH, NAMELY, RINGS, BRACELETS, RUBBER OR SILICON WRISTBANDS IN THE NATURE OF A BRACELET, EARRINGS, NECKLACES; PRECIOUS STONES; HOROLOGICAL AND CHRONOMETRIC INSTRUMENTS FOR CONSUMERS AND ATHLETES OF ALL AGES (U.S. CLS. 2, 27, 28 AND 50).

STEPHANIE ALI, EXAMINING ATTORNEY

**CLASS 14—(Continued).**

SN 85-069,138. DISNEY ONLINE STUDIOS CANADA INC., VANCOUVER, CANADA, FILED 6-22-2010.

**CLUB PENGUIN**

THE MARK CONSISTS OF STANDARD CHARACTERS WITHOUT CLAIM TO ANY PARTICULAR FONT, STYLE, SIZE, OR COLOR.

FOR JEWELRY; JEWELRY BOXES; JEWELRY CASES; KEY RINGS OF PRECIOUS METAL; NON-MONETARY COINS; COSTUME JEWELRY (U.S. CLS. 2, 27, 28 AND 50).

ELIZABETH KAJUBI, EXAMINING ATTORNEY

---

SN 85-072,865. REGO MANUFACTURING CO., INC., BUCYRUS, OH. FILED 6-28-2010.

**REGO**

THE MARK CONSISTS OF STANDARD CHARACTERS WITHOUT CLAIM TO ANY PARTICULAR FONT, STYLE, SIZE, OR COLOR.

OWNER OF U.S. REG. NO. 1,805,998.

SEC. 2(F).  
FOR BRACELETS; DIAMOND JEWELRY; GEMSTONE JEWELRY; JEWELRY; RINGS BEING JEWELRY (U.S. CLS. 2, 27, 28 AND 50).

FIRST USE 4-15-1991; IN COMMERCE 4-15-1991.  
HENRY S. ZAK, EXAMINING ATTORNEY

---

SN 85-083,001. NOVO LIMITED LIABILITY COMPANY, ANNAPOLIS JUNCTION, MD. FILED 7-13-2010.

**Christa Brook**

THE MARK CONSISTS OF STANDARD CHARACTERS WITHOUT CLAIM TO ANY PARTICULAR FONT, STYLE, SIZE, OR COLOR.

THE NAME(S), PORTRAIT(S), AND/OR SIGNATURE(S) SHOWN IN THE MARK DOES NOT IDENTIFY A PARTICULAR LIVING INDIVIDUAL.

FOR BEADS FOR USE IN THE MANUFACTURE OF JEWELRY; BRACELETS; CHARMS; CHARMS FOR COLLAR JEWELRY AND BRACELET; JEWELRY (U.S. CLS. 2, 27, 28 AND 50).

KATHERINE CHANG, EXAMINING ATTORNEY

**CLASS 14—(Continued).**

SN 85-117,730. MOJO MARKETING, BRIGHTWATERS, NY. AND IFE, WALTER J, BRIGHTWATERS, NY. AND GROOME, HARRY, ARLINGTON, MA. FILED 8-27-2010.

**Glam ♥ Ma**  
forever glam

THE COLOR(S) BLACK AND PINK IS/ARE CLAIMED AS A FEATURE OF THE MARK.

THE MARK CONSISTS OF THE WORDS "GLAM MA FOREVER GLAM" IN STYLIZED BLACK LETTERING WITH A SMALL PINK HEART LOCATED BETWEEN "GLAM" AND "MA". THE COLOR WHITE APPEARS AS BACKGROUND IN THE MARK AND IS NOT CLAIMED AS A FEATURE OF THE MARK.

FOR JEWELRY (U.S. CLS. 2, 27, 28 AND 50).  
NATALIE POLZER, EXAMINING ATTORNEY

SN 85-176,708. SANDBERG & SIKORSKI CORPORATION,  
NEW YORK, NY. FILED 11-15-2010.

**Bridal Symphony**

THE MARK CONSISTS OF STANDARD CHARACTERS WITHOUT CLAIM TO ANY PARTICULAR FONT, STYLE, SIZE, OR COLOR.

NO CLAIM IS MADE TO THE EXCLUSIVE RIGHT TO USE "BRIDAL", APART FROM THE MARK AS SHOWN.

FOR JEWELRY (U.S. CLS. 2, 27, 28 AND 50).  
RICHARD WHITE, EXAMINING ATTORNEY

**CLASS 14—(Continued).**

SN 85-178,533. STEPHANIE WELLS, DBA DOUBLE HAPPINESS JEWELRY, SAN DIEGO, CA. FILED 11-17-2010.

**Double Happiness Jewelry**

THE MARK CONSISTS OF STANDARD CHARACTERS WITHOUT CLAIM TO ANY PARTICULAR FONT, STYLE, SIZE, OR COLOR.

NO CLAIM IS MADE TO THE EXCLUSIVE RIGHT TO USE "JEWELRY", APART FROM THE MARK AS SHOWN.

FOR BRACELETS; BROACHES; CHARMS; COSTUME JEWELRY; DIAMOND JEWELRY; GEMSTONE JEWELRY; GOLD THREAD JEWELRY; IDENTIFICATION BRACELETS; JEWELRY; JEWELRY AND IMITATION JEWELRY; JEWELRY BROOCHES; JEWELRY CHAINS; JEWELRY FOR ATTACHMENT TO CLOTHING; JEWELRY FOR THE HEAD; JEWELRY IN THE NATURE OF ARMBANDS; JEWELRY, NAMELY, ARM CUFFS; JEWELRY, NAMELY, STONE PENDANTS; LAPEL PINS; PINS BEING JEWELRY; PLASTIC BRACELETS IN THE NATURE OF JEWELRY; RINGS; RINGS BEING JEWELRY; STAINLESS STEEL JEWELRY BRACELETS; WOMEN'S JEWELRY (U.S. CLS. 2, 27, 28 AND 50).

FIRST USE 1-1-2000; IN COMMERCE 6-1-2000.  
BRENDAN REGAN, EXAMINING ATTORNEY

SN 85-190,726. TALI LEHAVI, AKA TALI LEHAVI HAMER,  
SCOTTSDALE, AZ. FILED 12-4-2010.

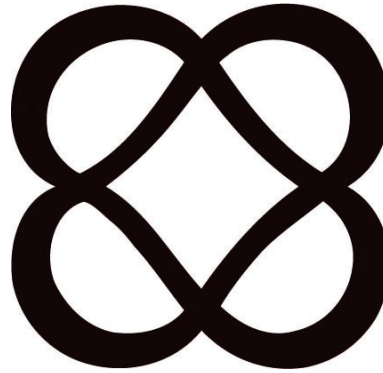

THE MARK CONSISTS OF TWO HEARTS OVERLAPPING IN OPPOSITE DIRECTIONS CREATING A HEART IN EVERY DIRECTION.

FOR ANKLE BRACELETS; BANGLE BRACELETS; BEADS FOR USE IN THE MANUFACTURE OF JEWELRY; BODY JEWELRY; BODY-PIERCING RINGS; BRACELETS; BRACELETS; BRACELETS AND JEWELRY FEATURING ELECTRONIC CHIPS FOR ATTRACTING ENERGY TO THE BODY WHEREIN THE ELECTRONIC CHIPS INCREASE IN POWER IN THE PRESENCE OF ELECTROMAGNETIC FIELDS, FOR THE PURPOSE OF RE-BALANCING THE HUMAN ENERGY FIELD; BRACELETS OF PRECIOUS METAL; BROACHES; BRONZE JEWELRY; BROOCHES; CAMEOS; CHARITY BRACELETS; CHARMS; CHARMS FOR COLLAR JEWELRY AND BRACELET; CLIP EARRINGS; COSTUME JEWELRY; CUFF LINKS AND TIE CLIPS; DIAMOND JEWELRY; EAR CLIPS; EAR STUDS; EARRINGS; EQUINE NECKLACES; GEMSTONE JEWELRY; GOLD THREAD JEWELRY; HAIR JEWELRY IN THE NATURE OF JEWELRY FOR USE IN THE HAIR; IDENTIFICATION BRACELETS; INEXPENSIVE NON-JEWELRY WATCHES; JEWEL PENDANTS; JEWELLERY CHAIN OF PRECIOUS METAL FOR BRACELETS; JEWELRY; JEWELRY AND IMITATION JEWELRY; JEW-

**CLASS 14—(Continued).**

ELRY ARMOIRES; JEWELRY BOXES; JEWELRY BOXES NOT OF METAL; JEWELRY BOXES OF METAL; JEWELRY BOXES OF PRECIOUS METAL; JEWELRY BROOCHES; JEWELRY CASES; JEWELRY CASES NOT OF PRECIOUS METAL; JEWELRY CASES OF PRECIOUS METAL; JEWELRY CASKETS; JEWELRY CASKETS OF PRECIOUS METAL; JEWELRY CHAINS; JEWELRY FINDINGS; JEWELRY FOR ATTACHMENT TO CLOTHING; JEWELRY FOR THE HEAD; JEWELRY IN THE NATURE OF ARMBANDS; JEWELRY INCORPORATING A COMPUTER STORAGE DEVICE CONTAINING MEDICAL INFORMATION FOR MEDICAL ALERT PURPOSES; JEWELRY MAKING KITS; JEWELRY ORGANIZERS; JEWELRY PINS FOR USE ON HATS; JEWELRY RING HOLDERS; JEWELRY STICKPINS; JEWELRY THAT FITS OVER THE FRONT TEETH; JEWELRY THAT INCORPORATES TECHNOLOGY FOR REBALANCING THE HUMAN ENERGY FIELD; JEWELRY TO BE AFFIXED TO BIKINIS; JEWELRY WATCHES; JEWELRY, NAMELY, AMULETS; JEWELRY, NAMELY, ANKLETS; JEWELRY, NAMELY, ARM CUFFS; JEWELRY, NAMELY, BRACELETS, WRISTBANDS AND NECKLACES THAT ALSO PROVIDES NOTIFICATION TO THE WEARER OF A PENDING MEDICAL RELATED TASK; JEWELRY, NAMELY, CROSSES; JEWELRY, NAMELY, DOG TAGS FOR WEAR BY HUMANS FOR DECORATIVE PURPOSES; JEWELRY, NAMELY, MAGNETIC NECKLACES; JEWELRY, NAMELY, MAGNETIC PENDANTS; JEWELRY, NAMELY, PRECIOUS METAL PLATED REAL LEAVES AND FLOWERS; JEWELRY, NAMELY, STONE PENDANTS; KEY RINGS OF PRECIOUS METAL; KEY RINGS OF PRECIOUS METALS; LAPEL PINS; LEATHER JEWELRY AND ACCESSORY BOXES; NECKLACES; NYLON ANKLE BRACELETS; NYLON BRACELETS; PENDANTS; PET JEWELRY; PINS BEING JEWELRY; PLASTIC BRACELETS IN THE NATURE OF JEWELRY; PRECIOUS AND SEMI-PRECIOUS CRYSTAL STONES AND BEADS FOR USE IN JEWELRY; RINGS; RINGS; RINGS BEING JEWELRY; RUBBER OR SILICON WRISTBANDS IN THE NATURE OF A BRACELET; SLAP BRACELETS; SLAPBAND BRACELETS; STAINLESS STEEL JEWELRY BRACELETS; TIE CLIPS; TIE CLIPS OF PRECIOUS METAL; WATCH BRACELETS; WATCHES AND JEWELRY; WATCHES, CLOCKS, JEWELRY AND IMITATION JEWELRY; WOMEN'S JEWELRY (U.S. CLS. 2, 27, 28 AND 50).

FIRST USE 5-1-1996; IN COMMERCE 12-16-2000.  
KATINA MISTER, EXAMINING ATTORNEY

SN 85-190,735. BAYBUTT, THERESA NEHMER, WELLESLEY, MA. FILED 12-4-2010.

**Treasure Bay Jewelry**

THE MARK CONSISTS OF STANDARD CHARACTERS WITHOUT CLAIM TO ANY PARTICULAR FONT, STYLE, SIZE, OR COLOR.

OWNER OF U.S. REG. NOS. 2,912,356 AND 3,006,941.  
NO CLAIM IS MADE TO THE EXCLUSIVE RIGHT TO USE "JEWELRY", APART FROM THE MARK AS SHOWN, FOR JEWELRY (U.S. CLS. 2, 27, 28 AND 50).  
TIMOTHY FINNEGAN, EXAMINING ATTORNEY

**CLASS 14—(Continued).**

SN 85-199,957. WASATCH KIOSKS, LLC, ST. GEORGE, UT. FILED 12-16-2010.

**XCELLERATED PERFORMANCE**

THE MARK CONSISTS OF STANDARD CHARACTERS WITHOUT CLAIM TO ANY PARTICULAR FONT, STYLE, SIZE, OR COLOR.

NO CLAIM IS MADE TO THE EXCLUSIVE RIGHT TO USE "PERFORMANCE", APART FROM THE MARK AS SHOWN.

FOR RUBBER OR SILICON WRISTBANDS IN THE NATURE OF A BRACELET (U.S. CLS. 2, 27, 28 AND 50).  
FIRST USE 7-15-2010; IN COMMERCE 7-29-2010.  
NANCY CLARKE, EXAMINING ATTORNEY

SN 85-203,685. STULLER, INC., LAFAYETTE, LA. FILED 12-22-2010.

**DURA COBALT**

THE MARK CONSISTS OF STANDARD CHARACTERS WITHOUT CLAIM TO ANY PARTICULAR FONT, STYLE, SIZE, OR COLOR.

NO CLAIM IS MADE TO THE EXCLUSIVE RIGHT TO USE "COBALT", APART FROM THE MARK AS SHOWN.

FOR JEWELRY MADE AT LEAST IN PART OF COBALT (U.S. CLS. 2, 27, 28 AND 50).  
RENEE MCCRAY, EXAMINING ATTORNEY

SN 85-206,823. JEWELEX NEW YORK, LTD., NEW YORK, NY. FILED 12-28-2010.



NO CLAIM IS MADE TO THE EXCLUSIVE RIGHT TO USE "DIAMOND COLLECTION", APART FROM THE MARK AS SHOWN.

THE MARK CONSISTS OF THE WORD "BALLERINA", THE WORDS "DIAMOND COLLECTION" BENEATH THE WORD "BALLERINA" AND THE WORDS "A VISION OF BEAUTY AND BRILLIANCE" BENEATH THE WORDS "DIAMOND COLLECTION", AND THE DESIGN OF A BALLERINA TO THE LEFT OF THE WORD "BALLERINA" AND A CIRCULAR SWIRL DESIGN BENEATH THE BALLERINA.

FOR JEWELRY, NAMELY, GOLD, PLATINUM, TITANIUM AND SILVER JEWELRY; AND GOLD, PLATINUM, TITANIUM AND SILVER JEWELRY WITH PRECIOUS STONES, NAMELY, DIAMONDS, RUBIES, EMERALDS, SAPPHIRES, AND SEMI-PRECIOUS COLORED STONES EMBEDDED THEREIN, AND PEARLS EMBEDDED THEREIN (U.S. CLS. 2, 27, 28 AND 50).

RONALD DELGIZZI, EXAMINING ATTORNEY

**CLASS 14—(Continued).**

SN 85-208,135. LOVENINAJANEXO, TAMPA, FL. FILED 12-30-2010.

## Love, Nina Jane

THE MARK CONSISTS OF STANDARD CHARACTERS WITHOUT CLAIM TO ANY PARTICULAR FONT, STYLE, SIZE, OR COLOR.

"NINA JANE" DOES NOT IDENTIFY A LIVING INDIVIDUAL.

FOR BRACELETS; EARRINGS; JEWELRY; NECKLACES (U.S. CLS. 2, 27, 28 AND 50).

FIRST USE 11-1-2009; IN COMMERCE 11-1-2009.  
CAROL SPILS, EXAMINING ATTORNEY

---

SN 85-208,346. MCH CO LLC, AKA FRUGAL CONTESSA, CHATHAM, NJ. FILED 12-30-2010.

## Frugal Contessa

THE MARK CONSISTS OF STANDARD CHARACTERS WITHOUT CLAIM TO ANY PARTICULAR FONT, STYLE, SIZE, OR COLOR.

FOR JEWELRY (U.S. CLS. 2, 27, 28 AND 50).  
FIRST USE 1-1-2007; IN COMMERCE 4-17-2007.  
JOHN GARTNER, EXAMINING ATTORNEY

---

SN 85-209,007. SEARS BRANDS, LLC, HOFFMAN ESTATES, IL. FILED 1-3-2011.

## ENCHANTED BRILLIANCE

THE MARK CONSISTS OF STANDARD CHARACTERS WITHOUT CLAIM TO ANY PARTICULAR FONT, STYLE, SIZE, OR COLOR.

NO CLAIM IS MADE TO THE EXCLUSIVE RIGHT TO USE "BRILLIANCE", APART FROM THE MARK AS SHOWN.

FOR JEWELRY (U.S. CLS. 2, 27, 28 AND 50).  
LINDA M. KING, EXAMINING ATTORNEY

**CLASS 14—(Continued).**

SN 85-209,113. SIMS, SAMUEL F., SAN DIEGO, CA. FILED 1-3-2011.



THE STIPPLING IS A FEATURE OF THE MARK.  
THE MARK CONSISTS OF A STYLIZED ASTERISK AND WORD "B.O.O.T." INSIDE A BOW-SHAPED DESIGN AND AN IMAGE OF A BOOT IN THE BACKGROUND.  
FOR LAPEL PINS (U.S. CLS. 2, 27, 28 AND 50).  
CAROL SPILS, EXAMINING ATTORNEY

---

SN 85-209,253. KAZANCHYAN, ANNA, WHITE PLAINS, NY, AND MARKARIAN, MARIAM AGHAVNI, WHITE PLAINS, NY. FILED 1-3-2011.

## THE NECKLACE SAVER

THE MARK CONSISTS OF STANDARD CHARACTERS WITHOUT CLAIM TO ANY PARTICULAR FONT, STYLE, SIZE, OR COLOR.

NO CLAIM IS MADE TO THE EXCLUSIVE RIGHT TO USE "NECKLACE", APART FROM THE MARK AS SHOWN.

FOR JEWELRY HOLDING, STORING, DISPLAYING AND TRANSPORTING DEVICE, NAMELY, JEWELRY SLEEVE (U.S. CLS. 2, 27, 28 AND 50).

RENEE MCCRAY, EXAMINING ATTORNEY

---

SN 85-211,925. MILLER, RACHAEL HOLLY, MOORPARK, CA. FILED 1-6-2011.

## GO SPORTS JEWELRY

THE MARK CONSISTS OF STANDARD CHARACTERS WITHOUT CLAIM TO ANY PARTICULAR FONT, STYLE, SIZE, OR COLOR.

OWNER OF U.S. REG. NO. 3,865,793.

FOR JEWELRY (U.S. CLS. 2, 27, 28 AND 50).

FIRST USE 1-6-2011; IN COMMERCE 1-6-2011.

BRENDAN MCCAULEY, EXAMINING ATTORNEY



**CLASS 14—(Continued).**

SN 85-212,721. HIRZINGER, JOSEF, FT LAUDERDALE, FL. FILED 1-7-2011.



THE MARK CONSISTS OF THE LETTERING "JHJ" WITH A GREEK CROSS FORMING THE CROSSBAR IN THE "H" AND A CROWN ABOVE THE LETTER "H". THE WORD "JOSEF" IS TO THE LEFT OF THE LETTERING. THE WORD "JOSEPH" IS TO THE RIGHT OF THE LETTERING. THE WORDING "WWW.JOSEF&JOSEPH.COM" APPEARS UNDERNEATH ALL OF THE WORDING.

FOR JEWELLERY AND WATCHES (U.S. CLS. 2, 27, 28 AND 50).

MARK SHINER, EXAMINING ATTORNEY

SN 85-213,747. NATALIA MARKETING, WALTHAM, MA. FILED 1-10-2011.

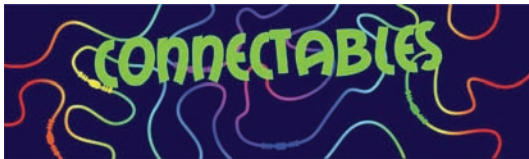

THE COLOR(S) RED, ORANGE, YELLOW, GREEN, LIGHT BLUE, DARK BLUE, PINK, PURPLE IS/ARE CLAIMED AS A FEATURE OF THE MARK.

THE MARK CONSISTS OF THE WORD "CONNECTABLES" IN BRIGHT GREEN LETTERS, TILTING TO THE LEFT. THE WORD IS PLACED ON A DARK BLUE BACKGROUND. OVER THE DARK BLUE BACKGROUND AND BEHIND THE WORD "CONNECTABLES", THERE IS A PATTERN THAT REPRESENTS A TANGLED CORD, IN RAINBOW EFFECT COLOR.

FOR CHARMS; JEWELRY (U.S. CLS. 2, 27, 28 AND 50).

FIRST USE 12-1-2010; IN COMMERCE 12-1-2010.

KAREN BRACEY, EXAMINING ATTORNEY

SN 85-214,252. LANCECO INDUSTRIES, INC., DBA C.G. CREATIONS, PEARL RIVER, NY. FILED 1-10-2011.

# OMNI-LOK

THE MARK CONSISTS OF STANDARD CHARACTERS WITHOUT CLAIM TO ANY PARTICULAR FONT, STYLE, SIZE, OR COLOR.

FOR JEWELRY (U.S. CLS. 2, 27, 28 AND 50).

C. DIONNE CLYBURN, EXAMINING ATTORNEY

**CLASS 14—(Continued).**

SN 85-218,428. SPATZ, MIKE, CHICAGO, IL. FILED 1-14-2011.



THE MARK CONSISTS OF THE LETTER "S" WITHIN A CIRCULAR SHAPE.

FOR ANKLE BRACELETS; BRACELETS; CHARMS; JEWELRY; NECKLACES (U.S. CLS. 2, 27, 28 AND 50).

MICHELLE DUBOIS, EXAMINING ATTORNEY

SN 85-218,432. SPATZ, MIKE, CHICAGO, IL. FILED 1-14-2011.

## SWITCHEE PODZ

THE MARK CONSISTS OF STANDARD CHARACTERS WITHOUT CLAIM TO ANY PARTICULAR FONT, STYLE, SIZE, OR COLOR.

FOR ANKLE BRACELETS; BRACELETS; CHARMS; JEWELRY; NECKLACES (U.S. CLS. 2, 27, 28 AND 50).

MICHELLE DUBOIS, EXAMINING ATTORNEY

SN 85-220,186. JEWELEX NEW YORK, LTD., NEW YORK, NY. FILED 1-18-2011.

ECOURA  
Lily BRIDAL

THE COLOR(S) GREEN AND BLACK IS/ARE CLAIMED AS A FEATURE OF THE MARK.

THE MARK CONSISTS OF THE LITERAL ELEMENT "ECOURA LILY BRIDAL" REPRESENTED IN STYLIZED FONT AND A DESIGN CONSISTING OF A STYLIZED LEAF BETWEEN THE LETTERS "O" AND THE "U" IN "ECOURA" WHEREIN THE ENTIRE WORD "ECOURA" AND THE LEAF DESIGN ARE IN THE COLOR GREEN, AND BENEATH THE WORD "ECOURA" ARE THE WORDS "LILY BRIDAL" IN THE COLOR BLACK. THE WORD "LILY" REPRESENTED IN STYLIZED CURSIVE FONT AND THE WORD "BRIDAL" REPRESENTED IN STYLIZED UPPERCASE LETTERS.

FOR JEWELRY, NAMELY, GOLD, PLATINUM, TITANIUM AND SILVER JEWELRY; AND GOLD, PLATINUM, TITANIUM AND SILVER JEWELRY WITH PRECIOUS STONES, NAMELY, DIAMONDS, RUBIES, EMERALDS, SAPPHIRES, AND SEMI-PRECIOUS COLORED STONES EMBEDDED THEREIN, AND PEARLS EMBEDDED THEREIN (U.S. CLS. 2, 27, 28 AND 50).

RONALD DELGIZZI, EXAMINING ATTORNEY

**CLASS 14—(Continued).**

SN 85-220,215. JEWELEX NEW YORK, LTD., NEW YORK, NY. FILED 1-18-2011.

**RADIANT** 

NO CLAIM IS MADE TO THE EXCLUSIVE RIGHT TO USE "RADIANT", APART FROM THE MARK AS SHOWN.

THE COLOR(S) BLUE AND BLACK IS/ARE CLAIMED AS A FEATURE OF THE MARK.

THE MARK CONSISTS OF THE WORD "RADIANT" REPRESENTED IN STYLIZED FONT IN THE COLOR BLACK AND A DESIGN CONSISTING OF A GRAPHIC REPRESENTATION OF A HEART IN THE COLOR BLUE AND LOCATED TO THE RIGHT OF THE WORD "RADIANT".

FOR JEWELRY, NAMELY, GOLD, PLATINUM, TITANIUM AND SILVER JEWELRY; AND GOLD, PLATINUM, TITANIUM AND SILVER JEWELRY WITH PRECIOUS STONES, NAMELY, DIAMONDS, RUBIES, EMERALDS, SAPPHIRES, AND SEMI-PRECIOUS COLORED STONES EMBEDDED THEREIN, AND PEARLS EMBEDDED THEREIN (U.S. CLS. 2, 27, 28 AND 50).

RONALD DELGIZZI, EXAMINING ATTORNEY

SN 85-222,145. NEW DOVER GROUP, VALLEY COTTAGE, NY. FILED 1-20-2011.

**GIULIO ROMANO**

THE MARK CONSISTS OF STANDARD CHARACTERS WITHOUT CLAIM TO ANY PARTICULAR FONT, STYLE, SIZE, OR COLOR.

THE NAME(S), PORTRAIT(S), AND/OR SIGNATURE(S) SHOWN IN THE MARK DOES NOT IDENTIFY A PARTICULAR LIVING INDIVIDUAL.

THE ENGLISH TRANSLATION OF "GIULIO ROMANO" IN THE MARK IS "JULIUS ROMAN".

FOR CHRONOGRAPHS AS WATCHES; JEWELRY WATCHES; SPORTS WATCHES; WATCHES (U.S. CLS. 2, 27, 28 AND 50).

RUSS HERMAN, EXAMINING ATTORNEY

**CLASS 14—(Continued).**

SN 85-228,833. CARTER, SHAWN, NEW YORK, NY. FILED 1-28-2011.

**AKA SHAWN CARTER**

THE MARK CONSISTS OF STANDARD CHARACTERS WITHOUT CLAIM TO ANY PARTICULAR FONT, STYLE, SIZE, OR COLOR.

THE NAME(S), PORTRAIT(S), AND/OR SIGNATURE(S) SHOWN IN THE MARK IDENTIFIES "SHAWN CARTER", WHOSE CONSENT(S) TO REGISTER IS MADE OF RECORD.

FOR JEWELRY OF PRECIOUS AND SEMI-PRECIOUS METALS, NAMELY, RINGS, EARRINGS, NECKLACES, BRACELETS, CUFF LINKS, PENDANTS, TUXEDO STUDS, AND WATCHES (U.S. CLS. 2, 27, 28 AND 50).

MATTHEW EINSTEIN, EXAMINING ATTORNEY

SN 85-230,169. PINYO K, LLC, SAN FRANCISCO, CA. FILED 1-31-2011.

**PINYO**

THE MARK CONSISTS OF STANDARD CHARACTERS WITHOUT CLAIM TO ANY PARTICULAR FONT, STYLE, SIZE, OR COLOR.

FOR JEWELRY (U.S. CLS. 2, 27, 28 AND 50).

NICHOLAS ALTREE, EXAMINING ATTORNEY

SN 85-230,188. PINYO K, LLC, SAN FRANCISCO, CA. FILED 1-31-2011.



**PINYO**

THE MARK CONSISTS OF THE STYLIZED WORDING "PINYO" BENEATH A CIRCULAR ABSTRACT RENDERING OF A HUMAN SKULL.

FOR JEWELRY (U.S. CLS. 2, 27, 28 AND 50).

NICHOLAS ALTREE, EXAMINING ATTORNEY

**CLASS 14—(Continued).**

SN 85-231,799. LANCECO INDUSTRIES, INC., DBA C.G. CREATIONS, PEARL RIVER, NY. FILED 2-1-2011.

**MULTI LOK**

THE MARK CONSISTS OF STANDARD CHARACTERS WITHOUT CLAIM TO ANY PARTICULAR FONT, STYLE, SIZE, OR COLOR.

FOR JEWELRY (U.S. CLS. 2, 27, 28 AND 50).  
C. DIONNE CLYBURN, EXAMINING ATTORNEY

SN 85-239,743. MILITTI SALES & PROMOTIONS, LLC, OMAHA, NE. FILED 2-11-2011.

**BAD**  
**BVD** JEWELRY

NO CLAIM IS MADE TO THE EXCLUSIVE RIGHT TO USE "JEWELRY", APART FROM THE MARK AS SHOWN. THE COLOR(S) RED AND BLACK IS/ARE CLAIMED AS A FEATURE OF THE MARK.

THE MARK CONSISTS OF "BAD" IN RED WITH A SHADOW OF "BAD" IN BLACK, THEN "JEWELRY" IN BLACK.

FOR JEWELRY (U.S. CLS. 2, 27, 28 AND 50).  
FIRST USE 1-1-2011; IN COMMERCE 1-1-2011.  
MARK PILARO, EXAMINING ATTORNEY

SN 85-249,954. CANARY INVESTMENTS, INC., HOUSTON, TX. FILED 2-23-2011.



THE MARK CONSISTS OF OVERLAPPING "V" AND "W" WITH A DIAMOND IMAGE.

FOR DIAMOND JEWELRY; CUT DIAMONDS; PRECIOUS AND SEMI-PRECIOUS GEMS (U.S. CLS. 2, 27, 28 AND 50).

FIRST USE 2-11-2011; IN COMMERCE 2-11-2011.  
JANICE L. MCMORROW, EXAMINING ATTORNEY

**CLASS 14—(Continued).**

SN 85-269,322. JUICY COUTURE, INC., PACOIMA, CA. FILED 3-17-2011.



OWNER OF U.S. REG. NO. 3,698,422.  
THE MARK CONSISTS OF STYLIZED LETTERS "J" AND "C" WITH A CROWN DESIGN ABOVE THE LETTERS.

FOR BRACELETS; CHARMS; CUFFLINKS; EARRINGS; JEWELRY; JEWELRY BOXES; JEWELRY CASES; JEWELRY, NAMELY, ANKLETS; KEY CHAINS AS JEWELLERY; NECKLACES; PENDANTS; PINS BEING JEWELRY; RINGS; WATCHES (U.S. CLS. 2, 27, 28 AND 50).

REGINA DRUMMOND, EXAMINING ATTORNEY

**CLASS 15—MUSICAL INSTRUMENTS**

SN 85-162,880. SCHECTER GUITAR RESEARCH, INC., BURBANK, CA. FILED 10-27-2010.

**sgt**  
by SCHECTER

OWNER OF U.S. REG. NOS. 3,334,506, 3,683,164 AND 3,739,170.

THE MARK CONSISTS OF THE STYLIZED LETTERS "S", "G", "R" WITH THE WORDS "BY SCHECTER" BELOW AND SLIGHTLY TO THE RIGHT.

FOR MUSICAL INSTRUMENTS, NAMELY, GUITARS AND BASS GUITARS (U.S. CLS. 2, 21 AND 36).

JASON BLAIR, EXAMINING ATTORNEY

**CLASS 15—(Continued).**

SN 85-186,768. JAMES ANDREW DUNLOP, BENICIA, CA. FILED 11-29-2010.

**CUSTOM BADASS MODIFICATIONS**

THE MARK CONSISTS OF STANDARD CHARACTERS WITHOUT CLAIM TO ANY PARTICULAR FONT, STYLE, SIZE, OR COLOR.

NO CLAIM IS MADE TO THE EXCLUSIVE RIGHT TO USE "CUSTOM" AND "MODIFICATIONS", APART FROM THE MARK AS SHOWN.

FOR ELECTRONIC SOUND ALTERING DEVICES, NAMELY, ELECTRONIC EFFECTS PEDALS FOR USE WITH MUSICAL INSTRUMENTS AND VOCAL SOUND (U.S. CLS. 2, 21 AND 36).

NAPOLEON SHARMA, EXAMINING ATTORNEY

SN 85-188,427. ROBERT C. DESTOCKI, DBA SHAKERSTIX, MOORPARK, CA. FILED 12-1-2010.

**SHAKERSTIX**  
THE REVOLUTIONARY NEW WAY TO KEEP THE BEAT

THE MARK CONSISTS OF THE STYLIZED WORDS "SHAKERSTIX" ABOVE THE PHRASE "THE REVOLUTIONARY NEW WAY TO KEEP THE BEAT". THE LETTER "A" IN "SHAKERSTIX" CONTAINS A STAR.

FOR DRUMSTICKS; PERCUSSION INSTRUMENTS (U.S. CLS. 2, 21 AND 36).

SANI KHOURI, EXAMINING ATTORNEY

SN 85-197,566. INSPIRED INSTRUMENTS, INC., CHATSWORTH, CA. FILED 12-14-2010.

**YOU ROCK Mode**  
Never Play a Wrong Note

THE MARK CONSISTS OF THE WORDING "YOU ROCK MODE" SUPERIMPOSED OVER A SERIES OF VERTICAL LINES AND THE WORDING "NEVER PLAY A WRONG NOTE" BENEATH IT.

FOR ELECTRONIC MUSICAL INSTRUMENTS (U.S. CLS. 2, 21 AND 36).

FIRST USE 7-1-2009; IN COMMERCE 12-1-2009.

KAREN BRACEY, EXAMINING ATTORNEY

**CLASS 15—(Continued).**

SN 85-199,906. ZION GUITARS, INC., GREENSBORO, NC. FILED 12-16-2010.

**Zion**  
GUITARS, INC.

NO CLAIM IS MADE TO THE EXCLUSIVE RIGHT TO USE GUITARS, INC., APART FROM THE MARK AS SHOWN.

THE COLOR(S) WHITE, BLACK AND GRAY IS/ARE CLAIMED AS A FEATURE OF THE MARK.

THE MARK CONSISTS OF THE WORD "ZION" IN HAND DRAWN GRAY AND WHITE SCRIPT OUTLINED IN BLACK WITH THE IMAGE OF A GUITAR HEADSTOCK TO ITS RIGHT SHOWING A BLACK OUTLINE WITH GRAY AND WHITE SHADOW FILL. THE WORDS "GUITARS, INC." ARE BELOW IN BLACK STANDARD FONT.

FOR ACOUSTIC GUITARS; ELECTRIC BASS GUITARS; ELECTRIC GUITARS (U.S. CLS. 2, 21 AND 36).

JASON TURNER, EXAMINING ATTORNEY

SN 85-206,723. CONCERT PARTS, INC., RIPLEY, MS. FILED 12-28-2010.

**C** CONCERT  
PARTS

NO CLAIM IS MADE TO THE EXCLUSIVE RIGHT TO USE "PARTS", APART FROM THE MARK AS SHOWN.

THE MARK CONSISTS OF THE STYLIZED TEXT "CONCERT PARTS". THE LETTER "C" HAS GUITAR STRINGS RUNNING VERTICALLY THROUGH IT. THERE IS A HORIZONTAL LINE BENEATH THE "O".

FOR GUITAR PICKS; MUSICAL INSTRUMENTS (U.S. CLS. 2, 21 AND 36).

NANCY CLARKE, EXAMINING ATTORNEY

**CLASS 15—(Continued).**

SN 85-208,445. INSPIRED INSTRUMENTS, INC., CHATSWORTH, CA. FILED 12-31-2010.

**NNT**  
Never Needs Tuning

NO CLAIM IS MADE TO THE EXCLUSIVE RIGHT TO USE "NEVER NEEDS TUNING", APART FROM THE MARK AS SHOWN.

THE MARK CONSISTS OF THE LETTERS "NNT" AS AN ABBREVIATION AND THE WORDS "NEVER NEEDS TUNING" BELOW THE ABBREVIATED LETTERS.

FOR ELECTRONIC MUSICAL INSTRUMENTS (U.S. CLS. 2, 21 AND 36).

FIRST USE 7-31-2009; IN COMMERCE 12-1-2009.  
KATINA MISTER, EXAMINING ATTORNEY

SN 85-209,021. DRUM RÖHL, LLC, NORTH EAST, PA. FILED 1-3-2011.

**DRUM RöhL**

NO CLAIM IS MADE TO THE EXCLUSIVE RIGHT TO USE "DRUM", APART FROM THE MARK AS SHOWN.

THE MARK CONSISTS OF THE WORD "DRUM" PLACED VERTICALLY ON THE IMMEDIATE LEFT OF THE LETTER "R" OF THE WORD "RÖHL," WITH AN UMLAUT ABOVE THE LETTER "O".

FOR DRUMS (U.S. CLS. 2, 21 AND 36).  
FIRST USE 11-22-2010; IN COMMERCE 11-22-2010.  
LAURA KOVALSKY, EXAMINING ATTORNEY

**CLASS 15—(Continued).**

SN 85-209,907. BRINKSCHULTE, ALEXA, LOS ANGELES, CA. FILED 1-4-2011.

**Alexa  
Drums**

NO CLAIM IS MADE TO THE EXCLUSIVE RIGHT TO USE "DRUMS", APART FROM THE MARK AS SHOWN.

THE MARK CONSISTS OF BOLD LETTERING, "ALEXA" ON TOP, "DRUMS" UNDERNEATH, WITH STARS ON TOP LEFT CORNER AND ONE STAR IN THE UNDERSCORE.

FOR DRUMS (U.S. CLS. 2, 21 AND 36).  
CAROLYN CATALDO, EXAMINING ATTORNEY

SN 85-210,578. MIDITRONIX, LLC, BOW, WA. FILED 1-5-2011.

**INHEAD**

THE MARK CONSISTS OF STANDARD CHARACTERS WITHOUT CLAIM TO ANY PARTICULAR FONT, STYLE, SIZE, OR COLOR.

FOR ELECTRONIC MUSICAL INSTRUMENTS FOR PLAYING ORIGINAL MUSIC OR FOR PLAYING MUSICALLY COMPATIBLE ACCOMPANIMENT TO A PRE-RECORDED PERFORMANCE (U.S. CLS. 2, 21 AND 36).

FIRST USE 12-15-2010; IN COMMERCE 12-15-2010.  
FLORENTINA BLANDU, EXAMINING ATTORNEY

SN 85-211,468. TRUTH CUSTOM DRUMS, INC., BEAVERTON, OR. FILED 1-5-2011.



NO CLAIM IS MADE TO THE EXCLUSIVE RIGHT TO USE "CUSTOM DRUMS", APART FROM THE MARK AS SHOWN.

THE MARK CONSISTS OF A TRADITIONAL CREST/



**CLASS 15—(Continued).**

SHIELD DESIGN, WITH A CROSS AND FOUR OPEN AREAS AROUND EACH QUADRANT OF THE CROSS SURROUNDED BY THE CREST BOUNDARIES, WITH THE WORDS "TRUTH CUSTOM DRUMS" POSITIONED AT THE WIDEST CENTRAL UPPER TOP AREA OF THE CREST. THERE ARE THREE CIRCLES, TWO AT THE LEFT AND RIGHT POINTS OF THE SHIELD AND ONE AT THE BOTTOM POINT OF THE SHIELD. THERE ARE THREE FIVE-POINTED STARS INSIDE THE LETTER "H". THE WORD "TRUTH" IS UNDERLINED BY A HORIZONTAL BAR THAT IS PARTLY FORMED BY THE LETTER "R".

FOR DRUMS (U.S. CLS. 2, 21 AND 36).  
FIRST USE 7-1-2005; IN COMMERCE 8-1-2005.  
AMY HELLA, EXAMINING ATTORNEY

---

SN 85-212,613. GIBSON GUITAR CORP., NASHVILLE, TN.  
FILED 1-7-2011.

**LES PAUL STEAMPUNK**

THE MARK CONSISTS OF STANDARD CHARACTERS WITHOUT CLAIM TO ANY PARTICULAR FONT, STYLE, SIZE, OR COLOR.

OWNER OF U.S. REG. NOS. 918,934 AND 1,539,282.  
"LES PAUL" IS THE NAME OF AN INDIVIDUAL WHO IS NO LONGER LIVING, HOWEVER HIS CONSENT IS OF RECORD.

FOR BASS GUITARS; ELECTRIC GUITARS; GUITARS (U.S. CLS. 2, 21 AND 36).  
FRANK LATTUCA, EXAMINING ATTORNEY

---

SN 85-218,860. MONTANA JOHN CHRISTIAN, DBA SINTI GUITAR WORKS, LANDENBERG, PA. FILED 1-16-2011.

**Sinti**

THE MARK CONSISTS OF STANDARD CHARACTERS WITHOUT CLAIM TO ANY PARTICULAR FONT, STYLE, SIZE, OR COLOR.

FOR MUSICAL INSTRUMENTS (U.S. CLS. 2, 21 AND 36).  
FIRST USE 10-8-2008; IN COMMERCE 10-8-2008.  
KIMBERLY FRYE, EXAMINING ATTORNEY

**CLASS 15—(Continued).**

SN 85-235,360. GIBSON GUITAR CORP., NASHVILLE, TN.  
FILED 2-7-2011.

**GIBSON FIREBIRD**

THE MARK CONSISTS OF STANDARD CHARACTERS WITHOUT CLAIM TO ANY PARTICULAR FONT, STYLE, SIZE, OR COLOR.

OWNER OF U.S. REG. NOS. 2,738,824, 3,914,522 AND OTHERS.

FOR ELECTRIC GUITARS; GUITARS (U.S. CLS. 2, 21 AND 36).

FIRST USE 12-31-1963; IN COMMERCE 12-31-1963.  
FRANK LATTUCA, EXAMINING ATTORNEY

**CLASS 16—PAPER GOODS AND PRINTED MATTER**

SN 76-705,064. MUASHER, GHADA, AMMAN 11183, JORDAN, FILED 10-25-2010.

**I Can**

THE MARK CONSISTS OF STANDARD CHARACTERS WITHOUT CLAIM TO ANY PARTICULAR FONT, STYLE, SIZE, OR COLOR.

FOR CHILDREN'S BOOKS AND TEACHING MATERIALS, NAMELY, CHILDREN'S BOOKS (U.S. CLS. 2, 5, 22, 23, 29, 37, 38 AND 50).

FIRST USE 5-11-2010; IN COMMERCE 5-11-2010.  
CARYN GLASSER, EXAMINING ATTORNEY

---

SN 77-342,887. ZENBU MEDIA LLC, NEW YORK, NY. FILED 12-3-2007.

**CIRCLE NEW YORK**

THE MARK CONSISTS OF STANDARD CHARACTERS WITHOUT CLAIM TO ANY PARTICULAR FONT, STYLE, SIZE, OR COLOR.

NO CLAIM IS MADE TO THE EXCLUSIVE RIGHT TO USE "NEW YORK", APART FROM THE MARK AS SHOWN.

FOR GUIDE BOOKS FEATURING TRAVEL, SHOPPING, DINING, AND EVENTS (U.S. CLS. 2, 5, 22, 23, 29, 37, 38 AND 50).

FIRST USE 8-10-2007; IN COMMERCE 8-10-2007.  
CURTIS FRENCH, EXAMINING ATTORNEY

**CLASS 16—(Continued).**

SN 77-698,749. MICHIGAN CONFERENCE ASSOCIATION OF SEVENTH-DAY ADVENTISTS, LANSING, MI. FILED 3-25-2009.

**Lifestyle Matters at Work**

THE MARK CONSISTS OF STANDARD CHARACTERS WITHOUT CLAIM TO ANY PARTICULAR FONT, STYLE, SIZE, OR COLOR.

OWNER OF U.S. REG. NO. 3,182,568.  
FOR EDUCATIONAL PUBLICATIONS, NAMELY, EDUCATIONAL LEARNING CARDS, FLASH CARDS, ACTIVITY CARDS, WORKBOOKS, TEXTBOOKS, ACTIVITY BOOKS, STORY BOOKS, PUZZLE BOOKS, PRINTED PUZZLES, TEACHER GUIDES, MANUALS, POSTERS AND EDUCATIONAL BOOKLETS IN THE FIELD OF HEALTHFUL LIVING PURSUANT TO THE BELIEFS OF THE SEVENTH-DAY ADVENTIST CHURCH (U.S. CLS. 2, 5, 22, 23, 29, 37, 38 AND 50).

FIRST USE 5-1-2008; IN COMMERCE 5-1-2008.  
CARYN GLASSER, EXAMINING ATTORNEY

SN 77-726,442. DOLCE, MICHAEL, HUNTINGTON BEACH, CA. FILED 4-30-2009.

**THE DOLCE DIET**

THE MARK CONSISTS OF STANDARD CHARACTERS WITHOUT CLAIM TO ANY PARTICULAR FONT, STYLE, SIZE, OR COLOR.

NO CLAIM IS MADE TO THE EXCLUSIVE RIGHT TO USE "DIET", APART FROM THE MARK AS SHOWN. THE ENGLISH TRANSLATION OF "DOLCE" IN THE MARK IS "DOLCE".

FOR A SERIES OF BOOKS AND WRITTEN ARTICLES IN THE FIELD OF DIET, HEALTH, FITNESS, EXERCISE, AND LIFESTYLE; BLANK JOURNAL BOOKS; BOOKS IN THE FIELD OF DIET, HEALTH, FITNESS, EXERCISE, AND LIFESTYLE; CHILDREN'S BOOKS; COOK BOOKS; EXERCISE BOOKS; REFERENCE BOOKS IN THE FIELD OF DIET, HEALTH, FITNESS, EXERCISE, AND LIFESTYLE; RESOURCE BOOKS IN THE FIELD OF DIET, HEALTH, FITNESS, EXERCISE, AND LIFESTYLE; SERIES OF FICTION WORKS, NAMELY, NOVELS AND BOOKS; SERIES OF NON-FICTION BOOKS IN THE FIELD OF DIET, HEALTH, FITNESS, EXERCISE, AND LIFESTYLE; WIREBOUND BOOKS (U.S. CLS. 2, 5, 22, 23, 29, 37, 38 AND 50).

DAVID TOOLEY, EXAMINING ATTORNEY

**CLASS 16—(Continued).**

SN 77-815,546. ESPEY, JULIA H., MEDINA, MN. FILED 8-28-2009.

**IF I WERE YOUR**

THE MARK CONSISTS OF STANDARD CHARACTERS WITHOUT CLAIM TO ANY PARTICULAR FONT, STYLE, SIZE, OR COLOR.

FOR A SERIES OF BOOKS AND WRITTEN ARTICLES IN THE FIELD OF PERSONAL INSPIRATION, PARENTING, LEAVING A LEGACY, COACHING, LIFESTYLE, RELATIONSHIPS, HEALTH, BUSINESS, WEALTH, HAPPINESS, AND FINANCIAL CONTRIBUTIONS; MAGAZINES IN THE FIELD OF PERSONAL INSPIRATION, PARENTING, LEAVING A LEGACY, COACHING, LIFESTYLE, RELATIONSHIPS, HEALTH, BUSINESS, WEALTH, HAPPINESS, AND FINANCIAL CONTRIBUTIONS; SERIES OF NON-FICTION BOOKS IN THE FIELD OF PERSONAL INSPIRATION, PARENTING, LEAVING A LEGACY, COACHING, LIFESTYLE, RELATIONSHIPS, HEALTH, BUSINESS, WEALTH, HAPPINESS, AND FINANCIAL CONTRIBUTIONS (U.S. CLS. 2, 5, 22, 23, 29, 37, 38 AND 50).

MEGHAN REINHART, EXAMINING ATTORNEY

SN 77-862,414. BRIDGEHEAD SOFTWARE LIMITED, ASHTEAD, SURREY, ENGLAND, FILED 11-2-2009.



THE COLOR(S) RED AND GRAY IS/ARE CLAIMED AS A FEATURE OF THE MARK.

THE MARK CONSISTS OF A RED CUBE ALONGSIDE THE GRAY WORD "BRIDGEHEAD", THE WHITE LINES IN THE CUBE REPRESENT TRANSPARENT AREAS AND ARE NOT CLAIMED AS A FEATURE OF THE MARK.

FOR PROPRIETARY SOFTWARE PROGRAMS AND DATA PROCESSING PROGRAMS IN PRINTED FORM; PROPRIETARY COMPUTER PROGRAM MANUALS FOR ELECTRONIC DATA MANAGEMENT, BACK-UP, RECOVERY AND ARCHIVING; PRINTED INFORMATIONAL, INSTRUCTIONAL, EDUCATIONAL, AND TEACHING MATERIALS IN THE FIELD OF PROPRIETARY COMPUTER SOFTWARE FOR USE IN ELECTRONIC DATA MANAGEMENT, BACK-UP, RECOVERY AND ARCHIVING; PUBLICATIONS, NAMELY, TECHNICAL MANUALS, USER GUIDES AND TRAINING MANUALS RELATING TO PROPRIETARY COMPUTER SOFTWARE FOR USE IN ELECTRONIC DATA MANAGEMENT, BACK-UP, RECOVERY AND ARCHIVING (U.S. CLS. 2, 5, 22, 23, 29, 37, 38 AND 50).

FIRST USE 2-0-2000; IN COMMERCE 2-0-2000.

KATHLEEN LORENZO, EXAMINING ATTORNEY

**CLASS 16—(Continued).**

SN 77-863,613. UNITED STATES SWIMMING, INC., DBA USA SWIMMING, COLORADO SPRINGS, CO. FILED 11-3-2009.



OWNER OF U.S. REG. NOS. 1,222,932, 3,062,502 AND OTHERS.

THE MARK CONSISTS OF THE STYLIZED WORDING "AMERICA'S SWIM TEAM" WITH A STYLIZED DRAWING OF A SOLID CIRCLE CONTAINING A STAR BETWEEN THE WORDS "SWIM" AND "TEAM"; A STYLIZED DRAWING OF A SHIELD APPEARS ABOVE CONTAINING THE STYLIZED WORDING "USA SWIMMING" AT THE TOP, VERTICAL STRIPES REPRESENTING SWIMMING LANES AT THE BOTTOM AND A STAR IN THE MIDDLE.

SEC. 2(F) AS TO "USA SWIMMING".

FOR PRINTED MATERIALS, NAMELY, POSTERS, DECALS, AND MAGAZINES, ALL IN THE FIELD OF THE GENERAL SPORT OF SWIMMING (U.S. CLS. 2, 5, 22, 23, 29, 37, 38 AND 50).

AMEEN IMAM, EXAMINING ATTORNEY

SN 77-863,624. UNITED STATES SWIMMING, INC., DBA USA SWIMMING, COLORADO SPRINGS, CO. FILED 11-3-2009.



OWNER OF U.S. REG. NOS. 1,222,932, 3,062,502 AND OTHERS.

THE MARK CONSISTS OF THE STYLIZED WORDING "AMERICA'S SWIM TEAM" WITH A STYLIZED DRAWING OF A SOLID CIRCLE CONTAINING A STAR BETWEEN THE WORDS "SWIM" AND "TEAM"; A STYLIZED DRAWING OF A SHIELD APPEARS TO THE LEFT CONTAINING THE STYLIZED WORDING "USA SWIMMING" AT THE TOP, VERTICAL STRIPES REPRESENTING SWIMMING LANES AT THE BOTTOM AND A STAR IN THE MIDDLE.

SEC. 2(F) AS TO "USA SWIMMING".

FOR PRINTED MATERIALS, NAMELY, POSTERS, DECALS, AND MAGAZINES, ALL IN THE FIELD OF THE GENERAL SPORT OF SWIMMING (U.S. CLS. 2, 5, 22, 23, 29, 37, 38 AND 50).

AMEEN IMAM, EXAMINING ATTORNEY

**CLASS 16—(Continued).**

SN 77-871,692. CARLA THOMPSON, WESTLAND, MI. FILED 11-12-2009.

## THE BUSY WOMAN'S POCKET GUIDE TO

THE MARK CONSISTS OF STANDARD CHARACTERS WITHOUT CLAIM TO ANY PARTICULAR FONT, STYLE, SIZE, OR COLOR.

NO CLAIM IS MADE TO THE EXCLUSIVE RIGHT TO USE "WOMAN'S POCKET GUIDE TO", APART FROM THE MARK AS SHOWN.

FOR A SERIES OF BOOKS, WRITTEN ARTICLES, HANDOUTS AND WORKSHEETS IN THE FIELD OF WOMEN'S NEEDS, NAMELY, PERSONAL SAFETY, NUTRITION, CAR REPAIRS, PERSONAL FINANCE, AND HOME REPAIRS (U.S. CLS. 2, 5, 22, 23, 29, 37, 38 AND 50).

LOURDES AYALA, EXAMINING ATTORNEY

SN 77-872,920. ULTRA GREEN PACKAGING, LLC, PLYMOUTH, MN. FILED 11-15-2009.

## TREE SAVER

THE MARK CONSISTS OF STANDARD CHARACTERS WITHOUT CLAIM TO ANY PARTICULAR FONT, STYLE, SIZE, OR COLOR.

OWNER OF U.S. REG. NO. 3,920,888.

FOR BIODEGRADABLE AND COMPOSTABLE PACKAGING AND CONTAINERS COMPRISED OF CELLULOSE FIBER IN THE NATURE OF A PAPER SUBSTITUTE FOR FOOD, BEVERAGES AND CONSUMER PRODUCTS; BIODEGRADABLE AND COMPOSTABLE PACKAGING AND CONTAINERS FOR FOOD SERVICE COMPRISED OF CELLULOSE FIBER IN THE NATURE OF A PAPER SUBSTITUTE; FACIAL TISSUE; TOILET TISSUE; BIODEGRADABLE CELLULOSE FIBER-BASED KITCHEN TOWELS (U.S. CLS. 2, 5, 22, 23, 29, 37, 38 AND 50).

FIRST USE 3-22-2010; IN COMMERCE 3-22-2010.

TIMOTHY FINNEGAN, EXAMINING ATTORNEY

SN 77-881,727. CALIFORNIA ASSOCIATION OF LEGAL DOCUMENT ASSISTANTS, AKA CALDA, FRESNO, CA. FILED 11-28-2009.



NO CLAIM IS MADE TO THE EXCLUSIVE RIGHT TO USE "CALIFORNIA ASSOCIATION OF LEGAL DOCUMENT ASSISTANTS" AND "EDUCATION, ETHICS, EXCELLENCE", APART FROM THE MARK AS SHOWN.

THE COLOR(S) BLUE AND YELLOW IS/ARE CLAIMED AS A FEATURE OF THE MARK.

THE MARK CONSISTS OF LINE 1. THE WORD "CALDA" IS IN BOLD, UPPER CASE LETTERS IN ROYAL BLUE. THE LAST LETTER WHICH IS THE LETTER "A" HAS AN

**CLASS 16—(Continued).**

IMAGE OF STATE OF "CALIFORNIA" SUPER IMPOSED OVER THE RIGHT LEG IN YELLOW. THE SUPER IMPOSED IMAGE IS THE SAME HEIGHT OF THE LAST LEG OF THE LETTER "A" HAD IT BEEN VISIBLE. LINE 2. "CALIFORNIA ASSOCIATION OF LEGAL DOCUMENT ASSISTANTS" IS IN BOLD, UPPER CASE LETTERS BUT SMALLER IN SIZE THAN LINE 1 AND IS IN ROYAL BLUE. LINE 2 IS APPROXIMATELY ONE SIXTH OF THE SIZE OF LINE 1. LINE 3. "SETTING THE STANDARD...EDUCATION, ETHICS, EXCELLENCE", ONLY THE FIRST LETTER IS IN UPPER CASE AND THE REST OF THE LINE IS IN LOWER CASE AND IS ALSO IN ROYAL BLUE IN REGULAR FONT. THERE ARE 3 DOTS FOLLOWING THE WORD "STANDARD". LINE 3 IS APPROXIMATELY ONE FIFTH OF THE SIZE OF LINE 1. ALL 3 LINES ARE THE SAME WIDTH. THE COLOR WHITE REPRESENTS A BACKGROUND AND IS NOT PART OF THE MARK.

FOR PRINTED EDUCATIONAL MATERIALS IN THE FIELD OF LEGAL FORMS PREPARATION (U.S. CLS. 2, 5, 22, 23, 29, 37, 38 AND 50).

FIRST USE 1-1-2004; IN COMMERCE 1-1-2004.

KHANH LE, EXAMINING ATTORNEY

SN 77-939,601. GREAT WALL STREET, LLC, WESTON, FL. FILED 2-19-2010.



NO CLAIM IS MADE TO THE EXCLUSIVE RIGHT TO USE "SINCE 1878", APART FROM THE MARK AS SHOWN. THE NAME(S), PORTRAIT(S), AND/OR SIGNATURE(S) SHOWN IN THE MARK DOES NOT IDENTIFY A PARTICULAR LIVING INDIVIDUAL.

THE MARK CONSISTS OF A STYLIZED REPRESENTATION OF THE DESIGNATION "J. O. WRIGHT SINCE 1878" WITH DIAMOND REPRESENTING PERIODS AFTER THE LETTERS "J" AND "O" AND A CROSS IN A CIRCLE REPRESENTING THE LETTER "O".

FOR PENS (U.S. CLS. 2, 5, 22, 23, 29, 37, 38 AND 50).

PRISCILLA MILTON, EXAMINING ATTORNEY

SN 77-939,622. GREAT WALL STREET, LLC, WESTON, FL. FILED 2-19-2010.



THE MARK CONSISTS OF A STYLIZED REPRESENTATION OF THE WORDING "REPORTER".

FOR PENS (U.S. CLS. 2, 5, 22, 23, 29, 37, 38 AND 50).

PRISCILLA MILTON, EXAMINING ATTORNEY

**CLASS 16—(Continued).**

SN 79-084,014. GUSTAV STABERNACK GMBH, FED REP GERMANY, FILED 4-27-2010.

STI

THE MARK CONSISTS OF STANDARD CHARACTERS WITHOUT CLAIM TO ANY PARTICULAR FONT, STYLE, SIZE, OR COLOR.

OWNER OF INTERNATIONAL REGISTRATION 0700306 DATED 5-15-1998, EXPIRES 5-15-2018.

FOR PAPER, CARDBOARD AND GOODS MADE FROM THESE MATERIALS, IN PARTICULAR STATIONERY CASES, PROTECTIVE WRAPPING MADE OF PAPER AND CARDBOARD, STAND-UPS FOR PRESENTING GOODS, NAMELY, PAPER DISPLAY BOXES; PRINTED CORRUGATED CARDBOARD AND ITEMS MADE THERE FROM, IN PARTICULAR PACKAGING AND SIGNBOARD DISPLAYS; PACKAGING AND ADVERTISING MEANS MADE OF FOLDABLE MATERIAL, NAMELY, FOLDING PAPER BOXES, GIFT PACKAGING BOXES, TRANSPORT PACKAGING AND ALL KIND OF PACKAGING MADE FROM PAPER CARTON BOARD OR CORRUGATED BOARD, NAMELY, DISPLAY BOXES, BROCHURES FOR THIRD PARTIES IN THE FIELD OF MARKETING AND BLANK FORMS FOR PACKAGING AND ADVERTISING, PAPER PARTY DECORATION, AND STAND-UPS, NAMELY, DISPLAY BOXES MADE OF PAPER AND/OR CARDBOARD TO BE USED FOR PROMOTION AND PRESENTING GOODS; MULTILAYER FOLDABLE MATERIALS AND MULTILAYER BLANKS FOR PACKAGING, NAMELY, CARDBOARD IN THE NATURE OF POSTERS, BLANK LABELS, BLANK CEILING HANGERS, NAMELY, DISPLAYS IN THE NATURE OF PAPER SIGN BOARDS, SALES FOLDERS, PRESENTATION FOLDERS, BROCHURE MAPS, COUNTER AND FLOOR STAND-UPS IN THE NATURE OF PAPER DISPLAY BOXES; PRINTED MATTER, NAMELY, BOOKS AND BROCHURES IN THE FIELD OF MARKETING, PACKAGING AND RELATED LOGISTICS BROCHURES, NAMELY, PRINTED MATERIAL IN THE NATURE OF COLOR SAMPLES; GENERAL PURPOSE PLASTIC BAGS AND PLASTIC BUBBLE PACKS FOR PACKAGING OR WRAPPING (U.S. CLS. 2, 5, 22, 23, 29, 37, 38 AND 50).

JESSICA A. POWERS, EXAMINING ATTORNEY

**CLASS 16—(Continued).**

SN 79-091,160. SHANDONG TRALIN PAPER CO., LTD, CHINA, FILED 7-20-2010.



OWNER OF INTERNATIONAL REGISTRATION 1061396 DATED 7-20-2010, EXPIRES 7-20-2020.

THE MARK CONSISTS OF THE WORDING "TRALIN" UNDERNEATH A HORIZONTAL LINE ABOVE WHICH APPEARS A DESIGN OF A TREE.

THE WORDING "TRALIN" HAS NO MEANING IN A FOREIGN LANGUAGE.

FOR PAPER; WOOD PULP PAPER; PRINTING PAPER; ART PAPER; COPY PAPER; CORRUGATED PAPER; PRINTED MATTER, NAMELY, NEWSPAPERS, PHOTOGRAPHS, MAGAZINES, PRINTED PERIODICALS, NEWSLETTERS, AND BROCHURES ALL IN THE FIELDS OF SECURITIES, OPTIONS AND OTHER FINANCIAL INSTRUMENTS; PAPER BAGS OR PLASTIC BAGS FOR PACKING; CARDBOARD; CARDBOARD BOXES AND CARTONS; KRAFT PAPER; CARTON MADE OF PAPER OR CARDBOARD (U.S. CLS. 2, 5, 22, 23, 29, 37, 38 AND 50).

ANDREA HACK, EXAMINING ATTORNEY

**CLASS 16—(Continued).**

SN 85-011,298. SILVERS, LINDA, E., DBA MONARCH MOON STUDIO, BETHESDA, MD. FILED 4-11-2010.



NO CLAIM IS MADE TO THE EXCLUSIVE RIGHT TO USE "STUDIO", APART FROM THE MARK AS SHOWN.

THE MARK CONSISTS OF THE SIDE VIEW OF A "MONARCH" BUTTERFLY STANDING ON THE UPPER LEFT PORTION OF THE MOON, AND THE WORDS "MONARCH MOON STUDIO" ARE WRAPPED IN A CURVED FASHION ALONG THE BOTTOM OF THE MOON.

FOR ART PRINTS ON CANVAS; CALENDARS; COLOR PRINTS; ENVELOPES; NOTE CARDS; PAPER STATIONERY; PHOTOGRAPHIC PRINTS; PHOTOGRAPHS; PICTURES; STATIONERY; UNMOUNTED AND MOUNTED PHOTOGRAPHS BOOKMARKS; PHOTOGRAPHS THAT HAVE BEEN COMPUTER MANIPULATED AND ENHANCED TO LOOK LIKE PAINTINGS; PICTURE BOOKS; PICTURE CARDS; PICTURE POSTCARDS; POSTCARDS; POSTERS (U.S. CLS. 2, 5, 22, 23, 29, 37, 38 AND 50).

MARTHA FROMM, EXAMINING ATTORNEY

SN 85-018,126. I AM AMERICA BOOKS, LLC, SCOTTSDALE, AZ. FILED 4-20-2010.



THE MARK CONSISTS OF STARS AND THE WORDS "I AM".

FOR PUBLICATIONS, NAMELY, BOOKS PROVIDING PICTURES AND TEXT GLORIFYING AMERICA AND THE INDIVIDUAL STATES IN THE FIELDS OF EDUCATION (U.S. CLS. 2, 5, 22, 23, 29, 37, 38 AND 50).

SOPHIA S. KIM, EXAMINING ATTORNEY



**CLASS 16—(Continued).**

SN 85-023,920. GUIDEPOSTS, A CHURCH CORPORATION, CARMEL, NY. FILED 4-27-2010.

**WHAT PRAYER CAN DO**

THE MARK CONSISTS OF STANDARD CHARACTERS WITHOUT CLAIM TO ANY PARTICULAR FONT, STYLE, SIZE, OR COLOR.

OWNER OF U.S. REG. NOS. 2,887,966 AND 2,920,443. SEC. 2(F).

FOR NEWSLETTER COLUMN FEATURING PERSONAL, SPIRITUAL, POSITIVE AND FAITH FILLED INFORMATION (U.S. CLS. 2, 5, 22, 23, 29, 37, 38 AND 50). FIRST USE 12-31-1993; IN COMMERCE 12-31-1993. ESTHER BELENKER, EXAMINING ATTORNEY

SN 85-026,060. DAP BRANDS COMPANY, MEDINA, OH. FILED 4-29-2010.

**CONTACTSTIK**

THE MARK CONSISTS OF STANDARD CHARACTERS WITHOUT CLAIM TO ANY PARTICULAR FONT, STYLE, SIZE, OR COLOR.

FOR ADHESIVE REPAIR STRIPS FOR HOUSEHOLD PURPOSES (U.S. CLS. 2, 5, 22, 23, 29, 37, 38 AND 50). JILL C. ALT, EXAMINING ATTORNEY

SN 85-039,209. NUBECO, LLC, CONCORD, CA. FILED 5-14-2010.

**TRADER VIC'S**

THE MARK CONSISTS OF STANDARD CHARACTERS WITHOUT CLAIM TO ANY PARTICULAR FONT, STYLE, SIZE, OR COLOR.

OWNER OF U.S. REG. NOS. 384,083, 2,552,786 AND 3,474,113.

FOR NOTE CARDS; POSTERS; PRINTED MENUS; RECIPE BOOKS (U.S. CLS. 2, 5, 22, 23, 29, 37, 38 AND 50). FIRST USE 0-0-1946; IN COMMERCE 0-0-1946. MARIA-VICTORIA SUAREZ, EXAMINING ATTORNEY

**CLASS 16—(Continued).**

SN 85-039,461. ROMANOFF PRODUCTS INC., CHATHAM, NY. FILED 5-14-2010.

**CREATIVITRAY**

THE MARK CONSISTS OF STANDARD CHARACTERS WITHOUT CLAIM TO ANY PARTICULAR FONT, STYLE, SIZE, OR COLOR.

FOR PLASTIC LAP DESKS, PLASTIC PEN AND PENCIL BOXES, PLASTIC STATIONERY BOXES AND PLASTIC PAINT BOXES (U.S. CLS. 2, 5, 22, 23, 29, 37, 38 AND 50).

FIRST USE 1-25-2008; IN COMMERCE 1-25-2008. SUSAN RICHARDS, EXAMINING ATTORNEY

SN 85-043,024. CURTIS KULIG, NEW YORK, NY. FILED 5-19-2010.



THE MARK CONSISTS OF THE TERM "LOVE ME" IN STYLIZED FONT WITH THE "M" APPEARING IN A HEART SHAPE AND WITH DRIPS APPEARING BELOW THE WORDING.

SEC. 2(F). FOR ART PRINTS (U.S. CLS. 2, 5, 22, 23, 29, 37, 38 AND 50).

FIRST USE 1-1-2004; IN COMMERCE 1-1-2005. CAROLINE WOOD, EXAMINING ATTORNEY

SN 85-047,103. WYNEWISHES, LLC, DBA WYNEWISHES, WALDWICK, NJ. FILED 5-25-2010.

**Wynewishes**

THE MARK CONSISTS OF STANDARD CHARACTERS WITHOUT CLAIM TO ANY PARTICULAR FONT, STYLE, SIZE, OR COLOR.

FOR GREETING CARD AND RIBBON SOLD TOGETHER AS A UNIT FOR AFFIXING TO WINE BOTTLES (U.S. CLS. 2, 5, 22, 23, 29, 37, 38 AND 50).

FIRST USE 6-1-2010; IN COMMERCE 6-1-2010. MICHAEL SOUDERS, EXAMINING ATTORNEY

**CLASS 16—(Continued).**

SN 85-048,936. PAULA ALFLEN, CEDAR, MI. FILED 5-27-2010.

**PRINTOONS**

THE MARK CONSISTS OF STANDARD CHARACTERS WITHOUT CLAIM TO ANY PARTICULAR FONT, STYLE, SIZE, OR COLOR.

FOR ARTS AND CRAFTS PAINT KITS (U.S. CLS. 2, 5, 22, 23, 29, 37, 38 AND 50).

FIRST USE 11-30-2009; IN COMMERCE 11-30-2009.

MATTHEW KLINE, EXAMINING ATTORNEY

SN 85-055,882. EVONIK STOCKHAUSEN GMBH, KREFELD, FED REP GERMANY, FILED 6-7-2010.

**STOKO REFRESH**

THE MARK CONSISTS OF STANDARD CHARACTERS WITHOUT CLAIM TO ANY PARTICULAR FONT, STYLE, SIZE, OR COLOR.

PRIORITY CLAIMED UNDER SEC. 44(D) ON ERP N CMNTY TM OFC APPLICATION NO. 008753493, FILED 12-14-2009, REG. NO. 008753493, DATED 8-2-2010, EXPIRES 12-14-2019.

OWNER OF U.S. REG. NOS. 1,291,666, 2,958,992 AND 3,334,481.

FOR PAPER, NAMELY, TOWELS OF PAPER, HANDKERCHIEFS OF PAPER, FACE TOWELS OF PAPER (U.S. CLS. 2, 5, 22, 23, 29, 37, 38 AND 50).

KATHERINE E. HALMEN, EXAMINING ATTORNEY

SN 85-058,092. SACHS, GEORGE, POWAY, CA. FILED 6-9-2010.

**DR. JOCKO**

THE MARK CONSISTS OF STANDARD CHARACTERS WITHOUT CLAIM TO ANY PARTICULAR FONT, STYLE, SIZE, OR COLOR.

OWNER OF U.S. REG. NO. 3,691,321.

FOR SERIES OF NON-FICTION CHILDREN'S BOOKS ON HEALTH, MEDICAL, FITNESS AND NUTRITION TOPICS; SERIES OF FICTION CHILDREN'S BOOKS; COLORING BOOKS; POSTERS; CALENDARS; STICKERS; DECALS; PENCILS; PENS; GREETING CARDS; NOTEBOOKS; NOTEPADS; WRITING JOURNALS; NEWSLETTERS IN THE FIELD OF HEALTH, MEDICINE, FITNESS, NUTRITION, AND ENTERTAINMENT; MAGAZINES IN THE FIELD OF HEALTH, MEDICINE, FITNESS, NUTRITION, AND ENTERTAINMENT; STATIONERY (U.S. CLS. 2, 5, 22, 23, 29, 37, 38 AND 50).

LEIGH CAROLINE CASE, EXAMINING ATTORNEY

**CLASS 16—(Continued).**

SN 85-058,256. REVISION, L.P., DALLAS, TX. FILED 6-9-2010.

**UV Wisdom**

THE MARK CONSISTS OF STANDARD CHARACTERS WITHOUT CLAIM TO ANY PARTICULAR FONT, STYLE, SIZE, OR COLOR.

NO CLAIM IS MADE TO THE EXCLUSIVE RIGHT TO USE "UV", APART FROM THE MARK AS SHOWN.

FOR ADVERTISING MATERIALS FOR OTHERS, NAMELY, POSTERS, FLYERS AND COUNTERCARDS IN THE NATURE OF PAPER PLACARDS USED TO PROMOTE COSMETIC PRODUCTS (U.S. CLS. 2, 5, 22, 23, 29, 37, 38 AND 50).

MEGHAN REINHART, EXAMINING ATTORNEY

SN 85-060,901. HARMONIX MUSIC SYSTEMS, INC., NEW YORK, NY. FILED 6-11-2010.



THE MARK CONSISTS OF THE WORDING "DANCE CENTRAL" IN A STYLIZED FONT AND A DESIGN THAT CONSIST OF A SHADED RECTANGLE.

FOR COMPUTER GAME INSTRUCTION MANUALS AND PUBLISHED GUIDES CONTAINING SUGGESTIONS ON HOW TO PLAY THE COMPUTER GAMES (U.S. CLS. 2, 5, 22, 23, 29, 37, 38 AND 50).

RENEE MCCRAY, EXAMINING ATTORNEY

SN 85-061,131. HOM ESSENCE, INC., LOS ALAMITOS, CA. FILED 6-11-2010.



**H O M E S S E N C E**

NO CLAIM IS MADE TO THE EXCLUSIVE RIGHT TO USE "HOME", APART FROM THE MARK AS SHOWN.

THE MARK CONSISTS OF THE LETTERS "H", "O" AND "M" IN SIDE-BY-SIDE SQUARE BOXES WITH A HORIZONTAL LINE OVER THE LETTER "O" AND THE WORDS "HOME ESSENCE" BELOW.

FOR STATIONERY AND ITEMS FOR STORAGE AND ORGANIZATION, NAMELY, PHOTO ALBUMS, BLANK JOURNALS, SCRAPBOOKS, GUEST BOOKS, GUEST JOURNALS, GREETING CARDS, PHOTO DISPLAY BOARDS AND PHOTO ENVELOPES (U.S. CLS. 2, 5, 22, 29, 37, 38 AND 50).

FIRST USE 2-28-2003; IN COMMERCE 2-28-2003.

JACQUELINE A. LAVINE, EXAMINING ATTORNEY

**CLASS 16—(Continued).**

SN 85-068,628. GRATITUDE SEASHELLS, LLC, WEST BLOOMFIELD, MI. FILED 6-22-2010.



THE COLOR(S) PLUM, PURPLE, CORAL, AND PINK IS/ARE CLAIMED AS A FEATURE OF THE MARK.

THE MARK CONSISTS OF FIVE FANG-SHAPED SEGMENTS DISPOSED IN ADJACENT AND SPACED RELATIONSHIP TO ONE ANOTHER TO FORM A SCALLOP-SHAPED SEASHELL, WHEREIN THE FIRST SEGMENT, ON THE FAR LEFT, IS THE LARGEST SEGMENT AND IS PLUM COLORED; THE SECOND SEGMENT IS ADJACENT TO THE FIRST SEGMENT, IS SMALLER THAN THE FIRST SEGMENT, AND IS PURPLE COLORED; THE THIRD SEGMENT IS ADJACENT TO THE SECOND SEGMENT, IS SMALLER THAN THE SECOND SEGMENT, AND IS CORAL COLORED; THE FOURTH SEGMENT IS ADJACENT TO THE THIRD SEGMENT, IS SMALLER THAN THE THIRD SEGMENT, AND IS PURPLE COLORED; AND THE FIFTH SEGMENT IS ADJACENT TO THE FOURTH SEGMENT, IS SMALLER THAN THE FOURTH SEGMENT, AND IS PINK COLORED.

FOR GIFT SETS CONSISTING PRIMARILY OF PRINTED MESSAGES CONTAINED IN A BAG, GIFT CARDS AND ALSO INCLUDING SEA SHELLS OR SEA GLASS (U.S. CLS. 2, 5, 22, 23, 29, 37, 38 AND 50).

FIRST USE 3-31-2009; IN COMMERCE 3-31-2009.

GINA FINK, EXAMINING ATTORNEY

SN 85-068,708. GRATITUDE SEASHELLS, LLC, WEST BLOOMFIELD, MI. FILED 6-22-2010.



THE MARK CONSISTS OF THE STYLIZED TEXT "GS". FOR GIFT SETS CONSISTING PRIMARILY OF PRINTED MESSAGES CONTAINED IN A BAG, GIFT CARDS AND ALSO INCLUDING SEA SHELLS OR SEA GLASS (U.S. CLS. 2, 5, 22, 23, 29, 37, 38 AND 50).

FIRST USE 3-31-2009; IN COMMERCE 3-31-2009.

GINA FINK, EXAMINING ATTORNEY

**CLASS 16—(Continued).**

SN 85-068,981. WILBERT FUNERAL SERVICES, INC., FOR-EST PARK, IL. FILED 6-22-2010.

**COMMEMORATIONS BY WILBERT**

THE MARK CONSISTS OF STANDARD CHARACTERS WITHOUT CLAIM TO ANY PARTICULAR FONT, STYLE, SIZE, OR COLOR.

OWNER OF U.S. REG. NOS. 760,486, 3,405,523 AND OTHERS.

FOR BOOKLETS AND BROCHURES IN THE FIELD OF CREMATION; DISPLAY MATERIALS, NAMELY, PRINTED CHARTS; SELECTION ROOM SIGNAGE, NAMELY, CORRUGATED PAPER PANELS LAMINATED WITH BLEACHED WHITE PAPER PRIMARILY FOR APPLICATION OF PRINTED MEDIA FOR FURTHER USE IN SIGNAGE APPLICATIONS, PAPER SIGNBOARDS, CARDBOARD SIGNBOARDS, AND PRINTED PAPER SIGNS (U.S. CLS. 2, 5, 22, 23, 29, 37, 38 AND 50).

FIRST USE 5-20-2010; IN COMMERCE 5-20-2010.

KIM MONINGHOFF, EXAMINING ATTORNEY

SN 85-069,590. VINTAGE TRUCK, LLC, YELLOW SPRINGS, OH. FILED 6-23-2010.

**VINTAGE TRUCK**

THE MARK CONSISTS OF STANDARD CHARACTERS WITHOUT CLAIM TO ANY PARTICULAR FONT, STYLE, SIZE, OR COLOR.

OWNER OF U.S. REG. NO. 2,809,570.

SEC. 2(F).

FOR MAGAZINES ABOUT TRUCKS (U.S. CLS. 2, 5, 22, 23, 29, 37, 38 AND 50).

FIRST USE 3-6-2002; IN COMMERCE 3-6-2002.

THOMAS MANOR, EXAMINING ATTORNEY

SN 85-070,973. NACKE, MARGARET E., GLENDALE, MO. FILED 6-24-2010.

**TALLYPACK PALS**

THE MARK CONSISTS OF STANDARD CHARACTERS WITHOUT CLAIM TO ANY PARTICULAR FONT, STYLE, SIZE, OR COLOR.

FOR PUBLICATIONS, NAMELY, CHILDREN'S BOOKS, CHILDREN'S ACTIVITY BOOKS, AND CHILDREN'S COLORING BOOKS (U.S. CLS. 2, 5, 22, 23, 29, 37, 38 AND 50).

JANET LEE, EXAMINING ATTORNEY

**CLASS 16—(Continued).**

SN 85-078,920. MITSUBISHI PENCIL COMPANY, LIMITED, TOKYO, JAPAN, FILED 7-6-2010.

**uni-ball VISION NEEDLE**

OWNER OF U.S. REG. NOS. 1,406,691, 3,219,457 AND OTHERS.

THE MARK CONSISTS OF THE LETTERS "UNI" WITH A RECTANGLE SEPARATING IT FROM THE WORD BALL AND THE WORDS "VISION NEEDLE".

FOR WRITING INSTRUMENTS (U.S. CLS. 2, 5, 22, 23, 29, 37, 38 AND 50).

FIRST USE 3-1-2007; IN COMMERCE 4-1-2007.  
EDWARD NELSON, EXAMINING ATTORNEY

---

SN 85-079,489. ADVANCE MAGAZINE PUBLISHERS INC., NEW YORK, NY. FILED 7-7-2010.

**FASHIONED FOR THE FUTURE**

THE MARK CONSISTS OF STANDARD CHARACTERS WITHOUT CLAIM TO ANY PARTICULAR FONT, STYLE, SIZE, OR COLOR.

FOR PRINTED PUBLICATIONS, NAMELY, MAGAZINES COVERING ALL ASPECTS OF SHOPPING, STYLE AND FASHION (U.S. CLS. 2, 5, 22, 23, 29, 37, 38 AND 50).

LEIGH CAROLINE CASE, EXAMINING ATTORNEY

---

SN 85-084,046. O'CONOR, SUZANNE M., EAST GRANBY, CT. FILED 7-14-2010.

**Maury the Mouse**

THE MARK CONSISTS OF STANDARD CHARACTERS WITHOUT CLAIM TO ANY PARTICULAR FONT, STYLE, SIZE, OR COLOR.

FOR CHILDREN'S BOOKS (U.S. CLS. 2, 5, 22, 23, 29, 37, 38 AND 50).

WILLIAM VERHOSEK, EXAMINING ATTORNEY

**CLASS 16—(Continued).**

SN 85-086,363. NO TEARS LEARNING, INC., DBA HAND-WRITING WITHOUT TEARS, CABIN JOHN, MD. FILED 7-16-2010.

**GET SET FOR SCHOOL**

THE MARK CONSISTS OF STANDARD CHARACTERS WITHOUT CLAIM TO ANY PARTICULAR FONT, STYLE, SIZE, OR COLOR.

FOR EDUCATIONAL PUBLICATIONS, NAMELY, WORK BOOKS AND RELATED TEACHERS GUIDES FOR PRE-K CHILDREN TO HELP DEVELOP FOUNDATION SKILLS INCLUDING SOCIALIZATION, LANGUAGE DEVELOPMENT, COORDINATION AND VISUAL RECALL SKILLS (U.S. CLS. 2, 5, 22, 23, 29, 37, 38 AND 50).

ZHALEH DELANEY, EXAMINING ATTORNEY

---

SN 85-086,712. WAXIE'S ENTERPRISES, INC., SAN DIEGO, CA. FILED 7-16-2010.

**KleenLine**

THE MARK CONSISTS OF STANDARD CHARACTERS WITHOUT CLAIM TO ANY PARTICULAR FONT, STYLE, SIZE, OR COLOR.

FOR TOILET TISSUE AND PAPER TOWELS (U.S. CLS. 2, 5, 22, 23, 29, 37, 38 AND 50).

CARYN GLASSER, EXAMINING ATTORNEY

**CLASS 16—(Continued).**

SN 85-089,880. LA TRIENNALE DI MILANO, MILAN, ITALY, FILED 7-21-2010.

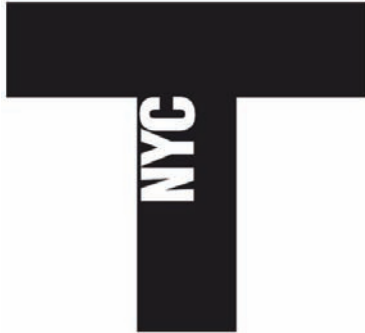

NO CLAIM IS MADE TO THE EXCLUSIVE RIGHT TO USE "NYC", APART FROM THE MARK AS SHOWN.

THE MARK CONSISTS OF THE LETTER "T" WITH THE WORDING "NYC" APPEARING INSIDE OF THE "T"

FOR BOOKS, MAGAZINES, NEWSPAPERS AND CATALOGUES IN THE FIELD OF ART AND SCIENCE; STATIONERY ITEMS, NAMELY, CALENDARS AND ALMANACS, NOTE PAD HOLDERS, PAPER HOLDERS, PAPER STANDS, PENCIL HOLDERS, PENCIL STANDS, PENCIL CASES, PAPER CLIP BOXES AND ADHESIVE TAPE DISPENSERS; PENS AND PENCILS (U.S. CLS. 2, 5, 22, 23, 29, 37, 38 AND 50).

SEAN CROWLEY, EXAMINING ATTORNEY

SN 85-091,650. VICTORIA PRINCIPAL PRODUCTIONS, INC., LOS ANGELES, CA. FILED 7-23-2010.

**THE WAR IN THE MIRROR**

THE MARK CONSISTS OF STANDARD CHARACTERS WITHOUT CLAIM TO ANY PARTICULAR FONT, STYLE, SIZE, OR COLOR.

FOR PUBLICATIONS, NAMELY, A SERIES OF BOOKS FEATURING LIFESTYLE, SELF-IMPROVEMENT, EDUCATION AND ENTERTAINMENT INFORMATION; DIARIES; POSTER BOOKS; WORD PUZZLE BOOKS; POSTCARDS; GREETING CARDS; CALENDARS, STATIONERY; ADDRESS AND SCHEDULE BOOKS; NOTEBOOKS; BOOK COVERS; PHOTOGRAPH ALBUMS; PAPER SUPPLIES AND DECORATIONS, NAMELY, PAPER NAPKINS, PAPER GIFT BAGS, PAPER PLACEMATS, PRINTED INVITATIONS, NOTE CARDS, PAPER BAGS, GIFT WRAPPING PAPER; PAPER GIFT TAGS; BANK CHECKS; CHECKBOOK COVERS; BUMPER STICKERS; NOTE PAPER; NOTE PADS; PAPER MEMO PAD CUBES; MEMO PADS; BOOKMARKS; BOOK HOLDERS (U.S. CLS. 2, 5, 22, 23, 29, 37, 38 AND 50).

DAVID TAYLOR, EXAMINING ATTORNEY

**CLASS 16—(Continued).**

SN 85-107,850. JASON NEWSTED, SAN FRANCISCO, CA. FILED 8-15-2010.

**MVEMJSUN**

THE MARK CONSISTS OF STANDARD CHARACTERS WITHOUT CLAIM TO ANY PARTICULAR FONT, STYLE, SIZE, OR COLOR.

FOR ARTWORK, NAMELY, ART PRINTS AND ART PICTURES; POSTCARDS; BOOKS IN THE FIELD OF ART; PAINTINGS AND THEIR REPRODUCTIONS (U.S. CLS. 2, 5, 22, 23, 29, 37, 38 AND 50).

FIRST USE 3-0-2007; IN COMMERCE 5-0-2010.

GEOFFREY FOSDICK, EXAMINING ATTORNEY

SN 85-108,363. HUSENAJ, PETRIT, AKA MY SOCIAL CHEF, NEW YORK, NY. FILED 8-16-2010.

**My Social Chef**

THE MARK CONSISTS OF STANDARD CHARACTERS WITHOUT CLAIM TO ANY PARTICULAR FONT, STYLE, SIZE, OR COLOR.

NO CLAIM IS MADE TO THE EXCLUSIVE RIGHT TO USE "CHEF", APART FROM THE MARK AS SHOWN.

FOR A SERIES OF BOOKS AND WRITTEN ARTICLES IN THE FIELD OF COOKING AND ENTERTAINING (U.S. CLS. 2, 5, 22, 23, 29, 37, 38 AND 50).

B. PARADEWELAI, EXAMINING ATTORNEY

SN 85-115,496. FASHION WORLD MEDIA, LLC, DBA FASHION 5.0, SAN DIEGO, CA 92107, CA. FILED 8-25-2010.

**FASHION 5.0**

THE MARK CONSISTS OF STANDARD CHARACTERS WITHOUT CLAIM TO ANY PARTICULAR FONT, STYLE, SIZE, OR COLOR.

NO CLAIM IS MADE TO THE EXCLUSIVE RIGHT TO USE "FASHION", APART FROM THE MARK AS SHOWN.

FOR MAGAZINES FEATURING FASHION, BEAUTY, LIFESTYLE, ENTERTAINMENT AND MUSIC (U.S. CLS. 2, 5, 22, 23, 29, 37, 38 AND 50).

FIRST USE 2-1-2009; IN COMMERCE 2-1-2010.

PAULA MAHONEY, EXAMINING ATTORNEY



**CLASS 16—(Continued).**

SN 85-121,400. MUSIC MASTERMIND, INC., CALABASAS, CA. FILED 9-2-2010.

**SILVERDOOR**

THE MARK CONSISTS OF STANDARD CHARACTERS WITHOUT CLAIM TO ANY PARTICULAR FONT, STYLE, SIZE, OR COLOR.

FOR SHEET MUSIC; EDUCATION PUBLICATIONS, NAMELY, TEXTBOOKS, MANUALS AND ACTIVITY BOOKS IN THE FIELD OF MUSIC; DECALS, POSTERS AND STATIONERY (U.S. CLS. 2, 5, 22, 23, 29, 37, 38 AND 50).

REBECCA SMITH, EXAMINING ATTORNEY

**CLASS 16—(Continued).**

SN 85-132,505. LEHAVI, TALI, AKA TALI LEHAVI HAMER, SCOTTSDALE, AZ. FILED 9-17-2010.

**Planet Heart**

THE MARK CONSISTS OF STANDARD CHARACTERS WITHOUT CLAIM TO ANY PARTICULAR FONT, STYLE, SIZE, OR COLOR.

FOR SERIES OF FICTION AND NON-FICTION BOOKS ON A VARIETY OF TOPICS (U.S. CLS. 2, 5, 22, 23, 29, 37, 38 AND 50).

FIRST USE 6-0-1996; IN COMMERCE 6-0-2003.

ARETHA SOMERVILLE, EXAMINING ATTORNEY

SN 85-124,074. WEIDER PUBLICATIONS, LLC, BOCA RATON, FL. FILED 9-7-2010.

**Natural Health**

OWNER OF U.S. REG. NO. 2,259,027.  
THE MARK CONSISTS OF THE WORDS "NATURAL HEALTH" IN A STYLIZED FONT.

SEC. 2(F).  
FOR GENERAL FEATURE MAGAZINE IN THE FIELD OF HEALTH, NUTRITION, PHYSICAL FITNESS AND HYGIENE (U.S. CLS. 2, 5, 22, 23, 29, 37, 38 AND 50).

ALYSSA STEEL, EXAMINING ATTORNEY

SN 85-136,347. TEGRANT ALLOYD BRANDS, INC., DEKALB, IL. FILED 9-23-2010.

**SYNERGREEN PACKAGING SOLUTIONS**

THE MARK CONSISTS OF STANDARD CHARACTERS WITHOUT CLAIM TO ANY PARTICULAR FONT, STYLE, SIZE, OR COLOR.

NO CLAIM IS MADE TO THE EXCLUSIVE RIGHT TO USE "PACKAGING SOLUTIONS", APART FROM THE MARK AS SHOWN.

FOR PAPER PACKAGING MATERIALS, NAMELY, BLISTER CARDS, INSERT CARDS, FOLDING CARTONS, TRAYS, SLEEVES, AND DISPLAYS (U.S. CLS. 2, 5, 22, 23, 29, 37, 38 AND 50).

SUZANNE BLANE, EXAMINING ATTORNEY

SN 85-124,332. SERG HOLDINGS, LLC, ORLANDO, FL. FILED 9-7-2010.

**Evolution Accelerator Profit Path Training Program**

THE MARK CONSISTS OF STANDARD CHARACTERS WITHOUT CLAIM TO ANY PARTICULAR FONT, STYLE, SIZE, OR COLOR.

NO CLAIM IS MADE TO THE EXCLUSIVE RIGHT TO USE "PROFIT" AND "TRAINING PROGRAM", APART FROM THE MARK AS SHOWN.

FOR EDUCATIONAL PUBLICATIONS, NAMELY, BOOKS, WORKBOOKS, MANUALS, WORKSHEETS, AND PRINTED TELEPHONE SCRIPTS, ALL FEATURING INFORMATION FOR USE IN SALES AND MARKETING IN THE HEALTH AND FITNESS INDUSTRY (U.S. CLS. 2, 5, 22, 23, 29, 37, 38 AND 50).

FIRST USE 1-31-2010; IN COMMERCE 3-31-2010.

ANDREA HACK, EXAMINING ATTORNEY

SN 85-150,085. KLEMENT, JUSTIN, WHITEHALL, PA. FILED 10-11-2010.

**enviousart**

THE MARK CONSISTS OF STANDARD CHARACTERS WITHOUT CLAIM TO ANY PARTICULAR FONT, STYLE, SIZE, OR COLOR.

FOR ART PICTURES; ART PRINTS; ART PRINTS ON CANVAS; FRAMED ART PICTURES (U.S. CLS. 2, 5, 22, 23, 29, 37, 38 AND 50).

FIRST USE 8-1-2010; IN COMMERCE 8-1-2010.

KIMBERLY FRYE, EXAMINING ATTORNEY

**CLASS 16—(Continued).**

SN 85-150,696. CONTINENTAL ACCESSORY CORPORATION, AMITYVILLE, NY. FILED 10-12-2010.



THE MARK CONSISTS OF THE TERM "IQ" AND THE WORDS "ORGANIZING MADE SMART" WITHIN A CIRCLE OF DOTS.

FOR NOTEBOOKS, DATED PLANNERS, UNDATED PLANNERS, ADDRESS BOOKS, MESSAGE PADS, JOURNALS, FOLDERS, BINDERS, CLIPBOARDS, COMPOSITION BOOKS, ACCORDION FILES, EXPANDING FILES, DESK ACCESSORIES, NAMELY, PENCIL CUPS, MAGAZINE FILES, LETTER TRAYS, DESK BLOTTERS, DESK TOP ORGANIZERS, INDEX CARDS AND HOLDERS, DOCUMENT FILES AND DIVIDERS (U.S. CLS. 2, 5, 22, 23, 29, 37, 38 AND 50).

JEFF DEFORD, EXAMINING ATTORNEY

**CLASS 16—(Continued).**

SN 85-155,405. LET'S DANCE WORLD, LLC, SHERMAN OAKS, CA. FILED 10-18-2010.

**DANCE PARTY IN A BOX**

THE MARK CONSISTS OF STANDARD CHARACTERS WITHOUT CLAIM TO ANY PARTICULAR FONT, STYLE, SIZE, OR COLOR.

FOR PARTY KIT COMPRISING PAPER PARTY DECORATIONS, NOISEMAKER PARTY FAVORS, PRERECORDED CDS FEATURING MUSIC, PRINTED DANCE INSTRUCTIONS, PAPER PARTY FAVORS AND PARTY FAVORS IN THE NATURE OF SMALL TOYS, SUNGLASSES, APPAREL IN THE NATURE OF LEOTARDS, T-SHIRTS, WRISTBANDS, LEGGINGS, FEDORAS AND HATS, PRINTED INVITATIONS, AND OTHER DANCE-RELATED PARAPHERNALIA, NAMELY, DANCE SHOES, POSTERS AND MIRROR BALLS FOR THROWING A DANCE PARTY (U.S. CLS. 2, 5, 22, 23, 29, 37, 38 AND 50).

MATTHEW PAPPAS, EXAMINING ATTORNEY

SN 85-150,756. MB PRODUCTS, WHITE PLAINS, NY. FILED 10-12-2010.



NO CLAIM IS MADE TO THE EXCLUSIVE RIGHT TO USE "PAINT", APART FROM THE MARK AS SHOWN.

THE MARK CONSISTS OF THE WORDS "PAINT APPEAL" IN A DONUT SHAPE, WITH A PAINT ROLLER SEPARATING THE WORDS "PAINT" AND "APPEAL", WITH A PULL APART SHEET IN THE CENTER OF THE DONUT, ALL SUPERIMPOSED ON A SILHOUETTE OF THE DONUT.

FOR PRINTED MATERIALS IN THE NATURE OF COLOR SAMPLES FOR PAINT (U.S. CLS. 2, 5, 22, 23, 29, 37, 38 AND 50).

TIMOTHY FINNEGAN, EXAMINING ATTORNEY

SN 85-162,725. CREATIVE TEACHING PRESS, INC., HUNTINGTON BEACH, CA. FILED 10-27-2010.

**CTP**

THE MARK CONSISTS OF STANDARD CHARACTERS WITHOUT CLAIM TO ANY PARTICULAR FONT, STYLE, SIZE, OR COLOR.

FOR INSTRUCTIONAL MATERIALS, NAMELY, NOTEPADS, CALENDARS, PRINTED CHARTS FOR DISPLAYING DATA, CHILDREN'S BOOKS, PRINTED MATERIAL FOR CLASSROOM BULLETIN BOARDS, NAMELY, PHOTOGRAPHS, ILLUSTRATIONS, AND PRINTED INSTRUCTIONAL PHRASES ON CARD STOCK IN THE FIELDS OF EDUCATIONAL SUBJECTS, NAMELY, ART, MATHEMATICS, MUSIC, PHONICS, READING, SCIENCE, SOCIAL STUDIES, SPANISH LANGUAGE, AND WRITING, PRINTED POSTERS, PRINTED STICKERS, AND PRINTED AWARD CERTIFICATES (U.S. CLS. 2, 5, 22, 23, 29, 37, 38 AND 50).

ROBIN CHOSID, EXAMINING ATTORNEY

**CLASS 16—(Continued).**

SN 85-164,578. SELLARS ABSORBENT MATERIALS, INC., MILWAUKEE, WI. FILED 10-29-2010.



OWNER OF U.S. REG. NO. 3,234,708.

THE COLOR(S) DARK GREEN, LIGHT GREEN, DARK BROWN, LIGHT BROWN, TAN, BLACK, WHITE, RED, GRAY, PURPLE, AND ORANGE IS/ARE CLAIMED AS A FEATURE OF THE MARK.

THE MARK CONSISTS OF THE IMAGE OF A WOMAN WITH THE WOMAN'S HAIR IN DARK BROWN, LIGHT BROWN, AND BLACK, HER FACE IN TAN WITH BLACK AND LIGHT BROWN HIGHLIGHTS, EYES IN BLACK, WHITE, AND DARK BROWN, WHITE TEETH AND RED LIPS WITH BLACK SHADING, RED AND WHITE EARRINGS, BLACK, WHITE, AND DARK BROWN EYEGLASSES, AND A DARK GREEN SHIRT WITH BLACK HIGHLIGHTS, GRAY SLACKS WITH A BLACK BELT, AN ORANGE TEE SHIRT UNDER THE SHIRT, WITH THE WOMAN HOLDING A PACKAGE OF PAPER TOWELS, THE PACKAGE IN GREEN AND WHITE WITH A PURPLE DESIGN ACROSS THE WHITE PORTION OF THE PACKAGE, WITH THE WORD "BRAVO" IN INITIAL CAPS IN WHITE WITH BLACK SHADOWING.

FOR PAPER TOWELS COMPRISED OF RECYCLED PAPER AND BINDING AGENTS; PAPER TOWELS COMPRISED OF WOOD PULP AND BINDING AGENTS (U.S. CLS. 2, 5, 22, 23, 29, 37, 38 AND 50).

FIRST USE 4-1-2010; IN COMMERCE 4-1-2010.

JOHN GARTNER, EXAMINING ATTORNEY

SN 85-172,145. CAROLINAS GOLF ASSOCIATION, WEST END, NC. FILED 11-9-2010.

## Carolinas Golf

THE MARK CONSISTS OF STANDARD CHARACTERS WITHOUT CLAIM TO ANY PARTICULAR FONT, STYLE, SIZE, OR COLOR.

SEC. 2(F).

FOR MAGAZINES FEATURING GOLF INCLUDING TOPICS RELATING TO GOLF IN NORTH CAROLINA AND SOUTH CAROLINA; MAGAZINES IN THE FIELD OF GOLF INCLUDING TOPICS RELATING TO GOLF IN NORTH CAROLINA AND SOUTH CAROLINA (U.S. CLS. 2, 5, 22, 23, 29, 37, 38 AND 50).

FIRST USE 6-1-1999; IN COMMERCE 6-1-1999.

FRANK LATTUCA, EXAMINING ATTORNEY

**CLASS 16—(Continued).**

SN 85-173,507. ORGANIZATIONAL DESIGN CONSULTANTS, NEWPORT COAST, CA. FILED 11-10-2010.

## CULTURE-GAP

THE MARK CONSISTS OF STANDARD CHARACTERS WITHOUT CLAIM TO ANY PARTICULAR FONT, STYLE, SIZE, OR COLOR.

FOR WRITTEN SURVEYS ASSESSING WORK GROUP VALUES (U.S. CLS. 2, 5, 22, 23, 29, 37, 38 AND 50).

FIRST USE 6-1-1982; IN COMMERCE 6-1-1982.

PRISCILLA MILTON, EXAMINING ATTORNEY

SN 85-177,028. INSCAPE PUBLISHING, INC., MINNEAPOLIS, MN. FILED 11-15-2010.



OWNER OF U.S. REG. NOS. 2,028,076, 2,740,991 AND OTHERS.

NO CLAIM IS MADE TO THE EXCLUSIVE RIGHT TO USE "DISC", APART FROM THE MARK AS SHOWN.

THE MARK CONSISTS OF A SOLID CIRCLE WITH THE WORD "DISC" APPEARING HORIZONTALLY OVER THE CENTER OF THE CIRCLE.

FOR PRINTED MATERIALS, NAMELY, PAMPHLETS, BROCHURES, MANUALS, AND TESTS IN THE FIELD OF BEHAVIOR EVALUATION, BEHAVIORAL COUNSELING, AND PERSONAL DEVELOPMENT, THAT ARE USED IN PARENTAL TRAINING, BUSINESS MANAGEMENT AND EMPLOYEE TRAINING (U.S. CLS. 2, 5, 22, 23, 29, 37, 38 AND 50).

ALYSSA STEEL, EXAMINING ATTORNEY

**CLASS 16—(Continued).**

SN 85-178,028. DAYSPRING CARDS, INC., SILOAM SPRINGS, AR. FILED 11-16-2010.

YOUR HEART. GOD'S LOVE.

THE MARK CONSISTS OF STANDARD CHARACTERS WITHOUT CLAIM TO ANY PARTICULAR FONT, STYLE, SIZE, OR COLOR.

FOR NOTEBOOKS, FOLDERS, PENCIL CASES, CALENDARS, GREETING CARDS, NOTE CARDS, FRAMED PART PRINTS, BLANK JOURNALS FOR PERSONAL USE, MEMO PADS, PAPER PLATES, PAPER NAPKINS, STATIONERY (U.S. CLS. 2, 5, 22, 23, 29, 37, 38 AND 50).

DANNEAN HETZEL, EXAMINING ATTORNEY

---

SN 85-180,442. BAKER & TAYLOR, INC., CHARLOTTE, NC. FILED 11-18-2010.

PAW PRINTS

THE MARK CONSISTS OF STANDARD CHARACTERS WITHOUT CLAIM TO ANY PARTICULAR FONT, STYLE, SIZE, OR COLOR.

FOR BOOKS FOR CHILDREN, ADOLESCENTS AND ADULTS ON A VARIETY OF FICTION AND NON-FICTION TOPICS THAT ARE PREBOUND WITH A LIBRARY-QUALITY REINFORCED SPINE INTENDED FOR THE LIBRARY AND EDUCATION MARKETS (U.S. CLS. 2, 5, 22, 23, 29, 37, 38 AND 50).

FIRST USE 5-0-2006; IN COMMERCE 5-0-2006.  
ELLEN PERKINS, EXAMINING ATTORNEY

---

SN 85-180,444. GREGORY, SCOTT, MASSAPEQUA, NY. FILED 11-18-2010.

Long Island Swimsuit  
Calendar

THE MARK CONSISTS OF STANDARD CHARACTERS WITHOUT CLAIM TO ANY PARTICULAR FONT, STYLE, SIZE, OR COLOR.

NO CLAIM IS MADE TO THE EXCLUSIVE RIGHT TO USE "CALENDAR", APART FROM THE MARK AS SHOWN.

SEC. 2(F).  
FOR CALENDARS (U.S. CLS. 2, 5, 22, 23, 29, 37, 38 AND 50).

FIRST USE 10-8-2005; IN COMMERCE 10-8-2005.  
WILLIAM ROSSMAN, EXAMINING ATTORNEY

**CLASS 16—(Continued).**

SN 85-186,213. BAKER & TAYLOR, INC., CHARLOTTE, NC. FILED 11-29-2010.

The logo features the word "PAW" in a bold, red, sans-serif font. A gray paw print is superimposed over the letter "A". Below "PAW" is the word "Prints" in a green, sans-serif font.

THE COLOR(S) RED, GREEN AND GRAY IS/ARE CLAIMED AS A FEATURE OF THE MARK.

THE MARK CONSISTS OF THE WORD "PAW" IN RED AND ABOVE THE TERM "PRINTS" IN GREEN. THE DESIGN OF A PAW IN GRAY IS SUPERIMPOSED OVER THE WORD "PAW" AND MAKES THE LETTER "A" IN "PAW".

FOR BOOKS FOR CHILDREN, ADOLESCENTS AND ADULTS ON A VARIETY OF FICTION AND NON-FICTION TOPICS THAT ARE PREBOUND WITH A LIBRARY-QUALITY REINFORCED SPINE INTENDED FOR THE LIBRARY AND EDUCATION MARKETS (U.S. CLS. 2, 5, 22, 23, 29, 37, 38 AND 50).

FIRST USE 7-19-2010; IN COMMERCE 7-19-2010.  
ELLEN PERKINS, EXAMINING ATTORNEY

---

SN 85-189,479. DINAH-MIGHT ADVENTURES, LP, COMFORT, TX. FILED 12-2-2010.

PROJECT EXPRESS

THE MARK CONSISTS OF STANDARD CHARACTERS WITHOUT CLAIM TO ANY PARTICULAR FONT, STYLE, SIZE, OR COLOR.

FOR EDUCATIONAL KITS SOLD AS A UNIT IN THE FIELDS OF LANGUAGE ARTS, MATH, SCIENCE, AND SOCIAL STUDIES CONSISTING OF PRINTED EDUCATIONAL AND INSTRUCTIONAL MATERIALS, AND EDUCATIONAL AND INSTRUCTIONAL OBJECTS AND SUPPLIES, NAMELY, FLASHCARDS, FOLDERS, PAPER, NOTEBOOKS, PLASTIC TRANSPARENCIES, PAPER AND CARDBOARD BOXES AND FOLDERS FOR ARRANGING THE PRINTED EDUCATIONAL AND INSTRUCTIONAL MATERIALS; PAPER AND CARDBOARD BOXES AND FOLDERS FOR ARRANGING THE PRINTED EDUCATIONAL AND INSTRUCTIONAL MATERIALS (U.S. CLS. 2, 5, 22, 23, 29, 37, 38 AND 50).

NATALIE POLZER, EXAMINING ATTORNEY

**CLASS 16—(Continued).**

SN 85-192,407. GAITHER, DOYLE H., CARMINE, TX. FILED 12-7-2010.

## LoveBlock

THE MARK CONSISTS OF STANDARD CHARACTERS WITHOUT CLAIM TO ANY PARTICULAR FONT, STYLE, SIZE, OR COLOR.

FOR NOVELTY GIFT ITEMS IN THE NATURE OF WOODEN BLOCK SHAPED HOLDERS SPECIALLY ADAPTED FOR HOLDING GREETING CARDS AND KEEPSAKE DOCUMENTS (U.S. CLS. 2, 5, 22, 23, 29, 37, 38 AND 50).

FIRST USE 4-1-1981; IN COMMERCE 4-1-1981.  
COLLEEN KEARNEY, EXAMINING ATTORNEY

SN 85-192,787. CELESTE DANIELS ADVERTISING AND DESIGN, INC., EUGENE, OR. FILED 12-8-2010.



NO CLAIM IS MADE TO THE EXCLUSIVE RIGHT TO USE "MAGAZINE", APART FROM THE MARK AS SHOWN.

THE COLOR(S) MAROON, BLACK AND WHITE IS/ARE CLAIMED AS A FEATURE OF THE MARK.

THE MARK CONSISTS OF UPPER CASE LETTERS TO SPELL THE WORD "AIRPLANISTA", WITH THE LETTERS "A I R" IN MAROON WITH A BLACK OUTLINE AND "P L A N I S T A" IN WHITE WITH A BLACK OUTLINE. THE WORD "MAGAZINE" IN THE COLOR BLACK IS AT AN ANGLE TO THE RIGHT OF THE LAST "A".

FOR GENERAL FEATURE MAGAZINE IN THE FIELD OF AVIATION (U.S. CLS. 2, 5, 22, 23, 29, 37, 38 AND 50).

FIRST USE 10-1-2010; IN COMMERCE 10-1-2010.  
KIMBERLY PERRY, EXAMINING ATTORNEY

SN 85-193,308. JONES, BETTE LEE, TULSA, OK. FILED 12-8-2010.

## BETTE JONES

THE MARK CONSISTS OF STANDARD CHARACTERS WITHOUT CLAIM TO ANY PARTICULAR FONT, STYLE, SIZE, OR COLOR.

"BETTE JONES" IDENTIFIES A LIVING INDIVIDUAL WHOSE CONSENT IS OF RECORD.

FOR LIMITED ART PRINTS, WATERCOLORS, PAINTINGS, NOTE CARDS AND POST CARDS (U.S. CLS. 2, 5, 22, 23, 29, 37, 38 AND 50).

FIRST USE 12-31-1997; IN COMMERCE 12-31-1998.  
NANCY CLARKE, EXAMINING ATTORNEY

**CLASS 16—(Continued).**

SN 85-194,120. SAMSILL CORPORATION, FORT WORTH, TX. FILED 12-9-2010.

## BINDERS FOR LIFE

THE MARK CONSISTS OF STANDARD CHARACTERS WITHOUT CLAIM TO ANY PARTICULAR FONT, STYLE, SIZE, OR COLOR.

NO CLAIM IS MADE TO THE EXCLUSIVE RIGHT TO USE "BINDERS", APART FROM THE MARK AS SHOWN. FOR BINDERS (U.S. CLS. 2, 5, 22, 23, 29, 37, 38 AND 50).

FIRST USE 9-1-2010; IN COMMERCE 9-1-2010.  
JEFFREY LOOK, EXAMINING ATTORNEY

SN 85-194,910. ROSEN, JEFFREY, AVENTURA, FL. FILED 12-10-2010.

## TEMPT TATTU

THE MARK CONSISTS OF STANDARD CHARACTERS WITHOUT CLAIM TO ANY PARTICULAR FONT, STYLE, SIZE, OR COLOR.

NO CLAIM IS MADE TO THE EXCLUSIVE RIGHT TO USE "TATTOO", APART FROM THE MARK AS SHOWN.

FOR TEMPORARY TATTOOS (U.S. CLS. 2, 5, 22, 23, 29, 37, 38 AND 50).

PRISCILLA MILTON, EXAMINING ATTORNEY

SN 85-194,932. ROSEN, JEFFREY, AVENTURA, FL. FILED 12-10-2010.

## TEMPT TATS

THE MARK CONSISTS OF STANDARD CHARACTERS WITHOUT CLAIM TO ANY PARTICULAR FONT, STYLE, SIZE, OR COLOR.

NO CLAIM IS MADE TO THE EXCLUSIVE RIGHT TO USE "TATS", APART FROM THE MARK AS SHOWN.

FOR TEMPORARY TATTOOS (U.S. CLS. 2, 5, 22, 23, 29, 37, 38 AND 50).

PRISCILLA MILTON, EXAMINING ATTORNEY



**CLASS 16—(Continued).**

SN 85-194,938. MCGARREY, DAVID B., CODY, WY. FILED 12-10-2010.



OWNER OF U.S. REG. NO. 3,729,721.  
THE COLOR(S) PINK, PURPLE, AND BLACK IS/ARE CLAIMED AS A FEATURE OF THE MARK.

THE MARK CONSISTS OF THE TERM "C.A.R.E." IN BLACK EXCEPT THE LETTER "A" WHICH IS DEPICTED AS A STYLIZED RIBBON IN PINK AND PURPLE; BENEATH APPEARS THE WORDING "CONSTRUCTION AND REMODELING EXPERTS" IN BLACK, FOLLOWED BY THE WORDING "FOR A CURE" IN BLACK, WITH THE LETTER "A" BEING DEPICTED AS A PINK AND PURPLE RIBBON DESIGN BETWEEN THE TERMS "FOR" AND "CURE".

FOR CHILDREN'S BOOKS; COLORING BOOKS (U.S. CLS. 2, 5, 22, 23, 29, 37, 38 AND 50).  
LAURA KOVALSKY, EXAMINING ATTORNEY

SN 85-198,151. FINLEY, JIMMY D., DBA FINLEY GALLERY LLC, HONOLULU, HI. FILED 12-15-2010.

**MASTER PEN KIT**

THE MARK CONSISTS OF STANDARD CHARACTERS WITHOUT CLAIM TO ANY PARTICULAR FONT, STYLE, SIZE, OR COLOR.

NO CLAIM IS MADE TO THE EXCLUSIVE RIGHT TO USE "PEN KIT", APART FROM THE MARK AS SHOWN.

FOR WRITING PEN KITS COMPRISING PARTS FOR MAKING WRITING PENS (U.S. CLS. 2, 5, 22, 23, 29, 37, 38 AND 50).

FIRST USE 11-27-2010; IN COMMERCE 11-27-2010.  
KEVON CHISOLM, EXAMINING ATTORNEY

**CLASS 16—(Continued).**

SN 85-199,564. UNITED SOCCER LEAGUES, LLC, TAMPA, FL. FILED 12-16-2010.

**USL BREAKAWAY**

THE MARK CONSISTS OF STANDARD CHARACTERS WITHOUT CLAIM TO ANY PARTICULAR FONT, STYLE, SIZE, OR COLOR.

OWNER OF U.S. REG. NOS. 2,340,635, 2,979,243 AND OTHERS.

FOR PERIODIC NEWSLETTERS PERTAINING TO SOCCER AND RELATED EVENTS (U.S. CLS. 2, 5, 22, 23, 29, 37, 38 AND 50).

JEFFREY LOOK, EXAMINING ATTORNEY

SN 85-199,991. MOTTONEN, DOUG P., SALT LAKE CITY, UT. FILED 12-16-2010.

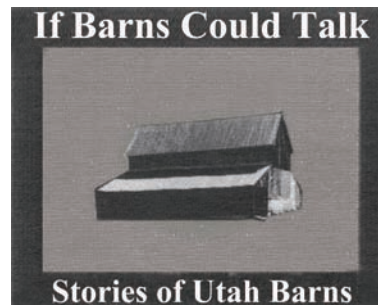

NO CLAIM IS MADE TO THE EXCLUSIVE RIGHT TO USE "STORIES OF UTAH BARNs", APART FROM THE MARK AS SHOWN.

THE MARK CONSISTS OF A DRAWING OF THE BROADSIDE OF A TWO-STORY WESTERN BARN WITH AN ANGLED FIRST-STORY ROOF, A STEEPLY PITCHED SECOND-STORY ROOF, AND WOODEN SLATTED WALLS, WITH THE WORDS "IF BARNs COULD TALK" SITUATED ABOVE THE IMAGE AND THE WORD "STORIES OF UTAH BARNs" SITUATED BELOW.

FOR BOOKS IN THE FIELD OF BARNs; CALENDARS; EDUCATIONAL BOOKS FEATURING PHOTOS OF HISTORIC BARNs (U.S. CLS. 2, 5, 22, 23, 29, 37, 38 AND 50).  
BARBARA BROWN, EXAMINING ATTORNEY

**CLASS 16—(Continued).**

SN 85-201,569. FINLEY, JIMMY D., DBA FINLEY GALLERY LLC, HONOLULU, HI. FILED 12-20-2010.

**ROOKIE PEN KIT**

THE MARK CONSISTS OF STANDARD CHARACTERS WITHOUT CLAIM TO ANY PARTICULAR FONT, STYLE, SIZE, OR COLOR.

NO CLAIM IS MADE TO THE EXCLUSIVE RIGHT TO USE "PEN KIT", APART FROM THE MARK AS SHOWN.

FOR WRITING PEN KITS COMPRISING PARTS FOR MAKING WRITING PENS (U.S. CLS. 2, 5, 22, 23, 29, 37, 38 AND 50).

KEVON CHISOLM, EXAMINING ATTORNEY

SN 85-203,209. LIFE PLUS STYLE LTD., NEW YORK, NY. FILED 12-21-2010.

**THE STORY OF MY LIFE**

THE MARK CONSISTS OF STANDARD CHARACTERS WITHOUT CLAIM TO ANY PARTICULAR FONT, STYLE, SIZE, OR COLOR.

FOR BLANK JOURNALS IN THE NATURE OF A DIARY (U.S. CLS. 2, 5, 22, 23, 29, 37, 38 AND 50).

FIRST USE 12-9-2010; IN COMMERCE 12-9-2010.

MICHAEL TANNER, EXAMINING ATTORNEY

SN 85-203,251. ZIA PROJECTS, INC., BEECH MOUNTAIN, NC. FILED 12-21-2010.

**SACRED TAHOE**

THE MARK CONSISTS OF STANDARD CHARACTERS WITHOUT CLAIM TO ANY PARTICULAR FONT, STYLE, SIZE, OR COLOR.

NO CLAIM IS MADE TO THE EXCLUSIVE RIGHT TO USE "TAHOE", APART FROM THE MARK AS SHOWN.

FOR BUMPER STICKERS; CALENDARS; CHILDREN'S WALL STICKERS AND MURALS; GREETING CARDS; GREETINGS CARDS AND POSTCARDS; MAGNETIC BUMPER STICKERS; MAPS; NOTE CARDS; POSTERS; PRINTED PAMPHLETS, BROCHURES, MANUALS, BOOKS, BOOKLETS, LEAFLETS, FLYERS, INFORMATIONAL SHEETS AND NEWSLETTERS, ADHESIVE BACKED STICKERS, AND KITS COMPRISING ONE OR MORE OF THE FOREGOING MATERIALS IN THE FIELD OF ENVIRONMENTAL PROTECTION AND CONSERVATION (U.S. CLS. 2, 5, 22, 23, 29, 37, 38 AND 50).

JUSTINE D. PARKER, EXAMINING ATTORNEY

**CLASS 16—(Continued).**

SN 85-203,923. PIGOTT, WILLIAM C. III, DBA RIPN LIP OUTFITTERS, N. FORT MYERS, FL. FILED 12-22-2010.

# RIP N LIP

## OUTFITTERS

NO CLAIM IS MADE TO THE EXCLUSIVE RIGHT TO USE "OUTFITTERS", APART FROM THE MARK AS SHOWN.

THE NAME(S), PORTRAIT(S), AND/OR SIGNATURE(S) SHOWN IN THE MARK DOES NOT IDENTIFY A PARTICULAR LIVING INDIVIDUAL.

THE COLOR(S) GOLD, NAVY BLUE IS/ARE CLAIMED AS A FEATURE OF THE MARK.

THE MARK CONSISTS OF "RIP N LIP" HAS THREE SMALL LINES UNDERNEATH "RIPN LIP" AND THEY ARE GOLD, "RIPN LIP" TEXT IS NAVY BLUE, OUTFITTERS IS ALSO NAVY BLUE.

THE ENGLISH TRANSLATION OF "RIPN LIP" IN THE MARK IS "RIPN LIP". THE WORDING "RIPN LIP" HAS NO MEANING IN A FOREIGN LANGUAGE.

SEC. 2(F).

FOR 3D DECALS FOR USE ON ANY SURFACE; ALBUMS FOR STICKERS; APPLIQUES IN THE FORM OF DECALS; BUMPER STICKERS; CHILDREN'S WALL STICKERS AND MURALS; DECALS; DECORATIVE DECALS FOR VEHICLE WINDOWS; DECORATIVE STICKERS FOR HELMETS; MAGNETIC BUMPER STICKERS; PRINTED MATERIAL IN THE NATURE OF DECALS FOR MAINTENANCE SERVICE AND APPOINTMENT REMINDERS; PRINTED PAMPHLETS, BROCHURES, MANUALS, BOOKS, BOOKLETS, LEAFLETS, FLYERS, INFORMATIONAL SHEETS AND NEWSLETTERS, ADHESIVE BACKED STICKERS, AND KITS COMPRISING ONE OR MORE OF THE FOREGOING MATERIALS IN THE FIELD OF OUTDOOR ACTIVITIES; STICKER ALBUMS; STICKERS; STICKERS; STICKERS AND DECALCOMANIAS; STICKERS AND STICKER ALBUMS; STICKERS AND TRANSFERS; IRON-ON, PLASTIC, CLING, STICKER-BACKED TRANSFERS (U.S. CLS. 2, 5, 22, 23, 29, 37, 38 AND 50).

JILL PRATER, EXAMINING ATTORNEY

SN 85-204,954. JOEL FRIED, CANTON, CT. AND SUSAN DECKER, NARRAGANSETT, RI. FILED 12-23-2010.

## FLOAT FREELY. SWIM DEEPLY. LOVE COMPLETELY.

THE MARK CONSISTS OF STANDARD CHARACTERS WITHOUT CLAIM TO ANY PARTICULAR FONT, STYLE, SIZE, OR COLOR.

FOR ADDRESS BOOKS; BLANK JOURNAL BOOKS; CALENDARS; CHILDREN'S BOOKS; GREETING CARDS; GREETINGS CARDS AND POSTCARDS; PAPER NAPKINS; PAPER TABLECLOTHS; PICTURE BOOKS; POSTCARDS; POSTERS; STATIONERY; STORY BOOKS (U.S. CLS. 2, 5, 22, 23, 29, 37, 38 AND 50).

FIRST USE 12-16-2010; IN COMMERCE 12-16-2010.

JAMES GRIFFIN, EXAMINING ATTORNEY

**CLASS 16—(Continued).**

SN 85-205,271. BROWNING, VICKY, HOLLY HILL, FL. FILED 12-23-2010.

## DigiArt Diaries

THE MARK CONSISTS OF STANDARD CHARACTERS WITHOUT CLAIM TO ANY PARTICULAR FONT, STYLE, SIZE, OR COLOR.

NO CLAIM IS MADE TO THE EXCLUSIVE RIGHT TO USE "DIGIART", APART FROM THE MARK AS SHOWN. FOR FRAMED PHOTOGRAPHS (U.S. CLS. 2, 5, 22, 23, 29, 37, 38 AND 50).

FIRST USE 11-23-2010; IN COMMERCE 11-23-2010.  
REGINA DRUMMOND, EXAMINING ATTORNEY

---

SN 85-205,387. ROBERTS, JUDSON W., DBA NORTHMAN BOOKS, HOUSTON, TX. FILED 12-23-2010.

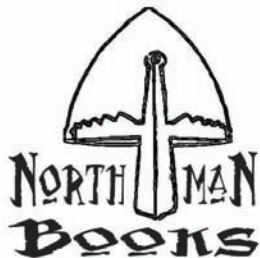

NO CLAIM IS MADE TO THE EXCLUSIVE RIGHT TO USE "NORTHMAN BOOKS", APART FROM THE MARK AS SHOWN.

THE MARK CONSISTS OF MEDIEVAL CONICAL HELMET WITH NASAL BAR ABOVE THE WORDS "NORTHMAN BOOKS".

FOR SERIES OF FICTION AND NON-FICTION BOOKS ON A VARIETY OF TOPICS (U.S. CLS. 2, 5, 22, 23, 29, 37, 38 AND 50).

FIRST USE 10-26-2010; IN COMMERCE 10-26-2010.  
GINA FINK, EXAMINING ATTORNEY

**CLASS 16—(Continued).**

SN 85-205,707. "MASK" MOTHERS AWARENESS ON SCHOOL AGE KIDS, SCOTTSDALE, AZ. FILED 12-26-2010.



OWNER OF U.S. REG. NO. 3,660,474.

NO CLAIM IS MADE TO THE EXCLUSIVE RIGHT TO USE "MOTHERS AWARENESS ON SCHOOL-AGE KIDS", APART FROM THE MARK AS SHOWN.

THE COLOR(S) KHAKI, PEACH, SEA GREEN, MAUVE AND BLACK IS/ARE CLAIMED AS A FEATURE OF THE MARK.

THE MARK CONSISTS OF FOUR FEMALE FIGURES WITH THEIR ARMS EXTENDED SO THEIR HANDS ARE TOUCHING; THE COLORS OF THE FIGURES FROM LEFT TO RIGHT ARE KHAKI, PEACH, SEA GREEN AND MAUVE; EACH FIGURE HAS BLACK HAIR AND NO FACIAL OR BODILY FEATURES; UNDER THE FEMALE FIGURES IS A BLACK SOLID DOWNWARDLY CURVED LINE WITH THE BLACK STYLIZED WORD "MASK" IN ALL CAPS BELOW THE LINE AND THE BLACK STYLIZED WORDS "MOTHERS AWARENESS ON SCHOOL-AGE KIDS" BELOW "MASK".

FOR MAGAZINES IN THE FIELD OF PARENTING AND EDUCATING PARENTS AND CHILDREN ABOUT SOCIAL ISSUES; PRINTED MATTER IN THE NATURE OF PROMOTIONAL MATERIALS FOR ADVERTISING AND MARKETING (U.S. CLS. 2, 5, 22, 23, 29, 37, 38 AND 50).

FIRST USE 4-11-2010; IN COMMERCE 10-1-2010.  
DAVID ELTON, EXAMINING ATTORNEY

---

SN 85-205,718. MOODY, BRANDI BOWEN, DBA EVER SO LOVELY, HOLLY SPRINGS, NC. FILED 12-26-2010.

## EVER SO LOVELY

THE MARK CONSISTS OF STANDARD CHARACTERS WITHOUT CLAIM TO ANY PARTICULAR FONT, STYLE, SIZE, OR COLOR.

FOR GENERAL FEATURE MAGAZINE IN THE FIELD OF DESIGN, WEDDINGS, ILLUSTRATION AND ART; INVITATION CARDS; NOTE PAPERS; PAPER STATIONERY; PAPER STATIONERY WITH INSPIRATIONAL MESSAGES IMPRINTED THEREON; PRINTED INVITATIONS (U.S. CLS. 2, 5, 22, 23, 29, 37, 38 AND 50).

FIRST USE 12-21-2007; IN COMMERCE 12-1-2009.  
CHRISTINE MARTIN, EXAMINING ATTORNEY

**CLASS 16—(Continued).**

SN 85-206,250. JEFF DUNHAM, LOS ANGELES, CA. FILED 12-27-2010.

JEFF DUNHAM

THE MARK CONSISTS OF STANDARD CHARACTERS WITHOUT CLAIM TO ANY PARTICULAR FONT, STYLE, SIZE, OR COLOR.

OWNER OF U.S. REG. NOS. 3,889,468, 3,889,470 AND OTHERS.

THE NAME "JEFF DUNHAM" IDENTIFIES A LIVING INDIVIDUAL WHOSE CONSENT IS OF RECORD.

FOR PAPER GOODS, NAMELY, CALENDARS (U.S. CLS. 2, 5, 22, 23, 29, 37, 38 AND 50).

FIRST USE 11-30-2010; IN COMMERCE 11-30-2010.

TARA PATE, EXAMINING ATTORNEY

SN 85-206,588. AURA LTD. CO., ALBUQUERQUE, NM. FILED 12-28-2010.

AURA MAGAZINE

THE MARK CONSISTS OF STANDARD CHARACTERS WITHOUT CLAIM TO ANY PARTICULAR FONT, STYLE, SIZE, OR COLOR.

NO CLAIM IS MADE TO THE EXCLUSIVE RIGHT TO USE "MAGAZINE", APART FROM THE MARK AS SHOWN.

FOR TRADE MAGAZINE FEATURING INFORMATION ON TOPICS AND CONSUMER PRODUCTS PERTAINING TO LIFESTYLES OF SPIRITUAL, MYSTICAL, HEALTHFUL AND ETHICAL RESPONSIBILITY, AND OF CULTURAL AND ENVIRONMENTAL AWARENESS (U.S. CLS. 2, 5, 22, 23, 29, 37, 38 AND 50).

FIRST USE 11-30-2005; IN COMMERCE 11-30-2005.

AISHA SALEM, EXAMINING ATTORNEY

**CLASS 16—(Continued).**

SN 85-207,784. BERCOM INTERNATIONAL, LLC, CHANHASSEN, MN. FILED 12-30-2010.

**HANDy  
Clip**

OWNER OF U.S. REG. NOS. 2,736,339, 3,802,869 AND OTHERS.

NO CLAIM IS MADE TO THE EXCLUSIVE RIGHT TO USE "CLIP", APART FROM THE MARK AS SHOWN.

THE MARK CONSISTS OF TWO WORDS, WITH THE FIRST WORD "HANDY" HAVING ITS FIRST FOUR LETTERS IN UPPER-CASE AND LAST LETTER IN LOWER-CASE, AND WITH THE SECOND WORD "CLIP" DISPOSED UNDER THE RIGHT PORTION OF THE FIRST WORD, IN THE SAME FONT AND TYPE SIZE, WITH ITS FIRST LETTER IN UPPER-CASE AND LAST THREE LETTERS IN LOWER-CASE.

FOR PAINTER'S TOOL, NAMELY, A PLASTIC CLIP FOR ATTACHING A PAINT APPLICATOR TO A PAINT CONTAINER (U.S. CLS. 2, 5, 22, 23, 29, 37, 38 AND 50).

EUGENIA MARTIN, EXAMINING ATTORNEY

SN 85-207,793. PATRICIA ZAPF, LITHIA, FL. FILED 12-30-2010.

EL JUEGO DE ESPERA

THE MARK CONSISTS OF STANDARD CHARACTERS WITHOUT CLAIM TO ANY PARTICULAR FONT, STYLE, SIZE, OR COLOR.

OWNER OF U.S. REG. NO. 3,754,664.

THE ENGLISH TRANSLATION OF "EL JUEGO DE ESPERA" IN THE MARK IS "THE WAITING GAME".

FOR PRINTED PAMPHLETS, BROCHURES, MANUALS, BOOKS, BOOKLETS, LEAFLETS, FLYERS, INFORMATIONAL SHEETS AND NEWSLETTERS, ADHESIVE BACKED STICKERS, AND KITS COMPRISING ONE OR MORE OF THE FOREGOING MATERIALS IN THE FIELD OF ADVERTISING CONSISTING OF CROSSWORDS, WORD PUZZLES, WORD FINDS, AND ADVERTISEMENTS AND COUPONS (U.S. CLS. 2, 5, 22, 23, 29, 37, 38 AND 50).

FIRST USE 7-1-2009; IN COMMERCE 7-1-2009.

KHANH LE, EXAMINING ATTORNEY

**CLASS 16—(Continued).**

SN 85-207,800. TERRAVENA, LLC, WINOOSKI, VT. FILED 12-30-2010.



THE COLOR(S) WHITE, LIGHT BROWN, LIGHT BLUE AND GREEN IS/ARE CLAIMED AS A FEATURE OF THE MARK.

THE MARK CONSISTS OF TWO GREEN MOUNTAINS WITH A LIGHT BLUE AND WHITE CASCADING RIVER IN BETWEEN THEM, AGAINST A LIGHT BLUE BACKGROUND THAT INCLUDES A LIGHT-BROWN HORIZONTAL ARROW, ALL BORDERED BY TWO CONCENTRIC CIRCLES, WITH THE INNER CIRCLE APPEARING IN WHITE AND THE OUTER CIRCLE APPEARING IN LIGHT BROWN.

FOR SERIES OF FICTION WORKS, NAMELY, NOVELS AND BOOKS (U.S. CLS. 2, 5, 22, 23, 29, 37, 38 AND 50).

FIRST USE 12-29-2010; IN COMMERCE 12-29-2010.  
JUDITH HELFMAN, EXAMINING ATTORNEY

SN 85-208,063. TERRAVENA, LLC, WINOOSKI, VT. FILED 12-30-2010.



OWNER OF U.S. REG. NOS. 3,850,281, 3,891,531 AND OTHERS.

THE COLOR(S) WHITE, LIGHT BROWN, MEDIUM BROWN, AND DARK BROWN IS/ARE CLAIMED AS A FEATURE OF THE MARK.

THE MARK CONSISTS OF THE WORDING "THE BROTHERS PLAD" IN STYLIZED WHITE LETTERING AGAINST A REPRESENTATION OF A WEATHERED, GENERALLY RECTANGULAR-SHAPED, WOODEN SIGNBOARD WITH CONCAVE CORNERS, APPEARING IN VARYING SHADES OF LIGHT AND MEDIUM BROWN, AND LINED WITH A SEEMINGLY WEATHERED WHITE PINSTRIPE. THE SIGNBOARD INCLUDES VARIOUS DESIGN ELEMENTS, INCLUDING TWO DARK-BROWN DEER ANTLERS LOCATED ON EACH SIDE OF THE WORD "THE", TWO DARK-BROWN HORIZONTAL ARROWS POINTING IN OPPOSITE DIRECTIONS LOCATED ABOVE THE WORD "BROTHERS", TWO DARK-BROWN FISHHOOKS LOCATED ON EACH SIDE OF THE WORD "PLAD", WITH WHITE CLOTHING BUTTONS LOCATED

**CLASS 16—(Continued).**

IN THE ARCS OF BOTH HOOKS, TWO DARK-BROWN HORIZONTAL FLINTLOCKS POINTING IN OPPOSITE DIRECTION LOCATED BELOW THE WORD "PLAD", APPARENT BULLETS HOLES APPEARING IN WHITE AND LOCATED AT THE UPPER RIGHT CONCAVE CORNER OF THE SIGNBOARD, TO THE LEFT OF THE WORD "THE", AND ALONG THE LOWER LEFT PINSTRIPE, A WHITE CRICKET LOCATED ABOVE THE LEFT FISHHOOK, AND A WHITE BEAVER LOCATED ABOVE THE RIGHT FISHHOOK.

FOR SERIES OF FICTION WORKS, NAMELY, NOVELS AND BOOKS (U.S. CLS. 2, 5, 22, 23, 29, 37, 38 AND 50).

FIRST USE 12-29-2010; IN COMMERCE 12-29-2010.  
JUDITH HELFMAN, EXAMINING ATTORNEY

SN 85-208,794. FIREPIT FRIENDS, LLC, DBA CONFETTI COUTURE, FORT COLLINS, CO. FILED 1-1-2011.

## Dessert Skirtz

THE MARK CONSISTS OF STANDARD CHARACTERS WITHOUT CLAIM TO ANY PARTICULAR FONT, STYLE, SIZE, OR COLOR.

NO CLAIM IS MADE TO THE EXCLUSIVE RIGHT TO USE "DESSERT", APART FROM THE MARK AS SHOWN.

FOR FOOD WRAPPERS (U.S. CLS. 2, 5, 22, 23, 29, 37, 38 AND 50).

FIRST USE 11-9-2010; IN COMMERCE 12-8-2010.  
TRACY FLETCHER, EXAMINING ATTORNEY

SN 85-208,870. LITWIN, BRADLEY N., PHILADELPHIA, PA. FILED 1-2-2011.

## MechaniCard

THE MARK CONSISTS OF STANDARD CHARACTERS WITHOUT CLAIM TO ANY PARTICULAR FONT, STYLE, SIZE, OR COLOR.

FOR GREETING CARDS (U.S. CLS. 2, 5, 22, 23, 29, 37, 38 AND 50).

FIRST USE 8-22-2010; IN COMMERCE 9-22-2010.  
KYLE PEETE, EXAMINING ATTORNEY



**CLASS 16—(Continued).**

SN 85-208,924. GNL ENTERTAINMENT, INC., WASHINGTON, DC. FILED 1-3-2011.

# Music-Ebru

THE MARK CONSISTS OF STANDARD CHARACTERS WITHOUT CLAIM TO ANY PARTICULAR FONT, STYLE, SIZE, OR COLOR.

THE ENGLISH TRANSLATION OF THE TURKISH WORD "EBRU" IN THE MARK IS "TURKISH PAPER MARBLING".

FOR PRINTED MUSIC BOOKS; SHEET MUSIC (U.S. CLS. 2, 5, 22, 23, 29, 37, 38 AND 50).

ANDREA HACK, EXAMINING ATTORNEY

**CLASS 16—(Continued).**

SN 85-211,290. HAGGERTY, BROOKE ANN, SEVERNA PARK, MD. FILED 1-5-2011.

# Yoga Earth Is

THE MARK CONSISTS OF STANDARD CHARACTERS WITHOUT CLAIM TO ANY PARTICULAR FONT, STYLE, SIZE, OR COLOR.

NO CLAIM IS MADE TO THE EXCLUSIVE RIGHT TO USE "YOGA", APART FROM THE MARK AS SHOWN.

FOR ART PRINTS; BLANK JOURNAL BOOKS; BOOK-MARKERS; BOOKMARKS; CALENDARS; CHILDREN'S BOOKS; COFFEE TABLE BOOKS FEATURING YOGA AND NATURE; DECALS; FLASH CARDS; GICLEE PRINTS; GREETING CARDS; MOTIVATIONAL CARDS; NOTE CARDS; POSTCARDS; POSTERS; PRINTED CALENDARS (U.S. CLS. 2, 5, 22, 23, 29, 37, 38 AND 50).

FIRST USE 9-11-2010; IN COMMERCE 9-11-2010.  
ANNE E. GUSTASON, EXAMINING ATTORNEY

SN 85-209,883. MEERMAN INDUSTRIES, INC, DBA BS SPLITTER, ATLANTA, GA. FILED 1-4-2011.



THE COLOR(S) BLACK AND WHITE IS/ARE CLAIMED AS A FEATURE OF THE MARK.

BLACK IS THE BACKGROUND FOR THE MARK; WHITE IS THE COLOR FOR THE WORDING "B S SPLITTER" IN THE MARK.

FOR A SERIES OF BOOKS AND WRITTEN ARTICLES IN THE FIELD OF SELF HELP (U.S. CLS. 2, 5, 22, 23, 29, 37, 38 AND 50).

AISHA SALEM, EXAMINING ATTORNEY

SN 85-211,299. BAILEY, CAREY CLEMONS, PHOENIX, AZ. FILED 1-5-2011.



THE MARK CONSISTS OF A CUPCAKE WITH A FLORAL LINER, AND ICING. THERE IS A POLK-A-DOTTED CHERRY ON TOP OF THE ICING, WITH A STEM AND LEAF COMING FROM CHERRY. UNDERNEATH THERE IS THE STYLIZED TEXT "CRAVINGS DESIRING GOD IN THE MIST OF MOTHERHOOD".

FOR MOTIVATIONAL CARDS (U.S. CLS. 2, 5, 22, 23, 29, 37, 38 AND 50).

KATHERINE STOIDES, EXAMINING ATTORNEY

**CLASS 16—(Continued).**

SN 85-212,218. REICHLLEY, LEIGH, LOS ANGELES, CA.  
FILED 1-6-2011.

**PRINCESS WEARS PANTS**

THE MARK CONSISTS OF STANDARD CHARACTERS  
WITHOUT CLAIM TO ANY PARTICULAR FONT, STYLE,  
SIZE, OR COLOR.

FOR CHILDREN'S BOOKS (U.S. CLS. 2, 5, 22, 23, 29, 37,  
38 AND 50).

JUDITH HELFMAN, EXAMINING ATTORNEY

---

SN 85-213,153. LIFE PLUS STYLE LTD., NEW YORK, NY.  
FILED 1-7-2011.

**I DREAM IN LETTERPRESS**

THE MARK CONSISTS OF STANDARD CHARACTERS  
WITHOUT CLAIM TO ANY PARTICULAR FONT, STYLE,  
SIZE, OR COLOR.

NO CLAIM IS MADE TO THE EXCLUSIVE RIGHT TO  
USE "LETTERPRESS", APART FROM THE MARK AS  
SHOWN.

FOR BLANK JOURNALS; MEMO PADS; NOTE  
CARDS; PEN AND PENCIL CASES; STATIONERY (U.S.  
CLS. 2, 5, 22, 23, 29, 37, 38 AND 50).

FIRST USE 12-9-2010; IN COMMERCE 12-9-2010.  
MICHAEL TANNER, EXAMINING ATTORNEY

---

SN 85-213,675. ZEIDMAN, ROBERT M., DBA Z ENTER-  
PRISES, CUPERTINO, CA. FILED 1-10-2011.

**Silicon Valley Napkin**

THE MARK CONSISTS OF STANDARD CHARACTERS  
WITHOUT CLAIM TO ANY PARTICULAR FONT, STYLE,  
SIZE, OR COLOR.

NO CLAIM IS MADE TO THE EXCLUSIVE RIGHT TO  
USE "NAPKIN", APART FROM THE MARK AS SHOWN.

SEC. 2(F).

FOR PAPER NAPKINS (U.S. CLS. 2, 5, 22, 23, 29, 37, 38  
AND 50).

FIRST USE 5-11-1986; IN COMMERCE 5-11-1986.  
MAUREEN DALL, EXAMINING ATTORNEY

**CLASS 16—(Continued).**

SN 85-213,951. HAPPINESS LOVES COMPANY, INC., EN-  
CINITAS, CA. FILED 1-10-2011.

**HAPPINESS LOVES COMPANY**

THE MARK CONSISTS OF STANDARD CHARACTERS  
WITHOUT CLAIM TO ANY PARTICULAR FONT, STYLE,  
SIZE, OR COLOR.

OWNER OF U.S. REG. NOS. 3,694,125 AND 3,752,127.

FOR A SERIES OF BOOKS AND WRITTEN ARTICLES  
IN THE FIELD OF COMEDY, DRAMA, ANIMATION,  
ROMANCE, RELATIONSHIPS, SELF AWARENESS,  
COMMUNITY AWARENESS, SELF IMPROVEMENT,  
MOTIVATION, SPIRITUALITY AND/OR ACTION/AD-  
VENTURE; ADDRESS BOOKS; APPOINTMENT BOOKS;  
BOOKMARKERS; BOOKMARKS; DECALS; DIARIES;  
METALLIC PAPER PARTY DECORATIONS; NOTE-  
BOOKS; PAPER CAKE DECORATIONS; PAPER NAP-  
KINS; PAPER NOTEBOOKS; PAPER PARTY BAGS;  
PAPER PARTY DECORATIONS; PAPER PARTY FA-  
VORS; PEN AND PENCIL CASES; PEN AND PENCIL  
HOLDERS; PEN AND PENCIL TRAYS; PENCILS; PENS;  
PRINTED PERIODICALS IN THE FIELD OF COMEDY,  
DRAMA, ANIMATION, ROMANCE, RELATIONSHIPS,  
SELF AWARENESS, COMMUNITY AWARENESS, SELF  
IMPROVEMENT, MOTIVATION, SPIRITUALITY AND/  
OR ACTION/ADVENTURE; SCRATCH PADS; STICKERS  
(U.S. CLS. 2, 5, 22, 23, 29, 37, 38 AND 50).

SANI KHOURI, EXAMINING ATTORNEY

---

SN 85-215,213. CHRISTIAN ART GIFTS, INC., LOMBARD,  
IL. FILED 1-11-2011.

**CHRISTIAN ART GIFTS**

THE MARK CONSISTS OF STANDARD CHARACTERS  
WITHOUT CLAIM TO ANY PARTICULAR FONT, STYLE,  
SIZE, OR COLOR.

OWNER OF U.S. REG. NOS. 2,918,253, 2,974,863 AND  
3,007,781.

SEC. 2(F).

FOR BOOKS REGARDING THE SUBJECT MATTER OF  
FAITH, AND RELIGION; STATIONERY; PAPER  
NOTE PADS; PENS; PENCILS; GIFT CARDS; DIARIES;  
WRITING JOURNALS; BOOK MARKS; BOOK COVERS  
AND CALENDARS (U.S. CLS. 2, 5, 22, 23, 29, 37, 38 AND  
50).

FIRST USE 5-0-2003; IN COMMERCE 5-0-2003.

WILLIAM ROSSMAN, EXAMINING ATTORNEY

**CLASS 16—(Continued).**

SN 85-215,976. LIFE PLUS STYLE LTD., NEW YORK, NY. FILED 1-12-2011.

**2 CENTS PLAIN**

THE MARK CONSISTS OF STANDARD CHARACTERS WITHOUT CLAIM TO ANY PARTICULAR FONT, STYLE, SIZE, OR COLOR.

NO CLAIM IS MADE TO THE EXCLUSIVE RIGHT TO USE "PLAIN", APART FROM THE MARK AS SHOWN, FOR BLANK JOURNALS IN THE NATURE OF A DIARY (U.S. CLS. 2, 5, 22, 23, 29, 37, 38 AND 50). FIRST USE 12-9-2010; IN COMMERCE 12-9-2010. MICHAEL TANNER, EXAMINING ATTORNEY

SN 85-216,229. OREGON CATHOLIC PRESS, DBA OCP PUBLICATIONS, PORTLAND, OR. FILED 1-12-2011.

**PALABRA, VIDA Y FE**

THE MARK CONSISTS OF STANDARD CHARACTERS WITHOUT CLAIM TO ANY PARTICULAR FONT, STYLE, SIZE, OR COLOR.

THE ENGLISH TRANSLATION OF "PALABRA, VIDA Y FE" IN THE MARK IS "WORD, LIFE AND FAITH". FOR PRAYER BOOKS (U.S. CLS. 2, 5, 22, 23, 29, 37, 38 AND 50).

FIRST USE 1-1-2007; IN COMMERCE 1-1-2007. TARAH HARDY, EXAMINING ATTORNEY

SN 85-216,358. WALERIUS, GREGORY J., LITTLETON, CO. FILED 1-12-2011.

**DIEHARD DIABETIC**

THE MARK CONSISTS OF STANDARD CHARACTERS WITHOUT CLAIM TO ANY PARTICULAR FONT, STYLE, SIZE, OR COLOR.

NO CLAIM IS MADE TO THE EXCLUSIVE RIGHT TO USE "DIABETIC", APART FROM THE MARK AS SHOWN.

FOR EDUCATIONAL KITS SOLD AS A UNIT IN THE FIELD OF DIABETES MANAGEMENT CONSISTING PRIMARILY OF EDUCATIONAL BOOKS AND ALSO INCLUDING DVDS AND T-SHIRTS (U.S. CLS. 2, 5, 22, 23, 29, 37, 38 AND 50).

DAVID HOFFMAN, EXAMINING ATTORNEY

**CLASS 16—(Continued).**

SN 85-217,279. SUSAN BLAND, FOX ISLAND, WA. AND JEFFREY S. BLAND, FOX ISLAND, WA. FILED 1-13-2011.



OWNER OF U.S. REG. NOS. 3,694,744 AND 3,694,745.

THE MARK CONSISTS OF THE LETTERS "IFM" WITH A SPIRAL DESIGN WHICH IS COMPRISED OF SPOTS TO THE LEFT OF THE LETTERS.

FOR BOOKS IN THE FIELD OF DISEASE PREVENTION AND MANAGEMENT (U.S. CLS. 2, 5, 22, 23, 29, 37, 38 AND 50).

BRIDGETT SMITH, EXAMINING ATTORNEY

SN 85-217,473. FELLER, CATHERINE, BASTROP, TX. FILED 1-13-2011.

**Hissyisms**

THE MARK CONSISTS OF STANDARD CHARACTERS WITHOUT CLAIM TO ANY PARTICULAR FONT, STYLE, SIZE, OR COLOR.

FOR BOOKMARKS; BUMPER STICKERS; GREETING CARDS (U.S. CLS. 2, 5, 22, 23, 29, 37, 38 AND 50).

SUZANNE BLANE, EXAMINING ATTORNEY

SN 85-221,135. FATHEAD, LLC, LIVONIA, MI. FILED 1-19-2011.

**FEEL THE REAL**

THE MARK CONSISTS OF STANDARD CHARACTERS WITHOUT CLAIM TO ANY PARTICULAR FONT, STYLE, SIZE, OR COLOR.

FOR POSTERS; ADHESIVE PLASTIC FILM WITH REMOVABLE PAPER FOR MOUNTING IMAGES FOR DECORATIVE PURPOSES (U.S. CLS. 2, 5, 22, 23, 29, 37, 38 AND 50).

AMY HELLA, EXAMINING ATTORNEY

**CLASS 16—(Continued).**

SN 85-221,154. FATHEAD, LLC, LIVONIA, MI. FILED 1-19-2011.

**Real You Can Feel**

THE MARK CONSISTS OF STANDARD CHARACTERS WITHOUT CLAIM TO ANY PARTICULAR FONT, STYLE, SIZE, OR COLOR.

FOR POSTERS; ADHESIVE PLASTIC FILM WITH REMOVABLE PAPER FOR MOUNTING IMAGES FOR DECORATIVE PURPOSES (U.S. CLS. 2, 5, 22, 23, 29, 37, 38 AND 50).

AMY HELLA, EXAMINING ATTORNEY

SN 85-221,158. FATHEAD, LLC, LIVONIA, MI. FILED 1-19-2011.

**Put Your Passion On Display**

THE MARK CONSISTS OF STANDARD CHARACTERS WITHOUT CLAIM TO ANY PARTICULAR FONT, STYLE, SIZE, OR COLOR.

FOR POSTERS; ADHESIVE PLASTIC FILM WITH REMOVABLE PAPER FOR MOUNTING IMAGES FOR DECORATIVE PURPOSES (U.S. CLS. 2, 5, 22, 23, 29, 37, 38 AND 50).

AMY HELLA, EXAMINING ATTORNEY

SN 85-229,764. THE READER'S DIGEST ASSOCIATION, INC., WHITE PLAINS, NY. FILED 1-31-2011.

**3-D MOVIE THEATER 3-D  
STORYBOOK & MOVIE PROJECTOR**

THE MARK CONSISTS OF STANDARD CHARACTERS WITHOUT CLAIM TO ANY PARTICULAR FONT, STYLE, SIZE, OR COLOR.

OWNER OF U.S. REG. NO. 2,907,708.

NO CLAIM IS MADE TO THE EXCLUSIVE RIGHT TO USE "3-D STORYBOOK & MOVIE PROJECTOR", APART FROM THE MARK AS SHOWN.

FOR CHILDREN'S BOOKS (U.S. CLS. 2, 5, 22, 23, 29, 37, 38 AND 50).

JEFFERY COWARD, EXAMINING ATTORNEY

**CLASS 16—(Continued).**

SN 85-233,926. HERNANDEZ JANICE M, GURNEE, IL. FILED 2-3-2011.

**SNAGGLE SNIT**

THE MARK CONSISTS OF STANDARD CHARACTERS WITHOUT CLAIM TO ANY PARTICULAR FONT, STYLE, SIZE, OR COLOR.

FOR CHILDREN'S BOOKS (U.S. CLS. 2, 5, 22, 23, 29, 37, 38 AND 50).

ANGELA M. MICHELI, EXAMINING ATTORNEY

SN 85-244,914. LIFETIME BRANDS, INC., GARDEN CITY, NY. FILED 2-17-2011.

**TABLETOP MEMORIES**

THE MARK CONSISTS OF STANDARD CHARACTERS WITHOUT CLAIM TO ANY PARTICULAR FONT, STYLE, SIZE, OR COLOR.

OWNER OF U.S. REG. NO. 2,930,180.

FOR PHOTO STORAGE BOXES; PHOTOGRAPH ALBUMS (U.S. CLS. 2, 5, 22, 23, 29, 37, 38 AND 50).

ALICIA COLLINS, EXAMINING ATTORNEY

SN 85-260,638. AHOLD LICENSING SARL, GENEVA, SWITZERLAND, FILED 3-8-2011.



OWNER OF U.S. REG. NOS. 2,871,579, 3,411,740 AND OTHERS.

THE COLOR(S) ORANGE, GRAY AND WHITE IS/ARE CLAIMED AS A FEATURE OF THE MARK.

THE MARK CONSISTS OF THE TRADE DRESS CHARACTERIZING THE FRONT FACE OF THE PACKAGING FOR APPLICANT'S GOODS, NAMELY (1) A WHITE HORIZONTAL BAR SPANNING THE LABEL OR PACKAGE FACE, (2) AN ORANGE BAR BELOW THE WHITE BAR, ALSO SPANNING THE LABEL OR PACKAGE FACE, (3) A

**CLASS 16—(Continued).**

DASHED LINE THAT APPEARS GRAY ON THE WHITE BACKGROUND AND WHITE ON THE ORANGE BACKGROUND. THE DASHED LINE EXTENDS HORIZONTALLY ALONG THE WHITE BAR, AND TURNS 90 DEGREES AT EACH END TO EXTEND DOWNWARDS INTO THE ORANGE BAR. THE DESIGN FURTHER COMPRISES (4) A GRAY SCISSORS DESIGN AND (5) THE WORD "GUARANTEED" APPEARING IN ORANGE ABOVE THE GRAY LINE AND THE WORD "VALUE" APPEARING IN ORANGE BELOW THE GRAY LINE.

SEC. 2(F) AS TO "GUARANTEED VALUE".

FOR PAPER NAPKINS; PAPER TOWELS; PLASTIC FOOD STORAGE BAGS FOR HOUSEHOLD USE; PLASTIC SANDWICH BAGS; PLASTIC TRASH BAGS; PLASTIC WRAP; TOILET TISSUE (U.S. CLS. 2, 5, 22, 23, 29, 37, 38 AND 50).

BRIDGETT SMITH, EXAMINING ATTORNEY

---

SN 85-260,919. AHOLD LICENSING SARL, GENEVA, SWITZERLAND, FILED 3-8-2011.



OWNER OF U.S. REG. NOS. 2,871,579, 3,411,740 AND OTHERS.

THE MARK CONSISTS OF A SCISSORS DESIGN WITH A DASHED LINE EXTENDING TO THE RIGHT OF THE SCISSORS. THE WORD "GUARANTEED" APPEARS ABOVE THE LINE AND THE WORD "VALUE" APPEARS BELOW THE LINE.

SEC. 2(F) AS TO "GUARANTEED VALUE".

FOR PAPER NAPKINS; PAPER TOWELS; PLASTIC FOOD STORAGE BAGS FOR HOUSEHOLD USE; PLASTIC SANDWICH BAGS; PLASTIC TRASH BAGS; PLASTIC WRAP; TOILET TISSUE (U.S. CLS. 2, 5, 22, 23, 29, 37, 38 AND 50).

BRIDGETT SMITH, EXAMINING ATTORNEY

**CLASS 17—RUBBER GOODS**

---

SN 85-024,407. THE FLEXAUST COMPANY, INC., WARSAW, IN. FILED 4-27-2010.

# FLEXSTAT

THE MARK CONSISTS OF STANDARD CHARACTERS WITHOUT CLAIM TO ANY PARTICULAR FONT, STYLE, SIZE, OR COLOR.

FOR NON-METAL STATIC DISSIPATIVE HOSES FOR USE WITH POWDER HANDLING AND/OR PLASTICS EXTRUSION FOR INDUSTRIAL USE (U.S. CLS. 1, 5, 12, 13, 35 AND 50).

LINDA ORNDORFF, EXAMINING ATTORNEY

**CLASS 17—(Continued).**

SN 85-121,944. LATICRETE INTERNATIONAL, INC., BETHANY, CT. FILED 9-2-2010.

# HYDRO BAN

THE MARK CONSISTS OF STANDARD CHARACTERS WITHOUT CLAIM TO ANY PARTICULAR FONT, STYLE, SIZE, OR COLOR.

FOR LIQUID RUBBER POLYMER FOR USE AS WATERPROOFING MEMBRANES IN CONSTRUCTION, REPAIR AND MAINTENANCE OF BUILDINGS (U.S. CLS. 1, 5, 12, 13, 35 AND 50).

FIRST USE 9-6-2006; IN COMMERCE 9-6-2006.

HEATHER BIDDULPH, EXAMINING ATTORNEY

---

SN 85-133,038. NANJING COMPTech MATERIALS CO., LTD., NANJING, CHINA, FILED 9-19-2010.



THE COLOR(S) RED BLUE AND BLACK IS/ARE CLAIMED AS A FEATURE OF THE MARK.

THE MARK CONSISTS OF A RED CRESCENT AND AN ABSTRACT BLUE ANCHOR FORMED AS A CIRCLE, WITH TWO BLACK CHINESE CHARACTERS ABOVE THE LATIN CHARACTERS "COMP TECH" DEPICTED TO THE RIGHT OF THE DESIGN ELEMENT.

THE NON-LATIN CHARACTERS IN THE MARK TRANSLITERATE TO KEN TE AND THIS HAS NO MEANING IN A FOREIGN LANGUAGE.

FOR CLUTCH LININGS; FLEXIBLE PLUMBING PIPES OF PLASTIC; GASKET SEALER FOR USE IN PLUMBING; INSULATING MATERIALS; LIQUID GASKET SEALER FOR AUTOMOTIVE USE; PADDING MATERIALS OF RUBBER OR PLASTIC; PIPE GASKETS; PLASTIC IN BARS, BLOCKS, PELLETS, RODS, SHEETS AND TUBES FOR GENERAL INDUSTRIAL USE; SEALING AND INSULATING MATERIALS; WATERTIGHT RINGS FOR PLUMBING PIPES (U.S. CLS. 1, 5, 12, 13, 35 AND 50).

FIRST USE 9-8-2008; IN COMMERCE 2-1-2009.

KATHERINE STOIDES, EXAMINING ATTORNEY



**CLASS 17—(Continued).**

SN 85-136,353. TEGRANT ALLOYD BRANDS, INC., DE-KALB, IL. FILED 9-23-2010.

**SYNERGREEN PACKAGING  
SOLUTIONS**

THE MARK CONSISTS OF STANDARD CHARACTERS WITHOUT CLAIM TO ANY PARTICULAR FONT, STYLE, SIZE, OR COLOR.

NO CLAIM IS MADE TO THE EXCLUSIVE RIGHT TO USE "PACKAGING SOLUTIONS", APART FROM THE MARK AS SHOWN.

FOR PACKAGING INSERTS MADE FROM PLASTIC FOAM (U.S. CLS. 1, 5, 12, 13, 35 AND 50).

SUZANNE BLANE, EXAMINING ATTORNEY

SN 85-143,776. HE, LI BIN, SAN FRANCISCO, CA. FILED 10-2-2010.



THE MARK CONSISTS OF LETTERS "VSK" IN UPPER CASE WITH A CURVED LINE AND A CROWN-SHAPED FIGURE ON TOP OF THE MIDDLE LETTER "S".

FOR ADHESIVE PLASTIC FILM FOR INDUSTRIAL AND COMMERCIAL USE; CLEAR SHEETS OF POLYMERIC FILM TO BE APPLIED TO AUTOMOTIVE VEHICLES TO COAT AND PROTECT THE VEHICLE'S FINISH; PLASTIC FILM FOR COMMERCIAL AND INDUSTRIAL USE; PLASTIC FILM THAT IS TINTED FOR USE IN HOME OR AUTO WINDOWS; PLASTIC SHEETING FOR AGRICULTURAL PURPOSES (U.S. CLS. 1, 5, 12, 13, 35 AND 50).

FIRST USE 1-1-1999; IN COMMERCE 1-1-1999.  
APRIL HESIK, EXAMINING ATTORNEY

**CLASS 17—(Continued).**

SN 85-191,188. SORBENT RECYCLERS INC., DBA INDUSTRIAL ABSORBENT SOLUTIONS, LANCASTER, SC. FILED 12-6-2010.

**Industrial Absorbent  
Solutions**

THE MARK CONSISTS OF STANDARD CHARACTERS WITHOUT CLAIM TO ANY PARTICULAR FONT, STYLE, SIZE, OR COLOR.

NO CLAIM IS MADE TO THE EXCLUSIVE RIGHT TO USE "INDUSTRIAL ABSORBENT", APART FROM THE MARK AS SHOWN.

FOR ABSORBENT PRODUCTS, NAMELY, PERFORATED PADS, FOR THE CONTAINMENT AND CLEAN-UP OF OIL BASED CHEMICALS, OILS AND LIQUIDS; OIL ABSORBENT PADS AND PILLOWS FOR CONTAINING OIL SPILLS (U.S. CLS. 1, 5, 12, 13, 35 AND 50).

STEPHANIE ALI, EXAMINING ATTORNEY

SN 85-208,511. SEALED AIR CORPORATION (US), ELMWOOD PARK, NJ. FILED 12-31-2010.

**ETHAFOAM AEROLITE**

THE MARK CONSISTS OF STANDARD CHARACTERS WITHOUT CLAIM TO ANY PARTICULAR FONT, STYLE, SIZE, OR COLOR.

OWNER OF U.S. REG. NOS. 726,386 AND 1,734,811.

FOR FOAM PRODUCTS FOR COMMERCIAL AND INDUSTRIAL USE, NAMELY, FOAMED POLYETHYLENE PLASTICS IN THE FORM OF SHEETS, BLOCKS AND RODS FOR USE IN MANUFACTURE OF LAND, SEA AND AIR VEHICLE CUSHIONS AND SEATS (U.S. CLS. 1, 5, 12, 13, 35 AND 50).

CHRISTINE COOPER, EXAMINING ATTORNEY

SN 85-213,738. LION COPOLYMER, LLC, BATON ROUGE, LA. FILED 1-10-2011.

**NICRYL**

THE MARK CONSISTS OF STANDARD CHARACTERS WITHOUT CLAIM TO ANY PARTICULAR FONT, STYLE, SIZE, OR COLOR.

FOR SYNTHETIC RUBBER (U.S. CLS. 1, 5, 12, 13, 35 AND 50).

HELENE LIWINSKI, EXAMINING ATTORNEY

**CLASS 17—(Continued).**

SN 85-215,388. GUARDIAN BUILDING PRODUCTS DISTRIBUTION, INC., GREENVILLE, SC. FILED 1-11-2011.

**FIBREGUARD**

THE MARK CONSISTS OF STANDARD CHARACTERS WITHOUT CLAIM TO ANY PARTICULAR FONT, STYLE, SIZE, OR COLOR.

PRIORITY CLAIMED UNDER SEC. 44(D) ON ERPNCMNTY TM OFC APPLICATION NO. 009642174, FILED 1-6-2011.

FOR BUILDING INSULATION (U.S. CLS. 1, 5, 12, 13, 35 AND 50).

ANGELA M. MICHELI, EXAMINING ATTORNEY

SN 85-218,494. SHERRILL, DAN, LEWISVILLE, TX. FILED 1-14-2011.

**RAPIDTHERM**

THE MARK CONSISTS OF STANDARD CHARACTERS WITHOUT CLAIM TO ANY PARTICULAR FONT, STYLE, SIZE, OR COLOR.

FOR HIGH TEMPERATURE INDUSTRIAL INDUCTION INSULATION BLANKET THAT FASTENS TO THE BARREL OF INJECTION MOLDING MACHINES (U.S. CLS. 1, 5, 12, 13, 35 AND 50).

FIRST USE 5-10-2010; IN COMMERCE 8-15-2010.  
KIM MONINGHOFF, EXAMINING ATTORNEY

SN 85-219,691. SEALED AIR CORPORATION (US), ELWOOD PARK, NJ. FILED 1-18-2011.

**FILL-AIR R5**

THE MARK CONSISTS OF STANDARD CHARACTERS WITHOUT CLAIM TO ANY PARTICULAR FONT, STYLE, SIZE, OR COLOR.

OWNER OF U.S. REG. NOS. 2,808,546, 2,953,524 AND 3,897,761.

FOR PLASTIC FILM PRODUCTS, NAMELY, RECYCLABLE PLASTIC MATERIALS USED IN CREATING INFLATED AIR CUSHION FOR USE IN RECYCLABLE PACKAGING (U.S. CLS. 1, 5, 12, 13, 35 AND 50).

CHRISTINE COOPER, EXAMINING ATTORNEY

**CLASS 17—(Continued).**

SN 85-232,911. TEKNOR APEX COMPANY, PAWTUCKET, RI. FILED 2-3-2011.

**APEX OVER 70 YEARS OF QUALITY**

THE MARK CONSISTS OF STANDARD CHARACTERS WITHOUT CLAIM TO ANY PARTICULAR FONT, STYLE, SIZE, OR COLOR.

OWNER OF U.S. REG. NOS. 1,633,203 AND 3,496,603.  
FOR GARDEN HOSES; WATERING HOSES (U.S. CLS. 1, 5, 12, 13, 35 AND 50).

PAM WILLIS, EXAMINING ATTORNEY

SN 85-241,827. ILLINOIS TOOL WORKS INC., GLENVIEW, IL. FILED 2-14-2011.

**G-FORCE**

THE MARK CONSISTS OF STANDARD CHARACTERS WITHOUT CLAIM TO ANY PARTICULAR FONT, STYLE, SIZE, OR COLOR.

FOR A SYSTEM COMPRISED PRIMARILY OF FOAM PADS AND STRAPS USED TO SECURE, STABILIZE, RESTRAIN AND PROTECT SHIPMENTS DURING TRANSPORT (U.S. CLS. 1, 5, 12, 13, 35 AND 50).

MARK PILARO, EXAMINING ATTORNEY

**CLASS 18—LEATHER GOODS**

SN 77-907,289. LF USA INC., NEW YORK, NY. FILED 1-7-2010.

**GIA MILANI**

THE MARK CONSISTS OF STANDARD CHARACTERS WITHOUT CLAIM TO ANY PARTICULAR FONT, STYLE, SIZE, OR COLOR.

THE NAME "GIA MILANI" DOES NOT IDENTIFY A LIVING INDIVIDUAL.

THE WORDING "GIA MILANI" HAS NO MEANING IN A FOREIGN LANGUAGE.

FOR HANDBAGS, PURSES, WALLETS, TRAVEL BAGS, TOTE BAGS, POCKET BOOKS, BRIEF CASES, BACKPACKS, MESSENGER BAGS, COSMETIC CASES SOLD EMPTY (U.S. CLS. 1, 2, 3, 22 AND 41).

JULIE VEPPUMTHARA, EXAMINING ATTORNEY

**CLASS 18—(Continued).**

SN 77-916,888. PAOLANTONIO, STEPHEN J., WAYNE, PA.  
FILED 1-21-2010.

**U.S. MALE BAG**

THE MARK CONSISTS OF STANDARD CHARACTERS WITHOUT CLAIM TO ANY PARTICULAR FONT, STYLE, SIZE, OR COLOR.

NO CLAIM IS MADE TO THE EXCLUSIVE RIGHT TO USE "BAG", APART FROM THE MARK AS SHOWN.

FOR GARMENT BAGS FOR TRAVEL, PURSES, SATCHELS, LUGGAGE, SHOULDER BAGS, CARRY-ON BAGS (U.S. CLS. 1, 2, 3, 22 AND 41).

KATHERINE CHANG, EXAMINING ATTORNEY

SN 79-086,714. MASHA KEJA S.A.R.L., FRANCE, FILED 6-14-2010.

**MASHA KEJA**

PRIORITY DATE OF 12-16-2009 IS CLAIMED.  
OWNER OF INTERNATIONAL REGISTRATION 1049403  
DATED 6-14-2010, EXPIRES 6-14-2020.

THE NAME(S), PORTRAIT(S), AND/OR SIGNATURE(S) SHOWN IN THE MARK IDENTIFIES MARIA KEJA-GARDEREAU, WHOSE CONSENT(S) TO REGISTER IS MADE OF RECORD.

THE MARK CONSISTS OF A GRAPHIC IN THE OVERALL SHAPE OF A BUTTERFLY, BUT COMBINED WITH THE SHAPE OF THE RUSSIAN IMPERIAL EAGLE. THE UPPER PORTION OF THE MARK'S "WINGS" COME TO A POINT IN A SHAPE RESEMBLING THE CROWN OF AN EAGLE. THE LOWER PORTION OF THE "WINGS" RESEMBLE A BUTTERFLY'S WINGS. THE ENTIRE GRAPHIC GIVES THE IMPRESSION OF BEING A CUT-OUT. THE STYLIZED WORDS "MASHA KEJA" APPEAR IMMEDIATELY BELOW THE GRAPHIC.

FOR HANDBAGS; BACKPACKS; WHEELED BAGS; TRAVELING BAGS; SUITCASES; SHOULDER BAGS; PURSES, NAMELY, CLUTCH PURSES, CLUTCHES, EVENING BAGS, MINAUDIERES AND PURSES; TRAVELING BAGS, NAMELY, GARMENT BAGS FOR TRAVEL, SATCHELS AND TOTE BAGS; BEACH BAGS; WALLETS; POUCHES OF LEATHER (U.S. CLS. 1, 2, 3, 22 AND 41).

ANDREA K. NADELMAN, EXAMINING ATTORNEY

**CLASS 18—(Continued).**

SN 79-092,318. JUAN MANUEL DIENTE SANZ, E-48960  
GALDACANO (VIZCAYA), SPAIN, FILED 12-23-2010.



OWNER OF INTERNATIONAL REGISTRATION 1064372  
DATED 12-23-2010, EXPIRES 12-23-2020.

THE MARK CONSISTS OF STYLIZED DESIGN OF A TORTOISE WITH THE LETTERS "CTTA" IN THE CENTER OF THE DESIGN AND THE TERM "CAMINATTA" BELOW THE DESIGN.

THE WORD(S) "CAMINATTA" HAS NO MEANING IN A FOREIGN LANGUAGE.

FOR BAGS, NAMELY, ALL-PURPOSE CARRYING BAGS, BEACH BAGS, CARRY-ON BAGS, CLUTCH BAGS, SHOPPING BAGS MADE OF LEATHER, OVERNIGHT BAGS, SHOULDER BAGS, TRAVEL BAGS; LEATHER AND IMITATION LEATHER; GOODS MADE OF LEATHER AND IMITATION LEATHER, NAMELY, LEATHER AND IMITATION LEATHER BAGS, TRUNKS AND TRAVELLING BAGS, WALLETS; ANIMAL SKINS; TRUNKS AND TRAVELING BAGS; UMBRELLAS, PARASOLS AND WALKING STICKS; WHIPS AND SADDLERY (U.S. CLS. 1, 2, 3, 22 AND 41).

DEIRDRE ROBERTSON, EXAMINING ATTORNEY

SN 85-009,018. BOLDRA, HEATHER, GASTONIA, NC. FILED  
4-8-2010.

**GREEN IS WHAT WE AIM FOR**

THE MARK CONSISTS OF STANDARD CHARACTERS WITHOUT CLAIM TO ANY PARTICULAR FONT, STYLE, SIZE, OR COLOR.

FOR PURSES, TOTE BAGS, BACKPACKS (U.S. CLS. 1, 2, 3, 22 AND 41).

MAYUR VAGHANI, EXAMINING ATTORNEY

**CLASS 18—(Continued).**

SN 85-024,476. HOLMES TARP SHOP, LTD., MILLERSBURG, OH. FILED 4-27-2010.

**E-Z HUNTER**

THE MARK CONSISTS OF STANDARD CHARACTERS WITHOUT CLAIM TO ANY PARTICULAR FONT, STYLE, SIZE, OR COLOR.

NO CLAIM IS MADE TO THE EXCLUSIVE RIGHT TO USE "HUNTER", APART FROM THE MARK AS SHOWN.

FOR HUNTING EQUIPMENT, NAMELY, WILD GAME SLING BAGS (U.S. CLS. 1, 2, 3, 22 AND 41).

SANI KHOURI, EXAMINING ATTORNEY

SN 85-045,099. NEW VIEW GIFTS & ACCESSORIES, LTD., MEDIA, PA. FILED 5-21-2010.

**REUSABLE WRAPPINGS**

THE MARK CONSISTS OF STANDARD CHARACTERS WITHOUT CLAIM TO ANY PARTICULAR FONT, STYLE, SIZE, OR COLOR.

NO CLAIM IS MADE TO THE EXCLUSIVE RIGHT TO USE "REUSABLE", APART FROM THE MARK AS SHOWN.

FOR TOTE BAGS (U.S. CLS. 1, 2, 3, 22 AND 41).

MARY CRAWFORD, EXAMINING ATTORNEY

SN 85-070,063. HOLMBERG, PATRICIA, HONOLULU, HI. FILED 6-23-2010.

**BAG SWAG**

THE MARK CONSISTS OF STANDARD CHARACTERS WITHOUT CLAIM TO ANY PARTICULAR FONT, STYLE, SIZE, OR COLOR.

NO CLAIM IS MADE TO THE EXCLUSIVE RIGHT TO USE "BAG", APART FROM THE MARK AS SHOWN.

FOR LUGGAGE COVERS (U.S. CLS. 1, 2, 3, 22 AND 41).

FIRST USE 5-15-2010; IN COMMERCE 11-15-2010.  
RONALD AIKENS, EXAMINING ATTORNEY

**CLASS 18—(Continued).**

SN 85-116,321. DIZ, THADEU, RIO DE JANEIRO, BRAZIL, FILED 8-26-2010.



THE MARK CONSISTS OF THE WORDS "ZEE" AND "DOG" SEPARATED BY A PERIOD, APPEARING BELOW THE IMAGE OF A DOG SKULL.

FOR PET PRODUCTS, NAMELY, PET RESTRAINING DEVICES CONSISTING OF LEASHES, COLLARS, HARNESSES, RESTRAINING STRAPS, AND LEASHES WITH LOCKING DEVICES; PET CLOTHING (U.S. CLS. 1, 2, 3, 22 AND 41).

JANICE KIM, EXAMINING ATTORNEY

SN 85-151,796. JESSIE GEORGINA, LLC, SAN DIEGO, CA. FILED 10-13-2010.

**LAG Bag**

THE MARK CONSISTS OF STANDARD CHARACTERS WITHOUT CLAIM TO ANY PARTICULAR FONT, STYLE, SIZE, OR COLOR.

NO CLAIM IS MADE TO THE EXCLUSIVE RIGHT TO USE "BAG", APART FROM THE MARK AS SHOWN.

FOR TRAVEL BAGS (U.S. CLS. 1, 2, 3, 22 AND 41).  
JENNY PARK, EXAMINING ATTORNEY

**CLASS 18—(Continued).**

SN 85-181,277. DIANE VON FURSTENBERG STUDIO, NEW MILFORD, CT. FILED 11-19-2010.



OWNER OF U.S. REG. NOS. 2,815,344, 3,778,688 AND OTHERS.

THE NAME(S), PORTRAIT(S), AND/OR SIGNATURE(S) SHOWN IN THE MARK IDENTIFIES "DIANE VON FURSTENBERG", WHOSE CONSENT(S) TO REGISTER IS MADE OF RECORD.

THE MARK CONSISTS OF THE WORD "DIANE" IN STYLIZED SCRIPT ABOVE THE STYLIZED WORDS "DIANE VON FURSTENBERG" IN LARGE AND SMALL BLOCK LETTERS, WHERE ALL ELEMENTS OF THE MARK ARE SET ON A RECTANGULAR BACKGROUND.

FOR LUGGAGE, GARMENT BAGS FOR TRAVEL, HANDBAGS, POCKETBOOKS, PURSES, CLUTCHES, TOTE BAGS, DUFFEL BAGS, BEACH BAGS, COSMETIC BAGS SOLD EMPTY, TOILETRY CASES SOLD EMPTY; WALLETS (U.S. CLS. 1, 2, 3, 22 AND 41).

ADA HAN, EXAMINING ATTORNEY

SN 85-182,661. PANACAVALLO, LLC, COHASSET, MA. FILED 11-22-2010.



THE MARK CONSISTS OF TWO HORSE HEADS FACING EACH OTHER WITH A STYLIZED CROSS IN A CIRCLE AND HORIZONTAL STIRRUP, WITH THE WORD "PANACAVALLO" BENEATH THE ENTIRE DESIGN.

THE WORDING "PANACAVALLO" HAS NO MEANING IN A FOREIGN LANGUAGE.

FOR HORSE TACK, NAMELY, RIDING CROPS, BRIDLES, REINS, LEADS, BITS, STIRRUP LEATHERS, GIRTH STRAPS, LUNGE LINES, HALTERS, HARNESSSES, SADDLERY, AND PADS FOR HORSE SADDLES (U.S. CLS. 1, 2, 3, 22 AND 41).

TINA L. SNAPP, EXAMINING ATTORNEY

**CLASS 18—(Continued).**

SN 85-182,683. PANACAVALLO, LLC, COHASSET, MA. FILED 11-22-2010.

**PANACAVALLO**

THE MARK CONSISTS OF STANDARD CHARACTERS WITHOUT CLAIM TO ANY PARTICULAR FONT, STYLE, SIZE, OR COLOR.

THE WORDING "PANACAVALLO" HAS NO MEANING IN A FOREIGN LANGUAGE.

FOR HORSE TACK, NAMELY, RIDING CROPS, BRIDLES, REINS, LEADS, BITS, STIRRUP LEATHERS, GIRTH STRAPS, LUNGE LINES, HALTERS, HARNESSSES, SADDLERY, AND PADS FOR HORSE SADDLES (U.S. CLS. 1, 2, 3, 22 AND 41).

TINA L. SNAPP, EXAMINING ATTORNEY

SN 85-183,315. PARABELLUM COLLECTION, INC., LOS ANGELES, CA. FILED 11-23-2010.

**PARABELLUM**

THE MARK CONSISTS OF STANDARD CHARACTERS WITHOUT CLAIM TO ANY PARTICULAR FONT, STYLE, SIZE, OR COLOR.

OWNER OF U.S. REG. NOS. 3,750,271 AND 3,750,702. FOR HANDBAGS FOR LADIES (U.S. CLS. 1, 2, 3, 22 AND 41).

COURTNEY ALVAREZ, EXAMINING ATTORNEY

SN 85-183,695. LU, LYNN, COVINA, CA. AND WU, TIFANY, COVINA, CA. FILED 11-23-2010.

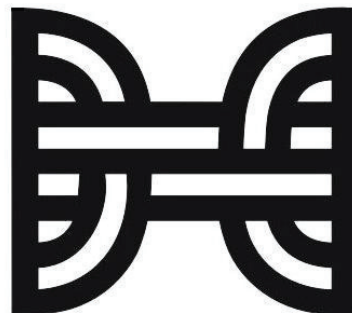

OWNER OF U.S. REG. NO. 3,815,155.

THE MARK CONSISTS OF INTERLOCKING WOVEN PATTERN.

FOR HAND BAGS, PURSES, LUGGAGE, COIN PURSES, WALLETS, JEWELRY ORGANIZERS FOR TRAVEL, COSMETIC CASES SOLD EMPTY, AND BUSINESS CARD CASES MADE OF LEATHER (U.S. CLS. 1, 2, 3, 22 AND 41).

FIRST USE 6-1-2006; IN COMMERCE 6-1-2006.

LAKEISHA LEWIS, EXAMINING ATTORNEY



**CLASS 18—(Continued).**

SN 85-196,193. LEGITIMUTT, LLC, MENLO PARK, CA. FILED 12-13-2010.

**MAKING WHOOPSIE**

THE MARK CONSISTS OF STANDARD CHARACTERS WITHOUT CLAIM TO ANY PARTICULAR FONT, STYLE, SIZE, OR COLOR.

FOR PET CLOTHING; PET ACCESSORIES, NAMELY, COLLARS FOR PETS, COLLARS FOR PETS BEARING MEDICAL INFORMATION, DISPOSABLE PET DIAPERS, ELECTRONIC PET COLLARS, SPECIALLY DESIGNED CANVAS, VINYL OR LEATHER BAGS ATTACHED TO ANIMAL LEASHES FOR HOLDING SMALL ITEMS SUCH AS KEYS, CREDIT CARDS, MONEY OR DISPOSABLE BAGS FOR DISPOSING OF PET WASTE, BOWS, CHARMS, BELLS, SILENCERS, SAFETY LIGHTS AND BLINKERS, PENDANTS, HAIR ORNAMENTS, PET RESTRAINING DEVICES CONSISTING OF LEASHES, COLLARS, HARNESSSES, RESTRAINING STRAPS, AND LEASHES WITH LOCKING DEVICES, AND PET TAGS SPECIALLY ADAPTED FOR ATTACHING TO PET LEASHES OR COLLARS (U.S. CLS. 1, 2, 3, 22 AND 41).

GRETTA YAO, EXAMINING ATTORNEY

**CLASS 18—(Continued).**

SN 85-196,210. LEGITIMUTT, LLC, MENLO PARK, CA. FILED 12-13-2010.

**AHOY BOY!**

THE MARK CONSISTS OF STANDARD CHARACTERS WITHOUT CLAIM TO ANY PARTICULAR FONT, STYLE, SIZE, OR COLOR.

FOR PET CLOTHING; PET ACCESSORIES, NAMELY, COLLARS FOR PETS, COLLARS FOR PETS BEARING MEDICAL INFORMATION, DISPOSABLE PET DIAPERS, ELECTRONIC PET COLLARS, SPECIALLY DESIGNED CANVAS, VINYL OR LEATHER BAGS ATTACHED TO ANIMAL LEASHES FOR HOLDING SMALL ITEMS SUCH AS KEYS, CREDIT CARDS, MONEY OR DISPOSABLE BAGS FOR DISPOSING OF PET WASTE, BOWS, CHARMS, BELLS, SILENCERS, SAFETY LIGHTS AND BLINKERS, PENDANTS, HAIR ORNAMENTS, PET RESTRAINING DEVICES CONSISTING OF LEASHES, COLLARS, HARNESSSES, RESTRAINING STRAPS, AND LEASHES WITH LOCKING DEVICES, AND PET TAGS SPECIALLY ADAPTED FOR ATTACHING TO PET LEASHES OR COLLARS (U.S. CLS. 1, 2, 3, 22 AND 41).

GRETTA YAO, EXAMINING ATTORNEY

SN 85-196,204. LEGITIMUTT, LLC, MENLO PARK, CA. FILED 12-13-2010.

**ROVER AND OUT**

THE MARK CONSISTS OF STANDARD CHARACTERS WITHOUT CLAIM TO ANY PARTICULAR FONT, STYLE, SIZE, OR COLOR.

FOR PET CLOTHING; PET ACCESSORIES, NAMELY COLLARS FOR PETS, COLLARS FOR PETS BEARING MEDICAL INFORMATION, DISPOSABLE PET DIAPERS, ELECTRONIC PET COLLARS, SPECIALLY DESIGNED CANVAS, VINYL OR LEATHER BAGS ATTACHED TO ANIMAL LEASHES FOR HOLDING SMALL ITEMS SUCH AS KEYS, CREDIT CARDS, MONEY OR DISPOSABLE BAGS FOR DISPOSING OF PET WASTE, BOWS, CHARMS, BELLS, SILENCERS, SAFETY LIGHTS AND BLINKERS, PENDANTS, HAIR ORNAMENTS, PET RESTRAINING DEVICES CONSISTING OF LEASHES, COLLARS, HARNESSSES, RESTRAINING STRAPS, AND LEASHES WITH LOCKING DEVICES, AND PET TAGS SPECIALLY ADAPTED FOR ATTACHING TO PET LEASHES OR COLLARS (U.S. CLS. 1, 2, 3, 22 AND 41).

GRETTA YAO, EXAMINING ATTORNEY

SN 85-197,482. JC 23 ENTERTAINMENT, INC., BEVERLY HILLS, CA. FILED 12-14-2010.

**WHAT I SEE RIGHT NOW**

THE MARK CONSISTS OF STANDARD CHARACTERS WITHOUT CLAIM TO ANY PARTICULAR FONT, STYLE, SIZE, OR COLOR.

FOR HANDBAGS, CLUTCHES, SHOULDER BAGS, TOTE BAGS, BACK PACKS, BOOK BAGS, DUFFLE BAGS, TRAVEL BAGS, SATCHELS, DRAW STRING BAGS, OVERNIGHT BAGS, WALLETS, KEY CASES, UMBRELLAS, ALL PURPOSE SPORTS BAGS, ATHLETIC BAGS, ATTACHE CASES, LEATHER BRIEFCASES, CLUTCH BAGS, BEACH BAGS, DIAPER BAGS, COSMETIC CASES SOLD EMPTY, TOILETRY CASES SOLD EMPTY, COIN PURSES, LUGGAGE TAGS, POCKETBOOKS, PURSES, LUGGAGE (U.S. CLS. 1, 2, 3, 22 AND 41).

LINDA ESTRADA, EXAMINING ATTORNEY

**CLASS 18—(Continued).**

SN 85-205,455. PAUL ROBILLARD, GABRIOLA BC, CANADA, FILED 12-23-2010.



NO CLAIM IS MADE TO THE EXCLUSIVE RIGHT TO USE "WINE", APART FROM THE MARK AS SHOWN.

THE MARK CONSISTS OF THE STYLIZED WORDING "WINE PILOT" BENEATH A WINE BOTTLE WITH WINGS PERPENDICULAR TO THE BODY OF THE BOTTLE.

FOR TRAVEL CASES, NOT FOR ANIMALS; WINE CARRYING CASES (U.S. CLS. 1, 2, 3, 22 AND 41).  
TAMARA FRAZIER, EXAMINING ATTORNEY

**CLASS 18—(Continued).**

SN 85-213,214. GJM,LLC, CHICAGO, IL. FILED 1-7-2011.

## Kumfy Koatz

THE MARK CONSISTS OF STANDARD CHARACTERS WITHOUT CLAIM TO ANY PARTICULAR FONT, STYLE, SIZE, OR COLOR.

NO CLAIM IS MADE TO THE EXCLUSIVE RIGHT TO USE "COATS", APART FROM THE MARK AS SHOWN.

FOR CLOTHING FOR ANIMALS; CLOTHING FOR DOMESTIC PETS; DIAPERS FOR DOGS; DOG APPAREL; DOG CLOTHING; DOG COATS; DOG COLLARS; DOG COLLARS AND LEADS; DOG LEASHES; DOG PARKAS; DOG SHOES; NECKWEAR FOR DOGS; PET CLOTHING (U.S. CLS. 1, 2, 3, 22 AND 41).

FIRST USE 3-1-2010; IN COMMERCE 6-1-2010.  
JENNIFER MARTIN, EXAMINING ATTORNEY

SN 85-214,017. PINYO K, LLC, SAN FRANCISCO, CA. FILED 1-10-2011.

## PINYO

THE MARK CONSISTS OF STANDARD CHARACTERS WITHOUT CLAIM TO ANY PARTICULAR FONT, STYLE, SIZE, OR COLOR.

FOR FASHION HANDBAGS (U.S. CLS. 1, 2, 3, 22 AND 41).

NICHOLAS ALTREE, EXAMINING ATTORNEY

SN 85-212,943. SINGER, MARILYN P, SNYDER, NY. AND SINGER, LAWRENCE H, SNYDER, NY. FILED 1-7-2011.



SN 85-215,246. DARLENE NEVIN, CARSON CITY, NV. FILED 1-11-2011.

## BAGS WITHOUT BAGGAGE

THE MARK CONSISTS OF STANDARD CHARACTERS WITHOUT CLAIM TO ANY PARTICULAR FONT, STYLE, SIZE, OR COLOR.

FOR ALL-PURPOSE CARRYING BAGS; ALL-PURPOSE REUSABLE CARRYING BAGS; AMENITY BAGS SOLD EMPTY; BABY CARRYING BAGS; BACKPACKS, BOOK BAGS, SPORTS BAGS, BUM BAGS, WALLETS AND HANDBAGS; BAGS FOR CARRYING BABIES' ACCESSORIES; BELT BAGS AND HIP BAGS; BOOK BAGS; CARRY-ALL BAGS; CARRY-ON BAGS; CLUTCH BAGS; COSMETIC BAGS SOLD EMPTY (U.S. CLS. 1, 2, 3, 22 AND 41).

FIRST USE 11-19-2010; IN COMMERCE 11-19-2010.  
BARBARA GAYNOR, EXAMINING ATTORNEY

THE MARK CONSISTS OF THE STYLIZED TEXT "SPOOKEZE" WITH A LINE GOING THROUGH THE LETTER "O'S".

FOR EAR VEILS FOR HORSES AND PONIES THAT FITS SNUGLY OVER THEIR EARS AND THE TOP OF THEIR HEAD, ATTACHING TO THE BRIDLE FOR PROVIDING NOISE BLOCKING TO REDUCE OR ELIMINATE NOISES OR SOUNDS THAT CAUSE THEM TO SPOOK (U.S. CLS. 1, 2, 3, 22 AND 41).

FIRST USE 1-1-2010; IN COMMERCE 1-1-2010.  
CAROLINE WOOD, EXAMINING ATTORNEY

**CLASS 18—(Continued).**

SN 85-215,291. LIBERTA, LLC, BOCA RATON, FL. FILED 1-11-2011.

**Art of Leather**

THE MARK CONSISTS OF STANDARD CHARACTERS WITHOUT CLAIM TO ANY PARTICULAR FONT, STYLE, SIZE, OR COLOR.

NO CLAIM IS MADE TO THE EXCLUSIVE RIGHT TO USE "LEATHER", APART FROM THE MARK AS SHOWN.

FOR LEATHER BAGS; SUITCASES AND WALLETS; LEATHER BRIEFCASES; LEATHER HANDBAGS; TRAVELLING CASES OF LEATHER (U.S. CLS. 1, 2, 3, 22 AND 41).

FIRST USE 10-1-2010; IN COMMERCE 10-1-2010.  
MAYUR VAGHANI, EXAMINING ATTORNEY

**CLASS 18—(Continued).**

SN 85-219,268. GTFM, INC., NEW YORK, NY. FILED 1-17-2011.

**FB**

THE MARK CONSISTS OF STANDARD CHARACTERS WITHOUT CLAIM TO ANY PARTICULAR FONT, STYLE, SIZE, OR COLOR.

OWNER OF U.S. REG. NOS. 2,065,987, 3,165,612 AND OTHERS.

FOR ALL PURPOSE SPORT BAGS; ALL-PURPOSE ATHLETIC BAGS; BACKPACKS; DUFFEL BAGS; GYM BAGS; HANDBAGS; KEY CASES; PURSES; SATCHELS; TRAVEL BAGS; UMBRELLAS; WALLETS (U.S. CLS. 1, 2, 3, 22 AND 41).

JOSETTE BEVERLY, EXAMINING ATTORNEY

SN 85-215,411. TAD DRAPER, DRAPER, UT. FILED 1-11-2011.

**WHIP IT**

THE MARK CONSISTS OF STANDARD CHARACTERS WITHOUT CLAIM TO ANY PARTICULAR FONT, STYLE, SIZE, OR COLOR.

FOR BELT BAGS; COIN HOLDERS IN THE NATURE OF WALLETS; POUCHES MADE OUT OF CLOTH; POUCHES OF TEXTILE; PURSES AND WALLETS; WALLETS; WALLETS AND WALLET INSERTS; WEARABLE STRAP-ON POUCH (U.S. CLS. 1, 2, 3, 22 AND 41).

FIRST USE 10-21-2010; IN COMMERCE 10-21-2010.  
AISHA CLARKE, EXAMINING ATTORNEY

SN 85-220,323. DELUNA BY DESIGN, INC., NEW YORK, NY. FILED 1-18-2011.

**MARISOL DELUNA**

THE MARK CONSISTS OF STANDARD CHARACTERS WITHOUT CLAIM TO ANY PARTICULAR FONT, STYLE, SIZE, OR COLOR.

THE NAME(S), PORTRAIT(S), AND/OR SIGNATURE(S) SHOWN IN THE MARK IDENTIFIES "MARISOL DELUNA", WHOSE CONSENT(S) TO REGISTER IS MADE OF RECORD.

FOR HANDBAGS (U.S. CLS. 1, 2, 3, 22 AND 41).

FIRST USE 1-1-1997; IN COMMERCE 1-1-1997.

JANICE L. MCMORROW, EXAMINING ATTORNEY

SN 85-217,629. MEADWESTVACO CORPORATION, RICHMOND, VA. FILED 1-14-2011.

**RIGHT SIZE. RIGHT FIT.**

THE MARK CONSISTS OF STANDARD CHARACTERS WITHOUT CLAIM TO ANY PARTICULAR FONT, STYLE, SIZE, OR COLOR.

FOR BACKPACKS AND TOTE BAGS (U.S. CLS. 1, 2, 3, 22 AND 41).

LINDA E. BLOHM, EXAMINING ATTORNEY

SN 85-246,961. D-GENERATION, INC. DAYTONA BEACH, FL. FILED S.R. 2-19-2011; AM. P.R. 3-25-2011.

**L3**

THE MARK CONSISTS OF STANDARD CHARACTERS WITHOUT CLAIM TO ANY PARTICULAR FONT, STYLE, SIZE, OR COLOR.

FOR HANDBAGS, PURSES AND WALLETS; LEATHER KEY CHAINS; LEATHER PURSES; TOTE BAGS (U.S. CLS. 1, 2, 3, 22 AND 41).

FIRST USE 11-13-2008; IN COMMERCE 11-13-2008.

JUSTINE D. PARKER, EXAMINING ATTORNEY

**CLASS 19—NON-METALLIC BUILDING MATERIALS**

SN 77-093,447. STONCOR GROUP, INC., MAPLE SHADE, NJ. FILED 1-29-2007.

# STONLOK

THE MARK CONSISTS OF STANDARD CHARACTERS WITHOUT CLAIM TO ANY PARTICULAR FONT, STYLE, SIZE, OR COLOR.

OWNER OF U.S. REG. NO. 1,655,954.

FOR INTERLOCKING INDIVIDUAL FLOORING TILES MADE OF POLYVINYL CHLORIDE, SOLD BY APPLICANT'S CAPTIVE COMMISSIONED SALES PERSONS, AGENTS AND DISTRIBUTORS, FOR USE IN COMMERCIAL, INDUSTRIAL AND INSTITUTIONAL SETTINGS (U.S. CLS. 1, 12, 33 AND 50).

MARLENE BELL, EXAMINING ATTORNEY

SN 77-610,761. TUBELITE INC., WALKER, MI. FILED 11-10-2008.

# THERML=BLOCK

THE MARK CONSISTS OF STANDARD CHARACTERS WITHOUT CLAIM TO ANY PARTICULAR FONT, STYLE, SIZE, OR COLOR.

FOR CONSTRUCTION MATERIALS, NAMELY, NON-METAL STRUTS FOR USE IN THE MANUFACTURE OF DOORS, WINDOWS, CURTAINWALLS, AND STORE-FRONT FRAMING (U.S. CLS. 1, 12, 33 AND 50).

WILLIAM ROSSMAN, EXAMINING ATTORNEY

SN 77-736,177. PATRIOT TIMBER PRODUCTS, INC., GREENSBORO, NC. FILED 5-13-2009.



# EcoPlywood

OWNER OF U.S. REG. NO. 3,057,204.

NO CLAIM IS MADE TO THE EXCLUSIVE RIGHT TO USE "ECOPLYWOOD", APART FROM THE MARK AS SHOWN.

THE NAME(S), PORTRAIT(S), AND/OR SIGNATURE(S) SHOWN IN THE MARK DOES NOT IDENTIFY A PARTICULAR LIVING INDIVIDUAL.

THE MARK CONSISTS OF WORD "ECOPLYWOOD" WITH IMAGE OF REVOLUTIONARY WAR ERA SOLDIER WITHIN A CIRCLE.

FOR BOARDS OF WOOD AND PANELS OF WOOD (U.S. CLS. 1, 12, 33 AND 50).

TOBY BULLOFF, EXAMINING ATTORNEY

**CLASS 19—(Continued).**

SN 77-778,090. SHIJIAZHUANG BAINIANQIAOJIANG WOODEN PRODUCTS CO., LTD., HEBEI PROVINCE, CHINA, FILED 7-9-2009.



NO CLAIM IS MADE TO THE EXCLUSIVE RIGHT TO USE THE NON-LATIN CHARACTERS THAT TRANSLITERATE TO "QIAO JIANG", APART FROM THE MARK AS SHOWN.

THE MARK CONSISTS OF FOUR STYLIZED CHINESE CHARACTERS.

THE ENGLISH TRANSLATION OF "BAI NIAN QIAO JIANG" IN THE MARK IS "CENTENNIAL SKILFUL CRAFTSMAN".

THE NON-LATIN CHARACTERS IN THE MARK TRANSLITERATE TO "BAI NIAN QIAO JIANG" AND THIS MEANS "CENTENNIAL SKILFUL CRAFTSMAN" IN ENGLISH.

FOR BURIAL VAULTS NOT OF METAL; FLOOR BOARDS; NON-METAL FLOOR TILES; NON-METAL GREENHOUSE FRAMES; PARQUET FLOOR BOARDS; PARQUET FLOORING; PLYWOOD; WORKS OF ART OF STONE, CONCRETE OR MARBLE (U.S. CLS. 1, 12, 33 AND 50).

FIRST USE 7-10-2008; IN COMMERCE 7-10-2008.

SHAUNIA CARLYLE, EXAMINING ATTORNEY

SN 77-843,219. QUADRO VENTURES INC., SURREY, B.C., CANADA, FILED 10-7-2009.

# DECORDEK

THE MARK CONSISTS OF STANDARD CHARACTERS WITHOUT CLAIM TO ANY PARTICULAR FONT, STYLE, SIZE, OR COLOR.

PRIORITY CLAIMED UNDER SEC. 44(D) ON CANADA APPLICATION NO. 1453309, FILED 9-28-2009, REG. NO. TMA786849, DATED 1-10-2011, EXPIRES 1-10-2026.

FOR NON-METAL ROOF AND DECK COVERINGS, NAMELY, VINYL COVERINGS FOR ROOFS AND DECKS (U.S. CLS. 1, 12, 33 AND 50).

AMY KERTGATE, EXAMINING ATTORNEY

**CLASS 19—(Continued).**

SN 77-843,225. QUADRO VENTURES INC., SURREY, B.C., CANADA, FILED 10-7-2009.

# PLAZADEK

THE MARK CONSISTS OF STANDARD CHARACTERS WITHOUT CLAIM TO ANY PARTICULAR FONT, STYLE, SIZE, OR COLOR.

PRIORITY CLAIMED UNDER SEC. 44(D) ON CANADA APPLICATION NO. 1453316, FILED 9-28-2009, REG. NO. TMA786847, DATED 1-10-2011, EXPIRES 1-10-2026.

FOR NON-METAL ROOF AND DECK COVERINGS, NAMELY, VINYL COVERINGS FOR ROOFS AND DECKS (U.S. CLS. 1, 12, 33 AND 50).

AMY KERTGATE, EXAMINING ATTORNEY

SN 77-843,235. QUADRO VENTURES INC., SURREY, B.C., CANADA, FILED 10-7-2009.

# TILEDEK

THE MARK CONSISTS OF STANDARD CHARACTERS WITHOUT CLAIM TO ANY PARTICULAR FONT, STYLE, SIZE, OR COLOR.

PRIORITY CLAIMED UNDER SEC. 44(D) ON CANADA APPLICATION NO. 1453311, FILED 9-28-2009, REG. NO. TMA786850, DATED 1-10-2011, EXPIRES 1-10-2026.

FOR NON-METAL ROOF AND DECK COVERINGS, NAMELY, VINYL COVERINGS FOR ROOFS AND DECKS (U.S. CLS. 1, 12, 33 AND 50).

AMY KERTGATE, EXAMINING ATTORNEY

SN 77-929,657. WELD, DON, DBA PHOENIX ENTERPRISES, FRESNO, CA. FILED 2-5-2010.



THE MARK CONSISTS OF HEAD OF MYTHICAL PHOENIX BIRD WITH WINGS SPREAD OUT OVER HEAD IN BLACK.

FOR LUMBER (U.S. CLS. 1, 12, 33 AND 50).  
FIRST USE 3-1-1995; IN COMMERCE 3-15-1995.  
SALLY SHIH, EXAMINING ATTORNEY

**CLASS 19—(Continued).**

SN 79-087,206. GRES PANARIA PORTUGAL, SA, PORTUGAL, FILED 8-2-2010.

# LOVE

CERAMIC TILES

OWNER OF INTERNATIONAL REGISTRATION 1050697 DATED 8-2-2010, EXPIRES 8-2-2020.

NO CLAIM IS MADE TO THE EXCLUSIVE RIGHT TO USE "CERAMIC TILES", APART FROM THE MARK AS SHOWN.

THE MARK CONSISTS OF THE STYLIZED WORDING "LOVE CERAMIC TILES" WITH THE DESIGN OF A HEART WITHIN THE LETTER "O" IN THE WORD "LOVE".

FOR NON-METALLIC BUILDING MATERIALS FOR FLOORINGS AND COVERINGS, NAMELY, CERAMIC TILES (U.S. CLS. 1, 12, 33 AND 50).

EVELYN BRADLEY, EXAMINING ATTORNEY

SN 79-093,123. NV SPANOLUX DIV. BALTERIO, B-8710 SINT-BAAFS-VIJVE, BELGIUM, FILED 12-15-2010.

# BALTERIO

THE MARK CONSISTS OF STANDARD CHARACTERS WITHOUT CLAIM TO ANY PARTICULAR FONT, STYLE, SIZE, OR COLOR.

OWNER OF INTERNATIONAL REGISTRATION 1002927 DATED 5-7-2009, EXPIRES 5-7-2019.

THE WORDING "BALTERIO" HAS NO MEANING IN A FOREIGN LANGUAGE.

FOR WOODEN FLOORS; PARQUET FLOORING AND PARQUET FLOORING BOARDS, INCLUDING LAMINATE PARQUET FLOORING AND PARQUET FLOORING BOARDS; PARQUET FLOORING VENEERED WITH WOOD; SHEET MATERIAL COMPRISING LAYERS OF WOOD VENEER PRESSED AND GLUED TOGETHER (U.S. CLS. 1, 12, 33 AND 50).

JAMES STEIN, EXAMINING ATTORNEY

SN 79-093,362. MAPEI S.P.A., ITALY, FILED 12-28-2010.

# ULTRAFLEX

THE MARK CONSISTS OF STANDARD CHARACTERS WITHOUT CLAIM TO ANY PARTICULAR FONT, STYLE, SIZE, OR COLOR.

PRIORITY DATE OF 12-20-2010 IS CLAIMED.

OWNER OF INTERNATIONAL REGISTRATION 1067097 DATED 12-28-2010, EXPIRES 12-28-2020.

FOR MORTAR AND IN PARTICULAR MORTAR FOR INTERNAL AND EXTERNAL APPLICATION OF STONES, CERAMICS AND PORCELAIN (U.S. CLS. 1, 12, 33 AND 50).

SAIMA MAKHDOOM, EXAMINING ATTORNEY



**CLASS 19—(Continued).**

SN 85-046,840. SERIOUS MATERIALS, INC., SUNNYVALE, CA. FILED 5-24-2010.

# iWindow

THE MARK CONSISTS OF STANDARD CHARACTERS WITHOUT CLAIM TO ANY PARTICULAR FONT, STYLE, SIZE, OR COLOR.

FOR INSULATED GLASS; LAMINATED FLAT GLASS; MODIFIED SHEET GLASS; NON-METAL WINDOWS; SAFETY GLASS FOR BUILDING PURPOSES; WINDOW CASEMENTS NOT OF METAL; WINDOW GLASS; WINDOW PANES (U.S. CLS. 1, 12, 33 AND 50).

KAREN K. BUSH, EXAMINING ATTORNEY

---

SN 85-064,707. THE MOLDING DEPOT, INC., TAMPA, FL. FILED 6-16-2010.

# DECO-FLASH

THE MARK CONSISTS OF STANDARD CHARACTERS WITHOUT CLAIM TO ANY PARTICULAR FONT, STYLE, SIZE, OR COLOR.

FOR NON-METAL WINDOW AND DOOR FRAMES; NON-METAL WEATHER RESISTANT BUILDING MATERIALS FOR WEATHERPROOFING, WINTERPROOFING AND WATERPROOFING WINDOWS, WINDOW OPENINGS, PERIMETERS OF WINDOWS, DOOR OPENINGS AND DOOR FRAMES, NAMELY, PLASTIC WEB-BING MATERIAL USED TO REINFORCE BITUMINOUS WATERPROOFING SHEETS; NON-METAL WINDOW OR DOOR CASEMENTS; A SYSTEM FOR WEATHERPROOFING, WINTERPROOFING AND WATERPROOFING WINDOWS, WINDOW OPENINGS, PERIMETERS OF WINDOWS, DOOR OPENINGS AND DOOR FRAMES, NAMELY, A SELF-INSTALLATION WINDOW AND DOOR FLASHING KIT COMPRISED OF NON-METAL WINDOW FRAMES (U.S. CLS. 1, 12, 33 AND 50).

FIRST USE 1-21-2009; IN COMMERCE 3-16-2009.  
JANET LEE, EXAMINING ATTORNEY

---

SN 85-068,289. HC BRIDGE COMPANY, LLC, WILMETTE, IL. FILED 6-22-2010.

# HCB

THE MARK CONSISTS OF STANDARD CHARACTERS WITHOUT CLAIM TO ANY PARTICULAR FONT, STYLE, SIZE, OR COLOR.

FOR BRIDGE BEAMS COMPOSED PRIMARILY OF NONMETAL MATERIALS (U.S. CLS. 1, 12, 33 AND 50).  
FIRST USE 3-31-2008; IN COMMERCE 3-31-2008.

JULIE VEPPUMTHARA, EXAMINING ATTORNEY

**CLASS 19—(Continued).**

SN 85-069,527. UNIMIN CORPORATION, NEW CANAAN, CT. FILED 6-23-2010.

# CHEMFLUX

THE MARK CONSISTS OF STANDARD CHARACTERS WITHOUT CLAIM TO ANY PARTICULAR FONT, STYLE, SIZE, OR COLOR.

FOR LIME AND LIMESTONE USED FOR INDUSTRIAL, METALLURGICAL AND MANUFACTURING APPLICATIONS; PROCESSED AND/OR TREATED INDUSTRIAL LIME AND LIMESTONE; PROCESSED AND/OR TREATED INDUSTRIAL LIME AND LIMESTONE USED IN ORE CONVERSION, METALLURGY, IRON AND STEEL MAKING PROCESSES (U.S. CLS. 1, 12, 33 AND 50).

C. DIONNE CLYBURN, EXAMINING ATTORNEY

---

SN 85-082,501. INTEPLAST GROUP, LTD., LIVINGSTON, NJ. FILED 7-12-2010.

# INTETRIM

THE MARK CONSISTS OF STANDARD CHARACTERS WITHOUT CLAIM TO ANY PARTICULAR FONT, STYLE, SIZE, OR COLOR.

THE WORDING "INTE" HAS NO MEANING IN A FOREIGN LANGUAGE.

FOR BUILDING MATERIALS, NAMELY, CELLULAR PVC TRIM (U.S. CLS. 1, 12, 33 AND 50).

LINDA ESTRADA, EXAMINING ATTORNEY

---

SN 85-082,638. INTEPLAST GROUP, LTD., LIVINGSTON, NJ. FILED 7-12-2010.

# INTE

THE MARK CONSISTS OF STANDARD CHARACTERS WITHOUT CLAIM TO ANY PARTICULAR FONT, STYLE, SIZE, OR COLOR.

THE WORDING "INTE" HAS NO MEANING IN A FOREIGN LANGUAGE.

FOR NONMETALLIC BUILDING MATERIALS, NAMELY, PLASTIC DECKING BOARDS, TRIMS, SIDINGS, FENCES, GUARD RAILS, MOLDINGS (U.S. CLS. 1, 12, 33 AND 50).

LINDA ESTRADA, EXAMINING ATTORNEY

**CLASS 19—(Continued).**

SN 85-088,392. GCC RIO GRANDE, INC., TIJERAS, NM.  
FILED 7-20-2010.



OWNER OF U.S. REG. NOS. 1,939,961 AND 1,939,962.  
NO CLAIM IS MADE TO THE EXCLUSIVE RIGHT TO  
USE "RIO GRANDE", APART FROM THE MARK AS  
SHOWN.

THE COLOR(S) RED, WHITE AND BLUE IS/ARE  
CLAIMED AS A FEATURE OF THE MARK.

THE MARK CONSISTS OF A DIAMOND BLOCK DESIGN  
COMPRISED OF TWO INTERLOCKING CHARACTERS.  
THE UPPER CHARACTER IS A DOWNWARD FACING  
"L" - SHAPE SHADED IN THE COLOR BLUE. THE LOWER  
CHARACTER IS A DOWNWARD FACING REVERSED "J" -  
SHAPE SHADED IN THE COLOR RED. THE LETTERS  
"GCC" ARE LOCATED TO THE RIGHT OF THE STYLIZED  
DESIGN SHADED IN THE COLOR BLUE. THE WORDS  
"RIO GRANDE" IN BLUE ARE LOCATED BELOW THE  
"GCC" LETTERS IN A SMALLER CHARACTER. THE  
BACKGROUND IS WHITE.

FOR CEMENT AGGREGATES; CEMENT MIXES;  
CONCRETE BLOCKS; GYPSUM; LIMESTONE (U.S.  
CLS. 1, 12, 33 AND 50).

FIRST USE 1-1-2002; IN COMMERCE 1-1-2002.  
KAELE KUNG, EXAMINING ATTORNEY

SN 85-091,406. INTEPLAST GROUP, LTD., LIVINGSTON, NJ.  
FILED 7-23-2010.



OWNER OF U.S. REG. NO. 2,724,251.  
NO CLAIM IS MADE TO THE EXCLUSIVE RIGHT TO  
USE "BOARD", APART FROM THE MARK AS SHOWN.

THE COLOR(S) BLACK, GREEN AND WHITE IS/ARE  
CLAIMED AS A FEATURE OF THE MARK.

THE MARK CONSISTS OF A HOUSE OUTLINED IN  
BLACK AND WHITE WITH GREEN IN THE TOP CONTAINING  
THE WORD "TUF" IN WHITE AND THE COLOR  
BLACK IN THE BOTTOM CONTAINING THE WORD  
"BOARD" IN WHITE AND THE WORDING "...DESIGNED  
FOR LIFE". IS BELOW THE HOUSE IN THE COLOR  
BLACK.

FOR NONMETALLIC BUILDING MATERIALS,  
NAMELY, PLASTIC DECKING BOARDS, TRIMS, SID-  
INGS, FENCES, GUARD RAILS, DECORATIVE MOLD-  
INGS (U.S. CLS. 1, 12, 33 AND 50).

FIRST USE 7-1-2010; IN COMMERCE 7-1-2010.  
LINDA ESTRADA, EXAMINING ATTORNEY

**CLASS 19—(Continued).**

SN 85-109,208. CHASE INDUSTRIES, INC., CINCINNATI,  
OH. FILED 8-17-2010.

**PERFASTRIP**

THE MARK CONSISTS OF STANDARD CHARACTERS  
WITHOUT CLAIM TO ANY PARTICULAR FONT, STYLE,  
SIZE, OR COLOR.

FOR NON-METAL PRE-PUNCHED STRIP DOORS  
SOLD ON A CONTINUOUS ROLL (U.S. CLS. 1, 12, 33  
AND 50).

FLORENTINA BLANDU, EXAMINING ATTORNEY

SN 85-137,568. MASONITE INTERNATIONAL CORPORA-  
TION, MISSISSAUGA, CANADA, FILED 9-24-2010.

**IRON SPRINGS**

THE MARK CONSISTS OF STANDARD CHARACTERS  
WITHOUT CLAIM TO ANY PARTICULAR FONT, STYLE,  
SIZE, OR COLOR.

FOR DOOR LITES, SIDE LITES AND TRANSOM  
LITES, ALL IN THE NATURE OF GLASS AND PLASTIC  
PANELS FOR DOORS AND DOOR ENTRANCEWAYS;  
DOOR LITES, SIDE LITES, TRANSOM LITES IN THE  
NATURE OF GLASS AND PLASTIC PANELS WHICH  
ARE SOLD AS AN INTEGRAL COMPONENT OF ENTRY  
DOORS AND DOOR ENTRANCEWAYS (U.S. CLS. 1, 12,  
33 AND 50).

MARK RADEMACHER, EXAMINING ATTORNEY

SN 85-166,667. CUSTOM BUILDING PRODUCTS, INC., SEAL  
BEACH, CA. FILED 11-1-2010.

**AMERICA'S #1 GROUT**

THE MARK CONSISTS OF STANDARD CHARACTERS  
WITHOUT CLAIM TO ANY PARTICULAR FONT, STYLE,  
SIZE, OR COLOR.

NO CLAIM IS MADE TO THE EXCLUSIVE RIGHT TO  
USE "GROUT", APART FROM THE MARK AS SHOWN.

SEC. 2(F).

FOR GROUTS (U.S. CLS. 1, 12, 33 AND 50).

FIRST USE 2-0-2006; IN COMMERCE 2-0-2006.

TARAH HARDY, EXAMINING ATTORNEY

**CLASS 19—(Continued).**

SN 85-169,078. BLACKLIDGE EMULSIONS, INC., GULF-PORT, MS. FILED 11-4-2010.

**ULTRAFUSE**

THE MARK CONSISTS OF STANDARD CHARACTERS WITHOUT CLAIM TO ANY PARTICULAR FONT, STYLE, SIZE, OR COLOR.

FOR ASPHALT IN THE NATURE OF ASPHALTIC COMPOSITION THAT IS MODIFIED WITH POLYMERS, CELLULOSIC OR MINERAL FIBERS AND/OR OTHER ADDITIVES TO CREATE A LIQUID ASPHALT THAT RESISTS DRAIN DOWN FOR OPEN GRADED FRICTION COURSE AND STONE MASTIC TYPE ASPHALT MIXES (U.S. CLS. 1, 12, 33 AND 50).

RAMONA ORTIGA, EXAMINING ATTORNEY

SN 85-169,998. THERESA MUSTAFA, HALEDON, NJ. FILED 11-5-2010.



THE COLOR(S) BLUE-GREEN (RGB 24.82.96) AND PURPLE (RGB 35.32.79) IS/ARE CLAIMED AS A FEATURE OF THE MARK.

THE MARK CONSISTS OF A STYLIZED CURVED BLUE-GREEN LETTER T ON TOP OF, BUT NOT TOUCHING, A STYLIZED PURPLE LETTER M WITH CURVED SIDES AND FLAT ACROSS THE BOTTOM.

FOR TILES OF CLAY, GLASS, GYPSUM, CERAMIC OR EARTHENWARE (U.S. CLS. 1, 12, 33 AND 50).

FIRST USE 7-1-2010; IN COMMERCE 10-1-2010.

DOMINICK J. SALEMI, EXAMINING ATTORNEY

SN 85-176,117. MCCANN CONCRETE PRODUCTS, INC., DORSEY, IL. FILED 11-13-2010.

**STONESILENCE**

THE MARK CONSISTS OF STANDARD CHARACTERS WITHOUT CLAIM TO ANY PARTICULAR FONT, STYLE, SIZE, OR COLOR.

FOR CONCRETE FENCING IN THE NATURE OF A NOISE BARRIER (U.S. CLS. 1, 12, 33 AND 50).

FIRST USE 1-11-1999; IN COMMERCE 1-11-1999.

EDWARD FENNESSY, EXAMINING ATTORNEY

**CLASS 19—(Continued).**

SN 85-188,396. VERMES, MICHAEL GYÖRGY ITE PAUL, 1185 MX AMSTELVEEN, NETHERLANDS, FILED 12-1-2010.

**MILLIONAIRE**

THE MARK CONSISTS OF STANDARD CHARACTERS WITHOUT CLAIM TO ANY PARTICULAR FONT, STYLE, SIZE, OR COLOR.

OWNER OF ERPN CMNTY TM OFC REG. NO. 009011081, DATED 12-22-2010, EXPIRES 3-23-2020.

FOR NON-METAL BUILDING MATERIALS, NAMELY, BUILDING PANELS IN THE NATURE OF DOOR PANELS AND WALL PANELS, ALL NOT SUITABLE FOR WRITING; NON-METAL BUILDING MATERIALS, NAMELY, BUILDING PANELS IN THE NATURE OF COMPOSITE PANELS AND TILES FOR WALLS, FLOORS OR CEILINGS; WOODEN BUILDING MATERIALS, NAMELY, BUILDING PANELS, WALL CLADDING DOOR PANELS, WALL PANELS, WOOD BOARDS; MOUNTING MATERIAL FOR THE AFORESAID PANELS AND WALL CLADDING, NAMELY, CONSTRUCTION MATERIALS, NAMELY, NON-METAL BONDING FASTENERS FOR MOUNTING AND DEMOUNTING OF CEILING AND WALL PANELS (U.S. CLS. 1, 12, 33 AND 50).

ANGELA DUONG, EXAMINING ATTORNEY

SN 85-191,997. INTERLOCK PAVING SYSTEMS, INC., HAMPTON, VA. FILED 12-7-2010.

**FOUR SEASONS PICP COLLECTION**

THE MARK CONSISTS OF STANDARD CHARACTERS WITHOUT CLAIM TO ANY PARTICULAR FONT, STYLE, SIZE, OR COLOR.

NO CLAIM IS MADE TO THE EXCLUSIVE RIGHT TO USE "PICP COLLECTION", APART FROM THE MARK AS SHOWN.

FOR PERMEABLE INTERLOCKING CONCRETE PAVERS FOR USE WHERE PERMEABLE SYSTEMS OR SURFACE TREATMENTS ARE CALLED FOR (U.S. CLS. 1, 12, 33 AND 50).

MARK RADEMACHER, EXAMINING ATTORNEY

**CLASS 19—(Continued).**

SN 85-193,609. THE COLEMAN COMPANY, INC., WICHITA, KS. FILED 12-8-2010.



OWNER OF U.S. REG. NOS. 2,965,056, 3,146,249 AND OTHERS.

THE MARK CONSISTS OF THE UNDERLINED WORD "COLEMAN" FOLLOWED BY A LANTERN DESIGN WITHIN A PARALLELOGRAM.

FOR RUBBER AND PLASTIC MOLDED FLOORING, ALL OF WHICH ARE MARKETED FOR USE IN GARAGES, UTILITY ROOMS, STORAGE SPACES, SHEDS AND WORKSHOPS (U.S. CLS. 1, 12, 33 AND 50).

GILBERT SWIFT, EXAMINING ATTORNEY

SN 85-198,364. ODL, INCORPORATED, ZEELAND, MI. FILED 12-15-2010.

## BELFLOWER

THE MARK CONSISTS OF STANDARD CHARACTERS WITHOUT CLAIM TO ANY PARTICULAR FONT, STYLE, SIZE, OR COLOR.

FOR NON-METAL WINDOWS, NAMELY, DOOR WINDOW GLASS (U.S. CLS. 1, 12, 33 AND 50).

EDWARD NELSON, EXAMINING ATTORNEY

SN 85-198,454. ODL, INCORPORATED, ZEELAND, MI. FILED 12-15-2010.

## TRACE

THE MARK CONSISTS OF STANDARD CHARACTERS WITHOUT CLAIM TO ANY PARTICULAR FONT, STYLE, SIZE, OR COLOR.

FOR NON-METAL WINDOWS, NAMELY, DOOR WINDOW GLASS (U.S. CLS. 1, 12, 33 AND 50).

EDWARD NELSON, EXAMINING ATTORNEY

**CLASS 19—(Continued).**

SN 85-203,323. ALLMINE PAVING LLC, INWOOD, WV. FILED 12-21-2010.



NO CLAIM IS MADE TO THE EXCLUSIVE RIGHT TO USE "ASPHALT", APART FROM THE MARK AS SHOWN. FOR ASPHALT USED IN CONSTRUCTION OF ROOFING PRODUCTS (U.S. CLS. 1, 12, 33 AND 50).

KATHRYN COWARD, EXAMINING ATTORNEY

SN 85-206,047. PULP STUDIO, INC., LOS ANGELES, CA. FILED 12-27-2010.

## OMBRA

THE MARK CONSISTS OF STANDARD CHARACTERS WITHOUT CLAIM TO ANY PARTICULAR FONT, STYLE, SIZE, OR COLOR.

THE ENGLISH TRANSLATION OF "OMBRA" IN THE MARK IS "SHADE" OR "SHADOW".

FOR DECORATIVE GLASS; INSULATED GLASS; INSULATING GLASS FOR WINDOWS FOR BUILDING PURPOSES (U.S. CLS. 1, 12, 33 AND 50).

SIMON TENG, EXAMINING ATTORNEY

SN 85-206,240. PULP STUDIO, INC., LOS ANGELES, CA. FILED 12-27-2010.

## CHROMAVISION

THE COLOR(S) BLACK AND RED IS/ARE CLAIMED AS A FEATURE OF THE MARK.

THE MARK CONSISTS OF THE WORD "CHROMAVISION" BROKEN INTO TWO SEGMENTS WITH THE WORD "CHROMA" SHADOWED BY THE COMPLETE WORD "CHROMAVISION". "CHROMAVISION" IS RED. THE SHADOWED "CHROMA" IS BLACK. THE "O" IN THE WORD "VISION" IS SHOWN AS THREE INTERLOCKING LETTER "O". ALL OF THIS IS UNDERLINED IN RED WITH A PORTION OF THE LINE SEPARATED APART BY THE LETTER "O" IN THE WORD "VISION".

FOR COLORED SHEET GLASS; DECORATIVE GLASS; GLASS FOR BUILDING; GLASS PANELS FOR BUILDING CONSTRUCTION PURPOSES; INSULATED GLASS; INSULATING GLASS FOR WINDOWS FOR BUILDING PURPOSES; LAMINATED FLAT GLASS; SAFETY GLASS FOR BUILDING PURPOSES (U.S. CLS. 1, 12, 33 AND 50).

SIMON TENG, EXAMINING ATTORNEY

**CLASS 19—(Continued).**

SN 85-206,405. GENFLEX ROOFING SYSTEMS, LLC, INDIANAPOLIS, IN. FILED 12-28-2010.

**GENTITE**

THE MARK CONSISTS OF STANDARD CHARACTERS WITHOUT CLAIM TO ANY PARTICULAR FONT, STYLE, SIZE, OR COLOR.  
OWNER OF U.S. REG. NOS. 3,592,818, 3,632,801 AND OTHERS.  
FOR BUILDING SEAM TAPE; NON-METAL BUILDING FLASHING; NON-METALLIC ROOF FLASHING; SEAM TAPE FOR BUILDING; PIPE BOOTS, NAMELY, NON-METALLIC FLASHING MATERIAL DESIGNED TO FLASH AROUND PIPES (U.S. CLS. 1, 12, 33 AND 50).  
FIRST USE 12-1-2010; IN COMMERCE 12-1-2010.  
GISELLE AGOSTO, EXAMINING ATTORNEY

SN 85-207,060. DREAMDEX LLC., PETALUMA, CA. FILED 12-29-2010.

**Real Wood. Perfected.**

THE MARK CONSISTS OF STANDARD CHARACTERS WITHOUT CLAIM TO ANY PARTICULAR FONT, STYLE, SIZE, OR COLOR.  
NO CLAIM IS MADE TO THE EXCLUSIVE RIGHT TO USE "REAL WOOD", APART FROM THE MARK AS SHOWN.  
FOR NON-METAL DECKING; WOODEN RAILINGS (U.S. CLS. 1, 12, 33 AND 50).  
FIRST USE 11-30-2010; IN COMMERCE 11-30-2010.  
TINA BROWN, EXAMINING ATTORNEY

**CLASS 19—(Continued).**

SN 85-209,548. GOODWOOD, INC., EL MONTE, CA. FILED 1-3-2011.

**LICO**

THE MARK CONSISTS OF STANDARD CHARACTERS WITHOUT CLAIM TO ANY PARTICULAR FONT, STYLE, SIZE, OR COLOR.  
THE WORDING "LICO" HAS NO MEANING IN A FOREIGN LANGUAGE.  
FOR BOARDS OF WOOD; CERAMIC TILES FOR FLOORING AND FACING; CHEMICALLY TREATED WOOD, NAMELY, WOOD BEAMS, WOOD BOARDS, WOOD JOISTS, WOOD RAFTERS, WOOD SIDING, WOOD TILE FLOORS AND FLOORING, WOOD TRIM, WOODEN BEAMS, WOODEN FLOORING, WOODEN RAILINGS, AND WOODEN WAINSCOTING, ALL OF THE ABOVE CONTAINING A FIRE RETARDANT CHEMICAL; FIREPROOF TILES; FLOOR BOARDS; FLOOR TILES OF WOOD; FLOORING UNDERLAYMENTS; GLUE-LAMINATED WOOD; LUMBER; MULTI-LAYERED WOOD; NON-METAL FLOOR TILES; NON-METAL FLOORS; PARQUET FLOORING; PLASTIC FLOORBOARDS; PLYWOOD; VINYL FLOORING; VINYL TILES; WOOD MOLDINGS; WOOD DOOR FRAMES; AND WOODEN DOORS (U.S. CLS. 1, 12, 33 AND 50).  
JULIE GUTTADAURO, EXAMINING ATTORNEY

SN 85-210,517. PERGO (EUROPE) AB, TRELLEBORG, SWEDEN, FILED 1-4-2011.

**PERGO MAX**

THE MARK CONSISTS OF STANDARD CHARACTERS WITHOUT CLAIM TO ANY PARTICULAR FONT, STYLE, SIZE, OR COLOR.  
OWNER OF U.S. REG. NOS. 3,147,660, 3,314,446 AND 3,314,449.  
FOR FLOORING, NAMELY, WOOD, THERMOSETTING LAMINATE, THERMOSETTING LAMINATE BONDED TO A BASE OF PARTICLE BOARD OR FIBERBOARD AND PARTICLE BOARD OR FIBERBOARD PROVIDED WITH A DECORATIVE SURFACE OR COATING (U.S. CLS. 1, 12, 33 AND 50).  
DEZMONA MIZELLE, EXAMINING ATTORNEY



**CLASS 19—(Continued).**

SN 85-211,111. THE TILE SHOP, LLC, PLYMOUTH, MN. FILED 1-5-2011.



OWNER OF U.S. REG. NOS. 3,442,292 AND 3,661,965.  
NO CLAIM IS MADE TO THE EXCLUSIVE RIGHT TO USE "FIRED EARTH CERAMICS" OR "DURABLE HANDCRAFTED QUALITY PORCELAIN BATHWARE", APART FROM THE MARK AS SHOWN.

THE MARK CONSISTS OF THREE KILNS, BELOW WHICH IS THE WORDING "FIRED EARTH CERAMICS". BELOW THAT IS THE WORDING "DURABLE HANDCRAFTED QUALITY PORCELAIN BATHWARE" WITH A HORIZONTAL LINE ON EITHER SIDE. ALL OF THE FOREGOING IS SURROUNDED BY A RECTANGLE.

FOR EARTHENWARE TILES; NON-METAL ROOFING TILES; NON-METAL TILES (U.S. CLS. 1, 12, 33 AND 50).  
KATHERINE CHANG, EXAMINING ATTORNEY

SN 85-212,789. ADVANCED HOME & GARDEN L.L.C., HAUPPAUGE, NY. FILED 1-7-2011.

**WHITEWATER**

THE MARK CONSISTS OF STANDARD CHARACTERS WITHOUT CLAIM TO ANY PARTICULAR FONT, STYLE, SIZE, OR COLOR.

FOR GUTTER INSERTS, NAMELY, NON-METAL DEBRIS GUARDS FOR GUTTERS (U.S. CLS. 1, 12, 33 AND 50).

SANDRA BUJA, EXAMINING ATTORNEY

SN 85-213,883. COMPONENT MANUFACTURING COMPANY, SIOUX FALLS, SD. FILED 1-10-2011.



OWNER OF U.S. REG. NOS. 2,886,296, 2,942,958 AND 3,024,332.

THE MARK CONSISTS OF THE WORD "REAVES" WITH A SILHOUETTE OF A BUILDING BEHIND THE LETTER "R".

FOR PREFABRICATED BUILDINGS COMPRISED PRIMARILY OF NON-METAL MATERIALS (U.S. CLS. 1, 12, 33 AND 50).

HELENE LIWINSKI, EXAMINING ATTORNEY

**CLASS 19—(Continued).**

SN 85-215,087. LSP PRODUCTS GROUP, INC., IRVING, TX. FILED 1-11-2011.

**HANG'EM**

THE MARK CONSISTS OF STANDARD CHARACTERS WITHOUT CLAIM TO ANY PARTICULAR FONT, STYLE, SIZE, OR COLOR.

FOR PLASTIC PIPE HANGERS FOR DRAIN, WASTE, AND VENT PIPE (U.S. CLS. 1, 12, 33 AND 50).

FIRST USE 8-16-1990; IN COMMERCE 8-16-1990.

DAVID TAYLOR, EXAMINING ATTORNEY

SN 85-215,482. MENTAL BLOX, PLANTATION, FL. FILED 1-11-2011.

**Just get it**

THE MARK CONSISTS OF STANDARD CHARACTERS WITHOUT CLAIM TO ANY PARTICULAR FONT, STYLE, SIZE, OR COLOR.

FOR WOOD BLOCKS (U.S. CLS. 1, 12, 33 AND 50).

BARBARA BROWN, EXAMINING ATTORNEY

SN 85-217,030. D.S. CREATIVE HOUSING LLC, DBA SAFEHUT, SANFORD, FL. FILED 1-13-2011.



THE MARK CONSISTS OF THREE SIDES OF A BOX, CONSISTING OF TWO SIDES AND A BOTTOM, WITH THE TOP SUSPENDED SLIGHTLY ABOVE IT. INSIDE THE BOX ARE FOUR DIAGONAL LINES; TWO ANGLED AT 60 DEGREES FROM OPPOSING BOTTOM CORNERS, THEN TWO MORE LINES ANGLED AT 45 DEGREES FROM THE SAME OPPOSING BOTTOM CORNERS CROSSING EACH OTHER IN THE MIDDLE TO SYMBOLIZE MOVEMENT. THE MARK IS CENTERED ABOVE THE WORDING "SAFEHUT" WITH "UNFOLDING SOLUTIONS" BENEATH.

FOR NON-METAL RESIDENTIAL AND AGRICULTURAL SHELTERS; NON-METAL SHELTER STRUCTURES; NON-METAL STORM SHELTERS (U.S. CLS. 1, 12, 33 AND 50).

TARAH HARDY, EXAMINING ATTORNEY

**CLASS 19—(Continued).**

SN 85-218,840. SHOWERS, ROBERT JAMES, STATE COLLEGE, PA. FILED 1-16-2011.

DECORSULITE

THE MARK CONSISTS OF THE STYLIZED WORD "DECORSULITE".  
FOR NON-METAL SKYLIGHTS; NON-METAL WINDOWS; VINYL WINDOWS; WINDOW GLASS; WINDOW PANES (U.S. CLS. 1, 12, 33 AND 50).  
DANNEAN HETZEL, EXAMINING ATTORNEY

**CLASS 20—FURNITURE AND ARTICLES NOT OTHERWISE CLASSIFIED**

SN 77-645,934. CARDER, STEPHEN, CARROLLTON, TX. FILED 1-8-2009.

Biostraw

THE MARK CONSISTS OF STANDARD CHARACTERS WITHOUT CLAIM TO ANY PARTICULAR FONT, STYLE, SIZE, OR COLOR.  
FOR DRINKING STRAWS (U.S. CLS. 2, 13, 22, 25, 32 AND 50).  
MICHAEL ENGEL, EXAMINING ATTORNEY

SN 77-897,857. MCCOURT MFG, FORT SMITH, AR. FILED 12-21-2009.

Econolite

THE MARK CONSISTS OF STANDARD CHARACTERS WITHOUT CLAIM TO ANY PARTICULAR FONT, STYLE, SIZE, OR COLOR.  
FOR TABLES (U.S. CLS. 2, 13, 22, 25, 32 AND 50).  
FIRST USE 12-18-2009; IN COMMERCE 12-21-2009.  
BARNEY CHARLON, EXAMINING ATTORNEY

**CLASS 20—(Continued).**

SN 77-934,489. ORG, USA, INC., DBA MAISPACE, BUDD LAKE, NJ. FILED 2-12-2010.

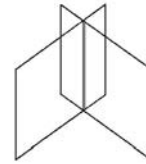

ALUR

THE MARK CONSISTS OF THE STYLIZED WORDING "ALUR" WITH THE DESIGN OF THE REPRESENTATION OF GLASS PANES CROSSING FORMED BY TWO INTERSECTING QUADRILATERALS.  
FOR MOVABLE WALL PARTITIONS MADE PRIMARILY OF GLASS HAVING EXTRUDED ALUMINUM FRAMES AND ACRYLIC DRY JOINTS (U.S. CLS. 2, 13, 22, 25, 32 AND 50).  
JAY BESCH, EXAMINING ATTORNEY

SN 77-963,652. CHRISTIAN & ASSOCIATES, INC., RALEIGH, NC. FILED 3-19-2010.



NO CLAIM IS MADE TO THE EXCLUSIVE RIGHT TO USE "MILL WOOD ART", APART FROM THE MARK AS SHOWN.

THE MARK CONSISTS OF AN IMAGE OF A SAW SURROUNDED BY A BORDER WITH THE STYLIZED WORDS "MILL WOOD ART" BELOW WITH A LINE BELOW THE WORDS.  
FOR WORKS OF ART MADE OF WOOD (U.S. CLS. 2, 13, 22, 25, 32 AND 50).  
FIRST USE 8-0-2009; IN COMMERCE 8-0-2009.  
MEGHAN REINHART, EXAMINING ATTORNEY

**CLASS 20—(Continued).**

SN 79-084,157. LI HONGMING, CHINA, FILED 5-10-2010.



OWNER OF INTERNATIONAL REGISTRATION 1043027  
DATED 5-10-2010, EXPIRES 5-10-2020.

THE MARK CONSISTS OF THE LETTERS "HQI" WITH AN INVERTED TRIANGLE INTERSECTING WITH THE LETTER "H".

FOR FURNITURE; MIRRORS, NAMELY, LOOKING GLASSES NOT FOR CARRYING WITH; NON-METAL FURNITURE FITTINGS, NAMELY, CASTERS, FURNITURE PARTITIONS, CLOTHES HOOKS, AND DOORS FOR FURNITURE; WORK BENCHES; DISPLAY BOARDS; RESINOUS ARTWARE, NAMELY, COLD CAST RESIN FIGURINES; NON-METAL BINS; COTTON PADDED MATTRESS; CURTAIN RINGS; BAMBOO AND WOOD ARTWARE, NAMELY, STATUE, SCULPTURE, AND ORNAMENTS MADE OF BAMBOO OR WOOD (U.S. CLS. 2, 13, 22, 25, 32 AND 50).

SHAILA SETTLES, EXAMINING ATTORNEY

---

SN 79-086,372. ACTONA COMPANY A/S, DENMARK, FILED 7-28-2010.



THE MARK CONSISTS OF STANDARD CHARACTERS WITHOUT CLAIM TO ANY PARTICULAR FONT, STYLE, SIZE, OR COLOR.

OWNER OF INTERNATIONAL REGISTRATION 1048444  
DATED 7-28-2010, EXPIRES 7-28-2020.

THE WORDING "ACTONA" HAS NO MEANING IN A FOREIGN LANGUAGE.

FOR FURNITURE; MIRRORS; PICTURE FRAMES; DRAWER PULLS OF PLASTIC OR OF WOOD, CORK, REED, CANE, WICKER, HORN, BONE, IVORY, WHALE BONE, SHELL, AMBER, MOTHER OF PEARL, MEERSCHAUM AND SUBSTITUTES FOR ALL OF THESE MATERIALS (U.S. CLS. 2, 13, 22, 25, 32 AND 50).

NATALIE POLZER, EXAMINING ATTORNEY

**CLASS 20—(Continued).**

SN 79-089,211. TONNELLERIE BEL AIR, FRANCE, FILED 9-30-2010.



OWNER OF INTERNATIONAL REGISTRATION 1056291  
DATED 9-30-2010, EXPIRES 9-30-2020.

NO CLAIM IS MADE TO THE EXCLUSIVE RIGHT TO USE "TONNELLERIE", APART FROM THE MARK AS SHOWN.

THE COLOR(S) GOLD AND BLACK IS/ARE CLAIMED AS A FEATURE OF THE MARK.

THE MARK CONSISTS OF THE WORDING "BEL AIR" IN A SCRIPT FONT IN GOLD, WITH THE WORD "BEL" APPEARING ABOVE AND TO THE LEFT OF "AIR", AND ALL APPEARING INSIDE/OUTSIDE OF THE BLANK LEFT PORTION OF AN INCOMPLETE CIRCLE IN GOLD WITH BLACK HIGHLIGHTING; THE WORDING "TONNELLERIE" APPEARS IN A LOWERCASE PRINT FONT IN BLACK ON THE RIGHT INSIDE BORDER OF THE CIRCLE.

THE ENGLISH TRANSLATION OF "TONNELLERIE" IN THE MARK IS "COOPERAGE".

FOR CONTAINERS OF WOOD FOR WINE AND ALCOHOL, NAMELY, CONTAINERS FOR THE TRANSPORTATION AND STORAGE OF WINE AND ALCOHOL, FOR PACKAGING WINE AND ALCOHOL (U.S. CLS. 2, 13, 22, 25, 32 AND 50).

RON FAIRBANKS, EXAMINING ATTORNEY

---

SN 79-090,585. GENESIN LUCA, ITALY, FILED 9-17-2010.



PRIORITY DATE OF 4-12-2010 IS CLAIMED.

OWNER OF INTERNATIONAL REGISTRATION 1060055  
DATED 9-17-2010, EXPIRES 9-17-2020.

THE MARK CONSISTS OF THE WORD "CUBEL" IN FANCY CHARACTERS.

THE WORD "CUBEL" HAS NO MEANING IN A FOREIGN LANGUAGE.

FOR MODULAR PADDED FURNITURE ELEMENT, MODULAR PADDED SOFA (U.S. CLS. 2, 13, 22, 25, 32 AND 50).

LIEF MARTIN, EXAMINING ATTORNEY

**CLASS 20—(Continued).**

SN 85-015,154. INNOMAX CORPORATION, DENVER, CO.  
FILED 4-15-2010.



NO CLAIM IS MADE TO THE EXCLUSIVE RIGHT TO USE "NATURAL" AND "PREMIUM ECO-FRIENDLY SLEEP PRODUCTS", APART FROM THE MARK AS SHOWN.

THE MARK CONSISTS OF A CIRCLE CONTAINING TWO LEAVES CONNECTED AT THE BASE, OVERLAPPING THE BOTTOM OF THE CIRCLE IS A RECTANGLE WITH ANGLED CORNERS, INSIDE WHICH IS THE TEXT "NATURAL RESERVE". BELOW THAT TEXT IS THE TEXT "PREMIUM ECO-FRIENDLY SLEEP PRODUCTS", WITH A STAR ON EACH SIDE.

FOR NATURAL MATTRESS TOPPERS, MATTRESSES AND PILLOWS, ALL MADE WITH MATERIALS AND/OR PROCESSES THAT MINIMIZE ENVIRONMENTAL IMPACT (U.S. CLS. 2, 13, 22, 25, 32 AND 50).

FIRST USE 12-5-2009; IN COMMERCE 12-5-2009.  
REBECCA EISINGER, EXAMINING ATTORNEY

---

SN 85-021,810. PRO MED KITS, DAVIS, CA. FILED 4-23-2010.

### TOURNIQUET APPLICATION BAND (T.A.B.)

THE MARK CONSISTS OF STANDARD CHARACTERS WITHOUT CLAIM TO ANY PARTICULAR FONT, STYLE, SIZE, OR COLOR.

NO CLAIM IS MADE TO THE EXCLUSIVE RIGHT TO USE "TOURNIQUET APPLICATION BAND", APART FROM THE MARK AS SHOWN.

FOR NON-MEDICAL, ADHESIVE IDENTIFICATION BRACELETS FOR USE IN THE HEALTHCARE INDUSTRY (U.S. CLS. 2, 13, 22, 25, 32 AND 50).

FIRST USE 9-29-2009; IN COMMERCE 9-29-2009.  
CAROLINE WOOD, EXAMINING ATTORNEY

---

SN 85-027,004. JUMBOCEL, S.A. DE C.V., APODACA, NUEVO LEON, MEXICO, FILED 4-30-2010.

## FIRMAFLEX

THE MARK CONSISTS OF STANDARD CHARACTERS WITHOUT CLAIM TO ANY PARTICULAR FONT, STYLE, SIZE, OR COLOR.

FOR NON-METAL PALLETS, NAMELY, CARRIERS MADE OF FLEXIBLE WOVEN POLYPROPYLENE FABRIC WITH BUILT IN PAPERBOARD CHANNELS TO ACCEPT FORKLIFT TINES (U.S. CLS. 2, 13, 22, 25, 32 AND 50).

LINDA ORNDORFF, EXAMINING ATTORNEY

**CLASS 20—(Continued).**

SN 85-038,191. AMINI INNOVATION CORPORATION, PICO RIVERA, CA. FILED 5-13-2010.

## HOLLYWOOD SWANK

THE MARK CONSISTS OF STANDARD CHARACTERS WITHOUT CLAIM TO ANY PARTICULAR FONT, STYLE, SIZE, OR COLOR.

NO CLAIM IS MADE TO THE EXCLUSIVE RIGHT TO USE "HOLLYWOOD", APART FROM THE MARK AS SHOWN.

FOR FURNITURE (U.S. CLS. 2, 13, 22, 25, 32 AND 50).  
FIRST USE 2-1-2010; IN COMMERCE 2-1-2010.  
SALLY SHIH, EXAMINING ATTORNEY

---

SN 85-046,035. SMART SPACE PRODUCTS, LLC, NEW YORK, NY. FILED 5-24-2010.

## SMART BAR

THE MARK CONSISTS OF STANDARD CHARACTERS WITHOUT CLAIM TO ANY PARTICULAR FONT, STYLE, SIZE, OR COLOR.

NO CLAIM IS MADE TO THE EXCLUSIVE RIGHT TO USE "BAR", APART FROM THE MARK AS SHOWN.

FOR FURNITURE, NAMELY, PORTABLE, FOLD-UP BEVERAGE AND DRINK SERVICE BAR THAT INCORPORATES AN LED LIGHTING FIXTURE (U.S. CLS. 2, 13, 22, 25, 32 AND 50).

FIRST USE 11-0-2008; IN COMMERCE 11-0-2008.  
ANTHONY RINKER, EXAMINING ATTORNEY

---

SN 85-051,067. BRV MARKETING LLC, OCONOMOWOC, WI. FILED 5-31-2010.

## CHEER CHAIR

THE MARK CONSISTS OF STANDARD CHARACTERS WITHOUT CLAIM TO ANY PARTICULAR FONT, STYLE, SIZE, OR COLOR.

NO CLAIM IS MADE TO THE EXCLUSIVE RIGHT TO USE "CHAIR", APART FROM THE MARK AS SHOWN.

FOR GAMING CHAIRS, NAMELY, INFLATABLE CHAIRS (U.S. CLS. 2, 13, 22, 25, 32 AND 50).

FIRST USE 11-2-2009; IN COMMERCE 5-28-2010.  
SEAN CROWLEY, EXAMINING ATTORNEY

**CLASS 20—(Continued).**

SN 85-065,639. C&T INTERNATIONAL, EAST RUTHERFORD, NJ. FILED 6-17-2010.

**SORELLE FURNITURE**

THE MARK CONSISTS OF STANDARD CHARACTERS WITHOUT CLAIM TO ANY PARTICULAR FONT, STYLE, SIZE, OR COLOR.

NO CLAIM IS MADE TO THE EXCLUSIVE RIGHT TO USE "FURNITURE", APART FROM THE MARK AS SHOWN.

THE ENGLISH TRANSLATION OF "SORELLE" IN THE MARK IS "LITTLE SISTERS".

FOR BABY CHANGING TABLES; BED RAILS; BEDS; CRADLES; CRIBS; DRESSERS; INFANT BEDS; PLAYPENS (U.S. CLS. 2, 13, 22, 25, 32 AND 50).

FIRST USE 12-31-2001; IN COMMERCE 12-31-2001.  
LINDSEY RUBIN, EXAMINING ATTORNEY

SN 85-075,316. INTUITIVE CABINETRY, INC., DENVER, CO. FILED 6-30-2010.

**INTUITIVE CABINETRY**

THE MARK CONSISTS OF STANDARD CHARACTERS WITHOUT CLAIM TO ANY PARTICULAR FONT, STYLE, SIZE, OR COLOR.

NO CLAIM IS MADE TO THE EXCLUSIVE RIGHT TO USE "CABINETRY", APART FROM THE MARK AS SHOWN.

FOR KITCHEN CABINETS (U.S. CLS. 2, 13, 22, 25, 32 AND 50).

DAVID I, EXAMINING ATTORNEY

SN 85-078,746. TODESCHINI S/A INDÚSTRIA E COMÉRCIO, RIO GRANDE DO SUL, BRAZIL, FILED 7-6-2010.

**Todeschini** 

OWNER OF U.S. REG. NO. 2,758,340.  
THE MARK CONSISTS OF THE WORD "TODESCHINI" WITH A HEART ABOVE AND TO THE RIGHT OF THE LETTER "I" IN "TODESCHINI".

FOR FURNITURE (U.S. CLS. 2, 13, 22, 25, 32 AND 50).  
PRISCILLA MILTON, EXAMINING ATTORNEY

**CLASS 20—(Continued).**

SN 85-109,752. ZENNOVATIONS INC., HENDERSON, NV. FILED 8-17-2010.

**All Tapped Out**

THE MARK CONSISTS OF STANDARD CHARACTERS WITHOUT CLAIM TO ANY PARTICULAR FONT, STYLE, SIZE, OR COLOR.

FOR UNFITTED NEOPRENE BEER KEG TAP COVERS (U.S. CLS. 2, 13, 22, 25, 32 AND 50).

FIRST USE 3-7-2010; IN COMMERCE 3-7-2010.  
KIMBERLY FRYE, EXAMINING ATTORNEY

SN 85-136,356. TEGRANT ALLOYD BRANDS, INC., DEKALB, IL. FILED 9-23-2010.

**SYNERGREEN PACKAGING SOLUTIONS**

THE MARK CONSISTS OF STANDARD CHARACTERS WITHOUT CLAIM TO ANY PARTICULAR FONT, STYLE, SIZE, OR COLOR.

NO CLAIM IS MADE TO THE EXCLUSIVE RIGHT TO USE "PACKAGING SOLUTIONS", APART FROM THE MARK AS SHOWN.

FOR PACKAGING MATERIALS, NAMELY, RIGID PLASTIC TRAYS, PLASTIC CLAMSHELL PACKAGING, AND PLASTIC BLISTERS FOR PACKAGING CHEMICAL, COMMERCIAL, CONSUMER, FOOD, MEDICAL, PHARMACEUTICAL, AND RETAIL PRODUCTS (U.S. CLS. 2, 13, 22, 25, 32 AND 50).

SUZANNE BLANE, EXAMINING ATTORNEY

SN 85-145,406. CORSICANA BEDDING, INC., CORSICANA, TX. FILED 10-5-2010.

**Sleepinc.**  
Dream Big.

NO CLAIM IS MADE TO THE EXCLUSIVE RIGHT TO USE "SLEEP INC.", APART FROM THE MARK AS SHOWN.  
THE MARK CONSISTS OF THE LETTERS "SLEEPINC." AND THE WORDS "DREAM BIG." UNDERNEATH. THE LETTER "L" IS FORMED IN THE SHAPE OF A CRESCENT MOON DESIGN WHICH EXTENDS UNDER THE LETTER "E" WHICH FOLLOWS THE LETTER "P".

FOR SLEEP PRODUCTS, NAMELY, BEDS, MATTRESSES, PILLOWS AND BOLSTERS; MATTRESS FOUNDATIONS, SPRING MATTRESSES (U.S. CLS. 2, 13, 22, 25, 32 AND 50).

FIRST USE 6-1-2009; IN COMMERCE 6-1-2009.  
MELISSA VALLILLO, EXAMINING ATTORNEY



**CLASS 20—(Continued).**

SN 85-179,191. MIE LE FURNITURE CO., LTD., TAOYUAN COUNTY 33377, TAIWAN, FILED 11-17-2010.



THE MARK CONSISTS OF THE WORDING "DAIERH" IN STYLIZED FONT INSIDE OF A BOX WITH AN ORNAMENTAL BORDER AND A CROWN ABOVE THE BOX.

THE WORDING "DAIERH" HAS NO MEANING IN A FOREIGN LANGUAGE.

FOR BED FRAMES; BEDS; BEDSIDE TABLES; BOOK-CASES; CHAIRS; COTS; DESKS; FURNITURE; MATTRESSES; PILLOWS; SOFAS; SPRING MATTRESSES; WARDROBES; WATER BEDS NOT FOR MEDICAL PURPOSES (U.S. CLS. 2, 13, 22, 25, 32 AND 50).

FIRST USE 6-4-2010; IN COMMERCE 6-4-2010.  
FRED CARL, EXAMINING ATTORNEY

SN 85-179,912. SHELFHELP, LLC, SAN ANTONIO, TX. FILED 11-18-2010.

## ShelfHelp

THE MARK CONSISTS OF STANDARD CHARACTERS WITHOUT CLAIM TO ANY PARTICULAR FONT, STYLE, SIZE, OR COLOR.

FOR STORAGE AND ORGANIZATION SYSTEMS COMPRISING SHELVES, DRAWERS, PEGBOARDS, BINS, BASKETS AND CABINET DOORS, SOLD AS A UNIT (U.S. CLS. 2, 13, 22, 25, 32 AND 50).

FIRST USE 5-15-2010; IN COMMERCE 5-15-2010.  
SUSAN RICHARDS, EXAMINING ATTORNEY

SN 85-193,926. AMERICAN SEATING COMPANY, GRAND RAPIDS, MI. FILED 12-9-2010.

## CORE

THE MARK CONSISTS OF STANDARD CHARACTERS WITHOUT CLAIM TO ANY PARTICULAR FONT, STYLE, SIZE, OR COLOR.

FOR AUDITORIUM SEATING FURNITURE (U.S. CLS. 2, 13, 22, 25, 32 AND 50).  
SIMON TENG, EXAMINING ATTORNEY

**CLASS 20—(Continued).**

SN 85-199,874. SERTA INC., HOFFMAN ESTATES, IL. FILED 12-16-2010.

## SCRUNCH PILLOW

THE MARK CONSISTS OF STANDARD CHARACTERS WITHOUT CLAIM TO ANY PARTICULAR FONT, STYLE, SIZE, OR COLOR.

NO CLAIM IS MADE TO THE EXCLUSIVE RIGHT TO USE "PILLOW", APART FROM THE MARK AS SHOWN.

FOR PILLOWS (U.S. CLS. 2, 13, 22, 25, 32 AND 50).  
BARBARA RUTLAND, EXAMINING ATTORNEY

SN 85-201,225. THOMAS HALL RAMIREZ, WINSTON SALEM, NC. FILED 12-18-2010.

## The Drinking Man's Chair

THE MARK CONSISTS OF STANDARD CHARACTERS WITHOUT CLAIM TO ANY PARTICULAR FONT, STYLE, SIZE, OR COLOR.

NO CLAIM IS MADE TO THE EXCLUSIVE RIGHT TO USE "CHAIR", APART FROM THE MARK AS SHOWN.

FOR CHAIRS (U.S. CLS. 2, 13, 22, 25, 32 AND 50).  
BARBARA A. GOLD, EXAMINING ATTORNEY

SN 85-201,888. AMERICAN REGISTRY, LLC, BOCA RATON, FL. FILED 12-20-2010.

## LIVE IT. LOVE IT. PLAQUE IT.

THE MARK CONSISTS OF STANDARD CHARACTERS WITHOUT CLAIM TO ANY PARTICULAR FONT, STYLE, SIZE, OR COLOR.

NO CLAIM IS MADE TO THE EXCLUSIVE RIGHT TO USE "PLAQUE", APART FROM THE MARK AS SHOWN.

FOR PLAQUES OF PLASTIC OR WOOD; PLASTIC BANNERS; VINYL BANNERS; WALL PLAQUES MADE OF PLASTIC OR WOOD (U.S. CLS. 2, 13, 22, 25, 32 AND 50).

FIRST USE 7-0-2010; IN COMMERCE 7-0-2010.  
FRED CARL, EXAMINING ATTORNEY

**CLASS 20—(Continued).**

SN 85-203,718. S&S INNOVATIONS, CORP, FRUITA, CO.  
FILED 12-22-2010.



NO CLAIM IS MADE TO THE EXCLUSIVE RIGHT TO USE "REUSABLE CANNING LIDS" AND "THE ORIGINAL, SINCE 1976", APART FROM THE MARK AS SHOWN.

THE MARK CONSISTS OF THE STYLIZED TEXT "TATTLER REUSABLE CANNING LIDS THE ORIGINAL, SINCE 1976".

FOR PLASTIC LIDS (U.S. CLS. 2, 13, 22, 25, 32 AND 50).  
FIRST USE 1-6-1976; IN COMMERCE 1-6-1976.  
ANNE FARRELL, EXAMINING ATTORNEY

SN 85-203,990. THE TILE SHOP, LLC, PLYMOUTH, MN.  
FILED 12-22-2010.



OWNER OF U.S. REG. NOS. 2,413,607, 3,108,881 AND 3,290,690.

NO CLAIM IS MADE TO THE EXCLUSIVE RIGHT TO USE "STONE STUDIOS", APART FROM THE MARK AS SHOWN.

THE MARK CONSISTS OF THE WORDS "RUSH RIVER" OVER THE LETTERS "R" AND "R" REVERSED. BELOW THAT IS AN IMAGE OF A RIVER FLOWING FROM THE LETTER "R". ALL OF THE FOREGOING APPEARS ON A RECTANGULAR BACKGROUND. BELOW THE RECTANGLE IS THE WORDING "STONE STUDIOS".

SEC. 2(F) AS TO "RUSH RIVER".  
FOR SHELVES; AND TOWEL RACKS (U.S. CLS. 2, 13, 22, 25, 32 AND 50).

KATHERINE CHANG, EXAMINING ATTORNEY

**CLASS 20—(Continued).**

SN 85-206,241. JEFF DUNHAM, LOS ANGELES, CA. FILED 12-27-2010.

# ACHMED

THE MARK CONSISTS OF STANDARD CHARACTERS WITHOUT CLAIM TO ANY PARTICULAR FONT, STYLE, SIZE, OR COLOR.

OWNER OF U.S. REG. NOS. 3,877,119, 3,896,456 AND OTHERS.

FOR PLASTIC TALKING KEY CHAINS (U.S. CLS. 2, 13, 22, 25, 32 AND 50).

FIRST USE 11-30-2010; IN COMMERCE 11-30-2010.

TARA PATE, EXAMINING ATTORNEY

SN 85-206,244. JEFF DUNHAM, LOS ANGELES, CA. FILED 12-27-2010.

# PEANUT

THE MARK CONSISTS OF STANDARD CHARACTERS WITHOUT CLAIM TO ANY PARTICULAR FONT, STYLE, SIZE, OR COLOR.

OWNER OF U.S. REG. NOS. 3,870,464, 3,882,782 AND OTHERS.

FOR PLASTIC TALKING KEY CHAINS (U.S. CLS. 2, 13, 22, 25, 32 AND 50).

FIRST USE 11-30-2010; IN COMMERCE 11-30-2010.

TARA PATE, EXAMINING ATTORNEY

SN 85-206,246. JEFF DUNHAM, LOS ANGELES, CA. FILED 12-27-2010.

# WALTER

THE MARK CONSISTS OF STANDARD CHARACTERS WITHOUT CLAIM TO ANY PARTICULAR FONT, STYLE, SIZE, OR COLOR.

OWNER OF U.S. REG. NOS. 3,870,488, 3,870,718 AND OTHERS.

FOR PLASTIC TALKING KEY CHAINS (U.S. CLS. 2, 13, 22, 25, 32 AND 50).

FIRST USE 11-30-2010; IN COMMERCE 11-30-2010.

TARA PATE, EXAMINING ATTORNEY

**CLASS 20—(Continued).**

SN 85-206,425. CROWN PET PRODUCTS, INC., CAPE CORAL, FL. FILED 12-28-2010.



NO CLAIM IS MADE TO THE EXCLUSIVE RIGHT TO USE "PET PRODUCTS", APART FROM THE MARK AS SHOWN.

THE COLOR(S) GOLD, GREEN AND WHITE IS/ARE CLAIMED AS A FEATURE OF THE MARK.

THE MARK CONSISTS OF A GOLD BURST WITH THE ARTISTIC RENDERING OF A HUMAN BEING IN WHITE INSIDE THE BURST. BELOW THE GOLD BURST IS A GREEN OVAL WITH THE STYLIZED WORDS "CROWN PET PRODUCTS" IN WHITE IN THE OVAL.

FOR PET CRATES; PET BEDS; NON-METAL SAFETY GATES FOR PETS (U.S. CLS. 2, 13, 22, 25, 32 AND 50).

FIRST USE 12-21-2010; IN COMMERCE 12-21-2010.  
KELLEY WELLS, EXAMINING ATTORNEY

SN 85-206,560. PEEK-A-BOO TOYS, LTD., PENNSAUKEN, NJ. FILED 12-28-2010.

## NekkinZ Just 4 Kids!

THE MARK CONSISTS OF STANDARD CHARACTERS WITHOUT CLAIM TO ANY PARTICULAR FONT, STYLE, SIZE, OR COLOR.

NO CLAIM IS MADE TO THE EXCLUSIVE RIGHT TO USE "JUST FOR KIDS", APART FROM THE MARK AS SHOWN.

FOR NECK SUPPORT CUSHIONS (U.S. CLS. 2, 13, 22, 25, 32 AND 50).

LAKEISHA LEWIS, EXAMINING ATTORNEY

SN 85-208,214. RESPECTFUL TRANSITIONS, MINNEAPOLIS, MN. FILED 12-30-2010.

## Respectful Transitions

THE MARK CONSISTS OF STANDARD CHARACTERS WITHOUT CLAIM TO ANY PARTICULAR FONT, STYLE, SIZE, OR COLOR.

FOR WORKS OF ART MADE OF WOOD (U.S. CLS. 2, 13, 22, 25, 32 AND 50).

FIRST USE 6-24-2010; IN COMMERCE 6-24-2010.  
ANGELA M. MICHELI, EXAMINING ATTORNEY

**CLASS 20—(Continued).**

SN 85-209,805. EXEMPLIS CORPORATION, CYPRESS, CA. FILED 1-4-2011.

## PROTOS

THE MARK CONSISTS OF STANDARD CHARACTERS WITHOUT CLAIM TO ANY PARTICULAR FONT, STYLE, SIZE, OR COLOR.

FOR FURNITURE (U.S. CLS. 2, 13, 22, 25, 32 AND 50).  
MATTHEW MCDOWELL, EXAMINING ATTORNEY

SN 85-211,998. EDSAL MANUFACTURING CO., INC., CHICAGO, IL. FILED 1-6-2011.

## Z-BEAM

THE MARK CONSISTS OF STANDARD CHARACTERS WITHOUT CLAIM TO ANY PARTICULAR FONT, STYLE, SIZE, OR COLOR.

FOR GENERAL PURPOSE BULK STORAGE RACKS OF METAL (U.S. CLS. 2, 13, 22, 25, 32 AND 50).

ANDREA K. NADELMAN, EXAMINING ATTORNEY

SN 85-212,002. EDSAL MANUFACTURING CO., INC., CHICAGO, IL. FILED 1-6-2011.

## ZBEAM

THE MARK CONSISTS OF "ZBEAM" IN FANCIFUL LETTERS WITH A DOUBLE UNDERLINE UNDER THE CHARACTERS.

FOR GENERAL PURPOSE BULK STORAGE RACKS OF METAL (U.S. CLS. 2, 13, 22, 25, 32 AND 50).

ANDREA K. NADELMAN, EXAMINING ATTORNEY

**CLASS 20—(Continued).**

SN 85-213,491. CHOICE CABINET, WILLOUGHBY HILLS, OH. FILED 1-8-2011.

**CHOICE**  
C a b i n e t

NO CLAIM IS MADE TO THE EXCLUSIVE RIGHT TO USE "CABINET", APART FROM THE MARK AS SHOWN.

THE MARK CONSISTS OF THE WORD "CHOICE" IN ALL CAPITAL LETTERS AND THE WORD "CABINET" SITUATED THEREUNDER, THE WORD "CABINET" HAVING ONLY ITS INITIAL LETTER CAPITALIZED, BEING IN A SMALLER FONT, AND HAVING SPACES BETWEEN LETTERS TO GENERALLY ALIGN IT WITH THE LENGTH OF THE WORD "CHOICE".

FOR KITCHEN CABINETS (U.S. CLS. 2, 13, 22, 25, 32 AND 50).

FIRST USE 5-1-2010; IN COMMERCE 5-1-2010.  
HEATHER SAPP, EXAMINING ATTORNEY

SN 85-213,741. BERCOM INTERNATIONAL, LLC, CHANHASSEN, MN. FILED 1-10-2011.

**PUT YOUR BUCKETS TO WORK**

THE MARK CONSISTS OF STANDARD CHARACTERS WITHOUT CLAIM TO ANY PARTICULAR FONT, STYLE, SIZE, OR COLOR.

FOR NON-METAL ATTACHMENT FOR 5-GALLON PLASTIC BUCKETS FOR USE IN CREATING A STABLE PLATFORM OR WORK SURFACE FROM SUCH BUCKETS, SUCH AS WOULD BE REQUIRED TO STACK SUCH BUCKETS OR USE THEM AS SUPPORTS FOR SAWHORSES, WORKBENCHES, SEATING AND THE LIKE (U.S. CLS. 2, 13, 22, 25, 32 AND 50).

EUGENIA MARTIN, EXAMINING ATTORNEY

SN 85-214,056. PLANET HOLLYWOOD (REGION IV), INC., ORLANDO, FL. FILED 1-10-2011.

**LIGHT PHANTASTIC**

THE MARK CONSISTS OF STANDARD CHARACTERS WITHOUT CLAIM TO ANY PARTICULAR FONT, STYLE, SIZE, OR COLOR.

NO CLAIM IS MADE TO THE EXCLUSIVE RIGHT TO USE "LIGHT", APART FROM THE MARK AS SHOWN.

FOR MIRRORS ENHANCED BY ELECTRIC LIGHTS (U.S. CLS. 2, 13, 22, 25, 32 AND 50).

ELLEN PERKINS, EXAMINING ATTORNEY

**CLASS 20—(Continued).**

SN 85-214,899. BREECE, ALAN, FALLSINGTON, PA. FILED 1-11-2011.



**Places-Please**  
Creative Name Plates

NO CLAIM IS MADE TO THE EXCLUSIVE RIGHT TO USE "NAME PLATES", APART FROM THE MARK AS SHOWN.

THE STIPPLING IS FOR SHADING PURPOSES.

THE MARK CONSISTS OF THE DESIGN OF TWO CHAMPAGNE GLASSES AND A SINGLE ROSE WITH A STEM INSIDE AN OVAL BACKGROUND WITH THE WORDS "PLACES-PLEASE" ABOVE THE WORDING "CREATIVE NAME PLATES".

FOR NON-METAL NAME PLATES (U.S. CLS. 2, 13, 22, 25, 32 AND 50).

FIRST USE 11-1-2007; IN COMMERCE 11-1-2007.

ROBIN CHOSID, EXAMINING ATTORNEY

SN 85-215,260. TOBEY, DAVID, NEW ROCHELLE, NY. FILED 1-11-2011.

**LEVITURE**

THE MARK CONSISTS OF STANDARD CHARACTERS WITHOUT CLAIM TO ANY PARTICULAR FONT, STYLE, SIZE, OR COLOR.

FOR SCULPTURES AND WORKS OF ART OF WOOD, PLASTER AND PLASTIC (U.S. CLS. 2, 13, 22, 25, 32 AND 50).

JILL C. ALT, EXAMINING ATTORNEY

SN 85-216,500. GRACIE, SEGINA, HERMOSA BEACH, CA. FILED 1-13-2011.

**PERCH**

THE MARK CONSISTS OF STANDARD CHARACTERS WITHOUT CLAIM TO ANY PARTICULAR FONT, STYLE, SIZE, OR COLOR.

FOR FURNITURE, NAMELY, CHAIRS, SOFAS (U.S. CLS. 2, 13, 22, 25, 32 AND 50).

FIRST USE 7-31-2010; IN COMMERCE 7-31-2010.

KAREN SEVERSON, EXAMINING ATTORNEY

**CLASS 20—(Continued).**

SN 85-217,413. STEPHENS, OWEN, BEAVERTON, OR. FILED 1-13-2011.



NO CLAIM IS MADE TO THE EXCLUSIVE RIGHT TO USE "UNIVERSAL CLIP", APART FROM THE MARK AS SHOWN.

THE STIPPLING IS FOR SHADING PURPOSES ONLY.

THE MARK CONSISTS OF THE STYLIZED WORDING "CROCJAW UNIVERSAL CLIP" AND A STYLIZED CROCODILE IN THE FORM OF A CLIP THAT IS ATTACHED TO A TUBING.

FOR PLASTIC CLIP FOR HOUSEHOLD USE THAT SNAPS TO ANY ROUND OR SQUARE RAIL TO SECURE ALL TYPES OF ITEMS (U.S. CLS. 2, 13, 22, 25, 32 AND 50).

DOUGLAS LEE, EXAMINING ATTORNEY

SN 85-230,500. ZINUS INC., DBA VIVON LIFE, HAYWARD, CA. FILED 1-31-2011.

## Vivon Love

THE MARK CONSISTS OF STANDARD CHARACTERS WITHOUT CLAIM TO ANY PARTICULAR FONT, STYLE, SIZE, OR COLOR.

NO CLAIM IS MADE TO THE EXCLUSIVE RIGHT TO USE "LOVE", APART FROM THE MARK AS SHOWN.

FOR BEDS, MATTRESSES, PILLOWS AND BOLSTERS; MATTRESS FOUNDATIONS; MATTRESS TOPPERS (U.S. CLS. 2, 13, 22, 25, 32 AND 50).

ALICIA COLLINS, EXAMINING ATTORNEY

**CLASS 20—(Continued).**

SN 85-230,512. ZINUS INC., DBA VIVON LIFE, HAYWARD, CA. FILED 1-31-2011.

## Vivon Joy

THE MARK CONSISTS OF STANDARD CHARACTERS WITHOUT CLAIM TO ANY PARTICULAR FONT, STYLE, SIZE, OR COLOR.

NO CLAIM IS MADE TO THE EXCLUSIVE RIGHT TO USE "JOY", APART FROM THE MARK AS SHOWN.

FOR BEDS, MATTRESSES, PILLOWS AND BOLSTERS; MATTRESS FOUNDATIONS; MATTRESS TOPPERS (U.S. CLS. 2, 13, 22, 25, 32 AND 50).

ALICIA COLLINS, EXAMINING ATTORNEY

SN 85-230,519. ZINUS INC., DBA VIVON LIFE, HAYWARD, CA. FILED 1-31-2011.

## Vivon Bliss

THE MARK CONSISTS OF STANDARD CHARACTERS WITHOUT CLAIM TO ANY PARTICULAR FONT, STYLE, SIZE, OR COLOR.

NO CLAIM IS MADE TO THE EXCLUSIVE RIGHT TO USE "BLISS", APART FROM THE MARK AS SHOWN.

FOR BEDS, MATTRESSES, PILLOWS AND BOLSTERS; MATTRESS FOUNDATIONS; MATTRESS TOPPERS (U.S. CLS. 2, 13, 22, 25, 32 AND 50).

ALICIA COLLINS, EXAMINING ATTORNEY

SN 85-230,542. ZINUS INC., DBA VIVON LIFE, HAYWARD, CA. FILED 1-31-2011.

## Vivon Comfort

THE MARK CONSISTS OF STANDARD CHARACTERS WITHOUT CLAIM TO ANY PARTICULAR FONT, STYLE, SIZE, OR COLOR.

NO CLAIM IS MADE TO THE EXCLUSIVE RIGHT TO USE "COMFORT", APART FROM THE MARK AS SHOWN.

FOR BEDS, MATTRESSES, PILLOWS AND BOLSTERS; MATTRESS FOUNDATIONS; MATTRESS TOPPERS (U.S. CLS. 2, 13, 22, 25, 32 AND 50).

FIRST USE 10-1-2010; IN COMMERCE 10-15-2010.

ALICIA COLLINS, EXAMINING ATTORNEY



**CLASS 20—(Continued).**

SN 85-230,577. ZINUS INC., DBA VIVON LIFE, HAYWARD, CA. FILED 1-31-2011.

## Vivon Harmony

THE MARK CONSISTS OF STANDARD CHARACTERS WITHOUT CLAIM TO ANY PARTICULAR FONT, STYLE, SIZE, OR COLOR.

NO CLAIM IS MADE TO THE EXCLUSIVE RIGHT TO USE "HARMONY", APART FROM THE MARK AS SHOWN.

FOR BEDS, MATTRESSES, PILLOWS AND BOLSTERS; MATTRESS FOUNDATIONS; MATTRESS TOPPERS (U.S. CLS. 2, 13, 22, 25, 32 AND 50).

FIRST USE 10-1-2010; IN COMMERCE 10-15-2010.  
ALICIA COLLINS, EXAMINING ATTORNEY

---

SN 85-242,777. FOREMOST GROUPS, INC., EAST HANOVER, NJ. FILED 2-15-2011.

## TODAY'S BATH

THE MARK CONSISTS OF STANDARD CHARACTERS WITHOUT CLAIM TO ANY PARTICULAR FONT, STYLE, SIZE, OR COLOR.

NO CLAIM IS MADE TO THE EXCLUSIVE RIGHT TO USE "BATH", APART FROM THE MARK AS SHOWN.

FOR BATHROOM FURNITURE, NAMELY, CABINETS, SHELF, VANITIES, AND MIRRORS (U.S. CLS. 2, 13, 22, 25, 32 AND 50).

FIRST USE 9-30-2007; IN COMMERCE 9-30-2007.  
ANGELA M. MICHELI, EXAMINING ATTORNEY

**CLASS 21—HOUSEWARES AND GLASS**

SN 77-741,561. REEVES, LYNN, DEL MAR, CA. FILED 5-20-2009.

## SIXPACKPOTS

THE MARK CONSISTS OF STANDARD CHARACTERS WITHOUT CLAIM TO ANY PARTICULAR FONT, STYLE, SIZE, OR COLOR.

FOR HOLDERS FOR FLOWERS AND PLANTS; PLANTERS FOR FLOWERS AND PLANTS; POTS (U.S. CLS. 2, 13, 23, 29, 30, 33, 40 AND 50).

FIRST USE 3-4-2010; IN COMMERCE 2-28-2011.  
GRETTA YAO, EXAMINING ATTORNEY

**CLASS 21—(Continued).**

SN 79-083,956. IITTALA GROUP OY AB, FINLAND, FILED 6-7-2010.

## OPTIHEAT

THE MARK CONSISTS OF STANDARD CHARACTERS WITHOUT CLAIM TO ANY PARTICULAR FONT, STYLE, SIZE, OR COLOR.

OWNER OF INTERNATIONAL REGISTRATION 1042633 DATED 6-7-2010, EXPIRES 6-7-2020.

FOR COOKING PANS AND ROASTING TINS; CONTAINERS FOR HOUSEHOLD OR KITCHEN USE; COMBS, CLEANING AND BATH SPONGES; CLEANING BRUSHES FOR HOUSEHOLD USE; BRUSH-MAKING MATERIALS; STEEL WOOL; UNWORKED OR SEMI-WORKED GLASS; BEVERAGE GLASSWARE, PORCELAIN AND EARTHENWARE BEVERAGE WARE (U.S. CLS. 2, 13, 23, 29, 30, 33, 40 AND 50).

DANIEL CAPSHAW, EXAMINING ATTORNEY

---

SN 79-091,036. BERIEF, PHILIPP, BERLIN, FED REP GERMANY, FILED 11-26-2010.

## phil goods

THE MARK CONSISTS OF STANDARD CHARACTERS WITHOUT CLAIM TO ANY PARTICULAR FONT, STYLE, SIZE, OR COLOR.

OWNER OF INTERNATIONAL REGISTRATION 1061232 DATED 11-26-2010, EXPIRES 11-26-2020.

NO CLAIM IS MADE TO THE EXCLUSIVE RIGHT TO USE "GOODS", APART FROM THE MARK AS SHOWN.

FOR COOKIE CUTTERS (U.S. CLS. 2, 13, 23, 29, 30, 33, 40 AND 50).

MARLENE BELL, EXAMINING ATTORNEY

**CLASS 21—(Continued).**

SN 79-092,885. VE.CA. VENETA CASALINGHI S.P.A., ITALY,  
FILED 8-11-2010.



PRIORITY DATE OF 3-1-2010 IS CLAIMED.  
OWNER OF INTERNATIONAL REGISTRATION 1065966  
DATED 8-11-2010, EXPIRES 8-11-2020.

THE MARK CONSISTS OF THE STYLIZED WORDING  
"VECA" WHERE THE RIGHT ARM OF THE "V" EXTENDS  
HORIZONTALLY OVER THE LETTERS "EC" AND FORMS  
THE RIGHT ARM OF THE "A".

THE WORDING "VECA" HAS NO MEANING IN A  
FOREIGN LANGUAGE.

FOR PLASTIC BUCKETS, MOLDED PLASTIC TUM-  
BLERS, TEA CANISTERS, PITCHERS, DISPENSERS FOR  
FACIAL TISSUES; EMPTY CONDIMENT HOLDERS,  
NAMELY, SALT AND PEPPER SHAKERS; CREAM  
AND SUGAR CONTAINERS AND DISPENSERS; EMPTY  
SOAP AND TOOTH BRUSH BOXES; BOWLS, CUPS,  
COLLAPSIBLE STORAGE CONTAINERS FOR DOMES-  
TIC USE, VACUUM JARS AND MIXERS, COCKTAIL  
AND BEVERAGE SHAKERS, RECIPE BOXES, BREAD  
BOXES AND TRAYS, PLASTIC CONTAINERS,  
NAMELY, CAKE BOXES AND TRAYS FOR HOUSE-  
HOLD USE, BUTTER BOXES AND TRAYS, REFRIG-  
ERATOR BOXES, NAMELY, ICE CUBE MOLDS FOR  
REFRIGERATORS, PIE HOLDERS TO CONTAIN  
BAKED PIES, LUNCH BOXES; CERAMIC SCULPTURES,  
VASES, VESSELS, BOWLS, PLATES AND POTS, FLOW-  
ER VASES AND BOWLS, FLOWER VASES AND BOWLS  
OF PRECIOUS METAL, VASES, VASES OF PRECIOUS  
METAL, VASES AND PLANTERS SOLD EMPTY,  
PLATES AND POTS; WASH BASINS FOR CHILDREN,  
CHAMBER POTS FOR BABIES, LAUNDRY HANGERS,  
PLASTIC BEAMS TO HANG LAUNDRY, WASH BOWLS,  
IN PLASTICS; VASES FOR FLOWERS MADE OF RESINS  
AND OF PLASTICS, SAUCERS, BOWLS IN PLASTICS,  
PAPER ROLL HOLDERS FOR HOUSEHOLD PURPOSE,  
TOILET ROLL HOLDERS, BUCKETS FOR DOMESTIC  
USE; WINDOW BOXES FOR DOMESTIC USE; TRAYS  
FOR DOMESTIC USE, DISH DRYING RACKS, CUT-  
LERY DRYING RACKS, BAKING PANS, SALAD  
BOWLS, CANDY BOXES FOR HOUSEHOLD PURPOSE,  
TRUGS IN THE NATURE OF WOODEN BASKETS FOR  
BREAD, SAUCEPANS, SALAD SPINNERS FOR DRYING  
VEGETABLES, SALTS SHAKERS, PASTA DRAINERS,  
RICE DRAINERS, TRAYS FOR HOUSEHOLD USE,  
CLEANING CLOTHS FOR HEATERS, LITER SCOOPS  
FOR THE DISPOSAL OF PET WASTE, FLY SWATTERS,  
STOOLS FOR HOUSEHOLD PURPOSE, SPAGHETTI  
HANDLERS, GRATERS FOR HOUSEHOLD PURPOSES,  
TOOTHPICK BOXES, NON-ELECTRIC JUICERS, FUN-  
NELS, COOKING FUNNELS, GLASSES, NAMELY,  
GLASS BEVERAGEWARE, CARAFES, TROLLEYS FOR  
HOUSEHOLD PURPOSES, DUSTBINS AND TRASH  
CANS FOR HOUSEHOLD PURPOSES; PORTABLE  
COOLERS; PORTABLE BEVERAGE COOLERS; THER-  
MAL INSULATED CONTAINERS FOR FOOD OR BEV-  
ERAGES; THERMAL INSULATED TOTE BAGS FOR  
FOOD OR BEVERAGES; THERMAL INSULATED WRAP  
FOR CANS TO KEEP THE CONTENTS COLD OR HOT;  
ICE BUCKETS; TOILET BRUSHES; DRINKING  
GLASSES; CUPS; DECORATIVE PLATES; HOUSEHOLD  
UTENSIL STRAINERS; COLANDERS FOR HOUSEHOLD  
USE; CITRUS-FRUIT SQUEEZERS; NAPKIN HOLDERS;  
MEAL TRAYS; HOUSEHOLD CONTAINERS FOR FOOD;  
TRIVETS; DECANTERS; HAND BASINS; BASINS; DUST  
BINS; TRASH CANS; BASKETS MADE OF PLASTIC  
MATERIAL; BABY BATHTUBS; CHAMBER POTS;  
BROOMS; BUTLERS' TRAYS, CANDLE SNUFFER AND  
TRAY COMBINATION MADE IN WHOLE OR IN PART

**CLASS 21—(Continued).**

OF PRECIOUS METAL, CANDLE SNUFFER AND TRAY  
COMBINATION, COMPOSTABLE AND BIODEGRAD-  
ABLE PLATES, BOWLS, CUPS AND TRAYS, CRUMB  
TRAYS, DISPOSABLE DINNERWARE, NAMELY,  
PLATES, BOWLS AND SERVING TRAYS, FLOWER  
AND PLANT CULTIVATION TRAYS MADE OF BIODE-  
GRADABLE MATERIAL, JAPANESE STYLE PERSONAL  
DINING TRAYS OR STANDS, NON-METALLIC TRAYS,  
SERVING TRAYS, TRAYS FOR DOMESTIC PURPOSES;  
ALL THE AFORESAID GOODS NOT SOLD VIA MAIL  
ORDER AND NOT SOLD TO RESTAURANTS OR  
HOTELS (U.S. CLS. 2, 13, 23, 29, 30, 33, 40 AND 50).  
TASNEEM HUSSAIN, EXAMINING ATTORNEY

SN 85-048,102. KISSMEYER, KIRSTEN, YVETTE, CAM-  
BRIDGE, MA. FILED 5-26-2010.

# Swiftez

THE MARK CONSISTS OF STANDARD CHARACTERS  
WITHOUT CLAIM TO ANY PARTICULAR FONT, STYLE,  
SIZE, OR COLOR.

FOR COMBINATION DUSTER AND MOP (U.S. CLS. 2,  
13, 23, 29, 30, 33, 40 AND 50).  
MARTHA FROMM, EXAMINING ATTORNEY

SN 85-058,919. CHARCOAL COMPANION INCORPORATED,  
DBA THE COMPANION GROUP, EMERYVILLE, CA.  
FILED 6-9-2010.

# STUFF-A-BURGER

THE MARK CONSISTS OF STANDARD CHARACTERS  
WITHOUT CLAIM TO ANY PARTICULAR FONT, STYLE,  
SIZE, OR COLOR.

FOR MEAT MOLD (U.S. CLS. 2, 13, 23, 29, 30, 33, 40  
AND 50).  
PAUL MORENO, EXAMINING ATTORNEY

**CLASS 21—(Continued).**

SN 85-067,224. SHANDONG ZHONGYI MACCA LIGHT INDUSTRIAL PRODUCTS CO.,LTD, ZIBO SHANDONG, CHINA, FILED 6-21-2010.



THE MARK CONSISTS OF THE WORDING "ZIBO" AND SPECIAL STYLIZED CIRCLE, WHICH CONSIST OF WORDING "IB" INSIDER, AND THE WORDING "ZIBO" IN END-TO-END ARRANGEMENT.

FOR BEER MUGS; CERAMIC HANDLES AND PULLS FOR CABINETS, DRAWERS AND FURNITURE; CERAMIC SCULPTURES, VASES, VESSELS, BOWLS, PLATES AND POTS; CHINA ORNAMENTS; COFFEE SERVICE; DRINKING VESSELS; EARTHENWARE BASINS; EARTHENWARE MUGS; FOOD PRESERVING JARS OF GLASS; FRUIT BOWLS OF GLASS; GLASS BEVERAGEWARE; GLASS BOWLS FOR LIVE GOLDFISH; GLASS BOXES; GLASS DISHES; GLASS JARS; GLASS MUGS; GLASS PANS; GLASS RODS; JARS FOR JAMS AND JELLIES OF EARTHENWARE; PORCELAIN CAKE DECORATIONS; PORCELAIN DOORKNOBS; PORCELAIN EGGS; PORCELAIN FLOWER POTS; PORCELAIN KNOBS; PORCELAIN MUGS; PORCELAIN OR EARTHENWARE DOORKNOBS; STAINED GLASS; STAINED GLASS FIGURINES; WORKS OF ART OF PORCELAIN, TERRA COTTA OR GLASS (U.S. CLS. 2, 13, 23, 29, 30, 33, 40 AND 50).

FIRST USE 9-6-2003; IN COMMERCE 12-8-2003.  
REGINA DRUMMOND, EXAMINING ATTORNEY

SN 85-102,686. HORANOFF, JERRY E, DOWNINGTOWN, PA. FILED 8-8-2010.

# Litter Loo

THE MARK CONSISTS OF STANDARD CHARACTERS WITHOUT CLAIM TO ANY PARTICULAR FONT, STYLE, SIZE, OR COLOR.

NO CLAIM IS MADE TO THE EXCLUSIVE RIGHT TO USE "LITTER", APART FROM THE MARK AS SHOWN.

FOR ANIMAL LITTER BOXES; ANIMAL LITTER PANS; AUTOMATED PET APPLIANCES, NAMELY, LITTER BOXES (U.S. CLS. 2, 13, 23, 29, 30, 33, 40 AND 50).

SOPHIA S. KIM, EXAMINING ATTORNEY

**CLASS 21—(Continued).**

SN 85-106,550. AUYSI INDUSTRIAL CO., LTD., SHULIN CITY (TAIPEI), TAIWAN, FILED 8-12-2010.



THE MARK CONSISTS OF THE WORD "AUYSI" WITH A THREE-PRONGED DESIGN OVER THE DOT IN THE LETTER "I" AND A FANCIFUL DESIGN OF A DOG ABOVE THE WORD "AUYSI".

THE WORDING "AUYSI" HAS NO MEANING IN A FOREIGN LANGUAGE.

FOR PET BRUSHES, CAGES FOR PETS, LITTER BOXES FOR PETS, PET FOOD BOWLS, SCOOPS FOR THE DISPOSAL OF PET WASTE (U.S. CLS. 2, 13, 23, 29, 30, 33, 40 AND 50).

FIRST USE 7-5-2010; IN COMMERCE 7-7-2010.  
WARREN L. OLANDRIA, EXAMINING ATTORNEY

SN 85-154,130. AZZIMONTI PAOLINO S.P.A., 28010 CALTIGNAGA (NO), ITALY, FILED 10-15-2010.



PRIORITY CLAIMED UNDER SEC. 44(D) ON ITALY APPLICATION NO. MI2010C01024, FILED 10-12-2010, REG. NO. 1423834, DATED 10-12-2010, EXPIRES 10-12-2020.

NO CLAIM IS MADE TO THE EXCLUSIVE RIGHT TO USE "CRYSTAL", APART FROM THE MARK AS SHOWN.

THE NAME(S), PORTRAIT(S), AND/OR SIGNATURE(S) SHOWN IN THE MARK DOES NOT IDENTIFY A PARTICULAR LIVING INDIVIDUAL.

THE MARK CONSISTS OF A TRIANGLE PLACED ON TOP OF A HORIZONTAL RECTANGLE THAT EXTENDS FROM THE RIGHT AND LEFT SIDES OF THE TRIANGLE, INSIDE A DOUBLE CIRCLE FRAME. THE WORDS "AZ CRYSTAL" APPEAR AT THE TOP OF THE CIRCLE FRAME, WITH SOLID CIRCLES PLACED IMMEDIATELY BEFORE AND AFTER THE WORDING. THE LETTERS "PA" APPEAR IN THE TRIANGLE, WITH THE WORDING "BY AZZIMONTI" EXTENDED OVER THE RIGHT SIDE OF THE RECTANGLE. THE WORD "JOHNGLASS" APPEARS IN THE BOTTOM HALF OF THE CIRCULAR FRAME, WITH SOLID CIRCLES PLACED BEFORE AND AFTER THE WORD.

FOR WORKS OF ART MADE OF GLASS, NAMELY, PHOTOGRAPHIC REPRODUCTIONS ON CRYSTAL GLASSES (U.S. CLS. 2, 13, 23, 29, 30, 33, 40 AND 50).

LIEF MARTIN, EXAMINING ATTORNEY

**CLASS 21—(Continued).**

SN 85-159,579. COOL POTS COMPANY, ELK GROVE, CA. FILED 10-22-2010.



NO CLAIM IS MADE TO THE EXCLUSIVE RIGHT TO USE "POTS" AND "WATER SAVER", APART FROM THE MARK AS SHOWN.

THE COLOR(S) BLUE, BLACK, WHITE IS/ARE CLAIMED AS A FEATURE OF THE MARK.

THE MARK CONSISTS OF THE WORD "COOL" IN WHITE AND BLUE WITH A BLACK BORDER; THE WORD "POTS" IN BLUE WITH A BLACK BORDER; AND "WATER SAVER" IN BLACK. THE WATER DROP BEHIND TEXT IS BLUE WITH WHITE SHADING. THE BLACK RECTANGULAR CARRIER REPRESENTS OUTLINING AND IS NOT PART OF THE MARK.

FOR A WHITE THERMAL INSULATING AGRICULTURAL WATER AND CROP SAVER NURSERY PLANT CONTAINER POT (U.S. CLS. 2, 13, 23, 29, 30, 33, 40 AND 50).

KATHLEEN M. VANSTON, EXAMINING ATTORNEY

**CLASS 21—(Continued).**

SN 85-176,102. BUBBA BRANDS, INC., SMYRNA, GA. FILED 11-13-2010.



THE MARK CONSISTS OF A LOWER CASE LETTER "B" CONTAINED INSIDE A RECTANGULAR DESIGN THAT HAS 2 BORDERS; THE DESIGN REPRESENTS A KEG; THE "B" IS LOCATED IN THE LOWER RIGHT OF THE DESIGN AND CONNECTS WITH THE INSIDE RECTANGULAR BORDER.

FOR HOUSEHOLD CONTAINERS, NAMELY, MUGS, TUMBLERS, JUGS, BOTTLES SOLD EMPTY; INSULATING SLEEVE HOLDERS FOR BEVERAGE CANS AND BOTTLES; PORTABLE BEVERAGE COOLERS (U.S. CLS. 2, 13, 23, 29, 30, 33, 40 AND 50).

FIRST USE 2-11-2010; IN COMMERCE 8-16-2010.  
CHRISIE B. KING, EXAMINING ATTORNEY

SN 85-171,486. KHAN, STEPHEN A., CHANDLER, AZ. FILED 11-8-2010.

## Eco Bay Home

THE MARK CONSISTS OF STANDARD CHARACTERS WITHOUT CLAIM TO ANY PARTICULAR FONT, STYLE, SIZE, OR COLOR.

NO CLAIM IS MADE TO THE EXCLUSIVE RIGHT TO USE "HOME", APART FROM THE MARK AS SHOWN.

FOR CUTTING BOARDS; DINNERWARE, NAMELY, PLATES, CUPS, AND SAUCERS (U.S. CLS. 2, 13, 23, 29, 30, 33, 40 AND 50).

JENNY PARK, EXAMINING ATTORNEY

SN 85-178,246. PROGRESSIVE INTERNATIONAL CORPORATION, KENT, WA. FILED 11-16-2010.

## SHARP STRAIGHT SIMPLE SMART

THE MARK CONSISTS OF STANDARD CHARACTERS WITHOUT CLAIM TO ANY PARTICULAR FONT, STYLE, SIZE, OR COLOR.

NO CLAIM IS MADE TO THE EXCLUSIVE RIGHT TO USE "SHARP STRAIGHT", APART FROM THE MARK AS SHOWN.

FOR CHEESE GRATERS; COOKING GRATERS; GRATERS FOR HOUSEHOLD PURPOSES (U.S. CLS. 2, 13, 23, 29, 30, 33, 40 AND 50).

ANTHONY RINKER, EXAMINING ATTORNEY

**CLASS 21—(Continued).**

SN 85-184,276. BUBBA BRANDS, INC., SMYRNA, GA. FILED 11-24-2010.

# ENVY

THE MARK CONSISTS OF STANDARD CHARACTERS WITHOUT CLAIM TO ANY PARTICULAR FONT, STYLE, SIZE, OR COLOR.

FOR DUAL-WALL VACUUM STAINLESS STEEL BOTTLES (U.S. CLS. 2, 13, 23, 29, 30, 33, 40 AND 50).  
CHRISIE B. KING, EXAMINING ATTORNEY

**CLASS 21—(Continued).**

SN 85-199,596. PERLIN, BARBARA, LOS ANGELES, CA. FILED 12-16-2010.

# THE FORTUNE FACTORY

THE MARK CONSISTS OF STANDARD CHARACTERS WITHOUT CLAIM TO ANY PARTICULAR FONT, STYLE, SIZE, OR COLOR.

FOR COOKIE SHAPING TOOL (U.S. CLS. 2, 13, 23, 29, 30, 33, 40 AND 50).  
JEFFREY LOOK, EXAMINING ATTORNEY

SN 85-191,217. MEMORIAL HEALTH SYSTEM, INC., SOUTH BEND, IN. FILED 12-6-2010.

# INNOSECTIONS TOPPER

THE MARK CONSISTS OF STANDARD CHARACTERS WITHOUT CLAIM TO ANY PARTICULAR FONT, STYLE, SIZE, OR COLOR.

FOR STORAGE DEVICE AND ACTIVITY CENTER, NAMELY, A LAZY SUSAN FOR STORING ART AND CREATIVE SUPPLIES (U.S. CLS. 2, 13, 23, 29, 30, 33, 40 AND 50).  
KATINA MISTER, EXAMINING ATTORNEY

SN 85-199,641. PERLIN, BARBARA, LOS ANGELES, CA. FILED 12-16-2010.

# LET'S MAKE A FORTUNE

THE MARK CONSISTS OF STANDARD CHARACTERS WITHOUT CLAIM TO ANY PARTICULAR FONT, STYLE, SIZE, OR COLOR.

FOR COOKIE SHAPING TOOL (U.S. CLS. 2, 13, 23, 29, 30, 33, 40 AND 50).  
JEFFREY LOOK, EXAMINING ATTORNEY

SN 85-191,531. KATRI, INC., SEATTLE, WA. FILED 12-6-2010.

# SAVING THE WORLD ONE BOTTLE AT A TIME

THE MARK CONSISTS OF STANDARD CHARACTERS WITHOUT CLAIM TO ANY PARTICULAR FONT, STYLE, SIZE, OR COLOR.

FOR NON-DISPOSABLE, SEALABLE HOT AND COLD BEVERAGWARE, AND NON-DISPOSABLE, SEALABLE, INSULATED HOT AND COLD BEVERAGE CONTAINERS FOR DOMESTIC USE (U.S. CLS. 2, 13, 23, 29, 30, 33, 40 AND 50).

FIRST USE 11-9-2010; IN COMMERCE 11-9-2010.  
GEOFFREY FOSDICK, EXAMINING ATTORNEY

SN 85-202,182. ALLEN REED COMPANY, INC., LOS ANGELES, CA. FILED 12-20-2010.

# slidenwrap

THE MARK CONSISTS OF STANDARD CHARACTERS WITHOUT CLAIM TO ANY PARTICULAR FONT, STYLE, SIZE, OR COLOR.

FOR INJECTED MOLDED DISPENSERS FOR PLASTIC WRAP, ALUMINUM FOIL AND PARCHMENT PAPER FOR RETAIL USE (U.S. CLS. 2, 13, 23, 29, 30, 33, 40 AND 50).

PRISCILLA MILTON, EXAMINING ATTORNEY



**CLASS 21—(Continued).**

SN 85-202,448. QUICKIE MANUFACTURING CORPORATION, CINNAMINSON, NJ. FILED 12-21-2010.



NO CLAIM IS MADE TO THE EXCLUSIVE RIGHT TO USE "DRY SHINE SPONGE", APART FROM THE MARK AS SHOWN.

THE COLOR(S) DARK BLUE, LIGHT BLUE, RED AND WHITE IS/ARE CLAIMED AS A FEATURE OF THE MARK.

THE MARK CONSISTS OF THE WORDS "DRY SHINE SPONGE" IN WHITE CAPITAL LETTERS. THE WORDS APPEAR ONE UNDER THE OTHER IN AN UPWARDS DIAGONAL DIRECTION. TO THE RIGHT OF THE WORD "DRY" THERE APPEARS A WHITE STARBURST. THE WORDS AND STARBURST ARE CONTAINED WITHIN A DARK BLUE BACKGROUND. BEHIND THE WORDING THERE APPEARS A LIGHT BLUE CIRCLE OUTLINED IN DARK BLUE AND RED CONCENTRIC CIRCLES.

FOR MOPS (U.S. CLS. 2, 13, 23, 29, 30, 33, 40 AND 50).  
SKYE YOUNG, EXAMINING ATTORNEY

SN 85-203,159. THE EVERCARE COMPANY, ALPHARETTA, GA. FILED 12-21-2010.

**GENTLE SWEEP**

THE MARK CONSISTS OF STANDARD CHARACTERS WITHOUT CLAIM TO ANY PARTICULAR FONT, STYLE, SIZE, OR COLOR.

NO CLAIM IS MADE TO THE EXCLUSIVE RIGHT TO USE "SWEEP", APART FROM THE MARK AS SHOWN.

FOR BROOM BRISTLES (U.S. CLS. 2, 13, 23, 29, 30, 33, 40 AND 50).

REBECCA SMITH, EXAMINING ATTORNEY

**CLASS 21—(Continued).**

SN 85-203,180. THE EVERCARE COMPANY, ALPHARETTA, GA. FILED 12-21-2010.

**FIRM SWEEP**

THE MARK CONSISTS OF STANDARD CHARACTERS WITHOUT CLAIM TO ANY PARTICULAR FONT, STYLE, SIZE, OR COLOR.

NO CLAIM IS MADE TO THE EXCLUSIVE RIGHT TO USE "SWEEP", APART FROM THE MARK AS SHOWN.

FOR BROOM BRISTLES (U.S. CLS. 2, 13, 23, 29, 30, 33, 40 AND 50).

REBECCA SMITH, EXAMINING ATTORNEY

SN 85-205,644. ILLINOIS TOOL WORKS INC., GLENVIEW, IL. FILED 12-25-2010.

**COVENTRY**

THE MARK CONSISTS OF STANDARD CHARACTERS WITHOUT CLAIM TO ANY PARTICULAR FONT, STYLE, SIZE, OR COLOR.

FOR WIPES USED IN CRITICAL CLEANING ENVIRONMENTS, NAMELY, FABRIC CLEAN ROOM WIPES AND NON-WOVEN DISPOSABLE TEXTILE WIPES NOT IMPREGNATED WITH CHEMICALS OR COMPOUNDS (U.S. CLS. 2, 13, 23, 29, 30, 33, 40 AND 50).

MARK PILARO, EXAMINING ATTORNEY

SN 85-208,521. ILLINOIS TOOL WORKS INC., GLENVIEW, IL. FILED 12-31-2010.

**QBE**

THE MARK CONSISTS OF STANDARD CHARACTERS WITHOUT CLAIM TO ANY PARTICULAR FONT, STYLE, SIZE, OR COLOR.

FOR WIPES, NAMELY, NON-WOVEN DISPOSABLE TEXTILE WIPES NOT IMPREGNATED WITH CHEMICALS OR COMPOUNDS; CLEANING AND WIPE MECHANISM FOR FIBER OPTICS AND END FACES, CONSISTING OF NON-WOVEN DISPOSABLE TEXTILE WIPES NOT IMPREGNATED WITH CHEMICALS OR COMPOUNDS AND A CONTAINMENT VESSEL (U.S. CLS. 2, 13, 23, 29, 30, 33, 40 AND 50).

MARK PILARO, EXAMINING ATTORNEY

**CLASS 21—(Continued).**

SN 85-210,849. MARLIN INDUSTRIAL PRODUCTS INC., TORONTO, ONTARIO, CANADA, FILED 1-5-2011.

**STICKY SWIPES**

THE MARK CONSISTS OF STANDARD CHARACTERS WITHOUT CLAIM TO ANY PARTICULAR FONT, STYLE, SIZE, OR COLOR.

PRIORITY CLAIMED UNDER SEC. 44(D) ON CANADA APPLICATION NO. 1506774, FILED 12-7-2010.

NO CLAIM IS MADE TO THE EXCLUSIVE RIGHT TO USE "STICKY", APART FROM THE MARK AS SHOWN.

FOR REUSABLE SCREEN CLEANING PADS FOR DIGITAL DEVICES, DIGITAL SCREENS, COMPUTERS, CELL PHONES, SMART PHONES, PERSONAL DIGITAL ASSISTANTS, PORTABLE DIGITAL MEDIA PLAYERS AND VIEWERS, LAPTOP COMPUTERS, COMPUTER MONITORS, TABLET COMPUTERS, TELEVISION MONITORS, FLAT SCREENS, CAMERA LENSES, MIRRORED SURFACE, EYE GLASSES, PORTABLE GAMING DEVICES, LCD, LED AND PLASMA SCREENS, DIGITAL PHOTO FRAMES, PROJECTOR LENSES, NAVIGATION SYSTEM DIGITAL SCREENS AND OTHER DEVICES UTILIZING A DISPLAY SCREEN (U.S. CLS. 2, 13, 23, 29, 30, 33, 40 AND 50).

FIRST USE 1-31-2009; IN COMMERCE 1-31-2009.  
REGINA DRUMMOND, EXAMINING ATTORNEY

SN 85-212,445. PAUL SALVINO, WAUCONDA, IL. FILED 1-7-2011.

**SAFECHIEF**

THE MARK CONSISTS OF STANDARD CHARACTERS WITHOUT CLAIM TO ANY PARTICULAR FONT, STYLE, SIZE, OR COLOR.

FOR COOKWARE, NAMELY, POTS, PANS, STEAMERS, AND ASSEMBLED COOKWARE IN THE NATURE OF A COVERED POT COMPRISING MULTIPLE COMPONENTS (U.S. CLS. 2, 13, 23, 29, 30, 33, 40 AND 50).  
KARANENDRA S. CHHINA, EXAMINING ATTORNEY

**CLASS 21—(Continued).**

SN 85-213,040. KENMARK SPORTS, LLC, HOUSTON, TX. FILED 1-7-2011.



NO CLAIM IS MADE TO THE EXCLUSIVE RIGHT TO USE "SPORTS", APART FROM THE MARK AS SHOWN.

THE MARK CONSISTS OF TWO CONCENTRIC OVAL DESIGNS CONTAINING THE TERMS "KENMARK SPORTS" IN STYLIZED LETTERING.

FOR EMPTY ALUMINUM WATER BOTTLES SOLD AS A UNIT WITH ARMBANDS CONSISTING OF A WATER BOTTLE HOLDER AND DETACHABLE POCKETS FOR CARRYING PORTABLE MUSIC PLAYERS, CELLULAR PHONES, WALLETS AND OTHER PERSONAL ITEMS; ALUMINUM WATER BOTTLES SOLD EMPTY (U.S. CLS. 2, 13, 23, 29, 30, 33, 40 AND 50).

ADA HAN, EXAMINING ATTORNEY

SN 85-213,100. TRU VUE, INC., MCCOOK, IL. FILED 1-7-2011.

**ULTRAVUE**

THE MARK CONSISTS OF STANDARD CHARACTERS WITHOUT CLAIM TO ANY PARTICULAR FONT, STYLE, SIZE, OR COLOR.

FOR GLASS SHEETS FOR PICTURE FRAMES AND DISPLAY CASES (U.S. CLS. 2, 13, 23, 29, 30, 33, 40 AND 50).

MATTHEW MCDOWELL, EXAMINING ATTORNEY

SN 85-213,785. LIFETIME BRANDS, INC., GARDEN CITY, NY. FILED 1-10-2011.

**POMERANTZ**

THE MARK CONSISTS OF STANDARD CHARACTERS WITHOUT CLAIM TO ANY PARTICULAR FONT, STYLE, SIZE, OR COLOR.

OWNER OF U.S. REG. NO. 2,424,149.

SEC. 2(F).

FOR BOWLS; BREAD BOXES; CANISTER SETS; COASTERS NOT OF PAPER AND NOT BEING TABLE LINEN; COUNTERTOP HOLDERS FOR PAPER TOWELS; DISH DRYING RACKS; HOUSEHOLD UTENSILS, NAMELY, BANANA HANGER, REVOLVING HOLDER WITH KITCHEN UTENSILS AND FLATWARE CADDIES; LAZY SUSANS; MUG TREES; NAPKIN HOLDERS; PLATES; RECIPE BOXES; SERVINGWARE FOR SERVING FOOD; SPICE RACKS; TRAYS FOR DOMESTIC PURPOSES; TRIVETS (U.S. CLS. 2, 13, 23, 29, 30, 33, 40 AND 50).

ALICIA COLLINS, EXAMINING ATTORNEY

**CLASS 21—(Continued).**

SN 85-215,117. HOMESTYLE DINING LLC, DBA PONDEROSA STEAKHOUSE, PLANO, TX. FILED 1-11-2011.

**PONDEROSA**

THE MARK CONSISTS OF STANDARD CHARACTERS WITHOUT CLAIM TO ANY PARTICULAR FONT, STYLE, SIZE, OR COLOR.

FOR HOUSEHOLD UTENSILS, NAMELY, FORKS, TONGS, TURNERS (U.S. CLS. 2, 13, 23, 29, 30, 33, 40 AND 50).

LESLEY LAMOTHE, EXAMINING ATTORNEY

SN 85-215,269. NORMAN DIRECT, LLC, NEW BERLIN, WI. FILED 1-11-2011.

**SIFT & TOSS**

THE MARK CONSISTS OF STANDARD CHARACTERS WITHOUT CLAIM TO ANY PARTICULAR FONT, STYLE, SIZE, OR COLOR.

FOR DISPOSABLE LINERS FOR LITTER BOXES (U.S. CLS. 2, 13, 23, 29, 30, 33, 40 AND 50).

NICHOLAS ALTREE, EXAMINING ATTORNEY

SN 85-216,003. RAY HUBERT, ST. ANNE, IL. FILED 1-12-2011.

**SWIVEL-T**

THE MARK CONSISTS OF STANDARD CHARACTERS WITHOUT CLAIM TO ANY PARTICULAR FONT, STYLE, SIZE, OR COLOR.

FOR CAMPING GRILLS (U.S. CLS. 2, 13, 23, 29, 30, 33, 40 AND 50).

CAROLINE WOOD, EXAMINING ATTORNEY

**CLASS 21—(Continued).**

SN 85-249,975. COLGATE-PALMOLIVE COMPANY, NEW YORK, NY. FILED 2-23-2011.

**OPTIC WHITE**

THE MARK CONSISTS OF STANDARD CHARACTERS WITHOUT CLAIM TO ANY PARTICULAR FONT, STYLE, SIZE, OR COLOR.

NO CLAIM IS MADE TO THE EXCLUSIVE RIGHT TO USE "WHITE", APART FROM THE MARK AS SHOWN.

FOR TOOTHBRUSHES (U.S. CLS. 2, 13, 23, 29, 30, 33, 40 AND 50).

MARK SHINER, EXAMINING ATTORNEY

SN 85-260,642. AHOLD LICENSING SARL, GENEVA, SWITZERLAND, FILED 3-8-2011.



OWNER OF U.S. REG. NOS. 2,871,579, 3,411,740 AND OTHERS.

THE COLOR(S) ORANGE, GRAY AND WHITE IS/ARE CLAIMED AS A FEATURE OF THE MARK.

THE MARK CONSISTS OF THE TRADE DRESS CHARACTERIZING THE FRONT FACE OF THE PACKAGING FOR APPLICANT'S GOODS, NAMELY (1) A WHITE HORIZONTAL BAR SPANNING THE LABEL OR PACKAGE FACE, (2) AN ORANGE BAR BELOW THE WHITE BAR, ALSO SPANNING THE LABEL OR PACKAGE FACE, (3) A DASHED LINE THAT APPEARS GRAY ON THE WHITE BACKGROUND AND WHITE ON THE ORANGE BACKGROUND. THE DASHED LINE EXTENDS HORIZONTALLY ALONG THE WHITE BAR, AND TURNS 90 DEGREES AT EACH END TO EXTEND DOWNWARDS INTO THE ORANGE BAR. THE DESIGN FURTHER COMPRISES (4) A GRAY SCISSORS DESIGN AND (5) THE WORD "GUARANTEED" APPEARING IN ORANGE ABOVE THE GRAY LINE AND THE WORD "VALUE" APPEARING IN ORANGE BELOW THE GRAY LINE.

SEC. 2(F) AS TO "GUARANTEED VALUE".  
FOR ABRASIVE PADS FOR KITCHEN OR DOMESTIC PURPOSES; DISPOSABLE TABLE PLATES; PLASTIC CUPS (U.S. CLS. 2, 13, 23, 29, 30, 33, 40 AND 50).

BRIDGETT SMITH, EXAMINING ATTORNEY

**CLASS 21—(Continued).**

SN 85-260,924. AHOLD LICENSING SARL, GENEVA, SWITZERLAND, FILED 3-8-2011.



OWNER OF U.S. REG. NOS. 2,871,579, 3,411,740 AND OTHERS.

THE MARK CONSISTS OF A SCISSORS DESIGN WITH A DASHED LINE EXTENDING TO THE RIGHT OF THE SCISSORS. THE WORD "GUARANTEED" APPEARS ABOVE THE LINE AND THE WORD "VALUE" APPEARS BELOW THE LINE.

SEC. 2(F) AS TO "GUARANTEED VALUE".

FOR ABRASIVE PADS FOR KITCHEN OR DOMESTIC PURPOSES; DISPOSABLE TABLE PLATES; PLASTIC CUPS (U.S. CLS. 2, 13, 23, 29, 30, 33, 40 AND 50).

BRIDGETT SMITH, EXAMINING ATTORNEY

**CLASS 22—CORDAGE AND FIBERS**

SN 85-035,322. TOTAL SHADE, INC., HENDERSON, NV. FILED 5-11-2010.

# MediaShade

THE MARK CONSISTS OF STANDARD CHARACTERS WITHOUT CLAIM TO ANY PARTICULAR FONT, STYLE, SIZE, OR COLOR.

FOR SUN SHADE IN THE NATURE OF AN AWNING FOR ATTACHMENT TO OUTDOOR FURNITURE (U.S. CLS. 1, 2, 7, 19, 22, 42 AND 50).

FIRST USE 4-30-2010; IN COMMERCE 4-30-2010.

GRETCHEN ULRICH, EXAMINING ATTORNEY

SN 85-054,716. TY-FLOT, INC., MANCHESTER, NH. FILED 6-4-2010.



THE MARK CONSISTS OF A CIRCLE WITH A HAND CLUTCHING A WRENCH AND THE LITERAL ELEMENT "STRONGHOLD" TO THE RIGHT OF THE CIRCLE.

FOR LANYARDS FOR HOLDING HAND TOOLS, PENS, PENCILS, BUCKETS, NECK, CAPS, AND HARD HATS (U.S. CLS. 1, 2, 7, 19, 22, 42 AND 50).

CAROLYN CATALDO, EXAMINING ATTORNEY

**CLASS 22—(Continued).**

SN 85-063,656. POOLMASTER, INC., SACRAMENTO, CA. FILED 6-15-2010.



NO CLAIM IS MADE TO THE EXCLUSIVE RIGHT TO USE "POOL SHOP", APART FROM THE MARK AS SHOWN.

THE MARK CONSISTS OF THE STYLIZED WORDS "POOL SHOP" WITH A HORIZONTAL LINE GOING THROUGH THE WORD "POOL".

SEC. 2(F).

FOR SWIMMING POOL SKIMMING NETS (U.S. CLS. 1, 2, 7, 19, 22, 42 AND 50).

FIRST USE 10-9-1995; IN COMMERCE 10-9-1995.

ANDREA K. NADELMAN, EXAMINING ATTORNEY

SN 85-167,700. DONG GUANG FINE HAU AUTOMOBILE ACCESSORIES LTD., DONG GUANG CITY, CHINA, FILED 11-3-2010.



NO CLAIM IS MADE TO THE EXCLUSIVE RIGHT TO USE "AUTOMOBILE ACCESSORIES", APART FROM THE MARK AS SHOWN.

THE MARK CONSISTS OF THE WORDS "FINEHAU AUTOMOBILE ACCESSORIES" WITH A LINE APPEARING BELOW THE WORD "FINEHAU" SEPARATING IT FROM THE WORDS "AUTOMOBILE ACCESSORIES" THE LETTER "F" APPEARING IN THE WORD "FINEHAU" IS CHIPPED AT THE TOP LEFT-HAND CORNER.

THE WORDING "FINEHAU" HAS NO MEANING IN A FOREIGN LANGUAGE.

FOR ARRAYS OF RESILIENT NON-METAL STRAPS THAT MAY BE ARRANGED IN PRESCRIBED ANGULAR ORIENTATIONS RELATIVE TO EACH OTHER TO ACCOMMODATE OBJECTS OF DIFFERENT SIZES, SHAPES AND CONFIGURATIONS IN ANY ONE OF A MULTIPLICITY OF DIFFERENT ARRANGEMENTS; BELTS, NOT OF METAL, FOR HANDLING LOADS; CABLE TIES AND STRAPS FOR FASTENING AND SECURING OBJECTS SUCH AS BUNDLES OF WIRE TOGETHER; CABLES, NOT OF METAL; CARGO AND CARRIER EQUIPMENT FOR VEHICLES, NAMELY, TOW ROPES, TOW STRAPS, RATCHET TIE-DOWN STRAPS, QUICK RELEASE TIE DOWN STRAPS, LASHING STRAPS, AND TARP STRAPS; LOAD LIFTING STRAPS; NON-METAL STRAPPING OR TIEDOWNS; NON-METAL SUPPORT STRAPS FOR HOLDING PLANTED TREES IN AN UPWARD POSITION; STRAPS FOR HANDLING LOADS; STRAPS FOR SECURING BALES; STRAPS FOR SECURING BUNDLES; TIE DOWN STRAPS (U.S. CLS. 1, 2, 7, 19, 22, 42 AND 50).

FIRST USE 1-1-2005; IN COMMERCE 1-1-2009.

PAUL F. GAST, EXAMINING ATTORNEY

**CLASS 22—(Continued).**

SN 85-197,101. PEACEFUL PLAYGROUNDS, INC., LAKE ELSINORE, CA. FILED 12-14-2010.



THE MARK CONSISTS OF A GROUP OF THREE AVATARS (HEAD AND CHEST ONLY) ABOVE THE WORD "ORGANIZABLES" IN LOWER CASE LETTERS.

FOR CLOTHES ORGANIZATION SYSTEM USED FOR STORAGE, NAMELY, A SET OF HANGING GARMENT BAGS THAT ORGANIZES CLOTHES AND ACCESSORIES FOR DAILY USE, SEVERAL DAYS WORTH AT A TIME (U.S. CLS. 1, 2, 7, 19, 22, 42 AND 50).

FIRST USE 11-1-2010; IN COMMERCE 11-1-2010.  
AISHA SALEM, EXAMINING ATTORNEY

SN 85-213,949. MADE FOR SHADE, CANTON, GA. FILED 1-10-2011.

## Made For Shade

THE MARK CONSISTS OF STANDARD CHARACTERS WITHOUT CLAIM TO ANY PARTICULAR FONT, STYLE, SIZE, OR COLOR.

FOR AWNINGS (U.S. CLS. 1, 2, 7, 19, 22, 42 AND 50).  
FIRST USE 1-1-2011; IN COMMERCE 1-1-2011.  
KHANH LE, EXAMINING ATTORNEY

**CLASS 23—YARNS AND THREADS**

SN 85-072,890. UNIVERSAL YARN, INC., CONCORD, NC. FILED 6-28-2010.

# GALA

THE MARK CONSISTS OF STANDARD CHARACTERS WITHOUT CLAIM TO ANY PARTICULAR FONT, STYLE, SIZE, OR COLOR.

FOR YARN (U.S. CL. 43).  
KRISTINA MORRIS, EXAMINING ATTORNEY

**CLASS 24—FABRICS**

SN 77-862,099. SHAVEL ASSOCIATES INC., DBA SHAVEL HOME PRODUCTS, PRINCETON, NJ. FILED 10-31-2009.

## ATHLETIX BED GEAR

THE MARK CONSISTS OF STANDARD CHARACTERS WITHOUT CLAIM TO ANY PARTICULAR FONT, STYLE, SIZE, OR COLOR.

NO CLAIM IS MADE TO THE EXCLUSIVE RIGHT TO USE "BED GEAR", APART FROM THE MARK AS SHOWN. FOR HOME TEXTILES, NAMELY, BED LINEN, BED SHEETS (U.S. CLS. 42 AND 50).

FIRST USE 2-11-2010; IN COMMERCE 2-11-2010.  
ODESSA BIBBINS, EXAMINING ATTORNEY

SN 77-909,473. DISNEY ENTERPRISES, INC., BURBANK, CA. FILED 1-11-2010.

## LIVE THE STORY

THE MARK CONSISTS OF STANDARD CHARACTERS WITHOUT CLAIM TO ANY PARTICULAR FONT, STYLE, SIZE, OR COLOR.

FOR TEXTILES AND TEXTILE ARTICLES, NAMELY, AFGHANS, BARBECUE MITTS, BATH LINEN, BED BLANKETS, BED CANOPIES, BED LINEN, CHILDREN'S BLANKETS, CLOTH PENNANTS, CRIB BUMPERS, CURTAINS, FABRICS FOR TEXTILE USE, FABRIC FLAGS, FELT PENNANTS, HANDKERCHIEFS, HOUSEHOLD LINEN, KITCHEN LINEN, RECEIVING BLANKETS, SILK BLANKETS, TOWELS, TABLE LINEN, TOWELS, TEXTILE FABRICS FOR HOME INTERIORS, WOOLEN BLANKETS, TEXTILE WALL HANGINGS, TAPESTRIES OF TEXTILE (U.S. CLS. 42 AND 50).

REGINA DRUMMOND, EXAMINING ATTORNEY

SN 79-085,414. MOSCHINO SPA, ITALY, FILED 2-12-2010.

# MOSCHINO

OWNER OF INTERNATIONAL REGISTRATION 0512549 DATED 5-11-1987, EXPIRES 5-11-2017.

OWNER OF U.S. REG. NOS. 1,824,407, 3,705,598 AND OTHERS.

THE ENGLISH TRANSLATION OF "MOSCHINO" IN THE MARK IS "LITTLE FLY".

FOR FABRICS, NAMELY, FABRICS FOR TEXTILE USE, TEXTILE FABRIC FOR MANUFACTURING ARTICLES OF CLOTHING, FABRICS FOR CURTAINS; BED AND TABLE COVERS, NAMELY, TABLE CLOTHS NOT OF PAPER; TEXTILE GOODS NOT INCLUDED IN OTHER CLASSES, NAMELY, CURTAINS OF TEXTILE, QUILTS OF TEXTILE, TEXTILE NAPKINS (U.S. CLS. 42 AND 50).

SANI KHOURI, EXAMINING ATTORNEY



**CLASS 24—(Continued).**

SN 79-087,149. NINGBO XIANFENG NEW MATERIAL CO., LTD., CHINA, FILED 7-28-2010.

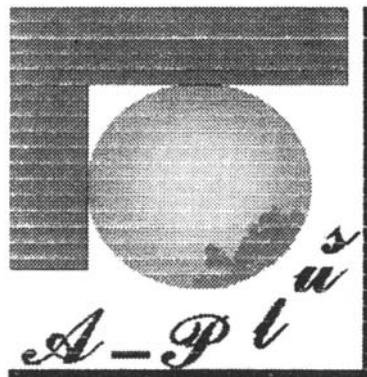

OWNER OF INTERNATIONAL REGISTRATION 1050566 DATED 7-28-2010, EXPIRES 7-28-2020.

FOR CANVAS FOR TAPESTRY OR EMBROIDERY; POLYESTER FABRIC; SUBSTITUTE FOR FABRICS, NAMELY, PLASTIC MATERIAL FOR USE IN THE MANUFACTURE OF FURNITURE COVERINGS; CURTAINS OF TEXTILE OR PLASTIC; TAPESTRY AND WALL HANGINGS OF TEXTILE; DRAPERY; DIMITY; BATH LINEN; OILCLOTH FOR USE AS TABLECLOTHS, NET CURTAINS (U.S. CLS. 42 AND 50).

JOSETTE BEVERLY, EXAMINING ATTORNEY

SN 85-062,374. CONSTRUCTION RESEARCH & TECHNOLOGY GMBH, TROSTBERG, FED REP GERMANY, FILED 6-14-2010.

# WBA

THE MARK CONSISTS OF STANDARD CHARACTERS WITHOUT CLAIM TO ANY PARTICULAR FONT, STYLE, SIZE, OR COLOR.

OWNER OF U.S. REG. NO. 3,500,334.

FOR FIRE RESISTANT FABRICS FOR USE IN THE BUILDING AND REPAIR INDUSTRIES, NAMELY, FIRE RESISTANT FABRICS FOR FIRE BARRIERS (U.S. CLS. 42 AND 50).

WILLIAM ROSSMAN, EXAMINING ATTORNEY

**CLASS 24—(Continued).**

SN 85-065,623. BROOKWOOD COMPANIES INCORPORATED, NEW YORK, NY. FILED 6-17-2010.

# MARATHON

THE MARK CONSISTS OF STANDARD CHARACTERS WITHOUT CLAIM TO ANY PARTICULAR FONT, STYLE, SIZE, OR COLOR.

FOR BREATHABLE FABRICS FOR THE MANUFACTURE OF ACTIVEWEAR, INCLUDING RUNNING SUITS, RUNNING TOPS, BOTTOMS, COORDINATED TOPS AND BOTTOMS, SHIRTS, SHORTS FOR USE BY THE MILITARY (U.S. CLS. 42 AND 50).

ANTHONY RINKER, EXAMINING ATTORNEY

SN 85-124,464. INDIGO ROOT, LLC, KIRKLAND, WA. FILED 9-7-2010.

# CandleClothes

THE MARK CONSISTS OF STANDARD CHARACTERS WITHOUT CLAIM TO ANY PARTICULAR FONT, STYLE, SIZE, OR COLOR.

FOR CANDLE HOLDERS IN THE NATURE OF DECORATIVE TEXTILE, VINYL OR TRANSLUCENT FABRIC COVERINGS FOR PLACING AROUND FLAMELESS CANDLES (U.S. CLS. 42 AND 50).

FIRST USE 8-11-2010; IN COMMERCE 8-16-2010.

SUSAN RICHARDS, EXAMINING ATTORNEY

SN 85-180,550. HOME SOURCE INTERNATIONAL, ATLANTA, GA. FILED 11-18-2010.

# SUITE FINEST

THE MARK CONSISTS OF STANDARD CHARACTERS WITHOUT CLAIM TO ANY PARTICULAR FONT, STYLE, SIZE, OR COLOR.

OWNER OF U.S. REG. NOS. 2,976,137 AND 3,797,059.

NO CLAIM IS MADE TO THE EXCLUSIVE RIGHT TO USE "FINEST", APART FROM THE MARK AS SHOWN.

FOR BEACH TOWELS, BATH TOWELS, KITCHEN TOWELS, TABLECLOTHS, TABLE RUNNERS ALL MADE OF FABRIC; VINYL TABLECLOTHS, TABLE MATS MADE OF FABRIC, BED SHEETS, PILLOWCASES, COMFORTERS (U.S. CLS. 42 AND 50).

PAUL MORENO, EXAMINING ATTORNEY

**CLASS 24—(Continued).**

SN 85-203,761. KAS AUSTRALIA PTY LIMITED, ALEXANDRIA, AUSTRALIA, FILED 12-22-2010.

## KAS COLORS

THE MARK CONSISTS OF STANDARD CHARACTERS WITHOUT CLAIM TO ANY PARTICULAR FONT, STYLE, SIZE, OR COLOR.

OWNER OF U.S. REG. NOS. 2,905,467 AND 2,905,471.

NO CLAIM IS MADE TO THE EXCLUSIVE RIGHT TO USE "COLORS", APART FROM THE MARK AS SHOWN.

FOR CUSHION COVERS; CURTAINS; BED SHEETS; BED LINEN; BED COVERS, NAMELY, COMFORTER, THROWS AND BED BLANKETS; BED SKIRTS; QUILT SETS COMPRISED OF PILLOW CASES, BED SHEETS, QUILT COVERS AND QUILTS; PILLOW CASES; COVERLETS IN THE NATURE OF BED RUGS; TEXTILE PLACEMATS; TEXTILE POT HOLDERS; TEXTILE OVEN GLOVES; TEXTILE NAPKINS; TOWELS; TEA TOWELS; UNFITTED FABRIC FURNITURE COVERS; TABLECLOTHS NOT OF PAPER (U.S. CLS. 42 AND 50).

WILLIAM VERHOSEK, EXAMINING ATTORNEY

**CLASS 24—(Continued).**

SN 85-206,492. LOFTX USA LLC, NEW YORK, NY. FILED 12-28-2010.

## BEACH ROLL AND GO

THE MARK CONSISTS OF STANDARD CHARACTERS WITHOUT CLAIM TO ANY PARTICULAR FONT, STYLE, SIZE, OR COLOR.

NO CLAIM IS MADE TO THE EXCLUSIVE RIGHT TO USE "BEACH", APART FROM THE MARK AS SHOWN.

FOR TOWELS (U.S. CLS. 42 AND 50).

JESSICA FATHY, EXAMINING ATTORNEY

SN 85-210,898. JIM F. CHUMBLEY, LYNNWOOD, WA. FILED 1-5-2011.

## Steam-A-Seam

THE MARK CONSISTS OF STANDARD CHARACTERS WITHOUT CLAIM TO ANY PARTICULAR FONT, STYLE, SIZE, OR COLOR.

OWNER OF U.S. REG. NO. 1,931,042.

FOR HEAT-ACTIVATED FABRIC ADHESIVE TAPE FOR USE IN SEWING AND OTHER FABRIC FASTENING APPLICATIONS (U.S. CLS. 42 AND 50).

FIRST USE 7-23-1994; IN COMMERCE 7-23-1994.

JEFFERY COWARD, EXAMINING ATTORNEY

SN 85-204,097. SELF STORAGE FLAGS, INC., DALLAS, TX. FILED 12-22-2010.



THE COLOR(S) BEIGE, BROWN, BLACK, GREY, RED, AND WHITE IS/ARE CLAIMED AS A FEATURE OF THE MARK.

THE MARK CONSISTS OF A BEIGE BOX CONTAINING A BROWN TEDDY BEAR WITH A BLACK NOSE, BLACK EYES, AND A RED BOW, A BLACK TABLE LAMP WITH A GREY LAMP SHADE, A BROWN BASEBALL MITT AND A WHITE BASEBALL WITH RED STITCHES, AND WITH THE WORDS "SELF STORAGE" WRITTEN IN BLACK STYLIZED FONT ACROSS THE FRONT OF THE BOX. THE COLOR BLACK ALSO APPEARS AS SHADOWING ON THE BEAR AND IN THE BASEBALL MITT. THE MARK APPEARS ON A WHITE BACKGROUND.

FOR CLOTH FLAGS (U.S. CLS. 42 AND 50).

KIM MONINGHOFF, EXAMINING ATTORNEY

SN 85-213,533. AMANDA MURPHY DESIGN, LLC, CHARLOTTE, NC. FILED 1-8-2011.

AMANDA *AM* MURPHY

"AMANDA MURPHY" IDENTIFIES A LIVING INDIVIDUAL WHOSE CONSENT IS OF RECORD.

THE MARK CONSISTS OF THE NAME "AMANDA MURPHY" WITH THE STYLIZED, OVERLAPPING LETTERS OF "A" AND AN "M" IN BETWEEN "AMANDA" AND "MURPHY".

FOR FABRICS FOR TEXTILE USE (U.S. CLS. 42 AND 50).

FIRST USE 10-1-2010; IN COMMERCE 10-1-2010.

CAROL SPILS, EXAMINING ATTORNEY

**CLASS 24—(Continued).**

SN 85-213,994. OVERSEAS DEVELOPMENT CORP, SAN DIEGO, CA. FILED 1-10-2011.

**DREAMLOVER**

THE MARK CONSISTS OF STANDARD CHARACTERS WITHOUT CLAIM TO ANY PARTICULAR FONT, STYLE, SIZE, OR COLOR.

OWNER OF U.S. REG. NO. 2,203,940.  
FOR BABY BLANKETS; BED BLANKETS; BLANKET THROWS; LAP BLANKETS (U.S. CLS. 42 AND 50).  
FIRST USE 11-20-1996; IN COMMERCE 3-10-1997.  
HEATHER SAPP, EXAMINING ATTORNEY

**CLASS 25—(Continued).**

SN 76-703,080. ALLWHITE, JAMES, PALM DESERT, CA. FILED 5-24-2010.



NO CLAIM IS MADE TO THE EXCLUSIVE RIGHT TO USE "EMBROIDERY", APART FROM THE MARK AS SHOWN.

THE COLOR(S) BLACK, WHITE, GOLDEN YELLOW AND MAROON IS/ARE CLAIMED AS A FEATURE OF THE MARK.

THE MARK CONSISTS OF THE STYLIZED BLACK WORDING "POSITIVE EXPRESSIONS EMBROIDERY", NEXT TO A MAROON AND GOLDEN YELLOW YIN & YANG, OVERLAID WITH THE WHITE SILHOUETTE OF A MAN SHOWING HIS ARMS AND LEGS IN DIFFERENT POSITIONS.

FOR PANTS, SHIRTS, JACKETS, SHOES, CAPS (U.S. CLS. 22 AND 39).

ROBIN MITTLER, EXAMINING ATTORNEY

SN 76-705,806. NJOKU, MCANTHONY O., LOS ANGELES, CA. FILED 12-27-2010.

**WRINGOUT****CLASS 25—CLOTHING**

SN 76-703,020. FETCHSPORT LLC, LOS ANGELES, CA. FILED 5-19-2010.

**FETCH**

THE MARK CONSISTS OF STANDARD CHARACTERS WITHOUT CLAIM TO ANY PARTICULAR FONT, STYLE, SIZE, OR COLOR.

FOR COLLAR AND CUFF PROTECTORS (U.S. CLS. 22 AND 39).

H. M. FISHER, EXAMINING ATTORNEY

SN 77-093,975. DIRT WEAR INC., MIRA LOMA, CA. FILED 1-29-2007.

**Dirtwear**

THE MARK CONSISTS OF STANDARD CHARACTERS WITHOUT CLAIM TO ANY PARTICULAR FONT, STYLE, SIZE, OR COLOR.

FOR CLOTHING NOT FOR PET OR ANIMAL USE, NAMELY, T-SHIRTS, BASEBALL CAPS, GYM SHORTS, HEADGEAR, NAMELY, HATS, SHORTS, TRACKSUITS, DRESSES, KNIT SHIRTS, PIQUE SHIRTS, SHIRTS, SHORTSLEEVED OR LONG-SLEEVED T-SHIRTS, SKIRTS AND DRESSES, AND POLO SHIRTS (U.S. CLS. 22 AND 39).

FIRST USE 1-15-2008; IN COMMERCE 1-15-2008.  
MARK RADEMACHER, EXAMINING ATTORNEY

THE MARK CONSISTS OF STANDARD CHARACTERS WITHOUT CLAIM TO ANY PARTICULAR FONT, STYLE, SIZE, OR COLOR.

OWNER OF U.S. REG. NO. 3,069,667.

FOR SHIRTS, SHORTS, PANTS, SKIRTS, SWEAT-SUITS, SWEAT PANTS, SWEAT SHIRTS, HATS, BELTS, CAPS, BEANIES, HOODED SWEATSHIRTS, SOCKS, SHOES, HEADBANDS, WRISTBANDS, UNDERWEAR, T-SHIRTS, DRESS SHIRTS, POLO SHIRTS, JACKETS (U.S. CLS. 22 AND 39).

FIRST USE 0-0-1998; IN COMMERCE 0-0-2003.  
BRIAN CALLAGHAN, EXAMINING ATTORNEY

**CLASS 25—(Continued).**

SN 77-605,269. INSPIRE ME JEANS, SAINT HELENA, CA.  
FILED 10-31-2008.

## Inspire Me Jeans

THE MARK CONSISTS OF STANDARD CHARACTERS WITHOUT CLAIM TO ANY PARTICULAR FONT, STYLE, SIZE, OR COLOR.

NO CLAIM IS MADE TO THE EXCLUSIVE RIGHT TO USE "JEANS", APART FROM THE MARK AS SHOWN.

FOR JEANS; KNIT SHIRTS (U.S. CLS. 22 AND 39).  
JEFF DEFORD, EXAMINING ATTORNEY

**CLASS 25—(Continued).**

SN 77-745,771. CHICAGO YACHT CLUB, CHICAGO, IL.  
FILED 5-27-2009.



OWNER OF U.S. REG. NO. 3,728,180.

THE MARK CONSISTS OF THE WORD "VERVE" IN CAPITAL LETTERS WITH A CURVED IMAGE UNDERNEATH.

FOR CLOTHING, NAMELY, T-SHIRTS AND SWEATSHIRTS (U.S. CLS. 22 AND 39).

FIRST USE 0-0-2002; IN COMMERCE 0-0-2002.

ESTHER A. BORSUK, EXAMINING ATTORNEY

SN 77-746,073. TRUJILLO, REYNALDO, LA PORTE, TX.  
FILED 5-27-2009.

## TRU. BLOODLINE FIGHT WEAR

THE MARK CONSISTS OF STANDARD CHARACTERS WITHOUT CLAIM TO ANY PARTICULAR FONT, STYLE, SIZE, OR COLOR.

NO CLAIM IS MADE TO THE EXCLUSIVE RIGHT TO USE "FIGHT WEAR", APART FROM THE MARK AS SHOWN.

FOR COMBATIVE SPORTS UNIFORMS; HATS; HEADWEAR; SHIRTS; SHORTS; SPORTS SHIRTS; SWEAT PANTS; TOPS (U.S. CLS. 22 AND 39).

LESLIE RICHARDS, EXAMINING ATTORNEY

SN 77-644,143. ALEXANDER JULIAN, INC., RIDGEFIELD, CT. FILED 1-6-2009.



OWNER OF U.S. REG. NOS. 1,243,991, 1,486,167 AND 2,297,272.

THE NAME(S), PORTRAIT(S), AND/OR SIGNATURE(S) SHOWN IN THE MARK IDENTIFIES "ALEXANDER JULIAN", WHOSE CONSENT(S) TO REGISTER IS MADE OF RECORD.

THE COLOR(S) BLACK, WHITE, RED, BURGUNDY, MUSTARD YELLOW, YELLOW, GREEN, SKY BLUE, BLUE, PURPLE AND BROWN IS/ARE CLAIMED AS A FEATURE OF THE MARK.

THE MARK CONSISTS OF A BLACK RECTANGLE ON WHICH APPEARS MULTI-COLORED THIN BAR DESIGN COMPRISED OF SQUARES IN THE COLORS RED, BURGUNDY, MUSTARD YELLOW, YELLOW, GREEN, SKY BLUE, BLUE, PURPLE AND BROWN BENEATH THE WORDS "ALEXANDER JULIAN", IN WHITE, AND ABOVE THE WORD "COLOURS", ALSO IN WHITE.

FOR CLOTHING, NAMELY, WOVEN SHIRTS, KNIT SHIRTS, SWEATERS, FLEECE PULLOVERS, NECKTIES, DENIM JACKETS, DENIM PANTS, DENIM SHIRTS, DENIM JEANS, HOSIERY, UNDERWEAR; BOTTOMS, NAMELY, PANTS, TROUSERS; OUTERWEAR, NAMELY, SPORTCOATS, JACKETS; AND FOOTWEAR (U.S. CLS. 22 AND 39).

MARTHA FROMM, EXAMINING ATTORNEY

SN 77-824,894. RBR, LLC, VERNON, CA. FILED 9-11-2009.

## THE BOYFRIEND

THE MARK CONSISTS OF STANDARD CHARACTERS WITHOUT CLAIM TO ANY PARTICULAR FONT, STYLE, SIZE, OR COLOR.

FOR JEANS, PANTS (U.S. CLS. 22 AND 39).

FIRST USE 7-0-2008; IN COMMERCE 7-0-2008.

WILLIAM ROSSMAN, EXAMINING ATTORNEY

**CLASS 25—(Continued).**

SN 77-863,618. UNITED STATES SWIMMING, INC., DBA USA SWIMMING, COLORADO SPRINGS, CO. FILED 11-3-2009.



OWNER OF U.S. REG. NOS. 1,222,932, 3,141,187 AND OTHERS.

THE MARK CONSISTS OF THE STYLIZED WORDING "AMERICA'S SWIM TEAM" WITH A STYLIZED DRAWING OF A SOLID CIRCLE CONTAINING A STAR BETWEEN THE WORDS "SWIM" AND "TEAM"; A STYLIZED DRAWING OF A SHIELD APPEARS ABOVE CONTAINING THE STYLIZED WORDING "USA SWIMMING" AT THE TOP, VERTICAL STRIPES REPRESENTING SWIMMING LANES AT THE BOTTOM AND A STAR IN THE MIDDLE.

SEC. 2(F) AS TO "USA SWIMMING".  
FOR CLOTHING, NAMELY, SWIM CAPS, SHIRTS, T-SHIRTS, POLO SHIRTS, SWEAT SHIRTS, JACKETS, HATS, AND SWIM WEAR, ALL FOR ACTIVITIES RELATED TO THE GENERAL SPORT OF SWIMMING (U.S. CLS. 22 AND 39).

AMEEN IMAM, EXAMINING ATTORNEY

SN 77-863,626. UNITED STATES SWIMMING, INC., DBA USA SWIMMING, COLORADO SPRINGS, CO. FILED 11-3-2009.



OWNER OF U.S. REG. NOS. 1,222,932, 3,141,187 AND OTHERS.

THE MARK CONSISTS OF THE STYLIZED WORDING "AMERICA'S SWIM TEAM" WITH A STYLIZED DRAWING OF A SOLID CIRCLE CONTAINING A STAR BETWEEN THE WORDS "SWIM" AND "TEAM"; A STYLIZED DRAWING OF A SHIELD APPEARS TO THE LEFT CONTAINING THE STYLIZED WORDING "USA SWIMMING" AT THE TOP, VERTICAL STRIPES REPRESENTING SWIMMING LANES AT THE BOTTOM AND A STAR IN THE MIDDLE.

SEC. 2(F) AS TO "USA SWIMMING".  
FOR CLOTHING, NAMELY, SWIM CAPS, SHIRTS, T-SHIRTS, POLO SHIRTS, SWEAT SHIRTS, JACKETS, HATS, AND SWIM WEAR, ALL FOR ACTIVITIES RELATED TO THE GENERAL SPORT OF SWIMMING (U.S. CLS. 22 AND 39).

AMEEN IMAM, EXAMINING ATTORNEY

**CLASS 25—(Continued).**

SN 77-896,237. DISNEY ENTERPRISES, INC., BURBANK, CA. FILED 12-17-2009.

**BLOC 28**

THE MARK CONSISTS OF STANDARD CHARACTERS WITHOUT CLAIM TO ANY PARTICULAR FONT, STYLE, SIZE, OR COLOR.

OWNER OF U.S. REG. NO. 3,600,443.

FOR CLOTHING, NAMELY, BEACHWEAR, BELTS, BOTTOMS, CLOAKS, CLOTH BIBS, COATS, CHAPS, COSTUMES FOR USE IN ROLE-PLAYING GAMES, BEACH COVER-UPS, DRESSES, EAR MUFFS, GLOVES, HOSIERY, INFANTWEAR, JACKETS, LEOTARDS, LINGERIE, LOUNGEWEAR, MITTENS, OVERALLS, PANTS, PONCHOS, RAINWEAR, SCARVES, SHIRTS, SHORTS, SLEEPWEAR, SOCKS, SWEATERS, SWEATSHIRTS, SWIMWEAR, SUITS, TIES, TOPS, UNDERWEAR, WRIST BANDS, HALLOWEEN COSTUMES; FOOTWEAR; HEADWEAR (U.S. CLS. 22 AND 39).

SUE LAWRENCE, EXAMINING ATTORNEY

SN 77-896,451. RIDOLFINO, CYNTHIA, TRENTON, NJ. FILED 12-18-2009.



THE MARK CONSISTS OF THE BARE BACKSIDE OF A SEATED NUDE HUMAN FIGURE IN BLACK AND WHITE WITH THE WORD "SICK" IN BLACK ON THE BOTTOM LEFT PORTION OF THE HUMAN FIGURE. THE GRAY REPRESENTS SHADING, AND IS NOT PART OF THE MARK.

FOR SHORT-SLEEVED OR LONG-SLEEVED T-SHIRTS (U.S. CLS. 22 AND 39).  
FIRST USE 5-11-2009; IN COMMERCE 5-25-2009.  
CHRISTINE COOPER, EXAMINING ATTORNEY



**CLASS 25—(Continued).**

SN 77-897,490. CELESTINE, EARL, NEW ORLEANS, LA.  
FILED 12-18-2009.



THE MARK CONSISTS OF ITALICIZED, SQUARE BOLD, CAPITAL LETTERS AND EXCLAMATION POINT.

FOR BASEBALL CAPS; CAPS; CAPS WITH VISORS; CHILDREN'S HEADWEAR; GOLF CAPS; GOLF SHORTS; HEADGEAR, NAMELY, HATS, CAPS; JACKETS; JACKETS AND SOCKS; KNITTED CAPS; MOTORCYCLE JACKETS; NOVELTY HEADWEAR WITH ATTACHED WIGS; OUTER JACKETS; RAIN JACKETS; SHORT TROUSERS; SHORT-SLEEVED OR LONG-SLEEVED T-SHIRTS; SHORT-SLEEVED SHIRTS; SHORTS; SKULL CAPS; SKULLIES; SLEEVED OR SLEEVELESS JACKETS; SPORTS JACKETS; SPORTS SHIRTS WITH SHORT SLEEVES; SWEAT JACKETS; SWEAT SHORTS; TIES; TRACK JACKETS; WALKING SHORTS; WIND-JACKETS (U.S. CLS. 22 AND 39).

ALEX KEAM, EXAMINING ATTORNEY

**CLASS 25—(Continued).**

SN 77-903,600. I APPAREL GROUP LLC, NEW YORK, NY.  
FILED 12-31-2009.



THE MARK CONSISTS OF STANDARD CHARACTERS WITHOUT CLAIM TO ANY PARTICULAR FONT, STYLE, SIZE, OR COLOR.

OWNER OF U.S. REG. NOS. 3,875,913 AND 3,906,587.

NO CLAIM IS MADE TO THE EXCLUSIVE RIGHT TO USE "DENIM", APART FROM THE MARK AS SHOWN.

FOR MEN'S, WOMEN'S, AND CHILDREN'S CLOTHING, NAMELY, SHIRTS, PANTS, SHORTS, JACKETS, AND KNITS, NAMELY, SHIRTS, PANTS, SHORTS, JACKETS, ALL THE FOREGOING MADE WHOLLY OR IN SUBSTANTIAL PART OF DENIM (U.S. CLS. 22 AND 39).

FIRST USE 12-1-2006; IN COMMERCE 12-1-2006.

JEAN IM, EXAMINING ATTORNEY

SN 77-903,593. I APPAREL GROUP LLC, NEW YORK, NY.  
FILED 12-31-2009.



THE MARK CONSISTS OF STANDARD CHARACTERS WITHOUT CLAIM TO ANY PARTICULAR FONT, STYLE, SIZE, OR COLOR.

FOR MEN'S, WOMEN'S, AND CHILDREN'S CLOTHING, NAMELY, SHIRTS, PANTS, SHORTS, JACKETS, SWEATERS, AND KNITS, NAMELY, KNIT TOPS, KNIT JACKETS, KNIT HATS (U.S. CLS. 22 AND 39).

FIRST USE 12-1-2006; IN COMMERCE 12-1-2006.

JEAN IM, EXAMINING ATTORNEY

SN 77-906,828. KNOLES, TERRENCE C., NOVATO, CA.  
FILED 1-7-2010.



THE MARK CONSISTS OF STANDARD CHARACTERS WITHOUT CLAIM TO ANY PARTICULAR FONT, STYLE, SIZE, OR COLOR.

FOR WEARABLE GARMENTS AND CLOTHING, NAMELY, SHIRTS (U.S. CLS. 22 AND 39).

FIRST USE 2-1-2007; IN COMMERCE 8-1-2007.

KATHERINE M. DUBRAY, EXAMINING ATTORNEY

**CLASS 25—(Continued).**

SN 77-908,875. DIA S.R.L., SORRENTO (NAPOLI), ITALY, FILED 1-11-2010.



PRIORITY CLAIMED UNDER SEC. 44(D) ON ITALY APPLICATION NO. VR2009C00069, FILED 9-14-2009, REG. NO. 0001383200, DATED 12-30-2010, EXPIRES 9-14-2019.

NO CLAIM IS MADE TO THE EXCLUSIVE RIGHT TO USE "CAPRI SANDALS", APART FROM THE MARK AS SHOWN.

THE MARK CONSISTS OF THE WORD "CAPRI" ABOVE THE WORD "SANDALS", WHICH IS WRITTEN ABOVE THE WORDING "BY DESPOSITO", ALL OF THE FOREGOING SUPERIMPOSED OVER TWO UNEVEN GEOGRAPHIC FORMS SURROUNDED BY TWO CURVED LINES FACING IN OPPOSITE DIRECTIONS.

FOR SANDALS, BATH SANDALS, BEACH SANDALS (U.S. CLS. 22 AND 39).

ANNE FARRELL, EXAMINING ATTORNEY

**CLASS 25—(Continued).**

SN 77-949,322. MEDINA, ALEJANDRO R., LONG BEACH, CA. FILED 3-3-2010.

**GrindTime Record Company**

THE MARK CONSISTS OF STANDARD CHARACTERS WITHOUT CLAIM TO ANY PARTICULAR FONT, STYLE, SIZE, OR COLOR.

NO CLAIM IS MADE TO THE EXCLUSIVE RIGHT TO USE "COMPANY", APART FROM THE MARK AS SHOWN.

FOR BASEBALL CAPS AND HATS; BELTS; BERMUDA SHORTS; BOTTOMS; CAMOUFLAGE PANTS; CAMOUFLAGE SHIRTS; CAMP SHIRTS; GOLF SHORTS; GYM SHORTS; HATS; HATS FOR INFANTS, BABIES, TODDLERS AND CHILDREN; HOODED SWEAT SHIRTS; JACKETS; JERSEYS; KNIT SHIRTS; LONG-SLEEVED SHIRTS; PANTIES, SHORTS AND BRIEFS; PANTS; POLO SHIRTS; SHIRTS; SHIRTS AND SHORT-SLEEVED SHIRTS; SHIRTS FOR INFANTS, BABIES, TODDLERS AND CHILDREN; SHORT TROUSERS; SHORT-SLEEVED SHIRTS; SPORTS CAPS AND HATS; SWEAT PANTS; SWEAT SHIRTS; SWEAT SHORTS; T-SHIRTS; TOBOGGAN HATS, PANTS AND CAPS; TOPS; WOMEN'S HATS AND HOODS (U.S. CLS. 22 AND 39).

KELLEY WELLS, EXAMINING ATTORNEY

SN 77-979,291. HASKELL INDIAN NATIONS UNIVERSITY, LAWRENCE, KS. FILED 3-19-2009.

**HASKELL**

THE MARK CONSISTS OF STANDARD CHARACTERS WITHOUT CLAIM TO ANY PARTICULAR FONT, STYLE, SIZE, OR COLOR.

SEC. 2(F).

FOR CLOTHING, NAMELY, SHIRTS, TIES, SHORTS, HATS AND COATS (U.S. CLS. 22 AND 39).

FIRST USE 0-0-1945; IN COMMERCE 0-0-1945.

SANJEEV VOHRA, EXAMINING ATTORNEY

SN 77-943,162. ERIC REMIG, DBA EARN YOUR STRIPES FISHING TEAM, BRICK, NJ. FILED 2-24-2010.



THE MARK CONSISTS OF THE PHRASE "EARN YOUR STRIPES" ARRANGED IN A FISH-LIKE SHAPE, THE WORDS "FISHING TEAM" UNDERNEATH THE WORD "STRIPES".

FOR FISHING SHIRTS; SKULL CAPS; SPORTS CAPS AND HATS (U.S. CLS. 22 AND 39).

REGINA DRUMMOND, EXAMINING ATTORNEY

SN 78-767,884. BYER CALIFORNIA, SAN FRANCISCO, CA. FILED 12-6-2005.

**B.WEAR**

THE MARK CONSISTS OF STANDARD CHARACTERS WITHOUT CLAIM TO ANY PARTICULAR FONT, STYLE, SIZE, OR COLOR.

FOR CLOTHING, NAMELY, DRESSES, SKIRTS, BLOUSES, SKORTS, SHORTS, SHIRTS, PANTS, JACKETS, SWEATERS, VESTS AND JUMPSUITS (U.S. CLS. 22 AND 39).

JIM RINGLE, EXAMINING ATTORNEY

**CLASS 25—(Continued).**

SN 78-834,407. TRI-SIS INC., LUNENBURG, ONTARIO, CANADA, FILED 3-10-2006.

**RELEAFWEAR**

THE MARK CONSISTS OF STANDARD CHARACTERS WITHOUT CLAIM TO ANY PARTICULAR FONT, STYLE, SIZE, OR COLOR.

PRIORITY CLAIMED UNDER SEC. 44(D) ON CANADA APPLICATION NO. 1273329, FILED 9-16-2005.

FOR UNDERGARMENTS; UNDERWEAR; TEXTILE DIAPERS; NURSING BRAS; HEADGEAR, NAMELY, HATS, CAPS, HEADBANDS AND SWEATBANDS; ARM-PIIT SHIELDS; LININGS, NAMELY, FINISHED TEXTILE LININGS FOR GUSSETS AND OTHERWISE IN ARTICLES OF CLOTHING AND FOR SWIMWEAR, SPORTSWEAR, WORKWEAR, UNDERWEAR AND UNDERGARMENTS (U.S. CLS. 22 AND 39).

KATHY DE JONGE, EXAMINING ATTORNEY

SN 79-086,498. ALPEX S.R.L., ITALY, FILED 7-9-2010.

**GROUSE CREEK**

PRIORITY DATE OF 6-14-2010 IS CLAIMED.

OWNER OF INTERNATIONAL REGISTRATION 1048798 DATED 7-9-2010, EXPIRES 7-9-2020.

THE MARK CONSISTS OF THE WORDING "GROUSE CREEK" IN STYLIZED TEXT BELOW THE STYLIZED DESIGN OF A GROUSE.

FOR CLOTHING, NAMELY, SKI SUITS, SKI JACKETS, SKI TROUSERS, JUMPERS, SWEATSHIRTS, SWEATSHIRTS MADE OF PILE, JACKETS AND PANTS MADE OF SOFT SHELL, TROUSERS, BUTTON-NECK SWEATERS, T-SHIRTS, GLOVES; FOOTWEAR, NAMELY, SNOWBOARD AND SKI BOOTS, SANDALS, TREKKING SHOES AND SPORTIVE SHOES; HEADGEAR, NAMELY, CAPS AND HATS (U.S. CLS. 22 AND 39).

JAMES MACFARLANE, EXAMINING ATTORNEY

SN 79-092,586. SHI XIUMING, HEILONGJIANG PROVINCE, CHINA, FILED 11-23-2010.

**Immortelle**

PRIORITY DATE OF 10-20-2010 IS CLAIMED.

OWNER OF INTERNATIONAL REGISTRATION 1065157 DATED 11-23-2010, EXPIRES 11-23-2020.

THE MARK CONSISTS OF THE STYLIZED WORDING "IMMORTELE".

FOR SHOES; BOOTS (U.S. CLS. 22 AND 39).

DANIEL CAPSHAW, EXAMINING ATTORNEY

**CLASS 25—(Continued).**

SN 85-003,424. MIRAYA, LLC, DBA RENETA J, IRVINE, CA, FILED 3-31-2010.

**Reneta J**

THE MARK CONSISTS OF STANDARD CHARACTERS WITHOUT CLAIM TO ANY PARTICULAR FONT, STYLE, SIZE, OR COLOR.

THE NAME(S), PORTRAIT(S), AND/OR SIGNATURE(S) SHOWN IN THE MARK IDENTIFIES RENETA JHUNJHNUWALA, WHOSE CONSENT(S) TO REGISTER IS MADE OF RECORD.

FOR WOMEN'S APPAREL, NAMELY, EMBROIDERED TOPS, DRESSES, SKIRTS, PANTS, SHORTS, AND LEGGINGS (U.S. CLS. 22 AND 39).

FIRST USE 0-0-2009; IN COMMERCE 0-0-2009.

ROBIN CHOSID, EXAMINING ATTORNEY

SN 85-019,781. PIRATE ENTERPRISES, LLC, MIAMI, FL, FILED 4-21-2010.

**ISLAMORADA**

NO CLAIM IS MADE TO THE EXCLUSIVE RIGHT TO USE "ISLAMORADA", APART FROM THE MARK AS SHOWN.

THE MARK CONSISTS OF THE PHRASE "YO-HO-HO" IN LARGE STYLIZED LETTERING CURVED OVER THE DESIGN OF A SKULL AND CROSSBONES, THE SKULL WEARING A STRIPED BANDANNA. BELOW THE DESIGN, THE WORD "ISLAMORADA" APPEARS IN SMALLER CAPITAL LETTERS.

FOR KNIT AND WOVEN CLOTHING, NAMELY, JACKETS, TOPS, TEE SHIRTS, HEAD WEAR, VESTS, PANTS AND SHORTS (U.S. CLS. 22 AND 39).

JILL C. ALT, EXAMINING ATTORNEY

**CLASS 25—(Continued).**

SN 85-022,364. BLACER, CHARLENE, STROUDSBURG, PA. FILED 4-24-2010.

**BEAUTRICHFUL**

THE MARK CONSISTS OF STANDARD CHARACTERS WITHOUT CLAIM TO ANY PARTICULAR FONT, STYLE, SIZE, OR COLOR.

FOR CLOTHING PRODUCTS, NAMELY, SHIRTS, PANTS, FOOTWEAR, HATS AND CAPS FOR CONSUMERS (U.S. CLS. 22 AND 39).

JOHN HWANG, EXAMINING ATTORNEY

SN 85-026,202. GROWING UP GROM, LLC, ENCINITAS, CA. FILED 4-29-2010.

**GROWING UP GROM**

THE MARK CONSISTS OF STANDARD CHARACTERS WITHOUT CLAIM TO ANY PARTICULAR FONT, STYLE, SIZE, OR COLOR.

FOR BABY LAYETTES FOR CLOTHING; BELTS; BELTS MADE OUT OF CLOTH; BOTTOMS; CHILDREN'S AND INFANTS' CLOTH BIBS; CLOTH DIAPERS; HOODS; INFANT AND TODDLER ONE PIECE CLOTHING; INFANT CLOTH DIAPERS; JACKETS; JERSEYS; NON-DISPOSABLE CLOTH TRAINING PANTS; SHORT SETS; SWADDLING CLOTHES; TOPS; WEARABLE GARMENTS AND CLOTHING, NAMELY, SHIRTS; WRAPS (U.S. CLS. 22 AND 39).

ROBIN CHOSID, EXAMINING ATTORNEY

SN 85-028,292. PASTOR, GREGORY, MANTUA, OH. FILED 5-3-2010.

**IF YOU SEE SOMETHING SAY SOMETHING**

THE MARK CONSISTS OF STANDARD CHARACTERS WITHOUT CLAIM TO ANY PARTICULAR FONT, STYLE, SIZE, OR COLOR.

FOR CLOTHING FOR CONSUMERS, NAMELY, SHIRTS, T-SHIRTS, PANTS, JACKETS, SWEATERS, HOODED T-SHIRTS, SKIRTS, FOOTWEAR AND HEADWEAR (U.S. CLS. 22 AND 39).

WILLIAM ROSSMAN, EXAMINING ATTORNEY

**CLASS 25—(Continued).**

SN 85-034,361. THIRD DEGREE BURN LLC, MOUNT LAUREL, NJ. FILED 5-10-2010.

**SKY FERREIRA**

THE MARK CONSISTS OF STANDARD CHARACTERS WITHOUT CLAIM TO ANY PARTICULAR FONT, STYLE, SIZE, OR COLOR.

THE NAME(S), PORTRAIT(S), AND/OR SIGNATURE(S) SHOWN IN THE MARK IDENTIFIES "SKY FERREIRA", WHOSE CONSENT(S) TO REGISTER IS MADE OF RECORD.

FOR CLOTHING, NAMELY, T-SHIRTS, BASEBALL JERSEYS, HOODED SWEATSHIRTS, CREW SWEATSHIRTS, BASEBALL CAPS AND HATS (U.S. CLS. 22 AND 39).

KRISTINA MORRIS, EXAMINING ATTORNEY

SN 85-034,865. COLLECTIVE BRANDS COOPERATIEF U.A., AMSTERDAM, NETHERLANDS, FILED 5-10-2010.

**HELPING PLAYERS RISE SINCE 1989**

THE MARK CONSISTS OF STANDARD CHARACTERS WITHOUT CLAIM TO ANY PARTICULAR FONT, STYLE, SIZE, OR COLOR.

FOR CLOTHING, NAMELY, SHIRTS, SHORTS, JACKETS, JERSEYS, COATS, PANTS, SWEATERS, SWEATSHIRTS, SWEATPANTS, SWEAT SUITS, WARM-UP SUITS, SWIMWEAR, SOCKS, BELTS, SUSPENDERS, WRIST BANDS; FOOTWEAR, NAMELY, ATHLETIC SHOES, CASUAL SHOES, EXERCISE SHOES, HIKING BOOTS, SNOWBOARD BOOTS; HEADGEAR, NAMELY, HATS, HEADBANDS (U.S. CLS. 22 AND 39).

LAURIE KAUFMAN, EXAMINING ATTORNEY

SN 85-034,983. MILLER, FRANK, EDINA, MN. FILED 5-11-2010.

**MILLER'S OATH**

THE MARK CONSISTS OF STANDARD CHARACTERS WITHOUT CLAIM TO ANY PARTICULAR FONT, STYLE, SIZE, OR COLOR.

FOR SHIRTS, SUITS, TIES (U.S. CLS. 22 AND 39). FIRST USE 12-1-2009; IN COMMERCE 5-1-2010.

DAVID COLLIER, EXAMINING ATTORNEY

**CLASS 25—(Continued).**

SN 85-035,077. MILLER, FRANK, EDINA, MN. FILED 5-11-2010.



THE MARK CONSISTS OF THE WORDS "MILLER'S OATH" WITH DESIGN OF A PICK AXE ABOVE THE WORDS.

FOR SHIRTS, SUITS, TIES (U.S. CLS. 22 AND 39).  
FIRST USE 12-1-2009; IN COMMERCE 5-1-2010.  
DAVID COLLIER, EXAMINING ATTORNEY

---

SN 85-037,288. CITRIX ONLINE, LLC, GOLETA, CA. FILED 5-13-2010.

NOT YOUR AVERAGE SUPPORT  
TOOL

THE MARK CONSISTS OF STANDARD CHARACTERS WITHOUT CLAIM TO ANY PARTICULAR FONT, STYLE, SIZE, OR COLOR.

FOR CLOTHING, NAMELY, T-SHIRTS (U.S. CLS. 22 AND 39).  
FIRST USE 4-30-2009; IN COMMERCE 4-30-2009.  
TINA L. SNAPP, EXAMINING ATTORNEY

---

SN 85-037,901. ROMEO, JULIE, SIGNAL MOUNTAIN, TN. FILED 5-13-2010.

FLUID FLAIR

THE MARK CONSISTS OF STANDARD CHARACTERS WITHOUT CLAIM TO ANY PARTICULAR FONT, STYLE, SIZE, OR COLOR.

FOR CLOTHING, NAMELY, T-SHIRTS, TECHNICAL ACTIVE WEAR SHIRTS, HATS, AND YOGA EXERCISE PANTS (U.S. CLS. 22 AND 39).  
KIM SAITO, EXAMINING ATTORNEY

**CLASS 25—(Continued).**

SN 85-041,242. SWEET PEOPLE APPAREL, INC., LOS ANGELES, CA. FILED 5-18-2010.

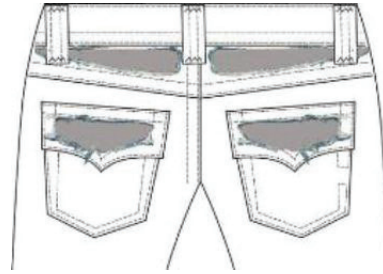

OWNER OF U.S. REG. NO. 3,494,338.  
THE MARK CONSISTS OF A FABRIC CUT OUT DESIGN ON THE POCKET FLAP AND UNDER THE WAIST OF THE PANTS. THE AREA OF THE CUTOUT IS REPLACED WITH A FABRIC INSERT WHICH DIFFERS IN DESIGN FROM THE REMAINING PANTS FABRIC.

SEC. 2(F).  
FOR APPAREL, NAMELY, JEANS AND PANTS (U.S. CLS. 22 AND 39).  
FIRST USE 9-29-2005; IN COMMERCE 9-29-2005.  
SUZANNE BLANE, EXAMINING ATTORNEY

---

SN 85-042,189. ASICS CORPORATION, CHUO-KU, KOBE, JAPAN, FILED 5-19-2010.

DOMAIN

THE MARK CONSISTS OF STANDARD CHARACTERS WITHOUT CLAIM TO ANY PARTICULAR FONT, STYLE, SIZE, OR COLOR.

OWNER OF U.S. REG. NO. 3,656,950.  
FOR ATHLETIC APPAREL, NAMELY, JERSEYS (U.S. CLS. 22 AND 39).  
FIRST USE 5-31-2009; IN COMMERCE 5-31-2009.  
JASON BLAIR, EXAMINING ATTORNEY



**CLASS 25—(Continued).**

SN 85-046,930. SON ENTERPRISES, ATLANTA, GA. FILED 5-25-2010.



THE MARK CONSISTS OF A CIRCLE WITH THE LINES OF THE CIRCLE THINNER IN CERTAIN AREAS; WHEREIN LETTER "B" IS WRITTEN INSIDE THE CIRCLE AND THE WORD "BLESSED" IS WRITTEN BELOW THE CIRCLE. FOR CLOTHING, NAMELY, T-SHIRTS, SWEAT-SHIRTS, JACKETS, RUNNING PANTS, JOGGING SUITS, SCARVES, SNEAKERS, UNDERWEAR, FOOTWEAR AND HEADWEAR (U.S. CLS. 22 AND 39). FIRST USE 11-6-2009; IN COMMERCE 1-25-2010. KEVON CHISOLM, EXAMINING ATTORNEY

SN 85-049,157. THE OUTLAWS MOTORCYCLE CLUB, INC., MILWAUKEE, WI. FILED 5-27-2010.

**OUTLAWS**

THE MARK CONSISTS OF STANDARD CHARACTERS WITHOUT CLAIM TO ANY PARTICULAR FONT, STYLE, SIZE, OR COLOR. OWNER OF U.S. REG. NO. 2,896,928. FOR T-SHIRTS (U.S. CLS. 22 AND 39). FIRST USE 1-1-1954; IN COMMERCE 1-1-1954. CAROLYN CATALDO, EXAMINING ATTORNEY

**CLASS 25—(Continued).**

SN 85-049,407. THE OUTLAWS MOTORCYCLE CLUB, INC., MILWAUKEE, WI. FILED 5-27-2010.



OWNER OF U.S. REG. NO. 2,935,807. NO CLAIM IS MADE TO THE EXCLUSIVE RIGHT TO USE "MC", APART FROM THE MARK AS SHOWN. THE MARK CONSISTS OF THE WORDS "OUTLAW MC" ABOVE A HUMAN SKULL POSITIONED IN FRONT OF A PAIR OF CROSSED PISTONS. FOR T-SHIRTS (U.S. CLS. 22 AND 39). FIRST USE 1-1-1954; IN COMMERCE 1-1-1954. CAROLYN CATALDO, EXAMINING ATTORNEY

SN 85-049,442. THE OUTLAWS MOTORCYCLE CLUB, INC., MILWAUKEE, WI. FILED 5-27-2010.



OWNER OF U.S. REG. NO. 2,937,357. THE MARK CONSISTS OF CROSSED PISTONS BEHIND A SKULL. FOR T-SHIRTS (U.S. CLS. 22 AND 39). FIRST USE 1-1-1954; IN COMMERCE 1-1-1954. CAROLYN CATALDO, EXAMINING ATTORNEY

SN 85-052,024. BIG TIME HOLDINGS, INC., ROME, GA. FILED 6-1-2010.

**DIGZ**

THE MARK CONSISTS OF STANDARD CHARACTERS WITHOUT CLAIM TO ANY PARTICULAR FONT, STYLE, SIZE, OR COLOR. FOR GLOVES (U.S. CLS. 22 AND 39). KAPIL BHANOT, EXAMINING ATTORNEY

**CLASS 25—(Continued).**

SN 85-052,951. BEATTY, WILLIAM K, DBA WILLIAM BEATTY APPAREL COMPANY, LLC, PHOENIX, AZ. FILED 6-2-2010.

**WILLIAM BEATTY**

THE MARK CONSISTS OF STANDARD CHARACTERS WITHOUT CLAIM TO ANY PARTICULAR FONT, STYLE, SIZE, OR COLOR.

THE NAME(S), PORTRAIT(S), AND/OR SIGNATURE(S) SHOWN IN THE MARK IDENTIFIES "WILLIAM BEATTY"; WHOSE CONSENT(S) TO REGISTER IS MADE OF RECORD.

FOR DRESS SHIRTS (U.S. CLS. 22 AND 39).  
KEVON CHISOLM, EXAMINING ATTORNEY

**CLASS 25—(Continued).**

SN 85-055,771. LOLITA CHARM, WEST COVINA, CA. FILED 6-6-2010.



THE COLOR(S) PINK AND RED IS/ARE CLAIMED AS A FEATURE OF THE MARK.

THE MARK CONSISTS OF THE WORDING "LOLITA CHARM" IN PINK WITH RED OUTLINING WITH A RED BOW OVER THE LETTER A OF THE WORD "CHARM".

FOR CLOTHING, NAMELY, BATHING SUITS, BLOUSES, HATS, SOCKS, TIGHTS, SHIRTS, SCARVES, GLOVES, SKIRTS, COATS, TROUSERS, PARKAS, JUMPERS, DRESSES, JACKETS, TEE-SHIRTS, WIND RESISTANT JACKETS, SKIRT SUITS, SHORTS, TROUSER SUITS, FOOTWEAR, MASQUERADE COSTUMES; APPAREL ACCESSORIES, NAMELY, BELTS AND SCARVES (U.S. CLS. 22 AND 39).

FIRST USE 3-8-2010; IN COMMERCE 3-8-2010.  
MARY BOAGNI, EXAMINING ATTORNEY

SN 85-056,407. DIRTY PLAYER LLC, CAPE CANAVERAL, FL. FILED 6-7-2010.



THE MARK CONSISTS OF THE WORDS "DIRTY PLAYER" WRITTEN IN A PAINT SPLATTER TYPE FONT WITH A STYLIZED "D" AND A STYLIZED "P".

FOR HATS; T-SHIRTS (U.S. CLS. 22 AND 39).  
FIRST USE 6-1-2010; IN COMMERCE 6-1-2010.  
KAREN BRACEY, EXAMINING ATTORNEY

SN 85-055,514. SCALI, DIANE, MANALAPAN, NJ. FILED 6-5-2010.

**DIANE & CO.**

THE MARK CONSISTS OF STANDARD CHARACTERS WITHOUT CLAIM TO ANY PARTICULAR FONT, STYLE, SIZE, OR COLOR.

NO CLAIM IS MADE TO THE EXCLUSIVE RIGHT TO USE "CO.", APART FROM THE MARK AS SHOWN.

FOR CLOTHING PRODUCTS, NAMELY, FORMAL WEAR AND EVENING WEAR IN THE NATURE OF DRESSES, BALL GOWNS, AND TUXEDOS; COUTURE CLOTHING, NAMELY, SHIRTS, PANTS; LADIES APPAREL FOR WOMEN, PROM, SWEET SIXTEEN, BAT MITZVAH, SPECIAL OCCASIONS, AND CHILDREN AND TEENS OF ALL AGES, NAMELY, DRESSES, TOPS, BOTTOMS, FOOTWEAR; CLOTHING ACCESSORIES, NAMELY, BELTS, SOCKS, SCARVES, AND TIES (U.S. CLS. 22 AND 39).

FIRST USE 1-1-2000; IN COMMERCE 1-1-2000.  
JEAN IM, EXAMINING ATTORNEY

SN 85-056,587. PIONEER GARMENT CO., LTD., BANGKOK, THAILAND, FILED 6-7-2010.

**Andrew & Audrey**

THE MARK CONSISTS OF STANDARD CHARACTERS WITHOUT CLAIM TO ANY PARTICULAR FONT, STYLE, SIZE, OR COLOR.

FOR APPAREL, NAMELY, TOPS, SHIRTS, PANTS, JEANS, SKIRTS; KNITS, NAMELY, SWEATERS, LEGGINGS, PANTS, TOPS, DRESSES, HATS, GLOVES, SCARVES, SOCKS, JACKETS; JUMPSUITS, SWEATERS, SHORTS, DRESSES, JACKETS, COATS, SWEATSHIRTS, SWEATPANTS, VESTS, HEADWEAR, HATS, UNDERWEAR, BRASSIERES, HOSIERY, SLEEPWEAR, SCARVES, GLOVES, MITTENS, BATHROBES, SLIPPERS, T-SHIRTS, TANK-TOPS, SHAWLS, BELTS, BLOUSES, LOUNGEWEAR, SWIMWEAR, HEADBANDS; SHOES; SHOWER CAPS, PONCHOS, EAR WARMERS, SOCKS, APRONS; CLOTH BIBS; LEG WARMERS (U.S. CLS. 22 AND 39).

APRIL ROACH, EXAMINING ATTORNEY

**CLASS 25—(Continued).**

SN 85-056,872. TANKWARE, LP, PHOENIX, AZ. FILED 6-8-2010.



THE STIPPLING IS FOR SHADING PURPOSES ONLY. THE COLOR(S) BLACK AND SILVER IS/ARE CLAIMED AS A FEATURE OF THE MARK.

THE MARK CONSISTS OF A TANK WITH THE WORD "TANKWARE" WRITTEN OVER THE DESIGN.

FOR ATHLETIC CLOTHING, NAMELY, TANK TOPS, UNDERWEAR, GLOVES USED FOR FITNESS PURPOSES, SHOES, HATS, T-SHIRTS, JOGGING SUITS, PANTS, SHORTS, SPORTS BRAS, UNDERGARMENTS, JACKETS, SOCKS, SWEATBANDS, SPORTS CLOTHING, NAMELY, UNIFORMS AND JERSEYS (U.S. CLS. 22 AND 39).

BARBARA BROWN, EXAMINING ATTORNEY

---

SN 85-057,844. MURATORI DESIGNS, LLC., SEATTLE, WA. FILED 6-8-2010.

# Muratori

THE MARK CONSISTS OF STANDARD CHARACTERS WITHOUT CLAIM TO ANY PARTICULAR FONT, STYLE, SIZE, OR COLOR.

THE ENGLISH TRANSLATION OF "MURATORI" IN THE MARK IS "MASON".

FOR CLOTHING, NAMELY, SHIRTS, PANTS, DRESSES, JACKETS, SKIRTS, SOCKS, BLOUSES, SUITS, AND BATHING SUITS (U.S. CLS. 22 AND 39).

FIRST USE 12-1-2008; IN COMMERCE 3-1-2009.

KAREN BRACEY, EXAMINING ATTORNEY

---

SN 85-059,687. IT FIGURES! LLC, NEW YORK, NY. FILED 6-10-2010.

# D CUP & UP

THE MARK CONSISTS OF STANDARD CHARACTERS WITHOUT CLAIM TO ANY PARTICULAR FONT, STYLE, SIZE, OR COLOR.

OWNER OF U.S. REG. NO. 2,115,686.

NO CLAIM IS MADE TO THE EXCLUSIVE RIGHT TO USE "D CUP", APART FROM THE MARK AS SHOWN.

FOR SWIMWEAR (U.S. CLS. 22 AND 39).

ROBIN CHOSID, EXAMINING ATTORNEY

**CLASS 25—(Continued).**

SN 85-060,538. RÖHNISCH SPORTSWEAR AB, 70006 ÖREBRO, SWEDEN, FILED 6-11-2010.



THE MARK CONSISTS OF THE STYLIZED LETTERS "RÖ" WITH THE LETTER "Ö" UPSIDE DOWN.

FOR CLOTHING, NAMELY, T-SHIRTS, TIGHTS, SHORT-PANTS, BERMUDA SHORTS, PANTS, TROUSERS, JACKETS, TRACK-SUITS, LEG WARMERS, SKIRTS, VESTS, UNDERWEAR, SWIMSUITS, SOCKS; SHOES, NAMELY, DRESS SHOES, AEROBIC SHOES, WALKING SHOES AND RUNNING SHOES; BELTS FOR CLOTHING, CAPS (U.S. CLS. 22 AND 39).

FIRST USE 8-15-2006; IN COMMERCE 4-15-2009.

INGA ERVIN, EXAMINING ATTORNEY

---

SN 85-060,865. JANET STRAIT, DBA SWASH BUCKLERS, LAGRANGE, KY. FILED 6-11-2010.

# SWASH-BUCKLERS

THE MARK CONSISTS OF STANDARD CHARACTERS WITHOUT CLAIM TO ANY PARTICULAR FONT, STYLE, SIZE, OR COLOR.

FOR CLOTHING OF LEATHER, NAMELY, BELTS, CUFFS, LEATHER VESTS, HAT BANDS, AND BOOT STRAPS (U.S. CLS. 22 AND 39).

FIRST USE 5-20-2004; IN COMMERCE 3-14-2006.

JOHN E. MICHOS, EXAMINING ATTORNEY

**CLASS 25—(Continued).**

SN 85-060,904. HARMONIX MUSIC SYSTEMS, INC., NEW YORK, NY. FILED 6-11-2010.



The logo for "DANCE CENTRAL" features the word "DANCE" in a bold, outlined, sans-serif font above the word "CENTRAL" in a similar font, both contained within a solid black rectangular background.

THE MARK CONSISTS OF THE WORDING "DANCE CENTRAL" IN A STYLIZED FONT AND A DESIGN THAT CONSIST OF A SHADED RECTANGLE.

FOR CLOTHING, NAMELY, BATHING SUITS, BELTS, HALLOWEEN COSTUMES, COATS, SOCKS, CLOTHING BELTS, FOOTWEAR, BANDANAS, DRESSES, GLOVES, GYM SHORTS, EAR MUFFS, NECK WEAR, JACKETS, PAJAMAS, PANTS, SHIRTS, SHORTS, SKI WEAR, SLACKS, SUN VISORS, SUSPENDERS, SWEATERS, TURTLENECKS, UNDERCLOTHES, VESTS, WARM-UP SUITS, HEADWEAR, BATHROBES, BEACHWEAR (U.S. CLS. 22 AND 39).

RENEE MCCRAY, EXAMINING ATTORNEY

SN 85-063,260. TIGER RAGS, INC., AUBURN, AL. FILED 6-15-2010.

RAGS IN A ROLL

THE MARK CONSISTS OF STANDARD CHARACTERS WITHOUT CLAIM TO ANY PARTICULAR FONT, STYLE, SIZE, OR COLOR.

NO CLAIM IS MADE TO THE EXCLUSIVE RIGHT TO USE "RAGS", APART FROM THE MARK AS SHOWN.

FOR CLOTHING, NAMELY, SHIRTS, T-SHIRTS (U.S. CLS. 22 AND 39).

SANI KHOURI, EXAMINING ATTORNEY

SN 85-063,471. ECO PRODUCT GROUP, LLC, PITTSBURGH, PA. FILED 6-15-2010.

GOLDSPORT

THE MARK CONSISTS OF STANDARD CHARACTERS WITHOUT CLAIM TO ANY PARTICULAR FONT, STYLE, SIZE, OR COLOR.

FOR FOOTCARE PRODUCTS, NAMELY, INSOLES, SANDALS (U.S. CLS. 22 AND 39).

EDWARD FENNESSY, EXAMINING ATTORNEY

**CLASS 25—(Continued).**

SN 85-064,926. DONGYUN WANG, ELMHURST, NY. FILED 6-16-2010.

SD.PC SUPERIOR FUR

THE MARK CONSISTS OF STANDARD CHARACTERS WITHOUT CLAIM TO ANY PARTICULAR FONT, STYLE, SIZE, OR COLOR.

NO CLAIM IS MADE TO THE EXCLUSIVE RIGHT TO USE "SUPERIOR FUR", APART FROM THE MARK AS SHOWN.

FOR FUR CLOAKS; FUR COATS AND JACKETS; FUR HATS; FUR MUFFS; FUR STOLE; CLOTHING MADE IN WHOLE OR PART OF FUR, NAMELY, CHILDREN'S HEADWEAR, COATS FOR MEN AND WOMEN, GLOVES, HATS FOR INFANTS, BABIES, TODDLERS AND CHILDREN, LEATHER BELTS, LEATHER COATS, LEATHER HATS, LEATHER HEADWEAR, LEATHER JACKETS, LEATHER PANTS, LEATHER SHIRTS, LEATHER SKIRTS, LEATHER VESTS, MEN'S AND WOMEN'S JACKETS, COATS, TROUSERS, VESTS, MEN'S SUITS, WOMEN'S SUITS, SHIRTS FOR INFANTS, BABIES, TODDLERS AND CHILDREN, SUITS OF LEATHER, TROUSERS OF LEATHER, WOMEN'S CEREMONIAL DRESSES, WOMEN'S HATS AND HOODS, WOMEN'S TOPS, NAMELY, CAMIS, AND CHILDREN'S AND INFANT'S APPAREL, NAMELY, JUMPERS, OVERALL SLEEPWEAR, PAJAMAS, ROMPERS AND ONE-PIECE GARMENTS (U.S. CLS. 22 AND 39).

FIRST USE 6-1-2008; IN COMMERCE 6-1-2008.

LEIGH LOWRY, EXAMINING ATTORNEY

SN 85-066,518. AZPB LIMITED PARTNERSHIP, PHOENIX, AZ. FILED 6-18-2010.



The logo for "ARIZONA" features the word in a stylized, outlined, serif font with a drop shadow effect, giving it a three-dimensional appearance.

OWNER OF U.S. REG. NO. 3,240,969.

THE MARK CONSISTS OF THE WORD "ARIZONA" IN STYLIZED TEXT.

FOR CLOTHING, NAMELY, JERSEYS, SHIRTS; HEADWEAR (U.S. CLS. 22 AND 39).

FIRST USE 11-7-2006; IN COMMERCE 11-7-2006.

NAPOLEON SHARMA, EXAMINING ATTORNEY

**CLASS 25—(Continued).**

SN 85-066,986. TAYLOR, KATHERINE, CARY, NC. FILED 6-19-2010.

**SHOW 'EM YOU'RE NUTZ!**

THE MARK CONSISTS OF STANDARD CHARACTERS WITHOUT CLAIM TO ANY PARTICULAR FONT, STYLE, SIZE, OR COLOR.

FOR CLOTHING, NAMELY, APRONS, T-SHIRTS, SWEATSHIRTS, SWEATPANTS, SOCKS AND HATS (U.S. CLS. 22 AND 39).

SOPHIA S. KIM, EXAMINING ATTORNEY

SN 85-068,196. TONE IT UP, LLC, HERMOSA BEACH, CA. FILED 6-22-2010.

**TONE IT UP**

THE MARK CONSISTS OF STANDARD CHARACTERS WITHOUT CLAIM TO ANY PARTICULAR FONT, STYLE, SIZE, OR COLOR.

FOR CLOTHING, NAMELY, YOGA PANTS, SHORTS, CAPRI PANTS, SPORTS BRAS, TANK TOPS, T-SHIRTS, LONG SLEEVE TOPS, SWEATSHIRTS, HEADBANDS, SHOES, WRISTBANDS, SWIMWEAR, SOCKS, AND HEADWEAR (U.S. CLS. 22 AND 39).

NICHOLAS ALTREE, EXAMINING ATTORNEY

SN 85-068,781. GOOD AND FAIR CLOTHING LLC, AUSTIN, TX. FILED 6-22-2010.

**GOOD & FAIR**

THE COLOR(S) RED AND GREY IS/ARE CLAIMED AS A FEATURE OF THE MARK.

THE MARK CONSISTS OF GREY LETTERS FOR THE WORDS "GOOD", "FAIR"; THE COLOR RED FOR THE "&"

FOR BOTTOMS; CLOTHING, NAMELY, BASE LAYERS; MUFFLERS; TOPS; WEARABLE GARMENTS AND CLOTHING, NAMELY, SHIRTS (U.S. CLS. 22 AND 39).

ROSELLE HERRERA, EXAMINING ATTORNEY

**CLASS 25—(Continued).**

SN 85-070,880. HANDS ON INTERNATIONAL, LLC, MASON, OH. FILED 6-24-2010.

**HANDS ON**

THE MARK CONSISTS OF STANDARD CHARACTERS WITHOUT CLAIM TO ANY PARTICULAR FONT, STYLE, SIZE, OR COLOR.

FOR GLOVES; GLOVES AS CLOTHING; GLOVES FOR APPAREL; MOTORCYCLE GLOVES; AUTOMOTIVE GLOVES, NAMELY, DRIVING AND RIDING GLOVES (U.S. CLS. 22 AND 39).

FIRST USE 6-3-2010; IN COMMERCE 6-3-2010.

STEPHANIE ALI, EXAMINING ATTORNEY

SN 85-070,890. HANDS ON INTERNATIONAL, LLC, MASON, OH. FILED 6-24-2010.



THE MARK CONSISTS OF A BLACK SILHOUETTE OF A TIGER POUNCING TO THE RIGHT. THE WORD "HANDS" ARE IN BLACK TO THE LEFT OF THE TIGER'S BODY AND THE WORD "ON" IN WHITE IS LOCATED WITHIN THE TIGER'S BODY.

FOR GLOVES; GLOVES AS CLOTHING; GLOVES FOR APPAREL; MOTORCYCLE GLOVES; AUTOMOTIVE GLOVES, NAMELY, DRIVING AND RIDING GLOVES (U.S. CLS. 22 AND 39).

FIRST USE 6-3-2010; IN COMMERCE 6-3-2010.

STEPHANIE ALI, EXAMINING ATTORNEY



**CLASS 25—(Continued).**

SN 85-072,049. BUM ESSENTIALS, INC., CLAYTON, NC. FILED 6-25-2010.



THE COLOR(S) GREEN, BLACK, PURPLE AND BLUE IS/ARE CLAIMED AS A FEATURE OF THE MARK.

THE MARK CONSISTS OF TOP LEFT HAS TWO GREEN LEAVES, THE WORD "BUM" IS WRITTEN IN BLACK ABOVE THE WORD "ESSENTIALS" WHICH IS WRITTEN IN PURPLE. HALF EARTH UNDER THE WORD ESSENTIALS IS GREEN AND BLUE.

FOR CLOTH DIAPERS (U.S. CLS. 22 AND 39).  
FIRST USE 3-1-2010; IN COMMERCE 3-22-2010.  
KHANH LE, EXAMINING ATTORNEY

SN 85-072,452. ROBERT J. MARTIN III, SOMERS, CT. AND MARK S. SAWYER, MEDFIELD, MA. FILED 6-27-2010.

**LIFE IS CANADA**

THE MARK CONSISTS OF STANDARD CHARACTERS WITHOUT CLAIM TO ANY PARTICULAR FONT, STYLE, SIZE, OR COLOR.

FOR T-SHIRTS (U.S. CLS. 22 AND 39).  
KATHERINE CHANG, EXAMINING ATTORNEY

SN 85-073,228. GARY ANDERSON, YONKERS, NY. FILED 6-28-2010.

**GARRICK ANDERSON**

THE MARK CONSISTS OF STANDARD CHARACTERS WITHOUT CLAIM TO ANY PARTICULAR FONT, STYLE, SIZE, OR COLOR.

THE NAME(S), PORTRAIT(S), AND/OR SIGNATURE(S) SHOWN IN THE MARK IDENTIFIES "GARRICK ANDERSON", WHOSE CONSENT(S) TO REGISTER IS MADE OF RECORD.

FOR HATS; HOSIERY; MEN'S SUITS; NECKWEAR; RAINCOATS; ROBES; SHIRTS; SHOES; SHORTS; SLEEPWEAR; SOCKS; SPORTS CAPS AND HATS; SPORTS JACKETS; SUSPENDERS; SWEATERS; TIES; TOPCOATS; TROUSERS; UNDERWEAR; VESTS; WAISTCOATS (U.S. CLS. 22 AND 39).

MICHAEL KEATING, EXAMINING ATTORNEY

**CLASS 25—(Continued).**

SN 85-073,256. BOUTIQUE NEWCITY (PUBLIC) COMPANY LIMITED, KLONGTOEY BANGKOK, THAILAND, FILED 6-28-2010.

# Jousse

THE MARK CONSISTS OF THE WORD "JOUSSE" IN STYLIZED FORM.

THE ENGLISH TRANSLATION OF "JOUSSE" IN THE MARK IS "JOYFUL".

FOR WOMEN'S CLOTHING, NAMELY, JACKETS, BLOUSES, SHIRTS, SKIRTS, PANTS, TANK TOPS, DRESSES (U.S. CLS. 22 AND 39).

EDWARD NELSON, EXAMINING ATTORNEY

SN 85-073,951. DRESSLER, FRED, WEST HARTFORD, CT. FILED 6-29-2010.

**CHIKCLOTHING**

THE MARK CONSISTS OF STANDARD CHARACTERS WITHOUT CLAIM TO ANY PARTICULAR FONT, STYLE, SIZE, OR COLOR.

FOR CLOTHING, NAMELY, SHIRTS, SHORTS, PANTS, COATS, JACKETS, DRESSES, SKIRTS, SWEATERS AND SWEAT SHIRTS, FOR WOMEN AND GIRLS (U.S. CLS. 22 AND 39).

HENRY S. ZAK, EXAMINING ATTORNEY

SN 85-074,367. KOLONGLOTECH, INC., GWACHEON-CITY, REPUBLIC OF KOREA, FILED 6-29-2010.

**HEATEX**

THE MARK CONSISTS OF STANDARD CHARACTERS WITHOUT CLAIM TO ANY PARTICULAR FONT, STYLE, SIZE, OR COLOR.

OWNER OF REPUBLIC OF KOREA REG. NO. 40-0751288, DATED 6-25-2008, EXPIRES 6-25-2018.

FOR MONEY BELTS; LEATHER SHOES; RUBBER SHOES; GALOSHES; GOLF SHOES; SHOE SOLES; WOODEN SHOES; ANGLERS' SHOES; BASKETBALL SHOES; SHOES; HEELS; MOUNTAINEERING BOOTS; RUGBY SHOES; LACE BOOTS; BATH SANDALS; BATH SLIPPERS; HALF-BOOTS; WINTER BOOTS; BOXING SHOES; BOOTS; VINYL SHOES; BEACH SHOES; SANDALS; SKI BOOTS; SLIPPERS; INNER SOLES; SOLES FOR FOOTWEAR; FOOTWEAR UPPERS; NON-SLIP HEELPIECES FOR BOOTS; NON-SLIP SOLES FOR BOOTS; TIPS FOR FOOTWEAR; DECORATIVE IRON FITTINGS FOR BOOTS; BASEBALL SHOES; ATHLETIC FOOTWEAR; ESPARTO SHOES OR SANDALS; OVERSHOES; RAIN BOOTS; TRACK AND FIELD SHOES; WORK SHOES AND BOOTS; LONG BOOTS; STRAW SANDALS; GYM-NASTIC SHOES; FOOTBALL BOOTS; LACE-UP BOOTS;

**CLASS 25—(Continued).**

HOCKEY SHOES; HANDBALL SHOES; KOREAN FENCING SUITS, NAMELY, KENDO OUTFITS; CYCLIST'S CLOTHING, NAMELY, JERSEYS FOR CYCLISTS, PANTS FOR CYCLISTS, JACKETS FOR CYCLISTS, JUMPERS FOR CYCLISTS; WET SUITS FOR WATER-SKIING; ANORAKS FOR EXERCISES; AEROBICS SUITS; JUDO SUITS; CLOTHING FOR GYMNASTICS, NAMELY, SHIRTS, PANTS, JACKETS, ATHLETIC UNIFORMS; TAEKWONDO SUITS; BREECHES FOR WEAR; HORSE-RIDING BOOTS; MASQUERADE COSTUMES; SCHOOL UNIFORMS; RAIN COATS; LONG COATS; LIVERIES; MANTLES; SHORTS; HALF-COATS; BLOUSONS; SARIS; SAFARIS SUITS; SUITS; SMOCKS; SKIRTS; SLACKS; MEN'S SUITS; ANORAK; CHILDREN'S CLOTHING, NAMELY, SHIRTS, PANTS, JACKETS, SUITS; TROUSERS; CEREMONIAL DRESSES FOR MEN, WOMEN, CHILDREN; OVERALLS; OVERCOATS; ONE PIECE SUITS; INFANTS' CLOTHING, NAMELY, INFANTS' TROUSERS, INFANT'S WEARABLE BLANKETS; EVENING DRESSES; JACKETS; WORKING CLOTHING, NAMELY, SHIRTS, PANTS, JACKETS, JUMPERS, UNIFORMS; JUMPERS; PAPER CLOTHING, NAMELY, DISPOSABLE GOWNS MADE OF NON-WOVEN TEXTILE FABRICS; DISPOSABLE PAPER HATS FOR USE AS CLOTHING ITEMS; DISPOSABLE GLOVES AS CLOTHING MADE OF NON-WOVEN TEXTILE FABRICS; CHASUBLES; BLUE JEANS; CAPES; COMBINATIONS; TOP COATS; TUXEDOS; TOGAS; TWO PIECE SUITS; TUNICS; PARKAS; PELISSES; FROCKS; COLLARS ATTACHED TO THE TOP BORDER OF A KOREAN COAT; TOPCOATS; JACKETS WORN OVER UPPER GARMENT; WOMEN'S WAISTCOATS; KOREAN-STYLE COAT OR JACKET; TROUSERS; UNDERWEARS; SKIRTS; GIRDLES; NIGHTGOWNS; BUTTON-FRONT ALOHA SHIRTS; NEGLIGEEES DRESSING GOWNS; ROMPERS; LEOTARDS; MANTILLAS; BATH ROBES; BODICES; BODY SHIRTS; BRASSIERES; BLOUSES; SHOWER CAPS; SHIRT YOKES; SHIRT FRONTS; UNDERGARMENTS; DRAWERS; UNDERSHIRTS; UNDERPANTS; BATHING CAPS; BATHING SUITS; BATHING DRAWERS; CHEMISETTES; CHEMISES; SWEATERS; SWEAT SHIRTS; SWEAT PANTS; SPORT SHIRTS; SLIPS; DRESS SHIRTS; ATHLETIC UNIFORMS; UNITARDS; COLLARS; SLEEPING GARMENTS; JERSEYS; VESTS; CARDIGANS; COLLAR PROTECTORS; COLLAR CUFFS; CAMISOLES; CORSETS; CORSELETS; COMBINATION UNDERWEAR; TANK TOPS; TEDDIES; TRACK SUITS; PANTYHOSE; PETTICOATS; POLO SHIRTS; PULL-OVERS; T-SHIRTS; SPATS; NECKTIES; SWEAT-ABSORBENT STOCKINGS; LEGWARMERS; LEGGINGS; MUFFS; MUFFLERS; BANDANAS; EAR MUFFS; WINTER GLOVES; KOREAN SOCKS; KOREAN SOCKS COVERS; MITTENS; VEILS; BOAS; FOOTMUFFS, NOT ELECTRICALLY HEATED; SHAWLS; SHOULDER WRAPS; WIMPLES; MANIPLES; SCARVES; STOCKINGS; HEELPIECES FOR STOCKINGS; STOLES; SOCKS; SOCKS COVER; POCKET SQUARES; ASCOTS; APRONS; STOCKINGS FOR EXERCISES; BABIES' DIAPERS OF TEXTILE; POCKETS FOR CLOTHING; TIGHTS; PELERINES; KOREAN TRADITIONAL HATS; NIGHTCAPS; KOREAN TRADITIONAL WINTER CAPS, NAMELY, NANBAWI KOREAN HEADBANDS OF HORSEHAIR, NAMELY, MANGGON; CAPS; SUN VISORS; BERETS; MITRES; HOODS; TURBANS; TOP HATS; WATER-PROOF CLOTHING, NAMELY, WATERPROOF JACKETS AND PANTS; GARTERS; KOREAN ANKLE BANDS, NAMELY, DAENIM; STOCKING SUSPENDERS; SOCK SUSPENDERS; SUSPENDERS; LEATHER BELTS (U.S. CLS. 22 AND 39).

JORDAN BAKER, EXAMINING ATTORNEY

**CLASS 25—(Continued).**

SN 85-074,950. IMAGEWEAR APPAREL CORP., WILMINGTON, DE. FILED 6-30-2010.

**DEPUTY DELUXE**

THE MARK CONSISTS OF STANDARD CHARACTERS WITHOUT CLAIM TO ANY PARTICULAR FONT, STYLE, SIZE, OR COLOR.

OWNER OF U.S. REG. NO. 2,788,942.  
NO CLAIM IS MADE TO THE EXCLUSIVE RIGHT TO USE "DELUXE", APART FROM THE MARK AS SHOWN.  
FOR PANTS; SHIRTS (U.S. CLS. 22 AND 39).  
FIRST USE 2-4-2004; IN COMMERCE 2-4-2004.  
SARA BENJAMIN, EXAMINING ATTORNEY

SN 85-075,425. ROBERT COMSTOCK DESIGN LLC, NEW YORK, NY. FILED 6-30-2010.

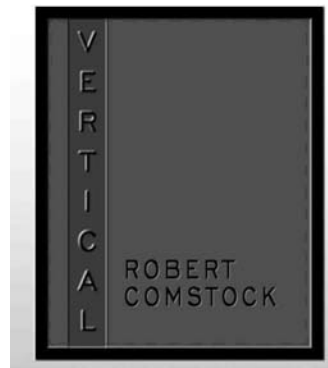

THE NAME(S), PORTRAIT(S), AND/OR SIGNATURE(S) SHOWN IN THE MARK IDENTIFIES "ROBERT COMSTOCK", WHOSE CONSENT(S) TO REGISTER IS MADE OF RECORD.

THE MARK CONSISTS OF THE WORDING "VERTICAL" APPEARING VERTICALLY ON A VERTICAL BAND TO THE LEFT OF THE WORDING "ROBERT COMSTOCK" HORIZONTALLY POSITIONED WITH THE WORD "ROBERT" OVER THE WORD "COMSTOCK", ALL ON A SHADED FIELD WITH A DARKER SHADED BORDER.  
FOR BOTTOMS; COATS; JACKETS; PANTS; SHIRTS; SWEATERS; TOPS (U.S. CLS. 22 AND 39).

FIRST USE 4-1-1986; IN COMMERCE 4-1-1986.  
HANNO RITTNER, EXAMINING ATTORNEY

**CLASS 25—(Continued).**

SN 85-075,941. FLAMING RIVER INDUSTRIES, INC., BE-  
REA, OH. FILED 7-1-2010.

STEERING YOU IN THE RIGHT  
DIRECTION

THE MARK CONSISTS OF STANDARD CHARACTERS  
WITHOUT CLAIM TO ANY PARTICULAR FONT, STYLE,  
SIZE, OR COLOR.  
FOR APPAREL, NAMELY, T-SHIRTS (U.S. CLS. 22  
AND 39).  
JEFF DEFORD, EXAMINING ATTORNEY

SN 85-085,095. JOSEPH WESLEY WARNE, FORT MYERS  
BEACH, FL. FILED 7-15-2010.

Think Outside Your Shell

THE MARK CONSISTS OF STANDARD CHARACTERS  
WITHOUT CLAIM TO ANY PARTICULAR FONT, STYLE,  
SIZE, OR COLOR.  
FOR CLOTHING, NAMELY, T-SHIRTS AND SWEAT-  
SHIRTS (U.S. CLS. 22 AND 39).  
JENNY PARK, EXAMINING ATTORNEY

SN 85-088,029. CLARKE, DENISE, BROOKLYN, NY. FILED  
7-19-2010.

Turajuku

THE MARK CONSISTS OF STANDARD CHARACTERS  
WITHOUT CLAIM TO ANY PARTICULAR FONT, STYLE,  
SIZE, OR COLOR.  
FOR ATHLETIC APPAREL, NAMELY, SHIRTS,  
PANTS, JACKETS, FOOTWEAR, HATS AND CAPS,  
ATHLETIC UNIFORMS (U.S. CLS. 22 AND 39).  
FIRST USE 6-16-2010; IN COMMERCE 6-16-2010.  
CHRIS WELLS, EXAMINING ATTORNEY

**CLASS 25—(Continued).**

SN 85-088,074. UCHINO CO., LTD., TOKYO, JAPAN, FILED  
7-19-2010.

AIR ROBE

THE MARK CONSISTS OF STANDARD CHARACTERS  
WITHOUT CLAIM TO ANY PARTICULAR FONT, STYLE,  
SIZE, OR COLOR.  
NO CLAIM IS MADE TO THE EXCLUSIVE RIGHT TO  
USE "ROBE", APART FROM THE MARK AS SHOWN.  
FOR ROBES (U.S. CLS. 22 AND 39).  
LOURDES AYALA, EXAMINING ATTORNEY

SN 85-094,362. HANSEN BEVERAGE COMPANY, CORONA,  
CA. FILED 7-28-2010.



THE MARK CONSISTS OF A STYLIZED LETTER M IN  
THE FORM OF A CLAW.  
FOR CLOTHING, NAMELY, T-SHIRTS, HOODED  
SHIRTS AND HOODED SWEATSHIRTS, SWEAT  
SHIRTS, JACKETS, PANTS, BANDANAS, SWEAT  
BANDS AND GLOVES; HEADGEAR, NAMELY HATS  
AND BEANIES (U.S. CLS. 22 AND 39).  
FIRST USE 5-24-2002; IN COMMERCE 6-30-2002.  
LEIGH LOWRY, EXAMINING ATTORNEY

**CLASS 25—(Continued).**

SN 85-095,586. 2B.RYCH LLC, NEW YORK, NY. FILED 7-29-2010.



OWNER OF U.S. REG. NO. 3,677,444.  
 THE MARK CONSISTS OF THE NUMERAL "2" IN STYLIZED FONT WITHIN A RECTANGLE WITH THREE CURVED CORNERS AND ONE RIGHT-ANGLE CORNER POSITIONED AT THE LOWER RIGHT SIDE ADJACENT TO A LOWER-CASE STYLIZED LETTER "b" AND PERIOD ALONGSIDE THE WORD "RYCH" IN STYLIZED FONT.  
 FOR WOMEN'S CLOTHING, NAMELY, SKIRTS, DRESSES, BLOUSES, T-SHIRTS, SWEATERS, JACKETS, BLAZERS, PANTS, SHORTS, VESTS AND COATS (U.S. CLS. 22 AND 39).  
 DAVID YONTEF, EXAMINING ATTORNEY

**CLASS 25—(Continued).**

SN 85-116,875. SKECHERS U.S.A., INC. II, MANHATTAN BEACH, CA. FILED 8-26-2010.

**SKECHERS RADIUS TONER**

THE MARK CONSISTS OF STANDARD CHARACTERS WITHOUT CLAIM TO ANY PARTICULAR FONT, STYLE, SIZE, OR COLOR.  
 OWNER OF U.S. REG. NOS. 1,851,977, 2,313,660 AND 3,146,139.  
 NO CLAIM IS MADE TO THE EXCLUSIVE RIGHT TO USE "TONER", APART FROM THE MARK AS SHOWN.  
 FOR FOOTWEAR (U.S. CLS. 22 AND 39).  
 MARY ROSSMAN, EXAMINING ATTORNEY

SN 85-116,887. SKECHERS U.S.A., INC. II, MANHATTAN BEACH, CA. FILED 8-26-2010.

**SRT SKECHERS RADIUS TONER**

SN 85-109,879. OSCAR M MORAN, REGO PARK, NY. FILED 8-17-2010.

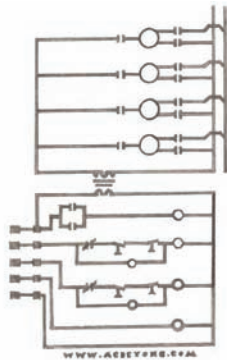

THE MARK CONSISTS OF A WIRING DIAGRAM OF AN AIR CONDITIONER, FEATURING MOTORS, SWITCHES, CONTACTS, COILS, PRESSURE SWITCHES, TRANSFORMER, CONNECTED THROUGH ELECTRICAL WIRES, ON A LADDER SCHEMATIC TYPE. BELOW THE WIRING DIAGRAM IS THE WORDING "WWW.ACBEYOND.COM".  
 FOR ATHLETIC APPAREL, NAMELY, SHIRTS, PANTS, JACKETS, FOOTWEAR, HATS AND CAPS, ATHLETIC UNIFORMS (U.S. CLS. 22 AND 39).  
 FIRST USE 8-12-2010; IN COMMERCE 8-12-2010.  
 STEVEN JACKSON, EXAMINING ATTORNEY

THE MARK CONSISTS OF STANDARD CHARACTERS WITHOUT CLAIM TO ANY PARTICULAR FONT, STYLE, SIZE, OR COLOR.  
 OWNER OF U.S. REG. NOS. 1,851,977, 3,146,139 AND OTHERS.  
 NO CLAIM IS MADE TO THE EXCLUSIVE RIGHT TO USE "TONER", APART FROM THE MARK AS SHOWN.  
 FOR FOOTWEAR (U.S. CLS. 22 AND 39).  
 MARY ROSSMAN, EXAMINING ATTORNEY

SN 85-117,284. LINE DRY INC., NEW YORK, NY. FILED 8-27-2010.

**LINE DRY**

THE MARK CONSISTS OF STANDARD CHARACTERS WITHOUT CLAIM TO ANY PARTICULAR FONT, STYLE, SIZE, OR COLOR.  
 FOR LOUNGEWEAR AND LEISUREWEAR, NAMELY, JEANS, SHIRTS, SHORTS, SKIRTS, AND DRESSES (U.S. CLS. 22 AND 39).  
 EMILY CHUO, EXAMINING ATTORNEY

**CLASS 25—(Continued).**

SN 85-117,357. WILD THINGS, LLC, NEWPORT, RI. FILED 8-27-2010.

**WT TACTICAL**

THE MARK CONSISTS OF STANDARD CHARACTERS WITHOUT CLAIM TO ANY PARTICULAR FONT, STYLE, SIZE, OR COLOR.

NO CLAIM IS MADE TO THE EXCLUSIVE RIGHT TO USE "TACTICAL", APART FROM THE MARK AS SHOWN.

FOR MILITARY CLOTHING, NAMELY, COLD-WEATHER GEAR FOR USE WITH MILITARY UNIFORMS, NAMELY, COATS, JACKETS, SHIRTS, PANTS; MOUNTAIN CLIMBING CLOTHING, NAMELY, HIGH ALTITUDE SUITS, JACKETS, PULLOVERS AND SHIRTS; SPORTSWEAR, NAMELY, SHIRTS, PANTS, SHORTS, HATS, SWEATSHIRTS, JACKETS, PULLOVERS, GLOVES, FLEECE TOPS (U.S. CLS. 22 AND 39).

FIRST USE 3-0-2010; IN COMMERCE 3-0-2010.  
LAKEISHA LEWIS, EXAMINING ATTORNEY

SN 85-123,648. LEKKAS, ANASTASIA, NEW YORK, NY. AND CAMBIOTIS, JOHN, NEW YORK, NY. FILED 9-6-2010.



THE MARK CONSISTS OF A COMBINATION OF TWO LETTERS, THE LOWER CASE GREEK "L" AND THE UPPER CASE GREEK "A" MIDSECTION (AS PART OF IT).

FOR CLOTHING FOR MEN, WOMEN, AND CHILDREN, NAMELY, DRESSES, BELTS, COATS, RAINCOATS, OVERCOATS, WAISTCOATS, BLOUSES AND PULLOVERS, JACKETS, TROUSERS, PANTS, SKIRTS, SUITS, SHIRTS, T-SHIRTS, SWEATERS, UNDERWEAR, SOCKS AND STOCKINGS, GLOVES, TIES, SCARVES, HATS, CAPS, BOOTS, SHOES AND SLIPPERS, TOPS (U.S. CLS. 22 AND 39).

SARA BENJAMIN, EXAMINING ATTORNEY

**CLASS 25—(Continued).**

SN 85-124,041. FOOT LOCKER RETAIL, INC., NEW YORK, NY. FILED 9-7-2010.



NO CLAIM IS MADE TO THE EXCLUSIVE RIGHT TO USE "TECHNOLOGY", APART FROM THE MARK AS SHOWN.

THE MARK CONSISTS OF THE WORD "EVAPOR" IN STYLIZED FORMAT WITH THE WORD "TECHNOLOGY" UNDERNEATH.

FOR ATHLETIC APPAREL, NAMELY, SHIRTS, T-SHIRTS, TRAINING TOPS, SHORTS, POLOS, TANK-TOPS, JACKETS, PANTS, TRACK PANTS, TRACK JACKETS, WORKOUT BRAS, FLEECE SHORTS, FLEECE SWEATPANTS, FLEECE SWEATSHIRTS; FLEECE JACKETS; HEADGEAR, NAMELY, HATS AND CAPS (U.S. CLS. 22 AND 39).

DAVID HOFFMAN, EXAMINING ATTORNEY

SN 85-133,974. SHEEPSKIN DIRECT, INC, NEW CARLISLE O, OH. FILED 9-20-2010.



THE MARK CONSISTS OF A PICTURE OF KOALAS WITH THE WORDS "MY KOALA" AND HEART SYMBOLS. FOR CLOTHING, NAMELY, SHEEPSKIN BOOTS (U.S. CLS. 22 AND 39).

FIRST USE 3-1-2010; IN COMMERCE 3-1-2010.  
EUGENIA MARTIN, EXAMINING ATTORNEY

SN 85-143,857. THE TRUSTEES OF THE THE SAMSON HOLDING TRUST, DATED DECEMBER 12, 2005, BEVERLY HILLS, CA. FILED 10-3-2010.

**ANTHONY HOPKINS**

THE MARK CONSISTS OF STANDARD CHARACTERS WITHOUT CLAIM TO ANY PARTICULAR FONT, STYLE, SIZE, OR COLOR.

OWNER OF U.S. REG. NOS. 3,783,752 AND 3,849,450.

THE NAME "ANTHONY HOPKINS" IDENTIFIES A LIVING INDIVIDUAL WHOSE CONSENT IS OF RECORD.

FOR CLOTHING, NAMELY, SHIRTS, T-SHIRTS; AND HEADWEAR (U.S. CLS. 22 AND 39).

KEVIN DINALLO, EXAMINING ATTORNEY



**CLASS 25—(Continued).**

SN 85-143,860. THE TRUSTEES OF THE THE SAMSON HOLDING TRUST, DATED DECEMBER 12, 2005, BEVERLY HILLS, CA. FILED 10-3-2010.



OWNER OF U.S. REG. NOS. 3,783,752 AND 3,849,450.  
THE NAME "ANTHONY HOPKINS" IDENTIFIES A LIVING INDIVIDUAL WHOSE CONSENT IS OF RECORD.  
THE COLOR(S) RED, BLACK AND YELLOW IS/ARE CLAIMED AS A FEATURE OF THE MARK.

THE MARK CONSISTS OF THE WORDS "ANTHONY HOPKINS" IN YELLOW LETTERS ENCLOSED WITHIN A CIRCULAR DESIGN OUTLINED IN THE COLOR YELLOW AND HAVING A BLACK COLORED BACKGROUND, WITH FANCIFUL DESIGNS OF RED GRIFFINS WITH YELLOW ACCENTS ON THE TONGUES, COLLARS AND CLAWS, APPEARING ON THE LEFT AND RIGHT SIDES OF THE CIRCULAR DESIGN FACING INWARD.

FOR CLOTHING, NAMELY, SHIRTS, T-SHIRTS; AND HEADWEAR (U.S. CLS. 22 AND 39).  
KEVIN DINALLO, EXAMINING ATTORNEY

**CLASS 25—(Continued).**

SN 85-147,854. SKECHERS U.S.A., INC. II, MANHATTAN BEACH, CA. FILED 10-7-2010.

**SKECHERS RADIUS TRAINER**

THE MARK CONSISTS OF STANDARD CHARACTERS WITHOUT CLAIM TO ANY PARTICULAR FONT, STYLE, SIZE, OR COLOR.

OWNER OF U.S. REG. NOS. 1,851,977, 3,146,139 AND OTHERS.

NO CLAIM IS MADE TO THE EXCLUSIVE RIGHT TO USE "TRAINER", APART FROM THE MARK AS SHOWN.

FOR FOOTWEAR (U.S. CLS. 22 AND 39).  
MARY ROSSMAN, EXAMINING ATTORNEY

SN 85-145,760. INNER AURA LLC, SCOTTSDALE, AZ. FILED 10-5-2010.



THE MARK CONSISTS OF A TRIANGLE SHAPE WITH THE STYLIZED TEXT "INNER AURA".  
FOR COATS; GOLF SHIRTS; HATS; PANTS; SHIRTS; SHORTS; UNDERWEAR (U.S. CLS. 22 AND 39).  
LAURIE MAYES, EXAMINING ATTORNEY

SN 85-155,571. HUGH SIMMS LLC, LOS ANGELES, CA. FILED 10-19-2010.



SN 85-147,682. WOLVERINE OUTDOORS, INC., ROCKFORD, MI. FILED 10-7-2010.



OWNER OF U.S. REG. NOS. 2,813,757, 3,368,041 AND OTHERS.

THE MARK CONSISTS OF THE WORD "MERRELL" WITHIN A DIAMOND DESIGN.

FOR BELTS; COATS; DRESSES; FOOTWEAR; GLOVES; HATS; JACKETS; PANTS; SCARVES; SHIRTS; SHORTS; SKIRTS; SKORTS; SOCKS; SWEATERS; SWEATSHIRTS; VESTS (U.S. CLS. 22 AND 39).  
CAROLINE WOOD, EXAMINING ATTORNEY

"HUGH SIMMS" IDENTIFIES A LIVING INDIVIDUAL WHOSE CONSENT IS OF RECORD.

THE COLOR(S) PURPLE, BLACK, AND WHITE IS/ARE CLAIMED AS A FEATURE OF THE MARK.

THE MARK CONSISTS OF A CREST DIVIDED INTO FOUR AREAS, WITH THE WHITE LETTER "H" IN THE UPPER LEFT PORTION, AND THE WHITE LETTER "S" IN THE LOWER RIGHT PORTION, WITH THE LOWER LEFT PORTION AND UPPER RIGHT PORTION OF THE CREST COMPRISING VERTICAL PURPLE AND WHITE STRIPES. CENTERED ABOVE THE CREST ARE THE BLACK LETTERS, "HS", WITH A BLACK WING ON EACH SIDE OF THE LETTERS, WITH BLACK IRON SCROLLING ON EACH SIDE OF THE CREST, WITH THE BLACK WORDING, "HUGH SIMMS" IN ALL CAPS CENTERED BELOW THE CREST.

FOR BOW TIES; NECKTIES; TIES (U.S. CLS. 22 AND 39).

FIRST USE 4-1-2009; IN COMMERCE 4-1-2009.  
ODESSA BIBBINS, EXAMINING ATTORNEY

**CLASS 25—(Continued).**

SN 85-160,811. SUNRISE FASHION RESOURCES, LLC, LOS ANGELES, CA. FILED 10-25-2010.

# R BRAND

THE MARK CONSISTS OF STANDARD CHARACTERS WITHOUT CLAIM TO ANY PARTICULAR FONT, STYLE, SIZE, OR COLOR.

NO CLAIM IS MADE TO THE EXCLUSIVE RIGHT TO USE "BRAND", APART FROM THE MARK AS SHOWN.

FOR CLOTHING, NAMELY, JEANS, PANTS, TOPS, JACKETS, SHORTS, SHIRTS, BOTTOMS AND DRESSES (U.S. CLS. 22 AND 39).

JULIE VEPPUMTHARA, EXAMINING ATTORNEY

---

SN 85-162,741. LANE BRYANT PURCHASING CORP, CO-LUMBUS, OH. FILED 10-27-2010.

# SMOOTH AFFAIR

THE MARK CONSISTS OF STANDARD CHARACTERS WITHOUT CLAIM TO ANY PARTICULAR FONT, STYLE, SIZE, OR COLOR.

FOR WOMEN'S WEARING APPAREL, NAMELY, BODY BRIEFS, BODY SHAPERS, BODY STOCKINGS, BODY SUITS, BODY WRAPS, BRAS, BRASSIERES, BUSTIERS, CAMISOLES, CHEMISES, CHEMISETTES, CONTROL UNDERGARMENTS, CORSETS, FOUNDATION GARMENTS, HOSIERY, LEGGINGS, LINGERIE, PANTIES, PANTYHOSE, LEG SHAPERS, SHAPING SHORTS, STOCKINGS, TEDDIES, THIGH SHAPERS, UNDERPANTS, UNDERWEAR (U.S. CLS. 22 AND 39).

THEODORE MCBRIDE, EXAMINING ATTORNEY

---

SN 85-162,789. LANE BRYANT PURCHASING CORP, CO-LUMBUS, OH. FILED 10-27-2010.

# VERY V

THE MARK CONSISTS OF STANDARD CHARACTERS WITHOUT CLAIM TO ANY PARTICULAR FONT, STYLE, SIZE, OR COLOR.

FOR WOMEN'S WEARING APPAREL, NAMELY, BODY BRIEFS, BODY SHAPERS, BODY STOCKINGS, BODY SUITS, BODY WRAPS, BRAS, BRASSIERES, BUSTIERS, CAMISOLES, CHEMISES, CHEMISETTES, CONTROL UNDERGARMENTS, CORSETS, FOUNDATION GARMENTS, HOSIERY, LEGGINGS, LINGERIE, PANTIES, PANTYHOSE, LEG SHAPERS, SHAPING SHORTS, STOCKINGS, TEDDIES, THIGH SHAPERS, UNDERPANTS, UNDERWEAR (U.S. CLS. 22 AND 39).

THEODORE MCBRIDE, EXAMINING ATTORNEY

**CLASS 25—(Continued).**

SN 85-162,822. LANE BRYANT PURCHASING CORP, CO-LUMBUS, OH. FILED 10-27-2010.

# SERIOUSLY SEAMLESS

THE MARK CONSISTS OF STANDARD CHARACTERS WITHOUT CLAIM TO ANY PARTICULAR FONT, STYLE, SIZE, OR COLOR.

FOR WOMEN'S WEARING APPAREL, NAMELY, BODY BRIEFS, BODY SHAPERS, BODY STOCKINGS, BODY SUITS, BODY WRAPS, BRAS, BRASSIERES, BUSTIERS, CAMISOLES, CHEMISES, CHEMISETTES, CONTROL UNDERGARMENTS, CORSETS, FOUNDATION GARMENTS, HOSIERY, LEGGINGS, LINGERIE, PANTIES, PANTYHOSE, LEG SHAPERS, SHAPING SHORTS, STOCKINGS, TEDDIES, THIGH SHAPERS, UNDERPANTS, UNDERWEAR (U.S. CLS. 22 AND 39).

THEODORE MCBRIDE, EXAMINING ATTORNEY

---

SN 85-162,857. LANE BRYANT PURCHASING CORP, CO-LUMBUS, OH. FILED 10-27-2010.

# MAKE IT BRIEF

THE MARK CONSISTS OF STANDARD CHARACTERS WITHOUT CLAIM TO ANY PARTICULAR FONT, STYLE, SIZE, OR COLOR.

FOR WOMEN'S WEARING APPAREL, NAMELY, BODY BRIEFS, BODY SHAPERS, BODY STOCKINGS, BODY SUITS, BODY WRAPS, BRAS, BRASSIERES, BUSTIERS, CAMISOLES, CHEMISES, CHEMISETTES, CONTROL UNDERGARMENTS, CORSETS, FOUNDATION GARMENTS, HOSIERY, LEGGINGS, LINGERIE, PANTIES, PANTYHOSE, LEG SHAPERS, SHAPING SHORTS, STOCKINGS, TEDDIES, THIGH SHAPERS, UNDERPANTS, UNDERWEAR (U.S. CLS. 22 AND 39).

THEODORE MCBRIDE, EXAMINING ATTORNEY

**CLASS 25—(Continued).**

SN 85-165,700. CAMERON LEE TILLMANN, AKA CAMERON EVIL, TEMECULA, CA. FILED 10-31-2010.

FIENDS FOREVER

THE MARK CONSISTS OF STANDARD CHARACTERS WITHOUT CLAIM TO ANY PARTICULAR FONT, STYLE, SIZE, OR COLOR.

FOR A-SHIRTS; APPAREL FOR DANCERS, NAMELY, TEE SHIRTS, SWEATSHIRTS, PANTS, LEGGINGS, SHORTS AND JACKETS; ATHLETIC APPAREL, NAMELY, SHIRTS, PANTS, JACKETS, FOOTWEAR, HATS AND CAPS, ATHLETIC UNIFORMS; BANDANAS; BEANIES; BELTS; BIKINIS; BRIEFS; BUTTON DOWN SHIRTS; CHILDREN'S AND INFANT'S APPAREL, NAMELY, JUMPERS, OVERALL SLEEPWEAR, PAJAMAS, ROMPERS AND ONE-PIECE GARMENTS; CLOTHING, NAMELY, ARM WARMERS; CORSETS; DRESS SHIRTS; DRESSES; FOOTWEAR; GLOVES; GLOVES AS CLOTHING; HALLOWEEN COSTUMES; HATS; HOODED SWEAT SHIRTS; INFANT AND TODDLER ONE PIECE CLOTHING; JACKETS; JERSEYS; LINGERIE; LONG-SLEEVED SHIRTS; MEN'S SUITS; PANTS; POLO SHIRTS; SCARVES; SHIRTS; SHIRTS FOR INFANTS, BABIES, TODDLERS AND CHILDREN; SHOES; SHORTS; SKIRTS; SLEEPWEAR; SOCKS; SOCKS AND STOCKINGS; SUITS; SWEATBANDS; SWEATSHIRTS; SWIM SUITS; T-SHIRTS; THONGS; TOPS; TRUNKS; UNDERWEAR; UNIFORMS; WEARABLE GARMENTS AND CLOTHING, NAMELY, SHIRTS; WOMEN'S UNDERWEAR; WRISTBANDS (U.S. CLS. 22 AND 39).

FIRST USE 10-31-1997; IN COMMERCE 10-31-2000.  
GENE MACIOL, EXAMINING ATTORNEY

SN 85-168,400. RECOVER GEAR, LLC, POINTE VEDRA BEACH, FL. FILED 11-3-2010.

110%

THE MARK CONSISTS OF STANDARD CHARACTERS WITHOUT CLAIM TO ANY PARTICULAR FONT, STYLE, SIZE, OR COLOR.

FOR BELTS; COATS; FOOTWEAR; GLOVES; HEADGEAR, NAMELY, CAPS, HATS, SWEAT BANDS, AND HEADBANDS; JACKETS; JOGGING OUTFITS; PANTS; SHIRTS; SHORTS; SOCKS; SPORTS BRAS; SWEATSUITS; UNDERGARMENTS; VESTS (U.S. CLS. 22 AND 39).

GIANCARLO CASTRO, EXAMINING ATTORNEY

**CLASS 25—(Continued).**

SN 85-169,219. SHAFFER, SUSAN HALLI, NEW YORK, NY. AND LIEBERMAN, AMY, NEW YORK, NY. FILED 11-4-2010.

we got this.

THE MARK CONSISTS OF STANDARD CHARACTERS WITHOUT CLAIM TO ANY PARTICULAR FONT, STYLE, SIZE, OR COLOR.

FOR HOODED SWEATSHIRTS; SWEATSHIRTS; SHORT-SLEEVED OR LONG-SLEEVED T-SHIRTS; T-SHIRTS (U.S. CLS. 22 AND 39).

HEATHER SAPP, EXAMINING ATTORNEY

SN 85-170,220. TOOMEY, LYNN, LUNENBURG, MA. FILED 11-5-2010.



THE COLOR(S) ORANGE, PURPLE, GREEN, BLUE, YELLOW, GRAY, RED, WHITE, BROWN, BLACK AND PINK IS/ARE CLAIMED AS A FEATURE OF THE MARK.

THE MARK CONSISTS OF THE WORD "PLAY" IN STYLIZED LETTERS LINED IN BLACK, WHEREIN THE LETTER "P" IS ORANGE AND INCLUDES A BASKETBALL IN ORANGE AND BLACK AND HOOP IN RED WITH BLACK LINED NETTING ON A WHITE BACKGROUND, AND FIVE BLACK PICTOGRAPHS OF A SWIMMER, BICYCLIST, RUNNER, SKIER AND WHEELCHAIR ATHLETE, WHEREIN THE LETTER "L" IS PURPLE AND RESEMBLES A HOCKEY STICK WITH WHITE SPOT, ACCOMPANIED BY A GRAY HOCKEY PUCK LINED IN BLACK, WHEREIN THE LETTER "A" IS GREEN AND TOPPED BY A RED BASEBALL CAP WITH THE LETTER "T" IN BLACK ON A WHITE CIRCLE, FORMS A TENNIS RACKET IN BLACK AND WHITE HITTING A GREEN TENNIS BALL WITH TWO WHITE STARS AROUND IT, INCLUDES A RED GOLF FLAG OVER A BLACK HOLE NEAR A WHITE GOLF BALL, AND STRADDLES A BLUE AND WHITE SOCCER BALL IN FRONT OF A BLUE AND WHITE GOAL LINED IN PART WITH BLACK, AND WHEREIN THE LETTER "Y" FORMS A FOOTBALL GOAL POST WITH A BLUE POST, BESIDE A TWO-TONE PINK VOLLEYBALL LINED IN BLACK, AND YELLOW UPRIGHTS BETWEEN WHICH A BROWN AND WHITE FOOTBALL LINED IN BLACK APPEARS.

FOR CAPS; HATS; JACKETS; PANTS; SHIRTS; SHIRTS AND SHORT-SLEEVED SHIRTS; SLEEPWEAR; SPORT SHIRTS; SWEAT SHIRTS; SWEATPANTS; SWEATSHIRTS; T-SHIRTS (U.S. CLS. 22 AND 39).

FIRST USE 2-2-2009; IN COMMERCE 2-2-2009.  
HANNO RITTNER, EXAMINING ATTORNEY

**CLASS 25—(Continued).**

SN 85-173,027. SKI TILL I DIE, HOBOKEN, NJ. FILED 11-9-2010.



THE COLOR(S) BLACK, GREEN, BLUE AND RED IS/ARE CLAIMED AS A FEATURE OF THE MARK.

THE MARK CONSISTS OF THE WORDING "SKI TILL I DIE" IN THE COLOR BLACK WITH A GREEN CIRCLE, BLUE SQUARE, BLACK DIAMOND AND TWO RED DIAMONDS USED AS DOTS IN THE "I".

FOR ATHLETIC APPAREL, NAMELY, SHIRTS, PANTS, JACKETS, FOOTWEAR, HATS AND CAPS, ATHLETIC UNIFORMS; GLOVES FOR APPAREL; HATS; LONG-SLEEVED SHIRTS; MOISTURE-WICKING SPORTS SHIRTS; SHIRTS; SHIRTS AND SHORT-SLEEVED SHIRTS; SHORT-SLEEVED SHIRTS; SKI AND SNOWBOARD SHOES AND PARTS THEREOF; SKI BIBS; SKI BOOT BAGS; SKI BOOTS; SKI GLOVES; SKI JACKETS; SKI MASKS; SKI PANTS; SKI SUITS; SKI SUITS FOR COMPETITION; SKI TROUSERS; SKI WEAR; SPORTS CAPS AND HATS; SWEAT SHIRTS; T-SHIRTS; TEE SHIRTS; TURTLE NECK SHIRTS; WEARABLE GARMENTS AND CLOTHING, NAMELY, SHIRTS (U.S. CLS. 22 AND 39).

LESLIE RICHARDS, EXAMINING ATTORNEY

SN 85-173,445. TANDARICH, MICHAEL R, KENNETT SQUARE, PA. FILED 11-10-2010.

# NO-COMPLY

THE MARK CONSISTS OF STANDARD CHARACTERS WITHOUT CLAIM TO ANY PARTICULAR FONT, STYLE, SIZE, OR COLOR.

FOR A-SHIRTS; ADHESIVE BRAS; ADULT NOVELTY GAG CLOTHING ITEM, NAMELY, SOCKS; AMERICAN FOOTBALL BIBS; ANGLERS' SHOES; ANKLE SOCKS; ANKLETS; ANORAKS; ANTI-PERSPIRANT SOCKS; APPAREL FOR DANCERS, NAMELY, TEE SHIRTS, SWEATSHIRTS, PANTS, LEGGINGS, SHORTS AND JACKETS; APRES-SKI SHOES; AQUA SHOES; ATHLETIC APPAREL, NAMELY, SHIRTS, PANTS, JACKETS, FOOTWEAR, HATS AND CAPS, ATHLETIC UNIFORMS; ATHLETIC SHOES; ATHLETIC TIGHTS; BABY BIBS NOT OF PAPER; BABY BODYSUITS; BABY BOTTOMS; BABY DOLL PYJAMAS; BABY LAYETTES FOR CLOTHING; BABY TOPS; BALACLAVAS; BALL GOWNS; BALLET SHOES; BALLET SLIPPERS; BALLOON PANTS; BALLROOM DANCING SHOES; BANDANAS; BANDEAU TOPS; BASEBALL CAPS; BASEBALL CAPS AND HATS; BASEBALL SHOES; BASEBALL UNIFORMS; BASELAYER BOTTOMS; BASELAYER TOPS; BASKETBALL SNEAKERS; BATH SLIPPERS; BATHING CAPS; BATHING COSTUMES; BATHING COSTUMES FOR WOMEN; BATHING SUITS; BATHING SUITS FOR MEN; BATHING TROUSERS; BATHROBES; BEACH COVER-UPS; BEACH FOOTWEAR; BEACH SHOES; BEACHWEAR; BED JACKETS; BELTS; BELTS FOR CLOTHING; BELTS MADE FROM IMITATION LEATHER; BELTS MADE OF LEATHER; BELTS MADE OUT OF CLOTH; BELTS OF TEXTILE; BELTS THAT ARE DESIGNED TO ACCOMMODATE PREGNANCY SIZE CHANGES; BERTS; BERMUDA SHORTS; BIB SHORTS; BIBS NOT OF CLOTH OR PAPER; BICYCLE GLOVES; BICYCLING GLOVES; BIKINIS; BLAZERS; BLOOMERS; BLOUSES; BLOUSONS; BOARD SHORTS; BOAT SHOES; BODY SHIRTS; BODY SUITS; BOLEROS; BOLO TIES; BOMBER JACKETS; BONNETS; BOOTIES; BOOTS; BOOTS FOR MOTORCYCLING; BOOTS FOR SPORT; BOTTOMS;

**CLASS 25—(Continued).**

BOW TIES; BOWLING SHOES; BOXER BRIEFS; BOXER SHORTS; BOXING SHOES; BOXING SHORTS; BRALLETES; BRAS; BRASSIERES; BRIEFS; BUCKET CAPS; BUSTIERS; BUTTON DOWN SHIRTS; BUTTON-FRONT ALOHA SHIRTS; CAFTANS; CAMISOLES; CAMOUFLAGE GLOVES; CAMOUFLAGE JACKETS; CAMOUFLAGE PANTS; CAMOUFLAGE SHIRTS; CAMOUFLAGE VESTS; CAMP SHIRTS; CANVAS SHOES; CAP PEAKS; CAP VISORS; CAPRI PANTS; CAPS; CAPS WITH VISORS; CARDIGANS; CARGO PANTS; CAT SUITS; CHEF'S COATS; CHEF'S HATS; CHILDREN'S AND INFANTS' APPAREL, NAMELY, JUMPERS, OVERALL SLEEPWEAR, PAJAMAS, ROMPERS AND ONE-PIECE GARMENTS; CHILDREN'S AND INFANTS' APPAREL TREATED WITH FIRE AND HEAT RETARDANTS, NAMELY, JUMPERS, OVERALL SLEEPWEAR, PAJAMAS, ROMPERS AND ONE-PIECE GARMENTS; CHILDREN'S AND INFANTS' CLOTH BIBS; CHILDREN'S CLOTH EATING BIBS; CHILDREN'S HEADWEAR; CLAM DIGGERS; CLEATS FOR ATTACHMENT TO SPORTS SHOES; CLIMBING BOOTS; CLIMBING FOOTWEAR; CLIMBING SHOES; CLOGS; CLOTH BIBS; CLOTH BIBS FOR ADULT DINERS; CLOTH BIBS FOR USE BY SENIOR CITIZENS OR PHYSICALLY- OR MENTALLY-CHALLENGED PERSONS; CLOTH DIAPERS; CLOTHING FOR ATHLETIC USE, NAMELY, PADDED ELBOW COMPRESSION SLEEVES BEING PART OF AN ATHLETIC GARMENT; CLOTHING FOR ATHLETIC USE, NAMELY, PADDED PANTS; CLOTHING FOR ATHLETIC USE, NAMELY, PADDED SHIRTS; CLOTHING FOR ATHLETIC USE, NAMELY, PADDED SHORTS; CLOTHING FOR BABIES, TODDLERS AND CHILDREN, TREATED WITH FIRE AND HEAT RETARDANTS, NAMELY, PAJAMAS, JACKETS, SHIRTS, PANTS, JUMPERS; CLOTHING FOR WEAR IN JUDO PRACTICES; CLOTHING FOR WEAR IN WRESTLING GAMES; CLOTHING ITEMS, NAMELY, ADHESIVE POCKETS THAT MAY BE AFFIXED DIRECTLY TO THE BODY AS A DECORATIVE PIECE OF CLOTHING WITH UTILITY; CLOTHING ITEMS, NAMELY, ADHESIVE POCKETS THAT MAY BE AFFIXED DIRECTLY TO THE INSIDE OF CLOTHING FOR STORAGE AND SAFEKEEPING OF PERSONAL ITEMS; CLOTHING, NAMELY, ARM WARMERS; CLOTHING, NAMELY, ATHLETIC SLEEVES; CLOTHING, NAMELY, BASE LAYERS; CLOTHING, NAMELY, FOLK COSTUMES; CLOTHING, NAMELY, HAND-WARMERS; CLOTHING, NAMELY, KHAKIS; CLOTHING, NAMELY, KNEE WARMERS; CLOTHING, NAMELY, MATERNITY BANDS; CLOTHING, NAMELY, NECK TUBES; CLOTHING, NAMELY, THOBES; CLOTHING, NAMELY, WRAP-AROUNDS; COATS; COATS FOR MEN AND WOMEN; COATS MADE OF COTTON; COATS OF DENIM; COLLARED SHIRTS; COMBATIVE SPORTS UNIFORMS; CORSELETS; CORSETS; CREW NECK SWEATERS; CREW NECKS; CROP TOPS; CUSTOM MADE TO MEASURE SUITS FOR MEN AND WOMEN; CYCLING SHOES; CYCLING SHORTS; CYCLISTS' JERSEYS; DANCE SHOES; DANCE SLIPPERS; DECK-SHOES; DENIM JACKETS; DENIMS; DISPOSABLE UNDERWEAR; DOWN JACKETS; DOWN SUITS; DRESS PANTS; DRESS SHIRTS; DRESS SUITS; DRIVERS; DRY SUITS; DUNGAREES; DUST COATS; DUSTERS; ESPADRILLES; EUROPEAN FOOTBALL BIBS; EYESHADES; FABRIC BELTS; FISHERMEN'S JACKETS; FISHING WADERS; FITTED SHOE OR BOOT COVERING TO PROTECT THE SHOES OR BOOT FROM WATER OR OTHER DAMAGE; FITTED SWIMMING COSTUMES WITH BRA CUPS; FLEECE BOTTOMS; FLEECE PULLOVERS; FLEECE SHORTS; FLEECE TOPS; FLEECE VESTS; FLIGHT SUITS; FLIP FLOPS; FOOTBALL BOOTS; FOOTBALL BOOTS AND STUDS THEREFOR; FOOTBALL SHOES; FOOTIES; FUR COATS; FUR COATS AND JACKETS; FUR HATS; FUR JACKETS; GIFT PACKAGES SOLD AS A UNIT CONSISTING PRIMARILY OF A SWEATSHIRT AND ALSO INCLUDING A PHOTO FRAME, A COFFEE MUG, AND A TOTE BAG; GLOVES; GLOVES AS CLOTHING; GLOVES FOR APPAREL; GLOVES FOR PERSONAL HAND CONDITIONING USE; GLOVES INCLUDING THOSE MADE OF SKIN, HIDE OR FUR; GOLF CAPS; GOLF CLEATS; GOLF PANTS, SHIRTS AND SKIRTS; GOLF SHIRTS; GOLF SHOES; GOLF SHORTS; GOLF TROUSERS; GYM BOOTS; GYM PANTS; GYM SHORTS; GYM SUITS; GYMNASMIC SHOES; HALTER TOPS; HANDBALL SHOES; HAT BANDS; HATS; HATS FOR INFANTS, BABIES, TODDLERS AND CHILDREN; HEADBANDS FOR CLOTHING; HEAVY



**CLASS 25—(Continued).**

COATS; HEAVY JACKETS; HEEL PIECES FOR SHOES; HIKING BOOTS; HOCKEY SHOES; HOODED PULL-OVERS; HOODS; HORSE-RIDING BOOTS; HUNTING BOOT BAGS; HUNTING JACKETS; HUNTING PANTS; HUNTING SHIRTS; INFANT AND TODDLER ONE PIECE CLOTHING; INFANT CLOTH DIAPERS; INFANTS' SHOES AND BOOTS; INFANTS' TROUSERS; INSERTS SPECIALLY ADAPTED FOR CLOTH DIAPERS MADE OF BAMBOO; INSERTS SPECIALLY ADAPTED FOR CLOTH DIAPERS MADE OF HEMP; INSERTS SPECIALLY ADAPTED FOR CLOTH DIAPERS MADE OF MICROFIBER; JACKET LINERS; JACKETS; JACKETS AND SOCKS; JEANS; JEGGINGS, NAMELY, PANTS THAT ARE PARTIALLY JEANS AND PARTIALLY LEGGINGS; JERSEYS; JOGGING OUTFITS; JOGGING PANTS; JOGGING SUITS; JUDO SUITS; JUMPSUITS; KARATE SUITS; KENDO OUTFITS; KNEE HIGHS; KNIT JACKETS; KNIT SHIRTS; KNIT TOPS; KNITTED CAPS; KNITTED GLOVES; KNITTED UNDERWEAR; KNOT CAPS; KNOTTED CAPS; LAB COATS; LADIES' SUITS; LADIES' UNDERWEAR; LEATHER BELTS; LEATHER BOOTS; LEATHER COATS; LEATHER HATS; LEATHER JACKETS; LEATHER PANTS; LEATHER SHIRTS; LEATHER SHOES; LEATHER SKIRTS; LEATHER VESTS; LEISURE SHOES; LEISURE SUITS; LIGHT-REFLECTING COATS; LIGHT-REFLECTING JACKETS; LINGERIE ACCESSORIES, NAMELY, REMOVABLE SILICONE BREAST ENHANCER PADS USED IN A BRA; LOAFERS; LONG JACKETS; LONG SLEEVE PULLOVERS; LONG SLEEVED VESTS; LONG UNDERWEAR; LONG-SLEEVED SHIRTS; LOUNGE PANTS; MEN'S AND WOMEN'S JACKETS, COATS, TROUSERS, VESTS; MEN'S DRESS SOCKS; MEN'S SOCKS; MEN'S SUITS; MEN'S SUITS, WOMEN'S SUITS; MEN'S UNDERWEAR; MIXED MARTIAL ARTS SUITS; MOCCASINS; MOCK TURTLE-NECK SWEATERS; MOCKNECKS; MOISTURE-WICKING SPORTS BRAS; MOISTURE-WICKING SPORTS PANTS; MOISTURE-WICKING SPORTS SHIRTS; MORNING COATS; MOTORCYCLE GLOVES; MOTORCYCLE JACKETS; MOTORCYCLE RAIN SUITS; MOUNTAINEERING SHOES; MUFFLERS; MULES; MUSCLE TOPS; NIGHT SHIRTS; NON-DISPOSABLE CLOTH TRAINING PANTS; ONE-PIECE PLAY SUITS; OPEN-NECKED SHIRTS; OUTDOOR GLOVES; OUTER JACKETS; OVER COATS; OVER SHIRTS; PADDED JACKETS; PADDING JACKETS; PANTIES, SHORTS AND BRIEFS; PANTS; PAPER HATS FOR USE AS CLOTHING ITEMS; PAPER SHOES USED WHEN GOING THROUGH METAL DETECTORS TO KEEP FEET AND SOCKS CLEAN; PARKAS; PARTS OF CLOTHING, NAMELY, GUSSETS FOR TIGHTS, GUSSETS FOR STOCKINGS, GUSSETS FOR BATHING SUITS, GUSSETS FOR UNDERWEAR, GUSSETS FOR LEOTARDS AND GUSSETS FOR FOOTLETS; PARTS OF CLOTHING, NAMELY, UNDERARM GUSSETS; PARTY HATS; PEACOATS; PEDAL PUSHERS; PERSPIRATION ABSORBENT STRAP TO BE USED IN THE BILL OF A HAT; PETTI-PANTS; PIQUE SHIRTS; PLAY SUITS; POCKET SQUARES; POLO KNIT TOPS; POLO SHIRTS; POLYMER CUSTOM CUSHIONED SHOE INSERTS FOR PRIMARILY NON-ORTHOPEDIC PURPOSES; PRAM SUITS; PROTECTIVE METAL MEMBERS FOR SHOES AND BOOTS; QUILTED VESTS; RAIN COATS; RAIN HATS; RAIN JACKETS; RAIN SUITS; RAINPROOF JACKETS; REVERSIBLE JACKETS; RIDING COATS; RIDING GLOVES; RIDING SHOES; RUBBER SHOES; RUGBY SHIRTS; RUGBY SHOES; RUGBY SHORTS; RUGBY TOPS; RUNNING PADS THAT STRAP ONTO SHOES; RUNNING SHOES; RUNNING SUITS; SAILOR SUITS; SANDALS AND BEACH SHOES; SCARFS; SCIENTIFIC AND TECHNOLOGICAL APPAREL, NAMELY, SHIRTS, PANTS, JACKETS, FOOTWEAR, HATS AND CAPS, UNIFORMS; SEDGE HATS (SUGE-GASA); SHELL JACKETS; SHIRTS; SHIRT FRONTS; SHIRT YOKES; SHIRTS; SHIRTS AND SHORT-SLEEVED SHIRTS; SHIRTS AND SLIPS; SHIRTS FOR INFANTS, BABIES, TODDLERS AND CHILDREN; SHIRTS FOR SUITS; SHOE COVERS FOR USE WHEN WEARING SHOES; SHOE DOWELS; SHOE INSERTS FOR PRIMARILY NON-ORTHOPEDIC PURPOSES; SHOE PEGS; SHOE SOLES; SHOE STRAPS; SHOES; SHOES SOLES FOR REPAIR; SHOES WITH HOOK AND PILE FASTENING TAPES; SHORT PETTICOATS; SHORT SETS; SHORT TROUSERS; SHORT-SLEEVED OR LONG-SLEEVED T-SHIRTS; SHORT-SLEEVED SHIRTS; SHORTS; SHOULDER WRAPS; SHOULDER WRAPS FOR CLOTHING; SHOWER CAPS; SKATING OUTFITS; SKI AND

**CLASS 25—(Continued).**

SNOWBOARD SHOES AND PARTS THEREOF; SKI BIBS; SKI BOOT BAGS; SKI BOOTS; SKI GLOVES; SKI JACKETS; SKI MASKS; SKI PANTS; SKI SUITS; SKI SUITS FOR COMPETITION; SKI TROUSERS; SKI WEAR; SKIING SHOES; SKIRT SUITS; SKULL CAPS; SLEEP PANTS; SLEEP SHIRTS; SLEEPING GARMENTS; SLEEVED OR SLEEVELESS JACKETS; SLEEVELESS JERSEYS; SLEEVES WORN SEPARATE AND APART FROM BLOUSES, SHIRTS AND OTHER TOPS; SLIDING SHORTS; SMALL HATS; SMOKING JACKETS; SNEAKERS; SNOW BOARDING SUITS; SNOW PANTS; SNOW SUITS; SNOWBOARD PANTS; SNOWBOARD TROUSERS; SOCCER SHOES; SOCKS; SOCKS AND STOCKINGS; SPORT COATS; SPORT SHIRTS; SPORT STOCKINGS; SPORTS BRA; SPORTS BRAS; SPORTS CAPS AND HATS; SPORTS JACKETS; SPORTS JERSEYS; SPORTS JERSEYS AND BREECHES FOR SPORTS; SPORTS OVER UNIFORMS; SPORTS OVERUNIFORMS; SPORTS PANTS; SPORTS SHIRTS; SPORTS SHIRTS WITH SHORT SLEEVES; SPORTS VESTS; STILETTO HEELS; STOCKINGS; STRAPLESS BRAS; STRAPS FOR BRAS; STRETCH PANTS; STUFF JACKETS; SUEDE JACKETS; SUIT COATS; SUITS; SUITS OF LEATHER; SWADDLING CLOTHES; SWEAT BANDS; SWEAT JACKETS; SWEAT PANTS; SWEAT SHIRTS; SWEAT SHORTS; SWEAT SUITS; SWEATERS; SWEATSOCKS; SWIM CAPS; SWIM SUITS; SWIM TRUNKS; SWIM WEAR; SWIM WEAR FOR GENTLEMEN AND LADIES; SWIMMING CAPS; SWIMMING COSTUMES; T-SHIRTS; TANK TOPS; TANKINIS; TAP PANTS; TAP SHOES; TENNIS SHOES; THERMAL SOCKS; THERMAL UNDERWEAR; THONGS; TIES; TOBOGGAN HATS, PANTS AND CAPS; TOE CAPS; TONGUE OR PULLSTRAP FOR SHOES AND BOOTS; TOP COATS; TOPS; TRACK AND FIELD SHOES; TRACK JACKETS; TRACK PANTS; TRACK SUITS; TRAINING SHOES; TRAINING SUITS; TROUSERS; TROUSERS FOR SWEATING; TROUSERS OF LEATHER; TRUNKS; TUBE TOPS; TUNICS; TURTLE NECK SHIRTS; TURTLENECK PULLOVERS; TURTLENECK SWEATERS; TURTLENECKS; UNDERARM CLOTHING SHIELDS; UNDERCLOTHES; UNDERGARMENTS, NAMELY, WASPIES; UNDERPANTS; UNDERSKIRTS; UNDERWEAR; UNDERWEAR, NAMELY, BOY SHORTS; UNION SUITS; V-NECK SWEATERS; VESTED SUITS; VOLLEYBALL JERSEYS; VOLLEYBALL SHOES; WALKING SHORTS; WARM UP OUTFITS; WARM UP SUITS; WATER REPELLING LEATHER SHOES AND BOOTS; WATERPROOF JACKETS AND PANTS; WATERPROOF LEATHER BOOTS; WATERPROOF LEATHER SHOES; WATERPROOF LEATHER SHOES AND BOOTS; WEARABLE GARMENTS AND CLOTHING, NAMELY, SHIRTS; WELTS FOR BOOTS AND SHOES; WET SUIT GLOVES; WET SUITS; WET SUITS FOR WATER-SKIING AND SUB-AQUA; WETSUITS FOR WATER-SKIING; WIND COATS; WIND PANTS; WIND RESISTANT JACKETS; WIND SHIRTS; WIND-JACKETS; WOMEN'S ATHLETIC TOPS WITH BUILT-IN BRAS; WOMEN'S SHOES; WOMEN'S UNDERWEAR; WOODEN CLOGS; WOODEN SHOES; WOODEN SUPPORTS OF JAPANESE STYLE WOODEN CLOGS; WOOLLEN SOCKS; WOOLLEN TIGHTS; WOOLLY HATS; WORK SHOES AND BOOTS; WOVEN BOTTOMS; WOVEN OR KNITTED UNDERWEAR; WOVEN TOPS; WRAPS; YOGA PANTS; YOGA SHIRTS; ZOOT SUITS (U.S. CLS. 22 AND 39).

ANDREA HACK, EXAMINING ATTORNEY



**CLASS 25—(Continued).**

SN 85-178,558. CHHEDA, NAINIL, WORCESTER, MA. FILED 11-17-2010.

**FASHION MADE SIMPLE**

THE MARK CONSISTS OF STANDARD CHARACTERS WITHOUT CLAIM TO ANY PARTICULAR FONT, STYLE, SIZE, OR COLOR.

NO CLAIM IS MADE TO THE EXCLUSIVE RIGHT TO USE "FASHION", APART FROM THE MARK AS SHOWN.

FOR MEN, WOMEN AND CHILDREN'S CLOTHING, NAMELY, PANTS, PANTS FOR BABIES, UNDERPANTS, CASUAL TOPS, DRESS SHIRTS, SUITS, VESTS, JACKETS, SWEATERS, SHORTS, TRUNKS, CASUAL PANTS, DRESS PANTS, JEANS, SWEAT PANTS, UNDERWEAR, FOOTWEAR, TOPS, SKIRTS, LEGGINGS, GOWNS, DRESSES, COATS, BRAS, PANTIES, T-SHIRTS, TANKS, PAJAMAS, NIGHTGOWNS, SHOES, SANDALS, BELTS, COATS, AND HEADWEAR (U.S. CLS. 22 AND 39).

KIMBERLY PERRY, EXAMINING ATTORNEY

**CLASS 25—(Continued).**

SN 85-181,113. SPELL C LLC, VAN NUYS, CA. FILED 11-19-2010.

**HERITAGE AND HOME**

THE MARK CONSISTS OF STANDARD CHARACTERS WITHOUT CLAIM TO ANY PARTICULAR FONT, STYLE, SIZE, OR COLOR.

FOR CLOTHING, NAMELY, MEN'S AND WOMEN'S CLOTHING, NAMELY, PANTS, SLACKS, JEANS, SHORTS, SKIRTS, SHIRTS, BLOUSES, SWEATERS, T-SHIRTS, TANK TOPS, DRESSES, VESTS, SOCKS, HOSIERY, JACKETS, COATS, SCARVES, GLOVES, NECKTIES, BELTS, SWIMWEAR, UNDERWEAR, SLIPS, CAMISOLES, BRAS, NIGHTGOWNS, PAJAMAS, ROBES; INFANTS AND CHILDREN'S CLOTHING, NAMELY, T-SHIRTS, SWEATERS, LONG SLEEVED SHIRTS, SHORTS, PANTS, JUMPERS, JUMPSUITS, OVERALLS, ONE-PIECE PLAYSUITS, PAJAMAS, SOCKS, DRESSES, SKIRTS; FOOTWEAR; HEADGEAR, NAMELY, HATS AND CAPS (U.S. CLS. 22 AND 39).

HAI-LY LAM, EXAMINING ATTORNEY

SN 85-181,103. SPELL C. LLC, VAN NUYS, CA. FILED 11-19-2010.



OWNER OF U.S. REG. NOS. 373,836, 1,644,461 AND OTHERS.

NO CLAIM IS MADE TO THE EXCLUSIVE RIGHT TO USE "AMERICAN" AND "SINCE 1973", APART FROM THE MARK AS SHOWN.

THE MARK CONSISTS OF THE WORDS "HERITAGE AND HOME CHEROKEE AN AMERICAN STANDARD SINCE 1973" WHERE THE WORD "CHEROKEE" IS IN A LARGER FONT WITH A DOUBLE LINE ABOVE AND BELOW THE WORD "CHEROKEE", AND A BORDER SURROUNDS THE ENTIRE DESIGN.

FOR CLOTHING, NAMELY, MEN'S AND WOMEN'S CLOTHING, NAMELY, PANTS, SLACKS, JEANS, SHORTS, SKIRTS, SHIRTS, BLOUSES, SWEATERS, T-SHIRTS, TANK TOPS, DRESSES, VESTS, SOCKS, HOSIERY, JACKETS, COATS, SCARVES, GLOVES, NECKTIES, BELTS, SWIMWEAR, UNDERWEAR, SLIPS, CAMISOLES, BRAS, NIGHTGOWNS, PAJAMAS, ROBES; INFANTS AND CHILDREN'S CLOTHING, NAMELY, T-SHIRTS, SWEATERS, LONG SLEEVED SHIRTS, SHORTS, PANTS, JUMPERS, JUMPSUITS, OVERALLS, ONE-PIECE PLAYSUITS, PAJAMAS, SOCKS, DRESSES, SKIRTS; FOOTWEAR; HEADGEAR, NAMELY, HATS AND CAPS (U.S. CLS. 22 AND 39).

KATHY DE JONGE, EXAMINING ATTORNEY

SN 85-181,308. DIANE VON FURSTENBERG STUDIO, NEW MILFORD, CT. FILED 11-19-2010.



OWNER OF U.S. REG. NOS. 2,276,188, 3,781,750 AND OTHERS.

THE NAME(S), PORTRAIT(S), AND/OR SIGNATURE(S) SHOWN IN THE MARK IDENTIFIES "DIANE VON FURSTENBERG", WHOSE CONSENT(S) TO REGISTER IS MADE OF RECORD.

THE MARK CONSISTS OF THE WORD "DIANE" IN STYLIZED SCRIPT ABOVE THE STYLIZED WORDS "DIANE VON FURSTENBERG" IN LARGE AND SMALL BLOCK LETTERS, WHERE ALL ELEMENTS OF THE MARK ARE SET ON A RECTANGULAR BACKGROUND.

FOR WEARING APPAREL, NAMELY, SUITS, SHORTS, T-SHIRTS, SKIRTS, SWEATERS, PANTS, JEANS, OVERALLS, SASHES, SHAWLS, VESTS, BLOUSES, JACKETS, KIMONOS, TUNICS, COATS, CULOTTES, DRESSES, SWEAT SUITS, SLEEPWEAR, SWIMWEAR, NECKWEAR; GLOVES, HATS, BELTS, SCARVES, HOSIERY, SOCKS AND FOOTWEAR (U.S. CLS. 22 AND 39).

ADA HAN, EXAMINING ATTORNEY

**CLASS 25—(Continued).**

SN 85-181,948. AUSTIN GUPPY LANDAVERE, SEVERN, MD. FILED 11-21-2010.



THE MARK CONSISTS OF THE STYLIZED WORDING "COLLEGE SWAGGER" WITH A STYLIZED CROWN. FOR T-SHIRTS (U.S. CLS. 22 AND 39). DOUGLAS LEE, EXAMINING ATTORNEY

SN 85-182,676. PANACAVALLO, LLC, COHASSET, MA. FILED 11-22-2010.



THE MARK CONSISTS OF TWO HORSE HEADS FACING EACH OTHER WITH A STYLIZED CROSS IN A CIRCLE AND HORIZONTAL STIRRUP, WITH THE WORD "PANACAVALLO" BENEATH THE ENTIRE DESIGN.

THE WORDING "PANACAVALLO" HAS NO MEANING IN A FOREIGN LANGUAGE.

FOR EQUESTRIAN APPAREL AND FOOTWEAR, NAMELY, BOOTS, BELL BOOTS, TURNOUT BOOTS, SHOES, SHIRTS, BLOUSES, JACKETS, PANTS, RIDING CHAPS, LEGGINGS, COATS, OVERCOATS, VESTS, TROUSERS, HALTERS, STOCKING SUSPENDERS, BRACES/SUSPENDERS, WAISTBANDS, BELTS, GLOVES, HATS, CAPS, VISORS AND SCARVES (U.S. CLS. 22 AND 39).

TINA L. SNAPP, EXAMINING ATTORNEY

**CLASS 25—(Continued).**

SN 85-182,694. PANACAVALLO, LLC, COHASSET, MA. FILED 11-22-2010.

**PANACAVALLO**

THE MARK CONSISTS OF STANDARD CHARACTERS WITHOUT CLAIM TO ANY PARTICULAR FONT, STYLE, SIZE, OR COLOR.

THE WORDING "PANACAVALLO" HAS NO MEANING IN A FOREIGN LANGUAGE.

FOR EQUESTRIAN APPAREL AND FOOTWEAR, NAMELY, BOOTS, BELL BOOTS, TURNOUT BOOTS, SHOES, SHIRTS, BLOUSES, JACKETS, PANTS, RIDING CHAPS, LEGGINGS, COATS, OVERCOATS, VESTS, TROUSERS, HALTERS, STOCKING SUSPENDERS, BRACES/SUSPENDERS, WAISTBANDS, BELTS, GLOVES, HATS, CAPS, VISORS AND SCARVES (U.S. CLS. 22 AND 39).

TINA L. SNAPP, EXAMINING ATTORNEY

SN 85-183,258. U.S. MARINE CORPS, A COMPONENT OF THE U.S. DEPARTMENT OF THE NAVY, WASHINGTON, DC. FILED 11-23-2010.

**LEATHERNECK**

THE MARK CONSISTS OF STANDARD CHARACTERS WITHOUT CLAIM TO ANY PARTICULAR FONT, STYLE, SIZE, OR COLOR.

FOR ATHLETIC APPAREL, NAMELY, SHIRTS, PANTS, JACKETS, FOOTWEAR, HATS AND CAPS, ATHLETIC UNIFORMS; GOLF PANTS, SHIRTS AND SKIRTS; GOLF SHIRTS; HOODED SWEAT SHIRTS; JACKETS; JERSEYS; LEATHER BELTS; MOISTURE-WICKING SPORTS SHIRTS; OPEN-NECKED SHIRTS; OVER SHIRTS; POLO SHIRTS; RUGBY SHIRTS; SHIRTS AND SHORT-SLEEVED SHIRTS; TIES (U.S. CLS. 22 AND 39).

FRANK LATTUCA, EXAMINING ATTORNEY

SN 85-184,139. ST.CYR, D'YANI, CARSON, CA. FILED 11-23-2010.

**D'Yani St.Cyr**

THE MARK CONSISTS OF STANDARD CHARACTERS WITHOUT CLAIM TO ANY PARTICULAR FONT, STYLE, SIZE, OR COLOR.

THE NAME "D'YANI ST.CYR" IDENTIFIES A LIVING INDIVIDUAL WHOSE CONSENT IS OF RECORD.

FOR BOTTOMS; COATS; DRESSES; JACKETS; PANTS; SHIRTS; SHOES; TOPS (U.S. CLS. 22 AND 39).

WILLIAM ROSSMAN, EXAMINING ATTORNEY

**CLASS 25—(Continued).**

SN 85-184,774. ZANONE, PATRICK, WYNNE, AR. FILED 11-24-2010.

# ScanIt Gear

THE MARK CONSISTS OF STANDARD CHARACTERS WITHOUT CLAIM TO ANY PARTICULAR FONT, STYLE, SIZE, OR COLOR.

NO CLAIM IS MADE TO THE EXCLUSIVE RIGHT TO USE "GEAR", APART FROM THE MARK AS SHOWN.

FOR CLOTHING, NAMELY, TEE SHIRTS, SWEATSHIRTS, JACKETS, AND HATS IMPRINTED OR EMBROIDERED WITH A CUSTOM ENCODED SCANNABLE IMAGE, LIKE A TWO-DIMENSIONAL BARCODE (U.S. CLS. 22 AND 39).

MARY ROSSMAN, EXAMINING ATTORNEY

**CLASS 25—(Continued).**

SN 85-186,397. WILLIAMS, GLENN, VIDOR, TX. AND DAVILA, JESSE, VIDOR, TX. AND SEIGRIST, WILLIAM, VIDOR, TX. FILED 11-29-2010.



OWNER OF U.S. REG. NO. 3,889,042.

NO CLAIM IS MADE TO THE EXCLUSIVE RIGHT TO USE "FIGHT WEAR", APART FROM THE MARK AS SHOWN.

THE MARK CONSISTS OF THE WORDING "360 FIGHT GEAR" INSIDE OF A CIRCLE THAT IS DIVIDED BY EIGHT STYLIZED DEPICTIONS OF TWO MALE FIGHTERS ENGAGED IN DIFFERENT FIGHT POSITIONS, EVENLY SPACED AROUND THE CIRCLE.

FOR CLOTHING, NAMELY, SHIRTS, T-SHIRTS, SWEATSHIRTS, HOODED T-SHIRTS, HOODED SWEATSHIRTS, TANK TOPS, JERSEYS, PANTS, SHORTS, JEANS, SWEATPANTS, JACKETS, COATS, FOOTWEAR, HATS, CAPS, BEANIES, SKULL CAPS, VISORS, ATHLETIC UNIFORMS, UNDERGARMENTS, BRIEFS, THONG UNDERWEAR, SOCKS, WRISTBANDS, HEADBANDS, BELTS, NECKTIES (U.S. CLS. 22 AND 39).

FIRST USE 11-8-2010; IN COMMERCE 11-8-2010.

JASON BLAIR, EXAMINING ATTORNEY

SN 85-185,918. MOTORCYCLE RADIO GARAGE LLC, ANTHEM, AZ. FILED 11-29-2010.

# Motorcycle Garage Wear

THE MARK CONSISTS OF STANDARD CHARACTERS WITHOUT CLAIM TO ANY PARTICULAR FONT, STYLE, SIZE, OR COLOR.

NO CLAIM IS MADE TO THE EXCLUSIVE RIGHT TO USE "WEAR", APART FROM THE MARK AS SHOWN.

FOR CLOTHING, NAMELY, SHIRTS; HATS (U.S. CLS. 22 AND 39).

EMILY CHUO, EXAMINING ATTORNEY

SN 85-186,833. ALESSANDRA M. FERREIRA, LOS ANGELES, CA. FILED 11-30-2010.

# MIHNDI

THE MARK CONSISTS OF STANDARD CHARACTERS WITHOUT CLAIM TO ANY PARTICULAR FONT, STYLE, SIZE, OR COLOR.

FOR CLOTHING, NAMELY, SHORTS, DRESSES, SHIRTS, JACKETS, COATS, T-SHIRTS, LONG SLEEVED T-SHIRTS, TANK TOPS, SKIRTS, PANTS, JEANS, SWEATPANTS, SWEATSHORTS, SWEAT JACKETS, HOODED SWEATSHIRTS, LOUNGEWEAR, SWIMWEAR, SWEATERS, LEGGINGS, FOOTWEAR, AND HEADWEAR (U.S. CLS. 22 AND 39).

KATHERINE E. HALMEN, EXAMINING ATTORNEY

**CLASS 25—(Continued).**

SN 85-188,196. BUTES, LLC, WILLIAMSVILLE, NY. FILED 12-1-2010.



NO CLAIM IS MADE TO THE EXCLUSIVE RIGHT TO USE "DESIGNED BY", APART FROM THE MARK AS SHOWN.

THE NAME(S), PORTRAIT(S), AND/OR SIGNATURE(S) SHOWN IN THE MARK IDENTIFIES "JAMES LEE MCFALL" AND "ASHLEY J. STEINFELD", WHOSE CONSENT(S) TO REGISTER IS MADE OF RECORD.

THE MARK CONSISTS OF A BUTTERFLY WITH THE CURSIVE WORD "MOTIVATOR" PRINTED OVER IT, THE LETTERS APPEARING TO BE SEWN TOGETHER, WITH A SEWING NEEDLE FINISHING OFF THE "R", ALONG WITH FIVE ACCENTING STARS. UNDER THE WORD "MOTIVATOR" IS THE WORDING "DESIGNED BY JIM-MYLEE & ASHLEY".

FOR CLOTHING, NAMELY, MEN'S AND WOMEN'S SHAPEWEAR, NAMELY, BODY SHAPERS AND LEG SHAPERS (U.S. CLS. 22 AND 39).

FIRST USE 9-13-2010; IN COMMERCE 9-13-2010.

KATHERINE E. HALMEN, EXAMINING ATTORNEY

**CLASS 25—(Continued).**

SN 85-188,964. CERWICK, FRED E., PAPILLION, NE. AND HANGZHOU YULLEX IMPORT & EXPORT CO., LTD., HANGZHOU, CHINA, FILED 12-2-2010.

**BIO GOWN**

THE MARK CONSISTS OF STANDARD CHARACTERS WITHOUT CLAIM TO ANY PARTICULAR FONT, STYLE, SIZE, OR COLOR.

NO CLAIM IS MADE TO THE EXCLUSIVE RIGHT TO USE "GOWN", APART FROM THE MARK AS SHOWN.

FOR GOWNS (U.S. CLS. 22 AND 39).

FIRST USE 11-10-2010; IN COMMERCE 11-10-2010.

TINA MAI, EXAMINING ATTORNEY

SN 85-189,358. SPELL C LLC, VAN NUYS, CA. FILED 12-2-2010.

SN 85-188,703. MIGHTY-O CORP., SEATTLE, WA. FILED 12-1-2010.



OWNER OF U.S. REG. NO. 3,928,426.

THE MARK CONSISTS OF THE TEXT "MIGHTY-O DONUTS" APPEARS ON AN OVAL WITH A STAR APPEARING BELOW THE TERM "MIGHTY-O" AND ABOVE THE TERM "DONUTS".

FOR T-SHIRTS (U.S. CLS. 22 AND 39).

FIRST USE 5-15-2000; IN COMMERCE 5-15-2000.

JOHN SCHUYLER YARD, EXAMINING ATTORNEY

**CHEROKEE AN AMERICAN STANDARD**

THE MARK CONSISTS OF STANDARD CHARACTERS WITHOUT CLAIM TO ANY PARTICULAR FONT, STYLE, SIZE, OR COLOR.

OWNER OF U.S. REG. NOS. 373,836, 1,644,461 AND OTHERS.

NO CLAIM IS MADE TO THE EXCLUSIVE RIGHT TO USE "AMERICAN", APART FROM THE MARK AS SHOWN.

FOR CLOTHING, NAMELY, MEN'S AND WOMEN'S CLOTHING, NAMELY, PANTS, SLACKS, JEANS, SHORTS, SKIRTS, SHIRTS, BLOUSES, SWEATERS, T-SHIRTS, TANK TOPS, DRESSES, VESTS, SOCKS, HOSIERY, JACKETS, COATS, SCARVES, GLOVES, NECKTIES, BELTS, SWIMWEAR, UNDERWEAR, SLIPS, CAMISOLES, BRAS, NIGHTGOWNS, PAJAMAS, ROBES; INFANTS AND CHILDREN'S CLOTHING, NAMELY, T-SHIRTS, SWEATERS, LONG SLEEVED SHIRTS, SHORTS, PANTS, JUMPERS, JUMPSUITS, OVERALLS, ONE-PIECE PLAYSUITS, PAJAMAS, SOCKS, DRESSES, SKIRTS; FOOTWEAR; HEADGEAR, NAMELY, HATS AND CAPS (U.S. CLS. 22 AND 39).

KATHLEEN M. VANSTON, EXAMINING ATTORNEY

**CLASS 25—(Continued).**

SN 85-190,696. TALI LEHAVI, AKA TALI LEHAVI HAMER, SCOTTSDALE, AZ. FILED 12-3-2010.

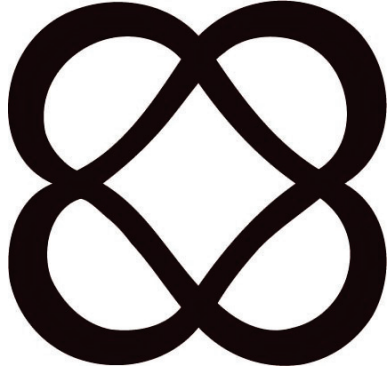

THE MARK CONSISTS OF TWO HEARTS IN OPPOSITE DIRECTION CREATE A HEART IN FOUR DIRECTIONS.

FOR A-SHIRTS; APPAREL FOR DANCERS, NAMELY, TEE SHIRTS, SWEATSHIRTS, PANTS, LEGGINGS, SHORTS AND JACKETS; ATHLETIC APPAREL, NAMELY, SHIRTS, PANTS, JACKETS, FOOTWEAR, HATS AND CAPS, ATHLETIC UNIFORMS; ATHLETIC FOOTWEAR; ATHLETIC SHOES; ATHLETIC TIGHTS; ATHLETIC UNIFORMS; BALLOON PANTS; BED JACKETS; BODY SHIRTS; BOMBER JACKETS; BRAS; BRIEFS; BUTTON DOWN SHIRTS; BUTTON-FRONT ALOHA SHIRTS; CAMOUFLAGE JACKETS; CAMOUFLAGE PANTS; CAMOUFLAGE SHIRTS; CAMP SHIRTS; CAPRI PANTS; CARGO PANTS; CHILDREN'S AND INFANT'S APPAREL, NAMELY, JUMPERS, OVERALL SLEEPWEAR, PAJAMAS, ROMPERS AND ONE-PIECE GARMENTS; CHILDREN'S AND INFANTS' APPAREL TREATED WITH FIRE AND HEAT RETARDANTS, NAMELY, JUMPERS, OVERALL SLEEPWEAR, PAJAMAS, ROMPERS AND ONE-PIECE GARMENTS; CLOTHING FOR ATHLETIC USE, NAMELY, PADDED PANTS; CLOTHING FOR BABIES, TODDLERS AND CHILDREN, TREATED WITH FIRE AND HEAT RETARDANTS, NAMELY, PAJAMAS, JACKETS, SHIRTS, PANTS, JUMPERS; COLLARED SHIRTS; DENIM JACKETS; DENIMS; DISPOSABLE UNDERWEAR; DOWN JACKETS; DRESS PANTS; DRESS SHIRTS; FISHERMEN'S JACKETS; FITTED SWIMMING COSTUMES WITH BRA CUPS; GLOVES FOR APPAREL; GOLF PANTS, SHIRTS AND SKIRTS; GYM PANTS; HEAVY JACKETS; HOODED SWEAT SHIRTS; INFANT DIAPER COVERS; INFANT WEAR; JACKET LINERS; JACKETS; JACKETS AND SOCKS; JEGGINGS, NAMELY, PANTS THAT ARE PARTIALLY JEANS AND PARTIALLY LEGGINGS; JOGGING PANTS; KNIT JACKETS; KNITTED UNDERWEAR; LADIES' UNDERWEAR; LEATHER JACKETS; LEATHER PANTS; LEOTARDS AND TIGHTS FOR WOMEN, MEN AND CHILDREN OF NYLON, COTTON OR OTHER TEXTILE FIBERS; LIGHT-REFLECTING JACKETS; LONG JACKETS; LONG UNDERWEAR; LOUNGE PANTS; MATERNITY BRAS; MEN'S AND WOMEN'S JACKETS, COATS, TROUSERS, VESTS; MEN'S UNDERWEAR; MOTORCYCLE JACKETS; NIGHT SHIRTS; NURSE PANTS; NURSE'S APPAREL, NAMELY, SCRUBS; OPEN-NECKED SHIRTS; OUTER JACKETS; OVER SHIRTS; PADDED JACKETS; PADDING JACKETS; PANTS; PARTS OF CLOTHING, NAMELY, GUSSETS FOR TIGHTS, GUSSETS FOR STOCKINGS, GUSSETS FOR BATHING SUITS, GUSSETS FOR UNDERWEAR, GUSSETS FOR LEOTARDS AND GUSSETS FOR FOOTLETS; PERSPIRATION ABSORBENT UNDERWEAR CLOTHING; PIQUE SHIRTS; POLO SHIRTS; RAIN JACKETS; RAIN WEAR; RAIN-PROOF JACKETS; REVERSIBLE JACKETS; RUGBY SHIRTS; SCIENTIFIC AND TECHNOLOGICAL APPAREL, NAMELY, SHIRTS, PANTS, JACKETS, FOOTWEAR, HATS AND CAPS, UNIFORMS; SHELL JACKETS; SHIRT FRONTS; SHIRTS; SHIRTS AND SHORT-SLEEVED SHIRTS; SHIRTS AND SLIPS; SHIRTS FOR INFANTS, BABIES, TODDLERS AND CHILDREN; SHIRTS FOR SUITS; SHOE COVERS FOR USE WHEN WEARING SHOES; SHORT-SLEEVED OR LONG-SLEEVED T-SHIRTS; SHORT-SLEEVED SHIRTS; SKI

**CLASS 25—(Continued).**

JACKETS; SKI PANTS; SKI WEAR; SKIRT SUITS; SKIRTS; SLEEP PANTS; SLEEP SHIRTS; SLEEVED OR SLEEVELESS JACKETS; SLEEVES WORN SEPARATE AND APART FROM BLOUSES, SHIRTS AND OTHER TOPS; SMOKING JACKETS; SNOW PANTS; SNOWBOARD JACKETS; SNOWBOARD PANTS; SOCKS; SOCKS AND STOCKINGS; SPORT SHIRTS; SPORTS BRA; SPORTS JACKETS; SPORTS PANTS; SPORTS SHIRTS; SPORTS SHIRTS WITH SHORT SLEEVES; STRAPLESS BRAS; STRAPS FOR BRAS; STRETCH PANTS; STUFF JACKETS; SUEDE JACKETS; SURF WEAR; SWEAT JACKETS; SWEAT PANTS; SWEAT SHIRTS; SWIM WEAR; SWIM WEAR FOR GENTLEMEN AND LADIES; T-SHIRTS; TAP PANTS; TEE SHIRTS; TENNIS WEAR; TEXTILE DIAPERS; THERMAL UNDERWEAR; THONGS; TIES; TOBOGGAN HATS, PANTS AND CAPS; TRACK JACKETS; TRACK PANTS; TRAVEL CLOTHING CONTAINED IN A PACKAGE COMPRISING REVERSIBLE JACKETS, PANTS, SKIRTS, TOPS AND A BELT OR SCARF; TRIATHLON CLOTHING, NAMELY, TRIATHLON TIGHTS, TRIATHLON SHORTS, TRIATHLON SINGLET, TRIATHLON SHIRTS, TRIATHLON SUITS; TURTLE NECK SHIRTS; UNDERWEAR; UNDERWEAR, NAMELY, BOY SHORTS; VISCOUS GEL POLYMER SOLD AS A COMPONENT OF FINISHED CUSTOM CUSHIONED FOOTWEAR FOR NON-ORTHOPEDIC PURPOSES AND APPAREL; WATERPROOF JACKETS AND PANTS; WEARABLE GARMENTS AND CLOTHING, NAMELY, SHIRTS; WIND PANTS; WIND RESISTANT JACKETS; WIND SHIRTS; WIND-JACKETS; WOMEN'S ATHLETIC TOPS WITH BUILT-IN BRAS; WOMEN'S UNDERWEAR; WOVEN OR KNITTED UNDERWEAR; YOGA PANTS; YOGA SHIRTS (U.S. CLS. 22 AND 39).

FIRST USE 5-1-1996; IN COMMERCE 5-1-2000.  
KATINA MISTER, EXAMINING ATTORNEY

SN 85-191,611. BARRERA, URBELINO, JACKSON HEIGHTS, NY. FILED 12-6-2010.



THE MARK CONSISTS OF THE WORDS "CRIME PAYS" IN STYLIZED FORM COMPOSED OF CONNECTED SCRIPT "C" AND "P" WITH WINGS AT BOTH ENDS OF LOGO WITH DRIPS ON THE "C", THE "E", THE "S", AND THE DOT ON THE "I".

FOR T-SHIRTS (U.S. CLS. 22 AND 39).  
EUGENIA MARTIN, EXAMINING ATTORNEY



**CLASS 25—(Continued).**

SN 85-191,815. LESLIE BEANS, SEATTLE, WA. FILED 12-7-2010.



THE NAME(S), PORTRAIT(S), AND/OR SIGNATURE(S) SHOWN IN THE MARK DOES NOT IDENTIFY A PARTICULAR LIVING INDIVIDUAL.

FOR BASEBALL CAPS AND HATS; BOXER SHORTS; HATS; HOODED SWEAT SHIRTS; LONG-SLEEVED SHIRTS; PANTIES, SHORTS AND BRIEFS; SHIRTS AND SHORT-SLEEVED SHIRTS; T-SHIRTS; TANK-TOPS (U.S. CLS. 22 AND 39).

FIRST USE 6-25-2010; IN COMMERCE 6-25-2010.  
WENDY GOODMAN, EXAMINING ATTORNEY

SN 85-192,179. SPELL C. LLC, VAN NUYS, CA. FILED 12-7-2010.

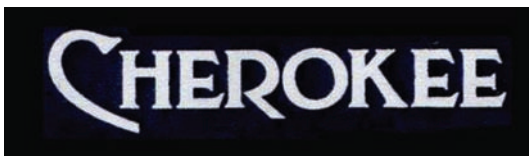

OWNER OF U.S. REG. NOS. 373,836, 1,644,461 AND OTHERS.

THE MARK CONSISTS OF THE WORD "CHEROKEE" WHERE THE "C" IS IN THE SHAPE OF A NAIL.

FOR CLOTHING, NAMELY, MEN'S AND WOMEN'S CLOTHING, NAMELY, PANTS, SLACKS, JEANS, SHORTS, SKIRTS, SHIRTS, BLOUSES, SWEATERS, T-SHIRTS, TANK TOPS, DRESSES, VESTS, SOCKS, HOSIERY, JACKETS, COATS, SCARVES, GLOVES, NECKTIES, BELTS, SWIMWEAR, UNDERWEAR, SLIPS, CAMISOLES, BRAS, NIGHTGOWNS, PAJAMAS, ROBES; INFANTS AND CHILDREN'S CLOTHING, NAMELY, T-SHIRTS, SWEATERS, LONG SLEEVED SHIRTS, SHORTS, PANTS, JUMPERS, JUMPSUITS, OVERALLS, ONE-PIECE PAYSUITS, PAJAMAS, SOCKS, DRESSES, SKIRTS; FOOTWEAR; HEADGEAR, NAMELY, HATS AND CAPS (U.S. CLS. 22 AND 39).

KATHY DE JONGE, EXAMINING ATTORNEY

**CLASS 25—(Continued).**

SN 85-192,227. SCHOTT, DANIEL, FORT WAYNE, IN. FILED 12-7-2010.



NO CLAIM IS MADE TO THE EXCLUSIVE RIGHT TO USE "KIDS", APART FROM THE MARK AS SHOWN. THE MARK CONSISTS OF "STICK-UP" IN STYLIZED FONT UNDERLINED; BELOW THE LINE IS "KIDS" IN STYLIZED FONT.

FOR HATS; JACKETS; SWEATSHIRTS; T-SHIRTS (U.S. CLS. 22 AND 39).

FIRST USE 12-0-2007; IN COMMERCE 12-0-2007.

RUSS HERMAN, EXAMINING ATTORNEY

SN 85-192,410. JACOBSON, STEVEN R, DBA WORK OR RIDE, INDEPENDENCE, MN. FILED 12-7-2010.

"Work Or Ride, You Decide"

THE MARK CONSISTS OF STANDARD CHARACTERS WITHOUT CLAIM TO ANY PARTICULAR FONT, STYLE, SIZE, OR COLOR.

FOR APPAREL SPECIFIC TO MOTORCYCLES, BICYCLES, FOUR WHEELERS, SNOWMOBILES, NAMELY, T-SHIRTS, PANTS, SWEATSHIRTS, JACKETS (U.S. CLS. 22 AND 39).

COURTNEY ALVAREZ, EXAMINING ATTORNEY

SN 85-196,212. SCHESKE, BRETT A, STURGIS, MI. FILED 12-13-2010.

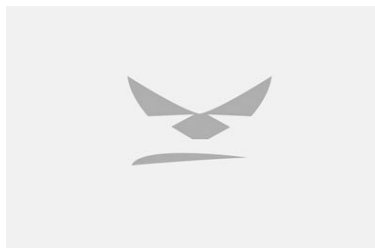

THE MARK CONSISTS OF AN ABSTRACT FACE DESIGN WITH TWO, TRIANGULAR-SHAPED EYES, A HEXAGON-SHAPED NOSE AND A SLANTED MOUTH.

FOR ATHLETIC APPAREL, NAMELY, SHIRTS, PANTS, JACKETS, FOOTWEAR, HATS AND CAPS, ATHLETIC UNIFORMS (U.S. CLS. 22 AND 39).

FIRST USE 11-1-2010; IN COMMERCE 11-12-2010.

MEGHAN REINHART, EXAMINING ATTORNEY

**CLASS 25—(Continued).**

SN 85-197,032. FRANKLIN DETRONE V., DBA TOEACHHISOWN CLOTHING COMPANY, ARLINGTON, TX. FILED 12-14-2010.

# TOEACHHISOWN

THE MARK CONSISTS OF STANDARD CHARACTERS WITHOUT CLAIM TO ANY PARTICULAR FONT, STYLE, SIZE, OR COLOR.

FOR ATHLETIC APPAREL, NAMELY, SHIRTS, PANTS, JACKETS, FOOTWEAR, HATS AND CAPS, ATHLETIC UNIFORMS (U.S. CLS. 22 AND 39).

FIRST USE 12-6-2010; IN COMMERCE 12-7-2010.  
H. M. FISHER, EXAMINING ATTORNEY

---

SN 85-198,322. CREDO MEUS QUIETIS LTD., TOKYO, JAPAN, FILED 12-15-2010.

# 020608 TEARS OF BLEU

THE MARK CONSISTS OF STANDARD CHARACTERS WITHOUT CLAIM TO ANY PARTICULAR FONT, STYLE, SIZE, OR COLOR.

OWNER OF JAPAN REG. NO. 5269356, DATED 10-2-2009, EXPIRES 10-2-2019.

THE ENGLISH TRANSLATION OF "BLEU" IN THE MARK IS "BLUE".

FOR CLOTHING, NAMELY, JEANS AND TROUSERS, GARTERS, SOCK SUSPENDERS, BRACES, WAIST-BANDS AND BELTS, FOOTWEAR, MASQUERADE COSTUMES, SPORTING/GYMNASTIC WEAR, NAMELY, T-SHIRTS, FASHION JERSEY TRACK BOTTOMS, JERSEY TOPS, PULLOVERS, JACKETS, SPECIAL SPORTING/GYMNASTIC FOOTWEAR (U.S. CLS. 22 AND 39).

JACQUELINE A. LAVINE, EXAMINING ATTORNEY

---

SN 85-199,015. BRANDED, LLC, DALLAS, TX. FILED 12-15-2010.

# Hunter Haig

THE MARK CONSISTS OF STANDARD CHARACTERS WITHOUT CLAIM TO ANY PARTICULAR FONT, STYLE, SIZE, OR COLOR.

THE NAME(S), PORTRAIT(S), AND/OR SIGNATURE(S) SHOWN IN THE MARK DOES NOT IDENTIFY A PARTICULAR LIVING INDIVIDUAL.

FOR CLOTHING, NAMELY, T-SHIRTS, SHIRTS, BLOUSES, SWEATERS, TOPS, PANTS, SHORTS, JEANS, DRESSES, SKIRTS, JACKETS, BLAZERS, SUITS, COATS, LOUNGEWEAR, SWEATSHIRTS, SOCKS, BELTS, SCARVES; FOOTWEAR; HEADWEAR (U.S. CLS. 22 AND 39).

RAMONA ORTIGA, EXAMINING ATTORNEY

**CLASS 25—(Continued).**

SN 85-199,784. ISLAND WORLD APPAREL, LOS ALAMITOS, CA. FILED 12-16-2010.

# ANTIQUA SWIM

THE MARK CONSISTS OF STANDARD CHARACTERS WITHOUT CLAIM TO ANY PARTICULAR FONT, STYLE, SIZE, OR COLOR.

NO CLAIM IS MADE TO THE EXCLUSIVE RIGHT TO USE "SWIM", APART FROM THE MARK AS SHOWN.

FOR SWIMSUITS (U.S. CLS. 22 AND 39).  
JULIE WATSON, EXAMINING ATTORNEY

---

SN 85-200,517. POMOLAS, LLC, CARROLLTON, GA. FILED 12-17-2010.



THE MARK CONSISTS OF THE ACRONYM "POMOLAS" INSIDE AN OVAL SHAPED BORDER AND THE WORDING "PEACE OF MIND ON LAND & SEA" RUNNING ALONG THE BOTTOM OF THE OVAL.

FOR HATS; JACKETS; PANTS; SANDALS; SHIRTS; SHORTS; SWEATSHIRTS; T-SHIRTS; TANK TOPS; VISORS; WRISTBANDS (U.S. CLS. 22 AND 39).  
PRISCILLA MILTON, EXAMINING ATTORNEY

---

SN 85-201,124. STURGILL, DENVER K, COLUMBUS, OH. FILED 12-17-2010.

# B.N.C.

THE MARK CONSISTS OF STANDARD CHARACTERS WITHOUT CLAIM TO ANY PARTICULAR FONT, STYLE, SIZE, OR COLOR.

FOR TOBOGGAN HAT (U.S. CLS. 22 AND 39).  
SUSAN RICHARDS, EXAMINING ATTORNEY

**CLASS 25—(Continued).**

SN 85-201,434. CHEN, SHUI, NEW YORK, NY. FILED 12-19-2010.

**SHUI CHEN NEW YORK**

THE MARK CONSISTS OF STANDARD CHARACTERS WITHOUT CLAIM TO ANY PARTICULAR FONT, STYLE, SIZE, OR COLOR.

NO CLAIM IS MADE TO THE EXCLUSIVE RIGHT TO USE "NEW YORK", APART FROM THE MARK AS SHOWN. THE NAME "SHUI CHEN" IDENTIFIES A LIVING INDIVIDUAL WHOSE CONSENT IS OF RECORD.

FOR BLOUSES; BRIDESMAID DRESSES; BUTTON DOWN SHIRTS; CAPES; CAPRI PANTS; CAPRIS; CARDIGANS; CAT SUITS; CATSUITS; CHEMISES; CHEMISSETTES; COATS; COATS FOR MEN AND WOMEN; COATS MADE OF COTTON; COATS OF DENIM; DENIM JACKETS; DENIMS; DOWN JACKETS; DOWN SUITS; DRESS PANTS; DRESS SHIRTS; DRESS SUITS; DRESSES; DRESSES MADE FROM SKINS; DRESSING GOWNS; DRESSING GOWNS AND BATH ROBES; EVENING DRESSES; EVENING GOWNS; FLEECE PULLOVERS; FLEECE TOPS; FOOTWEAR; FOOTWEAR FOR MEN; FOOTWEAR FOR MEN AND WOMEN; FUR COATS; FUR COATS AND JACKETS; GLOVES; GLOVES AS CLOTHING; GLOVES FOR APPAREL; GLOVES INCLUDING THOSE MADE OF SKIN, HIDE OR FUR; GOWNS; GREATCOATS; HATS; HEAVY COATS; HEAVY JACKETS; HOODED PULLOVERS; HOODED SWEAT SHIRTS; HOODED SWEATSHIRTS; HOODS; HOUSECOATS; INFANT WEAR; INFANTWEAR; JACKETS; JACKETS AND SOCKS; JEANS; KNIT BOTTOMS; KNIT DRESSES; KNIT SHIRTS; KNIT SKIRTS; KNIT TOPS; KNITTED CAPS; KNITTED GLOVES; LADIES' BOOTS; LADIES' SUITS; LEATHER JACKETS; LEATHER PANTS; LEATHER SHIRTS; LEATHER SHOES; LEATHER SKIRTS; LEATHER SLIPPERS; LEATHER VESTS; LONG SLEEVE PULLOVERS; LONG SLEEVED VESTS; MEN'S AND WOMEN'S JACKETS, COATS, TROUSERS, VESTS; MEN'S SUITS; MEN'S SUITS, WOMEN'S SUITS; NEGLIGEEES; NIGHT GOWNS; NIGHT SHIRTS; NIGHTWEAR; PARKAS; PULLOVERS; RAIN COATS; RAIN HATS; RAIN JACKETS; RAIN SLICKERS; RAIN SUITS; RAIN TROUSERS; RAIN WEAR; RAINCOATS; RAINPROOF JACKETS; RAINWEAR; SHAWLS AND HEADSCARVES; SHAWLS AND STOLEES; SHIRTS; SHIRTS AND SHORT-SLEEVED SHIRTS; SHIRTS AND SLIPS; SHIRTS FOR INFANTS, BABIES, TODDLERS AND CHILDREN; SHIRTS FOR SUITS; SHORT TROUSERS; SHORT-SLEEVED OR LONG-SLEEVED T-SHIRTS; SHORT-SLEEVED SHIRTS; SKIRT SUITS; SKIRTS; SKIRTS AND DRESSES; SLEEVED OR SLEEVELESS JACKETS; SLEEVELESS JERSEYS; SPORT COATS; SPORT SHIRTS; SPORTS JACKETS; SPORTS JERSEYS; SPORTS JERSEYS AND BREECHES FOR SPORTS; SPORTS PANTS; SPORTS SHIRTS; SUIT COATS; SUITS; SUITS OF LEATHER; T-SHIRTS; TANK TOPS; TANKTOPS; TANKINIS; TRACK JACKETS; TRACK PANTS; TRACK SUITS; TRACKSUITS; TRAINING SHOES; TURTLE NECK SHIRTS; TURTLENECK PULLOVERS; TURTLENECK SWEATERS; TURTLENECKS; TUXEDO BELTS; TUXEDOS; UNDERCLOTHES; WAIST BELTS; WEDDING DRESSES; WEDDING GOWNS; WIND COATS; WIND PANTS; WIND RESISTANT JACKETS; WIND SHIRTS; WIND VESTS; WIND-JACKETS; WOMEN'S CEREMONIAL DRESSES; WOMEN'S FOLDABLE SLIPPERS; WOMEN'S HATS AND HOODS; WOMEN'S SHOES; WOMEN'S SHOES, NAMELY, FOLDABLE FLATS; WOMEN'S TOPS, NAMELY, CAMIS; WOMEN'S UNDERWEAR; WOVEN BOTTOMS; WOVEN DRESSES (U.S. CLS. 22 AND 39).

FIRST USE 10-1-2010; IN COMMERCE 10-1-2010.  
BARBARA A. GOLD, EXAMINING ATTORNEY

**CLASS 25—(Continued).**

SN 85-201,442. PACIFIC HARBORS LLC, SHERWOOD, OR. FILED 12-19-2010.



THE COLOR(S) GRAY AND GREEN IS/ARE CLAIMED AS A FEATURE OF THE MARK.

THE MARK CONSISTS OF THE WORDING "UNICUTE" IN A STYLIZED FONT. THE LETTER "C" IS LARGER THAN THE OTHER LETTERS AND IS GREEN WITH GRAY OUTLINING. THE REMAINING LETTERING IS GRAY. THE COLORS BLACK AND WHITE REPRESENT BACKGROUND, SHADING AND TRANSPARENT AREAS AND ARE NOT PART OF THE MARK.

FOR FOOTWEAR FOR MEN AND WOMEN; PARTS OF CLOTHING, NAMELY, GUSSETS FOR TIGHTS, GUSSETS FOR STOCKINGS, GUSSETS FOR BATHING SUITS, GUSSETS FOR UNDERWEAR, GUSSETS FOR LEOTARDS AND GUSSETS FOR FOOTLETS; SWIMWEAR (U.S. CLS. 22 AND 39).

WENDY GOODMAN, EXAMINING ATTORNEY

SN 85-202,244. KOI DESIGN LLC, SANTA MONICA, CA. FILED 12-20-2010.



OWNER OF U.S. REG. NO. 3,878,421.  
THE NAME(S), PORTRAIT(S), AND/OR SIGNATURE(S) SHOWN IN THE MARK IDENTIFIES "KATHY PETERSON", WHOSE CONSENT(S) TO REGISTER IS MADE OF RECORD.

THE MARK CONSISTS OF THE WORD "KOI" WRITTEN VERTICALLY FROM TOP TO BOTTOM, NEXT TO A FISH AMIDST FLORAL ORNAMENTATION, NEXT TO THE WORDS "BY KATHY PETERSON" IN A SCRIPT FONT.

FOR FOOTWEAR; SHOES (U.S. CLS. 22 AND 39).  
FIRST USE 8-15-2010; IN COMMERCE 8-15-2010.  
JULIE GUTTADAURO, EXAMINING ATTORNEY

**CLASS 25—(Continued).**

SN 85-202,588. BRANDED, LLC, DALLAS, TX. FILED 12-21-2010.

**AK American Khakis**

THE MARK CONSISTS OF STANDARD CHARACTERS WITHOUT CLAIM TO ANY PARTICULAR FONT, STYLE, SIZE, OR COLOR.

NO CLAIM IS MADE TO THE EXCLUSIVE RIGHT TO USE "AMERICAN KHAKIS", APART FROM THE MARK AS SHOWN.

FOR CLOTHING, NAMELY, T-SHIRTS, SHIRTS, BLOUSES, SWEATERS, TOPS, PANTS, SHORTS, JEANS, DRESSES, SKIRTS, JACKETS, BLAZERS, SUITS, COATS, LOUNGEWEAR, SWEATSHIRTS, SOCKS, BELTS, SCARVES; FOOTWEAR, HEADWEAR (U.S. CLS. 22 AND 39).

TRACY CROSS, EXAMINING ATTORNEY

**CLASS 25—(Continued).**

SN 85-203,527. ARITZIA LP, VANCOUVER, BC, CANADA, FILED 12-22-2010.



THE MARK CONSISTS OF TWO DOGS FACING EACH OTHER, STANDING ON HIND LEGS WITH FRONT LEGS TOUCHING.

FOR BELTS; BLAZERS; BLOUSES; COATS; DRESSES; GLOVES; HATS; HEADBANDS; LINGERIE; MITTENS; OUTER JACKETS; PANTS; SCARVES; SHIRTS; SHORTS; SKIRTS; SOCKS; SWEATERS; T-SHIRTS; TANK TOPS; TIGHTS; TOQUES; TUNICS; UNDERWEAR; VESTS (U.S. CLS. 22 AND 39).

FIRST USE 10-1-2010; IN COMMERCE 10-1-2010.  
PAUL E. FAHRENKOPF, EXAMINING ATTORNEY

SN 85-202,673. MITCHELL, ALEXANDER, NORFOLK, VA. FILED 12-21-2010.

you're not getting the  
right attention if you're  
not getting herassed!

THE MARK CONSISTS OF STANDARD CHARACTERS WITHOUT CLAIM TO ANY PARTICULAR FONT, STYLE, SIZE, OR COLOR.

FOR DRESS PANTS; DRESSES; HATS; JEANS; SKIRTS; SOCKS; SUITS; SWEAT SUITS; SWEATERS; SWEATSHIRTS; T-SHIRTS; UNDERWEAR (U.S. CLS. 22 AND 39).

FIRST USE 5-17-2007; IN COMMERCE 5-17-2007.  
TRACY FLETCHER, EXAMINING ATTORNEY

SN 85-203,545. CLINTONCHARLIE, QUEENSLIFF, AUSTRALIA, FILED 12-22-2010.

SN 85-203,122. VA VA BLING, LLC, MELBOURNE, FL. FILED 12-21-2010.



THE MARK CONSISTS OF A KING'S CROWN THAT IS CLOSED AT THE TOP, PRESENTED OVER THE STYLIZED WORDS "VAVABLING" WITH FEATHERED WINGS EMANATING FROM THE TOP OF THE WORDING, WITH SCROLLED LINES AT THE BOTTOM.

FOR WEARABLE GARMENTS AND CLOTHING, NAMELY, SHIRTS (U.S. CLS. 22 AND 39).

FIRST USE 11-1-2010; IN COMMERCE 11-1-2010.  
TRACY WHITTAKER-BROWN, EXAMINING ATTORNEY

**BOOTYHUGGERS**

THE MARK CONSISTS OF STANDARD CHARACTERS WITHOUT CLAIM TO ANY PARTICULAR FONT, STYLE, SIZE, OR COLOR.

FOR CLOTHING, NAMELY, JEANS (U.S. CLS. 22 AND 39).

FIRST USE 12-12-2007; IN COMMERCE 12-12-2007.  
LAKEISHA LEWIS, EXAMINING ATTORNEY

**CLASS 25—(Continued).**

SN 85-203,924. COURTNYE JACKSON, CHICAGO, IL. FILED 12-22-2010.



OWNER OF U.S. REG. NO. 3,573,677.  
 THE COLOR(S) BLACK, GREY, BLUE, YELLOW AND RED IS/ARE CLAIMED AS A FEATURE OF THE MARK.  
 THE MARK CONSISTS OF THE WORD "7EVOLUTION" IN YELLOW IN FRONT OF A BLACK, RED, BLUE, AND YELLOW TREE WHEREIN THE TREE HAS A GRAY, BLACK, YELLOW OVAL SHADOW.  
 FOR BLOUSES; COATS; DRESSES; HATS; HOODED SWEATSHIRTS; HOODS; JACKETS; JEANS; SHIRTS; SOCKS; SWEATERS (U.S. CLS. 22 AND 39).  
 GEORGE LORENZO, EXAMINING ATTORNEY

**CLASS 25—(Continued).**

SN 85-205,399. ROSSER, COBY, WALLACE, SC. FILED 12-23-2010.



THE MARK CONSISTS OF STYLIZED WRITING IN FREEHAND CALLIGRAPHY THAT READS "PAPERINJAMAN", CENTERED UNDER A CIRCULAR GRAPHIC IN THE SHAPE OF A NINJA SMILEY FACE.  
 FOR BELTS; HATS; JACKETS; PANTS; SHIRTS; SHOES; SOCKS; UNDERGARMENTS (U.S. CLS. 22 AND 39).  
 AISHA SALEM, EXAMINING ATTORNEY

SN 85-205,484. ESTRELLA, RYAN, RICHMOND, CA. FILED 12-24-2010.

SN 85-205,351. DECARLO, ALAN, LOUDON, TN. FILED 12-23-2010.



NO CLAIM IS MADE TO THE EXCLUSIVE RIGHT TO USE "GOLF", APART FROM THE MARK AS SHOWN.  
 THE MARK CONSISTS OF THE STYLIZED TEXT "GOLF T7".  
 FOR HATS; JACKETS; PONCHOS; PULLOVERS; SHIRTS; SWEATERS; SWEATSHIRTS; T-SHIRTS; WIND RESISTANT JACKETS (U.S. CLS. 22 AND 39).  
 ROBIN CHOSID, EXAMINING ATTORNEY



THE COLOR(S) BLACK AND BROWN IS/ARE CLAIMED AS A FEATURE OF THE MARK.  
 THE MARK CONSISTS OF THE LETTERS "R" AND "E" IN BLACK COLOR WITHIN A CIRCLE SHADED BROWN AND HAVING A BLACK OUTLINE, THE LETTER "R" IS INVERSE AND COMBINED WITH THE ADJACENT LETTER "E", BELOW THE LETTERS "R" AND "E" THERE EXISTS WORDS "RICH EVOLUTION" IN BLACK AND THE WHITE COLOR BACKGROUND IS NOT CLAIMED.  
 FOR CLOTHING, NAMELY, TOPS, BOTTOMS, T-SHIRTS, SWEATERS, BEANIES, TANK TOPS, JEANS, HATS, COLLARED SHIRTS, HOODED SWEAT SHIRTS, CARDIGANS AND PULL OVERS SWEATERS (U.S. CLS. 22 AND 39).  
 EUGENIA MARTIN, EXAMINING ATTORNEY



**CLASS 25—(Continued).**

SN 85-205,507. JACKSON, ANTWAN, HAVELOCK, NC. AND JACKSON, TIMEKA, HAVELOCK, NC. FILED 12-24-2010.

MY SWEAT MY BLOOD MY TIME

THE MARK CONSISTS OF STANDARD CHARACTERS WITHOUT CLAIM TO ANY PARTICULAR FONT, STYLE, SIZE, OR COLOR.

FOR CLOTHING, NAMELY, T-SHIRTS, SWEAT SHIRTS, CAPS, PANTS, SHORTS, SOCKS, UNDERWEAR, SHOES, TANK TOPS (U.S. CLS. 22 AND 39).  
FLORENTINA BLANDU, EXAMINING ATTORNEY

**CLASS 25—(Continued).**

SN 85-205,838. HELMS, BENITA, VISTA, CA. FILED 12-27-2010.



SN 85-205,605. WALTER H. GIBSON, ALBANY, GA. FILED 12-24-2010.



NO CLAIM IS MADE TO THE EXCLUSIVE RIGHT TO USE "GEAR", APART FROM THE MARK AS SHOWN.

THE MARK CONSISTS OF A COUGAR WITH THE STYLIZED TEXT "COUGAR GEAR".

FOR BATHING SUITS; JACKETS; SHORTS; T-SHIRTS; TANK TOPS (U.S. CLS. 22 AND 39).  
JENNIFER DIXON, EXAMINING ATTORNEY

THE MARK CONSISTS OF A CARTOON IMAGE OF A SMILING PERSON WITH THE RIGHT HAND RAISED IN A POINTING GESTURE.

FOR SHORT-SLEEVED OR LONG-SLEEVED T-SHIRTS; T-SHIRTS (U.S. CLS. 22 AND 39).  
JENNY PARK, EXAMINING ATTORNEY

SN 85-206,219. PERMAUL, JENNIFER, CITRUS HEIGHTS, CA. FILED 12-27-2010.

SWEET MELONS

FITCORE

THE MARK CONSISTS OF STANDARD CHARACTERS WITHOUT CLAIM TO ANY PARTICULAR FONT, STYLE, SIZE, OR COLOR.

FOR APPAREL, NAMELY, T-SHIRTS, TANK TOPS, POLO SHIRTS, SPORTS BRAS, JACKETS, SPORTS JACKETS, COATS, RAIN SUITS, SWEATSHIRTS, SWEATPANTS, WARMUP SUITS, SWEATERS, JERSEYS, PULLOVERS, HOODED SWEATSHIRTS, TIGHTS, SHORTS, SHOES, SOCKS, SWEATBANDS, GLOVES, AND CAPS (U.S. CLS. 22 AND 39).

CHERYL CLAYTON, EXAMINING ATTORNEY

THE MARK CONSISTS OF STANDARD CHARACTERS WITHOUT CLAIM TO ANY PARTICULAR FONT, STYLE, SIZE, OR COLOR.

FOR CLOTHING, NAMELY, SWIM WEAR, BOARD SHORTS, T-SHIRTS, TANK TOPS, HALTER TOPS, TUBE TOPS, BLOUSES, SWEAT SHIRTS, HOODED SWEAT SHIRTS, SWEAT PANTS, SWEATERS, JEANS, CAPRIS, JACKETS, SKIRTS, DRESSES, UNDERWEAR, BRAS, HATS, VISORS, BEANIE CAPS, AND SOCKS; SLIPPERS; FLIP-FLOPS; SHOES; PAJAMAS; CAMISOLES (U.S. CLS. 22 AND 39).

ANTHONY RINKER, EXAMINING ATTORNEY

**CLASS 25—(Continued).**

SN 85-206,526. LOW, HARDY, RIALTO, CA. FILED 12-28-2010.

## Pradject 217

THE MARK CONSISTS OF STANDARD CHARACTERS WITHOUT CLAIM TO ANY PARTICULAR FONT, STYLE, SIZE, OR COLOR.

FOR MEN'S, WOMEN'S, CHILDREN'S, BABIES CLOTHING, NAMELY, SHIRTS, T-SHIRTS, SHIRTS THAT SNAP AT THE CROTCH, BODYSUITS, ROMPERS, PANTIES, DRESSES, SKIRTS, BLOUSES, JACKETS, COATS, FABRIC BELTS, LEATHER BELTS, CAPS, HATS, VISORS, BEANIES, FLEECE PULLOVERS, SWEATERS, JEANS, PANTS, TROUSERS, OVERALLS, SWEAT PANTS, POLO SHIRTS, SWEATSHIRTS, TANK TOPS, SHORTS, SWIM SUITS, TRUNKS, BANDANAS, SHOES, SANDALS, FOOTWEAR, THERMAL UNDERWEAR, SOCKS, NIGHT GOWNS, PAJAMAS, WIND SHIRTS, PONCHOS, VESTS, PARKAS, BOXER SHORTS, BRIEFS, UNDERWEAR, YOGA PANTS, BATHROBES, JERSEYS, CLOTH BIBS, CAPRI PANTS, CARDIGAN SWEATERS, SWEATER VESTS, BLAZERS (U.S. CLS. 22 AND 39).

PAUL F. GAST, EXAMINING ATTORNEY

**CLASS 25—(Continued).**

SN 85-206,850. JC 23 ENTERTAINMENT, INC., BEVERLY HILLS, CA. FILED 12-28-2010.



THE MARK CONSISTS OF STYLIZED CHARACTER SITTING IN YOGA STYLE.

FOR CLOTHING, FOOTWEAR AND HEADWEAR, NAMELY, T-SHIRTS, SWEAT SHIRTS, JERSEYS, SHORTS, SWEAT PANTS, JACKETS, HATS, CAPS, SCARVES, GLOVES, HOSIERY, NECKTIES, PAJAMAS, ROBES, NIGHT SHIRTS, NIGHT GOWNS, UNDERWEAR, HEAD BANDS, WRIST BANDS, SWIM SUITS, SKIRTS, SHIRTS, TANK TOPS, PANTS, COATS, SWEATERS, LEOTARDS, LEG WARMERS, STOCKINGS, SOCKS, PANTY HOSE, TIGHTS, BELTS, SHOES, ATHLETICS SHOES, SLIPPERS, BOOTS, SANDALS AND RAINWEAR (U.S. CLS. 22 AND 39).

CYNTHIA SLOAN, EXAMINING ATTORNEY

SN 85-206,787. CHOTCHKES ABROAD, INC., WESTLAKE, OH. FILED 12-28-2010.

## The Bridgets of Erin Boutique

THE MARK CONSISTS OF STANDARD CHARACTERS WITHOUT CLAIM TO ANY PARTICULAR FONT, STYLE, SIZE, OR COLOR.

NO CLAIM IS MADE TO THE EXCLUSIVE RIGHT TO USE "BOUTIQUE", APART FROM THE MARK AS SHOWN. FOR CAPS; DRESSES; HATS; SHIRTS; SOCKS; SWEATERS; SWEATPANTS; SWEATSHIRTS (U.S. CLS. 22 AND 39).

FIRST USE 12-0-1988; IN COMMERCE 12-0-1988.  
COLLEEN DOMBROW, EXAMINING ATTORNEY

SN 85-206,933. BONOMO, DANIEL, VIRGINIA BEACH, VA. FILED 12-29-2010.

## VA ALL DAY

THE MARK CONSISTS OF STANDARD CHARACTERS WITHOUT CLAIM TO ANY PARTICULAR FONT, STYLE, SIZE, OR COLOR.

NO CLAIM IS MADE TO THE EXCLUSIVE RIGHT TO USE "VA", APART FROM THE MARK AS SHOWN.

FOR CLOTHING, NAMELY, HATS, T-SHIRTS, PANTS, LONG-SLEEVED SHIRTS, JACKETS, SWEATERS, SOCKS, SHOES, BEANIES, HOODED T-SHIRTS, BANDANA, GLOVES, AND BELTS FOR CHILDREN, ADULTS, AND TEENS OF ALL AGES (U.S. CLS. 22 AND 39).

LAURIE MAYES, EXAMINING ATTORNEY

**CLASS 25—(Continued).**

SN 85-207,016. BRANDED, LLC, DALLAS, TX. FILED 12-29-2010.

## Body English

THE MARK CONSISTS OF STANDARD CHARACTERS WITHOUT CLAIM TO ANY PARTICULAR FONT, STYLE, SIZE, OR COLOR.

NO CLAIM IS MADE TO THE EXCLUSIVE RIGHT TO USE "BODY", APART FROM THE MARK AS SHOWN.

FOR CLOTHING, NAMELY, T-SHIRTS, SHIRTS, BLOUSES, SWEATERS, TOPS, PANTS, SHORTS, JEANS, DRESSES, SKIRTS, JACKETS, BLAZERS, SUITS, COATS, LOUNGEWEAR, SWEATSHIRTS, SOCKS, BELTS, SCARVES; FOOTWEAR, HEADWEAR (U.S. CLS. 22 AND 39).

TRACY CROSS, EXAMINING ATTORNEY

**CLASS 25—(Continued).**

SN 85-207,258. ABERCROMBIE & FITCH TRADING CO., NEW ALBANY, OH. FILED 12-29-2010.

## HOLLISTER CALI

THE MARK CONSISTS OF STANDARD CHARACTERS WITHOUT CLAIM TO ANY PARTICULAR FONT, STYLE, SIZE, OR COLOR.

OWNER OF U.S. REG. NOS. 3,310,650, 3,605,286 AND OTHERS.

NO CLAIM IS MADE TO THE EXCLUSIVE RIGHT TO USE "CALI", APART FROM THE MARK AS SHOWN.

FOR BELTS; BOTTOMS; COATS; DRESSES; FOOTWEAR; GLOVES; HEADWEAR; JACKETS; LEGGINGS; SCARVES; SLEEPWEAR; SWIM WEAR; TOPS; UNDERGARMENTS (U.S. CLS. 22 AND 39).

TRACY FLETCHER, EXAMINING ATTORNEY

SN 85-207,260. ABERCROMBIE & FITCH TRADING CO., NEW ALBANY, OH. FILED 12-29-2010.

## HCO SO CAL

THE MARK CONSISTS OF STANDARD CHARACTERS WITHOUT CLAIM TO ANY PARTICULAR FONT, STYLE, SIZE, OR COLOR.

OWNER OF U.S. REG. NOS. 3,393,268, 3,649,826 AND OTHERS.

NO CLAIM IS MADE TO THE EXCLUSIVE RIGHT TO USE "SO CAL", APART FROM THE MARK AS SHOWN.

FOR BELTS; BOTTOMS; COATS; DRESSES; FOOTWEAR; GLOVES; HEADWEAR; JACKETS; LEGGINGS; SCARVES; SLEEPWEAR; SWIM WEAR; TOPS; UNDERGARMENTS (U.S. CLS. 22 AND 39).

TRACY FLETCHER, EXAMINING ATTORNEY

SN 85-207,261. ABERCROMBIE & FITCH TRADING CO., NEW ALBANY, OH. FILED 12-29-2010.

## HCO SURF CLUB

THE MARK CONSISTS OF STANDARD CHARACTERS WITHOUT CLAIM TO ANY PARTICULAR FONT, STYLE, SIZE, OR COLOR.

OWNER OF U.S. REG. NOS. 3,393,268, 3,649,826 AND OTHERS.

NO CLAIM IS MADE TO THE EXCLUSIVE RIGHT TO USE "SURF CLUB", APART FROM THE MARK AS SHOWN.

FOR BELTS; BOTTOMS; COATS; DRESSES; FOOTWEAR; GLOVES; HEADWEAR; JACKETS; LEGGINGS; SCARVES; SLEEPWEAR; SWIM WEAR; TOPS; UNDERGARMENTS (U.S. CLS. 22 AND 39).

TRACY FLETCHER, EXAMINING ATTORNEY

SN 85-207,049. SAFIER, ERIC, DAWSONVILLE, GA. FILED 12-29-2010.



NO CLAIM IS MADE TO THE EXCLUSIVE RIGHT TO USE "MMA", APART FROM THE MARK AS SHOWN.

THE MARK CONSISTS OF THE WORDING "HOUSECAT MMA" BELOW THE STYLIZED DESIGN OF A CAT; ALL APPEARING ON A SHIELD DESIGN WITH AN ORNATE BORDER CONTAINING GUNS, WINGS AND BARBED WIRE.

FOR CLOTHING, NAMELY, T-SHIRTS, SHORTS, RASH GUARD, AND TOBOGGANS, NAMELY, HATS AND CAPS (U.S. CLS. 22 AND 39).

FIRST USE 10-20-2010; IN COMMERCE 11-20-2010.

JEFFERY COWARD, EXAMINING ATTORNEY

**CLASS 25—(Continued).**

SN 85-207,262. ABERCROMBIE & FITCH TRADING CO.,  
NEW ALBANY, OH. FILED 12-29-2010.

**HOLLISTER SURF CLUB**

THE MARK CONSISTS OF STANDARD CHARACTERS  
WITHOUT CLAIM TO ANY PARTICULAR FONT, STYLE,  
SIZE, OR COLOR.

OWNER OF U.S. REG. NOS. 3,310,650, 3,605,286 AND  
OTHERS.

NO CLAIM IS MADE TO THE EXCLUSIVE RIGHT TO  
USE "SURF CLUB", APART FROM THE MARK AS SHOWN.

FOR BELTS; BOTTOMS; COATS; DRESSES; FOOT-  
WEAR; GLOVES; HEADWEAR; JACKETS; LEGGINGS;  
SCARVES; SLEEPWEAR; SWIM WEAR; TOPS; UNDER-  
GARMENTS (U.S. CLS. 22 AND 39).

TRACY FLETCHER, EXAMINING ATTORNEY

---

SN 85-207,264. ABERCROMBIE & FITCH TRADING CO.,  
NEW ALBANY, OH. FILED 12-29-2010.

**HCO SURF COMPANY**

THE MARK CONSISTS OF STANDARD CHARACTERS  
WITHOUT CLAIM TO ANY PARTICULAR FONT, STYLE,  
SIZE, OR COLOR.

OWNER OF U.S. REG. NOS. 3,393,268, 3,649,826 AND  
OTHERS.

NO CLAIM IS MADE TO THE EXCLUSIVE RIGHT TO  
USE "SURF COMPANY", APART FROM THE MARK AS  
SHOWN.

FOR BELTS; BOTTOMS; COATS; DRESSES; FOOT-  
WEAR; GLOVES; HEADWEAR; JACKETS; LEGGINGS;  
SCARVES; SLEEPWEAR; SWIM WEAR; TOPS; UNDER-  
GARMENTS (U.S. CLS. 22 AND 39).

TRACY FLETCHER, EXAMINING ATTORNEY

---

SN 85-207,266. ABERCROMBIE & FITCH TRADING CO.,  
NEW ALBANY, OH. FILED 12-29-2010.

**HOLLISTER SURF COMPANY**

THE MARK CONSISTS OF STANDARD CHARACTERS  
WITHOUT CLAIM TO ANY PARTICULAR FONT, STYLE,  
SIZE, OR COLOR.

OWNER OF U.S. REG. NOS. 3,310,650, 3,605,286 AND  
OTHERS.

NO CLAIM IS MADE TO THE EXCLUSIVE RIGHT TO  
USE "SURF COMPANY", APART FROM THE MARK AS  
SHOWN.

FOR BELTS; BOTTOMS; COATS; DRESSES; FOOT-  
WEAR; GLOVES; HEADWEAR; JACKETS; LEGGINGS;  
SCARVES; SLEEPWEAR; SWIM WEAR; TOPS; UNDER-  
GARMENTS (U.S. CLS. 22 AND 39).

TRACY FLETCHER, EXAMINING ATTORNEY

**CLASS 25—(Continued).**

SN 85-207,271. ABERCROMBIE & FITCH TRADING CO.,  
NEW ALBANY, OH. FILED 12-29-2010.

**HCO SURF CHASERS**

THE MARK CONSISTS OF STANDARD CHARACTERS  
WITHOUT CLAIM TO ANY PARTICULAR FONT, STYLE,  
SIZE, OR COLOR.

OWNER OF U.S. REG. NOS. 3,393,268, 3,649,826 AND  
OTHERS.

NO CLAIM IS MADE TO THE EXCLUSIVE RIGHT TO  
USE "SURF", APART FROM THE MARK AS SHOWN.

FOR BELTS; BOTTOMS; COATS; DRESSES; FOOT-  
WEAR; GLOVES; HEADWEAR; JACKETS; LEGGINGS;  
SCARVES; SLEEPWEAR; SWIM WEAR; TOPS; UNDER-  
GARMENTS (U.S. CLS. 22 AND 39).

TRACY FLETCHER, EXAMINING ATTORNEY

---

SN 85-207,272. BOLAND, CHARLES B., LAWRENCEVILLE,  
GA. FILED 12-29-2010.

**Aqua Native**

THE MARK CONSISTS OF STANDARD CHARACTERS  
WITHOUT CLAIM TO ANY PARTICULAR FONT, STYLE,  
SIZE, OR COLOR.

FOR CLOTHING AND APPAREL FOR MEN, WOMEN  
AND CHILDREN, NAMELY, SHIRTS, T-SHIRTS,  
SHORTS, PANTS, SWEATPANTS; SWIM WEAR,  
NAMELY, BATHING SUITS, SWIM COVER -UPS, SAR-  
ONGS; HEADGEAR, NAMELY, HATS, HEADBANDS;  
OUTER WEAR, NAMELY, JACKETS, PANTS, PULL-  
OVERS, SWEATSHIRTS, HOODED PULLOVERS; SURF  
WEAR, WATER PROOF AND WATER REPELLENT  
CLOTHES, NAMELY, JACKETS, PANTS, FOOTWEAR;  
ATHLETIC WEAR, NAMELY, SHIRTS, SHORTS;  
LOUNGE WEAR, ROBES, SLEEP WEAR (U.S. CLS. 22  
AND 39).

ANGELA DUONG, EXAMINING ATTORNEY

**CLASS 25—(Continued).**

SN 85-207,273. ABERCROMBIE & FITCH TRADING CO.,  
NEW ALBANY, OH. FILED 12-29-2010.

**HOLLISTER SURF CHASERS**

THE MARK CONSISTS OF STANDARD CHARACTERS WITHOUT CLAIM TO ANY PARTICULAR FONT, STYLE, SIZE, OR COLOR.

OWNER OF U.S. REG. NOS. 3,310,650, 3,605,286 AND OTHERS.

NO CLAIM IS MADE TO THE EXCLUSIVE RIGHT TO USE "SURF", APART FROM THE MARK AS SHOWN.

FOR BELTS; BOTTOMS; COATS; DRESSES; FOOTWEAR; GLOVES; HEADWEAR; JACKETS; LEGGINGS; SCARVES; SLEEPWEAR; SWIM WEAR; TOPS; UNDERGARMENTS (U.S. CLS. 22 AND 39).

TRACY FLETCHER, EXAMINING ATTORNEY

---

SN 85-207,287. ABERCROMBIE & FITCH TRADING CO.,  
NEW ALBANY, OH. FILED 12-29-2010.

**HOLLISTER MALIBU**

THE MARK CONSISTS OF STANDARD CHARACTERS WITHOUT CLAIM TO ANY PARTICULAR FONT, STYLE, SIZE, OR COLOR.

OWNER OF U.S. REG. NOS. 3,310,650, 3,605,286 AND OTHERS.

NO CLAIM IS MADE TO THE EXCLUSIVE RIGHT TO USE "MALIBU", APART FROM THE MARK AS SHOWN.

FOR BELTS; BOTTOMS; COATS; DRESSES; FOOTWEAR; GLOVES; HEADWEAR; JACKETS; LEGGINGS; SCARVES; SLEEPWEAR; SWIM WEAR; TOPS; UNDERGARMENTS (U.S. CLS. 22 AND 39).

JOHN DALIER, EXAMINING ATTORNEY

---

SN 85-207,291. ABERCROMBIE & FITCH TRADING CO.,  
NEW ALBANY, OH. FILED 12-29-2010.

**HCO DEL MAR**

THE MARK CONSISTS OF STANDARD CHARACTERS WITHOUT CLAIM TO ANY PARTICULAR FONT, STYLE, SIZE, OR COLOR.

OWNER OF U.S. REG. NOS. 3,393,268, 3,649,826 AND OTHERS.

NO CLAIM IS MADE TO THE EXCLUSIVE RIGHT TO USE "DEL MAR", APART FROM THE MARK AS SHOWN.

FOR BELTS; BOTTOMS; COATS; DRESSES; FOOTWEAR; GLOVES; HEADWEAR; JACKETS; LEGGINGS; SCARVES; SLEEPWEAR; SWIM WEAR; TOPS; UNDERGARMENTS (U.S. CLS. 22 AND 39).

JOHN DALIER, EXAMINING ATTORNEY

**CLASS 25—(Continued).**

SN 85-207,296. ABERCROMBIE & FITCH TRADING CO.,  
NEW ALBANY, OH. FILED 12-29-2010.

**HOLLISTER DEL MAR**

THE MARK CONSISTS OF STANDARD CHARACTERS WITHOUT CLAIM TO ANY PARTICULAR FONT, STYLE, SIZE, OR COLOR.

OWNER OF U.S. REG. NOS. 3,310,650, 3,605,286 AND OTHERS.

NO CLAIM IS MADE TO THE EXCLUSIVE RIGHT TO USE "DEL MAR", APART FROM THE MARK AS SHOWN.

FOR BELTS; BOTTOMS; COATS; DRESSES; FOOTWEAR; GLOVES; HEADWEAR; JACKETS; LEGGINGS; SCARVES; SLEEPWEAR; SWIM WEAR; TOPS; UNDERGARMENTS (U.S. CLS. 22 AND 39).

JOHN DALIER, EXAMINING ATTORNEY

---

SN 85-207,298. ABERCROMBIE & FITCH TRADING CO.,  
NEW ALBANY, OH. FILED 12-29-2010.

**HCO SANTA MONICA**

THE MARK CONSISTS OF STANDARD CHARACTERS WITHOUT CLAIM TO ANY PARTICULAR FONT, STYLE, SIZE, OR COLOR.

OWNER OF U.S. REG. NOS. 3,393,268, 3,649,826 AND OTHERS.

NO CLAIM IS MADE TO THE EXCLUSIVE RIGHT TO USE "SANTA MONICA", APART FROM THE MARK AS SHOWN.

FOR BELTS; BOTTOMS; COATS; DRESSES; FOOTWEAR; GLOVES; HEADWEAR; JACKETS; LEGGINGS; SCARVES; SLEEPWEAR; SWIM WEAR; TOPS; UNDERGARMENTS (U.S. CLS. 22 AND 39).

JOHN DALIER, EXAMINING ATTORNEY

---

SN 85-207,300. ABERCROMBIE & FITCH TRADING CO.,  
NEW ALBANY, OH. FILED 12-29-2010.

**HOLLISTER SANTA MONICA**

THE MARK CONSISTS OF STANDARD CHARACTERS WITHOUT CLAIM TO ANY PARTICULAR FONT, STYLE, SIZE, OR COLOR.

OWNER OF U.S. REG. NOS. 3,310,650, 3,605,286 AND OTHERS.

NO CLAIM IS MADE TO THE EXCLUSIVE RIGHT TO USE "SANTA MONICA", APART FROM THE MARK AS SHOWN.

FOR BELTS; BOTTOMS; COATS; DRESSES; FOOTWEAR; GLOVES; HEADWEAR; JACKETS; LEGGINGS; SCARVES; SLEEPWEAR; SWIM WEAR; TOPS; UNDERGARMENTS (U.S. CLS. 22 AND 39).

JOHN DALIER, EXAMINING ATTORNEY



**CLASS 25—(Continued).**

SN 85-207,303. BOULINEAU, MELISSA, GULFPORT, FL. FILED 12-29-2010.



THE MARK CONSISTS OF THE STYLIZED WORDING "BEANWHERE WHERE ALL YOUR BEANS COME TRUE!" AND A CARTOON BEAN WITH EYES AND A MOUTH. FOR PANTS; SHORTS; SWEATSHIRTS; T-SHIRTS (U.S. CLS. 22 AND 39). HOWARD B. LEVINE, EXAMINING ATTORNEY

SN 85-207,391. ABERCROMBIE & FITCH TRADING CO., NEW ALBANY, OH. FILED 12-29-2010.

**HOLLISTER MALIBU MANIACS**

THE MARK CONSISTS OF STANDARD CHARACTERS WITHOUT CLAIM TO ANY PARTICULAR FONT, STYLE, SIZE, OR COLOR. OWNER OF U.S. REG. NOS. 3,310,650, 3,605,286 AND OTHERS. NO CLAIM IS MADE TO THE EXCLUSIVE RIGHT TO USE "MALIBU", APART FROM THE MARK AS SHOWN. FOR BELTS; BOTTOMS; COATS; DRESSES; FOOTWEAR; GLOVES; HEADWEAR; JACKETS; LEGGINGS; SCARVES; SLEEPWEAR; SWIM WEAR; TOPS; UNDERGARMENTS (U.S. CLS. 22 AND 39). TRACY FLETCHER, EXAMINING ATTORNEY

SN 85-207,491. LITTLE BAY ROOT LLC, PORTLAND, OR. FILED 12-29-2010.



THE MARK CONSISTS OF THE STYLIZED WORDING "LITTLE BAY ROOT" WITH A SMALL EVERGREEN TO THE RIGHT OF THE WORD "LITTLE". FOR HOODED SWEATSHIRTS; SWEATSHIRTS; T-SHIRTS; TANK TOPS (U.S. CLS. 22 AND 39). FIRST USE 7-1-2009; IN COMMERCE 7-1-2009. KELLY BOULTON, EXAMINING ATTORNEY

**CLASS 25—(Continued).**

SN 85-207,700. YOUNG, KEMANEY, NORTH HOLLYWOOD, CA. FILED 12-30-2010.



THE MARK CONSISTS OF A CUPCAKE, WHICH CONSTITUTES THE HEAD OF A CARTOON CHARACTER. FOR CLOTHING, NAMELY, SHIRT, JACKETS, SWEATERS, HOODED SWEATSHIRTS, DRESSES, PANTS, SKIRTS, YOGA PANTS, YOGA SHIRTS, GYM SUITS (U.S. CLS. 22 AND 39). EUGENIA MARTIN, EXAMINING ATTORNEY

SN 85-207,709. JACKSON, ANTWAN, HAVELOCK, NC. AND JACKSON, TIMEKA, HAVELOCK, NC. FILED 12-30-2010.



THE COLOR(S) RED, WHITE, BLACK, GOLD AND GREY IS/ARE CLAIMED AS A FEATURE OF THE MARK. THE MARK CONSISTS OF A LETTER "S" WRITTEN IN BLACK COLOR IN THE MIDDLE OF SHIELD WHICH IS IN RED AND WHITE COLOR HAVING WINGS AND THERE IS A CROWN WITH THORNS IN BLACK AND GOLD COLOR ON THE TOP OF THE SHIELD. BELOW THE SHIELD THERE IS A RIBBON IN GREY AND WHITE COLOR AND THE WORD "SACRIFICE" IS WRITTEN IN THE CENTER IN BLACK COLOR AS SHOWN IN THE MARK. THE WHITE BACKGROUND IS NOT CLAIMED AS THE FEATURE OF THE MARK. FOR CLOTHING, NAMELY, T-SHIRTS, SWEAT SHIRTS, CAPS (U.S. CLS. 22 AND 39). FLORENTINA BLANDU, EXAMINING ATTORNEY

**CLASS 25—(Continued).**

SN 85-207,738. THE AYE-MA CORPORATION, WILBRAHAM, MA. FILED 12-30-2010.



THE MARK CONSISTS OF THE OUTLINE OF A SIDE PROFILE OF A HUMAN FACE SITTING ON A SINGLE WAVY LINE ALL ENCLOSED WITHIN A BROKEN CIRCLE. A SEVEN-POINT STAR APPEARS IN THE UPPER RIGHT QUADRANT OF THE BROKEN CIRCLE.

FOR FASHION APPAREL AND ACCESSORIES, NAMELY, T-SHIRTS, POLO SHIRTS, SWEAT SHIRTS, HOODED SHIRTS, JACKETS, TANK TOPS, HATS, HEAD GEAR IN THE NATURE OF CAPS, SCARVES, SWEATERS, SWEATPANTS, PANTS, JEANS, SHORTS, SKIRTS, UNDERWEAR, SOCKS, UNIFORMS, AND LEG WEAR IN THE NATURE OF TIGHTS AND HOSIERY (U.S. CLS. 22 AND 39).

MAUREEN DALL, EXAMINING ATTORNEY

SN 85-207,748. THE AYE-MA CORPORATION, WILBRAHAM, MA. FILED 12-30-2010.



THE MARK CONSISTS OF THE LITERAL ELEMENT "FUN 2 B ME! (WHAT'S YOUR AYE-MA?)" PRESENTED IN THREE LINES OF TEXT. THE WORD "YOUR" IS UNDERLINED. A SEVEN-POINT STAR APPEARS ABOVE THE "N" IN "FUN".

THE WORDING "AYE-MA" HAS NO MEANING IN A FOREIGN LANGUAGE.

FOR FASHION APPAREL AND ACCESSORIES, NAMELY, T-SHIRTS, POLO SHIRTS, SWEAT SHIRTS, HOODED SHIRTS, JACKETS, TANK TOPS, HATS, HEAD GEAR IN THE NATURE OF CAPS, SCARVES, SWEATERS, SWEATPANTS, PANTS, JEANS, SHORTS, SKIRTS, UNDERWEAR, SOCKS, UNIFORMS, AND LEG WEAR IN THE NATURE OF TIGHTS AND HOSIERY (U.S. CLS. 22 AND 39).

MAUREEN DALL, EXAMINING ATTORNEY

**CLASS 25—(Continued).**

SN 85-207,911. BEERME, LLC, DBA LIVEME, SOUTH PORTLAND, ME. FILED 12-30-2010.

# LiveME

THE MARK CONSISTS OF STANDARD CHARACTERS WITHOUT CLAIM TO ANY PARTICULAR FONT, STYLE, SIZE, OR COLOR.

FOR CLOTHING, NAMELY, T-SHIRTS, LONG SLEEVE SHIRTS AND SWEATSHIRTS; ACCESSORIES AND APPAREL, NAMELY, HATS AND BANDANAS (U.S. CLS. 22 AND 39).

ALLISON HOLTZ, EXAMINING ATTORNEY

SN 85-208,039. EXTREME SPORTS DIVAS, LLC, OREGON, WI. FILED 12-30-2010.

# LIL SLED DIVAS

THE MARK CONSISTS OF STANDARD CHARACTERS WITHOUT CLAIM TO ANY PARTICULAR FONT, STYLE, SIZE, OR COLOR.

OWNER OF U.S. REG. NOS. 3,887,999 AND 3,932,547.

FOR HATS; SWEAT SHIRTS; WEARABLE GARMENTS AND CLOTHING, NAMELY, SHIRTS (U.S. CLS. 22 AND 39).

FIRST USE 10-15-2010; IN COMMERCE 10-15-2010.

MARK SHINER, EXAMINING ATTORNEY

SN 85-208,146. DML MARKETING GROUP, LTD, VAN NUYS, CA. FILED 12-30-2010.

# Pillow Pods

THE MARK CONSISTS OF STANDARD CHARACTERS WITHOUT CLAIM TO ANY PARTICULAR FONT, STYLE, SIZE, OR COLOR.

OWNER OF U.S. REG. NO. 3,554,809.

FOR SOCKS (U.S. CLS. 22 AND 39).

MARCIE MILONE, EXAMINING ATTORNEY

**CLASS 25—(Continued).**

SN 85-208,289. SEBAGO USA, LLC, ROCKFORD, MI. FILED 12-30-2010.

**DRYSIDES**

THE MARK CONSISTS OF STANDARD CHARACTERS WITHOUT CLAIM TO ANY PARTICULAR FONT, STYLE, SIZE, OR COLOR.

OWNER OF U.S. REG. NO. 3,928,803.  
FOR BELTS; COATS; GLOVES; HATS; JACKETS; PANTS; SCARVES; SHIRTS; SHORTS; SOCKS; SWEATERS; SWEATSHIRTS; VESTS (U.S. CLS. 22 AND 39).  
CORY BOONE, EXAMINING ATTORNEY

SN 85-208,388. WILLIAMS, ALVIA CRYSTAL, WASHINGTON, DC. FILED 12-30-2010.

**Foot Soothe**

THE MARK CONSISTS OF STANDARD CHARACTERS WITHOUT CLAIM TO ANY PARTICULAR FONT, STYLE, SIZE, OR COLOR.

NO CLAIM IS MADE TO THE EXCLUSIVE RIGHT TO USE "FOOT", APART FROM THE MARK AS SHOWN.

FOR HOSIERY, SOCKS, PANTYHOSE (U.S. CLS. 22 AND 39).

WANDA KAY PRICE, EXAMINING ATTORNEY

SN 85-208,844. CLARK, THERESA B., LEONARD, MI. FILED 1-2-2011.



The logo features the word "TURTLE" in a bold, stylized font with a small registered trademark symbol (®) to the upper right. Below "TURTLE" is the word "GLOVES" in a simpler, bold, sans-serif font.

NO CLAIM IS MADE TO THE EXCLUSIVE RIGHT TO USE "GLOVES", APART FROM THE MARK AS SHOWN.

THE MARK CONSISTS OF THE WORD "GLOVES" BELOW A STYLIZED TEXT OF THE WORD "TURTLE" IN THE SHAPE OF A TURTLE.

FOR CLOTHING, NAMELY, ARM WARMERS; CLOTHING, NAMELY, HAND-WARMERS; GLOVES; GLOVES AS CLOTHING; GLOVES FOR APPAREL; HATS; OUTDOOR GLOVES; SCARVES (U.S. CLS. 22 AND 39).

FIRST USE 12-22-2010; IN COMMERCE 12-22-2010.  
ROBIN MITTLER, EXAMINING ATTORNEY

**CLASS 25—(Continued).**

SN 85-209,239. THUNDERHEAD GEAR, LLC, HOUSTON, TX. FILED 1-3-2011.

**TOPsock**

THE MARK CONSISTS OF STANDARD CHARACTERS WITHOUT CLAIM TO ANY PARTICULAR FONT, STYLE, SIZE, OR COLOR.

FOR HEADWEAR (U.S. CLS. 22 AND 39).  
MICHAEL WEBSTER, EXAMINING ATTORNEY

SN 85-209,267. GNL ENTERTAINMENT, INC., WASHINGTON, DC. FILED 1-3-2011.

**Music-Ebru**

THE MARK CONSISTS OF STANDARD CHARACTERS WITHOUT CLAIM TO ANY PARTICULAR FONT, STYLE, SIZE, OR COLOR.

THE ENGLISH TRANSLATION OF THE TURKISH WORD "EBRU" IN THE MARK IS "TURKISH PAPER MARBLING".

FOR CLOTHING AND UNDERWEAR, NAMELY, JERSEYS, SHIRTS, T-SHIRTS, LINGERIE, BELTS, SCARVES, TIES, SHAWLS, WAISTCOATS, SKIRTS, RAINCOATS, OVERCOATS, BRACES, TROUSERS, DENIM TROUSERS, PULLOVERS, DRESSES, JACKETS, SASHES FOR WEAR, GLOVES, TIGHTS, SOCKS, BATHING SUITS, BATH ROBES, PAJAMAS, NIGHTSHIRTS, SHORTS, POCKET SQUARES; SHOES, BOOTS, SLIPPERS; HEADWEAR, NAMELY, HATS, CAPS AND BEANIES (U.S. CLS. 22 AND 39).

ANDREA HACK, EXAMINING ATTORNEY

SN 85-209,277. GNL ENTERTAINMENT, INC., WASHINGTON, DC. FILED 1-3-2011.

**Painted On Water**

THE MARK CONSISTS OF STANDARD CHARACTERS WITHOUT CLAIM TO ANY PARTICULAR FONT, STYLE, SIZE, OR COLOR.

FOR CLOTHING AND UNDERWEAR, NAMELY, JERSEYS, SHIRTS, T-SHIRTS, LINGERIE, BELTS, SCARVES, TIES, SHAWLS, WAISTCOATS, SKIRTS, RAINCOATS, OVERCOATS, BRACES, TROUSERS, DENIM TROUSERS, PULLOVERS, DRESSES, JACKETS, SASHES FOR WEAR, GLOVES, TIGHTS, SOCKS, BATHING SUITS, BATH ROBES, PAJAMAS, NIGHTSHIRTS, SHORTS, POCKET SQUARES; SHOES, BOOTS, SLIPPERS; HEADWEAR, NAMELY, HATS, CAPS AND BEANIES (U.S. CLS. 22 AND 39).

ANDREA HACK, EXAMINING ATTORNEY

**CLASS 25—(Continued).**

SN 85-209,575. JILL&DONNA, BLUFFTON, IN. FILED 1-3-2011.

# the drib

THE MARK CONSISTS OF STANDARD CHARACTERS WITHOUT CLAIM TO ANY PARTICULAR FONT, STYLE, SIZE, OR COLOR.

FOR CLOTH BIBS (U.S. CLS. 22 AND 39).  
FIRST USE 9-27-2005; IN COMMERCE 9-27-2005.  
JAMES GRIFFIN, EXAMINING ATTORNEY

SN 85-209,892. DOMINGEZ MUÑOZ, ELIANA MARGOT, MEDELLIN, ANTIOQUIA, COLOMBIA, AND DOMINGEZ MUÑOZ, EDWIN CAMILO, MEDELLIN, ANTIOQUIA, COLOMBIA, FILED 1-4-2011.



THE COLOR(S) RED AND WHITE IS/ARE CLAIMED AS A FEATURE OF THE MARK.

THE MARK CONSISTS OF THE WORDING "DI:TWO" IN WHITE LETTERING AGAINST A RED RECTANGULAR SHAPED BACKGROUND.

FOR BLOUSES; BRAS; DRESSES; JEANS; SHIRTS; SHORT TROUSERS; SHORTS; SKIRTS; SOCKS; SWIMWEAR; T-SHIRTS; THONGS (U.S. CLS. 22 AND 39).  
BRIDGETT SMITH, EXAMINING ATTORNEY

SN 85-210,047. OCEAN MINDED, INC., NIWOT, CO. FILED 1-4-2011.

# LIVE. PROTECT. RESPECT.

THE MARK CONSISTS OF STANDARD CHARACTERS WITHOUT CLAIM TO ANY PARTICULAR FONT, STYLE, SIZE, OR COLOR.

OWNER OF U.S. REG. NO. 3,917,328.  
FOR HATS (U.S. CLS. 22 AND 39).  
FIRST USE 3-22-2010; IN COMMERCE 3-22-2010.  
NANCY CLARKE, EXAMINING ATTORNEY

**CLASS 25—(Continued).**

SN 85-210,057. CUMINATO, FAITH, AUSTIN, TX. FILED 1-4-2011.

# Bella Bottoms

THE MARK CONSISTS OF STANDARD CHARACTERS WITHOUT CLAIM TO ANY PARTICULAR FONT, STYLE, SIZE, OR COLOR.

NO CLAIM IS MADE TO THE EXCLUSIVE RIGHT TO USE "BOTTOMS", APART FROM THE MARK AS SHOWN.

THE ENGLISH TRANSLATION OF "BELLA" IN THE MARK IS "BEAUTIFUL".

FOR CLOTH DIAPERS (U.S. CLS. 22 AND 39).  
FIRST USE 1-9-2001; IN COMMERCE 1-9-2001.  
PAUL F. GAST, EXAMINING ATTORNEY

SN 85-210,715. SNAPANTS, LLC, DAVIE, FL. FILED 1-5-2011.

# Snap it right every time!

THE MARK CONSISTS OF STANDARD CHARACTERS WITHOUT CLAIM TO ANY PARTICULAR FONT, STYLE, SIZE, OR COLOR.

FOR CHILDREN'S CLOTHING, NAMELY, ROMPERS FEATURING SPECIAL COLORED-CODED SNAP-ON FASTENERS (U.S. CLS. 22 AND 39).

SIMON TENG, EXAMINING ATTORNEY

SN 85-211,325. SANDERS, MICHAEL, LAS VEGAS, NV. FILED 1-5-2011.



THE MARK CONSISTS OF THE STYLIZED TEXT "MOSJR" WITHIN AN ABSTRACT DESIGN COMBINING THE FOUR PLAYING CARD SUITS, SPECIFICALLY, A DIAMOND, A CLUB, A SPADE AND A HEART.

FOR PANTS; SCARFS; SHIRTS; SHOES (U.S. CLS. 22 AND 39).

KATHERINE STOIDES, EXAMINING ATTORNEY

**CLASS 25—(Continued).**

SN 85-211,474. MEYERS, ARTURO, ROSEDALE, QUEENS, NY. FILED 1-5-2011.

## MichealTuro

THE MARK CONSISTS OF STANDARD CHARACTERS WITHOUT CLAIM TO ANY PARTICULAR FONT, STYLE, SIZE, OR COLOR.

THE NAME ARTURO MEYERS IDENTIFIES A LIVING INDIVIDUAL WHOSE CONSENT IS OF RECORD.

FOR HATS; JACKETS; PANTS; SHIRTS (U.S. CLS. 22 AND 39).

PAUL F. GAST, EXAMINING ATTORNEY

SN 85-211,742. SEYCHELLES IMPORTS, LLC, EL SEGUNDO, CA. FILED 1-6-2011.

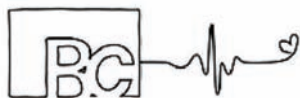

OWNER OF U.S. REG. NO. 3,004,155.

THE MARK CONSISTS OF THE STYLIZED LETTERS "BC" WITHIN A BOX WITH A FANCIFUL GEOMETRIC DESIGN WITH A HEART TO THE FAR RIGHT.

FOR FOOTWEAR (U.S. CLS. 22 AND 39).

STEPHANIE ALI, EXAMINING ATTORNEY

SN 85-211,830. VINCENT EDWARD JACKSON, MOBILE, AL. FILED 1-6-2011.

## 3 AUmigos 7, 34, 2

THE MARK CONSISTS OF STANDARD CHARACTERS WITHOUT CLAIM TO ANY PARTICULAR FONT, STYLE, SIZE, OR COLOR.

FOR APPAREL, NAMELY, SHIRTS, PANTS, JACKETS, HATS AND CAPS (U.S. CLS. 22 AND 39).

ALEXANDER L. POWERS, EXAMINING ATTORNEY

**CLASS 25—(Continued).**

SN 85-211,995. PEACHTREE AND 5TH, ATLANTA, GA. FILED 1-6-2011.

## Caboosier

THE MARK CONSISTS OF STANDARD CHARACTERS WITHOUT CLAIM TO ANY PARTICULAR FONT, STYLE, SIZE, OR COLOR.

FOR HATS; JEANS; PANTS; SHIRTS; SHORTS; SWEAT PANTS; SWEAT SHIRTS; T-SHIRTS; TANK-TOPS; UNDERWEAR (U.S. CLS. 22 AND 39).

GINA FINK, EXAMINING ATTORNEY

SN 85-212,243. GINLACK, SAA TAMBA, KAPAA, HI. FILED 1-6-2011.

## TAMBA

THE MARK CONSISTS OF STANDARD CHARACTERS WITHOUT CLAIM TO ANY PARTICULAR FONT, STYLE, SIZE, OR COLOR.

OWNER OF U.S. REG. NO. 3,040,317.

FOR CLOTHING, NAMELY, SHORTS, HATS, JEANS, PANTS, DRESS SHIRTS, SHIRTS, FOOTWEAR (U.S. CLS. 22 AND 39).

FIRST USE 11-0-2010; IN COMMERCE 11-0-2010.

ANGELA M. MICHELI, EXAMINING ATTORNEY

SN 85-212,253. KELLY, IAN, FLORISSANT, MO. AND MARTIN, YOMI, FLORISSANT, MO. FILED 1-6-2011.

## REBEL SOCIETY

THE MARK CONSISTS OF STANDARD CHARACTERS WITHOUT CLAIM TO ANY PARTICULAR FONT, STYLE, SIZE, OR COLOR.

FOR CLOTHING, NAMELY, SHOES, SOCKS, SHIRTS, PAJAMAS, BANDANAS, CAPS, HATS, HEADWEAR, SNEAKERS, BATHING SUITS, BATHROBES, COVERUPS, JACKETS, BELTS, SHORTS, GLOVES, BOOTS, PANTS, BOXER SHORTS, UNDERWEAR, VISORS, COATS, COVERALLS, SWEATERS, MITTENS, JERSEYS, SLIPPERS, DRESSES, VESTS, PULLOVERS, FLIP FLOPS, FOOTWEAR, SCARVES, HEADBANDS, INFANT AND TODDLER ONE PIECE CLOTHING, INFANT SLEEPERS, JEANS, JOGGING SUITS, JUMPERS, STOCKINGS, LEOTARDS, LINGERIE, LOUNGEWEAR, SLEEPWEAR, SKIRTS, NECKTIES, NIGHTGOWNS, RAINCOATS, ROBES, ROMPERS, SANDALS, T-SHIRTS, SUITS, SWEATBANDS, SWEAT SUITS, SWIMSUITS, AND UNDERWEAR (U.S. CLS. 22 AND 39).

PATRICIA EVANKO, EXAMINING ATTORNEY



**CLASS 25—(Continued).**

SN 85-212,403. BBFF, UNION, NJ. FILED 1-6-2011.



THE MARK CONSISTS OF THE WORDS "MY LUCKY FRIGGIN" IN STYLIZED TEXT, WITH THE "U" IN THE WORD "LUCKY" BEING IN THE SHAPE OF A HORSESHOE AND THE "I'S IN THE WORD "FRIGGIN" ARE DOTTED WITH STARS.

FOR SWEATSHIRTS; T-SHIRTS (U.S. CLS. 22 AND 39).  
LAKEISHA LEWIS, EXAMINING ATTORNEY

---

SN 85-212,522. BARRY, KELLY K., PORTLAND, ME. FILED 1-7-2011.



THE MARK CONSISTS OF THE TERM "EZ" THEN A DEPICTION OF AN EYE THEN THE TERM "ID", ALL WITHIN A RECTANGLE BORDER.

FOR CLOTHING, NAMELY, VESTS (U.S. CLS. 22 AND 39).

WILLIAM P. SHANAHAN, EXAMINING ATTORNEY

---

SN 85-212,778. ASHLEY BLUE APPAREL INC, MONTAUK, NY. FILED 1-7-2011.

ASHLEY BLUE

THE MARK CONSISTS OF STANDARD CHARACTERS WITHOUT CLAIM TO ANY PARTICULAR FONT, STYLE, SIZE, OR COLOR.

THE NAME(S), PORTRAIT(S), AND/OR SIGNATURE(S) SHOWN IN THE MARK DOES NOT IDENTIFY A PARTICULAR LIVING INDIVIDUAL.

FOR CLOTHING, NAMELY, KNIT PULLOVERS, KNIT CARDIGANS, PULLOVER SWEATERS, BUTTON DOWN SWEATERS, CARDIGANS, AND SWEATER COATS (U.S. CLS. 22 AND 39).

FIRST USE 3-0-2009; IN COMMERCE 4-0-2009.  
WENDY JUN, EXAMINING ATTORNEY

**CLASS 25—(Continued).**

SN 85-212,922. HARRIGAL, SUZETTE, THE WOODLANDS, TX. FILED 1-7-2011.

GEAUX-AAH

THE MARK CONSISTS OF STANDARD CHARACTERS WITHOUT CLAIM TO ANY PARTICULAR FONT, STYLE, SIZE, OR COLOR.

THE WORDING "GEAUX" HAS NO MEANING IN A FOREIGN LANGUAGE.

FOR BOAS (U.S. CLS. 22 AND 39).

HELENE LIWINSKI, EXAMINING ATTORNEY

---

SN 85-212,949. CJPM ENTERPRISES CORPORATION, CHICAGO, IL. FILED 1-7-2011.



THE MARK CONSISTS OF THE STYLIZED TEXT "WRIST REMOTE" WITH A WRIST ON THE TOP OF THE TEXT. A REMOTE IS IN PLACE OF THE LETTER "I".

FOR HATS; JACKETS AND SOCKS; PANTS; SHOES; SHORTS; SWEAT BANDS; SWEAT SHIRTS; SWEATERS; T-SHIRTS; WRISTBANDS (U.S. CLS. 22 AND 39).

CAROLINE WOOD, EXAMINING ATTORNEY

**CLASS 25—(Continued).**

SN 85-212,976. MITCHELL, KEVIN, BURLESON, TX. FILED 1-7-2011.



THE MARK CONSISTS OF A MOTORCYCLE SPROCKET WITH A CROSS, WINGS, CROWN OF THORNS, AND FLAMES. ON THE TOP AND AT THE BOTTOM THERE IS A BANNER WITH THE STYLIZED TEXT "FORGIVEN SONS" AND "PS421".

FOR HATS; JACKETS; T-SHIRTS; VESTS (U.S. CLS. 22 AND 39).

FIRST USE 6-15-2009; IN COMMERCE 6-15-2009.  
MARIA-VICTORIA SUAREZ, EXAMINING ATTORNEY

SN 85-213,023. MILL-TEX SPORTSWEAR INC., CULLODEN, WV. FILED 1-7-2011.

# MILL-TEX

THE MARK CONSISTS OF STANDARD CHARACTERS WITHOUT CLAIM TO ANY PARTICULAR FONT, STYLE, SIZE, OR COLOR.

FOR CLOTHING, NAMELY, SHIRTS; SWEATSHIRTS; PANTS; JACKETS; MEN'S SWEAT PANTS, CREW-NECK TEE SHIRTS, ZIPPERED HOODED SWEATSHIRTS, MESH SHORTS, FLANNEL PAJAMAS, BASIC PULL-OVERS, LONG SLEEVE CREW-NECK, LONG SLEEVE THERMAL TEE-SHIRTS, COLORED BLOCK HOODS, BASEBALL TEE-SHIRTS, FLEECE SWEAT-SHIRTS; WOMEN'S FLEECE SWEATSHIRTS, SILK-WASHED COMBED TEE-SHIRTS, BASEBALL TEE-SHIRTS, CAPRI PANTS, LAYER TEE-SHIRTS, ZIPPER HOODED SWEATSHIRTS, FLEECE SHORTS; GIRL'S CREW-NECK TEE SHIRTS; AND BOY'S BASIC PULLOVERS, CREW-NECK TEE-SHIRTS AND LONG-SLEEVE TEE-SHIRTS (U.S. CLS. 22 AND 39).

FIRST USE 11-15-2009; IN COMMERCE 11-15-2009.  
AISHA SALEM, EXAMINING ATTORNEY

**CLASS 25—(Continued).**

SN 85-213,091. CAP CLUB INC., BROWNSVILLE, TX. FILED 1-7-2011.

# Bred 2 Win

THE MARK CONSISTS OF STANDARD CHARACTERS WITHOUT CLAIM TO ANY PARTICULAR FONT, STYLE, SIZE, OR COLOR.

FOR HATS; SHORT-SLEEVED OR LONG-SLEEVED T-SHIRTS (U.S. CLS. 22 AND 39).

MICHAEL SOUDERS, EXAMINING ATTORNEY

SN 85-213,341. RINCON, SERGIO, DALLAS, TX. FILED 1-7-2011.

# Stokr

THE MARK CONSISTS OF STANDARD CHARACTERS WITHOUT CLAIM TO ANY PARTICULAR FONT, STYLE, SIZE, OR COLOR.

FOR ATHLETIC APPAREL, NAMELY, SHIRTS, PANTS, JACKETS, FOOTWEAR, HATS AND CAPS, ATHLETIC UNIFORMS (U.S. CLS. 22 AND 39).

RONALD DELGIZZI, EXAMINING ATTORNEY

SN 85-213,342. RINCON, SERGIO, DALLAS, TX. FILED 1-7-2011.

# Food Gang Industries

THE MARK CONSISTS OF STANDARD CHARACTERS WITHOUT CLAIM TO ANY PARTICULAR FONT, STYLE, SIZE, OR COLOR.

NO CLAIM IS MADE TO THE EXCLUSIVE RIGHT TO USE "INDUSTRIES", APART FROM THE MARK AS SHOWN.

FOR APRONS; CHEF'S COATS; CHEF'S HATS; HATS; JACKETS; SWEAT PANTS; SWEAT SHIRTS; SWEATERS; T-SHIRTS; UNIFORMS (U.S. CLS. 22 AND 39).

RONALD DELGIZZI, EXAMINING ATTORNEY

**CLASS 25—(Continued).**

SN 85-213,455. GESNER, DAVID, BROADWAY, NJ. FILED 1-8-2011.

imosh

THE MARK CONSISTS OF STANDARD CHARACTERS WITHOUT CLAIM TO ANY PARTICULAR FONT, STYLE, SIZE, OR COLOR.

OWNER OF U.S. REG. NO. 3,132,921.

FOR JACKETS; SHORT-SLEEVED OR LONG-SLEEVED T-SHIRTS; SWEAT SHIRTS (U.S. CLS. 22 AND 39).

FIRST USE 10-18-2000; IN COMMERCE 10-18-2000.

MICHAEL WEBSTER, EXAMINING ATTORNEY

SN 85-213,691. THOMAS SLOMKA, CLEVELAND, OH. FILED 1-10-2011.

ORIGINAL LUCKY 7

THE MARK CONSISTS OF STANDARD CHARACTERS WITHOUT CLAIM TO ANY PARTICULAR FONT, STYLE, SIZE, OR COLOR.

NO CLAIM IS MADE TO THE EXCLUSIVE RIGHT TO USE "ORIGINAL", APART FROM THE MARK AS SHOWN. FOR CLOTHING, NAMELY, T-SHIRTS, SWEATSHIRTS, SHIRTS, PANTS, SWEATPANTS, HATS, SHORTS, TANK TOPS, JERSEYS AND JACKETS (U.S. CLS. 22 AND 39).

MAYUR VAGHANI, EXAMINING ATTORNEY

SN 85-213,742. JOSHUA MAX KENT, ORCHARD LAKE, MI. FILED 1-10-2011.

Womp

THE MARK CONSISTS OF STANDARD CHARACTERS WITHOUT CLAIM TO ANY PARTICULAR FONT, STYLE, SIZE, OR COLOR.

FOR SHORT-SLEEVED OR LONG-SLEEVED T-SHIRTS (U.S. CLS. 22 AND 39).

HELENE LIWINSKI, EXAMINING ATTORNEY

**CLASS 25—(Continued).**

SN 85-213,749. DAS, BIDYUT, LONDON, UNITED KINGDOM, FILED 1-10-2011.



THE MARK CONSISTS OF A CROWN OR CREST APPEARING ABOVE THE LETTERS "BD".

FOR ACCESSORIES, NAMELY, HATS, GLOVES, TIES AND SCARVES (U.S. CLS. 22 AND 39).

AISHA SALEM, EXAMINING ATTORNEY

SN 85-213,781. PUSSER'S (2001) LTD., TORTOLA, BR. VIRGIN ISLANDS, FILED 1-10-2011.

CST.BVI

THE MARK CONSISTS OF STANDARD CHARACTERS WITHOUT CLAIM TO ANY PARTICULAR FONT, STYLE, SIZE, OR COLOR.

FOR T-SHIRTS, SHIRTS, CAPS AND HATS, SHORTS, TROUSERS, DRESSES AND SKIRTS, BATHING SUITS, SWEATERS, BLOUSES, SWEAT PANTS AND SWEATSHIRTS AND JACKETS (U.S. CLS. 22 AND 39).

MAUREEN DALL, EXAMINING ATTORNEY

SN 85-213,850. SALAMANCA, JIMMY, GROVELAND, IL. FILED 1-10-2011.



THE MARK CONSISTS OF THE STYLIZED WORDS "WILL FIGHT FOR FOOD". AN IMAGE OF A FACE INSIDE A CIRCLE TO THE RIGHT OF THE TEXT.

FOR ATHLETIC UNIFORMS; HATS; JACKETS; PANTS; SHIRTS; SHORTS (U.S. CLS. 22 AND 39).

KATHERINE STOIDES, EXAMINING ATTORNEY

**CLASS 25—(Continued).**

SN 85-213,862. GALEN D KAHLENBERG, MISSION, TX.  
FILED 1-10-2011.

**HUMAN ELEMENT**

THE MARK CONSISTS OF STANDARD CHARACTERS WITHOUT CLAIM TO ANY PARTICULAR FONT, STYLE, SIZE, OR COLOR.

FOR A-SHIRTS; ATHLETIC APPAREL, NAMELY, SHIRTS, PANTS, JACKETS, FOOTWEAR, HATS AND CAPS, ATHLETIC UNIFORMS; BEACHWEAR; BERMUDA SHORTS; BRIEFS; BUTTON DOWN SHIRTS; CAMOUFLAGE SHIRTS; CAMP SHIRTS; CLOTHING FOR BABIES, TODDLERS AND CHILDREN, TREATED WITH FIRE AND HEAT RETARDANTS, NAMELY, PAJAMAS, JACKETS, SHIRTS, PANTS, JUMPERS; COATS OF DENIM; CYCLING SHORTS; DENIM JACKETS; DENIMS; GOLF SHORTS; GYM SHORTS; JEANS; LADIES' UNDERWEAR; MEN'S UNDERWEAR; PANTIES, SHORTS AND BRIEFS; SHIRTS AND SHORT-SLEEVED SHIRTS; THERMAL UNDERWEAR; THONGS; UNDERWEAR; UNDERWEAR, NAMELY, BOY SHORTS; WOMEN'S UNDERWEAR; WOVEN OR KNITTED UNDERWEAR (U.S. CLS. 22 AND 39).

SCOTT BIBB, EXAMINING ATTORNEY

**CLASS 25—(Continued).**

SN 85-213,894. GALEN D KAHLENBERG, MISSION, TX.  
FILED 1-10-2011.

**little secrets**

THE MARK CONSISTS OF STANDARD CHARACTERS WITHOUT CLAIM TO ANY PARTICULAR FONT, STYLE, SIZE, OR COLOR.

FOR A-SHIRTS; ATHLETIC APPAREL, NAMELY, SHIRTS, PANTS, JACKETS, FOOTWEAR, HATS AND CAPS, ATHLETIC UNIFORMS; BERMUDA SHORTS; BOARD SHORTS; BOXER SHORTS; BRIEFS; CLOTHING FOR BABIES, TODDLERS AND CHILDREN, TREATED WITH FIRE AND HEAT RETARDANTS, NAMELY, PAJAMAS, JACKETS, SHIRTS, PANTS, JUMPERS; GOLF SHORTS; JEANS; KNIT SKIRTS; KNITTED UNDERWEAR; LADIES' UNDERWEAR; LEATHER SKIRTS; MEN'S UNDERWEAR; PANTIES, SHORTS AND BRIEFS; PARTS OF CLOTHING, NAMELY, GUSSETS FOR TIGHTS, GUSSETS FOR STOCKINGS, GUSSETS FOR BATHING SUITS, GUSSETS FOR UNDERWEAR, GUSSETS FOR LEOTARDS AND GUSSETS FOR FOOTLETS; SKIRT SUITS; SKIRTS; SKIRTS AND DRESSES; THONGS; UNDERWEAR; WOMEN'S UNDERWEAR; WOVEN OR KNITTED UNDERWEAR; WOVEN SKIRTS (U.S. CLS. 22 AND 39).

SCOTT BIBB, EXAMINING ATTORNEY

SN 85-213,970. GILBERT, RICHARD, NEW YORK, NY.  
FILED 1-10-2011.

**WAYCROSS**

THE MARK CONSISTS OF STANDARD CHARACTERS WITHOUT CLAIM TO ANY PARTICULAR FONT, STYLE, SIZE, OR COLOR.

FOR JEANS, PANTS, SWEATERS, JACKETS, COATS, SHIRTS, T-SHIRTS, SKIRTS, VESTS, TOPS, FOOTWEAR (U.S. CLS. 22 AND 39).

NAKIA HENRY, EXAMINING ATTORNEY

SN 85-213,992. JOHNSON III, WILLIAM H., RANCHO PALOS VERDES, CA. FILED 1-10-2011.



THE MARK CONSISTS OF THE STYLIZED WORDS "TEESCRUBS".

FOR T-SHIRTS (U.S. CLS. 22 AND 39).  
FIRST USE 7-15-2010; IN COMMERCE 8-1-2010.  
KATHERINE STOIDES, EXAMINING ATTORNEY

**HALSEY**

THE MARK CONSISTS OF STANDARD CHARACTERS WITHOUT CLAIM TO ANY PARTICULAR FONT, STYLE, SIZE, OR COLOR.

FOR CLOTHING, NAMELY, PANTS, SHORTS, JACKETS, SHIRTS, SWEATSHIRTS, VESTS, HEADWEAR (U.S. CLS. 22 AND 39).

H. M. FISHER, EXAMINING ATTORNEY

**CLASS 25—(Continued).**

SN 85-214,871. SALAMONE, ANDREW, SANTA CRUZ, CA. AND SALAMONE, LELIA, SANTA CRUZ, CA. FILED 1-11-2011.

**CLASS 25—(Continued).**

SN 85-215,204. WOODS, KATHY D., VALLEY VILLAGE, CA. AND WOODS, DANA MICHAEL, VALLEY VILLAGE, CA. FILED 1-11-2011.

# Chillwear

## Kathy D. Woods

THE MARK CONSISTS OF STANDARD CHARACTERS WITHOUT CLAIM TO ANY PARTICULAR FONT, STYLE, SIZE, OR COLOR.

FOR CLOTHING, NAMELY, SHIRTS, HATS, SHOES, MARTIAL ARTS UNIFORMS, MOISTURE-WICKING SPORTS SHIRTS, AND MOISTURE-WICKING SPORTS PANTS; CLOTHING WITH GEL PACKS DESIGNED TO KEEP THE WEARER COOL, NAMELY, SHIRTS, HATS, PANTS, SHIRTS, SCARVES, AND SHOES (U.S. CLS. 22 AND 39).

THOMAS MANOR, EXAMINING ATTORNEY

THE MARK CONSISTS OF STANDARD CHARACTERS WITHOUT CLAIM TO ANY PARTICULAR FONT, STYLE, SIZE, OR COLOR.

THE NAME "KATHY D. WOODS" IDENTIFIES A LIVING INDIVIDUAL WHOSE CONSENT IS OF RECORD.

FOR CLOTHING, NAMELY, SHIRTS, T-SHIRTS, JACKETS, COATS, FABRIC BELTS, LEATHER BELTS, CAPS, HATS, VISORS, BEANIES, FLEECE PULLOVERS, SWEATERS, JACKETS, JEANS, PANTS, TROUSERS, POLO SHIRTS, SWEAT PANTS, SWEATSHIRTS, SWEAT SUITS, TANK TOPS, SHORTS, FIGHTING SHORTS, SWIM SUITS, TRUNKS, BOARD SHORTS, BANDANAS, SHOES, SANDALS, BOOTS, FOOTWEAR, THERMAL UNDERWEAR, SOCKS, NIGHT GOWNS, PAJAMAS, WIND SHIRTS, PONCHOS, VESTS, PARKAS, BOXER SHORTS, BRIEFS, UNDERWEAR, BRAS, YOGA PANTS, BATHROBES, JERSEYS, CAPRI PANTS, CARDIGAN SWEATERS, SWEATER VESTS, BLAZERS, DRESS SHIRTS, SNAP CROTCH SHIRTS, BODY SUITS, ROMPERS, PANTIES, DRESSES, GLOVES, SKIRTS, BLOUSES (U.S. CLS. 22 AND 39).

JILL C. ALT, EXAMINING ATTORNEY

---

SN 85-215,148. CHOI, TAE YI, ARCADIA, CA. FILED 1-11-2011.

---

SN 85-215,271. THIS SHIRT HELPS, INC., TOLUCA LAKE, CA. FILED 1-11-2011.

## COWGIRL & DIAMONDS

## THIS SHIRT HELPS

THE MARK CONSISTS OF STANDARD CHARACTERS WITHOUT CLAIM TO ANY PARTICULAR FONT, STYLE, SIZE, OR COLOR.

FOR A-SHIRTS; LONG-SLEEVED SHIRTS (U.S. CLS. 22 AND 39).

NICHOLAS COLEMAN, EXAMINING ATTORNEY

THE MARK CONSISTS OF STANDARD CHARACTERS WITHOUT CLAIM TO ANY PARTICULAR FONT, STYLE, SIZE, OR COLOR.

NO CLAIM IS MADE TO THE EXCLUSIVE RIGHT TO USE "SHIRT", APART FROM THE MARK AS SHOWN.

FOR CLOTHING, NAMELY, SHIRTS, T-SHIRTS, PANTS, JEANS, SHORTS, JACKETS, SWEATERS, TOPS, BLOUSES, DRESSES, SKIRTS, BLAZERS, SOCKS, BASEBALL CAPS, KNIT CAPS, BELTS, WRISTBANDS, HEAD WRAPS, UNDERWEAR, PAJAMAS, TIES, LINGERIE, BELTS, BOOTS, SHOES, AND SANDALS (U.S. CLS. 22 AND 39).

MARK SHINER, EXAMINING ATTORNEY



**CLASS 25—(Continued).**

SN 85-215,331. ANDERSON, AARON W., AKA THA DOUBLE A, DAYTON, OH. FILED 1-11-2011.

# THA DOUBLE A

THE MARK CONSISTS OF STANDARD CHARACTERS WITHOUT CLAIM TO ANY PARTICULAR FONT, STYLE, SIZE, OR COLOR.

THE NAME "THA DOUBLE A" IDENTIFIES A LIVING INDIVIDUAL WHOSE CONSENT IS OF RECORD.

FOR BASEBALL CAPS; BASEBALL CAPS AND HATS; HATS; HOODED SWEAT SHIRTS; HOODED SWEATSHIRTS; JACKETS; JERSEYS; SHIRTS; SHORT-SLEEVED OR LONG-SLEEVED T-SHIRTS; SPORTS CAPS AND HATS; SWEATSHIRTS; T-SHIRTS; TANK TOPS; TANK-TOPS; TEE SHIRTS (U.S. CLS. 22 AND 39).  
FIRST USE 9-1-1999; IN COMMERCE 1-10-2011.

JAMES MACFARLANE, EXAMINING ATTORNEY

**CLASS 25—(Continued).**

SN 85-215,442. RUIS FASHION, INC., ONTARIO, CA. FILED 1-11-2011.

# RUIS

THE MARK CONSISTS OF THE TERM "RUIS" IN STYLIZED FORM.

FOR BATHING SUITS; BATHROBES; BELTS; BLOUSES; BODY SUITS; BRAS; DENIM JACKETS; DENIMS; DRESSES; DRESSING GOWNS; EVENING GOWNS; FOOTWEAR; FUR COATS AND JACKETS; GLOVES; GYM SUITS; HEADBANDS; HEAD WEAR; INSOLES; JACKETS; JEANS; JOGGING SUITS; LINGERIE; NIGHT GOWNS; NIGHT SHIRTS; PAJAMAS; PANTS; RAIN COATS; SCARVES; SHIRTS; SHORTS; SKIRTS; SLACKS; SOCKS; SUITS; SPORTS PANTS; SPORTS SHIRTS; SWEATERS; SWEAT PANTS; SWEAT SUITS; SWIMSUITS; SWIMWEAR; TIES; T-SHIRTS; AND UNDERWEAR (U.S. CLS. 22 AND 39).

FIRST USE 10-30-2009; IN COMMERCE 10-30-2009.

MARK SHINER, EXAMINING ATTORNEY

SN 85-215,414. GIRLS OF THE SOUTH, DIXIE, GA. FILED 1-11-2011.



THE MARK CONSISTS OF THE STYLIZED WORDS "GIRLS OF THE SOUTH". AN IMAGE OF A SUN IN THE BACKGROUND OF THE LETTERS "TH" IN THE WORD "SOUTH".

FOR CAPS; FLIP FLOPS; JACKETS; PAJAMAS; T-SHIRTS (U.S. CLS. 22 AND 39).

FIRST USE 5-28-2010; IN COMMERCE 5-28-2010.

AISHA CLARKE, EXAMINING ATTORNEY

SN 85-215,445. UNPAINTED EMPORIUM PRODUCTIONS, LLC, JERSEY CITY, NJ. FILED 1-11-2011.

# SATANIC PERVERTS

THE MARK CONSISTS OF STANDARD CHARACTERS WITHOUT CLAIM TO ANY PARTICULAR FONT, STYLE, SIZE, OR COLOR.

FOR BOTTOMS; BOXER SHORTS; CAPS; COATS; FOOTWEAR; HATS; HEADWEAR; JACKETS; PANTS; SHIRTS; SOCKS; SWEAT SHIRTS; SWIM SUITS; SWIMWEAR; T-SHIRTS; TOPS (U.S. CLS. 22 AND 39).

GINA HAYES, EXAMINING ATTORNEY

**CLASS 25—(Continued).**

SN 85-215,521. FENG LI, GUANGZHOU, GUANGDONG, CHINA, FILED 1-12-2011.

古色 SUSSI

THE MARK CONSISTS OF THE WORD "SUSSI" WITH THE SECOND "S" PLACED IN A LOWER POSITION AND TWO CHINESE CHARACTERS ON THE LEFT WITH STYLIZED DESIGN.

THE WORDING "SUSSI" HAS NO MEANING IN A FOREIGN LANGUAGE.

THE NON-LATIN CHARACTERS IN THE MARK TRANSLITERATE TO "GU"; "SE" AND THIS MEANS "ANCIENT"; "COLOR" IN ENGLISH.

FOR CHILDREN'S AND INFANT'S APPAREL, NAMELY, JUMPERS, OVERALL SLEEPWEAR, PAJAMAS, ROMPERS AND ONE-PIECE GARMENTS; DRESSES; FOOTWEAR; GLOVES AS CLOTHING; HEADWEAR; HOSIERY; JACKETS; LAYETTES; LEATHER BELTS; LEATHER JACKETS; LEATHER SHIRTS; LEATHER SKIRTS; NECKTIES; SHIRTS; T-SHIRTS; TROUSERS; TROUSERS OF LEATHER (U.S. CLS. 22 AND 39).

DANIEL CAPSHAW, EXAMINING ATTORNEY

SN 85-216,063. WHITE BAY PARTNERS, LLC, CHARLOTTEVILLE, VA. FILED 1-12-2011.

SOGGY DOLLAR

THE MARK CONSISTS OF STANDARD CHARACTERS WITHOUT CLAIM TO ANY PARTICULAR FONT, STYLE, SIZE, OR COLOR.

FOR CLOTHING AND APPAREL, NAMELY, T-SHIRTS, SHIRTS AND CASUAL TOPS WITH LONG AND SHORT SLEEVES, SLEEVELESS SHIRTS, TANK TOPS, SWEAT TOPS, SWIM WEAR, JACKETS, SHORTS, BOARD SHORTS, DRESSES, SKIRTS, LOUNGEWEAR, BELTS; HEADWEAR, BEANIES, HATS, VISORS, CAPS, SCARVES (U.S. CLS. 22 AND 39).

FIRST USE 3-15-1978; IN COMMERCE 2-28-2002.  
PAM WILLIS, EXAMINING ATTORNEY

**CLASS 25—(Continued).**

SN 85-216,208. KARSTEN MANUFACTURING CORPORATION, PHOENIX, AZ. FILED 1-12-2011.

K  
20

THE MARK CONSISTS OF A STYLIZED VERSION OF THE LETTER "K" AND THE NUMERAL "20".

FOR BELTS; HEADGEAR, NAMELY, HATS, CAPS, AND VISORS; JACKETS; PANTS; PULLOVERS; SHIRTS; SHORTS; SWEATERS; SWEATSHIRTS; VESTS; WIND SHIRTS (U.S. CLS. 22 AND 39).

ELI HELLMAN, EXAMINING ATTORNEY

SN 85-216,779. JOHNSON, CHARLES, LARAMIE, WY. FILED 1-13-2011.

7220

THE MARK CONSISTS OF STANDARD CHARACTERS WITHOUT CLAIM TO ANY PARTICULAR FONT, STYLE, SIZE, OR COLOR.

FOR PANTS, SHORTS, SHORT AND LONG SLEEVE T-SHIRTS, SHORT AND LONG SLEEVE SHIRTS, SWEAT SHIRTS, GOLF SHIRTS, WORK SHIRTS, V-NECK T-SHIRTS, HALTER TOPS, SWEAT PANTS, HOODED SWEATSHIRTS, TANK TOPS, TUBE TOPS, UNDERGARMENTS, UNDERWEAR, BOXER SHORTS, THONGS, SOCKS, LOUNGE PANTS, PAJAMAS, LINGERIE, TRACK SUITS, WIND SUITS, WARM UP SUITS, RUNNING SHORTS, JERSEYS, DRESSES, SKIRTS, SWIMWEAR, BIKINIS, SPORTS BRAS, BRAS, COATS, DENIM JACKETS, HOODED JACKETS, VARSITY JACKETS, SPORTS JACKETS, FLEECE JACKETS, GLOVES, MITTENS, HEADBANDS, FLEECE PULLOVERS, FLEECE VESTS, INFANT JUMPERS, INFANT ONE-PIECE PLAYWEAR, TIES, BELTS, HEADWEAR, CAPS, HATS, BALL CAPS, BEANIES, SCARFS, EAR MUFFS, FOOTWEAR, SHOES, SLIPPERS, SANDALS, BOOTS, AND BANDANAS (U.S. CLS. 22 AND 39).

FIRST USE 6-0-2007; IN COMMERCE 6-0-2007.  
NATALIE POLZER, EXAMINING ATTORNEY

**CLASS 25—(Continued).**

SN 85-217,318. JACQUES MORET, INC., NEW YORK, NY.  
FILED 1-13-2011.

**SLIM SCULPT**

THE MARK CONSISTS OF STANDARD CHARACTERS WITHOUT CLAIM TO ANY PARTICULAR FONT, STYLE, SIZE, OR COLOR.

NO CLAIM IS MADE TO THE EXCLUSIVE RIGHT TO USE "SLIM", APART FROM THE MARK AS SHOWN.

FOR TOPS, TANK TOPS, CROP TOPS, PANTS, CAPRI PANTS, CROP PANTS (U.S. CLS. 22 AND 39).

JAY BESCH, EXAMINING ATTORNEY

---

SN 85-217,454. TARADUFF LLC, NORTH LOGAN, UT.  
FILED 1-13-2011.



NO CLAIM IS MADE TO THE EXCLUSIVE RIGHT TO USE "BEARD" AND "BEANIE", APART FROM THE MARK AS SHOWN.

THE MARK CONSISTS OF STYLIZED WORDS "BEARD BEANIE" WITH AN IMAGE OF A HEAD WITH A HAT, MOUSTACHE AND BEARD.

FOR HATS; HEADGEAR, NAMELY, HATS WITH FACIAL COVERINGS (U.S. CLS. 22 AND 39).

FIRST USE 12-14-2010; IN COMMERCE 12-14-2010.  
TARAH HARDY, EXAMINING ATTORNEY

---

SN 85-217,767. THE BOPPY COMPANY, LLC, GOLDEN, CO.  
FILED 1-14-2011.

**BOPPY**

THE MARK CONSISTS OF STANDARD CHARACTERS WITHOUT CLAIM TO ANY PARTICULAR FONT, STYLE, SIZE, OR COLOR.

OWNER OF U.S. REG. NOS. 1,919,783, 3,735,282 AND OTHERS.

FOR NURSING APPAREL, NAMELY, NURSING COVERS (U.S. CLS. 22 AND 39).

WON TEAK OH, EXAMINING ATTORNEY

**CLASS 25—(Continued).**

SN 85-217,949. RYAN JAYNE, MERCED, CA. FILED 1-14-2011.

**flipped jigs**

THE MARK CONSISTS OF STANDARD CHARACTERS WITHOUT CLAIM TO ANY PARTICULAR FONT, STYLE, SIZE, OR COLOR.

FOR BEANIES; FISHING SHIRTS; FISHING VESTS; FISHING WADERS; HATS; HIP-GUARDS ESPECIALLY MADE FOR FISHING; JACKETS; PANTS; SWEAT SHIRTS; SWEATSHIRTS; T-SHIRTS; VISORS (U.S. CLS. 22 AND 39).

ANDREA K. NADELMAN, EXAMINING ATTORNEY

---

SN 85-218,056. STOLEN GIRLFRIENDS CLUB LIMITED,  
AUCKLAND 1021, NEW ZEALAND, FILED 1-14-2011.

**STOLEN GIRLFRIENDS CLUB**

THE MARK CONSISTS OF STANDARD CHARACTERS WITHOUT CLAIM TO ANY PARTICULAR FONT, STYLE, SIZE, OR COLOR.

OWNER OF NEW ZEALAND REG. NO. 714919, DATED 7-8-2004, EXPIRES 7-8-2014.

NO CLAIM IS MADE TO THE EXCLUSIVE RIGHT TO USE "CLUB", APART FROM THE MARK AS SHOWN.

FOR BELTS; BOW TIES; DRESSES; HATS; JEANS; JUMPERS; LEGGINGS; SHIRTS; SHOES; SHORTS; SKIRTS; SOCKS; SWEAT SHIRTS; T-SHIRTS; TIES; TIGHTS; TOPS; TROUSERS; WRISTBANDS (U.S. CLS. 22 AND 39).

FIRST USE 1-1-2005; IN COMMERCE 12-1-2006.

MATTHEW MCDOWELL, EXAMINING ATTORNEY

**CLASS 25—(Continued).**

SN 85-218,746. SIMS, MILDRED E., REDFORD, MI. FILED 1-15-2011.

**PWRNJZS**

THE MARK CONSISTS OF STANDARD CHARACTERS WITHOUT CLAIM TO ANY PARTICULAR FONT, STYLE, SIZE, OR COLOR.

FOR A-SHIRTS; ATHLETIC APPAREL, NAMELY, SHIRTS, PANTS, JACKETS, FOOTWEAR, HATS AND CAPS, ATHLETIC UNIFORMS; BUTTON DOWN SHIRTS; CAMP SHIRTS; COLLARED SHIRTS; GOLF SHIRTS; HOODED SWEAT SHIRTS; KNIT SHIRTS; LONG-SLEEVED SHIRTS; POLO SHIRTS; SCIENTIFIC AND TECHNOLOGICAL APPAREL, NAMELY, SHIRTS, PANTS, JACKETS, FOOTWEAR, HATS AND CAPS, UNIFORMS; SHIRT FRONTS; SHIRT INSERTS, NAMELY, DICKIES; SHORT-SLEEVED OR LONG-SLEEVED T-SHIRTS; SHORT-SLEEVED SHIRTS; SLEEP SHIRTS; SWEAT SHIRTS; T-SHIRTS; TEE SHIRTS; WEARABLE GARMENTS AND CLOTHING, NAMELY, SHIRTS (U.S. CLS. 22 AND 39).

SUSAN STIGLITZ, EXAMINING ATTORNEY

SN 85-218,825. CARPENTER JR, JAMES WILLIAM, GREENSBORO, NC. FILED 1-16-2011.



THE WORDING "CHRISTIAN BLAIR" DOES NOT IDENTIFY A LIVING INDIVIDUAL.

THE MARK CONSISTS OF THE WORDING "CHRISTIAN BLAIR" WITH THE WORDS SEPARATED BY A CURVED LINE DESIGN.

FOR ATHLETIC APPAREL, NAMELY, SHIRTS, PANTS, JACKETS, FOOTWEAR, HATS AND CAPS, ATHLETIC UNIFORMS; BATHING SUITS; BELTS; BIKINIS; CAPRIS; CAPS; CARDIGANS; DRESSES; KHAKIS; COATS; DRESS PANTS; FOOTWEAR; GLOVES; GOLF PANTS; GOLF SHIRTS; GOLF SHOES; GOLF SHORTS; HATS; HEADBANDS; HEAD WEAR; JACKETS; JERSEYS; KNICKERS; PANTS; PONCHOS; PULLOVERS; RAINWEAR; SHIRTS; SHOES; SHORTS; SKIRTS; SNEAKERS; SOCKS; SWEAT SUITS; SWEATERS; SWEATBANDS; TANK TOPS; TOPS; TRACK SUITS; TROUSERS; TURTLENECKS; T-SHIRTS; UNIFORMS; VESTS; VISORS; WRIST BANDS (U.S. CLS. 22 AND 39).

ANDREW RHIM, EXAMINING ATTORNEY

**CLASS 25—(Continued).**

SN 85-218,914. PERNIA, PATRICK, SAN JOSE, CA. FILED 1-17-2011.

**2 Le Monde**

THE MARK CONSISTS OF STANDARD CHARACTERS WITHOUT CLAIM TO ANY PARTICULAR FONT, STYLE, SIZE, OR COLOR.

THE ENGLISH TRANSLATION OF THE WORD "LE MONDE" IN THE MARK IS "THE WORLD".

FOR SWEATERS, BLAZERS, SHIRTS, POLO SHIRTS, DRESS SHIRTS, TURTLE NECK SHIRTS, TEE-SHIRTS, SWEATSHIRTS, KNIT SHIRTS, JACKETS, PARKAS, TROUSERS, PANTS, JEANS, DENIM JEANS, SHORTS, BERMUDA SHORTS, TRACK SUIT TROUSERS, TRACK SUITS, SKIRTS, DRESSES, BEACHWEAR, SOCKS, WRIST BANDS, HEAD BANDS, SCARVES, HEADWEAR, NECKWEAR, GLOVES, UNDERWEAR, FOOTWEAR (U.S. CLS. 22 AND 39).

MARLENE BELL, EXAMINING ATTORNEY

SN 85-218,924. PRIMARY NEW YORK, NEW YORK, NY. FILED 1-17-2011.

**Primary New York**

THE MARK CONSISTS OF STANDARD CHARACTERS WITHOUT CLAIM TO ANY PARTICULAR FONT, STYLE, SIZE, OR COLOR.

NO CLAIM IS MADE TO THE EXCLUSIVE RIGHT TO USE "NEW YORK", APART FROM THE MARK AS SHOWN.

FOR BELTS; BLOUSES; HATS; JACKETS; PANTS; SHOES (U.S. CLS. 22 AND 39).

FIRST USE 10-1-2009; IN COMMERCE 1-1-2010.

JOHN DWYER, EXAMINING ATTORNEY

SN 85-219,205. SHELL, MARTIN, COLUMBUS, OH. FILED 1-17-2011.

**SINGLE R U**

THE MARK CONSISTS OF STANDARD CHARACTERS WITHOUT CLAIM TO ANY PARTICULAR FONT, STYLE, SIZE, OR COLOR.

FOR ATHLETIC APPAREL, NAMELY, SHIRTS, PANTS, JACKETS, FOOTWEAR, HATS AND CAPS, ATHLETIC UNIFORMS; ATHLETIC SHOES; ATHLETIC TIGHTS; ATHLETIC UNIFORMS; HEADWEAR; LINGERIE; SPORT COATS; SPORT SHIRTS; SPORT STOCKINGS; SPORTS BRA; SPORTS CAPS AND HATS; SPORTS JACKETS; SPORTS JERSEYS; SPORTS OVER UNIFORMS; SPORTS PANTS; SPORTS SHIRTS; SPORTS VESTS; T-SHIRTS; UNDERWEAR (U.S. CLS. 22 AND 39).

SETH A. RAPPAPORT, EXAMINING ATTORNEY

**CLASS 25—(Continued).**

SN 85-219,238. MEE, AMELIA, LOS ANGELES, CA. FILED 1-17-2011.

# VELOCETTE

THE MARK CONSISTS OF STANDARD CHARACTERS WITHOUT CLAIM TO ANY PARTICULAR FONT, STYLE, SIZE, OR COLOR.

FOR BANDANAS; BELTS; BOOTS; CAPS; COATS; FOOTWEAR; GLOVES; HATS; JACKETS; JEANS; LEATHER BELTS; LEATHER JACKETS; PANTS; POLO SHIRTS; SCARVES; SHIRTS; SHOES; SWEAT SHIRTS; SWEATERS; T-SHIRTS; TOPS; TROUSERS (U.S. CLS. 22 AND 39).

MICHAEL ENGEL, EXAMINING ATTORNEY

**CLASS 25—(Continued).**

SN 85-219,295. GERGES, SABRI, MONTEBELLO, CA. FILED 1-17-2011.



THE MARK CONSISTS OF THE STYLIZED WORDS "DECEPTION". AN IMAGE OF A SNAKE WITH AN APPLE ABOVE THE TEXT.

FOR CLOTHING, NAMELY, T-SHIRTS, PANTS, SHORTS, POLO SHIRTS, BOXER SHORTS, SOCKS, SNEAKERS, SANDALS, TIES, HATS, BELTS, SWIMSUITS, SKIRTS, SHIRTS, DRESSES, TANK TOPS, SWEATSHIRTS, JACKETS, JERSEYS, WRISTBANDS, BEANIES (U.S. CLS. 22 AND 39).

FIRST USE 9-1-2009; IN COMMERCE 10-10-2009.  
DAVID I, EXAMINING ATTORNEY

SN 85-219,270. RGAL STEEL, CORP., MIAMI, FL. FILED 1-17-2011.



THE MARK CONSISTS OF A STYLIZED SPORTY REPRESENTATION OF A STICKMAN IN MOVEMENT.

FOR CLOTHING, NAMELY, PANTS, TANK TOPS, JACKETS, SHORTS, SPORTS SHOES, GLOVES, HATS, SOCKS, SPORTS BRAS, SHIRTS, T-SHIRTS, AND JOGGING SUITS (U.S. CLS. 22 AND 39).

MARC LEIPZIG, EXAMINING ATTORNEY

SN 85-219,326. S.W.B. APPAREL, INC., EASTRUTHERFORD, NJ. FILED 1-17-2011.

# STATUS QUO

THE MARK CONSISTS OF STANDARD CHARACTERS WITHOUT CLAIM TO ANY PARTICULAR FONT, STYLE, SIZE, OR COLOR.

FOR CLOTHING, NAMELY, T-SHIRTS, SHIRTS, SWEATSHIRTS, SWEATERS, JACKETS, RAINCOATS, JEANS, SHORTS, PANTS, TRACK SUITS, JOGGING SUITS, SWEATPANTS, FLEECE SHIRTS, FLEECE JACKETS, FLEECE PULLOVERS, SLEEPWEAR, UNDERWEAR, CAPRI PANTS, VESTS, POLO SHIRTS, DRESS SHIRTS, MESH SHIRTS, MESH SHORTS, JERSEYS, TANK TOPS, DOWN JACKETS, TRACK JACKETS, LEATHER JACKETS, SUEDE JACKETS, DENIM JACKETS, LEATHER PANTS, BELTS, GLOVES, SUSPENDERS, CAPS, HATS, VISORS, BASEBALL CAPS, SHOES AND SNEAKERS (U.S. CLS. 22 AND 39).

MATTHEW KLINE, EXAMINING ATTORNEY



**CLASS 25—(Continued).**

SN 85-219,336. DEYO, INC., GROVER BEACH, CA. FILED 1-17-2011.



OWNER OF U.S. REG. NOS. 2,310,141 AND 3,435,073.  
THE MARK CONSISTS OF AN OVAL EGG SHAPE INCORPORATING A STYLIZED LETTER "V" WITHIN AND THE WORD "VOLEA" DIRECTLY UNDERNEATH.  
THE ENGLISH TRANSLATION OF "VOLEA" IN THE MARK IS "TO FLY".

FOR ATHLETIC APPAREL, NAMELY, SHIRTS, PANTS, JACKETS, FOOTWEAR, HATS AND CAPS, ATHLETIC UNIFORMS; ATHLETIC TIGHTS; BIB TIGHTS; BICYCLE GLOVES; BICYCLING GLOVES; CLOTHING FOR ATHLETIC USE, NAMELY, PADDED SHORTS; CLOTHING, NAMELY, ARM WARMERS; CLOTHING, NAMELY, KNEE WARMERS; CYCLISTS' JERSEYS; EAR WARMERS; HEADBANDS; JACKETS; KNICKERS; LEG WARMERS; LIGHT-REFLECTING JACKETS; OUTER JACKETS; RAINPROOF JACKETS; SHELL JACKETS; SHOE COVERS FOR USE WHEN WEARING SHOES; SHORTS; SINGLET; SLEEVED OR SLEEVELESS JACKETS; SPORTS JACKETS; SPORTS JERSEYS; SPORTS VESTS; SWEAT JACKETS; TANK TOPS; TANK-TOPS; TRIATHLON CLOTHING, NAMELY, TRIATHLON TIGHTS, TRIATHLON SHORTS, TRIATHLON SINGLET, TRIATHLON SHIRTS, TRIATHLON SUITS; UNDERSHIRTS; WATERPROOF JACKETS AND PANTS; WIND RESISTANT JACKETS; WIND-JACKETS (U.S. CLS. 22 AND 39).

FIRST USE 11-15-2010; IN COMMERCE 11-15-2010.  
JORDAN BAKER, EXAMINING ATTORNEY

SN 85-219,435. OLDE PORT TRADERS, INC., QUINCY, MA. FILED 1-17-2011.

# DEWIX

THE MARK CONSISTS OF STANDARD CHARACTERS WITHOUT CLAIM TO ANY PARTICULAR FONT, STYLE, SIZE, OR COLOR.  
FOR SOCKS (U.S. CLS. 22 AND 39).  
GIANCARLO CASTRO, EXAMINING ATTORNEY

**CLASS 25—(Continued).**

SN 85-220,356. DELUNA BY DESIGN, INC., NEW YORK, NY. FILED 1-18-2011.

## MARISOL DELUNA

THE MARK CONSISTS OF STANDARD CHARACTERS WITHOUT CLAIM TO ANY PARTICULAR FONT, STYLE, SIZE, OR COLOR.

THE NAME(S), PORTRAIT(S), AND/OR SIGNATURE(S) SHOWN IN THE MARK IDENTIFIES "MARISOL DELUNA", WHOSE CONSENT(S) TO REGISTER IS MADE OF RECORD.

FOR SCARVES AND TIES DESIGNED SPECIFICALLY FOR EDUCATIONAL, SPORTS, CHARITABLE, POLITICAL, CIVIC AND SERVICE ORGANIZATIONS, MUNICIPALITIES AND OTHER GOVERNMENTAL AGENCIES, AND BUSINESSES (U.S. CLS. 22 AND 39).  
FIRST USE 1-1-1997; IN COMMERCE 1-1-1997.  
JANICE L. MCMORROW, EXAMINING ATTORNEY

SN 85-220,374. BBT, LLC, NEW EGYPT, NJ. FILED 1-18-2011.

## Deena Nicole

THE MARK CONSISTS OF STANDARD CHARACTERS WITHOUT CLAIM TO ANY PARTICULAR FONT, STYLE, SIZE, OR COLOR.

THE NAME(S), PORTRAIT(S), AND/OR SIGNATURE(S) SHOWN IN THE MARK IDENTIFIES DEENA NICOLE CORTESE, WHOSE CONSENT(S) TO REGISTER IS MADE OF RECORD.

FOR WEARABLE GARMENTS AND CLOTHING, NAMELY, SHIRTS (U.S. CLS. 22 AND 39).  
JACLYN KIDWELL WALKER, EXAMINING ATTORNEY

SN 85-220,389. LOGAN, MICHAEL K., SPRINGFIELD, VA. FILED 1-18-2011.

## TRAIN THE BODY STRENGTHEN THE MIND

THE MARK CONSISTS OF STANDARD CHARACTERS WITHOUT CLAIM TO ANY PARTICULAR FONT, STYLE, SIZE, OR COLOR.

FOR BEANIES; HATS; SHORTS; SWEATPANTS; SWEATSHIRTS; T-SHIRTS; TANK TOPS (U.S. CLS. 22 AND 39).

GRETTA YAO, EXAMINING ATTORNEY

**CLASS 25—(Continued).**

SN 85-220,451. BARTSCH, SCOTT, LOS ANGELES, CA.  
FILED 1-18-2011.

**The Blake Show**

THE MARK CONSISTS OF STANDARD CHARACTERS  
WITHOUT CLAIM TO ANY PARTICULAR FONT, STYLE,  
SIZE, OR COLOR.

FOR HATS; JACKETS; SHIRTS; SHOES (U.S. CLS. 22  
AND 39).

LOURDES AYALA, EXAMINING ATTORNEY

SN 85-220,939. NIEUWENHUIS, ELEANOR, LOS ANGELES,  
CA. FILED 1-19-2011.

**Mermaid Nation**

THE MARK CONSISTS OF STANDARD CHARACTERS  
WITHOUT CLAIM TO ANY PARTICULAR FONT, STYLE,  
SIZE, OR COLOR.

FOR SWIMWEAR (U.S. CLS. 22 AND 39).

ANDREA K. NADELMAN, EXAMINING ATTORNEY

SN 85-221,605. FRANCO, EDWIN, PONTIAC, MI. FILED 1-19-  
2011.

*Diva Fight Wear*



*Beauty Attitude Deadly*

NO CLAIM IS MADE TO THE EXCLUSIVE RIGHT TO  
USE "FIGHT WEAR", APART FROM THE MARK AS  
SHOWN.

THE MARK CONSISTS OF A TRIBAL BUTTERFLY  
INSIDE A TRIBAL HEART WITH THE WORDING "DIVA  
FIGHT WEAR" ABOVE THE HEART DESIGN AND THE  
WORDING "BEAUTY ATTITUDE DEADLY" BELOW THE  
HEART DESIGN.

FOR SWEAT BANDS; SWEAT SUITS; THONGS;  
WRISTBANDS (U.S. CLS. 22 AND 39).

COLLEEN DOMBROW, EXAMINING ATTORNEY

**CLASS 25—(Continued).**

SN 85-230,433. WM. WRIGLEY JR. COMPANY, CHICAGO,  
IL. FILED 1-31-2011.

**JUICY FRUIT**

THE MARK CONSISTS OF STANDARD CHARACTERS  
WITHOUT CLAIM TO ANY PARTICULAR FONT, STYLE,  
SIZE, OR COLOR.

OWNER OF U.S. REG. NOS. 105,032, 3,004,561 AND  
OTHERS.

FOR T-SHIRTS (U.S. CLS. 22 AND 39).

H. M. FISHER, EXAMINING ATTORNEY

SN 85-236,622. GLOBAL TRADEMARKS INC., STOCKER-  
TOWN, PA. FILED 2-8-2011.

**ECO INTIMATES**

THE MARK CONSISTS OF STANDARD CHARACTERS  
WITHOUT CLAIM TO ANY PARTICULAR FONT, STYLE,  
SIZE, OR COLOR.

NO CLAIM IS MADE TO THE EXCLUSIVE RIGHT TO  
USE "INTIMATES", APART FROM THE MARK AS SHOWN.  
FOR BODY SHAPERS; BRAS; CAMISOLES; PANTIES;  
TANK TOPS (U.S. CLS. 22 AND 39).

PAUL E. FAHRENKOPF, EXAMINING ATTORNEY

SN 85-238,970. GILBERT, RICHARD, NEW YORK, NY.  
FILED 2-10-2011.

**PUBLIC RECORD**

THE MARK CONSISTS OF STANDARD CHARACTERS  
WITHOUT CLAIM TO ANY PARTICULAR FONT, STYLE,  
SIZE, OR COLOR.

FOR JEANS, PANTS, SWEATERS, JACKETS, COATS,  
SHIRTS, T-SHIRTS, SKIRTS, VESTS, TOPS, FOOTWEAR  
(U.S. CLS. 22 AND 39).

NAKIA HENRY, EXAMINING ATTORNEY

**CLASS 25—(Continued).**

SN 85-241,813. LOLLY 38, LLC, WYOMISSING, PA. FILED 2-14-2011.

# TAFFY

THE MARK CONSISTS OF STANDARD CHARACTERS WITHOUT CLAIM TO ANY PARTICULAR FONT, STYLE, SIZE, OR COLOR.

FOR ACTIVEWEAR, NAMELY, PANTS, JACKETS, T-SHIRTS, AND TANK TOPS (U.S. CLS. 22 AND 39).

FIRST USE 3-0-2010; IN COMMERCE 3-0-2010.

REBECCA EISINGER, EXAMINING ATTORNEY

---

SN 85-248,064. CALVIN KLEIN TRADEMARK TRUST, WILMINGTON, DE. FILED 2-22-2011.

## CALVIN KLEIN INTIMATES

THE MARK CONSISTS OF STANDARD CHARACTERS WITHOUT CLAIM TO ANY PARTICULAR FONT, STYLE, SIZE, OR COLOR.

OWNER OF U.S. REG. NOS. 1,932,699, 3,320,669 AND OTHERS.

NO CLAIM IS MADE TO THE EXCLUSIVE RIGHT TO USE "INTIMATES", APART FROM THE MARK AS SHOWN.

FOR INTIMATE APPAREL AND FIGURE ENHANCING GARMENTS, NAMELY, BRAS, PANTIES, UNDERWEAR, UNDERPANTS, UNDERGARMENTS, UNDERCLOTHES, TEDDIES, SLIPS, SARONGS, NEGLIGENCE, LINGERIE, FOUNDATION GARMENTS, GIRDLES, CORSETS, CAMISOLES, BODY SLIPS AND BODY SUITS, SLEEPWEAR AND NIGHTGOWNS (U.S. CLS. 22 AND 39).

JANICE L. MCMORROW, EXAMINING ATTORNEY

---

SN 85-254,496. THIS SHIRT HELPS, INC., TOLUCA LAKE, CA. FILED 3-1-2011.

## AGENTS OF POSITIVITY

THE MARK CONSISTS OF STANDARD CHARACTERS WITHOUT CLAIM TO ANY PARTICULAR FONT, STYLE, SIZE, OR COLOR.

FOR CLOTHING, NAMELY, SHIRTS, T-SHIRTS, PANTS, JEANS, SHORTS, JACKETS, SWEATERS, TOPS, BLOUSES, DRESSES, SKIRTS, BLAZERS, SOCKS, BASEBALL CAPS, KNIT CAPS, BELTS, WRISTBANDS, HEAD WRAPS, UNDERWEAR, PAJAMAS, TIES, LINGERIE, BELTS, BOOTS, SHOES, AND SANDALS (U.S. CLS. 22 AND 39).

MARK SHINER, EXAMINING ATTORNEY

**CLASS 25—(Continued).**

SN 85-262,848. TRANSPACIFIC YACHT CLUB, NEWPORT BEACH, CA. FILED 3-9-2011.



OWNER OF U.S. REG. NOS. 1,823,302, 3,285,112 AND 3,764,161.

THE MARK CONSISTS OF SWALLOW-TAIL PENNANT WITH A FOUL ANCHOR. THE WIDTH OF THE BORDER AT THE HOIST IS ONE-HALF OF THAT AROUND THE BALANCE OF THE FIELD AND HAS SEVEN SMALL TRIANGLES. THE REMAINDER OF THE BORDER CONTAINS THIRTEEN STARS, SIX IN THE UPPER BORDER, SIX IN THE LOWER BORDER AND A SINGLE STAR IN THE APEX OF THE BORDER IN THE FLY OF THE PENNANT.

FOR BASEBALL CAPS; BELTS; BUTTON-FRONT ALOHA SHIRTS; MOISTURE-WICKING SPORTS SHIRTS; POLO SHIRTS; SWEAT SHIRTS; T-SHIRTS; TIES; VISORS (U.S. CLS. 22 AND 39).

FIRST USE 1-1-2000; IN COMMERCE 1-1-2000.

JEFFERY COWARD, EXAMINING ATTORNEY

---

SN 85-269,271. JUICY COUTURE, INC., PACOIMA, CA. FILED 3-17-2011.



OWNER OF U.S. REG. NO. 3,698,422.

THE MARK CONSISTS OF STYLIZED LETTERS "J" AND "C" WITH A CROWN DESIGN ABOVE THE LETTERS.

FOR BELTS; BLAZERS; BLOUSES; BOTTOMS; BRAS; COATS; DRESSES; FOOTWEAR; GLOVES; HEADWEAR; HOSIERY; JACKETS; JEANS; KNIT TOPS; LINGERIE; LOUNGEWEAR; NECKWEAR; PANTS; SCARVES; SHIRTS; SHORTS; SKIRTS; SLEEPWEAR; SOCKS; SUITS; SWEATERS; SWIMWEAR; T-SHIRTS; TOPS; TRACKSUITS; UNDERWEAR (U.S. CLS. 22 AND 39).

REGINA DRUMMOND, EXAMINING ATTORNEY

**CLASS 26—FANCY GOODS**

SN 85-208,312. LAUREN, LACIE F, LAYTON, UT. FILED 12-30-2010.



NO CLAIM IS MADE TO THE EXCLUSIVE RIGHT TO USE "HAIR EXTENSIONS", APART FROM THE MARK AS SHOWN.

THE COLOR(S) BLACK, BLUE, WHITE, LIME AND PINK IS/ARE CLAIMED AS A FEATURE OF THE MARK.

THE MARK CONSISTS OF THE WORDING "BELLA VIA HAIR EXTENSIONS" AND A DESIGN OF A FEMALE FACE WITH BLUE EYES, BLACK AND LIME HAIR, PINK LIPS, WHITE TEETH, BLACK EYELINER, BLACK EYEBROW, BLACK OUTLINED EAR, BLACK SEPARATION OF THE TEETH AND LIPS AND A LIME PAISLEY TATTOO OVER THE LEFT EYE. A STYLIZED PINK WORD "VIA" APPEARS BEHIND THE BLACK WORDS "BELLA" AND "HAIR EXTENSIONS", AND AT THE END OF WORDING "HAIR EXTENSIONS" APPEARS A MISCELLANEOUS DESIGN APPEARING IN THE COLOR LIME. ALL OF THE WORDING AND DESIGNS OF THE MARK APPEAR WITH A WHITE BACKGROUND.

THE ENGLISH TRANSLATION OF THE WORD "BELLA" IN THE MARK IS BEAUTIFUL.

FOR HAIR COLORING FOILS; HAIR EXTENSIONS; HAIR ORNAMENTS; HAIR RIBBONS (U.S. CLS. 37, 39, 40, 42 AND 50).

FIRST USE 11-4-2008; IN COMMERCE 1-1-2009.

SAMUEL E. SHARPER JR., EXAMINING ATTORNEY

SN 85-209,747. ADLER, CAROLYN, DBA KIBBONS RIBBONS, LAKE FOREST, IL. FILED 1-4-2011.

**KIBBONS RIBBONS**

THE MARK CONSISTS OF STANDARD CHARACTERS WITHOUT CLAIM TO ANY PARTICULAR FONT, STYLE, SIZE, OR COLOR.

NO CLAIM IS MADE TO THE EXCLUSIVE RIGHT TO USE "RIBBONS", APART FROM THE MARK AS SHOWN.

FOR SHOE LACES (U.S. CLS. 37, 39, 40, 42 AND 50).

MARTHA SANTOMARTINO, EXAMINING ATTORNEY

**CLASS 26—(Continued).**

SN 85-211,475. BLOCKIT NOW LLC, TARRYTOWN, NY. FILED 1-5-2011.

THE MARK CONSISTS OF THE STYLIZED TEXT "BLOCKIT NOW" WHERE THE WORD "NOW" APPEARS IN A RECTANGLE.

FOR HYPOALLERGENIC ADHESIVE STRIP THAT ATTACHES TO CLOTHING ITEMS TO PREVENT STAINS FROM PERSPIRATION, MAKEUP, AND DIRT (U.S. CLS. 37, 39, 40, 42 AND 50).

FIRST USE 8-0-2010; IN COMMERCE 9-0-2010.

KIM SAITO, EXAMINING ATTORNEY

SN 85-219,284. GTFM, INC., NEW YORK, NY. FILED 1-17-2011.

THE MARK CONSISTS OF STANDARD CHARACTERS WITHOUT CLAIM TO ANY PARTICULAR FONT, STYLE, SIZE, OR COLOR.

OWNER OF U.S. REG. NOS. 2,065,987, 3,165,612 AND OTHERS.

FOR BELT BUCKLES; CLOTHING BUCKLES; EMBROIDERED PATCHES FOR CLOTHING; HAT ORNAMENTS NOT OF PRECIOUS METAL; ORNAMENTAL CLOTH PATCHES; SHIRT BUTTONS; ZIPPER PULLS (U.S. CLS. 37, 39, 40, 42 AND 50).

JOSETTE BEVERLY, EXAMINING ATTORNEY

**CLASS 27—FLOOR COVERINGS**

SN 79-087,537. KABUSHIKI KAISHA DAIDOH LIMITED (ALSO TRADING AS DAIDOH LIMITED), JAPAN, FILED 9-8-2010.

# gredecana

THE MARK CONSISTS OF STANDARD CHARACTERS WITHOUT CLAIM TO ANY PARTICULAR FONT, STYLE, SIZE, OR COLOR.

PRIORITY DATE OF 8-6-2010 IS CLAIMED.

OWNER OF INTERNATIONAL REGISTRATION 1051632 DATED 9-8-2010, EXPIRES 9-8-2020.

OWNER OF U.S. REG. NO. 3,822,127.

THE WORDING "GREDECANA" HAS NO MEANING IN A FOREIGN LANGUAGE.

FOR CARPETS; RUGS; MATS, NAMELY, FLOOR MATS, DOOR MATS, CHAIR MATS, BATH MATS, BATH MATS FOR WASH PLACES, KITCHEN MATS, BATHROOM MATS, ENTRANCE MATS, BEACH MATS, GYMNASIUM MATS; FLOOR COVERINGS; WALL HANGINGS, NOT OF TEXTILE; WALLPAPER (U.S. CLS. 19, 20, 37, 42 AND 50).

DAVID HOFFMAN, EXAMINING ATTORNEY

SN 85-181,488. ERIC WILLIAMS, DBA SANISTEPER, ACWORTH, GA. AND JUSTIN DEMONE, DBA SANISTEPER, ACWORTH, GA. FILED 11-19-2010.



THE MARK CONSISTS OF A FOOTPRINT WITH THE WORDING "SANI STEPPER" WITHIN THE BOUNDARIES OF THE FOOTPRINT. THE WORDING "WHEN AND WHERE YOU NEED A CLEAN SPOT" APPEARS BELOW THE FOOTPRINT.

FOR BATH MATS; FLOOR MATS; PLASTIC BATH MATS (U.S. CLS. 19, 20, 37, 42 AND 50).

FIRST USE 11-1-2010; IN COMMERCE 11-8-2010.

COLLEEN DOMBROW, EXAMINING ATTORNEY

**CLASS 27—(Continued).**

SN 85-206,004. JOANNE DUGAN PHOTOGRAPHY LLC, DBA THE ALPHABET CITY, NEW YORK, NY. FILED 12-27-2010.



NO CLAIM IS MADE TO THE EXCLUSIVE RIGHT TO USE "WORD ART", APART FROM THE MARK AS SHOWN.

THE MARK CONSISTS OF THE WORDS "THE ALPHABET CITY" IN STYLIZED TYPEFACE ON A SUGGESTED BILLBOARD STRUCTURE ABOVE THE WORDING "WORD ART", WITH A BIRD ON THE BILLBOARD BETWEEN THE "L" AND "P".

FOR WALL HANGINGS, NAMELY, WORD ART CONSTITUTING ART WORK DEPICTING INDIVIDUAL LETTERS (U.S. CLS. 19, 20, 37, 42 AND 50).

FIRST USE 11-23-2010; IN COMMERCE 11-23-2010.

ROBIN MITTLER, EXAMINING ATTORNEY

SN 85-206,366. ACTION FLOOR SYSTEMS, LLC, MERCER, WI. FILED 12-28-2010.

# AIRRIDE

THE MARK CONSISTS OF STANDARD CHARACTERS WITHOUT CLAIM TO ANY PARTICULAR FONT, STYLE, SIZE, OR COLOR.

FOR STORAGE RACKS FOR USE IN THE INSTALLATION AND REMOVAL OF FLOOR COVERING MATERIALS (U.S. CLS. 19, 20, 37, 42 AND 50).

FIRST USE 2-9-2010; IN COMMERCE 2-9-2010.

MARK PILARO, EXAMINING ATTORNEY



**CLASS 28—TOYS AND SPORTING GOODS**

SN 76-705,483. STEICHEN, CRAIG, GREAT FALLS, MT.  
FILED 11-26-2010.

# SWEET HEAT

THE MARK CONSISTS OF STANDARD CHARACTERS WITHOUT CLAIM TO ANY PARTICULAR FONT, STYLE, SIZE, OR COLOR.

NO CLAIM IS MADE TO THE EXCLUSIVE RIGHT TO USE "HEAT", APART FROM THE MARK AS SHOWN.

FOR ELK AND DEER CHEMICAL SCENT LURES FOR USE IN HUNTING AND ELK AND DEER SCENT DISPERSAL LURES FOR USE IN HUNTING (U.S. CLS. 22, 23, 38 AND 50).

FIRST USE 1-4-2001; IN COMMERCE 1-4-2001.  
MARLENE BELL, EXAMINING ATTORNEY

**CLASS 28—(Continued).**

SN 77-905,861. NINTENDO CO., LTD., KYOTO, JAPAN,  
FILED 1-6-2010.

# Wii Relax

THE MARK CONSISTS OF STANDARD CHARACTERS WITHOUT CLAIM TO ANY PARTICULAR FONT, STYLE, SIZE, OR COLOR.

PRIORITY CLAIMED UNDER SEC. 44(D) ON JAPAN APPLICATION NO. 45-2009-0002, FILED 7-7-2009, REG. NO. 5391881, DATED 2-18-2011, EXPIRES 2-18-2021.

FOR CONSUMER VIDEO GAME APPARATUS, EXCLUDING APPARATUS ADAPTED TO BE USED WITH AN EXTERNAL DISPLAY SCREEN OR MONITOR; ACTION SKILL GAMES; ACTION-TYPE TARGET GAMES; ARCADE GAMES; ARCADE-TYPE ELECTRONIC VIDEO GAMES; BOARD GAMES; CARD GAMES; CASES FOR PLAY ACCESSORIES; ELECTRONIC GAME EQUIPMENT WITH A WATCH FUNCTION FOR PLAYING VIDEO GAMES OTHER THAN THOSE ADAPTED FOR USE WITH AN EXTERNAL DISPLAY SCREEN OR MONITOR; ELECTRONIC INTERACTIVE BOARD GAMES OTHER THAN THOSE ADAPTED FOR USE WITH AN EXTERNAL DISPLAY SCREEN OR MONITOR; EQUIPMENT SOLD AS A UNIT FOR PLAYING BOARD GAMES, CARD GAMES; HAND-HELD UNITS FOR PLAYING ELECTRONIC GAMES OTHER THAN THOSE ADAPTED FOR USE WITH AN EXTERNAL DISPLAY SCREEN OR MONITOR; HAND-HELD VIDEO GAME SYSTEMS OTHER THAN THOSE ADAPTED FOR USE WITH AN EXTERNAL DISPLAY SCREEN OR MONITOR, COMPRISING HAND-HELD UNITS FOR PLAYING VIDEO GAMES AND ASSOCIATED GAME CARTRIDGES OR GAME MEMORY CARDS PACKAGED AS A UNIT; PROMOTIONAL GAME CARDS; TRADING CARD GAMES (U.S. CLS. 22, 23, 38 AND 50).  
ANDREA HACK, EXAMINING ATTORNEY

SN 77-644,057. COUNTRY FEELING, CC, JEFFREYS BAY,  
SOUTH AFRICA, FILED 1-6-2009.

# COUNTRY FEELING

THE MARK CONSISTS OF STANDARD CHARACTERS WITHOUT CLAIM TO ANY PARTICULAR FONT, STYLE, SIZE, OR COLOR.

FOR SURFBOARDS (U.S. CLS. 22, 23, 38 AND 50).  
FIRST USE 1-15-2007; IN COMMERCE 1-15-2007.  
DAVID TOOLEY, EXAMINING ATTORNEY

SN 77-911,492. CORN-FUSION, ROCK HILL, SC. FILED 1-13-2010.



THE STIPPLING IS FOR SHADING PURPOSES ONLY.  
THE MARK CONSISTS OF "CORN-FUSION" LOGO ON TOP WITH A FUSION SYMBOL OVER A DEER HEAD AND THE PHRASE "DON'T FEED 'EM, CORN-FUSE 'EM" ON THE BOTTOM, "LIKE A CORNFIELD IN A BOTTLE". ON THE RIGHT, TO THE LEFT ARE "WWW.CORN-FUSION.COM" BELOW IT. ALL OF THIS IS ON A CORN BACKGROUND.

FOR LIQUID DEER ATTRACTANT THAT SMELLS LIKE CORN (U.S. CLS. 22, 23, 38 AND 50).  
FIRST USE 8-21-2009; IN COMMERCE 8-21-2009.  
MARTHA FROMM, EXAMINING ATTORNEY

**CLASS 28—(Continued).**

SN 77-920,773. DOHITOMI & CO., LTD., KATO-SHI, HYOGO-KEN, JAPAN, FILED 1-26-2010.

**TRINITY TREBLE HOOKS**

THE MARK CONSISTS OF STANDARD CHARACTERS WITHOUT CLAIM TO ANY PARTICULAR FONT, STYLE, SIZE, OR COLOR.

NO CLAIM IS MADE TO THE EXCLUSIVE RIGHT TO USE "TREBLE HOOKS", APART FROM THE MARK AS SHOWN.

FOR FISHING TACKLES (U.S. CLS. 22, 23, 38 AND 50).  
RUSS HERMAN, EXAMINING ATTORNEY

SN 77-925,162. NINTENDO CO., LTD., KYOTO, JAPAN, FILED 2-1-2010.



PRIORITY CLAIMED UNDER SEC. 44(D) ON JAPAN APPLICATION NO. 2009-088882, FILED 11-24-2009.

THE MARK CONSISTS OF THE WORD "WII", FOLLOWED BY TWO JAPANESE CHARACTERS, BENEATH THE WORDS IS A STYLIZED IMAGE OF A ROUND TABLE.

THE NON-LATIN CHARACTERS IN THE MARK TRANSLITERATE TO "NO MA" AND THIS MEANS "THE ROOM OF" IN ENGLISH.

FOR CARD GAMES AND EQUIPMENT SOLD AS A UNIT FOR PLAYING CARD GAMES; HANDHELD GAME APPARATUS WITH LIQUID CRYSTAL DISPLAYS; REPLACEMENT PARTS FOR HANDHELD GAME APPARATUS WITH LIQUID CRYSTAL DISPLAYS; ACCESSORIES FOR HANDHELD GAME APPARATUS WITH LIQUID CRYSTAL DISPLAYS, NAMELY, CARRYING CASES SPECIALLY ADAPTED FOR THE GAME APPARATUSES; DOLLS; GO GAMES; JAPANESE PLAYING CARDS, ALSO KNOWN AS UTAGARUTA; JAPANESE CHESS, ALSO KNOWN AS SHOGI GAMES; DICE; JAPANESE DICE GAMES, ALSO KNOWN AS SUGOROKU; DICE CUPS; DIAMOND GAMES, ALSO KNOWN AS CHINESE CHECKERS; CHESS GAMES; CHECKERS, NAMELY, CHECKER SETS; DOMINOES; PLAYING CARDS; JAPANESE PLAYING CARDS, ALSO KNOWN AS HANAFUDA; MAH-JONG; BILLIARD EQUIPMENT; AMUSEMENT GAME MACHINES; SPORTS EQUIPMENT, NAMELY, GOLF BALLS, IN-LINE SKATES, JUMP ROPES, ROLLER SKATES, SKATEBOARDS, SNOWBOARDS, SNOW SKIS, SPORTS BALLS, AND SWIMMING AIDS, NAMELY, POOL RINGS AND ARM FLOATS FOR RECREATIONAL USE; ARCADE VIDEO GAME MACHINES (U.S. CLS. 22, 23, 38 AND 50).

ANDREA HACK, EXAMINING ATTORNEY

**CLASS 28—(Continued).**

SN 77-966,435. MOE MOSTASHARI, BEVERLY HILLS, CA. FILED 3-23-2010.

**No Bust Blackjack**

THE MARK CONSISTS OF STANDARD CHARACTERS WITHOUT CLAIM TO ANY PARTICULAR FONT, STYLE, SIZE, OR COLOR.

NO CLAIM IS MADE TO THE EXCLUSIVE RIGHT TO USE "BLACKJACK", APART FROM THE MARK AS SHOWN.

SEC. 2(F).

FOR CARD GAMES (U.S. CLS. 22, 23, 38 AND 50).

FIRST USE 5-1-1999; IN COMMERCE 5-1-1999.

ASMAT KHAN, EXAMINING ATTORNEY

SN 79-078,552. DAVID STRUDWICK, NEW ZEALAND, AND ANDREW STRAWSON, NEW ZEALAND, FILED 9-18-2009.



PRIORITY DATE OF 8-27-2009 IS CLAIMED.

OWNER OF INTERNATIONAL REGISTRATION 1027879 DATED 9-18-2009, EXPIRES 9-18-2019.

NO CLAIM IS MADE TO THE EXCLUSIVE RIGHT TO USE "KITEBOARDING", APART FROM THE MARK AS SHOWN.

FOR SPORTING ARTICLES, NAMELY, KITEBOARDS, KITESURFING BOARDS, SURFBOARDS, WAKEBOARDS, PARACHUTES FOR KITEBOARDING, KITES FOR KITEBOARDING (U.S. CLS. 22, 23, 38 AND 50).

BERYL GARDNER, EXAMINING ATTORNEY

SN 79-086,768. HEINZ KETTLER GMBH & CO. KG, FED REP GERMANY, FILED 6-29-2010.

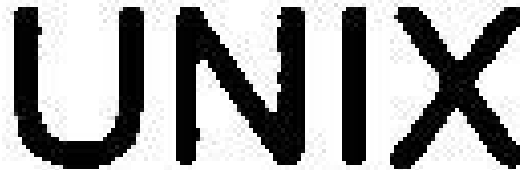

THE MARK CONSISTS OF STANDARD CHARACTERS WITHOUT CLAIM TO ANY PARTICULAR FONT, STYLE, SIZE, OR COLOR.

PRIORITY DATE OF 2-1-2010 IS CLAIMED.

OWNER OF INTERNATIONAL REGISTRATION 1049554 DATED 6-29-2010, EXPIRES 6-29-2020.

FOR SPORTS EQUIPMENT, NAMELY, CROSS-TRAINERS, NAMELY, EXERCISE MACHINES (U.S. CLS. 22, 23, 38 AND 50).

SANI KHOURI, EXAMINING ATTORNEY

**CLASS 28—(Continued).**

SN 79-087,124. HANGZHOU HUANYU ENTERPRISE CO., LTD., ZHEJIANG, CHINA, AND HANGZHOU HUANYU TOY CO., LTD., ZHEJIANG, CHINA, FILED 7-20-2010.



OWNER OF INTERNATIONAL REGISTRATION 1050510 DATED 7-20-2010, EXPIRES 7-20-2020.

THE MARK CONSISTS OF THE WORDING "HONNIEKIS" WITH DOTTED DESIGN OVER THE WORDING ENDING WITH A BUMBLEBEE DESIGN OVER THE LETTER "KIS", UNDERNEATH THIS WORDING AND DESIGN IS THREE CHINESE CHARACTERS, ALL WITHIN A RECTANGULAR CARRIER.

THE ENGLISH TRANSLATION OF THE FOREIGN WORD(S) IN THE MARK IS: THE FIRST CHARACTER MEANS SMILING; THE SECOND CHARACTER MEANS SWEET, AND THE THIRD CHARACTER MEANS CHILD; THE COMBINATION OF THE THREE CHINESE CHARACTERS HAS NO MEANING IN A FOREIGN LANGUAGE.

THE TRANSLITERATION OF THE NON-LATIN CHARACTERS IN THE MARK IS: MI MI ER.

FOR TOYS FOR DOMESTIC PETS; DOLLS' CLOTHES; DOLLS' HOUSES; DOLLS; SMART TOYS, NAMELY, CHRISTMAS TREES OF SYNTHETIC MATERIAL; BELLS FOR CHRISTMAS TREES; PLUSH TOYS; TOY BUILDING BLOCKS; ORNAMENTS FOR CHRISTMAS TREES, EXCEPT ILLUMINATION ARTICLES AND CONFECTIONERY (U.S. CLS. 22, 23, 38 AND 50).

JOSETTE BEVERLY, EXAMINING ATTORNEY

SN 85-024,135. O.K. TOYS, INC., LOS ANGELES, CA. FILED 4-27-2010.



THE MARKS CONSISTS OF STYLIZED TERM "STARRIORS" WITH TRIANGLE DESIGN FORMING PART OF THE LETTER "A".

FOR FANCIFUL FIGURINE TYPE MECHANICAL TOYS AND FANCIFUL SIMULATED TOY VEHICLES (U.S. CLS. 22, 23, 38 AND 50).

FIRST USE 5-23-1997; IN COMMERCE 5-23-1997.

GENE MACIOL, EXAMINING ATTORNEY

SN 85-038,907. ALLURE PET PRODUCTS, LLC, MORRISTOWN, NJ. FILED 5-14-2010.

## Ruff-Tex

THE MARK CONSISTS OF STANDARD CHARACTERS WITHOUT CLAIM TO ANY PARTICULAR FONT, STYLE, SIZE, OR COLOR.

FOR GAMES, TOYS, AND PLAYTHINGS, NAMELY, PET TOYS, STUFFED TOYS, SQUEEZE TOYS (U.S. CLS. 22, 23, 38 AND 50).

FIRST USE 7-20-2010; IN COMMERCE 8-0-2010.

JULIE GUTTADAURO, EXAMINING ATTORNEY

**CLASS 28—(Continued).**

SN 85-041,800. MEGAHOBBY.COM INC, DBA ATLANTIS MODEL COMPANY, EAST NORTHPORT, NY. FILED 5-18-2010.



THE MARK CONSISTS OF THE WORD "ATLANTIS" IN STYLIZED LETTERING ON TOP OF A BROKEN OVAL DESIGN.

FOR SCALE MODEL KITS (U.S. CLS. 22, 23, 38 AND 50).

FIRST USE 7-9-2009; IN COMMERCE 7-9-2009.

TARA PATE, EXAMINING ATTORNEY

SN 85-054,880. GTECH PRINTING CORPORATION, PROVIDENCE, RI. FILED 6-4-2010.

## uScratch

THE MARK CONSISTS OF STANDARD CHARACTERS WITHOUT CLAIM TO ANY PARTICULAR FONT, STYLE, SIZE, OR COLOR.

FOR LOTTERY TICKETS (U.S. CLS. 22, 23, 38 AND 50).

CAROLYN CATALDO, EXAMINING ATTORNEY

SN 85-069,175. JOHNSON GOLF GRIPS, INC., SANTA BARBARA, CA. FILED 6-22-2010.

## OPTI VIBE

THE MARK CONSISTS OF STANDARD CHARACTERS WITHOUT CLAIM TO ANY PARTICULAR FONT, STYLE, SIZE, OR COLOR.

FOR GOLF EQUIPMENT, NAMELY, GOLF CLUB GRIPS AND ACCESSORIES THEREFOR, NAMELY, WEIGHTS, SCREWS, AND PLUGS; GOLF CLUB PARTS, NAMELY, CONNECTORS FOR ATTACHING OR ASSEMBLING GOLF CLUBS (U.S. CLS. 22, 23, 38 AND 50).

FIRST USE 9-1-2009; IN COMMERCE 9-1-2009.

ELLEN PERKINS, EXAMINING ATTORNEY

**CLASS 28—(Continued).**

SN 85-072,645. CYNTHIA BAIN, AVENTURA, FL. FILED 6-28-2010.

**GOOSHDAGAMS**

THE MARK CONSISTS OF STANDARD CHARACTERS WITHOUT CLAIM TO ANY PARTICULAR FONT, STYLE, SIZE, OR COLOR.

FOR TOY DOLLS AND RELATED FICTITIOUS BIRTH-RECORDS (U.S. CLS. 22, 23, 38 AND 50).  
GRETTA YAO, EXAMINING ATTORNEY

SN 85-073,890. ZING TOYS, INC., BANKS, OR. FILED 6-29-2010.

**ZING AIR**

THE MARK CONSISTS OF STANDARD CHARACTERS WITHOUT CLAIM TO ANY PARTICULAR FONT, STYLE, SIZE, OR COLOR.

NO CLAIM IS MADE TO THE EXCLUSIVE RIGHT TO USE "AIR", APART FROM THE MARK AS SHOWN.

FOR BOOMERANGS; DARTS; FLYING DISCS; HAND-POWERED NON-MECHANICAL FLYING TOY; TOY GLIDERS; TOY GUNS; TOY PISTOLS; TOY ROCKETS; TOY WEAPONS (U.S. CLS. 22, 23, 38 AND 50).  
FIRST USE 6-1-2009; IN COMMERCE 6-1-2009.

ALEX KEAM, EXAMINING ATTORNEY

**CLASS 28—(Continued).**

SN 85-074,836. FREMANTLEMEDIA OPERATIONS BV, HILVERSUM, NETHERLANDS, FILED 6-30-2010.

**PLAY YOUR HUNCH**

THE MARK CONSISTS OF STANDARD CHARACTERS WITHOUT CLAIM TO ANY PARTICULAR FONT, STYLE, SIZE, OR COLOR.

OWNER OF U.S. REG. NO. 2,552,894.

FOR TARGET GAMES, BOARD GAMES AND CARD GAMES, KITES, TOY ACTION FIGURES, DISC-TYPE TOSS TOYS, TOY BOWS AND ARROWS BOWS AND ARROWS, BALLS FOR GAMES, BALLS FOR SPORTS, DOLLS, DOLL PLAYSETS, PLUSH TOYS, TOY VEHICLES, TOY BUCKET AND SHOVEL SETS, ROLLER SKATES, TOY MODEL HOBBYCRAFT KITS, TOY ROCKETS, TOY GUNS, TOY HOLSTERS, MUSICAL TOYS, JIGSAW PUZZLES, BADMINTON SETS, BUBBLE MAKING WANDS AND SOLUTION SETS, TOY FIGURINES, TOY BANKS, PUPPETS, TOY BALLOONS, YO-YOS, SKATEBOARDS, TOY SCOOTERS, FACE MASKS FOR COSTUMERY, STAND ALONE VIDEO GAME MACHINES, LCD GAME MACHINES; HAND HELD UNIT FOR PLAYING ELECTRONIC GAMES, BUT SPECIFICALLY EXCLUDING DICE GAMES AND COMPUTER SOFTWARE GAMES; LOTTERY TICKETS; CONFETTI; COIN-OPERATED AMUSEMENT MACHINES, PLAYING CARDS, PAPER PARTY HATS (U.S. CLS. 22, 23, 38 AND 50).

REBECCA SMITH, EXAMINING ATTORNEY

SN 85-075,352. MATTEL, INC., EL SEGUNDO, CA. FILED 6-30-2010.

**POWER PRO SPEEDWAY**

THE MARK CONSISTS OF STANDARD CHARACTERS WITHOUT CLAIM TO ANY PARTICULAR FONT, STYLE, SIZE, OR COLOR.

OWNER OF U.S. REG. NO. 3,131,009.

NO CLAIM IS MADE TO THE EXCLUSIVE RIGHT TO USE "POWER" AND "SPEEDWAY", APART FROM THE MARK AS SHOWN.

FOR REMOTE CONTROLLED TOY VEHICLE TRACK SETS AND ACCESSORIES THEREFOR (U.S. CLS. 22, 38 AND 50).

JESSICA FATHY, EXAMINING ATTORNEY

**CLASS 28—(Continued).**

SN 85-077,929. CHAPADOS, JANET G., DBA SWEAR BEARS, EDEN, VT. FILED 7-5-2010.

## Swear Bears

THE MARK CONSISTS OF STANDARD CHARACTERS WITHOUT CLAIM TO ANY PARTICULAR FONT, STYLE, SIZE, OR COLOR.

NO CLAIM IS MADE TO THE EXCLUSIVE RIGHT TO USE "BEARS", APART FROM THE MARK AS SHOWN. SEC. 2(F).

FOR TEDDY BEARS (U.S. CLS. 22, 23, 38 AND 50).  
FIRST USE 7-29-1993; IN COMMERCE 7-29-1993.  
RON FAIRBANKS, EXAMINING ATTORNEY

---

SN 85-078,656. GHOST SCENT CO., MARION, NC. FILED 7-6-2010.



THE MARK CONSISTS OF A DEER SKULL AND HORNS ATTACHED TO THE DEER SKULL.

FOR HUNTING AND OUTDOOR RECREATIONAL PRODUCTS, NAMELY, HUNTING GAME CALLS AND SCENT CAMOUFLAGE PRODUCTS, NAMELY, HUNTERS' SCENT CAMOUFLAGE AND ANIMAL URINES (U.S. CLS. 22, 23, 38 AND 50).

BARBARA GAYNOR, EXAMINING ATTORNEY

---

SN 85-081,749. WHAM-O, INC., EMERYVILLE, CA. FILED 7-9-2010.

## CLICK 'N HOOP

THE MARK CONSISTS OF STANDARD CHARACTERS WITHOUT CLAIM TO ANY PARTICULAR FONT, STYLE, SIZE, OR COLOR.

NO CLAIM IS MADE TO THE EXCLUSIVE RIGHT TO USE "HOOP", APART FROM THE MARK AS SHOWN.

FOR TOYS, GAMES, AND PLAYTHINGS, NAMELY, TOY HOOPS (U.S. CLS. 22, 23, 38 AND 50).

WILLIAM P. SHANAHAN, EXAMINING ATTORNEY

**CLASS 28—(Continued).**

SN 85-083,508. JIMMY HACK GOLF, LLC, EASLEY, SC. FILED 7-13-2010.



OWNER OF U.S. REG. NO. 3,441,271.

THE MARK CONSISTS OF THE TERMS "ORANGE" AND "WHIP" SEPARATED BY A SPHERE FROM WHICH A LEAF-BEARING STEM EXTENDS UPWARD.

FOR ATHLETIC TRAINING DEVICES IN THE NATURE OF GOLF, BASEBALL, AND TENNIS SWING AIDS, NAMELY, A FLEXIBLE SHAFT HAVING A COUNTERWEIGHTED HANDLE AND A WEIGHTED HEAD AT OPPOSITE ENDS FOR PRACTICING GOLF, BASEBALL AND TENNIS SWINGS TO IMPROVE SWING MOTION, BALANCE, COORDINATION, AND SWING MECHANICS; FITNESS DEVICES FOR REPLICATING UPPER AND LOWER BODY SWING MOTION AND MECHANICS IN THE NATURE OF A FLEXIBLE SHAFT HAVING A COUNTERWEIGHTED HANDLE AND A WEIGHTED HEAD AT OPPOSITE ENDS FOR PRACTICING ARM SWING MOTION TO IMPROVE FLEXIBILITY, MUSCLE TONE, BALANCE, COORDINATION, AND STRENGTH (U.S. CLS. 22, 23, 38 AND 50).

FIRST USE 1-16-2008; IN COMMERCE 1-16-2008.  
ERIN FALK, EXAMINING ATTORNEY

---

SN 85-085,383. SIMON GOLF COMPANY, LLC, INDIANAPOLIS, IN. FILED 7-15-2010.

## WEAPON

THE MARK CONSISTS OF STANDARD CHARACTERS WITHOUT CLAIM TO ANY PARTICULAR FONT, STYLE, SIZE, OR COLOR.

FOR GOLF CLUBS (U.S. CLS. 22, 23, 38 AND 50).  
ANDREA K. NADELMAN, EXAMINING ATTORNEY

---

SN 85-090,982. MAINWAY GOLF, INC., MINNEAPOLIS, MN. FILED 7-22-2010.

## GO FOR 2

THE MARK CONSISTS OF STANDARD CHARACTERS WITHOUT CLAIM TO ANY PARTICULAR FONT, STYLE, SIZE, OR COLOR.

FOR BOARD GAMES, CARD GAMES (U.S. CLS. 22, 23, 38 AND 50).

ELLEN B. AWRICH, EXAMINING ATTORNEY



**CLASS 28—(Continued).**

SN 85-115,899. SIMON & SCHUSTER, INC., NEW YORK, NY.  
FILED 8-25-2010.



OWNER OF U.S. REG. NOS. 2,600,713, 3,359,695 AND OTHERS.

THE STIPPLING IS A FEATURE OF THE MARK AND DOES NOT INDICATE COLOR.

THE MARK CONSISTS OF A RECTANGLE FEATURING DOLLS ON THE RIGHT AND LEFT HAND SIDES, EACH DOLL ENCLOSED WITHIN A CIRCLE, WITH THE WORDING "RAGGEDY ANN & ANDY" BETWEEN THE DOLLS, ALL SHOW AGAINST A BACKGROUND OF VERTICAL LINES.

FOR CHILDREN'S DRESS UP ACCESSORIES, NAMELY, TOY COSTUME JEWELRY, TOY PLASTIC BEADS, TOY MANICURE SETS; TOYS, NAMELY, BALL AND JACK SETS, JIGSAW PUZZLES, TOY SETS UTILIZING INTERCHANGEABLE DESIGN STICKERS, HOBBY CRAFT KITS COMPRISING OF PLASTIC, VINYL AND RESIN MOLDS AND MANIPULATIVE PUZZLES, AND TOY MUSICAL DISPLAY FIGURES (U.S. CLS. 22, 23, 38 AND 50).

ESTHER BELENKER, EXAMINING ATTORNEY

**CLASS 28—(Continued).**

SN 85-159,910. DOUGLAS P. ARDUINI, DBA NON-TRIVIAL QUEST LLC, SAN RAMON, CA. FILED 10-25-2010.



THE COLOR(S) WHITE, BLACK, RED, LIGHT VIOLET, DARK VIOLET, BLUE, AND GREY IS/ARE CLAIMED AS A FEATURE OF THE MARK.

THE MARK CONSISTS OF THE WORDS "NON-TRIVIAL QUEST" AND THE DESIGN OF RED FLAGS ON EITHER SIDE OF THE WORD "NON-." THE WORD "NON-" IS IN LIGHT VIOLET WITH BLACK SHADOW LINES. THE WORD "TRIVIAL" IS IN VIOLET WITH BLACK SHADOW LINES. THE WORD "QUEST" IS IN BLUE. THE ENTIRE WORDING AND DESIGN IS OUTLINED IN BLACK AND THE WORDS ARE SET ON A WHITE BACKGROUND. THERE IS GRAY SHADING IN BACK OF THE WORDS AND DESIGN TO MAKE THE MARK APPEAR IN THREE DIMENSIONS.

FOR BOARD GAMES (U.S. CLS. 22, 23, 38 AND 50).  
DAWN FELDMAN, EXAMINING ATTORNEY

SN 85-157,135. LET'S DANCE WORLD, LLC, SHERMAN OAKS, CA. FILED 10-20-2010.

**DANCE PARTY IN A BOX**

THE MARK CONSISTS OF STANDARD CHARACTERS WITHOUT CLAIM TO ANY PARTICULAR FONT, STYLE, SIZE, OR COLOR.

FOR DANCE PARTY GAME; PARTY KIT FOR THROWING DANCE PARTIES COMPRISING NOISE-MAKER PARTY FAVORS, PRERECORDED CDS FEATURING MUSIC, PRINTED DANCE INSTRUCTIONS, PAPER PARTY FAVORS AND PARTY FAVORS IN THE NATURE OF SMALL TOYS, SUNGLASSES, APPAREL IN THE NATURE OF LEOTARDS, T-SHIRTS, WRISTBANDS, LEGGINGS, FEDORAS AND HATS, PRINTED INVITATIONS, AND OTHER DANCE-RELATED PARAPHERNALIA, NAMELY, DANCE SHOES, POSTERS AND MIRROR BALLS (U.S. CLS. 22, 23, 38 AND 50).

MATTHEW PAPPAS, EXAMINING ATTORNEY

SN 85-172,761. NAVAJO NATION GAMING ENTERPRISE, CHURCH ROCK, NM. FILED 11-9-2010.

**FLOWING WATER NAVAJO CASINO**

THE MARK CONSISTS OF STANDARD CHARACTERS WITHOUT CLAIM TO ANY PARTICULAR FONT, STYLE, SIZE, OR COLOR.

OWNER OF U.S. REG. NOS. 3,721,178, 3,721,180 AND OTHERS.

NO CLAIM IS MADE TO THE EXCLUSIVE RIGHT TO USE "CASINO", APART FROM THE MARK AS SHOWN.

FOR GAMING AND CASINO EQUIPMENT, NAMELY, POKER CHIPS AND PLAYING CARDS; GOLF ACCESSORIES, NAMELY, GOLF BALLS, GOLF TEES, AND GOLF BALL MARKERS; STUFFED TOY ANIMALS (U.S. CLS. 22, 23, 38 AND 50).

DAWN FELDMAN, EXAMINING ATTORNEY

**CLASS 28—(Continued).**

SN 85-172,810. NAVAJO NATION GAMING ENTERPRISE, CHURCH ROCK, NM. FILED 11-9-2010.

TWIN ARROWS NAVAJO CASINO  
RESORT

THE MARK CONSISTS OF STANDARD CHARACTERS WITHOUT CLAIM TO ANY PARTICULAR FONT, STYLE, SIZE, OR COLOR.

OWNER OF U.S. REG. NOS. 3,721,178, 3,721,180 AND OTHERS.

NO CLAIM IS MADE TO THE EXCLUSIVE RIGHT TO USE "CASINO RESORT", APART FROM THE MARK AS SHOWN.

FOR GAMING AND CASINO EQUIPMENT, NAMELY, POKER CHIPS AND PLAYING CARDS; GOLF ACCESSORIES, NAMELY, GOLF BALLS, GOLF TEES, AND GOLF BALL MARKERS; STUFFED TOY ANIMALS (U.S. CLS. 22, 23, 38 AND 50).

DAWN FELDMAN, EXAMINING ATTORNEY

**CLASS 28—(Continued).**

SN 85-185,588. ENNEAGRAM GAME INVENTORS (PTY) LTD., BEDFORDVIEW, GAUTENG, SOUTH AFRICA, FILED 11-26-2010.

NINELIVES THE ENNEAGRAMGAME

THE MARK CONSISTS OF STANDARD CHARACTERS WITHOUT CLAIM TO ANY PARTICULAR FONT, STYLE, SIZE, OR COLOR.

NO CLAIM IS MADE TO THE EXCLUSIVE RIGHT TO USE "THE ENNEAGRAM GAME", APART FROM THE MARK AS SHOWN.

FOR BOARD GAMES (U.S. CLS. 22, 23, 38 AND 50).  
KRISTIN CARLSON, EXAMINING ATTORNEY

SN 85-194,325. E. MISHAN & SONS, INC., NEW YORK, NY. FILED 12-9-2010.

PUSHUP PUMP

THE MARK CONSISTS OF STANDARD CHARACTERS WITHOUT CLAIM TO ANY PARTICULAR FONT, STYLE, SIZE, OR COLOR.

NO CLAIM IS MADE TO THE EXCLUSIVE RIGHT TO USE "PUSHUP", APART FROM THE MARK AS SHOWN.

FOR MANUALLY-OPERATED EXERCISE EQUIPMENT (U.S. CLS. 22, 23, 38 AND 50).

ALEX KEAM, EXAMINING ATTORNEY

SN 85-195,265. GTECH PRINTING CORPORATION, PROVIDENCE, RI. FILED 12-10-2010.

CASH FARMER

THE MARK CONSISTS OF STANDARD CHARACTERS WITHOUT CLAIM TO ANY PARTICULAR FONT, STYLE, SIZE, OR COLOR.

NO CLAIM IS MADE TO THE EXCLUSIVE RIGHT TO USE "CASH", APART FROM THE MARK AS SHOWN.

FOR LOTTERY TICKETS (U.S. CLS. 22, 23, 38 AND 50).  
FIRST USE 8-18-2010; IN COMMERCE 8-18-2010.

GIANCARLO CASTRO, EXAMINING ATTORNEY

SN 85-175,831. AMUSEMENT PRODUCTS, LLC, CHATTANOOGA, TN. FILED 11-12-2010.



NO CLAIM IS MADE TO THE EXCLUSIVE RIGHT TO USE "BUMPER CARS", APART FROM THE MARK AS SHOWN.

THE COLOR(S) ORANGE, BLACK, YELLOW, RED AND BLUE IS/ARE CLAIMED AS A FEATURE OF THE MARK.

THE MARK CONSISTS OF AN ORANGE SPINNER IN THE BACKGROUND. IN FRONT OF THE SPINNER ARE THE STYLIZED WORDS "SPIN ZONE" IN YELLOW WITH RED OUTLINE. BETWEEN THE WORDS "SPIN ZONE" IS A BLACK SILHOUETTE OF A SPINNING/FALLING PERSON. BELOW ALL OF THIS ARE THE STYLIZED WORDS "BUMPER CARS" IN YELLOW AND OUTLINED IN BLUE. FOR AMUSEMENT RIDES, NAMELY, BUMPER CARS (U.S. CLS. 22, 23, 38 AND 50).

FIRST USE 11-30-2008; IN COMMERCE 11-30-2008.

CHRIS WELLS, EXAMINING ATTORNEY

**CLASS 28—(Continued).**

SN 85-196,105. STATHIS, EILEEN, BELLE HARBOR, NY.  
FILED 12-13-2010.

# Bungee Button

THE MARK CONSISTS OF STANDARD CHARACTERS WITHOUT CLAIM TO ANY PARTICULAR FONT, STYLE, SIZE, OR COLOR.  
FOR SPINNING TOYS (U.S. CLS. 22, 23, 38 AND 50).  
BRIDGETT SMITH, EXAMINING ATTORNEY

---

SN 85-197,871. BY GEORGE! INC., LAKE FOREST, CA.  
FILED 12-14-2010.

# TIC ATTACK TOE

THE MARK CONSISTS OF STANDARD CHARACTERS WITHOUT CLAIM TO ANY PARTICULAR FONT, STYLE, SIZE, OR COLOR.  
FOR TOYS, GAMES AND PLAYTHINGS, NAMELY, CARD GAMES AND ACCESSORIES THEREFOR, NAMELY, PLASTIC CARD HOLDER THAT DOUBLES AS A GAME BOARD (U.S. CLS. 22, 23, 38 AND 50).  
FIRST USE 1-6-2006; IN COMMERCE 2-5-2009.  
YAT SYE, LEE, EXAMINING ATTORNEY

---

SN 85-198,130. OSTROWSKI, MICHAEL S., LUDLOW, MA.  
FILED 12-15-2010.

# HEINIE SMOOCHER

THE MARK CONSISTS OF STANDARD CHARACTERS WITHOUT CLAIM TO ANY PARTICULAR FONT, STYLE, SIZE, OR COLOR.  
FOR NOVELTY TOYS, NAMELY, FAKE LIPS (U.S. CLS. 22, 23, 38 AND 50).  
PAUL F. GAST, EXAMINING ATTORNEY

**CLASS 28—(Continued).**

SN 85-202,709. INNOVATIVE PROCUREMENT, LLC, EL-DON, MO. FILED 12-21-2010.

# CONQUER THE OUTDOORS

THE MARK CONSISTS OF STANDARD CHARACTERS WITHOUT CLAIM TO ANY PARTICULAR FONT, STYLE, SIZE, OR COLOR.  
NO CLAIM IS MADE TO THE EXCLUSIVE RIGHT TO USE "OUTDOORS", APART FROM THE MARK AS SHOWN.  
FOR FISHING TACKLE; FISHING TACKLE BAGS; FISHING TACKLE BOXES; REELS FOR FISHING; RODS FOR FISHING (U.S. CLS. 22, 23, 38 AND 50).  
WILLIAM BRECKENFELD, EXAMINING ATTORNEY

---

SN 85-202,968. BUZZ BEE TOYS, INC., MT. LAUREL, NJ.  
FILED 12-21-2010.

# TURBO 12

THE MARK CONSISTS OF STANDARD CHARACTERS WITHOUT CLAIM TO ANY PARTICULAR FONT, STYLE, SIZE, OR COLOR.  
FOR TOY PROJECTILE SHOOTERS AND ACCESSORIES THEREFOR, EXCLUDING BUBBLES (U.S. CLS. 22, 23, 38 AND 50).  
TAMARA FRAZIER, EXAMINING ATTORNEY

---

SN 85-203,598. BUZZ BEE TOYS, INC., MT. LAUREL, NJ.  
FILED 12-22-2010.

# SURGE 6

THE MARK CONSISTS OF STANDARD CHARACTERS WITHOUT CLAIM TO ANY PARTICULAR FONT, STYLE, SIZE, OR COLOR.  
FOR TOY PROJECTILE SHOOTERS AND ACCESSORIES THEREFOR (U.S. CLS. 22, 23, 38 AND 50).  
TAMARA FRAZIER, EXAMINING ATTORNEY

**CLASS 28—(Continued).**

SN 85-203,621. BUZZ BEE TOYS, INC., MT. LAUREL, NJ.  
FILED 12-22-2010.

**RADS 12**

THE MARK CONSISTS OF STANDARD CHARACTERS WITHOUT CLAIM TO ANY PARTICULAR FONT, STYLE, SIZE, OR COLOR.  
FOR TOY PROJECTILE SHOOTERS AND ACCESSORIES THEREFOR (U.S. CLS. 22, 23, 38 AND 50).  
TAMARA FRAZIER, EXAMINING ATTORNEY

SN 85-204,517. BURNS, GRANT, VISTA, CA. FILED 12-22-2010.

**BareBack**  
skate boards

NO CLAIM IS MADE TO THE EXCLUSIVE RIGHT TO USE "SKATE BOARDS", APART FROM THE MARK AS SHOWN.

THE MARK CONSISTS OF THE WORDS "BAREBACK SKATE BOARDS" IN STYLIZED FONT.

FOR SKATEBOARDS (U.S. CLS. 22, 23, 38 AND 50).

FIRST USE 12-1-2008; IN COMMERCE 1-1-2009.

EMILY CHUO, EXAMINING ATTORNEY

SN 85-204,717. BUZZ BEE TOYS, INC., MT. LAUREL, NJ.  
FILED 12-23-2010.

**SURGE 10**

THE MARK CONSISTS OF STANDARD CHARACTERS WITHOUT CLAIM TO ANY PARTICULAR FONT, STYLE, SIZE, OR COLOR.

FOR TOY PROJECTILE SHOOTERS AND ACCESSORIES THEREFOR (U.S. CLS. 22, 23, 38 AND 50).

TAMARA FRAZIER, EXAMINING ATTORNEY

**CLASS 28—(Continued).**

SN 85-204,799. JONTI-CRAFT, INC., WABASSO, MN. FILED 12-23-2010.

**KYDZSUITE**

THE MARK CONSISTS OF STANDARD CHARACTERS WITHOUT CLAIM TO ANY PARTICULAR FONT, STYLE, SIZE, OR COLOR.

OWNER OF U.S. REG. NOS. 2,307,454, 2,307,455 AND 2,424,463.

FOR MODULAR PLAY SYSTEMS CONSISTING OF PANELS, POSTS, FRAMES, GATES, ARCHWAYS, AND ATTACHMENT AND SECURING PARTS AND ACCESSORIES THEREFOR, ALL SOLD INDIVIDUALLY OR IN CUSTOMIZABLE COMBINATIONS (U.S. CLS. 22, 23, 38 AND 50).

JUDITH HELFMAN, EXAMINING ATTORNEY

SN 85-205,200. ADVANTAGE BAIT COMPANY, ELK GROVE, IL. FILED 12-23-2010.

**EXTREME FLASH TECHNOLOGY**

THE MARK CONSISTS OF STANDARD CHARACTERS WITHOUT CLAIM TO ANY PARTICULAR FONT, STYLE, SIZE, OR COLOR.

NO CLAIM IS MADE TO THE EXCLUSIVE RIGHT TO USE "TECHNOLOGY", APART FROM THE MARK AS SHOWN.

FOR FISHING LURES; FISHING LURE PARTS; ARTIFICIAL FISHING LURES; FISHING LURES, NAMELY, SPOONS, BLADES, SPINNERS, AND ATTRACTORS (U.S. CLS. 22, 23, 38 AND 50).

MICHAEL KEATING, EXAMINING ATTORNEY

SN 85-206,753. GEORGE SINANIS, WEST BLOOMFIELD, MI.  
FILED 12-28-2010.

**Tee Rex**

THE MARK CONSISTS OF STANDARD CHARACTERS WITHOUT CLAIM TO ANY PARTICULAR FONT, STYLE, SIZE, OR COLOR.

NO CLAIM IS MADE TO THE EXCLUSIVE RIGHT TO USE "TEE", APART FROM THE MARK AS SHOWN.

FOR GOLF TEES (U.S. CLS. 22, 23, 38 AND 50).

MATTHEW KLINE, EXAMINING ATTORNEY

**CLASS 28—(Continued).**

SN 85-206,855. JC 23 ENTERTAINMENT, INC., BEVERLY HILLS, CA. FILED 12-28-2010.



THE MARK CONSISTS OF STYLIZED CHARACTER SITTING IN YOGA STYLE.

FOR TOYS, SPORTING GOODS, GAMES AND PLAYTHINGS, NAMELY, ACTION FIGURES AND ACCESSORIES THEREFOR; PLUSH TOYS; BALLOONS; BATHTUB TOYS; RIDE-ON TOYS; EQUIPMENT SOLD AS A UNIT FOR PLAYING CARD GAMES; TOY VEHICLES; DOLLS; FLYING DISCS; ELECTRONIC HAND-HELD GAME UNIT OTHER THAN THOSE ADAPTED FOR USE WITH AN EXTERNAL DISPLAY SCREEN OR MONITOR; GAME EQUIPMENT SOLD AS A UNIT FOR PLAYING A BOARD GAME, A CARD GAME, A MANIPULATIVE GAME, A PARLOR GAME AND AN ACTION TYPE TARGET GAME; STAND ALONE VIDEO OUTPUT GAME MACHINES; JIGSAW AND MANIPULATIVE PUZZLES; PAPER FACE MASKS; SKATEBOARDS, ICE SKATES; WATER SQUIRTING TOYS; BALLS, NAMELY, PLAYGROUND BALLS, SOCCER BALLS, BASEBALLS, BASKETBALLS, TENNIS BALLS, BASEBALL GLOVES, SWIMMING FLOATS FOR RECREATIONAL USE; KICKBOARD FLOTATION DEVICES FOR RECREATIONAL USE; SURFBOARDS; SWIM BOARDS FOR RECREATION USE; SWIM FINNS; TOY BAKE WARE AND TOY COOKWARE; TOY BANKS; TOY SNOW GLOBES; CHRISTMAS TREE ORNAMENTS; DOG AND CAT PLAY TOYS (U.S. CLS. 22, 23, 38 AND 50).

CYNTHIA SLOAN, EXAMINING ATTORNEY

SN 85-207,941. LUCKY CRAFT CO., LTD., OYABE-SHI, TOYAMA, JAPAN, FILED 12-30-2010.

**LC CRANK**

THE MARK CONSISTS OF STANDARD CHARACTERS WITHOUT CLAIM TO ANY PARTICULAR FONT, STYLE, SIZE, OR COLOR.

OWNER OF U.S. REG. NOS. 3,030,751, 3,661,254 AND 3,661,255.

NO CLAIM IS MADE TO THE EXCLUSIVE RIGHT TO USE "CRANK", APART FROM THE MARK AS SHOWN.

FOR FISHING EQUIPMENT, NAMELY, FISHING TACKLES, FISHING LURES, FISHING RODS AND FISHING LINES (U.S. CLS. 22, 23, 38 AND 50).

JANET LEE, EXAMINING ATTORNEY

**CLASS 28—(Continued).**

SN 85-208,001. LUCKY CRAFT CO., LTD., OYABE-SHI, TOYAMA, JAPAN, FILED 12-30-2010.

**RC CRANK**

THE MARK CONSISTS OF STANDARD CHARACTERS WITHOUT CLAIM TO ANY PARTICULAR FONT, STYLE, SIZE, OR COLOR.

NO CLAIM IS MADE TO THE EXCLUSIVE RIGHT TO USE "CRANK", APART FROM THE MARK AS SHOWN.

FOR FISHING EQUIPMENT, NAMELY, FISHING TACKLES, FISHING LURES, FISHING RODS AND FISHING LINES (U.S. CLS. 22, 23, 38 AND 50).

JANET LEE, EXAMINING ATTORNEY

SN 85-208,152. LUCKY CRAFT CO., LTD., OYABE-SHI, TOYAMA, JAPAN, FILED 12-30-2010.

**KJ PROP**

THE MARK CONSISTS OF STANDARD CHARACTERS WITHOUT CLAIM TO ANY PARTICULAR FONT, STYLE, SIZE, OR COLOR.

NO CLAIM IS MADE TO THE EXCLUSIVE RIGHT TO USE "PROP", APART FROM THE MARK AS SHOWN.

FOR FISHING EQUIPMENT, NAMELY, FISHING TACKLES, FISHING LURES, FISHING RODS AND FISHING LINES (U.S. CLS. 22, 23, 38 AND 50).

JANET LEE, EXAMINING ATTORNEY

SN 85-208,369. REQUISITE SOLUTIONS INC., CHICAGO, IL. FILED 12-30-2010.

**LEARNINGSCHOOL**

THE MARK CONSISTS OF STANDARD CHARACTERS WITHOUT CLAIM TO ANY PARTICULAR FONT, STYLE, SIZE, OR COLOR.

FOR EDUCATIONAL, DEVELOPMENTAL AND ACTIVITY TOYS, NAMELY, MAGNETIC BOARD PLAY SETS IN THE NATURE OF A CHILDREN'S MULTIPLE ACTIVITY TOY COMPRISING A MAGNETIC BOARD AND FLEXIBLE AND NON-FLEXIBLE MAGNETIC PIECES; ART, SCIENCE, LOGIC AND MATH SKILL GAMES; TOY CONSTRUCTION SETS; PLUSH MAGNETIC TOYS; BUILDING TOYS IN THE NATURE OF TOY BUILDING BLOCKS; BOARD AND PARLOR GAMES AND TOYS IN THE FORM OF KITS FOR CONSTRUCTING TOY VEHICLES (U.S. CLS. 22, 23, 38 AND 50).

FIRST USE 5-4-2005; IN COMMERCE 12-29-2010.

ROBIN CHOSID, EXAMINING ATTORNEY



**CLASS 28—(Continued).**

SN 85-209,036. LEE ANN MILLER, INDIANAPOLIS, IN. FILED 1-3-2011.

**WATERCLOUD**

THE MARK CONSISTS OF STANDARD CHARACTERS WITHOUT CLAIM TO ANY PARTICULAR FONT, STYLE, SIZE, OR COLOR.

FOR RECREATIONAL DEVICES FOR USE IN WATER, NAMELY, SWIM FLOATS AND WATER TOYS (U.S. CLS. 22, 23, 38 AND 50).

TAMARA FRAZIER, EXAMINING ATTORNEY

SN 85-209,083. BUZZ BEE TOYS, INC., MT. LAUREL, NJ. FILED 1-3-2011.



NO CLAIM IS MADE TO THE EXCLUSIVE RIGHT TO USE "FOOTBALL", APART FROM THE MARK AS SHOWN.

THE MARK CONSISTS OF THE WORDS "SOFT HANDS" CENTERED OVER THE WORD "FOOTBALL", INSIDE A RECTANGULAR BOX.

FOR FOAM FOOTBALLS (U.S. CLS. 22, 23, 38 AND 50).  
TAMARA FRAZIER, EXAMINING ATTORNEY

SN 85-209,092. BUZZ BEE TOYS, INC., MT. LAUREL, NJ. FILED 1-3-2011.



NO CLAIM IS MADE TO THE EXCLUSIVE RIGHT TO USE "SPIRAL FOOTBALL", APART FROM THE MARK AS SHOWN.

THE MARK CONSISTS OF THE WORDS "SOFT HANDS" CENTERED OVER THE WORDS "SPIRAL FOOTBALL", ALL WITHIN A RECTANGULAR BOX.

FOR FOAM FOOTBALLS (U.S. CLS. 22, 23, 38 AND 50).  
TAMARA FRAZIER, EXAMINING ATTORNEY

**CLASS 28—(Continued).**

SN 85-209,108. SEILER, PAUL, CAMBRIA, IL. FILED 1-3-2011.



NO CLAIM IS MADE TO THE EXCLUSIVE RIGHT TO USE "BASS LURES", APART FROM THE MARK AS SHOWN.

THE MARK CONSISTS OF THE STYLIZED WORDS "JAILBAIT BASS LURES". AN IMAGE OF A BASS FISH BEHIND BARS IN A JAIL.

FOR FISHING EQUIPMENT, NAMELY, FISHING JIGS AND FISHING LURES (U.S. CLS. 22, 23, 38 AND 50).

NAKIA HENRY, EXAMINING ATTORNEY

SN 85-210,138. RADIO FLYER, INC., CHICAGO, IL. FILED 1-4-2011.

**MOVE TO THE MUSIC!**

THE MARK CONSISTS OF STANDARD CHARACTERS WITHOUT CLAIM TO ANY PARTICULAR FONT, STYLE, SIZE, OR COLOR.

FOR RIDE-ON TOYS (U.S. CLS. 22, 23, 38 AND 50).  
JOHN DWYER, EXAMINING ATTORNEY

SN 85-210,814. SHIM, SOO JIN, SEOUL, REPUBLIC OF KOREA, FILED 1-5-2011.

**Ray's Fire Station**

THE MARK CONSISTS OF STANDARD CHARACTERS WITHOUT CLAIM TO ANY PARTICULAR FONT, STYLE, SIZE, OR COLOR.

PRIORITY CLAIMED UNDER SEC. 44(D) ON REPUBLIC OF KOREA APPLICATION NO. 40201055158, FILED 10-27-2010.

FOR DOLLS; ELECTRIC ACTION TOYS; ELECTRONIC ACTION TOYS; MECHANICAL TOYS; MODEL CARS; PAPER DOLLS; STUFFED TOYS; TOY BUILDING BLOCKS; TOY FIGURES; TOY VEHICLES (U.S. CLS. 22, 23, 38 AND 50).

BRIDGETT SMITH, EXAMINING ATTORNEY

**CLASS 28—(Continued).**

SN 85-212,791. MORAN, STEPHEN, SALEM, MA. FILED 1-7-2011.



THE MARK CONSISTS OF THE STYLIZED LETTERS "MMA" ABOVE THE STYLIZED WORD "MONSTERS". WINGS APPEAR ON EITHER SIDE OF "MMA", AND AN EYEBALL APPEARS IN PLACE OF THE "O" IN "MONSTERS".

FOR ACTION FIGURES; TOY ACTION FIGURES (U.S. CLS. 22, 23, 38 AND 50).

DAVID HOFFMAN, EXAMINING ATTORNEY

**CLASS 28—(Continued).**

SN 85-213,679. EVERMAX GLOBAL RESOURCE CO., LTD, SHANGHAI, CHINA, FILED 1-10-2011.



THE MARK CONSISTS OF A LEAF DESIGN INSIDE A OVAL MADE UP OF TWO BANDS.

FOR DOLLS AND DOLL ACCESSORIES, NAMELY, CLOTHING FOR DOLLS, DOLL ROOMS, DOLL BEDS, DOLL HOUSES, TOY FABRICS AND LINENS FOR DOLLS AND STROLLERS FOR DOLLS; DOLLS' HOUSES; DOLLS' ROOMS; JIGSAW PUZZLES; PLAY SWIMMING POOLS; ROCKING HORSES; TOY BUILDING BLOCKS; TOY SCOOTERS; TOY VEHICLES (U.S. CLS. 22, 23, 38 AND 50).

LEIGH CAROLINE CASE, EXAMINING ATTORNEY

SN 85-213,559. SNIPER PUTTERS, INC., WAPPINGER FALLS, NY. FILED 1-9-2011.

SEND IT

THE MARK CONSISTS OF STANDARD CHARACTERS WITHOUT CLAIM TO ANY PARTICULAR FONT, STYLE, SIZE, OR COLOR.

FOR GOLF PUTTERS (U.S. CLS. 22, 23, 38 AND 50). FIRST USE 12-31-2010; IN COMMERCE 12-31-2010. BARBARA RUTLAND, EXAMINING ATTORNEY

SN 85-213,681. EVERMAX GLOBAL RESOURCE CO., LTD, SHANGHAI, CHINA, FILED 1-10-2011.

Everyoung

THE MARK CONSISTS OF THE WORD "EVERYOUNG" WITH TWO LEAVES REPLACING THE UPPER PART OF THE LETTER "Y".

THE WORDING "EVERYOUNG" HAS NO MEANING IN A FOREIGN LANGUAGE.

FOR CHECKERS; CHESS GAMES; CHESSBOARDS; CHILDREN'S MULTIPLE ACTIVITY TOYS; CONSTRUCTION TOYS; JIGSAW PUZZLES; MECHANICAL TOYS; MUSICAL TOYS; PARLOR GAMES; TOY BUILDING BLOCKS (U.S. CLS. 22, 23, 38 AND 50).

LEIGH CAROLINE CASE, EXAMINING ATTORNEY

**CLASS 28—(Continued).**

SN 85-213,882. SARABELLA, NATALIE, CLARKSBURG, NJ.  
FILED 1-10-2011.

**Sarabella Creations**

THE MARK CONSISTS OF STANDARD CHARACTERS WITHOUT CLAIM TO ANY PARTICULAR FONT, STYLE, SIZE, OR COLOR.

NO CLAIM IS MADE TO THE EXCLUSIVE RIGHT TO USE "CREATIONS", APART FROM THE MARK AS SHOWN.

FOR CHRISTMAS TREE ORNAMENTS (U.S. CLS. 22, 23, 38 AND 50).

FIRST USE 1-1-1995; IN COMMERCE 1-30-1995.  
LANA PHAM, EXAMINING ATTORNEY

SN 85-214,025. PLAYMATES TOYS, INC., EL SEGUNDO, CA.  
FILED 1-10-2011.

**SWEET PEEKINS**

THE MARK CONSISTS OF STANDARD CHARACTERS WITHOUT CLAIM TO ANY PARTICULAR FONT, STYLE, SIZE, OR COLOR.

FOR DOLLS AND RELATED DOLL ACCESSORIES AND PLAYSETS THEREFOR (U.S. CLS. 22, 23, 38 AND 50).

KAPIL BHANOT, EXAMINING ATTORNEY

SN 85-215,420. AMS, LLC, DBA AMS BOWFISHING, STRATFORD, WI. FILED 1-11-2011.

**TIGER SHARK**

THE MARK CONSISTS OF STANDARD CHARACTERS WITHOUT CLAIM TO ANY PARTICULAR FONT, STYLE, SIZE, OR COLOR.

FOR ARCHERY EQUIPMENT AND ACCESSORIES, NAMELY, BOWS, BOWFISHING REELS, BOWFISHING ARROWS, ARROW RESTS, ARROW SAFETY SLIDES (U.S. CLS. 22, 23, 38 AND 50).

FIRST USE 9-27-2010; IN COMMERCE 12-1-2010.  
AISHA CLARKE, EXAMINING ATTORNEY

**CLASS 28—(Continued).**

SN 85-215,588. SNIPER PUTTERS, INC., WAPPINGER FALLS, NY. FILED 1-12-2011.

**SNIPER**

THE MARK CONSISTS OF STANDARD CHARACTERS WITHOUT CLAIM TO ANY PARTICULAR FONT, STYLE, SIZE, OR COLOR.

FOR GOLF PUTTERS (U.S. CLS. 22, 23, 38 AND 50).

FIRST USE 12-31-2010; IN COMMERCE 12-31-2010.  
BARBARA RUTLAND, EXAMINING ATTORNEY

SN 85-216,237. KARSTEN MANUFACTURING CORPORATION, PHOENIX, AZ. FILED 1-12-2011.

**K**  

---

**20**

THE MARK CONSISTS OF A STYLIZED VERSION OF THE LETTER "K" AND THE NUMERAL "20".

FOR GOLF CLUB BAGS; GOLF CLUBS; HEAD COVERS FOR GOLF CLUBS (U.S. CLS. 22, 23, 38 AND 50).  
ELI HELLMAN, EXAMINING ATTORNEY

SN 85-217,428. MICHAEL D. SHERLOCK, SAN DIEGO, CA.  
FILED 1-13-2011.

**DREGS**

THE MARK CONSISTS OF STANDARD CHARACTERS WITHOUT CLAIM TO ANY PARTICULAR FONT, STYLE, SIZE, OR COLOR.

FOR SNOWBOARD BINDINGS; SNOWBOARD DECKS; SNOWBOARDS; SURFBOARDS (U.S. CLS. 22, 23, 38 AND 50).

JUDITH HELFMAN, EXAMINING ATTORNEY

**CLASS 28—(Continued).**

SN 85-217,452. ROLLERBLADE USA, WEST LEBANON, NH.  
FILED 1-13-2011.



THE MARK CONSISTS OF THE STYLIZED TEXT "[ — ]  
BLANK".

FOR BOOT LINERS FOR ROLLER SKATES (U.S. CLS.  
22, 23, 38 AND 50).

FIRST USE 11-25-2009; IN COMMERCE 9-15-2010.  
TARAH HARDY, EXAMINING ATTORNEY

**CLASS 28—(Continued).**

SN 85-217,611. PENTLAND, HEATHER E. DARIEN, CT. AND  
BOETTIGER, PENELOPE A, HIGHLAND PARK, TX.  
FILED 1-14-2011.



when play was simple

THE COLOR(S) RED, BLUE, WHITE IS/ARE CLAIMED AS  
A FEATURE OF THE MARK.

THE MARK CONSISTS OF A BLUE-OUTLINED WHITE  
OVAL WITH "1978" IN RED INSIDE, AND THE WORDS  
"WHEN PLAY WAS SIMPLE" APPEARING IN RED UN-  
DERNEATH THE OVAL.

FOR CHILDREN'S MULTIPLE ACTIVITY TOYS (U.S.  
CLS. 22, 23, 38 AND 50).

FIRST USE 12-1-2010; IN COMMERCE 1-1-2011.  
BRENDAN REGAN, EXAMINING ATTORNEY

SN 85-219,288. GTFM, INC., NEW YORK, NY. FILED 1-17-  
2011.

FB

SQUISHEEZ

THE MARK CONSISTS OF STANDARD CHARACTERS  
WITHOUT CLAIM TO ANY PARTICULAR FONT, STYLE,  
SIZE, OR COLOR.

FOR A SERIES OF ONE INCH MOLDED PLASTIC  
TOY STATUETTES OF ANIMALS INDIVIDUALLY EN-  
CASED IN PLASTIC CAPSULES AND SOLD THROUGH  
COIN OPERATED VENDING MACHINES (U.S. CLS. 22,  
23, 38 AND 50).

SUZANNE BLANE, EXAMINING ATTORNEY

THE MARK CONSISTS OF STANDARD CHARACTERS  
WITHOUT CLAIM TO ANY PARTICULAR FONT, STYLE,  
SIZE, OR COLOR.

OWNER OF U.S. REG. NOS. 2,065,987, 3,165,612 AND  
OTHERS.

FOR ACTION FIGURES; ARCADE GAME MACHINES;  
ARTICLES OF CLOTHING FOR TOYS; ATHLETIC  
SUPPORTERS; BADMINTON SETS; BAGS FOR SKATE-  
BOARDS; BASEBALL BATS; BASEBALLS; BASKET-  
BALLS; BATTING GLOVES; BOBBLE HEAD DOLLS;  
CARD GAMES; DOLLS; FOOTBALLS; GAMING TA-  
BLES; GOLF BAGS; HAND PUPPETS; INFLATABLE  
TOYS; KITES; PARLOR GAMES; PLAYING CARDS;  
PLUSH DOLLS; SKATEBOARDS; SNOW BOARDS;  
SNOW SKIS; SOFTBALL BATS; SOFTBALLS; SPORT  
BALLS; STRESS RELIEF BALLS FOR HAND EXERCISE;  
TABLETOP GAMES; TENNIS RACKET COVERS (U.S.  
CLS. 22, 23, 38 AND 50).

JOSETTE BEVERLY, EXAMINING ATTORNEY

**CLASS 28—(Continued).**

SN 85-222,358. LAROSE INDUSTRIES, LLC, RANDOLPH, NJ. FILED 1-20-2011.

**MAGIC LITE ART**

THE MARK CONSISTS OF STANDARD CHARACTERS WITHOUT CLAIM TO ANY PARTICULAR FONT, STYLE, SIZE, OR COLOR.

NO CLAIM IS MADE TO THE EXCLUSIVE RIGHT TO USE "LIGHT", APART FROM THE MARK AS SHOWN.

FOR HAND HELD AND DESKTOP ELECTRONIC DRAWING TOY (U.S. CLS. 22, 23, 38 AND 50).

FIRST USE 10-22-2010; IN COMMERCE 10-22-2010.

C. DIONNE CLYBURN, EXAMINING ATTORNEY

---

SN 85-228,008. MAD DOGG ATHLETICS, INC., VENICE, CA. FILED 1-27-2011.

**FITCORE**

THE MARK CONSISTS OF STANDARD CHARACTERS WITHOUT CLAIM TO ANY PARTICULAR FONT, STYLE, SIZE, OR COLOR.

FOR EXERCISE EQUIPMENT, NAMELY, WEIGHT TRAINING MACHINES (U.S. CLS. 22, 23, 38 AND 50).

CHERYL CLAYTON, EXAMINING ATTORNEY

---

SN 85-241,582. TEAM BEANS, LLC, DBA FOREVER COLLECTIBLES, EDISON, NJ. FILED 2-14-2011.

**FOREVER SQUISHERZ**

THE MARK CONSISTS OF STANDARD CHARACTERS WITHOUT CLAIM TO ANY PARTICULAR FONT, STYLE, SIZE, OR COLOR.

OWNER OF U.S. REG. NO. 3,150,423.

FOR COLLECTABLE TOY FIGURES; PLAY FIGURES (U.S. CLS. 22, 23, 38 AND 50).

JOHN GARTNER, EXAMINING ATTORNEY

**CLASS 29—MEATS AND PROCESSED FOODS**

SN 77-459,266. POTOMAC VEGETABLE FARMS, INC., PURCELLVILLE, VA. FILED 4-28-2008.

**ecoganic**

THE MARK CONSISTS OF STANDARD CHARACTERS WITHOUT CLAIM TO ANY PARTICULAR FONT, STYLE, SIZE, OR COLOR.

FOR PICKLED VEGETABLES; PRESERVED FRUIT AND VEGETABLES; PROCESSED VEGETABLES; CANNED VEGETABLES; DRIED VEGETABLES; CANNED OR BOTTLED VEGETABLES (U.S. CL. 46).

MARC LEIPZIG, EXAMINING ATTORNEY

---

SN 77-654,667. FISHER/BLAINE SALES & MARKETING, INC., KANSAS CITY, KS. FILED 1-22-2009.

**BILADI**   
**HALAL**

NO CLAIM IS MADE TO THE EXCLUSIVE RIGHT TO USE "HALAL" AND THE NON-LATIN CHARACTERS THAT MEAN "HALAL", APART FROM THE MARK AS SHOWN.

THE MARK CONSISTS OF THE WORDS "BILADI HALAL" FOLLOWED BY THE ARABIC SCRIPT FOR THE ARABIC REPRESENTATION OF THE WORD "HALAL".

THE ENGLISH TRANSLATION OF THE ARABIC WORD "BILADI" IN THE MARK IS "THE COMFORTS AND WARMTH OF HOME", OR IN THE AMERICAN CULTURE "HOME SWEET HOME". THE NON-LATIN CHARACTERS IN THE MARK TRANSLITERATE TO "HALAL", AND THIS MEANS "ALLOWED" OR "PERMISSIBLE" IN ENGLISH.

FOR HALAL MEAT; HALAL PROCESSED MEAT, NAMELY, BEEF, LAMB, GOAT AND POULTRY (U.S. CL. 46).

FIRST USE 2-27-2006; IN COMMERCE 2-27-2006.

MICHELLE DUBOIS, EXAMINING ATTORNEY



**CLASS 29—(Continued).**

SN 77-752,280. KABUSHIKI KAISHA MITSUKAN GROUP HONSHA, AICHI-KEN, JAPAN, FILED 6-4-2009.



NO CLAIM IS MADE TO THE EXCLUSIVE RIGHT TO USE THE NON-LATIN CHARACTERS THAT TRANSLITERATE TO "MAME", APART FROM THE MARK AS SHOWN. THE COLOR(S) BROWN IS/ARE CLAIMED AS A FEATURE OF THE MARK.

THE MARK CONSISTS OF AN OUTLINE OF A SOYBEAN IN BROWN, WITH NON-LATIN CHARACTERS IN BROWN ON THE UPPER RIGHT SIDE OF MARK AND A HORIZONTAL LINE ABOVE A RECTANGLE, ABOVE TWO INWARD SLASHES, ABOVE AN ARCHED LINE, ALL IN THE COLOR BROWN AND REPRESENTING A HUMAN FACE ON THE LOWER LEFT SIDE OF MARK.

THE NON-LATIN CHARACTERS IN THE MARK TRANSLITERATE TO "TORO-MAME" AND THIS MEANS "SMOOTH AND PALATABLE BEANS" IN ENGLISH. FOR FERMENTED SOY BEANS (NATTO) (U.S. CL. 46). MICHAEL ENGEL, EXAMINING ATTORNEY

**CLASS 29—(Continued).**

SN 77-876,935. PARIS CROISSANT CO., LTD., KYOUNGKI-DO, REPUBLIC OF KOREA, FILED 11-19-2009.



PRIORITY CLAIMED UNDER SEC. 44(D) ON REPUBLIC OF KOREA APPLICATION NO. 2009-0035353, FILED 7-24-2009, REG. NO. 0836809, DATED 9-17-2010, EXPIRES 9-17-2020.

OWNER OF U.S. REG. NOS. 3,571,356, 3,665,546 AND OTHERS.

THE COLOR(S) BLUE AND WHITE IS/ARE CLAIMED AS A FEATURE OF THE MARK.

THE MARK CONSISTS OF THE LETTERS "P" AND "B" IN WHITE WITH A REPRESENTATION OF A TOWER THEREBETWEEN IN WHITE, WITHIN A BLUE RECTANGLE BACKGROUND.

FOR FRUIT JELLIES; JAMS; FRUITS, TINNED; VEGETABLES, TINNED; MARMALADE; FERMENTED MILK; YOGHURT; MILK; MILK-BASED BEVERAGES CONTAINING LACTIC AND BACTERIA; CHEESE; WHIPPED CREAM; SOUPS; VEGETABLE SALADS; FRUIT SALADS; APPLE PUREE; TOMATO PUREE; BUTTERCREAM; CRYSTALLIZED FRUITS; FROSTED FRUITS; FRUIT STEWED; FRUIT PRESERVED IN ALCOHOL; VEGETABLE PRESERVED IN ALCOHOL; PICKLES; COMPOTES CONTAINING CRANBERRY SAUCE (U.S. CL. 46).

ERNEST SHOSHO, EXAMINING ATTORNEY

SN 77-957,590. MONTALBANO AGRICOLA ALIMENTARE TOSCANA S.P.A., LAMPORECCHIO - PISTOIA, ITALY, FILED 3-12-2010.

## IL GENIO

THE MARK CONSISTS OF STANDARD CHARACTERS WITHOUT CLAIM TO ANY PARTICULAR FONT, STYLE, SIZE, OR COLOR.

PRIORITY CLAIMED UNDER SEC. 44(D) ON ITALY APPLICATION NO. FI2010C000, FILED 3-2-2010, REG. NO. 1311322, DATED 6-15-2010, EXPIRES 3-2-2020.

THE ENGLISH TRANSLATION OF "IL GENIO" IN THE MARK IS "THE GENIUS".

FOR OLIVE OIL, EDIBLE OILS AND FATS, PROCESSED OLIVES (U.S. CL. 46).

SEAN CROWLEY, EXAMINING ATTORNEY

**CLASS 29—(Continued).**

SN 77-966,872. SIMPLY DELISH PTY LTD., FAIRFIELD, VIC, AUSTRALIA, FILED 3-24-2010.

**SIMPLY DELISH CHUNKY DIPS**

THE MARK CONSISTS OF STANDARD CHARACTERS WITHOUT CLAIM TO ANY PARTICULAR FONT, STYLE, SIZE, OR COLOR.

PRIORITY CLAIMED UNDER SEC. 44(D) ON AUSTRALIA APPLICATION NO. 1328776, FILED 10-29-2009.

NO CLAIM IS MADE TO THE EXCLUSIVE RIGHT TO USE "CHUNKY DIPS", APART FROM THE MARK AS SHOWN.

FOR DIPS, SNACK DIPS AND SNACK FOOD DIPS IN THIS CLASS, DAIRY BASED DIPS, DIPS IN THIS CLASS CONTAINING MILK PRODUCTS, DIPS IN THIS CLASS CONTAINING CHEESE, DIPS IN THIS CLASS CONTAINING FRUIT, DIPS IN THIS CLASS CONTAINING VEGETABLES, DIPS IN THIS CLASS CONTAINING MEAT, DIPS IN THIS CLASS CONTAINING FISH, DIPS IN THIS CLASS CONTAINING POULTRY, DIPS IN THIS CLASS CONTAINING GAME, DIPS IN THIS CLASS CONTAINING EGG, DIPS IN THIS CLASS CONTAINING EDIBLE OILS AND DIPS IN THIS CLASS CONTAINING FATS (U.S. CL. 46).

FRANK LATTUCA, EXAMINING ATTORNEY

SN 79-084,210. HARVEY INDUSTRIES GROUP PTY LTD, AUSTRALIA, FILED 5-10-2010.



OWNER OF INTERNATIONAL REGISTRATION 1043185 DATED 5-10-2010, EXPIRES 5-10-2020.

NO CLAIM IS MADE TO THE EXCLUSIVE RIGHT TO USE "WESTERN AUSTRALIA", APART FROM THE MARK AS SHOWN.

THE NAME "HARVEY" DOES NOT IDENTIFY A LIVING INDIVIDUAL.

THE MARK CONSISTS OF THE WORDING "HARVEY BEEF" ABOVE THE WORDING "WESTERN AUSTRALIA", AND ABOVE ALL OF THE WORDING IS A BULL CENTERED BETWEEN THREE HORIZONTAL RAYS OR BANDS EMANATING FROM EACH SIDE OF THE BULL.

FOR PROTEINS OF ANIMAL ORIGIN BEING FOODSTUFFS FOR HUMAN CONSUMPTION; MEAT; MEAT PRODUCTS, NAMELY, LUNCHEON MEATS, HOT DOGS, AND HAMBURGER; SALTED MEATS (U.S. CL. 46).

SHAILA SETTLES, EXAMINING ATTORNEY

**CLASS 29—(Continued).**

SN 85-019,226. ROBERT QUATTRONE, INC., LYNDHURST, NJ, FILED 4-21-2010.



NO CLAIM IS MADE TO THE EXCLUSIVE RIGHT TO USE "BRAND" AND "SUPERFINE QUALITY ROMA PECORINO GENUINE ROMAN CHEESE-MADE IN ITALY-FROM SHEEP'S MILK", APART FROM THE MARK AS SHOWN.

THE MARK CONSISTS OF "REX-BRAND SUPERFINE QUALITY" WRITTEN IN THE MIDDLE OF THE CREST AND THE WORDING "LELLO CASTELLI DE CARLO S.R.L. ROMA PECORINO GENUINE ROMAN CHEESE-MADE IN ITALY-FROM SHEEP'S MILK" WRITTEN INSIDE THE PERIMETER SURROUNDING THE CREST. INSIDE OF THE CREST, IN THE UPPER LEFT HAND CORNER IS A LAUREL WREATH AND IN THE BOTTOM RIGHT HAND CORNER OF THE CREST IS A BUILDING. THE WORDS "REX BRAND" IS WRITTEN UNDER THE CREST.

FOR CHEESE (U.S. CL. 46).

FIRST USE 1-0-1955; IN COMMERCE 1-0-1955.

INGA ERVIN, EXAMINING ATTORNEY

SN 85-051,453. WHOLESOME GOODNESS LLC, LONG GROVE, IL, FILED 6-1-2010.



NO CLAIM IS MADE TO THE EXCLUSIVE RIGHT TO USE "ROASTED", APART FROM THE MARK AS SHOWN.

THE MARK CONSISTS OF THE WORDS "INFUSION" AND "ROASTED" SEPARATED BY TWO VERTICAL WAVY LINES WITH A RECTANGULAR BORDER DESIGN.

FOR SHELLED, ROASTED, OR PROCESSED NUTS AND PEANUTS (U.S. CL. 46).

DOUGLAS LEE, EXAMINING ATTORNEY

**CLASS 29—(Continued).**

SN 85-052,676. KAWASHO FOODS CORPORATION, TOKYO, JAPAN, FILED 6-2-2010.

# GEISHA

THE MARK CONSISTS OF STANDARD CHARACTERS WITHOUT CLAIM TO ANY PARTICULAR FONT, STYLE, SIZE, OR COLOR.

OWNER OF U.S. REG. NOS. 306,862, 991,554 AND 1,162,936.

FOR PROCESSED MEATS, FISH, SHELLFISH, POULTRY, GAME, FRUITS AND VEGETABLES; MEAT EXTRACT; VEGETABLE JUICE FOR COOKING; VEGETABLE BROTH FOR COOKING; EGGS; EDIBLE OILS AND FATS; PREPARATIONS FOR MAKING SOUP; PROTEIN FOR HUMAN CONSUMPTION; BEAN CURD (TOFU); BEAN MILK (TONYU) (U.S. CL. 46).

FIRST USE 5-11-1912; IN COMMERCE 5-11-1912.  
LAURA KOVALSKY, EXAMINING ATTORNEY

**CLASS 29—(Continued).**

SN 85-064,664. MIDWEST MEAT PACKING FACILITY, LLC, GIBBON, NE. FILED 6-16-2010.



THE COLOR(S) GREEN, LIGHT GREEN, DARK BROWN, RED, DARK RED, ORANGE, GOLD, AND DARK GOLD IS/ ARE CLAIMED AS A FEATURE OF THE MARK.

THE MARK CONSISTS OF THE STYLIZED WORDING "MOTHER'S CHOICE" IN CAPITALIZED, DARK BROWN BLOCK LETTERS. A GREEN AND LIGHT GREEN LEAF IS POSITIONED AS AN APOSTROPHE BETWEEN THE LETTERS "R" AND "S" IN THE WORD "MOTHER'S". UNDERNEATH THE WORD "CHOICE" IS A WAVY RED, DARK RED, AND ORANGE BANNER WITH A GOLD AND DARK GOLD LINE BORDER EMBELLISHMENT ON THE TOP AND BOTTOM OF THE BANNER.

FOR MEAT, FISH, POULTRY AND GAME (U.S. CL. 46).

DAVID TOOLEY, EXAMINING ATTORNEY

SN 85-101,088. TEXAS ROADHOUSE DELAWARE LLC, LOUISVILLE, KY. FILED 8-5-2010.

# ANDY'S STEAK

THE MARK CONSISTS OF STANDARD CHARACTERS WITHOUT CLAIM TO ANY PARTICULAR FONT, STYLE, SIZE, OR COLOR.

OWNER OF U.S. REG. NOS. 2,924,927 AND 3,021,520.

NO CLAIM IS MADE TO THE EXCLUSIVE RIGHT TO USE "STEAK", APART FROM THE MARK AS SHOWN.

FOR PREPARED ENTRÉES CONSISTING PRIMARILY OF MEAT (U.S. CL. 46).

SANJEEV VOHRA, EXAMINING ATTORNEY

SN 85-052,705. KAWASHO FOODS CORPORATION, TOKYO, JAPAN, FILED 6-2-2010.

# GEISHA

OWNER OF U.S. REG. NOS. 306,862, 991,554 AND 1,162,936.

THE MARK CONSISTS OF THE WORD "GEISHA" IN A STYLIZED FORMAT.

FOR PROCESSED MEATS, FISH, SHELLFISH, POULTRY, GAME, FRUITS AND VEGETABLES; MEAT EXTRACT; VEGETABLE JUICE FOR COOKING; VEGETABLE BROTH FOR COOKING; EGGS; EDIBLE OILS AND FATS; PREPARATIONS FOR MAKING SOUP; PROTEIN FOR HUMAN CONSUMPTION; BEAN CURD (TOFU); BEAN MILK (TONYU) (U.S. CL. 46).

FIRST USE 5-11-1912; IN COMMERCE 5-11-1912.  
LAURA KOVALSKY, EXAMINING ATTORNEY

SN 85-114,690. OMEGA PROTEIN, INC., HOUSTON, TX. FILED 8-24-2010.

# MORE THAN INGREDIENTS. INGENUITY.

THE MARK CONSISTS OF STANDARD CHARACTERS WITHOUT CLAIM TO ANY PARTICULAR FONT, STYLE, SIZE, OR COLOR.

FOR FOOD ADDITIVES, NAMELY, NATURAL FOOD EXTRACTS DERIVED FROM FISH, FISH OIL, FISH PROTEIN, ALGAE, SEAWEED, FISH OR SHARK CARTILAGE, OR SEASHELLS NOT FOR MEDICINAL PURPOSES AND FOR HUMAN CONSUMPTION (U.S. CL. 46).

FIRST USE 10-30-2009; IN COMMERCE 10-30-2009.  
CHERYL CLAYTON, EXAMINING ATTORNEY

**CLASS 29—(Continued).**

SN 85-116,240. HQ SUSTAINABLE MARITIME INDUSTRIES, INC., SEATTLE, WA. FILED 8-26-2010.



NO CLAIM IS MADE TO THE EXCLUSIVE RIGHT TO USE "WHOLLY NATURAL TILAPIA", APART FROM THE MARK AS SHOWN.

THE MARK CONSISTS OF THE STYLIZED WORDING "WHOLLY NATURAL TILAPIA" AND A DESIGN OF A HALOED FISH WITH AN EMBEDDED GRAIN STALK.

FOR SEAFOOD, NAMELY, WHOLLY NATURAL TILAPIA FISH; PREPARED FROZEN MEALS CONSISTING PRIMARILY OF WHOLLY NATURAL TILAPIA FISH (U.S. CL. 46).

ELLEN B. AWRICH, EXAMINING ATTORNEY

SN 85-117,838. NORTH DOWNS DAIRY COMPANY LIMITED, WINCANTON SOMERSET, UNITED KINGDOM, FILED 8-27-2010.

**GRADERS CHOICE**

THE MARK CONSISTS OF STANDARD CHARACTERS WITHOUT CLAIM TO ANY PARTICULAR FONT, STYLE, SIZE, OR COLOR.

FOR CHEESE, MILK AND YOGHURT (U.S. CL. 46).  
MARILYN IZZI, EXAMINING ATTORNEY

**CLASS 29—(Continued).**

SN 85-118,363. RICH AND WHOLESOME FOODS, LLC, BOULDER, CO. FILED 8-30-2010.



OWNER OF U.S. REG. NO. 3,572,932.

NO CLAIM IS MADE TO THE EXCLUSIVE RIGHT TO USE "RICH AND WHOLESOME FOODS, COMMON ALLERGEN-FREE, GLUTEN-FREE, DAIRY-FREE, GMO-FREE, NUT-FREE, SOY-FREE", APART FROM THE MARK AS SHOWN.

THE COLOR(S) BLUE, GREEN, WHITE AND BROWN IS/ARE CLAIMED AS A FEATURE OF THE MARK.

THE MARK CONSISTS OF A BLUE BACKGROUND WITH A TREE WITH A ROUNDED GREEN UPPER PORTION AND A SLIGHTLY CURVED BROWN TRUNK AND A WHITE CLOUD TO THE RIGHT OF THE TREE. THE WORDING "RICH AND WHOLESOME FOODS" IS IN BLUE ON THE CLOUD. THE WORDING "COMMON ALLERGEN-FREE" IS IN WHITE ON THE ROUNDED GREEN UPPER PORTION OF THE TREE. THE WORDING "GLUTEN-FREE DAIRY-FREE GMO-FREE NUT-FREE SOY-FREE" IS IN WHITE AND SURROUNDS THE ROUNDED GREEN UPPER PORTION OF THE TREE IN A CIRCULAR SHAPE.

FOR DAIRY AND SOY-FREE YOGURT (U.S. CL. 46).

FIRST USE 8-11-2010; IN COMMERCE 8-11-2010.

PAUL F. GAST, EXAMINING ATTORNEY

SN 85-160,934. GRUPO LA FLORIDA MEXICO, S. A. DE C. V., TLALNEPANTLA, EDO. DE, MEXICO, FILED 10-26-2010.

**EUROGLASS**

THE MARK CONSISTS OF STANDARD CHARACTERS WITHOUT CLAIM TO ANY PARTICULAR FONT, STYLE, SIZE, OR COLOR.

FOR MEAT, FISH, POULTRY AND GAME; MEAT EXTRACTS, PRESERVED, DRIED AND COOKED FRUITS AND VEGETABLES, DRIED AND COOKED; JELLIES AND JAMS; COMPOTES, EGGS, MILK AND MILK PRODUCTS, EXCLUDING ICE CREAM, ICE MILK AND FROZEN YOGURT; EDIBLE OILS AND FATS; MARGARINE; BUTTER; VEGETABLE FATS FOR FOOD, EDIBLE OILS; PEANUT BUTTER, MARGARINE OLEO, LARD, SHORTENING, CREAM (U.S. CL. 46).

INGRID C. EULIN, EXAMINING ATTORNEY

**CLASS 29—(Continued).**

SN 85-168,098. GENERAL MILLS MARKETING, INC., MINNEAPOLIS, MN. FILED 11-3-2010.

# GREEN GIANT

THE MARK CONSISTS OF STANDARD CHARACTERS WITHOUT CLAIM TO ANY PARTICULAR FONT, STYLE, SIZE, OR COLOR.

OWNER OF U.S. REG. NOS. 685,263, 826,189 AND OTHERS.

FOR VEGETABLE-BASED SNACK FOODS (U.S. CL. 46).

ERNEST SHOSHO, EXAMINING ATTORNEY

SN 85-171,289. SIMMONS, MARK, TINLEY PARK, IL. FILED 11-8-2010.

# Hot Coolies

THE MARK CONSISTS OF STANDARD CHARACTERS WITHOUT CLAIM TO ANY PARTICULAR FONT, STYLE, SIZE, OR COLOR.

NO CLAIM IS MADE TO THE EXCLUSIVE RIGHT TO USE "HOT", APART FROM THE MARK AS SHOWN.

FOR SHISH KABOB; MARINATED MEAT AND VEGETABLES (U.S. CL. 46).

EVELYN BRADLEY, EXAMINING ATTORNEY

**CLASS 29—(Continued).**

SN 85-177,857. CHENG, DAVID CHONG HISN, HACIENDA HEIGHTS, CA. FILED 11-16-2010.



THE COLOR(S) ORANGE, GREEN, BLUE, RED, WHITE, BLACK IS/ARE CLAIMED AS A FEATURE OF THE MARK.

THE MARK CONSISTS OF THE WORDING "SHAMMIR" IN WHITE WITH BLACK SHADING ACROSS THREE SQUARE BOXES. THE COLORS OF BOXES FROM LEFT TO RIGHT ARE ORANGE, GREEN, AND BLUE, ALL WITH BLACK SHADING. THREE CHINESE CHARACTERS IN RED WITH WHITE OUTLINING AND BLACK SHADING APPEAR ABOVE THE WORDING "SHAMMIR".

THE WORDING "SHAMMIR" HAS NO MEANING IN A FOREIGN LANGUAGE.

THE NON-LATIN CHARACTERS IN THE MARK TRANSLITERATE TO "XIANG MI ER" AND THIS HAS NO MEANING IN A FOREIGN LANGUAGE.

FOR FRUIT CHIPS; JELLY MADE FROM DEVILS' TONGUE ROOT (KONNYAKU); PREPARED NUTS; PROCESSED NUTS; PROCESSED VEGETABLES AND FRUITS; ROASTED NUTS; SEASONED NUTS; SNACK MIX CONSISTING OF DEHYDRATED FRUIT AND PROCESSED NUTS; SNACK MIX CONSISTING PRIMARILY OF PROCESSED FRUITS, PROCESSED NUTS AND/OR RAISINS; VEGETABLE CHIPS (U.S. CL. 46).

FIRST USE 2-1-2004; IN COMMERCE 2-15-2004.

CHRISTINE COOPER, EXAMINING ATTORNEY

SN 85-192,389. BETTY MAKER, DBA BLUEBERRY BLISS, JONESBORO, ME. FILED 12-7-2010.



NO CLAIM IS MADE TO THE EXCLUSIVE RIGHT TO USE "BLUEBERRY", APART FROM THE MARK AS SHOWN.

THE COLOR(S) BLUE AND WHITE IS/ARE CLAIMED AS A FEATURE OF THE MARK.

THE MARK CONSISTS OF THE STYLIZED WORDING "BLUEBERRY BLISS" IN BLUE. UNDERNEATH IS A STYLIZED BLUEBERRY BUSH IN WHITE AND BLUE.

FOR GOURMET JAMS, JELLIES AND FRUIT PRESERVES (U.S. CL. 46).

FIRST USE 1-1-1995; IN COMMERCE 1-1-1995.

SCOTT BIBB, EXAMINING ATTORNEY



**CLASS 29—(Continued).**

SN 85-196,260. NADEEM, AMER, FRESH MEADOW, NY. FILED 12-13-2010.

**Bismillah Fried Chicken**

THE MARK CONSISTS OF STANDARD CHARACTERS WITHOUT CLAIM TO ANY PARTICULAR FONT, STYLE, SIZE, OR COLOR.

NO CLAIM IS MADE TO THE EXCLUSIVE RIGHT TO USE "FRIED CHICKEN", APART FROM THE MARK AS SHOWN.

THE ENGLISH TRANSLATION OF THE WORD "BISMILLAH" IN THE MARK IS FIRST COMES GOD.

FOR FRIED CHICKEN (U.S. CL. 46).

ANGELA DUONG, EXAMINING ATTORNEY

---

SN 85-202,916. ANN'S HOUSE OF NUTS, INC., COLUMBIA, MD. FILED 12-21-2010.

**SNACK BAT**

THE MARK CONSISTS OF STANDARD CHARACTERS WITHOUT CLAIM TO ANY PARTICULAR FONT, STYLE, SIZE, OR COLOR.

NO CLAIM IS MADE TO THE EXCLUSIVE RIGHT TO USE "SNACK", APART FROM THE MARK AS SHOWN.

FOR PROCESSED EDIBLE SEEDS; PROCESSED SUNFLOWER SEEDS (U.S. CL. 46).

ROBIN CHOSID, EXAMINING ATTORNEY

---

SN 85-202,917. ANN'S HOUSE OF NUTS, INC., COLUMBIA, MD. FILED 12-21-2010.



NO CLAIM IS MADE TO THE EXCLUSIVE RIGHT TO USE "SNACK", APART FROM THE MARK AS SHOWN.

THE MARK CONSISTS OF THE WORDS "SNACK BAT" TO THE LEFT OF STYLIZED AND LARGER LETTERS "SB", THE LOWER RIGHT OF THE "S" OVERLAPPING THE UPPER LEFT OF THE "B", ALL TO THE LEFT OF A BASEBALL AND ENGULFED IN FLAMES EMANATING FROM THE LEFT SIDE OF THE BASEBALL AND ALL SUPERIMPOSED OVER STYLIZED LINES INDICATING MOTION TO THE RIGHT.

FOR PROCESSED EDIBLE SEEDS; PROCESSED SUNFLOWER SEEDS (U.S. CL. 46).

ROBIN CHOSID, EXAMINING ATTORNEY

**CLASS 29—(Continued).**

SN 85-203,702. SAPUTO CHEESE USA INC., LINCOLNSHIRE, IL. FILED 12-22-2010.

**GOLDEN STATE BRAND**

THE MARK CONSISTS OF STANDARD CHARACTERS WITHOUT CLAIM TO ANY PARTICULAR FONT, STYLE, SIZE, OR COLOR.

OWNER OF U.S. REG. NO. 2,258,347.

NO CLAIM IS MADE TO THE EXCLUSIVE RIGHT TO USE "BRAND", APART FROM THE MARK AS SHOWN.

SEC. 2(F).

FOR CHEESE (U.S. CL. 46).

DAVID ELTON, EXAMINING ATTORNEY

---

SN 85-205,126. TYSON FRESH MEATS, INC., SPRINGDALE, AR. FILED 12-23-2010.

**BACKYARD FLAVORS**

THE MARK CONSISTS OF STANDARD CHARACTERS WITHOUT CLAIM TO ANY PARTICULAR FONT, STYLE, SIZE, OR COLOR.

NO CLAIM IS MADE TO THE EXCLUSIVE RIGHT TO USE "FLAVORS", APART FROM THE MARK AS SHOWN.

FOR BEEF; PORK (U.S. CL. 46).

DARRYL SPRUILL, EXAMINING ATTORNEY

---

SN 85-205,260. INTERNATIONAL WHOLESALERS CORPORATION, WASHINGTON, DC. FILED 12-23-2010.

**ADEPA**

THE MARK CONSISTS OF STANDARD CHARACTERS WITHOUT CLAIM TO ANY PARTICULAR FONT, STYLE, SIZE, OR COLOR.

FOR EDIBLE PALM NUT CREAM (U.S. CL. 46).

RONALD MCMORROW, EXAMINING ATTORNEY

**CLASS 29—(Continued).**

SN 85-205,565. GRILLO'S PICKLES, LLC, NORWICH, CT.  
FILED 12-24-2010.



THE MARK CONSISTS OF A PICKLE WEARING A CAP WITH THE WORD "GRILLO'S" INSCRIBED ON IT, SUNGLASSES, AND SANDALS, RECLINING ON AN OUTDOOR LOUNGE CHAIR.

FOR PICKLES (U.S. CL. 46).  
FIRST USE 8-12-2008; IN COMMERCE 8-12-2008.  
FLORENTINA BLANDU, EXAMINING ATTORNEY

**CLASS 29—(Continued).**

SN 85-206,236. TUNA MEDITERREANEAN, INC., BROOKLYN, NY. FILED 12-27-2010.



NO CLAIM IS MADE TO THE EXCLUSIVE RIGHT TO USE "BRAND", APART FROM THE MARK AS SHOWN.

THE MARK CONSISTS OF THE WORDING "NAZAR BRAND" WITH THE DESIGN OF A TURKISH-STYLE EVIL EYE AMULET.

THE ENGLISH TRANSLATION OF "NAZAR" IN THE MARK IS "EVIL EYE."

FOR BEEF; BOLOGNA; CHEESE; CHICKEN; HOT DOGS; MEAT; MILK PRODUCTS EXCLUDING ICE CREAM, ICE MILK AND FROZEN YOGURT; MORTADELLA; PACKAGED MEATS; SALAMI; SAUSAGES; SAUSAGES, NAMELY, SUJUK; YOGURT; YOGURT DRINKS; YOGURT-BASED BEVERAGES (U.S. CL. 46).

FIRST USE 5-0-2010; IN COMMERCE 5-0-2010.  
SIMON TENG, EXAMINING ATTORNEY

SN 85-207,551. CHONGQING FULING HOT PICKLED MUSTARD TUBER GROUP CO.,LTD., CHONGQING CITY, CHINA, FILED 12-29-2010.

SN 85-205,894. ARCTIC FISHERIES LTD., BUFFALO, NY.  
FILED 12-27-2010.



NO CLAIM IS MADE TO THE EXCLUSIVE RIGHT TO USE "BRAND", APART FROM THE MARK AS SHOWN.

FOR FROZEN SEAFOOD AND PROCESSED SEAFOOD, FOR HUMAN CONSUMPTION AND NOT LIVE (U.S. CL. 46).

FIRST USE 8-12-2003; IN COMMERCE 8-12-2003.  
DEBRA LEE, EXAMINING ATTORNEY



OWNER OF U.S. REG. NO. 2,439,751.

THE MARK CONSISTS OF THE CHINESE CHARACTERS FOR THE WORDS "WU JIANG".

THE NON-LATIN CHARACTERS IN THE MARK TRANSLITERATE TO "WU JIANG" AND THIS MEANS "WU RIVER" IN ENGLISH.

FOR CANNED VEGETABLES; DRIED VEGETABLES; COOKED VEGETABLES; PRESERVED VEGETABLES; PICKLES; PRESERVED MUSHROOMS; PICCALILLI; PRESERVED TRUFFLES; VEGETABLE JUICE FOR COOKING; CANNED FRUITS; CANNED MEAT; SAUERKRAUT; JAM; TOMATO PUREE; SOUPS AND PREPARATIONS FOR MAKING SOUPS; AND CANNED FISH (U.S. CL. 46).

ANDREA K. NADELMAN, EXAMINING ATTORNEY

**CLASS 29—(Continued).**

SN 85-207,632. MORRIS PRODUCTS LLC, EAGLE, ID.  
FILED 12-29-2010.

**Zips Energy Sunflower Seeds**

THE MARK CONSISTS OF STANDARD CHARACTERS WITHOUT CLAIM TO ANY PARTICULAR FONT, STYLE, SIZE, OR COLOR.

NO CLAIM IS MADE TO THE EXCLUSIVE RIGHT TO USE "SUNFLOWER SEEDS", APART FROM THE MARK AS SHOWN.

FOR PROCESSED SUNFLOWER SEEDS (U.S. CL. 46).  
LAKEISHA LEWIS, EXAMINING ATTORNEY

---

SN 85-208,236. RASHIDA PURIFOY DEVELOPMENT LLC,  
GLENDALE, CA. FILED 12-30-2010.

**COUCH MIX**

THE MARK CONSISTS OF STANDARD CHARACTERS WITHOUT CLAIM TO ANY PARTICULAR FONT, STYLE, SIZE, OR COLOR.

NO CLAIM IS MADE TO THE EXCLUSIVE RIGHT TO USE "MIX", APART FROM THE MARK AS SHOWN.

FOR TRAIL MIX CONSISTING PRIMARILY OF PROCESSED NUTS, SEEDS, AND BACON CHUNKS (U.S. CL. 46).

FIRST USE 10-16-2010; IN COMMERCE 10-23-2010.  
ANGELA M. MICHELI, EXAMINING ATTORNEY

---

SN 85-208,272. DOLE FOOD COMPANY, INC., WESTLAKE VILLAGE, CA. FILED 12-30-2010.

**WINTER JUBILEE**

THE MARK CONSISTS OF STANDARD CHARACTERS WITHOUT CLAIM TO ANY PARTICULAR FONT, STYLE, SIZE, OR COLOR.

FOR PRE-CUT VEGETABLE SALAD (U.S. CL. 46).  
FIRST USE 10-31-2009; IN COMMERCE 10-31-2009.  
GRETTA YAO, EXAMINING ATTORNEY

**CLASS 29—(Continued).**

SN 85-210,158. CHIQUITA BRANDS, L.L.C., CINCINNATI, OH. FILED 1-4-2011.



OWNER OF U.S. REG. NOS. 670,320, 2,424,101 AND OTHERS.

THE MARK CONSISTS OF THE WORD "CHIQUITA" ENCOMPASSED BY A RECTANGULAR CARRIER PLACED OVER A STYLIZED BANANA LEAF DESIGN AND AN OVAL CONTAINING A STYLIZED LADY WEARING A HAT WITH FRUIT ON IT.

THE ENGLISH TRANSLATION OF THE WORD "CHIQUITA" IN THE MARK IS "LITTLE GIRL".

FOR PROCESSED FRUITS (U.S. CL. 46).  
JOHN DWYER, EXAMINING ATTORNEY

---

SN 85-210,633. LSE NUTRITIONALS, RICHMOND, VA.  
FILED 1-5-2011.

**X-O Bar**

THE MARK CONSISTS OF STANDARD CHARACTERS WITHOUT CLAIM TO ANY PARTICULAR FONT, STYLE, SIZE, OR COLOR.

NO CLAIM IS MADE TO THE EXCLUSIVE RIGHT TO USE "BAR", APART FROM THE MARK AS SHOWN.

FOR PROTEIN BASED, NUTRIENT-DENSE SNACK BARS (U.S. CL. 46).

ROBIN MITTLER, EXAMINING ATTORNEY

---

SN 85-210,702. ESPRIT EVENTS, INC., NEW YORK, NY.  
FILED 1-5-2011.

**Beyond Sushi**

THE MARK CONSISTS OF STANDARD CHARACTERS WITHOUT CLAIM TO ANY PARTICULAR FONT, STYLE, SIZE, OR COLOR.

NO CLAIM IS MADE TO THE EXCLUSIVE RIGHT TO USE "SUSHI", APART FROM THE MARK AS SHOWN.

FOR PREPARED ORGANIC AND KOSHER APPETIZERS CONSISTING PRIMARILY OF FRESH VEGETABLES AND FRUITS WITH TOFU-BASED DIPS (U.S. CL. 46).

FIRST USE 9-1-2010; IN COMMERCE 9-20-2010.  
PATRICIA EVANKO, EXAMINING ATTORNEY

**CLASS 29—(Continued).**

SN 85-211,051. CRAVE BROTHERS FARMSTEAD CHEESE, LLC, WATERLOO, WI. FILED 1-5-2011.

TAKE ME HOME AND TASTE THE  
SWEET CREAM DIFFERENCE

THE MARK CONSISTS OF STANDARD CHARACTERS WITHOUT CLAIM TO ANY PARTICULAR FONT, STYLE, SIZE, OR COLOR.

OWNER OF U.S. REG. NO. 3,879,877.  
FOR CHEESE (U.S. CL. 46).  
FIRST USE 2-16-2006; IN COMMERCE 2-16-2006.  
JOHN E. MICHOS, EXAMINING ATTORNEY

SN 85-213,446. GREAT CREATION'S LLC, DBA CREATIVE FOOD PRODUCTS, SPRINGDALE, AR. FILED 1-8-2011.

Auntie's

THE MARK CONSISTS OF STANDARD CHARACTERS WITHOUT CLAIM TO ANY PARTICULAR FONT, STYLE, SIZE, OR COLOR.

FOR FROZEN ENTREES CONSISTING PRIMARILY OF VEGETABLES AND MEAT AS WELL AS FRUIT COBBLERS (U.S. CL. 46).  
MICHAEL WEBSTER, EXAMINING ATTORNEY

SN 85-213,822. WELLSHIRE FARMS WEST, INC., SWEDENBORO, NJ. FILED 1-10-2011.



OWNER OF U.S. REG. NOS. 3,280,699, 3,345,721 AND 3,548,157.

THE MARK CONSISTS OF A HORIZONTAL OVAL DESIGN, CONTAINING THE LITERAL ELEMENT "WELLSHIRE" AT THE TOP OF THE DESIGN WITH THE DRAWING OF A BARN THAT INCLUDES A SILO, TREE AND SUN BELOW THE LITERAL ELEMENT.

FOR PROCESSED MEAT, NAMELY, BACON, HOT DOGS, SAUSAGES, HAM AND TURKEY (U.S. CL. 46).  
FIRST USE 7-1-2007; IN COMMERCE 9-15-2007.  
HEATHER SAPP, EXAMINING ATTORNEY

**CLASS 29—(Continued).**

SN 85-214,239. SOUTAR, LIA E., RANCHO CUCAMONGA, CA. FILED 1-10-2011.

DANITA SOUP

THE MARK CONSISTS OF STANDARD CHARACTERS WITHOUT CLAIM TO ANY PARTICULAR FONT, STYLE, SIZE, OR COLOR.

NO CLAIM IS MADE TO THE EXCLUSIVE RIGHT TO USE "SOUP", APART FROM THE MARK AS SHOWN.

FOR BROTH; DRINKABLE SOUPS; INSTANT OR PRE-COOKED SOUP; MIXES FOR MAKING SOUP; PREPARATIONS FOR MAKING SOUP; SOUP CONCENTRATES; SOUP MIXES; SOUPS; SOUPS AND PREPARATIONS FOR MAKING SOUPS (U.S. CL. 46).

C. DIONNE CLYBURN, EXAMINING ATTORNEY

SN 85-215,366. JUSTUS FOODS, INC., GEORGETOWN, TX. FILED 1-11-2011.

Fruit So Right

THE MARK CONSISTS OF STANDARD CHARACTERS WITHOUT CLAIM TO ANY PARTICULAR FONT, STYLE, SIZE, OR COLOR.

NO CLAIM IS MADE TO THE EXCLUSIVE RIGHT TO USE "FRUIT", APART FROM THE MARK AS SHOWN.

FOR FREEZE-DRIED FRUIT (U.S. CL. 46).  
TASNEEM HUSSAIN, EXAMINING ATTORNEY

SN 85-219,246. VENDITIO, LLC, CHICAGO, IL. FILED 1-17-2011.

SAN KENIO'S

THE MARK CONSISTS OF STANDARD CHARACTERS WITHOUT CLAIM TO ANY PARTICULAR FONT, STYLE, SIZE, OR COLOR.

THE WORDING "SAN KENIO'S" HAS NO MEANING IN A FOREIGN LANGUAGE.

FOR CANNED OR BOTTLED FOODS, NAMELY, JALAPENO PEPPERS, SERRANO PEPPERS, CHIPOTLE PEPPERS, BANANA PEPPER, TOMATILLO, TENDER CACTUS, BELL PEPPERS, AND FRUITS; CONDIMENTS, NAMELY, SAUCES AND SALSAS MADE OF JALAPENO PEPPERS, SERRANO PEPPERS, TOMATO AND TOMATILLOS (U.S. CL. 46).

KATHLEEN LORENZO, EXAMINING ATTORNEY

**CLASS 29—(Continued).**

SN 85-225,794. PROMOTION IN MOTION, INC., CLOSTER, NJ. FILED 1-25-2011.

**BERRYLICIOUS**

THE MARK CONSISTS OF STANDARD CHARACTERS WITHOUT CLAIM TO ANY PARTICULAR FONT, STYLE, SIZE, OR COLOR.

FOR PROCESSED FRUIT SNACKS, PROCESSED FRUIT ROLLS AND PROCESSED FRUIT BARS (U.S. CL. 46).

JUDITH HELFMAN, EXAMINING ATTORNEY

**CLASS 29—(Continued).**

SN 85-235,944. EGG TECH LTD., DAYTON, OH. FILED 2-7-2011.



THE COLOR(S) BLACK AND YELLOW IS/ARE CLAIMED AS A FEATURE OF THE MARK.

THE MARK CONSISTS OF DESIGN CONSISTING OF OUTLINE OF AN EGG IN BLACK WITH A YELLOW CHECKMARK.

FOR EGGS (U.S. CL. 46).

JOHN E. MICHOS, EXAMINING ATTORNEY

SN 85-235,883. GRUMA CORPORATION, IRVING, TX. FILED 2-7-2011.



OWNER OF U.S. REG. NOS. 1,705,245, 3,405,247 AND OTHERS.

THE COLOR(S) RED, GREEN, YELLOW, WHITE AND ORANGE IS/ARE CLAIMED AS A FEATURE OF THE MARK.

THE MARK CONSISTS OF A CIRCLE DESIGN, THE OUTER PERIMETER OF WHICH CONSISTS OF FOUR BANDS: ONE YELLOW, ONE RED, ONE YELLOW AND ONE GREEN. THE INTERIOR CIRCLE IS ORANGE. IN THE UPPER HALF OF THE INTERIOR OF THE CIRCLE IS A DEPICTION OF A PIG WHICH IS WHITE AND SHADED IN GREEN. THE LOWER HALF OF THE INTERIOR CIRCLE SHOWS THE WORDS "UN PEDACITO DE MEXICO" IN GREEN. ACROSS THE MIDDLE OF THE CIRCLE IS A WHITE BANNER OUTLINED IN GREEN WITH THE WORD "GUERRERO" IN STYLIZED GREEN LETTERS. THERE IS A GREEN STRIPE ACROSS THE TOP AND BOTTOM OF THE BANNER. ACROSS THE BOTTOM OF THE CIRCLE IS A RED BANNER OUTLINED IN GREEN. THERE IS A WHITE STRIPE ACROSS THE TOP AND THE BOTTOM OF THE BANNER.

THE ENGLISH TRANSLATION OF "GUERRERO" AND "UN PEDACITO DE MEXICO" IN THE MARK IS "WARRIOR" AND "A LITTLE PIECE OF MEXICO".

FOR CHICARRONES (PORK RINDS) (U.S. CL. 46).

FIRST USE 10-0-2008; IN COMMERCE 10-0-2008.

AISHA SALEM, EXAMINING ATTORNEY

SN 85-236,358. WELLSHIRE FARMS WEST, INC., SWEDENBORO, NJ. FILED 2-8-2011.

**ALWAYS IN GOOD TASTE,  
NATURALLY!**

THE MARK CONSISTS OF STANDARD CHARACTERS WITHOUT CLAIM TO ANY PARTICULAR FONT, STYLE, SIZE, OR COLOR.

OWNER OF U.S. REG. NO. 2,826,485.

FOR PROCESSED MEAT, NAMELY, BACON, SAUSAGES, TURKEY SNACK STICKS, HAM, TURKEY, ROAST BEEF, CORNED BEEF AND PASTRAMI (U.S. CL. 46).

HEATHER SAPP, EXAMINING ATTORNEY

SN 85-260,648. AHOLD LICENSING SARL, GENEVA, SWITZERLAND, FILED 3-8-2011.



OWNER OF U.S. REG. NOS. 2,871,579, 3,682,647 AND OTHERS.

THE COLOR(S) ORANGE, GRAY AND WHITE IS/ARE CLAIMED AS A FEATURE OF THE MARK.

THE MARK CONSISTS OF THE TRADE DRESS CHARACTERIZING THE FRONT FACE OF THE PACKAGING FOR APPLICANT'S GOODS, NAMELY (1) A WHITE HORIZONTAL BAR SPANNING THE LABEL OR PACKAGE FACE, (2) AN ORANGE BAR BELOW THE WHITE BAR, ALSO SPANNING THE LABEL OR PACKAGE FACE, (3) A



**CLASS 29—(Continued).**

DASHED LINE THAT APPEARS GRAY ON THE WHITE BACKGROUND AND WHITE ON THE ORANGE BACKGROUND. THE DASHED LINE EXTENDS HORIZONTALLY ALONG THE WHITE BAR, AND TURNS 90 DEGREES AT EACH END TO EXTEND DOWNWARDS INTO THE ORANGE BAR. THE DESIGN FURTHER COMPRISES (4) A GRAY SCISSORS DESIGN AND (5) THE WORD "GUARANTEED" APPEARING IN ORANGE ABOVE THE GRAY LINE AND THE WORD "VALUE" APPEARING IN ORANGE BELOW THE GRAY LINE.

SEC. 2(F) AS TO "GUARANTEED VALUE".

FOR APPLESAUCE; BACON; BROTH; CANNED FRUITS; CANNED PORK AND BEANS; CANNED VEGETABLES; CHEESE; CHILI; COOKING OIL; EVAPORATED MILK; FRANKFURTERS; FROZEN VEGETABLES; JELLIES; LUNCHEON MEATS; MARGARINE; NON-DAIRY CREAMER; PEANUT BUTTER; PICKLES; PROCESSED FISH; PROCESSED MEAT, NAMELY, CHICKEN; PROCESSED NUTS; PROCESSED POTATOES; SHORTENING; SOUPS (U.S. CL. 46).

BRIDGETT SMITH, EXAMINING ATTORNEY

SN 85-260,925. AHOLD LICENSING SARL, GENEVA, SWITZERLAND, FILED 3-8-2011.



OWNER OF U.S. REG. NOS. 2,871,579, 3,682,647 AND OTHERS.

THE MARK CONSISTS OF A SCISSORS DESIGN WITH A DASHED LINE EXTENDING TO THE RIGHT OF THE SCISSORS. THE WORD "GUARANTEED" APPEARS ABOVE THE LINE AND THE WORD "VALUE" APPEARS BELOW THE LINE.

SEC. 2(F) AS TO "GUARANTEED VALUE".

FOR APPLESAUCE; BACON; BROTH; CANNED FRUITS; CANNED PORK AND BEANS; CANNED VEGETABLES; CHEESE; CHILI; COOKING OIL; EVAPORATED MILK; FRANKFURTERS; FROZEN VEGETABLES; JELLIES; LUNCHEON MEATS; MARGARINE; NON-DAIRY CREAMER; PEANUT BUTTER; PICKLES; PROCESSED FISH; PROCESSED MEAT, NAMELY, CHICKEN; PROCESSED NUTS; PROCESSED POTATOES; SHORTENING; SOUPS (U.S. CL. 46).

BRIDGETT SMITH, EXAMINING ATTORNEY

**CLASS 30—STAPLE FOODS**

SN 76-705,636. EL PEKA FOODS LLC, NEW LONDON, CT. FILED 12-9-2010.

*Miss Hortencia's original Mexican Hot Sauce*

THE MARK CONSISTS OF STANDARD CHARACTERS WITHOUT CLAIM TO ANY PARTICULAR FONT, STYLE, SIZE, OR COLOR.

NO CLAIM IS MADE TO THE EXCLUSIVE RIGHT TO USE "ORIGINAL MEXICAN HOT SAUCE", APART FROM THE MARK AS SHOWN.

MISS HORTENCIA DOES NOT IDENTIFY A LIVING INDIVIDUAL.

FOR HOT SAUCE (U.S. CL. 46).

HOWARD SMIGA, EXAMINING ATTORNEY

**CLASS 30—(Continued).**

SN 77-255,027. 2128230 ONTARIO LIMITED, TORONTO, CANADA, FILED 8-14-2007.

# O'DOUGHS

THE MARK CONSISTS OF STANDARD CHARACTERS WITHOUT CLAIM TO ANY PARTICULAR FONT, STYLE, SIZE, OR COLOR.

PRIORITY CLAIMED UNDER SEC. 44(D) ON CANADA APPLICATION NO. 1358503, FILED 7-27-2007, REG. NO. TMA791225, DATED 2-21-2011, EXPIRES 2-21-2026.

FOR GLUTEN-FREE FOODS, ALL FRESH AND FROZEN, NAMELY, BREAD, BUNS, PIZZA CRUST, MUFFINS, CAKES, MUFFIN AND CAKE MIXES (U.S. CL. 46).

SARA BENJAMIN, EXAMINING ATTORNEY

SN 77-653,463. SAXBY FOODS LTD., EDMONTON, CANADA, FILED 1-21-2009.

# Flantastic

THE MARK CONSISTS OF STYLIZED TEXT STATING THE WORD "FLANTASTIC".

FOR BAKERY GOODS (U.S. CL. 46).

LANA PHAM, EXAMINING ATTORNEY

SN 77-764,547. LISCIO'S ITALIAN BAKERY, INC., GLASSBORO, NJ. FILED 6-20-2009.

## LISCIO'S BAKERY "It all starts with the bread!"

THE MARK CONSISTS OF STANDARD CHARACTERS WITHOUT CLAIM TO ANY PARTICULAR FONT, STYLE, SIZE, OR COLOR.

NO CLAIM IS MADE TO THE EXCLUSIVE RIGHT TO USE "BAKERY", APART FROM THE MARK AS SHOWN.

FOR BAKERY GOODS (U.S. CL. 46).

FIRST USE 1-1-2007; IN COMMERCE 1-1-2007.

GINA FINK, EXAMINING ATTORNEY

**CLASS 30—(Continued).**

SN 77-791,257. GELDA SCIENTIFIC AND INDUSTRIAL DEVELOPMENT CORPORATION, MISSISSAUGA, ONTARIO, CANADA, FILED 7-28-2009.

# NOOR

THE MARK CONSISTS OF STANDARD CHARACTERS WITHOUT CLAIM TO ANY PARTICULAR FONT, STYLE, SIZE, OR COLOR.

OWNER OF CANADA REG. NO. TMA791,318, DATED 2-22-2011, EXPIRES 2-22-2026.

THE ENGLISH TRANSLATION OF "NOOR" IN THE MARK IS LIGHT OR ILLUMINATION.

FOR RICE (U.S. CL. 46).

MATTHEW KLINE, EXAMINING ATTORNEY

SN 77-881,589. CANADA BREAD COMPANY, LIMITED, ETOBICOKE, ONTARIO, CANADA, FILED 11-27-2009.

# CHEVALIER OBSESSION

THE MARK CONSISTS OF STANDARD CHARACTERS WITHOUT CLAIM TO ANY PARTICULAR FONT, STYLE, SIZE, OR COLOR.

PRIORITY CLAIMED UNDER SEC. 44(D) ON CANADA APPLICATION NO. 1456602, FILED 10-23-2009, REG. NO. TMA782448, DATED 11-15-2010, EXPIRES 11-15-2025.

THE ENGLISH TRANSLATION OF "CHEVALIER" IN THE MARK IS "KNIGHT".

FOR BAKERY PRODUCTS, NAMELY, SNACK CAKES, PASTRIES, CAKES (U.S. CL. 46).

WENDY GOODMAN, EXAMINING ATTORNEY

SN 77-895,438. LOBLAWS INC., TORONTO, CANADA, FILED 12-17-2009.

# THE DECADENT

THE MARK CONSISTS OF STANDARD CHARACTERS WITHOUT CLAIM TO ANY PARTICULAR FONT, STYLE, SIZE, OR COLOR.

OWNER OF U.S. REG. NOS. 1,580,367 AND 3,106,828.

FOR FROZEN DESSERTS, NAMELY, ICE CREAM SANDWICHES (U.S. CL. 46).

ANTHONY RINKER, EXAMINING ATTORNEY

**CLASS 30—(Continued).**

SN 77-906,383. RICHIN TRADING INC., ALHAMBRA, CA. FILED 1-6-2010.

# TULIP

THE MARK CONSISTS OF STANDARD CHARACTERS WITHOUT CLAIM TO ANY PARTICULAR FONT, STYLE, SIZE, OR COLOR.

FOR COOKIES (U.S. CL. 46).

FIRST USE 12-9-2009; IN COMMERCE 12-9-2009.

LINDA M. KING, EXAMINING ATTORNEY

SN 77-916,314. PRODUCTOS EL MAJUELO, SOCIEDAD DE RESPONSABILIDAD LIMITADA, CADIZ, SPAIN, FILED 1-20-2010.

THE MARK CONSISTS OF THE WORDING "EL MAJUELO" IN A STYLIZED FONT HAVING AT THE UPPER RIGHT CORNER OF SUCH PHRASE AN OPEN CIRCLE WITH THE INTERNAL END WIDER THAN THE EXTERNAL END AND WHEREIN THE EXTERNAL END FORMS A CURVE WITH SPOTS, SIMULATING AN ARTISTIC CONDIMENT SPREADING DESIGN ON A PLATE OR SIMILAR SURFACE.

THE ENGLISH TRANSLATION OF "EL MAJUELO" IN THE MARK IS "YOUNG VINE" OR "HAWTHORNE".

FOR EDIBLE SALT; FLAVORINGS; FLAVOURED VINEGAR; MINERAL SALT FOR HUMAN CONSUMPTION; SALSA; SALT; SAUCES; VINEGAR; WINE VINEGAR (U.S. CL. 46).

FIRST USE 3-13-1997; IN COMMERCE 10-16-2003.

BRENDAN MCCAULEY, EXAMINING ATTORNEY

SN 77-961,889. FLOWERS BAKERIES BRANDS, LLC, THOMASVILLE, GA. FILED 3-18-2010.

THE COLOR(S) GREEN, BLACK, WHITE AND RED IS/ ARE CLAIMED AS A FEATURE OF THE MARK.

THE MARK CONSISTS OF THE WORD "JUAREZ" IN GREEN, BLACK, WHITE AND RED WITH A WHITE, BLACK AND GREEN SOMBRERO HAVING A RED STRIPE APPEARING OVER THE LETTER "A".

FOR CORN AND WHEAT TORTILLAS; CORN AND NACHO CHIPS (U.S. CL. 46).

FIRST USE 1-17-1985; IN COMMERCE 1-17-1985.

MARIAM MAHMOUDI, EXAMINING ATTORNEY

**CLASS 30—(Continued).**

SN 77-963,700. FLOWERS BAKERIES BRANDS, LLC, THOMASVILLE, GA. FILED 3-19-2010.



THE COLOR(S) BLACK, GREEN, WHITE, RED AND CREAM IS/ARE CLAIMED AS A FEATURE OF THE MARK. THE MARK CONSISTS OF THE WORD "JUAREZ" IN BLACK LETTERS WITH A GREEN LINE CENTERED ABOVE THE WORD "JUAREZ" WITH A GREEN, WHITE, RED AND BLACK SOMBRERO CENTERED ABOVE THE GREEN LINE, ALL AGAINST A WHITE OUTLINED CREAM BACKGROUND WITH WHITE SPECKLES AND ENCIRCLED IN A BLACK OUTLINED HALF RECTANGULAR AND HALF CURVED SHAPE.

FOR CORN AND WHEAT TORTILLAS; CORN AND NACHO CHIPS; SALSA (U.S. CL. 46).

MARIAM MAHMOUDI, EXAMINING ATTORNEY

SN 78-503,497. OLIVIERI FOODS LIMITED, HAMILTON, CANADA, FILED 10-21-2004.

# NUTRIWISE

THE MARK CONSISTS OF STANDARD CHARACTERS WITHOUT CLAIM TO ANY PARTICULAR FONT, STYLE, SIZE, OR COLOR.

FOR FRESH, DRY AND FROZEN PASTA (U.S. CL. 46). EDWARD NELSON, EXAMINING ATTORNEY

**CLASS 30—(Continued).**

SN 79-083,782. TIANJIN JIANFENG; NATURAL PRODUCT R&D CO., LTD., CHINA, FILED 6-1-2010.

# Appjfnol

## 尖峰苹果酚

OWNER OF INTERNATIONAL REGISTRATION 1042124 DATED 6-1-2010, EXPIRES 6-1-2020.

NO CLAIM IS MADE TO THE EXCLUSIVE RIGHT TO USE "APPJFNOL", APART FROM THE MARK AS SHOWN.

THE NON-LATIN CHARACTERS IN THE MARK TRANSLITERATE TO "JIAN FENG PING GUO FEN" AND THIS HAS NO MEANING IN A FOREIGN LANGUAGE.

FOR VEGETAL PREPARATIONS FOR USE AS COFFEE SUBSTITUTES (U.S. CL. 46).

WILLIAM VERHOSEK, EXAMINING ATTORNEY

SN 79-086,345. SARA LEE/DE N.V., NETHERLANDS, FILED 4-1-2010.

# L'OR

OWNER OF INTERNATIONAL REGISTRATION 0598575 DATED 2-9-1993, EXPIRES 2-9-2013.

THE ENGLISH TRANSLATION OF "L'OR" IN THE MARK IS "GOLD".

FOR COFFEE, INCLUDING FILTER-PACKAGED COFFEE, COFFEE EXTRACTS, SOLUBLE COFFEE, ARTIFICIAL COFFEE; BLENDS OF COFFEE AND ARTIFICIAL COFFEE; BLENDS OF COFFEE, MILK POWDER AND ARTIFICIAL COFFEE; ARTIFICIAL COFFEE, NAMELY, BLENDS OF COFFEE, CEREALS AND SPICES WITH ADDED FRUIT; TEA, TEA EXTRACTS, TEA SUBSTITUTES; SPICES AND PROCESSED HERBS FOR PREPARING BEVERAGES; SPICE AND PROCESSED HERB MIXTURES FOR PREPARING BEVERAGES; SPICE MIXTURES IN WHICH SPICES PREDOMINATE, WITH ADDED DRIED FRUIT FOR PREPARING BEVERAGES; INFUSIONS, NOT MEDICINAL, NAMELY, HERBAL AND TEA INFUSIONS (U.S. CL. 46).

KRISTINA MORRIS, EXAMINING ATTORNEY

SN 79-086,649. KOHJIN CO., LTD., JAPAN, FILED 8-6-2010.

# A J I T O P

THE MARK CONSISTS OF STANDARD CHARACTERS WITHOUT CLAIM TO ANY PARTICULAR FONT, STYLE, SIZE, OR COLOR.

PRIORITY DATE OF 7-22-2010 IS CLAIMED.

OWNER OF INTERNATIONAL REGISTRATION 1049205 DATED 8-6-2010, EXPIRES 8-6-2020.

THE WORDING "AJITOP" HAS NO MEANING IN A FOREIGN LANGUAGE.

FOR SEASONINGS; YEAST EXTRACTS FOR FOOD (U.S. CL. 46).

WILLIAM ROSSMAN, EXAMINING ATTORNEY

**CLASS 30—(Continued).**

SN 79-089,387. HANGZHOU LURUN TEA CO., LTD., CHINA, FILED 9-24-2010.



OWNER OF INTERNATIONAL REGISTRATION 1056793 DATED 9-24-2010, EXPIRES 9-24-2020.

THE MARK CONSISTS OF A DESIGN OF TWO LEAVES AND THE WORDING "YILI" AND "ULU" WITH CHINESE CHARACTERS FOR "YILI" BETWEEN THE TWO WORDS, ALL APPEARING UNDERNEATH THE DESIGN.

THE ENGLISH TRANSLATION OF "YILI" IN THE MARK IS ONE FORCE OR ONE POWER.

THE TRANSLITERATION OF THE NON-LATIN CHARACTERS IN THE MARK IS "YILI".

FOR COFFEE; TEA FLAVOR SOFT DRINKS; TEA; CANDY; VANILLA (U.S. CL. 46).

CHRISTOPHER BUONGIORNO, EXAMINING ATTORNEY

SN 85-022,627. OSMANSKI, JOHN M, MILWAUKEE, WI. FILED 4-25-2010.

# Bang!

THE MARK CONSISTS OF STANDARD CHARACTERS WITHOUT CLAIM TO ANY PARTICULAR FONT, STYLE, SIZE, OR COLOR.

FOR ICE AND ICE CREAMS (U.S. CL. 46).

CHRISTOPHER BUONGIORNO, EXAMINING ATTORNEY

**CLASS 30—(Continued).**

SN 85-040,410. ANDINAS FOOD CORP., AKA DELICIAS ANDINAS, MASPETH, NY. FILED 5-17-2010.



NO CLAIM IS MADE TO THE EXCLUSIVE RIGHT TO USE "ANDINAS", APART FROM THE MARK AS SHOWN.

THE COLOR(S) YELLOW AND GREEN IS/ARE CLAIMED AS A FEATURE OF THE MARK.

THE MARK CONSISTS OF THE WORDING "DELICIAS ANDINAS" WITH THE LETTER "A" FROM THE WORD "ANDINAS" ALSO USED AS THE LETTER "A" IN THE WORD "DELICIAS". ABOVE AND TO THE RIGHT OF THE WORDING ARE OUTLINES OF TWO MOUNTAINS. THE WORDING AND THE OUTLINES OF THE MOUNTAINS ARE IN YELLOW. THE BACKGROUND FOR THE ENTIRE MARK IS IN GREEN.

THE ENGLISH TRANSLATION OF "DELICIAS ANDINAS" IN THE MARK IS DELIGHTS OF THE ANDES.

FOR FOOD PRODUCTS, NAMELY, AREPAS OF DIFFERENT VARIETIES (U.S. CL. 46).

FIRST USE 1-13-2000; IN COMMERCE 1-13-2000.

DAVID MURRAY, EXAMINING ATTORNEY

SN 85-050,978. FREEDOM BAKING COMPANY, INC., GLENDALE, CA. FILED 5-30-2010.

## SHUSHAN LAVASH

THE MARK CONSISTS OF STANDARD CHARACTERS WITHOUT CLAIM TO ANY PARTICULAR FONT, STYLE, SIZE, OR COLOR.

NO CLAIM IS MADE TO THE EXCLUSIVE RIGHT TO USE "LAVASH", APART FROM THE MARK AS SHOWN.

FOR BREAD (U.S. CL. 46).

FIRST USE 2-10-1995; IN COMMERCE 2-10-1995.

SANJEEV VOHRA, EXAMINING ATTORNEY

SN 85-051,079. FREEDOM BAKING COMPANY, INC., GLENDALE, CA. FILED 5-31-2010.

## SASOON LAVASH

THE MARK CONSISTS OF STANDARD CHARACTERS WITHOUT CLAIM TO ANY PARTICULAR FONT, STYLE, SIZE, OR COLOR.

NO CLAIM IS MADE TO THE EXCLUSIVE RIGHT TO USE "LAVASH", APART FROM THE MARK AS SHOWN.

FOR BREAD (U.S. CL. 46).

FIRST USE 2-10-1995; IN COMMERCE 2-10-1995.

SANJEEV VOHRA, EXAMINING ATTORNEY

**CLASS 30—(Continued).**

SN 85-051,081. FREEDOM BAKING COMPANY, INC., GLENDALE, CA. FILED 5-31-2010.

**ROLL-A-BREAD WRAPS**

THE MARK CONSISTS OF STANDARD CHARACTERS WITHOUT CLAIM TO ANY PARTICULAR FONT, STYLE, SIZE, OR COLOR.

NO CLAIM IS MADE TO THE EXCLUSIVE RIGHT TO USE "WRAPS", APART FROM THE MARK AS SHOWN.

FOR BREAD (U.S. CL. 46).  
FIRST USE 2-10-2007; IN COMMERCE 2-10-2007.  
SANJEEV VOHRA, EXAMINING ATTORNEY

**CLASS 30—(Continued).**

SN 85-055,218. ANNIE'S HOMEGROWN, INC., NAPA, CA. FILED 6-4-2010.

**CINNAMON ROLL BUNNY O'S**

THE MARK CONSISTS OF STANDARD CHARACTERS WITHOUT CLAIM TO ANY PARTICULAR FONT, STYLE, SIZE, OR COLOR.

NO CLAIM IS MADE TO THE EXCLUSIVE RIGHT TO USE "CINNAMON ROLL", APART FROM THE MARK AS SHOWN.

FOR BREAKFAST CEREAL (U.S. CL. 46).  
CHRISTINE COOPER, EXAMINING ATTORNEY

SN 85-058,398. THE JAMES SKINNER CO., OMAHA, NE. FILED 6-9-2010.

**J. SKINNER**

THE MARK CONSISTS OF STANDARD CHARACTERS WITHOUT CLAIM TO ANY PARTICULAR FONT, STYLE, SIZE, OR COLOR.

THE NAME(S), PORTRAIT(S), AND/OR SIGNATURE(S) SHOWN IN THE MARK IDENTIFIES JAMES G. SKINNER, WHOSE CONSENT(S) TO REGISTER IS MADE OF RECORD.

FOR BAKERY GOODS (U.S. CL. 46).  
FIRST USE 6-6-2010; IN COMMERCE 6-6-2010.  
MARY ROSSMAN, EXAMINING ATTORNEY

SN 85-058,425. THE JAMES SKINNER CO., OMAHA, NE. FILED 6-9-2010.

**INDULGENT SELECTIONS**

THE MARK CONSISTS OF STANDARD CHARACTERS WITHOUT CLAIM TO ANY PARTICULAR FONT, STYLE, SIZE, OR COLOR.

NO CLAIM IS MADE TO THE EXCLUSIVE RIGHT TO USE "SELECTIONS", APART FROM THE MARK AS SHOWN.

FOR BAKERY GOODS (U.S. CL. 46).  
FIRST USE 6-6-2010; IN COMMERCE 6-6-2010.  
MARY ROSSMAN, EXAMINING ATTORNEY

SN 85-054,423. SHANG, ZEHUA, DBA SHANG TEA CO., KANSAS CITY, MO. AND DONOHUE-SHANG, SHANNON, DBA SHANG TEA CO., KANSAS CITY, MO. FILED 6-3-2010.



NO CLAIM IS MADE TO THE EXCLUSIVE RIGHT TO USE "TEA" OR THE NON-LATIN CHARACTER THAT TRANSLITERATES TO CHA, APART FROM THE MARK AS SHOWN.

THE COLOR(S) WHITE, BLACK, OLIVE GREEN, AND GREEN IS/ARE CLAIMED AS A FEATURE OF THE MARK.

THE MARK CONSISTS OF THE WORDING "SHANG TEA", IN STYLIZED WHITE FONT WITHIN A BLACK RECTANGLE OUTLINED IN OLIVE GREEN AND FEATURING ORNAMENTAL OLIVE GREEN BORDER DESIGNS ABOVE AND BELOW THE RECTANGLE. TWO CHINESE CHARACTERS IN GREEN ARE PLACED BETWEEN THE LETTERS SPELLING "TEA".

THE WORDING "SHANG" HAS NO MEANING IN A FOREIGN LANGUAGE.

THE NON-LATIN CHARACTER ON THE LEFT IN THE MARK TRANSLITERATES TO "SHANG" AND THIS HAS NO MEANING IN A FOREIGN LANGUAGE. THE NON-LATIN CHARACTER ON THE RIGHT IN THE MARK TRANSLITERATES TO CHA AND THIS MEANS "TEA" IN ENGLISH.

FOR LOOSE LEAF RED TEAS, LOOSE LEAF WHITE TEAS, LOOSE LEAF GREEN TEAS, LOOSE LEAF HERBAL TEAS, AND LOOSE LEAF JASMINE TEAS (U.S. CL. 46).

FIRST USE 11-30-2007; IN COMMERCE 3-1-2008.  
STEVEN PEREZ, EXAMINING ATTORNEY



**CLASS 30—(Continued).**

SN 85-059,136. THE JAMES SKINNER CO., OMAHA, NE.  
FILED 6-10-2010.



NO CLAIM IS MADE TO THE EXCLUSIVE RIGHT TO USE "ARTISAN BAKING", APART FROM THE MARK AS SHOWN.

THE NAME(S), PORTRAIT(S), AND/OR SIGNATURE(S) SHOWN IN THE MARK IDENTIFIES JAMES G. SKINNER, WHOSE CONSENT(S) TO REGISTER IS MADE OF RECORD.

THE MARK CONSISTS OF A RECTANGLE CONTAINING ROUGH EDGES, WITH THE WORDS "J. SKINNER" IN THE MIDDLE OF THE RECTANGLE, AND THE WORDS "MODERN ARTISAN BAKING" DIRECTLY BELOW THE RECTANGLE.

FOR BAKERY GOODS (U.S. CL. 46).  
FIRST USE 6-6-2010; IN COMMERCE 6-6-2010.  
MARY ROSSMAN, EXAMINING ATTORNEY

SN 85-061,881. CARELLA, JULIANNA, SAN FRANCISCO, CA. FILED 11-15-2010.

## Auntie Dolores

THE MARK CONSISTS OF STANDARD CHARACTERS WITHOUT CLAIM TO ANY PARTICULAR FONT, STYLE, SIZE, OR COLOR.

THE NAME "AUNTIE DOLORES" DOES NOT IDENTIFY A LIVING INDIVIDUAL.

FOR BAKERY ITEMS, NAMELY, BROWNIES, CHOCOLATE CHIP COOKIES, SAVORY PRETZELS, AND CARAMEL POPCORN (U.S. CL. 46).

FIRST USE 11-10-2010; IN COMMERCE 11-10-2010.  
LINDSEY RUBIN, EXAMINING ATTORNEY

SN 85-066,961. HAWAIIAN CHIP COMPANY LLC, HONOLULU, HI. FILED 6-18-2010.

## Kilauea Fire

THE MARK CONSISTS OF STANDARD CHARACTERS WITHOUT CLAIM TO ANY PARTICULAR FONT, STYLE, SIZE, OR COLOR.

OWNER OF U.S. REG. NO. 3,211,269.

FOR BARBECUE SAUCE; BARBEQUE SAUCE; HOT SAUCE; SAUCES; SAUCES FOR BARBECUED MEAT (U.S. CL. 46).

FIRST USE 3-0-2004; IN COMMERCE 11-0-2008.  
MAUREEN DALL, EXAMINING ATTORNEY

**CLASS 30—(Continued).**

SN 85-068,317. JOHNNY'S FINE FOODS, INC., TACOMA, WA. FILED 6-22-2010.

## JOHNNY'S

THE MARK CONSISTS OF STANDARD CHARACTERS WITHOUT CLAIM TO ANY PARTICULAR FONT, STYLE, SIZE, OR COLOR.

OWNER OF U.S. REG. NO. 964,757.

FOR SALAD DRESSINGS; BARBECUE AND OTHER SAUCES, NAMELY, SWEET HOT SAUCE, SALMON FINISHING SAUCE AND FRENCH DIP SAUCE; SEASONINGS AND SEASONING SALTS; DIETETIC SALT SUBSTITUTE ADAPTED FOR NON-MEDICAL PURPOSES; MEAT AND FOWL TENDERIZER; TERIYAKI MARINADE; AND MUSTARDS (U.S. CL. 46).

FIRST USE 3-1-1956; IN COMMERCE 6-1-1959.  
BARBARA RUTLAND, EXAMINING ATTORNEY

SN 85-068,321. JOHNNY'S FINE FOODS, INC., TACOMA, WA. FILED 6-22-2010.



OWNER OF U.S. REG. NO. 964,757.

THE MARK CONSISTS OF THE WORD "JOHNNY'S" STYLIZED WITH A LEAF DESIGN.

FOR SALAD DRESSINGS; BARBECUE AND OTHER SAUCES, NAMELY, SWEET HOT SAUCE, SALMON FINISHING SAUCE AND FRENCH DIP SAUCE; SEASONINGS AND SEASONING SALTS; DIETETIC SALT SUBSTITUTE ADAPTED FOR NON-MEDICAL PURPOSES; MEAT AND FOWL TENDERIZER; TERIYAKI MARINADE; AND MUSTARDS (U.S. CL. 46).

FIRST USE 3-1-1956; IN COMMERCE 6-1-1959.  
BARBARA RUTLAND, EXAMINING ATTORNEY

SN 85-069,666. FUDGIE WUDGIE, L.P., PITTSBURGH, PA. FILED 6-23-2010.

## FUDGIE WUDGIE HANDMADE FUDGE SQUARES

THE MARK CONSISTS OF STANDARD CHARACTERS WITHOUT CLAIM TO ANY PARTICULAR FONT, STYLE, SIZE, OR COLOR.

NO CLAIM IS MADE TO THE EXCLUSIVE RIGHT TO USE "HANDMADE FUDGE SQUARES", APART FROM THE MARK AS SHOWN.

FOR CHOCOLATE AND CHOCOLATES; CHOCOLATE CANDIES; FUDGE (U.S. CL. 46).

FIRST USE 4-0-2010; IN COMMERCE 4-0-2010.  
BARBARA BROWN, EXAMINING ATTORNEY

**CLASS 30—(Continued).**

SN 85-069,675. FUDGIE WUDGIE, L.P., PITTSBURGH, PA.  
FILED 6-23-2010.

**FUDGIE WUDGIES**

THE MARK CONSISTS OF STANDARD CHARACTERS WITHOUT CLAIM TO ANY PARTICULAR FONT, STYLE, SIZE, OR COLOR.

FOR CHOCOLATE AND CHOCOLATES; CHOCOLATE CANDIES; FUDGE (U.S. CL. 46).

FIRST USE 0-0-2009; IN COMMERCE 0-0-2009.  
BARBARA BROWN, EXAMINING ATTORNEY

SN 85-074,564. POPINA (VIC) PTY LIMITED, DANDENONG SOUTH, AUSTRALIA, FILED 6-30-2010.



OWNER OF AUSTRALIA REG. NO. 1305586, DATED 6-23-2009, EXPIRES 6-23-2019.

NO CLAIM IS MADE TO THE EXCLUSIVE RIGHT TO USE "SUPERFOODS", APART FROM THE MARK AS SHOWN.

THE MARK CONSISTS OF THE WORDS "GOODNESS SUPERFOODS" APPEARING IN A STYLIZED FONT, WITH A HORIZONTAL LINE OVER "GOOD". THE WORDS ARE WITHIN A RECTANGLE HAVING A CURVED CORNER.

FOR MUESLI; READY TO EAT, MUESLI DERIVED FOOD BARS; MUESLI-BASED SNACKS; BREAKFAST CEREALS; READY TO EAT, CEREAL DERIVED FOOD BARS; CEREAL BASED SNACK FOODS; CEREAL BREAKFAST PRODUCTS, NAMELY, BREADS AND FLATBREADS; CEREAL-BASED SNACKS (U.S. CL. 46).  
STEVEN R. FINE, EXAMINING ATTORNEY

SN 85-075,086. FLAMIN' JOES, INC., GREENACRES, WA.  
FILED 6-30-2010.

**CODE RED**

THE MARK CONSISTS OF STANDARD CHARACTERS WITHOUT CLAIM TO ANY PARTICULAR FONT, STYLE, SIZE, OR COLOR.

FOR SAUCES (U.S. CL. 46).  
FIRST USE 8-26-2005; IN COMMERCE 8-26-2005.  
JAY FLOWERS, EXAMINING ATTORNEY

**CLASS 30—(Continued).**

SN 85-089,840. CHRISTMAN, MARIA, NORTH PALM BEACH, FL. FILED 7-21-2010.

**MARIA'S HEALTHY BREAKFAST COOKIE**

THE MARK CONSISTS OF STANDARD CHARACTERS WITHOUT CLAIM TO ANY PARTICULAR FONT, STYLE, SIZE, OR COLOR.

NO CLAIM IS MADE TO THE EXCLUSIVE RIGHT TO USE "HEALTHY BREAKFAST COOKIE", APART FROM THE MARK AS SHOWN.

FOR COOKIES (U.S. CL. 46).  
FIRST USE 10-1-2006; IN COMMERCE 11-20-2006.  
ELIZABETH KAJUBI, EXAMINING ATTORNEY

SN 85-090,764. MARK-NYS, INC., SANTA MONICA, CA.  
FILED 7-22-2010.

**Original New York Seltzer**

THE MARK CONSISTS OF STANDARD CHARACTERS WITHOUT CLAIM TO ANY PARTICULAR FONT, STYLE, SIZE, OR COLOR.

NO CLAIM IS MADE TO THE EXCLUSIVE RIGHT TO USE "ORIGINAL NEW YORK", APART FROM THE MARK AS SHOWN.

FOR CANDY; PRETZELS (U.S. CL. 46).  
AISHA SALEM, EXAMINING ATTORNEY

SN 85-095,870. KAFFE MAGNUM OPUS, INC., MILLVILLE, NJ. FILED 7-29-2010.

**KAFFE EXOTICA**

THE MARK CONSISTS OF STANDARD CHARACTERS WITHOUT CLAIM TO ANY PARTICULAR FONT, STYLE, SIZE, OR COLOR.

NO CLAIM IS MADE TO THE EXCLUSIVE RIGHT TO USE "KAFFE". APART FROM THE MARK AS SHOWN. THE ENGLISH TRANSLATION OF "KAFFE" IN THE MARK IS "COFFEE".

FOR COFFEE (U.S. CL. 46).  
FIRST USE 8-21-2008; IN COMMERCE 8-21-2008.  
SETH A. RAPPAPORT, EXAMINING ATTORNEY

**CLASS 30—(Continued).**

SN 85-100,366. E & E PEL'S ENTERPRISES INC., PALM SPRINGS, CA. FILED 8-4-2010.



NO CLAIM IS MADE TO THE EXCLUSIVE RIGHT TO USE "ITALIAN ICES", APART FROM THE MARK AS SHOWN.

THE NAME(S), PORTRAIT(S), AND/OR SIGNATURE(S) SHOWN IN THE MARK DOES NOT IDENTIFY A PARTICULAR LIVING INDIVIDUAL.

THE MARK CONSISTS OF THREE LEMONS STAGGERED WITH THE STYLIZED TEXT "E. & E. PEL'S ITALIAN ICES".

FOR ITALIAN ICE (U.S. CL. 46).

FIRST USE 11-1-1986; IN COMMERCE 11-1-1986.  
MARY BOAGNI, EXAMINING ATTORNEY

SN 85-105,505. MOCHI CART, LLC, DENVER, CO. FILED 8-11-2010.



NO CLAIM IS MADE TO THE EXCLUSIVE RIGHT TO USE "MOCHI" AND "LLC", APART FROM THE MARK AS SHOWN.

THE COLOR(S) GREEN, ORANGE, YELLOW, WHITE AND BLACK IS/ARE CLAIMED AS A FEATURE OF THE MARK.

THE MARK CONSISTS OF THE WORDS "MOCHI CART" IN WHITE LETTERS OUTLINED IN BLACK AND "LLC" IN BLACK. THE "O" IN "MOCHI" IS A SERIES OF THREE-DIMENSIONAL CIRCULAR SHAPES IN GREEN WITH YELLOW SHADING AND ORANGE, EACH OUTLINED IN BLACK.

FOR CARAMEL TOPPING FOR ICE CREAM; DOUGH-ENROBED FOODS CONSISTING OF A DOUGH-BASED WRAPPER WITH FILLINGS CONSISTING PRIMARILY OF ICE CREAM AND OTHER DAIRY-BASED DESSERTS; ICE CREAM; ICE CREAM DESSERTS; ICE CREAM SANDWICHES; ICE CREAM SUBSTITUTE (U.S. CL. 46).

KATHLEEN M. VANSTON, EXAMINING ATTORNEY

**CLASS 30—(Continued).**

SN 85-106,748. DENNIS M. REMSBURGER, DBA REMSBURGER MAPLE FARM & APIARY, PLEASANT VALLEY, NY. FILED 8-13-2010.

We Make Life A Little  
Sweeter

THE MARK CONSISTS OF STANDARD CHARACTERS WITHOUT CLAIM TO ANY PARTICULAR FONT, STYLE, SIZE, OR COLOR.

FOR HONEY; MAPLE SYRUP (U.S. CL. 46).

FIRST USE 6-3-1995; IN COMMERCE 6-3-1995.

BARBARA BROWN, EXAMINING ATTORNEY

SN 85-107,448. EQUATOR ESTATE COFFEES & TEAS, INC., SAN RAFAEL, CA. FILED 8-13-2010.



OWNER OF U.S. REG. NOS. 3,142,138, 3,142,260 AND 3,142,261.

NO CLAIM IS MADE TO THE EXCLUSIVE RIGHT TO USE "COFFEES & TEAS", APART FROM THE MARK AS SHOWN.

THE COLOR(S) RED, BLACK, AND WHITE IS/ARE CLAIMED AS A FEATURE OF THE MARK.

THE MARK CONSISTS OF A RED RECTANGLE WITH A BLACK BAR ON THE TOP AND BOTTOM OF THE RECTANGLE. INSIDE THE RECTANGLE IS A BLACK RECTANGLE WITH THE WORDING "EQUATOR" AND "COFFEES & TEAS" IN WHITE.

FOR COFFEE; COFFEE BEANS; CAFFEINE-FREE COFFEE; TEA; HERBAL TEA FOR FOOD PURPOSES; GREEN TEA; OOLONG TEA (U.S. CL. 46).

LAKEISHA LEWIS, EXAMINING ATTORNEY

SN 85-108,300. NEKUTLI SA DE CV, CUQUÍO, JALISCO, MEXICO, FILED 8-16-2010.

CHO'KUA

OWNER OF MEXICO REG. NO. 1184518, DATED 6-29-2010, EXPIRES 6-29-2020.

THE MARK CONSISTS OF THE WORD "CHO'KUA" WITH STYLIZED LETTERS.

FOR CHOCOLATE AND CHOCOLATES (U.S. CL. 46).

JANICE L. MCMORROW, EXAMINING ATTORNEY

**CLASS 30—(Continued).**

SN 85-108,337. NEKUTLI SA DE CV, CUQUÍO, JALISCO, MEXICO, FILED 8-16-2010.



OWNER OF MEXICO REG. NO. 1177969, DATED 6-29-2010, EXPIRES 6-29-2020.

THE MARK CONSISTS OF STYLIZED DESIGN OF COCOA GRAINS IN A REPEATING PATTERN OF COLUMNS. THERE IS ONE DIAMOND DESIGN ON THE BOTTOM LEFT.

FOR CHOCOLATE AND CHOCOLATES (U.S. CL. 46).  
JANICE L. MCMORROW, EXAMINING ATTORNEY

**CLASS 30—(Continued).**

SN 85-127,172. VOSGES IP, LLC, CHICAGO, IL. FILED 9-10-2010.

THE MARK CONSISTS OF STANDARD CHARACTERS WITHOUT CLAIM TO ANY PARTICULAR FONT, STYLE, SIZE, OR COLOR.

THE NAME "MO'S" DOES NOT IDENTIFY A LIVING INDIVIDUAL.

FOR CONFECTIONERY PRODUCTS, NAMELY, CHOCOLATES IN BAR FORM CONTAINING BACON OR BACON FLAVORING, AND PANCAKE MIX CONTAINING CHOCOLATE BAR PIECES WITH BACON OR BACON FLAVORING (U.S. CL. 46).

FIRST USE 5-16-2007; IN COMMERCE 5-30-2007.

JAY BESCH, EXAMINING ATTORNEY

SN 85-132,037. SAPUTO BOULANGERIE INC./SAPUTO BAKERY INC., SAINT-LEONARD, CANADA, FILED 9-17-2010.

SN 85-124,295. PERFETTI VAN MELLE BENELUX B.V., BREDA, NETHERLANDS, FILED 9-7-2010.

THE MARK CONSISTS OF STANDARD CHARACTERS WITHOUT CLAIM TO ANY PARTICULAR FONT, STYLE, SIZE, OR COLOR.

FOR CONFECTIONERY PRODUCTS, NAMELY, CHEWING GUM, BUBBLE GUM AND CANDIES (U.S. CL. 46).

BRENDAN MCCAULEY, EXAMINING ATTORNEY



NO CLAIM IS MADE TO THE EXCLUSIVE RIGHT TO USE "CARAMEL", APART FROM THE MARK AS SHOWN.

THE MARK CONSISTS OF THE STYLIZED WORDING "AH CARAMEL!" FEATURED ON A SHADED DESIGN OF A HEART WITH HIGHLIGHTING TO GIVE THE IMPRESSION THAT THE HEART IS THREE DIMENSIONAL.

FOR PASTRIES AND DESSERTS, NAMELY, CAKES, SNACK CAKES, CAKE BARS (U.S. CL. 46).

CYNTHIA TRIPI, EXAMINING ATTORNEY

**CLASS 30—(Continued).**

SN 85-141,975. STARTER CHEF LLC, MANAHAWKIN, NJ. FILED 9-30-2010.



THE COLOR(S) ROYAL BLUE, WHITE AND BLACK IS/ ARE CLAIMED AS A FEATURE OF THE MARK.

THE MARK CONSISTS OF THE WORDING "STARTER CHEF" AND DESIGN. THE WORDING "STARTER CHEF" IS IN ROYAL BLUE AND APPEARS WITHIN THE DESIGN OF A CHEF'S HAT. THE TERM "STARTER" APPEARS ABOVE THE TERM "CHEF". THE CHEF'S HAT IS OUTLINED IN BLACK, AND THE BACKGROUND IS WHITE.

FOR BAKERY PRODUCTS; COOKIES; MUFFIN MIXES; PANCAKE MIXES; PIES (U.S. CL. 46).  
GENE MACIOL, EXAMINING ATTORNEY

SN 85-156,785. CARAVAN INGREDIENTS INC., LENEXA, KS. FILED 10-20-2010.

**PURPLE HARVEST BREAD**

THE MARK CONSISTS OF STANDARD CHARACTERS WITHOUT CLAIM TO ANY PARTICULAR FONT, STYLE, SIZE, OR COLOR.

NO CLAIM IS MADE TO THE EXCLUSIVE RIGHT TO USE "PURPLE" OR "BREAD", APART FROM THE MARK AS SHOWN.

FOR MIXES FOR BAKERY GOODS AND BASES FOR BREAD (U.S. CL. 46).

EVELYN BRADLEY, EXAMINING ATTORNEY

SN 85-159,670. REORIENT NATURALS, INC., SAN FRANCISCO, CA. FILED 10-23-2010.

**REORIENT**

THE MARK CONSISTS OF STANDARD CHARACTERS WITHOUT CLAIM TO ANY PARTICULAR FONT, STYLE, SIZE, OR COLOR.

FOR HERBAL TEA; NON-ALCOHOLIC BEVERAGES CONTAINING HERBAL EXTRACTS, NAMELY, HERBAL FOOD BEVERAGES (U.S. CL. 46).

DEBRA LEE, EXAMINING ATTORNEY

**CLASS 30—(Continued).**

SN 85-166,800. PAR DELA PIES, LLC, AKA PAR DELA BAKERY, STAFFORD SPRINGS, CT. FILED 11-2-2010.



NO CLAIM IS MADE TO THE EXCLUSIVE RIGHT TO USE "BAKERY", APART FROM THE MARK AS SHOWN.

THE COLOR(S) ORANGE, YELLOW, MAROON RED, CORAL ORANGE, LIGHT BROWN, BLACK AND OFF-WHITE IS/ARE CLAIMED AS A FEATURE OF THE MARK.

THE MARK CONSISTS OF A LARGE ORANGE CENTER CIRCLE, STATING "PAR DELA BAKERY" IN BLACK "LUKE" TYPE FONT. "PAR DELA" HAS AN ACCENT OVER THE "A", AND IS WRITTEN LARGER THAN THE TERM "BAKERY". ON THE UPPER LEFT OF THE LARGE CIRCLE IS A SMALLER CORAL ORANGE CIRCLE, OUTLINED IN MAROON. THERE IS A SIMILAR, BUT SLIGHTLY SMALLER ONE OF THESE SAME CORAL/MAROON CIRCLES ON THE LOWER RIGHT OF THE LARGE ORANGE CIRCLE. THE UPPER RIGHT HAS A SERIES OF 3 THIN-LINED BROWN CIRCLES THE ENTIRE LOGO IS OUTLINED IN A YELLOW AND OFF-WHITE HUE.

THE ENGLISH TRANSLATION OF "PAR DELA" IN THE MARK IS "BEYOND".

FOR FROZEN BREADS; FROZEN COOKIE DOUGH; FROZEN PIE CRUSTS; NON-DAIRY FROZEN CONFECTIONS (U.S. CL. 46).

FIRST USE 8-10-2009; IN COMMERCE 2-15-2010.  
ERNEST SHOSHO, EXAMINING ATTORNEY

SN 85-170,864. 1161396 ONTARIO INC., OAKVILLE, ON, CANADA, FILED 11-6-2010.

**Bunnyfields**

THE MARK CONSISTS OF STANDARD CHARACTERS WITHOUT CLAIM TO ANY PARTICULAR FONT, STYLE, SIZE, OR COLOR.

PRIORITY CLAIMED UNDER SEC. 44(D) ON CANADA APPLICATION NO. 1479945, FILED 5-6-2010, REG. NO. TMA793916, DATED 3-25-2011, EXPIRES 3-25-2026.

FOR (BASED ON INTENT TO USE) CANDY; CHOCOLATE (BASED ON 44(D) PRIORITY APPLICATION) CANDY; CHOCOLATE (U.S. CL. 46).

TARAH HARDY, EXAMINING ATTORNEY



**CLASS 30—(Continued).**

SN 85-176,998. WM. WRIGLEY JR. COMPANY, CHICAGO, IL. FILED 11-15-2010.

**MYSTERY FLAVOR**

THE MARK CONSISTS OF STANDARD CHARACTERS WITHOUT CLAIM TO ANY PARTICULAR FONT, STYLE, SIZE, OR COLOR.

OWNER OF U.S. REG. NO. 3,018,177.  
NO CLAIM IS MADE TO THE EXCLUSIVE RIGHT TO USE "FLAVOR", APART FROM THE MARK AS SHOWN.  
FOR CHEWING GUM (U.S. CL. 46).  
HENRY S. ZAK, EXAMINING ATTORNEY

**CLASS 30—(Continued).**

SN 85-183,653. SMALL PLANET FOODS, INC., MINNEAPOLIS, MN. FILED 11-23-2010.

**CHANGE FLOWS**

THE MARK CONSISTS OF STANDARD CHARACTERS WITHOUT CLAIM TO ANY PARTICULAR FONT, STYLE, SIZE, OR COLOR.

FOR GRAIN BASED FOODS, NAMELY, BREAKFAST CEREAL, SNACK FOOD OR PROCESSED GRAINS USED AS AN INGREDIENT FOR MAKING FOOD; GRAIN BASED SNACK BARS (U.S. CL. 46).  
JOSETTE BEVERLY, EXAMINING ATTORNEY

SN 85-177,894. VINCENT VAN GOGH CAFE, LLC, ASTORIA, NY. FILED 11-16-2010.

**VAN GOGH**

THE MARK CONSISTS OF STANDARD CHARACTERS WITHOUT CLAIM TO ANY PARTICULAR FONT, STYLE, SIZE, OR COLOR.

FOR COFFEE AND TEA (U.S. CL. 46).  
FIRST USE 7-28-2010; IN COMMERCE 7-28-2010.  
JANET LEE, EXAMINING ATTORNEY

SN 85-187,055. CARBERRY, MANITOBA STARCH PRODUCTS INC., CARBERRY, MANITOBA, CANADA. FILED 11-30-2010.

**MSP[RS]**

THE MARK CONSISTS OF STANDARD CHARACTERS WITHOUT CLAIM TO ANY PARTICULAR FONT, STYLE, SIZE, OR COLOR.

NO CLAIM IS MADE TO THE EXCLUSIVE RIGHT TO USE "RS", APART FROM THE MARK AS SHOWN.  
FOR POTATO STARCH (U.S. CL. 46).  
MARGARET POWER, EXAMINING ATTORNEY

SN 85-181,047. KRAFT FOODS GLOBAL BRANDS LLC, NORTHFIELD, IL. FILED 11-19-2010.

**NEWTON'S FRUIT THINS**

THE MARK CONSISTS OF STANDARD CHARACTERS WITHOUT CLAIM TO ANY PARTICULAR FONT, STYLE, SIZE, OR COLOR.

OWNER OF U.S. REG. NOS. 98,178, 1,669,627 AND 3,624,027.  
NO CLAIM IS MADE TO THE EXCLUSIVE RIGHT TO USE "FRUIT THINS", APART FROM THE MARK AS SHOWN.  
FOR COOKIES (U.S. CL. 46).  
RONALD MCMORROW, EXAMINING ATTORNEY

SN 85-187,259. THE C. F. SAUER COMPANY, RICHMOND, VA. FILED 11-30-2010.

**Duke's**

THE MARK CONSISTS OF STANDARD CHARACTERS WITHOUT CLAIM TO ANY PARTICULAR FONT, STYLE, SIZE, OR COLOR.

OWNER OF U.S. REG. NOS. 734,661, 1,650,276 AND OTHERS.  
FOR MAYONNAISE, TARTAR SAUCE, SANDWICH RELISH, SALAD DRESSING (U.S. CL. 46).  
FIRST USE 8-1-1921; IN COMMERCE 12-31-1947.  
TIMOTHY FINNEGAN, EXAMINING ATTORNEY

**CLASS 30—(Continued).**

SN 85-187,471. DANCING SANDWICH ENTERPRISES, INC.,  
ANN ARBOR, MI. FILED 11-30-2010.



NO CLAIM IS MADE TO THE EXCLUSIVE RIGHT TO USE "CASHEW", APART FROM THE MARK AS SHOWN. THE MARK CONSISTS OF THE WORD "CASHEW" WRITTEN ABOVE THE WORD "COW" ON A SHAPE COMPOSED OF AN OVAL OVER A RECTANGLE. FOR CANDY BARS (U.S. CL. 46). FIRST USE 2-0-2006; IN COMMERCE 2-0-2008. GENE MACIOL, EXAMINING ATTORNEY

SN 85-187,930. BAD BYRON'S SPECIALTY FOOD PRODUCTS, INC., SANTA ROSA BEACH, FL. FILED 12-1-2010.

## TEXAS TEA

THE MARK CONSISTS OF STANDARD CHARACTERS WITHOUT CLAIM TO ANY PARTICULAR FONT, STYLE, SIZE, OR COLOR. NO CLAIM IS MADE TO THE EXCLUSIVE RIGHT TO USE "TEXAS", APART FROM THE MARK AS SHOWN. FOR BARBECUE SAUCE (U.S. CL. 46). SANDRA BUJA, EXAMINING ATTORNEY

SN 85-189,183. SUNNYLAND BULGUR WHEAT, INC.,  
FRESNO, CA. FILED 12-2-2010.



**SUNNYLAND  
MILLS**

OWNER OF U.S. REG. NOS. 1,329,936 AND 2,161,513. NO CLAIM IS MADE TO THE EXCLUSIVE RIGHT TO USE "SINCE 1935" OR "MILLS", APART FROM THE MARK AS SHOWN. THE MARK CONSISTS OF TWO-TONED VERTICAL

**CLASS 30—(Continued).**

RECTANGLE WITH THE LEFT HALF OF THE RECTANGLE BEING LIGHTER THAN THE RIGHT HALF OF THE RECTANGLE; INSIDE THE RECTANGLE APPEARS A TWO-TONED VERTICAL STALK OF WHEAT WITH THE LEFT HALF OF THE WHEAT BEING LIGHTER THAN THE RIGHT HALF OF THE WHEAT; BELOW THE STALK OF WHEAT ON A DARK BACKGROUND IS THE WORDING "SINCE 1935"; ALL OF THE FOREGOING IS INSIDE A LARGER VERTICAL RECTANGLE; AND BELOW IS THE WORDING "SUNNYLAND MILLS". FOR PROCESSED GRAIN (U.S. CL. 46). FIRST USE 10-0-2003; IN COMMERCE 10-0-2003. ERNEST SHOSHO, EXAMINING ATTORNEY

SN 85-192,012. JOHNNY'S FINE FOODS, INC., TACOMA,  
WA. FILED 12-7-2010.

## POUR ON THE JOHNNY'S!

THE MARK CONSISTS OF STANDARD CHARACTERS WITHOUT CLAIM TO ANY PARTICULAR FONT, STYLE, SIZE, OR COLOR. FOR SPICES, SEASONINGS, SAUCES, AND SALAD DRESSINGS (U.S. CL. 46). BRIDGETT SMITH, EXAMINING ATTORNEY

SN 85-192,365. MULTIGRAINS BAKERY, LAWRENCE, MA.  
FILED 12-7-2010.



THE MARK CONSISTS OF A RECTANGULAR BOX WITH IMAGES OF BUTTER, CORN, BREAD, AND HONEY ON A TABLE AND THE WORDING "HOY ES EL DIA!" IN BETWEEN TWO HORIZONTAL LINES INSIDE OF A RECTANGULAR BOX WITH ROUGH EDGES AND THE WORDING "PARA PAN FANTASTICO!!" AT THE BOTTOM OF THE MARK WITHIN A HORIZONTAL LINE THAT RUNS THE LENGTH OF THE ENTIRE MARK. THE ENGLISH TRANSLATION OF "HOY ES EL DIA" AND "PARA PAN FANTASTICO" IN THE MARK IS TODAY IS THE DAY FOR FANTASTIC BREAD. FOR BAKERY GOODS (U.S. CL. 46). LINDSEY RUBIN, EXAMINING ATTORNEY

**CLASS 30—(Continued).**

SN 85-192,931. SONOMA SYRUP CO., INC., SONOMA, CA. FILED 12-8-2010.

**VANILLA BEAN EXTRACT  
'CRUSH'**

THE MARK CONSISTS OF STANDARD CHARACTERS WITHOUT CLAIM TO ANY PARTICULAR FONT, STYLE, SIZE, OR COLOR.

NO CLAIM IS MADE TO THE EXCLUSIVE RIGHT TO USE "VANILLA BEAN EXTRACT", APART FROM THE MARK AS SHOWN.

FOR VANILLA EXTRACT USED AS FLAVORING (U.S. CL. 46).

FIRST USE 11-7-2005; IN COMMERCE 11-7-2005.  
MEGHAN REINHART, EXAMINING ATTORNEY

SN 85-192,938. SONOMA SYRUP CO., INC., SONOMA, CA. FILED 12-8-2010.

**SONOMA SYRUP CO.**

THE MARK CONSISTS OF STANDARD CHARACTERS WITHOUT CLAIM TO ANY PARTICULAR FONT, STYLE, SIZE, OR COLOR.

NO CLAIM IS MADE TO THE EXCLUSIVE RIGHT TO USE "SYRUP CO.", APART FROM THE MARK AS SHOWN. SEC. 2(F).

FOR SIMPLE SYRUP FOR USE AS A FLAVORING SYRUP; FLAVORED SIMPLE SYRUP FOR USE AS A FLAVORING SYRUP; BREAKFAST SYRUP, NAMELY, FLAVORING SYRUP FOR BREAKFAST FOODS; VANILLA EXTRACT USED AS FLAVORING; ALMOND EXTRACT USED AS FLAVORING; LEMON EXTRACT USED AS FLAVORING (U.S. CL. 46).

FIRST USE 5-1-2002; IN COMMERCE 8-1-2002.  
MEGHAN REINHART, EXAMINING ATTORNEY

**CLASS 30—(Continued).**

SN 85-193,816. HERSHEY CHOCOLATE & CONFECTIONERY CORPORATION, WHEAT RIDGE, CO. FILED 12-9-2010.



OWNER OF U.S. REG. NOS. 680,105, 3,023,580 AND OTHERS.

NO CLAIM IS MADE TO THE EXCLUSIVE RIGHT TO USE "LOW FAT SNACK", "PEEL IT", CHERRY ARTIFICIALLY FLAVORED", "CANDY", AND THE PICTORIAL REPRESENTATION OF THE CHERRIES, APART FROM THE MARK AS SHOWN.

THE COLOR(S) WHITE, BLUE, RED, YELLOW, GREEN, AND PINK IS/ARE CLAIMED AS A FEATURE OF THE MARK.

THE MARK CONSISTS OF THE FOLLOWING: THREE WAVY BANDS COLORED RED, WHITE AND PINK FROM TOP TO BOTTOM. THE COLOR WHITE IN THIS PORTION OF THE MARK IS A TRANSPARENT AREA AND IS NOT PART OF THE MARK. THE MATTER SHOWN IN DOTTED LINES SHOWS POSITIONING OF THE MARK AND IS NOT PART OF THE MARK. LOCATED IN THE RED WAVY BAND IS THE WORD TWIZZLERS IN WHITE WITH A BLUE AND RED BORDER. INTERSECTING THE WORD IS A DESIGN OF RED CANDY WITH THE WORDS PEEL IT AND AN ARROW DESIGN, ALL IN WHITE. TO THE LEFT OF THE CANDY DESIGN ARE THE WORDS LOW FAT IN YELLOW AND SNACK IN WHITE. UNDERNEATH THE WORD TWIZZLERS ARE THE WORDS PULL 'N' PEEL CANDY IN YELLOW. AT THE BOTTOM OF THE MARK IS A DESIGN OF RED CHERRIES WITH GREEN STEMS AND THE WORDS CHERRY ARTIFICIALLY FLAVORED IN WHITE.

FOR CANDY (U.S. CL. 46).  
FIRST USE 8-1-2010; IN COMMERCE 8-1-2010.  
ERNEST SHOSHO, EXAMINING ATTORNEY

SN 85-195,795. LE PAFE, INC., MONTEBELLO, CA. FILED 12-11-2010.

**JOYFUL EATING EXPERIENCES**

THE MARK CONSISTS OF STANDARD CHARACTERS WITHOUT CLAIM TO ANY PARTICULAR FONT, STYLE, SIZE, OR COLOR.

FOR BAKERY PRODUCTS; BREAD; PASTRIES; BAGELS; MUFFINS; FROZEN YOGURT AND FROZEN CONFECTIONERY; ICE-CREAM; DESSERTS, NAMELY COOKIES, CAKES, CUP CAKES, PIES, BROWNIES, BARS, TORTES, TARTS, DOUGH SHELLS AND DOUGHNUTS; PRE-BAKED AND THAW AND SERVE PASTRIES AND BREAD (U.S. CL. 46).

FIRST USE 8-10-1991; IN COMMERCE 2-25-1992.  
SKYE YOUNG, EXAMINING ATTORNEY

**CLASS 30—(Continued).**

SN 85-196,136. RICARDO L TORRES, DORADO, PUERTO RICO, FILED 12-13-2010.

**Don't Worry, Tea Happy!**

THE MARK CONSISTS OF STANDARD CHARACTERS WITHOUT CLAIM TO ANY PARTICULAR FONT, STYLE, SIZE, OR COLOR.

FOR TEA (U.S. CL. 46).  
FIRST USE 2-1-2010; IN COMMERCE 2-1-2010.  
MARY ROSSMAN, EXAMINING ATTORNEY

SN 85-196,241. SNAPPY SALADS RESTAURANTS, DALLAS, TX. FILED 12-13-2010.

**SNAP WRAP**

THE MARK CONSISTS OF STANDARD CHARACTERS WITHOUT CLAIM TO ANY PARTICULAR FONT, STYLE, SIZE, OR COLOR.

NO CLAIM IS MADE TO THE EXCLUSIVE RIGHT TO USE "WRAP", APART FROM THE MARK AS SHOWN.  
FOR SANDWICHES AND WRAP SANDWICHES (U.S. CL. 46).

FIRST USE 12-31-2007; IN COMMERCE 12-31-2007.  
MARY ROSSMAN, EXAMINING ATTORNEY

SN 85-198,252. THE JEL SERT CO., WEST CHICAGO, IL. FILED 12-15-2010.

**POWER POPS**

THE MARK CONSISTS OF STANDARD CHARACTERS WITHOUT CLAIM TO ANY PARTICULAR FONT, STYLE, SIZE, OR COLOR.

NO CLAIM IS MADE TO THE EXCLUSIVE RIGHT TO USE "POPS", APART FROM THE MARK AS SHOWN.

FOR FLAVORED LIQUID SOLD IN PACKAGES TO BE FROZEN THERE IN FOR MAKING FROZEN CONFECTIONS (U.S. CL. 46).

KAREN K. BUSH, EXAMINING ATTORNEY

**CLASS 30—(Continued).**

SN 85-198,617. NEW ORLEANS HAMBURGER & SEAFOOD COMPANY, METAIRIE, LA. FILED 12-15-2010.

**The Original New Orleans BBQ  
Shrimp One-Handed Poboy**

THE MARK CONSISTS OF STANDARD CHARACTERS WITHOUT CLAIM TO ANY PARTICULAR FONT, STYLE, SIZE, OR COLOR.

OWNER OF U.S. REG. NO. 3,027,927.  
NO CLAIM IS MADE TO THE EXCLUSIVE RIGHT TO USE "NEW ORLEANS BBQ SHRIMP", APART FROM THE MARK AS SHOWN.  
SEC. 2(F) AS TO "THE ORIGINAL" AND "ONE-HANDED".

FOR SANDWICHES (U.S. CL. 46).  
FIRST USE 5-24-2010; IN COMMERCE 5-24-2010.  
DORITT L. CARROLL, EXAMINING ATTORNEY

SN 85-199,193. D. B. C. CORPORATION, DBA DEBEUKE-LAER CORP., MADISON, MS. FILED 12-16-2010.

**PIROUTWIST**

THE MARK CONSISTS OF STANDARD CHARACTERS WITHOUT CLAIM TO ANY PARTICULAR FONT, STYLE, SIZE, OR COLOR.

OWNER OF U.S. REG. NOS. 1,296,629, 1,297,882 AND 1,710,279.

FOR CHOCOLATES; CONFECTIONARIES, NAMELY, WAFERS, BAKERY GOODS, AND COOKIES (U.S. CL. 46).

REBECCA POVARCHUK, EXAMINING ATTORNEY

SN 85-199,718. THE JEL SERT CO., WEST CHICAGO, IL. FILED 12-16-2010.

**ROYAL**

THE MARK CONSISTS OF STANDARD CHARACTERS WITHOUT CLAIM TO ANY PARTICULAR FONT, STYLE, SIZE, OR COLOR.

OWNER OF U.S. REG. NOS. 145,488, 669,690 AND OTHERS.

FOR DESSERTS, NAMELY, CUSTARDS, GELATINS, PIE FILLINGS AND PUDDINGS (U.S. CL. 46).

KAREN K. BUSH, EXAMINING ATTORNEY

**CLASS 30—(Continued).**

SN 85-201,488. TEO, STEVEN, SINGAPORE, SINGAPORE, FILED 12-20-2010.

**MAQ ROMA**

THE MARK CONSISTS OF STANDARD CHARACTERS WITHOUT CLAIM TO ANY PARTICULAR FONT, STYLE, SIZE, OR COLOR.

FOR BAKING POWDER, COCOA-BASED BEVERAGES, COCOA BEVERAGES WITH MILK, COFFEE, COFFEE BEVERAGES WITH MILK, COFFEE-BASED BEVERAGES, GINGER, TEA, NOODLES, PASTA, READY-TO-EAT CEREALS, FOOD SEASONINGS, SAUCES, NATURAL SWEETENER, SPICES, INSTANT WHOLE MEAL RICE, READY TO EAT, CEREAL DERIVED FOOD BAR, COCOA POWDER (U.S. CL. 46).

FIRST USE 8-8-2008; IN COMMERCE 9-13-2008.  
HOWARD SMIGA, EXAMINING ATTORNEY

SN 85-201,915. PALAIS DES THES, PARIS, FRANCE, FILED 12-20-2010.

**Thé des Amants**

THE MARK CONSISTS OF STANDARD CHARACTERS WITHOUT CLAIM TO ANY PARTICULAR FONT, STYLE, SIZE, OR COLOR.

OWNER OF U.S. REG. NOS. 2,121,364, 2,457,426 AND 3,000,913.

NO CLAIM IS MADE TO THE EXCLUSIVE RIGHT TO USE "THE", APART FROM THE MARK AS SHOWN.

THE ENGLISH TRANSLATION OF "THE DES AMANTS" IN THE MARK IS "TEA OF LOVERS".

FOR TEA (U.S. CL. 46).  
FIRST USE 9-30-2000; IN COMMERCE 6-30-2001.  
JOHN GARTNER, EXAMINING ATTORNEY

SN 85-202,944. GRUMA CORPORATION, IRVING, TX, FILED 12-21-2010.



OWNER OF U.S. REG. NOS. 906,879 AND 1,804,672.  
THE MARK CONSISTS OF A SOMBRERO ON TOP OF A RECTANGLE CONTAINING THE WORD "DIANE'S".  
FOR TORTILLAS, TORTILLA PRODUCTS, NAMELY, TORTILLA CHIPS, TOSTADAS (U.S. CL. 46).  
AISHA SALEM, EXAMINING ATTORNEY

**CLASS 30—(Continued).**

SN 85-203,151. BATTER UP LLC, MIAMI, FL. FILED 12-21-2010.

**READY. SET. CUPCAKE!**

THE MARK CONSISTS OF STANDARD CHARACTERS WITHOUT CLAIM TO ANY PARTICULAR FONT, STYLE, SIZE, OR COLOR.

NO CLAIM IS MADE TO THE EXCLUSIVE RIGHT TO USE "CUPCAKE", APART FROM THE MARK AS SHOWN.

FOR PRE-MIXED, UNBAKED INGREDIENTS FOR BAKERY GOODS, NAMELY, MIXES FOR BAKERY GOODS SOLD PRE-PACKAGED TO CONSUMERS; BATTER FOR BAKERY GOODS; BUTTERCREAM FOR BAKERY GOODS; FROSTING; PRE-MIXED, UNBAKED INGREDIENTS FOR BAKERY GOODS, NAMELY, MIXES FOR BAKERY GOODS SOLD PRE-PACKAGED IN INDIVIDUAL FREEZER-GRADE DISPOSABLE PASTRY BAGS (U.S. CL. 46).

MICHAEL KEATING, EXAMINING ATTORNEY

SN 85-203,711. NEW WORLD PASTA COMPANY, HARRISBURG, PA. FILED 12-22-2010.

**RONZONI PASTA PORTIONS**

THE MARK CONSISTS OF STANDARD CHARACTERS WITHOUT CLAIM TO ANY PARTICULAR FONT, STYLE, SIZE, OR COLOR.

OWNER OF U.S. REG. NOS. 518,709, 3,708,698 AND OTHERS.

NO CLAIM IS MADE TO THE EXCLUSIVE RIGHT TO USE "PASTA PORTIONS", APART FROM THE MARK AS SHOWN.

FOR PASTA (U.S. CL. 46).  
HELENE LIWINSKI, EXAMINING ATTORNEY

SN 85-203,730. NEW WORLD PASTA COMPANY, HARRISBURG, PA. FILED 12-22-2010.

**SAN GIORGIO PASTA PORTIONS**

THE MARK CONSISTS OF STANDARD CHARACTERS WITHOUT CLAIM TO ANY PARTICULAR FONT, STYLE, SIZE, OR COLOR.

OWNER OF U.S. REG. NOS. 128,415, 1,547,584 AND OTHERS.

NO CLAIM IS MADE TO THE EXCLUSIVE RIGHT TO USE "PASTA PORTIONS", APART FROM THE MARK AS SHOWN.

FOR PASTA (U.S. CL. 46).  
HELENE LIWINSKI, EXAMINING ATTORNEY



**CLASS 30—(Continued).**

SN 85-203,754. NEW WORLD PASTA COMPANY, HARRISBURG, PA. FILED 12-22-2010.

**AMERICAN BEAUTY PASTA PORTIONS**

THE MARK CONSISTS OF STANDARD CHARACTERS WITHOUT CLAIM TO ANY PARTICULAR FONT, STYLE, SIZE, OR COLOR.

OWNER OF U.S. REG. NOS. 1,642,927, 3,152,270 AND OTHERS.

NO CLAIM IS MADE TO THE EXCLUSIVE RIGHT TO USE "PASTA PORTIONS", APART FROM THE MARK AS SHOWN.

FOR PASTA (U.S. CL. 46).  
HELENE LIWINSKI, EXAMINING ATTORNEY

**CLASS 30—(Continued).**

SN 85-203,773. NEW WORLD PASTA COMPANY, HARRISBURG, PA. FILED 12-22-2010.

**CREAMETTE HOMETOWN FAVORITE SINCE 1912 PASTA PORTIONS**

THE MARK CONSISTS OF STANDARD CHARACTERS WITHOUT CLAIM TO ANY PARTICULAR FONT, STYLE, SIZE, OR COLOR.

OWNER OF U.S. REG. NOS. 90,907, 576,129 AND OTHERS.

NO CLAIM IS MADE TO THE EXCLUSIVE RIGHT TO USE "SINCE 1912 PASTA PORTIONS", APART FROM THE MARK AS SHOWN.

FOR PASTA (U.S. CL. 46).  
HELENE LIWINSKI, EXAMINING ATTORNEY

SN 85-203,756. MICHAEL LYNCH, LENEXA, KS. FILED 12-22-2010.

**Lifesaver Chicken Sandwich**

THE MARK CONSISTS OF STANDARD CHARACTERS WITHOUT CLAIM TO ANY PARTICULAR FONT, STYLE, SIZE, OR COLOR.

NO CLAIM IS MADE TO THE EXCLUSIVE RIGHT TO USE "CHICKEN SANDWICH", APART FROM THE MARK AS SHOWN.

FOR CHICKEN SANDWICH (U.S. CL. 46).  
WENDY GOODMAN, EXAMINING ATTORNEY

SN 85-204,421. CAT DADDY, LLC, PORTLAND, OR. FILED 12-22-2010.



OWNER OF U.S. REG. NOS. 3,368,455, 3,760,795 AND 3,859,952.

NO CLAIM IS MADE TO THE EXCLUSIVE RIGHT TO USE "DOUGHNUT", APART FROM THE MARK AS SHOWN.

THE MARK CONSISTS OF STYLIZED WORDING "VOODOO DOUGHNUT THE MAGIC IS IN THE HOLE"; THE LETTER "V" IS COMPRISED OF A SNAKE WHO EMERGES FROM ABOVE THROUGH A STYLIZED DOUGHNUT FROM WHICH ARISES A VARIETY OF STYLIZED IMAGES INCLUDING SNAKES, PLAYING CARDS, SKULLS, RABBITS, VODOO DOLLS, HUMAN BUSTS, HUMAN HANDS, CANDLES, WANDS, STARS, A HUMAN EYE, A SPADE, A HEART, A PIPE, A DAGGER, AND A SKELETON; ON EITHER SIDE OF THE STYLIZED DOUGHNUT IS A STYLIZED MAGICIAN SHOOTING ELECTRICAL BOLTS AT THE DOUGHNUT, ONE WEARING A TOP HAT AND ONE HOLDING A TOP HAT FROM WHICH EMERGES A RABBIT; ALL SURROUNDED BY A STYLIZED SQUARE BORDER.

FOR DOUGHNUTS (U.S. CL. 46).  
FIRST USE 5-26-2010; IN COMMERCE 5-26-2010.  
DAVID TOOLEY, EXAMINING ATTORNEY

SN 85-203,760. NEW WORLD PASTA COMPANY, HARRISBURG, PA. FILED 12-22-2010.

**SKINNER PASTA PORTIONS**

THE MARK CONSISTS OF STANDARD CHARACTERS WITHOUT CLAIM TO ANY PARTICULAR FONT, STYLE, SIZE, OR COLOR.

OWNER OF U.S. REG. NOS. 670,993, 1,521,166 AND OTHERS.

NO CLAIM IS MADE TO THE EXCLUSIVE RIGHT TO USE "PASTA PORTIONS", APART FROM THE MARK AS SHOWN.

FOR PASTA (U.S. CL. 46).  
HELENE LIWINSKI, EXAMINING ATTORNEY

**CLASS 30—(Continued).**

SN 85-204,896. LABRIOLA, INC., DBA LABRIOLA BAKING COMPANY, ALSIP, IL. FILED 12-23-2010.

**THE RICHIE PRETZEL**

THE MARK CONSISTS OF STANDARD CHARACTERS WITHOUT CLAIM TO ANY PARTICULAR FONT, STYLE, SIZE, OR COLOR.

NO CLAIM IS MADE TO THE EXCLUSIVE RIGHT TO USE "PRETZEL", APART FROM THE MARK AS SHOWN. FOR PRETZELS, BREAD AND BREAD DOUGH (U.S. CL. 46).

REBECCA EISINGER, EXAMINING ATTORNEY

SN 85-206,173. VOSGES IP, LLC, CHICAGO, IL. FILED 12-27-2010.

**WILD VIOLET**

THE MARK CONSISTS OF STANDARD CHARACTERS WITHOUT CLAIM TO ANY PARTICULAR FONT, STYLE, SIZE, OR COLOR.

FOR SPECIALTY CONFECTIONERY PRODUCTS NOT CONTAINING VIOLET INGREDIENTS, FLAVOR, OR BEING VIOLET IN COLOR, NAMELY, SPECIALTY CHOCOLATES, CHOCOLATE BARS, AND CHOCOLATE TRUFFLES (U.S. CL. 46).

REBECCA POVARCHUK, EXAMINING ATTORNEY

SN 85-206,181. AVB, INC., MILWAUKIE, OR. FILED 12-27-2010.



OWNER OF U.S. REG. NO. 1,862,656.

THE MARK CONSISTS OF THE WORDS "NATURE BAKE" AND AN IMAGE OF A PIECE OF BREAD AND AN IMAGE OF A WHEAT STEM.

FOR BREAD (U.S. CL. 46).

FIRST USE 12-13-2010; IN COMMERCE 12-13-2010.

MARK PILARO, EXAMINING ATTORNEY

**CLASS 30—(Continued).**

SN 85-206,357. GREEN CHILE FOODS, INC., LAS CRUCES, NM. FILED 12-28-2010.

**Ravi-Olé**

THE MARK CONSISTS OF STANDARD CHARACTERS WITHOUT CLAIM TO ANY PARTICULAR FONT, STYLE, SIZE, OR COLOR.

THE ENGLISH TRANSLATION OF "OLÉ" IN THE MARK IS BRAVO.

FOR DOUGH-ENROBED FOODS CONSISTING OF A DOUGH-BASED WRAPPER WITH FILLINGS CONSISTING PRIMARILY OF MEATS, POULTRY, FISH, FRUITS AND VEGETABLES AND CHEESE (U.S. CL. 46).

ALLISON HOLTZ, EXAMINING ATTORNEY

SN 85-206,795. FULL CIRCLE EXCHANGE, LLC, EAGLE, ID. FILED 12-28-2010.



NO CLAIM IS MADE TO THE EXCLUSIVE RIGHT TO USE "COFFEEHOUSE", APART FROM THE MARK AS SHOWN.

THE LIKENESS (OR, "PORTRAIT") IN THE MARK DOES NOT IDENTIFY A LIVING INDIVIDUAL.

THE COLOR(S) LIGHT BLUE, BROWN, LIGHT BROWN, PINK, WHITE AND BLACK IS/ARE CLAIMED AS A FEATURE OF THE MARK.

THE MARK CONSISTS OF A STYLIZED DESIGN CONSISTING OF A MAN LOCATED IN THE CENTER OF THE DESIGN SHOWN LEANING ON A BLACK BAR WITH THE WORDS "A NEIGHBORHOOD COFFEEHOUSE" SHOWN IN WHITE CURSIVE LETTERING ON THE BOTTOM OF THE DESIGN. THE MAN HAS BLACK HAIR AND IS SHOWN WEARING GLASSES WITH BLACK FRAMES. HIS HEAD, ARMS AND HANDS ARE PINK WITH LIGHT BROWN SHADING. HE IS WEARING A WHITE SHIRT WITH LIGHT BLUE SHOWN AS SHADING, A WHITE-BIBBED APRON, WITH SOME LIGHT BLUE SHADING TOWARD THE BOTTOM OF THE APRON, AND A BLACK TIE BENEATH A WHITE COLLAR. THE BACKGROUND BEHIND THE TOP QUARTER OF THE MAN'S HEAD AND THE ENTIRE TOP ONE-QUARTER OF THE DESIGN IS COLORED LIGHT BLUE. IN THE CENTER OF THE LIGHT BLUE BACKGROUND IS THE WORD "JOE'S" SHOWN IN BROWN CURSIVE LETTERING AND DEPICTED ON A LEFT TO RIGHT UPWARD SLANT WITH A BROWN CURSIVE

**CLASS 30—(Continued).**

UNDERLINE MOVING UPWARD FROM LEFT TO RIGHT WHICH COMES TO A POINT IN THE OPPOSITE DIRECTION OF THE SLANT ENDING BEHIND THE "S" IN THE WORD "JOE'S". TWO BROWN LINES ARE SHOWN AT THE BOTTOM OF THE LIGHT BLUE BACKGROUND WITH THE WORD "PLACE" IN BLOCK CAPITAL LETTERING SHOWN IN BETWEEN THE TWO LINES JUST TO THE RIGHT OF THE MAN'S HEAD. UNDERNEATH THE LIGHT BLUE BACKGROUND, THE REMAINING BACKGROUND IS SHOWN IN WHITE.

FOR BLACK TEA; CAFFEINE-FREE COFFEE; CHAI TEA; CHOCOLATE; CHOCOLATE AND CHOCOLATES; CHOCOLATE BARK CONTAINING GROUND COFFEE BEANS; CHOCOLATE BARS; CHOCOLATE CANDIES; CHOCOLATE COVERED FRUIT; CHOCOLATE COVERED NUTS; CHOCOLATE COVERED ROASTED COFFEE BEANS; CHOCOLATE POWDER; CHOCOLATES AND CHOCOLATE BASED READY TO EAT CANDIES AND SNACKS; COFFEE; COFFEE AND TEA; COFFEE BEANS; CONFECTIONERIES, NAMELY, SNACK FOODS, NAMELY, CHOCOLATE; FILLED CHOCOLATE; FRUIT TEAS; GREEN TEA; GROUND COFFEE BEANS; HOT CHOCOLATE; ICED COFFEE; ICED TEA; INSTANT COFFEE; INSTANT TEA; JAPANESE GREEN TEA; MILK CHOCOLATE; OOLONG TEA; ROASTED COFFEE BEANS; SAGE TEA; SNACK FOODS, NAMELY, CHOCOLATE-BASED SNACK FOODS; SPICES; SUGAR-COATED COFFEE BEANS; TEA; TEA BAGS; TEA EXTRACTS; TEA FOR INFUSIONS; UNROASTED COFFEE (U.S. CL. 46).

KEVIN DINALLO, EXAMINING ATTORNEY

SN 85-206,800. MORRISON, MICHAEL C, WOODSTOCK, GA. FILED 12-28-2010.

**SAFARI SAUCE**

THE MARK CONSISTS OF STANDARD CHARACTERS WITHOUT CLAIM TO ANY PARTICULAR FONT, STYLE, SIZE, OR COLOR.

NO CLAIM IS MADE TO THE EXCLUSIVE RIGHT TO USE "SAUCE", APART FROM THE MARK AS SHOWN.

FOR READY-MADE SAUCES (U.S. CL. 46).  
JENNIFER DIXON, EXAMINING ATTORNEY

**CLASS 30—(Continued).**

SN 85-206,870. JC 23 ENTERTAINMENT, INC., BEVERLY HILLS, CA. FILED 12-28-2010.



THE MARK CONSISTS OF STYLIZED CHARACTER SITTING IN YOGA STYLE.

FOR COFFEE, TEA, COCOA, SUGAR, RICE, TAPIOCA, PUDDINGS, BREAD, PASTRY, EDIBLE ICES, HONEY, SPICES, ICE; PREPARATIONS MADE FROM FLOURS AND CEREALS, NAMELY, PASTA, BREAD, BREAD CRUMBS, BREAD DOUGH, BARLEY FLOUR, BREAD MIXES, BREAD ROLLS, BREAD STICKS, BREAKFAST CEREALS, BROWNIE MIXES, BUCKWHEAT FLOUR, BUNS, CAKE DOUGHS, CAKE MIXES, CAKES, CEREAL BASED ENERGY BARS AND SNACK FOOD, COOKIE DOUGH, COOKIE MIXES, COOKIES, CRACKERS, DANISH PASTRIES, DOUGH, DOUGHNUTS, EDIBLE FLOUR, FLOUR, GRAIN-BASED SNACK FOODS, GRANOLA, MIXES FOR BAKERY GOODS, MIXES FOR BREADING, MUFFIN MIXES, PANCAKE MIXES, PIE CRUSTS, PIES, TORTILLA CHIPS, WHEAT FLOUR, WHOLE MEAL BREAD; CONDIMENTS, NAMELY, MUSTARD, KETCHUP, RELISH, MAYONNAISE, SALAD DRESSING; CONFECTIONARY, NAMELY, CANDY, CHOCOLATE, CONFECTIONERY CHIPS FOR BAKING (U.S. CL. 46).

CYNTHIA SLOAN, EXAMINING ATTORNEY

SN 85-207,186. UNCLE HARRY'S, INC., VIRGINIA BEACH, VA. FILED 12-29-2010.

**UNCLE HARRY'S**

THE MARK CONSISTS OF STANDARD CHARACTERS WITHOUT CLAIM TO ANY PARTICULAR FONT, STYLE, SIZE, OR COLOR.

OWNER OF U.S. REG. NO. 2,753,914.

THE NAME "UNCLE HARRY" DOES NOT IDENTIFY A LIVING INDIVIDUAL.

FOR BAKERY DESSERTS; FROZEN CUSTARDS; ICE CREAM DESSERTS (U.S. CL. 46).

FIRST USE 5-0-1987; IN COMMERCE 5-0-1987.

JAMES GRIFFIN, EXAMINING ATTORNEY

**CLASS 30—(Continued).**

SN 85-208,029. KAMAL KHANBABAEI GENERAL TRADING CO. LLC, DUBAI, UNITED ARAB EMIR., FILED 12-30-2010.

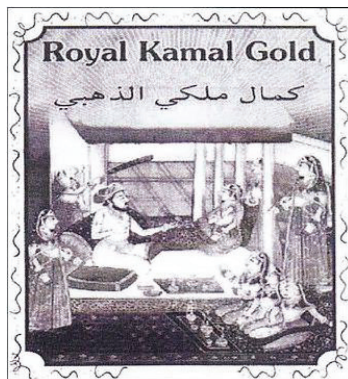

OWNER OF UNITED ARAB EMIR. REG. NO. 104549, DATED 6-15-2010, EXPIRES 2-22-2019.

THE MARK CONSISTS OF A DESIGN OF A KING WHO IS SITTING DOWN IN HIS BED WITH HIS ENTOURAGE THAT INCLUDES WIFE, CHILDREN AND THREE SERVANTS IN BLACK AND WHITE COLORS AND ABOVE THEREON THE EXPRESSION "ROYAL KAMAL GOLD" AND ITS ARABIC TRANSLATION AND ALL OF THESE ELEMENTS ARE INSIDE A FRAME IN A SPECIAL DESIGN IN BLACK AND WHITE COLORS MOTTLED FROM ITS BORDERS WITHIN BLACK SMALL LINES.

THE NON-LATIN CHARACTERS IN THE MARK TRANSLITERATE TO "KAMA MALAKI AL-DHAHABI" AND THIS MEANS "ROYAL KAMAL GOLD" IN ENGLISH.

FOR COFFEE, TEA, COCOA, SUGAR, RICE, TAPIOCA, SAGO, COFFEE SUBSTITUTES, FLOUR, BREAD, PASTRY, ICE, HONEY, TREACLE, YEAST, BAKING-POWDER, SALT, MUSTARD VINEGAR, SAUCES, SPICES, ICE (U.S. CL. 46).

ROSELLE HERRERA, EXAMINING ATTORNEY

**CLASS 30—(Continued).**

LETTERS ON A BLACK BANNER IMPOSED ON CONCENTRIC CIRCLES. THE THIN BLACK OUTER CIRCLE NEXT ENCLOSES A THIN WHITE CIRCLE. THE INNER YELLOW CIRCLE IS THE WIDEST. ON THE TOP THIRD, IT BEARS THE WORDING "ALL" AND "NATURAL" IN BLACK SEPARATED BY A SMALL BLACK FIVE POINTED STAR. THE LOWER THIRD OF THE WIDE YELLOW BAND BEARS THE WORDING "PREMIUM" AND "PIZZA" IN BLACK, ALSO SEPARATED BY A SMALL BLACK FIVE POINTED STAR.

FOR FRESH PIZZA; FROZEN DOUGH FOR USE AS PIZZA, BREAD OR OTHER BREAD-TYPE PRODUCTS; FROZEN FLOUR-FREE FOODS, NAMELY, WAFFLES, PANCAKES, CREPES, SANDWICH WRAPS, MUFFINS AND GRIDDLE CAKE SANDWICHES WHICH ARE PROTEIN-ENRICHED; FROZEN FOODS, NAMELY, GRAIN AND BREAD BASED APPETIZERS, HORS D'OEUVRES, AND CANAPES; PIZZA; PIZZA DOUGH; ALL OF THE FOREGOING MADE WITH NATURAL INGREDIENTS (U.S. CL. 46).

FIRST USE 1-1-2005; IN COMMERCE 1-1-2005.

H. M. FISHER, EXAMINING ATTORNEY

SN 85-208,830. GRILLED CHEESE & CO, CATONSVILLE, MD. FILED 1-2-2011.

## Crabby Melt

THE MARK CONSISTS OF STANDARD CHARACTERS WITHOUT CLAIM TO ANY PARTICULAR FONT, STYLE, SIZE, OR COLOR.

NO CLAIM IS MADE TO THE EXCLUSIVE RIGHT TO USE "MELT", APART FROM THE MARK AS SHOWN.

FOR SANDWICHES (U.S. CL. 46).

FIRST USE 5-16-2009; IN COMMERCE 5-16-2009.

ALLISON HOLTZ, EXAMINING ATTORNEY

SN 85-208,807. FORWARDCLICK INC, SOUTHWICK, MA. FILED 1-1-2011.



OWNER OF U.S. REG. NO. 2,914,637.

NO CLAIM IS MADE TO THE EXCLUSIVE RIGHT TO USE "ALL NATURAL PREMIUM PIZZA", APART FROM THE MARK AS SHOWN.

THE COLOR(S) YELLOW, BLACK, AND WHITE IS/ARE CLAIMED AS A FEATURE OF THE MARK.

THE MARK CONSISTS OF "ZANTO" IN WHITE CAPITAL

SN 85-208,880. PLOWMAN, SHEILA, DBA JUST FRUIT ZORBET, HAILEY, ID. FILED 1-2-2011.

## Just Fruit Zorbet

THE MARK CONSISTS OF STANDARD CHARACTERS WITHOUT CLAIM TO ANY PARTICULAR FONT, STYLE, SIZE, OR COLOR.

NO CLAIM IS MADE TO THE EXCLUSIVE RIGHT TO USE "FRUIT SORBET", APART FROM THE MARK AS SHOWN.

FOR SORBET; SORBETS (U.S. CL. 46).

FIRST USE 12-18-2010; IN COMMERCE 12-22-2010.

EDWARD FENNESSY, EXAMINING ATTORNEY



**CLASS 30—(Continued).**

SN 85-209,426. BLOOM, GARY, BOCA RATON, FL. FILED 1-3-2011.

U8

THE MARK CONSISTS OF STANDARD CHARACTERS WITHOUT CLAIM TO ANY PARTICULAR FONT, STYLE, SIZE, OR COLOR.

FOR SAUCES, MARINADES, SPICES, BARBECUE DRY RUB, DRY SPICE RUB FOR MEAT AND FISH, SAUCES FOR BARBECUED MEAT (U.S. CL. 46).  
JERI J. FICKES, EXAMINING ATTORNEY

---

SN 85-210,009. LEWIS BROTHERS BAKERIES, INCORPORATED, DBA LEWIS BAKERIES, INC., EVANSVILLE, IN. FILED 1-4-2011.

HEALTHY LIFE DIETER'S  
DREAM COME TRUE

THE MARK CONSISTS OF STANDARD CHARACTERS WITHOUT CLAIM TO ANY PARTICULAR FONT, STYLE, SIZE, OR COLOR.

OWNER OF U.S. REG. NOS. 1,815,479, 3,309,325 AND OTHERS.  
NO CLAIM IS MADE TO THE EXCLUSIVE RIGHT TO USE "DIETER'S", APART FROM THE MARK AS SHOWN.  
FOR BAKERY PRODUCTS (U.S. CL. 46).  
MARGARET POWER, EXAMINING ATTORNEY

---

SN 85-210,022. LEWIS BROTHERS BAKERIES, INCORPORATED, DBA LEWIS BAKERIES, INC., EVANSVILLE, IN. FILED 1-4-2011.

HEALTHY LIFE IS A DIETER'S  
DREAM COME TRUE

THE MARK CONSISTS OF STANDARD CHARACTERS WITHOUT CLAIM TO ANY PARTICULAR FONT, STYLE, SIZE, OR COLOR.

OWNER OF U.S. REG. NOS. 1,815,479, 3,309,325 AND OTHERS.  
FOR BAKERY PRODUCTS (U.S. CL. 46).  
MARGARET POWER, EXAMINING ATTORNEY

**CLASS 30—(Continued).**

SN 85-210,088. FERRERO S.P.A., ALBA, CUNEO, ITALY, FILED 1-4-2011.



The logo for "Kinder country" features the word "Kinder" in a bold, black, sans-serif font, and the word "country" in a red, lowercase, cursive font below it.

OWNER OF ITALY REG. NO. 561617, DATED 2-18-1992, EXPIRES 6-5-2019.

OWNER OF U.S. REG. NOS. 848,294, 3,606,223 AND OTHERS.

THE COLOR(S) BLACK, RED, BROWN AND WHITE IS/ARE CLAIMED AS A FEATURE OF THE MARK.

THE MARK CONSISTS OF THE REPRESENTATION OF THE STYLIZED WORD "KINDER" IN THICK LOWER CASE LETTERS HAVING THE INITIAL LETTER IN BLACK AND BIGGER THAN THE OTHER LETTERS THAT ARE IN RED; BELOW THE WORD "KINDER" IS THE STYLIZED WORD "COUNTRY" IN THICK BROWN ITALICS LETTERING, ALL ON A WHITE BACKGROUND.

THE ENGLISH TRANSLATION OF "KINDER" IN THE MARK IS "CHILDREN".

FOR CANDY (U.S. CL. 46).  
TINA BROWN, EXAMINING ATTORNEY

---

SN 85-210,549. NATURAL SUBSTITUTE INTERNATIONAL, INC., NORTHRIDGE, CA. FILED 1-5-2011.



The logo for "Orgave" features the word "Orgave" in a green, stylized font. The letter "v" is replaced by a green agave plant with a yellow drop coming out of one of its leaves. A gray reflection of the drop is shown below it.

THE COLOR(S) GREEN, YELLOW, WHITE, AND GRAY IS/ARE CLAIMED AS A FEATURE OF THE MARK.

THE MARK CONSISTS OF THE WORD "ORGAVE" IN GREEN IN A STYLIZED FONT WITH AN AGAVE PLANT IN WHITE AND OUTLINED IN GREEN, WITH LEAVES IN GREEN IN THE SHAPE OF A "V", AND A YELLOW DROP COMING OUT OF ONE OF THE LEAVES WITH A GRAY REFLECTION OF THE DROP BELOW.

FOR NATURAL SWEETENER (U.S. CL. 46).  
FIRST USE 12-1-2010; IN COMMERCE 12-1-2010.  
LEIGH CAROLINE CASE, EXAMINING ATTORNEY



**CLASS 30—(Continued).**

SN 85-210,801. COBIZCO FOOD INDUSTRIES SDN. BHD., PENANG, MALAYSIA, FILED 1-5-2011.



THE MARK CONSISTS OF THE STYLIZED WORDING "COBIZCO" IN LOWER CASE LETTERS WITH A LEAF ABOVE THE LETTER "I," ALL OF WHICH ARE SURROUNDED BY A BORDER.

THE WORDING "COBIZCO" HAS NO MEANING IN A FOREIGN LANGUAGE.

FOR (BASED ON INTENT-TO-USE) PREMIXED TEA; PREMIXED OATMEAL; PREMIXED CHOCOLATE MALT DRINK; TEA-BASED BEVERAGES; OATMEAL-BASED BEVERAGES; CHOCOLATE-BASED BEVERAGES; (BASED ON USE) PREMIXED COFFEE; PREMIXED CEREAL; COFFEE-BASED BEVERAGES; CEREAL-BASED BEVERAGES; CAPPUCINO; WHITE COFFEE (U.S. CL. 46).

FIRST USE 6-27-2000; IN COMMERCE 12-16-2010.  
AISHA SALEM, EXAMINING ATTORNEY

SN 85-211,103. JUANITA'S FOODS, WILMINGTON, CA. FILED 1-5-2011.



THE MARK CONSISTS OF STANDARD CHARACTERS WITHOUT CLAIM TO ANY PARTICULAR FONT, STYLE, SIZE, OR COLOR.

OWNER OF U.S. REG. NOS. 1,268,693, 1,554,914 AND OTHERS.

FOR NOODLES, NAMELY, DEHYDRATED NOODLE DISHES (U.S. CL. 46).

MICHAEL WEBSTER, EXAMINING ATTORNEY

SN 85-211,309. GG UNIQUEFIBER AS, HORTEN, NORWAY, FILED 1-5-2011.



THE MARK CONSISTS OF STANDARD CHARACTERS WITHOUT CLAIM TO ANY PARTICULAR FONT, STYLE, SIZE, OR COLOR.

FOR CRACKERS; CRISP BREAD; CRUSHED CRACKERS; CRUSHED CRISP BREAD; WHEAT BASED SNACKS; GRAIN BASED SNACKS; OAT BASED SNACKS (U.S. CL. 46).

FIRST USE 8-1-1955; IN COMMERCE 6-1-1978.

KATHERINE STOIDES, EXAMINING ATTORNEY

**CLASS 30—(Continued).**

SN 85-211,341. DC DREAMS, LLC, HOUSTON, TX. FILED 1-5-2011.



THE MARK CONSISTS OF STANDARD CHARACTERS WITHOUT CLAIM TO ANY PARTICULAR FONT, STYLE, SIZE, OR COLOR.

THE NAME "LILI ROSE" DOES NOT IDENTIFY A LIVING INDIVIDUAL.

FOR BAKERY DESSERTS; BAKERY GOODS; BAKERY PRODUCTS (U.S. CL. 46).

LINDA M. KING, EXAMINING ATTORNEY

SN 85-211,437. SHAKEY'S RESTAURANTS FRANCHISING CO., LLC, DBA SHAKEY'S, ALHAMBRA, CA. FILED 1-5-2011.



THE MARK CONSISTS OF STANDARD CHARACTERS WITHOUT CLAIM TO ANY PARTICULAR FONT, STYLE, SIZE, OR COLOR.

OWNER OF U.S. REG. NOS. 1,008,087, 1,985,736 AND OTHERS.

FOR FROZEN PIZZA AND UNBAKED PIZZA FOR CONSUMPTION OFF PREMISES (U.S. CL. 46).

AMY HELLA, EXAMINING ATTORNEY

SN 85-211,463. SHAKEY'S RESTAURANTS FRANCHISING CO., LLC, DBA SHAKEY'S, ALHAMBRA, CA. FILED 1-5-2011.



THE MARK CONSISTS OF STANDARD CHARACTERS WITHOUT CLAIM TO ANY PARTICULAR FONT, STYLE, SIZE, OR COLOR.

OWNER OF U.S. REG. NOS. 1,008,087, 1,985,736 AND OTHERS.

NO CLAIM IS MADE TO THE EXCLUSIVE RIGHT TO USE "TAKE AND BAKE", APART FROM THE MARK AS SHOWN.

FOR UNBAKED PIZZA FOR CONSUMPTION OFF PREMISES (U.S. CL. 46).

AMY HELLA, EXAMINING ATTORNEY

**CLASS 30—(Continued).**

SN 85-211,997. YSA FINE FOODS LLC, FREEPORT, NY. FILED 1-6-2011.

## Yolanda Pesto

THE MARK CONSISTS OF STANDARD CHARACTERS WITHOUT CLAIM TO ANY PARTICULAR FONT, STYLE, SIZE, OR COLOR.

NO CLAIM IS MADE TO THE EXCLUSIVE RIGHT TO USE "PESTO", APART FROM THE MARK AS SHOWN.

THE NAME(S), PORTRAIT(S), AND/OR SIGNATURE(S) SHOWN IN THE MARK DOES NOT IDENTIFY A PARTICULAR LIVING INDIVIDUAL.

FOR PESTO (U.S. CL. 46).

FIRST USE 9-10-2010; IN COMMERCE 9-10-2010.  
GINA FINK, EXAMINING ATTORNEY

**CLASS 30—(Continued).**

SN 85-213,374. CULTURAL VENTURES, GOSHEN, IN. AND GRABER MILLER, NILES D, GOSHEN, IN. AND WEAVER, HANS J, NEW HOLLAND, PA. FILED S.R. 1-7-2011; AM. P.R. 3-30-2011.

## Menno Tea

THE MARK CONSISTS OF STANDARD CHARACTERS WITHOUT CLAIM TO ANY PARTICULAR FONT, STYLE, SIZE, OR COLOR.

NO CLAIM IS MADE TO THE EXCLUSIVE RIGHT TO USE "TEA", APART FROM THE MARK AS SHOWN.

FOR TEA-BASED BEVERAGES (U.S. CL. 46).

FIRST USE 11-15-2010; IN COMMERCE 12-10-2010.  
ANNE E. GUSTASON, EXAMINING ATTORNEY

SN 85-212,977. YOGURT VENTURES U.S.A., INC., DBA FRESHENS, ATLANTA, GA. FILED 1-7-2011.

## THE ART OF HEALTHY EATING

THE MARK CONSISTS OF STANDARD CHARACTERS WITHOUT CLAIM TO ANY PARTICULAR FONT, STYLE, SIZE, OR COLOR.

FOR FROZEN YOGURT (U.S. CL. 46).

MARIA-VICTORIA SUAREZ, EXAMINING ATTORNEY

SN 85-213,649. IBAKEFOODS, LLC, BROOKLYN, NY. FILED 1-9-2011.

## ibakefoods

THE MARK CONSISTS OF STANDARD CHARACTERS WITHOUT CLAIM TO ANY PARTICULAR FONT, STYLE, SIZE, OR COLOR.

FOR COOKIE DOUGH; COOKIES (U.S. CL. 46).

FIRST USE 0-0-2010; IN COMMERCE 0-0-2010.

ELI HELLMAN, EXAMINING ATTORNEY

SN 85-213,141. WEAVER POPCORN COMPANY, INC., NOBLESVILLE, IN. FILED 1-7-2011.

## MIGHTY POP

THE MARK CONSISTS OF STANDARD CHARACTERS WITHOUT CLAIM TO ANY PARTICULAR FONT, STYLE, SIZE, OR COLOR.

OWNER OF U.S. REG. NO. 3,264,107.

FOR MICROWAVE POPCORN (U.S. CL. 46).

BRIAN CALLAGHAN, EXAMINING ATTORNEY

SN 85-213,685. MAIZORO S. DE R.L. DE C.V., MEXICO, MEXICO, FILED 1-10-2011.

## CHOCORROZ

THE MARK CONSISTS OF STANDARD CHARACTERS WITHOUT CLAIM TO ANY PARTICULAR FONT, STYLE, SIZE, OR COLOR.

THE WORDING "CHOCORROZ" HAS NO MEANING IN A FOREIGN LANGUAGE.

FOR BREAKFAST CEREALS; READY-TO-EAT CEREALS (U.S. CL. 46).

LEIGH CAROLINE CASE, EXAMINING ATTORNEY

**CLASS 30—(Continued).**

SN 85-213,969. MUNNINGS, MICHAEL, MELBOURNE, FL. AND MUNNINGS, JOYCE, MELBOURNE, FL. FILED 1-10-2011.

# Spogg

THE MARK CONSISTS OF STANDARD CHARACTERS WITHOUT CLAIM TO ANY PARTICULAR FONT, STYLE, SIZE, OR COLOR.

FOR SPICE BLENDS (U.S. CL. 46).  
FIRST USE 1-1-2007; IN COMMERCE 1-1-2011.  
NAKIA HENRY, EXAMINING ATTORNEY

SN 85-213,995. SARRIS HOLDINGS, LLP, CANONSBURG, PA. FILED 1-10-2011.

# WELLTHY CHOCOLATES

THE MARK CONSISTS OF STANDARD CHARACTERS WITHOUT CLAIM TO ANY PARTICULAR FONT, STYLE, SIZE, OR COLOR.

NO CLAIM IS MADE TO THE EXCLUSIVE RIGHT TO USE "CHOCOLATES", APART FROM THE MARK AS SHOWN.

FOR CANDY (U.S. CL. 46).  
HEATHER SAPP, EXAMINING ATTORNEY

SN 85-214,013. HANLON, GENEVIEVE DOUGHERTY, BRONX, NY. FILED 1-10-2011.

# Paleo Pasta!

THE MARK CONSISTS OF STANDARD CHARACTERS WITHOUT CLAIM TO ANY PARTICULAR FONT, STYLE, SIZE, OR COLOR.

NO CLAIM IS MADE TO THE EXCLUSIVE RIGHT TO USE "PASTA", APART FROM THE MARK AS SHOWN.

FOR DRIED PASTA; PASTA (U.S. CL. 46).  
ALICE BENMAMAN, EXAMINING ATTORNEY

**CLASS 30—(Continued).**

SN 85-215,106. MARS, INCORPORATED, MCLEAN, VA. FILED 1-11-2011.

# BALISTO

THE MARK CONSISTS OF STANDARD CHARACTERS WITHOUT CLAIM TO ANY PARTICULAR FONT, STYLE, SIZE, OR COLOR.

THE WORDING "BALISTO" HAS NO MEANING IN A FOREIGN LANGUAGE.

FOR CANDY (U.S. CL. 46).  
AISHA SALEM, EXAMINING ATTORNEY

SN 85-215,207. HOT FUSION LLC, OCEANSIDE, CA. FILED 1-11-2011.



NO CLAIM IS MADE TO THE EXCLUSIVE RIGHT TO USE "HOT SAUCE", APART FROM THE MARK AS SHOWN.

THE MARK CONSISTS OF A STYLIZED SPLASH WITH THE TEXT "AJISIMO HOT SAUCE" WRITTEN ACROSS IT.

FOR HOT SAUCE; SALAD DRESSINGS; SAUCES; SPICES (U.S. CL. 46).  
KIM SAITO, EXAMINING ATTORNEY

SN 85-215,317. WM. WRIGLEY JR. COMPANY, CHICAGO, IL. FILED 1-11-2011.

# HUBBA BUBBA

THE MARK CONSISTS OF STANDARD CHARACTERS WITHOUT CLAIM TO ANY PARTICULAR FONT, STYLE, SIZE, OR COLOR.

OWNER OF U.S. REG. NOS. 2,579,033, 3,620,252 AND OTHERS.

FOR FROZEN CONFECTIONS (U.S. CL. 46).  
H. M. FISHER, EXAMINING ATTORNEY

**CLASS 30—(Continued).**

SN 85-215,330. WM. WRIGLEY JR. COMPANY, CHICAGO, IL. FILED 1-11-2011.

**ALTOIDS**

THE MARK CONSISTS OF STANDARD CHARACTERS WITHOUT CLAIM TO ANY PARTICULAR FONT, STYLE, SIZE, OR COLOR.

OWNER OF U.S. REG. NOS. 1,250,585, 2,292,918 AND 2,863,776.

FOR FROZEN CONFECTIONS (U.S. CL. 46).  
H. M. FISHER, EXAMINING ATTORNEY

SN 85-215,477. CHARHON, TROY, DALLAS, TX. FILED 1-11-2011.

**Zeppelin**

THE MARK CONSISTS OF STANDARD CHARACTERS WITHOUT CLAIM TO ANY PARTICULAR FONT, STYLE, SIZE, OR COLOR.

FOR SANDWICHES (U.S. CL. 46).  
BARBARA BROWN, EXAMINING ATTORNEY

SN 85-215,503. A LITTLE TASTE OF NEW ORLEANS!, CHARLOTTE, NC. FILED 1-11-2011.

**A Little Taste of New Orleans!**

THE MARK CONSISTS OF STANDARD CHARACTERS WITHOUT CLAIM TO ANY PARTICULAR FONT, STYLE, SIZE, OR COLOR.

NO CLAIM IS MADE TO THE EXCLUSIVE RIGHT TO USE "NEW ORLEANS", APART FROM THE MARK AS SHOWN.

FOR PRALINES (U.S. CL. 46).  
FIRST USE 12-14-2010; IN COMMERCE 12-14-2010.  
HELENE LIWINSKI, EXAMINING ATTORNEY

**CLASS 30—(Continued).**

SN 85-217,495. BEAVERTON FOODS, INC., BEAVERTON, OR. FILED 1-13-2011.

**TULELAKE**

THE MARK CONSISTS OF STANDARD CHARACTERS WITHOUT CLAIM TO ANY PARTICULAR FONT, STYLE, SIZE, OR COLOR.

SEC. 2(F).  
FOR CONDIMENTS, NAMELY, HORSERADISHES (U.S. CL. 46).

FIRST USE 0-0-1959; IN COMMERCE 0-0-1959.  
LINDA POWELL, EXAMINING ATTORNEY

SN 85-217,783. FRITO-LAY NORTH AMERICA, INC., PLANO, TX. FILED 1-14-2011.



OWNER OF U.S. REG. NOS. 3,295,314, 3,295,315 AND OTHERS.

THE COLOR(S) DARK BROWN, GOLDEN YELLOW AND ORANGE IS/ARE CLAIMED AS A FEATURE OF THE MARK.

THE MARK CONSISTS OF THE WORD "DORITOS" IN DARK BROWN LETTERING WITH THE LETTERS APPEARING IN STAGGERED BLOCKS. THE FIRST BLOCK IS GOLDEN YELLOW, THE SECOND BLOCK IS ORANGE AND THE COLOR PATTERN CONTINUES EVERY OTHER BLOCK AND ENDS WITH A GOLDEN YELLOW BLOCK.

FOR CORN CHIPS; CORN-BASED SNACK FOODS; TORTILLA CHIPS (U.S. CL. 46).

FIRST USE 0-0-1968; IN COMMERCE 0-0-1968.  
TEJBIR SINGH, EXAMINING ATTORNEY

SN 85-219,171. WEAVER POPCORN COMPANY INC, NOBLESVILLE, IN. FILED 1-17-2011.

**WEAVER GOLD**

THE MARK CONSISTS OF STANDARD CHARACTERS WITHOUT CLAIM TO ANY PARTICULAR FONT, STYLE, SIZE, OR COLOR.

OWNER OF U.S. REG. NOS. 1,690,407, 2,992,289 AND OTHERS.

FOR MICROWAVE POPCORN (U.S. CL. 46).  
INGRID C. EULIN, EXAMINING ATTORNEY

**CLASS 30—(Continued).**

SN 85-236,900. HERSHEY CHOCOLATE & CONFECTIONERY CORPORATION, WHEAT RIDGE, CO. FILED 2-8-2011.

**PULL 'N' PEEL**

THE MARK CONSISTS OF STANDARD CHARACTERS WITHOUT CLAIM TO ANY PARTICULAR FONT, STYLE, SIZE, OR COLOR.

OWNER OF U.S. REG. NO. 1,889,412.  
FOR CANDY (U.S. CL. 46).  
FIRST USE 5-13-1994; IN COMMERCE 5-13-1994.  
TINA L. SNAPP, EXAMINING ATTORNEY

SN 85-238,517. VOSGES IP, LLC, CHICAGO, IL. FILED 2-10-2011.

**PEACE, LOVE, AND CHOCOLATE**

THE MARK CONSISTS OF STANDARD CHARACTERS WITHOUT CLAIM TO ANY PARTICULAR FONT, STYLE, SIZE, OR COLOR.

NO CLAIM IS MADE TO THE EXCLUSIVE RIGHT TO USE "CHOCOLATE", APART FROM THE MARK AS SHOWN.

FOR SPECIALTY CONFECTIONERY PRODUCTS, NAMELY, SPECIALTY CHOCOLATES, CHOCOLATE BARS, CHOCOLATE TRUFFLES, CAKES, TOFFEES, CARAMELS, COCOA, BONBONS, BROWNIES, COOKIES, PANCAKE MIXES, BAKING MIXES IN THE NATURE OF MIXES FOR BAKERY GOODS, CHOCOLATE COVERED FRUITS AND NUTS, CHOCOLATES CONTAINING FRUITS AND NUTS, AND ICE CREAM; SPECIALTY CONFECTIONERY PRODUCTS IN THE NATURE OF CHOCOLATE COLLECTIONS COMPRISED PRIMARILY OF CHOCOLATES, CHOCOLATE TRUFFLES, BONBONS, AND CHOCOLATE BARS (U.S. CL. 46).

FIRST USE 9-1-2005; IN COMMERCE 9-1-2005.  
REBECCA POVARCHUK, EXAMINING ATTORNEY

**CLASS 30—(Continued).**

SN 85-238,521. VOSGES IP, LLC, CHICAGO, IL. FILED 2-10-2011.

*peace, love, and chocolate*

NO CLAIM IS MADE TO THE EXCLUSIVE RIGHT TO USE "CHOCOLATE", APART FROM THE MARK AS SHOWN.

FOR SPECIALTY CONFECTIONERY PRODUCTS, NAMELY, SPECIALTY CHOCOLATES, CHOCOLATE BARS, CHOCOLATE TRUFFLES, CAKES, TOFFEES, CARAMELS, COCOA, BONBONS, BROWNIES, COOKIES, PANCAKE MIXES, BAKING MIXES IN THE NATURE OF MIXES FOR BAKERY GOODS, CHOCOLATE COVERED FRUITS AND NUTS, CHOCOLATES CONTAINING FRUITS AND NUTS, AND ICE CREAM; SPECIALTY CONFECTIONERY PRODUCTS IN THE NATURE OF CHOCOLATE COLLECTIONS COMPRISED PRIMARILY OF CHOCOLATES, CHOCOLATE TRUFFLES, BONBONS, AND CHOCOLATE BARS (U.S. CL. 46).

FIRST USE 5-1-2006; IN COMMERCE 5-1-2006.  
REBECCA POVARCHUK, EXAMINING ATTORNEY

SN 85-244,746. WM. WRIGLEY JR. COMPANY, CHICAGO, IL. FILED 2-17-2011.

**PULPADIP**

THE MARK CONSISTS OF STANDARD CHARACTERS WITHOUT CLAIM TO ANY PARTICULAR FONT, STYLE, SIZE, OR COLOR.

FOR CANDY (U.S. CL. 46).  
FIRST USE 12-22-1995; IN COMMERCE 6-12-1996.  
H. M. FISHER, EXAMINING ATTORNEY

SN 85-244,980. THE WILD MUFFIN, LLC, NASHVILLE, TN. FILED 2-17-2011.



NO CLAIM IS MADE TO THE EXCLUSIVE RIGHT TO USE "MUFFIN", APART FROM THE MARK AS SHOWN.

THE MARK CONSISTS OF A WOMAN HOLDING COOKING UTENSILS STANDING NEXT TO THE WORDS "THE WILD MUFFIN" AND ABOVE A WAVY LINE.

FOR BROWNIE MIXES; BROWNIES; COOKIE MIXES; COOKIES; MUFFIN MIXES; MUFFINS (U.S. CL. 46).  
FIRST USE 1-1-2005; IN COMMERCE 1-1-2005.  
SKYE YOUNG, EXAMINING ATTORNEY



**CLASS 30—(Continued).**

SN 85-248,167. SARRIS HOLDINGS, LLP, CANONSBURG, PA. FILED 2-22-2011.

# BashEgg

THE MARK CONSISTS OF STANDARD CHARACTERS WITHOUT CLAIM TO ANY PARTICULAR FONT, STYLE, SIZE, OR COLOR.

FOR EDIBLE CHOCOLATE PIÑATA FILLED WITH CANDIES AND INCLUDING A WOODEN MALLET FOR BREAKING THE PIÑATA, ALL SOLD AS A SINGLE UNIT (U.S. CL. 46).

FIRST USE 1-3-2011; IN COMMERCE 1-3-2011.  
HEATHER SAPP, EXAMINING ATTORNEY

**CLASS 30—(Continued).**

SN 85-260,650. AHOLD LICENSING SARL, GENEVA, SWITZERLAND, FILED 3-8-2011.



SN 85-251,862. WM. WRIGLEY JR. COMPANY, CHICAGO, IL. FILED 2-25-2011.

# MONSTER STASH

THE MARK CONSISTS OF STANDARD CHARACTERS WITHOUT CLAIM TO ANY PARTICULAR FONT, STYLE, SIZE, OR COLOR.

FOR CANDY (U.S. CL. 46).

H. M. FISHER, EXAMINING ATTORNEY

OWNER OF U.S. REG. NOS. 2,871,579, 3,682,647 AND OTHERS.

THE COLOR(S) ORANGE, GRAY AND WHITE IS/ARE CLAIMED AS A FEATURE OF THE MARK.

THE MARK CONSISTS OF THE TRADE DRESS CHARACTERIZING THE FRONT FACE OF THE PACKAGING FOR APPLICANT'S GOODS, NAMELY (1) A WHITE HORIZONTAL BAR SPANNING THE LABEL OR PACKAGE FACE, (2) AN ORANGE BAR BELOW THE WHITE BAR, ALSO SPANNING THE LABEL OR PACKAGE FACE, (3) A DASHED LINE THAT APPEARS GRAY ON THE WHITE BACKGROUND AND WHITE ON THE ORANGE BACKGROUND. THE DASHED LINE EXTENDS HORIZONTALLY ALONG THE WHITE BAR, AND TURNS 90 DEGREES AT EACH END TO EXTEND DOWNWARDS INTO THE ORANGE BAR. THE DESIGN FURTHER COMPRISES (4) A GRAY SCISSORS DESIGN AND (5) THE WORD "GUARANTEED" APPEARING IN ORANGE ABOVE THE GRAY LINE AND THE WORD "VALUE" APPEARING IN ORANGE BELOW THE GRAY LINE.

SEC. 2(F) AS TO "GUARANTEED VALUE".

FOR BISCUITS; BREAKFAST CEREALS; CAKES; CANDY; CHEESE FLAVORED SNACKS, NAMELY, CHEESE CURLS; CHOCOLATE CHIPS; CHOCOLATE SYRUP; COFFEE; COOKIES; CORN CHIPS; CRACKERS; EXTRACTS USED AS FLAVORING; FROZEN CONFECTIONS; GRAVIES; HONEY; HOT SAUCE; ICE CREAM; KETCHUP; MAYONNAISE; MIXES FOR MAKING BAKING BATTERS; MUFFINS; MUSTARD; OATMEAL; PACKAGED MEAL MIXES CONSISTING PRIMARILY OF PASTA OR RICE; PANCAKE MIXES; PIZZA; PREPARED PASTA; PROCESSED POPCORN; RELISH; RICE; SALAD DRESSING; SPICES; SUGAR; TEA; TOASTER PASTRIES; TOMATO SAUCE (U.S. CL. 46).

BRIDGETT SMITH, EXAMINING ATTORNEY

SN 85-251,878. WM. WRIGLEY JR. COMPANY, CHICAGO, IL. FILED 2-25-2011.

# RIDDLES

THE MARK CONSISTS OF STANDARD CHARACTERS WITHOUT CLAIM TO ANY PARTICULAR FONT, STYLE, SIZE, OR COLOR.

FOR CANDY (U.S. CL. 46).

H. M. FISHER, EXAMINING ATTORNEY

**CLASS 30—(Continued).**

SN 85-260,928. AHOLD LICENSING SARL, GENEVA, SWITZERLAND, FILED 3-8-2011.



OWNER OF U.S. REG. NOS. 2,871,579, 3,682,647 AND OTHERS.

THE MARK CONSISTS OF A SCISSORS DESIGN WITH A DASHED LINE EXTENDING TO THE RIGHT OF THE SCISSORS. THE WORD "GUARANTEED" APPEARS ABOVE THE LINE AND THE WORD "VALUE" APPEARS BELOW THE LINE.

SEC. 2(F) AS TO "GUARANTEED VALUE".

FOR BISCUITS; BREAKFAST CEREALS; CAKES; CANDY; CHEESE FLAVORED SNACKS, NAMELY, CHEESE CURLS; CHOCOLATE CHIPS; CHOCOLATE SYRUP; COFFEE; COOKIES; CORN CHIPS; CRACKERS; EXTRACTS USED AS FLAVORING; FROZEN CONFECTIONS; GRAVIES; HONEY; HOT SAUCE; ICE CREAM; KETCHUP; MAYONNAISE; MIXES FOR MAKING BAKING BATTERS; MUFFINS; MUSTARD; OATMEAL; PACKAGED MEAL MIXES CONSISTING PRIMARILY OF PASTA OR RICE; PANCAKE MIXES; PIZZA; PREPARED PASTA; PROCESSED POPCORN; RELISH; RICE; SALAD DRESSING; SPICES; SUGAR; TEA; TOASTER PASTRIES; TOMATO SAUCE (U.S. CL. 46).

BRIDGETT SMITH, EXAMINING ATTORNEY

**CLASS 31—NATURAL AGRICULTURAL PRODUCTS**

SN 77-425,351. MASTRONARDI PRODUCE LTD., SANTA BARBARA, CA. FILED 3-18-2008.

**MY GRILLING EGGPLANT**

THE MARK CONSISTS OF STANDARD CHARACTERS WITHOUT CLAIM TO ANY PARTICULAR FONT, STYLE, SIZE, OR COLOR.

PRIORITY CLAIMED UNDER SEC. 44(D) ON CANADA APPLICATION NO. 1384069, FILED 2-20-2008, REG. NO. TMA767,272, DATED 5-19-2010, EXPIRES 5-19-2025.

NO CLAIM IS MADE TO THE EXCLUSIVE RIGHT TO USE "GRILLING EGGPLANT", APART FROM THE MARK AS SHOWN.

FOR FRESH FRUIT AND VEGETABLES; FRESH FRUITS; FRUITS, NAMELY, FRESH, RAW AND UNPROCESSED FRUITS; FRESH, RAW AND UNPROCESSED EGGPLANTS; RAW FRUITS; UNPROCESSED FRUITS; FRESH VEGETABLES (U.S. CLS. 1 AND 46).

MIDGE BUTLER, EXAMINING ATTORNEY

**CLASS 31—(Continued).**

SN 77-425,397. MASTRONARDI PRODUCE LTD., SANTA BARBARA, CA. FILED 3-18-2008.

**MY SNACKING TOMATO**

THE MARK CONSISTS OF STANDARD CHARACTERS WITHOUT CLAIM TO ANY PARTICULAR FONT, STYLE, SIZE, OR COLOR.

PRIORITY CLAIMED UNDER SEC. 44(D) ON CANADA APPLICATION NO. 1384070, FILED 2-20-2008, REG. NO. TMA767,654, DATED 5-21-2010, EXPIRES 5-21-2025.

NO CLAIM IS MADE TO THE EXCLUSIVE RIGHT TO USE "TOMATO", APART FROM THE MARK AS SHOWN.

FOR FRESH, RAW AND UNPROCESSED FRUITS; FRESH, RAW AND UNPROCESSED TOMATOES (U.S. CLS. 1 AND 46).

FIRST USE 8-19-2008; IN COMMERCE 8-19-2008.

MIDGE BUTLER, EXAMINING ATTORNEY

SN 77-425,428. MASTRONARDI PRODUCE LTD., SANTA BARBARA, CA. FILED 3-18-2008.

**MY SALAD CUCUMBER**

THE MARK CONSISTS OF STANDARD CHARACTERS WITHOUT CLAIM TO ANY PARTICULAR FONT, STYLE, SIZE, OR COLOR.

PRIORITY CLAIMED UNDER SEC. 44(D) ON CANADA APPLICATION NO. 1384071, FILED 2-20-2008, REG. NO. TMA767,260, DATED 5-19-2010, EXPIRES 5-19-2025.

NO CLAIM IS MADE TO THE EXCLUSIVE RIGHT TO USE "SALAD CUCUMBER", APART FROM THE MARK AS SHOWN.

FOR FRESH, RAW AND UNPROCESSED FRUITS; FRESH PRODUCE, NAMELY, CUCUMBERS; FRESH, RAW AND UNPROCESSED CUCUMBERS (U.S. CLS. 1 AND 46).

FIRST USE 8-19-2008; IN COMMERCE 8-19-2008.

MIDGE BUTLER, EXAMINING ATTORNEY

SN 79-086,563. DR NEIL'S PET & EQUINE SUPPLIES PTY LIMITED, AUSTRALIA, FILED 8-2-2010.

**LICKABLES**

THE MARK CONSISTS OF STANDARD CHARACTERS WITHOUT CLAIM TO ANY PARTICULAR FONT, STYLE, SIZE, OR COLOR.

OWNER OF INTERNATIONAL REGISTRATION 1048975 DATED 8-2-2010, EXPIRES 8-2-2020.

FOR PET FOOD; EDIBLE CHEWS FOR ANIMALS; CEREAL BASED FOODSTUFFS FOR ANIMALS; MILK-BASED FOODSTUFFS FOR ANIMALS; DIGESTIBLE CHEWING BONES FOR DOGS; BISCUITS FOR ANIMALS; DOG BISCUITS; DOG FOOD; FOOD FOR ANIMALS; LITTER FOR ANIMALS (U.S. CLS. 1 AND 46).

EVELYN BRADLEY, EXAMINING ATTORNEY

**CLASS 31—(Continued).**

SN 85-070,355. OLDCASTLE LAWN & GARDEN, INC.,  
ATLANTA, GA. FILED 6-24-2010.

**SOIL DOCTOR**

THE MARK CONSISTS OF STANDARD CHARACTERS  
WITHOUT CLAIM TO ANY PARTICULAR FONT, STYLE,  
SIZE, OR COLOR.

OWNER OF U.S. REG. NOS. 2,853,661 AND 2,909,228.  
NO CLAIM IS MADE TO THE EXCLUSIVE RIGHT TO  
USE "SOIL", APART FROM THE MARK AS SHOWN.  
FOR MULCH (U.S. CLS. 1 AND 46).  
DAVID ELTON, EXAMINING ATTORNEY

**CLASS 31—(Continued).**

SN 85-183,906. EAST COAST EROSION BLANKETS, LLC,  
BERNVILLE, PA. FILED 11-23-2010.



NO CLAIM IS MADE TO THE EXCLUSIVE RIGHT TO  
USE "GROUND CONTROL", APART FROM THE MARK AS  
SHOWN.

THE MARK CONSISTS OF A STYLIZED CIRCLE WITH  
THE WORDING "GROUNDCONTROL" TO THE RIGHT OF  
THE CIRCLE.  
FOR MULCH (U.S. CLS. 1 AND 46).  
FIRST USE 4-1-2010; IN COMMERCE 6-15-2010.  
ROBERT C. CLARK JR., EXAMINING ATTORNEY

SN 85-140,873. KELLY FOODS CORPORATION, BERLIN,  
MD. FILED 9-29-2010.

**PROBIOTIC PLEASURES**

THE MARK CONSISTS OF STANDARD CHARACTERS  
WITHOUT CLAIM TO ANY PARTICULAR FONT, STYLE,  
SIZE, OR COLOR.

NO CLAIM IS MADE TO THE EXCLUSIVE RIGHT TO  
USE "PROBIOTIC", APART FROM THE MARK AS SHOWN.  
FOR PET FOOD CONTAINING PROBIOTICS; PET  
TREATS CONTAINING PROBIOTICS (U.S. CLS. 1 AND  
46).  
BRENDAN MCCAULEY, EXAMINING ATTORNEY

SN 85-193,265. GARDENS IN THE KOOP, INC., HILLSBOR-  
OUGH, NC. FILED 12-8-2010.

**THE GIGGLING GARDEN**

THE MARK CONSISTS OF STANDARD CHARACTERS  
WITHOUT CLAIM TO ANY PARTICULAR FONT, STYLE,  
SIZE, OR COLOR.

NO CLAIM IS MADE TO THE EXCLUSIVE RIGHT TO  
USE "GARDEN", APART FROM THE MARK AS SHOWN.  
FOR FLOWER SEEDS; ORGANIC GARDENING KIT  
FOR INDOOR AND OUTDOOR PLANTING COMPOSED  
PRIMARILY OF ORGANIC SEEDS FOR VEGETABLES  
AND FLOWERS AND ALSO INCLUDING AN EGG  
CARTON, COIR DISCS, AND INSTRUCTIONS; VEGE-  
TABLE SEEDS FOR PLANTING (U.S. CLS. 1 AND 46).  
FIRST USE 12-18-2009; IN COMMERCE 12-18-2009.  
BRIDGETT SMITH, EXAMINING ATTORNEY

SN 85-171,865. BAYER AKTIENGESELLSCHAFT, 51373 LE-  
VERKUSEN, FED REP GERMANY, FILED 11-8-2010.



OWNER OF FED REP GERMANY REG. NO. 302008062798,  
DATED 11-13-2008, EXPIRES 9-30-2018.  
OWNER OF U.S. REG. NO. 3,462,144.

THE MARK CONSISTS OF WORD "RENALZIN" WITH A  
STYLIZED "I" AND "N" FORMING A DESIGN OF A CAT.  
FOR FOODSTUFFS FOR ANIMALS; NON-MEDI-  
CATED ADDITIVES FOR FOODSTUFFS FOR ANIMALS  
(U.S. CLS. 1 AND 46).  
JOSETTE BEVERLY, EXAMINING ATTORNEY

SN 85-194,479. HORTECH, INC., SPRING LAKE, MI. FILED  
12-9-2010.

**GREEN MIST**

THE MARK CONSISTS OF STANDARD CHARACTERS  
WITHOUT CLAIM TO ANY PARTICULAR FONT, STYLE,  
SIZE, OR COLOR.

FOR LIVING PLANTS, NAMELY, PLANTS OF THE  
SEDUM VARIETY (U.S. CLS. 1 AND 46).  
FIRST USE 12-5-2010; IN COMMERCE 12-5-2010.  
ANDREA BUTLER, EXAMINING ATTORNEY

**CLASS 31—(Continued).**

SN 85-199,740. THE NUTRO COMPANY, FRANKLIN, TN.  
FILED 12-16-2010.

**ULTRA PURE**

THE MARK CONSISTS OF STANDARD CHARACTERS  
WITHOUT CLAIM TO ANY PARTICULAR FONT, STYLE,  
SIZE, OR COLOR.

FOR PET FOOD (U.S. CLS. 1 AND 46).  
ANDREA BUTLER, EXAMINING ATTORNEY

SN 85-202,046. CENTRAL NEBRASKA PACKING, INC.,  
NORTH PLATTE, NE. FILED 12-20-2010.



OWNER OF U.S. REG. NOS. 3,118,739 AND 3,178,889.  
NO CLAIM IS MADE TO THE EXCLUSIVE RIGHT TO  
USE "BRAND", APART FROM THE MARK AS SHOWN.

THE MARK CONSISTS OF AN OUTLINE OF THE MAP  
OF THE STATE OF NEBRASKA WITH THE WORDS  
"NEBRASKA BRAND" ACROSS THE MAP.

SEC. 2(F).  
FOR FEED FOR CAPTIVE AND FOR DOMESTI-  
CATED ANIMALS (U.S. CLS. 1 AND 46).  
FIRST USE 0-0-1946; IN COMMERCE 0-0-1946.  
ALICIA COLLINS, EXAMINING ATTORNEY

SN 85-204,402. AGRAQUEST, INC., DAVIS, CA. FILED 12-22-  
2010.

**BALANCE IS PERFORMANCE**

THE MARK CONSISTS OF STANDARD CHARACTERS  
WITHOUT CLAIM TO ANY PARTICULAR FONT, STYLE,  
SIZE, OR COLOR.

FOR ADDITIVES FOR ANIMAL FEED, IN THE  
NATURE OF DIRECT FED MICROBIAL ADDITIVES  
FOR USE AS NUTRITIONAL SUPPLEMENTS (U.S. CLS.  
1 AND 46).

WILLIAM ROSSMAN, EXAMINING ATTORNEY

**CLASS 31—(Continued).**

SN 85-207,322. PENNINGTON SEED, INC. OF NEBRASKA,  
MADISON, GA. FILED 12-29-2010.

**DR DISEASE RESISTANT**

THE MARK CONSISTS OF STANDARD CHARACTERS  
WITHOUT CLAIM TO ANY PARTICULAR FONT, STYLE,  
SIZE, OR COLOR.

OWNER OF U.S. REG. NO. 2,973,223.  
NO CLAIM IS MADE TO THE EXCLUSIVE RIGHT TO  
USE "DISEASE RESISTANT", APART FROM THE MARK  
AS SHOWN.

FOR GRASS SEED (U.S. CLS. 1 AND 46).  
SCOTT BIBB, EXAMINING ATTORNEY

SN 85-207,335. PENNINGTON SEED, INC. OF NEBRASKA,  
MADISON, GA. FILED 12-29-2010.

**ER EXTENDED ROOT**

THE MARK CONSISTS OF STANDARD CHARACTERS  
WITHOUT CLAIM TO ANY PARTICULAR FONT, STYLE,  
SIZE, OR COLOR.

OWNER OF U.S. REG. NO. 2,972,899.  
NO CLAIM IS MADE TO THE EXCLUSIVE RIGHT TO  
USE "EXTENDED ROOT", APART FROM THE MARK AS  
SHOWN.

FOR GRASS SEED (U.S. CLS. 1 AND 46).  
SCOTT BIBB, EXAMINING ATTORNEY

SN 85-208,049. SEED BOUND S.A.L., BEIRUT, LEBANON,  
FILED 12-30-2010.



NO CLAIM IS MADE TO THE EXCLUSIVE RIGHT TO  
USE "SEED", APART FROM THE MARK AS SHOWN.

THE MARK CONSISTS OF THE WORD "SEED" ABOVE,  
AND ENCLOSED BY EXTENSIONS OF THE "B" AND "D"  
IN THE WORD "BOUND".

FOR VEGETABLE SEEDS FOR PLANTING (U.S. CLS.  
1 AND 46).

FIRST USE 2-17-2010; IN COMMERCE 2-17-2010.  
LAURA HAMMEL, EXAMINING ATTORNEY

**CLASS 31—(Continued).**

SN 85-208,120. ARTHUR DOGSWELL, L.L.C., AKA DOGSWELL AND CATSWELL, LOS ANGELES, CA. FILED 12-30-2010.

**HAPPY HIPS**

THE MARK CONSISTS OF STANDARD CHARACTERS WITHOUT CLAIM TO ANY PARTICULAR FONT, STYLE, SIZE, OR COLOR.

OWNER OF U.S. REG. NOS. 3,028,301 AND 3,457,532. NO CLAIM IS MADE TO THE EXCLUSIVE RIGHT TO USE "HIPS", APART FROM THE MARK AS SHOWN. FOR EDIBLE CAT TREATS (U.S. CLS. 1 AND 46). FIRST USE 4-1-2006; IN COMMERCE 7-25-2006. MORGAN WYNNE, EXAMINING ATTORNEY

**CLASS 31—(Continued).**

SN 85-210,287. AHA MARKETING GROUP OF GREENDALE INVESTMENTS LLC, BARRINGTON, IL. FILED 1-4-2011.

**MY HEALTHY PUPPY**

THE MARK CONSISTS OF STANDARD CHARACTERS WITHOUT CLAIM TO ANY PARTICULAR FONT, STYLE, SIZE, OR COLOR.

NO CLAIM IS MADE TO THE EXCLUSIVE RIGHT TO USE "HEALTHY PUPPY", APART FROM THE MARK AS SHOWN.

FOR PET FOOD (U.S. CLS. 1 AND 46). FIRST USE 12-3-2009; IN COMMERCE 12-3-2009. ROBIN MITTLER, EXAMINING ATTORNEY

SN 85-209,593. DUDLEY GREER, TOLLESON, AZ. FILED 1-3-2011.

**COUNTRY KING**

THE MARK CONSISTS OF STANDARD CHARACTERS WITHOUT CLAIM TO ANY PARTICULAR FONT, STYLE, SIZE, OR COLOR.

OWNER OF U.S. REG. NO. 1,184,056. FOR FRESH VEGETABLES (U.S. CLS. 1 AND 46). FIRST USE 11-1-1979; IN COMMERCE 11-1-1979. MATTHEW MCDOWELL, EXAMINING ATTORNEY

SN 85-211,807. J. VARGAS ENTERPRISES, INC., FOREST HILLS, NY. FILED 1-6-2011.

**ECUANA**

THE MARK CONSISTS OF STANDARD CHARACTERS WITHOUT CLAIM TO ANY PARTICULAR FONT, STYLE, SIZE, OR COLOR.

FOR FRESH FRUIT AND VEGETABLES (U.S. CLS. 1 AND 46). THOMAS MANOR, EXAMINING ATTORNEY

SN 85-209,600. DUDLEY GREER, TOLLESON, AZ. FILED 1-3-2011.



OWNER OF U.S. REG. NO. 1,184,056. THE MARK CONSISTS OF THE WORDING "COUNTRY KING" WITHIN AN OVAL DESIGN UNDERNEATH A DESIGN OF A CROWN SUPERIMPOSED ON A DIAMOND SHAPED DESIGN.

FOR FRESH VEGETABLES (U.S. CLS. 1 AND 46). FIRST USE 1-1-2001; IN COMMERCE 1-1-2001. MATTHEW MCDOWELL, EXAMINING ATTORNEY

SN 85-213,680. EVERMAX GLOBAL RESOURCE CO., LTD, SHANGHAI, CHINA, FILED 1-10-2011.



THE MARK CONSISTS OF A LEAF DESIGN INSIDE A OVAL MADE UP OF TWO BANDS.

FOR FRESH BLUEBERRIES; FRESH FRUIT; FRESH FRUIT AND VEGETABLES; FRESH PEPPERS; FRESH POTATOES; FRESH VEGETABLES; FRESH ZUCCHINI; WATERMELON, FRESH (U.S. CLS. 1 AND 46).

LEIGH CAROLINE CASE, EXAMINING ATTORNEY



**CLASS 31—(Continued).**

SN 85-213,756. FIELD & FOREST PRODUCTS, INC., PESH-  
TIGO, WI. FILED 1-10-2011.

**FIELD & FOREST**

THE MARK CONSISTS OF STANDARD CHARACTERS  
WITHOUT CLAIM TO ANY PARTICULAR FONT, STYLE,  
SIZE, OR COLOR.

FOR LIVE MUSHROOMS AND MUSHROOM SPAWN  
(U.S. CLS. 1 AND 46).

FIRST USE 7-11-1989; IN COMMERCE 7-11-1989.  
WENDY JUN, EXAMINING ATTORNEY

**CLASS 31—(Continued).**

SN 85-215,325. W. ATLEE BURPEE COMPANY, WARMIN-  
STER, PA. FILED 1-11-2011.

**THE YEAR OF THE VEGETABLE**

THE MARK CONSISTS OF STANDARD CHARACTERS  
WITHOUT CLAIM TO ANY PARTICULAR FONT, STYLE,  
SIZE, OR COLOR.

NO CLAIM IS MADE TO THE EXCLUSIVE RIGHT TO  
USE "VEGETABLE", APART FROM THE MARK AS  
SHOWN.

FOR LIVING PLANTS; VEGETABLE SEEDS FOR  
PLANTING; SEEDS AND BULBS (U.S. CLS. 1 AND 46).

KATHERINE E. HALMEN, EXAMINING ATTORNEY

SN 85-217,705. ALL STATE PACKERS, INC., LODI, CA.  
FILED 1-14-2011.

**RIVER MAID**

THE MARK CONSISTS OF STANDARD CHARACTERS  
WITHOUT CLAIM TO ANY PARTICULAR FONT, STYLE,  
SIZE, OR COLOR.

OWNER OF U.S. REG. NO. 3,833,424.  
FOR FRESH FRUIT AND VEGETABLES (U.S. CLS. 1  
AND 46).

FIRST USE 1-1-1930; IN COMMERCE 1-1-1930.  
TRICIA SONNEBORN, EXAMINING ATTORNEY

SN 85-219,259. VENDITIO, LLC, CHICAGO, IL. FILED 1-17-  
2011.

**FRESCOPEÑO**

THE MARK CONSISTS OF THE WORD "KITTY" IN  
LOWERCASE SCRIPT WRITING FOLLOWED BY A DRAW-  
ING OF A CAT FACE HAVING ONE EYE OPEN AND ONE  
EYE CLOSED, WHICH IS THEN FOLLOWED BY THE  
WORD "CARE" IN LOWERCASE SCRIPT WRITING.

FOR LITTER FOR ANIMALS, NAMELY, NATURAL  
LITTER FOR DOMESTIC ANIMALS, ABSORPTIVE LIT-  
TER FOR DOMESTIC ANIMALS, SANITARY ABSORP-  
TIVE LITTER FOR DOMESTIC ANIMALS, AROMATIC  
LITTER FOR DOMESTIC ANIMALS, NATURAL LITTER  
FOR DOMESTIC ANIMALS BASED ON BENTONITE,  
AND AGGLOMERATIVE LITTER FOR DOMESTIC ANI-  
MALS (U.S. CLS. 1 AND 46).

SKYE YOUNG, EXAMINING ATTORNEY

THE MARK CONSISTS OF STANDARD CHARACTERS  
WITHOUT CLAIM TO ANY PARTICULAR FONT, STYLE,  
SIZE, OR COLOR.

THE WORDING "FRESCOPEÑO" HAS NO MEANING IN  
A FOREIGN LANGUAGE.

FOR FRESH FRUITS AND VEGETABLES, NAMELY,  
JALAPEÑO PEPPERS, SERRANO PEPPERS, BANANA  
PEPPERS, BELL PEPPERS AND TOMATILLO (U.S. CLS.  
1 AND 46).

KATHLEEN LORENZO, EXAMINING ATTORNEY



**CLASS 31—(Continued).**

SN 85-222,471. SYNGENTA PARTICIPATIONS AG, BASEL, SWITZERLAND, FILED 1-20-2011.

# Magelana

THE MARK CONSISTS OF STANDARD CHARACTERS WITHOUT CLAIM TO ANY PARTICULAR FONT, STYLE, SIZE, OR COLOR.

THE WORDING "MAGELANA" HAS NO MEANING IN A FOREIGN LANGUAGE.

FOR LIVING PLANTS (U.S. CLS. 1 AND 46).

KELLY CHOE, EXAMINING ATTORNEY

SN 85-260,931. AHOLD LICENSING SARL, GENEVA, SWITZERLAND, FILED 3-8-2011.



OWNER OF U.S. REG. NOS. 2,871,579, 3,147,919 AND 3,682,647.

THE MARK CONSISTS OF A SCISSORS DESIGN WITH A DASHED LINE EXTENDING TO THE RIGHT OF THE SCISSORS. THE WORD "GUARANTEED" APPEARS ABOVE THE LINE AND THE WORD "VALUE" APPEARS BELOW THE LINE.

SEC. 2(F) AS TO "GUARANTEED VALUE".

FOR CAT LITTER; DOG BISCUITS; FRESH FRUIT AND VEGETABLES; PET FOOD (U.S. CLS. 1 AND 46).

BRIDGETT SMITH, EXAMINING ATTORNEY

**CLASS 32—LIGHT BEVERAGES**

SN 76-705,832. USA MILLENNIUM, L.P., BEAUMONT, TX, FILED 12-29-2010.



THE MARK CONSISTS OF THE WORDING "ROBOIN 36"

**CLASS 32—(Continued).**

WITH A DESIGN OF A LIGHT STIPPLING WAVE SHAPED LINE DESCENDING FROM THE LEFT STEM OF THE LETTER "R" IN "ROBOIN" AND ENDING ON THE BOTTOM OF THE LETTERS "IN" IN THE WORDING "ROBOIN" AND ATTACHING THE NUMBER "36" IN THE SAME SHADE OF STIPPLING ON THE BOTTOM OF THE LETTERS "IN" IN THE WORDING "ROBOIN" FOR SHADING PURPOSE ONLY AND THE TOP OF LETTERS "ROBO" APPEARS IN DARKER STIPPLING FOR SHADING PURPOSES ONLY.

FOR NON-ALCOHOLIC, LIGHTLY CARBONATED BEVERAGES, NAMELY, RELAXATION DRINKS (U.S. CLS. 45, 46 AND 48).

SAMUEL E. SHARPER JR., EXAMINING ATTORNEY

SN 76-705,833. USA MILLENNIUM, L.P., BEAUMONT, TX, FILED 12-29-2010.

# ROBOIN 36

THE MARK CONSISTS OF STANDARD CHARACTERS WITHOUT CLAIM TO ANY PARTICULAR FONT, STYLE, SIZE, OR COLOR.

FOR NON-ALCOHOLIC, LIGHTLY CARBONATED BEVERAGES, NAMELY, RELAXATION DRINKS (U.S. CLS. 45, 46 AND 48).

SAMUEL E. SHARPER JR., EXAMINING ATTORNEY

SN 76-705,966. KARBACH BREWING COMPANY, LLC, HOUSTON, TX, FILED 1-11-2011.

# HOPTITUDE

THE MARK CONSISTS OF STANDARD CHARACTERS WITHOUT CLAIM TO ANY PARTICULAR FONT, STYLE, SIZE, OR COLOR.

FOR BEER (U.S. CLS. 45, 46 AND 48).

STEVEN PEREZ, EXAMINING ATTORNEY

SN 76-706,270. KARBACH BREWING COMPANY, LLC, HOUSTON, TX, FILED 2-4-2011.

# HOPADILLO

THE MARK CONSISTS OF STANDARD CHARACTERS WITHOUT CLAIM TO ANY PARTICULAR FONT, STYLE, SIZE, OR COLOR.

FOR BEER (U.S. CLS. 45, 46 AND 48).

STEVEN PEREZ, EXAMINING ATTORNEY

**CLASS 32—(Continued).**

SN 77-004,792. CERVEJARIA TERESOPOLIS LTDA, TERESOPOLIS, RIO DE JANEIRO, BRAZIL, FILED 9-21-2006.



NO CLAIM IS MADE TO THE EXCLUSIVE RIGHT TO USE "LOKAL" "BLACK" AND "BRAZILIAN BEER" AND "REIN", APART FROM THE MARK AS SHOWN.

THE MARK CONSISTS OF THE WORDS "BRAZILIAN BEER" IN STYLIZED LETTERS BELOW OF WHICH APPEARS THE WORD "LOKAL" IN STYLIZED LETTERS. THE RECTANGLE CONTAINS A THIN OUTER BORDER. IN THE LOWER LEFT HAND SIDE OF THE RECTANGLE APPEARS IN VERY SMALL STYLIZED LETTERS THE WORD "NATUR" OVER A RIBBON THAT IN TURN APPEARS OVER A DESIGN OF PLANTS AND LEAFS. OVER THE CENTER OF THE LOWER SIDE OF THE RECTANGLE APPEARS THE WORD "BLACK" IN STYLIZED LETTERS. IN THE LOWER RIGHT HAND SIDE OF THE RECTANGLE APPEARS IN VERY SMALL STYLIZED LETTERS THE WORD "REIN". THE LEFT AND RIGHT SIDES OF THE RECTANGLE CONTAIN TEETH LIKE EDGES FACING OUTWARDS.

THE FOREIGN WORDING IN THE MARK TRANSLATES INTO ENGLISH AS "LOCAL", "NATURE", "PURE".

FOR BEER; BLACK BEER; MALT BEER (U.S. CLS. 45, 46 AND 48).

NAAKWAMA ANKRAH, EXAMINING ATTORNEY

SN 77-647,473. EAUX VIVES WATER INC., TORONTO, ONTARIO, CANADA, FILED 1-12-2009.

# eska

PRIORITY CLAIMED UNDER SEC. 44(D) ON CANADA APPLICATION NO. 1422650, FILED 12-22-2008, REG. NO. TMA780905, DATED 10-27-2010, EXPIRES 10-27-2025.

THE MARK CONSISTS OF THE LETTERS "ESKA" WHERE THE LETTERS ARE MADE UP OF LOWER CASE AND UPPER CASE COMBINED.

FOR BOTTLED DRINKING WATER, NAMELY, FLAVORED AND UNFLAVORED WATER, SWEETENED AND UN-SWEETENED WATER, AERATED WATER, BOTTLED WATER, WATER BASED BEVERAGES, NAMELY, BOTTLED SPRING WATER, MINERAL WATER AND ARTESIAN WATER (U.S. CLS. 45, 46 AND 48).

SHAUNIA CARLYLE, EXAMINING ATTORNEY

**CLASS 32—(Continued).**

SN 77-925,193. MOUNTAIN CREST SRL, DBA MINHAS CRAFT BREWERY, MAXWELL, CHRIST CHURCH, BARBADOS, FILED 2-1-2010.

## DAMN GOOD BEER

THE MARK CONSISTS OF STANDARD CHARACTERS WITHOUT CLAIM TO ANY PARTICULAR FONT, STYLE, SIZE, OR COLOR.

NO CLAIM IS MADE TO THE EXCLUSIVE RIGHT TO USE "BEER", APART FROM THE MARK AS SHOWN.

FOR BEER; MALT LIQUOR (U.S. CLS. 45, 46 AND 48). FIRST USE 0-0-2001; IN COMMERCE 0-0-2004.

DOMINICK J. SALEMI, EXAMINING ATTORNEY

SN 78-310,636. CALIFORNIA GIANT, INC., WATSONVILLE, CA. FILED 10-7-2003.

## JUST STRAWBERRIES

NO CLAIM IS MADE TO THE EXCLUSIVE RIGHT TO USE "STRAWBERRIES", APART FROM THE MARK AS SHOWN.

FOR FRUIT DRINKS, FRUIT JUICE DRINKS, NON-ALCOHOLIC AND NON-CARBONATED FRUIT DRINKS AND NON-ALCOHOLIC AND NON-CARBONATED FRUIT JUICE DRINKS (U.S. CLS. 45, 46 AND 48).

LINDA ESTRADA, EXAMINING ATTORNEY

**CLASS 32—(Continued).**

SN 79-090,695. BRASSERIE LEFEBVRE S.A., BELGIUM, FILED 9-28-2010.



PRIORITY DATE OF 4-12-2010 IS CLAIMED.  
OWNER OF INTERNATIONAL REGISTRATION 1060315 DATED 9-28-2010, EXPIRES 9-28-2020.

NO CLAIM IS MADE TO THE EXCLUSIVE RIGHT TO USE "PILS" AND "BELGIAN SPIRIT", APART FROM THE MARK AS SHOWN.

THE COLOR(S) WHITE, RED, BLACK, BROWN, AND YELLOW IS/ARE CLAIMED AS A FEATURE OF THE MARK.

THE MARK CONSISTS OF THE WORDS "MANNEKEN PILS" IN A WHITE SQUARE WITH A RED BORDER. THE WORD "MANNEKEN" IS IN BLACK. THE LETTERS "P", "L", AND "S" IN "PILS" ARE BLACK. THE "I" IN "PILS" CONSISTS OF A BROWN COLORED ABSTRACT HUMAN DESIGN. THE DOT ABOVE THE I IN "PILS" IS RED. DIRECTLY UNDERNEATH THE SQUARE ARE THE WORDS "THE BELGIAN SPIRIT" IN YELLOW. ALL OF THE AFOREMENTIONED IS SET AGAINST A BLACK SQUARED BACKGROUND.

THE ENGLISH TRANSLATION OF "MANNEKEN" IN THE MARK IS "KID".

FOR BEER (U.S. CLS. 45, 46 AND 48).  
DOMINICK J. SALEMI, EXAMINING ATTORNEY

---

SN 85-039,326. EMERALD CITY BEER COMPANY, LLC, SEATTLE, WA. FILED 5-14-2010.

## Dottie's Seattle Lager

THE MARK CONSISTS OF STANDARD CHARACTERS WITHOUT CLAIM TO ANY PARTICULAR FONT, STYLE, SIZE, OR COLOR.

NO CLAIM IS MADE TO THE EXCLUSIVE RIGHT TO USE "SEATTLE LAGER", APART FROM THE MARK AS SHOWN.

FOR BEER (U.S. CLS. 45, 46 AND 48).  
AMEEN IMAM, EXAMINING ATTORNEY

**CLASS 32—(Continued).**

SN 85-071,980. DEL NORTE BREWING CO., LLC, DENVER, CO. FILED 6-25-2010.

## LUMINARIA

THE MARK CONSISTS OF STANDARD CHARACTERS WITHOUT CLAIM TO ANY PARTICULAR FONT, STYLE, SIZE, OR COLOR.

THE ENGLISH TRANSLATION OF "LUMINARIA" IN THE MARK IS LIGHTS.

FOR BEER (U.S. CLS. 45, 46 AND 48).  
STEPHANIE ALI, EXAMINING ATTORNEY

---

SN 85-078,332. LATCO BEVERAGES INDUSTRIA DE ALIMENTOS LTDA., CRUZEIRO DO OESTE, BRAZIL, FILED 7-6-2010.



PRIORITY CLAIMED UNDER SEC. 44(D) ON BRAZIL APPLICATION NO. 902306090, FILED 2-5-2010.

THE MARK CONSISTS OF A SHADED "X" HAVING A SERIES OF STAGGERED, VERTICALLY SPACED SQUARE DOTS RISING UP FROM A CENTER OF THE "X", WITH THE WORD "FORCE" IN FRONT OF THE "X".

FOR ENERGY DRINKS; AND POWDERS USED IN THE PREPARATION OF ENERGY DRINKS (U.S. CLS. 45, 46 AND 48).

TEJBIR SINGH, EXAMINING ATTORNEY

**CLASS 32—(Continued).**

SN 85-104,000. TRACE 44, INC., NEWPORT BEACH, CA.  
FILED S.R. 8-10-2010; AM. P.R. 4-13-2011.



NO CLAIM IS MADE TO THE EXCLUSIVE RIGHT TO USE "TRACE 44" AND "MINERAL-INFUSED SPORTS DRINK", APART FROM THE MARK AS SHOWN.

FOR ENERGY DRINKS; GUARANA DRINKS; ISOTONIC DRINKS; POWDERS USED IN THE PREPARATION OF ISOTONIC SPORTS DRINKS AND SPORTS BEVERAGES; SPORTS DRINKS (U.S. CLS. 45, 46 AND 48).

FIRST USE 4-7-2008; IN COMMERCE 4-7-2008.  
SIMON TENG, EXAMINING ATTORNEY

**CLASS 32—(Continued).**

GRAY, AND BLUISH-GRAY FEATHERS, BLACK AND BROWN EYES, BROWN FEET, AND A BROWN AND GRAY BEAK, WITH GREEN PREY UNDER ITS LEFT TALON. BEHIND THE OWL IS A SCENIC NIGHT SKY BACKGROUND, WITH A GRAY AND BLUISH-GRAY NEW MOON, WHITE STARS, LIGHT BLUE AND DARK BLUE SKY, AND THE BLACK SILHOUETTES OF MOUNTAINS AND TREES. THE ENTIRE BOTTOM PORTION OF THE MARK IS ON A QUADRILATERAL WITH GOLD BORDERS.

FOR BEER, ALE, LAGER, STOUT, PORTER, SHANDY (U.S. CLS. 45, 46 AND 48).

FIRST USE 1-28-1998; IN COMMERCE 1-28-1998.  
KIMBERLY FRYE, EXAMINING ATTORNEY

SN 85-154,291. NO LABEL BREWING COMPANY, DBA NO LABEL, KATY, TX. FILED 10-16-2010.

**NO LABEL Brewing Company**

SN 85-148,992. COTLEIGH BREWERY LIMITED, TAUNTON TA4 2RE, ENGLAND, FILED 10-9-2010.



OWNER OF U.S. REG. NO. 3,818,874.  
NO CLAIM IS MADE TO THE EXCLUSIVE RIGHT TO USE "BREWERY" AND "PREMIUM ALE", APART FROM THE MARK AS SHOWN.

THE COLOR(S) BROWN, WHITE, CREAM, YELLOW, GRAY, BLUISH GRAY, RED, BLACK, LIGHT BROWN, DARK BLUE, LIGHT BLUE, GREEN AND GOLD IS/ARE CLAIMED AS A FEATURE OF THE MARK.

THE MARK CONSISTS OF THE WORDING "COTLEIGH BREWERY BARN OWL PREMIUM ALE BEERS OF PREY" AND THE DESIGN OF A BARN OWL ON A SCENIC BACKGROUND. THE WORDING "COTLEIGH BREWERY" APPEARS AT THE TOP OF THE MARK, ON A BLACK QUADRILATERAL BORDERED IN CREAM AND RED. THE WORD "COTLEIGH" IS YELLOW WITH RED BORDERING AND THE WORD "BREWERY" IS CREAM. THE WORDING "BARN OWL" IS WHITE WITH GOLD OUTLINING AND APPEARS ON A DARK BLUE BANNER THAT IS BORDERED IN GOLD STRIPES. AT THE BOTTOM OF THE BANNER IS THE WORDING "PREMIUM ALE" IN WHITE ON A BLUE RECTANGLE THAT IS BORDERED IN GOLD. UNDERNEATH THIS IS THE WORDING "BEERS OF PREY" IN GOLD AGAINST A BLACK BACKGROUND. IN THE MIDDLE PORTION OF THE MARK IS THE IMAGE OF A BARN OWL, WITH WHITE, BROWN, LIGHT BROWN,

THE MARK CONSISTS OF STANDARD CHARACTERS WITHOUT CLAIM TO ANY PARTICULAR FONT, STYLE, SIZE, OR COLOR.

NO CLAIM IS MADE TO THE EXCLUSIVE RIGHT TO USE "BREWING COMPANY", APART FROM THE MARK AS SHOWN.

FOR BEER, ALE, LAGER, STOUT, PORTER, SHANDY (U.S. CLS. 45, 46 AND 48).

FIRST USE 12-3-2008; IN COMMERCE 12-3-2008.  
JAY FLOWERS, EXAMINING ATTORNEY

SN 85-166,067. CC1 LIMITED PARTNERSHIP, TOA BAJA, PUERTO RICO, FILED 11-1-2010.

# Nikini

THE MARK CONSISTS OF STANDARD CHARACTERS WITHOUT CLAIM TO ANY PARTICULAR FONT, STYLE, SIZE, OR COLOR.

FOR BOTTLED WATER (U.S. CLS. 45, 46 AND 48).  
KEVIN DINALLO, EXAMINING ATTORNEY



**CLASS 32—(Continued).**

SN 85-170,258. BOYLAN BOTTLING CO., TETERBORO, NJ.  
FILED 11-5-2010.

**MASH**

THE MARK CONSISTS OF STANDARD CHARACTERS WITHOUT CLAIM TO ANY PARTICULAR FONT, STYLE, SIZE, OR COLOR.

FOR NON-ALCOHOLIC BEVERAGES, NAMELY, FRUIT-FLAVORED BEVERAGES (U.S. CLS. 45, 46 AND 48).

FIRST USE 4-23-2007; IN COMMERCE 4-23-2007.  
MYRIAH HABEEB, EXAMINING ATTORNEY

**CLASS 32—(Continued).**

SN 85-171,163. CC1 LIMITED PARTNERSHIP, TOA BAJA,  
PUERTO RICO, FILED 11-8-2010.

**Malta Carolina**

THE MARK CONSISTS OF STANDARD CHARACTERS WITHOUT CLAIM TO ANY PARTICULAR FONT, STYLE, SIZE, OR COLOR.

NO CLAIM IS MADE TO THE EXCLUSIVE RIGHT TO USE "MALTA", APART FROM THE MARK AS SHOWN.

THE ENGLISH TRANSLATION OF "MALTA" IN THE MARK IS "MALT".

FOR NON-ALCOHOLIC MALT BEVERAGE (U.S. CLS. 45, 46 AND 48).

MICHAEL ENGEL, EXAMINING ATTORNEY

SN 85-170,707. PRODUCTORA DE JUGOS S.A., TULUA,  
VALLE DEL CAUCA, COLOMBIA, FILED 11-5-2010.



OWNER OF COLOMBIA REG. NO. 402996, DATED 6-9-2010, EXPIRES 6-9-2020.

OWNER OF U.S. REG. NO. 3,765,721.

NO CLAIM IS MADE TO THE EXCLUSIVE RIGHT TO USE "TUTTI FRUTTI" AND "CON FRUTA NATURAL", APART FROM THE MARK AS SHOWN.

THE COLOR(S) YELLOW, RED AND GREEN IS/ARE CLAIMED AS A FEATURE OF THE MARK.

THE MARK CONSISTS OF THE TERMS "TUTTI FRUTTI" ON TWO LINES IN YELLOW STYLIZED LETTERS DISPLAYED AGAINST A RED CIRCULAR BACKGROUND WITH AN INNER YELLOW BORDER AND AN OUTER GREEN BORDER, SUPERIMPOSED ON AN INCOMPLETE DIAMOND WITH ONLY THE EDGES SHOWING, IN GREEN WITH AN INNER YELLOW BORDER AND AN OUTER GREEN BORDER. A STYLIZED GREEN LEAF WITH A YELLOW BORDER IS POSITIONED IN A HORIZONTAL FASHION ABOVE "TUTTI". BELOW "TUTTI FRUTTI" ARE THE TERMS "CON FRUTA NATURAL" DISPLAYED IN RED AGAINST A YELLOW BANNER WITH A GREEN BORDER.

THE ENGLISH TRANSLATION OF "CON FRUTA NATURAL" IN THE MARK IS "WITH NATURAL FRUIT".

FOR FRUIT DRINKS, FRUIT BEVERAGES, FRUIT JUICES, FRUIT FLAVORED BEVERAGES, NON-ALCOHOLIC BEVERAGES CONTAINING FRUIT JUICE (U.S. CLS. 45, 46 AND 48).

PATRICIA EVANKO, EXAMINING ATTORNEY

SN 85-190,580. DS WATERS OF AMERICA, INC., ATLANTA,  
GA. FILED 12-3-2010.

**MOUNT OLYMPUS**

THE MARK CONSISTS OF STANDARD CHARACTERS WITHOUT CLAIM TO ANY PARTICULAR FONT, STYLE, SIZE, OR COLOR.

OWNER OF U.S. REG. NO. 2,310,943.

FOR BOTTLED WATER (U.S. CLS. 45, 46 AND 48).

BARBARA RUTLAND, EXAMINING ATTORNEY

SN 85-196,630. ANCHOR BREWING COMPANY LLC, SAN FRANCISCO, CA. FILED 12-13-2010.

**HUMMING ALE**

THE MARK CONSISTS OF STANDARD CHARACTERS WITHOUT CLAIM TO ANY PARTICULAR FONT, STYLE, SIZE, OR COLOR.

NO CLAIM IS MADE TO THE EXCLUSIVE RIGHT TO USE "ALE", APART FROM THE MARK AS SHOWN.

FOR BEER, ALE AND LAGER (U.S. CLS. 45, 46 AND 48).

FIRST USE 10-22-2009; IN COMMERCE 11-4-2009.

JEFFREY LOOK, EXAMINING ATTORNEY

**CLASS 32—(Continued).**

SN 85-197,974. IROQUOIS BREWING CO., LLC, GETZVILLE, NY. FILED 12-15-2010.

# SIMON PURE

THE MARK CONSISTS OF STANDARD CHARACTERS WITHOUT CLAIM TO ANY PARTICULAR FONT, STYLE, SIZE, OR COLOR.

FOR BEER, ALE AND PORTER (U.S. CLS. 45, 46 AND 48).

HEATHER SAPP, EXAMINING ATTORNEY

**CLASS 32—(Continued).**

SN 85-204,656. SEIBALD, DANIEL, NEW YORK, NY. FILED 12-23-2010.

# HYCU

THE MARK CONSISTS OF THE LITERAL ELEMENT "HYCU" REPRESENTED IN STYLIZED FONT WHEREIN THE LETTER "U" IS UNDERLINED.

THE WORDING "HYCU" HAS NO MEANING IN A FOREIGN LANGUAGE.

FOR FRUIT-BASED BEVERAGES; NON-ALCOHOLIC BEVERAGES CONTAINING FRUIT JUICES; NON-ALCOHOLIC FRUIT JUICE BEVERAGES (U.S. CLS. 45, 46 AND 48).

RONALD DELGIZZI, EXAMINING ATTORNEY

SN 85-200,717. FULTON, LLC, MINNEAPOLIS, MN. FILED 12-17-2010.

# LONELY BLONDE ALE

THE MARK CONSISTS OF STANDARD CHARACTERS WITHOUT CLAIM TO ANY PARTICULAR FONT, STYLE, SIZE, OR COLOR.

NO CLAIM IS MADE TO THE EXCLUSIVE RIGHT TO USE "BLONDE ALE", APART FROM THE MARK AS SHOWN.

FOR BEER (U.S. CLS. 45, 46 AND 48).

FIRST USE 6-28-2009; IN COMMERCE 6-1-2010.  
DARRYL SPRUILL, EXAMINING ATTORNEY

SN 85-205,761. BE ENTERPRISE PROPERTIES, LLC, KNOXVILLE, TN. FILED 12-27-2010.

# LIQUID PSYCHO

THE MARK CONSISTS OF STANDARD CHARACTERS WITHOUT CLAIM TO ANY PARTICULAR FONT, STYLE, SIZE, OR COLOR.

NO CLAIM IS MADE TO THE EXCLUSIVE RIGHT TO USE "LIQUID", APART FROM THE MARK AS SHOWN.

FOR ENERGY DRINKS (U.S. CLS. 45, 46 AND 48).

ZHALEH DELANEY, EXAMINING ATTORNEY

SN 85-205,810. ROWELL, DEBRA I, LAWTON, OK. FILED 12-27-2010.

SN 85-203,174. GREATER GOOD INC., CHESTNUT HILL, MA. FILED 12-21-2010.

# ICAN

THE MARK CONSISTS OF STANDARD CHARACTERS WITHOUT CLAIM TO ANY PARTICULAR FONT, STYLE, SIZE, OR COLOR.

FOR FLAVORED WATER; MINERAL WATER; SPRING WATER; DRINKING WATER (U.S. CLS. 45, 46 AND 48).

DOMINICK J. SALEMI, EXAMINING ATTORNEY



Red Earth Water  
Earth's Gift of Life

NO CLAIM IS MADE TO THE EXCLUSIVE RIGHT TO USE "WATER", APART FROM THE MARK AS SHOWN.

THE STIPPLING IS FOR SHADING PURPOSES ONLY.

THE MARK CONSISTS OF A TRADITIONAL INDIAN STYLE "THUNDER BIRD" WITH A FAN TAILED ENCLOSED IN A WATER DROP. INSIDE THERE IS THE STYLIZED TEXT "RED EARTH WATER". TO THE RIGHT THERE IS THE STYLIZED TEXT "RED EARTH WATER EARTH'S GIFT OF LIFE".

FOR BOTTLED WATER; DRINKING WATER (U.S. CLS. 45, 46 AND 48).

DOMINICK J. SALEMI, EXAMINING ATTORNEY

**CLASS 32—(Continued).**

SN 85-206,014. J1 GROUP, INC., MINNEAPOLIS, MN. FILED 12-27-2010.

**NO SHOES BEER**

THE MARK CONSISTS OF STANDARD CHARACTERS WITHOUT CLAIM TO ANY PARTICULAR FONT, STYLE, SIZE, OR COLOR.

NO CLAIM IS MADE TO THE EXCLUSIVE RIGHT TO USE "BEER", APART FROM THE MARK AS SHOWN.

FOR BEER, ALE, LAGER, STOUT AND PORTER (U.S. CLS. 45, 46 AND 48).

SANJEEV VOHRA, EXAMINING ATTORNEY

SN 85-206,122. OSKAR BLUES BREWERY LLC, LONGMONT, CO. FILED 12-27-2010.



NO CLAIM IS MADE TO THE EXCLUSIVE RIGHT TO USE "IMPERIAL STOUT", APART FROM THE MARK AS SHOWN.

THE MARK CONSISTS OF AN OVAL DESIGN WITH THE WORDS "TEN FIDY" CENTERED WITHIN THE OVAL, AND "IMPERIAL STOUT" UNDERNEATH "TEN FIDY". "TEN FIDY" ALSO HAS AN IMPERIAL CROWN DESIGN ON TOP OF THE "I" OF THE WORD "TEN FIDY".

THE WORDING "TEN FIDY" HAS NO MEANING IN A FOREIGN LANGUAGE.

FOR BEER, ALE, LAGER, STOUT AND PORTER (U.S. CLS. 45, 46 AND 48).

FIRST USE 1-1-2007; IN COMMERCE 1-1-2007.

ELIZABETH HUGHITT, EXAMINING ATTORNEY

SN 85-206,305. 603 BEVERAGE, INC., CARLSBAD, CA. FILED 12-28-2010.

**GO BIG ENERGY**

THE MARK CONSISTS OF STANDARD CHARACTERS WITHOUT CLAIM TO ANY PARTICULAR FONT, STYLE, SIZE, OR COLOR.

NO CLAIM IS MADE TO THE EXCLUSIVE RIGHT TO USE "ENERGY", APART FROM THE MARK AS SHOWN.

FOR NON-ALCOHOLIC FLAVORED ENERGY DRINK BEVERAGES (U.S. CLS. 45, 46 AND 48).

JEFFERY COWARD, EXAMINING ATTORNEY

**CLASS 32—(Continued).**

SN 85-209,515. BODY ARMOR NUTRITION, LLC, BEVERLEY HILLS, CA. FILED 1-3-2011.

**BA Energy**

THE MARK CONSISTS OF STANDARD CHARACTERS WITHOUT CLAIM TO ANY PARTICULAR FONT, STYLE, SIZE, OR COLOR.

NO CLAIM IS MADE TO THE EXCLUSIVE RIGHT TO USE "ENERGY", APART FROM THE MARK AS SHOWN.

FOR ISOTONIC DRINKS; SPORTS DRINKS, NAMELY, ENERGY DRINKS (U.S. CLS. 45, 46 AND 48).

ANDREA K. NADELMAN, EXAMINING ATTORNEY

SN 85-210,435. THE ZANIA CORPORATION, DBA ZANIA PURE JUICERS, BROOKLYN, NY. FILED 1-4-2011.

**ZANIA**

THE MARK CONSISTS OF STANDARD CHARACTERS WITHOUT CLAIM TO ANY PARTICULAR FONT, STYLE, SIZE, OR COLOR.

THE ENGLISH TRANSLATION OF THE WORD "ZANIA" IN THE MARK IS SOLUTIONS.

FOR FRUIT DRINKS AND FRUIT JUICES (U.S. CLS. 45, 46 AND 48).

FIRST USE 9-7-1998; IN COMMERCE 9-7-1998.

MAYUR VAGHANI, EXAMINING ATTORNEY

SN 85-213,656. GRAIN TO GREEN, CARLSBAD, CA. FILED 1-9-2011.

**CARLSBAD CHRONIC**

THE MARK CONSISTS OF STANDARD CHARACTERS WITHOUT CLAIM TO ANY PARTICULAR FONT, STYLE, SIZE, OR COLOR.

NO CLAIM IS MADE TO THE EXCLUSIVE RIGHT TO USE "CARLSBAD", APART FROM THE MARK AS SHOWN.

FOR BEER (U.S. CLS. 45, 46 AND 48).

FIRST USE 5-1-1997; IN COMMERCE 5-1-1997.

WARREN L. OLANDRIA, EXAMINING ATTORNEY

**CLASS 32—(Continued).**

SN 85-215,396. DAESANG AMERICA, INC., HACKENSACK, NJ. FILED 1-11-2011.

# VINKI

THE MARK CONSISTS OF STANDARD CHARACTERS WITHOUT CLAIM TO ANY PARTICULAR FONT, STYLE, SIZE, OR COLOR.

THE ENGLISH TRANSLATION OF "KI" IN THE MARK IS ENERGY.

FOR BEAUTY BEVERAGES, NAMELY, FRUIT JUICES AND ENERGY DRINKS CONTAINING NUTRITIONAL SUPPLEMENTS; ENERGY DRINKS; FRUIT BEVERAGES; FRUIT DRINKS; FRUIT DRINKS AND FRUIT JUICES; FRUIT DRINKS AND JUICES; FRUIT FLAVORED DRINKS; FRUIT FLAVORED SOFT DRINKS; FRUIT FLAVOURED DRINKS; FRUIT JUICES AND FRUIT DRINKS; FRUIT-BASED BEVERAGES; FRUIT-FLAVORED BEVERAGES; FRUIT-FLAVOURED BEVERAGES; NON-ALCOHOLIC BEVERAGES CONTAINING FRUIT JUICES; NON-ALCOHOLIC FRUIT JUICE BEVERAGES; SOFT DRINKS; SPORTS DRINKS; SPORTS DRINKS, NAMELY, ENERGY DRINKS; VEGETABLE DRINKS; VEGETABLE JUICE; VEGETABLE JUICES (U.S. CLS. 45, 46 AND 48).

KATHERINE M. DUBRAY, EXAMINING ATTORNEY

**CLASS 32—(Continued).**

SN 85-219,065. CATCO VATN ICELAND SPRING Á ÍSLANDI EHF., 110 REYKJAVÍK, ICELAND, FILED 1-17-2011.

# PLAY LONGER

THE MARK CONSISTS OF STANDARD CHARACTERS WITHOUT CLAIM TO ANY PARTICULAR FONT, STYLE, SIZE, OR COLOR.

FOR SPRING WATER (U.S. CLS. 45, 46 AND 48).  
RUSS HERMAN, EXAMINING ATTORNEY

SN 85-235,406. ALDI INC., BATAVIA, IL. FILED 2-7-2011.

# N2

THE MARK CONSISTS OF STANDARD CHARACTERS WITHOUT CLAIM TO ANY PARTICULAR FONT, STYLE, SIZE, OR COLOR.

FOR ENERGY DRINKS; ISOTONIC DRINKS; SPORTS DRINKS (U.S. CLS. 45, 46 AND 48).  
NAKIA HENRY, EXAMINING ATTORNEY

SN 85-252,090. MAD SCIENTISTS BREWING PARTNERS LLC, DBA SIXPOINT CRAFT ALES, BROOKLYN, NY. FILED 2-25-2011.

SN 85-219,046. CATCO VATN ICELAND SPRING Á ÍSLANDI EHF., 110 REYKJAVÍK, ICELAND, FILED 1-17-2011.



OWNER OF U.S. REG. NOS. 2,633,631 AND 2,822,044.  
THE COLOR(S) DARK BLUE, RED, GREEN, LIGHT BLUE, YELLOW AND GRAY IS/ARE CLAIMED AS A FEATURE OF THE MARK.

THE MARK CONSISTS OF THE LETTERS "SPRING" IN DARK BLUE, THE LETTER "L" IN RED, THE LETTER "E" IN GREEN, THE LETTER "T" IN LIGHT BLUE, THE LETTER "S" IN YELLOW, AND ALL LETTERS HAVE A GRAY BORDER.

FOR SPRING WATER (U.S. CLS. 45, 46 AND 48).  
RUSS HERMAN, EXAMINING ATTORNEY

SN 85-219,056. CATCO VATN ICELAND SPRING Á ÍSLANDI EHF., 110 REYKJAVÍK, ICELAND, FILED 1-17-2011.

# ICELAND SPRINGLETS

THE MARK CONSISTS OF STANDARD CHARACTERS WITHOUT CLAIM TO ANY PARTICULAR FONT, STYLE, SIZE, OR COLOR.

OWNER OF U.S. REG. NOS. 2,633,631 AND 2,822,044.  
NO CLAIM IS MADE TO THE EXCLUSIVE RIGHT TO USE "ICELAND", APART FROM THE MARK AS SHOWN.  
FOR SPRING WATER (U.S. CLS. 45, 46 AND 48).  
RUSS HERMAN, EXAMINING ATTORNEY

# HARBINGER

THE MARK CONSISTS OF STANDARD CHARACTERS WITHOUT CLAIM TO ANY PARTICULAR FONT, STYLE, SIZE, OR COLOR.

FOR BEER (U.S. CLS. 45, 46 AND 48).  
FIRST USE 2-18-2011; IN COMMERCE 2-18-2011.  
STEPHANIE ALI, EXAMINING ATTORNEY

**CLASS 32—(Continued).**

SN 85-260,658. AHOLD LICENSING SARL, GENEVA, SWITZERLAND, FILED 3-8-2011.



OWNER OF U.S. REG. NOS. 2,871,579, 3,682,647 AND OTHERS.

THE COLOR(S) ORANGE, GRAY AND WHITE IS/ARE CLAIMED AS A FEATURE OF THE MARK.

THE MARK CONSISTS OF THE TRADE DRESS CHARACTERIZING THE FRONT FACE OF THE PACKAGING FOR APPLICANT'S GOODS, NAMELY (1) A WHITE HORIZONTAL BAR SPANNING THE LABEL OR PACKAGE FACE, (2) AN ORANGE BAR BELOW THE WHITE BAR, ALSO SPANNING THE LABEL OR PACKAGE FACE, (3) A DASHED LINE THAT APPEARS GRAY ON THE WHITE BACKGROUND AND WHITE ON THE ORANGE BACKGROUND. THE DASHED LINE EXTENDS HORIZONTALLY ALONG THE WHITE BAR, AND TURNS 90 DEGREES AT EACH END TO EXTEND DOWNWARDS INTO THE ORANGE BAR. THE DESIGN FURTHER COMPRISES (4) A GRAY SCISSORS DESIGN AND (5) THE WORD "GUARANTEED" APPEARING IN ORANGE ABOVE THE GRAY LINE AND THE WORD "VALUE" APPEARING IN ORANGE BELOW THE GRAY LINE.

SEC. 2(F) AS TO "GUARANTEED VALUE".

FOR CONCENTRATES, SYRUPS OR POWDERS USED IN THE PREPARATION OF SOFT DRINKS; FRUIT JUICE; SOFT DRINKS (U.S. CLS. 45, 46 AND 48).

BRIDGETT SMITH, EXAMINING ATTORNEY

SN 85-260,934. AHOLD LICENSING SARL, GENEVA, SWITZERLAND, FILED 3-8-2011.



OWNER OF U.S. REG. NOS. 2,871,579, 3,147,919 AND 3,682,647.

THE MARK CONSISTS OF A SCISSORS DESIGN WITH A DASHED LINE EXTENDING TO THE RIGHT OF THE SCISSORS. THE WORD "GUARANTEED" APPEARS ABOVE THE LINE AND THE WORD "VALUE" APPEARS BELOW THE LINE.

SEC. 2(F) AS TO "GUARANTEED VALUE".

FOR CONCENTRATES, SYRUPS OR POWDERS USED IN THE PREPARATION OF SOFT DRINKS; FRUIT JUICE; SOFT DRINKS (U.S. CLS. 45, 46 AND 48).

BRIDGETT SMITH, EXAMINING ATTORNEY

**CLASS 33—WINES AND SPIRITS**

SN 76-705,842. MALGOR & CO., INC., CATAÑO, PUERTO RICO, FILED 12-29-2010.

**TRES CASTILLOS**

THE MARK CONSISTS OF STANDARD CHARACTERS WITHOUT CLAIM TO ANY PARTICULAR FONT, STYLE, SIZE, OR COLOR.

THE ENGLISH TRANSLATION OF "TRES CASTILLOS" IS "THREE CASTLES".

FOR LIQUEURS (U.S. CLS. 47 AND 49).

FIRST USE 0-0-1936; IN COMMERCE 0-0-1988.

JOHN SCHUYLER YARD, EXAMINING ATTORNEY

SN 76-705,847. MALGOR & CO., INC., CATAÑO, PUERTO RICO, FILED 12-29-2010.

**CARIBEO**

THE MARK CONSISTS OF STANDARD CHARACTERS WITHOUT CLAIM TO ANY PARTICULAR FONT, STYLE, SIZE, OR COLOR.

FOR WINES, LIQUOR AND RUM (U.S. CLS. 47 AND 49).

JOHN SCHUYLER YARD, EXAMINING ATTORNEY

SN 77-692,482. ICONOCLAST BEVERAGE COMPANY LLC, ROSEMEAD, CA. FILED 3-17-2009.



THE MARK CONSISTS OF A SCROLL CONTAINING THE WORDS "SINO" AND A SQUARE SHIELD CONTAINING THE LETTER "S" IN STYLIZED FONT.

THE ENGLISH TRANSLATION OF "SINO" IN THE MARK IS "DESTINY".

FOR ALCOHOLIC BEVERAGES, NAMELY, TEQUILA (U.S. CLS. 47 AND 49).

RONALD MCMORROW, EXAMINING ATTORNEY



**CLASS 33—(Continued).**

SN 77-798,090. PAGO DE LUNA, S.L., VALENCIA, SPAIN, FILED 8-5-2009.

PAGO DE LUNA

THE MARK CONSISTS OF STANDARD CHARACTERS WITHOUT CLAIM TO ANY PARTICULAR FONT, STYLE, SIZE, OR COLOR.

OWNER OF SPAIN REG. NO. 2507886, DATED 5-20-2003, EXPIRES 10-14-2012.

NO CLAIM IS MADE TO THE EXCLUSIVE RIGHT TO USE "PAGO", APART FROM THE MARK AS SHOWN.

THE ENGLISH TRANSLATION OF "PAGO DE LUNA" IN THE MARK IS "ESTATE" OR "VINEYARD LOT OF THE MOON".

FOR ALCOHOLIC BEVERAGES EXCEPT BEERS (U.S. CLS. 47 AND 49).

KATHLEEN M. VANSTON, EXAMINING ATTORNEY

**CLASS 33—(Continued).**

SN 79-083,899. CASTELL D'OR, S.L., E-08720 VILAFRANCA DEL PENEDES (BARCELON, SPAIN, FILED 5-27-2010.

PUPI TRE

THE MARK CONSISTS OF STANDARD CHARACTERS WITHOUT CLAIM TO ANY PARTICULAR FONT, STYLE, SIZE, OR COLOR.

OWNER OF INTERNATIONAL REGISTRATION 1042462 DATED 5-27-2010, EXPIRES 5-27-2020.

THE ENGLISH TRANSLATION OF THE WORD "PUPI TRE" IN THE MARK IS "DESK".

FOR WINES (U.S. CLS. 47 AND 49).

LANA PHAM, EXAMINING ATTORNEY

SN 79-086,684. BANCA MONTE DEI PASCHI DI SIENA S.P.A., ITALY, FILED 7-16-2010.

SN 77-909,630. VOLPÉ DISTILLERIES, INC., POINT VENTURE, TX. FILED 1-12-2010.



NO CLAIM IS MADE TO THE EXCLUSIVE RIGHT TO USE "HAND CRAFTED RUM", APART FROM THE MARK AS SHOWN.

THE COLOR(S) RED, BLACK, WHITE, BROWN, AND BRONZE IS/ARE CLAIMED AS A FEATURE OF THE MARK.

THE MARK CONSISTS OF A RED MOON WITH THE BLACK SILHOUETTE OF A STANDING FOX IN THE MIDDLE OF THE MOON, AND THE BLACK LETTER "V" SUPERIMPOSED OVER THE MOON. THE WORD "KARDIAC" IN RED AND OUTLINED IN WHITE IS SUPERIMPOSED OVER THE MOON AND LETTER "V" DESIGN. BELOW THE WORD "KARDIAC" IS THE WORDING "HAND CRAFTED RUM" IN THE COLOR WHITE. A RAGGED PIECE OF BROWN PARCHMENT PAPER EXTENDS FROM SIDE TO SIDE AND BEHIND THE MOON AND FOX DESIGN. THE WORD "VOLPÉ" IN THE COLOR WHITE APPEARS ABOVE THE MOON AND FOX DESIGN. THE ENTIRE LOGO SITS ON TOP OF A DESIGN OF VINES IN THE COLOR BRONZE AND A BLACK BACKGROUND.

THE ENGLISH TRANSLATION OF "VOLPÉ" IN THE MARK IS "FOX".

FOR DISTILLED SPIRIT PRODUCTS, NAMELY, RUM FOR CONSUMERS (U.S. CLS. 47 AND 49).

FIRST USE 7-13-2009; IN COMMERCE 7-13-2009.  
BARBARA GAYNOR, EXAMINING ATTORNEY



PRIORITY DATE OF 5-28-2010 IS CLAIMED.  
OWNER OF INTERNATIONAL REGISTRATION 1049298 DATED 7-16-2010, EXPIRES 7-16-2020.

NO CLAIM IS MADE TO THE EXCLUSIVE RIGHT TO USE "ROSSO", APART FROM THE MARK AS SHOWN.

THE COLOR(S) RED, WHITE AND BLACK IS/ARE CLAIMED AS A FEATURE OF THE MARK.

THE MARK CONSISTS OF A WHITE VERTICAL RECTANGLE WITH THE WORD "ROSSO" WRITTEN IN BLACK HORIZONTALLY ABOVE THE TERM "1472" WRITTEN IN RED VERTICALLY UNDERNEATH.

THE ENGLISH TRANSLATION OF THE FOREIGN WORD(S) IN THE MARK IS "RED".

FOR ALCOHOLIC BEVERAGES EXCEPT BEERS (U.S. CLS. 47 AND 49).

ALYSSA STEEL, EXAMINING ATTORNEY

**CLASS 33—(Continued).**

SN 79-086,685. BANCA MONTE DEI PASCHI DI SIENA S.P.A., ITALY, FILED 7-16-2010.



PRIORITY DATE OF 5-28-2010 IS CLAIMED.  
OWNER OF INTERNATIONAL REGISTRATION 1049299 DATED 7-16-2010, EXPIRES 7-16-2020.  
NO CLAIM IS MADE TO THE EXCLUSIVE RIGHT TO USE "ROSSO", APART FROM THE MARK AS SHOWN.  
THE COLOR(S) RED, BLACK AND WHITE IS/ARE CLAIMED AS A FEATURE OF THE MARK.  
THE MARK CONSISTS OF A SHADED BLACK VERTICAL RECTANGLE, WITH THE WORD "ROSSO" IN RED SUPERIMPOSED AT THE TOP HORIZONTALLY, APPEARING ABOVE THE TERM "1472" APPEARING IN WHITE SUPERIMPOSED VERTICALLY.  
THE ENGLISH TRANSLATION OF THE FOREIGN WORD(S) IN THE MARK IS "RED".  
FOR ALCOHOLIC BEVERAGES EXCEPT BEERS (U.S. CLS. 47 AND 49).  
ALYSSA STEEL, EXAMINING ATTORNEY

**CLASS 33—(Continued).**

SN 79-087,172. BANCA MONTE DEI PASCHI DI SIENA S.P.A., ITALY, FILED 7-16-2010.

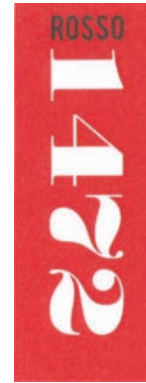

PRIORITY DATE OF 5-28-2010 IS CLAIMED.  
OWNER OF INTERNATIONAL REGISTRATION 1050612 DATED 7-16-2010, EXPIRES 7-16-2020.  
NO CLAIM IS MADE TO THE EXCLUSIVE RIGHT TO USE "ROSSO", APART FROM THE MARK AS SHOWN.  
THE COLOR(S) RED, BLACK AND WHITE IS/ARE CLAIMED AS A FEATURE OF THE MARK.  
THE MARK CONSISTS OF A SHADED RED VERTICAL RECTANGLE, WITH THE WORD "ROSSO" IN BLACK SUPERIMPOSED AT THE TOP HORIZONTALLY, APPEARING ABOVE THE TERM "1472" APPEARING IN WHITE SUPERIMPOSED VERTICALLY.  
THE ENGLISH TRANSLATION OF THE FOREIGN WORD(S) IN THE MARK IS: "RED".  
FOR ALCOHOLIC BEVERAGES EXCEPT BEERS (U.S. CLS. 47 AND 49).  
ALYSSA STEEL, EXAMINING ATTORNEY

SN 79-086,781. SOCIEDADE DOS VINHOS BORGES, S.A., PORTUGAL, FILED 6-30-2010.

**MEIA ENCOSTA**  
Portugal

OWNER OF INTERNATIONAL REGISTRATION 0390110 DATED 6-30-1972, EXPIRES 6-30-2012.  
OWNER OF U.S. REG. NO. 1,823,081.  
NO CLAIM IS MADE TO THE EXCLUSIVE RIGHT TO USE "PORTUGAL", APART FROM THE MARK AS SHOWN.  
THE ENGLISH TRANSLATION OF THE FOREIGN WORD(S) IN THE MARK IS: HALF SLOPE.  
FOR TABLE WINES (U.S. CLS. 47 AND 49).  
JOHN DALIER, EXAMINING ATTORNEY

SN 79-087,337. FOSTER'S BRANDS LIMITED, UNITED KINGDOM, FILED 8-20-2010.

**ROSEMOUNT BOTANICALS**

THE MARK CONSISTS OF STANDARD CHARACTERS WITHOUT CLAIM TO ANY PARTICULAR FONT, STYLE, SIZE, OR COLOR.  
PRIORITY DATE OF 3-10-2010 IS CLAIMED.  
OWNER OF INTERNATIONAL REGISTRATION 1051009 DATED 8-20-2010, EXPIRES 8-20-2020.  
OWNER OF U.S. REG. NOS. 1,337,079, 2,739,047 AND 2,884,095.  
NO CLAIM IS MADE TO THE EXCLUSIVE RIGHT TO USE "BOTANICALS", APART FROM THE MARK AS SHOWN.  
FOR WINE (U.S. CLS. 47 AND 49).  
HENRY S. ZAK, EXAMINING ATTORNEY

**CLASS 33—(Continued).**

SN 79-090,149. IPPONGI KUBOHONTEN CO., LTD., JAPAN,  
FILED 11-2-2010.



OWNER OF INTERNATIONAL REGISTRATION 1058763  
DATED 11-2-2010, EXPIRES 11-2-2020.

THE MARK CONSISTS OF THE STYLIZED WORDING  
"IPPONGI" AND THREE CHINESE CHARACTERS.

THE NON-LATIN CHARACTERS IN THE MARK TRANS-  
LITERATE TO "IPPONGI" AND THIS HAS NO MEANING  
IN A FOREIGN LANGUAGE.

FOR SAKE (U.S. CLS. 47 AND 49).

ROBERT STRUCK, EXAMINING ATTORNEY

SN 79-090,181. IPPONGI KUBOHONTEN CO., LTD., JAPAN,  
FILED 11-2-2010.



OWNER OF INTERNATIONAL REGISTRATION 1058872  
DATED 11-2-2010, EXPIRES 11-2-2020.

THE MARK CONSISTS OF CHINESE CHARACTERS.  
THE NON-LATIN CHARACTERS IN THE MARK TRANS-  
LITERATE TO "DENSHIN" AND THIS MEANS "COMMU-  
NICATION OF THE MIND" IN ENGLISH.

FOR SAKE (U.S. CLS. 47 AND 49).

ROBERT STRUCK, EXAMINING ATTORNEY

**CLASS 33—(Continued).**

SN 79-090,514. MAISON HEBRARD, F-33126 FRONSAC,  
FRANCE, FILED 11-17-2010.



THE MARK CONSISTS OF STANDARD CHARACTERS  
WITHOUT CLAIM TO ANY PARTICULAR FONT, STYLE,  
SIZE, OR COLOR.

PRIORITY DATE OF 6-15-2010 IS CLAIMED.

OWNER OF INTERNATIONAL REGISTRATION 1059878  
DATED 11-17-2010, EXPIRES 11-17-2020.

FOR ALCOHOLIC BEVERAGES EXCEPT BEERS;  
WINES, SPIRITS, ALCOHOLIC ESSENCES AND EX-  
TRACTS, ALCOHOLIC BEVERAGES CONTAINING  
FRUIT, ALCOHOLIC BEVERAGES IN THE NATURE  
OF DIGESTIFS, SPARKLING WINES, BIOLOGICAL  
WINES, ORGANIC WINES (U.S. CLS. 47 AND 49).

REBECCA GILBERT, EXAMINING ATTORNEY

SN 79-090,802. "YEREVAN ARARAT BRANDY-WINE-VOD-  
KA FACTORY" OJSC, ARMENIA, FILED 10-14-2010.





OWNER OF INTERNATIONAL REGISTRATION 1009080  
DATED 3-16-2009, EXPIRES 3-16-2019.

NO CLAIM IS MADE TO THE EXCLUSIVE RIGHT TO  
USE "CLASSIC", APART FROM THE MARK AS SHOWN.

THE ENGLISH TRANSLATION OF THE FOREIGN  
WORD(S) IN THE MARK IS "NOY CLASSIC".

THE TRANSLITERATION OF THE NON-LATIN CHAR-  
ACTERS IN THE MARK IS "NOY CLASSIC".

FOR ALCOHOLIC BEVERAGES EXCEPT BEER AND  
WINE, NAMELY, BRANDY (U.S. CLS. 47 AND 49).

CHRISTOPHER BUONGIORNO, EXAMINING ATTOR-  
NEY

**CLASS 33—(Continued).**

SN 79-090,803. "YEREVAN ARABAT BRANDY-WINE-VODKA FACTORY" OJSC, ARMENIA, FILED 10-14-2010.

ՆՈՅ ԱՐԱՍՊԵԼ  
НОЙ АРАСПЕЛ  
NOY ARASPEL

OWNER OF INTERNATIONAL REGISTRATION 1015798 DATED 3-16-2009, EXPIRES 3-16-2019.

THE ENGLISH TRANSLATION OF THE FOREIGN WORD(S) IN THE MARK IS NOY MYTH.

THE TRANSLITERATION OF THE NON-LATIN CHARACTERS IN THE MARK IS "NOY ARASPEL".

FOR ALCOHOLIC BEVERAGES EXCEPT BEER AND WINE, NAMELY, BRANDY (U.S. CLS. 47 AND 49).

CHRISTOPHER BUONGIORNO, EXAMINING ATTORNEY

SN 79-092,559. YEREVAN BRANDY COMPANY, CJSC, ARMENIA, FILED 11-4-2010.



PRIORITY DATE OF 5-5-2010 IS CLAIMED.

OWNER OF INTERNATIONAL REGISTRATION 1065091 DATED 11-4-2010, EXPIRES 11-4-2020.

OWNER OF U.S. REG. NOS. 1,983,815, 3,467,999 AND OTHERS.

THE COLOR(S) GOLDEN BEIGE, CLARET, BROWN, DARK BROWN, BLACK AND WHITE IS/ARE CLAIMED AS A FEATURE OF THE MARK.

THE MARK CONSISTS OF A QUADRILATERAL-SHAPED BOTTLE LABEL HAVING A ROUNDED TOP SIDE. THE OUTER PORTION OF THE LABEL APPEARS IN GOLDEN BEIGE, WITH AN INTERIOR AREA OUTLINED BY A THICK BLACK LINE THAT TRACES THE INTERIOR SHAPE OF THE LABEL, AND ALSO HAS A BOTTOM PORTION WITH A BLACK BACKGROUND. A THIN BROWN LINE TRACES THE INTERIOR SHAPE OF THE LABEL BETWEEN THE OUTER GOLDEN BEIGE PORTION, AND AN INNER GOLDEN BEIGE PORTION JUST BEFORE THE BLACK-OUTLINED INTERIOR AREA. WITHIN THE BLACK BACKGROUND OF THE INTERIOR IS A SERIES OF MEN IN CHARIOTS BEING LED BY HORSES, WITH ADDITIONAL MEN ON FOOT IN FRONT OF TWO OF THE CHARIOTS. THE MEN, HORSES, AND CHARIOTS ALL APPEAR IN GOLDEN BEIGE WITH BLACK OUTLINE AND DETAILING. BENEATH THEM IS A DARK BROWN QUADRILATERAL OUTLINED BY A THICK GOLDEN BEIGE LINE. ABOVE THEM IS AN AREA OUTLINED IN A THIN GOLDEN BEIGE LINE, FOLLOWED BY A THIN BLACK OUTLINE FORMING AN INNER AREA. THIS AREA CONTAINS A CLARET AND BLACK TOP AREA BEHIND AN IMAGE OF A MOUNTAIN RANGE APPEARING IN WHITE WITH GOLDEN BEIGE AND

**CLASS 33—(Continued).**

BROWN SHADING, UNDERNEATH WHICH IS THE WORDING "ARARAT", WITH WHITE LETTERS HAVING BROWN SHADING ALONG SOME EDGES, AND A BLACK OUTLINE. THERE IS A GOLDEN BEIGE BACKGROUND IN THIS INNER AREA. BENEATH "ARARAT" IS THE STYLIZED WORDING "NAIRI" IN BLACK LETTERS WITH WHITE OUTLINE, FOLLOWED BY A BLACK DOT OUTLINED IN WHITE, AND THEN NON-LATIN CHARACTERS IN BLACK LETTERS WITH WHITE OUTLINE THAT TRANSLITERATE TO "NAIRI".

THE TRANSLITERATION OF THE NON-LATIN CHARACTERS IN THE MARK IS: "NAIRI".

FOR ALCOHOLIC BEVERAGES EXCEPT BEER, NAMELY, BRANDY (U.S. CLS. 47 AND 49).

ANDREA HACK, EXAMINING ATTORNEY

SN 79-092,848. ROBERT OATLEY VINEYARDS PTY LTD, AUSTRALIA, FILED 1-13-2011.

# CHAIN OF FIRE

THE MARK CONSISTS OF STANDARD CHARACTERS WITHOUT CLAIM TO ANY PARTICULAR FONT, STYLE, SIZE, OR COLOR.

OWNER OF INTERNATIONAL REGISTRATION 1065880 DATED 1-13-2011, EXPIRES 1-13-2021.

FOR WINE (U.S. CLS. 47 AND 49).

KAREN SEVERSON, EXAMINING ATTORNEY

SN 79-092,926. DISTILLERIE GILBERT MICLO (SOCIÉTÉ PAR ACTIONS SIMPLIFIÉE), FRANCE, FILED 1-13-2011.

# GOLD UP

THE MARK CONSISTS OF STANDARD CHARACTERS WITHOUT CLAIM TO ANY PARTICULAR FONT, STYLE, SIZE, OR COLOR.

PRIORITY DATE OF 9-3-2010 IS CLAIMED.

OWNER OF INTERNATIONAL REGISTRATION 1066106 DATED 1-13-2011, EXPIRES 1-13-2021.

FOR SPIRITS, LIQUEURS, BRANDY, VODKA (U.S. CLS. 47 AND 49).

KAREN SEVERSON, EXAMINING ATTORNEY

SN 79-092,928. CANTINA DELLA VOLTA DI CHRISTIAN BELLEI & C. S.R.L., I-41030 BOMPORTO (MO), ITALY, FILED 12-15-2010.

# CANTINA DELLA VOLTA

THE MARK CONSISTS OF STANDARD CHARACTERS WITHOUT CLAIM TO ANY PARTICULAR FONT, STYLE, SIZE, OR COLOR.

PRIORITY DATE OF 7-6-2010 IS CLAIMED.

OWNER OF INTERNATIONAL REGISTRATION 1066113 DATED 12-15-2010, EXPIRES 12-15-2020.

THE ENGLISH TRANSLATION OF THE FOREIGN WORD(S) IN THE MARK IS: "CELLAR OF VAULT".

FOR ALCOHOLIC BEVERAGES EXCEPT BEERS; APERITIF WINES; RED WINES; SPARKLING WINES; STILL WINES; SWEET WINES; TABLE WINES; WHITE WINES; WINES; SPIRITS AND LIQUEURS (U.S. CLS. 47 AND 49).

JAMES STEIN, EXAMINING ATTORNEY

**CLASS 33—(Continued).**

SN 85-003,077. FINCAS PATAGONICAS, S.A., 5507 MENDOZA, ARGENTINA, FILED 3-31-2010.

# ZOLO

THE MARK CONSISTS OF STANDARD CHARACTERS WITHOUT CLAIM TO ANY PARTICULAR FONT, STYLE, SIZE, OR COLOR.

THE WORDING "ZOLO" HAS NO MEANING IN A FOREIGN LANGUAGE.

FOR WINES AND SPARKLING WINES (U.S. CLS. 47 AND 49).

FIRST USE 8-15-2006; IN COMMERCE 8-15-2006.

MARK SHINER, EXAMINING ATTORNEY

SN 85-004,195. BM SPIRITS CANADA INC., MONTREAL, QUEBEC, CANADA, FILED 4-1-2010.



MELANZ  
VODKA

PRIORITY CLAIMED UNDER SEC. 44(D) ON CANADA APPLICATION NO. 1473513, FILED 3-17-2010, REG. NO. 789504, DATED 2-11-2011, EXPIRES 2-2-2026.

NO CLAIM IS MADE TO THE EXCLUSIVE RIGHT TO USE "MELANZ" AND "VODKA", APART FROM THE MARK AS SHOWN.

THE MARK CONSISTS OF THE WORDS "MELANZ" AND "VODKA" IN STYLIZED LETTERS AND DESIGN OF THE SYMBOL SMALLER OR EQUAL TO.

THE ENGLISH TRANSLATION OF "MELANZ" IN THE MARK IS MIX.

FOR VODKA (U.S. CLS. 47 AND 49).

CHARISMA HAMPTON, EXAMINING ATTORNEY

SN 85-013,976. BODEGA DANTE ROBINO S.A., BUENOS AIRES, ARGENTINA, FILED 4-14-2010.

# CALDEN

THE MARK CONSISTS OF STANDARD CHARACTERS WITHOUT CLAIM TO ANY PARTICULAR FONT, STYLE, SIZE, OR COLOR.

FOR WINES (U.S. CLS. 47 AND 49).

GIANCARLO CASTRO, EXAMINING ATTORNEY

**CLASS 33—(Continued).**

SN 85-041,817. ENCOMIENDA DE CERVERA S.L, 13270 CUIDAD REAL, SPAIN, FILED 5-18-2010.



NO CLAIM IS MADE TO THE EXCLUSIVE RIGHT TO USE "TEMPRANILLOS BODEGAS ENCOMIENDA DE CERVERA", APART FROM THE MARK AS SHOWN.

THE COLOR(S) WHITE, BLACK, GOLD, RED, GREEN AND BLUE IS/ARE CLAIMED AS A FEATURE OF THE MARK.

THE MARK CONSISTS OF A PLUS SIGN NEXT TO A CAPITAL LETTER "C" INSIDE A CIRCLE THAT PARTIALLY COVERS THE UPPER SIDE OF A VERTICALLY POSITIONED RECTANGLE THAT IS DIVIDED INTO THREE THIRDS. IN THE UPPER THIRD APPEAR THE WORDS "POKER D TEMPRANILLOS" IN STYLIZED LETTERS, IN THE MIDDLE THIRD APPEAR FOUR POKER CARDS AND IN THE LOWER THIRD IS ALMOST EMPTY EXCEPT FOR A VERY TINY SQUARE THAT APPEARS IN THE LOWER CENTRAL AREA JUST ABOVE THE WORDS "BODEGAS ENCOMIENDA DE CERVERA". THE COLOR BLACK APPEARS INSIDE THE CIRCLE, IN THE BACKGROUND OF THE UPPER AND LOWER THIRDS OF THE RECTANGLE AND IN THE CHARACTERS THAT APPEAR IN TWO OF THE FOUR POKER CARDS. THE COLOR GOLD APPEARS IN THE OUTER RING OF THE CIRCLE, IN "+C", IN THE WORD "TEMPRANILLOS" AND IN THE WORDS "BODEGAS ENCOMIENDA DE CERVERA". THE COLOR WHITE APPEARS IN THE POKER CARDS AND IN THE WORDING "POKER D". THE COLOR RED APPEARS IN THE CHARACTERS THAT APPEAR IN THE OTHER TWO POKER CARDS. THE COLOR GREEN APPEARS IN THE BACKGROUND OF THE MIDDLE THIRD OF THE RECTANGLE. THE COLOR BLUE APPEARS IN THE TINY SQUARE.

THE ENGLISH TRANSLATION OF "BODEGAS ENCOMIENDA DE CERVERA" IN THE MARK IS "WINE CELLARS OF THE LAND GRANT ESTATE OF CERVERA".

FOR WINES MADE IN WHOLE OR IN SIGNIFICANT PART FROM TEMPRANILLO GRAPES (U.S. CLS. 47 AND 49).

KRISTIN DAHLING, EXAMINING ATTORNEY



**CLASS 33—(Continued).**

SN 85-043,407. THE TRUSTEES OF THE COPPOLA FAMILY TRUST, NAPA, CA. FILED 5-20-2010.



NO CLAIM IS MADE TO THE EXCLUSIVE RIGHT TO USE "LABEL", APART FROM THE MARK AS SHOWN.

THE COLOR(S) PURPLE AND BLACK IS/ARE CLAIMED AS A FEATURE OF THE MARK.

THE MARK CONSISTS OF THE WORDS "PLUM LABEL" IN BLACK MINIATURE LETTERING APPEARING AT THE BOTTOM CENTER OF A RECTANGULAR LABEL TOGETHER WITH THE DOMINANT COLOR GREEN APPEARING ON THE RECTANGULAR LABEL AND NECKWRAP OF A WINE BOTTLE. THE SHAPE OF THE BOTTLE IS SHOWN IN DOTTED LINES AND IS NOT CLAIMED AS A FEATURE OF THE MARK. IN ADDITION, THE SHAPE OF THE LABEL AND NECKWRAP IS NOT CLAIMED AS A FEATURE OF THE MARK.

FOR WINE (U.S. CLS. 47 AND 49).

KAPIL BHANOT, EXAMINING ATTORNEY

SN 85-044,785. DIAGEO NORTH AMERICA, INC., NORWALK, CT. FILED 5-21-2010.

**BULLEIT 95 RYE**

THE MARK CONSISTS OF STANDARD CHARACTERS WITHOUT CLAIM TO ANY PARTICULAR FONT, STYLE, SIZE, OR COLOR.

OWNER OF U.S. REG. NOS. 2,254,414, 3,301,661 AND OTHERS.

NO CLAIM IS MADE TO THE EXCLUSIVE RIGHT TO USE "95 RYE", APART FROM THE MARK AS SHOWN.

FOR ALCOHOLIC BEVERAGES EXCEPT BEERS (U.S. CLS. 47 AND 49).

BARNEY CHARLON, EXAMINING ATTORNEY

**CLASS 33—(Continued).**

SN 85-049,857. THE WINE GROUP LLC, TRACY, CA. FILED 5-27-2010.

**SWORE-RAY**

THE MARK CONSISTS OF STANDARD CHARACTERS WITHOUT CLAIM TO ANY PARTICULAR FONT, STYLE, SIZE, OR COLOR.

FOR LIQUEURS; PREPARED ALCOHOLIC COCKTAIL; PREPARED WINE COCKTAILS; SPIRITS; WINE; WINE-BASED DRINKS (U.S. CLS. 47 AND 49).

ROBERT STRUCK, EXAMINING ATTORNEY

SN 85-051,835. BROWN, DAVID C., NEWPORT COAST, CA. AND HERMAN, RYAN M., AVON, CO. FILED 6-1-2010.

**DOS SANTOS**

THE MARK CONSISTS OF STANDARD CHARACTERS WITHOUT CLAIM TO ANY PARTICULAR FONT, STYLE, SIZE, OR COLOR.

THE ENGLISH TRANSLATION OF "DOS SANTOS" IN THE MARK IS "TWO SAINTS".

FOR DISTILLED SPIRITS (U.S. CLS. 47 AND 49).

COLLEEN KEARNEY, EXAMINING ATTORNEY

SN 85-059,179. ALLIED DOMEQ SPIRITS & WINE LIMITED, LONDON W6 9RS, UNITED KINGDOM, FILED 6-10-2010.

**MIDNIGHT LABYRINTH**

THE MARK CONSISTS OF STANDARD CHARACTERS WITHOUT CLAIM TO ANY PARTICULAR FONT, STYLE, SIZE, OR COLOR.

PRIORITY CLAIMED UNDER SEC. 44(D) ON ERPNCMNTY TM OFC APPLICATION NO. 9165739, FILED 6-10-2010, REG. NO. 009165739, DATED 10-26-2010, EXPIRES 6-10-2020.

FOR ALCOHOLIC BEVERAGES, NAMELY, DISTILLED SPIRITS AND EXCLUDING WINE (U.S. CLS. 47 AND 49).

MARK RADEMACHER, EXAMINING ATTORNEY

**CLASS 33—(Continued).**

SN 85-072,842. MARSTON FAMILY VINEYARD, LLC, SANTA BARBARA, CA. FILED 6-28-2010.

# ALBION

THE MARK CONSISTS OF STANDARD CHARACTERS WITHOUT CLAIM TO ANY PARTICULAR FONT, STYLE, SIZE, OR COLOR.

FOR WINE (U.S. CLS. 47 AND 49).  
FIRST USE 6-21-2010; IN COMMERCE 6-21-2010.  
DANIEL CAPSHAW, EXAMINING ATTORNEY

SN 85-073,308. MARSTON FAMILY VINEYARD, LLC, SANTA BARBARA, CA. FILED 6-28-2010.

# ELIZABETHJOHN

THE MARK CONSISTS OF STANDARD CHARACTERS WITHOUT CLAIM TO ANY PARTICULAR FONT, STYLE, SIZE, OR COLOR.

THE NAME(S), PORTRAIT(S), AND/OR SIGNATURE(S) SHOWN IN THE MARK DOES NOT IDENTIFY A PARTICULAR LIVING INDIVIDUAL.

FOR ALCOHOLIC BEVERAGES EXCEPT BEERS (U.S. CLS. 47 AND 49).

FIRST USE 6-30-2007; IN COMMERCE 6-30-2007.  
DANIEL CAPSHAW, EXAMINING ATTORNEY

SN 85-074,224. SCHNEIDER, JOHN CHARLES, APPLE VALLEY, CA. AND SCHNEIDER, GEORGE WILLIAM, V, APPLE VALLEY, CA. AND SCHNEIDER, DAVID MICHAEL, APPLE VALLEY, CA. AND SCHNEIDER, GEORGE WILLIAM, APPLE VALLEY, CA. FILED 6-29-2010.

# Off The Grid

THE MARK CONSISTS OF STANDARD CHARACTERS WITHOUT CLAIM TO ANY PARTICULAR FONT, STYLE, SIZE, OR COLOR.

FOR WINES (U.S. CLS. 47 AND 49).  
EMILY CARLSEN, EXAMINING ATTORNEY

**CLASS 33—(Continued).**

SN 85-084,249. LONELY COW WINES (NZ) LIMITED, AUCKLAND, NEW ZEALAND, FILED 7-14-2010.

# LONELY COW

THE MARK CONSISTS OF STANDARD CHARACTERS WITHOUT CLAIM TO ANY PARTICULAR FONT, STYLE, SIZE, OR COLOR.

FOR WINE (U.S. CLS. 47 AND 49).  
FIRST USE 7-0-2009; IN COMMERCE 7-0-2009.  
LAKEISHA LEWIS, EXAMINING ATTORNEY

SN 85-084,258. LONELY COW WINES (NZ) LIMITED, AUCKLAND, NEW ZEALAND, FILED 7-14-2010.



THE MARK CONSISTS OF A PROFILE OF A COW STANDING ON A HILL OF GRASS NEXT TO A PALM TREE.

FOR WINE (U.S. CLS. 47 AND 49).  
FIRST USE 7-0-2009; IN COMMERCE 7-0-2009.  
LAKEISHA LEWIS, EXAMINING ATTORNEY

SN 85-088,532. SAZERAC COMPANY, INC., NEW ORLEANS, LA. FILED 7-20-2010.

# CORAZON BARREL EXPRESSIONS

THE MARK CONSISTS OF STANDARD CHARACTERS WITHOUT CLAIM TO ANY PARTICULAR FONT, STYLE, SIZE, OR COLOR.

OWNER OF U.S. REG. NOS. 2,460,552, 2,667,817 AND 3,287,327.

NO CLAIM IS MADE TO THE EXCLUSIVE RIGHT TO USE "BARREL EXPRESSIONS", APART FROM THE MARK AS SHOWN.

THE ENGLISH TRANSLATION OF "CORAZON" IN THE MARK IS "HEART".

FOR TEQUILA (U.S. CLS. 47 AND 49).  
SANI KHOURI, EXAMINING ATTORNEY

**CLASS 33—(Continued).**

SN 85-100,226. LAUGHLIN ORCHARDS, INC., CARLTON,  
OR. FILED 8-4-2010.

**BONNIE JEAN VINEYARD**

THE MARK CONSISTS OF STANDARD CHARACTERS WITHOUT CLAIM TO ANY PARTICULAR FONT, STYLE, SIZE, OR COLOR.

NO CLAIM IS MADE TO THE EXCLUSIVE RIGHT TO USE "VINEYARD", APART FROM THE MARK AS SHOWN. THE NAME(S), PORTRAIT(S), AND/OR SIGNATURE(S) SHOWN IN THE MARK DOES NOT IDENTIFY A PARTICULAR LIVING INDIVIDUAL.

FOR WINES (U.S. CLS. 47 AND 49).  
LESLIE RICHARDS, EXAMINING ATTORNEY

SN 85-108,656. SILICATEC RENTALS, INC., MINDEN, NV.  
FILED 8-16-2010.

**BUDGE BROWN**

THE MARK CONSISTS OF STANDARD CHARACTERS WITHOUT CLAIM TO ANY PARTICULAR FONT, STYLE, SIZE, OR COLOR.

THE NAME(S), PORTRAIT(S), AND/OR SIGNATURE(S) SHOWN IN THE MARK IDENTIFIES ROBERT H. "BROWN", SR., AKA "BUDGE BROWN", WHOSE CONSENT(S) TO REGISTER IS MADE OF RECORD.

FOR WINES (U.S. CLS. 47 AND 49).  
LINDA M. KING, EXAMINING ATTORNEY

SN 85-125,904. TRINITAS CELLARS, LLC, IRVINE, CA.  
FILED 9-9-2010.

TRINITAS



SUN \* SOIL \* HUMANITY

2010

*Moscato d' Stato*



OWNER OF U.S. REG. NOS. 2,859,002 AND 2,861,623.  
NO CLAIM IS MADE TO THE EXCLUSIVE RIGHT TO USE "MOSCATO" OR "2010", APART FROM THE MARK AS SHOWN.

THE COLOR(S) RED AND GOLD IS/ARE CLAIMED AS A FEATURE OF THE MARK.

THE MARK CONSISTS OF BOTH WORDS AND DESIGNS

**CLASS 33—(Continued).**

FEATURING THE COLORS RED AND GOLD. THE WORD "TRINITAS" IS IN RED STYLIZED FONT. UNDERNEATH THE WORD "TRINITAS" IS A RED SQUARE BOX WITHIN WHICH A GOLD SUN APPEARS ON THE UPPER LEFT CORNER. BELOW THE RED SQUARE BOX ARE THE WORDS "SUN+SOIL+HUMANITY" AND "2010" PRINTED IN GOLD STYLIZED FONT. THE WORDS "MOSCATO D' STATO" IN RED STYLIZED FONT APPEARS ABOVE THE RED FLOWER DESIGNS ON THE BOTTOM RIGHT CORNER OF THE MARK.

THE ENGLISH TRANSLATION OF "MOSCATO D' STATO" IN THE MARK IS "MUSCAT OF THE STATE".

FOR WINES (U.S. CLS. 47 AND 49).  
ERNEST SHOSH, EXAMINING ATTORNEY

SN 85-134,541. STAG'S LEAP WINE CELLARS, LLC, NAPA,  
CA. FILED 9-21-2010.

**CHASE CREEK**

THE MARK CONSISTS OF STANDARD CHARACTERS WITHOUT CLAIM TO ANY PARTICULAR FONT, STYLE, SIZE, OR COLOR.

FOR WINE (U.S. CLS. 47 AND 49).  
FIRST USE 5-12-2008; IN COMMERCE 5-12-2008.  
STEPHANIE ALI, EXAMINING ATTORNEY

SN 85-155,063. PASTERNAK WINE IMPORTS, LLC, HARRISON,  
NY. FILED 10-18-2010.

**TERRACITA**

THE MARK CONSISTS OF STANDARD CHARACTERS WITHOUT CLAIM TO ANY PARTICULAR FONT, STYLE, SIZE, OR COLOR.

FOR WINES (U.S. CLS. 47 AND 49).  
FIRST USE 6-0-2009; IN COMMERCE 6-0-2009.  
SANDRA BUJA, EXAMINING ATTORNEY

SN 85-166,043. CLUB CARIBE DISTILLERS, LLC, TOA BAJA,  
PUERTO RICO, FILED 11-1-2010.

**Black Roberts**

THE MARK CONSISTS OF STANDARD CHARACTERS WITHOUT CLAIM TO ANY PARTICULAR FONT, STYLE, SIZE, OR COLOR.

FOR RUM (U.S. CLS. 47 AND 49).  
BRIDGETT SMITH, EXAMINING ATTORNEY

**CLASS 33—(Continued).**

SN 85-168,021. ONYX SPIRITS COMPANY LLC, MANCHESTER, CT. FILED 11-3-2010.

**LITTLE BIRD**

THE MARK CONSISTS OF STANDARD CHARACTERS WITHOUT CLAIM TO ANY PARTICULAR FONT, STYLE, SIZE, OR COLOR.

FOR ALCOHOLIC BEVERAGES EXCEPT BEERS AND TEQUILA (U.S. CLS. 47 AND 49).  
AISHA SALEM, EXAMINING ATTORNEY

SN 85-173,015. TENNESSEE DISTILLING COMPANY, FRANKLIN, TN. FILED 11-9-2010.



NO CLAIM IS MADE TO THE EXCLUSIVE RIGHT TO USE "HANDCRAFTED TENNESSEE WHISKEY", APART FROM THE MARK AS SHOWN.

THE MARK CONSISTS OF THE WORDS "COLLIER AND MCKEEL" ON A SCROLL WITH A BARREL IN A CIRCLE BETWEEN, AND THE WORDS "HANDCRAFTED TENNESSEE WHISKEY" ON A SCROLL BELOW.

FOR DISTILLED SPIRITS (U.S. CLS. 47 AND 49).  
RAMONA ORTIGA, EXAMINING ATTORNEY

SN 85-177,405. BORBERG, ROBERT, FRASER, CO. FILED 11-16-2010.

**DURTY NANCY**

THE MARK CONSISTS OF STANDARD CHARACTERS WITHOUT CLAIM TO ANY PARTICULAR FONT, STYLE, SIZE, OR COLOR.

FOR WHISKEY (U.S. CLS. 47 AND 49).  
SEAN CROWLEY, EXAMINING ATTORNEY

**CLASS 33—(Continued).**

SN 85-180,200. INFOMAR INC., NEW YORK, NY. FILED 11-18-2010.

**Get Some**

THE MARK CONSISTS OF STANDARD CHARACTERS WITHOUT CLAIM TO ANY PARTICULAR FONT, STYLE, SIZE, OR COLOR.

FOR VODKA (U.S. CLS. 47 AND 49).  
ANGELA M. MICHELI, EXAMINING ATTORNEY

SN 85-181,224. PISCO PORTON, LLC, HOUSTON, TX. FILED 11-19-2010.

**PISCO PORTON THE AUTHENTIC PERUVIAN PISCO**

THE MARK CONSISTS OF STANDARD CHARACTERS WITHOUT CLAIM TO ANY PARTICULAR FONT, STYLE, SIZE, OR COLOR.

NO CLAIM IS MADE TO THE EXCLUSIVE RIGHT TO USE "PISCO" AND "THE AUTHENTIC PERUVIAN PISCO", APART FROM THE MARK AS SHOWN.

THE ENGLISH TRANSLATION OF "PORTON" IN THE MARK IS GATE.

FOR DISTILLED SPIRITS; BRANDY; PISCO (U.S. CLS. 47 AND 49).  
LANA PHAM, EXAMINING ATTORNEY

SN 85-184,904. BODEGAS TRUS S.L., VALLADOLID, SPAIN, FILED 11-24-2010.



PRIORITY CLAIMED UNDER SEC. 44(D) ON ERP N CMNTY TM OFC APPLICATION NO. 009288581, FILED 8-2-2010, REG. NO. 009288581, DATED 12-22-2010, EXPIRES 8-2-2020.

THE MARK CONSISTS OF A REPRESENTATION OF AN OWL WITH THE TERM "KREL" ACROSS ITS CHEST. THE WORDING "KREL" HAS NO MEANING IN A FOREIGN LANGUAGE.

FOR WINES (U.S. CLS. 47 AND 49).  
CHRISTOPHER BUONGIORNO, EXAMINING ATTORNEY

**CLASS 33—(Continued).**

SN 85-188,495. PANAMONTE LICENSING, LLC, SORRENTO, FL. FILED 12-1-2010.



NO CLAIM IS MADE TO THE EXCLUSIVE RIGHT TO USE "PURE PANAMANIAN", "OVER PROOF RUM", "PANAMA", "54% ALC/VOL", "108", "108 PROOF" AND "EST.1967", APART FROM THE MARK AS SHOWN.

THE COLOR(S) RED, GOLD, BLACK, BROWN, BLUE, GREEN, CREAM, YELLOW, AND WHITE IS/ARE CLAIMED AS A FEATURE OF THE MARK.

THE MARK CONSISTS OF A DRAWING OF THE UPPER-TORSO OF A WOMAN WITH RED HAIR, GREEN EYES, AND WEARING A RED DRESS, ABOVE A BLACK RIBBON-LIKE BANNER WITH THE WORDS, "PURE PANAMANIAN" IN WHITE, WITH A CREAM-COLORED OUTLINE AROUND THE BANNER; TO THE LEFT AND RIGHT SIDES OF THE WOMAN ARE THREE GOLD COINS; THE BACKGROUND AREA AROUND THE WOMAN IS RED; BELOW THE "PURE PANAMANIAN" BANNER ARE THE WORDS "OVER PROOF RUM" IN BLUE WITH A YELLOW OUTLINE AND A STAMP CONTAINING THE NUMBERS "108", BOTH OF WHICH ARE BROWN; BELOW THE WORDS "OVER PROOF RUM" AND THE STAMP ARE THE ITALICIZED WORDS, "PANAMA RED" IN RED; BELOW THE WORDS, "PANAMA RED" ARE "54% ALC/VOL" AND "108 PROOF" IN BLACK LETTERING, "RED SKY AT NIGHT, SAILOR'S DELIGHT" IN BROWN LETTERING, AND "EST. \* 1967" IN BLUE LETTERING; THE DESIGN AND LETTERING ARE WITHIN A GOLD FRAME.

FOR RUM (U.S. CLS. 47 AND 49).

CIMMERIAN COLEMAN, EXAMINING ATTORNEY

SN 85-191,333. CARIBBEAN DISTILLERS, LLC, LAKE ALFRED, FL. FILED 12-6-2010.

**DECLAN CREAM**

THE MARK CONSISTS OF STANDARD CHARACTERS WITHOUT CLAIM TO ANY PARTICULAR FONT, STYLE, SIZE, OR COLOR.

NO CLAIM IS MADE TO THE EXCLUSIVE RIGHT TO USE "CREAM", APART FROM THE MARK AS SHOWN.

FOR LIQUEURS (U.S. CLS. 47 AND 49).

GINA FINK, EXAMINING ATTORNEY

**CLASS 33—(Continued).**

SN 85-192,014. CARMICHAEL, MARTIN M, FALLS CHURCH, VA. FILED 12-7-2010.

**X-RAY**

THE MARK CONSISTS OF STANDARD CHARACTERS WITHOUT CLAIM TO ANY PARTICULAR FONT, STYLE, SIZE, OR COLOR.

OWNER OF U.S. REG. NO. 3,541,065.

FOR ALCOHOLIC MALT COOLERS (U.S. CLS. 47 AND 49).

BRIDGETT SMITH, EXAMINING ATTORNEY

SN 85-194,679. WAIS, JOSEPH J., ARROYO GRANDE, CA. FILED 12-9-2010.

**She Said Red Wine**

THE MARK CONSISTS OF STANDARD CHARACTERS WITHOUT CLAIM TO ANY PARTICULAR FONT, STYLE, SIZE, OR COLOR.

NO CLAIM IS MADE TO THE EXCLUSIVE RIGHT TO USE "RED WINE", APART FROM THE MARK AS SHOWN.

FOR WINES (U.S. CLS. 47 AND 49).

DAVID YONTEF, EXAMINING ATTORNEY

SN 85-194,789. BODEGAS SOLAR DE URBEZO, S. L., CARINENA, SPAIN, FILED 12-10-2010.

**SOLAR DE URBEZO**

THE MARK CONSISTS OF STANDARD CHARACTERS WITHOUT CLAIM TO ANY PARTICULAR FONT, STYLE, SIZE, OR COLOR.

THE ENGLISH TRANSLATION OF "SOLAR DE URBEZO" IN THE MARK IS URBEZO ESTATE.

FOR WINES (U.S. CLS. 47 AND 49).

AISHA CLARKE, EXAMINING ATTORNEY



**CLASS 33—(Continued).**

SN 85-200,806. STEPHENSON CELLARS LLC, WALLA WALLA, WA. FILED 12-17-2010.

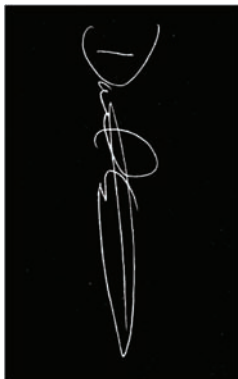

OWNER OF U.S. REG. NO. 3,316,358.  
THE NAME(S), PORTRAIT(S), AND/OR SIGNATURE(S) SHOWN IN THE MARK IDENTIFIES "DAVID STEPHENSON", WHOSE CONSENT(S) TO REGISTER IS MADE OF RECORD.

THE MARK CONSISTS OF THE SIGNATURE "DAVID STEPHENSON", WINEMAKER AND OWNER OF APPLICANT.

FOR WINES (U.S. CLS. 47 AND 49).  
FIRST USE 12-31-2003; IN COMMERCE 12-31-2003.  
ALLISON SCHRODY, EXAMINING ATTORNEY

SN 85-201,024. MAKO BRANDS, LLC, JUNO BEACH, FL. FILED 12-17-2010.



OWNER OF U.S. REG. NO. 3,068,807.  
NO CLAIM IS MADE TO THE EXCLUSIVE RIGHT TO USE "BRAND" OR "VODKA", APART FROM THE MARK AS SHOWN.

THE MARK CONSISTS OF THE WORD "MAKO" ABOVE THE WORD "VODKA" IN LARGE FONT. IN THE CENTER OF THE MARK, BETWEEN THE WORDS "MAKO" AND "VODKA", THE WORDS "MAKO" AND "BRAND" ARE WRITTEN FROM LEFT TO RIGHT IN SMALLER FONT, WITH THE DESIGN OF A MAKO APPEARING BETWEEN THE WORDS "MAKO" AND "BRAND". THE MAKO IS CURVED SO THAT ITS HEAD AND TAIL ARE POINTING TO THE LEFT. THE DESIGN OF A ROPE APPEARS ABOVE AND BELOW THE WORDS "MAKO" AND "BRAND" IN THE CENTER OF THE MARK.

FOR VODKA (U.S. CLS. 47 AND 49).  
BARBARA A. GOLD, EXAMINING ATTORNEY

**CLASS 33—(Continued).**

SN 85-201,233. LIMESTONE BRANCH DISTILLERS, INC., DBA LIMESTONE BRANCH DISTILLERY, LOUISVILLE, KY. FILED 12-18-2010.

**Richwood Reserve**

THE MARK CONSISTS OF STANDARD CHARACTERS WITHOUT CLAIM TO ANY PARTICULAR FONT, STYLE, SIZE, OR COLOR.

NO CLAIM IS MADE TO THE EXCLUSIVE RIGHT TO USE "RESERVE", APART FROM THE MARK AS SHOWN.  
FOR BOURBON; BOURBON WHISKY; DISTILLED SPIRITS (U.S. CLS. 47 AND 49).

ASMAT KHAN, EXAMINING ATTORNEY

SN 85-201,790. THE WINE GROUP LLC, TRACY, CA. FILED 12-20-2010.

**DOUBLE RAINBOW VINEYARDS**

THE MARK CONSISTS OF STANDARD CHARACTERS WITHOUT CLAIM TO ANY PARTICULAR FONT, STYLE, SIZE, OR COLOR.

NO CLAIM IS MADE TO THE EXCLUSIVE RIGHT TO USE "VINEYARDS", APART FROM THE MARK AS SHOWN.

FOR WINE (U.S. CLS. 47 AND 49).  
ELI HELLMAN, EXAMINING ATTORNEY

SN 85-202,324. SPANISH VINES, INC., COLUMBIA, SC. FILED 12-20-2010.

**ENCENDER**

THE MARK CONSISTS OF STANDARD CHARACTERS WITHOUT CLAIM TO ANY PARTICULAR FONT, STYLE, SIZE, OR COLOR.

THE ENGLISH TRANSLATION OF "ENCENDER" IN THE MARK IS "TO LIGHT".

FOR WINE (U.S. CLS. 47 AND 49).  
KATHERINE M. DUBRAY, EXAMINING ATTORNEY

**CLASS 33—(Continued).**

SN 85-202,467. PAZDAR BEVERAGE COMPANY LLC, DBA PAZDAR WINERY, SCOTCHTOWN, NY. FILED 12-21-2010.

**NAUGHTY VIRGIN**

THE MARK CONSISTS OF STANDARD CHARACTERS WITHOUT CLAIM TO ANY PARTICULAR FONT, STYLE, SIZE, OR COLOR.

FOR FORTIFIED WINES; RED WINE; WINE-BASED DRINKS; WINES AND FORTIFIED WINES (U.S. CLS. 47 AND 49).

FIRST USE 7-6-2006; IN COMMERCE 7-6-2006.  
WILLIAM VERHOSEK, EXAMINING ATTORNEY

SN 85-205,551. KALDOR, HEIDE R., DBA SEDONA WOMAN, LLC, SEDONA, AZ. FILED 12-24-2010.

**SEDONA WOMAN**

THE MARK CONSISTS OF STANDARD CHARACTERS WITHOUT CLAIM TO ANY PARTICULAR FONT, STYLE, SIZE, OR COLOR.

NO CLAIM IS MADE TO THE EXCLUSIVE RIGHT TO USE "SEDONA", APART FROM THE MARK AS SHOWN. FOR GRAPE WINE (U.S. CLS. 47 AND 49).

FIRST USE 5-22-2010; IN COMMERCE 5-22-2010.  
KYLE PEETE, EXAMINING ATTORNEY

SN 85-206,105. 1222403 ONTARIO LIMITED, TORONTO, ONTARIO, CANADA, FILED 12-27-2010.

**GESHEM PREMIUM VODKA**

THE MARK CONSISTS OF STANDARD CHARACTERS WITHOUT CLAIM TO ANY PARTICULAR FONT, STYLE, SIZE, OR COLOR.

NO CLAIM IS MADE TO THE EXCLUSIVE RIGHT TO USE "PREMIUM VODKA", APART FROM THE MARK AS SHOWN.

FOR ALCOHOLIC BEVERAGES, NAMELY, VODKA (U.S. CLS. 47 AND 49).  
KRISTIN DAHLING, EXAMINING ATTORNEY

**CLASS 33—(Continued).**

SN 85-206,520. ZWANENBERG FOOD GROUP (USA) INC., CINCINNATI, OH. FILED 12-28-2010.

**Longridge Winery**

THE MARK CONSISTS OF STANDARD CHARACTERS WITHOUT CLAIM TO ANY PARTICULAR FONT, STYLE, SIZE, OR COLOR.

NO CLAIM IS MADE TO THE EXCLUSIVE RIGHT TO USE "WINERY", APART FROM THE MARK AS SHOWN. FOR WINES AND SPIRITS (U.S. CLS. 47 AND 49).

ELISSA GARBER KON, EXAMINING ATTORNEY

SN 85-206,522. ZWANENBERG FOOD GROUP (USA) INC., CINCINNATI, OH. FILED 12-28-2010.

**Longridge Wines**

THE MARK CONSISTS OF STANDARD CHARACTERS WITHOUT CLAIM TO ANY PARTICULAR FONT, STYLE, SIZE, OR COLOR.

NO CLAIM IS MADE TO THE EXCLUSIVE RIGHT TO USE "WINES", APART FROM THE MARK AS SHOWN. FOR WINES AND SPIRITS (U.S. CLS. 47 AND 49).

ELISSA GARBER KON, EXAMINING ATTORNEY

SN 85-207,022. LANNOM, TODD, VIRGINIA BEACH, VA. FILED 12-29-2010.



NO CLAIM IS MADE TO THE EXCLUSIVE RIGHT TO USE "RESERVE", APART FROM THE MARK AS SHOWN.

THE COLOR(S) GOLD, RED, YELLOW, GREEN, PURPLE, BLUE, AND MAGENTA IS/ARE CLAIMED AS A FEATURE OF THE MARK.

THE MARK CONSISTS OF THE WORDING "PALETTE RESERVE" IN GOLD LETTERING BENEATH A DESIGN OF A GOLD ARTIST'S PALETTE WITH PAINT SLOTTES OF RED, YELLOW, GREEN, PURPLE, BLUE, AND MAGENTA. WHITE IS NOT CLAIMED AS A FEATURE OF THE MARK AND IS USED ONLY AS A BACKGROUND IN THE DRAWING.

FOR WINE (U.S. CLS. 47 AND 49).

FIRST USE 10-1-2009; IN COMMERCE 10-1-2009.

MATTHEW MCDOWELL, EXAMINING ATTORNEY

**CLASS 33—(Continued).**

SN 85-208,584. ATLANTIC BOTTLING LLC, OCEAN, NJ.  
FILED 12-31-2010.

## Tattoo Tony's

THE MARK CONSISTS OF STANDARD CHARACTERS WITHOUT CLAIM TO ANY PARTICULAR FONT, STYLE, SIZE, OR COLOR.

FOR APERITIF WINES; FORTIFIED WINES; KITS FOR MAKING WINE; LIQUEURS; PREPARED WINE COCKTAILS; STILL WINES (U.S. CLS. 47 AND 49).  
FIRST USE 12-31-2010; IN COMMERCE 12-31-2010.  
PRISCILLA MILTON, EXAMINING ATTORNEY

**CLASS 33—(Continued).**

SN 85-212,470. STRANGER & STRANGER INC, NEW YORK, NY. FILED 1-7-2011.

## THE THIRTEEN CLUB

THE MARK CONSISTS OF STANDARD CHARACTERS WITHOUT CLAIM TO ANY PARTICULAR FONT, STYLE, SIZE, OR COLOR.

FOR WHISKEY (U.S. CLS. 47 AND 49).  
WILLIAM P. SHANAHAN, EXAMINING ATTORNEY

SN 85-209,634. MENSANI INTERNATIONAL LTD, MARBELLA, SPAIN, FILED 1-4-2011.

## THE MAD DRINKS COMPANY

THE MARK CONSISTS OF STANDARD CHARACTERS WITHOUT CLAIM TO ANY PARTICULAR FONT, STYLE, SIZE, OR COLOR.

NO CLAIM IS MADE TO THE EXCLUSIVE RIGHT TO USE "DRINKS COMPANY", APART FROM THE MARK AS SHOWN.

FOR ALCOHOLIC BEVERAGES, NAMELY, SPIRITS AND WINE (U.S. CLS. 47 AND 49).  
PAUL F. GAST, EXAMINING ATTORNEY

SN 85-213,354. NORCAL WINERY & DISTILLERY, SEBASTOPOL, CA. FILED 1-7-2011.



THE MARK CONSISTS OF A CIRCLE WITH A BLACK BACKGROUND WITH A WHITE RELIEF IN THE SHAPE OF A WAVE.

FOR WINE AND VODKA (U.S. CLS. 47 AND 49).  
DAVID TAYLOR, EXAMINING ATTORNEY

SN 85-211,396. SMITH, GINEVRA CASA, WALLA WALLA, WA. AND SMITH, CHARLES, WALLA WALLA, WA. FILED 1-5-2011.



SN 85-213,716. PITTSBURGH DISTILLING COMPANY, LLC, PITTSBURGH, PA. FILED 1-10-2011.

## Wigle Westsylvania

NO CLAIM IS MADE TO THE EXCLUSIVE RIGHT TO USE "VINO", APART FROM THE MARK AS SHOWN.

THE MARK CONSISTS OF THE WORDING "VINO", WITH THE "I" BEING REPRESENTED BY A WINE BOTTLE WITH A RECTANGULAR BORDER.

THE ENGLISH TRANSLATION OF "VINO" IN THE MARK IS "WINE".

FOR WINES (U.S. CLS. 47 AND 49).  
KAPIL BHANOT, EXAMINING ATTORNEY

THE MARK CONSISTS OF STANDARD CHARACTERS WITHOUT CLAIM TO ANY PARTICULAR FONT, STYLE, SIZE, OR COLOR.

FOR DISTILLED SPIRITS (U.S. CLS. 47 AND 49).  
KAREN BRACEY, EXAMINING ATTORNEY

**CLASS 33—(Continued).**

SN 85-213,931. OLIVER WINE CO., INC., BLOOMINGTON, IN. FILED 1-10-2011.

**BEANBLOSSOM**

THE MARK CONSISTS OF STANDARD CHARACTERS WITHOUT CLAIM TO ANY PARTICULAR FONT, STYLE, SIZE, OR COLOR.

FOR HARD CIDER (U.S. CLS. 47 AND 49).  
FIRST USE 6-24-2009; IN COMMERCE 6-24-2009.  
BARBARA RUTLAND, EXAMINING ATTORNEY

SN 85-215,341. VINTAGE POINT, LLC, SONOMA, CA. FILED 1-11-2011.

**MOUNTAIN DOOR**

THE MARK CONSISTS OF STANDARD CHARACTERS WITHOUT CLAIM TO ANY PARTICULAR FONT, STYLE, SIZE, OR COLOR.

FOR WINE (U.S. CLS. 47 AND 49).  
KATHERINE E. HALMEN, EXAMINING ATTORNEY

SN 85-215,412. LENAHAN, CHRIS, PORTLAND, OR. FILED 1-11-2011.

**COLD STEEL**

THE MARK CONSISTS OF STANDARD CHARACTERS WITHOUT CLAIM TO ANY PARTICULAR FONT, STYLE, SIZE, OR COLOR.

FOR VODKA (U.S. CLS. 47 AND 49).  
AISHA CLARKE, EXAMINING ATTORNEY

**CLASS 33—(Continued).**

SN 85-215,899. YATES, MICHAEL C., DBA NAPA RED-WOODS ESTATE, NAPA, CA. FILED 1-12-2011.

**YATES FAMILY VINEYARD**

THE MARK CONSISTS OF STANDARD CHARACTERS WITHOUT CLAIM TO ANY PARTICULAR FONT, STYLE, SIZE, OR COLOR.

NO CLAIM IS MADE TO THE EXCLUSIVE RIGHT TO USE "FAMILY VINEYARD", APART FROM THE MARK AS SHOWN.

FOR ALCOHOLIC BEVERAGES EXCEPT BEERS (U.S. CLS. 47 AND 49).  
FIRST USE 2-5-2007; IN COMMERCE 2-5-2007.  
ALEXANDER L. POWERS, EXAMINING ATTORNEY

SN 85-216,245. ARBOR HILL ASSOCIATES, INC., NAPLES, NY. FILED 1-12-2011.

**Vine Valley**

THE MARK CONSISTS OF STANDARD CHARACTERS WITHOUT CLAIM TO ANY PARTICULAR FONT, STYLE, SIZE, OR COLOR.

FOR WINE (U.S. CLS. 47 AND 49).  
MORGAN WYNNE, EXAMINING ATTORNEY

SN 85-217,155. WENTE BROS., LIVERMORE, CA. FILED 1-13-2011.

**CALIFORNIA'S FIRST FAMILY  
OF CHARDONNAY**

THE MARK CONSISTS OF STANDARD CHARACTERS WITHOUT CLAIM TO ANY PARTICULAR FONT, STYLE, SIZE, OR COLOR.

NO CLAIM IS MADE TO THE EXCLUSIVE RIGHT TO USE "CALIFORNIA'S" AND "CHARDONNAY", APART FROM THE MARK AS SHOWN.

FOR WINE (U.S. CLS. 47 AND 49).  
KATHERINE M. DUBRAY, EXAMINING ATTORNEY

**CLASS 33—(Continued).**

SN 85-218,790. PERSPECTIVES UNLIMITED, NAPA, CA.  
FILED 1-16-2011.

# ShadowBox

THE MARK CONSISTS OF STANDARD CHARACTERS  
WITHOUT CLAIM TO ANY PARTICULAR FONT, STYLE,  
SIZE, OR COLOR.

FOR WINES (U.S. CLS. 47 AND 49).  
CORY BOONE, EXAMINING ATTORNEY

**CLASS 33—(Continued).**

SN 85-227,844. PHILLIPS PRODUCTS COMPANY, LLC,  
PRINCETON, MN. FILED 1-27-2011.

# ZAYLO AZUL

THE MARK CONSISTS OF STANDARD CHARACTERS  
WITHOUT CLAIM TO ANY PARTICULAR FONT, STYLE,  
SIZE, OR COLOR.

THE ENGLISH TRANSLATION OF "AZUL" IN THE  
MARK IS "BLUE". THE WORDING "ZAYLO" HAS NO  
MEANING IN A FOREIGN LANGUAGE.

FOR TEQUILA (U.S. CLS. 47 AND 49).  
TINA L. SNAPP, EXAMINING ATTORNEY

SN 85-226,284. FINE ESTATES FROM SPAIN, INC., DED-  
HAM, MA. FILED 1-26-2011.

# RIOMADRE

THE MARK CONSISTS OF STANDARD CHARACTERS  
WITHOUT CLAIM TO ANY PARTICULAR FONT, STYLE,  
SIZE, OR COLOR.

FOR WINE; SPARKLING WINE (U.S. CLS. 47 AND 49).  
GEOFFREY FOSDICK, EXAMINING ATTORNEY

SN 85-227,856. PHILLIPS PRODUCTS COMPANY, LLC,  
PRINCETON, MN. FILED 1-27-2011.

# ZUMBIDO

THE MARK CONSISTS OF STANDARD CHARACTERS  
WITHOUT CLAIM TO ANY PARTICULAR FONT, STYLE,  
SIZE, OR COLOR.

THE ENGLISH TRANSLATION OF "ZUMBIDO" IN THE  
MARK IS "HUMMING".

FOR DISTILLED SPIRITS (U.S. CLS. 47 AND 49).  
TINA L. SNAPP, EXAMINING ATTORNEY

SN 85-227,831. PHILLIPS PRODUCTS COMPANY, LLC,  
PRINCETON, MN. FILED 1-27-2011.

# DERECHO

THE MARK CONSISTS OF STANDARD CHARACTERS  
WITHOUT CLAIM TO ANY PARTICULAR FONT, STYLE,  
SIZE, OR COLOR.

THE ENGLISH TRANSLATION OF "DERECHO" IN THE  
MARK IS "UPRIGHT".

FOR DISTILLED SPIRITS (U.S. CLS. 47 AND 49).  
TINA L. SNAPP, EXAMINING ATTORNEY

SN 85-236,987. ONE PLUS TWO INC., CONCORD, CA. FILED  
2-8-2011.

# POMEGRANATE PASSION

THE MARK CONSISTS OF STANDARD CHARACTERS  
WITHOUT CLAIM TO ANY PARTICULAR FONT, STYLE,  
SIZE, OR COLOR.

NO CLAIM IS MADE TO THE EXCLUSIVE RIGHT TO  
USE "POMEGRANATE", APART FROM THE MARK AS  
SHOWN.

FOR WINE (U.S. CLS. 47 AND 49).  
BRENDAN MCCAULEY, EXAMINING ATTORNEY



**CLASS 33—(Continued).**

SN 85-236,992. ONE PLUS TWO INC., CONCORD, CA. FILED 2-8-2011.

**POMEGRANATE PLANET**

THE MARK CONSISTS OF STANDARD CHARACTERS WITHOUT CLAIM TO ANY PARTICULAR FONT, STYLE, SIZE, OR COLOR.

NO CLAIM IS MADE TO THE EXCLUSIVE RIGHT TO USE "POMEGRANATE", APART FROM THE MARK AS SHOWN.

FOR WINE (U.S. CLS. 47 AND 49).  
BRENDAN MCCAULEY, EXAMINING ATTORNEY

---

SN 85-237,261. ONE PLUS TWO INC., CONCORD, CA. FILED 2-8-2011.

**POMEGRANATE PLUS**

THE MARK CONSISTS OF STANDARD CHARACTERS WITHOUT CLAIM TO ANY PARTICULAR FONT, STYLE, SIZE, OR COLOR.

NO CLAIM IS MADE TO THE EXCLUSIVE RIGHT TO USE "POMEGRANATE", APART FROM THE MARK AS SHOWN.

FOR WINE (U.S. CLS. 47 AND 49).  
BRENDAN MCCAULEY, EXAMINING ATTORNEY

---

SN 85-248,493. BROWN-FORMAN CORPORATION, LOUISVILLE, KY. FILED 2-22-2011.

**LIVE THE LIFE WELL-CRAFTED**

THE MARK CONSISTS OF STANDARD CHARACTERS WITHOUT CLAIM TO ANY PARTICULAR FONT, STYLE, SIZE, OR COLOR.

FOR DISTILLED SPIRITS (U.S. CLS. 47 AND 49).  
FIRST USE 9-30-2009; IN COMMERCE 9-30-2009.  
DAWN FELDMAN, EXAMINING ATTORNEY

**CLASS 34—SMOKERS' ARTICLES**

SN 79-083,910. JAPAN TOBACCO INC., JAPAN, FILED 3-30-2010.



PRIORITY DATE OF 3-19-2010 IS CLAIMED.  
OWNER OF INTERNATIONAL REGISTRATION 1042494 DATED 3-30-2010, EXPIRES 3-30-2020.

THE COLOR(S) BLUE, SILVER, WHITE AND GREY IS/ARE CLAIMED AS A FEATURE OF THE MARK.

THE MARK CONSISTS OF A RECTANGLE DESIGN WITH THE COLORS BLUE, SILVER, WHITE AND GREY. THE COLOR SILVER APPEARING IN TWO HALF CIRCLES TOWARDS THE LEFT AND RIGHT INDIVIDUALLY, AND A SAUCER-LIKE SHAPE BETWEEN THE TWO HALF OVAL CIRCLES FORMING A LETTER SIMULATING AN "S", AND IN THE HORIZONTAL BAR APPEARING THERE BELOW; WITH THE COLOR BLUE APPEARING IN THE BACKGROUND FOR THE ENTIRE DESIGN IN THE SHAPE OF A RECTANGLE AND IN THE WORDS "ICE BLUE"; THE COLOR BLUE APPEARING MOSTLY CONCENTRATED AROUND THE UPPER PORTION OF THE MARK, AND IN THE ICE CUBES SHOWN IN THE LOWER PORTION OF THE MARK, WHERE THE COLOR BLUE BEING SHADED INTO LIGHT BLUE WITH THE COLORS GREY AND WHITE APPEARING AS TRANSCENDING FROM LIGHT BLUE INTO LIGHT GREY AND WHITE AT THE BOTTOM PORTION OF THE MARK TO SHOW THE ICE CUBE SHAPES IN THE MARK.

THE WORD "BLUE" APPEARING IN THE MARK HAS NO SIGNIFICANCE.

FOR RAW AND MANUFACTURED TOBACCO, SMOKING TOBACCO, PIPE TOBACCO, HAND-ROLLED TOBACCO, CHEWING TOBACCO; CIGARETTES, CIGARS, CIGARILLOS; SNUFF; MOIST TOBACCO POWDER, NAMELY, SNUSS; CIGARETTE PAPER, CIGARETTE TUBES; SMOKERS' ARTICLES, NAMELY, CIGARETTE PAPER, CIGARETTE FILTERS, CIGARETTE CASES NOT OF PRECIOUS METAL; CIGARETTE HOLDERS NOT OF PRECIOUS METAL; LIGHTERS FOR SMOKERS; MATCHES (U.S. CLS. 2, 8, 9 AND 17).

MARC LEIPZIG, EXAMINING ATTORNEY

**CLASS 34—(Continued).**

SN 79-084,936. EUROPEAN AND AMERICAN TOBACCO S.L., SPAIN, FILED 5-31-2010.



OWNER OF INTERNATIONAL REGISTRATION 1044775 DATED 5-31-2010, EXPIRES 5-31-2020.

THE NAME(S), PORTRAIT(S), AND/OR SIGNATURE(S) SHOWN IN THE MARK DOES NOT IDENTIFY A PARTICULAR LIVING INDIVIDUAL.

THE COLOR(S) YELLOW, GRAY AND BROWN IS/ARE CLAIMED AS A FEATURE OF THE MARK.

THE MARK CONSISTS OF THE WORDING "JIN LING" IN GRAY, THE DESIGN OF A FARM LANDSCAPE AND RAM IN BROWN, ALL SET AGAINST A YELLOW BACKGROUND.

THE ENGLISH TRANSLATION OF "JIN LING" IN THE MARK IS "GOLDEN HILL".

FOR CIGARETTES (U.S. CLS. 2, 8, 9 AND 17).  
SEAN CROWLEY, EXAMINING ATTORNEY

SN 85-055,511. STARBUZZ TOBACCO, INC., ANAHEIM, CA. FILED 6-5-2010.

# Blue Surfer

THE MARK CONSISTS OF STANDARD CHARACTERS WITHOUT CLAIM TO ANY PARTICULAR FONT, STYLE, SIZE, OR COLOR.

FOR PIPE TOBACCO; MOLASSES TOBACCO; TOBACCO; SMOKING TOBACCO; FLAVORED TOBACCO; TOBACCO SUBSTITUTE, NAMELY, HERBAL MOLASSES (U.S. CLS. 2, 8, 9 AND 17).

FIRST USE 8-16-2009; IN COMMERCE 8-16-2009.  
SAIMA MAKHDOOM, EXAMINING ATTORNEY

**CLASS 34—(Continued).**

SN 85-055,629. STARBUZZ TOBACCO, INC., ANAHEIM, CA. FILED 6-5-2010.

# Gee Spot

THE MARK CONSISTS OF STANDARD CHARACTERS WITHOUT CLAIM TO ANY PARTICULAR FONT, STYLE, SIZE, OR COLOR.

FOR PIPE TOBACCO; MOLASSES TOBACCO; TOBACCO; SMOKING TOBACCO; FLAVORED TOBACCO; TOBACCO SUBSTITUTE, NAMELY, HERBAL MOLASSES (U.S. CLS. 2, 8, 9 AND 17).

FIRST USE 8-11-2006; IN COMMERCE 8-11-2006.  
CAROLINE WOOD, EXAMINING ATTORNEY

SN 85-063,790. JENUWINE ARTICLES, INC., TROY, MI. FILED 6-15-2010.

# CASA REAL

THE MARK CONSISTS OF STANDARD CHARACTERS WITHOUT CLAIM TO ANY PARTICULAR FONT, STYLE, SIZE, OR COLOR.

THE ENGLISH TRANSLATION OF "CASA REAL" IN THE MARK IS ROYAL HOUSE.

FOR CIGAR BOXES; CIGAR CASES; CIGAR CUTTERS; CIGAR HOLDERS; CIGAR HUMIDIFIERS; CIGAR LIGHTERS; CIGAR TUBES; CIGAR WRAPS; CIGARS (U.S. CLS. 2, 8, 9 AND 17).

DAVID TOOLEY, EXAMINING ATTORNEY

SN 85-104,687. ADELSON, GARY, BLAINE, WA. FILED 8-11-2010.

# THE ENDD ELECTRONIC NICOTINE DELIVERY DEVICE

THE MARK CONSISTS OF STANDARD CHARACTERS WITHOUT CLAIM TO ANY PARTICULAR FONT, STYLE, SIZE, OR COLOR.

NO CLAIM IS MADE TO THE EXCLUSIVE RIGHT TO USE "ELECTRONIC NICOTINE DELIVERY DEVICE", APART FROM THE MARK AS SHOWN.

FOR TOBACCO AND SMOKERS' ARTICLES, NAMELY, ELECTRONIC CIGARETTES (U.S. CLS. 2, 8, 9 AND 17).

DAVID HOFFMAN, EXAMINING ATTORNEY

**CLASS 34—(Continued).**

SN 85-150,680. MAX ROHR, INC., WILMINGTON, DE.  
FILED 10-12-2010.

## Casa de Ortez

THE MARK CONSISTS OF STANDARD CHARACTERS WITHOUT CLAIM TO ANY PARTICULAR FONT, STYLE, SIZE, OR COLOR.

THE ENGLISH TRANSLATION OF "CASA DE ORTEZ" IN THE MARK IS "HOUSE OF ORTEZ".

FOR CIGARS (U.S. CLS. 2, 8, 9 AND 17).

FIRST USE 4-4-2011; IN COMMERCE 4-4-2011.

JIM RINGLE, EXAMINING ATTORNEY

**CLASS 34—(Continued).**

SN 85-200,293. VAPOR CORP., HALLANDALE, FL. FILED  
12-17-2010.

## E STAR

THE MARK CONSISTS OF STANDARD CHARACTERS WITHOUT CLAIM TO ANY PARTICULAR FONT, STYLE, SIZE, OR COLOR.

FOR ELECTRONIC CIGARETTES (U.S. CLS. 2, 8, 9 AND 17).

FIRST USE 7-28-2010; IN COMMERCE 11-4-2010.

KRISTIN DAHLING, EXAMINING ATTORNEY

SN 85-200,284. VAPOR CORP., HALLANDALE, FL. FILED  
12-17-2010.

## Vapor X

THE MARK CONSISTS OF STANDARD CHARACTERS WITHOUT CLAIM TO ANY PARTICULAR FONT, STYLE, SIZE, OR COLOR.

NO CLAIM IS MADE TO THE EXCLUSIVE RIGHT TO USE "VAPOR", APART FROM THE MARK AS SHOWN.

FOR ELECTRONIC CIGARETTES (U.S. CLS. 2, 8, 9 AND 17).

FIRST USE 8-14-2010; IN COMMERCE 10-5-2010.

KRISTIN DAHLING, EXAMINING ATTORNEY

SN 85-202,888. SWEDISH MATCH NORTH EUROPE AB,  
STOCKHOLM, SWEDEN, FILED 12-21-2010.

## General

SN 85-200,287. VAPOR CORP., HALLANDALE, FL. FILED  
12-17-2010.

## Altra

THE MARK CONSISTS OF STANDARD CHARACTERS WITHOUT CLAIM TO ANY PARTICULAR FONT, STYLE, SIZE, OR COLOR.

THE ENGLISH TRANSLATION OF THE WORD "ALTRA" IN THE MARK IS OTHER.

FOR ELECTRONIC CIGARETTES (U.S. CLS. 2, 8, 9 AND 17).

FIRST USE 4-19-2010; IN COMMERCE 10-12-2010.

KRISTIN DAHLING, EXAMINING ATTORNEY

OWNER OF SWEDEN REG. NO. 412964, DATED 9-24-2010,  
EXPIRES 9-24-2020.

OWNER OF U.S. REG. NOS. 3,018,074, 3,725,636 AND OTHERS.

THE MARK CONSISTS OF A STYLIZED VERSION OF THE WORD "GENERAL".

FOR TOBACCO; MATCHES; TOBACCO SUBSTITUTES NOT FOR MEDICAL PURPOSES; SNUFF AND TOBACCO ALTERNATIVES IN THE FORM OF PRODUCTS BASED ON VEGETABLE FIBERS, FOR ORAL USE, NOT FOR CONSUMPTION; SNUFF; TOBACCO FREE SNUFF; HERBAL SNUFF (U.S. CLS. 2, 8, 9 AND 17).

MARK PILARO, EXAMINING ATTORNEY

**CLASS 34—(Continued).**

SN 85-204,495. ELAKE ENTERPRISE, LLC, DBA CREMO CIGARS, MIAMI, FL. FILED 12-22-2010.



THE MARK CONSISTS OF "CREMO" IN STYLIZED FONT.

FOR CIGAR AND CIGARETTE BOXES; CIGAR AND CIGARETTE BOXES NOT OF PRECIOUS METAL; CIGAR AND CIGARETTE BOXES OF PRECIOUS METAL; CIGAR BOXES; CIGAR BOXES NOT OF PRECIOUS METAL; CIGAR BOXES OF PRECIOUS METAL; CIGAR CASES; CIGAR CASES OF PRECIOUS METAL; CIGAR CUTTERS; CIGAR HOLDERS; CIGAR HOLDERS OF PRECIOUS METAL; CIGAR HUMIDIFIERS; CIGAR LIGHTERS; CIGAR TUBES; CIGAR WRAPS; CIGARS; FILTERED CIGARS AND CIGARETTES; HOLDERS FOR CIGAR AND CIGARETTE OF PRECIOUS METAL; HOLDERS FOR CIGARS AND CIGARETTES; HOLDERS OF CIGARS AND CIGARETTES OF PRECIOUS METAL; NON-ELECTRIC CIGAR LIGHTERS NOT OF PRECIOUS METAL; SMOKERS' ARTICLES, NAMELY, CIGAR GLUE; SMOKERS' ARTICLES, NAMELY, CIGAR RELIGHTING LIQUID SOLUTION; SMOKERS' ARTICLES, NAMELY, CIGAR STORAGE TUBES; SMOKERS' ARTICLES, NAMELY, CONTAINMENT CLIPS USED TO KEEP A CIGAR FROM FALLING APART; SMOKERS' ARTICLES, NAMELY, OUTDOOR CIGAR AND CIGARETTE DISPOSAL UNITS; SMOKERS' ARTICLES, NAMELY, OUTDOOR RECEPTACLES FOR CIGAR AND CIGARETTE ASH AND WASTE; TOBACCO, CIGARS AND CIGARETTES (U.S. CLS. 2, 8, 9 AND 17).

JULIE VEPPUMTHARA, EXAMINING ATTORNEY

SN 85-206,446. STAR SCIENTIFIC, INC., GLEN ALLEN, VA. FILED 12-28-2010.

**STONEWALL MOIST-BDL**

THE MARK CONSISTS OF STANDARD CHARACTERS WITHOUT CLAIM TO ANY PARTICULAR FONT, STYLE, SIZE, OR COLOR.

OWNER OF U.S. REG. NOS. 2,832,419 AND 2,851,685. FOR SNUFF, COMPRESSED TOBACCO AND SMOKELESS TOBACCO (U.S. CLS. 2, 8, 9 AND 17).

AISHA CLARKE, EXAMINING ATTORNEY

**CLASS 34—(Continued).**

SN 85-206,554. AHMAD, THAER, UPLAND, CA. FILED 12-28-2010.



THE MARK CONSISTS OF THE WORD "SQUARE" SPELLED OUT, WITH A PICTURE OF A DISPOSABLE ELECTRONIC CIGARETTE IN THE MIDDLE OF THE "Q". FOR ELECTRIC CIGARETTES ; ELECTRIC CIGARS ; ELECTRIC SMOKING PIPES (U.S. CLS. 2, 8, 9 AND 17). FIRST USE 11-1-2009; IN COMMERCE 12-1-2009. KIMBERLY FRYE, EXAMINING ATTORNEY

SN 85-211,115. ANTHONY MORROW, ABILENE, TX. FILED 1-5-2011.



THE MARK CONSISTS OF STANDARD CHARACTERS WITHOUT CLAIM TO ANY PARTICULAR FONT, STYLE, SIZE, OR COLOR.

THE WORDING "NICATEA" HAS NO MEANING IN A FOREIGN LANGUAGE. FOR SMOKELESS TOBACCO; TOBACCO POUCHES (U.S. CLS. 2, 8, 9 AND 17).

LAURA KOVALSKY, EXAMINING ATTORNEY

SN 85-213,799. JOHNSON CREEK ENTERPRISES, LLC, JOHNSON CREEK, WI. FILED 1-10-2011.



THE MARK CONSISTS OF STANDARD CHARACTERS WITHOUT CLAIM TO ANY PARTICULAR FONT, STYLE, SIZE, OR COLOR.

FOR ELECTRONIC CIGARETTES (U.S. CLS. 2, 8, 9 AND 17).

JACQUELINE A. LAVINE, EXAMINING ATTORNEY

**CLASS 34—(Continued).**

SN 85-213,987. JAMESON CIGAR CO., LLC, PROCTORVILLE, OH. FILED 1-10-2011.



THE MARK CONSISTS OF AN EAGLE HOLDING A BANNER IN ITS TALONS, WITH THE WORDING "DECLARATION".

FOR CIGARS (U.S. CLS. 2, 8, 9 AND 17).  
FIRST USE 1-6-2010; IN COMMERCE 1-6-2010.  
AISHA SALEM, EXAMINING ATTORNEY

---

SN 85-239,025. WIND RIVER TOBACCO COMPANY, LLC, JACKSON, WY. FILED 2-10-2011.

**SNAKE RIVER**

THE MARK CONSISTS OF STANDARD CHARACTERS WITHOUT CLAIM TO ANY PARTICULAR FONT, STYLE, SIZE, OR COLOR.

FOR CHEWING TOBACCO; SMOKELESS TOBACCO (U.S. CLS. 2, 8, 9 AND 17).  
FIRST USE 11-0-2009; IN COMMERCE 11-0-2009.  
ASMAT KHAN, EXAMINING ATTORNEY

---

SN 85-265,579. WIND RIVER TOBACCO COMPANY, LLC, JACKSON, WY. FILED 3-13-2011.

**AMERICAN BISON**

THE MARK CONSISTS OF STANDARD CHARACTERS WITHOUT CLAIM TO ANY PARTICULAR FONT, STYLE, SIZE, OR COLOR.

OWNER OF U.S. REG. NOS. 2,811,662 AND 2,902,195.  
FOR SNUFF (U.S. CLS. 2, 8, 9 AND 17).  
FIRST USE 3-11-2011; IN COMMERCE 3-11-2011.  
ASMAT KHAN, EXAMINING ATTORNEY

**CLASS 35—(Continued).****SERVICE MARKS****CLASS 35—ADVERTISING AND BUSINESS**

SN 76-703,493. CITY OF MENOMINEE, MENOMINEE, MI. FILED 6-23-2010.



NO CLAIM IS MADE TO THE EXCLUSIVE RIGHT TO USE "MENOMINEE MICHIGAN" AND "MICHIGAN", APART FROM THE MARK AS SHOWN.

THE MARK CONSISTS OF THE DESIGN OF A LIGHTHOUSE INSIDE OF A PARTIAL CIRCLE OVER THE DESIGN OF A BANNER WITH THE STYLIZED WORDING "MICHIGAN" ON IT APPEARING OVER THE STYLIZED WORDING "MENOMINEE" APPEARING OVER THE STYLIZED WORDING "WHERE THE BEST OF MICHIGAN BEGINS".

FOR CHAMBER OF COMMERCE SERVICES, NAMELY, PROMOTING THE COMMUNITY, BUSINESS AND TOURISM IN THE MENOMINEE MICHIGAN AREA; CONVENTION AND VISITORS' BUREAU SERVICES, NAMELY, PROMOTING THE COMMUNITY, BUSINESS AND TOURISM IN THE MENOMINEE MICHIGAN AREA (U.S. CLS. 100, 101 AND 102).

FIRST USE 10-1-2005; IN COMMERCE 5-1-2006.  
AMY C. KEAN, EXAMINING ATTORNEY

---

SN 76-705,133. BATTS MORRISON WALES & LEE, P.A., ORLANDO, FL. FILED 10-29-2010.

**THE NONPROFIT WATCHMAN**

THE MARK CONSISTS OF STANDARD CHARACTERS WITHOUT CLAIM TO ANY PARTICULAR FONT, STYLE, SIZE, OR COLOR.

NO CLAIM IS MADE TO THE EXCLUSIVE RIGHT TO USE "NONPROFIT", APART FROM THE MARK AS SHOWN.

FOR ACCOUNTING AND BUSINESS AUDITING SERVICES (U.S. CLS. 100, 101 AND 102).

FIRST USE 3-1-2006; IN COMMERCE 3-1-2006.

ANN E. SAPPENFIELD, EXAMINING ATTORNEY



**CLASS 35—(Continued).**

SN 76-705,592. KEY PARTS, INC., LYNCHBURG, VA. FILED 12-6-2010.

**KLOKKERHOLM USA**

THE MARK CONSISTS OF STANDARD CHARACTERS WITHOUT CLAIM TO ANY PARTICULAR FONT, STYLE, SIZE, OR COLOR.

NO CLAIM IS MADE TO THE EXCLUSIVE RIGHT TO USE "USA", APART FROM THE MARK AS SHOWN.

FOR ONLINE RETAIL AND DIRECT WHOLESALE DISTRIBUTORSHIP FEATURING AUTO PARTS (U.S. CLS. 100, 101 AND 102).

FIRST USE 3-1-2010; IN COMMERCE 3-1-2010.  
TINA MAI, EXAMINING ATTORNEY

SN 76-705,869. GAP INTERNATIONAL, INC, SPRINGFIELD, PA. FILED 1-3-2011.

**Breakthrough leader**

THE MARK CONSISTS OF STANDARD CHARACTERS WITHOUT CLAIM TO ANY PARTICULAR FONT, STYLE, SIZE, OR COLOR.

OWNER OF U.S. REG. NOS. 3,371,557, 3,818,726 AND 3,864,683.

NO CLAIM IS MADE TO THE EXCLUSIVE RIGHT TO USE "LEADER", APART FROM THE MARK AS SHOWN.

FOR BUSINESS MANAGEMENT AND CONSULTING SERVICES (U.S. CLS. 100, 101 AND 102).

MARLENE BELL, EXAMINING ATTORNEY

SN 76-705,885. BRANSON/LAKES AREA CHAMBER OF COMMERCE AND CONVENTION & VISITORS BUREAU, BRANSON, MO. FILED 1-3-2011.

**ENTERTAINMENT THAT BRINGS US TOGETHER**

THE MARK CONSISTS OF STANDARD CHARACTERS WITHOUT CLAIM TO ANY PARTICULAR FONT, STYLE, SIZE, OR COLOR.

FOR PROMOTING TOURISM IN BRANSON, MO (U.S. CLS. 100, 101 AND 102).

HEATHER BIDDULPH, EXAMINING ATTORNEY

SN 76-706,135. ENNIS PAINT, INC., DALLAS, TX. FILED 1-26-2011.

**ENNIS TRAFFIC SAFETY CENTER ONE STOP**

THE MARK CONSISTS OF STANDARD CHARACTERS WITHOUT CLAIM TO ANY PARTICULAR FONT, STYLE, SIZE, OR COLOR.

OWNER OF U.S. REG. NO. 3,730,331.

NO CLAIM IS MADE TO THE EXCLUSIVE RIGHT TO USE "TRAFFIC SAFETY CENTER", APART FROM THE MARK AS SHOWN.

FOR RETAIL STORE SERVICES FEATURING PAINTS (U.S. CLS. 100, 101 AND 102).

DORITT L. CARROLL, EXAMINING ATTORNEY

**CLASS 35—(Continued).**

SN 76-706,137. ENNIS PAINT, INC., DALLAS, TX. FILED 1-26-2011.



OWNER OF U.S. REG. NO. 3,730,331.

NO CLAIM IS MADE TO THE EXCLUSIVE RIGHT TO USE "TRAFFIC SAFETY CENTER", APART FROM THE MARK AS SHOWN.

THE MARK CONSISTS OF A GLOBE HAVING TWO HIGHWAY STRIPES CIRCLING HALF OF THE GLOBE FROM THE LEFT SIDE WITH THE TEXT "ENNIS" ON THE LEFT AND A STOP SIGN ON THE RIGHT WITH THE TEXT "ONE STOP" INSIDE THE SIGN, BOTH UNDERLINED IN BOLD WITH THE TEXT "TRAFFIC SAFETY CENTER" DIRECTLY BELOW.

FOR RETAIL STORE SERVICES FEATURING PAINTS (U.S. CLS. 100, 101 AND 102).

DORITT L. CARROLL, EXAMINING ATTORNEY

SN 77-211,315. BELLSTAR HOTEL AND RESORTS LTD., CALGARY, ALBERTA, CANADA, FILED 6-20-2007.

**BELLSTAR**

THE MARK CONSISTS OF STANDARD CHARACTERS WITHOUT CLAIM TO ANY PARTICULAR FONT, STYLE, SIZE, OR COLOR.

PRIORITY CLAIMED UNDER SEC. 44(D) ON CANADA APPLICATION NO. 1346802, FILED 5-9-2007, REG. NO. TMA791385, DATED 2-23-2011, EXPIRES 2-23-2026.

FOR OPERATION OF RESORTS FOR OTHERS (U.S. CLS. 100, 101 AND 102).

CAROLYN CATALDO, EXAMINING ATTORNEY

SN 77-344,948. VALERO MARKETING AND SUPPLY COMPANY, SAN ANTONIO, TX. FILED 12-5-2007.

**READY 2 ROLL**

THE MARK CONSISTS OF STANDARD CHARACTERS WITHOUT CLAIM TO ANY PARTICULAR FONT, STYLE, SIZE, OR COLOR.

FOR RETAIL CONVENIENCE STORE SERVICES (U.S. CLS. 100, 101 AND 102).

SCOTT BIBB, EXAMINING ATTORNEY

**CLASS 35—(Continued).**

SN 77-413,041. PLANET GREEN CARTRIDGES, INC., DBA PLANET GREEN, CHATSWORTH, CA. FILED 3-4-2008.



NO CLAIM IS MADE TO THE EXCLUSIVE RIGHT TO USE "GREEN" AND THE REPRESENTATION OF THE "RECYCLING SYMBOL", APART FROM THE MARK AS SHOWN.

THE COLOR(S) WHITE, BLACK, GREEN, LIGHT GREEN, RED, ORANGE, YELLOW, BLUE, DARK BLUE, LIGHT BLUE AND PURPLE IS/ARE CLAIMED AS A FEATURE OF THE MARK.

THE MARK CONSISTS OF THE LETTERS "PG" IN STYLIZED WHITE FONT WITH A LIGHT GREEN INNER BORDER AGAINST A BLACK RECTANGULAR BACKGROUND WITH A WHITE AND BLACK BORDER. THE WORDS "PLANET GREEN" IN SMALLER BLACK STYLIZED FONT APPEAR TO THE LEFT OF "PG" WITHIN A VERTICAL WHITE STRIP. A GREEN RECYCLING SYMBOL APPEARS BETWEEN "PLANET" AND "GREEN". A DESIGN OF THE PLANET EARTH DEPICTED IN BLUE AND GREEN WITH BLACK SHADOWING APPEARS ABOVE THE LETTERS "PG". A RAINBOW DESIGN CIRCUMSCRIBES THE LOWER HALF OF THE PLANET, GRADUATING IN COLOR FROM LEFT TO RIGHT IN ORANGE, YELLOW, GREEN, LIGHT BLUE, BLUE, DARK BLUE, PURPLE TO RED.

FOR BUSINESS SERVICES, NAMELY, DEVELOPING FUND RAISING CAMPAIGNS FOR OTHERS INVOLVING THE COLLECTION AND PAYMENT OF CASH FOR USED RECYCLABLE MATERIALS, NAMELY, INK JET PRINTER CARTRIDGES, LASER TONER CARTRIDGES AND CELL PHONES (U.S. CLS. 100, 101 AND 102).

FIRST USE 1-0-2000; IN COMMERCE 1-0-2000.  
STEVEN PEREZ, EXAMINING ATTORNEY

**CLASS 35—(Continued).**

SN 77-680,469. WORLD MARKET CENTER VENTURE, LLC, LAS VEGAS, NV. FILED 2-27-2009.

GIFT HOME  
AT WORLD MARKET CENTER LAS VEGAS

NO CLAIM IS MADE TO THE EXCLUSIVE RIGHT TO USE "GIFT" OR "HOME" OR "MARKET CENTER", APART FROM THE MARK AS SHOWN.

THE COLOR(S) BLUE, AQUA, GREEN, LIME, RED, PURPLE, FUCHSIA, ORANGE, AND GRAY IS/ARE CLAIMED AS A FEATURE OF THE MARK.

THE MARK CONSISTS OF THE GRAY STYLIZED WORDS "GIFT HOME" OVER THE GRAY STYLIZED WORDS "AT WORLD MARKET CENTER LAS VEGAS", WITH AN ASSORTMENT OF BLUE, AQUA, GREEN, LIME, RED, PURPLE, FUCHSIA AND ORANGE COLORED CIRCLES SYMBOLIZING A PLUS SIGN IN BETWEEN THE GRAY STYLIZED WORDS "GIFT" AND "HOME".

SEC. 2(F) AS TO "WORLD MARKET CENTER LAS VEGAS".

FOR ARRANGING, ORGANIZING, PROMOTING AND CONDUCTING TRADE EXHIBITIONS, TRADE CONVENTIONS, TRADE SHOWS AND TRADE FAIRS IN THE FIELDS OF HOME, OFFICE AND HOSPITALITY FURNISHINGS; ADVERTISING AND MARKETING OF TRADE SHOWROOMS AND RELATED SHOWROOM FACILITIES AND SERVICES TO MANUFACTURERS OF GOODS IN THE FIELDS OF HOME, OFFICE AND HOSPITALITY FURNISHINGS; ADVERTISING AND MARKETING OF TRADE SHOWROOMS FOR DISPLAY AND EXHIBITION OF GOODS OF MANUFACTURERS IN THE FIELDS OF HOME, OFFICE AND HOSPITALITY FURNISHINGS TO RETAILERS OF HOME, OFFICE AND HOSPITALITY FURNISHINGS; RETAIL STORE SERVICES FEATURING A WIDE VARIETY OF CONSUMER GOODS OF OTHERS (U.S. CLS. 100, 101 AND 102).

FIRST USE 8-1-2009; IN COMMERCE 8-1-2009.  
ANDREW RHIM, EXAMINING ATTORNEY

SN 77-777,033. ATAIL, SOHRAB, DBA HENNESSY WOOD FLOORS, ANAHEIM, CA. FILED 7-8-2009.

## Hennessy Wood Floors

THE MARK CONSISTS OF STANDARD CHARACTERS WITHOUT CLAIM TO ANY PARTICULAR FONT, STYLE, SIZE, OR COLOR.

NO CLAIM IS MADE TO THE EXCLUSIVE RIGHT TO USE "WOOD FLOORS", APART FROM THE MARK AS SHOWN.

SEC. 2(F).

FOR (BASED ON USE IN COMMERCE) WHOLESALE DISTRIBUTORSHIPS FEATURING FLOORING(BASED ON INTENT TO USE) WHOLESALE AND RETAIL STORE SERVICES FEATURING FLOORING; WHOLESALE ORDERING SERVICES IN THE FIELD OF FLOORING (U.S. CLS. 100, 101 AND 102).

FIRST USE 4-1-2005; IN COMMERCE 4-1-2005.  
CHRISTINA SOBRAL, EXAMINING ATTORNEY

**CLASS 35—(Continued).**

SN 77-797,321. PAYMENT TRANSACTION SERVICES, INC., WALTHAM, MA. FILED 8-5-2009.

# CAPTURE CODA

THE MARK CONSISTS OF STANDARD CHARACTERS WITHOUT CLAIM TO ANY PARTICULAR FONT, STYLE, SIZE, OR COLOR.

FOR PROMOTING THE GOODS AND SERVICES OF OTHERS THROUGH THE ISSUANCE AND DISTRIBUTION OF DISCOUNT, GIFT AND LOYALTY REWARDS CARDS; PROMOTING THE GOODS AND SERVICES OF OTHERS THROUGH THE DISTRIBUTION BY MAIL, E-MAIL AND WIRELESS MEDIA OF CODES THAT MAY BE USED TO OBTAIN DISCOUNTS, GIFTS AND LOYALTY REWARDS; ADMINISTRATION OF A PROGRAM ENABLING PARTICIPANTS TO OBTAIN LOYALTY REWARDS, DISCOUNTS ON GOODS AND SERVICES AND PROMOTIONAL GIFTS VIA GIFT CARDS AND ELECTRONIC GIFT CARDS (U.S. CLS. 100, 101 AND 102).

JEAN IM, EXAMINING ATTORNEY

SN 77-808,988. TRANSEXACT LLC, NEW YORK, NY. FILED 8-20-2009.

# TRANSEXACT

THE MARK CONSISTS OF STANDARD CHARACTERS WITHOUT CLAIM TO ANY PARTICULAR FONT, STYLE, SIZE, OR COLOR.

FOR PROVIDING WEB-BASED AUCTIONS FOR REAL ESTATE MORTGAGE AND OTHER DEBT; PROVIDING WEB-BASED AUCTIONS FOR REAL PROPERTY (U.S. CLS. 100, 101 AND 102).

FLORENTINA BLANDU, EXAMINING ATTORNEY

SN 77-861,995. MONEY DOCTOR, MD CORPORATION, IRVINE, CA. FILED 10-30-2009.

**Su Lin CPA**



**Money**



NO CLAIM IS MADE TO THE EXCLUSIVE RIGHT TO USE "CPA", "DEBIT", "CREDIT", "MONEY" OR THE NON-LATIN CHARACTERS THAT TRANSLITERATE TO "MONEY", APART FROM THE MARK AS SHOWN.

THE NAME(S), PORTRAIT(S), AND/OR SIGNATURE(S) SHOWN IN THE MARK IDENTIFIES "SU LIN", A LIVING INDIVIDUAL, WHOSE CONSENT(S) TO REGISTER IS MADE OF RECORD.

THE MARK CONSISTS OF THREE PAIRS OF CIRCLES WHICH EQUATE TO TOTAL OF SIX. THE PAIR OF CIRCLES AT THE LEFT CONSISTS OF ONE CIRCLE IN DARK AND THE OTHER CIRCLE IN WHITE. THE WORDS "SU LIN" WITH "CPA" IN A BOX APPEAR INSIDE BOTH

**CLASS 35—(Continued).**

CIRCLES. ATOP AND ACROSS THE FIRST PAIR OF CIRCLES ARE THE WORDS "SU LIN CPA". THE MIDDLE PAIR OF CIRCLES HAS PROTRUDING PARTS AT THE RIMS. THE WORD "DEBIT" APPEARS IN ONE CIRCLE. THE WORD "CREDIT" APPEARS IN THE OTHER CIRCLE. THE PAIR AT THE RIGHT CONSISTS OF ONE CIRCLE IN DARK AND THE OTHER CIRCLE IN WHITE. EACH CIRCLE CONTAINS A DIFFERENT CHINESE CHARACTER INSIDE THE CIRCLE. ATOP AND ACROSS THE PAIR OF CIRCLES AT THE RIGHT IS THE WORD "MONEY".

THE NON-LATIN CHARACTERS IN THE MARK TRANSLITERATE TO CHIEN AND THIS MEANS "MONEY" IN ENGLISH.

FOR ACCOUNTING SERVICES, TAX PLANNING AND PREPARATION SERVICES (U.S. CLS. 100, 101 AND 102).

KIMBERLY FRYE, EXAMINING ATTORNEY

SN 77-863,587. UNITED STATES SWIMMING, INC., DBA USA SWIMMING, COLORADO SPRINGS, CO. FILED 11-3-2009.



OWNER OF U.S. REG. NOS. 3,015,366, 3,141,187 AND OTHERS.

THE MARK CONSISTS OF THE STYLIZED WORDING "AMERICA'S SWIM TEAM" WITH A STYLIZED DRAWING OF A SOLID CIRCLE CONTAINING A STAR BETWEEN THE WORDS "SWIM" AND "TEAM"; A STYLIZED DRAWING OF A SHIELD APPEARS ABOVE CONTAINING THE STYLIZED WORDING "USA SWIMMING" AT THE TOP AND A STYLIZED DRAWING OF VERTICAL STRIPES REPRESENTING SWIMMING LANES AT THE BOTTOM WITH A STYLIZED DRAWING OF A STAR IN THE MIDDLE.

SEC. 2(F) AS TO "USA SWIMMING".

FOR ASSOCIATION SERVICES, NAMELY, PROMOTING THE SPORT OF SWIMMING; PROMOTING INTEREST AND PARTICIPATION IN THE SPORT OF SWIMMING (U.S. CLS. 100, 101 AND 102).

AMEEN IMAM, EXAMINING ATTORNEY

**CLASS 35—(Continued).**

SN 77-863,620. UNITED STATES SWIMMING, INC., DBA USA SWIMMING, COLORADO SPRINGS, CO. FILED 11-3-2009.



OWNER OF U.S. REG. NOS. 1,222,932, 3,015,366 AND OTHERS.

THE MARK CONSISTS OF THE STYLIZED WORDING "AMERICA'S SWIM TEAM" WITH A STYLIZED DRAWING OF A SOLID CIRCLE CONTAINING A STAR BETWEEN THE WORDS "SWIM" AND "TEAM"; A STYLIZED DRAWING OF A SHIELD APPEARS ABOVE CONTAINING THE STYLIZED WORDING "USA SWIMMING" AT THE TOP AND A STYLIZED DRAWING OF VERTICAL STRIPES REPRESENTING SWIMMING LANES AT THE BOTTOM WITH A STYLIZED DRAWING OF A STAR IN THE MIDDLE.

SEC. 2(F) AS TO "USA SWIMMING".

FOR ASSOCIATION SERVICES, NAMELY, PROMOTING THE SPORT OF SWIMMING; PROMOTING INTEREST AND PARTICIPATION IN THE SPORT OF SWIMMING (U.S. CLS. 100, 101 AND 102).

AMEEN IMAM, EXAMINING ATTORNEY

SN 77-863,630. UNITED STATES SWIMMING, INC., DBA USA SWIMMING, COLORADO SPRINGS, CO. FILED 11-3-2009.



OWNER OF U.S. REG. NOS. 1,222,932, 3,015,366 AND OTHERS.

THE MARK CONSISTS OF THE STYLIZED WORDING "AMERICA'S SWIM TEAM" WITH A STYLIZED DRAWING OF A SOLID CIRCLE CONTAINING A STAR BETWEEN THE WORDS "SWIM" AND "TEAM"; A STYLIZED DRAWING OF A CIRCLE APPEARS TO THE LEFT CONTAINING A STYLIZED DRAWING OF A SHIELD WITH THE STYLIZED WORDING "USA SWIMMING" AT THE TOP, VERTICAL STRIPES REPRESENTING SWIMMING LANES AT THE BOTTOM AND A STAR IN THE MIDDLE.

SEC. 2(F) AS TO "USA SWIMMING".

FOR ASSOCIATION SERVICES, NAMELY, PROMOTING THE SPORT OF SWIMMING; PROMOTING INTEREST AND PARTICIPATION IN THE SPORT OF SWIMMING (U.S. CLS. 100, 101 AND 102).

AMEEN IMAM, EXAMINING ATTORNEY

**CLASS 35—(Continued).**

SN 77-864,184. IMAGEON CONSULTING, INC., NEW YORK, NY. FILED 11-3-2009.

# HRISON

THE MARK CONSISTS OF STANDARD CHARACTERS WITHOUT CLAIM TO ANY PARTICULAR FONT, STYLE, SIZE, OR COLOR.

FOR CONSULTING SERVICES IN THE FIELD OF HUMAN RESOURCES DEVELOPMENT, NAMELY, FOR THE PROMOTION OF EMPLOYEE RETENTION, CAREER GROWTH, AND INCREASED PRODUCTIVITY FOR EMPLOYEES AND EMPLOYERS; CONSULTING SERVICES IN THE FIELD OF HUMAN RESOURCES DEVELOPMENT, NAMELY, UTILIZING TECHNOLOGY FOR THE PROMOTION OF EMPLOYEE RETENTION, CAREER GROWTH AND INCREASED PRODUCTIVITY FOR EMPLOYEES AND EMPLOYERS; CONSULTING SERVICES IN THE FIELDS OF BUSINESS MANAGEMENT, HUMAN RESOURCES, AND BUSINESS ORGANIZATIONAL DESIGN; HUMAN RESOURCE ANALYSIS AND CONSULTING SERVICES; HUMAN RESOURCE SERVICES, NAMELY, COLLECTING, ANALYZING, REPORTING, AND PROVIDE FEEDBACK FROM INDIVIDUALS WHO SEPARATE FROM AN ORGANIZATION; HUMAN RESOURCES CONSULTATION (U.S. CLS. 100, 101 AND 102).

FIRST USE 11-2-2009; IN COMMERCE 11-2-2009.

ELLEN B. AWRICH, EXAMINING ATTORNEY

SN 77-865,156. MINASSIAN, SARKIS SERJEO, DBA SERJEO, BOSTON, MA. FILED 11-4-2009.



THE NAME(S), PORTRAIT(S), AND/OR SIGNATURE(S) SHOWN IN THE MARK IDENTIFIES SARKIS SERJEO MINASSIAN, WHOSE CONSENT(S) TO REGISTER IS MADE OF RECORD.

THE COLOR(S) BLUE AND WHITE IS/ARE CLAIMED AS A FEATURE OF THE MARK.

THE MARK CONSISTS OF THE WORD "SERJEO" IN STYLIZED WHITE FONT WITH A WHITE TRIANGLE ABOVE THE LETTER.

FOR WHOLESALE AND RETAIL STORE SERVICES FEATURING CUSTOM DESIGNED JEWELRY (U.S. CLS. 100, 101 AND 102).

FIRST USE 1-1-2000; IN COMMERCE 1-1-2000.

FRANK LATTUCA, EXAMINING ATTORNEY

**CLASS 35—(Continued).**

SN 77-871,099. EMERGENCY MEDICAL SERVICES CORPORATION, GREENWOOD VILLAGE, CO. FILED 11-12-2009.



OWNER OF U.S. REG. NOS. 1,317,259 AND 2,463,604.  
NO CLAIM IS MADE TO THE EXCLUSIVE RIGHT TO USE "INPATIENT SERVICES", APART FROM THE MARK AS SHOWN.

THE MARK CONSISTS OF THE WORD "EMCARE" WITH A CROSS OR PLUS DESIGN CONTAINED WITHIN THE LETTER 'C' WITH THE AN ARC SHAPE BELOW AND THE WORDS "INPATIENT SERVICES", AND THE PORTION OF THE MARK COMPRISED OF A CROSS DESIGN IS NOT DISPLAYED IN THE COLOR RED OR A COLORABLE IMITATION THEREOF; AND IS NOT USED AND WILL NOT BE USED IN THE COLOR RED OR A COLORABLE IMITATION THEREOF.

FOR MEDICAL CARE CENTER BUSINESS MANAGEMENT AND CONSULTATION; EMPLOYMENT STAFFING SERVICES FOR HOSPITALS AND HOSPITALISTS (U.S. CLS. 100, 101 AND 102).

FIRST USE 11-1-2007; IN COMMERCE 11-1-2007.  
STEVEN R. FINE, EXAMINING ATTORNEY

SN 77-871,102. EMERGENCY MEDICAL SERVICES CORPORATION, GREENWOOD VILLAGE, CO. FILED 11-12-2009.



NO CLAIM IS MADE TO THE EXCLUSIVE RIGHT TO USE "ANESTHESIA CARE", APART FROM THE MARK AS SHOWN.

THE MARK CONSISTS OF THE WORDS "ANESTHESIA-CARE" WITH A CROSS OR PLUS DESIGN CONTAINED WITHIN THE LETTER "C" AND A RECTANGULAR SHAPE TO THE LEFT OF THE DESIGN CONTAINING VARYING SIZES OF ELLIPSES, AND THE PORTION OF THE MARK COMPRISED OF A CROSS DESIGN IS NOT DISPLAYED IN THE COLOR RED OR A COLORABLE IMITATION THEREOF; AND IS NOT USED AND WILL NOT BE USED IN THE COLOR RED OR A COLORABLE IMITATION THEREOF.

FOR MEDICAL CARE CENTER BUSINESS MANAGEMENT AND CONSULTATION; EMPLOYMENT STAFFING SERVICES FOR HOSPITALS AND ANESTHESIOLOGY DEPARTMENTS (U.S. CLS. 100, 101 AND 102).

FIRST USE 11-1-2008; IN COMMERCE 11-1-2008.  
STEVEN R. FINE, EXAMINING ATTORNEY

**CLASS 35—(Continued).**

SN 77-877,701. NATIONAL ASSOCIATION OF PROFESSIONAL GERIATRIC CARE MANAGERS, TUCSON, AZ. FILED 11-20-2009.

NATIONAL ASSOCIATION OF  
PROFESSIONAL GERIATRIC  
CARE MANAGERS

THE MARK CONSISTS OF STANDARD CHARACTERS WITHOUT CLAIM TO ANY PARTICULAR FONT, STYLE, SIZE, OR COLOR.

NO CLAIM IS MADE TO THE EXCLUSIVE RIGHT TO USE "ASSOCIATION", APART FROM THE MARK AS SHOWN.

SEC. 2(F).

FOR ASSOCIATION SERVICES, NAMELY, PROMOTING THE INTERESTS OF GERIATRIC CARE PRACTITIONERS AND THE ADVANCEMENT OF DIGNIFIED CARE FOR THE ELDERLY AND THEIR FAMILIES; PROVIDING AN ON-LINE DIRECTORY FEATURING PROFILES AND CONTACT INFORMATION OF GERIATRIC CARE PRACTITIONERS (U.S. CLS. 100, 101 AND 102).

FIRST USE 0-0-1993; IN COMMERCE 0-0-1993.  
BARBARA BROWN, EXAMINING ATTORNEY

SN 77-880,109. NATIONAL ASSOCIATION OF PROFESSIONAL GERIATRIC CARE MANAGERS, TUCSON, AZ. FILED 11-24-2009.



National Association of  
Professional Geriatric Care Managers

NO CLAIM IS MADE TO THE EXCLUSIVE RIGHT TO USE "ASSOCIATION", APART FROM THE MARK AS SHOWN.

THE MARK CONSISTS OF A REPRESENTATION OF A RISING SUN OVER AN ARC REPRESENTING A HORIZON LINE UNDER WHICH THE LITERAL ELEMENT "NAPGCM" APPEARS STACKED OVER THE LITERAL ELEMENT "NATIONAL ASSOCIATION OF PROFESSIONAL GERIATRIC CARE MANAGERS".

SEC. 2(F) AS TO "NATIONAL ASSOCIATION OF PROFESSIONAL GERIATRIC CARE MANAGERS".

FOR ASSOCIATION SERVICES, NAMELY, PROMOTING THE INTERESTS OF GERIATRIC CARE PRACTITIONERS AND THE ADVANCEMENT OF DIGNIFIED CARE FOR THE ELDERLY AND THEIR FAMILIES; PROVIDING AN ON-LINE DIRECTORY FEATURING PROFILES AND CONTACT INFORMATION OF GERIATRIC CARE PRACTITIONERS (U.S. CLS. 100, 101 AND 102).

FIRST USE 8-0-2009; IN COMMERCE 8-0-2009.  
BARBARA BROWN, EXAMINING ATTORNEY



**CLASS 35—(Continued).**

SN 77-895,196. ECONOMIC DEVELOPMENT CENTER OF SAINT CHARLES COUNTY, DBA PARTNERS FOR PROGRESS OF GREATER ST. CHARLES, ST. CHARLES, MO. FILED 12-16-2009.

PARTNERS FOR PROGRESS OF  
GREATER ST. CHARLES

THE MARK CONSISTS OF STANDARD CHARACTERS WITHOUT CLAIM TO ANY PARTICULAR FONT, STYLE, SIZE, OR COLOR.

NO CLAIM IS MADE TO THE EXCLUSIVE RIGHT TO USE "GREATER ST. CHARLES", APART FROM THE MARK AS SHOWN.

FOR PROMOTING ECONOMIC DEVELOPMENT IN THE COUNTY OF ST. CHARLES, MISSOURI (U.S. CLS. 100, 101 AND 102).

FIRST USE 1-1-2009; IN COMMERCE 1-1-2009.  
LIEF MARTIN, EXAMINING ATTORNEY

---

SN 77-897,960. THRIVENT FINANCIAL FOR LUTHERANS, APPLETON, WI. FILED 12-21-2009.

CHOICE DOLLARS

THE MARK CONSISTS OF STANDARD CHARACTERS WITHOUT CLAIM TO ANY PARTICULAR FONT, STYLE, SIZE, OR COLOR.

NO CLAIM IS MADE TO THE EXCLUSIVE RIGHT TO USE "DOLLARS", APART FROM THE MARK AS SHOWN.

"DOLLARS" APPEARING IN THE MARK HAS NO SIGNIFICANCE NOR IS IT A TERM OF ART IN THE RELEVANT TRADE OR INDUSTRY OR AS APPLIED TO THE GOODS/SERVICES LISTED IN THE APPLICATION, OR ANY GEOGRAPHICAL SIGNIFICANCE.

FOR PROMOTING AND ADMINISTERING A LOYALTY INCENTIVE PROGRAM TO PROMOTE CHARITABLE PURPOSES (U.S. CLS. 100, 101 AND 102).

JANICE L. MCMORROW, EXAMINING ATTORNEY

**CLASS 35—(Continued).**

SN 77-910,279. LINCIR, MATT G, DBA ALVAS, SAN PEDRO, CA. FILED 1-12-2010.



NO CLAIM IS MADE TO THE EXCLUSIVE RIGHT TO USE "GIGHEAR.ORG", APART FROM THE MARK AS SHOWN.

THE MARK CONSISTS OF THE STYLIZED WORDING "GIGHEAR.ORG" SUPERIMPOSED OVER A DEPICTION OF A GLOBE WITH CONTINENTS. A DIFFERENT SHADE IS USED FOR EACH OF THE THREE TERMS, WITH THE TERM "GIG" APPEARING DIRECTLY OVER THE GLOBE, AND THE TERMS "HEAR.ORG" SLIGHTLY OVERLAPPING AND TO THE LOWER RIGHT OF THE WORD "GIG".

FOR PROMOTIONAL SERVICES, NAMELY, PROVIDING A WEBSITE AT WHICH ARTISTS CAN SHOWCASE THEIR TALENTS VIA AN ONLINE PORTFOLIO; PROVIDING ADVERTISING SERVICE TO DISTRIBUTE ADVERTISEMENTS FOR DISPLAY ON INTERNET, NAMELY, IN WEBSITES, SOCIAL CONVERSATIONS OVER THE INTERNET, EMAILS, MICROBLOGS, BLOGS, ELECTRONIC MESSAGES, INSTANT MESSAGES, TEXT MESSAGES, MULTIMEDIA MESSAGES, SOCIAL NETWORKS, STATUS UPDATES, FORUMS, ELECTRONIC BULLETIN BOARDS.; PROVIDING AN INTERNET WEBSITE PORTAL FEATURING LINKS TO MUSIC-RELATED MERCHANDISE FOR RETAIL PURPOSES (U.S. CLS. 100, 101 AND 102).

FIRST USE 1-14-2009; IN COMMERCE 1-20-2009.  
JERI J. FICKES, EXAMINING ATTORNEY

---

SN 77-914,913. VALUE IN LAND, INC., DOWNERS GROVE, IL. FILED 1-19-2010.

VALUE IN LAND

THE MARK CONSISTS OF STANDARD CHARACTERS WITHOUT CLAIM TO ANY PARTICULAR FONT, STYLE, SIZE, OR COLOR.

FOR REAL ESTATE SALES MANAGEMENT AND REAL ESTATE AGENT REFERRALS (U.S. CLS. 100, 101 AND 102).

FIRST USE 4-0-2002; IN COMMERCE 4-0-2002.  
MICHAEL ENGEL, EXAMINING ATTORNEY

**CLASS 35—(Continued).**

SN 77-925,157. NINTENDO CO., LTD., KYOTO, JAPAN,  
FILED 2-1-2010.



PRIORITY CLAIMED UNDER SEC. 44(D) ON JAPAN APPLICATION NO. 2009-088882, FILED 11-24-2009, REG. NO. 5333003, DATED 6-25-2010, EXPIRES 6-25-2020.

THE MARK CONSISTS OF THE WORD "WII", FOLLOWED BY TWO JAPANESE CHARACTERS. BENEATH THE WORDS IS A STYLIZED IMAGE OF A ROUND TABLE.

THE NON-LATIN CHARACTERS IN THE MARK TRANSLITERATE TO "NO MA" AND THIS MEANS "THE ROOM OF" IN ENGLISH.

FOR ADVERTISING AND PUBLICITY SERVICES; ADVERTISING BY MOTION PICTURES; DISTRIBUTION OF COMMERCIAL SAMPLES; RENTAL OF ADVERTISING SPACE ON THE INTERNET; ISSUANCE OF COUPONS FOR SALES PROMOTION OF THE GOODS OR SERVICES; PROMOTIONAL SERVICES, NAMELY, PROMOTING THE GOODS AND SERVICES OF OTHERS THROUGH CONTESTS; MARKETING RESEARCH; BUSINESS RESEARCH AND SURVEYS; CONDUCTING MARKET SURVEYS; PUBLIC OPINION SURVEYS; WHOLESALE AND RETAIL STORE SERVICES IN THE FIELD OF SPORTING GOODS, TOYS, DOLLS, GAMING MACHINES AND GAMING APPARATUS (U.S. CLS. 100, 101 AND 102).

ANDREA HACK, EXAMINING ATTORNEY

**CLASS 35—(Continued).**

SN 77-934,200. UBISOFT ENTERTAINMENT, RENNES, FRANCE, FILED 2-12-2010.

**UBI WORKSHOP**

THE MARK CONSISTS OF STANDARD CHARACTERS WITHOUT CLAIM TO ANY PARTICULAR FONT, STYLE, SIZE, OR COLOR.

OWNER OF U.S. REG. NOS. 2,976,757, 3,009,070 AND OTHERS.

NO CLAIM IS MADE TO THE EXCLUSIVE RIGHT TO USE "WORKSHOP", APART FROM THE MARK AS SHOWN.

FOR COMPUTERIZED ONLINE RETAIL STORE SERVICES FEATURING CLOTHING, HOUSEHOLD ACCESSORIES AND WARES, PAPER, CARDBOARD BOXES, ARTISTS' MATERIALS, NAMELY, PASTELS AND BRUSHES; COMPUTERIZED ONLINE RETAIL STORE SERVICES FEATURING ELECTRONIC GAME SOFTWARE AND ELECTRONIC GAMES, PRE-RECORDED AUDIO CASSETTES, PHONOGRAPH RECORDS, COMPACT DISCS, VIDEO CASSETTES, LASER VIDEO DISCS, DIGITAL VIDEO DISCS AND DIGITAL VERSATILE DISCS ALL FEATURING ARTS, MUSIC, VIDEO GAMES AND ENTERTAINMENT; COMPUTERIZED ONLINE RETAIL STORE SERVICES FEATURING DIGITAL AUDIO AND AUDIO VIDEO TAPES AND DISCS, LASER DISCS, MOTION PICTURE FILMS ALL FEATURING ARTS, VIDEO GAMES AND ENTERTAINMENT; COMPUTERIZED ONLINE RETAIL STORE SERVICES FEATURING COMPUTER PERIPHERAL AND MOUSE PADS; COMPUTERIZED ONLINE RETAIL STORE SERVICES FEATURING TOYS AND PLAYTHINGS, NAMELY, DOLLS, TOY ACTION FIGURES, PLUSH TOYS AND ACCESSORIES THEREOF, PLAYSETS FOR DOLLS AND TOY ACTION FIGURES, TOY VEHICLES AND HAND HELD UNITS FOR PLAYING ELECTRONIC GAMES OTHER THAN ADAPTED FOR USE WITH AN EXTERNAL DISPLAY SCREEN OR MONITOR (U.S. CLS. 100, 101 AND 102).

KHANH LE, EXAMINING ATTORNEY

SN 77-935,512. JET SET BONANZA, LLC, LAS VEGAS, NV,  
FILED 2-14-2010.

NO CLAIM IS MADE TO THE EXCLUSIVE RIGHT TO USE "PERSONALIZED DENTAL SOLUTION", APART FROM THE MARK AS SHOWN.

THE COLOR(S) GREEN, BLUE AND GREY IS/ARE CLAIMED AS A FEATURE OF THE MARK.

THE MARK CONSISTS OF THE STYLIZED WORDING "IDENTALFY", WITH THE "I" APPEARING IN GREEN, AND THE REST OF THE LETTERS IN BLUE, AND THE WORDING "PERSONALIZED DENTAL SOLUTION" APPEARING BELOW IN GREY.

FOR CONSULTING SERVICES IN THE FIELD OF DENTAL PRACTICE MANAGEMENT (U.S. CLS. 100, 101 AND 102).

FIRST USE 6-1-2009; IN COMMERCE 2-13-2010.

MARK PILARO, EXAMINING ATTORNEY

**CLASS 35—(Continued).**

SN 77-937,754. EXPERIAN DATA CORP., COSTA MESA, CA. FILED 2-17-2010.

## DATA ILLUMINATED BY RENTBUREAU

THE MARK CONSISTS OF STANDARD CHARACTERS WITHOUT CLAIM TO ANY PARTICULAR FONT, STYLE, SIZE, OR COLOR.

OWNER OF U.S. REG. NO. 3,297,901.  
FOR BUSINESS SERVICES, NAMELY, PROVIDING BUSINESS INFORMATION IN THE NATURE OF RENTAL HISTORY DATA AND LEASE DATA, AND REPORTS PREPARED FROM THAT DATA (U.S. CLS. 100, 101 AND 102).

FIRST USE 5-13-2009; IN COMMERCE 5-13-2009.  
JESSICA A. POWERS, EXAMINING ATTORNEY

SN 77-940,395. KOINONIA INTEGRATED SOLUTIONS, INC., DBA IT'S TIME 2, CASTRO VALLEY, CA. FILED 2-19-2010.

## It's Time 2

THE MARK CONSISTS OF STANDARD CHARACTERS WITHOUT CLAIM TO ANY PARTICULAR FONT, STYLE, SIZE, OR COLOR.

FOR CUSTOMER RELATIONSHIP MANAGEMENT (U.S. CLS. 100, 101 AND 102).

SARA BENJAMIN, EXAMINING ATTORNEY

SN 77-952,118. BESHARAT, MASSOUD, ELBERTON, GA. FILED 3-5-2010.



## BESHARAT GALLERY

NO CLAIM IS MADE TO THE EXCLUSIVE RIGHT TO USE "GALLERY", APART FROM THE MARK AS SHOWN.  
THE MARK CONSISTS OF A DRAWING OF LION'S HEAD WITH WORDS "BESHARAT GALLERY" BELOW WITH THE LETTER "B" IN THE LION'S HEAD.

FOR ART GALLERY (U.S. CLS. 100, 101 AND 102).  
FIRST USE 7-1-2009; IN COMMERCE 7-1-2009.  
STEVEN R. FINE, EXAMINING ATTORNEY

**CLASS 35—(Continued).**

SN 77-955,460. CHATHAM ADVISORS LIMITED, INCORPORATED, BRENTWOOD, TN. FILED 3-10-2010.



NO CLAIM IS MADE TO THE EXCLUSIVE RIGHT TO USE "FINANCIAL" OR "IMPLIED GROWTH RATE" OR "ADVISORS LTD", APART FROM THE MARK AS SHOWN.

THE MARK CONSISTS OF A RECTANGULAR DESIGN. INSIDE THE RECTANGLE ARE THE LETTERS "RIGR" WITH THE WORDS "REAL IMPLIED GROWTH RATE" UNDERNEATH THEM, WHICH IS WHAT THE LETTERS REPRESENT. THE DESIGN OF A GRAPH RUNS ACROSS THE CENTER PORTION OF THE RECTANGULAR MARK, INCLUDING BEHIND "RIGR" IN THE MARK. SEVERAL HORIZONTAL LINES ALSO RUN ACROSS THE ENTIRETY OF THE RECTANGULAR MARK. THE WORDS "CHATHAM ADVISORS LTD" APPEAR AT THE LOWER LEFT CORNER OF THE MARK IN DIMINUTIVE FONT. THE WORDS "THE FINANCIAL COMPASS" APPEAR IN THE UPPER RIGHT CORNER OF THE MARK IN A STYLIZED FORM. AN ANTIQUE COMPASS-ROSE ILLUSTRATION ALSO APPEARS IN THE UPPER RIGHT CORNER OF THE MARK WITH LINES WHICH RADIATE OUTWARD FROM THE COMPASS. A CIRCULAR ANCHOR EMBLEM APPEARS IN EACH CORNER OF THE MARK AND THE BORDER OF THE MARK CONSISTS OF TWO LINES REPRESENTING ROPES.

FOR BUSINESS PLAN CONSULTING; MARKETING ADVISORY SERVICES, NAMELY, ADVERTISING CONSULTATION SERVICES FOR ALL SERVICES INCLUDING SERVICES IN THE FIELDS OF STOCKS, EQUITIES, BONDS, NOTES, BILLS, OPTIONS, ETFS, MUTUAL FUNDS, COMMODITIES, DERIVATIVES, AS WELL AS ASSET BACKED SECURITIES OF ALL TYPES (U.S. CLS. 100, 101 AND 102).

MAUREEN DALL, EXAMINING ATTORNEY

SN 77-959,805. H.A. BRUNO, LLC, PARAMUS, NJ. FILED 3-16-2010.

## IFE

THE MARK CONSISTS OF STANDARD CHARACTERS WITHOUT CLAIM TO ANY PARTICULAR FONT, STYLE, SIZE, OR COLOR.

OWNER OF U.S. REG. NO. 3,749,027.  
FOR ARRANGING AND CONDUCTING TRADE SHOWS, EXHIBITIONS AND BUSINESS CONFERENCES IN THE FIELD OF FRANCHISING AND BUSINESS OPPORTUNITIES (U.S. CLS. 100, 101 AND 102).

FIRST USE 9-1-1991; IN COMMERCE 9-1-1991.  
BARNEY CHARLON, EXAMINING ATTORNEY

**CLASS 35—(Continued).**

SN 78-922,229. CLEON MEDIA INC., NORTH VANCOUVER, B. C., CANADA, FILED 7-4-2006.

# Webly

THE MARK CONSISTS OF STANDARD CHARACTERS WITHOUT CLAIM TO ANY PARTICULAR FONT, STYLE, SIZE, OR COLOR.

PRIORITY CLAIMED UNDER SEC. 44(D) ON CANADA APPLICATION NO. 1304251, FILED 6-8-2006.

THE WORDING "WEBLY" HAS NO MEANING IN A FOREIGN LANGUAGE.

FOR ADVERTISING AND INFORMATION DISTRIBUTION SERVICES, NAMELY, PROVIDING CLASSIFIED ADVERTISING SPACE VIA THE GLOBAL COMPUTER NETWORK FOR OTHERS; PROVIDING ONLINE COMPUTER DATABASES AND ONLINE SEARCHABLE DATABASES FEATURING CLASSIFIED LISTINGS AND WANT ADS (U.S. CLS. 100, 101 AND 102).

DEIRDRE ROBERTSON, EXAMINING ATTORNEY

**CLASS 35—(Continued).**

SN 79-084,789. TRANSFORM SOLAR PTY LTD, AUSTRALIA, FILED 6-2-2010.

# TRANSFORM SOLAR

THE MARK CONSISTS OF STANDARD CHARACTERS WITHOUT CLAIM TO ANY PARTICULAR FONT, STYLE, SIZE, OR COLOR.

PRIORITY DATE OF 12-2-2009 IS CLAIMED.

OWNER OF INTERNATIONAL REGISTRATION 1044490 DATED 6-2-2010, EXPIRES 6-2-2020.

NO CLAIM IS MADE TO THE EXCLUSIVE RIGHT TO USE "SOLAR", APART FROM THE MARK AS SHOWN.

FOR WHOLESALE AND RETAIL STORE SERVICES AND ON-LINE WHOLESALE AND RETAIL STORE SERVICES FEATURING RENEWABLE ENERGY EQUIPMENT FOR THE PRODUCTION, GENERATION, CONTROL, MEASUREMENT, STORAGE, DISTRIBUTION, TRANSPORTATION, SUPPLY, PROVISION AND USAGE OF ELECTRICITY, GAS, AND OTHER ENERGY; WHOLESALE AND RETAIL SERVICES THROUGH DIRECT SOLICITATION BY SALES AGENTS AND DISTRIBUTORS DIRECTED TO END USERS FEATURING RENEWABLE ENERGY EQUIPMENT FOR THE PRODUCTION, GENERATION, CONTROL, MEASUREMENT, STORAGE, DISTRIBUTION, TRANSPORTATION, SUPPLY, PROVISION AND USAGE OF ELECTRICITY, AND GAS, AND OTHER ENERGY; WHOLESALE AND RETAIL STORE SERVICES AND ON-LINE WHOLESALE AND RETAIL STORE SERVICES FEATURING GOODS FOR THE GENERATION AND UTILIZATION OF RENEWABLE ENERGY, NAMELY, SOLAR AND WIND SYSTEMS FOR ELECTRICITY GENERATION, APPARATUS FOR SOLAR HEATING, VENTILATION AND COOLING AND LIGHTING SYSTEMS, AND SOLAR ENERGY OPERATING APPARATUS, NAMELY, SOLAR CELLS AND SOLAR PANELS, POWER INVERTERS, AND VOLTAGE REGULATORS; WHOLESALE AND RETAIL SERVICES THROUGH DIRECT SOLICITATION BY SALES AGENTS AND DISTRIBUTORS DIRECTED TO END USERS FEATURING GOODS FOR THE GENERATION AND UTILIZATION OF RENEWABLE ENERGY, NAMELY, SOLAR AND WIND SYSTEMS FOR ELECTRICITY GENERATION, APPARATUS FOR SOLAR HEATING, VENTILATION AND COOLING AND LIGHTING SYSTEMS, AND SOLAR ENERGY OPERATING APPARATUS, NAMELY, SOLAR CELLS AND SOLAR PANELS, POWER INVERTERS, AND VOLTAGE REGULATORS; ADVISORY AND CONSULTANCY SERVICES RELATING TO THE FOREGOING WHOLESALE AND RETAIL STORE SERVICES; BUSINESS AND CONSUMER INFORMATION ADVISORY SERVICES IN THE FIELD OF SOLAR ENERGY AND RENEWABLE ENERGY SOURCES, MANUFACTURING, RESEARCH AND DEVELOPMENT, INSTALLATIONS, AND MAINTENANCE (U.S. CLS. 100, 101 AND 102).

WILLIAM ROSSMAN, EXAMINING ATTORNEY

SN 79-077,876. E-TAIL (UK) LTD, UNITED KINGDOM, FILED 8-19-2009.

# shut1

THE MARK CONSISTS OF STANDARD CHARACTERS WITHOUT CLAIM TO ANY PARTICULAR FONT, STYLE, SIZE, OR COLOR.

PRIORITY DATE OF 2-20-2009 IS CLAIMED.

OWNER OF INTERNATIONAL REGISTRATION 1026357 DATED 8-19-2009, EXPIRES 8-19-2019.

FOR AUCTION SERVICES ALL BEING PROVIDED ON-LINE; PROVISION OF COMMERCIAL BUSINESS INFORMATION, NAMELY, REGARDING ARRANGEMENTS FOR PICKUP, DELIVERY, STORAGE AND TRANSPORTATION OF DOCUMENTS, PACKAGES, FREIGHT AND PARCELS VIA GROUND CARRIERS (U.S. CLS. 100, 101 AND 102).

SUZANNE BLANE, EXAMINING ATTORNEY

**CLASS 35—(Continued).**

SN 79-085,207. TAKEO COMPANY LIMITED, JAPAN, FILED 6-29-2010.



PRIORITY DATE OF 2-10-2010 IS CLAIMED.  
OWNER OF INTERNATIONAL REGISTRATION 1045442 DATED 6-29-2010, EXPIRES 6-29-2020.  
OWNER OF U.S. REG. NOS. 3,550,414 AND 3,673,294.  
NO CLAIM IS MADE TO THE EXCLUSIVE RIGHT TO USE "PAPER PRODUCTS", APART FROM THE MARK AS SHOWN.

THE MARK CONSISTS OF A PEACOCK OVER THE WORDS "DRESSCO TAKEO PAPER PRODUCTS".

FOR RETAIL AND WHOLESALE STORE SERVICES FOR PAPER; RETAIL AND WHOLESALE STORE SERVICES FOR STATIONERY; RETAIL AND WHOLESALE STORE SERVICES FOR PICTURE POSTCARDS, SHEET MUSIC, SONG BOOKS, CALENDARS, PRINTED TIMETABLES, NEWSPAPERS, GEOGRAPHICAL MAPS, DIARIES (U.S. CLS. 100, 101 AND 102).

SANI KHOURI, EXAMINING ATTORNEY

SN 79-087,613. ZAKRYTOE AKTSIONERNOE OBSHCHESTVO "KOMPANIA RAZVITIA OBSHCHESTVENNYKH SVYAZEI", RUSSIAN FED., FILED 8-5-2010.



PRIORITY DATE OF 2-5-2010 IS CLAIMED.  
OWNER OF INTERNATIONAL REGISTRATION 1051865 DATED 8-5-2010, EXPIRES 8-5-2020.

THE COLOR(S) BLUE AND WHITE IS/ARE CLAIMED AS A FEATURE OF THE MARK.

THE MARK CONSISTS OF A BLUE OVAL WITH WHITE TRIANGULAR PORTIONS CUT OUT FROM IT NEXT TO THE WORD "CROS" WRITTEN IN BLUE.

FOR COMMERCIAL INFORMATION AGENCIES; ADVERTISING AGENCIES; PUBLICITY AGENCIES; RENTAL OF ADVERTISING SPACE; OPINION POLLING; MARKETING STUDIES; BUSINESS INFORMATION; BUSINESS INVESTIGATIONS; BUSINESS RESEARCH; MARKETING RESEARCH; BUSINESS MANAGEMENT AND ORGANIZATION CONSULTANCY; ADVISORY SERVICES FOR BUSINESS MANAGEMENT; BUSINESS ORGANIZATION CONSULTANCY; BUSINESS MANAGEMENT CONSULTANCY; PROFESSIONAL BUSINESS CONSULTANCY; BUSINESS MANAGEMENT OF PERFORMING ARTISTS; NEWS CLIPPING SERVICES; UPDATING OF ADVERTISING MATERIAL; WORD PROCESSING; ORGANIZATION OF EXHIBITIONS FOR COMMERCIAL OR ADVERTISING PURPOSES; ARRANGING NEWSPAPER SUBSCRIPTIONS FOR OTHERS; ORGANIZATION OF TRADE FAIRS FOR COMMER-

**CLASS 35—(Continued).**

CIAL AND ADVERTISING PURPOSES; SHOP WINDOW DRESSING; BUSINESS APPRAISALS; DATA SEARCH IN COMPUTER FILES FOR OTHERS; BUSINESS MANAGEMENT ASSISTANCE; COMMERCIAL AND INDUSTRIAL MANAGEMENT ASSISTANCE; ECONOMIC FORECASTING; RENTAL OF ADVERTISING TIME ON COMMUNICATION MEDIA; PUBLICITY MATERIAL RENTAL; PUBLICATION OF PUBLICITY TEXTS; RADIO ADVERTISING; PRODUCTION AND DISTRIBUTION OF RADIO COMMERCIALS; DIRECT MAIL ADVERTISING; DISSEMINATION OF ADVERTISING MATTER; ADVERTISING; PUBLICITY; ON-LINE ADVERTISING ON A COMPUTER NETWORK; ADVERTISING BY MAIL ORDER; TELEVISION ADVERTISING; PRODUCTION AND DISTRIBUTION OF TELEVISION COMMERCIALS; COMPILATION OF INFORMATION INTO COMPUTER DATABASES; BUSINESS INQUIRIES; SYSTEMIZATION OF INFORMATION INTO COMPUTER DATABASES; PUBLICITY COLUMNS PREPARATION; PUBLIC RELATIONS; LAYOUT SERVICES FOR ADVERTISING PURPOSES; PRESENTATION OF GOODS ON COMMUNICATION MEDIA, FOR RETAIL PURPOSES; WRITING OF PUBLICITY TEXTS; COMPILATION OF STATISTICS; EFFICIENCY EXPERTS (U.S. CLS. 100, 101 AND 102).

FRANK LATTUCA, EXAMINING ATTORNEY

SN 79-090,713. JOBYLON AB, SWEDEN, FILED 11-19-2010.

# JOBYLON

THE MARK CONSISTS OF STANDARD CHARACTERS WITHOUT CLAIM TO ANY PARTICULAR FONT, STYLE, SIZE, OR COLOR.

PRIORITY DATE OF 9-29-2010 IS CLAIMED.

OWNER OF INTERNATIONAL REGISTRATION 1060370 DATED 11-19-2010, EXPIRES 11-19-2020.

THE WORDING "JOBYLON" HAS NO MEANING IN A FOREIGN LANGUAGE.

FOR PROVIDING EMPLOYMENT INFORMATION VIA THE INTERNET REGARDING VACANT POSITIONS, THE LABOR MARKET, RECRUITMENT OF EMPLOYEES AND MANAGERS, RESUMES (CV), CAREER POSSIBILITIES AND WORK LIFE; EMPLOYMENT RECRUITING CONSULTATION VIA THE INTERNET REGARDING RECRUITMENT OF EMPLOYEES AND MANAGERS; PROVIDING ON-LINE EMPLOYMENT PLACEMENT SERVICES, NAMELY, MATCHING RESUMES AND POTENTIAL EMPLOYERS VIA A GLOBAL COMPUTER NETWORK AND VIA MOBILE PHONE (U.S. CLS. 100, 101 AND 102).

KATHERINE E. HALMEN, EXAMINING ATTORNEY



**CLASS 35—(Continued).**

SN 79-091,796. OCASIA LABS LIMITED, HERTFORDSHIRE  
AL5 3AB, UNITED KINGDOM, FILED 11-29-2010.

# Needz

THE MARK CONSISTS OF STANDARD CHARACTERS  
WITHOUT CLAIM TO ANY PARTICULAR FONT, STYLE,  
SIZE, OR COLOR.

OWNER OF INTERNATIONAL REGISTRATION 1063003  
DATED 11-29-2010, EXPIRES 11-29-2020.

FOR ADVERTISING SERVICES PROVIDED OVER  
THE INTERNET; BUSINESS MARKETING INFORMA-  
TION; MARKET ANALYSIS SERVICES RELATING TO  
THE SALE OF GOODS; MARKET ANALYSIS SERVICES  
RELATING TO THE AVAILABILITY OF GOODS (U.S.  
CLS. 100, 101 AND 102).

TASNEEM HUSSAIN, EXAMINING ATTORNEY

**CLASS 35—(Continued).**

SN 85-004,451. TXU ENERGY RETAIL COMPANY LLC,  
IRVING, TX. FILED 4-1-2010.



OWNER OF U.S. REG. NOS. 3,122,896 AND 3,232,624.  
NO CLAIM IS MADE TO THE EXCLUSIVE RIGHT TO  
USE "ENERGY", APART FROM THE MARK AS SHOWN.

THE MARK CONSISTS OF HALF OF A STAR WITHIN A  
CIRCLE BESIDE THE WORDING "TXU ENERGY". THE  
WORD "TXU" IS ABOVE THE WORD "ENERGY".

FOR PROCUREMENT FOR OTHERS, NAMELY, PUR-  
CHASING ELECTRIC ENERGY GENERATED BY  
OTHERS; PROVIDING ENERGY EFFICIENCY CON-  
SULTING FOR CONSUMERS CONSISTING OF PROVID-  
ING INFORMATION REGARDING MANAGING  
ELECTRICITY CONSUMPTION AND MAKING RECOM-  
MENDATIONS REGARDING ENERGY EFFICIENT  
PRODUCTS IN THE FIELD OF ELECTRICITY CON-  
SUMPTION (U.S. CLS. 100, 101 AND 102).

JULIE VEPPUMTHARA, EXAMINING ATTORNEY

SN 85-001,911. BENNETT, JENNIFER LYNN, CHARLOTTE,  
NC. FILED 3-30-2010.



SN 85-008,022. TXU ENERGY RETAIL COMPANY LLC,  
IRVING, TX. FILED 4-7-2010.

THE RIGHT THINGS. RIGHT NOW

THE COLOR(S) YELLOW, BLACK, GRAY AND WHITE  
IS/ARE CLAIMED AS A FEATURE OF THE MARK.

THE MARK CONSISTS OF A YELLOW RIBBON WITH  
BLACK OUTLINE AND A GRAY SHADOW WRAPPED  
AROUND A WHITE DOG BONE WITH BLACK OUTLINE  
BELOW THE BLACK STYLIZED WORDING "HOUND-  
S4HEROES".

FOR CHARITABLE SERVICES, NAMELY, ORGANIZ-  
ING AND CONDUCTING VOLUNTEER PROGRAMS  
AND COMMUNITY SERVICE PROJECTS AIMED AT  
INCREASING SUPPORT AND MORALE OF MEMBERS  
OF THE U.S. MILITARY (U.S. CLS. 100, 101 AND 102).

FIRST USE 3-3-2010; IN COMMERCE 3-7-2010.

KRISTINA MORRIS, EXAMINING ATTORNEY

THE MARK CONSISTS OF STANDARD CHARACTERS  
WITHOUT CLAIM TO ANY PARTICULAR FONT, STYLE,  
SIZE, OR COLOR.

FOR PROCUREMENT FOR OTHERS, NAMELY, PUR-  
CHASING ELECTRIC ENERGY GENERATED BY  
OTHERS; PROVIDING ENERGY EFFICIENCY CON-  
SULTING FOR CONSUMERS CONSISTING OF PROVID-  
ING INFORMATION REGARDING MANAGING  
ELECTRICITY CONSUMPTION AND MAKING RECOM-  
MENDATIONS REGARDING ENERGY EFFICIENT  
PRODUCTS IN THE FIELD OF ELECTRICITY CON-  
SUMPTION (U.S. CLS. 100, 101 AND 102).

JULIE VEPPUMTHARA, EXAMINING ATTORNEY

**CLASS 35—(Continued).**

SN 85-009,589. SEGMENT INTERNATIONAL LLC, NEWPORT BEACH, CA. FILED 4-8-2010.



NO CLAIM IS MADE TO THE EXCLUSIVE RIGHT TO USE "SEGMENT INTERNATIONAL", APART FROM THE MARK AS SHOWN.

THE COLOR(S) ORANGE, GREEN, AND BLACK IS/ARE CLAIMED AS A FEATURE OF THE MARK.

THE MARK CONSISTS OF THE COLOR ORANGE IN NATURAL TONES ON THE DEPICTION OF THE FRUIT AND ITS REFLECTION BELOW THE COLOR GREEN APPEARS IN NATURAL TONES ON THE DEPICTION OF THE LEAVES AND STEM OF THE FRUIT, AND THEIR REFLECTION BELOW. TO THE RIGHT THERE IS THE STYLIZED TEXT "SEGMENT INTERNATIONAL" IN BLACK.

FOR BUSINESS CONSULTATION, NAMELY, CONSUMER RESEARCH, QUALITATIVE BUSINESS RESEARCH, ETHNOGRAPHIC RESEARCH, RESEARCH IN THE FIELD OF BRANDING AND MARKET SEGMENTATION, AND BUSINESS RESEARCH USING OBSERVATION AND FOCUS GROUPS (U.S. CLS. 100, 101 AND 102).

STEVEN R. FINE, EXAMINING ATTORNEY

SN 85-010,225. TENE0 STRATEGY CONSULTING LLC, NEW YORK, NY. FILED 4-9-2010.



NO CLAIM IS MADE TO THE EXCLUSIVE RIGHT TO USE "STRATEGY CONSULTING", APART FROM THE MARK AS SHOWN.

THE MARK CONSISTS OF STYLIZED PARTIAL "T" INSIDE A STYLIZED SQUARE NEXT TO THE WORDING "TENE0 STRATEGY CONSULTING".

FOR STRATEGIC MANAGEMENT ADVISORY SERVICES TO BUSINESSES; ADVISING BUSINESSES ON DEVELOPMENT AND IMPLEMENTATION OF CORPORATE STRATEGY AND BUSINESS INITIATIVES; PROVIDING ADVISORY SERVICES IN THE FIELD OF MARKETING COMMUNICATIONS, MARKETING CONSULTING, MARKETING ANALYSIS, BUSINESS MARKETING SERVICES; INFORMATION IN THE FIELD OF GOVERNMENT AFFAIRS; PROVIDING ADVISORY SERVICES IN THE FIELD OF PUBLIC RELATIONS; PROVIDING ADVISORY SERVICES IN THE FIELD OF INVESTOR RELATIONS, NAMELY, FINANCIAL PUBLIC RELATIONS; PROVIDING ADVISORY SERVICES IN THE FIELD OF STRATEGY CONSULTING, NAMELY, BUSINESS STRATEGY DEVELOPMENT CONSULTING; PROVIDING ADVISORY SERVICES IN THE FIELD OF CRISIS MANAGEMENT, NAMELY, BUSINESS PLANNING AND BUSINESS CONTINUITY CONSULTING AND REPUTATION MANAGEMENT; MARKETING COMMUNICATIONS SERVICES, NAMELY, ADVISORY AND CONSULTING RELATING TO PUBLICITY, MAR-

**CLASS 35—(Continued).**

KETING COMMUNICATIONS, REPUTATION MANAGEMENT OR BUSINESS ADMINISTRATION, INCLUDING SUCH SERVICES PROVIDED ONLINE OR VIA THE INTERNET; MARKETING SERVICES, NAMELY, MARKETING CONSULTING, MARKETING ANALYSIS, BUSINESS MARKETING SERVICES; GOVERNMENT AFFAIRS SERVICES, NAMELY, GOVERNMENT RELATIONS CONSULTANCY SERVICES; PUBLIC RELATIONS SERVICES; INVESTOR RELATIONS, NAMELY, FINANCIAL PUBLIC RELATIONS; STRATEGY CONSULTING, NAMELY, BUSINESS STRATEGY DEVELOPMENT CONSULTING; CRISIS MANAGEMENT, NAMELY, BUSINESS PLANNING AND BUSINESS CONTINUITY CONSULTING, AND REPUTATION MANAGEMENT; PROVIDING MARKET ANALYSIS AND BUSINESS ADVISORY SERVICES TO SUPPORT CLIENTS IN THE AREAS OF RESTRUCTURING, MERGERS AND ACQUISITIONS, BUSINESS ENGINEERING; DEVELOPING FUNDRAISING CAMPAIGNS FOR OTHERS (U.S. CLS. 100, 101 AND 102).

FIRST USE 11-18-2009; IN COMMERCE 4-5-2010.

CHRISTOPHER BUONGIORNO, EXAMINING ATTORNEY

SN 85-013,696. LAMONTE WINSTON, OVERLAND PARK, KS. FILED 4-14-2010.



NO CLAIM IS MADE TO THE EXCLUSIVE RIGHT TO USE "GROUP", APART FROM THE MARK AS SHOWN.

THE MARK CONSISTS OF THE PHRASE "THE WINSTON GROUP" WITH THE INDIVIDUAL LETTERS "T", "W" AND "G" DISPOSED ABOVE THE PHRASE AGAINST A RECTANGULAR BACKDROP AND A STYLIZED, ENLARGED LETTER "W" LATERALLY DISPOSED TO THE INDIVIDUALIZED LETTERS.

FOR BUSINESS MANAGEMENT CONSULTING IN THE FIELD OF SPORTS (U.S. CLS. 100, 101 AND 102).

TEJBIR SINGH, EXAMINING ATTORNEY

SN 85-015,408. SCILD INNOVATIONS LLC, DBA SCILD INNOVATIONS LLC, SUNNYVALE, CA. FILED 4-16-2010.

SCILD

THE MARK CONSISTS OF STANDARD CHARACTERS WITHOUT CLAIM TO ANY PARTICULAR FONT, STYLE, SIZE, OR COLOR.

FOR BUSINESS DEVELOPMENT SERVICES, NAMELY, PROVIDING START-UP SUPPORT FOR BUSINESSES OF OTHERS (U.S. CLS. 100, 101 AND 102).

MICHELLE DUBOIS, EXAMINING ATTORNEY

**CLASS 35—(Continued).**

SN 85-016,131. JENNA IP HOLDING COMPANY, LLC,  
SCOTTSDALE, AZ. FILED 4-16-2010.

**CLUB JENNA**

THE MARK CONSISTS OF STANDARD CHARACTERS WITHOUT CLAIM TO ANY PARTICULAR FONT, STYLE, SIZE, OR COLOR.

OWNER OF U.S. REG. NOS. 2,471,558 AND 2,544,267.

NO CLAIM IS MADE TO THE EXCLUSIVE RIGHT TO USE "CLUB", APART FROM THE MARK AS SHOWN.

FOR ONLINE RETAIL STORE SERVICES FEATURING TEE SHIRTS, TANK TOPS, TOPS, SKIRTS, UNDERWEAR, HOSIERY, LINGERIE, BRAS, BUSTIERS, MENS WEAR, TWO PIECE CLOTHING SETS, COSTUMES, AND GLOVES (U.S. CLS. 100, 101 AND 102).

FIRST USE 6-22-1996; IN COMMERCE 6-22-1996.

ROBERT STRUCK, EXAMINING ATTORNEY

**CLASS 35—(Continued).**

SN 85-029,200. WHITECLOUD ANALYTICS, INC., BOISE, ID.  
FILED 5-3-2010.

**WHITECLOUD SPIRAL  
METHODOLOGY**

THE MARK CONSISTS OF STANDARD CHARACTERS WITHOUT CLAIM TO ANY PARTICULAR FONT, STYLE, SIZE, OR COLOR.

NO CLAIM IS MADE TO THE EXCLUSIVE RIGHT TO USE "SPIRAL METHODOLOGY", APART FROM THE MARK AS SHOWN.

FOR BUSINESS MANAGEMENT CONSULTING WITH RELATION TO OPERATION, STRATEGY, AND APPLICATION, PARTICULARLY SPECIALIZING IN THE USE OF ANALYTIC MODELS TO IMPROVE BEHAVIOR AND REACH A DESIRED PERFORMANCE IN THE FIELD OF HEALTHCARE (U.S. CLS. 100, 101 AND 102).

JACLYN KIDWELL WALKER, EXAMINING ATTORNEY

SN 85-019,532. PIERCE SALES COMPANY, INC., DBA  
RESTAURANT EQUIPMENT WORLD, ORLANDO, FL.  
FILED 4-21-2010.

**CRITICAL SUPPLY WORLD**

THE MARK CONSISTS OF STANDARD CHARACTERS WITHOUT CLAIM TO ANY PARTICULAR FONT, STYLE, SIZE, OR COLOR.

NO CLAIM IS MADE TO THE EXCLUSIVE RIGHT TO USE "SUPPLY WORLD", APART FROM THE MARK AS SHOWN.

FOR DISTRIBUTORSHIP SERVICES IN THE FIELD OF EQUIPMENT AND SUPPLIES PROCUREMENT AND DELIVERY, NAMELY, PROVIDING PRODUCTS ON A TIME-SENSITIVE BASIS TO LOCATIONS THROUGHOUT THE WORD (U.S. CLS. 100, 101 AND 102).

FIRST USE 1-20-2010; IN COMMERCE 1-20-2010.

INGA ERVIN, EXAMINING ATTORNEY

SN 85-031,417. US DEPARTMENT OF CREATIVE, INC.  
FRANKLIN, IN. FILED 5-6-2010.

**DEPARTMENT OF CREATIVE**

THE MARK CONSISTS OF STANDARD CHARACTERS WITHOUT CLAIM TO ANY PARTICULAR FONT, STYLE, SIZE, OR COLOR.

NO CLAIM IS MADE TO THE EXCLUSIVE RIGHT TO USE "CREATIVE", APART FROM THE MARK AS SHOWN.

FOR ADVERTISING, MARKETING, AND PROMOTION SERVICES AND RELATED CONSULTING (U.S. CLS. 100, 101 AND 102).

FIRST USE 1-1-2003; IN COMMERCE 1-1-2003.

KRISTIN DAHLING, EXAMINING ATTORNEY

SN 85-025,667. CHEMSIL SILICONES, INC., CHATSWORTH,  
CA. FILED 4-28-2010.

**CHEMSiL**  
**SILICONES**

NO CLAIM IS MADE TO THE EXCLUSIVE RIGHT TO USE "SILICONES", APART FROM THE MARK AS SHOWN.

THE MARK CONSISTS OF THE WORDS "CHEMSIL SILICONES", WITH A DROP AS THE DOT OF THE LETTER "I" OF "CHEMSIL".

FOR DISTRIBUTORSHIPS IN THE FIELD OF CHEMICALS FOR HAIR AND BODY CARE (U.S. CLS. 100, 101 AND 102).

FIRST USE 6-1-2000; IN COMMERCE 6-1-2000.

LOURDES AYALA, EXAMINING ATTORNEY

**alpha**<sup>245</sup>

THE MARK CONSISTS OF THE WORD "ALPHA" IN LOWER CASE LETTERS WITH THE NUMBERS "245" LISTED VERTICALLY.

FOR ADVERTISING AGENCY SERVICES, BUSINESS MARKETING AND CONSULTING SERVICES, ADVERTISING SERVICES, NAMELY, CREATING CORPORATE AND BRAND IDENTITY FOR OTHERS, SALES PROMOTION SERVICES; PROMOTION AND MARKETING SERVICES AND RELATED CONSULTING (U.S. CLS. 100, 101 AND 102).

MICHAEL SOUDERS, EXAMINING ATTORNEY

**CLASS 35—(Continued).**

SN 85-034,457. SCHWAN'S IP, LLC, MARSHALL, MN. FILED 5-10-2010.

**EAT FOR FREE**

THE MARK CONSISTS OF STANDARD CHARACTERS WITHOUT CLAIM TO ANY PARTICULAR FONT, STYLE, SIZE, OR COLOR.

FOR PROVIDING INCENTIVE AWARD PROGRAMS FOR CUSTOMERS THROUGH ISSUANCE AND PROCESSING OF LOYALTY POINTS FOR ON-LINE PURCHASE OF COMPANY'S GOODS AND SERVICES (U.S. CLS. 100, 101 AND 102).

FIRST USE 6-30-2009; IN COMMERCE 6-30-2009.  
GISELLE AGOSTO, EXAMINING ATTORNEY

SN 85-037,576. ALTUS HEALTHCARE MANAGEMENT, L.P., HOUSTON, TX. FILED 5-13-2010.



NO CLAIM IS MADE TO THE EXCLUSIVE RIGHT TO USE "HEALTHCARE MANAGEMENT SERVICES", APART FROM THE MARK AS SHOWN.

THE COLOR(S) PURPLE, YELLOW-BROWN, AND YELLOW-GOLD IS/ARE CLAIMED AS A FEATURE OF THE MARK.

THE MARK CONSISTS OF "ALTUS" IN PURPLE LETTERS WITH A YELLOW-BROWN MOUNTAIN PEAK ABOVE "ALTUS", AND "HEALTHCARE MANAGEMENT SERVICES" IN YELLOW-GOLD LETTERS BELOW "ALTUS". THE DESIGN IS ON A WHITE BACKGROUND. THE WHITE BACKGROUND IS NOT A FEATURE OF THE MARK.

FOR HEALTHCARE MANAGEMENT SERVICE ORGANIZATION (MSO) SERVICES, NAMELY, PROVIDING PRACTICE ORGANIZATION, MANAGEMENT AND ADMINISTRATIVE SUPPORT SERVICES TO INDIVIDUAL PHYSICIANS OR SMALL GROUP PRACTICES; HOSPITAL MANAGEMENT; HOSPITAL ADMINISTRATION SERVICES (U.S. CLS. 100, 101 AND 102).

FIRST USE 11-30-2004; IN COMMERCE 11-30-2004.  
MARK SPARACINO, EXAMINING ATTORNEY

**CLASS 35—(Continued).**

SN 85-039,033. NEUSTAR, INC., STERLING, VA. FILED 5-14-2010.

**POWERING THE FUTURE OF HELLO**

THE MARK CONSISTS OF STANDARD CHARACTERS WITHOUT CLAIM TO ANY PARTICULAR FONT, STYLE, SIZE, OR COLOR.

FOR COMPUTERIZED DATABASE MANAGEMENT AS A NEUTRAL THIRD-PARTY FOR SERVICE AND NETWORK PROVIDERS IN THE TELECOMMUNICATIONS, DATA COMMUNICATIONS AND NETWORK INDUSTRIES; PROVIDING A BUSINESS CLEARINGHOUSE FOR TRANSACTIONS BETWEEN SERVICE AND NETWORK PROVIDERS IN THE TELECOMMUNICATIONS, DATA COMMUNICATIONS AND NETWORK INDUSTRIES; ADMINISTRATION OF TELEPHONE NUMBER POOLING SERVICES; COMPUTERIZED DATABASE MANAGEMENT, NAMELY, MANAGING AND ADMINISTERING COMPUTERIZED DATABASES FEATURING TOP-LEVEL DOMAINS (U.S. CLS. 100, 101 AND 102).

MICHAEL WEBSTER, EXAMINING ATTORNEY

SN 85-041,407. NEUSTAR, INC., STERLING, VA. FILED 5-18-2010.

**THE FUTURE OF HELLO**

THE MARK CONSISTS OF STANDARD CHARACTERS WITHOUT CLAIM TO ANY PARTICULAR FONT, STYLE, SIZE, OR COLOR.

FOR COMPUTERIZED DATABASE MANAGEMENT AS A NEUTRAL THIRD-PARTY FOR SERVICE AND NETWORK PROVIDERS IN THE TELECOMMUNICATIONS, DATA COMMUNICATIONS AND NETWORK INDUSTRIES; PROVIDING A BUSINESS CLEARINGHOUSE FOR TRANSACTIONS BETWEEN SERVICE AND NETWORK PROVIDERS IN THE TELECOMMUNICATIONS, DATA COMMUNICATIONS AND NETWORK INDUSTRIES; ADMINISTRATION OF TELEPHONE NUMBER POOLING SERVICES; COMPUTERIZED DATABASE MANAGEMENT, NAMELY, MANAGING AND ADMINISTERING COMPUTERIZED DATABASES FEATURING TOP-LEVEL DOMAINS (U.S. CLS. 100, 101 AND 102).

MICHAEL WEBSTER, EXAMINING ATTORNEY

**CLASS 35—(Continued).**

SN 85-042,118. SHEA, DOYLE, CINCINNATI, OH. FILED 5-19-2010.

**PROMOPROMISE**

THE MARK CONSISTS OF STANDARD CHARACTERS WITHOUT CLAIM TO ANY PARTICULAR FONT, STYLE, SIZE, OR COLOR.

FOR ADVERTISING SERVICES; BUSINESS MANAGEMENT; BUSINESS ADMINISTRATION AND OFFICE FUNCTIONS FOR CONSUMERS (U.S. CLS. 100, 101 AND 102).

HELENE LIWINSKI, EXAMINING ATTORNEY

**CLASS 35—(Continued).**

SN 85-045,012. VIDEOLAND, LLC, DBA MODIA, HOUSTON, TX. FILED 5-21-2010.

**FULL HD EXPO**

THE MARK CONSISTS OF STANDARD CHARACTERS WITHOUT CLAIM TO ANY PARTICULAR FONT, STYLE, SIZE, OR COLOR.

NO CLAIM IS MADE TO THE EXCLUSIVE RIGHT TO USE "FULL HD", APART FROM THE MARK AS SHOWN.

FOR RETAIL STORE AND ONLINE RETAIL STORE SERVICES FEATURING HOME ENTERTAINMENT AND ELECTRONIC ACCESSORIES, NAMELY, TELEVISIONS, STEREOS, AUDIO RECEIVERS, AUDIO SPEAKERS, COMPACT DISC PLAYERS, DIGITAL VIDEO PLAYERS, SURROUND SOUND SYSTEMS, HOME AUTOMATION PRODUCTS, AND MEDIA SERVERS (U.S. CLS. 100, 101 AND 102).

FIRST USE 11-12-2009; IN COMMERCE 11-12-2009.

KRISTIN DAHLING, EXAMINING ATTORNEY

SN 85-042,253. FERGUSON ENTERPRISES, INC., NEWPORT NEWS, VA. FILED 5-19-2010.

**FERGUSON**  
*Bath & Kitchen Gallery*

OWNER OF U.S. REG. NOS. 1,192,372 AND 2,268,088.  
NO CLAIM IS MADE TO THE EXCLUSIVE RIGHT TO USE "BATH & KITCHEN GALLERY", APART FROM THE MARK AS SHOWN.

THE COLOR(S) BLUE (PANTONE 302 C) IS/ARE CLAIMED AS A FEATURE OF THE MARK.

THE MARK CONSISTS OF FOUR SEMICIRCLES, TWO FACING DOWN AND TWO FACING UP, AND THE WORD "FERGUSON" TO THE RIGHT OF THE DESIGN, WITH THE WORDING "BATH & KITCHEN GALLERY" BELOW AND IN ITALICS, ALL IN THE COLOR BLUE (PANTONE 302 C).

FOR WHOLESALE DISTRIBUTORSHIPS AND RETAIL STORES FEATURING PLUMBING, HEATING, VENTILATION, AIR CONDITIONING, ELECTRICAL AND BUILDING CONSTRUCTION SUPPLIES AND MATERIALS, TOOLS, WATER DISTRIBUTION, LIQUID AND GAS PIPE, VALVES AND FITTING PRODUCTS AND MATERIALS; PROCUREMENT, NAMELY, PURCHASING OF MAINTENANCE, REPAIR AND OPERATION MATERIALS FOR OTHERS FOR COMMERCIAL AND INDUSTRIAL USES (U.S. CLS. 100, 101 AND 102).

FIRST USE 6-30-2007; IN COMMERCE 6-30-2007.

JOHN GARTNER, EXAMINING ATTORNEY

SN 85-045,025. WAZZAMBA S.A., LUXEMBOURG, LUXEMBOURG, FILED 5-21-2010.

**DREAMTRIP**

THE MARK CONSISTS OF STANDARD CHARACTERS WITHOUT CLAIM TO ANY PARTICULAR FONT, STYLE, SIZE, OR COLOR.

FOR ADVERTISING VIA ELECTRONIC MEDIA AND SPECIFICALLY THE INTERNET; ON-LINE ADVERTISING ON A COMPUTER NETWORK; ADVERTISING AND PROMOTIONAL SERVICES; BUSINESS MANAGEMENT; BUSINESS ADMINISTRATION; COMPILATION AND SYSTEMIZATION OF INFORMATION INTO COMPUTER DATABASES; COMPUTERIZED DATABASE MANAGEMENT; DISTRIBUTION AND DISSEMINATION OF ADVERTISING MATERIALS, NAMELY, LEAFLETS, PROSPECTUSES, PRINTED MATERIAL, AND SAMPLES; DISTRIBUTION OF PRODUCTS FOR ADVERTISING PURPOSES; PROVIDING OFFICE FUNCTIONS; DATA SEARCH IN COMPUTER FILES FOR OTHERS, NAMELY, DATA PROCESSING SERVICES; PRESENTATION OF GOODS ON COMMUNICATION MEDIA FOR RETAIL PURPOSES; ORGANIZATION OF EXHIBITIONS AND TRADE FAIRS FOR COMMERCIAL OR ADVERTISING PURPOSES; SPONSORSHIP SEARCH (U.S. CLS. 100, 101 AND 102).

HAI-LY LAM, EXAMINING ATTORNEY



**CLASS 35—(Continued).**

SN 85-045,030. VIDEOLAND, LLC, DBA MODIA, DALLAS, TX. FILED 5-21-2010.

## 3D EXPO

THE MARK CONSISTS OF STANDARD CHARACTERS WITHOUT CLAIM TO ANY PARTICULAR FONT, STYLE, SIZE, OR COLOR.

NO CLAIM IS MADE TO THE EXCLUSIVE RIGHT TO USE "3D", APART FROM THE MARK AS SHOWN.

FOR RETAIL STORE AND ONLINE RETAIL STORE SERVICES FEATURING HOME ENTERTAINMENT AND ELECTRONIC ACCESSORIES, NAMELY, TELEVISIONS, STEREOS, AUDIO RECEIVERS, AUDIO SPEAKERS, COMPACT DISC PLAYERS, DIGITAL VIDEO PLAYERS, SURROUND SOUND SYSTEMS, HOME AUTOMATION PRODUCTS, AND MEDIA SERVERS (U.S. CLS. 100, 101 AND 102).

KRISTIN DAHLING, EXAMINING ATTORNEY

---

SN 85-045,429. UNIVERSAL CITY STUDIOS LLC, UNIVERSAL CITY, CA. FILED 5-21-2010.

## UNIVERSAL MUSIC GROUP

THE MARK CONSISTS OF STANDARD CHARACTERS WITHOUT CLAIM TO ANY PARTICULAR FONT, STYLE, SIZE, OR COLOR.

OWNER OF U.S. REG. NOS. 1,144,545 AND 1,637,487.

NO CLAIM IS MADE TO THE EXCLUSIVE RIGHT TO USE "MUSIC GROUP", APART FROM THE MARK AS SHOWN.

FOR DISTRIBUTORS HIP OF MUSIC; DISTRIBUTORSHIP IN THE FIELD OF MUSICAL AND NON-MUSICAL SOUND RECORDINGS AND VIDEO RECORDINGS; ADVERTISING AND PROMOTION SERVICES AND RELATED CONSULTING SERVICES; ADVERTISING AND PUBLICITY SERVICES; ASSOCIATION SERVICES, NAMELY, PROMOTING THE INTERESTS OF MUSICIANS, SINGERS, SONGWRITERS, MUSICAL PERFORMERS AND ARTISTS; COMPUTERIZED ONLINE ORDERING FEATURING GENERAL MERCHANDISE AND GENERAL CONSUMER GOODS; COMPUTERIZED ONLINE ORDERING SERVICES IN THE FIELD OF MUSK AND ENTERTAINMENT; COMPUTERIZED ONLINE RETAIL STORE SERVICES IN THE FIELD OF MUSIC AND ENTERTAINMENT; MAIL ORDER CATALOG SERVICES FEATURING CD'S, CASSETTES, DVD'S AND GENERAL MERCHANDISE; ONLINE RETAIL STORE SERVICES FEATURING DOWNLOADABLE PRE-RECORDED MUSIC AND AUDIO-VISUAL CONTENT AND GENERAL MERCHANDISE; ORGANIZATION OF PROMOTIONS USING AUDIO-VISUAL MEDIA; PREPARING AUDIO-VISUAL DISPLAYS IN THE FIELD OF MUSIC; PREPARING AUDIO VISUAL PRESENTATIONS FOR USE IN ADVERTISING; ARRANGING AND CONDUCTING FAIRS AND EXHIBITIONS FOR BUSINESS AND ADVERTISING PURPOSES; PROMOTING THE CONCERTS OF OTHERS; PROMOTING THE GOODS AND SERVICES OF OTHERS BY ARRANGING FOR SPONSORS TO AFFILIATE THEIR GOODS AND SERVICES WITH CONCERTS, MUSICAL AND SPORTS EVENTS; PROMOTING THE GOODS OF OTHERS BY PREPARING AND PLACING ADVERTISEMENTS IN AN ELECTRONIC MAGAZINE ACCESSED THROUGH A GLOBAL COMPUTER NETWORK; PROVIDING INFORMATION ABOUT THE GOODS AND

**CLASS 35—(Continued).**

SERVICES OF OTHERS VIA A GLOBAL COMPUTER NETWORK, RETAIL STORE SERVICES AVAILABLE THROUGH COMPUTER COMMUNICATIONS FEATURING CD'S CASSETTES, DVD'S, VIDEOCASSETTES AND LICENSED MERCHANDISE; MANAGEMENT SERVICES FOR PROFESSIONAL ARTISTS; TALENT AGENCY SERVICES; ADVERTISING, INCLUDING PROMOTION OF PRODUCTS AND SERVICES OF THIRD PARTIES THROUGH SPONSORING ARRANGEMENTS AND LICENSE AGREEMENTS RELATING TO MUSIC EVENTS; PROMOTING MUSIC COMPETITIONS AND EVENTS FOR OTHERS; PROMOTING GOODS AND SERVICES OF OTHERS BY ARRANGING FOR SPONSORS TO AFFILIATE THEIR GOODS AND SERVICES WITH MUSIC COMPETITIONS; PROMOTING THE INTERESTS OF PEOPLE INVOLVED AND CONCERNED WITH MUSIC; PROVIDING ONLINE REGISTRATION SERVICES FOR MUSIC COMPETITIONS; COMMERCIAL ADMINISTRATION OF THE LICENSING OF MUSICAL AND NON-MUSICAL SOUND RECORDINGS (U.S. CLS. 100, 101 AND 102).

FIRST USE 0-0-1999; IN COMMERCE 0-0-1999.  
MORGAN WYNNE, EXAMINING ATTORNEY

---

SN 85-047,172. WC RESEARCH, INC., WOBURN, MA. FILED 5-25-2010.



OWNER OF U.S. REG. NO. 3,855,600.

NO CLAIM IS MADE TO THE EXCLUSIVE RIGHT TO USE "CONGRESS", APART FROM THE MARK AS SHOWN.

THE MARK CONSISTS OF THE WORDING "THE WORLD HEALTH CARE CONGRESS" IN FRONT OF A GLOBE.

SEC. 2(F).

FOR ARRANGING AND CONDUCTING BUSINESS CONFERENCES (U.S. CLS. 100, 101 AND 102).

FIRST USE 1-5-2003; IN COMMERCE 1-5-2003.

NAPOLÉON SHARMA, EXAMINING ATTORNEY

**CLASS 35—(Continued).**

SN 85-048,246. MICRONOTES, INC., CAMBRIDGE, MA. FILED 5-26-2010.

# KULAQ

THE MARK CONSISTS OF STANDARD CHARACTERS WITHOUT CLAIM TO ANY PARTICULAR FONT, STYLE, SIZE, OR COLOR.

FOR MARKETING SERVICES, NAMELY, PROVIDING COMMUNICATIONS TO BUSINESS REGARDING THE MARKETING OF GOODS AND SERVICES; RETRIEVAL AND ANALYSIS OF CONSUMER DATA FOR MARKETING PURPOSES; MARKET RESEARCH SERVICES; ADVERTISING SERVICES; MARKET SURVEY SERVICES (U.S. CLS. 100, 101 AND 102).

FIRST USE 11-30-2009; IN COMMERCE 11-30-2009.  
MARIA-VICTORIA SUAREZ, EXAMINING ATTORNEY

SN 85-049,203. SPECIALTY REPORTS, INC., NEW YORK, NY. FILED 5-27-2010.

# CYCLECHEX

THE MARK CONSISTS OF STANDARD CHARACTERS WITHOUT CLAIM TO ANY PARTICULAR FONT, STYLE, SIZE, OR COLOR.

FOR PROVIDING BUSINESS AND CONSUMER INFORMATION IN THE FIELD OF MOTOR VEHICLE HISTORY INFORMATION (U.S. CLS. 100, 101 AND 102).

FIRST USE 4-5-2007; IN COMMERCE 4-5-2007.  
SARA BENJAMIN, EXAMINING ATTORNEY

SN 85-049,512. WIKITRADE, WASHINGTON, DC. FILED 5-27-2010.

# Wikitrade

THE MARK CONSISTS OF STANDARD CHARACTERS WITHOUT CLAIM TO ANY PARTICULAR FONT, STYLE, SIZE, OR COLOR.

FOR PROVIDING AN INTERNET WEBSITE FEATURING NEWS AND INFORMATION IN THE FIELD OF INTERNATIONAL TRADE (U.S. CLS. 100, 101 AND 102).

FIRST USE 10-10-2010; IN COMMERCE 10-10-2010.  
BARBARA GAYNOR, EXAMINING ATTORNEY

**CLASS 35—(Continued).**

SN 85-052,059. AKASHA COLLECTIVE, CO., DBA AKASHA COLLECTIVE, ST PAUL, MN. FILED 6-1-2010.



NO CLAIM IS MADE TO THE EXCLUSIVE RIGHT TO USE "COLLECTIVE", APART FROM THE MARK AS SHOWN.

THE COLOR(S) CREAM, RED AND PINK IS/ARE CLAIMED AS A FEATURE OF THE MARK.

THE MARK CONSISTS OF THE COLOR CREAM APPEARING IN AN INFINITY SYMBOL WITH SQUARED-OFF CORNERS IN THE UPPER-LEFT LOOP AND LOWER-RIGHT LOOP OF THE INFINITY SYMBOL SURROUNDED BY A RECTANGULAR BORDER AND IN THE WORDING "AKASHA COLLECTIVE"; THE COLOR RED FADING TO PINK APPEARS AS BACKGROUND, THE FADING FROM RED ON THE BOTTOM TO PINK ON THE TOP.

THE ENGLISH TRANSLATION OF THE WORD "AKASHA" IN THE MARK IS THE SANSKRIT WORD MEANING AETHER, ALSO SPELLED ETHER, IN BOTH ITS ELEMENTAL AND MYTHOLOGICAL SENSES.

FOR ADVERTISING AND MARKETING SERVICES, NAMELY, PROMOTING THE GOODS AND SERVICES OF OTHERS; ADVERTISING SERVICES, NAMELY, PROMOTING AND MARKETING THE GOODS AND SERVICES OF OTHERS THROUGH ALL PUBLIC COMMUNICATION MEANS; COMMERCIAL ADMINISTRATION OF THE LICENSING OF THE GOODS AND SERVICES OF OTHERS; ON-LINE ADVERTISING AND MARKETING SERVICES; PROMOTING THE GOODS AND SERVICES OF OTHERS BY DISTRIBUTING ADVERTISING MATERIALS THROUGH A VARIETY OF METHODS; PROMOTING THE GOODS AND SERVICES OF OTHERS BY MEANS OF DISTRIBUTING ADVERTISING ON THE INTERNET; PROMOTING THE GRAPHIC ARTS DESIGN SERVICES OF OTHERS BY MEANS OF A WEBSITE FEATURING GRAPHIC ARTWORK SUBMITTED BY GRAPHIC ART DESIGNERS; PROMOTING THE SALE OF GOODS AND SERVICES OF OTHERS THROUGH THE DISTRIBUTION OF PRINTED MATERIAL AND PROMOTIONAL CONTESTS; PROVIDING ADVERTISING SERVICE TO DISTRIBUTE ADVERTISEMENTS FOR DISPLAY ON INTERNET, NAMELY, IN WEBSITES, SOCIAL CONVERSATIONS OVER THE INTERNET, EMAILS, MICROBLOGS, BLOGS, ELECTRONIC MESSAGES, INSTANT MESSAGES, TEXT MESSAGES, MULTIMEDIA MESSAGES, SOCIAL NETWORKS, STATUS UPDATES, FORUMS, ELECTRONIC BULLETIN BOARDS (U.S. CLS. 100, 101 AND 102).

FIRST USE 4-16-2010; IN COMMERCE 5-27-2010.  
AISHA SALEM, EXAMINING ATTORNEY

**CLASS 35—(Continued).**

SN 85-053,105. SINGLETON, KATHRYN J., DBA ART HOUND, BROOKLYN, NY. FILED 6-2-2010.

# Art Hound

THE MARK CONSISTS OF STANDARD CHARACTERS WITHOUT CLAIM TO ANY PARTICULAR FONT, STYLE, SIZE, OR COLOR.

NO CLAIM IS MADE TO THE EXCLUSIVE RIGHT TO USE "ART", APART FROM THE MARK AS SHOWN.

FOR ART CONSULTING SERVICES IN THE FIELD OF VISUAL ARTS, NAMELY, ASSISTING CLIENTS IN FINDING ARTWORK FOR THEIR HOMES, RECOMMENDING ARTWORK AND ARTISTS TO CLIENTS, CONNECTING CLIENTS WITH ART GALLERIES AND ARTISTS (U.S. CLS. 100, 101 AND 102).

FIRST USE 11-19-2009; IN COMMERCE 6-1-2010.  
NAAKWAMA ANKRAH, EXAMINING ATTORNEY

---

SN 85-053,557. WOMEN AGAINST ABUSE, INC., PHILADELPHIA, PA. FILED 6-3-2010.

# iPledge

THE MARK CONSISTS OF STANDARD CHARACTERS WITHOUT CLAIM TO ANY PARTICULAR FONT, STYLE, SIZE, OR COLOR.

FOR CAMPAIGN TO PROMOTING PUBLIC AWARENESS OF DOMESTIC AND COMMUNITY VIOLENCE ISSUES AND TO ENCOURAGE OTHERS TO TAKE ACTION AGAINST VIOLENCE (U.S. CLS. 100, 101 AND 102).

FIRST USE 6-0-2008; IN COMMERCE 6-0-2008.  
CHRISTINA SOBRAL, EXAMINING ATTORNEY

---

SN 85-053,707. TADMOOR, LLC, GALENA, OH. FILED 6-3-2010.

# FIND REAL FOOD

THE MARK CONSISTS OF STANDARD CHARACTERS WITHOUT CLAIM TO ANY PARTICULAR FONT, STYLE, SIZE, OR COLOR.

NO CLAIM IS MADE TO THE EXCLUSIVE RIGHT TO USE "FIND" AND "FOOD", APART FROM THE MARK AS SHOWN.

FOR PROVIDING CONSUMER PRODUCT INFORMATION; PROVIDING COMPARISON SHOPPING INFORMATION, PROVIDING ONLINE DIRECTORY INFORMATION SERVICES ALSO FEATURING HYPERLINKS TO OTHER WEBSITES (U.S. CLS. 100, 101 AND 102).

LINDA LAVACHE, EXAMINING ATTORNEY

**CLASS 35—(Continued).**

SN 85-054,124. 4INFO, INC., SAN MATEO, CA. FILED 6-3-2010.

# adHaven

THE MARK CONSISTS OF STANDARD CHARACTERS WITHOUT CLAIM TO ANY PARTICULAR FONT, STYLE, SIZE, OR COLOR.

FOR DISSEMINATION OF ADVERTISING FOR OTHERS VIA THE INTERNET AND CELLULAR PHONE TEXT MESSAGES; ONLINE ADVERTISING SERVICES FOR OTHERS, NAMELY, PROVIDING ADVERTISING SPACE VIA MOBILE CHANNELS (U.S. CLS. 100, 101 AND 102).

ELIZABETH KAJUBI, EXAMINING ATTORNEY

---

SN 85-054,512. PET HEALTH USA INC., SUNRISE, FL. FILED 6-4-2010.



NO CLAIM IS MADE TO THE EXCLUSIVE RIGHT TO USE "PET HEALTH USA .COM" AND "WHERE PET PARENTS SHOP", APART FROM THE MARK AS SHOWN.

THE MARK CONSISTS OF THE IMAGE OF A PET PAW INTERTWINED WITH A HEART, SEPARATED FROM THE WORDING "PET HEALTH USA .COM WHERE PET PARENTS SHOP" BY A VERTICAL LINE. THE WORDS "PET" AND "HEALTH" ARE UNDERLINED.

FOR ON-LINE RETAIL STORE SERVICES FEATURING PET PRODUCTS (U.S. CLS. 100, 101 AND 102).

STEVEN JACKSON, EXAMINING ATTORNEY

**CLASS 35—(Continued).**

SN 85-055,884. MUTUAL TREE PROCESSAMENTO DE DADOS LTDA., SAO PAULO, BRAZIL, FILED 6-7-2010.



THE MARK CONSISTS OF A STYLIZED OUTLINE OF A TREE ON A HILL.

FOR PROMOTING THE GOODS AND SERVICES OF OTHERS THROUGH THE ADMINISTRATION OF CUSTOMER LOYALTY AND INCENTIVE PROGRAMS WITHIN A NETWORK OF CONSUMER MEMBERS AND A NETWORK OF BUSINESS AFFILIATES FOR PROMOTING RELATIONSHIPS BETWEEN CONSUMER MEMBERS AND BUSINESS AFFILIATES, FOR DISTRIBUTING COMMISSIONS TO CONSUMERS GENERATED BY CONSUMER MEMBER PURCHASES AT BUSINESS AFFILIATES, AND FOR DISTRIBUTING PORTIONS OF SUCH GENERATED COMMISSIONS AS DONATIONS TO ENVIRONMENTAL AND SOCIAL CAUSES (U.S. CLS. 100, 101 AND 102).

KATHERINE E. HALMEN, EXAMINING ATTORNEY

SN 85-057,654. BICYCLE MONKEY.COM LLC., CINCINNATI, OH. FILED 6-8-2010.

**BICYCLE MONKEY**

THE MARK CONSISTS OF STANDARD CHARACTERS WITHOUT CLAIM TO ANY PARTICULAR FONT, STYLE, SIZE, OR COLOR.

NO CLAIM IS MADE TO THE EXCLUSIVE RIGHT TO USE "BICYCLE", APART FROM THE MARK AS SHOWN, FOR ON-LINE AUCTION SERVICES (U.S. CLS. 100, 101 AND 102).

FIRST USE 9-1-2009; IN COMMERCE 6-7-2010.  
LIEF MARTIN, EXAMINING ATTORNEY

**CLASS 35—(Continued).**

SN 85-057,879. MERCHSOURCE, LLC, FOOTHILL RANCH, CA. FILED 6-8-2010.



THE MARK CONSISTS OF THREE DETACHED CURVED LINES FORMING A TRIANGLE SHAPE OVERLAYING THREE ADDITIONAL DETACHED CURVED LINES FORMING ANOTHER TRIANGLE SHAPE MAKING UP A STAR FORMATION WITH A DOT IN THE CENTER.

FOR WHOLESALE DISTRIBUTORSHIP FEATURING GENERAL MERCHANDISE (U.S. CLS. 100, 101 AND 102).

FIRST USE 1-31-2001; IN COMMERCE 1-31-2001.  
KYLE PEETE, EXAMINING ATTORNEY

SN 85-057,881. MERCHSOURCE, LLC, FOOTHILL RANCH, CA. FILED 6-8-2010.



OWNER OF U.S. REG. NO. 3,232,652.  
NO CLAIM IS MADE TO THE EXCLUSIVE RIGHT TO USE "ITEM COMPANY", APART FROM THE MARK AS SHOWN.

THE MARK CONSISTS OF THREE DETACHED CURVED LINES FORMING A TRIANGLE SHAPE OVERLAYING THREE ADDITIONAL DETACHED CURVED LINES FORMING ANOTHER TRIANGLE SHAPE MAKING UP A STAR FORMATION WITH A DOT IN THE CENTER TO THE LEFT WITH THE WORD "MERCHSOURCE" TO THE RIGHT AND THE WORDS "THE ITEM COMPANY" UNDERNEATH THE WORD "SOURCE" IN "MERCHSOURCE".

FOR WHOLESALE DISTRIBUTORSHIP FEATURING GENERAL MERCHANDISE (U.S. CLS. 100, 101 AND 102).

FIRST USE 1-31-2001; IN COMMERCE 1-31-2001.  
KYLE PEETE, EXAMINING ATTORNEY

**CLASS 35—(Continued).**

SN 85-058,095. ALTERNATIVE DELIVERY SOLUTIONS, INC., SAN ANTONIO, TX. FILED 6-9-2010.

**CLASS 35—(Continued).**

SN 85-061,439. BOSSMAN ENTERTAINMENT, INC., MIAMI, FL. AND SUMMERS, JUSTIN, MIAMI, FL. FILED 6-12-2010.

# VERITRAC

BOSSMAN ENTERTAINMENT, INC.

THE MARK CONSISTS OF STANDARD CHARACTERS WITHOUT CLAIM TO ANY PARTICULAR FONT, STYLE, SIZE, OR COLOR.

FOR PROMOTING THE GOODS AND SERVICES OF OTHERS VIA GLOBAL COMPUTER INFORMATION NETWORKS; PROMOTING THE GOODS AND SERVICES OF OTHERS BY DISTRIBUTING ADVERTISER MATERIALS THROUGH PRINT, AUDIO, VIDEO, DIGITAL, AND ONLINE MEDIUM; AND PROVIDING AN INTERNET PORTAL WEBSITE FOR THE TRACKING OF PACKAGES AND ADVERTISING MATERIALS IN TRANSIT (U.S. CLS. 100, 101 AND 102).

FIRST USE 6-1-2003; IN COMMERCE 6-1-2003.  
HOWARD B. LEVINE, EXAMINING ATTORNEY

THE MARK CONSISTS OF STANDARD CHARACTERS WITHOUT CLAIM TO ANY PARTICULAR FONT, STYLE, SIZE, OR COLOR.

OWNER OF U.S. REG. NO. 3,668,617.

NO CLAIM IS MADE TO THE EXCLUSIVE RIGHT TO USE "ENTERTAINMENT, INC.", APART FROM THE MARK AS SHOWN.

FOR ENTERTAINMENT AND MUSIC MANAGEMENT FOR OTHERS, NAMELY, BUSINESS CONSULTING, BUSINESS MANAGEMENT AND PROVIDING INFORMATION IN THE MUSIC BUSINESS FIELD; PROMOTING CONCERTS OF OTHERS, PROMOTING CLUBS OF OTHERS, PROMOTING MUSIC OF OTHERS (U.S. CLS. 100, 101 AND 102).

FIRST USE 5-1-2005; IN COMMERCE 5-1-2005.  
ASMAT KHAN, EXAMINING ATTORNEY

---

SN 85-058,440. ST. JOHNS RIVERKEEPER, INC., JACKSONVILLE, FL. FILED 6-9-2010.

---

SN 85-061,637. FELLUSS, SCOTT, CENTERPORT, NY. FILED 6-14-2010.

# GREEN MONSTER

# NAMING PORTAL

THE MARK CONSISTS OF STANDARD CHARACTERS WITHOUT CLAIM TO ANY PARTICULAR FONT, STYLE, SIZE, OR COLOR.

NO CLAIM IS MADE TO THE EXCLUSIVE RIGHT TO USE "GREEN", APART FROM THE MARK AS SHOWN.

FOR PROMOTING PUBLIC AWARENESS OF ENVIRONMENTAL MATTERS; PROMOTING THE INTERESTS OF PEOPLE CONCERNED WITH HEALTH, COMMUNITY AND ENVIRONMENTAL SUSTAINABILITY ISSUES (U.S. CLS. 100, 101 AND 102).

FIRST USE 7-1-2005; IN COMMERCE 7-1-2005.  
WENDY JUN, EXAMINING ATTORNEY

THE MARK CONSISTS OF STANDARD CHARACTERS WITHOUT CLAIM TO ANY PARTICULAR FONT, STYLE, SIZE, OR COLOR.

NO CLAIM IS MADE TO THE EXCLUSIVE RIGHT TO USE "PORTAL", APART FROM THE MARK AS SHOWN.

FOR ADVERTISING AND BUSINESS CONSULTATION, NAMELY, PROVIDING CONSULTANCY SERVICES TO BUSINESS ORGANIZATIONS AND TO PROFESSIONAL BUSINESSES, BUSINESS RESEARCH FOR CONSUMERS (U.S. CLS. 100, 101 AND 102).

NAKWAMA ANKRAH, EXAMINING ATTORNEY



**CLASS 35—(Continued).**

SN 85-061,942. FIREWING LLC, DBA FIREWING, FORT WORTH, TX. FILED 6-14-2010.

## natural rate of resale

THE MARK CONSISTS OF STANDARD CHARACTERS WITHOUT CLAIM TO ANY PARTICULAR FONT, STYLE, SIZE, OR COLOR.

NO CLAIM IS MADE TO THE EXCLUSIVE RIGHT TO USE "RATE OF RESALE", APART FROM THE MARK AS SHOWN.

FOR CONSULTING SERVICES, NAMELY, EXPERT ANALYSIS AND MANAGEMENT CONSULTING IN ECONOMICS AND ACCOUNTING; COST PRICE ANALYSIS; CREATION OF MARKETING TOOLS DESIGNED TO INCREASE A CLIENT COMPANY'S KNOWLEDGE OF CUSTOMER NEEDS, AND ITS COMPETITORS' PRODUCTS AND SERVICES, PRICING, ADVERTISING STRATEGY AND SALES STRATEGY; ECONOMIC FORECASTING AND ANALYSIS; PRICE COMPARING SERVICES; PRICE COMPARISON SERVICES (U.S. CLS. 100, 101 AND 102).

MARILYN IZZI, EXAMINING ATTORNEY

SN 85-063,585. THROUGH THE GARDEN GATE LLC, LOS ANGELES, CA. FILED 6-15-2010.

## greenlightjobs

THE MARK CONSISTS OF STANDARD CHARACTERS WITHOUT CLAIM TO ANY PARTICULAR FONT, STYLE, SIZE, OR COLOR.

FOR EMPLOYMENT AGENCY SERVICES, NAMELY, MATCHING JOB SEEKERS WITH SPECIAL SKILLS AND QUALIFICATIONS TO ENTERTAINMENT AND PRODUCTION INDUSTRY REQUIREMENTS FOR JOB PLACEMENT (U.S. CLS. 100, 101 AND 102).

FIRST USE 9-2-2002; IN COMMERCE 9-16-2002.

MARY ROSSMAN, EXAMINING ATTORNEY

SN 85-064,057. J&H ENTERPRISES, LLC, WILMINGTON, DE. FILED 6-16-2010.

## VIIAD COMPASS

THE MARK CONSISTS OF STANDARD CHARACTERS WITHOUT CLAIM TO ANY PARTICULAR FONT, STYLE, SIZE, OR COLOR.

OWNER OF U.S. REG. NO. 3,700,423.

FOR HEALTH CARE ADMINISTRATION SERVICES, NAMELY, ELECTRONIC PROCESSING OF HEALTH CARE PLAN INFORMATION FOR OTHERS (U.S. CLS. 100, 101 AND 102).

CURTIS FRENCH, EXAMINING ATTORNEY

**CLASS 35—(Continued).**

SN 85-065,527. FEDERAL ALLIANCE FOR SAFE HOMES, INC., AKA FLASH, TALLAHASSEE, FL. FILED 6-17-2010.

## GREAT HURRICANE BLOWOUT

THE MARK CONSISTS OF STANDARD CHARACTERS WITHOUT CLAIM TO ANY PARTICULAR FONT, STYLE, SIZE, OR COLOR.

NO CLAIM IS MADE TO THE EXCLUSIVE RIGHT TO USE "HURRICANE", APART FROM THE MARK AS SHOWN.

FOR PROMOTING PUBLIC AWARENESS OF HURRICANE SAFETY AND PREPAREDNESS ISSUES, AND PROVIDING BUSINESS, COMMERCIAL, AND CONSUMER INFORMATION ABOUT HURRICANE PREPAREDNESS PLANNING, NAMELY, EVACUATION PLANNING, DISASTER SUPPLY PLANNING, AND PERSONAL AND PROPERTY PROTECTION PLANNING (U.S. CLS. 100, 101 AND 102).

FIRST USE 2-15-2010; IN COMMERCE 2-15-2010.

HEATHER THOMPSON, EXAMINING ATTORNEY

SN 85-065,586. FEDERAL ALLIANCE FOR SAFE HOMES, INC., AKA FLASH, TALLAHASSEE, FL. FILED 6-17-2010.



NO CLAIM IS MADE TO THE EXCLUSIVE RIGHT TO USE "HURRICANE", APART FROM THE MARK AS SHOWN.

THE COLOR(S) BLUE, PURPLE, GREEN, AND GREY IS/ARE CLAIMED AS A FEATURE OF THE MARK.

THE MARK CONSISTS OF OF A BLUE WATER BOTTLE, GREEN PLUS SYMBOL, AND PURPLE FLASHLIGHT INSIDE A CIRCLE FORMED BY THREE COLORED SEGMENTS OF BLUE, GREEN AND PURPLE. TO THE RIGHT OF THE CIRCLE ARE THE WORDS "GREAT HURRICANE" IN GREEN ABOVE THE WORDS "BLOWOUT.ORG" IN PURPLE AND GREY.

FOR PROMOTING PUBLIC AWARENESS OF HURRICANE SAFETY AND PREPAREDNESS ISSUES, AND PROVIDING BUSINESS, COMMERCIAL, AND CONSUMER INFORMATION ABOUT HURRICANE PREPAREDNESS PLANNING, NAMELY, EVACUATION PLANNING, DISASTER SUPPLY PLANNING, AND PERSONAL AND PROPERTY PROTECTION PLANNING (U.S. CLS. 100, 101 AND 102).

FIRST USE 2-15-2010; IN COMMERCE 2-15-2010.

NICHOLAS COLEMAN, EXAMINING ATTORNEY

**CLASS 35—(Continued).**

SN 85-069,298. PHILLY BIOBREAK, PHILADELPHIA, PA. FILED 6-23-2010.

# BIOBREAK

THE MARK CONSISTS OF STANDARD CHARACTERS WITHOUT CLAIM TO ANY PARTICULAR FONT, STYLE, SIZE, OR COLOR.

FOR BUSINESS NETWORKING SERVICES, NAMELY, PROVIDING A FORUM FOR BUSINESS AND MARKETING AND NETWORKING OPPORTUNITIES, AND PROFESSIONAL COLLABORATION AND PARTNERING OPPORTUNITIES FOR MEMBERS OF THE BIOSCIENCE, BIOTECHNOLOGY, PHARMACEUTICAL, MEDICAL DEVICE AND VENTURE CAPITAL INDUSTRIES (U.S. CLS. 100, 101 AND 102).

FIRST USE 9-0-2007; IN COMMERCE 9-0-2007.

BARNEY CHARLON, EXAMINING ATTORNEY

**CLASS 35—(Continued).**

SN 85-070,717. SOLOMON INNOVATIONS CORP, NORTH LAS VEGAS, NV. FILED 6-24-2010.

# FABULOUS CHARACTERS

THE MARK CONSISTS OF STANDARD CHARACTERS WITHOUT CLAIM TO ANY PARTICULAR FONT, STYLE, SIZE, OR COLOR.

NO CLAIM IS MADE TO THE EXCLUSIVE RIGHT TO USE "CHARACTERS", APART FROM THE MARK AS SHOWN.

FOR MARKETING, ADVERTISING AND PROMOTING THE GOODS AND SERVICES OF OTHERS BY PROVIDING CUSTOMIZED EXHIBITS IN THE NATURE OF PERFORMANCES BY INDIVIDUALS COSTUMED AS FAMOUS PERSONALITIES AND FICTIONAL CHARACTERS (U.S. CLS. 100, 101 AND 102).

CARYN GLASSER, EXAMINING ATTORNEY

SN 85-071,201. GRACE LITES CORPORATION, TEMECULA, CA. FILED 6-24-2010.



NO CLAIM IS MADE TO THE EXCLUSIVE RIGHT TO USE "LITES CORPORATION", APART FROM THE MARK AS SHOWN.

THE COLOR(S) RED, BLACK IS/ARE CLAIMED AS A FEATURE OF THE MARK.

THE MARK CONSISTS OF THE WORD "GRACE" IN STYLIZED LETTERS IN RED, AND THE WORDS "LITES CORPORATION" IN BLACK.

FOR PROCUREMENT, NAMELY, PURCHASING FOR OTHERS OF LIGHTING CONTROLLERS FOR STAGE LIGHTING AND TELEVISION, PROJECTOR LAMPS, REFLECTOR LAMPS, FANCY LAMPS FOR DECORATING, ARCHITECTURAL LIGHTS, MOVING LIGHTS FOR USE IN TELEVISION AND IN PROVIDING CORPORATE PRESENTATIONS; RETAIL STORES FEATURING LIGHTING CONTROLLERS FOR STAGE LIGHTING AND TELEVISION, PROJECTION EQUIPMENT, PROJECTOR LAMPS, REFLECTOR LAMPS, FANCY LAMPS FOR DECORATING, ARCHITECTURAL LIGHTS, MOVING LIGHTS FOR USE IN TELEVISION AND IN PROVIDING CORPORATE PRESENTATIONS (U.S. CLS. 100, 101 AND 102).

ELISSA GARBER KON, EXAMINING ATTORNEY

SN 85-069,885. 4R VENTURES, LLC, WINTER PARK, FL. FILED 6-23-2010.



THE MARK CONSISTS OF THE NUMBER "4" COMBINED WITH THE LETTER "R" IN BRUSH STROKE CHARACTERS.

FOR CONCESSION STANDS FEATURING FOOD (U.S. CLS. 100, 101 AND 102).

DAVID TOOLEY, EXAMINING ATTORNEY

**CLASS 35—(Continued).**

SN 85-071,701. LEFEBVRE, NICOLE M, FORMERLY FERRARO, NICOLE M, LADSON, SC. FILED 6-25-2010.

## The Vehicle Wrap Store

THE MARK CONSISTS OF STANDARD CHARACTERS WITHOUT CLAIM TO ANY PARTICULAR FONT, STYLE, SIZE, OR COLOR.

NO CLAIM IS MADE TO THE EXCLUSIVE RIGHT TO USE "VEHICLE" AND "STORE", APART FROM THE MARK AS SHOWN.

FOR ADVERTISING AND MARKETING; ADVERTISING, MARKETING AND PROMOTION SERVICES; PREPARATION OF CUSTOM ADVERTISEMENTS FOR OTHERS; PROVIDING ADVERTISING SERVICES (U.S. CLS. 100, 101 AND 102).

FIRST USE 6-25-2010; IN COMMERCE 6-25-2010.  
SANJEEV VOHRA, EXAMINING ATTORNEY

---

SN 85-071,703. GEORGE, JOHN, DBA PEDDLER'S MALL, LLC, LOUISVILLE, KY. FILED 6-25-2010.

## PEDDLERS MALL

THE MARK CONSISTS OF STANDARD CHARACTERS WITHOUT CLAIM TO ANY PARTICULAR FONT, STYLE, SIZE, OR COLOR.

NO CLAIM IS MADE TO THE EXCLUSIVE RIGHT TO USE "MALL", APART FROM THE MARK AS SHOWN. SEC. 2(F).

FOR FLEA MARKETS (U.S. CLS. 100, 101 AND 102).  
FIRST USE 3-26-1999; IN COMMERCE 3-26-1999.  
BILL DAWE, EXAMINING ATTORNEY

---

SN 85-074,315. BROWN, LARRY LAWRENCE SR., MELROSE PARK, IL. FILED 6-29-2010.

## DUNN DEAL PRODUCTIONS

THE MARK CONSISTS OF STANDARD CHARACTERS WITHOUT CLAIM TO ANY PARTICULAR FONT, STYLE, SIZE, OR COLOR.

NO CLAIM IS MADE TO THE EXCLUSIVE RIGHT TO USE "PRODUCTIONS", APART FROM THE MARK AS SHOWN.

FOR ENTERTAINMENT MARKETING SERVICES, NAMELY, MARKETING, PROMOTION AND ADVERTISING FOR INDEPENDENT RECORDING ARTISTS (U.S. CLS. 100, 101 AND 102).

FIRST USE 5-15-1998; IN COMMERCE 12-31-1999.  
KATHLEEN M. VANSTON, EXAMINING ATTORNEY

**CLASS 35—(Continued).**

SN 85-075,735. PHILLY BIOBREAK, PHILADELPHIA, PA. FILED 7-1-2010.



NO CLAIM IS MADE TO THE EXCLUSIVE RIGHT TO USE "LIFE SCIENCES", APART FROM THE MARK AS SHOWN.

THE MARK CONSISTS OF THE WORD "BIOBREAK" WHICH APPEARS ABOVE THE WORDING "ENERGIZING LIFESCIENCES". A STARBURST CONTAINED WITHIN A BROKEN CIRCLE APPEARS TO THE LEFT OF THE WORDING.

FOR BUSINESS NETWORKING SERVICES, NAMELY, PROVIDING A FORUM FOR BUSINESS AND MARKETING AND NETWORKING OPPORTUNITIES, AND PROFESSIONAL COLLABORATION AND PARTNERING OPPORTUNITIES FOR MEMBERS OF THE BIOSCIENCE, BIOTECHNOLOGY, PHARMACEUTICAL, MEDICAL DEVICE AND VENTURE CAPITAL INDUSTRIES (U.S. CLS. 100, 101 AND 102).

FIRST USE 5-0-2010; IN COMMERCE 5-0-2010.  
BARNEY CHARLON, EXAMINING ATTORNEY

---

SN 85-076,224. UDELL JEWELERS, INC., DBA LONDON JEWELERS, GLEN COVE, NY. FILED 7-1-2010.



THE MARK CONSISTS OF THE WORDS "SAY I LONDON" IN CAPITAL LETTERS, WITH THE WORD "SAY" CENTERED OVER THE WORD "I" WHICH IS CENTERED OVER THE LETTERS "DO" IN THE WORD "LONDON" AND PRESENTED IN SOLID BLACK FONT, FORMING THE PHRASE "SAY I DO". THE FIRST THREE LETTERS "LON" AND THE FINAL "N" IN THE WORD "LONDON" ARE PRESENTED IN A BLACK AND WHITE OUTLINED FONT.

FOR RETAIL STORE AND ONLINE RETAIL STORE SERVICES FEATURING JEWELRY, WATCHES, CERAMIC FIGURINES AND DISHES, SILVER AND JEWELLED PICTURE FRAMES, CANDLES, FRAGRANCES, CIGAR ACCESSORIES, ART GLASSWARE, AND GLASS SCULPTURES (U.S. CLS. 100, 101 AND 102).

FIRST USE 1-9-2010; IN COMMERCE 1-9-2010.  
NICHOLAS ALTREE, EXAMINING ATTORNEY

**CLASS 35—(Continued).**

SN 85-078,729. MATTEL, INC., EL SEGUNDO, CA. FILED 7-6-2010.

# SEE 'N SAY

THE MARK CONSISTS OF STANDARD CHARACTERS WITHOUT CLAIM TO ANY PARTICULAR FONT, STYLE, SIZE, OR COLOR.

OWNER OF U.S. REG. NOS. 862,679, 2,122,290 AND 2,585,305.

FOR COMPUTERIZED ONLINE ORDERING SERVICES IN THE FIELD OF TOYS, GAMES AND PLAY-THINGS; ELECTRONIC COMMERCE SERVICES, NAMELY, PROVIDING INFORMATION ABOUT PRODUCTS VIA TELECOMMUNICATION NETWORKS FOR ADVERTISING AND SALES PURPOSES (U.S. CLS. 100, 101 AND 102).

JOSETTE BEVERLY, EXAMINING ATTORNEY

SN 85-078,731. MATTEL, INC., EL SEGUNDO, CA. FILED 7-6-2010.

# FISHER-PRICE

THE MARK CONSISTS OF STANDARD CHARACTERS WITHOUT CLAIM TO ANY PARTICULAR FONT, STYLE, SIZE, OR COLOR.

OWNER OF U.S. REG. NOS. 832,452, 3,279,454 AND OTHERS.

FOR COMPUTERIZED ONLINE ORDERING SERVICES IN THE FIELD OF TOYS, GAMES AND PLAY-THINGS; ELECTRONIC COMMERCE SERVICES, NAMELY, PROVIDING INFORMATION ABOUT PRODUCTS VIA TELECOMMUNICATION NETWORKS FOR ADVERTISING AND SALES PURPOSES (U.S. CLS. 100, 101 AND 102).

JOSETTE BEVERLY, EXAMINING ATTORNEY

**CLASS 35—(Continued).**

SN 85-078,732. STEREN ELECTRONICS INTERNATIONAL, LLC, SAN DIEGO, CA. FILED 7-6-2010.



NO CLAIM IS MADE TO THE EXCLUSIVE RIGHT TO USE "JUMPER SHOP", APART FROM THE MARK AS SHOWN.

THE MARK CONSISTS OF A ROUNDED CABLE WITH ONE END OF THE CABLE SHOWING AND AROUND THE FIRST THREE LETTERS OF "JUMPER" AND THE WORD "SHOP" BELOW THE LETTERS "PER" IN "JUMPER".

FOR WHOLESALE DISTRIBUTORSHIPS IN THE FIELD OF COAXIAL AND FIBER CABLE JUMPERS USED IN THE INSTALLATION OF BROADBAND CABLE, VOIP DIGITAL TELEPHONY, HDTV, DATA, STRUCTURED WIRING AND OTHER SYSTEMS (U.S. CLS. 100, 101 AND 102).

FIRST USE 12-0-1984; IN COMMERCE 12-0-1984.

JUSTINE D. PARKER, EXAMINING ATTORNEY

SN 85-080,140. MIZUNI, INC., ADDISON, TX. FILED 7-8-2010.

# MIZUNI

THE MARK CONSISTS OF STANDARD CHARACTERS WITHOUT CLAIM TO ANY PARTICULAR FONT, STYLE, SIZE, OR COLOR.

THE ENGLISH TRANSLATION OF THE WORD "MIZUNI" IN THE MARK IS "BOILED IN WATER".

FOR ENTERPRISE DATABASE MANAGEMENT SERVICES FOR MANAGING PRE-KINDERGARTEN THROUGH GRADUATE SCHOOL STUDENT INFORMATION TO HELP DETERMINE INSTRUCTIONAL DECISIONS BASED UPON STUDENT NEEDS (U.S. CLS. 100, 101 AND 102).

FIRST USE 3-1-2004; IN COMMERCE 3-1-2004.

EDWARD NELSON, EXAMINING ATTORNEY

SN 85-080,162. MIZUNI, INC., ADDISON, TX. FILED 7-8-2010.

# DELIVERING INFORMATION TO INSPIRE EDUCATION

THE MARK CONSISTS OF STANDARD CHARACTERS WITHOUT CLAIM TO ANY PARTICULAR FONT, STYLE, SIZE, OR COLOR.

FOR ENTERPRISE DATABASE MANAGEMENT SERVICES FOR MANAGING PRE-KINDERGARTEN THROUGH GRADUATE SCHOOL STUDENT INFORMATION TO HELP DETERMINE INSTRUCTIONAL DECISIONS BASED UPON STUDENT NEEDS (U.S. CLS. 100, 101 AND 102).

FIRST USE 12-1-2009; IN COMMERCE 12-1-2009.

EDWARD NELSON, EXAMINING ATTORNEY

**CLASS 35—(Continued).**

SN 85-080,524. JTH TAX, INC., VIRGINIA BEACH, VA. FILED 7-8-2010.

## Doña Libertad

THE MARK CONSISTS OF STANDARD CHARACTERS WITHOUT CLAIM TO ANY PARTICULAR FONT, STYLE, SIZE, OR COLOR.

THE ENGLISH TRANSLATION OF "DOÑA LIBERTAD" IN THE MARK IS "LADY LIBERTY".

FOR INCOME TAX PREPARATION; TAX FILING SERVICES (U.S. CLS. 100, 101 AND 102).

FRANK LATTUCA, EXAMINING ATTORNEY

---

SN 85-081,057. THE SOLOMON-PAGE GROUP LLC, NEW YORK, NY. FILED 7-9-2010.

## PREPTrak

THE MARK CONSISTS OF STANDARD CHARACTERS WITHOUT CLAIM TO ANY PARTICULAR FONT, STYLE, SIZE, OR COLOR.

OWNER OF U.S. REG. NO. 3,367,021.

FOR PROVIDING AN INTERNET WEBSITE PORTAL FEATURING INFORMATION IN THE FIELD OF EMPLOYMENT RECRUITMENT, PLACEMENT AND STAFFING (U.S. CLS. 100, 101 AND 102).

ALICE BENMAMAN, EXAMINING ATTORNEY

---

SN 85-082,044. WALLACE COFFEE, INC., HULL, MA. FILED 7-11-2010.

## 1st Stop Coffee

THE MARK CONSISTS OF STANDARD CHARACTERS WITHOUT CLAIM TO ANY PARTICULAR FONT, STYLE, SIZE, OR COLOR.

NO CLAIM IS MADE TO THE EXCLUSIVE RIGHT TO USE "COFFEE", APART FROM THE MARK AS SHOWN.

FOR DRIVE-THROUGH RETAIL STORE SERVICES FEATURING COFFEE AND RELATED GOODS (U.S. CLS. 100, 101 AND 102).

FIRST USE 1-1-1985; IN COMMERCE 1-1-1985.

PATRICIA EVANKO, EXAMINING ATTORNEY

**CLASS 35—(Continued).**

SN 85-083,518. PASQUALE DIPIPPO, DBA DIRTY CULTURE, CRANSTON, RI. FILED 7-13-2010.



THE MARK CONSISTS OF A FIRST FIVE-POINTED STAR, OUTLINED BY A SECOND FIVE POINTED STAR, WHICH IS OUTLINED BY A THIRD FIVE-POINTED STAR.

FOR RETAIL STORE SERVICES FEATURING CLOTHING (U.S. CLS. 100, 101 AND 102).

TEJBIR SINGH, EXAMINING ATTORNEY

---

SN 85-087,354. CHOOSEYOUREVENT.COM LTD, ILMINSTER, SOMERSET, UNITED KINGDOM, FILED 7-19-2010.



THE MARK CONSISTS OF A DESIGN COMPOSED OF A TRIANGLE AND THREE SEPARATE BARS OF DIFFERING LENGTHS EXTENDING DIAGONALLY FROM THE HYPOTENUSE OF THE TRIANGLE. NEXT TO THE DESIGN ARE THE WORDS "CHOOSEYOUREVENT.COM" AND UNDERNEATH THESE WORDS IS THE PHRASE "AN EXPERIENCE IN LIFE!"

FOR PROVIDING A SEARCHABLE ONLINE EVENT, VENUE AND ACTIVITY DIRECTORY SERVICE, ALLOWING VENDORS TO ADVERTISE, AND USERS TO ORDER, THEIR SERVICES VIA THE INTERNET IN THE FIELD OF ENTERTAINMENT AND EVENT VENUES FOR INDIVIDUAL, CORPORATE OR GROUP EVENTS OR ADVENTURE EXPERIENCES (U.S. CLS. 100, 101 AND 102).

FIRST USE 6-10-2000; IN COMMERCE 9-16-2010.

STEVEN R. FINE, EXAMINING ATTORNEY



**CLASS 35—(Continued).**

SN 85-088,005. EMPLOYERS SOLUTIONS, INC., SAN ANTONIO, TX. FILED 7-19-2010.

# eESI

THE MARK CONSISTS OF STANDARD CHARACTERS WITHOUT CLAIM TO ANY PARTICULAR FONT, STYLE, SIZE, OR COLOR.

FOR PROFESSIONAL EMPLOYER ORGANIZATION SERVICES IN THE NATURE OF EMPLOYEE LEASING (U.S. CLS. 100, 101 AND 102).

FIRST USE 3-1-2008; IN COMMERCE 3-1-2008.  
ANDREA HACK, EXAMINING ATTORNEY

---

SN 85-093,027. SPI CRM, INC., MANILA, PHILIPPINES, FILED 7-26-2010.

# SPI CRM

THE MARK CONSISTS OF STANDARD CHARACTERS WITHOUT CLAIM TO ANY PARTICULAR FONT, STYLE, SIZE, OR COLOR.

NO CLAIM IS MADE TO THE EXCLUSIVE RIGHT TO USE "CRM", APART FROM THE MARK AS SHOWN.

FOR CUSTOMER RELATIONSHIP MANAGEMENT (U.S. CLS. 100, 101 AND 102).

FIRST USE 6-30-2010; IN COMMERCE 6-30-2010.  
LANA PHAM, EXAMINING ATTORNEY

---

SN 85-093,421. MOVIE TICKETS.COM, INC., BOCA RATON, FL. FILED 7-27-2010.

# THE INTELLIGENT WAY TO GO TO THE MOVIES

THE MARK CONSISTS OF STANDARD CHARACTERS WITHOUT CLAIM TO ANY PARTICULAR FONT, STYLE, SIZE, OR COLOR.

OWNER OF U.S. REG. NO. 3,715,758.

FOR COMPUTERIZED ON-LINE ORDERING SERVICES IN THE FIELD OF MOVIE TICKETS, VIA AN INTERACTIVE GLOBAL COMPUTER NETWORK (U.S. CLS. 100, 101 AND 102).

DOMINIC J. FERRAIUOLO, EXAMINING ATTORNEY

**CLASS 35—(Continued).**

SN 85-095,831. HARRISON & STAR LLC, NEW YORK, NY. FILED 7-29-2010.

# BIOCLARA GROUP

THE MARK CONSISTS OF STANDARD CHARACTERS WITHOUT CLAIM TO ANY PARTICULAR FONT, STYLE, SIZE, OR COLOR.

OWNER OF U.S. REG. NO. 2,523,504.

NO CLAIM IS MADE TO THE EXCLUSIVE RIGHT TO USE "GROUP", APART FROM THE MARK AS SHOWN.

FOR BUSINESS CONSULTING SERVICES IN THE FIELD OF PHARMACEUTICALS AND BIOPHARMACEUTICALS AND RELATED TECHNOLOGIES, INCLUDING DEVELOPMENT, FORMULATION, EVALUATION, APPROVAL, DELIVERY, COMMERCIALIZATION, MARKETING, AND LIFE-CYCLE MANAGEMENT OF DRUGS; BUSINESS STRATEGIC CONSULTING SERVICES IN THE FIELD OF PHARMACEUTICALS AND BIOPHARMACEUTICALS AND RELATED TECHNOLOGIES, INCLUDING DEVELOPMENT, FORMULATION, EVALUATION, APPROVAL, DELIVERY, COMMERCIALIZATION, MARKETING AND LIFE-CYCLE MANAGEMENT OF DRUGS; ADVERTISING AND PUBLIC RELATIONS SERVICES IN THE FIELD OF HEALTHCARE AND PHARMACEUTICALS; MARKET RESEARCH AND ANALYSIS SERVICES IN THE FIELD OF PHARMACEUTICALS AND BIOPHARMACEUTICALS; EVENT MARKETING, INTERACTIVE MARKETING (U.S. CLS. 100, 101 AND 102).

CHARLES L. JENKINS, EXAMINING ATTORNEY

---

SN 85-098,462. INSTANTINTELL LLC, PHILADELPHIA, PA. FILED 8-2-2010.

# SpotBanks

THE MARK CONSISTS OF STANDARD CHARACTERS WITHOUT CLAIM TO ANY PARTICULAR FONT, STYLE, SIZE, OR COLOR.

FOR BUSINESS SERVICES, NAMELY, CUSTOMER AND CONSUMER RELATIONSHIP MANAGEMENT IN THE FIELD OF RETAIL BANKING (U.S. CLS. 100, 101 AND 102).

REBECCA SMITH, EXAMINING ATTORNEY

**CLASS 35—(Continued).**

SN 85-110,760. PRITCHARD, ANDREW F., CARMEL, IN. FILED 8-18-2010.

## ThoughtBurst

THE MARK CONSISTS OF STANDARD CHARACTERS WITHOUT CLAIM TO ANY PARTICULAR FONT, STYLE, SIZE, OR COLOR.

FOR BUSINESS CONSULTING SERVICES (U.S. CLS. 100, 101 AND 102).

FIRST USE 7-22-2010; IN COMMERCE 8-12-2010.  
SKYE YOUNG, EXAMINING ATTORNEY

SN 85-112,245. SAVE A LIFE ~ SAVE THE WORLD FOUNDATION, ASHBURN, VA. FILED 8-20-2010.

## I AM THE ONE MAKING A DIFFERENCE

THE MARK CONSISTS OF STANDARD CHARACTERS WITHOUT CLAIM TO ANY PARTICULAR FONT, STYLE, SIZE, OR COLOR.

FOR PROMOTING PUBLIC AWARENESS OF HEALTH AND DISEASE AND THE BENEFITS OF AND NEED FOR THE DONATION OF HOUSING ASSISTANCE AND ORGANS, TISSUES, CELLULAR MATERIALS AND BLOOD; CHARITABLE SERVICES, NAMELY, PROVIDING ADMINISTRATION AND MANAGEMENT OF EMERGENCY PLACEMENT HOUSING FACILITIES FOR PEOPLE IN NEED (U.S. CLS. 100, 101 AND 102).  
BILL DAWE, EXAMINING ATTORNEY

SN 85-116,167. JBZ&A, INC., WILLMINGTON, DE. FILED 8-26-2010.

## INSPIRING BUSINESS PERFORMANCE

THE MARK CONSISTS OF STANDARD CHARACTERS WITHOUT CLAIM TO ANY PARTICULAR FONT, STYLE, SIZE, OR COLOR.

NO CLAIM IS MADE TO THE EXCLUSIVE RIGHT TO USE "BUSINESS PERFORMANCE", APART FROM THE MARK AS SHOWN.

FOR SERVING AS AN OUTSOURCED HUMAN RESOURCES DEPARTMENT FOR OTHERS; SERVING AS A HUMAN RESOURCES DEPARTMENT FOR OTHERS, NAMELY, PROVIDING TO CLIENT COMPANIES DETAILED DEDUCTION REPORTS, TIMESHEETS, AND INVOICES FOR PAYROLL REPORTS, PROVIDING HUMAN RESOURCES FORMS, AND PROVIDING ANSWERS TO FREQUENTLY ASKED PERSONNEL QUESTIONS; HUMAN RESOURCES CONSULTING AND MANAGEMENT; EMPLOYEE AND CONTRACTOR EXPENSE MANAGEMENT SERVICES; PROVIDING A PLACE ON A WEB SITE FOR A CLIENT COMPANY TO POST JOB OPENINGS; PROVIDING A RESUME DATABASE OF PROSPECTIVE EMPLOYEES TO CLIENTS;

**CLASS 35—(Continued).**

PROMOTING THE GOODS AND SERVICES OF OTHERS BY PROVIDING A WEB SITE AT WHICH USERS CAN LINK TO THE WEB SITES OF OTHERS; PROMOTING THE GOODS AND SERVICES OF OTHERS, NAMELY, PROVIDING INFORMATION REGARDING DISCOUNTS, COUPONS, REBATES, VOUCHERS, AND SPECIAL OFFERS FOR THE GOODS AND SERVICES OF OTHERS FOR USE BY EMPLOYERS AND EMPLOYEES OF A COMPANY; MEDICAL REFERRAL SERVICES, NAMELY, PROVIDING INFORMATION ABOUT MEDICAL BENEFIT PROVIDERS TO A GIVEN EMPLOYEE; PROVIDING INFORMATION DIRECTLY AND VIA THE INTERNET IN THE FIELD OF EMPLOYMENT ADMINISTRATION; PROVIDING INFORMATION IN THE FIELD OF HUMAN RESOURCES; PROVIDING INFORMATION IN THE FIELDS OF EMPLOYEE ADMINISTRATION, PERSONNEL MANAGEMENT, EMPLOYMENT RECORDS, WAGE CLAIMS AND AUDITS, PAYROLL PREPARATION, PROCESSING, AND MANAGEMENT, HUMAN RESOURCES CONSULTING AND MANAGEMENT, EMPLOYMENT HIRING, RECRUITING, PLACEMENT, STAFFING AND CAREER NETWORKING, AND PERSONNEL RELOCATION, EMPLOYMENT VERIFICATION, TESTING TO DETERMINE JOB COMPETENCY AND COMPATIBILITY, EMPLOYEE PERFORMANCE MANAGEMENT, EMPLOYEE SELECTION USING PSYCHOLOGICAL AND SKILL TESTING, EMPLOYEE RETENTION, AND EMPLOYEE TERMINATION; PROVIDING INFORMATION IN THE FIELD OF BUSINESS VIA THE INTERNET; PROVIDING INFORMATION AND ANALYSIS IN THE FIELD OF BUSINESS; BUSINESS ADVICE AND INFORMATION; BUSINESS CONSULTING SERVICES; PROVIDING AN ON-LINE COMPUTER DATABASE IN THE FIELD OF BUSINESS ADVICE AND INFORMATION; PROVIDING AN ON-LINE COMPUTER DATABASE IN THE FIELD OF HUMAN RESOURCES; CONSULTING SERVICES IN THE FIELD OF HUMAN RESOURCES DEVELOPMENT, NAMELY, UTILIZING TECHNOLOGY FOR THE PROMOTION OF EMPLOYEE RETENTION, CAREER GROWTH AND INCREASED PRODUCTIVITY FOR EMPLOYEES AND EMPLOYERS; BUSINESS INVESTIGATIONS; PROMOTING THE SALE OF GOODS AND SERVICES OF OTHERS BY AWARDED PURCHASE POINTS FOR CREDIT CARD AND DEBIT CARD USE; TESTING TO DETERMINE JOB COMPETENCY AND COMPATIBILITY, NAMELY, EMPLOYEE AND PRE-EMPLOYMENT SKILL AND BEHAVIORAL ASSESSMENT SERVICES; BUSINESS SUCCESSION PLANNING; ADVERTISING, PROMOTION AND MARKETING SERVICES IN THE NATURE OF E-MAIL CAMPAIGNS FOR OTHERS; DISASTER RECOVERY SERVICES, NAMELY, BUSINESS PLANNING AND BUSINESS CONTINUITY CONSULTING; BUSINESS ORGANIZATION CONSULTING; COMMERCIAL INFORMATION AGENCY SERVICES FOR BUSINESSES IN THE AREAS OF CREDIT INFORMATION AND PRE-EMPLOYMENT SCREENING; PROVIDING RECORD-KEEPING FOR EMPLOYMENT RETIREMENT PLANS; PROFESSIONAL EMPLOYER ORGANIZATION SERVICES, NAMELY, SERVING AS AN OUTSOURCED HUMAN RESOURCES DEPARTMENT FOR OTHERS, SERVING AS A HUMAN RESOURCES DEPARTMENT FOR OTHERS, NAMELY, PROVIDING TO CLIENT COMPANIES DETAILED DEDUCTION REPORTS, TIMESHEETS, AND INVOICES FOR PAYROLL REPORTS, PROVIDING HUMAN RESOURCES FORMS, AND PROVIDING ANSWERS TO FREQUENTLY ASKED PERSONNEL QUESTIONS, HUMAN RESOURCES CONSULTING AND MANAGEMENT, EMPLOYEE AND CONTRACTOR EXPENSE MANAGEMENT SERVICES, PROVIDING A PLACE ON A WEB SITE FOR A CLIENT COMPANY TO POST JOB OPENINGS, PROVIDING A RESUME DATABASE OF PROSPECTIVE EMPLOYEES TO CLIENTS, PROMOTING THE GOODS AND SERVICES OF OTHERS BY PROVIDING A WEB SITE AT WHICH USERS CAN LINK TO THE WEB SITES OF OTHERS, PROMOTING THE GOODS AND SERVICES OF OTHERS, NAMELY, PROVIDING INFORMATION REGARDING DISCOUNTS, COUPONS, REBATES, VOUCHERS, AND SPECIAL OFFERS FOR THE GOODS AND SERVICES OF OTHERS FOR USE BY EMPLOYERS AND EMPLOYEES OF A COMPANY, MEDICAL REFERRAL SERVICES, NAMELY, PROVIDING INFORMATION ABOUT MEDICAL BENEFIT PROVIDERS TO A GIVEN EMPLOYEE, PROVIDING INFORMATION DIRECTLY AND VIA THE INTERNET IN THE FIELD OF EMPLOY-

**CLASS 35—(Continued).**

MENT ADMINISTRATION, PROVIDING INFORMATION IN THE FIELD OF HUMAN RESOURCES, PROVIDING INFORMATION IN THE FIELDS OF EMPLOYEE ADMINISTRATION, PERSONNEL MANAGEMENT, EMPLOYMENT RECORDS, WAGE CLAIMS AND AUDITS, PAYROLL PREPARATION, PROCESSING, AND MANAGEMENT, HUMAN RESOURCES CONSULTING AND MANAGEMENT, EMPLOYMENT HIRING, RECRUITING, PLACEMENT, STAFFING AND CAREER NETWORKING, AND PERSONNEL RELOCATION, EMPLOYMENT VERIFICATION, TESTING TO DETERMINE JOB COMPETENCY AND COMPATIBILITY, EMPLOYEE PERFORMANCE MANAGEMENT, EMPLOYEE SELECTION USING PSYCHOLOGICAL AND SKILL TESTING, EMPLOYEE RETENTION, AND EMPLOYEE TERMINATION, PROVIDING INFORMATION IN THE FIELD OF BUSINESS VIA THE INTERNET, PROVIDING INFORMATION AND ANALYSIS IN THE FIELD OF BUSINESS, BUSINESS ADVICE AND INFORMATION, BUSINESS CONSULTING SERVICES, PROVIDING AN ON-LINE COMPUTER DATABASE IN THE FIELD OF BUSINESS ADVICE AND INFORMATION, PROVIDING AN ON-LINE COMPUTER DATABASE IN THE FIELD OF HUMAN RESOURCES, CONSULTING SERVICES IN THE FIELD OF HUMAN RESOURCES DEVELOPMENT, NAMELY, UTILIZING TECHNOLOGY FOR THE PROMOTION OF EMPLOYEE RETENTION, CAREER GROWTH AND INCREASED PRODUCTIVITY FOR EMPLOYEES AND EMPLOYERS, BUSINESS INVESTIGATIONS, PROMOTING THE SALE OF GOODS AND SERVICES OF OTHERS BY AWARDING PURCHASE POINTS FOR CREDIT CARD AND DEBIT CARD USE, TESTING TO DETERMINE JOB COMPETENCY AND COMPATIBILITY, NAMELY, EMPLOYEE AND PRE-EMPLOYMENT SKILL AND BEHAVIORAL ASSESSMENT SERVICES, BUSINESS SUCCESSION PLANNING, ADVERTISING, PROMOTION AND MARKETING SERVICES IN THE NATURE OF E-MAIL CAMPAIGNS FOR OTHERS, DISASTER RECOVERY SERVICES, NAMELY, BUSINESS PLANNING AND BUSINESS CONTINUITY CONSULTING, BUSINESS ORGANIZATION CONSULTING, COMMERCIAL INFORMATION AGENCY SERVICES FOR BUSINESSES IN THE AREAS OF CREDIT INFORMATION AND PRE-EMPLOYMENT SCREENING, PROVIDING RECORD-KEEPING FOR EMPLOYMENT RETIREMENT PLANS (U.S. CLS. 100, 101 AND 102).

JENNIFER DIXON, EXAMINING ATTORNEY

SN 85-116,450. JJB&A, INC., WILLMINGTON, DE. FILED 8-26-2010.

**INSPERITY INSPIRING  
BUSINESS PERFORMANCE**

THE MARK CONSISTS OF STANDARD CHARACTERS WITHOUT CLAIM TO ANY PARTICULAR FONT, STYLE, SIZE, OR COLOR.

NO CLAIM IS MADE TO THE EXCLUSIVE RIGHT TO USE "BUSINESS PERFORMANCE", APART FROM THE MARK AS SHOWN.

FOR SERVING AS AN OUTSOURCED HUMAN RESOURCES DEPARTMENT FOR OTHERS; SERVING AS A HUMAN RESOURCES DEPARTMENT FOR OTHERS, NAMELY, PROVIDING TO CLIENT COMPANIES DETAILED DEDUCTION REPORTS, TIMESHEETS, AND INVOICES FOR PAYROLL REPORTS, PROVIDING HUMAN RESOURCES FORMS, AND PROVIDING ANSWERS TO FREQUENTLY ASKED PERSONNEL QUESTIONS; HUMAN RESOURCES CONSULTING AND MANAGEMENT; EMPLOYEE AND CONTRACTOR EXPENSE MANAGEMENT SERVICES; PROVIDING A PLACE ON A WEB SITE FOR A CLIENT COMPANY TO POST JOB OPENINGS; PROVIDING A RESUME DATABASE OF PROSPECTIVE EMPLOYEES TO CLIENTS; PROMOTING THE GOODS AND SERVICES OF OTHERS

**CLASS 35—(Continued).**

BY PROVIDING A WEB SITE AT WHICH USERS CAN LINK TO THE WEB SITES OF OTHERS; PROMOTING THE GOODS AND SERVICES OF OTHERS, NAMELY, PROVIDING INFORMATION REGARDING DISCOUNTS, COUPONS, REBATES, VOUCHERS, AND SPECIAL OFFERS FOR THE GOODS AND SERVICES OF OTHERS FOR USE BY EMPLOYERS AND EMPLOYEES OF A COMPANY; MEDICAL REFERRAL SERVICES, NAMELY, PROVIDING INFORMATION ABOUT MEDICAL BENEFIT PROVIDERS TO A GIVEN EMPLOYEE; PROVIDING INFORMATION DIRECTLY AND VIA THE INTERNET IN THE FIELD OF EMPLOYMENT ADMINISTRATION; PROVIDING INFORMATION IN THE FIELD OF HUMAN RESOURCES; PROVIDING INFORMATION IN THE FIELDS OF EMPLOYEE ADMINISTRATION, PERSONNEL MANAGEMENT, EMPLOYMENT RECORDS, WAGE CLAIMS AND AUDITS, PAYROLL PREPARATION, PROCESSING, AND MANAGEMENT, HUMAN RESOURCES CONSULTING AND MANAGEMENT, EMPLOYMENT HIRING, RECRUITING, PLACEMENT, STAFFING AND CAREER NETWORKING, AND PERSONNEL RELOCATION, EMPLOYMENT VERIFICATION, TESTING TO DETERMINE JOB COMPETENCY AND COMPATIBILITY, EMPLOYEE PERFORMANCE MANAGEMENT, EMPLOYEE SELECTION USING PSYCHOLOGICAL AND SKILL TESTING, EMPLOYEE RETENTION, AND EMPLOYEE TERMINATION; PROVIDING INFORMATION IN THE FIELD OF BUSINESS VIA THE INTERNET; PROVIDING INFORMATION AND ANALYSIS IN THE FIELD OF BUSINESS; BUSINESS ADVICE AND INFORMATION; BUSINESS CONSULTING SERVICES; PROVIDING AN ON-LINE COMPUTER DATABASE IN THE FIELD OF BUSINESS ADVICE AND INFORMATION; PROVIDING AN ON-LINE COMPUTER DATABASE IN THE FIELD OF HUMAN RESOURCES; CONSULTING SERVICES IN THE FIELD OF HUMAN RESOURCES DEVELOPMENT, NAMELY, UTILIZING TECHNOLOGY FOR THE PROMOTION OF EMPLOYEE RETENTION, CAREER GROWTH AND INCREASED PRODUCTIVITY FOR EMPLOYEES AND EMPLOYERS; BUSINESS INVESTIGATIONS; PROMOTING THE SALE OF GOODS AND SERVICES OF OTHERS BY AWARDING PURCHASE POINTS FOR CREDIT CARD AND DEBIT CARD USE; TESTING TO DETERMINE JOB COMPETENCY AND COMPATIBILITY, NAMELY, EMPLOYEE AND PRE-EMPLOYMENT SKILL AND BEHAVIORAL ASSESSMENT SERVICES; BUSINESS SUCCESSION PLANNING; ADVERTISING, PROMOTION AND MARKETING SERVICES IN THE NATURE OF E-MAIL CAMPAIGNS FOR OTHERS; DISASTER RECOVERY SERVICES, NAMELY, BUSINESS PLANNING AND BUSINESS CONTINUITY CONSULTING; BUSINESS ORGANIZATION CONSULTING; COMMERCIAL INFORMATION AGENCY SERVICES FOR BUSINESSES IN THE AREAS OF CREDIT INFORMATION AND PRE-EMPLOYMENT SCREENING; PROVIDING RECORD-KEEPING FOR EMPLOYMENT RETIREMENT PLANS; PROFESSIONAL EMPLOYER ORGANIZATION SERVICES, NAMELY, SERVING AS AN OUTSOURCED HUMAN RESOURCES DEPARTMENT FOR OTHERS, SERVING AS A HUMAN RESOURCES DEPARTMENT FOR OTHERS, NAMELY, PROVIDING TO CLIENT COMPANIES DETAILED DEDUCTION REPORTS, TIMESHEETS, AND INVOICES FOR PAYROLL REPORTS, PROVIDING HUMAN RESOURCES FORMS, AND PROVIDING ANSWERS TO FREQUENTLY ASKED PERSONNEL QUESTIONS, HUMAN RESOURCES CONSULTING AND MANAGEMENT, EMPLOYEE AND CONTRACTOR EXPENSE MANAGEMENT SERVICES, PROVIDING A PLACE ON A WEB SITE FOR A CLIENT COMPANY TO POST JOB OPENINGS; PROVIDING A RESUME DATABASE OF PROSPECTIVE EMPLOYEES TO CLIENTS, PROMOTING THE GOODS AND SERVICES OF OTHERS BY PROVIDING A WEB SITE AT WHICH USERS CAN LINK TO THE WEB SITES OF OTHERS, PROMOTING THE GOODS AND SERVICES OF OTHERS, NAMELY, PROVIDING INFORMATION REGARDING DISCOUNTS, COUPONS, REBATES, VOUCHERS, AND SPECIAL OFFERS FOR THE GOODS AND SERVICES OF OTHERS FOR USE BY EMPLOYERS AND EMPLOYEES OF A COMPANY, MEDICAL REFERRAL SERVICES, NAMELY, PROVIDING INFORMATION ABOUT MEDICAL BENEFIT PROVIDERS TO A GIVEN EMPLOYEE, PROVIDING INFORMATION DIRECTLY AND VIA THE INTERNET IN THE FIELD OF EMPLOYMENT ADMINISTRATION, PROVIDING INFORMA-

**CLASS 35—(Continued).**

TION IN THE FIELD OF HUMAN RESOURCES, PROVIDING INFORMATION IN THE FIELDS OF EMPLOYEE ADMINISTRATION, PERSONNEL MANAGEMENT, EMPLOYMENT RECORDS, WAGE CLAIMS AND AUDITS, PAYROLL PREPARATION, PROCESSING, AND MANAGEMENT, HUMAN RESOURCES CONSULTING AND MANAGEMENT, EMPLOYMENT HIRING, RECRUITING, PLACEMENT, STAFFING AND CAREER NETWORKING, AND PERSONNEL RELOCATION, EMPLOYMENT VERIFICATION, TESTING TO DETERMINE JOB COMPETENCY AND COMPATIBILITY, EMPLOYEE PERFORMANCE MANAGEMENT, EMPLOYEE SELECTION USING PSYCHOLOGICAL AND SKILL TESTING, EMPLOYEE RETENTION, AND EMPLOYEE TERMINATION, PROVIDING INFORMATION IN THE FIELD OF BUSINESS VIA THE INTERNET, PROVIDING INFORMATION AND ANALYSIS IN THE FIELD OF BUSINESS, BUSINESS ADVICE AND INFORMATION, BUSINESS CONSULTING SERVICES, PROVIDING AN ON-LINE COMPUTER DATABASE IN THE FIELD OF BUSINESS ADVICE AND INFORMATION, PROVIDING AN ON-LINE COMPUTER DATABASE IN THE FIELD OF HUMAN RESOURCES, CONSULTING SERVICES IN THE FIELD OF HUMAN RESOURCES DEVELOPMENT, NAMELY, UTILIZING TECHNOLOGY FOR THE PROMOTION OF EMPLOYEE RETENTION, CAREER GROWTH AND INCREASED PRODUCTIVITY FOR EMPLOYEES AND EMPLOYERS, BUSINESS INVESTIGATIONS, PROMOTING THE SALE OF GOODS AND SERVICES OF OTHERS BY AWARDING PURCHASE POINTS FOR CREDIT CARD AND DEBIT CARD USE, TESTING TO DETERMINE JOB COMPETENCY AND COMPATIBILITY, NAMELY, EMPLOYEE AND PRE-EMPLOYMENT SKILL AND BEHAVIORAL ASSESSMENT SERVICES, BUSINESS SUCCESSION PLANNING, ADVERTISING, PROMOTION AND MARKETING SERVICES IN THE NATURE OF E-MAIL CAMPAIGNS FOR OTHERS, DISASTER RECOVERY SERVICES, NAMELY, BUSINESS PLANNING AND BUSINESS CONTINUITY CONSULTING, BUSINESS ORGANIZATION CONSULTING; COMMERCIAL INFORMATION AGENCY SERVICES FOR BUSINESSES IN THE AREAS OF CREDIT INFORMATION AND PRE-EMPLOYMENT SCREENING, PROVIDING RECORD-KEEPING FOR EMPLOYMENT RETIREMENT PLANS (U.S. CLS. 100, 101 AND 102).

JENNIFER DIXON, EXAMINING ATTORNEY

SN 85-123,429. TYCO AGILE SYSTEMS, INC., BROOKLYN, NY. FILED 9-5-2010.

**BIDCHA**

THE MARK CONSISTS OF STANDARD CHARACTERS WITHOUT CLAIM TO ANY PARTICULAR FONT, STYLE, SIZE, OR COLOR.

FOR ON-LINE AUCTION SERVICES; AND ON-LINE AUCTION SERVICES FEATURING REVERSE AUCTIONS; ARRANGING AND CONDUCTING AUCTION SALES; PROVIDING AN ON-LINE WEBSITE FOR CONNECTING SELLERS WITH BUYERS; PROVIDING A WEB SITE FOR MANAGING, CONDUCTING AND ORGANIZING ON-LINE AUCTIONS (U.S. CLS. 100, 101 AND 102).

VERNA BETH RIRIE, EXAMINING ATTORNEY

**CLASS 35—(Continued).**

SN 85-125,469. SPORTSWEAR INC., SEATTLE, WA. FILED 9-8-2010.

**PREP SPORTSWEAR**

THE MARK CONSISTS OF STANDARD CHARACTERS WITHOUT CLAIM TO ANY PARTICULAR FONT, STYLE, SIZE, OR COLOR.

NO CLAIM IS MADE TO THE EXCLUSIVE RIGHT TO USE "SPORTSWEAR", APART FROM THE MARK AS SHOWN.

SEC. 2(F).

FOR ON-LINE RETAIL STORE SERVICES FEATURING APPAREL, CLOTHING, JACKETS, OUTERWEAR, SLEEPWEAR AND ROBES, BABY AND INFANT CLOTHING, HATS, CAPS, SOCKS, SCARVES, ACCESSORIES, HAIR ACCESSORIES, BAGS, BACKPACKS, DUFFEL BAGS, COOLERS, SEAT CUSHIONS, APRONS, BLANKETS, TOWELS, GIFT CARDS, PET CLOTHING AND ACCESSORIES, BUMPER STICKERS, DECALS, AND COVERS AND ACCESSORIES FOR ELECTRONIC DEVICES; ON-LINE RETAIL STORE SERVICES FEATURING A WIDE VARIETY OF CONSUMER GOODS OF OTHERS; PROVIDING CONSUMER PRODUCT INFORMATION AND REVIEWS VIA THE INTERNET (U.S. CLS. 100, 101 AND 102).

FIRST USE 6-6-2003; IN COMMERCE 7-1-2003.

GRETTA YAO, EXAMINING ATTORNEY

SN 85-126,423. IMPORT IMAGE RACING, CAPE CORAL, FL. FILED 9-9-2010.



THE MARK CONSISTS OF THE LETTERS "I", "P", AND "R" WITH AN OVAL CIRCLE GOING FROM THE TOP OF THE LETTER "R" AROUND THE FRONT OF THE "R" THEN UNDER THE "P" AND THE "I" ENDING AT THE LOWER LEFT SIDE OF THE "I".

FOR RETAIL STORE AND ON-LINE RETAIL STORE SERVICES FEATURING AUTOMOTIVE PARTS; WHOLESALE DISTRIBUTORSHIPS FEATURING AUTOMOTIVE PARTS (U.S. CLS. 100, 101 AND 102).

FIRST USE 7-27-2010; IN COMMERCE 7-27-2010.

JANET LEE, EXAMINING ATTORNEY

**CLASS 35—(Continued).**

SN 85-127,436. LUKIE GAMES, INC., MIAMI GARDENS, FL. FILED 9-10-2010.



NO CLAIM IS MADE TO THE EXCLUSIVE RIGHT TO USE "GAMES", APART FROM THE MARK AS SHOWN.

THE MARK CONSISTS OF A SQUARE WITH ROUNDED EDGES, FOUR ARROWS POINTING UP, DOWN, LEFT, AND RIGHT, AN L AND A PART OF A G WHICH COMBINED WITH THE L FORMS A LOWERCASE G. NEXT TO THE LOGO ARE THE WORDS "LUKIE GAMES".

FOR ON-LINE RETAIL STORE SERVICES FEATURING HOME VIDEO GAMES, SYSTEMS, AND ACCESSORIES (U.S. CLS. 100, 101 AND 102).

FIRST USE 1-23-2009; IN COMMERCE 1-23-2009.  
KATINA MISTER, EXAMINING ATTORNEY

**CLASS 35—(Continued).**

SN 85-128,851. NS FABRICATION LLC, WILMINGTON, NC. FILED 9-14-2010.



THE MARK CONSISTS OF A CIRCLE WITH A FRACTURED APPEARANCE WITH THE WORD "MOMENTUM" INSIDE OF A STYLIZED LETTER "M". THE ENTIRE CIRCLE IS SURROUNDED BY AN ADDITIONAL RING WITH SAME FRACTURED APPEARANCE.

FOR DISTRIBUTORSHIP IN THE FIELD OF AUTOMOBILE PERFORMANCE SPEED AND HANDLING PRODUCTS AND PARTS (U.S. CLS. 100, 101 AND 102).

FIRST USE 10-1-2009; IN COMMERCE 10-1-2009.  
ROBIN MITTLER, EXAMINING ATTORNEY

SN 85-128,832. NS FABRICATION LLC, WILMINGTON, NC. FILED 9-14-2010.



NO CLAIM IS MADE TO THE EXCLUSIVE RIGHT TO USE "PERFORMANCE", APART FROM THE MARK AS SHOWN.

THE MARK CONSISTS OF THE WORDS "MOMENTUM PERFORMANCE" WITH A STYLIZED LETTER "M" AT THE BEGINNING OF "MOMENTUM".

FOR DISTRIBUTORSHIP IN THE FIELD OF AUTOMOBILE PERFORMANCE SPEED AND HANDLING PRODUCTS AND PARTS (U.S. CLS. 100, 101 AND 102).

FIRST USE 10-1-2009; IN COMMERCE 10-1-2009.  
ROBIN MITTLER, EXAMINING ATTORNEY

SN 85-129,072. NS FABRICATION LLC, WILMINGTON, NC. FILED 9-14-2010.



THE MARK CONSISTS OF THE WORD "MOMENTUM" WRITTEN INSIDE OF A STYLIZED "M".

FOR DISTRIBUTORSHIP IN THE FIELD OF AUTOMOBILE PERFORMANCE SPEED AND HANDLING PRODUCTS AND PARTS (U.S. CLS. 100, 101 AND 102).

FIRST USE 10-1-2009; IN COMMERCE 10-1-2009.  
ROBIN MITTLER, EXAMINING ATTORNEY



**CLASS 35—(Continued).**

SN 85-129,133. NS FABRICATION LLC, WILMINGTON, NC. FILED 9-14-2010.

**Momentum Performance**

THE MARK CONSISTS OF STANDARD CHARACTERS WITHOUT CLAIM TO ANY PARTICULAR FONT, STYLE, SIZE, OR COLOR.

NO CLAIM IS MADE TO THE EXCLUSIVE RIGHT TO USE "PERFORMANCE", APART FROM THE MARK AS SHOWN.

FOR DISTRIBUTORSHIP IN THE FIELD OF AUTOMOBILE PERFORMANCE SPEED AND HANDLING PRODUCTS AND PARTS (U.S. CLS. 100, 101 AND 102).

FIRST USE 10-1-2009; IN COMMERCE 10-1-2009.  
ROBIN MITTLER, EXAMINING ATTORNEY

**CLASS 35—(Continued).**

SN 85-135,488. ZAPWERKS LLC, LEESBURG, VA. FILED 9-22-2010.

**The ParCard**

THE MARK CONSISTS OF STANDARD CHARACTERS WITHOUT CLAIM TO ANY PARTICULAR FONT, STYLE, SIZE, OR COLOR.

FOR ADMINISTRATION OF A DISCOUNT PROGRAM FOR ENABLING PARTICIPANTS TO OBTAIN DISCOUNTS ON GOODS AND SERVICES THROUGH USE OF A DISCOUNT MEMBERSHIP CARD AND OTHER MEDIA OUTLETS (U.S. CLS. 100, 101 AND 102).

FIRST USE 9-1-2010; IN COMMERCE 9-1-2010.  
DOMINICK J. SALEMI, EXAMINING ATTORNEY

SN 85-135,464. VETERANS OF VIETNAM MOTORCYCLE CLUB(NOMADS) OF AMERICA, SACRAMENTO, CA. FILED 9-22-2010.



NO CLAIM IS MADE TO THE EXCLUSIVE RIGHT TO USE "VETERANS OF VIETNAM", "MC", "AMERICA", "1959 1975" OR THE REPRESENTATION OF THE MAP OF VIETNAM, APART FROM THE MARK AS SHOWN.

THE MARK CONSISTS OF A ROUND CIRCLE WITH A SURROUNDING BORDER, WITH A DEPICTION OF THE COUNTRY "VIETNAM" IN THE MIDDLE OF THE CIRCLE. THE YEAR "1959" IS DEPICTED ON THE LEFT AND THE YEAR "1975" IS DEPICTED ON THE RIGHT SIDE OF THE CENTER LOGO. THE CIRCLE IS SURROUNDED BY AN OUTLINED TOP ROCKER PATCH, WITH THE WORDS "VETERANS OF VIETNAM" ALONG WITH AN OUTLINED BOTTOM ROCKER PATCH WITH THE WORD "AMERICA". A SMALL OUTLINED SQUARE PATCH IS BELOW THE RIGHT END OF THE TOP ROCKER, WITH THE LETTERS "MC" IN THE CENTER OF THE SQUARE.

FOR CHARITABLE SERVICES, NAMELY, PROMOTING AMERICAN VETERANS OF VIETNAM AND PROMOTING VETERANS RIDING MOTORCYCLES TOGETHER (U.S. CLS. 100, 101 AND 102).

FIRST USE 5-1-2004; IN COMMERCE 5-1-2004.  
MARIA-VICTORIA SUAREZ, EXAMINING ATTORNEY

SN 85-135,828. INDEPENDENT HEALTH ASSOCIATION, INC., WILLIAMSVILLE, NY. FILED 9-22-2010.

**SPECIALTY PHARMACY  
SERVICES YOU CAN RELY ON**

THE MARK CONSISTS OF STANDARD CHARACTERS WITHOUT CLAIM TO ANY PARTICULAR FONT, STYLE, SIZE, OR COLOR.

NO CLAIM IS MADE TO THE EXCLUSIVE RIGHT TO USE "SPECIALTY PHARMACY SERVICES", APART FROM THE MARK AS SHOWN.

FOR SPECIALTY PHARMACY SERVICES, NAMELY, DISTRIBUTORSHIP SERVICES IN THE FIELD OF SPECIAL PURPOSE HIGH-COST, INFUSION-BASED, INJECTABLE AND ORAL PHARMACEUTICALS FEATURING THE PROVISION OF PHARMACEUTICALS ORDERED BY HEALTH CARE PROVIDERS FOR USE BY HEALTH BENEFIT PLAN SUBSCRIBERS; ADMINISTERING PHARMACY REIMBURSEMENT PROGRAMS AND SERVICES IN THE FIELD OF SPECIALTY PHARMACEUTICALS FOR HEALTH BENEFIT PLAN SUBSCRIBERS (U.S. CLS. 100, 101 AND 102).

MAUREEN DALL, EXAMINING ATTORNEY

**CLASS 35—(Continued).**

SN 85-136,856. THE SEAM, LLC, MEMPHIS, TN. FILED 9-23-2010.

## Focused Markets

THE MARK CONSISTS OF STANDARD CHARACTERS WITHOUT CLAIM TO ANY PARTICULAR FONT, STYLE, SIZE, OR COLOR.

NO CLAIM IS MADE TO THE EXCLUSIVE RIGHT TO USE "MARKETS", APART FROM THE MARK AS SHOWN.

FOR OPERATING ON-LINE MARKETPLACES FOR BUYERS AND SELLERS OF GOODS AND SERVICES IN WHICH TRANSACTIONS OCCUR THROUGH A BIDDING PROCESS OR DIRECT SALE; COMPUTERIZED ON-LINE ORDERING SERVICES IN THE FIELD OF COMMODITIES, FOOD AND A WIDE VARIETY OF CONSUMER GOODS AND SERVICES OF OTHERS (U.S. CLS. 100, 101 AND 102).

FIRST USE 10-15-2009; IN COMMERCE 10-15-2009.  
MATTHEW MCDOWELL, EXAMINING ATTORNEY

SN 85-137,952. THE SEAM, LLC, MEMPHIS, TN. FILED 9-24-2010.



NO CLAIM IS MADE TO THE EXCLUSIVE RIGHT TO USE "FOOD & BEVERAGE MARKET SOLUTIONS", APART FROM THE MARK AS SHOWN.

THE MARK CONSISTS OF A PICTURE OF A FORK AND SPOON APPEARING TO TRANSMIT SOUND WAVES NEXT TO THE WORDS "FOOD & BEVERAGE MARKET SOLUTIONS".

FOR OPERATING ON-LINE MARKETPLACES FOR SELLERS OF GOODS AND/OR SERVICES IN THE FOOD AND BEVERAGE INDUSTRIES (U.S. CLS. 100, 101 AND 102).

FIRST USE 1-1-2010; IN COMMERCE 1-1-2010.  
MATTHEW MCDOWELL, EXAMINING ATTORNEY

SN 85-141,236. BALLOU, DANIEL H. JR., WILMINGTON, MA. FILED 9-29-2010.

## LOYAL SONS MC CHRIST JESUS

THE MARK CONSISTS OF STANDARD CHARACTERS WITHOUT CLAIM TO ANY PARTICULAR FONT, STYLE, SIZE, OR COLOR.

NO CLAIM IS MADE TO THE EXCLUSIVE RIGHT TO USE "MC", APART FROM THE MARK AS SHOWN.

FOR CLUB SERVICES, NAMELY, PROMOTING THE INTERESTS OF THE LOYAL SONS CHRISTIAN MOTORCYCLE CLUB MEMBERS (U.S. CLS. 100, 101 AND 102).

FIRST USE 8-2-2002; IN COMMERCE 8-2-2002.  
MAYUR VAGHANI, EXAMINING ATTORNEY

**CLASS 35—(Continued).**

SN 85-144,693. RTZ PRODUCTIONS, DBA MOSS ENVY, MINNEAPOLIS, MN. FILED 10-4-2010.



NO CLAIM IS MADE TO THE EXCLUSIVE RIGHT TO USE "ECO HOME & LIFE", APART FROM THE MARK AS SHOWN.

THE COLOR(S) GREEN AND GRAY IS/ARE CLAIMED AS A FEATURE OF THE MARK.

THE MARK CONSISTS OF THE STYLIZED WORDING "MOSS ENVY ECO HOME & LIFE" IN DIFFERENT SHADES OF GREEN WITH THE WORDING "ECO HOME & LIFE" IN GRAY UNDER THE WORDING "MOSS ENVY".

FOR RETAIL STORE SERVICES FEATURING GREEN AND ECO-FRIENDLY PRODUCTS IN THE NATURE OF HOME FURNISHINGS, DECOR, GIFTS, CLOTHING AND PERSONAL ACCESSORIES, BUILDING MATERIALS, CLEANING PRODUCTS, AND PERSONAL CARE PRODUCTS (U.S. CLS. 100, 101 AND 102).

FIRST USE 11-12-2009; IN COMMERCE 5-7-2010.  
LOURDES AYALA, EXAMINING ATTORNEY

SN 85-145,407. WCM INDUSTRIES, INC., COLORADO SPRINGS, CO. FILED 10-5-2010.

## EAGLE MOUNTAIN PRODUCTS CO.

THE MARK CONSISTS OF STANDARD CHARACTERS WITHOUT CLAIM TO ANY PARTICULAR FONT, STYLE, SIZE, OR COLOR.

NO CLAIM IS MADE TO THE EXCLUSIVE RIGHT TO USE "PRODUCTS CO.", APART FROM THE MARK AS SHOWN.

FOR COMPUTERIZED ON-LINE RETAIL STORE SERVICES IN THE FIELD OF PLUMBING PRODUCTS, PLUMBING SUPPLIES, PLUMBING FIXTURES, FAUCETS AND HYDRANTS; DISTRIBUTORSHIP SERVICES IN THE FIELD OF PLUMBING PRODUCTS, PLUMBING SUPPLIES, PLUMBING FIXTURES, FAUCETS AND HYDRANTS (U.S. CLS. 100, 101 AND 102).

FIRST USE 1-0-2001; IN COMMERCE 1-0-2001.  
ELLEN PERKINS, EXAMINING ATTORNEY

**CLASS 35—(Continued).**

SN 85-147,642. EDI HEALTH GROUP, INC., DBA DENTALX-CHANGE, IRVINE, CA. FILED 10-7-2010.

Click. Talk. Smile.

THE MARK CONSISTS OF STANDARD CHARACTERS WITHOUT CLAIM TO ANY PARTICULAR FONT, STYLE, SIZE, OR COLOR.

FOR PROVIDING AN ON-LINE DIRECTORY INFORMATION SERVICE FEATURING INFORMATION REGARDING DENTAL OFFICES (U.S. CLS. 100, 101 AND 102).

JAMES STEIN, EXAMINING ATTORNEY

SN 85-149,427. GUZZUMPS.COM LLC, KENILWORTH, NJ. FILED 10-11-2010.

Guzzumps

THE MARK CONSISTS OF STANDARD CHARACTERS WITHOUT CLAIM TO ANY PARTICULAR FONT, STYLE, SIZE, OR COLOR.

FOR ONLINE RETAIL STORE AND ONLINE AUCTION SERVICES FEATURING ELECTRONICS, NAMELY, CAMERAS, TVS, MEDIA PLAYERS, COMPUTERS, GAMING SYSTEMS, TABLETS, SMART PHONES, AUDIO SYSTEMS AND ELECTRONIC BOOK READERS, WOMEN FASHION ITEMS, NAMELY, HANDBAGS, SHOES AND APPAREL, VACATION PACKAGES, GIFT CARDS, HOME AND GARDEN ITEMS, NAMELY, WASHERS, DRYERS, PATIO SETS, AND GRILLS, JEWELRY FOR MEN AND WOMEN, NAMELY, WATCHES, NECKLACES, RINGS, BRACELETS AND EARRING (U.S. CLS. 100, 101 AND 102).

WON TEAK OH, EXAMINING ATTORNEY

**CLASS 35—(Continued).**

SN 85-149,435. GUZZUMPS.COM LLC, KENILWORTH, NJ. FILED 10-11-2010.



THE COLOR(S) DARK GREEN, MEDIUM GREEN AND LIGHT GREEN IS/ARE CLAIMED AS A FEATURE OF THE MARK.

THE MARK CONSISTS OF THE WORDING "GUZZUMP" IN SHADES OF GREEN WITH A CAPITAL "G" CARVED TO INCLUDE THE IMAGE OF A GAVEL WITHIN THE "G", FOLLOWED BY "UZZUMPS". SHADE OF GREEN GETS LIGHTER AS THE WORD CONTINUES. THERE IS A SHADOWING IN GREEN UNDERNEATH EACH LETTER.

FOR ONLINE RETAIL STORE AND ONLINE AUCTION SERVICES FEATURING ELECTRONICS, NAMELY, CAMERAS, TVS, MEDIA PLAYERS, COMPUTERS, GAMING SYSTEMS, TABLETS, SMART PHONES, AUDIO SYSTEMS AND ELECTRONIC BOOK READERS, WOMEN FASHION ITEMS, NAMELY, HANDBAGS, SHOES AND APPAREL, VACATION PACKAGES, GIFT CARDS, HOME AND GARDEN ITEMS, NAMELY, WASHERS, DRYERS, PATIO SETS, AND GRILLS, JEWELRY FOR MEN AND WOMEN, NAMELY, WATCHES, NECKLACES, RINGS, BRACELETS AND EARRINGS (U.S. CLS. 100, 101 AND 102).

WON TEAK OH, EXAMINING ATTORNEY

SN 85-153,138. ACCRETIVE HEALTH, INC., CHICAGO, IL. FILED 10-14-2010.

Accretive PAS

THE MARK CONSISTS OF STANDARD CHARACTERS WITHOUT CLAIM TO ANY PARTICULAR FONT, STYLE, SIZE, OR COLOR.

OWNER OF U.S. REG. NO. 3,708,267.

NO CLAIM IS MADE TO THE EXCLUSIVE RIGHT TO USE "PAS", APART FROM THE MARK AS SHOWN.

FOR BUSINESS CONSULTATION FOR HOSPITALS IN THE FIELD OF COMPLIANCE WITH INSURANCE COMPANY BILLING AND CODING REQUIREMENTS, AND IN THE FIELD OF MANAGING APPEALS FROM DENIALS OF REIMBURSEMENTS; BUSINESS CONSULTATION FOR HOSPITALS IN THE FIELD OF PROVIDING PATIENT LEVEL OF CARE RECOMMENDATIONS FOR PURPOSES OF LIMITING DENIALS OF CLAIMS AND ENSURING COMPLIANCE WITH INSURANCE COMPANY BILLING AND CODING REQUIREMENTS; BUSINESS CONSULTATION SERVICES, NAMELY, ANALYSIS OF HOSPITAL INSURANCE CLAIMS TO LIMIT DENIALS OF CLAIMS AND ENSURE COMPLIANCE WITH INSURANCE COMPANY BILLING AND CODING REQUIREMENTS; PROVIDING CONSULTATION SERVICES TO HOSPITALS ON AUDIT RISK ASSESSMENTS (U.S. CLS. 100, 101 AND 102).

FIRST USE 10-11-2010; IN COMMERCE 10-11-2010.

STEVEN R. FINE, EXAMINING ATTORNEY

**CLASS 35—(Continued).**

SN 85-153,586. MIDDLEBROOKS, RACHEL, ROCHESTER, NY. FILED 10-15-2010.



THE COLOR(S) PURPLE, GOLD, AND WHITE IS/ARE CLAIMED AS A FEATURE OF THE MARK.

THE MARK CONSISTS OF THE WORDS "QUEEN 2 REIGN" IN GOLD, INSIDE A PURPLE OVAL SHAPED DESIGN SURROUNDED BY SMALL PURPLE DIAMOND SHAPES; THE OVAL SHAPED DESIGN IS PURPLE WITH A WHITE BURST AT THE CENTER; THE WHITE BURST HAS THE NUMBER "2" IN THE CENTER OF IT; THERE IS A DARK PURPLE PASSION FLOWER IN THE BACKGROUND OF THE DESIGN; THE COLOR WHITE APPEARS BETWEEN THE SMALL PURPLE DIAMONDS ON THE OUTSIDE OF THE OVAL".

FOR ON-LINE RETAIL STORE SERVICES FEATURING A WIDE VARIETY OF CONSUMER GOODS OF OTHERS, NAMELY, WOMEN'S PRODUCTS FOR PERSONAL USE (U.S. CLS. 100, 101 AND 102).

GINA HAYES, EXAMINING ATTORNEY

---

SN 85-154,207. RATE-HIGHWAY, INC., HUNTINGTON BEACH, CA. FILED 10-15-2010.



NO CLAIM IS MADE TO THE EXCLUSIVE RIGHT TO USE "INC.", APART FROM THE MARK AS SHOWN.

THE MARK CONSISTS OF THE STYLIZED SYMBOL AND WORDS "\$ RATE-HIGHWAY, INC.". AN IMAGE OF A SHIELD WITH THE DOLLAR SIGN INSIDE.

FOR AUTOMOBILE RENTAL REVENUE MANAGEMENT SERVICES, NAMELY, PROVIDING OPTIMIZED PRICING AND RATE INFORMATION FOR THE AUTOMOBILE RENTAL INDUSTRY (U.S. CLS. 100, 101 AND 102).

FIRST USE 7-17-2003; IN COMMERCE 7-17-2003.  
DANIEL CAPSHAW, EXAMINING ATTORNEY

**CLASS 35—(Continued).**

SN 85-156,203. HAWAII ALLIANCE FOR ARTS EDUCATION, DBA HAWAII ARTS ALLIANCE, HONOLULU, HI. FILED 10-19-2010.



NO CLAIM IS MADE TO THE EXCLUSIVE RIGHT TO USE "ARTS", APART FROM THE MARK AS SHOWN.

THE MARK CONSISTS OF A DIAMOND DESIGN WITH THE WORD "ARTS" SPELLED OUT WITH THE TOP OF EACH LETTER IN A CORNER OF THE DIAMOND.

FOR ASSOCIATION SERVICES, NAMELY, PROMOTING ARTS EDUCATION FOR CHILDREN AND THEIR FAMILIES, LIFE-LONG LEARNING IN THE ARTS, AND THE INTERESTS OF ARTISTS, AND PROMOTING AND FOSTERING COOPERATION AND THE EXCHANGE OF INFORMATION AND IDEAS BETWEEN THE ARTS AND EDUCATION COMMUNITIES (U.S. CLS. 100, 101 AND 102).

FIRST USE 1-3-2000; IN COMMERCE 1-3-2000.  
JERI J. FICKES, EXAMINING ATTORNEY

---

SN 85-156,213. HAWAII ALLIANCE FOR ARTS EDUCATION, DBA HAWAII ARTS ALLIANCE, HONOLULU, HI. FILED 10-19-2010.

THE ARTS AT MARKS GARAGE

THE MARK CONSISTS OF STANDARD CHARACTERS WITHOUT CLAIM TO ANY PARTICULAR FONT, STYLE, SIZE, OR COLOR.

NO CLAIM IS MADE TO THE EXCLUSIVE RIGHT TO USE "ARTS", APART FROM THE MARK AS SHOWN.

FOR ORGANIZING COMMUNITY CULTURAL AND ARTS EVENTS (U.S. CLS. 100, 101 AND 102).

FIRST USE 0-0-2000; IN COMMERCE 11-0-2003.  
JERI J. FICKES, EXAMINING ATTORNEY

**CLASS 35—(Continued).**

SN 85-156,999. SEABRIGHT HOLDINGS, INC., SEATTLE, WA. FILED 10-20-2010.

# BrightCurePDQ

THE MARK CONSISTS OF STANDARD CHARACTERS WITHOUT CLAIM TO ANY PARTICULAR FONT, STYLE, SIZE, OR COLOR.

OWNER OF U.S. REG. NOS. 3,264,706 AND 3,264,707.

FOR MEDICAL CLAIMS MANAGEMENT SERVICES, NAMELY, REVIEW, MANAGEMENT AND AUTHORIZATION OF MEDICAL TREATMENTS AND MEDICATIONS PRESCRIBED FOR PERSONS INJURED AT WORK, THE MEDICAL MANAGEMENT SERVICES PROVIDED BY DOCTORS AND OTHER MEDICAL CARE PROVIDERS WORKING WITH CLAIM EXAMINERS ON BEHALF OF WORKERS COMPENSATION INSURANCE CARRIERS (U.S. CLS. 100, 101 AND 102).

DEZMONA MIZELLE, EXAMINING ATTORNEY

SN 85-159,542. NET-A-PORTER LIMITED, LONDON W12 7GF, UNITED KINGDOM, FILED 10-22-2010.

# MRPORTER.COM

THE MARK CONSISTS OF STANDARD CHARACTERS WITHOUT CLAIM TO ANY PARTICULAR FONT, STYLE, SIZE, OR COLOR.

PRIORITY CLAIMED UNDER SEC. 44(D) ON UNITED KINGDOM APPLICATION NO. 2548519, FILED 5-26-2010, REG. NO. 2548519, DATED 9-24-2010, EXPIRES 5-26-2020.

FOR THE PROVISION OF ON-LINE RETAIL STORE SERVICES CONNECTED WITH THE SALE OF CLOTHING, HEADGEAR AND FOOTWEAR, JEWELRY, WATCHES, FASHION ACCESSORIES, TEXTILES, COSMETICS, NON-MEDICATED TOILET PREPARATIONS, EYEWEAR, FROM AN INTERNET WEBSITE; THE PROVISION OF RETAIL SERVICES, NAMELY, HOME SHOPPING SERVICES CONNECTED WITH THE SALE OF CLOTHING, HEADGEAR AND FOOTWEAR, JEWELRY, WATCHES, FASHION ACCESSORIES, TEXTILES, COSMETICS, NON-MEDICATED TOILET PREPARATIONS, EYEWEAR, VIA A TELEVISION CHANNEL; THE PROVISION OF RETAIL SERVICES CONNECTED WITH THE SALE OF CLOTHING, HEADGEAR AND FOOTWEAR, JEWELRY, WATCHES, FASHION ACCESSORIES, TEXTILES, COSMETICS, NON-MEDICATED TOILET PREPARATIONS, EYEWEAR, VIA TELEPHONE, MOBILE PHONE, AND TELECOMMUNICATIONS DEVICES; THE PROVISION OF RETAIL SERVICES CONNECTED WITH THE SALE OF CLOTHING, HEADGEAR AND FOOTWEAR, JEWELRY, WATCHES, FASHION ACCESSORIES, TEXTILES, COSMETICS, NON-MEDICATED TOILET PREPARATIONS, EYEWEAR, BY WAY OF DIRECT MARKETING; THE PROVISION OF INFORMATION AND ADVICE IN RELATION TO RETAIL SERVICES; BUSINESS MANAGEMENT CONSULTANCY; PROVISION OF ADVICE AND ASSISTANCE IN THE SELECTION OF GOODS; ADVERTISING FOR OTHERS (U.S. CLS. 100, 101 AND 102).

FRANK LATTUCA, EXAMINING ATTORNEY

**CLASS 35—(Continued).**

SN 85-159,897. JIMENEZ, ARNOLD, M, TUCSON, AZ. FILED 10-25-2010.



THE COLOR(S) BLACK, RED, AND BROWN IS/ARE CLAIMED AS A FEATURE OF THE MARK.

THE MARK CONSISTS OF THE TERM "THIINK!" IN A VERTICAL POSITION WITH THE LETTERS "TH" AND "NK" AND THE EXCLAMATION POINT ALL IN THE COLOR BLACK AND THE LETTERS "III" IN RED; IMMEDIATELY UNDERNEATH THE TERM "THIINK!" IS A DESIGN OF A OPENED, BROWN BOX; TO THE RIGHT OF THE TERM "THIINK!" ARE THE TERMS "INFORM. INNOVATE. IMPLEMENT." IN RED.

FOR CONSULTANCY AND ADVISORY SERVICES IN THE FIELD OF BUSINESS STRATEGY; CONSULTATION SERVICES IN THE FIELD OF COMPANY, BUSINESS SECTOR AND INDUSTRY DATA AND RESEARCH; CONSULTATION SERVICES, NAMELY, CREATIVE AND STRATEGIC CONSULTATION REGARDING DEVELOPMENT AND PRODUCTION OF MARKETING CAMPAIGNS FOR OTHERS; CONSULTING IN THE FIELDS OF HEALTHCARE OPERATIONS MANAGEMENT AND HOSPITAL OPERATIONS MANAGEMENT; CONSULTING REGARDING INTELLECTUAL PROPERTY BUSINESS RISK MITIGATION PROCESSES; CONSULTING SERVICES IN BUSINESS LEADERSHIP DEVELOPMENT AND BUSINESS MANAGEMENT; CONSULTING SERVICES IN BUSINESS ORGANIZATION AND MANAGEMENT (U.S. CLS. 100, 101 AND 102).

CHRISTOPHER BUONGIORNO, EXAMINING ATTORNEY

SN 85-160,435. FISSION LLC, NEW YORK, NY. FILED 10-25-2010.

# NOOKBOOK

THE MARK CONSISTS OF STANDARD CHARACTERS WITHOUT CLAIM TO ANY PARTICULAR FONT, STYLE, SIZE, OR COLOR.

FOR PROVIDING A WEB SITE FOR USERS WITH SPECIFIC INFORMED RECOMMENDATIONS OF SPECIFIC CONSUMER PRODUCTS AND SERVICES VALIDATED BY THE INPUTTED PREFERENCES AND SOCIAL NETWORK OF THE USER; PROVIDING A WEB SITE FOR USERS WITH EXCLUSIVE PERSONALIZED RECOMMENDATIONS ON BOOKS, ELECTRONIC BOOKS, AUTHORS, BOOK SUBJECT MATTER, BOOK GENRES, MUSIC AND DIGITAL MEDIA ENTERTAINMENT (U.S. CLS. 100, 101 AND 102).

HAI-LY LAM, EXAMINING ATTORNEY



**CLASS 35—(Continued).**

SN 85-161,319. CAPABLE ANT, LLC, BILLINGS, MT. FILED 10-26-2010.



NO CLAIM IS MADE TO THE EXCLUSIVE RIGHT TO USE "GIFT CARD", APART FROM THE MARK AS SHOWN. THE MARK CONSISTS OF STYLIZED CURSIVE TEXT WITH THE WORDS "GIFT CARD GRANNY". TO THE RIGHT OF THE TEXT IS A CARTOON IMAGE OF AN ELDERLY WOMAN WEARING A DRESS, BELT AND CAPE. THE DRESS AND BELT HAVE A DOLLAR SIGN ON THEM. THE WOMAN IS HOLDING A WALKER WITH FLAMES AND SMOKE SHOOTING FROM THE BOTTOM OF IT.  
 FOR ONLINE SERVICE ENABLING USERS TO COMPARE BUYING AND SELLING PRICES OF DISCOUNTED GIFT CARDS (U.S. CLS. 100, 101 AND 102).  
 FIRST USE 11-1-2009; IN COMMERCE 11-1-2009.  
 CHERYL CLAYTON, EXAMINING ATTORNEY

**CLASS 35—(Continued).**

SN 85-166,054. KIDS FUN FLOPS, LAS VEGAS, NV. FILED 11-1-2010.



THE MARK CONSISTS OF THE CURVED WORDING "KIDS FUN FLOPS" WITH THE WORDING "KIDS MAKING TRACKS" UNDERNEATH IT. BETWEEN THE WORDS "KIDS" AND "MAKING" IS A PAIR OF SANDALS WITH DOLPHINS ON EACH SANDAL.  
 FOR ADVERTISING AND MARKETING SERVICES, NAMELY, PROMOTING THE GOODS AND SERVICES OF OTHERS (U.S. CLS. 100, 101 AND 102).  
 JANICE KIM, EXAMINING ATTORNEY

SN 85-164,186. CRITTERCURES PET CARE INC., SURREY, BC, CANADA, FILED 10-28-2010.



PRIORITY CLAIMED UNDER SEC. 44(D) ON CANADA APPLICATION NO. 1,501,417, FILED 10-27-2010.  
 NO CLAIM IS MADE TO THE EXCLUSIVE RIGHT TO USE "PREMIUM ANIMAL MEDICATION AT DISCOUNT PRICES", APART FROM THE MARK AS SHOWN.  
 THE MARK CONSISTS OF THE STYLIZED DESIGN OF A DOG'S HEAD SHOWN ON THE LEFT OF THE WORDING "CRITTER CURES", WHICH IS DISPLAYED ABOVE THE WORDING "PREMIUM ANIMAL MEDICATION AT DISCOUNT PRICES", WHICH IS DISPLAYED ABOVE THE STYLIZED DESIGNS, SHOWN FROM LEFT TO RIGHT, OF A HORSE, A PIG, A BIRD, A CAT AND A FISH.  
 FOR ON-LINE RETAIL STORE SERVICES FEATURING ANIMAL MEDICATIONS (U.S. CLS. 100, 101 AND 102).  
 FIRST USE 9-1-2010; IN COMMERCE 9-1-2010.  
 DAVID ELTON, EXAMINING ATTORNEY

SN 85-166,450. GANNETT SATELLITE INFORMATION NETWORK, INC., MCLEAN, VA. FILED 11-1-2010.

**CAPTIVATE OFFICE PULSE**

THE MARK CONSISTS OF STANDARD CHARACTERS WITHOUT CLAIM TO ANY PARTICULAR FONT, STYLE, SIZE, OR COLOR.  
 OWNER OF U.S. REG. NOS. 2,357,757 AND 3,719,060.  
 FOR CONDUCTING SURVEYS, POLLING AND MARKET RESEARCH; PROVIDING INFORMATION ABOUT SURVEYS, POLLING AND MARKET RESEARCH; REPORTING THE RESULTS OF SURVEYS, POLLING AND MARKET RESEARCH (U.S. CLS. 100, 101 AND 102).  
 RON FAIRBANKS, EXAMINING ATTORNEY

**CLASS 35—(Continued).**

SN 85-166,958. GERMAN FOODS NORTH AMERICA LLC, WASHINGTON, DC. FILED 11-2-2010.



NO CLAIM IS MADE TO THE EXCLUSIVE RIGHT TO USE "GERMANFOODS.ORG" AND "THE AUTHORITATIVE GUIDE TO GERMAN FOOD & BEVERAGES IN NORTH AMERICA", APART FROM THE MARK AS SHOWN.

THE COLOR(S) GOLD, RED, BLACK, WHITE AND GRAY IS/ARE CLAIMED AS A FEATURE OF THE MARK.

THE MARK CONSISTS OF THREE FREE-FORM BRUSH-STROKES, ONE EACH OF THE COLORS GOLD, RED AND BLACK, BRUSHED AT AN ANGLE, OVER WHICH APPEAR A WHITE VERTICALLY-ORIENTED SPOON, FORK AND KNIFE, TO THE RIGHT OF WHICH APPEAR THE STYLIZED WORDS "GERMANFOODS.ORG" IN BLACK LOWER CASE, AND BELOW THAT THE WORDS "THE AUTHORITATIVE GUIDE TO GERMAN FOOD & BEVERAGES IN NORTH AMERICA", IN GRAY.

FOR PROVIDING A WEBSITE FEATURING CONSUMER PRODUCT INFORMATION RELATING TO THE FOODS, BEVERAGES AND AGRICULTURAL PRODUCTS OF GERMANY AND GERMAN-SPEAKING COUNTRIES AND THE EXPORTING THEREOF TO THE UNITED STATES; PROMOTING THE FOODS, BEVERAGES AND AGRICULTURAL PRODUCTS OF GERMANY AND GERMAN-SPEAKING COUNTRIES; ADVERTISING SERVICES FOR THE FOODS, BEVERAGES AND AGRICULTURAL PRODUCTS OF GERMANY AND GERMAN-SPEAKING COUNTRIES; MARKETING, MARKET RESEARCH AND MARKET ANALYSIS IN THE FIELD OF FOODS, BEVERAGES AND AGRICULTURAL PRODUCTS (U.S. CLS. 100, 101 AND 102).

FIRST USE 1-1-2010; IN COMMERCE 1-1-2010.  
ELLEN PERKINS, EXAMINING ATTORNEY

SN 85-167,360. SEABRIGHT HOLDINGS, INC., SEATTLE, WA. FILED 11-2-2010.

## ReadyReturn

THE MARK CONSISTS OF STANDARD CHARACTERS WITHOUT CLAIM TO ANY PARTICULAR FONT, STYLE, SIZE, OR COLOR.

FOR PROVIDING WORK PLACEMENT AND REFERRAL SERVICES; PROVIDING INFORMATION SERVICES TO ASSIST EMPLOYERS IN PROVIDING RETURN-TO-WORK EMPLOYMENT OPPORTUNITIES FOR WORKERS RECOVERING FROM ON-THE-JOB INJURIES (U.S. CLS. 100, 101 AND 102).

DEZMONA MIZELLE, EXAMINING ATTORNEY

**CLASS 35—(Continued).**

SN 85-167,851. RAINBOW PLAY SYSTEMS, INC., BROOKINGS, SD. FILED 11-3-2010.

## RAINBOW SWINGSET SUPERSTORES

THE MARK CONSISTS OF STANDARD CHARACTERS WITHOUT CLAIM TO ANY PARTICULAR FONT, STYLE, SIZE, OR COLOR.

OWNER OF U.S. REG. NOS. 3,251,268, 3,693,650 AND OTHERS.

NO CLAIM IS MADE TO THE EXCLUSIVE RIGHT TO USE "SWINGSET SUPERSTORES", APART FROM THE MARK AS SHOWN.

FOR RETAIL STORE SERVICES FEATURING PLAYGROUND EQUIPMENT, NAMELY, PLAY STRUCTURES COMPRISED OF CLIMBING UNITS, PLATFORMS, SANDBOXES, SWINGSETS, JUNGLE GYMS, PLAYHOUSES, GYMNASTIC APPARATUS AND SLIDES (U.S. CLS. 100, 101 AND 102).

ELLEN PERKINS, EXAMINING ATTORNEY

SN 85-170,348. HAUTE GIRLS, WESLEY CHAPEL, FL. FILED 11-5-2010.

## HAUTE GIRLS

THE MARK CONSISTS OF STANDARD CHARACTERS WITHOUT CLAIM TO ANY PARTICULAR FONT, STYLE, SIZE, OR COLOR.

NO CLAIM IS MADE TO THE EXCLUSIVE RIGHT TO USE "GIRLS", APART FROM THE MARK AS SHOWN.

THE ENGLISH TRANSLATION OF "HAUTE" IN THE MARK IS FANCY.

FOR ON-LINE RETAIL STORE SERVICES FEATURING FASHION JEWELRY AND ACCESSORIES (U.S. CLS. 100, 101 AND 102).

NAKWAMA ANKRAH, EXAMINING ATTORNEY

**CLASS 35—(Continued).**

SN 85-170,464. SPECIAL TEAMS, INC., DBA SHTICKIT, ELDERSBURG, MD. FILED 11-5-2010.

# Shtickit

THE MARK CONSISTS OF STANDARD CHARACTERS WITHOUT CLAIM TO ANY PARTICULAR FONT, STYLE, SIZE, OR COLOR.

THE WORDING "SHTICKIT" HAS NO MEANING IN A FOREIGN LANGUAGE.

FOR ON-LINE BUSINESS DIRECTORIES FEATURING SPORTS EVENTS, SPORTS CAMPS, SPORTS ACTIVITIES, THEATER CLASSES, ART CLASSES, MUSIC CLASSES; PROVIDING A SEARCHABLE ONLINE ADVERTISING WEBSITE AND INFORMATIONAL GUIDE FEATURING THE GOODS AND SERVICES OF OTHER VENDORS VIA THE INTERNET IN THE FIELD OF ACTIVITIES, NAMELY, SPORTS EVENTS, SPORTS TOURNAMENTS, SPORTS CAMPS, ART CLASSES, THEATER CLASSES, AND MUSIC CLASSES (U.S. CLS. 100, 101 AND 102).

FIRST USE 8-1-2010; IN COMMERCE 11-1-2010.  
MYRIAH HABEEB, EXAMINING ATTORNEY

**CLASS 35—(Continued).**

SN 85-172,820. NAVAJO NATION GAMING ENTERPRISE, CHURCH ROCK, NM. FILED 11-9-2010.

TWIN ARROWS NAVAJO CASINO  
RESORT

THE MARK CONSISTS OF STANDARD CHARACTERS WITHOUT CLAIM TO ANY PARTICULAR FONT, STYLE, SIZE, OR COLOR.

OWNER OF U.S. REG. NOS. 3,721,178, 3,721,180 AND OTHERS.

NO CLAIM IS MADE TO THE EXCLUSIVE RIGHT TO USE "CASINO RESORT", APART FROM THE MARK AS SHOWN.

FOR RETAIL STORE SERVICES; CUSTOMER LOYALTY SERVICES AND CUSTOMER CLUB SERVICES, FOR COMMERCIAL, PROMOTIONAL AND/OR ADVERTISING PURPOSES (U.S. CLS. 100, 101 AND 102).

DAWN FELDMAN, EXAMINING ATTORNEY

SN 85-172,364. CELTIC OCEAN INTERNATIONAL, INC., DBA SELINA NATURALLY, ARDEN, NC. FILED 11-9-2010.

# SEA LAND NUTRITION

THE MARK CONSISTS OF STANDARD CHARACTERS WITHOUT CLAIM TO ANY PARTICULAR FONT, STYLE, SIZE, OR COLOR.

NO CLAIM IS MADE TO THE EXCLUSIVE RIGHT TO USE "NUTRITION", APART FROM THE MARK AS SHOWN.

FOR ONLINE RETAIL STORE SERVICES AND CATALOGUE ORDERING SERVICES FEATURING SALTS, HERBS, HERB BLENDS, NUTRITIONAL BARS, BEVERAGES, SWEETENERS, OILS, SEEDS, NUTS, NUT BUTTERS, DRIED FRUITS, PREPACKAGED FOOD PRODUCTS, FOOD GRAINS, CONDIMENTS, BODY CARE PRODUCTS, KITCHEN TOOLS, EXERCISE EQUIPMENT, HOME FURNISHINGS, BOOKS, CDS, DVDS, NUTRITIONAL SUPPLEMENTS, GIFT PACKAGES, AND EDUCATIONAL MATERIALS (U.S. CLS. 100, 101 AND 102).

SUSAN RICHARDS, EXAMINING ATTORNEY

SN 85-172,871. SCOTT, BRIDGETTE L., THE WOODLANDS, TX. FILED 11-9-2010.



NO CLAIM IS MADE TO THE EXCLUSIVE RIGHT TO USE "PAJAMAS FOR GIRLS", APART FROM THE MARK AS SHOWN.

THE MARK CONSISTS OF THE TERM "P-JAMMIES" IN STYLIZED FONT WITHIN A RECTANGULAR SHAPE CONSISTING OF TWO PARALLEL LINES DIRECTLY ABOVE AND BELOW THE TERM AND A FANCIFUL FLORAL DESIGN DIRECTLY TO THE RIGHT AND LEFT OF THE TERM. THE TERM "FOR GIRLS" APPEARS DIRECTLY BELOW THE RECTANGULAR SHAPE IN STYLIZED FONT. THE COLOR GRAY IS USED TO INDICATE BACKGROUND OR TRANSPARENT PORTIONS AND IS NOT PART OF THE MARK.

FOR RETAIL CLOTHING STORES (U.S. CLS. 100, 101 AND 102).

FIRST USE 10-22-2010; IN COMMERCE 10-22-2010.  
CYNTHIA SLOAN, EXAMINING ATTORNEY

**CLASS 35—(Continued).**

SN 85-172,950. ALVAREZ & MARSAL HOLDINGS, LLC,  
NEW YORK, NY. FILED 11-9-2010.

## Alvarez & Marsal Women's Leadership Connection

THE MARK CONSISTS OF STANDARD CHARACTERS  
WITHOUT CLAIM TO ANY PARTICULAR FONT, STYLE,  
SIZE, OR COLOR.

OWNER OF U.S. REG. NOS. 2,810,397, 2,864,713 AND  
3,710,397.

NO CLAIM IS MADE TO THE EXCLUSIVE RIGHT TO  
USE "WOMEN'S LEADERSHIP", APART FROM THE MARK  
AS SHOWN.

FOR ARRANGING AND CONDUCTING BUSINESS  
CONFERENCES (U.S. CLS. 100, 101 AND 102).

FIRST USE 6-13-2010; IN COMMERCE 6-13-2010.  
DANIEL CAPSHAW, EXAMINING ATTORNEY

---

SN 85-172,972. ALVAREZ & MARSAL HOLDINGS, LLC,  
NEW YORK, NY. FILED 11-9-2010.

## A&M WOMEN'S LEADERSHIP CONNECTION

THE MARK CONSISTS OF STANDARD CHARACTERS  
WITHOUT CLAIM TO ANY PARTICULAR FONT, STYLE,  
SIZE, OR COLOR.

OWNER OF U.S. REG. NO. 2,810,398.

NO CLAIM IS MADE TO THE EXCLUSIVE RIGHT TO  
USE "WOMEN'S LEADERSHIP", APART FROM THE MARK  
AS SHOWN.

FOR ARRANGING AND CONDUCTING BUSINESS  
CONFERENCES (U.S. CLS. 100, 101 AND 102).

DANIEL CAPSHAW, EXAMINING ATTORNEY

---

SN 85-173,098. MARY CAROL DOLIVIER, CHICAGO, IL,  
AND ARTHUR BLACKWOOD, DERBY, DE23 4EF, UNI-  
TED KINGDOM, FILED 11-9-2010.

## ETAVONNI

THE MARK CONSISTS OF STANDARD CHARACTERS  
WITHOUT CLAIM TO ANY PARTICULAR FONT, STYLE,  
SIZE, OR COLOR.

THE WORDING "ETAVONNI" HAS NO MEANING IN A  
FOREIGN LANGUAGE.

FOR BUSINESS CONSULTING SERVICES; BUSINESS  
MANAGEMENT CONSULTING SERVICES; BUSINESS  
OPERATIONS MANAGEMENT CONSULTING; BUSI-  
NESS PROCESS IMPROVEMENT SERVICES (U.S. CLS.  
100, 101 AND 102).

AISHA SALEM, EXAMINING ATTORNEY

**CLASS 35—(Continued).**

SN 85-173,806. CBI DISTRIBUTING CORP., HOFFMAN  
ESTATES, IL. FILED 11-10-2010.

## SECRET SANTA CIRCLE

THE MARK CONSISTS OF STANDARD CHARACTERS  
WITHOUT CLAIM TO ANY PARTICULAR FONT, STYLE,  
SIZE, OR COLOR.

NO CLAIM IS MADE TO THE EXCLUSIVE RIGHT TO  
USE "SECRET SANTA", APART FROM THE MARK AS  
SHOWN.

FOR PROVIDING ONLINE RETAIL STORE SERVICES  
FEATURING CLOTHING AND FASHION ACCESSORIES  
VIA A WEB SITE THAT HAS A SPECIFIC FEATURE  
THAT ALLOWS USERS TO GIVE AND RECEIVE PUR-  
CHASES THROUGH ANONYMOUS GIFT EXCHANGES  
(U.S. CLS. 100, 101 AND 102).

FIRST USE 11-28-2009; IN COMMERCE 11-28-2009.  
CORY BOONE, EXAMINING ATTORNEY

---

SN 85-174,642. MESSE DUSSELDORF GMBH, DUSSEL-  
DORF, FED REP GERMANY, FILED 11-11-2010.

## WIRE

THE MARK CONSISTS OF STANDARD CHARACTERS  
WITHOUT CLAIM TO ANY PARTICULAR FONT, STYLE,  
SIZE, OR COLOR.

OWNER OF U.S. REG. NO. 2,921,813.

SEC. 2(F).

FOR PLANNING, ARRANGING AND CONDUCTING  
TRADE FAIRS, EXHIBITIONS AND PRESENTATIONS  
IN WIRE PROCESSING MACHINERY, WIRE MANU-  
FACTURING MACHINERY, AND WIRE PRODUCT  
MANUFACTURING MACHINERY; ADVERTISING  
AGENCY SERVICES, BUSINESS MANAGEMENT CON-  
SULTATION (U.S. CLS. 100, 101 AND 102).

FIRST USE 12-31-1986; IN COMMERCE 12-31-1986.  
LINDA E. BLOHM, EXAMINING ATTORNEY

**CLASS 35—(Continued).**

SN 85-177,035. INSCAPE PUBLISHING, INC., MINNEAPOLIS, MN. FILED 11-15-2010.



OWNER OF U.S. REG. NOS. 2,028,076, 2,740,991 AND OTHERS.

NO CLAIM IS MADE TO THE EXCLUSIVE RIGHT TO USE "DiSC", APART FROM THE MARK AS SHOWN.

THE MARK CONSISTS OF A SOLID CIRCLE WITH THE WORD "DiSC" APPEARING HORIZONTALLY OVER THE CENTER OF THE CIRCLE.

FOR BUSINESS CONSULTATION SERVICES IN THE FIELDS OF MANAGEMENT, SUPERVISORY, AND INTERPERSONAL SKILLS, CUSTOMER SERVICE, AND EMPLOYEE TRAINING; DISTRIBUTORSHIP SERVICES IN THE FIELD OF PRE-RECORDED DVDS, CD-ROMS, COMPUTER SOFTWARE, AND PRINTED MATERIALS IN THE FIELD OF HUMAN RESOURCE DEVELOPMENT AND MANAGEMENT (U.S. CLS. 100, 101 AND 102).

ALYSSA STEEL, EXAMINING ATTORNEY

SN 85-178,150. JAMIE DANIELS, FARMINGTON HILLS, MI. FILED 11-16-2010.

**DANGLE DANGLE SNIPE**

THE MARK CONSISTS OF STANDARD CHARACTERS WITHOUT CLAIM TO ANY PARTICULAR FONT, STYLE, SIZE, OR COLOR.

FOR ON-LINE RETAIL STORE SERVICES FEATURING CLOTHING (U.S. CLS. 100, 101 AND 102).

FIRST USE 10-15-2010; IN COMMERCE 10-15-2010.  
NAPOLEON SHARMA, EXAMINING ATTORNEY

**CLASS 35—(Continued).**

SN 85-180,695. PUERTO RICO CONVENTION BUREAU, SAN JUAN, PUERTO RICO, FILED 11-19-2010.

**Puerto Rico Impeccable**

THE MARK CONSISTS OF STANDARD CHARACTERS WITHOUT CLAIM TO ANY PARTICULAR FONT, STYLE, SIZE, OR COLOR.

NO CLAIM IS MADE TO THE EXCLUSIVE RIGHT TO USE "PUERTO RICO", APART FROM THE MARK AS SHOWN.

THE ENGLISH TRANSLATION OF "IMPECCABLE" IN THE MARK IS IMPECCABLE.

FOR PROMOTING TOURISM IN PUERTO RICO (U.S. CLS. 100, 101 AND 102).

FIRST USE 7-1-2008; IN COMMERCE 7-1-2008.  
SALLY SHIH, EXAMINING ATTORNEY

SN 85-182,137. ZOOMERGY LLC, LOS ANGELES, CA. FILED 11-22-2010.

**Zoomergy**

THE MARK CONSISTS OF STANDARD CHARACTERS WITHOUT CLAIM TO ANY PARTICULAR FONT, STYLE, SIZE, OR COLOR.

FOR ADVERTISING AND MARKETING SERVICES IN THE AREAS OF E-COMMERCE, DIGITAL MEDIA AND PERFORMANCE MARKETING (U.S. CLS. 100, 101 AND 102).

FIRST USE 4-15-2010; IN COMMERCE 4-15-2010.  
ELISSA GARBER KON, EXAMINING ATTORNEY

SN 85-182,362. LOPEZ, MIRLA, MISSION, TX. FILED 11-22-2010.



NO CLAIM IS MADE TO THE EXCLUSIVE RIGHT TO USE "PET BOUTIQUE", APART FROM THE MARK AS SHOWN.

THE MARK CONSISTS OF THE STYLIZED TEXT "BLOOMINGTAILS PET BOUTIQUE".

FOR RETAIL STORE SERVICES FEATURING ACCESSORIES FOR DOGS, NAMELY, APPAREL, COLLARS, LEASHES, CARRIES, BEDS, HOUSEWARES, CHEW TOYS, GROOMING SUPPLIES, KENNELS, DOG JEWELRY, GOURMET TREATS AND DOG FOOD (U.S. CLS. 100, 101 AND 102).

FIRST USE 8-25-2010; IN COMMERCE 10-2-2010.  
GINA HAYES, EXAMINING ATTORNEY



**CLASS 35—(Continued).**

SN 85-183,301. DIBBS, INC., RENO, NV. FILED 11-23-2010.

**AWARENESS ENGINE**

THE MARK CONSISTS OF STANDARD CHARACTERS WITHOUT CLAIM TO ANY PARTICULAR FONT, STYLE, SIZE, OR COLOR.

NO CLAIM IS MADE TO THE EXCLUSIVE RIGHT TO USE "ENGINE", APART FROM THE MARK AS SHOWN.

FOR PROVIDING INFORMATION REGARDING THE GOODS AND SERVICES OF OTHERS TO USERS OF MOBILE DEVICES; PROVIDING INFORMATION REGARDING THE GOODS AND SERVICES OF OTHERS OBTAINED FROM MULTIPLE SOURCES TO USERS BASED ON PERCEIVED AND KNOWN USER INTERESTS; PROVIDING INFORMATION OBTAINED FROM SEARCH ENGINES REGARDING THE GOODS AND SERVICES OF OTHERS TO USERS OF MOBILE DEVICES; PROVIDING CUSTOMIZED INFORMATION OBTAINED FROM SEARCH ENGINES REGARDING THE GOODS AND SERVICES OF OTHERS TO USERS OF MOBILE DEVICES BASED ON USER INTERESTS; PROMOTING THE GOODS AND SERVICES OF OTHERS TO USERS OF MOBILE DEVICES; PROMOTING THE EVENTS OF OTHERS BY PROVIDING CUSTOMIZED INFORMATION REGARDING UPCOMING EVENTS BASED ON USER PREFERENCES TO MOBILE DEVICES; PROMOTING EVENTS OF OTHERS TO USERS OF MOBILE DEVICES; PROMOTING EVENTS OF OTHERS BASED ON PERCEIVED OR KNOWN USER INTEREST AND GEOGRAPHICAL LOCATION; PROVIDING INFORMATION REGARDING THE GOODS AND SERVICES OF OTHERS TO USERS BASED ON THE USER'S GEOGRAPHICAL LOCATION AND PREFERENCES; ADVERTISING SERVICES, NAMELY, SEARCHING VARIOUS SOURCES FOR INFORMATION REGARDING THE GOODS AND SERVICES OF OTHERS, FILTERING SEARCH RESULTS BASED ON COLLECTED USER PREFERENCE DATA, AND PROVIDING THE FILTERED SEARCH RESULTS REGARDING THE GOODS AND SERVICES OF OTHERS TO USERS VIA THEIR COMPUTERS OR MOBILE DEVICES, AUTOMATICALLY OR UPON DEMAND; ADVERTISING SERVICES, NAMELY, SEARCHING FOR INFORMATION REGARDING UPCOMING EVENTS, FILTERING SEARCH RESULTS BASED ON COLLECTED USER PREFERENCE DATA AND GEOGRAPHICAL LOCATION, AND PROVIDING THE FILTERED SEARCH RESULTS REGARDING UPCOMING EVENTS OF INTEREST WITHIN A DESIRED PROXIMITY TO USERS VIA THEIR COMPUTERS OR MOBILE DEVICES, AUTOMATICALLY OR UPON DEMAND (U.S. CLS. 100, 101 AND 102).

FIRST USE 4-0-2010; IN COMMERCE 4-0-2010.  
KATHY DE JONGE, EXAMINING ATTORNEY

**CLASS 35—(Continued).**

SN 85-184,364. FUSION HEALTH, PASADENA, CA. FILED 11-24-2010.

**OLIOS HEALTH**

THE MARK CONSISTS OF STANDARD CHARACTERS WITHOUT CLAIM TO ANY PARTICULAR FONT, STYLE, SIZE, OR COLOR.

NO CLAIM IS MADE TO THE EXCLUSIVE RIGHT TO USE "HEALTH", APART FROM THE MARK AS SHOWN.

FOR MEDICAL BILLING SERVICES; BUSINESS CONSULTING SERVICES IN THE FIELD OF MEDICAL OFFICE OPERATION; OFFICE ADMINISTRATION SERVICES, NAMELY, MANAGEMENT OF MEDICAL OFFICES FOR OTHERS (U.S. CLS. 100, 101 AND 102).

TARA PATE, EXAMINING ATTORNEY

---

SN 85-184,760. MEDICAL BILL CONSULTANTS, WILTON, CT. FILED 11-24-2010.

**Medical Bill Detectives**

THE MARK CONSISTS OF STANDARD CHARACTERS WITHOUT CLAIM TO ANY PARTICULAR FONT, STYLE, SIZE, OR COLOR.

NO CLAIM IS MADE TO THE EXCLUSIVE RIGHT TO USE "MEDICAL BILL", APART FROM THE MARK AS SHOWN.

FOR BILL AUDIT AND REVIEW SERVICES IN THE NATURE OF ANALYSIS OF MEDICAL AND HOSPITAL BILLS FOR ERRORS OR OVERCHARGES AND UNREASONABLE PRICING OF SERVICES AND MEDICATION (U.S. CLS. 100, 101 AND 102).

FIRST USE 2-1-2008; IN COMMERCE 2-1-2008.  
ELLEN PERKINS, EXAMINING ATTORNEY

---

SN 85-185,000. SAN PASQUAL CASINO DEVELOPMENT GROUP INC., VALLEY CENTER, CA. FILED 11-24-2010.

**VALLEY VIEW CASINO CENTER**

THE MARK CONSISTS OF STANDARD CHARACTERS WITHOUT CLAIM TO ANY PARTICULAR FONT, STYLE, SIZE, OR COLOR.

OWNER OF U.S. REG. NOS. 3,542,867, 3,857,074 AND 3,857,075.

NO CLAIM IS MADE TO THE EXCLUSIVE RIGHT TO USE "CASINO CENTER", APART FROM THE MARK AS SHOWN.

FOR CONCESSION STANDS FEATURING FOOD, SOUVENIRS AND GENERAL CONSUMER GOODS (U.S. CLS. 100, 101 AND 102).

JACLYN KIDWELL WALKER, EXAMINING ATTORNEY

**CLASS 35—(Continued).**

SN 85-185,942. GREEN BAY PACKERS, INC., GREEN BAY, WI. FILED 11-29-2010.

# TITLETOWN

THE MARK CONSISTS OF STANDARD CHARACTERS WITHOUT CLAIM TO ANY PARTICULAR FONT, STYLE, SIZE, OR COLOR.

OWNER OF U.S. REG. NO. 1,802,761.

FOR ADVERTISING OF COMMERCIAL OR RESIDENTIAL REAL ESTATE; EVENT PLANNING AND MANAGEMENT FOR MARKETING, BRANDING, PROMOTING OR ADVERTISING THE GOODS AND SERVICES OF OTHERS; MANAGING AND OPERATING RESORT HOTELS AND BUSINESS CONFERENCE CENTERS OF OTHERS; NEGOTIATION AND RENEGOTIATION FOR OTHERS OF LEASES AND SUBLEASES AND REAL ESTATE PURCHASE AGREEMENTS; PROVIDING REAL ESTATE LEADS FOR PROSPECTIVE PURCHASERS; REAL ESTATE ADVERTISING SERVICES; REAL ESTATE SALES MANAGEMENT; ADMINISTRATIVE MANAGEMENT OF A FOOTBALL-RELATED MUSEUM; BUSINESS MANAGEMENT FOR OTHERS, NAMELY, BUSINESS MANAGEMENT OF A FOOTBALL-RELATED MUSEUM (U.S. CLS. 100, 101 AND 102).

KAREN SEVERSON, EXAMINING ATTORNEY

**CLASS 35—(Continued).**

SN 85-189,113. BENCHMARK ACCOUNTING & TAX SERVICES LLC, DBA BATS ACCOUNTING, DUBLIN, OH. FILED 12-2-2010.

**GO EasyTax**  
Maximum Refund...Period

NO CLAIM IS MADE TO THE EXCLUSIVE RIGHT TO USE "TAX" OR "MAXIMUM REFUND", APART FROM THE MARK AS SHOWN.

THE COLOR(S) WHITE, ORANGE AND BROWN IS/ARE CLAIMED AS A FEATURE OF THE MARK.

THE MARK CONSISTS OF THE WORDING "GO" IN WHITE COLOR AND ENCLOSED IN AN ORANGE SQUARE BOX, THE WORDING "EASY TAX" IN WHITE COLOR AND ENCLOSED IN A BROWN RECTANGLE BOX, THE WORDING "MAXIMUM REFUND...PERIOD" IN BROWN COLOR.

FOR INCOME TAX PREPARATION (U.S. CLS. 100, 101 AND 102).

FIRST USE 10-1-2010; IN COMMERCE 10-1-2010.

TAMARA FRAZIER, EXAMINING ATTORNEY

SN 85-189,888. JD EVENTS LLC, TRUMBULL, CT. FILED 12-3-2010.

## CUSTOMER ENGAGEMENT TECHNOLOGY WORLD

SN 85-187,970. KIMBERLY A. TEN EICK, MARION, IA. FILED 12-1-2010.

# Intelligent Life Toys

THE MARK CONSISTS OF STANDARD CHARACTERS WITHOUT CLAIM TO ANY PARTICULAR FONT, STYLE, SIZE, OR COLOR.

NO CLAIM IS MADE TO THE EXCLUSIVE RIGHT TO USE "INTELLIGENT" AND "TOYS", APART FROM THE MARK AS SHOWN.

FOR RETAIL TOY STORES (U.S. CLS. 100, 101 AND 102).

WILLIAM BRECKENFELD, EXAMINING ATTORNEY

THE MARK CONSISTS OF STANDARD CHARACTERS WITHOUT CLAIM TO ANY PARTICULAR FONT, STYLE, SIZE, OR COLOR.

NO CLAIM IS MADE TO THE EXCLUSIVE RIGHT TO USE "CUSTOMER ENGAGEMENT TECHNOLOGY", APART FROM THE MARK AS SHOWN.

FOR ARRANGING AND CONDUCTING BUSINESS CONFERENCES AND EXPOSITIONS IN THE FIELD OF INTERACTIVE SELF-SERVICE KIOSKS AND SELF SERVICE BUSINESS SOLUTIONS, AND IN THE FIELD OF DIGITAL SIGNAGE, MOBILE DEVICES AND OTHER CUSTOMER-FACING TECHNOLOGIES AND APPLICATIONS (U.S. CLS. 100, 101 AND 102).

FIRST USE 11-10-2010; IN COMMERCE 11-10-2010.

ANNE MADDEN, EXAMINING ATTORNEY

**CLASS 35—(Continued).**

SN 85-190,285. BORLJA, ZIVA, PHILADELPHIA, PA. FILED 12-3-2010.



THE COLOR(S) WHITE, BLUE AND GRAY IS/ARE CLAIMED AS A FEATURE OF THE MARK.

THE MARK CONSISTS OF A FIVE-TOOTHED BLUE COG WITH AN INTERNAL GRAY RING CENTERED BETWEEN TWO OVERLAPPING BARS, BLUE ABOVE AND GRAY BELOW WITH A WHITE OUTLINE BETWEEN THEM, THAT HAVE CIRCULAR HINGED ENDS WHICH PROVIDE THE BACKGROUNDS FOR THE TWO MIRRORED AND INVERTED SETS OF WORDS "FLIPFLOPHUB" APPEARING IN THE COLOR WHITE.

FOR REFERRALS IN THE FIELD OF ONLINE TRAFFIC ANALYSIS (U.S. CLS. 100, 101 AND 102).

ARETHA SOMERVILLE, EXAMINING ATTORNEY

**CLASS 35—(Continued).**

SN 85-193,022. THE TOMORROW PROJECT, LLC, ZEPHYR COVE, NV. FILED 12-8-2010.



NO CLAIM IS MADE TO THE EXCLUSIVE RIGHT TO USE "WEEK", APART FROM THE MARK AS SHOWN.

THE MARK CONSISTS OF THE WORD "SOCIAL" APPEARING ABOVE A LINE WITH A STYLIZED LETTER "I" AND THE WORD "WEEK" APPEARING BELOW THE LINE.

FOR ARRANGING AND CONDUCTING BUSINESS CONFERENCES IN THE FIELDS OF BRANDING AND MARKETING (U.S. CLS. 100, 101 AND 102).

ALLISON SCHRODY, EXAMINING ATTORNEY

SN 85-193,716. VIRGO PUBLISHING, LLC, PHOENIX, AZ. FILED 12-8-2010.

**VISION2MOBILE**

THE MARK CONSISTS OF STANDARD CHARACTERS WITHOUT CLAIM TO ANY PARTICULAR FONT, STYLE, SIZE, OR COLOR.

FOR PROVIDING ONLINE MARKET INTELLIGENCE IN THE MOBILE BROADBAND, VIDEO AND INTERNET PROTOCOL TELEVISION MARKETS FOR THE EMERGING AND LEGACY SERVICE PROVIDER (U.S. CLS. 100, 101 AND 102).

TARAH HARDY, EXAMINING ATTORNEY

SN 85-192,517. SAN PASQUAL CASINO DEVELOPMENT GROUP INC., VALLEY CENTER, CA. FILED 12-7-2010.



SN 85-193,719. VIRGO PUBLISHING, LLC, PHOENIX, AZ. FILED 12-8-2010.

**V2M**

NO CLAIM IS MADE TO THE EXCLUSIVE RIGHT TO USE "CENTER", APART FROM THE MARK AS SHOWN.

THE MARK CONSISTS OF THE STYLIZED DESIGN OF A SERIES OF 5 RECTANGLES, A CENTER RECTANGLE WITH A STYLIZED FOUNTAIN, AND 5 ADDITIONAL STYLIZED RECTANGLES WITH THE STYLIZED WORDING "CENTER" APPEARING DIRECTLY UNDERNEATH.

FOR CONCESSION STANDS FEATURING FOOD, SOUVENIRS AND GENERAL CONSUMER GOODS (U.S. CLS. 100, 101 AND 102).

JACLYN KIDWELL WALKER, EXAMINING ATTORNEY

THE MARK CONSISTS OF STANDARD CHARACTERS WITHOUT CLAIM TO ANY PARTICULAR FONT, STYLE, SIZE, OR COLOR.

FOR PROVIDING ONLINE MARKET INTELLIGENCE IN THE MOBILE BROADBAND, VIDEO AND INTERNET PROTOCOL TELEVISION MARKETS FOR THE EMERGING AND LEGACY SERVICE PROVIDER (U.S. CLS. 100, 101 AND 102).

TARAH HARDY, EXAMINING ATTORNEY

**CLASS 35—(Continued).**

SN 85-193,846. ILLINOIS AGRICULTURAL ASSOCIATION, BLOOMINGTON, IL. FILED 12-9-2010.



NO CLAIM IS MADE TO THE EXCLUSIVE RIGHT TO USE "ILLINOIS FARM", APART FROM THE MARK AS SHOWN.

THE MARK CONSISTS OF THE WORDING "ILLINOIS FARM FAMILIES" AND A DESIGN ELEMENT COMPRISING A SPOON, FORK, AND KNIFE LOCATED BELOW THE WORDING. THE LETTERS "ILI" IN "FAMILIES" APPEAR AS ABSTRACT BUILDINGS. BELOW THE DESIGN ELEMENT IS THE WORDING "GROWING YOUR FOOD WITH CARE. WWW.WATCHUSGROW.ORG".

FOR PROMOTING PUBLIC AWARENESS OF AGRICULTURAL PRACTICES BY PROVIDING INFORMATION TO NON-FARMERS ABOUT FARMING AND FOOD PRODUCTION (U.S. CLS. 100, 101 AND 102).

FIRST USE 11-23-2010; IN COMMERCE 11-23-2010.  
LAURIE KAUFMAN, EXAMINING ATTORNEY

**CLASS 35—(Continued).**

SN 85-194,689. SMITH, SCOTT HUNTER, NEWARK, NJ. FILED 12-9-2010.



THE MARK CONSISTS OF THE WORD "NPLAY" IN STYLIZED FONT.

FOR PROMOTING PUBLIC AWARENESS OF THE NEED FOR CHANGING STATE EDUCATIONAL STANDARDS FOR PHYSICAL EXERCISE IN SCHOOLS TO REDUCE CHILDHOOD OBESITY (U.S. CLS. 100, 101 AND 102).

FIRST USE 10-1-2009; IN COMMERCE 10-1-2009.  
DAVID YONTEF, EXAMINING ATTORNEY

SN 85-194,477. TULIS, ROBERT W., DBA STRATEGIC TECHNICAL SOLUTIONS CONSULTING, LLC, ESCONDIDO, CA. FILED 12-9-2010.



THE COLOR(S) PLATINUM, LIGHT BLUE, DARK BLUE, GOLD AND WHITE IS/ARE CLAIMED AS A FEATURE OF THE MARK.

THE MARK CONSISTS OF THE LETTERS "STSC" IN WHITE AND PLATINUM IN A MODIFIED VERSION OF THE FONT ETHNOCENTRIC, EACH LETTER OVERLAPPING THE ONE BEFORE, WITH A WHITE GLOW SEPARATING EACH LETTER. IN THE BOWL OF THE FINAL LETTER "C", THE DESIGN OF A COMPASS, THE OUTER EDGE IN GOLD AND THE CENTER APPEARING WITH A MAP OF THE WORLD IN THE FACE OF THE COMPASS IN LIGHT AND DARK BLUE, AND THE ARROW OF THE COMPASS IN WHITE WITH A GOLD CENTER POINTING TO THE UPPER RIGHT.

FOR BUSINESS CONSULTING SERVICES IN THE FIELD OF GOVERNMENT CONTRACT PROCUREMENT (U.S. CLS. 100, 101 AND 102).

FIRST USE 12-7-2010; IN COMMERCE 12-7-2010.  
ANDREA BUTLER, EXAMINING ATTORNEY

SN 85-195,039. AKC MARKETING & CONSULTING, INC., JOHNSTON, IA. FILED 12-10-2010.



THE MARK CONSISTS OF STANDARD CHARACTERS WITHOUT CLAIM TO ANY PARTICULAR FONT, STYLE, SIZE, OR COLOR.

NO CLAIM IS MADE TO THE EXCLUSIVE RIGHT TO USE "MARKETING", APART FROM THE MARK AS SHOWN.

FOR ADVERTISING AND BUSINESS SERVICES, NAMELY, SECURING AIRTIME ON ALL FORMS OF MEDIA COMMUNICATIONS STATIONS, SYSTEMS, NETWORKS, AND SERVICES FOR THE PURPOSE OF PROMOTING THE GOODS AND SERVICES OF OTHERS; ADVERTISING AND MARKETING SERVICES, NAMELY, PROMOTING THE GOODS AND SERVICES OF OTHERS; ADVERTISING AND PROMOTIONAL SERVICES (U.S. CLS. 100, 101 AND 102).

FIRST USE 4-12-2007; IN COMMERCE 4-12-2007.  
NELSON SNYDER, EXAMINING ATTORNEY

**CLASS 35—(Continued).**

SN 85-195,376. DIRECTV SPORTS NETWORKS, LLC, SEATTLE, WA. FILED 12-10-2010.

**CLASS 35—(Continued).**

SN 85-195,619. DIRECTV SPORTS NETWORKS, LLC, SEATTLE, WA. FILED 12-10-2010.

ROOT SPORTS



THE MARK CONSISTS OF STANDARD CHARACTERS WITHOUT CLAIM TO ANY PARTICULAR FONT, STYLE, SIZE, OR COLOR.

OWNER OF U.S. REG. NO. 3,726,772.

NO CLAIM IS MADE TO THE EXCLUSIVE RIGHT TO USE "SPORTS", APART FROM THE MARK AS SHOWN.

FOR ADVERTISING AND MARKETING SERVICES, NAMELY, PREPARING AND PLACING ADVERTISEMENTS FOR OTHERS; PROMOTING THE GOODS AND SERVICES OF OTHERS THROUGH BROADCAST ADVERTISING AND BY ARRANGING FOR SPONSORS TO AFFILIATE THEIR GOODS AND SERVICES WITH FOOTBALL, BASKETBALL, BASEBALL, HOCKEY, TENNIS, GOLF, AUTO RACING, CRICKET, SOCCER, TRACK AND FIELD, EQUESTRIAN SPORTS AND RACING, ANIMAL RACING SPORTS, BOXING, FENCING, MARTIAL ARTS, MIXED MARTIAL ARTS, WRESTLING, CYCLING, FITNESS SPORTS, AEROBIC SPORTS, GYMNAS TIC SPORTS, WEIGHTLIFTING, SKATEBOARDING, SURFING, MOTORSPORTS, AUTO RACING, BOATING, BOAT RACING, FISHING, DIVING, WATER SPORTS, WINTER SPORTS, RACQUET SPORTS, SKATING, SKIING, SNOW SPORTS, ARCHERY, BILLIARDS, BOWLING, CROQUET, DISC GOLF, ACTION SPORTS, HURLING, LACROSSE, POLO, RUGBY, SOFTBALL, VOLLEYBALL, FRISBEE, CARDS AND OTHER TABLE GAMES, ROWING, SAILING, KAYAKING, CANOEING, CHEERLEADING, RODEO, COMBAT SPORTS, OLYMPIC SPORTS, HUNTING, OUTDOOR SPORTS; ADVERTISING AND MARKETING SERVICES, NAMELY, PREPARING AND PLACING MULTI-MEDIA ADVERTISING ON INTERACTIVE PLATFORMS AVAILABLE VIA A SATELLITE TRANSMISSION; ADVERTISING AND MARKETING SERVICES, NAMELY, PROVIDING THIRD PARTY MARKET RESEARCH; DISSEMINATION OF ADVERTISING FOR OTHERS VIA A SATELLITE TRANSMISSION (U.S. CLS. 100, 101 AND 102).

GISELLE AGOSTO, EXAMINING ATTORNEY

OWNER OF U.S. REG. NO. 3,726,772.

NO CLAIM IS MADE TO THE EXCLUSIVE RIGHT TO USE "SPORTS", APART FROM THE MARK AS SHOWN.

THE MARK CONSISTS OF THE WORD "ROOT", THE LETTERS "R" AND "T" HAVING TRIANGULAR NOTCHES CUT AT THE TOP, OVER THE WORD "SPORTS", ALL IN SLANTED LETTERS.

FOR ADVERTISING AND MARKETING SERVICES, NAMELY, PREPARING AND PLACING ADVERTISEMENTS FOR OTHERS; PROMOTING THE GOODS AND SERVICES OF OTHERS THROUGH BROADCAST ADVERTISING AND BY ARRANGING FOR SPONSORS TO AFFILIATE THEIR GOODS AND SERVICES WITH FOOTBALL, BASKETBALL, BASEBALL, HOCKEY, TENNIS, GOLF, AUTO RACING, CRICKET, SOCCER, TRACK AND FIELD, EQUESTRIAN SPORTS AND RACING, ANIMAL RACING SPORTS, BOXING, FENCING, MARTIAL ARTS, MIXED MARTIAL ARTS, WRESTLING, CYCLING, FITNESS SPORTS, AEROBIC SPORTS, GYMNAS TIC SPORTS, WEIGHTLIFTING, SKATEBOARDING, SURFING, MOTORSPORTS, AUTO RACING, BOATING, BOAT RACING, FISHING, DIVING, WATER SPORTS, WINTER SPORTS, RACQUET SPORTS, SKATING, SKIING, SNOW SPORTS, ARCHERY, BILLIARDS, BOWLING, CROQUET, DISC GOLF, ACTION SPORTS, HURLING, LACROSSE, POLO, RUGBY, SOFTBALL, VOLLEYBALL, FRISBEE, CARDS AND OTHER TABLE GAMES, ROWING, SAILING, KAYAKING, CANOEING, CHEERLEADING, RODEO, COMBAT SPORTS, OLYMPIC SPORTS, HUNTING, OUTDOOR SPORTS; ADVERTISING AND MARKETING SERVICES, NAMELY, PREPARING AND PLACING MULTI-MEDIA ADVERTISING ON INTERACTIVE PLATFORMS AVAILABLE VIA A SATELLITE TRANSMISSION; ADVERTISING AND MARKETING SERVICES, NAMELY, PROVIDING THIRD PARTY MARKET RESEARCH; DISSEMINATION OF ADVERTISING FOR OTHERS VIA A SATELLITE TRANSMISSION (U.S. CLS. 100, 101 AND 102).

GISELLE AGOSTO, EXAMINING ATTORNEY



**CLASS 35—(Continued).**

SN 85-196,195. MARIA SNYDER INC., NEW YORK, NY. FILED 12-13-2010.



NO CLAIM IS MADE TO THE EXCLUSIVE RIGHT TO USE "RECYCLE", APART FROM THE MARK AS SHOWN. THE NAME "RAY RECYCLE" DOES NOT IDENTIFY A LIVING INDIVIDUAL.

THE MARK CONSISTS OF A CIRCULAR CHARACTER, NAMELY A RECYCLE SYMBOL WITH FACE, HANDS, AND FEET WITH WORDS "RAY RECYCLE" BENEATH THE CHARACTER.

FOR PROMOTING PUBLIC AWARENESS OF ENVIRONMENTAL ISSUES AND INITIATIVES (U.S. CLS. 100, 101 AND 102).

FIRST USE 2-15-2005; IN COMMERCE 6-24-2009.  
JASON BLAIR, EXAMINING ATTORNEY

SN 85-196,347. MARIA SNYDER INC., NEW YORK, NY. FILED 12-13-2010.



THE NAME "SAMMY SUN" DOES NOT IDENTIFY A LIVING INDIVIDUAL.

THE MARK CONSISTS OF A CIRCULAR CHARACTER, NAMELY A SUN WEARING SUNGLASSES WITH FACE, HANDS AND FEET, WITH THE WORDS "SAMMY SUN" WRITTEN BENEATH IT.

FOR PROMOTING PUBLIC AWARENESS OF ENVIRONMENTAL ISSUES AND INITIATIVES (U.S. CLS. 100, 101 AND 102).

FIRST USE 2-15-2005; IN COMMERCE 6-24-2009.  
JASON BLAIR, EXAMINING ATTORNEY

**CLASS 35—(Continued).**

SN 85-197,906. TOUCHSTONE STANDARD CORPORATION, HENDERSON, NV. FILED 12-14-2010.

# ESQuery

THE MARK CONSISTS OF STANDARD CHARACTERS WITHOUT CLAIM TO ANY PARTICULAR FONT, STYLE, SIZE, OR COLOR.

FOR PROVIDING BUSINESS INFORMATION IN THE FIELD OF LICENSE AND DISCIPLINARY BACKGROUND AND TRIAL PERFORMANCE HISTORY OF ATTORNEYS (U.S. CLS. 100, 101 AND 102).

ANDREW RHIM, EXAMINING ATTORNEY

SN 85-198,287. SUGARLOAF RESIDENTIAL PROPERTY OWNERS ASSOCIATION, INC., DULUTH, GA. FILED 12-15-2010.

# Sugarloaf Country Club

THE MARK CONSISTS OF STANDARD CHARACTERS WITHOUT CLAIM TO ANY PARTICULAR FONT, STYLE, SIZE, OR COLOR.

OWNER OF U.S. REG. NOS. 2,125,650 AND 2,177,971.

NO CLAIM IS MADE TO THE EXCLUSIVE RIGHT TO USE "COUNTRY CLUB", APART FROM THE MARK AS SHOWN.

FOR COMMUNITY ASSOCIATION SERVICES, NAMELY, PROMOTING THE INTERESTS OF A COMMUNITY ASSOCIATION AND THE PROPERTY OWNERS WITHIN THE COMMUNITY BY ENFORCING COMPLIANCE WITH RESTRICTIVE COMMUNITY COVENANTS; PROMOTING THE SALE OF REAL ESTATE OF OTHERS THROUGH THE DISTRIBUTION OF PRINTED MATERIALS; REAL ESTATE SALES MANAGEMENT (U.S. CLS. 100, 101 AND 102).

FIRST USE 9-14-1995; IN COMMERCE 9-14-1995.  
BENJAMIN OKEKE, EXAMINING ATTORNEY

**CLASS 35—(Continued).**

SN 85-198,305. SUGARLOAF RESIDENTIAL PROPERTY OWNERS ASSOCIATION, INC., DULUTH, GA. FILED 12-15-2010.



OWNER OF U.S. REG. NOS. 2,125,650 AND 2,177,971.

THE MARK CONSISTS OF A SHIELD EMBLAZONED WITH THE INITIALS "CSC", THE SHIELD IS IN FRONT OF A PAIR OF CROSSED GOLF CLUBS SURROUNDED BY A WREATH WITH A BANNER CONTAINING THE WORDS "SUGARLOAF" UNDERNEATH.

FOR COMMUNITY ASSOCIATION SERVICES, NAMELY, PROMOTING THE INTERESTS OF A COMMUNITY ASSOCIATION AND THE PROPERTY OWNERS WITHIN THE COMMUNITY BY ENFORCING COMPLIANCE WITH RESTRICTIVE COMMUNITY COVENANTS; PROMOTING THE SALE OF REAL ESTATE OF OTHERS THROUGH THE DISTRIBUTION OF PRINTED MATERIAL; REAL ESTATE SALES MANAGEMENT (U.S. CLS. 100, 101 AND 102).

FIRST USE 9-14-1995; IN COMMERCE 9-14-1995.  
BENJAMIN OKEKE, EXAMINING ATTORNEY

---

SN 85-198,550. ONE TOUCH INTELLIGENCE, LLC, GREENWOOD VILLAGE, CO. FILED 12-15-2010.

## VIDEOTRAKER

THE MARK CONSISTS OF STANDARD CHARACTERS WITHOUT CLAIM TO ANY PARTICULAR FONT, STYLE, SIZE, OR COLOR.

OWNER OF U.S. REG. NO. 3,766,242.

FOR SUBSCRIPTION TO AN INFORMATION MEDIA PACKAGE WITH SEARCH AND REPORTING TOOLS IN THE NATURE OF PROVIDING INFORMATION AND ANALYSIS IN THE FIELDS OF TELEVISION PROGRAMMING AND TV LISTINGS FOR USE IN THE TELEVISION, INTERNET, AND ON DEMAND SECTORS (U.S. CLS. 100, 101 AND 102).

FIRST USE 11-29-2010; IN COMMERCE 11-29-2010.  
LINDA E. BLOHM, EXAMINING ATTORNEY

**CLASS 35—(Continued).**

SN 85-199,382. MEDIACOM COMMUNICATIONS CORPORATION, MIDDLETOWN, NY. FILED 12-16-2010.



OWNER OF U.S. REG. NO. 3,796,336.

THE MARK CONSISTS OF A STYLIZED LETTER "R" APPEARING INSIDE A SQUARE WITH ROUNDED CORNERS.

FOR ONLINE BUSINESS DIRECTORY SERVICES REGARDING THE PURCHASE AND SALE OF A WIDE VARIETY OF PRODUCTS AND SERVICES OF OTHERS (U.S. CLS. 100, 101 AND 102).

CORY BOONE, EXAMINING ATTORNEY

---

SN 85-199,387. MYRA A. CURTIS, BROOKLYN, NY. FILED 12-16-2010.

## Hip-Hop Chef

THE MARK CONSISTS OF STANDARD CHARACTERS WITHOUT CLAIM TO ANY PARTICULAR FONT, STYLE, SIZE, OR COLOR.

FOR ADVERTISING SERVICES (U.S. CLS. 100, 101 AND 102).

KATINA MISTER, EXAMINING ATTORNEY

---

SN 85-199,400. GONZALEZ, ROBERT, HATTIESBURG, MS. FILED 12-16-2010.

## awardism

THE MARK CONSISTS OF STANDARD CHARACTERS WITHOUT CLAIM TO ANY PARTICULAR FONT, STYLE, SIZE, OR COLOR.

FOR PROVIDING ON-LINE DIRECTORY INFORMATION SERVICES FEATURING INFORMATION REGARDING AWARDS AND HONORS PROGRAMS AND ALSO FEATURING HYPERLINKS TO OTHER WEB SITES (U.S. CLS. 100, 101 AND 102).

HOWARD SMIGA, EXAMINING ATTORNEY

**CLASS 35—(Continued).**

SN 85-199,423. VAN UDEN CENTER INC., QUEENS, NY. FILED 12-16-2010.



NO CLAIM IS MADE TO THE EXCLUSIVE RIGHT TO USE "CENTER", APART FROM THE MARK AS SHOWN. THE COLOR(S) GRAY, BLUE, WHITE AND TURQUOISE IS/ARE CLAIMED AS A FEATURE OF THE MARK.

THE MARK CONSISTS OF A DESIGN IN THE TOP PART OF THE MARK, WITH A GRAY ELLIPSE IN THE CENTER; A SEMI-ELLIPSE COLORED IN BLUE IS LOCATED INSIDE THE GRAY ELLIPSE; A SECOND SEMI-ELLIPSE COLORED IN WHITE IS LOCATED IN THE MIDDLE OF THE GRAY ELLIPSE; A THIRD SEMI-ELLIPSE COLORED IN TURQUOISE IS LOCATED AT TOP OF THE GRAY ELLIPSE; THE GRAY, BLUE, WHITE AND TURQUOISE ELLIPSES ARE SURROUNDED BY TWO DECLINING MOONS, THE ONE IN THE LEFT SIDE IS BLUE AND THE ONE IN THE RIGHT SIDE IS TURQUOISE. BELOW THE DESIGN IS THE STYLIZED WORDING "VAN UDEN CENTER" IN BLUE; ONE TURQUOISE LINE IS LOCATED AT TOP OF THE LETTERS "V", "A", "N", AND "U"; A SECOND TURQUOISE LINE IS LOCATED AT TOP OF THE WORD "CENTER"; AND A THIRD TURQUOISE LINE IS LOCATED AT THE BOTTOM OF THE WORDING "VAN UDEN CENTER".

FOR RETAIL STORE SERVICES FEATURING HEALTH FOODS, DIETARY SUPPLEMENTS, NUTRITIONAL SUPPLEMENTS, HERBS, VITAMINS, SPORTS NUTRITION PRODUCTS, FITNESS PRODUCTS AND APPAREL, COSMETICS, BODY CARE, DIAGNOSTIC EXERCISE OR AROMATHERAPY PRODUCTS; ADVERTISING OF HEALTH FOODS, DIETARY SUPPLEMENTS, NUTRITIONAL SUPPLEMENTS, HERBS, VITAMINS, SPORTS NUTRITION PRODUCTS, FITNESS PRODUCTS AND APPAREL, COSMETICS, BODY CARE, DIAGNOSTIC EXERCISE OR AROMATHERAPY PRODUCTS; ONLINE RETAIL STORE SERVICES FEATURING HEALTH FOODS, DIETARY SUPPLEMENTS, NUTRITIONAL SUPPLEMENTS, HERBS, VITAMINS, SPORTS NUTRITION PRODUCTS, FITNESS PRODUCTS AND APPAREL, COSMETICS, BODY CARE, DIAGNOSTIC EXERCISE OR AROMATHERAPY PRODUCTS (U.S. CLS. 100, 101 AND 102).

GENE MACIOL, EXAMINING ATTORNEY

SN 85-199,449. PKNY IP & FRANCHISE, LLC, NEW YORK, NY. FILED 12-16-2010.

**PAPAYA KING**

THE MARK CONSISTS OF STANDARD CHARACTERS WITHOUT CLAIM TO ANY PARTICULAR FONT, STYLE, SIZE, OR COLOR.

OWNER OF U.S. REG. NOS. 1,007,703, 1,155,823 AND OTHERS.

FOR RESTAURANT FRANCHISING, NAMELY, OFFERING TECHNICAL ASSISTANCE IN THE ESTABLISHMENT AND/OR OPERATION OF RESTAURANTS FEATURING THE SALE OF TROPICAL DRINKS, SMOOTHIES AND HOT DOGS (U.S. CLS. 100, 101 AND 102).

FIRST USE 10-21-2003; IN COMMERCE 10-21-2003.

GENE MACIOL, EXAMINING ATTORNEY

**CLASS 35—(Continued).**

SN 85-199,506. NORTHLIGHT POWER, LLC, BAINBRIDGE ISLAND, WA. FILED 12-16-2010.



**NORTHLIGHTPOWER**

*Streamlining solar.*

NO CLAIM IS MADE TO THE EXCLUSIVE RIGHT TO USE "POWER" AND "SOLAR", APART FROM THE MARK AS SHOWN.

THE MARK CONSISTS OF THE WORDS "NORTHLIGHT POWER STREAMLINING SOLAR". THE WORDS "NORTHLIGHT POWER" APPEAR ON ONE LINE AND THE WORDS "STREAMLINING SOLAR" APPEAR ON THE LINE BELOW. THERE IS A DESIGN WHICH SHOWS POWER LINES MEETING AND APPEARS TO THE LEFT OF THE WORDS.

FOR OPERATING SOLAR POWER GENERATION FACILITIES FOR OTHERS; BUSINESS MANAGEMENT SERVICES RELATING TO NEW, UTILITY-SCALE POWER PLANTS, NAMELY, ANALYSIS OF THE MARKET FOR NEW POWER PLANTS, DEFINING THE OVERALL SERVICE DELIVERY STRATEGY, ANALYZING THE COMMERCIAL FEASIBILITY OF NEW POWER PLANTS, SELECTING AND MANAGING POWER PLANT CONTRACTORS AND CONTRACT ENGINEERS FOR OTHERS, DEVELOPING BUDGETS AND TRACKING COSTS, AND CONSULTING IN THE FIELD OF PROCURING CONTRACTS FOR THE PURCHASE OF GOODS AND SERVICES; PROCUREMENT SERVICES, NAMELY, PURCHASING OF EQUIPMENT FOR POWER PLANTS FOR OTHERS; COMMISSIONING POWER PLANTS FOR OTHERS; NEGOTIATION OF CONTRACTS FOR THE BENEFIT OF OTHERS REGARDING ELECTRICAL POWER GENERATION, THE PURCHASE OF FUEL SUPPLIES AND ELECTRICAL TRANSMISSION SERVICES; ASSISTING WITH THE FORMATION AND NEGOTIATION OF CONTRACTS FOR THE SALE OF WHOLESALE POWER (U.S. CLS. 100, 101 AND 102).

FIRST USE 9-30-2010; IN COMMERCE 9-30-2010.

PATRICIA EVANKO, EXAMINING ATTORNEY

SN 85-199,605. SAFE-GUARD PRODUCTS INTERNATIONAL, LLC, ATLANTA, GA. FILED 12-16-2010.

**SAFE-GUARD**  
Products International, LLC



NO CLAIM IS MADE TO THE EXCLUSIVE RIGHT TO USE "PRODUCTS INTERNATIONAL, LLC", APART FROM THE MARK AS SHOWN.

THE MARK CONSISTS OF THE WORDS "SAFE-GUARD PRODUCTS INTERNATIONAL, LLC" CENTERED OVER A HORIZONTAL DIAMOND SHAPE WITH AN ILLUSTRATION OF A MAP OF THE WORLD OVERLAYING HORIZONTAL LINES WITHIN THE DIAMOND SHAPE.

FOR ADMINISTERING CONTRACTS FOR THE REPAIR OF MOTOR VEHICLE COMPONENTS (U.S. CLS. 100, 101 AND 102).

FIRST USE 0-0-2002; IN COMMERCE 0-0-2002.

BARNEY CHARLON, EXAMINING ATTORNEY

**CLASS 35—(Continued).**

SN 85-199,608. KINCORP LTD., TORONTO, CANADA,  
FILED 12-16-2010.

**ComplaintLink**

THE MARK CONSISTS OF STANDARD CHARACTERS WITHOUT CLAIM TO ANY PARTICULAR FONT, STYLE, SIZE, OR COLOR.

FOR PROVIDING AN INTERACTIVE CONSUMER INFORMATION WEBSITE AND DATABASE THAT ALLOWS CONSUMERS TO PROVIDE FEEDBACK REGARDING THE PRODUCTS AND SERVICES OF OTHERS AND THAT INCLUDES THE PARTICIPATION OF BUSINESS DECISION MAKERS WITHIN COMPANIES AND OTHER CONSUMERS; COMPILING AND ANALYZING CONSUMER FEEDBACK FOR CONSUMERS AND COMPANIES; PROVIDING AN INTERACTIVE WEBSITE THAT ALLOWS PERSONS TO REGISTER COMPLAINTS AGAINST COMPANIES AND/OR SERVICES OF ALL TYPES (U.S. CLS. 100, 101 AND 102).

FIRST USE 10-15-2010; IN COMMERCE 12-16-2010.  
BARNEY CHARLON, EXAMINING ATTORNEY

**CLASS 35—(Continued).**

SN 85-200,159. BATRUS HOLLWEG INTERNATIONAL SELECTION SERVICES, LTD., PLANO, TX. FILED 12-16-2010.

**BHI TALENT CONSULTING**

THE MARK CONSISTS OF STANDARD CHARACTERS WITHOUT CLAIM TO ANY PARTICULAR FONT, STYLE, SIZE, OR COLOR.

OWNER OF U.S. REG. NOS. 3,191,240 AND 3,676,425.  
NO CLAIM IS MADE TO THE EXCLUSIVE RIGHT TO USE "TALENT CONSULTING", APART FROM THE MARK AS SHOWN.

FOR CONSULTING SERVICES RELATED TO PRE-EMPLOYMENT TESTING AND ASSESSMENT TO DETERMINE EMPLOYMENT SKILLS THAT INCLUDES BENCHMARKS, EMPLOYEE DEVELOPMENT RELATING TO SELECTING, HIRING AND RETAINING TOP TALENT (U.S. CLS. 100, 101 AND 102).

FIRST USE 1-1-2010; IN COMMERCE 1-1-2010.  
ANTHONY RINKER, EXAMINING ATTORNEY

SN 85-199,960. THE FRENCH TROVE, LLC, SCOTTSDALE, AZ. FILED 12-16-2010.

**SEDUCTIVELY FRENCH**

THE MARK CONSISTS OF STANDARD CHARACTERS WITHOUT CLAIM TO ANY PARTICULAR FONT, STYLE, SIZE, OR COLOR.

NO CLAIM IS MADE TO THE EXCLUSIVE RIGHT TO USE "FRENCH", APART FROM THE MARK AS SHOWN.

FOR ON-LINE RETAIL STORE SERVICES FEATURING HOME FURNISHINGS AND DÉCOR ITEMS, HOUSEWARES, GIFTS, CHOCOLATES, CONFECTIONARIES, CLOTHING, LINGERIE, AND FASHION ACCESSORIES (U.S. CLS. 100, 101 AND 102).

CYNTHIA TRIPI, EXAMINING ATTORNEY

SN 85-200,927. FACECAKE MARKETING TECHNOLOGIES, INC., CALABASAS, CA. FILED 12-17-2010.

**COLORCLICK**

THE MARK CONSISTS OF STANDARD CHARACTERS WITHOUT CLAIM TO ANY PARTICULAR FONT, STYLE, SIZE, OR COLOR.

FOR ADVERTISING SERVICES, NAMELY, ONLINE PROMOTION OF PRODUCTS FOR OTHERS; ONLINE PRODUCT MERCHANDISING SERVICES PERMITTING USERS TO VISUALIZE USE AND PLACEMENT OF PRODUCTS, EXCLUDING PAINT COLORS, ONLINE THROUGH THE CREATION AND MANIPULATION OF DIGITAL IMAGES (U.S. CLS. 100, 101 AND 102).

PAUL E. FAHRENKOPF, EXAMINING ATTORNEY

**CLASS 35—(Continued).**

SN 85-201,002. CISCO TECHNOLOGY, INC., SAN JOSE, CA. FILED 12-17-2010.

# CISCO

THE MARK CONSISTS OF STANDARD CHARACTERS WITHOUT CLAIM TO ANY PARTICULAR FONT, STYLE, SIZE, OR COLOR.

OWNER OF U.S. REG. NOS. 2,959,329, 3,872,872 AND OTHERS.

FOR BUSINESS CONSULTING AND INFORMATION SERVICES; BUSINESS CONSULTING WITH RELATION TO STRATEGY, TECHNOLOGY DEPLOYMENT, SALES, AND BUSINESS PROCESSES; CHARITABLE SERVICES, NAMELY, ORGANIZING AND CONDUCTING VOLUNTEER PROGRAMS AND COMMUNITY SERVICE PROJECTS; CUSTOMER RELATIONSHIP MANAGEMENT; ENERGY USAGE MANAGEMENT; ENERGY USAGE MANAGEMENT INFORMATION SERVICES; DEMAND-SIDE MANAGEMENT, NAMELY, MANAGEMENT OF ENERGY CONSUMPTION BY ELECTRICAL APPLIANCES; CONSULTATION SERVICES IN ALL OF THE FOREGOING; INFORMATION SERVICES IN THE FIELD OF ENERGY EFFICIENCY; CUSTOMER SERVICE IN THE FIELDS OF TELECOMMUNICATIONS, COMPUTER NETWORKING, COMPUTER HARDWARE AND SOFTWARE AND TECHNOLOGY (U.S. CLS. 100, 101 AND 102).

FIRST USE 12-31-1985; IN COMMERCE 12-31-1985.  
JAMES GRIFFIN, EXAMINING ATTORNEY

SN 85-201,043. E QERINGER, MELBOURNE, FL. FILED 12-17-2010.



THE MARK CONSISTS OF THE WORDING "E QUERINGER" IN WHICH THE FIRST LETTER "E" IS SLANTED AND IS ENCIRCLED BY AN INCOMPLETE CIRCLE DESIGN AND THE WORDING APPEARS ABOVE THE PHRASE "A CONCIERGE FOR THE LUXURY LIFESTYLE".

FOR CORPORATE EVENT MANAGEMENT SERVICES; EVENT PLANNING AND MANAGEMENT FOR MARKETING, BRANDING, PROMOTING OR ADVERTISING THE GOODS AND SERVICES OF OTHERS; PROVIDING MARKETING AND PROMOTION OF SPECIAL EVENTS; SPECIAL EVENT PLANNING FOR BUSINESS PURPOSES (U.S. CLS. 100, 101 AND 102).

HAI-LY LAM, EXAMINING ATTORNEY

**CLASS 35—(Continued).**

SN 85-201,484. SALDIVAR, ANTHONY A., CORONA, CA. FILED 12-20-2010.

# HIP-HOP ALL-STARZ

THE MARK CONSISTS OF STANDARD CHARACTERS WITHOUT CLAIM TO ANY PARTICULAR FONT, STYLE, SIZE, OR COLOR.

NO CLAIM IS MADE TO THE EXCLUSIVE RIGHT TO USE "HIP-HOP", APART FROM THE MARK AS SHOWN.

FOR MARKETING AND ADVERTISING SERVICES FOR HIP-HOP ARTISTS, NAMELY, SINGERS, MUSICIANS, AND FASHION DESIGNERS (U.S. CLS. 100, 101 AND 102).

FIRST USE 4-20-2001; IN COMMERCE 4-20-2001.  
MARK T. MULLEN, EXAMINING ATTORNEY

SN 85-201,533. EDUCATION INDUSTRY ASSOCIATION, INC., ROCKVILLE, MD. FILED 12-20-2010.

OWNER OF U.S. REG. NO. 3,129,650.

THE MARK CONSISTS OF THE LOWERCASE LETTERS "EIA" WITH THE IMAGE OF AN APPLE WITHIN THE LETTER "A".

FOR ASSOCIATION SERVICES, NAMELY, PROMOTING THE INTERESTS OF PRIVATE EDUCATION PROVIDERS, NAMELY, TUTORS, ONLINE LEARNING PROVIDERS, ALTERNATIVE AND SPECIAL EDUCATION PROVIDERS, AND EDUCATION CONTENT DEVELOPERS AND PUBLISHERS; PROMOTING THE INTERESTS OF EDUCATION CONSULTANTS, NAMELY, SCHOOL MANAGEMENT AND TURN-AROUND CONSULTANTS; PROMOTING THE INTERESTS OF PROVIDERS OF EDUCATIONAL SERVICES TO STUDENTS WHICH SUPPLEMENT, COMPLEMENT, AND ENHANCE THE EDUCATIONAL SERVICES OF PUBLIC EDUCATION INSTITUTIONS; PROMOTING PUBLIC AWARENESS OF THE NEED FOR AND BENEFITS OF PRIVATE EDUCATION PROVIDERS, PRIVATE EDUCATION SERVICES, ALTERNATIVES TO PUBLIC EDUCATION, AND SUPPLEMENTS TO PUBLIC EDUCATION (U.S. CLS. 100, 101 AND 102).

FIRST USE 0-0-2002; IN COMMERCE 0-0-2002.  
EDWARD NELSON, EXAMINING ATTORNEY



**CLASS 35—(Continued).**

SN 85-201,697. VAN DOLDER, RICHARD, PORT MOODY, BC, CANADA, AND VAN DOLDER, SHERRY, PORT MOODY, BC, CANADA, FILED 12-20-2010.



**Towtruck America**

NO CLAIM IS MADE TO THE EXCLUSIVE RIGHT TO USE "TOW TRUCK AMERICA", APART FROM THE MARK AS SHOWN.

THE MARK CONSISTS OF THE STYLIZED TEXT "TOWTRUCK AMERICA" NEXT TO A CIRCULAR EMBLEM DESIGN FEATURING AN EAGLE, FIVE STARS AND A BANNER WITH THE WORD "TOWTRUCK".

FOR PROVIDING AN ON-LINE DIRECTORY INFORMATION SERVICE FEATURING INFORMATION REGARDING TOW TRUCKS, ROADSIDE ASSISTANCE, GARAGES, GLASS SHOPS, TIRE SHOPS AND BODY SHOPS (U.S. CLS. 100, 101 AND 102).

FIRST USE 8-20-2010; IN COMMERCE 8-27-2010.  
ALICE BENMAMAN, EXAMINING ATTORNEY

**CLASS 35—(Continued).**

SN 85-202,638. EA INDEPENDENT FRANCHISEE ASSOCIATION LLC, MOORESVILLE, NC. FILED 12-21-2010.



THE COLOR(S) LIME GREEN, DARK GREEN, ORANGE, RED, AND GOLDENROD IS/ARE CLAIMED AS A FEATURE OF THE MARK.

THE MARK CONSISTS OF THE LETTERS "EAIFA" IN LIME GREEN OUTLINED WITH DARK GREEN, WITH THE DOT OVER THE "I" REPLACED WITH A STYLIZED FLOWER FEATURING A RED CENTER, ORANGE SECOND LAYER AND GOLDENROD THIRD LAYER, WITH A WAVE BENEATH FADING FROM LIME GREEN TO ORANGE, AND THE LETTERS "EAIFA.COM" IN DARK GREEN FADING TO ORANGE.

FOR ASSOCIATION SERVICES, NAMELY, PROMOTING THE INTERESTS OF FRUIT ARRANGEMENT FRANCHISEES (U.S. CLS. 100, 101 AND 102).

FIRST USE 3-4-2010; IN COMMERCE 3-4-2010.  
KELLY CHOE, EXAMINING ATTORNEY

SN 85-201,991. FASTENAL IP COMPANY, WINONA, MN. FILED 12-20-2010.

**FAST SOLUTIONS**

THE MARK CONSISTS OF STANDARD CHARACTERS WITHOUT CLAIM TO ANY PARTICULAR FONT, STYLE, SIZE, OR COLOR.

NO CLAIM IS MADE TO THE EXCLUSIVE RIGHT TO USE "SOLUTIONS", APART FROM THE MARK AS SHOWN.

FOR MOBILE VENDING SERVICES IN THE FIELDS OF MAINTENANCE, REPAIR AND OPERATION SUPPLIES AND OFFICE SUPPLIES (U.S. CLS. 100, 101 AND 102).

FIRST USE 12-10-2010; IN COMMERCE 12-10-2010.  
STEVEN JACKSON, EXAMINING ATTORNEY

SN 85-202,712. ROCK YOUR BLOCK, LLC, MINNEAPOLIS, MN. FILED 12-21-2010.

**ROCK YOUR BLOCK**

THE MARK CONSISTS OF STANDARD CHARACTERS WITHOUT CLAIM TO ANY PARTICULAR FONT, STYLE, SIZE, OR COLOR.

FOR PROVIDING A WEBSITE FEATURING INFORMATION ON YOUTH EMPLOYMENT (U.S. CLS. 100, 101 AND 102).

FIRST USE 10-15-2010; IN COMMERCE 10-15-2010.  
MATTHEW PAPPAS, EXAMINING ATTORNEY

**CLASS 35—(Continued).**

SN 85-202,732. VANITY SHOP OF GRAND FORKS, INC., FARGO, ND. FILED 12-21-2010.

*Vanity*  
eVanity.com

OWNER OF U.S. REG. NOS. 1,780,669, 1,851,806 AND 3,691,496.

THE MARK CONSISTS OF THE WORD "VANITY" ABOVE THE WORD "EVANITY.COM" ALL IN STYLIZED FONT.

FOR ON-LINE RETAIL STORE SERVICES FEATURING COATS, JACKETS, BOOTS, JEANS, SHORTS, SCARVES, HATS, GLOVES, MITTENS, LEGGINGS, ROBES, BOOTS, SLIPPERS, SANDALS, HEADBANDS, BELTS, PANTS, SLACKS, TOPS, SHIRTS, T-SHIRTS, HOODED SWEATSHIRTS, VESTS, SWEATERS, DRESSES, SKIRTS, SHOES, FLIP FLOPS, TOTE BAGS, PURSES, WALLETS, JEWELRY, PERFUME, SUNGLASSES, JEGGINGS, AND TIGHTS (U.S. CLS. 100, 101 AND 102).

FIRST USE 11-23-2009; IN COMMERCE 11-23-2009.  
SUNG IN, EXAMINING ATTORNEY

SN 85-203,201. SPORT SUPPLY GROUP, INC., FARMERS BRANCH, TX. FILED 12-21-2010.

**GLSPORTS**

THE MARK CONSISTS OF STANDARD CHARACTERS WITHOUT CLAIM TO ANY PARTICULAR FONT, STYLE, SIZE, OR COLOR.

FOR MAIL ORDER CATALOG SERVICES, ONLINE RETAIL STORE SERVICES, AND WHOLESALE DISTRIBUTORSHIP SERVICES ALL IN THE FIELDS OF SPORTING AND ATHLETIC GOODS, EQUIPMENT AND SUPPLIES, PHYSICAL FITNESS AND EXERCISE EQUIPMENT, AND RECREATIONAL EQUIPMENT, SUPPLIES AND ACCESSORIES (U.S. CLS. 100, 101 AND 102).

FIRST USE 0-0-2006; IN COMMERCE 0-0-2006.  
C. DIONNE CLYBURN, EXAMINING ATTORNEY

**CLASS 35—(Continued).**

SN 85-203,325. CORNERSTONE PROPERTY MANAGEMENT, MORENO VALLEY, CA. FILED 12-21-2010.



NO CLAIM IS MADE TO THE EXCLUSIVE RIGHT TO USE "PROPERTY MANAGEMENT", APART FROM THE MARK AS SHOWN.

THE COLOR(S) WHITE, GREEN, DARK MAROON, GRAY IS/ARE CLAIMED AS A FEATURE OF THE MARK.

THE MARK CONSISTS OF AN OUTER SQUARE FILLED WITH DARK MAROON WITH THE STYLIZED LETTERS "CS" AND SCROLL DESIGN IN DARK MAROON; AND A WHITE RECTANGLE CONTAINING THE WORDING "CORNERSTONE PROPERTY MANAGEMENT" IN DARK MAROON BETWEEN THE LETTERS "CS" AND SCROLL DESIGN; THESE ELEMENTS ARE SUPERIMPOSED OVER A CIRCLE OUTLINED IN DARK MAROON AND WHITE CONTAINING A GRAY COBBLESTONE DESIGN, BELOW THESE ELEMENTS IS A HORIZONTAL LINE WITH CIRCLES IN SHADES OF GREEN AND GRAY.

FOR PROMOTION, ADVERTISING AND MARKETING OF RENTAL PROPERTIES INCLUDING VIA ON-LINE WEBSITES (U.S. CLS. 100, 101 AND 102).

FIRST USE 12-15-2010; IN COMMERCE 12-15-2010.  
BARBARA RUTLAND, EXAMINING ATTORNEY

SN 85-203,403. JG ADVENTURES CORPORATION, VERO BEACH, FL. FILED 12-21-2010.

*JG Adventures*  
Corporation

NO CLAIM IS MADE TO THE EXCLUSIVE RIGHT TO USE "CORPORATION", APART FROM THE MARK AS SHOWN.

THE MARK CONSISTS OF THE STYLIZED TEXT "JG ADVENTURES CORPORATION".

FOR RETAIL STORE SERVICES FEATURING REMOTE CONTROL TOY VEHICLES AND ACCESSORIES (U.S. CLS. 100, 101 AND 102).

FIRST USE 8-16-2010; IN COMMERCE 11-7-2010.  
KRISTIN DAHLING, EXAMINING ATTORNEY

**CLASS 35—(Continued).**

SN 85-203,713. THE FINANCIAL DISTRICT, BOSTON, MA.  
FILED 12-22-2010.

**THE FINANCIAL DISTRICT**

THE MARK CONSISTS OF STANDARD CHARACTERS WITHOUT CLAIM TO ANY PARTICULAR FONT, STYLE, SIZE, OR COLOR.

NO CLAIM IS MADE TO THE EXCLUSIVE RIGHT TO USE "FINANCIAL", APART FROM THE MARK AS SHOWN.

FOR PERSONNEL PLACEMENT (U.S. CLS. 100, 101 AND 102).

ROSELLE HERRERA, EXAMINING ATTORNEY

---

SN 85-203,774. INFINITY STAFFING SOLUTIONS, LLC,  
LAWRENCEVILLE, NJ. FILED 12-22-2010.

**INFINITY STAFFING SOLUTIONS**

THE MARK CONSISTS OF STANDARD CHARACTERS WITHOUT CLAIM TO ANY PARTICULAR FONT, STYLE, SIZE, OR COLOR.

NO CLAIM IS MADE TO THE EXCLUSIVE RIGHT TO USE "STAFFING SOLUTIONS", APART FROM THE MARK AS SHOWN.

FOR EMPLOYMENT AGENCY SERVICES, NAMELY, FILLING THE TEMPORARY AND PERMANENT STAFFING NEEDS OF BUSINESSES (U.S. CLS. 100, 101 AND 102).

FIRST USE 12-31-1996; IN COMMERCE 12-31-1996.  
HELENE LIWINSKI, EXAMINING ATTORNEY

---

SN 85-203,893. TEN EICK, KIMBERLY A., MARION, IA.  
FILED 12-22-2010.

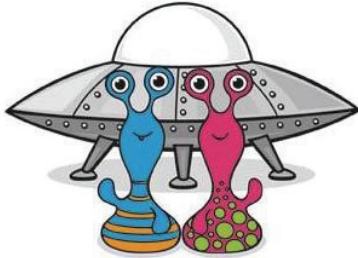

THE COLOR(S) BLUE, ORANGE, RED, GREEN, AND GREY IS/ARE CLAIMED AS A FEATURE OF THE MARK.

THE MARK CONSISTS OF A BLUE TWO-EYED ALIEN CHARACTER WITH ORANGE STRIPES AND A RED TWO-EYED ALIEN CHARACTER WITH GREEN CIRCLES IN FRONT OF A GREY SPACESHIP WITH SUPPORT LEGS AND A CLEAR SEMICIRCULAR TOP.

FOR RETAIL TOY STORES (U.S. CLS. 100, 101 AND 102).

MATTHEW KLINE, EXAMINING ATTORNEY

**CLASS 35—(Continued).**

SN 85-204,200. MARTIN, CARL E. MURPHYSBORO, IL.  
FILED 12-22-2010.



NO CLAIM IS MADE TO THE EXCLUSIVE RIGHT TO USE "BILLBOARD", APART FROM THE MARK AS SHOWN.

THE COLOR(S) CYAN BLACK WHITE IS/ARE CLAIMED AS A FEATURE OF THE MARK.

THE MARK CONSISTS OF THE WORDING "THE BILLBOARD FAMILY" ON A BLACK BACKGROUND. THE WORDS "THE" AND "FAMILY" ARE CYAN. THE WORD "BILLBOARD" IS WHITE. THE FONT IS RAAVI.

FOR ADVERTISING AGENCY SPECIALIZING IN THE DESIGN AND EXECUTION OF WORD OF MOUTH, VIRAL, BUZZ AND EXPERIENTIAL MARKETING PROGRAMS (U.S. CLS. 100, 101 AND 102).

FIRST USE 8-1-2010; IN COMMERCE 8-1-2010.

CHRISTINA SOBRAL, EXAMINING ATTORNEY

---

SN 85-204,498. NICOSIA, CLARISSA, SAN FRANCISCO, CA.  
FILED 12-22-2010.

**Green Glam Go**

THE MARK CONSISTS OF STANDARD CHARACTERS WITHOUT CLAIM TO ANY PARTICULAR FONT, STYLE, SIZE, OR COLOR.

NO CLAIM IS MADE TO THE EXCLUSIVE RIGHT TO USE "GREEN", APART FROM THE MARK AS SHOWN.

FOR PROVIDING AN INTERNET WEBSITE PORTAL FOR RETAIL PURPOSES FEATURING LINKS TO GREEN AND HANDMADE ELECTRONIC RETAILERS' GOODS AND SERVICES THAT ARE CATEGORIZED AS ENVIRONMENTALLY AND SOCIALLY RESPONSIBLE PRODUCTS AND BRANDS; PROVIDING AN INTERNET WEBSITE PORTAL FEATURING PROMOTION AND ADVERTISING FOR GREEN AND HANDMADE ELECTRONIC RETAILERS' GOODS AND SERVICES THAT ARE CATEGORIZED AS ENVIRONMENTALLY AND SOCIALLY RESPONSIBLE PRODUCTS AND BRANDS (U.S. CLS. 100, 101 AND 102).

KHANH LE, EXAMINING ATTORNEY

**CLASS 35—(Continued).**

SN 85-204,658. CASTLE SUPPLIES, INC., NORTH CHARLESTON, SC. FILED 12-23-2010.

**MODERN CLEANING**

THE MARK CONSISTS OF STANDARD CHARACTERS WITHOUT CLAIM TO ANY PARTICULAR FONT, STYLE, SIZE, OR COLOR.

NO CLAIM IS MADE TO THE EXCLUSIVE RIGHT TO USE "CLEANING", APART FROM THE MARK AS SHOWN. FOR RETAIL STORE AND ON-LINE RETAIL STORE SERVICES FEATURING CLEANING EQUIPMENT AND CLEANING SUPPLIES (U.S. CLS. 100, 101 AND 102).

FIRST USE 11-26-2003; IN COMMERCE 10-1-2010.  
RONALD DELGIZZI, EXAMINING ATTORNEY

**CLASS 35—(Continued).**

SN 85-205,183. ABERCROMBIE & FITCH TRADING CO., NEW ALBANY, OH. FILED 12-23-2010.

**GILLY HICKS GUYS**

THE MARK CONSISTS OF STANDARD CHARACTERS WITHOUT CLAIM TO ANY PARTICULAR FONT, STYLE, SIZE, OR COLOR.

OWNER OF U.S. REG. NOS. 3,584,446, 3,849,016 AND OTHERS.

THE NAME "GILLY HICKS GUYS" DOES NOT IDENTIFY A LIVING INDIVIDUAL.

FOR RETAIL STORE AND ON-LINE RETAIL STORE SERVICES FEATURING CLOTHING, CLOTHING ACCESSORIES, JEWELRY, BAGS, CANDLES AND PERSONAL CARE PRODUCTS AND PROVIDING A CUSTOMER LOYALTY PROGRAM TO PROMOTE CUSTOMER LOYALTY AND THE RETAIL SALE OF THE FOREGOING GOODS (U.S. CLS. 100, 101 AND 102).

DOMINICK J. SALEMI, EXAMINING ATTORNEY

SN 85-205,280. ROCKPORT, ANTHONY, LANCASTER, CA. FILED 12-23-2010.

**LocalLiving**

THE MARK CONSISTS OF STANDARD CHARACTERS WITHOUT CLAIM TO ANY PARTICULAR FONT, STYLE, SIZE, OR COLOR.

FOR BUSINESS MARKETING; PROVIDING AN ON-LINE DIRECTORY INFORMATION SERVICES FEATURING INFORMATION REGARDING PRODUCTS AND SERVICES OF LOCAL BUSINESSES (U.S. CLS. 100, 101 AND 102).

FIRST USE 11-12-2010; IN COMMERCE 11-12-2010.  
GIANCARLO CASTRO, EXAMINING ATTORNEY

SN 85-205,181. ABERCROMBIE & FITCH TRADING CO., NEW ALBANY, OH. FILED 12-23-2010.

**GILLY GUYS**

THE MARK CONSISTS OF STANDARD CHARACTERS WITHOUT CLAIM TO ANY PARTICULAR FONT, STYLE, SIZE, OR COLOR.

OWNER OF U.S. REG. NOS. 3,584,446, 3,849,016 AND OTHERS.

THE NAME "GILLY GUYS" DOES NOT IDENTIFY A LIVING INDIVIDUAL.

FOR RETAIL STORE AND ON-LINE RETAIL STORE SERVICES FEATURING CLOTHING, CLOTHING ACCESSORIES, JEWELRY, BAGS, CANDLES AND PERSONAL CARE PRODUCTS AND PROVIDING A CUSTOMER LOYALTY PROGRAM TO PROMOTE CUSTOMER LOYALTY AND THE RETAIL SALE OF THE FOREGOING GOODS (U.S. CLS. 100, 101 AND 102).

DOMINICK J. SALEMI, EXAMINING ATTORNEY

SN 85-205,585. BAMIN INC, NEW YORK, NY. FILED 12-24-2010.

**BAMIN**

THE MARK CONSISTS OF STANDARD CHARACTERS WITHOUT CLAIM TO ANY PARTICULAR FONT, STYLE, SIZE, OR COLOR.

FOR RETAIL STORE AND ON-LINE RETAIL STORE SERVICES FEATURING COMPONENTS CONSISTING OF FABRIC PANELS TO MAKE CLOTHES, BAGS AND ACCESSORIES THAT MAY BE CUSTOMIZED AND ASSEMBLED BY CONSUMERS (U.S. CLS. 100, 101 AND 102).

JENNY PARK, EXAMINING ATTORNEY

**CLASS 35—(Continued).**

SN 85-205,758. NATIONAL PORK BOARD, CLIVE, IA. FILED 12-27-2010.

**BE INSPIRED**

THE MARK CONSISTS OF STANDARD CHARACTERS WITHOUT CLAIM TO ANY PARTICULAR FONT, STYLE, SIZE, OR COLOR.

FOR PROMOTING THE INTERESTS OF THE MEMBERS OF THE PORK INDUSTRY (U.S. CLS. 100, 101 AND 102).

WENDY GOODMAN, EXAMINING ATTORNEY

SN 85-205,817. MATERIAL HANDLING INDUSTRY, DBA MATERIAL HANDLING INDUSTRY OF AMERICA, CHARLOTTE, NC. FILED 12-27-2010.



OWNER OF U.S. REG. NOS. 1,838,931, 2,129,438 AND 2,476,615.

NO CLAIM IS MADE TO THE EXCLUSIVE RIGHT TO USE "REUSABLE CONTAINER & PALLET ASSOCIATION", APART FROM THE MARK AS SHOWN.

THE MARK CONSISTS OF A QUADRILATERAL MADE OF FOUR BARS AND CONTAINING A STAR WITH FIVE POINTS FOLLOWED BY THE UNDERLINED LETTERS "RCPA" WITH THE TOP OF THE "C" ENDING IN AN ARROW AND THE PHRASE "REUSABLE CONTAINER & PALLET ASSOCIATION" BELOW THE QUADRILATERAL AND UNDERLINE.

FOR ASSOCIATION SERVICES, NAMELY, PROMOTING THE INTERESTS OF THE MATERIAL HANDLING INDUSTRY RELATING TO REUSABLE CONTAINERS AND PALLETS (U.S. CLS. 100, 101 AND 102).

FIRST USE 1-1-2010; IN COMMERCE 1-1-2010.

DOMINICK J. SALEMI, EXAMINING ATTORNEY

**CLASS 35—(Continued).**

SN 85-205,836. ZIA MANAGEMENT SERVICES, INC., OKLAHOMA CITY, OK. FILED 12-27-2010.



NO CLAIM IS MADE TO THE EXCLUSIVE RIGHT TO USE "CORE BUSINESS AND FINANCIAL SERVICES", APART FROM THE MARK AS SHOWN.

THE COLOR(S) GREEN, YELLOW, AND BROWN IS/ARE CLAIMED AS A FEATURE OF THE MARK.

THE MARK CONSISTS OF A SIX-POINTED STAR IN SHADES OF GREEN AND YELLOW IN THE UPPER LEFT OF THE MARK AND THE BROWN WORDING "CORE BUSINESS AND FINANCIAL SERVICES" BELOW AND TO THE RIGHT OF THE STAR.

FOR BUSINESS MANAGEMENT CONSULTATION AND SERVICES, NAMELY, MANAGING AND ADMINISTERING NON-CORE FUNCTIONS, NAMELY, MAILING AND SHIPPING, RECORDS MANAGEMENT, INFORMATION SERVICES, ADMINISTRATION, PAYROLL AND ACCOUNTING, AND TELEMARKETING SERVICES (U.S. CLS. 100, 101 AND 102).

FIRST USE 12-14-2007; IN COMMERCE 1-1-2008.

KRISTIN CARLSON, EXAMINING ATTORNEY

SN 85-205,887. PROFESSIONAL RESEARCH CONSULTING, SAN FRANCISCO, CA. FILED 12-27-2010.



NO CLAIM IS MADE TO THE EXCLUSIVE RIGHT TO USE "CLINICAL", APART FROM THE MARK AS SHOWN.

THE MARK CONSISTS OF THE STYLIZED TEXT "PRC CLINICAL" WITH A CURVE SHAPE DESIGN IN THE BACKGROUND.

FOR BUSINESS CONSULTING AND MANAGEMENT IN THE FIELD OF CLINICAL TRIALS, NAMELY, PROVIDING INFORMATION MANAGEMENT SERVICES (U.S. CLS. 100, 101 AND 102).

JENNY PARK, EXAMINING ATTORNEY



**CLASS 35—(Continued).**

SN 85-205,965. ARACHNIDWORKS, INC., FREDERICK, MD.  
FILED 12-27-2010.



NO CLAIM IS MADE TO THE EXCLUSIVE RIGHT TO USE "INC", APART FROM THE MARK AS SHOWN.

THE MARK CONSISTS OF A SOLID BLOCK WITH THE KNOCKOUT TEXT "ARACHNID WORKS INC." AND LINE-ART SPIDER IMAGE.

FOR ADVERTISING AND MARKETING; ADVERTISING COPYWRITING (U.S. CLS. 100, 101 AND 102).

FIRST USE 3-18-2000; IN COMMERCE 3-18-2000.  
ELIZABETH KAJUBI, EXAMINING ATTORNEY

**CLASS 35—(Continued).**

SN 85-206,202. BELLSON CORP, FOUNTAIN VALLEY, CA.  
FILED 12-27-2010.



NO CLAIM IS MADE TO THE EXCLUSIVE RIGHT TO USE "PARTY FAVORS", APART FROM THE MARK AS SHOWN.

THE MARK CONSISTS OF THE STYLIZED WORDING "PARTY FAVORS & MORE" WITH A PARTY HAT ON THE "P", FOUR PIECES OF CONFETTI BELOW AND TO THE LEFT OF "PARTY", ONE BLOWER BELOW "PARTY", AND TWO PIECES OF CONFETTI, THREE BALLOONS, AND ONE BLOWER TO THE RIGHT OF "MORE".

FOR RETAIL SHOPS FEATURING PARTY DECORATIONS, PARTY SUPPLIES, PARTY KITS, GOODIE BAGS (U.S. CLS. 100, 101 AND 102).

MAYUR VAGHANI, EXAMINING ATTORNEY

SN 85-206,000. BRANCO, VANESSA, FORT COLLINS, CO.  
FILED 12-27-2010.

## 5 or Dive

THE MARK CONSISTS OF STANDARD CHARACTERS WITHOUT CLAIM TO ANY PARTICULAR FONT, STYLE, SIZE, OR COLOR.

FOR PROVIDING A WEB SITE FEATURING REVIEWS FROM THE EDITORS, AND WHERE USERS CAN POST RATINGS, REVIEWS AND RECOMMENDATIONS ON PRODUCTS AND SERVICES FOR COMMERCIAL PURPOSES; PROMOTING THE GOODS AND SERVICES OF OTHERS BY PROVIDING A WEBSITE FEATURING COUPONS, REBATES, PRICE-COMPARISON INFORMATION, PRODUCT REVIEWS, LINKS TO THE RETAIL WEBSITES OF OTHERS, AND DISCOUNT INFORMATION (U.S. CLS. 100, 101 AND 102).

HELENE LIWINSKI, EXAMINING ATTORNEY

SN 85-206,301. JASMINE PHOTOGRAPHY, PORTLAND, OR.  
FILED 12-28-2010.

## THE ART OF WEDDINGS A SWANKIER KIND OF BRIDAL SHOW

THE MARK CONSISTS OF STANDARD CHARACTERS WITHOUT CLAIM TO ANY PARTICULAR FONT, STYLE, SIZE, OR COLOR.

NO CLAIM IS MADE TO THE EXCLUSIVE RIGHT TO USE "WEDDINGS" AND "BRIDAL SHOW", APART FROM THE MARK AS SHOWN.

FOR ARRANGING AND CONDUCTING TRADE SHOW EXHIBITIONS IN THE FIELD OF WEDDINGS AND BRIDAL-RELATED SERVICES AND PRODUCTS (U.S. CLS. 100, 101 AND 102).

FIRST USE 12-1-2004; IN COMMERCE 12-1-2004.  
ALICE BENMAMAN, EXAMINING ATTORNEY

**CLASS 35—(Continued).**

SN 85-206,472. SCIENTIFIC MARKETING CORP., DBA SCHERAGO INTERNATIONAL, JERSEY CITY, NJ. FILED 12-28-2010.

**NEW PRODUCTS REVIEW**

THE MARK CONSISTS OF STANDARD CHARACTERS WITHOUT CLAIM TO ANY PARTICULAR FONT, STYLE, SIZE, OR COLOR.

NO CLAIM IS MADE TO THE EXCLUSIVE RIGHT TO USE "NEW PRODUCTS", APART FROM THE MARK AS SHOWN.

SEC. 2(F).

FOR ADVERTISING, MARKETING AND PROMOTION SERVICES; ADVERTISING, MARKETING AND PROMOTION SERVICES, NAMELY, PROMOTING THE GOODS AND SERVICES OF OTHERS BY PROVIDING CUSTOMIZED VISUAL DISPLAYS FOR EXHIBITIONS AND EXPOSITIONS (U.S. CLS. 100, 101 AND 102).

FIRST USE 7-31-1976; IN COMMERCE 7-31-1976.  
HELENE LIWINSKI, EXAMINING ATTORNEY

SN 85-206,486. CULTURES FOR HEALTH, MILWAUKIE, OR. FILED 12-28-2010.

**Where Healthy Food Starts**

THE MARK CONSISTS OF STANDARD CHARACTERS WITHOUT CLAIM TO ANY PARTICULAR FONT, STYLE, SIZE, OR COLOR.

NO CLAIM IS MADE TO THE EXCLUSIVE RIGHT TO USE "HEALTHY FOOD", APART FROM THE MARK AS SHOWN.

FOR ON-LINE WHOLESALE AND RETAIL STORE SERVICES FEATURING HEALTH FOODS AND KITCHEN SUPPLIES (U.S. CLS. 100, 101 AND 102).

FIRST USE 12-7-2010; IN COMMERCE 12-7-2010.  
ALEXANDER L. POWERS, EXAMINING ATTORNEY

SN 85-206,650. S & R GLADDEN INC, GREENSBORO, NC. FILED 12-28-2010.



NO CLAIM IS MADE TO THE EXCLUSIVE RIGHT TO USE "OUR BUSINESS IS TAXES", APART FROM THE MARK AS SHOWN.

FOR INCOME TAX PREPARATION AND ELECTRONIC FILING SERVICES FOR FEDERAL AND STATE INCOME TAX RETURNS (U.S. CLS. 100, 101 AND 102).

FIRST USE 4-20-1993; IN COMMERCE 4-20-1993.  
KATHERINE M. DUBRAY, EXAMINING ATTORNEY

**CLASS 35—(Continued).**

SN 85-206,721. OPTIMUM CONSULTING, LLC, FORT WAYNE, IN. FILED 12-28-2010.



**Optimum Consulting, LLC**

Don't outsource. Optimize!

NO CLAIM IS MADE TO THE EXCLUSIVE RIGHT TO USE "CONSULTING, LLC", APART FROM THE MARK AS SHOWN.

THE MARK CONSISTS OF THE LITERAL ELEMENTS "OPTIMUM CONSULTING, LLC DON'T OUTSOURCE. OPTIMIZE!" AND ASSOCIATED DESIGN. THE DESIGN APPEARS ABOVE THE LITERAL ELEMENTS AND CONSISTS OF TWO CONCENTRIC OVALS, WITH A CIRCLE LOCATED WITHIN THE SHADED INNER OVAL, ALL APPEARING AGAINST A SHADED SQUARE-SHAPED CARRIER.

FOR OUTSOURCING SERVICES IN THE MEDICAL FIELD (U.S. CLS. 100, 101 AND 102).

JUDITH HELFMAN, EXAMINING ATTORNEY

SN 85-207,044. SILVER LINING PROJECT, LLC, MEQUON, WI. FILED 12-29-2010.



THE MARK CONSISTS OF TWO SNAKES THAT ARE A MIRROR IMAGE OF EACH OTHER, ONE WITH A SMIRK AND ONE WITH AN ADORABLE SMILE. THE WORDS "FEAR THE SNAKE" ARE ON THE LEFT, AND "LOVE THE SNAKE" IS ON THE RIGHT, BOTH IN INDIVIDUAL SCRIPT.

FOR PROVIDING A WEBSITE FEATURING INFORMATION ABOUT POLITICAL ISSUES (U.S. CLS. 100, 101 AND 102).

MAUREEN DALL, EXAMINING ATTORNEY

SN 85-207,046. FREEDOM TO LEAD INTERNATIONAL, CARY, NC. FILED 12-29-2010.

**FREEDOM TO LEAD INTERNATIONAL**

THE MARK CONSISTS OF STANDARD CHARACTERS WITHOUT CLAIM TO ANY PARTICULAR FONT, STYLE, SIZE, OR COLOR.

NO CLAIM IS MADE TO THE EXCLUSIVE RIGHT TO USE "INTERNATIONAL", APART FROM THE MARK AS SHOWN.

FOR EDUCATION LEADERSHIP DEVELOPMENT (U.S. CLS. 100, 101 AND 102).

FIRST USE 7-1-2009; IN COMMERCE 9-1-2009.  
MAUREEN DALL, EXAMINING ATTORNEY

**CLASS 35—(Continued).**

SN 85-207,070. PARRLEY INTERNATIONAL, INC., CHINO, CA. FILED 12-29-2010.



THE MARK CONSISTS OF THE STYLIZED WORDING "PARRLEY" IN WHICH EACH LETTER OF THE WORDING HAS GEOMETRIC SHAPES INCORPORATED INTO THE WORDING. THE LETTER "P" HAS A CIRCLE, THE LETTER "A" HAS A DIAMOND SHAPE AT TOP END OF THE LETTER AND A CIRCLE IN THE MIDDLE, THE TWO "R'S" EACH HAS A TRAPEZOID SHAPE ON TOP AND A CIRCLE AT THE BOTTOM, THE LETTER "L" HAS A DIAMOND SHAPE ON THE TOP, THE LETTER "E" HAS A CIRCLE ON THE RIGHT IN THE CENTER OF THE LETTER, THE LETTER "Y" HAS A CIRCLE IN THE MIDDLE.

FOR ONLINE SOCIAL VENTURE SERVICES, NAMELY, PROVIDING A WEBSITE FOR CONNECTING SELLERS WITH BUYERS FOR THE PURPOSE OF BUYING AND SELLING GENERAL GOODS AND SERVICES (U.S. CLS. 100, 101 AND 102).

JENNY PARK, EXAMINING ATTORNEY

**CLASS 35—(Continued).**

SN 85-207,308. STRATEGIC GROWTH ALLIANCE, LLC, ST. PETERSBURG, FL. FILED 12-29-2010.



NO CLAIM IS MADE TO THE EXCLUSIVE RIGHT TO USE "LLC", APART FROM THE MARK AS SHOWN.

THE MARK CONSISTS OF A SHADED RECTANGLE CONTAINING THE STYLIZED LETTERS "SGA LLC".

FOR VETERINARY PRACTICE BUSINESS MANAGEMENT FOR OTHERS (U.S. CLS. 100, 101 AND 102).

FIRST USE 1-31-2010; IN COMMERCE 1-31-2010.

JOHN DALIER, EXAMINING ATTORNEY

SN 85-207,189. VINTAGE MARKETING, INC., SANTA MONICA, CA. FILED 12-29-2010.

**Vintage Marketing, Inc.**

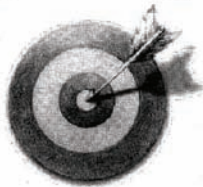

Marketing Well Targeted

NO CLAIM IS MADE TO THE EXCLUSIVE RIGHT TO USE "MARKETING, INC.", APART FROM THE MARK AS SHOWN.

THE MARK CONSISTS OF A CIRCULAR SHIELD WITH AN ARROW IN THE CENTER AND THE WORDS "VINTAGE MARKETING, INC." ABOVE AND "MARKETING WELL TARGETED" BELOW THE SHIELD.

FOR PROVIDING BUSINESS MARKETING INFORMATION (U.S. CLS. 100, 101 AND 102).

JAMES GRIFFIN, EXAMINING ATTORNEY

SN 85-207,432. BROKERS INTERNATIONAL, LTD., PANORA, IA. FILED 12-29-2010.

**MULTI CHOICE MARKETING GROUP**

THE MARK CONSISTS OF STANDARD CHARACTERS WITHOUT CLAIM TO ANY PARTICULAR FONT, STYLE, SIZE, OR COLOR.

OWNER OF U.S. REG. NOS. 2,928,378 AND 3,091,862.

NO CLAIM IS MADE TO THE EXCLUSIVE RIGHT TO USE "MARKETING GROUP", APART FROM THE MARK AS SHOWN.

SEC. 2(F).

FOR MARKETING SUPPORT SERVICES FOR ANNUITY PRODUCTS OF OTHERS, NAMELY, PROVIDING BUSINESS MARKETING INFORMATION OF PRODUCT FEATURES AND CHANGES FOR INDEPENDENT INSURANCE AGENTS (U.S. CLS. 100, 101 AND 102).

FIRST USE 9-23-2005; IN COMMERCE 9-23-2005.

APRIL ROACH, EXAMINING ATTORNEY

**CLASS 35—(Continued).**

SN 85-207,443. POHMEDIA, SUNRISE, FL. FILED 12-29-2010.

**RECONNAISSANCE**

THE MARK CONSISTS OF STANDARD CHARACTERS WITHOUT CLAIM TO ANY PARTICULAR FONT, STYLE, SIZE, OR COLOR.

FOR ADVERTISING AND ADVERTISEMENT SERVICES, NAMELY, PROVIDING TRACKING, ANALYZING, ANALYTICS, AND REPORTING OF ADVERTISING CAMPAIGNS (U.S. CLS. 100, 101 AND 102).

TRACY WHITTAKER-BROWN, EXAMINING ATTORNEY

**CLASS 35—(Continued).**

SN 85-207,586. HONEYMOON PIXIE, LLC, DBA HONEYMOONPIXIE.COM, WOODINVILLE, WA. FILED 12-29-2010.



SN 85-207,498. EDWARD CHEN, AKA JIANQIAO CHEN, MONTEREY PARK, CA. FILED 12-29-2010.



**Home Paradise**  
*Design Center*

OWNER OF U.S. REG. NO. 3,596,064.

NO CLAIM IS MADE TO THE EXCLUSIVE RIGHT TO USE "HOME" OR "DESIGN CENTER", APART FROM THE MARK AS SHOWN.

THE COLOR(S) YELLOW AND PURPLE IS/ARE CLAIMED AS A FEATURE OF THE MARK.

THE MARK CONSISTS OF A YELLOW CURVED PAINT BRUSH LINE ON THE LEFT AND THE STYLIZED WORDING "HOME PARADISE DESIGN CENTER" IN PURPLE ON THE RIGHT.

FOR WHOLESALE AND RETAIL STORE SERVICES AND ON-LINE RETAIL AND WHOLESALE STORE SERVICES FEATURING KITCHEN AND BATHROOM PRODUCTS AND ACCESSORIES; WHOLESALE AND RETAIL STORE SERVICES FEATURING KITCHEN AND BATHROOM PRODUCTS AND ACCESSORIES (U.S. CLS. 100, 101 AND 102).

FIRST USE 10-15-2009; IN COMMERCE 10-15-2009.  
KELLY BOULTON, EXAMINING ATTORNEY

NO CLAIM IS MADE TO THE EXCLUSIVE RIGHT TO USE "HONEYMOON", APART FROM THE MARK AS SHOWN.

THE COLOR(S) BLUE, TEAL, YELLOW AND BEIGE IS/ARE CLAIMED AS A FEATURE OF THE MARK.

THE MARK CONSISTS OF THE WORDS "HONEYMOON" AND "PIXIE" IN BLUE, WITH STARS DOTTING THE TWO "I" LETTERS IN "PIXIE", SEPARATED BY A BEIGE FAIRY WITH YELLOW HAIR IN A BLUE BODY-SUIT, BLUE SHOES, BLUE HEADBAND AND TEAL WINGS, HOLDING A BLUE WAND FROM WHICH CASCADING TEAL COLORED STARS EMANATE.

FOR BRIDAL REGISTRY SERVICES; GIFT REGISTRY SERVICES (U.S. CLS. 100, 101 AND 102).

FIRST USE 6-26-2010; IN COMMERCE 12-2-2010.  
BARNEY CHARLON, EXAMINING ATTORNEY

SN 85-207,636. KIND CLINICS LLC, SCOTTSDALE, AZ. FILED 12-29-2010.

**KIND CLINICS**

SN 85-207,566. THE JOY TEAM, VANCOUVER, WA. FILED 12-29-2010.

**The Joy Team**

THE MARK CONSISTS OF STANDARD CHARACTERS WITHOUT CLAIM TO ANY PARTICULAR FONT, STYLE, SIZE, OR COLOR.

NO CLAIM IS MADE TO THE EXCLUSIVE RIGHT TO USE "TEAM", APART FROM THE MARK AS SHOWN.

FOR PROMOTING PUBLIC AWARENESS OF CHOOSING JOY AND HAPPINESS THROUGH POSITIVE MESSAGING ON BILLBOARDS, ON THE INTERNET AND THROUGH SPEAKING ENGAGEMENTS (U.S. CLS. 100, 101 AND 102).

FIRST USE 11-30-2009; IN COMMERCE 2-19-2010.  
CHARLOTTE CORWIN, EXAMINING ATTORNEY

THE MARK CONSISTS OF STANDARD CHARACTERS WITHOUT CLAIM TO ANY PARTICULAR FONT, STYLE, SIZE, OR COLOR.

NO CLAIM IS MADE TO THE EXCLUSIVE RIGHT TO USE "CLINICS", APART FROM THE MARK AS SHOWN.

FOR BUSINESS CONSULTING AND INFORMATION SERVICES; BUSINESS DEVELOPMENT CONSULTING SERVICES; BUSINESS MANAGEMENT CONSULTING; BUSINESS MARKETING CONSULTING SERVICES (U.S. CLS. 100, 101 AND 102).

FIRST USE 11-0-2010; IN COMMERCE 11-0-2010.  
WILLIAM ROSSMAN, EXAMINING ATTORNEY

**CLASS 35—(Continued).**

SN 85-207,724. RSI RELO, INC, VISTA, CA. FILED 12-30-2010.



NO CLAIM IS MADE TO THE EXCLUSIVE RIGHT TO USE "MOVE" AND "GROUP", APART FROM THE MARK AS SHOWN.

THE COLOR(S) DARK BLUE, LIGHT BLUE, GREY IS/ ARE CLAIMED AS A FEATURE OF THE MARK.

THE MARK CONSISTS OF THE WORDS "MOVE MAN GROUP" IN DARK BLUE WITH A DESIGN OF FOUR GREY PEOPLE HOLDING A LIGHT BLUE HOUSE WHICH HAS THE OUTLINE OF THE WORLD IN DARK BLUE.

FOR MOVING AND RELOCATION SERVICES, NAMELY, PLANNING AND PROJECT OVERSIGHT OF HOME MOVING FOR OTHERS; RELOCATION SERVICES FOR BUSINESS (U.S. CLS. 100, 101 AND 102).

FIRST USE 10-1-2010; IN COMMERCE 10-1-2010.  
ANGELA DUONG, EXAMINING ATTORNEY

---

SN 85-207,842. WALDRON OF MARYLAND, INC., BALTIMORE, MD. FILED 12-30-2010.

**Waldron of Maryland, Inc.**

THE MARK CONSISTS OF STANDARD CHARACTERS WITHOUT CLAIM TO ANY PARTICULAR FONT, STYLE, SIZE, OR COLOR.

NO CLAIM IS MADE TO THE EXCLUSIVE RIGHT TO USE "MARYLAND, INC.", APART FROM THE MARK AS SHOWN.

FOR WHOLESALE DISTRIBUTORSHIP FEATURING HEATING, VENTILATION AND AIR CONDITIONING MATERIALS (U.S. CLS. 100, 101 AND 102).

FIRST USE 1-14-1981; IN COMMERCE 1-14-1981.  
ANDREA HACK, EXAMINING ATTORNEY

**CLASS 35—(Continued).**

SN 85-207,872. TELEMATCH, INC., SPRINGFIELD, VA. FILED 12-30-2010.

**FARM MARKET ID**

THE MARK CONSISTS OF STANDARD CHARACTERS WITHOUT CLAIM TO ANY PARTICULAR FONT, STYLE, SIZE, OR COLOR.

NO CLAIM IS MADE TO THE EXCLUSIVE RIGHT TO USE "FARM MARKET", APART FROM THE MARK AS SHOWN.

FOR BUSINESS MARKETING SERVICES, NAMELY, PROVIDING A DATABASE FEATURING FARM OWNERSHIP INFORMATION FOR THE PURPOSE OF CONNECTING AGRICULTURAL SELLERS TO POTENTIAL BUYERS (U.S. CLS. 100, 101 AND 102).

FIRST USE 3-14-1997; IN COMMERCE 3-14-1997.  
NATALIE POLZER, EXAMINING ATTORNEY

---

SN 85-207,878. TELEMATCH, INC., SPRINGFIELD, VA. FILED 12-30-2010.

**FMID**

THE MARK CONSISTS OF STANDARD CHARACTERS WITHOUT CLAIM TO ANY PARTICULAR FONT, STYLE, SIZE, OR COLOR.

FOR BUSINESS MARKETING SERVICES, NAMELY, PROVIDING A DATABASE FEATURING FARM OWNERSHIP INFORMATION FOR THE PURPOSE OF CONNECTING AGRICULTURAL SELLERS TO POTENTIAL BUYERS (U.S. CLS. 100, 101 AND 102).

FIRST USE 3-14-1997; IN COMMERCE 3-14-1997.  
NATALIE POLZER, EXAMINING ATTORNEY

---

SN 85-208,246. WEIDEL, ADAM, MONROE, GA. FILED 12-30-2010.

**Silverback Krew**

THE MARK CONSISTS OF STANDARD CHARACTERS WITHOUT CLAIM TO ANY PARTICULAR FONT, STYLE, SIZE, OR COLOR.

FOR ON-LINE RETAIL STORE SERVICES FEATURING HATS, SUNGLASSES, AND TOTE BAGS (U.S. CLS. 100, 101 AND 102).

FIRST USE 1-1-2010; IN COMMERCE 4-1-2010.  
ELLEN PERKINS, EXAMINING ATTORNEY



**CLASS 35—(Continued).**

SN 85-208,405. MICHAEL PATTERSON, SOUTH DENNIS, MA. AND ELIZABETH PATTERSON, SOUTH DENNIS, MA. FILED 12-30-2010.

## Drinking Company

THE MARK CONSISTS OF STANDARD CHARACTERS WITHOUT CLAIM TO ANY PARTICULAR FONT, STYLE, SIZE, OR COLOR.

NO CLAIM IS MADE TO THE EXCLUSIVE RIGHT TO USE "COMPANY", APART FROM THE MARK AS SHOWN.

FOR RETAIL STORE AND ON-LINE RETAIL STORE SERVICES FEATURING ALCOHOLIC AND NON-ALCOHOLIC BEVERAGES, CIGARS, COFFEE, TEA, FOOD, GOURMET FOOD, SPECIALTY FOOD, SODA, SPARKLING AND STILL WATER, LIME JUICE, DRINK MIXES, SAUCES, SALSAS, MARINADES, SNACK FOODS, BARWARE, GENERAL MERCHANDISE, GIFT BASKETS AND BOXES CONSISTING PRIMARILY OF WINE, GIFT BASKETS AND BOXES CONSISTING PRIMARILY OF LIQUOR, GIFT BASKETS AND BOXES CONSISTING PRIMARILY OF BEER, GIFT BASKETS AND BOXES CONSISTING PRIMARILY OF APERITIFS AND SPIRITS (U.S. CLS. 100, 101 AND 102).

KARANENDRA S. CHHINA, EXAMINING ATTORNEY

**CLASS 35—(Continued).**

SN 85-208,926. GNL ENTERTAINMENT, INC., WASHINGTON, DC. FILED 1-3-2011.

## Music-Ebru

THE MARK CONSISTS OF STANDARD CHARACTERS WITHOUT CLAIM TO ANY PARTICULAR FONT, STYLE, SIZE, OR COLOR.

THE ENGLISH TRANSLATION OF THE TURKISH WORD "EBRU" IN THE MARK IS "TURKISH PAPER MARBLING".

FOR PROVIDING AN INTERNET WEBSITE PORTAL FEATURING LINKS TO MUSIC-RELATED MERCHANDISE FOR RETAIL PURPOSES (U.S. CLS. 100, 101 AND 102).

ANDREA HACK, EXAMINING ATTORNEY

SN 85-208,998. CLUSS, PATRICIA A., PITTSBURGH, PA. FILED 1-3-2011.

## STANDING FIRM

THE MARK CONSISTS OF STANDARD CHARACTERS WITHOUT CLAIM TO ANY PARTICULAR FONT, STYLE, SIZE, OR COLOR.

FOR PUBLIC ADVOCACY TO PROMOTE CORPORATE AWARENESS IN THE BUSINESS COMMUNITY OF THE NEED TO ADDRESS DOMESTIC VIOLENCE AS A WORKPLACE ISSUE (U.S. CLS. 100, 101 AND 102).

JEAN IM, EXAMINING ATTORNEY

SN 85-208,656. NUCRAFT COMPANY, LLC, ARLINGTON, VA. FILED 12-31-2010.

## NUCRAFT CO

THE MARK CONSISTS OF STANDARD CHARACTERS WITHOUT CLAIM TO ANY PARTICULAR FONT, STYLE, SIZE, OR COLOR.

NO CLAIM IS MADE TO THE EXCLUSIVE RIGHT TO USE "CO", APART FROM THE MARK AS SHOWN.

FOR BUSINESS CONSULTING SERVICES IN THE FIELDS OF ENTREPRENEURSHIP, LEADERSHIP, NEW BUSINESS MODEL DESIGN, NEW PRODUCT DEVELOPMENT, BUSINESS GROWTH STRATEGY, BUSINESS PERFORMANCE ENHANCEMENT, BUSINESS MANAGEMENT AND REVENUE ENHANCEMENT STRATEGIES; BUSINESS APPRAISALS; ADVISING ON BUSINESS ACQUISITIONS AND MERGERS; AND CONDUCTING BUSINESS AND MARKET RESEARCH SURVEYS (U.S. CLS. 100, 101 AND 102).

FIRST USE 8-29-2010; IN COMMERCE 8-29-2010.

APRIL ROACH, EXAMINING ATTORNEY

SN 85-209,120. DO-ROCK ENTERPRISES, BLOOMINGTON, IN. FILED 1-3-2011.

## Famous For Fun

THE MARK CONSISTS OF STANDARD CHARACTERS WITHOUT CLAIM TO ANY PARTICULAR FONT, STYLE, SIZE, OR COLOR.

FOR DEALERSHIPS IN THE FIELD OF MOTORCYCLES (U.S. CLS. 100, 101 AND 102).

FIRST USE 1-5-2011; IN COMMERCE 1-5-2011.

FRANK LATTUCA, EXAMINING ATTORNEY

**CLASS 35—(Continued).**

SN 85-209,261. THE CUPCAKE STATION INCORPORATED, BIRMINGHAM, MI. FILED 1-3-2011.



NO CLAIM IS MADE TO THE EXCLUSIVE RIGHT TO USE "100% SCRATCH EVERY BATCH", APART FROM THE MARK AS SHOWN.

THE COLOR(S) GOLD, YELLOW, BROWN, BEIGE AND BLACK IS/ARE CLAIMED AS A FEATURE OF THE MARK.

THE MARK CONSISTS OF THE STYLIZED WORDING "100% SCRATCH EVERY BATCH" AND CUPCAKE AND SEAL DESIGN. THE SEAL IS CIRCULAR, CONSISTING OF CONCENTRIC RINGS COLORED BROWN, GOLD, BLACK, BEIGE, WITH A RIDGED OUTER BORDER IN GOLD. WITHIN THE BLACK RING APPEARS THE WORDING "100% SCRATCH" AT THE TOP AND THE WORDING "EVERY BATCH" AT THE BOTTOM. THE WORDING APPEARS IN YELLOW, AND IS SEPARATED AT LEFT AND RIGHT BY YELLOW WHEAT SHEAVES. WITHIN THE CIRCULAR SEAL IS A GOLD, YELLOW AND BROWN CUPCAKE AGAINST A BEIGE BACKGROUND.

FOR RETAIL BAKERY SHOPS (U.S. CLS. 100, 101 AND 102).

FIRST USE 1-1-2010; IN COMMERCE 1-1-2010.  
JERI J. FICKES, EXAMINING ATTORNEY

SN 85-209,522. HUMMEL, DENISE PIRROTI, DBA UNIVERSAL CONSENSUS, CARLSBAD, CA. FILED 1-3-2011.

**UNIVERSAL CONSENSUS**

THE MARK CONSISTS OF STANDARD CHARACTERS WITHOUT CLAIM TO ANY PARTICULAR FONT, STYLE, SIZE, OR COLOR.

FOR BUSINESS ORGANIZATION AND MANAGEMENT CONSULTING AND ADVISORY SERVICES (U.S. CLS. 100, 101 AND 102).

FIRST USE 2-1-2009; IN COMMERCE 2-1-2009.  
DOMINICK J. SALEMI, EXAMINING ATTORNEY

**CLASS 35—(Continued).**

SN 85-209,545. AVENUE K MARKETING, LLC, LOS ANGELES, CA. FILED 1-3-2011.

**AVENUE K**

THE MARK CONSISTS OF STANDARD CHARACTERS WITHOUT CLAIM TO ANY PARTICULAR FONT, STYLE, SIZE, OR COLOR.

FOR ADVERTISING; ADVERTISING AGENCY; ADVERTISING, PROMOTION AND MARKETING SERVICES FOR OTHERS, INCLUDING ON-LINE ADVERTISING ON A COMPUTER NETWORK, AND ADVERTISING FOR OTHERS IN AND ON PARKING FACILITIES AND ON COMMERCIAL PROPERTIES, AND ADVERTISING ON MOBILE DEVICES; ON-LINE ADVERTISING OF THE PRODUCTS AND SERVICES OF OTHERS VIA A WORLD WIDE WEB WEBSITE ON A COMPUTER NETWORK; PRODUCT DEMONSTRATION SERVICES; MARKETING CONSULTING; ADVERTISING, MARKETING AND PROMOTION SERVICES; DEVELOPING ADVERTISING AND PROMOTIONAL CAMPAIGNS FOR BUSINESSES; DEVELOPMENT OF MARKETING STRATEGIES AND CONCEPTS (U.S. CLS. 100, 101 AND 102).

ZHALEH DELANEY, EXAMINING ATTORNEY

SN 85-209,563. @VODKA INC., WILMINGTON, DE. FILED 1-3-2011.



NO CLAIM IS MADE TO THE EXCLUSIVE RIGHT TO USE "VODKA", APART FROM THE MARK AS SHOWN.

THE MARK CONSISTS OF THE TEXT "@VODKA". THE "V" HAS BEEN STYLIZED INTO A MARTINI-STYLE COCKTAIL GLASS, WITH AN OUTLINE AND LIQUID IN IT. THE "@" RESTS ON THE RIM OF THE COCKTAIL GLASS, IN A MANNER SIMILAR TO A COCKTAIL GARNISH.

FOR PROMOTIONAL AND MARKETING SERVICES FOR BEVERAGE COMPANIES, BARS, AND OTHER RELATED VENUES (U.S. CLS. 100, 101 AND 102).

FIRST USE 12-2-2010; IN COMMERCE 12-2-2010.  
JAMES GRIFFIN, EXAMINING ATTORNEY

**CLASS 35—(Continued).**

SN 85-209,725. GLOBE EXPRESS SERVICES, LTD., CHARLOTTE, NC. FILED 1-4-2011.

## SUPPLY CHAINS BUILT BY PEOPLE WHO CARE

THE MARK CONSISTS OF STANDARD CHARACTERS WITHOUT CLAIM TO ANY PARTICULAR FONT, STYLE, SIZE, OR COLOR.

FOR TRANSPORTATION LOGISTICS SERVICES, NAMELY, ARRANGING THE TRANSPORTATION OF GOODS FOR OTHERS AND PROVIDING INFORMATION MANAGEMENT SERVICES, NAMELY, SHIPMENT PROCESSING, PREPARING SHIPPING DOCUMENTS AND INVOICES, AND TRACKING DOCUMENTS, PACKAGES AND FREIGHT OVER COMPUTER NETWORKS (U.S. CLS. 100, 101 AND 102).

FIRST USE 10-16-2010; IN COMMERCE 10-16-2010.  
KATHERINE M. DUBRAY, EXAMINING ATTORNEY

---

SN 85-209,823. LIBREDIGITAL, INC., AUSTIN, TX. FILED 1-4-2011.

## SKYSHELF

THE MARK CONSISTS OF STANDARD CHARACTERS WITHOUT CLAIM TO ANY PARTICULAR FONT, STYLE, SIZE, OR COLOR.

OWNER OF U.S. REG. NO. 3,926,999.

FOR RETAIL STORE SERVICES IN THE FIELD OF ENTERTAINMENT AND DIGITAL MEDIA, FEATURING ELECTRONIC BOOKS, PRE-RECORDED AUDIO, INCLUDING MUSIC, AND AUDIOVISUAL WORKS, INCLUDING MOVIES, ELECTRONIC GAMES, AND RELATED MERCHANDISE, PROVIDED VIA THE INTERNET AND OTHER COMPUTER AND ELECTRONIC COMMUNICATION NETWORKS (U.S. CLS. 100, 101 AND 102).

KYLE PEETE, EXAMINING ATTORNEY

---

SN 85-210,302. AHA MARKETING GROUP OF GREENDALE INVESTMENTS LLC, BARRINGTON, IL. FILED 1-4-2011.

## MY HEALTHY PUPPY

THE MARK CONSISTS OF STANDARD CHARACTERS WITHOUT CLAIM TO ANY PARTICULAR FONT, STYLE, SIZE, OR COLOR.

NO CLAIM IS MADE TO THE EXCLUSIVE RIGHT TO USE "PUPPY", APART FROM THE MARK AS SHOWN. FOR RETAIL PET STORES (U.S. CLS. 100, 101 AND 102).

FIRST USE 11-30-2009; IN COMMERCE 11-30-2009.  
ROBIN MITTLER, EXAMINING ATTORNEY

**CLASS 35—(Continued).**

SN 85-210,527. MOREIRA, HECTOR ERNESTO, DBA MOREIRA, HECTOR ERNESTO, FEDERAL WAY, WA. FILED 1-5-2011.

## MOREIRA, HECTOR ERNESTO

THE MARK CONSISTS OF STANDARD CHARACTERS WITHOUT CLAIM TO ANY PARTICULAR FONT, STYLE, SIZE, OR COLOR.

THE NAME "MOREIRA, HECTOR ERNESTO" IDENTIFIES A LIVING INDIVIDUAL WHOSE CONSENT IS OF RECORD.

FOR ACCOUNT AUDITING; ACCOUNTING SERVICES; ADMINISTRATIVE ACCOUNTING; CONSULTING AND INFORMATION CONCERNING ACCOUNTING; COST ACCOUNTING; FORENSIC ACCOUNTING SERVICES (U.S. CLS. 100, 101 AND 102).

KAREN BRACEY, EXAMINING ATTORNEY

---

SN 85-211,002. CRUZ, PRISCILLA PANGELINAN, DBA PRISCILLA P CRUZ, FEDERAL WAY, WA. FILED 1-5-2011.

## CRUZ PRISCILLA PANGELINAN

THE MARK CONSISTS OF STANDARD CHARACTERS WITHOUT CLAIM TO ANY PARTICULAR FONT, STYLE, SIZE, OR COLOR.

THE NAME "CRUZ PRISCILLA PANGELINAN" IDENTIFIES A LIVING INDIVIDUAL WHOSE CONSENT IS OF RECORD.

FOR ACCOUNT AUDITING; ACCOUNTING CONSULTATION; ADMINISTRATIVE ACCOUNTING; COST ACCOUNTING; FORENSIC ACCOUNTING SERVICES (U.S. CLS. 100, 101 AND 102).

JOHN KELLY, EXAMINING ATTORNEY

**CLASS 35—(Continued).**

SN 85-211,010. THE SILVER SPOON, LLC, MEMPHIS, TN. FILED 1-5-2011.



NO CLAIM IS MADE TO THE EXCLUSIVE RIGHT TO USE "GROCER" AND "PURVEYOR OF FINE FOOD", APART FROM THE MARK AS SHOWN.

THE MARK CONSISTS OF A FLEUR DE LIS IN THE CENTER BACKGROUND WITH THE PHRASE "THE UPTOWN GROCER", WHICH IS STYLIZED AND ABOVE THE PHRASE "PURVEYOR OF FINE FOOD", WHICH IS IN ALL CAPS.

FOR MAIL ORDER, ON-LINE AND RETAIL STORE SERVICES FEATURING PREPARED FOODS, NAMELY, SOUP, MEAT, APPETIZERS, DESSERTS, AND OTHER ENTRÉE ITEMS FOR GIFT AND SELF-CONSUMPTION (U.S. CLS. 100, 101 AND 102).

FIRST USE 7-0-2010; IN COMMERCE 7-0-2010.  
HELENE LIWINSKI, EXAMINING ATTORNEY

SN 85-211,110. CHARGE ANYWHERE, LLC, COLUMBIA, MD. FILED 1-5-2011.

**PAYDUCATION**

THE MARK CONSISTS OF STANDARD CHARACTERS WITHOUT CLAIM TO ANY PARTICULAR FONT, STYLE, SIZE, OR COLOR.

FOR PROMOTING THE SALE OF MERCHANT SERVICES, PAYMENT SOFTWARE AND PAYMENT HARDWARE OF OTHERS THROUGH THE ADMINISTRATION OF AN INCENTIVE REWARDS PROGRAM WHEREBY BUSINESSES GENERATE MONEY FOR LOCAL SCHOOLS (U.S. CLS. 100, 101 AND 102).

LAURA KOVALSKY, EXAMINING ATTORNEY

SN 85-211,120. EXECUTIVES IN ACTION, DALLAS, TX. FILED 1-5-2011.

**EXECUTIVES IN ACTION**

THE MARK CONSISTS OF STANDARD CHARACTERS WITHOUT CLAIM TO ANY PARTICULAR FONT, STYLE, SIZE, OR COLOR.

NO CLAIM IS MADE TO THE EXCLUSIVE RIGHT TO USE "EXECUTIVES", APART FROM THE MARK AS SHOWN.

FOR CHARITABLE SERVICES, NAMELY, COORDINATION OF EXPERIENCED LEADERS FROM BUSINESS SECTOR AS PRO BONO CONSULTANTS TO CHARITABLE AGENCIES (U.S. CLS. 100, 101 AND 102).

FIRST USE 2-17-2009; IN COMMERCE 2-17-2009.  
KATHRYN COWARD, EXAMINING ATTORNEY

**CLASS 35—(Continued).**

SN 85-211,149. GSI HEALTH, LLC, AKA GOOD STEWARD INVESTMENTS HEALTH, LLC, PHILADELPHIA, PA. FILED 1-5-2011.



NO CLAIM IS MADE TO THE EXCLUSIVE RIGHT TO USE "HEALTH" AND "HEALTH INFORMATION TECHNOLOGY", APART FROM THE MARK AS SHOWN.

THE COLOR(S) BLACK, SILVER, RED, YELLOW, BLUE IS/ARE CLAIMED AS A FEATURE OF THE MARK.

THE MARK CONSISTS OF A SILVER AND BLACK STETHOSCOPE IN BETWEEN THE WORDS "GSI" AND "HEALTH". THE TOP OF THE STETHOSCOPE HAS SILVER AND BLACK BINAURAL PIECES THAT CRISS CROSS EACH OTHER. THE BOTTOM OF THE STETHOSCOPE BRANCHES AND LEADS TO TWO DISTINCT ENDINGS, ONE BEING AN ETHERNET CABLE, AND THE OTHER BEING A SILVER SINGLE SIDED TUNABLE. THE ETHERNET CABLE CONNECTOR IS TRANSPARENT AND INSIDE THE CONNECTOR ARE RED, BLUE AND YELLOW WIRES. THE STETHOSCOPE SITS BETWEEN THE WORDS "GSI" IN BOLD BLACK CAPITALIZED LETTERS AND "HEALTH", IN BOLD RED LETTERS WITH THE LETTER "H" CAPITALIZED. THE WORDING NEXT TO THE RIGHT SIDE OF THE ETHERNET SHOULD READ "DELIVERING ON THE PROMISE OF HEALTH INFORMATION TECHNOLOGY" IN BLACK LETTERS.

FOR MANAGED CARE SERVICES, NAMELY, ELECTRONIC PROCESSING OF HEALTH CARE INFORMATION (U.S. CLS. 100, 101 AND 102).

FIRST USE 11-23-2010; IN COMMERCE 11-23-2010.  
HEATHER SAPP, EXAMINING ATTORNEY

SN 85-211,173. LIGHT RAIL NOW, INC., VIRGINIA BEACH, VA. FILED 1-5-2011.



NO CLAIM IS MADE TO THE EXCLUSIVE RIGHT TO USE "LIGHT RAIL", APART FROM THE MARK AS SHOWN.

THE MARK CONSISTS OF A STYLIZED DEPICTION OF LIGHT RAIL TRANSPORTATION WITH "LIGHT RAIL NOW" TEXT BENEATH.

FOR PROMOTING PUBLIC AWARENESS OF THE NEED FOR A LIGHT RAIL SYSTEM IN VIRGINIA BY DEVELOPING GRASSROOTS SUPPORT NETWORKS FOR LIGHT RAIL TRANSPORTATION (U.S. CLS. 100, 101 AND 102).

FIRST USE 11-2-2010; IN COMMERCE 11-2-2010.  
HOWARD B. LEVINE, EXAMINING ATTORNEY

**CLASS 35—(Continued).**

SN 85-211,384. EXTRAS ON AVAIL LLC, LOS ANGELES, CA.  
FILED 1-5-2011.

**EXTRAS ON AVAIL CASTING**

THE MARK CONSISTS OF STANDARD CHARACTERS WITHOUT CLAIM TO ANY PARTICULAR FONT, STYLE, SIZE, OR COLOR.

NO CLAIM IS MADE TO THE EXCLUSIVE RIGHT TO USE "EXTRAS" AND "CASTING", APART FROM THE MARK AS SHOWN.

FOR EMPLOYMENT SERVICES IN THE NATURE OF TALENT CASTING IN THE FIELD(S) OF COMMERCIALS (U.S. CLS. 100, 101 AND 102).

BARBARA BROWN, EXAMINING ATTORNEY

SN 85-211,431. TEYSSIER, LEANN, CANONSBURG, PA.  
FILED 1-5-2011.

**Extreme Talent Showcase**

THE MARK CONSISTS OF STANDARD CHARACTERS WITHOUT CLAIM TO ANY PARTICULAR FONT, STYLE, SIZE, OR COLOR.

NO CLAIM IS MADE TO THE EXCLUSIVE RIGHT TO USE "TALENT SHOWCASE", APART FROM THE MARK AS SHOWN.

FOR ORGANIZING AND CONDUCTING CLASSES FOR ALL TYPES OF DANCE, SINGING AND VARIETY ARTS; ORGANIZING AND CONDUCTING TALENT COMPETITIONS FOR ALL TYPES OF DANCE, SINGING, AND VARIETY ARTS (U.S. CLS. 100, 101 AND 102).

FIRST USE 12-1-2009; IN COMMERCE 7-1-2010.  
PATRICIA EVANKO, EXAMINING ATTORNEY

SN 85-211,543. ANALYTICS NINJA LLC, LINCOLN, NE.  
FILED 1-6-2011.

**ANALYTICS NINJA**

THE MARK CONSISTS OF STANDARD CHARACTERS WITHOUT CLAIM TO ANY PARTICULAR FONT, STYLE, SIZE, OR COLOR.

NO CLAIM IS MADE TO THE EXCLUSIVE RIGHT TO USE "ANALYTICS", APART FROM THE MARK AS SHOWN.

FOR BUSINESS MARKETING CONSULTATION SERVICES IN THE FIELD OF WEB ANALYTICS; INTERNET MARKETING CONSULTING SERVICES (U.S. CLS. 100, 101 AND 102).

MICHAEL GAAFAR, EXAMINING ATTORNEY

**CLASS 35—(Continued).**

SN 85-211,578. BRUCE MELNICK, DAYTON, OH. FILED 1-6-2011.



NO CLAIM IS MADE TO THE EXCLUSIVE RIGHT TO USE "SEWING", APART FROM THE MARK AS SHOWN.

THE MARK CONSISTS OF A CELTIC, SCOTTISH BADGE, COMMONLY KNOWN AS A CLAN PIN THAT INCORPORATES A CREST, EMBLEM FEATURING A SPOOL OF THREAD CROSSED BY TWO DOWNWARD POINTING NEEDLES. THE CREST, EMBLEM IS SURROUNDED BY A BELT ARRANGED IN A CIRCULAR MANNER WITH THE END EXTENDING STRAIGHT DOWN. THE WORDS "A ROGUISH HIGHLANDER" ARE WRITTEN ON THE TOP CURVATURE OF THE BELT. THE WORDS "FOREVER SEWING" ARE WRITTEN DIAGONALLY ON EACH SIDE OF THE END EXTENDING DOWNWARD.

FOR ON-LINE RETAIL STORE SERVICES FEATURING SCOTTISH GENTLEMAN'S CLOTHING, ACCOUTERMENTS AND KILTS.; RETAIL STORE SERVICES FEATURING SCOTTISH GENTLEMAN'S CLOTHING, ACCOUTERMENTS AND KILTS (U.S. CLS. 100, 101 AND 102).

FIRST USE 9-6-2006; IN COMMERCE 9-11-2006.  
JENNIFER MARTIN, EXAMINING ATTORNEY

SN 85-211,618. SCHMERGEL, JOANNA, WABAN, MA.  
FILED 1-6-2011.

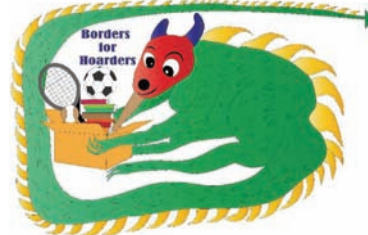

THE COLOR(S) GREEN, YELLOW, RED, BLUE, WHITE, BLACK, BROWN, ORANGE AND GRAY IS/ARE CLAIMED AS A FEATURE OF THE MARK.

THE MARK CONSISTS OF THE WORDING "BORDERS FOR HOARDERS" IN BLUE AND A GREEN AND YELLOW DRAGON WITH A RED FACE, BLUE HORNS AND WHITE AND BLACK EYES CLUTCHING A YELLOW BOX WITH RED, GREEN, BROWN, ORANGE AND YELLOW BOOKS, A BROWN AND WHITE TENNIS BALL, A BLACK AND WHITE SOCCER BALL AND A GRAY TENNIS RACKET.

FOR PROVIDING ORGANIZING SERVICES FOR INDIVIDUALS AT HOME, IN HOME OFFICES AND IN BUSINESS OFFICES, THAT PROVIDES HELP WITH TIME AND PAPER MANAGEMENT (U.S. CLS. 100, 101 AND 102).

MARY ROSSMAN, EXAMINING ATTORNEY



**CLASS 35—(Continued).**

SN 85-211,875. BAKER, RANDALL, DALLAS, TX. FILED 1-6-2011.

movi modern vintage home

THE MARK CONSISTS OF STANDARD CHARACTERS WITHOUT CLAIM TO ANY PARTICULAR FONT, STYLE, SIZE, OR COLOR.

NO CLAIM IS MADE TO THE EXCLUSIVE RIGHT TO USE "MODERN VINTAGE HOME", APART FROM THE MARK AS SHOWN.

FOR RETAIL STORE AND ON-LINE RETAIL STORE SERVICES FEATURING HOME FURNISHINGS, NOVELTIES, CANDLES, FURNITURE, AND SEASONAL MERCHANDISE (U.S. CLS. 100, 101 AND 102).

DAVID TAYLOR, EXAMINING ATTORNEY

**CLASS 35—(Continued).**

SN 85-212,111. RICHARD GATON, COLUMBIA, SC. FILED 1-6-2011.

WE ARE SOUTH CAROLINA

THE MARK CONSISTS OF STANDARD CHARACTERS WITHOUT CLAIM TO ANY PARTICULAR FONT, STYLE, SIZE, OR COLOR.

NO CLAIM IS MADE TO THE EXCLUSIVE RIGHT TO USE "SOUTH CAROLINA", APART FROM THE MARK AS SHOWN.

FOR ADVERTISING AND MARKETING SERVICES, NAMELY, PROMOTING THE GOODS AND SERVICES OF OTHERS; ENDORSEMENT SERVICES, NAMELY, PROMOTING THE GOODS AND SERVICES OF OTHERS; PROMOTING PUBLIC AWARENESS OF THE POSITIVE IMAGE OF THE STATE OF SOUTH CAROLINA THROUGH MARKETING, ADVERTISING, PRODUCT MERCHANDISING AND PUBLIC RELATIONS SERVICES (U.S. CLS. 100, 101 AND 102).

PAM WILLIS, EXAMINING ATTORNEY

SN 85-212,098. RICHARD GATON, COLUMBIA, SC. FILED 1-6-2011.

I AM SOUTH CAROLINA

THE MARK CONSISTS OF STANDARD CHARACTERS WITHOUT CLAIM TO ANY PARTICULAR FONT, STYLE, SIZE, OR COLOR.

NO CLAIM IS MADE TO THE EXCLUSIVE RIGHT TO USE "SOUTH CAROLINA", APART FROM THE MARK AS SHOWN.

FOR ADVERTISING AND MARKETING SERVICES, NAMELY, PROMOTING THE GOODS AND SERVICES OF OTHERS; ENDORSEMENT SERVICES, NAMELY, PROMOTING THE GOODS AND SERVICES OF OTHERS; PROMOTING PUBLIC AWARENESS OF THE POSITIVE IMAGE OF THE STATE OF SOUTH CAROLINA THROUGH MARKETING, ADVERTISING, PRODUCT MERCHANDISING AND PUBLIC RELATIONS SERVICES (U.S. CLS. 100, 101 AND 102).

PAM WILLIS, EXAMINING ATTORNEY

SN 85-212,123. RICHARD GATON, COLUMBIA, SC. FILED 1-6-2011.

WE'RE SOUTH CAROLINA

THE MARK CONSISTS OF STANDARD CHARACTERS WITHOUT CLAIM TO ANY PARTICULAR FONT, STYLE, SIZE, OR COLOR.

NO CLAIM IS MADE TO THE EXCLUSIVE RIGHT TO USE "SOUTH CAROLINA", APART FROM THE MARK AS SHOWN.

FOR ADVERTISING AND MARKETING SERVICES, NAMELY, PROMOTING THE GOODS AND SERVICES OF OTHERS; ENDORSEMENT SERVICES, NAMELY, PROMOTING THE GOODS AND SERVICES OF OTHERS; PROMOTING PUBLIC AWARENESS OF THE POSITIVE IMAGE OF THE STATE OF SOUTH CAROLINA THROUGH MARKETING, ADVERTISING, PRODUCT MERCHANDISING AND PUBLIC RELATIONS SERVICES (U.S. CLS. 100, 101 AND 102).

PAM WILLIS, EXAMINING ATTORNEY

**CLASS 35—(Continued).**

SN 85-212,139. RICHARD GATON, COLUMBIA, SC. FILED 1-6-2011.

**I'M SOUTH CAROLINA**

THE MARK CONSISTS OF STANDARD CHARACTERS WITHOUT CLAIM TO ANY PARTICULAR FONT, STYLE, SIZE, OR COLOR.

NO CLAIM IS MADE TO THE EXCLUSIVE RIGHT TO USE "SOUTH CAROLINA", APART FROM THE MARK AS SHOWN.

FOR ADVERTISING AND MARKETING SERVICES, NAMELY, PROMOTING THE GOODS AND SERVICES OF OTHERS; ENDORSEMENT SERVICES, NAMELY, PROMOTING THE GOODS AND SERVICES OF OTHERS; PROMOTING PUBLIC AWARENESS OF THE POSITIVE IMAGE OF THE STATE OF SOUTH CAROLINA THROUGH MARKETING, ADVERTISING, PRODUCT MERCHANDISING AND PUBLIC RELATIONS SERVICES (U.S. CLS. 100, 101 AND 102).

PAM WILLIS, EXAMINING ATTORNEY

SN 85-212,252. GLOBALSPEC, INC., EAST GREENBUSH, NY. FILED 1-6-2011.



THE MARK CONSISTS OF A STYLIZED LOWER CASE "E" WITHIN AN OPEN CIRCLE FOLLOWED BY LOWER CASE "EVENTS".

FOR ARRANGING AND CONDUCTING ONLINE BUSINESS CONFERENCES AND TRADE SHOWS IN THE FIELDS OF TECHNOLOGY, SCIENCE, ENGINEERING, MANUFACTURING, COMPONENTS, INSTRUMENTS, EQUIPMENT, MATERIALS, INFORMATION TECHNOLOGY, MOTION, SOFTWARE, AUTOMATION, DESIGN, POWER, FLUIDS, ELECTRONICS, TESTING, MEASUREMENT, TOOLS, CONSTRUCTION, IMAGING, PACKAGING, CHEMICALS, OPTICS, SEMICONDUCTORS, MAINTENANCE, ENERGY AND SERVICES RELATED TO THE FORGOING, NAMELY, ACOUSTICS AND AUDIO TECHNOLOGY, AEROSPACE TECHNOLOGY, ALTERNATIVE POWER, APPLIANCE TECHNOLOGY, AUTOMOTIVE TECHNOLOGY, BUILDING AND CONSTRUCTION, CHEMICAL MANUFACTURING, COATINGS AND SURFACE ENGINEERING, CONSTRUCTION TOOLS AND EQUIPMENT, DATA ACQUISITION, DEFENSE AND SECURITY TECHNOLOGY, DESIGN AND ANALYSIS SOFTWARE, DISPLAY TECHNOLOGIES, ELECTROMECHANICAL DRIVE SYSTEMS, ELECTRICAL COMPONENTS, ELECTRONIC COMPONENTS, ELECTRONIC PRODUCT DESIGN, ELECTRONIC TEST EQUIPMENT, ENGINEERING MANAGEMENT, ENVIRONMENTAL TECHNOLOGY, FASTENING, JOINING AND ASSEMBLY, FIBERS AND FABRICS, FOOD AND BEVERAGE TECHNOLOGY, GLASS AND CERAMICS, HEALTHCARE MANUFACTURING, HVAC, HYDRAULICS, INDUSTRIAL AUTOMATION, INDUSTRIAL MRO (MAINTENANCE, REPAIRS AND OPERATING), INDUSTRIAL PROCESSING EQUIPMENT, LAB EQUIPMENT, LIGHT AND LASER TECHNOLOGY, MACHINE TOOLS AND METAL WORKING, MATERIAL HANDLING, MECHANICAL COMPONENTS, MECHANICAL POWER TRANSMISSION, MEDICAL EQUIPMENT DESIGN, MEMS TECHNOLOGY, METALS AND ALLOYS, MOTION CONTROL COMPONENTS, MOTORS, NANO TECHNOLOGY, NET-

**CLASS 35—(Continued).**

WORKING AND COMMUNICATIONS, OIL AND GAS TECHNOLOGY, PACKAGING AND LABELING, PLANT AND FACILITIES ENGINEERING, PLASTICS AND RESINS, PLASTICS FABRICATION, PNEUMATICS, POWER GENERATION AND DISTRIBUTION, PUMP TECHNOLOGY, QUALITY CONTROL, ROBOTICS SYSTEMS, SCIENTIFIC INSTRUMENTS, SEMICONDUCTOR FABRICATION, SENSORS AND SWITCHES, SHOCK, VIBRATION AND NOISE, SOLUTIONS FOR INDUSTRIAL COMPUTING, SUPPLY CHAIN MANAGEMENT, QUALITY TEST AND MEASUREMENT, VALVE TECHNOLOGY, WIRE AND CABLE TECHNOLOGY, WIRELESS TECHNOLOGY, BUILDING AND CONSTRUCTION SERVICES, BUSINESS SERVICES, CALIBRATION AND TESTING SERVICES, CONTRACT MANUFACTURING AND FABRICATION, ELECTRICAL AND ELECTRONIC CONTRACT MANUFACTURING, ENGINEERING SERVICES, INDUSTRIAL AUTOMATION SERVICES, INDUSTRIAL MAINTENANCE, MATERIAL HANDLING AND PACKAGING SERVICES, SPECIALIZED INDUSTRIAL SERVICES, TRANSPORTATION TECHNOLOGY, MATERIAL HANDLING AND SUPPLY CHAIN TECHNOLOGY, POWER GENERATION AND DISTRIBUTION EQUIPMENT, INDUSTRIAL PROCESSING, WATER QUALITY AND WATER RECLAMATION, PRODUCT DESIGN, ALTERNATIVE AND RENEWABLE ENERGY, GREEN MANUFACTURING AND DESIGN, RESEARCH AND DEVELOPMENT, AND SOLAR ENERGY (U.S. CLS. 100, 101 AND 102).

FIRST USE 6-17-2009; IN COMMERCE 6-17-2009.

ANGELA M. MICHELI, EXAMINING ATTORNEY

SN 85-212,277. JACKSON, JON, LAGUNA HILLS, CA. FILED 1-6-2011.

**New World Lawyer**

THE MARK CONSISTS OF STANDARD CHARACTERS WITHOUT CLAIM TO ANY PARTICULAR FONT, STYLE, SIZE, OR COLOR.

NO CLAIM IS MADE TO THE EXCLUSIVE RIGHT TO USE "LAWYER", APART FROM THE MARK AS SHOWN.

FOR MARKETING CONSULTING SERVICES FOR LAWYERS (U.S. CLS. 100, 101 AND 102).

FIRST USE 1-1-2010; IN COMMERCE 1-1-2010.

MARIA-VICTORIA SUAREZ, EXAMINING ATTORNEY

SN 85-212,281. BATTELLE FOR KIDS, COLUMBUS, OH. FILED 1-6-2011.

**BFK•Evaluate**

OWNER OF U.S. REG. NOS. 3,870,167, 3,870,170 AND OTHERS.

FOR BUSINESS CONSULTING SERVICES, NAMELY, PROVIDING A BUSINESS SOLUTION THAT INCLUDES A VALIDATED, RESEARCH-BASED OBSERVATION INSTRUMENT TO ASSESS THE IMPACT OF EDUCATORS (U.S. CLS. 100, 101 AND 102).

MARIA-VICTORIA SUAREZ, EXAMINING ATTORNEY

**CLASS 35—(Continued).**

SN 85-212,394. GOZ, BRADFORD, NEW YORK, NY. FILED 1-6-2011.

**NEW FREEDOM CAPITAL**

THE MARK CONSISTS OF STANDARD CHARACTERS WITHOUT CLAIM TO ANY PARTICULAR FONT, STYLE, SIZE, OR COLOR.

NO CLAIM IS MADE TO THE EXCLUSIVE RIGHT TO USE "CAPITAL", APART FROM THE MARK AS SHOWN.

FOR BUSINESS CONSULTATION SERVICES TO ASSIST NON-PROFIT ORGANIZATIONS IN PLANNING, MANAGING, AND CONDUCTING FUNDRAISING ACTIVITIES VIA A GLOBAL COMPUTER NETWORK; BUSINESS DEVELOPMENT SERVICES; BUSINESS MARKETING SERVICES; BUSINESS SERVICES, NAMELY, MATCHING POTENTIAL PRIVATE INVESTORS WITH ENTREPRENEURS NEEDING FUNDING (U.S. CLS. 100, 101 AND 102).

SANDRA BUJA, EXAMINING ATTORNEY

**CLASS 35—(Continued).**

SN 85-212,741. ROSENBERG, MATTHEW, LOS ANGELES, CA. FILED 1-7-2011.



NO CLAIM IS MADE TO THE EXCLUSIVE RIGHT TO USE "MARKETING", APART FROM THE MARK AS SHOWN.

THE MARK CONSISTS OF THE STYLIZED TEXT "TOCO MARKETING" WITH A TOCO TOUCAN BIRD ON THE TOP TIGHT OF THE LOGO.

FOR ADVERTISING AND MARKETING SERVICES PROVIDED BY MEANS OF INDIRECT METHODS OF MARKETING COMMUNICATIONS, NAMELY, SOCIAL MEDIA, SEARCH ENGINE MARKETING, INQUIRY MARKETING, INTERNET MARKETING, MOBILE MARKETING, BLOGGING AND OTHER FORMS OF PASSIVE, SHARABLE OR VIRAL COMMUNICATIONS CHANNELS; CONSULTING SERVICES IN THE FIELD OF INTERNET MARKETING (U.S. CLS. 100, 101 AND 102).

JOHN E. MICHOS, EXAMINING ATTORNEY

SN 85-212,747. BRAINPIK, ATHENS, GA. FILED 1-7-2011.

**BRAINPIK**

THE MARK CONSISTS OF STANDARD CHARACTERS WITHOUT CLAIM TO ANY PARTICULAR FONT, STYLE, SIZE, OR COLOR.

FOR BUSINESS CONSULTING AND BUSINESS INFORMATION FOR ENTERPRISES (U.S. CLS. 100, 101 AND 102).

JOHN E. MICHOS, EXAMINING ATTORNEY

SN 85-212,589. NICHOLS, JOEL A., DBA JASPERDAILY, FT. WAYNE, IN. FILED 1-7-2011.

**classifieds. simplified.**

THE MARK CONSISTS OF STANDARD CHARACTERS WITHOUT CLAIM TO ANY PARTICULAR FONT, STYLE, SIZE, OR COLOR.

NO CLAIM IS MADE TO THE EXCLUSIVE RIGHT TO USE "CLASSIFIEDS", APART FROM THE MARK AS SHOWN.

FOR PROVIDING AN ON-LINE SEARCHABLE DATABASE FEATURING CLASSIFIED AD LISTINGS AND EMPLOYMENT OPPORTUNITIES (U.S. CLS. 100, 101 AND 102).

ANDREA BUTLER, EXAMINING ATTORNEY

SN 85-213,258. PASSIONATE PET, INC., IRVINE, CA. FILED 1-7-2011.

**Passionate Pet Superstore**

THE MARK CONSISTS OF STANDARD CHARACTERS WITHOUT CLAIM TO ANY PARTICULAR FONT, STYLE, SIZE, OR COLOR.

NO CLAIM IS MADE TO THE EXCLUSIVE RIGHT TO USE "PET SUPERSTORE", APART FROM THE MARK AS SHOWN.

FOR RETAIL STORE SERVICES FEATURING PET SUPPLIES (U.S. CLS. 100, 101 AND 102).

FIRST USE 3-1-2009; IN COMMERCE 1-1-2010.

KHANH LE, EXAMINING ATTORNEY

**CLASS 35—(Continued).**

SN 85-213,395. SHEARD, DANIEL, MIDDLETOWN, NJ. FILED 1-8-2011.

# LIVIN THE DREAM

THE MARK CONSISTS OF STANDARD CHARACTERS WITHOUT CLAIM TO ANY PARTICULAR FONT, STYLE, SIZE, OR COLOR.

FOR RETAIL AND ONLINE RETAIL NOVELTY STORE (U.S. CLS. 100, 101 AND 102).  
EUGENIA MARTIN, EXAMINING ATTORNEY

SN 85-213,396. KHIMENKO, ALEXEI, NASHVILLE, TN. FILED 1-8-2011.

# ALEKSEY'S

THE MARK CONSISTS OF STANDARD CHARACTERS WITHOUT CLAIM TO ANY PARTICULAR FONT, STYLE, SIZE, OR COLOR.

FOR WHOLESALE DISTRIBUTORSHIPS FEATURING WINE, SPIRITS AND BEERS (U.S. CLS. 100, 101 AND 102).

FIRST USE 9-1-2005; IN COMMERCE 9-1-2005.  
KYLE PEETE, EXAMINING ATTORNEY

SN 85-213,410. SHEARD, DANIEL, MIDDLETOWN, NJ. FILED 1-8-2011.



THE MARK CONSISTS OF THE LITERAL ELEMENTS "LIVIN THE DREAM" WHERE THERE IS A STAR MARK ABOVE THE LETTERS "I" AND "N" OF THE WORD "LIVIN" AND THE WORD "DREAM" IS UNDERLINED AND THE ENTIRE MARK HAS A SHADOW BOUNDARY AS SHOWN IN THE MARK.

FOR RETAIL AND ONLINE RETAIL NOVELTY STORE (U.S. CLS. 100, 101 AND 102).  
EUGENIA MARTIN, EXAMINING ATTORNEY

**CLASS 35—(Continued).**

SN 85-213,714. FOREFRONT ENTERPRISES, LLC, SAND SPRINGS, OK. FILED 1-10-2011.

# PRIMOVAPOR

THE MARK CONSISTS OF STANDARD CHARACTERS WITHOUT CLAIM TO ANY PARTICULAR FONT, STYLE, SIZE, OR COLOR.

FOR PROVIDING A SEARCHABLE ONLINE ADVERTISING WEBSITE AND INFORMATIONAL GUIDE FEATURING THE GOODS AND SERVICES OF OTHER VENDORS VIA THE INTERNET IN THE FIELD OF SMOKELESS TOBACCO PRODUCTS, E-CIGARETTES AND E-CIGARS; PROVIDING A SEARCHABLE WEBSITE FEATURING THE GOODS AND SERVICES OF OTHER VENDORS; PROVIDING A WEBSITE USED TO PLACE ON-LINE COMMERCIAL ORDERS IN THE FIELD OF SMOKELESS TOBACCO PRODUCTS, E-CIGARETTES AND E-CIGARS (U.S. CLS. 100, 101 AND 102).

DAVID HOFFMAN, EXAMINING ATTORNEY

SN 85-213,726. HOMETOWN EXPOSURE, INC., GRAND JUNCTION, MI. FILED 1-10-2011.

# HOMETOWN EXPOSURE

THE MARK CONSISTS OF STANDARD CHARACTERS WITHOUT CLAIM TO ANY PARTICULAR FONT, STYLE, SIZE, OR COLOR.

FOR ADVERTISING SERVICES (U.S. CLS. 100, 101 AND 102).

FIRST USE 9-3-2003; IN COMMERCE 9-3-2003.  
BARBARA RUTLAND, EXAMINING ATTORNEY

SN 85-213,791. SPECTRUM INTERACTIVE MEDIA, LLC., GARDNERVILLE, NV. FILED 1-10-2011.

# FanPilot

THE MARK CONSISTS OF STANDARD CHARACTERS WITHOUT CLAIM TO ANY PARTICULAR FONT, STYLE, SIZE, OR COLOR.

FOR ADVERTISING AND MARKETING SERVICES PROVIDED BY MEANS OF INDIRECT METHODS OF MARKETING COMMUNICATIONS, NAMELY, SOCIAL MEDIA, SEARCH ENGINE MARKETING, INQUIRY MARKETING, INTERNET MARKETING, MOBILE MARKETING, BLOGGING AND OTHER FORMS OF PASSIVE, SHARABLE OR VIRAL COMMUNICATIONS CHANNELS (U.S. CLS. 100, 101 AND 102).

FIRST USE 5-15-2010; IN COMMERCE 5-15-2010.  
GINA HAYES, EXAMINING ATTORNEY

**CLASS 35—(Continued).**

SN 85-213,797. CHINA DONGMAN ESTATE (INTL) GROUP LIMITED, SHEUNG WAN HK, HONG KONG, FILED 1-10-2011.



THE MARK CONSISTS OF FOUR CHINESE CHARACTER PRONOUNS KNOWN AS "DONG MAN DI GUO", PLACED HORIZONTALLY; UNDERNEATH IS THE PHRASE "CARTOON EMPIRE" IN CAPITAL LETTERS.

THE NON-LATIN CHARACTERS IN THE MARK TRANSLITERATE TO "DONG MAN DI GUO" AND THIS MEANS "ACTIVE" "OVERFLOW" "KING" AND "STATE" IN ENGLISH.

FOR ACCOUNT AUDITING; ADVERTISING SERVICES; COMMERCIAL ADMINISTRATION OF THE LICENSING OF THE GOODS AND SERVICES OF OTHERS; COMPUTER FILE MANAGEMENT; IMPORT AND EXPORT AGENCIES; ON-LINE ADVERTISING ON COMPUTER NETWORKS; ORGANIZATION OF EXHIBITIONS AND TRADE FAIRS FOR BUSINESS AND PROMOTIONAL PURPOSES; PRESENTATION OF GOODS ON COMMUNICATION MEDIA FOR RETAIL PURPOSES; PURCHASING AND PROCUREMENT SERVICES, NAMELY, PROCURING OF CONTRACTS FOR OTHERS FOR THE PURCHASE OF GOODS AND LABOR CONTRACTING SERVICES; RENTAL OF ADVERTISEMENT SPACE AND ADVERTISING MATERIAL; SECRETARIAL AND CLERICAL SERVICES (U.S. CLS. 100, 101 AND 102).

JACQUELINE A. LAVINE, EXAMINING ATTORNEY

SN 85-213,881. WIGGINS PAYROLL, INC., WEST CHESTER, PA. FILED 1-10-2011.

## Evolution Payroll Services

THE MARK CONSISTS OF STANDARD CHARACTERS WITHOUT CLAIM TO ANY PARTICULAR FONT, STYLE, SIZE, OR COLOR.

NO CLAIM IS MADE TO THE EXCLUSIVE RIGHT TO USE "PAYROLL SERVICES", APART FROM THE MARK AS SHOWN.

FOR PAYROLL PREPARATION (U.S. CLS. 100, 101 AND 102).

KHANH LE, EXAMINING ATTORNEY

**CLASS 35—(Continued).**

SN 85-213,887. PHARMERICA CORPORATION, LOUISVILLE, KY. FILED 1-10-2011.

## RXEXACT

THE MARK CONSISTS OF STANDARD CHARACTERS WITHOUT CLAIM TO ANY PARTICULAR FONT, STYLE, SIZE, OR COLOR.

FOR PHARMACY BILLING SERVICES, PROVIDING ONLINE PRICE VALIDATION FOR PRESCRIPTIONS AND RELATED REPORTS (U.S. CLS. 100, 101 AND 102).

FIRST USE 5-0-2010; IN COMMERCE 5-0-2010.

TINA MAI, EXAMINING ATTORNEY

SN 85-213,889. ECLAT VIBE LLC, COCONUT CREEK, FL. FILED 1-10-2011.



THE MARK CONSISTS OF THE STYLIZED WORDS "ECLAT VIBE". THE WORD "VIBE" IS WITHIN A CIRCLE.

FOR RETAIL STORE SERVICES FEATURING ACTIVEWEAR, SWIMWEAR, CLOTHING, BAGS, YOGA BAGS, MATS AND ACCESSORIES (U.S. CLS. 100, 101 AND 102).

FIRST USE 12-6-2010; IN COMMERCE 12-6-2010.

TINA MAI, EXAMINING ATTORNEY

SN 85-213,919. BUILD-A-BEAR RETAIL MANAGEMENT, INC., ST. LOUIS, MO. FILED 1-10-2011.

## CLUB BABW

THE MARK CONSISTS OF STANDARD CHARACTERS WITHOUT CLAIM TO ANY PARTICULAR FONT, STYLE, SIZE, OR COLOR.

OWNER OF U.S. REG. NOS. 2,553,637 AND 2,742,586.

NO CLAIM IS MADE TO THE EXCLUSIVE RIGHT TO USE "CLUB", APART FROM THE MARK AS SHOWN.

FOR CUSTOMER LOYALTY SERVICES AND CUSTOMER CLUB SERVICES FOR COMMERCIAL, PROMOTIONAL AND/OR ADVERTISING PURPOSES; CONSUMER REWARD PROGRAMS FOR ADVERTISING AND PROMOTIONAL PURPOSES WHICH PERMIT CONSUMERS TO EARN REWARDS, PRIZES AND COUPONS BASED ON PURCHASES AND OTHER ACTIVITIES (U.S. CLS. 100, 101 AND 102).

FIRST USE 2-18-2011; IN COMMERCE 2-18-2011.

KELLY BOULTON, EXAMINING ATTORNEY



**CLASS 35—(Continued).**

SN 85-213,943. REWARDTHEPUBLIC INC., SAUK CITY, WI.  
FILED 1-10-2011.

## RewardThePublic

THE MARK CONSISTS OF STANDARD CHARACTERS WITHOUT CLAIM TO ANY PARTICULAR FONT, STYLE, SIZE, OR COLOR.

FOR PROVIDING A WEBSITE FEATURING INFORMATION FOR CONSUMERS IN THE FIELD REWARD PROGRAMS, COUPONS, REBATES, PRODUCT-COMPARISON (U.S. CLS. 100, 101 AND 102).

KATHERINE M. DUBRAY, EXAMINING ATTORNEY

---

SN 85-213,975. SIGNATURE MD, INC., SANTA MONICA, CA. FILED 1-10-2011.

## SignatureMD

THE MARK CONSISTS OF STANDARD CHARACTERS WITHOUT CLAIM TO ANY PARTICULAR FONT, STYLE, SIZE, OR COLOR.

FOR BUSINESS CONSULTING SERVICES; BUSINESS CONSULTING SERVICES IN THE FIELD OF MEDICAL PRACTICES (U.S. CLS. 100, 101 AND 102).

FIRST USE 1-0-2007; IN COMMERCE 1-0-2007.

AMY HELLA, EXAMINING ATTORNEY

---

SN 85-213,985. DAVID AND SAM PR, LLC, PHOENIX, AZ. FILED 1-10-2011.

## UNLEASH YOUR BRAND'S GORILLA

THE MARK CONSISTS OF STANDARD CHARACTERS WITHOUT CLAIM TO ANY PARTICULAR FONT, STYLE, SIZE, OR COLOR.

FOR PUBLIC RELATIONS, MARKETING AND ADVERTISING SERVICES (U.S. CLS. 100, 101 AND 102).

FIRST USE 7-1-2009; IN COMMERCE 7-1-2009.

LAURIE KAUFMAN, EXAMINING ATTORNEY

**CLASS 35—(Continued).**

SN 85-213,998. FIVE STAR FOOD COMPANY, LLC, IRVINE, CA. FILED 1-10-2011.



NO CLAIM IS MADE TO THE EXCLUSIVE RIGHT TO USE "FOOD COMPANY", APART FROM THE MARK AS SHOWN.

THE COLOR(S) WHITE, BLACK, RED AND GOLD IS/ARE CLAIMED AS A FEATURE OF THE MARK.

THE MARK CONSISTS OF THE LITERAL ELEMENT "FIVE STAR 5 FOOD COMPANY" WITH THE WORDS "FIVE STAR" APPEARING IN WHITE COLOR AND IN UPPERCASE BLOCK LETTERS LOCATED ABOVE A HORIZONTAL RED LINE THAT IS IN TURN LOCATED ABOVE A STYLIZED, THREE-DIMENSIONAL NUMERAL "5" CANTED TO THE RIGHT IN THE COLOR GOLD AND OUTLINED IN THE COLOR LIGHT RED ALONG ITS VISIBLE EDGES, AND WHEREIN FIVE FIVE-POINTED GOLD STARS OUTLINED IN RED ARE LOCATED TO THE RIGHT OF THE NUMERAL "5" AND LOCATED ABOVE A SECOND HORIZONTAL RED LINE THAT IS LOCATED ABOVE THE WORDS "FOOD COMPANY" APPEARING IN WHITE COLOR AND UPPERCASE BLOCK LETTERS; THE LITERAL AND DESIGN ELEMENTS ARE SUPERIMPOSED UPON A BLACK BACKGROUND WITH THE TIP OF THE TOP OF THE NUMERAL "5" PROJECTING SLIGHTLY OFF THE BLACK BACKGROUND.

FOR INDEPENDENT SALES REPRESENTATIVES IN THE FIELD OF FOOD AND GROCERY ITEMS; WHOLESALE FOOD DISTRIBUTORSHIP SERVICES (U.S. CLS. 100, 101 AND 102).

FIRST USE 9-1-2010; IN COMMERCE 12-1-2010.

RONALD DELGIZZI, EXAMINING ATTORNEY

---

SN 85-214,036. TRICITIES MATTRESS LLC, JOHNSON CITY, TN. FILED 1-10-2011.

## Where everything is priced with you in mind

THE MARK CONSISTS OF STANDARD CHARACTERS WITHOUT CLAIM TO ANY PARTICULAR FONT, STYLE, SIZE, OR COLOR.

FOR RETAIL STORE SERVICES FEATURING MATTRESSES (U.S. CLS. 100, 101 AND 102).

FIRST USE 10-1-2010; IN COMMERCE 10-1-2010.

MARTHA FROMM, EXAMINING ATTORNEY

**CLASS 35—(Continued).**

SN 85-214,261. TRIATHLON PUBLISHING LIMITED, SHEUNG WAN, HONG KONG, FILED 1-10-2011.



THE MARK CONSISTS OF THE WORDING "BEYOND TRANSITION" IN LOWER CASE LETTERS WITH THREE SPHERES TO THE LEFT OF THE LETTER "B" IN A CURVED FORMATION.

FOR ONLINE ADVERTISING AND PROMOTIONAL SERVICES; PROMOTING SPORTS COMPETITIONS AND/OR EVENTS OF OTHERS; PROVIDING A WEB SITE THAT PROVIDES SPORTS LEAGUE MANAGEMENT; PROVIDING ON-LINE DIRECTORY INFORMATION SERVICES ALSO FEATURING HYPERLINKS TO OTHER WEB SITES (U.S. CLS. 100, 101 AND 102).

THOMAS MANOR, EXAMINING ATTORNEY

---

SN 85-214,267. SUSETTE M. MCNEEL, CPA, PLLC, TOMBALL, TX. FILED 1-10-2011.



NO CLAIM IS MADE TO THE EXCLUSIVE RIGHT TO USE "OPERATING RECOVERY", APART FROM THE MARK AS SHOWN.

THE COLOR(S) GREEN, BLACK, WHITE, GREY IS/ARE CLAIMED AS A FEATURE OF THE MARK.

THE MARK CONSISTS OF THE WORDING "ENHANCED" APPEARING IN STYLIZED FONT, THE COLOR BLACK, AND ALL CAPITAL LETTERS, BELOW THE "ENHANCED" WORDING APPEARS A SOLID GREY LINE, BELOW THE SOLID GREY LINE APPEARS THE WORDING "OPERATING RECOVERY" IN STYLIZED FONT, THE COLOR BLACK, AND ALL CAPITAL LETTERS, ABOVE THE "ENHANCED" WORDING APPEARS A GREEN HALF CIRCLE. WITHIN THE HALF CIRCLE APPEARS A BLACK SILHOUETTE OF AN OIL DRILL TOWER, THICK WHITE LINES APPEAR COMING OUT FROM THE SIDES OF THE OIL DRILL TOWER.

FOR OIL AND GAS TAX CONSULTATION (U.S. CLS. 100, 101 AND 102).

FIRST USE 7-5-2009; IN COMMERCE 7-5-2009.  
THOMAS MANOR, EXAMINING ATTORNEY

**CLASS 35—(Continued).**

SN 85-214,381. AUTHENTIC SPORTS MANAGEMENT, LLC, DEERFIELD BEACH, FL. FILED 1-10-2011.

AUTHENTIC SPORTS MANAGEMENT

THE MARK CONSISTS OF STANDARD CHARACTERS WITHOUT CLAIM TO ANY PARTICULAR FONT, STYLE, SIZE, OR COLOR.

NO CLAIM IS MADE TO THE EXCLUSIVE RIGHT TO USE "SPORTS MANAGEMENT", APART FROM THE MARK AS SHOWN.

FOR MANAGEMENT, REPRESENTATION AND PROMOTION OF PROFESSIONAL ATHLETES IN ATHLETICS AND ENTERTAINMENT; PROMOTING THE GOODS AND SERVICES OF OTHERS BY ARRANGING FOR SPONSORS AND ENDORSERS TO AFFILIATE THEIR GOODS AND SERVICES WITH ATHLETES (U.S. CLS. 100, 101 AND 102).

THOMAS MANOR, EXAMINING ATTORNEY

---

SN 85-214,514. AG ALLIANCE VENTURES, LLC, LOS ANGELES, CA. FILED 1-10-2011.

Flower Muse

THE MARK CONSISTS OF STANDARD CHARACTERS WITHOUT CLAIM TO ANY PARTICULAR FONT, STYLE, SIZE, OR COLOR.

NO CLAIM IS MADE TO THE EXCLUSIVE RIGHT TO USE "FLOWER", APART FROM THE MARK AS SHOWN.

FOR RETAIL FLORIST SHOPS (U.S. CLS. 100, 101 AND 102).

MAUREEN DALL, EXAMINING ATTORNEY

**CLASS 35—(Continued).**

SN 85-215,177. GOLF TOWN OPERATING LIMITED PARTNERSHIP, MARKHAM, ONTARIO, CANADA, FILED 1-11-2011.



OWNER OF U.S. REG. NO. 3,348,059.  
NO CLAIM IS MADE TO THE EXCLUSIVE RIGHT TO USE "GOLF", APART FROM THE MARK AS SHOWN.

THE COLOR(S) RED, WHITE AND GREEN IS/ARE CLAIMED AS A FEATURE OF THE MARK.

THE MARK CONSISTS OF THE STYLIZED GREEN LETTERING "GOLF" ATOP THE STYLIZED WHITE LETTERING "TOWN" ENCLOSED WITHIN A RED ELLIPTICAL SHAPE WITH A WHITE HOLE MARKER STEMMING FROM THE LETTER "O" IN "TOWN" AND THE WHITE FLAG APPEARING IN THE MIDDLE OF THE LETTER "O" IN "GOLF".

FOR RETAIL STORE SERVICES AND ON-LINE RETAIL SERVICES FEATURING GOLF EQUIPMENT, GOLF ACCESSORIES, GOLF APPAREL; RETAIL STORE SERVICES AND ON-LINE RETAIL SERVICES FEATURING GOLF-THEMED GOODS, NAMELY, GOLF-THEMED GIFTS, GOLF TRAINING AIDS, BOOKS, PRE-RECORDED DVDS, GAMES, JEWELRY, GOLF-THEMED COLLECTIBLES, SUNGLASSES, UMBRELLAS, TOWELS, GOLF CLUB BAGS, TRAVEL BAGS, MOTORIZED AND NON-MOTORIZED GOLF CARTS AND ACCESSORIES (U.S. CLS. 100, 101 AND 102).

FIRST USE 8-19-1998; IN COMMERCE 8-19-1998.  
JACQUELINE A. LAVINE, EXAMINING ATTORNEY

SN 85-215,212. ARTISTIC STONE GALLERY, INC., MENLO PARK, CA. FILED 1-11-2011.



THE MARK CONSISTS OF A SILHOUETTE OF A KANGAROO.

FOR WHOLESALE DISTRIBUTORSHIPS AND STORES FEATURING PRODUCTS OF STONE AND GLASS, NAMELY, SCULPTURES, TILES, MOSAICS, BORDERS, AND MEDALLIONS FOR INSTALLATION IN OR ON RESIDENTIAL AND COMMERCIAL BUILDINGS (U.S. CLS. 100, 101 AND 102).

FIRST USE 6-0-2008; IN COMMERCE 6-0-2008.  
INGA ERVIN, EXAMINING ATTORNEY

**CLASS 35—(Continued).**

SN 85-215,328. NIFTUS, LLC, BLUEFIELD, VA. FILED 1-11-2011.

# NIFTUS

THE MARK CONSISTS OF STANDARD CHARACTERS WITHOUT CLAIM TO ANY PARTICULAR FONT, STYLE, SIZE, OR COLOR.

THE WORDING "NIFTUS" HAS NO MEANING IN A FOREIGN LANGUAGE.

FOR WHOLESALE DISTRIBUTORSHIPS FEATURING PHARMACEUTICAL PRODUCTS, MEDICINE, SURGICAL GLOVES, SUTURES, SURGICAL TOOLS, SCISSORS, BANDAGES, AND CLOTHING FOR MEDICAL PROFESSIONALS (U.S. CLS. 100, 101 AND 102).

FIRST USE 7-12-2002; IN COMMERCE 7-12-2002.  
ELISSA GARBER KON, EXAMINING ATTORNEY

SN 85-215,352. W. ATLEE BURPEE COMPANY, WARMINSTER, PA. FILED 1-11-2011.

## THE YEAR OF THE VEGETABLE

THE MARK CONSISTS OF STANDARD CHARACTERS WITHOUT CLAIM TO ANY PARTICULAR FONT, STYLE, SIZE, OR COLOR.

NO CLAIM IS MADE TO THE EXCLUSIVE RIGHT TO USE "VEGETABLE", APART FROM THE MARK AS SHOWN.

FOR MAIL ORDER CATALOG SERVICES IN THE FIELD OF LIVING PLANTS, VEGETABLE SEEDS FOR PLANTING, SEEDS AND BULBS, AND GARDENING EQUIPMENT; RETAIL STORE SERVICES IN THE FIELD OF LIVING PLANTS, VEGETABLE SEEDS FOR PLANTING, SEEDS AND BULBS, AND GARDENING EQUIPMENT; ONLINE RETAIL STORE SERVICES FEATURING LIVING PLANTS, VEGETABLE SEEDS FOR PLANTING, SEEDS AND BULBS, AND GARDENING EQUIPMENT (U.S. CLS. 100, 101 AND 102).

KATHERINE E. HALMEN, EXAMINING ATTORNEY

SN 85-215,367. CARIBBEAN HOTEL & TOURISM ASSOCIATION, SAN JUAN, PUERTO RICO, FILED 1-11-2011.



NO CLAIM IS MADE TO THE EXCLUSIVE RIGHT TO USE "TOURISM", APART FROM THE MARK AS SHOWN.

THE COLOR(S) GREEN, LIGHT BLUE, YELLOW, PURPLE, ORANGE, NAVY BLUE IS/ARE CLAIMED AS A FEATURE OF THE MARK.

THE MARK CONSISTS OF THE DESIGN OF A FIVE

**CLASS 35—(Continued).**

POINT STAR, WITH EACH WEDGE OF THE STAR CONSISTING OF THE FOLLOWING DIFFERENT COLORS: GREEN, LIGHT BLUE, YELLOW, PURPLE, AND ORANGE. THE DESIGN OF THE FIVE POINT STAR IS LOCATED WITHIN A DESIGN OF A TREBLE SHAPED HEAD OR BOW OF A KEY WHICH IS COLORED NAVY BLUE. NEXT TO THE AFORESAID DESIGN ELEMENTS FOLLOWS THE LITERAL WORD ELEMENT IN THE COLOR NAVY BLUE: "TOURISM IS KEY". THE LITERAL WORD ELEMENT ALSO FORMS THE DESIGN OF THE BLADE OF THE KEY.

FOR PUBLIC ADVOCACY TO PROMOTE AWARENESS OF THE IMPORTANCE OF TOURISM (U.S. CLS. 100, 101 AND 102).

FIRST USE 7-0-2010; IN COMMERCE 9-9-2010.  
JASON TURNER, EXAMINING ATTORNEY

---

SN 85-215,409. MOBI MUNCH, INC., PASADENA, CA. FILED 1-11-2011.

**THE CHAIRMAN**

THE MARK CONSISTS OF STANDARD CHARACTERS WITHOUT CLAIM TO ANY PARTICULAR FONT, STYLE, SIZE, OR COLOR.

FOR MOBILE FOOD KIOSK SERVICES; MOBILE STREET VENDOR SERVICES FEATURING FOOD AND DRINK (U.S. CLS. 100, 101 AND 102).

AISHA CLARKE, EXAMINING ATTORNEY

---

SN 85-215,465. SIMERGY CONSULTING, LLC, NEW YORK, NY. FILED 1-11-2011.

**SimErgy**

THE MARK CONSISTS OF STANDARD CHARACTERS WITHOUT CLAIM TO ANY PARTICULAR FONT, STYLE, SIZE, OR COLOR.

OWNER OF U.S. REG. NO. 3,916,810.

FOR BUSINESS CONSULTATION IN THE FIELD OF ENTERPRISE RISK MANAGEMENT (U.S. CLS. 100, 101 AND 102).

FIRST USE 3-23-2010; IN COMMERCE 3-23-2010.  
REGINA DRUMMOND, EXAMINING ATTORNEY

**CLASS 35—(Continued).**

SN 85-215,760. FINCH INDUSTRIES, L.L.C., TRAVERSE CITY, MI. FILED 1-12-2011.

**IFLY AIRCRAFT**

THE MARK CONSISTS OF STANDARD CHARACTERS WITHOUT CLAIM TO ANY PARTICULAR FONT, STYLE, SIZE, OR COLOR.

FOR PROMOTING THE GOODS AND SERVICES OF OTHERS BY PROVIDING A WEB SITE AT WHICH USERS CAN LINK TO AVIATION GOODS AND SERVICES (U.S. CLS. 100, 101 AND 102).

FIRST USE 1-10-2011; IN COMMERCE 1-10-2011.  
JOHN SCHUYLER YARD, EXAMINING ATTORNEY

---

SN 85-215,887. GLOBAL NATURAL FARMS LLC, HOLLYWOOD, FL. FILED 1-12-2011.

**GNF**

THE MARK CONSISTS OF STANDARD CHARACTERS WITHOUT CLAIM TO ANY PARTICULAR FONT, STYLE, SIZE, OR COLOR.

FOR IMPORT SERVICES IN THE FIELD OF FRESH PRODUCE AND OTHER PERISHABLE FOODS (U.S. CLS. 100, 101 AND 102).

WILLIAM ROSSMAN, EXAMINING ATTORNEY

---

SN 85-216,168. IN COUNSEL WITH WOMEN, CLEVELAND, OH. FILED 1-12-2011.

**IN COUNSEL WITH WOMEN**

THE MARK CONSISTS OF STANDARD CHARACTERS WITHOUT CLAIM TO ANY PARTICULAR FONT, STYLE, SIZE, OR COLOR.

NO CLAIM IS MADE TO THE EXCLUSIVE RIGHT TO USE "WOMEN", APART FROM THE MARK AS SHOWN.

FOR ASSOCIATION SERVICES, NAMELY, PROMOTING THE ECONOMIC, LEADERSHIP AND PERSONAL GROWTH OF WOMEN OF HIGH ACCOMPLISHMENT; ORGANIZING, CONDUCTING AND HOSTING BUSINESS NETWORKING EVENTS FOR WOMEN OF HIGH ACCOMPLISHMENT (U.S. CLS. 100, 101 AND 102).

FIRST USE 8-27-2004; IN COMMERCE 8-27-2004.  
BARBARA BROWN, EXAMINING ATTORNEY

**CLASS 35—(Continued).**

SN 85-216,232. CBS INTERACTIVE INC., NEW YORK, NY.  
FILED 1-12-2011.

# GAMESPOT

THE MARK CONSISTS OF STANDARD CHARACTERS WITHOUT CLAIM TO ANY PARTICULAR FONT, STYLE, SIZE, OR COLOR.

FOR PROVIDING CONSUMER PRODUCT INFORMATION, NAMELY, NEWS, INFORMATION, REVIEWS, AND COMMENTARY ABOUT THE GOODS AND SERVICES OF OTHERS, VIA PODCASTS AND ELECTRONIC COMMUNICATION NETWORKS, IN THE FIELDS OF COMPUTERS, COMPUTER SOFTWARE, ELECTRONIC GAMING, SOFTWARE APPLICATION HOSTING, HIGH TECHNOLOGY, ELECTRONIC COMMUNICATIONS, CONSUMER ELECTRONICS AND DIGITAL TECHNOLOGIES (U.S. CLS. 100, 101 AND 102).

TRICIA SONNEBORN, EXAMINING ATTORNEY

**CLASS 35—(Continued).**

SN 85-216,738. SANLAND INVESTMENTS LIMITED,  
AGLANTZIAM, NICOSIA, CYPRUS, FILED 1-13-2011.

# JEXO

THE MARK CONSISTS OF STANDARD CHARACTERS WITHOUT CLAIM TO ANY PARTICULAR FONT, STYLE, SIZE, OR COLOR.

FOR ADVERTISING AND MARKETING SERVICES; CONSULTING SERVICES IN THE FIELD OF INTERNET MARKETING; ONLINE MARKETING SERVICES, NAMELY, AFFILIATE MARKETING SERVICES (U.S. CLS. 100, 101 AND 102).

REBECCA SMITH, EXAMINING ATTORNEY

SN 85-216,756. ADMIN ASSOCIATES LLC, PASADENA, CA.  
FILED 1-13-2011.

# PsychEZ

THE MARK CONSISTS OF STANDARD CHARACTERS WITHOUT CLAIM TO ANY PARTICULAR FONT, STYLE, SIZE, OR COLOR.

FOR APPOINTMENT SCHEDULING SERVICES; MEDICAL BILLING SUPPORT SERVICES (U.S. CLS. 100, 101 AND 102).

FIRST USE 4-1-2008; IN COMMERCE 6-1-2008.

LINDA E. BLOHM, EXAMINING ATTORNEY

SN 85-216,448. WIX, INC., SCOTTS VALLEY, CA. FILED 1-12-2011.

THE MARK CONSISTS OF THE STYLIZED TEXT "WIX" WITH A CANDLE IN PLACE OF THE LETTER "I".

FOR DO-IT-YOURSELF CANDLE AND SOAP MAKING STUDIO, PROVIDING THE USE OF VARIOUS SUPPLIES AND EQUIPMENT, NAMELY, CANDLE AND SOAP MOLDS, SOAP DYES, SOAP SCENTS, SOAP BASE AND WAX, BEESWAX, GLASS FOR GRANULATED CANDLES AND WICK (U.S. CLS. 100, 101 AND 102).

FIRST USE 6-5-2010; IN COMMERCE 6-5-2010.

LAURA KOVALSKY, EXAMINING ATTORNEY

SN 85-217,371. TRANSFAIR NORTH AMERICA INTERNATIONAL FREIGHT SERVICES, INC., DBA TRANSGROUP WORLDWIDE LOGISTICS, SEATTLE, WA. FILED 1-13-2011.

OWNER OF U.S. REG. NOS. 2,340,847, 2,374,785 AND OTHERS.

FOR ELECTRONIC SHIPMENT TRACKING AND NOTIFICATION SERVICES, NAMELY, THE USE OF ONLINE STATUS REPORTS, EXTRANET LISTINGS, INTERACTIVE VOICE MAIL REPORTS, AND FAX-ON-DEMAND REPORTS, TO TRACK FREIGHT SHIPMENTS WORLDWIDE (U.S. CLS. 100, 101 AND 102).

FIRST USE 3-1-2010; IN COMMERCE 3-1-2010.

KATHERINE CHANG, EXAMINING ATTORNEY



**CLASS 35—(Continued).**

SN 85-217,480. CYBER GATEWAYS INC., SMITHTOWN, NY.  
FILED 1-13-2011.

# HotRentals

THE MARK CONSISTS OF STANDARD CHARACTERS WITHOUT CLAIM TO ANY PARTICULAR FONT, STYLE, SIZE, OR COLOR.

FOR PROVIDING A WEB SITE WHICH FEATURES ADVERTISEMENTS FOR THE GOODS AND SERVICES OF OTHERS ON A GLOBAL COMPUTER NETWORK (U.S. CLS. 100, 101 AND 102).

SUZANNE BLANE, EXAMINING ATTORNEY

---

SN 85-217,518. RICHARD A. WALKER, ALPHARETTA, GA.  
FILED 1-13-2011.

# DRIVING THE GROWTH OF GEORGIA'S AUTOMOTIVE INDUSTRY

THE MARK CONSISTS OF STANDARD CHARACTERS WITHOUT CLAIM TO ANY PARTICULAR FONT, STYLE, SIZE, OR COLOR.

FOR ASSOCIATION SERVICES, NAMELY, PROMOTING THE INTERESTS OF THOSE INVOLVED IN THE AUTOMOTIVE INDUSTRY (U.S. CLS. 100, 101 AND 102).  
FIRST USE 7-20-2010; IN COMMERCE 11-9-2010.

CHARLOTTE CORWIN, EXAMINING ATTORNEY

---

SN 85-217,574. KLEVER MARKETING, INC., LOS ANGELES,  
CA. FILED 1-14-2011.

# KleverNET

THE MARK CONSISTS OF STANDARD CHARACTERS WITHOUT CLAIM TO ANY PARTICULAR FONT, STYLE, SIZE, OR COLOR.

FOR ADVERTISING AND COMMERCIAL INFORMATION SERVICES, VIA THE INTERNET; ADVICE AND INFORMATION ABOUT CUSTOMER SERVICES AND PRODUCT MANAGEMENT AND PRICES ON INTERNET SITES IN CONNECTION WITH PURCHASES MADE OVER THE INTERNET; DISSEMINATION OF ADVERTISING FOR OTHERS VIA AN ON-LINE COMMUNICATIONS NETWORK ON THE INTERNET; FACILITATING THE EXCHANGE OF NEEDED INFORMATION FOR FINANCIAL COMPENSATION VIA THE INTERNET INCLUDING DISCOUNT AND COUPONING OPPORTUNITIES; PROVIDING INFORMATION PERTAINING TO PROCUREMENT, BUYING, SELLING AND TENDERING INFORMATION AND OPPORTUNITIES RELATING TO GOODS AND SERVICES VIA COMPUTER, COMPUTER NETWORKS, TELEPHONE, THE INTERNET OR ELECTRONIC MAIL (U.S. CLS. 100, 101 AND 102).

LINDA E. BLOHM, EXAMINING ATTORNEY

**CLASS 35—(Continued).**

SN 85-217,576. KLEVER MARKETING, INC., LOS ANGELES,  
CA. FILED 1-14-2011.

# KleverSHOP

THE MARK CONSISTS OF STANDARD CHARACTERS WITHOUT CLAIM TO ANY PARTICULAR FONT, STYLE, SIZE, OR COLOR.

FOR ADVERTISING AND COMMERCIAL INFORMATION SERVICES, VIA THE INTERNET; ADVICE AND INFORMATION ABOUT CUSTOMER SERVICES AND PRODUCT MANAGEMENT AND PRICES ON INTERNET SITES IN CONNECTION WITH PURCHASES MADE OVER THE INTERNET; DISSEMINATION OF ADVERTISING FOR OTHERS VIA AN ON-LINE COMMUNICATIONS NETWORK ON THE INTERNET; FACILITATING THE EXCHANGE OF NEEDED INFORMATION FOR FINANCIAL COMPENSATION VIA THE INTERNET INCLUDING DISCOUNT AND COUPONING OPPORTUNITIES; PROVIDING INFORMATION PERTAINING TO PROCUREMENT, BUYING, SELLING AND TENDERING INFORMATION AND OPPORTUNITIES RELATING TO GOODS AND SERVICES VIA COMPUTER, COMPUTER NETWORKS, TELEPHONE, THE INTERNET OR ELECTRONIC MAIL (U.S. CLS. 100, 101 AND 102).

LINDA E. BLOHM, EXAMINING ATTORNEY

---

SN 85-217,577. KLEVER MARKETING, INC., LOS ANGELES,  
CA. FILED 1-14-2011.

# KleverBANK

THE MARK CONSISTS OF STANDARD CHARACTERS WITHOUT CLAIM TO ANY PARTICULAR FONT, STYLE, SIZE, OR COLOR.

FOR ADVERTISING AND COMMERCIAL INFORMATION SERVICES, VIA THE INTERNET; ADVICE AND INFORMATION ABOUT CUSTOMER SERVICES AND PRODUCT MANAGEMENT AND PRICES ON INTERNET SITES IN CONNECTION WITH PURCHASES MADE OVER THE INTERNET; DISSEMINATION OF ADVERTISING FOR OTHERS VIA AN ON-LINE COMMUNICATIONS NETWORK ON THE INTERNET; FACILITATING THE EXCHANGE OF NEEDED INFORMATION FOR FINANCIAL COMPENSATION VIA THE INTERNET INCLUDING DISCOUNT AND COUPONING OPPORTUNITIES; PROVIDING INFORMATION PERTAINING TO PROCUREMENT, BUYING, SELLING AND TENDERING INFORMATION AND OPPORTUNITIES RELATING TO GOODS AND SERVICES VIA COMPUTER, COMPUTER NETWORKS, TELEPHONE, THE INTERNET OR ELECTRONIC MAIL (U.S. CLS. 100, 101 AND 102).

LINDA E. BLOHM, EXAMINING ATTORNEY

**CLASS 35—(Continued).**

SN 85-217,693. JEEPNEE, SAN RAMON, CA. FILED 1-14-2011.

**JEEPNEE**

THE MARK CONSISTS OF STANDARD CHARACTERS WITHOUT CLAIM TO ANY PARTICULAR FONT, STYLE, SIZE, OR COLOR.

FOR EMPLOYMENT HIRING, RECRUITING, PLACEMENT, STAFFING AND CAREER NETWORKING SERVICES; PROVIDING AN ON-LINE SEARCHABLE DATABASE FEATURING EMPLOYMENT OPPORTUNITIES; PROVIDING ON-LINE EMPLOYMENT PLACEMENT SERVICES, NAMELY, MATCHING RESUMES AND POTENTIAL EMPLOYERS VIA A GLOBAL COMPUTER NETWORK (U.S. CLS. 100, 101 AND 102).

FIRST USE 12-27-2010; IN COMMERCE 12-27-2010.  
TRICIA SONNEBORN, EXAMINING ATTORNEY

---

SN 85-217,945. ED HERRINGTON, INC., HILLSDALE, NY.  
FILED 1-14-2011.

**WE SHARE YOUR PASSION**

THE MARK CONSISTS OF STANDARD CHARACTERS WITHOUT CLAIM TO ANY PARTICULAR FONT, STYLE, SIZE, OR COLOR.

FOR RETAIL STORE SERVICES IN THE FIELD OF LUMBER, MILLWORK, BUILDING SUPPLIES, AND BUILDING TOOLS AND HARDWARE (U.S. CLS. 100, 101 AND 102).

FIRST USE 9-0-2010; IN COMMERCE 9-0-2010.  
REBECCA SMITH, EXAMINING ATTORNEY

---

SN 85-218,346. BAZONZOES, WALLED LAKE, MI. FILED 1-14-2011.

**Bazonzoes**

THE MARK CONSISTS OF STANDARD CHARACTERS WITHOUT CLAIM TO ANY PARTICULAR FONT, STYLE, SIZE, OR COLOR.

FOR RETAIL STORE SERVICES FEATURING CLOTHING (U.S. CLS. 100, 101 AND 102).

GIANCARLO CASTRO, EXAMINING ATTORNEY

**CLASS 35—(Continued).**

SN 85-218,600. FERNANDEZ, RYAN G, LOS ANGELES, CA. FILED 1-15-2011.

**menugem**

THE MARK CONSISTS OF STANDARD CHARACTERS WITHOUT CLAIM TO ANY PARTICULAR FONT, STYLE, SIZE, OR COLOR.

FOR ADVERTISING AND DIRECTORY SERVICES, NAMELY, PROMOTING THE SERVICES OF OTHERS BY PROVIDING A WEB PAGE FEATURING LINKS TO THE WEBSITES OF OTHERS; PROMOTING THE GOODS AND SERVICES OF OTHERS BY PROVIDING A WEBSITE FEATURING COUPONS, REBATES, PRICE-COMPARISON INFORMATION, PRODUCT REVIEWS, LINKS TO THE RETAIL WEBSITES OF OTHERS, AND DISCOUNT INFORMATION; PROMOTING, ADVERTISING AND MARKETING OF THE BRANDS, PRODUCTS, SERVICES OR ONLINE WEBSITES OF INDIVIDUALS, BUSINESSES AND NONPROFIT ORGANIZATIONS; PROMOTION, ADVERTISING AND MARKETING OF ON-LINE WEBSITES; PROVIDING A SEARCHABLE ON-LINE ADVERTISING WEBSITE AND GUIDE FEATURING THE GOODS AND SERVICES OF OTHER VENDORS VIA THE INTERNET; PROVIDING A SEARCHABLE ONLINE ADVERTISING WEBSITE AND INFORMATIONAL GUIDE FEATURING THE GOODS AND SERVICES OF OTHER VENDORS VIA THE INTERNET IN THE FIELD OF FOOD SERVICE; PROVIDING A SEARCHABLE WEBSITE FEATURING THE GOODS AND SERVICES OF OTHER VENDORS; PROVIDING A WEBSITE FOR USERS WITH SPECIFIC INFORMED RECOMMENDATIONS OF SPECIFIC CONSUMER PRODUCTS AND SERVICES VALIDATED BY THE USERS' INPUTTED PREFERENCES AND SOCIAL NETWORK; PROVIDING A WEBSITE USED TO PLACE ON-LINE COMMERCIAL ORDERS IN THE FIELD OF FOOD SERVICE; PROVIDING A WEBSITE WHERE USERS CAN POST RATINGS, REVIEWS AND RECOMMENDATIONS ON RESTAURANTS, FOOD AND WINE FOR COMMERCIAL PURPOSES (U.S. CLS. 100, 101 AND 102).

FIRST USE 10-22-2009; IN COMMERCE 10-22-2009.  
NATALIE POLZER, EXAMINING ATTORNEY

---

SN 85-218,948. PREPAK SYSTEMS, INC., COOKEVILLE, TN.  
FILED 1-17-2011.

**APHENA**

THE MARK CONSISTS OF STANDARD CHARACTERS WITHOUT CLAIM TO ANY PARTICULAR FONT, STYLE, SIZE, OR COLOR.

FOR ORDER FULFILLMENT SERVICES (U.S. CLS. 100, 101 AND 102).

CAROLINE WOOD, EXAMINING ATTORNEY

**CLASS 35—(Continued).**

SN 85-218,956. PREPAK SYSTEMS, INC., COOKEVILLE, TN. FILED 1-17-2011.



THE MARK CONSISTS OF A DESIGN WITH AN OVERALL TRIANGULAR SHAPE. THE COLORS BLACK AND GRAY IN THE DRAWING REPRESENT SHADING AND ARE NOT PART OF THE MARK.

FOR ORDER FULFILLMENT SERVICES (U.S. CLS. 100, 101 AND 102).  
CAROLINE WOOD, EXAMINING ATTORNEY

SN 85-219,216. WHITE, LORRAINE, SARASOTA, FL. FILED 1-17-2011.

**Leadership Lifestyle Legacy**

THE MARK CONSISTS OF STANDARD CHARACTERS WITHOUT CLAIM TO ANY PARTICULAR FONT, STYLE, SIZE, OR COLOR.

FOR PROVIDING A WEBSITE FEATURING CONSUMER INFORMATION ABOUT TRACTORS AND UTILITY TERRAIN VEHICLES (U.S. CLS. 100, 101 AND 102).  
FIRST USE 1-1-1999; IN COMMERCE 11-15-2009.

LINDA E. BLOHM, EXAMINING ATTORNEY

SN 85-219,426. SLAVIS, ZACHARY RYAN, HUNTINGTON BEACH, CA. AND WOJNOWSKI, LUKASZ, LOS ANGELES, CA. FILED 1-17-2011.

**EMPLOYIST.COM**

THE MARK CONSISTS OF STANDARD CHARACTERS WITHOUT CLAIM TO ANY PARTICULAR FONT, STYLE, SIZE, OR COLOR.

FOR PROVIDING AN EMPLOYER WITH CANDIDATES OR POTENTIAL EMPLOYEES TO FILL TEMPORARY, CONTRACT AND PERMANENT POSITIONS; PROVIDING AN ON-LINE SEARCHABLE DATABASE FEATURING EMPLOYMENT OPPORTUNITIES AND CONTENT ABOUT EMPLOYMENT (U.S. CLS. 100, 101 AND 102).

JAMES LOVELACE, EXAMINING ATTORNEY

**CLASS 35—(Continued).**

SN 85-220,335. LARRY LATHAM, LAS VEGAS, NV. FILED 1-18-2011.

**AMERICABID**

THE MARK CONSISTS OF STANDARD CHARACTERS WITHOUT CLAIM TO ANY PARTICULAR FONT, STYLE, SIZE, OR COLOR.

FOR ONLINE AUCTION SERVICES CONDUCTED VIA A GLOBAL COMPUTER INFORMATION NETWORK (U.S. CLS. 100, 101 AND 102).

JOHN DALIER, EXAMINING ATTORNEY

SN 85-220,789. NEWTON EQUIPMENT LLC, DBA STEWART MARTIN EQUIPMENT, OKMULGEE, OK. FILED 1-19-2011.

**"If it's not orange, it's a lemon"**

THE MARK CONSISTS OF STANDARD CHARACTERS WITHOUT CLAIM TO ANY PARTICULAR FONT, STYLE, SIZE, OR COLOR.

FOR PROVIDING A WEBSITE FEATURING CONSUMER INFORMATION ABOUT TRACTORS AND UTILITY TERRAIN VEHICLES (U.S. CLS. 100, 101 AND 102).  
FIRST USE 1-1-1999; IN COMMERCE 11-15-2009.

LINDA E. BLOHM, EXAMINING ATTORNEY

SN 85-220,995. OPTIMIZE HIRE, LLC, 7100 SIX FORKS ROAD, NC. FILED 1-19-2011.



THE MARK CONSISTS OF THE WORD "OPTIMIZE" WITH A FILLED IN "O". THE PHRASE "SELECT AND HIRE THE BEST", UNDERNEATH "OPTIMIZE".

FOR PRE-EMPLOYMENT TESTING SERVICES, NAMELY, PROVIDING TESTS USED BY EMPLOYERS TO TEST POTENTIAL EMPLOYEES (U.S. CLS. 100, 101 AND 102).

MARK T. MULLEN, EXAMINING ATTORNEY

**CLASS 35—(Continued).**

SN 85-221,397. MAALOUF, TAREK I., HUNTSVILLE, TX. FILED 1-19-2011.

**SWAPPLASTIC.COM**

THE MARK CONSISTS OF STANDARD CHARACTERS WITHOUT CLAIM TO ANY PARTICULAR FONT, STYLE, SIZE, OR COLOR.  
FOR ON-LINE AUCTION SERVICES (U.S. CLS. 100, 101 AND 102).  
TOBY BULLOFF, EXAMINING ATTORNEY

---

SN 85-221,429. MAALOUF, TAREK I., HUNTSVILLE, TX. FILED 1-19-2011.

**GREEDYAUCTIONS.COM**

THE MARK CONSISTS OF STANDARD CHARACTERS WITHOUT CLAIM TO ANY PARTICULAR FONT, STYLE, SIZE, OR COLOR.  
FOR ON-LINE AUCTION SERVICES (U.S. CLS. 100, 101 AND 102).  
TOBY BULLOFF, EXAMINING ATTORNEY

---

SN 85-221,588. THE CONNECTED TABLE, INC., NEW YORK, NY. FILED 1-19-2011.

**THE CONNECTED TABLE**

THE MARK CONSISTS OF STANDARD CHARACTERS WITHOUT CLAIM TO ANY PARTICULAR FONT, STYLE, SIZE, OR COLOR.  
FOR ADVERTISING SERVICES; BRANDING SERVICES, NAMELY, CONSULTING, DEVELOPMENT, MANAGEMENT AND MARKETING OF BRANDS FOR BUSINESSES; EVENT PLANNING AND MANAGEMENT FOR MARKETING, BRANDING, PROMOTING OR ADVERTISING THE GOODS AND SERVICES OF OTHERS; PROVIDING MARKETING AND PROMOTION OF SPECIAL EVENTS; PUBLIC RELATIONS (U.S. CLS. 100, 101 AND 102).  
LINDA E. BLOHM, EXAMINING ATTORNEY

**CLASS 35—(Continued).**

SN 85-221,598. THE CONNECTED TABLE, INC., NEW YORK, NY. FILED 1-19-2011.

**EAT DRINK EXPLORE INSPIRE**

THE MARK CONSISTS OF STANDARD CHARACTERS WITHOUT CLAIM TO ANY PARTICULAR FONT, STYLE, SIZE, OR COLOR.  
FOR ADVERTISING SERVICES; BRANDING SERVICES, NAMELY, CONSULTING, DEVELOPMENT, MANAGEMENT AND MARKETING OF BRANDS FOR BUSINESSES; EVENT PLANNING AND MANAGEMENT FOR MARKETING, BRANDING, PROMOTING OR ADVERTISING THE GOODS AND SERVICES OF OTHERS; PROVIDING MARKETING AND PROMOTION OF SPECIAL EVENTS; PUBLIC RELATIONS (U.S. CLS. 100, 101 AND 102).  
LINDA E. BLOHM, EXAMINING ATTORNEY

---

SN 85-228,740. PREMIER, INC., CHARLOTTE, NC. FILED 1-28-2011.

**EXPRESSBUY**

THE MARK CONSISTS OF STANDARD CHARACTERS WITHOUT CLAIM TO ANY PARTICULAR FONT, STYLE, SIZE, OR COLOR.  
FOR ADMINISTRATION OF A DISCOUNT PROGRAM FOR ENABLING PARTICIPANTS TO OBTAIN DISCOUNTS ON GOODS AND SERVICES, NAMELY, PROVIDING A WEBSITE AND E-MAIL NOTIFICATIONS FEATURING DISCOUNTS, COUPONS, REBATES AND OTHER FORMS OF LOWER PRICES TO PARTICIPANTS (U.S. CLS. 100, 101 AND 102).  
KATHERINE STOIDES, EXAMINING ATTORNEY

**CLASS 35—(Continued).**

SN 85-234,527. CERTAINTTEED CORPORATION, VALLEY FORGE, PA. FILED 2-4-2011.

# LeadWorx

THE MARK CONSISTS OF THE STYLIZED WORDING "LEADWORX" WITH ONE ARM OF THE LETTER "X" COMPRISED OF A DESIGN OF THREE INTERSECTING TRIANGLES.

FOR LEAD GENERATION SERVICES IN THE BUILDING MATERIALS INDUSTRY IN THE NATURE OF GENERAL BUSINESS NETWORKING REFERRAL SERVICES, NAMELY, PROMOTING THE GOODS AND SERVICES OF OTHERS BY PASSING BUSINESS LEADS AND REFERRALS AMONG GROUP MEMBERS (U.S. CLS. 100, 101 AND 102).

FIRST USE 11-3-2010; IN COMMERCE 11-9-2010.  
CIMMERIAN COLEMAN, EXAMINING ATTORNEY

SN 85-237,734. THE TYLNEY GROUP, LLC, STUART, FL. FILED 2-9-2011.

# CLOUD FIRST

THE MARK CONSISTS OF STANDARD CHARACTERS WITHOUT CLAIM TO ANY PARTICULAR FONT, STYLE, SIZE, OR COLOR.

NO CLAIM IS MADE TO THE EXCLUSIVE RIGHT TO USE "CLOUD", APART FROM THE MARK AS SHOWN.

FOR BUSINESS CONSULTING SERVICES IN THE FIELD OF INFORMATION TECHNOLOGY; BUSINESS INFORMATION MANAGEMENT (U.S. CLS. 100, 101 AND 102).

FIRST USE 2-9-2011; IN COMMERCE 2-9-2011.  
BARBARA BROWN, EXAMINING ATTORNEY

SN 85-240,028. THE PLAN9 GROUP, LLC, SANTA MONICA, CA. FILED 2-11-2011.

# Plango!

THE MARK CONSISTS OF STANDARD CHARACTERS WITHOUT CLAIM TO ANY PARTICULAR FONT, STYLE, SIZE, OR COLOR.

FOR COMPUTERIZED ON-LINE ORDERING SERVICES IN THE FIELD OF TEACHING MATERIALS FOR FOREIGN LANGUAGE LEARNING (U.S. CLS. 100, 101 AND 102).

CYNTHIA TRIPI, EXAMINING ATTORNEY

**CLASS 35—(Continued).**

SN 85-243,525. PHILLIP HUEY, BIRMINGHAM, AL. FILED 2-16-2011.

# GiftQuest

THE MARK CONSISTS OF STANDARD CHARACTERS WITHOUT CLAIM TO ANY PARTICULAR FONT, STYLE, SIZE, OR COLOR.

FOR ONLINE AND MOBILE PHONE-BASED GIFT REGISTRY AND WISH LIST REGISTRY SERVICES; PROMOTING THE GOODS AND SERVICES OF OTHERS VIA A GLOBAL COMPUTER NETWORK (U.S. CLS. 100, 101 AND 102).

HELENE LIWINSKI, EXAMINING ATTORNEY

SN 85-243,933. LIFECARE, INC., SHELTON, CT. FILED 2-16-2011.

# LIFEMART

THE MARK CONSISTS OF STANDARD CHARACTERS WITHOUT CLAIM TO ANY PARTICULAR FONT, STYLE, SIZE, OR COLOR.

FOR ADMINISTRATION OF A DISCOUNT PROGRAM FOR ENABLING PARTICIPANTS TO OBTAIN DISCOUNTS ON GOODS AND SERVICES FROM PARTICIPATING PROVIDERS; ADMINISTRATION OF AN ONLINE DISCOUNT PROGRAM FOR EMPLOYERS ENABLING EMPLOYEES TO OBTAIN DISCOUNTS ON GOODS AND SERVICES FROM PARTICIPATING PROVIDERS (U.S. CLS. 100, 101 AND 102).

FIRST USE 2-14-2011; IN COMMERCE 2-14-2011.  
EVELYN BRADLEY, EXAMINING ATTORNEY

SN 85-244,186. TWO-CYLINDER, LTD., GRUNDY CENTER, IA. FILED 2-16-2011.

# Two-Cylinder Club

THE MARK CONSISTS OF STANDARD CHARACTERS WITHOUT CLAIM TO ANY PARTICULAR FONT, STYLE, SIZE, OR COLOR.

OWNER OF U.S. REG. NO. 2,818,911.

NO CLAIM IS MADE TO THE EXCLUSIVE RIGHT TO USE "CLUB", APART FROM THE MARK AS SHOWN.

SEC. 2(F) AS TO "TWO-CYLINDER".

FOR ARRANGING AND CONDUCTING TRADE SHOW EXHIBITIONS IN THE FIELD OF AGRICULTURAL VEHICLES (U.S. CLS. 100, 101 AND 102).

FIRST USE 3-1-1987; IN COMMERCE 3-1-1987.  
JENNIFER DIXON, EXAMINING ATTORNEY



**CLASS 35—(Continued).**

SN 85-250,965. ALLSTATE INSURANCE COMPANY, NORTHBROOK, IL. FILED 2-24-2011.



OWNER OF U.S. REG. NOS. 3,015,698 AND 3,017,917.  
NO CLAIM IS MADE TO THE EXCLUSIVE RIGHT TO USE "VOLUNTEER", APART FROM THE MARK AS SHOWN.

THE MARK CONSISTS OF THE WORDS "HELPING HANDS" WITH A HEART FOR THE DOT IN THE LETTER "I", WITH THE WORD "VOLUNTEER" BELOW IN A SOLID RECTANGLE.

FOR CHARITABLE SERVICES, NAMELY, ORGANIZING AND CONDUCTING VOLUNTEER PROGRAMS AND COMMUNITY SERVICE PROJECTS (U.S. CLS. 100, 101 AND 102).

FIRST USE 10-0-2008, THE MARK WAS FIRST USED ANYWHERE IN A DIFFERENT FORM OTHER THAN THAT SOUGHT TO BE REGISTERED AT LEAST AS EARLY AS 03/00/2002; IN COMMERCE 10-0-2008, THE MARK WAS FIRST USED IN COMMERCE IN A DIFFERENT FORM OTHER THAN THAT SOUGHT TO BE REGISTERED AT LEAST AS EARLY AS 03/00/2002.

VIVIAN MICZNIK FIRST, EXAMINING ATTORNEY

SN 85-251,649. MEIJER, INC., GRAND RAPIDS, MI. FILED 2-25-2011.

## Grand River Dairy

THE MARK CONSISTS OF STANDARD CHARACTERS WITHOUT CLAIM TO ANY PARTICULAR FONT, STYLE, SIZE, OR COLOR.

NO CLAIM IS MADE TO THE EXCLUSIVE RIGHT TO USE "DAIRY", APART FROM THE MARK AS SHOWN.

FOR DISTRIBUTORSHIP SERVICES IN THE FIELD OF DAIRY PRODUCTS, ICE CREAM, FRUIT JUICES AND WATER (U.S. CLS. 100, 101 AND 102).

DANNEAN HETZEL, EXAMINING ATTORNEY

**CLASS 35—(Continued).**

SN 85-259,425. FEDERAL EXPRESS CORPORATION, MEMPHIS, TN. FILED 3-7-2011.

## FedEx Custom Critical ShipmentAlert

THE MARK CONSISTS OF STANDARD CHARACTERS WITHOUT CLAIM TO ANY PARTICULAR FONT, STYLE, SIZE, OR COLOR.

OWNER OF U.S. REG. NOS. 2,657,697, 3,125,953 AND OTHERS.

NO CLAIM IS MADE TO THE EXCLUSIVE RIGHT TO USE "SHIPMENT ALERT", APART FROM THE MARK AS SHOWN.

FOR COMPUTERIZED TRACKING AND TRACING OF DOCUMENTS, PACKAGES AND FREIGHT IN TRANSIT (U.S. CLS. 100, 101 AND 102).

JOHN E. MICHOS, EXAMINING ATTORNEY

SN 85-267,250. ARMSTRONG GARDEN CENTERS, INC., GLENDORA, CA. FILED 3-15-2011.

## GARDENING WITHOUT GUESSWORK

THE MARK CONSISTS OF STANDARD CHARACTERS WITHOUT CLAIM TO ANY PARTICULAR FONT, STYLE, SIZE, OR COLOR.

NO CLAIM IS MADE TO THE EXCLUSIVE RIGHT TO USE "GARDENING", APART FROM THE MARK AS SHOWN.

FOR RETAIL LAWN, GARDEN AND NURSERY STORES (U.S. CLS. 100, 101 AND 102).

SUSAN RICHARDS, EXAMINING ATTORNEY

**CLASS 36—INSURANCE AND FINANCIAL**

SN 76-704,991. WINDWARD CAPITAL MANAGEMENT CO., LOS ANGELES, CA. FILED 10-20-2010.

## SLR CAPITAL MANAGEMENT

THE MARK CONSISTS OF STANDARD CHARACTERS WITHOUT CLAIM TO ANY PARTICULAR FONT, STYLE, SIZE, OR COLOR.

OWNER OF U.S. REG. NO. 2,320,830.

NO CLAIM IS MADE TO THE EXCLUSIVE RIGHT TO USE "CAPITAL MANAGEMENT", APART FROM THE MARK AS SHOWN.

FOR FINANCIAL SERVICES, NAMELY, PROVIDING INVESTMENT ADVICE AND MANAGEMENT OF ASSETS IN THE FORM OF SECURITIES TO ACHIEVE INVESTMENT GOALS (U.S. CLS. 100, 101 AND 102).

KATHERINE CONNOLLY, EXAMINING ATTORNEY

**CLASS 36—(Continued).**

SN 77-336,872. KLOSS, ROBERT E., DBA CLEARPLAN FINANCIAL, HAMBURG, NY. FILED 11-26-2007.

## Clearplan Financial

THE MARK CONSISTS OF STANDARD CHARACTERS WITHOUT CLAIM TO ANY PARTICULAR FONT, STYLE, SIZE, OR COLOR.

NO CLAIM IS MADE TO THE EXCLUSIVE RIGHT TO USE "FINANCIAL", APART FROM THE MARK AS SHOWN.

FOR FINANCIAL PLANNING; FINANCIAL PLANNING AND INVESTMENT ADVISORY SERVICES; FINANCIAL PLANNING FOR RETIREMENT; FINANCIAL PLANNING, NAMELY, THE CREATION OF PERSONALIZED STRATEGIES TO ACHIEVE FINANCIAL INDEPENDENCE; FINANCIAL PORTFOLIO ANALYSIS SERVICES; FINANCIAL PORTFOLIO MANAGEMENT; FINANCIAL ADVISORY AND CONSULTANCY SERVICES (U.S. CLS. 100, 101 AND 102).

FIRST USE 7-1-2007; IN COMMERCE 7-1-2007.  
DAVID TAYLOR, EXAMINING ATTORNEY

---

SN 77-680,482. WORLD MARKET CENTER VENTURE, LLC, LAS VEGAS, NV. FILED 2-27-2009.

**GIFT HOME**  
AT WORLD MARKET CENTER LAS VEGAS

NO CLAIM IS MADE TO THE EXCLUSIVE RIGHT TO USE "GIFT" OR "HOME" OR "MARKET CENTER", APART FROM THE MARK AS SHOWN.

THE COLOR(S) BLUE, AQUA, GREEN, LIME, RED, PURPLE, FUCHSIA, ORANGE, AND GRAY IS/ARE CLAIMED AS A FEATURE OF THE MARK.

THE MARK CONSISTS OF THE GRAY STYLIZED WORDS "GIFT HOME" OVER THE GRAY STYLIZED WORDS "AT WORLD MARKET CENTER LAS VEGAS", WITH AN ASSORTMENT OF BLUE, AQUA, GREEN, LIME, RED, PURPLE, FUCHSIA AND ORANGE COLORED CIRCLES SYMBOLIZING A PLUS SIGN IN BETWEEN THE GRAY STYLIZED WORDS "GIFT" AND "HOME".

SEC. 2(F) AS TO "WORLD MARKET CENTER LAS VEGAS".

FOR LEASING TRADE AND SHOWROOM EXHIBITION SPACE AND RETAIL SPACE TO MANUFACTURERS AND RETAILERS OF GOODS IN THE FIELDS OF HOME, OFFICE AND HOSPITALITY FURNISHINGS; SHOPPING MALL SERVICES, NAMELY, LEASING OF SHOPPING MALL SPACE (U.S. CLS. 100, 101 AND 102).

FIRST USE 8-1-2009; IN COMMERCE 8-1-2009.  
ANDREW RHIM, EXAMINING ATTORNEY

**CLASS 36—(Continued).**

SN 77-803,769. VIRGIN ENTERPRISES LIMITED, LONDON, UNITED KINGDOM, FILED 8-13-2009.

## VIRGIN MONEY EVERYONE'S BETTER OFF

THE MARK CONSISTS OF STANDARD CHARACTERS WITHOUT CLAIM TO ANY PARTICULAR FONT, STYLE, SIZE, OR COLOR.

PRIORITY CLAIMED UNDER SEC. 44(D) ON ERPNCMNTY TM OFC APPLICATION NO. 008473068, FILED 8-5-2009, REG. NO. 008473068, DATED 3-1-2010, EXPIRES 8-5-2019.

OWNER OF U.S. REG. NOS. 3,298,420, 3,398,247 AND OTHERS.

NO CLAIM IS MADE TO THE EXCLUSIVE RIGHT TO USE "MONEY", APART FROM THE MARK AS SHOWN.

FOR INSURANCE SERVICES, NAMELY, BROKERAGE, UNDERWRITING, ADMINISTRATION, APPRAISALS, AND CLAIMS ADJUSTMENT IN THE FIELDS OF LIFE INSURANCE, CAR INSURANCE, HOME INSURANCE, PET INSURANCE, AND TRAVEL INSURANCE; FINANCIAL AFFAIRS AND MONETARY AFFAIRS, NAMELY, FINANCIAL INFORMATION, MANAGEMENT AND ANALYSIS SERVICES; REAL ESTATE AFFAIRS, NAMELY, MORTGAGE LENDING; BANKING SERVICES; FINANCIAL CLEARING HOUSES; CREDIT CARD SERVICES; DEBIT CARD SERVICES; MORTGAGE BANKING; FINANCIAL CONSULTANCY; PROVISION OF FINANCIAL INFORMATION; FINANCIAL EVALUATION FOR INSURANCE PURPOSES; ELECTRONIC FUNDS TRANSFER; FINANCIAL SERVICES, NAMELY, MONEY LENDING; FINANCIAL SERVICES, NAMELY, INVESTMENT MANAGEMENT AND INVESTMENT OF FUNDS FOR OTHERS (U.S. CLS. 100, 101 AND 102).

STEVEN JACKSON, EXAMINING ATTORNEY

---

SN 77-910,448. GLOBAL GRID, LLC, LOS ANGELES, CA. FILED 1-12-2010.

## NATION'S FIRST HEALTH BANK

THE MARK CONSISTS OF STANDARD CHARACTERS WITHOUT CLAIM TO ANY PARTICULAR FONT, STYLE, SIZE, OR COLOR.

NO CLAIM IS MADE TO THE EXCLUSIVE RIGHT TO USE "FIRST HEALTH BANK", APART FROM THE MARK AS SHOWN.

FOR BANKING SERVICES (U.S. CLS. 100, 101 AND 102).

LINDSEY RUBIN, EXAMINING ATTORNEY

**CLASS 36—(Continued).**

SN 79-084,853. BEIJING SILK STREET CO., LTD., CHINA, FILED 6-29-2010.

秀水街  
XIU SHUI JIE

OWNER OF INTERNATIONAL REGISTRATION 1044652 DATED 6-29-2010, EXPIRES 6-29-2020.

THE MARK CONSISTS OF THREE CHINESE CHARACTERS AND THEIR TRANSLITERATION "XIU SHUI JIE".

THE ENGLISH TRANSLATION OF "XIU SHUI JIE" IN THE MARK IS "SILK STREET".

THE NON-LATIN CHARACTERS IN THE MARK TRANSLITERATE TO "XIU SHUI JIE" AND THIS MEANS "SILK ROAD" IN ENGLISH.

FOR LEASING OF REAL ESTATE; REAL ESTATE AGENCIES; HOUSING AGENCIES; REAL ESTATE MANAGEMENT; REAL ESTATE SERVICES, NAMELY, RENTAL OF OFFICES; SURETY SERVICES, NAMELY, SURETY FOR LEASES; FACTORING AGENCIES; FIDUCIARY SERVICES, NAMELY, FIDUCIARY REPRESENTATIVE SERVICES; COLLECTION OF RENT (U.S. CLS. 100, 101 AND 102).

CHRISTINE MARTIN, EXAMINING ATTORNEY

SN 85-032,110. THE OPERA FOUNDATION, INC., NEW YORK, NY. FILED 5-6-2010.



NO CLAIM IS MADE TO THE EXCLUSIVE RIGHT TO USE "THE OPERA FOUNDATION", APART FROM THE MARK AS SHOWN.

THE COLOR(S) RED AND BLACK IS/ARE CLAIMED AS A FEATURE OF THE MARK.

THE MARK CONSISTS OF THE WORDS "THE OPERA FOUNDATION" INSIDE A LARGE RED "O" WITH THE LETTER OF THE WORDS IN BLACK EXCEPT THE LETTER "O" IN "OPERA", WHICH IS IN RED.

FOR CHARITABLE FOUNDATION SERVICES, NAMELY, PROVIDING FUND RAISING ACTIVITIES, SUPPLEMENTAL FUNDING, SCHOLARSHIPS, STUDY GRANTS AND FINANCIAL ASSISTANCE FOR MUSICAL EDUCATIONAL PROGRAMS, PERFORMANCES AND ARTISTS (U.S. CLS. 100, 101 AND 102).

FIRST USE 1-31-2008; IN COMMERCE 1-31-2008.

BILL DAWE, EXAMINING ATTORNEY

**CLASS 36—(Continued).**

SN 85-040,379. GERBINO, KENNETH J., DBA KENNETH J. GERBINO AND COMPANY, LOS ANGELES, CA. FILED 5-17-2010.

**THE HAYEK PROPHECIES**

THE MARK CONSISTS OF STANDARD CHARACTERS WITHOUT CLAIM TO ANY PARTICULAR FONT, STYLE, SIZE, OR COLOR.

THE NAME SHOWN IN THE MARK DOES NOT IDENTIFY A PARTICULAR LIVING INDIVIDUAL.

FOR FINANCIAL CONSULTATION IN THE FIELD OF DEVELOPING INVESTMENT STRATEGIES, INVESTMENTS AND THE MANAGEMENT OF INVESTMENTS ACCORDING TO CLASSIC FINANCIAL AND ECONOMIC THEORIES (U.S. CLS. 100, 101 AND 102).

FIRST USE 11-15-2010; IN COMMERCE 11-15-2010.

HENRY S. ZAK, EXAMINING ATTORNEY

SN 85-040,757. ROCKLAND MANAGEMENT LLC, PRINCETON, NJ. FILED 5-17-2010.

**ROCKLAND MANAGEMENT**

THE MARK CONSISTS OF STANDARD CHARACTERS WITHOUT CLAIM TO ANY PARTICULAR FONT, STYLE, SIZE, OR COLOR.

NO CLAIM IS MADE TO THE EXCLUSIVE RIGHT TO USE "MANAGEMENT", APART FROM THE MARK AS SHOWN.

FOR ASSET MANAGEMENT AND INVESTMENT STRATEGY CONSULTING SERVICES DIRECTED TO INSTITUTIONAL INVESTORS, NAMELY, ANALYSIS, FORMATION, SELECTION AND MANAGEMENT OF VENTURE CAPITAL INTERESTS, AGGREGATED POOLS OF LIMITED PARTNERSHIP INTERESTS, PASSIVE PRIVATE MARKET PORTFOLIOS AND CO-INVESTMENTS NOT IN THE ENERGY OR NATURAL RESOURCES SECTORS; FINANCIAL INVESTMENT SERVICES, NAMELY, ACCOUNT DESIGN, DUE DILIGENCE AND MONITORING SERVICES DIRECTED TO INSTITUTIONAL INVESTORS IN THE FIELDS OF VENTURE CAPITAL INTERESTS, AGGREGATED POOLS OF LIMITED PARTNERSHIP INTERESTS, PASSIVE PRIVATE MARKET PORTFOLIOS AND CO-INVESTMENTS NOT IN THE ENERGY OR NATURAL RESOURCES SECTORS; ADVISORY SERVICES DIRECTED TO INSTITUTIONAL INVESTORS RELATED TO THE VALUATION, SALE OR PURCHASE OF LIMITED PARTNERSHIP INTERESTS IN THE SECONDARY MARKET, NOT IN THE ENERGY OR NATURAL RESOURCES SECTORS (U.S. CLS. 100, 101 AND 102).

FIRST USE 1-31-2009; IN COMMERCE 1-31-2009.

MICHAEL LITZAU, EXAMINING ATTORNEY

**CLASS 36—(Continued).**

SN 85-041,101. PALMETTO ELECTRIC COOPERATIVE, INC., RIDGELAND, SC. FILED 5-18-2010.



OWNER OF U.S. REG. NO. 1,627,592.  
NO CLAIM IS MADE TO THE EXCLUSIVE RIGHT TO USE "ROUND UP", APART FROM THE MARK AS SHOWN.  
THE COLOR(S) BLACK, ORANGE, BLUE AND WHITE IS/ARE CLAIMED AS A FEATURE OF THE MARK.

THE MARK CONSISTS OF THE WORDING "OPERATION ROUND UP", WITH THREE HORIZONTAL BLACK LINES WITH THE WORD "OPERATION" IN BLACK ON THE UPPER LEFT, AN ORANGE SPHERE, FADING TO WHITE AT THE TOP, IN THE LOWER CENTER WITH THE WORD "ROUND" IN BLACK FOLLOWING ITS PERIPHERY, AND A BLUE AND BLACK TRIANGLE ON THE UPPER RIGHT WITH THE WORD "UP" IN WHITE, OUTLINED IN BLACK, IN THE TRIANGLE.

FOR CHARITABLE FUND RAISING SERVICES FOR WORTHWHILE COMMUNITY ACTIVITIES BY ROUNDING UP ELECTRIC BILLS TO AN EVEN DOLLAR AMOUNT, FOR DONATION (U.S. CLS. 100, 101 AND 102).

FIRST USE 9-4-1989; IN COMMERCE 9-4-1989.  
FRED CARL, EXAMINING ATTORNEY

**CLASS 36—(Continued).**

SN 85-045,825. MEGAN MCAEENEY, NAPERVILLE, IL. AND JAMES P. MCAVEENEY, NAPERVILLE, IL. FILED 5-23-2010.

## Students Give Back

THE MARK CONSISTS OF STANDARD CHARACTERS WITHOUT CLAIM TO ANY PARTICULAR FONT, STYLE, SIZE, OR COLOR.

FOR CHARITABLE FUNDRAISING SERVICES BY MEANS OF ORGANIZING AND CONDUCTING SPECIAL EVENTS; CHARITABLE FUNDRAISING SERVICES BY MEANS OF RUNNING AND WALKING EVENTS; CHARITABLE FUNDRAISING SERVICES USING PROCEEDS FROM CD'S, TO PROVIDE FOOD, BLANKETS, SHELTER, OTHER RELIEF MATERIALS, BLOOD, AND FINANCIAL ASSISTANCE TO VICTIMS OF DISEASES AND DISASTERS IN THE U.S.; CHARITABLE FUNDRAISING SERVICES, NAMELY, ORGANIZING AND CONDUCTING FUNDRAISING EVENTS TO ENCOURAGE INTERCOLLEGIATE ATHLETIC PROGRAMS; CHARITABLE FUNDRAISING SERVICES, NAMELY, ORGANIZING AND CONDUCTING FUNDRAISING FOOD TASTING EVENTS; CHARITABLE FUNDRAISING SERVICES, NAMELY, ORGANIZING AND CONDUCTING MUSICAL ENTERTAINMENT EVENTS FEATURING FOOD AND WINE; CHARITABLE SERVICES, NAMELY, ORGANIZING FUNDRAISING SERVICES AND EVENTS TO RAISE FUNDS FOR RESEARCH IN THE FIELD OF NEPHROTIC SYNDROME AND FOCAL SEGMENTAL GLOMERULOSCLEROSIS (FSGS); CHARITABLE SERVICES, NAMELY, ORGANIZING FUNDRAISING SERVICES AND EVENTS TO RAISE FUNDS IN THE FIELD OF NOT FOR PROFIT SCHOOLS; FUNDRAISING SERVICES, NAMELY, ORGANIZING FUNDRAISERS FOR SCHOOLS AND OTHER GROUPS; CHARITABLE FUNDRAISING; CHARITABLE FUNDRAISING SERVICES; CHARITABLE FUNDRAISING SERVICES BY MEANS OF SELLING NFL FOOTBALL WEEKLY PICK CARDS TO RAISE FUNDS FOR NOT FOR PROFIT SCHOOLS (U.S. CLS. 100, 101 AND 102).

FIRST USE 5-23-2010; IN COMMERCE 5-23-2010.  
NAKIA HENRY, EXAMINING ATTORNEY

SN 85-049,536. LANSING AUTOMAKERS FEDERAL CREDIT UNION, LANSING, MI. FILED 5-27-2010.



THE MARK CONSISTS OF A WHEEL IMAGE ABOVE AND TO SLIGHTLY TO THE RIGHT OF WORD "WHEEL". CIRCLING THE WHEEL IMAGE ARE THE WORDS "WOMEN HELPING EDUCATE EVERY LADY" WITH EACH WORD SEPARATED BY A DOT.

FOR CREDIT UNION SERVICES (U.S. CLS. 100, 101 AND 102).

FIRST USE 3-1-2010; IN COMMERCE 3-1-2010.  
ALICE BENMAMAN, EXAMINING ATTORNEY

**CLASS 36—(Continued).**

SN 85-050,508. CHILLINGWORTH INVESTMENTS, LLC, DBA CAPITALVALUE, ENGLEWOOD, CO. FILED 5-28-2010.

# VALUEDRIVERS

THE MARK CONSISTS OF STANDARD CHARACTERS WITHOUT CLAIM TO ANY PARTICULAR FONT, STYLE, SIZE, OR COLOR.

FOR BUSINESS BROKERAGE SERVICES AND RELATED CONSULTING PERTAINING TO PROCUREMENT, BUYING, SELLING AND TENDERING INFORMATION AND OPPORTUNITIES; AND BUSINESS VALUATION SERVICES (U.S. CLS. 100, 101 AND 102).

FIRST USE 1-1-2002; IN COMMERCE 3-13-2002.  
JAMES GRIFFIN, EXAMINING ATTORNEY

**CLASS 36—(Continued).**

SN 85-061,619. MAX EXCHANGE INVESTORS LLC, BETHESDA, MD. FILED 6-13-2010.

# MAX MORTGAGE ASSET EXCHANGE

THE MARK CONSISTS OF STANDARD CHARACTERS WITHOUT CLAIM TO ANY PARTICULAR FONT, STYLE, SIZE, OR COLOR.

NO CLAIM IS MADE TO THE EXCLUSIVE RIGHT TO USE "MORTGAGE ASSET EXCHANGE", APART FROM THE MARK AS SHOWN.

FOR PROVISION OF A FINANCIAL EXCHANGE FOR TRADING MORTGAGES AND MORTGAGE-BACKED ASSETS AND SECURITIES (U.S. CLS. 100, 101 AND 102).  
REBECCA EISINGER, EXAMINING ATTORNEY

SN 85-060,233. MAXOUT SAVINGS ADVISORS, HOUSTON, TX. FILED 6-11-2010.

# SAVE AGGRESSIVELY AND INVEST CONSERVATIVELY

THE MARK CONSISTS OF STANDARD CHARACTERS WITHOUT CLAIM TO ANY PARTICULAR FONT, STYLE, SIZE, OR COLOR.

FOR INSURANCE AND FINANCIAL SERVICES, NAMELY, FINANCIAL PLANNING FOR RETIREMENT AND INVESTMENT MANAGEMENT (U.S. CLS. 100, 101 AND 102).

FIRST USE 9-4-2005; IN COMMERCE 10-4-2005.  
AMEEN IMAM, EXAMINING ATTORNEY

SN 85-065,082. PROJECT 10, HOUSTON, TX. FILED 6-17-2010.

# PROJECT 10

THE MARK CONSISTS OF STANDARD CHARACTERS WITHOUT CLAIM TO ANY PARTICULAR FONT, STYLE, SIZE, OR COLOR.

NO CLAIM IS MADE TO THE EXCLUSIVE RIGHT TO USE "PROJECT", APART FROM THE MARK AS SHOWN.

FOR CHARITABLE FOUNDATION SERVICES, NAMELY, PROVIDING FINANCIAL SUPPORT TO DISADVANTAGED INDIVIDUALS AND COMMUNITIES TO HELP IMPROVE HEALTH, EDUCATION, SHELTER, AND ENVIRONMENT (U.S. CLS. 100, 101 AND 102).

FIRST USE 8-1-2009; IN COMMERCE 8-1-2009.  
EUGENIA MARTIN, EXAMINING ATTORNEY

SN 85-061,020. BONDWAVE LLC, WHEATON, IL. FILED 6-11-2010.

# BONDALERT

THE MARK CONSISTS OF STANDARD CHARACTERS WITHOUT CLAIM TO ANY PARTICULAR FONT, STYLE, SIZE, OR COLOR.

FOR FINANCIAL PORTFOLIO ANALYSIS SERVICES, NAMELY, MONITORING OF PORTFOLIOS CONTAINING INVESTMENT SECURITIES (U.S. CLS. 100, 101 AND 102).

FIRST USE 6-9-2010; IN COMMERCE 6-9-2010.  
KATHERINE M. DUBRAY, EXAMINING ATTORNEY

SN 85-065,998. HOUSE HUNTERS, LONG BEACH, CA. FILED 6-18-2010.

# CARING REALTY

THE MARK CONSISTS OF STANDARD CHARACTERS WITHOUT CLAIM TO ANY PARTICULAR FONT, STYLE, SIZE, OR COLOR.

NO CLAIM IS MADE TO THE EXCLUSIVE RIGHT TO USE "REALTY", APART FROM THE MARK AS SHOWN.

FOR FINANCIAL EVALUATION FOR INSURANCE PURPOSES; FINANCIAL EVALUATION OF REAL ESTATE; BANKING; REAL ESTATE BROKERAGE (U.S. CLS. 100, 101 AND 102).

JENNIFER MARTIN, EXAMINING ATTORNEY



**CLASS 36—(Continued).**

SN 85-072,874. AFFINITY CREDIT UNION, DES MOINES, IA. FILED 6-28-2010.

## MiOportunidad

THE MARK CONSISTS OF STANDARD CHARACTERS WITHOUT CLAIM TO ANY PARTICULAR FONT, STYLE, SIZE, OR COLOR.

THE ENGLISH TRANSLATION OF "MIOPORTUNIDAD" IN THE MARK IS "MY OPPORTUNITY".

FOR COMPREHENSIVE PROGRAM OF FINANCIAL PRODUCTS, NAMELY, DEBIT CARD SERVICES AND SAVINGS ACCOUNT SERVICES, AS WELL AS FINANCIAL ADVISORY AND CONSULTANCY SERVICES DESIGNED TO ASSIST FIRST AND SECOND GENERATION HISPANICS IN MANAGING THEIR MONEY AND BUILDING A STRONG FINANCIAL FUTURE (U.S. CLS. 100, 101 AND 102).

HENRY S. ZAK, EXAMINING ATTORNEY

SN 85-073,503. WILEY GROUP HOLDINGS, LLC, DBA COMPETITIVE ADVANTAGE ASSET MANAGEMENT, MASON, OH. FILED 6-29-2010.

## Competitive Advantage Asset Management

THE MARK CONSISTS OF STANDARD CHARACTERS WITHOUT CLAIM TO ANY PARTICULAR FONT, STYLE, SIZE, OR COLOR.

NO CLAIM IS MADE TO THE EXCLUSIVE RIGHT TO USE "ASSET MANAGEMENT", APART FROM THE MARK AS SHOWN.

FOR INVESTMENT ADVICE IN THE FIELD OF REAL ESTATE INVESTMENT (U.S. CLS. 100, 101 AND 102).

FIRST USE 6-24-2010; IN COMMERCE 6-24-2010.

ADA HAN, EXAMINING ATTORNEY

SN 85-075,009. LAST MILE TECHNOLOGIES, LLC, MIDLOTHIAN, VA. FILED 6-30-2010.

## MY VALUE MY CONTROL

THE MARK CONSISTS OF STANDARD CHARACTERS WITHOUT CLAIM TO ANY PARTICULAR FONT, STYLE, SIZE, OR COLOR.

FOR FINANCIAL TRANSACTION SERVICES, NAMELY, PROVIDING SECURE COMMERCIAL TRANSACTIONS AND PAYMENT OPTIONS USING A MOBILE DEVICE AT A POINT OF SALE; FINANCIAL SERVICES, NAMELY, PROVIDING ELECTRONIC PROCESSING OF CREDIT CARD TRANSACTIONS AND ELECTRONIC PAYMENTS VIA A GLOBAL COMPUTER NETWORK; FINANCIAL SERVICES, NAMELY, PROCESSING ELECTRONIC PAYMENTS MADE THROUGH PREPAID CARDS (U.S. CLS. 100, 101 AND 102).

COURTNEY ALVAREZ, EXAMINING ATTORNEY

**CLASS 36—(Continued).**

SN 85-076,210. UDELL JEWELERS, INC., DBA LONDON JEWELERS, NEW YORK, NY. FILED 7-1-2010.



THE MARK CONSISTS OF THE WORDS "SAY I LONDON" IN CAPITAL LETTERS, WITH THE WORD "SAY" CENTERED OVER THE WORD "I" WHICH IS CENTERED OVER THE LETTERS "DO" IN THE WORD "LONDON" AND PRESENTED IN SOLID BLACK FONT, FORMING THE PHRASE "SAY I DO". THE FIRST THREE LETTERS "LON" AND THE FINAL "N" IN THE WORD "LONDON" ARE PRESENTED IN A BLACK AND WHITE OUTLINED FONT.

FOR EXCHANGING GOLD OF OTHERS FOR CASH; JEWELRY AND WATCH APPRAISAL SERVICES (U.S. CLS. 100, 101 AND 102).

FIRST USE 1-9-2010; IN COMMERCE 1-9-2010.

NICHOLAS ALTREE, EXAMINING ATTORNEY

SN 85-076,784. TRADD COMPANIES, LLC, MYRTLE BEACH, SC. FILED 7-2-2010.



NO CLAIM IS MADE TO THE EXCLUSIVE RIGHT TO USE "COMMERCIAL", APART FROM THE MARK AS SHOWN.

THE MARK CONSISTS OF THE WORDING " T TRADD COMMERCIAL" FEATURING A STYLIZED CIRCLE WITH THE LETTER "T" INSIDE OF THE CIRCLE TO THE LEFT OF THE WORDING.

FOR REAL ESTATE AGENCY SERVICES; REAL ESTATE BROKERAGE SERVICES; REAL ESTATE LEASING SERVICES; REAL ESTATE LISTING SERVICES; REAL ESTATE MANAGEMENT SERVICES; REAL ESTATE SITE SELECTION SERVICES (U.S. CLS. 100, 101 AND 102).

FIRST USE 12-31-2005; IN COMMERCE 12-31-2005.

LOURDES AYALA, EXAMINING ATTORNEY

**CLASS 36—(Continued).**

SN 85-090,293. ELLISON, JOANN, DETROIT, MI. FILED 7-22-2010.



NO CLAIM IS MADE TO THE EXCLUSIVE RIGHT TO USE "MEMORIAL ARTS FUND", APART FROM THE MARK AS SHOWN.

THE NAME(S), PORTRAIT(S), AND/OR SIGNATURE(S) SHOWN IN THE MARK DOES NOT IDENTIFY A PARTICULAR LIVING INDIVIDUAL.

THE COLOR(S) GOLD, GREEN, YELLOW, BLACK, WHITE AND RED IS/ARE CLAIMED AS A FEATURE OF THE MARK.

THE MARK CONSISTS OF LEFT-FACING PROFILE OF A SILHOUETTED BLACK MAN WITH LOOSE DREADLOCKS WITHIN A SQUARE; TOP TRIANGULAR HALF OF SQUARE IS GOLD; LOWER TRIANGULAR HALF OF SQUARE IS GREEN; TWO HALVES OF SQUARE DIVIDED BY A YELLOW ROPE LINE; TEXT "JASON ELLISON" IS IN BLACK; TEXT "MEMORIAL FUND" IS WHITE; TEXT "ARTS" IS RED.

FOR CHARITABLE FUND RAISING SERVICES; MEMORIAL FUND RAISING (U.S. CLS. 100, 101 AND 102). FIRST USE 2-1-2010; IN COMMERCE 5-1-2010.

LINDA ORNDORFF, EXAMINING ATTORNEY

SN 85-094,274. WESTERN MONEY SYSTEMS, SPARKS, NV. FILED 7-27-2010.

**CASINOXCHANGE**

THE MARK CONSISTS OF STANDARD CHARACTERS WITHOUT CLAIM TO ANY PARTICULAR FONT, STYLE, SIZE, OR COLOR.

FOR FINANCIAL SERVICES, NAMELY, ASSISTING OTHERS WITH COMPLETION OF FINANCIAL TRANSACTIONS, NAMELY, ELECTRONIC MONEY TRANSFER, ELECTRONIC MONEY TRANSFER SERVICES, CASH REPLACEMENT SERVICES RENDERED BY CREDIT CARD, ALL OF THE FOREGOING BEING FOR CUSTOMERS AT GAMING AND WAGERING ESTABLISHMENTS; FINANCIAL SERVICES, NAMELY, ASSISTING OTHERS WITH COMPLETION OF FINANCIAL TRANSACTIONS, NAMELY, ISSUING NON-MAGNETICALLY ENCODED STORED VALUE CARDS AND TICKETS ALLOWING USERS TO TRANSFER FINANCIAL VALUE FROM ONE GAMING MACHINE TO ANOTHER, AND RELATED MONITORING IN THE NATURE OF CONSULTING SERVICES IN CONNECTION WITH THE FOREGOING (U.S. CLS. 100, 101 AND 102).

MAUREEN DALL, EXAMINING ATTORNEY

**CLASS 36—(Continued).**

SN 85-096,641. LAST MILE TECHNOLOGIES, LLC, MIDLOTHIAN, VA. FILED 7-30-2010.

**MY CONTROL MY VALUE**

THE MARK CONSISTS OF STANDARD CHARACTERS WITHOUT CLAIM TO ANY PARTICULAR FONT, STYLE, SIZE, OR COLOR.

FOR FINANCIAL TRANSACTION SERVICES, NAMELY, PROVIDING SECURE COMMERCIAL TRANSACTIONS AND PAYMENT OPTIONS USING A MOBILE DEVICE AT A POINT OF SALE; FINANCIAL SERVICES, NAMELY, PROVIDING ELECTRONIC PROCESSING OF CREDIT CARD TRANSACTIONS AND ELECTRONIC PAYMENTS VIA A GLOBAL COMPUTER NETWORK; FINANCIAL SERVICES, NAMELY, PROCESSING ELECTRONIC PAYMENTS MADE THROUGH PREPAID CARDS (U.S. CLS. 100, 101 AND 102).

COURTNEY ALVAREZ, EXAMINING ATTORNEY

SN 85-097,883. TAYLOR HAUGEN FOUNDATION, INC., VALPARAISO, FL. FILED 8-2-2010.



NO CLAIM IS MADE TO THE EXCLUSIVE RIGHT TO USE "FOUNDATION", APART FROM THE MARK AS SHOWN.

THE NAME(S), PORTRAIT(S), AND/OR SIGNATURE(S) SHOWN IN THE MARK DOES NOT IDENTIFY A PARTICULAR LIVING INDIVIDUAL.

THE COLOR(S) MAROON, GOLD AND GREY IS/ARE CLAIMED AS A FEATURE OF THE MARK.

THE MARK CONSISTS OF A LARGE STYLIZED "T" IN MAROON WITH GOLD AND GREY TRIM AND THE "#80" IN GOLD ON THE BOTTOM OF THE "T". THE WORD "TAYLOR" IS GREY AND ON THE LEFT OF THE "T" AND THE WORD "HAUGEN" IS IN GREY AND ON THE RIGHT OF THE "T". BELOW THE "T" IS THE WORD "FOUNDATION" IN MAROON AND BELOW THAT IS THE PHRASE "DON'T QUIT... NEVER GIVE UP" ALSO IN MAROON.

FOR CHARITABLE FOUNDATION SERVICES, NAMELY, PROVIDING FUNDRAISING ACTIVITIES, FUNDING, SCHOLARSHIPS AND/OR FINANCIAL ASSISTANCE FOR FAITH-BASED, OUTGOING, COMMUNITY-ORIENTED, ACADEMICALLY-PROFICIENT ATHLETES IN THE LOCAL COMMUNITY; PROVIDING COLLEGE SCHOLARSHIPS; PROVIDING EDUCATIONAL SCHOLARSHIPS (U.S. CLS. 100, 101 AND 102).

FIRST USE 11-15-2008; IN COMMERCE 11-15-2008.

BRIAN CALLAGHAN, EXAMINING ATTORNEY

**CLASS 36—(Continued).**

SN 85-100,085. MYWEALTH, LLC, LAS VEGAS, NV. FILED 8-4-2010.



NO CLAIM IS MADE TO THE EXCLUSIVE RIGHT TO USE "BANKING", APART FROM THE MARK AS SHOWN. THE MARK CONSISTS OF VERTICALLY STACKED RECTANGLES OVER A HORIZONTAL LINE, THE WORDS "MYWEALTH BANKING" POSITIONED OVER THE HORIZONTAL LINE, AND THE WORDS "WHERE YOU BUILD WEALTH BY BECOMING YOUR OWN BANKER" POSITIONED UNDER THE HORIZONTAL LINE.

FOR INSURANCE AND FINANCIAL INFORMATION AND CONSULTANCY SERVICES (U.S. CLS. 100, 101 AND 102).

JAMES GRIFFIN, EXAMINING ATTORNEY

---

SN 85-112,238. SAVE A LIFE ~ SAVE THE WORLD FOUNDATION, ASHBURN, VA. FILED 8-20-2010.

**I AM THE ONE MAKING A  
DIFFERENCE**

THE MARK CONSISTS OF STANDARD CHARACTERS WITHOUT CLAIM TO ANY PARTICULAR FONT, STYLE, SIZE, OR COLOR.

FOR CHARITABLE FUND-RAISING SERVICES (U.S. CLS. 100, 101 AND 102).

BILL DAWE, EXAMINING ATTORNEY

---

SN 85-113,473. POMCO, INC., SYRACUSE, NY. FILED 8-23-2010.

**POMCO GROUP**

THE MARK CONSISTS OF STANDARD CHARACTERS WITHOUT CLAIM TO ANY PARTICULAR FONT, STYLE, SIZE, OR COLOR.

OWNER OF U.S. REG. NO. 1,931,512.

NO CLAIM IS MADE TO THE EXCLUSIVE RIGHT TO USE "GROUP", APART FROM THE MARK AS SHOWN.

FOR ADMINISTRATION OF EMPLOYEE BENEFIT PLANS CONCERNING INSURANCE AND FINANCE (U.S. CLS. 100, 101 AND 102).

FIRST USE 0-0-2008; IN COMMERCE 0-0-2008.

JULIE VEPPUMTHARA, EXAMINING ATTORNEY

**CLASS 36—(Continued).**

SN 85-120,802. HEALTH CARE GROUP, SAN DIEGO, CA. FILED 9-1-2010.



NO CLAIM IS MADE TO THE EXCLUSIVE RIGHT TO USE "SENIOR VET BENEFIT ASSIST", APART FROM THE MARK AS SHOWN.

THE MARK CONSISTS OF THE STYLIZED WORDING "SENIOR VET BENEFIT ASSIST" FEATURING A CREST WITH A BANNER IN THE MIDDLE WITH 5 STARS ABOVE THE BANNER AND THE WORD "BENEFIT" IN THE BANNER AND "ASSIST" BELOW THE WORD "BENEFIT".

FOR PROVIDING CONSULTING IN THE FIELD OF FINANCIAL BENEFITS FOR VETERANS, NAMELY, DISABILITY, PENSION AND RESIDENTIAL BENEFITS (U.S. CLS. 100, 101 AND 102).

FIRST USE 8-9-2010; IN COMMERCE 8-9-2010.

LOURDES AYALA, EXAMINING ATTORNEY

---

SN 85-125,697. UNITED STATES COMMODITY FUNDS LLC, ALAMEDA, CA. FILED 9-9-2010.

**USCI UNITED STATES  
COMMODITY INDEX FUND**

THE MARK CONSISTS OF STANDARD CHARACTERS WITHOUT CLAIM TO ANY PARTICULAR FONT, STYLE, SIZE, OR COLOR.

OWNER OF U.S. REG. NO. 3,600,670.

NO CLAIM IS MADE TO THE EXCLUSIVE RIGHT TO USE "UNITED STATES COMMODITY INDEX FUND", APART FROM THE MARK AS SHOWN.

FOR FUND INVESTMENT SERVICES (U.S. CLS. 100, 101 AND 102).

FIRST USE 8-10-2010; IN COMMERCE 8-10-2010.

JASON TURNER, EXAMINING ATTORNEY

**CLASS 36—(Continued).**

SN 85-125,701. UNITED STATES COMMODITY FUNDS LLC, ALAMEDA, CA. FILED 9-9-2010.



OWNER OF U.S. REG. NO. 3,600,670.  
NO CLAIM IS MADE TO THE EXCLUSIVE RIGHT TO USE "UNITED STATES COMMODITY INDEX FUND", APART FROM THE MARK AS SHOWN.

THE MARK CONSISTS OF THE TERMS "USCI UNITED STATES COMMODITY INDEX FUND" AND DESIGNS IN SQUARES OF BEANS, OIL FIELD EQUIPMENT, GRAIN, CATTLE, HAMMERS AND A GOLD BAR.

FOR FUND INVESTMENT SERVICES (U.S. CLS. 100, 101 AND 102).

FIRST USE 8-10-2010; IN COMMERCE 8-10-2010.  
JASON TURNER, EXAMINING ATTORNEY

---

SN 85-125,830. CLAIMS RESOURCE MANAGEMENT, INC., ACTON, CA. FILED 9-9-2010.

CLAIMS RESOURCE MANAGEMENT  
INC.

THE MARK CONSISTS OF STANDARD CHARACTERS WITHOUT CLAIM TO ANY PARTICULAR FONT, STYLE, SIZE, OR COLOR.

NO CLAIM IS MADE TO THE EXCLUSIVE RIGHT TO USE "RESOURCE MANAGEMENT INC.", APART FROM THE MARK AS SHOWN.

SEC. 2(F).  
FOR CLAIMS ADJUSTMENT IN THE FIELD OF INSURANCE; ELECTRONIC PROCESSING OF INSURANCE CLAIMS AND PAYMENT DATA; INSURANCE ADMINISTRATION SERVICES, NAMELY, ASSISTING OTHERS WITH ADJUSTING INSURANCE CLAIMS; INSURANCE CLAIMS ADMINISTRATION; INSURANCE CLAIMS PROCESSING (U.S. CLS. 100, 101 AND 102).

FIRST USE 0-0-1988; IN COMMERCE 0-0-1988.  
STEVEN PEREZ, EXAMINING ATTORNEY

---

SN 85-125,933. FAMILY MOTOR COACH ASSOCIATION, INC., CINCINNATI, OH. FILED 9-9-2010.

FMCA REWARDS

THE MARK CONSISTS OF STANDARD CHARACTERS WITHOUT CLAIM TO ANY PARTICULAR FONT, STYLE, SIZE, OR COLOR.

NO CLAIM IS MADE TO THE EXCLUSIVE RIGHT TO USE "REWARDS", APART FROM THE MARK AS SHOWN.

FOR INSURANCE SERVICES FOR MOTORCOACH OWNERS, NAMELY, PROVISION OF AN ACCIDENT INSURANCE PLAN (U.S. CLS. 100, 101 AND 102).

FLORENTINA BLANDU, EXAMINING ATTORNEY

**CLASS 36—(Continued).**

SN 85-127,581. THE TRUSTEES OF THE COHEN FAMILY TRUST DATED 1/16/95, BAKERSFIELD, CA. FILED 9-11-2010.



NO CLAIM IS MADE TO THE EXCLUSIVE RIGHT TO USE "APARTMENTS", APART FROM THE MARK AS SHOWN.

THE MARK CONSISTS OF "KERN APARTMENTS" STYLIZED FEATURING AN ANGLED ROOF AS PART OF THE LETTER "K".

FOR REAL ESTATE RENTAL SERVICES, NAMELY, RENTAL OF RESIDENTIAL HOUSING (U.S. CLS. 100, 101 AND 102).

FIRST USE 1-29-2009; IN COMMERCE 1-29-2009.  
BERYL GARDNER, EXAMINING ATTORNEY

---

SN 85-136,314. HRS MANAGEMENT LLC, NEW YORK, NY. FILED 9-23-2010.

HRS MANAGEMENT LLC

THE MARK CONSISTS OF STANDARD CHARACTERS WITHOUT CLAIM TO ANY PARTICULAR FONT, STYLE, SIZE, OR COLOR.

NO CLAIM IS MADE TO THE EXCLUSIVE RIGHT TO USE "MANAGEMENT LLC", APART FROM THE MARK AS SHOWN.

FOR FINANCIAL SERVICES, NAMELY, FUND MANAGEMENT AND INVESTMENT ADVISORY SERVICES (U.S. CLS. 100, 101 AND 102).

REGINA DRUMMOND, EXAMINING ATTORNEY

---

SN 85-136,315. HRS MANAGEMENT LLC, NEW YORK, NY. FILED 9-23-2010.

HRS INVESTMENT HOLDINGS LLC

THE MARK CONSISTS OF STANDARD CHARACTERS WITHOUT CLAIM TO ANY PARTICULAR FONT, STYLE, SIZE, OR COLOR.

NO CLAIM IS MADE TO THE EXCLUSIVE RIGHT TO USE "INVESTMENT HOLDINGS LLC", APART FROM THE MARK AS SHOWN.

FOR FINANCIAL SERVICES, NAMELY, FUND MANAGEMENT AND INVESTMENT ADVISORY SERVICES (U.S. CLS. 100, 101 AND 102).

REGINA DRUMMOND, EXAMINING ATTORNEY

**CLASS 36—(Continued).**

SN 85-136,651. KLH GROUP, DBA KETSYN REALTY, LAGRANGE, GA. FILED 9-23-2010.



THE COLOR(S) GREEN, BLACK AND WHITE IS/ARE CLAIMED AS A FEATURE OF THE MARK.

THE MARK CONSISTS OF A CURVED BLACK ARROW WITH A BLACK AND WHITE BORDER, THE WORDING "KETSYN" IN GREEN, AND THE WORDING "ESTABLISHED TO SERVE YOUR NEEDS" IN BLACK.

FOR REAL ESTATE BROKERAGE (U.S. CLS. 100, 101 AND 102).

FIRST USE 8-15-2010; IN COMMERCE 8-20-2010.  
ANGELA DUONG, EXAMINING ATTORNEY

SN 85-147,301. CM&F GROUP, INC., NEW YORK, NY. FILED 10-7-2010.

**NP SECURE**

THE MARK CONSISTS OF STANDARD CHARACTERS WITHOUT CLAIM TO ANY PARTICULAR FONT, STYLE, SIZE, OR COLOR.

NO CLAIM IS MADE TO THE EXCLUSIVE RIGHT TO USE "NP", APART FROM THE MARK AS SHOWN.

FOR PROVIDING MEDICAL MALPRACTICE AND LIABILITY INSURANCE UNDERWRITING, ADMINISTRATION, CONSULTING AND BROKERAGE SERVICES FOR NURSE PRACTITIONERS (U.S. CLS. 100, 101 AND 102).

FIRST USE 9-1-2009; IN COMMERCE 9-1-2009.  
ANDREA K. NADELMAN, EXAMINING ATTORNEY

SN 85-147,310. CM&F GROUP, INC., NEW YORK, NY. FILED 10-7-2010.

**PA PROTECT**

THE MARK CONSISTS OF STANDARD CHARACTERS WITHOUT CLAIM TO ANY PARTICULAR FONT, STYLE, SIZE, OR COLOR.

NO CLAIM IS MADE TO THE EXCLUSIVE RIGHT TO USE "PA", APART FROM THE MARK AS SHOWN.

FOR PROVIDING MEDICAL MALPRACTICE AND LIABILITY INSURANCE UNDERWRITING, ADMINISTRATION, CONSULTING AND BROKERAGE SERVICES FOR PHYSICIAN ASSISTANTS (U.S. CLS. 100, 101 AND 102).

FIRST USE 9-1-2009; IN COMMERCE 9-1-2009.  
ANDREA K. NADELMAN, EXAMINING ATTORNEY

**CLASS 36—(Continued).**

SN 85-148,579. WORKCOMPEDI, INC., HOLBROOK, NY. FILED 10-8-2010.

**COMPFAX**

THE MARK CONSISTS OF STANDARD CHARACTERS WITHOUT CLAIM TO ANY PARTICULAR FONT, STYLE, SIZE, OR COLOR.

THE WORDING "COMPFAX" HAS NO MEANING IN A FOREIGN LANGUAGE.

FOR ELECTRONIC PROCESSING OF INSURANCE CLAIMS AND PAYMENT DATA; INSURANCE ADMINISTRATION IN THE FIELD OF WORKERS' COMPENSATION (U.S. CLS. 100, 101 AND 102).

FIRST USE 1-0-2009; IN COMMERCE 1-0-2009.  
MYRIAH HABEEB, EXAMINING ATTORNEY

SN 85-157,639. BONNIE, NANA, LAUREL, MD. FILED 10-21-2010.

**FEEDFOREVER**

THE MARK CONSISTS OF STANDARD CHARACTERS WITHOUT CLAIM TO ANY PARTICULAR FONT, STYLE, SIZE, OR COLOR.

FOR CHARITABLE FUNDRAISING SERVICES, NAMELY, RAISING FUNDS FOR THE PURPOSE OF HUNGER RELIEF AROUND THE WORLD (U.S. CLS. 100, 101 AND 102).

ELLEN PERKINS, EXAMINING ATTORNEY

SN 85-158,328. ALLSTATE INSURANCE COMPANY, NORTHBROOK, IL. FILED 10-21-2010.

**CHICAGO'S OWN GOOD HANDS**

THE MARK CONSISTS OF STANDARD CHARACTERS WITHOUT CLAIM TO ANY PARTICULAR FONT, STYLE, SIZE, OR COLOR.

OWNER OF U.S. REG. NOS. 1,122,022, 3,548,130 AND OTHERS.

NO CLAIM IS MADE TO THE EXCLUSIVE RIGHT TO USE "CHICAGO'S", APART FROM THE MARK AS SHOWN.

FOR INSURANCE SERVICES, NAMELY, WRITING AND UNDERWRITING INSURANCE IN THE FIELDS OF PROPERTY, LIABILITY, AND CASUALTY, AND PROVIDING ANCILLARY SERVICES THERETO, NAMELY, ADMINISTRATION AND CLAIMS ADJUSTMENT (U.S. CLS. 100, 101 AND 102).

PAM WILLIS, EXAMINING ATTORNEY



**CLASS 36—(Continued).**

SN 85-160,138. CONCEPT CAPITAL ADVISORS, LLC, GARDEN CITY, NY. FILED 10-25-2010.



NO CLAIM IS MADE TO THE EXCLUSIVE RIGHT TO USE "RISK", APART FROM THE MARK AS SHOWN.

THE COLOR(S) BLUE, GRAY, WHITE IS/ARE CLAIMED AS A FEATURE OF THE MARK.

THE MARK CONSISTS OF A BLUE RECTANGLE CONTAINING THE WORD "RISKONE" WITH "RISK" IN GRAY AND "ONE" IN WHITE, AND "BY RISK RESOURCES" IN WHITE.

FOR FINANCIAL SERVICES, NAMELY, PROVIDING QUANTITATIVE REPORTING AND QUALITATIVE ADVISORY SERVICES TARGETING THE RISK CONTROL PROCESS FOR FINANCIAL PROFESSIONALS (U.S. CLS. 100, 101 AND 102).

FIRST USE 3-1-2010; IN COMMERCE 3-1-2010.  
TEJBIR SINGH, EXAMINING ATTORNEY

**CLASS 36—(Continued).**

SN 85-161,795. ASSURANT, INC., NEW YORK, NY. FILED 10-26-2010.

**PRESERVE YOUR EVERYDAY**

THE MARK CONSISTS OF STANDARD CHARACTERS WITHOUT CLAIM TO ANY PARTICULAR FONT, STYLE, SIZE, OR COLOR.

FOR INSURANCE SERVICES, NAMELY, UNDERWRITING AND ADMINISTRATION OF INSURANCE THAT PROVIDES A BENEFIT EQUAL TO THE PAYMENT OBLIGATIONS OF THE INSURED FOR CREDIT CARDS, INSTALLMENT LOANS, HOME RELATED LOANS, AUTO LOANS AND PERSONAL LOANS IN THE EVENT OF ACCIDENTAL DEATH, ALL OTHER CAUSES OF DEATH, DISABILITY, UNEMPLOYMENT AND HOSPITALIZATION (U.S. CLS. 100, 101 AND 102).

KIM MONINGHOFF, EXAMINING ATTORNEY

SN 85-161,810. ASSURANT, INC., NEW YORK, NY. FILED 10-26-2010.

SN 85-161,792. ASSURANT, INC., NEW YORK, NY. FILED 10-26-2010.

**CRADLE**

THE MARK CONSISTS OF STANDARD CHARACTERS WITHOUT CLAIM TO ANY PARTICULAR FONT, STYLE, SIZE, OR COLOR.

FOR INSURANCE SERVICES, NAMELY, UNDERWRITING AND ADMINISTRATION OF INSURANCE THAT PROVIDES A BENEFIT EQUAL TO THE PAYMENT OBLIGATIONS OF THE INSURED FOR CREDIT CARDS, INSTALLMENT LOANS, HOME RELATED LOANS, AUTO LOANS AND PERSONAL LOANS IN THE EVENT OF ACCIDENTAL DEATH, ALL OTHER CAUSES OF DEATH, DISABILITY, UNEMPLOYMENT AND HOSPITALIZATION (U.S. CLS. 100, 101 AND 102).

KIM MONINGHOFF, EXAMINING ATTORNEY



THE COLOR(S) BLUE AND GOLD IS/ARE CLAIMED AS A FEATURE OF THE MARK.

THE MARK CONSISTS OF CURVED LINES SUGGESTING THE BODY OF A HUMAN FIGURE IN MOTION, TOPPED BY A CIRCLE REPRESENTING THE HEAD. THE BODY AND ONE ARM OF THE FIGURE ARE DEPICTED BY ONE CONTINUOUS CURVED LINE SHOWN IN THE COLOR BLUE. A LEG AND THE OTHER ARM ARE DEPICTED BY SHORTER CURVED LINES SHOWN IN THE COLOR GOLD. THE HEAD IS DEPICTED AS A GOLD CIRCLE.

FOR INSURANCE SERVICES, NAMELY, UNDERWRITING AND ADMINISTRATION OF INSURANCE THAT PROVIDES A BENEFIT EQUAL TO THE PAYMENT OBLIGATIONS OF THE INSURED FOR CREDIT CARDS, INSTALLMENT LOANS, HOME RELATED LOANS, AUTO LOANS AND PERSONAL LOANS IN THE EVENT OF ACCIDENTAL DEATH, ALL OTHER CAUSES OF DEATH, DISABILITY, UNEMPLOYMENT AND HOSPITALIZATION (U.S. CLS. 100, 101 AND 102).

KIM MONINGHOFF, EXAMINING ATTORNEY

**CLASS 36—(Continued).**

SN 85-163,849. AMERICAN GENERAL FINANCE, INC., EVANSVILLE, IN. FILED 10-28-2010.

**SPRINGLEAF**

THE MARK CONSISTS OF STANDARD CHARACTERS WITHOUT CLAIM TO ANY PARTICULAR FONT, STYLE, SIZE, OR COLOR.

FOR CONSUMER LENDING SERVICES; INSURANCE UNDERWRITING IN THE FIELD OF LIFE, ACCIDENTAL DEATH AND DISMEMBERMENT, DISABILITY AND CREDIT INSURANCE (U.S. CLS. 100, 101 AND 102).  
NAKIA HENRY, EXAMINING ATTORNEY

SN 85-163,861. AMERICAN GENERAL FINANCE, INC., EVANSVILLE, IN. FILED 10-28-2010.

**SPRINGLEAF FINANCE**

THE MARK CONSISTS OF STANDARD CHARACTERS WITHOUT CLAIM TO ANY PARTICULAR FONT, STYLE, SIZE, OR COLOR.

NO CLAIM IS MADE TO THE EXCLUSIVE RIGHT TO USE "FINANCE", APART FROM THE MARK AS SHOWN.

FOR CONSUMER LENDING SERVICES; INSURANCE UNDERWRITING IN THE FIELD OF LIFE, ACCIDENTAL DEATH AND DISMEMBERMENT, DISABILITY AND CREDIT INSURANCE (U.S. CLS. 100, 101 AND 102).  
NAKIA HENRY, EXAMINING ATTORNEY

SN 85-163,864. AMERICAN GENERAL FINANCE, INC., EVANSVILLE, IN. FILED 10-28-2010.

**SPRINGLEAF FINANCIAL**

THE MARK CONSISTS OF STANDARD CHARACTERS WITHOUT CLAIM TO ANY PARTICULAR FONT, STYLE, SIZE, OR COLOR.

NO CLAIM IS MADE TO THE EXCLUSIVE RIGHT TO USE "FINANCIAL", APART FROM THE MARK AS SHOWN.

FOR CONSUMER LENDING SERVICES; INSURANCE UNDERWRITING IN THE FIELD OF LIFE, ACCIDENTAL DEATH AND DISMEMBERMENT, DISABILITY AND CREDIT INSURANCE (U.S. CLS. 100, 101 AND 102).  
NAKIA HENRY, EXAMINING ATTORNEY

**CLASS 36—(Continued).**

SN 85-163,956. MASSACHUSETTS MUTUAL LIFE INSURANCE COMPANY, SPRINGFIELD, MA. FILED 10-28-2010.

미리 계획하고 준비하면 달라집니다

THE MARK CONSISTS OF 14 KOREAN CHARACTERS. THE ENGLISH TRANSLATION OF THE KOREAN CHARACTERS IN THE MARK IS "IF YOU PLAN AHEAD, YOU CAN MAKE A DIFFERENCE IN YOUR FUTURE".

THE NON-LATIN CHARACTERS IN THE MARK TRANSLITERATE TO: FIRST TWO CHARACTERS ARE MI-RI, NEXT FOUR CHARACTERS ARE GE-WHECK-HA-GO, THE NEXT FOUR CHARACTERS ARE JOON-BI-HA-MYUN AND THE LAST FIVE CHARACTERS ARE DAL-LA-JIP-NI-DA AND THIS MEANS IF YOU PLAN AHEAD, YOU CAN MAKE A DIFFERENCE IN YOUR FUTURE IN ENGLISH.

FOR INSURANCE AND FINANCIAL SERVICES, NAMELY, ACTUARIAL SERVICES, INSURANCE ADMINISTRATION, FINANCIAL ANALYSIS AND CONSULTATION; UNDERWRITING, ISSUING AND ADMINISTRATION OF LIFE INSURANCE; ASSET MANAGEMENT; ANNUITY UNDERWRITING; FINANCIAL ADMINISTRATION OF RETIREMENT PLANS; FINANCIAL MANAGEMENT SERVICES, NAMELY, INCOME MANAGEMENT; FINANCIAL PLANNING FOR RETIREMENT; RETIREMENT PLAN ADMINISTRATION SERVICES; DISABILITY INSURANCE SERVICES; LONG TERM CARE INSURANCE SERVICES; FINANCIAL INFORMATION PROVIDED BY ELECTRONIC MEANS; INSURANCE AND SECURITIES BROKERAGE; BROKER-DEALER SERVICES, NAMELY, PURCHASE AND SALE OF SECURITIES PRODUCTS, NAMELY, MUTUAL FUNDS AND UNIT INVESTMENT TRUSTS; MUTUAL FUND DISTRIBUTION SERVICES; ADMINISTRATION OF EMPLOYEE BENEFIT PLANS; FIDUCIARY REPRESENTATIVE SERVICES; ELECTRONIC FUNDS TRANSFERS; INVESTMENT ADVICE; INVESTMENT MANAGEMENT; MONEY MANAGEMENT; MUTUAL FUND INVESTMENT SERVICES; ADMINISTRATION OF EMPLOYEE PENSION PLANS; POOLED INVESTMENT FUND MANAGEMENT; RETIREMENT INVESTMENT MANAGEMENT; ESTATE TRUST MANAGEMENT SERVICES; SECURITIES UNDERWRITING (U.S. CLS. 100, 101 AND 102).

FIRST USE 4-1-2008; IN COMMERCE 4-1-2008.

KATHY DE JONGE, EXAMINING ATTORNEY

**CLASS 36—(Continued).**

SN 85-163,964. AMERICAN GENERAL FINANCE, INC., EVANSVILLE, IN. FILED 10-28-2010.

**CLASS 36—(Continued).**

SN 85-164,071. MASSACHUSETTS MUTUAL LIFE INSURANCE COMPANY, SPRINGFIELD, MA. FILED 10-28-2010.



**SPRINGLEAF FINANCIAL SERVICES**

THE MARK CONSISTS OF STANDARD CHARACTERS WITHOUT CLAIM TO ANY PARTICULAR FONT, STYLE, SIZE, OR COLOR.

NO CLAIM IS MADE TO THE EXCLUSIVE RIGHT TO USE "FINANCIAL SERVICES", APART FROM THE MARK AS SHOWN.

FOR CONSUMER LENDING SERVICES; INSURANCE UNDERWRITING IN THE FIELD OF LIFE, ACCIDENTAL DEATH AND DISMEMBERMENT, DISABILITY AND CREDIT INSURANCE (U.S. CLS. 100, 101 AND 102). NAKIA HENRY, EXAMINING ATTORNEY

OWNER OF U.S. REG. NOS. 2,593,720, 3,744,355 AND OTHERS.

NO CLAIM IS MADE TO THE EXCLUSIVE RIGHT TO USE THE NON-LATIN CHARACTERS THAT TRANSLITERATE TO FA, EE, NEN, CIAL, GU, ROUP, APART FROM THE MARK AS SHOWN.

THE MARK CONSISTS OF THE WORDING "MASSMUTUAL" TO THE RIGHT OF A SQUARE CONTAINING TWO PARALLEL, CURVED LINES EXTENDING FROM THE LEFT SIDE OF THE BOTTOM EDGE TO THE UPPER PORTION OF THE RIGHT SIDE; ELEVEN KOREAN CHARACTERS APPEAR DIRECTLY BELOW THE WORDING.

THE NON-LATIN CHARACTERS IN THE MARK TRANSLITERATE TO MA, SSU, MU, CHU, AL, FA, EE, NEN, CIAL, GU, ROUP AND THIS MEANS "MASSMUTUAL" FINANCIAL GROUP IN ENGLISH.

FOR INSURANCE AND FINANCIAL SERVICES, NAMELY, ACTUARIAL SERVICES, INSURANCE ADMINISTRATION, FINANCIAL ANALYSIS AND CONSULTATION; UNDERWRITING, ISSUING AND ADMINISTRATION OF LIFE INSURANCE; ASSET MANAGEMENT; ANNUITY UNDERWRITING; FINANCIAL ADMINISTRATION OF RETIREMENT PLANS; FINANCIAL MANAGEMENT SERVICES, NAMELY, INCOME MANAGEMENT; FINANCIAL PLANNING FOR RETIREMENT; RETIREMENT PLAN ADMINISTRATION SERVICES; DISABILITY INSURANCE SERVICES; LONG TERM CARE INSURANCE SERVICES; FINANCIAL INFORMATION PROVIDED BY ELECTRONIC MEANS; INSURANCE AND SECURITIES BROKERAGE; BROKER-DEALER SERVICES, NAMELY, PURCHASE AND SALE OF SECURITIES PRODUCTS, NAMELY, MUTUAL FUNDS AND UNIT INVESTMENT TRUSTS; MUTUAL FUND DISTRIBUTION SERVICES; ADMINISTRATION OF EMPLOYEE BENEFIT PLANS; FIDUCIARY REPRESENTATIVE SERVICES; ELECTRONIC FUNDS TRANSFERS; INVESTMENT ADVICE; INVESTMENT MANAGEMENT; MONEY MANAGEMENT; MUTUAL FUND INVESTMENT SERVICES; ADMINISTRATION OF EMPLOYEE PENSION PLANS; POOLED INVESTMENT FUND MANAGEMENT; RETIREMENT INVESTMENT MANAGEMENT; ESTATE TRUST MANAGEMENT SERVICES; SECURITIES UNDERWRITING (U.S. CLS. 100, 101 AND 102).

FIRST USE 4-1-2008; IN COMMERCE 4-1-2008. KATHY DE JONGE, EXAMINING ATTORNEY

**CLASS 36—(Continued).**

SN 85-166,701. SEVEN STILL WATERS INC., FARMINGTON, UT. FILED 11-1-2010.

**SEVEN STILL WATERS**

THE MARK CONSISTS OF STANDARD CHARACTERS WITHOUT CLAIM TO ANY PARTICULAR FONT, STYLE, SIZE, OR COLOR.

FOR CHARITABLE FOUNDATION SERVICES, NAMELY, PROVIDING FUNDRAISING ACTIVITIES, FUNDING, SCHOLARSHIPS AND/OR FINANCIAL ASSISTANCE FOR AT RISK WOMEN AND CHILDREN (U.S. CLS. 100, 101 AND 102).

FIRST USE 3-1-2008; IN COMMERCE 5-1-2008.  
DORITT L. CARROLL, EXAMINING ATTORNEY

SN 85-172,332. ELIZABETH ELAM, DBA LINK COWORK-  
ING, AUSTIN, TX. FILED 11-9-2010.



NO CLAIM IS MADE TO THE EXCLUSIVE RIGHT TO USE "COWORKING", APART FROM THE MARK AS SHOWN.

THE MARK CONSISTS OF A CIRCLE WITH 4 LINKS AND THE STYLIZED TEXT "LINK COWORKING BRINGING PEOPLE TOGETHER".

FOR LEASING, SUBLEASING, AND RENTING OF FURNISHED AND UNFURNISHED OFFICE AND BUSINESS SPACES, NAMELY, OFFICES, DESK SPACES, WORK SPACES, CONFERENCE ROOMS, MEETING ROOMS, KITCHENS, AND LOUNGES (U.S. CLS. 100, 101 AND 102).

FIRST USE 4-10-2009; IN COMMERCE 5-14-2010.  
CHRISTINA SOBRAL, EXAMINING ATTORNEY

SN 85-173,488. USABLE MUTUAL INSURANCE COMPANY,  
LITTLE ROCK, AR. FILED 11-10-2010.

**USAbLe Life AccessAble**

THE MARK CONSISTS OF STANDARD CHARACTERS WITHOUT CLAIM TO ANY PARTICULAR FONT, STYLE, SIZE, OR COLOR.

OWNER OF U.S. REG. NOS. 1,482,030, 1,482,689 AND 3,313,905.

NO CLAIM IS MADE TO THE EXCLUSIVE RIGHT TO USE "LIFE", APART FROM THE MARK AS SHOWN.

FOR UNDERWRITING OF LIFE INSURANCE, HEALTH INSURANCE AND DISABILITY INSURANCE (U.S. CLS. 100, 101 AND 102).

RENEE MCCRAY, EXAMINING ATTORNEY

**CLASS 36—(Continued).**

SN 85-173,751. ADVANCED SMILE CARE, LLP, DBA AD-  
VANCED SMILE CARE, SAN ANTONIO, TX. FILED 11-10-  
2010.



THE COLOR(S) GREEN AND WHITE IS/ARE CLAIMED AS A FEATURE OF THE MARK.

THE MARK CONSISTS OF A GREEN CIRCLE WITH A TOOTH INSIDE OF IT WHERE THE BOTTOM OF THE TOOTH IS GREEN AND THE TOP OF THE TOOTH IS WHITE WHERE THE INSIDE OF THE TOOTH IS A WHITE HEART. THE WORDS "FIGHT PLAQUE GIVE BACK" APPEAR IN THE COLOR GREEN AND ARE SHOWN TO THE LEFT OF THE DESIGN.

FOR CHARITABLE FUNDRAISING SERVICES BY MEANS OF COLLECTING MONEY FROM DENTISTS BASED ON THE AMOUNT OF CLEANINGS THEY DO IN A MONTH TO BE POOLED AND GIVEN TO A PRE-CHOSEN CHARITY IN THE COMMUNITY (U.S. CLS. 100, 101 AND 102).

BRIDGETT SMITH, EXAMINING ATTORNEY

SN 85-174,011. PAN-AMERICAN LIFE INSURANCE COM-  
PANY, NEW ORLEANS, LA. FILED 11-10-2010.

**PANACARE DISCOUNT MEDICAL  
PLAN**

THE MARK CONSISTS OF STANDARD CHARACTERS WITHOUT CLAIM TO ANY PARTICULAR FONT, STYLE, SIZE, OR COLOR.

OWNER OF U.S. REG. NO. 3,770,448.

NO CLAIM IS MADE TO THE EXCLUSIVE RIGHT TO USE "DISCOUNT MEDICAL PLAN", APART FROM THE MARK AS SHOWN.

FOR HEALTH AND LIFE INSURANCE UNDERWRITING AND ADMINISTRATION SERVICES (U.S. CLS. 100, 101 AND 102).

MARY BOAGNI, EXAMINING ATTORNEY

**CLASS 36—(Continued).**

SN 85-174,016. PAN-AMERICAN LIFE INSURANCE COMPANY, NEW ORLEANS, LA. FILED 11-10-2010.

PANAMEX DISCOUNT MEDICAL  
PLAN

THE MARK CONSISTS OF STANDARD CHARACTERS WITHOUT CLAIM TO ANY PARTICULAR FONT, STYLE, SIZE, OR COLOR.

OWNER OF U.S. REG. NO. 3,770,448.

NO CLAIM IS MADE TO THE EXCLUSIVE RIGHT TO USE "DISCOUNT MEDICAL PLAN", APART FROM THE MARK AS SHOWN.

FOR HEALTH AND LIFE INSURANCE UNDERWRITING AND ADMINISTRATION SERVICES (U.S. CLS. 100, 101 AND 102).

MARY BOAGNI, EXAMINING ATTORNEY

SN 85-174,505. LOFTWAY INC, LOS ANGELES, CA. FILED 11-11-2010.



NO CLAIM IS MADE TO THE EXCLUSIVE RIGHT TO USE "LOFT", APART FROM THE MARK AS SHOWN.

THE STIPPLING IS FOR SHADING PURPOSES ONLY.

THE MARK CONSISTS OF THE TEXT "LOFT WAY" WRITTEN INSIDE A CIRCLE WITH A TWO-TONE BACKGROUND WHERE "LOFT" IS PRESENTED ON THE SHADED SIDE AND "WAY" IS PRESENTED ON THE NON-SHADED SIDE OF THE CIRCLE. THE MARK HAS A CIRCULAR BORDER AROUND IT DESIGNED TO RESEMBLE METAL.

FOR REAL ESTATE AGENCIES (U.S. CLS. 100, 101 AND 102).

FIRST USE 1-1-2003; IN COMMERCE 1-1-2003.

DANIEL CAPSHAW, EXAMINING ATTORNEY

**CLASS 36—(Continued).**

SN 85-174,718. THE DUNKIN' DONUTS & BASKIN-ROBBINS COMMUNITY FOUNDATION, CANTON, MA. FILED 11-11-2010.



THE COLOR(S) ORANGE, PINK, BLUE, BLACK, AND WHITE IS/ARE CLAIMED AS A FEATURE OF THE MARK.

THE MARK CONSISTS OF THE LETTERS "DDBR" IN LOWER CASE BLOCK FORM. THE LETTERS ARE OUTLINED IN THE COLOR BLACK. THE FIRST LETTER "D" IS SHOWN IN THE COLOR ORANGE, WITH A WHITE PLUS SIGN INSIDE OF THE LETTER. THE SECOND LETTER "D" IS SHOWN IN THE COLOR PINK, WITH A WHITE HEART INSIDE OF THE LETTER. THE LETTER "B" IS SHOWN IN THE COLOR BLUE WITH A WHITE HAND INSIDE OF THE LETTER. THE LETTER "R" IS SHOWN IN THE COLOR PINK.

FOR CHARITABLE FOUNDATION SERVICES, NAMELY, PROVIDING FUNDING AND FUNDRAISING ACTIVITIES FOR THE PREVENTION OF HUNGER, AND FOR CHILDREN'S HEALTH AND NEIGHBORHOOD SAFETY (U.S. CLS. 100, 101 AND 102).

FIRST USE 4-15-2010; IN COMMERCE 4-15-2010.

EUGENIA MARTIN, EXAMINING ATTORNEY

SN 85-178,127. AMERICAN GENERAL FINANCE, INC., EVANSVILLE, IN. FILED 11-16-2010.



NO CLAIM IS MADE TO THE EXCLUSIVE RIGHT TO USE "FINANCIAL", APART FROM THE MARK AS SHOWN.

THE MARK CONSISTS OF AN IMAGE OF A LEAF ALIGNED TO THE LEFT SIDE FOLLOWING THE WORDS "SPRINGLEAF FINANCIAL".

FOR CONSUMER LENDING SERVICES; INSURANCE UNDERWRITING IN THE FIELD OF LIFE, ACCIDENTAL DEATH AND DISMEMBERMENT, DISABILITY AND CREDIT INSURANCE (U.S. CLS. 100, 101 AND 102).

NAKIA HENRY, EXAMINING ATTORNEY



**CLASS 36—(Continued).**

SN 85-179,676. HOME ENTERTAINMENT DISTRIBUTORS, INC., DBA INSURERS WORLD, CANTON, MA. FILED 11-18-2010.

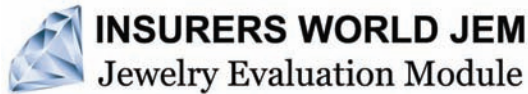

NO CLAIM IS MADE TO THE EXCLUSIVE RIGHT TO USE "INSURERS" AND "JEWELRY EVALUATION MODULE", APART FROM THE MARK AS SHOWN.

THE COLOR(S) BLACK, DARK BLUE, AND LIGHT BLUE IS/ARE CLAIMED AS A FEATURE OF THE MARK.

THE MARK CONSISTS OF A DIAMOND SHADED WITH DARK BLUE AND LIGHT BLUE FACETS; TO THE RIGHT OF THE DIAMOND IS THE BLACK WORDING "INSURERS WORLD JEM" IN ALL CAPITAL LETTERS. IMMEDIATELY BELOW IS THE BLACK WORDING "JEWELRY EVALUATION MODULE".

FOR INSURANCE ADMINISTRATION SERVICES, NAMELY, ASSISTING OTHERS WITH ADJUSTING INSURANCE CLAIMS (U.S. CLS. 100, 101 AND 102).

FIRST USE 0-0-2008; IN COMMERCE 0-0-2008.  
JORDAN BAKER, EXAMINING ATTORNEY

**CLASS 36—(Continued).**

SN 85-182,098. LIFETIME DREAMS REAL ESTATE SERVICES, LLC, RIDGELEY, WV. FILED 11-22-2010.

LIFETIME DREAMS REAL  
ESTATE SERVICES

THE MARK CONSISTS OF STANDARD CHARACTERS WITHOUT CLAIM TO ANY PARTICULAR FONT, STYLE, SIZE, OR COLOR.

NO CLAIM IS MADE TO THE EXCLUSIVE RIGHT TO USE "REAL ESTATE SERVICES", APART FROM THE MARK AS SHOWN.

FOR REAL ESTATE BROKERAGE (U.S. CLS. 100, 101 AND 102).

FIRST USE 9-1-2010; IN COMMERCE 9-1-2010.  
KEVIN DINALLO, EXAMINING ATTORNEY

SN 85-179,691. SYMMETRIA CAPITAL, LLC, FRANKLIN, TN. FILED 11-18-2010.

symmetria  
CAPITAL

NO CLAIM IS MADE TO THE EXCLUSIVE RIGHT TO USE "CAPITAL", APART FROM THE MARK AS SHOWN.

THE MARK CONSISTS OF THE WORDING "SYMMETRIA CAPITAL" IN STYLIZED FORM.

FOR FINANCIAL ANALYSIS AND FINANCIAL PORTFOLIO ANALYSIS SERVICES, EQUITY CAPITAL INVESTMENT AND CAPITAL INVESTMENT SERVICES, FINANCIAL RISK MANAGEMENT AND FINANCIAL RISK MANAGEMENT CONSULTATION, ALL OF THE AFORESAID SERVICES PROVIDED TO A LIMITED NUMBER OF HIGH NET WORTH CLIENTS (U.S. CLS. 100, 101 AND 102).

FIRST USE 1-2-2009; IN COMMERCE 1-2-2009.  
CARYN GLASSER, EXAMINING ATTORNEY

SN 85-183,971. RISK EVALUATION AND DESIGN LLC, DURHAM, NC. FILED 11-23-2010.

RED

THE MARK CONSISTS OF STANDARD CHARACTERS WITHOUT CLAIM TO ANY PARTICULAR FONT, STYLE, SIZE, OR COLOR.

FOR MANAGING UNDERWRITING SERVICES IN THE AREA OF INSURANCE IN THE FIELDS OF PROPERTY INSURANCE, AUTO INSURANCE, CASUALTY INSURANCE, WORKERS COMPENSATION; INSURANCE UNDERWRITING SERVICES AND REINSURANCE UNDERWRITING SERVICES IN THE FIELD OF PROPERTY AND CASUALTY INSURANCE; WRITING PROPERTY AND CASUALTY INSURANCE (U.S. CLS. 100, 101 AND 102).

FIRST USE 6-0-2009; IN COMMERCE 6-0-2009.  
WANDA KAY PRICE, EXAMINING ATTORNEY

**CLASS 36—(Continued).**

SN 85-183,989. RISK EVALUATION AND DESIGN LLC, DURHAM, NC. FILED 11-23-2010.



THE COLOR(S) RED IS/ARE CLAIMED AS A FEATURE OF THE MARK.

THE MARK CONSISTS OF A RED SQUARE WITH THE LETTERS "R E D" APPEARING IN THE LOWER HALF OF THE SQUARE.

FOR MANAGING UNDERWRITING SERVICES IN THE AREA OF INSURANCE IN THE FIELDS OF PROPERTY INSURANCE, AUTO INSURANCE, CASUALTY INSURANCE, WORKERS COMPENSATION; INSURANCE UNDERWRITING SERVICES AND REINSURANCE UNDERWRITING SERVICES IN THE FIELD OF PROPERTY AND CASUALTY INSURANCE; WRITING PROPERTY AND CASUALTY INSURANCE (U.S. CLS. 100, 101 AND 102).

FIRST USE 6-0-2009; IN COMMERCE 6-0-2009.

WANDA KAY PRICE, EXAMINING ATTORNEY

SN 85-185,425. METROPOLITAN WEST CAPITAL MANAGEMENT, LLC, NEWPORT BEACH, CA. FILED 11-26-2010.

CAPITAL VISIONS

THE MARK CONSISTS OF STANDARD CHARACTERS WITHOUT CLAIM TO ANY PARTICULAR FONT, STYLE, SIZE, OR COLOR.

NO CLAIM IS MADE TO THE EXCLUSIVE RIGHT TO USE "CAPITAL", APART FROM THE MARK AS SHOWN.

FOR FINANCIAL ANALYSIS AND CONSULTATION; FINANCIAL MANAGEMENT; FINANCIAL PORTFOLIO MANAGEMENT; FINANCIAL RESEARCH AND INFORMATION SERVICES (U.S. CLS. 100, 101 AND 102).

FIRST USE 12-31-1997; IN COMMERCE 12-31-1997.

KRISTINA MORRIS, EXAMINING ATTORNEY

**CLASS 36—(Continued).**

SN 85-186,265. RADIAN GROUP INC., PHILADELPHIA, PA. FILED 11-29-2010.



OWNER OF U.S. REG. NOS. 2,513,095, 2,932,319 AND OTHERS.

NO CLAIM IS MADE TO THE EXCLUSIVE RIGHT TO USE "MI", APART FROM THE MARK AS SHOWN.

THE COLOR(S) WHITE, TAN, PINK, GREEN AND BLACK IS/ARE CLAIMED AS A FEATURE OF THE MARK.

THE MARK CONSISTS OF THE WORDS "BIRD ON THE STREET" SHOWN IN WHITE AND THE WORDS "LEARN WHY RADIAN MI" SHOWN IN TAN. THE LITERAL ELEMENT IS PRESENTED WITHIN A GREEN CIRCULAR DESIGN WHICH ALSO INCLUDES A STYLIZED FLAMINGO HEAD SHOWN IN PINK WITH A BLACK AND TAN BEAK.

FOR REAL ESTATE MORTGAGE INSURANCE UNDERWRITING SERVICES (U.S. CLS. 100, 101 AND 102).

FIRST USE 11-23-2010; IN COMMERCE 11-23-2010.

STEVEN JACKSON, EXAMINING ATTORNEY

SN 85-186,466. FIVEPOINT FEDERAL CREDIT UNION, NEDERLAND, TX. FILED 11-29-2010.



OWNER OF U.S. REG. NOS. 2,961,560 AND 2,968,703.

NO CLAIM IS MADE TO THE EXCLUSIVE RIGHT TO USE "CREDIT UNION", APART FROM THE MARK AS SHOWN.

THE MARK CONSISTS OF A STYLIZED NUMBER "5" WITH THREE POINTS OF A FIVE-POINTED STAR CUT OUT FROM THE TOP PORTION OF THE NUMBER "5" AND THE WORDING "FIVEPOINT" OVER THE WORDS "CREDIT UNION". ALL WORDS TO THE RIGHT OF THE NUMBER "5".

FOR CREDIT UNION SERVICES (U.S. CLS. 100, 101 AND 102).

FIRST USE 9-7-2004; IN COMMERCE 9-7-2004.

TINA BROWN, EXAMINING ATTORNEY

**CLASS 36—(Continued).**

SN 85-186,509. FIVEPOINT FEDERAL CREDIT UNION, NEDERLAND, TX. FILED 11-29-2010.



OWNER OF U.S. REG. NO. 2,961,560.  
 THE MARK CONSISTS OF A STYLIZED NUMBER "5" WITH THREE POINTS OF A FIVE-POINTED STAR CUT OUT FROM THE TOP PORTION OF NUMBER "5".  
 FOR CREDIT UNION SERVICES (U.S. CLS. 100, 101 AND 102).  
 FIRST USE 9-7-2004; IN COMMERCE 9-7-2004.  
 TINA BROWN, EXAMINING ATTORNEY

SN 85-188,095. ENABLE QUALITY HEALTH, LLC, OVERLAND PARK, KS. FILED 12-1-2010.

**SES Score**

THE MARK CONSISTS OF STANDARD CHARACTERS WITHOUT CLAIM TO ANY PARTICULAR FONT, STYLE, SIZE, OR COLOR.  
 NO CLAIM IS MADE TO THE EXCLUSIVE RIGHT TO USE "SCORE", APART FROM THE MARK AS SHOWN.  
 FOR INSURANCE SERVICES, NAMELY, PROVIDING INDEPENDENT SCORING SERVICE RELATED TO EXISTING MEDICAL SERVICES IN A SPECIFIC GEOGRAPHIC REGION FOR INSURANCE EVALUATION PURPOSES (U.S. CLS. 100, 101 AND 102).  
 RUDY R. SINGLETON, EXAMINING ATTORNEY

**CLASS 36—(Continued).**

SN 85-188,897. HARTFORD FIRE INSURANCE COMPANY, HARTFORD, CT. FILED 12-2-2010.



THE COLOR(S) RED AND BLUE IS/ARE CLAIMED AS A FEATURE OF THE MARK.

THE MARK CONSISTS OF RED AND BLUE FLOWING PARTICLES.

FOR AGENCY AND BROKERAGE SERVICES IN THE FIELDS OF LIFE INSURANCE, LONG TERM CARE INSURANCE, ANNUITIES, INVESTMENTS, RETIREMENT PLANS, MARINE INSURANCE, BUSINESS AND COMMERCIAL INSURANCE, PROPERTY AND CASUALTY INSURANCE, GROUP BENEFIT PLANS, AND EMPLOYEE BENEFIT PLANS; ANNUITY UNDERWRITING SERVICES; ISSUANCE AND ADMINISTRATION OF ANNUITIES; INVESTMENT SERVICES, NAMELY, ASSET MANAGEMENT SERVICES; FINANCIAL ASSET MANAGEMENT SERVICES; BANKING SERVICES, NAMELY, ADMINISTERING A SAVINGS ACCOUNT BY WHICH INSURANCE PAYABLE TO AN INSURED ARE DEPOSITED INTO A BANK ACCOUNT FROM WHICH THE INSURED CAN WITHDRAW MONEY BY WRITING CHECKS ON THAT ACCOUNT; EMPLOYEE BENEFITS, NAMELY, ADMINISTRATIVE SERVICES FOR EMPLOYEE BENEFITS AND ADMINISTRATION OF EMPLOYEE BENEFIT PLANS; ESTATE SERVICES, NAMELY, ESTATE TRUST MANAGEMENT SERVICES AND ESTATE PLANNING SERVICES; FINANCIAL SERVICES, NAMELY, FINANCIAL ANALYSIS AND FINANCIAL CONSULTATION IN THE FIELDS OF LIFE INSURANCE, LONG TERM CARE INSURANCE, ANNUITIES, INVESTMENTS, RETIREMENT PLANNING; FINANCIAL SERVICES, NAMELY, BROKERAGE AND ADMINISTRATION OF ANNUITIES AND PENSIONS; FINANCIAL PLANNING SERVICES; FINANCIAL PORTFOLIO MANAGEMENT SERVICES; FINANCIAL ANALYSIS AND CONSULTATION; FINANCIAL INVESTMENT IN THE FIELD OF FINANCIAL MANAGEMENT, FINANCIAL PORTFOLIO ANALYSIS SERVICES; FINANCIAL SERVICES IN THE NATURE OF AN INVESTMENT SECURITY; PROVIDING INFORMATION AND ADVICE IN THE FIELD OF FINANCE, FINANCIAL INVESTMENTS, FINANCIAL VALUATIONS, AND THE FINANCIAL ASPECTS OF RETIREMENT; INSURANCE SERVICES, NAMELY, INSURANCE UNDERWRITING, ISSUING, ADMINISTRATION, AGENCY AND BROKERAGE SERVICES IN THE FIELDS OF WORKERS COMPENSATION MANAGED HEALTH CARE INSURANCE, INDIVIDUAL LIFE INSURANCE, AUTO INSURANCE, ACCIDENT INSURANCE, HOMEOWNERS INSURANCE, FLOOD INSURANCE, FIRE INSURANCE, REINSURANCE, PROPERTY AND CASUALTY INSURANCE, MARINE INSURANCE, DISABILITY INSURANCE, GROUP BENEFITS INSURANCE, GROUP LIFE INSURANCE, GROUP ACCIDENT INSURANCE, GROUP REINSURANCE, SPECIALTY COMMERCIAL INSURANCE, LONG TERM CARE INSURANCE, HOME AND COMMERCIAL, FOR ALL TYPES OF INSURANCE; INSURANCE CLAIMS ADMINISTRATION; INSURANCE CLAIMS PROCESSING; INSURANCE CONSULTATION; INSURANCE CONSULTATION, NAMELY, INSURANCE SERVICES IN THE NATURE OF LOSS CONTROL MANAGEMENT FOR OTHERS; INSURANCE UNDERWRITING CONSULTATION; PROVIDING AUTOMOBILE INSURANCE POLICY RATE PRICE QUOTE INFORMATION SERVICES BY MAIL AND GLOBAL COMPUTER NETWORK; PROVIDING INFORMATION ABOUT INSURANCE POLICIES AND SERVICES VIA THE WORLD WIDE COMPUTER NETWORK; ONLINE FINANCIAL PLANNING SERVICES; PROVIDING A WEB SITE THAT ASSISTS FINANCIAL PROFESSIONALS IN THE MANAGEMENT OF RETIREMENT ACCOUNTS; INVESTMENT SERVICES, NAMELY, INVESTMENT MANAGEMENT AND ADVISORY SERVICES IN THE FIELDS OF MUTUAL FUNDS, ANNUITIES, COLLEGE

**CLASS 36—(Continued).**

SAVINGS, RETIREMENT PLANNING, INVESTMENT MANAGEMENT; INVESTMENT ADVICE; INVESTMENT ADVISORY SERVICES; INVESTMENT BROKERAGE; INVESTMENT BY ELECTRONIC MEANS; INVESTMENT CONSULTATION; INVESTMENT DISTRIBUTION OF ANNUITIES AND OF VARIABLE ANNUITIES; INVESTMENT OF FUNDS FOR OTHERS; MUTUAL FUND SERVICES, NAMELY, MUTUAL FUND BROKERAGE SERVICES, ESTABLISHING MUTUAL FUNDS FOR OTHERS, BROKERAGE AND ADMINISTRATION OF MUTUAL FUNDS, FUND INVESTMENT, FUND INVESTMENT CONSULTATION, MUTUAL FUND DISTRIBUTION; RETIREMENT SERVICES, NAMELY, RETIREMENT PLANNING SERVICES, ADMINISTRATIVE SERVICES FOR RETIREMENT PLANS, FINANCIAL ADMINISTRATION OF RETIREMENT PLANS; FINANCIAL RISK MANAGEMENT SERVICES, NAMELY, RISK MANAGEMENT CONSULTATION AND RISK FINANCING SERVICES; SPONSORSHIP AND PHILANTHROPIC SERVICES, NAMELY, FINANCIAL SPONSORSHIP OF ATHLETIC EVENTS AND TEAMS, AND CULTURAL, MEDIA AND EXHIBITIONS FOCUSING ON THE ABILITIES OF ALL PEOPLE INCLUDING PEOPLE WITH DISABILITIES (U.S. CLS. 100, 101 AND 102).

FIRST USE 2-0-2009; IN COMMERCE 2-0-2009.  
LAURIE MAYES, EXAMINING ATTORNEY

SN 85-188,901. HARTFORD FIRE INSURANCE COMPANY, HARTFORD, CT. FILED 12-2-2010.



THE COLOR(S) RED AND BLUE IS/ARE CLAIMED AS A FEATURE OF THE MARK.

THE MARK CONSISTS OF RED AND BLUE FLOWING PARTICLES.

FOR AGENCY AND BROKERAGE SERVICES IN THE FIELDS OF LIFE INSURANCE, LONG TERM CARE INSURANCE, ANNUITIES, INVESTMENTS, RETIREMENT PLANS, MARINE INSURANCE, BUSINESS AND COMMERCIAL INSURANCE, PROPERTY AND CASUALTY INSURANCE, GROUP BENEFIT PLANS, AND EMPLOYEE BENEFIT PLANS; ANNUITY UNDERWRITING SERVICES; ISSUANCE AND ADMINISTRATION OF ANNUITIES; INVESTMENT SERVICES, NAMELY, ASSET MANAGEMENT SERVICES; FINANCIAL ASSET MANAGEMENT SERVICES; BANKING SERVICES, NAMELY, ADMINISTERING A SAVINGS ACCOUNT BY WHICH INSURANCE PAYABLE TO AN INSURED ARE DEPOSITED INTO A BANK ACCOUNT FROM WHICH THE INSURED CAN WITHDRAW MONEY BY WRITING CHECKS ON THAT ACCOUNT; EMPLOYEE BENEFITS, NAMELY, ADMINISTRATIVE SERVICES FOR EMPLOYEE BENEFITS AND ADMINISTRATION OF EMPLOYEE BENEFIT PLANS; ESTATE SERVICES, NAMELY, ESTATE TRUST MANAGEMENT SERVICES AND ESTATE PLANNING SERVICES; FINANCIAL SERVICES, NAMELY, FINANCIAL ANALYSIS AND FINANCIAL CONSULTATION IN THE FIELDS OF LIFE INSURANCE, LONG TERM CARE INSURANCE, ANNUITIES, INVESTMENTS, RETIREMENT PLANNING; FINANCIAL SERVICES, NAMELY, BROKERAGE AND ADMINISTRATION OF ANNUITIES AND PENSIONS; FINANCIAL PLANNING SERVICES; FINANCIAL PORTFOLIO MANAGEMENT SERVICES; FINANCIAL ANALYSIS AND CONSULTATION; FINANCIAL INVESTMENT IN THE FIELD OF FINANCIAL MANAGEMENT, FINANCIAL PORTFOLIO ANALYSIS SERVICES; FINANCIAL SERVICES IN THE NATURE OF AN INVESTMENT SECURITY; PROVIDING INFORMATION AND ADVICE IN THE FIELD OF FINANCE, FINANCIAL INVESTMENTS, FINANCIAL VALUATIONS, AND

**CLASS 36—(Continued).**

THE FINANCIAL ASPECTS OF RETIREMENT; INSURANCE SERVICES, NAMELY, INSURANCE UNDERWRITING, ISSUING, ADMINISTRATION, AGENCY AND BROKERAGE SERVICES IN THE FIELDS OF WORKERS COMPENSATION MANAGED HEALTH CARE INSURANCE, INDIVIDUAL LIFE INSURANCE, AUTO INSURANCE, ACCIDENT INSURANCE, HOMEOWNERS INSURANCE, FLOOD INSURANCE, FIRE INSURANCE, REINSURANCE, PROPERTY AND CASUALTY INSURANCE, MARINE INSURANCE, DISABILITY INSURANCE, GROUP BENEFITS INSURANCE, GROUP LIFE INSURANCE, GROUP ACCIDENT INSURANCE, GROUP REINSURANCE, SPECIALTY COMMERCIAL INSURANCE, LONG TERM CARE INSURANCE, HOME AND COMMERCIAL, FOR ALL TYPES OF INSURANCE; INSURANCE CLAIMS ADMINISTRATION; INSURANCE CLAIMS PROCESSING; INSURANCE CONSULTATION; INSURANCE CONSULTATION, NAMELY, INSURANCE SERVICES IN THE NATURE OF LOSS CONTROL MANAGEMENT FOR OTHERS; INSURANCE UNDERWRITING CONSULTATION; PROVIDING AUTOMOBILE INSURANCE POLICY RATE PRICE QUOTE INFORMATION SERVICES BY MAIL AND GLOBAL COMPUTER NETWORK; PROVIDING INFORMATION ABOUT INSURANCE POLICIES AND SERVICES VIA THE WORLD WIDE COMPUTER NETWORK; ONLINE FINANCIAL PLANNING SERVICES; PROVIDING A WEB SITE THAT ASSISTS FINANCIAL PROFESSIONALS IN THE MANAGEMENT OF RETIREMENT ACCOUNTS; INVESTMENT SERVICES, NAMELY, INVESTMENT MANAGEMENT AND ADVISORY SERVICES IN THE FIELDS OF MUTUAL FUNDS, ANNUITIES, COLLEGE SAVINGS, RETIREMENT PLANNING, INVESTMENT MANAGEMENT; INVESTMENT ADVICE; INVESTMENT ADVISORY SERVICES; INVESTMENT BROKERAGE; INVESTMENT BY ELECTRONIC MEANS; INVESTMENT CONSULTATION; INVESTMENT DISTRIBUTION OF ANNUITIES AND OF VARIABLE ANNUITIES; INVESTMENT OF FUNDS FOR OTHERS; MUTUAL FUND SERVICES, NAMELY, MUTUAL FUND BROKERAGE SERVICES, ESTABLISHING MUTUAL FUNDS FOR OTHERS, BROKERAGE AND ADMINISTRATION OF MUTUAL FUNDS, FUND INVESTMENT, FUND INVESTMENT CONSULTATION, MUTUAL FUND DISTRIBUTION; RETIREMENT SERVICES, NAMELY, RETIREMENT PLANNING SERVICES, ADMINISTRATIVE SERVICES FOR RETIREMENT PLANS, FINANCIAL ADMINISTRATION OF RETIREMENT PLANS; FINANCIAL RISK MANAGEMENT SERVICES, NAMELY, RISK MANAGEMENT CONSULTATION AND RISK FINANCING SERVICES; SPONSORSHIP AND PHILANTHROPIC SERVICES, NAMELY, FINANCIAL SPONSORSHIP OF ATHLETIC EVENTS AND TEAMS, AND CULTURAL, MEDIA AND EXHIBITIONS FOCUSING ON THE ABILITIES OF ALL PEOPLE INCLUDING PEOPLE WITH DISABILITIES (U.S. CLS. 100, 101 AND 102).

FIRST USE 2-0-2009; IN COMMERCE 2-0-2009.  
LAURIE MAYES, EXAMINING ATTORNEY

**CLASS 36—(Continued).**

SN 85-189,025. BENNINGHOFF, CHARLES, HENDERSON, NV. FILED 12-2-2010.

## Gift Safe

THE MARK CONSISTS OF STANDARD CHARACTERS WITHOUT CLAIM TO ANY PARTICULAR FONT, STYLE, SIZE, OR COLOR.

NO CLAIM IS MADE TO THE EXCLUSIVE RIGHT TO USE "GIFT", APART FROM THE MARK AS SHOWN.

FOR CHARITABLE FUNDRAISING SERVICES, NAMELY, SECURING, DISBURSING AND ACCOUNTING OF FINANCIAL DONATIONS, GIFTS, ALMS, BEQUESTS, CONTRIBUTIONS OR ANY OTHER FORM OF ELEEMOSYNARY TRANSFER OF MONETARY PROPERTY, ONLINE OR BY PHYSICAL DELIVERY (U.S. CLS. 100, 101 AND 102).

FIRST USE 9-29-2010; IN COMMERCE 9-29-2010.  
SOPHIA S. KIM, EXAMINING ATTORNEY

SN 85-193,056. YOST, ERIKA, DENVER, CO. FILED 12-8-2010.

## A Girl's Best Fund

THE MARK CONSISTS OF STANDARD CHARACTERS WITHOUT CLAIM TO ANY PARTICULAR FONT, STYLE, SIZE, OR COLOR.

FOR CHARITABLE FUNDRAISING SERVICES, NAMELY, RAISING FUNDS FOR GIRLS' EDUCATION AND HEALTH GLOBALLY (U.S. CLS. 100, 101 AND 102).  
ROBERT C. CLARK JR., EXAMINING ATTORNEY

SN 85-193,910. NATIONAL ASSOCIATION FOR INFORMATION DESTRUCTION, PHOENIX, AZ. FILED 12-9-2010.

## DOWNSTREAM DATA COVERAGE

THE MARK CONSISTS OF STANDARD CHARACTERS WITHOUT CLAIM TO ANY PARTICULAR FONT, STYLE, SIZE, OR COLOR.

NO CLAIM IS MADE TO THE EXCLUSIVE RIGHT TO USE "DATA COVERAGE", APART FROM THE MARK AS SHOWN.

FOR INSURANCE SERVICES, NAMELY, UNDERWRITING, ISSUANCE AND ADMINISTRATION OF PROFESSIONAL LIABILITY INSURANCE (U.S. CLS. 100, 101 AND 102).  
EDWARD NELSON, EXAMINING ATTORNEY

**CLASS 36—(Continued).**

SN 85-194,012. TRU STUDENT, INC., HELENA, MT. FILED 12-9-2010.

## AMICUS FEDERAL EDUCATION LOAN SERVICING

THE MARK CONSISTS OF STANDARD CHARACTERS WITHOUT CLAIM TO ANY PARTICULAR FONT, STYLE, SIZE, OR COLOR.

NO CLAIM IS MADE TO THE EXCLUSIVE RIGHT TO USE "FEDERAL EDUCATION LOAN SERVICING", APART FROM THE MARK AS SHOWN.

THE ENGLISH TRANSLATION OF "AMICUS" IN THE MARK IS FRIEND.

FOR SERVICING EDUCATIONAL LOANS (U.S. CLS. 100, 101 AND 102).

JACQUELINE A. LAVINE, EXAMINING ATTORNEY

SN 85-194,483. PROSHARE ADVISORS LLC, BETHESDA, MD. FILED 12-9-2010.

## ULTRAPRO SHORT

THE MARK CONSISTS OF STANDARD CHARACTERS WITHOUT CLAIM TO ANY PARTICULAR FONT, STYLE, SIZE, OR COLOR.

NO CLAIM IS MADE TO THE EXCLUSIVE RIGHT TO USE "SHORT", APART FROM THE MARK AS SHOWN.

FOR FINANCIAL SERVICES, NAMELY, INVESTMENT ADVISORY AND INVESTMENT MANAGEMENT SERVICES; INVESTMENTS IN THE NATURE OF EXCHANGE-TRADED FUNDS (U.S. CLS. 100, 101 AND 102).

FIRST USE 6-25-2009; IN COMMERCE 6-25-2009.  
JORDAN BAKER, EXAMINING ATTORNEY

SN 85-194,512. PROSHARE ADVISORS LLC, BETHESDA, MD. FILED 12-9-2010.

## PROSHARES ULTRASHORT

THE MARK CONSISTS OF STANDARD CHARACTERS WITHOUT CLAIM TO ANY PARTICULAR FONT, STYLE, SIZE, OR COLOR.

OWNER OF U.S. REG. NO. 3,262,904.

NO CLAIM IS MADE TO THE EXCLUSIVE RIGHT TO USE "ULTRASHORT", APART FROM THE MARK AS SHOWN.

FOR FINANCIAL SERVICES, NAMELY, INVESTMENT ADVISORY AND INVESTMENT MANAGEMENT SERVICES; INVESTMENTS IN THE NATURE OF EXCHANGE-TRADED FUNDS (U.S. CLS. 100, 101 AND 102).

FIRST USE 7-13-2006; IN COMMERCE 7-13-2006.  
JORDAN BAKER, EXAMINING ATTORNEY



**CLASS 36—(Continued).**

SN 85-196,556. GORDON BROTHERS GROUP, LLC, BOSTON, MA. FILED 12-13-2010.

**1903 FUNDS**

THE MARK CONSISTS OF STANDARD CHARACTERS WITHOUT CLAIM TO ANY PARTICULAR FONT, STYLE, SIZE, OR COLOR.

OWNER OF U.S. REG. NOS. 2,993,710, 3,455,365 AND 3,464,131.

NO CLAIM IS MADE TO THE EXCLUSIVE RIGHT TO USE "FUNDS", APART FROM THE MARK AS SHOWN. SEC. 2(F).

FOR PRIVATE INVESTMENT FUND SERVICES; INVESTING THE FUNDS OF OTHERS; INVESTMENT ADVISORY SERVICES (U.S. CLS. 100, 101 AND 102).

AMEEN IMAM, EXAMINING ATTORNEY

---

SN 85-198,728. AMERICAN SPECIALTY INSURANCE & RISK SERVICES, INC., TAMPA, FL. FILED 12-15-2010.

**INSURING AMERICA'S  
PASTIMES AND FUTURE TIMES**

THE MARK CONSISTS OF STANDARD CHARACTERS WITHOUT CLAIM TO ANY PARTICULAR FONT, STYLE, SIZE, OR COLOR.

OWNER OF U.S. REG. NO. 3,159,465.

FOR FINANCIAL SERVICES, NAMELY, INSURANCE UNDERWRITING AND BROKERAGE SERVICES IN THE FIELD OF PROPERTY, CASUALTY, ACCIDENT, HEALTH AND LIFE INSURANCE; CONSULTING SERVICES IN THE FIELD OF INSURANCE; INSURANCE CONSULTING SERVICES REGARDING CRISIS MANAGEMENT, CLAIMS MANAGEMENT AND LOSS PREVENTION (U.S. CLS. 100, 101 AND 102).

FIRST USE 11-0-2009; IN COMMERCE 11-0-2009.

RUDY R. SINGLETON, EXAMINING ATTORNEY

**CLASS 36—(Continued).**

SN 85-199,611. SAFE-GUARD PRODUCTS INTERNATIONAL, LLC, ATLANTA, GA. FILED 12-16-2010.

**SAFE-GUARD**  
Products International, LLC



NO CLAIM IS MADE TO THE EXCLUSIVE RIGHT TO USE "PRODUCTS INTERNATIONAL, LLC", APART FROM THE MARK AS SHOWN.

THE MARK CONSISTS OF THE WORDS "SAFE-GUARD PRODUCTS INTERNATIONAL, LLC" CENTERED OVER A HORIZONTAL DIAMOND SHAPE WITH AN ILLUSTRATION OF A MAP OF THE WORLD OVERLAYING HORIZONTAL LINES WITHIN THE DIAMOND SHAPE.

FOR PROVIDING VEHICLE SERVICES AGREEMENTS ON VEHICLES MANUFACTURED BY OTHERS FOR MECHANICAL BREAKDOWN AND SERVICING; PREPAID AUTOMOBILE PREVENTATIVE MAINTENANCE SERVICE PLANS; ADMINISTERING AUTOMOBILE LOAN AND LEASE PAYOFF WAIVER PLANS; DEBT CANCELLATION SERVICES USING PROCEEDS FROM AUTOMOBILE INSURANCE; PROVIDING VEHICLE SERVICES AGREEMENTS ON VEHICLES MANUFACTURED BY OTHERS FOR EXCESS WEAR AND TEAR; PROVIDING INFORMATION TO AUTOMOBILE DEALERSHIPS VIA A SECURE WEBSITE REGARDING FINANCE AND INSURANCE PRODUCTS (U.S. CLS. 100, 101 AND 102).

FIRST USE 0-0-1997; IN COMMERCE 0-0-1997.

BARNEY CHARLON, EXAMINING ATTORNEY

---

SN 85-199,810. RABID REAL ESTATE INC., AUSTIN, TX. FILED 12-16-2010.

**AUSTIN ROCK CITY REALTY**

THE MARK CONSISTS OF STANDARD CHARACTERS WITHOUT CLAIM TO ANY PARTICULAR FONT, STYLE, SIZE, OR COLOR.

NO CLAIM IS MADE TO THE EXCLUSIVE RIGHT TO USE "AUSTIN CITY REALTY", APART FROM THE MARK AS SHOWN.

FOR REAL ESTATE BROKERAGE SERVICES (U.S. CLS. 100, 101 AND 102).

FIRST USE 12-2-2010; IN COMMERCE 12-2-2010.

REGINA DRUMMOND, EXAMINING ATTORNEY

**CLASS 36—(Continued).**

SN 85-200,323. ADVANCED WEALTH ADVISERS, LLC, NOVI, MI. FILED 12-17-2010.



NO CLAIM IS MADE TO THE EXCLUSIVE RIGHT TO USE "LLC" AND "WEALTH ADVISERS", APART FROM THE MARK AS SHOWN.

THE COLOR(S) BLUE AND RED IS/ARE CLAIMED AS A FEATURE OF THE MARK.

THE MARK CONSISTS OF A FANCIFUL DEPICTION OF THE LETTERS "AWA" WITH AN ARC HORIZONTALLY BIsectING THE LETTERS "AWA" AND THE PORTION OF THE LETTERS "AWA" BELOW THE ARC ARE SPACED FROM THE ARC AND ARE RED IN COLOR AND THE REMAINDER OF THE LETTERS "AWA" AND THE ARC ARE BLUE IN COLOR. THE LETTERS "AWA" ARE CENTERED ABOVE THE WORDS "ADVANCED WEALTH" THAT ARE BLUE IN COLOR. THE WORDS "ADVANCED WEALTH" ARE CENTERED ABOVE THE WORD "ADVISERS" THAT IS BLUE IN COLOR. AN ELONGATED TRIANGLE EXTENDS FROM THE LETTER "A" OF "ADVISERS" SUCH THAT THE ELONGATED TRIANGLE EXTENDS BELOW THE LETTERS "ADVA" OF THE WORD "ADVANCED" AND ANOTHER ELONGATED TRIANGLE EXTENDS FROM THE LAST LETTER "S" IN "ADVISERS" SUCH THAT THE ELONGATED TRIANGLE EXTENDS BELOW EACH OF THE LETTERS "EALTH", WHERE EACH OF THE ELONGATED TRIANGLES ARE RED IN COLOR. THE LETTERS "LLC", WHICH ARE RED IN COLOR, ARE ABOVE THE LETTER "H" IN "WEALTH".

FOR ESTATE PLANNING; ESTATE TRUST PLANNING; FINANCIAL CONSULTANCY AND INSURANCE CONSULTANCY; FINANCIAL PLANNING AND INVESTMENT ADVISORY SERVICES; FINANCIAL SERVICES, NAMELY, BROKER/DEALER SERVICES ON SECURITIES EXCHANGES AND OVER-THE-COUNTER MARKETS; INSURANCE BROKERAGE; INSURANCE BROKERAGE IN THE FIELD OF LIFE INSURANCE, HEALTH INSURANCE, AND PROPERTY AND CASUALTY INSURANCE; INSURANCE CONSULTANCY; PROVIDING STOCK/SECURITIES MARKET INFORMATION; SECURITY BROKERAGE (U.S. CLS. 100, 101 AND 102).

APRIL ROACH, EXAMINING ATTORNEY

SN 85-200,438. C&S WHOLESALE GROCERS, INC., KEENE, NH. FILED 12-17-2010.



THE MARK CONSISTS OF A STYLIZED CIRCLE OF FOUR PEOPLE STANDING ON FOUR OVALS.

FOR CHARITABLE FUNDRAISING; CHARITABLE FUNDRAISING SERVICES; CHARITABLE FUND RAISING SERVICES BY MEANS OF A GOLF EVENT; CHARITABLE SERVICES, NAMELY, PROVIDING FINANCIAL SUPPORT TO CHARITIES SUPPORTING CHILDREN (U.S. CLS. 100, 101 AND 102).

FIRST USE 8-3-2010; IN COMMERCE 8-3-2010.  
MAYUR VAGHANI, EXAMINING ATTORNEY

**CLASS 36—(Continued).**

SN 85-200,755. TAP AMERICA, SEATTLE, WA. FILED 12-17-2010.



THE COLOR(S) BLUE AND WHITE IS/ARE CLAIMED AS A FEATURE OF THE MARK.

THE MARK CONSISTS OF WHITE WINGS SPANNING UPWARDS WITH "T.A.P." ALONG THE TOP AND "TOLERANCE", "AMERICANISM", "PATRIOTISM" IN WHITE ON A BLUE BACKGROUND.

FOR CHARITABLE FUNDRAISING SERVICES BY MEANS OF SELLING T-SHIRTS TO RAISE FUNDS FOR HOMELESS AND NEEDY ORGANIZATIONS THAT ENCOURAGE LEADERSHIP, CHARACTER, COMPASSION AND GOOD CITIZENSHIP (U.S. CLS. 100, 101 AND 102).

JANICE KIM, EXAMINING ATTORNEY

SN 85-200,778. LENZSAVER, INC., SAN DIEGO, CA. FILED 12-17-2010.

## LenzSaver Headlight Protection Plan

THE MARK CONSISTS OF STANDARD CHARACTERS WITHOUT CLAIM TO ANY PARTICULAR FONT, STYLE, SIZE, OR COLOR.

NO CLAIM IS MADE TO THE EXCLUSIVE RIGHT TO USE "PROTECTION PLAN", APART FROM THE MARK AS SHOWN.

FOR EXTENDED WARRANTY SERVICES, NAMELY, SERVICE CONTRACTS (U.S. CLS. 100, 101 AND 102).

FIRST USE 10-1-2010; IN COMMERCE 10-1-2010.

NAKWAMA ANKRAH, EXAMINING ATTORNEY

**CLASS 36—(Continued).**

SN 85-201,468. DATAVI, LLC, PLANO, TX. FILED 12-19-2010.



NO CLAIM IS MADE TO THE EXCLUSIVE RIGHT TO USE "NET", APART FROM THE MARK AS SHOWN.

THE COLOR(S) BLUE, GRAY, AND BLACK IS/ARE CLAIMED AS A FEATURE OF THE MARK.

THE MARK CONSISTS OF A SPHERE IN SHADES OF BLUE WITH THE STYLIZED WORDING "P3" IN GRAY ON THE SPHERE. THE WORD "NET" APPEARS IN BLACK TO THE RIGHT OF THE SPHERE AND HAS A GRAY REFLECTION. THE WORDING "BUILDING VALUE ONE CONNECTION AT A TIME" APPEARS IN BLACK BENEATH THE "P3 NET".

FOR ELECTRONIC PROCESSING OF INSURANCE CLAIMS AND PAYMENT DATA (U.S. CLS. 100, 101 AND 102).

FIRST USE 9-1-2010; IN COMMERCE 10-1-2010.  
JENNIFER MARTIN, EXAMINING ATTORNEY

SN 85-201,973. MERIT PROPERTY MANAGEMENT, INC., ALISO VIEJO, CA. FILED 12-20-2010.

---

MAS

THE MARK CONSISTS OF STANDARD CHARACTERS WITHOUT CLAIM TO ANY PARTICULAR FONT, STYLE, SIZE, OR COLOR.

OWNER OF U.S. REG. NOS. 2,705,078 AND 3,807,987.

FOR REAL PROPERTY MANAGEMENT AND CONSULTATION RELATED THERETO, DIRECTED TOWARD COMMUNITY HOMEOWNERS ASSOCIATIONS (U.S. CLS. 100, 101 AND 102).

JOHN SCHUYLER YARD, EXAMINING ATTORNEY

SN 85-202,068. MONTAGU PRIVATE EQUITY LLP, LONDON SE1 2AP, UNITED KINGDOM, FILED 12-20-2010.

---

MONTAGU

THE MARK CONSISTS OF STANDARD CHARACTERS WITHOUT CLAIM TO ANY PARTICULAR FONT, STYLE, SIZE, OR COLOR.

FOR FINANCIAL SERVICES, NAMELY, INVESTMENT ADVISORY SERVICES, INVESTMENT MANAGEMENT SERVICES AND ASSET MANAGEMENT SERVICES (U.S. CLS. 100, 101 AND 102).

FIRST USE 3-0-2003; IN COMMERCE 3-0-2003.  
ALICIA COLLINS, EXAMINING ATTORNEY

**CLASS 36—(Continued).**

SN 85-202,531. MB FIELD SERVICES, INC., ATLANTA, GA. FILED 12-21-2010.

MB FIELD SERVICES

THE MARK CONSISTS OF STANDARD CHARACTERS WITHOUT CLAIM TO ANY PARTICULAR FONT, STYLE, SIZE, OR COLOR.

FOR EVALUATIONS AND ASSESSMENT OF RESIDENTIAL AND COMMERCIAL REAL ESTATE AND PROVIDING PHOTOGRAPHS AND WRITTEN REVIEWS OF SAID PROPERTIES IN CONNECTION THEREWITH (U.S. CLS. 100, 101 AND 102).

FIRST USE 8-0-2009; IN COMMERCE 8-0-2009.  
FLORENTINA BLANDU, EXAMINING ATTORNEY

SN 85-202,547. ALL RISKS, LTD., COCKEYSVILLE, MD. FILED 12-21-2010.

---

allrisks

OWNER OF U.S. REG. NOS. 2,822,676 AND 3,355,333.  
THE MARK CONSISTS OF THE WORK "ALLRISKS" IN STYLIZED FONT WITH A DOT INSIDE THE "A".

SEC. 2(F) "ALL RISKS".

FOR UNDERWRITING AND BROKERING FOR ALL TYPES OF INSURANCE (U.S. CLS. 100, 101 AND 102).

FIRST USE 5-0-2007; IN COMMERCE 5-0-2007.

MARY ROSSMAN, EXAMINING ATTORNEY

SN 85-202,660. PUREWEST, INC., BOZEMAN, MT. FILED 12-21-2010.

---

PUREWEST

THE MARK CONSISTS OF STANDARD CHARACTERS WITHOUT CLAIM TO ANY PARTICULAR FONT, STYLE, SIZE, OR COLOR.

OWNER OF U.S. REG. NO. 3,794,940.  
FOR REAL ESTATE SERVICE, NAMELY, RENTAL PROPERTY MANAGEMENT (U.S. CLS. 100, 101 AND 102).

SUNG IN, EXAMINING ATTORNEY

**CLASS 36—(Continued).**

SN 85-202,883. AMERICAN GENERAL FINANCE, INC., EVANSVILLE, IN. FILED 12-21-2010.

**LENDING MADE PERSONAL**

THE MARK CONSISTS OF STANDARD CHARACTERS WITHOUT CLAIM TO ANY PARTICULAR FONT, STYLE, SIZE, OR COLOR.

NO CLAIM IS MADE TO THE EXCLUSIVE RIGHT TO USE "LENDING", APART FROM THE MARK AS SHOWN.

FOR CONSUMER LENDING SERVICES; INSURANCE UNDERWRITING IN THE FIELD OF LIFE, ACCIDENTAL DEATH AND DISMEMBERMENT, DISABILITY AND CREDIT INSURANCE (U.S. CLS. 100, 101 AND 102).  
NAKIA HENRY, EXAMINING ATTORNEY

---

SN 85-202,919. AMERICAN GENERAL FINANCE, INC., EVANSVILLE, IN. FILED 12-21-2010.

**PEOPLE FRIENDLY FINANCING**

THE MARK CONSISTS OF STANDARD CHARACTERS WITHOUT CLAIM TO ANY PARTICULAR FONT, STYLE, SIZE, OR COLOR.

NO CLAIM IS MADE TO THE EXCLUSIVE RIGHT TO USE "FINANCING", APART FROM THE MARK AS SHOWN.

FOR CONSUMER LENDING SERVICES; INSURANCE UNDERWRITING IN THE FIELD OF LIFE, ACCIDENTAL DEATH AND DISMEMBERMENT, DISABILITY AND CREDIT INSURANCE (U.S. CLS. 100, 101 AND 102).  
NAKIA HENRY, EXAMINING ATTORNEY

---

SN 85-203,910. DUNBAR ARMORED, INC., HUNT VALLEY, MD. FILED 12-22-2010.

**Dunbar** Integrated Image Deposit Verification

NO CLAIM IS MADE TO THE EXCLUSIVE RIGHT TO USE "INTEGRATED IMAGE DEPOSIT VERIFICATION", APART FROM THE MARK AS SHOWN.

THE COLOR(S) RED, BLACK AND WHITE IS/ARE CLAIMED AS A FEATURE OF THE MARK.

THE MARK CONSISTS OF THE COLOR RED THAT APPEARS IN THE TERM "DUNBAR", THE COLOR WHITE APPEARS IN THE SHOOTING STAR DESIGN THAT RUNS THROUGH THE TERM "DUNBAR" AND THE COLOR BLACK APPEARS IN THE TERMS INTEGRATED IMAGE DEPOSIT VERIFICATION. THE MARK IS PRESENTED ON A TRANSPARENT BACKGROUND AND NO OTHER COLORS ARE CLAIMED.

FOR CASH MANAGEMENT SERVICES, NAMELY, PROVIDING FINANCIAL INFORMATION AND FINANCIAL INFORMATION PROCESSING OF CONTENTS OF SECURED DEPOSITS ON COMPUTER PROGRAM ACCESSIBLE BY CUSTOMERS ON A SECURE WEBSITE (U.S. CLS. 100, 101 AND 102).

FIRST USE 10-14-2010; IN COMMERCE 10-14-2010.  
JILL PRATER, EXAMINING ATTORNEY

**CLASS 36—(Continued).**

SN 85-204,313. TCF FINANCIAL CORPORATION, WAYZATA, MN. FILED 12-22-2010.



OWNER OF U.S. REG. NOS. 1,054,475, 3,454,849 AND OTHERS.

NO CLAIM IS MADE TO THE EXCLUSIVE RIGHT TO USE "EQUIPMENT FINANCE", APART FROM THE MARK AS SHOWN.

THE MARK CONSISTS OF THE WORDING "TCF EQUIPMENT FINANCE" SHOWN WITH A CURVED SEMICIRCLE.

FOR FINANCIAL SERVICES, NAMELY, EQUIPMENT FINANCE (U.S. CLS. 100, 101 AND 102).

FIRST USE 4-1-2005; IN COMMERCE 4-1-2005.

WILLIAM ROSSMAN, EXAMINING ATTORNEY

---

SN 85-204,401. BUYERMLS, LLC, OAKS, PA. FILED 12-22-2010.

**THE OTHER HALF OF REAL ESTATE**

THE MARK CONSISTS OF STANDARD CHARACTERS WITHOUT CLAIM TO ANY PARTICULAR FONT, STYLE, SIZE, OR COLOR.

NO CLAIM IS MADE TO THE EXCLUSIVE RIGHT TO USE "REAL ESTATE", APART FROM THE MARK AS SHOWN.

FOR PROVIDING INFORMATION IN THE FIELD OF REAL ESTATE VIA THE INTERNET (U.S. CLS. 100, 101 AND 102).

JAMES MACFARLANE, EXAMINING ATTORNEY

---

SN 85-204,855. GORDON BROTHERS GROUP, LLC, BOSTON, MA. FILED 12-23-2010.

**1903 DEBT FUNDS**

THE MARK CONSISTS OF STANDARD CHARACTERS WITHOUT CLAIM TO ANY PARTICULAR FONT, STYLE, SIZE, OR COLOR.

OWNER OF U.S. REG. NOS. 2,993,710, 3,455,365 AND 3,464,131.

NO CLAIM IS MADE TO THE EXCLUSIVE RIGHT TO USE "DEBT FUNDS", APART FROM THE MARK AS SHOWN.

SEC. 2(F).

FOR PRIVATE INVESTMENT FUND SERVICES; INVESTING THE FUNDS OF OTHERS; INVESTMENT ADVISORY SERVICES (U.S. CLS. 100, 101 AND 102).

FIRST USE 9-6-2006; IN COMMERCE 9-6-2006.

AMEEN IMAM, EXAMINING ATTORNEY

**CLASS 36—(Continued).**

SN 85-204,870. GORDON BROTHERS GROUP, LLC, BOSTON, MA. FILED 12-23-2010.

**1903 EQUITY FUND**

THE MARK CONSISTS OF STANDARD CHARACTERS WITHOUT CLAIM TO ANY PARTICULAR FONT, STYLE, SIZE, OR COLOR.

OWNER OF U.S. REG. NOS. 2,993,710, 3,455,365 AND 3,464,131.

NO CLAIM IS MADE TO THE EXCLUSIVE RIGHT TO USE "EQUITY FUND", APART FROM THE MARK AS SHOWN.

SEC. 2(F).

FOR PRIVATE INVESTMENT FUND SERVICES; INVESTING THE FUNDS OF OTHERS; INVESTMENT ADVISORY SERVICES (U.S. CLS. 100, 101 AND 102).

FIRST USE 2-28-2006; IN COMMERCE 2-28-2006.  
AMEEN IMAM, EXAMINING ATTORNEY

SN 85-205,464. CFF PARTNERS INC., BEIJING, CHINA, FILED 12-23-2010.

**CFF Partners**

THE MARK CONSISTS OF STANDARD CHARACTERS WITHOUT CLAIM TO ANY PARTICULAR FONT, STYLE, SIZE, OR COLOR.

NO CLAIM IS MADE TO THE EXCLUSIVE RIGHT TO USE "PARTNERS", APART FROM THE MARK AS SHOWN.

FOR CAPITAL INVESTMENT CONSULTING; CAPITAL INVESTMENT SERVICES; VENTURE CAPITAL FINANCING; VENTURE CAPITAL FUND MANAGEMENT (U.S. CLS. 100, 101 AND 102).

FIRST USE 1-1-2009; IN COMMERCE 1-1-2009.  
BARBARA BROWN, EXAMINING ATTORNEY

SN 85-205,508. HARP-WEAVER LLC, PHILADELPHIA, PA. FILED 12-24-2010.

**HARP-WEAVER**

THE MARK CONSISTS OF STANDARD CHARACTERS WITHOUT CLAIM TO ANY PARTICULAR FONT, STYLE, SIZE, OR COLOR.

FOR PROVIDING PHILANTHROPIC CONSULTING SERVICES TO WEALTH ADVISORS, FAMILY OFFICES, NON-PROFIT ORGANIZATIONS AND FOR-PROFIT ORGANIZATIONS, FAMILIES AND INDIVIDUALS IN INVESTING FINANCIAL RESOURCES IN THE NOT FOR PROFIT SECTOR (U.S. CLS. 100, 101 AND 102).

FIRST USE 3-15-2010; IN COMMERCE 11-11-2010.  
FLORENTINA BLANDU, EXAMINING ATTORNEY

**CLASS 36—(Continued).**

SN 85-205,989. O BEE CREDIT UNION, TUMWATER, WA. FILED 12-27-2010.



NO CLAIM IS MADE TO THE EXCLUSIVE RIGHT TO USE "CREDIT UNION", APART FROM THE MARK AS SHOWN.

THE COLOR(S) BROWN AND GRAY IS/ARE CLAIMED AS A FEATURE OF THE MARK.

THE MARK CONSISTS OF THE COLORS BROWN AND GRAY ARE CLAIMED AS A FEATURE OF THE MARK. THE COLOR BROWN APPEARS IN THE TEXT OF THE WORDING "O BEE", AND AS THE SHADING BEHIND THE STYLIZED BUILDING DESIGN. THE COLOR GRAY APPEARS IN THE TEXT OF THE WORDING "CREDIT UNION", AND AS THE SHADING IN THE BUILDING DESIGN, THE WAVE DESIGNS APPEARING BELOW THE BUILDING, AND THE CIRCULAR BAND THAT PARTIALLY ENCOMPASSES THE BUILDING DESIGN.

FOR CREDIT UNIONS (U.S. CLS. 100, 101 AND 102).  
FIRST USE 1-1-2005; IN COMMERCE 1-1-2005.  
ELI HELLMAN, EXAMINING ATTORNEY

SN 85-206,316. SIMS, RICHARD M. III, DUTCH FLAT, CA. FILED 12-28-2010.

**THE COMMITTEE FOR AN IMPARTIAL JUDICIARY**

NO CLAIM IS MADE TO THE EXCLUSIVE RIGHT TO USE "THE COMMITTEE FOR AN IMPARTIAL JUDICIARY", APART FROM THE MARK AS SHOWN.

THE MARK CONSISTS OF A FEMALE, BLIND-FOLDED FIGURE HOLDING A BALANCE SCALE IN ONE HAND AND A SWORD IN THE OPPOSITE HAND WITH THE LITERAL ELEMENT "THE COMMITTEE FOR AN IMPARTIAL JUDICIARY" HORIZONTALLY CENTERED BELOW THE FEMALE FIGURE.

FOR CHARITABLE SERVICES, NAMELY, PROVIDING FINANCIAL SUPPORT TO INCUMBENT JUDGES IN ELECTIONS (U.S. CLS. 100, 101 AND 102).

BENJAMIN OKEKE, EXAMINING ATTORNEY



**CLASS 36—(Continued).**

SN 85-207,038. AEI FUND MANAGEMENT, INC., ST. PAUL, MN. FILED 12-29-2010.

**MARKET CRITICAL REAL ESTATE**

THE MARK CONSISTS OF STANDARD CHARACTERS WITHOUT CLAIM TO ANY PARTICULAR FONT, STYLE, SIZE, OR COLOR.

NO CLAIM IS MADE TO THE EXCLUSIVE RIGHT TO USE "MARKET" AND "REAL ESTATE", APART FROM THE MARK AS SHOWN.

FOR REAL ESTATE INVESTMENT MANAGEMENT (U.S. CLS. 100, 101 AND 102).

FIRST USE 12-27-2010; IN COMMERCE 12-27-2010.  
ROBIN MITTLER, EXAMINING ATTORNEY

---

SN 85-207,604. SECONDMARKET HOLDINGS, INC., NEW YORK, NY. FILED 12-29-2010.

**HPPO**

THE MARK CONSISTS OF STANDARD CHARACTERS WITHOUT CLAIM TO ANY PARTICULAR FONT, STYLE, SIZE, OR COLOR.

FOR FINANCIAL SERVICES, NAMELY, PROVIDING FINANCIAL ADVICE AND MANAGEMENT OF CAPITAL RAISING EVENTS AND HYBRID PRIVATE-PUBLIC OFFERINGS FROM LONG TERM PUBLIC AND PRIVATE FUNDING SOURCES, NAMELY, PRIVATE EQUITY FIRMS, VENTURE CAPITAL FIRMS, CROSS-OVER FUNDS, MUTUAL FUNDS AND PUBLIC EQUITY FUNDS (U.S. CLS. 100, 101 AND 102).

MARGARET POWER, EXAMINING ATTORNEY

---

SN 85-207,672. ONE WILLIAM STREET CAPITAL MANAGEMENT, L.P., NEW YORK, NY. FILED 12-29-2010.

**OWS**

THE MARK CONSISTS OF STANDARD CHARACTERS WITHOUT CLAIM TO ANY PARTICULAR FONT, STYLE, SIZE, OR COLOR.

FOR FINANCIAL SERVICES, NAMELY, ASSET MANAGEMENT SERVICES, INVESTMENT MANAGEMENT SERVICES, AND INVESTMENT ADVISORY SERVICES (U.S. CLS. 100, 101 AND 102).

FIRST USE 1-1-2010; IN COMMERCE 1-1-2010.  
KEVIN CORWIN, EXAMINING ATTORNEY

**CLASS 36—(Continued).**

SN 85-207,676. ONE WILLIAM STREET CAPITAL MANAGEMENT, L.P., NEW YORK, NY. FILED 12-29-2010.

**ONE WILLIAM STREET CAPITAL MANAGEMENT**

THE MARK CONSISTS OF STANDARD CHARACTERS WITHOUT CLAIM TO ANY PARTICULAR FONT, STYLE, SIZE, OR COLOR.

NO CLAIM IS MADE TO THE EXCLUSIVE RIGHT TO USE "CAPITAL MANAGEMENT", APART FROM THE MARK AS SHOWN.

FOR FINANCIAL SERVICES, NAMELY, ASSET MANAGEMENT SERVICES, INVESTMENT MANAGEMENT SERVICES, AND INVESTMENT ADVISORY SERVICES (U.S. CLS. 100, 101 AND 102).

FIRST USE 1-1-2010; IN COMMERCE 1-1-2010.  
KEVIN CORWIN, EXAMINING ATTORNEY

---

SN 85-208,133. ASSET PROTECTION PARTNERS, LLC, GREENWICH, CT. FILED 12-30-2010.

**MARRIAGE MULLIGAN**

THE MARK CONSISTS OF STANDARD CHARACTERS WITHOUT CLAIM TO ANY PARTICULAR FONT, STYLE, SIZE, OR COLOR.

NO CLAIM IS MADE TO THE EXCLUSIVE RIGHT TO USE "MARRIAGE", APART FROM THE MARK AS SHOWN.

FOR INSURANCE ADMINISTRATION AND INSURANCE BROKERAGE IN THE FIELDS OF ASSET PROTECTION INSURANCE AND FINANCIAL GUARANTEE INSURANCE (U.S. CLS. 100, 101 AND 102).

CAROL SPILS, EXAMINING ATTORNEY

---

SN 85-208,313. ANACAPA PARTNERS MANAGEMENT LLC, HALF MOON BAY, CA. FILED 12-30-2010.

**ANACAPA PARTNERS**

THE MARK CONSISTS OF STANDARD CHARACTERS WITHOUT CLAIM TO ANY PARTICULAR FONT, STYLE, SIZE, OR COLOR.

NO CLAIM IS MADE TO THE EXCLUSIVE RIGHT TO USE "PARTNERS", APART FROM THE MARK AS SHOWN.

FOR VENTURE CAPITAL SERVICES, NAMELY, PROVIDING FINANCING TO COMPANIES AND ENTREPRENEURS; PRIVATE EQUITY FUNDING SERVICES; PROVIDING FINANCIAL ADVISORY SERVICES TO COMPANIES AND ENTREPRENEURS (U.S. CLS. 100, 101 AND 102).

FIRST USE 7-20-2010; IN COMMERCE 7-20-2010.  
SAMUEL E. SHARPER JR., EXAMINING ATTORNEY

**CLASS 36—(Continued).**

SN 85-208,404. JUST PEANUTS!, LEE'S SUMMIT, MO. FILED 12-30-2010.

***JUST Peanuts!***  
We Can Make A Difference Together

THE COLOR(S) PURPLE AND BLACK IS/ARE CLAIMED AS A FEATURE OF THE MARK.

THE MARK CONSISTS OF A STYLIZED "JUST PEANUTS!" IN PURPLE, WITH "JUST" AND "P" BEING IN UPPERCASE, ABOVE "WE CAN MAKE A DIFFERENCE TOGETHER" IN BLACK WITH "W", "C", "M", "A", "D" AND "T" BEING IN UPPERCASE.

FOR CHARITABLE FUNDRAISING (U.S. CLS. 100, 101 AND 102).

FIRST USE 9-1-2007; IN COMMERCE 9-1-2010.

KARANENDRA S. CHHINA, EXAMINING ATTORNEY

**CLASS 36—(Continued).**

SN 85-208,959. SPC FINANCIAL, INC., ROCKVILLE, MD. FILED 1-3-2011.

**SPC Financial**

THE MARK CONSISTS OF STANDARD CHARACTERS WITHOUT CLAIM TO ANY PARTICULAR FONT, STYLE, SIZE, OR COLOR.

NO CLAIM IS MADE TO THE EXCLUSIVE RIGHT TO USE "FINANCIAL", APART FROM THE MARK AS SHOWN.

FOR FINANCIAL PLANNING AND INVESTMENT ADVISORY SERVICES (U.S. CLS. 100, 101 AND 102).

FIRST USE 11-20-1991; IN COMMERCE 11-20-1991.

JOHN DWYER, EXAMINING ATTORNEY

SN 85-209,056. UWHARRIE CAPITAL CORP, ALBEMARLE, NC. FILED 1-3-2011.

**E-ZMORTGAGE**

THE MARK CONSISTS OF STANDARD CHARACTERS WITHOUT CLAIM TO ANY PARTICULAR FONT, STYLE, SIZE, OR COLOR.

FOR BANKING; FINANCIAL SERVICES, NAMELY, MONEY LENDING; MORTGAGE BANKING; MORTGAGE LENDING (U.S. CLS. 100, 101 AND 102).

ALICIA COLLINS, EXAMINING ATTORNEY

SN 85-208,748. JUST PEANUTS!, LEE'S SUMMIT, MO. FILED 1-1-2011.

**disease,**  
**HELP FIND A Cure.**  
One disease at a TIME.

SN 85-209,427. MIDWEST REALTY VENTURES LLC, DBA PRUDENTIAL RUBLOFF PROPERTIES, CHICAGO, IL. FILED 1-3-2011.

**ONE MAGNIFICENT ADDRESS**

THE COLOR(S) BLACK, LIGHT BLUE, ORANGE, AND PURPLE IS/ARE CLAIMED AS A FEATURE OF THE MARK.

THE MARK CONSISTS OF STYLIZED TEXT FOR THE WORD "DISEASE" IN LOWERCASE LIGHT BLUE FOLLOWED BY AN ORANGE COMMA ABOVE "HELP FIND A" IN ORANGE IN UPPERCASE FOLLOW BY THE STYLIZED TEXT FOR THE WORD "CURE" IN PURPLE WITH CAPITALIZED "C" FOLLOWED BY A ORANGE PERIOD. BELOW THIS IS THE STYLIZED TEXT FOR THE WORD "ONE" IN PURPLE WITH CAPITALIZED "O" FOLLOWED BY "DISEASE" IN LOWERCASE LIGHT BLUE FOLLOWED BY "AT A TIME" IN BLACK WITH "TIME" BEING IN UPPERCASE FOLLOWED BY A PERIOD ALSO IN BLACK.

FOR CHARITABLE FUNDRAISING SERVICES (U.S. CLS. 100, 101 AND 102).

FIRST USE 12-31-2010; IN COMMERCE 12-31-2010.

KARANENDRA S. CHHINA, EXAMINING ATTORNEY

THE MARK CONSISTS OF STANDARD CHARACTERS WITHOUT CLAIM TO ANY PARTICULAR FONT, STYLE, SIZE, OR COLOR.

FOR RESIDENTIAL REAL ESTATE AGENCY SERVICES; REAL ESTATE BROKERAGE; REAL ESTATE LISTING; LEASING OF REAL ESTATE; PROVIDING INFORMATION IN THE FIELD OF REAL ESTATE VIA THE INTERNET; REAL ESTATE CONSULTANCY; REAL ESTATE MANAGEMENT SERVICES; FINANCIAL VALUATION OF REAL ESTATE; REAL ESTATE FINANCING SERVICES; FINANCIAL SERVICES, NAMELY, MORTGAGE PLANNING (U.S. CLS. 100, 101 AND 102).

FIRST USE 1-15-2008; IN COMMERCE 1-15-2008.

JERI J. FICKES, EXAMINING ATTORNEY

**CLASS 36—(Continued).**

SN 85-209,913. DIXIE STAMPEDE, LLC, PIGEON FORGE, TN. FILED 1-4-2011.

WORLD CHOICE INVESTMENTS,  
LLC

THE MARK CONSISTS OF STANDARD CHARACTERS WITHOUT CLAIM TO ANY PARTICULAR FONT, STYLE, SIZE, OR COLOR.

NO CLAIM IS MADE TO THE EXCLUSIVE RIGHT TO USE "INVESTMENTS, LLC", APART FROM THE MARK AS SHOWN.

FOR FINANCIAL INVESTMENT IN THE FIELD OF ENTERTAINMENT (U.S. CLS. 100, 101 AND 102).

FIRST USE 5-27-2010; IN COMMERCE 5-27-2010.

DAVID ELTON, EXAMINING ATTORNEY

---

SN 85-209,929. DIXIE STAMPEDE, LLC, PIGEON FORGE, TN. FILED 1-4-2011.



NO CLAIM IS MADE TO THE EXCLUSIVE RIGHT TO USE "INVESTMENTS", APART FROM THE MARK AS SHOWN.

THE MARK CONSISTS OF THE TERMS "WORLD", "CHOICE", AND "INVESTMENTS" STACKED ONE ON THE OTHER TO THE LEFT OF A STYLIZED GLOBE DESIGN.

FOR FINANCIAL INVESTMENT IN THE FIELD OF ENTERTAINMENT (U.S. CLS. 100, 101 AND 102).

FIRST USE 5-27-2010; IN COMMERCE 5-27-2010.

DAVID ELTON, EXAMINING ATTORNEY

---

SN 85-209,943. DIXIE STAMPEDE, LLC, PIGEON FORGE, TN. FILED 1-4-2011.



NO CLAIM IS MADE TO THE EXCLUSIVE RIGHT TO USE "INVESTMENTS, LLC", APART FROM THE MARK AS SHOWN.

THE MARK CONSISTS OF THE TERMS "WORLD", "CHOICE", AND "INVESTMENTS, LLC" STACKED ONE ON THE OTHER TO THE LEFT OF A STYLIZED GLOBE DESIGN.

FOR FINANCIAL INVESTMENT IN THE FIELD OF ENTERTAINMENT (U.S. CLS. 100, 101 AND 102).

FIRST USE 5-27-2010; IN COMMERCE 5-27-2010.

DAVID ELTON, EXAMINING ATTORNEY

**CLASS 36—(Continued).**

SN 85-209,957. DIXIE STAMPEDE, LLC, PIGEON FORGE, TN. FILED 1-4-2011.

GREAT CHOICE INVESTMENTS,  
LLC

THE MARK CONSISTS OF STANDARD CHARACTERS WITHOUT CLAIM TO ANY PARTICULAR FONT, STYLE, SIZE, OR COLOR.

NO CLAIM IS MADE TO THE EXCLUSIVE RIGHT TO USE "INVESTMENTS, LLC", APART FROM THE MARK AS SHOWN.

FOR FINANCIAL INVESTMENT IN THE FIELD OF ENTERTAINMENT (U.S. CLS. 100, 101 AND 102).

FIRST USE 5-27-2010; IN COMMERCE 5-27-2010.

DAVID ELTON, EXAMINING ATTORNEY

---

SN 85-210,146. EDIFY, RANCHO SANTA FE, CA. FILED 1-4-2011.

Edify

THE MARK CONSISTS OF STANDARD CHARACTERS WITHOUT CLAIM TO ANY PARTICULAR FONT, STYLE, SIZE, OR COLOR.

FOR CHARITABLE FOUNDATION SERVICES, NAMELY, PROVIDING FUNDRAISING ACTIVITIES, FUNDING, SCHOLARSHIPS AND/OR FINANCIAL ASSISTANCE FOR EDUCATION IN OTHER COUNTRIES THROUGH MICRO-FINANCE; CHARITABLE FOUNDATION SERVICES, NAMELY, PROVIDING FUNDRAISING ACTIVITIES, SUPPLEMENTAL FUNDING, CAPITAL IMPROVEMENT FUNDING, SCHOLARSHIPS AND FINANCIAL ASSISTANCE FOR PROGRAMS AND SERVICES OF OTHERS; CHARITABLE SERVICES, NAMELY, GRANTING FUNDS TO SCHOOLS; CHARITABLE SERVICES, NAMELY, PROVIDING FINANCIAL SUPPORT TO PEOPLE FROM DISADVANTAGED COUNTRIES FOR THE PURPOSE OF FACILITATING EDUCATIONAL OPPORTUNITIES (U.S. CLS. 100, 101 AND 102).

FIRST USE 12-8-2010; IN COMMERCE 12-8-2010.

JOHN DWYER, EXAMINING ATTORNEY

**CLASS 36—(Continued).**

SN 85-210,369. VERA FINANCIAL SOLUTIONS, LLC, CLARKSTON, MI. FILED 1-4-2011.

## Vera Financial Solutions

THE MARK CONSISTS OF STANDARD CHARACTERS WITHOUT CLAIM TO ANY PARTICULAR FONT, STYLE, SIZE, OR COLOR.

NO CLAIM IS MADE TO THE EXCLUSIVE RIGHT TO USE "FINANCIAL SOLUTIONS", APART FROM THE MARK AS SHOWN.

FOR FINANCIAL ADVICE AND CONSULTANCY SERVICES (U.S. CLS. 100, 101 AND 102).

FIRST USE 11-1-2010; IN COMMERCE 11-1-2010.

HEATHER BIDDULPH, EXAMINING ATTORNEY

---

SN 85-210,425. VERA FINANCIAL SOLUTIONS, LLC, CLARKSTON, MI. FILED 1-4-2011.



NO CLAIM IS MADE TO THE EXCLUSIVE RIGHT TO USE "FINANCIAL SOLUTIONS", APART FROM THE MARK AS SHOWN.

THE COLOR(S) WHITE, LIGHT BLUE, AND DARK BLUE IS/ARE CLAIMED AS A FEATURE OF THE MARK.

THE MARK CONSISTS OF A WHITE ROAD GOING OFF IN THE DISTANCE WITHIN A CIRCLE WITH DARK BLUE AT THE BOTTOM AND LIGHT BLUE AT THE TOP. AT THE END OF THE ROAD IS A WHITE ARCHING HORIZON AND A WHITE STAR BURST. AT THE BOTTOM OF THE CIRCLE ARE THE WORDS "VERA FINANCIAL SOLUTIONS" IN DARK BLUE. THE CROSS BAR IN THE LETTER "A" BEGINS THE BOTTOM OF THE CIRCLE. "FINANCIAL SOLUTIONS" SITS UNDER THE WORD "VERA" AND THE CIRCLE.

FOR FINANCIAL ADVICE AND CONSULTANCY SERVICES (U.S. CLS. 100, 101 AND 102).

FIRST USE 11-1-2010; IN COMMERCE 11-1-2010.

HEATHER BIDDULPH, EXAMINING ATTORNEY

**CLASS 36—(Continued).**

SN 85-211,048. BENITECTS, LLC, ST. LOUIS, MO. FILED 1-5-2011.

## Designing and Building Better Benefits

THE MARK CONSISTS OF STANDARD CHARACTERS WITHOUT CLAIM TO ANY PARTICULAR FONT, STYLE, SIZE, OR COLOR.

NO CLAIM IS MADE TO THE EXCLUSIVE RIGHT TO USE "BENEFITS", APART FROM THE MARK AS SHOWN.

FOR ADVISORY SERVICES IN THE FIELD OF EMPLOYEE BENEFITS FOR GROUP HEALTHCARE AND BUSINESS INSURANCE OFFERED TO EMPLOYEES IN ADDITION TO STANDARD BENEFITS SUCH AS MEDICAL, DENTAL, LIFE INSURANCE INCLUDING SHORT TERM DISABILITY, LONG TERM DISABILITY, CANCER INSURANCE, ACCIDENTAL DEATH AND DISMEMBERMENT INSURANCE AND RELATED VOLUNTARY SERVICES (U.S. CLS. 100, 101 AND 102).

FIRST USE 4-9-2008; IN COMMERCE 7-1-2008.

JOHN E. MICHOS, EXAMINING ATTORNEY

---

SN 85-211,100. SAFEPATH BENEFITS, INC., NEW YORK, NY. FILED 1-5-2011.



NO CLAIM IS MADE TO THE EXCLUSIVE RIGHT TO USE "BENEFITS", APART FROM THE MARK AS SHOWN. THE COLOR(S) GREEN AND GREY IS/ARE CLAIMED AS A FEATURE OF THE MARK.

THE MARK CONSISTS OF THE WORD "SAFEPATH" IN GREEN AND THE WORD "BENEFITS" IN GREY, WITH A CONCAVE ARC IN GREY ABOVE THE WORD "SAFEPATH" AND A CONVEX ARC IN GREEN ABOVE THE WORD "BENEFITS".

FOR INSURANCE SERVICES, NAMELY, THE BROKERAGE OF ACCIDENT, HEALTH, DRUG, DENTAL AND FINAL EXPENSE POLICIES (U.S. CLS. 100, 101 AND 102).

FIRST USE 9-13-2010; IN COMMERCE 9-13-2010.

MICHAEL WEBSTER, EXAMINING ATTORNEY

**CLASS 36—(Continued).**

SN 85-211,286. PARASOL INVESTMENT MANAGEMENT, LLC, WESTMONT, IL. FILED 1-5-2011.

## PARASOL INVESTMENT MANAGEMENT

THE MARK CONSISTS OF STANDARD CHARACTERS WITHOUT CLAIM TO ANY PARTICULAR FONT, STYLE, SIZE, OR COLOR.

NO CLAIM IS MADE TO THE EXCLUSIVE RIGHT TO USE "INVESTMENT MANAGEMENT", APART FROM THE MARK AS SHOWN.

FOR INVESTMENT MANAGEMENT SERVICES (U.S. CLS. 100, 101 AND 102).

KATHERINE CONNOLLY, EXAMINING ATTORNEY

**CLASS 36—(Continued).**

SN 85-211,673. RESTORE FINANCIAL SERVICES NETWORK, LLC, PORTLAND, OR. FILED 1-6-2011.

## Restore Financial Services Network

THE MARK CONSISTS OF STANDARD CHARACTERS WITHOUT CLAIM TO ANY PARTICULAR FONT, STYLE, SIZE, OR COLOR.

NO CLAIM IS MADE TO THE EXCLUSIVE RIGHT TO USE "FINANCIAL SERVICES NETWORK", APART FROM THE MARK AS SHOWN.

FOR COLLECTION OF DEBTS; DEBT COLLECTION; DEBT COLLECTION AGENCIES; DEBT RECOVERY AND COLLECTION AGENCIES; REPOSSESSION SERVICES IN THE NATURE OF DEBT COLLECTION (U.S. CLS. 100, 101 AND 102).

JOHN SCHUYLER YARD, EXAMINING ATTORNEY

SN 85-212,065. HOLLIS & ASSOCIATES, INC., MONTGOMERY, IL. FILED 1-6-2011.

## Insurance Counts

THE MARK CONSISTS OF STANDARD CHARACTERS WITHOUT CLAIM TO ANY PARTICULAR FONT, STYLE, SIZE, OR COLOR.

NO CLAIM IS MADE TO THE EXCLUSIVE RIGHT TO USE "INSURANCE", APART FROM THE MARK AS SHOWN.

FOR INSURANCE AGENCIES (U.S. CLS. 100, 101 AND 102).

FIRST USE 5-1-2005; IN COMMERCE 5-1-2005.

H. M. FISHER, EXAMINING ATTORNEY

SN 85-212,078. TIMOTHY J BAKER, MANCHESTER, CT. FILED 1-6-2011.

## IndexAid

THE MARK CONSISTS OF STANDARD CHARACTERS WITHOUT CLAIM TO ANY PARTICULAR FONT, STYLE, SIZE, OR COLOR.

FOR ADVICE RELATING TO INVESTMENTS (U.S. CLS. 100, 101 AND 102).

FRANK LATTUCA, EXAMINING ATTORNEY

SN 85-211,585. VSPACE DALLAS, LLC, DBA VSPACE, IRVING, TX. FILED 1-6-2011.



NO CLAIM IS MADE TO THE EXCLUSIVE RIGHT TO USE "SPACE", APART FROM THE MARK AS SHOWN.

THE COLOR(S) BLUE AND WHITE IS/ARE CLAIMED AS A FEATURE OF THE MARK.

THE MARK CONSISTS OF A BLUE UPPER-CASE "V" WITH THE WORD "SPACE" IN LOWER-CASE WHITE LETTERS IMBEDDED INTO THE RIGHT-HAND ARM OF THE "V" WHICH IS SURROUNDED BY A BLUE SQUARE THAT HAS A SPACE OPENING ON THE UPPER RIGHT-HAND CORNER; THE OPENING OF THE BLUE SQUARE HAS THREE BLUE WI-FI WAVES THAT APPEAR TO BE COMING OUT OF THE SQUARE AND THE TOP-RIGHT-SIDE OF THE "V".

FOR INCUBATION SERVICES, NAMELY, RENTAL OF OFFICE SPACE TO FREELANCERS, START UPS, EXISTING BUSINESS, AND NON-PROFITS (U.S. CLS. 100, 101 AND 102).

ELISSA GARBER KON, EXAMINING ATTORNEY



**CLASS 36—(Continued).**

SN 85-212,202. PGPRESENTS, LLC, SHEPHARDSTOWN, WV.  
FILED 1-6-2011.

**PG ON-CALL**

THE MARK CONSISTS OF STANDARD CHARACTERS  
WITHOUT CLAIM TO ANY PARTICULAR FONT, STYLE,  
SIZE, OR COLOR.

FOR CREDIT AND FINANCIAL CONSULTATION;  
STUDENT LOAN SERVICES (U.S. CLS. 100, 101 AND  
102).

SUZANNE BLANE, EXAMINING ATTORNEY

---

SN 85-212,210. PGPRESENTS, LLC, SHEPHARDSTOWN, WV.  
FILED 1-6-2011.

**PG TRIAGE**

THE MARK CONSISTS OF STANDARD CHARACTERS  
WITHOUT CLAIM TO ANY PARTICULAR FONT, STYLE,  
SIZE, OR COLOR.

FOR CREDIT AND FINANCIAL CONSULTATION;  
STUDENT LOAN SERVICES (U.S. CLS. 100, 101 AND  
102).

SUZANNE BLANE, EXAMINING ATTORNEY

---

SN 85-212,343. LIBREMAX CAPITAL, LLC, NEW YORK, NY.  
FILED 1-6-2011.

**LIBREMAX CAPITAL**

THE MARK CONSISTS OF STANDARD CHARACTERS  
WITHOUT CLAIM TO ANY PARTICULAR FONT, STYLE,  
SIZE, OR COLOR.

NO CLAIM IS MADE TO THE EXCLUSIVE RIGHT TO  
USE "CAPITAL", APART FROM THE MARK AS SHOWN.

THE ENGLISH TRANSLATION OF THE WORD "LIBRE"  
IN THE MARK IS FREE.

FOR FINANCIAL SERVICES, NAMELY, INVEST-  
MENT MANAGEMENT AND ADVISORY SERVICES  
(U.S. CLS. 100, 101 AND 102).

FIRST USE 10-1-2010; IN COMMERCE 10-1-2010.

SANDRA BUJA, EXAMINING ATTORNEY

**CLASS 36—(Continued).**

SN 85-212,801. RESIDENTIAL FINANCE CORPORATION,  
COLUMBUS, OH. FILED 1-7-2011.

**PROLENDING NETWORK**

THE MARK CONSISTS OF STANDARD CHARACTERS  
WITHOUT CLAIM TO ANY PARTICULAR FONT, STYLE,  
SIZE, OR COLOR.

NO CLAIM IS MADE TO THE EXCLUSIVE RIGHT TO  
USE "NETWORK", APART FROM THE MARK AS SHOWN.

FOR BANKING AND FINANCING SERVICES; FINAN-  
CIAL SERVICES, NAMELY, MORTGAGE REFINAN-  
CING; MORTGAGE BANKING SERVICES, NAMELY,  
ORIGINATION, ACQUISITION, SERVICING, SECURITI-  
ZATION AND BROKERAGE OF MORTGAGE LOANS;  
MORTGAGE LENDING (U.S. CLS. 100, 101 AND 102).

FIRST USE 1-6-2011; IN COMMERCE 1-6-2011.

LAURIE KAUFMAN, EXAMINING ATTORNEY

---

SN 85-212,945. WORLDWIDE REALTY PROFESSIONALS  
INC., BOZEMAN, MT. FILED 1-7-2011.

**worldwide**  
REALTY PROFESSIONALS

---

NO CLAIM IS MADE TO THE EXCLUSIVE RIGHT TO  
USE "WORLDWIDE REALTY PROFESSIONALS", APART  
FROM THE MARK AS SHOWN.

THE MARK CONSISTS OF THE STYLIZED TEXT  
"WORLDWIDE REALTY PROFESSIONALS" UNDER-  
LINED. THERE IS A STYLIZED RING AROUND THE "O".

FOR REAL ESTATE BROKERAGE (U.S. CLS. 100, 101  
AND 102).

FIRST USE 12-7-2010; IN COMMERCE 12-7-2010.

CAROLINE WOOD, EXAMINING ATTORNEY

---

SN 85-213,192. FEDERATED MUTUAL INSURANCE COM-  
PANY, OWATONNA, MN. FILED 1-7-2011.

**PREMIER SELECT**

THE MARK CONSISTS OF STANDARD CHARACTERS  
WITHOUT CLAIM TO ANY PARTICULAR FONT, STYLE,  
SIZE, OR COLOR.

OWNER OF U.S. REG. NO. 1,631,863.

FOR BUSINESS INCOME INSURANCE UNDERWRIT-  
ING SERVICES (U.S. CLS. 100, 101 AND 102).

FIRST USE 5-5-1990; IN COMMERCE 5-5-1990.

KATHERINE M. DUBRAY, EXAMINING ATTORNEY

**CLASS 36—(Continued).**

SN 85-213,448. BRYDELS MARKETING, LLC, BATON ROUGE, LA. FILED 1-8-2011.

# JOYUP

THE MARK CONSISTS OF STANDARD CHARACTERS WITHOUT CLAIM TO ANY PARTICULAR FONT, STYLE, SIZE, OR COLOR.

FOR CHARITABLE FUNDRAISING SERVICES VIA THE ONLINE DISTRIBUTION OF THIRD PARTY REBATES AND COUPONS; CHARITABLE FUNDRAISING SERVICES VIA THE DISTRIBUTION OF THIRD PARTY REBATES AND COUPONS; CHARITABLE FUNDRAISING SERVICES VIA THE ONLINE PROMOTION OF THIRD PARTY REBATES AND COUPONS; CHARITABLE FUNDRAISING SERVICES VIA THE PROMOTION OF THIRD PARTY REBATES AND COUPONS (U.S. CLS. 100, 101 AND 102).

DAVID TOOLEY, EXAMINING ATTORNEY

---

SN 85-213,451. BRYDELS MARKETING, LLC, BATON ROUGE, LA. FILED 1-8-2011.

# GOODSAVE

THE MARK CONSISTS OF STANDARD CHARACTERS WITHOUT CLAIM TO ANY PARTICULAR FONT, STYLE, SIZE, OR COLOR.

FOR CHARITABLE FUNDRAISING SERVICES VIA THE ONLINE DISTRIBUTION OF THIRD PARTY REBATES AND COUPONS; CHARITABLE FUNDRAISING SERVICES VIA THE DISTRIBUTION OF THIRD PARTY REBATES AND COUPONS; CHARITABLE FUNDRAISING SERVICES VIA THE ONLINE PROMOTION OF THIRD PARTY REBATES AND COUPONS; CHARITABLE FUNDRAISING SERVICES VIA THE PROMOTION OF THIRD PARTY REBATES AND COUPONS (U.S. CLS. 100, 101 AND 102).

DAVID TOOLEY, EXAMINING ATTORNEY

**CLASS 36—(Continued).**

SN 85-213,744. GLUCK, LAURENCE, DBA STELLAR MANAGEMENT, NEW YORK, NY. FILED 1-10-2011.

# STELLAR MANAGEMENT

THE MARK CONSISTS OF STANDARD CHARACTERS WITHOUT CLAIM TO ANY PARTICULAR FONT, STYLE, SIZE, OR COLOR.

NO CLAIM IS MADE TO THE EXCLUSIVE RIGHT TO USE "MANAGEMENT", APART FROM THE MARK AS SHOWN.

FOR CLASSIFIED REAL ESTATE LISTINGS OF APARTMENT RENTALS AND HOUSING RENTALS; COMMERCIAL AND RESIDENTIAL REAL ESTATE AGENCY SERVICES; PROVIDING REAL ESTATE LISTINGS AND REAL ESTATE INFORMATION VIA THE INTERNET; REAL ESTATE RENTAL SERVICES, NAMELY, RENTAL OF RESIDENTIAL HOUSING; REAL ESTATE SERVICE, NAMELY, RENTAL PROPERTY MANAGEMENT; REAL ESTATE SERVICES, NAMELY, LEASING AND MANAGEMENT FOR OTHERS OF RESIDENTIAL CONDOMINIUMS LOCATED WITHIN HOTEL DEVELOPMENTS; REAL ESTATE SERVICES, NAMELY, RENTAL OF SHORT-TERM FURNISHED APARTMENTS; REAL ESTATE SERVICES, NAMELY, RENTAL, BROKERAGE, LEASING AND MANAGEMENT OF COMMERCIAL PROPERTY, OFFICES AND OFFICE SPACE (U.S. CLS. 100, 101 AND 102).

FIRST USE 0-0-1985; IN COMMERCE 0-0-1985.  
ERNEST SHOSHO, EXAMINING ATTORNEY

---

SN 85-213,786. ILLINOIS STUDENT ASSISTANCE COMMISSION, DEERFIELD, IL. FILED 1-10-2011.

# PAY EARLY. PAY LESS. PAY SMART.

THE MARK CONSISTS OF STANDARD CHARACTERS WITHOUT CLAIM TO ANY PARTICULAR FONT, STYLE, SIZE, OR COLOR.

FOR FINANCIAL SERVICES, NAMELY, LOAN PROGRAMS FOR PROVIDING FINANCIAL AID INFORMATION AND STUDENT LOAN GUARANTY SERVICES (U.S. CLS. 100, 101 AND 102).

GINA HAYES, EXAMINING ATTORNEY

**CLASS 36—(Continued).**

SN 85-213,846. CASHNETPLUS, LOS ANGELES, CA. FILED 1-10-2011.

# PawnZone

THE MARK CONSISTS OF STANDARD CHARACTERS WITHOUT CLAIM TO ANY PARTICULAR FONT, STYLE, SIZE, OR COLOR.

FOR PAWN SHOPS; ONLINE PAWN SHOPS (U.S. CLS. 100, 101 AND 102).

FIRST USE 7-1-2008; IN COMMERCE 7-1-2008.

REBECCA POVARCHUK, EXAMINING ATTORNEY

**CLASS 36—(Continued).**

SN 85-215,085. IRONSHORE INC., GEORGE TOWN, CAYMAN ISLANDS, FILED 1-11-2011.

# TECHDEFENDER

THE MARK CONSISTS OF STANDARD CHARACTERS WITHOUT CLAIM TO ANY PARTICULAR FONT, STYLE, SIZE, OR COLOR.

FOR INSURANCE UNDERWRITING SERVICES IN THE FIELD OF PROFESSIONAL LIABILITY (U.S. CLS. 100, 101 AND 102).

DAVID TAYLOR, EXAMINING ATTORNEY

SN 85-213,875. RON DICKERSON REO LLC, ATLANTA, GA. FILED 1-10-2011.



NO CLAIM IS MADE TO THE EXCLUSIVE RIGHT TO USE "LLC", APART FROM THE MARK AS SHOWN.

THE MARK CONSISTS OF A GLOBE DESIGN HAVING FOUR VERTICAL CURVED BANDS AND THE WORDING "RONDICKERSONREO LLC" IN THE CENTER WITH "RONDICKERSONREO" HORIZONTAL AND "LLC" VERTICAL; AND THE WORDS "ALWAYS, BE, CLOSING" BELOW THE GLOBE DESIGN.

FOR REAL ESTATE AGENCIES (U.S. CLS. 100, 101 AND 102).

FIRST USE 12-8-2010; IN COMMERCE 12-8-2010.

MAYUR VAGHANI, EXAMINING ATTORNEY

SN 85-215,118. SOUTHWEST FEDERAL CREDIT UNION, ALBUQUERQUE, NM. FILED 1-11-2011.

## "Your Best Interest Is Our Business"

THE MARK CONSISTS OF STANDARD CHARACTERS WITHOUT CLAIM TO ANY PARTICULAR FONT, STYLE, SIZE, OR COLOR.

FOR ARRANGING AND PROVISION OF CREDIT, LOANS, INSURANCE, CURRENCY EXCHANGE AND TRAVELLERS CHEQUES; CHARGE CARD AND CREDIT CARD SERVICES; CONSUMER CREDIT CONSULTATION; CREDIT AND DEBIT CARD SERVICES; CREDIT AND FINANCIAL CONSULTATION; CREDIT AND LOAN SERVICES; CREDIT CARD AND DEBIT CARD SERVICES; CREDIT UNION SERVICES; CREDIT UNIONS; ISSUING CREDIT CARDS; ISSUING OF TRAVELLERS' CHEQUES AND LETTERS OF CREDIT (U.S. CLS. 100, 101 AND 102).

FIRST USE 1-1-1999; IN COMMERCE 1-1-1999.

MARK SHINER, EXAMINING ATTORNEY

SN 85-214,199. LIBREMAX CAPITAL, LLC, NEW YORK, NY. FILED 1-10-2011.

# LibreMax

THE MARK CONSISTS OF STANDARD CHARACTERS WITHOUT CLAIM TO ANY PARTICULAR FONT, STYLE, SIZE, OR COLOR.

THE ENGLISH TRANSLATION OF THE WORD "LIBRE" IN THE MARK IS "FREE".

FOR FINANCIAL SERVICES, NAMELY, INVESTMENT MANAGEMENT AND ADVISORY SERVICES (U.S. CLS. 100, 101 AND 102).

FIRST USE 10-1-2010; IN COMMERCE 10-1-2010.

SANDRA BUJA, EXAMINING ATTORNEY

SN 85-215,239. OCEANCONNECT.COM, INC., WHITE PLAINS, NY. FILED 1-11-2011.

# BIOFUELSCONNECT

THE MARK CONSISTS OF STANDARD CHARACTERS WITHOUT CLAIM TO ANY PARTICULAR FONT, STYLE, SIZE, OR COLOR.

FOR BROKERAGE SERVICES IN THE FIELD OF BIOFUELS AND RELATED NON-HYDROCARBON-BASED FUELS; BROKERAGE OF ENERGY TAX CREDITS, ALLOWANCES OR OFFSETS OF OTHERS (U.S. CLS. 100, 101 AND 102).

FIRST USE 8-1-2006; IN COMMERCE 8-1-2006.

ELISSA GARBER KON, EXAMINING ATTORNEY

**CLASS 36—(Continued).**

SN 85-215,339. JUICY COUTURE, INC., PACOIMA, CA.  
FILED 1-11-2011.

**COUTURE FOR A CAUSE**

THE MARK CONSISTS OF STANDARD CHARACTERS WITHOUT CLAIM TO ANY PARTICULAR FONT, STYLE, SIZE, OR COLOR.  
FOR CHARITABLE FUNDRAISING SERVICES (U.S. CLS. 100, 101 AND 102).  
REGINA DRUMMOND, EXAMINING ATTORNEY

SN 85-215,483. FRASER, JAMES, PASADENA, CA. FILED 1-11-2011.



THE MARK CONSISTS OF A CHECK MARK SYMBOL INSIDE THE SILHOUETTE OF A HOUSE, TO THE LEFT OF THE TERM "RENOVATIONREADY".  
FOR REAL ESTATE CONSULTATION (U.S. CLS. 100, 101 AND 102).  
BARBARA BROWN, EXAMINING ATTORNEY

SN 85-216,005. BACERA GROUP LLC, ALHAMBRA, CA.  
FILED 1-12-2011.



THE COLOR(S) GREEN, GOLD, AND WHITE IS/ARE CLAIMED AS A FEATURE OF THE MARK.  
THE MARK CONSISTS OF A STYLIZED CAPITAL LETTER "B", WITH THE TOP CURVED LINE CONSISTING OF THE COLORS GOLD AND WHITE, WHILE THE BOTTOM TWO LINES CONSIST OF THE COLOR GREEN.  
FOR ADVICE RELATING TO INVESTMENTS (U.S. CLS. 100, 101 AND 102).  
FIRST USE 6-1-2008; IN COMMERCE 6-1-2008.  
CAROLINE WOOD, EXAMINING ATTORNEY

**CLASS 36—(Continued).**

SN 85-216,853. AMERREN TECHNOLOGIES, INC., AUSTIN, TX. FILED 1-13-2011.



NO CLAIM IS MADE TO THE EXCLUSIVE RIGHT TO USE "TECHNOLOGIES", APART FROM THE MARK AS SHOWN.

THE COLOR(S) DARK BLUE, LIGHT BLUE, WHITE, YELLOW AND BLACK IS/ARE CLAIMED AS A FEATURE OF THE MARK.

THE MARK CONSISTS OF THE WORD "AMERREN" APPEARING IN DARK BLUE LOWER CASE LETTERING PARTIALLY OUTLINED IN BLACK AND WITH LIGHT BLUE SHADOWING, WITH THE LETTER "A" AND A PORTION OF THE LETTER "M" APPEARING IN A YELLOW ROUNDED TRIANGLE PARTIALLY OUTLINED IN WHITE AND PARTIALLY OUTLINED IN BLACK CONTAINED WITHIN A LARGER BLUE CIRCLE WHICH IS ALSO PARTIALLY OUTLINED IN WHITE AND PARTIALLY OUTLINED IN BLACK AND THE WORD "TECHNOLOGIES" APPEARING IN LIGHT BLUE SHADED LETTERING BELOW AND TO THE RIGHT OF THE BLUE CIRCLE.

FOR PROVIDING ON-LINE, REAL-TIME SERVICES TO MEDICAL PROFESSIONALS IN THE NATURE OF A DATABASE AND NON-DOWNLOADABLE SOFTWARE APPLICATION FOR TRACKING, MONITORING, AND GENERATING REPORTS ABOUT PATIENT INSURANCE BENEFIT AND ELIGIBILITY INFORMATION (U.S. CLS. 100, 101 AND 102).

LINDA E. BLOHM, EXAMINING ATTORNEY

SN 85-217,400. BACERA GROUP LLC, ALHAMBRA, CA.  
FILED 1-13-2011.

# Bacera

THE MARK CONSISTS OF STANDARD CHARACTERS WITHOUT CLAIM TO ANY PARTICULAR FONT, STYLE, SIZE, OR COLOR.

FOR BROKERAGE SERVICES IN THE FIELD OF SECURITIES AND COMMODITIES INVESTING (U.S. CLS. 100, 101 AND 102).

FIRST USE 6-1-2008; IN COMMERCE 6-1-2008.  
CAROLINE WOOD, EXAMINING ATTORNEY

**CLASS 36—(Continued).**

SN 85-220,466. 65RETIRE, IRVINE, CA. FILED 1-18-2011.

**THE IDEAL RETIREMENT  
SOLUTION**

THE MARK CONSISTS OF STANDARD CHARACTERS WITHOUT CLAIM TO ANY PARTICULAR FONT, STYLE, SIZE, OR COLOR.

NO CLAIM IS MADE TO THE EXCLUSIVE RIGHT TO USE "RETIREMENT", APART FROM THE MARK AS SHOWN.

FOR FINANCIAL PLANNING FOR RETIREMENT; INSURANCE CONSULTATION, BROKERAGE AND AGENCY SERVICES; INVESTMENT CONSULTATION AND BROKERAGE SERVICES (U.S. CLS. 100, 101 AND 102).

FIRST USE 7-1-2009; IN COMMERCE 7-1-2009.  
JORDAN BAKER, EXAMINING ATTORNEY

SN 85-220,473. 65RETIRE, IRVINE, CA. FILED 1-18-2011.

**THE IDEAL LIFESTYLE BUILDER**

THE MARK CONSISTS OF STANDARD CHARACTERS WITHOUT CLAIM TO ANY PARTICULAR FONT, STYLE, SIZE, OR COLOR.

FOR FINANCIAL PLANNING FOR RETIREMENT; INSURANCE CONSULTATION, BROKERAGE AND AGENCY SERVICES; INVESTMENT CONSULTATION AND BROKERAGE SERVICES (U.S. CLS. 100, 101 AND 102).

FIRST USE 7-1-2009; IN COMMERCE 7-1-2009.  
JORDAN BAKER, EXAMINING ATTORNEY

SN 85-220,479. 65RETIRE, IRVINE, CA. FILED 1-18-2011.

**THE FUTURE LIFESTYLE  
PREDICTOR**

THE MARK CONSISTS OF STANDARD CHARACTERS WITHOUT CLAIM TO ANY PARTICULAR FONT, STYLE, SIZE, OR COLOR.

FOR FINANCIAL PLANNING FOR RETIREMENT; INSURANCE CONSULTATION, BROKERAGE AND AGENCY SERVICES; INVESTMENT CONSULTATION AND BROKERAGE SERVICES (U.S. CLS. 100, 101 AND 102).

FIRST USE 7-1-2009; IN COMMERCE 7-1-2009.  
JORDAN BAKER, EXAMINING ATTORNEY

**CLASS 36—(Continued).**

SN 85-220,496. ALTERNATIVAS EN MEDIO DE PAGO, S.A. DE C.V., MEXICO, D.F., MEXICO, FILED 1-18-2011.

**SOCIAL TRANSACTIONS**

THE MARK CONSISTS OF STANDARD CHARACTERS WITHOUT CLAIM TO ANY PARTICULAR FONT, STYLE, SIZE, OR COLOR.

FOR ELECTRONIC FUNDS TRANSFER; FINANCIAL AFFAIRS AND MONETARY AFFAIRS, NAMELY, FINANCIAL INFORMATION, MANAGEMENT AND ANALYSIS SERVICES (U.S. CLS. 100, 101 AND 102).

DEIRDRE ROBERTSON, EXAMINING ATTORNEY

SN 85-221,451. 65RETIRE, IRVINE, CA. FILED 1-19-2011.

**OUR GOAL IS YOUR FREEDOM**

THE MARK CONSISTS OF STANDARD CHARACTERS WITHOUT CLAIM TO ANY PARTICULAR FONT, STYLE, SIZE, OR COLOR.

FOR FINANCIAL PLANNING FOR RETIREMENT; INSURANCE CONSULTATION, BROKERAGE AND AGENCY SERVICES; INVESTMENT CONSULTATION AND BROKERAGE SERVICES (U.S. CLS. 100, 101 AND 102).

FIRST USE 7-1-2009; IN COMMERCE 7-1-2009.  
JORDAN BAKER, EXAMINING ATTORNEY

SN 85-223,313. T. ROWE PRICE GROUP, INC., BALTIMORE, MD. FILED 1-21-2011.



THE MARK CONSISTS OF THREE VERTICAL BANDS WHICH CURVE UP AND TO THE RIGHT CONVERGING TOGETHER INTO A POINT AT THE TOP.

FOR FINANCIAL ADMINISTRATION OF EMPLOYER-SPONSORED RETIREMENT PLANS FOR RETIREMENT PLAN PROVIDERS AND RETIREMENT PLAN PARTICIPANTS (U.S. CLS. 100, 101 AND 102).

KELLEY WELLS, EXAMINING ATTORNEY



**CLASS 36—(Continued).**

SN 85-223,333. T. ROWE PRICE GROUP, INC., BALTIMORE, MD. FILED 1-21-2011.



THE COLOR(S) BLUE, GRAY, GREEN AND WHITE IS/ ARE CLAIMED AS A FEATURE OF THE MARK.

THE MARK CONSISTS OF THE FOLLOWING: THREE VERTICAL BANDS WHICH CURVE UP AND TO THE RIGHT CONVERGING TOGETHER INTO A POINT AT THE TOP. THE FIRST BAND IS IN BLUE, THE SECOND BAND IS IN GRAY AND THE THIRD BAND IS IN GREEN. ALL THREE BANDS DARKEN AT THE TOP WHERE THEY MEET AND THERE ARE WHITE LINES BETWEEN THE BANDS UNTIL THEY CONVERGE.

FOR FINANCIAL ADMINISTRATION OF EMPLOYER-SPONSORED RETIREMENT PLANS FOR RETIREMENT PLAN PROVIDERS AND RETIREMENT PLAN PARTICIPANTS (U.S. CLS. 100, 101 AND 102).

KELLEY WELLS, EXAMINING ATTORNEY

SN 85-237,713. ASSURANT, INC., NEW YORK, NY. FILED 2-9-2011.

**ASSURANT HEALTH ACCESS**

THE MARK CONSISTS OF STANDARD CHARACTERS WITHOUT CLAIM TO ANY PARTICULAR FONT, STYLE, SIZE, OR COLOR.

OWNER OF U.S. REG. NOS. 2,543,367, 3,880,185 AND OTHERS.

NO CLAIM IS MADE TO THE EXCLUSIVE RIGHT TO USE "HEALTH", APART FROM THE MARK AS SHOWN.

FOR INSURANCE SERVICES FOR INDIVIDUALS AND FAMILIES, NAMELY, HEALTH, LIFE, DENTAL, VISION, AND CANCER INSURANCE UNDERWRITING (U.S. CLS. 100, 101 AND 102).

SANDRA BUJA, EXAMINING ATTORNEY

**CLASS 36—(Continued).**

SN 85-238,753. THE MOSAIC COMPANY, PLYMOUTH, MN. FILED 2-10-2011.

**HARVEST HEDGE**

THE MARK CONSISTS OF STANDARD CHARACTERS WITHOUT CLAIM TO ANY PARTICULAR FONT, STYLE, SIZE, OR COLOR.

NO CLAIM IS MADE TO THE EXCLUSIVE RIGHT TO USE "HEDGE", APART FROM THE MARK AS SHOWN.

FOR FINANCIAL RISK MANAGEMENT SERVICES FOR AGRICULTURAL COMMODITIES (U.S. CLS. 100, 101 AND 102).

PAUL F. GAST, EXAMINING ATTORNEY

SN 85-239,113. OM FINANCIAL LIFE INSURANCE COMPANY, BALTIMORE, MD. FILED 2-10-2011.

**FG GUARANTEE-PLATINUM**

THE MARK CONSISTS OF STANDARD CHARACTERS WITHOUT CLAIM TO ANY PARTICULAR FONT, STYLE, SIZE, OR COLOR.

OWNER OF U.S. REG. NO. 3,773,281.

FOR ANNUITY UNDERWRITING; LIFE INSURANCE UNDERWRITING (U.S. CLS. 100, 101 AND 102).

CHERYL CLAYTON, EXAMINING ATTORNEY

SN 85-241,528. COMPASS BANCSHARES, INC., BIRMINGHAM, AL. FILED 2-14-2011.

**TEAM. WORKS. ON TOUR**

THE MARK CONSISTS OF STANDARD CHARACTERS WITHOUT CLAIM TO ANY PARTICULAR FONT, STYLE, SIZE, OR COLOR.

FOR BANKING SERVICES; AND FOR BANKING SERVICES OFFERED TO OTHERS VIA SPORTS THEMED ADVERTISEMENTS (U.S. CLS. 100, 101 AND 102).

ELIZABETH HUGHITT, EXAMINING ATTORNEY

**CLASS 36—(Continued).**

SN 85-244,580. CDOC, INC., CARMEL, IN. FILED 2-17-2011.

**WASHINGTON NATIONAL TERM  
LIFE PLUS**

THE MARK CONSISTS OF STANDARD CHARACTERS WITHOUT CLAIM TO ANY PARTICULAR FONT, STYLE, SIZE, OR COLOR.

OWNER OF U.S. REG. NOS. 3,263,912, 3,263,914 AND OTHERS.

NO CLAIM IS MADE TO THE EXCLUSIVE RIGHT TO USE "NATIONAL TERM LIFE", APART FROM THE MARK AS SHOWN.

FOR SERVICES IN THE FIELD OF LIFE INSURANCE, NAMELY, UNDERWRITING TERM LIFE INSURANCE (U.S. CLS. 100, 101 AND 102).

ALICE BENMAMAN, EXAMINING ATTORNEY



SN 85-249,717. IRONSHORE INC., GEORGE TOWN, CAYMAN ISLANDS, FILED 2-23-2011.

**ADVISERGUARD**

THE MARK CONSISTS OF STANDARD CHARACTERS WITHOUT CLAIM TO ANY PARTICULAR FONT, STYLE, SIZE, OR COLOR.

FOR INSURANCE UNDERWRITING SERVICES IN THE FIELD OF PROFESSIONAL LIABILITY (U.S. CLS. 100, 101 AND 102).

DAVID TAYLOR, EXAMINING ATTORNEY



SN 85-255,061. OM FINANCIAL LIFE INSURANCE COMPANY, BALTIMORE, MD. FILED 3-1-2011.

**FGNY GUARANTEE-PLUS**

THE MARK CONSISTS OF STANDARD CHARACTERS WITHOUT CLAIM TO ANY PARTICULAR FONT, STYLE, SIZE, OR COLOR.

FOR ANNUITY UNDERWRITING; LIFE INSURANCE UNDERWRITING (U.S. CLS. 100, 101 AND 102).

CHERYL CLAYTON, EXAMINING ATTORNEY

**CLASS 36—(Continued).**

SN 85-256,875. OM FINANCIAL LIFE INSURANCE COMPANY, BALTIMORE, MD. FILED 3-3-2011.

**PROSPERITY ELITE**

THE MARK CONSISTS OF STANDARD CHARACTERS WITHOUT CLAIM TO ANY PARTICULAR FONT, STYLE, SIZE, OR COLOR.

OWNER OF U.S. REG. NO. 2,205,947.

FOR ANNUITY UNDERWRITING; LIFE INSURANCE UNDERWRITING (U.S. CLS. 100, 101 AND 102).

CHERYL CLAYTON, EXAMINING ATTORNEY



SN 85-257,926. OM FINANCIAL LIFE INSURANCE COMPANY, BALTIMORE, MD. FILED 3-4-2011.

**FG IMMEDIATE-SAFEGUARD**

THE MARK CONSISTS OF STANDARD CHARACTERS WITHOUT CLAIM TO ANY PARTICULAR FONT, STYLE, SIZE, OR COLOR.

OWNER OF U.S. REG. NO. 3,773,202.

FOR ANNUITY UNDERWRITING; LIFE INSURANCE UNDERWRITING (U.S. CLS. 100, 101 AND 102).

CHERYL CLAYTON, EXAMINING ATTORNEY



SN 85-257,957. NATIONWIDE MUTUAL INSURANCE COMPANY, COLUMBUS, OH. FILED 3-4-2011.

**NO DRAWING-SENSORY  
MARK**

THE MARK IS A SOUND. THE MARK CONSISTS OF THREE ORCHESTRAL HITS CONSISTING OF A G5 CHORD LASTING FOR AN EIGHTH BEAT, A BB5 CHORD LASTING FOR A QUARTER BEAT, AND A C5 CHORD LASTING FOR AN EIGHTH BEAT.

FOR INSURANCE SERVICES, NAMELY, ADMINISTRATION, BROKERAGE, AND UNDERWRITING FOR ALL TYPES OF INSURANCE; INSURANCE CLAIMS ADMINISTRATION AND CLAIMS PROCESSING SERVICES; INSURANCE AGENCY SERVICES (U.S. CLS. 100, 101 AND 102).

FIRST USE 2-12-2010; IN COMMERCE 2-12-2010.

JASON BLAIR, EXAMINING ATTORNEY

**CLASS 37—CONSTRUCTION AND REPAIR**

**CLASS 37—(Continued).**

SN 77-413,047. PLANET GREEN CARTRIDGES, INC., DBA PLANET GREEN, CHATSWORTH, CA. FILED 3-4-2008.

SN 78-843,880. DRAIN DOCTORS, INC., TAMPA, FL. FILED 3-22-2006.



NO CLAIM IS MADE TO THE EXCLUSIVE RIGHT TO USE "GREEN" AND THE REPRESENTATION OF THE RECYCLING SYMBOL, APART FROM THE MARK AS SHOWN.

THE COLOR(S) WHITE, BLACK, GREEN, LIGHT GREEN, RED, ORANGE, YELLOW, BLUE, DARK BLUE, LIGHT BLUE AND PURPLE IS/ARE CLAIMED AS A FEATURE OF THE MARK.

THE MARK CONSISTS OF THE LETTERS "PG" IN STYLIZED WHITE FONT WITH A LIGHT GREEN INNER BORDER AGAINST A BLACK RECTANGULAR BACKGROUND WITH A WHITE BORDER. THE WORDS "PLANET GREEN" IN SMALLER BLACK STYLIZED FONT APPEAR TO THE LEFT OF "PG", WRITTEN VERTICALLY INSTEAD OF HORIZONTALLY. A GREEN RECYCLING SYMBOL APPEARS BETWEEN "PLANET" AND "GREEN". A DESIGN OF THE PLANET EARTH DEPICTED IN BLUE AND GREEN APPEARS ABOVE THE LETTERS "PG". A RAINBOW DESIGN CIRCUMSCRIBES THE LOWER HALF OF THE PLANET, GRADUATING IN COLOR FROM LEFT TO RIGHT IN ORANGE, YELLOW, GREEN, LIGHT BLUE, BLUE, DARK BLUE, PURPLE TO RED.

FOR COLLECTION OF USED INKJET PRINTER CARTRIDGES FOR RECYCLING; REMANUFACTURE OF USED INKJET PRINTER CARTRIDGES TO THE ORDER AND/OR SPECIFICATION OF OTHERS (U.S. CLS. 100, 103 AND 106).

FIRST USE 1-0-2000; IN COMMERCE 1-0-2000.

STEVEN PEREZ, EXAMINING ATTORNEY

SN 77-918,363. S2ONE, INC., SHERWOOD, OR. FILED 1-22-2010.

**MAKING SURE YOU'RE WELL RECEIVED**

THE MARK CONSISTS OF STANDARD CHARACTERS WITHOUT CLAIM TO ANY PARTICULAR FONT, STYLE, SIZE, OR COLOR.

FOR INSTALLATION, MAINTENANCE, AND REPAIR OF TELEVISION BROADCASTING SYSTEMS; CONSULTING SERVICES IN THE FIELD OF INSTALLING, MAINTAINING AND REPAIRING TELEVISION BROADCAST SYSTEMS (U.S. CLS. 100, 103 AND 106).

FIRST USE 7-1-2005; IN COMMERCE 7-1-2005.

CARRIE GENOVESE, EXAMINING ATTORNEY



SUBJECT TO CONCURRENT USE PROCEEDING WITH APPLICATION SERIAL NO. 78775617, APPLICANT CLAIMS THE EXCLUSIVE RIGHT TO USE THE MARK IN THE AREA COMPRISING THE GEOGRAPHICAL TERRITORY CONSISTING OF THE ENTIRE UNITED STATES WITH THE EXCEPTION OF THE STATES OF TEXAS, NEW MEXICO, OKLAHOMA, ARKANSAS AND LOUISIANA.

THE MARK CONSISTS OF TWO SNAKES, TWO WINGS AND A PLUNGER.

FOR PLUMBING SERVICES; PLUMBING CONTRACTOR SERVICE (U.S. CLS. 100, 103 AND 106).

FIRST USE 3-31-2003; IN COMMERCE 3-31-2003.

DAVID COLLIER, EXAMINING ATTORNEY

SN 85-047,938. RACE CONSTRUCTION, HAYWARD, CA. FILED 5-26-2010.



NO CLAIM IS MADE TO THE EXCLUSIVE RIGHT TO USE "CONSTRUCTION", APART FROM THE MARK AS SHOWN.

THE COLOR(S) ORANGE, WHITE AND GREY IS/ARE CLAIMED AS A FEATURE OF THE MARK.

THE MARK CONSISTS OF THE WORD "RACE" WHEREIN THE LETTERS "R" AND "E" ARE WRITTEN IN ORANGE COLOR. THE LETTERS "A" AND "C" ARE WRITTEN IN WHITE COLOR ON A ORANGE BACKGROUND AND THE WORD "CONSTRUCTION" IS WRITTEN IN GREY COLOR BELOW THE WORD "RACE".

FOR CONSTRUCTION AND REPAIR SERVICES, NAMELY, BUILDING CONSTRUCTION; RESIDENTIAL HOME REPAIR AND INSTALLATION OF ROOFS, WINDOWS, DOORS, CABINETS, FLOORING FOR CONSUMERS (U.S. CLS. 100, 103 AND 106).

MICHAEL WEBSTER, EXAMINING ATTORNEY

**CLASS 37—(Continued).**

SN 85-058,393. JOHN P SINISI CONSULTING, LLC, DBA FIRESTOP INSPECTOR, MANASQUAN, NJ. FILED 6-9-2010.

## Firestop Inspector

THE MARK CONSISTS OF STANDARD CHARACTERS WITHOUT CLAIM TO ANY PARTICULAR FONT, STYLE, SIZE, OR COLOR.

NO CLAIM IS MADE TO THE EXCLUSIVE RIGHT TO USE "INSPECTOR", APART FROM THE MARK AS SHOWN. SEC. 2(F).

FOR BUILDING INSPECTION SERVICES PROVIDED IN THE COURSE OF BUILDING CONSTRUCTION FOCUSING ON BUILDING FIRE AND LIFE SAFETY (U.S. CLS. 100, 103 AND 106).

FIRST USE 11-18-2002; IN COMMERCE 11-18-2002.  
JULIE GUTTADAURO, EXAMINING ATTORNEY

---

SN 85-072,542. LINDA PEREZ, BIG SPRING, TX. FILED 6-28-2010.



NO CLAIM IS MADE TO THE EXCLUSIVE RIGHT TO USE "VERDE RECYCLING", APART FROM THE MARK AS SHOWN.

THE COLOR(S) LIGHT GREEN, GRAY AND WHITE IS/ ARE CLAIMED AS A FEATURE OF THE MARK.

THE MARK CONSISTS OF THE WORD "VERDE" IN LIGHT GREEN; THE WORD "RECYCLING" IN GRAY; TWO LEAVES IN LIGHT GREEN WITH WHITE VEINS WHICH CONNECT TO THE TOP OF THE "V" IN "VERDE"; ALL AGAINST A WHITE BACKGROUND.

THE ENGLISH TRANSLATION OF THE WORD "VERDE" IN THE MARK IS GREEN.

FOR PLASTICS, ALUMINUM, PAPER AND CARDBOARD COLLECTION FOR RECYCLING (U.S. CLS. 100, 103 AND 106).

FIRST USE 3-1-2010; IN COMMERCE 4-14-2010.  
HEATHER SAPP, EXAMINING ATTORNEY

**CLASS 37—(Continued).**

SN 85-073,165. ALLCRAFT RESTORATION LTD., COLUMBUS, OH. FILED 6-28-2010.

## ALL CRAFT RESTORATION

THE MARK CONSISTS OF STANDARD CHARACTERS WITHOUT CLAIM TO ANY PARTICULAR FONT, STYLE, SIZE, OR COLOR.

NO CLAIM IS MADE TO THE EXCLUSIVE RIGHT TO USE "RESTORATION", APART FROM THE MARK AS SHOWN.

FOR BUILDING CONSTRUCTION; BUILDING REPAIR; BUILDING INSPECTION; BUILDING RESTORATION; BUILDING RECONSTRUCTION; REPAIR AND INSTALLATION OF ROOFING, EXTERIOR SIDING, RAIN GUTTERS, DRYWALL, AND WINDOWS (U.S. CLS. 100, 103 AND 106).

FIRST USE 6-9-2010; IN COMMERCE 6-28-2010.  
PATRICIA EVANKO, EXAMINING ATTORNEY

---

SN 85-076,188. UDELL JEWELERS, INC., DBA LONDON JEWELERS, GLEN COVE, NY. FILED 7-1-2010.



THE MARK CONSISTS OF THE WORDS "SAY I LONDON" IN CAPITAL LETTERS, WITH THE WORD "SAY" CENTERED OVER THE WORD "I" WHICH IS CENTERED OVER THE LETTERS "D","O" IN THE WORD "LONDON" AND PRESENTED IN SOLID BLACK FONT, FORMING THE PHRASE "SAY I DO". THE FIRST THREE LETTERS "L","O","N" AND THE FINAL "N" IN THE WORD "LONDON" ARE PRESENTED IN A BLACK AND WHITE OUTLINED FONT.

FOR JEWELRY AND WATCH REPAIR SERVICES (U.S. CLS. 100, 103 AND 106).

FIRST USE 1-9-2010; IN COMMERCE 1-9-2010.  
NICHOLAS ALTREE, EXAMINING ATTORNEY

**CLASS 37—(Continued).**

SN 85-096,903. KAFFENBARGER TRUCK EQUIPMENT CO., DBA GARLAND MODIFICATION CENTER, NEW CARLISLE, OH. FILED 7-30-2010.

GARLAND MODIFICATION CENTER

THE MARK CONSISTS OF STANDARD CHARACTERS WITHOUT CLAIM TO ANY PARTICULAR FONT, STYLE, SIZE, OR COLOR.

OWNER OF U.S. REG. NO. 2,980,148.

NO CLAIM IS MADE TO THE EXCLUSIVE RIGHT TO USE "MODIFICATION CENTER", APART FROM THE MARK AS SHOWN.

SEC. 2(F).

FOR TRUCK MODIFICATION AND CONVERSION SERVICES (U.S. CLS. 100, 103 AND 106).

FIRST USE 6-0-2002; IN COMMERCE 6-0-2002.

HEATHER SAPP, EXAMINING ATTORNEY

**CLASS 37—(Continued).**

SN 85-133,814. ZAVALA, JAVIER, DBA J&B PROFESSIONAL CLEANING SERVICE, HOUSTON, TX. FILED 9-20-2010.



NO CLAIM IS MADE TO THE EXCLUSIVE RIGHT TO USE "PROFESSIONAL CLEANING SERVICE EST. 1995", APART FROM THE MARK AS SHOWN.

THE COLOR(S) BLUE AND WHITE IS/ARE CLAIMED AS A FEATURE OF THE MARK.

THE MARK CONSISTS OF WHITE "J" "B" INSIDE OF BLUE DIAMOND, BLUE & INSIDE WHITE "JB" LETTERS, BLUE DIAMOND INSIDE BLUE AND WHITE CIRCLES.

FOR CARPET CLEANING; CLEANING OF BUILDINGS; CLEANING OF COMMERCIAL PREMISES; CLEANING OF INDUSTRIAL PREMISES; CLEANING OF RESIDENTIAL HOUSES; WINDOW CLEANING (U.S. CLS. 100, 103 AND 106).

FIRST USE 6-1-2010; IN COMMERCE 6-1-2010.

SUE LAWRENCE, EXAMINING ATTORNEY

SN 85-165,523. JOHNSTOWN CORPORATION, PIKESVILLE, MD. FILED 10-30-2010.

SN 85-114,706. PEPSICO, INC., PURCHASE, NY. FILED 8-24-2010.



DREAM MACHINE

THE MARK CONSISTS OF STANDARD CHARACTERS WITHOUT CLAIM TO ANY PARTICULAR FONT, STYLE, SIZE, OR COLOR.

FOR BOTTLE AND CAN COLLECTION FOR RECYCLING (U.S. CLS. 100, 103 AND 106).

THOMAS MANOR, EXAMINING ATTORNEY

NO CLAIM IS MADE TO THE EXCLUSIVE RIGHT TO USE "GREEN DRY CLEANERS" OR THE REPRESENTATION OF THE UNIVERSAL RECYCLING SYMBOL, APART FROM THE MARK AS SHOWN.

THE COLOR(S) RED, LIGHT GREEN, AND DARK GREEN IS/ARE CLAIMED AS A FEATURE OF THE MARK.

THE MARK CONSISTS OF THE WORDING "77 GREEN DRY CLEANERS", WITH THREE CURVED ARROWS, ARRANGED IN THE SHAPE OF A RECYCLING SYMBOL WITH A GLOBE IN THE CENTER, IN THE LOWER LEFT CORNER OF THE MARK. THE WORDS "77" AND "DRY CLEANERS" ARE RED, "GREEN" IS DARK GREEN, AND THE ARROWS AND GLOBE ARE LIGHT GREEN AND DARK GREEN.

FOR DRY CLEANING SERVICES FEATURING NON-TOXIC AND ECOLOGICALLY SAFE CLEANING AGENTS (U.S. CLS. 100, 103 AND 106).

LIEF MARTIN, EXAMINING ATTORNEY



**CLASS 37—(Continued).**

SN 85-176,729. HARDENED STRUCTURES HARDENED SHELTERS, LLC, VIRGINIA BEACH, VA. FILED 11-15-2010.

## HARDENED STRUCTURES HARDENED SHELTERS

THE MARK CONSISTS OF STANDARD CHARACTERS WITHOUT CLAIM TO ANY PARTICULAR FONT, STYLE, SIZE, OR COLOR.

OWNER OF U.S. REG. NO. 3,730,298.

NO CLAIM IS MADE TO THE EXCLUSIVE RIGHT TO USE "STRUCTURES AND SHELTERS", APART FROM THE MARK AS SHOWN.

FOR CONSTRUCTION MANAGEMENT SERVICES, NAMELY, CONSTRUCTION PROGRAM MANAGEMENT OF RESIDENTIAL AND COMMERCIAL STRUCTURES AND FACILITIES BUILT TO WITHSTAND SEVERE STORMS, NATURAL DISASTERS, ASSAULTS AND CONVENTIONAL, NUCLEAR, BIOLOGICAL AND CHEMICAL WEAPONS AND TO PROVIDE AN INDEPENDENT LIFE SUSTAINING ENVIRONMENT AFTER SUCH EVENTS (U.S. CLS. 100, 103 AND 106).

FIRST USE 3-19-2008; IN COMMERCE 3-19-2008.

C. DIONNE CLYBURN, EXAMINING ATTORNEY

SN 85-178,673. FANNON, CAROL H., DBA DIAMOND RESTORATION, CONCORD, NC. FILED 11-17-2010.



NO CLAIM IS MADE TO THE EXCLUSIVE RIGHT TO USE "RESTORATION" OR "WIND WATER FIRE", APART FROM THE MARK AS SHOWN.

THE COLOR(S) BLUE, RED, GREEN, ORANGE, WHITE, YELLOW AND BLACK IS/ARE CLAIMED AS A FEATURE OF THE MARK.

THE MARK CONSISTS OF ONE LARGE GEOMETRICAL SHAPED DIAMOND CREATED BY FOUR SMALLER GEOMETRICAL SHAPED DIAMONDS. IN A CLOCKWISE POSITION, BLUE IS THE COLOR OF THE TOP DIAMOND (12 O'CLOCK), WHITE IS THE COLOR OF THE NEXT DIAMOND (3 O'CLOCK), GREEN IS THE COLOR OF THE NEXT DIAMOND (6 O'CLOCK), RED IS THE COLOR OF THE NEXT DIAMOND (9 O'CLOCK). THE DIAMONDS ARE ALL OUTLINED IN BLACK. THE CAPITAL LETTER D IN BLUE IS INSIDE THE WHITE DIAMOND AND CONTINUES TO THE RIGHT TO SPELL "DIAMOND" IN CAPITAL LETTERS IN BLUE. THE WORD "RESTORATION" IN BLUE FOLLOWS, TO THE RIGHT OF THE WORD "DIAMOND". A BLUE BAR OUTLINED IN BLACK IS UNDERNEATH THE WORDING WITH THE WORDS "WIND", "WATER" AND "FIRE" AND TWO CIRCLES IN WHITE. MOVING WATER IN BLUE AND WHITE IS AT THE VERY BOTTOM AND CLIMBING FLAMES IN RED, YELLOW, AND BLACK TO THE RIGHT.

FOR RESTORATION SERVICES IN THE FIELD OF WATER, SMOKE AND FIRE DAMAGE; SELF-PERFORM CONSTRUCTION SKILLED TRADES, NAMELY, CONCRETE WORK, CARPENTRY AND SELECTIVE DEMOLITION SERVICES (U.S. CLS. 100, 103 AND 106).

FIRST USE 9-1-2009; IN COMMERCE 9-1-2009.

DOUGLAS LEE, EXAMINING ATTORNEY

**CLASS 37—(Continued).**

SN 85-181,914. ISELEY, DAVID A, DBA BEE NATURAL CARPET CLEANING, OWASSO, OK. FILED 11-21-2010.

## Bee Natural Carpet Cleaning

THE MARK CONSISTS OF STANDARD CHARACTERS WITHOUT CLAIM TO ANY PARTICULAR FONT, STYLE, SIZE, OR COLOR.

NO CLAIM IS MADE TO THE EXCLUSIVE RIGHT TO USE "NATURAL CARPET CLEANING", APART FROM THE MARK AS SHOWN.

FOR CARPET AND RUG CLEANING (U.S. CLS. 100, 103 AND 106).

FIRST USE 7-20-2009; IN COMMERCE 7-20-2009.

NAKWAMA ANKRAH, EXAMINING ATTORNEY

SN 85-188,804. BARBANO, JAMES R, HICKORY, NC. FILED S.R. 12-1-2010; AM. P.R. 3-10-2011.

## 3rd Rock Plumbing

THE MARK CONSISTS OF STANDARD CHARACTERS WITHOUT CLAIM TO ANY PARTICULAR FONT, STYLE, SIZE, OR COLOR.

NO CLAIM IS MADE TO THE EXCLUSIVE RIGHT TO USE "PLUMBING", APART FROM THE MARK AS SHOWN. FOR PLUMBING CONTRACTOR SERVICES (U.S. CLS. 100, 103 AND 106).

FIRST USE 4-1-2010; IN COMMERCE 4-1-2010.

JAY FLOWERS, EXAMINING ATTORNEY

SN 85-189,204. TELELIX INC, VALLEY STREAM, NY. FILED 12-2-2010.



NO CLAIM IS MADE TO THE EXCLUSIVE RIGHT TO USE "NEW ALARMS", APART FROM THE MARK AS SHOWN.

THE MARK CONSISTS OF THE STYLIZED DESIGN OF A HOME WITH AN ANTENNA ON TOP EMITTING STYLIZED WAVES OF ENERGY DEPICTED AS FOUR CURVED LINES; BENEATH APPEARS THE TERM "NEW-ALARMS".

FOR INSTALLATION OF SECURITY ALARMS AND SECURITY MONITORING SYSTEMS (U.S. CLS. 100, 103 AND 106).

FIRST USE 8-3-2004; IN COMMERCE 7-12-2009.

JIM RINGLE, EXAMINING ATTORNEY

**CLASS 37—(Continued).**

SN 85-192,177. ALEX DUARTE, PEABODY, MA. FILED 12-7-2010.



THE MARK CONSISTS OF LINES IN A STYLIZED FORM THAT REPRESENT THE OUTLINE OF A DETACHED HOUSE WITH A SHADED CIRCLE IN THE CENTER. TO THE RIGHT OF THE HOUSE IS THE STYLIZED LETTERING "MA".

FOR RESIDENTIAL AND COMMERCIAL CLEANING SERVICES (U.S. CLS. 100, 103 AND 106).

FIRST USE 6-1-2010; IN COMMERCE 6-1-2010.

ALICIA COLLINS, EXAMINING ATTORNEY

**CLASS 37—(Continued).**

SN 85-194,525. COWBOY CLEANERS LTD., SAN ANTONIO, TX. FILED 12-9-2010.

**COWBOY CLEANERS**

THE MARK CONSISTS OF STANDARD CHARACTERS WITHOUT CLAIM TO ANY PARTICULAR FONT, STYLE, SIZE, OR COLOR.

NO CLAIM IS MADE TO THE EXCLUSIVE RIGHT TO USE "CLEANERS", APART FROM THE MARK AS SHOWN.

FOR CLOTHES, DRAPES, AND FABRIC CLEANING, INCLUDING DRY CLEANING (U.S. CLS. 100, 103 AND 106).

FIRST USE 12-31-1970; IN COMMERCE 12-31-1970.

REBECCA POVARCHUK, EXAMINING ATTORNEY

SN 85-192,329. PELICAN GLASS, INC., VISTA, CA. FILED 12-7-2010.



OWNER OF U.S. REG. NOS. 3,907,494 AND 3,907,495.  
NO CLAIM IS MADE TO THE EXCLUSIVE RIGHT TO USE "WINDOWS & REMODELING", APART FROM THE MARK AS SHOWN.

THE MARK CONSISTS OF THE UNDERLINED WORD "PELICAN" IN UPPER CASE LETTERS WITH A ROOF OVER THE TOP OF THE LETTERS AND THE SILHOUETTE OF A PELICAN ON TOP OF THE "I" IN "PELICAN" AND UNDER/INSIDE THE ROOF SHAPE. THE WORDS "WINDOWS & REMODELING" APPEAR BELOW THE UNDERLINED WORD "PELICAN".

FOR BUILDING CONSTRUCTION, REMODELING AND REPAIR; INSTALLATION OF DOORS AND WINDOWS (U.S. CLS. 100, 103 AND 106).

FIRST USE 11-1-2010; IN COMMERCE 11-1-2010.

ANTHONY RINKER, EXAMINING ATTORNEY

SN 85-195,426. DMARXOS LLC, HOFFMAN ESTATES, IL. FILED 12-10-2010.

**ATLAS CAR WASH**

THE MARK CONSISTS OF STANDARD CHARACTERS WITHOUT CLAIM TO ANY PARTICULAR FONT, STYLE, SIZE, OR COLOR.

NO CLAIM IS MADE TO THE EXCLUSIVE RIGHT TO USE "CAR WASH", APART FROM THE MARK AS SHOWN.

FOR CAR WASHING SERVICES, AUTOMOBILE DETAILING SERVICES, AUTOMOBILE POLISHING, AUTOMOBILE CLEANING SERVICES, AUTOMATED CAR WASHING SERVICES, HAND CAR WASH, SELF-SERVICE CAR WASH SERVICES AND SELF-SERVICE AUTOMOBILE INTERIOR AUTOMOBILE CARE SERVICES (U.S. CLS. 100, 103 AND 106).

DOMINIC FATHY, EXAMINING ATTORNEY

**CLASS 37—(Continued).**

SN 85-199,502. NORTHLIGHT POWER, LLC, BAINBRIDGE ISLAND, WA. FILED 12-16-2010.



NO CLAIM IS MADE TO THE EXCLUSIVE RIGHT TO USE "POWER" AND "SOLAR", APART FROM THE MARK AS SHOWN.

THE MARK CONSISTS OF THE WORDS "NORTHLIGHT POWER STREAMLINING SOLAR". THE WORDS "NORTHLIGHT POWER" APPEAR ON ONE LINE AND THE WORDS "STREAMLINING SOLAR" APPEAR ON THE LINE BELOW. THERE IS A DESIGN WHICH SHOWS POWER LINES MEETING AND APPEARS TO THE LEFT OF THE WORDS.

FOR CONSTRUCTION MANAGEMENT AND SUPERVISION SERVICES CONCERNING THE ERECTION AND CONSTRUCTION OF POWER PLANTS, AND THE MAINTENANCE AND REPAIR OF POWER PLANTS (U.S. CLS. 100, 103 AND 106).

FIRST USE 9-30-2010; IN COMMERCE 9-30-2010.  
PATRICIA EVANKO, EXAMINING ATTORNEY

**CLASS 37—(Continued).**

SN 85-200,078. GROSVENOR USA LIMITED, SAN FRANCISCO, CA. FILED 12-16-2010.

**LIVING CITIES**

THE MARK CONSISTS OF STANDARD CHARACTERS WITHOUT CLAIM TO ANY PARTICULAR FONT, STYLE, SIZE, OR COLOR.

FOR REAL ESTATE DEVELOPMENT AND CONSTRUCTION OF COMMERCIAL, RESIDENTIAL, MIXED-USE, INDUSTRIAL, AND HOTEL PROPERTY; PLANNING OF RESIDENTIAL AND MIXED-USE COMMUNITIES; INSPECTION SERVICES IN THE COURSE OF CONSTRUCTION OF COMMERCIAL, RESIDENTIAL, MIXED-USE, AND HOTEL PROPERTY (U.S. CLS. 100, 103 AND 106).

FIRST USE 3-0-2007; IN COMMERCE 3-0-2007.  
ZHALEH DELANEY, EXAMINING ATTORNEY

SN 85-200,270. B.O.G. PEST CONTROL, HARWOOD, MD. FILED 12-17-2010.

**B.O.G. PEST CONTROL  
PROTECT YOUR PAD**

THE MARK CONSISTS OF STANDARD CHARACTERS WITHOUT CLAIM TO ANY PARTICULAR FONT, STYLE, SIZE, OR COLOR.

NO CLAIM IS MADE TO THE EXCLUSIVE RIGHT TO USE "PEST CONTROL", APART FROM THE MARK AS SHOWN.

FOR PEST CONTROL SERVICES (U.S. CLS. 100, 103 AND 106).

THOMAS MANOR, EXAMINING ATTORNEY

SN 85-200,071. GROSVENOR USA LIMITED, SAN FRANCISCO, CA. FILED 12-16-2010.



THE MARK CONSISTS OF THREE EARS OF WHEAT CURVED TO FORM CIRCLE.

FOR REAL ESTATE DEVELOPMENT AND CONSTRUCTION OF COMMERCIAL, RESIDENTIAL, MIXED-USE, INDUSTRIAL, AND HOTEL PROPERTY; PLANNING OF RESIDENTIAL AND MIXED-USE COMMUNITIES; INSPECTION SERVICES IN THE COURSE OF CONSTRUCTION OF COMMERCIAL, RESIDENTIAL, MIXED-USE, AND HOTEL PROPERTY (U.S. CLS. 100, 103 AND 106).

FIRST USE 2-0-2004; IN COMMERCE 2-0-2004.  
ZHALEH DELANEY, EXAMINING ATTORNEY

SN 85-201,456. TRAVERSE CITY PUBLIC SERVICE GARAGE, LC, TRAVERSE CITY, MI. FILED 12-19-2010.

**TC PUBLIC SERVICE GARAGE**

THE MARK CONSISTS OF STANDARD CHARACTERS WITHOUT CLAIM TO ANY PARTICULAR FONT, STYLE, SIZE, OR COLOR.

NO CLAIM IS MADE TO THE EXCLUSIVE RIGHT TO USE "PUBLIC SERVICE GARAGE", APART FROM THE MARK AS SHOWN.

FOR CAR REPAIR AND MAINTENANCE (U.S. CLS. 100, 103 AND 106).

TINA L. SNAPP, EXAMINING ATTORNEY

**CLASS 37—(Continued).**

SN 85-203,102. NATIONAL RESTORATION, INCORPORATED, WATERFORD, WI. FILED 12-21-2010.



THE MARK CONSISTS OF A CIRCLE AROUND A FLAME AND WATER DROPLET DESIGN.

FOR PROFESSIONAL SERVICES RENDERED TO REMEDY THE RESULTS OF FIRE, WATER OR OTHER DISASTER DAMAGE OR DEATH, NAMELY, MOLD CLEANING AND REMOVAL, BIOLOGICAL HAZARDOUS MATERIAL CLEAN-UP AND DISPOSAL, AND CONSULTING RELATED THERETO (U.S. CLS. 100, 103 AND 106).

FIRST USE 0-0-2007; IN COMMERCE 0-0-2007.  
REBECCA POVARCHUK, EXAMINING ATTORNEY

SN 85-205,109. ROSARIO, RAYMOND, LYNDHURST, NJ. FILED 12-23-2010.

# CANARIA

THE MARK CONSISTS OF STANDARD CHARACTERS WITHOUT CLAIM TO ANY PARTICULAR FONT, STYLE, SIZE, OR COLOR.

THE ENGLISH TRANSLATION OF THE WORD "CANARIA" IN THE MARK IS "OF OR FROM THE CANARY ISLANDS".

FOR REPAIR OF MUSICAL INSTRUMENTS; REPAIR OR MAINTENANCE OF MUSICAL INSTRUMENTS; RESTORATION OF MUSICAL INSTRUMENTS (U.S. CLS. 100, 103 AND 106).

FIRST USE 12-23-2010; IN COMMERCE 12-23-2010.  
LIEF MARTIN, EXAMINING ATTORNEY

**CLASS 37—(Continued).**

SN 85-205,827. STERILIZER TECHNICAL SPECIALISTS EAST, INC., DBA STS NORTH AMERICA, CHAGRIN FALLS, OH. FILED 12-27-2010.

## STS North America

THE MARK CONSISTS OF STANDARD CHARACTERS WITHOUT CLAIM TO ANY PARTICULAR FONT, STYLE, SIZE, OR COLOR.

NO CLAIM IS MADE TO THE EXCLUSIVE RIGHT TO USE "NORTH AMERICA", APART FROM THE MARK AS SHOWN.

FOR MAINTENANCE AND REPAIR OF MEDICAL DIAGNOSTIC EQUIPMENT; REPAIR SERVICES FOR MEDICAL DIAGNOSTIC IMAGING, CLINICAL AND BIOMEDICAL EQUIPMENT; TECHNICAL SUPPORT SERVICES, NAMELY, TROUBLESHOOTING IN THE NATURE OF REPAIR OF MEDICAL EQUIPMENT (U.S. CLS. 100, 103 AND 106).

FIRST USE 2-0-2008; IN COMMERCE 7-30-2008.  
AMEEN IMAM, EXAMINING ATTORNEY

SN 85-206,337. WHIRLPOOL PROPERTIES, INC., ST. JOSEPH, MI. FILED 12-28-2010.

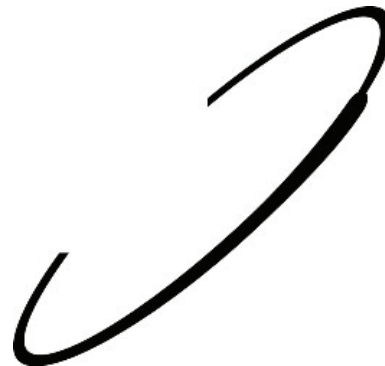

OWNER OF U.S. REG. NOS. 1,832,430, 3,463,701 AND OTHERS.

THE MARK CONSISTS OF A RING.

FOR SERVICES FOR THE INSTALLATION, REPAIR AND MAINTENANCE OF CLOTHES WASHING AND DRYING APPARATUS, DISHWASHERS, REFRIGERATORS AND FREEZERS, RANGES, OVENS AND SURFACE UNITS, MICROWAVE OVENS, COOKTOPS, EXHAUST HOODS, AIR CONDITIONERS, DEHUMIDIFIERS, FOOD WASTE DISPOSERS, FOOD WASTE AND TRASH COMPACTORS, ICE MAKERS, ELECTRICALLY OPERATED HOT WATER DISPENSERS, COMPRESSORS FOR REFRIGERATION AND AIR CONDITIONING (U.S. CLS. 100, 103 AND 106).

HELENE LIWINSKI, EXAMINING ATTORNEY

**CLASS 37—(Continued).**

SN 85-206,355. WHIRLPOOL PROPERTIES, INC., ST. JOSEPH, MI. FILED 12-28-2010.



OWNER OF U.S. REG. NOS. 1,137,316, 2,799,094 AND OTHERS.

THE MARK CONSISTS OF A SWIRL.

FOR SERVICES FOR THE INSTALLATION, REPAIR AND MAINTENANCE OF CLOTHES WASHING AND DRYING APPARATUS, DISHWASHERS, REFRIGERATORS AND FREEZERS, RANGES, OVENS AND SURFACE UNITS, MICROWAVE OVENS, COOKTOPS, EXHAUST HOODS, AIR CONDITIONERS, DEHUMIDIFIERS, FOOD WASTE DISPOSERS, FOOD WASTE AND TRASH COMPACTORS, ICE MAKERS, ELECTRICALLY OPERATED HOT WATER DISPENSERS, COMPRESSORS FOR REFRIGERATION AND AIR CONDITIONING (U.S. CLS. 100, 103 AND 106).

HELENE LIWINSKI, EXAMINING ATTORNEY

**CLASS 37—(Continued).**

SN 85-209,305. PARTS NOW! LLC, MIDDLETON, WI. FILED 1-3-2011.

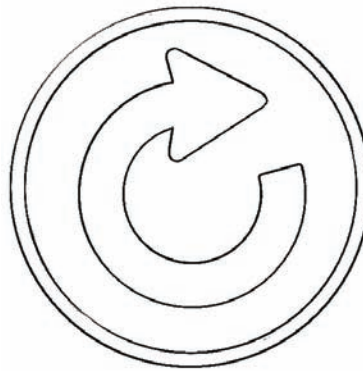

SN 85-207,075. REED & REED, INC., WOOLWICH, ME. FILED 12-29-2010.

## Reed & Reed Wind Power Services

THE MARK CONSISTS OF STANDARD CHARACTERS WITHOUT CLAIM TO ANY PARTICULAR FONT, STYLE, SIZE, OR COLOR.

NO CLAIM IS MADE TO THE EXCLUSIVE RIGHT TO USE "WIND POWER SERVICES", APART FROM THE MARK AS SHOWN.

FOR CONSTRUCTION OF WIND POWER PROJECTS, NAMELY, UTILITY SCALE WIND FARMS; CONSTRUCTION PROJECT MANAGEMENT SERVICES IN THE FIELD OF CONSTRUCTION OF RENEWABLE ENERGY AND ENERGY GENERATION EQUIPMENT SUPPORT STRUCTURES AND ANCILLARY STRUCTURES FOR SUPPORTING METEOROLOGICAL DATA GATHERING EQUIPMENT; CONSULTING SERVICES IN THE FIELD OF CONSTRUCTION OF WIND ENERGY FACILITIES (U.S. CLS. 100, 103 AND 106).

FIRST USE 1-1-2006; IN COMMERCE 1-1-2006.

JENNY PARK, EXAMINING ATTORNEY

OWNER OF U.S. REG. NOS. 3,336,288, 3,464,057 AND OTHERS.

THE MARK CONSISTS OF AN ARROW TRAVELING ALONG A CIRCULAR PATH WITHIN A CIRCLE.

FOR TECHNICAL SUPPORT AND CONSULTATION, NAMELY, CONSULTATION REGARDING THE INSTALLATION, MAINTENANCE, AND REPAIR OF COMPUTER PRINTERS, COMPUTER PRINTER SUBASSEMBLIES, MULTIFUNCTION PRINTERS, MULTIFUNCTION PRINTER SUBASSEMBLIES, TELEFACSIMILE MACHINES, PHOTOCOPIERS, COMPUTERS, MAGNETIC AND OPTICAL DATA STORAGE DRIVES, OPTICAL SCANNERS, COMPUTER NETWORK ROUTERS, COMPUTER NETWORK HUBS, COMPUTER NETWORK CARDS, COMPUTER POWER SUPPLIES, COMPUTER BATTERIES, TONER CARTRIDGES, AND INK CARTRIDGES; INSTALLATION, MAINTENANCE, AND REPAIR OF COMPUTER PRINTERS, COMPUTER PRINTER SUBASSEMBLIES, MULTIFUNCTION PRINTERS, MULTIFUNCTION PRINTER SUBASSEMBLIES, TELEFACSIMILE MACHINES, PHOTOCOPIERS, COMPUTERS, MAGNETIC AND OPTICAL DATA STORAGE DRIVES, OPTICAL SCANNERS, COMPUTER NETWORK ROUTERS, COMPUTER NETWORK HUBS, COMPUTER NETWORK CARDS, COMPUTER POWER SUPPLIES, COMPUTER BATTERIES, TONER CARTRIDGES, AND INK CARTRIDGES (U.S. CLS. 100, 103 AND 106).

FIRST USE 0-0-2006; IN COMMERCE 0-0-2006.

KELLY CHOE, EXAMINING ATTORNEY



**CLASS 37—(Continued).**

SN 85-209,789. HARVARD MAINTENANCE, INC., NEW YORK, NY. FILED 1-4-2011.



OWNER OF U.S. REG. NOS. 2,825,189 AND 2,825,190.  
NO CLAIM IS MADE TO THE EXCLUSIVE RIGHT TO USE "CARE", APART FROM THE MARK AS SHOWN.

THE COLOR(S) DARK BLUE AND GREEN IS/ARE CLAIMED AS A FEATURE OF THE MARK.

THE MARK CONSISTS OF THE TERM "HARVARD" IN DARK BLUE, WITH THE RIGHT SIDE OF THE "V" EXTENDING ABOVE THE OTHER LETTERS, FOLLOWED BY THE TERM "CARE" IN GREEN.

FOR CLEANING OF BUILDINGS AND FACILITIES; MAINTENANCE AND RENOVATION OF BUILDINGS AND FACILITIES; JANITORIAL SERVICES; CARPET AND RUG CLEANING AND SHAMPOOING; WINDOW CLEANING; TRASH COLLECTION; WASTE DISPOSAL FOR OTHERS; CLEANING, BUFFING AND POLISHING OF METAL AND STONE; DOOR MAINTENANCE AND REPAIR SERVICES; FURNITURE RESTORATION, REPAIR AND MAINTENANCE; FLOOR SANDING; PEST CONTROL AND EXTERMINATION OTHER THAN FOR AGRICULTURE (U.S. CLS. 100, 103 AND 106).

PAUL E. FAHRENKOPF, EXAMINING ATTORNEY

SN 85-209,812. HARVARD MAINTENANCE, INC., NEW YORK, NY. FILED 1-4-2011.



OWNER OF U.S. REG. NOS. 2,825,189 AND 2,825,190.  
NO CLAIM IS MADE TO THE EXCLUSIVE RIGHT TO USE "CLEAN", APART FROM THE MARK AS SHOWN.

THE COLOR(S) DARK BLUE AND GREEN IS/ARE CLAIMED AS A FEATURE OF THE MARK.

THE MARK CONSISTS OF THE TERM "HARVARD" IN DARK BLUE, WITH THE RIGHT SIDE OF THE "V" EXTENDING ABOVE THE OTHER LETTERS, FOLLOWED BY THE TERM "CLEAN" IN GREEN.

FOR CLEANING OF BUILDINGS AND FACILITIES; MAINTENANCE AND RENOVATION OF BUILDINGS AND FACILITIES; JANITORIAL SERVICES; CARPET AND RUG CLEANING AND SHAMPOOING; WINDOW CLEANING; TRASH COLLECTION; WASTE DISPOSAL FOR OTHERS; CLEANING, BUFFING AND POLISHING OF METAL AND STONE; DOOR MAINTENANCE AND REPAIR SERVICES; FURNITURE RESTORATION, REPAIR AND MAINTENANCE; FLOOR SANDING; PEST CONTROL AND EXTERMINATION OTHER THAN FOR AGRICULTURE (U.S. CLS. 100, 103 AND 106).

PAUL E. FAHRENKOPF, EXAMINING ATTORNEY

**CLASS 37—(Continued).**

SN 85-209,830. HARVARD MAINTENANCE, INC., NEW YORK, NY. FILED 1-4-2011.



OWNER OF U.S. REG. NOS. 2,825,189 AND 2,825,190.  
NO CLAIM IS MADE TO THE EXCLUSIVE RIGHT TO USE "DOORS", APART FROM THE MARK AS SHOWN.

THE COLOR(S) DARK BLUE AND GREEN IS/ARE CLAIMED AS A FEATURE OF THE MARK.

THE MARK CONSISTS OF THE TERM "HARVARD" IN DARK BLUE, WITH THE RIGHT SIDE OF THE "V" EXTENDING ABOVE THE OTHER LETTERS, FOLLOWED BY THE TERM "DOORS" IN GREEN.

FOR CLEANING OF BUILDINGS AND FACILITIES; MAINTENANCE AND RENOVATION OF BUILDINGS AND FACILITIES; CLEANING, BUFFING AND POLISHING OF METAL AND STONE; DOOR MAINTENANCE AND REPAIR SERVICES (U.S. CLS. 100, 103 AND 106).

PAUL E. FAHRENKOPF, EXAMINING ATTORNEY

SN 85-210,067. HARVARD MAINTENANCE, INC., NEW YORK, NY. FILED 1-4-2011.



OWNER OF U.S. REG. NOS. 2,825,189 AND 2,825,190.  
NO CLAIM IS MADE TO THE EXCLUSIVE RIGHT TO USE "WINDOWS", APART FROM THE MARK AS SHOWN.

THE COLOR(S) DARK BLUE AND GREEN IS/ARE CLAIMED AS A FEATURE OF THE MARK.

THE MARK CONSISTS OF THE TERM "HARVARD" IN DARK BLUE, WITH THE RIGHT SIDE OF THE "V" EXTENDING ABOVE THE OTHER LETTERS, FOLLOWED BY THE TERM "WINDOWS" IN GREEN.

FOR CLEANING OF BUILDINGS AND FACILITIES; MAINTENANCE AND RENOVATION OF BUILDINGS AND FACILITIES; WINDOW CLEANING; CLEANING, BUFFING AND POLISHING OF METAL AND STONE (U.S. CLS. 100, 103 AND 106).

PAUL E. FAHRENKOPF, EXAMINING ATTORNEY

SN 85-210,136. KORTE, RYAN, FLAGSTAFF, AZ. FILED 1-4-2011.

**GET COMFY. SAVE MONEY.**

THE MARK CONSISTS OF STANDARD CHARACTERS WITHOUT CLAIM TO ANY PARTICULAR FONT, STYLE, SIZE, OR COLOR.

FOR BUILDING RENOVATION SERVICES (U.S. CLS. 100, 103 AND 106).

FIRST USE 5-1-2010; IN COMMERCE 5-1-2010.  
FRANK LATTUCA, EXAMINING ATTORNEY

**CLASS 37—(Continued).**

SN 85-210,629. F. L. ROBERTS & CO., INC., SPRINGFIELD, MA. FILED 1-5-2011.



OWNER OF U.S. REG. NO. 2,415,697.  
 NO CLAIM IS MADE TO THE EXCLUSIVE RIGHT TO USE "NOZZLE CARWASH" OR "SERVICE", APART FROM THE MARK AS SHOWN.  
 THE NAME "F.L. ROBERTS" DOES NOT IDENTIFY A LIVING INDIVIDUAL.  
 THE MARK CONSISTS OF THE IMAGE OF A NOZZLE SPRAYING LIQUID ONTO THE IMAGE OF A CAR. THE WORD PORTION OF THE MARK CONSISTS OF THE WORDS "GOLDEN NOZZLE" ON THE FIRST LINE, THE WORDS "CARWASH" ON THE SECOND LINE AND THE WORDS "AN F.L. ROBERTS SERVICE" ON THE THIRD LINE.  
 FOR CAR WASH SERVICES (U.S. CLS. 100, 103 AND 106).  
 FIRST USE 6-1-1989; IN COMMERCE 6-1-1989.  
 BRIAN PINO, EXAMINING ATTORNEY

SN 85-210,896. COMPUTER HOSPITAL INC., NESCONSET, NY. FILED 1-5-2011.



NO CLAIM IS MADE TO THE EXCLUSIVE RIGHT TO USE "COMPUTER" AND "WALK-IN PC CARE", APART FROM THE MARK AS SHOWN.  
 THE MARK CONSISTS OF TWO CONCENTRIC CIRCLES WITH AN OUTLINED CROSS APPEARING IN THE MIDDLE CIRCLE AND THE STYLIZED WORDING "COMPUTER HOSPITAL" APPEARING AROUND THE TOP OF THE INNER CIRCLE AND "WALK-IN PC CARE" APPEARING AROUND THE BOTTOM.  
 FOR REPAIR OR MAINTENANCE OF COMPUTERS (U.S. CLS. 100, 103 AND 106).  
 JENNIFER MARTIN, EXAMINING ATTORNEY

**CLASS 37—(Continued).**

SN 85-212,313. DAYSPRING SERVICES, INC., MISSOULA, MT. FILED 1-6-2011.

**911 FOR YOUR HOME**

THE MARK CONSISTS OF STANDARD CHARACTERS WITHOUT CLAIM TO ANY PARTICULAR FONT, STYLE, SIZE, OR COLOR.  
 OWNER OF U.S. REG. NO. 3,830,661.  
 FOR BUILDING RESTORATION (U.S. CLS. 100, 103 AND 106).  
 FIRST USE 8-31-2004; IN COMMERCE 8-31-2004.  
 ODESSA BIBBINS, EXAMINING ATTORNEY

SN 85-213,138. LUCAS OIL PRODUCTS, INC, CORONA, CA. FILED 1-7-2011.

**LUCAS OIL**

THE MARK CONSISTS OF STANDARD CHARACTERS WITHOUT CLAIM TO ANY PARTICULAR FONT, STYLE, SIZE, OR COLOR.  
 OWNER OF U.S. REG. NOS. 2,904,296 AND 3,334,531.  
 NO CLAIM IS MADE TO THE EXCLUSIVE RIGHT TO USE "OIL", APART FROM THE MARK AS SHOWN.  
 FOR VEHICLE LUBRICATION AND OIL CHANGE SERVICES (U.S. CLS. 100, 103 AND 106).  
 FRANK LATTUCA, EXAMINING ATTORNEY

SN 85-213,958. HIGH'S OF BALTIMORE, INCORPORATED, HANOVER, MD. FILED 1-10-2011.

**BTG**

THE MARK CONSISTS OF STANDARD CHARACTERS WITHOUT CLAIM TO ANY PARTICULAR FONT, STYLE, SIZE, OR COLOR.  
 FOR VEHICLE SERVICE STATIONS (U.S. CLS. 100, 103 AND 106).  
 JULIE VEPPUMTHARA, EXAMINING ATTORNEY

**CLASS 37—(Continued).**

SN 85-215,096. THE TRUSTEES OF THE MAUD HARRISON GIBBS TRUST, ALBUQUERQUE, NM. FILED 1-11-2011.

# BRAEBANK

THE MARK CONSISTS OF STANDARD CHARACTERS WITHOUT CLAIM TO ANY PARTICULAR FONT, STYLE, SIZE, OR COLOR.

FOR REAL ESTATE SERVICES, NAMELY, THE DEVELOPMENT AND CONSTRUCTION OF RESIDENTIAL HOMES (U.S. CLS. 100, 103 AND 106).

EUGENIA MARTIN, EXAMINING ATTORNEY

SN 85-215,287. EMS USA, INC., HOUSTON, TX. FILED 1-11-2011.

# ZAVAL-TEX

THE MARK CONSISTS OF STANDARD CHARACTERS WITHOUT CLAIM TO ANY PARTICULAR FONT, STYLE, SIZE, OR COLOR.

FOR PIPELINE CONSTRUCTION, REHABILITATION AND MAINTENANCE MANAGEMENT (U.S. CLS. 100, 103 AND 106).

FIRST USE 0-0-1986; IN COMMERCE 0-0-1986.

WILLIAM ROSSMAN, EXAMINING ATTORNEY

SN 85-218,118. HARVARD BUILDING SERVICES, INC., NEW YORK, NY. FILED 1-14-2011.

# CIMETICS

THE MARK CONSISTS OF STANDARD CHARACTERS WITHOUT CLAIM TO ANY PARTICULAR FONT, STYLE, SIZE, OR COLOR.

FOR PEST CONTROL SERVICES; PEST CONTROL AND EXTERMINATION SERVICES, OTHER THAN FOR AGRICULTURAL PURPOSES, NAMELY, BED BUG EXTERMINATION AND REMEDIATION SERVICES (U.S. CLS. 100, 103 AND 106).

CAROLINE WOOD, EXAMINING ATTORNEY

**CLASS 37—(Continued).**

SN 85-219,317. HANDYMAN CAN INC., OAKDALE, MN. FILED 1-17-2011.



OWNER OF U.S. REG. NO. 3,010,448.

NO CLAIM IS MADE TO THE EXCLUSIVE RIGHT TO USE "HANDYMAN" AND "HANDYMAN", APART FROM THE MARK AS SHOWN.

THE MARK CONSISTS OF A MAN ON A LADDER HOLDING A DRILL WITH THE WORDS "THE HANDYMAN CAN, YES, THE HANDYMAN CAN" SURROUNDED BY MUSICAL NOTES.

FOR BUILDING CONSTRUCTION SERVICES; HANDYMAN SERVICE, NAMELY, BUILDING REPAIR AND MAINTENANCE (U.S. CLS. 100, 103 AND 106).

FIRST USE 11-19-2010; IN COMMERCE 11-19-2010.

JAY FLOWERS, EXAMINING ATTORNEY

**CLASS 38—COMMUNICATION**

SN 77-910,042. UPWARD UNLIMITED, SPARTANBURG, SC.  
FILED 1-12-2010.



OWNER OF U.S. REG. NOS. 2,170,652, 3,043,557 AND 3,043,635.

THE MARK CONSISTS OF A FIVE POINTED STAR WHICH IS OUTLINED AND HAS ELONGATED ARMS POINTING WEST AND SOUTHWEST WITH THE WORD "UPWARD" OUTLINED AND RESTING ON THE WEST AND EAST POINTING ARMS OF THE STAR WITH THE NORTH POINTING ARM OF THE STAR FORMING THE LETTER "A" IN THE WORD "UPWARD". THE INTERIOR OF THE STAR FORMS A SECOND FIVE POINTED STAR WITH AN ELONGATED SOUTHEASTERN ARM AND TRUNCATED WEST AND EAST ARMS.

FOR BROADCASTING PROGRAMS VIA A GLOBAL COMPUTER NETWORK; COMPUTER AIDED TRANSMISSION OF INFORMATION AND IMAGES; ELECTRONIC EXCHANGE OF DATA STORED IN DATABASES ACCESSIBLE VIA TELECOMMUNICATION NETWORKS; PROVIDING ON-LINE COMMUNICATIONS LINKS WHICH TRANSFER THE WEB SITE USER TO OTHER LOCAL AND GLOBAL WEB PAGES; STREAMING OF AUDIO MATERIAL ON THE INTERNET; STREAMING OF VIDEO MATERIAL ON THE INTERNET, PROVIDED IN ASSOCIATION WITH THE ORGANIZATION OF SPORTS PROGRAMS AS PART OF A COMPREHENSIVE YOUTH MINISTERIAL PROGRAM (U.S. CLS. 100, 101 AND 104).

GENE MACIOL, EXAMINING ATTORNEY

SN 77-917,939. FINE LIVING NETWORK, LLC, KNOXVILLE, TN. FILED 1-22-2010.

**FINE LIVING NETWORK**

THE MARK CONSISTS OF STANDARD CHARACTERS WITHOUT CLAIM TO ANY PARTICULAR FONT, STYLE, SIZE, OR COLOR.

NO CLAIM IS MADE TO THE EXCLUSIVE RIGHT TO USE "NETWORK", APART FROM THE MARK AS SHOWN. FOR CABLE TELEVISION BROADCASTING SERVICES (U.S. CLS. 100, 101 AND 104).

FIRST USE 3-30-2008; IN COMMERCE 3-30-2008.  
PRISCILLA MILTON, EXAMINING ATTORNEY

**CLASS 38—(Continued).**

SN 77-925,146. NINTENDO CO., LTD., KYOTO, JAPAN,  
FILED 2-1-2010.



PRIORITY CLAIMED UNDER SEC. 44(D) ON JAPAN APPLICATION NO. 2009-088882, FILED 11-24-2009, REG. NO. 5333003, DATED 6-25-2010, EXPIRES 6-25-2020.

THE MARK CONSISTS OF THE WORD "WII", FOLLOWED BY TWO JAPANESE CHARACTERS, BENEATH THE WORDS IS A STYLIZED IMAGE OF A ROUND TABLE.

THE NON-LATIN CHARACTERS IN THE MARK TRANSLITERATE TO "NO MA" AND THIS MEANS "THE ROOM OF" IN ENGLISH.

FOR ELECTRONIC BULLETIN BOARD SERVICES; PROVIDING INFORMATION IN THE FIELD OF ELECTRONIC BULLETIN BOARDS; TELECOMMUNICATIONS SERVICES, NAMELY, TRANSMISSION OF IMAGES, PICTURES, MUSIC, SOUNDS, MOVIES, GAMES BY MEANS OF TELECOMMUNICATIONS NETWORKS THROUGH A CONSUMER VIDEO GAME APPARATUS; PROVIDING INFORMATION ON THE TRANSMISSION OF IMAGES, PICTURES, MUSIC, SOUNDS, MOVIES, GAMES BY MEANS OF TELECOMMUNICATIONS NETWORKS THROUGH A CONSUMER VIDEO GAME APPARATUS; TELECOMMUNICATION SERVICES, NAMELY, ELECTRONIC, ELECTRIC, AND DIGITAL TRANSMISSION OF IMAGES, PICTURES, MUSIC, SOUNDS, MOVIES, GAMES BY MEANS OF WIRELESS COMMUNICATION NETWORKS THROUGH HANDHELD GAME MACHINES WITH LIQUID CRYSTAL DISPLAYS; PROVIDING INFORMATION ON ELECTRONIC, ELECTRIC, AND DIGITAL TRANSMISSION OF IMAGES, PICTURES, MUSIC, SOUNDS, MOVIES, GAMES BY MEANS OF WIRELESS COMMUNICATION NETWORKS THROUGH HANDHELD GAME MACHINES WITH LIQUID CRYSTAL DISPLAYS; ELECTRONIC, ELECTRIC, AND DIGITAL TRANSMISSION OF VOICE, DATA, IMAGES, SIGNALS, AND MESSAGES OVER A GLOBAL COMMUNICATIONS NETWORK; TELECOMMUNICATION SERVICES, NAMELY, TRANSMISSION OF PODCASTS, TELECOMMUNICATION ACCESS SERVICES, LOCAL AND LONG DISTANCE TRANSMISSION OF VOICE, DATA AND GRAPHICS BY MEANS OF TELEPHONE, CABLE, CELLULAR AND SATELLITE TRANSMISSIONS; BROADCASTING, NAMELY, TELEVISION, VIDEO, INTERNET, VIDEO GAME APPARATUS BROADCASTING; NEWS AGENCIES, NAMELY, GATHERING AND DISSEMINATION OF NEWS (U.S. CLS. 100, 101 AND 104).

ANDREA HACK, EXAMINING ATTORNEY

**CLASS 38—(Continued).**

SN 79-087,795. NÜRNBERGMESSE GMBH, FED REP GERMANY, FILED 6-19-2010.



OWNER OF INTERNATIONAL REGISTRATION 1052335 DATED 6-19-2010, EXPIRES 6-19-2020.

OWNER OF U.S. REG. NOS. 2,703,776 AND 2,703,813.

NO CLAIM IS MADE TO THE EXCLUSIVE RIGHT TO USE "NÜRNBERG MESSE", APART FROM THE MARK AS SHOWN.

THE COLOR(S) BLACK AND RED-ORANGE IS/ARE CLAIMED AS A FEATURE OF THE MARK.

THE MARK CONSISTS OF THE WORDS "NÜRNBERG MESSE" IN BLACK WITH A RED-ORANGE RHOMBOID BETWEEN THE WORDS.

THE ENGLISH TRANSLATION OF "MESSE" IN THE MARK IS TRADE FAIR.

FOR TELECOMMUNICATION, NAMELY, PROVIDING MULTIPLE-USER ACCESS TO INFORMATION ON THE INTERNET CONCERNING TRADE FAIRS, EXHIBITIONS, CONGRESSES AND CONVENTIONS, PROVIDING ACCESS TO DATABASES, PROVIDING ON-LINE FORUMS IN VIRTUAL FORM ON THE INTERNET FOR NETWORKING PURPOSES AND INFORMATION EXCHANGE BETWEEN TRADE FAIR, EXHIBITION, CONGRESS AND CONGRESS EXHIBITORS, VISITORS AND OTHER PARTICIPANTS, PROVIDING INTERNET PLATFORMS FOR OTHERS, NAMELY, A COMMUNICATION PLATFORM FOR NETWORKING PURPOSES AND INFORMATION EXCHANGE BETWEEN TRADE FAIR, EXHIBITION, CONGRESS AND CONVENTION EXHIBITORS, VISITORS AND OTHER PARTICIPANTS (U.S. CLS. 100, 101 AND 104).

LINDSEY RUBIN, EXAMINING ATTORNEY

SN 85-001,663. INTERNATIONAL DATA GROUP, INC., FRAMINGHAM, MA. FILED 3-30-2010.

**MOBILE & WIRELESS WORLD**

THE MARK CONSISTS OF STANDARD CHARACTERS WITHOUT CLAIM TO ANY PARTICULAR FONT, STYLE, SIZE, OR COLOR.

OWNER OF U.S. REG. NO. 2,810,526.

NO CLAIM IS MADE TO THE EXCLUSIVE RIGHT TO USE "MOBILE & WIRELESS", APART FROM THE MARK AS SHOWN.

FOR PROVIDING ONLINE INFORMATION IN THE FIELD OF TELECOMMUNICATIONS AND ONLINE ELECTRONIC COMMUNICATIONS SERVICES (U.S. CLS. 100, 101 AND 104).

JASON BLAIR, EXAMINING ATTORNEY

**CLASS 38—(Continued).**

SN 85-017,382. US FINANCIAL SOLUTIONS, LLC., TUSTIN, CA. FILED 4-19-2010.

**Dish A Net Satellite**

THE MARK CONSISTS OF STANDARD CHARACTERS WITHOUT CLAIM TO ANY PARTICULAR FONT, STYLE, SIZE, OR COLOR.

NO CLAIM IS MADE TO THE EXCLUSIVE RIGHT TO USE "DISH" AND "NET SATELLITE", APART FROM THE MARK AS SHOWN.

FOR INTERNET SERVICE PROVIDER (ISP); SATELLITE TRANSMISSION SERVICES; TRANSMISSION OF RADIO AND TELEVISION PROGRAMMES BY SATELLITE (U.S. CLS. 100, 101 AND 104).

FIRST USE 3-10-2004; IN COMMERCE 3-10-2004.

MIDGE BUTLER, EXAMINING ATTORNEY

SN 85-038,652. COOKING CHANNEL, LLC, CINCINNATI, OH. FILED 5-14-2010.

**COOKING CHANNEL HD**

THE MARK CONSISTS OF STANDARD CHARACTERS WITHOUT CLAIM TO ANY PARTICULAR FONT, STYLE, SIZE, OR COLOR.

NO CLAIM IS MADE TO THE EXCLUSIVE RIGHT TO USE "CHANNEL HD", APART FROM THE MARK AS SHOWN.

SEC. 2(F).

FOR CABLE TELEVISION BROADCASTING SERVICES (U.S. CLS. 100, 101 AND 104).

FIRST USE 5-31-2010; IN COMMERCE 5-31-2010.

INGRID C. EULIN, EXAMINING ATTORNEY

SN 85-044,020. TURNER GENERAL ENTERTAINMENT NETWORKS INDIA LIMITED, MAHIPALPUR, NEW DELHI, INDIA, FILED 5-20-2010.

**IMAGINE DIL SE**

THE MARK CONSISTS OF STANDARD CHARACTERS WITHOUT CLAIM TO ANY PARTICULAR FONT, STYLE, SIZE, OR COLOR.

THE ENGLISH TRANSLATION OF "DIL SE" IN THE MARK IS "FROM THE HEART".

FOR CABLE TELEVISION AND SATELLITE TELEVISION BROADCASTING SERVICES; STREAMING OF AUDIO, VIDEO AND AUDIOVISUAL MATERIALS OVER THE INTERNET (U.S. CLS. 100, 101 AND 104).

AMY KERTGATE, EXAMINING ATTORNEY



**CLASS 38—(Continued).**

SN 85-046,403. ECOATM, INC., SAN DIEGO, CA. FILED 5-24-2010.

# ecoTEXT

THE MARK CONSISTS OF STANDARD CHARACTERS WITHOUT CLAIM TO ANY PARTICULAR FONT, STYLE, SIZE, OR COLOR.

FOR COMMUNICATION SERVICES, NAMELY, PROVIDING E-MAIL NOTIFICATION ALERTS OF CHANGING VALUES ON MOBILE PHONES, UPDATES ON LIFECYCLES OF MOBILE PHONES, THE NEAREST LOCATION FOR RECYCLING A MOBILE PHONE, AND OFFERS FOR RECYCLING MOBILE PHONES AND PURCHASING NEW MOBILE PHONES (U.S. CLS. 100, 101 AND 104).

ANN E. SAPPENFIELD, EXAMINING ATTORNEY

SN 85-065,768. STREAMLIVEMEDIA, INC., SAMMAMISH, WA. FILED 6-17-2010.

# WE BRIDGE COMMUNICATION GAPS

THE MARK CONSISTS OF STANDARD CHARACTERS WITHOUT CLAIM TO ANY PARTICULAR FONT, STYLE, SIZE, OR COLOR.

FOR CONSULTING IN THE FIELDS OF COMMUNICATIONS, NAMELY, VISUAL, AURAL, AND DATA TRANSMISSIONS, TELECOMMUNICATIONS SYSTEMS, COMMUNICATION SYSTEMS ARCHITECTURE, COMMUNICATION SYSTEMS IMPLEMENTATION, AND COMMUNICATION SYSTEMS MANAGEMENT (U.S. CLS. 100, 101 AND 104).

FIRST USE 6-16-2010; IN COMMERCE 6-16-2010.  
EUGENIA MARTIN, EXAMINING ATTORNEY

SN 85-096,697. CIMA TELECOM INC., MIAMI, FL. FILED 7-30-2010.

# AURIS VIRTUAL CLEC

THE MARK CONSISTS OF STANDARD CHARACTERS WITHOUT CLAIM TO ANY PARTICULAR FONT, STYLE, SIZE, OR COLOR.

NO CLAIM IS MADE TO THE EXCLUSIVE RIGHT TO USE "VIRTUAL CLEC", APART FROM THE MARK AS SHOWN.

FOR TELECOMMUNICATIONS SERVICES, NAMELY, VOICE OVER INTERNET PROTOCOL (VOIP) SERVICES (U.S. CLS. 100, 101 AND 104).

FIRST USE 7-26-2010; IN COMMERCE 7-26-2010.  
STEVEN JACKSON, EXAMINING ATTORNEY

**CLASS 38—(Continued).**

SN 85-121,403. MUSIC MASTERMIND, INC., CALABASAS, CA. FILED 9-2-2010.

# SILVERDOOR

THE MARK CONSISTS OF STANDARD CHARACTERS WITHOUT CLAIM TO ANY PARTICULAR FONT, STYLE, SIZE, OR COLOR.

FOR STREAMING OF AUDIO, VISUAL AND AUDIO-VISUAL MATERIAL VIA A GLOBAL COMPUTER NETWORK (U.S. CLS. 100, 101 AND 104).

REBECCA SMITH, EXAMINING ATTORNEY

SN 85-131,199. ISAAC S. DANIEL, MIRAMAR, FL. FILED 9-16-2010.

# P240

THE MARK CONSISTS OF STANDARD CHARACTERS WITHOUT CLAIM TO ANY PARTICULAR FONT, STYLE, SIZE, OR COLOR.

FOR TELECOMMUNICATIONS AND INFORMATION TECHNOLOGY SERVICES, NAMELY, TRANSMISSION OF DATA AND INFORMATION VIA SATELLITE AND GLOBAL COMMUNICATION NETWORKS (U.S. CLS. 100, 101 AND 104).

DAVID C. REIHNER, EXAMINING ATTORNEY

SN 85-176,530. KUUZUU, INC., SAN FRANCISCO, CA. FILED 11-15-2010.

# KUUZUU

THE MARK CONSISTS OF STANDARD CHARACTERS WITHOUT CLAIM TO ANY PARTICULAR FONT, STYLE, SIZE, OR COLOR.

FOR AUDIO AND VIDEO BROADCASTING SERVICES OVER THE INTERNET AND OTHER COMMUNICATIONS NETWORKS (U.S. CLS. 100, 101 AND 104).

JACLYN KIDWELL WALKER, EXAMINING ATTORNEY

**CLASS 38—(Continued).**

SN 85-185,403. BROADVIEW NETWORKS, INC., RYE BROOK, NY. FILED 11-26-2010.

**OFFICESUITE**

THE MARK CONSISTS OF STANDARD CHARACTERS WITHOUT CLAIM TO ANY PARTICULAR FONT, STYLE, SIZE, OR COLOR.

FOR COMMUNICATION SERVICES, NAMELY, PROVIDING HIGH SPEED MULTIPLE USER ACCESS TO A GLOBAL OR PRIVATE NETWORK FOR VOICE AND DATA TRANSMISSIONS (U.S. CLS. 100, 101 AND 104).  
PRISCILLA MILTON, EXAMINING ATTORNEY

---

SN 85-186,113. BROADVIEW NETWORKS, INC., RYE BROOK, NY. FILED 11-29-2010.

**BROADVIEW OFFICESUITE**

THE MARK CONSISTS OF STANDARD CHARACTERS WITHOUT CLAIM TO ANY PARTICULAR FONT, STYLE, SIZE, OR COLOR.

OWNER OF U.S. REG. NOS. 2,494,916 AND 2,828,186.  
FOR COMMUNICATION SERVICES, NAMELY, PROVIDING HIGH SPEED MULTIPLE USER ACCESS TO A GLOBAL OR PRIVATE NETWORK FOR VOICE AND DATA TRANSMISSIONS (U.S. CLS. 100, 101 AND 104).  
PRISCILLA MILTON, EXAMINING ATTORNEY

---

SN 85-190,343. TRACFONE WIRELESS, INC., MIAMI, FL. FILED 12-3-2010.

**TRANSFER TRACFONE**

THE MARK CONSISTS OF STANDARD CHARACTERS WITHOUT CLAIM TO ANY PARTICULAR FONT, STYLE, SIZE, OR COLOR.

OWNER OF U.S. REG. NOS. 3,538,118, 3,828,140 AND OTHERS.

NO CLAIM IS MADE TO THE EXCLUSIVE RIGHT TO USE "TRANSFER", APART FROM THE MARK AS SHOWN.

FOR PROVIDING TELECOMMUNICATION SERVICES ENABLING TRANSFERS OF FUNDS FROM ONE ACCOUNT TO ANOTHER VIA CELLULAR PHONES AND OTHER WIRELESS ELECTRONIC COMMUNICATION DEVICES (U.S. CLS. 100, 101 AND 104).

THOMAS MANOR, EXAMINING ATTORNEY

**CLASS 38—(Continued).**

SN 85-190,348. TRACFONE WIRELESS, INC., MIAMI, FL. FILED 12-3-2010.

**TRANSFERNET TRACFONE**

THE MARK CONSISTS OF STANDARD CHARACTERS WITHOUT CLAIM TO ANY PARTICULAR FONT, STYLE, SIZE, OR COLOR.

OWNER OF U.S. REG. NOS. 3,538,118, 3,828,140 AND OTHERS.

FOR TELECOMMUNICATIONS SERVICES, NAMELY, PROVIDING ELECTRONIC COMMUNICATIONS NETWORK SERVICES FOR TRANSFER OF FUNDS FROM ONE ACCOUNT TO ANOTHER ACCOUNT VIA AN ELECTRONIC COMMUNICATIONS DEVICE, WITH A FEATURE WHICH WILL IDENTIFY THE ESTABLISHMENTS WHERE TRANSFERS OF FUNDS FROM ONE ACCOUNT TO ANOTHER ACCOUNT VIA CELLULAR PHONES AND OTHER WIRELESS ELECTRONIC COMMUNICATION DEVICES WILL BE POSSIBLE (U.S. CLS. 100, 101 AND 104).

THOMAS MANOR, EXAMINING ATTORNEY

---

SN 85-191,460. SEARCHLIGHT SYSTEMS, INC., SAN RAMON, CA. FILED 12-6-2010.

**LIKE HOTTIES**

THE MARK CONSISTS OF STANDARD CHARACTERS WITHOUT CLAIM TO ANY PARTICULAR FONT, STYLE, SIZE, OR COLOR.

FOR INTERNET BASED SOCIAL NETWORKING SERVICES WHERE USERS CAN POST AND/OR COMMENT ON PHOTOGRAPHS, PICTURES, AND OTHER DIGITAL VISUAL IMAGES, AND WHICH ALLOWS USERS TO SHARE CONTENT BETWEEN DIFFERENT SOCIAL NETWORKING WEBSITES (U.S. CLS. 100, 101 AND 104).

DORITT L. CARROLL, EXAMINING ATTORNEY

**CLASS 38—(Continued).**

SN 85-195,378. DIRECTV SPORTS NETWORKS, LLC, SEATTLE, WA. FILED 12-10-2010.

# ROOT SPORTS

THE MARK CONSISTS OF STANDARD CHARACTERS WITHOUT CLAIM TO ANY PARTICULAR FONT, STYLE, SIZE, OR COLOR.

OWNER OF U.S. REG. NO. 3,726,772.  
NO CLAIM IS MADE TO THE EXCLUSIVE RIGHT TO USE "SPORTS", APART FROM THE MARK AS SHOWN.

FOR BROADCASTING PROGRAMS VIA A GLOBAL COMPUTER NETWORK; VIDEO-ON-DEMAND TRANSMISSION SERVICES; TRANSMISSION OF PAY-PER-VIEW TELEVISION AND OTHER AUDIO, VIDEO, AND AUDIOVISUAL MATERIALS; STREAMING OF AUDIO AND VIDEO MATERIAL ON THE INTERNET, OTHER COMPUTER NETWORKS, WIRELESS NETWORKS AND ELECTRONIC COMMUNICATION NETWORKS; ELECTRONIC TRANSMISSION OF DATA VIA GLOBAL COMPUTER NETWORKS, WIRELESS NETWORKS AND ELECTRONIC COMMUNICATION NETWORKS (U.S. CLS. 100, 101 AND 104).

GISELLE AGOSTO, EXAMINING ATTORNEY

SN 85-195,620. DIRECTV SPORTS NETWORKS, LLC, SEATTLE, WA. FILED 12-10-2010.



OWNER OF U.S. REG. NO. 3,726,772.  
NO CLAIM IS MADE TO THE EXCLUSIVE RIGHT TO USE "SPORTS", APART FROM THE MARK AS SHOWN.

THE MARK CONSISTS OF THE WORD "ROOT", THE LETTERS "R" AND "T" HAVING TRIANGULAR NOTCHES CUT AT THE TOP, OVER THE WORD "SPORTS", ALL IN SLANTED LETTERS.

FOR BROADCASTING PROGRAMS VIA A GLOBAL COMPUTER NETWORK; VIDEO-ON-DEMAND TRANSMISSION SERVICES; TRANSMISSION OF PAY-PER-VIEW TELEVISION AND OTHER AUDIO, VIDEO, AND AUDIOVISUAL MATERIALS; STREAMING OF AUDIO AND VIDEO MATERIAL ON THE INTERNET, OTHER COMPUTER NETWORKS, WIRELESS NETWORKS AND ELECTRONIC COMMUNICATION NETWORKS; ELECTRONIC TRANSMISSION OF DATA VIA GLOBAL COMPUTER NETWORKS, WIRELESS NETWORKS AND ELECTRONIC COMMUNICATION NETWORKS (U.S. CLS. 100, 101 AND 104).

GISELLE AGOSTO, EXAMINING ATTORNEY

**CLASS 38—(Continued).**

SN 85-195,731. MILLER INTERNATIONAL MARKETING & CONSULTING, INC., DBA HOTSPOT INTERNATIONAL, SAN DIEGO, CA. FILED 12-10-2010.

# Hotspot International

THE MARK CONSISTS OF STANDARD CHARACTERS WITHOUT CLAIM TO ANY PARTICULAR FONT, STYLE, SIZE, OR COLOR.

NO CLAIM IS MADE TO THE EXCLUSIVE RIGHT TO USE "HOTSPOT", APART FROM THE MARK AS SHOWN. SEC. 2(F).

FOR PROVIDING ACCESS TO THE INTERNET; PROVIDING MULTIPLE USER WIRELESS ACCESS TO THE INTERNET; WIRELESS BROADBAND COMMUNICATION SERVICES (U.S. CLS. 100, 101 AND 104).

FIRST USE 9-30-2002; IN COMMERCE 9-30-2002.

MARK SHINER, EXAMINING ATTORNEY

SN 85-198,286. MILLER INTERNATIONAL MARKETING & CONSULTING, INC., DBA HOTSPOT INTERNATIONAL, SAN DIEGO, CA. FILED 12-15-2010.



NO CLAIM IS MADE TO THE EXCLUSIVE RIGHT TO USE "HOTSPOT" AND "HIGH SPEED INTERNET ACCESS", APART FROM THE MARK AS SHOWN.

THE COLOR(S) BLACK, RED AND ORANGE IS/ARE CLAIMED AS A FEATURE OF THE MARK.

THE MARK CONSISTS OF THE STYLIZED WORD "HOTSPOT" IN BLACK ABOVE NINE RECTANGLES WITH ROUNDED CORNERS ARRANGED IN A SQUARE, THREE COLUMNS OF THREE. IN THE RIGHT AND LEFT COLUMNS, THE RECTANGLES ARE RED. IN THE CENTER COLUMN THE TOP AND BOTTOM RECTANGLES ARE BLACK, AND THE CENTER IS ORANGE. BELOW THE DESIGN ARE THE WORDS "HIGH SPEED" CENTERED ABOVE THE WORDS "INTERNET ACCESS" ALL IN BLACK STYLIZED FONT.

FOR PROVIDING ACCESS TO THE INTERNET; PROVIDING MULTIPLE USER WIRELESS ACCESS TO THE INTERNET; WIRELESS BROADBAND COMMUNICATION SERVICES (U.S. CLS. 100, 101 AND 104).

FIRST USE 1-31-2002; IN COMMERCE 1-31-2002.

MARK SHINER, EXAMINING ATTORNEY

**CLASS 38—(Continued).**

SN 85-199,309. NEVER BUSY LLC, MOUNT KISCO, NY. FILED 12-16-2010.

**NEVER BUSY**

THE MARK CONSISTS OF STANDARD CHARACTERS WITHOUT CLAIM TO ANY PARTICULAR FONT, STYLE, SIZE, OR COLOR.

FOR TELECOMMUNICATION SERVICES, NAMELY, LOCAL AND LONG DISTANCE TRANSMISSION OF VOICE, DATA, GRAPHICS AND VIDEO BY MEANS OF BROADBAND, COPPER AND OPTICAL OR WIRELESS NETWORKS (U.S. CLS. 100, 101 AND 104).

FIRST USE 5-12-2006; IN COMMERCE 5-12-2006.

DOMINIC J. FERRAIUOLO, EXAMINING ATTORNEY

---

SN 85-199,417. INFINITY LEARNING SOLUTIONS INC., AKA DIGITALCHALK, ASHEVILLE, NC. FILED 12-16-2010.

**HDLearn**  
TECHNOLOGY

NO CLAIM IS MADE TO THE EXCLUSIVE RIGHT TO USE "TECHNOLOGY", APART FROM THE MARK AS SHOWN.

THE COLOR(S) DARK BLUE-PURPLE AND LIGHT BLUE IS/ARE CLAIMED AS A FEATURE OF THE MARK.

THE MARK CONSISTS OF THE LITERAL ELEMENTS "HDLEARN TECHNOLOGY"; "HD" AND "TECHNOLOGY" APPEAR IN DARK BLUE-PURPLE AND "LEARN" APPEARS IN LIGHT BLUE.

FOR VIDEO BROADCASTING SERVICES OVER THE INTERNET OR OTHER COMMUNICATIONS NETWORK, NAMELY, ELECTRONICALLY TRANSMITTING VIDEO CLIPS (U.S. CLS. 100, 101 AND 104).

FIRST USE 12-6-2010; IN COMMERCE 12-6-2010.

CHRISIE B. KING, EXAMINING ATTORNEY

---

SN 85-205,220. HURRELL, DOUG, SARATOGA, CA. FILED 12-23-2010.

**MY CORPORATE STUDIO**

THE MARK CONSISTS OF STANDARD CHARACTERS WITHOUT CLAIM TO ANY PARTICULAR FONT, STYLE, SIZE, OR COLOR.

NO CLAIM IS MADE TO THE EXCLUSIVE RIGHT TO USE "CORPORATE STUDIO", APART FROM THE MARK AS SHOWN.

FOR STREAMING OF AUDIO, VISUAL AND AUDIO-VISUAL MATERIAL VIA A GLOBAL COMPUTER NETWORK (U.S. CLS. 100, 101 AND 104).

FIRST USE 2-20-2008; IN COMMERCE 7-8-2008.

SAMUEL E. SHARPER JR., EXAMINING ATTORNEY

**CLASS 38—(Continued).**

SN 85-205,253. FITFINDER LIMITED, LONDON, UNITED KINGDOM, FILED 12-23-2010.

**FITFINDER**

THE MARK CONSISTS OF STANDARD CHARACTERS WITHOUT CLAIM TO ANY PARTICULAR FONT, STYLE, SIZE, OR COLOR.

FOR PROVIDING ACCESS TO A SOCIAL NETWORKING TOOL IN RELATION TO PEOPLES' LOCATION; PROVIDING ACCESS TO INFORMATION, AUDIO, AND VIDEO VIA WEBSITES, ONLINE FORUMS, CHAT ROOMS, LISTSERVS AND BLOGS OVER THE INTERNET; PROVIDING ON-LINE CHAT ROOMS AND ELECTRONIC BULLETIN BOARDS FOR TRANSMISSION OF MESSAGES AMONG USERS IN THE FIELD OF GENERAL INTEREST (U.S. CLS. 100, 101 AND 104).

ALLISON SCHRODY, EXAMINING ATTORNEY

---

SN 85-206,025. TOWNSQUARE MEDIA BROADCASTING, LLC, GREENWICH, CT. FILED 12-27-2010.

**105.7 Crush FM**

THE MARK CONSISTS OF STANDARD CHARACTERS WITHOUT CLAIM TO ANY PARTICULAR FONT, STYLE, SIZE, OR COLOR.

NO CLAIM IS MADE TO THE EXCLUSIVE RIGHT TO USE "105.7" AND "FM", APART FROM THE MARK AS SHOWN.

FOR RADIO BROADCASTING (U.S. CLS. 100, 101 AND 104).

ROBIN MITTLER, EXAMINING ATTORNEY

**CLASS 38—(Continued).**

SN 85-206,035. GLOBAL RADIO SERVICE, INC., FREMONT, CA. FILED 12-27-2010.

**BOLO NETWORK**

THE MARK CONSISTS OF STANDARD CHARACTERS WITHOUT CLAIM TO ANY PARTICULAR FONT, STYLE, SIZE, OR COLOR.

NO CLAIM IS MADE TO THE EXCLUSIVE RIGHT TO USE "NETWORK", APART FROM THE MARK AS SHOWN.

FOR INTERNET MULTIMEDIA BROADCASTING SERVICES; INTERNET RADIO SERVICES, NAMELY, TRANSMISSION OF MULTIMEDIA MATERIAL OVER CONVENTIONAL AM/FM (AMPLITUDE MODULATION/FREQUENCY MODULATION) FREQUENCIES AND TRANSMISSION OF MULTIMEDIA MATERIAL VIA THE INTERNET; AUDIO AND VIDEO BROADCASTING SERVICES OVER THE INTERNET; STREAMING OF AUDIO, VISUAL AND TEXT MATERIAL ON THE INTERNET; ELECTRONIC TRANSMISSION OF VOICE, DATA AND IMAGES BY TELEVISION AND VIDEO BROADCASTING; ELECTRONIC TRANSMISSION OF MESSAGES AND DATA; ELECTRONIC TRANSMISSION AND STREAMING OF DIGITAL MULTIMEDIA CONTENT VIA GLOBAL AND LOCAL COMPUTER NETWORKS; TRANSMISSION OF AUDIO, VIDEO, DATA AND TEXT BY MEANS OF TELECOMMUNICATION NETWORKS, WIRELESS COMMUNICATION NETWORKS, DIGITAL NETWORKS AND THE INTERNET (U.S. CLS. 100, 101 AND 104).

LAKEISHA LEWIS, EXAMINING ATTORNEY

**CLASS 38—(Continued).**

SN 85-212,245. DREW BRANDS, LLC, MOORPARK, CA. FILED 1-6-2011.



NO CLAIM IS MADE TO THE EXCLUSIVE RIGHT TO USE "DIGITAL", "ENTERTAINMENT WORLDWIDE", AND "TV", APART FROM THE MARK AS SHOWN.

THE COLOR(S) BLUE, GREEN, ORANGE, RED, BLACK, WHITE AND GRAY IS/ARE CLAIMED AS A FEATURE OF THE MARK.

THE MARK CONSISTS OF A BLACK BACKGROUND WITH FOUR SQUARES ACROSS IT, IN THE COLORS BLUE, GREEN, ORANGE AND RED, RESPECTIVELY. ON EACH OF THE FOUR SQUARES IS A WHITE LETTER AND WHITE TEXT, AS FOLLOWS: "D DIGITAL" ON THE FIRST SQUARE, "R REVOLUTION" ON THE SECOND SQUARE, "E ENTERTAINMENT" ON THE THIRD SQUARE, AND "W WORLDWIDE" ON THE FOURTH SQUARE. BELOW THE SQUARES IS THE WHITE WORD "TV", WHICH BREAKS UP A GRAY LINE THAT RUNS BELOW THE SQUARES.

FOR INTERNET PROTOCOL TELEVISION (IPTV) TRANSMISSION SERVICES (U.S. CLS. 100, 101 AND 104).

FIRST USE 12-15-2010; IN COMMERCE 12-15-2010.  
REBECCA EISINGER, EXAMINING ATTORNEY

SN 85-208,282. PRESTON M. SINGER, VAN NUYS, CA. FILED 12-30-2010.

**KICK BACK & RELAX**

THE MARK CONSISTS OF STANDARD CHARACTERS WITHOUT CLAIM TO ANY PARTICULAR FONT, STYLE, SIZE, OR COLOR.

FOR INTERNET RADIO BROADCASTING SERVICES (U.S. CLS. 100, 101 AND 104).

FIRST USE 7-1-2005; IN COMMERCE 7-1-2005.  
CORY BOONE, EXAMINING ATTORNEY

SN 85-212,284. DREW BRANDS, LLC, MOORPARK, CA. FILED 1-6-2011.

**DIGITAL REVOLUTION  
ENTERTAINMENT WORLDWIDE**

THE MARK CONSISTS OF STANDARD CHARACTERS WITHOUT CLAIM TO ANY PARTICULAR FONT, STYLE, SIZE, OR COLOR.

NO CLAIM IS MADE TO THE EXCLUSIVE RIGHT TO USE "DIGITAL" AND "ENTERTAINMENT WORLDWIDE", APART FROM THE MARK AS SHOWN.

FOR TELEVISION BROADCASTING (U.S. CLS. 100, 101 AND 104).

FIRST USE 12-15-2010; IN COMMERCE 12-15-2010.  
REBECCA EISINGER, EXAMINING ATTORNEY



**CLASS 38—(Continued).**

SN 85-212,695. JIFF INC., DBA JIFF INC., PALO ALTO, CA.  
FILED 1-7-2011.

# JIFF

THE MARK CONSISTS OF STANDARD CHARACTERS WITHOUT CLAIM TO ANY PARTICULAR FONT, STYLE, SIZE, OR COLOR.

FOR PROVIDING ON-LINE CHAT ROOMS FOR TRANSMISSION OF MESSAGES AMONG COMPUTER USERS CONCERNING HEALTH AND MEDICINE; PROVIDING ON-LINE ELECTRONIC BULLETIN BOARDS FOR TRANSMISSION OF MESSAGES AMONG COMPUTER USERS CONCERNING HEALTH AND MEDICINE; PROVIDING ON-LINE FORUMS FOR TRANSMISSION OF MESSAGES AMONG COMPUTER USERS CONCERNING HEALTH AND MEDICINE (U.S. CLS. 100, 101 AND 104).

BRENDAN MCCAULEY, EXAMINING ATTORNEY

SN 85-215,423. TALK FREE, INC., SAN FRANCISCO, CA.  
FILED 1-11-2011.

# TALKFREE

THE MARK CONSISTS OF STANDARD CHARACTERS WITHOUT CLAIM TO ANY PARTICULAR FONT, STYLE, SIZE, OR COLOR.

FOR VOICE OVER INTERNET PROTOCOL (VOIP) SERVICES (U.S. CLS. 100, 101 AND 104).

AISHA CLARKE, EXAMINING ATTORNEY

SN 85-216,228. CBS INTERACTIVE INC., NEW YORK, NY.  
FILED 1-12-2011.

# GAMESPOT

THE MARK CONSISTS OF STANDARD CHARACTERS WITHOUT CLAIM TO ANY PARTICULAR FONT, STYLE, SIZE, OR COLOR.

FOR PROVIDING ACCESS TO INFORMATION, AUDIO, AND VIDEO VIA WEBSITES, ONLINE FORUMS, CHAT ROOMS AND BLOGS OVER THE INTERNET; PROVIDING ON-LINE CHAT ROOMS AND ELECTRONIC BULLETIN BOARDS FOR TRANSMISSION OF MESSAGES AMONG TEACHERS IN THE FIELD OF ENTERTAINMENT, VIDEO GAMES, COMPUTER GAMES AND GAMING (U.S. CLS. 100, 101 AND 104).

TRICIA SONNEBORN, EXAMINING ATTORNEY

**CLASS 38—(Continued).**

SN 85-216,573. HSU, ROGER Y. K., CHAGRIN FALLS, OH.  
FILED 1-13-2011.

# GRAMPS LIKE ME

THE MARK CONSISTS OF STANDARD CHARACTERS WITHOUT CLAIM TO ANY PARTICULAR FONT, STYLE, SIZE, OR COLOR.

FOR PROVIDING A WEB SITE DIRECTED AT SENIORS FEATURING ON-LINE FORUMS FOR TRANSMISSION OF MESSAGES AMONG COMPUTER USERS CONCERNING THE FIELDS OF HEALTH AND FITNESS, RETIREMENT, FAMILY AND ENTERTAINMENT (U.S. CLS. 100, 101 AND 104).

ANDREA K. NADELMAN, EXAMINING ATTORNEY

SN 85-219,234. HSU, ROGER Y. K., CHAGRIN FALLS, OH.  
FILED 1-17-2011.

# GRAMPS LIKE US

THE MARK CONSISTS OF STANDARD CHARACTERS WITHOUT CLAIM TO ANY PARTICULAR FONT, STYLE, SIZE, OR COLOR.

FOR PROVIDING A WEB SITE DIRECTED AT SENIORS FEATURING ONLINE FORUMS FOR TRANSMISSION OF MESSAGES AMONG COMPUTER USERS CONCERNING THE FIELDS OF HEALTH AND FITNESS, RETIREMENT, FAMILY AND ENTERTAINMENT (U.S. CLS. 100, 101 AND 104).

ANDREA K. NADELMAN, EXAMINING ATTORNEY

SN 85-219,244. HSU, ROGER Y. K., CHAGRIN FALLS, OH.  
FILED 1-17-2011.

# GRMPS

THE MARK CONSISTS OF STANDARD CHARACTERS WITHOUT CLAIM TO ANY PARTICULAR FONT, STYLE, SIZE, OR COLOR.

FOR PROVIDING A WEB SITE DIRECTED AT SENIORS FEATURING ONLINE FORUMS FOR TRANSMISSION OF MESSAGES AMONG COMPUTER USERS CONCERNING THE FIELDS OF HEALTH AND FITNESS, RETIREMENT, FAMILY AND ENTERTAINMENT (U.S. CLS. 100, 101 AND 104).

ANDREA K. NADELMAN, EXAMINING ATTORNEY

**CLASS 38—(Continued).**

SN 85-220,590. HSU, ROGER Y. K., CHAGRIN FALLS, OH. FILED 1-19-2011.

GRAMPS

THE MARK CONSISTS OF STANDARD CHARACTERS WITHOUT CLAIM TO ANY PARTICULAR FONT, STYLE, SIZE, OR COLOR.

FOR PROVIDING A WEB SITE DIRECTED AT SENIORS FEATURING ONLINE FORUMS FOR TRANSMISSION OF MESSAGES AMONG COMPUTER USERS CONCERNING THE FIELDS OF HEALTH AND FITNESS, RETIREMENT, FAMILY AND ENTERTAINMENT (U.S. CLS. 100, 101 AND 104).

ANDREA K. NADELMAN, EXAMINING ATTORNEY

**CLASS 38—(Continued).**

SN 85-223,556. TOWNSQUARE MEDIA BROADCASTING, LLC, GREENWICH, CT. FILED 1-21-2011.



NO CLAIM IS MADE TO THE EXCLUSIVE RIGHT TO USE "105.7", "FM" AND "90S", APART FROM THE MARK AS SHOWN.

THE COLOR(S) BLACK, BLUE, RED, WHITE IS/ARE CLAIMED AS A FEATURE OF THE MARK.

THE MARK CONSISTS OF BLACK BACKGROUND WITH BLUE, BLACK AND WHITE WATERSPOTS WHICH ARE UNDERNEATH "105.7 CRUSH FM 90S" AND MORE, WITH "105.7" AND "FM" AND "90S" AND MORE IN WHITE, AND "CRUSH" IN RED WITH WHITE OUTLINE.

FOR RADIO BROADCASTING (U.S. CLS. 100, 101 AND 104).

ROBIN MITTLER, EXAMINING ATTORNEY

SN 85-223,517. TOWNSQUARE MEDIA BROADCASTING, LLC, GREENWICH, CT. FILED 1-21-2011.



NO CLAIM IS MADE TO THE EXCLUSIVE RIGHT TO USE "105.7" AND "FM", APART FROM THE MARK AS SHOWN.

THE COLOR(S) BLACK, BLUE, RED, WHITE IS/ARE CLAIMED AS A FEATURE OF THE MARK.

THE MARK CONSISTS OF BLACK BACKGROUND WITH BLUE, BLACK AND WHITE WATERSPOTS WHICH ARE UNDERNEATH "105.7" CRUSH FM", WITH "105.7" AND "FM" IN WHITE, AND "CRUSH" IN RED WITH WHITE OUTLINE.

FOR RADIO BROADCASTING (U.S. CLS. 100, 101 AND 104).

ROBIN MITTLER, EXAMINING ATTORNEY

SN 85-224,111. TOWNSQUARE MEDIA BROADCASTING, LLC, GREENWICH, CT. FILED 1-24-2011.



THE COLOR(S) BLACK, BLUE, RED, WHITE IS/ARE CLAIMED AS A FEATURE OF THE MARK.

THE MARK CONSISTS OF BLACK BACKGROUND WITH BLUE, BLACK AND WHITE WATERSPOTS, WITH "105.7CRUSHFM.COM" ON TOP OF THE WATERSPOTS, "105.7" AND "FM" ARE IN WHITE, "CRUSH.COM" IN RED WITH WHITE OUTLINE.

FOR RADIO BROADCASTING (U.S. CLS. 100, 101 AND 104).

ROBIN MITTLER, EXAMINING ATTORNEY

**CLASS 38—(Continued).**

SN 85-232,101. SUMMER INFANT (USA), INC., WOONSOCKET, RI. FILED 2-2-2011.

**THE BEST TIME OF YOUR LIFE**

THE MARK CONSISTS OF STANDARD CHARACTERS WITHOUT CLAIM TO ANY PARTICULAR FONT, STYLE, SIZE, OR COLOR.

OWNER OF U.S. REG. NO. 3,636,403.

FOR PROVIDING A WEB-BASED ELECTRONIC BULLETIN BOARD AND MESSAGE SERVICE FOR TRANSMISSION AND POSTING OF MESSAGES AMONG USERS IN THE FIELD OF JUVENILE PRODUCTS, PARENTAL ADVICE AND INFORMATION, CHILD-CARE ADVICE AND INFORMATION, CARETAKER ADVICE AND INFORMATION, CHILD ACTIVITY ADVICE AND INFORMATION, CHILD-RAISING SUGGESTIONS AND INFORMATION, CHILD SAFETY ADVICE AND INFORMATION, CHILDREN'S HEALTH AND NUTRITION, AND PRE-NATAL ADVICE AND INFORMATION (U.S. CLS. 100, 101 AND 104).

FIRST USE 12-1-2010; IN COMMERCE 12-1-2010.  
JUDITH HELFMAN, EXAMINING ATTORNEY

SN 85-234,422. HSU, ROGER Y. K., CHAGRIN FALLS, OH. FILED 2-4-2011.

**GRANNYS LIKE ME**

THE MARK CONSISTS OF STANDARD CHARACTERS WITHOUT CLAIM TO ANY PARTICULAR FONT, STYLE, SIZE, OR COLOR.

FOR PROVIDING A WEB SITE DIRECTED AT SENIORS FEATURING ONLINE FORUMS FOR TRANSMISSION OF MESSAGES AMONG COMPUTER USERS CONCERNING THE FIELDS OF HEALTH AND FITNESS, RETIREMENT, FAMILY AND ENTERTAINMENT (U.S. CLS. 100, 101 AND 104).

ANDREA K. NADELMAN, EXAMINING ATTORNEY

SN 85-237,878. BOGDAN RENTEA, AUSTIN, TX. FILED 2-9-2011.



THE MARK CONSISTS OF THE WORDS "TEXT UR MIND" WITH "UR" APPEARING IN AN OVAL CONVERSATION BUBBLE.

FOR PROVIDING ONLINE FORUMS FOR THE TRANSMISSION OF MESSAGES BY USERS OF MOBILE DEVICES CONCERNING REVIEWS, RECOMMENDATIONS, OPINIONS AND INFORMATION RELATING TO PRODUCTS, SERVICES, EXPERIENCES, EVENTS AND ACTIVITIES (U.S. CLS. 100, 101 AND 104).

ANGELA M. MICHELI, EXAMINING ATTORNEY

**CLASS 38—(Continued).**

SN 85-237,883. BOGDAN RENTEA, AUSTIN, TX. FILED 2-9-2011.

**TEXT ABOUT IT (BEFORE THAT FEELING IS GONE!)**

THE MARK CONSISTS OF STANDARD CHARACTERS WITHOUT CLAIM TO ANY PARTICULAR FONT, STYLE, SIZE, OR COLOR.

FOR PROVIDING ONLINE FORUMS FOR THE TRANSMISSION OF MESSAGES BY USERS OF MOBILE DEVICES CONCERNING REVIEWS, RECOMMENDATIONS, OPINIONS AND INFORMATION RELATING TO PRODUCTS, SERVICES, EXPERIENCES, EVENTS AND ACTIVITIES (U.S. CLS. 100, 101 AND 104).

ANGELA M. MICHELI, EXAMINING ATTORNEY

SN 85-240,332. TV ONE, LLC, SILVER SPRING, MD. FILED 2-11-2011.



OWNER OF U.S. REG. NOS. 2,929,758, 2,929,759 AND 2,998,957.

NO CLAIM IS MADE TO THE EXCLUSIVE RIGHT TO USE "TV", APART FROM THE MARK AS SHOWN.

THE MARK CONSISTS OF THE WORDS "TV" AND "ONE", ALL IN CAPITAL LETTERS. THE WORD "TV" SITS WITHIN THE LETTER "O" INTERSECTING THE LEFT SIDE OF THE LOOP OF THE "O".

FOR CABLE TELEVISION BROADCASTING (U.S. CLS. 100, 101 AND 104).

REBECCA POVARCHUK, EXAMINING ATTORNEY

SN 85-240,343. TV ONE, LLC, SILVER SPRING, MD. FILED 2-11-2011.



OWNER OF U.S. REG. NOS. 2,929,758, 2,929,759 AND 2,998,957.

NO CLAIM IS MADE TO THE EXCLUSIVE RIGHT TO USE "TV", APART FROM THE MARK AS SHOWN.

FOR CABLE TELEVISION BROADCASTING (U.S. CLS. 100, 101 AND 104).

REBECCA POVARCHUK, EXAMINING ATTORNEY

**CLASS 38—(Continued).**

SN 85-245,213. VITAL PHARMACEUTICALS, INC., WESTON, FL. FILED 2-17-2011.

**VPX POWER HIT RADIO**

THE MARK CONSISTS OF STANDARD CHARACTERS WITHOUT CLAIM TO ANY PARTICULAR FONT, STYLE, SIZE, OR COLOR.

NO CLAIM IS MADE TO THE EXCLUSIVE RIGHT TO USE "HIT RADIO", APART FROM THE MARK AS SHOWN. FOR RADIO AND TELEVISION BROADCASTING SERVICES; RADIO BROADCASTING; RADIO BROADCASTING OF INFORMATION AND OTHER PROGRAMS (U.S. CLS. 100, 101 AND 104).

CHRISTINA SOBRAL, EXAMINING ATTORNEY

**CLASS 39—(Continued).**

SN 77-862,941. AIRPET ANIMAL TRANSPORT, INC, BRISBANE, CA. FILED 11-2-2009.

**PET EXPRESS**

THE MARK CONSISTS OF STANDARD CHARACTERS WITHOUT CLAIM TO ANY PARTICULAR FONT, STYLE, SIZE, OR COLOR.

SEC. 2(F).  
FOR TRANSPORTATION OF PETS FOR OTHERS (U.S. CLS. 100 AND 105).  
FIRST USE 12-31-1978; IN COMMERCE 12-31-1978.  
DAWN HAN, EXAMINING ATTORNEY

**CLASS 39—TRANSPORTATION AND STORAGE**

SN 76-705,321. PINK JEEP TOURS-LAS VEGAS, LAS VEGAS, NV. FILED 11-12-2010.

**Trek for the Cure**

THE MARK CONSISTS OF STANDARD CHARACTERS WITHOUT CLAIM TO ANY PARTICULAR FONT, STYLE, SIZE, OR COLOR.

FOR CONDUCTING SIGHTSEEING TOURS FOR OTHERS (U.S. CLS. 100 AND 105).

MARY BOAGNI, EXAMINING ATTORNEY

SN 77-932,571. GREG MICHAELS, EMERYVILLE, CA. FILED 2-10-2010.

**EARTH CUBED**

THE MARK CONSISTS OF STANDARD CHARACTERS WITHOUT CLAIM TO ANY PARTICULAR FONT, STYLE, SIZE, OR COLOR.

FOR ADVENTURE TRAVEL GUIDE SERVICES (U.S. CLS. 100 AND 105).  
FIRST USE 4-1-2008; IN COMMERCE 4-1-2008.  
LAKEISHA LEWIS, EXAMINING ATTORNEY

SN 77-385,815. PINNACLE TRANSPORTATION SYSTEMS, INC., MESA, AZ. FILED 1-31-2008.

**PINNACLE TRANSPORTATION**

THE MARK CONSISTS OF STANDARD CHARACTERS WITHOUT CLAIM TO ANY PARTICULAR FONT, STYLE, SIZE, OR COLOR.

NO CLAIM IS MADE TO THE EXCLUSIVE RIGHT TO USE "TRANSPORTATION", APART FROM THE MARK AS SHOWN.

FOR TRANSPORTATION OF MANUFACTURED BUILDINGS (U.S. CLS. 100 AND 105).

FIRST USE 3-31-2005; IN COMMERCE 3-31-2005.  
RONALD MCMORROW, EXAMINING ATTORNEY

SN 79-084,476. CITY SIGHTSEEING LIMITED, UNITED KINGDOM, FILED 6-15-2010.



The logo for CitySightseeing features the words "CitySightseeing" in a stylized, rounded font. The letters are primarily dark pink with a thick yellow outline, giving it a 3D, bubbly appearance.

PRIORITY DATE OF 12-22-2009 IS CLAIMED.  
OWNER OF INTERNATIONAL REGISTRATION 1043733 DATED 6-15-2010, EXPIRES 6-15-2020.

THE COLOR(S) DARK PINK AND YELLOW IS/ARE CLAIMED AS A FEATURE OF THE MARK.

THE MARK CONSISTS OF THE WORDS "CITYSIGHTSEEING" IN DARK PINK WITH A YELLOW OUTLINE.

SEC. 2(F).  
FOR TRANSPORT SERVICES; TRAVEL ARRANGEMENT SERVICES; TOURISM SERVICES; ARRANGING AND CONDUCTING TOURS; BOOKING AGENCY SERVICES FOR TOURS (U.S. CLS. 100 AND 105).  
DAWN FELDMAN, EXAMINING ATTORNEY

**CLASS 39—(Continued).**

SN 85-043,848. JETSUITE, LLC, LONG BEACH, CA. FILED 5-20-2010.

# JETSEAT

THE MARK CONSISTS OF STANDARD CHARACTERS WITHOUT CLAIM TO ANY PARTICULAR FONT, STYLE, SIZE, OR COLOR.

FOR AIR TRANSPORTATION SERVICES; AIR TAXI TRANSPORT SERVICES AND AIR CHARTER TRANSPORTATION SERVICES; AIR TRANSPORT BY JET; RESERVATION AND BOOKING OF SEATS FOR JET TRAVEL; LOANING AND RENTAL OF AIRPLANES, JET AIRPLANES AND AIRCRAFT (U.S. CLS. 100 AND 105).

HELENE LIWINSKI, EXAMINING ATTORNEY

**CLASS 39—(Continued).**

SN 85-059,324. ADULTCELLS, INC., EVANSTON, IL. FILED 6-10-2010.



NO CLAIM IS MADE TO THE EXCLUSIVE RIGHT TO USE "ADULTCELLS", APART FROM THE MARK AS SHOWN.

THE COLOR(S) BLACK AND LIGHT BLUE IS/ARE CLAIMED AS A FEATURE OF THE MARK.

THE MARK CONSISTS OF THE STYLIZED WORDS "ADULTCELLS" IN BLACK, WITH A LIGHT BLUE SWIRL GOING THROUGH THE WORD, NARROWING AT THE LEFT AND ENDING IN A THREE LIGHT BLUE TEARDROP SHAPES ABOVE THE LETTER "A".

FOR BIOMEDICAL SERVICES, NAMELY, THE STORAGE OF ADULT HUMAN CELLS FOR MEDICAL USE (U.S. CLS. 100 AND 105).

FIRST USE 3-1-2006; IN COMMERCE 3-1-2006.

JERI J. FICKES, EXAMINING ATTORNEY

SN 85-050,377. WHEATLAND ENTERPRISES, INC., DBA OVERLAND LIMOUSINE SERVICE, LEAWOOD, KS. FILED 5-28-2010.

# OVERLAND LIMOUSINE

THE MARK CONSISTS OF STANDARD CHARACTERS WITHOUT CLAIM TO ANY PARTICULAR FONT, STYLE, SIZE, OR COLOR.

NO CLAIM IS MADE TO THE EXCLUSIVE RIGHT TO USE "LIMOUSINE", APART FROM THE MARK AS SHOWN.

SEC. 2(F).

FOR TRANSPORTATION OF PASSENGERS BY LIMOUSINE, BUSES, VANS, AND OTHER AUTOMOBILES (U.S. CLS. 100 AND 105).

FIRST USE 9-0-1979; IN COMMERCE 9-0-1979.

ANTHONY RINKER, EXAMINING ATTORNEY

SN 85-063,289. URBAN ADVENTOURS LLC, BOSTON, MA. FILED 6-15-2010.



# URBAN ADVENTOURS

BOSTON BICYCLE TOURS & RENTALS

NO CLAIM IS MADE TO THE EXCLUSIVE RIGHT TO USE "URBAN" AND "BOSTON BICYCLE TOURS & RENTALS" AND THE PICTORIAL REPRESENTATION OF A BICYCLE, APART FROM THE MARK AS SHOWN.

THE MARK CONSISTS OF A DESIGN OF A BICYCLE INSIDE A BROKEN CIRCLE, UNDERNEATH WHICH ARE THE WORDS "URBAN ADVENTOURS" IN STYLIZED TYPE, AND BENEATH THAT THE WORDS "BOSTON BICYCLE TOURS & RENTALS" IN SMALLER STYLIZED TYPE.

FOR ORGANIZING AND CONDUCTING GUIDED BICYCLE TOURS (U.S. CLS. 100 AND 105).

FIRST USE 1-1-2009; IN COMMERCE 1-1-2009.

NICHOLAS ALTREE, EXAMINING ATTORNEY



**CLASS 39—(Continued).**

SN 85-063,468. AMERICAN AIRLINES, INC., FORT WORTH, TX. FILED 6-15-2010.



OWNER OF U.S. REG. NOS. 514,293, 2,985,493 AND OTHERS.

THE COLOR(S) RED AND BLUE IS/ARE CLAIMED AS A FEATURE OF THE MARK.

THE MARK CONSISTS OF THE LETTERS "AA" WITH AN EAGLE DESIGN ELEMENT. THE FIRST APPEARING "A" IS IN THE COLOR RED. THE EAGLE DESIGN ELEMENT AND THE SECOND APPEARING "A" ARE IN THE COLOR BLUE.

FOR TRANSPORTATION OF PASSENGERS BY AIR (U.S. CLS. 100 AND 105).

FIRST USE 4-1-1969; IN COMMERCE 4-1-1969.

SETH A. RAPPAPORT, EXAMINING ATTORNEY

**CLASS 39—(Continued).**

SN 85-066,354. SUPERSHUTTLE INTERNATIONAL, INC., SCOTTSDALE, AZ. FILED 6-18-2010.



NO CLAIM IS MADE TO THE EXCLUSIVE RIGHT TO USE "YOUR NON-STOP AIRPORT RIDE", APART FROM THE MARK AS SHOWN.

THE MARK CONSISTS OF THREE LINES OF TEXT STACKED ON TOP OF EACH OTHER. THE FIRST LINE IS THE WORD "EXPRESS" IN BOLD LETTERS, THE SECOND LINE IS THE PHRASE "BY SUPER SHUTTLE" AND THE LAST LINE IS THE PHRASE "YOUR NON-STOP AIRPORT RIDE".

FOR TRANSPORTATION SERVICES, NAMELY, AIRPORT GROUND, CHARTER, AND DOOR-TO-DOOR TRANSPORTATION SERVICES OF PASSENGERS BY MOTOR VEHICLES (U.S. CLS. 100 AND 105).

JACQUELINE A. LAVINE, EXAMINING ATTORNEY

SN 85-066,337. SUPERSHUTTLE INTERNATIONAL, INC., SCOTTSDALE, AZ. FILED 6-18-2010.



GO 4 FREE

THE MARK CONSISTS OF THE WORD "EXPRESS" IN BOLD LETTERS ABOVE THE PHRASE "BY SUPER SHUTTLE".

FOR TRANSPORTATION SERVICES, NAMELY, AIRPORT GROUND, CHARTER, AND DOOR-TO-DOOR TRANSPORTATION SERVICES OF PASSENGERS BY MOTOR VEHICLES (U.S. CLS. 100 AND 105).

JACQUELINE A. LAVINE, EXAMINING ATTORNEY

THE MARK CONSISTS OF STANDARD CHARACTERS WITHOUT CLAIM TO ANY PARTICULAR FONT, STYLE, SIZE, OR COLOR.

NO CLAIM IS MADE TO THE EXCLUSIVE RIGHT TO USE "FOR FREE", APART FROM THE MARK AS SHOWN.

FOR TRANSPORT OF PERSONS (U.S. CLS. 100 AND 105).

DEBRA LEE, EXAMINING ATTORNEY

**CLASS 39—(Continued).**

SN 85-071,186. ESTUDILLO, ROBERTO, SAN YSIDRO, CA.  
FILED 6-24-2010.



NO CLAIM IS MADE TO THE EXCLUSIVE RIGHT TO USE "FOR FREE", APART FROM THE MARK AS SHOWN. THE COLOR(S) BLUE AND ORANGE IS/ARE CLAIMED AS A FEATURE OF THE MARK.

THE MARK CONSISTS OF THE WORD "GO" IN THE COLOR BLUE WITH THE NUMBER "4" IN THE COLOR ORANGE APPEARING JUST BELOW AND SLIGHTLY OVERLAPPING THE BOTTOM SIDE OF THE LETTER "O" IN THE WORD "GO", AND THE WORD "FREE" IN THE COLOR BLUE APPEARING BELOW THE NUMBER "4" WITH THE LETTERS "R" AND "E" IN THE WORD "FREE" SLIGHTLY OVERLAPPING THE BOTTOM OF THE NUMBER "4".

FOR TRANSPORT OF PERSONS (U.S. CLS. 100 AND 105).

DEBRA LEE, EXAMINING ATTORNEY

SN 85-075,616. MOVING SOLUTIONS, INC., FORT SMITH, AR. FILED 7-1-2010.

## U-PACK MOVING

THE MARK CONSISTS OF STANDARD CHARACTERS WITHOUT CLAIM TO ANY PARTICULAR FONT, STYLE, SIZE, OR COLOR.

OWNER OF U.S. REG. NOS. 2,571,652 AND 2,834,028.

NO CLAIM IS MADE TO THE EXCLUSIVE RIGHT TO USE "MOVING", APART FROM THE MARK AS SHOWN.

FOR TRANSPORTATION SERVICES; NAMELY, FREIGHT FORWARDING THE GOODS OF OTHERS BY TRUCK, SHIP AND AIR (U.S. CLS. 100 AND 105).

KIMBERLY PERRY, EXAMINING ATTORNEY

**CLASS 39—(Continued).**

SN 85-095,347. ULTIMATE JOURNEYS, LLC, SEATTLE, WA.  
FILED 7-28-2010.



OWNER OF U.S. REG. NOS. 2,880,373, 2,887,685 AND OTHERS.

NO CLAIM IS MADE TO THE EXCLUSIVE RIGHT TO USE "JOURNEYS" AND "TRAVEL", APART FROM THE MARK AS SHOWN.

THE MARK CONSISTS OF "ULTIMATE JOURNEYS" WHICH ARE STACKED IN TWO LINES, THE WORDS "TRAVEL. EXPERIENCE. GROW." WHICH APPEAR ON ONE LINE BELOW "ULTIMATE JOURNEYS". THERE IS A CIRCLE WITH A COMBINED "UJ" CHARACTER IN THE MIDDLE TO THE LEFT OF THE REST OF THE WORDING.

FOR TRAVEL AGENCY SERVICES, NAMELY, MAKING RESERVATIONS AND BOOKINGS FOR TRANSPORTATION; ORGANIZING TRAVEL TOURS AND EXCURSIONS FOR TOURISTS; TRAVEL GUIDE SERVICES; TRAVEL INFORMATION SERVICES (U.S. CLS. 100 AND 105).

FIRST USE 2-14-2010; IN COMMERCE 2-14-2010.

SIMON TENG, EXAMINING ATTORNEY

SN 85-111,978. AIR CHINA LIMITED, BEIJING, CHINA,  
FILED 8-20-2010.



NO CLAIM IS MADE TO THE EXCLUSIVE RIGHT TO USE "AIR" AND THE NON-LATIN CHARACTERS THAT TRANSLITERATE TO "AIR" AND "LIMITED", APART FROM THE MARK AS SHOWN.

THE COLOR(S) RED AND BLACK IS/ARE CLAIMED AS A FEATURE OF THE MARK.

THE MARK CONSISTS OF THE WORDS "PHOENIX MILES" IN A STYLIZED BLACK FONT, BELOW WHICH ARE FOUR BLACK NON-LATIN CHARACTERS. TO THE RIGHT APPEARS A CURVED DOUBLE-SIDED RED ARROW, AND TO THE LEFT APPEARS A BLACK VERTICAL LINE. TO THE LEFT OF THE BLACK LINE IS A PHOENIX OR BIRD DESIGN COMPOSED OF THREE RED CURVED LINES, BELOW WHICH APPEAR THE WORDS "AIR CHINA" IN A STYLIZED BLACK FONT. BELOW THE WORDS "AIR CHINA" APPEARS EIGHT BLACK NON-LATIN CHARACTERS.

THE NON-LATIN CHARACTERS IN THE MARK TRANSLITERATE TO ZHONG GUO GUO JI HANG KONG GONG SI AND THIS MEANS "AIR CHINA" LIMITED IN ENGLISH. SEC. 2(F) AS TO "AIR CHINA" AND THE NON-LATIN CHARACTERS THAT TRANSLITERATE TO "AIR CHINA" LIMITED.

FOR TRANSPORTATION SERVICES, NAMELY, AIR-LINE PASSENGER SERVICES IN THE NATURE OF FREQUENT FLYER PROGRAMS; AIR TRANSPORT; PASSENGER TRANSPORT; ARRANGING OF TOURS; BOOKING OF SEATS FOR TRAVEL (U.S. CLS. 100 AND 105).

FIRST USE 5-28-1995; IN COMMERCE 5-28-1995.

CHRISTINA SOBRAL, EXAMINING ATTORNEY

**CLASS 39—(Continued).**

SN 85-120,375. SPOKANE TRANSIT AUTHORITY, SPOKANE, WA. FILED 8-31-2010.



NO CLAIM IS MADE TO THE EXCLUSIVE RIGHT TO USE "SPOKANE TRANSIT", APART FROM THE MARK AS SHOWN.

THE MARK CONSISTS OF A STYLIZED "S" AND A STYLIZED "T" IN A CIRCLE, WITH THE LETTERS FORMING A RAIL, TO THE RIGHT OF THE CIRCLE ARE THE WORDS "SPOKANE TRANSIT HOW A GREAT CITY MOVES".

FOR MASS TRANSIT SERVICES FOR THE GENERAL PUBLIC (U.S. CLS. 100 AND 105).

FIRST USE 7-1-2007; IN COMMERCE 7-1-2007.

LINDA MICKLEBURGH, EXAMINING ATTORNEY

---

SN 85-121,404. MUSIC MASTERMIND, INC., CALABASAS, CA. FILED 9-2-2010.

## SILVERDOOR

THE MARK CONSISTS OF STANDARD CHARACTERS WITHOUT CLAIM TO ANY PARTICULAR FONT, STYLE, SIZE, OR COLOR.

FOR ELECTRONIC STORAGE OF DATA AND DIGITAL CONTENT; COMPUTERIZED-DATA-STORAGE SERVICES; COMPUTERIZED-DATA-STORAGE SERVICES FOR DIGITAL TEXT, DATA, IMAGE, AUDIO AND VIDEO WORKS; DATA STORAGE OF ELECTRONIC MUSIC (U.S. CLS. 100 AND 105).

REBECCA SMITH, EXAMINING ATTORNEY

---

SN 85-136,933. BAYLEY, MARK, LAKE ARROWHEAD, CA. FILED 9-23-2010.

## LAKE ARROWHEAD AIRPORT

THE MARK CONSISTS OF STANDARD CHARACTERS WITHOUT CLAIM TO ANY PARTICULAR FONT, STYLE, SIZE, OR COLOR.

NO CLAIM IS MADE TO THE EXCLUSIVE RIGHT TO USE "AIRPORT", APART FROM THE MARK AS SHOWN.

SEC. 2(F).

FOR AIRPORT SERVICES (U.S. CLS. 100 AND 105).

FIRST USE 0-0-2002; IN COMMERCE 0-0-2002.

SUZANNE BLANE, EXAMINING ATTORNEY

**CLASS 39—(Continued).**

SN 85-140,179. BI-STATE DEVELOPMENT AGENCY OF THE MISSOURI/ILLINOIS METROPOLITAN DISTRICT, DBA METRO, ST. LOUIS, MO. FILED 9-28-2010.



NO CLAIM IS MADE TO THE EXCLUSIVE RIGHT TO USE "METRO", APART FROM THE MARK AS SHOWN.

THE COLOR(S) BLACK, RED, BLUE AND WHITE IS/ARE CLAIMED AS A FEATURE OF THE MARK.

THE MARK CONSISTS OF THE LETTER "M" IN WHITE COLOR, INSIDE A RED SQUARE, SUPERIMPOSED OVER A BLUE CIRCLE, WITH THE WORD "METRO" IN BLACK COLOR UNDERNEATH.

SEC. 2(F).

FOR BUS TRANSPORT; PASSENGER TRAIN TRANSPORT; TRANSPORT OF PASSENGERS; TRANSPORT OF PASSENGERS BY LIGHT RAIL, BUS AND VAN (U.S. CLS. 100 AND 105).

FIRST USE 2-1-2003; IN COMMERCE 2-1-2003.

TEJBIR SINGH, EXAMINING ATTORNEY

---

SN 85-158,394. BI-STATE DEVELOPMENT AGENCY OF THE MISSOURI/ILLINOIS METROPOLITAN DISTRICT, DBA METRO, ST. LOUIS, MO. FILED 10-21-2010.



THE COLOR(S) RED, WHITE AND BLUE IS/ARE CLAIMED AS A FEATURE OF THE MARK.

THE MARK CONSISTS OF THE LETTER "M" IN WHITE COLOR, INSIDE A RED SQUARE, SUPERIMPOSED OVER A BLUE CIRCLE.

SEC. 2(F).

FOR MASS TRANSIT SERVICES FOR THE GENERAL PUBLIC (U.S. CLS. 100 AND 105).

FIRST USE 2-1-2003; IN COMMERCE 2-1-2003.

TEJBIR SINGH, EXAMINING ATTORNEY

**CLASS 39—(Continued).**

SN 85-164,525. **STOR-ALL SYSTEMS, INC.**, DEERFIELD BEACH, FL. FILED 10-29-2010.



OWNER OF U.S. REG. NOS. 2,962,249 AND 3,037,550.  
NO CLAIM IS MADE TO THE EXCLUSIVE RIGHT TO USE "STORAGE", APART FROM THE MARK AS SHOWN. THE COLOR(S) PURPLE AND GREEN IS/ARE CLAIMED AS A FEATURE OF THE MARK.

THE MARK CONSISTS OF THE WORDING "STOR ALL STORAGE" IN PURPLE WITH A GREEN CIRCLE BETWEEN "STOR" AND "ALL". AROUND THE WORDING ARE GREEN DOUBLE CIRCLES.

FOR LEASING OF FIXED AND MOVABLE STORAGE CONTAINERS TO COMMERCIAL AND RESIDENTIAL USERS (U.S. CLS. 100 AND 105).

FIRST USE 2-20-2007; IN COMMERCE 2-20-2007.  
KAPIL BHANOT, EXAMINING ATTORNEY

SN 85-176,854. **FIRELANDS ACQUISITION, LLC**, CHAMPAIGN, IL. FILED 11-15-2010.

THE COLOR(S) BLACK AND YELLOW IS/ARE CLAIMED AS A FEATURE OF THE MARK.

THE MARK CONSISTS OF THE WORD "FIRELANDS" IN BLACK BLOCK STYLIZED LETTERS WITH A DISTINCTIVE YELLOW TRIANGLE CONTAINED WITHIN THE UPPER LEFT CORNER OF THE LETTER "F".

FOR DISTRIBUTION SERVICES, NAMELY, DELIVERY OF MID-TIER HOBBY PRODUCTS FROM EXCLUSIVE PRODUCT LINES AND PROPRIETARY PRODUCTS (U.S. CLS. 100 AND 105).

DOMINIC FATHY, EXAMINING ATTORNEY

SN 85-199,211. **NEW CENTURY TRANSPORTATION, INC.**, WESTAMPTON, NJ. FILED 12-16-2010.

NO CLAIM IS MADE TO THE EXCLUSIVE RIGHT TO USE "LLC", APART FROM THE MARK AS SHOWN.

THE MARK CONSISTS OF THE WORDING "WESTERNFREIGHTWAYS" IN CAPITAL LETTERS. BELOW THAT THERE APPEARS A SOLID LINE. BELOW THE LINE, TO THE RIGHT, THERE APPEARS THE CAPITAL LETTERS "LLC".

FOR TRANSPORTATION AND DELIVERY SERVICES BY ROAD (U.S. CLS. 100 AND 105).

FIRST USE 12-18-1991; IN COMMERCE 12-18-1991.  
JOHN KELLY, EXAMINING ATTORNEY

**CLASS 39—(Continued).**

SN 85-199,389. **TACA INTERNATIONAL AIRLINES, S.A.**, CUSCATLAN LA LIBERTAD, EL SALVADOR, FILED 12-16-2010.

THE MARK CONSISTS OF STANDARD CHARACTERS WITHOUT CLAIM TO ANY PARTICULAR FONT, STYLE, SIZE, OR COLOR.

OWNER OF U.S. REG. NOS. 2,995,261, 3,023,363 AND 3,530,361.

FOR AIRLINE TRANSPORTATION SERVICES (U.S. CLS. 100 AND 105).

FIRST USE 7-29-1995; IN COMMERCE 7-29-1995.  
GENE MACIOL, EXAMINING ATTORNEY

SN 85-202,208. **LAKE NORMANDY, LLC**, ADDISON, TX. FILED 12-20-2010.

THE MARK CONSISTS OF STANDARD CHARACTERS WITHOUT CLAIM TO ANY PARTICULAR FONT, STYLE, SIZE, OR COLOR.

FOR PROVIDING A WEBSITE FEATURING INFORMATION ON TRAVEL (U.S. CLS. 100 AND 105).

FIRST USE 12-11-2010; IN COMMERCE 12-11-2010.  
ROBIN MITTLER, EXAMINING ATTORNEY

SN 85-203,289. **THE SUMMER LADY, INC.**, WOODMERE, NY. FILED 12-21-2010.

THE MARK CONSISTS OF STANDARD CHARACTERS WITHOUT CLAIM TO ANY PARTICULAR FONT, STYLE, SIZE, OR COLOR.

OWNER OF U.S. REG. NO. 2,596,141.

FOR ADVISORY SERVICES IN THE NATURE OF PROVIDING TRAVEL AND STUDENT TOUR INFORMATION SERVICES (U.S. CLS. 100 AND 105).

FIRST USE 10-0-2003; IN COMMERCE 10-0-2003.  
COLLEEN KEARNEY, EXAMINING ATTORNEY

**CLASS 39—(Continued).**

SN 85-203,731. VINTAGE NEW YORK TOURS. LLC, BROOKLYN, NY. FILED 12-22-2010.

**The Levys' Unique New York!**

THE MARK CONSISTS OF STANDARD CHARACTERS WITHOUT CLAIM TO ANY PARTICULAR FONT, STYLE, SIZE, OR COLOR.

NO CLAIM IS MADE TO THE EXCLUSIVE RIGHT TO USE "NEW YORK", APART FROM THE MARK AS SHOWN. FOR TOUR GUIDE SERVICES (U.S. CLS. 100 AND 105).

FIRST USE 2-18-2005; IN COMMERCE 2-18-2005.  
JAMES A. RAUEN, EXAMINING ATTORNEY

**CLASS 39—(Continued).**

SN 85-204,507. REAL NEW YORK TOURS, NEW YORK, NY. FILED 12-22-2010.

**Real New York Tours**

THE MARK CONSISTS OF STANDARD CHARACTERS WITHOUT CLAIM TO ANY PARTICULAR FONT, STYLE, SIZE, OR COLOR.

NO CLAIM IS MADE TO THE EXCLUSIVE RIGHT TO USE "NEW YORK TOURS", APART FROM THE MARK AS SHOWN.

FOR CONDUCTING SIGHTSEEING TOURS FOR OTHERS; PERSONAL TOUR GUIDE SERVICES; TOUR CONDUCTING; TOUR GUIDE SERVICES; TOUR OPERATING (U.S. CLS. 100 AND 105).

FIRST USE 1-4-2007; IN COMMERCE 1-4-2007.  
EMILY CHUO, EXAMINING ATTORNEY

SN 85-203,915. PLANET ASSIST, INC., MIAMI LAKES, FL. FILED 12-22-2010.



THE COLOR(S) RED, BLUE, GRAY, AND WHITE IS/ARE CLAIMED AS A FEATURE OF THE MARK.

THE MARK CONSISTS OF A BLUE CIRCLE WITH A RED TRIANGLE OUTLINED IN WHITE WITHIN IT, THE WORD "PLANET" APPEARING IN BLUE TO THE RIGHT OF THE CIRCLE DESIGN, AND THE WORD "ASSIST" APPEARING IN RED TO THE RIGHT OF THE WORD "PLANET", A BLUE LINE APPEARING UNDER THE WORDS "PLANET ASSIST", AND THE WORDING "THE SAFEST WAY TO TRAVEL" APPEARING IN GRAY BELOW THE WORD BLUE LINE AND THE WORD "ASSIST". THE COLOR WHITE APPEARING IN THE BACKGROUND OF THE MARK REPRESENTS TRANSPARENT AREAS AND THEREFORE IS NOT PART OF THE MARK.

FOR COORDINATING TRAVEL ARRANGEMENTS FOR INDIVIDUALS AND FOR GROUPS; TRANSPORT OF PERSONS AND GOODS; TRAVEL AGENCY SERVICES, NAMELY, MAKING RESERVATIONS AND BOOKINGS FOR TRANSPORTATION (U.S. CLS. 100 AND 105).

JILL PRATER, EXAMINING ATTORNEY

SN 85-204,876. PEDAL OR NOT INCORPORATED, SANTA MONICA, CA. FILED 12-23-2010.



NO CLAIM IS MADE TO THE EXCLUSIVE RIGHT TO USE "PEDAL", APART FROM THE MARK AS SHOWN.

THE COLOR(S) PURPLE, GREEN, BLACK, WHITE, AND YELLOW IS/ARE CLAIMED AS A FEATURE OF THE MARK.

THE MARK CONSISTS OF A PURPLE BIKE FRAME WITH GREEN WHEELS AND HANDLES AND BLACK TIRES, SPOKES, HANDLEBARS, PEDALS, SEAT, AND SHADOWING, WITH A BLACK AND WHITE ELECTRIC PLUG GOING INTO A PURPLE RECTANGULAR BACKGROUND WHERE THE WORDING "PEDAL OR NOT" IN YELLOW IS LOCATED.

FOR CONDUCTING SIGHTSEEING TOURS BY BICYCLE (U.S. CLS. 100 AND 105).

FIRST USE 10-0-2010; IN COMMERCE 10-0-2010.  
NICHOLAS COLEMAN, EXAMINING ATTORNEY



**CLASS 39—(Continued).**

SN 85-205,806. SUNZIA TRANSMISSION, LLC, PHOENIX, AZ. FILED 12-27-2010.



NO CLAIM IS MADE TO THE EXCLUSIVE RIGHT TO USE THE OUTLINES OF THE STATES OF ARIZONA AND NEW MEXICO, APART FROM THE MARK AS SHOWN.

THE COLOR(S) RED, YELLOW, BLUE AND PUCE IS/ARE CLAIMED AS A FEATURE OF THE MARK.

THE MARK CONSISTS OF THE STYLIZED WORD "SUNZIA" FLANKED ON THE LEFT BY AN OUTLINE OF THE STATE OF ARIZONA WITH A PUCE, YELLOW AND RED STAR BURST OVER A BLUE FIELD, AND ON THE LEFT BY AN OUTLINE OF THE STATE OF NEW MEXICO WITH A NATIVE AMERICAN ZIA SYMBOL IN RED AGAINST A YELLOW FIELD.

THE ENGLISH TRANSLATION OF "ZIA" IN THE MARK IS AN "ANCIENT ZIA PUEBLO SUN SYMBOL".

FOR UTILITY SERVICES, NAMELY, TRANSMISSION OF ELECTRICITY (U.S. CLS. 100 AND 105).

FIRST USE 4-19-2010; IN COMMERCE 4-19-2010.

DOMINICK J. SALEMI, EXAMINING ATTORNEY

**CLASS 39—(Continued).**

SN 85-206,672. BUTLER, DAVID R., ANN ARBOR, MI. FILED 12-28-2010.

**Word of Mouth Taxi**

THE MARK CONSISTS OF STANDARD CHARACTERS WITHOUT CLAIM TO ANY PARTICULAR FONT, STYLE, SIZE, OR COLOR.

NO CLAIM IS MADE TO THE EXCLUSIVE RIGHT TO USE "TAXI", APART FROM THE MARK AS SHOWN.

FOR TAXI TRANSPORT (U.S. CLS. 100 AND 105).

LAURA HAMMEL, EXAMINING ATTORNEY

SN 85-205,859. FLAT RATE MOVERS, LTD., DBA FLAT-RATE MOVING, BRONX, NY. FILED 12-27-2010.

**Moving Registry**

THE MARK CONSISTS OF STANDARD CHARACTERS WITHOUT CLAIM TO ANY PARTICULAR FONT, STYLE, SIZE, OR COLOR.

NO CLAIM IS MADE TO THE EXCLUSIVE RIGHT TO USE "MOVING", APART FROM THE MARK AS SHOWN.

FOR FURNITURE MOVING; MOVING COMPANY SERVICES; MOVING VAN SERVICES; MOVING VAN TRANSPORT; TRANSPORT SERVICES, NAMELY, LOCAL, INTERSTATE AND INTERNATIONAL MOVING SERVICES (U.S. CLS. 100 AND 105).

ROBIN MITTLER, EXAMINING ATTORNEY

SN 85-209,079. AMERICAN HORSE TRAILER RENTAL, INC., VISALIA, CA. FILED 1-3-2011.



SN 85-206,271. CHECK BOX TRAVEL, LLC, LAS VEGAS, NV. FILED 12-28-2010.

**CHECK BOX TRAVEL**

THE MARK CONSISTS OF STANDARD CHARACTERS WITHOUT CLAIM TO ANY PARTICULAR FONT, STYLE, SIZE, OR COLOR.

NO CLAIM IS MADE TO THE EXCLUSIVE RIGHT TO USE "TRAVEL", APART FROM THE MARK AS SHOWN.

FOR ONLINE TRIP AND TRAVEL RESERVATION SERVICES (U.S. CLS. 100 AND 105).

KEVON CHISOLM, EXAMINING ATTORNEY

OWNER OF U.S. REG. NO. 3,884,561.

NO CLAIM IS MADE TO THE EXCLUSIVE RIGHT TO USE "AMERICAN HORSE TRAILER RENTALS", APART FROM THE MARK AS SHOWN.

THE COLOR(S) BROWN, BLACK, BLUE, WHITE, RED, TAN, AND BEIGE IS/ARE CLAIMED AS A FEATURE OF THE MARK.

THE MARK CONSISTS OF THE FOLLOWING: A HORSE HEAD IN BROWN AND BLACK, PICTURED IN A BEIGE AND BLACK HORSESHOE FOLLOWED BY THE WORDS "AMERICAN HORSE" IN BROWN AND OUTLINED IN WHITE, OVER THE WORDS "TRAILER RENTALS" IN BROWN AND OUTLINED IN WHITE, ALL IN A BROWN AND TAN RECTANGULAR FRAME SURROUNDED BY BEIGE STITCHING AND WITH THE SILHOUETTE OF AN AMERICAN FLAG IN BLUE, RED, AND WHITE IMAGED UNDER THE HORSE'S HEAD.

FOR TRUCK AND TRAILER RENTAL (U.S. CLS. 100 AND 105).

FIRST USE 5-31-2010; IN COMMERCE 5-31-2010.

TINA L. SNAPP, EXAMINING ATTORNEY

**CLASS 39—(Continued).**

SN 85-210,024. PINNACLE AIRLINES CORP., MEMPHIS, TN.  
FILED 1-4-2011.

**MESABA AIRLINES**

THE MARK CONSISTS OF STANDARD CHARACTERS WITHOUT CLAIM TO ANY PARTICULAR FONT, STYLE, SIZE, OR COLOR.

NO CLAIM IS MADE TO THE EXCLUSIVE RIGHT TO USE "AIRLINES", APART FROM THE MARK AS SHOWN. SEC. 2(F).

FOR AIRLINE TRANSPORTATION SERVICES (U.S. CLS. 100 AND 105).

FIRST USE 3-4-1981; IN COMMERCE 3-4-1981.  
PAUL F. GAST, EXAMINING ATTORNEY

---

SN 85-212,162. SHAUN C. ROBINSON, DBA STRONG COLLEGE STUDENTS, TAMPA, FL. FILED 1-6-2011.

**Strong College Students**

THE MARK CONSISTS OF STANDARD CHARACTERS WITHOUT CLAIM TO ANY PARTICULAR FONT, STYLE, SIZE, OR COLOR.

NO CLAIM IS MADE TO THE EXCLUSIVE RIGHT TO USE "COLLEGE STUDENTS", APART FROM THE MARK AS SHOWN.

FOR MOVING COMPANY SERVICES (U.S. CLS. 100 AND 105).

FIRST USE 6-0-2004; IN COMMERCE 6-0-2004.  
KEVON CHISOLM, EXAMINING ATTORNEY

---

SN 85-212,312. CLEAN ONES CORPORATION, PORTLAND, OR. FILED 1-6-2011.

**WE ARE YOUR BRAND**

THE MARK CONSISTS OF STANDARD CHARACTERS WITHOUT CLAIM TO ANY PARTICULAR FONT, STYLE, SIZE, OR COLOR.

FOR PACKAGING ARTICLES TO THE ORDER AND SPECIFICATION OF OTHERS; AND PRIVATE LABELING OF MERCHANDISE TO THE ORDER AND SPECIFICATION OF OTHERS (U.S. CLS. 100 AND 105).

DANIEL CAPSHAW, EXAMINING ATTORNEY

**CLASS 39—(Continued).**

SN 85-212,352. SHAUN C. ROBINSON, DBA STRONG COLLEGE STUDENTS, TAMPA, FL. FILED 1-6-2011.



**"MOVERS WITH KNOWLEDGE"**

NO CLAIM IS MADE TO THE EXCLUSIVE RIGHT TO USE "COLLEGE STUDENTS" AND "MOVERS", APART FROM THE MARK AS SHOWN.

THE MARK CONSISTS OF THE STYLIZED WORD "STRONG" CENTERED ABOVE THE WORDS "COLLEGE STUDENTS" IN STYLIZED FONT INSIDE A SOLID RECTANGLE CARRIER. TO THE LEFT OF THE DESCRIBED WORDS IS A SOLID CIRCULAR CARRIER WITH AN OUTLINE CONTAINING A DRAWING OF A MALE TORSO, CENTERED BELOW THE DRAWING AND WORDS. IN QUOTATION MARKS, ARE THE WORDS "MOVERS WITH KNOWLEDGE" IN STYLIZED FONT.

FOR MOVING COMPANY SERVICES (U.S. CLS. 100 AND 105).

FIRST USE 6-0-2004; IN COMMERCE 6-0-2004.  
KEVON CHISOLM, EXAMINING ATTORNEY

---

SN 85-212,533. SEKO WORLDWIDE, LLC, ITASCA, IL. FILED 1-7-2011.

**SEKO LOGISTICS -  
INTELLIGENCE DELIVERED**

THE MARK CONSISTS OF STANDARD CHARACTERS WITHOUT CLAIM TO ANY PARTICULAR FONT, STYLE, SIZE, OR COLOR.

OWNER OF U.S. REG. NOS. 1,470,985, 2,117,536 AND OTHERS.

NO CLAIM IS MADE TO THE EXCLUSIVE RIGHT TO USE "LOGISTICS", APART FROM THE MARK AS SHOWN.

FOR FREIGHT TRANSPORTATION AND LOGISTICAL SERVICES BY TRUCK, AIR AND SEA, AND RELATED WAREHOUSING SERVICES (U.S. CLS. 100 AND 105).

MARK SHINER, EXAMINING ATTORNEY

---

SN 85-212,749. JOHNSON, SEAN, LONG ISLAND CITY, NY. FILED 1-7-2011.

**modhop**

THE MARK CONSISTS OF STANDARD CHARACTERS WITHOUT CLAIM TO ANY PARTICULAR FONT, STYLE, SIZE, OR COLOR.

FOR PROVIDING ON-LINE REVIEWS OF AIRPLANE TRAVEL (U.S. CLS. 100 AND 105).

FIRST USE 1-1-2006; IN COMMERCE 1-1-2010.  
JOHN E. MICHOS, EXAMINING ATTORNEY

**CLASS 39—(Continued).**

SN 85-213,794. SHERMANSTRAVEL MEDIA, LLC, NEW YORK, NY. FILED 1-10-2011.

**SMART LUXURY**

THE MARK CONSISTS OF STANDARD CHARACTERS WITHOUT CLAIM TO ANY PARTICULAR FONT, STYLE, SIZE, OR COLOR.

OWNER OF U.S. REG. NOS. 3,323,029 AND 3,766,534. FOR TRAVEL AGENCY SERVICES, NAMELY, TRAVEL TOUR PLANNING, MAKING RESERVATIONS AND BOOKINGS FOR TRANSPORTATION, ARRANGING TOURS, AND SPECIAL EXCURSIONS (U.S. CLS. 100 AND 105).

JACQUELINE A. LAVINE, EXAMINING ATTORNEY

**CLASS 39—(Continued).**

SN 85-214,896. AMERICAN EXPRESS MARKETING & DEVELOPMENT CORP., NEW YORK, NY. FILED 1-11-2011.

**TASTEBLAZER**

THE MARK CONSISTS OF STANDARD CHARACTERS WITHOUT CLAIM TO ANY PARTICULAR FONT, STYLE, SIZE, OR COLOR.

FOR ARRANGING TRAVEL TOURS FEATURING A CUSTOMIZED MYSTERY TRIP BASED ON RESPONSES TO A QUIZ; ARRANGING A CUSTOMIZED MYSTERY TRIP BASED ON RESPONSES TO A QUIZ, NAMELY, MAKING RESERVATIONS AND BOOKINGS FOR TRANSPORTATION (U.S. CLS. 100 AND 105).

KYLE PEETE, EXAMINING ATTORNEY

SN 85-214,413. REYNOLDS, RHETT, TAMPA, FL. FILED 1-10-2011.

**City Cycle**

THE MARK CONSISTS OF STANDARD CHARACTERS WITHOUT CLAIM TO ANY PARTICULAR FONT, STYLE, SIZE, OR COLOR.

FOR LIMOUSINE SERVICES (U.S. CLS. 100 AND 105).

SANJEEV VOHRA, EXAMINING ATTORNEY

SN 85-214,906. AMERICAN EXPRESS MARKETING & DEVELOPMENT CORP., NEW YORK, NY. FILED 1-11-2011.

**TRENGINEER**

THE MARK CONSISTS OF STANDARD CHARACTERS WITHOUT CLAIM TO ANY PARTICULAR FONT, STYLE, SIZE, OR COLOR.

FOR ARRANGING TRAVEL TOURS FEATURING A CUSTOMIZED MYSTERY TRIP BASED ON RESPONSES TO A QUIZ; ARRANGING A CUSTOMIZED MYSTERY TRIP BASED ON RESPONSES TO A QUIZ, NAMELY, MAKING RESERVATIONS AND BOOKINGS FOR TRANSPORTATION (U.S. CLS. 100 AND 105).

KYLE PEETE, EXAMINING ATTORNEY

SN 85-214,892. AMERICAN EXPRESS MARKETING & DEVELOPMENT CORP., NEW YORK, NY. FILED 1-11-2011.

**CYBER SURVIVOR**

THE MARK CONSISTS OF STANDARD CHARACTERS WITHOUT CLAIM TO ANY PARTICULAR FONT, STYLE, SIZE, OR COLOR.

NO CLAIM IS MADE TO THE EXCLUSIVE RIGHT TO USE "CYBER", APART FROM THE MARK AS SHOWN.

FOR ARRANGING TRAVEL TOURS FEATURING A CUSTOMIZED MYSTERY TRIP BASED ON RESPONSES TO A QUIZ; ARRANGING A CUSTOMIZED MYSTERY TRIP BASED ON RESPONSES TO A QUIZ, NAMELY, MAKING RESERVATIONS AND BOOKINGS FOR TRANSPORTATION (U.S. CLS. 100 AND 105).

KYLE PEETE, EXAMINING ATTORNEY

SN 85-214,911. AMERICAN EXPRESS MARKETING & DEVELOPMENT CORP., NEW YORK, NY. FILED 1-11-2011.

**ADRENALISTA**

THE MARK CONSISTS OF STANDARD CHARACTERS WITHOUT CLAIM TO ANY PARTICULAR FONT, STYLE, SIZE, OR COLOR.

FOR ARRANGING TRAVEL TOURS FEATURING A CUSTOMIZED MYSTERY TRIP BASED ON RESPONSES TO A QUIZ; ARRANGING A CUSTOMIZED MYSTERY TRIP BASED ON RESPONSES TO A QUIZ, NAMELY, MAKING RESERVATIONS AND BOOKINGS FOR TRANSPORTATION (U.S. CLS. 100 AND 105).

KYLE PEETE, EXAMINING ATTORNEY

**CLASS 39—(Continued).**

SN 85-214,923. AMERICAN EXPRESS MARKETING & DEVELOPMENT CORP., NEW YORK, NY. FILED 1-11-2011.

**GLAMDIGGER**

THE MARK CONSISTS OF STANDARD CHARACTERS WITHOUT CLAIM TO ANY PARTICULAR FONT, STYLE, SIZE, OR COLOR.

FOR ARRANGING TRAVEL TOURS FEATURING A CUSTOMIZED MYSTERY TRIP BASED ON RESPONSES TO A QUIZ; ARRANGING A CUSTOMIZED MYSTERY TRIP BASED ON RESPONSES TO A QUIZ, NAMELY, MAKING RESERVATIONS AND BOOKINGS FOR TRANSPORTATION (U.S. CLS. 100 AND 105).  
KYLE PEETE, EXAMINING ATTORNEY

**CLASS 39—(Continued).**

SN 85-214,950. AMERICAN EXPRESS MARKETING & DEVELOPMENT CORP., NEW YORK, NY. FILED 1-11-2011.

**CELEBUTANTE**

THE MARK CONSISTS OF STANDARD CHARACTERS WITHOUT CLAIM TO ANY PARTICULAR FONT, STYLE, SIZE, OR COLOR.

FOR ARRANGING TRAVEL TOURS FEATURING A CUSTOMIZED MYSTERY TRIP BASED ON RESPONSES TO A QUIZ; ARRANGING A CUSTOMIZED MYSTERY TRIP BASED ON RESPONSES TO A QUIZ, NAMELY, MAKING RESERVATIONS AND BOOKINGS FOR TRANSPORTATION (U.S. CLS. 100 AND 105).  
KYLE PEETE, EXAMINING ATTORNEY

SN 85-214,935. AMERICAN EXPRESS MARKETING & DEVELOPMENT CORP., NEW YORK, NY. FILED 1-11-2011.

**RUSTIKEER**

THE MARK CONSISTS OF STANDARD CHARACTERS WITHOUT CLAIM TO ANY PARTICULAR FONT, STYLE, SIZE, OR COLOR.

FOR ARRANGING TRAVEL TOURS FEATURING A CUSTOMIZED MYSTERY TRIP BASED ON RESPONSES TO A QUIZ; ARRANGING A CUSTOMIZED MYSTERY TRIP BASED ON RESPONSES TO A QUIZ, NAMELY, MAKING RESERVATIONS AND BOOKINGS FOR TRANSPORTATION (U.S. CLS. 100 AND 105).  
KYLE PEETE, EXAMINING ATTORNEY

SN 85-214,961. AMERICAN EXPRESS MARKETING & DEVELOPMENT CORP., NEW YORK, NY. FILED 1-11-2011.

**YORCERER**

THE MARK CONSISTS OF STANDARD CHARACTERS WITHOUT CLAIM TO ANY PARTICULAR FONT, STYLE, SIZE, OR COLOR.

FOR ARRANGING TRAVEL TOURS FEATURING A CUSTOMIZED MYSTERY TRIP BASED ON RESPONSES TO A QUIZ; ARRANGING A CUSTOMIZED MYSTERY TRIP BASED ON RESPONSES TO A QUIZ, NAMELY, MAKING RESERVATIONS AND BOOKINGS FOR TRANSPORTATION (U.S. CLS. 100 AND 105).  
KYLE PEETE, EXAMINING ATTORNEY

SN 85-214,941. AMERICAN EXPRESS MARKETING & DEVELOPMENT CORP., NEW YORK, NY. FILED 1-11-2011.

**SCENESTER**

THE MARK CONSISTS OF STANDARD CHARACTERS WITHOUT CLAIM TO ANY PARTICULAR FONT, STYLE, SIZE, OR COLOR.

FOR ARRANGING TRAVEL TOURS FEATURING A CUSTOMIZED MYSTERY TRIP BASED ON RESPONSES TO A QUIZ; ARRANGING A CUSTOMIZED MYSTERY TRIP BASED ON RESPONSES TO A QUIZ, NAMELY, MAKING RESERVATIONS AND BOOKINGS FOR TRANSPORTATION (U.S. CLS. 100 AND 105).  
KYLE PEETE, EXAMINING ATTORNEY

SN 85-215,036. AMERICAN EXPRESS MARKETING & DEVELOPMENT CORP., NEW YORK, NY. FILED 1-11-2011.

**HIPLOMAT**

THE MARK CONSISTS OF STANDARD CHARACTERS WITHOUT CLAIM TO ANY PARTICULAR FONT, STYLE, SIZE, OR COLOR.

FOR ARRANGING TRAVEL TOURS FEATURING A CUSTOMIZED MYSTERY TRIP BASED ON RESPONSES TO A QUIZ; ARRANGING A CUSTOMIZED MYSTERY TRIP BASED ON RESPONSES TO A QUIZ, NAMELY, MAKING RESERVATIONS AND BOOKINGS FOR TRANSPORTATION (U.S. CLS. 100 AND 105).  
KYLE PEETE, EXAMINING ATTORNEY

**CLASS 39—(Continued).**

SN 85-215,397. POPS' PEDICABS LLC, DBA POPS' PEDI-CABS, RAMONA, CA. FILED 1-11-2011.

Why Stroll...When you can  
Roll?

THE MARK CONSISTS OF STANDARD CHARACTERS WITHOUT CLAIM TO ANY PARTICULAR FONT, STYLE, SIZE, OR COLOR.

FOR CONDUCTING SIGHTSEEING TOURS BY PEDICAB; TRANSPORTATION SERVICES, NAMELY, PROVIDING SHUTTLE SERVICES BY PEDICAB (U.S. CLS. 100 AND 105).

FIRST USE 8-3-2005; IN COMMERCE 8-3-2005.  
KATHERINE M. DUBRAY, EXAMINING ATTORNEY

SN 85-217,888. PIZZA HUT, INC., DALLAS, TX. FILED 1-14-2011.

CHECK IN AND STAY IN. WE  
DELIVER!

THE MARK CONSISTS OF STANDARD CHARACTERS WITHOUT CLAIM TO ANY PARTICULAR FONT, STYLE, SIZE, OR COLOR.

NO CLAIM IS MADE TO THE EXCLUSIVE RIGHT TO USE "WE DELIVER!", APART FROM THE MARK AS SHOWN.

FOR PIZZA, COOKED PASTA AND COOKED CHICKEN DELIVERY SERVICES (U.S. CLS. 100 AND 105).

FIRST USE 1-10-2011; IN COMMERCE 1-10-2011.  
COURTNEY ALVAREZ, EXAMINING ATTORNEY

SN 85-218,312. PIZZA HUT, INC., DALLAS, TX. FILED 1-14-2011.

NO MORE TRAVELING TODAY.  
WE DELIVER!

THE MARK CONSISTS OF STANDARD CHARACTERS WITHOUT CLAIM TO ANY PARTICULAR FONT, STYLE, SIZE, OR COLOR.

NO CLAIM IS MADE TO THE EXCLUSIVE RIGHT TO USE "WE DELIVER!", APART FROM THE MARK AS SHOWN.

FOR PIZZA, COOKED PASTA AND COOKED CHICKEN DELIVERY SERVICES (U.S. CLS. 100 AND 105).

FIRST USE 1-10-2011; IN COMMERCE 1-10-2011.  
COURTNEY ALVAREZ, EXAMINING ATTORNEY

**CLASS 39—(Continued).**

SN 85-218,950. PREPAK SYSTEMS, INC., COOKEVILLE, TN. FILED 1-17-2011.

APHENA

THE MARK CONSISTS OF STANDARD CHARACTERS WITHOUT CLAIM TO ANY PARTICULAR FONT, STYLE, SIZE, OR COLOR.

FOR PACKAGING ARTICLES TO THE ORDER AND SPECIFICATION OF OTHERS (U.S. CLS. 100 AND 105).

CAROLINE WOOD, EXAMINING ATTORNEY

SN 85-218,952. PREPAK SYSTEMS, INC., COOKEVILLE, TN. FILED 1-17-2011.



THE MARK CONSISTS OF A DESIGN WITH AN OVERALL TRIANGULAR SHAPE. THE COLORS BLACK AND GRAY IN THE DRAWING REPRESENT SHADING AND ARE NOT PART OF THE MARK.

FOR PACKAGING ARTICLES TO THE ORDER AND SPECIFICATION OF OTHERS (U.S. CLS. 100 AND 105).

CAROLINE WOOD, EXAMINING ATTORNEY

SN 85-239,770. HENDRICKS INVESTMENT HOLDINGS, LLC, SILVER SPRING, MD. FILED 2-11-2011.



NO CLAIM IS MADE TO THE EXCLUSIVE RIGHT TO USE "AIR TOURS", APART FROM THE MARK AS SHOWN.

THE MARK CONSISTS OF A SUN IN THE LEFT CORNER WITH A BIRD IN THE CENTER OF THE SUN, ABOVE THE WORD "GATEWAY CANYONS AIRTOURS".

FOR ARRANGING, ORGANIZING, AND CONDUCTING SIGHTSEEING TOURS (U.S. CLS. 100 AND 105).

FIRST USE 4-0-2010; IN COMMERCE 4-0-2010.  
HOWARD B. LEVINE, EXAMINING ATTORNEY



**CLASS 39—(Continued).**

SN 85-259,422. FEDERAL EXPRESS CORPORATION, MEMPHIS, TN. FILED 3-7-2011.

## FEDEX CUSTOM CRITICAL ShipmentRescue

THE MARK CONSISTS OF STANDARD CHARACTERS WITHOUT CLAIM TO ANY PARTICULAR FONT, STYLE, SIZE, OR COLOR.

OWNER OF U.S. REG. NOS. 2,657,697, 2,764,608 AND 3,125,953.

NO CLAIM IS MADE TO THE EXCLUSIVE RIGHT TO USE "SHIPMENT RESCUE", APART FROM THE MARK AS SHOWN.

FOR PROVIDING EMERGENCY SHIPPING SERVICES FOR CARGO (U.S. CLS. 100 AND 105).

JOHN E. MICHOS, EXAMINING ATTORNEY

**CLASS 40—(Continued).**

SN 77-899,317. ANOPLATE CORPORATION, SYRACUSE, NY. FILED 12-22-2009.

## Anoplate

THE MARK CONSISTS OF STANDARD CHARACTERS WITHOUT CLAIM TO ANY PARTICULAR FONT, STYLE, SIZE, OR COLOR.

FOR METAL FINISHING SERVICES, NAMELY, PLATING OF COPPER, NICKEL, CHROMIUM, ZINC, SILVER, GOLD, CADMIUM AND TIN; METAL FINISHING SERVICES, NAMELY ANODIZING OF LIGHT METALS; METAL FINISHING SERVICES, NAMELY, APPLICATION OF PASSIVATING AND PHOSPHATING CONVERSION COATINGS; AND METAL FINISHING SERVICES, NAMELY DRY FILM LUBRICATION (U.S. CLS. 100, 103 AND 106).

FIRST USE 12-31-1960; IN COMMERCE 12-31-1960.  
JESSICA FATHY, EXAMINING ATTORNEY

**CLASS 40—MATERIAL TREATMENT**

SN 77-644,285. MASABA, INC., VERMILLION, SD. FILED 1-6-2009.

## KOLMAN

THE MARK CONSISTS OF STANDARD CHARACTERS WITHOUT CLAIM TO ANY PARTICULAR FONT, STYLE, SIZE, OR COLOR.

OWNER OF U.S. REG. NO. 887,843.  
SEC. 2(F).

FOR CUSTOM MANUFACTURE OF MACHINERY FOR HANDLING AND PROCESSING AGGREGATE AND OTHER LOOSE MATERIALS, NAMELY, MINERALS, ROCKS, AND GRAINS, PURSUANT TO THE ORDER AND SPECIFICATIONS OF OTHERS (U.S. CLS. 100, 103 AND 106).

LAURIE KAUFMAN, EXAMINING ATTORNEY

SN 77-951,844. COTT BEVERAGES INC., TAMPA, FL. FILED 3-5-2010.

## COTT

THE MARK CONSISTS OF STANDARD CHARACTERS WITHOUT CLAIM TO ANY PARTICULAR FONT, STYLE, SIZE, OR COLOR.

OWNER OF U.S. REG. NOS. 540,457, 679,364 AND 749,859.  
SEC. 2(F).

FOR MANUFACTURING SERVICES FOR OTHERS IN THE FIELD OF NON-ALCOHOLIC BEVERAGES, AND SYRUPS AND CONCENTRATES USED IN THE PREPARATION OF SOFT DRINKS (U.S. CLS. 100, 103 AND 106).

FIRST USE 12-31-1990; IN COMMERCE 12-31-1990.  
CYNTHIA TRIPI, EXAMINING ATTORNEY

SN 77-875,552. PSB, INC., LAKE FOREST, CA. FILED 11-18-2009.

## EcoSmart

THE MARK CONSISTS OF STANDARD CHARACTERS WITHOUT CLAIM TO ANY PARTICULAR FONT, STYLE, SIZE, OR COLOR.

FOR PRINTING (U.S. CLS. 100, 103 AND 106).  
FIRST USE 7-20-2009; IN COMMERCE 7-20-2009.  
MICHELE SWAIN, EXAMINING ATTORNEY

SN 85-053,963. TRI TOOL INC., RANCHO CORDOVA, CA. FILED 6-3-2010.

## Tri Tool Thermal Services

THE MARK CONSISTS OF STANDARD CHARACTERS WITHOUT CLAIM TO ANY PARTICULAR FONT, STYLE, SIZE, OR COLOR.

OWNER OF U.S. REG. NOS. 1,868,004 AND 2,637,058.  
NO CLAIM IS MADE TO THE EXCLUSIVE RIGHT TO USE "TOOL THERMAL SERVICES", APART FROM THE MARK AS SHOWN.

FOR WELDING (U.S. CLS. 100, 103 AND 106).  
NAKIA HENRY, EXAMINING ATTORNEY

**CLASS 40—(Continued).**

SN 85-198,311. RECPLAS SERVICOS DE RECICLAGEM DE PLASTICOS LTDA., DIAS D'AVILA/BA, BRAZIL, FILED 12-15-2010.



NO CLAIM IS MADE TO THE EXCLUSIVE RIGHT TO USE "REC PLAS", APART FROM THE MARK AS SHOWN. THE MARK CONSISTS OF THE TERM "REC" IN STYLIZED FONT ABOVE THE TERM "PLAS" IN STYLIZED FONT INSIDE A CIRCLE COMPOSED OF THREE PARTIAL ARROWS WITH TWO BREAKS.

FOR RECYCLING OF WASTE AND TRASH; SORTING OF WASTE AND RECYCLABLE MATERIAL; WASTE TREATMENT (U.S. CLS. 100, 103 AND 106).  
ANDREA K. NADELMAN, EXAMINING ATTORNEY

SN 85-198,595. DYNAMIC MANUFACTURING SOLUTIONS, LLC, AUSTIN, TX. FILED 12-15-2010.



NO CLAIM IS MADE TO THE EXCLUSIVE RIGHT TO USE "MANUFACTURING SOLUTIONS, LLC", APART FROM THE MARK AS SHOWN.

THE MARK CONSISTS OF THE STYLIZED TEXT "DMS" ABOVE THE STYLIZED WORDING, "DYNAMIC MANUFACTURING SOLUTIONS, LLC" HAVING A HORIZONTAL LINE IN-BETWEEN.

FOR CONTRACT MANUFACTURING IN THE FIELD OF PHARMACEUTICALS, MICRO-ELECTRONICS, AND GREEN TECHNOLOGY (U.S. CLS. 100, 103 AND 106).  
FIRST USE 4-1-2009; IN COMMERCE 4-1-2009.  
JULIE GUTTADAURO, EXAMINING ATTORNEY

**CLASS 40—(Continued).**

SN 85-199,483. NORTHLIGHT POWER, LLC, BAINBRIDGE ISLAND, WA. FILED 12-16-2010.



NO CLAIM IS MADE TO THE EXCLUSIVE RIGHT TO USE "POWER", APART FROM THE MARK AS SHOWN.

THE MARK CONSISTS OF THE WORDS "NORTHLIGHT POWER". THERE IS A DESIGN WHICH SHOWS POWER LINES MEETING AND APPEARS TO THE LEFT OF THE WORDS.

FOR GENERATION OF POWER THROUGH OPERATION OF SOLAR POWER COLLECTING EQUIPMENT AND FACILITIES (U.S. CLS. 100, 103 AND 106).

FIRST USE 9-30-2010; IN COMMERCE 9-30-2010.  
PATRICIA EVANKO, EXAMINING ATTORNEY

SN 85-199,500. NORTHLIGHT POWER, LLC, BAINBRIDGE ISLAND, WA. FILED 12-16-2010.



NO CLAIM IS MADE TO THE EXCLUSIVE RIGHT TO USE "POWER" AND "SOLAR", APART FROM THE MARK AS SHOWN.

THE MARK CONSISTS OF THE WORDS "NORTHLIGHT POWER STREAMLINING SOLAR". THE WORDS "NORTHLIGHT POWER" APPEAR ON ONE LINE AND THE WORDS "STREAMLINING SOLAR" APPEAR ON THE LINE BELOW. THERE IS A DESIGN WHICH SHOWS POWER LINES MEETING AND APPEARS TO THE LEFT OF THE WORDS.

FOR GENERATION OF POWER THROUGH OPERATION OF SOLAR POWER COLLECTING EQUIPMENT AND FACILITIES (U.S. CLS. 100, 103 AND 106).

FIRST USE 9-30-2010; IN COMMERCE 9-30-2010.  
PATRICIA EVANKO, EXAMINING ATTORNEY

**CLASS 40—(Continued).**

SN 85-199,612. SAFE-GUARD PRODUCTS INTERNATIONAL, LLC, ATLANTA, GA. FILED 12-16-2010.

**SAFE-GUARD**  
Products International, LLC



OWNER OF U.S. REG. NO. 3,904,179.  
NO CLAIM IS MADE TO THE EXCLUSIVE RIGHT TO USE "PRODUCTS INTERNATIONAL, LLC", APART FROM THE MARK AS SHOWN.

THE MARK CONSISTS OF THE WORDS "SAFE-GUARD PRODUCTS INTERNATIONAL, LLC" CENTERED OVER A HORIZONTAL DIAMOND SHAPE WITH AN ILLUSTRATION OF A MAP OF THE WORLD OVERLAYING HORIZONTAL LINES WITHIN THE DIAMOND SHAPE.

FOR ETCHING OF TRACEABLE IDENTIFICATION NUMBERS ON AUTOMOBILE WINDOWS FOR AUTOMOBILE POST-THEFT IDENTIFICATION (U.S. CLS. 100, 103 AND 106).

FIRST USE 0-0-1994; IN COMMERCE 0-0-1994.  
BARNEY CHARLON, EXAMINING ATTORNEY

SN 85-201,063. PROPTOLOGY FX. INC., NORTH HOLLYWOOD, CA. FILED 12-17-2010.

**44 Props**

THE MARK CONSISTS OF STANDARD CHARACTERS WITHOUT CLAIM TO ANY PARTICULAR FONT, STYLE, SIZE, OR COLOR.

NO CLAIM IS MADE TO THE EXCLUSIVE RIGHT TO USE "PROPS", APART FROM THE MARK AS SHOWN.

FOR CUSTOM FABRICATION OF MODELS, SETS AND PROPS FOR MOTION PICTURES, VIDEOS, COMMERCIALS AND MOVIE TRAILERS (U.S. CLS. 100, 103 AND 106).

RAMONA ORTIGA, EXAMINING ATTORNEY

**CLASS 40—(Continued).**

SN 85-204,924. DMR PRINT, INC., DBA AMBIT PRESS, AMBIT CREATIVE GROUP, MINUTEMAN PRESS OF CAMBRIDGE, CAMBRIDGE, MA. FILED 12-23-2010.

**Business Card Block Party**

THE MARK CONSISTS OF STANDARD CHARACTERS WITHOUT CLAIM TO ANY PARTICULAR FONT, STYLE, SIZE, OR COLOR.

NO CLAIM IS MADE TO THE EXCLUSIVE RIGHT TO USE "BUSINESS CARD", APART FROM THE MARK AS SHOWN.

FOR ENVIRONMENTALLY-FRIENDLY BUSINESS PRINTING SERVICES, NAMELY, BUSINESS CARDS (U.S. CLS. 100, 103 AND 106).

KHANH LE, EXAMINING ATTORNEY

SN 85-207,068. SWEET CHEEKS, INC., HOLLY SPRINGS, NC. FILED 12-29-2010.

**HEAVENLY BAKED GOODS**

THE MARK CONSISTS OF STANDARD CHARACTERS WITHOUT CLAIM TO ANY PARTICULAR FONT, STYLE, SIZE, OR COLOR.

NO CLAIM IS MADE TO THE EXCLUSIVE RIGHT TO USE "BAKED GOODS", APART FROM THE MARK AS SHOWN.

FOR BAKERY SERVICES, NAMELY, THE MANUFACTURE OF BAKERY PRODUCTS TO ORDER AND/OR SPECIFICATION OF OTHERS (U.S. CLS. 100, 103 AND 106).

JEFFERY COWARD, EXAMINING ATTORNEY

SN 85-207,504. RITTENHOUSE, JOHN, MELROSE PARK, IL. FILED 12-29-2010.

**DUROTAPE**

THE MARK CONSISTS OF STANDARD CHARACTERS WITHOUT CLAIM TO ANY PARTICULAR FONT, STYLE, SIZE, OR COLOR.

FOR CONVERSION OF LARGE ROLLS OF PAPER TAPE INTO SMALLER ROLLS OF PAPER TAPE (U.S. CLS. 100, 103 AND 106).

KELLY BOULTON, EXAMINING ATTORNEY

**CLASS 40—(Continued).**

SN 85-208,874. CLEAN WIND ENERGY, INC, ANNAPOLIS, MD. FILED 1-2-2011.



NO CLAIM IS MADE TO THE EXCLUSIVE RIGHT TO USE "CLEAN WIND ENERGY", APART FROM THE MARK AS SHOWN.

THE COLOR(S) LIGHT BLUE, MEDIUM BLUE AND DARK BLUE IS/ARE CLAIMED AS A FEATURE OF THE MARK.

THE MARK CONSISTS OF THE WORDS "CLEAN WIND ENERGY" IN A TWO TONED ARRANGEMENT WITH LIGHT BLUE AT THE TOP OF THE LETTERS AND DARK BLUE AT THE BOTTOM OF THE LETTERS. A MEDIUM BLUE STRIP ENCIRCLES THE WORDS "CLEAN WIND ENERGY" AND THREE FANCIFUL BIRDS' HEADS - ONE OF EACH IN LIGHT BLUE, MEDIUM BLUE AND DARK BLUE - ARE PLACED ABOVE THE WORDS "CLEAN WIND ENERGY" WITH THE THREE BIRDS' HEADS OVERLAPPING ONE ANOTHER. THE COLOR WHITE REPRESENTS TRANSPARENT AREAS AND IS NOT A PART OF THE MARK.

FOR CONSULTING SERVICES IN THE FIELD OF PRODUCTION OF WIND ENERGY; ENERGY GENERATION SERVICES; GENERATION OF ENERGY; PRODUCTION OF ENERGY; PRODUCTION OF WIND ENERGY (U.S. CLS. 100, 103 AND 106).

RUDY R. SINGLETON, EXAMINING ATTORNEY

---

SN 85-209,074. RICHARDS, DAVID, DBA DAVEY CRACKETT'S PECAN CRACKING SHED, HATTIESBURG, MS. FILED 1-3-2011.

**DAVEY CRACKETT**

THE MARK CONSISTS OF STANDARD CHARACTERS WITHOUT CLAIM TO ANY PARTICULAR FONT, STYLE, SIZE, OR COLOR.

THE NAME(S), PORTRAIT(S), AND/OR SIGNATURE(S) SHOWN IN THE MARK DOES NOT IDENTIFY A PARTICULAR LIVING INDIVIDUAL.

SEC. 2(F).  
FOR FOOD PROCESSING (U.S. CLS. 100, 103 AND 106).

FIRST USE 12-1-2009; IN COMMERCE 12-1-2009.  
SANDRA BUJA, EXAMINING ATTORNEY

**CLASS 40—(Continued).**

SN 85-209,099. RICHARDS, DAVID, DBA DAVEY CRACKETT'S PECAN CRACKING SHED, HATTIESBURG, MS. FILED 1-3-2011.



THE MARK CONSISTS OF A SQUIREL WEARING A COONSKIN HAT STANDING NEXT TO A BUCKET OF SHELLED PECANS.

SEC. 2(F).  
FOR FOOD PROCESSING (U.S. CLS. 100, 103 AND 106).

FIRST USE 12-1-2009; IN COMMERCE 12-1-2009.  
SANDRA BUJA, EXAMINING ATTORNEY

---

SN 85-213,398. SHELBY STEPHENS, DBA HIDDON CONCEPTS, SAN LUIS OBISPO, CA. FILED 1-8-2011.

**what's your motive?**

THE MARK CONSISTS OF STANDARD CHARACTERS WITHOUT CLAIM TO ANY PARTICULAR FONT, STYLE, SIZE, OR COLOR.

FOR CUSTOMIZED IMPRINTING OF COMPANY NAMES AND LOGOS ON THE GOODS OF OTHERS, NAMELY, ON PROMOTIONAL MERCHANDISE, APPAREL AND CORPORATE GIFTS (U.S. CLS. 100, 103 AND 106).

CORY BOONE, EXAMINING ATTORNEY

---

SN 85-214,010. TOP METAL BUYERS, INC., EAST ST. LOUIS, IL. FILED S.R. 1-10-2011; AM. P.R. 3-29-2011.

**Get Weighed Get Paid**

THE MARK CONSISTS OF STANDARD CHARACTERS WITHOUT CLAIM TO ANY PARTICULAR FONT, STYLE, SIZE, OR COLOR.

FOR FERROUS AND NON-FERROUS SCRAP METAL RECYCLING (U.S. CLS. 100, 103 AND 106).  
FIRST USE 5-4-2009; IN COMMERCE 5-4-2009.  
KAPIL BHANOT, EXAMINING ATTORNEY

**CLASS 40—(Continued).**

SN 85-218,946. PREPAK SYSTEMS, INC., COOKEVILLE, TN. FILED 1-17-2011.

# APHENA

THE MARK CONSISTS OF STANDARD CHARACTERS WITHOUT CLAIM TO ANY PARTICULAR FONT, STYLE, SIZE, OR COLOR.

FOR MANUFACTURING SERVICES FOR OTHERS IN THE FIELD OF PHARMACEUTICALS (U.S. CLS. 100, 103 AND 106).

CAROLINE WOOD, EXAMINING ATTORNEY

SN 85-218,953. PREPAK SYSTEMS, INC., COOKEVILLE, TN. FILED 1-17-2011.



THE MARK CONSISTS OF A DESIGN WITH AN OVERALL TRIANGULAR SHAPE. THE COLORS BLACK AND GRAY IN THE DRAWING REPRESENT SHADING AND ARE NOT PART OF THE MARK.

FOR MANUFACTURING SERVICES FOR OTHERS IN THE FIELD OF PHARMACEUTICALS (U.S. CLS. 100, 103 AND 106).

CAROLINE WOOD, EXAMINING ATTORNEY

**CLASS 41—EDUCATION AND ENTERTAINMENT**

SN 76-702,569. ASHBURY RECORDS, LLC, SAN FRANCISCO, CA. FILED 4-21-2010.

# HALSTED

THE MARK CONSISTS OF STANDARD CHARACTERS WITHOUT CLAIM TO ANY PARTICULAR FONT, STYLE, SIZE, OR COLOR.

FOR LIVE MUSICAL PERFORMANCES BY A BAND (U.S. CLS. 100, 101 AND 107).

DAVID HOFFMAN, EXAMINING ATTORNEY

**CLASS 41—(Continued).**

SN 76-705,382. PJA, INC., ERIE, PA. FILED 11-17-2010.

## SNOWFIGHTERS UNIVERSITY

THE MARK CONSISTS OF STANDARD CHARACTERS WITHOUT CLAIM TO ANY PARTICULAR FONT, STYLE, SIZE, OR COLOR.

NO CLAIM IS MADE TO THE EXCLUSIVE RIGHT TO USE "SNOWFIGHTERS", APART FROM THE MARK AS SHOWN.

FOR EDUCATIONAL SERVICES, NAMELY, CLASSES, SEMINARS, WORKSHOPS, DEMONSTRATIONS AND TRAINING IN SNOW REMOVAL (U.S. CLS. 100, 101 AND 107).

BRIAN CALLAGHAN, EXAMINING ATTORNEY

SN 76-705,714. MARTIN COHEN, MONTVALE, NJ. FILED 12-17-2010.

# CONGAHEAD

THE MARK CONSISTS OF STANDARD CHARACTERS WITHOUT CLAIM TO ANY PARTICULAR FONT, STYLE, SIZE, OR COLOR.

FOR PUBLICATION OF MUSICAL TEXTS (U.S. CLS. 100, 101 AND 107).

MARLENE BELL, EXAMINING ATTORNEY

SN 76-705,754. THE COOPER INSTITUTE, DALLAS, TX. FILED 12-22-2010.



OWNER OF U.S. REG. NO. 3,707,253. NO CLAIM IS MADE TO THE EXCLUSIVE RIGHT TO USE "HEALTHY", APART FROM THE MARK AS SHOWN.

THE MARK CONSISTS OF AN APPLE DESIGN WITH A LEAF AT THE TOP OF THE APPLE; INSIDE THE APPLE IS A DEPICTION OF A HUMAN RUNNING; BENEATH THIS APPLE DESIGN IS THE TERM "HEALTHY ZONE" IN STYLIZED LETTERING, WHERE THE TERM "HEALTHY" IS UNDERLINED.

FOR PROVIDING RECOGNITION AND INCENTIVES BY THE WAY OF AWARDS TO DEMONSTRATE EXCELLENCE IN THE FIELD OF HEALTHY PRACTICES IN SCHOOLS, NAMELY, HONORING AND FEATURING SCHOOLS FOR THEIR HEALTHY PRACTICES AND ASSISTING SCHOOLS IN CREATING A SCHOOL ENVIRONMENT THAT IS OPTIMAL IN PROMOTING HEALTHY BEHAVIORS (U.S. CLS. 100, 101 AND 107).

FIRST USE 9-29-2010; IN COMMERCE 9-29-2010.

BENJAMIN OKEKE, EXAMINING ATTORNEY



**CLASS 41—(Continued).**

SN 77-261,264. STORYHIGHWAY, INC., NORFOLK, VA.  
FILED 8-22-2007.

**LUCKY LOUIE**

THE MARK CONSISTS OF STANDARD CHARACTERS WITHOUT CLAIM TO ANY PARTICULAR FONT, STYLE, SIZE, OR COLOR.

OWNER OF U.S. REG. NO. 1,413,335.  
FOR ENTERTAINMENT SERVICES IN THE NATURE OF AN ON-GOING ANIMATED CHILDREN'S TELEVISION PROGRAM (U.S. CLS. 100, 101 AND 107).  
PAUL MORENO, EXAMINING ATTORNEY

**CLASS 41—(Continued).**

SN 77-581,172. SCOTT FOSTER, DBA AFFABLE COMICS,  
VANCOUVER, CANADA, FILED 9-29-2008.

**WAR BEE**

THE MARK CONSISTS OF STANDARD CHARACTERS WITHOUT CLAIM TO ANY PARTICULAR FONT, STYLE, SIZE, OR COLOR.

PRIORITY CLAIMED UNDER SEC. 44(D) ON CANADA APPLICATION NO. 1411613, FILED 9-22-2008, REG. NO. TMA792,844, DATED 3-15-2011, EXPIRES 3-15-2026.

FOR ENTERTAINMENT SERVICES IN THE NATURE OF ON-GOING TELEVISION PROGRAMS FEATURING LIVE-ACTION, COMEDY, MUSICAL, DRAMA, DOCUMENTARIES AND ANIMATION FEATURING FICTIONAL HEROIC AND VILLAINOUS CHARACTERS; PRODUCTION OF ON-GOING TELEVISION PROGRAMS FEATURING LIVE-ACTION, COMEDY, MUSICAL, DRAMA, DOCUMENTARIES AND ANIMATION FEATURING FICTIONAL HEROIC AND VILLAINOUS CHARACTERS; PRODUCTION OF MOTION PICTURE THEATRICAL FILMS FEATURING LIVE-ACTION, COMEDY, MUSICAL, DRAMA, DOCUMENTARIES AND ANIMATION FEATURING FICTIONAL HEROIC AND VILLAINOUS CHARACTERS; ENTERTAINMENT IN THE NATURE OF LIVE PERFORMANCES BY FICTIONAL HEROIC AND VILLAINOUS CHARACTERS; DISTRIBUTION OF LIVE-ACTION, COMEDY, MUSICAL, DRAMA, DOCUMENTARIES AND ANIMATED MOTION PICTURE THEATRICAL FILMS; ANIMATION, FILM AND MUSIC PRODUCTION FOR DISTRIBUTION VIA THE GLOBAL COMPUTER INFORMATION NETWORK; PROVIDING ENTERTAINMENT INFORMATION ABOUT TELEVISION PROGRAMS AND MOTION PICTURE FILMS FEATURING FICTIONAL HEROIC AND VILLAINOUS CHARACTERS VIA A GLOBAL COMPUTER ELECTRONIC GAME SERVICES PROVIDED VIA A GLOBAL COMPUTER INFORMATION NETWORK; PROVIDING ON-LINE PUBLICATIONS IN THE NATURE OF BOOKS, COMIC BOOKS, CHILDREN'S BOOKS AND MAGAZINES FEATURING INFORMATION ABOUT FICTIONAL HEROIC AND VILLAINOUS CHARACTERS IN THE FIELD OF ANIMATION; PUBLICATION OF ELECTRONIC BOOKS ON-LINE; PUBLICATION OF PRINTED MEDIA AND RECORDINGS, NAMELY, MULTIMEDIA PUBLISHING OF BOOKS, COMIC BOOKS, CHILDREN'S BOOKS, MAGAZINES, GAMES AND MUSIC; ELECTRONIC PUBLISHING SERVICES, NAMELY, PUBLICATION OF TEXT AND GRAPHIC WORKS OF OTHERS ON CD AND DVD FEATURING ANIMATION; EDITING OR RECORDING OF SOUNDS AND IMAGES; ENTERTAINMENT, NAMELY, LIVE PERFORMANCES BY MUSICAL BANDS OR ROCK GROUPS; PRESENTATION OF LIVE MUSICAL, ROCK AND DANCE SHOW PERFORMANCES; ANIMATION PRODUCTION SERVICES; PUBLISHING SERVICES, NAMELY, PUBLISHING OF BOOKS, COMIC BOOKS, CHILDREN'S BOOKS AND MUSIC (U.S. CLS. 100, 101 AND 107).

MATTHEW KLINE, EXAMINING ATTORNEY

SN 77-361,035. KUKLACHEV, YURI, MOSCOW, RUSSIAN  
FED., FILED 12-28-2007.

**MOSCOW CATS THEATRE**

THE MARK CONSISTS OF STANDARD CHARACTERS WITHOUT CLAIM TO ANY PARTICULAR FONT, STYLE, SIZE, OR COLOR.

NO CLAIM IS MADE TO THE EXCLUSIVE RIGHT TO USE "THEATRE", APART FROM THE MARK AS SHOWN.  
SEC. 2(F).

FOR ARRANGING FOR TICKET RESERVATIONS FOR SHOWS AND OTHER ENTERTAINMENT EVENTS; BOOKING OF SEATS FOR SHOWS; BOOKING OF SEATS FOR SHOWS AND BOOKING OF THEATRE TICKETS; CONDUCTING ENTERTAINMENT EXHIBITIONS IN THE NATURE OF VISUAL AND AUDIO PERFORMANCES; ENTERTAINMENT IN THE NATURE OF AN ON-GOING SPECIAL VARIETY, NEWS, MUSIC OR COMEDY SHOW FEATURING CATS, PERFORMING TRICKS, BROADCAST OVER TELEVISION, SATELLITE, AUDIO, AND VIDEO MEDIA; ENTERTAINMENT IN THE NATURE OF MAGIC SHOWS; ENTERTAINMENT IN THE NATURE OF VISUAL AND AUDIO PERFORMANCES, AND MUSICAL, VARIETY, NEWS AND COMEDY SHOWS; PRESENTATION OF LIVE SHOW PERFORMANCES; PRODUCTION AND DISTRIBUTION OF TELEVISION SHOWS AND MOVIES; PLANNING ARRANGEMENT OF SHOWING MOVIES, SHOWS, PLAYS OR MUSICAL PERFORMANCES; ENTERTAINMENT IN THE NATURE OF LIVE PERFORMANCES BY CLOWNS WITH CATS AND/OR DOGS (U.S. CLS. 100, 101 AND 107).

FIRST USE 0-0-1977; IN COMMERCE 1-0-2001.

HEATHER THOMPSON, EXAMINING ATTORNEY

**CLASS 41—(Continued).**

SN 77-588,760. APEX, LLC, PAWTUCKET, RI. FILED 10-8-2008.

**Apex University**

THE MARK CONSISTS OF STANDARD CHARACTERS WITHOUT CLAIM TO ANY PARTICULAR FONT, STYLE, SIZE, OR COLOR.

NO CLAIM IS MADE TO THE EXCLUSIVE RIGHT TO USE "UNIVERSITY", APART FROM THE MARK AS SHOWN.

FOR ARRANGING OF EDUCATIONAL SERVICES, NAMELY, EDUCATIONAL DEMONSTRATIONS; PROVISION OF CLASSES, SEMINARS, WORKSHOPS, TRAINING AND INSTRUCTION IN THE FIELDS OF PERSONAL AND PROFESSIONAL TOPICS OF INTEREST IN THE NATURE OF BUSINESS MARKETING AND HEALTHY LIFESTYLES (U.S. CLS. 100, 101 AND 107).

FIRST USE 0-0-1994; IN COMMERCE 1-1-1995.  
TRACY WHITTAKER-BROWN, EXAMINING ATTORNEY

**CLASS 41—(Continued).**

SN 77-594,547. UBM MEDICA LLC, JERSEY CITY, NJ. FILED 10-16-2008.

**CANCERNETWORK.COM**

THE MARK CONSISTS OF STANDARD CHARACTERS WITHOUT CLAIM TO ANY PARTICULAR FONT, STYLE, SIZE, OR COLOR.

OWNER OF U.S. REG. NOS. 3,823,613 AND 3,918,440.  
SEC. 2(F).

FOR PROVIDING WEBCASTS IN THE FIELDS OF MEDICINE AND HEALTHCARE; PROVIDING ONLINE JOURNALS, NAMELY, BLOGS IN THE FIELDS OF MEDICINE AND HEALTHCARE; PROVIDING NON-DOWNLOADABLE ONLINE PUBLICATIONS IN THE NATURE OF NEWSLETTERS AND ARTICLES IN THE FIELD OF MEDICINE AND HEALTHCARE; EDUCATIONAL SERVICES, NAMELY, ARRANGING AND CONDUCTING CONFERENCES AND SEMINARS IN THE FIELDS OF MEDICINE AND HEALTHCARE; PROVIDING ONLINE CONTINUING EDUCATION SEMINARS IN THE FIELD OF MEDICINE AND HEALTHCARE (U.S. CLS. 100, 101 AND 107).

FIRST USE 8-23-2007; IN COMMERCE 8-23-2007.  
KAREN BRACEY, EXAMINING ATTORNEY

SN 77-588,785. APEX, LLC, PAWTUCKET, RI. FILED 10-8-2008.

**Apex**

THE MARK CONSISTS OF STANDARD CHARACTERS WITHOUT CLAIM TO ANY PARTICULAR FONT, STYLE, SIZE, OR COLOR.

FOR ARRANGING OF EDUCATIONAL SERVICES, NAMELY, EDUCATIONAL DEMONSTRATIONS; PROVISION OF CLASSES, SEMINARS, WORKSHOPS, TRAINING AND INSTRUCTION IN THE FIELDS OF PERSONAL AND PROFESSIONAL TOPICS OF INTEREST IN THE NATURE OF BUSINESS MARKETING AND HEALTHY LIFESTYLES (U.S. CLS. 100, 101 AND 107).

FIRST USE 0-0-1951; IN COMMERCE 0-0-1951.  
TRACY WHITTAKER-BROWN, EXAMINING ATTORNEY

SN 77-718,319. WINFIELD SOLUTIONS, LLC., SHOREVIEW, MN. FILED 4-21-2009.

**AGRISOLUTIONS**

THE MARK CONSISTS OF STANDARD CHARACTERS WITHOUT CLAIM TO ANY PARTICULAR FONT, STYLE, SIZE, OR COLOR.

SEC. 2(F).  
FOR EDUCATIONAL SERVICES, NAMELY, CONDUCTING WORKSHOPS, SEMINARS IN THE FIELD OF AGRICULTURAL CROP PRODUCTION AND DISTRIBUTION OF TRAINING MATERIAL IN CONNECTION THEREWITH FOR MARKETING OF AGRICULTURAL CHEMICALS AND PLANT NUTRIENTS (U.S. CLS. 100, 101 AND 107).

FIRST USE 3-29-2002; IN COMMERCE 3-29-2002.  
CHRISTINE COOPER, EXAMINING ATTORNEY

**CLASS 41—(Continued).**

SN 77-765,899. UMG RECORDINGS, INC., SANTA MONICA, CA. FILED 6-23-2009.

## TEEN ISLAND

THE MARK CONSISTS OF STANDARD CHARACTERS WITHOUT CLAIM TO ANY PARTICULAR FONT, STYLE, SIZE, OR COLOR.

NO CLAIM IS MADE TO THE EXCLUSIVE RIGHT TO USE "TEEN", APART FROM THE MARK AS SHOWN.

FOR PRODUCTION OF TELEVISION AND RADIO PROGRAMS; DISTRIBUTION OF TELEVISION AND RADIO PROGRAMS FOR OTHERS; PRODUCTION AND PUBLISHING OF MUSIC; PROVIDING ONLINE ENTERTAINMENT, NAMELY, PROVIDING SOUND AND VIDEO RECORDINGS IN THE FIELD OF MUSIC AND MUSIC-BASED ENTERTAINMENT; ENTERTAINMENT SERVICES, NAMELY, PROVIDING ONLINE, NON-DOWNLOADABLE PRERECORDED MUSICAL SOUND AND VIDEO RECORDINGS VIA A GLOBAL COMPUTER NETWORK; FAN CLUBS; DEVELOPMENT AND DISSEMINATION OF EDUCATIONAL MATERIALS OF OTHERS IN THE FIELD OF MUSIC AND ENTERTAINMENT; RADIO ENTERTAINMENT PRODUCTION AND DISTRIBUTION; AUDIO AND SOUND RECORDING AND PRODUCTION; RECORD PRODUCTION; VIDEOTAPE PRODUCTION; PRODUCTION OF MOTION PICTURE FILMS; DISTRIBUTION OF MOTION PICTURE FILMS; TELEVISION PROGRAM SYNDICATION; ENTERTAINMENT IN THE NATURE OF ONGOING TELEVISION PROGRAMS IN THE FIELD OF MUSIC AND ENTERTAINMENT; ENTERTAINMENT, NAMELY, A CONTINUING MUSIC AND ENTERTAINMENT SHOW DISTRIBUTED OVER TELEVISION, SATELLITE, AUDIO, AND VIDEO MEDIA; PUBLICATION OF BOOKS AND MAGAZINES; ENTERTAINMENT IN THE NATURE OF ONGOING RADIO PROGRAMS IN THE FIELD OF MUSIC AND ENTERTAINMENT; ENTERTAINMENT IN THE NATURE OF LIVE CONCERTS AND PERFORMANCES BY MUSICAL ARTISTS AND GROUPS; ENTERTAINMENT SERVICES, NAMELY, PERSONAL APPEARANCES BY MUSICAL GROUPS, MUSICAL ARTISTS, AND CELEBRITIES; ENTERTAINMENT SERVICES IN THE NATURE OF LIVE PERFORMANCES RENDERED BY MUSICAL ARTISTS THROUGH THE MEDIUMS OF TELEVISION, RADIO, AND AUDIO AND VIDEO RECORDINGS; ENTERTAINMENT SERVICES, NAMELY, PERFORMANCES BY MUSICAL ARTISTS RENDERED LIVE AND RECORDED FOR FUTURE DISTRIBUTION; EDUCATIONAL AND ENTERTAINMENT SERVICES, NAMELY, PRODUCTION AND PRESENTATION OF TELEVISION SHOWS, SPORTS EVENTS, FASHION SHOWS, GAME SHOWS, MUSIC SHOWS, AWARD SHOWS, AND COMEDY SHOWS BEFORE LIVE AUDIENCES THAT ARE ALL BROADCAST LIVE OR TAPED FOR LATER BROADCAST; ENTERTAINMENT SERVICES, NAMELY, PROVIDING A WEB SITE FEATURING PHOTOGRAPHS AND MULTIMEDIA MATERIALS IN THE FIELD OF MUSIC AND MUSIC-RELATED ENTERTAINMENT, MUSICAL PERFORMANCES, MUSICAL VIDEOS AND RELATED FILM CLIPS; ENTERTAINMENT SERVICES, NAMELY, PROVIDING ON-LINE REVIEWS OF MUSIC, MUSICAL ARTISTS, AND MUSIC VIDEOS; ENTERTAINMENT SERVICES, NAMELY, PROVIDING NON-DOWNLOADABLE PRERECORDED MUSIC, INFORMATION IN THE FIELD OF MUSIC, AND COMMENTARY AND ARTICLES ABOUT MUSIC, ALL ON-LINE VIA A GLOBAL COMPUTER NETWORK; ENTERTAINMENT

**CLASS 41—(Continued).**

SERVICES, NAMELY, LIVE, TELEVISED AND MOVIE APPEARANCES BY A PROFESSIONAL ENTERTAINER; CONDUCTING ENTERTAINMENT EXHIBITIONS IN THE NATURE OF MUSIC FESTIVALS; ENTERTAINMENT SERVICES, NAMELY, CONDUCTING EXHIBITIONS IN THE FIELD OF MUSIC AND THE ARTS; ORGANIZING EXHIBITIONS FOR ENTERTAINMENT PURPOSES FEATURING MUSIC AND THE ARTS; PUBLISHING OF WEB MAGAZINES; AND PREPARING AUDIO-VISUAL DISPLAYS IN THE FIELD OF MUSIC FOR ENTERTAINMENT PURPOSES (U.S. CLS. 100, 101 AND 107).

CORY BOONE, EXAMINING ATTORNEY

SN 77-791,671. G4 MEDIA, INC., LOS ANGELES, CA. FILED 7-28-2009.

## DUTY FREE TV

THE MARK CONSISTS OF STANDARD CHARACTERS WITHOUT CLAIM TO ANY PARTICULAR FONT, STYLE, SIZE, OR COLOR.

NO CLAIM IS MADE TO THE EXCLUSIVE RIGHT TO USE "TV", APART FROM THE MARK AS SHOWN.

FOR PRODUCTION AND DISTRIBUTION OF TELEVISION PROGRAMS; THE PROVISION OF ONGOING TELEVISION PROGRAMS FEATURING UNIQUE TV SHOWS FROM AROUND THE WORLD; PRODUCTION AND DISTRIBUTION OF TELEVISION PROGRAMS FEATURING UNIQUE TV SHOWS FROM AROUND THE WORLD AVAILABLE VIA THE INTERNET; THE PROVISION OF ONGOING TELEVISION PROGRAMS FEATURING UNIQUE TV SHOWS FROM AROUND THE WORLD DELIVERED VIA THE INTERNET; PRODUCTION AND DISTRIBUTION OF TELEVISION PROGRAMS FEATURING UNIQUE TV SHOWS FROM AROUND THE WORLD AVAILABLE VIA WIRELESS AND MOBILE DEVICES; THE PROVISION OF ONGOING TELEVISION PROGRAMS FEATURING UNIQUE TV SHOWS FROM AROUND THE WORLD DELIVERED VIA WIRELESS AND MOBILE DEVICES; PROVIDING ON-LINE JOURNALS, NAMELY, BLOGS IN THE FIELDS OF ENTERTAINMENT AND UNIQUE TV SHOWS FROM AROUND THE WORLD; VIDEO FILMING AND RECORDING; PROVIDING INFORMATION REGARDING THE FOREGOING VIA GLOBAL COMPUTER NETWORKS AND WIRELESS NETWORKS, NAMELY, INFORMATION NEWS, COMMENTARY AND ARTICLES IN THE FIELDS OF ENTERTAINMENT AND UNIQUE TV SHOWS FROM AROUND THE WORLD (U.S. CLS. 100, 101 AND 107).

B. PARADEWELAI, EXAMINING ATTORNEY

**CLASS 41—(Continued).**

SN 77-826,591. REDEEMER CITYNET, NEW YORK, NY. FILED 9-15-2009.

**REDEEMER CITY TO CITY**

THE MARK CONSISTS OF STANDARD CHARACTERS WITHOUT CLAIM TO ANY PARTICULAR FONT, STYLE, SIZE, OR COLOR.

FOR AUDIO RECORDING AND PRODUCTION; DEVELOPMENT AND DISSEMINATION OF EDUCATIONAL MATERIALS OF OTHERS IN THE FIELD OF CHURCH PLANTING, URBAN RENEWAL AND RELIGIOUS INSTRUCTION; EDUCATION SERVICES, NAMELY, PROVIDING CLASSES, SEMINARS, WORKSHOPS, ONLINE NON-DOWNLOADABLE BOOKS, ONLINE PUBLICATIONS IN THE NATURE OF E-BOOKS AND WEB ARTICLES, ALL IN THE FIELD OF CHURCH PLANTING, URBAN RENEWAL AND RELIGIOUS INSTRUCTION; EDUCATIONAL SERVICES, NAMELY, DEVELOPING, ARRANGING, AND CONDUCTING EDUCATIONAL CONFERENCES AND PROGRAMS AND PROVIDING COURSES OF INSTRUCTION IN THE FIELD OF CHURCH PLANTING, URBAN RENEWAL AND RELIGIOUS INSTRUCTION; PROVIDING PODCASTS IN THE FIELD OF CHURCH PLANTING, URBAN RENEWAL AND RELIGIOUS INSTRUCTION; FILM AND VIDEO PRODUCTION; PROVIDING A WEB SITE THAT FEATURES INFORMAL INSTRUCTION ON CHURCH PLANTING, URBAN RENEWAL AND RELIGIOUS INSTRUCTION (U.S. CLS. 100, 101 AND 107).

FIRST USE 8-31-2009; IN COMMERCE 8-31-2009.  
GISELLE AGOSTO, EXAMINING ATTORNEY

---

SN 77-847,138. KABUSHIKI KAISHA TAITO, TOKYO 151-0053, JAPAN, FILED 10-12-2009.

**CHASE H.Q.**

THE MARK CONSISTS OF STANDARD CHARACTERS WITHOUT CLAIM TO ANY PARTICULAR FONT, STYLE, SIZE, OR COLOR.

OWNER OF U.S. REG. NO. 1,548,466.  
FOR (BASED ON USE IN COMMERCE) ENTERTAINMENT SERVICES, NAMELY, PROVIDING ON-LINE COMPUTER GAMES; ENTERTAINMENT SERVICES, NAMELY, PROVIDING ON-LINE REVIEWS OF COMPUTER GAMES; ENTERTAINMENT SERVICES, NAMELY, PROVIDING A WEB SITE FEATURING COMPUTER GAMES; PROVIDING A WEB SITE THAT HAS A DATABANK CONTAINING COMPUTER GAMES AND PROVIDING GAME PLAYERS ON SAID SITE ACCESS TO THE GAMES IN SAID DATABANK; (BASED ON INTENT TO USE) ENTERTAINMENT SERVICES, NAMELY, ARRANGING AND CONDUCTING OF COMPETITIONS FOR COMPUTER GAMES (U.S. CLS. 100, 101 AND 107).

FIRST USE 4-0-2006; IN COMMERCE 4-0-2006.  
ANNE E. GUSTASON, EXAMINING ATTORNEY

**CLASS 41—(Continued).**

SN 77-854,765. OUTTA MY HEAD PRODUCTIONS, INC., MADISON, AL. FILED 10-22-2009.



THE MARK CONSISTS OF AN IMAGE OF A HOLLOW MASK FOR A HUMAN HEAD. THE MASK APPEARS TO BE SCULPTURED TO EXHIBIT A HUMAN FACE INCLUDING A NOSE AT THE CENTER OF THE MASK AND A MOUTH BELOW THE NOSE. TWO HOLES IN THE MASK ARE POSITIONED ON OPPOSITE SIDES OF THE NOSE, AND EACH HOLE IS IN THE SHAPE OF AN EYE. THE TOP OF THE MASK HAS A STRIP THAT IS SPIRALED UPWARD IN A DIRECTION AWAY FROM THE FACE. A BALL APPEARS WITHIN THE MASK AND IS VISIBLE THROUGH THE HOLES AND THROUGH SPACES BETWEEN THE SPIRALING STRIP AT THE TOP OF THE MASK.

FOR ENTERTAINMENT SERVICES, NAMELY, PRODUCTION AND DISTRIBUTION OF MOTION PICTURE FILMS, ANIMATED MOVIES, TELEVISION PROGRAMS, AND ANIMATED VIDEOS; PROVIDING ONLINE COMPUTER GAMES; PROVIDING ONLINE VIDEO GAMES; PROVIDING ON-GOING ANIMATED TELEVISION PROGRAMS; PUBLICATION OF PRINTED MATTER FEATURING CARTOON CHARACTERS FOR CHILDREN; AND PUBLICATION OF BOOKS AND MAGAZINES FOR CHILDREN (U.S. CLS. 100, 101 AND 107).

LESLIE RICHARDS, EXAMINING ATTORNEY

---

SN 77-889,978. TEN THIRTY EIGHT, INC., DBA THE MAYAN NIGHTCLUB, LOS ANGELES, CA. FILED 12-9-2009.

**MAYAN**

THE MARK CONSISTS OF STANDARD CHARACTERS WITHOUT CLAIM TO ANY PARTICULAR FONT, STYLE, SIZE, OR COLOR.

FOR MUSIC HALL, DISCOTHEQUE SERVICES, DANCE CLUB SERVICES, ENTERTAINMENT, NAMELY, LIVE PERFORMANCES IN THE NATURE OF VARIETY SHOWS, MUSIC CONCERTS, AND THEATER PRODUCTIONS; AND LIVE PERFORMANCES OF MUSIC GROUPS (U.S. CLS. 100, 101 AND 107).

FIRST USE 7-1-1990; IN COMMERCE 7-1-1990.  
SUE LAWRENCE, EXAMINING ATTORNEY

**CLASS 41—(Continued).**

SN 77-901,122. TEV LAW GROUP PC, DBA ZEGARELLI LAW GROUP, PITTSBURGH, PA. FILED 12-27-2009.

**STAND FOR AMERICA**

THE MARK CONSISTS OF STANDARD CHARACTERS WITHOUT CLAIM TO ANY PARTICULAR FONT, STYLE, SIZE, OR COLOR.

FOR ON-LINE ELECTRONIC AND EMAIL NEWSLETTERS IN THE FIELD OF ECONOMICS, HISTORY, PHILOSOPHY, RELIGION, PATRIOTISM AND NATIONAL INTERESTS; EDUCATIONAL SERVICES, NAMELY, PROVIDING SEMINARS IN THE FIELD OF SELF-IMPROVEMENT; ENTERTAINMENT SERVICES, NAMELY, CONDUCTING CONTESTS, CONDUCTING PARTIES, LIVE MUSICAL PERFORMANCES (U.S. CLS. 100, 101 AND 107).

AMY C. KEAN, EXAMINING ATTORNEY

SN 77-902,728. MODERN SURREALIST LLC, WINFIELD, IL. FILED 12-30-2009.

**America's Next Top Crafter**

THE MARK CONSISTS OF STANDARD CHARACTERS WITHOUT CLAIM TO ANY PARTICULAR FONT, STYLE, SIZE, OR COLOR.

NO CLAIM IS MADE TO THE EXCLUSIVE RIGHT TO USE "AMERICA'S" AND "CRAFTER", APART FROM THE MARK AS SHOWN.

FOR ENTERTAINMENT, NAMELY, A CONTINUING CRAFTING COMPETITION SHOW BROADCAST OVER TELEVISION, SATELLITE, AUDIO, AND VIDEO MEDIA (U.S. CLS. 100, 101 AND 107).

HOWARD B. LEVINE, EXAMINING ATTORNEY

SN 77-906,477. BAGS4KIDS FOUNDATION, CALIFORNIA CITY, CA. FILED 1-6-2010.

**bags4kids**

THE MARK CONSISTS OF STANDARD CHARACTERS WITHOUT CLAIM TO ANY PARTICULAR FONT, STYLE, SIZE, OR COLOR.

SEC. 2(F).

FOR CHARITABLE SERVICES, NAMELY, PROVIDING CARE PACKAGES IN THE FORM OF FILLED BACKPACKS AND BAGS CONTAINING TOYS, BOOKS, SCHOOL SUPPLIES, COLORING BOOKS AND CRAYONS TO CHILDREN WHO HAVE BEEN DISPLACED OR ARE IN A CRISES (U.S. CLS. 100, 101 AND 107).

FIRST USE 6-0-2002; IN COMMERCE 6-0-2002.

STEVEN PEREZ, EXAMINING ATTORNEY

**CLASS 41—(Continued).**

SN 77-921,134. WAEL KABBANI, SAN FRANCISCO, CA. FILED 1-27-2010.

**BLUE TSUNAMI**

THE MARK CONSISTS OF STANDARD CHARACTERS WITHOUT CLAIM TO ANY PARTICULAR FONT, STYLE, SIZE, OR COLOR.

FOR ENTERTAINMENT SERVICES, NAMELY, PROVIDING A WEBSITE FEATURING CARTOONS, COMIC BOOK CHARACTERS AND NON-DOWNLOADABLE INTERACTIVE GAMES (U.S. CLS. 100, 101 AND 107).

INGRID C. EULIN, EXAMINING ATTORNEY

SN 77-949,218. HODGES, ASH, NEWPORT BEACH, CA. FILED 3-3-2010.



NO CLAIM IS MADE TO THE EXCLUSIVE RIGHT TO USE "DIRT", APART FROM THE MARK AS SHOWN.

THE COLOR(S) WHITE, BLACK, BROWN, BLUE, RED IS/ ARE CLAIMED AS A FEATURE OF THE MARK.

THE MARK CONSISTS OF A PICTURE OF A SHARK IN THE COLOR BLUE OUTLINED IN THE COLORS BLACK AND WHITE WITH THE COLOR RED APPEARING IN THE WHITE OF THE EYES. THE LETTERS "DI" "R" "T" ARE IN THE COLOR WHITE APPEARING ON THE BODY OF THE SHARK OVER A BLACK BACKGROUND WITH THE LETTERS "DI" APPEARING INSIDE A BOX OUTLINED IN WHITE, THE LETTER "R" APPEARING INSIDE A BOX OUTLINED IN WHITE, THE LETTER "T" APPEARING INSIDE A BOX OUTLINED IN WHITE WHICH LETTERS APPEAR OVER THE LETTERS "S" "H" "A" "R" "K" WHICH



**CLASS 41—(Continued).**

ARE IN THE COLOR WHITE OVER A BLACK BACKGROUND WITH THE LETTER "S" APPEARING INSIDE A BOX OUTLINED IN WHITE, THE LETTER "H" APPEARING INSIDE A BOX OUTLINED IN WHITE, THE LETTER "A" APPEARING INSIDE A BOX OUTLINED IN WHITE, THE LETTER "R" APPEARING INSIDE A BOX OUTLINED IN WHITE, THE LETTER "K" APPEARING INSIDE A BOX OUTLINED IN WHITE, WITH CLOUDS OF DIRT IN THE COLOR BROWN APPEARING UNDERNEATH AND BEHIND THE SHARK, ALL OVER A BLACK BACKGROUND.

FOR ENTERTAINMENT SERVICES, NAMELY, ORGANIZING CURRENT ACTION SPORTS, MOTOR SPORTS AND MOTOR CROSS EVENTS; PROVIDING COMMENTARY IN THE FIELD OF ACTION SPORTS, MOTOR SPORTS AND MOTOR CROSS EVENTS WITH BACKGROUND MUSICAL ARRANGEMENTS AND RECORDINGS; PROVIDING A WEBSITE FEATURING ENTERTAINMENT INFORMATION, NAMELY, VIDEO PRESENTATIONS, INFORMATION, OPINIONS, COMMENTARY AND IMAGES IN THE FIELD OF MOTOR SPORTS AND ACTION SPORTS WITH BACKGROUND MUSICAL ARRANGEMENTS AND RECORDINGS; ENTERTAINMENT SERVICES, NAMELY, PROVIDING A WEB SITE FEATURING VIDEO PRESENTATIONS IN THE FIELD OF SPORTS, MOTOR SPORTS AND ACTION SPORTS WITH BACKGROUND MUSICAL ARRANGEMENTS; ON-LINE JOURNALS, NAMELY, BLOGS IN THE FIELD OF SPORTS, MOTOR SPORTS AND ACTION SPORTS (U.S. CLS. 100, 101 AND 107).

FIRST USE 5-1-2009; IN COMMERCE 5-1-2009.  
MICHELE SWAIN, EXAMINING ATTORNEY

SN 79-086,553. FUTURE PRESIDENTS ENTERTAINMENT V.O.F., NETHERLANDS, FILED 2-1-2010.

**FUTURE PRESIDENTS**

THE MARK CONSISTS OF STANDARD CHARACTERS WITHOUT CLAIM TO ANY PARTICULAR FONT, STYLE, SIZE, OR COLOR.

PRIORITY DATE OF 9-29-2009 IS CLAIMED.

OWNER OF INTERNATIONAL REGISTRATION 1048949 DATED 2-1-2010, EXPIRES 2-1-2020.

FOR ENTERTAINMENT, NAMELY, LIVE MUSIC CONCERTS; LIVE MUSIC CONCERT PERFORMANCES; MUSIC COMPOSITIONS FOR OTHERS; MUSIC PRODUCTION SERVICES; SCRIPTWRITING SERVICES; LAYOUT, WRITING AND EDITING OF TEXTS; AUDIO-VISUAL PRODUCTIONS, OTHER THAN FOR ADVERTISING PURPOSES; WRITING AND LAYOUT FOR TEXTS, OTHER THAN FOR ADVERTISING PURPOSES; ADVISORY, CONSULTANCY AND INFORMATION REGARDING AFOREMENTIONED SERVICES (U.S. CLS. 100, 101 AND 107).

JOHN WILKE, EXAMINING ATTORNEY

SN 79-090,959. CATAPULT INNOVATIONS PTY LTD, AUSTRALIA, FILED 10-15-2010.

**player load**

THE MARK CONSISTS OF STANDARD CHARACTERS WITHOUT CLAIM TO ANY PARTICULAR FONT, STYLE, SIZE, OR COLOR.

OWNER OF INTERNATIONAL REGISTRATION 1060998 DATED 10-15-2010, EXPIRES 10-15-2020.

FOR ATHLETIC TRAINING SERVICES, NAMELY, ANALYZING AND INTERPRETING DATA TO MONITOR THE PROGRESS AND PERFORMANCE OF ATHLETES (U.S. CLS. 100, 101 AND 107).

JULIE VEPPUMTHARA, EXAMINING ATTORNEY

**CLASS 41—(Continued).**

SN 85-011,750. EL.EN S.P.A., 50041 CALENZANO (FI), ITALY, FILED 4-12-2010.

**THE DEKA DIFFERENCE**

THE MARK CONSISTS OF STANDARD CHARACTERS WITHOUT CLAIM TO ANY PARTICULAR FONT, STYLE, SIZE, OR COLOR.

FOR EDUCATIONAL SERVICES, NAMELY, PROVIDING SEMINARS, WEBINARS, WORKSHOPS, CONGRESS LECTURES AND SYMPOSIA IN THE FIELD OF LASER-ASSISTED DENTISTRY (U.S. CLS. 100, 101 AND 107).

FIRST USE 6-1-2009; IN COMMERCE 6-1-2009.  
MARC LEIPZIG, EXAMINING ATTORNEY

SN 85-016,079. JENNA IP HOLDING COMPANY, LLC, SCOTTSDALE, AZ. FILED 4-16-2010.

**CLUB JENNA**

THE MARK CONSISTS OF STANDARD CHARACTERS WITHOUT CLAIM TO ANY PARTICULAR FONT, STYLE, SIZE, OR COLOR.

OWNER OF U.S. REG. NOS. 2,471,558 AND 2,544,267.

NO CLAIM IS MADE TO THE EXCLUSIVE RIGHT TO USE "CLUB", APART FROM THE MARK AS SHOWN.

FOR ENTERTAINMENT SERVICES, NAMELY, PROVIDING VISUAL IMAGES AND ARTICLES IN THE FIELD OF ADULT ENTERTAINMENT VIA A GLOBAL COMPUTER NETWORK, THE INTERNET OR THE WORLD WIDE WEB (U.S. CLS. 100, 101 AND 107).

FIRST USE 6-1-2000; IN COMMERCE 6-1-2000.  
ROBERT STRUCK, EXAMINING ATTORNEY

**CLASS 41—(Continued).**

SN 85-030,559. STENSLAND, JESSICA L, SAN DIEGO, CA. FILED 5-5-2010.

**MOVEMENTU**  
\* prepare to perform \*

THE MARK CONSISTS OF THE STYLIZED WORDS "MOVEMENTU PREPARE TO PERFORM" WITH A STAR TO THE LEFT AND RIGHT OF "PREPARE TO PERFORM".

FOR EDUCATION SERVICES, NAMELY, PROVIDING ON-LINE INFORMATION IN THE FIELD OF SPORTS PERFORMANCE, NAMELY, EXERCISE AND FITNESS AND CONSULTATION RELATED THERETO; EDUCATION SERVICES, NAMELY, PROVIDING LIVE WORKSHOPS IN THE FIELD OF HEALTH AND SPORTS PERFORMANCE; PROVIDING ASSISTANCE, PERSONAL TRAINING AND PHYSICAL FITNESS CONSULTATION TO CORPORATE CLIENTS TO HELP THEIR EMPLOYEES MAKE PHYSICAL FITNESS, STRENGTH, CONDITIONING, AND EXERCISE ALTERATIONS IN THEIR DAILY LIVING; PROVIDING ASSISTANCE, PERSONAL TRAINING AND PHYSICAL FITNESS CONSULTATION TO INDIVIDUALS TO HELP THEM MAKE PHYSICAL FITNESS, STRENGTH, CONDITIONING, AND EXERCISE IMPROVEMENT IN THEIR DAILY LIVING (U.S. CLS. 100, 101 AND 107).

FIRST USE 9-11-2009; IN COMMERCE 9-11-2009.  
JESSICA A. POWERS, EXAMINING ATTORNEY

**CLASS 41—(Continued).**

SN 85-034,367. THIRD DEGREE BURN LLC, MOUNT LAUREL, NJ. FILED 5-10-2010.

**SKY FERREIRA**

THE MARK CONSISTS OF STANDARD CHARACTERS WITHOUT CLAIM TO ANY PARTICULAR FONT, STYLE, SIZE, OR COLOR.

THE NAME(S), PORTRAIT(S), AND/OR SIGNATURE(S) SHOWN IN THE MARK IDENTIFIES "SKY FERREIRA", WHOSE CONSENT(S) TO REGISTER IS MADE OF RECORD.

FOR ENTERTAINMENT, NAMELY, PROVIDING LIVE CONCERTS AND MUSICAL AND VOCAL PERFORMANCES (U.S. CLS. 100, 101 AND 107).

KRISTINA MORRIS, EXAMINING ATTORNEY

SN 85-031,978. TERUMO CARDIOVASCULAR SYSTEMS CORPORATION, ANN ARBOR, MI. FILED 5-6-2010.

OPTIMIZING CONDUIT QUALITY

THE MARK CONSISTS OF STANDARD CHARACTERS WITHOUT CLAIM TO ANY PARTICULAR FONT, STYLE, SIZE, OR COLOR.

OWNER OF U.S. REG. NO. 3,132,745.

NO CLAIM IS MADE TO THE EXCLUSIVE RIGHT TO USE "CONDUIT QUALITY", APART FROM THE MARK AS SHOWN.

FOR EDUCATIONAL SERVICES, NAMELY, PROVIDING CLASSES, SEMINARS, CONFERENCES, AND WORKSHOPS IN THE FIELD OF CARDIAC SURGERY, AND THE DISTRIBUTION OF COURSE MATERIALS IN CONNECTION THEREWITH (U.S. CLS. 100, 101 AND 107).

KHANH LE, EXAMINING ATTORNEY

SN 85-035,581. SPIDERWOOD STUDIOS, LLC, DBA SPIDERWOOD STUDIOS, AUSTIN, TX. FILED 5-11-2010.

**SPIDERWOOD**  
*Studios*

NO CLAIM IS MADE TO THE EXCLUSIVE RIGHT TO USE "STUDIOS", APART FROM THE MARK AS SHOWN.

THE COLOR(S) BROWN, GOLD, RED, AND BLACK IS/ARE CLAIMED AS A FEATURE OF THE MARK.

THE MARK CONSISTS OF THE WORD "SPIDERWOOD" IN ALL CAPS IN THE COLOR BROWN WITH A GOLD HIGHLIGHT COLOR RUNNING IN A HORIZONTAL LINE THROUGH THE MIDDLE OF THE LETTERS. THE WORD IS ALSO OUTLINED IN BLACK. BENEATH THE TERM "SPIDERWOOD" IS THE TERM "STUDIOS" IN A RED SCRIPT.

FOR FILM AND VIDEO PRODUCTION; FILM STUDIOS (U.S. CLS. 100, 101 AND 107).

FIRST USE 11-8-2006; IN COMMERCE 11-8-2006.  
ELLEN PERKINS, EXAMINING ATTORNEY

**CLASS 41—(Continued).**

SN 85-038,585. COOKING CHANNEL, LLC, CINCINNATI, OH. FILED 5-14-2010.

**COOKING CHANNEL ON DEMAND**

THE MARK CONSISTS OF STANDARD CHARACTERS WITHOUT CLAIM TO ANY PARTICULAR FONT, STYLE, SIZE, OR COLOR.

NO CLAIM IS MADE TO THE EXCLUSIVE RIGHT TO USE "CHANNEL ON DEMAND", APART FROM THE MARK AS SHOWN.

SEC. 2(F).

FOR ENTERTAINMENT SERVICES, NAMELY, THE PRODUCTION OF LIVE AND ON-DEMAND TELEVISION PROGRAMS, DISTRIBUTED OVER TELEVISION, SATELLITE, WIRELESS, AUDIO AND VIDEO MEDIA, FIBER OPTICS, CABLE AND A GLOBAL COMPUTER NETWORK (U.S. CLS. 100, 101 AND 107).

FIRST USE 6-1-2010; IN COMMERCE 6-1-2010.  
INGRID C. EULIN, EXAMINING ATTORNEY

**CLASS 41—(Continued).**

GRAY, BLACK AND PEACH PENCIL THAT IS TO THE LEFT OF AN OPEN BOOK WITH A GREEN COVER WITH THE WORD "MAC" WRITTEN IN GRAY ON THE LEFT WHITE PAGE AND THE SYMBOL AND WORD "& HOLLY" WRITTEN IN ORANGE ON THE RIGHT WHITE PAGE, A FEMALE FIGURE STANDS TO THE RIGHT OF THE BOOK WITH YELLOW HAIR AND PEACH SKIN IN A PINK DRESS AND PINK PANTS HOLDING A BLACK, GRAY AND BROWN PAINTBRUSH WITH RED PAINT ON THE TIP

FOR CUSTOM WRITING SERVICES; EDUCATIONAL AND ENTERTAINMENT SERVICES, NAMELY, PROVIDING ON-LINE INTERACTIVE CHILDREN'S STORIES; ENTERTAINMENT AND EDUCATION SERVICES IN THE NATURE OF A SERIES OF SHORT SHOWS FEATURING CHILDREN'S STORIES DISTRIBUTED TO MOBILE HANDSETS, WHICH MAY INCLUDE VIDEO, TEXT, PHOTOS, ILLUSTRATIONS OR HYPERTEXT; ENTERTAINMENT IN THE NATURE OF RECITATION OF CHILDREN'S STORIES; ENTERTAINMENT SERVICES IN THE NATURE OF DEVELOPMENT, CREATION, PRODUCTION AND POST-PRODUCTION SERVICES OF MULTIMEDIA ENTERTAINMENT CONTENT; POEM AND LYRIC WRITING; PUBLICATION OF BOOKS; PUBLICATION OF PRINTED MATTER; PUBLISHING OF BOOKS, E-BOOKS, AUDIO BOOKS, MUSIC AND ILLUSTRATIONS; WRITING OF TEXTS OTHER THAN PUBLICITY TEXTS (U.S. CLS. 100, 101 AND 107).

FIRST USE 3-17-2010; IN COMMERCE 3-17-2010.  
ANTHONY RINKER, EXAMINING ATTORNEY

SN 85-040,100. STANDOFF STUDIOS, LLC, LINCOLNTON, GA. FILED 5-17-2010.

SN 85-039,860. COLGAN, MICHAEL ANGELO, JOHNS ISLAND, SC. AND SOOD, HOLLY HUNTER, JOHNS ISLAND, SC. FILED 5-17-2010.

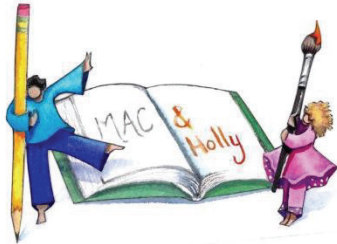

THE COLOR(S) BLUE, DARK BLUE, BROWN, GREEN, PINK, ORANGE, RED, YELLOW, WHITE, BLACK, GRAY, PEACH IS/ARE CLAIMED AS A FEATURE OF THE MARK.

THE MARK CONSISTS OF A DANCING MALE FIGURE WITH BLACK HAIR AND PEACH SKIN IN A BLUE SHIRT AND DARK BLUE PANTS HOLDING A YELLOW, PINK,

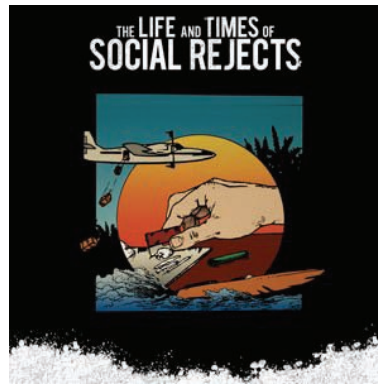

NO CLAIM IS MADE TO THE EXCLUSIVE RIGHT TO USE "THE LIFE AND TIMES OF SOCIAL REJECTS", APART FROM THE MARK AS SHOWN.

THE COLOR(S) THE COLORS BLACK, WHITE, DARK BLUE, GRAY BROWN, ORANGE, CREAM, SILVER AND GREEN IS/ARE CLAIMED AS A FEATURE OF THE MARK.

THE MARK CONSISTS OF A BROAD BLACK SQUARE BORDER WITH WHITE COCAINE POWDER AT THE BOTTOM, THE WORDING "THE LIFE AND TIMES OF SOCIAL REJECTS" APPEARS IN WHITE AT THE TOP, INSIDE THE BORDER IS A SQUARE CONTAINING A LANDSCAPE SCENE WITH A DARK BLUE SKY, PALM

**CLASS 41—(Continued).**

TREES IN BLACK AND BLUE AND WHITE WATER AT THE BOTTOM, THE SKY CONTAINS A GRAY AIRPLANE DROPPING BROWN BALES INTO THE WATER NEAR AN ORANGE SPEED BOAT. IN THE CENTER OF THE SCENE IS A LARGE ORANGE SUN, INSIDE THE SUN APPEARS A CREAM-COLORED HUMAN HAND HOLDING A SILVER RAZOR BLADE WITH A BROWN TOP CUTTING OUT WHITE COCAINE POWDER INTO ROWS ON A SILVER MIRROR, A GREEN MARIJUANA CIGARETTE APPEARS BELOW THE HAND ON A BROWN BACKGROUND.

FOR ENTERTAINMENT IN THE NATURE OF ON-GOING TELEVISION PROGRAMS IN THE FIELD OF REAL LIFE-BASED DRAMA; ENTERTAINMENT IN THE NATURE OF A DRAMATIC TELEVISION SERIES; ENTERTAINMENT SERVICES IN THE NATURE OF CREATION, DEVELOPMENT, AND PRODUCTION OF TELEVISION PROGRAMMING; ENTERTAINMENT SERVICES, NAMELY, AN ON-GOING SERIES FEATURING REAL LIFE-BASED DRAMA PROVIDED THROUGH TELEVISION; ENTERTAINMENT SERVICES, NAMELY, THE PROVISION OF CONTINUING REAL LIFE-BASED DRAMA FEATURING AN EPISODIC MINI-SERIES DELIVERED BY TELEVISION; ENTERTAINMENT, NAMELY, PRODUCTION OF AN EPISODIC TELEVISION SERIES BASED ON REAL-LIFE DRAMATIC AND HISTORICAL EVENTS (U.S. CLS. 100, 101 AND 107).

FIRST USE 6-16-2007; IN COMMERCE 6-16-2007.

JEFF DEFORD, EXAMINING ATTORNEY

SN 85-041,975. W-A-Y PROGRAM INCORPORATED, DBA WIDENING ADVANCEMENTS FOR YOUTH, ANN ARBOR, MI. FILED 5-18-2010.



NO CLAIM IS MADE TO THE EXCLUSIVE RIGHT TO USE "PROGRAM", APART FROM THE MARK AS SHOWN. THE COLOR(S) TEAL, ORANGE AND WHITE IS/ARE CLAIMED AS A FEATURE OF THE MARK.

THE MARK CONSISTS OF A STYLIZED LIGHTBULB OUTLINED IN TEAL, WITH SCREW BASE DELINEATED IN TEAL AND ORANGE RADIATING LINES ABOVE IT SUGGESTING LIGHT EMISSION. THIS LIGHTBULB IMAGE IS SIMULTANEOUSLY A STYLIZED IMAGE OF A GLOBE WITH VERTICAL AND HORIZONTAL LINES CROSSING IT IN TEAL. TO THE RIGHT OF THIS IMAGE IS VERBIAGE: "W-A-Y PROGRAM" IN TEAL AND WIDENING ADVANCEMENTS FOR YOUTH" IN ORANGE BELOW.

FOR EDUCATION SERVICES, NAMELY, PROVIDING LIVE AND ON-LINE CLASSES IN THE FIELD OF GENERAL K-12 EDUCATION (U.S. CLS. 100, 101 AND 107).

ROSELLE HERRERA, EXAMINING ATTORNEY

**CLASS 41—(Continued).**

SN 85-043,419. INTERWEAVE PRESS, LLC, LOVELAND, CO. FILED 5-20-2010.

**Interweave Bead Fest**

THE MARK CONSISTS OF STANDARD CHARACTERS WITHOUT CLAIM TO ANY PARTICULAR FONT, STYLE, SIZE, OR COLOR.

OWNER OF U.S. REG. NOS. 2,502,940, 3,167,717 AND OTHERS.

NO CLAIM IS MADE TO THE EXCLUSIVE RIGHT TO USE "FEST", APART FROM THE MARK AS SHOWN.

SEC. 2(F) AS TO "BEAD FEST".

FOR ORGANIZATION OF EDUCATIONAL AND CULTURAL EXHIBITIONS AND WORKSHOPS IN THE FIELD OF HANDCRAFTS (U.S. CLS. 100, 101 AND 107).

FIRST USE 4-0-2008; IN COMMERCE 4-0-2008.

DAVID TOOLEY, EXAMINING ATTORNEY

SN 85-044,040. TURNER GENERAL ENTERTAINMENT NETWORKS INDIA LIMITED, MAHIPALPUR, NEW DELHI, INDIA, FILED 5-20-2010.

**IMAGINE DIL SE**

THE MARK CONSISTS OF STANDARD CHARACTERS WITHOUT CLAIM TO ANY PARTICULAR FONT, STYLE, SIZE, OR COLOR.

THE ENGLISH TRANSLATION OF "DIL SE" IN THE MARK IS "FROM THE HEART".

FOR ENTERTAINMENT SERVICES, NAMELY, MULTIMEDIA PROGRAMMING FEATURING COMEDY, ACTION, ADVENTURE, DOCUMENTARIES, NEWS, TALK SHOWS AND/OR REALITY DISTRIBUTED VIA VARIOUS PLATFORMS ACROSS MULTIPLE FORMS OF TRANSMISSION MEDIA (U.S. CLS. 100, 101 AND 107).

AMY KERTGATE, EXAMINING ATTORNEY

SN 85-046,395. TRY PLAN B, L.L.C., PROVIDENCE, RI. FILED 5-24-2010.

**EVE L.**

THE MARK CONSISTS OF STANDARD CHARACTERS WITHOUT CLAIM TO ANY PARTICULAR FONT, STYLE, SIZE, OR COLOR.

FOR ENTERTAINMENT SERVICES, NAMELY, A GLOW IN THE DARK MINIATURE GOLF COURSE, VIDEO GAME ARCADE, REDEMPTION GAME ARCADE, NAMELY, AN AMUSEMENT ARCADE FEATURING GAMES THAT DISPENSE TICKETS WHICH MAY BE REDEEMED FOR PRIZES AND CONDUCTING BIRTHDAY PARTIES (U.S. CLS. 100, 101 AND 107).

DOMINIC FATHY, EXAMINING ATTORNEY

**CLASS 41—(Continued).**

SN 85-046,455. TRY PLAN B, L.L.C., PROVIDENCE, RI.  
FILED 5-24-2010.

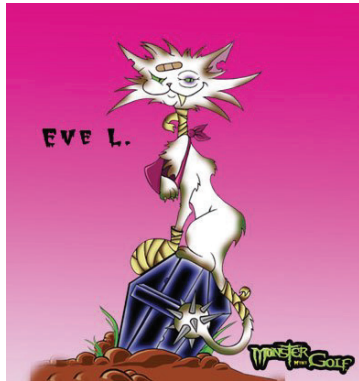

OWNER OF U.S. REG. NO. 3,579,061.  
NO CLAIM IS MADE TO THE EXCLUSIVE RIGHT TO USE "MINI GOLF", APART FROM THE MARK AS SHOWN. THE COLOR(S) PINK, WHITE, BLACK, BLUE, BROWN, GREEN, PURPLE, GRAY, YELLOW AND BEIGE IS/ARE CLAIMED AS A FEATURE OF THE MARK.

THE MARK CONSISTS OF THE WORDING "EVE L." IN THE COLOR BLACK, THE DESIGN OF A CAT, AND THE WORDING "MONSTER MINI GOLF." IN THE WITH "MONSTER" AND "GOLF." IN GREEN AND THE WORD "MINI" IN YELLOW OUTLINED IN BLACK. THE CAT DESIGN IS PRIMARILY WHITE WITH BLACK OUTLINING AND BROWN SHADING, A BEIGE BANDAGE ON THE FOREHEAD OF THE CAT, GREEN EYES, BLUE SHADING OVER THE RIGHT EYE, A PURPLE SLING HOLDING THE RIGHT ARM, A BEIGE BANDAGE OVER ON THE LEFT FRONT FOOT, THE NECK AND THE TAIL, THE RIGHT ARM OF THE CAT IN A PURPLE SLING, AND GRAY SPIKES COMING OUT OF THE TAIL. THE CAT IS SITTING ON A BLACK CHEST WITH BLUE SHADING AND THE CHEST IS SITUATED IN A BROWN MOUND OF DIRT WITH A FEW GREEN STRANDS OF GRASS IN THE DIRT. ALL ELEMENTS ARE ON A PINK BACKGROUND

FOR ENTERTAINMENT SERVICES, NAMELY, A GLOW IN THE DARK MINIATURE GOLF COURSE, VIDEO GAME ARCADE, REDEMPTION GAME ARCADE, NAMELY, AN AMUSEMENT ARCADE FEATURING GAMES THAT DISPENSE TICKETS WHICH MAY BE REDEEMED FOR PRIZES, AND CONDUCTING BIRTHDAY PARTIES (U.S. CLS. 100, 101 AND 107).

DOMINIC FATHY, EXAMINING ATTORNEY

**CLASS 41—(Continued).**

SN 85-046,499. TRY PLAN B, L.L.C., PROVIDENCE, RI.  
FILED 5-24-2010.



OWNER OF U.S. REG. NO. 3,579,061.

NO CLAIM IS MADE TO THE EXCLUSIVE RIGHT TO USE "MINI GOLF", APART FROM THE MARK AS SHOWN. THE COLOR(S) BLACK, BLUE, LIGHT BLUE, RED, GREEN, PURPLE, YELLOW AND ORANGE IS/ARE CLAIMED AS A FEATURE OF THE MARK.

THE MARK CONSISTS OF THE WORDING "GLO-ZO" IN THE COLOR GREEN, THE DESIGN OF A CLOWN, AND THE WORDING "MONSTER MINI GOLF." IN THE WITH "MONSTER" AND "GOLF." IN GREEN AND THE WORD "MINI" IN YELLOW. THE CLOWN HAS ORANGE AND YELLOW FLAMING EARS, A BLUE HAT WITH A LIGHT BLUE GLOWING POM POM AT THE TOP AND A GREEN BRIM. THE CLOWN'S FACE AND TEETH ARE A SHADE OF BLUE, THE CLOWN HAS RED LIPS AND TONGUE, A RED NOSE, GREEN EYES WITH BLACK DETAILS, DARK BLUE AND DARK SHADING AROUND THE EYES AND RED ACCENTS ARE AROUND THE ENTIRE HEAD. TWO PURPLE TREES WITH BLACK ACCENTS APPEAR ON EACH SIDE OF THE CLOWN'S FACE WITH YELLOW EYES AND MOUTHS. ALL ELEMENTS ARE ON A BLACK BACKGROUND.

FOR ENTERTAINMENT SERVICES, NAMELY, A GLOW IN THE DARK MINIATURE GOLF COURSE, VIDEO GAME ARCADE, REDEMPTION GAME ARCADE, NAMELY, AN AMUSEMENT ARCADE FEATURING GAMES THAT DISPENSE TICKETS WHICH MAY BE REDEEMED FOR PRIZES AND CONDUCTING BIRTHDAY PARTIES (U.S. CLS. 100, 101 AND 107).

DOMINIC FATHY, EXAMINING ATTORNEY

SN 85-050,212. LIGHTING SCIENCE GROUP CORPORATION, SATELLITE BEACH, FL. FILED 5-28-2010.

**LUMENS4HUMANS**

THE MARK CONSISTS OF STANDARD CHARACTERS WITHOUT CLAIM TO ANY PARTICULAR FONT, STYLE, SIZE, OR COLOR.

FOR EDUCATIONAL SERVICES, NAMELY, CLASSES, SEMINARS AND WORKSHOPS IN THE FIELD OF LIGHTING (U.S. CLS. 100, 101 AND 107).

MARY BOAGNI, EXAMINING ATTORNEY



**CLASS 41—(Continued).**

SN 85-051,010. CHARITABLE GOLF EVENTS, INC., GREENWOOD VILLAGE, CO. FILED 5-30-2010.

**PRO LEGENDS GOLF**

THE MARK CONSISTS OF STANDARD CHARACTERS WITHOUT CLAIM TO ANY PARTICULAR FONT, STYLE, SIZE, OR COLOR.

NO CLAIM IS MADE TO THE EXCLUSIVE RIGHT TO USE "PRO" AND "GOLF", APART FROM THE MARK AS SHOWN.

FOR ORGANISATION OF GOLF TOURNAMENTS FOR AMATEUR GOLFERS TO PLAY WITH ALUMNI MAJOR LEAGUE FOOTBALL, BASKETBALL, HOCKEY AND BASEBALL PLAYERS (U.S. CLS. 100, 101 AND 107).  
JOHN SCHUYLER YARD, EXAMINING ATTORNEY

SN 85-055,729. CLACKA HOLDINGS, LLC, DBA THE ACADEMY, LEHI, UT. FILED 6-6-2010.

**RIVEN ACADEMY**

THE MARK CONSISTS OF STANDARD CHARACTERS WITHOUT CLAIM TO ANY PARTICULAR FONT, STYLE, SIZE, OR COLOR.

NO CLAIM IS MADE TO THE EXCLUSIVE RIGHT TO USE "ACADEMY", APART FROM THE MARK AS SHOWN.

FOR PROVIDING FITNESS, SPORTS AND FITNESS TRAINING, AND EXERCISE FACILITIES (U.S. CLS. 100, 101 AND 107).

LESLIE RICHARDS, EXAMINING ATTORNEY

SN 85-056,469. RIPPLEROCK, LLC, INDIANAPOLIS, IN. FILED 6-7-2010.

**RIPPLEROCK**

THE MARK CONSISTS OF STANDARD CHARACTERS WITHOUT CLAIM TO ANY PARTICULAR FONT, STYLE, SIZE, OR COLOR.

FOR PROJECT MANAGEMENT TRAINING SERVICES IN THE FIELD OF SOFTWARE DEVELOPMENT (U.S. CLS. 100, 101 AND 107).

FIRST USE 3-8-2010; IN COMMERCE 3-8-2010.

AMY KERTGATE, EXAMINING ATTORNEY

**CLASS 41—(Continued).**

SN 85-056,481. RIPPLEROCK, LLC, INDIANAPOLIS, IN. FILED 6-7-2010.



THE MARK CONSISTS OF THE STYLIZED WORD "RIPPLEROCK" WITH A CIRCULAR DESIGN RESEMBLING RIPPLING WATER APPEARING BELOW AND TO THE RIGHT OF THE LETTER "K" IN "RIPPLEROCK".

FOR PROJECT MANAGEMENT TRAINING SERVICES IN THE FIELD OF SOFTWARE DEVELOPMENT (U.S. CLS. 100, 101 AND 107).

FIRST USE 3-8-2010; IN COMMERCE 3-8-2010.

AMY KERTGATE, EXAMINING ATTORNEY

SN 85-059,931. GRADUS, WARREN, YONKERS, NY. AND MILANO, FRED, MASSAPEQUA, NY. FILED 6-10-2010.

**THE BELMONTS**

THE MARK CONSISTS OF STANDARD CHARACTERS WITHOUT CLAIM TO ANY PARTICULAR FONT, STYLE, SIZE, OR COLOR.

SEC. 2(F).

FOR ENTERTAINMENT SERVICES, NAMELY, LIVE PERFORMANCES BY A SINGING GROUP (U.S. CLS. 100, 101 AND 107).

FIRST USE 1-0-1957; IN COMMERCE 1-0-1957.

CIMMERIAN COLEMAN, EXAMINING ATTORNEY

SN 85-060,907. HARMONIX MUSIC SYSTEMS, INC., NEW YORK, NY. FILED 6-11-2010.



THE MARK CONSISTS OF THE WORDING "DANCE CENTRAL" IN A STYLIZED FONT AND A DESIGN THAT CONSIST OF A SHADED RECTANGLE.

FOR ENTERTAINMENT SERVICES, NAMELY, PROVIDING AN ON-LINE COMPUTER GAME FOR OTHERS OVER GLOBAL AND LOCAL AREA COMPUTER NETWORKS; PROVIDING INFORMATION, NEWS, AND COMMENTARY IN THE FIELD OF COMPUTER GAMES, VIDEO GAMES, AND COMPUTER AND VIDEO GAMES RELATED PRODUCTS, OVER A GLOBAL COMPUTER NETWORK (U.S. CLS. 100, 101 AND 107).

RENEE MCCRAY, EXAMINING ATTORNEY

**CLASS 41—(Continued).**

SN 85-061,168. AKINS, VERA, SCOTTSDALE, AZ. FILED 6-11-2010.

**CE Buffet, where thought  
is the food**

THE MARK CONSISTS OF STANDARD CHARACTERS WITHOUT CLAIM TO ANY PARTICULAR FONT, STYLE, SIZE, OR COLOR.

NO CLAIM IS MADE TO THE EXCLUSIVE RIGHT TO USE "CE", APART FROM THE MARK AS SHOWN.

FOR CONTINUING EDUCATION SERVICES, NAMELY, PROVIDING LIVE AND ON-LINE CONTINUING PROFESSIONAL EDUCATION SEMINARS IN THE FIELD OF LAW AND MENTAL HEALTH (U.S. CLS. 100, 101 AND 107).

BRIAN CALLAGHAN, EXAMINING ATTORNEY

SN 85-061,923. DENVER SCHOOL DISTRICT #1, DENVER, CO. FILED 6-14-2010.



NO CLAIM IS MADE TO THE EXCLUSIVE RIGHT TO USE "PORTAL", APART FROM THE MARK AS SHOWN.

THE MARK CONSISTS OF SILHOUETTE OF A DOOR AND DOOR FRAME, TO THE RIGHT OF WHICH IS THE UNDERSCORED WORD "PORTAL".

FOR CONSULTATION IN THE FIELD OF K-12 EDUCATIONAL SYSTEMS; EDUCATION SERVICES, NAMELY, PROVIDING METRICS AND INFORMATION FOR SCHOOL ADMINISTRATORS, STAFF, TEACHERS, PARENTS AND STUDENTS IN THE FIELD OF MEASURING AND ADDRESSING SCHOOL, TEACHER AND STUDENT PERFORMANCE; EDUCATIONAL RESEARCH SERVICES VIA INTERNET; EDUCATIONAL SERVICES, NAMELY, OFFERING OF ASSESSMENTS AND SURVEYS IN THE FIELD OF EDUCATOR TRAINING AND PERFORMANCE FOR THE PURPOSE OF IMPROVING TEACHING PROCEDURES (U.S. CLS. 100, 101 AND 107).

ERNEST SHOSHO, EXAMINING ATTORNEY

**CLASS 41—(Continued).**

SN 85-062,306. LIFELONG EDUCATION INSTITUTE, MILL VALLEY, CA. FILED 6-14-2010.



NO CLAIM IS MADE TO THE EXCLUSIVE RIGHT TO USE "INTEGRATED SCIENCE PROGRAM", APART FROM THE MARK AS SHOWN.

THE COLOR(S) YELLOW, BLUE, BLACK AND WHITE IS/ARE CLAIMED AS A FEATURE OF THE MARK.

THE MARK CONSISTS OF THE LETTERS "I", "S" AND "P" IN BLACK, EACH CONTAINED WITHIN A SEPARATE WHITE-OUTLINED HEXAGON. THESE ELEMENTS APPEAR ON A BLUE BACKGROUND. TO THE RIGHT IS THE WORDING "INTEGRATED SCIENCE PROGRAM" IN BLACK STACKED VERTICALLY OVER THE WORDING "LEARN SCIENCE IN MONTHS NOT YEARS" IN BLACK. THESE ELEMENTS APPEAR ON A YELLOW BACKGROUND.

FOR EDUCATIONAL SERVICES, NAMELY, CONDUCTING CLASSES, SEMINARS, TRAINING AND WORKSHOPS IN THE FIELD OF SCIENCE AND DISTRIBUTING EDUCATIONAL MATERIALS AND CURRICULUM IN CONNECTION THEREWITH (U.S. CLS. 100, 101 AND 107).

MARLENE BELL, EXAMINING ATTORNEY

SN 85-063,466. SIEMENS ENTERPRISE COMMUNICATIONS GMBH & CO. KG, MUNCHEN, FED REP GERMANY, FILED 6-15-2010.

**MYCOR**

THE MARK CONSISTS OF STANDARD CHARACTERS WITHOUT CLAIM TO ANY PARTICULAR FONT, STYLE, SIZE, OR COLOR.

PRIORITY CLAIMED UNDER SEC. 44(D) ON FED REP GERMANY APPLICATION NO. 302009074222, FILED 12-16-2009, REG. NO. 302009074222, DATED 12-16-2009, EXPIRES 12-31-2019.

FOR EDUCATION SERVICES, NAMELY, PROVIDING CLASSES, SEMINARS AND WORKSHOPS IN THE FIELD OF TELECOMMUNICATIONS TECHNOLOGY REGARDING THE SETTING UP AND OPERATION OF TELECOMMUNICATION SYSTEMS AND TELECOMMUNICATION NETWORKS; TRAINING SERVICES IN THE FIELD OF TELECOMMUNICATIONS TECHNOLOGY REGARDING THE SETTING UP AND OPERATION OF TELECOMMUNICATION SYSTEMS AND TELECOMMUNICATION NETWORKS (U.S. CLS. 100, 101 AND 107).

ERIN FALK, EXAMINING ATTORNEY

**CLASS 41—(Continued).**

SN 85-064,937. VALENCIA RAY, MD, DBA VALENCIA RAY, LLC, NAPERVILLE, IL. FILED 6-17-2010.

## Mind Muscle Minutes

THE MARK CONSISTS OF STANDARD CHARACTERS WITHOUT CLAIM TO ANY PARTICULAR FONT, STYLE, SIZE, OR COLOR.

FOR BUSINESS EDUCATION AND TRAINING SERVICES, NAMELY, DEVELOPING, AND FACILITATING CUSTOMIZED IN-COMPANY LEADERSHIP AND EXECUTIVE DEVELOPMENT PROGRAMS, PROVIDING EXECUTIVE COACHING SERVICES, AND PROVIDING PUBLIC AND IN-COMPANY KEYNOTE PRESENTATIONS TO BUSINESS LEADERS; EDUCATIONAL AND ENTERTAINMENT SERVICES, NAMELY, PROVIDING MOTIVATIONAL SPEAKING SERVICES IN THE FIELD OF PERSONAL DEVELOPMENT; LIFE COACHING SERVICES IN THE FIELD OF PERSONAL DEVELOPMENT; PERSONAL COACHING SERVICES IN THE FIELD OF PERSONAL DEVELOPMENT; PROFESSIONAL COACHING SERVICES IN THE FIELD OF PERSONAL DEVELOPMENT; PROVIDING GROUP COACHING AND LEARNING FORUMS IN THE FIELD OF LEADERSHIP DEVELOPMENT; PROVIDING GROUP COACHING IN THE FIELD OF PERSONAL DEVELOPMENT; TELEPROMPTING SERVICES PROVIDED TO FILM AND TELEVISION AND CORPORATE PUBLIC SPEAKING (U.S. CLS. 100, 101 AND 107).

FIRST USE 10-9-2009; IN COMMERCE 10-12-2009.  
JOHN SCHUYLER YARD, EXAMINING ATTORNEY

SN 85-064,957. LITE FARE, LLC, PONTE VEDRA BEACH, FL. FILED 6-17-2010.

## SNACTOR

THE MARK CONSISTS OF STANDARD CHARACTERS WITHOUT CLAIM TO ANY PARTICULAR FONT, STYLE, SIZE, OR COLOR.

FOR ENTERTAINMENT SERVICES, NAMELY, ENTERTAINMENT INFORMATION; MOVIE ENTERTAINMENT, NAMELY, PROVIDING A WEBSITE AND BLOGS FEATURING INFORMATION AND COMMENTARY ON ACTORS AND ACTRESSES FOR ENTERTAINMENT PURPOSES (U.S. CLS. 100, 101 AND 107).

FIRST USE 4-1-2010; IN COMMERCE 6-3-2010.  
THOMAS MANOR, EXAMINING ATTORNEY

**CLASS 41—(Continued).**

SN 85-065,794. BUTLER, CAMERON, PORTLAND, OR. FILED 6-17-2010.



NO CLAIM IS MADE TO THE EXCLUSIVE RIGHT TO USE "STUDIOS", APART FROM THE MARK AS SHOWN.

THE MARK CONSISTS OF THE STYLIZED TEXT "[BAMF] STUDIOS".

FOR RECORDING STUDIOS (U.S. CLS. 100, 101 AND 107).

REGINA DRUMMOND, EXAMINING ATTORNEY

SN 85-067,228. SUPPES, WILLIAM, BEECHER, IL. FILED 6-21-2010.

## IRONHORSEMUSIC

THE MARK CONSISTS OF STANDARD CHARACTERS WITHOUT CLAIM TO ANY PARTICULAR FONT, STYLE, SIZE, OR COLOR.

FOR ENTERTAINMENT SERVICES, NAMELY, LIVE MUSICAL PERFORMANCES BY A MUSICAL BAND (U.S. CLS. 100, 101 AND 107).

REGINA DRUMMOND, EXAMINING ATTORNEY

SN 85-069,959. ZERO GRAVITY, LLC, MCLEAN, VA. FILED 6-23-2010.

## HIPS DOUBLE TIME PRODUCTIONS

THE MARK CONSISTS OF STANDARD CHARACTERS WITHOUT CLAIM TO ANY PARTICULAR FONT, STYLE, SIZE, OR COLOR.

NO CLAIM IS MADE TO THE EXCLUSIVE RIGHT TO USE "PRODUCTIONS", APART FROM THE MARK AS SHOWN.

FOR COMPOSITION OF MUSIC FOR OTHERS; CONSULTATION AND ADVICE REGARDING MUSICAL SELECTIONS AND ARRANGEMENTS FOR SOUND RECORDINGS AND LIVE PERFORMANCES; ENTERTAINMENT INFORMATION SERVICES, NAMELY, PROVIDING INFORMATION AND NEWS RELEASES ABOUT A MUSICAL ARTIST; ENTERTAINMENT SERVICES IN THE NATURE OF LIVE MUSICAL PERFORMANCES; ENTERTAINMENT SERVICES IN THE NATURE OF RECORDING, PRODUCTION AND POST-PRODUCTION SERVICES IN THE FIELDS OF MUSIC; ENTERTAINMENT SERVICES, NAMELY, DANCE EVENTS BY A RECORDING ARTIST; ENTERTAINMENT SERVICES, NAMELY, PROVIDING INFORMATION ABOUT A RECORDING ARTIST VIA AN ONLINE NETWORK; ENTERTAINMENT SERVICES, NAMELY, PROVIDING NON-DOWNLOADABLE PLAYBACK OF MUSIC VIA GLOBAL COMMUNICATIONS NETWORKS; ENTERTAINMENT, NAMELY, LIVE MUSIC CON-

**CLASS 41—(Continued).**

CERTS; ENTERTAINMENT, NAMELY, LIVE PERFORMANCES BY A MUSICAL BAND; ENTERTAINMENT, NAMELY, LIVE PERFORMANCES BY MUSICAL BANDS; FILM AND VIDEO PRODUCTION; FILM AND VIDEO PRODUCTION CONSULTING SERVICES; MULTIMEDIA ENTERTAINMENT SERVICES IN THE NATURE OF RECORDING, PRODUCTION AND POST-PRODUCTION SERVICES IN THE FIELDS OF MUSIC, VIDEO, AND FILMS; MUSIC PRODUCTION SERVICES; MUSIC PUBLISHING SERVICES; MUSIC VIDEO PRODUCTION; PLANNING ARRANGEMENT OF SHOWING MOVIES, SHOWS, PLAYS OR MUSICAL PERFORMANCES; PRESENTATION OF MUSICAL PERFORMANCE; PRODUCTION OF MUSICAL SOUND RECORDING; PRODUCTION OF SOUND AND MUSIC VIDEO RECORDINGS; PROVIDING A WEBSITE FEATURING INFORMATION IN THE FIELD OF MUSIC AND ENTERTAINMENT; PROVIDING AN INTERNET WEBSITE PORTAL FEATURING LINKS TO MUSICAL ARTIST WEBSITES AND MUSIC PERFORMANCE TICKET INFORMATION; PROVIDING AN INTERNET WEBSITE PORTAL IN THE FIELD OF MUSIC; PROVISION OF INFORMATION RELATING TO MUSIC; RECORD PRODUCTION; VIDEO PRODUCTION SERVICES (U.S. CLS. 100, 101 AND 107).

SAIMA MAKHDOOM, EXAMINING ATTORNEY

SN 85-070,030. THE CELL THEATRE COMPANY, LTD., DBA THE CELL, NEW YORK, NY. FILED 6-23-2010.

**A Twenty First Century  
Salon**

THE MARK CONSISTS OF STANDARD CHARACTERS WITHOUT CLAIM TO ANY PARTICULAR FONT, STYLE, SIZE, OR COLOR.

FOR ENTERTAINMENT AND EDUCATION SERVICES IN THE NATURE OF LIVE DANCE AND MUSICAL PERFORMANCES; ENTERTAINMENT IN THE NATURE OF THEATER PRODUCTIONS; ENTERTAINMENT IN THE NATURE OF VISUAL AND AUDIO PERFORMANCES, AND MUSICAL, VARIETY, NEWS AND COMEDY SHOWS; ENTERTAINMENT IN THE NATURE OF VISUAL AND AUDIO PERFORMANCES, NAMELY, MUSICAL BAND, ROCK GROUP, GYMNASTIC, DANCE, AND BALLET PERFORMANCES; ENTERTAINMENT IN THE NATURE OF VISUAL AND AUDIO PERFORMANCES BY AN ACTOR; ENTERTAINMENT SERVICES IN THE NATURE OF LIVE MUSICAL PERFORMANCES; ORGANIZING CULTURAL AND ARTS EVENTS; PLANNING ARRANGEMENT OF SHOWING MOVIES, SHOWS, PLAYS OR MUSICAL PERFORMANCES; PRESENTATION OF LIVE SHOW PERFORMANCES; PRESENTATION OF MUSICAL PERFORMANCE (U.S. CLS. 100, 101 AND 107).

FIRST USE 11-15-2009; IN COMMERCE 11-15-2009.

MARK SHINER, EXAMINING ATTORNEY

**CLASS 41—(Continued).**

SN 85-070,982. FRANCISCO NUNEZ, NEW YORK, NY. FILED 6-24-2010.



NO CLAIM IS MADE TO THE EXCLUSIVE RIGHT TO USE "RADIO", APART FROM THE MARK AS SHOWN. THE MARK CONSISTS OF THE WORD "RADIO" ON TOP OF THE WORD "RADIANCE" WITH A DESIGN OF SOUND WAVES TO THE RIGHT OF BOTH WORDS.

FOR PRODUCTION AND DISTRIBUTION OF RADIO PROGRAMS (U.S. CLS. 100, 101 AND 107).

FIRST USE 7-1-2008; IN COMMERCE 7-1-2008.  
GINA FINK, EXAMINING ATTORNEY

SN 85-071,001. FRANCISCO NUNEZ, NEW YORK, NY. FILED 6-24-2010.

**RADIO RADIANCE**

THE MARK CONSISTS OF STANDARD CHARACTERS WITHOUT CLAIM TO ANY PARTICULAR FONT, STYLE, SIZE, OR COLOR.

NO CLAIM IS MADE TO THE EXCLUSIVE RIGHT TO USE "RADIO", APART FROM THE MARK AS SHOWN. FOR PRODUCTION AND DISTRIBUTION OF RADIO PROGRAMS (U.S. CLS. 100, 101 AND 107).

FIRST USE 7-1-2008; IN COMMERCE 7-1-2008.  
GINA FINK, EXAMINING ATTORNEY

SN 85-071,106. TRIPOLI ROCKETRY ASSOCIATION, INC., HIGHLANDS RANCH, CO. FILED 6-24-2010.

**LDERS**

THE MARK CONSISTS OF STANDARD CHARACTERS WITHOUT CLAIM TO ANY PARTICULAR FONT, STYLE, SIZE, OR COLOR.

SEC. 2(F).

FOR ORGANIZING AND CONDUCTING EDUCATIONAL AND ENTERTAINMENT EXHIBITIONS IN THE NATURE OF CONVENTIONS IN THE FIELD OF ROCKETRY (U.S. CLS. 100, 101 AND 107).

FIRST USE 7-0-1961; IN COMMERCE 7-0-1961.

ALICE BENMAMAN, EXAMINING ATTORNEY

**CLASS 41—(Continued).**

SN 85-073,251. BIOTECH PRIMER, INC., TOWSON, MD.  
FILED 6-28-2010.



OWNER OF U.S. REG. NOS. 3,031,517 AND 3,040,228.  
NO CLAIM IS MADE TO THE EXCLUSIVE RIGHT TO USE "BIOTECH" AND "INDUSTRY KNOWLEDGE", APART FROM THE MARK AS SHOWN.

THE COLOR(S) BLUE, BLACK AND WHITE IS/ARE CLAIMED AS A FEATURE OF THE MARK.

THE MARK CONSISTS OF THE WORD "BIOTECH" IN THE COLOR BLACK, THE WORD "PRIMER" IN BLUE WITH THE LETTER "I" IN THE WORD "PRIMER" IS IN THE IMAGE OF A TEST TUBE AND ABOVE THE TEST TUBE IS A DNA MOLECULE IN BLUE FORMING THE DOT FOR THE LETTER "I", THE STYLIZED LETTER "I" IS IN BLUE AND WHITE AND THE WORDS "INDUSTRY KNOWLEDGE DELIVERED" ARE IN THE COLOR BLACK.

FOR EDUCATIONAL SERVICES, NAMELY, PROVIDING SEMINARS AND CLASSES IN THE FIELDS OF LIFE SCIENCES AND BIOTECHNOLOGY (U.S. CLS. 100, 101 AND 107).

FIRST USE 6-30-2008; IN COMMERCE 6-30-2008.  
EDWARD NELSON, EXAMINING ATTORNEY

SN 85-073,367. BLANTON, KYLE WAYNE, LAS VEGAS, NV.  
FILED 6-28-2010.

### Kyle Wayne Presents The Mighty Vegas Shows

THE MARK CONSISTS OF STANDARD CHARACTERS WITHOUT CLAIM TO ANY PARTICULAR FONT, STYLE, SIZE, OR COLOR.

NO CLAIM IS MADE TO THE EXCLUSIVE RIGHT TO USE "VEGAS SHOWS", APART FROM THE MARK AS SHOWN.

THE NAME "KYLE WAYNE" IDENTIFIES A LIVING INDIVIDUAL WHOSE CONSENT IS OF RECORD.

FOR EDUCATIONAL AND ENTERTAINMENT SERVICES IN THE FORM OF CIRCUS PERFORMANCES, CIRCUS FESTIVALS, AND FAIRS; PROVIDING AN ONLINE DATABASE FEATURING INFORMATION REGARDING ENTERTAINMENT, CIRCUSES, PERFORMERS, AND PRODUCTION SHOWS (U.S. CLS. 100, 101 AND 107).

FIRST USE 1-1-2003; IN COMMERCE 1-1-2003.  
CHRISTINA SOBRAL, EXAMINING ATTORNEY

**CLASS 41—(Continued).**

SN 85-074,677. THE WALLACE ENTERPRISES, INC.,  
FRANKLIN, TN. FILED 6-30-2010.



OWNER OF U.S. REG. NO. 3,869,465.

NO CLAIM IS MADE TO THE EXCLUSIVE RIGHT TO USE "SURGICAL SPECIALTIES COMPANY", APART FROM THE MARK AS SHOWN.

THE MARK CONSISTS OF THE WORDING "AMERICAN SURGICAL" UNDERLINED, WITH THE WORDING "SPECIALTIES COMPANY" BENEATH THE LINE AND WITH A DESIGN ELEMENT TO THE LEFT OF THE WORDING COMPRISED OF A SQUARE FORMED BY HORIZONTAL STRIPES THAT IS BISECTED BY A DIAGONAL LINE GOING UP AND TO THE RIGHT. THE SQUARE HAS AS STAR TO ITS RIGHT THAT IS HALF IN THE SQUARE AND HALF OUT OF THE SQUARE.

SEC. 2(F) AS TO "AMERICAN SURGICAL SPECIALTIES COMPANY".

FOR EDUCATION SERVICES, NAMELY, PROVIDING TRAINING SERVICES IN THE FIELD OF PROPER USE, STORAGE, MAINTENANCE AND REPAIR OF SURGICAL AND MEDICAL DEVICES, INSTRUMENTS AND EQUIPMENT (U.S. CLS. 100, 101 AND 107).

FIRST USE 3-1-2010; IN COMMERCE 3-1-2010.

JENNIFER VASQUEZ, EXAMINING ATTORNEY

SN 85-074,842. GEOFFREY SELZER, WEST HILLS, CA.  
FILED 6-30-2010.

### LUMINOUS BOOKS

THE MARK CONSISTS OF STANDARD CHARACTERS WITHOUT CLAIM TO ANY PARTICULAR FONT, STYLE, SIZE, OR COLOR.

NO CLAIM IS MADE TO THE EXCLUSIVE RIGHT TO USE "BOOKS", APART FROM THE MARK AS SHOWN.

FOR MULTIMEDIA PUBLISHING OF ARTWORK, TEXT, AUDIO, VIDEO, 3-D ANIMATION, AUDIO-VIDEO ENTERTAINMENT, BOOKS, MAGAZINES, PERIODICALS, ELECTRONIC PUBLICATIONS, SOFTWARE, GAMES, MUSIC AND REAL-TIME DATA AND CONTENT, ALL OF THE FOREGOING NOT IN THE FIELD OF RELIGION; PUBLICATION OF ELECTRONIC PUBLICATIONS, ELECTRONIC MAGAZINES, ELECTRONIC PERIODICALS AND ELECTRONIC BOOKS, ALL OF THE FOREGOING NOT IN THE FIELD OF RELIGION; PROVIDING NON-DOWNLOADABLE, ON-LINE PUBLICATIONS IN THE NATURE OF ELECTRONIC MAGAZINES, ELECTRONIC PERIODICALS AND ELECTRONIC BOOKS ON A WIDE RANGE OF TOPICS OF GENERAL INTEREST, NAMELY, ART, EDUCATION, SPORTS, BEAUTY, RETAIL SALES, PETS, AUTOMOBILES, DO-IT-YOURSELF, HISTORY, TRAVEL, SCIENCE, FASHION, TECHNOLOGY, CHILDREN'S CONTENT, GREEN TOPICS AND SUSTAINABILITY, GARDENING, MUSIC, SCIENCE FICTION, FOOD, WINE, HEALTH AND WELLNESS, FILMS, GAMES, NEWS AND CURRENT EVENTS, ARCHITECTURE AND INTERIOR DESIGN, ALL OF THE FOREGOING NOT IN THE FIELD OF RELIGION (U.S. CLS. 100, 101 AND 107).

MARTHA SANTOMARTINO, EXAMINING ATTORNEY



**CLASS 41—(Continued).**

SN 85-076,240. MINYANVILLE PUBLISHING & MULTI-MEDIA, LLC, NEW YORK, NY. FILED 7-1-2010.

**POP BIZ**

THE MARK CONSISTS OF STANDARD CHARACTERS WITHOUT CLAIM TO ANY PARTICULAR FONT, STYLE, SIZE, OR COLOR.

NO CLAIM IS MADE TO THE EXCLUSIVE RIGHT TO USE "BIZ", APART FROM THE MARK AS SHOWN.

FOR PRODUCTION OF TELEVISION PROGRAMS IN THE FIELDS OF NEWS, BUSINESS AND FINANCE (U.S. CLS. 100, 101 AND 107).

PRISCILLA MILTON, EXAMINING ATTORNEY

**CLASS 41—(Continued).**

SN 85-076,986. INVIDIATA, SHAE, OAKVILLE, CANADA, FILED 7-2-2010.

**FREE THEM - BUY ONE TO  
FREE ONE**

THE MARK CONSISTS OF STANDARD CHARACTERS WITHOUT CLAIM TO ANY PARTICULAR FONT, STYLE, SIZE, OR COLOR.

FOR EDUCATIONAL SERVICES, NAMELY, PROVIDING COURSES OF INSTRUCTION AND TRAINING BY WAY OF WORKSHOPS, SEMINARS, CLASSES, FORUMS AND SPEECHES IN THE FIELDS OF SOCIAL JUSTICE AND HUMAN RIGHTS, AND DISTRIBUTING PRINTED EDUCATIONAL MATERIALS IN CONNECTION THEREWITH; PROVIDING ONLINE COURSES OF INSTRUCTION AND TRAINING VIA A GLOBAL COMMUNICATIONS NETWORK FEATURING WORKSHOPS, SEMINARS, CLASSES, FORUMS AND SPEECHES IN THE FIELDS OF SOCIAL INJUSTICE AND HUMAN RIGHTS (U.S. CLS. 100, 101 AND 107).

RUSS HERMAN, EXAMINING ATTORNEY

SN 85-076,373. V-DAY CORPORATION, NEW YORK, NY. FILED 7-1-2010.

**V-MEN**

THE MARK CONSISTS OF STANDARD CHARACTERS WITHOUT CLAIM TO ANY PARTICULAR FONT, STYLE, SIZE, OR COLOR.

OWNER OF U.S. REG. NO. 2,997,189.

FOR PROVIDING A WEBSITE FEATURING INFORMATION FOR PRODUCING THEATRICAL AND EDUCATIONAL EVENTS FOR THE EMPOWERMENT OF WOMEN AND GIRLS AND PREVENTION OF VIOLENCE AGAINST WOMEN AND GIRLS; PROVIDING A WEBSITE FEATURING ARTICLES WRITTEN BY MEN ON THE SUBJECT OF PREVENTING VIOLENCE AGAINST WOMEN AND GIRLS AND EMPOWERING WOMEN AND GIRLS (U.S. CLS. 100, 101 AND 107).

FIRST USE 8-31-2009; IN COMMERCE 8-31-2009.

STEVEN R. FINE, EXAMINING ATTORNEY

SN 85-078,354. UBISOFT ENTERTAINMENT, RENNES, FRANCE, FILED 7-6-2010.

**UBICONNECT**

THE MARK CONSISTS OF STANDARD CHARACTERS WITHOUT CLAIM TO ANY PARTICULAR FONT, STYLE, SIZE, OR COLOR.

OWNER OF U.S. REG. NOS. 2,097,109, 2,911,567 AND OTHERS.

FOR ENTERTAINMENT SERVICES, NAMELY, PROVIDING AN ON-LINE COMPUTER GAME FOR OTHERS OVER LOCAL AREA COMPUTER NETWORKS AND PROVIDING TECHNICAL INFORMATION ON-LINE RELATING TO COMPUTER GAMES, VIDEO GAMES AND COMPUTER AND VIDEO GAMES RELATED PRODUCTS, NAMELY, COMPUTER MONITORS, COMPUTER PROCESSORS, COMPUTER CONTROLLERS FOR ELECTRONIC VIDEO GAMES, GRAPHIC CARDS, SPEAKERS, CONSOLE VIDEO GAME MACHINES, CONSOLE VIDEO GAME CONTROLLERS, AND MOBILE PHONES (U.S. CLS. 100, 101 AND 107).

JENNY PARK, EXAMINING ATTORNEY

**CLASS 41—(Continued).**

SN 85-079,482. MILWAUKEE BREWING COMPANY, MILWAUKEE, WI. FILED 7-7-2010.

**BEER ME THAT ROCK**

THE MARK CONSISTS OF STANDARD CHARACTERS WITHOUT CLAIM TO ANY PARTICULAR FONT, STYLE, SIZE, OR COLOR.  
FOR GUIDED TOURS OF A BREWERY (U.S. CLS. 100, 101 AND 107).  
FIRST USE 3-1-2010; IN COMMERCE 5-1-2010.  
KAREN SEVERSON, EXAMINING ATTORNEY

SN 85-079,892. PACIFIC SPORTS, LLC, ANAHEIM, CA 92806, CA. FILED 7-7-2010.



NO CLAIM IS MADE TO THE EXCLUSIVE RIGHT TO USE "NEWPORT BEACH TRIATHLON", APART FROM THE MARK AS SHOWN.

THE COLOR(S) PURPLE, GRAY/LIGHT PURPLE, MAGENTA/RED, GOLD, BLACK, DARK PURPLE, RED AND WHITE IS/ARE CLAIMED AS A FEATURE OF THE MARK.

THE MARK CONSISTS OF BRUSHES OF COLOR IN PURPLE OUTLINED IN GRAY/LIGHT PURPLE, MAGENTA/RED OUTLINED IN GRAY/LIGHT PURPLE AND GOLD OUTLINED IN GRAY/LIGHT PURPLE FORMING A TRIANGLE OVER A RECTANGLE OF BLACK WITH A SMALL RECTANGULAR BOX WITH THE LETTERS "K" IN GOLD ON A BACKGROUND OF DARK PURPLE AND "C" IN GRAY/LIGHT PURPLE ON A BACKGROUND OF MAGENTA/RED IN A RECTANGULAR BOX OUTLINED IN GOLD WITH THE WORDS "KRING & CHUNG" IN UPPER AND LOWER CASE IN WHITE BELOW THE TRIANGLE WITH THE WORDS "NEWPORT BEACH" BELOW "KRING & CHUNG" IN ALL CAPS WRITTEN IN GOLD AND OUTLINED IN RED AND PURPLE WITH THE WORD "TRIATHLON" WRITTEN IN WHITE AT THE BOTTOM OF THE BLACK RECTANGLE.

FOR ORGANIZING SPORTING EVENTS, NAMELY, TRIATHLONS; PROVIDING INFORMATION AND INSTRUCTION IN THE FIELD OF TRIATHLON EVENTS (U.S. CLS. 100, 101 AND 107).

FIRST USE 1-1-2010; IN COMMERCE 1-1-2010.

ROBERT C. CLARK JR., EXAMINING ATTORNEY

**CLASS 41—(Continued).**

SN 85-086,789. CASA DEL HERRERO FOUNDATION, SANTA BARBARA, CA. FILED 7-16-2010.

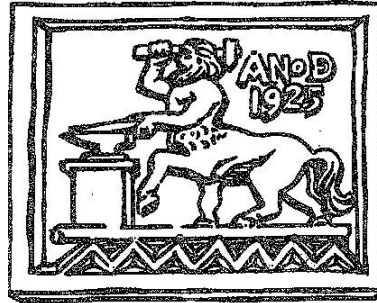

NO CLAIM IS MADE TO THE EXCLUSIVE RIGHT TO USE "1925", APART FROM THE MARK AS SHOWN.

THE MARK CONSISTS OF A CENTAUR (HALF HORSE AND HALF MAN) WITH ONE HAND HOLDING AN ANVIL AND OTHER HAND SWINGING A HAMMER, AND THE WORDING "ANOD 1925" IN THE UPPER RIGHT CORNER. THE CENTAUR STANDS ON A STYLIZED PLATFORM AND IS SURROUNDED BY A RECTANGULAR FRAME, WHICH IS DRAWN TO REPRESENT THREE DIMENSIONS.

THE WORDING "ANOD 1925" HAS NO MEANING IN A FOREIGN LANGUAGE.

FOR GARDENS FOR PUBLIC ADMISSION; GUIDED TOURS OF AN HISTORICAL SITE; MUSEUM SERVICES, NAMELY, EXHIBITING TO THE PUBLIC A HISTORICAL SITE (U.S. CLS. 100, 101 AND 107).

FIRST USE 6-29-1925; IN COMMERCE 7-31-1993.

LANA PHAM, EXAMINING ATTORNEY

SN 85-089,029. ENOTES.COM, INC., SEATTLE, WA. FILED 7-20-2010.

**ENOTES**

THE MARK CONSISTS OF STANDARD CHARACTERS WITHOUT CLAIM TO ANY PARTICULAR FONT, STYLE, SIZE, OR COLOR.

FOR PROVIDING INFORMATION IN THE FIELD OF LITERATURE AND LITERARY AUTHORS BY MEANS OF A GLOBAL COMMUNICATION NETWORK; PROVIDING NON-DOWNLOADABLE STUDY GUIDES, CRITICAL COMMENTARY, SUPPLEMENTAL EDUCATIONAL MATERIALS, REFERENCE MATERIAL, AND CONTENT AND CRITICAL ANALYSIS IN THE FIELD OF LITERATURE AND LITERARY AUTHORS TO INDIVIDUAL USERS, BUSINESSES, AND ACADEMIC INSTITUTIONS BY MEANS OF A GLOBAL COMMUNICATION NETWORK (U.S. CLS. 100, 101 AND 107).

FIRST USE 9-21-2002; IN COMMERCE 9-21-2002.

TINA L. SNAPP, EXAMINING ATTORNEY

**CLASS 41—(Continued).**

SN 85-090,394. RICHARD M. MILBURN HIGH SCHOOL, INC., SALEM, MA. FILED 7-22-2010.

## Milburn High School Online

THE MARK CONSISTS OF STANDARD CHARACTERS WITHOUT CLAIM TO ANY PARTICULAR FONT, STYLE, SIZE, OR COLOR.

OWNER OF U.S. REG. NO. 2,059,068.

NO CLAIM IS MADE TO THE EXCLUSIVE RIGHT TO USE "HIGH SCHOOL ONLINE", APART FROM THE MARK AS SHOWN.

SEC. 2(F) AS TO "MILBURN".

FOR EDUCATION SERVICES, NAMELY, PROVIDING ON-LINE HIGH SCHOOL AND SECONDARY SCHOOL CLASSES IN THE FIELD OF HIGH SCHOOL DIPLOMAS (U.S. CLS. 100, 101 AND 107).

FIRST USE 4-20-2009; IN COMMERCE 4-20-2009.

REGINA DRUMMOND, EXAMINING ATTORNEY

**CLASS 41—(Continued).**

SN 85-095,047. RODRIGUEZ, JOSE MARCOS MARTINEZ, SANTA CATARINA, NUEVO, MEXICO, AND REYES, TITO JUNCO, MEXICO, DF, MEXICO, AND ESPINA, BENETIA VASSIALIADI, ZAPOPAN, JALISCO, MEXICO, FILED 7-28-2010.

## SUPER ORIGINAL TROPICANA DE BENETIA

THE MARK CONSISTS OF STANDARD CHARACTERS WITHOUT CLAIM TO ANY PARTICULAR FONT, STYLE, SIZE, OR COLOR.

NO CLAIM IS MADE TO THE EXCLUSIVE RIGHT TO USE "SUPER ORIGINAL", APART FROM THE MARK AS SHOWN.

FOR ENTERTAINMENT SERVICES, NAMELY, LIVE PERFORMANCES AND APPEARANCES BY A MUSIC AND VOCAL GROUP, AND LIVE PERFORMANCES AND APPEARANCES FEATURING PRERECORDED MUSIC, BY A MUSIC AND VOCAL GROUP (U.S. CLS. 100, 101 AND 107).

EVELYN BRADLEY, EXAMINING ATTORNEY

SN 85-091,933. TELEVISA, S.A. DE C.V., SANTA FE, MEXICO, FILED 7-23-2010.



OWNER OF MEXICO REG. NO. 1108575, DATED 5-28-2009, EXPIRES 5-28-2019.

OWNER OF U.S. REG. NO. 3,546,958.

THE MARK CONSISTS OF THE LITERAL ELEMENT "LOCAS DE AMOR" WITHIN A STYLIZED HEART DESIGN WITH THE TERM "LOCAS" APPEARING ABOVE "DE AMOR".

THE ENGLISH TRANSLATION OF "LOCAS DE AMOR" IN THE MARK IS "CRAZY OF LOVE".

FOR ENTERTAINMENT SERVICES, NAMELY, AN ONGOING DRAMATIC TELEVISION PROGRAM (U.S. CLS. 100, 101 AND 107).

THOMAS MANOR, EXAMINING ATTORNEY

SN 85-095,441. SEIDEN, JASON P, HIGHLAND PARK, IL. FILED 7-29-2010.

## FAIL SPECTACULARLY!

THE MARK CONSISTS OF STANDARD CHARACTERS WITHOUT CLAIM TO ANY PARTICULAR FONT, STYLE, SIZE, OR COLOR.

FOR ENTERTAINMENT SERVICES, NAMELY, PROVIDING A WEB SITE FEATURING PHOTOGRAPHIC, VIDEO AND PROSE PRESENTATIONS FEATURING PERSONAL COACHING SERVICES IN THE FIELD OF PROFESSIONAL AND PERSONAL DEVELOPMENT. ENTERTAINMENT SERVICES, NAMELY, PROVIDING A WEB SITE FEATURING PHOTOGRAPHIC, VIDEO AND PROSE PRESENTATIONS FEATURING A MOTIVATIONAL AND EDUCATIONAL SPEAKER IN THE FIELD OF PROFESSIONAL AND PERSONAL DEVELOPMENT (U.S. CLS. 100, 101 AND 107).

FIRST USE 4-3-2008; IN COMMERCE 4-3-2008.

JANICE KIM, EXAMINING ATTORNEY

**CLASS 41—(Continued).**

SN 85-100,908. SCHOOL STUDY COUNCIL OF OHIO, WESTERVILLE, OH. FILED 8-5-2010.

Martin W. Essex School for  
the Gifted and Talented

THE MARK CONSISTS OF STANDARD CHARACTERS WITHOUT CLAIM TO ANY PARTICULAR FONT, STYLE, SIZE, OR COLOR.

NO CLAIM IS MADE TO THE EXCLUSIVE RIGHT TO USE "SCHOOL FOR THE GIFTED AND TALENTED", APART FROM THE MARK AS SHOWN.

THE NAME(S), PORTRAIT(S), AND/OR SIGNATURE(S) SHOWN IN THE MARK DOES NOT IDENTIFY A PARTICULAR LIVING INDIVIDUAL.

SEC. 2(F).

FOR EDUCATION SERVICES, NAMELY, PROVIDING CLASSES IN THE FIELDS OF HIGH LEVEL COGNITIVE PROCESSING, MORAL AND ETHICAL DECISIONS, ADVANCED CITIZENSHIP RESPONSIBILITIES, AND PERSONAL ADVANCEMENT (U.S. CLS. 100, 101 AND 107).

FIRST USE 6-1-1977; IN COMMERCE 6-1-1977.

EDWARD FENNESSY, EXAMINING ATTORNEY

SN 85-103,041. BLAINBROOK ENTERTAINMENT CENTER, INC., BLAINE, MN. FILED 8-9-2010.



THE MARK CONSISTS OF THE WORD "BLAINBROOK" IN OLD COLONIAL TEXT, ABOVE A CIRCLE DIVIDED INTO FOUR PARTS, ONE CONTAINING A BOWLING BALL, ONE CONTAINING A BASEBALL, ONE CONTAINING A FOOTBALL, AND ONE CONTAINING A BASKETBALL; THE CIRCLE IS SURROUNDED BY A FLORAL-LIKE DESIGN.

FOR AMUSEMENT CENTERS; BOWLING ALLEYS (U.S. CLS. 100, 101 AND 107).

FIRST USE 1-1-1974; IN COMMERCE 1-1-1974.

JAMES A. RAUEN, EXAMINING ATTORNEY

**CLASS 41—(Continued).**

SN 85-109,497. EDELMAN, MARC L., WINTER PARK, FL. FILED 8-17-2010.

SportsJudge

THE MARK CONSISTS OF STANDARD CHARACTERS WITHOUT CLAIM TO ANY PARTICULAR FONT, STYLE, SIZE, OR COLOR.

FOR ENTERTAINMENT SERVICES IN THE NATURE OF FANTASY SPORTS LEAGUES (U.S. CLS. 100, 101 AND 107).

FIRST USE 3-15-2006; IN COMMERCE 1-15-2007.

SUSAN LESLIE DUBOIS, EXAMINING ATTORNEY

SN 85-113,933. THE OHIO STATE UNIVERSITY, COLUMBUS, OH. FILED 8-23-2010.



OWNER OF U.S. REG. NOS. 1,294,114 AND 1,294,115.

THE MARK CONSISTS OF A LARGE BLOCK LETTER "O" WITH THE WORDS "OHIO STATE" WRITTEN IN AN ARC OVER THE CENTER OF THE "O".

SEC. 2(F).

FOR ENTERTAINMENT SERVICES, NAMELY, PROVIDING COLLEGE LEVEL SPORT EXHIBITION EVENTS AND RECREATION PROGRAMS; EDUCATIONAL SERVICES, NAMELY, PROVIDING COURSES OF INSTRUCTION IN SPORTS, FITNESS AND EXERCISE; PROVIDING A WEBSITE CONTAINING NEWS AND INFORMATION RELATING TO SPORTS AND RECREATION EVENTS, INCLUDING GAME SCHEDULES AND TICKET SALES (U.S. CLS. 100, 101 AND 107).

FIRST USE 9-0-1992; IN COMMERCE 9-0-1992.

KATHERINE M. DUBRAY, EXAMINING ATTORNEY

**CLASS 41—(Continued).**

SN 85-118,372. THE NAVIGATORS, COLORADO SPRINGS, CO. FILED 8-30-2010.



OWNER OF U.S. REG. NOS. 1,168,719, 2,937,757 AND OTHERS.

THE MARK CONSISTS OF THE WORD "THE" FOLLOWED BY A SINGLE SAIL DESIGN CONTAINED INSIDE A SOLID CIRCLE FOLLOWED BY THE WORD "NAVIGATORS".

FOR PROVIDING A WEBSITE FEATURING RESOURCES, NAMELY, NON-DOWNLOADABLE PUBLICATIONS IN THE NATURE OF NEWSLETTERS, BROCHURES, DEVOTIONALS, AND STUDY/TEACHING TOOLS IN THE FIELD OF CHRISTIAN RELIGION (U.S. CLS. 100, 101 AND 107).

FIRST USE 9-1-2001; IN COMMERCE 1-1-2003.  
THOMAS MANOR, EXAMINING ATTORNEY

---

SN 85-126,582. K. LYNN ACADEMICS, INC., CASSELBERRY, FL. FILED 9-10-2010.



THE NAME "KLYNN" IN THE MARK IDENTIFIES KRISTEN LYNN HATER, A LIVING INDIVIDUAL WHOSE CONSENT IS OF RECORD.

THE MARK CONSISTS OF THE STYLIZED RIGHT PORTION OF THE LETTER "K", THE LETTER "L", AND THE STYLIZED RIGHT PORTION OF THE LETTER "A" FORMING THE STYLIZED TERM "KLA", AND THE COMBINATION OF "K", "LYNN", AND "ACADEMICS" FORMING THE WORDING "KLYNNACADEMICS" IN STYLIZED FONT.

FOR EDUCATIONAL SERVICES, NAMELY, SCHOLASTIC ADVISING IN THE NATURE OF EDUCATIONAL COUNSELING SERVICES TO ASSIST STUDENTS IN PLANNING AND PREPARING FOR FURTHER EDUCATION; EDUCATIONAL SERVICES, NAMELY, SCHOLASTIC ADVISING IN THE NATURE OF CAREER COUNSELING; EDUCATIONAL SERVICES, NAMELY, TUTORING SERVICES DELIVERED BY TRAINED PROFESSIONAL TUTORS IN ONE-ON-ONE SESSIONS IN THE AREAS OF READING, WRITING, RESEARCH, MATHEMATICS, SCIENCES, STUDY SKILLS AND TEST PREPARATION (U.S. CLS. 100, 101 AND 107).

FIRST USE 7-27-2010; IN COMMERCE 7-27-2010.  
JOHN KELLY, EXAMINING ATTORNEY

**CLASS 41—(Continued).**

SN 85-126,585. K. LYNN ACADEMICS, INC., CASSELBERRY, FL. FILED 9-10-2010.

K. LYNN ACADEMICS

THE MARK CONSISTS OF STANDARD CHARACTERS WITHOUT CLAIM TO ANY PARTICULAR FONT, STYLE, SIZE, OR COLOR.

NO CLAIM IS MADE TO THE EXCLUSIVE RIGHT TO USE "ACADEMICS", APART FROM THE MARK AS SHOWN.

THE NAME "K. LYNN" IN THE MARK IDENTIFIES KRISTEN LYNN HATER, A LIVING INDIVIDUAL WHOSE CONSENT IS OF RECORD.

FOR EDUCATIONAL SERVICES, NAMELY, SCHOLASTIC ADVISING IN THE NATURE OF EDUCATIONAL COUNSELING SERVICES TO ASSIST STUDENTS IN PLANNING AND PREPARING FOR FURTHER EDUCATION; EDUCATIONAL SERVICES, NAMELY, SCHOLASTIC ADVISING IN THE NATURE OF CAREER COUNSELING; EDUCATIONAL SERVICES, NAMELY, TUTORING SERVICES DELIVERED BY TRAINED PROFESSIONAL TUTORS IN ONE-ON-ONE SESSIONS IN THE AREAS OF READING, WRITING, RESEARCH, MATHEMATICS, SCIENCES, STUDY SKILLS AND TEST PREPARATION (U.S. CLS. 100, 101 AND 107).

FIRST USE 7-27-2010; IN COMMERCE 7-27-2010.  
JOHN KELLY, EXAMINING ATTORNEY

---

SN 85-127,576. MAZEPLAY, FIRTH, ID. FILED 9-11-2010.

FSI: FARM SCENE  
INVESTIGATION

THE MARK CONSISTS OF STANDARD CHARACTERS WITHOUT CLAIM TO ANY PARTICULAR FONT, STYLE, SIZE, OR COLOR.

NO CLAIM IS MADE TO THE EXCLUSIVE RIGHT TO USE "FARM", APART FROM THE MARK AS SHOWN.

FOR ENTERTAINMENT SERVICES, NAMELY, PROVIDING OUTDOOR RECREATIONAL FACILITIES ON A FARM FOR PLAYING GAMES IN A CORNFIELD MAZE (U.S. CLS. 100, 101 AND 107).

FIRST USE 1-18-2010; IN COMMERCE 1-18-2010.  
BERYL GARDNER, EXAMINING ATTORNEY



**CLASS 41—(Continued).**

SN 85-127,753. LAFOND, ARTHUR J., PRIOR LAKE, MN. FILED 9-13-2010.

**DIGITAL MOB**

THE MARK CONSISTS OF STANDARD CHARACTERS WITHOUT CLAIM TO ANY PARTICULAR FONT, STYLE, SIZE, OR COLOR.

NO CLAIM IS MADE TO THE EXCLUSIVE RIGHT TO USE "DIGITAL", APART FROM THE MARK AS SHOWN.

FOR MULTIMEDIA ENTERTAINMENT SERVICES IN THE NATURE OF RECORDING, PRODUCTION AND POST-PRODUCTION SERVICES IN THE FIELDS OF MUSIC, VIDEO, AND FILMS (U.S. CLS. 100, 101 AND 107).

FIRST USE 8-5-2003; IN COMMERCE 8-5-2003.

COURTNEY ALVAREZ, EXAMINING ATTORNEY

SN 85-137,073. DANNY TYRON PEARSON, AUBURN, WA. FILED 9-23-2010.

**Connectwerks**

THE MARK CONSISTS OF STANDARD CHARACTERS WITHOUT CLAIM TO ANY PARTICULAR FONT, STYLE, SIZE, OR COLOR.

FOR PROVIDING EDUCATIONAL MENTORING SERVICES AND PROGRAMS IN THE FIELD OF ELEMENTARY, MIDDLE AND HIGH SCHOOL EDUCATION FEATURING NON-TRADITIONAL EDUCATION, MUSIC, HEALTH, WELLNESS AND ELEMENTARY, MIDDLE AND HIGH SCHOOL EDUCATIONAL CURRICULA PROVIDED VIA THE INTERNET AND IN THE SCHOOL CLASSROOM (U.S. CLS. 100, 101 AND 107).

FIRST USE 4-5-2006; IN COMMERCE 4-5-2006.

EUGENIA MARTIN, EXAMINING ATTORNEY

SN 85-137,101. BLACK CARD RADIO, INC., ONTARIO, CA. FILED 9-23-2010.

**BLACK CARD RADIO**

THE MARK CONSISTS OF STANDARD CHARACTERS WITHOUT CLAIM TO ANY PARTICULAR FONT, STYLE, SIZE, OR COLOR.

NO CLAIM IS MADE TO THE EXCLUSIVE RIGHT TO USE "RADIO", APART FROM THE MARK AS SHOWN.

FOR DISTRIBUTION OF RADIO PROGRAMS FOR OTHERS; RADIO PROGRAM SYNDICATION (U.S. CLS. 100, 101 AND 107).

FIRST USE 12-15-2009; IN COMMERCE 12-15-2009.

SUE LAWRENCE, EXAMINING ATTORNEY

**CLASS 41—(Continued).**

SN 85-137,977. PEARSON, DANNY T, AUBURN, WA. FILED 9-24-2010.

**I Am Music Project...**

THE MARK CONSISTS OF STANDARD CHARACTERS WITHOUT CLAIM TO ANY PARTICULAR FONT, STYLE, SIZE, OR COLOR.

FOR PROVIDING EDUCATIONAL MENTORING SERVICES AND PROGRAMS IN THE FIELD OF MENTORING THROUGH MUSIC INSTRUCTION TO PROVIDE AND DEVELOPMENT SELF IMPROVEMENT, AUDIO RECORDINGS, AUDIO MIXING, SONGWRITING, ARTIST PERFORMANCES, MUSIC INSTRUCTION, MUSIC BUSINESS INSTRUCTION, MUSIC WORKSHOPS, MUSIC STUDIO RECORDING, AND DIGITAL RECORDING (U.S. CLS. 100, 101 AND 107).

FIRST USE 6-28-2010; IN COMMERCE 6-28-2010.

RICHARD WHITE, EXAMINING ATTORNEY

SN 85-140,506. PERFECT WORLD ENTERTAINMENT, INC., FOSTER CITY, CA. FILED 9-29-2010.



THE COLOR(S) BLACK, DARK BROWN, BROWN, WHITE, TAN, RUSTY ORANGE, AND SKY BLUE IS/ARE CLAIMED AS A FEATURE OF THE MARK.

THE MARK CONSISTS OF A BLACK BACKGROUND WITH THE WORD "PERFECT" IS WRITTEN IN LARGE, BUBBLE LETTERS WHICH ARE A FADED, RUSTY ORANGE IN COLOR. THE WORD "PERFECT" BEGINS ABOVE THE LOWER CASE LETTER "E" IN THE SECOND TITLE WORD, "GETAWAY", AND CONTINUES TO THE END OF THE WORD SO THAT THE "T" IN "PERFECT" RESTS ON TOP, THOUGH JUST SLIGHTLY TO THE RIGHT, OF THE "Y" IN "GETAWAY". "GETAWAY" IS SCRAWLED IN THE SAME TYPE OF LARGE, BUBBLE LETTERS WHICH ARE SKY BLUE IN COLOR. BOTH WORDS ARE OUTLINED, SHADED WITH A WHITE AND BROWN BORDER. THE "P" IN "PERFECT" SITS ON AN EIGHT-PEGGED, WOODEN STEERING WHEEL (HELM) LIKE THAT FOUND ON A NAUTICAL, SAILING VESSEL. INSIDE THE SHIP'S STEERING WHEEL IS ANOTHER, SMALLER EIGHT-PEGGED WHEEL. EACH "PEG" OF THIS INNER-WHEEL IS ATTACHED TOGETHER BY BANDS OF THE COLOR WHITE. EACH BAND ALSO HAS A SMALL SLIT, OR CUT IN ITS CENTER SO THAT THE ENTIRE SMALLER WHEEL MORE CLOSELY RESEMBLES A "LIFE PRESERVER" NESTLED INSIDE THE PREVIOUSLY DESCRIBED LARGER STEERING WHEEL. AT THE VERY CENTER OF THE LARGE, DARK BROWN SHIP'S WHEEL RESTS A TAN-COLORED HEART. THE BOTTOM THREE "PEGS" OF THE LARGE, WOODEN-LOOKING HELM ARE MOSTLY HIDDEN BY THE "P" IN "PERFECT" AND THE "GE" OF THE WORD, "GETAWAY". THE STEERING WHEEL IS OUTLINED, SHADED WITH A WHITE-COLORED BORDER WHICH IS THEN OUTLINED IN A BROWN-COLORED BORDER THAT MATCHES THE COLOR OF THE HELM.

FOR ENTERTAINMENT SERVICES, NAMELY, PROVIDING ONLINE COMPUTER GAMES (U.S. CLS. 100, 101 AND 107).

ROBERT C. CLARK JR., EXAMINING ATTORNEY

**CLASS 41—(Continued).**

SN 85-140,954. HEARTS AT HOME, BLOOMINGTON, IL.  
FILED 9-29-2010.

## The Go-To Place for Moms

THE MARK CONSISTS OF STANDARD CHARACTERS WITHOUT CLAIM TO ANY PARTICULAR FONT, STYLE, SIZE, OR COLOR.

NO CLAIM IS MADE TO THE EXCLUSIVE RIGHT TO USE "MOMS", APART FROM THE MARK AS SHOWN.

FOR DEVELOPMENT AND DISSEMINATION OF EDUCATIONAL MATERIALS AND THE CONDUCTING OF WORKSHOPS, CONFERENCES AND LEARNING FORUMS FOR MOTHERS IN THE AREA OF PARENTING, MARRIAGE, FAMILY MANAGEMENT, PERSONAL, AND SPIRITUAL TOPICS (U.S. CLS. 100, 101 AND 107).

WILLIAM VERHOSEK, EXAMINING ATTORNEY

---

SN 85-140,977. HEARTS AT HOME, BLOOMINGTON, IL.  
FILED 9-29-2010.

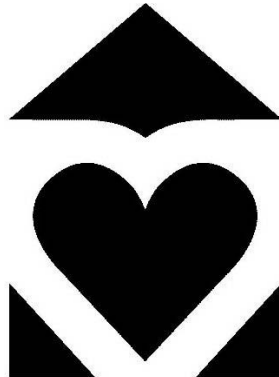

THE MARK CONSISTS OF A HEART LOCATED WITHIN A FIGURE RESEMBLING A HOUSE.

FOR DEVELOPMENT AND DISSEMINATION OF EDUCATIONAL MATERIALS AND THE CONDUCTING OF WORKSHOPS, CONFERENCES AND LEARNING FORUMS FOR MOTHERS IN THE AREA OF PARENTING, MARRIAGE, FAMILY MANAGEMENT, PERSONAL, AND SPIRITUAL TOPICS (U.S. CLS. 100, 101 AND 107).

WILLIAM VERHOSEK, EXAMINING ATTORNEY

**CLASS 41—(Continued).**

SN 85-142,356. RCN TELEVISION S.A., BOGOTA, D.C.,  
COLOMBIA, FILED 9-30-2010.

## UN SUEÑO LLAMADO SALSA

THE MARK CONSISTS OF STANDARD CHARACTERS WITHOUT CLAIM TO ANY PARTICULAR FONT, STYLE, SIZE, OR COLOR.

THE ENGLISH TRANSLATION OF "UN SUEÑO LLAMADO SALSA" IN THE MARK IS "A DREAM CALLED SALSA".

FOR ENTERTAINMENT IN THE NATURE OF AN ONGOING TELEVISION PROGRAM IN THE FIELD OF FAMILY DRAMA (U.S. CLS. 100, 101 AND 107).

ALLISON HOLTZ, EXAMINING ATTORNEY

---

SN 85-144,240. ECHO FOUNDATION, INC., DBA ECHO  
CENTER, CULVER CITY, CA. FILED 10-4-2010.

## Echo Center

THE MARK CONSISTS OF STANDARD CHARACTERS WITHOUT CLAIM TO ANY PARTICULAR FONT, STYLE, SIZE, OR COLOR.

NO CLAIM IS MADE TO THE EXCLUSIVE RIGHT TO USE "CENTER", APART FROM THE MARK AS SHOWN.

FOR EDUCATIONAL SERVICES IN THE NATURE OF MAINSTREAMING DEAF AND HARD OF HEARING STUDENTS IN SCHOOLS (U.S. CLS. 100, 101 AND 107).

FIRST USE 4-1-1987; IN COMMERCE 4-1-1987.

TINA MAI, EXAMINING ATTORNEY

**CLASS 41—(Continued).**

SN 85-148,848. ONPOINT CONSULTING, NEW YORK, NY. FILED 10-8-2010.



THE MARK CONSISTS OF THE STYLIZED PHRASE "INFLUENCE WITH IMPACT" ABOVE THE STYLIZED PHRASE "GAIN SUPPORT AND COMMITMENT" ALL TO THE LEFT OF A STYLIZED DESIGN OF A TARGET IN THE CENTER WITH A SERIES OF EIGHT CURVED BANDS WITH CIRCLES IN THE CENTER, ALL REPRESENTING A TABLE WITH 8 HIGHLY STYLIZED PEOPLE SITTING AROUND IT.

FOR BUSINESS EDUCATION AND TRAINING SERVICES, NAMELY, DEVELOPING MANAGEMENT, LEADERSHIP AND EXECUTIVE DEVELOPMENT PRODUCTS, NAMELY DEVELOPMENT OF EDUCATIONAL MATERIALS OF OTHERS IN THE FIELD OF LEADERSHIP AND MANAGEMENT, AND FACILITATING PUBLIC AND IN-COMPANY EDUCATIONAL PROGRAMS IN THE FIELD OF LEADERSHIP AND EXECUTIVE DEVELOPMENT, PROVIDING EXECUTIVE COACHING SERVICES, AND PROVIDING PUBLIC AND IN-COMPANY KEYNOTE PRESENTATIONS TO BUSINESS LEADERS (U.S. CLS. 100, 101 AND 107).

FIRST USE 1-1-2008; IN COMMERCE 1-1-2008.  
MYRIAH HABEEB, EXAMINING ATTORNEY

SN 85-149,417. LGM CONSULTING SERVICES, LLC., DBA PHOTOBOOTHSOCIAL.COM, BOCA RATON, FL. FILED 10-11-2010.



NO CLAIM IS MADE TO THE EXCLUSIVE RIGHT TO USE "PHOTO BOOTH", APART FROM THE MARK AS SHOWN.

THE COLOR(S) RED, ORANGE, YELLOW, LIGHT GRAY, WHITE AND BLACK IS/ARE CLAIMED AS A FEATURE OF THE MARK.

THE MARK CONSISTS OF THE WORD "PHOTOBOOTH" IN ALL CAPITAL LETTERS IN BLACK WITH A WHITE OUTLINE POSITIONED STRAIGHT AGAINST A LIGHT GRAY BACKGROUND; THE LETTER "P" HAS A WIDER POST IMITATING PHOTOGRAPHIC FILM. THE WORD "SOCIAL.COM" IS WRITTEN WITH A CAPITAL "S", IN BLACK WITH A WHITE OUTLINE SLANTED ACROSS A LIGHT GRAY BACKGROUND. THE BACKGROUND IS A MARQUEE WITH A RED OUTLINE, WHITE CIRCULAR SHAPES, SOME REFLECTING A SPARKLE, AGAINST ORANGE AND YELLOW SHAPED AS HALF CIRCLES AND ROUNDED SHAPES INTO THE MARQUEE.

FOR RENTAL OF PORTABLE PHOTOGRAPHY AND/OR VIDEOGRAPHY BOOTHS FOR TAKING OF PICTURES AND VIDEOS (U.S. CLS. 100, 101 AND 107).

FIRST USE 6-1-2008; IN COMMERCE 6-1-2008.  
DANNEAN HETZEL, EXAMINING ATTORNEY

**CLASS 41—(Continued).**

SN 85-154,781. LOPEZ, LEON BILL, GARDENA, CA. FILED 10-18-2010.

**AUTOMATIC SUCCESS**

THE MARK CONSISTS OF STANDARD CHARACTERS WITHOUT CLAIM TO ANY PARTICULAR FONT, STYLE, SIZE, OR COLOR.

FOR LIFE COACHING SERVICES IN THE FIELD OF LIFE TRANSFORMATION; PERSONAL COACHING SERVICES IN THE FIELD OF CORE DEVELOPMENT; PROFESSIONAL COACHING SERVICES IN THE FIELD OF PERSONAL IMPROVEMENT (U.S. CLS. 100, 101 AND 107).

MICHAEL WEBSTER, EXAMINING ATTORNEY

SN 85-155,010. GOLD PALMS, INC., LAKE WORTH, FL. FILED 10-18-2010.

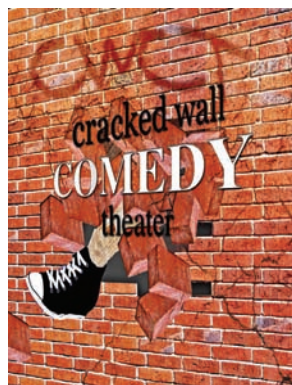

NO CLAIM IS MADE TO THE EXCLUSIVE RIGHT TO USE "COMEDY THEATER", APART FROM THE MARK AS SHOWN.

THE COLOR(S) RED, BLACK, WHITE, ORANGE, AND TAN IS/ARE CLAIMED AS A FEATURE OF THE MARK.

THE MARK CONSISTS OF A BRICK WALL BACKGROUND COMPOSED OF ORANGE AND RED WITH WHITE IN THE CRACKS. THE WORDING "CRACKED WALL" IN BLACK STYLIZED LETTERS; "COMEDY" BELOW "CRACKED WALL" IN WHITE STYLIZED LETTERS OUTLINED IN BLACK; "THEATER" IN BLACK STYLIZED LETTERS BELOW "COMEDY"; COMING THROUGH THE WALL IS A TAN LEG WITH A BLACK SNEAKER AND WHITE LACES AND BOTTOM; BEHIND THE LEG IS A BLACK BACKGROUND; ABOVE THE TERMS "CRACKED WALL" IS "CWCT" IN RED SPRAY PAINT.

FOR DIRECTION OR PRESENTATION OF PLAYS; ENTERTAINMENT IN THE NATURE OF VISUAL AND AUDIO PERFORMANCES, AND MUSICAL, VARIETY, NEWS AND COMEDY SHOWS; ENTERTAINMENT SERVICES IN THE NATURE OF COMEDY SHOWS; ENTERTAINMENT, NAMELY, PRODUCTION OF PLAYS (U.S. CLS. 100, 101 AND 107).

FIRST USE 10-1-2010; IN COMMERCE 10-1-2010.  
DANNEAN HETZEL, EXAMINING ATTORNEY

**CLASS 41—(Continued).**

SN 85-157,679. PRACTICE POINT COMMUNICATIONS, INC., OLDSMAR, FL. FILED 10-21-2010.



NO CLAIM IS MADE TO THE EXCLUSIVE RIGHT TO USE "PULMONARY ARTERIAL HYPERTENSION AN EXPERT EDUCATOR'S CME LECTURE SERIES" AND THE PICTORIAL REPRESENTATION OF THE RESPIRATORY SYSTEM, APART FROM THE MARK AS SHOWN.

THE MARK CONSISTS OF THE STYLIZED WORDING "SIMPLY SPEAKING" AROUND A CIRCLE CONTAINING THE SILHOUETTE OF A PERSON, DEPICTING THE RESPIRATORY SYSTEM, AND THE WORDING "PULMONARY ARTERIAL HYPERTENSION" TO THE RIGHT SIDE OF THE CIRCLE. THE WORDING "AN EXPERT EDUCATOR'S CME LECTURE SERIES" UNDERNEATH BETWEEN TWO LINES.

FOR EDUCATIONAL SERVICES, NAMELY, PROVIDING CONTINUING EDUCATIONAL COURSES TO PROFESSIONALS IN THE MEDICAL FIELD (U.S. CLS. 100, 101 AND 107).

FIRST USE 7-0-2007; IN COMMERCE 7-0-2007.  
MARLENE BELL, EXAMINING ATTORNEY

**CLASS 41—(Continued).**

SN 85-157,683. PRACTICE POINT COMMUNICATIONS, INC., OLDSMAR, FL. FILED 10-21-2010.



NO CLAIM IS MADE TO THE EXCLUSIVE RIGHT TO USE "HIV" AND "AN EXPERT EDUCATOR'S CME LECTURE SERIES", APART FROM THE MARK AS SHOWN.

THE MARK CONSISTS OF THE STYLIZED WORDING "SIMPLY SPEAKING" CENTERED AROUND A CIRCLE WITH THE DESIGN OF TWO HUMAN HEADS, EACH ON OPPOSITE SIDES FACING EACH OTHER AND THE LETTERS "H","I","V" TO THE RIGHT SIDE. THE WORDING "AN EXPERT EDUCATOR'S CME LECTURE SERIES" INSIDE A BANNER UNDERNEATH.

FOR EDUCATIONAL SERVICES, NAMELY, PROVIDING CONTINUING EDUCATIONAL COURSES TO PROFESSIONALS IN THE MEDICAL FIELD (U.S. CLS. 100, 101 AND 107).

FIRST USE 10-0-2005; IN COMMERCE 10-0-2005.  
MARLENE BELL, EXAMINING ATTORNEY

SN 85-157,682. PRACTICE POINT COMMUNICATIONS, INC., OLDSMAR, FL. FILED 10-21-2010.



NO CLAIM IS MADE TO THE EXCLUSIVE RIGHT TO USE "HBV" AND "AN EXPERT EDUCATOR'S CME LECTURE SERIES", APART FROM THE MARK AS SHOWN.

THE MARK CONSISTS OF THE STYLIZED WORDING "SIMPLY SPEAKING" CENTERED AROUND A CIRCLE WITH THE DESIGN OF TWO HUMAN HEADS FACING EACH OTHER AND THE LETTERS "H","B","V" TO THE RIGHT. THE WORDING "AN EXPERT EDUCATOR'S CME LECTURE SERIES" INSIDE A BANNER UNDERNEATH.

FOR EDUCATIONAL SERVICES, NAMELY, PROVIDING CONTINUING EDUCATIONAL COURSES TO PROFESSIONALS IN THE MEDICAL FIELD (U.S. CLS. 100, 101 AND 107).

FIRST USE 1-0-2007; IN COMMERCE 1-0-2007.  
MARLENE BELL, EXAMINING ATTORNEY

SN 85-157,687. PRACTICE POINT COMMUNICATIONS, INC., OLDSMAR, FL. FILED 10-21-2010.



NO CLAIM IS MADE TO THE EXCLUSIVE RIGHT TO USE "CLINICAL" AND "VIEWPOINTS" AND "A CME LECTURE SERIES FOR HCV", APART FROM THE MARK AS SHOWN.

THE MARK CONSISTS OF THE WORD "CLINICAL" WITH A DESIGN FEATURING THREE FIGURES SURROUNDED BY A CURLING LINE AND FOLLOWED BY THE WORD "VIEWPOINTS". THE WORDING "A CME LECTURE SERIES FOR HCV" APPEARS UNDERNEATH.

FOR EDUCATIONAL SERVICES, NAMELY, PROVIDING CONTINUING EDUCATIONAL COURSES TO PROFESSIONALS IN THE MEDICAL FIELD (U.S. CLS. 100, 101 AND 107).

FIRST USE 8-0-2010; IN COMMERCE 8-0-2010.  
MARLENE BELL, EXAMINING ATTORNEY

**CLASS 41—(Continued).**

SN 85-157,691. PRACTICE POINT COMMUNICATIONS, INC., OLDSMAR, FL. FILED 10-21-2010.



NO CLAIM IS MADE TO THE EXCLUSIVE RIGHT TO USE "CLINICAL" AND "VIEWPOINTS" AND "A CME LECTURE SERIES FOR EPILEPSY", APART FROM THE MARK AS SHOWN.

THE MARK CONSISTS OF THE WORD "CLINICAL" WITH A DESIGN FEATURING THREE FIGURES SURROUNDED BY A CURLING LINE AND FOLLOWED BY THE WORD "VIEWPOINTS". THE WORDING "A CME LECTURE SERIES FOR EPILEPSY" APPEARS UNDERNEATH.

FOR EDUCATIONAL SERVICES, NAMELY, PROVIDING CONTINUING EDUCATIONAL COURSES TO PROFESSIONALS IN THE MEDICAL FIELD (U.S. CLS. 100, 101 AND 107).

FIRST USE 4-1-2010; IN COMMERCE 4-1-2010.  
MARLENE BELL, EXAMINING ATTORNEY

SN 85-158,237. BAYOU GIRLS REALITY, LLC, LACOMBE, LA. FILED 10-21-2010.

---

## BAYOU GIRLS

THE MARK CONSISTS OF STANDARD CHARACTERS WITHOUT CLAIM TO ANY PARTICULAR FONT, STYLE, SIZE, OR COLOR.

NO CLAIM IS MADE TO THE EXCLUSIVE RIGHT TO USE "GIRLS", APART FROM THE MARK AS SHOWN.

FOR ENTERTAINMENT SERVICES IN THE NATURE OF AN ONGOING TV REALITY SHOW (U.S. CLS. 100, 101 AND 107).

MICHELLE DUBOIS, EXAMINING ATTORNEY

SN 85-158,776. MIDNIGHT TRADER, INC., BETHESDA, MD. FILED 10-22-2010.

---

## midnight trader

THE MARK CONSISTS OF STANDARD CHARACTERS WITHOUT CLAIM TO ANY PARTICULAR FONT, STYLE, SIZE, OR COLOR.

NO CLAIM IS MADE TO THE EXCLUSIVE RIGHT TO USE "TRADER", APART FROM THE MARK AS SHOWN.

FOR PROVIDE ONLINE PUBLICATION, NAMELY, NEWS BULLETINS IN THE FIELD OF STOCK MARKET NEWS (U.S. CLS. 100, 101 AND 107).

FIRST USE 10-1-1999; IN COMMERCE 10-1-1999.  
JEAN IM, EXAMINING ATTORNEY

**CLASS 41—(Continued).**

SN 85-159,046. GOGO, INC., MINNEAPOLIS, MN. FILED 10-22-2010.



THE COLOR(S) BROWN, SEPIA, TAUPE, RED, TAN, GOLDENROD, GOLD, BEIGE, BLACK, SILVER, AND WHITE IS/ARE CLAIMED AS A FEATURE OF THE MARK.

THE MARK CONSISTS OF A FEMALE CHARACTER NAMED "GIGI" WITH BROWN HAIR, BROWN EYES, BROWN EYEBROWS, SEPIA SHADING IN HAIR, TAUPE SHADING ON BOTTOMSIDE OF HAIR, RED DRESS, RED LIPS, RED SHADING ON HEELS OF SHOES, TAN SKIN, GOLDENROD SHADING UNDERNEATH EYE, NECK, CHEST, ARMS AND LEGS, GOLD NECKLACE, BLACK PUPILS, BLACK EYELIDS, BLACK SHOES, SILVER CHAIR, SILVER SPECKLES ON DRESS, SILVER SPOT ON BOTTOM LIP, WHITE IN EYES, AND WHITE SPARKLES ON TOP AND BOTTOM OF DRESS. ALSO, THE WORD "GIGI'S" IS RED, THE WORD "GUIDE" IS BROWN, AND THE WORDS "FOR THE GIRL ON THE GO" ARE SILVER.

FOR ON-LINE JOURNALS, NAMELY, BLOGS FEATURING A DIVERSE RANGE OF INFORMATION OF GENERAL INTEREST TO WOMEN (U.S. CLS. 100, 101 AND 107).

FIRST USE 11-3-2010; IN COMMERCE 11-3-2010.  
H. M. FISHER, EXAMINING ATTORNEY

SN 85-159,809. LINCOLN, WENDY, LEE, PORTLAND, OR. AND LINCOLN, TRACY, DAVID, PORTLAND, OR. FILED 10-24-2010.

---

## Hot Kitchen

THE MARK CONSISTS OF STANDARD CHARACTERS WITHOUT CLAIM TO ANY PARTICULAR FONT, STYLE, SIZE, OR COLOR.

NO CLAIM IS MADE TO THE EXCLUSIVE RIGHT TO USE "KITCHEN", APART FROM THE MARK AS SHOWN.

FOR DIRECTION OF MAKING RADIO OR TELEVISION PROGRAMS; EDUCATION AND ENTERTAINMENT SERVICES, NAMELY, ONGOING TELEVISION PUBLIC SERVICE ANNOUNCEMENTS AND ONGOING TELEVISION PROGRAMS IN THE FIELD OF COOKING AND HOMEMAKING; EDUCATIONAL AND ENTERTAINMENT SERVICES, NAMELY, A CONTINUING PROGRAM ABOUT COOKING AND HOMEMAKING ACCESSIBLE BY RADIO, TELEVISION, SATELLITE, AUDIO, VIDEO AND COMPUTER NETWORKS; ENTERTAINMENT IN THE NATURE OF VISUAL AND AUDIO PERFORMANCES BY A PROFESSIONAL CHEF, ACTORS, SPOKESPERSONS, HOSTS, MUSICIANS, AND/OR DANCERS; ENTERTAINMENT MEDIA PRODUCTION SERVICES FOR MOTION PICTURES, TELEVISION AND INTERNET; ENTERTAINMENT SERVICES IN THE NATURE OF CREATION, DEVELOPMENT, AND PRODUCTION OF TELEVISION PROGRAMMING; ENTERTAINMENT SERVICES, NAMELY, AN ONGOING SERIES FEATURING COOKING AND HOMEMAKING PROVIDED THROUGH TELEVISION, SATEL-



**CLASS 41—(Continued).**

LITE, AUDIO, VIDEO, COMPUTER NETWORKS, AND DIGITAL MEDIA NETWORKS; ENTERTAINMENT SERVICES, NAMELY, PROVIDING ON-GOING WEBISODES FEATURING COOKING AND HOMEMAKING VIA A GLOBAL COMPUTER NETWORK; ENTERTAINMENT SERVICES, NAMELY, PROVIDING PODCASTS IN THE FIELD OF COOKING AND HOMEMAKING; ENTERTAINMENT SERVICES, NAMELY, PROVIDING VIDEO PODCASTS IN THE FIELD OF COOKING AND HOMEMAKING; ENTERTAINMENT SERVICES, NAMELY, PROVIDING WEBCASTS IN THE FIELD OF COOKING AND HOMEMAKING; PRODUCTION OF CABLE TELEVISION PROGRAMS; PRODUCTION OF RADIO OR TELEVISION PROGRAMS; PROVIDING A WEB SITE WHERE USERS CAN POST RATINGS, REVIEWS AND RECOMMENDATIONS ON EVENTS AND ACTIVITIES IN THE FIELD OF ENTERTAINMENT AND EDUCATION; PROVIDING A WEBSITE FEATURING ENTERTAINMENT INFORMATION; TELEVISION SHOW PRODUCTION; TELEVISION, VIDEO AND MOVIE FILMING SERVICES (U.S. CLS. 100, 101 AND 107).

FIRST USE 9-1-2009; IN COMMERCE 9-1-2009.  
TINA L. SNAPP, EXAMINING ATTORNEY

SN 85-160,147. SKYDIVE KY LLC, GREENSBURG, KY.  
FILED 10-25-2010.

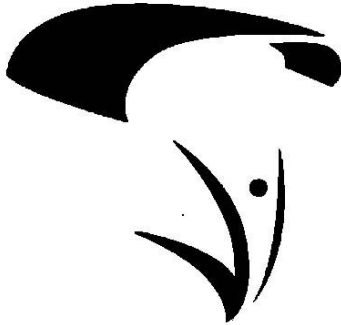

THE MARK CONSISTS OF A STYLIZED DESIGN OF A HUMAN UNDER A PARACHUTE.

FOR INSTRUCTION IN THE FIELD OF SKYDIVING; EDUCATIONAL DEMONSTRATIONS OF SKYDIVING; ENTERTAINMENT SERVICES IN THE NATURE OF ORGANIZING, ARRANGING AND CONDUCTING SKYDIVING EXCURSIONS (U.S. CLS. 100, 101 AND 107).

FIRST USE 3-8-2008; IN COMMERCE 4-1-2008.  
AISHA SALEM, EXAMINING ATTORNEY

SN 85-161,097. DURR, RICHARD E., WELLINGTON, FL.  
FILED 10-26-2010.

learn a living

THE MARK CONSISTS OF STANDARD CHARACTERS WITHOUT CLAIM TO ANY PARTICULAR FONT, STYLE, SIZE, OR COLOR.

FOR PROVIDING A WEB SITE THAT FEATURES INFORMATION ABOUT ONLINE HIGHER EDUCATION RESOURCES (U.S. CLS. 100, 101 AND 107).

FIRST USE 10-22-2010; IN COMMERCE 10-22-2010.  
KATHERINE CONNOLLY, EXAMINING ATTORNEY

**CLASS 41—(Continued).**

SN 85-163,334. EMORY UNIVERSITY, ATLANTA, GA.  
FILED 10-28-2010.

**TESTAMENTS OF THE HEART**

THE MARK CONSISTS OF STANDARD CHARACTERS WITHOUT CLAIM TO ANY PARTICULAR FONT, STYLE, SIZE, OR COLOR.

FOR ENTERTAINMENT AND EDUCATIONAL SERVICES, NAMELY, DISPLAYS, EXHIBITS, AND CONDUCTING PROGRAMS IN THE FIELD OF HISTORY; ARRANGING AND CONDUCTING MUSICAL CONCERTS (U.S. CLS. 100, 101 AND 107).

FIRST USE 9-6-2010; IN COMMERCE 9-6-2010.  
ANTHONY RINKER, EXAMINING ATTORNEY

SN 85-164,637. 2181355 ONTARIO INC., GUELPH, ONTARIO, CANADA, FILED 10-29-2010.

INGAMER

THE MARK CONSISTS OF STANDARD CHARACTERS WITHOUT CLAIM TO ANY PARTICULAR FONT, STYLE, SIZE, OR COLOR.

PRIORITY CLAIMED UNDER SEC. 44(D) ON CANADA APPLICATION NO. 1498767, FILED 10-6-2010.

FOR ENTERTAINMENT SERVICES, NAMELY, PROVIDING ON-LINE AND MOBILE INTERACTIVE REAL-TIME SOCIAL, SPORTS AND FANTASY GAMES (U.S. CLS. 100, 101 AND 107).

DOMINICK J. SALEMI, EXAMINING ATTORNEY

**CLASS 41—(Continued).**

SN 85-164,917. ORANGE COUNTY YOUTH SPORTS ASSOCIATION, ROSSMOOR, CA. FILED 10-29-2010.



OWNER OF U.S. REG. NOS. 3,872,272, 3,872,273 AND 3,878,727.

NO CLAIM IS MADE TO THE EXCLUSIVE RIGHT TO USE "LOS ALAMITOS - SEAL BEACH", APART FROM THE MARK AS SHOWN.

THE COLOR(S) WHITE, GRAY, BLACK AND RED IS/ARE CLAIMED AS A FEATURE OF THE MARK.

THE MARK CONSISTS OF A RECTANGLE OUTLINED IN BLACK WITH AN OVAL INSIDE THE RECTANGLE OUTLINED IN BLACK WITH THE WORDS "LOS ALAMITOS-SEAL BEACH FRIDAY NIGHT LIGHTS" IN WHITE; ANOTHER GRAY OVAL OUTLINED IN BLACK AND WITHIN THE GRAY OVAL AN OVAL WHITE BACKGROUND WITH THE LETTERS "FNL" IN RED OUTLINED IN WHITE AND BLACK WITH RED FOOTBALL LACES ABOVE "FNL" AND A FOOTBALL FIELD IN WHITE AND BLACK BENEATH THE "FNL".

SEC. 2(F).

FOR AMATEUR YOUTH SPORTS SERVICES, NAMELY, ORGANIZING AND PROVIDING YOUTH SPORTS ACTIVITIES; ARRANGING AND CONDUCTING YOUTH FOOTBALL PROGRAMS; COACHING IN THE FIELD OF SPORTS; ENCOURAGING AMATEUR SPORTS AND PHYSICAL EDUCATION BY ORGANIZING, SANCTIONING, CONDUCTING, REGULATING AND GOVERNING AMATEUR ATHLETIC PROGRAMS AND ACTIVITIES; ENTERTAINMENT AND EDUCATIONAL SERVICES, NAMELY, PROVIDING A WEBSITE THAT DISPLAYS VARIOUS REQUESTS, REVIEWS, RECOMMENDATIONS, RANKINGS, TRACKINGS, VOTES, AND INFORMATION RELATING TO UNCREATED, UNRELEASED, NEW, SPECIAL, POPULAR, AND RARE PRODUCTS, SERVICES, AND EVENTS IN THE FIELDS OF POP CULTURE, ENTERTAINMENT, EDUCATION, AND SPORTS, ALL EXCLUSIVELY FOR NON-BUSINESS AND NON-COMMERCIAL TRANSACTIONS AND PURPOSES; ENTERTAINMENT IN THE NATURE OF FOOTBALL GAMES; ENTERTAINMENT IN THE NATURE OF FLAG FOOTBALL GAMES; ENTERTAINMENT SERVICES, NAMELY, ORGANIZING AND STAGING AN ANNUAL POST-SEASON INTERCOLLEGIATE FOOTBALL GAME; ENTERTAINMENT SERVICES, NAMELY, PARTICIPATION IN FLAG FOOTBALL; OFFICIATING AT SPORTS CONTESTS; OPERATION OF SPORTS CAMPS; ORGANISATION OF SPORTS COMPETITIONS; ORGANISATION OF SPORTS EVENTS IN THE FIELD OF FOOTBALL; ORGANIZING EXHIBITIONS FOR FLAG FOOTBALL; ORGANIZING SPORTING EVENTS, NAMELY, FLAG FOOTBALL; ORGANIZING, ARRANGING, AND CONDUCTING FLAG FOOTBALL EVENTS; PROVIDING A WEB SITE FEATURING INFORMATION ON YOUTH SPORTS; PROVIDING A WEB SITE FEATURING SPORTING INFORMATION; PROVIDING A WEB SITE THAT PRO-

**CLASS 41—(Continued).**

VIDES SPORTS LEAGUE PLAYER STATISTICS; PROVIDING A WEBSITE FEATURING ONLINE SPORTS TRAINING AND TRAINING ADVICE AND THE RECORDING OF TRAINING AND WORKOUTS; PROVIDING A WEBSITE FOR ENTERTAINMENT PURPOSES WHERE USERS CAN VIEW AND POST COMMENTS, PHOTOS, VIDEOS FEATURING FLAG FOOTBALL; PROVIDING FACILITIES FOR SPORTS TOURNAMENTS; PROVIDING FACILITIES FOR FLAG FOOTBALL TOURNAMENTS; PROVIDING NEWS AND INFORMATION IN THE FIELD OF SPORTS; PROVIDING SPORTS FACILITIES; PROVIDING SPORTS FACILITIES FOR FLAG FOOTBALL; PROVIDING VARIOUS FACILITIES FOR AN ARRAY OF SPORTING EVENTS, SPORTS AND ATHLETIC COMPETITIONS AND AWARDS PROGRAMMES; PROVISION OF INFORMATION RELATING TO SPORTS AND SPORTING EVENTS; SPORT CAMPS; SPORTS CAMP SERVICES; SPORTS INSTRUCTION SERVICES; SPORTS REFEREEING AND OFFICIATING; SPORTS TRAINING SERVICES (U.S. CLS. 100, 101 AND 107).

FIRST USE 5-1-2006; IN COMMERCE 5-1-2006.

WILLIAM BRECKENFELD, EXAMINING ATTORNEY

SN 85-165,077. ORANGE COUNTY YOUTH SPORTS ASSOCIATION, ROSSMOOR, CA. FILED 10-29-2010.

**FRIDAY NIGHT LIGHTS**

THE MARK CONSISTS OF STANDARD CHARACTERS WITHOUT CLAIM TO ANY PARTICULAR FONT, STYLE, SIZE, OR COLOR.

OWNER OF U.S. REG. NOS. 3,872,272, 3,872,273 AND 3,878,727.

SEC. 2(F).

FOR AMATEUR YOUTH SPORTS SERVICES, NAMELY, ORGANIZING AND PROVIDING YOUTH SPORTS ACTIVITIES; ARRANGING AND CONDUCTING YOUTH FOOTBALL PROGRAMS; COACHING IN THE FIELD OF SPORTS; ENCOURAGING AMATEUR SPORTS AND PHYSICAL EDUCATION BY ORGANIZING, SANCTIONING, CONDUCTING, REGULATING AND GOVERNING AMATEUR ATHLETIC PROGRAMS AND ACTIVITIES; ENTERTAINMENT IN THE NATURE OF FOOTBALL GAMES; ENTERTAINMENT IN THE NATURE OF FLAG FOOTBALL GAMES; ENTERTAINMENT SERVICES, NAMELY, ORGANIZING AND STAGING AN ANNUAL POST-SEASON INTERCOLLEGIATE FOOTBALL GAME; OFFICIATING AT SPORTS CONTESTS; OPERATION OF SPORTS CAMPS; ORGANIZATION OF SPORTS COMPETITIONS; ORGANIZATION OF SPORTS EVENTS IN THE FIELD OF FOOTBALL; ORGANIZING COMMUNITY SPORTING AND CULTURAL EVENTS; ORGANIZING EXHIBITIONS FOR FLAG FOOTBALL; ORGANIZING SPORTING EVENTS, NAMELY, FLAG FOOTBALL; ORGANIZING, ARRANGING, AND CONDUCTING FLAG FOOTBALL EVENTS; PROVIDING A WEB SITE FEATURING INFORMATION ON YOUTH SPORTS; PROVIDING A WEB SITE FEATURING SPORTING INFORMATION; PROVIDING A

**CLASS 41—(Continued).**

WEB SITE THAT PROVIDES SPORTS LEAGUE PLAYER STATISTICS; PROVIDING A WEBSITE FEATURING ONLINE SPORTS TRAINING AND TRAINING ADVICE AND THE RECORDING OF TRAINING AND WORK-OUTS; PROVIDING A WEBSITE FOR ENTERTAINMENT PURPOSES WHERE USERS CAN VIEW AND POST COMMENTS, PICTURES, VIDEOS FEATURING FLAG FOOTBALL; PROVIDING FACILITIES FOR SPORTS TOURNAMENTS; PROVIDING FACILITIES FOR FLAG FOOTBALL TOURNAMENTS; PROVIDING NEWS AND INFORMATION IN THE FIELD OF SPORTS; PROVIDING SPORTS FACILITIES; PROVIDING SPORTS FACILITIES FOR FLAG FOOTBALL; PROVIDING VARIOUS FACILITIES FOR AN ARRAY OF SPORTING EVENTS, SPORTS AND ATHLETIC COMPETITIONS AND AWARDS PROGRAMMES; PROVISION OF INFORMATION RELATING TO SPORTS AND SPORTING EVENTS; SPORT CAMPS; SPORTS CAMP SERVICES; SPORTS INSTRUCTION SERVICES; SPORTS REFEREEING AND OFFICIATING; SPORTS TRAINING SERVICES (U.S. CLS. 100, 101 AND 107).

FIRST USE 5-1-2006; IN COMMERCE 5-1-2006.  
WILLIAM BRECKENFELD, EXAMINING ATTORNEY

**CLASS 41—(Continued).**

SN 85-165,201. ORANGE COUNTY YOUTH SPORTS ASSOCIATION, ROSSMOOR, CA. FILED 10-29-2010.

**FRIDAY NIGHT LIGHTS YOUTH  
FLAG FOOTBALL**

THE MARK CONSISTS OF STANDARD CHARACTERS WITHOUT CLAIM TO ANY PARTICULAR FONT, STYLE, SIZE, OR COLOR.

OWNER OF U.S. REG. NOS. 3,872,272, 3,872,273 AND 3,878,727.

NO CLAIM IS MADE TO THE EXCLUSIVE RIGHT TO USE "YOUTH FLAG FOOTBALL", APART FROM THE MARK AS SHOWN.

SEC. 2(F).

FOR AMATEUR YOUTH SPORTS SERVICES, NAMELY, ORGANIZING AND PROVIDING YOUTH SPORTS ACTIVITIES; ARRANGING AND CONDUCTING YOUTH FOOTBALL PROGRAMS; COACHING IN THE FIELD OF SPORTS; ENCOURAGING AMATEUR SPORTS AND PHYSICAL EDUCATION BY ORGANIZING, SANCTIONING, CONDUCTING, REGULATING AND GOVERNING AMATEUR ATHLETIC PROGRAMS AND ACTIVITIES; ENTERTAINMENT IN THE NATURE OF FOOTBALL GAMES; ENTERTAINMENT IN THE NATURE OF FLAG FOOTBALL GAMES; ENTERTAINMENT IN THE NATURE OF FLAG FOOTBALL GAMES; ENTERTAINMENT SERVICES, NAMELY, PARTICIPATION IN FLAG FOOTBALL; OFFICIATING AT SPORTS CONTESTS; ORGANIZATION OF SPORTS EVENTS IN THE FIELD OF FOOTBALL; ORGANIZING EXHIBITIONS FOR FLAG FOOTBALL; ORGANIZING SPORTING EVENTS, NAMELY, FLAG FOOTBALL; PROVIDING A WEB SITE FEATURING INFORMATION ON YOUTH SPORTS; PROVIDING A WEB SITE FEATURING SPORTING INFORMATION; PROVIDING A WEB SITE THAT PROVIDES SPORTS LEAGUE PLAYER STATISTICS; PROVIDING A WEBSITE FEATURING ONLINE SPORTS TRAINING AND TRAINING ADVICE AND THE RECORDING OF TRAINING AND WORK-OUTS; PROVIDING A WEBSITE FOR ENTERTAINMENT PURPOSES WHERE USERS CAN VIEW AND POST COMMENTS, PICTURES, VIDEOS FEATURING FLAG FOOTBALL; PROVIDING FACILITIES FOR SPORTS TOURNAMENTS; PROVIDING FACILITIES FOR FLAG FOOTBALL TOURNAMENTS; PROVIDING NEWS AND INFORMATION IN THE FIELD OF SPORTS; PROVIDING SPORTS FACILITIES; PROVIDING SPORTS FACILITIES FOR FLAG FOOTBALL; PROVIDING VARIOUS FACILITIES FOR AN ARRAY OF SPORTING EVENTS, SPORTS AND ATHLETIC COMPETITIONS AND AWARDS PROGRAMMES; PROVISION OF INFORMATION RELATING TO ORGANIZING COMMUNITY SPORTING AND CULTURAL ACTIVITIES, CONTESTS AND GAMES; PROVISION OF INFORMATION RELATING TO SPORTS AND SPORTING EVENTS; PROVISION OF INFORMATION RELATING TO THE ORGANIZING OF EDUCATIONAL, CULTURAL, SPORTING, OR ENTERTAINMENT EXHIBITIONS; SPORT CAMPS; SPORTS CAMP SERVICES; SPORTS INSTRUCTION SERVICES; SPORTS REFEREEING AND OFFICIATING; TIMING OF SPORTS EVENTS (U.S. CLS. 100, 101 AND 107).

FIRST USE 5-1-2006; IN COMMERCE 5-1-2006.

WILLIAM BRECKENFELD, EXAMINING ATTORNEY

SN 85-165,107. HIP LICENSING LLC, CHEYENNE, WY. FILED 10-29-2010.

**RAVEN PORN REVIEWS**

THE MARK CONSISTS OF STANDARD CHARACTERS WITHOUT CLAIM TO ANY PARTICULAR FONT, STYLE, SIZE, OR COLOR.

NO CLAIM IS MADE TO THE EXCLUSIVE RIGHT TO USE "PORN REVIEWS", APART FROM THE MARK AS SHOWN.

FOR ENTERTAINMENT SERVICES, NAMELY, PROVIDING ON-LINE REVIEWS OF WEB SITES, MOTION PICTURES, PRODUCTS, SERVICE PROVIDERS, AND PERSONALITIES; ON-LINE PUBLICATION OF JOURNALS, BLOGS, AND AN ONLINE DATABASE FEATURING INFORMATION REGARDING WEB SITES, MOTION PICTURES, PRODUCTS, SERVICE PROVIDERS, AND ENTERTAINMENT PERSONALITIES, IN THE NATURE OF PICTURES, VIDEOS, STATISTICS, AND TEXTUAL MATTER; PROVIDING AN ONLINE INFORMATION PORTAL PROVIDED OVER THE INTERNET FOR DISSEMINATION OF INFORMATION DEALING WITH WEB SITES, MOTION PICTURES, PRODUCTS, SERVICE PROVIDERS, AND ENTERTAINMENT PERSONALITIES, ALL IN THE FIELD OF ADULT ENTERTAINMENT (U.S. CLS. 100, 101 AND 107).

FIRST USE 9-22-2009; IN COMMERCE 9-22-2009.

KATINA MISTER, EXAMINING ATTORNEY

**CLASS 41—(Continued).**

SN 85-165,240. INNER BEAUTY WORKSHOPS, MOUNT SINAI, NY. FILED 10-29-2010.



*Inner Beauty Workshops*

NO CLAIM IS MADE TO THE EXCLUSIVE RIGHT TO USE "WORKSHOPS", APART FROM THE MARK AS SHOWN.

THE STIPPLING IS FOR SHADING PURPOSES ONLY. THE MARK CONSISTS OF A CAPITAL "H" WITH THE LETTERS "IBW" IN SCRIPT, A FLORAL SPRAY BEHIND THE LETTERS, AND THE WORDS "INNER BEAUTY WORKSHOPS" UNDERNEATH.

FOR EDUCATION SERVICES, NAMELY, PROVIDING WORKSHOPS IN THE FIELDS OF HEALTH AND WELLNESS; LIFE COACHING SERVICES IN THE FIELD OF HEALTH AND WELLNESS (U.S. CLS. 100, 101 AND 107).

FIRST USE 9-21-2010; IN COMMERCE 9-21-2010. APRIL HESIK, EXAMINING ATTORNEY

**CLASS 41—(Continued).**

SN 85-167,796. SMITH TRAVEL RESEARCH, INC., HENDERSONVILLE, TN. FILED 11-3-2010.

HOTEL INVESTMENT BAROMETER

THE MARK CONSISTS OF STANDARD CHARACTERS WITHOUT CLAIM TO ANY PARTICULAR FONT, STYLE, SIZE, OR COLOR.

NO CLAIM IS MADE TO THE EXCLUSIVE RIGHT TO USE "HOTEL INVESTMENT", APART FROM THE MARK AS SHOWN.

FOR PROVIDING NEWSLETTERS IN THE FIELD OF HOTEL REAL ESTATE TRENDS, HOTEL REAL ESTATE DATA AND HOTEL REAL ESTATE NEWSWORTHY EVENTS VIA E-MAIL; PROVIDING ON-LINE NEWSLETTERS IN THE FIELD OF HOTEL REAL ESTATE TRENDS, HOTEL REAL ESTATE DATA AND HOTEL REAL ESTATE NEWSWORTHY EVENTS (U.S. CLS. 100, 101 AND 107).

ROBERT C. CLARK JR., EXAMINING ATTORNEY

SN 85-168,211. SOLOMON, RICHARD, NEW YORK, NY. FILED 11-3-2010.

SN 85-165,396. FREMD - IMMORTAL SIBLINGS VENTURES LLC, HONOLULU, HI. FILED 10-29-2010.

FREMD - IMMORTAL SIBLINGS VENTURES LLC



NO CLAIM IS MADE TO THE EXCLUSIVE RIGHT TO USE "A NEW ILLUSTRATORS CONTEST", APART FROM THE MARK AS SHOWN.

THE MARK CONSISTS OF THE WORD "BREAK" ABOVE THE WORD "THROUGH" WITH THE WORDS "A NEW ILLUSTRATORS CONTEST" TO THE RIGHT OF THE WORD "BREAK" AND ABOVE THE WORD "THROUGH" WITH THE LETTERS "E", "A", AND "K" IN STYLIZED FORMAT.

FOR PROVIDING RECOGNITION AND INCENTIVES BY THE WAY OF AWARDS AND CONTESTS TO DEMONSTRATE EXCELLENCE IN THE FIELD OF ART, ART ILLUSTRATIONS AND GRAPHIC DESIGNS (U.S. CLS. 100, 101 AND 107).

C. DIONNE CLYBURN, EXAMINING ATTORNEY

THE MARK CONSISTS OF STANDARD CHARACTERS WITHOUT CLAIM TO ANY PARTICULAR FONT, STYLE, SIZE, OR COLOR.

NO CLAIM IS MADE TO THE EXCLUSIVE RIGHT TO USE "VENTURES LLC", APART FROM THE MARK AS SHOWN.

FOR ENTERTAINMENT, NAMELY, PRODUCTION OF PLAYS, MOVIES, TELEVISION SHOWS; PUBLICATION OF BOOKS (U.S. CLS. 100, 101 AND 107).

LINDA ORNDORFF, EXAMINING ATTORNEY

**CLASS 41—(Continued).**

SN 85-168,626. SHOWSTOPPERS PLUS, INC., NORTH BRUNSWICK, NJ. FILED S.R. 11-3-2010; AM. P.R. 4-7-2011.

## Funabilities

THE MARK CONSISTS OF STANDARD CHARACTERS WITHOUT CLAIM TO ANY PARTICULAR FONT, STYLE, SIZE, OR COLOR.

FOR EDUCATIONAL AND ENTERTAINMENT SERVICES, NAMELY, PROVIDING MOTIVATIONAL AND EDUCATIONAL SPEAKERS IN THE FIELD OF SELF-AND PERSONAL IMPROVEMENT (U.S. CLS. 100, 101 AND 107).

FIRST USE 6-1-2010; IN COMMERCE 6-1-2010.  
GEOFFREY FOSDICK, EXAMINING ATTORNEY

---

SN 85-168,772. SACHS, IAN, PARADISE VALLEY, AZ. FILED 11-4-2010.

## FRAT CASTLES

THE MARK CONSISTS OF STANDARD CHARACTERS WITHOUT CLAIM TO ANY PARTICULAR FONT, STYLE, SIZE, OR COLOR.

NO CLAIM IS MADE TO THE EXCLUSIVE RIGHT TO USE "FRAT", APART FROM THE MARK AS SHOWN.

FOR EDUCATIONAL AND ENTERTAINMENT SERVICES, NAMELY, PROVIDING A WEBSITE FEATURING VIRTUAL TOURS OF FRATERNITY AND SORORITY HOUSES ON COLLEGE CAMPUSES (U.S. CLS. 100, 101 AND 107).

JULIE GUTTADAURO, EXAMINING ATTORNEY

---

SN 85-171,982. ADRENALINE SPORTS MANAGEMENT INC., CARY, IL. FILED 11-8-2010.

## Santa Hustle

THE MARK CONSISTS OF STANDARD CHARACTERS WITHOUT CLAIM TO ANY PARTICULAR FONT, STYLE, SIZE, OR COLOR.

FOR ORGANIZING, ARRANGING AND CONDUCTING SPORTING EVENTS, NAMELY, 5K, 8K AND/OR 10K RUNNING RACES; ORGANIZING RELATED SPORTING AND ENTERTAINMENT EVENTS, NAMELY, ARRANGING AND CONDUCTING ATHLETIC COMPETITIONS, ATHLETIC TRAINING SERVICES; ENTERTAINMENT SERVICES, NAMELY, ORGANIZING COMMUNITY FAIRS FEATURING VENDOR BOOTHS OF FOOD AND RACE RELATED SPORTING GOODS (U.S. CLS. 100, 101 AND 107).

FIRST USE 3-5-2010; IN COMMERCE 3-5-2010.  
MICHELE SWAIN, EXAMINING ATTORNEY

**CLASS 41—(Continued).**

SN 85-172,252. CHARLES G. KOCH CHARITABLE FOUNDATION, WICHITA, KS. FILED 11-9-2010.

## LIBERTY@WORK

THE MARK CONSISTS OF STANDARD CHARACTERS WITHOUT CLAIM TO ANY PARTICULAR FONT, STYLE, SIZE, OR COLOR.

FOR EDUCATIONAL SERVICES, NAMELY, PROVIDING COURSES, INSTRUCTION, AND ONLINE INFORMATION ABOUT EDUCATION, ALL IN THE FIELDS OF GOVERNMENT, FINANCE, AND POLICY, AND DISTRIBUTING PRINTED MATERIAL IN CONNECTION THEREWITH (U.S. CLS. 100, 101 AND 107).

GENE MACIOL, EXAMINING ATTORNEY

---

SN 85-172,440. CRYSTAL JOYCE, POWELL, OH. FILED 11-9-2010.



THE COLOR(S) GREEN, WHITE, BLUE AND GREY IS/ ARE CLAIMED AS A FEATURE OF THE MARK.

THE MARK CONSISTS OF A GREEN AND WHITE GLOBE WITH BLUE ARROW SWOOSH DESIGN ACROSS THE FRONT OF THE GLOBE, WITH SLIGHT GREY SHADOW BELOW THE GLOBE AND THE BLUE LETTERS "USGTC" BELOW THE GREY SHADOW.

FOR MEMBERSHIP CLUB SERVICES, NAMELY, PROVIDING TRAINING TO MEMBERS IN THE FIELD OF GREEN TECHNOLOGY CERTIFICATION; TEACHING AND TRAINING IN BUSINESS, INDUSTRY AND INFORMATION TECHNOLOGY (U.S. CLS. 100, 101 AND 107).

CHRISTINA SOBRAL, EXAMINING ATTORNEY



**CLASS 41—(Continued).**

SN 85-172,840. NAVAJO NATION GAMING ENTERPRISE, CHURCH ROCK, NM. FILED 11-9-2010.

**TWIN ARROWS NAVAJO CASINO  
RESORT**

THE MARK CONSISTS OF STANDARD CHARACTERS WITHOUT CLAIM TO ANY PARTICULAR FONT, STYLE, SIZE, OR COLOR.

OWNER OF U.S. REG. NOS. 3,721,178, 3,721,180 AND OTHERS.

NO CLAIM IS MADE TO THE EXCLUSIVE RIGHT TO USE "CASINO RESORT", APART FROM THE MARK AS SHOWN.

FOR PROVIDING CASINOS AND GAMING FACILITIES; CASINOS; PROVIDING CASINO SERVICES FEATURING A CASINO PLAYERS REWARDS PROGRAM; PROVIDING INFORMATION IN THE FIELDS OF CASINO AND GAMING SERVICES; ENTERTAINMENT SERVICES, NAMELY, CONCERTS, LIVE MUSIC, COMEDY AND VARIETY SHOWS, CABARETS, CONDUCTING LIVE POKER GAMES AND TOURNAMENTS, CONDUCTING LIVE BLACKJACK CARD GAME TOURNAMENTS, CONDUCTING SLOT MACHINE TOURNAMENTS, AND CONDUCTING BINGO TOURNAMENTS (U.S. CLS. 100, 101 AND 107).

DAWN FELDMAN, EXAMINING ATTORNEY

SN 85-173,261. AVE MARIA UNIVERSITY, INC., AVE MARIA, FL. FILED 11-10-2010.



THE COLOR(S) WHITE, BLUE AND GOLD IS/ARE CLAIMED AS A FEATURE OF THE MARK.

THE MARK CONSISTS OF THE INTERLOCKING LETTERS "AM", WITH THE LETTER "A" IN WHITE AND THE LETTER "M" IN BLUE, AND A RING OF BLUE STARS TO THE LEFT AND THE RIGHT OF AND ABOVE THE LETTERS, ALL AGAINST A GOLD SQUARE BACKGROUND.

FOR ORGANIZING EXHIBITIONS FOR COLLEGIATE ATHLETICS, COLLEGIATE TOURNAMENTS, AND COLLEGIATE ATHLETIC GAMES; ARRANGING AND CONDUCTING EDUCATIONAL CONFERENCES; ORGANIZING FESTIVALS FEATURING A VARIETY OF ACTIVITIES, NAMELY, SPORTING EVENTS; ARRANGING AND CONDUCTING ATHLETIC COMPETITIONS; ENTERTAINMENT IN THE NATURE OF ATHLETIC EVENTS (U.S. CLS. 100, 101 AND 107).

STEVEN R. FINE, EXAMINING ATTORNEY

**CLASS 41—(Continued).**

SN 85-176,420. LAKELAND FINANCE, LLC, CHARLOTTESVILLE, VA. FILED 11-15-2010.

**FESTIVAL OF GOLD**

THE MARK CONSISTS OF STANDARD CHARACTERS WITHOUT CLAIM TO ANY PARTICULAR FONT, STYLE, SIZE, OR COLOR.

NO CLAIM IS MADE TO THE EXCLUSIVE RIGHT TO USE "FESTIVAL", APART FROM THE MARK AS SHOWN. FOR ORGANIZING AND CONDUCTING MUSICAL PERFORMANCES AND SHOWCASES (U.S. CLS. 100, 101 AND 107).

FIRST USE 0-0-1994; IN COMMERCE 0-0-1994.

CHRIS WELLS, EXAMINING ATTORNEY

SN 85-176,431. LAKELAND FINANCE, LLC, CHARLOTTESVILLE, VA. FILED 11-15-2010.



NO CLAIM IS MADE TO THE EXCLUSIVE RIGHT TO USE "FESTIVAL", APART FROM THE MARK AS SHOWN.

THE MARK CONSISTS OF A WREATH WITH "FESTIVAL OF GOLD" EXTENDING HORIZONTALLY THROUGH THE WREATH AT THE LETTERS "ST" AND "GO".

FOR ORGANIZING AND CONDUCTING MUSICAL PERFORMANCES AND SHOWCASES (U.S. CLS. 100, 101 AND 107).

FIRST USE 0-0-1994; IN COMMERCE 0-0-1994.

CHRIS WELLS, EXAMINING ATTORNEY

SN 85-177,061. BACCOUCHE, DR. AZIZA, WASHINGTON, DC. FILED 11-15-2010.

**Dr. Z**

THE MARK CONSISTS OF STANDARD CHARACTERS WITHOUT CLAIM TO ANY PARTICULAR FONT, STYLE, SIZE, OR COLOR.

THE NAME(S), PORTRAIT(S), AND/OR SIGNATURE(S) SHOWN IN THE MARK IDENTIFIES "DR. AZIZA BACCOUCHE", WHOSE CONSENT(S) TO REGISTER IS MADE OF RECORD.

FOR EDUCATIONAL SERVICES, NAMELY, PROVIDING INTERNSHIPS AND EXCHANGE PROGRAMS IN THE FIELDS OF BUSINESS, SCIENCE, RESEARCH, AND HUMANITIES (U.S. CLS. 100, 101 AND 107).

VERNA BETH RIRIE, EXAMINING ATTORNEY

**CLASS 41—(Continued).**

SN 85-177,318. SHUFFLE MASTER, INC., LAS VEGAS, NV.  
FILED 11-15-2010.

**HIGH FIVE POKER PROGRESSIVE**

THE MARK CONSISTS OF STANDARD CHARACTERS WITHOUT CLAIM TO ANY PARTICULAR FONT, STYLE, SIZE, OR COLOR.

OWNER OF U.S. REG. NO. 2,873,343.

NO CLAIM IS MADE TO THE EXCLUSIVE RIGHT TO USE "POKER PROGRESSIVE", APART FROM THE MARK AS SHOWN.

FOR ENTERTAINMENT SERVICES, NAMELY, PROVIDING A LIVE GAME OF CHANCE IN A CASINO (U.S. CLS. 100, 101 AND 107).

NAPOLEON SHARMA, EXAMINING ATTORNEY

SN 85-177,329. SHUFFLE MASTER, INC., LAS VEGAS, NV.  
FILED 11-15-2010.

**HIGH FIVE POKER**

THE MARK CONSISTS OF STANDARD CHARACTERS WITHOUT CLAIM TO ANY PARTICULAR FONT, STYLE, SIZE, OR COLOR.

OWNER OF U.S. REG. NO. 2,873,343.

NO CLAIM IS MADE TO THE EXCLUSIVE RIGHT TO USE "POKER", APART FROM THE MARK AS SHOWN.

FOR ENTERTAINMENT SERVICES, NAMELY, PROVIDING A LIVE GAME OF CHANCE IN A CASINO (U.S. CLS. 100, 101 AND 107).

NAPOLEON SHARMA, EXAMINING ATTORNEY

SN 85-177,709. LAKELAND FINANCE, LLC, CHARLOTTESVILLE, VA. FILED 11-16-2010.

**HERITAGE CHILDREN'S CHOIR FESTIVALS**

THE MARK CONSISTS OF STANDARD CHARACTERS WITHOUT CLAIM TO ANY PARTICULAR FONT, STYLE, SIZE, OR COLOR.

NO CLAIM IS MADE TO THE EXCLUSIVE RIGHT TO USE "CHILDREN'S CHOIR FESTIVALS", APART FROM THE MARK AS SHOWN.

FOR ORGANIZING AND CONDUCTING MUSICAL PERFORMANCES, CONCERTS, AND SHOWCASES (U.S. CLS. 100, 101 AND 107).

FIRST USE 0-0-1998; IN COMMERCE 0-0-1998.

CHRIS WELLS, EXAMINING ATTORNEY

**CLASS 41—(Continued).**

SN 85-177,728. LAKELAND FINANCE, LLC, CHARLOTTESVILLE, VA. FILED 11-16-2010.



NO CLAIM IS MADE TO THE EXCLUSIVE RIGHT TO USE "CHILDREN'S CHOIR FESTIVALS", APART FROM THE MARK AS SHOWN.

THE MARK CONSISTS OF THREE SIMPLE IMAGES OF CHILDREN WITH TWO GIRLS IN THE BACK AND A BOY CENTERED AND BELOW IN FRONT. THE CHILDREN HAVE OPEN MOUTHS WITH NO OTHER DEFINITION. THE WORDS "HERITAGE CHILDREN'S CHOIR FESTIVALS" ARE STACKED BELOW.

FOR ORGANIZING AND CONDUCTING MUSICAL PERFORMANCES, CONCERTS, AND SHOWCASES (U.S. CLS. 100, 101 AND 107).

FIRST USE 0-0-1999; IN COMMERCE 0-0-1999.

CHRIS WELLS, EXAMINING ATTORNEY

SN 85-179,678. COLDWELL BANKER REAL ESTATE LLC, PARSIPPANY, NJ. FILED 11-18-2010.



NO CLAIM IS MADE TO THE EXCLUSIVE RIGHT TO USE "UNIVERSITY", APART FROM THE MARK AS SHOWN.

THE MARK CONSISTS OF THE DESIGN OF A GRADUATION CAP WITH TASSEL INSIDE A SHADED CIRCLE WITH THE WORDS "COLDWELL BANKER" ABOVE THE WORD "UNIVERSITY" TO THE RIGHT OF THE DESIGN.

FOR EDUCATIONAL SERVICES, NAMELY, CONDUCTING WORKSHOPS, CONFERENCES, CLASSES AND/OR SEMINARS IN THE FIELD OF REAL ESTATE BROKERAGE (U.S. CLS. 100, 101 AND 107).

FIRST USE 11-30-2009; IN COMMERCE 11-30-2009.

ROBERT C. CLARK JR., EXAMINING ATTORNEY

**CLASS 41—(Continued).**

SN 85-182,259. EDGARSTAT, LLC, BETHESDA, MD. FILED 11-22-2010.

## EDGARSTAT REVIEW

THE MARK CONSISTS OF STANDARD CHARACTERS WITHOUT CLAIM TO ANY PARTICULAR FONT, STYLE, SIZE, OR COLOR.

OWNER OF U.S. REG. NO. 3,305,407.

NO CLAIM IS MADE TO THE EXCLUSIVE RIGHT TO USE "REVIEW", APART FROM THE MARK AS SHOWN.

FOR PROVIDING A WEBSITE FEATURING ONLINE PUBLICATIONS, NAMELY, REPORTS IN THE FIELD OF FINANCIAL INFORMATION RELATED TO COMPANIES LISTED BY THE UNITED STATES SECURITIES AND EXCHANGE COMMISSION (U.S. CLS. 100, 101 AND 107).

JANICE L. MCMORROW, EXAMINING ATTORNEY

**CLASS 41—(Continued).**

SN 85-184,628. COLOAN BRANDS, LLC, FREEHOLD, NJ. FILED 11-24-2010.



SN 85-183,132. SUFFOLK UNIVERSITY, BOSTON, MA. FILED 11-23-2010.



THE MARK CONSISTS OF A PORTION OF A BUILDING THAT INCLUDES A DOME ON TOP, A SERIES OF WINDOWS, BALCONY, DENTILS AND ARCHITECTURAL DETAILS.

FOR EDUCATIONAL SERVICES, NAMELY, PROVIDING COURSES OF INSTRUCTION AND TRAINING AT THE UNDERGRADUATE, GRADUATE, POST-GRADUATE, AND PROFESSIONAL LEVELS; ENTERTAINMENT SERVICES, NAMELY, ORGANIZING AND CONDUCTING ATHLETIC EVENTS, LECTURES, CONCERTS, FINE ART EXHIBITIONS, AND THEATER PRODUCTIONS (U.S. CLS. 100, 101 AND 107).

FIRST USE 7-31-2008; IN COMMERCE 7-31-2008.

EDWARD NELSON, EXAMINING ATTORNEY

OWNER OF U.S. REG. NO. 3,869,732.

THE NAME SHOWN IN THE MARK DOES NOT IDENTIFY A LIVING INDIVIDUAL.

THE MARK CONSISTS OF THE STYLIZED TEXT "COLOAN WILL COLOAN". THE "C" HAS TWO QUOTATION MARKS INSIDE OF IT. THE "O" HAS TWO QUOTATION MARKS INSIDE OF IT FOLLOWED BY AN ARROW GOING THROUGH IT. THE "L" HAS A SLIGHT CURVED SHAPE WITH AN ARROW AT THE END. THE "O" HAS TWO QUOTATION MARKS INSIDE OF IT FOLLOWED BY AN ARROW GOING THROUGH INTO THE BOTTOM OF THE PREVIOUS LETTER, "L". THE "A" HAS A CURSIVE LOOK TO IT, WITH THE BOTTOM RIGHT END OF IT CURVING OUT INTO THE MIDDLE OF THE LETTER AND BACK OUT WITH AN ARROW. THE "N" HAS A SLIGHT ITALICIZED LOOK TO IT, WITH THE TOP RIGHT END OF THE LETTER CURVING OUT. UNDERNEATH THE WORD "COLOAN" IS AN UNDERLINE UNDER THE FIRST LETTER "O" AND THE LETTER "A". UNDERNEATH THE LINE IS THE LETTER "W" WITH THE RIGHT SIDE CURVED IN. NEXT IS THE LETTER "I" WHICH IS SLIGHTLY CROOKED AND DOTTED WITH A STAR SYMBOL. THE "L" NEXT TO THE LETTER "I" IS SLIGHTLY ITALICIZED WITH THE BOTTOM OF THE LETTER CURVED IN. THE "L" TO THE RIGHT OF THE PREVIOUS LETTER "L" IS SLIGHTLY ITALICIZED WITH THE BOTTOM OF THE LETTER CURVED IN. THERE IS A CURVY LINE IN THE SHAPE OF A "W" CONNECTING THE BOTTOM LEFT CORNER OF THE LETTER "L" TO THE LETTER "C". THE LETTER "C" IS IN A CURSIVE SHAPE MERGING INTO THE NEXT LETTER "O". THE LETTER "O" HAS TWO DOTS INSIDE OF IT. THE "L" TO THE RIGHT OF THE LETTER "O" IS SLIGHTLY ITALICIZED WITH THE BOTTOM OF THE LETTER CURVED INTO THE NEXT LETTER, "O". THE LETTER "O" HAS TWO DOTS INSIDE OF IT. THE LETTER "A" IS SLANTED TO THE RIGHT. THE LETTER "N" IS SLANTED AND LOOKS SIMILAR TO THE LETTER "V".

FOR ENTERTAINMENT, NAMELY, PRODUCTION OF MOTION PICTURES, TELEVISION AND INTERNET PROGRAMS (U.S. CLS. 100, 101 AND 107).

RENEE MCCRAY, EXAMINING ATTORNEY

**CLASS 41—(Continued).**

SN 85-184,666. GREEN BAY PACKERS, INC., GREEN BAY, WI. FILED 11-24-2010.

# TITLETOWN

THE MARK CONSISTS OF STANDARD CHARACTERS WITHOUT CLAIM TO ANY PARTICULAR FONT, STYLE, SIZE, OR COLOR.

OWNER OF U.S. REG. NO. 1,802,761.

FOR CONCERT BOOKING; ENTERTAINMENT SERVICES, NAMELY, ORGANIZING AND CONDUCTING AN ARRAY OF ATHLETIC EVENTS RENDERED LIVE AND RECORDED FOR THE PURPOSE OF DISTRIBUTION THROUGH BROADCAST MEDIA; MUSEUM SERVICES; PROVIDING RECREATION FACILITIES; RENTAL OF RECREATIONAL FACILITIES FOR PLAYING SPORTS, SPORTS TRAINING, AND GROUP RECREATION EVENTS; RUNNING OF A FOOTBALL-RELATED MUSEUM (U.S. CLS. 100, 101 AND 107).

KAREN SEVERSON, EXAMINING ATTORNEY

SN 85-185,292. HOMIE INTERNATIONAL CORPORATION, LEWES, DE. FILED 11-25-2010.

# Hip Hop Babe

THE MARK CONSISTS OF STANDARD CHARACTERS WITHOUT CLAIM TO ANY PARTICULAR FONT, STYLE, SIZE, OR COLOR.

NO CLAIM IS MADE TO THE EXCLUSIVE RIGHT TO USE "HIP HOP", APART FROM THE MARK AS SHOWN.

FOR ADMISSION TICKET RESERVATION AND BOOKING SERVICES FOR NIGHT CLUBS AND NIGHT CLUB EVENTS; AMATEUR YOUTH SPORTS SERVICES, NAMELY, ORGANIZING AND PROVIDING YOUTH SPORTS ACTIVITIES; AMUSEMENT ARCADE SERVICES; AMUSEMENT ARCADES; AMUSEMENT CENTERS; AMUSEMENT PARK AND THEME PARK SERVICES; AMUSEMENT PARKS; ARRANGING AND CONDUCTING ATHLETIC COMPETITIONS; ARRANGING AND CONDUCTING CANOPY TOURS AND ZIP LINE EVENTS FOR ENTERTAINMENT PURPOSES; ARRANGING AND CONDUCTING EDUCATIONAL CONFERENCES; ARRANGING AND CONDUCTING INCENTIVE AWARD PROGRAMS TO ENCOURAGE THE FREQUENT, CONTINUED AND EFFECTIVE PRACTICE OF PHYSICAL EXERCISE; ARRANGING AND CONDUCTING LIVE, INTERACTIVE, TREASURE HUNT GAMING ADVENTURES; ARRANGING AND CONDUCTING NIGHTCLUB ENTERTAINMENT EVENTS; ARRANGING AND CONDUCTING NIGHTCLUB PARTIES; ARRANGING AND CONDUCTING OF CONCERTS; ARRANGING AND CONDUCTING SPECIAL EVENTS FOR SOCIAL ENTERTAINMENT PURPOSES; ARRANGING AND CONDUCTING TOURS OF CRUISE SHIPS; ARRANGING FOR TICKET RESERVATIONS FOR SHOWS AND OTHER ENTERTAINMENT EVENTS; ARRANGING OF BEAUTY CONTESTS; ARRANGING OF CONTESTS; ARRANGING OF SEMINARS; ARRANGING PROFESSIONAL WORKSHOP AND TRAINING COURSES; ARRANGING, ORGANIZING, CONDUCTING AND HOSTING BIRTHDAY PARTIES; ARRANGING, ORGANIZING, CONDUCTING, AND HOSTING SOCIAL ENTERTAINMENT EVENTS; ART EXHIBITION SERVICES; ART EXHIBITIONS; AUDIO AND VIDEO RECORDING SERVICES; AUDIO PRODUCTION SERVICES, NAMELY, CREATING AND

**CLASS 41—(Continued).**

PRODUCING AMBIENT SOUNDSCAPES, AND SOUND STORIES FOR MUSEUMS, GALLERIES, ATTRACTIONS, PODCASTS, BROADCASTS, WEBSITES AND GAMES; AUDIO RECORDING AND PRODUCTION; BALLET SCHOOLS; BEAUTY ARTS INSTRUCTION; BOOK AND REVIEW PUBLISHING; BOOK PUBLISHING; BOOKING OF ENTERTAINMENT HALLS; BOOKING OF SEATS FOR SHOWS; BOOKING OF SEATS FOR SHOWS AND BOOKING OF THEATRE TICKETS; BOOKING OF SEATS FOR SHOWS AND SPORTS EVENTS; BUSINESS TRAINING; BUSINESS TRAINING CONSULTANCY SERVICES; CABARETS; CABLE TELEVISION PROGRAMMING; CAREER COUNSELING; CAVES FOR PUBLIC ADMISSION; CHOREOGRAPHY SERVICES FOR OTHERS; CINEMA STUDIOS; CINEMA THEATERS; CINEMATOGRAPHIC ADAPTATION AND EDITING; COMPOSITION OF MUSIC FOR OTHERS; CONCERT BOOKING; CONDUCTING AND PROVIDING FACILITIES FOR SPECIAL EVENTS FEATURING CASINO AND GAMING CONTESTS AND TOURNAMENTS; CONDUCTING LOTTERIES FOR OTHERS; CONDUCTING WORKSHOPS AND SEMINARS IN PERSONAL AWARENESS; CONDUCTING WORKSHOPS AND SEMINARS IN SELF AWARENESS; CONSULTATION AND ADVICE REGARDING MUSICAL SELECTIONS AND ARRANGEMENTS FOR SOUND RECORDINGS AND LIVE PERFORMANCES; CONSULTATION AND ADVICE REGARDING THE RENTAL OF RECORDING STUDIOS AND VENUES; CONSULTATION IN THE FIELD OF SPECIAL EVENT PLANNING FOR SOCIAL ENTERTAINMENT PURPOSES; CONSULTING SERVICES IN THE FIELDS OF FITNESS AND EXERCISE; CUSTOM WRITING SERVICES; DANCE CLUB SERVICES; DANCE EVENTS; DANCE INSTRUCTION; DANCE INSTRUCTION FOR CHILDREN; DANCE RESERVATION SERVICES, NAMELY, ARRANGING FOR ADMISSION TO DANCE EVENTS; DANCE SCHOOLS; DANCE STUDIOS; DESKTOP PUBLISHING FOR OTHERS; DEVELOPING TRAINING SYSTEMS AND LEARNING METHODOLOGIES FOR OTHERS; DIGITAL IMAGING SERVICES; DIGITAL VIDEO, AUDIO, AND MULTIMEDIA PUBLISHING SERVICES; DINNER THEATERS; DIRECTION OF MAKING RADIO OR TELEVISION PROGRAMS; DIRECTION OR PRESENTATION OF PLAYS; DISC JOCKEYS FOR PARTIES AND SPECIAL EVENTS; DISCOTHEQUES; DISTRIBUTION OF MOTION PICTURE FILMS; DISTRIBUTION OF RADIO PROGRAMS FOR OTHERS; DISTRIBUTION OF TELEVISION PROGRAMMING TO CABLE TELEVISION SYSTEMS; DISTRIBUTION OF TELEVISION PROGRAMS FOR OTHERS; DUBBING; DUBBING SERVICES; EDITING OF RADIO AND TELEVISION PROGRAMMES; EDITING OR RECORDING OF SOUNDS AND IMAGES; EDITORIAL CONSULTATION; EDITORIAL REPORTING SERVICES; EDUCATION SERVICES, NAMELY, PROVIDING ONLINE COGNITIVE ASSESSMENTS AND TRAINING PROGRAMS THAT HELP IDENTIFY COGNITIVE STRENGTHS AND WEAKNESSES OF AN INDIVIDUAL; EDUCATIONAL AND ENTERTAINMENT SERVICES, NAMELY, A CONTINUING PROGRAM ABOUT HIP HOP MUSIC, DANCE SHOWS AND BEAUTY CONTESTS ACCESSIBLE BY RADIO, TELEVISION, SATELLITE, AUDIO, VIDEO AND COMPUTER NETWORKS; EDUCATIONAL AND ENTERTAINMENT SERVICES, NAMELY, PROVIDING MOTIVATIONAL AND EDUCATIONAL SPEAKERS; EDUCATIONAL SERVICES IN THE NATURE OF BEAUTY SCHOOLS; EDUCATIONAL SERVICES, NAMELY, CONDUCTING WORKSHOPS IN THE FIELD OF BLACK MUSIC; EDUCATIONAL SERVICES, NAMELY, DEVELOPING AND CONDUCTING TRAINING COURSES AND DISTRIBUTION OF TRAINING MATERIALS IN CONNECTION THEREWITH FOR SUBJECT MATTERS AS REQUESTED BY CUSTOMERS; ELECTRONIC DESKTOP PUBLISHING; ELECTRONIC GAMES SERVICES PROVIDED BY MEANS OF THE INTERNET; ENCOURAGING AMATEUR SPORTS AND PHYSICAL EDUCATION BY ORGANIZING, SANCTIONING, CONDUCTING, REGULATING AND GOVERNING AMATEUR ATHLETIC PROGRAMS AND ACTIVITIES; ENCOURAGING PARTICIPATION IN CHEERLEADING, DANCE AND SPIRIT-RELATED COMPETITIONS AND EVENTS BY ESTABLISHING RULES AND PROVIDING GOVERNANCE FOR THE COMPETITIONS AND EVENTS; ENTERTAINMENT AND EDUCATION SERVICES IN THE NATURE OF A SERIES OF SHORT SHOWS FEATURING HIP HOP MUSIC, DANCE SHOWS



**CLASS 41—(Continued).**

AND BEAUTY CONTESTS DISTRIBUTED TO MOBILE HANDSETS, WHICH MAY INCLUDE VIDEO, TEXT, PHOTOS, ILLUSTRATIONS OR HYPERTEXT; ENTERTAINMENT AND EDUCATION SERVICES IN THE NATURE OF LIVE DANCE AND MUSICAL PERFORMANCES; ENTERTAINMENT AND EDUCATION SERVICES, NAMELY, PROVIDING RECOGNITION AND INCENTIVES BY WAY OF CELEBRATIONS AND AWARDS TO GIRLS FROM UNDERSERVED COMMUNITIES WHO HAVE COMPLETED THEIR HIGH SCHOOL CAREERS SUCCESSFULLY AND WHO ARE GOING ON TO COLLEGE; ENTERTAINMENT AND EDUCATIONAL SERVICES IN THE NATURE OF ONLINE COMPETITIONS IN THE FIELD OF ENTERTAINMENT, EDUCATION, CULTURE, SPORTS, AND OTHER NON-BUSINESS AND NON-COMMERCIAL FIELDS; ENTERTAINMENT AND EDUCATIONAL SERVICES, NAMELY, PROVIDING ADVICE AND INFORMATION FOR MUSIC, VIDEO AND FILM CONCEPT AND SCRIPT DEVELOPMENT; ENTERTAINMENT EVENT BOOKING AGENCIES; ENTERTAINMENT IN THE NATURE OF AN ON-GOING SPECIAL VARIETY, NEWS, MUSIC OR COMEDY SHOW FEATURING HIP HOP MUSIC, DANCE SHOWS AND BEAUTY CONTESTS BROADCAST OVER TELEVISION, SATELLITE, AUDIO, AND VIDEO MEDIA; ENTERTAINMENT IN THE NATURE OF BALLET PERFORMANCES; ENTERTAINMENT IN THE NATURE OF BEAUTY PAGEANTS; ENTERTAINMENT IN THE NATURE OF DANCE PERFORMANCES; ENTERTAINMENT IN THE NATURE OF FASHION SHOWS; ENTERTAINMENT IN THE NATURE OF LASER SHOWS; ENTERTAINMENT IN THE NATURE OF LIGHT SHOWS; ENTERTAINMENT IN THE NATURE OF LIVE PERFORMANCES BY HIP HOP ARTISTS AND DANCERS; ENTERTAINMENT IN THE NATURE OF LIVE RADIO PERSONALITY PERFORMANCES; ENTERTAINMENT IN THE NATURE OF LIVE STAGE PERFORMANCES IN THE NATURE OF HIP HOP MUSIC, DANCE SHOWS AND BEAUTY CONTESTS OR LECTURE FOR HIRE IN THE FIELD OF HIP HOP MUSIC AND YOUTH CULTURE BY AN INDIVIDUAL; ENTERTAINMENT IN THE NATURE OF MAGIC SHOWS; ENTERTAINMENT IN THE NATURE OF ON-GOING TELEVISION PROGRAMS IN THE FIELD OF HIP HOP MUSIC AND YOUTH CULTURE; ENTERTAINMENT IN THE NATURE OF ORCHESTRA PERFORMANCES; ENTERTAINMENT IN THE NATURE OF SYMPHONY ORCHESTRA PERFORMANCES; ENTERTAINMENT IN THE NATURE OF TELEVISION NEWS SHOWS; ENTERTAINMENT IN THE NATURE OF THEATER PRODUCTIONS; ENTERTAINMENT IN THE NATURE OF VISUAL AND AUDIO PERFORMANCES BY HIP HOP ARTISTS, DANCE SHOWS AND BEAUTY CONTESTS; ENTERTAINMENT IN THE NATURE OF VISUAL AND AUDIO PERFORMANCES, AND MUSICAL, VARIETY, NEWS AND COMEDY SHOWS; ENTERTAINMENT IN THE NATURE OF VISUAL AND AUDIO PERFORMANCES, NAMELY, MUSICAL BAND, ROCK GROUP, GYMNASTIC, DANCE, AND BALLET PERFORMANCES; ENTERTAINMENT IN THE NATURE OF VISUAL AND AUDIO PERFORMANCES BY AN ACTOR; ENTERTAINMENT INFORMATION; ENTERTAINMENT INFORMATION SERVICES, NAMELY, PROVIDING INFORMATION AND NEWS RELEASES ABOUT A MUSICAL ARTIST; ENTERTAINMENT MEDIA PRODUCTION SERVICES FOR MOTION PICTURES, TELEVISION AND INTERNET; ENTERTAINMENT SERVICES BY A MUSICAL ARTIST AND PRODUCER, NAMELY, MUSICAL COMPOSITION FOR OTHERS AND PRODUCTION OF MUSICAL SOUND RECORDINGS; ENTERTAINMENT SERVICES IN THE NATURE OF A NON-FICTION TELEVISION PROGRAMMING SERIES ON TOPICS RELATING TO FAMILY STORIES TOLD BY FAMILY MEMBERS TO PRESERVE THEIR HERITAGE; ENTERTAINMENT SERVICES IN THE NATURE OF AN ON-GOING REALITY BASED TELEVISION PROGRAM; ENTERTAINMENT SERVICES IN THE NATURE OF COMEDY SHOWS; ENTERTAINMENT SERVICES IN THE NATURE OF CREATION, DEVELOPMENT, AND PRODUCTION OF TELEVISION PROGRAMMING; ENTERTAINMENT SERVICES IN THE NATURE OF DEVELOPMENT, CREATION, PRODUCTION AND POST-PRODUCTION SERVICES OF MULTIMEDIA ENTERTAINMENT CONTENT; ENTERTAINMENT SERVICES IN THE NATURE OF LIVE MUSICAL PERFORMANCES; ENTERTAINMENT SERVICES IN THE NATURE OF PRESENTING LIVE MUSICAL PERFORMANCES; EN-

**CLASS 41—(Continued).**

TERAINMENT SERVICES IN THE NATURE OF RECORDING, PRODUCTION AND POST-PRODUCTION SERVICES IN THE FIELD OF MUSIC; ENTERTAINMENT SERVICES, NAMELY, A MULTIMEDIA PROGRAM SERIES FEATURING COMEDY, ACTION AND ADVENTURE DISTRIBUTED VIA VARIOUS PLATFORMS ACROSS MULTIPLE FORMS OF TRANSMISSION MEDIA; ENTERTAINMENT SERVICES, NAMELY, AN ON-GOING TELEVISION GAME SHOW AND GAMES OF CHANCE TO BE PLAYED AT A CASINO; ENTERTAINMENT SERVICES, NAMELY, AN ON-LINE ACTIVITY WHERE YOU CREATE YOUR OWN MUSIC VIDEOS; ENTERTAINMENT SERVICES, NAMELY, BODY PAINTING SERVICES HELD AT SPECIAL EVENTS; ENTERTAINMENT SERVICES, NAMELY, CABARETS; ENTERTAINMENT SERVICES, NAMELY, CHEERLEADING; ENTERTAINMENT SERVICES, NAMELY, CONDUCTING ALTERNATE REALITY GAMES VIA THE INTERNET; ENTERTAINMENT SERVICES, NAMELY, CONDUCTING CARNIVALS; ENTERTAINMENT SERVICES, NAMELY, CONDUCTING CONTESTS; ENTERTAINMENT SERVICES, NAMELY, CONDUCTING FAIRS; ENTERTAINMENT SERVICES, NAMELY, CONDUCTING PARTIES; ENTERTAINMENT SERVICES, NAMELY, CONDUCTING PARTIES FOR THE PURPOSE OF DATING AND SOCIAL INTRODUCTION FOR ADULTS; ENTERTAINMENT SERVICES, NAMELY, DISPLAYING A SERIES OF FILMS; ENTERTAINMENT SERVICES, NAMELY, FIREWORKS DISPLAYS; ENTERTAINMENT SERVICES, NAMELY, LIVE, TELEVISED AND MOVIE APPEARANCES BY A PROFESSIONAL ENTERTAINER; ENTERTAINMENT SERVICES, NAMELY, MULTIMEDIA PRODUCTION SERVICES; ENTERTAINMENT SERVICES, NAMELY, NON-DOWNLOADABLE RINGTONES, PRE-RECORDED MUSIC, AND GRAPHICS PRESENTED TO MOBILE COMMUNICATIONS DEVICES VIA A GLOBAL COMPUTER NETWORK AND WIRELESS NETWORKS; ENTERTAINMENT SERVICES, NAMELY, PERSONAL APPEARANCES BY A HIP HOP ARTIST; ENTERTAINMENT SERVICES, NAMELY, PLANNING AND CONDUCTING A SERIES OF FILM FESTIVALS; ENTERTAINMENT SERVICES, NAMELY, PRODUCING CHEERLEADING, DANCE AND SPIRIT-RELATED COMPETITIONS AND EVENTS; ENTERTAINMENT SERVICES, NAMELY, PRODUCTION AND DISTRIBUTION OF A GAME SHOW; ENTERTAINMENT SERVICES, NAMELY, PRODUCTION AND DISTRIBUTION OF A QUIZ SHOW; ENTERTAINMENT SERVICES, NAMELY, PRODUCTION OF COMPUTER-GENERATED IMAGERY FOR USE IN MOTION PICTURES; ENTERTAINMENT SERVICES, NAMELY, PRODUCTION OF SPECIAL EFFECTS INCLUDING MODEL-MAKING SERVICES AND RELATED PHYSICAL PRODUCTION ELEMENTS FOR USE IN MOTION PICTURES; ENTERTAINMENT SERVICES, NAMELY, PRODUCTION OF SPECIAL EFFECTS INCLUDING MODEL-MAKING SERVICES, COMPUTER-GENERATED IMAGERY AND COMPUTER-GENERATED GRAPHICS FOR THE PRODUCTION OF MOTION PICTURES, VIDEOS, AND MOVIE TRAILERS; ENTERTAINMENT SERVICES, NAMELY, PROVIDING A WEB SITE FEATURING PHOTOGRAPHIC AND PROSE PRESENTATIONS FEATURING HIP HOP ARTISTS, DANCE SHOWS AND BEAUTY CONTESTS; ENTERTAINMENT SERVICES, NAMELY, PROVIDING A WEB SITE FEATURING PHOTOGRAPHIC, AUDIO, VIDEO AND PROSE PRESENTATIONS FEATURING HIP HOP MUSIC, DANCE SHOWS AND BEAUTY CONTESTS; ENTERTAINMENT SERVICES, NAMELY, PROVIDING A WEB SITE FEATURING PHOTOGRAPHIC, VIDEO AND PROSE PRESENTATIONS FEATURING HIP HOP MUSIC, DANCE SHOWS AND BEAUTY CONTESTS; ENTERTAINMENT SERVICES, NAMELY, PROVIDING A WEBSITE AT WHICH THE GENERAL PUBLIC CAN RECEIVE ADVICE FROM AN INDIVIDUAL CONCERNING RELATIONSHIPS, SUCH ADVICE BEING FOR ENTERTAINMENT PURPOSES ONLY; ENTERTAINMENT SERVICES, NAMELY, PROVIDING A WEBSITE AT WHICH THE GENERAL PUBLIC CAN RECEIVE ADVICE FROM AN INDIVIDUAL OR ENTITY CONCERNING HAPPINESS, SUCH ADVICE BEING FOR ENTERTAINMENT PURPOSES ONLY; ENTERTAINMENT SERVICES, NAMELY, PROVIDING A WEBSITE FEATURING GAMES AND PUZZLES; ENTERTAINMENT SERVICES, NAMELY, PROVIDING AN ONLINE INTERACTIVE DATABASE OF PHOTOS AND VIDEOS



**CLASS 41—(Continued).**

IN THE FIELD OF BODY ART, NAMELY, PIERCING, TATTOOS, SCARIFICATION, SUBINCISION, CASTRATION; ENTERTAINMENT SERVICES, NAMELY, PROVIDING GAMES OF CHANCE VIA THE INTERNET; ENTERTAINMENT SERVICES, NAMELY, PROVIDING INFORMATION ABOUT A RECORDING ARTIST VIA AN ONLINE NETWORK; ENTERTAINMENT SERVICES, NAMELY, PROVIDING INFORMATION BY MEANS OF A GLOBAL COMPUTER NETWORK IN THE FIELDS OF CELEBRITIES, ENTERTAINMENT, AND POPULAR CULTURE; ENTERTAINMENT SERVICES, NAMELY, PROVIDING LIVE ENTERTAINMENT BY DANCERS VIA THE INTERNET; ENTERTAINMENT SERVICES, NAMELY, PROVIDING NON-DOWNLOADABLE PLAYBACK OF MUSIC VIA GLOBAL COMMUNICATIONS NETWORKS; ENTERTAINMENT SERVICES, NAMELY, PROVIDING NONDOWNLOADABLE PRERECORDED MUSIC, INFORMATION IN THE FIELD OF MUSIC, AND COMMENTARY AND ARTICLES ABOUT MUSIC, ALL ON-LINE VIA A GLOBAL COMPUTER NETWORK; ENTERTAINMENT SERVICES, NAMELY, PROVIDING ON-LINE COMPUTER GAMES; ENTERTAINMENT SERVICES, NAMELY, PROVIDING ONLINE ELECTRONIC GAMES; ENTERTAINMENT SERVICES, NAMELY, PROVIDING ONLINE VIDEO GAMES; ENTERTAINMENT SERVICES, NAMELY, PROVIDING TEMPORARY USE OF NON-DOWNLOADABLE ELECTRONIC GAMES; ENTERTAINMENT SERVICES, NAMELY, PROVIDING TEMPORARY USE OF NON-DOWNLOADABLE VIDEO GAMES; ENTERTAINMENT SERVICES, NAMELY, PROVIDING VIDEO PODCASTS IN THE FIELD OF HIP HOP MUSIC, DANCE SHOWS AND BEAUTY CONTESTS; ENTERTAINMENT SERVICES, NAMELY, PROVIDING VIRTUAL ENVIRONMENTS IN WHICH USERS CAN INTERACT FOR RECREATIONAL, LEISURE OR ENTERTAINMENT PURPOSES; ENTERTAINMENT TICKET AGENCY SERVICES; ENTERTAINMENT, NAMELY, A CONTINUING HIP HOP MUSIC, DANCE SHOW AND BEAUTY CONTEST SHOW BROADCAST OVER TELEVISION, SATELLITE, AUDIO, AND VIDEO MEDIA; ENTERTAINMENT, NAMELY, LIGHTING PRODUCTION; ENTERTAINMENT, NAMELY, LIVE MUSIC CONCERTS; ENTERTAINMENT, NAMELY, LIVE PERFORMANCES BY A MUSICAL BAND; ENTERTAINMENT, NAMELY, LIVE PERFORMANCES BY MUSICAL BANDS; ENTERTAINMENT, NAMELY, LIVE PERFORMANCES BY ROCK GROUPS; ENTERTAINMENT, NAMELY, PREPARATION OF SPECIAL EFFECTS; ENTERTAINMENT, NAMELY, TELEVISION NEWS SHOWS; FAN CLUBS; FASHION MODELING FOR ENTERTAINMENT PURPOSES; FIGURE SALONS; FILM AND VIDEO FILM PRODUCTION; FILM AND VIDEO PRODUCTION; FILM AND VIDEO PRODUCTION CONSULTING SERVICES; FILM AND VIDEO TAPE FILM PRODUCTION; FILM DISTRIBUTION; FILM EDITING; FILM MASTERING SERVICES; FILM PRODUCTION; FILM RENTAL; FILM STUDIOS; HAIRDRESSING INSTRUCTION; HOLIDAY CAMP SERVICES; HOSTING A BACK TO SCHOOL EVENT IN A SHOPPING CENTER FEATURING PRIZES, GAMES, MUSIC, AND A FASHION SHOW; INFORMATION RELATING TO ENTERTAINMENT AND EDUCATION, PROVIDED ON-LINE FROM A COMPUTER DATABASE OR THE INTERNET; INTERPRETER SERVICES; LIVE PERFORMANCES BY A MUSICAL GROUP; LIVE PERFORMANCES FEATURING PRERECORDED VOCAL AND INSTRUMENTAL PERFORMANCES VIEWED ON A BIG SCREEN; MAGAZINE PUBLISHING; MASTER OF CEREMONY SERVICES FOR PARTIES AND SPECIAL EVENTS; MEDIA PRODUCTION LOCATION SCOUTING SERVICES FOR ENTERTAINMENT PURPOSES; MEDIA PRODUCTION SERVICES, NAMELY, VIDEO AND FILM PRODUCTION; MODELING FOR ARTISTS; MODELING FOR ARTISTS; MOTION PICTURE AND VIDEO RENTAL SERVICES; MOTION PICTURE CAMERA RENTAL SERVICES; MOTION PICTURE FILM PRODUCTION; MOTION PICTURE RENTAL; MOTION PICTURE SONG PRODUCTION; MOTION PICTURE THEATERS; MOVIE STUDIOS; MOVIE THEATERS; MULTIMEDIA ENTERTAINMENT SERVICES IN THE NATURE OF DEVELOPMENT, PRODUCTION AND POST-PRODUCTION SERVICES IN THE FIELDS OF VIDEO AND FILMS; MULTIMEDIA ENTERTAINMENT SERVICES IN THE NATURE OF RECORDING, PRODUCTION AND POST-PRODUCTION SERVICES IN THE FIELDS OF MUSIC, VIDEO, AND FILMS; MULTIMEDIA ENTERTAINMENT SOFTWARE PRODUCTION SER-

**CLASS 41—(Continued).**

VICES; MULTIMEDIA PUBLISHING OF BOOKS, MAGAZINES, JOURNALS, SOFTWARE, GAMES, MUSIC, AND ELECTRONIC PUBLICATIONS; MUSIC COMPOSITION AND TRANSCRIPTION FOR OTHERS; MUSIC COMPOSITION FOR OTHERS; MUSIC PRODUCTION SERVICES; MUSIC PUBLISHING SERVICES; MUSIC SELECTION SERVICES FOR USE IN TELEVISION, FILM, RADIO AND VIDEO GAMES; MUSIC TRANSCRIPTION FOR OTHERS; MUSIC VIDEO PRODUCTION; MUSIC-HALLS; MUSICAL EVENT BOOKING AGENCIES; NEWS REPORTER SERVICES IN THE NATURE OF NEWS ANALYSIS AND NEWS COMMENTARY; NEWS REPORTERS SERVICES; NEWS SYNDICATION FOR THE BROADCASTING INDUSTRY; NEWS SYNDICATION REPORTING; NEWSPAPER PUBLICATION; NEWSPAPER PUBLISHING; NIGHT CLUB RESERVATION SERVICES, NAMELY, ARRANGING FOR ADMISSION TO NIGHT CLUBS AND NIGHT CLUB EVENTS; NIGHT CLUBS; NIGHTS-CLUBS; ON-LINE ADMISSION TICKET AGENCY SERVICES FOR ENTERTAINMENT, EDUCATIONAL, SPORTING AND CULTURAL EVENTS; ON-LINE ENTERTAINMENT TICKET AGENCY SERVICES; ONLINE ELECTRONIC PUBLISHING OF BOOKS AND PERIODICALS; OPERATING OF A DISCOTHEQUE; OPERATING OF FILM STUDIOS; OPERATING OF LOTTERIES; OPERATION OF ROBOTIC CAMERAS, VIDEO EQUIPMENT AND/OR AUDIO EQUIPMENT FOR PRODUCTION OF INTERNET TELECONFERENCING, TELECONFERENCING OR TELEVISION PROGRAMS; OPERATION OF VIDEO EQUIPMENT OR AUDIO EQUIPMENT ETC. FOR PRODUCTION OF RADIO OR TELEVISION PROGRAMS; ORCHESTRA SERVICES; ORGANIZATION OF EXHIBITIONS FOR CULTURAL OR EDUCATIONAL PURPOSES; ORGANIZATION OF FASHION SHOWS FOR ENTERTAINMENT PURPOSES; ORGANIZATION OF CULTURAL SHOWS; ORGANIZATION OF DANCING EVENTS; ORGANIZATION OF EVENTS FOR CULTURAL PURPOSES; ORGANIZATION OF EXHIBITIONS FOR CULTURAL OR EDUCATIONAL PURPOSES; ORGANIZATION OF EXHIBITIONS FOR MUSICAL ENTERTAINMENT; ORGANIZATION OF LOTTERIES; ORGANIZATION OF SHOWS FOR CULTURAL PURPOSES; ORGANIZING AND ARRANGING EXHIBITIONS FOR ENTERTAINMENT PURPOSES; ORGANIZING AND HOSTING OF EVENTS FOR CULTURAL PURPOSES; ORGANIZING COMMUNITY FESTIVALS FEATURING A VARIETY OF ACTIVITIES, NAMELY, ART EXHIBITIONS, HERITAGE MARKETS, ETHNIC DANCES, AND THE LIKE; ORGANIZING COMMUNITY SPORTING AND CULTURAL EVENTS; ORGANIZING CULTURAL AND ARTS EVENTS; PARTY AND WEDDING PLANNING AND COORDINATION SERVICES; PARTY AND WEDDING PLANNING CONSULTATION SERVICES; PARTY PLANNING; PARTY PLANNING CONSULTATION; PERFORMANCE HALL RENTAL SERVICES; PERSONAL FITNESS TRAINING SERVICES FEATURING AEROBIC AND ANAEROBIC ACTIVITIES COMBINED WITH RESISTANCE AND FLEXIBILITY TRAINING; PHOTO EDITING; PHOTOGRAPHIC AND VIDEO SERVICES, NAMELY, PHOTOGRAPHIC AND VIDEO CAPTURE; PHOTOGRAPHIC COMPOSITION FOR OTHERS; PHOTOGRAPHIC COMPUTER IMAGING; PHOTOGRAPHIC REPORTING; PHOTOGRAPHY; PHYSICAL FITNESS CONDITIONING CLASSES; PHYSICAL FITNESS CONSULTATION; PHYSICAL FITNESS INSTRUCTION; PLANNING ARRANGEMENT OF SHOWING MOVIES, SHOWS, PLAYS OR MUSICAL PERFORMANCES; POEM AND LYRIC WRITING; PORTRAIT PHOTOGRAPHY; POST-PRODUCTION EDITING SERVICES IN THE FIELD OF MUSIC, VIDEOS AND FILM; PREPARING SUBTITLES FOR MOVIES; PREPARING SURTITLES FOR LIVE THEATRICAL EVENTS; PRESENTATION OF LIVE COMEDY SHOWS; PRESENTATION OF LIVE SHOW PERFORMANCES; PRESENTATION OF MUSICAL PERFORMANCE; PRODUCING ONGOING TELEVISION PROGRAMS ON BLACKJACK CARD TOURNAMENTS; PRODUCTION AND DISTRIBUTION OF INDEPENDENT MOTION PICTURES; PRODUCTION AND DISTRIBUTION OF MONOSCOPIC AND STEREOSCOPIC, ELECTRONIC, DIGITAL VIDEO AND FILM; PRODUCTION AND DISTRIBUTION OF MOTION PICTURES; PRODUCTION AND DISTRIBUTION OF RADIO PROGRAMMES; PRODUCTION AND DISTRIBUTION OF RADIO PROGRAMS; PRODUCTION OF AUDIO RECORDING; PRODUCTION OF CABLE TELEVISION PROGRAMS;

**CLASS 41—(Continued).**

PRODUCTION OF CLOSED CAPTION TELEVISION PROGRAMS; PRODUCTION OF DVDS FEATURING HIP HOP MUSIC, DANCE SHOWS AND BEAUTY CONTESTS; PRODUCTION OF DVDS, VIDEOTAPES AND TELEVISION PROGRAMS FEATURING HIP HOP MUSIC, DANCE SHOWS AND BEAUTY CONTESTS; PRODUCTION OF FILM STUDIES; PRODUCTION OF FILMS; PRODUCTION OF HUMOROUS VIDEOS FOR THE INTERNET; PRODUCTION OF MONOSCOPIC AND/OR STEREOSCOPIC, ELECTRONIC, DIGITAL VIDEO AND/OR FILM; PRODUCTION OF MUSICAL SOUND RECORDING; PRODUCTION OF MUSICAL VIDEOS; PRODUCTION OF RADIO AND TELEVISION PROGRAMMES; PRODUCTION OF RADIO AND TELEVISION PROGRAMS; PRODUCTION OF RADIO OR TELEVISION PROGRAMS; PRODUCTION OF RADIO PROGRAMMES; PRODUCTION OF RADIO PROGRAMS; PRODUCTION OF SOUND AND IMAGE RECORDINGS ON SOUND AND IMAGE CARRIERS; PRODUCTION OF SOUND AND MUSIC VIDEO RECORDINGS; PRODUCTION OF SOUND RECORDINGS; PRODUCTION OF TELEVISION AND RADIO PROGRAMMES; PRODUCTION OF TELEVISION PROGRAMS; PRODUCTION OF VIDEO AND COMPUTER GAME SOFTWARE; PRODUCTION OF VIDEO AND CREATION OF VISUAL EFFECTS FOR OTHERS FOR USE IN DVDS, TELEVISION PROGRAMS AND ON WEB SITES; PRODUCTION OF VIDEO CASSETTES; PRODUCTION OF VIDEO DISCS AND TAPES; PRODUCTION OF VIDEO DISCS FOR OTHERS; PRODUCTION OF VISUAL EFFECTS FOR VIDEOS, DVDS, TELEVISION AND FOR INTERNET WEB SITES; PROGRAMMING ON A GLOBAL COMPUTER NETWORK; PROOF READING OF MANUSCRIPTS; PROVIDING A DATABASE FEATURING INFORMATION ABOUT ARTISTS; PROVIDING A WEB SITE WHERE USERS CAN POST RATINGS, REVIEWS AND RECOMMENDATIONS ON EVENTS AND ACTIVITIES IN THE FIELD OF ENTERTAINMENT AND EDUCATION; PROVIDING A WEBSITE AT WHICH SENIOR CITIZENS CAN SUBMIT FOR JUDGING IN A TALENT CONTEST AUDIO AND VIDEO OF PERFORMANCES SHOWCASING THEIR TALENT; PROVIDING A WEBSITE FEATURING ENTERTAINMENT INFORMATION; PROVIDING A WEBSITE FEATURING INFORMATION ABOUT ARTISTIC STYLES; PROVIDING A WEBSITE FEATURING INFORMATION IN THE FIELD OF MUSIC AND ENTERTAINMENT; PROVIDING A WEBSITE FEATURING NON-DOWNLOADABLE VIDEOS, NAMELY, VIDEO PRESENTATIONS OF A COMEDIC NATURE; PROVIDING A WEBSITE FOR PERSONS TO REGISTER FOR SURPRISE EVENTS AND CLASSES FOR THE PURPOSE OF ENTERTAINMENT; PROVIDING ADVICE AND INFORMATION IN THE FIELD OF EDUCATIONAL AND ENTERTAINMENT ACTIVITIES AND EVENTS FOR CHILDREN; PROVIDING AMUSEMENT ARCADE SERVICES; PROVIDING AMUSEMENT FACILITIES; PROVIDING AN EDUCATIONAL WEBSITE IN THE FIELDS OF MUSIC AND ENTERTAINMENT; PROVIDING AN INTERNET WEBSITE PORTAL FEATURING LINKS TO MUSICAL ARTIST WEBSITES AND MUSIC PERFORMANCE TICKET INFORMATION; PROVIDING AN INTERNET WEBSITE PORTAL IN THE FIELD OF ENTERTAINMENT, CULTURAL AND SPORTING EVENTS; PROVIDING AN INTERNET WEBSITE PORTAL IN THE FIELD OF MUSIC; PROVIDING AUDIO OR VIDEO STUDIOS; PROVIDING DANCE HALLS; PROVIDING FACILITIES FOR GAME SHOWS; PROVIDING FACILITIES FOR MOVIES, SHOWS, PLAYS, MUSIC OR EDUCATIONAL TRAINING; PROVIDING FACILITIES FOR PRODUCING VIDEO, CINEMA AND PHOTOGRAPHY PRODUCTIONS; PROVIDING FACILITIES FOR RECREATION ACTIVITIES; PROVIDING INFORMATION AND ARTICLES IN THE FIELD OF FILM, FILMMAKING, AND ENTERTAINMENT VIA A GLOBAL COMPUTER NETWORK; PROVIDING INFORMATION IN THE FIELD OF ENTERTAINMENT, FEATURING ANIMATION RENDERED BY MEANS OF A GLOBAL COMPUTER NETWORK; PROVIDING INFORMATION, NEWS AND COMMENTARY IN THE FIELD OF ENTERTAINMENT; PROVIDING INFORMATION, NEWS AND COMMENTARY IN THE FIELD OF RECREATION AND LEISURE ACTIVITIES; PROVIDING ON-LINE ENTERTAINMENT INFORMATION, NAMELY, INFORMATION ABOUT TELEVISION PROGRAMMING; PROVIDING ON-LINE NON-DOWNLOADABLE GENERAL FEATURE MAGAZINES; PROVIDING ON-LINE NON-DOWNLOADABLE

**CLASS 41—(Continued).**

NEWSPAPERS; PROVIDING ONLINE INTERVIEWS FEATURING HIP HOP ARTISTS AND OTHER CELEBRITIES IN THE FIELD OF HIP HOP MUSIC, DANCE SHOWS AND BEAUTY CONTESTS FOR ENTERTAINMENT PURPOSES; PROVIDING RATINGS FOR TELEVISION, MOVIE, MUSIC, VIDEO AND VIDEO GAME CONTENT; PROVIDING RECREATION FACILITIES; PROVIDING THEATER LISTINGS; PROVIDING VOICE OVERS FOR TAPES, RECORDS AND OTHER RECORDED MEDIA FOR ENTERTAINMENT AND EDUCATION PURPOSES; PROVISION OF CINEMA FACILITIES; PROVISION OF INFORMATION RELATING TO AMUSEMENT PARK SHOWS; PROVISION OF INFORMATION RELATING TO DISTRIBUTION OF TELEVISION SHOWS, MOTION PICTURE FILM AND RADIO SHOWS; PROVISION OF INFORMATION RELATING TO EDUCATIONAL AND ENTERTAINMENT ACTIVITIES AND EVENTS FOR CHILDREN; PROVISION OF INFORMATION RELATING TO LIVE ENTERTAINMENT; PROVISION OF INFORMATION RELATING TO LIVE PERFORMANCES, ROAD SHOWS, LIVE STAGE EVENTS, THEATRICAL PERFORMANCES, LIVE MUSIC CONCERTS AND AUDIENCE PARTICIPATION IN SUCH EVENTS; PROVISION OF INFORMATION RELATING TO MULTIMEDIA ENTERTAINMENT SOFTWARE PRODUCTION SERVICES; PROVISION OF INFORMATION RELATING TO MULTIMEDIA PUBLISHING; PROVISION OF INFORMATION RELATING TO MUSIC; PROVISION OF INFORMATION RELATING TO ORGANIZING COMMUNITY SPORTING AND CULTURAL ACTIVITIES, CONTESTS AND GAMES; PROVISION OF INFORMATION RELATING TO PUBLISHING OF ELECTRONIC PUBLICATIONS; PROVISION OF INFORMATION RELATING TO SPORTING, CULTURAL AND LIVE THEATRICAL PRODUCTIONS; PROVISION OF INFORMATION RELATING TO TELEVISION, MOTION PICTURE FILM, AUDIO AND RADIO PRODUCTION; PROVISION OF INFORMATION RELATING TO THE ORGANIZING OF EDUCATIONAL, CULTURAL, SPORTING, OR ENTERTAINMENT EXHIBITIONS; PROVISION OF INFORMATION RELATING TO THEATRE PRODUCTIONS; PROVISION OF NON-DOWNLOADABLE FILMS AND MOVIES VIA A VIDEO-ON-DEMAND SERVICE; PROVISION OF NON-DOWNLOADABLE FILMS AND TELEVISION PROGRAMMES VIA A VIDEO-ON-DEMAND SERVICE; PUBLICATION AND EDITING OF PRINTED MATTER; PUBLICATION OF BOOKS; PUBLICATION OF BOOKS, MAGAZINES, ALMANACS AND JOURNALS; PUBLICATION OF BOOKS, OF MAGAZINES, OF JOURNALS, OF NEWSPAPERS, OF PERIODICALS, OF CATALOGS, OF BROCHURES; PUBLICATION OF BOOKS, REVIEWS; PUBLICATION OF BROCHURES; PUBLICATION OF ELECTRONIC MAGAZINES; PUBLICATION OF ELECTRONIC NEWSPAPERS ACCESSIBLE VIA A GLOBAL COMPUTER NETWORK; PUBLICATION OF JOURNALS; PUBLICATION OF LEAFLETS; PUBLICATION OF MAGAZINES; PUBLICATION OF MANUALS; PUBLICATION OF MUSICAL TEXTS; PUBLICATION OF PERIODICALS; PUBLICATION OF PRINTED MATTER; PUBLICATION OF TEXT BOOKS; PUBLICATION OF TEXTS, BOOKS, MAGAZINES AND OTHER PRINTED MATTER; PUBLICATION OF THE EDITORIAL CONTENT OF SITES ACCESSIBLE VIA A GLOBAL COMPUTER NETWORK; PUBLISHING OF BOOKS AND REVIEWS; PUBLISHING OF BOOKS, E-BOOKS, AUDIO BOOKS, MUSIC AND ILLUSTRATIONS; PUBLISHING OF BOOKS, MAGAZINES; PUBLISHING OF ELECTRONIC PUBLICATIONS; PUBLISHING OF WEB MAGAZINES; RADIO ENTERTAINMENT PRODUCTION; RADIO ENTERTAINMENT SERVICES, NAMELY, RADIO PROGRAMS FEATURING PERFORMANCES BY A HIP HOP ARTIST; RADIO PROGRAM SYNDICATION; RADIO PROGRAMMING; RECORD MASTER PRODUCTION; RECORD MASTERING; RECORD PRODUCTION; RECORDING STUDIO SERVICES; RECORDING STUDIOS; RECREATIONAL CAMPS; RENTAL AND COMPUTERIZED ON-LINE RENTAL SERVICES FEATURING INTERACTIVE SOFTWARE AND HARDWARE HOME ENTERTAINMENT AND CONSUMER ELECTRONICS IN THE NATURE OF MOTION PICTURES, FILMS, MOVIES, PRERECORDED DIGITAL VERSATILE DISCS (OR DVDS), PRERECORDED VIDEOTAPE CASSETTES, AUDIO, AUDIO RECORDINGS IN A VARIETY OF GENRES; RENTAL AND LEASING OF PROFESSIONAL SOUND EQUIPMENT AND PARTS; RENTAL OF ARTWORK; RENTAL OF AUDIO EQUIPMENT; RENTAL OF AUDIOVISUAL

**CLASS 41—(Continued).**

EQUIPMENT; RENTAL OF CAMERAS; RENTAL OF CINE-FILMS; RENTAL OF CINEMA FILMS; RENTAL OF CINEMA PROJECTION APPARATUS AND ACCESSORIES; RENTAL OF CINEMATOGRAPHIC MACHINES AND APPARATUS; RENTAL OF COMPUTER GAME PROGRAMS; RENTAL OF COMPUTER GAME SOFTWARE; RENTAL OF DANCE FLOORS; RENTAL OF FACILITIES AND EQUIPMENT FOR THE PRODUCTION OF RADIO AND TELEVISION PROGRAMS, MUSICAL AND THEATRICAL PRODUCTIONS, NAMELY, PERFORMANCE VENUES, STUDIOS, SETS, DRESSING ROOMS; RENTAL OF FACILITIES AND EQUIPMENT FOR THE PRODUCTION OF TELEVISION PROGRAMS; RENTAL OF FILM PROJECTION EQUIPMENT; RENTAL OF FILMS; RENTAL OF GAME MACHINES AND APPARATUS; RENTAL OF IMAGE-RECORDED MAGNETIC TAPES; RENTAL OF LIGHTING APPARATUS FOR THEATRICAL SETS OR TELEVISION STUDIOS; RENTAL OF MOTION PICTURE FILMS; RENTAL OF MOTION PICTURES; RENTAL OF MOTION PICTURES AND OF SOUND RECORDINGS; RENTAL OF MOVIE PROJECTORS AND ACCESSORIES; RENTAL OF MOVIE PROJECTORS AND THEIR ACCESSORIES; RENTAL OF MUSICAL INSTRUMENTS; RENTAL OF OVERHEAD PROJECTORS; RENTAL OF PAINTINGS AND CALLIGRAPHIC WORKS; RENTAL OF PHONOGRAPHIC AND MUSIC RECORDINGS; RENTAL OF PHOTOGRAPHIC EQUIPMENT; RENTAL OF PORTABLE PHOTOGRAPHY AND/OR VIDEOGRAPHY BOOTHS FOR TAKING OF PICTURES AND VIDEOS; RENTAL OF PRE-RECORDED VIDEOS THAT MAY BE DOWNLOADED FROM AN INTERNET WEB SITE; RENTAL OF RECORDS OR SOUND-RECORDED MAGNETIC TAPES; RENTAL OF SOUND RECORDINGS; RENTAL OF STADIUM FACILITIES; RENTAL OF STAGE AND MOVIE EQUIPMENT, NAMELY, CAMERA EQUIPMENT, LIGHTING EQUIPMENT AND GRIP EQUIPMENT; RENTAL OF TAPE RECORDING EQUIPMENT; RENTAL OF VIDEO CAMERAS; RENTAL OF VIDEO CASSETTE RECORDERS; RENTAL OF VIDEO GAMES; RENTAL OF VIDEO SCREENS; RENTAL OF VIDEO TAPES; RENTAL OF VIDEO TAPES AND MOTION PICTURES; RENTAL OF VIDEOTAPE CASSETTES; RENTAL OF VIDEOTAPES; RENTAL OF VIDEOTAPES, VIDEOCASSETTES AND VIDEOGRAMS; RENTAL SERVICES FOR AUDIO AND VIDEO EQUIPMENT; SCRIPT WRITING SERVICES; SOCIAL CLUB SERVICES, NAMELY, ARRANGING, ORGANIZING, AND HOSTING SOCIAL EVENTS, GET-TOGETHERS, AND PARTIES FOR CLUB MEMBERS; SONG WRITING SERVICES; SOUND RECORDING STUDIOS; SPECIAL EFFECTS ANIMATION SERVICES FOR FILM AND VIDEO; SPECIAL EVENT PLANNING FOR SOCIAL ENTERTAINMENT PURPOSES; SUBTITLING; SWEEPSTAKE SERVICES; SWEEPSTAKE SERVICES PROVIDED OVER A GLOBAL COMPUTER NETWORK; TEACHING OF BEAUTY SKILLS; TELEPROMPTING SERVICES PROVIDED TO FILM AND TELEVISION AND CORPORATE PUBLIC SPEAKING; TELEVISION AND RADIO PROGRAMMING; TELEVISION PROGRAM SYNDICATION; TELEVISION PROGRAMMING; TELEVISION SCHEDULING; TELEVISION SHOW PRODUCTION; TELEVISION, VIDEO AND MOVIE FILMING SERVICES; THEATRICAL AND MUSICAL FLOOR SHOWS PROVIDED AT DISCOTHEQUES AND NIGHT-CLUBS; THEATRICAL AND MUSICAL FLOOR SHOWS PROVIDED AT PERFORMANCE VENUES; THEATRICAL BOOKING AGENCIES; THEATRICAL TICKET AGENCIES; TICKET AGENCY SERVICES FOR ENTERTAINMENT EVENTS; TICKET RESERVATION AND BOOKING SERVICES FOR ENTERTAINMENT, SPORTING AND CULTURAL EVENTS; TRAINING OF DANCE INSTRUCTORS; TRANSLATION; TRANSLATION SERVICES; VIDEO ARCADE SERVICES; VIDEO EDITING; VIDEO MASTERING SERVICES; VIDEO PRODUCTION SERVICES; VIDEO RECORDING OF PERSONAL GENERAL DOCUMENTARIES; VIDEO RECORDING SERVICES; VIDEO TAPE EDITING; VIDEO TAPE FILM PRODUCTION; VIDEO TAPE RECORDING FOR OTHERS; VIDEOGRAPHY SERVICES; VIDEOTAPE PRODUCTION; VIDEOTAPING; VIDEOTAPING FOR PERSONAL INVENTORY PURPOSES; WRITING OF ARTICLES FOR JOURNALS OTHER THAN FOR ADVERTISING OR PUBLICITY; WRITING OF ARTICLES FOR PERIODICALS OTHER THAN FOR ADVERTISING OR PUBLICITY; WRITING OF TEXTS; WRITTEN TEXT EDITING (U.S. CLS. 100, 101 AND 107).

BERYL GARDNER, EXAMINING ATTORNEY

**CLASS 41—(Continued).**

SN 85-185,535. SCHMITT, JAIME STOVER, SANTA ROSA, CA. FILED 11-26-2010.

# SPANDA

THE MARK CONSISTS OF STANDARD CHARACTERS WITHOUT CLAIM TO ANY PARTICULAR FONT, STYLE, SIZE, OR COLOR.

THE ENGLISH TRANSLATION OF "SPANDA" IN THE MARK IS "MOVEMENT".

FOR EDUCATIONAL SERVICES, NAMELY, CONDUCTING CLASSES, WORKSHOPS, RETREATS, SEMINARS, INDIVIDUAL INSTRUCTION, DISTANCE LEARNING INSTRUCTION AND TEACHER'S TRAINING IN THE FIELD OF HOLISTIC EXERCISE INVOLVING YOGA, MOVEMENT, DANCE AND MEDITATION AND DISTRIBUTION OF COURSE AND EDUCATIONAL MATERIALS IN CONNECTION THEREWITH (U.S. CLS. 100, 101 AND 107).

FIRST USE 2-16-1999; IN COMMERCE 2-16-1999.  
MARGARET POWER, EXAMINING ATTORNEY

SN 85-185,545. WILSON, ERIKA D., FAYETTEVILLE, GA. FILED 11-26-2010.

# Citizen Literature

THE MARK CONSISTS OF STANDARD CHARACTERS WITHOUT CLAIM TO ANY PARTICULAR FONT, STYLE, SIZE, OR COLOR.

NO CLAIM IS MADE TO THE EXCLUSIVE RIGHT TO USE "LITERATURE", APART FROM THE MARK AS SHOWN.

FOR ON-LINE JOURNALS, NAMELY, BLOGS FEATURING REVIEWS OF INDEPENDENT BOOKS AND E-BOOKS FROM SMALLER PUBLISHING HOUSES AND INDEPENDENT AUTHORS; PROVIDING A WEBSITE FEATURING WRITING CONTESTS, INDEPENDENT PUBLISHING INDUSTRY NEWS, COVERAGE OF EVENTS AND CONFERENCES, "BEST OF" FEATURES, OPINION, INTERVIEWS, AND ORIGINAL USER SUBMITTED CONTENT (U.S. CLS. 100, 101 AND 107).

FRED CARL, EXAMINING ATTORNEY

**CLASS 41—(Continued).**

SN 85-187,033. VISTA VOCATIONAL & LIFE SKILLS CENTER, WESTBROOK, CT. FILED 11-30-2010.

## Vista Vocational & Life Skills Center

THE MARK CONSISTS OF STANDARD CHARACTERS WITHOUT CLAIM TO ANY PARTICULAR FONT, STYLE, SIZE, OR COLOR.

NO CLAIM IS MADE TO THE EXCLUSIVE RIGHT TO USE "VOCATIONAL & LIFE SKILLS CENTER", APART FROM THE MARK AS SHOWN.

FOR EDUCATION SERVICES, NAMELY, POST-SECONDARY INSTRUCTION, VOCATIONAL INSTRUCTION, MENTORING, TUTORING, CLASSES, SEMINARS, AND WORKSHOPS FOR INDIVIDUALS WITH AUTISM, LEARNING DISABILITIES, EPILEPSY, TRAUMATIC BRAIN INJURIES, AND OTHER DEVELOPMENTAL DISABILITIES (U.S. CLS. 100, 101 AND 107).

FIRST USE 1-12-1998; IN COMMERCE 1-12-1998.  
PAUL F. GAST, EXAMINING ATTORNEY

**CLASS 41—(Continued).**

SN 85-188,092. BLUE FEDORA, LLC, LAFAYETTE, IN. FILED 12-1-2010.

## MALL OR NOTHING

THE MARK CONSISTS OF STANDARD CHARACTERS WITHOUT CLAIM TO ANY PARTICULAR FONT, STYLE, SIZE, OR COLOR.

FOR PROVIDING TEMPORARY USE OF NON-DOWNLOADABLE INTERACTIVE COMPUTER GAMES VIA THE INTERNET AND WIRELESS DEVICES (U.S. CLS. 100, 101 AND 107).

RUDY R. SINGLETON, EXAMINING ATTORNEY

SN 85-187,699. KAMBAM, SHRAVAN R, NEW YORK, NY. FILED 11-30-2010.

## AllianceMD

THE MARK CONSISTS OF STANDARD CHARACTERS WITHOUT CLAIM TO ANY PARTICULAR FONT, STYLE, SIZE, OR COLOR.

FOR NEWS REPORTER SERVICES IN THE NATURE OF NEWS ANALYSIS AND NEWS COMMENTARY; NEWS REPORTERS SERVICES; NEWS SYNDICATION FOR THE BROADCASTING INDUSTRY; NEWS SYNDICATION REPORTING; PROVIDING AN INTERNET NEWS PORTAL FEATURING LINKS TO NEWS STORIES AND ARTICLES IN THE FIELD OF CURRENT EVENTS; PROVIDING INFORMATION, NEWS AND COMMENTARY IN THE FIELD OF CURRENT EVENTS IN THE FIELDS OF MEDICINE, SCIENCE, ENGINEERING, AND LAW; PROVIDING INFORMATION, NEWS AND COMMENTARY IN THE FIELD OF ENTERTAINMENT; PROVIDING NEWS AND INFORMATION IN THE FIELD OF SPORTS (U.S. CLS. 100, 101 AND 107).

FIRST USE 7-1-2007; IN COMMERCE 7-1-2007.  
JEAN IM, EXAMINING ATTORNEY

SN 85-188,518. A STEP ABOVE ENTERTAINMENT, LLC, BERKELEY HEIGHTS, NJ. FILED 12-1-2010.

## A Step Above Entertainment, LLC

THE MARK CONSISTS OF STANDARD CHARACTERS WITHOUT CLAIM TO ANY PARTICULAR FONT, STYLE, SIZE, OR COLOR.

NO CLAIM IS MADE TO THE EXCLUSIVE RIGHT TO USE "ENTERTAINMENT, LLC", APART FROM THE MARK AS SHOWN.

FOR DISC JOCKEYS FOR PARTIES AND SPECIAL EVENTS; VIDEO JOCKEYS FOR PARTIES AND SPECIAL EVENTS (U.S. CLS. 100, 101 AND 107).

CIMMERIAN COLEMAN, EXAMINING ATTORNEY



**CLASS 41—(Continued).**

SN 85-188,986. RECKITT BENCKISER N.V., 2132 WT HOOFDDORP, NETHERLANDS, FILED 12-2-2010.



PRIORITY CLAIMED UNDER SEC. 44(D) ON ERPN CMNTY TM OFC APPLICATION NO. 009172651, FILED 6-14-2010, REG. NO. 9172651, DATED 11-29-2010, EXPIRES 6-14-2020.

THE COLOR(S) PINK BLUE AND WHITE IS/ARE CLAIMED AS A FEATURE OF THE MARK.

THE MARK CONSISTS OF THE WORD "POWERBRANDS" IN PINK, OUTLINED IN WHITE AND BLUE, SUPERIMPOSED OVER AN ILLUSTRATION OF THREE EXECUTIVES DEPICTED IN SHADOW IN BLUE AND WHITE ALL ON A WHITE BACKGROUND SURROUNDED BY A THIN BLUE LINE.

FOR EDUCATION AND ENTERTAINMENT SERVICES, NAMELY, PROVIDING AN ONLINE EDUCATIONAL GAME IN THE FIELD OF BUSINESS, MARKETING, ADVERTISING AND CAREERS; ELECTRONIC GAMES SERVICES, NAMELY, PROVIDING ON-LINE COMPUTER GAMES; BUSINESS TRAINING SERVICES; BUSINESS TRAINING PROVIDED THROUGH AN ON-LINE GAME (U.S. CLS. 100, 101 AND 107).

FIRST USE 7-15-2010; IN COMMERCE 7-15-2010.  
ERNEST SHOSHO, EXAMINING ATTORNEY

**CLASS 41—(Continued).**

SN 85-189,443. CULINARY HALL OF FAME, LLC, STEAM-BOAT SPRINGS, CO. FILED 12-2-2010.



OWNER OF U.S. REG. NO. 3,038,552.

NO CLAIM IS MADE TO THE EXCLUSIVE RIGHT TO USE "CULINARY HALL OF FAME", APART FROM THE MARK AS SHOWN.

THE MARK CONSISTS OF A RIBBON AWARD WITH THE WORDS "CULINARY HALL OF FAME" IN THE CIRCLE AROUND A CHEF'S HAT.

FOR MUSEUM SERVICES; ENTERTAINMENT SERVICES, NAMELY, ORGANIZING AND CONDUCTING CULINARY COMPETITIONS; PROVIDING INCENTIVES THROUGH THE ISSUANCE OF AWARDS FOR EXCELLENCE IN THE CULINARY FIELD, DINING GALA AND BALLS; ENTERTAINMENT IN THE NATURE OF CONDUCTING PROFESSIONAL CULINARY ARTS AND CULINARY RELATED EXHIBITIONS FOR ENTERTAINMENT AND EDUCATIONAL PURPOSES; CONSULTING IN THE FIELD OF PROFESSIONAL CULINARY ARTS AND CULINARY RELATED EXHIBITIONS FOR ENTERTAINMENT AND EDUCATIONAL PURPOSES (U.S. CLS. 100, 101 AND 107).  
CHRISTINE COOPER, EXAMINING ATTORNEY

SN 85-189,033. MINNESOTA GOVERNOR'S COUNCIL ON DEVELOPMENTAL DISABILITIES, ST. PAUL, MN. FILED 12-2-2010.

---

**PARTNERS IN POLICYMAKING**

THE MARK CONSISTS OF STANDARD CHARACTERS WITHOUT CLAIM TO ANY PARTICULAR FONT, STYLE, SIZE, OR COLOR.

NO CLAIM IS MADE TO THE EXCLUSIVE RIGHT TO USE "POLICYMAKING", APART FROM THE MARK AS SHOWN.

SEC. 2(F).

FOR LEADERSHIP TRAINING PROGRAM FOR PARENTS OF CHILDREN WITH DISABILITIES AND ADULTS WITH DISABILITIES (U.S. CLS. 100, 101 AND 107).

FIRST USE 5-1-1987; IN COMMERCE 5-1-1987.  
SOPHIA S. KIM, EXAMINING ATTORNEY

SN 85-190,904. HOFFMAN, BRAD, AKA MY LEARNING SPRINGBOARD, NEW YORK, NY. FILED 12-5-2010.

---

**Learning Concierge**

THE MARK CONSISTS OF STANDARD CHARACTERS WITHOUT CLAIM TO ANY PARTICULAR FONT, STYLE, SIZE, OR COLOR.

NO CLAIM IS MADE TO THE EXCLUSIVE RIGHT TO USE "LEARNING", APART FROM THE MARK AS SHOWN.

FOR EDUCATIONAL SERVICES, NAMELY, DEVELOPING AND CONDUCTING CUSTOMIZED TRAINING COURSES AND PROGRAMS AND DISTRIBUTION OF TRAINING AND CURRICULUM MATERIALS IN CONNECTION THEREWITH FOR SUBJECT MATTERS AS REQUESTED BY CUSTOMERS OF ALL AGES (U.S. CLS. 100, 101 AND 107).

KELLEY WELLS, EXAMINING ATTORNEY



**CLASS 41—(Continued).**

SN 85-191,618. BLAKELY, SUSAN S., DBA LEGALPERSPECTIVES LLC, GREAT FALLS, VA. FILED 12-6-2010.

**BEST FRIENDS AT THE BAR**

THE MARK CONSISTS OF STANDARD CHARACTERS WITHOUT CLAIM TO ANY PARTICULAR FONT, STYLE, SIZE, OR COLOR.

OWNER OF U.S. REG. NO. 3,914,869.

FOR EDUCATIONAL SERVICES, NAMELY, ARRANGING AND CONDUCTING COLLOQUIUMS, SEMINARS, CONFERENCES, WORKSHOPS, MEETINGS, LECTURES, TUTORIALS, ONE-ON-ONE DISCUSSIONS, ALL IN THE LEGAL FIELD AND PROFESSIONAL DEVELOPMENT (U.S. CLS. 100, 101 AND 107).

FIRST USE 2-10-2010; IN COMMERCE 3-10-2010.

KATHLEEN LORENZO, EXAMINING ATTORNEY

SN 85-192,010. PACIFIC EDUCATION CORPORATION, INC., DBA OREGON CULINARY INSTITUTE AND PIONEER PACIFIC COLLEGE, PORTLAND, OR. FILED 12-7-2010.

**KITCHEN NINJA**

THE MARK CONSISTS OF STANDARD CHARACTERS WITHOUT CLAIM TO ANY PARTICULAR FONT, STYLE, SIZE, OR COLOR.

NO CLAIM IS MADE TO THE EXCLUSIVE RIGHT TO USE "KITCHEN", APART FROM THE MARK AS SHOWN.

FOR EDUCATION SERVICES, NAMELY, PROVIDING COURSES OF INSTRUCTION IN THE FIELDS OF CULINARY ARTS, BAKING ARTS, PASTRY ARTS, AND RESTAURANT MANAGEMENT; AND ORGANIZING CULINARY COMPETITIONS (U.S. CLS. 100, 101 AND 107).

FIRST USE 9-29-2009; IN COMMERCE 9-29-2009.

BRIDGETT SMITH, EXAMINING ATTORNEY

SN 85-192,197. HER CAMPUS MEDIA LLC, DBA HER CAMPUS MEDIA, CAMBRIDGE, MA. FILED 12-7-2010.

**HER CAMPUS**

THE MARK CONSISTS OF STANDARD CHARACTERS WITHOUT CLAIM TO ANY PARTICULAR FONT, STYLE, SIZE, OR COLOR.

NO CLAIM IS MADE TO THE EXCLUSIVE RIGHT TO USE "CAMPUS", APART FROM THE MARK AS SHOWN.

FOR PROVIDING ON-LINE MAGAZINES IN THE FIELD OF RELEVANT TOPICS TO COLLEGE WOMEN, COMPRISING FASHION, HEALTH, PERSONAL RELATIONSHIPS, CAREERS, ACADEMICS, POP CULTURE, AND CURRENT EVENTS (U.S. CLS. 100, 101 AND 107).

FIRST USE 1-0-2009; IN COMMERCE 9-0-2009.

EVELYN BRADLEY, EXAMINING ATTORNEY

**CLASS 41—(Continued).**

SN 85-192,244. HER CAMPUS MEDIA LLC, DBA HER CAMPUS MEDIA, CAMBRIDGE, MA. FILED 12-7-2010.



NO CLAIM IS MADE TO THE EXCLUSIVE RIGHT TO USE "CAMPUS", APART FROM THE MARK AS SHOWN.

THE MARK CONSISTS OF THE WORDS "HER CAMPUS" IN STYLIZED UPPERCASE FONT WITH A FOUR POINTED CROWN OPEN AT THE TOP ON THE LETTER "H" AND A MORTARBOARD WITH A TASSEL ON THE LETTERS "U" AND "S".

FOR PROVIDING ON-LINE MAGAZINES IN THE FIELD OF RELEVANT TOPICS TO COLLEGE WOMEN, COMPRISING FASHION, HEALTH, PERSONAL RELATIONSHIPS, CAREERS, ACADEMICS, POP CULTURE, AND CURRENT EVENTS (U.S. CLS. 100, 101 AND 107).

FIRST USE 1-0-2009; IN COMMERCE 9-0-2009.

EVELYN BRADLEY, EXAMINING ATTORNEY

SN 85-193,718. NEWMAN CONNECTION, INC, WILMINGTON, DE. FILED 12-8-2010.

**Sacred Lives**

THE MARK CONSISTS OF STANDARD CHARACTERS WITHOUT CLAIM TO ANY PARTICULAR FONT, STYLE, SIZE, OR COLOR.

FOR EDUCATION SERVICES, NAMELY, PROVIDING ON-LINE COLLEGE LEVEL CLASSES IN THE FIELD OF CATHOLICISM (U.S. CLS. 100, 101 AND 107).

MATTHEW MCDOWELL, EXAMINING ATTORNEY

SN 85-193,751. GIVANS, JEREMY TIBERIAS, HOUSTON, TX. FILED 12-8-2010.

**Movement Of Kingz  
Entertainment**

THE MARK CONSISTS OF STANDARD CHARACTERS WITHOUT CLAIM TO ANY PARTICULAR FONT, STYLE, SIZE, OR COLOR.

NO CLAIM IS MADE TO THE EXCLUSIVE RIGHT TO USE "ENTERTAINMENT", APART FROM THE MARK AS SHOWN.

FOR ENTERTAINMENT SERVICES IN THE NATURE OF RECORDING, PRODUCTION AND POST-PRODUCTION SERVICES IN THE FIELD OF MUSIC (U.S. CLS. 100, 101 AND 107).

PAUL E. FAHRENKOPF, EXAMINING ATTORNEY

**CLASS 41—(Continued).**

SN 85-193,945. GAMIN' RIDE FRANCHISE SYSTEMS INC, TOMS RIVER, NY. FILED 12-9-2010.

# Glamour Ride

THE MARK CONSISTS OF STANDARD CHARACTERS WITHOUT CLAIM TO ANY PARTICULAR FONT, STYLE, SIZE, OR COLOR.

FOR ARRANGING, ORGANIZING, CONDUCTING, AND HOSTING SOCIAL ENTERTAINMENT EVENTS; CONDUCTING ENTERTAINMENT EXHIBITIONS IN THE NATURE OF A MOBILE TRAILER FEATURING WOMEN'S BEAUTIFICATION SERVICES, MUSIC (U.S. CLS. 100, 101 AND 107).

ERNEST SHOSHO, EXAMINING ATTORNEY

---

SN 85-194,240. BROWN JR. PHD, CHARLES H., CHARLOTTE, NC. FILED 12-9-2010.



THE MARK CONSISTS OF THE OUTLINE OF A MAN'S HEAD FACING TO THE ONE SIDE IN PROFILE WITH THE WORDS "GET YOUR HEAD IN THE GAME" INSIDE THE OUTLINE.

FOR EDUCATION SERVICES, NAMELY, COUNSELING AND LIFE-COACHING SERVICES IN THE FIELDS OF SPORTS PERFORMANCE, CAREER COUNSELING AND PERFORMING ARTS PERFORMANCE AND THE DISTRIBUTION OF COURSE MATERIALS IN CONNECTION THEREWITH (U.S. CLS. 100, 101 AND 107).

FIRST USE 12-6-2010; IN COMMERCE 12-6-2010.  
SEAN CROWLEY, EXAMINING ATTORNEY

**CLASS 41—(Continued).**

SN 85-194,263. BROWN JR. PHD, CHARLES H., CHARLOTTE, NC. FILED 12-9-2010.



THE MARK CONSISTS OF THE OUTLINE OF A MAN'S HEAD FACING TO THE LEFT SIDE IN PROFILE CONTAINED WITHIN AN OUTLINED RECTANGULAR BOX.

FOR EDUCATION SERVICES, NAMELY, COUNSELING AND LIFE-COACHING SERVICES IN THE FIELDS OF SPORTS PERFORMANCE, CAREER COUNSELING AND PERFORMING ARTS PERFORMANCE AND THE DISTRIBUTION OF COURSE MATERIALS IN CONNECTION THEREWITH (U.S. CLS. 100, 101 AND 107).

FIRST USE 12-6-2010; IN COMMERCE 12-6-2010.  
SEAN CROWLEY, EXAMINING ATTORNEY

---

SN 85-194,545. SHADOW HOLDINGS, LLC, COLUMBUS, OH. FILED 12-9-2010.

# Shadowbox Live

THE MARK CONSISTS OF STANDARD CHARACTERS WITHOUT CLAIM TO ANY PARTICULAR FONT, STYLE, SIZE, OR COLOR.

OWNER OF U.S. REG. NOS. 2,306,126, 3,043,464 AND 3,212,677.

NO CLAIM IS MADE TO THE EXCLUSIVE RIGHT TO USE "LIVE", APART FROM THE MARK AS SHOWN.

FOR ENTERTAINMENT SERVICES, NAMELY, THE PRODUCTION AND PRESENTATION OF LIVE DRAMATIC, COMEDIC, AND MUSICAL PERFORMANCES; EDUCATION SERVICES, NAMELY, PROVIDING SEMINARS AND WORKSHOPS IN THE FIELDS OF MUSIC, COMEDY, AND DANCE (U.S. CLS. 100, 101 AND 107).

FIRST USE 9-2-2010; IN COMMERCE 9-2-2010.  
KATHERINE CONNOLLY, EXAMINING ATTORNEY

**CLASS 41—(Continued).**

SN 85-195,209. 2201 COLLINS NIGHTCLUB MANAGEMENT, LLC, MIAMI BEACH, FL. FILED 12-10-2010.



THE MARK CONSISTS OF THE WORD "WALL" IN STYLIZED FORMAT.

FOR NIGHT CLUB SERVICES (U.S. CLS. 100, 101 AND 107).

FIRST USE 7-18-2009; IN COMMERCE 7-18-2009.  
RONALD MCMORROW, EXAMINING ATTORNEY

---

SN 85-195,381. DIRECTV SPORTS NETWORKS, LLC, SEATTLE, WA. FILED 12-10-2010.

## ROOT SPORTS

THE MARK CONSISTS OF STANDARD CHARACTERS WITHOUT CLAIM TO ANY PARTICULAR FONT, STYLE, SIZE, OR COLOR.

OWNER OF U.S. REG. NO. 3,726,772.

NO CLAIM IS MADE TO THE EXCLUSIVE RIGHT TO USE "SPORTS", APART FROM THE MARK AS SHOWN.

FOR DISTRIBUTION OF TELEVISION PROGRAMS FOR OTHERS; TELEVISION PROGRAMMING; PROGRAMMING ON A GLOBAL COMPUTER NETWORK; ENTERTAINMENT SERVICES IN THE NATURE OF ONGOING TELEVISION SHOWS FEATURING NEWS, SPORTS AND VARIETY; PROVIDING ON-LINE INFORMATION IN THE FIELD OF SPORTS, CURRENT SPORTS NEWS AND SPORTS ENTERTAINMENT VIA A GLOBAL COMPUTER NETWORK AND WIRELESS COMMUNICATION NETWORKS; ENTERTAINMENT SERVICES IN THE NATURE OF SCHEDULING AND PROGRAMMING IN THE FIELD OF SPORTS ON A GLOBAL COMPUTER NETWORK AND WIRELESS COMMUNICATION NETWORKS; ONLINE ENTERTAINMENT IN THE NATURE OF NON-DOWNLOADABLE VIDEO CLIPS, PHOTOGRAPHS AND ARTICLES IN THE FIELD OF SPORTS VIA A GLOBAL COMMUNICATIONS NETWORK AND WIRELESS COMMUNICATION NETWORKS; ENTERTAINMENT SERVICES, NAMELY, PROVIDING A WEBSITE IN THE FIELD OF SPORTS FEATURING NON-DOWNLOADABLE TELEVISION PROGRAMS, SPORTS INFORMATION, PREVIEWS, INTERVIEWS, ALERTS, ELECTRONIC SCHEDULING GUIDES, CONTESTS, VIDEO CLIPS, PHOTOGRAPHS, HIGHLIGHTS OF SPORTING EVENTS, ONLINE SPORTS GAMES, ARTICLES AND ENTERTAINMENT AND SPORTS RELATED NEWS; PRODUCTION AND DISTRIBUTION OF TELEVISION PROGRAMS FEATURING SPORTS AND ENTERTAINMENT; ON-LINE NEWSLETTERS FEATURING GENERAL INFORMATION RELATING TO SPORTS; ONLINE JOURNALS, NAMELY, BLOGS FEATURING INFORMATION IN THE FIELD OF SPORTS, GENERAL INTEREST, CURRENT SPORTS NEWS AND ENTERTAINMENT; ENTERTAINMENT SERVICES, NAMELY, PROVIDING PODCASTS IN THE FIELD OF SPORTS, NEWS AND ENTERTAINMENT; PROVIDING ON-LINE INFORMATION VIA THE INTERNET IN THE FIELD OF FANTASY SPORTS LEAGUES; PROMOTIONAL SWEEPSTAKES (U.S. CLS. 100, 101 AND 107).

GISELLE AGOSTO, EXAMINING ATTORNEY

**CLASS 41—(Continued).**

SN 85-195,569. MOODY BIBLE INSTITUTE, CHICAGO, IL. FILED 12-10-2010.

## MIDDAY CONNECTION

THE MARK CONSISTS OF STANDARD CHARACTERS WITHOUT CLAIM TO ANY PARTICULAR FONT, STYLE, SIZE, OR COLOR.

NO CLAIM IS MADE TO THE EXCLUSIVE RIGHT TO USE "MIDDAY", APART FROM THE MARK AS SHOWN.

FOR ENTERTAINMENT, NAMELY, A CONTINUING VARIETY SHOW BROADCAST OVER RADIO FEATURING LIFE STYLE, RELIGIOUS, AND SOCIAL TOPICS DIRECTED TO THE COMMUNITY OF WOMEN (U.S. CLS. 100, 101 AND 107).

FIRST USE 11-22-2008; IN COMMERCE 11-22-2008.  
ROBERT C. CLARK JR., EXAMINING ATTORNEY

---

SN 85-195,621. DIRECTV SPORTS NETWORKS, LLC, SEATTLE, WA. FILED 12-10-2010.



OWNER OF U.S. REG. NO. 3,726,772.

NO CLAIM IS MADE TO THE EXCLUSIVE RIGHT TO USE "SPORTS", APART FROM THE MARK AS SHOWN.

THE MARK CONSISTS OF THE WORD "ROOT", THE LETTERS "R" AND "T" HAVING TRIANGULAR NOTCHES CUT AT THE TOP, OVER THE WORD "SPORTS", ALL IN SLANTED LETTERS.

FOR DISTRIBUTION OF TELEVISION PROGRAMS FOR OTHERS; TELEVISION PROGRAMMING; PROGRAMMING ON A GLOBAL COMPUTER NETWORK; ENTERTAINMENT SERVICES IN THE NATURE OF ONGOING TELEVISION SHOWS FEATURING NEWS, SPORTS AND VARIETY; PROVIDING ON-LINE INFORMATION IN THE FIELD OF SPORTS, CURRENT SPORTS NEWS AND SPORTS ENTERTAINMENT VIA A GLOBAL COMPUTER NETWORK AND WIRELESS COMMUNICATION NETWORKS; ENTERTAINMENT SERVICES IN THE NATURE OF SCHEDULING AND PROGRAMMING IN THE FIELD OF SPORTS ON A GLOBAL COMPUTER NETWORK AND WIRELESS COMMUNICATION NETWORKS; ONLINE ENTERTAINMENT IN THE NATURE OF NON-DOWNLOADABLE VIDEO CLIPS, PHOTOGRAPHS AND ARTICLES IN THE FIELD OF SPORTS VIA A GLOBAL COMMUNICATIONS NETWORK AND WIRELESS COMMUNICATION NETWORKS; ENTERTAINMENT SERVICES,

**CLASS 41—(Continued).**

NAMELY, PROVIDING A WEBSITE IN THE FIELD OF SPORTS FEATURING NON-DOWNLOADABLE TELEVISION PROGRAMS, SPORTS INFORMATION, PREVIEWS, INTERVIEWS, ALERTS, ELECTRONIC SCHEDULING GUIDES, CONTESTS, VIDEO CLIPS, PHOTOGRAPHS, HIGHLIGHTS OF SPORTING EVENTS, ONLINE SPORTS GAMES, ARTICLES AND ENTERTAINMENT AND SPORTS RELATED NEWS; PRODUCTION AND DISTRIBUTION OF TELEVISION PROGRAMS FEATURING SPORTS AND ENTERTAINMENT; ON-LINE NEWSLETTERS FEATURING GENERAL INFORMATION RELATING TO SPORTS; ONLINE JOURNALS, NAMELY, BLOGS FEATURING INFORMATION IN THE FIELD OF SPORTS, GENERAL INTEREST, CURRENT SPORTS NEWS AND ENTERTAINMENT; ENTERTAINMENT SERVICES, NAMELY, PROVIDING PODCASTS IN THE FIELD OF SPORTS, NEWS AND ENTERTAINMENT; PROVIDING ON-LINE INFORMATION VIA THE INTERNET IN THE FIELD OF FANTASY SPORTS LEAGUES; PROMOTIONAL SWEEPSTAKES (U.S. CLS. 100, 101 AND 107).

GISELLE AGOSTO, EXAMINING ATTORNEY

SN 85-196,486. FRED WEHREBERG CIRCUIT OF THEATRES, INC., ST. LOUIS, MO. FILED 12-13-2010.

**FIVE STAR LOUNGE**

THE MARK CONSISTS OF STANDARD CHARACTERS WITHOUT CLAIM TO ANY PARTICULAR FONT, STYLE, SIZE, OR COLOR.

NO CLAIM IS MADE TO THE EXCLUSIVE RIGHT TO USE "LOUNGE", APART FROM THE MARK AS SHOWN.

FOR ENTERTAINMENT SERVICES, NAMELY, MOTION PICTURE THEATERS HAVING CUSTOM SEATING AND ON CALL FOOD AND BEVERAGE SERVICE (U.S. CLS. 100, 101 AND 107).

FIRST USE 10-8-2010; IN COMMERCE 10-8-2010.  
SHAUNIA CARLYLE, EXAMINING ATTORNEY

SN 85-196,653. ISLE OF CAPRI CASINOS, INC., ST. LOUIS, IL. FILED 12-13-2010.



NO CLAIM IS MADE TO THE EXCLUSIVE RIGHT TO USE "HEADS UP POKER CHAMPIONSHIP", APART FROM THE MARK AS SHOWN.

THE MARK CONSISTS OF THE PHRASE "BATTLE ON THE" ENCIRCLING THE IMAGE OF AN ALLIGATOR IN A SWAMP, WITH THE WORD "BAYOU" WRITTEN ON A RIBBON BELOW THE IMAGE, ALL OF WHICH APPEARS ABOVE THE TEXT "HEADS UP POKER CHAMPIONSHIP".

FOR GAMBLING SERVICES (U.S. CLS. 100, 101 AND 107).

EUGENIA MARTIN, EXAMINING ATTORNEY

**CLASS 41—(Continued).**

SN 85-196,937. BOOKER, RICHARD, MIAMI, FL. FILED 12-13-2010.

**9 Mile Music Festival**

THE MARK CONSISTS OF STANDARD CHARACTERS WITHOUT CLAIM TO ANY PARTICULAR FONT, STYLE, SIZE, OR COLOR.

NO CLAIM IS MADE TO THE EXCLUSIVE RIGHT TO USE "MUSIC FESTIVAL", APART FROM THE MARK AS SHOWN.

FOR ARRANGING AND CONDUCTING OF CONCERTS; CONCERT BOOKING; ENTERTAINMENT IN THE NATURE OF LIVE STAGE PERFORMANCES IN THE NATURE OF MUSIC OR LECTURE FOR HIRE IN THE FIELD OF MUSIC BY AN INDIVIDUAL; ENTERTAINMENT, NAMELY, LIVE MUSIC CONCERTS; PROVISION OF INFORMATION RELATING TO LIVE PERFORMANCES, ROAD SHOWS, LIVE STAGE EVENTS, THEATRICAL PERFORMANCES, LIVE MUSIC CONCERTS AND AUDIENCE PARTICIPATION IN SUCH EVENTS (U.S. CLS. 100, 101 AND 107).

FIRST USE 12-3-2010; IN COMMERCE 12-3-2010.  
TARA PATE, EXAMINING ATTORNEY

SN 85-197,010. THE SOCIETY OF NAVAL ARCHITECTS & MARINE ENGINEERS, JERSEY CITY, NJ. FILED 12-14-2010.



THE COLOR(S) BLUE AND GREEN IS/ARE CLAIMED AS A FEATURE OF THE MARK.

THE MARK CONSISTS OF THE WORDING "SEAPERCH TEACH BUILD BECOME" APPEARING IN THE COLOR BLUE AND WRITTEN IN STYLIZED FONT, WITH THE TERMS "TEACH BUILD BECOME" APPEARING UNDER THE TERM "SEAPERCH"; TO THE RIGHT OF THE TERM "SEAPERCH" ARE 2 STYLIZED FISH DESIGNS OUTLINED IN GREEN AND PARTIALLY COLORED IN BLUE; BEHIND THE FISH DESIGNS ARE 3 GREEN CIRCLES REPRESENTING AIR BUBBLES; GREEN CIRCLES APPEAR BETWEEN THE TERMS "TEACH BUILD BECOME".

FOR EDUCATIONAL SERVICES, NAMELY, PROVIDING COURSES OF INSTRUCTION AT THE K-12 LEVEL, NAMELY, A K-12 TEACHING AND TRAINING PROGRAM INVOLVING UNDERWATER ROBOTICS FOR STUDENTS TO LEARN ABOUT NAVAL ARCHITECTURE, MARINE AND OCEAN ENGINEERING AND PROVIDING CAREER COUNSELING, NAMELY, ADVICE CONCERNING EDUCATION OPTIONS IN THESE FIELDS, AS THE NEXT GENERATION OF ENGINEERS (U.S. CLS. 100, 101 AND 107).

FIRST USE 6-12-2007; IN COMMERCE 6-12-2007.  
RICHARD WHITE, EXAMINING ATTORNEY

**CLASS 41—(Continued).**

SN 85-197,794. NEW YORK PUDDING PARTNERS, LLC, NEW YORK, NY. FILED 12-14-2010.

## New York Pudding

THE MARK CONSISTS OF STANDARD CHARACTERS WITHOUT CLAIM TO ANY PARTICULAR FONT, STYLE, SIZE, OR COLOR.

NO CLAIM IS MADE TO THE EXCLUSIVE RIGHT TO USE "NEW YORK", APART FROM THE MARK AS SHOWN. FOR PROVIDING ON-LINE NON-DOWNLOADABLE GENERAL FEATURE MAGAZINES (U.S. CLS. 100, 101 AND 107).

FIRST USE 8-30-2009; IN COMMERCE 10-1-2009.  
KATHRYN COWARD, EXAMINING ATTORNEY

---

SN 85-197,929. REILLY, PATRICK, SAN DIEGO, CA. FILED 12-14-2010.

## Rockstar Trainer

THE MARK CONSISTS OF STANDARD CHARACTERS WITHOUT CLAIM TO ANY PARTICULAR FONT, STYLE, SIZE, OR COLOR.

NO CLAIM IS MADE TO THE EXCLUSIVE RIGHT TO USE "TRAINER", APART FROM THE MARK AS SHOWN.

FOR ENTERTAINMENT, NAMELY, A CONTINUING FITNESS SHOW BROADCAST OVER TELEVISION; PHYSICAL FITNESS TRAINING SERVICES (U.S. CLS. 100, 101 AND 107).

FIRST USE 10-1-2010; IN COMMERCE 10-1-2010.  
CAROL SPILS, EXAMINING ATTORNEY

**CLASS 41—(Continued).**

SN 85-198,397. VIRGIL BRANNON, JONESBORO, GA. FILED 12-15-2010.



THE COLOR(S) BLUE, YELLOW, GREEN, TEAL, RED, BROWN, BEIGE, BLACK AND WHITE IS/ARE CLAIMED AS A FEATURE OF THE MARK.

THE MARK CONSISTS OF FOUR CHILDREN SURROUNDING A DESIGN OF A YELLOW SUN, A WHITE CLOUD AND THE WORDS IN BLACK "I AM VISION". THE FIRST CHILD ON THE LEFT IS A BOY SHOWN IN BLACK, BROWN AND A BLUE SHIRT, THE SECOND CHILD IS A BOY SHOWN IN BROWN AND BEIGE WEARING A YELLOW AND GREEN SHIRT, THE THIRD CHILD IS A BOY SHOWN IN BLACK, BROWN AND A TEAL SHIRT AND THE FOURTH CHILD IS A GIRL SHOWN IN BLACK, BEIGE AND A RED SHIRT.

FOR CHARITABLE SERVICES, NAMELY, ACADEMIC MENTORING OF SCHOOL AGE CHILDREN (U.S. CLS. 100, 101 AND 107).

FIRST USE 8-22-2008; IN COMMERCE 8-22-2008.  
GISELLE AGOSTO, EXAMINING ATTORNEY

---

SN 85-198,750. OHIO VALLEY CONFERENCE, BRENTWOOD, TN. FILED S.R. 12-15-2010; AM. P.R. 4-8-2011.

## MUSIC CITY MADNESS

THE MARK CONSISTS OF STANDARD CHARACTERS WITHOUT CLAIM TO ANY PARTICULAR FONT, STYLE, SIZE, OR COLOR.

NO CLAIM IS MADE TO THE EXCLUSIVE RIGHT TO USE "MUSIC CITY", APART FROM THE MARK AS SHOWN.

FOR ENTERTAINMENT IN THE NATURE OF BASKETBALL GAMES (U.S. CLS. 100, 101 AND 107).

FIRST USE 10-13-2010; IN COMMERCE 10-13-2010.  
NELSON SNYDER, EXAMINING ATTORNEY



**CLASS 41—(Continued).**

SN 85-199,161. PRITCHARD, RICHARD, SYDNEY, NEW SOUTH WALES, AUSTRALIA, FILED 12-16-2010.



NO CLAIM IS MADE TO THE EXCLUSIVE RIGHT TO USE "DIGITAL MOTION COMICS", APART FROM THE MARK AS SHOWN.

THE COLOR(S) RED AND WHITE IS/ARE CLAIMED AS A FEATURE OF THE MARK.

THE MARK CONSISTS OF THE LITERAL ELEMENTS "DMC DIGITAL MOTION COMICS" IN THE COLOR WHITE ON A RED BACKGROUND WHERE THE LETTERS "D" AND "C" ARE ROTATED 90 DEGREES CLOCKWISE AS SHOWN IN THE MARK.

FOR ENTERTAINMENT SERVICES, NAMELY, PROVIDING A WEB SITE FEATURING REVIEWS AND RATINGS CONCERNING ANIMATED COMICS (U.S. CLS. 100, 101 AND 107).

BARNEY CHARLON, EXAMINING ATTORNEY

---

SN 85-199,205. ZUREK DESIGN, BETHLEHEM, PA. FILED 12-16-2010.

**BIG BRAND SYSTEM**

THE MARK CONSISTS OF STANDARD CHARACTERS WITHOUT CLAIM TO ANY PARTICULAR FONT, STYLE, SIZE, OR COLOR.

NO CLAIM IS MADE TO THE EXCLUSIVE RIGHT TO USE "BRAND SYSTEM", APART FROM THE MARK AS SHOWN.

FOR EDUCATION IN THE FIELD OF GRAPHIC DESIGN AND BRANDING RENDERED THROUGH CORRESPONDENCE COURSES (U.S. CLS. 100, 101 AND 107).

DAVID HOFFMAN, EXAMINING ATTORNEY

**CLASS 41—(Continued).**

SN 85-199,281. GREEN MONKEY, INC., SOUTH MIAMI, FL. FILED 12-16-2010.

**MAT CRAWL**

THE MARK CONSISTS OF STANDARD CHARACTERS WITHOUT CLAIM TO ANY PARTICULAR FONT, STYLE, SIZE, OR COLOR.

FOR ARRANGING PROFESSIONAL WORKSHOP AND TRAINING COURSES; EDUCATION SERVICES, NAMELY, PROVIDING CLASSES, SEMINARS, AND WORKSHOPS IN THE FIELD OF YOGA, PILATES, AND OTHER MIND-BODY PRACTICES; ENTERTAINMENT SERVICES, NAMELY, PROVIDING A WEB SITE FEATURING PHOTOGRAPHIC, AUDIO, VIDEO AND PROSE PRESENTATIONS FEATURING YOGA, PILATES, AND OTHER MIND-BODY PRACTICES; MEDITATION TRAINING; ORGANIZING, ARRANGING, AND CONDUCTING EXHIBITIONS, SEMINARS AND CONFERENCES IN THE FIELD OF YOGA, PILATES AND OTHER MIND-BODY PRACTICES; PHYSICAL FITNESS CONDITIONING CLASSES; PHYSICAL FITNESS CONSULTATION; PHYSICAL FITNESS INSTRUCTION; PROVIDING ASSISTANCE, PERSONAL TRAINING AND PHYSICAL FITNESS CONSULTATION TO CORPORATE CLIENTS TO HELP THEIR EMPLOYEES MAKE PHYSICAL FITNESS, STRENGTH, CONDITIONING, AND EXERCISE ALTERATIONS IN THEIR DAILY LIVING; PROVIDING ASSISTANCE, PERSONAL TRAINING AND PHYSICAL FITNESS CONSULTATION TO INDIVIDUALS TO HELP THEM MAKE PHYSICAL FITNESS, STRENGTH, CONDITIONING, AND EXERCISE IMPROVEMENT IN THEIR DAILY LIVING; PROVIDING FITNESS AND EXERCISE FACILITIES; YOGA INSTRUCTION (U.S. CLS. 100, 101 AND 107).

FIRST USE 8-1-2010; IN COMMERCE 8-1-2010.

KATHERINE E. HALMEN, EXAMINING ATTORNEY

---

SN 85-199,623. KARL DAVID MOKAL, DBA STREETWISE MUSIC INSTRUCTION, INDIAN TRAIL, NC. FILED 12-16-2010.

**Streetwise Music Instruction**

THE MARK CONSISTS OF STANDARD CHARACTERS WITHOUT CLAIM TO ANY PARTICULAR FONT, STYLE, SIZE, OR COLOR.

NO CLAIM IS MADE TO THE EXCLUSIVE RIGHT TO USE "MUSIC INSTRUCTION", APART FROM THE MARK AS SHOWN.

FOR PROVIDING FACILITIES FOR MOVIES, SHOWS, PLAYS, MUSIC OR EDUCATIONAL TRAINING (U.S. CLS. 100, 101 AND 107).

FIRST USE 11-23-1999; IN COMMERCE 12-25-2001.

REGINA DRUMMOND, EXAMINING ATTORNEY

**CLASS 41—(Continued).**

SN 85-199,666. THE MAX CURE FOUNDATION, WEST-FIELD, NJ. FILED 12-16-2010.

**BE BRAVE GOURMET**

THE MARK CONSISTS OF STANDARD CHARACTERS WITHOUT CLAIM TO ANY PARTICULAR FONT, STYLE, SIZE, OR COLOR.

NO CLAIM IS MADE TO THE EXCLUSIVE RIGHT TO USE "GOURMET", APART FROM THE MARK AS SHOWN.

FOR EDUCATIONAL AND ENTERTAINMENT SERVICES, NAMELY, PROVIDING RECREATIONAL COOKING PROGRAMS FOR CHILDREN IN ORDER TO FOSTER HEALTHY EATING CHOICES (U.S. CLS. 100, 101 AND 107).

BRIAN CALLAGHAN, EXAMINING ATTORNEY

---

SN 85-199,701. THE MAX CURE FOUNDATION, INC., ROSELAND, NJ. FILED 12-16-2010.

**BE BRAVE BOOT CAMP**

THE MARK CONSISTS OF STANDARD CHARACTERS WITHOUT CLAIM TO ANY PARTICULAR FONT, STYLE, SIZE, OR COLOR.

NO CLAIM IS MADE TO THE EXCLUSIVE RIGHT TO USE "BOOT CAMP", APART FROM THE MARK AS SHOWN.

FOR EDUCATIONAL AND ENTERTAINMENT SERVICES, NAMELY, PROVIDING CHILDREN'S PROGRAMS THAT FOCUS ON ATHLETIC EVENTS, RECREATIONAL ACTIVITIES, SELF-ESTEEM BUILDING EXERCISES, AND PHYSICAL FITNESS (U.S. CLS. 100, 101 AND 107).

ANNE E. GUSTASON, EXAMINING ATTORNEY

**CLASS 41—(Continued).**

SN 85-200,283. THE NATIONAL COLLEGIATE ATHLETIC ASSOCIATION, INDIANAPOLIS, IN. FILED 12-17-2010.

**NCAA KIDS**

THE MARK CONSISTS OF STANDARD CHARACTERS WITHOUT CLAIM TO ANY PARTICULAR FONT, STYLE, SIZE, OR COLOR.

OWNER OF U.S. REG. NOS. 976,117, 2,912,607 AND OTHERS.

NO CLAIM IS MADE TO THE EXCLUSIVE RIGHT TO USE "KIDS", APART FROM THE MARK AS SHOWN.

FOR ENTERTAINMENT AND EDUCATIONAL SERVICES, NAMELY, PROVIDING COMMUNITY PROGRAMS PROMOTING EDUCATION, ATHLETICS, HEALTHY LIFESTYLES, SPORTSMANSHIP AND CAREERS DIRECTED TO YOUTH; ENTERTAINMENT AND EDUCATIONAL SERVICES, NAMELY, PROVIDING A WEB SITE FEATURING INFORMATION, ONLINE GAMES AND ACTIVITIES RELATED TO COMMUNITY PROGRAMS PROMOTING EDUCATION, ATHLETICS, HEALTHY LIFESTYLES, SPORTSMANSHIP AND CAREERS DIRECTED TO YOUTH (U.S. CLS. 100, 101 AND 107).

MARILYN IZZI, EXAMINING ATTORNEY

---

SN 85-200,610. SAMUELS, DAVID, FAIRFIELD, CT. FILED 12-17-2010.

**The Caribbean Jazz Project**

THE MARK CONSISTS OF STANDARD CHARACTERS WITHOUT CLAIM TO ANY PARTICULAR FONT, STYLE, SIZE, OR COLOR.

NO CLAIM IS MADE TO THE EXCLUSIVE RIGHT TO USE "CARIBBEAN JAZZ", APART FROM THE MARK AS SHOWN.

FOR ENTERTAINMENT SERVICES BY A MUSICAL ARTIST AND PRODUCER, NAMELY, MUSICAL COMPOSITION FOR OTHERS AND PRODUCTION OF MUSICAL SOUND RECORDINGS (U.S. CLS. 100, 101 AND 107).

FIRST USE 1-28-1994; IN COMMERCE 3-15-1995.

RONALD AIKENS, EXAMINING ATTORNEY

**CLASS 41—(Continued).**

SN 85-201,237. ANIMAL LEADERSHIP LLC, MINOCQUA, WI. FILED 12-18-2010.

## Animal Leadership

THE MARK CONSISTS OF STANDARD CHARACTERS WITHOUT CLAIM TO ANY PARTICULAR FONT, STYLE, SIZE, OR COLOR.

NO CLAIM IS MADE TO THE EXCLUSIVE RIGHT TO USE "LEADERSHIP", APART FROM THE MARK AS SHOWN.

FOR EDUCATIONAL AND ENTERTAINMENT SERVICES, NAMELY, PROVIDING MOTIVATIONAL SPEAKING SERVICES IN THE FIELD OF PERSONAL DEVELOPMENT AND LEADERSHIP; LIFE COACHING SERVICES IN THE FIELD OF PERSONAL DEVELOPMENT AND LEADERSHIP; PERSONAL COACHING SERVICES IN THE FIELD OF PERSONAL DEVELOPMENT AND LEADERSHIP; PROFESSIONAL COACHING SERVICES IN THE FIELD OF PERSONAL DEVELOPMENT AND LEADERSHIP; PROVIDING GROUP COACHING AND LEARNING FORUMS IN THE FIELD OF LEADERSHIP DEVELOPMENT (U.S. CLS. 100, 101 AND 107).

FIRST USE 9-22-2010; IN COMMERCE 11-29-2010.  
ASMAT KHAN, EXAMINING ATTORNEY

SN 85-201,264. TOUGH LOVE YOGA LLC, ATLANTA, GA. FILED 12-18-2010.



NO CLAIM IS MADE TO THE EXCLUSIVE RIGHT TO USE "YOGA", APART FROM THE MARK AS SHOWN.

THE COLOR(S) RED, WHITE, AND BLACK IS/ARE CLAIMED AS A FEATURE OF THE MARK.

THE MARK CONSISTS OF TWO BLACK COBRA SNAKES WITH WHITE UNDERBELLIES, WHITE HOODS WITH BLACK STRIPES, WHITE EYES, AND BLACK TONGUES. THE SNAKES TAILS ARE INTERTWINED WITH THE REMAINDER OF THEIR BODIES FORMING A HEART SHAPE, WITH THEIR HEADS AND HOODS FACING EACH OTHER. IN THE CENTER OF THE HEART SHAPE CREATED BY THE SNAKES' BODIES, THE WORDS "TOUGH LOVE YOGA" APPEAR IN RED LETTERS IN SAMARKAN FONT.

FOR YOGA INSTRUCTION (U.S. CLS. 100, 101 AND 107).

FIRST USE 4-30-2010; IN COMMERCE 4-30-2010.  
STEVEN PEREZ, EXAMINING ATTORNEY

**CLASS 41—(Continued).**

SN 85-201,924. ATLANTA NATIONAL LEAGUE BASEBALL CLUB, INC., ATLANTA, GA. FILED 12-20-2010.

## HOMER THE BRAVE

THE MARK CONSISTS OF STANDARD CHARACTERS WITHOUT CLAIM TO ANY PARTICULAR FONT, STYLE, SIZE, OR COLOR.

OWNER OF U.S. REG. NO. 3,764,026.

FOR ENTERTAINMENT SERVICES IN THE NATURE OF LIVE BASEBALL EXHIBITIONS AND BASEBALL EXHIBITIONS RENDERED THROUGH TELEVISION, SATELLITE, VIDEO MEDIA AND VIA A GLOBAL COMPUTER NETWORK; LIVE PERFORMANCES BY COSTUMED CHARACTERS AND PERFORMANCES FEATURING COSTUMED CHARACTERS EXHIBITED OVER TELEVISION, SATELLITE, VIDEO MEDIA AND VIA A GLOBAL COMPUTER NETWORK (U.S. CLS. 100, 101 AND 107).

FIRST USE 9-0-1987; IN COMMERCE 9-0-1987.  
LINDA ORNDORFF, EXAMINING ATTORNEY

SN 85-201,947. GOLD'S GYM LICENSING LLC, IRVING, TX. FILED 12-20-2010.

## GOLD'S GYM EXPRESS

THE MARK CONSISTS OF STANDARD CHARACTERS WITHOUT CLAIM TO ANY PARTICULAR FONT, STYLE, SIZE, OR COLOR.

OWNER OF U.S. REG. NOS. 1,203,098, 3,316,556 AND OTHERS.

NO CLAIM IS MADE TO THE EXCLUSIVE RIGHT TO USE "GYM", APART FROM THE MARK AS SHOWN.

FOR GYMNASIUM SERVICES; PROVIDING EXERCISE AND FITNESS FACILITIES; PROVIDING INSTRUCTION IN EXERCISE AND FITNESS (U.S. CLS. 100, 101 AND 107).

FIRST USE 7-10-2010; IN COMMERCE 7-10-2010.  
KIMBERLY PERRY, EXAMINING ATTORNEY

**CLASS 41—(Continued).**

SN 85-202,262. SERVICE EXCELLENCE TRAINING, KYLE, TX. FILED 12-20-2010.



NO CLAIM IS MADE TO THE EXCLUSIVE RIGHT TO USE "SERVICE EXCELLENCE TRAINING", APART FROM THE MARK AS SHOWN.

THE MARK CONSISTS OF A CIRCULAR SHIELD THAT HAS THE WORDS "SERVICE EXCELLENCE TRAINING" WRITTEN ON AN OUTER RING. THERE ARE TWO STARS THAT SEPERATE THE WORD "TRAINING" FROM THE WORDS "SERVICE EXCELLENCE". INSIDE THE INNER CIRCLE, THERE IS A LION WITH A SCROLL ABOVE HIS HEAD. THERE IS A WREATH THAT SURRONS THE LION.

FOR BUSINESS TRAINING CONSULTANCY SERVICES; TRAINING SERVICES IN THE FIELD OF RESIDENTIAL HOME REPAIR SERVICES (U.S. CLS. 100, 101 AND 107).

ALEXANDER L. POWERS, EXAMINING ATTORNEY

SN 85-202,542. HIGH DRAMA PRODUCTIONS, LLC, STEAMBOAT SPRINGS, CO. FILED 12-21-2010.

**High Drama Productions**

THE MARK CONSISTS OF STANDARD CHARACTERS WITHOUT CLAIM TO ANY PARTICULAR FONT, STYLE, SIZE, OR COLOR.

NO CLAIM IS MADE TO THE EXCLUSIVE RIGHT TO USE "PRODUCTIONS", APART FROM THE MARK AS SHOWN.

FOR ENTERTAINMENT SERVICES, NAMELY, MULTIMEDIA PRODUCTION SERVICES (U.S. CLS. 100, 101 AND 107).

FIRST USE 1-1-1990; IN COMMERCE 1-1-1990.

JERI J. FICKES, EXAMINING ATTORNEY

**CLASS 41—(Continued).**

SN 85-202,758. BODY INFUSION BY HER, LLC, WILMINGTON, MA. FILED 12-21-2010.

**BODY INFUSION BY HER**

THE MARK CONSISTS OF STANDARD CHARACTERS WITHOUT CLAIM TO ANY PARTICULAR FONT, STYLE, SIZE, OR COLOR.

FOR PHYSICAL FITNESS TRAINING SERVICES (U.S. CLS. 100, 101 AND 107).

ZHALEH DELANEY, EXAMINING ATTORNEY

SN 85-202,761. AS YOU SOW FOUNDATION, SAN FRANCISCO, CA. FILED 12-21-2010.



THE MARK CONSISTS OF LOWERCASE LETTERS SPELLING "PROXYPREVIEW", ENCLOSED IN SQUARE BRACKETS.

FOR PROVIDING ON-LINE PUBLICATIONS IN THE NATURE OF A YEARLY BUSINESS REPORT IN THE FIELD OF PROXY RESOLUTIONS (U.S. CLS. 100, 101 AND 107).

FIRST USE 3-1-2005; IN COMMERCE 3-1-2005.

ELIZABETH KAJUBI, EXAMINING ATTORNEY

SN 85-203,020. DECHKAMPU, SURAPON, DACULA, GA. FILED 12-21-2010.

**BANGKOK FIGHT NIGHT**

THE MARK CONSISTS OF STANDARD CHARACTERS WITHOUT CLAIM TO ANY PARTICULAR FONT, STYLE, SIZE, OR COLOR.

NO CLAIM IS MADE TO THE EXCLUSIVE RIGHT TO USE "FIGHT NIGHT", APART FROM THE MARK AS SHOWN.

FOR ORGANIZING LIVE MIXED MARTIAL ARTS EVENTS AND COMPETITIONS (U.S. CLS. 100, 101 AND 107).

FIRST USE 12-1-2007; IN COMMERCE 12-1-2007.

LESLEY LAMOTHE, EXAMINING ATTORNEY

**CLASS 41—(Continued).**

SN 85-203,294. THE SUMMER LADY, INC., WOODMERE, NY. FILED 12-21-2010.

**CAMP TO CAMPUS**

THE MARK CONSISTS OF STANDARD CHARACTERS WITHOUT CLAIM TO ANY PARTICULAR FONT, STYLE, SIZE, OR COLOR.

OWNER OF U.S. REG. NO. 2,596,141.

FOR ADVISORY SERVICES IN THE NATURE OF PROVIDING INFORMATION ON SUMMER CAMPS, EDUCATIONAL INTERNSHIP PROGRAMS IN THE FIELDS OF BUSINESS, SCIENCE, RESEARCH AND HUMANITIES, AND SPORTS, ACADEMIC, WEIGHT LOSS, LANGUAGE IMMERSION AND COMMUNITY SERVICE RELATED SUMMER CAMPS (U.S. CLS. 100, 101 AND 107).

FIRST USE 10-0-2003; IN COMMERCE 10-0-2003.

COLLEEN KEARNEY, EXAMINING ATTORNEY

---

SN 85-203,364. MIGHTY OAK ENTERTAINMENT, INC., NEWPORT BEACH, CA. FILED 12-21-2010.

**STORY OF MY VIDEO**

THE MARK CONSISTS OF STANDARD CHARACTERS WITHOUT CLAIM TO ANY PARTICULAR FONT, STYLE, SIZE, OR COLOR.

NO CLAIM IS MADE TO THE EXCLUSIVE RIGHT TO USE "VIDEO", APART FROM THE MARK AS SHOWN.

FOR ENTERTAINMENT IN THE NATURE OF ON-GOING TELEVISION PROGRAMS IN THE FIELD OF VISUAL FOOTAGE AND FILMMAKING; ENTERTAINMENT SERVICES, NAMELY, PROVIDING ON-GOING TELEVISION PROGRAMS IN THE FIELD OF VISUAL FOOTAGE AND FILMMAKING VIA A GLOBAL COMPUTER NETWORK (U.S. CLS. 100, 101 AND 107).

NAPOLÉON SHARMA, EXAMINING ATTORNEY

---

SN 85-203,394. GRAYSON, ANGELA J, DBA THE ALLIUM GARDEN, WILMINGTON, DE. FILED 12-21-2010.

**THE ALLIUM GARDEN**

THE MARK CONSISTS OF STANDARD CHARACTERS WITHOUT CLAIM TO ANY PARTICULAR FONT, STYLE, SIZE, OR COLOR.

NO CLAIM IS MADE TO THE EXCLUSIVE RIGHT TO USE "GARDEN", APART FROM THE MARK AS SHOWN.

FOR ON-LINE JOURNALS, NAMELY, BLOGS FEATURING GARDEN AND TRAVEL RELATED CONTENT (U.S. CLS. 100, 101 AND 107).

FIRST USE 6-19-2010; IN COMMERCE 6-19-2010.

ALLISON SCHRODY, EXAMINING ATTORNEY

**CLASS 41—(Continued).**

SN 85-203,720. ALFORD, BARRY, FRESNO, CA. FILED 12-22-2010.



NO CLAIM IS MADE TO THE EXCLUSIVE RIGHT TO USE "SANTA CLAUS WORLD TOUR", APART FROM THE MARK AS SHOWN.

THE MARK CONSISTS OF A CHRISTMAS ORNAMENT WITH AN IMAGE OF SANTA CLAUS AND HIS SLEIGH FLYING OVER THE NORTH POLE VILLAGE WITH STARS AND SNOWFLAKES IN THE SKY AND A SIGN LANGUAGE I LOVE YOU SYMBOL AT THE TOP. THE STYLIZED TEXT "SANTA CLAUS WORLD TOUR" APPEARS AROUND THE ORNAMENT.

FOR ENTERTAINMENT SERVICES, NAMELY, LIVE APPEARANCES BY A PROFESSIONAL ENTERTAINER (U.S. CLS. 100, 101 AND 107).

ANNE FARRELL, EXAMINING ATTORNEY

---

SN 85-203,819. HEIMAN, PETER A, DBA ENBEEJAM STUDIOS, DOWNINGTOWN, PA. FILED 12-22-2010.



NO CLAIM IS MADE TO THE EXCLUSIVE RIGHT TO USE "MUSIC" AND "COMPANY", APART FROM THE MARK AS SHOWN.

"PETE MICHAELS" IDENTIFIES THE STAGE NAME OF PETER HEIMAN, A LIVING INDIVIDUAL WHOSE CONSENT IS OF RECORD.

THE MARK CONSISTS OF THE WORDING "MUSIC MEMORIES WITH PETE MICHAELS & COMPANY". THE WORDING "MUSIC MEMORIES" IS IN LARGER FONT WITHIN A MUSICAL STAFF, TO THE RIGHT OF TWO TREBLE CLEF DESIGNS. THE DESIGN OF A 1950'S STYLE MICROPHONE SEPARATES THE WORDING "MUSIC" AND "MEMORIES" WITHIN THE MUSICAL STAFF. THE LETTERS "WPMC" APPEAR ABOVE THE MICROPHONE DESIGN. THE WORDING "WITH PETE MICHAELS & COMPANY" APPEARS IN SMALLER FONT BELOW AND TOWARDS THE RIGHT SIDE OF THE MUSICAL STAFF.

FOR ENTERTAINMENT SERVICES, NAMELY, PROVIDING AN ON-GOING RADIO PROGRAM IN THE FIELD OF OLDIES FEATURING POPULAR SONGS FROM THE 1950S THROUGH THE 1970S (U.S. CLS. 100, 101 AND 107).

FIRST USE 4-1-1998; IN COMMERCE 4-1-1998.

DAVID HOFFMAN, EXAMINING ATTORNEY



**CLASS 41—(Continued).**

SN 85-203,906. NATIONAL ACADEMY OF RECORDINGS ARTS & SCIENCES, INC., SANTA MONICA, CA. FILED 12-22-2010.



OWNER OF U.S. REG. NOS. 3,068,324, 3,925,299 AND OTHERS.

THE MARK CONSISTS OF A STYLIZED IMAGE OF A GRAMOPHONE, FACING LEFT.

FOR EDUCATIONAL SERVICES, NAMELY, PROVIDING INCENTIVES TO PEOPLE TO DEMONSTRATE EXCELLENCE IN THE FIELDS OF MUSIC AND VIDEO ARTS AND SCIENCES THROUGH THE ISSUANCE OF AWARDS; ENTERTAINMENT SERVICES, NAMELY, LIVE PERFORMANCES BY MUSICAL ARTISTS AND MUSICAL GROUPS; ENTERTAINMENT IN THE NATURE OF TELEVISED MUSIC AWARDS PROGRAMS; AN ANNUAL AWARDS PROGRAM FOR THE PRESENTATION OF AWARDS IN RECOGNITION OF DISTINGUISHED ACHIEVEMENT IN THE FIELD OF MUSIC; PROVIDING A WEBSITE FEATURING NON-DOWNLOADABLE MUSICAL PERFORMANCES, MUSICAL VIDEOS, RELATED FILM CLIPS, PHOTOGRAPHS, AND OTHER MULTIMEDIA MATERIALS FEATURING MUSICAL ENTERTAINMENT (U.S. CLS. 100, 101 AND 107).

FIRST USE 5-31-2007; IN COMMERCE 5-31-2007.  
LINDSEY RUBIN, EXAMINING ATTORNEY

**CLASS 41—(Continued).**

SN 85-203,916. LAYDOWN RECORDS, MELBOURNE, FL. FILED 12-22-2010.



NO CLAIM IS MADE TO THE EXCLUSIVE RIGHT TO USE "RECORDS", APART FROM THE MARK AS SHOWN. THE STIPPLING IS FOR SHADING PURPOSES ONLY.

THE MARK CONSISTS OF THE LETTERS SPELLING THE WORDS "LAYDOWN RECORDS", AND A CHALKED OUTLINE OF A BODY LAYING ON TOP OF A RECORD.

FOR MULTIMEDIA ENTERTAINMENT SERVICES IN THE NATURE OF RECORDING, PRODUCTION AND POST-PRODUCTION SERVICES IN THE FIELDS OF MUSIC, VIDEO, AND FILMS (U.S. CLS. 100, 101 AND 107).

JILL PRATER, EXAMINING ATTORNEY

SN 85-204,521. RAY KEITH MOORE, GRADENA, CA. FILED 12-22-2010.



OWNER OF U.S. REG. NO. 3,510,685.

"RAY SPEAKMOORE" IDENTIFIES THE STAGE NAME OF RAY MOORE, A LIVING INDIVIDUAL WHOSE CONSENT IS OF RECORD.

THE MARK CONSISTS OF THE WORDS "RAY" AND "SPEAKMOORE", WITH THE WORD "RAY" ABOVE THE WORD "SPEAKMOORE", AND WITH BOTH WORDS LEFT JUSTIFIED; A SILHOUETTE OF A MUSICIAN WEARING A HAT, AND HOLDING A MICROPHONE IN ONE HAND WHILE HOLDING HIS OTHER ARM OUT IN FRONT OF HIM; THE SILHOUETTE IS SURROUNDED BY A DIALOGUE BUBBLE AND IS LOCATED TO THE RIGHT OF THE WORD "RAY" AND ABOVE THE WORD "SPEAKMOORE".

FOR ENTERTAINMENT IN THE NATURE OF VISUAL AND AUDIO PERFORMANCES BY A MUSICIAN; ENTERTAINMENT IN THE NATURE OF ACTING IN MOTION PICTURES, FILM, AND TELEVISION, AND LIVE THEATRICAL PERFORMANCES AND TELEVISION APPEARANCES; ENTERTAINMENT SERVICES IN THE NATURE OF LIVE MUSICAL PERFORMANCES; ENTERTAINMENT SERVICES, NAMELY, LIVE, TELEVISED AND MOVIE APPEARANCES BY A PROFESSIONAL ENTERTAINER; MOTION PICTURE FILM PRODUCTION AND DIRECTING; MULTIMEDIA ENTERTAINMENT SERVICES IN THE NATURE OF RECORDING, PRODUCTION AND POST-PRODUCTION SERVICES IN THE FIELDS OF MUSIC, VIDEO, AND FILMS (U.S. CLS. 100, 101 AND 107).

FIRST USE 1-15-2007; IN COMMERCE 1-15-2007.  
EMILY CHUO, EXAMINING ATTORNEY

**CLASS 41—(Continued).**

SN 85-204,773. JACOBSON, WILLIAM A., BARRINGTON, RI. FILED 12-23-2010.

**LEGAL INSURRECTION**

THE MARK CONSISTS OF STANDARD CHARACTERS WITHOUT CLAIM TO ANY PARTICULAR FONT, STYLE, SIZE, OR COLOR.

NO CLAIM IS MADE TO THE EXCLUSIVE RIGHT TO USE "LEGAL", APART FROM THE MARK AS SHOWN.

FOR ON-LINE JOURNALS, NAMELY, BLOGS FEATURING NEWS, ANALYSIS AND COMMENTARY ON LEGAL, POLITICAL AND ECONOMIC ISSUES (U.S. CLS. 100, 101 AND 107).

FIRST USE 10-1-2008; IN COMMERCE 10-1-2008.  
INGA ERVIN, EXAMINING ATTORNEY

SN 85-204,832. JASON HOWELL COMPANY, ARLINGTON, VA. FILED 12-23-2010.

**PATRIOTIC DEVELOPMENT**

THE MARK CONSISTS OF STANDARD CHARACTERS WITHOUT CLAIM TO ANY PARTICULAR FONT, STYLE, SIZE, OR COLOR.

FOR CONDUCTING WORKSHOPS AND SEMINARS IN THE FIELD OF PERSONAL GROWTH AND MOTIVATION; EDUCATIONAL AND ENTERTAINMENT SERVICES, NAMELY, PROVIDING MOTIVATIONAL SPEAKING SERVICES IN THE FIELD OF PERSONAL GROWTH AND MOTIVATION; PERSONAL COACHING SERVICES IN THE FIELD OF PERSONAL GROWTH AND MOTIVATION; PROFESSIONAL COACHING SERVICES IN THE FIELD OF PERSONAL GROWTH AND MOTIVATION; PROVIDING GROUP COACHING IN THE FIELD OF PERSONAL GROWTH AND MOTIVATION (U.S. CLS. 100, 101 AND 107).

FIRST USE 10-0-2009; IN COMMERCE 10-0-2009.  
COLLEEN KEARNEY, EXAMINING ATTORNEY

**CLASS 41—(Continued).**

SN 85-205,470. AMERICAN INSTITUTES HOLDINGS, LLC, WHITE PLAINS, NY. FILED 12-23-2010.



NO CLAIM IS MADE TO THE EXCLUSIVE RIGHT TO USE "AMERICAN INSTITUTE", APART FROM THE MARK AS SHOWN.

THE MARK CONSISTS OF A FOUR-SECTIONED DIAMOND WITH INSCRIBED CONCENTRIC CIRCLES TO THE LEFT OF THE WORDS "AMERICANINSTITUTE" UNDERLINED BY A LINE TERMINATING IN A JAGGED EDGE ON THE RIGHT SIDE.

FOR IT TRAINING SERVICES; MEDICAL TRAINING AND TEACHING; TEACHING AND TRAINING IN BUSINESS, INDUSTRY AND INFORMATION TECHNOLOGY; TEACHING IN THE FIELD OF ENGLISH AS A SECOND LANGUAGE (ESL); TRAINING IN THE USE OF MEDICAL SONOGRAPHY EQUIPMENT; TRAINING SERVICES IN THE FIELD OF HEALTH, MEDICINE, BUSINESS, LAW AND COMPUTERS; VOCATIONAL EDUCATION IN THE FIELDS OF HEALTH CARE, DENTAL CARE, MEDICAL ADMINISTRATION, PHARMACY, COSMETOLOGY, MASSAGE, BUSINESS, COMPUTERS AND PARALEGAL SERVICES (U.S. CLS. 100, 101 AND 107).

FIRST USE 11-20-2008; IN COMMERCE 4-7-2009.  
BARBARA BROWN, EXAMINING ATTORNEY

SN 85-205,475. ATI ENTERPRISES, INC., NORTH RICHLAND HILLS, TX. FILED 12-23-2010.



NO CLAIM IS MADE TO THE EXCLUSIVE RIGHT TO USE "DALLAS NURSING INSTITUTE", APART FROM THE MARK AS SHOWN.

THE MARK CONSISTS OF THE WORDS "DALLAS NURSING INSTITUTE" IN BLOCK FORM, EXCEPTING THE INITIAL "N" OF "NURSING", WHICH IS PROMINENT AND STYLIZED WITH A SINUSOIDAL UNDERSCORE EXTENDING TO THE SECOND "N" OF "NURSING".

FOR EDUCATION SERVICES, NAMELY, PROVIDING CLASSES AND COURSES IN THE FIELD OF NURSING; EDUCATIONAL SERVICES IN THE NATURE OF NURSING SCHOOLS; MEDICAL TRAINING AND TEACHING (U.S. CLS. 100, 101 AND 107).

FIRST USE 1-2-2007; IN COMMERCE 8-11-2008.  
BENJAMIN OKEKE, EXAMINING ATTORNEY

**CLASS 41—(Continued).**

SN 85-205,527. PRAY-THINK-ACT MINISTRIES, INC., NEW WILMINGTON, PA. FILED 12-24-2010.

PRAY-THINK-ACT MINISTRIES,  
INC

THE MARK CONSISTS OF STANDARD CHARACTERS WITHOUT CLAIM TO ANY PARTICULAR FONT, STYLE, SIZE, OR COLOR.

NO CLAIM IS MADE TO THE EXCLUSIVE RIGHT TO USE "MINISTRIES, INC.", APART FROM THE MARK AS SHOWN.

FOR EDUCATION SERVICES, NAMELY, PROVIDING SEMINARS IN THE FIELD OF RELIGIOUS INSTRUCTION (U.S. CLS. 100, 101 AND 107).

FIRST USE 2-10-1982; IN COMMERCE 2-19-1982.  
REGINA DRUMMOND, EXAMINING ATTORNEY

---

SN 85-205,587. OREGON BREWING COMPANY, NEWPORT, OR. FILED 12-24-2010.

GREAT AMERICAN NANO FEST

THE MARK CONSISTS OF STANDARD CHARACTERS WITHOUT CLAIM TO ANY PARTICULAR FONT, STYLE, SIZE, OR COLOR.

OWNER OF U.S. REG. NO. 3,260,925.

NO CLAIM IS MADE TO THE EXCLUSIVE RIGHT TO USE "FEST", APART FROM THE MARK AS SHOWN.

FOR ARRANGING AND CONDUCTING ENTERTAINMENT EXHIBITIONS IN THE NATURE OF FESTIVALS FEATURING BREWERIES AND THEIR PRODUCTS (U.S. CLS. 100, 101 AND 107).

THOMAS MANOR, EXAMINING ATTORNEY

---

SN 85-205,748. HAYES, JOSEPH, MOUNT PLEASANT, TX. FILED 12-27-2010.

COOL ANGER

THE MARK CONSISTS OF STANDARD CHARACTERS WITHOUT CLAIM TO ANY PARTICULAR FONT, STYLE, SIZE, OR COLOR.

NO CLAIM IS MADE TO THE EXCLUSIVE RIGHT TO USE "ANGER", APART FROM THE MARK AS SHOWN.

FOR EDUCATIONAL SERVICES, NAMELY, CONDUCTING CLASSES, SEMINARS, WORKSHOPS, AND TRAINING IN THE FIELD OF ANGER MANAGEMENT, THERAPY, AND TREATMENT AND DISTRIBUTION OF COURSE AND EDUCATIONAL MATERIALS IN CONNECTION THEREWITH (U.S. CLS. 100, 101 AND 107).

FIRST USE 3-16-2006; IN COMMERCE 3-16-2006.  
SANJEEV VOHRA, EXAMINING ATTORNEY

**CLASS 41—(Continued).**

SN 85-205,760. RAYE, JULIANNA, LOS ANGELES, CA. FILED 12-27-2010.

POP GO ZEN

THE MARK CONSISTS OF STANDARD CHARACTERS WITHOUT CLAIM TO ANY PARTICULAR FONT, STYLE, SIZE, OR COLOR.

NO CLAIM IS MADE TO THE EXCLUSIVE RIGHT TO USE "ZEN", APART FROM THE MARK AS SHOWN.

FOR EDUCATIONAL SERVICES, NAMELY, CONDUCTING CLASSES, SEMINARS, CONFERENCES AND WORKSHOPS IN THE FIELDS OF HEALTH, WELLNESS, MEDITATION, MOTIVATION, INSPIRATION, STRESS REDUCTION, MUSIC AND THE ARTS (U.S. CLS. 100, 101 AND 107).

ZHALEH DELANEY, EXAMINING ATTORNEY

---

SN 85-205,886. CHRISTINA LUCY COMPANY, MISSION VIEJO, CA. FILED 12-27-2010.

**CODE PINK**  
**BOOT CAMP**

NO CLAIM IS MADE TO THE EXCLUSIVE RIGHT TO USE "BOOT CAMP", APART FROM THE MARK AS SHOWN.

THE MARK CONSISTS OF THE STYLIZED WORDING "CODE PINK" ON TOP AND THE WORDING "BOOT CAMP" BELOW IN WHICH THE LETTERS "OO" IN "BOOT" ARE REPLACED WITH TWO DOG TAGS ATTACHED TO A CHAIN HANGING FROM THE LETTER "D" IN "CODE".

FOR PHYSICAL FITNESS CONDITIONING CLASSES (U.S. CLS. 100, 101 AND 107).

FIRST USE 1-1-2008; IN COMMERCE 1-1-2008.  
JENNY PARK, EXAMINING ATTORNEY

**CLASS 41—(Continued).**

SN 85-205,905. PRICE, ANGELA, LOS ANGELES, CA. FILED 12-27-2010.



NO CLAIM IS MADE TO THE EXCLUSIVE RIGHT TO USE "MODEL .COM", APART FROM THE MARK AS SHOWN.

THE MARK CONSISTS OF A GRAPHIC OF 2 HANDS HOLDING A CARDBOARD RIPPED SIGN WITH THE STYLIZED WORDS "FEED A MODEL .COM" WRITTEN ON IT.

FOR ENTERTAINMENT SERVICES, NAMELY, MULTIMEDIA PRODUCTION SERVICES; FASHION MODELING FOR ENTERTAINMENT PURPOSES; PHOTOGRAPHY SERVICES (U.S. CLS. 100, 101 AND 107).

FIRST USE 4-25-2006; IN COMMERCE 9-25-2006.  
DEBRA LEE, EXAMINING ATTORNEY

**CLASS 41—(Continued).**

SN 85-206,221. TOP RATE TUTORS, LLC, WINNETKA, IL. FILED 12-27-2010.

**TOP RATE TUTORS**

THE MARK CONSISTS OF STANDARD CHARACTERS WITHOUT CLAIM TO ANY PARTICULAR FONT, STYLE, SIZE, OR COLOR.

NO CLAIM IS MADE TO THE EXCLUSIVE RIGHT TO USE "TUTORS", APART FROM THE MARK AS SHOWN.

FOR EDUCATION SERVICES, NAMELY, PROVIDING TUTORING IN THE FIELDS OF MATHEMATICS, ENGLISH, SCIENCE, SOCIAL STUDIES, FOREIGN LANGUAGES, EXECUTIVE FUNCTIONING, STANDARDIZED TESTS FOR COLLEGE ADMISSIONS, AND APPLYING TO COLLEGE (U.S. CLS. 100, 101 AND 107).

FIRST USE 0-0-2008; IN COMMERCE 0-0-2008.  
REBECCA POVARCHUK, EXAMINING ATTORNEY

SN 85-206,233. IRON FIST LEAGUE LLC, WOODBRIDGE, VA. FILED 12-27-2010.



NO CLAIM IS MADE TO THE EXCLUSIVE RIGHT TO USE "LEAGUE" AND "DC - MD - VA", APART FROM THE MARK AS SHOWN.

THE STIPPLING IS FOR SHADING PURPOSES ONLY.

THE MARK CONSISTS OF A METAL ROBOTIC FIST FEATURING SUNRAYS IN A CIRCULAR BORDER. ABOVE THIS ARE THE WORDS "IRON FIST LEAGUE." AT THE BOTTOM OF THE CIRCULAR BORDER IS A SCROLL BANNER FEATURING THE WORDS "DC - MD - VA".

FOR ARRANGING AND CONDUCTING WARGAMING SPECIAL EVENTS FOR SOCIAL ENTERTAINMENT PURPOSES (U.S. CLS. 100, 101 AND 107).

SIMON TENG, EXAMINING ATTORNEY

SN 85-206,140. KULAPA, INC. TORRANCE, CA. FILED 12-27-2010.

**KULAPA**

THE MARK CONSISTS OF STANDARD CHARACTERS WITHOUT CLAIM TO ANY PARTICULAR FONT, STYLE, SIZE, OR COLOR.

THE WORDING "KULAPA" HAS NO MEANING IN A FOREIGN LANGUAGE.

FOR ENTERTAINMENT SERVICES, NAMELY, PROVIDING ON-LINE COMPUTER GAMES (U.S. CLS. 100, 101 AND 107).

CORY BOONE, EXAMINING ATTORNEY

**CLASS 41—(Continued).**

SN 85-206,237. PERCUSSION KINGS, LLC, DECATUR, GA.  
FILED 12-27-2010.



NO CLAIM IS MADE TO THE EXCLUSIVE RIGHT TO USE "PERCUSSION", APART FROM THE MARK AS SHOWN.

THE MARK CONSISTS OF A DRUM TILTED ON A MANTLE WITH TWO DRUMSTICKS CROSSING. A CROWN IS ON TOP OF THE DRUM. THE MANTLE HAS WINGS ON EACH SIDE. THE WORDS "PERCUSSION KINGS" ARE AT THE BOTTOM OF THE IMAGE IN ALL CAPITAL LETTERS. "PERCUSSION" IS ON TOP OF "KINGS". THE BLACK BACKGROUND IS NOT PART OF THE MARK.

FOR ENTERTAINMENT IN THE NATURE OF LIVE PERFORMANCES BY A MUSICAL ENSEMBLE (U.S. CLS. 100, 101 AND 107).

SIMON TENG, EXAMINING ATTORNEY

SN 85-206,302. LANE, LARRY, LOS ANGELES, CA. FILED  
12-28-2010.

# LIRYC

THE MARK CONSISTS OF STANDARD CHARACTERS WITHOUT CLAIM TO ANY PARTICULAR FONT, STYLE, SIZE, OR COLOR.

FOR MUSIC COMPOSITION SERVICES FOR OTHERS (U.S. CLS. 100, 101 AND 107).

FIRST USE 10-1-2002; IN COMMERCE 7-1-2004.

ALICE BENMAMAN, EXAMINING ATTORNEY

SN 85-206,387. VANGALIS, ANGELA J. COPPELL, TX.  
FILED S.R. 12-28-2010; AM. P.R. 3-25-2011.

# Tangle Time

THE MARK CONSISTS OF STANDARD CHARACTERS WITHOUT CLAIM TO ANY PARTICULAR FONT, STYLE, SIZE, OR COLOR.

NO CLAIM IS MADE TO THE EXCLUSIVE RIGHT TO USE "TANGLE", APART FROM THE MARK AS SHOWN.

FOR EDUCATIONAL SERVICES, NAMELY, CONDUCTING CLASSES, SEMINARS, AND WORKSHOPS IN THE FIELD OF ART (U.S. CLS. 100, 101 AND 107).

FIRST USE 10-12-2010; IN COMMERCE 10-12-2010.

BRENDAN MCCAULEY, EXAMINING ATTORNEY

**CLASS 41—(Continued).**

SN 85-206,570. FOOTBALL TECH, LLC, KNOXVILLE, TN.  
FILED 12-28-2010.



NO CLAIM IS MADE TO THE EXCLUSIVE RIGHT TO USE "FOOTBALL", APART FROM THE MARK AS SHOWN.

THE MARK CONSISTS OF THE PHRASE "FOOTBALL TECH" AND THREE STARS ALONG THE IMAGE OF A SHIELD WITH THE PARTIAL IMAGE OF A FOOTBALL EXTENDING ABOVE THE WORDED PHRASE.

FOR PROVIDING FOOTBALL CAMPS AND ORGANIZING FOOTBALL GAMES (U.S. CLS. 100, 101 AND 107).

FIRST USE 11-15-2010; IN COMMERCE 11-15-2010.

MAYUR VAGHANI, EXAMINING ATTORNEY



**CLASS 41—(Continued).**

SN 85-206,627. PAMELA H. DIXON, WEST BABYLON, NY.  
FILED 12-28-2010.



THE COLOR(S) BLACK, WHITE, GRAY AND PURPLE IS/  
ARE CLAIMED AS A FEATURE OF THE MARK.

THE MARK CONSISTS OF BLACK AND GREY STYLIZED LETTERS "S" "C" "H" "R" "O" "E" "D" "E" "R" AN APOSTROPHE " ' " "S" - SPACE - NEW WORD "G" "H" "O" "S" "T" ON A WHITE BACKGROUND WITH PURPLE EDGES AND A STYLIZED DRAWING OF A BLACK AND PURPLE GUITAR IN THE LOWER LEFT HAND CORNER AND A STYLIZED DRAWING OF A BLACK AND WHITE KEYBOARD IN THE UPPER RIGHT-HAND CORNER.

FOR ENTERTAINMENT IN THE NATURE OF LIVE PERFORMANCES BY A MUSICAL GROUP; ENTERTAINMENT IN THE NATURE OF VISUAL AND AUDIO PERFORMANCES BY A MUSICAL GROUP; ENTERTAINMENT IN THE NATURE OF VISUAL AND AUDIO PERFORMANCES, NAMELY, MUSICAL BAND, ROCK GROUP, GYMNASTIC, DANCE, AND BALLET PERFORMANCES; ENTERTAINMENT SERVICES IN THE NATURE OF LIVE MUSICAL PERFORMANCES; ENTERTAINMENT SERVICES IN THE NATURE OF PRESENTING LIVE MUSICAL PERFORMANCES; ENTERTAINMENT SERVICES IN THE NATURE OF RECORDING, PRODUCTION AND POST-PRODUCTION SERVICES IN THE FIELD OF MUSIC (U.S. CLS. 100, 101 AND 107).

FIRST USE 4-10-2010; IN COMMERCE 4-10-2010.  
STEVEN JACKSON, EXAMINING ATTORNEY

SN 85-206,711. BERSSET-PRICE, VALERIE, BEAVERTON, OR.  
FILED 12-28-2010.

## Professional Passport

THE MARK CONSISTS OF STANDARD CHARACTERS WITHOUT CLAIM TO ANY PARTICULAR FONT, STYLE, SIZE, OR COLOR.

NO CLAIM IS MADE TO THE EXCLUSIVE RIGHT TO USE "PROFESSIONAL", APART FROM THE MARK AS SHOWN.

FOR ARRANGING PROFESSIONAL WORKSHOPS AND TRAINING COURSES; BUSINESS EDUCATION AND TRAINING SERVICES, NAMELY, DEVELOPING, AND FACILITATING CUSTOMIZED IN-COMPANY LEADERSHIP AND EXECUTIVE DEVELOPMENT PROGRAMS, PROVIDING EXECUTIVE COACHING SERVICES, AND PROVIDING PUBLIC AND IN-COMPANY KEYNOTE PRESENTATIONS TO BUSINESS LEADERS (U.S. CLS. 100, 101 AND 107).

LAKEISHA LEWIS, EXAMINING ATTORNEY

**CLASS 41—(Continued).**

SN 85-206,808. FINAL CUT MEDIA, INC., MODESTO, CA.  
FILED 12-28-2010.



NO CLAIM IS MADE TO THE EXCLUSIVE RIGHT TO USE "AMERICAN CAGE FIGHTER", APART FROM THE MARK AS SHOWN.

THE MARK CONSISTS OF A FIVE POINT STAR AND THE WORD "AMERICAN" ABOVE THE WORD "CAGE-FIGHTER", THE FIRST "A" IN "AMERICAN" CONTAINED IN THE STAR.

FOR ENTERTAINMENT IN THE NATURE OF ONGOING TELEVISION PROGRAMS IN THE FIELD OF MIXED MARTIAL ARTS; ENTERTAINMENT MEDIA PRODUCTION SERVICES FOR MOTION PICTURES, TELEVISION AND INTERNET; ENTERTAINMENT SERVICES, NAMELY, AN ON-GOING SERIES FEATURING MIXED MARTIAL ARTS PROVIDED THROUGH CABLE TELEVISION AND INTERNET (U.S. CLS. 100, 101 AND 107).

FIRST USE 10-1-2010; IN COMMERCE 10-11-2010.  
LINDA M. KING, EXAMINING ATTORNEY

SN 85-206,866. JC 23 ENTERTAINMENT, INC., BEVERLY HILLS, CA. FILED 12-28-2010.



THE MARK CONSISTS OF STYLIZED CHARACTER SITTING IN YOGA STYLE.

FOR ENTERTAINMENT SERVICES, NAMELY, PRODUCTION AND DISTRIBUTION OF MOTION PICTURES, TELEVISION PROGRAMMING, FILMED OR LIVE THEATRICAL EVENTS, FILMED OR LIVE SPORTS EVENTS; DISTRIBUTION OF MOTION PICTURE FILMS, AND TELEVISION PROGRAMMING FOR OTHERS (U.S. CLS. 100, 101 AND 107).

CYNTHIA SLOAN, EXAMINING ATTORNEY

**CLASS 41—(Continued).**

SN 85-207,164. WORLD TAEKWONDO ACADEMY INC./MN., MAPLE GROVE, MN. FILED 12-29-2010.



NO CLAIM IS MADE TO THE EXCLUSIVE RIGHT TO USE "TAEKWONDO ACADEMY" AND "SINCE 1969", APART FROM THE MARK AS SHOWN.

THE MARK CONSISTS OF THE WORDS "DISCOVER THE BLACK BELT WITHIN", WHICH ARE ABOVE THE WORD "WORLD", WHICH IS ABOVE THE WORD "TAEKWONDO", WHICH IS WITHIN A DEPICTION OF A BLACK BELT AND WHICH IS ABOVE THE WORD "ACADEMY", WHICH IS ABOVE THE WORDS "SINCE 1969". THERE IS A CIRCLE BEHIND THE WORDS "WORLD TAEKWONDO ACADEMY".

FOR TAEKWONDO AND MARTIAL ARTS INSTRUCTION; ORGANIZATION OF TAEKWONDO AND MARTIAL ARTS COMPETITIONS (U.S. CLS. 100, 101 AND 107).

BARBARA GAYNOR, EXAMINING ATTORNEY

SN 85-207,475. WILLIAMSON, CHRIS, BURLINGAME, CA. FILED 12-29-2010.

## Ferric Press

THE MARK CONSISTS OF STANDARD CHARACTERS WITHOUT CLAIM TO ANY PARTICULAR FONT, STYLE, SIZE, OR COLOR.

NO CLAIM IS MADE TO THE EXCLUSIVE RIGHT TO USE "PRESS", APART FROM THE MARK AS SHOWN.

FOR MULTIMEDIA PUBLISHING OF BOOKS, MAGAZINES, JOURNALS, SOFTWARE, GAMES, MUSIC, AND ELECTRONIC PUBLICATIONS (U.S. CLS. 100, 101 AND 107).

ANNE E. GUSTASON, EXAMINING ATTORNEY

**CLASS 41—(Continued).**

SN 85-207,480. BURNELL, PHILIP, STRATFORD, CT. FILED 12-29-2010.

## DarksydePhil

THE MARK CONSISTS OF STANDARD CHARACTERS WITHOUT CLAIM TO ANY PARTICULAR FONT, STYLE, SIZE, OR COLOR.

FOR ENTERTAINMENT SERVICES, NAMELY, PROVIDING NON-DOWNLOADABLE VIDEOS IN THE FIELD OF VIDEO GAMING (U.S. CLS. 100, 101 AND 107).

FIRST USE 1-1-2002; IN COMMERCE 1-1-2010.  
KELLY BOULTON, EXAMINING ATTORNEY

SN 85-207,711. SAHA, SUBIR, EDISON, NJ. FILED 12-30-2010.

## TRAINEEPEDIA

THE MARK CONSISTS OF STANDARD CHARACTERS WITHOUT CLAIM TO ANY PARTICULAR FONT, STYLE, SIZE, OR COLOR.

FOR ARRANGING AND CONDUCTING TRAINING WORKSHOPS IN THE FIELD OF INFORMATION TECHNOLOGY, MANAGEMENT AND QUALITY ASSURANCE; PROVIDING QUALITY ASSURANCE COURSE INSTRUCTION AND TRAINING; PROVIDING VOCATIONAL GUIDANCE, IN THE FIELD OF INFORMATION TECHNOLOGY AND MANAGEMENT (U.S. CLS. 100, 101 AND 107).

FIRST USE 4-30-2010; IN COMMERCE 6-1-2010.  
SANDRA BUJA, EXAMINING ATTORNEY

SN 85-207,753. DOC CLUB LA, LOS ANGELES, CA. FILED 12-30-2010.

## DOCCLUBLA

THE MARK CONSISTS OF STANDARD CHARACTERS WITHOUT CLAIM TO ANY PARTICULAR FONT, STYLE, SIZE, OR COLOR.

FOR PROMOTION OF DOCUMENTARY FILM MAKERS THROUGH THE SCREENING OF DOCUMENTARY FILMS (U.S. CLS. 100, 101 AND 107).

FIRST USE 8-0-2008; IN COMMERCE 8-21-2009.  
DAVID HOFFMAN, EXAMINING ATTORNEY

**CLASS 41—(Continued).**

SN 85-208,027. JEFF AND JULIE PHOTOGRAPHY, INC.,  
CARMEL, IN. FILED 12-30-2010.

*Jeff & Julie*  
— PHOTOGRAPHY —

NO CLAIM IS MADE TO THE EXCLUSIVE RIGHT TO USE "PHOTOGRAPHY", APART FROM THE MARK AS SHOWN.

THE MARK CONSISTS OF THE LITERAL ELEMENTS "JEFF & JULIE PHOTOGRAPHY" WITH THE DESIGN OF HORIZONTAL LINES ON BOTH SIDES OF THE WORD "PHOTOGRAPHY."

FOR PHOTOGRAPHY SERVICES, NAMELY, WEDDING, PORTRAITS, AND PET PHOTOGRAPHY (U.S. CLS. 100, 101 AND 107).

FIRST USE 12-29-2010; IN COMMERCE 12-29-2010.  
JUDITH HELFMAN, EXAMINING ATTORNEY

**CLASS 41—(Continued).**

SN 85-208,064. JEFF AND JULIE PHOTOGRAPHY, INC.,  
CARMEL, IN. FILED 12-30-2010.

FOR PHOTOGRAPHY SERVICES, NAMELY, WEDDING, PORTRAIT AND PET PHOTOGRAPHY (U.S. CLS. 100, 101 AND 107).

FIRST USE 12-29-2010; IN COMMERCE 12-29-2010.  
JUDITH HELFMAN, EXAMINING ATTORNEY

SN 85-208,229. METWEST TERRA HOSPITALITY, WILSON,  
WY. FILED 12-30-2010.

**In2itive Hospitality**

SN 85-208,041. HARRIS II, WILLIAM F., MONTPELIER  
STATION, VA. FILED 12-30-2010.

*Constitutio*

THE MARK CONSISTS OF "CONSTITUTIO" IN STYLIZED CURSIVE FONT.

THE ENGLISH TRANSLATION OF "CONSTITUTIO" IN THE MARK IS "EDICT" OR "DECREE".

FOR EDUCATION SERVICES, NAMELY, PROVIDING INTERACTIVE INSTRUCTION, COURSES, SEMINARS AND WORKSHOPS IN THE FIELD OF PROFESSIONAL DEVELOPMENT RELATED TO THE AMERICAN FOUNDING AND THE VALUES OF A WELL-ORDERED COMMUNITY MORE BROADLY FOR TEACHERS, JOURNALISTS, APPELLATE JUDGES, SENIOR STATE AND FEDERAL OFFICIALS AND OTHER OPINION LEADERS (U.S. CLS. 100, 101 AND 107).

LAKEISHA LEWIS, EXAMINING ATTORNEY

THE MARK CONSISTS OF STANDARD CHARACTERS WITHOUT CLAIM TO ANY PARTICULAR FONT, STYLE, SIZE, OR COLOR.

NO CLAIM IS MADE TO THE EXCLUSIVE RIGHT TO USE "HOSPITALITY", APART FROM THE MARK AS SHOWN.

FOR PROVIDING SERVICE AND TECHNICAL JOB SKILLS TRAINING PROGRAMS FOR THE HOTEL, MOTEL, RESTAURANT AND SERVICE INDUSTRIES (U.S. CLS. 100, 101 AND 107).

ANGELA M. MICHELI, EXAMINING ATTORNEY

SN 85-208,231. SLIX MEDIA, HOUSTON, TX. FILED 12-30-2010.

**Next Play**

THE MARK CONSISTS OF STANDARD CHARACTERS WITHOUT CLAIM TO ANY PARTICULAR FONT, STYLE, SIZE, OR COLOR.

NO CLAIM IS MADE TO THE EXCLUSIVE RIGHT TO USE "PLAY", APART FROM THE MARK AS SHOWN.

FOR PROVIDING A WEBSITE FEATURING A VARIETY OF ONLINE GAMES (U.S. CLS. 100, 101 AND 107).

FIRST USE 8-26-2010; IN COMMERCE 8-26-2010.  
ANGELA M. MICHELI, EXAMINING ATTORNEY

**CLASS 41—(Continued).**

SN 85-208,245. DOUGLAS, MARK ANDREW, PALMETTO, FL. FILED 12-30-2010.

Excellence Is Never An  
Accident

THE MARK CONSISTS OF STANDARD CHARACTERS WITHOUT CLAIM TO ANY PARTICULAR FONT, STYLE, SIZE, OR COLOR.

FOR EDUCATION SERVICES, NAMELY, MENTORING IN THE FIELD OF ATHLETIC TRAINING; PERSONAL COACHING SERVICES IN THE FIELD OF ATHLETIC TRAINING; PHYSICAL FITNESS TRAINING SERVICES (U.S. CLS. 100, 101 AND 107).

FIRST USE 12-2-2010; IN COMMERCE 12-2-2010.  
ELLEN PERKINS, EXAMINING ATTORNEY

SN 85-208,258. NORTH, DAN, BROKEN ARROW, OK. FILED 12-30-2010.

**Spire**  
Performance Group

NO CLAIM IS MADE TO THE EXCLUSIVE RIGHT TO USE "PERFORMANCE GROUP", APART FROM THE MARK AS SHOWN.

THE MARK CONSISTS OF THE TERM "SPIRE" FEATURING AN ABSTRACT DESIGN ABOVE THE LETTERS "PIRE". WITH A STYLIZED TRIANGLE ABOVE THE LETTER "I" AND FOUR HORIZONTAL LINES ON EACH SIDE OF THE "I", AND THE WORDING "PERFORMANCE GROUP" BELOW.

FOR BUSINESS EDUCATION AND TRAINING SERVICES, NAMELY, DEVELOPING, AND FACILITATING CUSTOMIZED IN-COMPANY LEADERSHIP AND EXECUTIVE DEVELOPMENT PROGRAMS, PROVIDING EXECUTIVE COACHING SERVICES, AND PROVIDING PUBLIC AND IN-COMPANY KEYNOTE PRESENTATIONS TO BUSINESS LEADERS (U.S. CLS. 100, 101 AND 107).

DAVID TAYLOR, EXAMINING ATTORNEY

**CLASS 41—(Continued).**

SN 85-208,261. RACEP2R, INC., MURRIETA, CA. FILED 12-30-2010.



OWNER OF U.S. REG. NO. 3,690,330.  
NO CLAIM IS MADE TO THE EXCLUSIVE RIGHT TO USE "RACEWAY" AND "INDOOR KARTING", APART FROM THE MARK AS SHOWN.

THE MARK CONSISTS OF A CHECKERED FLAG TO THE LEFT WITH AN IMAGE OF A GO KART RACER AND TO THE RIGHT OF THE RACER THE WORDS "POLE POSITION RACEWAY" AND UNDERNEATH A LINE THE WORDS "INDOOR KARTING".

FOR PROVIDING FACILITIES FOR THE RACING OF GO KARTS (U.S. CLS. 100, 101 AND 107).

FIRST USE 8-1-2005; IN COMMERCE 9-14-2005.  
PAUL E. FAHRENKOPF, EXAMINING ATTORNEY

SN 85-208,365. JANGDHARI, ASHOKA, HARRISBURG, PA. FILED 12-30-2010.



NO CLAIM IS MADE TO THE EXCLUSIVE RIGHT TO USE "INTERACTIVE EDUCATIONAL SOLUTIONS", APART FROM THE MARK AS SHOWN.

THE MARK CONSISTS OF THE TEXT "IE S INTERACTIVE EDUCATIONAL SOLUTIONS" INSIDE A RECTANGLE, WITH A HAND PRINT BETWEEN "IE" AND "S".

FOR EDUCATION SERVICES, NAMELY, PROVIDING KINDERGARTEN THROUGH 12TH GRADE (K-12) CLASSROOM INSTRUCTION (U.S. CLS. 100, 101 AND 107).

ROBIN CHOSID, EXAMINING ATTORNEY

**CLASS 41—(Continued).**

SN 85-208,525. AMERICAN TREIBBALL ASSOCIATION, NORTHGLENN, CO. FILED 12-31-2010.



THE COLOR(S) BLUE AND RED IS/ARE CLAIMED AS A FEATURE OF THE MARK.

THE MARK CONSISTS OF A RED SILHOUETTE OF A DOG RUNNING IN FRONT OF A SOLID BLUE CIRCLE WITH THE WORDS "AMERICAN", IN RED, AND "TREIBBALL", IN BLUE, ABOVE THE BLUE CIRCLE, AND THE WORD "ASSOCIATION", IN RED, BELOW THE BLUE CIRCLE, AND ON THE RIGHT EDGE OF THE BLUE CIRCLE TWO BLUE STARS ABOVE TWO RED STARS.

FOR A MEMBER ORGANIZATION PROVIDING TRAINING, COMPETITION AND PROMOTION OF THE RECREATIONAL DOG SPORT OF TREIBBALL (U.S. CLS. 100, 101 AND 107).

FIRST USE 7-1-2010; IN COMMERCE 7-1-2010.  
THOMAS MANOR, EXAMINING ATTORNEY

**CLASS 41—(Continued).**

SN 85-208,725. LEWIS, JOHN-PAUL T., DBA TRANSFIGURATION PRODUCTIONS, FULLERTON, CA. FILED 12-31-2010.

**TRANSFIGURATION PRODUCTIONS**

THE MARK CONSISTS OF STANDARD CHARACTERS WITHOUT CLAIM TO ANY PARTICULAR FONT, STYLE, SIZE, OR COLOR.

NO CLAIM IS MADE TO THE EXCLUSIVE RIGHT TO USE "PRODUCTIONS", APART FROM THE MARK AS SHOWN.

FOR CINEMA STUDIOS (U.S. CLS. 100, 101 AND 107).  
FIRST USE 1-14-2010; IN COMMERCE 6-12-2010.  
RICHARD WHITE, EXAMINING ATTORNEY

SN 85-208,795. OH, JONATHAN A., COLUMBIA, SC. FILED 1-1-2011.

**Linked Press**

SN 85-208,591. C.E.O. CHILDREN'S ENTREPRENEURIAL ORGANIZATION, INC., NEW YORK CITY, NY. FILED 12-31-2010.

**CEO Children's  
Entrepreneurial  
Organization**

THE MARK CONSISTS OF STANDARD CHARACTERS WITHOUT CLAIM TO ANY PARTICULAR FONT, STYLE, SIZE, OR COLOR.

NO CLAIM IS MADE TO THE EXCLUSIVE RIGHT TO USE "CHILDREN'S ENTREPRENEURIAL ORGANIZATION", APART FROM THE MARK AS SHOWN.

FOR EDUCATION SERVICES, NAMELY, MENTORING YOUTH IN THE FIELD OF BUSINESS (U.S. CLS. 100, 101 AND 107).

FLORENTINA BLANDU, EXAMINING ATTORNEY

THE MARK CONSISTS OF STANDARD CHARACTERS WITHOUT CLAIM TO ANY PARTICULAR FONT, STYLE, SIZE, OR COLOR.

NO CLAIM IS MADE TO THE EXCLUSIVE RIGHT TO USE "PRESS", APART FROM THE MARK AS SHOWN.

FOR ENTERTAINMENT SERVICES, NAMELY, PROVIDING RADIO PROGRAMS IN THE FIELD OF NEWS, NEWS COMMENTARY AND EDITORIAL COMMENTARY VIA A GLOBAL COMPUTER NETWORK; ENTERTAINMENT SERVICES, NAMELY, PROVIDING WEBCASTS IN THE FIELD OF NEWS, NEWS COMMENTARY AND EDITORIAL COMMENTARY; ENTERTAINMENT SERVICES, NAMELY, THE PROVISION OF CONTINUING PROGRAMS FEATURING NEWS AND COMMENTARY DELIVERED BY INTERNET BROADCAST; ENTERTAINMENT, NAMELY, A CONTINUING NEWS, NEWS COMMENTARY AND EDITORIAL COMMENTARY SHOW BROADCAST OVER TELEVISION, SATELLITE, AUDIO, AND VIDEO MEDIA; ENTERTAINMENT, NAMELY, A CONTINUING NEWS, NEWS COMMENTARY AND EDITORIAL COMMENTARY SHOW BROADCAST OVER THE INTERNET; ENTERTAINMENT, NAMELY, TELEVISION NEWS SHOWS; NEWS AGENCIES, NAMELY, GATHERING AND DISSEMINATION OF NEWS; NEWS REPORTER SERVICES IN THE NATURE OF NEWS ANALYSIS AND NEWS COMMENTARY; NEWS REPORTERS SERVICES; NEWS SYNDICATION REPORTING (U.S. CLS. 100, 101 AND 107).

TRACY FLETCHER, EXAMINING ATTORNEY



**CLASS 41—(Continued).**

SN 85-208,886. CHEGG, INC., SANTA CLARA, CA. FILED 1-2-2011.

crAmster.com

OWNER OF U.S. REG. NO. 3,190,758.  
THE COLOR(S) BLACK AND RED IS/ARE CLAIMED AS A FEATURE OF THE MARK.

THE MARK CONSISTS OF THE WORD "CRAMSTER.COM", WHEREIN THE TEXT IS IN LOWERCASE BLACK LETTERS, EXCEPT THE "A" IS UPPERCASE, RED, AND HAS A RED "+" AS A SUPERSCRIPIT.

FOR EDUCATIONAL SERVICES, NAMELY, PROVIDING ON-LINE LEARNING RESOURCES IN THE NATURE OF STUDY GUIDES AND STUDY MATERIALS FOR STUDENTS OF PRIMARY, SECONDARY AND COLLEGE LEVELS (U.S. CLS. 100, 101 AND 107).

FIRST USE 9-0-2008; IN COMMERCE 9-0-2008.

MARGARET POWER, EXAMINING ATTORNEY

---

SN 85-208,922. GENTZ, ADAM C., DBA STRENGTH CENTER, HENDERSON, NV. FILED 1-3-2011.

## TRAIN OUT LOUD

THE MARK CONSISTS OF STANDARD CHARACTERS WITHOUT CLAIM TO ANY PARTICULAR FONT, STYLE, SIZE, OR COLOR.

NO CLAIM IS MADE TO THE EXCLUSIVE RIGHT TO USE "TRAIN", APART FROM THE MARK AS SHOWN.

FOR CONSULTING SERVICES IN THE FIELDS OF FITNESS AND EXERCISE; HEALTH CLUB SERVICES, NAMELY, PROVIDING INSTRUCTION AND EQUIPMENT IN THE FIELD OF PHYSICAL EXERCISE; PERSONAL TRAINING PROVIDED IN CONNECTION WITH WEIGHT LOSS AND EXERCISE PROGRAMS; PHYSICAL FITNESS STUDIO SERVICES, NAMELY, PROVIDING EXERCISE CLASSES, BODY SCULPTING CLASSES, AND GROUP FITNESS CLASSES; PHYSICAL FITNESS STUDIO SERVICES, NAMELY, PROVIDING GROUP EXERCISE INSTRUCTION, EQUIPMENT, AND FACILITIES; PROVIDING A WEB SITE FEATURING INFORMATION ON EXERCISE AND FITNESS; PROVIDING ASSISTANCE, PERSONAL TRAINING AND PHYSICAL FITNESS CONSULTATION TO CORPORATE CLIENTS TO HELP THEIR EMPLOYEES MAKE PHYSICAL FITNESS, STRENGTH, CONDITIONING, AND EXERCISE ALTERATIONS IN THEIR DAILY LIVING; PROVIDING ASSISTANCE, PERSONAL TRAINING AND PHYSICAL FITNESS CONSULTATION TO INDIVIDUALS TO HELP THEM MAKE PHYSICAL FITNESS, STRENGTH, CONDITIONING, AND EXERCISE IMPROVEMENT IN THEIR DAILY LIVING; PROVIDING CLASSES, WORKSHOPS, SEMINARS AND CAMPS IN THE FIELDS OF FITNESS, EXERCISE, BOXING, KICK BOXING AND MIXED MARTIAL ARTS; PROVIDING FITNESS AND EXERCISE FACILITIES; PROVIDING FITNESS AND EXERCISE STUDIO SERVICES, NAMELY, PILATES INSTRUCTION AND TRAINING; PROVIDING INFORMATION IN THE FIELD OF EXERCISE TRAINING (U.S. CLS. 100, 101 AND 107).

FIRST USE 1-18-2010; IN COMMERCE 9-1-2010.

DAVID ELTON, EXAMINING ATTORNEY

**CLASS 41—(Continued).**

SN 85-208,925. GNL ENTERTAINMENT, INC., WASHINGTON, DC. FILED 1-3-2011.

## Music-Ebru

THE MARK CONSISTS OF STANDARD CHARACTERS WITHOUT CLAIM TO ANY PARTICULAR FONT, STYLE, SIZE, OR COLOR.

THE ENGLISH TRANSLATION OF THE TURKISH WORD "EBRU" IN THE MARK IS "TURKISH PAPER MARBLING".

FOR ENTERTAINMENT INFORMATION SERVICES, NAMELY, PROVIDING INFORMATION AND NEWS RELEASES ABOUT A MUSICAL ARTIST; ENTERTAINMENT SERVICES IN THE NATURE OF LIVE MUSICAL PERFORMANCES; ENTERTAINMENT, NAMELY, LIVE MUSIC CONCERTS; ENTERTAINMENT, NAMELY, LIVE PERFORMANCES BY A MUSICAL BAND; PROVIDING AN INTERNET WEBSITE PORTAL FEATURING LINKS TO MUSICAL ARTIST WEBSITES AND MUSIC PERFORMANCE TICKET INFORMATION; PROVIDING AN INTERNET WEBSITE PORTAL IN THE FIELD OF MUSIC (U.S. CLS. 100, 101 AND 107).

ANDREA HACK, EXAMINING ATTORNEY

---

SN 85-208,963. THE READER'S DIGEST ASSOCIATION, INC., WHITE PLAINS, NY. FILED 1-3-2011.

## PRIZE DIGEST

THE MARK CONSISTS OF STANDARD CHARACTERS WITHOUT CLAIM TO ANY PARTICULAR FONT, STYLE, SIZE, OR COLOR.

OWNER OF U.S. REG. NOS. 2,151,348, 3,276,093 AND OTHERS.

NO CLAIM IS MADE TO THE EXCLUSIVE RIGHT TO USE "PRIZE", APART FROM THE MARK AS SHOWN.

FOR ENTERTAINMENT SERVICES, NAMELY, PROVIDING SWEEPSTAKES, CONTESTS AND GAMES ACCESSIBLE VIA GLOBAL COMPUTER NETWORKS, MOBILE TELEPHONES, WIRELESS NETWORKS AND OTHER DIGITAL COMMUNICATIONS NETWORKS AND DEVICES; ADMINISTERING SWEEPSTAKES, CONTESTS AND GAMES ACCESSIBLE VIA GLOBAL COMPUTER NETWORKS, MOBILE TELEPHONES, WIRELESS NETWORKS AND OTHER DIGITAL COMMUNICATIONS NETWORKS AND DEVICES FOR OTHERS (U.S. CLS. 100, 101 AND 107).

JEFFERY COWARD, EXAMINING ATTORNEY

**CLASS 41—(Continued).**

SN 85-209,019. EAST YORK UNIVERSITY COLLEGE LTD, ROSEAU VALLEY, DOMINICA, FILED 1-3-2011.



THE COLOR(S) DARK PURPLE, RED, WHITE, AND GOLD IS/ARE CLAIMED AS A FEATURE OF THE MARK.

THE MARK CONSISTS OF A SHIELD DESIGN OUTLINED IN WHITE AND DARK PURPLE WITH THE TERM "EAST" TO THE LEFT AND THE TERM "YORK" TO THE RIGHT, BOTH IN DARK PURPLE LETTERS. BELOW THE SHIELD DESIGN ARE THE WORDS "GRADIBVS ASCENDIMVS" IN DARK PURPLE INSIDE OF A DARK PURPLE BANNER. THE SHIELD DESIGN IS CRENNELLATED AT THE TOP. THE UPPER PORTION OF THE SHIELD IS RED WHILE THE BOTTOM PORTION IS DARK PURPLE. AT THE TOP OF THE SHIELD IS AN OPEN WHITE AND GOLD BOOK WITH THE LEFT PAGE CONTAINING THE TERMS "DEI GRATIA" IN GOLD. THE RIGHT PAGE CONTAINS THE ROMAN NUMERALS "XVII" IN GOLD. BELOW THE BOOK IS A GOLD AND WHITE LION HOLDING A WHITE AND GOLD ROLLED SCROLL WITH A RED RIBBON.

THE ENGLISH TRANSLATION OF GRADIBVS ASCENDIMVS, DEI GRATIA IN THE MARK IS "ASCENDING BY DEGREES, BY THE GRACE OF GOD".

FOR EDUCATIONAL SERVICES, NAMELY, PROVIDING LIVE AND ON-LINE CLASSES, SEMINARS, AND WORKSHOPS IN THE FIELDS OF BUSINESS, THEOLOGY STUDIES, SOCIAL SCIENCES AND TECHNOLOGY STUDIES (U.S. CLS. 100, 101 AND 107).

FIRST USE 12-18-2010; IN COMMERCE 12-18-2010.  
MICHAEL KEATING, EXAMINING ATTORNEY

**CLASS 41—(Continued).**

SN 85-209,363. STEPHEN M. KRAUSE, KIRKLAND, WA, FILED 1-3-2011.



NO CLAIM IS MADE TO THE EXCLUSIVE RIGHT TO USE "POST", APART FROM THE MARK AS SHOWN.

THE COLOR(S) GREEN AND BLACK IS/ARE CLAIMED AS A FEATURE OF THE MARK.

THE MARK CONSISTS OF A GREEN ABSTRACT DESIGN BEHIND THE BLACK STYLIZED WORDS "GROOVY-POST". THE COLOR WHITE REPRESENTS BACKGROUND AND IS NOT PART OF THE MARK.

FOR ON-LINE JOURNALS, NAMELY, BLOGS FEATURING HOW-TO TUTORIALS AND TIPS IN THE FIELD OF THE USE OF COMPUTERS, MOBILE DEVICES AND INFORMATION TECHNOLOGY; ON-LINE JOURNALS, NAMELY, BLOGS FEATURING SECTOR NEWS AND REVIEWS OF PRODUCTS AND SERVICES, NAMELY, COMPUTER HARDWARE, SOFTWARE, MOBILE DEVICES, AND SOFTWARE THEREFOR, CONSUMER ELECTRONICS, AND SERVICES PROVIDED BY THIRD PARTIES TO COMPUTER AND MOBILE DEVICE USERS (U.S. CLS. 100, 101 AND 107).

FIRST USE 2-7-2007; IN COMMERCE 2-7-2007.

JACQUELINE A. LAVINE, EXAMINING ATTORNEY

SN 85-209,035. KELLEY, RICHARD, AUSTIN, TX, FILED 1-3-2011.

**THE FITNESS RESPONSE**

THE MARK CONSISTS OF STANDARD CHARACTERS WITHOUT CLAIM TO ANY PARTICULAR FONT, STYLE, SIZE, OR COLOR.

NO CLAIM IS MADE TO THE EXCLUSIVE RIGHT TO USE "FITNESS", APART FROM THE MARK AS SHOWN.

FOR EDUCATION SERVICES, NAMELY, PROVIDING SEMINARS IN THE FIELD OF FITNESS, HEALTH AND NUTRITION, AND DISTRIBUTION OF COURSE MATERIAL IN CONNECTION THEREWITH (U.S. CLS. 100, 101 AND 107).

TAMARA FRAZIER, EXAMINING ATTORNEY

SN 85-209,521. EDHAT, INC., SANTA BARBARA, CA, FILED 1-3-2011.

**Edhat**

THE MARK CONSISTS OF STANDARD CHARACTERS WITHOUT CLAIM TO ANY PARTICULAR FONT, STYLE, SIZE, OR COLOR.

FOR ON-LINE ELECTRONIC NEWSLETTER, DELIVERED BY E-MAIL FOR A MULTI-CLIENT MARKET FEATURING NEWS ITEMS, ADVERTISEMENTS, UPCOMING EVENTS AND FEATURE ARTICLES SPECIFIC TO THE CALIFORNIA CENTRAL COAST, NAMELY, SANTA BARBARA, SAN LUIS OBISPO AND VENTURA COUNTIES (U.S. CLS. 100, 101 AND 107).

FIRST USE 11-10-2003; IN COMMERCE 11-10-2003.

DOMINICK J. SALEMI, EXAMINING ATTORNEY

**CLASS 41—(Continued).**

SN 85-209,555. CASTILLO, ANA L., DBA ENTERTAIN MY PARTY LLC, AVONDALE, AZ. FILED S.R. 1-3-2011; AM. P.R. 3-29-2011.



NO CLAIM IS MADE TO THE EXCLUSIVE RIGHT TO USE "ENTERTAIN" AND "PARTY", APART FROM THE MARK AS SHOWN.

THE COLOR(S) DARK RED AND BLACK IS/ARE CLAIMED AS A FEATURE OF THE MARK.

THE MARK CONSISTS OF THE WORDING "ENTERTAIN" IN EDWARDIAN STYLIZED FONT IN THE COLOR DARK RED WITH A MUSICAL NOTE IN THE COLOR BLACK ABOVE THE LETTER "I" ABOVE THE WORDING "MY PARTY" IN THE COLOR BLACK.

FOR PROVIDING A WEBSITE FEATURING ENTERTAINMENT INFORMATION (U.S. CLS. 100, 101 AND 107).

FIRST USE 12-2-2010; IN COMMERCE 12-9-2010.  
WILLIAM ROSSMAN, EXAMINING ATTORNEY

---

SN 85-209,558. P E 3 FOUNDATION, AUSTIN, TX. FILED 1-3-2011.



THE MARK CONSISTS OF THE LETTERS "PE" AND NUMBER "3" IN LARGE TYPE ABOVE THE WORDS "MIND", "BODY" AND "SPIRIT" IN SMALLER TYPE.

FOR EDUCATIONAL SERVICES, NAMELY, DEVELOPING CURRICULUM FOR SCHOOLS IN ORDER TO IMPROVE PHYSICAL FITNESS, NUTRITION AND OTHER HEALTHY BEHAVIORS IN AT-RISK STUDENTS (U.S. CLS. 100, 101 AND 107).

JAMES GRIFFIN, EXAMINING ATTORNEY

---

SN 85-209,678. SILVER STEP, LLC, PARK RIDGE, IL. FILED 1-4-2011.

**SILVER STEP**

THE MARK CONSISTS OF STANDARD CHARACTERS WITHOUT CLAIM TO ANY PARTICULAR FONT, STYLE, SIZE, OR COLOR.

FOR EDUCATIONAL SERVICES, NAMELY, CONDUCTING AND ORGANIZING CLASSES, SEMINARS, CONFERENCES AND WORKSHOPS IN THE FIELD OF PERSONAL FINANCE, AS WELL AS THE DISTRIBUTION OF COURSE MATERIALS IN CONNECTION THEREWITH (U.S. CLS. 100, 101 AND 107).

SUSAN RICHARDS, EXAMINING ATTORNEY

**CLASS 41—(Continued).**

SN 85-209,712. ISLE OF CAPRI CASINOS, INC., ST. LOUIS, MO. FILED 1-4-2011.

**ISLE OPEN**

THE MARK CONSISTS OF STANDARD CHARACTERS WITHOUT CLAIM TO ANY PARTICULAR FONT, STYLE, SIZE, OR COLOR.

OWNER OF U.S. REG. NOS. 2,939,807, 3,667,148 AND OTHERS.

NO CLAIM IS MADE TO THE EXCLUSIVE RIGHT TO USE "OPEN", APART FROM THE MARK AS SHOWN.

FOR GAMBLING SERVICES (U.S. CLS. 100, 101 AND 107).

FIRST USE 10-1-2010; IN COMMERCE 10-1-2010.  
EUGENIA MARTIN, EXAMINING ATTORNEY

---

SN 85-209,713. ISLE OF CAPRI CASINOS, INC., ST. LOUIS, MO. FILED 1-4-2011.

**ISLE POKER CLASSIC**

THE MARK CONSISTS OF STANDARD CHARACTERS WITHOUT CLAIM TO ANY PARTICULAR FONT, STYLE, SIZE, OR COLOR.

OWNER OF U.S. REG. NOS. 2,939,807, 3,667,148 AND OTHERS.

NO CLAIM IS MADE TO THE EXCLUSIVE RIGHT TO USE "POKER CLASSIC", APART FROM THE MARK AS SHOWN.

FOR GAMBLING SERVICES (U.S. CLS. 100, 101 AND 107).

FIRST USE 1-0-2009; IN COMMERCE 1-0-2009.  
EUGENIA MARTIN, EXAMINING ATTORNEY

**CLASS 41—(Continued).**

SN 85-209,889. FATHERLEY, DUSTIN, TUCSON, AZ. FILED 1-4-2011.



THE MARK CONSISTS OF GREEK LETTER "ALPHA" WITH THE GREEK LETTER "OMEGA" SET BEHIND IT. FOR ENTERTAINMENT SERVICES IN THE NATURE OF LIVE MUSICAL PERFORMANCES (U.S. CLS. 100, 101 AND 107).

FIRST USE 6-10-2006; IN COMMERCE 6-1-2008.  
BARBARA BROWN, EXAMINING ATTORNEY

SN 85-210,106. MARTINEZ, JR., JOSE, NEW YORK, NY. FILED 1-4-2011.

---

## Latino Review

THE MARK CONSISTS OF STANDARD CHARACTERS WITHOUT CLAIM TO ANY PARTICULAR FONT, STYLE, SIZE, OR COLOR.

NO CLAIM IS MADE TO THE EXCLUSIVE RIGHT TO USE "REVIEW", APART FROM THE MARK AS SHOWN. SEC. 2(F).

FOR ENTERTAINMENT AND EDUCATIONAL SERVICES IN THE NATURE OF ON-LINE COMPETITIONS IN THE FIELD OF ENTERTAINMENT, EDUCATION, CULTURE, SPORTS, AND OTHER NON-BUSINESS AND NON-COMMERCIAL FIELDS; ENTERTAINMENT AND EDUCATIONAL SERVICES, NAMELY, PROVIDING A WEBSITE THAT DISPLAYS VARIOUS REQUESTS, REVIEWS, RECOMMENDATIONS, RANKINGS, TRACKINGS, VOTES, AND INFORMATION RELATING TO UNCREATED, UNRELEASED, NEW, SPECIAL, POPULAR, AND RARE PRODUCTS, SERVICES, AND EVENTS IN THE FIELDS OF POP CULTURE, ENTERTAINMENT, EDUCATION, AND SPORTS, ALL EXCLUSIVELY FOR NON-BUSINESS AND NON-COMMERCIAL TRANSACTIONS AND PURPOSES; ENTERTAINMENT AND EDUCATIONAL SERVICES, NAMELY, PROVIDING ADVICE AND INFORMATION FOR MUSIC, VIDEO AND FILM CONCEPT AND SCRIPT DEVELOPMENT; ENTERTAINMENT SERVICES, NAMELY, PROVIDING ON-LINE REVIEWS OF MOVIES, TELEVISION PROGRAMS AND ON-LINE FILM, ON A WEBSITE (U.S. CLS. 100, 101 AND 107).

FIRST USE 1-1-2000; IN COMMERCE 1-1-2000.  
PAUL F. GAST, EXAMINING ATTORNEY

**CLASS 41—(Continued).**

SN 85-210,162. HAVERFIELD INTERNATIONAL INCORPORATED, DBA HAVERFIELD AVIATION, INC., GETTYSBURG, PA. FILED 1-4-2011.

## HAVERFIELDTECH

THE MARK CONSISTS OF STANDARD CHARACTERS WITHOUT CLAIM TO ANY PARTICULAR FONT, STYLE, SIZE, OR COLOR.

OWNER OF U.S. REG. NOS. 1,645,516, 1,682,224 AND 3,140,874.

SEC. 2(F) AS TO "HAVERFIELD".

FOR EDUCATIONAL SERVICES, NAMELY, CONDUCTING TRAINING IN THE FIELDS OF INSPECTION, MAINTENANCE AND REPAIR OF ELECTRICAL POWER TRANSMISSION LINES DONE BY HELICOPTER; EDUCATIONAL SERVICES, NAMELY, CONDUCTING TRAINING VIA THE INTERNET IN THE FIELDS OF INSPECTION, MAINTENANCE AND REPAIR OF ELECTRICAL POWER TRANSMISSION LINES DONE BY HELICOPTER (U.S. CLS. 100, 101 AND 107).

FIRST USE 2-0-2008; IN COMMERCE 2-0-2008.

MATTHEW MCDOWELL, EXAMINING ATTORNEY

SN 85-210,213. TENNIS ANYWHERE, INC., MARIETTA, GA. FILED 1-4-2011.

---

## TENNIS ANYWHERE

THE MARK CONSISTS OF STANDARD CHARACTERS WITHOUT CLAIM TO ANY PARTICULAR FONT, STYLE, SIZE, OR COLOR.

NO CLAIM IS MADE TO THE EXCLUSIVE RIGHT TO USE "TENNIS", APART FROM THE MARK AS SHOWN.

FOR PROVIDING A WEB-BASED SYSTEM AND ON-LINE PORTAL FOR MEMBERS TO PARTICIPATE IN AND SCHEDULE TENNIS ACTIVITIES, NAMELY, OPERATION AND COORDINATION OF PICK UP GAMES, CLINICS, DRILLS, AND TOURNAMENTS (U.S. CLS. 100, 101 AND 107).

COLLEEN KEARNEY, EXAMINING ATTORNEY

**CLASS 41—(Continued).**

SN 85-210,275. TUCSON OSTEOPATHIC MEDICAL FOUNDATION, TUCSON, AZ. FILED 1-4-2011.

SOUTHWESTERN CONFERENCE ON  
MEDICINE

THE MARK CONSISTS OF STANDARD CHARACTERS WITHOUT CLAIM TO ANY PARTICULAR FONT, STYLE, SIZE, OR COLOR.

NO CLAIM IS MADE TO THE EXCLUSIVE RIGHT TO USE "CONFERENCE", APART FROM THE MARK AS SHOWN.

SEC. 2(F).

FOR EDUCATIONAL SERVICES, NAMELY, ARRANGING AND CONDUCTING CONFERENCES IN THE FIELD OF MEDICINE (U.S. CLS. 100, 101 AND 107).

FIRST USE 4-0-1991; IN COMMERCE 4-0-1991.

BARBARA BROWN, EXAMINING ATTORNEY

**CLASS 41—(Continued).**

SN 85-210,797. EMPOWER STUDENTS OF TEXAS, LLC, AUSTIN, TX. FILED 1-5-2011.

Empower Students of Texas

THE MARK CONSISTS OF STANDARD CHARACTERS WITHOUT CLAIM TO ANY PARTICULAR FONT, STYLE, SIZE, OR COLOR.

NO CLAIM IS MADE TO THE EXCLUSIVE RIGHT TO USE "STUDENTS" AND "TEXAS", APART FROM THE MARK AS SHOWN.

FOR EDUCATIONAL SERVICES, NAMELY, PROVIDING INTERNSHIPS AND APPRENTICESHIPS IN THE FIELD OF ACCOUNTING, ADVERTISING, ANIMAL CONSERVATION, BANKING, COMMUNICATIONS, EDUCATION, ENTERTAINMENT, EVENT PLANNING, FUNDRAISING, FINANCE, HOSPITAL ADMINISTRATION, HUMAN RESOURCES, INFORMATION TECHNOLOGY, INTERNATIONAL BUSINESS, MARKETING, MUSIC, NURSING, PHOTOJOURNALISM, PHYSICAL THERAPY, PUBLIC RELATIONS, RETAIL, SPORTS PROMOTION AND VIDEO PRODUCTION (U.S. CLS. 100, 101 AND 107).

FIRST USE 4-1-2008; IN COMMERCE 4-1-2008.

KAREN K. BUSH, EXAMINING ATTORNEY

SN 85-210,431. HERMANN, JEREMY CLEMENS, HUDSON, MA. AND HERMANN, ANETTE JOY, HUDSON, MA. FILED 1-4-2011.

SN 85-211,072. SAN ANTONIO OPERA, FORMERLY THE SAN ANTONIO POCKET OPERA, SAN ANTONIO, TX. FILED 1-5-2011.



NO CLAIM IS MADE TO THE EXCLUSIVE RIGHT TO USE "PHOTO BOOTH RENTALS", APART FROM THE MARK AS SHOWN.

THE COLOR(S) BLACK AND RED IS/ARE CLAIMED AS A FEATURE OF THE MARK.

THE MARK CONSISTS OF THE WORDING, "BEHIND THE CURTAIN" WHERE THE WORDS "BEHIND THE" IN BLACK ARE SEEN SHOWING PARTLY THROUGH THE DESIGN OF A CURTAIN IN OPAQUE RED, AND THE WORD "CURTAIN" IN RED IS SHOWN IN FRONT OF THE OPAQUE CURTAIN DESIGN; THE WORDING, "PHOTO BOOTH RENTALS" IN BLACK IS AT RIGHT; THE COLOR WHITE REPRESENTS OUTLINING AROUND THE WORD, "CURTAIN" AND IT IS NOT PART OF THE MARK.

FOR DIGITAL IMAGING SERVICES; PHOTOGRAPHY SERVICES; RENTAL OF PORTABLE PHOTOGRAPHY AND/OR VIDEOGRAPHY BOOTHS FOR TAKING OF PICTURES AND VIDEOS (U.S. CLS. 100, 101 AND 107).

FIRST USE 3-15-2010; IN COMMERCE 5-22-2010.

GILBERT SWIFT, EXAMINING ATTORNEY



NO CLAIM IS MADE TO THE EXCLUSIVE RIGHT TO USE "OPERA", APART FROM THE MARK AS SHOWN.

THE COLOR(S) RED AND BLACK IS/ARE CLAIMED AS A FEATURE OF THE MARK.

THE MARK CONSISTS OF THE TERMS "SAN ANTONIO" IN BLACK IN A LOWER CASE FONT POSITIONED ABOVE THE TERM "OPERA" IN BLACK, ALSO IN A LOWER CASE BUT LARGER FONT, A RED SWIRLING LINE IS POSITIONED TO THE LEFT AND ABOVE "SAN ANTONIO".

SEC. 2(F) AS TO SAN ANTONIO.

FOR ENTERTAINMENT, NAMELY, PRODUCTION OF OPERAS (U.S. CLS. 100, 101 AND 107).

FIRST USE 11-0-2007, THE MARK WAS FIRST USED ANYWHERE IN A DIFFERENT FORM OTHER THAN THAT SOUGHT TO BE REGISTERED AT LEAST AS EARLY AS 00/00/1996; IN COMMERCE 11-0-2007, THE MARK WAS FIRST USED IN COMMERCE IN A DIFFERENT FORM OTHER THAN THAT SOUGHT TO BE REGISTERED AT LEAST AS EARLY AS 00/00/1996.

ALICE BENMAMAN, EXAMINING ATTORNEY



**CLASS 41—(Continued).**

SN 85-211,215. AYOUB, DANIEL, LAVAL, CANADA, FILED 1-5-2011.

sportsnetics

THE MARK CONSISTS OF STANDARD CHARACTERS WITHOUT CLAIM TO ANY PARTICULAR FONT, STYLE, SIZE, OR COLOR.

FOR PROVIDING A WEB SITE THAT PROVIDES SPORTS LEAGUE PLAYER STATISTICS; PROVIDING A WEBSITE FOR ENTERTAINMENT PURPOSES WHERE USERS CAN VIEW AND POST STATISTICS FEATURING SPORTS LEAGUES (U.S. CLS. 100, 101 AND 107).

FIRST USE 1-5-2011; IN COMMERCE 1-5-2011.  
KIM SAITO, EXAMINING ATTORNEY

**CLASS 41—(Continued).**

SN 85-211,441. WHITEHEAD, JENISE, AKA ANUSHKA LOU, LOS ANGELES, CA. FILED 1-5-2011.

Anushka Lou

THE NAME "ANUSHKA LOU" IDENTIFIES THE PSEUDONYM OF JENISE L. WHITEHEAD, A LIVING INDIVIDUAL WHOSE CONSENT IS OF RECORD.

THE COLOR(S) PURPLE IS/ARE CLAIMED AS A FEATURE OF THE MARK.

THE MARK CONSISTS OF STYLIZED "ANUSHKA LOU" IN PURPLE.

FOR PROVIDING A WEBSITE FEATURING INFORMATION ABOUT ARTISTIC STYLES; PROVIDING A WEBSITE FEATURING INFORMATION IN THE FIELD OF MUSIC AND ENTERTAINMENT (U.S. CLS. 100, 101 AND 107).

FIRST USE 5-19-2010; IN COMMERCE 6-25-2010.  
JENNIFER MARTIN, EXAMINING ATTORNEY

SN 85-211,527. BROOKS, CORDEZ, MORRILTON, AR. FILED 1-6-2011.

SN 85-211,363. POWELLS, STACEY, MAMMOTH LAKES, CA. FILED 1-5-2011.

EXHAUSTED PARENT NETWORK



NO CLAIM IS MADE TO THE EXCLUSIVE RIGHT TO USE "ENT", APART FROM THE MARK AS SHOWN.

THE MARK CONSISTS OF WORDS "SMASH HOOKZ ENT" WITH TWO DOTS ON BOTH SIDES OF THE WORD "ENT", ALL WITHIN AN ABSTRACT BOUNDARY AS SHOWN IN THE MARK.

FOR ENTERTAINMENT RENDERED BY A MUSICAL GROUP, NAMELY, ENTERTAINMENT IN THE NATURE OF VISUAL AND AUDIO PERFORMANCES BY A MUSICAL ACT; LIVE PERFORMANCES BY A MUSICAL ACT; MULTIMEDIA ENTERTAINMENT SERVICES IN THE NATURE OF RECORDING, PRODUCTION AND POST-PRODUCTION SERVICES IN THE FIELD OF MUSIC AND VIDEO; ENTERTAINMENT SERVICES BY A MUSICAL GROUP, NAMELY, MUSICAL COMPOSITION AND PRODUCTION OF MUSICAL SOUND RECORDINGS (U.S. CLS. 100, 101 AND 107).

DORITT L. CARROLL, EXAMINING ATTORNEY

THE MARK CONSISTS OF STANDARD CHARACTERS WITHOUT CLAIM TO ANY PARTICULAR FONT, STYLE, SIZE, OR COLOR.

NO CLAIM IS MADE TO THE EXCLUSIVE RIGHT TO USE "PARENT NETWORK", APART FROM THE MARK AS SHOWN.

FOR ENTERTAINMENT SERVICES, NAMELY, PROVIDING A WEB SITE FEATURING PHOTOGRAPHIC, AUDIO, VIDEO AND PROSE PRESENTATIONS FEATURING PARENTING; ENTERTAINMENT SERVICES, NAMELY, PROVIDING AN ON-GOING RADIO PROGRAM IN THE FIELD OF PARENTING (U.S. CLS. 100, 101 AND 107).

FIRST USE 8-31-2003; IN COMMERCE 7-15-2005.  
SANI KHOURI, EXAMINING ATTORNEY

**CLASS 41—(Continued).**

SN 85-211,775. NAVAJO NATION GAMING ENTERPRISE, CHURCH ROCK, NM. FILED 1-6-2011.

## FLOWING WATER NAVAJO CASINO

THE MARK CONSISTS OF STANDARD CHARACTERS WITHOUT CLAIM TO ANY PARTICULAR FONT, STYLE, SIZE, OR COLOR.

OWNER OF U.S. REG. NOS. 3,721,178, 3,721,180 AND OTHERS.

NO CLAIM IS MADE TO THE EXCLUSIVE RIGHT TO USE "CASINO", APART FROM THE MARK AS SHOWN.

FOR PROVIDING CASINOS AND GAMING FACILITIES; CASINOS; PROVIDING CASINO SERVICES FEATURING A CASINO PLAYERS REWARDS PROGRAM (U.S. CLS. 100, 101 AND 107).

FIRST USE 10-13-2010; IN COMMERCE 10-13-2010.  
DAWN FELDMAN, EXAMINING ATTORNEY

---

SN 85-211,783. NAVAJO NATION GAMING ENTERPRISE, CHURCH ROCK, NM. FILED 1-6-2011.



OWNER OF U.S. REG. NOS. 3,721,178, 3,721,180 AND OTHERS.

NO CLAIM IS MADE TO THE EXCLUSIVE RIGHT TO USE "CASINO", APART FROM THE MARK AS SHOWN.

THE MARK CONSISTS OF THE WORDS "FLOWING WATER NAVAJO CASINO" WITH THE CROSSING OF THE LETTER "E" IN THE WORDS "WATER" WITH A DESIGN REPRESENTING WATER. ABOVE THE WORDS, THERE IS A DESIGN OF FLOWING WATER AND GRASS, AS WELL AS A HILL AND MOUNTAIN DESIGN ABOVE THE FLOWING WATER AND GRASS DESIGN. BELOW THE WORDS IS A BASKET-WEAVE DESIGN.

FOR PROVIDING CASINOS AND GAMING FACILITIES; CASINOS; PROVIDING CASINO SERVICES FEATURING A CASINO PLAYERS REWARDS PROGRAM (U.S. CLS. 100, 101 AND 107).

FIRST USE 10-13-2010; IN COMMERCE 10-13-2010.  
DAWN FELDMAN, EXAMINING ATTORNEY

**CLASS 41—(Continued).**

SN 85-212,230. REICHLLEY, LEIGH, LOS ANGELES, CA. FILED 1-6-2011.

## PRINCESS WEARS PANTS

THE MARK CONSISTS OF STANDARD CHARACTERS WITHOUT CLAIM TO ANY PARTICULAR FONT, STYLE, SIZE, OR COLOR.

FOR ON-LINE JOURNALS, NAMELY, BLOGS FEATURING INFORMATION AND RESOURCES FOR MOTHERS (U.S. CLS. 100, 101 AND 107).

FIRST USE 12-25-2010; IN COMMERCE 12-25-2010.  
JUDITH HELFMAN, EXAMINING ATTORNEY

---

SN 85-212,807. CALIFORNIA ONLINE POKER ASSOCIATION LLC, LOS ANGELES, CA. FILED 1-7-2011.

COPA

THE MARK CONSISTS OF STANDARD CHARACTERS WITHOUT CLAIM TO ANY PARTICULAR FONT, STYLE, SIZE, OR COLOR.

FOR PROVIDING INSTRUCTIONAL INFORMATION ON POKER; PROVIDING ON-LINE POKER GAMES (U.S. CLS. 100, 101 AND 107).

LEIGH CAROLINE CASE, EXAMINING ATTORNEY

**CLASS 41—(Continued).**

SN 85-212,925. GREGORY M. VECCHI, STAFFORD, VA.  
FILED 1-7-2011.



NO CLAIM IS MADE TO THE EXCLUSIVE RIGHT TO USE "WING TSUNG CONCEPTS", APART FROM THE MARK AS SHOWN.

THE COLOR(S) RED AND BLACK IS/ARE CLAIMED AS A FEATURE OF THE MARK.

THE MARK CONSISTS OF ONE RED EQUILATERAL TRIANGLE (POINTING DOWN) OVER AND OFFSET OVER ONE BLACK EQUILATERAL TRIANGLE (POINTING DOWN) WITH THE WORDS "WING TSUNG" IN BLACK REGULAR FONT CENTERED UNDER THE BLACK TRIANGLE POINT AND THE WORD "CONCEPTS" IN BLACK ITALICIZED FONT CENTERED UNDER "WING TSUNG".

THE ENGLISH TRANSLATION OF "WING TSUNG" IN THE MARK IS "ETERNAL SPRINGTIME".

FOR MARTIAL ARTS INSTRUCTION; OPERATING OF MARTIAL ARTS' SCHOOLS; OPERATING OF MARTIAL ARTS' STUDIOS (U.S. CLS. 100, 101 AND 107).

HELENE LIWINSKI, EXAMINING ATTORNEY

SN 85-213,296. ISSUES TV, LLC, BEDFORD HILLS, NY.  
FILED 1-7-2011.



THE MARK CONSISTS OF A SOLID RECTANGLE SURROUNDING AN OUTLINE OF A MAGNIFYING GLASS.

FOR PROVIDING A WEBSITE FEATURING NON-DOWNLOADABLE VIDEO AND AUDIO FILES FEATURING WORLD WIDE NEWS CONTENT (U.S. CLS. 100, 101 AND 107).

FIRST USE 6-1-2010; IN COMMERCE 6-1-2010.  
ALYSSA STEEL, EXAMINING ATTORNEY

**CLASS 41—(Continued).**

SN 85-213,347. WINTERTON RACQUETBALL INC., LIVERPOOL, NY. FILED 1-7-2011.

## Coach's Corner

THE MARK CONSISTS OF STANDARD CHARACTERS WITHOUT CLAIM TO ANY PARTICULAR FONT, STYLE, SIZE, OR COLOR.

FOR COACHING AND TRAINING IN THE FIELD OF RACQUETBALL (U.S. CLS. 100, 101 AND 107).

RONALD DELGIZZI, EXAMINING ATTORNEY

SN 85-213,357. PURPLE PIG PHOTOGRAPHY, LLC, DBA PURPLE PIG PHOTOGRAPHY, BROOKLYN PARK, MN.  
FILED 1-7-2011.



NO CLAIM IS MADE TO THE EXCLUSIVE RIGHT TO USE "PHOTOGRAPHY", APART FROM THE MARK AS SHOWN.

THE COLOR(S) PURPLE, PINK, WHITE, AND BLACK IS/ARE CLAIMED AS A FEATURE OF THE MARK.

THE MARK CONSISTS OF THE LITERAL ELEMENT "PURPLE PIG PHOTOGRAPHY" REPRESENTED IN SCRIPT TYPE WITH THE WORDS "PURPLE PIG" LOCATED ABOVE THE WORD "PHOTOGRAPHY" AND APPEARING IN THE COLOR BLACK, AND A DESIGN CONSISTING OF A GRAPHIC REPRESENTATION OF A PIG LOCATED TO THE LEFT OF, AND LEANING AGAINST, THE FIRST LETTER "P" IN THE WORD "PURPLE" AND WHEREIN THE PIG'S BODY APPEARS OVERALL IN THE COLOR PURPLE, THE PIG'S NOSE AND THE INSIDE PORTIONS OF ITS EARS APPEAR IN THE COLOR PINK, THE COLOR WHITE APPEARS ON THE EDGES OF THE PIG'S FEET AND HANDS, AND THE PIG'S EYES, NOSTRILS, SMILE, UPRIGHT HAIR, AND LINES REPRESENTING SEPARATIONS ON ITS FEET, ALONG WITH THE OUTLINING OF ITS BODY AND FEATURES APPEAR IN THE COLOR BLACK.

FOR PHOTOGRAPHY (U.S. CLS. 100, 101 AND 107).  
FIRST USE 10-1-2010; IN COMMERCE 10-1-2010.  
RONALD DELGIZZI, EXAMINING ATTORNEY

**CLASS 41—(Continued).**

SN 85-213,360. PURPLE PIG PHOTOGRAPHY, LLC, DBA PURPLE PIG PHOTOGRAPHY, BROOKLYN PARK, MN. FILED 1-7-2011.



THE COLOR(S) PURPLE, PINK, WHITE, AND BLACK IS/ARE CLAIMED AS A FEATURE OF THE MARK.  
 THE MARK CONSISTS OF A GRAPHIC REPRESENTATION OF A PIG PICTURED IN LEANING STANCE, WHEREIN THE PIG'S BODY APPEARS OVERALL IN THE COLOR PURPLE, ITS UPRIGHT HAIR APPEARS IN A DARKER SHADE OF PURPLE, THE PIG'S NOSE AND THE INSIDE PORTIONS OF ITS EARS APPEAR IN THE COLOR PINK, THE COLOR WHITE APPEARS ON THE EDGES OF THE PIG'S FEET AND HANDS, AND THE PIG'S EYES, NOSTRILS, SMILE, AND LINES REPRESENTING SEPARATIONS ON ITS FEET, ALONG WITH THE OUTLINING OF ITS BODY AND FEATURES APPEAR IN THE COLOR BLACK, AND WHEREIN THE PIG IS SUPERIMPOSED UPON A RECTANGULAR SHAPED BACKGROUND.  
 FOR PHOTOGRAPHY (U.S. CLS. 100, 101 AND 107).  
 RONALD DELGIZZI, EXAMINING ATTORNEY

SN 85-213,367. LOCUS PUBLISHING COMPANY, TAIPEI, TAIWAN, FILED 1-7-2011.

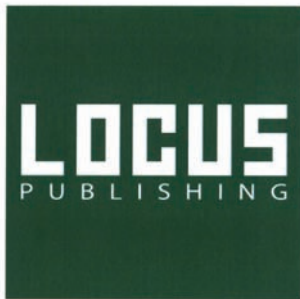

NO CLAIM IS MADE TO THE EXCLUSIVE RIGHT TO USE "PUBLISHING", APART FROM THE MARK AS SHOWN.  
 THE COLOR(S) GREEN AND WHITE IS/ARE CLAIMED AS A FEATURE OF THE MARK.  
 THE MARK CONSISTS OF THE WORDS "LOCUS PUBLISHING" IN WHITE LETTERS ON A GREEN BACKGROUND.  
 FOR PUBLISHING OF BOOKS AND JOURNALS (U.S. CLS. 100, 101 AND 107).  
 FIRST USE 5-26-2010; IN COMMERCE 5-26-2010.  
 RONALD DELGIZZI, EXAMINING ATTORNEY

**CLASS 41—(Continued).**

SN 85-213,459. THREE FERNS FILMS, LLC, ROCKVILLE, MD. FILED 1-8-2011.

# Three Ferns

THE MARK CONSISTS OF STANDARD CHARACTERS WITHOUT CLAIM TO ANY PARTICULAR FONT, STYLE, SIZE, OR COLOR.  
 FOR FILM AND VIDEO PRODUCTION; MULTIMEDIA ENTERTAINMENT SERVICES IN THE NATURE OF RECORDING, PRODUCTION AND POST-PRODUCTION SERVICES IN THE FIELDS OF MUSIC, VIDEO, AND FILMS (U.S. CLS. 100, 101 AND 107).  
 FIRST USE 7-12-2010; IN COMMERCE 7-12-2010.  
 ALEXANDER L. POWERS, EXAMINING ATTORNEY

SN 85-213,615. RICCIO, DAMION, ORLANDO, FL. FILED 1-9-2011.



THE COLOR(S) RED, BLUE, & YELLOW IS/ARE CLAIMED AS A FEATURE OF THE MARK.  
 THE MARK CONSISTS OF BLUE SMILEY JAPANESE STYLIZED ROBOT CHARACTER. THE WORD "LITTLE" IN YELLOW & THE WORD "EGOS" IN RED.  
 FOR PHOTOGRAPHY (U.S. CLS. 100, 101 AND 107).  
 FIRST USE 6-11-2010; IN COMMERCE 9-6-2010.  
 JAMES GRIFFIN, EXAMINING ATTORNEY

SN 85-213,739. 360 FOOTBALL ACADEMY, LLC, ATLANTA, GA. FILED 1-10-2011.

# TTP

THE MARK CONSISTS OF STANDARD CHARACTERS WITHOUT CLAIM TO ANY PARTICULAR FONT, STYLE, SIZE, OR COLOR.  
 FOR ATHLETIC TRAINING SERVICES (U.S. CLS. 100, 101 AND 107).  
 MAYUR VAGHANI, EXAMINING ATTORNEY

**CLASS 41—(Continued).**

SN 85-213,774. CENTRAL PARK TAEKWONDO LLC, NEW YORK, NY. FILED 1-10-2011.

HARMONY. UNITY. COMMUNITY.

THE MARK CONSISTS OF STANDARD CHARACTERS WITHOUT CLAIM TO ANY PARTICULAR FONT, STYLE, SIZE, OR COLOR.  
FOR MARTIAL ARTS INSTRUCTION (U.S. CLS. 100, 101 AND 107).  
APRIL ROACH, EXAMINING ATTORNEY

SN 85-213,775. PHILIP CARTER, NEW YORK, NY. FILED 1-10-2011.

THE END OF LIFE

THE MARK CONSISTS OF STANDARD CHARACTERS WITHOUT CLAIM TO ANY PARTICULAR FONT, STYLE, SIZE, OR COLOR.  
FOR ENTERTAINMENT IN THE NATURE OF ONGOING TELEVISION PROGRAMS IN THE FIELD OF DRAMATIC PROGRAMMING; ENTERTAINMENT SERVICES IN THE NATURE OF CREATION, DEVELOPMENT, AND PRODUCTION OF TELEVISION PROGRAMMING; ENTERTAINMENT, NAMELY, A CONTINUING DRAMATIC PROGRAM SHOW BROADCAST OVER TELEVISION, SATELLITE, AUDIO, AND VIDEO MEDIA; ENTERTAINMENT, NAMELY, A CONTINUING DRAMATIC FICTIONAL SHOW BROADCAST OVER TELEVISION; ENTERTAINMENT, NAMELY, PRODUCTION OF TELEVISION SHOWS; TELEVISION SHOW PRODUCTION (U.S. CLS. 100, 101 AND 107).  
AISHA SALEM, EXAMINING ATTORNEY

SN 85-213,833. DUNN, NANCY, SANTA BARBARA, CA. FILED 1-10-2011.

litanow.com

THE MARK CONSISTS OF STANDARD CHARACTERS WITHOUT CLAIM TO ANY PARTICULAR FONT, STYLE, SIZE, OR COLOR.  
FOR ON-LINE JOURNALS, NAMELY, BLOGS FEATURING THE SUBJECT OF SELF-HELP (U.S. CLS. 100, 101 AND 107).  
FIRST USE 11-22-2010; IN COMMERCE 11-22-2010.  
APRIL ROACH, EXAMINING ATTORNEY

**CLASS 41—(Continued).**

SN 85-213,974. BLACK ENTERTAINMENT TELEVISION LLC, AKA BET, WASHINGTON, DC. FILED 1-10-2011.

LET'S STAY TOGETHER

THE MARK CONSISTS OF STANDARD CHARACTERS WITHOUT CLAIM TO ANY PARTICULAR FONT, STYLE, SIZE, OR COLOR.  
FOR ENTERTAINMENT SERVICES, NAMELY, AN ONGOING SERIES FEATURING COMEDIC, SCRIPTED MATERIAL PROVIDED THROUGH TELEVISION, SATELLITE, CABLE, WIRELESS AND THE INTERNET (U.S. CLS. 100, 101 AND 107).  
FIRST USE 4-14-2010; IN COMMERCE 4-14-2010.  
AMY HELLA, EXAMINING ATTORNEY

SN 85-214,257. DR. JOHN F. DEMARTINI, HOUSTON, TX. FILED 1-10-2011.

FACETIME

THE MARK CONSISTS OF STANDARD CHARACTERS WITHOUT CLAIM TO ANY PARTICULAR FONT, STYLE, SIZE, OR COLOR.  
FOR EDUCATIONAL SERVICES, NAMELY, CONDUCTING INTERACTIVE ONLINE EDUCATIONAL CLASSES, SEMINARS AND WORKSHOPS IN THE FIELD OF PERSONAL IMPROVEMENT (U.S. CLS. 100, 101 AND 107).  
C. DIONNE CLYBURN, EXAMINING ATTORNEY

SN 85-214,316. HAYES, JOSEPH, NAPLES, FL. FILED 1-10-2011.

on the spot fitness

THE MARK CONSISTS OF STANDARD CHARACTERS WITHOUT CLAIM TO ANY PARTICULAR FONT, STYLE, SIZE, OR COLOR.  
NO CLAIM IS MADE TO THE EXCLUSIVE RIGHT TO USE "FITNESS", APART FROM THE MARK AS SHOWN.  
FOR PROVIDING PHYSICAL FITNESS INSTRUCTION AND MARTIAL ARTS INSTRUCTION (U.S. CLS. 100, 101 AND 107).  
SANJEEV VOHRA, EXAMINING ATTORNEY



**CLASS 41—(Continued).**

SN 85-214,488. MCLAUGHLIN, MICHAEL, EVANSTON, IL. FILED 1-10-2011.

## Weekend Vinyl

THE MARK CONSISTS OF STANDARD CHARACTERS WITHOUT CLAIM TO ANY PARTICULAR FONT, STYLE, SIZE, OR COLOR.

FOR ENTERTAINMENT, NAMELY, LIVE PERFORMANCES BY A MUSICAL BAND (U.S. CLS. 100, 101 AND 107).

FIRST USE 4-26-2010; IN COMMERCE 4-26-2010.  
SANJEEV VOHRA, EXAMINING ATTORNEY

SN 85-214,809. BLACK ENTERTAINMENT TELEVISION LLC, AKA BET, WASHINGTON, DC. FILED 1-11-2011.



THE MARK CONSISTS OF THE WORDS "LET'S STAY TOGETHER" WITH TWO CONNECTED HEARTS TO THE RIGHT OF THE WORDING.

FOR ENTERTAINMENT SERVICES, NAMELY, AN ON-GOING SERIES FEATURING COMEDIC, SCRIPTED MATERIAL PROVIDED THROUGH TELEVISION, SATELLITE, CABLE, WIRELESS AND THE INTERNET (U.S. CLS. 100, 101 AND 107).

FIRST USE 4-14-2010; IN COMMERCE 4-14-2010.  
AMY HELLA, EXAMINING ATTORNEY

SN 85-214,959. PRIMO INNOVO, LLC, GLENVIEW, IL. FILED 1-11-2011.

## DONE DEAL GAMES

THE MARK CONSISTS OF STANDARD CHARACTERS WITHOUT CLAIM TO ANY PARTICULAR FONT, STYLE, SIZE, OR COLOR.

NO CLAIM IS MADE TO THE EXCLUSIVE RIGHT TO USE "GAMES", APART FROM THE MARK AS SHOWN.

FOR ENTERTAINMENT SERVICES, NAMELY, PROVIDING ON-LINE COMPUTER GAMES (U.S. CLS. 100, 101 AND 107).

SKYE YOUNG, EXAMINING ATTORNEY

**CLASS 41—(Continued).**

SN 85-215,134. VERMA, VIMAL, EDISON, NJ. FILED 1-11-2011.

## PANNING THE AMERICAN DESI EXPERIENCE

THE MARK CONSISTS OF STANDARD CHARACTERS WITHOUT CLAIM TO ANY PARTICULAR FONT, STYLE, SIZE, OR COLOR.

OWNER OF U.S. REG. NOS. 3,715,945 AND 3,715,946.  
FOR ENTERTAINMENT AND MEDIA SERVICES, NAMELY, ONGOING TELEVISION PROGRAMS IN THE FIELDS OF MUSIC, COMEDY, DRAMA, NEWS, SPORTS, LIFESTYLES AND TOPICS OF GENERAL INTEREST DISTRIBUTED VIA CABLE, SATELLITE AND THE INTERNET (U.S. CLS. 100, 101 AND 107).

FIRST USE 1-1-2008; IN COMMERCE 1-1-2008.  
DAVID HOFFMAN, EXAMINING ATTORNEY

SN 85-215,172. VERMA, VIMAL, EDISON, NJ. FILED 1-11-2011.



OWNER OF U.S. REG. NOS. 3,715,945 AND 3,715,946.  
NO CLAIM IS MADE TO THE EXCLUSIVE RIGHT TO USE "DESI", APART FROM THE MARK AS SHOWN.

THE COLOR(S) RED, WHITE, BLUE AND BLACK IS/ARE CLAIMED AS A FEATURE OF THE MARK.

THE MARK CONSISTS OF A STAR SHAPE WITH WHITE STARS OVER A BLUE BACKGROUND ON THE UPPER LEFT SIDE OF THE STAR SHAPE AND RED AND WHITE STRIPES ON THE BOTTOM AND RIGHT SIDES OF THE STAR SHAPE. THE STAR SHAPE IS OVER AN IMAGE OF A FILM NEGATIVE THAT IS BLACK IN COLOR AND HAS THE WORDS "PAN DESI" IN WHITE LETTERING IN A BLUE BANNER ACROSS THE FRONT OF THE STAR SHAPE. THE COLOR WHITE IN THE SQUARE SHAPES LOCATED ON THE FILM NEGATIVE REPRESENT TRANSPARENT AREAS AND ARE NOT CLAIM AS A FEATURE OF THE MARK. THE INTERIOR PORTION OF THE NEGATIVE BEHIND THE STAR SHAPE FEATURES THE COLOR WHITE WITH GRAY SHADING. THE LETTER "D" IN THE WORD "DESI" HAS AN IMAGE OF TWO HANDS FOLDED TOGETHER TO FORM ONE SIDE OF THE LETTER, IN THE COLOR WHITE.

FOR ENTERTAINMENT AND MEDIA SERVICES, NAMELY, ONGOING TELEVISION PROGRAMS IN THE FIELDS OF MUSIC, COMEDY, DRAMA, NEWS, SPORTS, LIFESTYLES AND TOPICS OF GENERAL INTEREST DISTRIBUTED VIA CABLE, SATELLITE AND THE INTERNET (U.S. CLS. 100, 101 AND 107).

FIRST USE 4-0-2008; IN COMMERCE 4-0-2008.  
DAVID HOFFMAN, EXAMINING ATTORNEY

**CLASS 41—(Continued).**

SN 85-215,327. BEAUCHAMP, STEFFANIE A, SHORELINE, WA. FILED 1-11-2011.

**VIOLET HEART**

THE MARK CONSISTS OF STANDARD CHARACTERS WITHOUT CLAIM TO ANY PARTICULAR FONT, STYLE, SIZE, OR COLOR.

FOR ENTERTAINMENT SERVICES IN THE NATURE OF LIVE MUSICAL PERFORMANCES (U.S. CLS. 100, 101 AND 107).

FIRST USE 7-31-2010; IN COMMERCE 7-31-2010.  
EDWARD FENNESSY, EXAMINING ATTORNEY

SN 85-215,351. STIR THE POT, LLC, CORINTH, TX. FILED 1-11-2011.

**Stir the Pot**

THE MARK CONSISTS OF STANDARD CHARACTERS WITHOUT CLAIM TO ANY PARTICULAR FONT, STYLE, SIZE, OR COLOR.

FOR ENTERTAINMENT IN THE NATURE OF ON-GOING TELEVISION PROGRAMS IN THE FIELD OF SOCIAL AND POLITICAL COMMENTARY (U.S. CLS. 100, 101 AND 107).

MARK SHINER, EXAMINING ATTORNEY

SN 85-215,379. THE DAVE ANDERSON CORPORATION, AGOURA HILLS, CA. FILED 1-11-2011.

**Simply The Best Customer Service**

THE MARK CONSISTS OF STANDARD CHARACTERS WITHOUT CLAIM TO ANY PARTICULAR FONT, STYLE, SIZE, OR COLOR.

FOR EDUCATIONAL SERVICES, NAMELY, CONDUCTING TRAINING WORKSHOPS IN THE FIELD OF CUSTOMER SERVICE AND DISTRIBUTION OF TRAINING MATERIAL IN CONNECTION THEREWITH (U.S. CLS. 100, 101 AND 107).

FIRST USE 10-1-2010; IN COMMERCE 10-1-2010.  
JILL PRATER, EXAMINING ATTORNEY

**CLASS 41—(Continued).**

SN 85-215,385. SESCOOPS LLC, BOCA RATON, FL. FILED 1-11-2011.

**SESCOOPS**  
SPORTS ENTERTAINMENT SCOOPS

NO CLAIM IS MADE TO THE EXCLUSIVE RIGHT TO USE "SPORTS ENTERTAINMENT", APART FROM THE MARK AS SHOWN.

THE MARK CONSISTS OF THE STYLIZED TEXT "SESCOOPS SPORTS ENTERTAINMENT SCOOPS".

FOR ENTERTAINMENT SERVICES, NAMELY, PROVISION OF ON-GOING MULTIMEDIA PROGRAMS FEATURING PROFESSIONAL WRESTLING AND MIXED MARTIAL ARTS NEWS, DISTRIBUTED VIA THE INTERNET, TELEVISION AND RADIO (U.S. CLS. 100, 101 AND 107).

FIRST USE 3-8-2004; IN COMMERCE 3-8-2004.  
KATHERINE E. HALMEN, EXAMINING ATTORNEY

SN 85-215,727. ELIZABETH ROSENBLUM, SAN ANTONIO, TX. FILED 1-12-2011.

**STREET2FEET**

THE MARK CONSISTS OF STANDARD CHARACTERS WITHOUT CLAIM TO ANY PARTICULAR FONT, STYLE, SIZE, OR COLOR.

FOR PHYSICAL FITNESS TRAINING SERVICES (U.S. CLS. 100, 101 AND 107).

FIRST USE 2-0-2009; IN COMMERCE 2-0-2009.  
RAMONA ORTIGA, EXAMINING ATTORNEY

SN 85-215,734. ELIZABETH ROSENBLUM, SAN ANTONIO, TX. FILED 1-12-2011.



THE MARK CONSISTS OF A SLIGHTLY ANGLED HORIZONTAL BANNER WITH THE WORDS "STREET2FEET" DIRECTLY OVER "RUNNING THE GOOD RACE" ALL ATOP A FOOTPRINT THAT IS SLIGHTLY ANGLED.

FOR PHYSICAL FITNESS TRAINING SERVICES (U.S. CLS. 100, 101 AND 107).

FIRST USE 9-0-2010; IN COMMERCE 9-0-2010.  
RAMONA ORTIGA, EXAMINING ATTORNEY

**CLASS 41—(Continued).**

SN 85-216,531. RASMUSSEN, CHRISTINA P, LEXINGTON, MA. FILED 1-13-2011.

## Second Firsts

THE MARK CONSISTS OF STANDARD CHARACTERS WITHOUT CLAIM TO ANY PARTICULAR FONT, STYLE, SIZE, OR COLOR.

FOR LIFE COACHING SERVICES IN THE FIELD OF GRIEF AND LOSS; PERSONAL COACHING SERVICES IN THE FIELD OF GRIEF AND LOSS; PROFESSIONAL COACHING SERVICES IN THE FIELD OF GRIEF AND LOSS; PROVIDING GROUP COACHING AND LEARNING FORUMS IN THE FIELD OF LEADERSHIP DEVELOPMENT (U.S. CLS. 100, 101 AND 107).

REBECCA SMITH, EXAMINING ATTORNEY

SN 85-216,561. NAMI, DBA NATIONAL ALLIANCE ON MENTAL ILLNESS, ARLINGTON, VA. FILED 1-13-2011.

## NAMI Peer-to-Peer

THE MARK CONSISTS OF STANDARD CHARACTERS WITHOUT CLAIM TO ANY PARTICULAR FONT, STYLE, SIZE, OR COLOR.

OWNER OF U.S. REG. NOS. 3,718,501, 3,746,237 AND 3,856,512.

FOR EDUCATIONAL SERVICES, NAMELY, CONDUCTING EDUCATIONAL PROGRAMS FOR PEOPLE WITH MENTAL ILLNESS (U.S. CLS. 100, 101 AND 107).

FIRST USE 3-0-2001; IN COMMERCE 3-0-2001.  
JORDAN BAKER, EXAMINING ATTORNEY

SN 85-216,759. MANDEL, JENNIFER, LOS ANGELES, CA. FILED 1-13-2011.



NO CLAIM IS MADE TO THE EXCLUSIVE RIGHT TO USE "COLLEGE", APART FROM THE MARK AS SHOWN. THE MARK CONSISTS OF A CIRCLE WITH THE STYLIZED TEXT "COLLEGE RIGHT".

FOR EDUCATIONAL CONSULTING THAT PROVIDES GUIDANCE TO HIGH SCHOOL STUDENTS AND THEIR PARENTS ABOUT COLLEGE ADMISSIONS, SPECIFICALLY, COLLEGE SELECTION, COMPLETING ADMISSIONS APPLICATIONS, AND PREPARATION FOR COLLEGE ADMISSION INTERVIEWS (U.S. CLS. 100, 101 AND 107).

FIRST USE 12-1-2009; IN COMMERCE 12-1-2009.  
REBECCA GILBERT, EXAMINING ATTORNEY

**CLASS 41—(Continued).**

SN 85-216,881. SANDLER SYSTEMS, INC., DBA SANDLER TRAINING, OWINGS MILLS, MD. FILED 1-13-2011.



OWNER OF U.S. REG. NOS. 3,427,940, 3,501,552 AND OTHERS.

NO CLAIM IS MADE TO THE EXCLUSIVE RIGHT TO USE "ONLINE", APART FROM THE MARK AS SHOWN.

THE MARK CONSISTS OF THE LETTER "S" BETWEEN TWO ARROWS AND THE WORDS "SANDLER ONLINE" AND "FINDING POWER IN REINFORCEMENT".

FOR EDUCATION SERVICES, NAMELY, PROVIDING LIVE AND ON-LINE TRAINING AND REINFORCEMENT IN THE FIELD OF INCREASING THE EFFECTIVENESS OF PERSONS WHOSE GOAL IS TO EFFECTUATE PURCHASES OF PRODUCTS OR SERVICES (U.S. CLS. 100, 101 AND 107).

FIRST USE 6-8-2010; IN COMMERCE 6-8-2010.  
PAUL F. GAST, EXAMINING ATTORNEY

SN 85-217,044. AHSOTAN, LLC, DAVIE, FL. FILED 1-13-2011.

## SPORTSALITY

THE MARK CONSISTS OF STANDARD CHARACTERS WITHOUT CLAIM TO ANY PARTICULAR FONT, STYLE, SIZE, OR COLOR.

FOR ONLINE ELECTRONIC PUBLISHING OF BOOKS AND PERIODICALS; WRITING OF ARTICLES FOR PERIODICALS OTHER THAN FOR ADVERTISING OR PUBLICITY (U.S. CLS. 100, 101 AND 107).

SANI KHOURI, EXAMINING ATTORNEY

SN 85-217,423. THEORIE INC., SAN DIEGO, CA. FILED 1-13-2011.

## betwixt

THE MARK CONSISTS OF STANDARD CHARACTERS WITHOUT CLAIM TO ANY PARTICULAR FONT, STYLE, SIZE, OR COLOR.

FOR LAYOUT SERVICES OTHER THAN FOR ADVERTISING PURPOSES; PHOTOGRAPHY; PHOTOGRAPHY SERVICES; POST-PRODUCTION EDITING SERVICES IN THE FIELD OF MUSIC, VIDEOS AND FILM; VIDEOGRAPHY SERVICES (U.S. CLS. 100, 101 AND 107).

FIRST USE 12-1-2010; IN COMMERCE 12-1-2010.  
JACQUELINE A. LAVINE, EXAMINING ATTORNEY

**CLASS 41—(Continued).**

SN 85-217,884. DIRECTV SPORTS NETWORKS, LLC, SEATTLE, WA. FILED 1-14-2011.

# ROOT SPORTS

OWNER OF U.S. REG. NO. 3,726,772.

NO CLAIM IS MADE TO THE EXCLUSIVE RIGHT TO USE "SPORTS", APART FROM THE MARK AS SHOWN.

THE MARK CONSISTS OF THE WORD "ROOT", THE LETTERS "R" AND "T" HAVING TRIANGULAR NOTCHES CUT AT THE TOP, ADJACENT TO THE WORD "SPORTS", ALL IN SLANTED LETTERS.

FOR DISTRIBUTION OF TELEVISION PROGRAMS FOR OTHERS; TELEVISION PROGRAMMING; PROGRAMMING ON A GLOBAL COMPUTER NETWORK; ENTERTAINMENT SERVICES IN THE NATURE OF ONGOING TELEVISION SHOWS FEATURING NEWS, SPORTS AND VARIETY; PROVIDING ON-LINE INFORMATION IN THE FIELD OF SPORTS, CURRENT SPORTS NEWS AND SPORTS ENTERTAINMENT VIA A GLOBAL COMPUTER NETWORK AND WIRELESS COMMUNICATION NETWORKS; ENTERTAINMENT SERVICES IN THE NATURE OF SCHEDULING AND PROGRAMMING IN THE FIELD OF SPORTS ON A GLOBAL COMPUTER NETWORK AND WIRELESS COMMUNICATION NETWORKS; ONLINE ENTERTAINMENT IN THE NATURE OF NON-DOWNLOADABLE VIDEO CLIPS, PHOTOGRAPHS AND ARTICLES IN THE FIELD OF SPORTS VIA A GLOBAL COMMUNICATIONS NETWORK AND WIRELESS COMMUNICATION NETWORKS; ENTERTAINMENT SERVICES, NAMELY, PROVIDING A WEBSITE IN THE FIELD OF SPORTS FEATURING NON-DOWNLOADABLE TELEVISION PROGRAMS, SPORTS INFORMATION, PREVIEWS, INTERVIEWS, ALERTS, ELECTRONIC SCHEDULING GUIDES, CONTESTS, VIDEO CLIPS, PHOTOGRAPHS, HIGHLIGHTS OF SPORTING EVENTS, ONLINE SPORTS GAMES, ARTICLES AND ENTERTAINMENT AND SPORTS RELATED NEWS; PRODUCTION AND DISTRIBUTION OF TELEVISION PROGRAMS FEATURING SPORTS AND ENTERTAINMENT; ON-LINE NEWSLETTERS FEATURING GENERAL INFORMATION RELATING TO SPORTS; ONLINE JOURNALS, NAMELY, BLOGS FEATURING INFORMATION IN THE FIELD OF SPORTS, GENERAL INTEREST, CURRENT SPORTS NEWS AND ENTERTAINMENT; ENTERTAINMENT SERVICES, NAMELY, PROVIDING PODCASTS IN THE FIELD OF SPORTS, NEWS AND ENTERTAINMENT; PROVIDING ON-LINE INFORMATION VIA THE INTERNET IN THE FIELD OF FANTASY SPORTS LEAGUES; PROMOTIONAL SWEEPSTAKES (U.S. CLS. 100, 101 AND 107).  
GISELLE AGOSTO, EXAMINING ATTORNEY

SN 85-218,113. PENA PRODUCTIONS LLC, ABSECON, NJ. FILED 1-14-2011.

## MEN WITHOUT SHIRTS

THE MARK CONSISTS OF STANDARD CHARACTERS WITHOUT CLAIM TO ANY PARTICULAR FONT, STYLE, SIZE, OR COLOR.

FOR ENTERTAINMENT IN THE NATURE OF LIVE DANCE, MUSICAL AND VARIETY SHOWS AND PERFORMANCES (U.S. CLS. 100, 101 AND 107).

CAROLINE WOOD, EXAMINING ATTORNEY

**CLASS 41—(Continued).**

SN 85-218,343. ELDER, MARY S., SEATTLE, WA. FILED 1-14-2011.

## Free Range Fitness

THE MARK CONSISTS OF STANDARD CHARACTERS WITHOUT CLAIM TO ANY PARTICULAR FONT, STYLE, SIZE, OR COLOR.

NO CLAIM IS MADE TO THE EXCLUSIVE RIGHT TO USE "FITNESS", APART FROM THE MARK AS SHOWN.

FOR EDUCATIONAL SERVICES, NAMELY, PROVIDING SEMINARS AND CLASSES IN THE FIELD OF OUTDOOR FITNESS; PROVIDING INFORMATION VIA A WEBSITE IN THE FIELD OF OUTDOOR FITNESS (U.S. CLS. 100, 101 AND 107).

FIRST USE 7-0-2010; IN COMMERCE 1-1-2011.

GIANCARLO CASTRO, EXAMINING ATTORNEY

SN 85-218,387. ENERGY CORPORATION, NEW ORLEANS, LA. FILED 1-14-2011.



THE COLOR(S) BLUE, LIGHT BLUE, GREEN, TEAL, AND GRAY IS/ARE CLAIMED AS A FEATURE OF THE MARK.

THE MARK CONSISTS OF A GRAY ROADWAY PASSING BETWEEN GREEN MOUNTAINS AGAINST A LIGHT BLUE SKY WITH FACING BLUE AND TEAL HUMAN SILHOUETTES POSITIONED ON THE ROADWAY CASTING GRAY SHADOWS, WITH THE GRAY WORDING "UNDERSTANDING TO ACTION" ARCHED ABOVE THE SILHOUETTES, ALL WITHIN A CIRCULAR BORDER WITH THE BLUE WORDING "PATHWAYS" ABOVE, THE GREEN WORDING "FROM POVERTY" BELOW, AND CONNECTED BY ARCS ON EITHER SIDE THAT FADE FROM BLUE TO GREEN GOING FROM TOP TO BOTTOM.

FOR EDUCATION SERVICES, NAMELY, PROVIDING WORKSHOPS IN THE FIELDS OF POVERTY AWARENESS AND POVERTY UNDERSTANDING (U.S. CLS. 100, 101 AND 107).

SEAN CROWLEY, EXAMINING ATTORNEY

**CLASS 41—(Continued).**

SN 85-218,731. SPENCER DREIER, NEW YORK, NY. FILED 1-15-2011.

## Blue Pencil Editing

THE MARK CONSISTS OF STANDARD CHARACTERS WITHOUT CLAIM TO ANY PARTICULAR FONT, STYLE, SIZE, OR COLOR.

NO CLAIM IS MADE TO THE EXCLUSIVE RIGHT TO USE "EDITING", APART FROM THE MARK AS SHOWN. FOR WRITTEN TEXT EDITING (U.S. CLS. 100, 101 AND 107).

KHANH LE, EXAMINING ATTORNEY

SN 85-218,737. SOCIAL MEDIA AND MORE, LLC, MARINA DEL REY, CA. FILED 1-15-2011.

## NETIQUETTE EXPERT

THE MARK CONSISTS OF STANDARD CHARACTERS WITHOUT CLAIM TO ANY PARTICULAR FONT, STYLE, SIZE, OR COLOR.

FOR EDUCATIONAL AND ENTERTAINMENT SERVICES, NAMELY, PROVIDING MOTIVATIONAL SPEAKING SERVICES IN THE FIELD OF PROTOCOL, CUSTOM, BEST PRACTICES AND MANNERS ONLINE AND IN SOCIAL MEDIA; ON-LINE JOURNALS, NAMELY, BLOGS FEATURING INFORMATION AND RESOURCES IN THE FIELD OF PROTOCOL, CUSTOM, BEST PRACTICES AND MANNERS ONLINE AND IN SOCIAL MEDIA; PERSONAL COACHING SERVICES IN THE FIELD OF PROTOCOL, CUSTOM, BEST PRACTICES AND MANNERS ONLINE AND IN SOCIAL MEDIA (U.S. CLS. 100, 101 AND 107).

FIRST USE 10-15-2008; IN COMMERCE 10-15-2008.  
JIM RINGLE, EXAMINING ATTORNEY

SN 85-218,904. PURDUE RESEARCH FOUNDATION, WEST LAFAYETTE, IN. FILED 1-17-2011.

## EPICS

THE MARK CONSISTS OF STANDARD CHARACTERS WITHOUT CLAIM TO ANY PARTICULAR FONT, STYLE, SIZE, OR COLOR.

FOR PROVIDING COURSES OF INSTRUCTION AT THE COLLEGE LEVEL, NAMELY, AN EDUCATIONAL PROGRAM IN WHICH STUDENTS ARE TRAINED IN THE FIELD OF ENGINEERING BY ASSISTING AND SOLVING PROBLEMS FOR COMMUNITY SERVICE AGENCIES (U.S. CLS. 100, 101 AND 107).

FIRST USE 7-15-1996; IN COMMERCE 3-15-1997.  
KAREN K. BUSH, EXAMINING ATTORNEY

**CLASS 41—(Continued).**

SN 85-218,928. MARK, NIKKI, LOS ANGELES, CA. FILED 1-17-2011.

## Mommy Brings Home the Bacon

THE MARK CONSISTS OF STANDARD CHARACTERS WITHOUT CLAIM TO ANY PARTICULAR FONT, STYLE, SIZE, OR COLOR.

FOR ENTERTAINMENT SERVICES IN THE NATURE OF ON-GOING TELEVISION PROGRAMS IN THE FIELD OF CHILDREN'S ENTERTAINMENT (U.S. CLS. 100, 101 AND 107).

JENNIFER VASQUEZ, EXAMINING ATTORNEY

SN 85-219,390. PERKINS, REBECCA, ANTIOCH, CA. FILED 1-17-2011.



NO CLAIM IS MADE TO THE EXCLUSIVE RIGHT TO USE "SKATERS", APART FROM THE MARK AS SHOWN.

THE MARK CONSISTS OF THE STYLIZED WORDS "THE DAMNED SKATERS" TO THE LEFT OF A DRAWING OF A VAMPIRE FEMALE WEARING A LONG DRESS AND ROLLER DERBY EQUIPMENT, NAMELY, A HELMET AND SKATES.

FOR EDUCATION SERVICES, NAMELY, PROVIDING CLASSES, SEMINARS, WORKSHOPS AND TRAINING IN THE FIELD OF ROLLER DERBY PARTICIPATION, SKILL DEVELOPMENT AND PHYSICAL CONDITIONING; ENTERTAINMENT IN THE NATURE OF COMPETITIONS IN THE FIELD OF ROLLER DERBY; ENTERTAINMENT IN THE NATURE OF LIVE PERFORMANCES BY ROLLER DERBY ATHLETES; ORGANIZING SPORTING EVENTS, NAMELY, ROLLER DERBY COMPETITIONS (U.S. CLS. 100, 101 AND 107).

FIRST USE 12-1-2010; IN COMMERCE 12-1-2010.  
TOBY BULLOFF, EXAMINING ATTORNEY



**CLASS 41—(Continued).**

SN 85-219,558. PROVIDENT ADVERTISING & MARKETING, INC., CLEARWATER, FL. FILED 1-18-2011.

## Bob's Bowling

THE MARK CONSISTS OF STANDARD CHARACTERS WITHOUT CLAIM TO ANY PARTICULAR FONT, STYLE, SIZE, OR COLOR.

NO CLAIM IS MADE TO THE EXCLUSIVE RIGHT TO USE "BOWLING", APART FROM THE MARK AS SHOWN. FOR BOWLING ALLEYS (U.S. CLS. 100, 101 AND 107). RONALD MCMORROW, EXAMINING ATTORNEY

SN 85-219,777. SERVICE INSTITUTE, INC, BELLINGHAM, WA. FILED 1-18-2011.

## VETSEGE

THE MARK CONSISTS OF STANDARD CHARACTERS WITHOUT CLAIM TO ANY PARTICULAR FONT, STYLE, SIZE, OR COLOR.

FOR EDUCATION SERVICES, NAMELY, PROVIDING MENTORING, TUTORING, CLASSES, SEMINARS AND WORKSHOPS IN THE FIELD OF HUMAN RESOURCES AND HELPING MILITARY VETERANS DEVELOP RESILIENCY SKILLS TO HELP THEM MAKE SUCCESSFUL TRANSITIONS TO CIVILIAN LIFE (U.S. CLS. 100, 101 AND 107). GIANCARLO CASTRO, EXAMINING ATTORNEY

SN 85-220,333. MICHAEL GERSHE, CUYAHOGA FALLS, OH. FILED 1-18-2011.

## THE MAGIC OF LIFE

THE MARK CONSISTS OF STANDARD CHARACTERS WITHOUT CLAIM TO ANY PARTICULAR FONT, STYLE, SIZE, OR COLOR.

FOR EDUCATIONAL AND ENTERTAINMENT SERVICES, NAMELY, PROVIDING MOTIVATIONAL SPEAKING SERVICES IN THE FIELD OF ALCOHOL AWARENESS (U.S. CLS. 100, 101 AND 107).

FIRST USE 8-31-1994; IN COMMERCE 8-31-1994. JOHN DWYER, EXAMINING ATTORNEY

**CLASS 41—(Continued).**

SN 85-220,803. THREE FERNS FILMS, LLC, ROCKVILLE, MD. FILED 1-19-2011.



THE COLOR(S) GREEN AND BROWN, FOR THE FERNS, IS/ARE CLAIMED AS A FEATURE OF THE MARK.

THE MARK CONSISTS OF THREE TALL GREEN FERNS, WITH A PORTION OF A BROWN FERN IN THE FOREGROUND AT THE RIGHT EDGE; THE COLOR BLACK REPRESENTS THE BACKGROUND AND IS NOT CLAIMED AS PART OF THE MARK.

FOR FILM AND VIDEO PRODUCTION; MULTIMEDIA ENTERTAINMENT SERVICES IN THE NATURE OF RECORDING, PRODUCTION AND POST-PRODUCTION SERVICES IN THE FIELDS OF MUSIC, VIDEO, AND FILMS (U.S. CLS. 100, 101 AND 107).

FIRST USE 7-12-2010; IN COMMERCE 7-12-2010.

ALEXANDER L. POWERS, EXAMINING ATTORNEY

SN 85-229,798. DISCOVERY COMMUNICATIONS, LLC, SILVER SPRING, MD. FILED 1-31-2011.

## FLYING WILD ALASKA

THE MARK CONSISTS OF STANDARD CHARACTERS WITHOUT CLAIM TO ANY PARTICULAR FONT, STYLE, SIZE, OR COLOR.

NO CLAIM IS MADE TO THE EXCLUSIVE RIGHT TO USE "ALASKA", APART FROM THE MARK AS SHOWN.

FOR ENTERTAINMENT AND EDUCATIONAL SERVICES IN THE NATURE OF TELEVISION AND MULTIMEDIA PROGRAM SERIES FEATURING SUBJECTS OF GENERAL HUMAN INTEREST DISTRIBUTED VIA VARIOUS PLATFORMS ACROSS MULTIPLE FORMS OF TRANSMISSION MEDIA; PROVIDING ENTERTAINMENT INFORMATION TO OTHERS VIA A GLOBAL COMPUTER NETWORK (U.S. CLS. 100, 101 AND 107).

FIRST USE 1-14-2011; IN COMMERCE 1-14-2011.

MATTHEW MCDOWELL, EXAMINING ATTORNEY

**CLASS 41—(Continued).**

SN 85-229,823. PHI THETA KAPPA, AKA PHI THETA KAPPA NATIONAL HONOR SOCIETY, JACKSON, MS. FILED 1-31-2011.

**PHI THETA KAPPA**

THE MARK CONSISTS OF STANDARD CHARACTERS WITHOUT CLAIM TO ANY PARTICULAR FONT, STYLE, SIZE, OR COLOR.

OWNER OF U.S. REG. NOS. 1,837,832, 1,844,370 AND OTHERS.

THE WORDING "PHI THETA KAPPA" HAS NO MEANING IN A FOREIGN LANGUAGE.

FOR PROVIDING EDUCATIONAL MENTORING SERVICES AND PROGRAMS IN THE FIELD OF COMMUNITY COLLEGE SCHOLARSHIP (U.S. CLS. 100, 101 AND 107).

FIRST USE 1-0-1918; IN COMMERCE 1-0-1918.  
ROBIN MITTLER, EXAMINING ATTORNEY

SN 85-236,390. BLACK ENTERTAINMENT TELEVISION LLC, DBA BET, WASHINGTON, DC. FILED 2-8-2011.



OWNER OF U.S. REG. NO. 3,126,169.

THE MARK CONSISTS OF THE WORDING "RIP THE RUNWAY" WITH A STAR ABOVE THE "R" OF "RIP" AND A FANCIFUL EYE WITH STARS AND MUSIC NOTES EMBEDDED IN THE LONG EYE LASHES BESIDE THE WORD "THE" AND ABOVE THE WORD "WAY" IN "RUNWAY".

FOR ENTERTAINMENT IN THE NATURE OF ONGOING TELEVISION PROGRAMS IN THE FIELD OF FASHION AND MUSIC (U.S. CLS. 100, 101 AND 107).

AMY HELLA, EXAMINING ATTORNEY

SN 85-243,989. NBC FOURTH REALTY CORP., NORTH LAS VEGAS, NV. FILED 2-16-2011.

**T.J. MAXX**

THE MARK CONSISTS OF STANDARD CHARACTERS WITHOUT CLAIM TO ANY PARTICULAR FONT, STYLE, SIZE, OR COLOR.

OWNER OF U.S. REG. NOS. 1,637,243, 2,430,299 AND OTHERS.

THE NAME "T.J. MAXX" DOES NOT IDENTIFY A LIVING INDIVIDUAL.

FOR ENTERTAINMENT SERVICES, NAMELY, CONDUCTING CONTESTS (U.S. CLS. 100, 101 AND 107).

FIRST USE 9-0-1990; IN COMMERCE 9-0-1990.  
JAMES GRIFFIN, EXAMINING ATTORNEY

**CLASS 41—(Continued).**

SN 85-247,145. HORSELAND LLC, VERNON HILLS, IL. FILED 2-20-2011.

**Bzuzu**

THE MARK CONSISTS OF STANDARD CHARACTERS WITHOUT CLAIM TO ANY PARTICULAR FONT, STYLE, SIZE, OR COLOR.

FOR ENTERTAINMENT SERVICES, NAMELY, PROVIDING ON-LINE COMPUTER GAMES (U.S. CLS. 100, 101 AND 107).

FIRST USE 2-19-2011; IN COMMERCE 2-19-2011.

MARTHA SANTOMARTINO, EXAMINING ATTORNEY

SN 85-247,684. POPSTAR! PUBLISHING, LLC, ORLANDO, FL. FILED 2-21-2011.

**POPSTAR! 2011**

THE MARK CONSISTS OF STANDARD CHARACTERS WITHOUT CLAIM TO ANY PARTICULAR FONT, STYLE, SIZE, OR COLOR.

OWNER OF U.S. REG. NO. 3,498,173.

NO CLAIM IS MADE TO THE EXCLUSIVE RIGHT TO USE "2011", APART FROM THE MARK AS SHOWN.

FOR ENTERTAINMENT SERVICES IN THE NATURE OF LIVE-ACTION, COMEDY AND DRAMA TELEVISION SERIES; ENTERTAINMENT SERVICES, NAMELY, A CONTINUING MUSICAL VARIETY PROGRAM FEATURING STAGE EVENTS, MUSIC AWARDS, THEATRICAL PERFORMANCES, CONCERTS, LIVE PERFORMANCES, AUDIENCE PARTICIPATION EVENTS, ENTERTAINMENT, AND INFORMATION RELATING TO MUSIC (U.S. CLS. 100, 101 AND 107).

LAKEISHA LEWIS, EXAMINING ATTORNEY

SN 85-249,408. SELECTION MANAGEMENT SYSTEMS, INC., CINCINNATI, OH. FILED 2-23-2011.

**TEAM  
FASTRAX.ORG**

NO CLAIM IS MADE TO THE EXCLUSIVE RIGHT TO USE "TEAM", APART FROM THE MARK AS SHOWN.

THE MARK CONSISTS OF THE WORDING "TEAM FASTRAX.ORG" WITH AN ARCH EXTENDING FROM THE FIRST "A" TO THE "X" IN "FASTRAX".

FOR ENTERTAINMENT SERVICES, NAMELY, PARTICIPATION IN NATIONAL AND INTERNATIONAL SKYDIVING COMPETITIONS AND EXHIBITIONS; CONDUCTING SKYDIVING EXHIBITIONS IN THE NATURE OF AEROBATIC PERFORMANCES AND COMEDY PERFORMANCES (U.S. CLS. 100, 101 AND 107).

FIRST USE 6-0-2004; IN COMMERCE 6-0-2004.

ASMAT KHAN, EXAMINING ATTORNEY

**CLASS 41—(Continued).**

SN 85-253,500. UNITED SOCCER LEAGUES, LLC, TAMPA, FL. FILED 2-28-2011.



OWNER OF U.S. REG. NOS. 2,340,635, 2,979,243 AND OTHERS.

NO CLAIM IS MADE TO THE EXCLUSIVE RIGHT TO USE "SOCCER LEAGUES", APART FROM THE MARK AS SHOWN.

THE COLOR(S) GREEN, BLACK, WHITE, YELLOW, AND ORANGE IS/ARE CLAIMED AS A FEATURE OF THE MARK.

THE MARK CONSISTS OF A GREEN SHIELD BORDERED BY A BLACK OUTLINE WITH A YELLOW BANNER AT THE TOP OF THE SHIELD THAT INCLUDES THE LETTERING "UNITED SOCCER LEAGUES" IN BLACK FONT, AND THE LETTERING "USL" IN WHITE FONT APPEARING BENEATH THE BANNER, AND WITH A BLACK AND WHITE SOCCER BALL WITH YELLOW AND ORANGE FLAMES PROJECTING ABOVE THE SOCCER BALL AND PARTIALLY BEHIND THE LETTERING "USL".

FOR ENTERTAINMENT SERVICES, NAMELY, ORGANIZING, CONDUCTING AND STAGING SPORTING EVENTS IN THE NATURE OF SOCCER EVENTS, SOCCER MATCHES AND SOCCER EXHIBITION GAMES (U.S. CLS. 100, 101 AND 107).

FIRST USE 1-31-2005; IN COMMERCE 1-31-2005.  
JEFFREY LOOK, EXAMINING ATTORNEY

SN 85-271,160. PLANET HOLLYWOOD (REGION IV), INC., ORLANDO, FL. FILED 3-18-2011.

**PLANET SPORTS**

THE MARK CONSISTS OF STANDARD CHARACTERS WITHOUT CLAIM TO ANY PARTICULAR FONT, STYLE, SIZE, OR COLOR.

NO CLAIM IS MADE TO THE EXCLUSIVE RIGHT TO USE "SPORTS", APART FROM THE MARK AS SHOWN.

FOR CASINO SERVICES (U.S. CLS. 100, 101 AND 107).  
ELLEN PERKINS, EXAMINING ATTORNEY

**CLASS 42—SCIENTIFIC AND COMPUTER SERVICES**

SN 77-432,215. MAINCLOUD LLC, CHICAGO, IL. FILED 3-26-2008.

**YOUREPORT.COM**

THE MARK CONSISTS OF STANDARD CHARACTERS WITHOUT CLAIM TO ANY PARTICULAR FONT, STYLE, SIZE, OR COLOR.

FOR COMPUTER SERVICES, NAMELY, PROVIDING A NEWS AGGREGATION SITE WHICH ALLOWS THE USER TO VIEW EXISTING FEEDS FROM NEWSPAPERS AND ONLINE PUBLICATIONS AND THEN ASSEMBLE THE INFORMATION TO CREATE USER SPECIFIC NEWSPAPERS OR REPORTS (U.S. CLS. 100 AND 101).

FIRST USE 11-6-2008; IN COMMERCE 11-6-2008.  
MIDGE BUTLER, EXAMINING ATTORNEY

SN 77-709,074. SIMPLEGRID TECHNOLOGY, INC., MIDDLETOWN, NJ. FILED 4-7-2009.

**simplegrid**

THE MARK CONSISTS OF STANDARD CHARACTERS WITHOUT CLAIM TO ANY PARTICULAR FONT, STYLE, SIZE, OR COLOR.

FOR COMPUTER HARDWARE AND SOFTWARE CONSULTING SERVICES; INTEGRATION OF COMPUTER SYSTEMS AND NETWORKS; COMPUTER SERVICES, NAMELY, REMOTE MONITORING AND DISASTER RECOVERY SERVICES (U.S. CLS. 100 AND 101).

FIRST USE 3-1-2009; IN COMMERCE 3-1-2009.  
MARGERY A. TIERNEY, EXAMINING ATTORNEY

SN 77-756,116. INVENTIV HEALTH, INC., SOMERSET, NJ. FILED 6-10-2009.

**INVENTIV CLINICAL**

THE MARK CONSISTS OF STANDARD CHARACTERS WITHOUT CLAIM TO ANY PARTICULAR FONT, STYLE, SIZE, OR COLOR.

OWNER OF U.S. REG. NOS. 3,331,958, 3,426,747 AND OTHERS.

NO CLAIM IS MADE TO THE EXCLUSIVE RIGHT TO USE "CLINICAL", APART FROM THE MARK AS SHOWN.

FOR CLINICAL RESEARCH SERVICES, NAMELY, CONDUCTING CLINICAL TRIALS AND RELATED SCIENTIFIC CLINICAL RESEARCH SERVICES TO ASSIST MEDICAL, BIOPHARMECEUTICAL AND BIOTECHNOLOGY COMPANIES WITH APPLICATIONS FOR DRUG APPROVAL (U.S. CLS. 100 AND 101).

FIRST USE 6-1-2006; IN COMMERCE 6-1-2006.  
MATTHEW EINSTEIN, EXAMINING ATTORNEY

**CLASS 42—(Continued).**

SN 77-756,183. INVENTIV HEALTH, INC., SOMERSET, NJ. FILED 6-10-2009.



OWNER OF U.S. REG. NOS. 3,331,958, 3,426,747 AND OTHERS.

NO CLAIM IS MADE TO THE EXCLUSIVE RIGHT TO USE "CLINICAL", APART FROM THE MARK AS SHOWN.

THE COLOR(S) RED, YELLOW, WHITE, ORANGE, LIGHT BLUE, AND BLUE IS/ARE CLAIMED AS A FEATURE OF THE MARK.

THE MARK CONSISTS OF THE LITERAL ELEMENT "INVENTIV" IN WHITE INSIDE A BLUE SQUARE DESIGN, THE WORDING "CLINICAL" IN BLUE, AND AN ABSTRACT ZIGZAG DESIGN IN THE BLUE SQUARE IN THE COLORS ORANGE, YELLOW, RED, AND LIGHT BLUE.

FOR CLINICAL RESEARCH SERVICES, NAMELY, CONDUCTING CLINICAL TRIALS AND RELATED SCIENTIFIC CLINICAL RESEARCH SERVICES TO ASSIST MEDICAL, BIOPHARMACEUTICAL AND BIOTECHNOLOGY COMPANIES WITH APPLICATIONS FOR DRUG APPROVAL (U.S. CLS. 100 AND 101).

FIRST USE 6-1-2006; IN COMMERCE 6-1-2006.  
MATTHEW EINSTEIN, EXAMINING ATTORNEY

---

SN 77-762,916. CLERISOFT INC, FREMONT, CA. FILED 6-18-2009.

Cloud your enterprise!

THE MARK CONSISTS OF STANDARD CHARACTERS WITHOUT CLAIM TO ANY PARTICULAR FONT, STYLE, SIZE, OR COLOR.

FOR BUSINESS TECHNOLOGY SOFTWARE CONSULTATION SERVICES; COMPUTER SOFTWARE CONSULTING; COMPUTER SOFTWARE DEVELOPMENT; COMPUTER PROGRAMMING DEVELOPMENT FOR OTHERS (U.S. CLS. 100 AND 101).

FIRST USE 6-1-2009; IN COMMERCE 6-1-2009.  
JAMES A. RAUEN, EXAMINING ATTORNEY

**CLASS 42—(Continued).**

SN 77-779,483. ASTROGENETIX, INC., AUSTIN, TX. FILED 7-13-2009.

**ASTROGENETIX**

THE MARK CONSISTS OF STANDARD CHARACTERS WITHOUT CLAIM TO ANY PARTICULAR FONT, STYLE, SIZE, OR COLOR.

FOR MICROGRAVITY PROCESSING, NAMELY, SCIENTIFIC AND MEDICAL RESEARCH AND LABORATORY SERVICES FOR SCIENTIFIC AND MEDICAL RESEARCH IN THE FIELDS OF BIOTECHNOLOGY AND PHARMACEUTICALS; RESEARCH AND DEVELOPMENT OF BIOTECHNOLOGY PRODUCTS, ALL OF THE FOREGOING PROVIDED IN A MICROGRAVITY ENVIRONMENT AND THROUGH MANNED SPACE FLIGHT (U.S. CLS. 100 AND 101).

KATHERINE CHANG, EXAMINING ATTORNEY

---

SN 77-861,362. CRYPTOGRAPHY RESEARCH, INC., SAN FRANCISCO, CA. FILED 10-30-2009.

**CRYPTOFIREWALL**

THE MARK CONSISTS OF STANDARD CHARACTERS WITHOUT CLAIM TO ANY PARTICULAR FONT, STYLE, SIZE, OR COLOR.

FOR HARDWARE AND SOFTWARE DESIGN AND DEVELOPMENT; ELECTRONIC DESIGN SERVICES FOR SECURITY PURPOSES IN THE FIELD OF ELECTRONIC DEVICE SECURITY (U.S. CLS. 100 AND 101).

FIRST USE 12-0-2000; IN COMMERCE 12-0-2006.  
MEGHAN REINHART, EXAMINING ATTORNEY

---

SN 77-894,956. CANYON BICYCLES GMBH, 56073 KOBLENZ, FED REP GERMANY, FILED 12-16-2009.

**CANYON PPS**

THE MARK CONSISTS OF THE WORD "CANYON" IN AN ITALIC FONT WITH THE BOTTOM OF THE LETTERS CUT OFF AND THE LETTERS "PPS" IN SMALLER ROMAN TYPE.

FOR BIOMECHANICAL ANALYSIS OF ATHLETES, NAMELY, ANALYSIS OF THE SIZE OF CYCLING ATHLETES' UPPER AND LOWER ARMS AND LEGS, HANDS, FEET AND TOTAL LENGTH TO DETERMINE THE MOST EFFICIENT BICYCLE DESIGN FOR THAT ATHLETE (U.S. CLS. 100 AND 101).

CHARISMA HAMPTON, EXAMINING ATTORNEY

**CLASS 42—(Continued).**

SN 77-907,262. ILAND INTERNET SOLUTIONS CORPORATION, HOUSTON, TX. FILED 1-7-2010.

**ILAND CONTINUITY CLOUD**

THE MARK CONSISTS OF STANDARD CHARACTERS WITHOUT CLAIM TO ANY PARTICULAR FONT, STYLE, SIZE, OR COLOR.

NO CLAIM IS MADE TO THE EXCLUSIVE RIGHT TO USE "CONTINUITY CLOUD", APART FROM THE MARK AS SHOWN.

FOR COMPUTER SERVICES, NAMELY, PROVIDING COMPUTER REMOTE BACKUP INFRASTRUCTURE AND CONSULTING SERVICES FOR COMPUTER DISASTER RECOVERY AND UNPREDICTABLE COMPUTER DOWNTIME (U.S. CLS. 100 AND 101).

FIRST USE 9-17-2009; IN COMMERCE 9-17-2009.  
DEZMONA MIZELLE, EXAMINING ATTORNEY

SN 77-930,971. ROBINSON, TIA MARIA, MIAMI, FL. FILED 2-8-2010.



THE NAME "TIA MARIA" IDENTIFIES A LIVING INDIVIDUAL WHOSE CONSENT IS OF RECORD.

THE COLOR(S) SALMON AND RED IS/ARE CLAIMED AS A FEATURE OF THE MARK.

THE MARK CONSISTS THE STYLIZED TERM "TIA" IN RED WITH THE DOT OF THE LETTER "I" IN THE COLOR SALMON, AND THE TERM "MARIA" IN THE COLOR SALMON WITH THE DOT OF THE LETTER "I" IN RED.

FOR DESIGN OF INTERIOR DECOR; INTERIOR DESIGN SERVICES INCLUDING SPACE PLANNING, FURNITURE SELECTION, MATERIAL AND SURFACE SELECTION (U.S. CLS. 100 AND 101).

CHRISTOPHER BUONGIORNO, EXAMINING ATTORNEY

SN 77-933,447. NOTIVUS, LLC, ALPHARETTA, GA. FILED 2-11-2010.



THE MARK CONSISTS OF STANDARD CHARACTERS WITHOUT CLAIM TO ANY PARTICULAR FONT, STYLE, SIZE, OR COLOR.

FOR PROVIDING TEMPORARY USE OF ONLINE, NON-DOWNLOADABLE SOFTWARE FOR USE IN DATABASE MANAGEMENT IN THE FIELD OF EMPLOYMENT SCREENING AND PERSONNEL ASSESSMENTS (U.S. CLS. 100 AND 101).

FIRST USE 1-1-2008; IN COMMERCE 1-1-2008.  
TOBY BULLOFF, EXAMINING ATTORNEY

**CLASS 42—(Continued).**

SN 79-086,746. EQAICC, REPUBLIC OF KOREA, FILED 5-19-2010.



PRIORITY DATE OF 12-23-2009 IS CLAIMED.  
OWNER OF INTERNATIONAL REGISTRATION 1049490 DATED 5-19-2010, EXPIRES 5-19-2020.

NO CLAIM IS MADE TO THE EXCLUSIVE RIGHT TO USE "EUROPEAN QUALITY ASSURANCE", APART FROM THE MARK AS SHOWN.

THE MARK CONSISTS OF THE LETTERING "EQAICC" BETWEEN BARS ABOVE THE WORDING "EUROPEAN QUALITY ASSURANCE".

FOR INSPECTION AGENCY SERVICES, NAMELY, INSPECTION OF GOODS FOR QUALITY CONTROL; QUALITY CONTROL FOR OTHERS; PACKING INSPECTION SERVICES; CONSULTANCY IN THE FIELD OF ENVIRONMENTAL PROTECTION, NAMELY, EVALUATING AND TESTING THE ENVIRONMENTAL QUALITIES AND IMPACT OF THE PRODUCTS AND SERVICES OF OTHERS; TESTING, ANALYSIS AND EVALUATION OF THE GOODS AND SERVICES OF OTHERS FOR THE PURPOSE OF CERTIFICATION; TESTING, ANALYSIS AND EVALUATION OF THE SERVICES OF OTHERS FOR THE PURPOSE OF CERTIFICATION; TESTING, ANALYSIS AND EVALUATION OF THE GOODS OF OTHERS FOR THE PURPOSE OF CERTIFICATION; WORKPLACE CERTIFICATION SERVICES, NAMELY, CONDUCTING SURVEYS AND TESTING FOR WORKPLACE EXCELLENCE (U.S. CLS. 100 AND 101).

MARIAM MAHMOUDI, EXAMINING ATTORNEY

SN 79-087,282. TESTEX AG, SWITZERLAND, FILED 8-16-2010.



THE MARK CONSISTS OF STANDARD CHARACTERS WITHOUT CLAIM TO ANY PARTICULAR FONT, STYLE, SIZE, OR COLOR.

OWNER OF INTERNATIONAL REGISTRATION 1050883 DATED 8-16-2010, EXPIRES 8-16-2020.

FOR SCIENTIFIC RESEARCH, TECHNOLOGICAL RESEARCH IN THE FIELD OF TEXTILES, INDUSTRIAL ANALYSIS AND RESEARCH IN THE FIELD OF TEXTILES; CONSULTING IN THE FIELD OF TEXTILE PHYSICS, TEXTILE CHEMISTRY, AND MATERIAL TESTING; SCIENTIFIC RESEARCH SERVICES IN THE NATURE OF MONITORING, TESTING AND ANALYZING THE IMPACT OF TEXTILES AND TEXTILE PRODUCTION ON POLLUTION, THE ENVIRONMENT AND THE HEALTH EFFECT ON EMPLOYEES ENGAGED IN THE PRODUCTION OF SAID TEXTILES; CONSULTING SERVICES CONCERNING MONITORING, TESTING AND ANALYZING THE IMPACT OF TEXTILES AND TEXTILE PRODUCTION ON POLLUTION; THE ENVIRONMENT AND THE HEALTH EFFECT ON EMPLOYEES ENGAGED IN THE PRODUCTION OF SAID TEXTILES; SCIENTIFIC AND INDUSTRIAL RESEARCH RELATING TO TEXTILES, NAMELY, TEXTILE-PHYSICAL AND TEXTILE-CHEMICAL EXAMINATIONS OF FIBERS, YARNS, THREADS, FABRICS, MESH CLOTHS, FLEECES AND OTHER TEXTILES; MATERIALS TESTING, NAMELY, FIBER TESTING, YARN TESTING, TEXTILE DEFECT AND DAMAGE TESTING; TESTING



**CLASS 42—(Continued).**

TEXTILE RESPONSE TO ENVIRONMENTAL INFLUENCES, TESTING TEXTILE COLOR FASTNESS, COLOR MEASUREMENT, DEGREE OF WHITENESS, UV TRANSMISSION, FLAMMABILITY; SCIENTIFIC AND INDUSTRIAL RESEARCH RELATING TO TEXTILES, NAMELY, PERFORMING TRACE ANALYSIS, RESIDUE ANALYSIS, WASHING POWDERS AND WASHING PROGRAMS AND DYESTUFF ANALYSIS; TESTING SERVICES, NAMELY, CONDUCTING TESTS OF THE TEXTILE GOODS AND SERVICES OF OTHERS FOR THE PURPOSE OF CERTIFICATION THAT PERSONAL PROTECTIVE EQUIPMENT USED IN TEXTILE RELATED SERVICES AND TEXTILE PRODUCTS MEET INDUSTRY STANDARDS; ANALYSIS AND EVALUATION OF TEXTILE GOODS OF OTHERS FOR THE PURPOSE OF CERTIFICATION; DEVELOPMENT OF SCIENTIFIC TESTING METHODS RELATING TO THE AFOREMENTIONED FIELDS; RENTAL OF TEXTILE AND FIBER TESTING APPARATUS; DESIGN AND DEVELOPMENT OF COMPUTER HARDWARE AND SOFTWARE (U.S. CLS. 100 AND 101).

JERI J. FICKES, EXAMINING ATTORNEY

SN 85-021,368. WESTERHOLM TOMAS, HELSINKI, FINLAND, FILED 4-23-2010.

# SKYHIGH

THE MARK CONSISTS OF STANDARD CHARACTERS WITHOUT CLAIM TO ANY PARTICULAR FONT, STYLE, SIZE, OR COLOR.

FOR COMPUTER SOFTWARE DESIGN AND DEVELOPMENT; DESIGN, CREATION, HOSTING AND MAINTENANCE OF INTERNET SITES FOR THIRD PARTIES (U.S. CLS. 100 AND 101).

JOHN HWANG, EXAMINING ATTORNEY

SN 85-031,303. SERVICEMESH, INC., LOS ANGELES, CA. FILED 5-5-2010.

# ROBOOPS

THE MARK CONSISTS OF STANDARD CHARACTERS WITHOUT CLAIM TO ANY PARTICULAR FONT, STYLE, SIZE, OR COLOR.

FOR SOFTWARE AS A SERVICE (SAAS) SERVICES FEATURING SOFTWARE ALLOWING USERS TO RETRIEVE, UPLOAD, MANAGE, AND INTEGRATE THIRD-PARTY INFORMATION TECHNOLOGY (IT) SYSTEMS SOFTWARE AND DATA IN THE FIELD OF INTERNET CLOUD COMPUTING (U.S. CLS. 100 AND 101).

DOMINIC J. FERRAIUOLO, EXAMINING ATTORNEY

**CLASS 42—(Continued).**

SN 85-039,489. BLINK INTERACTIVE, INC., AMSTERDAM, NETHERLANDS, FILED 5-15-2010.



THE COLOR(S) BLACK, WHITE AND GREEN IS/ARE CLAIMED AS A FEATURE OF THE MARK.

THE MARK CONSISTS OF A ROUNDED EDGE RECTANGLE, WHERE THE LEFT PORTION OF THE RECTANGLE IS IN GREEN COLOR AND THE RIGHT PORTION OF THE RECTANGLE IS IN BLACK COLOR. THE LEFT GREEN PORTION OF THE RECTANGLE CONTAINS AN EIGHT-POINT STAR IN WHITE COLOR. THE RIGHT BLACK PORTION OF THE RECTANGLE CONTAINS THE WORD "BLINK" WHERE THE "I" IS IN GREEN COLOR AND THE REST OF THE TERM "BLINK" IS IN WHITE COLOR.

FOR COMPUTER PROGRAMMING TO ENABLE THE PROVISION OF INFORMATION AND CONTENT TO BE ACCESSED OR DISPLAYED BY MOBILE TELEPHONES AND OTHER MOBILE COMMUNICATION APPARATUS, AS WELL AS BY PERSONAL COMPUTERS; COMPUTER PROGRAMMING TO ENABLE THE PURCHASING OF DIVERSE SERVICES VIA MOBILE TELEPHONES AND OTHER MOBILE COMMUNICATION APPARATUS, AS WELL AS VIA PERSONAL COMPUTERS; DESIGN AND DEVELOPMENT OF MULTIMEDIA PRODUCTS; DEVELOPMENT OF NEW TECHNOLOGIES IN THE FIELD OF TELEVISION; SERVICES OF INFORMATION AND COMMUNICATION TECHNOLOGY-SPECIALISTS, NAMELY, DISPOSING SOFTWARE IN CONNECTION WITH THE IMPLEMENTATION OF MOBILE SERVICE AND "MOBILE DIRECT RESPONSE" SERVICES; DEVELOPMENT UPDATING AND MAINTENANCE OF SOFTWARE; SO CALLED "CROSSPLATFORM" CONVERSION OF DIGITAL FANS OF DIGITAL CONTENT; DEVELOPMENT OF TECHNOLOGIES FOR CONSTRUCTION OR CIRCUITS FOR WIRELESS COMMUNICATION, AS WELL AS FOR ELECTRONIC DATA PROCESSING AND CONSUMER ELECTRONICS; PROVIDING OF ACCESS TIME TO DIGITAL CONTENT ON THE INTERNET FOR MOBILE TELEPHONES; DESIGN, DEVELOPMENT AND IMPLEMENTATION OF SOFTWARE FOR MOBILE TELEPHONY; PROGRAMMING OF MOBILE TELEPHONES WITH SOUND RECORDINGS, MAINLY FOR USE AS RING TONES, GRAPHICS AND LOGO'S FOR MOBILE TELEPHONES; MANAGEMENT OF WEB SITES, NAMELY, MONITORING THE WEBSITES OF OTHERS RELATED TO RING TONES, GRAPHICS AND LOGO'S FOR MOBILE TELEPHONES TO IMPROVE SALABILITY AND PERFORMANCE OF WEBSITES OF OTHERS; PROVIDING INFORMATION AT THE SPECIFIC REQUEST OF END-USERS BY MEANS OF TELEPHONE OR GLOBAL COMPUTER NETWORKS (U.S. CLS. 100 AND 101).

FIRST USE 10-2-2007; IN COMMERCE 10-2-2007.  
RAMONA ORTIGA, EXAMINING ATTORNEY

**CLASS 42—(Continued).**

SN 85-040,080. GEOEYE ANALYTICS INC., DULLES, VA. FILED 5-17-2010.

# SAR ANALYST

THE MARK CONSISTS OF STANDARD CHARACTERS WITHOUT CLAIM TO ANY PARTICULAR FONT, STYLE, SIZE, OR COLOR.

NO CLAIM IS MADE TO THE EXCLUSIVE RIGHT TO USE "SAR", APART FROM THE MARK AS SHOWN.

FOR PROVIDING TEMPORARY USE OF NON-DOWNLOADABLE SOFTWARE FOR SPATIAL DATA ANALYSIS AND FOR THE ANALYSIS OF SYNTHETIC APERTURE RADAR DATA SETS (U.S. CLS. 100 AND 101).

PAULA MAHONEY, EXAMINING ATTORNEY

**CLASS 42—(Continued).**

SN 85-043,146. LANDAUER, INC., GLENWOOD, IL. FILED 5-19-2010.

# VERIFII

THE MARK CONSISTS OF STANDARD CHARACTERS WITHOUT CLAIM TO ANY PARTICULAR FONT, STYLE, SIZE, OR COLOR.

FOR QUALITY ASSURANCE SERVICES IN THE FIELD OF DOSIMETRY; TESTING AND EVALUATION OF DOSIMETRY EQUIPMENT, NAMELY, LINEAR ACCELERATORS, CT SIMULATORS AND PET/CT SIMULATORS, FOR THE PURPOSES OF QUALITY ASSURANCE AND SETTING MEASUREMENTS (U.S. CLS. 100 AND 101).

SEAN CROWLEY, EXAMINING ATTORNEY

SN 85-043,696. BENCH TREE GROUP, LLC, GEORGETOWN, TX. FILED 5-20-2010.

# RIG PORTAL

THE MARK CONSISTS OF STANDARD CHARACTERS WITHOUT CLAIM TO ANY PARTICULAR FONT, STYLE, SIZE, OR COLOR.

FOR PROVIDING TEMPORARY USE OF ONLINE NONDOWNLOADABLE SOFTWARE FOR USE IN TRACKING, MONITORING, RECORDING, AND ANALYZING DATA AND PERFORMANCE OF PUMPS AND PUMPING SYSTEMS (U.S. CLS. 100 AND 101).

MORGAN WYNNE, EXAMINING ATTORNEY

SN 85-043,976. MARSH, JOSEPH, MASSAPEQUA PARK, NY. FILED 5-20-2010.

# We Speak Geek (So You Don't Have To)

THE MARK CONSISTS OF STANDARD CHARACTERS WITHOUT CLAIM TO ANY PARTICULAR FONT, STYLE, SIZE, OR COLOR.

FOR COMPUTER HARDWARE AND SOFTWARE CONSULTING SERVICES; COMPUTER PROJECT MANAGEMENT SERVICES; COMPUTER SERVICES, NAMELY, TECHNOLOGY AND OPERATIONS INTEGRATION, PROCESS AUTOMATION RELATING TO WORKFORCE MANAGEMENT USING WEB-BASED SOFTWARE SERVICES (ASP, SAAS, ET AL); ADVISORY SERVICES IN THE FIELD OF PRODUCT DEVELOPMENT AND QUALITY IMPROVEMENT OF SOFTWARE; UPDATING AND DESIGN OF COMPUTER SOFTWARE; TECHNICAL ADVICE RELATING TO OPERATION OF COMPUTERS (U.S. CLS. 100 AND 101).

FIRST USE 12-29-2008; IN COMMERCE 12-29-2008.  
BARBARA RUTLAND, EXAMINING ATTORNEY

SN 85-041,483. IFA SYSTEMS AG, FRECHEN, FED REP GERMANY, FILED 5-18-2010.



THE COLOR(S) BLACK AND RED IS/ARE CLAIMED AS A FEATURE OF THE MARK.

THE MARK CONSISTS OF THE TERM "IFA" IN STYLIZED BLACK LOWER-CASE LETTERS, WITH THE DOT OVER THE LETTER "I" COMPRISED OF A LARGE RED CIRCLE.

FOR COMPUTER SOFTWARE DESIGN SERVICES RENDERED TO HEALTH CARE PROFESSIONALS (U.S. CLS. 100 AND 101).

FIRST USE 1-1-2002; IN COMMERCE 1-1-2002.  
MICHAEL KEATING, EXAMINING ATTORNEY

**CLASS 42—(Continued).**

SN 85-044,835. CSG GOVERNMENT SOLUTIONS, INC., FORMERLY CHICAGO SYSTEMS GROUP, INC., CHICAGO, IL. FILED 5-21-2010.



THE COLOR(S) RED, WHITE AND BLUE IS/ARE CLAIMED AS A FEATURE OF THE MARK.

THE MARK CONSISTS OF THE STYLIZED LETTERS "CSG" IN BLUE AND WHITE, AND THE TERM "REALIZE," WITH THE LETTERS "REAL" IN UPPERCASE AND IN RED WITH THE "R" IN LARGER TYPE, AND "IZE" IN LOWER CASE AND IN BLUE, WITH A BLUE CURVE FROM THE END OF "REALIZE" CURVING APPROXIMATELY HALF-WAY AROUND THE BOTTOM OF THE MARK.

FOR DESIGN, DEVELOPMENT, INSTALLATION AND MAINTENANCE OF COMPUTER SOFTWARE FOR FEDERAL, STATE, AND LOCAL GOVERNMENT AND GOVERNMENT-SPONSORED AGENCIES IN THE AREAS OF MEDICAID AND OTHER HEALTH INSURANCE, HUMAN SERVICES, UNEMPLOYMENT COMPENSATION, AND WORKFORCE DEVELOPMENT PROGRAMS (U.S. CLS. 100 AND 101).

FIRST USE 11-19-2009; IN COMMERCE 11-19-2009.  
JAMES MACFARLANE, EXAMINING ATTORNEY

**CLASS 42—(Continued).**

SN 85-046,018. CSG GOVERNMENT SOLUTIONS, INC., FORMERLY CHICAGO SYSTEMS GROUP, INC., CHICAGO, IL. FILED 5-24-2010.

CSG REALize

THE MARK CONSISTS OF STANDARD CHARACTERS WITHOUT CLAIM TO ANY PARTICULAR FONT, STYLE, SIZE, OR COLOR.

FOR DESIGN, DEVELOPMENT, INSTALLATION AND MAINTENANCE OF COMPUTER SOFTWARE FOR FEDERAL, STATE, AND LOCAL GOVERNMENT AND GOVERNMENT-SPONSORED AGENCIES IN THE AREAS OF MEDICAID AND OTHER HEALTH INSURANCE, HUMAN SERVICES, UNEMPLOYMENT COMPENSATION, AND WORKFORCE DEVELOPMENT PROGRAMS (U.S. CLS. 100 AND 101).

FIRST USE 11-19-2009; IN COMMERCE 11-19-2009.  
JAMES MACFARLANE, EXAMINING ATTORNEY

SN 85-045,135. ALTICOR INC., ADA, MI. FILED 5-21-2010.

INTELLIGENT WIRELESS POWER

SN 85-046,039. CSG GOVERNMENT SOLUTIONS, INC., FORMERLY CHICAGO SYSTEMS GROUP, INC., CHICAGO, IL. FILED 5-24-2010.



THE COLOR(S) RED, WHITE AND BLUE IS/ARE CLAIMED AS A FEATURE OF THE MARK.

THE MARK CONSISTS OF THE STYLIZED WORDING "TEAM CSG," WITH THE WORD "TEAM" IN ALL CAPITALS, WITH "T" SLIGHTLY LARGER AND IN BLUE, "E" IN RED, AND "AM" IN BLUE. THE LETTERING "CSG" ALSO APPEARS IN ALL CAPITALS IN THE COLORS BLUE AND WHITE. A HORIZONTAL BLUE LINE APPEARS AT THE TOP OF THE MARK, AND A SECOND HORIZONTAL BLUE LINE APPEARS AT THE BOTTOM OF THE MARK BELOW THE WORD "TEAM".

FOR DESIGN, DEVELOPMENT, INSTALLATION AND MAINTENANCE OF COMPUTER SOFTWARE FOR FEDERAL, STATE, AND LOCAL GOVERNMENT AND GOVERNMENT-SPONSORED AGENCIES IN THE AREAS OF MEDICAID AND OTHER HEALTH INSURANCE, HUMAN SERVICES, UNEMPLOYMENT COMPENSATION, AND WORKFORCE DEVELOPMENT PROGRAMS (U.S. CLS. 100 AND 101).

FIRST USE 9-17-2009; IN COMMERCE 9-17-2009.  
JAMES MACFARLANE, EXAMINING ATTORNEY

THE MARK CONSISTS OF STANDARD CHARACTERS WITHOUT CLAIM TO ANY PARTICULAR FONT, STYLE, SIZE, OR COLOR.

NO CLAIM IS MADE TO THE EXCLUSIVE RIGHT TO USE "WIRELESS POWER", APART FROM THE MARK AS SHOWN.

FOR ENGINEERING AND DESIGN FOR OTHERS IN THE FIELD OF PORTABLE ELECTRONICS WIRELESS POWER CONTROL, COMPUTER NETWORKS, SOFTWARE, AND ENGINEERING FOR THE FIELD OF INDUCTIVE TRANSMISSION OR RECEPTION OF ELECTRIC POWER OR DATA; AND TECHNICAL SUPPORT, NAMELY, TROUBLESHOOTING IN THE NATURE OF DIAGNOSING PROBLEMS FOR OTHERS IN THE FIELD OF INDUCTIVE TRANSMISSION OR RECEPTION OF ELECTRIC POWER OR DATA (U.S. CLS. 100 AND 101).

ALLISON HOLTZ, EXAMINING ATTORNEY

**CLASS 42—(Continued).**

SN 85-046,077. CSG GOVERNMENT SOLUTIONS, INC., FORMERLY CHICAGO SYSTEMS GROUP, INC., CHICAGO, IL. FILED 5-24-2010.

# TeamCSG

THE MARK CONSISTS OF STANDARD CHARACTERS WITHOUT CLAIM TO ANY PARTICULAR FONT, STYLE, SIZE, OR COLOR.

FOR DESIGN, DEVELOPMENT, INSTALLATION AND MAINTENANCE OF COMPUTER SOFTWARE FOR FEDERAL, STATE, AND LOCAL GOVERNMENT AND GOVERNMENT-SPONSORED AGENCIES IN THE AREAS OF MEDICAID AND OTHER HEALTH INSURANCE, HUMAN SERVICES, UNEMPLOYMENT COMPENSATION, AND WORKFORCE DEVELOPMENT PROGRAMS (U.S. CLS. 100 AND 101).

FIRST USE 9-17-2009; IN COMMERCE 9-17-2009.  
JAMES MACFARLANE, EXAMINING ATTORNEY

---

SN 85-046,112. CSG GOVERNMENT SOLUTIONS, INC., FORMERLY CHICAGO SYSTEMS GROUP, INC., CHICAGO, IL. FILED 5-24-2010.

## CSG Government Solutions

THE MARK CONSISTS OF STANDARD CHARACTERS WITHOUT CLAIM TO ANY PARTICULAR FONT, STYLE, SIZE, OR COLOR.

NO CLAIM IS MADE TO THE EXCLUSIVE RIGHT TO USE "GOVERNMENT SOLUTIONS", APART FROM THE MARK AS SHOWN.

FOR DESIGN, DEVELOPMENT, INSTALLATION AND MAINTENANCE OF COMPUTER SOFTWARE FOR FEDERAL, STATE, AND LOCAL GOVERNMENT AND GOVERNMENT-SPONSORED AGENCIES IN THE AREAS OF MEDICAID AND OTHER HEALTH INSURANCE, HUMAN SERVICES, UNEMPLOYMENT COMPENSATION, AND WORKFORCE DEVELOPMENT PROGRAMS (U.S. CLS. 100 AND 101).

FIRST USE 5-19-2009; IN COMMERCE 5-19-2009.  
JAMES MACFARLANE, EXAMINING ATTORNEY

**CLASS 42—(Continued).**

SN 85-047,083. SOPTIONS LTD, OMER, ISRAEL, FILED 5-25-2010.

# LIVECITY

THE MARK CONSISTS OF STANDARD CHARACTERS WITHOUT CLAIM TO ANY PARTICULAR FONT, STYLE, SIZE, OR COLOR.

FOR INTERNET SERVICES, NAMELY, PROVIDING A WEBSITE FEATURING NON-DOWNLOADABLE SOFTWARE FOR WEBSITE DEVELOPMENT, AND PROVIDING A WEBSITE WHERE USERS CAN CREATE A WEBSITE AND COMPLETE DOMAIN NAME REGISTRATION; COMPUTER SOFTWARE DEVELOPMENT IN THE FIELD OF WEBSITE BUILDER SOFTWARE, DOMAIN REGISTRATION SOFTWARE AND MOBILE CONTENT MANAGEMENT SYSTEM (CMS) SOFTWARE; PROVIDING SOFTWARE INTERFACES AVAILABLE OVER A NETWORK IN ORDER TO CREATE PERSONALIZED ON-LINE INFORMATION SERVICES; PROVIDING A WEBSITE FEATURING NON-DOWNLOADABLE SOFTWARE APPLICATIONS FOR TRANSMISSION OF AUDIO, VIDEO, PHOTOGRAPHIC IMAGES, TEXT, GRAPHICS AND DATA; DESIGN AND DEVELOPMENT OF COMPUTER SOFTWARE; DEVELOPMENT, MAINTENANCE AND HOSTING OF WEBSITES AND WEB SERVICES; PROVISION OF WEB TOOLS FOR WEBSITE DEVELOPMENT, NAMELY, DEVELOPING AND PROVIDING ONLINE INTERNET-BASED SOFTWARE FOR RETRIEVING INFORMATION FROM SEARCHABLE INDEXES AND DATABASES OF INFORMATION, INCLUDING TEXT, AUDIO, VIDEO AND RSS (REAL SIMPLE SYNDICATION) BY MEANS OF THE INTERNET AND OTHER COMPUTER INFORMATION NETWORKS; DEVELOPMENT OF INTERNET SEARCH ENGINES AND WEB APPLICATIONS, NAMELY, PROVIDING A WEBSITE FEATURING NON-DOWNLOADABLE SOFTWARE FOR INTERFACES AVAILABLE OVER A NETWORK TO CREATE A PERSONALIZED ON-LINE INFORMATION DATABASE; DEVELOPMENT OF SEARCHABLE INDEXES FOR WEBSITES AND WEB SERVICES, NAMELY, PROVIDING INFORMATION FROM SEARCHABLE INDEXES AND DATABASES OF INFORMATION, INCLUDING TEXT, ELECTRONIC DOCUMENTS, DATABASES, GRAPHICS AND AUDIO VISUAL INFORMATION, ON COMPUTER AND COMMUNICATION NETWORKS; DATA MINING AND DATA ANALYSIS SERVICES, NAMELY, PROVIDING ONLINE USE OF SOFTWARE FOR USE IN EXTRACTION AND RETRIEVAL OF INFORMATION AND DATA MINING OVER A GLOBAL COMPUTER NETWORK; COMPUTER AND SOFTWARE CONSULTANCY SERVICES, NAMELY, CONSULTANCY AND TECHNICAL SUPPORT IN RELATION TO DEVELOPMENT, MAINTENANCE AND HOSTING OF WEBSITES AND WEB SERVICES; COMPUTER AND SOFTWARE DESIGN SERVICES FOR OTHERS (U.S. CLS. 100 AND 101).

FIRST USE 5-15-2004; IN COMMERCE 5-15-2004.  
LINDA MICKLEBURGH, EXAMINING ATTORNEY

**CLASS 42—(Continued).**

SN 85-048,672. NEUROCRINE BIOSCIENCES, INC., SAN DIEGO, CA. FILED 5-26-2010.

# SiNERG

THE MARK CONSISTS OF STANDARD CHARACTERS WITHOUT CLAIM TO ANY PARTICULAR FONT, STYLE, SIZE, OR COLOR.

FOR RESEARCH AND DEVELOPMENT SERVICES IN THE FIELD OF PHARMACEUTICALS, INCLUDING ASSAYS AND ASSAY SYSTEMS, CHEMICAL SYNTHETIC, PURIFICATION AND ANALYTICAL METHODOLOGIES (U.S. CLS. 100 AND 101).

JULIE WATSON, EXAMINING ATTORNEY

---

SN 85-052,704. FREEMAN, DELORES R., UPPER MARLBORO, MD. FILED 6-2-2010.



NO CLAIM IS MADE TO THE EXCLUSIVE RIGHT TO USE "STUDIOS", APART FROM THE MARK AS SHOWN.

THE COLOR(S) BLACK, WHITE, GREY AND RED IS/ARE CLAIMED AS A FEATURE OF THE MARK.

THE MARK CONSISTS OF A DESIGN CONSISTING OF A CIRCLE HAVING A BLACK RING, A WHITE INNER RING, AND A RED INNER RING. FOUR WHITE STARS APPEAR ON THE TOP CIRCULAR PORTION OF THE DESIGN. WITH THE DESIGN APPEAR TWO BLACK HORSES OVERLAIN ON EITHER SIDE OF A CREST-LIKE GREY SHIELD AND THE CIRCLE. BOTH HORSES ARE FACED OUTWARD AND REARED ON THEIR HIND LEGS. A BLACK RIBBON IS FORMED UNDER THE HIND HOOFS OF EACH HORSE. BOTH RIBBONS EXTEND FROM THE HOOFS OF A RESPECTIVE HORSE TO OVERLAY A PORTION OF THE BOTTOM OF THE SHIELD. A STAR IS CENTERED ON AND OVERLAYS A PORTION OF BOTH HORSES AND THE SHIELD. A RED ROMAN NUMERAL "V" IS CENTERED ON AND OVERLAYS A CENTRAL-CENTERED STAR. THE WORDS "FIVE STAR STUDIOS" ARE CENTERED BELOW THE CIRCLE, CREST, STAR, HORSE, AND RIBBON COMBINATION. THE ENTIRE DESIGN HAS A BACKGROUND WHITE SHADOW. THE REMAINING BLACK IN THE MARK REPRESENTS BACKGROUND AND IS NOT PART OF THE MARK.

FOR COMPUTER SERVICES, NAMELY, DESIGNING AND IMPLEMENTING NON-BASKETBALL RELATED WEB SITES FOR OTHERS; CREATING AND DESIGNING NON-BASKETBALL RELATED WEB PAGES FOR OTHERS; DESIGNING AND DEVELOPING NON-BASKETBALL RELATED WEBPAGES ON THE INTERNET; PROVIDING GRAPHIC AND MULTIMEDIA DESIGN SERVICES FOR THE PURPOSE OF PROMOTING THE NON-BASKETBALL RELATED GOODS AND SERVICES OF OTHERS; NON-BASKETBALL RELATED WEBSITE DEVELOPMENT FOR OTHERS (U.S. CLS. 100 AND 101).

JACLYN KIDWELL WALKER, EXAMINING ATTORNEY

**CLASS 42—(Continued).**

SN 85-058,198. SULLIVAN, RACHEL M., WOODBURY, MN. FILED 6-9-2010.

# ENERJIAZE KIDS

THE MARK CONSISTS OF STANDARD CHARACTERS WITHOUT CLAIM TO ANY PARTICULAR FONT, STYLE, SIZE, OR COLOR.

NO CLAIM IS MADE TO THE EXCLUSIVE RIGHT TO USE "KIDS", APART FROM THE MARK AS SHOWN.

FOR COMPUTER SERVICES, NAMELY, CREATING AN ON-LINE COMMUNITY FOR REGISTERED USERS TO RECEIVE INFORMATION REGARDING JUVENILE IDIOPATHIC ARTHRITIS, TO PARTICIPATE IN DISCUSSIONS, TO RECEIVE ONLINE SUPPORT FROM HEALTHCARE PRACTITIONERS, TO TRACK AND JOURNAL PHYSICAL ACTIVITIES, TO FORM VIRTUAL COMMUNITIES, AND TO ENGAGE IN SOCIAL NETWORKING (U.S. CLS. 100 AND 101).

CIMMERIAN COLEMAN, EXAMINING ATTORNEY

---

SN 85-061,794. DENVER SCHOOL DISTRICT #1, DENVER, CO. FILED 6-14-2010.

# DIGITAL DOOR

THE MARK CONSISTS OF STANDARD CHARACTERS WITHOUT CLAIM TO ANY PARTICULAR FONT, STYLE, SIZE, OR COLOR.

NO CLAIM IS MADE TO THE EXCLUSIVE RIGHT TO USE "DIGITAL", APART FROM THE MARK AS SHOWN.

FOR APPLICATION SERVICE PROVIDER (ASP) FEATURING SOFTWARE FOR USE BY SCHOOL ADMINISTRATORS, STAFF, TEACHERS, PARENTS AND STUDENTS IN MONITORING AND ANALYZING METRICS AND INFORMATION CONCERNING SCHOOL, STUDENT AND STAFF PERFORMANCE; COMPUTER SERVICE, NAMELY, ACTING AS AN APPLICATION SERVICE PROVIDER IN THE FIELD OF KNOWLEDGE MANAGEMENT TO HOST COMPUTER APPLICATION SOFTWARE FOR CREATING SEARCHABLE DATABASES OF INFORMATION AND DATA (U.S. CLS. 100 AND 101).

ERNEST SHOSHO, EXAMINING ATTORNEY



**CLASS 42—(Continued).**

SN 85-061,806. DENVER SCHOOL DISTRICT #1, DENVER, CO. FILED 6-14-2010.



NO CLAIM IS MADE TO THE EXCLUSIVE RIGHT TO USE "PORTAL", APART FROM THE MARK AS SHOWN.

THE MARK CONSISTS OF A SILHOUETTE OF A DOOR AND DOOR FRAME NEXT TO WHICH IS THE UNDERSCORED WORD "PORTAL".

FOR APPLICATION SERVICE PROVIDER (ASP) FEATURING SOFTWARE FOR USE BY SCHOOL ADMINISTRATORS, STAFF, TEACHERS, PARENTS AND STUDENTS IN MONITORING AND ANALYZING METRICS AND INFORMATION CONCERNING SCHOOL, STUDENT AND STAFF PERFORMANCE; COMPUTER SERVICE, NAMELY, ACTING AS AN APPLICATION SERVICE PROVIDER IN THE FIELD OF KNOWLEDGE MANAGEMENT TO HOST COMPUTER APPLICATION SOFTWARE FOR CREATING SEARCHABLE DATABASES OF INFORMATION AND DATA (U.S. CLS. 100 AND 101).

ERNEST SHOSHO, EXAMINING ATTORNEY

**CLASS 42—(Continued).**

SN 85-063,668. BUSINESS SERVICES INC., SAN JOSE, CA. FILED 6-15-2010.



SN 85-063,047. BRISTOL-MYERS SQUIBB COMPANY, NEW YORK, NY. FILED 6-15-2010.

ASIDE: A PHASE IIIB,  
MULTI-CENTER, RANDOMIZED,  
DOUBLE-BLIND, DOUBLE-DUMMY  
STUDY TO EVALUATE THE  
EFFICACY AND SAFETY OF  
ABATACEPT ADMINISTERED  
SUBCUTANEOUSLY AND  
INTRAVENOUSLY IN SUBJECTS  
WITH RHEUMATOID ARTHRITIS,  
RECEIVING BACKGROUND  
METHOTREXATE, AND  
EXPERIENCING AN INADEQUATE  
RESPONSE TO METHOTREXATE

THE MARK CONSISTS OF STANDARD CHARACTERS WITHOUT CLAIM TO ANY PARTICULAR FONT, STYLE, SIZE, OR COLOR.

NO CLAIM IS MADE TO THE EXCLUSIVE RIGHT TO USE "A PHASE IIIB, MULTI-CENTER, RANDOMIZED, DOUBLE-BLIND, DOUBLE-DUMMY STUDY TO EVALUATE THE EFFICACY AND SAFETY OF ABATACEPT ADMINISTERED SUBCUTANEOUSLY AND INTRAVENOUSLY IN SUBJECTS WITH RHEUMATOID ARTHRITIS, RECEIVING BACKGROUND METHOTREXATE, AND EXPERIENCING AN INADEQUATE RESPONSE TO METHOTREXATE", APART FROM THE MARK AS SHOWN.

FOR MEDICAL AND SCIENTIFIC RESEARCH, NAMELY, CONDUCTING CLINICAL TRIALS RELATING TO PHARMACEUTICAL PREPARATIONS FOR HUMAN USE (U.S. CLS. 100 AND 101).

JENNIFER VASQUEZ, EXAMINING ATTORNEY

NO CLAIM IS MADE TO THE EXCLUSIVE RIGHT TO USE "INTERVIEW", APART FROM THE MARK AS SHOWN.

THE MARK CONSISTS OF THE STYLIZED TEXT "INT R VIEW" WITH THE LETTER "R" IN "INT R VIEW" DISPLAYED ON THE DESIGN OF A COMPUTER MONITOR.

FOR SOFTWARE AS A SERVICE (SAAS) SERVICES THAT PROVIDE COLLECTION, RECORDING, STORING, MANAGING, TRACKING, CONVERTING AND ANALYZING DATA IN THE FIELD OF TALENT ACQUISITION (SCREENING, RECRUITING, ASSESSMENT, INTERVIEW TRAINING AND DATING); INTEGRATION WITH APPLICANT TRACKING SYSTEMS, HUMAN RESOURCES MANAGEMENT SYSTEMS, TALENT MANAGEMENT SYSTEMS AND RELATIONSHIP TRACKING SYSTEMS; STATISTICAL AND MANAGEMENT REPORTS ON CUSTOMER SUPPORT SERVICES; FACILITATE COMMUNICATIONS WITH PEER PROFESSIONALS, CUSTOMERS AND BETWEEN CUSTOMERS SYNCHRONOUSLY AND ASYNCHRONOUSLY; AND SEARCH ENGINES FOR MULTIMEDIA STORED IN SAID SYSTEMS (U.S. CLS. 100 AND 101).

FIRST USE 7-24-2010; IN COMMERCE 9-9-2010.

KELLEY WELLS, EXAMINING ATTORNEY

**CLASS 42—(Continued).**

SN 85-063,708. BUSINESS SERVICES INC., SAN JOSE, CA.  
FILED 6-15-2010.

PROFIT FROM OUR INNOVATION

THE MARK CONSISTS OF STANDARD CHARACTERS WITHOUT CLAIM TO ANY PARTICULAR FONT, STYLE, SIZE, OR COLOR.

FOR SOFTWARE AS A SERVICE (SAAS) SERVICES FEATURING HOSTED SOFTWARE FOR USE BY CORPORATIONS FOR COLLECTING, RECORDING, STORING, MANAGING, TRACKING, CONVERTING AND ANALYZING DATA IN THE FIELDS OF CUSTOMER INFORMATION, CUSTOMER SUPPORT SERVICES, CUSTOMER TRAINING, EMPLOYEE EFFICIENCY, CUSTOMER SATISFACTION, TALENT ACQUISITION, SCREENING, RECRUITING, ASSESSMENT, INTERVIEW TRAINING AND DATING AND HOSTED SOFTWARE FOR INTEGRATING AUTOMATED BUSINESS PROCESS SYSTEMS, NAMELY, CUSTOMER RELATIONSHIP MANAGEMENT SYSTEMS, APPLICANT TRACKING SYSTEMS, HUMAN RESOURCES MANAGEMENT SYSTEMS, TALENT MANAGEMENT SYSTEMS, ENTERPRISE RESOURCE MANAGEMENT AND PLANNING SYSTEMS, SECURITY MONITORING SYSTEMS, SECURITY ASSESSMENT SYSTEMS AND SITUATIONAL AWARENESS SYSTEMS AND FOR SEARCHING MULTIMEDIA STORED IN SAID SYSTEMS; SOFTWARE AS A SERVICE (SAAS) SERVICES FEATURING HOSTED SOFTWARE FOR USE BY CORPORATIONS FOR COLLECTING, RECORDING, STORING, MANAGING, TRACKING, CONVERTING AND ANALYZING STATISTICAL AND MANAGEMENT REPORTS ON CUSTOMER INFORMATION MANAGEMENT, CUSTOMER SUPPORT SERVICES, CUSTOMER TRAINING, EMPLOYEE EFFICIENCY, SECURITY ASSESSMENT AND SITUATIONAL AWARENESS IN ORDER TO FACILITATE COMMUNICATIONS WITH PEER PROFESSIONALS, CUSTOMERS AND BETWEEN CUSTOMERS SYNCHRONOUSLY AND ASYNCHRONOUSLY (U.S. CLS. 100 AND 101).

FIRST USE 7-24-2010; IN COMMERCE 9-9-2010.  
KELLEY WELLS, EXAMINING ATTORNEY

**CLASS 42—(Continued).**

SN 85-063,772. BUSINESS SERVICES INC., SAN JOSE, CA.  
FILED 6-15-2010.



THE MARK CONSISTS OF A STYLIZED COMBINATION OF TEXT AND GRAPHIC ELEMENTS. THE TEXT CONSISTS OF THE LETTERS "BSI" IN A BOLD CUSTOMIZED FONT. THE GRAPHICS ELEMENT CONSISTS OF A SWIRL OF CHEVRONS MOVING COUNTER-CLOCKWISE, EMANATING FROM THE "BSI" TEXT AND TERMINATING ON THE "BSI" TEXT LIKE A HANDLE ON A CUP. THERE ARE 8 CHEVRONS IN THE DESIGN AND THEY START SMALL, GROW IN SIZE AND THEN SHRINK DOWN TO THE STARTING SIZE.

FOR SOFTWARE AS A SERVICE (SAAS) SERVICES FEATURING HOSTED SOFTWARE FOR USE BY CORPORATIONS FOR COLLECTING, RECORDING, STORING, MANAGING, TRACKING, CONVERTING AND ANALYZING DATA IN THE FIELDS OF CUSTOMER INFORMATION, CUSTOMER SUPPORT SERVICES, CUSTOMER TRAINING, EMPLOYEE EFFICIENCY, CUSTOMER SATISFACTION, TALENT ACQUISITION, SCREENING, RECRUITING, ASSESSMENT, INTERVIEW TRAINING AND DATING AND HOSTED SOFTWARE FOR INTEGRATING AUTOMATED BUSINESS PROCESS SYSTEMS, NAMELY, CUSTOMER RELATIONSHIP MANAGEMENT SYSTEMS, APPLICANT TRACKING SYSTEMS, HUMAN RESOURCES MANAGEMENT SYSTEMS, TALENT MANAGEMENT SYSTEMS, ENTERPRISE RESOURCE MANAGEMENT AND PLANNING SYSTEMS, SECURITY MONITORING SYSTEMS, SECURITY ASSESSMENT SYSTEMS AND SITUATIONAL AWARENESS SYSTEMS AND FOR SEARCHING MULTIMEDIA STORED IN SAID SYSTEMS. SOFTWARE AS A SERVICE (SAAS) SERVICES FEATURING HOSTED SOFTWARE FOR USE BY CORPORATIONS FOR COLLECTING, RECORDING, STORING, MANAGING, TRACKING, CONVERTING AND ANALYZING STATISTICAL AND MANAGEMENT REPORTS ON CUSTOMER INFORMATION MANAGEMENT, CUSTOMER SUPPORT SERVICES, CUSTOMER TRAINING, EMPLOYEE EFFICIENCY, SECURITY ASSESSMENT AND SITUATIONAL AWARENESS IN ORDER TO FACILITATE COMMUNICATIONS WITH PEER PROFESSIONALS, CUSTOMERS AND BETWEEN CUSTOMERS SYNCHRONOUSLY AND ASYNCHRONOUSLY (U.S. CLS. 100 AND 101).

FIRST USE 7-24-2010; IN COMMERCE 9-9-2010.  
KELLEY WELLS, EXAMINING ATTORNEY

**CLASS 42—(Continued).**

SN 85-063,773. WEBSense, INC., SAN DIEGO, CA. FILED 6-15-2010.

# DEFENSIO

THE MARK CONSISTS OF STANDARD CHARACTERS WITHOUT CLAIM TO ANY PARTICULAR FONT, STYLE, SIZE, OR COLOR.

FOR WEB SECURITY SERVICES, NAMELY, PROVIDING A WEBSITE FEATURING ON-LINE NON-DOWNLOADABLE SOFTWARE THAT SCANS WEB POSTINGS FOR THREATS (U.S. CLS. 100 AND 101).

FIRST USE 11-7-2007; IN COMMERCE 11-7-2007.  
H. M. FISHER, EXAMINING ATTORNEY

---

SN 85-064,428. HAND HUGS DESIGN LLC, PORTLAND, OR. FILED 6-16-2010.

# HAND HUGS

THE MARK CONSISTS OF STANDARD CHARACTERS WITHOUT CLAIM TO ANY PARTICULAR FONT, STYLE, SIZE, OR COLOR.

FOR WEBSITE DESIGN AND DEVELOPMENT FOR OTHERS; GRAPHIC DESIGN (U.S. CLS. 100 AND 101).

FIRST USE 9-1-2009; IN COMMERCE 10-1-2009.  
BILL DAWE, EXAMINING ATTORNEY

---

SN 85-065,896. QUALCOMM INCORPORATED, SAN DIEGO, CA. FILED 6-17-2010.

# SEAANGEL

THE MARK CONSISTS OF STANDARD CHARACTERS WITHOUT CLAIM TO ANY PARTICULAR FONT, STYLE, SIZE, OR COLOR.

FOR COMPUTER SOFTWARE SUPPORT IN THE NATURE OF TECHNICAL SUPPORT SERVICES, NAMELY, TROUBLESHOOTING OF COMPUTER SOFTWARE PROBLEMS; COMPUTER SOFTWARE MAINTENANCE AND UPGRADING (U.S. CLS. 100 AND 101).

ROBERT STRUCK, EXAMINING ATTORNEY

**CLASS 42—(Continued).**

SN 85-066,088. CSG GOVERNMENT SOLUTIONS, INC., FORMERLY CHICAGO SYSTEMS GROUP, INC., CHICAGO, IL. FILED 6-18-2010.



NO CLAIM IS MADE TO THE EXCLUSIVE RIGHT TO USE "GOVERNMENT SOLUTIONS", APART FROM THE MARK AS SHOWN.

THE COLOR(S) BLUE AND WHITE IS/ARE CLAIMED AS A FEATURE OF THE MARK.

THE MARK CONSISTS OF THE STYLIZED CONNECTED BLOCK LETTERS "CSG" APPEARING IN BLUE AND WHITE, ABOVE THE WORDS "GOVERNMENT SOLUTIONS" IN BLUE, WITH A BLUE CURVE FROM THE END OF "GOVERNMENT SOLUTIONS" AROUND THE BOTTOM OF SUCH WORDS, SUCH CURVE WIDENING AT THE BOTTOM RIGHT AND TAPERING THINNER TO THE LEFT END THEREOF.

FOR PLANNING, DESIGN, AND MANAGEMENT OF INFORMATION TECHNOLOGY SYSTEMS FOR FEDERAL, STATE, AND LOCAL GOVERNMENT AND GOVERNMENT-SPONSORED AGENCIES IN THE AREAS OF MEDICAID AND OTHER HEALTH INSURANCE, HUMAN SERVICES, UNEMPLOYMENT COMPENSATION, AND WORKFORCE DEVELOPMENT PROGRAMS (U.S. CLS. 100 AND 101).

FIRST USE 8-7-2009; IN COMMERCE 8-7-2009.  
JAMES MACFARLANE, EXAMINING ATTORNEY

---

SN 85-066,718. COMMONWEALTH REIT, NEWTON, MA. FILED 6-18-2010.

# COMMON WEALTH REIT

THE MARK CONSISTS OF STANDARD CHARACTERS WITHOUT CLAIM TO ANY PARTICULAR FONT, STYLE, SIZE, OR COLOR.

NO CLAIM IS MADE TO THE EXCLUSIVE RIGHT TO USE "REIT", APART FROM THE MARK AS SHOWN.

FOR COMPUTER SERVICES, NAMELY, MAINTAINING WEB SITES FOR OTHERS FOR REAL PROPERTY MANAGEMENT (U.S. CLS. 100 AND 101).

DAVID COLLIER, EXAMINING ATTORNEY

**CLASS 42—(Continued).**

SN 85-070,303. ILER, KENT, LAGRANGE, OH. FILED 6-24-2010.

# ILER

THE MARK CONSISTS OF STANDARD CHARACTERS WITHOUT CLAIM TO ANY PARTICULAR FONT, STYLE, SIZE, OR COLOR.

SEC. 2(F).

FOR SCIENTIFIC AND TECHNOLOGICAL SERVICES, NAMELY, ANALYSIS, TESTING IN THE FIELDS OF COMPUTER HARDWARE AND SOFTWARE; RESEARCH AND DEVELOPMENT OF COMPUTER SOFTWARE; COMPUTER SOFTWARE DESIGN FOR OTHERS; COMPUTER SYSTEM DESIGN SERVICES; DESIGN AND DEVELOPMENT OF COMPUTER HARDWARE AND SOFTWARE FOR CONSUMERS (U.S. CLS. 100 AND 101).

FIRST USE 10-1-1994; IN COMMERCE 10-1-1994.

SKYE YOUNG, EXAMINING ATTORNEY

---

SN 85-073,048. SHORTLIST\_0 DESIGN GROUP, LLC, BRONX, NY. FILED 6-28-2010.

# SHORTLIST\_0

THE MARK CONSISTS OF STANDARD CHARACTERS WITHOUT CLAIM TO ANY PARTICULAR FONT, STYLE, SIZE, OR COLOR.

FOR RESEARCH AND ANALYSIS AND CONSULTING IN APPLYING TECHNOLOGY IN THE FIELD OF ENGINEERING, MATHEMATICS, SCIENCE, BUILDING CONSTRUCTION ENGINEERING, ARCHITECTURE AND ENVIRONMENTAL SUSTAINABILITY; COMPUTER SOFTWARE DEVELOPMENT AND DESIGN IN THE FIELD OF ENGINEERING, MATHEMATICS, SCIENCE, BUILDING CONSTRUCTION ENGINEERING, ARCHITECTURE AND ENVIRONMENTAL SUSTAINABILITY (U.S. CLS. 100 AND 101).

ESTHER A. BORSUK, EXAMINING ATTORNEY

---

SN 85-073,920. IP MINING CORPORATION, NEWPORT BEACH, CA. FILED 6-29-2010.

# LOCALIZ

THE MARK CONSISTS OF STANDARD CHARACTERS WITHOUT CLAIM TO ANY PARTICULAR FONT, STYLE, SIZE, OR COLOR.

FOR PROVIDING TEMPORARY USE OF ON-LINE NON-DOWNLOADABLE SOFTWARE FOR USE IN DATABASE MANAGEMENT OF INFORMATION AND STATISTICS GATHERED IN CONNECTION WITH ADVERTISING (U.S. CLS. 100 AND 101).

APRIL HESIK, EXAMINING ATTORNEY

**CLASS 42—(Continued).**

SN 85-074,227. SIGNALDEMAND, INC., SAN FRANCISCO, CA. FILED 6-29-2010.

# SignalDemand MarketForecaster

THE MARK CONSISTS OF STANDARD CHARACTERS WITHOUT CLAIM TO ANY PARTICULAR FONT, STYLE, SIZE, OR COLOR.

OWNER OF U.S. REG. NOS. 3,002,648, 3,230,884 AND 3,538,264.

NO CLAIM IS MADE TO THE EXCLUSIVE RIGHT TO USE "MARKET FORECASTER", APART FROM THE MARK AS SHOWN.

FOR PROVIDING TEMPORARY USE OF ON-LINE NON-DOWNLOADABLE SOFTWARE FOR USE BY GROWERS, MANUFACTURERS, RETAILERS, RESTAURANTS AND FOOD INDUSTRY PLAYERS TO MANAGE, FORECAST, TRACK, ANALYZE, REPORT AND MARKET DATA THROUGH FORECAST ENGINES, DEMAND MODELS, AND COST MODELS IN THE FIELD OF COMMODITY-BASED VALUE CHAINS (U.S. CLS. 100 AND 101).

FIRST USE 5-11-2009; IN COMMERCE 5-11-2009.

EMILY CARLSEN, EXAMINING ATTORNEY

---

SN 85-075,140. COLLINS, WILLIAM, FAYETTEVILLE, AR. FILED 6-30-2010.

# KINGDOM MARKETPLACE

THE MARK CONSISTS OF STANDARD CHARACTERS WITHOUT CLAIM TO ANY PARTICULAR FONT, STYLE, SIZE, OR COLOR.

NO CLAIM IS MADE TO THE EXCLUSIVE RIGHT TO USE "MARKETPLACE", APART FROM THE MARK AS SHOWN.

FOR COMPUTER SERVICES, NAMELY, CREATING AN ON-LINE COMMUNITY FOR REGISTERED USERS TO PARTICIPATE IN DISCUSSIONS, GET FEEDBACK FROM THEIR PEERS, FORM VIRTUAL COMMUNITIES, AND ENGAGE IN SOCIAL NETWORKING, FEATURING BUSINESS, FINANCIAL, LEGAL, ENTREPRENEURSHIP, ENTERTAINMENT, PERSONAL, HEALTH AND WELLNESS, EDUCATIONAL, PHILANTHROPY, AND FAITH-BASED CONTENT; PROVIDING A WEB SITE FEATURING TEMPORARY USE OF NON-DOWNLOADABLE SOFTWARE ALLOWING WEB SITE USERS TO UPLOAD, POST AND DISPLAY ONLINE VIDEOS FOR SHARING WITH OTHERS FOR ENTERTAINMENT PURPOSES (U.S. CLS. 100 AND 101).

CHRISTINE COOPER, EXAMINING ATTORNEY

**CLASS 42—(Continued).**

SN 85-077,592. PROMETHEAN LIMITED, BLACKBURN, LANCASHIRE, UNITED KINGDOM, FILED 7-2-2010.

# DATAQUBE

THE MARK CONSISTS OF STANDARD CHARACTERS WITHOUT CLAIM TO ANY PARTICULAR FONT, STYLE, SIZE, OR COLOR.

FOR COMPUTER SERVICES, NAMELY, COMPUTER SOFTWARE DEVELOPMENT OF WEB APPLICATIONS FOR INTERNET USERS THAT NEED TO ORGANIZE AND MANIPULATE DATA; PROVIDING ONLINE, NON-DOWNLOADABLE SOFTWARE FOR ORGANIZATION AND MANIPULATION OF DATA IN THE FIELD OF EARLY LEARNING, PRIMARY, SECONDARY, AND POST-SECONDARY EDUCATION; DATA WAREHOUSING (U.S. CLS. 100 AND 101).

FIRST USE 8-31-2009; IN COMMERCE 8-31-2009.

RUDY R. SINGLETON, EXAMINING ATTORNEY

**CLASS 42—(Continued).**

SN 85-085,080. INNERLINK, INC., LANCASTER, PA. FILED 7-15-2010.

# Health eAchievement

THE MARK CONSISTS OF STANDARD CHARACTERS WITHOUT CLAIM TO ANY PARTICULAR FONT, STYLE, SIZE, OR COLOR.

NO CLAIM IS MADE TO THE EXCLUSIVE RIGHT TO USE "HEALTH", APART FROM THE MARK AS SHOWN.

FOR COMPUTER SERVICES, NAMELY, PROVIDING A WEB-BASED SYSTEM AND ONLINE PORTAL FEATURING ON-LINE NON-DOWNLOADABLE SOFTWARE FOR THE COMPREHENSIVE MANAGEMENT OF ELECTRONIC HEALTH RECORDS AND DIGITAL HEALTH INFORMATION FOR SCHOOLS AND FOR MONITORING STUDENT HEALTH AND FITNESS PARAMETERS (U.S. CLS. 100 AND 101).

FIRST USE 9-11-2009; IN COMMERCE 12-2-2009.

ANGELA DUONG, EXAMINING ATTORNEY

SN 85-077,743. PROTOHIT, INC., ALBUQUERQUE, NM. FILED 7-3-2010.

# Protohit

THE MARK CONSISTS OF STANDARD CHARACTERS WITHOUT CLAIM TO ANY PARTICULAR FONT, STYLE, SIZE, OR COLOR.

FOR SOFTWARE AS A SERVICE (SAAS) SERVICES FEATURING SOFTWARE IN THE FIELD OF PATIENT TREATMENT OPTIMIZATION FOR USE BY PHYSICIANS, NURSES, PHYSICAL THERAPISTS, AND OTHER HEALTH CARE PROVIDERS, CLINICS, MANAGED HEALTHCARE ORGANIZATIONS, HEALTH PLAN PROVIDERS, MEDICAL INSURERS, EMPLOYEE ASSISTANCE PLANS, PRIVATE AND PUBLIC EMPLOYERS, SOCIAL WORKERS AND COUNSELORS, THAT ALLOWS USERS TO ENTER, PROCESS AND MANAGE PATIENT-RELATED DATA AND WHICH SOFTWARE COLLECTS AND ANALYZES HEALTH DATA TO DEVELOP, MONITOR AND REPORT EFFECTIVE TREATMENT PROCEDURES AND PROTOCOLS (U.S. CLS. 100 AND 101).

BARBARA GAYNOR, EXAMINING ATTORNEY

SN 85-089,043. ENOTES.COM, INC., SEATTLE, WA. FILED 7-20-2010.

# ENOTES

THE MARK CONSISTS OF STANDARD CHARACTERS WITHOUT CLAIM TO ANY PARTICULAR FONT, STYLE, SIZE, OR COLOR.

FOR COMPUTER SERVICES, NAMELY, HOSTING ON-LINE WEB FACILITIES FOR INDIVIDUALS, SCHOOLS AND ACADEMIC INSTITUTIONS, AND BUSINESSES FOR ORGANIZING AND CONDUCTING ONLINE MEETINGS, GATHERINGS, AND INTERACTIVE DISCUSSIONS THAT ALLOW PARTICIPANTS TO SHARE INFORMATION VIA A GLOBAL COMPUTER NETWORK; COMPUTER SERVICES, NAMELY, HOSTING ON-LINE WEB FACILITIES, FOR EDUCATORS AND LEARNERS FOR ORGANIZING AND CONDUCTING ONLINE MEETINGS, GATHERINGS, AND INTERACTIVE DISCUSSIONS THAT ALLOW PARTICIPANTS TO EXCHANGE INFORMATION VIA A GLOBAL COMPUTER NETWORK; COMPUTER SERVICES, NAMELY, CREATING AN ON-LINE COMMUNITY FOR REGISTERED USERS TO PARTICIPATE IN DISCUSSIONS, GET FEEDBACK FROM THEIR PEERS AND FROM EDUCATORS, FORM VIRTUAL COMMUNITIES, AND ENGAGE IN SOCIAL NETWORKING (U.S. CLS. 100 AND 101).

FIRST USE 1-26-2007; IN COMMERCE 1-26-2007.

TINA L. SNAPP, EXAMINING ATTORNEY



**CLASS 42—(Continued).**

SN 85-090,539. JAMESTOWN BUILDERS, LLC, FORT COLLINS, CO. FILED 7-22-2010.

**RE-HISTORIC**

THE MARK CONSISTS OF STANDARD CHARACTERS WITHOUT CLAIM TO ANY PARTICULAR FONT, STYLE, SIZE, OR COLOR.

FOR ARCHITECTURAL DESIGN SERVICES; INTERIOR DESIGN SERVICES; URBAN PLANNING AND DESIGN SERVICES (U.S. CLS. 100 AND 101).

JILL C. ALT, EXAMINING ATTORNEY

**CLASS 42—(Continued).**

SN 85-093,821. RUMPELSTILTSKIN INDUSTRIES, LLC, VENICE, CA. FILED 7-27-2010.



SN 85-091,089. PRIMED TO IMPRESS, INC., NAPERVILLE, IL. FILED 7-22-2010.



THE COLOR(S) ORANGE AND GREY IS/ARE CLAIMED AS A FEATURE OF THE MARK.

THE MARK CONSISTS OF A BUSINESS MAN IN MOTION RUNNING FORWARD FROM LEFT TO THE RIGHT WITH A BRIEFCASE EXTENDING OFF HIS ARM ON THE RIGHT, WHICH CONSISTS OF AN ORANGE BODY COLOR AND A DARK GREY FORWARD SHADOW. UNDERNEATH THE MAN JUST DESCRIBED IS A DARK GREY CHECKERED PATTERN THAT IS A FINISH LINE THAT THE MAN IS RUNNING ACROSS. THIS FINISH LINE GOES FROM THE BOTTOM LEFT AND GETS SMALLER IN DEPTH TO THE UPPER RIGHT HAND CORNER. THE WORDS "PRIMED TO IMPRESS!" IS IN GREY AND IS IN ALL CAPS, WITH THE "TO" BEING HALF THE SIZE OF THE "PRIMED" AND "IMPRESS!" WORDS. A MAJOR ASPECT IS THE EXPLANATION MARK AT THE END OF THE "PRIMED TO IMPRESS!" THE WHITE IN THE MARK IS FOR BACKGROUND PURPOSES AND IS NOT CLAIMED AS A FEATURE OF A MARK.

FOR PROVIDING A WEBSITE THAT ENABLES USERS TO SUBSCRIBE TO COACHING, MENTORING, AND/OR EDUCATIONAL SERVICES AND TO ENABLE USERS TO AUTHOR AND PUBLISH INSTRUCTIONAL CONTENT FOR OTHERS (U.S. CLS. 100 AND 101).

FIRST USE 1-10-2010; IN COMMERCE 1-10-2010.

DEZMONA MIZELLE, EXAMINING ATTORNEY

THE MARK CONSISTS OF THE STYLIZED LETTERS "R" AND "I" WITH AN IMAGE OF A FLOWER EMERGING OVER THE LETTER "I".

FOR SCIENTIFIC AND TECHNOLOGICAL SERVICES, NAMELY, RESEARCH AND ANALYSIS OF THE COMPOSITION AND CONTENT OF BIOACTIVE PLANT MATERIALS, NAMELY, LIVING AND DRIED PLANTS, RAW AND PROCESSED PLANT MATERIALS, PLANT PARTS AND WHOLE PLANTS, BOTANICAL PRODUCTS, NAMELY, POWDERS, LIQUID EXTRACTS, TABLETS AND PILLS, AND PLANT-DERIVED NUTRACEUTICALS AND PHARMACEUTICALS AND PROVIDING TECHNICAL REPORTS IN CONNECTION WITH SAME; SCIENTIFIC AND TECHNOLOGICAL SERVICES, NAMELY, THE IDENTIFICATION, DETECTION AND SCREENING OF RESIDUES AND HARMFUL SUBSTANCES, NAMELY, MOLD, FUNGUS, HEAVY METALS, PESTICIDES, HERBICIDES, FUNGICIDES, TOXINS, PARASITES, MICROBIOLOGICAL CONTAMINANTS, AND INDUSTRIAL CONTAMINANTS IN BIOACTIVE PLANT MATERIALS AND PROVIDING TECHNICAL REPORTS IN CONNECTION WITH SAME; SCIENTIFIC AND TECHNOLOGICAL SERVICES, NAMELY, ANALYSIS OF THE CHEMICAL CONTENT, MOISTURE CONTENT, AND LEVEL OF ONE OR MORE ACTIVE INGREDIENTS IN BIOACTIVE PLANT MATERIALS AND PROVIDING TECHNICAL REPORTS IN CONNECTION WITH SAME; SCIENTIFIC AND TECHNOLOGICAL SERVICES, NAMELY, SCIENTIFIC RESEARCH AND ANALYSIS RELATING TO THE STERILIZATION, REDUCTION, AND REMOVAL OF ONE OR MORE CHEMICAL COMPONENTS, ONE OR MORE CONTAMINANTS, AND MOISTURE FROM BIOACTIVE PLANT MATERIALS AND PROVIDING TECHNICAL REPORTS IN CONNECTION WITH SAME; TESTING, ANALYSIS AND EVALUATION OF THE GOODS AND SERVICES OF OTHERS FOR THE PURPOSE OF CERTIFICATION (U.S. CLS. 100 AND 101).

MICHAEL KEATING, EXAMINING ATTORNEY

**CLASS 42—(Continued).**

SN 85-097,874. AMERICAN SCHOOL COUNSELOR ASSOCIATION, ALEXANDRIA, VA. FILED 8-2-2010.



OWNER OF U.S. REG. NOS. 3,533,868 AND 3,820,626.  
NO CLAIM IS MADE TO THE EXCLUSIVE RIGHT TO USE "RECOGNIZED" OR "MODEL PROGRAM", APART FROM THE MARK AS SHOWN.

THE MARK CONSISTS OF A LARGE SHADED DIAMOND WITH TWO SMALLER DIAMONDS INSIDE WITH ARROWS ON THE DIAMONDS POINTING TO THE TOP CORNER OF THE SHADED DIAMOND AND TWO SHADED ARROWS IN THE DIAMONDS POINTING TO THE TOP OUTER SIDES. EACH CORNER OF THE LARGE SHADED DIAMOND HAS A SMALLER SHADED DIAMOND AT THE TIP WITH THE WORDS "RECOGNIZED," "ASCA," "MODEL," "PROGRAM," AND "RAMP," RESPECTIVELY, ON EACH SIDE OF THE LARGE SHADED DIAMOND.

FOR ACCREDITATION SERVICES, NAMELY, EVALUATING ORGANIZATIONS TO DETERMINE WHETHER THE ORGANIZATIONS CONFORM TO AN ESTABLISHED STANDARD (U.S. CLS. 100 AND 101).  
STEVEN JACKSON, EXAMINING ATTORNEY

SN 85-104,013. UTILIGENCE LIMITED, TA UTILIGENCE, ABU DHABI, UNITED ARAB EMIR., FILED 8-10-2010.

# Utiligence

THE MARK CONSISTS OF STANDARD CHARACTERS WITHOUT CLAIM TO ANY PARTICULAR FONT, STYLE, SIZE, OR COLOR.

OWNER OF UNITED KINGDOM REG. NO. 2552814, DATED 7-13-2010, EXPIRES 7-12-2020.

FOR CONSULTING SERVICES IN THE FIELDS OF ENERGY MEASUREMENT TO IMPROVE ENERGY EFFICIENCY (U.S. CLS. 100 AND 101).

FLORENTINA BLANDU, EXAMINING ATTORNEY

**CLASS 42—(Continued).**

SN 85-115,929. CIMA TELECOM INC., MIAMI, FL. FILED 8-25-2010.

## AURIS MOBILE APPS

THE MARK CONSISTS OF STANDARD CHARACTERS WITHOUT CLAIM TO ANY PARTICULAR FONT, STYLE, SIZE, OR COLOR.

NO CLAIM IS MADE TO THE EXCLUSIVE RIGHT TO USE "MOBILE APPS", APART FROM THE MARK AS SHOWN.

FOR APPLICATION SERVICE PROVIDER, NAMELY, HOSTING, MANAGING, DEVELOPING, AND MAINTAINING COMPUTER SOFTWARE APPLICATIONS OF OTHERS FOR USE WITH MOBILE COMMUNICATIONS DEVICES (U.S. CLS. 100 AND 101).

FIRST USE 12-0-2009; IN COMMERCE 12-0-2009.  
STEVEN JACKSON, EXAMINING ATTORNEY

SN 85-119,142. CROWNPEAK TECHNOLOGY, LOS ANGELES, CA. FILED 8-30-2010.

## Crownpeak Web Content Optimizer

THE MARK CONSISTS OF STANDARD CHARACTERS WITHOUT CLAIM TO ANY PARTICULAR FONT, STYLE, SIZE, OR COLOR.

OWNER OF U.S. REG. NO. 3,028,518.

NO CLAIM IS MADE TO THE EXCLUSIVE RIGHT TO USE "WEB CONTENT OPTIMIZER", APART FROM THE MARK AS SHOWN.

FOR PROVIDING TEMPORARY USE OF ONLINE NON-DOWNLOADABLE SOFTWARE, NAMELY, SOFTWARE TO TRACK WEB SITE USER ACTIVITY, DELIVER TARGETED DATA AND INFORMATION TO WEB SITE USERS BASED ON AMBIENT, BEHAVIORAL, OR EXPLICITLY PROVIDED DATA, MEASURE USER AFFINITY FOR MATERIAL AND CONTENT ALTERNATIVES, AND CAPTURE AND REPORT ON DATA SUBMITTED BY WEB SITE USERS VIA THE APPLICATION; PROVIDING TEMPORARY USE OF ONLINE NON-DOWNLOADABLE SOFTWARE, NAMELY, COMPUTER SOFTWARE CODE FOR USE IN CONNECTION WITH DEVELOPING, MANAGING, UPDATING, AND MAINTAINING WEB SITES, INTRANETS, EXTRANETS AND OTHER WEB-BASED DATA REPOSITORIES; COMPUTER SERVICES, NAMELY, MAINTAINING WEB SITES FOR OTHERS; COMPUTER SERVICES, NAMELY, CUSTOMIZATION, CONFIGURATION, AND INTEGRATION OF NON-DOWNLOADABLE SOFTWARE; COMPUTER SERVICES, NAMELY, PROVIDING TEMPORARY USE OF NON-DOWNLOADABLE ONLINE SOFTWARE DEVELOPMENT KITS TO ENABLE OTHERS TO DEVELOP, MANAGE, UPDATE, AND MAINTAIN WEB SITES, INTRANETS, EXTRANETS, AND OTHER WEB-BASED DATA REPOSITORIES (U.S. CLS. 100 AND 101).

FIRST USE 8-10-2010; IN COMMERCE 8-10-2010.

H. M. FISHER, EXAMINING ATTORNEY

**CLASS 42—(Continued).**

SN 85-119,158. CROWNPEAK TECHNOLOGY, LOS ANGELES, CA. FILED 8-30-2010.

ENSURING YOUR WEB CONTENT  
SUCCESS

THE MARK CONSISTS OF STANDARD CHARACTERS WITHOUT CLAIM TO ANY PARTICULAR FONT, STYLE, SIZE, OR COLOR.

NO CLAIM IS MADE TO THE EXCLUSIVE RIGHT TO USE "WEB CONTENT", APART FROM THE MARK AS SHOWN.

FOR PROVIDING TEMPORARY USE OF ONLINE NON-DOWNLOADABLE SOFTWARE, NAMELY, SOFTWARE TO TRACK WEB SITE USER ACTIVITY, DELIVER TARGETED DATA AND INFORMATION TO WEB SITE USERS BASED ON AMBIENT, BEHAVIORAL, OR EXPLICITLY PROVIDED DATA, MEASURE USER AFFINITY FOR MATERIAL AND CONTENT ALTERNATIVES, AND CAPTURE AND REPORT ON DATA SUBMITTED BY WEB SITE USERS VIA THE APPLICATION; PROVIDING TEMPORARY USE OF ONLINE NON-DOWNLOADABLE SOFTWARE, NAMELY, COMPUTER SOFTWARE CODE FOR USE IN CONNECTION WITH DEVELOPING, MANAGING, UPDATING, AND MAINTAINING WEB SITES, INTRANETS, EXTRANETS AND OTHER WEB-BASED DATA REPOSITORIES; COMPUTER SERVICES, NAMELY, MAINTAINING WEB SITES FOR OTHERS; COMPUTER SERVICES, NAMELY, CUSTOMIZATION, CONFIGURATION, AND INTEGRATION OF NON-DOWNLOADABLE SOFTWARE; COMPUTER SERVICES, NAMELY, PROVIDING TEMPORARY USE OF NON-DOWNLOADABLE ONLINE SOFTWARE DEVELOPMENT KITS TO ENABLE OTHERS TO DEVELOP, MANAGE, UPDATE, AND MAINTAIN WEB SITES, INTRANETS, EXTRANETS, AND OTHER WEB-BASED DATA REPOSITORIES (U.S. CLS. 100 AND 101).

FIRST USE 7-17-2009; IN COMMERCE 7-17-2009.

H. M. FISHER, EXAMINING ATTORNEY

SN 85-120,093. HORN, RACHEL, LAREDO, TX. FILED 8-31-2010.

RACHEL HORN

THE MARK CONSISTS OF STANDARD CHARACTERS WITHOUT CLAIM TO ANY PARTICULAR FONT, STYLE, SIZE, OR COLOR.

THE NAME(S), PORTRAIT(S), AND/OR SIGNATURE(S) SHOWN IN THE MARK IDENTIFIES "RACHEL HORN", WHOSE CONSENT(S) TO REGISTER IS MADE OF RECORD.

FOR INTERIOR DESIGN SERVICES AND ARCHITECTURAL DESIGN SERVICES (U.S. CLS. 100 AND 101).

FIRST USE 1-1-2001; IN COMMERCE 1-1-2001.

SANJEEV VOHRA, EXAMINING ATTORNEY

**CLASS 42—(Continued).**

SN 85-121,406. MUSIC MASTERMIND, INC., CALABASAS, CA. FILED 9-2-2010.

SILVERDOOR

THE MARK CONSISTS OF STANDARD CHARACTERS WITHOUT CLAIM TO ANY PARTICULAR FONT, STYLE, SIZE, OR COLOR.

FOR COMPUTER SERVICES, NAMELY, HOSTING ON-LINE WEB FACILITIES FOR OTHERS TO SHOW-CASE MUSICAL COMPOSITION AND TALENTS AND FOR FACILITATING AND CONDUCTING ON-LINE CONNECTIONS, COLLABORATIONS AND INTERACTIVE DISCUSSIONS ABOUT MUSIC COMPOSITION AND MUSIC; PROVIDING A WEBSITE THAT ALLOWS USERS TO UPLOAD AND DOWNLOAD MUSIC AND VIDEOS; CREATING AN ON-LINE COMMUNITY FOR USERS TO PARTICIPATE IN DISCUSSIONS, GET FEEDBACK FROM THEIR PEERS, FORM VIRTUAL COMMUNITIES AND ENGAGE IN SOCIAL NETWORKING (U.S. CLS. 100 AND 101).

REBECCA SMITH, EXAMINING ATTORNEY

SN 85-128,669. MGL AMERICAS INC., CRANBURY, NJ. FILED 9-13-2010.

UltraCloud

THE MARK CONSISTS OF STANDARD CHARACTERS WITHOUT CLAIM TO ANY PARTICULAR FONT, STYLE, SIZE, OR COLOR.

FOR CLOUD COMPUTING FEATURING COMPUTER SOFTWARE AND TECHNIQUES FOR CLOUD SOLUTIONS TO ACCELERATE APPLICATIONS, FINANCIAL MODELS, NUMBER CRUNCHING ALGORITHMS, VOLUMINOUS DATA PROCESSING USING PARALLELIZATION TECHNIQUES, LEVERAGING OPTIMAL USE OF CPU CORES, MEMORY AND COMPUTE NODES OVER A NETWORK/GRID/CLUSTER IN THE FIELD OF FINANCE, HEALTHCARE, LIFE SCIENCES, WEATHER MODELING, AEROSPACE, CREATIVE INDUSTRY AND OTHER INDUSTRIES WHERE LARGE AMOUNT OF DATA AND/OR COMPUTE-BOUND JOB NEEDS TO BE PROCESSED IN THE SHORTEST POSSIBLE TIME (U.S. CLS. 100 AND 101).

FIRST USE 1-2-2010; IN COMMERCE 4-3-2010.

HEATHER SAPP, EXAMINING ATTORNEY

**CLASS 42—(Continued).**

SN 85-134,488. AMITECH SOLUTIONS, ST LOUIS, MO. FILED 9-21-2010.



**Amitech Solutions**  
*Performance Optimized*

THE MARK CONSISTS OF THE STYLIZED WORDING "AMITECH SOLUTIONS PERFORMANCE OPTIMIZED" AND THE TRIANGULAR DESIGN WITH CURVED CORNERS INSIDE A CIRCLE DIVIDED LIKE A PUZZLE AND THE SLIGHT REFLECTION OF THE DESIGN.

FOR COMPUTER SOFTWARE TECHNOLOGY CONSULTING (U.S. CLS. 100 AND 101).

FIRST USE 5-1-2009; IN COMMERCE 5-1-2009.

HOWARD B. LEVINE, EXAMINING ATTORNEY

---

SN 85-136,201. NUTECH ENERGY ALLIANCE, LTD., HUMBLE, TX. FILED 9-23-2010.

**NULOOK**

THE MARK CONSISTS OF STANDARD CHARACTERS WITHOUT CLAIM TO ANY PARTICULAR FONT, STYLE, SIZE, OR COLOR.

OWNER OF U.S. REG. NO. 2,926,886.

FOR FORMATION ANALYSIS, INTERPRETATION, AND CONSULTATION SERVICES FOR OIL AND GAS FIELD EXPLORATION, USING A SOFTWARE-CONTROLLED PROCESS; COMPUTER MODELING SERVICES, NAMELY, COMPUTER SIMULATION FROM COMPUTER SOFTWARE FOR OTHERS TO CONDUCT ANALYSIS, INTERPRETATION, MODELING, AND CONSULTATION SERVICES FOR OIL AND GAS FIELD EXPLORATION (U.S. CLS. 100 AND 101).

FIRST USE 5-15-1997; IN COMMERCE 5-15-1997.

NAKIA HENRY, EXAMINING ATTORNEY

---

SN 85-136,213. NUTECH ENERGY ALLIANCE, LTD., HUMBLE, TX. FILED 9-23-2010.

**NUFIT**

THE MARK CONSISTS OF STANDARD CHARACTERS WITHOUT CLAIM TO ANY PARTICULAR FONT, STYLE, SIZE, OR COLOR.

FOR FORMATION ANALYSIS, INTERPRETATION, AND CONSULTATION SERVICES FOR OIL AND GAS FIELD EXPLORATION, USING A SOFTWARE-CONTROLLED PROCESS; COMPUTER MODELING SERVICES, NAMELY, COMPUTER SIMULATION FROM COMPUTER SOFTWARE FOR OTHERS TO CONDUCT ANALYSIS, INTERPRETATION, MODELING, AND CONSULTATION SERVICES FOR OIL AND GAS FIELD EXPLORATION (U.S. CLS. 100 AND 101).

NAKIA HENRY, EXAMINING ATTORNEY

**CLASS 42—(Continued).**

SN 85-138,527. THE ENDURANCE INTERNATIONAL GROUP, INC., BURLINGTON, MA. FILED 9-27-2010.

**SPRY**

THE MARK CONSISTS OF STANDARD CHARACTERS WITHOUT CLAIM TO ANY PARTICULAR FONT, STYLE, SIZE, OR COLOR.

FOR HOSTING OF DIGITAL CONTENT ON THE INTERNET; HOSTING OF WEB SITES; HOSTING THE SOFTWARE, WEBSITES AND OTHER COMPUTER APPLICATIONS OF OTHERS ON A VIRTUAL PRIVATE SERVER; PROVIDING TECHNICAL SUPPORT SERVICES IN CONNECTION WITH WEB HOSTING SERVICES ON A VIRTUAL PRIVATE SERVER, NAMELY, TROUBLESHOOTING OF COMPUTER SOFTWARE PROBLEMS (U.S. CLS. 100 AND 101).

FIRST USE 3-26-2002; IN COMMERCE 3-26-2002.

LINDA M. KING, EXAMINING ATTORNEY

---

SN 85-139,298. LEE, SEUNG W., GARDENA, CA. FILED 9-27-2010.



THE COLOR(S) GREEN, YELLOW AND WHITE IS/ARE CLAIMED AS A FEATURE OF THE MARK.

THE MARK CONSISTS OF THE OUTLINE OF AN EGG SHAPE IN THE COLOR GREEN WITH A YELLOW YOKE DESIGN INSIDE THE OUTLINE AND THE LETTERS "SFU" IN GREEN TO THE RIGHT OF THE YOKE DESIGN. THE AREA BETWEEN THE YELLOW YOKE AND THE GREEN OUTLINE APPEARS IN WHITE.

FOR FOOD SAFETY TESTING AND CONSULTATION; QUALITY MANAGEMENT SERVICES, NAMELY, QUALITY EVALUATION AND ANALYSIS, QUALITY ASSURANCE AND QUALITY CONTROL IN THE FIELD OF FOOD PREPARATION AND HEAT PASTEURIZATION PROCESSES FOR SHELL EGGS (U.S. CLS. 100 AND 101).

DORITT L. CARROLL, EXAMINING ATTORNEY

**CLASS 42—(Continued).**

SN 85-140,928. ELECTRONIC THEATRE CONTROLS, INC., MIDDLETON, WA. FILED 9-29-2010.

# ETCSELECT

THE MARK CONSISTS OF STANDARD CHARACTERS WITHOUT CLAIM TO ANY PARTICULAR FONT, STYLE, SIZE, OR COLOR.

FOR COMPUTER SERVICES, NAMELY, PROVIDING ONLINE NONDOWNLOADABLE SOFTWARE THAT ENABLES USERS TO DESIGN, SELECT OR ORDER LIGHTING AND LIGHTING CONTROL SYSTEMS (U.S. CLS. 100 AND 101).

FIRST USE 2-1-2009; IN COMMERCE 2-1-2009.  
JAY FLOWERS, EXAMINING ATTORNEY

SN 85-143,997. TENCENT HOLDINGS LIMITED, GEORGE TOWN, GC, CAYMAN ISLANDS, FILED 10-4-2010.



THE MARK CONSISTS OF THE WORD "PAIPAI", WHERE EACH LETTER IS ENCLOSED IN A QUADRILATERAL DEVICE AND THE SIX QUADRILATERAL DEVICES ARE PARTIALLY OVERLAPPING EACH OTHER.

THE WORDING "PAIPAI" HAS NO MEANING IN A FOREIGN LANGUAGE.

FOR PROVIDING CUSTOMIZED ON-LINE WEB PAGES FEATURING USER-DEFINED INFORMATION, WHICH INCLUDES SEARCH ENGINES AND ON-LINE WEB LINKS TO OTHER WEB SITES TO FACILITATE E-COMMERCE AND REAL WORLD BUSINESS TRANSACTIONS; COMPUTER SERVICE, NAMELY, ACTING AS AN APPLICATION SERVICE PROVIDER IN THE FIELD OF KNOWLEDGE MANAGEMENT TO HOST COMPUTER APPLICATION SOFTWARE FOR SEARCHING AND RETRIEVING INFORMATION FROM DATABASES AND COMPUTER NETWORKS; HOSTING OF WEB SITES; DEVELOPING AND HOSTING A SERVER ON A GLOBAL COMPUTER NETWORK FOR THE PURPOSE OF FACILITATING E-COMMERCE VIA SUCH A SERVER (U.S. CLS. 100 AND 101).

BARBARA RUTLAND, EXAMINING ATTORNEY

**CLASS 42—(Continued).**

SN 85-144,316. CORE LABORATORIES GLOBAL NV, WILLEMSTAD CURACAO, NETHERLANDS ANTILLES, FILED 10-4-2010.

# MR SHALE

THE MARK CONSISTS OF STANDARD CHARACTERS WITHOUT CLAIM TO ANY PARTICULAR FONT, STYLE, SIZE, OR COLOR.

FOR GEOLOGICAL ANALYSIS FOR OTHERS OF EARTH CORES FOR USE IN THE EXPLORATION FOR AND PRODUCTION OF OIL AND GAS (U.S. CLS. 100 AND 101).

RENEE SERVANCE, EXAMINING ATTORNEY

SN 85-144,650. TECHVALENS SOFTWARE SOLUTIONS LLC, TAMPA, FL. FILED 10-4-2010.



THE STIPPLING IS A FEATURE OF THE MARK AND DOES NOT INDICATE COLOR.

THE COLOR(S) BLACK, RED AND GRAY IS/ARE CLAIMED AS A FEATURE OF THE MARK.

THE MARK CONSIST OF THE WORDING "TECH" IN THE COLOR BLACK, THE WORDING "VALENS" IS IN THE COLOR RED, THE LETTER "V" IS SHAPED LIKE A CHECK IN THE COLOR RED, AND THERE ARE THREE SIGNAL MARK IS IN THE COLOR GRAY AND BLACK.

THE ENGLISH TRANSLATION OF "VALENS" IN THE MARK IS "POWER". THE WORDING "TECHVALENS" HAS NO MEANING IN A FOREIGN LANGUAGE.

FOR APPLICATION SERVICE PROVIDER, NAMELY, HOSTING, MANAGING, DEVELOPING, AND MAINTAINING APPLICATIONS, SOFTWARE, AND WEB SITES, IN THE FIELDS OF PERSONAL PRODUCTIVITY, WIRELESS COMMUNICATION, MOBILE INFORMATION ACCESS, AND REMOTE DATA MANAGEMENT FOR WIRELESS DELIVERY OF CONTENT TO HANDHELD COMPUTERS, LAPTOPS AND MOBILE ELECTRONIC DEVICES; CUSTOMIZED SOFTWARE DEVELOPMENT SERVICES; DESIGN, DEVELOPMENT, INSTALLATION AND MAINTENANCE OF COMPUTER SOFTWARE; DESIGNING AND DEVELOPING COMPUTER GAME SOFTWARE AND VIDEO GAME SOFTWARE FOR USE WITH COMPUTERS, VIDEO GAME PROGRAM SYSTEMS AND COMPUTER NETWORKS; DEVELOPING COMPUTER SOFTWARE; DEVELOPMENT AND IMPLEMENTATION OF SOFTWARE, HARDWARE AND TECHNOLOGY SOLUTIONS FOR THE PURPOSE OF PRODUCTIZATION OF ELECTRONIC COMPONENTS AND ELECTRONIC SYSTEMS; DEVELOPMENT, UPDATING AND MAINTENANCE OF SOFTWARE AND DATA BASES; RESEARCH, DEVELOPMENT, DESIGN AND UPGRADING OF COMPUTER SOFTWARE; SOFTWARE DESIGN AND DEVELOPMENT; SOFTWARE DEVELOPMENT AND PRODUCT DEVELOPMENT IN THE FIELD OF WIRELESS DEVICES (U.S. CLS. 100 AND 101).

FIRST USE 6-19-2008; IN COMMERCE 6-19-2008.

ANNE E. GUSTASON, EXAMINING ATTORNEY



**CLASS 42—(Continued).**

SN 85-149,739. ENDPOINT, LLC, SAN FRANCISCO, CA. FILED 10-11-2010.

endpoint

THE MARK CONSISTS OF STANDARD CHARACTERS WITHOUT CLAIM TO ANY PARTICULAR FONT, STYLE, SIZE, OR COLOR.

FOR COMPUTER SERVICES, NAMELY, PROVIDING A WEB-BASED SYSTEM AND ON-LINE PORTAL FEATURING ON-LINE NON-DOWNLOADABLE SOFTWARE THAT ENABLES USERS TO ACCESS INFORMATION RELATED TO CLINICAL TRIALS IN THE FIELD OF MEDICINE (U.S. CLS. 100 AND 101).

FIRST USE 12-1-2009; IN COMMERCE 12-1-2009.  
APRIL HESIK, EXAMINING ATTORNEY

SN 85-152,297. ESOLUTIONSGROUP LIMITED, WATERLOO, ONTARIO, CANADA, FILED 10-14-2010.

2big4email

THE MARK CONSISTS OF STANDARD CHARACTERS WITHOUT CLAIM TO ANY PARTICULAR FONT, STYLE, SIZE, OR COLOR.

PRIORITY CLAIMED UNDER SEC. 44(D) ON CANADA APPLICATION NO. 1497087, FILED 9-23-2010.

FOR PROVIDING TEMPORARY USE OF ON-LINE NON-DOWNLOADABLE SOFTWARE FOR THE EXCHANGE (UPLOADING AND DOWNLOADING) OF ELECTRONIC FILES BETWEEN THIRD PARTIES (U.S. CLS. 100 AND 101).

FIRST USE 9-21-2010; IN COMMERCE 9-21-2010.  
BRIAN PINO, EXAMINING ATTORNEY

**CLASS 42—(Continued).**

SN 85-154,168. FASTURTLE INTERACTIVE, LLC, SCOTTSDALE, AZ. FILED 10-15-2010.

FASTURTLE

THE MARK CONSISTS OF STANDARD CHARACTERS WITHOUT CLAIM TO ANY PARTICULAR FONT, STYLE, SIZE, OR COLOR.

FOR APPLICATION SERVICE PROVIDER, NAMELY, HOSTING, MANAGING, DEVELOPING, ANALYZING, AND MAINTAINING APPLICATIONS, SOFTWARE, AND WEB SITES, OF OTHERS IN THE FIELDS OF ADVERTISING AND MARKETING; COMPUTER PROGRAMMING SERVICES, NAMELY, CREATING AN ON-LINE COMMUNITY FOR REGISTERED USERS TO PARTICIPATE IN DISCUSSIONS, GET FEEDBACK FROM THEIR PEERS, FORM VIRTUAL COMMUNITIES, AND ENGAGE IN SOCIAL NETWORKING; DESIGNING AND IMPLEMENTING NETWORK WEB PAGES FOR OTHERS; COMPUTER SERVICES, NAMELY, SEARCH ENGINE OPTIMIZATION; HOMEPAGE AND WEBPAGE DESIGN; PROVIDING CUSTOMIZED ON-LINE WEB PAGES FEATURING USER-DEFINED INFORMATION, WHICH INCLUDES SEARCH ENGINES AND ON-LINE WEB LINKS TO OTHER WEB SITES (U.S. CLS. 100 AND 101).

FIRST USE 11-30-2000; IN COMMERCE 11-30-2000.  
DANIEL CAPSHAW, EXAMINING ATTORNEY

SN 85-156,413. MOBILE COMPLETE, INC., SAN MATEO, CA. FILED 10-19-2010.

MONITORANYWHERE

THE MARK CONSISTS OF STANDARD CHARACTERS WITHOUT CLAIM TO ANY PARTICULAR FONT, STYLE, SIZE, OR COLOR.

FOR PROVIDING A WEB-BASED SERVICE FEATURING TECHNOLOGY THAT ENABLES MONITORING FOR MOBILE APPLICATIONS AND MOBILE SERVICES (U.S. CLS. 100 AND 101).

FIRST USE 7-0-2009; IN COMMERCE 7-0-2009.  
ANNE E. GUSTASON, EXAMINING ATTORNEY

**CLASS 42—(Continued).**

SN 85-161,608. NET POWER AND LIGHT, INC., SAN FRANCISCO, CA. FILED 10-26-2010.

**SENTIO CODEC**

THE MARK CONSISTS OF STANDARD CHARACTERS WITHOUT CLAIM TO ANY PARTICULAR FONT, STYLE, SIZE, OR COLOR.

NO CLAIM IS MADE TO THE EXCLUSIVE RIGHT TO USE "CODEC", APART FROM THE MARK AS SHOWN.

FOR DISTRIBUTED COMPUTING FEATURING NON-DOWNLOADABLE SOFTWARE FOR USE IN PROVIDING, HOSTING, MANAGING, DEVELOPING, AND MAINTAINING APPLICATIONS, SOFTWARE, WEB SITES, AND DATABASES FOR WIRELESS COMMUNICATION, MOBILE INFORMATION ACCESS, AND REMOTE DATA MANAGEMENT FOR WIRELESS DELIVERY OF DATA AND CONTENT TO HANDHELD COMPUTERS, LAPTOPS, PERSONAL COMPUTERS, MOBILE PHONES, TV'S, PROJECTORS, STAND-ALONE HARDWARE DECODERS AND MOBILE ELECTRONIC DEVICES; DISTRIBUTED COMPUTING FEATURING NON-DOWNLOADABLE SOFTWARE ALLOWING USERS TO UPLOAD, POST AND DISPLAY ONLINE DIGITAL CONTENT FOR SHARING WITH OTHERS FOR ENTERTAINMENT PURPOSES; COMPUTER SERVICES, NAMELY, INTERACTIVE HOSTING SERVICES WHICH ALLOW USERS TO COLLABORATE IN THE PREPARATION, UPLOADING, DOWNLOADING, SHARING, PUBLISHING, RECEPTION AND TRANSMISSION OF DIGITAL CONTENT TO REMOTE DEVICES; COMPUTER SERVICES, NAMELY, INTERACTIVE HOSTING SERVICES WHICH ALLOW USERS TO COLLABORATE IN THE PREPARATION, UPLOADING, DOWNLOADING, SHARING, PUBLISHING, RECEPTION AND TRANSMISSION OF DIGITAL CONTENT TO REMOTE DEVICES FOR THE PURPOSE OF COMMUNICATING AND SHARING EXPERIENCES AND FOR ENTERTAINMENT PURPOSES (U.S. CLS. 100 AND 101).

GINA HAYES, EXAMINING ATTORNEY

SN 85-163,819. COBB ENTERPRISES, INC., CLOVIS, CA. FILED 10-28-2010.

**HI-TECH HEALTH**

THE MARK CONSISTS OF STANDARD CHARACTERS WITHOUT CLAIM TO ANY PARTICULAR FONT, STYLE, SIZE, OR COLOR.

NO CLAIM IS MADE TO THE EXCLUSIVE RIGHT TO USE "HI-TECH", APART FROM THE MARK AS SHOWN.

FOR CONSULTING SERVICES IN THE FIELD OF ELECTRONIC SYSTEM DESIGN (U.S. CLS. 100 AND 101).

DOMINICK J. SALEMI, EXAMINING ATTORNEY

**CLASS 42—(Continued).**

SN 85-165,889. EVIDON, INC., NEW YORK, NY. FILED 11-1-2010.

**EVIDON INFORM**

THE MARK CONSISTS OF STANDARD CHARACTERS WITHOUT CLAIM TO ANY PARTICULAR FONT, STYLE, SIZE, OR COLOR.

FOR PROVIDING TEMPORARY USE OF ONLINE NON-DOWNLOADABLE SOFTWARE FOR ONLINE PUBLISHERS TO MONITOR THIRD PARTY DATA COLLECTION AND AD PLACEMENT; PROVIDING TEMPORARY USE OF ONLINE NON-DOWNLOADABLE SOFTWARE THAT PROVIDES INTERNET USERS WITH EVIDENCE OF THIRD PARTY COMPLIANCE WITH INDUSTRY GUIDELINES; PROVIDING TEMPORARY USE OF ONLINE NON-DOWNLOADABLE SOFTWARE THAT PROVIDES INTERNET USERS WITH INFORMATION ON DATA COLLECTION PRACTICES AND THE ABILITY TO VIEW AND BLOCK THE TRACKING SETTINGS, WEB BUGS, WIDGETS AND ADVERTISING SERVICES ASSOCIATED WITH WEBSITES VISITED; COMPUTER SERVICES, NAMELY, ACTING AS AN APPLICATION SERVICE PROVIDER TO HOST COMPUTER SOFTWARE FOR THE COLLECTION, USE AND SHARING OF DATA GATHERED IN THE COURSE OF E-COMMERCE TRANSACTIONS, INTERNET WEBSITE USAGE AND ELECTRONIC MAIL USAGE (U.S. CLS. 100 AND 101).

LINDA E. BLOHM, EXAMINING ATTORNEY

SN 85-166,268. ADVANCED HEALTH MEDIA, LLC, BRIDGEWATER, NJ. FILED 11-1-2010.

**Audience Generation  
Exchange (AGX)**

THE MARK CONSISTS OF STANDARD CHARACTERS WITHOUT CLAIM TO ANY PARTICULAR FONT, STYLE, SIZE, OR COLOR.

NO CLAIM IS MADE TO THE EXCLUSIVE RIGHT TO USE "AUDIENCE GENERATION", APART FROM THE MARK AS SHOWN.

FOR PLATFORM AS A SERVICE (PAAS) FEATURING COMPUTER SOFTWARE PLATFORMS FOR HEALTH CARE PROFESSIONALS FOR CENTRALIZED REGISTRATION FOR EDUCATIONAL PROGRAMS AND COMPREHENSIVE ATTENDEE TRACKING (U.S. CLS. 100 AND 101).

FIRST USE 2-1-2010; IN COMMERCE 2-1-2010.

JERI J. FICKES, EXAMINING ATTORNEY

**CLASS 42—(Continued).**

SN 85-167,735. CONSCIOUS INNOVATIONS, ELGIN, IL. FILED 11-3-2010.

CONSCIOUS INNOVATIONS

THE MARK CONSISTS OF STANDARD CHARACTERS WITHOUT CLAIM TO ANY PARTICULAR FONT, STYLE, SIZE, OR COLOR.

NO CLAIM IS MADE TO THE EXCLUSIVE RIGHT TO USE "INNOVATIONS", APART FROM THE MARK AS SHOWN.

FOR TECHNOLOGY CONSULTATION SERVICES AND TECHNOLOGY RESEARCH SERVICES IN THE FIELD OF ALTERNATIVE ENERGY AND GREEN TECHNOLOGIES (U.S. CLS. 100 AND 101).

FIRST USE 4-10-2007; IN COMMERCE 4-10-2007.

RUDY R. SINGLETON, EXAMINING ATTORNEY

**CLASS 42—(Continued).**

SN 85-172,319. COLLABORATIVE SYSTEMS, KING OF PRUSSIA, PA. FILED 11-9-2010.



THE COLOR(S) NAVY BLUE, BLUE, SKY BLUE, LIGHT BLUE, PALE BLUE, BLACK AND WHITE IS/ARE CLAIMED AS A FEATURE OF THE MARK.

THE MARK CONSISTS OF THE STYLIZED WORD "COLLABORATIVE" IN NAVY BLUE; ABOVE WHICH IS A CIRCLE FORMED BY THREE BLUE ARROWS HAVING A SKY BLUE AND WHITE BACKGROUND; IN THE FOREGROUND OF THE CIRCLE ARE THREE INTERTWINED HANDS EACH IN A DIFFERENT COLOR, NAMELY, SKY BLUE, PALE BLUE AND LIGHT BLUE, ALL OF WHICH ARE OUTLINED IN BLACK.

FOR COMPUTER SOFTWARE CONSULTANCY (U.S. CLS. 100 AND 101).

FIRST USE 11-1-2010; IN COMMERCE 11-1-2010.

JULIE GUTTADAURO, EXAMINING ATTORNEY

SN 85-168,977. BRIGHTACT LLC, MENLO PARK, CA. FILED 11-4-2010.

DEMO  
RIGHT

NO CLAIM IS MADE TO THE EXCLUSIVE RIGHT TO USE "DEMO", APART FROM THE MARK AS SHOWN.

THE MARK CONSISTS OF THE TERM "DEMO", WITH A DOT WITHIN THE "M", ABOVE THE TERM "RIGHT".

FOR PROVIDING TEMPORARY USE OF ONLINE, ON-DEMAND, NONDOWNLOADABLE COMPUTER SOFTWARE FOR CREATING, TESTING, ANALYZING, AND EVALUATING PROTOTYPES OF MOBILE COMPUTER SOFTWARE APPLICATIONS, AND FOR COLLECTING USER FEEDBACK VIA THE INTERNET AND WIRELESS HANDHELD DEVICES (U.S. CLS. 100 AND 101).

FIRST USE 10-3-2010; IN COMMERCE 10-3-2010.

KIMBERLY PERRY, EXAMINING ATTORNEY

SN 85-174,874. PHAZ2, LOS ANGELES, CA. FILED 11-11-2010.

Phaz2

THE MARK CONSISTS OF THE WORD "PHAZ" AND THE NUMBER "2".

FOR COMPUTER SOFTWARE DEVELOPMENT IN THE FIELD OF MOBILE APPLICATIONS (U.S. CLS. 100 AND 101).

FIRST USE 9-9-2006; IN COMMERCE 9-9-2006.

EMILY CHUO, EXAMINING ATTORNEY

**CLASS 42—(Continued).**

SN 85-176,526. KUUZUU, INC., SAN FRANCISCO, CA. FILED 11-15-2010.

KUUZUU

THE MARK CONSISTS OF STANDARD CHARACTERS WITHOUT CLAIM TO ANY PARTICULAR FONT, STYLE, SIZE, OR COLOR.

FOR PROVIDING ONLINE NON-DOWNLOADABLE SOFTWARE FOR RECORDING, TRANSMITTING, VIEWING, STORING, ARCHIVING, UPLOADING, DISPLAYING AND SHARING AUDIO AND VIDEO CONTENT (U.S. CLS. 100 AND 101).

JACLYN KIDWELL WALKER, EXAMINING ATTORNEY

---

SN 85-176,794. MINUS INC., LAS VEGAS, NV. FILED 11-15-2010.

MINUS

THE MARK CONSISTS OF STANDARD CHARACTERS WITHOUT CLAIM TO ANY PARTICULAR FONT, STYLE, SIZE, OR COLOR.

FOR ONLINE COMPUTER SERVICES, NAMELY, PROVIDING AN INTERACTIVE WEB SITE THAT ALLOWS USERS TO CREATE, SHARE, MANAGE, UPLOAD, EDIT, AND SHOWCASE ELECTRONIC CONTENT; FILE SHARING SERVICES, NAMELY, PROVIDING A WEBSITE FEATURING TECHNOLOGY ENABLING USERS TO UPLOAD AND DOWNLOAD ELECTRONIC FILES; PROVIDING A WEB SITE THAT ENABLES INTERNET USERS TO SHARE PHOTOGRAPHS, VIDEOS, DOCUMENTS, IMAGES, AND LINKS (U.S. CLS. 100 AND 101).

FIRST USE 10-13-2010; IN COMMERCE 10-13-2010.

ALLISON HOLTZ, EXAMINING ATTORNEY

**CLASS 42—(Continued).**

SN 85-177,040. INSCAPE PUBLISHING, INC., MINNEAPOLIS, MN. FILED 11-15-2010.



OWNER OF U.S. REG. NOS. 2,028,076, 2,740,991 AND OTHERS.

NO CLAIM IS MADE TO THE EXCLUSIVE RIGHT TO USE "DISC", APART FROM THE MARK AS SHOWN.

THE MARK CONSISTS OF A SOLID CIRCLE WITH THE WORD "DISC" APPEARING HORIZONTALLY OVER THE CENTER OF THE CIRCLE.

FOR PROVIDING TEMPORARY USE OF ONLINE NON-DOWNLOADABLE SOFTWARE CONTAINING INSTRUCTIONAL AND EXPLANATORY TEXTS, QUESTIONS, RESPONSES AND INTERPRETIVE DATA FOR USE IN BEHAVIOR EVALUATION, BEHAVIORAL COUNSELING, PERSONAL DEVELOPMENT, BUSINESS MANAGEMENT AND EMPLOYEE TRAINING (U.S. CLS. 100 AND 101).

ALYSSA STEEL, EXAMINING ATTORNEY

---

SN 85-177,371. POWER CONSULTING GROUP, INC., NEW YORK, NY. FILED 11-15-2010.

TECHNOLOGY IS FOR PEOPLE

THE MARK CONSISTS OF STANDARD CHARACTERS WITHOUT CLAIM TO ANY PARTICULAR FONT, STYLE, SIZE, OR COLOR.

NO CLAIM IS MADE TO THE EXCLUSIVE RIGHT TO USE "TECHNOLOGY", APART FROM THE MARK AS SHOWN.

FOR TECHNICAL SUPPORT, MAINTENANCE, MONITORING, AND CONFIGURATION MANAGEMENT OF SOFTWARE FOR COMPUTER SYSTEMS; CREATION, DESIGN, DEVELOPMENT, INTEGRATION INTO COMPUTER SYSTEMS AND NETWORKS, INSTALLATION AND MAINTENANCE OF COMPUTER SOFTWARE, WEBSITES AND DATABASES (U.S. CLS. 100 AND 101).

FIRST USE 5-1-2008; IN COMMERCE 6-1-2008.

TINA MAI, EXAMINING ATTORNEY

**CLASS 42—(Continued).**

SN 85-177,756. PEISER, DAVID R., ENCINITAS, CA. FILED 11-16-2010.

# Greenliness

THE MARK CONSISTS OF STANDARD CHARACTERS WITHOUT CLAIM TO ANY PARTICULAR FONT, STYLE, SIZE, OR COLOR.

FOR PROVIDING A WEBSITE FEATURING RESEARCH INFORMATION, NEWS AND COMMENTARY IN THE FIELD OF ENVIRONMENTAL PROTECTION (U.S. CLS. 100 AND 101).

FIRST USE 6-30-2009; IN COMMERCE 6-30-2009.  
TAMARA FRAZIER, EXAMINING ATTORNEY

**CLASS 42—(Continued).**

SN 85-181,287. STEM SOFTWARE, LLC, ODESSA, TX. FILED 11-19-2010.



THE MARK CONSISTS OF THE WORD "STEM", WHEREIN THE LETTER "T" IS COMPRISED AS FOLLOWS: THE VERTICAL BASE OF THE LETTER RESEMBLES THAT OF A PLANT STEM AND SAID STEM IS CROSSED WITH AN "INFINITY" SYMBOL SO AS TO RESEMBLE THE LETTER "T".

FOR SOFTWARE AS A SERVICE (SAAS) SERVICES FEATURING SOFTWARE FOR USE IN FIELD SERVICE MANAGEMENT AND BUSINESS MANAGEMENT, USE IN THE FORM OF ADMINISTRATION, TRACKING, AND MANAGEMENT OF DISPATCH, REPORTS, PERSONNEL, WORK ORDERS, EQUIPMENT, PARTS, TICKETS, AND INVOICES BY INDIVIDUALS, ORGANIZATIONS, AND BUSINESSES IN VARIOUS SERVICE INDUSTRIES, NAMELY, LOCKSMITH, COMPUTER, ELECTRONICS, OIL AND GAS, HEALTH CARE, LEGAL SERVICES, MANUFACTURING, MARKETING, AND PROFESSIONAL SERVICES (U.S. CLS. 100 AND 101).

FIRST USE 8-15-2009; IN COMMERCE 8-15-2009.  
JOHN DWYER, EXAMINING ATTORNEY

SN 85-186,471. SHRISHTI INC., DBA EDOSSEA, INC., ANKENY, IA. FILED 11-29-2010.

SN 85-178,789. TUNECORE, INC., BROOKLYN, NY. FILED 11-17-2010.

# Bibliocore



NO CLAIM IS MADE TO THE EXCLUSIVE RIGHT TO USE THE DESIGN OF THE CADUCEUS, APART FROM THE MARK AS SHOWN.

THE MARK CONSISTS OF THE STYLIZED WORD "EDOSSEA"; TO THE LEFT IS AN ABSTRACT DESIGN RESEMBLING A CLOUD AND CONTAINING THREE GEOMETRIC SHAPES RESEMBLING SHEETS OF PAPER; ON ONE OF THE SHAPES IS A CADUCEUS SURROUNDED BY A CIRCLE COMPRISED OF CURVED BANDS; THREE SPHERES SURROUND THE EXTERIOR OF THE CLOUD.

FOR SOFTWARE AS A SERVICE (SAAS) SERVICES, NAMELY, HOSTING SOFTWARE FOR USE BY OTHERS FOR USE BY ENABLING DENTISTS AND PHYSICIANS TO ELECTRONICALLY SHARE X-RAYS, CHARTS, AND OTHER MEDICAL RECORDS WITH SPECIALISTS (U.S. CLS. 100 AND 101).

FIRST USE 11-15-2008; IN COMMERCE 3-1-2010.  
JULIE GUTTADAURO, EXAMINING ATTORNEY

THE MARK CONSISTS OF STANDARD CHARACTERS WITHOUT CLAIM TO ANY PARTICULAR FONT, STYLE, SIZE, OR COLOR.

FOR PROVIDING A WEB-BASED SERVICE FEATURING TECHNOLOGY THAT ENABLES USERS TO MANAGE THE PRODUCTION AND PUBLICATION OF ELECTRONIC BOOKS (E-BOOKS) AND RELATED DIGITAL CONTENT AND OFFER THEM FOR SALE TO THE GENERAL PUBLIC (U.S. CLS. 100 AND 101).

KATHERINE STOIDES, EXAMINING ATTORNEY



**CLASS 42—(Continued).**

SN 85-186,902. GATHER, INC., BOSTON, MA. FILED 11-30-2010.

**SKYWORD**

THE MARK CONSISTS OF STANDARD CHARACTERS WITHOUT CLAIM TO ANY PARTICULAR FONT, STYLE, SIZE, OR COLOR.

FOR PLATFORM AS A SERVICE (PAAS) FEATURING COMPUTER SOFTWARE PROGRAMS TO MANAGE CONTENT CREATORS AND CONTENT CREATION IN THE FORM OF TEXT, IMAGES, VIDEOS, SOUND AND THE LIKE BASED ON CONSUMER DEMAND FOR SPECIFIC INFORMATION (U.S. CLS. 100 AND 101).

PATRICIA EVANKO, EXAMINING ATTORNEY

SN 85-187,892. HEIRLOOM LABS LLC, PORTLAND, OR. FILED 12-1-2010.

**HEIRLOOM LABS**

THE MARK CONSISTS OF STANDARD CHARACTERS WITHOUT CLAIM TO ANY PARTICULAR FONT, STYLE, SIZE, OR COLOR.

NO CLAIM IS MADE TO THE EXCLUSIVE RIGHT TO USE "HEIRLOOM", APART FROM THE MARK AS SHOWN.

FOR COMPUTER SERVICES, NAMELY, DESIGN AND DEVELOPMENT OF WEB SITES FOR THE INTERNET FOR OTHERS (U.S. CLS. 100 AND 101).

AMEEN IMAM, EXAMINING ATTORNEY

SN 85-187,928. SARASOTA DESIGN, LLC, UNIVERSITY PARK, FL. FILED 12-1-2010.

**Poshy**

THE MARK CONSISTS OF STANDARD CHARACTERS WITHOUT CLAIM TO ANY PARTICULAR FONT, STYLE, SIZE, OR COLOR.

FOR CUSTOM DESIGN OF BABY AND CHILDREN APPAREL BASED ON PERSONAL SELECTIONS MADE BY THE CUSTOMER (U.S. CLS. 100 AND 101).

FIRST USE 4-1-2007; IN COMMERCE 5-1-2007.

DAVID TAYLOR, EXAMINING ATTORNEY

**CLASS 42—(Continued).**

SN 85-187,932. DILLON, GREGORY L, DBA G & E SOFTWARE, SODDY DAISY, TN. FILED 12-1-2010.

**Time and Material PLUS II**

THE MARK CONSISTS OF STANDARD CHARACTERS WITHOUT CLAIM TO ANY PARTICULAR FONT, STYLE, SIZE, OR COLOR.

NO CLAIM IS MADE TO THE EXCLUSIVE RIGHT TO USE "TIME AND MATERIAL", APART FROM THE MARK AS SHOWN.

FOR SOFTWARE AS A SERVICE (SAAS) SERVICES FEATURING SOFTWARE FOR CALCULATING BILLING FOR TIME AND MATERIALS, CALCULATING PAYMENT PRICES AND CREATING BILLS (U.S. CLS. 100 AND 101).

FIRST USE 7-1-2009; IN COMMERCE 11-13-2010.

AMEEN IMAM, EXAMINING ATTORNEY

SN 85-190,064. PETER ELLIOTT BLACK, DBA WATERSHED MANAGEMENT, SYRACUSE, NY. FILED 12-3-2010.



NO CLAIM IS MADE TO THE EXCLUSIVE RIGHT TO USE "WATERSHED MANAGEMENT", APART FROM THE MARK AS SHOWN.

THE COLOR(S) GREEN, BEIGE AND BLUE IS/ARE CLAIMED AS A FEATURE OF THE MARK.

THE MARK CONSISTS OF A GREEN CIRCULAR DESIGN WITH THE WORDS "WATERSHED" IN GREEN UPPERCASE STYLIZED FONT AT THE TOP AND "MANAGEMENT" IN GREEN UPPERCASE STYLIZED FONT AT THE BOTTOM. IN THE CENTER OF THE CIRCLE IS A DESIGN MADE WITH FOUR CHEVRONS, TWO IN BLUE POINTING DOWN, AND TWO IN BEIGE POINTING UP.

FOR TECHNICAL SCIENTIFIC CONSULTING AND RESEARCH IN THE FIELD OF WATERSHED MANAGEMENT, NAMELY, CONDUCTING HYDROLOGICAL SURVEYS, DRAFTING REPORTS AND PROVIDING PROFESSIONAL OPINIONS CONCERNING HYDROLOGY, WATER QUALITY, ENVIRONMENTAL IMPACT ANALYSIS, AND WATER AND RELATED LAND RESOURCES MANAGEMENT POLICY (U.S. CLS. 100 AND 101).

FIRST USE 0-0-1964; IN COMMERCE 0-0-1964.

JANET LEE, EXAMINING ATTORNEY

**CLASS 42—(Continued).**

SN 85-191,880. AVEPOINT, INC., JERSEY CITY, NJ. FILED 12-7-2010.

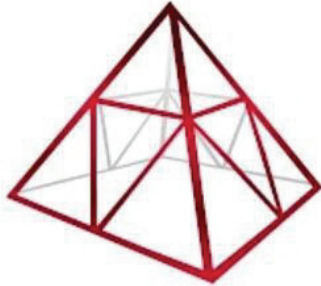

THE COLOR(S) RED, BLACK, GRAY, AND WHITE IS/ ARE CLAIMED AS A FEATURE OF THE MARK.

THE MARK CONSISTS OF A PYRAMID WHERE THE FRONT SIDE OF THE PYRAMID IS IN THE COLORS RED AND BLACK, THE BACK SIDES OF THE PYRAMID ARE THE COLOR GRAY, AND THE SPACE INSIDE THE PYRAMID IS THE COLOR WHITE.

FOR COMPUTER CONSULTING SERVICES AND DESIGN AND DEVELOPMENT OF CUSTOMIZED SOFTWARE, ALL IN CONNECTION WITH DATA BACK UP, PROTECTION, ARCHIVING, DISASTER RECOVERY, MIGRATION AND CONTENT MANAGEMENT; RELATED TECHNICAL SUPPORT SERVICES, NAMELY, TROUBLESHOOTING IN THE NATURE OF DIAGNOSING COMPUTER HARDWARE AND SOFTWARE PROBLEMS (U.S. CLS. 100 AND 101).

FIRST USE 6-15-2010; IN COMMERCE 6-15-2010.  
ROBIN CHOSID, EXAMINING ATTORNEY

SN 85-192,283. CARASOFT TECHNOLOGY CORPORATION, RESTON, VA. FILED 12-7-2010.

**DCO**

THE MARK CONSISTS OF STANDARD CHARACTERS WITHOUT CLAIM TO ANY PARTICULAR FONT, STYLE, SIZE, OR COLOR.

OWNER OF U.S. REG. NO. 3,915,298.

FOR PROVIDING ON-LINE NON-DOWNLOADABLE SOFTWARE FOR FACILITATING ONLINE PRESENTATIONS, APPLICATION SHARING, SCREEN SHARING, FILE SHARING, PANEL DISCUSSIONS, LIVE CHAT, INTERACTIVE POLLING, ATTENDANCE MONITORING, AND INSTANT MESSAGING (U.S. CLS. 100 AND 101).

FIRST USE 10-0-2007; IN COMMERCE 10-0-2007.  
EVELYN BRADLEY, EXAMINING ATTORNEY

**CLASS 42—(Continued).**

SN 85-196,608. ALPER, LORI, DBA GROOVY GREEN LIVIN, BEDFORD, MA. FILED 12-13-2010.

**GROOVY GREEN LIVIN**

THE MARK CONSISTS OF STANDARD CHARACTERS WITHOUT CLAIM TO ANY PARTICULAR FONT, STYLE, SIZE, OR COLOR.

NO CLAIM IS MADE TO THE EXCLUSIVE RIGHT TO USE "GREEN", APART FROM THE MARK AS SHOWN.

FOR PROVIDING TECHNOLOGICAL AND SCIENTIFIC INFORMATION ABOUT ENVIRONMENTALLY-CONSCIOUS AND GREEN INNOVATIONS (U.S. CLS. 100 AND 101).

FIRST USE 12-4-2009; IN COMMERCE 12-4-2009.  
NAKIA HENRY, EXAMINING ATTORNEY

SN 85-199,026. REGULAR GUY COMPUTER SERVICES, LLC, OVERLAND PARK, KS. FILED 12-15-2010.



NO CLAIM IS MADE TO THE EXCLUSIVE RIGHT TO USE "COMPUTER SERVICES", APART FROM THE MARK AS SHOWN.

THE MARK CONSISTS OF THE WORDS "REGULAR GUY COMPUTER SERVICES" WITH THE "Y" IN THE WORD "GUY" TRAILING INTO A COMPUTER MOUSE. THE WORDS "COMPUTER SERVICES" ARE IN SMALL FONT DIRECTLY UNDERNEATH THE WORDS "REGULAR GUY" WHICH ARE IN A LARGE FONT.

FOR COMPUTER CONSULTATION; COMPUTER VIRUS PROTECTION SERVICES; INSTALLATION, REPAIR AND MAINTENANCE OF COMPUTER SOFTWARE; MAINTENANCE AND UPGRADING OF COMPUTER SOFTWARE; TECHNICAL SUPPORT SERVICES, NAMELY, TROUBLESHOOTING IN THE NATURE OF DIAGNOSING COMPUTER HARDWARE AND SOFTWARE PROBLEMS; TECHNICAL SUPPORT SERVICES, NAMELY, TROUBLESHOOTING OF COMPUTER SOFTWARE PROBLEMS (U.S. CLS. 100 AND 101).

FIRST USE 1-1-2007; IN COMMERCE 1-1-2007.  
TARA PATE, EXAMINING ATTORNEY

**CLASS 42—(Continued).**

SN 85-199,397. HOUHOU, FAISSAL, SINGAPORE, SINGAPORE, FILED 12-16-2010.

# TheBootic

THE MARK CONSISTS OF STANDARD CHARACTERS WITHOUT CLAIM TO ANY PARTICULAR FONT, STYLE, SIZE, OR COLOR.

THE WORDING "THEBOOTIC" HAS NO MEANING IN A FOREIGN LANGUAGE.

FOR DESIGN, CREATION, HOSTING, MAINTENANCE OF WEBSITES FOR OTHERS; MAINTENANCE OF WEBSITES AND HOSTING ON-LINE WEB FACILITIES FOR OTHERS; PROVIDING TEMPORARY USE OF ON-LINE NON-DOWNLOADABLE SOFTWARE AND APPLICATIONS FOR MATCHING POSSIBLE SUPPLIERS TO PROSPECTIVE ONLINE MERCHANTS AND ACCOMMODATING MULTIPLE TYPES OF PAYMENT AND DEBT TRANSACTIONS BETWEEN THEM; WEB SITE HOSTING SERVICES (U.S. CLS. 100 AND 101).

JULIE VEPPUMTHARA, EXAMINING ATTORNEY

**CLASS 42—(Continued).**

SN 85-199,495. ROYBAL, MATTHEW, SAN ANSELMO, CA. FILED 12-16-2010.



NO CLAIM IS MADE TO THE EXCLUSIVE RIGHT TO USE "WEALTH", APART FROM THE MARK AS SHOWN.

THE MARK CONSISTS OF A STYLIZED DESIGN OF AN EMBOSSED COIN FEATURING THE LETTERS "RW" WITH A SHADOW EFFECT BENEATH THE COIN DESIGN; TO THE RIGHT APPEARS THE TERM "RYSING WEALTH" IN STYLIZED LETTERING.

FOR PROVIDING A WEBSITE FEATURING RESOURCES, NAMELY, NON-DOWNLOADABLE SOFTWARE FOR THE ANALYSIS AND DATABASE MANAGEMENT OF REAL ESTATE PURCHASES, AS INVESTMENTS IN THE FIELD OF REAL ESTATE (U.S. CLS. 100 AND 101).

FIRST USE 9-28-2010; IN COMMERCE 12-1-2010.  
JIM RINGLE, EXAMINING ATTORNEY

SN 85-199,488. NORTHLIGHT POWER, LLC, BAINBRIDGE ISLAND, WA. FILED 12-16-2010.



NO CLAIM IS MADE TO THE EXCLUSIVE RIGHT TO USE "POWER", APART FROM THE MARK AS SHOWN.

THE MARK CONSISTS OF THE WORDS "NORTHLIGHT POWER". THERE IS A DESIGN WHICH SHOWS POWER LINES MEETING AND APPEARS TO THE LEFT OF THE WORDS.

FOR CONSULTING SERVICES REGARDING ENGINEERING AND DESIGN OF POWER PLANTS (U.S. CLS. 100 AND 101).

FIRST USE 9-30-2010; IN COMMERCE 9-30-2010.  
PATRICIA EVANKO, EXAMINING ATTORNEY

SN 85-199,498. NORTHLIGHT POWER, LLC, BAINBRIDGE ISLAND, WA. FILED 12-16-2010.



NO CLAIM IS MADE TO THE EXCLUSIVE RIGHT TO USE "POWER" AND "SOLAR", APART FROM THE MARK AS SHOWN.

THE MARK CONSISTS OF THE WORDS "NORTHLIGHT POWER STREAMLINING SOLAR". THE WORDS "NORTHLIGHT POWER" APPEAR ON ONE LINE AND THE WORDS "STREAMLINING SOLAR" APPEAR ON THE LINE BELOW. THERE IS A DESIGN WHICH SHOWS POWER LINES MEETING AND APPEARS TO THE LEFT OF THE WORDS.

FOR CONSULTING SERVICES REGARDING ENGINEERING AND DESIGN OF POWER PLANTS (U.S. CLS. 100 AND 101).

FIRST USE 9-30-2010; IN COMMERCE 9-30-2010.  
PATRICIA EVANKO, EXAMINING ATTORNEY

**CLASS 42—(Continued).**

SN 85-199,767. ADVANCED PROFESSIONAL CONSULTING, INC. TA VETTCORP, DARLINGTON, MD. FILED 12-16-2010.



NO CLAIM IS MADE TO THE EXCLUSIVE RIGHT TO USE "VETERAN TECHNOLOGISTS", APART FROM THE MARK AS SHOWN.

THE COLOR(S) GRAY/SILVER AND MAROON IS/ARE CLAIMED AS A FEATURE OF THE MARK.

THE MARK CONSISTS OF TWO (2) DOGTAGS OFFSET. THE FOREMOST DOGTAG IS VERTICAL AND THE LATTER IS OFFSET AT AN ANGLE. THE DOGTAGS ARE GRAY/SILVER WITH A WHITE DOT IN THE TOP CENTER. THE "VETTCORP" LOGO IS CENTERED AND THE WORDS SPELLING "VETERAN TECHNOLOGISTS" ARE SPELLED OUT BENEATH. THE SECOND CAPITOL "T" IS ENLARGED TO DENOTE "TECHNOLOGISTS". ALL LETTERS ARE MAROON AGAINST A WHITE BACKGROUND. THE COLOR WHITE REPRESENTS TRANSPARENT AREAS AND IS NOT CLAIMED AS A FEATURE OF THE MARK.

FOR CONSULTING IN THE FIELD OF INFORMATION TECHNOLOGY (U.S. CLS. 100 AND 101).

FIRST USE 5-2-2008; IN COMMERCE 10-1-2010.  
DAVID HOFFMAN, EXAMINING ATTORNEY

---

SN 85-199,932. CELL THERAPEUTICS, INC., SEATTLE, WA. FILED 12-16-2010.

## PIX-R TRIAL

THE MARK CONSISTS OF STANDARD CHARACTERS WITHOUT CLAIM TO ANY PARTICULAR FONT, STYLE, SIZE, OR COLOR.

NO CLAIM IS MADE TO THE EXCLUSIVE RIGHT TO USE "TRIAL", APART FROM THE MARK AS SHOWN.

FOR MEDICAL AND SCIENTIFIC RESEARCH, NAMELY, CONDUCTING CLINICAL TRIALS FOR PHARMACEUTICAL PREPARATIONS USED FOR THE TREATMENT OF CANCER (U.S. CLS. 100 AND 101).

ALICIA COLLINS, EXAMINING ATTORNEY

**CLASS 42—(Continued).**

SN 85-201,301. LAVVA, INC., CALGARY, ALBERTA, CANADA, FILED 12-18-2010.

## GO SOCIAL

THE MARK CONSISTS OF STANDARD CHARACTERS WITHOUT CLAIM TO ANY PARTICULAR FONT, STYLE, SIZE, OR COLOR.

NO CLAIM IS MADE TO THE EXCLUSIVE RIGHT TO USE "SOCIAL", APART FROM THE MARK AS SHOWN.

FOR PROVIDING A WEB HOSTING PLATFORM THAT ALLOWS ONE PERSON USING ONE SEARCH ENGINE TO COMMUNICATE WITH ANOTHER PERSON USING A DIFFERENT SEARCH ENGINE ABOUT THE SAME OR SIMILAR TOPIC (U.S. CLS. 100 AND 101).

FIRST USE 3-21-2009; IN COMMERCE 3-21-2009.  
SKYE YOUNG, EXAMINING ATTORNEY

---

SN 85-201,302. LAVVA, INC., CALGARY, ALBERTA, CANADA, FILED 12-18-2010.

## LAVVA

THE MARK CONSISTS OF STANDARD CHARACTERS WITHOUT CLAIM TO ANY PARTICULAR FONT, STYLE, SIZE, OR COLOR.

FOR COMPUTER SERVICES, NAMELY, PROVIDING SEARCH ENGINES FOR OBTAINING DATA ON A GLOBAL COMPUTER NETWORK (U.S. CLS. 100 AND 101).

FIRST USE 3-21-2009; IN COMMERCE 3-21-2009.  
SKYE YOUNG, EXAMINING ATTORNEY

---

SN 85-201,701. BOYLSTON TECHNOLOGY GROUP, INC., BOSTON, MA. FILED 12-20-2010.

## @cars

THE MARK CONSISTS OF STANDARD CHARACTERS WITHOUT CLAIM TO ANY PARTICULAR FONT, STYLE, SIZE, OR COLOR.

FOR CUSTOMIZED SEARCHING, NAMELY, PROVIDING SPECIFIC INFORMATION ON CARS AS REQUESTED BY CUSTOMERS VIA THE INTERNET (U.S. CLS. 100 AND 101).

FIRST USE 11-1-2010; IN COMMERCE 11-1-2010.  
KATHERINE M. DUBRAY, EXAMINING ATTORNEY

**CLASS 42—(Continued).**

SN 85-203,061. GENESIS NETWORKS, INC., SAN ANTONIO, TX. FILED 12-21-2010.

**MOBILE SMART HANDS**

THE MARK CONSISTS OF STANDARD CHARACTERS WITHOUT CLAIM TO ANY PARTICULAR FONT, STYLE, SIZE, OR COLOR.

NO CLAIM IS MADE TO THE EXCLUSIVE RIGHT TO USE "MOBILE SMART", APART FROM THE MARK AS SHOWN.

FOR PROVIDING ON-LINE, NON-DOWNLOADABLE COMPUTER SOFTWARE FOR TRACKING, MANAGING, PROCESSING, AND OPTIMIZING THE ASSIGNMENT OF WORK ORDERS AND INCIDENTS WITH TECHNICIANS OR TRADE PROFESSIONALS, AND FOR PROVIDING ACCESS TO A DATABASE OF TECHNICIANS AND TECHNICAL PROFESSIONALS FOR A VIRTUAL MOBILE AND ON DEMAND WORKFORCE (U.S. CLS. 100 AND 101).

ANNE FARRELL, EXAMINING ATTORNEY

SN 85-203,676. HNTB HOLDINGS LTD, KANSAS CITY, MO. FILED 12-22-2010.



THE MARK CONSISTS OF THE WORD "RAILADVISED" NEXT TO THE STYLIZED DESIGN OF A RAILROAD TRACK.

FOR PROVIDING ONLINE NONDOWNLOADABLE SOFTWARE AND SOFTWARE TOOLS FOR PROVIDING RAILROAD RAIL SYSTEM CONDITION DATA AND MONITORING AND CONTROLLING RAILROAD TRANSPORTATION ASSETS (U.S. CLS. 100 AND 101).

ANTHONY RINKER, EXAMINING ATTORNEY

SN 85-203,816. POWELL INVESTORS GROUP, LLC, SOUTH-BURY, CT. FILED 12-22-2010.

**LOVE THE SPACE YOU'RE IN**

THE MARK CONSISTS OF STANDARD CHARACTERS WITHOUT CLAIM TO ANY PARTICULAR FONT, STYLE, SIZE, OR COLOR.

OWNER OF U.S. REG. NO. 3,037,819. FOR INTERIOR DECORATING (U.S. CLS. 100 AND 101).

FIRST USE 9-8-2004; IN COMMERCE 9-8-2004. DAVID HOFFMAN, EXAMINING ATTORNEY

**CLASS 42—(Continued).**

SN 85-204,618. HICKEY, BRIAN, SAN FRANCISCO, CA. FILED 12-23-2010.

**DONATIONTO**

THE MARK CONSISTS OF STANDARD CHARACTERS WITHOUT CLAIM TO ANY PARTICULAR FONT, STYLE, SIZE, OR COLOR.

FOR SOFTWARE AS A SERVICE, NAMELY, HOSTING SOFTWARE THAT ALLOWS USERS TO CREATE A DONATION WEB SITE PAGE TO ACCEPT DONATIONS ONLINE (U.S. CLS. 100 AND 101).

FIRST USE 7-8-2010; IN COMMERCE 11-16-2010.

ODESSA BIBBINS, EXAMINING ATTORNEY

SN 85-204,633. STEVE HERBST, CARLISLE, MA. FILED 12-23-2010.

**DISCOVER YOUR OWN IDEAS**

THE MARK CONSISTS OF STANDARD CHARACTERS WITHOUT CLAIM TO ANY PARTICULAR FONT, STYLE, SIZE, OR COLOR.

FOR SOFTWARE AS A SERVICE (SAAS) SERVICES FEATURING SOFTWARE FOR WRITING, TEACHING OF WRITING AND LITERACY SKILLS, BRAINSTORMING AND IDEA GENERATION, AND EDUCATIONAL TESTING (U.S. CLS. 100 AND 101).

KIM MONINGHOFF, EXAMINING ATTORNEY

SN 85-205,017. THINKRONIZE, INC., CINCINNATI, OH. FILED 12-23-2010.

**IGOTTA**

THE MARK CONSISTS OF STANDARD CHARACTERS WITHOUT CLAIM TO ANY PARTICULAR FONT, STYLE, SIZE, OR COLOR.

FOR COMPUTER SERVICES, NAMELY, ACTING AS AN APPLICATION SERVICE PROVIDER TO HOST COMPUTER APPLICATION SOFTWARE ON AN INTERACTIVE EDUCATIONAL WORKSPACE WEBSITE FOR THE COLLECTION, EDITING, ORGANIZING, MODIFYING, BOOK MARKING, TRANSMISSION, STORAGE AND SHARING OF EDUCATIONAL MATERIALS AND INFORMATION AMONG MULTIPLE USERS BY MEANS OF THE GLOBAL COMPUTER NETWORK (U.S. CLS. 100 AND 101).

JAMES MACFARLANE, EXAMINING ATTORNEY



**CLASS 42—(Continued).**

SN 85-205,029. THINKKRONIZE, INC., CINCINNATI, OH. FILED 12-23-2010.

# IGOTTANT

THE MARK CONSISTS OF STANDARD CHARACTERS WITHOUT CLAIM TO ANY PARTICULAR FONT, STYLE, SIZE, OR COLOR.

FOR COMPUTER SERVICES, NAMELY, ACTING AS AN APPLICATION SERVICE PROVIDER TO HOST COMPUTER APPLICATION SOFTWARE ON AN INTERACTIVE EDUCATIONAL WORKSPACE WEBSITE FOR THE COLLECTION, EDITING, ORGANIZING, MODIFYING, BOOK MARKING, TRANSMISSION, STORAGE AND SHARING OF EDUCATIONAL MATERIALS AND INFORMATION AMONG MULTIPLE USERS BY MEANS OF THE GLOBAL COMPUTER NETWORK (U.S. CLS. 100 AND 101).

JAMES MACFARLANE, EXAMINING ATTORNEY

**CLASS 42—(Continued).**

SN 85-206,082. DAYTON/MIAMI VALLEY ENTREPRENEURS CENTER INC., DBA THE ENTREPRENEURS CENTER, DAYTON, OH. FILED 12-27-2010.



THE MARK CONSISTS OF A GRAPHIC DEPICTING A SIGN OR LICENSE PLATE WITH AN ABSTRACT DEPICTION OF A STAR-LIKE PERSON IN THE BOTTOM LEFT CORNER. THE WORDING "ADVANCE TO PROFIT" IS ABOVE AND TO THE RIGHT OF THE FIGURE, WITH THE LETTER "A" DRAWN WITH LINES COMING FROM IT, AS IF IN MOTION.

FOR INNOVATION CONSULTING SERVICES, NAMELY, ADVISING OTHERS IN THE AREAS OF PRODUCT DEVELOPMENT (U.S. CLS. 100 AND 101).

FIRST USE 10-4-2010; IN COMMERCE 10-14-2010.  
INGA ERVIN, EXAMINING ATTORNEY

SN 85-206,592. THOMAS, JOCELYN, BOWIE, MD. FILED 12-28-2010.

NO CLAIM IS MADE TO THE EXCLUSIVE RIGHT TO USE "WEB DESIGNS", APART FROM THE MARK AS SHOWN.

THE MARK CONSISTS OF THE WORDING "INNOVATIVE WEBDESIGNS" IN HIGHLY STYLIZED FONT.

FOR DESIGN, CREATION, HOSTING, MAINTENANCE OF WEBSITES FOR OTHERS (U.S. CLS. 100 AND 101).

FIRST USE 5-27-2008; IN COMMERCE 5-27-2008.  
AISHA SALEM, EXAMINING ATTORNEY

SN 85-205,853. LUA TECHNOLOGIES, LLC, WILMINGTON, DE. FILED 12-27-2010.

# LUA TECHNOLOGIES

THE MARK CONSISTS OF STANDARD CHARACTERS WITHOUT CLAIM TO ANY PARTICULAR FONT, STYLE, SIZE, OR COLOR.

NO CLAIM IS MADE TO THE EXCLUSIVE RIGHT TO USE "TECHNOLOGIES", APART FROM THE MARK AS SHOWN.

FOR SOFTWARE AS A SERVICE (SAAS) SERVICES FEATURING SOFTWARE FOR MANAGING FILM PRODUCTION PROCESSES, CREATING, DOCUMENTING, SHARING AND ARCHIVING FILM PROJECTS, DATA MINING AND FOR COLLECTING, EDITING, ORGANIZING, MODIFYING, BOOKMARKING, TRANSMISSION, STORAGE AND SHARING OF DATA AND INFORMATION FOR USE IN ASSISTING WITH FILM PRODUCTION (U.S. CLS. 100 AND 101).

JEFFERY COWARD, EXAMINING ATTORNEY

SN 85-206,710. ALACRITY SOLUTIONS LLC, LUFKIN, TX. FILED 12-28-2010.

# ALACRITY SOLUTIONS LLC

THE MARK CONSISTS OF STANDARD CHARACTERS WITHOUT CLAIM TO ANY PARTICULAR FONT, STYLE, SIZE, OR COLOR.

NO CLAIM IS MADE TO THE EXCLUSIVE RIGHT TO USE "SOLUTIONS LLC", APART FROM THE MARK AS SHOWN.

FOR IT CONSULTING SERVICES (U.S. CLS. 100 AND 101).

MARK SHINER, EXAMINING ATTORNEY

**CLASS 42—(Continued).**

SN 85-207,176. VERTETUDE, LIMITED LIABILITY PARTNERSHIP, SEATTLE, WA. FILED 12-29-2010.

**VERTETUDE**

THE MARK CONSISTS OF STANDARD CHARACTERS WITHOUT CLAIM TO ANY PARTICULAR FONT, STYLE, SIZE, OR COLOR.

FOR ARCHITECTURAL CONSULTANCY; ARCHITECTURAL DESIGN; GRAPHIC DESIGN; INDUSTRIAL DESIGN; INTERIOR DESIGN SERVICES; NEW PRODUCT DESIGN SERVICES; PACKAGING DESIGN (U.S. CLS. 100 AND 101).

JAMES GRIFFIN, EXAMINING ATTORNEY

SN 85-207,629. FEARLESS SOLUTIONS, LLC, BALTIMORE, MD. FILED 12-29-2010.



THE MARK CONSISTS OF THE WORD "FEARLESS" OVER THE WORD "SOLUTIONS" WITH A HORIZONTAL LINE SEPARATING THEM.

FOR COMPUTER SECURITY CONSULTANCY IN THE FIELD OF SCANNING AND PENETRATION TESTING OF COMPUTERS AND NETWORKS TO ASSESS INFORMATION SECURITY VULNERABILITY; COMPUTER SECURITY SERVICE, NAMELY, RESTRICTING ACCESS TO AND BY COMPUTER NETWORKS TO AND OF UNDESIRE WEB SITES, MEDIA AND INDIVIDUALS AND FACILITIES; COMPUTER SOFTWARE DESIGN IN THE FIELD OF COMPUTER SECURITY; COMPUTER SOFTWARE DEVELOPMENT IN THE FIELD OF IN THE FIELD OF COMPUTER SECURITY FOR MOBILE APPLICATIONS; DESIGN FOR OTHERS IN THE FIELD OF COMPUTER NETWORKS, SOFTWARE, AND ENGINEERING FOR THE FEDERAL GOVERNMENT, HEALTH SECTOR, FINANCIAL SECTOR AND COMMERCIAL SECTOR IN THE FIELD OF COMPUTER SECURITY; DESIGN OF INFORMATION GRAPHICS AND DATA VISUALIZATION MATERIALS; IT CONSULTING SERVICES (U.S. CLS. 100 AND 101).

FIRST USE 6-1-2010; IN COMMERCE 6-1-2010.

MATTHEW EINSTEIN, EXAMINING ATTORNEY

**CLASS 42—(Continued).**

SN 85-208,127. MICHELLE JACOBSON, DENVER, CO. FILED 12-30-2010.

**DOYENNE DESIGN**

THE MARK CONSISTS OF STANDARD CHARACTERS WITHOUT CLAIM TO ANY PARTICULAR FONT, STYLE, SIZE, OR COLOR.

NO CLAIM IS MADE TO THE EXCLUSIVE RIGHT TO USE "DESIGN", APART FROM THE MARK AS SHOWN.

FOR DESIGN OF SPECIALTY INTERIOR AND EXTERIOR ENVIRONMENT SETTINGS; INTERIOR DESIGN SERVICES; INTERIOR DESIGN SERVICES INCLUDING SPACE PLANNING, FURNITURE SELECTION, MATERIAL AND SURFACE SELECTION (U.S. CLS. 100 AND 101).

FIRST USE 11-10-2010; IN COMMERCE 12-2-2010.

ALLISON SCHRODY, EXAMINING ATTORNEY

SN 85-208,357. OUNPHACHANH, WALTER, HIGH POINT, NC. FILED 12-30-2010.



THE MARK CONSISTS OF A CIRCLE WITH THREE ARCHING LINES AND THE TERM "JIGOWORLD.COM" OVERLAYING IT.

FOR COMPUTER SERVICES, NAMELY, CREATING AN ON-LINE COMMUNITY FOR REGISTERED USERS TO PARTICIPATE IN DISCUSSIONS, GET FEEDBACK FROM THEIR PEERS, FORM VIRTUAL COMMUNITIES, AND ENGAGE IN SOCIAL NETWORKING (U.S. CLS. 100 AND 101).

JOHN DWYER, EXAMINING ATTORNEY

SN 85-209,106. STIX FOR CHIX, LLC, HINGHAM, MA. FILED 1-3-2011.

**STIX FOR CHIX**

THE MARK CONSISTS OF STANDARD CHARACTERS WITHOUT CLAIM TO ANY PARTICULAR FONT, STYLE, SIZE, OR COLOR.

FOR GRAPHIC ART DESIGN FOR ATHLETIC EQUIPMENT; COMMERCIAL ART DESIGN FOR ATHLETIC EQUIPMENT (U.S. CLS. 100 AND 101).

NAKIA HENRY, EXAMINING ATTORNEY

**CLASS 42—(Continued).**

SN 85-209,594. THE VISIBILITY COMPANY, BRENTWOOD, TN. FILED 1-3-2011.

# PROPEL

THE MARK CONSISTS OF STANDARD CHARACTERS WITHOUT CLAIM TO ANY PARTICULAR FONT, STYLE, SIZE, OR COLOR.

FOR PROVIDING A WEB SITE FEATURING TECHNOLOGY THAT ENABLES USERS TO ENTER, ACCESS, TRACK, MONITOR AND GENERATE HEALTH AND MEDICAL INFORMATION AND REPORTS (U.S. CLS. 100 AND 101).

FIRST USE 11-15-2009; IN COMMERCE 11-15-2009.  
SHAUNIA CARLYLE, EXAMINING ATTORNEY

**CLASS 42—(Continued).**

SN 85-210,755. LUA TECHNOLOGIES, LLC, WILMINGTON, DE. FILED 1-5-2011.



NO CLAIM IS MADE TO THE EXCLUSIVE RIGHT TO USE "TECHNOLOGIES", APART FROM THE MARK AS SHOWN.

THE MARK CONSISTS OF THE WORD "LUA" ON TOP OF THE WORD "TECHNOLOGIES" WITH A STYLIZED REPRESENTATION OF THE KINGDOM OF HAWAII'S ROYAL AL'I HEADDRESS, MOST COMMONLY SEEN WORN BY KING KAMEHAMEHA, TO THE RIGHT OF THE TERM "LUA".

FOR SOFTWARE AS A SERVICE (SAAS) SERVICES FEATURING SOFTWARE FOR MANAGING FILM PRODUCTION PROCESSES, CREATING, DOCUMENTING, SHARING AND ARCHIVING FILM PROJECTS, DATA MINING AND FOR COLLECTING, EDITING, ORGANIZING, MODIFYING, BOOKMARKING, TRANSMISSION, STORAGE AND SHARING OF DATA AND INFORMATION FOR USE IN ASSISTING WITH FILM PRODUCTION (U.S. CLS. 100 AND 101).

JEFFERY COWARD, EXAMINING ATTORNEY

SN 85-210,781. LUA TECHNOLOGIES, LLC, WILMINGTON, DE. FILED 1-5-2011.

SN 85-209,886. MIYACOR, LLC, NORTH EAST, MD. FILED 1-4-2011.

# Miyacor



THE MARK CONSISTS OF THE WORD "LUA" WITH A STYLIZED REPRESENTATION OF THE KINGDOM OF HAWAII'S ROYAL AL'I HEADDRESS, MOST COMMONLY SEEN WORN BY KING KAMEHAMEHA, TO THE RIGHT OF THE TERM "LUA".

FOR SOFTWARE AS A SERVICE (SAAS) SERVICES FEATURING SOFTWARE FOR MANAGING FILM PRODUCTION PROCESSES, CREATING, DOCUMENTING, SHARING AND ARCHIVING FILM PROJECTS, DATA MINING AND FOR COLLECTING, EDITING, ORGANIZING, MODIFYING, BOOKMARKING, TRANSMISSION, STORAGE AND SHARING OF DATA AND INFORMATION FOR USE IN ASSISTING WITH FILM PRODUCTION (U.S. CLS. 100 AND 101).

JEFFERY COWARD, EXAMINING ATTORNEY

THE MARK CONSISTS OF STANDARD CHARACTERS WITHOUT CLAIM TO ANY PARTICULAR FONT, STYLE, SIZE, OR COLOR.

THE WORDING "MIYACOR" HAS NO MEANING IN A FOREIGN LANGUAGE.

FOR ENGINEERING (U.S. CLS. 100 AND 101).  
FIRST USE 7-23-2000; IN COMMERCE 7-23-2000.  
BARBARA BROWN, EXAMINING ATTORNEY

**CLASS 42—(Continued).**

SN 85-210,932. NORMAN GULACK ANDERSON, ROCKVILLE, MD. FILED 1-5-2011.

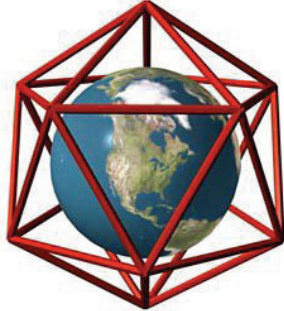

THE COLOR(S) COLORS BLUE, BROWN, GREEN, WHITE AND RED IS/ARE CLAIMED AS A FEATURE OF THE MARK.

THE MARK CONSISTS OF A THREE DIMENSIONAL IMAGE OF THE PLANET EARTH WITH THE WATER SHOWN IN BLUE AND THE CONTINENTS SHOWN IN THE COLORS BROWN, GREEN AND WHITE, ALL SHOWN CONTAINED INSIDE A RED WIRE FRAME ICOSAEDRON.

FOR DEVELOPMENT OF NEW TECHNOLOGY FOR OTHERS IN THE FIELD OF VIROLOGY; MEDICAL AND SCIENTIFIC RESEARCH IN THE FIELD OF VIROLOGY; RESEARCH AND DEVELOPMENT OF VACCINES AND MEDICINES (U.S. CLS. 100 AND 101).

RUDY R. SINGLETON, EXAMINING ATTORNEY

SN 85-211,666. 3DREX & ANIREX STUDIOS, INC., GRAYSLAKE, IL. FILED 1-6-2011.

## 3DREX

THE MARK CONSISTS OF STANDARD CHARACTERS WITHOUT CLAIM TO ANY PARTICULAR FONT, STYLE, SIZE, OR COLOR.

OWNER OF U.S. REG. NOS. 2,917,066, 2,927,472 AND 2,927,475.

FOR PROVIDING WEB SITE DESIGN FOR OTHERS; COMPUTER GRAPHICS DESIGN SERVICES, NAMELY, CREATION OF 2D ANIMATION AND 3D COMPUTER MODELS, MODELING, AND RENDERING; COMPUTER SERVICES, NAMELY, DESIGNING AND IMPLEMENTING NETWORK WEB PAGES FOR OTHERS; COMPUTER SERVICES, NAMELY, DESIGNING AND IMPLEMENTING WEB SITES FOR OTHERS; CREATING AND DESIGNING WEB PAGES FOR OTHERS; CREATING OR MAINTAINING WEB SITES FOR OTHERS; CREATION AND MAINTENANCE OF WEB SITES FOR OTHERS; CREATION AND PROVISION OF WEB PAGES TO AND FOR THIRD PARTIES; CREATION, DESIGN, DEVELOPMENT AND MAINTENANCE OF WEB SITES FOR THIRD PARTIES; DESIGN AND MAINTENANCE OF WEB SITES FOR OTHERS; DESIGN OF HOME PAGES; DESIGN OF HOME PAGES AND WEB SITES; DESIGN OF HOME PAGES, COMPUTER SOFTWARE AND WEB SITES; DESIGN OF INFORMATION GRAPHICS AND DATA VISUALIZATION MATERIALS; GRAPHIC ART DESIGN; GRAPHIC DESIGN; GRAPHIC DESIGN SERVICES; INDUSTRIAL AND GRAPHIC ART DESIGN; MULTIDISCIPLINARY GRAPHIC DESIGN SERVICES; PROVIDING COMPUTER PROGRAMMING SERVICES TO CUSTOMERS THAT ENABLES THEM TO

**CLASS 42—(Continued).**

PROVIDE VIDEO AND AUDIO CONTENT ON THEIR WEB SITES; PROVIDING CUSTOMIZED ON-LINE WEB PAGES AND DATA FEEDS FEATURING USER-DEFINED INFORMATION, WHICH INCLUDES BLOG POSTS, NEW MEDIA CONTENT, OTHER ON-LINE CONTENT, AND ON-LINE WEB LINKS TO OTHER WEBSITES; PROVIDING GRAPHIC AND MULTIMEDIA DESIGN SERVICES FOR THE PURPOSE OF PROMOTING THE GOODS AND SERVICES OF OTHERS; TECHNICAL SUPPORT SERVICES, NAMELY, INSTALLATION, ADMINISTRATION, AND TROUBLESHOOTING OF WEB AND DATABASE APPLICATIONS; THINK TANK SERVICES, NAMELY, PROVIDING NEW IDEAS AND CONCEPTS FOR WEB-BASED APPLICATIONS FOR OTHERS; VISUAL DESIGN SERVICES IN THE NATURE OF DESIGNING VISUAL ELEMENTS FOR ON-LINE, BROADCAST, PRINT, OUTDOOR AND OTHER COMMUNICATION MEDIA; WEB PUBLISHING, NAMELY, CREATING A WEBSITE AND UPLOADING IT ONTO AN INTERNET SERVER; WEB SITE DESIGN; WEB SITE DEVELOPMENT FOR OTHERS (U.S. CLS. 100 AND 101).

FIRST USE 5-30-2003; IN COMMERCE 5-30-2003.

HEATHER THOMPSON, EXAMINING ATTORNEY

SN 85-211,709. PLAN GENIUS, LLC, RICHMOND, VA. FILED 1-6-2011.

## Plan Genius

THE MARK CONSISTS OF STANDARD CHARACTERS WITHOUT CLAIM TO ANY PARTICULAR FONT, STYLE, SIZE, OR COLOR.

NO CLAIM IS MADE TO THE EXCLUSIVE RIGHT TO USE "PLAN", APART FROM THE MARK AS SHOWN.

FOR PROVIDING TEMPORARY USE OF ON-LINE NONDOWNLOADABLE SOFTWARE AND APPLICATIONS FOR ONLINE SCHEDULING, DOCUMENT CREATION, EMAIL MARKETING, AND CUSTOMER DATABASE MANAGEMENT (U.S. CLS. 100 AND 101).

FIRST USE 2-17-2010; IN COMMERCE 4-15-2010.

ELLEN BURNS, EXAMINING ATTORNEY

SN 85-212,000. GLOBAL BEND INCORPORATED, HAMILTON, CANADA, FILED 1-6-2011.

## GLOBAL BEND

THE MARK CONSISTS OF STANDARD CHARACTERS WITHOUT CLAIM TO ANY PARTICULAR FONT, STYLE, SIZE, OR COLOR.

FOR RENTAL OF COMPUTER HARDWARE AND COMPUTER SOFTWARE; RENTAL OF WEB SERVERS; SERVICES FOR MAINTENANCE OF COMPUTER SOFTWARE; UPDATING AND MAINTENANCE OF COMPUTER SOFTWARE (U.S. CLS. 100 AND 101).

GINA FINK, EXAMINING ATTORNEY

**CLASS 42—(Continued).**

SN 85-212,066. GONZO SYSTEMS, INC, LAND O LAKES, FL.  
FILED 1-6-2011.

## Gonzo Systems

THE MARK CONSISTS OF STANDARD CHARACTERS WITHOUT CLAIM TO ANY PARTICULAR FONT, STYLE, SIZE, OR COLOR.

NO CLAIM IS MADE TO THE EXCLUSIVE RIGHT TO USE "SYSTEMS", APART FROM THE MARK AS SHOWN.

FOR COMPUTER SERVICES, NAMELY, SEARCH ENGINE OPTIMIZATION; HOSTING THE WEB SITES OF OTHERS; WEB SITE DESIGN; WEBSITE DEVELOPMENT FOR OTHERS (U.S. CLS. 100 AND 101).

FIRST USE 10-1-1995; IN COMMERCE 6-10-1997.

H. M. FISHER, EXAMINING ATTORNEY

**CLASS 42—(Continued).**

SN 85-213,460. 2612LLC, WASHINGTON, DC. FILED 1-8-2011.



THE MARK CONSISTS OF A FEMALE WITH A SKIRT SUIT IN FRONT OF LINE OF 7 PEOPLE ENCLOSED IN A SHAPE OVAL. ON THE TOP THERE IS THE STYLIZED TEXT "SEVEN2ONEMEET.COM".

FOR COMPUTER SERVICES, NAMELY, CREATING AN ON-LINE COMMUNITY FOR REGISTERED USERS TO PARTICIPATE IN DISCUSSIONS, GET FEEDBACK FROM THEIR PEERS, FORM VIRTUAL COMMUNITIES, AND ENGAGE IN SOCIAL NETWORKING FEATURING INFORMATION ON RESTAURANTS, ENTERTAINMENT, AND LIFESTYLES WITHIN THE LOCAL AREA (U.S. CLS. 100 AND 101).

MICHAEL WEBSTER, EXAMINING ATTORNEY

SN 85-212,233. DEMAND CHAIN, INC., SAN FRANCISCO, CA. FILED 1-6-2011.

## HOMERUN

THE MARK CONSISTS OF STANDARD CHARACTERS WITHOUT CLAIM TO ANY PARTICULAR FONT, STYLE, SIZE, OR COLOR.

OWNER OF U.S. REG. NO. 3,918,015.

FOR HOSTING AN ONLINE WEBSITE FEATURING COLLECTIVE PURCHASING AND DEALS (U.S. CLS. 100 AND 101).

FIRST USE 11-1-2009; IN COMMERCE 11-1-2009.

CARYN GLASSER, EXAMINING ATTORNEY

SN 85-213,568. CLICK N' KIDS, INC., AGOURA HILLS, CA.  
FILED 1-9-2011.

## CLICKN MATH

SN 85-213,302. NORTHERN LAKE SERVICE, INCORPORATED, CRANDON, WI. FILED 1-7-2011.

## Great People. Trusted Results.

THE MARK CONSISTS OF STANDARD CHARACTERS WITHOUT CLAIM TO ANY PARTICULAR FONT, STYLE, SIZE, OR COLOR.

FOR LABORATORY RESEARCH IN THE FIELD OF ENVIRONMENTAL SCIENCES, NAMELY, BACTERIOLOGY, CHEMICAL ANALYSIS, WATER ANALYSIS, SOIL (U.S. CLS. 100 AND 101).

FIRST USE 10-15-2009; IN COMMERCE 12-15-2010.

STEVEN JACKSON, EXAMINING ATTORNEY

THE MARK CONSISTS OF STANDARD CHARACTERS WITHOUT CLAIM TO ANY PARTICULAR FONT, STYLE, SIZE, OR COLOR.

NO CLAIM IS MADE TO THE EXCLUSIVE RIGHT TO USE "MATH", APART FROM THE MARK AS SHOWN.

FOR EDUCATION SERVICES, NAMELY, PROVIDING ON-LINE USE OF ON-LINE NON-DOWNLOADABLE SOFTWARE ON A TEMPORARY BASIS FOR INSTRUCTION IN THE FIELD OF MATHEMATICS (U.S. CLS. 100 AND 101).

MARK SHINER, EXAMINING ATTORNEY



**CLASS 42—(Continued).**

SN 85-213,616. SPARTZ, INC., LAPORTE, IN. FILED 1-9-2011.

**OMG FACTS**

THE MARK CONSISTS OF STANDARD CHARACTERS WITHOUT CLAIM TO ANY PARTICULAR FONT, STYLE, SIZE, OR COLOR.

NO CLAIM IS MADE TO THE EXCLUSIVE RIGHT TO USE "FACTS", APART FROM THE MARK AS SHOWN.

FOR PROVIDING A WEBSITE THAT ALLOWS USERS TO SUBMIT FACTS AND TO VOTE ON THEIR FAVORITES WHICH WILL THEN BE DISPLAYED ON THE WEBSITE AFTER BEING RESEARCHED AND CHECKED BY THE WEBSITE OPERATORS (U.S. CLS. 100 AND 101).

FIRST USE 2-1-2010; IN COMMERCE 2-1-2010.  
JAMES GRIFFIN, EXAMINING ATTORNEY

---

SN 85-213,762. WEATHER DECISION TECHNOLOGIES INC., NORMAN, OK. FILED 1-10-2011.

**WAAS**

THE MARK CONSISTS OF STANDARD CHARACTERS WITHOUT CLAIM TO ANY PARTICULAR FONT, STYLE, SIZE, OR COLOR.

FOR WEATHER INFORMATION SERVICES (U.S. CLS. 100 AND 101).

JOHN E. MICHOS, EXAMINING ATTORNEY

---

SN 85-213,768. WEATHER DECISION TECHNOLOGIES INC., NORMAN, OK. FILED 1-10-2011.

**WEATHER AS A SERVICE**

THE MARK CONSISTS OF STANDARD CHARACTERS WITHOUT CLAIM TO ANY PARTICULAR FONT, STYLE, SIZE, OR COLOR.

NO CLAIM IS MADE TO THE EXCLUSIVE RIGHT TO USE "WEATHER", APART FROM THE MARK AS SHOWN.

FOR PROVIDING WEATHER INFORMATION SERVICES (U.S. CLS. 100 AND 101).

JOHN E. MICHOS, EXAMINING ATTORNEY

**CLASS 42—(Continued).**

SN 85-213,815. NMLR GROUP, LLC, MIAMI, FL. FILED 1-10-2011.

 The logo for G-luxe STUDIO features a stylized 'G' inside a circle, followed by the word 'luxe' in a lowercase serif font and 'STUDIO' in a smaller, spaced-out uppercase sans-serif font below it.

NO CLAIM IS MADE TO THE EXCLUSIVE RIGHT TO USE "STUDIO", APART FROM THE MARK AS SHOWN.

FOR INTERIOR DESIGN SERVICES (U.S. CLS. 100 AND 101).

KATHRYN COWARD, EXAMINING ATTORNEY

---

SN 85-213,947. BESTCOMM NETWORKS, INC., TUCSON, AZ. FILED 1-10-2011.

**MSPX**

THE MARK CONSISTS OF STANDARD CHARACTERS WITHOUT CLAIM TO ANY PARTICULAR FONT, STYLE, SIZE, OR COLOR.

FOR COMPUTER SERVICES, NAMELY, ON-LINE SCANNING, DETECTING, QUARANTINING AND ELIMINATING VIRUSES, WORMS, TROJANS, SPYWARE, ADWARE, MALWARE AND UNAUTHORIZED DATA AND PROGRAMS ON COMPUTERS AND ELECTRONIC DEVICES; COMPUTER VIRUS PROTECTION SERVICES; IT INTEGRATION SERVICES (U.S. CLS. 100 AND 101).

FIRST USE 7-3-2010; IN COMMERCE 8-9-2010.  
LANA PHAM, EXAMINING ATTORNEY

---

SN 85-214,148. SEALED AIR CORPORATION (US), ELWOOD PARK, NJ. FILED 1-10-2011.

 The logo for SMARTlife features the word 'SMARTlife' in a bold, sans-serif font. The letter 'A' is replaced by an upward-pointing arrowhead. This arrowhead is part of a circular graphic formed by three arrows pointing clockwise, which surrounds the right side of the text.

THE MARK CONSISTS OF THE STYLIZED WORDING "SMARTLIFE" WHERE THE LETTER "A" IS IN THE FORMAT OF AN UPWARD POINTING ARROWHEAD WHICH FORMS ONE SEGMENT OF THREE ARROWS FORMING A CIRCLE THAT SURROUNDS THE RIGHT SIDE PORTION OF THE WORDING.

FOR TECHNICAL CONSULTING IN THE FIELD OF PRODUCT MATERIALS AND DESIGN, NAMELY, PACKAGING AND PACKAGING SUSTAINABILITY (U.S. CLS. 100 AND 101).

CHRISTINE COOPER, EXAMINING ATTORNEY

**CLASS 42—(Continued).**

SN 85-214,675. ITX CAPITAL CORP., PITTSFORD, NY.  
FILED 1-11-2011.

# MOBILITYCMS

THE MARK CONSISTS OF THE WORDING "MOBILITYCMS" IN CAPITAL LETTERING WITH THE WORD "MOBILITY" SUBSTANTIALLY BOLDER THAN THE LETTERS "CMS".

FOR PROVIDING A WEB-BASED CONTENT-MANAGEMENT SYSTEM FOR MANAGING SOFTWARE APPLICATIONS (U.S. CLS. 100 AND 101).

FIRST USE 5-15-2009; IN COMMERCE 5-15-2009.  
RON FAIRBANKS, EXAMINING ATTORNEY

**CLASS 42—(Continued).**

SN 85-217,588. AGILICA CORPORATION, ORLAND PARK, IL. FILED 1-14-2011.

# AGILICA

THE MARK CONSISTS OF STANDARD CHARACTERS WITHOUT CLAIM TO ANY PARTICULAR FONT, STYLE, SIZE, OR COLOR.

FOR DESIGN AND DEVELOPMENT OF COMPUTER SOFTWARE, WEBSITES, EDUCATION PROGRAMS, WEB APPLICATIONS, MOBILE TECHNOLOGY, ELECTRONIC COMMUNICATION, AND DIGITAL TECHNOLOGIES (U.S. CLS. 100 AND 101).

FIRST USE 5-3-2010; IN COMMERCE 10-1-2010.  
SANI KHOURI, EXAMINING ATTORNEY

SN 85-214,939. MANIGAULT JR., MARVIN, APO, CA. FILED 1-11-2011.

THE MARK CONSISTS OF THE INITIALS "MIP". THE "I" OF THE INITIALS REPRESENTS A SPRAY CAN TOP.

FOR DESIGN FOR OTHERS IN THE FIELD OF CLOTHING; GRAPHIC DESIGN; INDUSTRIAL DESIGN (U.S. CLS. 100 AND 101).

SKYE YOUNG, EXAMINING ATTORNEY

SN 85-217,662. ZAC SOLUTIONS, INC., RICHARDSON, TX. FILED 1-14-2011.

# ZAC Solutions

THE MARK CONSISTS OF STANDARD CHARACTERS WITHOUT CLAIM TO ANY PARTICULAR FONT, STYLE, SIZE, OR COLOR.

NO CLAIM IS MADE TO THE EXCLUSIVE RIGHT TO USE "SOLUTIONS", APART FROM THE MARK AS SHOWN.

FOR COMPUTER SERVICES, NAMELY, REMOTE AND ON-SITE MANAGEMENT OF THE INFORMATION TECHNOLOGY (IT) CLOUD COMPUTING SYSTEMS OF OTHERS; CONSULTING IN THE FIELD OF INFORMATION TECHNOLOGY; CONSULTING IN THE FIELD OF VIRTUALIZATION TECHNOLOGIES FOR ENTERPRISES AND BUSINESSES; INFORMATION TECHNOLOGY CONSULTATION; PLANNING, DESIGN AND IMPLEMENTATION OF VIRTUALIZATION TECHNOLOGIES FOR ENTERPRISES AND BUSINESSES; PLANNING, DESIGN AND MANAGEMENT OF INFORMATION TECHNOLOGY SYSTEMS (U.S. CLS. 100 AND 101).

FIRST USE 12-1-2005; IN COMMERCE 1-1-2006.  
GIANCARLO CASTRO, EXAMINING ATTORNEY

SN 85-217,455. PETER WITTWER NORTH AMERICA, INC., LARGO, FL. FILED 1-13-2011.

# TransPort Explorer

THE MARK CONSISTS OF STANDARD CHARACTERS WITHOUT CLAIM TO ANY PARTICULAR FONT, STYLE, SIZE, OR COLOR.

NO CLAIM IS MADE TO THE EXCLUSIVE RIGHT TO USE "TRANSPORT", APART FROM THE MARK AS SHOWN.

FOR SOFTWARE AS A SERVICE (SAAS) SERVICES FEATURING SOFTWARE FOR TRACKING AND TRACING SHIPMENTS, LOGISTICS, AND TRANSPORTATION (U.S. CLS. 100 AND 101).

FIRST USE 1-1-2002; IN COMMERCE 1-1-2002.  
TARAH HARDY, EXAMINING ATTORNEY

SN 85-218,781. WHITTAKER, ANWAR, PHILADELPHIA, PA. FILED 1-16-2011.

# Never Get A Computer Virus Again

THE MARK CONSISTS OF STANDARD CHARACTERS WITHOUT CLAIM TO ANY PARTICULAR FONT, STYLE, SIZE, OR COLOR.

FOR COMPUTER VIRUS PROTECTION SERVICES (U.S. CLS. 100 AND 101).

STEVEN R. FINE, EXAMINING ATTORNEY

**CLASS 42—(Continued).**

SN 85-218,944. LEGG, JAMES, HOLLYWOOD, CA. FILED 1-17-2011.

# Memorys

THE MARK CONSISTS OF STANDARD CHARACTERS WITHOUT CLAIM TO ANY PARTICULAR FONT, STYLE, SIZE, OR COLOR.

FOR COMPUTER SERVICES, NAMELY, CREATING AN ON-LINE COMMUNITY FOR REGISTERED USERS TO PARTICIPATE IN DISCUSSIONS, GET FEEDBACK FROM THEIR PEERS, FORM VIRTUAL COMMUNITIES, AND ENGAGE IN SOCIAL NETWORKING (U.S. CLS. 100 AND 101).

FIRST USE 1-1-2008; IN COMMERCE 1-1-2008.  
NANCY CLARKE, EXAMINING ATTORNEY

---

SN 85-218,965. MAKE ME SOCIAL, LLC, BALTIMORE, MD. FILED 1-17-2011.

# COMPLITRIX

THE MARK CONSISTS OF STANDARD CHARACTERS WITHOUT CLAIM TO ANY PARTICULAR FONT, STYLE, SIZE, OR COLOR.

FOR SOFTWARE AS A SERVICE (SAAS) SERVICES FEATURING SOFTWARE FOR MANAGING MARKETING, PUBLIC RELATIONS, REGULATORY AND LEGAL COMPLIANCE FOR SOCIAL NETWORK COMMUNICATIONS (U.S. CLS. 100 AND 101).

CAROLINE WOOD, EXAMINING ATTORNEY

---

SN 85-219,327. BACKSTOP LLP, WASHINGTON, DC. FILED 1-17-2011.

# BACKSTOP

THE MARK CONSISTS OF STANDARD CHARACTERS WITHOUT CLAIM TO ANY PARTICULAR FONT, STYLE, SIZE, OR COLOR.

FOR COMPUTER SERVICE, NAMELY, ACTING AS AN APPLICATION SERVICE PROVIDER IN THE FIELD OF INFORMATION MANAGEMENT TO HOST COMPUTER APPLICATION SOFTWARE FOR THE PURPOSE OF SEARCHING, IDENTIFYING, PRIORITIZING, AND USING MACHINE-LEARNING AND OTHER ANALYTICAL TECHNIQUES TO ANALYZE ELECTRONIC DATA, RECORDS, AND DOCUMENTS (U.S. CLS. 100 AND 101).

FIRST USE 12-31-2007; IN COMMERCE 12-31-2007.  
MATTHEW KLINE, EXAMINING ATTORNEY

**CLASS 42—(Continued).**

SN 85-219,428. WAVEMARKET, INC., EMERYVILLE, CA. FILED 1-17-2011.

# SAFELY

THE MARK CONSISTS OF STANDARD CHARACTERS WITHOUT CLAIM TO ANY PARTICULAR FONT, STYLE, SIZE, OR COLOR.

FOR APPLICATION SERVICE PROVIDER (ASP) FEATURING SOFTWARE FOR USE IN TRACKING AND LOCATING MOBILE DEVICES; PROVIDING ON-LINE NON-DOWNLOADABLE SOFTWARE FOR MONITORING SOCIAL NETWORK AND MOBILE COMMUNICATIONS USAGE; SOFTWARE DEVELOPMENT IN THE FIELD OF TRACKING, MONITORING AND CONTROLLING MOBILE COMMUNICATIONS DEVICES (U.S. CLS. 100 AND 101).

JAMES LOVELACE, EXAMINING ATTORNEY

---

SN 85-220,414. FEARLESS SOLUTIONS, LLC, BALTIMORE, MD. FILED 1-18-2011.

# Fearless Solutions

THE MARK CONSISTS OF STANDARD CHARACTERS WITHOUT CLAIM TO ANY PARTICULAR FONT, STYLE, SIZE, OR COLOR.

FOR COMPUTER SECURITY CONSULTANCY IN THE FIELD OF SCANNING AND PENETRATION TESTING OF COMPUTERS AND NETWORKS TO ASSESS INFORMATION SECURITY VULNERABILITY; COMPUTER SECURITY SERVICE, NAMELY, RESTRICTING ACCESS TO AND BY COMPUTER NETWORKS TO AND OF UNDESIRE WEB SITES, MEDIA AND INDIVIDUALS AND FACILITIES; COMPUTER SOFTWARE DESIGN IN THE FIELD OF COMPUTER SECURITY; COMPUTER SOFTWARE DEVELOPMENT IN THE FIELD OF IN THE FIELD OF COMPUTER SECURITY FOR MOBILE APPLICATIONS; DESIGN FOR OTHERS IN THE FIELD OF COMPUTER NETWORKS, SOFTWARE, AND ENGINEERING FOR THE FEDERAL GOVERNMENT, HEALTH SECTOR, FINANCIAL SECTOR AND COMMERCIAL SECTOR IN THE FIELD OF COMPUTER SECURITY; DESIGN OF INFORMATION GRAPHICS AND DATA VISUALIZATION MATERIALS; IT CONSULTING SERVICES (U.S. CLS. 100 AND 101).

FIRST USE 2-5-2009; IN COMMERCE 2-5-2009.  
MATTHEW EINSTEIN, EXAMINING ATTORNEY

**CLASS 42—(Continued).**

SN 85-221,190. INCOMeworks, LLC, LAKE FOREST, IL. FILED 1-19-2011.

**INCOMeworks**

THE MARK CONSISTS OF STANDARD CHARACTERS WITHOUT CLAIM TO ANY PARTICULAR FONT, STYLE, SIZE, OR COLOR.

OWNER OF U.S. REG. NOS. 2,968,752 AND 2,974,550. FOR PROVIDING ON-LINE NON-DOWNLOADABLE SOFTWARE FOR REAL ESTATE TAX ASSESSMENT AND EDUCATION ON INCOME ANALYSIS AS APPLIED TO REAL ESTATE TAX ASSESSMENT (U.S. CLS. 100 AND 101).

FIRST USE 2-21-2005; IN COMMERCE 2-21-2005. GIANCARLO CASTRO, EXAMINING ATTORNEY

**CLASS 42—(Continued).**

SN 85-229,040. ENTERTAINMENT AUCTION ASSOCIATION, INC., SAN FRANCISCO, CA. FILED 1-28-2011.



THE COLOR(S) LIGHT AND DARK GRAY, WHITE IS/ ARE CLAIMED AS A FEATURE OF THE MARK.

THE MARK CONSISTS OF DARK GRAY SQUARE WHITE BORDER WITH ROUNDED CORNERS, WITH "EAA" IN BOTTOM PORTION OF SQUARE IN WHITE LETTERS, AND LIGHT GRAY GAVEL ABOVE "EAA".

FOR TESTING, ANALYSIS, AND EVALUATION OF THE ONLINE AUCTION SERVICES OF OTHERS FOR THE PURPOSE OF CERTIFICATION (U.S. CLS. 100 AND 101).

FIRST USE 12-6-2010; IN COMMERCE 12-6-2010. JOHN SCHUYLER YARD, EXAMINING ATTORNEY

SN 85-230,528. EDUCATIONAL RECORDS BUREAU, NEW YORK, NY. FILED 1-31-2011.

**ECAA** EARLY CHILDHOOD  
ADMISSIONS ASSESSMENT

NO CLAIM IS MADE TO THE EXCLUSIVE RIGHT TO USE "EARLY CHILDHOOD ADMISSIONS ASSESSMENT", APART FROM THE MARK AS SHOWN.

THE MARK CONSISTS OF THE LETTERS "ECAA" PLACED TO THE LEFT OF THE WORDS "EARLY CHILDHOOD" WHICH APPEAR DIRECTLY ABOVE THE WORDS "ADMISSIONS ASSESSMENT".

FOR PROVIDING COMPUTER-ADAPTIVE STANDARDIZED TESTS VIA THE INTERNET TO ASSESS EARLY CHILDHOOD DEVELOPMENT (U.S. CLS. 100 AND 101). ARETHA SOMERVILLE, EXAMINING ATTORNEY

SN 85-227,876. WEATHER DECISION TECHNOLOGIES INC., NORMAN, OK. FILED 1-27-2011.



THE MARK CONSISTS OF A TORNADO WITHIN A CIRCLE.

FOR PROVIDING WEATHER INFORMATION SERVICES (U.S. CLS. 100 AND 101).

FIRST USE 12-1-2008; IN COMMERCE 12-1-2008. JOHN E. MICHOS, EXAMINING ATTORNEY

SN 85-243,667. BRISTOL-MYERS SQUIBB COMPANY, NEW YORK, NY. FILED 2-16-2011.



FOR MEDICAL AND SCIENTIFIC RESEARCH, NAMELY, CONDUCTING CLINICAL TRIALS RELATING TO PHARMACEUTICAL PREPARATIONS FOR HUMAN USE (U.S. CLS. 100 AND 101).

WENDY GOODMAN, EXAMINING ATTORNEY

**CLASS 42—(Continued).**

SN 85-247,356. WEATHER DECISION TECHNOLOGIES INC.,  
NORMAN, OK. FILED 2-21-2011.

# WDT

THE MARK CONSISTS OF STANDARD CHARACTERS WITHOUT CLAIM TO ANY PARTICULAR FONT, STYLE, SIZE, OR COLOR.

FOR WEATHER PRESENTATION SERVICES, NAMELY, METEOROLOGICAL FORECASTING AND PROVIDING METEOROLOGICAL INFORMATION (U.S. CLS. 100 AND 101).

FIRST USE 5-31-2000; IN COMMERCE 5-31-2000.  
JOHN E. MICHOS, EXAMINING ATTORNEY

SN 85-247,572. WEATHER DECISION TECHNOLOGIES INC.,  
NORMAN, OK. FILED 2-21-2011.



THE MARK CONSISTS OF "WDT" WITH A CLOUD AND LIGHTNING BOLT BEHIND THE LETTER "T" LAID ON TOP OF A DOUBLE RINGED OVAL.

FOR WEATHER PRESENTATION SERVICES, NAMELY, METEOROLOGICAL FORECASTING AND PROVIDING METEOROLOGICAL INFORMATION (U.S. CLS. 100 AND 101).

FIRST USE 1-31-2005; IN COMMERCE 1-31-2005.  
JOHN E. MICHOS, EXAMINING ATTORNEY

**CLASS 42—(Continued).**

SN 85-264,581. HEWLETT-PACKARD DEVELOPMENT COMPANY, L.P., HOUSTON, TX. FILED 3-11-2011.

# EVERYBODY ON

THE MARK CONSISTS OF STANDARD CHARACTERS WITHOUT CLAIM TO ANY PARTICULAR FONT, STYLE, SIZE, OR COLOR.

FOR COMPUTER SERVICES, NAMELY, COMPUTER SYSTEMS ANALYSIS, COMPUTER SYSTEMS PLANNING, COMPUTER SYSTEMS INTEGRATION, COMPUTER SYSTEMS DESIGN; COMPUTER CONSULTATION, NAMELY, PROVIDING ASSISTANCE TO OTHERS IN THE DEVELOPMENT OF INTERNET PORTALS AND IN THE DESIGN AND DEVELOPMENT OF COMPUTER SOFTWARE FOR THE IMPROVEMENTS OF PURCHASING FUNCTIONS OF BUSINESS FOR USE IN THE FIELD OF ELECTRONIC COMMERCE; COMPUTER CONSULTATION SERVICES IN THE FIELD OF INTERNET AND INTRANET NETWORK SECURITY; RENTAL OF COMPUTER SOFTWARE, COMPUTER HARDWARE AND COMPUTER PERIPHERALS TO OTHERS ON A SUBSCRIPTION AND PAY-PER-USE BASIS; COMPUTER TECHNOLOGY SUPPORT SERVICES, NAMELY, HELP DESK SERVICES PROVIDED ON A SUBSCRIPTION AND PAY-PER-USE BASIS; HOSTING OF DIGITAL CONTENT ON THE INTERNET; SOFTWARE AS A SERVICE (SAAS) SERVICES, NAMELY, HOSTING SOFTWARE FOR USE BY OTHERS IN THE FIELD OF INFORMATION TECHNOLOGY; COMPUTER SERVICES, NAMELY, REMOTE AND ON-SITE MANAGEMENT OF THE INFORMATION TECHNOLOGY (IT) SYSTEMS OF OTHERS; INFORMATION TECHNOLOGY CONSULTATION; DESIGN, INSTALLATION, MAINTENANCE AND REPAIR OF COMPUTER SOFTWARE; INTEGRATION OF COMPUTER SYSTEMS AND NETWORKS; COMPUTER NETWORK MANAGEMENT SERVICES, NAMELY, PLANNING AND DEVELOPMENT OF ELECTRONIC COMMUNICATION NETWORKS, AND PROVIDING TECHNICAL SUPPORT IN THE NATURE OF HELP DESK SERVICES, 24X7 MONITORING OF NETWORK SYSTEMS, SERVERS AND WEB AND DATABASE APPLICATIONS AND NOTIFICATION OF RELATED EVENTS AND ALERTS FOR ELECTRONIC COMMUNICATIONS NETWORKS; DATABASE DEVELOPMENT SERVICES; COMPUTER PROGRAMMING SERVICES; CONSULTING SERVICES FOR OTHERS IN THE SELECTION, IMPLEMENTATION AND USE OF COMPUTER SOFTWARE USED TO MONITOR AND MANAGE TRANSACTIONS AND ACTIVITIES IN A MISSION CRITICAL ENVIRONMENT; TECHNICAL SUPPORT SERVICES, NAMELY, TROUBLESHOOTING OF COMPUTER SOFTWARE PROBLEMS; DATA MINING; INFORMATION MANAGEMENT SERVICES, NAMELY, ACTING AS AN APPLICATION SERVICE PROVIDER IN THE FIELD OF KNOWLEDGE MANAGEMENT TO HOST COMPUTER APPLICATION SOFTWARE FOR THE COLLECTION, EDITING, ORGANIZING, MODIFYING, BOOK MARKING, TRANSMISSION, STORAGE AND SHARING OF DATA AND INFORMATION; CUSTOM DESIGN OF COMPUTERS FOR OTHERS; DATA BACKUP SERVICES FOR COMPUTER HARD DRIVES AND COMPUTER STORAGE MEDIA; COMPUTER DATA RECOVERY SERVICES; DATA MIGRATION SERVICES; DATA ENCRYPTION SERVICES; RENTAL AND LEASING SERVICES OF COMPUTER HARDWARE AND COMPUTER PERIPHERALS; PROVIDING GRAPHIC ART DESIGN SERVICES VIA COMMUNICATIONS NETWORKS; SCIENTIFIC AND INDUSTRIAL RESEARCH IN THE FIELD OF COMPUTER SCIENCE AND INFORMATION TECHNOLOGY (U.S. CLS. 100 AND 101).

JOHN WILKE, EXAMINING ATTORNEY



**CLASS 42—(Continued).**

SN 85-975,111. INTERNATIONAL DATA GROUP, INC., FRAMINGHAM, MA. FILED 3-30-2010.

**MOBILE & WIRELESS WORLD**

THE MARK CONSISTS OF STANDARD CHARACTERS WITHOUT CLAIM TO ANY PARTICULAR FONT, STYLE, SIZE, OR COLOR.

OWNER OF U.S. REG. NO. 2,810,526.

NO CLAIM IS MADE TO THE EXCLUSIVE RIGHT TO USE "MOBILE & WIRELESS", APART FROM THE MARK AS SHOWN.

FOR PROVIDING A WEBSITE OF INFORMATION IN THE FIELD OF COMPUTERS AND COMPUTER SOFTWARE (U.S. CLS. 100 AND 101).

JASON BLAIR, EXAMINING ATTORNEY

**CLASS 43—HOTEL AND RESTAURANT SERVICES**

SN 77-310,190. CAFE RIO, INCORPORATED, SALT LAKE CITY, UT. FILED 10-22-2007.



THE COLOR(S) GREEN, YELLOW, ORANGE, RED, PURPLE AND BLUE IS/ARE CLAIMED AS A FEATURE OF THE MARK.

THE MARK CONSISTS OF COLORED DESIGNS ON THE SURFACE OF TABLES AND CHAIRS. A COLOR GREEN AND YELLOW COMBINATION AND DESIGN APPLIED TO THE SURFACES OF A CHAIR, A GREEN AND PURPLE COLOR COMBINATION AND DESIGN APPLIED TO THE SURFACES OF A CHAIR, A RED, ORANGE AND PURPLE COLOR COMBINATION AND DESIGN APPLIED TO THE SURFACES OF A CHAIR, AND A YELLOW, GREEN AND BLUE COLOR COMBINATION AND DESIGN APPLIED TO THE SURFACES OF A TABLE. THE SHAPE OF THE TABLE AND CHAIRS IS REPRESENTED IN BROKEN OR DOTTED LINES IN THE DRAWING TO SHOW PLACEMENT OF THE MARK AND TO DEPICT THE COMMERCIAL IMPRESSION OF THE MARK. THE SHAPE OF THE TABLE AND CHAIRS IS NOT CLAIMED AS A FEATURE OF THE MARK.

SEC. 2(F).

FOR RESTAURANT SERVICES FEATURING MEXICAN FOOD (U.S. CLS. 100 AND 101).

FIRST USE 6-0-1997; IN COMMERCE 6-0-1997.

DAWN FELDMAN, EXAMINING ATTORNEY

**CLASS 43—(Continued).**

SN 77-585,100. EL PARADOR HOLDING CORPORATION, MIAMI, FL. FILED 10-3-2008.



NO CLAIM IS MADE TO THE EXCLUSIVE RIGHT TO USE "EL PARADOR" AND "FOOD BY THE POUND", APART FROM THE MARK AS SHOWN.

THE MARK CONSISTS OF THE WORDS "EL PARADOR" IN A LARGE FONT ON TOP OF THE WORDS "FOOD BY THE POUND" INSIDE OF AN OVAL SHAPE WITH THE DESIGN OF A CHEF WEARING A CHEF'S HAT ON THE RIGHT HAND SIDE WITH HIS HEAD THROUGH THE "O" IN "PARADOR".

THE FOREIGN WORDING IN THE MARK TRANSLATES INTO ENGLISH AS "THE COUNTRY INN" OR "HOTEL".

FOR CARRY-OUT RESTAURANTS (U.S. CLS. 100 AND 101).

FIRST USE 7-31-1998; IN COMMERCE 7-31-1998.

MICHAEL WEBSTER, EXAMINING ATTORNEY

SN 77-653,707. SERVICIOS TURISTICOS EXCLUSIVOS, S.A. DE C.V., NUEVO VALLARTA, MEXICO, FILED 1-21-2009.



NO CLAIM IS MADE TO THE EXCLUSIVE RIGHT TO USE "MANSIONS", APART FROM THE MARK AS SHOWN.

THE MARK CONSISTS OF THE WORDS "MANSIONS OF THE WORLD" IN A STYLIZED FORM BELOW A FEATHER DESIGN. THE FEATHER DESIGN IS CASTING A SHADOW.

FOR HOTEL, RESTAURANT AND BAR SERVICES; PROVIDING ADVICE TO TOURISTS AND BUSINESS TRAVELERS ON HOTEL AND RESTAURANT DESTINATIONS; RESORT LODGING SERVICES (U.S. CLS. 100 AND 101).

STEVEN JACKSON, EXAMINING ATTORNEY

**CLASS 43—(Continued).**

SN 77-678,437. NEGIN NIKNAFS, DBA THE HOT LUNCH LADY, MISSION VIEJO, CA. FILED 2-25-2009.

## The Hot Lunch Lady

THE MARK CONSISTS OF STANDARD CHARACTERS WITHOUT CLAIM TO ANY PARTICULAR FONT, STYLE, SIZE, OR COLOR.

NO CLAIM IS MADE TO THE EXCLUSIVE RIGHT TO USE "HOT LUNCH", APART FROM THE MARK AS SHOWN.

FOR CATERING OF FOOD AND DRINKS; PREPARATION OF FOOD AND BEVERAGES (U.S. CLS. 100 AND 101).

FIRST USE 11-1-2008; IN COMMERCE 11-1-2008.  
ARETHA SOMERVILLE, EXAMINING ATTORNEY

**CLASS 43—(Continued).**

SN 77-715,089. LANDMARK VENTURES, LLC, DBA MARIO'S FISHBOWL LLC, MORGANTOWN, WV. FILED 4-16-2009.

## Mario's Fishbowl

THE MARK CONSISTS OF STANDARD CHARACTERS WITHOUT CLAIM TO ANY PARTICULAR FONT, STYLE, SIZE, OR COLOR.

THE NAME(S), PORTRAIT(S), AND/OR SIGNATURE(S) SHOWN IN THE MARK DOES NOT IDENTIFY A PARTICULAR LIVING INDIVIDUAL.

FOR BAR AND RESTAURANT SERVICES; CARRY-OUT RESTAURANTS; RESTAURANT; RESTAURANT SERVICES, INCLUDING SIT-DOWN SERVICE OF FOOD AND TAKE-OUT RESTAURANT SERVICES; RESTAURANT SERVICES, NAMELY, PROVIDING OF FOOD AND BEVERAGES FOR CONSUMPTION ON AND OFF THE PREMISES; TAKE-OUT RESTAURANT SERVICES (U.S. CLS. 100 AND 101).

FIRST USE 7-31-1963; IN COMMERCE 7-31-1963.  
LINDA ESTRADA, EXAMINING ATTORNEY

SN 77-781,067. ENTERTAINMENT ENTERPRISES INC., EAST HILLS, NY. FILED 7-14-2009.

## HRH HIS ROYAL HIGHNESS

THE MARK CONSISTS OF STANDARD CHARACTERS WITHOUT CLAIM TO ANY PARTICULAR FONT, STYLE, SIZE, OR COLOR.

FOR RESTAURANT SERVICES; BAR SERVICES; COCKTAIL LOUNGES; RESTAURANT LOUNGES (U.S. CLS. 100 AND 101).

INGRID C. EULIN, EXAMINING ATTORNEY

SN 77-680,490. WORLD MARKET CENTER VENTURE, LLC, LAS VEGAS, NV. FILED 2-27-2009.

**GIFT HOME**  
AT WORLD MARKET CENTER LAS VEGAS

NO CLAIM IS MADE TO THE EXCLUSIVE RIGHT TO USE "GIFT" OR "HOME" OR "MARKET CENTER", APART FROM THE MARK AS SHOWN.

THE COLOR(S) BLUE, AQUA, GREEN, LIME, RED, PURPLE, FUCHSIA, ORANGE, AND GRAY IS/ARE CLAIMED AS A FEATURE OF THE MARK.

THE MARK CONSISTS OF THE GRAY STYLIZED WORDS "GIFT HOME" OVER THE GRAY STYLIZED WORDS "AT WORLD MARKET CENTER LAS VEGAS", WITH AN ASSORTMENT OF BLUE, AQUA, GREEN, LIME, RED, PURPLE, FUCHSIA AND ORANGE COLORED CIRCLES SYMBOLIZING A PLUS SIGN IN BETWEEN THE GRAY STYLIZED WORDS "GIFT" AND "HOME".

SEC. 2(F) AS TO "WORLD MARKET CENTER LAS VEGAS".

FOR PROVIDING SHOWROOM, CONFERENCE, EXHIBITION AND MEETING FACILITIES (U.S. CLS. 100 AND 101).

FIRST USE 8-1-2009; IN COMMERCE 8-1-2009.  
ANDREW RHIM, EXAMINING ATTORNEY

SN 77-867,281. FOOD SERVICES, INC., EDEN PRAIRIE, MN. FILED 11-6-2009.

## HOME OF THE JUICY LUCY

THE MARK CONSISTS OF STANDARD CHARACTERS WITHOUT CLAIM TO ANY PARTICULAR FONT, STYLE, SIZE, OR COLOR.

FOR RESTAURANT SERVICES (U.S. CLS. 100 AND 101).

FIRST USE 0-0-1996; IN COMMERCE 0-0-1996.  
CHARLES L. JENKINS, EXAMINING ATTORNEY

**CLASS 43—(Continued).**

SN 77-896,385. CRAVE HOSPITALITY LLC, EDEN PRAIRIE, MN. FILED 12-18-2009.

# CRAVE

THE MARK CONSISTS OF STANDARD CHARACTERS WITHOUT CLAIM TO ANY PARTICULAR FONT, STYLE, SIZE, OR COLOR.

CONCURRENT USE INFORMATION. THE APPLICANT SEEKS REGISTRATION OF THE MARK FOR RESTAURANT AND BAR SERVICES EVERYWHERE IN THE UNITED STATES EXCEPT A 50-MILE RADIUS AROUND DEARBORN, MICHIGAN, WITHOUT RESTRICTION AS TO MODE OF USE. ON INFORMATION AND BELIEF, IN ADDITION TO THE APPLICANT'S USE OF THE MARK, THE MARK HAS BEEN CONCURRENTLY USED IN COMMERCE IN CONNECTION WITH RESTAURANT AND BAR SERVICES BY KHALIL RAMADAN OF 466 BILTMORE, DEARBORN HEIGHTS, MICHIGAN 48127 ("CONCURRENT USER") OR HIS PRIVIES, SINCE OCTOBER 22, 2004. ON INFORMATION AND BELIEF, THE CONCURRENT USER OWNS U.S. TRADEMARK REGISTRATION NO. 3,568,957. ON INFORMATION AND BELIEF, THE CONCURRENT USER HAS USED THE MARK IN DEARBORN, MICHIGAN, OTHER THAN USE OF THE MARK IN ASSOCIATION WITH RESTAURANT AND BAR SERVICES, THE APPLICANT HAS NO KNOWLEDGE OF MODE OF THE CONCURRENT USER'S USE OR WHETHER THE CONCURRENT USER'S USE HAS BEEN CONTINUOUS AND EXCLUSIVE SINCE OCTOBER 22, 2004. NO ONE ELSE EXCEPT AS SPECIFIED IN THE APPLICATION HAS THE RIGHT TO USE THE MARK.

FOR RESTAURANT AND BAR SERVICES (U.S. CLS. 100 AND 101).

FIRST USE 2-8-2007; IN COMMERCE 2-8-2007.  
NANCY CLARKE, EXAMINING ATTORNEY

SN 77-896,389. CRAVE HOSPITALITY LLC, EDEN PRAIRIE, MN. FILED 12-18-2009.

# CRAVE

CONCURRENT USE INFORMATION. THE APPLICANT SEEKS REGISTRATION OF THE MARK FOR RESTAURANT AND BAR SERVICES EVERYWHERE IN THE UNITED STATES EXCEPT A 50-MILE RADIUS AROUND DEARBORN, MICHIGAN, WITHOUT RESTRICTION AS TO MODE OF USE. ON INFORMATION AND BELIEF, IN ADDITION TO THE APPLICANT'S USE OF THE MARK, THE MARK HAS BEEN CONCURRENTLY USED IN COMMERCE IN CONNECTION WITH RESTAURANT AND BAR SERVICES BY KHALIL RAMADAN OF 466 BILTMORE, DEARBORN HEIGHTS, MICHIGAN 48127 ("CONCURRENT USER") OR HIS PRIVIES, SINCE OCTOBER 22, 2004. ON INFORMATION AND BELIEF, THE CONCURRENT USER OWNS U.S. TRADEMARK REGIS-

**CLASS 43—(Continued).**

TRATION NO. 3,568,957. ON INFORMATION AND BELIEF, THE CONCURRENT USER HAS USED THE MARK IN DEARBORN, MICHIGAN, OTHER THAN USE OF THE MARK IN ASSOCIATION WITH RESTAURANT AND BAR SERVICES, THE APPLICANT HAS NO KNOWLEDGE OF MODE OF THE CONCURRENT USER'S USE OR WHETHER THE CONCURRENT USER'S USE HAS BEEN CONTINUOUS AND EXCLUSIVE SINCE OCTOBER 22, 2004. NO ONE ELSE EXCEPT AS SPECIFIED IN THE APPLICATION HAS THE RIGHT TO USE THE MARK.

THE COLOR(S) BROWN AND RED IS/ARE CLAIMED AS A FEATURE OF THE MARK.

THE MARK CONSISTS OF THE STYLIZED WORD "CRAVE" WITH THE LETTER "V" IN RED AND THE REMAINING LETTERS IN BROWN.

FOR RESTAURANT AND BAR SERVICES (U.S. CLS. 100 AND 101).

FIRST USE 2-8-2007; IN COMMERCE 2-8-2007.  
NANCY CLARKE, EXAMINING ATTORNEY

SN 77-926,257. VELEZ, JAIME, UNION, NJ. FILED 2-2-2010.

# Noches de Colombia Restaurante

THE MARK CONSISTS OF STANDARD CHARACTERS WITHOUT CLAIM TO ANY PARTICULAR FONT, STYLE, SIZE, OR COLOR.

NO CLAIM IS MADE TO THE EXCLUSIVE RIGHT TO USE "RESTAURANTE", APART FROM THE MARK AS SHOWN.

THE ENGLISH TRANSLATION OF "NOCHES DE COLOMBIA RESTAURANTE" IN THE MARK IS "COLOMBIAN NIGHTS RESTAURANT".

FOR RESTAURANT SERVICES (U.S. CLS. 100 AND 101).

FIRST USE 1-10-1996; IN COMMERCE 1-10-1996.  
SUSAN HAYASH, EXAMINING ATTORNEY

SN 85-034,894. ZHEN'S INC, NORTH BEND, OR. FILED 5-11-2010.

# momiji

NO CLAIM IS MADE TO THE EXCLUSIVE RIGHT TO USE "MOMIJI" OR THE NON-LATIN CHARACTERS THAT TRANSLITERATE TO "SUSHI", APART FROM THE MARK AS SHOWN.

THE COLOR(S) BLUE, GOLD, BLACK, WHITE, AND RED IS/ARE CLAIMED AS A FEATURE OF THE MARK.

THE MARK CONSISTS OF THE WORDS "MOMIJI"

**CLASS 43—(Continued).**

WRITTEN IN LARGE BLUE STYLIZED FONT WITH A SMALL GOLD BORDER ALONG THE EDGES OF THE FONT. A BLUE DIAMOND SHAPE ON THE RIGHT WITH A BLACK AND WHITE LANTERN INSIDE THE BLUE DIAMOND SHAPE WHICH IS OUTLINED IN BLACK ON THE RIGHT SIDE. THE WORDS SUSHI WRITTEN IN BLACK IN JAPANESE HIRAKANA CHARACTERS ON THE LANTERN WITH TWO RED/GOLD MAPLE LEAVES ON BOTH THE LEFT AND RIGHT SIDES ON EITHER SIDE OF SUSHI.

THE ENGLISH TRANSLATION OF "MOMJI" IN THE MARK IS "MAPLE".

THE NON-LATIN CHARACTERS IN THE MARK TRANSLITERATE TO "SUSHI" AND THIS MEANS "SUSHI" IN ENGLISH.

FOR JAPANESE RESTAURANTS, SUSHI BARS AND CATERING SERVICES (U.S. CLS. 100 AND 101).  
 LOURDES AYALA, EXAMINING ATTORNEY

SN 85-038,770. SEAN BRAUSER, DBA ROMEO'S PIZZA, INC., MEDINA, OH. FILED 5-14-2010.

# Romeo's Pizza

THE MARK CONSISTS OF STANDARD CHARACTERS WITHOUT CLAIM TO ANY PARTICULAR FONT, STYLE, SIZE, OR COLOR.

NO CLAIM IS MADE TO THE EXCLUSIVE RIGHT TO USE "PIZZA", APART FROM THE MARK AS SHOWN.

FOR BAR AND RESTAURANT SERVICES; RESTAURANT SERVICES, INCLUDING SIT-DOWN SERVICE OF FOOD AND TAKE-OUT RESTAURANT SERVICES (U.S. CLS. 100 AND 101).

C. DIONNE CLYBURN, EXAMINING ATTORNEY

SN 85-038,797. SEAN BRAUSER, DBA ROMEO'S PIZZA, INC., MEDINA, OH. FILED 5-14-2010.



NO CLAIM IS MADE TO THE EXCLUSIVE RIGHT TO USE "PIZZA", APART FROM THE MARK AS SHOWN.

THE COLOR(S) BLACK, RED, WHITE, GREEN, GRAY, AND TAN IS/ARE CLAIMED AS A FEATURE OF THE MARK.

THE MARK CONSISTS OF A MAN WHOSE FACE AND HAND APPEAR IN THE COLOR TAN. HE HAS A BLACK

**CLASS 43—(Continued).**

MUSTACHE, A BLACK EYE BROW AND EYE, AND GRAY HAIR. HE IS WEARING A BLACK SUIT WITH GRAY PIN STRIPES, A WHITE-COLLAR SHIRT, A RED TIE, AND A WHITE CUFF WITH A BLACK BUTTON. HE IS WEARING A BLACK HAT WITH A WHITE BAND AND A RED FEATHER. THE WORD "ROMEO'S" IS DISPLAYED IN RED CAPITAL LETTERS, OUTLINED IN WHITE, BELOW THE MAN. A GREEN BANNER WITH THE WORD "PIZZA" IN WHITE CAPITAL LETTERS APPEARS BELOW THE WORD "ROMEO'S".

FOR BAR AND RESTAURANT SERVICES; RESTAURANT SERVICES, INCLUDING SIT-DOWN SERVICE OF FOOD AND TAKE-OUT RESTAURANT SERVICES (U.S. CLS. 100 AND 101).

C. DIONNE CLYBURN, EXAMINING ATTORNEY

SN 85-044,013. ANDY'S FROZEN CUSTARD, INC., SPRINGFIELD, MO. FILED 5-20-2010.



NO CLAIM IS MADE TO THE EXCLUSIVE RIGHT TO USE "REAL FROZEN CUSTARD MADE FRESH EVERY HOUR", APART FROM THE MARK AS SHOWN.

THE MARK CONSISTS OF THE STYLIZED WORDS "REAL FROZEN CUSTARD MADE FRESH EVERY HOUR REALLY" WITH AN IMAGE OF A FROZEN DESSERT CONE POSITIONED THEREWITH.

SEC. 2(F) AS TO "DESIGN REPRESENTATION OF A FROZEN DESSERT CONE".

FOR RESTAURANT SERVICES FEATURING FROZEN CUSTARD (U.S. CLS. 100 AND 101).

FIRST USE 2-18-2010; IN COMMERCE 2-18-2010.

DAVID H. STINE, EXAMINING ATTORNEY

SN 85-047,850. STAN'S FINE TACOS AND CHILI BAR LLC, DBA STAN'S FINE TACOS AND CHILI BAR, SEATTLE, WA. FILED 5-26-2010.

Welcome to Stan's where  
 the customer is always  
 second and we don't test  
 for drugs.

THE MARK CONSISTS OF STANDARD CHARACTERS WITHOUT CLAIM TO ANY PARTICULAR FONT, STYLE, SIZE, OR COLOR.

FOR RESTAURANT AND BAR SERVICES (U.S. CLS. 100 AND 101).

AMY KERTGATE, EXAMINING ATTORNEY

**CLASS 43—(Continued).**

SN 85-053,005. ABEC RESORTS, INC., DESTIN, FL. FILED 6-2-2010.



NO CLAIM IS MADE TO THE EXCLUSIVE RIGHT TO USE "BEACH TOWERS", APART FROM THE MARK AS SHOWN.

THE MARK CONSISTS OF A CIRCLE DESIGN TO THE LEFT OF THE WORDS "SILVER BEACH TOWERS".

FOR RESORT HOTEL SERVICES (U.S. CLS. 100 AND 101).

FIRST USE 12-0-2008; IN COMMERCE 12-0-2008.  
AISHA CLARKE, EXAMINING ATTORNEY

**CLASS 43—(Continued).**

SN 85-053,032. ABEC RESORTS, INC., DESTIN, FL. FILED 6-2-2010.



NO CLAIM IS MADE TO THE EXCLUSIVE RIGHT TO USE "BEACH RESORT & SPA", APART FROM THE MARK AS SHOWN.

THE MARK CONSISTS OF A SHELL DESIGN TO THE LEFT OF THE WORDS "SILVER SHELLS BEACH RESORT & SPA".

FOR RESORT HOTEL SERVICES; RESTAURANT AND BAR SERVICES; SPA SERVICES, NAMELY, PROVIDING TEMPORARY ACCOMMODATIONS AND MEALS TO CLIENTS OF A HEALTH OR BEAUTY SPA (U.S. CLS. 100 AND 101).

FIRST USE 12-0-2008; IN COMMERCE 12-0-2008.  
AISHA CLARKE, EXAMINING ATTORNEY

SN 85-055,024. ABEC RESORTS, INC., DESTIN, FL. FILED 6-4-2010.

**SILVER BEACH TOWERS**

THE MARK CONSISTS OF STANDARD CHARACTERS WITHOUT CLAIM TO ANY PARTICULAR FONT, STYLE, SIZE, OR COLOR.

NO CLAIM IS MADE TO THE EXCLUSIVE RIGHT TO USE "BEACH TOWERS", APART FROM THE MARK AS SHOWN.

FOR RESORT HOTEL SERVICES (U.S. CLS. 100 AND 101).

FIRST USE 12-0-1999; IN COMMERCE 12-0-1999.  
AISHA CLARKE, EXAMINING ATTORNEY

SN 85-053,016. ABEC RESORTS, INC., DESTIN, FL. FILED 6-2-2010.

**SILVER SHELLS BEACH RESORT & SPA**

SN 85-058,492. BURGERMEISTER MANAGEMENT, INC., AKA BÜRGERMEISTER, SAN FRANCISCO, CA. FILED 6-9-2010.

**MeisterMobile**

THE MARK CONSISTS OF STANDARD CHARACTERS WITHOUT CLAIM TO ANY PARTICULAR FONT, STYLE, SIZE, OR COLOR.

NO CLAIM IS MADE TO THE EXCLUSIVE RIGHT TO USE "BEACH RESORT AND SPA", APART FROM THE MARK AS SHOWN.

FOR RESORT HOTEL SERVICES; RESTAURANT AND BAR SERVICES; SPA SERVICES, NAMELY, PROVIDING TEMPORARY ACCOMMODATIONS AND MEALS TO CLIENTS OF A HEALTH OR BEAUTY SPA (U.S. CLS. 100 AND 101).

FIRST USE 12-0-1997; IN COMMERCE 12-0-1997.  
AISHA CLARKE, EXAMINING ATTORNEY

THE MARK CONSISTS OF STANDARD CHARACTERS WITHOUT CLAIM TO ANY PARTICULAR FONT, STYLE, SIZE, OR COLOR.

THE ENGLISH TRANSLATION OF "MEISTER" IN THE MARK IS "MAYOR OR HEAD OF A TOWN".

FOR CATERING OF FOOD AND DRINKS (U.S. CLS. 100 AND 101).

FIRST USE 11-4-2008; IN COMMERCE 11-4-2008.  
JOHN DALIER, EXAMINING ATTORNEY



**CLASS 43—(Continued).**

SN 85-063,902. KONG, JEFFREY, SOUTH SAN FRANCISCO, CA. FILED 6-16-2010.



NO CLAIM IS MADE TO THE EXCLUSIVE RIGHT TO USE "FRESH GRILL", APART FROM THE MARK AS SHOWN.

THE COLOR(S) GREY, RED, ORANGE, WHITE, BLACK AND YELLOW IS/ARE CLAIMED AS A FEATURE OF THE MARK.

THE MARK CONSISTS OF A UPSIDE DOWN QUESTION MARK WHICH IS IN GREY MOHAWK EYES AND A RED TONGUE STICKING UPWARDS. THE UPSIDE DOWN QUESTION MARK IS IN ORANGE COLOR WITH GREY AND WHITE OUTLINE. ON THE LEFT HAND SIDE OF THE QUESTION MARK THE WORD "IZ" IS WRITTEN AND THE WORD "IT" IS WRITTEN ON THE RIGHT HAND SIDE. BOTH THE WORDS ARE IN BLACK COLOR WITH GREY AND WHITE OUTLINE. THE WORDS "FRESH GRILL" ARE WRITTEN AT THE BOTTOM WHICH IS IN BLACK COLOR WITH WHITE OUTLINE AND BACKGROUND IS IN ORANGE AND YELLOW STRIPES WITH SWIRLS AND RED STARS AS SHOWN IN THE MARK.

FOR RESTAURANT SERVICES, NAMELY, MOBILE SERVICES FOR PROVIDING FOOD AND DRINK FOR CONSUMERS (U.S. CLS. 100 AND 101).

GINA FINK, EXAMINING ATTORNEY

SN 85-065,582. J&J OPERATIONS HCC, LCC, CRANBERRY TOWNSHIP, PA. FILED 6-17-2010.

**THE REEL HOUSE RESTAURANT**

THE MARK CONSISTS OF STANDARD CHARACTERS WITHOUT CLAIM TO ANY PARTICULAR FONT, STYLE, SIZE, OR COLOR.

NO CLAIM IS MADE TO THE EXCLUSIVE RIGHT TO USE "RESTAURANT", APART FROM THE MARK AS SHOWN.

FOR BAR AND RESTAURANT SERVICES (U.S. CLS. 100 AND 101).

EUGENIA MARTIN, EXAMINING ATTORNEY

**CLASS 43—(Continued).**

SN 85-069,243. CAFE' AT SUN CITY INC., FLORENCE, AZ. FILED 6-23-2010.

**CAFE' AT SUN CITY**

THE MARK CONSISTS OF STANDARD CHARACTERS WITHOUT CLAIM TO ANY PARTICULAR FONT, STYLE, SIZE, OR COLOR.

NO CLAIM IS MADE TO THE EXCLUSIVE RIGHT TO USE "CAFE'", APART FROM THE MARK AS SHOWN.

FOR RESTAURANT SERVICES, NAMELY, PROVIDING OF FOOD AND DRINK FOR CONSUMERS (U.S. CLS. 100 AND 101).

FIRST USE 3-15-2010; IN COMMERCE 4-1-2010.

MICHAEL SOUDERS, EXAMINING ATTORNEY

SN 85-071,820. MALCOLM, DESMOND A., FT. LAUDERDALE, FL. AND MALCOLM, CATHERINE A., FT. LAUDERDALE, FL. FILED 6-25-2010.

**JERK MACHINE**

THE MARK CONSISTS OF STANDARD CHARACTERS WITHOUT CLAIM TO ANY PARTICULAR FONT, STYLE, SIZE, OR COLOR.

OWNER OF U.S. REG. NO. 1,883,767.

NO CLAIM IS MADE TO THE EXCLUSIVE RIGHT TO USE "JERK", APART FROM THE MARK AS SHOWN.

FOR RESTAURANT SERVICES, CARRYOUT RESTAURANT SERVICES, CATERING AND FOOD PREPARATION SERVICES (U.S. CLS. 100 AND 101).

FIRST USE 8-7-1983; IN COMMERCE 12-31-1989.

KIMBERLY FRYE, EXAMINING ATTORNEY

SN 85-082,102. SASSY GREENS LLC, DBA CHOPPED GREENS, CHAPEL HILL, NC. FILED 7-11-2010.



NO CLAIM IS MADE TO THE EXCLUSIVE RIGHT TO USE "CHOPPED GREENS", APART FROM THE MARK AS SHOWN.

THE MARK CONSISTS OF CIRCLES AND PARTIAL CIRCLES OVER THE WORDING "CHOPPED GREENS".

FOR RESTAURANT SERVICES, NAMELY, PROVIDING OF FOOD AND BEVERAGES FOR CONSUMPTION ON AND OFF THE PREMISES (U.S. CLS. 100 AND 101).

RAMONA ORTIGA, EXAMINING ATTORNEY

**CLASS 43—(Continued).**

SN 85-086,364. BIRRIERIAS JARAMILLO, S.A. DE C.V., CALERA DE VICTOR ROSAL, MEXICO, FILED 7-16-2010.



OWNER OF MEXICO REG. NO. 975796, DATED 3-9-2007, EXPIRES 10-19-2016.

NO CLAIM IS MADE TO THE EXCLUSIVE RIGHT TO USE "BIRRIERIAS", APART FROM THE MARK AS SHOWN.

THE WORDING JARAMILLO BIRRIERIAS DOES NOT IDENTIFY A LIVING INDIVIDUAL.

THE COLOR(S) LIGHT GREEN, AND BRIGHT PINK IS/ ARE CLAIMED AS A FEATURE OF THE MARK.

THE MARK CONSISTS OF A FIGURE THAT RESEMBLES THE OUTLINE OF A RAM IN LIGHT GREEN COLOR. THE DRAWING CONSISTS OF TWO LINES. THE FIRST LINE HAS THREE CURVES AND IT INCREASES IN THICKNESS. THE SECOND LINE CONSISTS OF A THICK CURVE COMPLETING THE OUTLINE OF THE PEPPER FIGURE. BELOW THE DRAWING IS THE WORD "JARAMILLO" WITH A SPECIAL DESIGN CHARACTERS WITH A LETTER "J" BEING SIGNIFICANTLY LARGER THAN THE OTHER LETTERS IN BRIGHT PINK COLOR. THE FONT IS CURSIVE. THE SECOND WORD IS "BIRRIERIAS", IN CAPS AND WITH A NON-CURSIVE FONT IN LIGHT GREEN COLOR.

THE ENGLISH TRANSLATION OF BIRRIERIAS THE MARK IS "A PLACE WHERE BIRRIA, A MEXICAN DISH IS SOLD."

FOR BAR AND RESTAURANT SERVICES; CAFE AND RESTAURANT SERVICES; CAFE-RESTAURANTS; CAFETERIA AND RESTAURANT SERVICES; CARRY-OUT RESTAURANTS; CONSULTATION SERVICES IN THE FIELD OF RESTAURANT MENU DEVELOPMENT; DELICATESSENS; FAST FOOD AND NON-STOP RESTAURANT SERVICES; FAST-FOOD RESTAURANTS; FAST-FOOD RESTAURANTS AND SNACKBARS; FROZEN YOGURT SHOP SERVICES IN THE NATURE OF A RESTAURANT; HOTEL AND RESTAURANT RESERVATION SERVICES; HOTEL AND RESTAURANT SERVICES; HOTEL, BAR AND RESTAURANT SERVICES; HOTEL, MOTEL, RESTAURANT, BAR AND CATERING SERVICES; HOTEL, RESTAURANT AND BAR SERVICES; HOTEL, RESTAURANT AND CATERING SERVICES; ICE CREAM SHOP SERVICES IN THE NATURE OF A RESTAURANT; PROVIDING ADVICE TO TOURISTS AND BUSINESS TRAVELERS ON HOTEL AND RESTAURANT DESTINATIONS; PROVIDING ON-LINE REVIEWS OF RESTAURANTS AND HOTELS; PROVIDING PROGRESSIVE DINNER EVENTS WHERE PARTICIPANTS SAMPLE MEALS AND DRINKS AT A SERIES OF RESTAURANTS; PROVIDING REVIEWS OF RESTAURANTS; PROVISION OF FOOD AND DRINK IN

**CLASS 43—(Continued).**

RESTAURANTS; RESERVATION OF RESTAURANTS; RESTAURANT; RESTAURANT AND BAR SERVICES; RESTAURANT AND BAR SERVICES, INCLUDING RESTAURANT CARRYOUT SERVICES; RESTAURANT AND CAFE SERVICES; RESTAURANT AND CATERING SERVICES; RESTAURANT AND HOTEL SERVICES; RESTAURANT SERVICES; RESTAURANT SERVICES FEATURING SANDWICHES; RESTAURANT SERVICES FEATURING MEXICAN FOOD; RESTAURANT SERVICES, INCLUDING SIT-DOWN SERVICE OF FOOD AND TAKE-OUT RESTAURANT SERVICES; RESTAURANT SERVICES, NAMELY, PROVIDING OF FOOD AND BEVERAGES FOR CONSUMPTION ON AND OFF THE PREMISES; RESTAURANT, BAR AND CATERING SERVICES; RESTAURANTS; RESTAURANTS FEATURING HOME DELIVERY; SELF SERVICE RESTAURANTS; SELF-SERVICE RESTAURANTS; TAKE-OUT RESTAURANT SERVICES; TRAVEL AGENCY SERVICES, NAMELY, MAKING RESERVATIONS AND BOOKINGS FOR RESTAURANTS AND MEALS (U.S. CLS. 100 AND 101).

NAKWAMA ANKRAH, EXAMINING ATTORNEY

SN 85-090,444. MOOSE & MONKEY CORP., NEW YORK, NY. FILED 7-22-2010.



NO CLAIM IS MADE TO THE EXCLUSIVE RIGHT TO USE "N.Y.C.", APART FROM THE MARK AS SHOWN.

"JOEDOE" IDENTIFIES THE NICKNAME OF JOSEPH DOBIAS, A LIVING INDIVIDUAL WHOSE CONSENT IS OF RECORD.

THE MARK CONSISTS OF THE STYLIZED WORDS AND LETTERS "JOEDOE N.Y.C." INSIDE A STYLIZED DRAWING OF A RECTANGULAR SHAPED DESIGN.

FOR CATERING; RESTAURANT; RESTAURANT SERVICES (U.S. CLS. 100 AND 101).

FIRST USE 2-1-2008; IN COMMERCE 2-1-2008.

AMEEN IMAM, EXAMINING ATTORNEY

**CLASS 43—(Continued).**

SN 85-095,349. ULTIMATE JOURNEYS, LLC, SEATTLE, WA. FILED 7-28-2010.



OWNER OF U.S. REG. NOS. 2,880,373, 2,887,685 AND OTHERS.

NO CLAIM IS MADE TO THE EXCLUSIVE RIGHT TO USE "JOURNEYS" AND "TRAVEL", APART FROM THE MARK AS SHOWN.

THE MARK CONSISTS OF "ULTIMATE JOURNEYS" WHICH ARE STACKED IN TWO LINES, THE WORDS "TRAVEL. EXPERIENCE. GROW." WHICH APPEAR ON ONE LINE BELOW "ULTIMATE JOURNEYS". THERE IS A CIRCLE WITH A COMBINED "UJ" CHARACTER IN THE MIDDLE TO THE LEFT OF THE REST OF THE WORDING.

FOR TRAVEL AGENCY SERVICES, NAMELY, MAKING RESERVATIONS AND BOOKINGS FOR TEMPORARY LODGINGS AND RESTAURANTS AND MEALS (U.S. CLS. 100 AND 101).

FIRST USE 2-14-2010; IN COMMERCE 2-14-2010.  
SIMON TENG, EXAMINING ATTORNEY

SN 85-106,874. LOVIN' SPOONS, LLC, RANCHO SANTA FE, CA. FILED 8-13-2010.

## LOVIN' SPOONS

THE MARK CONSISTS OF STANDARD CHARACTERS WITHOUT CLAIM TO ANY PARTICULAR FONT, STYLE, SIZE, OR COLOR.

FOR RESTAURANT SERVICES FEATURING FROZEN YOGURT, YOGURT-BASED FROZEN CONFECTIONS, FROZEN YOGURT SHAKES, FROZEN YOGURT PIES AND CAKES (U.S. CLS. 100 AND 101).

JASON TURNER, EXAMINING ATTORNEY

**CLASS 43—(Continued).**

SN 85-107,639. KEM'S HOUSE INC., AKA KEMS HOUSE INC., BARTLETT, TN. FILED 8-14-2010.



NO CLAIM IS MADE TO THE EXCLUSIVE RIGHT TO USE "INC. AND SERVING CHILDREN WITH DISABILITIES", APART FROM THE MARK AS SHOWN.

THE COLOR(S) ROYAL BLUE AND GOLD IS/ARE CLAIMED AS A FEATURE OF THE MARK.

THE MARK CONSISTS OF A SQUARE BACKGROUND IN ROYAL BLUE WITH THE WORDING "KEM'S HOUSE INC." IN GOLD LETTERS WITH A GOLD GIRL WEARING A GOLD DRESS AND A GOLD BOY WEARING A GOLD CAP STANDING SIDE BY SIDE HOLDING HANDS WITH THEIR OUTER ARM STRETCHED OUT TOWARD THE MANY GOLD STARS THAT SURROUND THEM. BELOW IS THE WORDING "SERVING CHILDREN WITH DISABILITIES" IN GOLD.

FOR CHARITABLE SERVICES, NAMELY, PROVIDING CHILD CARE FOR SPECIAL NEEDS CHILDREN AND THEIR SIBLINGS (U.S. CLS. 100 AND 101).

FIRST USE 7-29-2010; IN COMMERCE 8-12-2010.  
REBECCA SMITH, EXAMINING ATTORNEY

SN 85-111,970. CARIBBEAN GROUP MARKETING ORGANIZATION CORP., SAN JUAN, PUERTO RICO, FILED 8-20-2010.



NO CLAIM IS MADE TO THE EXCLUSIVE RIGHT TO USE "BANANA" "FRAPPES & ENSALADAS DE FRUTAS", APART FROM THE MARK AS SHOWN.

THE COLOR(S) GOLD, YELLOW, GREEN, GRAY, BLACK, AND WHITE IS/ARE CLAIMED AS A FEATURE OF THE MARK.

THE MARK CONSISTS OF A YELLOW CIRCLE WITH THE WORDS "FRAPPES & ENSALADAS DE FRUTAS" WRITTEN IN GOLD ON TOP OF THE CIRCLE, A YELLOW, GREEN, BLACK AND GRAY BANANA DRAWING SUPERIMPOSED ON TOP OF THE YELLOW CIRCLE AND THE WORDS "BANANA HOUSE" SUPERIMPOSED ON THE CIRCLE AND THE BANANA DRAWING IN GREEN, GRAY AND BLACK.

THE ENGLISH TRANSLATION OF "FRAPPES & ENSALADAS DE FRUTAS" IN THE MARK IS "SMOOTHIES & FRUIT SALADS".

FOR SNACK BAR SERVICES (U.S. CLS. 100 AND 101).  
JACQUELINE A. LAVINE, EXAMINING ATTORNEY

**CLASS 43—(Continued).**

SN 85-125,473. ROUTE 60 & ASSOC. LLC, NORFOLK, VA.  
FILED 9-8-2010.



NO CLAIM IS MADE TO THE EXCLUSIVE RIGHT TO USE "GRILL & RAW BAR", APART FROM THE MARK AS SHOWN.

THE MARK CONSISTS OF THE WORDING "CAPTAIN GROOVY'S" ON TOP AND IN STYLIZED FONT. DIRECTLY BELOW THE WORDING "CAPTAIN GROOVY'S" IS A DESIGN OF A FISH WEARING SUNGLASSES. DIRECTLY BELOW THE FISH DESIGN IS THE WORDING "GRILL & RAW BAR".

FOR RESTAURANT, BAR AND CATERING SERVICES (U.S. CLS. 100 AND 101).  
FIRST USE 9-21-2007; IN COMMERCE 9-21-2007.  
MARY BOAGNI, EXAMINING ATTORNEY

**CLASS 43—(Continued).**

SN 85-145,007. WEE WATCH DAY CARE SYSTEMS, INC.,  
UNIONVILLE, ONATARIO, CANADA, FILED 10-5-2010.



PRIORITY CLAIMED UNDER SEC. 44(D) ON CANADA APPLICATION NO. 1476000, FILED 4-7-2010, REG. NO. TMA793946, DATED 3-28-2011, EXPIRES 3-28-2026.

OWNER OF U.S. REG. NOS. 2,096,946 AND 3,453,749.  
THE MARK CONSISTS OF THE WORD "WEEWATCH" WITH A CURVED DOUBLE-BAND TO THE LEFT OF THIS WORD.

FOR PRIVATE HOME CHILD CARE SERVICES (U.S. CLS. 100 AND 101).  
RONALD MCMORROW, EXAMINING ATTORNEY

SN 85-128,184. WALKS AND WAGS, INC., MOBILE, AL.  
FILED 9-13-2010.

**WALKS AND WAGS, INC**

THE MARK CONSISTS OF STANDARD CHARACTERS WITHOUT CLAIM TO ANY PARTICULAR FONT, STYLE, SIZE, OR COLOR.

NO CLAIM IS MADE TO THE EXCLUSIVE RIGHT TO USE "WALKS" AND "INC", APART FROM THE MARK AS SHOWN.

FOR DOG DAYCARE, AND PET BOARDING (U.S. CLS. 100 AND 101).

FIRST USE 4-1-1991; IN COMMERCE 4-1-1991.  
VIVIAN MICZNIK FIRST, EXAMINING ATTORNEY

SN 85-145,965. REYNOLDS, WILLIAM ANTHONY, MOUNTAIN VIEW, CA. FILED 10-6-2010.



NO CLAIM IS MADE TO THE EXCLUSIVE RIGHT TO USE "BOSTON CHOWDER HOUSE", APART FROM THE MARK AS SHOWN.

THE COLOR(S) BLUE, LIGHT BLUE, WHITE, BLACK, RED, LIGHT RED, BROWN, TAN AND GRAY IS/ARE CLAIMED AS A FEATURE OF THE MARK.

THE MARK CONSISTS OF THE WORDING "BILLY'S BOSTON CHOWDER HOUSE" IN A STYLIZED FONT, AND A DESIGN THAT CONSISTS OF A NAUTICAL LIFESAVER WITH A ROPE SURROUNDING IT. INSIDE THE LIFESAVER IS A LOBSTER HOLDING A BOTTLE OF BEER WITH A BOWL FULL OF CHOWDER CLAMS. THE WORDING "BILLY'S" IS IN THE COLORS LIGHT BLUE AND WHITE AND OUTLINED IN BLACK. THE WORDING "BOSTON CHOWDER HOUSE" IS IN THE COLOR WHITE AND OUTLINED IN BLACK. THE NAUTICAL LIFESAVER IS IN WHITE AND GRAY WITH BLUE STRIPES. THE ROPE IS IN BLUE. THE LOBSTER IS IN RED, WHITE, BLACK, GRAY AND LIGHT RED. THE BOTTLE OF BEER IS IN BROWN AND TAN. THE BOWL IS IN GRAY, WHITE AND BLACK, AND THE CHOWDER CLAMS ARE IN GRAY, WHITE, BLACK AND LIGHT RED.

FOR RESTAURANT SERVICES (U.S. CLS. 100 AND 101).  
RENEE MCCRAY, EXAMINING ATTORNEY

SN 85-140,885. SCHANTZ, DOUGLAS W, WASHINGTON, DC. FILED 9-29-2010.

**NELLIE'S SPORTS BAR**

THE MARK CONSISTS OF STANDARD CHARACTERS WITHOUT CLAIM TO ANY PARTICULAR FONT, STYLE, SIZE, OR COLOR.

NO CLAIM IS MADE TO THE EXCLUSIVE RIGHT TO USE "SPORTS BAR", APART FROM THE MARK AS SHOWN.

FOR CAFE-RESTAURANTS (U.S. CLS. 100 AND 101).  
FIRST USE 7-15-2007; IN COMMERCE 7-15-2008.  
KATHERINE CHANG, EXAMINING ATTORNEY

**CLASS 43—(Continued).**

SN 85-149,711. LOCKHART, CATHLEEN, EDINBURGH, UNITED KINGDOM, FILED 10-11-2010.

# The PadPod

THE MARK CONSISTS OF STANDARD CHARACTERS WITHOUT CLAIM TO ANY PARTICULAR FONT, STYLE, SIZE, OR COLOR.

OWNER OF ERPN CMNTY TM OFC REG. NO. 9049008, DATED 10-12-2010, EXPIRES 4-22-2020.

FOR AGENCY SERVICES FOR THE RESERVATION OF HOTELS AND TEMPORARY ACCOMMODATIONS FOR TRAVEL, NAMELY, ARRANGING TEMPORARY ACCOMMODATION FOR TRAVELERS, PROVIDING PERSONALIZED INFORMATION ABOUT TEMPORARY ACCOMMODATION AND HOTELS FOR TRAVEL VIA THE INTERNET, AND MAKING ON-LINE BOOKINGS AND RESERVATIONS OF HOTELS AND TEMPORARY ACCOMMODATIONS FOR TRAVEL, AND PROVIDING A WEB-SITE FOR MAKING RESERVATIONS AND BOOKING OF TEMPORARY TRAVEL ACCOMMODATION AND HOTELS (U.S. CLS. 100 AND 101).

SEAN CROWLEY, EXAMINING ATTORNEY

**CLASS 43—(Continued).**

SN 85-170,524. ISIDOR PAIEWONSKY ASSOCIATES, INC., ST. THOMAS, US VIRGIN ISLANDS, FILED 11-5-2010.

# CAFÉ AMICI

THE MARK CONSISTS OF STANDARD CHARACTERS WITHOUT CLAIM TO ANY PARTICULAR FONT, STYLE, SIZE, OR COLOR.

NO CLAIM IS MADE TO THE EXCLUSIVE RIGHT TO USE "CAFE", APART FROM THE MARK AS SHOWN.

THE ENGLISH TRANSLATION OF "CAFÉ AMICI" IN THE MARK IS "FRIENDS CAFE".

FOR CAFE AND RESTAURANT SERVICES (U.S. CLS. 100 AND 101).

FIRST USE 12-31-1983; IN COMMERCE 12-31-1989.

ALLISON SCHRODY, EXAMINING ATTORNEY

SN 85-167,620. MASON, BRADLEY R., CARLSBAD, CA. FILED 11-2-2010.



THE COLOR(S) BLACK, GRAY, WHITE AND ORANGE IS/ARE CLAIMED AS A FEATURE OF THE MARK.

THE MARK CONSISTS OF A STYLIZED FLAME HAVING A BLACK BORDER, AN ORANGE MID-SECTION, AND A WHITE CENTER WITH A GRAY FRAMED HEARTH SURROUNDING THE CORNERS AND THE BOTTOM OF THE FLAME.

FOR CAFE AND RESTAURANT SERVICES (U.S. CLS. 100 AND 101).

BERYL GARDNER, EXAMINING ATTORNEY

SN 85-177,042. FRESH POMMES FRITES, LLC, WAYNE, NJ. FILED 11-15-2010.



NO CLAIM IS MADE TO THE EXCLUSIVE RIGHT TO USE "FRESH POMMES FRITES" AND "AUTHENTIC BELGIAN FRITES", APART FROM THE MARK AS SHOWN.

THE COLOR(S) BLACK, YELLOW AND RED IS/ARE CLAIMED AS A FEATURE OF THE MARK.

THE MARK CONSISTS OF THE WORDS "FRESH POMMES FRITES AUTHENTIC BELGIAN FRITES" IN BLACK LETTERS WITH A TRIANGULAR SHAPED CONTAINER IN RED TO THE RIGHT OF THE WORDS WITH YELLOW FRENCH FRITES PROTRUDING FROM THE TOP OF THE CONTAINER.

THE ENGLISH TRANSLATION OF "POMMES FRITES" IN THE MARK IS "FRENCH FRITES".

FOR RESTAURANT SERVICES (U.S. CLS. 100 AND 101).

FIRST USE 10-26-2010; IN COMMERCE 10-26-2010.

RAMONA ORTIGA, EXAMINING ATTORNEY



**CLASS 43—(Continued).**

SN 85-177,924. THE KESSLER ENTERPRISE, INC., ORLANDO, FL. FILED 11-16-2010.

**BOHEMIAN BAR AND GRILL**

THE MARK CONSISTS OF STANDARD CHARACTERS WITHOUT CLAIM TO ANY PARTICULAR FONT, STYLE, SIZE, OR COLOR.

OWNER OF U.S. REG. NOS. 3,321,098, 3,706,762 AND OTHERS.

NO CLAIM IS MADE TO THE EXCLUSIVE RIGHT TO USE "BAR AND GRILL", APART FROM THE MARK AS SHOWN.

FOR BAR AND RESTAURANT SERVICES (U.S. CLS. 100 AND 101).

FIRST USE 10-1-2010; IN COMMERCE 10-1-2010.  
LESLEY LAMOTHE, EXAMINING ATTORNEY

SN 85-184,977. SAN PASQUAL CASINO DEVELOPMENT GROUP INC., VALLEY CENTER, CA. FILED 11-24-2010.

**VALLEY VIEW CASINO CENTER**

THE MARK CONSISTS OF STANDARD CHARACTERS WITHOUT CLAIM TO ANY PARTICULAR FONT, STYLE, SIZE, OR COLOR.

OWNER OF U.S. REG. NOS. 3,542,867, 3,857,074 AND 3,857,075.

NO CLAIM IS MADE TO THE EXCLUSIVE RIGHT TO USE "CASINO CENTER", APART FROM THE MARK AS SHOWN.

FOR ARENA SERVICES, NAMELY, PROVIDING FACILITIES FOR SPORTS, CONCERTS, CONVENTIONS, EXHIBITIONS, SPORTING EVENTS, POLITICAL AND RELIGIOUS RALLIES, SOCIAL FUNCTIONS, AND RECREATIONAL ACTIVITIES (U.S. CLS. 100 AND 101).

JACLYN KIDWELL WALKER, EXAMINING ATTORNEY

SN 85-185,974. MALTA, ROBERT, NEW YORK, NY. FILED 11-29-2010.



NO CLAIM IS MADE TO THE EXCLUSIVE RIGHT TO USE "CAFE", APART FROM THE MARK AS SHOWN.

THE COLOR(S) BLUE AND WHITE IS/ARE CLAIMED AS A FEATURE OF THE MARK.

THE MARK CONSISTS OF THE WORDING "FILM CENTER CAFE" WITH THE WORDS "FILM" AND "CAFE" IN BLUE, AND "CENTER" IN WHITE. THE BLACK IN THE MARK IS INTENDED TO INDICATE BACKGROUND AND IS NOT PART OF THE MARK.

FOR BAR AND RESTAURANT SERVICES (U.S. CLS. 100 AND 101).

FIRST USE 1-1-1996; IN COMMERCE 1-1-1996.  
JAMES GRIFFIN, EXAMINING ATTORNEY

**CLASS 43—(Continued).**

SN 85-191,914. LIVE! HOLDINGS, LLC, BALTIMORE, MD. FILED 12-7-2010.

**Chapel Spirits**

THE MARK CONSISTS OF STANDARD CHARACTERS WITHOUT CLAIM TO ANY PARTICULAR FONT, STYLE, SIZE, OR COLOR.

NO CLAIM IS MADE TO THE EXCLUSIVE RIGHT TO USE "SPIRITS", APART FROM THE MARK AS SHOWN.

FOR RESTAURANT AND BAR SERVICES (U.S. CLS. 100 AND 101).

TARA PATE, EXAMINING ATTORNEY

SN 85-191,986. KOBAYAKI RESTAURANT PARTNERS, LLC, ELMHURST, NY. FILED 12-7-2010.

**Kobeyaki**

THE MARK CONSISTS OF STANDARD CHARACTERS WITHOUT CLAIM TO ANY PARTICULAR FONT, STYLE, SIZE, OR COLOR.

THE WORDING "KOBAYAKI" HAS NO MEANING IN A FOREIGN LANGUAGE.

FOR BAR AND RESTAURANT SERVICES; CAFE-RESTAURANTS (U.S. CLS. 100 AND 101).

FIRST USE 12-1-2010; IN COMMERCE 12-1-2010.  
MAYUR VAGHANI, EXAMINING ATTORNEY

SN 85-192,542. SAN PASQUAL CASINO DEVELOPMENT GROUP INC., VALLEY CENTER, CA. FILED 12-7-2010.



NO CLAIM IS MADE TO THE EXCLUSIVE RIGHT TO USE "CENTER", APART FROM THE MARK AS SHOWN.

THE MARK CONSISTS OF A STYLIZED SERIES OF 5 RECTANGLES, A CENTER RECTANGLE WITH A STYLIZED FOUNTAIN, AND 5 ADDITIONAL STYLIZED RECTANGLES WITH THE STYLIZED WORDING "CENTER" APPEARING DIRECTLY UNDERNEATH.

FOR ARENA SERVICES, NAMELY, PROVIDING FACILITIES FOR SPORTS, CONCERTS, CONVENTIONS, EXHIBITIONS, SPORTING EVENTS, POLITICAL AND RELIGIOUS RALLIES, SOCIAL FUNCTIONS, AND RECREATIONAL ACTIVITIES (U.S. CLS. 100 AND 101).

JACLYN KIDWELL WALKER, EXAMINING ATTORNEY

**CLASS 43—(Continued).**

SN 85-192,988. PHILABUNDANCE, PHILADELPHIA, PA. FILED 12-8-2010.



NO CLAIM IS MADE TO THE EXCLUSIVE RIGHT TO USE "HUNGER", APART FROM THE MARK AS SHOWN.

THE COLOR(S) GREEN AND YELLOW IS/ARE CLAIMED AS A FEATURE OF THE MARK.

THE MARK CONSISTS OF A GREEN OPEN PARENTHESIS WITH "SQUASH" IN GREEN LETTERS WITH A CLOSED PARENTHESIS, ALSO IN GREEN, WITH THE WORD "HUNGER" BELOW "SQUASH" IN YELLOW LETTERING AND THE DRAWING OF A SQUASH ON TOP OF THE WORDING "SQUASH", WHERE THE SQUASH IS YELLOW WITH A GREEN SPROUT AND END.

FOR CHARITABLE SERVICES, NAMELY, PROVIDING FOOD TO THOSE IN NEED; PROVIDING NON-MEDICAL ASSISTED LIVING IN THE NATURE OF FOOD PREPARATION (U.S. CLS. 100 AND 101).

TINA BROWN, EXAMINING ATTORNEY

---

SN 85-194,279. DOWNTOWN GRILLE CAFÉ, LLC, WOLFEBORO, NH. FILED 12-9-2010.



NO CLAIM IS MADE TO THE EXCLUSIVE RIGHT TO USE "GRILLECAFE", APART FROM THE MARK AS SHOWN.

THE COLOR(S) BROWN, TEAL BLUE AND YELLOW IS/ARE CLAIMED AS A FEATURE OF THE MARK.

THE MARK CONSISTS OF THE WORDS "DOWNTOWN" IN BROWN ABOVE A BROWN RECTANGLE CONTAINING THE WORDS "GRILLE" IN TEAL BLUE AND "CAFÉ" IN YELLOW. THE BACKGROUND EXTENDS TO THE LEFT IN SAIL-LIKE SHAPES OF (FROM RIGHT TO LEFT) TEAL BLUE AND BROWN.

FOR CAFE AND RESTAURANT SERVICES (U.S. CLS. 100 AND 101).

FIRST USE 8-14-2010; IN COMMERCE 8-14-2010.

ANNE MADDEN, EXAMINING ATTORNEY

**CLASS 43—(Continued).**

SN 85-194,469. MISTER GYROS FAMOUS TWO, LLC, FORT LAUDERDALE, FL. FILED 12-9-2010.



NO CLAIM IS MADE TO THE EXCLUSIVE RIGHT TO USE "FRESH" AND "GREEK", APART FROM THE MARK AS SHOWN.

THE COLOR(S) BLUE, GREEN AND ORANGE IS/ARE CLAIMED AS A FEATURE OF THE MARK.

THE MARK CONSISTS OF THE STYLIZED WORDING "GYROVILLE" ABOVE THE WORDING "REALLY FRESH. REALLY GREEK." THE LETTERS "GYRO" IN THE WORDING "GYROVILLE" ARE IN DARK BLUE. THE LETTERS "VILLE" IN THE WORDING "GYROVILLE" ARE IN LIGHT BLUE. THERE IS AN ABSTRACT DESIGN IN THE COLOR GREEN REPRESENTING A VERTICAL ROTISSERIE LOCATED AS A SUBSTITUTE FOR A DOT ABOVE THE LETTER "I" IN THE WORDING "GYROVILLE". THE WORDING "REALLY FRESH. REALLY GREEK." IS IN THE COLOR ORANGE.

FOR RESTAURANT SERVICES; TAKE-OUT RESTAURANT SERVICES; CATERING; MOBILE CAFE SERVICES FOR PROVIDING FOOD AND DRINK (U.S. CLS. 100 AND 101).

FIRST USE 9-9-2010; IN COMMERCE 9-9-2010.

NAPOLEON SHARMA, EXAMINING ATTORNEY

---

SN 85-194,820. 2201 COLLINS NIGHTCLUB MANAGEMENT, LLC, MIAMI BEACH, FL. FILED 12-10-2010.



THE MARK CONSISTS OF THE WORD "WALL" IN STYLIZED FORMAT.

FOR BAR AND COCKTAIL LOUNGE SERVICES (U.S. CLS. 100 AND 101).

FIRST USE 7-18-2009; IN COMMERCE 7-18-2009.

RONALD MCMORROW, EXAMINING ATTORNEY

**CLASS 43—(Continued).**

SN 85-195,110. PATEL, VINAY, SANTA ROSA, CA. FILED 12-10-2010.



NO CLAIM IS MADE TO THE EXCLUSIVE RIGHT TO USE "TANDOOR INDIAN RESTAURANT", APART FROM THE MARK AS SHOWN.

THE COLOR(S) BLACK, BROWN, ORANGE, WHITE AND YELLOW IS/ARE CLAIMED AS A FEATURE OF THE MARK.

THE MARK CONSISTS OF A CLAY OVEN WHICH IS BROWN IN COLOR WITH BLACK HIGHLIGHTS, AND FLAMES WHICH ARE ORANGE AND YELLOW WITH BLACK HIGHLIGHTS, AND THE WORDS "SIZZLING TANDOOR INDIAN RESTAURANT" IN BLACK AND PARTIALLY OUTLINED IN WHITE, AND BELOW THE IMAGE THE PHRASE "IT'S A CULINARY NIRVANA HERE!" IN BROWN".

FOR RESTAURANT AND BAR SERVICES, INCLUDING RESTAURANT CARRYOUT SERVICES (U.S. CLS. 100 AND 101).

FIRST USE 1-1-2005; IN COMMERCE 1-1-2005.  
MICHELE SWAIN, EXAMINING ATTORNEY

**CLASS 43—(Continued).**

SN 85-195,404. BMG HARVEST II, INC., DBA FRENCH ACCENT, CHICAGO, IL. FILED 12-10-2010.



OWNER OF U.S. REG. NO. 3,223,691.

THE MARK CONSISTS OF THE TERM "FRENCH ACCENT BY MARKET CREATIONS" WITH THE TERM "FRENCH" IN WHITE WITH A BLUE OUTLINE, THE TERM "ACCENT" IN WHITE WITH A RED OUTLINE AND THE TERM "BY MARKET CREATIONS" IN BLUE. A WHITE CHEF'S HAT WITH BLACK OUTLINES APPEARS ABOVE THE WORDING AN OVAL APPEARS BEHIND THE ENTIRE MARK THAT CONTAINS A MISCELLANEOUS DESIGN IN WHITE AND LIGHT TAN.

FOR BAR AND RESTAURANT SERVICES; CAFE AND RESTAURANT SERVICES; CAFE-RESTAURANTS; CAFETERIA AND RESTAURANT SERVICES; CARRY-OUT RESTAURANTS; CATERING; CATERING FOR THE PROVISION OF FOOD AND BEVERAGES; CATERING IN FAST-FOOD CAFETERIAS; CATERING OF FOOD AND DRINKS; CATERING SERVICES; DELICATESSENS; FAST FOOD AND NON-STOP RESTAURANT SERVICES; FAST-FOOD RESTAURANT SERVICES; FAST-FOOD RESTAURANTS; FAST-FOOD RESTAURANTS AND SNACKBARS; FROZEN YOGURT SHOP SERVICES IN THE NATURE OF A RESTAURANT; HOTEL AND RESTAURANT SERVICES; HOTEL, BAR AND RESTAURANT SERVICES; HOTEL, MOTEL, RESTAURANT, BAR AND CATERING SERVICES; HOTEL, RESTAURANT AND BAR SERVICES; HOTEL, RESTAURANT AND CATERING SERVICES; ICE CREAM SHOP SERVICES IN THE NATURE OF A RESTAURANT; MOBILE RESTAURANT SERVICES; RESTAURANT; RESTAURANT AND BAR SERVICES; RESTAURANT AND BAR SERVICES, INCLUDING RESTAURANT CARRYOUT SERVICES; RESTAURANT AND CAFE SERVICES; RESTAURANT AND CATERING SERVICES; RESTAURANT AND HOTEL SERVICES; RESTAURANT SERVICES; RESTAURANT SERVICES FEATURING SANDWICHES; RESTAURANT SERVICES FEATURING FRENCH FUSION CUISINE; RESTAURANT SERVICES, INCLUDING SIT-DOWN SERVICE OF FOOD AND TAKE-OUT RESTAURANT SERVICES; RESTAURANT SERVICES, NAMELY, PROVIDING OF FOOD AND BEVERAGES FOR CONSUMPTION ON AND OFF THE PREMISES; RESTAURANT, BAR AND CATERING SERVICES; RESTAURANTS; RESTAURANTS FEATURING HOME DELIVERY; SALAD BARS; SELF SERVICE RESTAURANTS; SELF-SERVICE RESTAURANTS; TAKE-OUT RESTAURANT SERVICES (U.S. CLS. 100 AND 101).

FIRST USE 9-1-2010; IN COMMERCE 9-1-2010.  
GIANCARLO CASTRO, EXAMINING ATTORNEY

**CLASS 43—(Continued).**

SN 85-197,421. MISTER GYROS FAMOUS TWO, LLC, FORT LAUDERDALE, FL. FILED 12-14-2010.



NO CLAIM IS MADE TO THE EXCLUSIVE RIGHT TO USE "FRESH" AND "GREEK", APART FROM THE MARK AS SHOWN.

THE MARK CONSISTS OF THE STYLIZED WORDING "GYROVILLE" ABOVE THE WORDING "REALLY FRESH. REALLY GREEK." THERE IS AN ABSTRACT DESIGN REPRESENTING A VERTICAL ROTISSERIE LOCATED AS A SUBSTITUTE FOR A DOT ABOVE THE LETTER "I" IN THE WORDING "GYROVILLE".

FOR RESTAURANT SERVICES; TAKE-OUT RESTAURANT SERVICES; CATERING; MOBILE CAFE SERVICES FOR PROVIDING FOOD AND DRINK (U.S. CLS. 100 AND 101).

FIRST USE 9-9-2010; IN COMMERCE 9-9-2010.  
NAPOLEON SHARMA, EXAMINING ATTORNEY

SN 85-197,701. DIAGEO NORTH AMERICA, INC., NORWALK, CT. FILED 12-14-2010.

**CAPTAIN MORGAN'S LOOKOUT**

THE MARK CONSISTS OF STANDARD CHARACTERS WITHOUT CLAIM TO ANY PARTICULAR FONT, STYLE, SIZE, OR COLOR.

OWNER OF U.S. REG. NOS. 972,985, 3,509,465 AND OTHERS.

THE NAME(S), PORTRAIT(S), AND/OR SIGNATURE(S) SHOWN IN THE MARK DOES NOT IDENTIFY A PARTICULAR LIVING INDIVIDUAL.

FOR BAR AND RESTAURANT SERVICES (U.S. CLS. 100 AND 101).

FONG HSU, EXAMINING ATTORNEY

SN 85-198,020. LUDWIG, AARON, HARRISONBURG, VA. FILED 12-15-2010.

**JACK BROWN'S**

THE MARK CONSISTS OF STANDARD CHARACTERS WITHOUT CLAIM TO ANY PARTICULAR FONT, STYLE, SIZE, OR COLOR.

THE NAME(S), PORTRAIT(S), AND/OR SIGNATURE(S) SHOWN IN THE MARK DOES NOT IDENTIFY A PARTICULAR LIVING INDIVIDUAL.

FOR RESTAURANT AND BAR SERVICES (U.S. CLS. 100 AND 101).

FIRST USE 4-4-2009; IN COMMERCE 4-4-2009.  
SIMON TENG, EXAMINING ATTORNEY

**CLASS 43—(Continued).**

SN 85-198,943. THINK SALAD!, LLC, CHATTANOOGA, TN. FILED 12-15-2010.



NO CLAIM IS MADE TO THE EXCLUSIVE RIGHT TO USE "SALAD!", APART FROM THE MARK AS SHOWN.

THE MARK CONSISTS OF THE TEXT "THINK SALAD!" IN YIKES FONT.

FOR RESTAURANT SERVICES (U.S. CLS. 100 AND 101).

FIRST USE 12-1-2008; IN COMMERCE 12-1-2008.  
MARY ROSSMAN, EXAMINING ATTORNEY

SN 85-202,556. BECK FAMILY RESTAURANTS, LLC., DALLAS, TX. FILED 12-21-2010.



NO CLAIM IS MADE TO THE EXCLUSIVE RIGHT TO USE "DINER", APART FROM THE MARK AS SHOWN.

THE MARK CONSISTS OF A CIRCLE ENCLOSING THE WORDS "DI DI'S TAMALE DINER", WITH "TAMALE" CENTERED IN ALL CAPITAL LETTERS AND THE OTHER WORDS IN A STYLIZED SCRIPT. ABOVE "TAMALE" ARE THREE REPRESENTATIONS OF EARS OF CORN WITH THE TERM "DI DI'S" TO THEIR LEFT. BELOW "TAMALE" AND "DINER" ARE THREE STARS.

FOR RESTAURANT SERVICES, INCLUDING SIT-DOWN SERVICE OF FOOD AND TAKE-OUT RESTAURANT SERVICES (U.S. CLS. 100 AND 101).

VIVIAN MICZNIK FIRST, EXAMINING ATTORNEY

**CLASS 43—(Continued).**

SN 85-202,602. FUZION FOOD GROUP USA, INC., SIOUX FALLS, SD. FILED 12-21-2010.



OWNER OF U.S. REG. NOS. 3,618,165 AND 3,624,574.  
NO CLAIM IS MADE TO THE EXCLUSIVE RIGHT TO USE "CAFE", APART FROM THE MARK AS SHOWN.

THE MARK CONSISTS OF THE STYLIZED WORDING "FUZION CAFE" AND A BROKEN CIRCLE. A PORTION OF THE WORD "FUZION" APPEARS INSIDE THE CIRCLE. THE WORD "CAFE" APPEARS UNDERNEATH THE WORD "FUZION". A HORIZONTAL LINE APPEARS ABOVE THE LETTER "U" IN THE WORD "FUZION".

FOR RESTAURANT AND BAR SERVICES (U.S. CLS. 100 AND 101).

EVELYN BRADLEY, EXAMINING ATTORNEY

SN 85-203,269. ECO CATERS, INC. SAN DIEGO, CA. FILED 12-21-2010.

# Eco Caters

THE MARK CONSISTS OF STANDARD CHARACTERS WITHOUT CLAIM TO ANY PARTICULAR FONT, STYLE, SIZE, OR COLOR.

NO CLAIM IS MADE TO THE EXCLUSIVE RIGHT TO USE "ECO", APART FROM THE MARK AS SHOWN.

FOR RESTAURANT, BAR AND CATERING SERVICES (U.S. CLS. 100 AND 101).

FIRST USE 9-15-2007; IN COMMERCE 9-15-2007.  
CAROLYN CATALDO, EXAMINING ATTORNEY

**CLASS 43—(Continued).**

SN 85-204,624. IMPACT RESTAURANT MANAGEMENT INC., VALPARAISO, IN. FILED 12-23-2010.



NO CLAIM IS MADE TO THE EXCLUSIVE RIGHT TO USE "EATERY & GRILLE", APART FROM THE MARK AS SHOWN.

THE COLOR(S) BLACK, WHITE, BLUE, RED, AND TAN IS/ARE CLAIMED AS A FEATURE OF THE MARK.

THE MARK CONSISTS OF A FIGURE OF THE TORSO OF A MAN IN PROFILE IN BLACK AND WHITE. BENEATH THE FIGURE OF THE MAN IS A RECTANGLE WITH INDENTED CORNERS. THE RECTANGLE IS BLUE, WITH A BORDER OF A BLACK LINE, A WHITE LINE AND A BLACK LINE. INSIDE THE RECTANGLE, THE STYLIZED WORDS "INDUSTRIAL REVOLUTION" IN WHITE APPEAR ABOVE THE STYLIZED WORDS "EATERY & GRILLE" IN TAN; THREE DOTS IN MEDIUM BLUE APPEAR ON BOTH SIDES OF THE WORDS "EATERY & GRILLE", OVERLAPPING THE BOTTOM OF THE BLUE RECTANGLE IS A RECTANGLE WITH INDENTED CORNERS. THE RECTANGLE IS RED, WITH A BORDER OF A BLACK LINE, A WHITE LINE AND A BLACK LINE. INSIDE THE RECTANGLE ARE THE STYLIZED WORDS "SALUTING AMERICA'S GREATNESS" IN WHITE. BEHIND THE FIGURE OF THE MAN AND THE RECTANGLES IS A CIRCLE IN THE COLOR TAN WITH A BORDER OF A BLACK LINE, A WHITE LINE AND A BLACK LINE; AT THE BOTTOM OF THE CIRCLE IS AN EAGLE IN BLACK AND WHITE.

FOR RESTAURANT AND BAR SERVICES (U.S. CLS. 100 AND 101).

FIRST USE 5-6-2010; IN COMMERCE 5-6-2010.  
ODESSA BIBBINS, EXAMINING ATTORNEY

SN 85-205,115. CREATIVE DESIGN FZ, DUBAI, UNITED ARAB EMIR., FILED 12-23-2010.

# LITTLE BUDDHA

THE MARK CONSISTS OF STANDARD CHARACTERS WITHOUT CLAIM TO ANY PARTICULAR FONT, STYLE, SIZE, OR COLOR.

OWNER OF U.S. REG. NO. 3,154,431.

THE NAME "LITTLE BUDDHA" DOES NOT IDENTIFY A LIVING INDIVIDUAL.

FOR RESTAURANT SERVICES, CAFE SERVICES, BAR SERVICES, HOTEL SERVICES AND PROVIDING TEMPORARY ACCOMMODATION (U.S. CLS. 100 AND 101).

FIRST USE 11-1-2001; IN COMMERCE 11-1-2001.  
JAMES MACFARLANE, EXAMINING ATTORNEY



**CLASS 43—(Continued).**

SN 85-205,369. DINE AND RIDE, LLC, VENICE, CA. FILED 12-23-2010.



THE MARK CONSISTS OF FOUR SQUARES WITH AN IMAGE IN EACH. TO THE RIGHT THERE IS THE STYLIZED TEXT "DINE & RIDE".

FOR PROVIDING INFORMATION IN THE FIELD OF RESTAURANTS VIA THE INTERNET; PROVIDING ONLINE RESTAURANT RESERVATIONS (U.S. CLS. 100 AND 101).

FIRST USE 4-1-2008; IN COMMERCE 6-20-2008.  
ELIZABETH KAJUBI, EXAMINING ATTORNEY

SN 85-205,789. HOLY BAGELS AND PIZZERIA, CORP., AVENTURA, FL. FILED 12-27-2010.



NO CLAIM IS MADE TO THE EXCLUSIVE RIGHT TO USE "BAGELS & PIZZERIA", APART FROM THE MARK AS SHOWN.

THE COLOR(S) BLACK AND BROWN IS/ARE CLAIMED AS A FEATURE OF THE MARK.

THE MARK CONSISTS OF A BROWN BAGEL WITH A BLACK HAT AND BLACK CURLY HAIR COMING FROM THE HAT ON THE SIDES OF THE BAGEL WITH THE WORDS "HOLY BAGELS & PIZZERIA" APPEARING IN BLACK NEXT TO THE BAGEL.

FOR RESTAURANT SERVICES FEATURING BAGELS, A DELI AND PIZZERIA (U.S. CLS. 100 AND 101).

FIRST USE 4-23-2010; IN COMMERCE 4-23-2010.  
MARK PILARO, EXAMINING ATTORNEY

**CLASS 43—(Continued).**

SN 85-206,144. YELLOW VASE, LLC, REDONDO BEACH, CA. FILED 12-27-2010.



THE COLOR(S) WHITE, YELLOW, BROWN, AND GREEN IS/ARE CLAIMED AS A FEATURE OF THE MARK.

THE MARK CONSISTS OF THE WORDING "YELLOW VASE" AND DESIGNS. THE WORDING IS WHITE AND APPEARS WITHIN A BROWN SQUARE BELOW YELLOW DESIGNS OF FLOWERS AND VINES IN A VASE. THERE IS A THICK, SQUARE YELLOW BORDER AROUND THE BROWN SQUARE. OUTSIDE OF THE YELLOW BORDER, THERE ARE DESIGNS OF GREEN VINES AND LEAVES.

FOR CAFE: CAFE AND RESTAURANT SERVICES; CAFE-RESTAURANTS; CARRY-OUT RESTAURANTS; RESTAURANT; RESTAURANT AND CAFE SERVICES; RESTAURANT AND CATERING SERVICES; RESTAURANT SERVICES; RESTAURANT SERVICES FEATURING SANDWICHES; RESTAURANT SERVICES, INCLUDING SIT-DOWN SERVICE OF FOOD AND TAKE-OUT RESTAURANT SERVICES; RESTAURANT SERVICES, NAMELY, PROVIDING OF FOOD AND BEVERAGES FOR CONSUMPTION ON AND OFF THE PREMISES; RESTAURANT, BAR AND CATERING SERVICES; TAKE-OUT RESTAURANT SERVICES (U.S. CLS. 100 AND 101).

FIRST USE 11-1-2008; IN COMMERCE 11-1-2008.  
CORY BOONE, EXAMINING ATTORNEY

SN 85-206,490. UNIQUE BRANDS ENTERPRISES, LLC, CORAL GABLES, FL. FILED 12-28-2010.

# LE CHIQUÉ

THE MARK CONSISTS OF STANDARD CHARACTERS WITHOUT CLAIM TO ANY PARTICULAR FONT, STYLE, SIZE, OR COLOR.

THE ENGLISH TRANSLATION OF THE WORD "CHIQUÉ" IN THE MARK IS "CHEW".

FOR BAR AND RESTAURANT SERVICES (U.S. CLS. 100 AND 101).

FIRST USE 11-0-2008; IN COMMERCE 11-0-2008.  
JANET LEE, EXAMINING ATTORNEY

**CLASS 43—(Continued).**

SN 85-207,341. RENDON, ANGEL MARIO, MISSION, TX.  
FILED 12-29-2010.

## GUZZI'S PIZZA GOURMET STYLE

THE MARK CONSISTS OF STANDARD CHARACTERS WITHOUT CLAIM TO ANY PARTICULAR FONT, STYLE, SIZE, OR COLOR.

NO CLAIM IS MADE TO THE EXCLUSIVE RIGHT TO USE "PIZZA" AND "GOURMET STYLE", APART FROM THE MARK AS SHOWN.

FOR CARRY-OUT RESTAURANTS; DELICATESSENS; FAST FOOD AND NON-STOP RESTAURANT SERVICES; FAST-FOOD RESTAURANTS; FAST-FOOD RESTAURANTS AND SNACKBARS; MOBILE RESTAURANT SERVICES; PIZZA PARLORS; PROVIDING PROGRESSIVE DINNER EVENTS WHERE PARTICIPANTS SAMPLE MEALS AND DRINKS AT A SERIES OF RESTAURANTS; PROVISION OF FOOD AND DRINK IN RESTAURANTS; RESTAURANT AND BAR SERVICES; RESTAURANT AND BAR SERVICES, INCLUDING RESTAURANT CARRYOUT SERVICES; RESTAURANT AND CAFE SERVICES; RESTAURANT AND CATERING SERVICES; RESTAURANT SERVICES; RESTAURANT SERVICES FEATURING SANDWICHES; RESTAURANT SERVICES FEATURING PIZZA AND ITALIAN FOOD; RESTAURANT SERVICES, INCLUDING SIT-DOWN SERVICE OF FOOD AND TAKE-OUT RESTAURANT SERVICES; RESTAURANT SERVICES, NAMELY, PROVIDING OF FOOD AND BEVERAGES FOR CONSUMPTION ON AND OFF THE PREMISES; RESTAURANT, BAR AND CATERING SERVICES; RESTAURANTS FEATURING HOME DELIVERY; SALAD BARS; SELF SERVICE RESTAURANTS; TAKE-OUT RESTAURANT SERVICES (U.S. CLS. 100 AND 101).

FIRST USE 12-1-2009; IN COMMERCE 1-9-2010.  
JEAN IM, EXAMINING ATTORNEY

**CLASS 43—(Continued).**

SN 85-207,433. TACO ANA FRANCHISING LLC, WEST DES MOINES, IA. FILED 12-29-2010.



NO CLAIM IS MADE TO THE EXCLUSIVE RIGHT TO USE "TACO", APART FROM THE MARK AS SHOWN.

THE NAME "ANA" DOES NOT IDENTIFY A LIVING INDIVIDUAL.

THE MARK CONSISTS OF THE WORDS "TACO ANA" IN STYLIZED TEXT WITH A CACTUS AND HOT PEPPERS LOCATED ABOVE THE WORDS. BEHIND THE CACTUS AND HOT PEPPERS IS A SEMI-CIRCLE WITH DOTS SERVING AS THE BACKGROUND.

FOR RESTAURANT SERVICES (U.S. CLS. 100 AND 101).

LAKEISHA LEWIS, EXAMINING ATTORNEY

SN 85-207,492. KEY WEST TACOS, WEST CAPE MAY, NJ.  
FILED 12-29-2010.



SN 85-207,402. TACO ANA FRANCHISING LLC, WEST DES MOINES, IA. FILED 12-29-2010.

## TACO ANA

THE MARK CONSISTS OF STANDARD CHARACTERS WITHOUT CLAIM TO ANY PARTICULAR FONT, STYLE, SIZE, OR COLOR.

NO CLAIM IS MADE TO THE EXCLUSIVE RIGHT TO USE "TACO", APART FROM THE MARK AS SHOWN.

THE NAME "ANA" DOES NOT IDENTIFY A LIVING INDIVIDUAL.

FOR RESTAURANT SERVICES (U.S. CLS. 100 AND 101).

LAKEISHA LEWIS, EXAMINING ATTORNEY

NO CLAIM IS MADE TO THE EXCLUSIVE RIGHT TO USE "TACOS", APART FROM THE MARK AS SHOWN.

THE STIPPLING IS FOR SHADING PURPOSES ONLY.

THE MARK CONSISTS OF A TACO WITH CABBAGE AND TOMATOES ON TOP, SURROUNDED BY PALM TREES. A CUT LIME IS TO THE RIGHT AND LEFT OF THE TACO. THE STYLIZED WORDING "KEY WEST TACO" IS ABOVE THE DESIGN WITH RAYS COMING FROM THE WORDS. THE DESIGN AND WORDING IS SURROUNDED BY A RECTANGLE WITH JAGGED EDGES AND HOT PEPPERS AT THE UPPER CORNERS.

FOR RESTAURANT SERVICES (U.S. CLS. 100 AND 101).

FIRST USE 4-25-2009; IN COMMERCE 4-25-2009.  
KELLY BOULTON, EXAMINING ATTORNEY

**CLASS 43—(Continued).**

SN 85-207,553. LI, ZONGYAN, ROWLAND HEIGHTS, CA. FILED 12-29-2010.

**YOGURT DOZENS**

THE MARK CONSISTS OF STANDARD CHARACTERS WITHOUT CLAIM TO ANY PARTICULAR FONT, STYLE, SIZE, OR COLOR.

NO CLAIM IS MADE TO THE EXCLUSIVE RIGHT TO USE "YOGURT", APART FROM THE MARK AS SHOWN.

FOR BAR AND RESTAURANT SERVICES; CAFE AND RESTAURANT SERVICES; CAFE-RESTAURANTS; CAFETERIA AND RESTAURANT SERVICES; CARRY-OUT RESTAURANTS; RESTAURANT; RESTAURANT AND BAR SERVICES; RESTAURANT AND BAR SERVICES, INCLUDING RESTAURANT CARRYOUT SERVICES; RESTAURANT AND CAFE SERVICES; RESTAURANT AND CATERING SERVICES; RESTAURANT SERVICES; RESTAURANT SERVICES, INCLUDING SIT-DOWN SERVICE OF FOOD AND TAKE-OUT RESTAURANT SERVICES; RESTAURANT SERVICES, NAMELY, PROVIDING OF FOOD AND BEVERAGES FOR CONSUMPTION ON AND OFF THE PREMISES; RESTAURANT, BAR AND CATERING SERVICES; RESTAURANTS; RESTAURANTS FEATURING HOME DELIVERY; SELF SERVICE RESTAURANTS; SELF-SERVICE RESTAURANTS; TAKE-OUT RESTAURANT SERVICES (U.S. CLS. 100 AND 101).

NATALIE POLZER, EXAMINING ATTORNEY

**CLASS 43—(Continued).**

SN 85-207,906. SCHAFFLER, THOMAS, MEMPHIS, TN. FILED 12-30-2010.



NO CLAIM IS MADE TO THE EXCLUSIVE RIGHT TO USE "MEMORY CARE ASSISTED LIVING" NEIGHBORHOODS", APART FROM THE MARK AS SHOWN.

THE MARK CONSISTS OF THE STYLIZED WORDS "CLARITY POINTE MEMORY CARE ASSISTED LIVING" NEIGHBORHOODS OUR DIFFERENCE IS CLEAR". AN IMAGE OF A STYLIZED STARBURST IN THE BACKGROUND OF THE WORDS "CLARITY POINTE".

FOR PROVIDING ASSISTED LIVING FACILITIES FOR ALZHEIMER'S AND DEMENTIA PATIENTS (U.S. CLS. 100 AND 101).

FIRST USE 9-1-2010; IN COMMERCE 9-1-2010.

MICHAEL KEATING, EXAMINING ATTORNEY

SN 85-208,241. THE KING'S RANCH AND HANNAH HOMES, INC., CHELSEA, AL. FILED 12-30-2010.

SN 85-207,744. PROVIDENT ISLAND RESORTS, LLC, DBA SUNSET VISTAS BEACHFRONT SUITES, CLEARWATER, FL. FILED 12-30-2010.

**SUNSET VISTAS BEACHFRONT SUITES**



THE MARK CONSISTS OF STANDARD CHARACTERS WITHOUT CLAIM TO ANY PARTICULAR FONT, STYLE, SIZE, OR COLOR.

NO CLAIM IS MADE TO THE EXCLUSIVE RIGHT TO USE "BEACHFRONT SUITES", APART FROM THE MARK AS SHOWN.

FOR PROVIDING TEMPORARY LODGING SERVICES IN THE NATURE OF A CONDOMINIUM HOTEL (U.S. CLS. 100 AND 101).

FIRST USE 2-1-2007; IN COMMERCE 2-1-2009.

HEATHER SAPP, EXAMINING ATTORNEY

THE MARK CONSISTS OF CROSS SUPERIMPOSED ON A HOUSE, ALL WITHIN A CIRCLE.

FOR CHARITABLE SERVICES, NAMELY, PROVIDING GROUP HOMES AND LONG-TERM TEMPORARY HOUSING FOR AT-RISK CHILDREN, YOUTH, WOMEN, AND MOTHERS WITH CHILDREN (U.S. CLS. 100 AND 101).

FIRST USE 9-0-2010; IN COMMERCE 9-0-2010.

ELLEN PERKINS, EXAMINING ATTORNEY

**CLASS 43—(Continued).**

SN 85-208,378. LAI GROUP III, INC., ARCADIA, CA. FILED 12-30-2010.



THE COLOR(S) GREEN IS/ARE CLAIMED AS A FEATURE OF THE MARK.

THE MARK CONSISTS OF A GREEN CIRCLE WITH TWO GREEN PALM TREE IMAGES EXTENDING FROM THE BOTTOM OF THE CIRCLE. EACH PALM TREE HAS A CURVED GREEN STEM AND GREEN FRONDS FLOWERING OUT FROM THE TOP OF EACH STEM AND BEYOND THE GREEN CIRCLE. THE WHITE INSIDE THE CIRCLE IN THE DRAWING IS BACKGROUND AND IS NOT A FEATURE OF THE MARK.

FOR EXTENDED-STAY HOTELS; HOTEL ACCOMMODATION SERVICES; HOTEL AND MOTEL SERVICES; HOTEL SERVICES; HOTEL, MOTEL, RESTAURANT, BAR AND CATERING SERVICES; HOTELS; MOTELS; PROVIDING HOTEL ACCOMMODATION; PROVIDING TEMPORARY LODGING SERVICES IN THE NATURE OF A CONDOMINIUM HOTEL; RESIDENTIAL HOTELS; RESTAURANT AND HOTEL SERVICES (U.S. CLS. 100 AND 101).

FIRST USE 12-7-2010; IN COMMERCE 12-7-2010.  
ROBIN CHOSID, EXAMINING ATTORNEY

SN 85-208,578. RJ INVESTMENTS INTERNATIONAL INC., CINCINNATI, OH. FILED 12-31-2010.

not just raw fish.

THE MARK CONSISTS OF STANDARD CHARACTERS WITHOUT CLAIM TO ANY PARTICULAR FONT, STYLE, SIZE, OR COLOR.

NO CLAIM IS MADE TO THE EXCLUSIVE RIGHT TO USE "RAW FISH", APART FROM THE MARK AS SHOWN. FOR RESTAURANT SERVICES (U.S. CLS. 100 AND 101).

FIRST USE 5-25-2010; IN COMMERCE 5-25-2010.  
PRISCILLA MILTON, EXAMINING ATTORNEY

**CLASS 43—(Continued).**

SN 85-208,893. WIEBE, PAMELA NELL, GAINESVILLE, TX. FILED 1-2-2011.

Let's Talk Turkey

THE MARK CONSISTS OF STANDARD CHARACTERS WITHOUT CLAIM TO ANY PARTICULAR FONT, STYLE, SIZE, OR COLOR.

NO CLAIM IS MADE TO THE EXCLUSIVE RIGHT TO USE "TURKEY", APART FROM THE MARK AS SHOWN.

FOR FAST-FOOD RESTAURANTS AND SNACKBARS (U.S. CLS. 100 AND 101).

JANICE KIM, EXAMINING ATTORNEY

SN 85-209,244. PIZZA SOLA, INC., PITTSBURGH, PA. FILED 1-3-2011.



OWNER OF U.S. REG. NO. 3,489,201.

NO CLAIM IS MADE TO THE EXCLUSIVE RIGHT TO USE "PIZZA" AND "REAL. GOOD. PIZZA", APART FROM THE MARK AS SHOWN.

THE MARK CONSISTS OF THE WORDS "PIZZA SOLA" ARE SHOWN IN FULL CAPITAL LETTERS WITH SHADOWING SUPERIMPOSED ON A TRIANGULAR DESIGN. THE WORDS "REAL. GOOD. PIZZA." ARE SHOWN IN LOWER CASE LETTERS WITHIN A BANNER DESIGN BENEATH "PIZZA SOLA" AND ARE ALSO SUPERIMPOSED ON THE TRIANGULAR DESIGN.

THE ENGLISH TRANSLATION OF THE WORD "SOLA" IN THE MARK IS "ALONE".

FOR RESTAURANT SERVICES; TAKE-OUT RESTAURANT SERVICES (U.S. CLS. 100 AND 101).

FIRST USE 4-0-2008; IN COMMERCE 4-0-2008.

MICHAEL WEBSTER, EXAMINING ATTORNEY

**CLASS 43—(Continued).**

SN 85-209,544. MCNAB, ROBERT RAY, COLUMBUS, MS. FILED 1-3-2011.



THE COLOR(S) BLACK, WHITE, GREEN, YELLOW, RED AND BROWN IS/ARE CLAIMED AS A FEATURE OF THE MARK.

THE MARK CONSISTS OF A GREEN AND YELLOW COLORED ALLIGATOR WITH BLACK AND WHITE EYES AND WHITE TEETH WEARING A RED BANDANNA AND HOLDING A BROWN SIGN WITH THE WORDS "CRAWGATORS" IN RED ACROSS THE FRONT AND A RED COLORED CRAWFISH WITH BLACK AND WHITE EYES NEXT TO THE ALLIGATOR ALL OUTLINED IN THE COLOR BLACK.

FOR BAR AND RESTAURANT SERVICES (U.S. CLS. 100 AND 101).

FIRST USE 7-16-2009; IN COMMERCE 9-16-2009. ZHALEH DELANEY, EXAMINING ATTORNEY

SN 85-210,635. LUIS, RAUL, MONTEREY PARK, CA. FILED 1-5-2011.



NO CLAIM IS MADE TO THE EXCLUSIVE RIGHT TO USE "BURRITO", APART FROM THE MARK AS SHOWN.

THE MARK CONSISTS OF THE STYLIZED TEXT "BAD AZZ BURRITO" WITH AN IMAGE OF A DONKEY IN A CIRCLE.

FOR RESTAURANT SERVICES (U.S. CLS. 100 AND 101).

FIRST USE 11-8-2010; IN COMMERCE 11-8-2010. ROBIN MITTLER, EXAMINING ATTORNEY

**CLASS 43—(Continued).**

SN 85-210,676. RAYMOND, STACI, NAPA, CA. FILED 1-5-2011.

RotiQ

THE MARK CONSISTS OF STANDARD CHARACTERS WITHOUT CLAIM TO ANY PARTICULAR FONT, STYLE, SIZE, OR COLOR.

THE WORDING "ROTIQ" HAS NO MEANING IN A FOREIGN LANGUAGE.

FOR RESTAURANT SERVICES (U.S. CLS. 100 AND 101).

AISHA SALEM, EXAMINING ATTORNEY

SN 85-211,305. OKURA, ALBERT, CHINO, CA. FILED 1-5-2011.



OWNER OF U.S. REG. NO. 2,666,886.

NO CLAIM IS MADE TO THE EXCLUSIVE RIGHT TO USE "POLLO" AND "THE BEST TASTING CHICKEN", APART FROM THE MARK AS SHOWN.

THE MARK CONSISTS OF THE WORDING "JUAN POLLO" IN STYLIZED LETTERING WITH A DESIGN OF A CHICKEN WITH HUMAN ATTRIBUTES WEARING A HAT, A VEST AND A TIE IN BETWEEN THESE TWO WORDS, WITH THE WORDING "THE BEST TASTING CHICKEN" IN STYLIZED LETTERING DEPICTED BENEATH THE WORDING "JUAN POLLO".

THE ENGLISH TRANSLATION OF "POLLO" IS "CHICKEN".

FOR RESTAURANT SERVICES (U.S. CLS. 100 AND 101).

FIRST USE 1-1-1984; IN COMMERCE 1-9-1984. KATHERINE STOIDES, EXAMINING ATTORNEY

SN 85-211,769. NAVAJO NATION GAMING ENTERPRISE, CHURCH ROCK, NM. FILED 1-6-2011.

CEDAR BOW RESTAURANT

THE MARK CONSISTS OF STANDARD CHARACTERS WITHOUT CLAIM TO ANY PARTICULAR FONT, STYLE, SIZE, OR COLOR.

NO CLAIM IS MADE TO THE EXCLUSIVE RIGHT TO USE "RESTAURANT", APART FROM THE MARK AS SHOWN.

FOR BAR AND RESTAURANT SERVICES (U.S. CLS. 100 AND 101).

DAWN FELDMAN, EXAMINING ATTORNEY



**CLASS 43—(Continued).**

SN 85-212,368. SURPLUS ONE, INC., MOUNT PROSPECT, IL.  
FILED 1-6-2011.

**DOG PLAY DAY CARE**

THE MARK CONSISTS OF STANDARD CHARACTERS WITHOUT CLAIM TO ANY PARTICULAR FONT, STYLE, SIZE, OR COLOR.

NO CLAIM IS MADE TO THE EXCLUSIVE RIGHT TO USE "DOG" AND "DAY CARE", APART FROM THE MARK AS SHOWN.

FOR DOG DAY CARE SERVICES; PET BOARDING SERVICES; PET DAY CARE SERVICES (U.S. CLS. 100 AND 101).

FIRST USE 6-0-2009; IN COMMERCE 6-0-2009.  
BENJAMIN OKEKE, EXAMINING ATTORNEY

SN 85-212,449. DECKER, BRAD, CHARLOTTE, NC. FILED 1-7-2011.

**SUSHI LOVE**

THE MARK CONSISTS OF STANDARD CHARACTERS WITHOUT CLAIM TO ANY PARTICULAR FONT, STYLE, SIZE, OR COLOR.

NO CLAIM IS MADE TO THE EXCLUSIVE RIGHT TO USE "SUSHI", APART FROM THE MARK AS SHOWN.

FOR RESTAURANTS (U.S. CLS. 100 AND 101).  
H. M. FISHER, EXAMINING ATTORNEY

SN 85-212,453. ASIAN FUSION FOOD INC., WEST COVINA, CA. FILED 1-7-2011.

**froyo licious**

THE MARK CONSISTS OF STANDARD CHARACTERS WITHOUT CLAIM TO ANY PARTICULAR FONT, STYLE, SIZE, OR COLOR.

NO CLAIM IS MADE TO THE EXCLUSIVE RIGHT TO USE "FROYO", APART FROM THE MARK AS SHOWN.

FOR FAST-FOOD RESTAURANT SERVICES (U.S. CLS. 100 AND 101).

FIRST USE 1-1-2011; IN COMMERCE 1-1-2011.  
H. M. FISHER, EXAMINING ATTORNEY

**CLASS 43—(Continued).**

SN 85-212,743. LANTSMAN MARAT, STUDIO CITY, CA.  
AND LANTSMAN ZOYA, STUDIO CITY, CA. FILED 1-7-2011.

**City of Love**

THE MARK CONSISTS OF STANDARD CHARACTERS WITHOUT CLAIM TO ANY PARTICULAR FONT, STYLE, SIZE, OR COLOR.

FOR RESTAURANTS (U.S. CLS. 100 AND 101).  
JOHN E. MICHOS, EXAMINING ATTORNEY

SN 85-212,885. PLANET HOLLYWOOD (REGION IV), INC., ORLANDO, FL. FILED 1-7-2011.

**ph screening room**

NO CLAIM IS MADE TO THE EXCLUSIVE RIGHT TO USE "SCREENING ROOM", APART FROM THE MARK AS SHOWN.

THE MARK CONSISTS OF TWO LOWER CASE LETTERS, "PH", THAT ARE PLACED WITHIN TWO SEMI-CIRCLES OF DIFFERENT DIAMETERS FOLLOWED BY THE WORDS "SCREENING ROOM".

FOR RESTAURANT AND BAR SERVICES (U.S. CLS. 100 AND 101).

ELLEN PERKINS, EXAMINING ATTORNEY

SN 85-213,914. DELICIOUSLY YOURS PERSONAL CHEF SERVICE LLC, DBA DELICIOUSLY YOURS, NEW ROCHELLE, NY. FILED 1-10-2011.

**Deliciously Yours**

THE MARK CONSISTS OF STANDARD CHARACTERS WITHOUT CLAIM TO ANY PARTICULAR FONT, STYLE, SIZE, OR COLOR.

FOR CATERING FOR THE PROVISION OF FOOD AND BEVERAGES; CATERING OF FOOD AND DRINKS; CATERING SERVICES (U.S. CLS. 100 AND 101).

FIRST USE 12-31-2010; IN COMMERCE 12-31-2010.  
LANA PHAM, EXAMINING ATTORNEY

**CLASS 43—(Continued).**

SN 85-213,933. PLANET HOLLYWOOD (REGION IV), INC., ORLANDO, FL. FILED 1-10-2011.



NO CLAIM IS MADE TO THE EXCLUSIVE RIGHT TO USE "SCREENING ROOM", APART FROM THE MARK AS SHOWN.

THE MARK CONSISTS OF A MARTINI GLASS, A FILM REEL, AND A LOUNGE CHAIR ILLUSTRATION DIRECTLY ABOVE TWO LOWER CASE LETTERS, "PH", THAT ARE PLACED WITHIN TWO SEMI-CIRCLES OF DIFFERENT DIAMETERS FOLLOWED BY THE WORDS "SCREENING ROOM".

FOR RESTAURANT AND BAR SERVICES (U.S. CLS. 100 AND 101).

ELLEN PERKINS, EXAMINING ATTORNEY

**CLASS 43—(Continued).**

SN 85-215,088. PEREZ BENATAR, ADRIANA, AVENTURA, MD. FILED 1-11-2011.



THE MARK CONSISTS OF THE FIGURE OF A SMALL BOWL WITH A TRIANGLE FIGURE ON TOP AND THREE DROPS COMING OUT OF THE BOWL.

FOR RESTAURANT SERVICES (U.S. CLS. 100 AND 101).

FIRST USE 1-1-2011; IN COMMERCE 1-1-2011.  
INGA ERVIN, EXAMINING ATTORNEY

SN 85-214,662. CAPONIES INC, MUNDELEIN, IL. FILED 1-11-2011.



THE MARK CONSISTS OF A PERSON WEARING A HAT AND SMOKING A CIGAR. ON THE TOP THERE IS THE STYLIZED TEXT "CAPONIES".

FOR RESTAURANT SERVICES (U.S. CLS. 100 AND 101).

FIRST USE 4-1-1993; IN COMMERCE 4-1-1993.  
AISHA SALEM, EXAMINING ATTORNEY

SN 85-216,800. BROOKLYN'S RESTAURANTS LLC, STILLWATER, OK. FILED 1-13-2011.



NO CLAIM IS MADE TO THE EXCLUSIVE RIGHT TO USE "CONTEMPORARY COMFORT FOOD" OR "CELLAR", APART FROM THE MARK AS SHOWN.

THE MARK CONSISTS OF DESIGNS AND STYLIZED WORDING. THE OUTER PORTION OF THE MARK IS A SQUARE BORDER WITH FOUR SPOTLIGHTS OVERHANGING THE TOP OF THE BORDER. WITHIN THE SQUARE IS A RECTANGULAR BORDER AROUND THE STYLIZED WORDING "BROOKLYN'S CONTEMPORARY COMFORT FOOD", WITH THE "Y" IN "BROOKLYN'S" EXTENDING DOWN AND LOOPING AROUND TO FORM AN EMPTY PLATE, AND A FORK AND A SPOON APPEAR AT THE BOTTOM OF THE PLATE. BELOW THIS DESIGN APPEARS AN OVAL BORDER AROUND THE STYLIZED WORDING "THE CELLAR @ BROOKLYN'S", A DESIGN OF A BUNCH OF GRAPES, AND A WINE GLASS.

FOR RESTAURANT AND BAR SERVICES; WINE BARS (U.S. CLS. 100 AND 101).

ANDREW LEASER, EXAMINING ATTORNEY

**CLASS 43—(Continued).**

SN 85-217,072. FUZION FOOD GROUP USA, INC., SIOUX FALLS, SD. FILED 1-13-2011.



OWNER OF U.S. REG. NOS. 3,618,165 AND 3,624,574.  
NO CLAIM IS MADE TO THE EXCLUSIVE RIGHT TO USE "GRILLE", APART FROM THE MARK AS SHOWN.  
THE MARK CONSISTS OF THE STYLIZED WORDING "FUZION GRILLE" AND A BROKEN CIRCLE DESIGN. A PORTION OF THE WORD "FUZION" APPEARS INSIDE THE CIRCLE. THE WORD "GRILLE" APPEARS UNDERNEATH THE WORD "FUZION". A HORIZONTAL LINE APPEARS ABOVE THE LETTER "U" IN THE WORD "FUZION".  
FOR RESTAURANT AND BAR SERVICES (U.S. CLS. 100 AND 101).  
EVELYN BRADLEY, EXAMINING ATTORNEY

SN 85-217,159. SMART COW, LLC, DENVER, CO. FILED 1-13-2011.



NO CLAIM IS MADE TO THE EXCLUSIVE RIGHT TO USE "YOGURT BAR", APART FROM THE MARK AS SHOWN.  
THE COLOR(S) RED, WHITE, AND BLUE IS/ARE CLAIMED AS A FEATURE OF THE MARK.  
THE MARK CONSISTS OF A STYLIZED COW WITH A BLUE SQUARE HEAD AND RECTANGULAR MIDLINE SKULL, OVAL EARS, TRAPEZOIDAL BODY, AND TRIANGULAR LEGS AND HIND QUARTERS; RED THREE ARCED TAIL, TRIANGULAR HORNS, OVAL NOSE, HALF TONGUE, UTTERS, CIRCULAR BODY SPOTS AND OUTLINED EYES; AND SEVERAL WHITE SPOTS AND NOSTRILS. BELOW THE COW THE LANGUAGE "SMART COW" IN RED WHERE THE "S" CONSISTS OF TWO SEMI-CIRCLES, THE "M" TWO UPWARD TRAPEZOIDS IN THE FORM OF A MOUNTAIN WITH A TRIANGLE BENEATH, THE "A" A FILLED IN TRIANGLE, THE "R" AN UPWARD RECTANGLE WITH A BLOCK "R", THE "O" A FILLED IN CIRCLE AND THE "W" A MIRROR IMAGE OF THE "M". BELOW THE LANGUAGE "SMART COW" THE BLUE LANGUAGE "YOGURT BAR".  
FOR FROZEN YOGURT SHOP SERVICES IN THE NATURE OF A RESTAURANT (U.S. CLS. 100 AND 101).  
EMILY CHUO, EXAMINING ATTORNEY

**CLASS 43—(Continued).**

SN 85-218,261. CDKITCHEN, INC., LEANDER, TX. FILED 1-14-2011.

## CDKITCHEN

THE MARK CONSISTS OF STANDARD CHARACTERS WITHOUT CLAIM TO ANY PARTICULAR FONT, STYLE, SIZE, OR COLOR.  
FOR PROVIDING A WEB SITE FEATURING INFORMATION ON RECIPES, INGREDIENTS AND COOKING INFORMATION; PROVIDING A DATABASE IN THE FIELD OF RECIPES, INGREDIENTS AND COOKING INFORMATION (U.S. CLS. 100 AND 101).  
FIRST USE 10-7-1998; IN COMMERCE 10-7-1998.  
PRISCILLA MILTON, EXAMINING ATTORNEY

SN 85-218,902. B HOTEL GROUP, LLC, WESTON, FL. FILED 1-17-2011.

## B BROOKLYN

THE MARK CONSISTS OF STANDARD CHARACTERS WITHOUT CLAIM TO ANY PARTICULAR FONT, STYLE, SIZE, OR COLOR.  
NO CLAIM IS MADE TO THE EXCLUSIVE RIGHT TO USE "BROOKLYN", APART FROM THE MARK AS SHOWN.  
FOR HOTEL, RESORT LODGING AND MOTEL SERVICES; RESTAURANT, CATERING, BAR AND COCKTAIL LOUNGE SERVICES; PROVISION OF GENERAL PURPOSE FACILITIES FOR MEETINGS, CONFERENCES AND EXHIBITIONS; PROVISION OF BANQUET AND SOCIAL FUNCTION FACILITIES FOR SPECIAL OCCASIONS; HOTEL SERVICES FOR PREFERRED CUSTOMERS; SPA SERVICES, NAMELY, PROVIDING TEMPORARY ACCOMMODATIONS AND MEALS TO CLIENTS OF A HEALTH OR BEAUTY SPA; AND RESERVATION SERVICES FOR HOTEL ACCOMMODATIONS FOR OTHERS (U.S. CLS. 100 AND 101).  
KAREN K. BUSH, EXAMINING ATTORNEY

SN 85-219,693. MORGANS GROUP LLC, NEW YORK, NY. FILED 1-18-2011.

## MR. H

THE MARK CONSISTS OF STANDARD CHARACTERS WITHOUT CLAIM TO ANY PARTICULAR FONT, STYLE, SIZE, OR COLOR.  
THE NAME "MR. H" DOES NOT IDENTIFY A LIVING INDIVIDUAL.  
FOR BAR AND RESTAURANT SERVICES (U.S. CLS. 100 AND 101).  
JAMES A. RAUEN, EXAMINING ATTORNEY

**CLASS 43—(Continued).**

SN 85-226,619. HARDEE'S FOOD SYSTEMS, INC., ST. LOUIS, MO. AND CARL KARCHER ENTERPRISES, INC., CARPINTERIA, CA. FILED 1-26-2011.

**JUST THE WAY IT IS**

THE MARK CONSISTS OF STANDARD CHARACTERS WITHOUT CLAIM TO ANY PARTICULAR FONT, STYLE, SIZE, OR COLOR.

FOR RESTAURANT SERVICES (U.S. CLS. 100 AND 101).

CAROLINE WOOD, EXAMINING ATTORNEY

SN 85-229,267. INTREPID GAMING, LLC, LAS VEGAS, NV. FILED 1-28-2011.

**RITORNO AI FONDAMENTALI,  
BAMBINO!**

THE MARK CONSISTS OF STANDARD CHARACTERS WITHOUT CLAIM TO ANY PARTICULAR FONT, STYLE, SIZE, OR COLOR.

THE ENGLISH TRANSLATION OF "RITORNO AI FONDAMENTALI, BAMBINO!" IN THE MARK IS "BACK TO BASICS, BABY!"

FOR BAR AND COCKTAIL LOUNGE SERVICES; BAR AND RESTAURANT SERVICES; BAR SERVICES (U.S. CLS. 100 AND 101).

Laurie Kaufman, Examining Attorney

SN 85-233,320. MORGANS GROUP LLC, NEW YORK, NY. FILED 2-3-2011.

**MISTER H**

THE MARK CONSISTS OF STANDARD CHARACTERS WITHOUT CLAIM TO ANY PARTICULAR FONT, STYLE, SIZE, OR COLOR.

THE NAME "MISTER H" DOES NOT IDENTIFY A LIVING INDIVIDUAL.

FOR BAR AND RESTAURANT SERVICES (U.S. CLS. 100 AND 101).

JAMES A. RAUEN, EXAMINING ATTORNEY

**CLASS 43—(Continued).**

SN 85-235,933. PLANET HOLLYWOOD (REGION IV), INC., ORLANDO, FL. FILED 2-7-2011.

**PLANET HOLLYWOOD**

THE MARK CONSISTS OF STANDARD CHARACTERS WITHOUT CLAIM TO ANY PARTICULAR FONT, STYLE, SIZE, OR COLOR.

OWNER OF U.S. REG. NOS. 3,386,957, 3,566,996 AND 3,710,585.

FOR HOTELS AND RESORT LODGING SERVICES (U.S. CLS. 100 AND 101).

FIRST USE 11-17-2007; IN COMMERCE 11-17-2007.

ELLEN PERKINS, EXAMINING ATTORNEY

SN 85-241,658. HARDEE'S FOOD SYSTEMS, INC., ST. LOUIS, MO. AND CARL KARCHER ENTERPRISES, INC., CARPENTERIA, CA. FILED 2-14-2011.



OWNER OF U.S. REG. NOS. 2,292,781, 3,295,053 AND OTHERS.

THE MARK CONSISTS OF THE STYLIZED WORD "HARDEE'S" WITH A STAR WITH A SMILING FACE.

FOR RESTAURANT SERVICES (U.S. CLS. 100 AND 101).

FIRST USE 7-21-2008; IN COMMERCE 7-21-2008.

CAROLINE WOOD, EXAMINING ATTORNEY

SN 85-250,139. INTREPID GAMING, LLC, LAS VEGAS, NV. FILED 2-23-2011.

**THE PALIO**

THE MARK CONSISTS OF STANDARD CHARACTERS WITHOUT CLAIM TO ANY PARTICULAR FONT, STYLE, SIZE, OR COLOR.

FOR BAR AND COCKTAIL LOUNGE SERVICES; BAR AND RESTAURANT SERVICES; BAR SERVICES (U.S. CLS. 100 AND 101).

Laurie Kaufman, Examining Attorney

**CLASS 43—(Continued).**

SN 85-271,148. PLANET HOLLYWOOD (REGION IV), INC.,  
ORLANDO, FL. FILED 3-18-2011.

**PLANET SPORTS**

THE MARK CONSISTS OF STANDARD CHARACTERS WITHOUT CLAIM TO ANY PARTICULAR FONT, STYLE, SIZE, OR COLOR.

NO CLAIM IS MADE TO THE EXCLUSIVE RIGHT TO USE "SPORTS", APART FROM THE MARK AS SHOWN. FOR RESTAURANT, BAR AND HOTEL SERVICES (U.S. CLS. 100 AND 101).

ELLEN PERKINS, EXAMINING ATTORNEY

SN 85-975,158. 4R VENTURES, LLC, WINTER PARK, FL.  
FILED 6-23-2010.



THE MARK CONSISTS OF THE NUMBER "4" COMBINED WITH THE LETTER "R" IN BRUSH STROKE CHARACTERS.

FOR RESTAURANT AND CATERING SERVICES (U.S. CLS. 100 AND 101).

FIRST USE 11-11-2005; IN COMMERCE 10-26-2009.

DAVID TOOLEY, EXAMINING ATTORNEY

**CLASS 44—MEDICAL, BEAUTY AND AGRICULTURAL SERVICES**

SN 76-705,246. MID CITIES DENTAL, HURST, TX. FILED 11-8-2010.

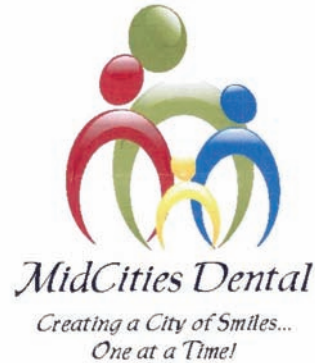

NO CLAIM IS MADE TO THE EXCLUSIVE RIGHT TO USE "MIDCITIES DENTAL", APART FROM THE MARK AS SHOWN.

THE COLOR(S) GREEN, RED, BLUE, YELLOW AND BLACK IS/ARE CLAIMED AS A FEATURE OF THE MARK.

THE MARK CONSISTS OF A COMBINATION OF FOUR DIFFERENT PICTURES THAT APPEAR AS TEETH WITH THE IMPRESSION THAT THEY ARE A FAMILY. THE LARGEST TOOTH CHARACTER IS GREEN IN THE BACK MIDDLE, THE SECOND LARGEST ON THE LEFT IS RED, THE THIRD LARGEST ON THE RIGHT IS BLUE AND THE SMALLEST IN THE LOWER CENTER IS YELLOW. UNDERNEATH THE LOGO IS THE WORDING "MIDCITIES DENTAL" AND "CREATING A CITY OF SMILES... ONE AT A TIME!" IN BLACK.

FOR DENTIST SERVICES; DENTAL IMPLANT AND ORTHODONTIST SERVICES (U.S. CLS. 100 AND 101).

FIRST USE 1-1-2010; IN COMMERCE 1-1-2010.

JAMES GRIFFIN, EXAMINING ATTORNEY

SN 77-795,920. LOMA LINDA UNIVERSITY ADVENTIST HEALTH SCIENCES CENTER, INC., LOMA LINDA, CA.  
FILED 8-3-2009.



THE MARK CONSISTS OF A SILHOUETTE OF A MAN JUMPING WITH HIS ARMS AND LEGS OUTSTRETCHED. TO THE LEFT OF THE FIGURE IS THE WORD "LIVING" AND TO THE RIGHT OF THE FIGURE IS THE WORD "WHOLE".

FOR MEDICAL TESTING SERVICES IN THE FIELD OF HEALTHFUL LIVING, NAMELY, IN THE FIELD OF OVERALL HEALTH (U.S. CLS. 100 AND 101).

FIRST USE 10-31-2006; IN COMMERCE 2-17-2009.

CURTIS FRENCH, EXAMINING ATTORNEY



**CLASS 44—(Continued).**

SN 77-888,067. SOUTHWEST GENERAL HEALTH CENTER, CLEVELAND, OH. FILED 12-7-2009.

SOUTHWEST GENERAL MEDICAL  
GROUP

THE MARK CONSISTS OF STANDARD CHARACTERS WITHOUT CLAIM TO ANY PARTICULAR FONT, STYLE, SIZE, OR COLOR.

NO CLAIM IS MADE TO THE EXCLUSIVE RIGHT TO USE "MEDICAL GROUP", APART FROM THE MARK AS SHOWN.

SEC. 2(F) AS TO "SOUTHWEST GENERAL".

FOR PHYSICIAN SERVICES, NAMELY, BEHAVIORAL HEALTH, FAMILY MEDICINE, ONCOLOGY, INTERNAL MEDICINE, NEUROSURGERY, ORTHOPEDICS, GENERAL SURGERY, OBSTETRICS AND GYNECOLOGY (U.S. CLS. 100 AND 101).

FIRST USE 1-1-2008; IN COMMERCE 1-1-2008.

GISELLE AGOSTO, EXAMINING ATTORNEY

---

SN 77-905,502. EXPRESSMED URGENT CARE CENTERS, LLC, SPANISH FORK, UT. FILED 1-5-2010.

ExpressMD

THE MARK CONSISTS OF STANDARD CHARACTERS WITHOUT CLAIM TO ANY PARTICULAR FONT, STYLE, SIZE, OR COLOR.

FOR URGENT MEDICAL CARE CENTERS (U.S. CLS. 100 AND 101).

GINA FINK, EXAMINING ATTORNEY

---

SN 77-950,408. SHLOSBERG, STUART, BEVERLY HILLS, CA. FILED 3-4-2010.

SECURE SMILES

THE MARK CONSISTS OF STANDARD CHARACTERS WITHOUT CLAIM TO ANY PARTICULAR FONT, STYLE, SIZE, OR COLOR.

FOR DENTISTRY SERVICES, NAMELY, DENTAL IMPLANTS SERVICES (U.S. CLS. 100 AND 101).

MARIA-VICTORIA SUAREZ, EXAMINING ATTORNEY

**CLASS 44—(Continued).**

SN 79-085,164. GUANGZHOU YUZUTANG THERAPEUTIC CO., LTD., GUANGDONG 510620, CHINA, FILED 7-1-2010.



OWNER OF INTERNATIONAL REGISTRATION 0854436 DATED 2-28-2005, EXPIRES 2-28-2015.

NO CLAIM IS MADE TO THE EXCLUSIVE RIGHT TO USE THE NON-LATIN CHARACTERS THAT TRANSLITERATE TO "ZU TANG", APART FROM THE MARK AS SHOWN.

THE MARK CONSISTS OF THREE CHINESE CHARACTERS INSIDE A GENERALLY RECTANGULAR SHAPED CARRIER MADE OF BRUSH STROKES.

THE NON-LATIN CHARACTERS IN THE MARK TRANSLITERATE TO "YU ZU TANG" AND THIS MEANS "IMPERIAL FOOT HALL" IN ENGLISH.

FOR MANICURING, HEALTH CARE, MASSAGE, OPERATION OF PUBLIC BATHS FOR HYGIENE PURPOSES, PHYSICAL THERAPY, SANATORIUM, CONValesCENT HOMES, CHIROPRACTICS (U.S. CLS. 100 AND 101).

MARTHA FROMM, EXAMINING ATTORNEY

---

SN 79-085,269. GUANGZHOU YUZUTANG THERAPEUTIC CO., LTD., CHINA, FILED 5-18-2010.



Yuzutang

OWNER OF INTERNATIONAL REGISTRATION 1045600 DATED 5-18-2010, EXPIRES 5-18-2020.

NO CLAIM IS MADE TO THE EXCLUSIVE RIGHT TO USE "ZU TANG", APART FROM THE MARK AS SHOWN.

THE MARK CONSISTS OF THREE CHINESE CHARACTERS INSIDE A GENERALLY RECTANGULAR SHAPED CARRIER MADE OF BRUSH STROKES. THE WORDING "YUZUTANG" APPEARS ALONG THE BOTTOM OF THE MARK.

THE ENGLISH TRANSLATION OF "YUZUTANG" IN THE MARK IS "IMPERIAL FOOT HALL".

THE NON-LATIN CHARACTERS IN THE MARK TRANSLITERATE TO "YU ZU TANG" AND THIS MEANS "IMPERIAL FOOT HALL" IN ENGLISH.

FOR MANICURING; HEALTH CARE; MASSAGE FOR MEDICAL PURPOSE; OPERATION OF PUBLIC BATHS FOR HYGIENE PURPOSES; PHYSIOTHERAPY; CONValesCENT HOMES; SANATORIUMS; MASSAGE (U.S. CLS. 100 AND 101).

MARTHA FROMM, EXAMINING ATTORNEY

**CLASS 44—(Continued).**

SN 85-003,842. UHS OF DELAWARE, INC., KING OF PRUSSIA, PA. FILED 4-1-2010.



OWNER OF U.S. REG. NOS. 2,649,125, 2,804,443 AND 3,059,851.

NO CLAIM IS MADE TO THE EXCLUSIVE RIGHT TO USE "CHILDREN'S MEDICAL CENTER" AND "HOSPITAL", APART FROM THE MARK AS SHOWN.

THE MARK CONSISTS OF A DESIGN OF TWO PANDA BEARS ABOVE THE WORDS "CHILDREN'S MEDICAL CENTER AT SUMMERLIN HOSPITAL", WITH A HORIZONTAL LINE SEPARATING "CHILDREN'S MEDICAL CENTER" FROM "AT SUMMERLIN HOSPITAL".

SEC. 2(F) AS TO "SUMMERLIN".  
FOR MEDICAL AND HEALTHCARE SERVICES (U.S. CLS. 100 AND 101).

FIRST USE 3-0-2007; IN COMMERCE 3-0-2007.  
KRISTIN CARLSON, EXAMINING ATTORNEY

SN 85-009,262. NATIONAL PACE ASSOCIATION, ALEXANDRIA, VA. FILED 4-8-2010.



OWNER OF U.S. REG. NOS. 1,696,685, 3,721,928 AND 3,721,929.

NO CLAIM IS MADE TO THE EXCLUSIVE RIGHT TO USE "PROVIDER", APART FROM THE MARK AS SHOWN.

THE MARK CONSISTS OF THE TERM "PACE PROVIDER" BELOW TWO IMAGES, ONCE CONSISTING OF AN OPEN RECTANGLE COMBINED WITH AN OPEN TRIANGLE, THE SECOND CONSISTING OF TWO INTERLOCKING OVALS, EACH TOPPED WITH A SMALLER OVAL.

FOR PROVIDING INFORMATION ABOUT HEALTHCARE FOR OLDER ADULTS (U.S. CLS. 100 AND 101).  
FIRST USE 4-6-2010; IN COMMERCE 4-6-2010.  
BRIAN CALLAGHAN, EXAMINING ATTORNEY

**CLASS 44—(Continued).**

SN 85-016,286. UHS OF DELAWARE, INC., KING OF PRUSSIA, PA. FILED 4-16-2010.



OWNER OF U.S. REG. NOS. 3,043,670 AND 3,547,315.  
NO CLAIM IS MADE TO THE EXCLUSIVE RIGHT TO USE "THE HEADACHE CENTER", APART FROM THE MARK AS SHOWN.

THE MARK CONSISTS OF THE STYLIZED WORDING "THE HEADACHE CENTER OF NORTHERN NEVADA" TO THE RIGHT OF A STAGGERED MOUNTAIN DESIGN.

SEC. 2(F) AS TO "NORTHERN NEVADA".  
FOR MEDICAL AND HEALTH CARE SERVICES, INCLUDING PAIN MANAGEMENT SERVICES (U.S. CLS. 100 AND 101).

KRISTIN CARLSON, EXAMINING ATTORNEY

SN 85-035,320. TAIRE HAIR SALON INC., HUNTINGDON VALLEY, PA. FILED 5-11-2010.

# TAIRE

THE MARK CONSISTS OF STANDARD CHARACTERS WITHOUT CLAIM TO ANY PARTICULAR FONT, STYLE, SIZE, OR COLOR.

THE ENGLISH TRANSLATION OF "TAIRE" IN THE MARK IS "HUSH UP".

FOR BEAUTY SPA SERVICES, NAMELY, COSMETIC BODY CARE; BODY WAXING SERVICES; HAIR SALON SERVICES (U.S. CLS. 100 AND 101).

FIRST USE 3-16-2010; IN COMMERCE 3-16-2010.  
WON TEAK OH, EXAMINING ATTORNEY

SN 85-039,454. CAPNA MANAGEMENT, INC., LAS VEGAS, NV. FILED 5-14-2010.

A COMPANY OWNED AND  
OPERATED BY VETERINARIANS  
FOR VETERINARIANS

THE MARK CONSISTS OF STANDARD CHARACTERS WITHOUT CLAIM TO ANY PARTICULAR FONT, STYLE, SIZE, OR COLOR.

FOR VETERINARY SERVICES (U.S. CLS. 100 AND 101).

RUDY R. SINGLETON, EXAMINING ATTORNEY

**CLASS 44—(Continued).**

SN 85-041,055. HMP COMMUNICATIONS, LLC, MALVERN, PA. FILED 5-18-2010.

**EXPERIENCE AF SOLUTIONS**

THE MARK CONSISTS OF STANDARD CHARACTERS WITHOUT CLAIM TO ANY PARTICULAR FONT, STYLE, SIZE, OR COLOR.

NO CLAIM IS MADE TO THE EXCLUSIVE RIGHT TO USE "AF SOLUTIONS", APART FROM THE MARK AS SHOWN.

FOR PROVIDING ONLINE INFORMATION IN THE MEDICAL AND HEALTHCARE FIELDS (U.S. CLS. 100 AND 101).

KHANH LE, EXAMINING ATTORNEY

---

SN 85-043,426. DICKRAN BABIGIAN, NEWTON, MA. FILED 5-20-2010.

**GREEN ENVY**

THE MARK CONSISTS OF STANDARD CHARACTERS WITHOUT CLAIM TO ANY PARTICULAR FONT, STYLE, SIZE, OR COLOR.

FOR HOME NATURAL GRASS SEEDING, MOWING, FEEDING AND WEED AND PEST PREVENTION SERVICES; YARD PREPARATION AND MAINTENANCE; NATURAL SOD INSTALLATION AND MAINTENANCE (U.S. CLS. 100 AND 101).

FIRST USE 4-4-2006; IN COMMERCE 4-4-2006.

ALLISON SCHRODY, EXAMINING ATTORNEY

---

SN 85-055,362. OTT, HOLLY, DBA IMAGINE SALON, GLENDALE, AZ. FILED 6-4-2010.

**Imagine Salon**

THE MARK CONSISTS OF STANDARD CHARACTERS WITHOUT CLAIM TO ANY PARTICULAR FONT, STYLE, SIZE, OR COLOR.

NO CLAIM IS MADE TO THE EXCLUSIVE RIGHT TO USE "SALON", APART FROM THE MARK AS SHOWN.

FOR COMPLETE HAIR CARE, CUTTING, WAXING AND STYLING SERVICES (U.S. CLS. 100 AND 101).

FIRST USE 1-17-2007; IN COMMERCE 2-1-2007.

JAMES STEIN, EXAMINING ATTORNEY

**CLASS 44—(Continued).**

SN 85-059,502. NUFACTOR, INC., TEMECULA, CA. FILED 6-10-2010.

**INFUSEAMERICA**

THE MARK CONSISTS OF STANDARD CHARACTERS WITHOUT CLAIM TO ANY PARTICULAR FONT, STYLE, SIZE, OR COLOR.

FOR HEALTH CARE SERVICES IN THE NATURE OF INFUSION SERVICES, NAMELY, PROVIDING INTRAVENOUS AND SUBCUTANEOUS BIOPHARMACEUTICALS, BIOLOGICS AND PHARMACEUTICALS AND THE INFUSION OF INTRAVENOUS AND SUBCUTANEOUS BIOPHARMACEUTICALS, BIOLOGICS AND PHARMACEUTICALS TO PATIENTS (U.S. CLS. 100 AND 101).

NAAKWAMA ANKRAH, EXAMINING ATTORNEY

---

SN 85-061,793. ALZCARE, INC., HAMILTON, NJ. FILED 6-14-2010.

**ALZCARE**

THE MARK CONSISTS OF STANDARD CHARACTERS WITHOUT CLAIM TO ANY PARTICULAR FONT, STYLE, SIZE, OR COLOR.

FOR HOME HEALTH CARE SERVICES (U.S. CLS. 100 AND 101).

ELLEN B. AWRICH, EXAMINING ATTORNEY

---

SN 85-065,138. JJZ INC., BUTLER, PA. FILED 6-17-2010.

**SERENITY ON THE GREEN**

THE MARK CONSISTS OF STANDARD CHARACTERS WITHOUT CLAIM TO ANY PARTICULAR FONT, STYLE, SIZE, OR COLOR.

FOR DAY SPA SERVICES, NAMELY, MESSAGES AND FACIALS (U.S. CLS. 100 AND 101).

NAPOLEON SHARMA, EXAMINING ATTORNEY

**CLASS 44—(Continued).**

SN 85-074,472. LITTLE " B" ENTERPRISES LLC, LAKEWOOD, CO. FILED 6-30-2010.

**A BRIGHTER SMILE LLC**

THE MARK CONSISTS OF STANDARD CHARACTERS WITHOUT CLAIM TO ANY PARTICULAR FONT, STYLE, SIZE, OR COLOR.

NO CLAIM IS MADE TO THE EXCLUSIVE RIGHT TO USE "LLC", APART FROM THE MARK AS SHOWN.

FOR MEDICAL, HYGIENIC AND BEAUTY CARE SERVICES FEATURING TEETH WHITENING FOR HUMANS (U.S. CLS. 100 AND 101).

ELISSA GARBER KON, EXAMINING ATTORNEY

SN 85-079,302. MCMAHON - BOWMAN RANCH, L.L.C., SAN ANTONIO, TX. FILED 7-7-2010.

**ADVENTURE HORSES**

THE MARK CONSISTS OF STANDARD CHARACTERS WITHOUT CLAIM TO ANY PARTICULAR FONT, STYLE, SIZE, OR COLOR.

NO CLAIM IS MADE TO THE EXCLUSIVE RIGHT TO USE "HORSES", APART FROM THE MARK AS SHOWN.

FOR HORSE BREEDING; HORSE FARM SERVICES (U.S. CLS. 100 AND 101).

FIRST USE 0-0-1995; IN COMMERCE 0-0-1995.

JAMES STEIN, EXAMINING ATTORNEY

SN 85-080,265. AMERICAN FITNESS ASSOCIATES, INC., UNION, NJ. FILED 7-8-2010.

**IMAGE 2000 BODY REJUVENATION CENTER**

THE MARK CONSISTS OF STANDARD CHARACTERS WITHOUT CLAIM TO ANY PARTICULAR FONT, STYLE, SIZE, OR COLOR.

OWNER OF U.S. REG. NO. 2,827,548.

NO CLAIM IS MADE TO THE EXCLUSIVE RIGHT TO USE "BODY REJUVENATION CENTER", APART FROM THE MARK AS SHOWN.

FOR BEAUTY SPA SERVICES, NAMELY, SKIN AND BODY CARE (U.S. CLS. 100 AND 101).

FIRST USE 6-1-2010; IN COMMERCE 6-1-2010.

KATINA MISTER, EXAMINING ATTORNEY

**CLASS 44—(Continued).**

SN 85-094,011. ANNE ARUNDEL HEALTH SYSTEM, INC., ANNAPOLIS, MD. FILED 7-27-2010.



NO CLAIM IS MADE TO THE EXCLUSIVE RIGHT TO USE "DIAGNOSTICS IMAGING", APART FROM THE MARK AS SHOWN.

THE MARK CONSISTS OF THE WORDS "ANNE ARUNDEL" OVER THE WORDS "DIAGNOSTICS IMAGING" WITH A DESIGN TO THE LEFT OF THE WORDS.

SEC. 2(F) AS TO "ANNE ARUNDEL".

FOR MEDICAL DIAGNOSTIC IMAGING, MONITORING AND REPORTING (U.S. CLS. 100 AND 101).

FIRST USE 0-0-2009; IN COMMERCE 0-0-2009.

DAVID HOFFMAN, EXAMINING ATTORNEY

SN 85-094,397. PENA, JOE ANTHONY, VICTORIA, TX. FILED 7-28-2010.

**Joe Anthony**

THE MARK CONSISTS OF STANDARD CHARACTERS WITHOUT CLAIM TO ANY PARTICULAR FONT, STYLE, SIZE, OR COLOR.

THE NAME(S), PORTRAIT(S), AND/OR SIGNATURE(S) SHOWN IN THE MARK IDENTIFIES "JOE ANTHONY" PENA, WHOSE CONSENT(S) TO REGISTER IS MADE OF RECORD.

FOR HAIR SALON SERVICES (U.S. CLS. 100 AND 101).

NAAKWAMA ANKRAH, EXAMINING ATTORNEY

SN 85-100,454. "AA" PROSTHETIC SERVICES, INC., BROWNWOOD, TX. FILED 8-4-2010.



NO CLAIM IS MADE TO THE EXCLUSIVE RIGHT TO USE "PROSTHETIC SERVICES" AND THE PICTORIAL REPRESENTATION OF THE STATE OF TEXAS, APART FROM THE MARK AS SHOWN.

THE MARK CONSISTS OF A PICTORIAL REPRESENTATION OF THE STATE OF TEXAS. THE REPRESENTATION OF TEXAS IS DIVIDED INTO THREE SECTIONS BY A VERTICAL AND A HORIZONTAL LINE AND A DIFFERENCE IN SHADING. A STAR APPEARS IN THE CENTER

**CLASS 44—(Continued).**

OF THE PICTORIAL REPRESENTATION APPROXIMATING THE GEOGRAPHIC LOCATION OF BROWNWOOD, TEXAS. TWO DIAGONAL LINES EXTEND FROM THIS STAR AND HOLD A CIRCLE AT THEIR TERMINAL ENDS. THE CIRCLE IS DIVIDED IN HALF HORIZONTALLY AND OUTLINED. THE TOP HALF CONTAINS A SMALL SEMICIRCLE AND THE LETTERS "A" "A" "P" "S" PRESENTED IN STYLIZED FONT. THE BOTTOM PORTION OF THE CIRCLE CONTAINS THE WORDING " "AA" PROSTHETIC SERVICES" PRESENTED IN STYLIZED FONT WITH EACH ELEMENT STACKED ABOVE THE OTHER.

FOR FITTING OF PROSTHETICS AND ORTHOTICS (U.S. CLS. 100 AND 101).

FIRST USE 7-27-2010; IN COMMERCE 7-27-2010.  
GRETCHEN ULRICH, EXAMINING ATTORNEY

---

SN 85-101,924. CEBADO, S.A., BARCELONA, SPAIN, FILED 8-6-2010.

# CEBADO

THE MARK CONSISTS OF STANDARD CHARACTERS WITHOUT CLAIM TO ANY PARTICULAR FONT, STYLE, SIZE, OR COLOR.

THE ENGLISH TRANSLATION OF "CEBADO" IS "LARGE".

FOR HAIR CUTTING AND HAIR DRESSING SERVICES (U.S. CLS. 100 AND 101).

BARBARA GAYNOR, EXAMINING ATTORNEY

---

SN 85-116,205. JBZ&A, INC., WILLMINGTON, DE. FILED 8-26-2010.

# INSPIRING BUSINESS PERFORMANCE

THE MARK CONSISTS OF STANDARD CHARACTERS WITHOUT CLAIM TO ANY PARTICULAR FONT, STYLE, SIZE, OR COLOR.

FOR EMPLOYEE DRUG TESTING FOR SUBSTANCE ABUSE; PROVIDING INFORMATION IN THE FIELD OF BEHAVIORAL AND PSYCHOLOGICAL TESTING AND ASSESSMENT OF EMPLOYEES (U.S. CLS. 100 AND 101).

JENNIFER DIXON, EXAMINING ATTORNEY

**CLASS 44—(Continued).**

SN 85-116,532. JBZ&A, INC., WILLMINGTON, DE. FILED 8-26-2010.

# INSPERITY INSPIRING BUSINESS PERFORMANCE

THE MARK CONSISTS OF STANDARD CHARACTERS WITHOUT CLAIM TO ANY PARTICULAR FONT, STYLE, SIZE, OR COLOR.

FOR EMPLOYEE DRUG TESTING FOR SUBSTANCE ABUSE; PROVIDING INFORMATION IN THE FIELD OF BEHAVIORAL AND PSYCHOLOGICAL TESTING AND ASSESSMENT OF EMPLOYEES (U.S. CLS. 100 AND 101).

JENNIFER DIXON, EXAMINING ATTORNEY

---

SN 85-117,080. DNA HEALTH SERVICES, DBA DNA HOME HEALTH SERVICES, DALLAS, TX. FILED 8-26-2010.

# DnA Health Services

THE MARK CONSISTS OF STANDARD CHARACTERS WITHOUT CLAIM TO ANY PARTICULAR FONT, STYLE, SIZE, OR COLOR.

NO CLAIM IS MADE TO THE EXCLUSIVE RIGHT TO USE "HEALTH SERVICES", APART FROM THE MARK AS SHOWN.

THE WORDING "DNA" HAS NO MEANING IN A FOREIGN LANGUAGE.

FOR HOME HEALTH CARE SERVICES, NAMELY, SKILL NURSING SERVICES, NAMELY, MEDICATION ADMINISTRATION, WOUND CARE; THERAPEUTIC SERVICES, NAMELY, PHYSICAL THERAPY, SPEECH-LANGUAGE PATHOLOGY SERVICES, OCCUPATIONAL THERAPY, MEDICAL SERVICES, AND HOME HEALTH CARE SERVICES; REHABILITATION SERVICES IN THE NATURE OF HELPING PATIENTS REGAIN RANGE OF MOTION AND AMBULATION (U.S. CLS. 100 AND 101).

ARETHA SOMERVILLE, EXAMINING ATTORNEY

---

SN 85-121,174. TROY, ELSA, SANDY, UT. AND SLOVIK, JOSHUA, SANDY, UT. FILED 9-1-2010.

# RemedyEHR

THE MARK CONSISTS OF STANDARD CHARACTERS WITHOUT CLAIM TO ANY PARTICULAR FONT, STYLE, SIZE, OR COLOR.

FOR MAINTAINING PATIENT MEDICAL RECORDS AND FILES (U.S. CLS. 100 AND 101).

FIRST USE 10-1-2009; IN COMMERCE 10-1-2009.

KELLY CHOE, EXAMINING ATTORNEY



**CLASS 44—(Continued).**

SN 85-130,665. DUKARSKI, CHRISTOPHER A, BEVERLY, MA. FILED 9-15-2010.

# OrthoWell

THE MARK CONSISTS OF STANDARD CHARACTERS WITHOUT CLAIM TO ANY PARTICULAR FONT, STYLE, SIZE, OR COLOR.

FOR PHYSICAL THERAPY (U.S. CLS. 100 AND 101).  
FIRST USE 9-1-2010; IN COMMERCE 9-1-2010.  
LAURIE KAUFMAN, EXAMINING ATTORNEY

SN 85-146,800. SONOTEMPS, INC., TARPON SPRINGS, FL. FILED 10-6-2010.

## ULTRASOUND 2 GO

THE MARK CONSISTS OF STANDARD CHARACTERS WITHOUT CLAIM TO ANY PARTICULAR FONT, STYLE, SIZE, OR COLOR.

NO CLAIM IS MADE TO THE EXCLUSIVE RIGHT TO USE "ULTRASOUND", APART FROM THE MARK AS SHOWN.  
FOR MEDICAL IMAGING SERVICES (U.S. CLS. 100 AND 101).  
MATTHEW KLINE, EXAMINING ATTORNEY

SN 85-159,011. SPACE COAST MEDICAL ASSOCIATES, LLP, TITUSVILLE, FL. FILED 10-22-2010.



NO CLAIM IS MADE TO THE EXCLUSIVE RIGHT TO USE "SPACE COAST CANCER CENTER", APART FROM THE MARK AS SHOWN.

THE MARK CONSISTS OF THE WORDS "SPACE COAST" IN BLOCK PRINT; THE WORD "CANCER" IN BLOCK PRINT UNDERNEATH THE WORDS "SPACE COAST"; THE WORD "CENTER" IN BLOCK PRINT UNDERNEATH THE WORD "CANCER"; A LINE UNDERNEATH THE WORD "CENTER"; THE WORDS "HOPE", "HEALTH", AND "HEALING" UNDERNEATH THE LINE; A DESIGN OF THE LETTERS "SCCC" INTERTWINED WITH BORDER ON THE LEFT SIDE OF THE WORDS "SPACE COAST CANCER CENTER HOPE HEALTH HEALING".

FOR HEALTH CARE AND MEDICAL SERVICES, NAMELY, RADIATION, ONCOLOGY, HEMATOLOGY, AND CANCER TREATMENT SERVICES; PROVIDING HEALTH INFORMATION ABOUT CANCER AND HEALTH CARE (U.S. CLS. 100 AND 101).

FIRST USE 10-31-2009; IN COMMERCE 10-31-2009.  
RONALD MCMORROW, EXAMINING ATTORNEY

**CLASS 44—(Continued).**

SN 85-161,593. WOMEN'S CLINICAL RESEARCH CENTER, P.S., SEATTLE, WA. FILED 10-26-2010.



NO CLAIM IS MADE TO THE EXCLUSIVE RIGHT TO USE "SEATTLE WOMEN'S HEALTH RESEARCH GYNECOLOGY", APART FROM THE MARK AS SHOWN.

THE MARK CONSISTS OF A CIRCLE OVER A PLUS SYMBOL IN A CIRCLE WITH THE WORDS "SEATTLE WOMEN'S HEALTH RESEARCH GYNECOLOGY" PRINTED TO THE RIGHT OF THE CIRCLE.

FOR PHYSICIAN SERVICES; MEDICAL CLINICS; MEDICAL SERVICES; MEDICAL AND SCIENTIFIC RESEARCH, NAMELY, CONDUCTING CLINICAL TRIALS (U.S. CLS. 100 AND 101).  
MICHAEL WEBSTER, EXAMINING ATTORNEY

SN 85-167,913. SLEEP MEDICINE ASSOCIATES OF TX, DALLAS, TX. FILED 11-3-2010.

## STILLSNORING

THE MARK CONSISTS OF STANDARD CHARACTERS WITHOUT CLAIM TO ANY PARTICULAR FONT, STYLE, SIZE, OR COLOR.

FOR PROVIDING A WEBSITE FEATURING INFORMATION ABOUT SNORING AND SLEEP APNEA; PROVIDING A WEBSITE FEATURING INFORMATION ABOUT TREATMENT OPTIONS FOR SNORING AND SLEEP APNEA (U.S. CLS. 100 AND 101).

FIRST USE 10-13-2010; IN COMMERCE 10-13-2010.  
RAMONA ORTIGA, EXAMINING ATTORNEY

SN 85-189,176. CLARIAN HEALTH PARTNERS, INC., INDIANAPOLIS, IN. FILED 12-2-2010.

## THE STRENGTH IT TAKES

THE MARK CONSISTS OF STANDARD CHARACTERS WITHOUT CLAIM TO ANY PARTICULAR FONT, STYLE, SIZE, OR COLOR.

FOR HOSPITAL SERVICES, AND HEALTH CARE SERVICES (U.S. CLS. 100 AND 101).

SUE LAWRENCE, EXAMINING ATTORNEY

**CLASS 44—(Continued).**

SN 85-190,664. JOHNSTON, JENNIFER L., PERRY, MI.  
FILED 12-3-2010.

## Waxbitch

THE MARK CONSISTS OF STANDARD CHARACTERS WITHOUT CLAIM TO ANY PARTICULAR FONT, STYLE, SIZE, OR COLOR.

FOR BODY WAXING SERVICES; HEALTH SPA SERVICES FOR HEALTH AND WELLNESS OF THE BODY AND SPIRIT, NAMELY, PROVIDING MASSAGE, FACIAL AND BODY TREATMENT SERVICES, COSMETIC BODY CARE SERVICES (U.S. CLS. 100 AND 101).

FIRST USE 7-14-2008; IN COMMERCE 7-14-2008.  
TINA BROWN, EXAMINING ATTORNEY

---

SN 85-191,021. HOME HEALTHCARE PARTNERS, DALLAS,  
TX. FILED 12-6-2010.

## VitalSteps

THE MARK CONSISTS OF STANDARD CHARACTERS WITHOUT CLAIM TO ANY PARTICULAR FONT, STYLE, SIZE, OR COLOR.

FOR PROVIDING A FOLLOW-UP HEALTHCARE MEDICAL PROGRAM TO SUPPORT PATIENT HEALTH AND SAFETY DURING THE CRITICAL TRANSITION PERIOD IMMEDIATELY FOLLOWING DISCHARGE FROM TELEHEALTH SERVICES AND IN CONNECTION WITH THE AFOREMENTIONED, MEDICAL HEALTHCARE INTERVENTIONS WILL BE DEPLOYED IN THE EVENT THAT DECLINE OR HIGH RISK FACTORS ARE IDENTIFIED (U.S. CLS. 100 AND 101).

JENNIFER VASQUEZ, EXAMINING ATTORNEY

---

SN 85-191,035. DAVID M. MILLS, MD, FACS, P.A., GULF  
BREEZE, FL. FILED 12-6-2010.



NO CLAIM IS MADE TO THE EXCLUSIVE RIGHT TO USE "FLORIDA SURGICAL ARTS", APART FROM THE MARK AS SHOWN.

THE MARK CONSISTS OF THE LETTERS "FSA" ON A TOP LINE, WITH THE WORDS "FLORIDA SURGICAL ARTS" ON A SECOND LINE. THE LETTER "F" HAS A DEPICTION OF A WOMAN'S FACE WITHIN THE LETTER, AND A DEPICTION OF A SCALPEL MERGED WITH A PAINT BRUSH IS SHOWN WITHIN THE LETTERS "S" AND "A".

FOR COSMETIC AND PLASTIC SURGERY (U.S. CLS. 100 AND 101).

FIRST USE 9-1-2010; IN COMMERCE 10-1-2010.  
LIEF MARTIN, EXAMINING ATTORNEY

**CLASS 44—(Continued).**

SN 85-191,889. HOME HEALTHCARE PARTNERS, DALLAS,  
TX. FILED 12-7-2010.

## CareCycle Solutions

THE MARK CONSISTS OF STANDARD CHARACTERS WITHOUT CLAIM TO ANY PARTICULAR FONT, STYLE, SIZE, OR COLOR.

NO CLAIM IS MADE TO THE EXCLUSIVE RIGHT TO USE "SOLUTIONS", APART FROM THE MARK AS SHOWN.

FOR INTEGRATED HEALTHCARE SERVICES THAT FOCUS ON MANAGING GEOGRAPHICALLY DISBURSED PATIENTS FROM A CENTRAL LOCATION, WITH INDIVIDUALIZED PLANS OF CARE FOR THEIR MEDICAL CONDITIONS AND WHILE MEASURING RISK-ADJUSTED OUTCOMES AND COSTS (U.S. CLS. 100 AND 101).

JENNIFER VASQUEZ, EXAMINING ATTORNEY

---

SN 85-193,439. MESSAGE ESCAPES, INC., PHOENIX, AZ.  
FILED 12-8-2010.

## MESSAGE ESCAPES

THE MARK CONSISTS OF STANDARD CHARACTERS WITHOUT CLAIM TO ANY PARTICULAR FONT, STYLE, SIZE, OR COLOR.

NO CLAIM IS MADE TO THE EXCLUSIVE RIGHT TO USE "MESSAGE", APART FROM THE MARK AS SHOWN.

FOR HEALTH SPA SERVICES, NAMELY, BODY WRAPS, MUD TREATMENTS, SEAWEED TREATMENTS, HYDROTHERAPY BATHS, AND BODY SCRUBS; MASSAGE THERAPY SERVICES; MASSAGES (U.S. CLS. 100 AND 101).

TINA BROWN, EXAMINING ATTORNEY

**CLASS 44—(Continued).**

SN 85-200,091. PHARMAVITE LLC, MISSION HILLS, CA. FILED 12-16-2010.

NATURE MADE, SAFELY MADE,  
PURELY MADE

THE MARK CONSISTS OF STANDARD CHARACTERS WITHOUT CLAIM TO ANY PARTICULAR FONT, STYLE, SIZE, OR COLOR.

OWNER OF U.S. REG. NOS. 1,963,505, 2,592,200 AND OTHERS.

FOR DIETARY AND NUTRITIONAL GUIDANCE; PROVIDING HEALTHY LIFESTYLE AND NUTRITION SERVICES, NAMELY, PERSONAL ASSESSMENTS AND COUNSELING; PROVIDING INFORMATION AND ADVICE ABOUT VITAMINS, MINERALS AND DIETARY SUPPLEMENTS; PROVIDING ASSISTANCE, NUTRITIONAL FITNESS EVALUATION, AND CONSULTATION TO INDIVIDUALS TO HELP THEM MAKE HEALTH, WELLNESS, AND NUTRITIONAL CHANGES TO THEIR DAILY LIVING TO IMPROVE THEIR HEALTH; PROVIDING A WEBSITE FEATURING INFORMATION AND ADVICE IN THE FIELDS OF DIETARY SUPPLEMENTS, NUTRITION, HEALTH, AND LIFESTYLE WELLNESS; DIETARY SUPPLEMENT, WELLNESS, NUTRITION, AND HEALTH-RELATED CONSULTATION SERVICES (U.S. CLS. 100 AND 101).

JESSICA FATHY, EXAMINING ATTORNEY

**CLASS 44—(Continued).**

SN 85-203,601. PREMIER, INC., CHARLOTTE, NC. FILED 12-22-2010.



THE COLOR(S) RED, LIGHT GREEN, DARK GREEN, YELLOW AND WHITE IS/ARE CLAIMED AS A FEATURE OF THE MARK.

THE MARK CONSISTS OF A STYLIZED RED APPLE WITH A GREEN LEAF IN A YELLOW BACKGROUND WITHIN A DARK GREEN CIRCULAR SEAL DESIGN WITH A LIGHT GREEN BORDER WITH THE WORDING "CHOICE 365" IN LIGHT GREEN LETTERING AND THE WORDING "CHOOSE HEALTHY OPTIONS IN CONSUMPTION EVERYDAY" IN WHITE LETTERING APPEARING IN THE RIM OF THE CIRCLE.

FOR WELLNESS PROGRAMS, NAMELY, PROVIDING INFORMATION AND COUNSELING ON NUTRITION, FITNESS AND HEALTHY LIVING (U.S. CLS. 100 AND 101).

KATHERINE STOIDES, EXAMINING ATTORNEY

SN 85-202,966. KELLEY AND KELLEY, INC., WESTBOROUGH, MA. FILED 12-21-2010.



NO CLAIM IS MADE TO THE EXCLUSIVE RIGHT TO USE "LAWN AERATION", APART FROM THE MARK AS SHOWN.

THE MARK CONSISTS OF A RECTANGULAR BOX WITH THE STYLIZED TEXT "LAWN AERATION PLUS".

FOR LAWN CARE (U.S. CLS. 100 AND 101).  
FIRST USE 7-11-2004; IN COMMERCE 7-11-2004.  
LAKEISHA LEWIS, EXAMINING ATTORNEY

SN 85-203,707. LIPMAN, KEITH, PHOENIX, AZ. FILED 12-22-2010.



NO CLAIM IS MADE TO THE EXCLUSIVE RIGHT TO USE "TAN", APART FROM THE MARK AS SHOWN.

THE MARK CONSISTS OF A SQUARE WITH THE STYLIZED TEXT "TAN UNITED".

FOR TANNING SALONS (U.S. CLS. 100 AND 101).  
GEOFFREY FOSDICK, EXAMINING ATTORNEY

**CLASS 44—(Continued).**

SN 85-203,950. BYRD, JEFFREY, LAS VEGAS, NV. FILED 12-22-2010.

## Adobe Massage Therapy

THE MARK CONSISTS OF STANDARD CHARACTERS WITHOUT CLAIM TO ANY PARTICULAR FONT, STYLE, SIZE, OR COLOR.

NO CLAIM IS MADE TO THE EXCLUSIVE RIGHT TO USE "MASSAGE THERAPY", APART FROM THE MARK AS SHOWN.

FOR MASSAGE THERAPY SERVICES (U.S. CLS. 100 AND 101).

HENRY S. ZAK, EXAMINING ATTORNEY

SN 85-205,368. THE MAKEUP LAB ARTISTRY, NEW ORLEANS, LA. FILED 12-23-2010.

## The Makeup Lab

THE MARK CONSISTS OF STANDARD CHARACTERS WITHOUT CLAIM TO ANY PARTICULAR FONT, STYLE, SIZE, OR COLOR.

NO CLAIM IS MADE TO THE EXCLUSIVE RIGHT TO USE "MAKEUP", APART FROM THE MARK AS SHOWN.

FOR APPLICATION SERVICES IN THE FIELD OF MAKEUP, NAMELY, IN PERSON MAKEUP CONSULTATION AND MAKEUP APPLICATION; ONLINE MAKEUP CONSULTATION SERVICES; ON-LOCATION MAKEUP APPLICATION SERVICES FOR WEDDINGS, PHOTO SHOOTS, FASHION, SPECIAL EFFECTS, BODY PAINTING, TELEVISION, FILM, AND THEATER (U.S. CLS. 100 AND 101).

ELIZABETH KAJUBI, EXAMINING ATTORNEY

**CLASS 44—(Continued).**

SN 85-205,805. SAITES, JOHN, BURTON, MI. FILED 12-27-2010.



NO CLAIM IS MADE TO THE EXCLUSIVE RIGHT TO USE "FASHION" AND "SALON", APART FROM THE MARK AS SHOWN.

THE MARK CONSISTS OF "P IV F" WITHIN A SQUARE BOX ALONG THE LEFT SIDE OF THE LOGO, THE WORDS "PASSION FOR FASHION SALON EDITION" UNDER THE SQUARE; A FEMALE FACE WITH A FLOWER IN FLOWING HAIR AND CIRCLES COMING OFF OF THE HAIR, ALL ALONG THE RIGHT SIDE OF THE SQUARE.

FOR HAIR SALON SERVICES; HAIR CUTTING SERVICES; HAIR STYLING; HAIR COLOR SALON SERVICES; HAIR EXTENSION SERVICES; MANICURE AND PEDICURE SERVICES; NAIL CARE SALONS; PERSONAL HAIR REMOVAL SERVICES; MAKE-UP APPLICATION SERVICES (U.S. CLS. 100 AND 101).

DOMINICK J. SALEMI, EXAMINING ATTORNEY

SN 85-205,996. GLOBAL INFECTION CONTROL CONSULTANTS LLC, BLUFFTON, SC. FILED 12-27-2010.

## The M3 System

THE MARK CONSISTS OF STANDARD CHARACTERS WITHOUT CLAIM TO ANY PARTICULAR FONT, STYLE, SIZE, OR COLOR.

NO CLAIM IS MADE TO THE EXCLUSIVE RIGHT TO USE "SYSTEM", APART FROM THE MARK AS SHOWN.

FOR MEDICAL CONSULTING SERVICES IN THE FIELD OF DISEASE INFECTION CONTROL (U.S. CLS. 100 AND 101).

BERYL GARDNER, EXAMINING ATTORNEY

**CLASS 44—(Continued).**

SN 85-206,112. DAVIS, EDWARD, SAUSALITO, CA. FILED 12-27-2010.

## Performance Psychiatry

THE MARK CONSISTS OF STANDARD CHARACTERS WITHOUT CLAIM TO ANY PARTICULAR FONT, STYLE, SIZE, OR COLOR.

NO CLAIM IS MADE TO THE EXCLUSIVE RIGHT TO USE "PSYCHIATRY", APART FROM THE MARK AS SHOWN.

FOR PSYCHIATRIC SERVICES (U.S. CLS. 100 AND 101).

FIRST USE 8-2-2003; IN COMMERCE 8-2-2003.  
SANJEEV VOHRA, EXAMINING ATTORNEY

---

SN 85-206,801. NO WORRIES CORPORATION, BEAVER-TON, OR. FILED 12-28-2010.

## NO WORRIES

THE MARK CONSISTS OF STANDARD CHARACTERS WITHOUT CLAIM TO ANY PARTICULAR FONT, STYLE, SIZE, OR COLOR.

FOR PRIVATE NURSING SERVICES, NAMELY, GERIATRIC, POST-SURGICAL, AT-HOME AND AWAY FROM HOME NURSING; CONSULTATION IN THE FIELD OF NURSING AND HOME HEALTH CARE (U.S. CLS. 100 AND 101).

FIRST USE 9-17-1996; IN COMMERCE 9-17-1996.  
JENNIFER DIXON, EXAMINING ATTORNEY

---

SN 85-206,942. ULTRATAN, INC., GREENVILLE, SC. FILED 12-29-2010.

## ULTRASKIN WAX CENTER

THE MARK CONSISTS OF STANDARD CHARACTERS WITHOUT CLAIM TO ANY PARTICULAR FONT, STYLE, SIZE, OR COLOR.

NO CLAIM IS MADE TO THE EXCLUSIVE RIGHT TO USE "WAX CENTER", APART FROM THE MARK AS SHOWN.

FOR BODY WAXING SERVICES; COSMETIC SKIN CARE SERVICES; MASSAGES (U.S. CLS. 100 AND 101).  
FIRST USE 12-10-2010; IN COMMERCE 12-10-2010.

JOHN SCHUYLER YARD, EXAMINING ATTORNEY

**CLASS 44—(Continued).**

SN 85-207,172. EAST TENNESSEE MEDICAL GROUP, P.C., ALCOA, TN. FILED 12-29-2010.

## ETMG CENTER FOR SLEEP MEDICINE

THE MARK CONSISTS OF STANDARD CHARACTERS WITHOUT CLAIM TO ANY PARTICULAR FONT, STYLE, SIZE, OR COLOR.

NO CLAIM IS MADE TO THE EXCLUSIVE RIGHT TO USE "CENTER FOR SLEEP MEDICINE", APART FROM THE MARK AS SHOWN.

FOR MEDICAL SERVICES RELATING TO THE TREATMENT OF SLEEP DISORDERS AND OTHER SLEEP RELATED CONDITIONS (U.S. CLS. 100 AND 101).

FIRST USE 7-1-2006; IN COMMERCE 7-1-2006.  
ROBIN CHOSID, EXAMINING ATTORNEY

---

SN 85-208,187. DEPARTMENT OF VETERANS AFFAIRS, WASHINGTON, DC. FILED 12-30-2010.



THE MARK CONSISTS OF A BUTTON DESIGN WITH AN ARROW POINTING DOWN TO AN OPEN RECTANGLE REPRESENTING A COMPUTER.

FOR PROVIDING INFORMATION IN THE FIELD OF HEALTH; PROVIDING INFORMATION IN THE FIELD OF MEDICINE (U.S. CLS. 100 AND 101).

FIRST USE 8-31-2010; IN COMMERCE 8-31-2010.  
HOWARD B. LEVINE, EXAMINING ATTORNEY



**CLASS 44—(Continued).**

SN 85-208,230. DEPARTMENT OF VETERANS AFFAIRS, WASHINGTON, DC. FILED 12-30-2010.



**Blue Button  
Download  
My Data**

THE MARK CONSISTS OF THE WORDING "BLUE BUTTON DOWNLOAD MY DATA" AND A BUTTON WITH AN ARROW POINTING DOWN INTO AN OPEN RECTANGLE REPRESENTING A COMPUTER.

FOR PROVIDING INFORMATION IN THE FIELD OF HEALTH; PROVIDING INFORMATION IN THE FIELD OF MEDICINE (U.S. CLS. 100 AND 101).

FIRST USE 8-31-2010; IN COMMERCE 8-31-2010.  
HOWARD B. LEVINE, EXAMINING ATTORNEY

SN 85-209,098. GREEN AND SOLAR MICROCITIES, LLC, NEW YORK, NY. FILED 1-3-2011.

## Green and Solar Microcities

THE MARK CONSISTS OF STANDARD CHARACTERS WITHOUT CLAIM TO ANY PARTICULAR FONT, STYLE, SIZE, OR COLOR.

NO CLAIM IS MADE TO THE EXCLUSIVE RIGHT TO USE "GREEN AND SOLAR", APART FROM THE MARK AS SHOWN.

FOR AGRICULTURAL SERVICES, NAMELY, PLANTING, GROWING, FERTILIZING, PRUNING AND PICKING CORN AND SOYBEANS FOR OTHERS; AQUACULTURE SERVICES, NAMELY, THE CULTIVATION AND BREEDING OF PLANTS OR ANIMALS IN A WATER ENVIRONMENT; CONTRACT FARMING FOR OTHERS (U.S. CLS. 100 AND 101).

FIRST USE 9-7-2010; IN COMMERCE 9-7-2010.  
CAROL SPILS, EXAMINING ATTORNEY

SN 85-210,103. LASER BELLA OF AMERICA, LLC, FORMERLY LP COSMETIC OF AMERICA, LLC, PITTSBURGH, PA. FILED 1-4-2011.

## LASER BELLA

THE MARK CONSISTS OF STANDARD CHARACTERS WITHOUT CLAIM TO ANY PARTICULAR FONT, STYLE, SIZE, OR COLOR.

NO CLAIM IS MADE TO THE EXCLUSIVE RIGHT TO USE "LASER", APART FROM THE MARK AS SHOWN.

THE TERM "BELLA" TRANSLATES INTO ENGLISH AS "BEAUTIFUL".

FOR SKIN CARE SERVICES, COSMETIC PROCEDURES, LASER HAIR REMOVAL, MEDICAL SERVICES, LASER LIPOSUCTION PROCEDURES, LIPOSUCTION PROCEDURES (U.S. CLS. 100 AND 101).

PAUL F. GAST, EXAMINING ATTORNEY

**CLASS 44—(Continued).**

SN 85-210,436. KUBERIET, ASHLEY M, SPRINGFIELD, NJ, AND MCAVOY, KRISTEN, SPRINGFIELD, NJ. FILED 1-4-2011.

## Pin It Up

THE MARK CONSISTS OF STANDARD CHARACTERS WITHOUT CLAIM TO ANY PARTICULAR FONT, STYLE, SIZE, OR COLOR.

FOR BEAUTY SALON SERVICES; HEALTH SPA SERVICES FOR HEALTH AND WELLNESS OF THE BODY AND SPIRIT, NAMELY, PROVIDING MASSAGE, FACIAL AND BODY TREATMENT SERVICES, COSMETIC BODY CARE SERVICES; PROVIDING ON-SITE BEAUTY SERVICES, NAMELY, HAIR STYLING AND MAKE-UP APPLICATION SERVICES (U.S. CLS. 100 AND 101).

SANDRA BUJA, EXAMINING ATTORNEY

SN 85-210,710. WILLIS N. BROWN, JR., DUBLIN, OH. FILED 1-5-2011.

## "C"ing is Believing

THE MARK CONSISTS OF STANDARD CHARACTERS WITHOUT CLAIM TO ANY PARTICULAR FONT, STYLE, SIZE, OR COLOR.

FOR OPTICAL SERVICES, NAMELY, OPTOMETRY AND OPTICIAN SERVICES (U.S. CLS. 100 AND 101).

FIRST USE 12-1-2010; IN COMMERCE 12-1-2010.

REBECCA POVARCHUK, EXAMINING ATTORNEY

SN 85-210,957. SERENITY WAX, LLC, LAS VEGAS, NV. FILED 1-5-2011.

## MODERN BODY WAX

THE MARK CONSISTS OF STANDARD CHARACTERS WITHOUT CLAIM TO ANY PARTICULAR FONT, STYLE, SIZE, OR COLOR.

NO CLAIM IS MADE TO THE EXCLUSIVE RIGHT TO USE "BODY WAX", APART FROM THE MARK AS SHOWN.

FOR BODY WAXING SERVICES; BODY WAXING SERVICES FOR HAIR REMOVAL IN HUMANS; BODY WAXING SERVICES FOR THE HUMAN BODY (U.S. CLS. 100 AND 101).

FIRST USE 12-1-2010; IN COMMERCE 12-1-2010.

SANI KHOURI, EXAMINING ATTORNEY

**CLASS 44—(Continued).**

SN 85-212,386. ROCCO, JACK, ALTOONA, PA. FILED 1-6-2011.



THE MARK CONSISTS OF THE TEXT "OPERATION SMALL STEPS" WRITTEN IN A WAVE-LIKE FORMAT WITH INFANT FOOTPRINTS FLANKING EACH SIDE (TOP AND BOTTOM) OF THE TEXT DESIGN.

FOR CHARITABLE SERVICES, NAMELY, PROVIDING MEDICAL SERVICES IN AREAS OF NEED WHERE ACCESS TO SUCH SERVICES IS LIMITED OR UNAVAILABLE (U.S. CLS. 100 AND 101).

LAKEISHA LEWIS, EXAMINING ATTORNEY

**CLASS 44—(Continued).**

SN 85-213,371. LIGHTHOUSE NUTRITION AND WELLNESS, GIG HARBOR, WA. FILED 1-7-2011.



NO CLAIM IS MADE TO THE EXCLUSIVE RIGHT TO USE "WEIGHT LOSS", APART FROM THE MARK AS SHOWN.

THE COLOR(S) RED, GREEN, WHITE, VARIOUS SHADES OF YELLOW, VARIOUS SHADES OF BLUE, AND BLACK IS/ARE CLAIMED AS A FEATURE OF THE MARK.

THE MARK CONSISTS OF THE LITERAL ELEMENT "SEE THE LITE! AMAZING WEIGHT LOSS FOR LIFE", AND A DESIGN CONSISTING OF A GRAPHIC REPRESENTATION OF A FLAME IN THE COLOR YELLOW WITH THE COLOR BLUE IN THE MIDDLE BOTTOM OF THE FLAME AND WHERE THE BLUE AND THE YELLOW COLORS BOTH GRADUALLY FADE TO THE COLOR WHITE AT THEIR UPPER PORTIONS, WITH TWO GREEN LEAVES JUST BELOW THE ENTIRE FLAME, AND A RED APPLE WITH A BLACK STEM TILTED TO THE LEFT, EMBEDDED WITHIN THE BOTTOM PART OF THE INSIDE OF THE FLAME AND THE ENTIRE FLAME DESIGN AND ALL DESIGN FEATURES THEREIN ARE ALSO OUTLINED IN THE COLOR BLACK, AND WHEREIN FIVE SMALL STREAKS OF LIGHT REPRESENTED IN TEARDROP SHAPE IN THE COLOR YELLOW AND OUTLINED IN BLACK APPEAR TO EMANATE FROM AND SURROUND THE TOP OF THE FLAME, WHEREIN THE WORDS "SEE THE LITE!" ARE REPRESENTED IN A STYLIZED FONT WITH THE WORD "SEE" LOCATED ABOVE THE WORD "THE" WHICH IS LOCATED ABOVE THE WORD "LITE!" AND WHEREIN FURTHER THE WORDS "SEE THE LITE!" ARE REPRESENTED IN STYLIZED FONT AND LOCATED TO THE RIGHT OF THE FLAME DESIGN, AND WHEREIN THE WORDS "AMAZING WEIGHT LOSS FOR LIFE" ARE REPRESENTED IN UPPER AND LOWERCASE BLOCK LETTERING AND ARE LOCATED HORIZONTALLY UNDER THE FLAME DESIGN, THE LITERAL ELEMENT APPEARING IN THE COLOR BLACK.

FOR PROVIDING WEIGHT LOSS PROGRAM SERVICES (U.S. CLS. 100 AND 101).

FIRST USE 1-7-2010; IN COMMERCE 1-7-2010.

RONALD DELGIZZI, EXAMINING ATTORNEY

SN 85-213,148. INTRINSIC MEDICAL IMAGING LLC, HOWELL, MI. FILED 1-7-2011.

**INTRINSIC**

THE MARK CONSISTS OF STANDARD CHARACTERS WITHOUT CLAIM TO ANY PARTICULAR FONT, STYLE, SIZE, OR COLOR.

FOR MEDICAL IMAGING SERVICES (U.S. CLS. 100 AND 101).

THEODORE MCBRIDE, EXAMINING ATTORNEY

**CLASS 44—(Continued).**

SN 85-213,771. THINSITE, LLC, MANHASSET, NY. FILED 1-10-2011.

**THIN-ALYSIS**

THE MARK CONSISTS OF STANDARD CHARACTERS WITHOUT CLAIM TO ANY PARTICULAR FONT, STYLE, SIZE, OR COLOR.

FOR PROVIDING INFORMATION ON MAINTAINING A HEALTHY LIFESTYLE AND LOSING WEIGHT; PROVIDING WEIGHT LOSS PROGRAM SERVICES; WEIGHT MANAGEMENT SERVICES, NAMELY, PROVIDING WEIGHT LOSS AND/OR WEIGHT MAINTENANCE PROGRAMS; WEIGHT REDUCTION DIET PLANNING AND SUPERVISION (U.S. CLS. 100 AND 101).

FIRST USE 2-1-2009; IN COMMERCE 2-1-2009.  
LANA PHAM, EXAMINING ATTORNEY

**CLASS 44—(Continued).**

SN 85-237,619. VITAMIN SHOPPE INDUSTRIES INC., NORTH BERGEN, NJ. FILED 2-9-2011.

**AMAZING WELLNESS**

THE MARK CONSISTS OF STANDARD CHARACTERS WITHOUT CLAIM TO ANY PARTICULAR FONT, STYLE, SIZE, OR COLOR.

OWNER OF U.S. REG. NO. 3,935,082.

NO CLAIM IS MADE TO THE EXCLUSIVE RIGHT TO USE "WELLNESS", APART FROM THE MARK AS SHOWN.

FOR PROVIDING A WEB SITE FEATURING INFORMATION ON HEALTH, NUTRITION, DIETARY AND NUTRITIONAL GUIDANCE; WEIGHT REDUCTION AND DIET PLANNING (U.S. CLS. 100 AND 101).

ALEXANDER L. POWERS, EXAMINING ATTORNEY

SN 85-214,329. THE GENERAL HOSPITAL CORPORATION, BOSTON, MA. FILED 1-10-2011.

**CRIMSON CARE COLLABORATIVE**

THE MARK CONSISTS OF STANDARD CHARACTERS WITHOUT CLAIM TO ANY PARTICULAR FONT, STYLE, SIZE, OR COLOR.

NO CLAIM IS MADE TO THE EXCLUSIVE RIGHT TO USE "CARE COLLABORATIVE", APART FROM THE MARK AS SHOWN.

FOR HEALTH CARE SERVICES RENDERED TO PATIENTS WHO DO NOT HAVE PRIMARY CARE PHYSICIANS, IN THE CONTEXT OF A PROGRAM WHEREBY MEDICAL STUDENTS TAKE PART IN THE PROVISION OF SUCH SERVICES; PROVIDING COUNSELING AND INFORMATION TO PATIENTS IN THE FIELD OF HEALTH CARE FOR THE PURPOSE OF FACILITATING SUBSEQUENT LONG-TERM PRIMARY CARE BY OTHERS (U.S. CLS. 100 AND 101).

FIRST USE 3-1-2010; IN COMMERCE 3-1-2010.  
THOMAS MANOR, EXAMINING ATTORNEY

**CLASS 45—PERSONAL AND LEGAL SERVICES**

SN 76-703,992. ARTHUR H. STROCK, BELVIDERE, NJ. FILED 8-2-2010.



THE MARK CONSISTS OF THE WORDING "LIVE BY YOUR DREAMS" WITH A DESIGN OF A CRESCENT MOON. THE LETTER "L" APPEARS LARGELY ON THE LEFT SIDE OF THE WORDING WITH "LIVE" APPEARING ABOVE "BY YOUR" WHICH IS ABOVE "DREAMS". THERE IS A HORIZONTAL LINE UNDER THE WORDING.

FOR PROVIDING A WEBSITE THAT FEATURES DREAM POSTINGS AND DREAM INTERPRETATIONS BY WEBSITE VISITORS (U.S. CLS. 100 AND 101).

FIRST USE 9-2-2009; IN COMMERCE 5-6-2010.  
KATHERINE CONNOLLY, EXAMINING ATTORNEY

**CLASS 45—(Continued).**

SN 77-870,521. CHECKING IN DAILY MONITORING SERVICE., PARADISE, CA. FILED 11-11-2009.



THE MARK CONSISTS OF THE DESIGN OF A CHECK MARK.

FOR MONITORING EMAILS FROM SUBSCRIBERS AND NOTIFYING SUBSCRIBER-SELECTED RESPONDERS IN EMERGENCY SITUATIONS WHERE SUBSCRIBERS' HEALTH OR WELFARE IS AT RISK (U.S. CLS. 100 AND 101).

KAELIE KUNG, EXAMINING ATTORNEY

SN 85-038,584. FARSEDAKIS HOLDINGS, LLC, BOCA RATON, FL. FILED 5-14-2010.



NO CLAIM IS MADE TO THE EXCLUSIVE RIGHT TO USE "ID RATING", APART FROM THE MARK AS SHOWN. THE MARK CONSISTS OF A STYLIZED TAG TO THE LEFT OF THE WORDS "ID RATING".

FOR ONLINE IDENTITY RELIABILITY SERVICES TO CONFIRM A PERSON'S OR A COMPANY'S IDENTITY ON THE INTERNET (U.S. CLS. 100 AND 101).

NAKIA HENRY, EXAMINING ATTORNEY

SN 85-043,939. RIFAT, TURAN, EAST SUSSEX, BN2 9NL, UNITED KINGDOM, FILED 5-20-2010.

**BONE GENERATORS**

THE MARK CONSISTS OF STANDARD CHARACTERS WITHOUT CLAIM TO ANY PARTICULAR FONT, STYLE, SIZE, OR COLOR.

OWNER OF UNITED KINGDOM REG. NO. 2461785, DATED 12-21-2007, EXPIRES 7-13-2017.

FOR PSYCHIC CONSULTANCY (U.S. CLS. 100 AND 101).

KAREN SEVERSON, EXAMINING ATTORNEY

**CLASS 45—(Continued).**

SN 85-046,865. ARAUJO, JESSICA, SPANISH FORT, AL. FILED 5-25-2010.



NO CLAIM IS MADE TO THE EXCLUSIVE RIGHT TO USE ".COM", APART FROM THE MARK AS SHOWN.

THE MARK CONSISTS OF A DESIGN OF TWO INTERLOCKING SPEECH BUBBLES WHICH DOUBLE AS MALE AND FEMALE GENDER SYMBOLS. TO THE RIGHT OF THE DESIGN IS THE WORDING "DATEBOOKFINDER-.COM" IN STYLIZED FONT, WITH THE ELEMENT ".COM" PLACED VERTICALLY.

FOR COMPUTER DATING SERVICES; DATING SERVICES; DATING SERVICES, NAMELY, PROVIDING AN ON-LINE COMPUTER DATABASE FEATURING SINGLE PEOPLE INTERESTED IN MEETING OTHER SINGLE PEOPLE; INTERNET BASED SOCIAL NETWORKING, INTRODUCTION, AND DATING SERVICES; INTERNET-BASED DATING, SOCIAL INTRODUCTION AND SOCIAL NETWORKING SERVICES (U.S. CLS. 100 AND 101).

FIRST USE 4-0-2010; IN COMMERCE 4-0-2010.

STEVEN PEREZ, EXAMINING ATTORNEY

SN 85-050,410. AMICUS LAW GROUP, PC, SEATTLE, WA. FILED 5-28-2010.

**AMICUS LAW GROUP, PC**

THE MARK CONSISTS OF STANDARD CHARACTERS WITHOUT CLAIM TO ANY PARTICULAR FONT, STYLE, SIZE, OR COLOR.

NO CLAIM IS MADE TO THE EXCLUSIVE RIGHT TO USE "LAW GROUP, PC", APART FROM THE MARK AS SHOWN.

THE ENGLISH TRANSLATION OF "AMICUS" IN THE MARK IS "FRIEND".

FOR PROVISION OF LEGAL SERVICES AND ADVICE BY A LAW FIRM (U.S. CLS. 100 AND 101).

FIRST USE 10-1-2001; IN COMMERCE 10-1-2001.

MARIA-VICTORIA SUAREZ, EXAMINING ATTORNEY

**CLASS 45—(Continued).**

SN 85-066,907. BARRY KURTZ, A PROFESSIONAL CORPORATION, ENCINO, CA 91436, CA. FILED 6-18-2010.



Law Offices of  
**BARRY KURTZ**  
 A Professional Corporation  
*Franchise Law First and Foremost*

OWNER OF U.S. REG. NO. 3,708,565.  
 NO CLAIM IS MADE TO THE EXCLUSIVE RIGHT TO USE "LAW OFFICES", "A PROFESSIONAL CORPORATION", AND "FRANCHISE LAW", APART FROM THE MARK AS SHOWN.

THE NAME(S), PORTRAIT(S), AND/OR SIGNATURE(S) SHOWN IN THE MARK IDENTIFIES "BARRY KURTZ", WHOSE CONSENT(S) TO REGISTER IS MADE OF RECORD.

THE MARK CONSISTS OF OUTLINE OF THE STYLIZED LETTER "B" ATTACHED TO A FILLED IN STYLIZED LETTER "K", ABOVE THE WORDS "LAW OFFICES OF", ABOVE THE WORDS "BARRY KURTZ", ABOVE THE WORDS "A PROFESSIONAL CORPORATION" WITH A LINE UNDERNEATH AND THE ITALICIZED WORDS "FRANCHISE LAW FIRST AND FOREMOST" UNDERNEATH THE LINE.

FOR LEGAL SERVICES (U.S. CLS. 100 AND 101).  
 FIRST USE 3-1-2009; IN COMMERCE 3-1-2009.  
 JAMES STEIN, EXAMINING ATTORNEY

**CLASS 45—(Continued).**

SN 85-093,104. SAFEHOME, INC., OVERLAND PARK, KS. FILED 7-26-2010.



NO CLAIM IS MADE TO THE EXCLUSIVE RIGHT TO USE "SUPPORT FOR SURVIVORS OF DOMESTIC VIOLENCE", APART FROM THE MARK AS SHOWN.

THE MARK CONSISTS OF THE WORDING "SAFEHOME" APPEARING WITHIN TWO HORIZONTAL LINES WITH DESIGN ELEMENTS TRANSFORMING FROM A HEART TO A BUTTERFLY APPEARING ON TOP OF THE WORDING. DIRECTLY BELOW IS THE WORDING "SUPPORT FOR SURVIVORS OF DOMESTIC VIOLENCE".

SEC. 2(F) AS TO "SAFEHOME".

FOR SUPPORT SERVICES FOR SURVIVORS OF DOMESTIC VIOLENCE IN THE NATURE OF TWENTY-FOUR-HOUR CRISES HOTLINE SERVICES, NAMELY, PROVIDING COUNSELING, INTERVIEWING THE VICTIM, IDENTIFYING THE PROBLEM AND SUGGESTING WHERE HELP CAN BE OBTAINED TO THE VICTIMS OF DOMESTIC VIOLENCE (U.S. CLS. 100 AND 101).

FIRST USE 1-1-1997; IN COMMERCE 1-1-1997.

NAAKWAMA ANKRAH, EXAMINING ATTORNEY

SN 85-103,859. MATTEL, INC., EL SEGUNDO, CA. FILED 8-10-2010.

**HOT WHEELS**

THE MARK CONSISTS OF STANDARD CHARACTERS WITHOUT CLAIM TO ANY PARTICULAR FONT, STYLE, SIZE, OR COLOR.

OWNER OF U.S. REG. NOS. 3,192,156, 3,600,236 AND OTHERS.

FOR ONLINE SOCIAL NETWORKING SERVICES PROVIDED THROUGH A TOY WEBSITE (U.S. CLS. 100 AND 101).

VIVIAN MICZNIK FIRST, EXAMINING ATTORNEY



**CLASS 45—(Continued).**

SN 85-110,646. METROPOLITAN ORGANIZING, LLC, CARY, NC. FILED 8-18-2010.

**MANAGING MODERN LIFE**

THE MARK CONSISTS OF STANDARD CHARACTERS WITHOUT CLAIM TO ANY PARTICULAR FONT, STYLE, SIZE, OR COLOR.

FOR PROVIDING INFORMATION IN THE FIELD OF TIME MANAGEMENT TO INDIVIDUALS FOR PERSONAL PURPOSES IN THE NATURE OF PAPER MANAGEMENT, CLUTTER MANAGEMENT, AND GENERAL ARRANGING AND ORGANIZING OF BELONGINGS FOR HOMES (U.S. CLS. 100 AND 101).

FIRST USE 6-1-2007; IN COMMERCE 6-1-2007.

ROBERT L. LORENZO, EXAMINING ATTORNEY

SN 85-116,544. JBZ&A, INC., WILLMINGTON, DE. FILED 8-26-2010.

**INSPERITY INSPIRING  
BUSINESS PERFORMANCE**

THE MARK CONSISTS OF STANDARD CHARACTERS WITHOUT CLAIM TO ANY PARTICULAR FONT, STYLE, SIZE, OR COLOR.

FOR CURRENT EMPLOYEE AND PRE-EMPLOYMENT BACKGROUND SCREENING FOR OTHERS; PROVIDING INFORMATION IN THE FIELD OF WORKPLACE SAFETY REQUIREMENTS; PROVIDING INFORMATION AND CONSULTING SERVICES DIRECTLY AND VIA THE INTERNET REGARDING GOVERNMENT REGULATORY AND REPORTING REQUIREMENTS FOR EMPLOYMENT; EMPLOYMENT VERIFICATION SERVICES, NAMELY, PROVIDING A SERVICE TO EMPLOYERS TO VERIFY AN EMPLOYEE'S RIGHT TO WORK STATUS IN THE UNITED STATES, AND PROVISION OF REPORTS RELATING TO SAME (U.S. CLS. 100 AND 101).

JENNIFER DIXON, EXAMINING ATTORNEY

SN 85-118,882. THE NAVIGATORS, COLORADO SPRINGS, CO. FILED 8-30-2010.



OWNER OF U.S. REG. NOS. 1,168,719, 2,937,757 AND OTHERS.

THE MARK CONSISTS OF THE WORD "THE" FOLLOWED BY A SINGLE SAIL DESIGN CONTAINED INSIDE A SOLID CIRCLE FOLLOWED BY THE WORD "NAVIGATORS".

FOR EVANGELISTIC MINISTERIAL SERVICES, NAMELY, PROMOTING THE CHRISTIAN RELIGION (U.S. CLS. 100 AND 101).

FIRST USE 9-1-2001; IN COMMERCE 1-1-2003.

THOMAS MANOR, EXAMINING ATTORNEY

**CLASS 45—(Continued).**

SN 85-131,269. SINGLETON, RICKEY, BURNHAM, IL. FILED 9-16-2010.

**Supernatural Empowerment**

THE MARK CONSISTS OF STANDARD CHARACTERS WITHOUT CLAIM TO ANY PARTICULAR FONT, STYLE, SIZE, OR COLOR.

NO CLAIM IS MADE TO THE EXCLUSIVE RIGHT TO USE "SUPERNATURAL", APART FROM THE MARK AS SHOWN.

SEC. 2(F).

FOR MINISTERIAL SERVICES FEATURING TOPICS IN THE FIELDS OF PERSONAL MOTIVATION AND INSPIRATION (U.S. CLS. 100 AND 101).

FIRST USE 1-2-2000; IN COMMERCE 1-2-2000.

LINDA M. KING, EXAMINING ATTORNEY

SN 85-137,155. MATCHSIGN.COM, LLC, STAMFORD, CT. FILED 9-24-2010.

**MATCHSIGN**

THE MARK CONSISTS OF STANDARD CHARACTERS WITHOUT CLAIM TO ANY PARTICULAR FONT, STYLE, SIZE, OR COLOR.

FOR ASTROLOGICAL FORECASTING; DATING SERVICES, NAMELY, PROVIDING AN ON-LINE COMPUTER DATABASE FEATURING SINGLE PEOPLE INTERESTED IN MEETING OTHER SINGLE PEOPLE (U.S. CLS. 100 AND 101).

FIRST USE 3-20-2010; IN COMMERCE 3-20-2010.

DANIEL CAPSHAW, EXAMINING ATTORNEY

SN 85-175,995. GIETZEN, TYLER, DBA TALK TRUCKS, LAS VEGAS, NV. FILED 11-12-2010.

**TALK TRUCKS**

THE MARK CONSISTS OF STANDARD CHARACTERS WITHOUT CLAIM TO ANY PARTICULAR FONT, STYLE, SIZE, OR COLOR.

NO CLAIM IS MADE TO THE EXCLUSIVE RIGHT TO USE "TRUCKS", APART FROM THE MARK AS SHOWN.

FOR PROVIDING A SOCIAL NETWORKING WEBSITE FOR USE BY TRUCK ENTHUSIASTS FOR COMMUNICATING, TRADING PARTS, AND SCHEDULING SOCIAL GATHERINGS (U.S. CLS. 100 AND 101).

LAURA HAMMEL, EXAMINING ATTORNEY

**CLASS 45—(Continued).**

SN 85-180,625. CHEN, GEORGE, DBA CPATCOCA, LOS GATOS, CA. FILED S.R. 11-19-2010; AM. P.R. 1-3-2011.

# Cpatcoca

THE MARK CONSISTS OF STANDARD CHARACTERS WITHOUT CLAIM TO ANY PARTICULAR FONT, STYLE, SIZE, OR COLOR.

FOR PATENT AGENT SERVICES (U.S. CLS. 100 AND 101).

FIRST USE 2-0-2010; IN COMMERCE 5-0-2010.  
FRANK LATTUCA, EXAMINING ATTORNEY

---

SN 85-181,167. ICUREDMYSELF.COM LLC, GLENSIDE, PA. FILED 11-19-2010.

# HEARTBEAT

THE MARK CONSISTS OF STANDARD CHARACTERS WITHOUT CLAIM TO ANY PARTICULAR FONT, STYLE, SIZE, OR COLOR.

FOR CONDUCTING ON-LINE PERSONAL LIFESTYLE PERFORMANCE ASSESSMENTS BASED ON PRINCIPLES OF EMOTIONAL HAPPINESS BY MEANS OF THE USERS' INPUTTED PREFERENCES AND SOCIAL NETWORK; INTERNET-BASED SOCIAL NETWORKING SERVICES; ON-LINE SOCIAL NETWORKING SERVICES (U.S. CLS. 100 AND 101).

JUSTINE D. PARKER, EXAMINING ATTORNEY

---

SN 85-181,966. DOCUCODERS, LLC, POLAND, OH. FILED 11-21-2010.

# Contemporary Consultants Company

THE MARK CONSISTS OF STANDARD CHARACTERS WITHOUT CLAIM TO ANY PARTICULAR FONT, STYLE, SIZE, OR COLOR.

NO CLAIM IS MADE TO THE EXCLUSIVE RIGHT TO USE "CONSULTANTS COMPANY", APART FROM THE MARK AS SHOWN.

FOR REGULATORY COMPLIANCE CONSULTING IN THE NATURE OF MEDICAL RECORD CONSULTING FOR NURSING HOMES, NAMELY, PERFORMING REVIEW OF PATIENT RECORDS FOR COMPLIANCE WITH LAWS AND REGULATIONS (U.S. CLS. 100 AND 101).

FIRST USE 5-1-1981; IN COMMERCE 5-1-1981.  
JOHN KELLY, EXAMINING ATTORNEY

**CLASS 45—(Continued).**

SN 85-182,889. SIMPL, LLC, CHEVY CHASE, MD. FILED 11-22-2010.

# SIMPL

THE MARK CONSISTS OF STANDARD CHARACTERS WITHOUT CLAIM TO ANY PARTICULAR FONT, STYLE, SIZE, OR COLOR.

FOR ON-LINE SOCIAL NETWORKING SERVICES (U.S. CLS. 100 AND 101).

FIRST USE 6-1-2010; IN COMMERCE 6-1-2010.  
STEVEN JACKSON, EXAMINING ATTORNEY

---

SN 85-186,050. CLEANING FOR A REASON, LEWISVILLE, TX. FILED 11-29-2010.



OWNER OF U.S. REG. NO. 3,460,090.  
NO CLAIM IS MADE TO THE EXCLUSIVE RIGHT TO USE "CLEANING", APART FROM THE MARK AS SHOWN. THE COLOR(S) PINK AND BLACK IS/ARE CLAIMED AS A FEATURE OF THE MARK.

THE MARK CONSISTS OF PINK RIBBON WITH THE WORDING "CLEANING" IN BLACK GOING THROUGH THE CENTER OF THE PINK RIBBON WITH THE WORDING "FOR A REASON" IN BLACK UNDERLINED IN BLACK BELOW THE WORD "CLEANING".

FOR CHARITABLE SERVICES, NAMELY, GRANTING WISHES OF PERSONS UNDERGOING CANCER TREATMENT (U.S. CLS. 100 AND 101).

FIRST USE 6-1-2006; IN COMMERCE 7-1-2006.  
CHRISTINA SOBRAL, EXAMINING ATTORNEY

**CLASS 45—(Continued).**

SN 85-193,043. DINKIN, AARON, SCHENECTADY, NY. FILED 12-8-2010.

THE STYLIZED MARK CONSISTS OF THE FOLLOWING: A TILDE NEXT TO THE NUMERAL "7" FOLLOWED BY ANOTHER TILDE WHICH IS NEXT TO THE WORDING "CYAN FOX" WHICH IS FOLLOWED BY ANOTHER TILDE THEN THE NUMERAL "7" AND THEN A TILDE.

FOR ON-LINE SOCIAL NETWORKING SERVICES; INTERNET-BASED SOCIAL NETWORKING AND SOCIAL INTRODUCTION SERVICES; ON-LINE SOCIAL NETWORKING SERVICES, NAMELY, FACILITATING SOCIAL INTERACTION AMONG INDIVIDUALS WITH PARTICULAR HOBBIES, INTERESTS AND BACKGROUNDS; PROVIDING A SOCIAL NETWORKING WEBSITE FOR ENTERTAINMENT PURPOSES; MONITORING OF COMPUTER SYSTEMS FOR SECURITY PURPOSES (U.S. CLS. 100 AND 101).

WENDY GOODMAN, EXAMINING ATTORNEY

SN 85-196,104. SUMPRAXIS LLC, DBA SUMPRAXIS LLC, JUPITER, FL. FILED 12-13-2010.



THE MARK CONSISTS OF THE WORD "SUMPRAXIS" COMBINED WITH A SERIES OF TRIANGLES COMBINED TO FORM A MISCELLANEOUS DESIGN.

FOR DOMAIN NAME REGISTRATION SERVICES, NAMELY, CONDUCTING DOMAIN NAME SEARCHES FOR THE PURPOSE OF PROVIDING LEGAL ADVICE ON DOMAIN NAME REGISTRATION; LEGAL DOCUMENT PREPARATION AND RESEARCH SERVICES FOR ATTORNEYS; LEGAL RESEARCH; LEGAL SERVICES; LEGAL SERVICES, NAMELY, INTELLECTUAL PROPERTY CONSULTING SERVICES IN THE FIELD OF INVENTION, IDENTIFICATION, STRATEGY, ANALYTICS, AND INVENTION; LEGAL SERVICES, NAMELY, PREPARATION OF APPLICATIONS FOR TRADEMARK REGISTRATION; LEGAL SERVICES, NAMELY, PROVIDING CUSTOMIZED INFORMATION, COUNSELING, ADVICE AND LITIGATION SERVICES IN ALL AREAS OF INTERNATIONAL LAW; LEGAL SERVICES, NAMELY, TRADEMARK MAINTENANCE SERVICES; LEGAL SERVICES, NAMELY, TRADEMARK SEARCHING AND CLEARANCE SERVICES; LICENSING OF COMPUTER SOFTWARE; LICENSING OF INTELLECTUAL PROPERTY; LICENSING OF SOFTWARE FOR MANAGEMENT OF INTELLECTUAL PROPERTY; PATENT LICENSING; PROVIDING INFORMATION IN THE FIELD OF INTELLECTUAL PROPERTY LEGAL SERVICES; PROVIDING INFORMATION RELATING TO LEGAL AFFAIRS (U.S. CLS. 100 AND 101).

FIRST USE 9-19-2003; IN COMMERCE 9-19-2003.

BRIDGETT SMITH, EXAMINING ATTORNEY

**CLASS 45—(Continued).**

SN 85-196,108. RUSSELL PIPER, READING, PA. FILED 12-13-2010.

Caring Matters Home Care

THE MARK CONSISTS OF STANDARD CHARACTERS WITHOUT CLAIM TO ANY PARTICULAR FONT, STYLE, SIZE, OR COLOR.

NO CLAIM IS MADE TO THE EXCLUSIVE RIGHT TO USE "HOME CARE", APART FROM THE MARK AS SHOWN.

FOR PROVIDING NON-MEDICAL IN-HOME PERSONAL SERVICES FOR INDIVIDUALS INCLUDING CHECKING HOME CONDITION, SUPPLIES AND INDIVIDUAL WELL-BEING, SCHEDULING APPOINTMENTS, RUNNING ERRANDS, MAKING SAFETY CHECKS, AND PROVIDING ON-LINE INFORMATION RELATED TO THE PERSONAL SERVICES (U.S. CLS. 100 AND 101).

BRIDGETT SMITH, EXAMINING ATTORNEY

SN 85-199,492. NORTHLIGHT POWER, LLC, BAINBRIDGE ISLAND, WA. FILED 12-16-2010.



NORTHLIGHTPOWER

NO CLAIM IS MADE TO THE EXCLUSIVE RIGHT TO USE "POWER", APART FROM THE MARK AS SHOWN.

THE MARK CONSISTS OF THE WORDS "NORTHLIGHT POWER". THERE IS A DESIGN WHICH SHOWS POWER LINES MEETING AND APPEARS TO THE LEFT OF THE WORDS.

FOR OBTAINING ENVIRONMENTAL, DESIGN, ZONING AND OTHER GOVERNMENTAL PERMITS FOR POWER PLANTS FOR OTHERS (U.S. CLS. 100 AND 101).

FIRST USE 9-30-2010; IN COMMERCE 9-30-2010.

PATRICIA EVANKO, EXAMINING ATTORNEY

**CLASS 45—(Continued).**

SN 85-199,493. NORTHLIGHT POWER, LLC, BAINBRIDGE ISLAND, WA. FILED 12-16-2010.



NO CLAIM IS MADE TO THE EXCLUSIVE RIGHT TO USE "POWER" AND "SOLAR", APART FROM THE MARK AS SHOWN.

THE MARK CONSISTS OF THE WORDS "NORTHLIGHT POWER STREAMLINING SOLAR". THE WORDS "NORTHLIGHT POWER" APPEAR ON ONE LINE AND THE WORDS "STREAMLINING SOLAR" APPEAR ON THE LINE BELOW. THERE IS A DESIGN WHICH SHOWS POWER LINES MEETING AND APPEARS TO THE LEFT OF THE WORDS.

FOR OBTAINING ENVIRONMENTAL, DESIGN, ZONING AND OTHER GOVERNMENTAL PERMITS FOR POWER PLANTS FOR OTHERS (U.S. CLS. 100 AND 101).

FIRST USE 9-30-2010; IN COMMERCE 9-30-2010.  
PATRICIA EVANKO, EXAMINING ATTORNEY

**CLASS 45—(Continued).**

SN 85-203,868. ALL-Q-TELL, INC., DALLAS, TX. FILED 12-22-2010.

**CYBER WATCH**

THE MARK CONSISTS OF STANDARD CHARACTERS WITHOUT CLAIM TO ANY PARTICULAR FONT, STYLE, SIZE, OR COLOR.

NO CLAIM IS MADE TO THE EXCLUSIVE RIGHT TO USE "CYBER", APART FROM THE MARK AS SHOWN.

FOR SECURITY CONSULTANCY (U.S. CLS. 100 AND 101).

DANNEAN HETZEL, EXAMINING ATTORNEY

SN 85-201,415. DOSHI, SATISH JAYANTILAL, WALNUT CREEK, CA. FILED 12-19-2010.

**HOTFUSE**

THE MARK CONSISTS OF STANDARD CHARACTERS WITHOUT CLAIM TO ANY PARTICULAR FONT, STYLE, SIZE, OR COLOR.

OWNER OF U.S. REG. NO. 3,856,284.  
FOR INTERNET-BASED SOCIAL NETWORKING SERVICES (U.S. CLS. 100 AND 101).

FIRST USE 12-1-2010; IN COMMERCE 12-1-2010.  
KELLY BOULTON, EXAMINING ATTORNEY

SN 85-204,482. BLUE MOON DETECTIVE AGENCY, LLC, WEBSTER, TX. FILED 12-22-2010.



SN 85-203,854. ALL-Q-TELL, INC., DALLAS, TX. FILED 12-22-2010.

**SECURE WORLD**

THE MARK CONSISTS OF STANDARD CHARACTERS WITHOUT CLAIM TO ANY PARTICULAR FONT, STYLE, SIZE, OR COLOR.

NO CLAIM IS MADE TO THE EXCLUSIVE RIGHT TO USE "SECURE", APART FROM THE MARK AS SHOWN.

FOR MONITORING OF SECURITY SYSTEMS (U.S. CLS. 100 AND 101).

DANNEAN HETZEL, EXAMINING ATTORNEY

NO CLAIM IS MADE TO THE EXCLUSIVE RIGHT TO USE "INVESTIGATIONS" AND "SECURITY & PROTECTION", APART FROM THE MARK AS SHOWN.

THE MARK CONSISTS OF A SKYLINE WITH A MOON AND STARS. UNDERNEATH THERE IS THE STYLIZED TEXT "BLUE MOON INVESTIGATIONS SECURITY & PROTECTION".

FOR PRIVATE INVESTIGATION (U.S. CLS. 100 AND 101).

LAKEISHA LEWIS, EXAMINING ATTORNEY

**CLASS 45—(Continued).**

SN 85-204,535. ANIMAL ADVOCATES ALLIANCE, LOS ANGELES, CA. FILED 12-22-2010.



OWNER OF U.S. REG. NO. 3,736,244.  
NO CLAIM IS MADE TO THE EXCLUSIVE RIGHT TO USE "ANIMAL ADVOCATES ALLIANCE", APART FROM THE MARK AS SHOWN.

THE MARK CONSISTS OF A STYLIZED SILHOUETTE OF A BIRD IN FLIGHT SUPERIMPOSED OVER A STYLIZED IMAGE OF A WHITE UPPER PORTION OF A CAT, BOTH OF WHICH ARE SUPERIMPOSED OVER A SILHOUETTE OF A DOG'S HEAD. THE CAT AND DOG ARE FACING AWAY FROM THE BIRD. THE TERM "ANIMAL ADVOCATES ALLIANCE" APPEARS TO THE RIGHT OF THE IMAGE PORTION OF THE MARK IN AN UPPERCASE STYLIZED FONT, EACH WORD INDENTED SLIGHTLY MORE THAN THE PRECEDING WORD AND PROGRESSING DOWNWARD WITH EACH WORD.

FOR PROVIDING A WEB SITE FEATURING LISTINGS AND PHOTOGRAPHS OF PETS AVAILABLE FOR ADOPTION AND RELATED INFORMATION CONCERNING PET ADOPTION (U.S. CLS. 100 AND 101).

FIRST USE 1-19-2009; IN COMMERCE 1-19-2009.  
JUDITH HELFMAN, EXAMINING ATTORNEY

SN 85-204,555. DEXTER F. GEORGE, TRUSTEE OF THE GEORGE REVOCABLE TRUST, SUNRISE, FL. FILED 12-22-2010.



NO CLAIM IS MADE TO THE EXCLUSIVE RIGHT TO USE "PRE-SUIT RESOLUTION SERVICES", APART FROM THE MARK AS SHOWN.

THE COLOR(S) RED, WHITE AND BLACK IS/ARE CLAIMED AS A FEATURE OF THE MARK.

THE MARK CONSISTS OF STYLIZED COMPOSITE LETTERS "PRS", WITH A VERTICAL COLUMN OF RED AND WHITE, AND CURVED AREA, FORMING LETTERS "P" AND "R" AND REVERSED "S", IN BLACK AND FRAMED IN BLACK LINED RECTANGLE, AND IN UNCLE BOB FONT, TEXT "PRE-SUIT RESOLUTION SERVICES", IN BLACK, AND BELOW, "MEDIATE NOT LITIGATE - PROVIDING RELIEF FOR THE COURTS AND LITIGANTS", IN RED, WITH BLACK LINE ABOVE AND BELOW STYLIZED LETTERS "PRS" AND TEXT.

FOR ALTERNATIVE DISPUTE RESOLUTION SERVICES (U.S. CLS. 100 AND 101).

FIRST USE 12-20-2010, THE MARK WAS FIRST USED ANYWHERE IN A DIFFERENT FORM OTHER THAN THAT SOUGHT TO BE REGISTERED AT LEAST AS EARLY AS 12/20/2010; IN COMMERCE 12-20-2010, THE MARK WAS FIRST USED IN COMMERCE IN A DIFFERENT FORM OTHER THAN THAT SOUGHT TO BE REGISTERED AT LEAST AS EARLY AS 12/20/2010.

BRIAN CALLAGHAN, EXAMINING ATTORNEY

**CLASS 45—(Continued).**

SN 85-205,477. HIPPOCRATES UNIVERSITY, LAS VEGAS, NV. AND HRABAL, ANTONIN, LAS VEGAS, NV. FILED 12-24-2010.



THE COLOR(S) RED, WHITE AND BLUE IS/ARE CLAIMED AS A FEATURE OF THE MARK.

THE MARK CONSISTS OF A STYLIZED BLUE CROSS WITH A WHITE RAY OF LIGHT INCORPORATING A RED HEART DESIGN ALL AGAINST A BLUE BACKGROUND.

FOR RELIGIOUS AND SPIRITUAL SERVICES, NAMELY, PROVIDING GATHERINGS AND RETREATS TO DEVELOP AND ENHANCE THE SPIRITUAL LIVES OF INDIVIDUALS (U.S. CLS. 100 AND 101).

FIRST USE 12-1-2002; IN COMMERCE 12-1-2002.  
TAMARA FRAZIER, EXAMINING ATTORNEY

SN 85-206,747. AMAN, DAVID, NEW ORLEANS, LA. FILED 12-28-2010.

structology

THE MARK CONSISTS OF STANDARD CHARACTERS WITHOUT CLAIM TO ANY PARTICULAR FONT, STYLE, SIZE, OR COLOR.

FOR PERSONAL GROWTH AND MOTIVATION CONSULTING SERVICES; PERSONAL LIFESTYLE CONSULTING SERVICES (U.S. CLS. 100 AND 101).

STEVEN R. FINE, EXAMINING ATTORNEY



**CLASS 45—(Continued).**

SN 85-206,877. WELL LIFE RESOURCES LLC, NEW BALTIMORE, MI. FILED 12-28-2010.

## The Virtual Caregiver

THE MARK CONSISTS OF STANDARD CHARACTERS WITHOUT CLAIM TO ANY PARTICULAR FONT, STYLE, SIZE, OR COLOR.

NO CLAIM IS MADE TO THE EXCLUSIVE RIGHT TO USE "VIRTUAL", APART FROM THE MARK AS SHOWN.

FOR PERSONAL REMINDER SERVICES IN THE AREA OF UPCOMING IMPORTANT DATES AND EVENTS (U.S. CLS. 100 AND 101).

ROBIN CHOSID, EXAMINING ATTORNEY

**CLASS 45—(Continued).**

SN 85-209,674. BROOKS, MANDELA, BALTIMORE, MD. FILED 1-4-2011.



SN 85-209,236. BONNER KIERNAN TREBACH & CROCIATA LLP, WASHINGTON, DC. FILED 1-3-2011.

## BONNER KIERNAN

THE MARK CONSISTS OF STANDARD CHARACTERS WITHOUT CLAIM TO ANY PARTICULAR FONT, STYLE, SIZE, OR COLOR.

THE NAME "BONNER KIERNAN" DOES NOT IDENTIFY A LIVING INDIVIDUAL.

FOR LEGAL SERVICES (U.S. CLS. 100 AND 101).

FIRST USE 11-20-2009; IN COMMERCE 11-20-2009.

STEVEN PEREZ, EXAMINING ATTORNEY

THE COLOR(S) DARK BLUE, BLUE AND ORANGE IS/ARE CLAIMED AS A FEATURE OF THE MARK.

THE MARK CONSISTS OF TWO SQUARES NEXT TO EACH OTHER WITH THE EDGES CUT FROM THE CORNER; WHEREIN THERE IS A FIGURE OF A MALE IN BLUE AND A FEMALE IN BLUE. THE FEMALE FIGURE HAS A DARK BLUE BACKGROUND BEHIND HER AND THE MALE HAS AN ORANGE BACKGROUND BEHIND HIM. THE WORD "TRYSTT" IS WRITTEN BELOW THE FIGURE OF MALE AND A FEMALE IN THE ORANGE COLOR. THE BLUE BACKGROUND IS CLAIMED AS A FEATURE OF THE MARK.

FOR INTERNET BASED SOCIAL NETWORKING SERVICES (U.S. CLS. 100 AND 101).

SUSAN RICHARDS, EXAMINING ATTORNEY

SN 85-209,237. O'CONNOR, ACCIANI & LEVY, CO. LPA, CINCINNATI, OH. FILED 1-3-2011.

## Attorneys You Know ... Attorneys You Trust

THE MARK CONSISTS OF STANDARD CHARACTERS WITHOUT CLAIM TO ANY PARTICULAR FONT, STYLE, SIZE, OR COLOR.

FOR LEGAL SERVICES (U.S. CLS. 100 AND 101).

FIRST USE 1-1-2009; IN COMMERCE 1-1-2009.

MICHAEL WEBSTER, EXAMINING ATTORNEY

SN 85-209,882. HARVARD MAINTENANCE, INC., NEW YORK, NY. FILED 1-4-2011.

OWNER OF U.S. REG. NOS. 2,825,189 AND 2,825,190. NO CLAIM IS MADE TO THE EXCLUSIVE RIGHT TO USE "PROTECT", APART FROM THE MARK AS SHOWN.

THE COLOR(S) DARK BLUE AND RED IS/ARE CLAIMED AS A FEATURE OF THE MARK.

THE MARK CONSISTS OF THE TERM "HARVARD" IN DARK BLUE, WITH THE RIGHT SIDE OF THE "V" EXTENDING ABOVE THE OTHER LETTERS, FOLLOWED BY THE TERM "PROTECT" IN RED.

FOR SECURITY GUARD SERVICES; MONITORING SECURITY SYSTEMS (U.S. CLS. 100 AND 101).

PAUL E. FAHRENKOPF, EXAMINING ATTORNEY

**CLASS 45—(Continued).**

SN 85-210,411. YAEGER, JUNGBAUER & BARCZAK, PLC,  
ST. PAUL, MN. FILED 1-4-2011.

**YAEGER, JUNGBAUER &  
BARCZAK, PLC**

THE MARK CONSISTS OF STANDARD CHARACTERS  
WITHOUT CLAIM TO ANY PARTICULAR FONT, STYLE,  
SIZE, OR COLOR.

NO CLAIM IS MADE TO THE EXCLUSIVE RIGHT TO  
USE "PLC", APART FROM THE MARK AS SHOWN.  
FOR LEGAL SERVICES (U.S. CLS. 100 AND 101).  
FIRST USE 0-0-1996; IN COMMERCE 0-0-1996.  
GILBERT SWIFT, EXAMINING ATTORNEY

SN 85-210,741. RUN LOCAL LOCKSMITH, INC., CENTER-  
LINE, MI. FILED 1-5-2011.

**RUNLOCAL LOCKSMITH**

THE MARK CONSISTS OF STANDARD CHARACTERS  
WITHOUT CLAIM TO ANY PARTICULAR FONT, STYLE,  
SIZE, OR COLOR.

NO CLAIM IS MADE TO THE EXCLUSIVE RIGHT TO  
USE "LOCKSMITH", APART FROM THE MARK AS  
SHOWN.  
FOR LOCKSMITHING, NAMELY, OPENING OF  
LOCKS (U.S. CLS. 100 AND 101).  
FIRST USE 12-31-2008; IN COMMERCE 12-31-2008.  
MAYUR VAGHANI, EXAMINING ATTORNEY

SN 85-210,756. RUN LOCAL LOCKSMITH, INC., CENTER-  
LINE, MI. FILED 1-5-2011.



NO CLAIM IS MADE TO THE EXCLUSIVE RIGHT TO  
USE "LOCKSMITH", APART FROM THE MARK AS  
SHOWN.

THE MARK CONSISTS OF THE STYLIZED TEXT "RUN-  
LOCAL" THAT IS SLIGHTLY ARCUATE POSITIONED  
ABOVE THE STYLIZED TEXT "LOCKSMITH" AND HAV-  
ING A KEY POSITIONED BENEATH THE TEXT.  
FOR LOCKSMITHING, NAMELY, OPENING OF  
LOCKS (U.S. CLS. 100 AND 101).  
FIRST USE 12-31-2008; IN COMMERCE 12-31-2008.  
MAYUR VAGHANI, EXAMINING ATTORNEY

**CLASS 45—(Continued).**

SN 85-211,230. FIESTA CATERING INTERNATIONAL, INC.,  
CAVE HILL, ST. MICHAEL, BARBADOS, FILED 1-5-2011.

**XXXCUPID.COM**

THE MARK CONSISTS OF STANDARD CHARACTERS  
WITHOUT CLAIM TO ANY PARTICULAR FONT, STYLE,  
SIZE, OR COLOR.

FOR DATING SERVICES (U.S. CLS. 100 AND 101).  
FIRST USE 5-19-2010; IN COMMERCE 5-19-2010.  
COLLEEN DOMBROW, EXAMINING ATTORNEY

SN 85-211,248. FIESTA CATERING INTERNATIONAL, INC.,  
CAVE HILL, ST. MICHAEL, BARBADOS, FILED 1-5-2011.

**XXXMATCH.COM**

THE MARK CONSISTS OF STANDARD CHARACTERS  
WITHOUT CLAIM TO ANY PARTICULAR FONT, STYLE,  
SIZE, OR COLOR.

FOR DATING SERVICES (U.S. CLS. 100 AND 101).  
FIRST USE 11-26-2009; IN COMMERCE 11-26-2009.  
COLLEEN DOMBROW, EXAMINING ATTORNEY

SN 85-211,817. FIESTA CATERING INTERNATIONAL, INC.,  
CAVE HILL, ST. MICHAEL, BARBADOS, FILED 1-6-2011.

**FLIRT, DATE, FALL IN  
LOVE...**

THE MARK CONSISTS OF STANDARD CHARACTERS  
WITHOUT CLAIM TO ANY PARTICULAR FONT, STYLE,  
SIZE, OR COLOR.

FOR DATING SERVICES (U.S. CLS. 100 AND 101).  
FIRST USE 12-28-2008; IN COMMERCE 12-28-2008.  
COLLEEN DOMBROW, EXAMINING ATTORNEY

**CLASS 45—(Continued).**

SN 85-213,345. RAYKER HOLDINGS, LLC, CORINTH, TX.  
FILED 1-7-2011.

# Ideayst

THE MARK CONSISTS OF STANDARD CHARACTERS WITHOUT CLAIM TO ANY PARTICULAR FONT, STYLE, SIZE, OR COLOR.

FOR ONLINE SOCIAL NETWORKING SERVICES PROVIDED THROUGH A COMMUNITY WEBSITE (U.S. CLS. 100 AND 101).

RONALD DELGIZZI, EXAMINING ATTORNEY

**CLASS 45—(Continued).**

SN 85-215,466. CLAYTON, HOWARTH & CANNON, P.C.,  
DBA CLAYTON, HOWARTH & CANNON, SANDY, UT.  
FILED 1-11-2011.

WE CAN MAKE YOUR CLIENTS  
IP CHAMPIONS

THE MARK CONSISTS OF STANDARD CHARACTERS WITHOUT CLAIM TO ANY PARTICULAR FONT, STYLE, SIZE, OR COLOR.

FOR LEGAL SERVICES (U.S. CLS. 100 AND 101).

FIRST USE 1-0-2011; IN COMMERCE 1-0-2011.

GINA HAYES, EXAMINING ATTORNEY

SN 85-213,892. SELLERS INTERNATIONAL LLC, NEW  
YORK, NY. FILED 1-10-2011.

LAW MADE SIMPLE.

THE MARK CONSISTS OF STANDARD CHARACTERS WITHOUT CLAIM TO ANY PARTICULAR FONT, STYLE, SIZE, OR COLOR.

NO CLAIM IS MADE TO THE EXCLUSIVE RIGHT TO USE "LAW", APART FROM THE MARK AS SHOWN.

FOR PROVIDING AN ON-LINE INTERACTIVE DATABASE FEATURING CASE SUMMARIES OF LEGAL OPINIONS (U.S. CLS. 100 AND 101).

HEATHER SAPP, EXAMINING ATTORNEY

SN 85-215,472. CLAYTON, HOWARTH & CANNON, P.C.,  
SANDY, UT. FILED 1-11-2011.

WE CAN MAKE YOU AN IP  
CHAMPION

THE MARK CONSISTS OF STANDARD CHARACTERS WITHOUT CLAIM TO ANY PARTICULAR FONT, STYLE, SIZE, OR COLOR.

FOR LEGAL SERVICES (U.S. CLS. 100 AND 101).

GINA HAYES, EXAMINING ATTORNEY

SN 85-214,027. COVENANT WORLD MISSION, INC., FAIR-  
DALE, KY. FILED 1-10-2011.

# Kanisa's Call

THE MARK CONSISTS OF STANDARD CHARACTERS WITHOUT CLAIM TO ANY PARTICULAR FONT, STYLE, SIZE, OR COLOR.

FOR CHARITABLE OUTREACH SERVICES, NAMELY, PROVIDING COUNSELING SERVICES IN THE FIELD OF RELIGION; EVANGELISTIC AND MINISTERIAL SERVICES (U.S. CLS. 100 AND 101).

PAM WILLIS, EXAMINING ATTORNEY

SN 85-217,453. GALTON, CUNNINGHAM & BOURGEOIS,  
PLLC, DBA LAKESIDE MEDIATION CENTER, AUSTIN,  
TX. FILED 1-13-2011.

# The Lakeside Solution

THE MARK CONSISTS OF STANDARD CHARACTERS WITHOUT CLAIM TO ANY PARTICULAR FONT, STYLE, SIZE, OR COLOR.

NO CLAIM IS MADE TO THE EXCLUSIVE RIGHT TO USE "SOLUTION", APART FROM THE MARK AS SHOWN.

FOR ALTERNATIVE DISPUTE RESOLUTION (U.S. CLS. 100 AND 101).

FIRST USE 12-1-2010; IN COMMERCE 12-1-2010.

TARAH HARDY, EXAMINING ATTORNEY

**CLASS 45—(Continued).**

SN 85-221,518. NETFORCE GLOBAL LLC, LYNNWOOD, WA. FILED 1-19-2011.

**CLASS 45—(Continued).**

SN 85-243,809. KARMA ARMY, LLC, FARMINGTON, CT. FILED 2-16-2011.

**NETFORCE GLOBAL**

**KARMA ARMY**

THE MARK CONSISTS OF STANDARD CHARACTERS WITHOUT CLAIM TO ANY PARTICULAR FONT, STYLE, SIZE, OR COLOR.

NO CLAIM IS MADE TO THE EXCLUSIVE RIGHT TO USE "GLOBAL", APART FROM THE MARK AS SHOWN, FOR BACKGROUND INVESTIGATION AND RE-SEARCH SERVICES (U.S. CLS. 100 AND 101).  
FIRST USE 9-17-2008; IN COMMERCE 9-17-2008.  
REBECCA SMITH, EXAMINING ATTORNEY

THE MARK CONSISTS OF STANDARD CHARACTERS WITHOUT CLAIM TO ANY PARTICULAR FONT, STYLE, SIZE, OR COLOR.

FOR LOST PROPERTY RETURN SERVICES, NAMELY, TRACKING, MONITORING, LOCATING AND RECOVERING EQUIPMENT IN THE EVENT OF THEFT (U.S. CLS. 100 AND 101).  
FIRST USE 3-10-2009; IN COMMERCE 3-10-2009.  
SKYE YOUNG, EXAMINING ATTORNEY

\* \* \* \* \*

SECTION 4.—PRIOR UNITED STATES CLASSIFICATION

APPLICATION IN ONE CLASS

COLLECTIVE MEMBERSHIP MARKS

CLASS 200—COLLECTIVE MEMBERSHIP  
SN 85-064,275. IRON HORSEMEN, INC., ONTARIO CENTER, NY. FILED 6-16-2010.



NO CLAIM IS MADE TO THE EXCLUSIVE RIGHT TO USE "MC", APART FROM THE MARK AS SHOWN.  
THE COLOR(S) BLACK, WHITE, YELLOW, RED, BLUE AND GRAY IS/ARE CLAIMED AS A FEATURE OF THE MARK.

THE MARK CONSISTS OF A BLACK DIAMOND WITH AN IMAGE OF A GRAY HORSE HEAD WITH EARS DEPICTED AS WINGS WHICH ARE YELLOW, WHITE, RED AND BLUE. THE HORSE'S MOUTH AND EARS ARE RED. BEHIND THE HORSE IS THE TEXT "1%ER" AND THE LETTERS "MC" ARE BELOW THE HORSE.

FOR INDICATING MEMBERSHIP IN AN ASSOCIATION OF MOTORCYCLE DRIVERS.  
REGINA DRUMMOND, EXAMINING ATTORNEY

SN 85-088,300. INDEPENDENT EDUCATION, INC., WASHINGTON, DC. FILED 7-20-2010.



NO CLAIM IS MADE TO THE EXCLUSIVE RIGHT TO USE "EDUCATION", APART FROM THE MARK AS SHOWN.

THE MARK CONSISTS OF THE STYLIZED LETTERS "iii" FOLLOWED BY A VERTICAL LINE AND THE WORDING "INDEPENDENT EDUCATION" WITH THE WORDING "SCHOOLS FOR EVERY CHILD" BELOW.

FOR INDICATING MEMBERSHIP IN AN ASSOCIATION OF INDEPENDENT SCHOOLS.  
HEATHER SAPP, EXAMINING ATTORNEY

SN 85-201,851. ASSOCIATION OF DENTAL IMPLANT AUXILIARIES, UPPER MONTCLAIR, NJ. FILED 12-20-2010.

ADIA

THE MARK CONSISTS OF STANDARD CHARACTERS WITHOUT CLAIM TO ANY PARTICULAR FONT, STYLE, SIZE, OR COLOR.

FOR INDICATING MEMBERSHIP IN AN ORGANIZATION OF ORAL IMPLANTOLOGY/IMPLANT DENTISTRY PROFESSIONALS.

FIRST USE 9-0-2005; IN COMMERCE 9-0-2005.  
MICHAEL KEATING, EXAMINING ATTORNEY

SN 85-205,975. DEACONS OF DEADWOOD, AKA DEACONS OF DEADWOOD M/C, HOUSTON, TX. FILED 12-27-2010.



THE COLOR(S) GREEN, WHITE, BLACK, RED AND GRAY IS/ARE CLAIMED AS A FEATURE OF THE MARK.

THE MARK CONSISTS OF A CENTER ILLUSTRATED WHITE SKELETON HAND HOLDING THE PLAYING CARDS ACE OF CLUBS, ACE OF SPADES, "9" OF DIAMONDS, "8" OF CLUBS, AND "8" OF SPADES AGAINST A GREEN CIRCLE BACKGROUND. THE CENTER IMAGE HAS CURVED ATTACHED QUADRILATERALS ABOVE



AND BELOW. THE BACKGROUND OF BOTH QUADRILATERALS IS GRAY. THE TOP QUADRILATERAL HAS THE WORD "DEACONS" IN BLACK LETTERING. THE BOTTOM QUADRILATERAL HAS THE WORD "DEADWOOD" IN BLACK LETTERING. THE ACE OF CLUBS, ACE OF SPADES, "8" OF CLUBS AND "8" OF SPADES ARE LETTERED IN BLACK. THE "9" OF DIAMONDS IS LETTERED IN RED. ALL FIVE PLAYING CARDS HAVE A WHITE BACKGROUND. THE ENTIRE MARK IS OUTLINED IN BLACK.

FOR INDICATING MEMBERSHIP IN AN ORGANIZATION OF MOTORCYCLISTS DEDICATED TO HELPING CHILDREN'S CHARITIES .

FIRST USE 4-29-2002; IN COMMERCE 4-29-2002. JACQUELINE A. LAVINE, EXAMINING ATTORNEY

THE CERTIFICATION MARK AS USED BY AUTHORIZED PERSONS CERTIFIES THAT THE SERVICES WITH WHICH THE MARK IS ASSOCIATED MEET THE CERTIFIER'S STANDARDS AS TO METHODOLOGY IN THE CONDUCT OF WORKSHOPS AND SEMINARS IN THE FIELD OF PERSONAL MOTIVATION AND SELF IMPROVEMENT.

FOR CONDUCTING WORKSHOPS AND SEMINARS IN THE FIELD OF PERSONAL MOTIVATION AND SELF-IMPROVEMENT.

FIRST USE 10-31-2008; IN COMMERCE 10-31-2008. HOWARD B. LEVINE, EXAMINING ATTORNEY

CERTIFICATION MARKS

CLASS B—SERVICES

SN 77-909,149. ONCOLOGY REHAB PARTNERS, LLC, MARLBOROUGH, MA. FILED 1-11-2010.

STAR Clinician

THE MARK CONSISTS OF STANDARD CHARACTERS WITHOUT CLAIM TO ANY PARTICULAR FONT, STYLE, SIZE, OR COLOR.

NO CLAIM IS MADE TO THE EXCLUSIVE RIGHT TO USE "CLINICIAN", APART FROM THE MARK AS SHOWN.

THE CERTIFICATION MARK, AS INTENDED TO BE USED BY AUTHORIZED PERSONS, IS INTENDED TO CERTIFY THAT THE INDIVIDUALS DISPLAYING THE MARK HAVE COMPLETED THE EDUCATIONAL REQUIREMENTS OF THE CERTIFIER AND CONTINUE TO MEET THE CONTINUING EDUCATIONAL REQUIREMENTS OF THE CERTIFIER.

FOR ONCOLOGY REHABILITATION SERVICES. SANI KHOURI, EXAMINING ATTORNEY

THE MARK CONSISTS OF STANDARD CHARACTERS WITHOUT CLAIM TO ANY PARTICULAR FONT, STYLE, SIZE, OR COLOR.

NO CLAIM IS MADE TO THE EXCLUSIVE RIGHT TO USE "CERTIFIED", APART FROM THE MARK AS SHOWN.

THE CERTIFICATION MARK, AS USED BY AUTHORIZED PERSONS, CERTIFIES THAT A LEVEL OF EDUCATION, TRAINING AND EXPERIENCE INCLUDING TESTING AND CONTINUING EDUCATION REQUIREMENTS RELATING TO MEDICAL RECORDS HAVE BEEN MET.

SEC. 2(F). FOR MAINTAINING PATIENT MEDICAL RECORDS AND FILES.

FIRST USE 1-1-2000; IN COMMERCE 1-1-2000. DAVID TAYLOR, EXAMINING ATTORNEY

SN 85-199,988. AMERICAN ASSOCIATION OF MEDICAL AUDIT SPECIALISTS, WHEAT RIDGE, CO. FILED 12-16-2010.

SN 85-157,895. SYNERGISTIC PRODUCTIONS, INC. LONGMONT, CO. FILED 10-21-2010.

Certified by Melisa Pearce Equine Gestalt Coaching Method

THE MARK CONSISTS OF STANDARD CHARACTERS WITHOUT CLAIM TO ANY PARTICULAR FONT, STYLE, SIZE, OR COLOR.

NO CLAIM IS MADE TO THE EXCLUSIVE RIGHT TO USE "CERTIFIED BY" AND "EQUINE GESTALT COACHING METHOD", APART FROM THE MARK AS SHOWN.

THE NAME "MELISA PEARCE" IDENTIFIES A LIVING INDIVIDUAL WHOSE CONSENT IS OF RECORD.

CMAS

THE MARK CONSISTS OF STANDARD CHARACTERS WITHOUT CLAIM TO ANY PARTICULAR FONT, STYLE, SIZE, OR COLOR.

THE CERTIFICATION MARK, AS USED BY AUTHORIZED PERSONS, CERTIFIES THAT A LEVEL OF EDUCATION, TRAINING AND EXPERIENCE INCLUDING TESTING AND CONTINUING EDUCATION REQUIREMENTS RELATING TO MEDICAL RECORDS HAVE BEEN MET.

FOR MAINTAINING PATIENT MEDICAL RECORDS AND FILES .

FIRST USE 1-1-2000; IN COMMERCE 1-1-2000. DAVID TAYLOR, EXAMINING ATTORNEY

# TRADEMARK REGISTRATIONS ISSUED

## PRINCIPAL REGISTER

### SECTION 1.— INTERNATIONAL CLASSIFICATION

The short titles associated below with the international class numbers are terms designed merely for quick identification and are not an official part of the international classification. The full names of international classes are given in section 6.1 of the trademark rules of practice.

The designation "U.S. Cl." appearing in this section refers to the U.S. class in effect prior to Sep. 1, 1973 rather than the international class which applies to applications filed on or after that date. For adoption of international classification see notice in the OFFICIAL GAZETTE of Jun. 26, 1973 (911 O.G. TM 210).

#### CLASS 1—CHEMICALS

- 3,960,351. **VEM (STYLIZED)**. VACUUM ENGINEERING & MATERIALS CO., INC., MULTIPLE CLASS, (INT. CLS. 1 AND 6), (U.S. CLS. 1, 2, 5, 6, 10, 12, 13, 14, 23, 25, 26, 46 AND 50). SN 77-788,023. PUB. 3-1-2011. FILED 7-23-2009.
- 3,960,383. **MPOWER (STANDARD CHARACTER)**. FARMS AND FAMILIES OF NORTH AMERICA INC., MULTIPLE CLASS, (INT. CLS. 1, 5 AND 31), (U.S. CLS. 1, 5, 6, 10, 18, 26, 44, 46, 51 AND 52). SN 77-822,921. PUB. 3-1-2011. FILED 9-9-2009.
- 3,960,392. **PBI (STANDARD CHARACTER)**. KX TECHNOLOGIES LLC, MULTIPLE CLASS, (INT. CLS. 1 AND 11), (U.S. CLS. 1, 5, 6, 10, 13, 21, 23, 26, 31, 34 AND 46). SN 77-830,926. PUB. 3-1-2011. FILED 9-21-2009.
- 3,960,444. **CERES NANO AND DESIGN**. CERES NANOSCIENCES, LLLP, (U.S. CLS. 1, 5, 6, 10, 26 AND 46). SN 77-902,191. PUB. 3-1-2011. FILED 12-29-2009.
- 3,960,461. **J JIN HONG AND DESIGN**. WEIHAI JINHONG CHEMICAL CO., LTD., (U.S. CLS. 1, 5, 6, 10, 26 AND 46). SN 77-920,491. PUB. 3-1-2011. FILED 1-26-2010.
- 3,960,628. **QPROTEOME (STANDARD CHARACTER)**. QIAGEN GMBH, MULTIPLE CLASS, (INT. CLS. 1, 5 AND 9), (U.S. CLS. 1, 5, 6, 10, 18, 21, 23, 26, 36, 38, 44, 46, 51 AND 52). SN 78-629,724. PUB. 3-1-2011. FILED 5-13-2005.
- 3,960,644. **ADDI-MOL (STANDARD CHARACTER)**. CHEMISCHE WERKE KLUTHE GMBH, MULTIPLE CLASS, (INT. CLS. 1, 3 AND 4), (U.S. CLS. 1, 4, 5, 6, 10, 15, 26, 46, 50, 51 AND 52). SN 79-068,681. PUB. 3-1-2011. FILED 5-6-2009.
- 3,960,653. **HERTZ & SELCK (STANDARD CHARACTER)**. HERTZ & SELCK GMBH & CO., MULTIPLE CLASS, (INT. CLS. 1, 3, 30, 32 AND 33), (U.S. CLS. 1, 4, 5, 6, 10, 26, 45, 46, 47, 48, 49, 50, 51 AND 52). SN 79-072,786. PUB. 3-1-2011. FILED 5-20-2009.
- 3,960,662. **DIAMOND TAQ (STANDARD CHARACTER)**. EUROGENTEC S.A., (U.S. CLS. 1, 5, 6, 10, 26 AND 46). SN 79-075,066. PUB. 3-1-2011. FILED 5-29-2009.
- 3,960,665. **MISCELLANEOUS DESIGN**. SANTARIS PHARMA A/S, MULTIPLE CLASS, (INT. CLS. 1, 5 AND 42), (U.S. CLS. 1, 5, 6, 10, 18, 26, 44, 46, 51, 52, 100 AND 101). SN 79-075,435. PUB. 3-1-2011. FILED 8-13-2009.
- 3,960,667. **MATRISTYPT (STANDARD CHARACTER)**. DR. SUWELACK SKIN & HEALTH CARE AG, MULTIPLE CLASS, (INT. CLS. 1 AND 5), (U.S. CLS. 1, 5, 6, 10, 18, 26, 44, 46, 51 AND 52). SN 79-075,505. PUB. 3-1-2011. FILED 10-9-2009.
- 3,960,693. **MISCELLANEOUS DESIGN**. HEINRICH HAHNE GMBH & CO. KG, MULTIPLE CLASS, (INT. CLS. 1, 2, 17 AND 19), (U.S. CLS. 1, 5, 6, 10, 11, 12, 13, 16, 26, 33, 35, 46 AND 50). SN 79-080,371. PUB. 3-1-2011. FILED 1-2-2010.
- 3,960,705. **POWER OF POWDER (STANDARD CHARACTER)**. HÖGANÄS AB, MULTIPLE CLASS, (INT. CLS. 1, 6 AND 42), (U.S. CLS. 1, 2, 5, 6, 10, 12, 13, 14, 23, 25, 26, 46, 50, 100 AND 101). SN 79-081,110. PUB. 3-1-2011. FILED 3-11-2010.
- 3,960,712. **STARAQUA (STANDARD CHARACTER)**. STARAQUA WATER TREATMENT SYSTEMS, S.L., MULTIPLE CLASS, (INT. CLS. 1 AND 11), (U.S. CLS. 1, 5, 6, 10, 13, 21, 23, 26, 31, 34 AND 46). SN 79-081,509. PUB. 3-1-2011. FILED 2-18-2010.
- 3,960,713. **HYDRA IQ (STANDARD CHARACTER)**. BEIERS-DORF AG, MULTIPLE CLASS, (INT. CLS. 1 AND 3), (U.S. CLS. 1, 4, 5, 6, 10, 26, 46, 50, 51 AND 52). SN 79-081,556. PUB. 3-1-2011. FILED 3-17-2010.
- 3,960,740. **TECNOFREN (STANDARD CHARACTER)**. TECHNOLOGIC 3 SRL, MULTIPLE CLASS, (INT. CLS. 1 AND 6), (U.S. CLS. 1, 2, 5, 6, 10, 12, 13, 14, 23, 25, 26, 46 AND 50). SN 79-082,692. PUB. 3-1-2011. FILED 3-23-2010.
- 3,960,757. **SAVOSIL (STANDARD CHARACTER)**. EVONIK DEGUSSA GMBH, MULTIPLE CLASS, (INT. CLS. 1, 2, 9, 10, 11, 19, 21 AND 40), (U.S. CLS. 1, 2, 5, 6, 10, 11, 12, 13, 16, 21, 23, 26, 29, 30, 31, 33, 34, 36, 38, 39, 40, 44, 46, 50, 100, 103 AND 106). SN 79-083,616. PUB. 3-1-2011. FILED 3-19-2010.
- 3,960,761. **METCOCLAD (STANDARD CHARACTER)**. SULZER METCO MANAGEMENT AG, MULTIPLE CLASS, (INT. CLS. 1, 6 AND 7), (U.S. CLS. 1, 2, 5, 6, 10, 12, 13, 14, 19, 21, 23, 25, 26, 31, 34, 35, 46 AND 50). SN 79-083,708. PUB. 3-1-2011. FILED 3-29-2010.
- 3,960,792. **SNF (STANDARD CHARACTER)**. S.P.C.M. SA, (U.S. CLS. 1, 5, 6, 10, 26 AND 46). SN 79-085,682. PUB. 3-1-2011. FILED 2-25-2010.
- 3,960,809. **DRILLOX (STANDARD CHARACTER)**. SOLVAY SA, MULTIPLE CLASS, (INT. CLS. 1 AND 40), (U.S. CLS. 1, 5, 6, 10, 26, 46, 100, 103 AND 106). SN 79-086,568. PUB. 3-1-2011. FILED 8-9-2010.
- 3,960,829. **POLYQUEL (STANDARD CHARACTER)**. BROMINE COMPOUNDS LTD., (U.S. CLS. 1, 5, 6, 10, 26 AND 46). SN 79-088,753. PUB. 3-1-2011. FILED 9-16-2010.
- 3,960,833. **ICROSS (STANDARD CHARACTER)**. ALBERT HANDTMANN ELTEKA GMBH & CO. KG, MULTIPLE CLASS, (INT. CLS. 1, 7 AND 17), (U.S. CLS. 1, 5, 6, 10, 12, 13, 19, 21, 23, 26, 31, 34, 35, 46 AND 50). SN 79-090,096. PUB. 3-1-2011. FILED 9-7-2010.
- 3,960,868. **NATION-E (STANDARD CHARACTER)**. NATION-E AG, MULTIPLE CLASS, (INT. CLS. 1, 4, 9, 39 AND 40), (U.S. CLS. 1, 5, 6, 10, 15, 21, 23, 26, 36, 38, 46, 100, 103, 105 AND 106). SN 85-009,499. PUB. 3-1-2011. FILED 4-8-2010.
- 3,960,933. **SIVERAS (STANDARD CHARACTER)**. TORAY KABUSHIKI KAISHA (TORAY INDUSTRIES, INC.), (U.S. CLS. 1, 5, 6, 10, 26 AND 46). SN 85-037,310. PUB. 11-23-2010. FILED 5-13-2010.
- 3,960,982. **GIBREL AND DESIGN**. MICHAEL J. KIRKORIAN, (U.S. CLS. 1, 5, 6, 10, 26 AND 46). SN 85-063,692. PUB. 3-1-2011. FILED 6-15-2010.
- 3,961,050. **EVASIN (STANDARD CHARACTER)**. CHANG CHUN PETROCHEMICAL CO., LTD., (U.S. CLS. 1, 5, 6, 10, 26 AND 46). SN 85-094,600. PUB. 3-1-2011. FILED 7-28-2010.
- 3,961,197. **ARLON (STANDARD CHARACTER)**. ARLON, INC., MULTIPLE CLASS, (INT. CLS. 1 AND 17), (U.S. CLS. 1, 5, 6, 10, 12, 13, 26, 35, 46 AND 50). SN 85-122,610. PUB. 3-1-2011. FILED 9-3-2010.
- 3,961,228. **KANEPEARL (STANDARD CHARACTER)**. KANEKA CORPORATION, (U.S. CLS. 1, 5, 6, 10, 26 AND 46). SN 85-123,835. PUB. 3-1-2011. FILED 9-7-2010.
- 3,961,330. **FM FUSION&MOTION AND DESIGN**. CAR FORT INC., (U.S. CLS. 1, 5, 6, 10, 26 AND 46). SN 85-127,734. PUB. 3-1-2011. FILED 9-13-2010.
- 3,961,379. **STARFOUNT (STANDARD CHARACTER)**. ACTEGA KELSTAR, INC., (U.S. CLS. 1, 5, 6, 10, 26 AND 46). SN

- 85-128,463. PUB. 3-1-2011. FILED 9-13-2010.
- 3,961,431. **THERMIDE (STANDARD CHARACTER)**. MADVIN, JEREMY, AKA JEREMY MADVIN, (U.S. CLS. 1, 5, 6, 10, 26 AND 46). SN 85-129,169. PUB. 3-1-2011. FILED 9-14-2010.
- 3,961,478. **SURFABUTTER (STANDARD CHARACTER)**. SURFATECH CORPORATION, (U.S. CLS. 1, 5, 6, 10, 26 AND 46). SN 85-129,695. PUB. 3-1-2011. FILED 9-14-2010.
- 3,961,630. **ENVIROTAC II (STANDARD CHARACTER)**. EP&A ENVIROTAC, INC., (U.S. CLS. 1, 5, 6, 10, 26 AND 46). SN 85-131,704. PUB. 3-1-2011. FILED 9-16-2010.
- 3,961,709. **PURE BIOLOGICAL SYSTEMS, INC PURE SOLUTIONS FOR TODAY'S AGRICULTURAL NEEDS AND DESIGN**. PURE BIOLOGICAL SYSTEMS, INC., (U.S. CLS. 1, 5, 6, 10, 26 AND 46). SN 85-134,709. PUB. 3-1-2011. FILED 9-21-2010.
- 3,961,777. **SUPER SPREAD (STANDARD CHARACTER)**. WILBUR-ELLIS COMPANY, (U.S. CLS. 1, 5, 6, 10, 26 AND 46). SN 85-143,145. PUB. 3-1-2011. FILED 10-1-2010.
- 3,961,783. **BRISTLE MAGIC AND DESIGN**. KRON, HERMAN R., (U.S. CLS. 1, 5, 6, 10, 26 AND 46). SN 85-143,683. PUB. 3-1-2011. FILED 10-1-2010.

---

## CLASS 2—PAINTS

- 3,960,296. **LINOPRINT AND DESIGN**. HEIDELBERGER DRUCKMASCHINEN AG, MULTIPLE CLASS, (INT. CLS. 2 AND 7), (U.S. CLS. 6, 11, 13, 16, 19, 21, 23, 31, 34 AND 35). SN 77-566,341. PUB. 3-1-2011. FILED 9-10-2008.
- 3,960,693 ( *See Class 1 for this trademark*).
- 3,960,757 ( *See Class 1 for this trademark*).
- 3,960,889. **ENDURA OS (STANDARD CHARACTER)**. US FLOORS, INC., (U.S. CLS. 6, 11 AND 16). SN 85-016,812. PUB. 3-1-2011. FILED 4-19-2010.
- 3,961,240. **LIVE LAUGH LOVE (STANDARD CHARACTER)**. D-GENERATION, INC., (U.S. CLS. 6, 11 AND 16). SN 85-124,416. PUB. 3-1-2011. FILED 9-7-2010.
- 3,961,332. **CPXTRA (STYLIZED)**. DAVIS, SILVIA D., DBA BULLARD INTERNATIONAL, (U.S. CLS. 6, 11 AND 16). SN 85-127,737. PUB. 3-1-2011. FILED 9-13-2010.
- 3,961,668. **BULLET LINER (STANDARD CHARACTER)**. BURTON POLYMER LABORATORIES, INC., (U.S. CLS. 6, 11 AND 16). SN 85-132,489. PUB. 3-1-2011. FILED 9-17-2010.
- 3,961,672. **AMERICAN PRIDE (STANDARD CHARACTER)**. SOUTHERN DIVERSIFIED PRODUCTS, LLC, (U.S. CLS. 6, 11 AND 16). SN 85-132,509. PUB. 3-1-2011. FILED 9-17-2010.

---

## CLASS 3—COSMETICS AND CLEANING PREPARATIONS

- 3,960,224. **DON'S COME BACK HAIR (STYLIZED)**. DON'S COME BACK, LLC, (U.S. CLS. 1, 4, 6, 50, 51 AND 52). SN 76-689,820. PUB. 3-1-2011. FILED 5-20-2008.
- 3,960,241. **LANELL (STANDARD CHARACTER)**. JASON & JEAN PRODUCTS INC., (U.S. CLS. 1, 4, 6, 50, 51 AND 52). SN 76-703,661. PUB. 2-8-2011. FILED 7-6-2010.
- 3,960,257. **DERMAGEN (STANDARD CHARACTER)**. J. CANON, INC., (U.S. CLS. 1, 4, 6, 50, 51 AND 52). SN 77-019,596. PUB. 3-1-2011. FILED 10-12-2006.
- 3,960,355. **BLUEHORIZON (STANDARD CHARACTER)**. BLUE HORIZON IDEAS LIMITED, MULTIPLE CLASS, (INT. CLS. 3, 9 AND 17), (U.S. CLS. 1, 4, 5, 6, 12, 13, 21, 23, 26, 35, 36, 38, 50, 51 AND 52). SN 77-799,295. PUB. 3-1-2011. FILED 8-7-2009.
- 3,960,418. **GRAY RIDDANCE (STANDARD CHARACTER)**. PRYOR, PAULA, DBA PERMA YOUTH HEALTH, (U.S. CLS. 1, 4, 6, 50, 51 AND 52). SN 77-863,927. PUB. 3-1-2011. FILED 11-3-2009.
- 3,960,546. **GOLD N' DELICIOUS TANS AND DESIGN**. PRICE, MANDIE L, DBA GOLD N' DELICIOUS TANS, MULTIPLE CLASS, (INT. CLS. 3 AND 44), (U.S. CLS. 1, 4, 6, 50, 51, 52, 100 AND 101). SN 77-959,211. PUB. 3-1-2011. FILED 3-15-2010.
- 3,960,549. **PYLO (STANDARD CHARACTER)**. SOURCE INDUSTRIES, INC., MULTIPLE CLASS, (INT. CLS. 3, 9, 14, 18, 25 AND 35), (U.S. CLS. 1, 2, 3, 4, 6, 21, 22, 23, 26, 27, 28, 36, 38, 39, 41, 50, 51, 52, 100, 101 AND 102). SN 77-959,749. PUB. 3-1-2011. FILED 3-16-2010.
- 3,960,634. **EVENESCENCE (STANDARD CHARACTER)**. ENVIRON SKIN CARE (PROPRIETARY) LIMITED, (U.S. CLS. 1, 4, 6, 50, 51 AND 52). SN 78-918,838. PUB. 3-1-2011. FILED 6-28-2006.
- 3,960,644 ( *See Class 1 for this trademark*).
- 3,960,653 ( *See Class 1 for this trademark*).
- 3,960,660. **ACM 1899 AND DESIGN**. A.C. MILAN S.P.A., MULTIPLE CLASS, (INT. CLS. 3, 6, 8, 9, 14, 15, 16, 18, 20, 24, 25, 28, 30, 32, 35, 38, 41, 42 AND 45), (U.S. CLS. 1, 2, 3, 4, 5, 6, 12, 13, 14, 21, 22, 23, 25, 26, 27, 28, 29, 32, 36, 37, 38, 39, 41, 42, 44, 45, 46, 48, 50, 51, 52, 100, 101, 102, 104 AND 107). SN 79-074,922. PUB. 3-1-2011. FILED 7-30-2009.
- 3,960,663. **VSR AND DESIGN**. FREY MEDICAL TECHNOLOGIES AG, MULTIPLE CLASS, (INT. CLS. 3, 14, 18, 20, 21 AND 25), (U.S. CLS. 1, 2, 3, 4, 6, 13, 22, 23, 25, 27, 28, 29, 30, 32, 33, 39, 40, 41, 50, 51 AND 52). SN 79-075,076. PUB. 3-1-2011. FILED 7-1-2009.
- 3,960,664. **VESYOR (STANDARD CHARACTER)**. FREY MEDICAL TECHNOLOGIES AG, MULTIPLE CLASS, (INT. CLS. 3, 14, 18, 20, 21 AND 25), (U.S. CLS. 1, 2, 3, 4, 6, 13, 22, 23, 25, 27, 28, 29, 30, 32, 33, 39, 40, 41, 50, 51 AND 52). SN 79-075,077. PUB. 3-1-2011. FILED 7-1-2009.
- 3,960,713 ( *See Class 1 for this trademark*).
- 3,960,810. **MY BEAUTY CARE AND DESIGN**. ACT COSMETICS GMBH, MULTIPLE CLASS, (INT. CLS. 3, 5 AND 21), (U.S. CLS. 1, 2, 4, 6, 13, 18, 23, 29, 30, 33, 40, 44, 46, 50, 51 AND 52). SN 79-086,858. PUB. 3-1-2011. FILED 6-29-2010.
- 3,960,811. **INEY (STYLIZED)**. OBSHESTVO S OGRANICHENNOY OTVETSTVENNOSTYU "SPLAT-COSMETICA", (U.S. CLS. 1, 4, 6, 50, 51 AND 52). SN 79-086,887. PUB. 3-1-2011. FILED 7-12-2010.
- 3,960,838. **IRIDIA SALERM (STANDARD CHARACTER)**. VICTORIANO MARTÍNEZ VICARIO, (U.S. CLS. 1, 4, 6, 50, 51 AND 52). SN 85-000,539. PUB. 3-1-2011. FILED 3-29-2010.
- 3,960,912. **KEEN CREAM AND DESIGN**. GREENLANDS FARM, LLC, DBA WHIFF WHIMS, (U.S. CLS. 1, 4, 6, 50, 51 AND 52). SN 85-027,768. PUB. 3-1-2011. FILED 4-30-2010.
- 3,960,913. **DEARIE DOUSE FRANKLY PURE & SIMPLE BODY BATH WHIFF WHIMS AND DESIGN**. GREENLANDS FARM, LLC, DBA WHIFF WHIMS, (U.S. CLS. 1, 4, 6, 50, 51 AND 52). SN 85-027,791. PUB. 3-1-2011. FILED 4-30-2010.
- 3,960,992. **SOLIQUE (STANDARD CHARACTER)**. GRAND STREAM ENTERPRISE, INC., (U.S. CLS. 1, 4, 6, 50, 51 AND 52). SN 85-067,997. PUB. 12-14-2010. FILED 6-21-2010.
- 3,961,022. **H N E W S AND DESIGN**. HERMES INTERNATIONAL, (U.S. CLS. 1, 4, 6, 50, 51 AND 52). SN 85-081,119. PUB. 3-1-2011. FILED 7-9-2010.
- 3,961,046. **THE ROCK STAR NAILS (STANDARD CHARACTER)**. KIBLER, ANDREA J., DBA THE ROCK STAR NAILS, AND KIBLER, DAVID W., (U.S. CLS. 1, 4, 6, 50, 51 AND 52). SN 85-092,172. PUB. 3-1-2011. FILED 7-24-2010.
- 3,961,082. **SAFE SWIM (STANDARD CHARACTER)**. SELECTED CHEMICAL PRODUCTS COMPANY, DBA SELECTED BEAUTY PRODUCTS COMPANY, (U.S. CLS. 1, 4, 6, 50, 51 AND 52). SN 85-103,005. PUB. 3-1-2011. FILED 8-9-2010.
- 3,961,089. **WIG IT (STYLIZED)**. SWING IT INC., (U.S. CLS. 1, 4, 6, 50, 51 AND 52). SN 85-103,633. PUB. 3-1-2011. FILED 8-9-2010.
- 3,961,142. **S T (STYLIZED)**. SAN-TEC, INC., (U.S. CLS. 1, 4, 6, 50, 51 AND 52). SN 85-115,386. PUB. 3-1-2011. FILED 8-25-2010.
- 3,961,145. **BOCOMO KIND (STANDARD CHARACTER)**. BOCOMO BAY INC., (U.S. CLS. 1, 4, 6, 50, 51 AND 52). SN 85-115,517. PUB. 3-1-2011. FILED 8-25-2010.
- 3,961,163. **UV DAMAGE RECOVERY (STANDARD CHARACTER)**. SUN RESEARCH LLC, (U.S. CLS. 1, 4, 6, 50, 51 AND 52). SN 85-118,221. PUB. 3-1-2011. FILED 8-29-2010.
- 3,961,323. **CHERRY JACK COUTURE AND DESIGN**. JAMIE LYNN LIVINGSTON, (U.S. CLS. 1, 4, 6, 50, 51 AND 52). SN

- 85-127,558. PUB. 3-1-2011. FILED 9-11-2010.
- 3,961,334. **ECZEMADERM (STANDARD CHARACTER)**. ZYLOO RESEARCH LABORATORIES LLC, (U.S. CLS. 1, 4, 6, 50, 51 AND 52). SN 85-127,806. PUB. 3-1-2011. FILED 9-13-2010.
- 3,961,335. **THE SCIENCE OF ATTRACTION (STANDARD CHARACTER)**. ZYLOO RESEARCH LABORATORIES LLC, (U.S. CLS. 1, 4, 6, 50, 51 AND 52). SN 85-127,821. PUB. 3-1-2011. FILED 9-13-2010.
- 3,961,411. **BLUEBEARDS (STANDARD CHARACTER)**. BLUEBEARDS INC., (U.S. CLS. 1, 4, 6, 50, 51 AND 52). SN 85-128,901. PUB. 3-1-2011. FILED 9-14-2010.
- 3,961,413. **TREASURE IS... AND DESIGN**. YEAGER, SANDRA, (U.S. CLS. 1, 4, 6, 50, 51 AND 52). SN 85-128,919. PUB. 3-1-2011. FILED 9-14-2010.
- 3,961,449. **E=MC HAIRED (STANDARD CHARACTER)**. BEDDA HEDDA HAIR, LTD., (U.S. CLS. 1, 4, 6, 50, 51 AND 52). SN 85-129,329. PUB. 3-1-2011. FILED 9-14-2010.
- 3,961,454. **KERASMART (STANDARD CHARACTER)**. BEDDA HEDDA HAIR, LTD., (U.S. CLS. 1, 4, 6, 50, 51 AND 52). SN 85-129,368. PUB. 3-1-2011. FILED 9-14-2010.
- 3,961,505. **FLEX-I-FILE AND DESIGN**. PROFILE ACCESSORIES, INC., (U.S. CLS. 1, 4, 6, 50, 51 AND 52). SN 85-130,209. PUB. 3-1-2011. FILED 9-15-2010.
- 3,961,527. **SEVANI (STANDARD CHARACTER)**. SKIN SPECIALIST, LLC, (U.S. CLS. 1, 4, 6, 50, 51 AND 52). SN 85-130,388. PUB. 3-1-2011. FILED 9-15-2010.
- 3,961,607. **FOR PEOPLE WITH LIPS (STANDARD CHARACTER)**. GOOD FOR THE GOOSE PRODUCTS, LLC, (U.S. CLS. 1, 4, 6, 50, 51 AND 52). SN 85-131,465. PUB. 3-1-2011. FILED 9-16-2010.
- 3,961,681. **MIX LOCAL (STANDARD CHARACTER)**. REPLENISH BOTTLING, LLC, (U.S. CLS. 1, 4, 6, 50, 51 AND 52). SN 85-132,644. PUB. 3-1-2011. FILED 9-17-2010.
- 3,961,699. **WELCOME MATTE (STANDARD CHARACTER)**. LAURA GELLER MAKE-UP STUDIOS, LTD, (U.S. CLS. 1, 4, 6, 50, 51 AND 52). SN 85-133,117. PUB. 3-1-2011. FILED 9-20-2010.
- 3,961,747. **THE PERFECT PAIRING (STANDARD CHARACTER)**. LAURA GELLER MAKE-UP STUDIOS, LTD, (U.S. CLS. 1, 4, 6, 50, 51 AND 52). SN 85-140,571. PUB. 3-1-2011. FILED 9-29-2010.
- 3,961,796. **SWEET BUBBLE SOAP CAFE (STANDARD CHARACTER)**. SPRIZZARE SOAP CAFE LLC, DBA SWEET BUBBLE SOAP CAFE, (U.S. CLS. 1, 4, 6, 50, 51 AND 52). SN 85-146,360. PUB. 3-1-2011. FILED 10-6-2010.
- 3,961,814. **ONE SMALL SCOOP FOR MANKIND, ONE GIANT LEAP FOR MOTHER EARTH. (STANDARD CHARACTER)**. CHANSON WATER USA, INC., (U.S. CLS. 1, 4, 6, 50, 51 AND 52). SN 85-148,877. PUB. 3-1-2011. FILED 10-8-2010.
- 3,961,855. **PLCENTX-FORTE (STANDARD CHARACTER)**. DIVINE HEALING SOCIETY, INC, (U.S. CLS. 1, 4, 6, 50, 51 AND 52). SN 85-150,129. PUB. 3-1-2011. FILED 10-11-2010.
- 3,961,856. **GRANDMA'S SECRET SPOT REMOVER (STANDARD CHARACTER)**. PORRARO, RICHARD A., (U.S. CLS. 1, 4, 6, 50, 51 AND 52). SN 85-150,132. PUB. 3-1-2011. FILED 10-11-2010.
- 3,961,903. **CONFIDENCE (STANDARD CHARACTER)**. ZYLOO RESEARCH LABORATORIES LLC, (U.S. CLS. 1, 4, 6, 50, 51 AND 52). SN 85-163,159. PUB. 3-1-2011. FILED 10-27-2010.
- 3,961,924. **ABDOMETRIC (STANDARD CHARACTER)**. L'ORÉAL, (U.S. CLS. 1, 4, 6, 50, 51 AND 52). SN 85-170,288. PUB. 3-1-2011. FILED 11-5-2010.
- 3,961,939. **RESPLENDENT (STANDARD CHARACTER)**. WAM ESSENTIALS, INC, (U.S. CLS. 1, 4, 6, 50, 51 AND 52). SN 85-174,122. PUB. 3-1-2011. FILED 11-10-2010.

#### CLASS 4—LUBRICANTS AND FUELS

- 3,960,414. **EXXON REGULAR PLUS SUPREME AND DESIGN**. EXXON MOBIL CORPORATION, MULTIPLE CLASS, (INT. CLS. 4 AND 35), (U.S. CLS. 1, 6, 15, 100, 101 AND 102). SN 77-859,402. PUB. 3-1-2011. FILED 10-28-2009.
- 3,960,483. **POWER RS (STANDARD CHARACTER)**. CAS-

- TROL LIMITED, (U.S. CLS. 1, 6 AND 15). SN 77-936,365. PUB. 3-1-2011. FILED 2-16-2010.
- 3,960,644 ( *See Class 1 for this trademark*).
- 3,960,760. **OON HOME RECYCLING SOLUTIONS (STYLIZED)**. OON-RECYCLING SOLUTIONS, S.A., MULTIPLE CLASS, (INT. CLS. 4, 7 AND 40), (U.S. CLS. 1, 6, 13, 15, 19, 21, 23, 31, 34, 35, 100, 103 AND 106). SN 79-083,666. PUB. 3-1-2011. FILED 3-23-2010.
- 3,960,868 ( *See Class 1 for this trademark*).
- 3,960,882. **BORAID (STANDARD CHARACTER)**. TRAYLOR BROS., INC., (U.S. CLS. 1, 6 AND 15). SN 85-014,401. PUB. 3-1-2011. FILED 4-15-2010.
- 3,960,910. **PARADISE IN YOUR BACKYARD (STANDARD CHARACTER)**. LAMPLIGHT FARMS INCORPORATED, MULTIPLE CLASS, (INT. CLS. 4, 5 AND 11), (U.S. CLS. 1, 6, 13, 15, 18, 21, 23, 31, 34, 44, 46, 51 AND 52). SN 85-025,983. PUB. 3-1-2011. FILED 4-29-2010.
- 3,961,004. **PB-50 (STANDARD CHARACTER)**. THE B'LASTER CORPORATION, (U.S. CLS. 1, 6 AND 15). SN 85-071,460. PUB. 11-23-2010. FILED 6-25-2010.
- 3,961,882. **PYRO-KOTE (STANDARD CHARACTER)**. JAX, INC., FORMERLY BEHNKE LUBRICANTS, INC., (U.S. CLS. 1, 6 AND 15). SN 85-152,971. PUB. 3-1-2011. FILED 10-14-2010.

#### CLASS 5—PHARMACEUTICALS

- 3,960,268. **SUPER ANABOLIC AMINO 20000 (STANDARD CHARACTER)**. A & A RESEARCH AND DEVELOPMENT W.L.L. (HOLDING), (U.S. CLS. 6, 18, 44, 46, 51 AND 52). SN 77-275,988. PUB. 3-1-2011. FILED 9-10-2007.
- 3,960,269. **SUPER POWER AMINO 2244 (STANDARD CHARACTER)**. A & A RESEARCH AND DEVELOPMENT W.L.L. (HOLDING), (U.S. CLS. 6, 18, 44, 46, 51 AND 52). SN 77-276,005. PUB. 3-1-2011. FILED 9-10-2007.
- 3,960,273. **THERMIC (STYLIZED)**. THERM-IC PRODUCTS GMBH, MULTIPLE CLASS, (INT. CLS. 5, 9, 11 AND 25), (U.S. CLS. 6, 13, 18, 21, 22, 23, 26, 31, 34, 36, 38, 39, 44, 46, 51 AND 52). SN 77-317,175. PUB. 3-1-2011. FILED 10-30-2007.
- 3,960,294. **ATENATIV (STANDARD CHARACTER)**. OCTAPHARMA AG, (U.S. CLS. 6, 18, 44, 46, 51 AND 52). SN 77-554,139. PUB. 3-1-2011. FILED 8-22-2008.
- 3,960,359. **PINNACLE LABORATORIES (STANDARD CHARACTER)**. WINTON, WENDY C., (U.S. CLS. 6, 18, 44, 46, 51 AND 52). SN 77-806,731. PUB. 3-1-2011. FILED 8-18-2009.
- 3,960,363. **S.T.O.R.M. (STANDARD CHARACTER)**. NORTH AMERICAN RESCUE, LLC, (U.S. CLS. 6, 18, 44, 46, 51 AND 52). SN 77-809,202. PUB. 3-1-2011. FILED 8-20-2009.
- 3,960,383 ( *See Class 1 for this trademark*).
- 3,960,446. **UNICORN DF (STANDARD CHARACTER)**. SULPHUR MILLS LTD., (U.S. CLS. 6, 18, 44, 46, 51 AND 52). SN 77-905,779. PUB. 11-23-2010. FILED 1-6-2010.
- 3,960,497. **FACSECURE (STANDARD CHARACTER)**. ADVANCED FUSION, LLC, (U.S. CLS. 6, 18, 44, 46, 51 AND 52). SN 77-944,866. PUB. 3-1-2011. FILED 2-25-2010.
- 3,960,513. **MISCELLANEOUS DESIGN**. GUANGXI GOLDEN THROAT CO., LTD., MULTIPLE CLASS, (INT. CLS. 5 AND 30), (U.S. CLS. 6, 18, 44, 46, 51 AND 52). SN 77-948,455. PUB. 3-1-2011. FILED 3-2-2010.
- 3,960,566. **DR CLARK RESEARCH ASSOCIATION (STANDARD CHARACTER)**. DR. CLARK RESEARCH ASSOCIATION, MULTIPLE CLASS, (INT. CLS. 5, 10 AND 35), (U.S. CLS. 6, 18, 26, 39, 44, 46, 51, 52, 100, 101 AND 102). SN 77-964,900. PUB. 3-1-2011. FILED 3-22-2010.
- 3,960,567. **DR CLARK ZENTRUM (STANDARD CHARACTER)**. DR. CLARK RESEARCH ASSOCIATION, MULTIPLE CLASS, (INT. CLS. 5, 10 AND 35), (U.S. CLS. 6, 18, 26, 39, 44, 46, 51, 52, 100, 101 AND 102). SN 77-964,907. PUB. 3-1-2011. FILED 3-22-2010.
- 3,960,571. **PRO-5 (STANDARD CHARACTER)**. PROTHERA, INC., (U.S. CLS. 6, 18, 44, 46, 51 AND 52). SN 77-965,435. PUB. 3-1-2011. FILED 3-22-2010.
- 3,960,587. **IMMUNOPOLIS (STANDARD CHARACTER)**. UGUR SAHIN, MULTIPLE CLASS, (INT. CLS. 5, 42 AND 44), (U.S. CLS. 6, 18, 44, 46, 51, 52, 100 AND 101). SN 77-967,071. PUB. 3-1-2011. FILED 3-24-2010.



- 3,960,589. **MISCELLANEOUS DESIGN. ARES TRADING S.A., MULTIPLE CLASS, (INT. CLS. 5, 10, 41 AND 44), (U.S. CLS. 6, 18, 26, 39, 44, 46, 51, 52, 100, 101 AND 107).** SN 77-967,336. PUB. 3-1-2011. FILED 3-24-2010.
- 3,960,591. **EARTH'S BALANCE (STANDARD CHARACTER). MILLENNIUM LAWNS, INC., (U.S. CLS. 6, 18, 44, 46, 51 AND 52).** SN 77-967,385. PUB. 3-1-2011. FILED 3-24-2010.
- 3,960,604. **TEVA CLOZAPINE AND DESIGN. TEVA PHARMACEUTICALS USA, INC., (U.S. CLS. 6, 18, 44, 46, 51 AND 52).** SN 77-969,618. PUB. 3-1-2011. FILED 3-26-2010.
- 3,960,628 ( *See Class 1 for this trademark*).
- 3,960,631. **PROTON PILL (STANDARD CHARACTER). NEW AGEING INTERNATIONAL PTY LTD, (U.S. CLS. 6, 18, 44, 46, 51 AND 52).** SN 78-731,729. PUB. 1-8-2008. FILED 10-12-2005.
- 3,960,665 ( *See Class 1 for this trademark*).
- 3,960,667 ( *See Class 1 for this trademark*).
- 3,960,674. **NZHEALTH NATURALLY BRINGING OUT THE BEST OF NATURE AND DESIGN. NZ HEALTH NATURALLY PTY LIMITED, (U.S. CLS. 6, 18, 44, 46, 51 AND 52).** SN 79-076,463. PUB. 3-1-2011. FILED 10-19-2009.
- 3,960,678. **BELLEMONT EMOTIONSESENTIELLES AND DESIGN. LOUISE DE BELLEMONT, MULTIPLE CLASS, (INT. CLS. 5, 6, 9, 10, 11, 12, 18, 20, 21, 25 AND 27), (U.S. CLS. 1, 2, 3, 6, 12, 13, 14, 18, 19, 20, 21, 22, 23, 25, 26, 29, 30, 31, 32, 33, 34, 35, 36, 37, 38, 39, 40, 41, 42, 44, 46, 50, 51 AND 52).** SN 79-077,348. PUB. 3-1-2011. FILED 10-16-2009.
- 3,960,699. **AUROFLUID (STANDARD CHARACTER). CENDRES + MÉTAUX HOLDING SA, (U.S. CLS. 6, 18, 44, 46, 51 AND 52).** SN 79-080,732. PUB. 3-1-2011. FILED 1-20-2010.
- 3,960,709. **DR. RATH'S PHYTOBIOLOGICALS (STANDARD CHARACTER). DR. MED. MATTHIAS RATH, MULTIPLE CLASS, (INT. CLS. 5 AND 29), (U.S. CLS. 6, 18, 44, 46, 51 AND 52).** SN 79-081,310. PUB. 3-1-2011. FILED 4-7-2010.
- 3,960,727. **BENECOL AND DESIGN. RAVINTORAISIO OY, MULTIPLE CLASS, (INT. CLS. 5, 29, 30 AND 32), (U.S. CLS. 6, 18, 44, 45, 46, 48, 51 AND 52).** SN 79-082,110. PUB. 3-1-2011. FILED 3-31-2010.
- 3,960,749. **EVERXAN (STANDARD CHARACTER). BIOFARMA, (U.S. CLS. 6, 18, 44, 46, 51 AND 52).** SN 79-083,166. PUB. 3-1-2011. FILED 3-8-2010.
- 3,960,750. **PLAYZIR (STANDARD CHARACTER). SUDIMPLANT, MULTIPLE CLASS, (INT. CLS. 5, 9 AND 10), (U.S. CLS. 6, 18, 21, 23, 26, 36, 38, 39, 44, 46, 51 AND 52).** SN 79-083,346. PUB. 3-1-2011. FILED 2-22-2010.
- 3,960,766. **STRICTUS (STANDARD CHARACTER). WINDGAN TRADING S.A., (U.S. CLS. 6, 18, 44, 46, 51 AND 52).** SN 79-084,087. PUB. 3-1-2011. FILED 5-18-2010.
- 3,960,767. **DORMAX BY ESYON (STANDARD CHARACTER). FEEDBACK TRAYER, S.L., (U.S. CLS. 6, 18, 44, 46, 51 AND 52).** SN 79-084,104. PUB. 3-1-2011. FILED 4-5-2010.
- 3,960,772. **IMPAZA (STYLIZED). OBSHESTVO S OGRANICHENNOI; OTVETSTVENNOSTYU; "NAUCHNO-PROIZVODSTVENNAYA FIRMA; "MATERIA MEDICA HOLDING", (U.S. CLS. 6, 18, 44, 46, 51 AND 52).** SN 79-084,336. PUB. 3-1-2011. FILED 2-4-2010.
- 3,960,773. **ANAFERON (STYLIZED). OBSHESTVO S OGRANICHENNOI; OTVETSTVENNOSTYU; "NAUCHNO-PROIZVODSTVENNAYA FIRMA; "MATERIA MEDICA HOLDING", (U.S. CLS. 6, 18, 44, 46, 51 AND 52).** SN 79-084,337. PUB. 3-1-2011. FILED 2-4-2010.
- 3,960,810 ( *See Class 3 for this trademark*).
- 3,960,820. **DROSSAPHARM (STYLIZED). DROSSAPHARM AG, (U.S. CLS. 6, 18, 44, 46, 51 AND 52).** SN 79-087,755. PUB. 3-1-2011. FILED 6-17-2010.
- 3,960,863. **MISCELLANEOUS DESIGN. G. POHL-BOSKAMP GMBH & CO. KG, (U.S. CLS. 6, 18, 44, 46, 51 AND 52).** SN 85-007,532. PUB. 2-1-2011. FILED 4-6-2010.
- 3,960,910 ( *See Class 4 for this trademark*).
- 3,960,950. **PURE ROMANCE (STANDARD CHARACTER). PURE ROMANCE, INC., MULTIPLE CLASS, (INT. CLS. 5, 10, 16, 25, 28, 35 AND 41), (U.S. CLS. 2, 5, 6, 18, 22, 23, 26, 29, 37, 38, 39, 44, 46, 50, 51, 52, 100, 101, 102 AND 107).** SN 85-045,201. PUB. 3-1-2011. FILED 5-21-2010.
- 3,961,030. **PROFUSE (STANDARD CHARACTER). PROFUSE HEALTH, LLC, (U.S. CLS. 6, 18, 44, 46, 51 AND 52).** SN 85-085,265. PUB. 3-1-2011. FILED 7-15-2010.
- 3,961,070. **WOODWARD'S AND DESIGN. BEDESSEE IM-PORTS LTD., MULTIPLE CLASS, (INT. CLS. 5 AND 30), (U.S. CLS. 6, 18, 44, 46, 51 AND 52).** SN 85-101,812. PUB. 1-25-2011. FILED 8-6-2010.
- 3,961,074. **AROMATHERAPY PASTILLES (STANDARD CHARACTER). ETHNOMEDICINE PRESERVATION PROJECT, (U.S. CLS. 6, 18, 44, 46, 51 AND 52).** SN 85-102,400. PUB. 3-1-2011. FILED 8-6-2010.
- 3,961,098. **OPC-MAX (STANDARD CHARACTER). ANDY LI, (U.S. CLS. 6, 18, 44, 46, 51 AND 52).** SN 85-105,517. PUB. 1-25-2011. FILED 8-11-2010.
- 3,961,110. **GOLD NATURALS STAY HEALTHY AND STRONG! AND DESIGN. TAVERAS, CARMEN, R. DBA GOLD NATURALS, (U.S. CLS. 6, 18, 44, 46, 51 AND 52).** SN 85-108,745. PUB. 3-1-2011. FILED 8-16-2010.
- 3,961,151. **VERVE (STANDARD CHARACTER). VEMMA NUTRITION COMPANY, MULTIPLE CLASS, (INT. CLS. 5 AND 32), (U.S. CLS. 6, 18, 44, 45, 46, 48, 51 AND 52).** SN 85-116,934. PUB. 3-1-2011. FILED 8-26-2010.
- 3,961,183. **THE EXTRA STUFF (STANDARD CHARACTER). DETOXIFY, LLC, (U.S. CLS. 6, 18, 44, 46, 51 AND 52).** SN 85-121,136. PUB. 3-1-2011. FILED 9-1-2010.
- 3,961,234. **(FLAVOX) (STYLIZED). AGRI LABORATORIES, LTD., (U.S. CLS. 6, 18, 44, 46, 51 AND 52).** SN 85-124,126. PUB. 3-1-2011. FILED 9-7-2010.
- 3,961,239. **INSTACAINE (STANDARD CHARACTER). TRANSBARRIER PHN.C.ARMACEUTICALS, I, (U.S. CLS. 6, 18, 44, 46, 51 AND 52).** SN 85-124,400. PUB. 3-1-2011. FILED 9-7-2010.
- 3,961,250. **NEO-OXY 100/100 MR (STANDARD CHARACTER). PENNFIELD OIL COMPANY, (U.S. CLS. 6, 18, 44, 46, 51 AND 52).** SN 85-124,945. PUB. 3-1-2011. FILED 9-8-2010.
- 3,961,309. **ABSORBONAL (STANDARD CHARACTER). NU-VONYX INC, (U.S. CLS. 6, 18, 44, 46, 51 AND 52).** SN 85-127,249. PUB. 3-1-2011. FILED 9-10-2010.
- 3,961,333. **SOLURAL (STANDARD CHARACTER). MENPER DISTRIBUTORS INC., (U.S. CLS. 6, 18, 44, 46, 51 AND 52).** SN 85-127,800. PUB. 3-1-2011. FILED 9-13-2010.
- 3,961,346. **EGROVAN (STANDARD CHARACTER). GLAXO GROUP LIMITED, (U.S. CLS. 6, 18, 44, 46, 51 AND 52).** SN 85-128,070. PUB. 3-1-2011. FILED 9-13-2010.
- 3,961,348. **ELPICA (STANDARD CHARACTER). GLAXO GROUP LIMITED, (U.S. CLS. 6, 18, 44, 46, 51 AND 52).** SN 85-128,072. PUB. 3-1-2011. FILED 9-13-2010.
- 3,961,349. **LUPELIC (STANDARD CHARACTER). GLAXO GROUP LIMITED, (U.S. CLS. 6, 18, 44, 46, 51 AND 52).** SN 85-128,075. PUB. 3-1-2011. FILED 9-13-2010.
- 3,961,350. **ELUPIQ (STANDARD CHARACTER). GLAXO GROUP LIMITED, (U.S. CLS. 6, 18, 44, 46, 51 AND 52).** SN 85-128,078. PUB. 3-1-2011. FILED 9-13-2010.
- 3,961,351. **TOPLERA (STANDARD CHARACTER). GLAXO GROUP LIMITED, (U.S. CLS. 6, 18, 44, 46, 51 AND 52).** SN 85-128,082. PUB. 3-1-2011. FILED 9-13-2010.
- 3,961,381. **NEO40 AND DESIGN. NEOGENIS LABORATORIES, INC, (U.S. CLS. 6, 18, 44, 46, 51 AND 52).** SN 85-128,536. PUB. 3-1-2011. FILED 9-13-2010.
- 3,961,384. **PURNAIL (STANDARD CHARACTER). VANGUARD HEALTHCARE PRODUCTS, INC., (U.S. CLS. 6, 18, 44, 46, 51 AND 52).** SN 85-128,557. PUB. 3-1-2011. FILED 9-13-2010.
- 3,961,392. **N-CLOSE (STANDARD CHARACTER). AALNEX, INC., (U.S. CLS. 6, 18, 44, 46, 51 AND 52).** SN 85-128,716. PUB. 3-1-2011. FILED 9-14-2010.
- 3,961,403. **MOBILE BONES (STANDARD CHARACTER). BLASKEY, GUY, DBA POOCH AND MUTT, (U.S. CLS. 6, 18, 44, 46, 51 AND 52).** SN 85-128,848. PUB. 3-1-2011. FILED 9-14-2010.
- 3,961,407. **CYCLO REM (STANDARD CHARACTER). INFINITELABS LLC, (U.S. CLS. 6, 18, 44, 46, 51 AND 52).** SN 85-128,875. PUB. 3-1-2011. FILED 9-14-2010.
- 3,961,415. **CYCLO BOLAN (STANDARD CHARACTER). INFINITELABS LLC, (U.S. CLS. 6, 18, 44, 46, 51 AND 52).** SN 85-128,933. PUB. 3-1-2011. FILED 9-14-2010.
- 3,961,424. **INFINITE PRO (STANDARD CHARACTER). INFINITELABS LLC, (U.S. CLS. 6, 18, 44, 46, 51 AND 52).** SN 85-129,081. PUB. 3-1-2011. FILED 9-14-2010.
- 3,961,438. **PRODERMIX (STANDARD CHARACTER). GTJ ENTERPRISES, INC., DBA AMERICAN NUTRITION CONSULTANTS, (U.S. CLS. 6, 18, 44, 46, 51 AND 52).** SN



85-129,240. PUB. 3-1-2011. FILED 9-14-2010.

3,961,466. **JOINTFLEX (STANDARD CHARACTER)**. ALTERNA-JF LLC, (U.S. CLS. 6, 18, 44, 46, 51 AND 52). SN 85-129,531. PUB. 3-1-2011. FILED 9-14-2010.

3,961,560. **PRECISE (STANDARD CHARACTER)**. JOHNSON & JOHNSON, (U.S. CLS. 6, 18, 44, 46, 51 AND 52). SN 85-130,822. PUB. 3-1-2011. FILED 9-16-2010.

3,961,628. **ARDYSS (STANDARD CHARACTER)**. OPPORTUNITY HOLDING, LLC, (U.S. CLS. 6, 18, 44, 46, 51 AND 52). SN 85-131,686. PUB. 3-1-2011. FILED 9-16-2010.

3,961,639. **POOCH AND MUTT (STANDARD CHARACTER)**. BLASKEY, GUY, DBA POOCH AND MUTT, (U.S. CLS. 6, 18, 44, 46, 51 AND 52). SN 85-131,809. PUB. 3-1-2011. FILED 9-17-2010.

3,961,642. **OMNIZYME (STANDARD CHARACTER)**. ROCKY FORK FORMULAS, INC, (U.S. CLS. 6, 18, 44, 46, 51 AND 52). SN 85-131,956. PUB. 3-1-2011. FILED 9-17-2010.

3,961,644. **LEANICORE (STANDARD CHARACTER)**. BOND LABORATORIES, INC., (U.S. CLS. 6, 18, 44, 46, 51 AND 52). SN 85-131,996. PUB. 3-1-2011. FILED 9-17-2010.

3,961,647. **(CORE)ACTIVE (STANDARD CHARACTER)**. BOND LABORATORIES, INC., (U.S. CLS. 6, 18, 44, 46, 51 AND 52). SN 85-132,009. PUB. 3-1-2011. FILED 9-17-2010.

3,961,717. **NEO40 (STANDARD CHARACTER)**. NEOGENIS LABORATORIES, INC, (U.S. CLS. 6, 18, 44, 46, 51 AND 52). SN 85-135,602. PUB. 3-1-2011. FILED 9-22-2010.

3,961,737. **READY PAKS (STANDARD CHARACTER)**. TOTAL RESOURCES INTERNATIONAL, (U.S. CLS. 6, 18, 44, 46, 51 AND 52). SN 85-138,911. PUB. 3-1-2011. FILED 9-27-2010.

3,961,745. **VEVENU (STANDARD CHARACTER)**. GLAXO GROUP LIMITED, (U.S. CLS. 6, 18, 44, 46, 51 AND 52). SN 85-140,051. PUB. 3-1-2011. FILED 9-28-2010.

3,961,746. **CONECTRIC (STANDARD CHARACTER)**. GLAXO GROUP LIMITED, (U.S. CLS. 6, 18, 44, 46, 51 AND 52). SN 85-140,054. PUB. 3-1-2011. FILED 9-28-2010.

3,961,785. **TRU-FULVIC (STANDARD CHARACTER)**. NATREON, INC., (U.S. CLS. 6, 18, 44, 46, 51 AND 52). SN 85-143,753. PUB. 3-1-2011. FILED 10-2-2010.

3,961,805. **MINI PAK (STANDARD CHARACTER)**. LEVY, NATALIE, (U.S. CLS. 6, 18, 44, 46, 51 AND 52). SN 85-147,989. PUB. 3-1-2011. FILED 10-7-2010.

3,961,828. **HEALTHCEUTICALS (STANDARD CHARACTER)**. SCHELLING, CHRISTIANNE E, (U.S. CLS. 6, 18, 44, 46, 51 AND 52). SN 85-149,599. PUB. 3-1-2011. FILED 10-11-2010.

3,961,837. **PURA-PHOS (STANDARD CHARACTER)**. FEED PRODUCTS NORTH, INC., (U.S. CLS. 6, 18, 44, 46, 51 AND 52). SN 85-149,851. PUB. 3-1-2011. FILED 10-11-2010.

3,961,866. **ZIRMATIA (STANDARD CHARACTER)**. BOEHRINGER INGELHEIM INTERNATIONAL GMBH, (U.S. CLS. 6, 18, 44, 46, 51 AND 52). SN 85-151,684. PUB. 3-1-2011. FILED 10-13-2010.

3,961,874. **ANEPHLA (STANDARD CHARACTER)**. MITSUBISHI TANABE PHARMA CORPORATION, (U.S. CLS. 6, 18, 44, 46, 51 AND 52). SN 85-152,503. PUB. 3-1-2011. FILED 10-14-2010.

3,961,875. **LIMZORBA (STANDARD CHARACTER)**. MITSUBISHI TANABE PHARMA CORPORATION, (U.S. CLS. 6, 18, 44, 46, 51 AND 52). SN 85-152,511. PUB. 3-1-2011. FILED 10-14-2010.

3,961,876. **PALNEPH (STANDARD CHARACTER)**. MITSUBISHI TANABE PHARMA CORPORATION, (U.S. CLS. 6, 18, 44, 46, 51 AND 52). SN 85-152,523. PUB. 3-1-2011. FILED 10-14-2010.

3,961,877. **VIMZORPA (STANDARD CHARACTER)**. MITSUBISHI TANABE PHARMA CORPORATION, (U.S. CLS. 6, 18, 44, 46, 51 AND 52). SN 85-152,532. PUB. 3-1-2011. FILED 10-14-2010.

3,961,890. **BLUE BOMBSHELL (STANDARD CHARACTER)**. WILBUR-ELLIS COMPANY, (U.S. CLS. 6, 18, 44, 46, 51 AND 52). SN 85-157,899. PUB. 3-1-2011. FILED 10-21-2010.

3,961,891. **READYCEF (STANDARD CHARACTER)**. VIRBAC S.A., (U.S. CLS. 6, 18, 44, 46, 51 AND 52). SN 85-158,091. PUB. 3-1-2011. FILED 10-21-2010.

3,961,914. **BIOACTIVE TRUFIBER (STANDARD CHARACTER)**. MASTER SUPPLEMENTS, INC., (U.S. CLS. 6, 18, 44, 46, 51 AND 52). SN 85-166,414. PUB. 3-1-2011. FILED 11-1-2010.

**CLASS 6—METAL GOODS**

3,960,252. **AERO (STANDARD CHARACTER)**. MARKS, NORMAN H., AND MARKS, KENNETH R., (U.S. CLS. 2, 12, 13, 14, 23, 25 AND 50). SN 76-704,750. PUB. 3-1-2011. FILED 10-4-2010.

3,960,281. **AEROFIX (STANDARD CHARACTER)**. HÄFELE GMBH & CO. KG, MULTIPLE CLASS, (INT. CLS. 6, 9, 20 AND 21), (U.S. CLS. 2, 12, 13, 14, 21, 22, 23, 25, 26, 29, 30, 32, 33, 36, 38, 40 AND 50). SN 77-461,142. PUB. 11-23-2010. FILED 4-29-2008.

3,960,295. **SPEED SPOUT (STANDARD CHARACTER)**. EMCO WHEATON CORP., (U.S. CLS. 2, 12, 13, 14, 23, 25 AND 50). SN 77-566,091. PUB. 3-1-2011. FILED 9-9-2008.

3,960,351 ( *See Class 1 for this trademark*).

3,960,370. **COLORTECH (STANDARD CHARACTER)**. WATERSAVER FAUCET CO., MULTIPLE CLASS, (INT. CLS. 6 AND 11), (U.S. CLS. 2, 12, 13, 14, 21, 23, 25, 31, 34 AND 50). SN 77-813,276. PUB. 3-1-2011. FILED 8-26-2009.

3,960,441. **KOMPOFERM (STANDARD CHARACTER)**. EGGERSMANN, KARLGÜNTNER, MULTIPLE CLASS, (INT. CLS. 6, 7, 11, 37, 40 AND 42), (U.S. CLS. 2, 12, 13, 14, 19, 21, 23, 25, 31, 34, 35, 50, 100, 101, 103 AND 106). SN 77-897,972. PUB. 3-1-2011. FILED 12-21-2009.

3,960,545. **TRITON STALL SYSTEMS AND DESIGN**. PILOT PLASTICS, LLC, (U.S. CLS. 2, 12, 13, 14, 23, 25 AND 50). SN 77-958,665. PUB. 3-1-2011. FILED 3-15-2010.

3,960,651. **MISCELLANEOUS DESIGN**. CARGOTEC PATENTER AB, MULTIPLE CLASS, (INT. CLS. 6, 9, 12, 19 AND 42), (U.S. CLS. 1, 2, 12, 13, 14, 19, 21, 23, 25, 26, 31, 33, 35, 36, 38, 44, 50, 100 AND 101). SN 79-071,460. PUB. 3-1-2011. FILED 5-20-2009.

3,960,660 ( *See Class 3 for this trademark*).

3,960,661. **VMZINC (STYLIZED)**. UMICORE, SOCIÉTÉ ANONYME, MULTIPLE CLASS, (INT. CLS. 6 AND 37), (U.S. CLS. 2, 12, 13, 14, 23, 25, 50, 100, 103 AND 106). SN 79-074,985. PUB. 3-1-2011. FILED 7-15-2009.

3,960,678 ( *See Class 5 for this trademark*).

3,960,689. **AVESTA WELDING (STYLIZED)**. BÖHLER WELDING GROUP NORDIC AB, MULTIPLE CLASS, (INT. CLS. 6 AND 9), (U.S. CLS. 2, 12, 13, 14, 21, 23, 25, 26, 36, 38 AND 50). SN 79-079,468. PUB. 3-1-2011. FILED 9-9-2009.

3,960,705 ( *See Class 1 for this trademark*).

3,960,719. **KONVORTEC (STANDARD CHARACTER)**. LOBODA, ARVID THORWALD, MULTIPLE CLASS, (INT. CLS. 6 AND 9), (U.S. CLS. 2, 12, 13, 14, 21, 23, 25, 26, 36, 38 AND 50). SN 79-081,759. PUB. 3-1-2011. FILED 2-18-2010.

3,960,739. **MISCELLANEOUS DESIGN**. SUMINISTROS A. LORENZO BARROSO, S.A., MULTIPLE CLASS, (INT. CLS. 6, 7 AND 35), (U.S. CLS. 2, 12, 13, 14, 19, 21, 23, 25, 31, 34, 35, 50, 100, 101 AND 102). SN 79-082,641. PUB. 3-1-2011. FILED 4-7-2010.

3,960,740 ( *See Class 1 for this trademark*).

3,960,745. **SOMMER AND DESIGN**. SOMMER METALLBAU-STAHLBAU; GMBH & CO. KG, MULTIPLE CLASS, (INT. CLS. 6 AND 19), (U.S. CLS. 1, 2, 12, 13, 14, 23, 25, 33 AND 50). SN 79-082,934. PUB. 3-1-2011. FILED 2-23-2010.

3,960,761 ( *See Class 1 for this trademark*).

3,960,777. **MISCELLANEOUS DESIGN**. COMMANDITAIRE VENNOOTSCHAP HOEIJZERFABRIEK—WERKMAN & CO., MULTIPLE CLASS, (INT. CLS. 6, 8 AND 35), (U.S. CLS. 2, 12, 13, 14, 23, 25, 28, 44, 50, 100, 101 AND 102). SN 79-084,430. PUB. 3-1-2011. FILED 6-15-2010.

3,960,778. **BG DOOR INTERNATIONAL AND DESIGN**. BG DOOR INTERNATIONAL V.O.F., (U.S. CLS. 2, 12, 13, 14, 23, 25 AND 50). SN 79-084,490. PUB. 3-1-2011. FILED 4-8-2010.

3,960,824. **LDX 2404 (STANDARD CHARACTER)**. OUTOKUMPU OYJ, (U.S. CLS. 2, 12, 13, 14, 23, 25 AND 50). SN 79-088,168. PUB. 3-1-2011. FILED 9-16-2010.

3,961,129. **ECCO-SEAL (STANDARD CHARACTER)**. ECCO HEATING PRODUCTS LTD., (U.S. CLS. 2, 12, 13, 14, 23, 25 AND 50). SN 85-111,644. PUB. 3-1-2011. FILED 8-19-2010.

3,961,248. **CAMBRIDGE RESOURCES (STANDARD CHARACTER)**. CODA RESOURCES, LTD., (U.S. CLS. 2, 12, 13, 14, 23, 25 AND 50). SN 85-124,821. PUB. 3-1-2011. FILED 9-8-2010.

3,961,270. **CRIMSON AV MOUNTING SOLUTIONS AND DESIGN**. CRIMSON AV, LLC., (U.S. CLS. 2, 12, 13, 14, 23,

25 AND 50). SN 85-126,279. PUB. 3-1-2011. FILED 9-9-2010.  
 3,961,440. **SOLID-JET (STANDARD CHARACTER)**. STEINEN HOLDINGS, INC., MULTIPLE CLASS, (INT. CLS. 6 AND 7), (U.S. CLS. 2, 12, 13, 14, 19, 21, 23, 25, 31, 34, 35 AND 50). SN 85-129,270. PUB. 3-1-2011. FILED 9-14-2010.  
 3,961,504. **MOORE ROOM (STANDARD CHARACTER)**. SIERRA DESIGN MANUFACTURING, INC., DBA MOORE ROOM, (U.S. CLS. 2, 12, 13, 14, 23, 25 AND 50). SN 85-130,197. PUB. 3-1-2011. FILED 9-15-2010.  
 3,961,515. **MISCELLANEOUS DESIGN**. JBS FISHING LINE, LLC, MULTIPLE CLASS, (INT. CLS. 6, 9, 16, 21 AND 25), (U.S. CLS. 2, 5, 12, 13, 14, 21, 22, 23, 25, 26, 29, 30, 33, 36, 37, 38, 39, 40 AND 50). SN 85-130,284. PUB. 3-1-2011. FILED 9-15-2010.  
 3,961,554. **I LOVE JESUS AND DESIGN**. JESUS HEART FOUNDATION, INC., (U.S. CLS. 2, 12, 13, 14, 23, 25 AND 50). SN 85-130,678. PUB. 3-1-2011. FILED 9-15-2010.  
 3,961,713. **NO STOP (STANDARD CHARACTER)**. LINCOLN GLOBAL, INC., (U.S. CLS. 2, 12, 13, 14, 23, 25 AND 50). SN 85-135,192. PUB. 3-1-2011. FILED 9-22-2010.  
 3,961,761. **RX DRUG SAFE (STANDARD CHARACTER)**. RX SAFES, INC., (U.S. CLS. 2, 12, 13, 14, 23, 25 AND 50). SN 85-141,627. PUB. 3-1-2011. FILED 9-30-2010.  
 3,961,942. **SINCE 1895 AND DESIGN**. BOARD OF REGENTS OF THE UNIVERSITY SYSTEM OF GEORGIA, MULTIPLE CLASS, (INT. CLS. 6 AND 41), (U.S. CLS. 2, 12, 13, 14, 23, 25, 50, 100, 101 AND 107). SN 85-174,449. PUB. 3-1-2011. FILED 11-11-2010.

## CLASS 7—MACHINERY

3,960,296 ( *See Class 2 for this trademark* ).  
 3,960,322. **MBF ECLIPSE (STANDARD CHARACTER)**. MBF STAINLESS VALVES LTD., (U.S. CLS. 13, 19, 21, 23, 31, 34 AND 35). SN 77-696,051. PUB. 3-1-2011. FILED 3-20-2009.  
 3,960,368. **AJW AVIATION (STANDARD CHARACTER)**. A J WALTER AVIATION LTD, MULTIPLE CLASS, (INT. CLS. 7, 9 AND 12), (U.S. CLS. 13, 19, 21, 23, 26, 31, 34, 35, 36, 38 AND 44). SN 77-811,250. PUB. 3-1-2011. FILED 8-24-2009.  
 3,960,379. **POWERTECOUTBOARDS (STANDARD CHARACTER)**. PUSTERLA, SERGIO, ESTEBAN, (U.S. CLS. 13, 19, 21, 23, 31, 34 AND 35). SN 77-819,903. PUB. 3-1-2011. FILED 9-3-2009.  
 3,960,396. **ONE BLAST (STANDARD CHARACTER)**. BLAST-MASTER MANAGEMENT PTY LTD, (U.S. CLS. 13, 19, 21, 23, 31, 34 AND 35). SN 77-831,895. PUB. 3-1-2011. FILED 9-22-2009.  
 3,960,398. **BLASTONE (STANDARD CHARACTER)**. BLAST-MASTER MANAGEMENT PTY LTD, (U.S. CLS. 13, 19, 21, 23, 31, 34 AND 35). SN 77-832,077. PUB. 3-1-2011. FILED 9-22-2009.  
 3,960,407. **TERS (STANDARD CHARACTER)**. BIBBY SCIENTIFIC LIMITED, MULTIPLE CLASS, (INT. CLS. 7 AND 9), (U.S. CLS. 13, 19, 21, 23, 26, 31, 34, 35, 36 AND 38). SN 77-844,060. PUB. 3-1-2011. FILED 10-8-2009.  
 3,960,441 ( *See Class 6 for this trademark* ).  
 3,960,452. **IE2 (STANDARD CHARACTER)**. AVCO CORPORATION, (U.S. CLS. 13, 19, 21, 23, 31, 34 AND 35). SN 77-913,874. PUB. 3-1-2011. FILED 1-18-2010.  
 3,960,460. **DURALAST PROVEN TOUGH (STANDARD CHARACTER)**. AUTOZONE PARTS, INC., MULTIPLE CLASS, (INT. CLS. 7, 9 AND 12), (U.S. CLS. 13, 19, 21, 23, 26, 31, 34, 35, 36, 38 AND 44). SN 77-919,289. PUB. 3-1-2011. FILED 1-25-2010.  
 3,960,479. **PLASMAFICATION (STANDARD CHARACTER)**. SCHNEER, BARRY A, (U.S. CLS. 13, 19, 21, 23, 31, 34 AND 35). SN 77-933,426. PUB. 3-1-2011. FILED 2-11-2010.  
 3,960,595. **MIYAKOSHI PRINTING MACHINERY CO., LTD (STYLIZED)**. MIYAKOSHI PRINTING MACHINERY CO., LTD., (U.S. CLS. 13, 19, 21, 23, 31, 34 AND 35). SN 77-968,487. PUB. 3-1-2011. FILED 3-25-2010.  
 3,960,650. **PROTEAN (STANDARD CHARACTER)**. PROTEAN POWER PTY LTD, MULTIPLE CLASS, (INT. CLS. 7, 37, 39, 40 AND 42), (U.S. CLS. 13, 19, 21, 23, 31, 34, 35, 100, 101, 103, 105 AND 106). SN 79-071,005. PUB. 3-1-2011. FILED 5-25-2009.

3,960,658. **BULMOR (STANDARD CHARACTER)**. INDUSTRIE HOLDING GMBH, MULTIPLE CLASS, (INT. CLS. 7, 9, 12, 35, 36, 37 AND 42), (U.S. CLS. 13, 19, 21, 23, 26, 31, 34, 35, 36, 38, 44, 100, 101, 102, 103 AND 106). SN 79-074,686. PUB. 3-1-2011. FILED 7-21-2009.  
 3,960,701. **V90-3.0 MW (STANDARD CHARACTER)**. VESTAS WIND SYSTEMS A/S, (U.S. CLS. 13, 19, 21, 23, 31, 34 AND 35). SN 79-080,889. PUB. 3-1-2011. FILED 3-24-2010.  
 3,960,717. **IPR AND DESIGN**. IPR - INTELLIGENTE PERIPHERIEN; FÜR ROBOTER GMBH, MULTIPLE CLASS, (INT. CLS. 7 AND 9), (U.S. CLS. 13, 19, 21, 23, 26, 31, 34, 35, 36 AND 38). SN 79-081,715. PUB. 3-1-2011. FILED 3-19-2010.  
 3,960,718. **IBLADE (STYLIZED)**. CURSOR OY, (U.S. CLS. 13, 19, 21, 23, 31, 34 AND 35). SN 79-081,754. PUB. 3-1-2011. FILED 3-19-2010.  
 3,960,722. **AIRDOLPHIN (STANDARD CHARACTER)**. ZEPHYR CORPORATION, (U.S. CLS. 13, 19, 21, 23, 31, 34 AND 35). SN 79-081,970. PUB. 3-1-2011. FILED 3-16-2010.  
 3,960,733. **PUYOU (STYLIZED)**. TIANJIN PUYOU MECH. & ELEC.; EQUIPMENT MFG. CO., LTD., MULTIPLE CLASS, (INT. CLS. 7 AND 9), (U.S. CLS. 13, 19, 21, 23, 26, 31, 34, 35, 36 AND 38). SN 79-082,343. PUB. 3-1-2011. FILED 4-6-2010.  
 3,960,739 ( *See Class 6 for this trademark* ).  
 3,960,747. **MGMRESTOP (STANDARD CHARACTER)**. M.G.M. MOTORI ELETTRICI S.P.A., (U.S. CLS. 13, 19, 21, 23, 31, 34 AND 35). SN 79-083,025. PUB. 3-1-2011. FILED 4-9-2010.  
 3,960,759. **KOMTRAX AND DESIGN**. KABUSHIKI KAISHA KOMATSU SEISAKUSHO; (KOMATSU LTD.), MULTIPLE CLASS, (INT. CLS. 7, 9, 12, 37 AND 42), (U.S. CLS. 13, 19, 21, 23, 26, 31, 34, 35, 36, 38, 44, 100, 101, 103 AND 106). SN 79-083,661. PUB. 3-1-2011. FILED 3-19-2010.  
 3,960,760 ( *See Class 4 for this trademark* ).  
 3,960,761 ( *See Class 1 for this trademark* ).  
 3,960,764. **X W AND DESIGN**. FU AN SHI XIN WANG; DIAN JI YOU XIAN GONG SI, (U.S. CLS. 13, 19, 21, 23, 31, 34 AND 35). SN 79-083,944. PUB. 3-1-2011. FILED 4-5-2010.  
 3,960,775. **SUNROLL (STANDARD CHARACTER)**. FIVES STEIN, MULTIPLE CLASS, (INT. CLS. 7, 11 AND 40), (U.S. CLS. 13, 19, 21, 23, 31, 34, 35, 100, 103 AND 106). SN 79-084,374. PUB. 3-1-2011. FILED 5-31-2010.  
 3,960,794. **PKM 60 (STYLIZED)**. PEDROLLO S.P.A., (U.S. CLS. 13, 19, 21, 23, 31, 34 AND 35). SN 79-085,828. PUB. 3-1-2011. FILED 6-11-2010.  
 3,960,798. **V52-850 KW (STANDARD CHARACTER)**. VESTAS WIND SYSTEMS A/S, (U.S. CLS. 13, 19, 21, 23, 31, 34 AND 35). SN 79-086,295. PUB. 3-1-2011. FILED 8-19-2010.  
 3,960,799. **V82-1.65 MW (STANDARD CHARACTER)**. VESTAS WIND SYSTEMS A/S, (U.S. CLS. 13, 19, 21, 23, 31, 34 AND 35). SN 79-086,296. PUB. 3-1-2011. FILED 8-19-2010.  
 3,960,800. **V80-1.8 MW (STANDARD CHARACTER)**. VESTAS WIND SYSTEMS A/S, (U.S. CLS. 13, 19, 21, 23, 31, 34 AND 35). SN 79-086,297. PUB. 3-1-2011. FILED 8-19-2010.  
 3,960,801. **V80-2.0 MW (STANDARD CHARACTER)**. VESTAS WIND SYSTEMS A/S, (U.S. CLS. 13, 19, 21, 23, 31, 34 AND 35). SN 79-086,298. PUB. 3-1-2011. FILED 8-19-2010.  
 3,960,802. **V90-1.8 MW (STANDARD CHARACTER)**. VESTAS WIND SYSTEMS A/S, (U.S. CLS. 13, 19, 21, 23, 31, 34 AND 35). SN 79-086,299. PUB. 3-1-2011. FILED 8-19-2010.  
 3,960,803. **V90-2.0 MW (STANDARD CHARACTER)**. VESTAS WIND SYSTEMS A/S, (U.S. CLS. 13, 19, 21, 23, 31, 34 AND 35). SN 79-086,300. PUB. 3-1-2011. FILED 8-19-2010.  
 3,960,804. **V100-1.8 MW (STANDARD CHARACTER)**. VESTAS WIND SYSTEMS A/S, (U.S. CLS. 13, 19, 21, 23, 31, 34 AND 35). SN 79-086,301. PUB. 3-1-2011. FILED 8-19-2010.  
 3,960,805. **V112-3.0 MW (STANDARD CHARACTER)**. VESTAS WIND SYSTEMS A/S, (U.S. CLS. 13, 19, 21, 23, 31, 34 AND 35). SN 79-086,302. PUB. 3-1-2011. FILED 8-19-2010.  
 3,960,812. **V60-850 KW (STANDARD CHARACTER)**. VESTAS WIND SYSTEMS A/S, (U.S. CLS. 13, 19, 21, 23, 31, 34 AND 35). SN 79-086,918. PUB. 3-1-2011. FILED 8-19-2010.  
 3,960,813. **SANGANG AND DESIGN**. ZHEJIANG SANOU MACHINERY LIMITED COMPANY, (U.S. CLS. 13, 19, 21, 23, 31, 34 AND 35). SN 79-087,051. PUB. 3-1-2011. FILED 6-18-2010.  
 3,960,817. **GANSOW (STANDARD CHARACTER)**. IP CLEANING S.P.A., (U.S. CLS. 13, 19, 21, 23, 31, 34 AND 35). SN 79-087,634. PUB. 3-1-2011. FILED 6-25-2010.

3,960,833 ( *See Class 1 for this trademark* ).

3,960,850. **SIPHONFLOW (STANDARD CHARACTER)**. BULK TANK INC., (U.S. CLS. 13, 19, 21, 23, 31, 34 AND 35). SN 85-004,415. PUB. 3-1-2011. FILED 4-1-2010.

3,960,887. **ICORE (STANDARD CHARACTER)**. CORPRO SYSTEMS LIMITED, MULTIPLE CLASS, (INT. CLS. 7 AND 9), (U.S. CLS. 13, 19, 21, 23, 26, 31, 34, 35, 36 AND 38). SN 85-015,455. PUB. 3-1-2011. FILED 4-16-2010.

3,960,947. **STINGRAY AND DESIGN**. MURPHY'S WAVES LIMITED, (U.S. CLS. 13, 19, 21, 23, 31, 34 AND 35). SN 85-044,537. PUB. 3-1-2011. FILED 5-21-2010.

3,961,139. **W AND DESIGN**. AKTIEBOLAGET ELECTROLUX, (U.S. CLS. 13, 19, 21, 23, 31, 34 AND 35). SN 85-114,774. PUB. 3-1-2011. FILED 8-24-2010.

3,961,140. **WASCOMAT (STANDARD CHARACTER)**. AKTIEBOLAGET ELECTROLUX, (U.S. CLS. 13, 19, 21, 23, 31, 34 AND 35). SN 85-114,784. PUB. 3-1-2011. FILED 8-24-2010.

3,961,251. **GLOBAL PUMP AND DESIGN**. GLOBAL PUMP COMPANY, L.L.C., (U.S. CLS. 13, 19, 21, 23, 31, 34 AND 35). SN 85-125,066. PUB. 3-1-2011. FILED 9-8-2010.

3,961,306. **MAGNAFLOW PERFORMANCE EXHAUST AND DESIGN**. CAR SOUND EXHAUST SYSTEM, INC., (U.S. CLS. 13, 19, 21, 23, 31, 34 AND 35). SN 85-127,223. PUB. 3-1-2011. FILED 9-10-2010.

3,961,311. **MAGNAFLOW EXHAUST PRODUCTS AND DESIGN**. CAR SOUND EXHAUST SYSTEM, INC., (U.S. CLS. 13, 19, 21, 23, 31, 34 AND 35). SN 85-127,258. PUB. 3-1-2011. FILED 9-10-2010.

3,961,312. **MAGNAFLOW EXHAUST PRODUCTS (STANDARD CHARACTER)**. CAR SOUND EXHAUST SYSTEM, INC., (U.S. CLS. 13, 19, 21, 23, 31, 34 AND 35). SN 85-127,269. PUB. 3-1-2011. FILED 9-10-2010.

3,961,315. **MAGNAFLOW PERFORMANCE EXHAUST (STYLIZED)**. CAR SOUND EXHAUST SYSTEM, INC., (U.S. CLS. 13, 19, 21, 23, 31, 34 AND 35). SN 85-127,370. PUB. 3-1-2011. FILED 9-10-2010.

3,961,376. **MAGNAFUEL (STANDARD CHARACTER)**. MAGNAFUEL PRODUCTS, INC., MULTIPLE CLASS, (INT. CLS. 7 AND 9), (U.S. CLS. 13, 19, 21, 23, 26, 31, 34, 35, 36 AND 38). SN 85-128,422. PUB. 3-1-2011. FILED 9-13-2010.

3,961,439. **J&N (STANDARD CHARACTER)**. J&N AUTO ELECTRIC, INC., MULTIPLE CLASS, (INT. CLS. 7, 9 AND 12), (U.S. CLS. 13, 19, 21, 23, 26, 31, 34, 35, 36, 38 AND 44). SN 85-129,251. PUB. 3-1-2011. FILED 9-14-2010.

3,961,440 ( *See Class 6 for this trademark* ).

3,961,463. **VICON AND DESIGN**. PLASMA AUTOMATION INC., (U.S. CLS. 13, 19, 21, 23, 31, 34 AND 35). SN 85-129,518. PUB. 3-1-2011. FILED 9-14-2010.

3,961,464. **VICON (STANDARD CHARACTER)**. PLASMA AUTOMATION INC., (U.S. CLS. 13, 19, 21, 23, 31, 34 AND 35). SN 85-129,522. PUB. 3-1-2011. FILED 9-14-2010.

3,961,570. **TANTEC (STANDARD CHARACTER)**. TANTEC GMBH, (U.S. CLS. 13, 19, 21, 23, 31, 34 AND 35). SN 85-130,996. PUB. 3-1-2011. FILED 9-16-2010.

3,961,573. **EZ-JAW (STANDARD CHARACTER)**. KABA ILCO CORP., (U.S. CLS. 13, 19, 21, 23, 31, 34 AND 35). SN 85-131,024. PUB. 3-1-2011. FILED 9-16-2010.

3,961,662. **M-BRAD (STANDARD CHARACTER)**. AUGUST RUEGGERBERG GMBH & CO. KG, (U.S. CLS. 13, 19, 21, 23, 31, 34 AND 35). SN 85-132,402. PUB. 3-1-2011. FILED 9-17-2010.

3,961,748. **EZMOUNT (STANDARD CHARACTER)**. AUGUST RUEGGERBERG GMBH & CO. KG, (U.S. CLS. 13, 19, 21, 23, 31, 34 AND 35). SN 85-140,684. PUB. 3-1-2011. FILED 9-29-2010.

3,961,844. **ROTO GRIPP (STANDARD CHARACTER)**. ADVANCED RAIL CONCEPTS, LLC, (U.S. CLS. 13, 19, 21, 23, 31, 34 AND 35). SN 85-149,951. PUB. 3-1-2011. FILED 10-11-2010.

3,961,847. **ADVANCED RAIL CONCEPTS (STANDARD CHARACTER)**. ADVANCED RAIL CONCEPTS, LLC, (U.S. CLS. 13, 19, 21, 23, 31, 34 AND 35). SN 85-149,993. PUB. 3-1-2011. FILED 10-11-2010.

3,961,899. **EXMARK AND DESIGN**. EXMARK MANUFACTURING COMPANY INCORPORATED, (U.S. CLS. 13, 19, 21, 23, 31, 34 AND 35). SN 85-162,053. PUB. 3-1-2011. FILED 10-27-2010.

3,961,940. **IRON EAGLE (STANDARD CHARACTER)**. MAGIC

CIRCLE CORPORATION, DBA DIXIE CHOPPER, (U.S. CLS. 13, 19, 21, 23, 31, 34 AND 35). SN 85-174,184. PUB. 3-1-2011. FILED 11-11-2010.

3,961,941. **SNUBRITE (STANDARD CHARACTER)**. HARNISCHFEGER TECHNOLOGIES, INC., (U.S. CLS. 13, 19, 21, 23, 31, 34 AND 35). SN 85-174,383. PUB. 3-1-2011. FILED 11-11-2010.

---

## CLASS 8—HAND TOOLS

3,960,229. **KERASYS (STANDARD CHARACTER)**. HERAEUS KULZER GMBH, MULTIPLE CLASS, (INT. CLS. 8, 9 AND 17), (U.S. CLS. 1, 5, 12, 13, 21, 23, 26, 28, 35, 36, 38, 44 AND 50). SN 76-702,018. PUB. 9-28-2010. FILED 3-12-2010.

3,960,614. **DR. SLICK (STANDARD CHARACTER)**. DR. SLICK CO., (U.S. CLS. 23, 28 AND 44). SN 77-970,078. PUB. 3-1-2011. FILED 3-26-2010.

3,960,615. **DR. SLICK CO. AND INSTRUMENTS FOR ANGLERS AND DESIGN**. DR. SLICK CO., (U.S. CLS. 23, 28 AND 44). SN 77-970,096. PUB. 3-1-2011. FILED 3-26-2010.

3,960,660 ( *See Class 3 for this trademark* ).

3,960,777 ( *See Class 6 for this trademark* ).

3,960,797. **CLARINGTON FORGE (STANDARD CHARACTER)**. ROLLINS BULLDOG TOOLS LIMITED, (U.S. CLS. 23, 28 AND 44). SN 79-086,213. PUB. 3-1-2011. FILED 6-6-2010.

3,961,138. **DIVOTPACK (STANDARD CHARACTER)**. SCHWEGMAN, KATIE R., (U.S. CLS. 23, 28 AND 44). SN 85-114,637. PUB. 3-1-2011. FILED 8-24-2010.

3,961,659. **DEUCE (STANDARD CHARACTER)**. WEAVER, MATTHEW, (U.S. CLS. 23, 28 AND 44). SN 85-132,246. PUB. 3-1-2011. FILED 9-17-2010.

3,961,693. **HUY (STANDARD CHARACTER)**. BUI, PHUONG B, DBA NGHIA NIPPERS USA, (U.S. CLS. 23, 28 AND 44). SN 85-132,882. PUB. 3-1-2011. FILED 9-18-2010.

3,961,878. **TURBOPRO (STANDARD CHARACTER)**. JPJ INVESTMENT HOLDING CORP., (U.S. CLS. 23, 28 AND 44). SN 85-152,560. PUB. 3-1-2011. FILED 10-14-2010.

---

## CLASS 9—ELECTRICAL AND SCIENTIFIC APPARATUS

3,960,226. **HUBBS MACHINE & MANUFACTURING, INC (STANDARD CHARACTER)**. HUBBS MACHINE & MANUFACTURING, INC., MULTIPLE CLASS, (INT. CLS. 9 AND 42), (U.S. CLS. 21, 23, 26, 36, 38, 100 AND 101). SN 76-698,492. PUB. 3-1-2011. FILED 7-17-2009.

3,960,229 ( *See Class 8 for this trademark* ).

3,960,231. **SARTORIUS ALLSUITE (STANDARD CHARACTER)**. SARTORIUS AG, (U.S. CLS. 21, 23, 26, 36 AND 38). SN 76-702,114. PUB. 3-1-2011. FILED 3-17-2010.

3,960,256. **B-FORMAT (STANDARD CHARACTER)**. SOUND-FIELD LIMITED, (U.S. CLS. 21, 23, 26, 36 AND 38). SN 77-012,689. PUB. 3-1-2011. FILED 10-3-2006.

3,960,258. **METROSONICS (STANDARD CHARACTER)**. METROSONICS CONCEPTS LIMITED, MULTIPLE CLASS, (INT. CLS. 9 AND 41), (U.S. CLS. 21, 23, 26, 36, 38, 100, 101 AND 107). SN 77-086,256. PUB. 12-18-2007. FILED 1-19-2007.

3,960,260. **MISCELLANEOUS DESIGN**. CHORION RIGHTS LIMITED, MULTIPLE CLASS, (INT. CLS. 9, 16, 25, 28, 38 AND 41), (U.S. CLS. 2, 5, 21, 22, 23, 26, 29, 36, 37, 38, 39, 50, 100, 101, 104 AND 107). SN 77-140,634. PUB. 11-23-2010. FILED 3-26-2007.

3,960,272. **LITTLE MISS SCARY AND DESIGN**. THOIP, MULTIPLE CLASS, (INT. CLS. 9, 16, 25, 28 AND 41), (U.S. CLS. 2, 5, 21, 22, 23, 26, 29, 36, 37, 38, 39, 50, 100, 101 AND 107). SN 77-312,640. PUB. 8-18-2009. FILED 10-24-2007.

3,960,273 ( *See Class 5 for this trademark* ).

3,960,276. **LOGIGAIA (STANDARD CHARACTER)**. MURATA MACHINERY, LTD., (U.S. CLS. 21, 23, 26, 36 AND 38). SN 77-339,923. PUB. 3-1-2011. FILED 11-29-2007.

3,960,280. **WPM (STANDARD CHARACTER)**. TRIRIGA INC., MULTIPLE CLASS, (INT. CLS. 9, 35 AND 42), (U.S. CLS. 21,



- 23, 26, 36, 38, 100, 101 AND 102). SN 77-447,938. PUB. 3-1-2011. FILED 4-14-2008.
- 3,960,281 ( *See Class 6 for this trademark*).
- 3,960,282. **DSNET (STANDARD CHARACTER)**. CLEVERSAFE, INC., (U.S. CLS. 21, 23, 26, 36 AND 38). SN 77-472,764. PUB. 3-1-2011. FILED 5-13-2008.
- 3,960,286. **MISCELLANEOUS DESIGN**. BRAVOSOLUTION S.P.A., MULTIPLE CLASS, (INT. CLS. 9, 35, 38, 41 AND 42), (U.S. CLS. 21, 23, 26, 36, 38, 100, 101, 102, 104 AND 107). SN 77-500,743. PUB. 3-1-2011. FILED 6-17-2008.
- 3,960,289. **OCULUS INFO INC. (STANDARD CHARACTER)**. OCULUS INFO INC., MULTIPLE CLASS, (INT. CLS. 9 AND 42), (U.S. CLS. 21, 23, 26, 36, 38, 100 AND 101). SN 77-525,924. PUB. 3-1-2011. FILED 7-18-2008.
- 3,960,292. **GREENEDGE (STANDARD CHARACTER)**. HARMAN INTERNATIONAL INDUSTRIES, INCORPORATED, MULTIPLE CLASS, (INT. CLS. 9 AND 40), (U.S. CLS. 21, 23, 26, 36, 38, 100, 103 AND 106). SN 77-542,654. PUB. 3-1-2011. FILED 8-8-2008.
- 3,960,312. **SLIDELOCK (STANDARD CHARACTER)**. SLIDEME LLC, DBA SLIDEME, (U.S. CLS. 21, 23, 26, 36 AND 38). SN 77-659,135. PUB. 3-1-2011. FILED 1-29-2009.
- 3,960,331. **FIXED NOISE (STANDARD CHARACTER)**. FIXED NOISE, INC., DBA FIXED NOISE, INC., AND ARDALAN, JOANNA, (U.S. CLS. 21, 23, 26, 36 AND 38). SN 77-723,163. PUB. 3-1-2011. FILED 4-27-2009.
- 3,960,339. **HUXLEY THE DYSTOPIA AND DESIGN**. WEBZEN INC, MULTIPLE CLASS, (INT. CLS. 9, 16, 28, 41 AND 42), (U.S. CLS. 2, 5, 21, 22, 23, 26, 29, 36, 37, 38, 50, 100, 101 AND 107). SN 77-754,997. PUB. 3-1-2011. FILED 6-9-2009.
- 3,960,343. **MYTH WAR LEGENDS OF THE DARK 3 AND DESIGN**. IGG INC, MULTIPLE CLASS, (INT. CLS. 9 AND 41), (U.S. CLS. 21, 23, 26, 36, 38, 100, 101 AND 107). SN 77-769,734. PUB. 3-1-2011. FILED 6-28-2009.
- 3,960,349. **COWBELL GAMES BUNCH (STANDARD CHARACTER)**. COWBELL GAMES BUNCH, (U.S. CLS. 21, 23, 26, 36 AND 38). SN 77-782,553. PUB. 3-1-2011. FILED 7-16-2009.
- 3,960,353. **FILTRATE (STANDARD CHARACTER)**. FILTRATE PTY. LTD., MULTIPLE CLASS, (INT. CLS. 9 AND 25), (U.S. CLS. 21, 22, 23, 26, 36, 38 AND 39). SN 77-794,246. PUB. 3-1-2011. FILED 7-31-2009.
- 3,960,355 ( *See Class 3 for this trademark*).
- 3,960,356. **CITIZEN KATE (STANDARD CHARACTER)**. JULIA SVOBODA, (U.S. CLS. 21, 23, 26, 36 AND 38). SN 77-801,059. PUB. 8-10-2010. FILED 8-10-2009.
- 3,960,358. **VOLCANO (STANDARD CHARACTER)**. TECHFLEX, INC., (U.S. CLS. 21, 23, 26, 36 AND 38). SN 77-803,826. PUB. 3-1-2011. FILED 8-13-2009.
- 3,960,368 ( *See Class 7 for this trademark*).
- 3,960,373. **PICTURE WIZARD AND DESIGN**. LG ELECTRONICS INC., (U.S. CLS. 21, 23, 26, 36 AND 38). SN 77-815,112. PUB. 3-1-2011. FILED 8-28-2009.
- 3,960,377. **TOOB AND DESIGN**. TOOB LLC, (U.S. CLS. 21, 23, 26, 36 AND 38). SN 77-818,899. PUB. 3-1-2011. FILED 9-2-2009.
- 3,960,378. **HI-Q AND DESIGN**. AASTRA TECHNOLOGIES LIMITED, (U.S. CLS. 21, 23, 26, 36 AND 38). SN 77-819,378. PUB. 3-1-2011. FILED 9-3-2009.
- 3,960,380. **MICHAEL FRANTI AND SPEARHEAD (STANDARD CHARACTER)**. MICHAEL FRANTI, MULTIPLE CLASS, (INT. CLS. 9 AND 41), (U.S. CLS. 21, 23, 26, 36, 38, 100, 101 AND 107). SN 77-820,072. PUB. 3-1-2011. FILED 9-3-2009.
- 3,960,384. **BECOMING (STANDARD CHARACTER)**. HARDQUIN, JASON E., AND MILLER, JERRY L., AND PESSOA, CESAR J., (U.S. CLS. 21, 23, 26, 36 AND 38). SN 77-824,335. PUB. 3-1-2011. FILED 9-10-2009.
- 3,960,393. **REPORTSNOW (STANDARD CHARACTER)**. REPORTSNOW, INC., FORMERLY DOMINION SOFTWARE, LLC, (U.S. CLS. 21, 23, 26, 36 AND 38). SN 77-831,280. PUB. 8-31-2010. FILED 9-21-2009.
- 3,960,394. **SYNEXXUS (STANDARD CHARACTER)**. SYNEXXUS, INC., MULTIPLE CLASS, (INT. CLS. 9, 35 AND 42), (U.S. CLS. 21, 23, 26, 36, 38, 100, 101 AND 102). SN 77-831,301. PUB. 1-25-2011. FILED 9-21-2009.
- 3,960,395. **INTRICON (STANDARD CHARACTER)**. INTRICON CORPORATION, MULTIPLE CLASS, (INT. CLS. 9 AND 10), (U.S. CLS. 21, 23, 26, 36, 38, 39 AND 44). SN 77-831,894. PUB. 3-1-2011. FILED 9-22-2009.
- 3,960,397. **MISCELLANEOUS DESIGN**. ALIBABA GROUP HOLDING LIMITED, MULTIPLE CLASS, (INT. CLS. 9, 35, 36, 38, 39, 41 AND 42), (U.S. CLS. 21, 23, 26, 36, 38, 100, 101, 102, 104, 105 AND 107). SN 77-832,028. PUB. 3-1-2011. FILED 9-22-2009.
- 3,960,400. **ONEINTERFACE (STANDARD CHARACTER)**. GLOBAL REFUND HOLDINGS AB, MULTIPLE CLASS, (INT. CLS. 9, 36 AND 38), (U.S. CLS. 21, 23, 26, 36, 38, 100, 101, 102 AND 104). SN 77-834,875. PUB. 3-1-2011. FILED 9-25-2009.
- 3,960,405. **M MCAFEE AND DESIGN**. MCAFEE, INC., MULTIPLE CLASS, (INT. CLS. 9, 37 AND 42), (U.S. CLS. 21, 23, 26, 36, 38, 100, 101, 103 AND 106). SN 77-843,666. PUB. 3-1-2011. FILED 10-7-2009.
- 3,960,406. **M AND DESIGN**. MCAFEE, INC., MULTIPLE CLASS, (INT. CLS. 9, 37 AND 42), (U.S. CLS. 21, 23, 26, 36, 38, 100, 101, 103 AND 106). SN 77-843,670. PUB. 3-1-2011. FILED 10-7-2009.
- 3,960,407 ( *See Class 7 for this trademark*).
- 3,960,422. **IPASSWORD (STANDARD CHARACTER)**. AGILE WEB SOLUTIONS, INC., (U.S. CLS. 21, 23, 26, 36 AND 38). SN 77-872,651. PUB. 3-1-2011. FILED 11-13-2009.
- 3,960,423. **DATAIUM (STANDARD CHARACTER)**. DATAIUM, LLC, (U.S. CLS. 21, 23, 26, 36 AND 38). SN 77-875,357. PUB. 3-1-2011. FILED 11-18-2009.
- 3,960,429. **THE SHAKERS (STANDARD CHARACTER)**. LEE, CHRISTOPHER MARK, (U.S. CLS. 21, 23, 26, 36 AND 38). SN 77-878,963. PUB. 3-1-2011. FILED 11-23-2009.
- 3,960,431. **IPICO (STANDARD CHARACTER)**. IPICO INNOVATION INC., (U.S. CLS. 21, 23, 26, 36 AND 38). SN 77-882,886. PUB. 3-1-2011. FILED 12-1-2009.
- 3,960,439. **RAISIN' RECORDS (STANDARD CHARACTER)**. BNL ENTERTAINMENT INC., MULTIPLE CLASS, (INT. CLS. 9 AND 41), (U.S. CLS. 21, 23, 26, 36, 38, 100, 101 AND 107). SN 77-896,781. PUB. 3-1-2011. FILED 12-18-2009.
- 3,960,443. **DCLM (STANDARD CHARACTER)**. LITERA CORP., (U.S. CLS. 21, 23, 26, 36 AND 38). SN 77-901,125. PUB. 3-1-2011. FILED 12-27-2009.
- 3,960,451. **MARINE TECHNOLOGY SOCIETY (STANDARD CHARACTER)**. MARINE TECHNOLOGY SOCIETY, INC., AKA MTS, MULTIPLE CLASS, (INT. CLS. 9, 16, 35, 36 AND 41), (U.S. CLS. 2, 5, 21, 22, 23, 26, 29, 36, 37, 38, 50, 100, 101, 102 AND 107). SN 77-911,917. PUB. 3-1-2011. FILED 1-14-2010.
- 3,960,456. **LCBC (STANDARD CHARACTER)**. LANCASTER COUNTY BIBLE CHURCH, MULTIPLE CLASS, (INT. CLS. 9, 41 AND 45), (U.S. CLS. 21, 23, 26, 36, 38, 100, 101 AND 107). SN 77-918,038. PUB. 3-1-2011. FILED 1-22-2010.
- 3,960,457. **LIVES CHANGED BY CHRIST (STANDARD CHARACTER)**. LANCASTER COUNTY BIBLE CHURCH, MULTIPLE CLASS, (INT. CLS. 9, 41 AND 45), (U.S. CLS. 21, 23, 26, 36, 38, 100, 101 AND 107). SN 77-918,057. PUB. 3-1-2011. FILED 1-22-2010.
- 3,960,458. **LCBC AND DESIGN**. LANCASTER COUNTY BIBLE CHURCH, MULTIPLE CLASS, (INT. CLS. 9, 41 AND 45), (U.S. CLS. 21, 23, 26, 36, 38, 100, 101 AND 107). SN 77-918,085. PUB. 3-1-2011. FILED 1-22-2010.
- 3,960,460 ( *See Class 7 for this trademark*).
- 3,960,466. **ALIMAMA (STANDARD CHARACTER)**. ALIBABA GROUP HOLDING LIMITED, MULTIPLE CLASS, (INT. CLS. 9, 35, 38 AND 42), (U.S. CLS. 21, 23, 26, 36, 38, 100, 101, 102 AND 104). SN 77-922,826. PUB. 3-1-2011. FILED 1-28-2010.
- 3,960,468. **LADY GAGA (STANDARD CHARACTER)**. ATE MY HEART INC., MULTIPLE CLASS, (INT. CLS. 9, 16, 25, 35, 38 AND 41), (U.S. CLS. 2, 5, 21, 22, 23, 26, 29, 36, 37, 38, 39, 50, 100, 101, 102, 104 AND 107). SN 77-925,278. PUB. 3-1-2011. FILED 2-1-2010.
- 3,960,469. **INTELLIGYM (STANDARD CHARACTER)**. ACE - APPLIED COGNITIVE ENGINEERING, LTD., (U.S. CLS. 21, 23, 26, 36 AND 38). SN 77-926,068. PUB. 3-1-2011. FILED 2-2-2010.
- 3,960,478. **INSTRUCTOR (STANDARD CHARACTER)**. SARIN TECHNOLOGIES, LTD., (U.S. CLS. 21, 23, 26, 36 AND 38). SN 77-933,247. PUB. 3-1-2011. FILED 2-11-2010.
- 3,960,481. **TRUBEND AND DESIGN**. TRUBEND SYSTEMS, INC., (U.S. CLS. 21, 23, 26, 36 AND 38). SN 77-933,561. PUB.

- 3-1-2011. FILED 2-11-2010.
- 3,960,492. **NOVO ALTUM (STANDARD CHARACTER)**. NOVO ALTUM LIMITED, MULTIPLE CLASS, (INT. CLS. 9, 16, 35, 36, 41 AND 45), (U.S. CLS. 2, 5, 21, 22, 23, 26, 29, 36, 37, 38, 50, 100, 101, 102 AND 107). SN 77-942,632. PUB. 3-1-2011. FILED 2-23-2010.
- 3,960,498. **CROSS FIELD FILMS (STANDARD CHARACTER)**. SAME SEEDS DIFFERENT WINDS FOUNDATION, MULTIPLE CLASS, (INT. CLS. 9 AND 41), (U.S. CLS. 21, 23, 26, 36, 38, 100, 101 AND 107). SN 77-945,268. PUB. 3-1-2011. FILED 2-25-2010.
- 3,960,503. **FT FIITOTECH AND DESIGN**. FIITOTECH COMPANY LIMITED, MULTIPLE CLASS, (INT. CLS. 9, 35, 41 AND 42), (U.S. CLS. 21, 23, 26, 36, 38, 100, 101, 102 AND 107). SN 77-946,019. PUB. 3-1-2011. FILED 2-26-2010.
- 3,960,510. **DIGITAL INFUZION (STANDARD CHARACTER)**. HEMANT VIRKAR, MULTIPLE CLASS, (INT. CLS. 9, 35, 42 AND 44), (U.S. CLS. 21, 23, 26, 36, 38, 100, 101 AND 102). SN 77-946,855. PUB. 3-1-2011. FILED 2-28-2010.
- 3,960,529. **MISCELLANEOUS DESIGN**. PEARL JAM, L.L.C., MULTIPLE CLASS, (INT. CLS. 9, 16 AND 25), (U.S. CLS. 2, 5, 21, 22, 23, 26, 29, 36, 37, 38, 39 AND 50). SN 77-953,649. PUB. 3-1-2011. FILED 3-8-2010.
- 3,960,535. **PEARL JAM AND DESIGN**. PEARL JAM, L.L.C., MULTIPLE CLASS, (INT. CLS. 9, 16 AND 25), (U.S. CLS. 2, 5, 21, 22, 23, 26, 29, 36, 37, 38, 39 AND 50). SN 77-954,786. PUB. 3-1-2011. FILED 3-9-2010.
- 3,960,549 ( *See Class 3 for this trademark*).
- 3,960,550. **CULINARY BUSINESS ACADEMY EXPERIENTIS COQUUS AND DESIGN**. CULINARY BUSINESS ACADEMY LLC, (U.S. CLS. 21, 23, 26, 36 AND 38). SN 77-959,806. PUB. 3-1-2011. FILED 3-16-2010.
- 3,960,551. **CULINARY BUSINESS ACADEMY (STANDARD CHARACTER)**. CULINARY BUSINESS ACADEMY LLC, (U.S. CLS. 21, 23, 26, 36 AND 38). SN 77-959,816. PUB. 3-1-2011. FILED 3-16-2010.
- 3,960,557. **MAXCYTE GT (STANDARD CHARACTER)**. MAXCYTE, INC., (U.S. CLS. 21, 23, 26, 36 AND 38). SN 77-961,177. PUB. 3-1-2011. FILED 3-17-2010.
- 3,960,558. **ARDENT SKY (STYLIZED)**. ARDENTSKY, LLC, MULTIPLE CLASS, (INT. CLS. 9, 35 AND 42), (U.S. CLS. 21, 23, 26, 36, 38, 100, 101 AND 102). SN 77-961,338. PUB. 3-1-2011. FILED 3-17-2010.
- 3,960,560. **ZADOK (STANDARD CHARACTER)**. HASTY, PAUL, (U.S. CLS. 21, 23, 26, 36 AND 38). SN 77-961,810. PUB. 3-1-2011. FILED 3-18-2010.
- 3,960,564. **PRI-STAT (STANDARD CHARACTER)**. PREMIUM KNOWLEDGE GROUP, MULTIPLE CLASS, (INT. CLS. 9 AND 35), (U.S. CLS. 21, 23, 26, 36, 38, 100, 101 AND 102). SN 77-962,896. PUB. 3-1-2011. FILED 3-19-2010.
- 3,960,565. **U.S. KUKKIWON U.S. TAEKWONDO HEADQUARTERS AND DESIGN**. LEE, SANG, AND LEE, JAY, MULTIPLE CLASS, (INT. CLS. 9, 18, 25, 41 AND 42), (U.S. CLS. 1, 2, 3, 21, 22, 23, 26, 36, 38, 39, 41, 100, 101 AND 107). SN 77-964,510. PUB. 3-1-2011. FILED 3-22-2010.
- 3,960,573. **LINECT (STANDARD CHARACTER)**. ZUMTOBEL LIGHTING GMBH, MULTIPLE CLASS, (INT. CLS. 9 AND 11), (U.S. CLS. 13, 21, 23, 26, 31, 34, 36 AND 38). SN 77-965,866. PUB. 3-1-2011. FILED 3-23-2010.
- 3,960,574. **LI-NECT AND DESIGN**. ZUMTOBEL LIGHTING GMBH, MULTIPLE CLASS, (INT. CLS. 9 AND 11), (U.S. CLS. 13, 21, 23, 26, 31, 34, 36 AND 38). SN 77-965,898. PUB. 3-1-2011. FILED 3-23-2010.
- 3,960,575. **SNAP-N-GO CHAPS THE CHAP THAT'S A SNAP! (STANDARD CHARACTER)**. MOORE, JOHN A., (U.S. CLS. 21, 23, 26, 36 AND 38). SN 77-965,946. PUB. 3-1-2011. FILED 3-23-2010.
- 3,960,596. **MIYAKOSHI PRINTING MACHINERY CO., LTD (STYLIZED)**. MIYAKOSHI PRINTING MACHINERY CO., LTD., (U.S. CLS. 21, 23, 26, 36 AND 38). SN 77-968,513. PUB. 3-1-2011. FILED 3-25-2010.
- 3,960,599. **EXECUTIVE ANALYZER (STANDARD CHARACTER)**. WWW VIAJEZ COM, S.A. DE C.V., (U.S. CLS. 21, 23, 26, 36 AND 38). SN 77-969,134. PUB. 3-1-2011. FILED 3-26-2010.
- 3,960,600. **VACATION ASSEMBLER (STANDARD CHARACTER)**. WWW VIAJEZ COM, S.A. DE C.V., (U.S. CLS. 21, 23, 26, 36 AND 38). SN 77-969,143. PUB. 3-1-2011. FILED 3-26-2010.
- 3,960,605. **B-CALM (STANDARD CHARACTER)**. B-CALM, LLC, (U.S. CLS. 21, 23, 26, 36 AND 38). SN 77-969,671. PUB. 3-1-2011. FILED 3-26-2010.
- 3,960,619. **MADMEN AND DESIGN**. LIONS GATE ENTERTAINMENT, INC., MULTIPLE CLASS, (INT. CLS. 9, 21, 34 AND 41), (U.S. CLS. 2, 8, 9, 13, 17, 21, 23, 26, 29, 30, 33, 36, 38, 40, 50, 100, 101 AND 107). SN 77-979,823. PUB. 3-1-2011. FILED 1-21-2010.
- 3,960,621. **CS CONTROL SOLUTIONS INC. INNOVATIVE SOLUTIONS FOR A WORLD IN MOTION WWW.CONTROLS.COM AND DESIGN**. CONTROL SOLUTIONS LLC, (U.S. CLS. 21, 23, 26, 36 AND 38). SN 77-981,094. PUB. 5-19-2009. FILED 7-11-2007.
- 3,960,622. **BICO AUSTRALIA AND DESIGN**. BICO AUSTRALIA PTY LIMITED, MULTIPLE CLASS, (INT. CLS. 9, 14 AND 25), (U.S. CLS. 2, 21, 22, 23, 26, 27, 28, 36, 38, 39 AND 50). SN 77-981,533. PUB. 12-4-2007. FILED 9-19-2006.
- 3,960,626. **DUNDEE WEALTH BANK (STYLIZED)**. DUNDEE CORPORATION, MULTIPLE CLASS, (INT. CLS. 9 AND 36), (U.S. CLS. 21, 23, 26, 36, 38, 100, 101 AND 102). SN 78-492,061. PUB. 3-1-2011. FILED 9-30-2004.
- 3,960,628 ( *See Class 1 for this trademark*).
- 3,960,638. **BONBON (STANDARD CHARACTER)**. ALEXANDRA SELECTION, MULTIPLE CLASS, (INT. CLS. 9, 14, 18 AND 26), (U.S. CLS. 1, 2, 3, 21, 22, 23, 26, 27, 28, 36, 37, 38, 39, 40, 41, 42 AND 50). SN 79-003,271. PUB. 3-1-2011. FILED 5-11-2004.
- 3,960,640. **SYSTEM@TIC PARIS-REGION AND DESIGN**. OPTICSVALLEY, MULTIPLE CLASS, (INT. CLS. 9, 38 AND 42), (U.S. CLS. 21, 23, 26, 36, 38, 100, 101 AND 104). SN 79-027,922. PUB. 3-1-2011. FILED 10-14-2005.
- 3,960,641. **EPIHELP (STANDARD CHARACTER)**. BOEHLKE, RAIMAR, MULTIPLE CLASS, (INT. CLS. 9, 35, 38, 41, 42 AND 44), (U.S. CLS. 21, 23, 26, 36, 38, 100, 101, 102, 104 AND 107). SN 79-058,951. PUB. 3-1-2011. FILED 2-1-2008.
- 3,960,642. **EURESCOM (STYLIZED)**. EURESCOM-EUROPEAN INSTITUTE; FOR RESEARCH AND STRATEGIC STUDIES; IN TELECOMMUNICATION-GMBH, MULTIPLE CLASS, (INT. CLS. 9, 38 AND 42), (U.S. CLS. 21, 23, 26, 36, 38, 100, 101 AND 104). SN 79-065,866. PUB. 3-1-2011. FILED 1-22-2008.
- 3,960,643. **\*BLUE (STYLIZED)**. NORDIC SEMICONDUCTOR ASA, (U.S. CLS. 21, 23, 26, 36 AND 38). SN 79-067,834. PUB. 3-1-2011. FILED 1-28-2009.
- 3,960,645. **BEBOOK AND DESIGN**. BEBOOK, MULTIPLE CLASS, (INT. CLS. 9, 16, 35, 38, 39, 41 AND 42), (U.S. CLS. 2, 5, 21, 22, 23, 26, 29, 36, 37, 38, 50, 100, 101, 102, 104, 105 AND 107). SN 79-068,789. PUB. 8-31-2010. FILED 9-19-2008.
- 3,960,648. **NEWSTIN (STANDARD CHARACTER)**. NEWSTIN A.S., MULTIPLE CLASS, (INT. CLS. 9, 35, 36, 38, 41 AND 42), (U.S. CLS. 21, 23, 26, 36, 38, 100, 101, 102, 104 AND 107). SN 79-070,844. PUB. 3-1-2011. FILED 12-15-2008.
- 3,960,649. **MUEGGE (STANDARD CHARACTER)**. ROTH & RAU MUEGGE GMBH, MULTIPLE CLASS, (INT. CLS. 9, 37, 41 AND 42), (U.S. CLS. 21, 23, 26, 36, 38, 100, 101, 103, 106 AND 107). SN 79-070,949. PUB. 3-1-2011. FILED 2-27-2009.
- 3,960,651 ( *See Class 6 for this trademark*).
- 3,960,655. **MUM KNOWS BEST.COM AND DESIGN**. MUM KNOWS BEST LIMITED, MULTIPLE CLASS, (INT. CLS. 9, 16, 35 AND 41), (U.S. CLS. 2, 5, 21, 22, 23, 26, 29, 36, 37, 38, 50, 100, 101, 102 AND 107). SN 79-073,303. PUB. 3-1-2011. FILED 4-30-2009.
- 3,960,656. **B-PACK (STANDARD CHARACTER)**. B-PACK, MULTIPLE CLASS, (INT. CLS. 9 AND 42), (U.S. CLS. 21, 23, 26, 36, 38, 100 AND 101). SN 79-073,932. PUB. 3-1-2011. FILED 8-21-2009.
- 3,960,658 ( *See Class 7 for this trademark*).
- 3,960,660 ( *See Class 3 for this trademark*).
- 3,960,666. **H (STYLIZED)**. LAGARDERE SCA, MULTIPLE CLASS, (INT. CLS. 9, 16, 28, 35, 38, 41 AND 42), (U.S. CLS. 2, 5, 21, 22, 23, 26, 29, 36, 37, 38, 50, 100, 101, 102, 104 AND 107). SN 79-075,495. PUB. 3-1-2011. FILED 4-9-2009.
- 3,960,668. **XSERIES (STANDARD CHARACTER)**. NOKIA CORPORATION, (U.S. CLS. 21, 23, 26, 36 AND 38). SN 79-075,546. PUB. 6-22-2010. FILED 10-13-2009.
- 3,960,669. **STAFF & LINE AND DESIGN**. STAFF AND LINE, MULTIPLE CLASS, (INT. CLS. 9, 35, 38 AND 42), (U.S. CLS.



- 21, 23, 26, 36, 38, 100, 101, 102 AND 104). SN 79-075,650. PUB. 3-1-2011. FILED 7-31-2009.
- 3,960,671. **MISCELLANEOUS DESIGN**. CASARINI, ANNA, MULTIPLE CLASS, (INT. CLS. 9, 12 AND 25), (U.S. CLS. 19, 21, 22, 23, 26, 31, 35, 36, 38, 39 AND 44). SN 79-075,768. PUB. 3-1-2011. FILED 11-4-2009.
- 3,960,673. **KÖRPERTECH ARMOUR SKIN AND DESIGN**. BLITZ-CORPORATION LTD, MULTIPLE CLASS, (INT. CLS. 9, 25 AND 28), (U.S. CLS. 21, 22, 23, 26, 36, 38, 39 AND 50). SN 79-076,309. PUB. 3-1-2011. FILED 8-26-2009.
- 3,960,675. **VIVENDI, A WORLD OF TELECOMMUNICATIONS (STANDARD CHARACTER)**. VIVENDI, MULTIPLE CLASS, (INT. CLS. 9, 16, 35, 38, 41 AND 42), (U.S. CLS. 2, 5, 21, 22, 23, 26, 29, 36, 37, 38, 50, 100, 101, 102, 104 AND 107). SN 79-076,925. PUB. 3-1-2011. FILED 6-8-2009.
- 3,960,676. **VIVENDI, A WORLD OF VIDEO GAMES (STANDARD CHARACTER)**. VIVENDI, MULTIPLE CLASS, (INT. CLS. 9, 16, 28, 38, 41 AND 42), (U.S. CLS. 2, 5, 21, 22, 23, 26, 29, 36, 37, 38, 50, 100, 101, 104 AND 107). SN 79-076,958. PUB. 3-1-2011. FILED 6-8-2009.
- 3,960,678 ( *See Class 5 for this trademark*).
- 3,960,680. **GLOBAL BLUE (STANDARD CHARACTER)**. GLOBAL BLUE HOLDINGS AB, MULTIPLE CLASS, (INT. CLS. 9, 16, 35 AND 36), (U.S. CLS. 2, 5, 21, 22, 23, 26, 29, 36, 37, 38, 50, 100, 101 AND 102). SN 79-077,888. PUB. 3-1-2011. FILED 12-8-2009.
- 3,960,683. **SANREMO (STANDARD CHARACTER)**. SANDVIK MINING AND CONSTRUCTION OY, MULTIPLE CLASS, (INT. CLS. 9 AND 42), (U.S. CLS. 21, 23, 26, 36, 38, 100 AND 101). SN 79-078,237. PUB. 3-1-2011. FILED 10-8-2009.
- 3,960,689 ( *See Class 6 for this trademark*).
- 3,960,694. **FLARESonic (STANDARD CHARACTER)**. ELSTER NV/SA, (U.S. CLS. 21, 23, 26, 36 AND 38). SN 79-080,650. PUB. 3-1-2011. FILED 2-18-2010.
- 3,960,695. **BIOSonic (STANDARD CHARACTER)**. ELSTER NV/SA, (U.S. CLS. 21, 23, 26, 36 AND 38). SN 79-080,651. PUB. 3-1-2011. FILED 2-18-2010.
- 3,960,696. **Q.Sonic (STANDARD CHARACTER)**. ELSTER NV/SA, (U.S. CLS. 21, 23, 26, 36 AND 38). SN 79-080,711. PUB. 3-1-2011. FILED 2-18-2010.
- 3,960,697. **VX.Sonic (STANDARD CHARACTER)**. ELSTER NV/SA, (U.S. CLS. 21, 23, 26, 36 AND 38). SN 79-080,713. PUB. 3-1-2011. FILED 2-18-2010.
- 3,960,698. **M.Sonic (STANDARD CHARACTER)**. ELSTER NV/SA, (U.S. CLS. 21, 23, 26, 36 AND 38). SN 79-080,715. PUB. 3-1-2011. FILED 2-18-2010.
- 3,960,702. **KEDU (STYLIZED)**. ZHEJIANG KEDU ELECTRIC MANUFACTURING CO., LTD., (U.S. CLS. 21, 23, 26, 36 AND 38). SN 79-080,925. PUB. 3-1-2011. FILED 2-22-2010.
- 3,960,707. **WARGAMING.NET AND DESIGN**. WARGAMING.NET LLP, MULTIPLE CLASS, (INT. CLS. 9, 16 AND 41), (U.S. CLS. 2, 5, 21, 22, 23, 26, 29, 36, 37, 38, 50, 100, 101 AND 107). SN 79-081,202. PUB. 3-1-2011. FILED 3-19-2010.
- 3,960,708. **ENHANCING LIFE WITH LIGHT (STANDARD CHARACTER)**. KONINKLIJKE PHILIPS ELECTRONICS N.V., MULTIPLE CLASS, (INT. CLS. 9, 11 AND 42), (U.S. CLS. 13, 21, 23, 26, 31, 34, 36, 38, 100 AND 101). SN 79-081,240. PUB. 3-1-2011. FILED 3-23-2010.
- 3,960,714. **BEEWI (STYLIZED)**. VOXLAND, MULTIPLE CLASS, (INT. CLS. 9, 35 AND 38), (U.S. CLS. 21, 23, 26, 36, 38, 100, 101, 102 AND 104). SN 79-081,601. PUB. 3-1-2011. FILED 7-10-2009.
- 3,960,716. **FUGRO WORLD (STANDARD CHARACTER)**. FUGRO N.V., MULTIPLE CLASS, (INT. CLS. 9, 35, 41 AND 42), (U.S. CLS. 21, 23, 26, 36, 38, 100, 101, 102 AND 107). SN 79-081,656. PUB. 3-1-2011. FILED 3-18-2010.
- 3,960,717 ( *See Class 7 for this trademark*).
- 3,960,719 ( *See Class 6 for this trademark*).
- 3,960,720. **CRIZAL EASY (STANDARD CHARACTER)**. ESSLOR INTERNATIONAL (COMPAGNIE GENERALE D'OPTIQUE), MULTIPLE CLASS, (INT. CLS. 9 AND 40), (U.S. CLS. 21, 23, 26, 36, 38, 100, 103 AND 106). SN 79-081,841. PUB. 3-1-2011. FILED 3-10-2010.
- 3,960,723. **INPOTRON SCHALTNETZTEILE SWITCH MODE POWER SUPPLIES AND DESIGN**. INPOTRON SCHALTNETZTEILE GMBH, MULTIPLE CLASS, (INT. CLS. 9 AND 42), (U.S. CLS. 21, 23, 26, 36, 38, 100 AND 101). SN 79-081,988. PUB. 3-1-2011. FILED 2-10-2010.
- 3,960,726. **SP AND DESIGN**. ZHEJIANG ANTONG ELECTRIC CO., LTD., (U.S. CLS. 21, 23, 26, 36 AND 38). SN 79-082,107. PUB. 3-1-2011. FILED 2-24-2010.
- 3,960,730. **CONNECTED-CAR (STANDARD CHARACTER)**. IMST GMBH, MULTIPLE CLASS, (INT. CLS. 9 AND 42), (U.S. CLS. 21, 23, 26, 36, 38, 100 AND 101). SN 79-082,251. PUB. 3-1-2011. FILED 3-3-2010.
- 3,960,731. **TELECA (STANDARD CHARACTER)**. TELECA AB, MULTIPLE CLASS, (INT. CLS. 9, 38 AND 42), (U.S. CLS. 21, 23, 26, 36, 38, 100, 101 AND 104). SN 79-082,285. PUB. 3-1-2011. FILED 2-5-2010.
- 3,960,732. **FIRSTVIEW (STANDARD CHARACTER)**. OCEANUS OPERATING COMPANY LIMITED, MULTIPLE CLASS, (INT. CLS. 9 AND 42), (U.S. CLS. 21, 23, 26, 36, 38, 100 AND 101). SN 79-082,333. PUB. 3-1-2011. FILED 3-29-2010.
- 3,960,733 ( *See Class 7 for this trademark*).
- 3,960,734. **VISCOMAN (STANDARD CHARACTER)**. GILSON SAS, (U.S. CLS. 21, 23, 26, 36 AND 38). SN 79-082,440. PUB. 3-1-2011. FILED 4-12-2010.
- 3,960,744. **NEZCA (STYLIZED)**. KIYOHARA KABUSHIKI KAISHA, MULTIPLE CLASS, (INT. CLS. 9, 14, 18, 25 AND 26), (U.S. CLS. 1, 2, 3, 21, 22, 23, 26, 27, 28, 36, 37, 38, 39, 40, 41, 42 AND 50). SN 79-082,853. PUB. 3-1-2011. FILED 3-10-2010.
- 3,960,750 ( *See Class 5 for this trademark*).
- 3,960,754. **OSLUX (STANDARD CHARACTER)**. OSRAM; GESELLSCHAFT MIT BESCHRÄNKTER HAFTUNG, DBA OSRAM GMBH, MULTIPLE CLASS, (INT. CLS. 9 AND 11), (U.S. CLS. 13, 21, 23, 26, 31, 34, 36 AND 38). SN 79-083,423. PUB. 3-1-2011. FILED 5-4-2010.
- 3,960,757 ( *See Class 1 for this trademark*).
- 3,960,759 ( *See Class 7 for this trademark*).
- 3,960,762. **X GSSM AND DESIGN**. GLOBAL SAFETY; SOLUTIONS & MANAGEMENT PTY LTD, (U.S. CLS. 21, 23, 26, 36 AND 38). SN 79-083,760. PUB. 3-1-2011. FILED 4-16-2010.
- 3,960,771. **LOCATEL (STANDARD CHARACTER)**. LOCATEL FRANCE, MULTIPLE CLASS, (INT. CLS. 9, 37, 38 AND 42), (U.S. CLS. 21, 23, 26, 36, 38, 100, 101, 103, 104 AND 106). SN 79-084,325. PUB. 3-1-2011. FILED 12-2-2009.
- 3,960,776. **ECP (STANDARD CHARACTER)**. AT & S AUSTRIA TECHNOLOGIE & SYSTEMTECHNIK AKTIENGESELLSCHAFT, MULTIPLE CLASS, (INT. CLS. 9 AND 42), (U.S. CLS. 21, 23, 26, 36, 38, 100 AND 101). SN 79-084,376. PUB. 3-1-2011. FILED 4-20-2010.
- 3,960,784. **XMPRO (STANDARD CHARACTER)**. OXEMIN PTY LIMITED, MULTIPLE CLASS, (INT. CLS. 9 AND 42), (U.S. CLS. 21, 23, 26, 36, 38, 100 AND 101). SN 79-084,939. PUB. 3-1-2011. FILED 3-31-2010.
- 3,960,786. **MISCELLANEOUS DESIGN**. GUANGZHOU HONGLI OPTO-ELECTRONIC CO., LTD., MULTIPLE CLASS, (INT. CLS. 9 AND 11), (U.S. CLS. 13, 21, 23, 26, 31, 34, 36 AND 38). SN 79-085,205. PUB. 3-1-2011. FILED 5-21-2010.
- 3,960,787. **FRUIT NINJA AND DESIGN**. HALFBRICK STUDIOS PTY LTD, (U.S. CLS. 21, 23, 26, 36 AND 38). SN 79-085,213. PUB. 3-1-2011. FILED 7-12-2010.
- 3,960,795. **ABBEY ROAD STUDIOS AND DESIGN**. EMI (IP) LIMITED, MULTIPLE CLASS, (INT. CLS. 9, 16, 18, 25, 38, 41 AND 42), (U.S. CLS. 1, 2, 3, 5, 21, 22, 23, 26, 29, 36, 37, 38, 39, 41, 50, 100, 101, 104 AND 107). SN 79-085,903. PUB. 3-1-2011. FILED 5-7-2010.
- 3,960,808. **UTALK (STANDARD CHARACTER)**. EUROTALK LIMITED, (U.S. CLS. 21, 23, 26, 36 AND 38). SN 79-086,527. PUB. 11-23-2010. FILED 4-27-2010.
- 3,960,821. **SKIIPRACK (STANDARD CHARACTER)**. SEMIKRON INTERNATIONAL GMBH, (U.S. CLS. 21, 23, 26, 36 AND 38). SN 79-087,846. PUB. 3-1-2011. FILED 6-18-2010.
- 3,960,822. **D Y N A S T R O N-R (STANDARD CHARACTER)**. KABUSHIKI KAISHA TOSHIBA, (U.S. CLS. 21, 23, 26, 36 AND 38). SN 79-087,877. PUB. 3-1-2011. FILED 9-13-2010.
- 3,960,825. **EJENDALS (STYLIZED)**. PER-OLOF EJENDAL AKTIEBOLAG, (U.S. CLS. 21, 23, 26, 36 AND 38). SN 79-088,329. PUB. 3-1-2011. FILED 5-25-2010.
- 3,960,827. **JALAS AND DESIGN**. PER-OLOF EJENDAL AKTIEBOLAG, MULTIPLE CLASS, (INT. CLS. 9 AND 25), (U.S. CLS. 21, 22, 23, 26, 36, 38 AND 39). SN 79-088,505. PUB. 3-1-2011. FILED 5-25-2010.
- 3,960,828. **SFI (STANDARD CHARACTER)**. SCHUBERTH

- GMBH, (U.S. CLS. 21, 23, 26, 36 AND 38), SN 79-088,616. PUB. 3-1-2011. FILED 9-10-2010.
- 3,960,830. **SQUISH (STYLIZED)**, LOADING MEDIA SARL, MULTIPLE CLASS, (INT. CLS. 9, 16, 28 AND 41), (U.S. CLS. 2, 5, 21, 22, 23, 26, 29, 36, 37, 38, 50, 100, 101 AND 107). SN 79-089,391. PUB. 3-1-2011. FILED 9-8-2010.
- 3,960,842. **CON-VERSE BY ROSTRA (STYLIZED)**, ROSTRA PRECISION CONTROLS, INC., (U.S. CLS. 21, 23, 26, 36 AND 38), SN 85-002,078. PUB. 8-31-2010. FILED 3-30-2010.
- 3,960,845. **HOLISTIC MANAGEMENT INTERNATIONAL / HEALTHY LAND / SUSTAINABLE FUTURE AND DESIGN**, HOLISTIC MANAGEMENT INTERNATIONAL, MULTIPLE CLASS, (INT. CLS. 9, 35 AND 41), (U.S. CLS. 21, 23, 26, 36, 38, 100, 101, 102 AND 107). SN 85-002,357. PUB. 3-1-2011. FILED 3-30-2010.
- 3,960,860. **INVEOR (STANDARD CHARACTER)**, KOSTAL INDUSTRIE ELECTRIK GMBH, (U.S. CLS. 21, 23, 26, 36 AND 38), SN 85-007,104. PUB. 3-1-2011. FILED 4-6-2010.
- 3,960,866. **BEYONDTRUST PRIVILEGE, MADE SIMPLE AND DESIGN**, BEYONDTRUST SOFTWARE, INC., (U.S. CLS. 21, 23, 26, 36 AND 38), SN 85-008,227. PUB. 3-1-2011. FILED 4-7-2010.
- 3,960,868 ( *See Class 1 for this trademark*).
- 3,960,877. **ASSURE6 (STANDARD CHARACTER)**, COMMAND INFORMATION, INC., (U.S. CLS. 21, 23, 26, 36 AND 38), SN 85-012,043. PUB. 3-1-2011. FILED 4-12-2010.
- 3,960,878. **INSTAPARK (STANDARD CHARACTER)**, NBO GROUP, INC., (U.S. CLS. 21, 23, 26, 36 AND 38), SN 85-012,144. PUB. 3-1-2011. FILED 4-12-2010.
- 3,960,883. **XPAND ONE (STANDARD CHARACTER)**, X6D LIMITED, (U.S. CLS. 21, 23, 26, 36 AND 38), SN 85-014,415. PUB. 3-1-2011. FILED 4-15-2010.
- 3,960,887 ( *See Class 7 for this trademark*).
- 3,960,890. **TE AND DESIGN**, DELTA T ENGINEERING, LLC, (U.S. CLS. 21, 23, 26, 36 AND 38), SN 85-017,170. PUB. 3-1-2011. FILED 4-19-2010.
- 3,960,892. **BOLA AND DESIGN**, PLAYDOM, INC., MULTIPLE CLASS, (INT. CLS. 9, 41, 42 AND 45), (U.S. CLS. 21, 23, 26, 36, 38, 100, 101 AND 107). SN 85-017,808. PUB. 3-1-2011. FILED 4-20-2010.
- 3,960,894. **SKEDS AND DESIGN**, 365 SCHEDULE, LTD., MULTIPLE CLASS, (INT. CLS. 9 AND 42), (U.S. CLS. 21, 23, 26, 36, 38, 100 AND 101). SN 85-018,019. PUB. 3-1-2011. FILED 4-20-2010.
- 3,960,904. **BIOMATCH (STANDARD CHARACTER)**, PRECISE BIOMETRICS AB, MULTIPLE CLASS, (INT. CLS. 9 AND 42), (U.S. CLS. 21, 23, 26, 36, 38, 100 AND 101). SN 85-022,739. PUB. 3-1-2011. FILED 4-26-2010.
- 3,960,906. **MASTERTRON (STANDARD CHARACTER)**, NIHON VIDEO SYSTEM CO., LTD., (U.S. CLS. 21, 23, 26, 36 AND 38), SN 85-023,275. PUB. 3-1-2011. FILED 4-26-2010.
- 3,960,916. **TANGO AND DESIGN**, HEALTH CARE SUCCESS OY, (U.S. CLS. 21, 23, 26, 36 AND 38), SN 85-028,784. PUB. 3-1-2011. FILED 5-3-2010.
- 3,960,921. **TOTAL DYNAMICS SOLUTIONS AND DESIGN**, TOTAL DYNAMICS SOLUTIONS, LLC, MULTIPLE CLASS, (INT. CLS. 9 AND 42), (U.S. CLS. 21, 23, 26, 36, 38, 100 AND 101). SN 85-031,582. PUB. 3-1-2011. FILED 5-6-2010.
- 3,960,940. **50 MINERS (STANDARD CHARACTER)**, ARISTOCRAT TECHNOLOGIES PTY LTD, (U.S. CLS. 21, 23, 26, 36 AND 38), SN 85-040,251. PUB. 3-1-2011. FILED 5-17-2010.
- 3,960,941. **GANGSTER'S GOLD (STANDARD CHARACTER)**, ARISTOCRAT TECHNOLOGIES PTY LTD, (U.S. CLS. 21, 23, 26, 36 AND 38), SN 85-040,321. PUB. 3-1-2011. FILED 5-17-2010.
- 3,960,942. **JADE GARDEN (STANDARD CHARACTER)**, ARISTOCRAT TECHNOLOGIES PTY LTD, (U.S. CLS. 21, 23, 26, 36 AND 38), SN 85-040,341. PUB. 3-1-2011. FILED 5-17-2010.
- 3,960,943. **WILD TOOTH (STANDARD CHARACTER)**, ARISTOCRAT TECHNOLOGIES PTY LTD, (U.S. CLS. 21, 23, 26, 36 AND 38), SN 85-040,358. PUB. 3-1-2011. FILED 5-17-2010.
- 3,960,944. **HAX (STANDARD CHARACTER)**, HAX TECHNOLOGIES, LLC, (U.S. CLS. 21, 23, 26, 36 AND 38), SN 85-040,378. PUB. 3-1-2011. FILED 5-17-2010.
- 3,960,959. **MANICOTTI (STANDARD CHARACTER)**, ROSS, DAVID JONATHAN, (U.S. CLS. 21, 23, 26, 36 AND 38), SN 85-047,174. PUB. 3-1-2011. FILED 5-25-2010.
- 3,960,963. **MCOMETMP (STANDARD CHARACTER)**, SYSTEMS ENGINEERING ASSOCIATES INTERNATIONAL INC., (U.S. CLS. 21, 23, 26, 36 AND 38), SN 85-048,832. PUB. 3-1-2011. FILED 5-26-2010.
- 3,960,965. **ZAPSHIELD (STANDARD CHARACTER)**, RAUCKMAN UTILITY PRODUCTS, L.L.C., (U.S. CLS. 21, 23, 26, 36 AND 38), SN 85-052,573. PUB. 3-1-2011. FILED 6-2-2010.
- 3,960,969. **THE SCOOP (STANDARD CHARACTER)**, THE NEW YORK TIMES COMPANY, MULTIPLE CLASS, (INT. CLS. 9 AND 41), (U.S. CLS. 21, 23, 26, 36, 38, 100, 101 AND 107). SN 85-056,217. PUB. 11-9-2010. FILED 6-7-2010.
- 3,960,999. **MALAVIDA (STANDARD CHARACTER)**, ONTECNIA MEDIA NETWORKS, S.L., MULTIPLE CLASS, (INT. CLS. 9 AND 38), (U.S. CLS. 21, 23, 26, 36, 38, 100, 101 AND 104). SN 85-070,579. PUB. 1-4-2011. FILED 6-24-2010.
- 3,961,007. **VITAL (STANDARD CHARACTER)**, VTLS, INC., (U.S. CLS. 21, 23, 26, 36 AND 38), SN 85-073,743. PUB. 3-1-2011. FILED 6-29-2010.
- 3,961,014. **STENOFLEX (STANDARD CHARACTER)**, ERIC MARAIS, (U.S. CLS. 21, 23, 26, 36 AND 38), SN 85-078,094. PUB. 3-1-2011. FILED 7-6-2010.
- 3,961,023. **TXTR \* - ( ) < > , — — . . AND DESIGN**, RUBY JR, RALPH, MULTIPLE CLASS, (INT. CLS. 9 AND 25), (U.S. CLS. 21, 22, 23, 26, 36, 38 AND 39). SN 85-081,724. PUB. 3-1-2011. FILED 7-9-2010.
- 3,961,028. **LABREPORT (STANDARD CHARACTER)**, INCOGEN, INC., (U.S. CLS. 21, 23, 26, 36 AND 38), SN 85-085,101. PUB. 3-1-2011. FILED 7-15-2010.
- 3,961,059. **IZ+REAL AND DESIGN**, IZ+ REAL ENTERTAINMENT, LLC, DBA IZ+ REAL ENT, (U.S. CLS. 21, 23, 26, 36 AND 38), SN 85-097,536. PUB. 3-1-2011. FILED 7-31-2010.
- 3,961,062. **WRANGLER JEANS CO ESTABLISHED 1947 (STANDARD CHARACTER)**, WRANGLER APPAREL CORP., (U.S. CLS. 21, 23, 26, 36 AND 38), SN 85-099,621. PUB. 3-1-2011. FILED 8-4-2010.
- 3,961,064. **BLUE TECH (STANDARD CHARACTER)**, BLUE TECH, INC., MULTIPLE CLASS, (INT. CLS. 9 AND 42), (U.S. CLS. 21, 23, 26, 36, 38, 100 AND 101). SN 85-100,205. PUB. 3-1-2011. FILED 8-4-2010.
- 3,961,099. **TRIPSTIX (STANDARD CHARACTER)**, DIVERSIFIED ENDEAVORS INC., (U.S. CLS. 21, 23, 26, 36 AND 38), SN 85-105,569. PUB. 3-1-2011. FILED 8-11-2010.
- 3,961,107. **TRUEVIEW (STANDARD CHARACTER)**, TRUEVIEW ENHANCED VISION SYSTEMS, LLC, (U.S. CLS. 21, 23, 26, 36 AND 38), SN 85-107,835. PUB. 3-1-2011. FILED 8-15-2010.
- 3,961,154. **ADA-CAT (STANDARD CHARACTER)**, MISERICORDIA UNIVERSITY, (U.S. CLS. 21, 23, 26, 36 AND 38), SN 85-117,221. PUB. 3-1-2011. FILED 8-27-2010.
- 3,961,166. **SAM MOON (STANDARD CHARACTER)**, SAM MOON TRADING ENTERPRISE, LTD., MULTIPLE CLASS, (INT. CLS. 9, 14 AND 18), (U.S. CLS. 1, 2, 3, 21, 22, 23, 26, 27, 28, 36, 38, 41 AND 50). SN 85-118,661. PUB. 3-1-2011. FILED 8-30-2010.
- 3,961,202. **CHANGING MODES (STANDARD CHARACTER)**, GRIFFITHS, WENDY, (U.S. CLS. 21, 23, 26, 36 AND 38), SN 85-122,768. PUB. 3-1-2011. FILED 9-3-2010.
- 3,961,245. **WORLD OF ANDOR (STANDARD CHARACTER)**, PAIDPOST INC, AKA VERAXON ENTERTAINMENT, MULTIPLE CLASS, (INT. CLS. 9 AND 41), (U.S. CLS. 21, 23, 26, 36, 38, 100, 101 AND 107). SN 85-124,683. PUB. 3-1-2011. FILED 9-8-2010.
- 3,961,280. **GRIDFLO AND DESIGN**, LONG, MICHAEL V, (U.S. CLS. 21, 23, 26, 36 AND 38), SN 85-126,655. PUB. 3-1-2011. FILED 9-10-2010.
- 3,961,290. **SAVE ONE BANK (STANDARD CHARACTER)**, BROOKS ENTERTAINMENT INC., (U.S. CLS. 21, 23, 26, 36 AND 38), SN 85-126,764. PUB. 3-1-2011. FILED 9-10-2010.
- 3,961,291. **FLOMOTION (STANDARD CHARACTER)**, AMAZING BOOKS LLC, (U.S. CLS. 21, 23, 26, 36 AND 38), SN 85-126,771. PUB. 3-1-2011. FILED 9-10-2010.
- 3,961,302. **HOT STORM AND DESIGN**, ADULT SOURCE MEDIA, INC., (U.S. CLS. 21, 23, 26, 36 AND 38), SN 85-127,082. PUB. 3-1-2011. FILED 9-10-2010.
- 3,961,325. **PROGRAMA TU MENTE AND DESIGN**, S&L MARKETING GROUP, (U.S. CLS. 21, 23, 26, 36 AND 38), SN 85-127,661. PUB. 3-1-2011. FILED 9-12-2010.
- 3,961,329. **ITEACHER (STANDARD CHARACTER)**, S&L MARKETING GROUP, (U.S. CLS. 21, 23, 26, 36 AND 38).

- SN 85-127,717. PUB. 3-1-2011. FILED 9-12-2010.
- 3,961,340. **BLUE SPIDER ANALYTICS (STYLIZED)**. BLUE SPIDER ANALYTICS, INC. (U.S. CLS. 21, 23, 26, 36 AND 38). SN 85-127,921. PUB. 3-1-2011. FILED 9-13-2010.
- 3,961,341. **MISCELLANEOUS DESIGN. BLUE SPIDER ANALYTICS, INC.** (U.S. CLS. 21, 23, 26, 36 AND 38). SN 85-127,946. PUB. 3-1-2011. FILED 9-13-2010.
- 3,961,353. **AGVANCE AND DESIGN. SOFTWARE SOLUTIONS INTEGRATED, LLC.** (U.S. CLS. 21, 23, 26, 36 AND 38). SN 85-128,108. PUB. 3-1-2011. FILED 9-13-2010.
- 3,961,355. **TALK2ME (STANDARD CHARACTER)**. APPLICATIONS TECHNOLOGY, INC., (U.S. CLS. 21, 23, 26, 36 AND 38). SN 85-128,176. PUB. 3-1-2011. FILED 9-13-2010.
- 3,961,365. **AMEREX DEFENSE (STANDARD CHARACTER)**. AMEREX CORPORATION, (U.S. CLS. 21, 23, 26, 36 AND 38). SN 85-128,288. PUB. 3-1-2011. FILED 9-13-2010.
- 3,961,373. **COMPASS (STANDARD CHARACTER)**. TWELVE SOUTH, LLC. (U.S. CLS. 21, 23, 26, 36 AND 38). SN 85-128,365. PUB. 3-1-2011. FILED 9-13-2010.
- 3,961,376 ( *See Class 7 for this trademark*).
- 3,961,380. **BC (STYLIZED)**. BETHUNE-COOKMAN UNIVERSITY INC., MULTIPLE CLASS, (INT. CLS. 9, 16, 24, 25, 28 AND 41). (U.S. CLS. 2, 5, 21, 22, 23, 26, 29, 36, 37, 38, 39, 42, 50, 100, 101 AND 107). SN 85-128,474. PUB. 3-1-2011. FILED 9-13-2010.
- 3,961,387. **THE ENTERTAINMEAPP AND DESIGN. HERISUE LLC**, (U.S. CLS. 21, 23, 26, 36 AND 38). SN 85-128,595. PUB. 3-1-2011. FILED 9-13-2010.
- 3,961,398. **ZENIMAX (STANDARD CHARACTER)**. ZENIMAX MEDIA INC., (U.S. CLS. 21, 23, 26, 36 AND 38). SN 85-128,824. PUB. 3-1-2011. FILED 9-14-2010.
- 3,961,401. **MELTLAB (STANDARD CHARACTER)**. SPARKMAN INTERPRISES, LLC, (U.S. CLS. 21, 23, 26, 36 AND 38). SN 85-128,842. PUB. 3-1-2011. FILED 9-14-2010.
- 3,961,421. **NEUVAL (STANDARD CHARACTER)**. NEUROTRON, INC. (U.S. CLS. 21, 23, 26, 36 AND 38). SN 85-129,026. PUB. 3-1-2011. FILED 9-14-2010.
- 3,961,439 ( *See Class 7 for this trademark*).
- 3,961,443. **MSIA-TIPS (STANDARD CHARACTER)**. INTRINSIC BIOPROBES, INC., (U.S. CLS. 21, 23, 26, 36 AND 38). SN 85-129,295. PUB. 3-1-2011. FILED 9-14-2010.
- 3,961,446. **TALARI (STANDARD CHARACTER)**. TALARI NETWORKS, INC., (U.S. CLS. 21, 23, 26, 36 AND 38). SN 85-129,310. PUB. 3-1-2011. FILED 9-14-2010.
- 3,961,450. **BAROMETERIT (STANDARD CHARACTER)**. BAROMETER INC., MULTIPLE CLASS, (INT. CLS. 9 AND 42), (U.S. CLS. 21, 23, 26, 36, 38, 100 AND 101). SN 85-129,335. PUB. 3-1-2011. FILED 9-14-2010.
- 3,961,468. **AEROFLY5 (STYLIZED)**. IKARUS USA LLC, (U.S. CLS. 21, 23, 26, 36 AND 38). SN 85-129,574. PUB. 3-1-2011. FILED 9-14-2010.
- 3,961,473. **SURFDOG (STANDARD CHARACTER)**. SURFDOG, INC., (U.S. CLS. 21, 23, 26, 36 AND 38). SN 85-129,635. PUB. 3-1-2011. FILED 9-14-2010.
- 3,961,480. **ROCK RIVER (STANDARD CHARACTER)**. BARJAN LLC, (U.S. CLS. 21, 23, 26, 36 AND 38). SN 85-129,708. PUB. 3-1-2011. FILED 9-14-2010.
- 3,961,495. **POPIRIS (STANDARD CHARACTER)**. IDEAL BINARY, LTD., (U.S. CLS. 21, 23, 26, 36 AND 38). SN 85-130,081. PUB. 3-1-2011. FILED 9-15-2010.
- 3,961,497. **MINIMOD (STANDARD CHARACTER)**. POWER SOLUTIONS, INC., (U.S. CLS. 21, 23, 26, 36 AND 38). SN 85-130,096. PUB. 3-1-2011. FILED 9-15-2010.
- 3,961,503. **MVEST (STANDARD CHARACTER)**. CGI INFORMATION SYSTEMS AND MANAGEMENT CONSULTANTS INC., (U.S. CLS. 21, 23, 26, 36 AND 38). SN 85-130,164. PUB. 3-1-2011. FILED 9-15-2010.
- 3,961,515 ( *See Class 6 for this trademark*).
- 3,961,524. **IDIA (STANDARD CHARACTER)**. WEBSTER VETERINARY SUPPLY, INC., (U.S. CLS. 21, 23, 26, 36 AND 38). SN 85-130,376. PUB. 3-1-2011. FILED 9-15-2010.
- 3,961,535. **READY. BILLING. ABLE. (STANDARD CHARACTER)**. REDI2 TECHNOLOGIES, INC., MULTIPLE CLASS, (INT. CLS. 9 AND 42), (U.S. CLS. 21, 23, 26, 36, 38, 100 AND 101). SN 85-130,489. PUB. 3-1-2011. FILED 9-15-2010.
- 3,961,540. **THORKOM (STANDARD CHARACTER)**. COOPER TECHNOLOGIES COMPANY, (U.S. CLS. 21, 23, 26, 36 AND 38). SN 85-130,545. PUB. 3-1-2011. FILED 9-15-2010.
- 3,961,545. **ENERGYZERO (STANDARD CHARACTER)**. KIM, WON JIN, (U.S. CLS. 21, 23, 26, 36 AND 38). SN 85-130,581. PUB. 3-1-2011. FILED 9-15-2010.
- 3,961,548. **TIMEWAVE THEORY (STANDARD CHARACTER)**. ORTIZ, MATTHEW, (U.S. CLS. 21, 23, 26, 36 AND 38). SN 85-130,647. PUB. 3-1-2011. FILED 9-15-2010.
- 3,961,551. **EMILY'S GIRL WORLD (STANDARD CHARACTER)**. W3 INNOVATIONS, LLC, DBA BROKEN THUMBS APPS, (U.S. CLS. 21, 23, 26, 36 AND 38). SN 85-130,662. PUB. 3-1-2011. FILED 9-15-2010.
- 3,961,555. **I LOVE JESUS WWW.FOREVERLOVEJESUS.COM AND DESIGN. JESUS HEART FOUNDATION, INC.,** (U.S. CLS. 21, 23, 26, 36 AND 38). SN 85-130,685. PUB. 3-1-2011. FILED 9-15-2010.
- 3,961,580. **PRIME EVIL (STANDARD CHARACTER)**. EICHORN, ANDREW, AND GUKELBERGER, TODD, (U.S. CLS. 21, 23, 26, 36 AND 38). SN 85-131,098. PUB. 3-1-2011. FILED 9-16-2010.
- 3,961,581. **MESSAGESYNC (STANDARD CHARACTER)**. INDIANA PAGING NETWORK, INC., (U.S. CLS. 21, 23, 26, 36 AND 38). SN 85-131,113. PUB. 3-1-2011. FILED 9-16-2010.
- 3,961,583. **BRAINFLEXERS (STANDARD CHARACTER)**. C.D. MEYER, INC., (U.S. CLS. 21, 23, 26, 36 AND 38). SN 85-131,121. PUB. 3-1-2011. FILED 9-16-2010.
- 3,961,602. **TRAILSPRO (STANDARD CHARACTER)**. ROCZEY, KEVIN, DBA TRAILSPRO, (U.S. CLS. 21, 23, 26, 36 AND 38). SN 85-131,353. PUB. 3-1-2011. FILED 9-16-2010.
- 3,961,606. **SUNFLEX (STANDARD CHARACTER)**. STEUP, MIKE, (U.S. CLS. 21, 23, 26, 36 AND 38). SN 85-131,453. PUB. 3-1-2011. FILED 9-16-2010.
- 3,961,614. **SHORTCAST (STANDARD CHARACTER)**. SHORTCAST INC, (U.S. CLS. 21, 23, 26, 36 AND 38). SN 85-131,597. PUB. 3-1-2011. FILED 9-16-2010.
- 3,961,641. **VDATS (STANDARD CHARACTER)**. UNITED STATES AIR FORCE, (U.S. CLS. 21, 23, 26, 36 AND 38). SN 85-131,875. PUB. 3-1-2011. FILED 9-17-2010.
- 3,961,643. **FULL SERVICE FREE TO GUEST (STANDARD CHARACTER)**. ENSEO, INC., (U.S. CLS. 21, 23, 26, 36 AND 38). SN 85-131,989. PUB. 3-1-2011. FILED 9-17-2010.
- 3,961,645. **MISCELLANEOUS DESIGN. EDROVER INC.,** (U.S. CLS. 21, 23, 26, 36 AND 38). SN 85-131,998. PUB. 3-1-2011. FILED 9-17-2010.
- 3,961,723. **MARIE PARIE (STANDARD CHARACTER)**. MARIE FRANCINE LINDA GAYET, MULTIPLE CLASS, (INT. CLS. 9 AND 41), (U.S. CLS. 21, 23, 26, 36, 38, 100, 101 AND 107). SN 85-136,059. PUB. 3-1-2011. FILED 9-22-2010.
- 3,961,724. **SUPPORTACUS A UNIVERSAL SERVICE REQUEST MANAGEMENT SYSTEM AND DESIGN. DIGITAL NEXUS TECHNOLOGIES, INC.,** (U.S. CLS. 21, 23, 26, 36 AND 38). SN 85-136,272. PUB. 3-1-2011. FILED 9-23-2010.
- 3,961,733. **INC RESEARCH (STANDARD CHARACTER)**. INC RESEARCH, INC., MULTIPLE CLASS, (INT. CLS. 9, 41 AND 42), (U.S. CLS. 21, 23, 26, 36, 38, 100, 101 AND 107). SN 85-138,041. PUB. 3-1-2011. FILED 9-24-2010.
- 3,961,755. **CORE PARTNERS AND DESIGN. COREPARTNERS, INC.** (U.S. CLS. 21, 23, 26, 36 AND 38). SN 85-140,926. PUB. 3-1-2011. FILED 9-29-2010.
- 3,961,756. **ASG-WORKFLOWDIRECT (STANDARD CHARACTER)**. ALLEN SYSTEMS GROUP, INC., (U.S. CLS. 21, 23, 26, 36 AND 38). SN 85-140,979. PUB. 3-1-2011. FILED 9-29-2010.
- 3,961,768. **SNAPCAL (STANDARD CHARACTER)**. INFOTERIA CORPORATION, (U.S. CLS. 21, 23, 26, 36 AND 38). SN 85-142,211. PUB. 3-1-2011. FILED 9-30-2010.
- 3,961,782. **MUSICOREY (STANDARD CHARACTER)**. MUSICOREY, (U.S. CLS. 21, 23, 26, 36 AND 38). SN 85-143,573. PUB. 3-1-2011. FILED 10-1-2010.
- 3,961,794. **TALK WITH FISH (STANDARD CHARACTER)**. BAMBENEK, GREGORY, (U.S. CLS. 21, 23, 26, 36 AND 38). SN 85-145,851. PUB. 3-1-2011. FILED 10-5-2010.
- 3,961,797. **ELIPSE SCADA (STANDARD CHARACTER)**. ELIPSE SOFTWARE CORPORATION, (U.S. CLS. 21, 23, 26, 36 AND 38). SN 85-146,397. PUB. 3-1-2011. FILED 10-6-2010.
- 3,961,799. **ILAP (STANDARD CHARACTER)**. RAIN DESIGN INC, (U.S. CLS. 21, 23, 26, 36 AND 38). SN 85-146,793. PUB. 3-1-2011. FILED 10-6-2010.
- 3,961,809. **SKYFIBER AND DESIGN. SKYFIBER, INC.,** (U.S.



- CLS. 21, 23, 26, 36 AND 38). SN 85-148,513. PUB. 3-1-2011. FILED 10-8-2010.
- 3,961,810. **XTG TECHNOLOGY (STANDARD CHARACTER)**. LENMAR ENTERPRISES, INC., (U.S. CLS. 21, 23, 26, 36 AND 38). SN 85-148,593. PUB. 3-1-2011. FILED 10-8-2010.
- 3,961,815. **RAPFORMED (STANDARD CHARACTER)**. SCOTT, DAVID, (U.S. CLS. 21, 23, 26, 36 AND 38). SN 85-148,927. PUB. 3-1-2011. FILED 10-8-2010.
- 3,961,838. **VEHICLEGUARD (STANDARD CHARACTER)**. M2 COMPANIES, (U.S. CLS. 21, 23, 26, 36 AND 38). SN 85-149,861. PUB. 3-1-2011. FILED 10-11-2010.
- 3,961,845. **LIVIN' THE YAY! LIFE! (STANDARD CHARACTER)**. CONSCIOUSLY CREATIVE LLC, (U.S. CLS. 21, 23, 26, 36 AND 38). SN 85-149,966. PUB. 3-1-2011. FILED 10-11-2010.
- 3,961,858. **NUPACK (STANDARD CHARACTER)**. CALIFORNIA INSTITUTE OF TECHNOLOGY, (U.S. CLS. 21, 23, 26, 36 AND 38). SN 85-150,135. PUB. 3-1-2011. FILED 10-11-2010.
- 3,961,861. **JUGGLA (STANDARD CHARACTER)**. MINERVINO, ANTHONY, DBA JUGGLA, (U.S. CLS. 21, 23, 26, 36 AND 38). SN 85-151,322. PUB. 3-1-2011. FILED 10-13-2010.
- 3,961,870. **DIGIZOID AND DESIGN**. BERG, PAUL G, (U.S. CLS. 21, 23, 26, 36 AND 38). SN 85-152,038. PUB. 3-1-2011. FILED 10-13-2010.
- 3,961,879. **VANTAGE (STANDARD CHARACTER)**. COMPUTWARE CORPORATION, (U.S. CLS. 21, 23, 26, 36 AND 38). SN 85-152,570. PUB. 3-1-2011. FILED 10-14-2010.
- 3,961,883. **MANERA (STYLIZED)**. F ONE SARL, MULTIPLE CLASS, (INT. CLS. 9, 12, 18, 22, 25 AND 28), (U.S. CLS. 1, 2, 3, 7, 19, 21, 22, 23, 26, 31, 35, 36, 38, 39, 41, 42, 44 AND 50). SN 85-154,096. PUB. 3-1-2011. FILED 10-15-2010.
- 3,961,892. **MEGAWIN (STANDARD CHARACTER)**. TOURNAMENT ONE CORP, (U.S. CLS. 21, 23, 26, 36 AND 38). SN 85-158,786. PUB. 3-1-2011. FILED 10-22-2010.
- 3,961,893. **RACE 2 RICHES (STANDARD CHARACTER)**. TOURNAMENT ONE CORP, (U.S. CLS. 21, 23, 26, 36 AND 38). SN 85-159,220. PUB. 3-1-2011. FILED 10-22-2010.
- 3,961,901. **AN ORIGINAL PENGUIN BY MUNSINGWEAR AND DESIGN**. PEI LICENSING, INC., (U.S. CLS. 21, 23, 26, 36 AND 38). SN 85-162,396. PUB. 3-1-2011. FILED 10-27-2010.
- 3,961,902. **AN ORIGINAL PENGUIN BY MUNSINGWEAR (STANDARD CHARACTER)**. PEI LICENSING, INC., (U.S. CLS. 21, 23, 26, 36 AND 38). SN 85-162,707. PUB. 3-1-2011. FILED 10-27-2010.
- 3,961,913. **EARTH FLIGHT SIM (STANDARD CHARACTER)**. PAIDPOST INC, AKA VERAXON ENTERTAINMENT, (U.S. CLS. 21, 23, 26, 36 AND 38). SN 85-165,542. PUB. 3-1-2011. FILED 10-30-2010.
- 3,961,925. **SLATE DIGITAL (STANDARD CHARACTER)**. YELLOW MATTER ENTERTAINMENT, LLC, (U.S. CLS. 21, 23, 26, 36 AND 38). SN 85-170,659. PUB. 3-1-2011. FILED 11-5-2010.
- 3,961,929. **THORIMAGE (STANDARD CHARACTER)**. THORLABS, INC., (U.S. CLS. 21, 23, 26, 36 AND 38). SN 85-172,229. PUB. 3-1-2011. FILED 11-9-2010.
- 3,961,931. **WWDBLAST (STANDARD CHARACTER)**. ADVANCE MAGAZINE PUBLISHERS INC., (U.S. CLS. 21, 23, 26, 36 AND 38). SN 85-173,269. PUB. 3-1-2011. FILED 11-10-2010.
- 3,961,934. **SAINT LOUIS UNIVERSITY AD . MAJOREM . DEI . GLORIAM IHS 1818 AND DESIGN**. SAINT LOUIS UNIVERSITY, (U.S. CLS. 21, 23, 26, 36 AND 38). SN 85-174,015. PUB. 3-1-2011. FILED 11-10-2010.
- 3,960,567 ( *See Class 5 for this trademark*).
- 3,960,589 ( *See Class 5 for this trademark*).
- 3,960,678 ( *See Class 5 for this trademark*).
- 3,960,706. **MEDENTIS (STANDARD CHARACTER)**. SCHOLZ, ALEXANDER, MULTIPLE CLASS, (INT. CLS. 10 AND 41), (U.S. CLS. 26, 39, 44, 100, 101 AND 107). SN 79-081,144. PUB. 3-1-2011. FILED 3-17-2010.
- 3,960,750 ( *See Class 5 for this trademark*).
- 3,960,757 ( *See Class 1 for this trademark*).
- 3,960,823. **RISE WIRELESS 2 AND DESIGN**. OTICON A/S, (U.S. CLS. 26, 39 AND 44). SN 79-087,946. PUB. 3-1-2011. FILED 9-9-2010.
- 3,960,826. **MCITECT (STANDARD CHARACTER)**. DIAGENIC ASA, MULTIPLE CLASS, (INT. CLS. 10, 35 AND 44), (U.S. CLS. 26, 39, 44, 100, 101 AND 102). SN 79-088,408. PUB. 3-1-2011. FILED 7-14-2010.
- 3,960,847. **TRUE NORTH MAGNETICS (STANDARD CHARACTER)**. CREATIVE BIOCHEMICAL, INCORPORATED, DBA TRUE NORTH MAGNETICS, (U.S. CLS. 26, 39 AND 44). SN 85-003,218. PUB. 3-1-2011. FILED 3-31-2010.
- 3,960,914. **CATH CHECK (STANDARD CHARACTER)**. SUPERIOR MEDICAL LLC, (U.S. CLS. 26, 39 AND 44). SN 85-028,265. PUB. 3-1-2011. FILED 5-2-2010.
- 3,960,949. **PURE ROMANCE AND DESIGN**. PURE ROMANCE, INC., MULTIPLE CLASS, (INT. CLS. 10, 25, 28, 35 AND 41), (U.S. CLS. 22, 23, 26, 38, 39, 44, 50, 100, 101, 102 AND 107). SN 85-045,191. PUB. 3-1-2011. FILED 5-21-2010.
- 3,960,950 ( *See Class 5 for this trademark*).
- 3,961,032. **MISCELLANEOUS DESIGN**. EMERGE MEDICAL, INC., (U.S. CLS. 26, 39 AND 44). SN 85-085,527. PUB. 3-1-2011. FILED 7-15-2010.
- 3,961,067. **OTTU (STANDARD CHARACTER)**. ASPIDE MEDICAL, (U.S. CLS. 26, 39 AND 44). SN 85-101,105. PUB. 3-1-2011. FILED 8-5-2010.
- 3,961,366. **THE ONE (STANDARD CHARACTER)**. MUELLER SPORTS MEDICINE, INC., MULTIPLE CLASS, (INT. CLS. 10 AND 28), (U.S. CLS. 22, 23, 26, 38, 39, 44 AND 50). SN 85-128,299. PUB. 3-1-2011. FILED 9-13-2010.
- 3,961,409. **BABYCOMFYNOSE (STANDARD CHARACTER)**. BABYCOMFYNOSE, LLC, (U.S. CLS. 26, 39 AND 44). SN 85-128,882. PUB. 3-1-2011. FILED 9-14-2010.
- 3,961,420. **LUBRICITY+ (STANDARD CHARACTER)**. GALT MEDICAL CORP., (U.S. CLS. 26, 39 AND 44). SN 85-129,008. PUB. 3-1-2011. FILED 9-14-2010.
- 3,961,541. **SPIROL (STANDARD CHARACTER)**. EPIMED INTERNATIONAL, INC., (U.S. CLS. 26, 39 AND 44). SN 85-130,551. PUB. 3-1-2011. FILED 9-15-2010.
- 3,961,679. **ADAM FRAME (STANDARD CHARACTER)**. BEAM ASSOCIATES LLC, (U.S. CLS. 26, 39 AND 44). SN 85-132,617. PUB. 3-1-2011. FILED 9-17-2010.
- 3,961,682. **ADAM FRAME WITH PALEY'S METHOD (STANDARD CHARACTER)**. BEAM ASSOCIATES LLC, (U.S. CLS. 26, 39 AND 44). SN 85-132,648. PUB. 3-1-2011. FILED 9-17-2010.
- 3,961,804. **PRESSWRAP (STANDARD CHARACTER)**. PRESSMAN, STUART, (U.S. CLS. 26, 39 AND 44). SN 85-147,837. PUB. 3-1-2011. FILED 10-7-2010.
- 3,961,812. **CONTURA (STANDARD CHARACTER)**. SENORX, INC., (U.S. CLS. 26, 39 AND 44). SN 85-148,739. PUB. 3-1-2011. FILED 10-8-2010.
- 3,961,935. **SAINT LOUIS UNIVERSITY AD . MAJOREM . DEI . GLORIAM IHS 1818 AND DESIGN**. SAINT LOUIS UNIVERSITY, (U.S. CLS. 26, 39 AND 44). SN 85-174,019. PUB. 3-1-2011. FILED 11-10-2010.
- 3,961,949. **LAWTON (STANDARD CHARACTER)**. AMESCUA, GERARDO, (U.S. CLS. 26, 39 AND 44). SN 85-183,411. PUB. 3-1-2011. FILED 11-23-2010.

---

#### CLASS 10—MEDICAL APPARATUS

- 3,960,270. **SAVE (STANDARD CHARACTER)**. AUTOMEDX, INC., (U.S. CLS. 26, 39 AND 44). SN 77-277,707. PUB. 3-1-2011. FILED 9-12-2007.
- 3,960,395 ( *See Class 9 for this trademark*).
- 3,960,408. **PUMPEASE (STANDARD CHARACTER)**. WENDY BELL, MULTIPLE CLASS, (INT. CLS. 10 AND 25), (U.S. CLS. 22, 26, 39 AND 44). SN 77-845,027. PUB. 3-1-2011. FILED 10-9-2009.
- 3,960,566 ( *See Class 5 for this trademark*).

---

#### CLASS 11—ENVIRONMENTAL CONTROL APPARATUS

- 3,960,242. **TATTOO FLASHLIGHT (STYLIZED)**. IBT HOLDINGS, LLC, (U.S. CLS. 13, 21, 23, 31 AND 34). SN 76-703,672. PUB. 3-1-2011. FILED 7-6-2010.
- 3,960,273 ( *See Class 5 for this trademark*).
- 3,960,328. **DRAINWAVE (STANDARD CHARACTER)**. DU-

- CANE R & D PTY LTD, (U.S. CLS. 13, 21, 23, 31 AND 34). SN 77-711,113. PUB. 3-1-2011. FILED 4-9-2009.
- 3,960,361. **ECOFRIDGE (STANDARD CHARACTER)**, UKRAM INDUSTRIES LIMITED, (U.S. CLS. 13, 21, 23, 31 AND 34). SN 77-807,214. PUB. 3-1-2011. FILED 8-18-2009.
- 3,960,370 ( *See Class 6 for this trademark*).
- 3,960,392 ( *See Class 1 for this trademark*).
- 3,960,432. **SUNPAN MODERN HOME WWW. SUNPANIMPORTS.COM AND DESIGN**, SUNPAN TRADING & IMPORT INC., MULTIPLE CLASS, (INT. CLS. 11 AND 20), (U.S. CLS. 2, 13, 21, 22, 23, 25, 31, 32, 34 AND 50). SN 77-885,494. PUB. 3-1-2011. FILED 12-3-2009.
- 3,960,441 ( *See Class 6 for this trademark*).
- 3,960,524. **BAWELL (STANDARD CHARACTER)**, COLLINS, MICHAEL T, (U.S. CLS. 13, 21, 23, 31 AND 34). SN 77-952,511. PUB. 3-1-2011. FILED 3-6-2010.
- 3,960,570. **PIC-A-WATT (STANDARD CHARACTER)**, KING ELECTRICAL MANUFACTURING COMPANY, (U.S. CLS. 13, 21, 23, 31 AND 34). SN 77-965,207. PUB. 3-1-2011. FILED 3-22-2010.
- 3,960,572. **OXYGENIUS (STANDARD CHARACTER)**, DR. CLARK RESEARCH ASSOCIATION, (U.S. CLS. 13, 21, 23, 31 AND 34). SN 77-965,575. PUB. 3-1-2011. FILED 3-23-2010.
- 3,960,573 ( *See Class 9 for this trademark*).
- 3,960,574 ( *See Class 9 for this trademark*).
- 3,960,586. **DIAL-A-WATT (STANDARD CHARACTER)**, KING ELECTRICAL MANUFACTURING COMPANY, (U.S. CLS. 13, 21, 23, 31 AND 34). SN 77-967,061. PUB. 3-1-2011. FILED 3-24-2010.
- 3,960,678 ( *See Class 5 for this trademark*).
- 3,960,708 ( *See Class 9 for this trademark*).
- 3,960,710. **REMIS (STANDARD CHARACTER)**, REMIS GSELLSCHAFT FÜR ENTWICKLUNG; UND VERTRIEB VON TECHNISCHEN; ELEMENTEN MBH, MULTIPLE CLASS, (INT. CLS. 11 AND 12), (U.S. CLS. 13, 19, 21, 23, 31, 34, 35 AND 44). SN 79-081,444. PUB. 3-1-2011. FILED 3-3-2010.
- 3,960,711. **AQUASPHERE (STANDARD CHARACTER)**, ZODIAC MARINE & POOL, (U.S. CLS. 13, 21, 23, 31 AND 34). SN 79-081,490. PUB. 3-1-2011. FILED 4-7-2010.
- 3,960,712 ( *See Class 1 for this trademark*).
- 3,960,715. **HANSALIVING (STANDARD CHARACTER)**, HANSA METALLWERKE AG, MULTIPLE CLASS, (INT. CLS. 11, 20 AND 21), (U.S. CLS. 2, 13, 21, 22, 23, 25, 29, 30, 31, 32, 33, 34, 40 AND 50). SN 79-081,635. PUB. 3-1-2011. FILED 2-23-2010.
- 3,960,721. **HYDROHELIO (STANDARD CHARACTER)**, LEHLE GMBH, MULTIPLE CLASS, (INT. CLS. 11 AND 42), (U.S. CLS. 13, 21, 23, 31, 34, 100 AND 101). SN 79-081,923. PUB. 3-1-2011. FILED 3-16-2010.
- 3,960,736. **HANSAHOME (STANDARD CHARACTER)**, HANSA METALLWERKE AG, MULTIPLE CLASS, (INT. CLS. 11, 20 AND 21), (U.S. CLS. 2, 13, 21, 22, 23, 25, 29, 30, 31, 32, 33, 34, 40 AND 50). SN 79-082,533. PUB. 3-1-2011. FILED 2-23-2010.
- 3,960,754 ( *See Class 9 for this trademark*).
- 3,960,757 ( *See Class 1 for this trademark*).
- 3,960,775 ( *See Class 7 for this trademark*).
- 3,960,781. **SYSTEMPOOL (STYLIZED)**, SYSTEM-POOL, S.A., (U.S. CLS. 13, 21, 23, 31 AND 34). SN 79-084,602. PUB. 3-1-2011. FILED 6-9-2010.
- 3,960,786 ( *See Class 9 for this trademark*).
- 3,960,855. **ENFLITE AND DESIGN**, LIFEPORT INC, (U.S. CLS. 13, 21, 23, 31 AND 34). SN 85-005,426. PUB. 3-1-2011. FILED 4-2-2010.
- 3,960,858. **HYDRO-MASTER (STANDARD CHARACTER)**, STORMWATER FILTERS CORP, (U.S. CLS. 13, 21, 23, 31 AND 34). SN 85-006,773. PUB. 3-1-2011. FILED 4-5-2010.
- 3,960,910 ( *See Class 4 for this trademark*).
- 3,960,964. **TURBO KLONE (STANDARD CHARACTER)**, EVERYTHING GREEN HYDROPONICS, LLC, MULTIPLE CLASS, (INT. CLS. 11 AND 35), (U.S. CLS. 13, 21, 23, 31, 34, 100, 101 AND 102). SN 85-049,290. PUB. 3-1-2011. FILED 5-27-2010.
- 3,961,237. **POWERWALL (STYLIZED)**, POWERWALL, INCORPORATED, MULTIPLE CLASS, (INT. CLS. 11 AND 20), (U.S. CLS. 2, 13, 21, 22, 23, 25, 31, 32, 34 AND 50). SN 85-124,318. PUB. 3-1-2011. FILED 9-7-2010.
- 3,961,241. **ICE CREAM BALL (STANDARD CHARACTER)**, INDUSTRIAL REVOLUTION, INC., (U.S. CLS. 13, 21, 23, 31 AND 34). SN 85-124,564. PUB. 3-1-2011. FILED 9-8-2010.
- 3,961,276. **LIT LIFE (STANDARD CHARACTER)**, SUMMER LONDON DZIGNS LLC, (U.S. CLS. 13, 21, 23, 31 AND 34). SN 85-126,472. PUB. 3-1-2011. FILED 9-9-2010.
- 3,961,283. **AS FUNCTIONAL AS IT IS BEAUTIFUL (STANDARD CHARACTER)**, VTB, INC., (U.S. CLS. 13, 21, 23, 31 AND 34). SN 85-126,685. PUB. 3-1-2011. FILED 9-10-2010.
- 3,961,285. **BELLA CASA (STANDARD CHARACTER)**, VTB, INC., (U.S. CLS. 13, 21, 23, 31 AND 34). SN 85-126,697. PUB. 3-1-2011. FILED 9-10-2010.
- 3,961,394. **DUELER (STANDARD CHARACTER)**, WARD, STUART J, (U.S. CLS. 13, 21, 23, 31 AND 34). SN 85-128,780. PUB. 3-1-2011. FILED 9-14-2010.
- 3,961,395. **SUGAIRE (STANDARD CHARACTER)**, WARD, STUART J, (U.S. CLS. 13, 21, 23, 31 AND 34). SN 85-128,788. PUB. 3-1-2011. FILED 9-14-2010.
- 3,961,396. **POSITIVE PRIME FEED SYSTEM (STANDARD CHARACTER)**, STUART J WARD, (U.S. CLS. 13, 21, 23, 31 AND 34). SN 85-128,803. PUB. 3-1-2011. FILED 9-14-2010.
- 3,961,442. **SAVE SMART (STANDARD CHARACTER)**, LASKO HOLDINGS, INC., (U.S. CLS. 13, 21, 23, 31 AND 34). SN 85-129,283. PUB. 3-1-2011. FILED 9-14-2010.
- 3,961,453. **SJEH (STANDARD CHARACTER)**, SJHI (XIAMEN) CO., LTD., (U.S. CLS. 13, 21, 23, 31 AND 34). SN 85-129,349. PUB. 3-1-2011. FILED 9-14-2010.
- 3,961,457. **SHIELD LIFE (STANDARD CHARACTER)**, ORION ELECTRONICS, INC., (U.S. CLS. 13, 21, 23, 31 AND 34). SN 85-129,449. PUB. 3-1-2011. FILED 9-14-2010.
- 3,961,488. **MAXG (STANDARD CHARACTER)**, UMA DISTRIBUTORS, LLC, (U.S. CLS. 13, 21, 23, 31 AND 34). SN 85-129,866. PUB. 3-1-2011. FILED 9-15-2010.
- 3,961,501. **TOP-LINE (STANDARD CHARACTER)**, COMPONENT HARDWARE GROUP, INC., (U.S. CLS. 13, 21, 23, 31 AND 34). SN 85-130,151. PUB. 3-1-2011. FILED 9-15-2010.
- 3,961,523. **SKH (STANDARD CHARACTER)**, SJHI (XIAMEN) CO., LTD., (U.S. CLS. 13, 21, 23, 31 AND 34). SN 85-130,359. PUB. 3-1-2011. FILED 9-15-2010.
- 3,961,528. **SJHI (STANDARD CHARACTER)**, SJHI (XIAMEN) CO., LTD., (U.S. CLS. 13, 21, 23, 31 AND 34). SN 85-130,399. PUB. 3-1-2011. FILED 9-15-2010.
- 3,961,563. **PYROT (STANDARD CHARACTER)**, VIESSMANN WERKE GMBH & CO. KG, (U.S. CLS. 13, 21, 23, 31 AND 34). SN 85-130,846. PUB. 3-1-2011. FILED 9-16-2010.
- 3,961,663. **WATCO (STANDARD CHARACTER)**, WCM INDUSTRIES, INC., (U.S. CLS. 13, 21, 23, 31 AND 34). SN 85-132,417. PUB. 3-1-2011. FILED 9-17-2010.
- 3,961,664. **WCM (STANDARD CHARACTER)**, WCM INDUSTRIES, INC., (U.S. CLS. 13, 21, 23, 31 AND 34). SN 85-132,422. PUB. 3-1-2011. FILED 9-17-2010.
- 3,961,665. **ROGER'S (STANDARD CHARACTER)**, WCM INDUSTRIES, INC., (U.S. CLS. 13, 21, 23, 31 AND 34). SN 85-132,433. PUB. 3-1-2011. FILED 9-17-2010.
- 3,961,666. **ROGER'S AND DESIGN**, WCM INDUSTRIES, INC., (U.S. CLS. 13, 21, 23, 31 AND 34). SN 85-132,441. PUB. 3-1-2011. FILED 9-17-2010.
- 3,961,667. **...ALWAYS A STEP AHEAD (STANDARD CHARACTER)**, WCM INDUSTRIES, INC., (U.S. CLS. 13, 21, 23, 31 AND 34). SN 85-132,443. PUB. 3-1-2011. FILED 9-17-2010.
- 3,961,690. **"WE'LL GET YOU BREWING" (STANDARD CHARACTER)**, JOHN W. HAGGARD JR., DBA ALL COFFEE CONCEPTS LLC, (U.S. CLS. 13, 21, 23, 31 AND 34). SN 85-132,849. PUB. 3-1-2011. FILED 9-18-2010.
- 3,961,730. **BADGERLAND TANKS AND DESIGN**, HOT WATER PRODUCTS, INC., (U.S. CLS. 13, 21, 23, 31 AND 34). SN 85-137,364. PUB. 3-1-2011. FILED 9-24-2010.
- 3,961,829. **GEOWISE AND DESIGN**, RICHARD RUE, (U.S. CLS. 13, 21, 23, 31 AND 34). SN 85-149,622. PUB. 3-1-2011. FILED 10-11-2010.

---

## CLASS 12—VEHICLES

- 3,960,235. **PROFESSIONAL GRADE SRT STEERING . RIDE . TRACTION AND DESIGN**, FEDERATED AUTO PARTS DISTRIBUTORS, INC., (U.S. CLS. 19, 21, 23, 31, 35 AND 44).



SN 76-702,384. PUB. 3-1-2011. FILED 4-6-2010.

3,960,293. **SHIFT—THE WAY YOU MOVE (STANDARD CHARACTER)**. NISSAN JIDOSHA KABUSHIKI KAISHA, DBA NISSAN MOTOR CO., LTD., MULTIPLE CLASS, (INT. CLS. 12, 35 AND 37), (U.S. CLS. 19, 21, 23, 31, 35, 44, 100, 101, 102, 103 AND 106). SN 77-551,157. PUB. 3-1-2011. FILED 8-20-2008.

3,960,362. **ULTRA SKID (STANDARD CHARACTER)**. TITAN TIRE CORPORATION, (U.S. CLS. 19, 21, 23, 31, 35 AND 44). SN 77-808,943. PUB. 3-1-2011. FILED 8-20-2009.

3,960,368 ( *See Class 7 for this trademark*).

3,960,369. **BCYCLE AND DESIGN**. B-CYCLE, LLC, MULTIPLE CLASS, (INT. CLS. 12, 35 AND 39), (U.S. CLS. 19, 21, 23, 31, 35, 44, 100, 101, 102 AND 105). SN 77-811,402. PUB. 3-1-2011. FILED 8-24-2009.

3,960,430. **M MONO DI FORZA BY SAVINI AND DESIGN**. KIM, GUN WOO, AKA KIM, GREG W., (U.S. CLS. 19, 21, 23, 31, 35 AND 44). SN 77-880,976. PUB. 3-1-2011. FILED 11-25-2009.

3,960,460 ( *See Class 7 for this trademark*).

3,960,491. **EUROTECH WHEELS (STANDARD CHARACTER)**. EUROTECH WHEELS, LLC, (U.S. CLS. 19, 21, 23, 31, 35 AND 44). SN 77-941,540. PUB. 1-25-2011. FILED 2-22-2010.

3,960,647. **SANYO AND DESIGN**. SANYO ELECTRIC CO., LTD., (U.S. CLS. 19, 21, 23, 31, 35 AND 44). SN 79-070,645. PUB. 3-1-2011. FILED 5-1-2009.

3,960,651 ( *See Class 6 for this trademark*).

3,960,652. **EURO TGV (STANDARD CHARACTER)**. SOCIÉTÉ NATIONALE DES CHEMINS DE FER FRANÇAIS (SNCF), MULTIPLE CLASS, (INT. CLS. 12, 16, 35, 38, 39 AND 43), (U.S. CLS. 2, 5, 19, 21, 22, 23, 29, 31, 35, 37, 38, 44, 50, 100, 101, 102, 104 AND 105). SN 79-072,398. PUB. 3-1-2011. FILED 3-25-2009.

3,960,657. **JETMAN (STANDARD CHARACTER)**. ROSSY YVES, MULTIPLE CLASS, (INT. CLS. 12, 16, 25 AND 28), (U.S. CLS. 2, 5, 19, 21, 22, 23, 29, 31, 35, 37, 38, 39, 44 AND 50). SN 79-074,137. PUB. 3-1-2011. FILED 5-26-2009.

3,960,658 ( *See Class 7 for this trademark*).

3,960,671 ( *See Class 9 for this trademark*).

3,960,678 ( *See Class 5 for this trademark*).

3,960,682. **UP (STANDARD CHARACTER)**. UP INTERNATIONAL GMBH, MULTIPLE CLASS, (INT. CLS. 12 AND 28), (U.S. CLS. 19, 21, 22, 23, 31, 35, 38, 44 AND 50). SN 79-078,212. PUB. 11-23-2010. FILED 1-13-2010.

3,960,710 ( *See Class 11 for this trademark*).

3,960,742. **SAXESS RACE (STANDARD CHARACTER)**. BEHR INDUSTRY GMBH & CO. KG, MULTIPLE CLASS, (INT. CLS. 12 AND 37), (U.S. CLS. 19, 21, 23, 31, 35, 44, 100, 103 AND 106). SN 79-082,774. PUB. 3-1-2011. FILED 4-26-2010.

3,960,743. **328 (STANDARD CHARACTER)**. 328 SUPPORT SERVICES GMBH, (U.S. CLS. 19, 21, 23, 31, 35 AND 44). SN 79-082,843. PUB. 3-1-2011. FILED 5-6-2010.

3,960,759 ( *See Class 7 for this trademark*).

3,960,806. **BABYSWEET (STANDARD CHARACTER)**. WERNER CHRIST GMBH, MULTIPLE CLASS, (INT. CLS. 12, 18, 20, 24 AND 25), (U.S. CLS. 1, 2, 3, 13, 19, 21, 22, 23, 25, 31, 32, 35, 39, 41, 42, 44 AND 50). SN 79-086,350. PUB. 3-1-2011. FILED 6-5-2010.

3,960,832. **QUARTUM AND DESIGN**. ZAKRYTE AKTSIONERNE TOVARYSTVO "ROSAVA", (U.S. CLS. 19, 21, 23, 31, 35 AND 44). SN 79-089,746. PUB. 3-1-2011. FILED 10-13-2010.

3,960,876. **VANISHYBRID (STANDARD CHARACTER)**. VANISH CAMO, LLC, (U.S. CLS. 19, 21, 23, 31, 35 AND 44). SN 85-011,531. PUB. 3-1-2011. FILED 4-12-2010.

3,961,105. **TUFFPADS BLUES (STANDARD CHARACTER)**. BLS ENTERPRISES, INC., (U.S. CLS. 19, 21, 23, 31, 35 AND 44). SN 85-107,201. PUB. 3-1-2011. FILED 8-13-2010.

3,961,179. **LONG RIDE SHIELDS (STANDARD CHARACTER)**. AFTER MARKET ACCESSORIES GROUP, LLC, (U.S. CLS. 19, 21, 23, 31, 35 AND 44). SN 85-120,844. PUB. 3-1-2011. FILED 9-1-2010.

3,961,439 ( *See Class 7 for this trademark*).

3,961,441. **SURVIVALIST (STANDARD CHARACTER)**. DYNACRAFT BSC, INC., (U.S. CLS. 19, 21, 23, 31, 35 AND 44). SN 85-129,279. PUB. 3-1-2011. FILED 9-14-2010.

3,961,493. **SEA KING (STANDARD CHARACTER)**. SABIA JR., VINCENT F., (U.S. CLS. 19, 21, 23, 31, 35 AND 44). SN 85-

130,004. PUB. 3-1-2011. FILED 9-15-2010.

3,961,708. **GRASS MASTER (STANDARD CHARACTER)**. F.B.T. ENTERPRISES, INC., (U.S. CLS. 19, 21, 23, 31, 35 AND 44). SN 85-134,518. PUB. 3-1-2011. FILED 9-21-2010.

3,961,808. **SLUMBER PARTY (STANDARD CHARACTER)**. DYNACRAFT BSC, INC., (U.S. CLS. 19, 21, 23, 31, 35 AND 44). SN 85-148,501. PUB. 3-1-2011. FILED 10-8-2010.

3,961,841. **MISCELLANEOUS DESIGN**. NORTH AMERICAN BUS INDUSTRIES, INC., (U.S. CLS. 19, 21, 23, 31, 35 AND 44). SN 85-149,923. PUB. 3-1-2011. FILED 10-11-2010.

3,961,862. **FREEFALL (STANDARD CHARACTER)**. DYNACRAFT BSC, INC., (U.S. CLS. 19, 21, 23, 31, 35 AND 44). SN 85-151,341. PUB. 3-1-2011. FILED 10-13-2010.

3,961,883 ( *See Class 9 for this trademark*).

3,961,887. **INSPIRE (STANDARD CHARACTER)**. DYNACRAFT BSC, INC., (U.S. CLS. 19, 21, 23, 31, 35 AND 44). SN 85-156,754. PUB. 3-1-2011. FILED 10-20-2010.

3,961,888. **THE CRACKIN (STANDARD CHARACTER)**. DYNACRAFT BSC, INC., (U.S. CLS. 19, 21, 23, 31, 35 AND 44). SN 85-156,803. PUB. 3-1-2011. FILED 10-20-2010.

3,961,889. **SUMMER BLAST (STANDARD CHARACTER)**. DYNACRAFT BSC, INC., (U.S. CLS. 19, 21, 23, 31, 35 AND 44). SN 85-156,857. PUB. 3-1-2011. FILED 10-20-2010.

3,961,906. **OTTER (STANDARD CHARACTER)**. DYNACRAFT BSC, INC., (U.S. CLS. 19, 21, 23, 31, 35 AND 44). SN 85-164,608. PUB. 3-1-2011. FILED 10-29-2010.

---

#### CLASS 13—FIREARMS

3,960,330. **TTR (STANDARD CHARACTER)**. POLYZOS, ATHANASIOS, (U.S. CLS. 2 AND 9). SN 77-718,328. PUB. 3-1-2011. FILED 4-21-2009.

3,961,448. **BLAST O MANIA (STANDARD CHARACTER)**. AMERICAN PROMOTIONAL EVENTS, INC., DBA TNT FIREWORKS, (U.S. CLS. 2 AND 9). SN 85-129,314. PUB. 3-1-2011. FILED 9-14-2010.

3,961,506. **BEE HIVE (STANDARD CHARACTER)**. AMERICAN PROMOTIONAL EVENTS, INC., DBA TNT FIREWORKS, (U.S. CLS. 2 AND 9). SN 85-130,227. PUB. 3-1-2011. FILED 9-15-2010.

3,961,588. **THRILLER (STANDARD CHARACTER)**. AMERICAN PROMOTIONAL EVENTS, INC., DBA TNT FIREWORKS, (U.S. CLS. 2 AND 9). SN 85-131,169. PUB. 3-1-2011. FILED 9-16-2010.

3,961,590. **THE NITE THRILLER (STANDARD CHARACTER)**. AMERICAN PROMOTIONAL EVENTS, INC., DBA TNT FIREWORKS, (U.S. CLS. 2 AND 9). SN 85-131,187. PUB. 3-1-2011. FILED 9-16-2010.

3,961,653. **BERSA AND DESIGN**. EAGLE IMPORTS, INC., MULTIPLE CLASS, (INT. CLS. 13 AND 25), (U.S. CLS. 2, 9, 22 AND 39). SN 85-132,075. PUB. 3-1-2011. FILED 9-17-2010.

3,961,773. **BUFFALO BRADY LEATHER (STANDARD CHARACTER)**. TATONKA TRADING COMPANY, (U.S. CLS. 2 AND 9). SN 85-142,657. PUB. 3-1-2011. FILED 9-30-2010.

---

#### CLASS 14—JEWELRY

3,960,264. **MORANA AND DESIGN**. MORANA ACCESSORIES LTDA EPP, (U.S. CLS. 2, 27, 28 AND 50). SN 77-212,061. PUB. 3-1-2011. FILED 6-21-2007.

3,960,266. **TOCARA (STANDARD CHARACTER)**. TOCARA INC., MULTIPLE CLASS, (INT. CLS. 14, 16 AND 35), (U.S. CLS. 2, 5, 22, 23, 27, 28, 29, 37, 38, 50, 100, 101 AND 102). SN 77-253,830. PUB. 3-1-2011. FILED 8-13-2007.

3,960,297. **THE WEEKEND STORE (STANDARD CHARACTER)**. BRODIE, ADJOWAH, DBA THE WEEKEND STORE, (U.S. CLS. 2, 27, 28 AND 50). SN 77-567,177. PUB. 3-1-2011. FILED 9-10-2008.

3,960,494. **NUMIS NETWORK (STANDARD CHARACTER)**. NUMIS NETWORK, LLC, DBA NUMIS NETWORK, (U.S. CLS. 2, 27, 28 AND 50). SN 77-943,580. PUB. 3-1-2011. FILED 2-24-2010.

3,960,520. **PETALS OF HONOR AND DESIGN**. CONWELL

ENTERPRISES, INC., (U.S. CLS. 2, 27, 28 AND 50). SN 77-950,524. PUB. 3-1-2011. FILED 3-4-2010.

3,960,531. **DHARMA JEWELRY DESIGNS (STANDARD CHARACTER)**. ELMASSIAN, DIKRAN A., DBA DHARMA JEWELRY DESIGNS, AND DEVES, ANTONIS, DBA DHARMA JEWELRY DESIGNS, (U.S. CLS. 2, 27, 28 AND 50). SN 77-954,023. PUB. 3-1-2011. FILED 3-9-2010.

3,960,549 ( *See Class 3 for this trademark*).

3,960,588. **SYDNEY SIMONE (STANDARD CHARACTER)**. LYDELL JEWELRY DESIGN STUDIO, INC., (U.S. CLS. 2, 27, 28 AND 50). SN 77-967,317. PUB. 3-1-2011. FILED 3-24-2010.

3,960,590. **ZOE + SYD (STANDARD CHARACTER)**. LYDELL JEWELRY DESIGN STUDIO, INC., (U.S. CLS. 2, 27, 28 AND 50). SN 77-967,337. PUB. 3-1-2011. FILED 3-24-2010.

3,960,606. **THE SUPERIOR LABOR (STYLIZED)**. NAP INCORPORATED, MULTIPLE CLASS, (INT. CLS. 14 AND 18), (U.S. CLS. 1, 2, 3, 22, 27, 28, 41 AND 50). SN 77-969,752. PUB. 3-1-2011. FILED 3-26-2010.

3,960,622 ( *See Class 9 for this trademark*).

3,960,638 ( *See Class 9 for this trademark*).

3,960,660 ( *See Class 3 for this trademark*).

3,960,663 ( *See Class 3 for this trademark*).

3,960,664 ( *See Class 3 for this trademark*).

3,960,725. **XIRAFFA AND DESIGN**. SUDAFRICA IMPORT-EXPORT, S.L., (U.S. CLS. 2, 27, 28 AND 50). SN 79-082,079. PUB. 3-1-2011. FILED 4-13-2010.

3,960,728. **DIAMANTI (STYLIZED)**. FLAVIA DIAMANTI, (U.S. CLS. 2, 27, 28 AND 50). SN 79-082,146. PUB. 3-1-2011. FILED 3-25-2010.

3,960,744 ( *See Class 9 for this trademark*).

3,960,758. **ROMANOFF AND DESIGN**. WATCH COMPANY ROMANOFF, (U.S. CLS. 2, 27, 28 AND 50). SN 79-083,655. PUB. 3-1-2011. FILED 12-4-2009.

3,960,774. **ARIGATO AND DESIGN**. PINKBUDDHA CO., LTD., (U.S. CLS. 2, 27, 28 AND 50). SN 79-084,349. PUB. 3-1-2011. FILED 3-2-2010.

3,960,954. **COIN MOGUL (STANDARD CHARACTER)**. DBGRX INC., DBA COINMOGUL.COM, (U.S. CLS. 2, 27, 28 AND 50). SN 85-045,779. PUB. 3-1-2011. FILED 5-23-2010.

3,960,978. **LIVE LOVE LAUGH (STANDARD CHARACTER)**. D-GENERATION, INC., (U.S. CLS. 2, 27, 28 AND 50). SN 85-060,969. PUB. 3-1-2011. FILED 6-11-2010.

3,961,073. **PS (STYLIZED)**. PROENZA SCHOULER, LLC, (U.S. CLS. 2, 27, 28 AND 50). SN 85-102,238. PUB. 3-1-2011. FILED 8-6-2010.

3,961,158. **ACRYLICANA (STANDARD CHARACTER)**. MARY WINKLER, (U.S. CLS. 2, 27, 28 AND 50). SN 85-117,683. PUB. 3-1-2011. FILED 8-27-2010.

3,961,166 ( *See Class 9 for this trademark*).

3,961,406. **MODIFINI (STANDARD CHARACTER)**. GENUINE GEM INC., MULTIPLE CLASS, (INT. CLS. 14 AND 25), (U.S. CLS. 2, 22, 27, 28, 39 AND 50). SN 85-128,861. PUB. 3-1-2011. FILED 9-14-2010.

3,961,566. **FICD AND DESIGN**. INTERNATIONAL COLLEGE OF DENTISTS, MULTIPLE CLASS, (INT. CLS. 14 AND 16), (U.S. CLS. 2, 5, 22, 23, 27, 28, 29, 37, 38 AND 50). SN 85-130,930. PUB. 3-1-2011. FILED 9-16-2010.

3,961,597. **CAMPGIRL (STANDARD CHARACTER)**. RISE AND SHINE, LLC, (U.S. CLS. 2, 27, 28 AND 50). SN 85-131,282. PUB. 3-1-2011. FILED 9-16-2010.

3,961,605. **M AND DESIGN**. PO SUN HON, (U.S. CLS. 2, 27, 28 AND 50). SN 85-131,440. PUB. 3-1-2011. FILED 9-16-2010.

3,961,648. **CARLY'S CLOSET AND DESIGN**. CHURCHILL, CARLY, DBA CARLY'S CLOSET, (U.S. CLS. 2, 27, 28 AND 50). SN 85-132,040. PUB. 3-1-2011. FILED 9-17-2010.

3,961,729. **RAIDLIGHT AND DESIGN**. RAIDLIGHT, MULTIPLE CLASS, (INT. CLS. 14, 18 AND 25), (U.S. CLS. 1, 2, 3, 22, 27, 28, 39, 41 AND 50). SN 85-137,279. PUB. 3-1-2011. FILED 9-24-2010.

3,961,759. **ANYTHING LUXURIOUS BEGINS AND ENDS AS A LABOR OF LOVE (STANDARD CHARACTER)**. KATHARINE JAMES, INC., (U.S. CLS. 2, 27, 28 AND 50). SN 85-141,491. PUB. 3-1-2011. FILED 9-29-2010.

3,961,800. **M AND DESIGN**. MINOT STATE UNIVERSITY, MULTIPLE CLASS, (INT. CLS. 14, 16, 25 AND 41), (U.S. CLS. 2, 5, 22, 23, 27, 28, 29, 37, 38, 39, 50, 100, 101 AND 107). SN 85-146,975. PUB. 3-1-2011. FILED 10-7-2010.

3,961,933. **SAINT LOUIS UNIVERSITY AD . MAJOREM . DEI . GLORIAM IHS 1818 AND DESIGN**. SAINT LOUIS UNIVERSITY, (U.S. CLS. 2, 27, 28 AND 50). SN 85-174,014. PUB. 3-1-2011. FILED 11-10-2010.

---

## CLASS 15—MUSICAL INSTRUMENTS

3,960,342. **MR. B'S BOTTLENECK GUITAR SLIDES HAND-CRAFTED WITH PRIDE FROM RECYCLED GLASS BOTTLES IN THE USA MRBSGUITARSLIDES.COM AND DESIGN**. ERIC BRENTON SADREAMELI, DBA MR. B'S AUTHENTIC BOTTLENECK SLIDES, (U.S. CLS. 2, 21 AND 36). SN 77-768,226. PUB. 3-1-2011. FILED 6-25-2009.

3,960,660 ( *See Class 3 for this trademark*).

3,960,879. **AUSTIN BAZAAR AND DESIGN**. AUSTIN BAZAAR INCORPORATED, (U.S. CLS. 2, 21 AND 36). SN 85-012,234. PUB. 9-7-2010. FILED 4-12-2010.

---

## CLASS 16—PAPER GOODS AND PRINTED MATTER

3,960,234. **STARLETTES (STANDARD CHARACTER)**. JOHNSON, KATHLEEN B., (U.S. CLS. 2, 5, 22, 23, 29, 37, 38 AND 50). SN 76-702,260. PUB. 3-1-2011. FILED 3-29-2010.

3,960,254. **NATIONAL GARDENING ASSOCIATION (STANDARD CHARACTER)**. NATIONAL GARDENING ASSOCIATION, INC., (U.S. CLS. 2, 5, 22, 23, 29, 37, 38 AND 50). SN 76-704,816. PUB. 3-1-2011. FILED 10-8-2010.

3,960,260 ( *See Class 9 for this trademark*).

3,960,262. **AMBER (STANDARD CHARACTER)**. ARCTIC PAPER KOSTRZYN S.A., (U.S. CLS. 2, 5, 22, 23, 29, 37, 38 AND 50). SN 77-161,572. PUB. 3-1-2011. FILED 4-20-2007.

3,960,266 ( *See Class 14 for this trademark*).

3,960,272 ( *See Class 9 for this trademark*).

3,960,299. **LIVE LAUGH LOVE (STANDARD CHARACTER)**. D-GENERATION, INC., (U.S. CLS. 2, 5, 22, 23, 29, 37, 38 AND 50). SN 77-569,525. PUB. 3-1-2011. FILED 9-14-2008.

3,960,333. **RADIOLOGY BUSINESS MANAGEMENT ASSOCIATION (STANDARD CHARACTER)**. RADIOLOGY BUSINESS MANAGEMENT ASSOCIATION, MULTIPLE CLASS, (INT. CLS. 16, 35 AND 41), (U.S. CLS. 2, 5, 22, 23, 29, 37, 38, 50, 100, 101, 102 AND 107). SN 77-727,362. PUB. 3-1-2011. FILED 5-1-2009.

3,960,339 ( *See Class 9 for this trademark*).

3,960,350. **HUG-A-BUG (STANDARD CHARACTER)**. MIGHTY LION VENTURES LP, (U.S. CLS. 2, 5, 22, 23, 29, 37, 38 AND 50). SN 77-783,249. PUB. 3-1-2011. FILED 7-16-2009.

3,960,372. **OPENHEART (STANDARD CHARACTER)**. OTOPPIO PTY LIMITED, (U.S. CLS. 2, 5, 22, 23, 29, 37, 38 AND 50). SN 77-814,789. PUB. 6-15-2010. FILED 8-28-2009.

3,960,442. **GRACIE AND MO (STANDARD CHARACTER)**. GRACIE AND MO, LLC, (U.S. CLS. 2, 5, 22, 23, 29, 37, 38 AND 50). SN 77-900,642. PUB. 3-1-2011. FILED 12-23-2009.

3,960,449. **SOHO AND DESIGN**. PUBLICACIONES SEMANA S.A., (U.S. CLS. 2, 5, 22, 23, 29, 37, 38 AND 50). SN 77-910,091. PUB. 3-1-2011. FILED 1-12-2010.

3,960,451 ( *See Class 9 for this trademark*).

3,960,462. **TREPAK INNOVATIVE PACKAGING AND DESIGN**. TREPAK SA DE CV, (U.S. CLS. 2, 5, 22, 23, 29, 37, 38 AND 50). SN 77-920,683. PUB. 3-1-2011. FILED 1-26-2010.

3,960,463. **TREPAK (STANDARD CHARACTER)**. TREPAK SA DE CV, (U.S. CLS. 2, 5, 22, 23, 29, 37, 38 AND 50). SN 77-920,714. PUB. 3-1-2011. FILED 1-26-2010.

3,960,468 ( *See Class 9 for this trademark*).

3,960,470. **3 WISE KINGS (STANDARD CHARACTER)**. ROBIN BRITT, DBA BRITT'S INDUSTRIES, (U.S. CLS. 2, 5, 22, 23, 29, 37, 38 AND 50). SN 77-927,065. PUB. 3-1-2011. FILED 2-3-2010.

3,960,471. **MISCELLANEOUS DESIGN**. ROBIN BRITT, DBA BRITT'S INDUSTRIES, (U.S. CLS. 2, 5, 22, 23, 29, 37, 38 AND 50). SN 77-927,085. PUB. 3-1-2011. FILED 2-3-2010.

3,960,492 ( *See Class 9 for this trademark*).

- 3,960,509. **EXECUTIVE LIFESTYLE MAGAZINE (STANDARD CHARACTER)**. EXECUTIVE FUSION, INC., (U.S. CLS. 2, 5, 22, 23, 29, 37, 38 AND 50). SN 77-946,654. PUB. 3-1-2011. FILED 2-27-2010.
- 3,960,511. **QWEST (STANDARD CHARACTER)**. QWEST COMMUNICATIONS INTERNATIONAL INC., (U.S. CLS. 2, 5, 22, 23, 29, 37, 38 AND 50). SN 77-948,007. PUB. 3-1-2011. FILED 3-2-2010.
- 3,960,518. **AMERICAN ARCHITECTURAL FOUNDATION (STANDARD CHARACTER)**. THE AMERICAN ARCHITECTURAL FOUNDATION, INC., MULTIPLE CLASS, (INT. CLS. 16, 36 AND 41), (U.S. CLS. 2, 5, 22, 23, 29, 37, 38, 50, 100, 101, 102 AND 107). SN 77-950,395. PUB. 3-1-2011. FILED 3-4-2010.
- 3,960,529 ( *See Class 9 for this trademark*).
- 3,960,535 ( *See Class 9 for this trademark*).
- 3,960,553. **DYNAMITE COUPONS (STANDARD CHARACTER)**. STARK, CLARA C, (U.S. CLS. 2, 5, 22, 23, 29, 37, 38 AND 50). SN 77-960,129. PUB. 3-1-2011. FILED 3-16-2010.
- 3,960,555. **DEZIGN STYLER (STANDARD CHARACTER)**. FRIEND, RACHEL ANN, (U.S. CLS. 2, 5, 22, 23, 29, 37, 38 AND 50). SN 77-960,576. PUB. 3-1-2011. FILED 3-16-2010.
- 3,960,556. **THE AMERICAN JOURNAL OF CLINICAL NUTRITION (STANDARD CHARACTER)**. AMERICAN SOCIETY FOR NUTRITION, MULTIPLE CLASS, (INT. CLS. 16 AND 41), (U.S. CLS. 2, 5, 22, 23, 29, 37, 38, 50, 100, 101 AND 107). SN 77-960,825. PUB. 3-1-2011. FILED 3-17-2010.
- 3,960,580. **PITCHFORK AND DESIGN**. ARIZONA BOARD OF REGENTS, FOR AND ON BEHALF OF ARIZONA STATE UNIVERSITY, (U.S. CLS. 2, 5, 22, 23, 29, 37, 38 AND 50). SN 77-966,442. PUB. 3-1-2011. FILED 3-23-2010.
- 3,960,602. **FLEXPAC CLEAN EARTH SYSTEMS, INC. AND DESIGN**. CLEAN EARTH SYSTEMS, INC., (U.S. CLS. 2, 5, 22, 23, 29, 37, 38 AND 50). SN 77-969,322. PUB. 3-1-2011. FILED 3-26-2010.
- 3,960,645 ( *See Class 9 for this trademark*).
- 3,960,652 ( *See Class 12 for this trademark*).
- 3,960,655 ( *See Class 9 for this trademark*).
- 3,960,657 ( *See Class 12 for this trademark*).
- 3,960,660 ( *See Class 3 for this trademark*).
- 3,960,666 ( *See Class 9 for this trademark*).
- 3,960,675 ( *See Class 9 for this trademark*).
- 3,960,676 ( *See Class 9 for this trademark*).
- 3,960,680 ( *See Class 9 for this trademark*).
- 3,960,707 ( *See Class 9 for this trademark*).
- 3,960,780. **A ARNOLD MANAGEMENT (STYLIZED)**. DR. FRANK ARNOLD, MULTIPLE CLASS, (INT. CLS. 16, 35 AND 41), (U.S. CLS. 2, 5, 22, 23, 29, 37, 38, 50, 100, 101, 102 AND 107). SN 79-084,555. PUB. 3-1-2011. FILED 5-25-2010.
- 3,960,795 ( *See Class 9 for this trademark*).
- 3,960,830 ( *See Class 9 for this trademark*).
- 3,960,884. **WICK RITE (STANDARD CHARACTER)**. K2 CONCEPTS INCORPORATED, (U.S. CLS. 2, 5, 22, 23, 29, 37, 38 AND 50). SN 85-014,670. PUB. 3-1-2011. FILED 4-15-2010.
- 3,960,891. **I H.E.L.P. MAGAZINE AND DESIGN**. H.E.L.P. CORP, INC., (U.S. CLS. 2, 5, 22, 23, 29, 37, 38 AND 50). SN 85-017,504. PUB. 3-1-2011. FILED 4-19-2010.
- 3,960,950 ( *See Class 5 for this trademark*).
- 3,960,970. **ON THE OTHER SIDE LIES REALITY (STANDARD CHARACTER)**. MCKAY, HARRY J., (U.S. CLS. 2, 5, 22, 23, 29, 37, 38 AND 50). SN 85-056,661. PUB. 3-1-2011. FILED 6-7-2010.
- 3,961,001. **MISCELLANEOUS DESIGN**. Y'S PUBLISHING CO., INC., (U.S. CLS. 2, 5, 22, 23, 29, 37, 38 AND 50). SN 85-070,997. PUB. 3-1-2011. FILED 6-24-2010.
- 3,961,043. **STRATEGIC PLAY (STANDARD CHARACTER)**. 2124708 ONTARIO LTD, MULTIPLE CLASS, (INT. CLS. 16 AND 41), (U.S. CLS. 2, 5, 22, 23, 29, 37, 38, 50, 100, 101 AND 107). SN 85-091,388. PUB. 3-1-2011. FILED 7-23-2010.
- 3,961,053. **KRAMES PATIENT EDUCATION (STANDARD CHARACTER)**. THE STAYWELL COMPANY, LLC, MULTIPLE CLASS, (INT. CLS. 16, 42 AND 44), (U.S. CLS. 2, 5, 22, 23, 29, 37, 38, 50, 100 AND 101). SN 85-095,056. PUB. 3-1-2011. FILED 7-28-2010.
- 3,961,069. **FIRST STRIKE (STANDARD CHARACTER)**. THE HUMANE SOCIETY OF THE UNITED STATES, MULTIPLE CLASS, (INT. CLS. 16 AND 35), (U.S. CLS. 2, 5, 22, 23, 29, 37, 38, 50, 100, 101 AND 102). SN 85-101,479. PUB. 3-1-2011. FILED 8-5-2010.
- 3,961,161. **LIVE THE ACTIVE LIFE (STANDARD CHARACTER)**. MARIAH MEDIA INC., MULTIPLE CLASS, (INT. CLS. 16 AND 41), (U.S. CLS. 2, 5, 22, 23, 29, 37, 38, 50, 100, 101 AND 107). SN 85-118,084. PUB. 3-1-2011. FILED 8-28-2010.
- 3,961,193. **HEARTLAND MUSIC AMERICA'S #1 MUSIC CATALOG (STANDARD CHARACTER)**. DIRECT HOLDINGS AMERICAS INC., (U.S. CLS. 2, 5, 22, 23, 29, 37, 38 AND 50). SN 85-122,495. PUB. 3-1-2011. FILED 9-3-2010.
- 3,961,196. **ARLON (STANDARD CHARACTER)**. ARLON, INC., MULTIPLE CLASS, (INT. CLS. 16, 17 AND 42), (U.S. CLS. 1, 2, 5, 12, 13, 22, 23, 29, 35, 37, 38, 50, 100 AND 101). SN 85-122,608. PUB. 3-1-2011. FILED 9-3-2010.
- 3,961,275. **K KID MOVES AND DESIGN**. KID MOVES LLC, (U.S. CLS. 2, 5, 22, 23, 29, 37, 38 AND 50). SN 85-126,470. PUB. 3-1-2011. FILED 9-9-2010.
- 3,961,318. **HEALTHY MOVEMENT FOR LIFE (STANDARD CHARACTER)**. KID MOVES LLC, (U.S. CLS. 2, 5, 22, 23, 29, 37, 38 AND 50). SN 85-127,452. PUB. 3-1-2011. FILED 9-10-2010.
- 3,961,374. **WILDEYE (STANDARD CHARACTER)**. BERNTSEN, KIRSTEN L, (U.S. CLS. 2, 5, 22, 23, 29, 37, 38 AND 50). SN 85-128,397. PUB. 3-1-2011. FILED 9-13-2010.
- 3,961,380 ( *See Class 9 for this trademark*).
- 3,961,385. **ALUMNI BIRTH CERTIFICATE (STANDARD CHARACTER)**. ATHLETIC BIRTH CERTIFICATE, INC., (U.S. CLS. 2, 5, 22, 23, 29, 37, 38 AND 50). SN 85-128,589. PUB. 3-1-2011. FILED 9-13-2010.
- 3,961,390. **HINDESIGHT (STANDARD CHARACTER)**. HINDES, GARY, (U.S. CLS. 2, 5, 22, 23, 29, 37, 38 AND 50). SN 85-128,661. PUB. 3-1-2011. FILED 9-13-2010.
- 3,961,404. **M AND DESIGN**. I AM MAD AT YOU CARDS, INC., (U.S. CLS. 2, 5, 22, 23, 29, 37, 38 AND 50). SN 85-128,858. PUB. 3-1-2011. FILED 9-14-2010.
- 3,961,405. **I AM MAD AT YOU CARDS (STANDARD CHARACTER)**. I AM MAD AT YOU CARDS, INC., (U.S. CLS. 2, 5, 22, 23, 29, 37, 38 AND 50). SN 85-128,860. PUB. 3-1-2011. FILED 9-14-2010.
- 3,961,418. **PARK PLACE (STANDARD CHARACTER)**. NEW JERSEY MONTHLY, LLC, (U.S. CLS. 2, 5, 22, 23, 29, 37, 38 AND 50). SN 85-128,974. PUB. 3-1-2011. FILED 9-14-2010.
- 3,961,475. **I AM MAD AT YOU CARDS AND DESIGN**. I AM MAD AT YOU CARDS, INC., (U.S. CLS. 2, 5, 22, 23, 29, 37, 38 AND 50). SN 85-129,662. PUB. 3-1-2011. FILED 9-14-2010.
- 3,961,492. **THE PAINTED ESSAY (STANDARD CHARACTER)**. LEDDY, DIANA, (U.S. CLS. 2, 5, 22, 23, 29, 37, 38 AND 50). SN 85-129,982. PUB. 3-1-2011. FILED 9-15-2010.
- 3,961,496. **THE FRONT PERCH (STANDARD CHARACTER)**. THE GABRIEL FOUNDATION, (U.S. CLS. 2, 5, 22, 23, 29, 37, 38 AND 50). SN 85-130,087. PUB. 3-1-2011. FILED 9-15-2010.
- 3,961,509. **TWIN RIVERS OPAQUE (STANDARD CHARACTER)**. TWIN RIVERS PAPER COMPANY LLC, (U.S. CLS. 2, 5, 22, 23, 29, 37, 38 AND 50). SN 85-130,233. PUB. 3-1-2011. FILED 9-15-2010.
- 3,961,510. **CUSTOM SNOWCOTE (STANDARD CHARACTER)**. TWIN RIVERS PAPER COMPANY LLC, (U.S. CLS. 2, 5, 22, 23, 29, 37, 38 AND 50). SN 85-130,234. PUB. 3-1-2011. FILED 9-15-2010.
- 3,961,511. **CUSTOM SUPREME (STANDARD CHARACTER)**. TWIN RIVERS PAPER COMPANY LLC, (U.S. CLS. 2, 5, 22, 23, 29, 37, 38 AND 50). SN 85-130,237. PUB. 3-1-2011. FILED 9-15-2010.
- 3,961,512. **BAXTER BOOK (STANDARD CHARACTER)**. KATAHDIN PAPER COMPANY LLC, (U.S. CLS. 2, 5, 22, 23, 29, 37, 38 AND 50). SN 85-130,249. PUB. 3-1-2011. FILED 9-15-2010.
- 3,961,513. **BAXTER SATIN (STANDARD CHARACTER)**. KATAHDIN PAPER COMPANY LLC, (U.S. CLS. 2, 5, 22, 23, 29, 37, 38 AND 50). SN 85-130,251. PUB. 3-1-2011. FILED 9-15-2010.
- 3,961,514. **TRAVELER OVERSEAS (STANDARD CHARACTER)**. TRAVELER OVERSEAS MAGAZINE, L.L.C., (U.S. CLS. 2, 5, 22, 23, 29, 37, 38 AND 50). SN 85-130,279. PUB. 3-1-2011. FILED 9-15-2010.
- 3,961,515 ( *See Class 6 for this trademark*).
- 3,961,566 ( *See Class 14 for this trademark*).
- 3,961,577. **SIGNATURES OF THE SAVIOR (STYLIZED)**.



KING, LINDA LUE, (U.S. CLS. 2, 5, 22, 23, 29, 37, 38 AND 50). SN 85-131,076. PUB. 3-1-2011. FILED 9-16-2010.

3,961,584. **QUALI-TECH (STANDARD CHARACTER)**, LAKIM INDUSTRIES, INC., DBA QUALI-TECH MFG. CO., (U.S. CLS. 2, 5, 22, 23, 29, 37, 38 AND 50). SN 85-131,145. PUB. 3-1-2011. FILED 9-16-2010.

3,961,609. **ORIGINAL MOONSHINE (STANDARD CHARACTER)**, STILLHOUSE, LLC, (U.S. CLS. 2, 5, 22, 23, 29, 37, 38 AND 50). SN 85-131,494. PUB. 3-1-2011. FILED 9-16-2010.

3,961,651. **NOVEL THOTZ (STANDARD CHARACTER)**, FIELD CRAFTS, INC., (U.S. CLS. 2, 5, 22, 23, 29, 37, 38 AND 50). SN 85-132,062. PUB. 3-1-2011. FILED 9-17-2010.

3,961,683. **AUTOFOCUS (STANDARD CHARACTER)**, TARGET MEDIA PARTNERS OPERATING COMPANY, LLC, (U.S. CLS. 2, 5, 22, 23, 29, 37, 38 AND 50). SN 85-132,662. PUB. 3-1-2011. FILED 9-17-2010.

3,961,706. **HELPMATE (STANDARD CHARACTER)**, BARJAN LLC, (U.S. CLS. 2, 5, 22, 23, 29, 37, 38 AND 50). SN 85-134,236. PUB. 3-1-2011. FILED 9-21-2010.

3,961,734. **KICK-ASS (STANDARD CHARACTER)**, MILLAR-WORLD LIMITED, AND ROMITA, JOHN S., (U.S. CLS. 2, 5, 22, 23, 29, 37, 38 AND 50). SN 85-138,182. PUB. 3-1-2011. FILED 9-24-2010.

3,961,764. **PROPER BOSTONIANS (STANDARD CHARACTER)**, IMPROPER PUBLICATIONS, INC., (U.S. CLS. 2, 5, 22, 23, 29, 37, 38 AND 50). SN 85-141,946. PUB. 3-1-2011. FILED 9-30-2010.

3,961,766. **LAST SCENE HERE (STANDARD CHARACTER)**, IMPROPER PUBLICATIONS, INC., (U.S. CLS. 2, 5, 22, 23, 29, 37, 38 AND 50). SN 85-141,964. PUB. 3-1-2011. FILED 9-30-2010.

3,961,800 ( *See Class 14 for this trademark*).

3,961,803. **EZRA TAFT BENSON AGRICULTURE AND FOOD INSTITUTE (STANDARD CHARACTER)**, INTELLECTUAL RESERVE, INC., MULTIPLE CLASS, (INT. CLS. 16 AND 41), (U.S. CLS. 2, 5, 22, 23, 29, 37, 38, 50, 100, 101 AND 107). SN 85-147,737. PUB. 3-1-2011. FILED 10-7-2010.

3,961,806. **UNIVERSITAS SANCTI LUDOVICI 1818 RELIGIONI ET BONIS ARTIBUS IHS AND DESIGN**, SAINT LOUIS UNIVERSITY, (U.S. CLS. 2, 5, 22, 23, 29, 37, 38 AND 50). SN 85-148,245. PUB. 3-1-2011. FILED 10-8-2010.

3,961,807. **JOB START 101 SMART TIPS AND REAL-WORLD TRAINING AND DESIGN**, THE BUSINESS ROUNDTABLE, (U.S. CLS. 2, 5, 22, 23, 29, 37, 38 AND 50). SN 85-148,418. PUB. 3-1-2011. FILED 10-8-2010.

3,961,840. **MISCELLANEOUS DESIGN**, SUNRISE PUBLICATIONS, INC., DBA SUNRISE GREETINGS, (U.S. CLS. 2, 5, 22, 23, 29, 37, 38 AND 50). SN 85-149,881. PUB. 3-1-2011. FILED 10-11-2010.

3,961,843. **ZEDURA (STANDARD CHARACTER)**, 1821 COMICS, LLC, (U.S. CLS. 2, 5, 22, 23, 29, 37, 38 AND 50). SN 85-149,948. PUB. 3-1-2011. FILED 10-11-2010.

3,961,943. **TREE POWER PLANTING TREES FOR PUBLIC POWER CUSTOMERS AND DESIGN**, AMERICAN PUBLIC POWER ASSOCIATION, MULTIPLE CLASS, (INT. CLS. 16, 35 AND 44), (U.S. CLS. 2, 5, 22, 23, 29, 37, 38, 50, 100, 101 AND 102). SN 85-174,650. PUB. 3-1-2011. FILED 11-11-2010.

3,961,951. **TEXASMONTHLY (STYLIZED)**, EMMIS PUBLISHING, L.P., MULTIPLE CLASS, (INT. CLS. 16 AND 41), (U.S. CLS. 2, 5, 22, 23, 29, 37, 38, 50, 100, 101 AND 107). SN 85-190,271. PUB. 3-1-2011. FILED 12-3-2010.

### CLASS 17—RUBBER GOODS

3,960,229 ( *See Class 8 for this trademark*).

3,960,236. **VISEAL (STANDARD CHARACTER)**, OLIVERTOLAS HEALTHCARE PACKAGING, LLC, (U.S. CLS. 1, 5, 12, 13, 35 AND 50). SN 76-702,411. PUB. 3-1-2011. FILED 4-8-2010.

3,960,317. **CURL-FREE (STANDARD CHARACTER)**, D & K GROUP, INC., (U.S. CLS. 1, 5, 12, 13, 35 AND 50). SN 77-682,071. PUB. 3-1-2011. FILED 3-3-2009.

3,960,355 ( *See Class 3 for this trademark*).

3,960,693 ( *See Class 1 for this trademark*).

3,960,738. **LANCORE (STANDARD CHARACTER)**, LANTOR

B.V., MULTIPLE CLASS, (INT. CLS. 17, 19 AND 24), (U.S. CLS. 1, 5, 12, 13, 33, 35, 42 AND 50). SN 79-082,580. PUB. 3-1-2011. FILED 4-9-2010.

3,960,833 ( *See Class 1 for this trademark*).

3,961,026. **LOVIEW (STYLIZED)**, WINTECH AMERICA, INC., (U.S. CLS. 1, 5, 12, 13, 35 AND 50). SN 85-083,286. PUB. 3-1-2011. FILED 7-13-2010.

3,961,196 ( *See Class 16 for this trademark*).

3,961,197 ( *See Class 1 for this trademark*).

3,961,267. **GPT GLOSS PROTECTION TECHNOLOGY AA AND DESIGN**, ARMANDO ÁLVAREZ, S.A., (U.S. CLS. 1, 5, 12, 13, 35 AND 50). SN 85-126,113. PUB. 3-1-2011. FILED 9-9-2010.

3,961,697. **CHILON (STYLIZED)**, NANJING COMPTech MATERIALS CO., LTD., (U.S. CLS. 1, 5, 12, 13, 35 AND 50). SN 85-133,036. PUB. 3-1-2011. FILED 9-19-2010.

3,961,791. **UNICOVER (STANDARD CHARACTER)**, SHER-RILL, DAN, (U.S. CLS. 1, 5, 12, 13, 35 AND 50). SN 85-144,491. PUB. 3-1-2011. FILED 10-4-2010.

### CLASS 18—LEATHER GOODS

3,960,263. **LONDON SOHO NEW YORK (STANDARD CHARACTER)**, CONAIR CORPORATION, (U.S. CLS. 1, 2, 3, 22 AND 41). SN 77-210,108. PUB. 3-1-2011. FILED 6-19-2007.

3,960,517. **LZ EVERGREEN LZ (STYLIZED)**, LIZHAN ENVIRONMENTAL CORPORATION, (U.S. CLS. 1, 2, 3, 22 AND 41). SN 77-950,138. PUB. 3-1-2011. FILED 3-4-2010.

3,960,548. **LANCÔME PARIS (STANDARD CHARACTER)**, LANCÔME PARFUMS ET BEAUTE & CIE, (U.S. CLS. 1, 2, 3, 22 AND 41). SN 77-959,701. PUB. 3-1-2011. FILED 3-16-2010.

3,960,549 ( *See Class 3 for this trademark*).

3,960,565 ( *See Class 9 for this trademark*).

3,960,606 ( *See Class 14 for this trademark*).

3,960,624. **NOOITGEDAGT (STANDARD CHARACTER)**, CFP EUROPE B.V., MULTIPLE CLASS, (INT. CLS. 18, 25 AND 28), (U.S. CLS. 1, 2, 3, 22, 23, 38, 39, 41 AND 50). SN 77-981,808. PUB. 8-3-2010. FILED 8-31-2009.

3,960,630. **BENCH AND DESIGN**, AMERICANA INTERNATIONAL LIMITED, MULTIPLE CLASS, (INT. CLS. 18 AND 25), (U.S. CLS. 1, 2, 3, 22, 39 AND 41). SN 78-669,654. PUB. 3-1-2011. FILED 7-13-2005.

3,960,638 ( *See Class 9 for this trademark*).

3,960,660 ( *See Class 3 for this trademark*).

3,960,663 ( *See Class 3 for this trademark*).

3,960,664 ( *See Class 3 for this trademark*).

3,960,678 ( *See Class 5 for this trademark*).

3,960,735. **CASAL SPORT AND DESIGN**, SPORTS ET LOISIRS, MULTIPLE CLASS, (INT. CLS. 18, 25, 28 AND 35), (U.S. CLS. 1, 2, 3, 22, 23, 38, 39, 41, 50, 100, 101 AND 102). SN 79-082,459. PUB. 3-1-2011. FILED 3-25-2010.

3,960,744 ( *See Class 9 for this trademark*).

3,960,768. **M AND DESIGN**, TATJANA FRISCH, MULTIPLE CLASS, (INT. CLS. 18, 20, 24 AND 35), (U.S. CLS. 1, 2, 3, 13, 22, 25, 32, 41, 42, 50, 100, 101 AND 102). SN 79-084,158. PUB. 1-25-2011. FILED 12-22-2009.

3,960,770. **MISCELLANEOUS DESIGN**, FRED PERRY (HOLDINGS) LIMITED, (U.S. CLS. 1, 2, 3, 22 AND 41). SN 79-084,324. PUB. 3-1-2011. FILED 3-4-2010.

3,960,795 ( *See Class 9 for this trademark*).

3,960,806 ( *See Class 12 for this trademark*).

3,960,834. **GEEKIT AND DESIGN**, MMH PTY LTD, MULTIPLE CLASS, (INT. CLS. 18 AND 20), (U.S. CLS. 1, 2, 3, 13, 22, 25, 32, 41 AND 50). SN 79-975,080. PUB. 11-23-2010. FILED 11-30-2007.

3,960,920. **BOA NOITE (STANDARD CHARACTER)**, LUXE INNOVATIONS, LLC, (U.S. CLS. 1, 2, 3, 22 AND 41). SN 85-030,873. PUB. 3-1-2011. FILED 5-5-2010.

3,960,989. **PEACE ROCKS AND DESIGN**, LOUIS SIMPSON AND SAMUEL'S LLC, (U.S. CLS. 1, 2, 3, 22 AND 41). SN 85-067,433. PUB. 3-1-2011. FILED 6-21-2010.

3,961,000. **XFORCE (STYLIZED)**, PACIFIC ENTERMARK VERTRIEBSGESELLSCHAFT MBH, MULTIPLE CLASS, (INT. CLS. 18, 25 AND 28), (U.S. CLS. 1, 2, 3, 22, 23, 38, 39, 41 AND 50). SN 85-070,803. PUB. 3-1-2011. FILED 6-24-2010.

- 3,961,002. **SWITCH STICKS (STANDARD CHARACTER)**. SWITCH STICKS LTD., (U.S. CLS. 1, 2, 3, 22 AND 41). SN 85-071,007. PUB. 3-1-2011. FILED 6-24-2010.
- 3,961,159. **ORGANIZED TRAVEL (STANDARD CHARACTER)**. A&A MERCHANDISING, INC., (U.S. CLS. 1, 2, 3, 22 AND 41). SN 85-117,909. PUB. 3-1-2011. FILED 8-27-2010. 3,961,166 ( *See Class 9 for this trademark*).
- 3,961,174. **MISCELLANEOUS DESIGN**. DIGICERT, INC., MULTIPLE CLASS, (INT. CLS. 18, 21, 25 AND 45), (U.S. CLS. 1, 2, 3, 13, 22, 23, 29, 30, 33, 39, 40, 41, 50, 100 AND 101). SN 85-120,002. PUB. 3-1-2011. FILED 8-31-2010.
- 3,961,231. **J WORLD (STYLIZED)**. J WORLD SPORTS, INC., FORMERLY J WORLD PRODUCTS, INC., (U.S. CLS. 1, 2, 3, 22 AND 41). SN 85-123,867. PUB. 3-1-2011. FILED 9-7-2010.
- 3,961,477. **ROCK WEAR FOR DOGS (& HUMANS TOO!) AND DESIGN**. KATYAMUSIC, LLC, (U.S. CLS. 1, 2, 3, 22 AND 41). SN 85-129,685. PUB. 3-1-2011. FILED 9-14-2010.
- 3,961,629. **NITE BEAMS (STANDARD CHARACTER)**. NITE BEAM PRODUCTS, LLC, MULTIPLE CLASS, (INT. CLS. 18, 25 AND 26), (U.S. CLS. 1, 2, 3, 22, 37, 39, 40, 41, 42 AND 50). SN 85-131,693. PUB. 3-1-2011. FILED 9-16-2010.
- 3,961,660. **PE (STYLIZED)**. PEI LICENSING, INC., (U.S. CLS. 1, 2, 3, 22 AND 41). SN 85-132,383. PUB. 3-1-2011. FILED 9-17-2010.
- 3,961,700. **PE (STYLIZED)**. PEI LICENSING, INC., (U.S. CLS. 1, 2, 3, 22 AND 41). SN 85-133,167. PUB. 3-1-2011. FILED 9-20-2010.
- 3,961,729 ( *See Class 14 for this trademark*).
- 3,961,865. **VELOMAN (STANDARD CHARACTER)**. GILSTON, JACK DAVID, (U.S. CLS. 1, 2, 3, 22 AND 41). SN 85-151,657. PUB. 3-1-2011. FILED 10-13-2010.
- 3,961,883 ( *See Class 9 for this trademark*).
- 3,961,937. **SAINT LOUIS UNIVERSITY AD . MAJOREM . DEI . GLORIAM IHS 1818 AND DESIGN**. SAINT LOUIS UNIVERSITY, (U.S. CLS. 1, 2, 3, 22 AND 41). SN 85-174,025. PUB. 3-1-2011. FILED 11-10-2010.

#### CLASS 19—NON-METALLIC BUILDING MATERIALS

- 3,960,284. **FOREVER TUFF (STANDARD CHARACTER)**. JOHNSON PREMIUM HARDWOOD FLOORING, INC., (U.S. CLS. 1, 12, 33 AND 50). SN 77-487,938. PUB. 4-21-2009. FILED 5-31-2008.
- 3,960,305. **VINTAGE PIONEERED SOLID HARDWOOD FLOORING AND DESIGN**. COMPUTERSHARE TRUST COMPANY OF CANADA, (U.S. CLS. 1, 12, 33 AND 50). SN 77-602,968. PUB. 3-1-2011. FILED 10-29-2008.
- 3,960,338. **FRAMING ON STONE AND DESIGN**. KRAFFT, JACK S., DBA FRAMING ON STONE, AND KRAFFT, LINDA S., DBA FRAMING ON STONE, (U.S. CLS. 1, 12, 33 AND 50). SN 77-752,999. PUB. 3-1-2011. FILED 6-5-2009.
- 3,960,477. **SUREDOME (STYLIZED)**. ADVANCED SURFACE SYSTEMS LLC, AKA AKA ASSI, (U.S. CLS. 1, 12, 33 AND 50). SN 77-931,754. PUB. 3-1-2011. FILED 2-9-2010.
- 3,960,651 ( *See Class 6 for this trademark*).
- 3,960,693 ( *See Class 1 for this trademark*).
- 3,960,738 ( *See Class 17 for this trademark*).
- 3,960,745 ( *See Class 6 for this trademark*).
- 3,960,757 ( *See Class 1 for this trademark*).
- 3,960,769. **FIRST CORPORATION AND DESIGN**. FIRST CORPORATION S.R.L., (U.S. CLS. 1, 12, 33 AND 50). SN 79-084,307. PUB. 3-1-2011. FILED 11-16-2009.
- 3,960,783. **YÜKSEL SERAMİK AND DESIGN**. YÜKSEL SERAMİK SANAYİ VE TİCARET ANONİM ŞİRKETİ, (U.S. CLS. 1, 12, 33 AND 50). SN 79-084,718. PUB. 3-1-2011. FILED 3-12-2010.
- 3,961,052. **ALASTICK SHOTCRETE (STANDARD CHARACTER)**. DELTA INDUSTRIAL SERVICES INC, (U.S. CLS. 1, 12, 33 AND 50). SN 85-094,743. PUB. 3-1-2011. FILED 7-28-2010.
- 3,961,310. **LEGANTE CERAMICHE AND DESIGN**. LONGUST DISTRIBUTING, INC., (U.S. CLS. 1, 12, 33 AND 50). SN 85-127,255. PUB. 3-1-2011. FILED 9-10-2010.
- 3,961,314. **LEGANTE (STANDARD CHARACTER)**. LONGUST DISTRIBUTING, INC., (U.S. CLS. 1, 12, 33 AND 50). SN 85-

- 127,321. PUB. 3-1-2011. FILED 9-10-2010.
- 3,961,494. **AEROLENZ (STANDARD CHARACTER)**. AEROLENZ LLC, (U.S. CLS. 1, 12, 33 AND 50). SN 85-130,050. PUB. 3-1-2011. FILED 9-15-2010.
- 3,961,731. **COMFY CABIN (STANDARD CHARACTER)**. OURPET'S COMPANY, (U.S. CLS. 1, 12, 33 AND 50). SN 85-137,562. PUB. 3-1-2011. FILED 9-24-2010.
- 3,961,900. **D DAL TILE AND DESIGN**. DAL TILE DISTRIBUTION, INC., (U.S. CLS. 1, 12, 33 AND 50). SN 85-162,150. PUB. 3-1-2011. FILED 10-27-2010.

#### CLASS 20—FURNITURE AND ARTICLES NOT OTHERWISE CLASSIFIED

- 3,960,259. **SIBERIAN SNOW DOWN (STANDARD CHARACTER)**. NORTHERN FEATHER CANADA LTD., MULTIPLE CLASS, (INT. CLS. 20 AND 24), (U.S. CLS. 2, 13, 22, 25, 32, 42 AND 50). SN 77-101,548. PUB. 3-1-2011. FILED 2-7-2007.
- 3,960,281 ( *See Class 6 for this trademark*).
- 3,960,285. **DEXTER (STANDARD CHARACTER)**. ALLSEATING CORPORATION, (U.S. CLS. 2, 13, 22, 25, 32 AND 50). SN 77-500,730. PUB. 3-1-2011. FILED 6-17-2008.
- 3,960,399. **DURA BIKE LOCKER AND DESIGN**. HANNAN SPECIALTIES, INC., (U.S. CLS. 2, 13, 22, 25, 32 AND 50). SN 77-834,403. PUB. 3-1-2011. FILED 9-24-2009.
- 3,960,404. **LABEL OUT LOUD (STANDARD CHARACTER)**. MABEL'S LABELS INC., MULTIPLE CLASS, (INT. CLS. 20 AND 24), (U.S. CLS. 2, 13, 22, 25, 32, 42 AND 50). SN 77-841,143. PUB. 3-1-2011. FILED 10-5-2009.
- 3,960,426. **THE ORIGINAL CAPTAIN'S BED SINCE 1969 AND DESIGN**. GOTHIC CABINET CRAFT INC., (U.S. CLS. 2, 13, 22, 25, 32 AND 50). SN 77-878,364. PUB. 3-1-2011. FILED 11-22-2009.
- 3,960,427. **THE ORIGINAL PLATFORM BED SINCE 1969 AND DESIGN**. GOTHIC CABINET CRAFT INC., (U.S. CLS. 2, 13, 22, 25, 32 AND 50). SN 77-878,368. PUB. 3-1-2011. FILED 11-22-2009.
- 3,960,428. **THE ORIGINAL STORAGE BED SINCE 1969 AND DESIGN**. GOTHIC CABINET CRAFT INC., (U.S. CLS. 2, 13, 22, 25, 32 AND 50). SN 77-878,372. PUB. 3-1-2011. FILED 11-22-2009.
- 3,960,432 ( *See Class 11 for this trademark*).
- 3,960,521. **NO NASTY NEST (STANDARD CHARACTER)**. YANECKO, MICHAEL J., DBA NO NASTY NEST, AND YANECKO, JANE, DBA NO NASTY NEST, (U.S. CLS. 2, 13, 22, 25, 32 AND 50). SN 77-950,592. PUB. 3-1-2011. FILED 3-4-2010.
- 3,960,554. **GBS AND DESIGN**. GBS, INC., MULTIPLE CLASS, (INT. CLS. 20 AND 24), (U.S. CLS. 2, 13, 22, 25, 32, 42 AND 50). SN 77-960,490. PUB. 3-1-2011. FILED 3-16-2010.
- 3,960,568. **NEWBURY (STANDARD CHARACTER)**. RESTORATION HARDWARE, INC., MULTIPLE CLASS, (INT. CLS. 20 AND 21), (U.S. CLS. 2, 13, 22, 23, 25, 29, 30, 32, 33, 40 AND 50). SN 77-964,918. PUB. 3-1-2011. FILED 3-22-2010.
- 3,960,579. **PRELUDE (STANDARD CHARACTER)**. MBC IP CO., (U.S. CLS. 2, 13, 22, 25, 32 AND 50). SN 77-966,351. PUB. 3-1-2011. FILED 3-23-2010.
- 3,960,601. **LOTTE AND DESIGN**. LOTTE SHOPPING CO., LTD., (U.S. CLS. 2, 13, 22, 25, 32 AND 50). SN 77-969,314. PUB. 3-1-2011. FILED 3-26-2010.
- 3,960,660 ( *See Class 3 for this trademark*).
- 3,960,663 ( *See Class 3 for this trademark*).
- 3,960,664 ( *See Class 3 for this trademark*).
- 3,960,678 ( *See Class 5 for this trademark*).
- 3,960,688. **VIAL (STANDARD CHARACTER)**. VIAL GMBH, MULTIPLE CLASS, (INT. CLS. 20 AND 21), (U.S. CLS. 2, 13, 22, 23, 25, 29, 30, 32, 33, 40 AND 50). SN 79-079,271. PUB. 3-1-2011. FILED 9-18-2009.
- 3,960,692. **CHAIRLESS (STANDARD CHARACTER)**. VITRA PATENTE AG, MULTIPLE CLASS, (INT. CLS. 20, 26 AND 28), (U.S. CLS. 2, 13, 22, 23, 25, 32, 37, 38, 39, 40, 42 AND 50). SN 79-080,335. PUB. 3-1-2011. FILED 2-1-2010.
- 3,960,715 ( *See Class 11 for this trademark*).
- 3,960,736 ( *See Class 11 for this trademark*).



3,960,768 ( *See Class 18 for this trademark.*)  
 3,960,806 ( *See Class 12 for this trademark.*)  
 3,960,819. **INNOVATION UNITED (STANDARD CHARACTER)**. INNOVATION RANDERS A/S, (U.S. CLS. 2, 13, 22, 25, 32 AND 50). SN 79-087,716. PUB. 3-1-2011. FILED 9-13-2010.  
 3,960,834 ( *See Class 18 for this trademark.*)  
 3,960,859. **RUSSEL WRIGHT (STANDARD CHARACTER)**. WRIGHT, ANN, (U.S. CLS. 2, 13, 22, 25, 32 AND 50). SN 85-006,788. PUB. 3-1-2011. FILED 4-5-2010.  
 3,960,870. **MISCELLANEOUS DESIGN**. JANG SOO FURNISHING, INC., (U.S. CLS. 2, 13, 22, 25, 32 AND 50). SN 85-009,674. PUB. 3-1-2011. FILED 4-8-2010.  
 3,961,100. **NAMOR THE SUB-MARINER (STANDARD CHARACTER)**. MARVEL CHARACTERS, INC., (U.S. CLS. 2, 13, 22, 25, 32 AND 50). SN 85-106,238. PUB. 3-1-2011. FILED 8-12-2010.  
 3,961,237 ( *See Class 11 for this trademark.*)  
 3,961,258. **ARTISTIC FREEDOM DESIGNS (STANDARD CHARACTER)**. PETER VIVIAN, AND AMY FREDERICK, (U.S. CLS. 2, 13, 22, 25, 32 AND 50). SN 85-125,513. PUB. 3-1-2011. FILED 9-9-2010.  
 3,961,435. **AARTING (STANDARD CHARACTER)**. AARTING IP HOLDER LLC, MULTIPLE CLASS, (INT. CLS. 20, 35 AND 42), (U.S. CLS. 2, 13, 22, 25, 32, 50, 100, 101 AND 102). SN 85-129,203. PUB. 3-1-2011. FILED 9-14-2010.  
 3,961,489. **MY FAVORITE BUG AND DESIGN**. MY FAVORITE BUG, LLC, (U.S. CLS. 2, 13, 22, 25, 32 AND 50). SN 85-129,939. PUB. 3-1-2011. FILED 9-15-2010.  
 3,961,788. **ISLAND FISH BAR AND DESIGN**. PENDLETON, DIANE, (U.S. CLS. 2, 13, 22, 25, 32 AND 50). SN 85-144,063. PUB. 3-1-2011. FILED 10-4-2010.

---

## CLASS 21—HOUSEWARES AND GLASS

3,960,281 ( *See Class 6 for this trademark.*)  
 3,960,415. **PS3 (STYLIZED)**. KABUSHIKI KAISHA SONY COMPUTER ENTERTAINMENT, TA SONY COMPUTER ENTERTAINMENT INC., MULTIPLE CLASS, (INT. CLS. 21, 24 AND 25), (U.S. CLS. 2, 13, 22, 23, 29, 30, 33, 39, 40, 42 AND 50). SN 77-861,870. PUB. 3-1-2011. FILED 10-30-2009.  
 3,960,419. **MISCELLANEOUS DESIGN**. SEATTLE UNIVERSITY, MULTIPLE CLASS, (INT. CLS. 21, 25 AND 41), (U.S. CLS. 2, 13, 22, 23, 29, 30, 33, 39, 40, 50, 100, 101 AND 107). SN 77-865,850. PUB. 9-28-2010. FILED 11-5-2009.  
 3,960,467. **IGLU (STYLIZED)**. RAKKU INC., (U.S. CLS. 2, 13, 23, 29, 30, 33, 40 AND 50). SN 77-924,884. PUB. 3-1-2011. FILED 2-1-2010.  
 3,960,515. **WYOMING COWBOYS (STANDARD CHARACTER)**. UNIVERSITY OF WYOMING, MULTIPLE CLASS, (INT. CLS. 21 AND 28), (U.S. CLS. 2, 13, 22, 23, 29, 30, 33, 38, 40 AND 50). SN 77-949,378. PUB. 9-28-2010. FILED 3-3-2010.  
 3,960,525. **HAIRSQUARE (STYLIZED)**. PRIOR, KRISTINA L., (U.S. CLS. 2, 13, 23, 29, 30, 33, 40 AND 50). SN 77-952,666. PUB. 3-1-2011. FILED 3-7-2010.  
 3,960,568 ( *See Class 20 for this trademark.*)  
 3,960,619 ( *See Class 9 for this trademark.*)  
 3,960,663 ( *See Class 3 for this trademark.*)  
 3,960,664 ( *See Class 3 for this trademark.*)  
 3,960,678 ( *See Class 5 for this trademark.*)  
 3,960,679. **SPIEGELAU (STANDARD CHARACTER)**. KRISTALLGLASFABRIK SPIEGELAU GMBH, (U.S. CLS. 2, 13, 23, 29, 30, 33, 40 AND 50). SN 79-077,548. PUB. 3-1-2011. FILED 12-3-2009.  
 3,960,687. **THERMO SILVER AND DESIGN**. THERMOHAUSER GMBH, (U.S. CLS. 2, 13, 23, 29, 30, 33, 40 AND 50). SN 79-079,204. PUB. 3-1-2011. FILED 1-27-2010.  
 3,960,688 ( *See Class 20 for this trademark.*)  
 3,960,715 ( *See Class 11 for this trademark.*)  
 3,960,736 ( *See Class 11 for this trademark.*)  
 3,960,757 ( *See Class 1 for this trademark.*)  
 3,960,810 ( *See Class 3 for this trademark.*)  
 3,960,873. **PORTAPEEL (STANDARD CHARACTER)**. INNOVATIVE MED INC., (U.S. CLS. 2, 13, 23, 29, 30, 33, 40 AND 50). SN 85-010,293. PUB. 3-1-2011. FILED 4-9-2010.  
 3,961,040. **LENS JACKETS (STYLIZED)**. LENS JACKETS,

(U.S. CLS. 2, 13, 23, 29, 30, 33, 40 AND 50). SN 85-089,300. PUB. 3-1-2011. FILED 7-21-2010.  
 3,961,174 ( *See Class 18 for this trademark.*)  
 3,961,408. **A MAKEOVER FOR YOUR LIPSTICK (STANDARD CHARACTER)**. DIVINE INNOVATIONS, LLC, (U.S. CLS. 2, 13, 23, 29, 30, 33, 40 AND 50). SN 85-128,880. PUB. 3-1-2011. FILED 9-14-2010.  
 3,961,436. **NINETEEN 13 AND DESIGN**. PACIFIC MARKET INTERNATIONAL, LLC, (U.S. CLS. 2, 13, 23, 29, 30, 33, 40 AND 50). SN 85-129,218. PUB. 3-1-2011. FILED 9-14-2010.  
 3,961,467. **FRIDGE-TAMER (STANDARD CHARACTER)**. KEITH M. CUMMING, (U.S. CLS. 2, 13, 23, 29, 30, 33, 40 AND 50). SN 85-129,550. PUB. 3-1-2011. FILED 9-14-2010.  
 3,961,470. **CAN-TAMER (STANDARD CHARACTER)**. KEITH M. CUMMING, (U.S. CLS. 2, 13, 23, 29, 30, 33, 40 AND 50). SN 85-129,584. PUB. 3-1-2011. FILED 9-14-2010.  
 3,961,471. **CUPBOARD-TAMER (STANDARD CHARACTER)**. CUMMING, KEITH M., (U.S. CLS. 2, 13, 23, 29, 30, 33, 40 AND 50). SN 85-129,612. PUB. 3-1-2011. FILED 9-14-2010.  
 3,961,515 ( *See Class 6 for this trademark.*)  
 3,961,537. **COOLER BY DESIGN (STANDARD CHARACTER)**. PBR INDUSTRIES, INC., (U.S. CLS. 2, 13, 23, 29, 30, 33, 40 AND 50). SN 85-130,496. PUB. 3-1-2011. FILED 9-15-2010.  
 3,961,559. **VICIOUS HUNTING AND DESIGN**. JBS FISHING LINE, LLC, (U.S. CLS. 2, 13, 23, 29, 30, 33, 40 AND 50). SN 85-130,778. PUB. 3-1-2011. FILED 9-16-2010.  
 3,961,650. **NEUSPRUE (STANDARD CHARACTER)**. THE BELL GROUP, AKA RIO GRANDE, (U.S. CLS. 2, 13, 23, 29, 30, 33, 40 AND 50). SN 85-132,055. PUB. 3-1-2011. FILED 9-17-2010.  
 3,961,654. **MIX, MELT & GLOSS (STANDARD CHARACTER)**. DIVINE INNOVATIONS, LLC, (U.S. CLS. 2, 13, 23, 29, 30, 33, 40 AND 50). SN 85-132,107. PUB. 3-1-2011. FILED 9-17-2010.  
 3,961,685. **I LOVE JESUS AND DESIGN**. JESUS HEART FOUNDATION, INC., (U.S. CLS. 2, 13, 23, 29, 30, 33, 40 AND 50). SN 85-132,687. PUB. 3-1-2011. FILED 9-17-2010.  
 3,961,686. **HEMICASA (STANDARD CHARACTER)**. HEMISPHERE TRADING OF NY, LLC, (U.S. CLS. 2, 13, 23, 29, 30, 33, 40 AND 50). SN 85-132,728. PUB. 3-1-2011. FILED 9-18-2010.  
 3,961,938. **SAINT LOUIS UNIVERSITY AD . MAJOREM . DEI . GLORIAM IHS 1818 AND DESIGN**. SAINT LOUIS UNIVERSITY, (U.S. CLS. 2, 13, 23, 29, 30, 33, 40 AND 50). SN 85-174,029. PUB. 3-1-2011. FILED 11-10-2010.

---

## CLASS 22—CORDAGE AND FIBERS

3,960,522. **SUDDEN SHADE (STANDARD CHARACTER)**. THE DEWITT COMPANY, INC., (U.S. CLS. 1, 2, 7, 19, 22, 42 AND 50). SN 77-950,883. PUB. 3-1-2011. FILED 3-4-2010.  
 3,960,724. **ATLANTICA AND DESIGN**. FISHERING SERVICE LIMITED, (U.S. CLS. 1, 2, 7, 19, 22, 42 AND 50). SN 79-082,040. PUB. 3-1-2011. FILED 11-16-2009.  
 3,960,814. **PALMIYE AND DESIGN**. SKAN IÇ VE DİSTİCARET İNSAAT ELEKTRONİK TEKSTİL GIDA VE MADEN SANAYİ ANONİM ŞİRKETİ, (U.S. CLS. 1, 2, 7, 19, 22, 42 AND 50). SN 79-087,073. PUB. 3-1-2011. FILED 5-5-2010.  
 3,961,066. **WE HAVE A STRAP FOR THAT (STANDARD CHARACTER)**. DONNA S FOSTER, DBA STRAPWORKS, (U.S. CLS. 1, 2, 7, 19, 22, 42 AND 50). SN 85-100,430. PUB. 3-1-2011. FILED 8-4-2010.  
 3,961,502. **WINDPADDLE (STANDARD CHARACTER)**. WILTZ, NICHOLAS MARK, (U.S. CLS. 1, 2, 7, 19, 22, 42 AND 50). SN 85-130,153. PUB. 3-1-2011. FILED 9-15-2010.  
 3,961,883 ( *See Class 9 for this trademark.*)

---

## CLASS 23—YARNS AND THREADS

3,961,711. **LIVE LAUGH LOVE (STANDARD CHARACTER)**. D-GENERATION, INC., (U.S. CL. 43). SN 85-134,957. PUB. 3-1-2011. FILED 9-21-2010.

**CLASS 24—FABRICS**

- 3,960,259 ( *See Class 20 for this trademark.* )  
 3,960,404 ( *See Class 20 for this trademark.* )  
 3,960,415 ( *See Class 21 for this trademark.* )  
 3,960,504. **PELLE D'ANGELO (STANDARD CHARACTER)**. ESE INC., (U.S. CLS. 42 AND 50). SN 77-946,026. PUB. 3-1-2011. FILED 2-26-2010.  
 3,960,533. **EURO DRY (STANDARD CHARACTER)**. CANADIAN GENERAL-TOWER LIMITED, (U.S. CLS. 42 AND 50). SN 77-954,383. PUB. 3-1-2011. FILED 3-9-2010.  
 3,960,554 ( *See Class 20 for this trademark.* )  
 3,960,660 ( *See Class 3 for this trademark.* )  
 3,960,738 ( *See Class 17 for this trademark.* )  
 3,960,765. **G GLP AND DESIGN**. ZHEJIANG GANGLONG; NEW MATERIAL CO.,LTD, (U.S. CLS. 42 AND 50). SN 79-084,003. PUB. 3-1-2011. FILED 3-26-2010.  
 3,960,768 ( *See Class 18 for this trademark.* )  
 3,960,806 ( *See Class 12 for this trademark.* )  
 3,961,054. **SHOW NO (STANDARD CHARACTER)**. EHLER, SHELLY, (U.S. CLS. 42 AND 50). SN 85-095,379. PUB. 3-1-2011. FILED 7-28-2010.  
 3,961,189. . **JB . JULIA B. AND DESIGN**. JB CUSTOM LINENS, LLC, (U.S. CLS. 42 AND 50). SN 85-121,829. PUB. 3-1-2011. FILED 9-2-2010.  
 3,961,380 ( *See Class 9 for this trademark.* )  
 3,961,707. **SMART-FAB AND DESIGN**. DISPO-BUD MARKETING, DBA DISPOBUD, (U.S. CLS. 42 AND 50). SN 85-134,402. PUB. 3-1-2011. FILED 9-21-2010.  
 3,961,852. **EQUALITY BEYOND GENDER (STANDARD CHARACTER)**. PRETE JR., PETER ALLEN, MULTIPLE CLASS, (INT. CLS. 24 AND 25), (U.S. CLS. 22, 39, 42 AND 50). SN 85-150,024. PUB. 3-1-2011. FILED 10-11-2010.  
 3,961,853. **MISCELLANEOUS DESIGN**. PRETE JR., PETER ALLEN, MULTIPLE CLASS, (INT. CLS. 24 AND 25), (U.S. CLS. 22, 39, 42 AND 50). SN 85-150,029. PUB. 3-1-2011. FILED 10-11-2010.

**CLASS 25—CLOTHING**

- 3,960,238. **HONOR ATHLETICS AND DESIGN**. PROKARATE & BOXING SUPPLIES, INC., MULTIPLE CLASS, (INT. CLS. 25 AND 28), (U.S. CLS. 22, 23, 38, 39 AND 50). SN 76-702,779. PUB. 3-1-2011. FILED 5-3-2010.  
 3,960,243. **MISCELLANEOUS DESIGN**. HERRICK, STEVEN MICHAEL, (U.S. CLS. 22 AND 39). SN 76-703,720. PUB. 3-1-2011. FILED 7-9-2010.  
 3,960,260 ( *See Class 9 for this trademark.* )  
 3,960,261. **ENJOI (STANDARD CHARACTER)**. CHOMP, INC., (U.S. CLS. 22 AND 39). SN 77-148,819. PUB. 3-1-2011. FILED 4-4-2007.  
 3,960,271. **GREEN IS THE NEW BLACK (STANDARD CHARACTER)**. JOHNSON, JILL L., (U.S. CLS. 22 AND 39). SN 77-288,894. PUB. 3-1-2011. FILED 9-25-2007.  
 3,960,272 ( *See Class 9 for this trademark.* )  
 3,960,273 ( *See Class 5 for this trademark.* )  
 3,960,277. **DOBAMBOO (STANDARD CHARACTER)**. JELIAS ENTERPRISE LTD, (U.S. CLS. 22 AND 39). SN 77-376,415. PUB. 3-1-2011. FILED 1-21-2008.  
 3,960,291. **STONZ AND DESIGN**. STONZ WEAR INCORPORATED, (U.S. CLS. 22 AND 39). SN 77-535,559. PUB. 3-1-2011. FILED 7-31-2008.  
 3,960,302. **CL (STYLIZED)**. TESSITURA CARLO LAMPERTI E FIGLIO S.P.A., (U.S. CLS. 22 AND 39). SN 77-586,415. PUB. 3-1-2011. FILED 10-6-2008.  
 3,960,307. **COUNTRY FEELING (STANDARD CHARACTER)**. BUSHMAN, JEFFREY, (U.S. CLS. 22 AND 39). SN 77-627,871. PUB. 1-25-2011. FILED 12-5-2008.  
 3,960,314. **STEVE TRASH (STANDARD CHARACTER)**. CONCRETE DREAM, INC., MULTIPLE CLASS, (INT. CLS. 25 AND 28), (U.S. CLS. 22, 23, 38, 39 AND 50). SN 77-673,675. PUB. 3-1-2011. FILED 2-19-2009.  
 3,960,348. **YOURGANIC BY YOUR|SELF (STANDARD CHARACTER)**. 4086864 CANADA INC., (U.S. CLS. 22 AND 39). SN 77-782,382. PUB. 3-1-2011. FILED 7-16-2009.  
 3,960,353 ( *See Class 9 for this trademark.* )  
 3,960,357. **RAW DIAMOND (STANDARD CHARACTER)**. DENIM PROJECT LLC, (U.S. CLS. 22 AND 39). SN 77-802,334. PUB. 1-25-2011. FILED 8-11-2009.  
 3,960,408 ( *See Class 10 for this trademark.* )  
 3,960,413. **CITYSLIPS AND DESIGN**. FUNK-TIONAL ENTERPRISES, LLC, (U.S. CLS. 22 AND 39). SN 77-858,607. PUB. 3-1-2011. FILED 10-27-2009.  
 3,960,415 ( *See Class 21 for this trademark.* )  
 3,960,417. **STELLA CRUZ (STANDARD CHARACTER)**. TWIN HEART CLOTHING INC., (U.S. CLS. 22 AND 39). SN 77-863,731. PUB. 3-1-2011. FILED 11-3-2009.  
 3,960,419 ( *See Class 21 for this trademark.* )  
 3,960,434. **ROOTED IN PEACE (STANDARD CHARACTER)**. BLUE WATER ENTERTAINMENT, INC., (U.S. CLS. 22 AND 39). SN 77-892,035. PUB. 3-1-2011. FILED 12-11-2009.  
 3,960,453. **THE BURIED LIFE (STANDARD CHARACTER)**. THE BURIED LIFE, INC., (U.S. CLS. 22 AND 39). SN 77-915,371. PUB. 3-1-2011. FILED 1-19-2010.  
 3,960,455. **EVERYDAY STRUGGLE CLOTHING COMPANY (STANDARD CHARACTER)**. BRADLEY, DARRELL C., (U.S. CLS. 22 AND 39). SN 77-917,712. PUB. 3-1-2011. FILED 1-22-2010.  
 3,960,468 ( *See Class 9 for this trademark.* )  
 3,960,480. **RED WAGON BABY AND DESIGN**. FARLEY, AFTON, DBA RED WAGON BABY, (U.S. CLS. 22 AND 39). SN 77-933,451. PUB. 3-1-2011. FILED 2-11-2010.  
 3,960,506. **BEAUTIFUL PEOPLE (STYLIZED)**. 37.37, INC., (U.S. CLS. 22 AND 39). SN 77-946,336. PUB. 3-1-2011. FILED 2-26-2010.  
 3,960,529 ( *See Class 9 for this trademark.* )  
 3,960,535 ( *See Class 9 for this trademark.* )  
 3,960,539. **BEST AND DESIGN**. SHIM, SUN, MULTIPLE CLASS, (INT. CLS. 25 AND 28), (U.S. CLS. 22, 23, 38, 39 AND 50). SN 77-956,892. PUB. 3-1-2011. FILED 3-11-2010.  
 3,960,549 ( *See Class 3 for this trademark.* )  
 3,960,565 ( *See Class 9 for this trademark.* )  
 3,960,603. **PHI KAPPA PSI EST. 1852 AND DESIGN**. PHI KAPPA PSI, MULTIPLE CLASS, (INT. CLS. 25 AND 35), (U.S. CLS. 22, 39, 100, 101 AND 102). SN 77-969,607. PUB. 3-1-2011. FILED 3-26-2010.  
 3,960,613. **MISCELLANEOUS DESIGN**. LINDSEY CREATIONS, INC., (U.S. CLS. 22 AND 39). SN 77-970,019. PUB. 3-1-2011. FILED 3-26-2010.  
 3,960,616. **LA CONDUCT (STANDARD CHARACTER)**. DISORDERLY KIDS, LLC, (U.S. CLS. 22 AND 39). SN 77-970,161. PUB. 3-1-2011. FILED 3-26-2010.  
 3,960,617. **APPROPRIATE BEHAVIOR (STANDARD CHARACTER)**. DISORDERLY KIDS, LLC, (U.S. CLS. 22 AND 39). SN 77-970,165. PUB. 3-1-2011. FILED 3-26-2010.  
 3,960,618. **L.A. CONDUCT GIRLS CLOTHING CO. AND DESIGN**. DISORDERLY KIDS, LLC, (U.S. CLS. 22 AND 39). SN 77-970,181. PUB. 3-1-2011. FILED 3-26-2010.  
 3,960,622 ( *See Class 9 for this trademark.* )  
 3,960,624 ( *See Class 18 for this trademark.* )  
 3,960,630 ( *See Class 18 for this trademark.* )  
 3,960,637. **C.I. CASTRO & CO. (STANDARD CHARACTER)**. C.I. CASTRO & CO., INC., (U.S. CLS. 22 AND 39). SN 78-954,623. PUB. 3-1-2011. FILED 8-17-2006.  
 3,960,639. **VINCENT A BIG STEP FOR SMALL FEET (STYLIZED)**. VINCENT SHOE STORE SWEDEN AB, (U.S. CLS. 22 AND 39). SN 79-023,994. PUB. 1-9-2007. FILED 4-5-2006.  
 3,960,654. **TWOTHIRDS (STANDARD CHARACTER)**. TWOTHIRDS CLOTHING GMBH, (U.S. CLS. 22 AND 39). SN 79-073,028. PUB. 3-1-2011. FILED 8-7-2009.  
 3,960,657 ( *See Class 12 for this trademark.* )  
 3,960,660 ( *See Class 3 for this trademark.* )  
 3,960,663 ( *See Class 3 for this trademark.* )  
 3,960,664 ( *See Class 3 for this trademark.* )  
 3,960,671 ( *See Class 9 for this trademark.* )  
 3,960,673 ( *See Class 9 for this trademark.* )  
 3,960,677. **ECTROPY (STANDARD CHARACTER)**. STÉPHANE KAY, MULTIPLE CLASS, (INT. CLS. 25, 35, 41 AND 42), (U.S. CLS. 22, 39, 100, 101, 102 AND 107). SN 79-076,972. PUB. 3-1-2011. FILED 9-9-2009.  
 3,960,678 ( *See Class 5 for this trademark.* )  
 3,960,703. **MANIFATTURA R. VALENTI (STANDARD CHARACTER)**. MANIFATTURA R. VALENTI S.R.L., (U.S. CLS. 22 AND 39). SN 79-080,937. PUB. 3-1-2011. FILED 2-12-2010.

- 3,960,735 ( *See Class 18 for this trademark*).
- 3,960,737. **TGKP (STANDARD CHARACTER)**. ERNEMANN DESIGN GMBH, (U.S. CLS. 22 AND 39). SN 79-082,549. PUB. 3-1-2011. FILED 5-6-2010.
- 3,960,744 ( *See Class 9 for this trademark*).
- 3,960,785. **LISA BLUE (STANDARD CHARACTER)**. GARYSON NOMINEES PTY LTD (AS TRUSTEE FOR THE LISA BURKE FAMILY TRUST), (U.S. CLS. 22 AND 39). SN 79-084,996. PUB. 3-1-2011. FILED 5-11-2010.
- 3,960,793. **DAVID DAVID AND DESIGN**. DAVID DAVID LONDON LIMITED, (U.S. CLS. 22 AND 39). SN 79-085,743. PUB. 3-1-2011. FILED 7-12-2010.
- 3,960,795 ( *See Class 9 for this trademark*).
- 3,960,796. **GSK MOSCOW MADE IN RUSSIA AND DESIGN**. OBCHTCHESTVO S OGRANITCHENNOY OTVETSTVENNOSTYOU "GRICHKO", MULTIPLE CLASS, (INT. CLS. 25 AND 35), (U.S. CLS. 22, 39, 100, 101 AND 102). SN 79-085,989. PUB. 3-1-2011. FILED 3-23-2010.
- 3,960,806 ( *See Class 12 for this trademark*).
- 3,960,827 ( *See Class 9 for this trademark*).
- 3,960,849. **SKINNY B (STANDARD CHARACTER)**. UNIVERSAL INTIMATES, LLC, (U.S. CLS. 22 AND 39). SN 85-003,848. PUB. 3-1-2011. FILED 4-1-2010.
- 3,960,852. **BE HAPPY. LIVE COMFORTABLY. (STANDARD CHARACTER)**. ADMUNDSON, RICHARD, (U.S. CLS. 22 AND 39). SN 85-004,957. PUB. 3-1-2011. FILED 4-2-2010.
- 3,960,899. **TO WIN (STANDARD CHARACTER)**. NO REST AT THE TOP, INC, (U.S. CLS. 22 AND 39). SN 85-019,242. PUB. 3-1-2011. FILED 4-21-2010.
- 3,960,900. **CHESAPEAKEMAN (STANDARD CHARACTER)**. THE COLUMBIA TRIATHLON ASSOCIATION, INC., MULTIPLE CLASS, (INT. CLS. 25 AND 41), (U.S. CLS. 22, 39, 100, 101 AND 107). SN 85-019,335. PUB. 3-1-2011. FILED 4-21-2010.
- 3,960,934. **TREAD EARTH LIGHTLY (STANDARD CHARACTER)**. SOCKWA CORPORATION, (U.S. CLS. 22 AND 39). SN 85-037,428. PUB. 3-1-2011. FILED 5-13-2010.
- 3,960,935. **SARAMAX (STANDARD CHARACTER)**. SARAMAX APPAREL GROUP, INC., (U.S. CLS. 22 AND 39). SN 85-037,961. PUB. 3-1-2011. FILED 5-13-2010.
- 3,960,946. **THE ABBOT PEDERSON COLLECTION (STANDARD CHARACTER)**. PEI LICENSING, INC., (U.S. CLS. 22 AND 39). SN 85-043,120. PUB. 3-1-2011. FILED 5-19-2010.
- 3,960,949 ( *See Class 10 for this trademark*).
- 3,960,950 ( *See Class 5 for this trademark*).
- 3,960,960. **ETHNIC TOPS AND DESIGN**. ETHNIC TOPS, (U.S. CLS. 22 AND 39). SN 85-047,560. PUB. 3-1-2011. FILED 5-25-2010.
- 3,960,975. **MISCELLANEOUS DESIGN**. TAHOE BOARD WORKS, LLC, (U.S. CLS. 22 AND 39). SN 85-060,024. PUB. 11-23-2010. FILED 6-10-2010.
- 3,960,976. **MISCELLANEOUS DESIGN**. TAHOE BOARD WORKS, LLC, (U.S. CLS. 22 AND 39). SN 85-060,037. PUB. 11-23-2010. FILED 6-10-2010.
- 3,960,984. **C-17 GLOBEMASTER III (STANDARD CHARACTER)**. BOEING MANAGEMENT COMPANY, (U.S. CLS. 22 AND 39). SN 85-064,745. PUB. 3-1-2011. FILED 6-16-2010.
- 3,960,985. **C-17 (STANDARD CHARACTER)**. BOEING MANAGEMENT COMPANY, (U.S. CLS. 22 AND 39). SN 85-064,749. PUB. 3-1-2011. FILED 6-16-2010.
- 3,960,991. **AIR HOLE FACE MASKS YOU IDIOT AND DESIGN**. AIRHOLE FACEMASKS INC., (U.S. CLS. 22 AND 39). SN 85-067,920. PUB. 3-1-2011. FILED 6-21-2010.
- 3,960,993. **PEACE ROCS AND DESIGN**. LOUIS SIMPSON AND SAMUEL'S LLC, (U.S. CLS. 22 AND 39). SN 85-068,261. PUB. 3-1-2011. FILED 6-22-2010.
- 3,961,000 ( *See Class 18 for this trademark*).
- 3,961,015. **NHL STANLEY CUP FINAL AND DESIGN**. NATIONAL HOCKEY LEAGUE, (U.S. CLS. 22 AND 39). SN 85-078,712. PUB. 3-1-2011. FILED 7-6-2010.
- 3,961,023 ( *See Class 9 for this trademark*).
- 3,961,041. **TORMENTA (STANDARD CHARACTER)**. LUGO, TEODOLO, (U.S. CLS. 22 AND 39). SN 85-090,144. PUB. 3-1-2011. FILED 7-22-2010.
- 3,961,068. **DAYTONA BEACH BIKE RALLY (STANDARD CHARACTER)**. CONSOLIDATED DISTRIBUTORS INC, (U.S. CLS. 22 AND 39). SN 85-101,129. PUB. 11-23-2010. FILED 8-5-2010.
- 3,961,108. **FIVE ELEMENTZ (STANDARD CHARACTER)**. WISE BUYS INC., (U.S. CLS. 22 AND 39). SN 85-107,904. PUB. 3-1-2011. FILED 8-16-2010.
- 3,961,124. **AKSEL AND DESIGN**. AKSEL GROUP, INC, (U.S. CLS. 22 AND 39). SN 85-110,698. PUB. 3-1-2011. FILED 8-18-2010.
- 3,961,128. **BUILT FOR MAN (STANDARD CHARACTER)**. BUILT FOR MAN LLC, (U.S. CLS. 22 AND 39). SN 85-111,571. PUB. 3-1-2011. FILED 8-19-2010.
- 3,961,133. **UNIVERSITAS SANCTI LUDOVICI 1818 RELIGIONI ET BONIS ARTIBUS IHS AND DESIGN**. SAINT LOUIS UNIVERSITY, MULTIPLE CLASS, (INT. CLS. 25 AND 41), (U.S. CLS. 22, 39, 100, 101 AND 107). SN 85-112,470. PUB. 3-1-2011. FILED 8-20-2010.
- 3,961,174 ( *See Class 18 for this trademark*).
- 3,961,185. **CELESTE (STANDARD CHARACTER)**. CELESTE FOOTWEAR, TA CELESTE FOOTWEAR, (U.S. CLS. 22 AND 39). SN 85-121,563. PUB. 3-1-2011. FILED 9-2-2010.
- 3,961,200. **FO2 (STYLIZED)**. FLAT-OUT EVENTS, LLC, (U.S. CLS. 22 AND 39). SN 85-122,711. PUB. 3-1-2011. FILED 9-3-2010.
- 3,961,233. **S F AND DESIGN**. PS CORP LTD., (U.S. CLS. 22 AND 39). SN 85-124,084. PUB. 3-1-2011. FILED 9-7-2010.
- 3,961,246. **BLUNTS BITCHES & FORTIES (STANDARD CHARACTER)**. ESPINO, PAUL, (U.S. CLS. 22 AND 39). SN 85-124,749. PUB. 3-1-2011. FILED 9-8-2010.
- 3,961,255. **NEGRO GOLF 1926 1962 NECKBONE CIRCUIT AND DESIGN**. VINTAGE SPORTSWEAR, INC., (U.S. CLS. 22 AND 39). SN 85-125,286. PUB. 3-1-2011. FILED 9-8-2010.
- 3,961,259. **OLD SCHOOL LAX AND DESIGN**. OLD SCHOOL LLC, (U.S. CLS. 22 AND 39). SN 85-125,651. PUB. 3-1-2011. FILED 9-9-2010.
- 3,961,260. **PUBLIC WORKS DEPARTMENT PWD AND DESIGN**. PUBLIC WORKS DEPARTMENT, LLC, (U.S. CLS. 22 AND 39). SN 85-125,703. PUB. 3-1-2011. FILED 9-9-2010.
- 3,961,262. **KABACCHA (STANDARD CHARACTER)**. ARORA, KABEER, TA KABACCHA INC, (U.S. CLS. 22 AND 39). SN 85-125,730. PUB. 3-1-2011. FILED 9-9-2010.
- 3,961,277. **OLD SCHOOL SPORTFISHING AND DESIGN**. OLD SCHOOL LLC, (U.S. CLS. 22 AND 39). SN 85-126,614. PUB. 3-1-2011. FILED 9-10-2010.
- 3,961,375. **RUFFLE RUMPS (STANDARD CHARACTER)**. RUFFLEBUTTS, INC., (U.S. CLS. 22 AND 39). SN 85-128,413. PUB. 3-1-2011. FILED 9-13-2010.
- 3,961,380 ( *See Class 9 for this trademark*).
- 3,961,402. **EYEN (STANDARD CHARACTER)**. LIPING, WANG, (U.S. CLS. 22 AND 39). SN 85-128,846. PUB. 3-1-2011. FILED 9-14-2010.
- 3,961,406 ( *See Class 14 for this trademark*).
- 3,961,419. **SOCKTACULAR! (STANDARD CHARACTER)**. K B SOCKS, INC., (U.S. CLS. 22 AND 39). SN 85-129,007. PUB. 3-1-2011. FILED 9-14-2010.
- 3,961,427. **DIRTY 530 (STANDARD CHARACTER)**. PUCKETT, MICHAEL, AND PUCKETT, SHERRY, (U.S. CLS. 22 AND 39). SN 85-129,100. PUB. 3-1-2011. FILED 9-14-2010.
- 3,961,433. **MOUNT TEC (STANDARD CHARACTER)**. M3 NORDIC AB, (U.S. CLS. 22 AND 39). SN 85-129,179. PUB. 3-1-2011. FILED 9-14-2010.
- 3,961,455. **MARSEILLE AND DESIGN**. KISCHE USA LLC, (U.S. CLS. 22 AND 39). SN 85-129,374. PUB. 3-1-2011. FILED 9-14-2010.
- 3,961,459. **MISCELLANEOUS DESIGN**. FIGHTERGIRLS-COM, LLC, (U.S. CLS. 22 AND 39). SN 85-129,457. PUB. 3-1-2011. FILED 9-14-2010.
- 3,961,484. **GLOW ME (STANDARD CHARACTER)**. KOSH-FAM, SAMUEL, (U.S. CLS. 22 AND 39). SN 85-129,767. PUB. 3-1-2011. FILED 9-15-2010.
- 3,961,485. **METAMAN (STANDARD CHARACTER)**. WOLLOVER, DAVID R., (U.S. CLS. 22 AND 39). SN 85-129,773. PUB. 3-1-2011. FILED 9-15-2010.
- 3,961,487. **SATINBUTTERFLY AND DESIGN**. SATIN BUTTERFLY BABY BOUTIQUE, L.L.C., DBA SATIN BUTTERFLY BABY BOUTIQUE, (U.S. CLS. 22 AND 39). SN 85-129,865. PUB. 3-1-2011. FILED 9-15-2010.
- 3,961,515 ( *See Class 6 for this trademark*).
- 3,961,525. **OLD SCHOOL LINKS AND DESIGN**. OLD SCHOOL LLC, (U.S. CLS. 22 AND 39). SN 85-130,385. PUB. 3-1-2011. FILED 9-15-2010.



- 3,961,556. **L.A. IDOL USA AND DESIGN**. LA IDOL FASHION, INC., (U.S. CLS. 22 AND 39). SN 85-130,694. PUB. 3-1-2011. FILED 9-15-2010.
- 3,961,571. **MISCELLANEOUS DESIGN**. LALUEZA, NICHOLAS, (U.S. CLS. 22 AND 39). SN 85-131,010. PUB. 3-1-2011. FILED 9-16-2010.
- 3,961,585. **BEN SHERMAN (STANDARD CHARACTER)**. BEN SHERMAN GROUP LIMITED, (U.S. CLS. 22 AND 39). SN 85-131,150. PUB. 3-1-2011. FILED 9-16-2010.
- 3,961,600. **X (STYLIZED)**. CNXXN LLC, (U.S. CLS. 22 AND 39). SN 85-131,315. PUB. 3-1-2011. FILED 9-16-2010.
- 3,961,601. **ANDA & MASHA (STANDARD CHARACTER)**. ANDA & MASHA LLC, MULTIPLE CLASS, (INT. CLS. 25 AND 45), (U.S. CLS. 22, 39, 100 AND 101). SN 85-131,349. PUB. 3-1-2011. FILED 9-16-2010.
- 3,961,603. **LIVE LOVE FIGHT (STANDARD CHARACTER)**. WORLD MARTIAL ARTS INTERNATIONAL LTD., (U.S. CLS. 22 AND 39). SN 85-131,373. PUB. 3-1-2011. FILED 9-16-2010.
- 3,961,615. **C NICE (STANDARD CHARACTER)**. C FOR YOU APPAREL GROUP INC., (U.S. CLS. 22 AND 39). SN 85-131,610. PUB. 3-1-2011. FILED 9-16-2010.
- 3,961,621. **MEAT BUN (STANDARD CHARACTER)**. MEAT BUN, LLC, (U.S. CLS. 22 AND 39). SN 85-131,656. PUB. 3-1-2011. FILED 9-16-2010.
- 3,961,622. **ARDYSS (STANDARD CHARACTER)**. OPPORTUNITY HOLDING, LLC, (U.S. CLS. 22 AND 39). SN 85-131,660. PUB. 3-1-2011. FILED 9-16-2010.
- 3,961,629 ( *See Class 18 for this trademark*).
- 3,961,649. **NOVEL THOTZ (STANDARD CHARACTER)**. FIELD CRAFTS, INC., (U.S. CLS. 22 AND 39). SN 85-132,044. PUB. 3-1-2011. FILED 9-17-2010.
- 3,961,653 ( *See Class 13 for this trademark*).
- 3,961,689. **TEMPORARY ROMANCE (STANDARD CHARACTER)**. WADA, HIROSHI, DBA TEMPORARY ROMANCE, (U.S. CLS. 22 AND 39). SN 85-132,847. PUB. 3-1-2011. FILED 9-18-2010.
- 3,961,729 ( *See Class 14 for this trademark*).
- 3,961,732. **NCIS (STANDARD CHARACTER)**. CBS STUDIOS, INC., (U.S. CLS. 22 AND 39). SN 85-137,919. PUB. 3-1-2011. FILED 9-24-2010.
- 3,961,772. **CHRIS & CAROL (STANDARD CHARACTER)**. CHRIS & CAROL APPAREL, INC., (U.S. CLS. 22 AND 39). SN 85-142,610. PUB. 3-1-2011. FILED 9-30-2010.
- 3,961,774. **BACK OFF BABY (STANDARD CHARACTER)**. VICTORIA'S SECRET STORES BRAND MANAGEMENT, INC., (U.S. CLS. 22 AND 39). SN 85-142,782. PUB. 3-1-2011. FILED 10-1-2010.
- 3,961,790. **JUMAE INTERNATIONAL LOVE THE SKIN YOU'RE IN! AND DESIGN**. COLUMBUS, KEZMIT, (U.S. CLS. 22 AND 39). SN 85-144,440. PUB. 3-1-2011. FILED 10-4-2010.
- 3,961,800 ( *See Class 14 for this trademark*).
- 3,961,802. **CATAclySMIC (STANDARD CHARACTER)**. SHOWVAKER, JESSE A, (U.S. CLS. 22 AND 39). SN 85-147,673. PUB. 3-1-2011. FILED 10-7-2010.
- 3,961,852 ( *See Class 24 for this trademark*).
- 3,961,853 ( *See Class 24 for this trademark*).
- 3,961,871. **LOVE PANDA AND DESIGN**. CUTE BRANDS INC, (U.S. CLS. 22 AND 39). SN 85-152,189. PUB. 3-1-2011. FILED 10-13-2010.
- 3,961,883 ( *See Class 9 for this trademark*).
- 3,961,944. **GOTCHA AND DESIGN**. PEI LICENSING, INC., (U.S. CLS. 22 AND 39). SN 85-174,652. PUB. 3-1-2011. FILED 11-11-2010.

---

### CLASS 26—FANCY GOODS

- 3,960,638 ( *See Class 9 for this trademark*).
- 3,960,692 ( *See Class 20 for this trademark*).
- 3,960,744 ( *See Class 9 for this trademark*).
- 3,961,629 ( *See Class 18 for this trademark*).

### CLASS 27—FLOOR COVERINGS

- 3,960,678 ( *See Class 5 for this trademark*).
- 3,960,885. **ULTRA TURF (STANDARD CHARACTER)**. CREATIVE SPORT CONCEPTS, INC., (U.S. CLS. 19, 20, 37, 42 AND 50). SN 85-015,095. PUB. 3-1-2011. FILED 4-15-2010.
- 3,961,269. **EARTH MINDED (STANDARD CHARACTER)**. HOME LEGEND, LLC., (U.S. CLS. 19, 20, 37, 42 AND 50). SN 85-126,257. PUB. 3-1-2011. FILED 9-9-2010.

---

### CLASS 28—TOYS AND SPORTING GOODS

- 3,960,238 ( *See Class 25 for this trademark*).
- 3,960,260 ( *See Class 9 for this trademark*).
- 3,960,272 ( *See Class 9 for this trademark*).
- 3,960,314 ( *See Class 25 for this trademark*).
- 3,960,319. **KEISER (STANDARD CHARACTER)**. KEISER CORPORATION, (U.S. CLS. 22, 23, 38 AND 50). SN 77-685,680. PUB. 3-1-2011. FILED 3-6-2009.
- 3,960,339 ( *See Class 9 for this trademark*).
- 3,960,360. **LIVING RAINBOWS (STANDARD CHARACTER)**. SAHA, PAMELA, (U.S. CLS. 22, 23, 38 AND 50). SN 77-806,892. PUB. 3-1-2011. FILED 8-18-2009.
- 3,960,371. **JUNKER JANE (STANDARD CHARACTER)**. ZACCHINO, CATHERINE, AND ZACCHINO, DOMINIC, (U.S. CLS. 22, 23, 38 AND 50). SN 77-814,747. PUB. 3-1-2011. FILED 8-28-2009.
- 3,960,482. **BIGGER BETTER BUBBELZ AND DESIGN**. BRAND NEW MARKETING & DESIGN, INC., (U.S. CLS. 22, 23, 38 AND 50). SN 77-934,535. PUB. 3-1-2011. FILED 12-12-2010.
- 3,960,515 ( *See Class 21 for this trademark*).
- 3,960,539 ( *See Class 25 for this trademark*).
- 3,960,597. **V VOCIFER AND DESIGN**. TAJMAHAL SPORTS COMPANY, U.S.A. CORP., (U.S. CLS. 22, 23, 38 AND 50). SN 77-968,737. PUB. 3-1-2011. FILED 3-25-2010.
- 3,960,624 ( *See Class 18 for this trademark*).
- 3,960,635. **TP (STANDARD CHARACTER)**. PHARES TIMOTHY J, (U.S. CLS. 22, 23, 38 AND 50). SN 78-935,322. PUB. 3-1-2011. FILED 7-21-2006.
- 3,960,657 ( *See Class 12 for this trademark*).
- 3,960,660 ( *See Class 3 for this trademark*).
- 3,960,666 ( *See Class 9 for this trademark*).
- 3,960,673 ( *See Class 9 for this trademark*).
- 3,960,676 ( *See Class 9 for this trademark*).
- 3,960,682 ( *See Class 12 for this trademark*).
- 3,960,692 ( *See Class 20 for this trademark*).
- 3,960,735 ( *See Class 18 for this trademark*).
- 3,960,755. **STAR FRIENDS AND DESIGN**. BANDAĀ S.A., (U.S. CLS. 22, 23, 38 AND 50). SN 79-083,503. PUB. 3-1-2011. FILED 4-9-2010.
- 3,960,789. **DUNGAN (STANDARD CHARACTER)**. UNGA B.V., (U.S. CLS. 22, 23, 38 AND 50). SN 79-085,503. PUB. 3-1-2011. FILED 7-19-2010.
- 3,960,830 ( *See Class 9 for this trademark*).
- 3,960,856. **F FORTITUDE (STYLIZED)**. FORTITUDE SKIS, INC., DBA FORTITUDE SKIS, INC., (U.S. CLS. 22, 23, 38 AND 50). SN 85-006,325. PUB. 3-1-2011. FILED 4-5-2010.
- 3,960,907. **BAKING TIME! (STANDARD CHARACTER)**. MATTEL, INC., (U.S. CLS. 22, 23, 38 AND 50). SN 85-023,986. PUB. 3-1-2011. FILED 4-27-2010.
- 3,960,918. **ATTACK PACK (STANDARD CHARACTER)**. MATTEL, INC., (U.S. CLS. 22, 23, 38 AND 50). SN 85-029,751. PUB. 3-1-2011. FILED 5-4-2010.
- 3,960,949 ( *See Class 10 for this trademark*).
- 3,960,950 ( *See Class 5 for this trademark*).
- 3,960,952. **PAUL HURRION (STANDARD CHARACTER)**. GROOVE EQUIPMENT LTD., (U.S. CLS. 22, 23, 38 AND 50). SN 85-045,647. PUB. 3-1-2011. FILED 5-22-2010.
- 3,960,967. **MISCELLANEOUS DESIGN**. TAHOE BOARD WORKS, LLC, (U.S. CLS. 22, 23, 38 AND 50). SN 85-055,615. PUB. 11-23-2010. FILED 6-5-2010.
- 3,960,968. **MISCELLANEOUS DESIGN**. TAHOE BOARD WORKS, LLC, (U.S. CLS. 22, 23, 38 AND 50). SN 85-055,620. PUB. 11-23-2010. FILED 6-5-2010.
- 3,960,980. **MR. CREEPY (STANDARD CHARACTER)**. GO-

- LAD, ADAR, (U.S. CLS. 22, 23, 38 AND 50). SN 85-062,893. PUB. 11-16-2010. FILED 6-15-2010.  
3,961,000 ( *See Class 18 for this trademark* ).
- 3,961,020. **IT (STANDARD CHARACTER)**. INCREDIBLE TECHNOLOGIES, INC., (U.S. CLS. 22, 23, 38 AND 50). SN 85-080,533. PUB. 3-1-2011. FILED 7-8-2010.
- 3,961,243. **MIND YOUR OWN BUSINESS (STANDARD CHARACTER)**. RIOU, COLIN B, (U.S. CLS. 22, 23, 38 AND 50). SN 85-124,654. PUB. 3-1-2011. FILED 9-8-2010.
- 3,961,289. **THE ARC MASTER (STANDARD CHARACTER)**. SWINGLE, CHARLES, AND BEHRENS, WILHELM, (U.S. CLS. 22, 23, 38 AND 50). SN 85-126,762. PUB. 3-1-2011. FILED 9-10-2010.
- 3,961,305. **REAL CRAW (STANDARD CHARACTER)**. EBSCO INDUSTRIES, INC., (U.S. CLS. 22, 23, 38 AND 50). SN 85-127,192. PUB. 3-1-2011. FILED 9-10-2010.
- 3,961,362. **CC PROFESSIONAL AND DESIGN**. COMBAT CORNER LLC, DBA COMBAT CORNER PROFESSIONAL, (U.S. CLS. 22, 23, 38 AND 50). SN 85-128,279. PUB. 3-1-2011. FILED 9-13-2010.
- 3,961,366 ( *See Class 10 for this trademark* ).
- 3,961,380 ( *See Class 9 for this trademark* ).
- 3,961,456. **ZIVA (STANDARD CHARACTER)**. ONE WELLNESS, LTD., (U.S. CLS. 22, 23, 38 AND 50). SN 85-129,439. PUB. 3-1-2011. FILED 9-14-2010.
- 3,961,529. **WILDCRAFT (STANDARD CHARACTER)**. LEARNINGHERBS.COM, LLC, (U.S. CLS. 22, 23, 38 AND 50). SN 85-130,401. PUB. 3-1-2011. FILED 9-15-2010.
- 3,961,598. **SOCCER BINGO AND DESIGN**. SPORTS BINGO, INC., (U.S. CLS. 22, 23, 38 AND 50). SN 85-131,302. PUB. 3-1-2011. FILED 9-16-2010.
- 3,961,634. **ZOMBIE KILLER AND DESIGN**. G & P INDUSTRIAL CO. LIMITED, (U.S. CLS. 22, 23, 38 AND 50). SN 85-131,737. PUB. 3-1-2011. FILED 9-16-2010.
- 3,961,636. **MISCELLANEOUS DESIGN**. G & P INDUSTRIAL CO. LIMITED, (U.S. CLS. 22, 23, 38 AND 50). SN 85-131,745. PUB. 3-1-2011. FILED 9-16-2010.
- 3,961,640. **MINERAL MANIA (STANDARD CHARACTER)**. DUSZA, STEVEN WAYNE, (U.S. CLS. 22, 23, 38 AND 50). SN 85-131,852. PUB. 3-1-2011. FILED 9-17-2010.
- 3,961,691. **FOREVER ELF FASHIONS (STANDARD CHARACTER)**. ELF MAGIC, LLC, (U.S. CLS. 22, 23, 38 AND 50). SN 85-132,850. PUB. 3-1-2011. FILED 9-18-2010.
- 3,961,692. **ELFITS AND DESIGN**. ELF MAGIC, LLC, (U.S. CLS. 22, 23, 38 AND 50). SN 85-132,856. PUB. 3-1-2011. FILED 9-18-2010.
- 3,961,720. **YS-7+ (STANDARD CHARACTER)**. GRAPHITE DESIGN INTERNATIONAL INC., (U.S. CLS. 22, 23, 38 AND 50). SN 85-136,049. PUB. 3-1-2011. FILED 9-22-2010.
- 3,961,721. **YS-6+ (STANDARD CHARACTER)**. GRAPHITE DESIGN INTERNATIONAL INC., (U.S. CLS. 22, 23, 38 AND 50). SN 85-136,053. PUB. 3-1-2011. FILED 9-22-2010.
- 3,961,722. **YS-5+ (STANDARD CHARACTER)**. GRAPHITE DESIGN INTERNATIONAL INC., (U.S. CLS. 22, 23, 38 AND 50). SN 85-136,055. PUB. 3-1-2011. FILED 9-22-2010.
- 3,961,834. **DAYBREAK (STANDARD CHARACTER)**. TIMOTHY R. ROBERTO, (U.S. CLS. 22, 23, 38 AND 50). SN 85-149,796. PUB. 3-1-2011. FILED 10-11-2010.
- 3,961,883 ( *See Class 9 for this trademark* ).
- 3,961,936. **SAINT LOUIS UNIVERSITY AD . MAJOREM . DEI . GLORIAM IHS 1818 AND DESIGN**. SAINT LOUIS UNIVERSITY, (U.S. CLS. 22, 23, 38 AND 50). SN 85-174,024. PUB. 3-1-2011. FILED 11-10-2010.
- 3,961,956. **SPEAKERSTARZ (STANDARD CHARACTER)**. BUILD-A-BEAR RETAIL MANAGEMENT, INC., (U.S. CLS. 22, 23, 38 AND 50). SN 85-193,488. PUB. 3-1-2011. FILED 12-8-2010.
- INC., (U.S. CL. 46). SN 77-969,924. PUB. 3-1-2011. FILED 3-26-2010.
- 3,960,670. **GELAGRI LANDERNEAU AND DESIGN**. GELAGRI BRETAGNE, MULTIPLE CLASS, (INT. CLS. 29, 30 AND 31), (U.S. CLS. 1 AND 46). SN 79-075,654. PUB. 3-1-2011. FILED 7-7-2009.
- 3,960,709 ( *See Class 5 for this trademark* ).
- 3,960,727 ( *See Class 5 for this trademark* ).
- 3,960,790. **PRODOTTI STELLA AND DESIGN**. PRODOTTI STELLA S.P.A., MULTIPLE CLASS, (INT. CLS. 29 AND 30), (U.S. CL. 46). SN 79-085,517. PUB. 3-1-2011. FILED 5-27-2010.
- 3,961,003. **GUSTARE OILS & VINEGARS AND DESIGN**. GUSTARE, LLC, MULTIPLE CLASS, (INT. CLS. 29 AND 30), (U.S. CL. 46). SN 85-071,451. PUB. 3-1-2011. FILED 6-25-2010.
- 3,961,126. **MOTHER'S MAID (STANDARD CHARACTER)**. BURNETTE FOODS, INC., FORMERLY ELK RAPIDS PACKING CO., MULTIPLE CLASS, (INT. CLS. 29 AND 32), (U.S. CLS. 45, 46 AND 48). SN 85-111,365. PUB. 3-1-2011. FILED 8-19-2010.
- 3,961,134. **PAMPLONA (STANDARD CHARACTER)**. PAMPLONA FOODS, INC., MULTIPLE CLASS, (INT. CLS. 29, 30 AND 32), (U.S. CLS. 45, 46 AND 48). SN 85-112,913. PUB. 3-1-2011. FILED 8-21-2010.
- 3,961,261. **CHOCTAW MAID (STANDARD CHARACTER)**. TYSON FARMS, INC., (U.S. CL. 46). SN 85-125,729. PUB. 3-1-2011. FILED 9-9-2010.
- 3,961,316. **MISCELLANEOUS DESIGN**. WARNOCK FOODS PRODUCTS, INC., MULTIPLE CLASS, (INT. CLS. 29 AND 30), (U.S. CL. 46). SN 85-127,414. PUB. 3-1-2011. FILED 9-10-2010.
- 3,961,320. **TAY HO (STANDARD CHARACTER)**. WEST LAKE FOOD CORPORATION, DBA BANH CUON TAY HO RESTAURANT CORPORATION, (U.S. CL. 46). SN 85-127,487. PUB. 3-1-2011. FILED 9-11-2010.
- 3,961,611. **WE RAISE ABOVE (STANDARD CHARACTER)**. COLORADO BOXED BEEF CO., (U.S. CL. 46). SN 85-131,515. PUB. 3-1-2011. FILED 9-16-2010.
- 3,961,736. **COMPROMISE ELSEWHERE. (STANDARD CHARACTER)**. FRANK BRUNCKHORST CO., L.L.C., (U.S. CL. 46). SN 85-138,749. PUB. 3-1-2011. FILED 9-27-2010.
- 3,961,739. **AZUMAGOURMET SALAD (STANDARD CHARACTER)**. AZUMA FOODS INTERNATIONAL INC. USA, AKA AFI, (U.S. CL. 46). SN 85-139,122. PUB. 3-1-2011. FILED 9-27-2010.
- 3,961,742. **BE AND DESIGN**. SHERWOOD BRANDS, LLC, (U.S. CL. 46). SN 85-139,518. PUB. 3-1-2011. FILED 9-28-2010.
- 3,961,795. **KEN'S CHOPHOUSE JERKY (STANDARD CHARACTER)**. BLUM, KENNETH L, (U.S. CL. 46). SN 85-146,204. PUB. 3-1-2011. FILED 10-6-2010.
- 3,961,831. **NEW HOPE MILLS (STANDARD CHARACTER)**. NEW HOPE MILLS INC., MULTIPLE CLASS, (INT. CLS. 29, 30 AND 31), (U.S. CLS. 1 AND 46). SN 85-149,715. PUB. 3-1-2011. FILED 10-11-2010.
- 3,961,904. **SPAM AND DESIGN**. HORMEL FOODS, LLC, (U.S. CL. 46). SN 85-163,762. PUB. 3-1-2011. FILED 10-28-2010.
- 3,961,917. **MILK & MILKSHAKES HERSHEY'S AND DESIGN**. HERSHEY CHOCOLATE & CONFECTIONERY CORPORATION, (U.S. CL. 46). SN 85-167,102. PUB. 3-1-2011. FILED 11-2-2010.
- 3,961,957. **FRY-KING (STANDARD CHARACTER)**. CARGILL, INCORPORATED, (U.S. CL. 46). SN 85-193,927. PUB. 3-1-2011. FILED 12-9-2010.

---

### CLASS 30—STAPLE FOODS

### CLASS 29—MEATS AND PROCESSED FOODS

- 3,960,265. **BIMBO (STANDARD CHARACTER)**. GRUPO BIMBO, S.A. B. DE C.V., (U.S. CL. 46). SN 77-222,867. PUB. 3-1-2011. FILED 7-5-2007.
- 3,960,582. **YANNI AND DESIGN**. KAROUN DAIRIES, INC., (U.S. CL. 46). SN 77-966,577. PUB. 3-1-2011. FILED 3-23-2010.
- 3,960,611. **MISCELLANEOUS DESIGN**. AJINOMOTO CO., INC., (U.S. CL. 46). SN 76-704,819. PUB. 3-1-2011. FILED 10-8-2010.
- 3,960,298. **THE BLACK BEAR MICRO ROASTERY AND DESIGN**. WOLFE'S BOROUGH COFFEE, INC., DBA THE BLACK BEAR MICRO ROASTERY, (U.S. CL. 46). SN 77-569,507. PUB. 3-1-2011. FILED 9-14-2008.
- 3,960,313. **A MOSAIC OF TASTES (STANDARD CHARACTER)**. ELATINFOOD, L.L.C., MULTIPLE CLASS, (INT. CLS. 30, 35 AND 43), (U.S. CLS. 46, 100, 101 AND 102). SN



- 77-671,161. PUB. 3-1-2011. FILED 2-16-2009.
- 3,960,334. **DRAGON (STANDARD CHARACTER)**. LATCHMAN, ROBERT, (U.S. CL. 46). SN 77-739,245. PUB. 3-9-2010. FILED 5-18-2009.
- 3,960,345. **THE ARISTOCRAT AND DESIGN**. HEIRS OF ALEX AND ENGRACIA REYES SR., INC., MULTIPLE CLASS, (INT. CLS. 30 AND 43), (U.S. CLS. 46, 100 AND 101). SN 77-771,817. PUB. 3-1-2011. FILED 6-30-2009.
- 3,960,409. **CLUB COFFEE SINCE/DEPUIS 1906 AND DESIGN**. CLUB COFFEE COMPANY INC., (U.S. CL. 46). SN 77-847,619. PUB. 3-1-2011. FILED 10-13-2009.
- 3,960,454. **QUEEN BEE GARDENS AND DESIGN**. QUEEN BEE GARDENS, LTD., (U.S. CL. 46). SN 77-917,031. PUB. 3-1-2011. FILED 1-21-2010.
- 3,960,513 ( *See Class 5 for this trademark*).
- 3,960,523. **TW AND DESIGN**. TSIT WING INTERNATIONAL COMPANY LIMITED, (U.S. CL. 46). SN 77-951,037. PUB. 1-11-2011. FILED 3-4-2010.
- 3,960,561. **MILANO (STANDARD CHARACTER)**. PRODUCTORA Y COMERCIALIZADORA DE PASTAS, INC., (U.S. CL. 46). SN 77-961,967. PUB. 3-1-2011. FILED 3-18-2010.
- 3,960,563. **A ANGI'S ARTISAN TREATS AND DESIGN**. RENO BASTIAN ENTERPRISES, INC., (U.S. CL. 46). SN 77-962,437. PUB. 3-1-2011. FILED 3-18-2010.
- 3,960,577. **BUENO (STANDARD CHARACTER)**. EL ENCANTO, INC., (U.S. CL. 46). SN 77-966,251. PUB. 3-1-2011. FILED 3-23-2010.
- 3,960,629. **DOUBLE FUDGE FRENZY (STANDARD CHARACTER)**. WELLS' DAIRY, INC. (U.S. CL. 46). SN 78-659,502. PUB. 2-10-2009. FILED 6-28-2005.
- 3,960,653 ( *See Class 1 for this trademark*).
- 3,960,660 ( *See Class 3 for this trademark*).
- 3,960,670 ( *See Class 29 for this trademark*).
- 3,960,681. **ETI WANTED AND DESIGN**. ETI GIDA; SANAYI VE TICARET ANONIM SIRKETI, (U.S. CL. 46). SN 79-077,948. PUB. 3-1-2011. FILED 11-12-2009.
- 3,960,727 ( *See Class 5 for this trademark*).
- 3,960,746. **MISCELLANEOUS DESIGN**. NEWBY TEAS (U.K.) LIMITED, (U.S. CL. 46). SN 79-082,981. PUB. 3-1-2011. FILED 4-30-2010.
- 3,960,782. **[CHOCO] IN (STYLIZED)**. ZOTTER HOLDING GMBH, (U.S. CL. 46). SN 79-084,605. PUB. 3-1-2011. FILED 3-1-2010.
- 3,960,788. **RYABA AND DESIGN**. OTKRYTOE AKTSIONERNOE OBSHCHESTVO "NIZHEGORODSKY MASLO-ZHIROVOY KOMBINAT", (U.S. CL. 46). SN 79-085,366. PUB. 3-1-2011. FILED 7-16-2010.
- 3,960,790 ( *See Class 29 for this trademark*).
- 3,960,840. **YOGURT PIZAZZ AND DESIGN**. YOGURT PIZAZZ, LLC, DBA YOGURT PIZAZZ, (U.S. CL. 46). SN 85-001,008. PUB. 3-1-2011. FILED 3-29-2010.
- 3,960,853. **PERKYMoose (STANDARD CHARACTER)**. PERKY MOOSE LLC, DBA PERKY MOOSE LLC, (U.S. CL. 46). SN 85-005,038. PUB. 3-1-2011. FILED 4-2-2010.
- 3,960,857. **BAKE SHOPPE COOKIE DOUGH MINIATURES (STANDARD CHARACTER)**. PROMOTION IN MOTION, INC., (U.S. CL. 46). SN 85-006,394. PUB. 3-1-2011. FILED 4-5-2010.
- 3,960,924. **JON DONAIRE AND DESIGN**. RICH PRODUCTS CORPORATION, (U.S. CL. 46). SN 85-033,637. PUB. 3-1-2011. FILED 5-8-2010.
- 3,960,948. **SEMILLA DE ORO (STANDARD CHARACTER)**. SARA LEE BAKERY GROUP, INC., (U.S. CL. 46). SN 85-044,865. PUB. 3-1-2011. FILED 5-21-2010.
- 3,960,966. **GLACIER CONFECTION (STANDARD CHARACTER)**. GLACIER INVESTMENTS, LLC, DBA GLACIER CONFECTION, (U.S. CL. 46). SN 85-054,758. PUB. 3-1-2011. FILED 6-4-2010.
- 3,960,987. **GRANDOUGH BAKING COMPANY AND DESIGN**. LEGACY BAKING COMPANY, LLC, (U.S. CL. 46). SN 85-065,095. PUB. 3-1-2011. FILED 6-17-2010.
- 3,961,003 ( *See Class 29 for this trademark*).
- 3,961,070 ( *See Class 5 for this trademark*).
- 3,961,092. **MALLO NUT (STANDARD CHARACTER)**. GORANT CHOCOLATIER, LLC, (U.S. CL. 46). SN 85-104,507. PUB. 1-25-2011. FILED 8-10-2010.
- 3,961,134 ( *See Class 29 for this trademark*).
- 3,961,148. **MERCHANTS OF TEA AND DESIGN**. ABEYSE-
- KARA, JAYARANJAN, (U.S. CL. 46). SN 85-115,949. PUB. 3-1-2011. FILED 8-25-2010.
- 3,961,210. **CHOCOLATE FOX (STANDARD CHARACTER)**. FOX CULINARY LLC, (U.S. CL. 46). SN 85-123,225. PUB. 3-1-2011. FILED 9-3-2010.
- 3,961,271. **HORNEY TOADS SAUCES AND RUBS TOAD SAUCE AND DESIGN**. VAN TUYL, THOMAS R, DBA HORNEY TOADS, (U.S. CL. 46). SN 85-126,295. PUB. 3-1-2011. FILED 9-9-2010.
- 3,961,282. **THE VELVET CHOCOLATIER (STANDARD CHARACTER)**. THE VELVET CHOCOLATIER LLC, (U.S. CL. 46). SN 85-126,675. PUB. 3-1-2011. FILED 9-10-2010.
- 3,961,293. **CHEF CREATED...NATURE INSPIRED! (STANDARD CHARACTER)**. DREW'S LLC, (U.S. CL. 46). SN 85-126,822. PUB. 3-1-2011. FILED 9-10-2010.
- 3,961,316 ( *See Class 29 for this trademark*).
- 3,961,437. **SIMON SAYS BROWNIES CHEWY & GOEY TO GO! AND DESIGN**. SIMON, STACY, (U.S. CL. 46). SN 85-129,219. PUB. 3-1-2011. FILED 9-14-2010.
- 3,961,460. **P.H.A.T. (STANDARD CHARACTER)**. ASSOCIATED FOOD STORES, INC., (U.S. CL. 46). SN 85-129,472. PUB. 3-1-2011. FILED 9-14-2010.
- 3,961,481. **DELTA BARREL (STANDARD CHARACTER)**. GIFFORD, JACILYN, AND KRAMER, KENNETH, (U.S. CL. 46). SN 85-129,716. PUB. 3-1-2011. FILED 9-14-2010.
- 3,961,593. **MEMPHIS ORIGINAL BARBECUE SAUCE (STANDARD CHARACTER)**. STICKY RIBHOUSE, LLC, (U.S. CL. 46). SN 85-131,235. PUB. 3-1-2011. FILED 9-16-2010.
- 3,961,658. **GOEZONTA (STANDARD CHARACTER)**. AHMANN, DOUGLAS, (U.S. CL. 46). SN 85-132,237. PUB. 3-1-2011. FILED 9-17-2010.
- 3,961,671. **SIDECAKES (STANDARD CHARACTER)**. BOB EVANS FARMS, INC., (U.S. CL. 46). SN 85-132,508. PUB. 3-1-2011. FILED 9-17-2010.
- 3,961,727. **CASHEWTOPIA (STANDARD CHARACTER)**. LISA PROTTER, (U.S. CL. 46). SN 85-136,504. PUB. 3-1-2011. FILED 9-23-2010.
- 3,961,781. **PILGRIM'S PROGRESS (STANDARD CHARACTER)**. ERIK'S DELICAFE, INC., (U.S. CL. 46). SN 85-143,526. PUB. 3-1-2011. FILED 10-1-2010.
- 3,961,831 ( *See Class 29 for this trademark*).
- 3,961,872. **HERSHEY'S AND DESIGN**. HERSHEY CHOCOLATE & CONFECTIONERY CORPORATION, (U.S. CL. 46). SN 85-152,425. PUB. 3-1-2011. FILED 10-14-2010.
- 3,961,915. **FROM CHOCOLATE TOWN, U.S.A. HERSHEY, PA (STANDARD CHARACTER)**. HERSHEY CHOCOLATE & CONFECTIONERY CORPORATION, (U.S. CL. 46). SN 85-167,097. PUB. 3-1-2011. FILED 11-2-2010.
- 3,961,916. **SYMPHONY (STYLIZED)**. HERSHEY CHOCOLATE & CONFECTIONERY CORPORATION, (U.S. CL. 46). SN 85-167,100. PUB. 3-1-2011. FILED 11-2-2010.
- 3,961,918. **MR. GOODBAR (STYLIZED)**. HERSHEY CHOCOLATE & CONFECTIONERY CORPORATION, (U.S. CL. 46). SN 85-167,355. PUB. 3-1-2011. FILED 11-2-2010.
- 3,961,923. **DEVONSHIRE (STANDARD CHARACTER)**. U.S. FOODSERVICE, INC., (U.S. CL. 46). SN 85-170,106. PUB. 3-1-2011. FILED 11-5-2010.
- 3,961,932. **BUBBAQUE'S IT'S THE PITS. AND DESIGN**. BUBBAQUE'S, LLC, MULTIPLE CLASS, (INT. CLS. 30, 35 AND 43), (U.S. CLS. 46, 100, 101 AND 102). SN 85-173,862. PUB. 3-1-2011. FILED 11-10-2010.

---

### CLASS 31—NATURAL AGRICULTURAL PRODUCTS

- 3,960,267. **CHEILJEDANG (STANDARD CHARACTER)**. CJ CHEILJEDANG CORPORATION, (U.S. CLS. 1 AND 46). SN 77-266,987. PUB. 3-1-2011. FILED 8-29-2007.
- 3,960,383 ( *See Class 1 for this trademark*).
- 3,960,670 ( *See Class 29 for this trademark*).
- 3,960,700. **MERA DOG AND DESIGN**. MERA TIERNARUNG GMBH, (U.S. CLS. 1 AND 46). SN 79-080,857. PUB. 3-1-2011. FILED 11-17-2009.
- 3,960,729. **GMP+ FEED SAFETY ASSURANCE AND DESIGN**. STICHTING GMP + INTERNATIONAL, MULTIPLE CLASS, (INT. CLS. 31, 42 AND 44), (U.S. CLS. 1, 46, 100

AND 101). SN 79-082,240. PUB. 3-1-2011. FILED 3-10-2010.  
 3,960,818. **RUMINUP (STANDARD CHARACTER)**. IDEMIT-SU KOSAN CO., LTD., (U.S. CLS. 1 AND 46). SN 79-087,680. PUB. 3-1-2011. FILED 9-16-2010.  
 3,960,961. **VENECIA GOLD AND DESIGN**. C.I. BANACOL, S.A., (U.S. CLS. 1 AND 46). SN 85-048,211. PUB. 3-1-2011. FILED 5-26-2010.  
 3,961,113. **FAMILY TREE (STANDARD CHARACTER)**. FOREST WOOD FIBER PRODUCTS, INC., (U.S. CLS. 1 AND 46). SN 85-109,032. PUB. 3-1-2011. FILED 8-17-2010.  
 3,961,114. **FOREST'S FINEST (STANDARD CHARACTER)**. FOREST WOOD FIBER PRODUCTS, INC., (U.S. CLS. 1 AND 46). SN 85-109,037. PUB. 3-1-2011. FILED 8-17-2010.  
 3,961,115. **FAMILY TREE CONSISTENT QUALITY... IT'S IN THE BAG FOREST'S FINEST AND DESIGN**. FOREST WOOD FIBER PRODUCTS, INC., (U.S. CLS. 1 AND 46). SN 85-109,041. PUB. 3-1-2011. FILED 8-17-2010.  
 3,961,169. **PREMIUM PICK (STANDARD CHARACTER)**. LIBERTY BLOOMS, INC., (U.S. CLS. 1 AND 46). SN 85-119,278. PUB. 3-1-2011. FILED 8-30-2010.  
 3,961,170. **PET'S HEALTHY CHOICE (STANDARD CHARACTER)**. FURRY FRIENDS INC, (U.S. CLS. 1 AND 46). SN 85-119,281. PUB. 3-1-2011. FILED 8-30-2010.  
 3,961,209. **HONEY NUGGETS AND DESIGN**. WESTLAKE MILLER LLC, (U.S. CLS. 1 AND 46). SN 85-123,169. PUB. 3-1-2011. FILED 9-3-2010.  
 3,961,344. **ALLERGIX (STANDARD CHARACTER)**. VETS CHOICE, INC. (U.S. CLS. 1 AND 46). SN 85-128,027. PUB. 3-1-2011. FILED 9-13-2010.  
 3,961,410. **APRIL (STANDARD CHARACTER)**. AFFINITY PETCARE S.A., (U.S. CLS. 1 AND 46). SN 85-128,890. PUB. 3-1-2011. FILED 9-14-2010.  
 3,961,677. **ACIDZORB (STANDARD CHARACTER)**. LBI.LLC, AKA LITTLE BITS INC, (U.S. CLS. 1 AND 46). SN 85-132,607. PUB. 3-1-2011. FILED 9-17-2010.  
 3,961,704. **HYDROLICIOUS (STANDARD CHARACTER)**. NORTHERN LATITUDE CEA, LLC, (U.S. CLS. 1 AND 46). SN 85-133,980. PUB. 3-1-2011. FILED 9-20-2010.  
 3,961,738. **ULTRA MICRO CRYSTALS (STANDARD CHARACTER)**. ULTRA PET COMPANY, INC., (U.S. CLS. 1 AND 46). SN 85-138,999. PUB. 3-1-2011. FILED 9-27-2010.  
 3,961,831 ( *See Class 29 for this trademark* ).  
 3,961,958. **RANCHERS STOCK (STANDARD CHARACTER)**. CARGILL, INCORPORATED, (U.S. CLS. 1 AND 46). SN 85-194,828. PUB. 3-1-2011. FILED 12-10-2010.

### CLASS 32—LIGHT BEVERAGES

3,960,340. **GO LOCO (STANDARD CHARACTER)**. INVENTIVE PRODUCTS, LLC, (U.S. CLS. 45, 46 AND 48). SN 77-759,734. PUB. 3-1-2011. FILED 6-15-2009.  
 3,960,381. **BANG (STANDARD CHARACTER)**. ORANGE BANG, INC., (U.S. CLS. 45, 46 AND 48). SN 77-822,181. PUB. 3-1-2011. FILED 9-8-2009.  
 3,960,386. **SYMMETRY GENESIS (STANDARD CHARACTER)**. SYMMETRY CORPORATION, (U.S. CLS. 45, 46 AND 48). SN 77-827,095. PUB. 3-1-2011. FILED 9-15-2009.  
 3,960,485. **GENUINE PRIDE (STANDARD CHARACTER)**. VINOS LOCOS CON ALMA (VILCA) SA, MULTIPLE CLASS, (INT. CLS. 32 AND 33), (U.S. CLS. 45, 46, 47, 48 AND 49). SN 77-938,463. PUB. 3-1-2011. FILED 2-18-2010.  
 3,960,592. **MOCHA 8 RUSH AND DESIGN**. KERSHENSTINE, TIMOTHY A., (U.S. CLS. 45, 46 AND 48). SN 77-968,140. PUB. 3-1-2011. FILED 3-25-2010.  
 3,960,653 ( *See Class 1 for this trademark* ).  
 3,960,660 ( *See Class 3 for this trademark* ).  
 3,960,727 ( *See Class 5 for this trademark* ).  
 3,960,751. **PF AND DESIGN**. P&F WINERIES S.A., MULTIPLE CLASS, (INT. CLS. 32, 33 AND 35), (U.S. CLS. 45, 46, 47, 48, 49, 100, 101 AND 102). SN 79-083,376. PUB. 3-1-2011. FILED 4-28-2010.  
 3,960,752. **PF PUKLAVEC & FRIENDS AND DESIGN**. P&F WINERIES S.A., MULTIPLE CLASS, (INT. CLS. 32, 33 AND 35), (U.S. CLS. 45, 46, 47, 48, 49, 100, 101 AND 102). SN 79-083,377. PUB. 3-1-2011. FILED 4-28-2010.  
 3,960,753. **PF PUKLAVEC & FRIENDS SINCE 1934 AND**

**DESIGN**. P&F WINERIES S.A., MULTIPLE CLASS, (INT. CLS. 32, 33 AND 35), (U.S. CLS. 45, 46, 47, 48, 49, 100, 101 AND 102). SN 79-083,378. PUB. 3-1-2011. FILED 4-28-2010.  
 3,960,763. **PUKLAVEC & FRIENDS (STANDARD CHARACTER)**. P&F WINERIES S.A., MULTIPLE CLASS, (INT. CLS. 32, 33 AND 35), (U.S. CLS. 45, 46, 47, 48, 49, 100, 101 AND 102). SN 79-083,859. PUB. 3-1-2011. FILED 4-20-2010.  
 3,960,990. **TONI (STANDARD CHARACTER)**. ALFORD BUSINESS INC., (U.S. CLS. 45, 46 AND 48). SN 85-067,843. PUB. 11-23-2010. FILED 6-21-2010.  
 3,961,012. **FIESTA AMORE (STANDARD CHARACTER)**. CAFFE D'AMORE, INC., (U.S. CLS. 45, 46 AND 48). SN 85-077,527. PUB. 3-1-2011. FILED 7-2-2010.  
 3,961,051. **FLAT EARTH BREWING (STANDARD CHARACTER)**. FLAT EARTH BREWING COMPANY, (U.S. CLS. 45, 46 AND 48). SN 85-094,629. PUB. 1-25-2011. FILED 7-28-2010.  
 3,961,104. **AROOGA'S AMBER ALE (STANDARD CHARACTER)**. AROOGA'S GRILLE HOUSE & SPORTS BAR HOLDINGS, LP, (U.S. CLS. 45, 46 AND 48). SN 85-107,096. PUB. 3-1-2011. FILED 8-13-2010.  
 3,961,126 ( *See Class 29 for this trademark* ).  
 3,961,134 ( *See Class 29 for this trademark* ).  
 3,961,151 ( *See Class 5 for this trademark* ).  
 3,961,173. **NUTRI DENSE (STANDARD CHARACTER)**. HEALTH FUSION BRANDS, INC., (U.S. CLS. 45, 46 AND 48). SN 85-119,702. PUB. 3-1-2011. FILED 8-31-2010.  
 3,961,199. **TORCH (STANDARD CHARACTER)**. 638 BREWING COMPANY, INC. DBA FOOTHILLS BREWING, (U.S. CLS. 45, 46 AND 48). SN 85-122,619. PUB. 3-1-2011. FILED 9-3-2010.  
 3,961,652. **6 SHOOTER (STANDARD CHARACTER)**. E4 BEVERAGES LLC, (U.S. CLS. 45, 46 AND 48). SN 85-132,063. PUB. 3-1-2011. FILED 9-17-2010.  
 3,961,710. **LIVE LAUGH LOVE (STANDARD CHARACTER)**. D-GENERATION, INC., (U.S. CLS. 45, 46 AND 48). SN 85-134,942. PUB. 3-1-2011. FILED 9-21-2010.

### CLASS 33—WINES AND SPIRITS

3,960,382. **TAG (STYLIZED)**. MAVERICK DISTILLERY LIMITED, (U.S. CLS. 47 AND 49). SN 77-822,591. PUB. 3-1-2011. FILED 9-9-2009.  
 3,960,389. **COOKAL (STANDARD CHARACTER)**. PROBST, LAURENT, (U.S. CLS. 47 AND 49). SN 77-828,867. PUB. 3-1-2011. FILED 9-17-2009.  
 3,960,485 ( *See Class 32 for this trademark* ).  
 3,960,609. **CADORO (STANDARD CHARACTER)**. CANTINE RIUNITE & CIV - SOCIETA COOPERATIVA AGRICOLA, (U.S. CLS. 47 AND 49). SN 77-969,835. PUB. 8-17-2010. FILED 3-26-2010.  
 3,960,653 ( *See Class 1 for this trademark* ).  
 3,960,684. **DE LOUISSUN AND DESIGN**. LANKAO LUIS WINEMADE CO., LTD., (U.S. CLS. 47 AND 49). SN 79-078,500. PUB. 3-1-2011. FILED 1-14-2010.  
 3,960,686. **DELICIA DE BACO (STYLIZED)**. SEÑORIO DE VILLARRICA, S.L., (U.S. CLS. 47 AND 49). SN 79-078,875. PUB. 3-1-2011. FILED 1-12-2010.  
 3,960,690. **LOUIS XIII DE REMY MARTIN AND DESIGN**. E. REMY MARTIN & C<sup>o</sup>, (U.S. CLS. 47 AND 49). SN 79-079,484. PUB. 3-1-2011. FILED 12-30-2009.  
 3,960,691. **SEÑORIO DE VILLARRICA AND DESIGN**. SEÑORIO DE VILLARRICA, S.L., (U.S. CLS. 47 AND 49). SN 79-080,007. PUB. 3-1-2011. FILED 2-3-2010.  
 3,960,751 ( *See Class 32 for this trademark* ).  
 3,960,752 ( *See Class 32 for this trademark* ).  
 3,960,753 ( *See Class 32 for this trademark* ).  
 3,960,763 ( *See Class 32 for this trademark* ).  
 3,960,791. **F AND DESIGN**. LES VINS SKALLI, (U.S. CLS. 47 AND 49). SN 79-085,524. PUB. 3-1-2011. FILED 6-30-2010.  
 3,960,816. **GOTO (STYLIZED)**. AZIENDA AGRICOLA RICCI LUCA, (U.S. CLS. 47 AND 49). SN 79-087,595. PUB. 3-1-2011. FILED 8-5-2010.  
 3,960,839. **BOWMAN BROTHERS (STANDARD CHARACTER)**. SAZERAC COMPANY, INC., (U.S. CLS. 47 AND 49). SN 85-000,867. PUB. 3-1-2011. FILED 3-29-2010.  
 3,960,995. **MISCELLANEOUS DESIGN**. HEINEN'S, INC.,

- (U.S. CLS. 47 AND 49). SN 85-068,666. PUB. 3-1-2011. FILED 6-22-2010.
- 3,961,055. **LUSITANO AND DESIGN. VINICOLA VALE DO BARRO, SA.** (U.S. CLS. 47 AND 49). SN 85-095,540. PUB. 3-1-2011. FILED 7-29-2010.
- 3,961,203. **ELISIR M.P. ROUX AND DESIGN. ABSENTE LLC.** (U.S. CLS. 47 AND 49). SN 85-122,787. PUB. 3-1-2011. FILED 9-3-2010.
- 3,961,213. **FRUIT LAB (STANDARD CHARACTER). MODERN SPIRITS LLC.** (U.S. CLS. 47 AND 49). SN 85-123,365. PUB. 3-1-2011. FILED 9-4-2010.
- 3,961,274. **TWOMEY (STANDARD CHARACTER). TWOMEY CELLARS, LLC.** (U.S. CLS. 47 AND 49). SN 85-126,424. PUB. 3-1-2011. FILED 9-9-2010.
- 3,961,287. **GUSTAV (STANDARD CHARACTER). T. EDWARD WINES LTD..** (U.S. CLS. 47 AND 49). SN 85-126,747. PUB. 3-1-2011. FILED 9-10-2010.
- 3,961,288. **MONT ST. VINCENT (STANDARD CHARACTER). T. EDWARD WINES LTD..** (U.S. CLS. 47 AND 49). SN 85-126,757. PUB. 3-1-2011. FILED 9-10-2010.
- 3,961,300. **BODAN ROAN (STANDARD CHARACTER). T. EDWARD WINES LTD..** (U.S. CLS. 47 AND 49). SN 85-126,933. PUB. 3-1-2011. FILED 9-10-2010.
- 3,961,531. **HERETIC (STANDARD CHARACTER). Q4X, INC..** (U.S. CLS. 47 AND 49). SN 85-130,449. PUB. 3-1-2011. FILED 9-15-2010.
- 3,961,533. **THE PEASANT (STANDARD CHARACTER). Q4X, INC..** (U.S. CLS. 47 AND 49). SN 85-130,461. PUB. 3-1-2011. FILED 9-15-2010.
- 3,961,536. **CYPHER (STANDARD CHARACTER). Q4X, INC..** (U.S. CLS. 47 AND 49). SN 85-130,492. PUB. 3-1-2011. FILED 9-15-2010.
- 3,961,538. **MONARCHY (STANDARD CHARACTER). Q4X, INC..** (U.S. CLS. 47 AND 49). SN 85-130,498. PUB. 3-1-2011. FILED 9-15-2010.
- 3,961,567. **DELICIOUSLY INVITING VINO WITH ATTITUDE GET YOUR DRESS ON! AND DESIGN. LONE STAR KEMAH VENTURES.** (U.S. CLS. 47 AND 49). SN 85-130,939. PUB. 3-1-2011. FILED 9-16-2010.
- 3,961,572. **MAP OF THE ISLAND OF BARBADOS MOUNT GAY RUM BARBADOS PERFECTED BY TRADITION SINCE 1703 ECLIPSE PRODUCT OF BARBADOS PRODUCED, BLENDED AND EXPORTED BY MOUNT GAY DISTILLERIES LIMITED BRANDONS, ST. MICHAEL, BARBADOS, WEST INDIES MC AND DESIGN. MOUNT GAY DISTILLERIES LIMITED.** (U.S. CLS. 47 AND 49). SN 85-131,015. PUB. 3-1-2011. FILED 9-16-2010.
- 3,961,608. **ROCKWELL BROWN (STANDARD CHARACTER). ROCKWELL BROWN WINES LLC, DBA ROCKWELL BROWN WINES.** (U.S. CLS. 47 AND 49). SN 85-131,469. PUB. 3-1-2011. FILED 9-16-2010.
- 3,961,678. **SNAGGED (STANDARD CHARACTER). BALTIMORE BEND VINEYARD, LLC.** (U.S. CLS. 47 AND 49). SN 85-132,613. PUB. 3-1-2011. FILED 9-17-2010.
- 3,961,715. **ROCKFACE (STANDARD CHARACTER). T. EDWARD WINES LTD..** (U.S. CLS. 47 AND 49). SN 85-135,593. PUB. 3-1-2011. FILED 9-22-2010.
- 3,961,716. **PIE DE PALO (STANDARD CHARACTER). T. EDWARD WINES LTD..** (U.S. CLS. 47 AND 49). SN 85-135,600. PUB. 3-1-2011. FILED 9-22-2010.
- 3,961,718. **PUNTA PAYS (STANDARD CHARACTER). T. EDWARD WINES LTD..** (U.S. CLS. 47 AND 49). SN 85-135,613. PUB. 3-1-2011. FILED 9-22-2010.
- 3,961,895. **PROHIBITION IS OVER (STANDARD CHARACTER). STILLHOUSE, LLC.** (U.S. CLS. 47 AND 49). SN 85-161,043. PUB. 3-1-2011. FILED 10-26-2010.
- 3,961,945. **WENTE VINEYARDS FAMILY OWNED. ESTATE GROWN. SUSTAINABLY FARMED. AND DESIGN. WENTE BROS..** (U.S. CLS. 47 AND 49). SN 85-175,949. PUB. 3-1-2011. FILED 11-12-2010.

---

#### CLASS 34—SMOKERS' ARTICLES

- 3,960,619 ( *See Class 9 for this trademark.* )
- 3,960,632. **NAVAJO ARTS & CRAFTS GUILD (STANDARD CHARACTER). NAVAJO ARTS & CRAFTS ENTERPRISE,**

- (U.S. CLS. 2, 8, 9 AND 17). SN 78-863,410. PUB. 3-1-2011. FILED 4-18-2006.
- 3,960,633. **NAVAJO (STANDARD CHARACTER). NAVAJO ARTS & CRAFTS ENTERPRISE.** (U.S. CLS. 2, 8, 9 AND 17). SN 78-883,220. PUB. 3-1-2011. FILED 5-15-2006.
- 3,960,911. **BOGAR (STANDARD CHARACTER). JOSEPH M. ANDERSON.** (U.S. CLS. 2, 8, 9 AND 17). SN 85-026,570. PUB. 3-1-2011. FILED 4-29-2010.
- 3,961,222. **S THE SAFECIG AND DESIGN. THE SAFE CIG, LLC.** (U.S. CLS. 2, 8, 9 AND 17). SN 85-123,642. PUB. 3-1-2011. FILED 9-6-2010.
- 3,961,544. **DARKSOUL (STANDARD CHARACTER). INHALE, INC..** (U.S. CLS. 2, 8, 9 AND 17). SN 85-130,579. PUB. 3-1-2011. FILED 9-15-2010.
- 3,961,547. **DANGEROUS (STANDARD CHARACTER). INHALE, INC..** (U.S. CLS. 2, 8, 9 AND 17). SN 85-130,601. PUB. 3-1-2011. FILED 9-15-2010.
- 3,961,712. **LIVE LAUGH LOVE (STANDARD CHARACTER). D-GENERATION, INC..** (U.S. CLS. 2, 8, 9 AND 17). SN 85-134,966. PUB. 3-1-2011. FILED 9-21-2010.
- 3,961,846. **DYNASTY (STANDARD CHARACTER). DHANRAJ IMPORTS, INC., DBA DHANRAJ IMPORTS, INC..** (U.S. CLS. 2, 8, 9 AND 17). SN 85-149,987. PUB. 3-1-2011. FILED 10-11-2010.

---

#### SERVICE MARKS

#### CLASS 35—ADVERTISING AND BUSINESS

- 3,960,227. **BLUPRINT ENTERTAINMENT AND DESIGN. BLU PRINT ENTERTAINMENT, INC..** (U.S. CLS. 100, 101 AND 102). SN 76-699,914. PUB. 3-1-2011. FILED 10-16-2009.
- 3,960,228. **WS LIVE (STANDARD CHARACTER). WSOL, INC..** (U.S. CLS. 100, 101 AND 102). SN 76-700,114. PUB. 3-1-2011. FILED 10-29-2009.
- 3,960,244. **CRITICAL BREAKTHROUGH CONVERSATIONS (STANDARD CHARACTER). BUCKNER & COMPANY, INC..** (U.S. CLS. 100, 101 AND 102). SN 76-703,926. PUB. 3-1-2011. FILED 7-27-2010.
- 3,960,246. **TRI STATE OUTFITTERS (STANDARD CHARACTER). TRI-STATE DISTRIBUTORS, INC..** (U.S. CLS. 100, 101 AND 102). SN 76-703,990. PUB. 3-1-2011. FILED 8-2-2010.
- 3,960,248. **MPI MARKETING PARTNERS INC. AND DESIGN. MARKETING PARTNERS, INC..** (U.S. CLS. 100, 101 AND 102). SN 76-704,076. PUB. 3-1-2011. FILED 8-11-2010.
- 3,960,266 ( *See Class 14 for this trademark.* )
- 3,960,278. **ECOMART (STANDARD CHARACTER). GLOBAL-FORCE NETWORK INC..** (U.S. CLS. 100, 101 AND 102). SN 77-405,478. PUB. 3-1-2011. FILED 2-25-2008.
- 3,960,280 ( *See Class 9 for this trademark.* )
- 3,960,283. **IBW INTERNATIONAL BONDED WAREHOUSES IMPORTS FROM AROUND THE WORLD AND DESIGN. IBW HOLDINGS, LLC.** (U.S. CLS. 100, 101 AND 102). SN 77-477,852. PUB. 3-1-2011. FILED 5-19-2008.
- 3,960,286 ( *See Class 9 for this trademark.* )
- 3,960,293 ( *See Class 12 for this trademark.* )
- 3,960,309. **OHIO (STYLIZED). DEPARTMENT OF DEVELOPMENT OF STATE OF OHIO.** (U.S. CLS. 100, 101 AND 102). SN 77-636,932. PUB. 3-1-2011. FILED 12-19-2008.
- 3,960,313 ( *See Class 30 for this trademark.* )
- 3,960,321. **MYCITY (STANDARD CHARACTER). 411 WEB DIRECTORY INC..** (U.S. CLS. 100, 101 AND 102). SN 77-692,821. PUB. 3-1-2011. FILED 3-17-2009.
- 3,960,323. **CATALYST HEALTHCARE RESEARCH AND DESIGN. PRINCE MARKETING & COMMUNICATIONS, INC., DBA PRINCE MARKET RESEARCH, INC..** (U.S. CLS. 100, 101 AND 102). SN 77-698,967. PUB. 10-27-2009. FILED 3-25-2009.
- 3,960,325. **AH AND DESIGN. ASSOCIATION HEADQUARTERS, INC., MULTIPLE CLASS, (INT. CLS. 35, 36 AND 42),** (U.S. CLS. 100, 101 AND 102). SN 77-702,154. PUB. 3-1-2011. FILED 3-30-2009.
- 3,960,329. **PROFIL (STANDARD CHARACTER). PROFIL INSTITUTE FOR CLINICAL RESEARCH, INC., MULTIPLE**



- CLASS. (INT. CLS. 35, 41, 42 AND 44), (U.S. CLS. 100, 101, 102 AND 107). SN 77-711,465. PUB. 11-23-2010. FILED 4-10-2009.
- 3,960,333 ( *See Class 16 for this trademark*).
- 3,960,336. **BURSANET (STANDARD CHARACTER)**. ACTINVER, S.A. DE C.V. SOCIEDAD OPERADORA DE SOCIEDADES DE INVERSION, MULTIPLE CLASS, (INT. CLS. 35 AND 36), (U.S. CLS. 100, 101 AND 102). SN 77-747,277. PUB. 8-17-2010. FILED 5-29-2009.
- 3,960,341. **TRUE SKOOL AND DESIGN**. SALGADO, RENOIR A., DBA TRUE SKOOL, (U.S. CLS. 100, 101 AND 102). SN 77-765,149. PUB. 3-1-2011. FILED 6-22-2009.
- 3,960,347. **MISCELLANEOUS DESIGN**. FLOWENERGY, L.L.C., MULTIPLE CLASS, (INT. CLS. 35 AND 42), (U.S. CLS. 100, 101 AND 102). SN 77-782,040. PUB. 3-1-2011. FILED 7-15-2009.
- 3,960,352. **IN-SYNC BRANDING (STANDARD CHARACTER)**. STARFISH, LLC, (U.S. CLS. 100, 101 AND 102). SN 77-791,243. PUB. 3-1-2011. FILED 7-28-2009.
- 3,960,364. **MISCELLANEOUS DESIGN**. WILDLIFEDIRECT, INC., MULTIPLE CLASS, (INT. CLS. 35 AND 36), (U.S. CLS. 100, 101 AND 102). SN 77-809,885. PUB. 3-1-2011. FILED 8-21-2009.
- 3,960,365. **WILDLIFEDIRECT (STANDARD CHARACTER)**. WILDLIFEDIRECT, INC., MULTIPLE CLASS, (INT. CLS. 35 AND 36), (U.S. CLS. 100, 101 AND 102). SN 77-809,887. PUB. 3-1-2011. FILED 8-21-2009.
- 3,960,366. **STARTEK@HOME (STANDARD CHARACTER)**. STARTEK, INC., (U.S. CLS. 100, 101 AND 102). SN 77-810,563. PUB. 3-1-2011. FILED 8-21-2009.
- 3,960,367. **STARTEK@HOME AND DESIGN**. STARTEK, INC., (U.S. CLS. 100, 101 AND 102). SN 77-810,577. PUB. 3-1-2011. FILED 8-21-2009.
- 3,960,369 ( *See Class 12 for this trademark*).
- 3,960,375. **ACME SCALE (STANDARD CHARACTER)**. ACME SCALE CO., DBA ACME SCALE SYSTEMS, INC., MULTIPLE CLASS, (INT. CLS. 35, 37 AND 42), (U.S. CLS. 100, 101, 102, 103 AND 106). SN 77-815,500. PUB. 3-1-2011. FILED 8-28-2009.
- 3,960,376. **THE SULLIVAN GROUP (STANDARD CHARACTER)**. MANOR CAPITAL, LLC, MULTIPLE CLASS, (INT. CLS. 35 AND 36), (U.S. CLS. 100, 101 AND 102). SN 77-815,561. PUB. 3-1-2011. FILED 8-28-2009.
- 3,960,387. **BIG WARDROBE.COM AND DESIGN**. BIG WARDROBE LIMITED, (U.S. CLS. 100, 101 AND 102). SN 77-827,844. PUB. 3-1-2011. FILED 9-16-2009.
- 3,960,390. **MC MILOU COUTURE AND DESIGN**. MILOU COUTURE INC., (U.S. CLS. 100, 101 AND 102). SN 77-829,734. PUB. 3-1-2011. FILED 9-18-2009.
- 3,960,391. **PRIVACYSTAR (STANDARD CHARACTER)**. FIRST ORION CORP., DBA FIRST ORION, MULTIPLE CLASS, (INT. CLS. 35 AND 38), (U.S. CLS. 100, 101, 102 AND 104). SN 77-830,719. PUB. 3-1-2011. FILED 9-21-2009.
- 3,960,394 ( *See Class 9 for this trademark*).
- 3,960,397 ( *See Class 9 for this trademark*).
- 3,960,403. **KWIK KOPY AND DESIGN**. I.C.E.D. MANAGEMENT, INC., MULTIPLE CLASS, (INT. CLS. 35 AND 40), (U.S. CLS. 100, 101, 102, 103 AND 106). SN 77-840,902. PUB. 2-8-2011. FILED 10-4-2009.
- 3,960,414 ( *See Class 4 for this trademark*).
- 3,960,416. **PET PRODUCT NEWS INTERNATIONAL (STANDARD CHARACTER)**. BOWTIE, INC., (U.S. CLS. 100, 101 AND 102). SN 77-862,026. PUB. 3-1-2011. FILED 10-31-2009.
- 3,960,420. **CHARITY TRUCKS (STANDARD CHARACTER)**. CHARITY TRUCKS LTD., (U.S. CLS. 100, 101 AND 102). SN 77-868,183. PUB. 3-1-2011. FILED 11-9-2009.
- 3,960,435. **PARTS COALITION PREVENTING ALCOHOL RELATED TRAUMA IN SALINAS (STANDARD CHARACTER)**. SUN STREET CENTERS, (U.S. CLS. 100, 101 AND 102). SN 77-893,129. PUB. 3-1-2011. FILED 12-14-2009.
- 3,960,451 ( *See Class 9 for this trademark*).
- 3,960,459. **DAWN ENERGY (STANDARD CHARACTER)**. DAWN ENERGY LIMITED, MULTIPLE CLASS, (INT. CLS. 35, 36, 40 AND 42), (U.S. CLS. 100, 101, 102, 103 AND 106). SN 77-918,114. PUB. 3-1-2011. FILED 1-22-2010.
- 3,960,466 ( *See Class 9 for this trademark*).
- 3,960,468 ( *See Class 9 for this trademark*).
- 3,960,472. **HOSPITALITY QUOTIENT (STANDARD CHARACTER)**. USHG, LLC, MULTIPLE CLASS, (INT. CLS. 35 AND 41), (U.S. CLS. 100, 101, 102 AND 107). SN 77-928,516. PUB. 3-1-2011. FILED 2-4-2010.
- 3,960,473. **HQ HOSPITALITY QUOTIENT AND DESIGN**. USHG, LLC, MULTIPLE CLASS, (INT. CLS. 35 AND 41), (U.S. CLS. 100, 101, 102 AND 107). SN 77-929,181. PUB. 3-1-2011. FILED 2-5-2010.
- 3,960,474. **HQ HOSPITALITY QUOTIENT AND DESIGN**. USHG, LLC, MULTIPLE CLASS, (INT. CLS. 35 AND 41), (U.S. CLS. 100, 101, 102 AND 107). SN 77-929,220. PUB. 3-1-2011. FILED 2-5-2010.
- 3,960,475. **GIG NEWTON (STANDARD CHARACTER)**. AEU MEDIA GROUP, LLC, (U.S. CLS. 100, 101 AND 102). SN 77-929,863. PUB. 3-1-2011. FILED 2-6-2010.
- 3,960,490. **NETBIZ (STANDARD CHARACTER)**. NETBIZ, INC., MULTIPLE CLASS, (INT. CLS. 35 AND 42), (U.S. CLS. 100, 101 AND 102). SN 77-941,520. PUB. 3-1-2011. FILED 2-22-2010.
- 3,960,492 ( *See Class 9 for this trademark*).
- 3,960,493. **NOT JUST ANOTHER PRETTY FACE (STANDARD CHARACTER)**. HYDE PARK ART CENTER, (U.S. CLS. 100, 101 AND 102). SN 77-942,814. PUB. 3-1-2011. FILED 2-23-2010.
- 3,960,495. **FITPASS NETWORK (STANDARD CHARACTER)**. FITPASS NETWORK LLC, MULTIPLE CLASS, (INT. CLS. 35 AND 41), (U.S. CLS. 100, 101, 102 AND 107). SN 77-944,566. PUB. 3-1-2011. FILED 2-25-2010.
- 3,960,496. **N2EX (STANDARD CHARACTER)**. OMX AB, MULTIPLE CLASS, (INT. CLS. 35, 36, 41 AND 42), (U.S. CLS. 100, 101, 102 AND 107). SN 77-944,626. PUB. 3-1-2011. FILED 2-25-2010.
- 3,960,500. **WE THINK BEYOND THE LABEL.ORG (STANDARD CHARACTER)**. HEALTH & DISABILITY ADVOCATES, MULTIPLE CLASS, (INT. CLS. 35 AND 36), (U.S. CLS. 100, 101 AND 102). SN 77-945,298. PUB. 3-1-2011. FILED 2-25-2010.
- 3,960,501. **GCA SERVICES GROUP (STANDARD CHARACTER)**. GCA SERVICES GROUP, INC., MULTIPLE CLASS, (INT. CLS. 35, 37, 39, 41 AND 44), (U.S. CLS. 100, 101, 102, 103, 105, 106 AND 107). SN 77-945,300. PUB. 3-1-2011. FILED 2-25-2010.
- 3,960,502. **GCA AND DESIGN**. GCA SERVICES GROUP, INC., MULTIPLE CLASS, (INT. CLS. 35, 37, 39, 41 AND 44), (U.S. CLS. 100, 101, 102, 103, 105, 106 AND 107). SN 77-945,320. PUB. 3-1-2011. FILED 2-25-2010.
- 3,960,503 ( *See Class 9 for this trademark*).
- 3,960,510 ( *See Class 9 for this trademark*).
- 3,960,516. **THE GOOD AMERICAN POST (STANDARD CHARACTER)**. TISHA TRINETTE CASIDA, (U.S. CLS. 100, 101 AND 102). SN 77-949,704. PUB. 3-1-2011. FILED 3-3-2010.
- 3,960,519. **FUN CITY USA (STANDARD CHARACTER)**. ORLANDO INFORMATION NETWORK INC, (U.S. CLS. 100, 101 AND 102). SN 77-950,497. PUB. 3-1-2011. FILED 3-4-2010.
- 3,960,534. **DIVDAT (STANDARD CHARACTER)**. DIVERSIFIED DATA PROCESSING & CONSULTING, INC., DBA DIVDAT, MULTIPLE CLASS, (INT. CLS. 35 AND 36), (U.S. CLS. 100, 101 AND 102). SN 77-954,634. PUB. 3-1-2011. FILED 3-9-2010.
- 3,960,537. **JBR AND DESIGN**. JBR ENVIRONMENTAL CONSULTANTS, INC., MULTIPLE CLASS, (INT. CLS. 35, 37, 42 AND 45), (U.S. CLS. 100, 101, 102, 103 AND 106). SN 77-955,988. PUB. 3-1-2011. FILED 3-10-2010.
- 3,960,541. **TRANSPARENT HEALTH NETWORK AND DESIGN**. TRANSPARENT HEALTH GROUP LLC, (U.S. CLS. 100, 101 AND 102). SN 77-957,382. PUB. 3-1-2011. FILED 3-12-2010.
- 3,960,543. **MISCELLANEOUS DESIGN**. SUMITOMO FORESTRY CO., LTD., MULTIPLE CLASS, (INT. CLS. 35, 36, 37 AND 42), (U.S. CLS. 100, 101, 102, 103 AND 106). SN 77-958,131. PUB. 3-1-2011. FILED 3-12-2010.
- 3,960,544. **MISCELLANEOUS DESIGN**. SUMITOMO FORESTRY CO., LTD., MULTIPLE CLASS, (INT. CLS. 35, 36, 37 AND 42), (U.S. CLS. 100, 101, 102, 103 AND 106). SN 77-958,155. PUB. 3-1-2011. FILED 3-12-2010.
- 3,960,547. **SPONSORSHIP LIVE (STANDARD CHARACTER)**. GARRITY, MATTHEW, (U.S. CLS. 100, 101 AND 102). SN 77-959,466. PUB. 3-1-2011. FILED 3-15-2010.

- 3,960,549 ( *See Class 3 for this trademark.*)  
 3,960,558 ( *See Class 9 for this trademark.*)  
 3,960,562. **FUSIONBEADS.COM (STANDARD CHARACTER).** FUSION BEADS, INC., MULTIPLE CLASS, (INT. CLS. 35 AND 41), (U.S. CLS. 100, 101, 102 AND 107). SN 77-962,313. PUB. 3-1-2011. FILED 3-18-2010.  
 3,960,564 ( *See Class 9 for this trademark.*)  
 3,960,566 ( *See Class 5 for this trademark.*)  
 3,960,567 ( *See Class 5 for this trademark.*)  
 3,960,578. **BRIEFCASE ANALYTICS (STANDARD CHARACTER).** RICHARD J. CELLINI, (U.S. CLS. 100, 101 AND 102). SN 77-966,289. PUB. 3-1-2011. FILED 3-23-2010.  
 3,960,603 ( *See Class 25 for this trademark.*)  
 3,960,610. **CAPSTRAT (STANDARD CHARACTER).** CAPSTRAT, INC., MULTIPLE CLASS, (INT. CLS. 35 AND 42), (U.S. CLS. 100, 101 AND 102). SN 77-969,853. PUB. 3-1-2011. FILED 3-26-2010.  
 3,960,623. **ZESTIVITIES! AND DESIGN.** ZESTIVITIES!, INC., (U.S. CLS. 100, 101 AND 102). SN 77-981,778. PUB. 8-17-2010. FILED 3-24-2010.  
 3,960,636. **MARKLAND STREET (STANDARD CHARACTER).** ELLIOTT & PAGE LIMITED, MULTIPLE CLASS, (INT. CLS. 35 AND 36), (U.S. CLS. 100, 101 AND 102). SN 78-946,006. PUB. 3-1-2011. FILED 8-7-2006.  
 3,960,641 ( *See Class 9 for this trademark.*)  
 3,960,645 ( *See Class 9 for this trademark.*)  
 3,960,646. **WARGAME (STANDARD CHARACTER).** JEAN-MARC MENAT, MULTIPLE CLASS, (INT. CLS. 35, 41 AND 42), (U.S. CLS. 100, 101, 102 AND 107). SN 79-070,499. PUB. 11-23-2010. FILED 4-28-2009.  
 3,960,648 ( *See Class 9 for this trademark.*)  
 3,960,652 ( *See Class 12 for this trademark.*)  
 3,960,655 ( *See Class 9 for this trademark.*)  
 3,960,658 ( *See Class 7 for this trademark.*)  
 3,960,659. **EDUTRAINMENT (STANDARD CHARACTER).** ALBRECHT KRESSE, MULTIPLE CLASS, (INT. CLS. 35, 39 AND 41), (U.S. CLS. 100, 101, 102, 105 AND 107). SN 79-074,743. PUB. 3-1-2011. FILED 9-3-2009.  
 3,960,660 ( *See Class 3 for this trademark.*)  
 3,960,666 ( *See Class 9 for this trademark.*)  
 3,960,669 ( *See Class 9 for this trademark.*)  
 3,960,672. **CASINOGUIDE (STANDARD CHARACTER).** CHANCE PUBLICATIONS N.V., (U.S. CLS. 100, 101 AND 102). SN 79-076,200. PUB. 3-1-2011. FILED 9-29-2009.  
 3,960,675 ( *See Class 9 for this trademark.*)  
 3,960,677 ( *See Class 25 for this trademark.*)  
 3,960,680 ( *See Class 9 for this trademark.*)  
 3,960,685. **GAME TALENTS (STYLIZED).** DAVID ROULIN, (U.S. CLS. 100, 101 AND 102). SN 79-078,720. PUB. 3-1-2011. FILED 12-24-2009.  
 3,960,704. **KMS TEAM AND DESIGN.** KMS TEAM GMBH, MULTIPLE CLASS, (INT. CLS. 35, 41 AND 42), (U.S. CLS. 100, 101, 102 AND 107). SN 79-081,059. PUB. 3-1-2011. FILED 1-25-2010.  
 3,960,714 ( *See Class 9 for this trademark.*)  
 3,960,716 ( *See Class 9 for this trademark.*)  
 3,960,735 ( *See Class 18 for this trademark.*)  
 3,960,739 ( *See Class 6 for this trademark.*)  
 3,960,748. **PRIVACY AND DESIGN.** AGENCIA ESPAÑOLA DE PROTECCION DE DATOS, MULTIPLE CLASS, (INT. CLS. 35, 41 AND 45), (U.S. CLS. 100, 101, 102 AND 107). SN 79-083,026. PUB. 3-1-2011. FILED 4-6-2010.  
 3,960,751 ( *See Class 32 for this trademark.*)  
 3,960,752 ( *See Class 32 for this trademark.*)  
 3,960,753 ( *See Class 32 for this trademark.*)  
 3,960,763 ( *See Class 32 for this trademark.*)  
 3,960,768 ( *See Class 18 for this trademark.*)  
 3,960,777 ( *See Class 6 for this trademark.*)  
 3,960,780 ( *See Class 16 for this trademark.*)  
 3,960,796 ( *See Class 25 for this trademark.*)  
 3,960,826 ( *See Class 10 for this trademark.*)  
 3,960,835. **AXA ASSISTANCE REDEFINING / SERVICE AND DESIGN.** AXA, MULTIPLE CLASS, (INT. CLS. 35, 36, 37, 38, 39, 41, 43 AND 45), (U.S. CLS. 100, 101, 102, 103, 104, 105, 106 AND 107). SN 79-975,160. PUB. 3-1-2011. FILED 4-29-2009.  
 3,960,836. **NEW WAYS OF WORKING (STANDARD CHARACTER).** NEW WAYS OF WORKING LLC, (U.S. CLS. 100, 101 AND 102). SN 85-000,125. PUB. 3-1-2011. FILED 3-27-2010.  
 3,960,837. **RUNNERS ON A MISSION (STANDARD CHARACTER).** THE RUNNERS ON A MISSION FOUNDATION, AKA THE ROAM FOUNDATION, (U.S. CLS. 100, 101 AND 102). SN 85-000,303. PUB. 3-1-2011. FILED 3-28-2010.  
 3,960,844. **NO VACANCY AND DESIGN.** THE BOOSALIS GROUP, INC., (U.S. CLS. 100, 101 AND 102). SN 85-002,168. PUB. 3-1-2011. FILED 3-30-2010.  
 3,960,845 ( *See Class 9 for this trademark.*)  
 3,960,846. **CITYOF.COM (STANDARD CHARACTER).** THE-CITYOF.COM, LLC, (U.S. CLS. 100, 101 AND 102). SN 85-002,419. PUB. 3-1-2011. FILED 3-30-2010.  
 3,960,851. **BILL THE BUTCHER THE ONLY MEAT TO EAT AND DESIGN.** BILL THE BUTCHER, INC., (U.S. CLS. 100, 101 AND 102). SN 85-004,752. PUB. 3-1-2011. FILED 4-1-2010.  
 3,960,854. **GREAT WALL ADVERTISING (STANDARD CHARACTER).** GREAT WALL ADVERTISING LLC, (U.S. CLS. 100, 101 AND 102). SN 85-005,229. PUB. 3-1-2011. FILED 4-2-2010.  
 3,960,861. **FKC (STANDARD CHARACTER).** FKC.COM LTD., (U.S. CLS. 100, 101 AND 102). SN 85-007,139. PUB. 3-1-2011. FILED 4-6-2010.  
 3,960,871. **PD SIXTY (STANDARD CHARACTER).** PD SIXTY DISTRIBUTOR INC, (U.S. CLS. 100, 101 AND 102). SN 85-009,867. PUB. 3-1-2011. FILED 4-8-2010.  
 3,960,872. **PD60 (STANDARD CHARACTER).** PD SIXTY DISTRIBUTOR INC, (U.S. CLS. 100, 101 AND 102). SN 85-009,876. PUB. 3-1-2011. FILED 4-8-2010.  
 3,960,880. **LEAF LOCATOR (STANDARD CHARACTER).** FRESH EXPRESS INCORPORATED, (U.S. CLS. 100, 101 AND 102). SN 85-012,550. PUB. 3-1-2011. FILED 4-13-2010.  
 3,960,881. **FACES OF FRESH (STANDARD CHARACTER).** FRESH EXPRESS INCORPORATED, (U.S. CLS. 100, 101 AND 102). SN 85-012,582. PUB. 3-1-2011. FILED 4-13-2010.  
 3,960,919. **GROWINGTOGETHER (STANDARD CHARACTER).** LAND O'LAKES, INC., (U.S. CLS. 100, 101 AND 102). SN 85-029,774. PUB. 3-1-2011. FILED 5-4-2010.  
 3,960,926. **ROY LOMAS CARPETS (STANDARD CHARACTER).** ROY LOMAS CARPET CONTRACTOR, INC., (U.S. CLS. 100, 101 AND 102). SN 85-033,876. PUB. 3-1-2011. FILED 5-10-2010.  
 3,960,928. **MISCELLANEOUS DESIGN.** FLOOR USA, INC., (U.S. CLS. 100, 101 AND 102). SN 85-034,248. PUB. 3-1-2011. FILED 5-10-2010.  
 3,960,938. **KILOWATTS ELECTRIC & LIGHTING SUPPLY (STANDARD CHARACTER).** KILOWATTS ELECTRIC SUPPLY, CORP., (U.S. CLS. 100, 101 AND 102). SN 85-039,170. PUB. 3-1-2011. FILED 5-14-2010.  
 3,960,945. **A A ABEL & ASSOCIATES CONSULTING AND DESIGN.** RYU, SEUNG KYUN, (U.S. CLS. 100, 101 AND 102). SN 85-041,821. PUB. 3-1-2011. FILED 5-18-2010.  
 3,960,949 ( *See Class 10 for this trademark.*)  
 3,960,950 ( *See Class 5 for this trademark.*)  
 3,960,953. **MEDICAL BRIDGES BRIDGING THE HEALTH-CARE GAP WORLDWIDE AND DESIGN.** MEDICAL BRIDGES, INC., (U.S. CLS. 100, 101 AND 102). SN 85-045,694. PUB. 3-1-2011. FILED 5-22-2010.  
 3,960,955. **MEDICAL BRIDGES AND DESIGN.** MEDICAL BRIDGES, INC., (U.S. CLS. 100, 101 AND 102). SN 85-045,810. PUB. 3-1-2011. FILED 5-23-2010.  
 3,960,964 ( *See Class 11 for this trademark.*)  
 3,960,971. **SANDLOT SOLUTIONS (STANDARD CHARACTER).** SANDLOT, LLC, MULTIPLE CLASS, (INT. CLS. 35, 41 AND 42), (U.S. CLS. 100, 101, 102 AND 107). SN 85-057,757. PUB. 3-1-2011. FILED 6-8-2010.  
 3,960,973. **UNIVERSITIES ALLIED FOR ESSENTIAL MEDICINES (STANDARD CHARACTER).** UNIVERSITIES ALLIED FOR ESSENTIAL MEDICINES, CORP., AKA UAEM, (U.S. CLS. 100, 101 AND 102). SN 85-059,373. PUB. 3-1-2011. FILED 6-10-2010.  
 3,960,977. **SCRUM PATHWAYS (STANDARD CHARACTER).** 3BACK LLC, MULTIPLE CLASS, (INT. CLS. 35 AND 41), (U.S. CLS. 100, 101, 102 AND 107). SN 85-060,932. PUB. 3-1-2011. FILED 6-11-2010.  
 3,960,979. **LIVE MORE. MISS NOTHING. (STANDARD CHARACTER).** CLARK REALTY MANAGEMENT, LLC, (U.S. CLS. 100, 101 AND 102). SN 85-061,121. PUB. 3-1-2011.



- FILED 6-11-2010.
- 3,960,983. **WHERE SCIENCE DELIVERS PERFORMANCE (STANDARD CHARACTER)**. AWS TRUEPOWER, LLC, (U.S. CLS. 100, 101 AND 102). SN 85-064,007. PUB. 3-1-2011. FILED 6-16-2010.
- 3,960,986. **MUSIC 180 AND DESIGN**. CONNECTED CREATIVES, INC., (U.S. CLS. 100, 101 AND 102). SN 85-064,844. PUB. 3-1-2011. FILED 6-16-2010.
- 3,960,997. **AGILE PATHWAYS (STANDARD CHARACTER)**. 3BACK LLC, MULTIPLE CLASS, (INT. CLS. 35 AND 41), (U.S. CLS. 100, 101, 102 AND 107). SN 85-069,876. PUB. 3-1-2011. FILED 6-23-2010.
- 3,960,998. **ALIBRIS (STANDARD CHARACTER)**. ALIBRIS, INC., MULTIPLE CLASS, (INT. CLS. 35 AND 42), (U.S. CLS. 100, 101 AND 102). SN 85-070,557. PUB. 3-1-2011. FILED 6-24-2010.
- 3,961,006. **ASAPS (STANDARD CHARACTER)**. THE AMERICAN SOCIETY FOR AESTHETIC PLASTIC SURGERY, AKA THE AESTHETIC SOCIETY, (U.S. CLS. 100, 101 AND 102). SN 85-072,412. PUB. 3-1-2011. FILED 6-26-2010.
- 3,961,008. **THE ART OF PERCEPTION (STANDARD CHARACTER)**. 360 INNOVATIVE MARKETING AND COMMUNICATIONS, LLC, DBA 360 INNOVATIVE MARKETING AND COMMUNICATIONS, LLC., (U.S. CLS. 100, 101 AND 102). SN 85-074,317. PUB. 3-1-2011. FILED 6-29-2010.
- 3,961,009. **GET CONNECTED! (STANDARD CHARACTER)**. CALIFORNIA EMERGING TECHNOLOGY FUND, MULTIPLE CLASS, (INT. CLS. 35 AND 41), (U.S. CLS. 100, 101, 102 AND 107). SN 85-075,227. PUB. 3-1-2011. FILED 6-30-2010.
- 3,961,010. **GET CONNECTED! YOUR LIFE MADE EASIER (STANDARD CHARACTER)**. CALIFORNIA EMERGING TECHNOLOGY FUND, MULTIPLE CLASS, (INT. CLS. 35 AND 41), (U.S. CLS. 100, 101, 102 AND 107). SN 85-075,269. PUB. 3-1-2011. FILED 6-30-2010.
- 3,961,017. **THE VOICE OF SPECIALTY PHARMA (STANDARD CHARACTER)**. SPECIALTY PHARMA ASSOCIATION, (U.S. CLS. 100, 101 AND 102). SN 85-079,294. PUB. 3-1-2011. FILED 7-7-2010.
- 3,961,019. **SAVE AND DESIGN**. FOOD CIRCUS SUPERMARKETS, INC., (U.S. CLS. 100, 101 AND 102). SN 85-080,243. PUB. 3-1-2011. FILED 7-8-2010.
- 3,961,021. **SPECIALTY PHARMA ASSOCIATION AND DESIGN**. SPECIALTY PHARMA ASSOCIATION, (U.S. CLS. 100, 101 AND 102). SN 85-081,068. PUB. 3-1-2011. FILED 7-9-2010.
- 3,961,029. **GHX CONNECT PLUS (STANDARD CHARACTER)**. GLOBAL HEALTHCARE EXCHANGE, LLC, MULTIPLE CLASS, (INT. CLS. 35 AND 42), (U.S. CLS. 100, 101 AND 102). SN 85-085,176. PUB. 3-1-2011. FILED 7-15-2010.
- 3,961,031. **SCISIVE AND DESIGN**. SCISIVE CONSULTING LP, (U.S. CLS. 100, 101 AND 102). SN 85-085,526. PUB. 3-1-2011. FILED 7-15-2010.
- 3,961,034. **WORKFLEX (STANDARD CHARACTER)**. WORKFLEX SOLUTIONS LLC, MULTIPLE CLASS, (INT. CLS. 35 AND 42), (U.S. CLS. 100, 101 AND 102). SN 85-087,744. PUB. 3-1-2011. FILED 7-19-2010.
- 3,961,035. **MISCELLANEOUS DESIGN**. WORKFLEX SOLUTIONS LLC, MULTIPLE CLASS, (INT. CLS. 35 AND 42), (U.S. CLS. 100, 101 AND 102). SN 85-087,748. PUB. 3-1-2011. FILED 7-19-2010.
- 3,961,038. **CB CIGAR BLOGS AND DESIGN**. TAFT, RAY, MULTIPLE CLASS, (INT. CLS. 35 AND 41), (U.S. CLS. 100, 101, 102 AND 107). SN 85-088,992. PUB. 11-23-2010. FILED 7-20-2010.
- 3,961,039. **RECOVERY+SOLUTIONS, INC. (STANDARD CHARACTER)**. RECOVERY+SOLUTIONS, INC., (U.S. CLS. 100, 101 AND 102). SN 85-089,011. PUB. 3-1-2011. FILED 7-20-2010.
- 3,961,057. **RE-PAP (STANDARD CHARACTER)**. ASSOCIATED HEALTHCARE SYSTEMS, INC., DBA C-PAP XPRESS, (U.S. CLS. 100, 101 AND 102). SN 85-095,819. PUB. 3-1-2011. FILED 7-29-2010.
- 3,961,063. **MISCELLANEOUS DESIGN**. LIFEGUARD STORE, INC., THE, (U.S. CLS. 100, 101 AND 102). SN 85-100,044. PUB. 3-1-2011. FILED 8-4-2010.
- 3,961,065. **PARAMOUNT EQUITY INSURANCE SERVICES (STANDARD CHARACTER)**. PARAMOUNT EQUITY, (U.S. CLS. 100, 101 AND 102). SN 85-100,280. PUB. 3-1-2011. FILED 8-4-2010.
- 3,961,069 ( *See Class 16 for this trademark*).
- 3,961,072. **SAVOYA LOCAL (STANDARD CHARACTER)**. SAVOYA, (U.S. CLS. 100, 101 AND 102). SN 85-101,888. PUB. 3-1-2011. FILED 8-6-2010.
- 3,961,075. **MAKING INSURANCE EASY. (STANDARD CHARACTER)**. QUOTEWIZARD.COM, LLC, (U.S. CLS. 100, 101 AND 102). SN 85-102,432. PUB. 3-1-2011. FILED 8-6-2010.
- 3,961,076. **YOU DESERVE BETTER RATES! (STANDARD CHARACTER)**. QUOTEWIZARD.COM, LLC, (U.S. CLS. 100, 101 AND 102). SN 85-102,440. PUB. 3-1-2011. FILED 8-6-2010.
- 3,961,079. **ISBT INTERNATIONAL SOCIETY OF BEVERAGE TECHNOLOGISTS AND DESIGN**. INTERNATIONAL SOCIETY OF BEVERAGE TECHNOLOGISTS, (U.S. CLS. 100, 101 AND 102). SN 85-102,838. PUB. 3-1-2011. FILED 8-9-2010.
- 3,961,080. **ISBT INTERNATIONAL SOCIETY OF BEVERAGE TECHNOLOGISTS (STANDARD CHARACTER)**. INTERNATIONAL SOCIETY OF BEVERAGE TECHNOLOGISTS, (U.S. CLS. 100, 101 AND 102). SN 85-102,839. PUB. 3-1-2011. FILED 8-9-2010.
- 3,961,086. **YUZZIT (STANDARD CHARACTER)**. YUZZIT, LLC, (U.S. CLS. 100, 101 AND 102). SN 85-103,264. PUB. 3-1-2011. FILED 8-9-2010.
- 3,961,090. **ENRITE AND DESIGN**. PETRO SERVICES, INC., (U.S. CLS. 100, 101 AND 102). SN 85-103,839. PUB. 3-1-2011. FILED 8-10-2010.
- 3,961,091. **GREAT UNIVERSITIES UNLEASHED (STANDARD CHARACTER)**. 2TOR, INC., MULTIPLE CLASS, (INT. CLS. 35 AND 41), (U.S. CLS. 100, 101, 102 AND 107). SN 85-104,286. PUB. 3-1-2011. FILED 8-10-2010.
- 3,961,101. **ELECTION ARENA AND DESIGN**. CONNECTED PLANET SOLUTIONS, LTD., (U.S. CLS. 100, 101 AND 102). SN 85-106,353. PUB. 3-1-2011. FILED 8-12-2010.
- 3,961,116. **PAPA MURPHY'S PIZZA AND DESIGN**. PAPA MURPHY'S INTERNATIONAL LLC, (U.S. CLS. 100, 101 AND 102). SN 85-109,299. PUB. 3-1-2011. FILED 8-17-2010.
- 3,961,119. **BENEFITS REALIZED (STANDARD CHARACTER)**. TRINET HR CORPORATION, MULTIPLE CLASS, (INT. CLS. 35, 36 AND 42), (U.S. CLS. 100, 101 AND 102). SN 85-109,717. PUB. 3-1-2011. FILED 8-17-2010.
- 3,961,120. **Q QUALITY SOLUTIONS, INC. TOTAL FACILITIES MANAGEMENT AND DESIGN**. QUALITY SOLUTIONS, INC., (U.S. CLS. 100, 101 AND 102). SN 85-110,072. PUB. 3-1-2011. FILED 8-18-2010.
- 3,961,121. **MISCELLANEOUS DESIGN**. MEDIA BOOST LTD., (U.S. CLS. 100, 101 AND 102). SN 85-110,219. PUB. 3-1-2011. FILED 8-18-2010.
- 3,961,123. **THE FLEX GEAR (STANDARD CHARACTER)**. M&M INCORPORATED, (U.S. CLS. 100, 101 AND 102). SN 85-110,680. PUB. 3-1-2011. FILED 8-18-2010.
- 3,961,125. **VINEYARD KINDA LIFE AND DESIGN**. VINEYARD KINDA, INC., (U.S. CLS. 100, 101 AND 102). SN 85-110,816. PUB. 3-1-2011. FILED 8-18-2010.
- 3,961,131. **SURFACES U.S.A. THE NATURAL STONE & TILE SUPERSTORE AND DESIGN**. SURFACES USA, (U.S. CLS. 100, 101 AND 102). SN 85-111,833. PUB. 3-1-2011. FILED 8-19-2010.
- 3,961,136. **REDNECK TECHS (STANDARD CHARACTER)**. MELROSE TELEPHONE COMPANY, MULTIPLE CLASS, (INT. CLS. 35 AND 37), (U.S. CLS. 100, 101, 102, 103 AND 106). SN 85-113,888. PUB. 3-1-2011. FILED 8-23-2010.
- 3,961,146. **PPL GROUP DISTRESSED ASSET SOLUTIONS AND DESIGN**. PERFECTION PLANT LIQUIDATIONS, LLC, (U.S. CLS. 100, 101 AND 102). SN 85-115,658. PUB. 3-1-2011. FILED 8-25-2010.
- 3,961,147. **ICOUNT (STANDARD CHARACTER)**. VOYCIT, INC., MULTIPLE CLASS, (INT. CLS. 35 AND 45), (U.S. CLS. 100, 101 AND 102). SN 85-115,909. PUB. 3-1-2011. FILED 8-25-2010.
- 3,961,155. **SKIN OF STEEL MELANOMA AWARENESS AND RESEARCH AND DESIGN**. SKIN OF STEEL, NFP, MULTIPLE CLASS, (INT. CLS. 35 AND 36), (U.S. CLS. 100, 101 AND 102). SN 85-117,273. PUB. 3-1-2011. FILED 8-27-2010.
- 3,961,157. **DRIVE WITH THE LEADER! (STANDARD CHARACTER)**. BENNETT AUTO SUPPLY, INC., (U.S. CLS. 100, 101 AND 102). SN 85-117,596. PUB. 3-1-2011. FILED 8-27-

- 2010.
- 3,961,176. **ONE SCRIBE MEDIA (STANDARD CHARACTER)**. ONE SCRIBE MEDIA LLC, (U.S. CLS. 100, 101 AND 102). SN 85-120,724. PUB. 3-1-2011. FILED 9-1-2010.
- 3,961,178. **EPALS BOOK SHOP (STANDARD CHARACTER)**. EPALS, INC., (U.S. CLS. 100, 101 AND 102). SN 85-120,837. PUB. 3-1-2011. FILED 9-1-2010.
- 3,961,201. **UNITED ENERGY TRADING (STANDARD CHARACTER)**. UNITED ENERGY TRADING, LLC, (U.S. CLS. 100, 101 AND 102). SN 85-122,745. PUB. 3-1-2011. FILED 9-3-2010.
- 3,961,204. **MISCELLANEOUS DESIGN**. TRILIX MARKETING GROUP, INC., (U.S. CLS. 100, 101 AND 102). SN 85-122,829. PUB. 3-1-2011. FILED 9-3-2010.
- 3,961,220. **NMEDIA (STANDARD CHARACTER)**. NEW MEXICO ENTERTAINMENT & DIGITAL INDUSTRY ASSOCIATION, (U.S. CLS. 100, 101 AND 102). SN 85-123,611. PUB. 3-1-2011. FILED 9-6-2010.
- 3,961,224. **BUMPER TO BUMPER MY PLACE FOR PARTS AND DESIGN**. AFTERMARKET AUTO PARTS ALLIANCE, INC., (U.S. CLS. 100, 101 AND 102). SN 85-123,746. PUB. 3-1-2011. FILED 9-7-2010.
- 3,961,225. **AUTO VALUE MY PLACE FOR PARTS AND DESIGN**. AFTERMARKET AUTO PARTS ALLIANCE, INC., (U.S. CLS. 100, 101 AND 102). SN 85-123,748. PUB. 3-1-2011. FILED 9-7-2010.
- 3,961,230. **BREWER EDUCATIONAL RESOURCES AND DESIGN**. BREWER EDUCATIONAL RESOURCES, INC., (U.S. CLS. 100, 101 AND 102). SN 85-123,849. PUB. 3-1-2011. FILED 9-7-2010.
- 3,961,236. **ANTHONY & SONS LITTLE ITALY (STANDARD CHARACTER)**. ANTHONY & SONS ITALIAN BAKERY, INC., MULTIPLE CLASS, (INT. CLS. 35 AND 43), (U.S. CLS. 100, 101 AND 102). SN 85-124,293. PUB. 3-1-2011. FILED 9-7-2010.
- 3,961,238. **ANTHONY & SONS LITTLE ITALY BAKERY MARKET CAFE AND DESIGN**. ANTHONY & SONS ITALIAN BAKERY, INC., MULTIPLE CLASS, (INT. CLS. 35 AND 43), (U.S. CLS. 100, 101 AND 102). SN 85-124,323. PUB. 3-1-2011. FILED 9-7-2010.
- 3,961,247. **THREE LITTLE MONKEYS (STANDARD CHARACTER)**. THREE LITTLE MONKEYS, LLC, (U.S. CLS. 100, 101 AND 102). SN 85-124,751. PUB. 3-1-2011. FILED 9-8-2010.
- 3,961,249. **WNT PET SUPPLIES (STANDARD CHARACTER)**. WAG-N-TRAIN LLC, (U.S. CLS. 100, 101 AND 102). SN 85-124,889. PUB. 3-1-2011. FILED 9-8-2010.
- 3,961,264. **LIPS BY CARLA (STANDARD CHARACTER)**. LBC LIPS BY CARLA, (U.S. CLS. 100, 101 AND 102). SN 85-125,817. PUB. 3-1-2011. FILED 9-9-2010.
- 3,961,281. **APCO WORLDWIDE (STYLIZED)**. APCO WORLDWIDE, INC., (U.S. CLS. 100, 101 AND 102). SN 85-126,673. PUB. 3-1-2011. FILED 9-10-2010.
- 3,961,299. **BEHIND THE BLUE LINE (STANDARD CHARACTER)**. BEHIND THE BLUE LINE, (U.S. CLS. 100, 101 AND 102). SN 85-126,929. PUB. 3-1-2011. FILED 9-10-2010.
- 3,961,303. **A AUSTEN GROUP AND DESIGN**. THE AUSTEN GROUP, L.L.C., (U.S. CLS. 100, 101 AND 102). SN 85-127,164. PUB. 3-1-2011. FILED 9-10-2010.
- 3,961,304. **YOUR PARTNER FOR MEDICAL SUPPLY MANAGEMENT (STANDARD CHARACTER)**. HOME HEALTHCARE SOLUTIONS, INC., (U.S. CLS. 100, 101 AND 102). SN 85-127,186. PUB. 3-1-2011. FILED 9-10-2010.
- 3,961,307. **WHERE CULTURE AND COMMERCE MEET (STANDARD CHARACTER)**. CHICAGO CULTURAL MILE ASSOCIATION, INC., MULTIPLE CLASS, (INT. CLS. 35 AND 41), (U.S. CLS. 100, 101, 102 AND 107). SN 85-127,237. PUB. 3-1-2011. FILED 9-10-2010.
- 3,961,313. **AUSTEN GROUP (STANDARD CHARACTER)**. THE AUSTEN GROUP, L.L.C., (U.S. CLS. 100, 101 AND 102). SN 85-127,270. PUB. 3-1-2011. FILED 9-10-2010.
- 3,961,317. **ACCUTRANS INC. (STANDARD CHARACTER)**. ACCUTRANS, (U.S. CLS. 100, 101 AND 102). SN 85-127,435. PUB. 3-1-2011. FILED 9-10-2010.
- 3,961,326. **ART CART NYC (STANDARD CHARACTER)**. ART CART NYC LTD., MULTIPLE CLASS, (INT. CLS. 35 AND 41), (U.S. CLS. 100, 101, 102 AND 107). SN 85-127,665. PUB. 3-1-2011. FILED 9-12-2010.
- 3,961,336. **EVERYTHING CABINS! (STANDARD CHARACTER)**. EVERYTHING CABINS, LLC, (U.S. CLS. 100, 101 AND 102). SN 85-127,824. PUB. 3-1-2011. FILED 9-13-2010.
- 3,961,339. **ARTS & BYTES (STYLIZED)**. PIRAT FREDERIC, (U.S. CLS. 100, 101 AND 102). SN 85-127,875. PUB. 3-1-2011. FILED 9-13-2010.
- 3,961,343. **MISTY MOUNTAIN TEAS AND DESIGN**. MISTY MOUNTAIN TEAS, (U.S. CLS. 100, 101 AND 102). SN 85-128,004. PUB. 3-1-2011. FILED 9-13-2010.
- 3,961,356. **DAM FIREWORKS (STANDARD CHARACTER)**. DAM FIREWORKS LTD, (U.S. CLS. 100, 101 AND 102). SN 85-128,180. PUB. 3-1-2011. FILED 9-13-2010.
- 3,961,357. **CHANGE IS THE ONLY CONSTANT (STANDARD CHARACTER)**. CITOC, (U.S. CLS. 100, 101 AND 102). SN 85-128,193. PUB. 3-1-2011. FILED 9-13-2010.
- 3,961,360. **V AND DESIGN**. VB ENTERPRISES, LLC, DBA VELVET BOX, (U.S. CLS. 100, 101 AND 102). SN 85-128,267. PUB. 3-1-2011. FILED 9-13-2010.
- 3,961,368. **EXPERIENCE GRAND RAPIDS AND DESIGN**. GRAND RAPIDS/KENT COUNTY CONVENTION & VISITORS BUREAU, (U.S. CLS. 100, 101 AND 102). SN 85-128,332. PUB. 3-1-2011. FILED 9-13-2010.
- 3,961,370. **EXPERIENCE GRAND RAPIDS (STANDARD CHARACTER)**. GRAND RAPIDS/KENT COUNTY CONVENTION & VISITORS BUREAU, (U.S. CLS. 100, 101 AND 102). SN 85-128,340. PUB. 3-1-2011. FILED 9-13-2010.
- 3,961,371. **UNDERGROUND BOOK CLUB (STANDARD CHARACTER)**. ATTACK! MARKETING AND PROMOTIONS, LLC, (U.S. CLS. 100, 101 AND 102). SN 85-128,345. PUB. 3-1-2011. FILED 9-13-2010.
- 3,961,377. **HORSE PRESENCE (STANDARD CHARACTER)**. FORWARD, ANDREW W., DBA HORSE PRESENCE, AND BROWN, JUDE, DBA HORSE PRESENCE, (U.S. CLS. 100, 101 AND 102). SN 85-128,435. PUB. 3-1-2011. FILED 9-13-2010.
- 3,961,389. **EDUCATED EQUESTRIANS (STANDARD CHARACTER)**. HELPFUL HORSEMANSHIP, INC, (U.S. CLS. 100, 101 AND 102). SN 85-128,653. PUB. 3-1-2011. FILED 9-13-2010.
- 3,961,400. **LINKMEDIA 360 (STANDARD CHARACTER)**. NATIONAL YELLOW PAGES MEDIA, LLC, (U.S. CLS. 100, 101 AND 102). SN 85-128,834. PUB. 3-1-2011. FILED 9-14-2010.
- 3,961,412. **SUPPLYLOGIX (STANDARD CHARACTER)**. SUPPLYLOGIX, INC., (U.S. CLS. 100, 101 AND 102). SN 85-128,914. PUB. 3-1-2011. FILED 9-14-2010.
- 3,961,416. **BEAUTIFUL BROWN GIRL (STANDARD CHARACTER)**. BEAUTIFUL BROWN GIRL, INC, (U.S. CLS. 100, 101 AND 102). SN 85-128,934. PUB. 3-1-2011. FILED 9-14-2010.
- 3,961,422. **DATCCI MEDICAL SOLUTIONS AND DESIGN**. DATCCI CORP, (U.S. CLS. 100, 101 AND 102). SN 85-129,039. PUB. 3-1-2011. FILED 9-14-2010.
- 3,961,423. **DATCCI (STANDARD CHARACTER)**. DATCCI CORP, (U.S. CLS. 100, 101 AND 102). SN 85-129,080. PUB. 3-1-2011. FILED 9-14-2010.
- 3,961,425. **GIRAPPS (STANDARD CHARACTER)**. SCIAQUA, MICHEAL, (U.S. CLS. 100, 101 AND 102). SN 85-129,086. PUB. 3-1-2011. FILED 9-14-2010.
- 3,961,428. **REVENUE BEAST (STANDARD CHARACTER)**. JEFF CHRISTIAN & COMPANY LLC, (U.S. CLS. 100, 101 AND 102). SN 85-129,128. PUB. 3-1-2011. FILED 9-14-2010.
- 3,961,429. **REAL MODELS FOR REAL CLOTHES FOR REAL PEOPLE (STANDARD CHARACTER)**. THE RAGE GROUP INC., DBA RAGE MODELS, RAGE TALENT AGENCY, RTA-RAGE TALENT AGENCY, RTA, RAGEWEAR, RAGE MODELS & TALENT, LA FIT MODELS, (U.S. CLS. 100, 101 AND 102). SN 85-129,131. PUB. 3-1-2011. FILED 9-14-2010.
- 3,961,434. **RAGE MODELS (STANDARD CHARACTER)**. THE RAGE GROUP INC., DBA RAGE MODELS, RAGE TALENT AGENCY, RTA-RAGE TALENT AGENCY, RTA, RAGEWEAR, RAGE MODELS & TALENT, LA FIT MODELS, (U.S. CLS. 100, 101 AND 102). SN 85-129,181. PUB. 3-1-2011. FILED 9-14-2010.
- 3,961,435 ( *See Class 20 for this trademark*).
- 3,961,458. **MARKETOONIST (STANDARD CHARACTER)**. MARKETOONIST, LLC, (U.S. CLS. 100, 101 AND 102). SN 85-129,453. PUB. 3-1-2011. FILED 9-14-2010.

- 3,961,462. **SONOMA COUNTY TOURISM BUREAU (STANDARD CHARACTER)**. SONOMA COUNTY TOURISM BUREAU, INC., (U.S. CLS. 100, 101 AND 102). SN 85-129,512. PUB. 3-1-2011. FILED 9-14-2010.
- 3,961,472. **SENTIMENT360 (STANDARD CHARACTER)**. COOPER, GARY, (U.S. CLS. 100, 101 AND 102). SN 85-129,622. PUB. 3-1-2011. FILED 9-14-2010.
- 3,961,483. **COCOCOZY (STANDARD CHARACTER)**. SHELTON, COLETTE M., DBA COCOCOZY, (U.S. CLS. 100, 101 AND 102). SN 85-129,739. PUB. 3-1-2011. FILED 9-15-2010.
- 3,961,500. **WHAT'S IN YOUR HEALTH RECORDS? (STANDARD CHARACTER)**. NL&C, LLC, (U.S. CLS. 100, 101 AND 102). SN 85-130,137. PUB. 3-1-2011. FILED 9-15-2010.
- 3,961,507. **A DOG NAMED PUSSIE AND DESIGN**. 3KIB, LLC, (U.S. CLS. 100, 101 AND 102). SN 85-130,228. PUB. 3-1-2011. FILED 9-15-2010.
- 3,961,508. **YOTTAQUEST (STANDARD CHARACTER)**. FAY, MATTHEW M., DBA YOTTAQUEST, (U.S. CLS. 100, 101 AND 102). SN 85-130,229. PUB. 3-1-2011. FILED 9-15-2010.
- 3,961,517. **QUANTIFIICIENT (STANDARD CHARACTER)**. E3 PERFORMANCE GROUP, LLC, (U.S. CLS. 100, 101 AND 102). SN 85-130,307. PUB. 3-1-2011. FILED 9-15-2010.
- 3,961,518. **ESSEX (STANDARD CHARACTER)**. ESSEX TECHNOLOGY GROUP, INC., (U.S. CLS. 100, 101 AND 102). SN 85-130,320. PUB. 3-1-2011. FILED 9-15-2010.
- 3,961,519. **COME ON OVER (STANDARD CHARACTER)**. THE TOWN OF MOUNT PLEASANT, (U.S. CLS. 100, 101 AND 102). SN 85-130,323. PUB. 3-1-2011. FILED 9-15-2010.
- 3,961,526. **PROJECTS THAT MATTER (STANDARD CHARACTER)**. MECHANICAL ELECTRICAL SHEET METAL ALLIANCE (MESA), DBA MESA, (U.S. CLS. 100, 101 AND 102). SN 85-130,387. PUB. 3-1-2011. FILED 9-15-2010.
- 3,961,530. **THE SKY IS NOT THE LIMIT (STANDARD CHARACTER)**. CHAMBER OF COMMERCE OF HUNTSVILLE/MADISON COUNTY, INC., (U.S. CLS. 100, 101 AND 102). SN 85-130,416. PUB. 3-1-2011. FILED 9-15-2010.
- 3,961,539. **SERVICE IS OUR BEST PART. (STANDARD CHARACTER)**. ADVANCE AUTO INNOVATIONS, LLC, MULTIPLE CLASS, (INT. CLS. 35, 37, 40 AND 42), (U.S. CLS. 100, 101, 102, 103 AND 106). SN 85-130,527. PUB. 3-1-2011. FILED 9-15-2010.
- 3,961,549. **KEEN (STANDARD CHARACTER)**. KEEN ASSOCIATES, LLC, (U.S. CLS. 100, 101 AND 102). SN 85-130,650. PUB. 3-1-2011. FILED 9-15-2010.
- 3,961,561. **MISCELLANEOUS DESIGN**. THE TOWN OF MOUNT PLEASANT, (U.S. CLS. 100, 101 AND 102). SN 85-130,826. PUB. 3-1-2011. FILED 9-16-2010.
- 3,961,565. **MISCELLANEOUS DESIGN**. BLAKEY, COLLEEN BANKS, DBA RAINCHECK SOLUTIONS, INC., (U.S. CLS. 100, 101 AND 102). SN 85-130,910. PUB. 3-1-2011. FILED 9-16-2010.
- 3,961,568. **FLORAPALOOZA (STANDARD CHARACTER)**. SENECHAL, AMY, (U.S. CLS. 100, 101 AND 102). SN 85-130,958. PUB. 3-1-2011. FILED 9-16-2010.
- 3,961,569. **UNLIMITED BUDGET AND DESIGN**. BUDGET RENT A CAR SYSTEM, INC., (U.S. CLS. 100, 101 AND 102). SN 85-130,990. PUB. 3-1-2011. FILED 9-16-2010.
- 3,961,579. **THE WHOLE WORLD AHEAD OF YOU. OUR COMMUNITY BEHIND YOU. (STANDARD CHARACTER)**. SETON HALL UNIVERSITY, (U.S. CLS. 100, 101 AND 102). SN 85-131,092. PUB. 3-1-2011. FILED 9-16-2010.
- 3,961,582. **OMNIRAIL (STANDARD CHARACTER)**. EASY-MAIL INTERACTIVE, INC., DBA EMI ONLINE RESEARCH SOLUTIONS, (U.S. CLS. 100, 101 AND 102). SN 85-131,115. PUB. 3-1-2011. FILED 9-16-2010.
- 3,961,587. **LION WORLD AND DESIGN**. LIONBRIDGE TECHNOLOGIES, INC., (U.S. CLS. 100, 101 AND 102). SN 85-131,166. PUB. 3-1-2011. FILED 9-16-2010.
- 3,961,594. **MISCELLANEOUS DESIGN**. JENNER SALES CORP., MULTIPLE CLASS, (INT. CLS. 35 AND 37), (U.S. CLS. 100, 101, 102, 103 AND 106). SN 85-131,243. PUB. 3-1-2011. FILED 9-16-2010.
- 3,961,596. **FRESH LIFELINES FOR YOUTH (STANDARD CHARACTER)**. FRESH LIFELINES FOR YOUTH, INC., MULTIPLE CLASS, (INT. CLS. 35 AND 36), (U.S. CLS. 100, 101 AND 102). SN 85-131,281. PUB. 3-1-2011. FILED 9-16-2010.
- 3,961,599. **THE NEXT BEST THING TO A GREAT IDEA, IS KNOWING WHERE TO FIND ONE (STANDARD CHARACTER)**. SONNENBERG & PARTNERS, LLC, (U.S. CLS. 100, 101 AND 102). SN 85-131,305. PUB. 3-1-2011. FILED 9-16-2010.
- 3,961,610. **YARDIGREEN (STANDARD CHARACTER)**. YARDIGREEN, INC., (U.S. CLS. 100, 101 AND 102). SN 85-131,511. PUB. 3-1-2011. FILED 9-16-2010.
- 3,961,616. **CHRIS & CAROL APPAREL (STANDARD CHARACTER)**. CHRIS & CAROL APPAREL, INC., DBA CHRIS & CAROL APPAREL, (U.S. CLS. 100, 101 AND 102). SN 85-131,618. PUB. 3-1-2011. FILED 9-16-2010.
- 3,961,620. **ARDYSS (STANDARD CHARACTER)**. OPPORTUNITY HOLDING, LLC, (U.S. CLS. 100, 101 AND 102). SN 85-131,642. PUB. 3-1-2011. FILED 9-16-2010.
- 3,961,625. **GROVER BEACH A GREAT PLACE TO SPREAD YOUR WINGS (STANDARD CHARACTER)**. CITY OF GROVER BEACH, (U.S. CLS. 100, 101 AND 102). SN 85-131,675. PUB. 3-1-2011. FILED 9-16-2010.
- 3,961,626. **"SMART STORAGE SOLUTIONS" (STANDARD CHARACTER)**. TWO-TWENTY RECORDS MANAGEMENT, LLC, (U.S. CLS. 100, 101 AND 102). SN 85-131,680. PUB. 3-1-2011. FILED 9-16-2010.
- 3,961,627. **GROVER BEACH A GREAT PLACE TO SPREAD YOUR WINGS AND DESIGN**. CITY OF GROVER BEACH, (U.S. CLS. 100, 101 AND 102). SN 85-131,685. PUB. 3-1-2011. FILED 9-16-2010.
- 3,961,633. **MOBILE LOAVES & FISHES (STANDARD CHARACTER)**. MOBILE LOAVES & FISHES, INC., (U.S. CLS. 100, 101 AND 102). SN 85-131,736. PUB. 3-1-2011. FILED 9-16-2010.
- 3,961,646. **THE TEACHERS' LOUNGE (STANDARD CHARACTER)**. THE TEACHERS' LOUNGE, INC., (U.S. CLS. 100, 101 AND 102). SN 85-132,006. PUB. 3-1-2011. FILED 9-17-2010.
- 3,961,680. **WE'RE ABOUT AS AMERICAN AS IT GETS (STANDARD CHARACTER)**. SINCLAIR FINANCE COMPANY, MULTIPLE CLASS, (INT. CLS. 35 AND 37), (U.S. CLS. 100, 101, 102, 103 AND 106). SN 85-132,623. PUB. 3-1-2011. FILED 9-17-2010.
- 3,961,684. **YOSEXI (STANDARD CHARACTER)**. REDMAN, MALIK Y., (U.S. CLS. 100, 101 AND 102). SN 85-132,676. PUB. 3-1-2011. FILED 9-17-2010.
- 3,961,703. **WILD WOMEN IN LISTED DERIVATIVES (STYLIZED)**. SAUCIER, DIANE E., AND TITLEBAUM, JESSICA, (U.S. CLS. 100, 101 AND 102). SN 85-133,849. PUB. 3-1-2011. FILED 9-20-2010.
- 3,961,735. **CITY SPROUTS (STANDARD CHARACTER)**. CITY SPROUTS, (U.S. CLS. 100, 101 AND 102). SN 85-138,694. PUB. 3-1-2011. FILED 9-27-2010.
- 3,961,740. **AD.LY (STANDARD CHARACTER)**. ADLY, INC., (U.S. CLS. 100, 101 AND 102). SN 85-139,302. PUB. 3-1-2011. FILED 9-27-2010.
- 3,961,743. **EXPO PLANIT (STANDARD CHARACTER)**. PROMOTIONAL PRODUCTS ASSOCIATION INTERNATIONAL, (U.S. CLS. 100, 101 AND 102). SN 85-139,571. PUB. 3-1-2011. FILED 9-28-2010.
- 3,961,749. **PPAI EXPO (STANDARD CHARACTER)**. PROMOTIONAL PRODUCTS ASSOCIATION INTERNATIONAL, (U.S. CLS. 100, 101 AND 102). SN 85-140,691. PUB. 3-1-2011. FILED 9-29-2010.
- 3,961,750. **PPAI DECORATE (STANDARD CHARACTER)**. PROMOTIONAL PRODUCTS ASSOCIATION INTERNATIONAL, (U.S. CLS. 100, 101 AND 102). SN 85-140,728. PUB. 3-1-2011. FILED 9-29-2010.
- 3,961,751. **PPAI BRAND (STANDARD CHARACTER)**. PROMOTIONAL PRODUCTS ASSOCIATION INTERNATIONAL, (U.S. CLS. 100, 101 AND 102). SN 85-140,740. PUB. 3-1-2011. FILED 9-29-2010.
- 3,961,762. **DRAKE (STANDARD CHARACTER)**. DRAKE INTERNATIONAL INC., MULTIPLE CLASS, (INT. CLS. 35 AND 41), (U.S. CLS. 100, 101, 102 AND 107). SN 85-141,684. PUB. 3-1-2011. FILED 9-30-2010.
- 3,961,769. **CLOSING THE LOOP IN HEALTH CARE (STANDARD CHARACTER)**. LOOPBACK, LLC, DBA LOOPBACK COMMUNICATIONS, (U.S. CLS. 100, 101 AND 102). SN 85-142,250. PUB. 3-1-2011. FILED 9-30-2010.
- 3,961,779. **SCM SOLUTIONS LLC AND DESIGN**. SCM SOLUTIONS, LLC, (U.S. CLS. 100, 101 AND 102). SN 85-



- 143,180. PUB. 3-1-2011. FILED 10-1-2010.
- 3,961,801. **FRANCHISE LOGISTICS CHARTING A COURSE FOR YOUR NEW BUSINESS AND DESIGN.** FRANCHISE LOGISTICS, L.L.C., (U.S. CLS. 100, 101 AND 102). SN 85-147,578. PUB. 3-1-2011. FILED 10-7-2010.
- 3,961,813. **ANTON NEHMEH (STANDARD CHARACTER).** NEHMEH ENTREPRISES & INDUSTRIES LLC, (U.S. CLS. 100, 101 AND 102). SN 85-148,860. PUB. 3-1-2011. FILED 10-8-2010.
- 3,961,816. **ONE MORE CUSTOMER (STANDARD CHARACTER).** LODESTAR TECHNOLOGY LABS LLC, (U.S. CLS. 100, 101 AND 102). SN 85-149,052. PUB. 3-1-2011. FILED 10-9-2010.
- 3,961,820. **THERATAPE (STANDARD CHARACTER).** OPTIMAL HEALTH SYSTEMS LLC, (U.S. CLS. 100, 101 AND 102). SN 85-149,188. PUB. 3-1-2011. FILED 10-10-2010.
- 3,961,821. **MITIG8 AND DESIGN.** MITIG8 LTD., MULTIPLE CLASS, (INT. CLS. 35, 36, 42 AND 45), (U.S. CLS. 100, 101 AND 102). SN 85-149,282. PUB. 3-1-2011. FILED 10-11-2010.
- 3,961,823. **SMOOTHER MOVES CALCULATOR (STANDARD CHARACTER).** PACER INTERNATIONAL, INC., MULTIPLE CLASS, (INT. CLS. 35 AND 39), (U.S. CLS. 100, 101, 102 AND 105). SN 85-149,483. PUB. 3-1-2011. FILED 10-11-2010.
- 3,961,826. **CRUISERWORKS (STANDARD CHARACTER).** J & C CRAWFORD, INC., DBA CRUISERWORKS, (U.S. CLS. 100, 101 AND 102). SN 85-149,558. PUB. 3-1-2011. FILED 10-11-2010.
- 3,961,835. **PILOTS, INVENTORS AND BUILDERS FOR A CONNECTED WORLD. (STANDARD CHARACTER).** RMSG, LLC, (U.S. CLS. 100, 101 AND 102). SN 85-149,797. PUB. 3-1-2011. FILED 10-11-2010.
- 3,961,850. **THE GAYBIRDS (STANDARD CHARACTER).** PRETE JR., PETER ALLEN, (U.S. CLS. 100, 101 AND 102). SN 85-150,014. PUB. 3-1-2011. FILED 10-11-2010.
- 3,961,851. **MISCELLANEOUS DESIGN.** PRETE JR., PETER ALLEN, (U.S. CLS. 100, 101 AND 102). SN 85-150,019. PUB. 3-1-2011. FILED 10-11-2010.
- 3,961,868. **THE MISS AND DESIGN.** THE MISS, LLC, (U.S. CLS. 100, 101 AND 102). SN 85-151,858. PUB. 3-1-2011. FILED 10-13-2010.
- 3,961,880. **GET SERIOUS ABOUT STROKE (STANDARD CHARACTER).** BOEHRINGER INGELHEIM PHARMACEUTICALS, INC., MULTIPLE CLASS, (INT. CLS. 35 AND 44), (U.S. CLS. 100, 101 AND 102). SN 85-152,833. PUB. 3-1-2011. FILED 10-14-2010.
- 3,961,881. **MISCELLANEOUS DESIGN.** ORGANIZATION UNITED FOR RESPECT AT WALMART, (U.S. CLS. 100, 101 AND 102). SN 85-152,956. PUB. 3-1-2011. FILED 10-14-2010.
- 3,961,884. **THE STOCK MARKET AND DESIGN.** FERGUSON ENTERPRISES, INC., (U.S. CLS. 100, 101 AND 102). SN 85-156,090. PUB. 3-1-2011. FILED 10-19-2010.
- 3,961,885. **THE STOCK MARKET AND DESIGN.** FERGUSON ENTERPRISES, INC., (U.S. CLS. 100, 101 AND 102). SN 85-156,143. PUB. 3-1-2011. FILED 10-19-2010.
- 3,961,907. **HELLO ARIZONA! AND DESIGN.** MEARS ACQUISITION COMPANY, (U.S. CLS. 100, 101 AND 102). SN 85-165,148. PUB. 3-1-2011. FILED 10-29-2010.
- 3,961,908. **HELLO FLORIDA! AND DESIGN.** MEARS ACQUISITION COMPANY, (U.S. CLS. 100, 101 AND 102). SN 85-165,161. PUB. 3-1-2011. FILED 10-29-2010.
- 3,961,909. **HELLO LAS VEGAS! AND DESIGN.** MEARS ACQUISITION COMPANY, (U.S. CLS. 100, 101 AND 102). SN 85-165,171. PUB. 3-1-2011. FILED 10-29-2010.
- 3,961,910. **HELLO ARIZONA! A FULL SERVICE DESTINATION MANAGEMENT COMPANY AND DESIGN.** MEARS ACQUISITION COMPANY, (U.S. CLS. 100, 101 AND 102). SN 85-165,186. PUB. 3-1-2011. FILED 10-29-2010.
- 3,961,911. **HELLO FLORIDA! A FULL SERVICE DESTINATION MANAGEMENT COMPANY AND DESIGN.** MEARS ACQUISITION COMPANY, (U.S. CLS. 100, 101 AND 102). SN 85-165,202. PUB. 3-1-2011. FILED 10-29-2010.
- 3,961,912. **HELLO LAS VEGAS! A FULL SERVICE DESTINATION MANAGEMENT COMPANY AND DESIGN.** MEARS ACQUISITION COMPANY, (U.S. CLS. 100, 101 AND 102). SN 85-165,211. PUB. 3-1-2011. FILED 10-29-2010.
- 3,961,919. **LUCKY STRIKE (STANDARD CHARACTER).** LUCKY STRIKE ENTERTAINMENT, LLC, (U.S. CLS. 100, 101 AND 102). SN 85-168,445. PUB. 3-1-2011. FILED 11-3-2010.
- 3,961,921. **WISE BUY (STANDARD CHARACTER).** PENNY-WISE POWER LLC, (U.S. CLS. 100, 101 AND 102). SN 85-169,925. PUB. 3-1-2011. FILED 11-5-2010.
- 3,961,927. **SAMPLE SPOT (STANDARD CHARACTER).** TARGET BRANDS, INC., (U.S. CLS. 100, 101 AND 102). SN 85-171,718. PUB. 3-1-2011. FILED 11-8-2010.
- 3,961,930. **ROSES FOR AUTISM AND DESIGN.** ABILITY BEYOND DISABILITY, INC., (U.S. CLS. 100, 101 AND 102). SN 85-172,748. PUB. 3-1-2011. FILED 11-9-2010.
- 3,961,932 ( *See Class 30 for this trademark.* )
- 3,961,943 ( *See Class 16 for this trademark.* )
- 3,961,953. **MELTING THE ICE. ONE CUBE AT A TIME. (STANDARD CHARACTER).** MINORITY PASSPORT INTERNATIONAL LLC, (U.S. CLS. 100, 101 AND 102). SN 85-191,782. PUB. 3-1-2011. FILED 12-6-2010.
- 3,961,959. **INTERNATIONAL SPY MUSEUM (STANDARD CHARACTER).** THE HOUSE ON F STREET, LLC, MULTIPLE CLASS, (INT. CLS. 35 AND 41), (U.S. CLS. 100, 101, 102 AND 107). SN 85-975,003. PUB. 9-28-2010. FILED 4-30-2010.

---

### CLASS 36—INSURANCE AND FINANCIAL

- 3,960,220. **V I S T A WEALTH STRATEGIES AND DESIGN.** JUDY L. REDPATH, DBA VISTA WEALTH STRATEGIES, (U.S. CLS. 100, 101 AND 102). SN 76-668,480. PUB. 3-1-2011. FILED 11-3-2006.
- 3,960,221. **VISTA WEALTH STRATEGIES (STANDARD CHARACTER).** JUDY L. REDPATH, DBA VISTA WEALTH STRATEGIES, (U.S. CLS. 100, 101 AND 102). SN 76-671,243. PUB. 3-1-2011. FILED 1-10-2007.
- 3,960,222. **SUMMIT EXECUTIVE REALTY AND DESIGN.** SUMMIT EXECUTIVE REALTY JEFFREY & ASSOCIATES, LLC, (U.S. CLS. 100, 101 AND 102). SN 76-676,368. PUB. 3-1-2011. FILED 5-3-2007.
- 3,960,230. **BALTIMORE TAILGATORS SOCIETY AND DESIGN.** THE BALTIMORE TAILQATORS SOCIETY, INC., (U.S. CLS. 100, 101 AND 102). SN 76-702,038. PUB. 3-1-2011. FILED 3-15-2010.
- 3,960,247. **THE GENTLEMEN'S BALL (STANDARD CHARACTER).** ADVANCE MAGAZINE PUBLISHERS INC, (U.S. CLS. 100, 101 AND 102). SN 76-704,010. PUB. 3-1-2011. FILED 8-2-2010.
- 3,960,250. **LOOK-BACK (STANDARD CHARACTER).** PERFORMANCE TRUST CAPITAL PARTNERS, LLC, (U.S. CLS. 100, 101 AND 102). SN 76-704,426. PUB. 3-1-2011. FILED 9-9-2010.
- 3,960,279. **PARAGON WEALTH MANAGEMENT (STANDARD CHARACTER).** PARAGON CAPITAL MANAGEMENT, INC., (U.S. CLS. 100, 101 AND 102). SN 77-427,343. PUB. 3-1-2011. FILED 3-20-2008.
- 3,960,300. **TD ASSET MANAGEMENT POLICY PRO (STANDARD CHARACTER).** THE TORONTO-DOMINION BANK, (U.S. CLS. 100, 101 AND 102). SN 77-581,359. PUB. 3-1-2011. FILED 9-29-2008.
- 3,960,308. **FIRST HOME (STANDARD CHARACTER).** WELLS FARGO & COMPANY, (U.S. CLS. 100, 101 AND 102). SN 77-628,727. PUB. 3-1-2011. FILED 12-8-2008.
- 3,960,324. **GREATBANC (STANDARD CHARACTER).** GREATBANC, INC., (U.S. CLS. 100, 101 AND 102). SN 77-701,272. PUB. 3-1-2011. FILED 3-27-2009.
- 3,960,325 ( *See Class 35 for this trademark.* )
- 3,960,335. **NASHVILLE IN NAPA (STANDARD CHARACTER).** CALI, DEBORAH K, (U.S. CLS. 100, 101 AND 102). SN 77-743,772. PUB. 3-1-2011. FILED 5-24-2009.
- 3,960,336 ( *See Class 35 for this trademark.* )
- 3,960,364 ( *See Class 35 for this trademark.* )
- 3,960,365 ( *See Class 35 for this trademark.* )
- 3,960,376 ( *See Class 35 for this trademark.* )
- 3,960,397 ( *See Class 9 for this trademark.* )
- 3,960,400 ( *See Class 9 for this trademark.* )
- 3,960,421. **THE BONE MARROW FOUNDATION AND DESIGN.** THE BONE MARROW FOUNDATION, (U.S. CLS. 100, 101 AND 102). SN 77-871,913. PUB. 6-15-2010. FILED 11-13-2009.

- 3,960,450. **MHT SECURITIES AND DESIGN**. MHT SECURITIES, L.P., (U.S. CLS. 100, 101 AND 102). SN 77-910,228. PUB. 3-1-2011. FILED 1-12-2010.
- 3,960,451 ( *See Class 9 for this trademark*).
- 3,960,459 ( *See Class 35 for this trademark*).
- 3,960,484. **MISCELLANEOUS DESIGN**. WORLD ACCESS, INC., AKA MONDIAL ASSISTANCE, (U.S. CLS. 100, 101 AND 102). SN 77-937,895. PUB. 3-1-2011. FILED 2-17-2010.
- 3,960,492 ( *See Class 9 for this trademark*).
- 3,960,496 ( *See Class 35 for this trademark*).
- 3,960,500 ( *See Class 35 for this trademark*).
- 3,960,518 ( *See Class 16 for this trademark*).
- 3,960,527. **GUIDESPARK (STANDARD CHARACTER)**. GUIDESPARK, INC., MULTIPLE CLASS, (INT. CLS. 36 AND 41), (U.S. CLS. 100, 101, 102 AND 107). SN 77-953,326. PUB. 3-1-2011. FILED 3-8-2010.
- 3,960,528. **VETERANS OF VALOR (STANDARD CHARACTER)**. VETERANS OF VALOR, INC., MULTIPLE CLASS, (INT. CLS. 36 AND 45), (U.S. CLS. 100, 101 AND 102). SN 77-953,477. PUB. 3-1-2011. FILED 3-8-2010.
- 3,960,532. **NETRAFFLE.ORG (STYLIZED)**. MCD ENTERPRISES, INC., (U.S. CLS. 100, 101 AND 102). SN 77-954,093. PUB. 3-1-2011. FILED 3-9-2010.
- 3,960,534 ( *See Class 35 for this trademark*).
- 3,960,540. **G GALLAGHER BENEFIT SERVICES, INC. THINKING AHEAD AND DESIGN**. ARTHUR J. GALLAGHER & CO., (U.S. CLS. 100, 101 AND 102). SN 77-956,926. PUB. 3-1-2011. FILED 3-11-2010.
- 3,960,543 ( *See Class 35 for this trademark*).
- 3,960,544 ( *See Class 35 for this trademark*).
- 3,960,576. **KID-CHING! AND DESIGN**. KIDCHING, (U.S. CLS. 100, 101 AND 102). SN 77-966,061. PUB. 3-1-2011. FILED 3-23-2010.
- 3,960,585. **WISEMAN INSURANCE AGENCY (STANDARD CHARACTER)**. WISEMAN INSURANCE AGENCY, LLC, (U.S. CLS. 100, 101 AND 102). SN 77-966,763. PUB. 3-1-2011. FILED 3-24-2010.
- 3,960,626 ( *See Class 9 for this trademark*).
- 3,960,636 ( *See Class 35 for this trademark*).
- 3,960,648 ( *See Class 9 for this trademark*).
- 3,960,658 ( *See Class 7 for this trademark*).
- 3,960,680 ( *See Class 9 for this trademark*).
- 3,960,835 ( *See Class 35 for this trademark*).
- 3,960,865. **CTX CARBON TRADEXCHANGE AND DESIGN**. CARBON TRADE EXCHANGE PTY LTD, (U.S. CLS. 100, 101 AND 102). SN 85-007,821. PUB. 3-1-2011. FILED 4-6-2010.
- 3,960,869. **HERMES AND DESIGN**. HERMES FUND MANAGERS LIMITED, (U.S. CLS. 100, 101 AND 102). SN 85-009,672. PUB. 3-1-2011. FILED 4-8-2010.
- 3,960,886. **INQUBIT (STANDARD CHARACTER)**. INQUBIT, INC., (U.S. CLS. 100, 101 AND 102). SN 85-015,318. PUB. 3-1-2011. FILED 4-15-2010.
- 3,960,888. **CLEANOFFER.COM AND DESIGN**. CLEANOFFER, INC., (U.S. CLS. 100, 101 AND 102). SN 85-015,763. PUB. 3-1-2011. FILED 4-16-2010.
- 3,960,897. **THE SAMUEL ROBERTS NOBLE FOUNDATION (STANDARD CHARACTER)**. THE SAMUEL ROBERTS NOBLE FOUNDATION, INC., MULTIPLE CLASS, (INT. CLS. 36, 41, 42 AND 44), (U.S. CLS. 100, 101, 102 AND 107). SN 85-018,898. PUB. 3-1-2011. FILED 4-20-2010.
- 3,960,915. **JC&M SINCE 1982 AND DESIGN**. JAY, COBB & MARLEY, (U.S. CLS. 100, 101 AND 102). SN 85-028,717. PUB. 3-1-2011. FILED 5-3-2010.
- 3,960,931. **DAVE NEE FOUNDATION (STANDARD CHARACTER)**. DAVID DAWES NEE II FOUNDATION, DBA THE DAVE NEE FOUNDATION, MULTIPLE CLASS, (INT. CLS. 36 AND 41), (U.S. CLS. 100, 101, 102 AND 107). SN 85-036,530. PUB. 3-1-2011. FILED 5-12-2010.
- 3,960,932. **DAVE NEE FOUNDATION AND DESIGN**. DAVID DAWES NEE II FOUNDATION, DBA THE DAVE NEE FOUNDATION, MULTIPLE CLASS, (INT. CLS. 36 AND 41), (U.S. CLS. 100, 101, 102 AND 107). SN 85-036,584. PUB. 3-1-2011. FILED 5-12-2010.
- 3,960,936. **QUETICO (STANDARD CHARACTER)**. QUETICO PARTNERS LLC, (U.S. CLS. 100, 101 AND 102). SN 85-038,025. PUB. 3-1-2011. FILED 5-13-2010.
- 3,960,956. **LT AND DESIGN**. FNF INTELLECTUAL PROPERTY HOLDINGS, INC., (U.S. CLS. 100, 101 AND 102). SN 85-046,191. PUB. 3-1-2011. FILED 5-24-2010.
- 3,960,981. **LT AND DESIGN**. FNF INTELLECTUAL PROPERTY HOLDINGS, INC., (U.S. CLS. 100, 101 AND 102). SN 85-062,911. PUB. 3-1-2011. FILED 6-15-2010.
- 3,961,027. **THE MERRIAM AGENCY (STANDARD CHARACTER)**. CHARLES W. MERRIAM & SON, INC., DBA THE MERRIAM AGENCY, (U.S. CLS. 100, 101 AND 102). SN 85-085,088. PUB. 3-1-2011. FILED 7-15-2010.
- 3,961,036. **FIRST MARINE (STANDARD CHARACTER)**. AMERICAN MODERN INSURANCE GROUP, INC., (U.S. CLS. 100, 101 AND 102). SN 85-088,746. PUB. 3-1-2011. FILED 7-20-2010.
- 3,961,037. **FIRST MARINE INSURANCE (STANDARD CHARACTER)**. AMERICAN MODERN INSURANCE COMPANY, INC., (U.S. CLS. 100, 101 AND 102). SN 85-088,760. PUB. 3-1-2011. FILED 7-20-2010.
- 3,961,078. **CROWN FAMILY PHILANTHROPIES (STANDARD CHARACTER)**. ARIE AND IDA CROWN MEMORIAL, (U.S. CLS. 100, 101 AND 102). SN 85-102,593. PUB. 3-1-2011. FILED 8-7-2010.
- 3,961,103. **TRADEBANK - THE SMARTER WAY TO BARTER (STANDARD CHARACTER)**. TRADEBANK INTERNATIONAL, INC., (U.S. CLS. 100, 101 AND 102). SN 85-106,783. PUB. 3-1-2011. FILED 8-13-2010.
- 3,961,119 ( *See Class 35 for this trademark*).
- 3,961,135. **TROOPONS (STANDARD CHARACTER)**. SUPPORT OUR TROOPS FOUNDATION, INC., (U.S. CLS. 100, 101 AND 102). SN 85-112,930. PUB. 3-1-2011. FILED 8-21-2010.
- 3,961,149. **NBPETTRUSTS AND DESIGN**. NIEDWESKE, LINDA, (U.S. CLS. 100, 101 AND 102). SN 85-116,013. PUB. 3-1-2011. FILED 8-25-2010.
- 3,961,152. **DING SHIELD AND DESIGN**. DENT WIZARD INTERNATIONAL CORPORATION, (U.S. CLS. 100, 101 AND 102). SN 85-116,958. PUB. 3-1-2011. FILED 8-26-2010.
- 3,961,155 ( *See Class 35 for this trademark*).
- 3,961,184. **RIOCAN (STANDARD CHARACTER)**. RIOCAN REAL ESTATE INVESTMENT TRUST, (U.S. CLS. 100, 101 AND 102). SN 85-121,267. PUB. 3-1-2011. FILED 9-1-2010.
- 3,961,194. **SARASOTA MONEY CENTRAL AND DESIGN**. LEEDOM MANAGEMENT GROUP, INC., (U.S. CLS. 100, 101 AND 102). SN 85-122,516. PUB. 3-1-2011. FILED 9-3-2010.
- 3,961,198. **MISCELLANEOUS DESIGN**. DALLAS COUNTY COMMUNITY COLLEGE DISTRICT, (U.S. CLS. 100, 101 AND 102). SN 85-122,616. PUB. 3-1-2011. FILED 9-3-2010.
- 3,961,205. **MISCELLANEOUS DESIGN**. LAMBI FUND OF HAITI, (U.S. CLS. 100, 101 AND 102). SN 85-122,879. PUB. 3-1-2011. FILED 9-3-2010.
- 3,961,242. **MUTUAL. STRONG. TRUSTED. PARTNERS FOR YOUR FUTURE. (STANDARD CHARACTER)**. UNIFI MUTUAL HOLDING COMPANY, (U.S. CLS. 100, 101 AND 102). SN 85-124,601. PUB. 3-1-2011. FILED 9-8-2010.
- 3,961,266. **K-9'S AGAINST CANCER BWB CAMP BOW WOW'S BOW WOW BUDDIES FOUNDATION AND DESIGN**. THE BOW WOW BUDDIES FOUNDATION, INC., (U.S. CLS. 100, 101 AND 102). SN 85-125,842. PUB. 3-1-2011. FILED 9-9-2010.
- 3,961,295. **IS YOUR CARSAFE? (STANDARD CHARACTER)**. CARSAFE LLC, (U.S. CLS. 100, 101 AND 102). SN 85-126,847. PUB. 3-1-2011. FILED 9-10-2010.
- 3,961,321. **GOLD N CONNECTION (STANDARD CHARACTER)**. GOLD N CONNECTION LLC, (U.S. CLS. 100, 101 AND 102). SN 85-127,524. PUB. 3-1-2011. FILED 9-11-2010.
- 3,961,364. **THE DONOR TREE AND DESIGN**. DONORTREE, LLC, (U.S. CLS. 100, 101 AND 102). SN 85-128,286. PUB. 3-1-2011. FILED 9-13-2010.
- 3,961,367. **ONLINE BUMPER STICKER (STANDARD CHARACTER)**. THE DONOR TREE, LLC, (U.S. CLS. 100, 101 AND 102). SN 85-128,314. PUB. 3-1-2011. FILED 9-13-2010.
- 3,961,391. **COLLARS FOR A CAUSE (STANDARD CHARACTER)**. CHISHOLM, BRETT J, (U.S. CLS. 100, 101 AND 102). SN 85-128,711. PUB. 3-1-2011. FILED 9-13-2010.
- 3,961,452. **GLOBALIZE YOUR THINKING (STANDARD CHARACTER)**. OPPENHEIMERFUNDS, INC., (U.S. CLS. 100, 101 AND 102). SN 85-129,348. PUB. 3-1-2011. FILED 9-14-2010.
- 3,961,474. **G. (STYLIZED)**. GRANDPOINT BANK, (U.S. CLS. 100, 101 AND 102). SN 85-129,651. PUB. 3-1-2011. FILED 9-



- 14-2010.  
 3,961,521. **GO FURTHER TOGETHER (STANDARD CHARACTER)**, SUMMER STREET CAPITAL PARTNERS, LLC, (U.S. CLS. 100, 101 AND 102). SN 85-130,357. PUB. 3-1-2011. FILED 9-15-2010.  
 3,961,542. **WE'RE NOT A BANK. WE'RE BETTER. (STANDARD CHARACTER)**, PROFESSIONAL FEDERAL CREDIT UNION, (U.S. CLS. 100, 101 AND 102). SN 85-130,553. PUB. 3-1-2011. FILED 9-15-2010.  
 3,961,552. **COMPLETE COLLECTION SERVICES, INC. (STANDARD CHARACTER)**, COMPLETE COLLECTION SERVICES, INC., (U.S. CLS. 100, 101 AND 102). SN 85-130,676. PUB. 3-1-2011. FILED 9-15-2010.  
 3,961,596 ( *See Class 35 for this trademark* ).  
 3,961,655. **PRUBENEFIT LAUREATE (STANDARD CHARACTER)**, THE PRUDENTIAL INSURANCE COMPANY OF AMERICA, (U.S. CLS. 100, 101 AND 102). SN 85-132,217. PUB. 3-1-2011. FILED 9-17-2010.  
 3,961,725. **MISCELLANEOUS DESIGN**, GREAT LAKES REAL ESTATE, INC., (U.S. CLS. 100, 101 AND 102). SN 85-136,290. PUB. 3-1-2011. FILED 9-23-2010.  
 3,961,754. **PROMINENT PROPERTIES (STANDARD CHARACTER)**, CAPACITY COVERAGE COMPANY OF NEW JERSEY, INC., (U.S. CLS. 100, 101 AND 102). SN 85-140,881. PUB. 3-1-2011. FILED 9-29-2010.  
 3,961,787. **TELIXX (STANDARD CHARACTER)**, SINGH, TEJINDER, (U.S. CLS. 100, 101 AND 102). SN 85-143,955. PUB. 3-1-2011. FILED 10-4-2010.  
 3,961,821 ( *See Class 35 for this trademark* ).  
 3,961,824. **GOOD SENSE & SOUND DECISIONS (STANDARD CHARACTER)**, GOODSTEIN & ASSOCIATES, LLC, (U.S. CLS. 100, 101 AND 102). SN 85-149,545. PUB. 3-1-2011. FILED 10-11-2010.  
 3,961,848. **WINE, WAGS & DOG TAGS (STANDARD CHARACTER)**, TAMAR GELLER MEDIA, LLC, (U.S. CLS. 100, 101 AND 102). SN 85-150,000. PUB. 3-1-2011. FILED 10-11-2010.  
 3,961,867. **UNIFI RETIREMENT ADVANTAGE ELITE (STANDARD CHARACTER)**, UNIFI MUTUAL HOLDING COMPANY, (U.S. CLS. 100, 101 AND 102). SN 85-151,690. PUB. 3-1-2011. FILED 10-13-2010.  
 3,961,920. **THE HARTFORD'S SAVER CERTAINTY (STANDARD CHARACTER)**, HARTFORD FIRE INSURANCE COMPANY, (U.S. CLS. 100, 101 AND 102). SN 85-168,789. PUB. 3-1-2011. FILED 11-4-2010.  
 3,961,922. **GIFTCARD AND DESIGN**, TARGET BRANDS, INC., (U.S. CLS. 100, 101 AND 102). SN 85-170,004. PUB. 3-1-2011. FILED 11-5-2010.  
 3,961,928. **LITTLE 77 BY AMERICAN EAGLE (STYLIZED)**, RETAIL ROYALTY COMPANY, (U.S. CLS. 100, 101 AND 102). SN 85-172,112. PUB. 3-1-2011. FILED 11-9-2010.

### CLASS 37—CONSTRUCTION AND REPAIR

- 3,960,218. **GOLD STAR**, COSTCO WHOLESALE MEMBERSHIP, INC., (U.S. CLS. 100, 103 AND 106). SN 76-009,448. PUB. 3-1-2011. FILED 3-24-2000.  
 3,960,219. **YES YES (STYLIZED)**, YES YES, INC., (U.S. CLS. 100, 103 AND 106). SN 76-621,541. PUB. 6-6-2006. FILED 11-22-2004.  
 3,960,223. **BLE PROCESS (STYLIZED)**, KABUSHIKI KAISHA TOSHIBA, (U.S. CLS. 100, 103 AND 106). SN 76-678,139. PUB. 3-1-2011. FILED 6-12-2007.  
 3,960,293 ( *See Class 12 for this trademark* ).  
 3,960,374. **IBES (STANDARD CHARACTER)**, HESCO, MULTIPLE CLASS, (INT. CLS. 37 AND 42), (U.S. CLS. 100, 101, 103 AND 106). SN 77-815,410. PUB. 3-1-2011. FILED 8-28-2009.  
 3,960,375 ( *See Class 35 for this trademark* ).  
 3,960,388. **HUAWEI AND DESIGN**, HUAWEI TECHNOLOGIES CO., LTD., MULTIPLE CLASS, (INT. CLS. 37 AND 42), (U.S. CLS. 100, 101, 103 AND 106). SN 77-828,404. PUB. 3-1-2011. FILED 9-17-2009.  
 3,960,405 ( *See Class 9 for this trademark* ).  
 3,960,406 ( *See Class 9 for this trademark* ).  
 3,960,433. **JIFFY TECH (STANDARD CHARACTER)**, PORZILLI, LOUIS B, MULTIPLE CLASS, (INT. CLS. 37 AND 42), (U.S. CLS. 100, 101, 103 AND 106). SN 77-889,362. PUB. 3-1-2011. FILED 12-9-2009.  
 3,960,441 ( *See Class 6 for this trademark* ).  
 3,960,476. **POWERHAWKE (STANDARD CHARACTER)**, MCPHEE ELECTRIC, LTD., (U.S. CLS. 100, 103 AND 106). SN 77-930,476. PUB. 3-1-2011. FILED 2-8-2010.  
 3,960,501 ( *See Class 35 for this trademark* ).  
 3,960,502 ( *See Class 35 for this trademark* ).  
 3,960,512. **CLEANWAY AND DESIGN**, CLEANWAY INDUSTRIES, INC., (U.S. CLS. 100, 103 AND 106). SN 77-948,422. PUB. 3-1-2011. FILED 3-2-2010.  
 3,960,537 ( *See Class 35 for this trademark* ).  
 3,960,538. **LIFE DECK COATING INSTALLATIONS AND DESIGN**, PACIFIC PEBBLES CORPORATION, (U.S. CLS. 100, 103 AND 106). SN 77-956,576. PUB. 3-1-2011. FILED 3-11-2010.  
 3,960,542. **ABENER (STANDARD CHARACTER)**, ABENER ENERGIA S.A., MULTIPLE CLASS, (INT. CLS. 37 AND 42), (U.S. CLS. 100, 101, 103 AND 106). SN 77-957,914. PUB. 3-1-2011. FILED 3-12-2010.  
 3,960,543 ( *See Class 35 for this trademark* ).  
 3,960,544 ( *See Class 35 for this trademark* ).  
 3,960,620. **E-SERVICES PROGRAM (STANDARD CHARACTER)**, HERTZ EQUIPMENT RENTAL CORPORATION, MULTIPLE CLASS, (INT. CLS. 37 AND 40), (U.S. CLS. 100, 103 AND 106). SN 77-980,685. PUB. 3-1-2011. FILED 9-22-2008.  
 3,960,649 ( *See Class 9 for this trademark* ).  
 3,960,650 ( *See Class 7 for this trademark* ).  
 3,960,658 ( *See Class 7 for this trademark* ).  
 3,960,661 ( *See Class 6 for this trademark* ).  
 3,960,742 ( *See Class 12 for this trademark* ).  
 3,960,759 ( *See Class 7 for this trademark* ).  
 3,960,771 ( *See Class 9 for this trademark* ).  
 3,960,835 ( *See Class 35 for this trademark* ).  
 3,960,841. **PRICE-RITE AUTO CARE (STANDARD CHARACTER)**, PRICE-RITE AUTO CARE INC., DBA PRICE-RITE AUTO CARE INC., (U.S. CLS. 100, 103 AND 106). SN 85-001,441. PUB. 7-13-2010. FILED 3-29-2010.  
 3,960,917. **GET STORKED (STANDARD CHARACTER)**, TBL PARTNERS, LLC, (U.S. CLS. 100, 103 AND 106). SN 85-029,465. PUB. 3-1-2011. FILED 5-4-2010.  
 3,960,930. **POTTERBUILT (STANDARD CHARACTER)**, POTTER ENTERPRISES LLC., (U.S. CLS. 100, 103 AND 106). SN 85-035,991. PUB. 3-1-2011. FILED 5-11-2010.  
 3,960,937. **HORWATH HTL AND DESIGN**, HORWATH INTERNATIONAL REGISTRATION, LTD., MULTIPLE CLASS, (INT. CLS. 37, 39, 41 AND 43), (U.S. CLS. 100, 101, 103, 105, 106 AND 107). SN 85-039,145. PUB. 3-1-2011. FILED 5-14-2010.  
 3,961,033. **Q-TRENCH SOLUTION THE EDGE TO GET AHEAD (STYLIZED)**, QUANTA ASSOCIATES, L.P., (U.S. CLS. 100, 103 AND 106). SN 85-087,041. PUB. 3-1-2011. FILED 7-16-2010.  
 3,961,106. **ELKHORN HEATING & AIR CONDITIONING, INC. AND DESIGN**, ELKHORN TECHNICAL RESOURCES, INC., DBA ELKHORN HEATING & AIR CONDITIONING, INC., (U.S. CLS. 100, 103 AND 106). SN 85-107,686. PUB. 3-1-2011. FILED 8-14-2010.  
 3,961,136 ( *See Class 35 for this trademark* ).  
 3,961,263. **TRIOrganics (STANDARD CHARACTER)**, KRISTOPHER GOODRICH, (U.S. CLS. 100, 103 AND 106). SN 85-125,800. PUB. 3-1-2011. FILED 9-9-2010.  
 3,961,319. **TOTAL IMAGE PROTECTION AND DESIGN**, TOTAL IMAGE PROTECTION, INC., (U.S. CLS. 100, 103 AND 106). SN 85-127,482. PUB. 3-1-2011. FILED 9-11-2010.  
 3,961,539 ( *See Class 35 for this trademark* ).  
 3,961,594 ( *See Class 35 for this trademark* ).  
 3,961,675. **COCOON (STANDARD CHARACTER)**, KLUDGE INC., (U.S. CLS. 100, 103 AND 106). SN 85-132,550. PUB. 3-1-2011. FILED 9-17-2010.  
 3,961,676. **CHORES, TO-DOS & ACTS OF KINDNESS (STANDARD CHARACTER)**, MEMA MATES LLC, (U.S. CLS. 100, 103 AND 106). SN 85-132,558. PUB. 3-1-2011. FILED 9-17-2010.  
 3,961,680 ( *See Class 35 for this trademark* ).  
 3,961,775. **XPRESSFIX (STANDARD CHARACTER)**, XPRESSFIX, LLC, (U.S. CLS. 100, 103 AND 106). SN 85-143,061. PUB.

- 3-1-2011. FILED 10-1-2010.  
 3,961,778. **SANDLIN REMODELING (STANDARD CHARACTER)**. JB SANDLIN REAL ESTATE, DBA SANDLIN REMODELING, (U.S. CLS. 100, 103 AND 106). SN 85-143,163. PUB. 3-1-2011. FILED 10-1-2010.  
 3,961,786. **ELKHORN ELECTRIC, INC. AND DESIGN**. ELKHORN TECHNICAL RESOURCES, INC., DBA ELKHORN ELECTRIC, INC., (U.S. CLS. 100, 103 AND 106). SN 85-143,875. PUB. 3-1-2011. FILED 10-3-2010.  
 3,961,789. **AUTO VALUE CENTROS DE SERVICIO CERTIFICADOS AND DESIGN**. AFTERMARKET AUTO PARTS ALLIANCE, INC., (U.S. CLS. 100, 103 AND 106). SN 85-144,154. PUB. 3-1-2011. FILED 10-4-2010.  
 3,961,954. **MOUSE ROADBLOCK (STANDARD CHARACTER)**. ROSARIO, PAUL, AND ROSARIO, JEANNE, AND KAPS, THOMAS, AND KAPS, THERESA, (U.S. CLS. 100, 103 AND 106). SN 85-193,068. PUB. 3-1-2011. FILED 12-8-2010.  
 3,961,955. **ROADBLOCK (STANDARD CHARACTER)**. ROSARIO, PAUL, AND ROSARIO, JEANNE, AND KAPS, THOMAS, AND KAPS, THERESA, (U.S. CLS. 100, 103 AND 106). SN 85-193,302. PUB. 3-1-2011. FILED 12-8-2010.

---

### CLASS 38—COMMUNICATION

- 3,960,260 ( *See Class 9 for this trademark* ).  
 3,960,286 ( *See Class 9 for this trademark* ).  
 3,960,288. **CLEAR MEDIA PARTNERS AND DESIGN**. CLEAR MEDIA PARTNERS, INC., (U.S. CLS. 100, 101 AND 104). SN 77-518,583. PUB. 3-1-2011. FILED 7-10-2008.  
 3,960,316. **MEGAFLIRT (STANDARD CHARACTER)**. MEGAMEDIA LTD., MULTIPLE CLASS, (INT. CLS. 38, 39, 42 AND 45), (U.S. CLS. 100, 101, 104 AND 105). SN 77-679,436. PUB. 3-1-2011. FILED 2-26-2009.  
 3,960,332. **SERVICE CLOUD (STANDARD CHARACTER)**. SALESFORCE.COM, INC., (U.S. CLS. 100, 101 AND 104). SN 77-726,135. PUB. 3-1-2011. FILED 4-30-2009.  
 3,960,391 ( *See Class 35 for this trademark* ).  
 3,960,397 ( *See Class 9 for this trademark* ).  
 3,960,400 ( *See Class 9 for this trademark* ).  
 3,960,401. **IN TOUCH MINISTRIES (STANDARD CHARACTER)**. IN TOUCH MINISTRIES, INC., (U.S. CLS. 100, 101 AND 104). SN 77-837,142. PUB. 3-1-2011. FILED 9-29-2009.  
 3,960,466 ( *See Class 9 for this trademark* ).  
 3,960,468 ( *See Class 9 for this trademark* ).  
 3,960,505. **FANBOX (STANDARD CHARACTER)**. FANBOX, INC., MULTIPLE CLASS, (INT. CLS. 38, 41, 42 AND 45), (U.S. CLS. 100, 101, 104 AND 107). SN 77-946,106. PUB. 3-1-2011. FILED 2-26-2010.  
 3,960,514. **IP-485 (STANDARD CHARACTER)**. PCN TECHNOLOGY, INC., (U.S. CLS. 100, 101 AND 104). SN 77-948,710. PUB. 3-1-2011. FILED 3-2-2010.  
 3,960,640 ( *See Class 9 for this trademark* ).  
 3,960,641 ( *See Class 9 for this trademark* ).  
 3,960,642 ( *See Class 9 for this trademark* ).  
 3,960,645 ( *See Class 9 for this trademark* ).  
 3,960,648 ( *See Class 9 for this trademark* ).  
 3,960,652 ( *See Class 12 for this trademark* ).  
 3,960,660 ( *See Class 3 for this trademark* ).  
 3,960,666 ( *See Class 9 for this trademark* ).  
 3,960,669 ( *See Class 9 for this trademark* ).  
 3,960,675 ( *See Class 9 for this trademark* ).  
 3,960,676 ( *See Class 9 for this trademark* ).  
 3,960,714 ( *See Class 9 for this trademark* ).  
 3,960,731 ( *See Class 9 for this trademark* ).  
 3,960,771 ( *See Class 9 for this trademark* ).  
 3,960,795 ( *See Class 9 for this trademark* ).  
 3,960,835 ( *See Class 35 for this trademark* ).  
 3,960,999 ( *See Class 9 for this trademark* ).  
 3,961,084. **C-SCADE (STANDARD CHARACTER)**. BOEHRINGER INGELHEIM INTERNATIONAL GMBH, MULTIPLE CLASS, (INT. CLS. 38, 41 AND 42), (U.S. CLS. 100, 101, 104 AND 107). SN 85-103,127. PUB. 3-1-2011. FILED 8-9-2010.  
 3,961,212. **TOP 10 BITCH LIST (STANDARD CHARACTER)**. BITCHROOM, INC., (U.S. CLS. 100, 101 AND 104). SN 85-123,362. PUB. 3-1-2011. FILED 9-4-2010.

- 3,961,215. **PUT IT ON BLAST AND DESIGN**. BITCHROOM, INC., (U.S. CLS. 100, 101 AND 104). SN 85-123,409. PUB. 3-1-2011. FILED 9-5-2010.  
 3,961,223. **PRESS8 HOSTED PHONE SYSTEMS AND DESIGN**. PRESS 8, LP, (U.S. CLS. 100, 101 AND 104). SN 85-123,719. PUB. 3-1-2011. FILED 9-7-2010.  
 3,961,337. **PLAYERS CLUB INTERNET CAFE (STANDARD CHARACTER)**. DABISH, ROB, (U.S. CLS. 100, 101 AND 104). SN 85-127,849. PUB. 3-1-2011. FILED 9-13-2010.  
 3,961,784. **FORUMPI (STANDARD CHARACTER)**. MINORITY PASSPORT INTERNATIONAL LLC, (U.S. CLS. 100, 101 AND 104). SN 85-143,733. PUB. 3-1-2011. FILED 10-2-2010.  
 3,961,819. **ALLEGED (STANDARD CHARACTER)**. ALLEGED MEDIA, INC., (U.S. CLS. 100, 101 AND 104). SN 85-149,143. PUB. 3-1-2011. FILED 10-10-2010.

---

### CLASS 39—TRANSPORTATION AND STORAGE

- 3,960,316 ( *See Class 38 for this trademark* ).  
 3,960,369 ( *See Class 12 for this trademark* ).  
 3,960,397 ( *See Class 9 for this trademark* ).  
 3,960,410. **ADVENTURE ACCESS (STANDARD CHARACTER)**. INTREPID TRAVEL PTY LTD, MULTIPLE CLASS, (INT. CLS. 39, 41 AND 43), (U.S. CLS. 100, 101, 105 AND 107). SN 77-850,460. PUB. 3-1-2011. FILED 10-16-2009.  
 3,960,486. **JEFFERSON ISLAND STORAGE & HUB (STANDARD CHARACTER)**. AGL RESOURCES INC., (U.S. CLS. 100 AND 105). SN 77-939,658. PUB. 3-1-2011. FILED 2-19-2010.  
 3,960,501 ( *See Class 35 for this trademark* ).  
 3,960,502 ( *See Class 35 for this trademark* ).  
 3,960,569. **THE BAR HOPPER AND DESIGN**. BJORK, BRYCE, (U.S. CLS. 100 AND 105). SN 77-964,929. PUB. 3-1-2011. FILED 3-22-2010.  
 3,960,645 ( *See Class 9 for this trademark* ).  
 3,960,650 ( *See Class 7 for this trademark* ).  
 3,960,652 ( *See Class 12 for this trademark* ).  
 3,960,659 ( *See Class 35 for this trademark* ).  
 3,960,835 ( *See Class 35 for this trademark* ).  
 3,960,864. **ONIONS EVERYDAY FROM EVERYWHERE (STANDARD CHARACTER)**. DEBRUYN PRODUCE COMPANY, (U.S. CLS. 100 AND 105). SN 85-007,674. PUB. 3-1-2011. FILED 4-6-2010.  
 3,960,868 ( *See Class 1 for this trademark* ).  
 3,960,909. **BRIDGESTONE BANDAG TIRE SOLUTIONS (STANDARD CHARACTER)**. BRIDGESTONE CORPORATION, (U.S. CLS. 100 AND 105). SN 85-024,926. PUB. 3-1-2011. FILED 4-28-2010.  
 3,960,937 ( *See Class 37 for this trademark* ).  
 3,960,974. **CHINA ROAD TOURS (STANDARD CHARACTER)**. CHINA ROAD, LTD., (U.S. CLS. 100 AND 105). SN 85-059,537. PUB. 3-1-2011. FILED 6-10-2010.  
 3,961,127. **DON'T LEAVE TOWN WITHOUT US (STANDARD CHARACTER)**. ANAT, LLC, (U.S. CLS. 100 AND 105). SN 85-111,464. PUB. 3-1-2011. FILED 8-19-2010.  
 3,961,175. **DILIGENCE ON DEMAND (STANDARD CHARACTER)**. HAYNES AND BOONE, LLP, (U.S. CLS. 100 AND 105). SN 85-120,717. PUB. 3-1-2011. FILED 9-1-2010.  
 3,961,252. **RECONNECTFIRST (STANDARD CHARACTER)**. MILLENNIUM CAPITAL AND RECOVERY CORPORATION, (U.S. CLS. 100 AND 105). SN 85-125,124. PUB. 3-1-2011. FILED 9-8-2010.  
 3,961,254. **RECONNECTFIRST (STYLIZED)**. MILLENNIUM CAPITAL AND RECOVERY CORPORATION, (U.S. CLS. 100 AND 105). SN 85-125,278. PUB. 3-1-2011. FILED 9-8-2010.  
 3,961,369. **SOUTHERN REFRIGERATED TRANSPORT (STANDARD CHARACTER)**. SOUTHERN REFRIGERATED TRANSPORT, INC., (U.S. CLS. 100 AND 105). SN 85-128,334. PUB. 3-1-2011. FILED 9-13-2010.  
 3,961,372. **SRT (STANDARD CHARACTER)**. SOUTHERN REFRIGERATED TRANSPORT, INC., (U.S. CLS. 100 AND 105). SN 85-128,364. PUB. 3-1-2011. FILED 9-13-2010.  
 3,961,522. **PTT AND DESIGN**. POLLINA TOURS AND TRAVEL, INC., (U.S. CLS. 100 AND 105). SN 85-130,358.

- PUB. 3-1-2011. FILED 9-15-2010.  
 3,961,575. **CSAL AND DESIGN**. CSAL CANADA-STATES-  
 AFRICA-LINE INC., (U.S. CLS. 100 AND 105). SN 85-  
 131,064. PUB. 3-1-2011. FILED 9-16-2010.  
 3,961,701. **C AND DESIGN**. ENTERPRISE HOLDINGS, INC.,  
 (U.S. CLS. 100 AND 105). SN 85-133,332. PUB. 3-1-2011.  
 FILED 9-20-2010.  
 3,961,792. **AEROFLOT (STANDARD CHARACTER)**. AERO-  
 FLOT RUSSIAN AIRLINES, (U.S. CLS. 100 AND 105). SN  
 85-145,186. PUB. 3-1-2011. FILED 10-5-2010.  
 3,961,823 ( *See Class 35 for this trademark*).  
 3,961,854. **THA (STYLIZED)**. THE HERITAGE ARCHIVES,  
 (U.S. CLS. 100 AND 105). SN 85-150,077. PUB. 3-1-2011.  
 FILED 10-11-2010.  
 3,961,898. **AMERICAN STEAMSHIP COMPANY (STANDARD  
 CHARACTER)**. GATX CORPORATION, (U.S. CLS. 100  
 AND 105). SN 85-161,514. PUB. 3-1-2011. FILED 10-26-2010.  
 3,961,926. **COUCH CAB (STANDARD CHARACTER)**. COMFY  
 COUCH COMPANY, (U.S. CLS. 100 AND 105). SN 85-  
 171,143. PUB. 3-1-2011. FILED 11-8-2010.

#### CLASS 40—MATERIAL TREATMENT

- 3,960,292 ( *See Class 9 for this trademark*).  
 3,960,315. **R ROYAL TECHNOLOGIES AND DESIGN**. ROYAL  
 TECHNOLOGIES CORPORATION, MULTIPLE CLASS,  
 (INT. CLS. 40 AND 42), (U.S. CLS. 100, 101, 103 AND 106).  
 SN 77-679,065. PUB. 12-1-2009. FILED 2-26-2009.  
 3,960,337. **COUNTER REVOLUTION (STANDARD CHARAC-  
 TER)**. COUNTER REVOLUTION INC, (U.S. CLS. 100, 103  
 AND 106). SN 77-752,977. PUB. 3-1-2011. FILED 6-5-2009.  
 3,960,403 ( *See Class 35 for this trademark*).  
 3,960,441 ( *See Class 6 for this trademark*).  
 3,960,459 ( *See Class 35 for this trademark*).  
 3,960,620 ( *See Class 37 for this trademark*).  
 3,960,650 ( *See Class 7 for this trademark*).  
 3,960,720 ( *See Class 9 for this trademark*).  
 3,960,757 ( *See Class 1 for this trademark*).  
 3,960,760 ( *See Class 4 for this trademark*).  
 3,960,775 ( *See Class 7 for this trademark*).  
 3,960,809 ( *See Class 1 for this trademark*).  
 3,960,868 ( *See Class 1 for this trademark*).  
 3,961,093. **HOTPRINTS (STANDARD CHARACTER)**. HOT-  
 PRINTS LIMITED, (U.S. CLS. 100, 103 AND 106). SN 85-  
 104,668. PUB. 3-1-2011. FILED 8-11-2010.  
 3,961,109. **CLEANER SKIES AND DESIGN**. CLIFF WIL-  
 LIAMS, (U.S. CLS. 100, 103 AND 106). SN 85-108,123. PUB.  
 3-1-2011. FILED 8-16-2010.  
 3,961,111. **DENTAL PRO AND DESIGN**. DENTAL PRO, LLC,  
 (U.S. CLS. 100, 103 AND 106). SN 85-108,769. PUB. 3-1-2011.  
 FILED 8-16-2010.  
 3,961,296. **THE SMARTER WATER (STANDARD CHARAC-  
 TER)**. MACHAIRA ENERGY, LLC, (U.S. CLS. 100, 103  
 AND 106). SN 85-126,863. PUB. 3-1-2011. FILED 9-10-2010.  
 3,961,397. **QUALITY SHREDDING AND DESIGN**. QUALITY  
 SHREDDING CORP., (U.S. CLS. 100, 103 AND 106). SN 85-  
 128,811. PUB. 3-1-2011. FILED 9-14-2010.  
 3,961,539 ( *See Class 35 for this trademark*).  
 3,961,550. **MELINDESIGN (STANDARD CHARACTER)**.  
 O'KEEFE, MELINDA, (U.S. CLS. 100, 103 AND 106). SN  
 85-130,655. PUB. 3-1-2011. FILED 9-15-2010.  
 3,961,661. **EVERY EGG HAS ITS DAY! (STANDARD CHAR-  
 ACTER)**. NEWMARKET IMPRESSIONS, LLC, (U.S. CLS.  
 100, 103 AND 106). SN 85-132,390. PUB. 3-1-2011. FILED 9-  
 17-2010.  
 3,961,673. **ALGENOL (STANDARD CHARACTER)**. ALGENOL  
 BIOFUELS INC., MULTIPLE CLASS, (INT. CLS. 40, 42  
 AND 44), (U.S. CLS. 100, 101, 103 AND 106). SN 85-132,513.  
 PUB. 3-1-2011. FILED 9-17-2010.  
 3,961,833. **SIMPLY CANVAS (STANDARD CHARACTER)**.  
 SIMPLY CANVAS, INC., (U.S. CLS. 100, 103 AND 106). SN  
 85-149,777. PUB. 3-1-2011. FILED 10-11-2010.  
 3,961,836. **SIMPLY CANVAS AND DESIGN**. SIMPLY CAN-  
 VAS, INC., (U.S. CLS. 100, 103 AND 106). SN 85-149,805.  
 PUB. 3-1-2011. FILED 10-11-2010.  
 3,961,905. **PIER (POLLUTION INCIDENT AND ENVIRON-**

**MENTAL RESPONSE) (STANDARD CHARACTER)**. AKI-  
 TA, INC., (U.S. CLS. 100, 103 AND 106). SN 85-164,509. PUB.  
 3-1-2011. FILED 10-29-2010.

#### CLASS 41—EDUCATION AND ENTERTAINMENT

- 3,960,232. **SHEN YUN PERFORMING ARTS AND DESIGN**.  
 SHEN YUN PERFORMING ARTS, INC., (U.S. CLS. 100, 101  
 AND 107). SN 76-702,153. PUB. 3-1-2011. FILED 3-19-2010.  
 3,960,233. **SHEN YUN (STANDARD CHARACTER)**. SHEN  
 YUN PERFORMING ARTS, INC., (U.S. CLS. 100, 101 AND  
 107). SN 76-702,154. PUB. 3-1-2011. FILED 3-19-2010.  
 3,960,237. **G MOVIES AND DESIGN**. GOSPEL MUSIC CHAN-  
 NEL, LLC, (U.S. CLS. 100, 101 AND 107). SN 76-702,726.  
 PUB. 3-1-2011. FILED 4-29-2010.  
 3,960,239. **UPLIFTEducation SHINE THROUGH. AND  
 DESIGN**. UPLIFT EDUCATION, (U.S. CLS. 100, 101 AND  
 107). SN 76-703,272. PUB. 3-1-2011. FILED 6-7-2010.  
 3,960,240. **GRAB SOME TREETIME (STANDARD CHARAC-  
 TER)**. ADVENTURE FOREST LLC, (U.S. CLS. 100, 101  
 AND 107). SN 76-703,626. PUB. 3-1-2011. FILED 7-2-2010.  
 3,960,245. **GQ M2M (STANDARD CHARACTER)**. ADVANCE  
 MAGAZINE PUBLISHERS INC., (U.S. CLS. 100, 101 AND  
 107). SN 76-703,984. PUB. 3-1-2011. FILED 8-2-2010.  
 3,960,251. **HOLLEY LSFEST.COM AND DESIGN**. HOLLEY  
 PERFORMANCE PRODUCTS, INC., (U.S. CLS. 100, 101  
 AND 107). SN 76-704,735. PUB. 3-1-2011. FILED 9-30-2010.  
 3,960,258 ( *See Class 9 for this trademark*).  
 3,960,260 ( *See Class 9 for this trademark*).  
 3,960,272 ( *See Class 9 for this trademark*).  
 3,960,274. **WIMAX FORUM GLOBAL CONGRESS (STAN-  
 DARD CHARACTER)**. WIMAX FORUM, (U.S. CLS. 100, 101  
 AND 107). SN 77-326,001. PUB. 9-1-2009. FILED 11-9-2007.  
 3,960,275. **WIMAX FORUM CONGRESS EVENT SERIES  
 (STANDARD CHARACTER)**. WIMAX FORUM, (U.S. CLS.  
 100, 101 AND 107). SN 77-326,058. PUB. 9-8-2009. FILED 11-  
 9-2007.  
 3,960,286 ( *See Class 9 for this trademark*).  
 3,960,290. **JETSET STUDIOS (STANDARD CHARACTER)**.  
 JETSET STUDIOS, INC., (U.S. CLS. 100, 101 AND 107). SN  
 77-530,961. PUB. 3-1-2011. FILED 7-24-2008.  
 3,960,301. **THE PINNACLE AWAITS (STANDARD CHARAC-  
 TER)**. THE NATIONAL COLLEGIATE ATHLETIC ASSO-  
 CIATION, (U.S. CLS. 100, 101 AND 107). SN 77-586,395.  
 PUB. 3-1-2011. FILED 10-6-2008.  
 3,960,304. **THE ALL BALL BAND (STANDARD CHARACTER)**.  
 WHITE, JAMES E. JR., DBA JIM WHITE ENTERPRISES,  
 (U.S. CLS. 100, 101 AND 107). SN 77-595,069. PUB. 3-1-2011.  
 FILED 10-17-2008.  
 3,960,310. **DOUBLEDAY FIELD (STANDARD CHARACTER)**.  
 VILLAGE OF COOPERSTOWN, (U.S. CLS. 100, 101 AND  
 107). SN 77-642,721. PUB. 3-1-2011. FILED 1-2-2009.  
 3,960,311. **COVENANT PRODUCTIONS (STANDARD CHAR-  
 ACTER)**. ANDERSON UNIVERSITY, INC., DBA COVE-  
 NANT PRODUCTIONS, (U.S. CLS. 100, 101 AND 107). SN  
 77-654,978. PUB. 3-1-2011. FILED 1-23-2009.  
 3,960,326. **LIVING WHOLE AND DESIGN**. LOMA LINDA  
 UNIVERSITY ADVENTIST HEALTH SCIENCES CENTER,  
 INC., (U.S. CLS. 100, 101 AND 107). SN 77-706,744. PUB. 8-  
 11-2009. FILED 4-3-2009.  
 3,960,329 ( *See Class 35 for this trademark*).  
 3,960,333 ( *See Class 16 for this trademark*).  
 3,960,339 ( *See Class 9 for this trademark*).  
 3,960,343 ( *See Class 9 for this trademark*).  
 3,960,380 ( *See Class 9 for this trademark*).  
 3,960,385. **MILLES!ME! AND DESIGN**. CLUB GASTRONO-  
 MICO MILLESIME, S.L., (U.S. CLS. 100, 101 AND 107). SN  
 77-824,788. PUB. 3-1-2011. FILED 9-11-2009.  
 3,960,397 ( *See Class 9 for this trademark*).  
 3,960,402. **64TH TIEN SHAN PAI CHIEN - LIANG HUANG  
 AND DESIGN**. HUANG'S INC., (U.S. CLS. 100, 101 AND  
 107). SN 77-839,627. PUB. 3-1-2011. FILED 10-1-2009.  
 3,960,410 ( *See Class 39 for this trademark*).  
 3,960,419 ( *See Class 21 for this trademark*).  
 3,960,424. **TEJANO MUSIC AWARDS (STANDARD CHAR-**



- ACTER). TEXAS TALENT MUSICIANS ASSOCIATION, (U.S. CLS. 100, 101 AND 107). SN 77-877,814. PUB. 3-1-2011. FILED 11-20-2009.
- 3,960,425. **MOMMY DADDY UNIVERSITY (STANDARD CHARACTER)**. CUNNINGHAM, BELINDA ANNA, DBA CUNNINGHAM ENTERPRISES, AND CUNNINGHAM, LARA, (U.S. CLS. 100, 101 AND 107). SN 77-878,303. PUB. 3-1-2011. FILED 11-22-2009.
- 3,960,439 ( *See Class 9 for this trademark*).
- 3,960,445. **AMERICAN SCHOOL CHARTERED 1897 TRAINING THE KEY TO SUCCESS AND DESIGN**. AMERICAN SCHOOL OF CORRESPONDENCE, AKA AMERICAN SCHOOL, (U.S. CLS. 100, 101 AND 107). SN 77-902,469. PUB. 3-1-2011. FILED 12-29-2009.
- 3,960,447. **RAW AND DESIGN**. WORLD WRESTLING ENTERTAINMENT, INC., (U.S. CLS. 100, 101 AND 107). SN 77-909,119. PUB. 3-1-2011. FILED 1-11-2010.
- 3,960,448. **BLACK REBEL MOTORCYCLE CLUB (STANDARD CHARACTER)**. HAYES, PETER, AND BEEN, ROBERT, (U.S. CLS. 100, 101 AND 107). SN 77-909,995. PUB. 3-1-2011. FILED 1-12-2010.
- 3,960,451 ( *See Class 9 for this trademark*).
- 3,960,456 ( *See Class 9 for this trademark*).
- 3,960,457 ( *See Class 9 for this trademark*).
- 3,960,458 ( *See Class 9 for this trademark*).
- 3,960,465. **EMPLOYER ADVANTAGE THE VALLEY HEALTH SYSTEM AND DESIGN**. UHS OF DELAWARE, INC., MULTIPLE CLASS. (INT. CLS. 41 AND 44), (U.S. CLS. 100, 101 AND 107). SN 77-922,661. PUB. 11-23-2010. FILED 1-28-2010.
- 3,960,468 ( *See Class 9 for this trademark*).
- 3,960,472 ( *See Class 35 for this trademark*).
- 3,960,473 ( *See Class 35 for this trademark*).
- 3,960,474 ( *See Class 35 for this trademark*).
- 3,960,487. **LOUISIANA MEDICAL CENTER & HEART HOSPITAL (STANDARD CHARACTER)**. MEDCATH INCORPORATED, MULTIPLE CLASS. (INT. CLS. 41 AND 44), (U.S. CLS. 100, 101 AND 107). SN 77-940,285. PUB. 3-1-2011. FILED 2-19-2010.
- 3,960,492 ( *See Class 9 for this trademark*).
- 3,960,495 ( *See Class 35 for this trademark*).
- 3,960,496 ( *See Class 35 for this trademark*).
- 3,960,498 ( *See Class 9 for this trademark*).
- 3,960,499. **GRANDCANYONNEWS.COM (STANDARD CHARACTER)**. WESTERN NEWS&INFO, INC., (U.S. CLS. 100, 101 AND 107). SN 77-945,282. PUB. 3-1-2011. FILED S.R. 2-25-2010; AM. P.R. 2-25-2010.
- 3,960,501 ( *See Class 35 for this trademark*).
- 3,960,502 ( *See Class 35 for this trademark*).
- 3,960,503 ( *See Class 9 for this trademark*).
- 3,960,505 ( *See Class 38 for this trademark*).
- 3,960,518 ( *See Class 16 for this trademark*).
- 3,960,526. **HIGH OCTANE THEATRE (STANDARD CHARACTER)**. NATIONAL ASSOCIATION FOR STOCK CAR AUTO RACING, INC., (U.S. CLS. 100, 101 AND 107). SN 77-952,750. PUB. 3-1-2011. FILED 3-8-2010.
- 3,960,527 ( *See Class 36 for this trademark*).
- 3,960,530. **RED STAR LINE AND DESIGN**. MUSEA EN ERFGOED ANTWERPEN, (U.S. CLS. 100, 101 AND 107). SN 77-953,793. PUB. 3-1-2011. FILED 3-9-2010.
- 3,960,556 ( *See Class 16 for this trademark*).
- 3,960,562 ( *See Class 35 for this trademark*).
- 3,960,565 ( *See Class 9 for this trademark*).
- 3,960,589 ( *See Class 5 for this trademark*).
- 3,960,593. **BUENA VIDA SOCIAL CLUB AND DESIGN**. BUENA VIDA SOCIAL CLUB, INC., (U.S. CLS. 100, 101 AND 107). SN 77-968,148. PUB. 3-1-2011. FILED 3-25-2010.
- 3,960,598. **CHEAT SHEET (STANDARD CHARACTER)**. RTST, INC., (U.S. CLS. 100, 101 AND 107). SN 77-969,124. PUB. 3-1-2011. FILED 3-26-2010.
- 3,960,619 ( *See Class 9 for this trademark*).
- 3,960,627. **MYTHBUSTERS (STANDARD CHARACTER)**. DISCOVERY COMMUNICATIONS, INC., (U.S. CLS. 100, 101 AND 107). SN 78-600,559. PUB. 5-9-2006. FILED 4-1-2005.
- 3,960,641 ( *See Class 9 for this trademark*).
- 3,960,645 ( *See Class 9 for this trademark*).
- 3,960,646 ( *See Class 35 for this trademark*).
- 3,960,648 ( *See Class 9 for this trademark*).
- 3,960,649 ( *See Class 9 for this trademark*).
- 3,960,655 ( *See Class 9 for this trademark*).
- 3,960,659 ( *See Class 35 for this trademark*).
- 3,960,660 ( *See Class 3 for this trademark*).
- 3,960,666 ( *See Class 9 for this trademark*).
- 3,960,675 ( *See Class 9 for this trademark*).
- 3,960,676 ( *See Class 9 for this trademark*).
- 3,960,677 ( *See Class 25 for this trademark*).
- 3,960,704 ( *See Class 35 for this trademark*).
- 3,960,706 ( *See Class 10 for this trademark*).
- 3,960,707 ( *See Class 9 for this trademark*).
- 3,960,716 ( *See Class 9 for this trademark*).
- 3,960,748 ( *See Class 35 for this trademark*).
- 3,960,756. **A CHOCOLATE ACADEMY AND DESIGN**. BARRY CALLEBAUT AG, MULTIPLE CLASS. (INT. CLS. 41 AND 43), (U.S. CLS. 100, 101 AND 107). SN 79-083,507. PUB. 3-1-2011. FILED 5-4-2010.
- 3,960,780 ( *See Class 16 for this trademark*).
- 3,960,795 ( *See Class 9 for this trademark*).
- 3,960,830 ( *See Class 9 for this trademark*).
- 3,960,835 ( *See Class 35 for this trademark*).
- 3,960,843. **TEENNICK HALO AWARDS (STANDARD CHARACTER)**. VIACOM INTERNATIONAL INC., (U.S. CLS. 100, 101 AND 107). SN 85-002,144. PUB. 3-1-2011. FILED 3-30-2010.
- 3,960,845 ( *See Class 9 for this trademark*).
- 3,960,874. **GRANT ANGELWISHES AND TRAVEL.ORG TRAVEL ANGELS GRANTING WISHES AND DESIGN**. TRAVEL ANGELS NETWORK, INC., (U.S. CLS. 100, 101 AND 107). SN 85-010,836. PUB. 3-1-2011. FILED 4-9-2010.
- 3,960,875. **SHOT LAB AND DESIGN**. HARVEY, MARVIN, (U.S. CLS. 100, 101 AND 107). SN 85-010,842. PUB. 9-28-2010. FILED 4-9-2010.
- 3,960,892 ( *See Class 9 for this trademark*).
- 3,960,893. **LA LITTERATURE SIGGI DIMANCHE A CELEBRATION OF FRANCOPHONE AFRICA AND THE FRENCH SPEAKING AFRICAN DIASPORA AND DESIGN**. NEWBERRY, KYMBERLY S., DBA "SIGGI DIMANCHE", (U.S. CLS. 100, 101 AND 107). SN 85-017,826. PUB. 3-1-2011. FILED 4-20-2010.
- 3,960,897 ( *See Class 36 for this trademark*).
- 3,960,898. **INTEGRITY BEEF AND DESIGN**. THE SAMUEL ROBERTS NOBLE FOUNDATION, INC., (U.S. CLS. 100, 101 AND 107). SN 85-018,911. PUB. 3-1-2011. FILED 4-20-2010.
- 3,960,900 ( *See Class 25 for this trademark*).
- 3,960,922. **MAN CAVE SPORTS LLC (STANDARD CHARACTER)**. MAN CAVE SPORTS LLC, (U.S. CLS. 100, 101 AND 107). SN 85-032,359. PUB. 3-1-2011. FILED 5-6-2010.
- 3,960,923. **KIT AND DESIGN**. KIDS INCLUDED TOGETHER - SAN DIEGO, INC., (U.S. CLS. 100, 101 AND 107). SN 85-033,379. PUB. 3-1-2011. FILED 5-7-2010.
- 3,960,929. **LIQUID LIFESTYLE (STANDARD CHARACTER)**. LIQUID LIFESTYLE PROMOTIONS, (U.S. CLS. 100, 101 AND 107). SN 85-035,811. PUB. 3-1-2011. FILED 5-11-2010.
- 3,960,931 ( *See Class 36 for this trademark*).
- 3,960,932 ( *See Class 36 for this trademark*).
- 3,960,937 ( *See Class 37 for this trademark*).
- 3,960,949 ( *See Class 10 for this trademark*).
- 3,960,950 ( *See Class 5 for this trademark*).
- 3,960,962. **JESSE WHITE TUMBLERS (STANDARD CHARACTER)**. JESSE WHITE FOUNDATION, LTD., (U.S. CLS. 100, 101 AND 107). SN 85-048,805. PUB. 3-1-2011. FILED 5-26-2010.
- 3,960,969 ( *See Class 9 for this trademark*).
- 3,960,971 ( *See Class 35 for this trademark*).
- 3,960,977 ( *See Class 35 for this trademark*).
- 3,960,988. **CARING CONNECTIONS (STANDARD CHARACTER)**. HOME INSTEAD, INC., (U.S. CLS. 100, 101 AND 107). SN 85-066,534. PUB. 3-1-2011. FILED 6-18-2010.
- 3,960,996. **SKYDIVE UNIVERSITY SAFETY . SKILLS . SUCCESS (STYLIZED)**. SKYDIVE UNIVERSITY, INC., (U.S. CLS. 100, 101 AND 107). SN 85-069,823. PUB. 3-1-2011. FILED 6-23-2010.
- 3,960,997 ( *See Class 35 for this trademark*).
- 3,961,005. **THE PATHFINDER SCHOOL (STANDARD CHARACTER)**. SURFACE STRIKE MANAGEMENT, (U.S. CLS. 100, 101 AND 107). SN 85-072,341. PUB. 3-1-2011. FILED 6-

- 26-2010.  
 3,961,009 ( *See Class 35 for this trademark*).  
 3,961,010 ( *See Class 35 for this trademark*).  
 3,961,016. **MARIN WAVES (STANDARD CHARACTER)**. MARIN WAVES TRACK & FIELD CLUB, LLC, (U.S. CLS. 100, 101 AND 107). SN 85-078,954. PUB. 3-1-2011. FILED 7-6-2010.  
 3,961,018. **MISS RENNUNLINE SEE, HEAR, SAY, DO ... INTERACTIVE FUN LEARNING WWW.MISSRENNUNLINE.COM (STANDARD CHARACTER)**. GENIUS KIDS DEVELOPMENT, INC., (U.S. CLS. 100, 101 AND 107). SN 85-079,580. PUB. 3-1-2011. FILED 7-7-2010.  
 3,961,025. **HUCKIN HUGE (STANDARD CHARACTER)**. HOWARD, JAMES, (U.S. CLS. 100, 101 AND 107). SN 85-082,907. PUB. 3-1-2011. FILED 7-12-2010.  
 3,961,038 ( *See Class 35 for this trademark*).  
 3,961,043 ( *See Class 16 for this trademark*).  
 3,961,044. **HONEYBEA DRAGONFLY BUNGLUBUG THE BEA & THE BUG & THE DRAGONFLY AND DESIGN**. NEMEC, GALE B., (U.S. CLS. 100, 101 AND 107). SN 85-091,746. PUB. 3-1-2011. FILED 7-23-2010.  
 3,961,047. **SXM (STANDARD CHARACTER)**. BANNISTER, THOMAS E., (U.S. CLS. 100, 101 AND 107). SN 85-092,353. PUB. 1-4-2011. FILED 7-25-2010.  
 3,961,048. **HAHALUJAH! (STANDARD CHARACTER)**. HOWARD, VEDA N., (U.S. CLS. 100, 101 AND 107). SN 85-092,370. PUB. 3-1-2011. FILED 7-25-2010.  
 3,961,049. **JUST WRITE 4 KIDS AND DESIGN**. SHEILA FRIEDMAN, FORMERLY STOLTZ/FRIEDMAN ASSOCIATES, AND DR. DONALD R. STOLTZ, FORMERLY STOLTZ/FRIEDMAN ASSOCIATES, (U.S. CLS. 100, 101 AND 107). SN 85-093,736. PUB. 3-1-2011. FILED 7-27-2010.  
 3,961,061. **THE GREEN MICROGYM (STANDARD CHARACTER)**. THE GREEN MICROGYM, INC., (U.S. CLS. 100, 101 AND 107). SN 85-099,444. PUB. 3-1-2011. FILED 8-3-2010.  
 3,961,071. **FOVEA AND DESIGN**. FOVEA APPAREL BOUTIQUE, LLC, DBA FOVEA, (U.S. CLS. 100, 101 AND 107). SN 85-101,858. PUB. 3-1-2011. FILED 8-6-2010.  
 3,961,077. **S RED UMBRELLA PHOTOGRAPHY AND DESIGN**. STANDISH, JODI, (U.S. CLS. 100, 101 AND 107). SN 85-102,518. PUB. 3-1-2011. FILED 8-7-2010.  
 3,961,081. **CBR HORIZON SERIES (STANDARD CHARACTER)**. CHAMPIONSHIP BULL RIDING, INC., (U.S. CLS. 100, 101 AND 107). SN 85-102,906. PUB. 1-25-2011. FILED 8-9-2010.  
 3,961,083. **TAKSHASHILA UNIVERSITY (STANDARD CHARACTER)**. DEEPAK, ADARSH, DBA TAKSHASHILA UNIVERSITY, (U.S. CLS. 100, 101 AND 107). SN 85-103,061. PUB. 3-1-2011. FILED 8-9-2010.  
 3,961,084 ( *See Class 38 for this trademark*).  
 3,961,085. **TAKSHA UNIVERSITY (STANDARD CHARACTER)**. TAKSHA UNIVERSITY, AKA TAKSHA UNIVERSITY, (U.S. CLS. 100, 101 AND 107). SN 85-103,135. PUB. 3-1-2011. FILED 8-9-2010.  
 3,961,088. **ACTION AGENT PONYUP (STANDARD CHARACTER)**. PAKRA LLC, (U.S. CLS. 100, 101 AND 107). SN 85-103,330. PUB. 3-1-2011. FILED 8-9-2010.  
 3,961,091 ( *See Class 35 for this trademark*).  
 3,961,097. **ADVICOLOGY AND DESIGN**. MITCHELL, RONALD, (U.S. CLS. 100, 101 AND 107). SN 85-105,416. PUB. 3-1-2011. FILED 8-11-2010.  
 3,961,118. **THE ORCHARD (STANDARD CHARACTER)**. ORCHARD ENTERPRISES NY, INC., (U.S. CLS. 100, 101 AND 107). SN 85-109,627. PUB. 3-1-2011. FILED 8-17-2010.  
 3,961,130. **RX REBECCA KATZ TRANSFORMING HEALTH THROUGH THE POWER OF FOOD AND DESIGN**. KATZ, REBECCA, (U.S. CLS. 100, 101 AND 107). SN 85-111,758. PUB. 3-1-2011. FILED 8-19-2010.  
 3,961,132. **HIGATV PRODUCTIONS LLC (STANDARD CHARACTER)**. HIGATV PRODUCTIONS LLC, (U.S. CLS. 100, 101 AND 107). SN 85-112,082. PUB. 3-1-2011. FILED 8-20-2010.  
 3,961,133 ( *See Class 25 for this trademark*).  
 3,961,150. **DOWNZAPT (STANDARD CHARACTER)**. BERRYHILL, MARK N., DBA UNCONVENTIONAL PARTNERS LLC, (U.S. CLS. 100, 101 AND 107). SN 85-116,561. PUB. 3-1-2011. FILED 8-26-2010.  
 3,961,153. **AUNT DOLLY'S GARAGE (STANDARD CHARACTER)**. PENDERGAFT, ROBERT L., DBA AUNT DOLLY'S GARAGE, (U.S. CLS. 100, 101 AND 107). SN 85-117,142. PUB. 3-1-2011. FILED 8-27-2010.  
 3,961,161 ( *See Class 16 for this trademark*).  
 3,961,171. **CORNERSTONE PHOTOGRAPHY (STANDARD CHARACTER)**. CORNERSTONE PHOTOGRAPHY, INC., (U.S. CLS. 100, 101 AND 107). SN 85-119,332. PUB. 3-1-2011. FILED 8-31-2010.  
 3,961,177. **CONTROLLED REMOTE VIEWING (STANDARD CHARACTER)**. BUCHANAN, LEONARD E., DBA PROBLEMS SOLUTIONS INNOVATIONS, (U.S. CLS. 100, 101 AND 107). SN 85-120,833. PUB. 3-1-2011. FILED 9-1-2010.  
 3,961,182. **QUALITY, CONVENIENCE & VALUE (STANDARD CHARACTER)**. WEBCE LP LLLP, (U.S. CLS. 100, 101 AND 107). SN 85-120,946. PUB. 3-1-2011. FILED 9-1-2010.  
 3,961,188. **MISCELLANEOUS DESIGN**. WEBCE LP LLLP, (U.S. CLS. 100, 101 AND 107). SN 85-121,751. PUB. 3-1-2011. FILED 9-2-2010.  
 3,961,192. **FUR PEACE RANCH (STANDARD CHARACTER)**. FUR PEACE RANCH, INC., (U.S. CLS. 100, 101 AND 107). SN 85-122,467. PUB. 3-1-2011. FILED 9-3-2010.  
 3,961,206. **CELEBRATION LANE (STANDARD CHARACTER)**. KEMPER DEVELOPMENT COMPANY, (U.S. CLS. 100, 101 AND 107). SN 85-122,948. PUB. 3-1-2011. FILED 9-3-2010.  
 3,961,207. **LIFEFLOW MEDITATION (STANDARD CHARACTER)**. MIND & BODY RESEARCH LTD., (U.S. CLS. 100, 101 AND 107). SN 85-122,997. PUB. 3-1-2011. FILED 9-3-2010.  
 3,961,208. **PROJECT MEDITATION (STANDARD CHARACTER)**. MIND & BODY RESEARCH LTD., (U.S. CLS. 100, 101 AND 107). SN 85-123,009. PUB. 3-1-2011. FILED 9-3-2010.  
 3,961,214. **ALL STAR CAST (STANDARD CHARACTER)**. GIANT KILLER PRODUCTIONS, INC., (U.S. CLS. 100, 101 AND 107). SN 85-123,395. PUB. 3-1-2011. FILED 9-4-2010.  
 3,961,217. **LOVE MENTORING (STANDARD CHARACTER)**. KIRSCHNER, DIANA, (U.S. CLS. 100, 101 AND 107). SN 85-123,514. PUB. 3-1-2011. FILED 9-6-2010.  
 3,961,218. **SUICIDE DYNAMICS (STANDARD CHARACTER)**. INTERNET PHYSICIAN INC, (U.S. CLS. 100, 101 AND 107). SN 85-123,550. PUB. 3-1-2011. FILED 9-6-2010.  
 3,961,219. **MAMAFIT (STANDARD CHARACTER)**. KAKITA, JENNIFER, (U.S. CLS. 100, 101 AND 107). SN 85-123,562. PUB. 3-1-2011. FILED 9-6-2010.  
 3,961,221. **POWER TO THE COUPLE (STANDARD CHARACTER)**. REPUBLIC INC., DBA WEDDING REPUBLIC, (U.S. CLS. 100, 101 AND 107). SN 85-123,617. PUB. 3-1-2011. FILED 9-6-2010.  
 3,961,226. **FERGUSON CENTER FOR THE ARTS AND DESIGN**. FERGUSON ENTERPRISES, INC., (U.S. CLS. 100, 101 AND 107). SN 85-123,758. PUB. 3-1-2011. FILED 9-7-2010.  
 3,961,227. **FERGUSON CENTER FOR THE ARTS AND DESIGN**. FERGUSON ENTERPRISES, INC., (U.S. CLS. 100, 101 AND 107). SN 85-123,762. PUB. 3-1-2011. FILED 9-7-2010.  
 3,961,229. **ALPHA PSI OMEGA (STANDARD CHARACTER)**. ALPHA PSI OMEGA, (U.S. CLS. 100, 101 AND 107). SN 85-123,843. PUB. 3-1-2011. FILED 9-7-2010.  
 3,961,235. **KIDS & PROS DEVELOPING CHARACTER AND SKILLS THROUGH ATHLETICS AND DESIGN**. 6 CURRYS, INC, (U.S. CLS. 100, 101 AND 107). SN 85-124,227. PUB. 3-1-2011. FILED 9-7-2010.  
 3,961,245 ( *See Class 9 for this trademark*).  
 3,961,257. **NETCOM INFORMATION TECHNOLOGY (STANDARD CHARACTER)**. NETCOM INFORMATION TECHNOLOGY, INC., (U.S. CLS. 100, 101 AND 107). SN 85-125,389. PUB. 3-1-2011. FILED 9-8-2010.  
 3,961,265. **K-9'S AGAINST CANCER BWB CAMP BOW WOW'S BOW WOW BUDDIES FOUNDATION AND DESIGN**. THE BOW WOW BUDDIES FOUNDATION, INC., (U.S. CLS. 100, 101 AND 107). SN 85-125,840. PUB. 3-1-2011. FILED 9-9-2010.  
 3,961,272. **SLOTS VILLAGE (STANDARD CHARACTER)**. TOPEKA INVESTMENTS MANAGEMENT LIMITED, (U.S. CLS. 100, 101 AND 107). SN 85-126,315. PUB. 3-1-2011. FILED 9-9-2010.  
 3,961,279. **HP HOUSATONIC PRESS AND DESIGN**. MYRIN INSTITUTE, INC., THE, (U.S. CLS. 100, 101 AND 107). SN 85-126,637. PUB. 3-1-2011. FILED 9-10-2010.  
 3,961,298. **DEAR BAD DAD (STANDARD CHARACTER)**. THE BERMINATOR, LLC, DBA DEAR BAD DAD, LLC, (U.S.



- CLS. 100, 101 AND 107). SN 85-126,920. PUB. 3-1-2011. FILED 9-10-2010.
- 3,961,307 ( *See Class 35 for this trademark*).
- 3,961,308. **CHARLOTTE SPEED DEMONS AND DESIGN**. RACE CITY ROLLER DERBY, INC., (U.S. CLS. 100, 101 AND 107). SN 85-127,246. PUB. 3-1-2011. FILED 9-10-2010.
- 3,961,322. **C'MON GOLISANO CHILDREN'S MUSEUM OF NAPLES (STANDARD CHARACTER)**. GOLISANO CHILDREN'S MUSEUM OF NAPLES, INC., (U.S. CLS. 100, 101 AND 107). SN 85-127,547. PUB. 3-1-2011. FILED 9-11-2010.
- 3,961,324. **MISCELLANEOUS DESIGN**. BLUE SPRUCE FARM, INC., (U.S. CLS. 100, 101 AND 107). SN 85-127,611. PUB. 3-1-2011. FILED 9-12-2010.
- 3,961,326 ( *See Class 35 for this trademark*).
- 3,961,327. **RECYCLED MOVIES AT FRESH PRICES (STANDARD CHARACTER)**. FUCHS, ANDREAS, DBA CREATIVE CINEMA, (U.S. CLS. 100, 101 AND 107). SN 85-127,694. PUB. 3-1-2011. FILED 9-12-2010.
- 3,961,328. **MULTISGREEN (STANDARD CHARACTER)**. FUCHS, ANDREAS, DBA CREATIVE CINEMA, (U.S. CLS. 100, 101 AND 107). SN 85-127,698. PUB. 3-1-2011. FILED 9-12-2010.
- 3,961,331. **THE SEXUAL OUTLAWS (STANDARD CHARACTER)**. MYERS, CHARLES DAVID NEFF, (U.S. CLS. 100, 101 AND 107). SN 85-127,735. PUB. 3-1-2011. FILED 9-13-2010.
- 3,961,338. **THE NEW ROYALTY (STANDARD CHARACTER)**. THE EUPHORIA ENTERTAINMENT LLC, (U.S. CLS. 100, 101 AND 107). SN 85-127,850. PUB. 3-1-2011. FILED 9-13-2010.
- 3,961,347. **SOC (STANDARD CHARACTER)**. AMERICAN ASSOCIATION OF STATE COLLEGES AND UNIVERSITIES, (U.S. CLS. 100, 101 AND 107). SN 85-128,071. PUB. 3-1-2011. FILED 9-13-2010.
- 3,961,352. **YOGA WEST (STANDARD CHARACTER)**. KIMBERLY ELLNER, DBA YOGA WEST, (U.S. CLS. 100, 101 AND 107). SN 85-128,083. PUB. 3-1-2011. FILED 9-13-2010.
- 3,961,354. **TWP AND DESIGN**. TODD WINSLOW PIERCE LLC, (U.S. CLS. 100, 101 AND 107). SN 85-128,122. PUB. 3-1-2011. FILED 9-13-2010.
- 3,961,361. **HI INFIDELITY AND DESIGN**. MIKULSKIS, DAVID, (U.S. CLS. 100, 101 AND 107). SN 85-128,268. PUB. 3-1-2011. FILED 9-13-2010.
- 3,961,380 ( *See Class 9 for this trademark*).
- 3,961,388. **REINVENTED LIVING (STANDARD CHARACTER)**. DIXON, JACQUELYN D, (U.S. CLS. 100, 101 AND 107). SN 85-128,640. PUB. 3-1-2011. FILED 9-13-2010.
- 3,961,393. **PRAUS LLC AND DESIGN**. PRAUS, LLC, (U.S. CLS. 100, 101 AND 107). SN 85-128,725. PUB. 3-1-2011. FILED 9-14-2010.
- 3,961,447. **CULINARY FIGHT NIGHT (STANDARD CHARACTER)**. THE KLEIN GROUP, INC., (U.S. CLS. 100, 101 AND 107). SN 85-129,313. PUB. 3-1-2011. FILED 9-14-2010.
- 3,961,451. **GOOD MATTERS (STANDARD CHARACTER)**. TOM'S OF MAINE, INC., MULTIPLE CLASS, (INT. CLS. 41 AND 42), (U.S. CLS. 100, 101 AND 107). SN 85-129,337. PUB. 3-1-2011. FILED 9-14-2010.
- 3,961,476. **BATTLE AT THE CAPITAL (STANDARD CHARACTER)**. SOTO, MARK, (U.S. CLS. 100, 101 AND 107). SN 85-129,673. PUB. 3-1-2011. FILED 9-14-2010.
- 3,961,479. **TENNXPILES (STANDARD CHARACTER)**. MICHAEL SHANNON PHILLIPS, (U.S. CLS. 100, 101 AND 107). SN 85-129,700. PUB. 3-1-2011. FILED 9-14-2010.
- 3,961,486. **A CAREER THAT LOVES YOU BACK (STANDARD CHARACTER)**. BRADFORD CAPITAL PARTNERS, (U.S. CLS. 100, 101 AND 107). SN 85-129,793. PUB. 3-1-2011. FILED 9-15-2010.
- 3,961,490. **HERO COMPLEX (STANDARD CHARACTER)**. LOS ANGELES TIMES COMMUNICATIONS, LLC, (U.S. CLS. 100, 101 AND 107). SN 85-129,952. PUB. 3-1-2011. FILED 9-15-2010.
- 3,961,499. **THE HOWLERS (STANDARD CHARACTER)**. MANCILLAS, ELIJAH, AND MANCILLAS, JOSHUA, (U.S. CLS. 100, 101 AND 107). SN 85-130,134. PUB. 3-1-2011. FILED 9-15-2010.
- 3,961,532. **AWKWARD FAMILY PET PHOTOS (STANDARD CHARACTER)**. AWKWARD FAMILY, LLC, (U.S. CLS. 100, 101 AND 107). SN 85-130,452. PUB. 3-1-2011. FILED 9-15-2010.
- 3,961,534. **RIVER CITY (STANDARD CHARACTER)**. PINNACLE ENTERTAINMENT, INC., (U.S. CLS. 100, 101 AND 107). SN 85-130,473. PUB. 3-1-2011. FILED 9-15-2010.
- 3,961,562. **MISCELLANEOUS DESIGN**. LOYALIST COLLEGE, (U.S. CLS. 100, 101 AND 107). SN 85-130,837. PUB. 3-1-2011. FILED 9-16-2010.
- 3,961,574. **P THE PATH WE CHOSE AND DESIGN**. PATH STUDIOS, LLC, (U.S. CLS. 100, 101 AND 107). SN 85-131,057. PUB. 3-1-2011. FILED 9-16-2010.
- 3,961,576. **KNOWLEDGE MATTERS (STANDARD CHARACTER)**. WEBCE LP LLLP, (U.S. CLS. 100, 101 AND 107). SN 85-131,072. PUB. 3-1-2011. FILED 9-16-2010.
- 3,961,586. **BEASTS & LUNATICS (STANDARD CHARACTER)**. STEVENS, DENNIS L., (U.S. CLS. 100, 101 AND 107). SN 85-131,163. PUB. 3-1-2011. FILED 9-16-2010.
- 3,961,604. **LUPE FUENTES (STANDARD CHARACTER)**. LUPE FUENTES, LLC, (U.S. CLS. 100, 101 AND 107). SN 85-131,431. PUB. 3-1-2011. FILED 9-16-2010.
- 3,961,619. **ARDYSS (STANDARD CHARACTER)**. OPPORTUNITY HOLDING, LLC, (U.S. CLS. 100, 101 AND 107). SN 85-131,638. PUB. 3-1-2011. FILED 9-16-2010.
- 3,961,623. **BREAD CRUMBS (STANDARD CHARACTER)**. BREAD CRUMBS, (U.S. CLS. 100, 101 AND 107). SN 85-131,670. PUB. 3-1-2011. FILED 9-16-2010.
- 3,961,656. **I CLUBIN AND DESIGN**. DE NINA, BERNI, (U.S. CLS. 100, 101 AND 107). SN 85-132,222. PUB. 3-1-2011. FILED 9-17-2010.
- 3,961,657. **ILOVELUPE.COM (STANDARD CHARACTER)**. LUPE FUENTES, LLC, (U.S. CLS. 100, 101 AND 107). SN 85-132,234. PUB. 3-1-2011. FILED 9-17-2010.
- 3,961,669. **MADISON SQUARE GARDEN BOXING (STANDARD CHARACTER)**. MADISON SQUARE GARDEN, L.P., (U.S. CLS. 100, 101 AND 107). SN 85-132,496. PUB. 3-1-2011. FILED 9-17-2010.
- 3,961,670. **HISTORY IS IN OUR CORNER (STANDARD CHARACTER)**. MADISON SQUARE GARDEN, L.P., (U.S. CLS. 100, 101 AND 107). SN 85-132,506. PUB. 3-1-2011. FILED 9-17-2010.
- 3,961,687. **ALONG THOSE LINES (STANDARD CHARACTER)**. BIRD, BENJAMIN, (U.S. CLS. 100, 101 AND 107). SN 85-132,741. PUB. 3-1-2011. FILED 9-18-2010.
- 3,961,688. **PAGEANTS UNIVERSE (STANDARD CHARACTER)**. UNITY INTERNATIONAL FOUNDATION, (U.S. CLS. 100, 101 AND 107). SN 85-132,742. PUB. 3-1-2011. FILED 9-18-2010.
- 3,961,694. **THE NAKED FOOT (STANDARD CHARACTER)**. LAUREN JONES, DBA L2S, (U.S. CLS. 100, 101 AND 107). SN 85-132,887. PUB. 3-1-2011. FILED 9-18-2010.
- 3,961,714. **PRICE PERSPECTIVE (STANDARD CHARACTER)**. T. ROWE PRICE GROUP, INC., (U.S. CLS. 100, 101 AND 107). SN 85-135,394. PUB. 3-1-2011. FILED 9-22-2010.
- 3,961,723 ( *See Class 9 for this trademark*).
- 3,961,733 ( *See Class 9 for this trademark*).
- 3,961,741. **AMERICAN TREBLE (STANDARD CHARACTER)**. AMERICAN TREBLE, LLC, (U.S. CLS. 100, 101 AND 107). SN 85-139,395. PUB. 3-1-2011. FILED 9-27-2010.
- 3,961,752. **PPAI EXPO EDUCATION (STANDARD CHARACTER)**. PROMOTIONAL PRODUCTS ASSOCIATION INTERNATIONAL, (U.S. CLS. 100, 101 AND 107). SN 85-140,781. PUB. 3-1-2011. FILED 9-29-2010.
- 3,961,760. **MODEL MOVES (STANDARD CHARACTER)**. EHLERS, SHAWN, (U.S. CLS. 100, 101 AND 107). SN 85-141,508. PUB. 3-1-2011. FILED 9-29-2010.
- 3,961,762 ( *See Class 35 for this trademark*).
- 3,961,763. **HABANA/HARLEM (STANDARD CHARACTER)**. HABANA HARLEM, LLC, (U.S. CLS. 100, 101 AND 107). SN 85-141,885. PUB. 3-1-2011. FILED 9-30-2010.
- 3,961,798. **MD MAGAZINE (STANDARD CHARACTER)**. INTELLISPHERE, LLC, (U.S. CLS. 100, 101 AND 107). SN 85-146,476. PUB. 3-1-2011. FILED 10-6-2010.
- 3,961,800 ( *See Class 14 for this trademark*).
- 3,961,803 ( *See Class 16 for this trademark*).
- 3,961,817. **MASTER'S VOICE (STANDARD CHARACTER)**. MASTER'S VOICE, INC., (U.S. CLS. 100, 101 AND 107). SN 85-149,076. PUB. 3-1-2011. FILED 10-9-2010.
- 3,961,818. **YESTERDAY'S TOP SECRETS (STANDARD CHARACTER)**. ANSTAETT, TIM, (U.S. CLS. 100, 101

- AND 107). SN 85-149,140. PUB. 3-1-2011. FILED 10-10-2010.
- 3,961,825. **HIGH GEAR (STANDARD CHARACTER)**. KENNEY, KRISTIN N., (U.S. CLS. 100, 101 AND 107). SN 85-149,555. PUB. 3-1-2011. FILED 10-11-2010.
- 3,961,827. **BALL YALL (STANDARD CHARACTER)**. BRYAN N. HADLEY, (U.S. CLS. 100, 101 AND 107). SN 85-149,563. PUB. 3-1-2011. FILED 10-11-2010.
- 3,961,830. **CHRIST INTERNATIONAL CENTER AND DESIGN**. CHRIST INTERNATIONAL CENTER, (U.S. CLS. 100, 101 AND 107). SN 85-149,689. PUB. 3-1-2011. FILED 10-11-2010.
- 3,961,842. **APOCRYPHAL PRESS (STANDARD CHARACTER)**. KORSON, THOMAS E., (U.S. CLS. 100, 101 AND 107). SN 85-149,946. PUB. 3-1-2011. FILED 10-11-2010.
- 3,961,849. **DRAGONSAGA AND DESIGN**. GRAVITY INTERACTIVE, INC., (U.S. CLS. 100, 101 AND 107). SN 85-150,009. PUB. 3-1-2011. FILED 10-11-2010.
- 3,961,859. **ALWAYS PRESENTABLE AND DESIGN**. ALWAYS PRESENTABLE MUSIC & ENTERTAINMENT COMPANY INC., (U.S. CLS. 100, 101 AND 107). SN 85-150,306. PUB. 3-1-2011. FILED 10-12-2010.
- 3,961,864. **UNSUCK IT (STANDARD CHARACTER)**. MULE DESIGN STUDIO, INC., (U.S. CLS. 100, 101 AND 107). SN 85-151,610. PUB. 3-1-2011. FILED 10-13-2010.
- 3,961,869. **HOOPPLAY USA.COM (STANDARD CHARACTER)**. ELITE SPORTING EVENTS, INC., (U.S. CLS. 100, 101 AND 107). SN 85-151,960. PUB. 3-1-2011. FILED 10-13-2010.
- 3,961,886. **MISCELLANEOUS DESIGN**. ADLER TRAINING, MULTIPLE CLASS, (INT. CLS. 41 AND 44), (U.S. CLS. 100, 101 AND 107). SN 85-156,574. PUB. 3-1-2011. FILED 10-19-2010.
- 3,961,942 ( *See Class 6 for this trademark*).
- 3,961,946. **THE GIST BLOG AND DESIGN**. NEWGISTICS, INC., (U.S. CLS. 100, 101 AND 107). SN 85-177,683. PUB. 3-1-2011. FILED 11-16-2010.
- 3,961,950. **ONE ON ONE BASKETBALL TRAINING AND DESIGN**. ONE ON ONE BASKETBALL, INC., (U.S. CLS. 100, 101 AND 107). SN 85-188,626. PUB. 3-1-2011. FILED 12-1-2010.
- 3,961,951 ( *See Class 16 for this trademark*).
- 3,961,952. **PLAY THE MUSIC. PLAY THE GAME. (STANDARD CHARACTER)**. STEREOFAME, INC., (U.S. CLS. 100, 101 AND 107). SN 85-190,770. PUB. 3-1-2011. FILED 12-4-2010.
- 3,961,959 ( *See Class 35 for this trademark*).
- 3,960,226 ( *See Class 9 for this trademark*).
- 3,960,280 ( *See Class 9 for this trademark*).
- 3,960,286 ( *See Class 9 for this trademark*).
- 3,960,289 ( *See Class 9 for this trademark*).
- 3,960,303. **SKILLBUILDER (STANDARD CHARACTER)**. BASE CORP., (U.S. CLS. 100 AND 101). SN 77-589,653. PUB. 3-1-2011. FILED 10-9-2008.
- 3,960,315 ( *See Class 40 for this trademark*).
- 3,960,316 ( *See Class 38 for this trademark*).
- 3,960,318. **HOPAD BUILDER (STANDARD CHARACTER)**. CLICK SALES INC., (U.S. CLS. 100 AND 101). SN 77-684,756. PUB. 7-14-2009. FILED 3-5-2009.
- 3,960,320. **E AND DESIGN**. REALESPLACE LLC, (U.S. CLS. 100 AND 101). SN 77-687,488. PUB. 3-1-2011. FILED 3-10-2009.
- 3,960,325 ( *See Class 35 for this trademark*).
- 3,960,327. **CHORUS (STANDARD CHARACTER)**. ENVIO NETWORKS, INC., (U.S. CLS. 100 AND 101). SN 77-709,227. PUB. 3-1-2011. FILED 4-8-2009.
- 3,960,329 ( *See Class 35 for this trademark*).
- 3,960,339 ( *See Class 9 for this trademark*).
- 3,960,347 ( *See Class 35 for this trademark*).
- 3,960,354. **ONE NEB AND DESIGN**. INGENIATRICS TECHNOLOGIAS, S.L., (U.S. CLS. 100 AND 101). SN 77-797,948. PUB. 11-2-2010. FILED 8-5-2009.
- 3,960,374 ( *See Class 37 for this trademark*).
- 3,960,375 ( *See Class 35 for this trademark*).
- 3,960,388 ( *See Class 37 for this trademark*).
- 3,960,394 ( *See Class 9 for this trademark*).
- 3,960,397 ( *See Class 9 for this trademark*).
- 3,960,405 ( *See Class 9 for this trademark*).
- 3,960,406 ( *See Class 9 for this trademark*).
- 3,960,433 ( *See Class 37 for this trademark*).
- 3,960,436. **FOREIGN TRADE SERVICE INSPECTIONS AND DESIGN**. FOREIGN TRADE SERVICE CORPORATION, THE, DBA FOREIGN TRADE SERVICE, (U.S. CLS. 100 AND 101). SN 77-896,109. PUB. 3-1-2011. FILED 12-17-2009.
- 3,960,441 ( *See Class 6 for this trademark*).
- 3,960,459 ( *See Class 35 for this trademark*).
- 3,960,466 ( *See Class 9 for this trademark*).
- 3,960,489. **ESSAY TAMER (STANDARD CHARACTER)**. WISECHOICE BRANDS, LLC, DBA WISECHOICE, (U.S. CLS. 100 AND 101). SN 77-941,445. PUB. 3-1-2011. FILED 2-22-2010.
- 3,960,490 ( *See Class 35 for this trademark*).
- 3,960,496 ( *See Class 35 for this trademark*).
- 3,960,503 ( *See Class 9 for this trademark*).
- 3,960,505 ( *See Class 38 for this trademark*).
- 3,960,507. **QUIRKY (STANDARD CHARACTER)**. QUIRKY, INC., (U.S. CLS. 100 AND 101). SN 77-946,558. PUB. 3-1-2011. FILED 2-27-2010.
- 3,960,510 ( *See Class 9 for this trademark*).
- 3,960,536. **SCIENTIFIC BRAIN TRAINING PRO (STANDARD CHARACTER)**. HAPPYNEURON INC., (U.S. CLS. 100 AND 101). SN 77-954,952. PUB. 3-1-2011. FILED 3-9-2010.
- 3,960,537 ( *See Class 35 for this trademark*).
- 3,960,542 ( *See Class 37 for this trademark*).
- 3,960,543 ( *See Class 35 for this trademark*).
- 3,960,544 ( *See Class 35 for this trademark*).
- 3,960,558 ( *See Class 9 for this trademark*).
- 3,960,559. **MORE THAN YOUR IT DEPARTMENT (STANDARD CHARACTER)**. MACHADO CONSULTING, INC., (U.S. CLS. 100 AND 101). SN 77-961,654. PUB. 3-1-2011. FILED 3-17-2010.
- 3,960,565 ( *See Class 9 for this trademark*).
- 3,960,583. **LOCATION MATTERS (STANDARD CHARACTER)**. STAHL, THOMAS A., (U.S. CLS. 100 AND 101). SN 77-966,631. PUB. 3-1-2011. FILED 3-23-2010.
- 3,960,587 ( *See Class 5 for this trademark*).
- 3,960,607. **CCI (STANDARD CHARACTER)**. CLEAR CARBON INNOVATIONS LLC, (U.S. CLS. 100 AND 101). SN 77-969,787. PUB. 3-1-2011. FILED 3-26-2010.
- 3,960,608. **CCI AND DESIGN**. CLEAR CARBON INNOVATIONS LLC, (U.S. CLS. 100 AND 101). SN 77-969,808. PUB. 3-1-2011. FILED 3-26-2010.
- 3,960,610 ( *See Class 35 for this trademark*).
- 3,960,640 ( *See Class 9 for this trademark*).
- 3,960,641 ( *See Class 9 for this trademark*).
- 3,960,642 ( *See Class 9 for this trademark*).
- 3,960,645 ( *See Class 9 for this trademark*).
- 3,960,646 ( *See Class 35 for this trademark*).
- 3,960,648 ( *See Class 9 for this trademark*).
- 3,960,649 ( *See Class 9 for this trademark*).
- 3,960,650 ( *See Class 7 for this trademark*).
- 3,960,651 ( *See Class 6 for this trademark*).
- 3,960,656 ( *See Class 9 for this trademark*).
- 3,960,658 ( *See Class 7 for this trademark*).
- 3,960,660 ( *See Class 3 for this trademark*).
- 3,960,665 ( *See Class 1 for this trademark*).
- 3,960,666 ( *See Class 9 for this trademark*).
- 3,960,669 ( *See Class 9 for this trademark*).
- 3,960,675 ( *See Class 9 for this trademark*).
- 3,960,676 ( *See Class 9 for this trademark*).
- 3,960,677 ( *See Class 25 for this trademark*).
- 3,960,683 ( *See Class 9 for this trademark*).
- 3,960,704 ( *See Class 35 for this trademark*).
- 3,960,705 ( *See Class 1 for this trademark*).
- 3,960,708 ( *See Class 9 for this trademark*).
- 3,960,716 ( *See Class 9 for this trademark*).
- 3,960,721 ( *See Class 11 for this trademark*).
- 3,960,723 ( *See Class 9 for this trademark*).
- 3,960,729 ( *See Class 31 for this trademark*).
- 3,960,730 ( *See Class 9 for this trademark*).
- 3,960,731 ( *See Class 9 for this trademark*).
- 3,960,732 ( *See Class 9 for this trademark*).

## CLASS 42—SCIENTIFIC AND COMPUTER SERVICES

- 3,960,759 ( *See Class 7 for this trademark.*)  
 3,960,771 ( *See Class 9 for this trademark.*)  
 3,960,776 ( *See Class 9 for this trademark.*)  
 3,960,784 ( *See Class 9 for this trademark.*)  
 3,960,795 ( *See Class 9 for this trademark.*)  
 3,960,831. **RACKTIVITY (STANDARD CHARACTER)**. RACKTIVITY, NAAMLOZE VENNOOTSCHAP, (U.S. CLS. 100 AND 101). SN 79-089,554. PUB. 3-1-2011. FILED 9-15-2010.  
 3,960,862. **TENCAP (STANDARD CHARACTER)**. TENCAP TENNIS, LLC, (U.S. CLS. 100 AND 101). SN 85-007,324. PUB. 3-1-2011. FILED 4-6-2010.  
 3,960,867. **WEBFOSSIL (STANDARD CHARACTER)**. TIMOTHY J. MCGUINNESS, AKA TIM MCGUINNESS, (U.S. CLS. 100 AND 101). SN 85-008,557. PUB. 3-1-2011. FILED 4-7-2010.  
 3,960,892 ( *See Class 9 for this trademark.*)  
 3,960,894 ( *See Class 9 for this trademark.*)  
 3,960,895. **CHANNELCLOUD (STANDARD CHARACTER)**. SEHGAL AMAN, DBA CHANNELVISSION INC., (U.S. CLS. 100 AND 101). SN 85-018,755. PUB. 3-1-2011. FILED 4-20-2010.  
 3,960,896. **CLOUDVISSION (STANDARD CHARACTER)**. SEHGAL AMAN, DBA CHANNELVISSION INC., (U.S. CLS. 100 AND 101). SN 85-018,762. PUB. 3-1-2011. FILED 4-20-2010.  
 3,960,897 ( *See Class 36 for this trademark.*)  
 3,960,904 ( *See Class 9 for this trademark.*)  
 3,960,921 ( *See Class 9 for this trademark.*)  
 3,960,939. **T TRICEN AND DESIGN**. TRICEN TECHNOLOGIES, INC., DBA TRICEN TECHNOLOGIES, (U.S. CLS. 100 AND 101). SN 85-040,163. PUB. 3-1-2011. FILED 5-17-2010.  
 3,960,958. **C-A-A-S (STANDARD CHARACTER)**. SEHGAL AMAN, DBA CHANNELVISSION INC., (U.S. CLS. 100 AND 101). SN 85-046,307. PUB. 3-1-2011. FILED 5-24-2010.  
 3,960,971 ( *See Class 35 for this trademark.*)  
 3,960,998 ( *See Class 35 for this trademark.*)  
 3,961,029 ( *See Class 35 for this trademark.*)  
 3,961,034 ( *See Class 35 for this trademark.*)  
 3,961,035 ( *See Class 35 for this trademark.*)  
 3,961,045. **KRAMES ONLINE (STANDARD CHARACTER)**. THE STAYWELL COMPANY, LLC, (U.S. CLS. 100 AND 101). SN 85-091,754. PUB. 3-1-2011. FILED 7-23-2010.  
 3,961,053 ( *See Class 16 for this trademark.*)  
 3,961,056. **THE POWER OF THE PLATFORM (STANDARD CHARACTER)**. INXPO, INC., (U.S. CLS. 100 AND 101). SN 85-095,610. PUB. 3-1-2011. FILED 7-29-2010.  
 3,961,060. **FLOW DYNAMICS (STANDARD CHARACTER)**. BADGER METER, INC., (U.S. CLS. 100 AND 101). SN 85-099,175. PUB. 3-1-2011. FILED 8-3-2010.  
 3,961,064 ( *See Class 9 for this trademark.*)  
 3,961,084 ( *See Class 38 for this trademark.*)  
 3,961,087. **A REMARKABLE LEARNING COMPANY (STANDARD CHARACTER)**. PAKRA LLC, (U.S. CLS. 100 AND 101). SN 85-103,329. PUB. 3-1-2011. FILED 8-9-2010.  
 3,961,096. **ICR (STANDARD CHARACTER)**. ICR, INC., (U.S. CLS. 100 AND 101). SN 85-105,277. PUB. 3-1-2011. FILED 8-11-2010.  
 3,961,102. **MISCELLANEOUS DESIGN**. MONKEY MEDIA SOFTWARE INC., (U.S. CLS. 100 AND 101). SN 85-106,485. PUB. 3-1-2011. FILED 8-12-2010.  
 3,961,119 ( *See Class 35 for this trademark.*)  
 3,961,143. **MISCELLANEOUS DESIGN**. IMPERIAL PUBLISHING, INC., (U.S. CLS. 100 AND 101). SN 85-115,450. PUB. 3-1-2011. FILED 8-25-2010.  
 3,961,162. **DATAGRID AND DESIGN**. SAMUEL, GAW, TA DATAGRID STORAGE, (U.S. CLS. 100 AND 101). SN 85-118,143. PUB. 3-1-2011. FILED 8-28-2010.  
 3,961,164. **CHT (STANDARD CHARACTER)**. COMPLIANT HEALTHCARE TECHNOLOGIES, LLC, (U.S. CLS. 100 AND 101). SN 85-118,417. PUB. 3-1-2011. FILED 8-30-2010.  
 3,961,168. **CONNANCE EVI (STANDARD CHARACTER)**. CONNANCE, INC., (U.S. CLS. 100 AND 101). SN 85-118,754. PUB. 3-1-2011. FILED 8-30-2010.  
 3,961,196 ( *See Class 16 for this trademark.*)  
 3,961,244. **ALS (STANDARD CHARACTER)**. ALS CANADA LTD., (U.S. CLS. 100 AND 101). SN 85-124,675. PUB. 3-1-2011. FILED 9-8-2010.  
 3,961,256. **CUFOLIO (STANDARD CHARACTER)**. GEORGIA CORPORATE FEDERAL CREDIT UNION, (U.S. CLS. 100 AND 101). SN 85-125,290. PUB. 3-1-2011. FILED 9-8-2010.  
 3,961,273. **IF AND DESIGN**. IMAGINATION FACTORY, INC., THE, AKA IFI, (U.S. CLS. 100 AND 101). SN 85-126,385. PUB. 3-1-2011. FILED 9-9-2010.  
 3,961,284. **FRONTIERS OF ENGINEERING (STANDARD CHARACTER)**. NATIONAL ACADEMY OF ENGINEERING FUND, (U.S. CLS. 100 AND 101). SN 85-126,693. PUB. 3-1-2011. FILED 9-10-2010.  
 3,961,286. **RENKARA (STANDARD CHARACTER)**. SIEG, CHARLES R., (U.S. CLS. 100 AND 101). SN 85-126,722. PUB. 3-1-2011. FILED 9-10-2010.  
 3,961,292. **SARASOHO (STANDARD CHARACTER)**. SARASOHO ENTERPRISE CONTENT MGMT & DESIGN, (U.S. CLS. 100 AND 101). SN 85-126,776. PUB. 3-1-2011. FILED 9-10-2010.  
 3,961,358. **CARBONPIG (STANDARD CHARACTER)**. CHANGE FOR CLIMATE LLC, DBA CARBONPIG, (U.S. CLS. 100 AND 101). SN 85-128,234. PUB. 3-1-2011. FILED 9-13-2010.  
 3,961,383. **PHENOMENAL SUPPORT (STANDARD CHARACTER)**. PRACTICE FUSION, INC., MULTIPLE CLASS, (INT. CLS. 42 AND 44), (U.S. CLS. 100 AND 101). SN 85-128,549. PUB. 3-1-2011. FILED 9-13-2010.  
 3,961,417. **FEFFIGHTERS (STANDARD CHARACTER)**. TRANSPARENT FINANCIAL SERVICES, INC., (U.S. CLS. 100 AND 101). SN 85-128,940. PUB. 3-1-2011. FILED 9-14-2010.  
 3,961,426. **OMNI-PLANT THE APPLICATION OF KNOWLEDGE AND DESIGN**. OMNI-PLANT CORPORATION, (U.S. CLS. 100 AND 101). SN 85-129,087. PUB. 3-1-2011. FILED 9-14-2010.  
 3,961,435 ( *See Class 20 for this trademark.*)  
 3,961,445. **MSIA (STANDARD CHARACTER)**. INTRINSIC BIOPROBES, INC., (U.S. CLS. 100 AND 101). SN 85-129,308. PUB. 3-1-2011. FILED 9-14-2010.  
 3,961,450 ( *See Class 9 for this trademark.*)  
 3,961,451 ( *See Class 41 for this trademark.*)  
 3,961,482. **REVPAR GURU (STANDARD CHARACTER)**. REVPAR GURU, INC., (U.S. CLS. 100 AND 101). SN 85-129,721. PUB. 3-1-2011. FILED 9-14-2010.  
 3,961,535 ( *See Class 9 for this trademark.*)  
 3,961,539 ( *See Class 35 for this trademark.*)  
 3,961,546. **TALKING SIP CIRRUS (STANDARD CHARACTER)**. IVR TECHNOLOGIES, INC., (U.S. CLS. 100 AND 101). SN 85-130,587. PUB. 3-1-2011. FILED 9-15-2010.  
 3,961,558. **ON THE FLY COMPUTER GUY (STANDARD CHARACTER)**. M. E. REDMOND GROUP, INC., DBA ON THE FLY COMPUTER GUY, (U.S. CLS. 100 AND 101). SN 85-130,710. PUB. 3-1-2011. FILED 9-15-2010.  
 3,961,564. **LAUNCH SOMETHING (STANDARD CHARACTER)**. LAUNCH, LLC, DBA LAUNCH SOMETHING, (U.S. CLS. 100 AND 101). SN 85-130,881. PUB. 3-1-2011. FILED 9-16-2010.  
 3,961,617. **CREATINGWILL.COM AND DESIGN**. CREATINGWILL.COM LLC, MULTIPLE CLASS, (INT. CLS. 42 AND 45), (U.S. CLS. 100 AND 101). SN 85-131,622. PUB. 3-1-2011. FILED 9-16-2010.  
 3,961,618. **CREATINGWILL.COM (STANDARD CHARACTER)**. CREATINGWILL.COM LLC, MULTIPLE CLASS, (INT. CLS. 42 AND 45), (U.S. CLS. 100 AND 101). SN 85-131,624. PUB. 3-1-2011. FILED 9-16-2010.  
 3,961,632. **VERCURY (STANDARD CHARACTER)**. VERCURY INC., (U.S. CLS. 100 AND 101). SN 85-131,733. PUB. 3-1-2011. FILED 9-16-2010.  
 3,961,638. **THUMBLETS (STANDARD CHARACTER)**. GOOD EGG CLUB LLC, (U.S. CLS. 100 AND 101). SN 85-131,777. PUB. 3-1-2011. FILED 9-17-2010.  
 3,961,673 ( *See Class 40 for this trademark.*)  
 3,961,695. **YWN (STANDARD CHARACTER)**. WHITTINGTON, COZY, DBA KNOWLEDGEPATH, MULTIPLE CLASS, (INT. CLS. 42 AND 45), (U.S. CLS. 100 AND 101). SN 85-132,916. PUB. 3-1-2011. FILED 9-19-2010.  
 3,961,726. **VETERANCAREGIVER.COM FOR THOSE WHO CARE (STYLIZED)**. WISEHEALTH, INC., (U.S. CLS. 100 AND 101). SN 85-136,448. PUB. 3-1-2011. FILED 9-23-2010.  
 3,961,728. **FOREVER FAMILY DESIGNS (STANDARD CHARACTER)**. FOREVER FAMILY DESIGNS, LLC, (U.S. CLS.



100 AND 101). SN 85-137,078. PUB. 3-1-2011. FILED 9-23-2010.  
 3,961,733 ( *See Class 9 for this trademark*).  
 3,961,757. **P AND DESIGN**. PLAXO, INC., MULTIPLE CLASS, (INT. CLS. 42 AND 45), (U.S. CLS. 100 AND 101). SN 85-141,172. PUB. 3-1-2011. FILED 9-29-2010.  
 3,961,767. **REALPRO ADVANTAGE (STANDARD CHARACTER)**. REALPRO TRAINING AND CONSULTING, (U.S. CLS. 100 AND 101). SN 85-142,040. PUB. 3-1-2011. FILED 9-30-2010.  
 3,961,770. **BENCH TREE (STANDARD CHARACTER)**. BENCH TREE GROUP, LLC, (U.S. CLS. 100 AND 101). SN 85-142,262. PUB. 3-1-2011. FILED 9-30-2010.  
 3,961,771. **WHERE KNOWLEDGE GENERATES SOLUTIONS (STANDARD CHARACTER)**. KFORCE INC., (U.S. CLS. 100 AND 101). SN 85-142,273. PUB. 3-1-2011. FILED 9-30-2010.  
 3,961,776. **ETCH U PRODUCTIONS (STANDARD CHARACTER)**. BROWN, CHRISTOPHER, (U.S. CLS. 100 AND 101). SN 85-143,083. PUB. 3-1-2011. FILED 10-1-2010.  
 3,961,780. **V2CONNECT (STANDARD CHARACTER)**. BROADSOFT, INC., (U.S. CLS. 100 AND 101). SN 85-143,360. PUB. 3-1-2011. FILED 10-1-2010.  
 3,961,793. **RENDERINSPECTOR (STANDARD CHARACTER)**. COMPUWARE CORPORATION, (U.S. CLS. 100 AND 101). SN 85-145,473. PUB. 3-1-2011. FILED 10-5-2010.  
 3,961,821 ( *See Class 35 for this trademark*).  
 3,961,857. **CROOSTER (STANDARD CHARACTER)**. CROOSTER CORP, (U.S. CLS. 100 AND 101). SN 85-150,133. PUB. 3-1-2011. FILED 10-11-2010.  
 3,961,894. **BABY TRAX (STANDARD CHARACTER)**. PROGENYHEALTH, INC., (U.S. CLS. 100 AND 101). SN 85-159,248. PUB. 3-1-2011. FILED 10-22-2010.  
 3,961,960. **GIZMO (STANDARD CHARACTER)**. LAZEL, INC., (U.S. CLS. 100 AND 101). SN 85-975,190. PUB. 1-18-2011. FILED 5-20-2010.

#### CLASS 43—HOTEL AND RESTAURANT SERVICES

3,960,249. **THERAPEASE CUISINE AND DESIGN**. THERAPEASE CUISINE, INC, MULTIPLE CLASS, (INT. CLS. 43 AND 44), (U.S. CLS. 100 AND 101). SN 76-704,111. PUB. 3-1-2011. FILED 8-13-2010.  
 3,960,287. **STUBB'S (STANDARD CHARACTER)**. ONE WORLD FOODS, INC., DBA STUBB'S LEGENDARY KITCHEN, INC., (U.S. CLS. 100 AND 101). SN 77-513,645. PUB. 3-1-2011. FILED 7-2-2008.  
 3,960,313 ( *See Class 30 for this trademark*).  
 3,960,345 ( *See Class 30 for this trademark*).  
 3,960,410 ( *See Class 39 for this trademark*).  
 3,960,411. **LIVE. LOVE. LE BLANC. (STANDARD CHARACTER)**. PALACE HOLDING, S.A. DE C.V., MULTIPLE CLASS, (INT. CLS. 43 AND 44), (U.S. CLS. 100 AND 101). SN 77-853,664. PUB. 3-1-2011. FILED 10-21-2009.  
 3,960,581. **PITCHFORK AND DESIGN**. ARIZONA BOARD OF REGENTS, FOR AND ON BEHALF OF ARIZONA STATE UNIVERSITY, (U.S. CLS. 100 AND 101). SN 77-966,507. PUB. 3-1-2011. FILED 3-23-2010.  
 3,960,584. **ECO2TARIAN (STANDARD CHARACTER)**. OTARIAN LONDON LIMITED, (U.S. CLS. 100 AND 101). SN 77-966,698. PUB. 3-1-2011. FILED 3-23-2010.  
 3,960,594. **MISCELLANEOUS DESIGN**. THE SQUEEZE INN LLC, (U.S. CLS. 100 AND 101). SN 77-968,266. PUB. 3-1-2011. FILED 3-25-2010.  
 3,960,612. **CHESTERFIELD TOM THUMB DAY CARE CENTER & KINDERGARTEN AND DESIGN**. CHESTERFIELD TOM THUMB DAY CARE & KINDERGARTEN #2, (U.S. CLS. 100 AND 101). SN 77-970,012. PUB. 3-1-2011. FILED 3-26-2010.  
 3,960,625. **MISCELLANEOUS DESIGN**. PENROD BROTHERS, INC., (U.S. CLS. 100 AND 101). SN 78-384,409. PUB. 10-25-2005. FILED 3-15-2004.  
 3,960,652 ( *See Class 12 for this trademark*).  
 3,960,756 ( *See Class 41 for this trademark*).  
 3,960,779. **MISCELLANEOUS DESIGN**. SHANGHAI YANG LIPENG FRIED DUMPLING RESTAURANT MANAGE-

MENT CO., LTD., (U.S. CLS. 100 AND 101). SN 79-084,538. PUB. 3-1-2011. FILED 4-26-2010.  
 3,960,807. **CEENA AND DESIGN**. LEE KANG HUN, (U.S. CLS. 100 AND 101). SN 79-086,492. PUB. 3-1-2011. FILED 7-7-2010.  
 3,960,815. **SUSHIP (STYLIZED)**. EAST HEAVEN CO., LTD., (U.S. CLS. 100 AND 101). SN 79-087,594. PUB. 3-1-2011. FILED 9-10-2010.  
 3,960,835 ( *See Class 35 for this trademark*).  
 3,960,901. **FUDDS EXOTIC BURGERS (STANDARD CHARACTER)**. LUBY'S FUDDRUCKERS RESTAURANTS, LLC, (U.S. CLS. 100 AND 101). SN 85-019,441. PUB. 3-1-2011. FILED 4-21-2010.  
 3,960,903. **MISCELLANEOUS DESIGN**. LE, HUNG, DBA THE YABBY HUT, AND THE YABBY HUT, LLC, DBA THE YABBY HUT, (U.S. CLS. 100 AND 101). SN 85-022,169. PUB. 3-1-2011. FILED 4-23-2010.  
 3,960,908. **SUSHI CHOO CHOO AND DESIGN**. LIN, QI DONG, (U.S. CLS. 100 AND 101). SN 85-024,538. PUB. 3-1-2011. FILED 4-27-2010.  
 3,960,937 ( *See Class 37 for this trademark*).  
 3,961,011. **KUNG FU TEA AND DESIGN**. KF TEA USA INC, (U.S. CLS. 100 AND 101). SN 85-075,650. PUB. 3-1-2011. FILED 7-1-2010.  
 3,961,094. **CRAZY CUBAN (STANDARD CHARACTER)**. RAMIREZ, JANICE, AND RAMIREZ, ALDO, (U.S. CLS. 100 AND 101). SN 85-105,038. PUB. 3-1-2011. FILED 8-11-2010.  
 3,961,095. **PAJAMACHEF.NET ONLINE PERSONAL CHEF & COOKING INSTRUCTION AND DESIGN**. GAYLON, ALISA F., DBA PAJAMACHEF.NET BY GAYLON FUENTE RESTAURANT CONCEPTS, LLC, AND FUENTE, JOHN B., DBA PAJAMACHEF.NET BY GAYLON FUENTE RESTAURANT CONCEPTS, LLC, (U.S. CLS. 100 AND 101). SN 85-105,229. PUB. 3-1-2011. FILED 8-11-2010.  
 3,961,156. **ZAVINO WINE BAR PIZZERIA (STYLIZED)**. VESPER HOSPITALITY INVESTMENTS, LLC, (U.S. CLS. 100 AND 101). SN 85-117,543. PUB. 3-1-2011. FILED 8-27-2010.  
 3,961,172. **SUSHIPOP FRESH FAST SUSHI AND DESIGN**. SUSHI POP, LLC, (U.S. CLS. 100 AND 101). SN 85-119,385. PUB. 3-1-2011. FILED 8-31-2010.  
 3,961,181. **TRUE FOOD KITCHEN GLOBALLY INSPIRED CUISINE AND DESIGN**. FRC BALANCE LLC, (U.S. CLS. 100 AND 101). SN 85-120,928. PUB. 3-1-2011. FILED 9-1-2010.  
 3,961,186. **THE GARLIC GURU (STANDARD CHARACTER)**. THE GARLIC GURU, (U.S. CLS. 100 AND 101). SN 85-121,596. PUB. 3-1-2011. FILED 9-2-2010.  
 3,961,187. **JTM CORNER (STANDARD CHARACTER)**. JTM PROVISIONS COMPANY, INC., (U.S. CLS. 100 AND 101). SN 85-121,692. PUB. 3-1-2011. FILED 9-2-2010.  
 3,961,236 ( *See Class 35 for this trademark*).  
 3,961,238 ( *See Class 35 for this trademark*).  
 3,961,268. **LIVE HERE EAT FREE (STANDARD CHARACTER)**. THE SIEGEL GROUP NEVADA, INC., (U.S. CLS. 100 AND 101). SN 85-126,223. PUB. 3-1-2011. FILED 9-9-2010.  
 3,961,294. **INTERVIEW CARE (STANDARD CHARACTER)**. BORG HOLDINGS INC, (U.S. CLS. 100 AND 101). SN 85-126,833. PUB. 3-1-2011. FILED 9-10-2010.  
 3,961,301. **HILLBILLY'S CABIN RESTAURANT (STANDARD CHARACTER)**. TYTOM, INC., (U.S. CLS. 100 AND 101). SN 85-126,934. PUB. 3-1-2011. FILED 9-10-2010.  
 3,961,363. **FINE DINING BETWEEN TWO BUNS (STANDARD CHARACTER)**. FLIP, LLC, (U.S. CLS. 100 AND 101). SN 85-128,283. PUB. 3-1-2011. FILED 9-13-2010.  
 3,961,382. **GROCERY DASH (STANDARD CHARACTER)**. VITIENE, ERIKA SARAH, (U.S. CLS. 100 AND 101). SN 85-128,540. PUB. 3-1-2011. FILED 9-13-2010.  
 3,961,414. **CHARLIE & JAKE'S BAR-B-QUE (STANDARD CHARACTER)**. WALKER OF MELBOURNE, (U.S. CLS. 100 AND 101). SN 85-128,930. PUB. 3-1-2011. FILED 9-14-2010.  
 3,961,430. **SAFE SPOT (STANDARD CHARACTER)**. ROBERT JASON NICEWARNER, (U.S. CLS. 100 AND 101). SN 85-129,163. PUB. 3-1-2011. FILED 9-14-2010.  
 3,961,432. **THAI BAMBOO (STANDARD CHARACTER)**. THAI BAMBOO RESTAURANT, L.L.C., (U.S. CLS. 100 AND 101). SN 85-129,177. PUB. 3-1-2011. FILED 9-14-2010.  
 3,961,491. **MISCELLANEOUS DESIGN**. BRUCE K. KOELLER, INC., (U.S. CLS. 100 AND 101). SN 85-129,972. PUB. 3-

- 1-2011. FILED 9-15-2010.  
 3,961,516. **TIN LIZZY'S TAQUERIA CANTINA (STANDARD CHARACTER)**. TIN LIZZY'S HOLDINGS, LLC, (U.S. CLS. 100 AND 101). SN 85-130,304. PUB. 3-1-2011. FILED 9-15-2010.  
 3,961,578. **LITTLE PRINCE KIDS CAFE AND DESIGN**. CHANG LEE, (U.S. CLS. 100 AND 101). SN 85-131,080. PUB. 3-1-2011. FILED 9-16-2010.  
 3,961,591. **8 K (STYLIZED)**. VICEROY HOTELS, L.L.C., (U.S. CLS. 100 AND 101). SN 85-131,204. PUB. 3-1-2011. FILED 9-16-2010.  
 3,961,635. **MOBILE LOAVES & FISHES MIRACLES ON WHEELS AND DESIGN**. MOBILE LOAVES & FISHES, INC., (U.S. CLS. 100 AND 101). SN 85-131,743. PUB. 3-1-2011. FILED 9-16-2010.  
 3,961,637. **ASHOKA THE GREAT (STANDARD CHARACTER)**. ASHOKA THE GREAT, INC. DBA ASHOKA THE GREAT, (U.S. CLS. 100 AND 101). SN 85-131,765. PUB. 3-1-2011. FILED 9-17-2010.  
 3,961,674. **LIGHTNIN' JACK'S BBQ AND DESIGN**. HASSAN, RICHARD, (U.S. CLS. 100 AND 101). SN 85-132,524. PUB. 3-1-2011. FILED 9-17-2010.  
 3,961,696. **WYNFIELD COLLECTION (STANDARD CHARACTER)**. QUEENSBURY HOSPITALITY LLC, (U.S. CLS. 100 AND 101). SN 85-132,994. PUB. 3-1-2011. FILED 9-19-2010.  
 3,961,705. **COMMUNITY FIRST! (STANDARD CHARACTER)**. MOBILE LOAVES & FISHES, INC., (U.S. CLS. 100 AND 101). SN 85-134,124. PUB. 3-1-2011. FILED 9-20-2010.  
 3,961,753. **RUTH'S CHRIS STEAK HOUSE US PRIME AND DESIGN**. RUTH'S HOSPITALITY GROUP, INC., (U.S. CLS. 100 AND 101). SN 85-140,803. PUB. 3-1-2011. FILED 9-29-2010.  
 3,961,839. **AGHA JUICE (STANDARD CHARACTER)**. AGHA JUICE, LLC, (U.S. CLS. 100 AND 101). SN 85-149,877. PUB. 3-1-2011. FILED 10-11-2010.  
 3,961,860. **THE ELIOT HOTEL AND DESIGN**. ELIOT HOTEL, INC., (U.S. CLS. 100 AND 101). SN 85-151,219. PUB. 3-1-2011. FILED 10-13-2010.  
 3,961,863. **MOLLY SPILLANE'S (STANDARD CHARACTER)**. 211 MAMARONECK AVE. RESTAURANT, LLC, (U.S. CLS. 100 AND 101). SN 85-151,513. PUB. 3-1-2011. FILED 10-13-2010.  
 3,961,873. **FRIENDS KABOB (STANDARD CHARACTER)**. SEPANTA DESIGN, LLC, (U.S. CLS. 100 AND 101). SN 85-152,445. PUB. 3-1-2011. FILED 10-14-2010.  
 3,961,932 ( *See Class 30 for this trademark*).  
 3,961,947. **ISPICE GOURMET INDIAN CUISINE AND DESIGN**. ISPICE LLC, (U.S. CLS. 100 AND 101). SN 85-179,814. PUB. 3-1-2011. FILED 11-18-2010.  
 3,960,502 ( *See Class 35 for this trademark*).  
 3,960,508. **TEAMDOPAMINE AND DESIGN**. DAVID BRIZER, DBA DAVID BRIZER, M.D., PLLC, (U.S. CLS. 100 AND 101). SN 77-946,561. PUB. 3-1-2011. FILED 2-27-2010.  
 3,960,510 ( *See Class 9 for this trademark*).  
 3,960,546 ( *See Class 3 for this trademark*).  
 3,960,587 ( *See Class 5 for this trademark*).  
 3,960,589 ( *See Class 5 for this trademark*).  
 3,960,641 ( *See Class 9 for this trademark*).  
 3,960,729 ( *See Class 31 for this trademark*).  
 3,960,741. **FILOSOFIA ALIMENTARE (STANDARD CHARACTER)**. ALBERICO LEMME, (U.S. CLS. 100 AND 101). SN 79-082,753. PUB. 3-1-2011. FILED 2-19-2010.  
 3,960,826 ( *See Class 10 for this trademark*).  
 3,960,848. **THE LEADER IN ORGANIC-BASED LAWN CARE (STANDARD CHARACTER)**. NATURALAWN OF AMERICA, INC., (U.S. CLS. 100 AND 101). SN 85-003,346. PUB. 3-1-2011. FILED 3-31-2010.  
 3,960,897 ( *See Class 36 for this trademark*).  
 3,960,925. **PEDIATRIC HEART CENTER PHC AND DESIGN**. PEDIATRIC HEART CENTER, (U.S. CLS. 100 AND 101). SN 85-033,837. PUB. 3-1-2011. FILED 5-10-2010.  
 3,960,927. **ALL ABOUT BABIES MIDWIFERY AND DESIGN**. AAB MIDWIFERY, P.C., (U.S. CLS. 100 AND 101). SN 85-034,070. PUB. 3-1-2011. FILED 5-10-2010.  
 3,960,957. **MIND REDESIGN AND DESIGN**. TYMAX MARKETING GROUP, LLC, DBA MIND REDESIGN, (U.S. CLS. 100 AND 101). SN 85-046,293. PUB. 3-1-2011. FILED 5-24-2010.  
 3,960,972. **ORTHONOW (STANDARD CHARACTER)**. BADIA HAND TO SHOULDER, LLC, (U.S. CLS. 100 AND 101). SN 85-058,615. PUB. 3-1-2011. FILED 6-9-2010.  
 3,960,994. **THE DREAM WORKS (STANDARD CHARACTER)**. THE DREAM WORKS, INC., (U.S. CLS. 100 AND 101). SN 85-068,557. PUB. 11-23-2010. FILED 6-22-2010.  
 3,961,053 ( *See Class 16 for this trademark*).  
 3,961,058. **ARBOR-NOMICS (STANDARD CHARACTER)**. ARBOR-NOMICS TURF, INC., (U.S. CLS. 100 AND 101). SN 85-096,015. PUB. 3-1-2011. FILED 7-29-2010.  
 3,961,112. **MY FAVORITE GROOMER! AND DESIGN**. MY FAVORITE GROOMER, (U.S. CLS. 100 AND 101). SN 85-108,771. PUB. 3-1-2011. FILED 8-16-2010.  
 3,961,117. **I AM THE DONATION GENERATION (STANDARD CHARACTER)**. LIFESOUTH COMMUNITY BLOOD CENTERS, INC., (U.S. CLS. 100 AND 101). SN 85-109,516. PUB. 3-1-2011. FILED 8-17-2010.  
 3,961,137. **PRINCIPAL WELLNESS COMPANY AND DESIGN**. PRINCIPAL FINANCIAL SERVICES, INC., (U.S. CLS. 100 AND 101). SN 85-113,939. PUB. 3-1-2011. FILED 8-23-2010.  
 3,961,141. **LIVE LAUGH LOVE (STANDARD CHARACTER)**. D-GENERATION, INC., (U.S. CLS. 100 AND 101). SN 85-115,195. PUB. 3-1-2011. FILED 8-25-2010.  
 3,961,190. **MISCELLANEOUS DESIGN**. PAGLIERANI, STEVEN, (U.S. CLS. 100 AND 101). SN 85-122,175. PUB. 3-1-2011. FILED 9-2-2010.  
 3,961,191. **THE EMERGENCE ALLIANCE (STANDARD CHARACTER)**. PAGLIERANI, STEVEN, (U.S. CLS. 100 AND 101). SN 85-122,178. PUB. 3-1-2011. FILED 9-2-2010.  
 3,961,195. **EYECANHEAR (STANDARD CHARACTER)**. EYE CAN HEAR, LLC, (U.S. CLS. 100 AND 101). SN 85-122,576. PUB. 3-1-2011. FILED 9-3-2010.  
 3,961,216. **ARBORSCAPE (STANDARD CHARACTER)**. ARBORSCAPE LLC, (U.S. CLS. 100 AND 101). SN 85-123,425. PUB. 3-1-2011. FILED 9-5-2010.  
 3,961,232. **VETMATRIX (STANDARD CHARACTER)**. INTERNET MATRIX, INC., DBA VETMATRIX, (U.S. CLS. 100 AND 101). SN 85-123,890. PUB. 3-1-2011. FILED 9-7-2010.  
 3,961,253. **CHUNG DAM SPA & FITNESS (STANDARD CHARACTER)**. YOO, SOO HYUN, (U.S. CLS. 100 AND 101). SN 85-125,149. PUB. 3-1-2011. FILED 9-8-2010.  
 3,961,359. **INDEPENDENCE (STANDARD CHARACTER)**. DAVE WILSON NURSERY INC., (U.S. CLS. 100 AND 101). SN 85-128,237. PUB. 3-1-2011. FILED 9-13-2010.  
 3,961,378. **ROCK STAR TAN BAR AND DESIGN**. NW ALPENGLOW, INC., (U.S. CLS. 100 AND 101). SN 85-128,451. PUB. 3-1-2011. FILED 9-13-2010.  
 3,961,383 ( *See Class 42 for this trademark*).

---

#### CLASS 44—MEDICAL, BEAUTY AND AGRICULTURAL SERVICES

- 3,960,225. **MISCELLANEOUS DESIGN**. CANHOO(USA) INC, (U.S. CLS. 100 AND 101). SN 76-698,129. PUB. 3-1-2011. FILED 6-26-2009.  
 3,960,249 ( *See Class 43 for this trademark*).  
 3,960,329 ( *See Class 35 for this trademark*).  
 3,960,344. **INSTANT DIAGNOSTIC SYSTEMS (STANDARD CHARACTER)**. HARVARD DRUG GROUP, LLC, (U.S. CLS. 100 AND 101). SN 77-771,388. PUB. 3-1-2011. FILED 6-30-2009.  
 3,960,411 ( *See Class 43 for this trademark*).  
 3,960,440. **LIVITICIAN (STANDARD CHARACTER)**. KLEIN, DEBORA A., (U.S. CLS. 100 AND 101). SN 77-896,807. PUB. 3-1-2011. FILED 12-18-2009.  
 3,960,464. **MESSAGE ENVY AND DESIGN**. MESSAGE ENVY FRANCHISING, LLC, (U.S. CLS. 100 AND 101). SN 77-921,887. PUB. 3-1-2011. FILED 1-27-2010.  
 3,960,465 ( *See Class 41 for this trademark*).  
 3,960,487 ( *See Class 41 for this trademark*).  
 3,960,488. **WITHOUT MY LASHES I AM NOTHING (STANDARD CHARACTER)**. SCHROEDER, SANDI, (U.S. CLS. 100 AND 101). SN 77-941,019. PUB. 3-1-2011. FILED 2-22-2010.  
 3,960,501 ( *See Class 35 for this trademark*).



- 3,961,386. **THE BRIGHTER WAY TO A BETTER SMILE (STANDARD CHARACTER)**. NATIONAL ORTHODONTIX MGMT, PLLC, DBA SUN ORTHODONTIX, (U.S. CLS. 100 AND 101). SN 85-128,590. PUB. 3-1-2011. FILED 9-13-2010.
- 3,961,399. **WELLIENT (STANDARD CHARACTER)**. HEALTHICUE, LLC, (U.S. CLS. 100 AND 101). SN 85-128,826. PUB. 3-1-2011. FILED 9-14-2010.
- 3,961,444. **THE HART TECHNIQUE PHYSICAL THERAPY AND DESIGN**. HART PHYSICAL THERAPY, LLC, (U.S. CLS. 100 AND 101). SN 85-129,297. PUB. 3-1-2011. FILED 9-14-2010.
- 3,961,498. **MHM (STYLIZED)**. MHM SERVICES, INC., (U.S. CLS. 100 AND 101). SN 85-130,111. PUB. 3-1-2011. FILED 9-15-2010.
- 3,961,543. **IAMNIVERSE (STANDARD CHARACTER)**. COLE, CARLTON J., (U.S. CLS. 100 AND 101). SN 85-130,574. PUB. 3-1-2011. FILED 9-15-2010.
- 3,961,553. **BEST LITTLE HAIR HOUSE (STANDARD CHARACTER)**. SCHWORAK ENTERPRISES LLC, DBA BEST LITTLE HAIR HOUSE, (U.S. CLS. 100 AND 101). SN 85-130,677. PUB. 3-1-2011. FILED S.R. 9-15-2010; AM. P.R. 12-22-2010.
- 3,961,557. **CRYSTAL DENTAL (STANDARD CHARACTER)**. ARASH AGHAKHANI D.D.S, INC., (U.S. CLS. 100 AND 101). SN 85-130,709. PUB. 3-1-2011. FILED 9-15-2010.
- 3,961,589. **CARELOCK AND DESIGN**. ELITE CARE MANAGEMENT GROUP, LLC., (U.S. CLS. 100 AND 101). SN 85-131,171. PUB. 3-1-2011. FILED 9-16-2010.
- 3,961,595. **G AND DESIGN**. GENESIS HEALTH INSTITUTE, P.L.L.C., (U.S. CLS. 100 AND 101). SN 85-131,258. PUB. 3-1-2011. FILED 9-16-2010.
- 3,961,612. **BEING WELL. WELL BEING. (STANDARD CHARACTER)**. EDMONDS FAMILY MEDICINE CLINIC, PS, (U.S. CLS. 100 AND 101). SN 85-131,536. PUB. 3-1-2011. FILED 9-16-2010.
- 3,961,613. **EMPOWERING PEOPLE TO LEAD HEALTHIER LIVES (STANDARD CHARACTER)**. EDMONDS FAMILY MEDICINE CLINIC, PS, (U.S. CLS. 100 AND 101). SN 85-131,585. PUB. 3-1-2011. FILED 9-16-2010.
- 3,961,624. **KARMEN (STANDARD CHARACTER)**. VERDUZCO EDUARDO, DBA KARMEN, (U.S. CLS. 100 AND 101). SN 85-131,674. PUB. 3-1-2011. FILED 9-16-2010.
- 3,961,631. **MUSIC 4 LIFE (STANDARD CHARACTER)**. SEMINARCONCERTS INTERNATIONAL INC., DBA MUSIC 4 LIFE, (U.S. CLS. 100 AND 101). SN 85-131,728. PUB. 3-1-2011. FILED 9-16-2010.
- 3,961,673 ( *See Class 40 for this trademark*).
- 3,961,698. **RFV (STANDARD CHARACTER)**. MENTAL HEALTH RESOURCE FOUNDATION, DBA UPWARD REACH, (U.S. CLS. 100 AND 101). SN 85-133,066. PUB. 3-1-2011. FILED 9-19-2010.
- 3,961,702. **EYECANHEAR AND DESIGN**. EYE CAN HEAR, LLC, (U.S. CLS. 100 AND 101). SN 85-133,549. PUB. 3-1-2011. FILED 9-20-2010.
- 3,961,719. **E-CEPH WEB (STANDARD CHARACTER)**. RMO, INC., (U.S. CLS. 100 AND 101). SN 85-135,749. PUB. 3-1-2011. FILED 9-22-2010.
- 3,961,744. **FREEDOM URGENT CARE QUALITY . CONVENIENCE . COMMITMENT AND DESIGN**. FREEDOM URGENT CARE, PLLC, (U.S. CLS. 100 AND 101). SN 85-139,874. PUB. 3-1-2011. FILED 9-28-2010.
- 3,961,758. **IMAGE LIGHTLY (STANDARD CHARACTER)**. BETH ISRAEL DEACONESS MEDICAL CENTER, INC., (U.S. CLS. 100 AND 101). SN 85-141,274. PUB. 3-1-2011. FILED 9-29-2010.
- 3,961,811. **STAR ACCESS (STANDARD CHARACTER)**. LONE STAR WELLNESS HOLDINGS, LLC, (U.S. CLS. 100 AND 101). SN 85-148,679. PUB. 3-1-2011. FILED 10-8-2010.
- 3,961,880 ( *See Class 35 for this trademark*).
- 3,961,886 ( *See Class 41 for this trademark*).
- 3,961,896. **A POSITIVE IMPACT. ON HEALTHCARE. AND ON LIVES. (STANDARD CHARACTER)**. PURDUE PHARMA L.P., (U.S. CLS. 100 AND 101). SN 85-161,055. PUB. 3-1-2011. FILED 10-26-2010.
- 3,961,897. **RXSAFETYMATTERS AND DESIGN**. PURDUE PHARMA L.P., (U.S. CLS. 100 AND 101). SN 85-161,079. PUB. 3-1-2011. FILED 10-26-2010.
- 3,961,943 ( *See Class 16 for this trademark*).
- CLASS 45—PERSONAL AND LEGAL SERVICES**
- 3,960,253. **TRADEMARK PLUS (STANDARD CHARACTER)**. SIEBAY INC., (U.S. CLS. 100 AND 101). SN 76-704,796. PUB. 3-1-2011. FILED 10-6-2010.
- 3,960,316 ( *See Class 38 for this trademark*).
- 3,960,412. **ERNEST (STANDARD CHARACTER)**. CHERRY, JOHN R., III, (U.S. CLS. 100 AND 101). SN 77-853,691. PUB. 3-1-2011. FILED 10-21-2009.
- 3,960,456 ( *See Class 9 for this trademark*).
- 3,960,457 ( *See Class 9 for this trademark*).
- 3,960,458 ( *See Class 9 for this trademark*).
- 3,960,492 ( *See Class 9 for this trademark*).
- 3,960,505 ( *See Class 38 for this trademark*).
- 3,960,528 ( *See Class 36 for this trademark*).
- 3,960,537 ( *See Class 35 for this trademark*).
- 3,960,552. **SUZETIQUE (STANDARD CHARACTER)**. LEVESQUE, SUZETTE M., (U.S. CLS. 100 AND 101). SN 77-960,119. PUB. 3-1-2011. FILED 3-16-2010.
- 3,960,660 ( *See Class 3 for this trademark*).
- 3,960,748 ( *See Class 35 for this trademark*).
- 3,960,835 ( *See Class 35 for this trademark*).
- 3,960,892 ( *See Class 9 for this trademark*).
- 3,960,902. **BAYWOOD HOME CARE YOUR HOME. OUR SUPPORT. YOUR PEACE OF MIND. AND DESIGN**. MINNESOTA LIVING ASSISTANCE, INC., DBA BAYWOOD HOME CARE, (U.S. CLS. 100 AND 101). SN 85-021,066. PUB. 3-1-2011. FILED 4-22-2010.
- 3,960,951. **TRUTH BE TOLD POLYGRAPHS AND DESIGN**. JEFFERSON, RACHEL, DBA TRUTH BE TOLD POLYGRAPH SERVICES, (U.S. CLS. 100 AND 101). SN 85-045,347. PUB. 11-23-2010. FILED S.R. 5-21-2010; AM. P.R. 9-23-2010.
- 3,961,013. **STYLE BITE (STANDARD CHARACTER)**. UZZARDI, CHRISTINA MARIE, DBA STYLE BITE, (U.S. CLS. 100 AND 101). SN 85-077,750. PUB. 3-1-2011. FILED 7-3-2010.
- 3,961,024. **PROCOPIO AND DESIGN**. PROCOPIO, CORY, HARGREAVES & SAVITCH LLP, (U.S. CLS. 100 AND 101). SN 85-082,351. PUB. 3-1-2011. FILED 7-12-2010.
- 3,961,042. **RENTMEN AND DESIGN**. RENTMEN LTD, (U.S. CLS. 100 AND 101). SN 85-091,224. PUB. 3-1-2011. FILED 7-23-2010.
- 3,961,122. **MISCELLANEOUS DESIGN**. PARLANTI & PARLANTI LLP, (U.S. CLS. 100 AND 101). SN 85-110,588. PUB. 3-1-2011. FILED 8-18-2010.
- 3,961,147 ( *See Class 35 for this trademark*).
- 3,961,160. **SPEDIA (STANDARD CHARACTER)**. SPEDIA, INC., (U.S. CLS. 100 AND 101). SN 85-117,961. PUB. 3-1-2011. FILED 8-27-2010.
- 3,961,167. **POSITIVE NEWS WITH PURPOSE (STANDARD CHARACTER)**. GLOBAL POSITIVE, LLC, (U.S. CLS. 100 AND 101). SN 85-118,723. PUB. 3-1-2011. FILED 8-30-2010.
- 3,961,174 ( *See Class 18 for this trademark*).
- 3,961,180. **CALLED.COM (STANDARD CHARACTER)**. MDL INNOVATIONS, DBA CALLED.COM, (U.S. CLS. 100 AND 101). SN 85-120,923. PUB. 3-1-2011. FILED 9-1-2010.
- 3,961,278. **FULL SERVICE REGULATORY COMPLIANCE FOR THE FUTURE (STANDARD CHARACTER)**. C. HUMPHREY & ASSOCIATES, P.A., (U.S. CLS. 100 AND 101). SN 85-126,628. PUB. 3-1-2011. FILED 9-10-2010.
- 3,961,297. **WE JUMP START START UPS (STANDARD CHARACTER)**. FURMAN GREGORY LLC, DBA FURMAN GREGORY DEPTULA, (U.S. CLS. 100 AND 101). SN 85-126,906. PUB. 3-1-2011. FILED 9-10-2010.
- 3,961,342. **RED FLAG REPORTING AND DESIGN**. BCG RESOURCES, INC., (U.S. CLS. 100 AND 101). SN 85-127,957. PUB. 3-1-2011. FILED 9-13-2010.
- 3,961,345. **GRATITUDE GURU (STANDARD CHARACTER)**. VICTORIA LOVELAND-COEN, (U.S. CLS. 100 AND 101). SN 85-128,034. PUB. 3-1-2011. FILED 9-13-2010.
- 3,961,461. **BLOGMOS (STANDARD CHARACTER)**. THE CENTER FOR OPTIMAL ADULT DEVELOPMENT, (U.S. CLS. 100 AND 101). SN 85-129,490. PUB. 3-1-2011. FILED 9-14-2010.
- 3,961,465. **ALTERA LAW GROUP (STANDARD CHARACTER)**. ALTERA LAW GROUP, L.L.C., (U.S. CLS. 100 AND 101). SN 85-129,526. PUB. 3-1-2011. FILED 9-14-2010.
- 3,961,469. **PUTTILIKE (STANDARD CHARACTER)**. WAP-

NICK, EMILIE, (U.S. CLS. 100 AND 101). SN 85-129,578.  
PUB. 3-1-2011. FILED 9-14-2010.  
3,961,520. **DLA PIPER AND DESIGN**. GLOBAL NAME  
SERVICES LLP, (U.S. CLS. 100 AND 101). SN 85-130,345.  
PUB. 3-1-2011. FILED 9-15-2010.  
3,961,592. **FAMILY LAW MATTERS (STANDARD CHARAC-  
TER)**. KATHLEEN M. MURPHY, (U.S. CLS. 100 AND 101).  
SN 85-131,220. PUB. 3-1-2011. FILED 9-16-2010.  
3,961,601 ( *See Class 25 for this trademark*).  
3,961,617 ( *See Class 42 for this trademark*).  
3,961,618 ( *See Class 42 for this trademark*).  
3,961,695 ( *See Class 42 for this trademark*).  
3,961,757 ( *See Class 42 for this trademark*).  
3,961,821 ( *See Class 35 for this trademark*).  
3,961,822. **REFINING THE DETAILS (STANDARD CHARAC-  
TER)**. POLISH MINISTRIES INCORPORATED, (U.S. CLS.  
100 AND 101). SN 85-149,481. PUB. 3-1-2011. FILED 10-11-  
2010.  
3,961,832. **CHRIST INTERNATIONAL CENTER AND DE-  
SIGN**. CHRIST INTERNATIONAL CENTER, (U.S. CLS.  
100 AND 101). SN 85-149,767. PUB. 3-1-2011. FILED 10-11-  
2010.  
3,961,948. **SMARTADVOCATE (STANDARD CHARACTER)**.  
PARKER WAICHMAN ALONSO LLP, (U.S. CLS. 100 AND  
101). SN 85-180,693. PUB. 3-1-2011. FILED 11-19-2010.

\* \* \* \* \*

SECTION 2.—PRIOR UNITED STATES CLASSIFICATION

COLLECTIVE MEMBERSHIP MARKS

**CLASS 200—COLLECTIVE MEMBERSHIP**

3,961,144. **SPECIALTY PHARMA ASSOCIATION AND DESIGN.** SPECIALTY PHARMA ASSOCIATION, SN 85-115,474. PUB. 3-1-2011. FILED 8-25-2010.

3,961,211. **E-MPA (STANDARD CHARACTER).** E-RATE MANAGEMENT PROFESSIONALS ASSOCIATION, INC., SN 85-123,337. PUB. 3-1-2011. FILED 9-4-2010.

3,961,765. **NIRI (STANDARD CHARACTER).** NATIONAL INVESTOR RELATIONS INSTITUTE, SN 85-141,960. PUB. 3-1-2011. FILED 9-30-2010.

REVOCABLE TRUST, SN 77-622,216. PUB. 3-1-2011. FILED 11-26-2008.

3,960,346. **IBMS INTERNATIONAL BOARD OF MEDICINE AND SURGERY AND DESIGN.** KALIN, DAVID P., DBA INTERNATIONAL BOARD OF MEDICINE AND SURGERY, SN 77-777,459. PUB. 3-1-2011. FILED 7-9-2009.

3,960,437. **GMS (STANDARD CHARACTER).** EMPLOYEE RELOCATION COUNCIL, INC., SN 77-896,571. PUB. 3-1-2011. FILED 12-18-2009.

3,960,438. **G . M . S GLOBAL MOBILITY SPECIALIST AND DESIGN.** EMPLOYEE RELOCATION COUNCIL, INC., SN 77-896,609. PUB. 3-1-2011. FILED 12-18-2009.

3,960,905. **WEDDING CAPITAL OF THE SOUTH (STANDARD CHARACTER).** EUREKA SPRINGS CITY ADVERTISING AND PROMOTIONS COMMISSION, SN 85-023,122. PUB. 3-1-2011. FILED S.R. 4-26-2010; AM. P.R. 12-30-2010.

---

CERTIFICATION MARKS

CLASS B—SERVICES

3,960,306. **CERTIFIED IN DISASTER PREPAREDNESS, CDP-I (STANDARD CHARACTER).** ROBERT L. O'BLOCK

3,961,165. **CERTIFIED VIRTUAL ASSISTANT (STANDARD CHARACTER).** INTERNATIONAL VIRTUAL ASSISTANTS ASSOCIATION, SN 85-118,461. PUB. 3-1-2011. FILED 8-30-2010.

\* \* \* \* \*

# TRADEMARK REGISTRATIONS ISSUED UNDER SECTION 1(d)

The following marks have registered on the Principal Register pursuant to the intent-to-use provisions of Section 1(d) of the Trademark Act of 1946, as amended.

## SECTION 1.— INTERNATIONAL CLASSIFICATION

The short titles associated below with the international class numbers are terms designed merely for quick identification and are not an official part of the international classification. The full names of international classes are given in section 6.1 of the trademark rules of practice.

The designation "U.S. Cl." appearing in this section refers to the U.S. class in effect prior to Sep. 1, 1973 rather than the international class which applies to applications filed on or after that date. For adoption of international classification see notice in the OFFICIAL GAZETTE of Jun. 26, 1973 (911 O.G. TM 210).

### Application in more than one class

3,961,962. ALTA VIA CONSULTING, LLC, KNOXVILLE, TN.  
SN 76-658,813. PUB. 6-22-2010, FILED 4-21-2006.

3,961,965. CALPITO, CHRISTOPHER LAWRENCE, IMPERIAL BEACH, CA. SN 76-668,347. PUB. 12-15-2009, FILED 11-1-2006.

# ALTA VIA

THE MARK CONSISTS OF STANDARD CHARACTERS WITHOUT CLAIM TO ANY PARTICULAR FONT, STYLE, SIZE, OR COLOR.

OWNER OF U.S. REG. NO. 2,538,959.

#### CLASS 35—ADVERTISING AND BUSINESS

FOR MANAGEMENT AND BUSINESS CONSULTING SERVICES IN THE FIELD OF COMPUTER SOFTWARE DESIGN, DEVELOPMENT AND IMPLEMENTATION (U.S. CLS. 100, 101 AND 102).

FIRST USE 12-6-2010; IN COMMERCE 12-6-2010.

#### CLASS 41—EDUCATION AND ENTERTAINMENT

FOR TRAINING IN THE USE OF COMPUTER SOFTWARE (U.S. CLS. 100, 101 AND 107).

FIRST USE 12-6-2010; IN COMMERCE 12-6-2010.

#### CLASS 42—SCIENTIFIC AND COMPUTER SERVICES

FOR CONSULTING SERVICES IN THE FIELD OF DESIGN, SELECTION, IMPLEMENTATION AND USE OF COMPUTER HARDWARE AND SOFTWARE SYSTEMS FOR OTHERS; COMPUTER SOFTWARE DESIGN, COMPUTER PROGRAMMING AND MAINTENANCE OF SOFTWARE (U.S. CLS. 100 AND 101).

FIRST USE 12-6-2010; IN COMMERCE 12-6-2010.

# HAWAIIAN RAIN

THE MARK CONSISTS OF STANDARD CHARACTERS WITHOUT CLAIM TO ANY PARTICULAR FONT, STYLE, SIZE, OR COLOR.

NO CLAIM IS MADE TO THE EXCLUSIVE RIGHT TO USE "HAWAIIAN", APART FROM THE MARK AS SHOWN.

#### CLASS 30—STAPLE FOODS

FOR COFFEE BASED BEVERAGES, COCOA BASED BEVERAGES AND HERBAL DRINKS, NAMELY, HERBAL FOOD BEVERAGES (U.S. CL. 46).

FIRST USE 6-2-2010; IN COMMERCE 6-2-2010.

#### CLASS 32—LIGHT BEVERAGES

FOR BOTTLED NON-CARBONATED WATER, BOTTLED CARBONATED SPARKLING WATER, ENERGY DRINKS AND BOTTLED CARBONATED FRUIT FLAVORED DRINKS (U.S. CLS. 45, 46 AND 48).

FIRST USE 6-2-2010; IN COMMERCE 6-2-2010.

---

3,961,972. BASTIANON, LYNN, SANTA ROSA, CA. SN 76-687,370. PUB. 1-6-2009, FILED 3-5-2008.

# SNIFF & SWIRL

THE MARK CONSISTS OF STANDARD CHARACTERS WITHOUT CLAIM TO ANY PARTICULAR FONT, STYLE, SIZE, OR COLOR.

**CLASS 16—PAPER GOODS AND PRINTED MATTER**

FOR COMIC STRIPS; PRINTED INSTRUCTIONAL, EDUCATIONAL, AND TEACHING MATERIALS IN THE FIELD OF WINE AND THE WINE INDUSTRY; EDUCATIONAL BOOKS IN THE FIELD OF WINE AND THE WINE INDUSTRY; COMIC BOOKS AND POSTERS; PAPER WINE LABELS (U.S. CLS. 2, 5, 22, 23, 29, 37, 38 AND 50).

FIRST USE 6-0-2007; IN COMMERCE 6-0-2007.

**CLASS 33—WINES AND SPIRITS**

FOR WINES, ALCOHOLIC BEVERAGES, EXCEPT BEER (U.S. CLS. 47 AND 49).

FIRST USE 6-0-2007; IN COMMERCE 6-0-2007.

3,961,973. MILLER, RACHEL JEAN, PLACITAS, NM. AND MASSENGILL, JIM, PLACITAS, NM. SN 76-688,923. PUB. 7-20-2010, FILED 4-23-2008.

**JAVELINA WISDOM**

THE MARK CONSISTS OF STANDARD CHARACTERS WITHOUT CLAIM TO ANY PARTICULAR FONT, STYLE, SIZE, OR COLOR.

**CLASS 16—PAPER GOODS AND PRINTED MATTER**

FOR PAPER, NAMELY, NEWSLETTERS AND INFORMATIONAL FLYERS IN THE FIELD OF PERSONAL AND COMMUNITY MOTIVATION; GOODS MADE FROM PAPER, NAMELY, ENVELOPES AND CONTAINERS, BAGS FOR PACKAGING; PRINTED MATTER, NAMELY, BOOKS, GREETING CARDS, WORKBOOKS, ART PRINTS AND PICTURES AND ART REPRODUCTIONS IN THE FIELD OF PERSONAL AND COMMUNITY MOTIVATION; FICTIONAL AND NON-FICTIONAL BOOKS AND PAMPHLETS IN THE FIELD OF PERSONAL MOTIVATION AND COMMUNITY ORGANIZING; PHOTOGRAPHS; STATIONERY; INSTRUCTIONAL AND TEACHING MATERIAL, NAMELY, WORKBOOKS AND PRINTED TEACHING MATERIALS IN THE FIELD OF COMMUNITY ORGANIZING (U.S. CLS. 2, 5, 22, 23, 29, 37, 38 AND 50).

FIRST USE 7-1-2008; IN COMMERCE 3-11-2011.

**CLASS 25—CLOTHING**

FOR APPAREL, NAMELY, SHIRTS; OUTERWEAR, NAMELY, HATS, JACKETS, AND SPORTS JACKETS, SPORTS PANTS, SPORTS JERSEYS, SPORTS OVERUNIFORMS, AND SPORTS SHOES (U.S. CLS. 22 AND 39).

FIRST USE 7-1-2008; IN COMMERCE 3-11-2011.

**CLASS 41—EDUCATION AND ENTERTAINMENT**

FOR EDUCATION, NAMELY, PROVIDING COURSES AND SEMINARS IN THE FIELD OF COMMUNITY ORGANIZING; PROVIDING TRAINING, NAMELY, PROVIDING COURSES AND SEMINARS IN THE FIELD OF COMMUNITY ORGANIZING SERVICES; PROVIDING CULTURAL ACTIVITIES, NAMELY, CROSS-CULTURAL EXCHANGE MEETINGS AND MUSICAL, DANCE AND DRAMATIC PERFORMANCES (U.S. CLS. 100, 101 AND 107).

FIRST USE 7-1-2008; IN COMMERCE 3-11-2011.

**CLASS 45—PERSONAL AND LEGAL SERVICES**

FOR PERSONAL AND SOCIAL SERVICES RENDERED BY OTHERS TO MEET THE NEEDS OF INDIVIDUALS, ORGANIZATIONS, COMMUNITIES, AND GOVERNMENTS, NAMELY, PERSONAL MOTIVATION COUNSELING (U.S. CLS. 100 AND 101).

FIRST USE 7-1-2008; IN COMMERCE 3-11-2011.

3,961,974. MILLER, RACHEL JEAN, PLACITAS, NM. AND MASSENGILL, JIM, PLACITAS, NM. SN 76-688,925. PUB. 7-20-2010, FILED 4-23-2008.

**DO IT WHILE YOU CAN KID**

THE MARK CONSISTS OF STANDARD CHARACTERS WITHOUT CLAIM TO ANY PARTICULAR FONT, STYLE, SIZE, OR COLOR.

**CLASS 16—PAPER GOODS AND PRINTED MATTER**

FOR PAPER, NAMELY, NEWSLETTERS AND INFORMATIONAL FLYERS IN THE FIELD OF PERSONAL AND COMMUNITY MOTIVATION; GOODS MADE FROM PAPER, NAMELY, ENVELOPES AND CONTAINERS, BAGS FOR PACKAGING; PRINTED MATTER, NAMELY, BOOKS, GREETING CARDS, WORKBOOKS, ART PRINTS AND PICTURES AND ART REPRODUCTIONS IN THE FIELD OF PERSONAL AND COMMUNITY MOTIVATION; FICTIONAL AND NON-FICTIONAL BOOKS AND PAMPHLETS IN THE FIELD OF PERSONAL MOTIVATION AND COMMUNITY ORGANIZING; PHOTOGRAPHS; STATIONERY; INSTRUCTIONAL AND TEACHING MATERIAL, NAMELY, WORKBOOKS AND PRINTED TEACHING MATERIALS IN THE FIELD OF COMMUNITY ORGANIZING (U.S. CLS. 2, 5, 22, 23, 29, 37, 38 AND 50).

FIRST USE 7-1-2008; IN COMMERCE 3-11-2011.

**CLASS 41—EDUCATION AND ENTERTAINMENT**

FOR EDUCATION, NAMELY, PROVIDING COURSES AND SEMINARS IN THE FIELD OF COMMUNITY ORGANIZING; PROVIDING TRAINING, NAMELY, PROVIDING COURSES AND SEMINARS IN THE FIELD OF COMMUNITY ORGANIZING SERVICES; PROVIDING CULTURAL ACTIVITIES, NAMELY, CROSS-CULTURAL EXCHANGE MEETINGS AND MUSICAL, DANCE AND DRAMATIC PERFORMANCES (U.S. CLS. 100, 101 AND 107).

FIRST USE 7-1-2008; IN COMMERCE 3-11-2011.

**CLASS 45—PERSONAL AND LEGAL SERVICES**

FOR PERSONAL AND SOCIAL SERVICES RENDERED BY OTHERS TO MEET THE NEEDS OF INDIVIDUALS, ORGANIZATIONS, COMMUNITIES, AND GOVERNMENTS, NAMELY, PERSONAL MOTIVATION COUNSELING (U.S. CLS. 100 AND 101).

FIRST USE 7-1-2008; IN COMMERCE 3-11-2011.



3,961,975. MILLER, RACHEL JEAN, PLACITAS, NM. AND MASSENGILL, JIM, PLACITAS, NM. SN 76-688,926. PUB. 7-20-2010, FILED 4-23-2008.

3,961,976. MILLER, RACHEL JEAN, PLACITAS, NM. AND MASSENGILL, JIM, PLACITAS, NM. SN 76-688,927. PUB. 7-20-2010, FILED 4-23-2008.



THE MARK CONSISTS OF TWO STYLIZED JAVELINAS, BETWEEN WHICH IS THE WORDING "JAVELINA WISDOM".

#### **CLASS 16—PAPER GOODS AND PRINTED MATTER**

FOR PAPER, NAMELY, NEWSLETTERS AND INFORMATIONAL FLYERS IN THE FIELD OF PERSONAL AND COMMUNITY MOTIVATION; GOODS MADE FROM PAPER, NAMELY, ENVELOPES AND CONTAINERS, BAGS FOR PACKAGING; PRINTED MATTER, NAMELY, BOOKS, GREETING CARDS, WORKBOOKS, ART PRINTS AND PICTURES AND ART REPRODUCTIONS IN THE FIELD OF PERSONAL AND COMMUNITY MOTIVATION; FICTIONAL AND NON-FICTIONAL BOOKS AND PAMPHLETS IN THE FIELD OF PERSONAL MOTIVATION AND COMMUNITY ORGANIZING; PHOTOGRAPHS; STATIONERY; INSTRUCTIONAL AND TEACHING MATERIAL, NAMELY, WORKBOOKS AND PRINTED TEACHING MATERIALS IN THE FIELD OF COMMUNITY ORGANIZING (U.S. CLS. 2, 5, 22, 23, 29, 37, 38 AND 50).

FIRST USE 7-1-2008; IN COMMERCE 3-11-2011.

#### **CLASS 25—CLOTHING**

FOR APPAREL, NAMELY, SHIRTS; OUTERWEAR, NAMELY, HATS, JACKETS, AND SPORTS JACKETS, SPORTS PANTS, SPORTS JERSEYS, SPORTS OVERSWEATERS, AND SPORTS SHOES (U.S. CLS. 22 AND 39).

FIRST USE 7-1-2008; IN COMMERCE 3-11-2011.

#### **CLASS 41—EDUCATION AND ENTERTAINMENT**

FOR EDUCATION, NAMELY, PROVIDING COURSES AND SEMINARS IN THE FIELD OF COMMUNITY ORGANIZING; PROVIDING TRAINING, NAMELY, PROVIDING COURSES AND SEMINARS IN THE FIELD OF COMMUNITY ORGANIZING SERVICES; PROVIDING CULTURAL ACTIVITIES, NAMELY, CROSS-CULTURAL EXCHANGE MEETINGS AND MUSICAL, DANCE AND DRAMATIC PERFORMANCES (U.S. CLS. 100, 101 AND 107).

FIRST USE 7-1-2008; IN COMMERCE 3-11-2011.

#### **CLASS 45—PERSONAL AND LEGAL SERVICES**

FOR PERSONAL AND SOCIAL SERVICES RENDERED BY OTHERS TO MEET THE NEEDS OF INDIVIDUALS, ORGANIZATIONS, COMMUNITIES, AND GOVERNMENTS, NAMELY, PERSONAL MOTIVATION COUNSELING (U.S. CLS. 100 AND 101).

FIRST USE 7-1-2008; IN COMMERCE 3-11-2011.



THE MARK CONSISTS OF THE WORDING "DO IT WHILE YOU CAN KID" ARCHED ABOVE A STYLIZED JAVELINA.

#### **CLASS 16—PAPER GOODS AND PRINTED MATTER**

FOR PAPER, NAMELY, NEWSLETTERS AND INFORMATIONAL FLYERS IN THE FIELD OF PERSONAL AND COMMUNITY MOTIVATION; GOODS MADE FROM PAPER, NAMELY, ENVELOPES AND CONTAINERS, BAGS FOR PACKAGING; PRINTED MATTER, NAMELY, BOOKS, GREETING CARDS, WORKBOOKS, ART PRINTS AND PICTURES AND ART REPRODUCTIONS IN THE FIELD OF PERSONAL AND COMMUNITY MOTIVATION; FICTIONAL AND NON-FICTIONAL BOOKS AND PAMPHLETS IN THE FIELD OF PERSONAL MOTIVATION AND COMMUNITY ORGANIZING; PHOTOGRAPHS; STATIONERY; INSTRUCTIONAL AND TEACHING MATERIAL, NAMELY, WORKBOOKS AND PRINTED TEACHING MATERIALS IN THE FIELD OF COMMUNITY ORGANIZING (U.S. CLS. 2, 5, 22, 23, 29, 37, 38 AND 50).

FIRST USE 7-1-2008; IN COMMERCE 3-11-2011.

#### **CLASS 41—EDUCATION AND ENTERTAINMENT**

FOR EDUCATION, NAMELY, PROVIDING COURSES AND SEMINARS IN THE FIELD OF COMMUNITY ORGANIZING; PROVIDING TRAINING, NAMELY, PROVIDING COURSES AND SEMINARS IN THE FIELD OF COMMUNITY ORGANIZING SERVICES; PROVIDING CULTURAL ACTIVITIES, NAMELY, CROSS-CULTURAL EXCHANGE MEETINGS AND MUSICAL, DANCE AND DRAMATIC PERFORMANCES (U.S. CLS. 100, 101 AND 107).

FIRST USE 7-1-2008; IN COMMERCE 3-11-2011.

#### **CLASS 45—PERSONAL AND LEGAL SERVICES**

FOR PERSONAL AND SOCIAL SERVICES RENDERED BY OTHERS TO MEET THE NEEDS OF INDIVIDUALS, ORGANIZATIONS, COMMUNITIES, AND GOVERNMENTS, NAMELY, PERSONAL MOTIVATION COUNSELING (U.S. CLS. 100 AND 101).

FIRST USE 7-1-2008; IN COMMERCE 3-11-2011.

3,961,984. BARRIER SYSTEMS, INC., VACAVILLE, CA. SN 76-699,329. PUB. 7-6-2010, FILED 9-4-2009.

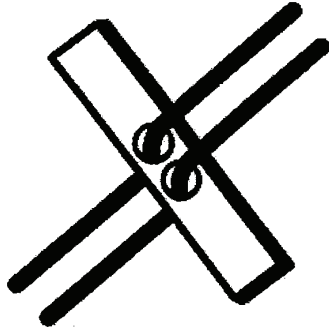

THE MARK CONSISTS OF A DESIGN OF TWO CABLE SEGMENTS PASSING THROUGH TWO SPACED HOLES IN A RECTANGLE, SUCH THAT THE TWO CABLES AND RECTANGLE FORM A LETTER "X".

#### CLASS 6—METAL GOODS

FOR ENERGY ABSORBING DEVICES OF METAL FOR ABSORBING ENERGY UPON VEHICLE IMPACT, NAMELY, CRASH CUSHIONS FOR USE AS CRASH BARRIERS AND CRASH BARRIER END TERMINALS, ALL OF METAL (U.S. CLS. 2, 12, 13, 14, 23, 25 AND 50).  
FIRST USE 8-12-2008; IN COMMERCE 8-12-2008.

#### CLASS 12—VEHICLES

FOR TRUCK-MOUNTED ATTENUATORS OF METAL FOR ABSORBING ENERGY UPON VEHICLE IMPACT (U.S. CLS. 19, 21, 23, 31, 35 AND 44).  
FIRST USE 8-12-2008; IN COMMERCE 8-12-2008.

3,961,985. BOULDIN CORPORATION, MCMINNVILLE, TN. SN 76-699,607. PUB. 3-23-2010, FILED 9-24-2009.

**WastAway**

OWNER OF U.S. REG. NO. 2,882,349.  
THE STIPPLING IS NOT A FEATURE OF THE MARK.

#### CLASS 7—MACHINERY

FOR MACHINES FOR MANUFACTURE OF A WASTE-TO-ENERGY GENERATION SYSTEM WHICH PROCESSES MUNICIPAL SOLID WASTE INTO FUEL; MACHINES FOR MANUFACTURE OF A WASTE-TO-PRODUCT GENERATION SYSTEM WHICH PROCESSES MUNICIPAL SOLID WASTE INTO EXTRUDED PRODUCTS, SOIL AMENDMENTS, ANIMAL BEDDING (U.S. CLS. 13, 19, 21, 23, 31, 34 AND 35).  
FIRST USE 10-1-2009; IN COMMERCE 10-1-2009.

#### CLASS 40—MATERIAL TREATMENT

FOR WASTE-TO-ENERGY GENERATION SERVICES AND WASTE-TO-PRODUCTS GENERATION SERVICES; SOLID WASTE LANDFILL SERVICES, NAMELY, THE PROCESSING OF MUNICIPAL SOLID WASTE INTO FUEL AND THE PROCESSING OF MUNICIPAL SOLID WASTE INTO EXTRUDED PRODUCTS, INTO SOIL AMENDMENTS AND INTO ANIMAL BEDDING (U.S. CLS. 100, 103 AND 106).  
FIRST USE 10-1-2009; IN COMMERCE 10-1-2009.

3,961,986. RYLAND ORGANIZATION COMPANY, CALABASAS, CA. SN 76-699,794. PUB. 8-3-2010, FILED 10-8-2009.



OWNER OF U.S. REG. NO. 3,468,476 AND OTHERS.  
THE MARK CONSISTS OF THE WORDING "HOUSEWORKS" WITH A DESIGN OF A TRIANGLE ABOVE THE WORD AND GRASS BELOW THE WORD.

#### CLASS 37—CONSTRUCTION AND REPAIR

FOR CONSTRUCTION SERVICES, NAMELY, PLANNING, LAYING OUT AND CONSTRUCTION OF NEW RESIDENTIAL HOMES BASED ON DESIGN AND CONSTRUCTION CRITERIA THAT PROVIDES HIGHER ENERGY EFFICIENCIES AND IMPROVED ENVIRONMENTAL QUALITY CONTROL FEATURES; PROVIDING INFORMATION VIA THE INTERNET AND WORLD WIDE WEB RELATING TO BUILDING CONSTRUCTION OPTIONS THAT PROVIDE HIGHER ENERGY EFFICIENCIES AND IMPROVED ENVIRONMENTAL QUALITY CONTROL FEATURES; CONSULTATION IN THE FIELD OF BUILDING CONSTRUCTION, NAMELY, PROVIDING CONSULTATION TO POTENTIAL HOME BUYERS REGARDING CONSTRUCTION OPTIONS THAT PROVIDE HIGHER ENERGY EFFICIENCIES AND IMPROVED ENVIRONMENTAL QUALITY CONTROL FEATURES (U.S. CLS. 100, 103 AND 106).  
FIRST USE 10-1-2009; IN COMMERCE 10-1-2009.

#### CLASS 42—SCIENTIFIC AND COMPUTER SERVICES

FOR PROVIDING CONSULTATION SERVICES TO NEW HOME BUYERS RELATING TO RESIDENTIAL HOME DESIGNS, SPECIFICALLY, DESIGNS THAT PROVIDE HIGHER ENERGY EFFICIENCIES AND IMPROVED ENVIRONMENTAL QUALITY CONTROL FEATURES; PROVIDING INFORMATION VIA THE INTERNET AND WORLD WIDE WEB ABOUT DESIGNING RESIDENTIAL HOMES THAT PROVIDE HIGHER ENERGY EFFICIENCIES AND IMPROVED ENVIRONMENTAL QUALITY CONTROL FEATURES (U.S. CLS. 100 AND 101).  
FIRST USE 10-1-2009; IN COMMERCE 10-1-2009.

3,962,002. WALLDINGER RACING, INC., INDIANAPOLIS, IN. SN 77-010,405. PUB. 7-24-2007, FILED 9-29-2006.

## AJ ALLMENDINGER

THE MARK CONSISTS OF STANDARD CHARACTERS WITHOUT CLAIM TO ANY PARTICULAR FONT, STYLE, SIZE, OR COLOR.

THE NAME "AJ ALLMENDINGER" IDENTIFIES A LIVING INDIVIDUAL WHOSE CONSENT IS OF RECORD.

### CLASS 16—PAPER GOODS AND PRINTED MATTER

FOR POSTERS; AND CALENDARS (U.S. CLS. 2, 5, 22, 23, 29, 37, 38 AND 50).

FIRST USE 7-0-2010; IN COMMERCE 7-0-2010.

### CLASS 25—CLOTHING

FOR CLOTHING, NAMELY, HATS AND CAPS, SHIRTS, JACKETS, AND SWEATSHIRTS, ALL OFFERED AS MOTORSPORTS AFFINITY MERCHANDISE (U.S. CLS. 22 AND 39).

FIRST USE 3-0-2007; IN COMMERCE 3-0-2007.

### CLASS 41—EDUCATION AND ENTERTAINMENT

FOR PROVIDING A WEBSITE OFFERING INFORMATION FOR MOTOR SPORTS AND RACING FANS (U.S. CLS. 100, 101 AND 107).

FIRST USE 3-0-2007; IN COMMERCE 3-0-2007.

---

3,962,004. INTERUSH HOLDINGS LTD., IRVINE, CA. SN 77-019,585. PUB. 1-15-2008, FILED 10-12-2006.

## INTERUSH

THE MARK CONSISTS OF STANDARD CHARACTERS WITHOUT CLAIM TO ANY PARTICULAR FONT, STYLE, SIZE, OR COLOR.

### CLASS 35—ADVERTISING AND BUSINESS

FOR PROVIDING CONSUMER PRODUCT INFORMATION VIA THE INTERNET; PROVIDING COMPARISON SHOPPING INFORMATION VIA THE INTERNET; DISSEMINATION OF ADVERTISING FOR OTHERS VIA THE INTERNET; AND PROVIDING ONLINE DIRECTORY INFORMATION SERVICES ALSO FEATURING HYPERLINKS TO OTHER WEBSITES; COMPUTERIZED ONLINE RETAIL AND WHOLESALE SERVICES AND DISTRIBUTORSHIP SERVICES IN THE FIELD OF DOWNLOADABLE COMPUTER SOFTWARE APPLICATIONS, COMPUTER PROGRAMS, DIETARY SUPPLEMENTS, AND ONLINE HEALTH MONITORING EQUIPMENT; BUSINESS CONSULTATION IN THE NATURE OF RENDERING ASSISTANCE TO OTHERS IN CONNECTION WITH THE ESTABLISHMENT AND OPERATION OF DISTRIBUTORSHIPS IN THE FIELD OF DOWNLOADABLE COMPUTER SOFTWARE APPLICATIONS, ONLINE MULTIMEDIA COMPUTER PROGRAMS, COMPUTER PROGRAMS, ONLINE VIDEO CONFERENCING TECHNOLOGY AND SOFTWARE, DIETARY SUPPLEMENTS, AND ONLINE HEALTH MONITORING EQUIPMENT; ASSOCIATION SERVICES, NAMELY, PROMOTING THE INTERESTS OF INDEPENDENT BUSINESS OWNERS; OFFERING TECHNICAL ASSISTANCE IN CONNECTION WITH THE ESTABLISHMENT AND/OR OPERATION OF PERSON-TO-PERSON RETAIL MERCHANDISING OF DOWNLOADABLE COMPUTER SOFTWARE APPLICATIONS, COMPUTER PROGRAMS, DIETARY SUPPLEMENTS, AND ONLINE HEALTH MONITORING EQUIPMENT; ONLINE ADVERTISING AND MARKETING SERVICES (U.S. CLS. 100, 101 AND 102).

FIRST USE 9-23-2007; IN COMMERCE 1-1-2011.

### CLASS 38—COMMUNICATION

FOR PROVIDING ON-LINE ELECTRONIC BULLETIN BOARDS, AND FORUMS FOR TRANSMISSION OF MESSAGES AMONG COMPUTER USERS CONCERNING A WIDE VARIETY OF TOPICS AND FIELDS VIA THE INTERNET; PROVIDING MULTIPLE-USER ACCESS TO THE INTERNET FOR THE TRANSFER AND DISSEMINATION OF A WIDE RANGE OF INFORMATION AND SERVICES, AND FOR ACCESSING THIRD PARTY AND PROPRIETARY WEB SITES; ON-LINE BROADCASTING OF ENTERTAINMENT PROGRAMS; PROVIDING ONLINE COMMUNICATIONS LINKS WHICH TRANSFER THE WEBSITE USER TO OTHER LOCAL AND GLOBAL WEBPAGES PROVIDING INFORMATION CONCERNING NEWS, WEATHER, SPORTS, AND CURRENT EVENTS; ELECTRONIC DELIVERY OF COMPUTER SOFTWARE APPLICATIONS, ONLINE ADVERTISEMENTS, AND ONLINE HEALTH MONITORING EQUIPMENT VIA A GLOBAL COMPUTER NETWORK (U.S. CLS. 100, 101 AND 104).

FIRST USE 9-23-2007; IN COMMERCE 1-1-2011.

### CLASS 39—TRANSPORTATION AND STORAGE

FOR DISTRIBUTION SERVICES, NAMELY, DELIVERY OF COMPUTER PROGRAMS, DIETARY SUPPLEMENTS, HEALTH MONITORING DEVICES, AND NATURAL FOODS (U.S. CLS. 100 AND 105).

FIRST USE 9-23-2007; IN COMMERCE 1-1-2011.

### CLASS 41—EDUCATION AND ENTERTAINMENT

FOR ENTERTAINMENT SERVICES, NAMELY, PROVIDING CURRENT-EVENT REPORTING ABOUT NEWS AND SPORTS INFORMATION VIA THE INTERNET, ELECTRONIC COMMUNICATIONS NETWORK, AND COMPUTER NETWORKS; PROVIDING ONLINE COMPUTER GAMES; PROVIDING ONLINE EDUCATIONAL INFORMATION IN THE FIELDS OF LANGUAGE INSTRUCTION AND CULTURE VIA THE INTERNET, ELECTRONIC COMMUNICATIONS NETWORKS, AND COMPUTER NETWORKS; ONLINE JOURNALS, NAMELY, BLOGS FEATURING DISCUSSIONS REGARDING ONLINE ADVERTISING, AUTO RACING, AND THE OPERATION OF PERSON-TO-PERSON RETAIL MERCHANDISING OF DOWNLOADABLE COMPUTER SOFTWARE APPLICATIONS, ONLINE FLASH-BASED COMPUTER PROGRAMS, COMPUTER PROGRAMS, ONLINE VIDEO CONFERENCING TECHNOLOGY AND SOFTWARE, DIETARY SUPPLEMENTS, AND ONLINE HEALTH MONITORING EQUIPMENT (U.S. CLS. 100, 101 AND 107).

FIRST USE 9-23-2007; IN COMMERCE 1-1-2011.

#### **CLASS 42—SCIENTIFIC AND COMPUTER SERVICES**

FOR COMPUTER SERVICES, NAMELY, CREATING INDEXES OF INFORMATION, SITES, AND OTHER RESOURCES AVAILABLE ON COMPUTER NETWORKS; SEARCHING AND RETRIEVING INFORMATION, SITES, AND OTHER RESOURCES AVAILABLE ON COMPUTER NETWORKS AT THE SPECIFIC REQUEST OF END-USERS BY MEANS OF TELEPHONE AND/OR THE INTERNET; PROVIDING WEATHER INFORMATION VIA THE INTERNET, ELECTRONIC COMMUNICATIONS NETWORK, AND COMPUTER NETWORKS (U.S. CLS. 100 AND 101).

FIRST USE 9-23-2007; IN COMMERCE 1-1-2011.

#### **CLASS 45—PERSONAL AND LEGAL SERVICES**

FOR PROVIDING INFORMATION REGARDING ASTROLOGY AND HOROSCOPES VIA THE INTERNET (U.S. CLS. 100 AND 101).

FIRST USE 9-23-2007; IN COMMERCE 1-1-2011.

3,962,005. M&G DURAVENT, INC., VACAVILLE, CA. SN 77-025,245. PUB. 12-4-2007, FILED 10-19-2006.

# GREENVENT

THE MARK CONSISTS OF STANDARD CHARACTERS WITHOUT CLAIM TO ANY PARTICULAR FONT, STYLE, SIZE, OR COLOR.

#### **CLASS 6—METAL GOODS**

FOR METAL CHIMNEYS; METAL CONNECTOR PIPES AND FITTINGS FOR USE IN VENTING; METAL STOVE PIPES AND FITTINGS THEREOF (U.S. CLS. 2, 12, 13, 14, 23, 25 AND 50).

FIRST USE 2-18-2011; IN COMMERCE 2-18-2011.

#### **CLASS 11—ENVIRONMENTAL CONTROL APPARATUS**

FOR DIRECT VENTS FOR GAS, OIL AND SOLID FUEL APPLIANCES (U.S. CLS. 13, 21, 23, 31 AND 34).

FIRST USE 2-18-2011; IN COMMERCE 2-18-2011.

3,962,006. INTERUSH HOLDINGS LTD., IRVINE, CA. SN 77-025,415. PUB. 1-15-2008, FILED 10-19-2006.



THE MARK CONSISTS OF A SQUARE DIVIDED INTO NINE EQUALLY SIZED SQUARE BOXES TO THE RIGHT OF WHICH APPEARS THE WORD "INTERUSH".

#### **CLASS 35—ADVERTISING AND BUSINESS**

FOR PROVIDING CONSUMER PRODUCT INFORMATION VIA THE INTERNET; PROVIDING COMPARISON SHOPPING INFORMATION VIA THE INTERNET; DISSEMINATION OF ADVERTISING FOR OTHERS VIA THE INTERNET; AND PROVIDING ONLINE DIRECTORY INFORMATION SERVICES ALSO FEATURING HYPERLINKS TO OTHER WEBSITES; COMPUTERIZED ONLINE RETAIL AND WHOLESALE SERVICES AND DISTRIBUTORSHIP SERVICES IN THE FIELD OF DOWNLOADABLE COMPUTER SOFTWARE APPLICATIONS, COMPUTER PROGRAMS, DIETARY SUPPLEMENTS, AND ONLINE HEALTH MONITORING EQUIPMENT; BUSINESS CONSULTATION IN THE NATURE OF RENDERING ASSISTANCE TO OTHERS IN CONNECTION WITH THE ESTABLISHMENT AND OPERATION OF DISTRIBUTORSHIPS IN THE FIELD OF DOWNLOADABLE COMPUTER SOFTWARE APPLICATIONS, ONLINE MULTIMEDIA COMPUTER PROGRAMS, COMPUTER PROGRAMS, ONLINE VIDEO CONFERENCING TECHNOLOGY AND SOFTWARE, DIETARY SUPPLEMENTS, AND ONLINE HEALTH MONITORING EQUIPMENT; ASSOCIATION SERVICES, NAMELY, PROMOTING THE INTERESTS OF INDEPENDENT BUSINESS OWNERS; OFFERING TECHNICAL ASSISTANCE IN CONNECTION WITH THE ESTABLISHMENT AND/OR OPERATION OF PERSON-TO-PERSON RETAIL MERCHANDISING OF DOWNLOADABLE COMPUTER SOFTWARE APPLICATIONS, COMPUTER PROGRAMS, DIETARY SUPPLEMENTS, AND ONLINE HEALTH MONITORING EQUIPMENT; ONLINE ADVERTISING AND MARKETING SERVICES (U.S. CLS. 100, 101 AND 102).

FIRST USE 9-23-2007; IN COMMERCE 1-1-2011.

#### **CLASS 38—COMMUNICATION**

FOR PROVIDING ON-LINE ELECTRONIC BULLETIN BOARDS, AND FORUMS FOR TRANSMISSION OF MESSAGES AMONG COMPUTER USERS CONCERNING A WIDE VARIETY OF TOPICS AND FIELDS VIA THE INTERNET; PROVIDING MULTIPLE-USER ACCESS TO THE INTERNET FOR THE TRANSFER AND DISSEMINATION OF A WIDE RANGE OF INFORMATION AND SERVICES, AND FOR ACCESSING THIRD PARTY AND PROPRIETARY WEB SITES; ON-LINE BROADCASTING OF ENTERTAINMENT PROGRAMS; PROVIDING ONLINE COMMUNICATIONS LINKS WHICH TRANSFER THE WEBSITE USER TO OTHER LOCAL AND GLOBAL WEBPAGES PROVIDING INFORMATION CONCERNING NEWS, WEATHER, SPORTS, AND CURRENT EVENTS; ELECTRONIC DELIVERY OF COMPUTER SOFTWARE APPLICATIONS, ONLINE ADVERTISEMENTS, AND ONLINE HEALTH MONITORING EQUIPMENT VIA A GLOBAL COMPUTER NETWORK (U.S. CLS. 100, 101 AND 104).

FIRST USE 9-23-2007; IN COMMERCE 1-1-2011.

#### **CLASS 39—TRANSPORTATION AND STORAGE**

FOR DISTRIBUTION SERVICES, NAMELY, DELIVERY OF COMPUTER PROGRAMS, DIETARY SUPPLEMENTS, HEALTH MONITORING DEVICES, AND NATURAL FOODS (U.S. CLS. 100 AND 105).

FIRST USE 9-23-2007; IN COMMERCE 1-1-2011.

**CLASS 41—EDUCATION AND ENTERTAINMENT**

FOR ENTERTAINMENT SERVICES, NAMELY, PROVIDING CURRENT-EVENT REPORTING ABOUT NEWS AND SPORTS INFORMATION VIA THE INTERNET, ELECTRONIC COMMUNICATIONS NETWORK, AND COMPUTER NETWORKS; PROVIDING ONLINE COMPUTER GAMES; PROVIDING ONLINE EDUCATIONAL INFORMATION IN THE FIELDS OF LANGUAGE INSTRUCTION AND CULTURE VIA THE INTERNET, ELECTRONIC COMMUNICATIONS NETWORKS, AND COMPUTER NETWORKS; ONLINE JOURNALS, NAMELY, BLOGS FEATURING DISCUSSIONS REGARDING ONLINE ADVERTISING, AUTO RACING, AND THE OPERATION OF PERSON-TO-PERSON RETAIL MERCHANDISING OF DOWNLOADABLE COMPUTER SOFTWARE APPLICATIONS, ONLINE FLASH-BASED COMPUTER PROGRAMS, COMPUTER PROGRAMS, ONLINE VIDEO CONFERENCING TECHNOLOGY AND SOFTWARE, DIETARY SUPPLEMENTS, AND ONLINE HEALTH MONITORING EQUIPMENT (U.S. CLS. 100, 101 AND 107).

FIRST USE 9-23-2007; IN COMMERCE 1-1-2011.

**CLASS 42—SCIENTIFIC AND COMPUTER SERVICES**

FOR COMPUTER SERVICES, NAMELY, CREATING INDEXES OF INFORMATION, SITES, AND OTHER RESOURCES AVAILABLE ON COMPUTER NETWORKS; SEARCHING AND RETRIEVING INFORMATION, SITES, AND OTHER RESOURCES AVAILABLE ON COMPUTER NETWORKS AT THE SPECIFIC REQUEST OF END-USERS BY MEANS OF TELEPHONE AND/OR THE INTERNET; PROVIDING WEATHER INFORMATION VIA THE INTERNET, ELECTRONIC COMMUNICATIONS NETWORK, AND COMPUTER NETWORKS (U.S. CLS. 100 AND 101).

FIRST USE 9-23-2007; IN COMMERCE 1-1-2011.

**CLASS 45—PERSONAL AND LEGAL SERVICES**

FOR PROVIDING INFORMATION REGARDING ASTROLOGY AND HOROSCOPES VIA THE INTERNET (U.S. CLS. 100 AND 101).

FIRST USE 9-23-2007; IN COMMERCE 1-1-2011.

3,962,013. HYDROPOOL INC., MISSISSAUGA, CANADA. SN 77-069,219. PUB. 12-18-2007, FILED 12-21-2006.

# HYDROGUIDE

THE MARK CONSISTS OF STANDARD CHARACTERS WITHOUT CLAIM TO ANY PARTICULAR FONT, STYLE, SIZE, OR COLOR.

**CLASS 1—CHEMICALS**

FOR WATER TREATMENT CHEMICALS FOR USE IN SWIMMING POOLS AND SPAS (U.S. CLS. 1, 5, 6, 10, 26 AND 46).

FIRST USE 1-1-2008; IN COMMERCE 1-1-2008.

**CLASS 11—ENVIRONMENTAL CONTROL APPARATUS**

FOR ENERGY EFFICIENT SPAS IN THE NATURE OF HEATED POOLS AND HOT TUBS; SWIM SPAS IN THE NATURE OF HEATED POOLS; WHIRLPOOL SPAS; SAUNAS; ACCESSORIES SPECIALLY ADAPTED FOR POOLS AND SPAS, NAMELY, FLOATING FITTED SPA COVERS, CARTRIDGE FILTER ELEMENTS FOR FILTER SYSTEMS FOR SPAS, FITTED BASES FOR SPAS, SPA COVER REMOVING DEVICE, CUP HOLDERS AND CADDIES FOR HOLDING DRINKS IN SPAS, GRAB HANDLES, ELECTRIC LIGHTING FIXTURES, HAND-HELD HOT TUB JETS AND STEPS FOR SPAS (U.S. CLS. 13, 21, 23, 31 AND 34).

FIRST USE 1-1-2008; IN COMMERCE 1-1-2008.

**CLASS 19—NON-METALLIC BUILDING MATERIALS**

FOR NON-METAL SWIMMING POOLS; GAZEBOS NOT PRIMARILY OF METAL (U.S. CLS. 1, 12, 33 AND 50).

FIRST USE 1-1-2008; IN COMMERCE 1-1-2008.

3,962,017. APPLIED RESEARCH ASSOCIATES, INC., ALBUQUERQUE, NM. SN 77-090,838. PUB. 7-17-2007, FILED 1-25-2007.

# SIMWARS

THE MARK CONSISTS OF STANDARD CHARACTERS WITHOUT CLAIM TO ANY PARTICULAR FONT, STYLE, SIZE, OR COLOR.

**CLASS 9—ELECTRICAL AND SCIENTIFIC APPARATUS**

FOR COMPUTER SIMULATION SOFTWARE FOR TRAINING AND EDUCATIONAL PURPOSES FOR USE IN THE MILITARY, HOMELAND DEFENSE, LAW ENFORCEMENT AND FIRST RESPONDER FIELDS PROVIDED IN PACKAGED AND DOWNLOADABLE FORM, AND INSTRUCTIONAL MANUALS SOLD AS A UNIT; COMPUTER SOFTWARE FOR TRAINING AND EDUCATIONAL PURPOSES FOR USE IN THE MILITARY, HOMELAND DEFENSE, LAW ENFORCEMENT AND FIRST RESPONDER FIELDS PROVIDED IN PACKAGED AND DOWNLOADABLE FORM, AND INSTRUCTIONAL MANUALS SOLD AS A UNIT (U.S. CLS. 21, 23, 26, 36 AND 38).

FIRST USE 1-14-2004; IN COMMERCE 12-1-2004.

**CLASS 41—EDUCATION AND ENTERTAINMENT**

FOR TRAINING AND EDUCATIONAL SERVICES, NAMELY, PROVIDING COMPUTER BASED SIMULATION TRAINING IN THE FIELDS OF MILITARY, HOMELAND DEFENSE, LAW ENFORCEMENT AND FIRST RESPONDER (U.S. CLS. 100, 101 AND 107).

FIRST USE 1-14-2004; IN COMMERCE 12-1-2004.



**CLASS 42—SCIENTIFIC AND COMPUTER SERVICES**

FOR COMPUTER SOFTWARE CONSULTATION; DESIGN, DEVELOPMENT AND IMPLEMENTATION OF SOFTWARE; MAINTENANCE OF COMPUTER SOFTWARE; PROVIDING ON-LINE NON-DOWNLOADABLE SOFTWARE FOR TRAINING AND EDUCATIONAL PURPOSES FOR USE IN THE MILITARY, HOMELAND DEFENSE, LAW ENFORCEMENT AND FIRST RESPONDER FIELDS; TECHNICAL SUPPORT SERVICES, NAMELY, TROUBLESHOOTING OF COMPUTER HARDWARE AND SOFTWARE PROBLEMS (U.S. CLS. 100 AND 101).

FIRST USE 1-14-2004; IN COMMERCE 12-1-2004.

3,962,018. APPLIED RESEARCH ASSOCIATES, INC., ALBUQUERQUE, NM. SN 77-090,853. PUB. 7-17-2007, FILED 1-25-2007.



THE MARK CONSISTS OF A TARGET AND CROSSHAIRS DESIGN WITH A CIRCLE IN THE MIDDLE.

**CLASS 9—ELECTRICAL AND SCIENTIFIC APPARATUS**

FOR COMPUTER SIMULATION SOFTWARE FOR TRAINING AND EDUCATIONAL PURPOSES FOR USE IN THE MILITARY, HOMELAND DEFENSE, LAW ENFORCEMENT AND FIRST RESPONDER FIELDS PROVIDED IN PACKAGED AND DOWNLOADABLE FORM, AND INSTRUCTIONAL MATERIALS SOLD AS A UNIT; COMPUTER SOFTWARE FOR TRAINING AND EDUCATIONAL PURPOSES FOR USE IN THE MILITARY, HOMELAND DEFENSE, LAW ENFORCEMENT AND FIRST RESPONDER FIELDS PROVIDED IN PACKAGED AND DOWNLOADABLE FORM, AND INSTRUCTIONAL MANUALS SOLD AS A UNIT (U.S. CLS. 21, 23, 26, 36 AND 38).

FIRST USE 1-14-2004; IN COMMERCE 12-1-2004.

**CLASS 41—EDUCATION AND ENTERTAINMENT**

FOR TRAINING AND EDUCATIONAL SERVICES, NAMELY, PROVIDING COMPUTER BASED SIMULATION TRAINING IN THE FIELDS OF MILITARY, HOMELAND DEFENSE, LAW ENFORCEMENT AND FIRST RESPONDER (U.S. CLS. 100, 101 AND 107).

FIRST USE 1-14-2004; IN COMMERCE 12-1-2004.

**CLASS 42—SCIENTIFIC AND COMPUTER SERVICES**

FOR COMPUTER SOFTWARE CONSULTATION; DESIGN, DEVELOPMENT AND IMPLEMENTATION OF SOFTWARE; MAINTENANCE OF COMPUTER SOFTWARE; PROVIDING ON-LINE NON-DOWNLOADABLE SOFTWARE FOR TRAINING AND EDUCATIONAL PURPOSES FOR USE IN THE MILITARY, HOMELAND DEFENSE, LAW ENFORCEMENT AND FIRST RESPONDER FIELDS; TECHNICAL SUPPORT SERVICES, NAMELY, TROUBLESHOOTING OF COMPUTER HARDWARE AND SOFTWARE PROBLEMS (U.S. CLS. 100 AND 101).

FIRST USE 1-14-2004; IN COMMERCE 12-1-2004.

3,962,021. TOTAL GRAIN MARKETING, LLC, BLOOMINGTON, IL. SN 77-101,479. PUB. 3-4-2008, FILED 2-7-2007.

**TOTAL GRAIN MARKETING**

THE MARK CONSISTS OF STANDARD CHARACTERS WITHOUT CLAIM TO ANY PARTICULAR FONT, STYLE, SIZE, OR COLOR.

NO CLAIM IS MADE TO THE EXCLUSIVE RIGHT TO USE "GRAIN MARKETING", APART FROM THE MARK AS SHOWN.

**CLASS 35—ADVERTISING AND BUSINESS**

FOR DIRECT MARKETING AND MERCHANDISING OF GRAIN; PROCUREMENT SERVICES, NAMELY, PROCURING CONTRACTS FOR OTHERS FOR THE PURCHASE OR STORAGE OF GRAIN (U.S. CLS. 100, 101 AND 102).

FIRST USE 9-30-2008; IN COMMERCE 9-30-2008.

**CLASS 39—TRANSPORTATION AND STORAGE**

FOR STORAGE OF GRAIN; CARGO HANDLING OF GRAIN (U.S. CLS. 100 AND 105).

FIRST USE 9-30-2008; IN COMMERCE 9-30-2008.

3,962,028. CNL INTELLECTUAL PROPERTIES, INC., ORLANDO, FL. SN 77-123,959. PUB. 1-15-2008, FILED 3-6-2007.

**TIC: Talent, Ideas and Capital**

THE MARK CONSISTS OF STANDARD CHARACTERS WITHOUT CLAIM TO ANY PARTICULAR FONT, STYLE, SIZE, OR COLOR.

NO CLAIM IS MADE TO THE EXCLUSIVE RIGHT TO USE "CAPITAL", APART FROM THE MARK AS SHOWN.

**CLASS 35—ADVERTISING AND BUSINESS**

FOR BUSINESS STRATEGIC PLANNING AND CONSULTING SERVICES, PLANNING AND CONSULTING SERVICES IN THE DEVELOPMENT AND GROWTH OF BUSINESSES (U.S. CLS. 100, 101 AND 102).

FIRST USE 3-8-2011; IN COMMERCE 3-8-2011.

**CLASS 36—INSURANCE AND FINANCIAL**

FOR REAL ESTATE DEVELOPMENT, INVESTMENT BROKERAGE, CONSULTING AND MANAGEMENT SERVICES; REAL ESTATE INVESTMENT TRUST SERVICES; MORTGAGE AND COMMERCIAL FINANCING SERVICES; INVESTMENT AND COMMERCIAL BANKING SERVICES; BROKER/DEALER SERVICES IN THE FIELD OF INVESTMENT SECURITIES, FRANCHISE MORTGAGE, MERGERS AND ACQUISITIONS, REAL ESTATE AND INVESTMENT ADVISORY SERVICES; FINANCIAL ADVISORY SERVICES (U.S. CLS. 100, 101 AND 102).

FIRST USE 3-8-2011; IN COMMERCE 3-8-2011.

3,962,032. RUBBER VULK-PNEUS E ACESSORIOS, LDA, 3750-599 AGUEDA, PORTUGAL. SN 77-134,353. PUB. 1-5-2010, FILED 3-19-2007.

3,962,033. SB WORLDWIDE, LLC, BATTLE CREEK, MI. SN 77-141,042. PUB. 9-25-2007, FILED 3-27-2007.

## RUBBER VULK

THE MARK CONSISTS OF STANDARD CHARACTERS WITHOUT CLAIM TO ANY PARTICULAR FONT, STYLE, SIZE, OR COLOR.

OWNER OF ERPN CMNTY TM OFC REG. NO. 004496063, DATED 7-12-2006, EXPIRES 6-16-2015.

NO CLAIM IS MADE TO THE EXCLUSIVE RIGHT TO USE "RUBBER", APART FROM THE MARK AS SHOWN.

### CLASS 1—CHEMICALS

FOR CHEMICAL CLEANERS USED IN THE INDUSTRIES OF MANUFACTURING, REPAIR AND RETREADING OF TIRES AND INNER TUBES FOR VEHICLES; ADHESIVES AND GLUES FOR INDUSTRIAL PURPOSES (U.S. CLS. 1, 5, 6, 10, 26 AND 46).

FIRST USE 6-27-2007; IN COMMERCE 6-27-2007.

### CLASS 6—METAL GOODS

FOR METAL BOLTS AND METAL NUTS FOR FIXING WHEEL RIMS TO VEHICLES, USED FOR ADJUSTING THE CAMBER; METAL CLAMPS (U.S. CLS. 2, 12, 13, 14, 23, 25 AND 50).

FIRST USE 6-27-2007; IN COMMERCE 6-27-2007.

### CLASS 7—MACHINERY

FOR PNEUMATIC HAND TOOLS USED FOR MOUNTING AND DEMOUNTING TIRES AND BRACES THEREFOR (U.S. CLS. 13, 19, 21, 23, 31, 34 AND 35).

FIRST USE 6-27-2007; IN COMMERCE 6-27-2007.

### CLASS 8—HAND TOOLS

FOR HAND TOOLS, NAMELY, SOCKET WRENCHES FOR VALVE FIXATION AND REAMERS; PLIERS; RASPS; NON-POWERED, NON-PNEUMATIC HAND TOOLS USED FOR MOUNTING AND DEMOUNTING TIRES AND BRACES THEREFOR (U.S. CLS. 23, 28 AND 44).

FIRST USE 6-27-2007; IN COMMERCE 6-27-2007.

### CLASS 12—VEHICLES

FOR VALVES FOR VEHICLE TIRES, NAMELY, COVERS, STEMS, CAPS, ALL FOR AND SOLD TOGETHER WITH VALVES; VALVES FOR VEHICLE TIRES, NAMELY, VALVE PARTS, PLASTIC AND METALLIC FLEXIBLE VALVE EXTENSIONS, VALVE REDUCERS, O-RINGS FOR AND SOLD TOGETHER WITH VALVES; CLAMPS FOR VALVE EXTENSIONS FOR VEHICLE TIRES; PIN PLUGS FOR VEHICLE TIRES; REPAIR MATERIAL FOR VEHICLE TIRES, NAMELY, REPAIR PATCHES AND RUBBER INSERTS; WHEEL RIMS FOR VEHICLE TIRES; INNER TUBES FOR VEHICLE TIRES (U.S. CLS. 19, 21, 23, 31, 35 AND 44).

FIRST USE 6-27-2007; IN COMMERCE 6-27-2007.

## SUNDAY BOYFRIEND

THE MARK CONSISTS OF STANDARD CHARACTERS WITHOUT CLAIM TO ANY PARTICULAR FONT, STYLE, SIZE, OR COLOR.

### CLASS 25—CLOTHING

FOR CLOTHING, NAMELY, PANTS, SHORTS, SWEATSHIRTS, T-SHIRTS, UNDERWEAR, PAJAMAS, JACKETS AND HATS (U.S. CLS. 22 AND 39).

FIRST USE 9-30-2007; IN COMMERCE 10-15-2007.

### CLASS 45—PERSONAL AND LEGAL SERVICES

FOR ONLINE SOCIAL NETWORKING SERVICES (U.S. CLS. 100 AND 101).

FIRST USE 1-1-2007; IN COMMERCE 10-15-2007.

3,962,045. HICO, INC., ENCINO, CA. SN 77-210,095. PUB. 12-4-2007, FILED 6-19-2007.

## CELLUSPA

THE MARK CONSISTS OF STANDARD CHARACTERS WITHOUT CLAIM TO ANY PARTICULAR FONT, STYLE, SIZE, OR COLOR.

### CLASS 3—COSMETICS AND CLEANING PREPARATIONS

FOR COSMETIC PRODUCTS, NAMELY, SKIN CLEANSING CREAMS, CELLULITE REDUCING LOTIONS, AND SKIN LOTION (U.S. CLS. 1, 4, 6, 50, 51 AND 52).

FIRST USE 2-25-2011; IN COMMERCE 2-25-2011.

### CLASS 10—MEDICAL APPARATUS

FOR ELECTRIC MASSAGE APPLIANCES, NAMELY, ELECTRIC VIBRATING MASSAGER AND ELECTRIC WEARABLE MASSAGERS (U.S. CLS. 26, 39 AND 44).

FIRST USE 2-25-2011; IN COMMERCE 2-25-2011.

3,962,046. LEMMON, TIMOTHY J., NEW YORK, NY. SN 77-214,816. PUB. 1-29-2008, FILED 6-25-2007.

## INTELLERUS

THE MARK CONSISTS OF STANDARD CHARACTERS WITHOUT CLAIM TO ANY PARTICULAR FONT, STYLE, SIZE, OR COLOR.

### CLASS 16—PAPER GOODS AND PRINTED MATTER

FOR PUBLICATIONS, NAMELY, REPORTS, DIRECTORIES, BROCHURES, LEAFLETS, NEWSLETTERS, BOOKLETS, PAMPHLETS, POSTCARDS, FLYERS, MAGAZINE SUPPLEMENTS TO NEWSPAPERS, MAGAZINES AND TRADE AND PROFESSIONAL BOOKS IN THE FIELDS OF NEWS, BUSINESS FINANCE, CURRENT EVENTS, ENTERTAINMENT, SPORTS, HUMAN INTEREST STORIES, SECURITIES, AND SECURITIES MARKETS (U.S. CLS. 2, 5, 22, 23, 29, 37, 38 AND 50).  
FIRST USE 2-1-2009; IN COMMERCE 2-1-2009.

### CLASS 35—ADVERTISING AND BUSINESS

FOR BUSINESS INFORMATION SERVICES, NAMELY, COMPANY NEWS, COMPANY ANALYSIS AND PROFILE INFORMATION, EARNINGS STATEMENTS, ESTIMATES AND GUIDELINES, ANALYST PRESENTATIONS AND RECOMMENDATIONS, PRESS RELEASES AND SECURITIES AND EXCHANGE COMMISSION FILINGS, BUSINESS INVESTIGATION, BUSINESS MANAGEMENT, ECONOMIC FORECASTING, BUSINESS RESEARCH AND STATISTICAL INFORMATION; CONSULTING SERVICES IN THE FIELD OF BUSINESS MANAGEMENT AND ADMINISTRATION; SERVICES IN ADMINISTRATION AND IN BUSINESS MANAGEMENT AND ORGANIZATION, NAMELY, BOOKKEEPING, PAYROLL ADMINISTRATIVE SERVICES FOR OTHERS, BUSINESS DEVELOPMENT SERVICES, NAMELY, PROVIDING START-UP SUPPORT FOR BUSINESSES OF OTHERS; MANAGING BUSINESS ORGANIZATIONS, AND DISSOLVING BUSINESS ORGANIZATIONS, NAMELY, BUSINESS CONSULTATION IN THE FIELD OF DISSOLUTION OF BUSINESSES AND PREPARATION OF BUSINESS DISSOLUTION DOCUMENTS; COMMERCIAL INFORMATION AND INQUIRIES IN THE FIELD OF INTERNATIONAL BUSINESS OPERATIONS; JOB PLACEMENT AND HUMAN RESOURCES SERVICES, NAMELY, PERSONNEL SELECTION FOR OTHERS; COMMERCIAL MANAGEMENT OF COMPANIES, BUSINESSES AND INSTITUTES; COMMERCIAL ASSISTANCE FOR THE MANAGEMENT OF COMPANIES, BUSINESSES AND INSTITUTES, NAMELY, PROVIDING ASSISTANCE IN THE MANAGEMENT OF BUSINESS ACTIVITIES; BUSINESS DISSOLUTION ANALYSIS AND BUSINESS DISSOLUTION MANAGEMENT FOR COMPANIES, BUSINESSES AND INSTITUTES (U.S. CLS. 100, 101 AND 102).  
FIRST USE 2-1-2009; IN COMMERCE 2-1-2009.

### CLASS 36—INSURANCE AND FINANCIAL

FOR COMPUTER NETWORKS AND GLOBAL COMMUNICATION NETWORKS; INFORMATION SERVICES RELATING TO FINANCIAL NEWS, SECURITIES, AND SECURITIES MARKETS; FINANCIAL SERVICES IN THE NATURE OF INVESTMENT MANAGEMENT, INVESTMENT ADVICE, FINANCIAL CONSULTATION; INVESTMENT SERVICES IN THE NATURE OF ASSET MANAGEMENT, FUND MANAGEMENT OF CAPITAL INVESTMENT FUND (U.S. CLS. 100, 101 AND 102).  
FIRST USE 2-1-2009; IN COMMERCE 2-1-2009.

3,962,053. NATIVE AMERICAN NATURAL FOODS, KYLE, SD. SN 77-219,750. PUB. 10-7-2008, FILED 6-29-2007.



NO CLAIM IS MADE TO THE EXCLUSIVE RIGHT TO USE "NATIVE AMERICAN" FOR INTERNATIONAL CLASSES 14 AND 25 AND "NATIVE AMERICAN NATURAL FOODS" FOR INTERNATIONAL CLASS 29, APART FROM THE MARK AS SHOWN.

### CLASS 14—JEWELRY

FOR JEWELRY (U.S. CLS. 2, 27, 28 AND 50).  
FIRST USE 11-1-2007; IN COMMERCE 11-1-2007.

### CLASS 25—CLOTHING

FOR CLOTHING, NAMELY, HATS, SHIRTS (U.S. CLS. 22 AND 39).  
FIRST USE 11-1-2007; IN COMMERCE 11-1-2007.

### CLASS 29—MEATS AND PROCESSED FOODS

FOR NATURAL FOODS, NAMELY, DRIED MEAT AND FRUIT (U.S. CL. 46).  
FIRST USE 11-1-2007; IN COMMERCE 11-1-2007.

3,962,058. KAYSER-ROTH CORPORATION, GREENSBORO, NC. SN 77-223,200. PUB. 12-18-2007, FILED 7-6-2007.

## HUE

THE MARK CONSISTS OF STANDARD CHARACTERS WITHOUT CLAIM TO ANY PARTICULAR FONT, STYLE, SIZE, OR COLOR.

OWNER OF U.S. REG. NOS. 1,250,432, 2,944,689, AND OTHERS.

### CLASS 20—FURNITURE AND ARTICLES NOT OTHERWISE CLASSIFIED

FOR PILLOWS (U.S. CLS. 2, 13, 22, 25, 32 AND 50).  
FIRST USE 3-10-2011; IN COMMERCE 3-10-2011.

### CLASS 24—FABRICS

FOR BED LINENS, NAMELY, BED BLANKETS, BED SHEETS, PILLOW CASES, AND BEACH TOWELS (U.S. CLS. 42 AND 50).  
FIRST USE 3-10-2011; IN COMMERCE 3-10-2011.

3,962,059. FINKELSTEIN, ADAM, PORT WASHINGTON, NY. SN 77-223,380. PUB. 1-1-2008, FILED 7-6-2007.

# FindtheWill.com

THE MARK CONSISTS OF STANDARD CHARACTERS WITHOUT CLAIM TO ANY PARTICULAR FONT, STYLE, SIZE, OR COLOR.

## CLASS 38—COMMUNICATION

FOR FACSIMILE TRANSMISSION OF DOCUMENTS VIA A GLOBAL COMPUTER NETWORK (U.S. CLS. 100, 101 AND 104).  
FIRST USE 1-1-2011; IN COMMERCE 1-1-2011.

## CLASS 39—TRANSPORTATION AND STORAGE

FOR ELECTRONIC STORAGE OF FILES AND DOCUMENTS (U.S. CLS. 100 AND 105).  
FIRST USE 1-1-2011; IN COMMERCE 1-1-2011.

## CLASS 42—SCIENTIFIC AND COMPUTER SERVICES

FOR ONLINE DOCUMENT RETRIEVAL SERVICES (U.S. CLS. 100 AND 101).  
FIRST USE 1-1-2011; IN COMMERCE 1-1-2011.

3,962,063. RYBOVICH BOAT COMPANY, LLLP, FORT LAUDERDALE, FL. SN 77-232,136. PUB. 12-11-2007, FILED 7-17-2007.

# REFIT. REFRESH. REFUEL. RELAX.

THE MARK CONSISTS OF STANDARD CHARACTERS WITHOUT CLAIM TO ANY PARTICULAR FONT, STYLE, SIZE, OR COLOR.

## CLASS 35—ADVERTISING AND BUSINESS

FOR RETAIL STORE SERVICES FEATURING BOAT PARTS, CONVENIENCE STORE ITEMS (U.S. CLS. 100, 101 AND 102).  
FIRST USE 7-17-2007; IN COMMERCE 7-17-2007.

## CLASS 37—CONSTRUCTION AND REPAIR

FOR BOAT REPAIR; BOAT ENGINE REPAIR AND MAINTENANCE; ELECTRICAL REPAIRS AND INSTALLATION OF ELECTRICAL WIRING AND COMPONENTS FOR BOATS; AND CARPENTRY SERVICES FOR BOATS (U.S. CLS. 100, 103 AND 106).  
FIRST USE 7-17-2007; IN COMMERCE 7-17-2007.

## CLASS 39—TRANSPORTATION AND STORAGE

FOR MARINA SERVICES; AND BOAT STORAGE (U.S. CLS. 100 AND 105).  
FIRST USE 7-17-2007; IN COMMERCE 7-17-2007.

## CLASS 40—MATERIAL TREATMENT

FOR MACHINE SHOP SERVICES, NAMELY, MACHINING BOAT PARTS FOR OTHERS (U.S. CLS. 100, 103 AND 106).  
FIRST USE 7-17-2007; IN COMMERCE 7-17-2007.

## CLASS 41—EDUCATION AND ENTERTAINMENT

FOR PROVIDING INDOOR RECREATION FACILITIES IN THE NATURE OF WORKOUT FITNESS CENTERS; AND PROVIDING SWIMMING POOLS (U.S. CLS. 100, 101 AND 107).  
FIRST USE 10-0-2008; IN COMMERCE 10-0-2008.

## CLASS 43—HOTEL AND RESTAURANT SERVICES

FOR RESTAURANT AND BAR SERVICES (U.S. CLS. 100 AND 101).  
FIRST USE 10-0-2008; IN COMMERCE 10-0-2008.

3,962,065. TOP DOWN SIDING, LLC, VERO BEACH, FL. SN 77-236,884. PUB. 12-25-2007, FILED 7-24-2007.

# TDS

THE MARK CONSISTS OF STANDARD CHARACTERS WITHOUT CLAIM TO ANY PARTICULAR FONT, STYLE, SIZE, OR COLOR.

## CLASS 6—METAL GOODS

FOR EXTERIOR BUILDING SIDING AND ROOFING MATERIALS MADE OF METAL, NAMELY, PANELS, PLANKS, TILES, SHEETS, STRIPS AND SHINGLES (U.S. CLS. 2, 12, 13, 14, 23, 25 AND 50).  
FIRST USE 2-28-2011; IN COMMERCE 2-28-2011.

## CLASS 19—NON-METALLIC BUILDING MATERIALS

FOR EXTERIOR BUILDING SIDING AND ROOFING MATERIALS MADE OF NON-METALLIC MATERIALS, NAMELY, PANELS, PLANKS, TILES, SHEETS, STRIPS AND SHINGLES (U.S. CLS. 1, 12, 33 AND 50).  
FIRST USE 2-28-2011; IN COMMERCE 2-28-2011.

## CLASS 37—CONSTRUCTION AND REPAIR

FOR SIDING AND ROOFING INSTALLATION SERVICES (U.S. CLS. 100, 103 AND 106).  
FIRST USE 2-28-2011; IN COMMERCE 2-28-2011.

3,962,067. EMCO CHEMICAL DISTRIBUTORS, INC., NORTH CHICAGO, IL. SN 77-238,690. PUB. 6-10-2008, FILED 7-25-2007.



OWNER OF U.S. REG. NO. 2,188,800.  
THE COLOR(S) BLUE AND GREEN IS/ARE CLAIMED AS A FEATURE OF THE MARK.  
THE MARK CONSISTS OF THE WORD "EMCO" APPEARING OVER A GREEN RECTANGLE WHICH CONTAINS THE WORDS "OUR LINE IS GREEN" IN BLUE PRINT.

### CLASS 39—TRANSPORTATION AND STORAGE

FOR DELIVERY OF INDUSTRIAL AND SPECIALTY CHEMICALS BY TRUCK AND RAIL (U.S. CLS. 100 AND 105).  
FIRST USE 10-1-2008; IN COMMERCE 10-1-2008.

### CLASS 40—MATERIAL TREATMENT

FOR TREATMENT OF INDUSTRIAL AND SPECIALTY CHEMICALS, NAMELY, TO COMPOUND AND FORMULATE SUCH CHEMICALS PER CUSTOMER AND INTERNAL SPECIFICATIONS (U.S. CLS. 100, 103 AND 106).  
FIRST USE 10-1-2008; IN COMMERCE 10-1-2008.

### CLASS 42—SCIENTIFIC AND COMPUTER SERVICES

FOR TESTING OF INDUSTRIAL AND SPECIALTY CHEMICALS PER CUSTOMER AND INTERNAL SPECIFICATIONS (U.S. CLS. 100 AND 101).  
FIRST USE 10-1-2008; IN COMMERCE 10-1-2008.

3,962,068. CONCUR TECHNOLOGIES, INC., REDMOND, WA. SN 77-242,427. PUB. 7-1-2008, FILED 7-30-2007.

**CLICK.DONE.**

THE MARK CONSISTS OF STANDARD CHARACTERS WITHOUT CLAIM TO ANY PARTICULAR FONT, STYLE, SIZE, OR COLOR.

### CLASS 41—EDUCATION AND ENTERTAINMENT

FOR TRAINING IN THE FIELD OF INSTALLATION AND OPERATION OF COMPUTER SOFTWARE; TRAINING IN THE FIELD OF BUSINESS PROCESS AUTOMATION RELATING TO EMPLOYEE SPENDING, SUCH AS TRAVEL AND EXPENSE MANAGEMENT, EXPENSE REPORTING, TRAVEL BOOKING, MEETING MANAGEMENT, VENDOR PAYMENT MANAGEMENT, AND PAYMENT PROCESSING (U.S. CLS. 100, 101 AND 107).  
FIRST USE 10-31-2007; IN COMMERCE 10-31-2007.

### CLASS 42—SCIENTIFIC AND COMPUTER SERVICES

FOR CONSULTING SERVICES IN CONNECTION WITH THE INSTALLATION AND OPERATION OF COMPUTER SOFTWARE; CONSULTING SERVICES IN CONNECTION WITH THE INSTALLATION AND OPERATION OF ENTERPRISE COMPUTER SOFTWARE; CONSULTING SERVICES IN THE FIELD OF BUSINESS PROCESS AUTOMATION RELATING TO EMPLOYEE SPENDING, SUCH AS TRAVEL AND EXPENSE MANAGEMENT, EXPENSE REPORTING AND TRAVEL BOOKING, MEETING MANAGEMENT, VENDOR PAYMENT MANAGEMENT, AND PAYMENT PROCESSING; APPLICATION SERVICE PROVIDER (ASP) SERVICES FEATURING SOFTWARE FOR AUTOMATING BUSINESS PROCESSES RELATING TO EMPLOYEE SPENDING, SUCH AS TRAVEL AND EXPENSE MANAGEMENT, EXPENSE REPORTING AND TRAVEL BOOKING, MEETING MANAGEMENT, VENDOR PAYMENT MANAGEMENT, AND PAYMENT PROCESSING (U.S. CLS. 100 AND 101).

FIRST USE 2-21-2010; IN COMMERCE 2-21-2010.

3,962,072. STAWITZ, NANCY L., NEW CUMBERLAND, PA. SN 77-253,107. PUB. 3-25-2008, FILED 8-11-2007.

**KIKADOJU**

THE MARK CONSISTS OF STANDARD CHARACTERS WITHOUT CLAIM TO ANY PARTICULAR FONT, STYLE, SIZE, OR COLOR.

THE WORDING "KIKADOJU" HAS NO MEANING IN A FOREIGN LANGUAGE.

### CLASS 3—COSMETICS AND CLEANING PREPARATIONS

FOR ESSENTIAL OILS FOR PERSONAL USE, NAMELY, PERFUMED OILS AND AROMATHERAPY OILS; MASSAGE OILS; BODY OILS; ESSENTIAL OILS FOR HOUSEHOLD USE; PERFUMERY; PERFUMING SACHETS; SACHETS; NON-MEDICATED HAND SALVES; HAND BALMS; HAND LOTIONS; BATH AND SHOWER PRODUCTS, NAMELY, BATH SOAPS IN LIQUID, SOLID OR GEL FORM, AND BATH SALTS; FOOT SCRUBS; EXFOLIANTS FOR SKIN; BODY SCRUBS; FACIAL SCRUBS; SOAPS, NAMELY, BAR SOAPS, BATH SOAPS, HAND SOAPS, SOAPS FOR BODY CARE, AND PERFUMED SOAPS; MASSAGE LUBRICANTS, NAMELY, MASSAGE LOTIONS; LIP BALMS (U.S. CLS. 1, 4, 6, 50, 51 AND 52).

FIRST USE 6-22-2007; IN COMMERCE 6-22-2007.

### CLASS 16—PAPER GOODS AND PRINTED MATTER

FOR BLANK JOURNAL BOOKS; BLANK WRITING JOURNALS; DIARIES; CARDS, NAMELY, NOTE CARDS; BLANK NOTE CARDS; BLANK CARDS; BLANK POSTCARDS; PRINTS IN THE NATURE OF PHOTOGRAPHS AND PICTURES; PHOTOGRAPHIC PRINTS; PICTURES; PRINTS; ART PICTURES; ART PRINTS; PRINTED ART REPRODUCTIONS; GRAPHIC ART REPRODUCTIONS; PICTURE BOOKS; BOOKS FEATURING ARTWORK, SPIRITUALITY, AND NATURE; POSTERS; STATIONERY (U.S. CLS. 2, 5, 22, 23, 29, 37, 38 AND 50).

FIRST USE 8-21-2007; IN COMMERCE 8-21-2007.



3,962,074. CROWN CAP (1987) LTD., WINNIPEG, MANITOBA, CANADA. SN 77-262,647. PUB. 7-13-2010, FILED 8-23-2007.



PRIORITY CLAIMED UNDER SEC. 44(D) ON CANADA APPLICATION NO. 1,361,326, FILED 8-17-2007, REG. NO. TMA766,312, DATED 5-11-2010, EXPIRES 5-11-2025.

THE MARK CONSISTS OF TWO STYLIZED LETTER 'C'S AND THE DESIGN OF A CROWN.

#### CLASS 25—CLOTHING

FOR WEARING APPAREL, NAMELY, SHAWLS, WRAPS AND SCARVES; HEADWEAR, NAMELY, HATS, CAPS, TOQUES, BALACLAVAS, HOODS, EAR MUFFS AND HEADBANDS; HANDWEAR, NAMELY, GLOVES AND MITTENS (U.S. CLS. 22 AND 39).  
FIRST USE 12-0-2007; IN COMMERCE 5-0-2008.

#### CLASS 35—ADVERTISING AND BUSINESS

FOR ONLINE RETAIL STORE SERVICES FEATURING WEARING APPAREL, HEADWEAR AND HANDWEAR (U.S. CLS. 100, 101 AND 102).  
FIRST USE 1-0-2008; IN COMMERCE 1-0-2008.

#### CLASS 40—MATERIAL TREATMENT

FOR MANUFACTURING FOR OTHERS OF WEARING APPAREL, NAMELY, SHAWLS, WRAPS AND SCARVES; HEADWEAR, NAMELY, HATS, CAPS, TOQUES, BALACLAVAS, HOODS, EAR MUFFS AND HEADBANDS; HANDWEAR, NAMELY, GLOVES AND MITTENS (U.S. CLS. 100, 103 AND 106).  
FIRST USE 3-0-2008; IN COMMERCE 3-0-2008.

3,962,075. CROWN CAP (1987) LTD., WINNIPEG, MANITOBA, CANADA. SN 77-262,750. PUB. 7-13-2010, FILED 8-23-2007.

**CROWNCAP**

THE MARK CONSISTS OF STANDARD CHARACTERS WITHOUT CLAIM TO ANY PARTICULAR FONT, STYLE, SIZE, OR COLOR.

PRIORITY CLAIMED UNDER SEC. 44(D) ON CANADA APPLICATION NO. 1,361,324, FILED 8-17-2007, REG. NO. TMA766,381, DATED 5-11-2010, EXPIRES 5-11-2025.

OWNER OF U.S. REG. NOS. 1,972,276 AND 3,190,513.

#### CLASS 25—CLOTHING

FOR WEARING APPAREL, NAMELY, SHAWLS, WRAPS AND SCARVES; HEADWEAR, NAMELY, HATS, CAPS, TOQUES, BALACLAVAS, HOODS, EAR MUFFS AND HEADBANDS; HANDWEAR, NAMELY, GLOVES AND MITTENS (U.S. CLS. 22 AND 39).

FIRST USE 12-0-2007; IN COMMERCE 5-0-2008.

#### CLASS 35—ADVERTISING AND BUSINESS

FOR ONLINE RETAIL STORE SERVICES FEATURING WEARING APPAREL, HEADWEAR AND HANDWEAR (U.S. CLS. 100, 101 AND 102).

FIRST USE 1-0-2008; IN COMMERCE 1-0-2008.

#### CLASS 40—MATERIAL TREATMENT

FOR MANUFACTURING FOR OTHERS OF WEARING APPAREL, NAMELY, SHAWLS, WRAPS AND SCARVES; HEADWEAR, NAMELY, HATS, CAPS, TOQUES, BALACLAVAS, HOODS, EAR MUFFS AND HEADBANDS; HANDWEAR, NAMELY, GLOVES AND MITTENS (U.S. CLS. 100, 103 AND 106).

FIRST USE 3-0-2008; IN COMMERCE 3-0-2008.

3,962,076. CROWN CAP (1987) LTD., WINNIPEG, MANITOBA, CANADA. SN 77-262,769. PUB. 7-20-2010, FILED 8-23-2007.

**CC CROWN CAP**

PRIORITY CLAIMED UNDER SEC. 44(D) ON CANADA APPLICATION NO. 1361325, FILED 8-17-2007, REG. NO. TMA766,317, DATED 5-11-2010, EXPIRES 5-11-2025.

OWNER OF U.S. REG. NOS. 1,972,276 AND 3,190,513.

THE MARK CONSISTS OF TWO "CC"'S AND CROWN DESIGN.

#### CLASS 25—CLOTHING

FOR WEARING APPAREL, NAMELY, SHAWLS, WRAPS AND SCARVES; HEADWEAR, NAMELY, HATS, CAPS, TOQUES, BALACLAVAS, HOODS, EAR MUFFS AND HEADBANDS; HANDWEAR, NAMELY, GLOVES AND MITTENS (U.S. CLS. 22 AND 39).

FIRST USE 12-0-2007; IN COMMERCE 5-0-2008.

#### CLASS 35—ADVERTISING AND BUSINESS

FOR ONLINE RETAIL STORE SERVICES FEATURING WEARING APPAREL, HEADWEAR AND HANDWEAR (U.S. CLS. 100, 101 AND 102).

FIRST USE 1-0-2008; IN COMMERCE 1-0-2008.

#### CLASS 40—MATERIAL TREATMENT

FOR MANUFACTURING FOR OTHERS OF WEARING APPAREL, NAMELY, SHAWLS, WRAPS AND SCARVES; HEADWEAR, NAMELY, HATS, CAPS, TOQUES, BALACLAVAS, HOODS, EAR MUFFS AND HEADBANDS; HANDWEAR, NAMELY, GLOVES AND MITTENS (U.S. CLS. 100, 103 AND 106).

FIRST USE 3-0-2008; IN COMMERCE 3-0-2008.

3,962,086. MICHAEL J. FREEMAN, GLEN COVE, NY. SN 77-296,933. PUB. 5-19-2009, FILED 10-5-2007.

# 2-XL

THE MARK CONSISTS OF STANDARD CHARACTERS WITHOUT CLAIM TO ANY PARTICULAR FONT, STYLE, SIZE, OR COLOR.

## CLASS 9—ELECTRICAL AND SCIENTIFIC APPARATUS

FOR PRE-RECORDED AUDIO DIGITAL MEDIA FOR AN INTERACTIVE TALKING ROBOT THAT CONTAINS QUESTIONS AND ANSWERS THAT FEATURE EDUCATIONAL AND HUMOROUS VERBAL RESPONSES TO A CHILD'S INPUT (U.S. CLS. 21, 23, 26, 36 AND 38).

FIRST USE 12-1-2009; IN COMMERCE 12-1-2009.

## CLASS 28—TOYS AND SPORTING GOODS

FOR AN INTERACTIVE TALKING TOY ROBOT THAT CONTAINS QUESTIONS AND ANSWERS THAT FEATURES EDUCATIONAL AND HUMOROUS VERBAL RESPONSES TO A CHILD'S INPUT (U.S. CLS. 22, 23, 38 AND 50).

FIRST USE 12-1-2009; IN COMMERCE 12-1-2009.

3,962,087. HECHO LATINO INC., DALLAS, TX. SN 77-301,483. PUB. 5-20-2008, FILED 10-11-2007.

# HECHO FUERTE

THE MARK CONSISTS OF STANDARD CHARACTERS WITHOUT CLAIM TO ANY PARTICULAR FONT, STYLE, SIZE, OR COLOR.

THE FOREIGN WORDING IN THE MARK TRANSLATES INTO ENGLISH AS "MADE STRONG".

## CLASS 14—JEWELRY

FOR JEWELRY, NAMELY, BRACELETS AND NECKLACES, NOT INCLUDING SILICON OR RUBBER WRISTBANDS (U.S. CLS. 2, 27, 28 AND 50).

FIRST USE 3-16-2011; IN COMMERCE 3-16-2011.

## CLASS 25—CLOTHING

FOR CLOTHING, NAMELY, HATS, CAPS, VISORS, SHIRTS, T-SHIRTS, TANK-TOPS, KNIT TOPS, WOVEN TOPS, HALTER TOPS, SWIMWEAR, UNDERWEAR, BOXER SHORTS, DRESSES, SKIRTS, BELTS, FOOTWEAR, SWEATERS, VESTS, SCARVES AND TIES (U.S. CLS. 22 AND 39).

FIRST USE 3-16-2011; IN COMMERCE 3-16-2011.

## CLASS 35—ADVERTISING AND BUSINESS

FOR RETAIL STORE SERVICES, ON-LINE RETAIL STORE SERVICES AND MAIL ORDER CATALOG SERVICES FEATURING CLOTHING AND JEWELRY, NOT INCLUDING SILICON OR RUBBER WRISTBANDS (U.S. CLS. 100, 101 AND 102).

FIRST USE 3-16-2011; IN COMMERCE 3-16-2011.

3,962,089. NETCONNECT HEALTHCARE SYSTEMS, LLC, ST. PETERSBURG, FL. SN 77-302,299. PUB. 4-22-2008, FILED 10-11-2007.

# NETCONNECT

THE MARK CONSISTS OF STANDARD CHARACTERS WITHOUT CLAIM TO ANY PARTICULAR FONT, STYLE, SIZE, OR COLOR.

## CLASS 9—ELECTRICAL AND SCIENTIFIC APPARATUS

FOR COMPUTER SOFTWARE FOR MEDICAL BILLING, MEDICAL BILLING CLAIMS PREPARATION, AND MEDICAL BILLING CLAIMS SUBMISSION (U.S. CLS. 21, 23, 26, 36 AND 38).

FIRST USE 6-10-2010; IN COMMERCE 7-8-2010.

## CLASS 42—SCIENTIFIC AND COMPUTER SERVICES

FOR PROVIDING TEMPORARY USE OF ON-LINE NON-DOWNLOADABLE COMPUTER SOFTWARE FOR USE IN MEDICAL BILLING, MEDICAL BILLING CLAIMS PREPARATION, AND MEDICAL BILLING CLAIMS SUBMISSION; APPLICATION SERVICE PROVIDER (ASP), NAMELY, HOSTING COMPUTER SOFTWARE FOR USE IN MEDICAL BILLING, MEDICAL BILLING CLAIMS PREPARATION, AND MEDICAL BILLING CLAIMS SUBMISSION FOR OTHERS; APPLICATION SERVICE PROVIDER (ASP) FEATURING COMPUTER SOFTWARE FOR USE IN MEDICAL BILLING, MEDICAL BILLING CLAIMS PREPARATION, AND MEDICAL BILLING CLAIMS SUBMISSION FOR OTHERS (U.S. CLS. 100 AND 101).

FIRST USE 6-10-2010; IN COMMERCE 7-8-2010.

3,962,098. THE JIM HENSON COMPANY, INC., LOS ANGELES, CA. SN 77-339,318. PUB. 7-15-2008, FILED 11-28-2007.

# SID THE SCIENCE KID

THE MARK CONSISTS OF STANDARD CHARACTERS WITHOUT CLAIM TO ANY PARTICULAR FONT, STYLE, SIZE, OR COLOR.

**CLASS 9—ELECTRICAL AND SCIENTIFIC APPARATUS**

FOR AUDIOVISUAL RECORDINGS FEATURING CHILDREN'S TELEVISION SHOWS; DVDS FEATURING CHILDREN'S TELEVISION SHOWS; SOUND RECORDINGS FEATURING CHILDREN'S TELEVISION SHOWS; DOWNLOADABLE SOUND RECORDINGS FEATURING CHILDREN'S TELEVISION SHOWS; DOWNLOADABLE AUDIOVISUAL RECORDINGS FEATURING CHILDREN'S TELEVISION SHOWS (U.S. CLS. 21, 23, 26, 36 AND 38).

FIRST USE 0-0-2009; IN COMMERCE 0-0-2009.

3,962,103. TEXTILE DECOR UK LTD, UXBRIDGE, UNITED KINGDOM. SN 77-358,807. PUB. 12-1-2009, FILED 12-22-2007.

**CASTLE HILL**  
L O N D O N

**CLASS 16—PAPER GOODS AND PRINTED MATTER**

FOR PRINTED MATERIALS, NAMELY, CHILDREN'S STORYBOOKS; POSTERS, STICKERS AND GREETING CARDS; PAPER PARTY SUPPLIES, NAMELY, METALLIC PAPER PARTY DECORATIONS, PAPER PARTY BAGS, PAPER PARTY DECORATIONS (U.S. CLS. 2, 5, 22, 23, 29, 37, 38 AND 50).

FIRST USE 0-0-2010; IN COMMERCE 0-0-2010.

NO CLAIM IS MADE TO THE EXCLUSIVE RIGHT TO USE "LONDON", APART FROM THE MARK AS SHOWN.

THE COLOR(S) BLACK, WHITE AND GOLD IS/ARE CLAIMED AS A FEATURE OF THE MARK.

THE MARK CONSISTS OF BLACK LETTERS OF THE WORDS "CASTLE HILL" UNDERLINED IN GOLD AND BELOW THAT THE WORD "LONDON" IN BLACK. AT THE BOTTOM OF THE MARK IS A SHADED RECTANGLE BISECTED BY A WHITE LINE IN THE SHAPE OF A HILL WITH THE WHITE LETTER "C" ABOVE THE PEAK OF THE HILL AND THE WHITE LETTER "H" BELOW IT. THE SHADED RECTANGLE IS OUTLINED IN WHITE AND GOLD.

**CLASS 25—CLOTHING**

FOR CLOTHING, NAMELY, SHIRTS, SLEEPWEAR (U.S. CLS. 22 AND 39).

FIRST USE 0-0-2010; IN COMMERCE 0-0-2010.

**CLASS 24—FABRICS**

FOR BED LINEN; TABLE LINEN; BATH LINEN; BED BLANKETS; BED COVERS; BED SKIRTS; BLANKET TROWS; CHILDREN'S BLANKETS; COMFORTERS; MATTRESS COVERS; CRIB BUMPER; CRIB LINEN SETS; TOWELS; COVERLETS; CURTAINS; FABRIC VALANCES; CUSHION COVERS AND DUVETS; COTTON FABRIC (U.S. CLS. 42 AND 50).

FIRST USE 1-1-1981; IN COMMERCE 1-1-1981.

**CLASS 28—TOYS AND SPORTING GOODS**

FOR TOYS, NAMELY, PRESCHOOL LEARNING AND DEVELOPMENT TOYS, HOBBY CRAFT KITS FOR SCIENCE PROJECTS AND EXPERIMENTS, PLUSH TOYS AND PLUSH DOLLS, SCIENCE AND NATURE TOYS, PLAYTHINGS AND ACTIVITY KITS, NAMELY, TOY MICROSCOPES, CHILD-ACTIVITY INSECT VIEWERS, OUTDOOR EXPLORATION TOYS, SCIENCE-THEMED ACTIVITY AND PLAY SETS, CHILD-ACTIVITY PLANT GROWING KITS, CHILD-ACTIVITY BIOLOGY SETS, CHILD-ACTIVITY EARTH SCIENCE SETS, CHILD-ACTIVITY PHYSICS SETS; GAMES, NAMELY, PUZZLES (U.S. CLS. 22, 23, 38 AND 50).

FIRST USE 0-0-2009; IN COMMERCE 0-0-2009.

**CLASS 27—FLOOR COVERINGS**

FOR BATH MATS; CARPETS AND RUGS; CARPETS, RUGS, MATS AND MATTING, LINOLEUM FOR COVERING EXISTING FLOORS; FABRIC BATH MATS; PLASTIC BATH MATS; RUBBER BATH MATS; RUGS; TEXTILE BATH MATS; NON-TEXTILE WALL COVERINGS; NON-TEXTILE WALL HANGINGS; TEXTILE LINED WALLPAPER FOR USE IN THE HOME; TEXTILE LINED WALLPAPER (U.S. CLS. 19, 20, 37, 42 AND 50).

FIRST USE 1-0-1981; IN COMMERCE 1-0-1981.

**CLASS 38—COMMUNICATION**

FOR STREAMING OF AUDIO-VISUAL MATERIAL ON THE INTERNET (U.S. CLS. 100, 101 AND 104).

FIRST USE 0-0-2009; IN COMMERCE 0-0-2009.

3,962,114. AHRENS, JASON T., TUKWILA, WA. AND CHURCHILL, SARAJEAN E, TUKWILA, WA. SN 77-387,404. PUB. 6-17-2008, FILED 2-4-2008.

**hiddenfeet**

THE MARK CONSISTS OF STANDARD CHARACTERS WITHOUT CLAIM TO ANY PARTICULAR FONT, STYLE, SIZE, OR COLOR.

**CLASS 41—EDUCATION AND ENTERTAINMENT**

FOR ENTERTAINMENT SERVICES, NAMELY, A SERIES OF TELEVISION PROGRAMS IN THE FIELDS OF CHILDREN'S ENTERTAINMENT AND MUSIC, ANIMATED TELEVISION PROGRAMS IN THE FIELDS OF CHILDREN'S ENTERTAINMENT AND MUSIC; A SERIES OF CHILDREN'S TELEVISION PROGRAMS (U.S. CLS. 100, 101 AND 107).

FIRST USE 0-0-2008; IN COMMERCE 0-0-2008.

**CLASS 9—ELECTRICAL AND SCIENTIFIC APPARATUS**

FOR AUDIO AND VIDEO RECORDINGS FEATURING MODELS (U.S. CLS. 21, 23, 26, 36 AND 38).

FIRST USE 4-4-2009; IN COMMERCE 5-4-2009.

**CLASS 41—EDUCATION AND ENTERTAINMENT**

FOR PHOTOGRAPHY (U.S. CLS. 100, 101 AND 107).  
FIRST USE 4-4-2009; IN COMMERCE 5-4-2009.

3,962,118. FREEDOM COMMUNICATIONS, INC., DBA THE ORANGE COUNTY REGISTER, SANTA ANA, CA. SN 77-397,573. PUB. 12-16-2008, FILED 2-14-2008.

**ORANGE COUNTY REGISTER  
COMMUNICATIONS**

THE MARK CONSISTS OF STANDARD CHARACTERS WITHOUT CLAIM TO ANY PARTICULAR FONT, STYLE, SIZE, OR COLOR.

OWNER OF U.S. REG. NOS. 2,319,974, 2,603,658, AND OTHERS.  
SEC. 2(F).

**CLASS 16—PAPER GOODS AND PRINTED MATTER**

FOR PRINTED PUBLICATIONS, NAMELY, NEWSPAPERS FOR GENERAL CIRCULATION; AND MAGAZINES, NEWSLETTERS, INSERTS, AND FLYERS IN THE FIELDS OF NEWS, EVENTS, EDUCATION, ENTERTAINMENT, FINANCE, GOVERNMENT, HEALTH, RELIGION, SHOPPING, SPORTS, TECHNOLOGY, TRANSPORTATION, TRAVEL, BUSINESS, COMMENTARY, HOME AND GARDEN, NATURE, INVESTIGATIONS, MULTIMEDIA, OBITUARIES, CLASSIFIEDS, JOBS, VEHICLES, COUPONS, DISCOUNTS, SALES AND WEATHER (U.S. CLS. 2, 5, 22, 23, 29, 37, 38 AND 50).  
FIRST USE 1-1-2008; IN COMMERCE 1-1-2008.

**CLASS 35—ADVERTISING AND BUSINESS**

FOR CHARITABLE SERVICES, NAMELY, ORGANIZING AND CONDUCTING VOLUNTEER PROGRAMS AND COMMUNITY SERVICE PROJECTS; PUBLIC RELATIONS AND ADVERTISING AGENCY (U.S. CLS. 100, 101 AND 102).  
FIRST USE 1-1-2008; IN COMMERCE 1-1-2008.

**CLASS 36—INSURANCE AND FINANCIAL**

FOR CHARITABLE SERVICES, NAMELY, CHARITABLE FUNDRAISING AND SHARING PROFITS FROM PUBLICATION SUBSCRIPTION SALES WITH NOT-FOR-PROFIT ORGANIZATIONS (U.S. CLS. 100, 101 AND 102).  
FIRST USE 2-2-2011; IN COMMERCE 2-2-2011.

**CLASS 41—EDUCATION AND ENTERTAINMENT**

FOR PUBLICATION SERVICES, NAMELY, PUBLICATION OF PRINTED MATERIALS, MAGAZINES AND NEWSPAPERS FOR OTHERS; EDUCATIONAL SERVICES, NAMELY, CONDUCTING SEMINARS AND WORKSHOPS IN THE FIELDS OF PUBLISHING, JOURNALISM AND COMMUNICATIONS; PROVIDING ONLINE PUBLICATIONS, NAMELY, NEWSLETTERS, ONLINE NEWSPAPERS AND ON-LINE MAGAZINES IN THE FIELDS OF NEWS, EVENTS, EDUCATION, ENTERTAINMENT, FINANCE, GOVERNMENT, HEALTH, RELIGION, SHOPPING, SPORTS, TECHNOLOGY, TRANSPORTATION, TRAVEL, BUSINESS, COMMENTARY, HOME AND GARDEN, NATURE, INVESTIGATIONS, MULTIMEDIA, OBITUARIES, CLASSIFIEDS, JOBS, VEHICLES, COUPONS, DISCOUNTS, SALES AND WEATHER (U.S. CLS. 100, 101 AND 107).  
FIRST USE 1-1-2008; IN COMMERCE 1-1-2008.

3,962,129. JUST ONE MORE RESTAURANT CORPORATION, NEW YORK, NY. SN 77-419,206. PUB. 6-30-2009, FILED 3-11-2008.



OWNER OF U.S. REG. NOS. 1,278,386, 2,311,432, AND OTHERS.

THE MARK CONSISTS OF THE WORD "PALM", THE "L" OF WHICH IS A STYLIZED PALM TREE.

**CLASS 8—HAND TOOLS**

FOR TABLEWARE, NAMELY, KNIVES, FORKS AND SPOONS (U.S. CLS. 23, 28 AND 44).  
FIRST USE 6-1-2009; IN COMMERCE 6-1-2009.

**CLASS 11—ENVIRONMENTAL CONTROL APPARATUS**

FOR BARBECUE GRILLS (U.S. CLS. 13, 21, 23, 31 AND 34).  
FIRST USE 3-15-2011; IN COMMERCE 3-15-2011.

**CLASS 21—HOUSEWARES AND GLASS**

FOR SALT AND PEPPER SHAKERS; DRINKING GLASSES (U.S. CLS. 2, 13, 23, 29, 30, 33, 40 AND 50).  
FIRST USE 6-1-2009; IN COMMERCE 6-1-2009.

**CLASS 24—FABRICS**

FOR TABLE LINEN (U.S. CLS. 42 AND 50).  
FIRST USE 6-1-2009; IN COMMERCE 6-1-2009.

3,962,137. STATE OF FLORIDA, DEPARTMENT OF TRANSPORTATION, TALLAHASSEE, FL. SN 77-434,569. PUB. 12-22-2009, FILED 3-28-2008.



THE COLOR(S) BLUE, RED AND WHITE IS/ARE CLAIMED AS A FEATURE OF THE MARK.

THE MARK CONSISTS OF A RED LOWERCASE LETTER "E" SURROUNDED BY A BLUE CIRCLE WITH THREE BLUE WINGS COMING OUT OF THE LEFT SIDE OF THE CIRCLE. THE BACKGROUND OF THE MARK IS WHITE.

**CLASS 36—INSURANCE AND FINANCIAL**

FOR HIGHWAY TOLL COLLECTION SERVICES (U.S. CLS. 100, 101 AND 102).  
FIRST USE 1-1-2009; IN COMMERCE 1-1-2009.

**CLASS 39—TRANSPORTATION AND STORAGE**

FOR PROVIDING VEHICULAR TRAFFIC INFORMATION IN THE NATURE OF TRAFFIC FLOW INFORMATION, SAID INFORMATION GATHERED VIA CLOSED-CIRCUIT TELEVISION CAMERAS AND PROVIDED TO THE PUBLIC VIA ELECTRONIC MESSAGE SIGNS AND RAMP SIGNALS (U.S. CLS. 100 AND 105).

FIRST USE 1-1-2009; IN COMMERCE 1-1-2009.

**CLASS 42—SCIENTIFIC AND COMPUTER SERVICES**

FOR TRAFFIC MANAGEMENT SERVICES, NAMELY, REDUCING TRAFFIC CONGESTION BY MONITORING VEHICULAR TRAFFIC VIA CLOSED-CIRCUIT TELEVISION CAMERAS; DESIGN AND ENGINEERING SERVICES IN THE FIELD OF TRAFFIC MANAGEMENT AND CONTROL, NAMELY, DESIGNING AND ENGINEERING NEW AND EXISTING EXPRESSWAYS AND FREEWAYS (U.S. CLS. 100 AND 101).

FIRST USE 1-1-2009; IN COMMERCE 1-1-2009.

---

3,962,139. AVARIA HEALTH & BEAUTY CORP., ONTARIO, N2L 5V4, CANADA. SN 77-440,964. PUB. 6-29-2010, FILED 4-5-2008.

IAMPUR

THE MARK CONSISTS OF STANDARD CHARACTERS WITHOUT CLAIM TO ANY PARTICULAR FONT, STYLE, SIZE, OR COLOR.

PRIORITY CLAIMED UNDER SEC. 44(D) ON CANADA APPLICATION NO. 1388993, FILED 3-27-2008, REG. NO. TMA760,689, DATED 3-3-2010, EXPIRES 3-3-2025.

**CLASS 3—COSMETICS AND CLEANING PREPARATIONS**

FOR COSMETIC PRODUCTS, NAMELY, HAIR SHAMPOOS; ANTI-AGING PRODUCTS, NAMELY, ANTI AGING EYE GEL, ANTI AGING NIGHT TIME SERUM FOR THE FACE, ANTI AGING DAY TIME CREAM FOR THE FACE, ANTI AGING NIGHT TIME CREAM FOR THE FACE, SKIN TONER; SKIN CARE PRODUCTS, NAMELY, NON-MEDICATED TOPICAL SCAR REDUCING OINTMENT FOR THE SKIN, GENTLE DAILY FACIAL CLEANSER, MOISTURIZING BODY LOTION, MOISTURIZING HAND LOTION; ESSENTIAL OILS, NAMELY, ESSENTIAL OIL FOR TOPICAL SKIN MOISTURIZING AND PREVENTING OF FINE LINES AND WRINKLES (U.S. CLS. 1, 4, 6, 50, 51 AND 52).

FIRST USE 9-0-2010; IN COMMERCE 9-0-2010.

**CLASS 5—PHARMACEUTICALS**

FOR BODY HEALTH PRODUCTS, NAMELY, PAIN RELIEVING TOPICAL CREAM, MEDICATED DANDRUFF SHAMPOO (U.S. CLS. 6, 18, 44, 46, 51 AND 52).

FIRST USE 9-0-2010; IN COMMERCE 9-0-2010.

3,962,144. ALMOST FAMOUS, MIAMI, FL. SN 77-461,784. PUB. 12-16-2008, FILED 4-30-2008.

Almost Famous

THE MARK CONSISTS OF STANDARD CHARACTERS WITHOUT CLAIM TO ANY PARTICULAR FONT, STYLE, SIZE, OR COLOR.

**CLASS 41—EDUCATION AND ENTERTAINMENT**

FOR ENTERTAINMENT IN THE NATURE OF ONGOING TELEVISION PROGRAMS IN THE FIELD OF REALITY TALENT SEARCH TV SHOW, COMEDY, AND VARIETY EXCLUDING CULINARY ARTS, TELEVISION SHOW PRODUCTION, MUSIC PRODUCTION SERVICES, AND MUSIC PUBLISHING SERVICES (U.S. CLS. 100, 101 AND 107).

FIRST USE 12-6-2008; IN COMMERCE 10-23-2010.

**CLASS 45—PERSONAL AND LEGAL SERVICES**

FOR ONLINE SOCIAL NETWORKING SERVICES (U.S. CLS. 100 AND 101).

FIRST USE 5-21-2008; IN COMMERCE 10-15-2008.

---

3,962,145. FIRST DATA CORPORATION, GREENWOOD VILLAGE, CO. SN 77-462,002. PUB. 9-22-2009, FILED 4-30-2008.



The logo for First Data consists of a stylized 'F' and 'D' symbol on the left, composed of blue and orange geometric shapes. To the right of the symbol, the words 'First Data' are written in a bold, black, sans-serif font.

OWNER OF U.S. REG. NOS. 1,912,728, 2,493,237, AND OTHERS.

NO CLAIM IS MADE TO THE EXCLUSIVE RIGHT TO USE "DATA", APART FROM THE MARK AS SHOWN.

THE COLOR(S) BLUE, ORANGE AND BLACK IS/ARE CLAIMED AS A FEATURE OF THE MARK.

THE MARK CONSISTS OF THE STYLIZED LETTER "F" IN BLUE AND THE STYLIZED LETTER "D" IN ORANGE AND THE WORDING "FIRST DATA" IN BLACK.



**CLASS 9—ELECTRICAL AND SCIENTIFIC APPARATUS**

FOR COMPUTER SOFTWARE FOR USE BY MERCHANTS TO PROCESS PAYMENT TRANSACTIONS MADE BY CHECK, CREDIT, DEBIT OR STORED VALUE CARD OVER A GLOBAL COMPUTER NETWORK; COMBINATION ELECTRONIC TERMINAL, PRINTER, CHECK READER, CARD READER AND PAYMENT TRANSACTION STORAGE DEVICE FOR USE IN THE APPROVAL AND PROCESSING OF CHECK, CREDIT, DEBIT AND STORED VALUE CARD PAYMENTS; AND COMPUTER HARDWARE, NAMELY, TERMINALS, PRINTERS, CHECK READERS, CONTACTLESS READERS, CELLULAR WIRELESS COMPUTER TERMINALS FOR USE IN CONNECTION WITH CHECK, CREDIT CARD, DEBIT CARD AND STORED VALUE CARD TRANSACTIONS, TRANSACTION AUTHORIZATIONS AND PAYMENT PROCESSING SERVICES (U.S. CLS. 21, 23, 26, 36 AND 38).

FIRST USE 3-0-2009; IN COMMERCE 3-0-2009.

**CLASS 38—COMMUNICATION**

FOR ELECTRONIC MAIL SERVICES, NAMELY, ELECTRONIC RECEIPT AND TRANSMISSION OF TEXT, FILES, GRAPHICS AND DATA VIA COMPUTER NETWORKS AND MOBILE COMMUNICATION DEVICES; ELECTRONIC TRANSMISSION OF DATA AND DOCUMENTS VIA TELEPHONES, COMPUTERS AND MOBILE COMMUNICATION DEVICES OVER A GLOBAL COMPUTER NETWORK; AND TELECOMMUNICATIONS SERVICES, NAMELY, ELECTRONIC AND DIGITAL TRANSMISSION OF VOICE, DATA, IMAGES, SIGNALS, AND MESSAGES ENABLING MERCHANTS AND FINANCIAL INSTITUTIONS TO NOTIFY CUSTOMERS OF TIME-CRITICAL EVENTS THROUGH INTERACTIVE VOICE RESPONSE, TEXT MESSAGING, BROADCAST MESSAGING, E-MAIL AND INSTANT MESSAGING USING WIRELESS APPLICATION PROTOCOL FOR MOBILE COMMUNICATION, FAX AND PAGER DEVICES (U.S. CLS. 100, 101 AND 104).

FIRST USE 5-1-2008; IN COMMERCE 5-1-2008.

**CLASS 42—SCIENTIFIC AND COMPUTER SERVICES**

FOR PROVIDING TEMPORARY USE OF ON-LINE, NON-DOWNLOADABLE SOFTWARE FOR USE BY MERCHANTS TO PROCESS PAYMENT TRANSACTIONS MADE BY CHECK, CREDIT, DEBIT OR STORED VALUE CARD OVER A GLOBAL COMPUTER NETWORK; PROVIDING TEMPORARY USE OF ON-LINE NON-DOWNLOADABLE SOFTWARE FOR USE IN ANALYZING CREDIT AND DEBIT CARD EXPENDITURES AND GENERATING REPORTS RELATING THERETO; EQUIPMENT LEASING, NAMELY, LEASING OF COMPUTER HARDWARE AND PERIPHERAL EQUIPMENT FOR USE IN POINT OF SALE TRANSACTIONS; COMPUTER SERVICES, NAMELY, DESIGNING AND MAINTAINING COMPUTER PROGRAMS FOR OTHERS IN THE FIELD OF PAYMENT PROCESSING SERVICES, CUSTOMER LOYALTY SERVICES AND RECEIVABLES MANAGEMENT SERVICES, EXCLUDING MORTGAGE LENDING AND CLOSING SERVICES; COMPUTER SERVICES, NAMELY, DESIGNING COMPUTER NETWORKS FOR OTHERS IN THE FIELD OF PAYMENT PROCESSING SERVICES, CUSTOMER LOYALTY SERVICES AND RECEIVABLES MANAGEMENT SERVICES; DATA ENCRYPTION AND DATA SECURITY SERVICES, NAMELY, PROVIDING SECURITY AND ANONYMITY FOR ELECTRONICALLY TRANSMITTED PAYMENT TRANSACTIONS; WEB SERVICE SOLUTIONS, NAMELY, WEB SITE HOSTING SERVICES AND DESIGN OF WEB SITES FOR OTHERS, NAMELY, WEB BASED STORES; WEBSITE DESIGN AND WEBSITE MANAGEMENT SERVICES FOR FINANCIAL INSTITUTIONS; CONSULTING SERVICES IN THE FIELD OF COMPUTER-BASED INFORMATION SYSTEMS FOR BUSINESSES WHICH UTILIZE PAYMENT PROCESSING SERVICES, CUSTOMER LOYALTY SERVICES AND RECEIVABLES MANAGEMENT SERVICES; COMPUTER SERVICES, NAMELY, IMPLEMENTING E-COMMERCE WEB SITES FOR OTHERS; PROVIDING TEMPORARY USE OF ON-LINE NON-DOWNLOADABLE SOFTWARE IN THE NATURE OF AN ONLINE INTERACTIVE COMPUTER DATABASE WHICH ANALYZES FINAN-

CIAL DATA FOR USE IN AUTHORIZING OR DECLINING CHECK-RELATED TRANSACTIONS; PROVIDING TEMPORARY USE OF ON-LINE NON-DOWNLOADABLE SOFTWARE IN THE NATURE OF AN ONLINE INTERACTIVE COMPUTER DATABASE WHICH ANALYZES DATA FOR USE IN AUTHENTICATION OF USERS AND PAYMENTS IN ONLINE FINANCIAL TRANSACTIONS; PROVIDING TEMPORARY USE OF ON-LINE NON-DOWNLOADABLE SOFTWARE TO THE FINANCIAL SERVICES INDUSTRY FOR ANALYZING FINANCIAL DATA USED TO AUTHORIZE OR DECLINE CONSUMER CREDIT REQUESTS; GRAPHIC DESIGN OF FINANCIAL STATEMENTS AND CREDIT, DEBIT AND STORED VALUE CARDS FOR OTHERS (U.S. CLS. 100 AND 101).

FIRST USE 5-1-2008; IN COMMERCE 5-1-2008.

3,962,147. THE NIELSEN COMPANY (US), LLC, SCHAMBURG, IL. SN 77-465,932. PUB. 11-25-2008, FILED 5-5-2008.

# STELLAR

THE MARK CONSISTS OF STANDARD CHARACTERS WITHOUT CLAIM TO ANY PARTICULAR FONT, STYLE, SIZE, OR COLOR.

**CLASS 35—ADVERTISING AND BUSINESS**

FOR MARKET RESEARCH AND MEDIA RATING RESEARCH SERVICES; PROVIDING VIEWERSHIP AND RATINGS INFORMATION, ADVERTISING, AND DEMOGRAPHIC INFORMATION REGARDING TELEVISION, CABLE, AND OTHER AUDIOVISUAL MEDIA BROADCASTS, NARROWCASTS, AND TRANSMISSIONS; AND PROVIDING TEMPORARY ACCESS TO ONLINE COMPUTER DATABASES FOR USE IN ACCESSING, REVIEWING, AND PREPARING REPORTS FROM MARKET RESEARCH AND MEDIA RATING RESEARCH INFORMATION, AND VIEWERSHIP AND RATINGS INFORMATION, ADVERTISING, AND DEMOGRAPHIC INFORMATION REGARDING TELEVISION, CABLE, AND OTHER AUDIOVISUAL MEDIA BROADCASTS, NARROWCASTS, AND TRANSMISSIONS (U.S. CLS. 100, 101 AND 102).

FIRST USE 5-31-2004; IN COMMERCE 9-27-2004.

**CLASS 38—COMMUNICATION**

FOR PROVIDING TEMPORARY ACCESS TO NON-DOWNLOADABLE DATABASE MANAGEMENT SOFTWARE FOR USE IN ACCESSING, REVIEWING, AND PREPARING REPORTS FROM MARKET RESEARCH AND MEDIA RATING RESEARCH INFORMATION, AND VIEWERSHIP AND RATINGS INFORMATION, ADVERTISING, AND DEMOGRAPHIC INFORMATION REGARDING TELEVISION, CABLE, AND OTHER AUDIOVISUAL MEDIA BROADCASTS, NARROWCASTS, AND TRANSMISSIONS (U.S. CLS. 100, 101 AND 104).

FIRST USE 5-31-2004; IN COMMERCE 9-27-2004.

3,962,149. EARLY ALZHEIMER'S FOUNDATION, INC., NEW YORK, NY. SN 77-476,964. PUB. 12-8-2009, FILED 5-16-2008.

3,962,164. RENZ, AMY, MARBLEHEAD, MA. SN 77-504,309. PUB. 12-16-2008, FILED 6-20-2008.

## THE MEMORY TREE

THE MARK CONSISTS OF STANDARD CHARACTERS WITHOUT CLAIM TO ANY PARTICULAR FONT, STYLE, SIZE, OR COLOR.

### CLASS 9—ELECTRICAL AND SCIENTIFIC APPARATUS

FOR AUDIO-VISUAL AND AUDIO RECORDINGS, NAMELY, COMPACT DISCS, CD-ROMS AND DVDS, ALL FEATURING INFORMATION AND HELP FOR PEOPLE AFFLICTED WITH ALZHEIMER'S AND THEIR LOVED ONES AND CAREGIVERS (U.S. CLS. 21, 23, 26, 36 AND 38).

FIRST USE 11-0-2006; IN COMMERCE 11-0-2006.

### CLASS 16—PAPER GOODS AND PRINTED MATTER

FOR PRINTED AND RELATED MATTER, NAMELY, CALENDARS, LEAFLETS, AND BROCHURES WHICH PROVIDE INFORMATION AND HELP FOR PEOPLE AFFLICTED WITH ALZHEIMER'S AND RELATED DISEASES AND CAREGIVERS (U.S. CLS. 2, 5, 22, 23, 29, 37, 38 AND 50).

FIRST USE 10-0-2005; IN COMMERCE 10-0-2005.

### CLASS 36—INSURANCE AND FINANCIAL

FOR CHARITABLE FUND RAISING (U.S. CLS. 100, 101 AND 102).

FIRST USE 10-0-2005; IN COMMERCE 10-0-2005.

### CLASS 41—EDUCATION AND ENTERTAINMENT

FOR EDUCATIONAL SERVICES, NAMELY, CONDUCTING CLASSES, SEMINARS, ARRANGING FOR DISCUSSION GROUPS AND WORKSHOPS IN THE FIELD OF ALZHEIMER'S AND RELATED DISEASES FOR AFFLICTED INDIVIDUALS, THEIR FAMILIES, FRIENDS AND CAREGIVERS (U.S. CLS. 100, 101 AND 107).

FIRST USE 4-0-2006; IN COMMERCE 4-0-2006.

### CLASS 44—MEDICAL, BEAUTY AND AGRICULTURAL SERVICES

FOR PROVIDING INFORMATION THROUGH A WEBSITE PERTAINING TO ALZHEIMER'S AND RELATED DISEASES; PROVIDING MEDICAL INFORMATION ABOUT ALZHEIMER'S AND CURRENT THERAPIES (U.S. CLS. 100 AND 101).

FIRST USE 11-0-2006; IN COMMERCE 11-0-2006.

## WE WALK HEART FIRST

THE MARK CONSISTS OF STANDARD CHARACTERS WITHOUT CLAIM TO ANY PARTICULAR FONT, STYLE, SIZE, OR COLOR.

### CLASS 31—NATURAL AGRICULTURAL PRODUCTS

FOR HOMEMADE DOG COOKIES (U.S. CLS. 1 AND 46).

FIRST USE 10-12-2010; IN COMMERCE 10-12-2010.

### CLASS 36—INSURANCE AND FINANCIAL

FOR CHARITABLE FUNDRAISING SERVICES, NAMELY, RAISING FUNDS THROUGH THE SALE OF HOMEMADE DOG COOKIES TO BENEFIT THE WELFARE, RESCUE, SHELTER AND HUMANE TREATMENT OF ANIMALS THROUGH COMMUNITY AND NATIONAL OUTREACH PROGRAMS (U.S. CLS. 100, 101 AND 102).

FIRST USE 10-12-2010; IN COMMERCE 10-12-2010.

3,962,165. PHYSIK INSTRUMENTE (PI) GMBH & CO. KG, KARLSRUHE, FED REP GERMANY. SN 77-505,615. PUB. 7-7-2009, FILED 6-23-2008.

PIline

OWNER OF U.S. REG. NO. 2,609,100.

THE MARK CONSISTS OF THE LETTERS "PI" AS CAPITAL LETTERS (UPPER CASE) FOLLOWED BY THE LETTERS "LINE" IN LOWER CASE.

### CLASS 7—MACHINERY

FOR ELECTROMOTIVE DRIVES FOR SINGLE-AXIS AND MULTI-AXIS POSITIONING SYSTEMS, PIEZOELECTRIC DRIVES FOR SINGLE-AXIS AND MULTI-AXIS POSITIONING SYSTEMS; PIEZOELECTRIC MOTORS FOR PRECISION MICROPOSITIONING APPARATUS; PIEZOELECTRIC LINEAR MOTORS (U.S. CLS. 13, 19, 21, 23, 31, 34 AND 35).

FIRST USE 5-31-2003; IN COMMERCE 5-31-2003.

### CLASS 9—ELECTRICAL AND SCIENTIFIC APPARATUS

FOR SCIENTIFIC APPARATUS AND INSTRUMENTS, NAMELY, PRECISION MICROPOSITIONING APPARATUS; CONTROLLERS FOR PRECISION MICROPOSITIONING APPARATUS (U.S. CLS. 21, 23, 26, 36 AND 38).

FIRST USE 5-31-2003; IN COMMERCE 5-31-2003.

3,962,167. PHYSIK INSTRUMENTE (PI) GMBH & CO. KG, KARLSRUHE, FED REP GERMANY. SN 77-505,742. PUB. 6-30-2009, FILED 6-23-2008.

## PIEZOWALK

THE MARK CONSISTS OF STANDARD CHARACTERS WITHOUT CLAIM TO ANY PARTICULAR FONT, STYLE, SIZE, OR COLOR.

### CLASS 7—MACHINERY

FOR ELECTROMOTIVE DRIVES FOR SINGLE-AXIS AND MULTI-AXIS POSITIONING SYSTEMS, PIEZO-ELECTRIC DRIVES FOR SINGLE-AXIS AND MULTI-AXIS POSITIONING SYSTEMS; PIEZOELECTRIC MOTORS FOR PRECISION MICROPOSITIONING APPARATUS (U.S. CLS. 13, 19, 21, 23, 31, 34 AND 35).

FIRST USE 5-31-1995; IN COMMERCE 5-31-1995.

### CLASS 9—ELECTRICAL AND SCIENTIFIC APPARATUS

FOR SCIENTIFIC APPARATUS AND INSTRUMENTS, NAMELY, PRECISION MICROPOSITIONING APPARATUS; CONTROLLERS FOR PRECISION MICROPOSITIONING APPARATUS (U.S. CLS. 21, 23, 26, 36 AND 38).

FIRST USE 5-31-1995; IN COMMERCE 5-31-1995.

3,962,168. FETCH TECHNOLOGIES, EL SEGUNDO, CA. SN 77-508,931. PUB. 11-24-2009, FILED 6-26-2008.

## FETCH TECHNOLOGIES

THE MARK CONSISTS OF STANDARD CHARACTERS WITHOUT CLAIM TO ANY PARTICULAR FONT, STYLE, SIZE, OR COLOR.

NO CLAIM IS MADE TO THE EXCLUSIVE RIGHT TO USE "TECHNOLOGIES", APART FROM THE MARK AS SHOWN.

### CLASS 9—ELECTRICAL AND SCIENTIFIC APPARATUS

FOR COMPUTER SOFTWARE FOR DESIGNATION AND RETRIEVAL OF INFORMATION, INFORMATION AGENTS, DATA MINING, AND DATA GATHERING; COMPUTER SOFTWARE FOR SEARCHING, COLLECTING, CATEGORIZING, STORING AND RETRIEVING DATA; COMPUTER SOFTWARE FOR EXTRACTION, INTEGRATION, INDEXING, MANAGEMENT AND DISPLAY OF DATA AND CONTENT ACROSS COMPUTER AND COMMUNICATIONS NETWORKS; DATABASE MANAGEMENT SOFTWARE; COMPUTER SEARCH ENGINE SOFTWARE; COMPUTER SOFTWARE FOR INFORMATION MANAGEMENT (U.S. CLS. 21, 23, 26, 36 AND 38).

FIRST USE 12-31-2001; IN COMMERCE 12-31-2001.

### CLASS 42—SCIENTIFIC AND COMPUTER SERVICES

FOR PROVIDING TEMPORARY USE OF NON-DOWNLOADABLE SOFTWARE FOR COLLECTION, CATEGORIZATION, STORING, AND RETRIEVING DATA; PROVIDING TEMPORARY USE OF NON-DOWNLOADABLE SOFTWARE FOR EXTRACTION, INTEGRATION, INDEXING, MANAGEMENT AND DISPLAY OF DATA AND CONTENT ACROSS COMPUTER AND COMMUNICATIONS NETWORKS; PROVIDING TEMPORARY USE OF NON-DOWNLOADABLE SOFTWARE FOR DATABASE MANAGEMENT (U.S. CLS. 100 AND 101).

FIRST USE 12-31-2001; IN COMMERCE 12-31-2001.

3,962,173. BIOMÉRIEUX, INC., DURHAM, NC. SN 77-523,447. PUB. 8-10-2010, FILED 7-16-2008.

## BACT/ALERT

THE MARK CONSISTS OF STANDARD CHARACTERS WITHOUT CLAIM TO ANY PARTICULAR FONT, STYLE, SIZE, OR COLOR.

OWNER OF U.S. REG. NOS. 1,663,146, 2,017,525, AND OTHERS.

### CLASS 1—CHEMICALS

FOR CHEMICALS FOR USE IN INDUSTRY AND SCIENCE; REAGENTS, CHEMICAL PREPARATIONS IN THE FORM OF CULTURE MEDIA AND CHEMICAL SOLUTIONS FOR IN VITRO DIAGNOSIS TO CONTROL AND DETECT CONTAMINATING SUBSTANCES IN INDUSTRIAL, AGRICULTURAL, COSMETIC AND PHARMACEUTICAL PRODUCTS FOR SCIENTIFIC OR RESEARCH USE (U.S. CLS. 1, 5, 6, 10, 26 AND 46).

FIRST USE 1-1-2008; IN COMMERCE 1-1-2008.

### CLASS 5—PHARMACEUTICALS

FOR REAGENTS AND MEDIA FOR MEDICAL AND VETERINARY DIAGNOSIS (U.S. CLS. 6, 18, 44, 46, 51 AND 52).

FIRST USE 5-1-1989; IN COMMERCE 5-1-1989.

### CLASS 9—ELECTRICAL AND SCIENTIFIC APPARATUS

FOR SCIENTIFIC APPARATUS AND INSTRUMENTS FOR CONTROLLING AND DETECTING CONTAMINATING SUBSTANCES IN INDUSTRIAL, AGRO-FOOD-STUFF, COSMETIC AND PHARMACEUTICAL PRODUCTS; DIAGNOSIS APPARATUS AND INSTRUMENTS, NOT FOR MEDICAL USE, NAMELY, SCIENTIFIC EQUIPMENT AND DEVICES FOR THE ISOLATION, IDENTIFICATION, QUANTIFICATION, REVELATION, CONTROL AND DETECTION OF CONTAMINATING SUBSTANCES USED FOR TESTING OR FOR MANUAL AND/OR AUTOMATED TESTING IN INDUSTRIAL APPLICATIONS, NAMELY, FOR THE ANALYSIS OF AN INDUSTRIAL SAMPLE, A COSMETIC SAMPLE OR AN ENVIRONMENTAL SAMPLE TO DETERMINE CONTAMINANTS, TO DETERMINE COMPOSITION, AND TO CONTROL QUALITY; SOFTWARE USED TO PROCESS AND INTERPRET THE RESULTS OF THE ABOVE TESTS (U.S. CLS. 21, 23, 26, 36 AND 38).

FIRST USE 1-1-2008; IN COMMERCE 1-1-2008.

**CLASS 10—MEDICAL APPARATUS**

FOR APPARATUS AND INSTRUMENTS FOR MEDICAL AND VETERINARY DIAGNOSIS, NAMELY, EQUIPMENT AND DEVICES IN THE NATURE OF BACTERIOLOGIC ANALYSERS, MICROBIOLOGIC ANALYSERS USED FOR TESTING OR FOR MANUAL OR FOR AUTOMATED TESTING TO PERFORM BLOOD CULTURE, BODY FLUID CULTURE AND MYCOBACTERIAL TESTING FOR DETECTING MICRO-ORGANISMS, BACTERIA, YEAST, VIRUSES, IN MEDICAL AND CLINICAL APPLICATIONS (U.S. CLS. 26, 39 AND 44).

FIRST USE 5-1-1989; IN COMMERCE 5-1-1989.

3,962,174. LEMORD, IAN C.A., DBA LEMORD, IAN C.A., BROOKLYN, NY. SN 77-526,469. PUB. 6-30-2009, FILED 7-18-2008.



THE MARK CONSISTS OF A SILHOUETTE OF A MAN WEARING A T-SHIRT, FEDORA, JACKET, PANTS, SHOES, AND BELT. THE FEDORA AND BELT BUCKLE DEPICT SCORPIONS. THE MAN HAS ONE HAND NEAR HIS PANTS POCKET AND ONE HAND NEAR HIS CHIN. HIS ANKLES ARE CROSSED. THE MAN IS LEANING AGAINST A VERTICAL LINE THAT REPRESENTS A WALL.

**CLASS 18—LEATHER GOODS**

FOR BACKPACKS; BOOK BAGS; SPORTS BAGS; BUM BAGS; WALLETS; HANDBAGS; CARD WALLETS; PURSES; KEY WALLETS; LEATHER BAGS; SUITCASES; POCKET WALLETS; WALLET INSERTS; WALLETS WITH CARD COMPARTMENTS (U.S. CLS. 1, 2, 3, 22 AND 41).

FIRST USE 11-1-2009; IN COMMERCE 2-7-2011.

**CLASS 25—CLOTHING**

FOR A-SHIRTS; ANKLE SOCKS; ANKLETS; ATHLETIC APPAREL, NAMELY, SHIRTS, PANTS, JACKETS, FOOTWEAR, HATS AND CAPS, ATHLETIC UNIFORMS; ATHLETIC SHOES; BELTS OF TEXTILE; BOOTS; BRIEFS; BUTTON-FRONT ALOHA SHIRTS; CAMP SHIRTS; CANVAS SHOES; CAPRI PANTS; CARGO PANTS; CREWNECK SWEATERS; CYCLISTS' JERSEYS; DECK-SHOES; DENIMS; DISPOSABLE UNDERWEAR; DRESS SHIRTS; DRIVERS; FABRIC BELTS; FUR HATS; GOLF SHIRTS; HAT BANDS; HATS; HOODED PULL-OVERS; HOODED SWEAT SHIRTS; HOODS; INFANTS' SHOES AND BOOTS; INSOLES; JERSEYS; JOGGING PANTS; KNIT SHIRTS; KNITTED UNDERWEAR; LEATHER BELTS; LEATHER PANTS; LEATHER SHOES; LONG UNDERWEAR; LONG-SLEEVED SHIRTS; LOUNGE PANTS; MEN'S SOCKS; MOCK TURTLE-NECK SWEATERS; MOISTURE-WICKING SPORTS PANTS; MOISTURE-WICKING SPORTS SHIRTS; MONEY BELTS; NIGHT SHIRTS; OPEN-NECKED SHIRTS; PANTS; PERSPIRATION ABSORBENT UNDERWEAR CLOTHING; PIQUE SHIRTS; POLO SHIRTS; RUBBER SHOES; RUGBY SHIRTS; SHIRT FRONTS; SHIRT YOKES; SHIRTS; SHOE PEGS; SHOE SOLES; SHOE STRAPS; SHOES; SHOES SOLES FOR REPAIR; SHORT-SLEEVED OR LONG-SLEEVED T-SHIRTS; SKI PANTS; SLEEP SHIRTS; SLEEVELESS JERSEYS; SMALL HATS; SOCKS; SOCKS AND STOCKINGS; SPORT SHIRTS; STRETCH PANTS; SUSPENDER BELTS FOR MEN; SWEAT PANTS; SWEAT SHIRTS; SWEATERS; T-SHIRTS; TENNIS SHOES; THONGS; TOBOGGAN HATS, PANTS AND CAPS; TONGUE OR PULLSTRAP FOR SHOES AND BOOTS; TRACK PANTS; TRAINING SHOES; TRAVEL CLOTHING CONTAINED IN A PACKAGE COMPRISING REVERSIBLE JACKETS, PANTS, SKIRTS, TOPS AND A BELT OR SCARF; TRIATHLON CLOTHING, NAMELY, TRIATHLON TIGHTS, TRIATHLON SHORTS, TRIATHLON SINGLET, TRIATHLON SHIRTS, TRIATHLON SUITS; TURTLENECK SWEATERS; TUXEDO BELTS; UNDERWEAR; UNDERWEAR, NAMELY, BOY SHORTS; V-NECK SWEATERS; WAIST BELTS; WATERPROOF JACKETS AND PANTS; WEARABLE GARMENTS AND CLOTHING, NAMELY, SHIRTS; WIND PANTS; WIND SHIRTS; WOOLLY HATS; WORK SHOES AND BOOTS; WRAP BELTS FOR KIMONOS (DATEMAKI); YOGA PANTS, YOGA SHIRTS (U.S. CLS. 22 AND 39).

FIRST USE 11-1-2009; IN COMMERCE 2-7-2011.

3,962,179. OPEN COMPLIANCE & ETHICS GROUP, PHOENIX, AZ. SN 77-536,681. PUB. 12-14-2010, FILED 8-1-2008.

**GRC-IT BLUEPRINT**

THE MARK CONSISTS OF STANDARD CHARACTERS WITHOUT CLAIM TO ANY PARTICULAR FONT, STYLE, SIZE, OR COLOR.

OWNER OF U.S. REG. NO. 3,225,920.

NO CLAIM IS MADE TO THE EXCLUSIVE RIGHT TO USE "GRC-IT", APART FROM THE MARK AS SHOWN.

**CLASS 35—ADVERTISING AND BUSINESS**

FOR PROVIDING BUSINESS CONSULTING AND ADVISORY SERVICES TO ORGANIZATIONS SEEKING TO APPLY BUSINESS QUALITY, BUSINESS PRINCIPLES AND VALUE ENHANCEMENT EFFORTS TO GOVERNANCE, RISK, MANAGEMENT, INTERNAL CONTROLS AND COMPLIANCE CAPABILITIES AND PROGRAMS (U.S. CLS. 100, 101 AND 102).

FIRST USE 0-0-2010; IN COMMERCE 0-0-2010.

**CLASS 42—SCIENTIFIC AND COMPUTER SERVICES**

FOR TESTING, ANALYSIS AND EVALUATION OF SERVICE PROVIDERS, WHO DEVELOP AND AUDIT CORPORATE GOVERNANCE, RISK MANAGEMENT, INTERNAL CONTROL AND COMPLIANCE POLICIES AND PROCEDURES OF INDIVIDUAL ORGANIZATIONS, FOR THE PURPOSES OF CERTIFICATION OF SUCH SERVICE PROVIDERS WITH REGARD TO THEIR KNOWLEDGE AND APPLICATION OF PRINCIPLES AND ELEMENTS; TESTING, ANALYSIS AND EVALUATION OF SERVICE PROVIDERS, WHO DEVELOP AND PROVIDE SOFTWARE RELATED TO MANAGEMENT OF ORGANIZATIONAL GOVERNANCE, RISK MANAGEMENT, INTERNAL CONTROL AND COMPLIANCE POLICIES AND PROCEDURES, FOR THE PURPOSES OF CERTIFICATION OF SUCH SERVICE PROVIDERS WITH REGARD TO THEIR KNOWLEDGE AND APPLICATION OF PRINCIPLES AND ELEMENTS; PROVIDING TEMPORARY USE OF NON-DOWNLOADABLE COMPUTER SOFTWARE FOR GOVERNANCE, RISK AND COMPLIANCE MANAGEMENT; DEVELOPING AND DISSEMINATING VOLUNTARY CORPORATE COMPLIANCE STANDARDS, GUIDELINES AND CERTIFICATIONS RELATED TO LAW AND ETHICS AND THE APPLICATION OF BUSINESS PRINCIPLES TO GOVERNANCE, RISK MANAGEMENT, INTERNAL CONTROLS AND COMPLIANCE CAPABILITIES AND PROGRAMS (U.S. CLS. 100 AND 101).

FIRST USE 0-0-2010; IN COMMERCE 0-0-2010.

3,962,197. JOAN BOYCE, LLC, NEW YORK, NY. SN 77-553,393. PUB. 1-5-2010, FILED 8-22-2008.



THE MARK CONSISTS OF SCRIPT LETTERING FOR THE LETTERS "J" AND "B" WHEREIN THE LETTERS SHARE A COMMON PORTION OF THE DESIGN.

**CLASS 18—LEATHER GOODS**

FOR POCKETBOOKS (U.S. CLS. 1, 2, 3, 22 AND 41).  
FIRST USE 3-31-2011; IN COMMERCE 3-31-2011.

**CLASS 25—CLOTHING**

FOR SHOES; WOMEN'S SHOES (U.S. CLS. 22 AND 39).  
FIRST USE 3-31-2011; IN COMMERCE 3-31-2011.

3,962,180. THE SMILEY GROUP, INC., LOS ANGELES, CA.  
SN 77-537,080. PUB. 6-16-2009, FILED 8-1-2008.

3,962,199. STEWART-HAAS RACING, LLC, KANNAPOLIS, NC. SN 77-554,709. PUB. 7-7-2009, FILED 8-25-2008.

LEAD. LOVE. SAVE. SERVE.

39

THE MARK CONSISTS OF STANDARD CHARACTERS WITHOUT CLAIM TO ANY PARTICULAR FONT, STYLE, SIZE, OR COLOR.

THE MARK CONSISTS OF STANDARD CHARACTERS WITHOUT CLAIM TO ANY PARTICULAR FONT, STYLE, SIZE, OR COLOR.

**CLASS 16—PAPER GOODS AND PRINTED MATTER**

FOR BOOKMARKS; EDUCATIONAL PUBLICATIONS, NAMELY, WORKBOOKS IN THE FIELD OF POLITICAL COMMENTARY AND PERSONAL MOTIVATION (U.S. CLS. 2, 5, 22, 23, 29, 37, 38 AND 50).

FIRST USE 8-1-2007; IN COMMERCE 8-1-2007.

**CLASS 25—CLOTHING**

FOR CLOTHING, NAMELY, T-SHIRTS, POLO SHIRTS, BASEBALL CAPS (U.S. CLS. 22 AND 39).

FIRST USE 8-1-2007; IN COMMERCE 8-1-2007.

**CLASS 5—PHARMACEUTICALS**

FOR PAPER AIR FRESHENERS (U.S. CLS. 6, 18, 44, 46, 51 AND 52).

FIRST USE 7-1-2010; IN COMMERCE 7-1-2010.

**CLASS 6—METAL GOODS**

FOR METAL GOODS, NAMELY, MONEY BANKS, KEY CHAINS, KEY RINGS, KEY CLIPS, LOCK BOXES, COMMEMORATIVE COLLECTOR PLATES OF NON-PRECIOUS METAL, NON-LUMINOUS AND NON-MECHANICAL METAL SIGNS, LICENSE PLATES, COLLECTOR TINS SOLD EMPTY, DECORATIVE TINS SOLD EMPTY, HOLIDAY ORNAMENTS NOT BEING TREE ORNAMENTS, METAL KEY FOBS, PLAQUES AND PHOTO PLAQUES OF METAL; DESK ORNAMENTS OF METAL (U.S. CLS. 2, 12, 13, 14, 23, 25 AND 50).

FIRST USE 8-13-2010; IN COMMERCE 8-13-2010.



**CLASS 9—ELECTRICAL AND SCIENTIFIC APPARATUS**

FOR PRE-RECORDED AUDIO, VIDEO, COMPUTER AND LASER DISCS FEATURING RACING THEMES; PRE-RECORDED AUDIO, VIDEO, COMPUTER AND LASER DISCS FEATURING SPORTS AND MUSIC; PRE-RECORDED AUDIO AND VIDEO CASSETTES, PRE-RECORDED AUDIO AND VIDEO TAPES, PRE-RECORDED COMPACT DISCS, AND PRE-RECORDED COMPUTER DISCS FEATURING SPORTS AND MUSIC; COMPUTER ACCESSORIES, NAMELY, COMPUTER MICE, COMPUTER MOUSE PADS, COMPUTER DISC CASES, COMPUTER CARRYING CASES AND KEYBOARD WRIST PADS FOR COMPUTER USERS; COMPUTER SOFTWARE FOR STORING, RECEIVING, RETRIEVING, DISPLAYING, ANALYZING AND PROCESSING INFORMATION, DATA, STATISTICS AND TRIVIA RELATING TO SPORTS AND MUSIC; COMPUTER SOFTWARE FOR USE AS A SCREEN SAVER FEATURING SPORTS AND MUSIC; VIDEO GAME COMPUTER SOFTWARE; VIDEO GAME CARTRIDGES; VIDEO GAME MACHINES FOR USE WITH A TELEVISION; RADIOS; TELEPHONES; WALKIE-TALKIES; BINOCULARS; SUNGLASSES, EYEGGLASS CASES; DECORATIVE MAGNETS; AND CELLULAR TELEPHONE CARRYING CASES; SLOT MACHINES; COMPUTER GAME CARTRIDGES; MAGNETICALLY ENCODED CREDIT, DEBIT AND GIFT CARDS; MAGNETICALLY ENCODED TELEPHONE CALLING CARDS (U.S. CLS. 21, 23, 26, 36 AND 38).

FIRST USE 8-17-2010; IN COMMERCE 8-17-2010.

**CLASS 12—VEHICLES**

FOR LICENSE PLATE FRAMES, LICENSE PLATE HOLDERS; VISOR COVERS FOR CAR WINDSHIELD VISORS, AUTOMOBILE WINDSHIELD SUNSHADES AND AUTOMOBILE MUD FLAPS; AUTOMOBILE STRUCTURAL PARTS, NAMELY, REPLICA CAR AND TRUCK SIDE PORTIONS OF PLASTIC, REPLICA CAR AND TRUCK FRONT END PORTIONS OF PLASTIC, REPLICA HOODS OF PLASTIC, AND REPLICA TRUNK LIDS OF PLASTIC (U.S. CLS. 19, 21, 23, 31, 35 AND 44).

FIRST USE 8-16-2010; IN COMMERCE 8-16-2010.

**CLASS 14—JEWELRY**

FOR JEWELRY AND ACCESSORIES TO BE MARKETED AS GOODS ASSOCIATED WITH A STOCK CAR RACING TEAM, NAMELY, EARRINGS, NECKLACES, BRACELETS, BROOCHES, ANKLETS, FINGER RINGS, AND TOE RINGS, OF PRECIOUS METAL; WATCHES, CLOCKS AND WALL CLOCKS, TRADING CARDS MADE OF PRECIOUS METALS; JEWELRY, NAMELY, CHARMS FOR CHARM BRACELETS, EARRINGS, NECKLACES, PENDANTS, LAPEL PINS, RINGS, TIE FASTENERS, TIE CLASPS, WATCH BANDS; NON-MONETARY COINS OF PRECIOUS METAL (U.S. CLS. 2, 27, 28 AND 50).

FIRST USE 8-16-2010; IN COMMERCE 8-16-2010.

**CLASS 16—PAPER GOODS AND PRINTED MATTER**

FOR PRINTED MATERIAL, NAMELY, BROCHURES, MAGAZINES, NEWSLETTERS, PAMPHLETS, SOUVENIR PROGRAMS, STATISTICAL RECORD SHEETS AND BOOKS, ALL FEATURING SPORTS AND MUSIC; COMMEMORATIVE STAMP SHEETS; NOTE CARDS, MEMO PADS, NOTE PADS, FOLDERS, ADDRESS BOOKS, PAINTINGS, BINDERS, BOOKS FEATURING RACING THEMES, BUMPER STICKERS, CALENDARS, CARDBOARD BOXES, COLORING BOOKS, COMMEMORATIVE SHEETS OF TRADING CARDS, CREDIT CARDS WITHOUT MAGNETIC CODING, DECALS, ERASERS, FRAMED PHOTOGRAPHS, MOUNTED AND UNMOUNTED PHOTOGRAPHS, ART PRINTS, PHOTOGRAPHIC PRINTS, LIMITED EDITION PICTORIAL PRINTS, LITHOGRAPHIC PRINTS, PAPER MAGAZINE COVERS, BOOK COVERS, DECALS FOR MODEL CARS, PAPER NAPKINS, NOTEBOOKS, PAPER PENNANTS,

PAPER BANNERS, PENCILS, PENS, PAPER IDENTIFICATION TAGS, DAILY PLANNERS, STATIONERY, STATIONERY-TYPE PORTFOLIOS, PLACE MATS MADE OF PAPER, POST CARDS, POSTERS, STATIC DECALS, STICKERS, PAPER TABLE LINEN, TRADING CARDS, FRAMED TRADING CARDS, WINDOW DECALS, SUBJECT NOTEBOOKS NOT WIRE-BOUND; METAL MONEY CLIPS; MONEY CLIPS OF PRECIOUS METAL MARKETED AS GOODS ASSOCIATED WITH A STOCK CAR RACING TEAM; TRADING CARDS MADE OF NON-PRECIOUS METAL; METAL POSTERS; MONEY CLIPS (U.S. CLS. 2, 5, 22, 23, 29, 37, 38 AND 50).

FIRST USE 1-1-2010; IN COMMERCE 1-1-2010.

**CLASS 18—LEATHER GOODS**

FOR LUGGAGE AND RELATED ITEMS TO BE MARKETED AS GOODS ASSOCIATED WITH A STOCK CAR RACING TEAM, NAMELY, LUGGAGE, ATHLETIC BAGS, SHOE BAGS FOR TRAVEL, OVERNIGHT BAGS, BACK PACKS, FANNY PACKS, WAIST PACKS, DIAPER BAGS, DUFFEL BAGS, TOTE BAGS, BOOK BAGS, TRAVEL BAGS, ALL PURPOSE SPORTS BAGS, GYM BAGS, GARMENT BAGS FOR TRAVEL, HANDBAGS, PURSES, TOILETRY CASES SOLD EMPTY, COSMETIC CASES SOLD EMPTY, TRUNKS, BRIEFCASES, ATTACHE CASES, SUITCASES, KNAPSACKS, BUSINESS CARD CASES, KEY CASES, BILLFOLDS, WALLETS, LUGGAGE TAGS, BELT BAGS, AND UMBRELLAS; LEATHER PET COLLARS, FABRIC PET COLLARS, FABRIC PET LEASHES, SPORTSWEAR CLOTHING FOR DOGS, LEATHER PHOTO KEY CHAINS (U.S. CLS. 1, 2, 3, 22 AND 41).

FIRST USE 8-17-2010; IN COMMERCE 8-17-2010.

**CLASS 20—FURNITURE AND ARTICLES NOT OTHERWISE CLASSIFIED**

FOR PET CUSHIONS, WRITING TABLES, NON-METAL KEY RINGS; NON-METAL AND NON-LEATHER KEY CHAINS; PLASTIC PHOTO KEY CHAINS; KEY FOBS, NOT OF METAL; PHOTO PLAQUES OF PLASTIC AND WOOD; PLAQUES OF PLASTIC AND WOOD; NON-METAL BOTTLE CAPS HAVING A RACING THEME, PICTURE FRAMES, FURNITURE FOR ADULTS, FURNITURE FOR CHILDREN; WOODEN PLAQUES; CHAIRS; PORTABLE FOLDING CHAIRS; NON-METAL NOVELTY LICENSE PLATES; PLASTIC LICENSE PLATES; SEAT CUSHIONS; CUSHIONS; PORTABLE BEDS FOR DOGS; DESK ORNAMENTS OF PLASTER, PLASTIC AND WOOD; DECORATIVE WINDOW ORNAMENTS OF PLASTIC, ACRYLIC AND VINYL; MAGNETIC VINYL DECORATIVE EMBLEMS; PLASTIC PENNANTS AND PLASTIC BANNERS; FIGURINES AND SCULPTURES MADE OF PLASTIC; FIGURINES AND SCULPTURES MADE OF ACRYLIC; WIND CHIMES; MEMORABILIA DISPLAY FRAMES OF PLASTIC AND ACRYLIC; DECORATIVE BOXES MADE OF PLASTIC AND ACRYLIC FOR DIECAST MINIATURE AUTOMOBILES; BASEBALLS AND SPORTS SCENES (U.S. CLS. 2, 13, 22, 25, 32 AND 50).

FIRST USE 1-1-2009; IN COMMERCE 1-1-2009.

**CLASS 21—HOUSEWARES AND GLASS**

FOR HOUSEWARES, NAMELY, SHOT GLASSES, PLATES, DRINKING GLASSES, CUPS, MUGS AND DRINKING STEINS, COMMEMORATIVE COLLECTOR PLATES, COFFEE CUPS, MUGS IN THE SHAPE OF HELMETS, JUICE CUPS AND PET FEEDING DISHES; GLASS, NAMELY, GLASS ETCHED BY ACID; PAPER CUPS; PLASTIC COASTERS; COASTERS NOT MADE OF PAPER OR CLOTH; BOTTLE OPENERS; HOUSEHOLD CONTAINERS FOR FOOD, NAMELY, RUBBER, PLASTIC AND FOAM INSULATING FOOD CONTAINERS; PORTABLE BEVERAGE COOLERS, THERMAL INSULATED COOLER BAGS FOR BEVERAGES, INSULATED PORTABLE SPORTS COOLERS, THERMAL INSULATED CONTAINERS FOR CAN BEVERAGES, PLASTIC SPORTS BOTTLES SOLD EMPTY, PLASTIC WATER

BOTTLES SOLD EMPTY, NON-METAL HELMET PIGGY BANKS, MEAL TRAYS, LUNCH BOXES, TRASH CANS, AND WASTEPAPER BASKETS; DECORATIVE BOXES MADE OF CERAMIC; FIGURINES AND SCULPTURES MADE OF CHINA, PORCELAIN, EARTHENWARE, GLASS, CRYSTAL, TERRA COTTA AND CERAMIC; MINIATURE FUEL CANS SOLD EMPTY; PLAQUES AND PHOTO PLAQUES OF CHINA, CRYSTAL, EARTHENWARE, GLASS, PORCELAIN AND TERRA COTTA; DESK ORNAMENTS OF CHINA, CRYSTAL, EARTHENWARE, GLASS, PORCELAIN AND TERRA COTTA (U.S. CLS. 2, 13, 23, 29, 30, 33, 40 AND 50).

FIRST USE 1-1-2010; IN COMMERCE 1-1-2010.

#### CLASS 24—FABRICS

FOR AFGHANS, DECORATIVE BED LINEN, BED BLANKETS, BLANKETS FOR BED AND OUTDOOR USE, TABLE CLOTHS MADE OF CLOTH, BED SHEETS, PILLOWCASES, TOWELS, COTTON FABRIC, CLOTH FLAGS, CLOTH PENNANTS, CLOTH BANNERS, AND FABRIC TABLE LINEN (U.S. CLS. 42 AND 50).

FIRST USE 1-1-2010; IN COMMERCE 1-1-2010.

#### CLASS 25—CLOTHING

FOR CLOTHING MARKETED AS GOODS ASSOCIATED WITH A STOCK CAR RACING TEAM, NAMELY, CLOTHING BELTS, SUSPENDERS, HEAD BANDS, WRIST BANDS, LEATHER JACKETS, LEATHER CAPS, SHORTS WITH BEVERAGE HOLDING LOOPS, CLOTH BIBS, BOXER SHORTS, BUTTON DOWN COLLAR SHIRTS, CREW NECK SHIRTS, FASHION SHIRTS, GOLF SHIRTS, SOCKS WITH TRACTION GRIPPING SOLES, HATS, CAPS, INFANT SHIRTS, JACKETS, JERSEYS, NECKTIES, PANTS, SPORT SHIRTS, POLO SHIRTS, PULLOVER SHIRTS, RUGBY SHIRTS, SHOES, FOOTWEAR, SPORT SHORTS, SHORTS, SOCKS, HOSIERY, SUNSUITS, DRESSES, SKIRTS, SWEATERS, LONG PANTS, SWEATPANTS, SWEATSHIRTS, SWEATSUITS, WARM-UP SUITS, T-SHIRTS, TANK TOPS, TANK TOP DRESSES, BATHING SUITS, TOBOGGAN-TYPE KNIT CAPS, PANTS, TROUSERS, TURTLENECK SHIRTS, VISORS, COATS, GLOVES, SCARVES, BANDANAS, WIND-RESISTANT SUITS, RAINCOATS, PONCHOS, PAJAMAS, NIGHT SHIRTS, NIGHT GOWNS AND ROBES; MASQUERADE COSTUMES, NAMELY, REPLICA DRIVER SUITS, REPLICA DRIVER HELMETS AND BASEBALL UNIFORMS; AND INFANT WEAR, SLEEP AND PLAY SETS FEATURING INFANT CLOTHING FOR USE AS SLEEPWEAR OR PLAYWEAR, AND CLOTH BABY BIBS NOT OF PAPER; HAT BANDS (U.S. CLS. 22 AND 39).

FIRST USE 1-1-2009; IN COMMERCE 1-1-2009.

#### CLASS 26—FANCY GOODS

FOR FANCY GOODS, NAMELY, HAT PINS; ORNAMENTAL NOVELTY PINS NOT OF PRECIOUS METAL; ZIPPER PULLS, SHOE LACES, BELT BUCKLES NOT OF PRECIOUS METAL; HAT PINS OF PRECIOUS METAL MARKETED AS GOODS ASSOCIATED WITH A STOCK CAR RACING TEAM (U.S. CLS. 37, 39, 40, 42 AND 50).

FIRST USE 2-1-2010; IN COMMERCE 2-1-2010.

#### CLASS 27—FLOOR COVERINGS

FOR FLOOR MATS FOR AUTOMOTIVE VEHICLES (U.S. CLS. 19, 20, 37, 42 AND 50).

FIRST USE 2-4-2010; IN COMMERCE 2-4-2010.

#### CLASS 28—TOYS AND SPORTING GOODS

FOR MINIATURE TOYS, NAMELY, AUTOMOBILES, AUTOMOBILE HOODS, AIRPLANES, TRUCKS, BOATS, MOTORCYCLES AND ALL-TERRAIN VEHICLES; RADIO-CONTROLLED TOY CARS, AIRPLANES, TRUCKS, BOATS, MOTORCYCLES AND ALL-TERRAIN VEHICLES; TOY MODEL AUTOMOBILES, AIRPLANES, TRUCKS, BOATS, MOTORCYCLES AND ALL-TERRAIN VEHICLES; AUTOMOBILE, AIRPLANE, TRUCK, BOAT, MOTORCYCLE, AND ALL-TERRAIN VEHICLE TOY BANKS; TOY SLOT TRACK CARS AND TRUCKS; TOY PEDAL STOCK CARS AND TRUCKS; SPORTS BALLS, NAMELY, BASEBALLS, BASKETBALLS, FOOTBALLS,

BEACH BALLS, TENNIS BALLS, VOLLEYBALLS, SOCCER BALLS AND GOLF BALLS; GOLF BAGS, BASEBALL TABLE TOP GAMES; SPORTS BOARD GAMES; DOLLS; STUFFED TOYS; STUFFED TOY ANIMALS; STUFFED TOY CARS AND TRUCKS; TOY ACTION FIGURES; CHRISTMAS TREE ORNAMENTS; BALLOONS, BASEBALL BATS; MINIATURE BASEBALL BATS; INFLATABLE BASEBALL BATS; REPLICA BATTING HELMETS; MINIATURE BATTING HELMETS; MINIATURE RACING HELMETS; YO-YOS; STAND ALONE AND HAND-HELD VIDEO GAME MACHINES; PLAYING CARDS; MINIATURE CARS MADE OF PEWTER; HAND-HELD UNITS FOR PLAYING ELECTRONIC GAMES; TOY REPLICA CAR AND TRUCK SIDE PORTIONS OF PLASTIC, TOY REPLICA CAR AND TRUCK FRONT END PORTIONS MADE OF PLASTIC, TOY REPLICA HOODS OF PLASTIC, TOY REPLICA TRUNK LIDS OF PLASTIC; TOY BANKS, TOY TRACTOR/TRAILERS OF METAL AND PLASTIC, TOY CARS OF PLASTIC AND METAL, TOY VEHICLE HAULERS, TOY MODEL CARS AND RELATED ACCESSORIES SOLD AS A UNIT, BABY RATTLES, TOY TRUCKS, WOODEN TOY CARS, MINIATURE TOY HELMETS, DIECAST TOY CARS, AND DIECAST TOY VEHICLE HAULERS; METAL BASEBALL HOLDERS; HOLIDAY TREE ORNAMENTS (U.S. CLS. 22, 23, 38 AND 50).

FIRST USE 1-1-2010; IN COMMERCE 1-1-2010.

#### CLASS 35—ADVERTISING AND BUSINESS

FOR ADVERTISING SERVICES, NAMELY, PROVIDING ADVERTISING SPACE ON AN AUTOMOBILE PARTICIPATING IN STOCK CAR EVENTS (U.S. CLS. 100, 101 AND 102).

FIRST USE 2-7-2009; IN COMMERCE 2-7-2009.

#### CLASS 41—EDUCATION AND ENTERTAINMENT

FOR ENTERTAINMENT SERVICES IN THE NATURE OF PARTICIPATING IN PROFESSIONAL AUTOMOBILE RACES AND AUTO RACING EXHIBITIONS; ENTERTAINMENT SERVICES IN THE NATURE OF BASEBALL GAMES AND RELATED EXHIBITIONS; ENTERTAINMENT SERVICES IN THE NATURE OF LIVE MUSICAL CONCERTS; ENTERTAINMENT, NAMELY, LIVE PERFORMANCES BY A MUSICAL BAND; ENTERTAINMENT IN THE NATURE OF VISUAL AND AUDIO PERFORMANCES, AND MUSICAL, VARIETY, NEWS AND COMEDY SHOWS (U.S. CLS. 100, 101 AND 107).

FIRST USE 2-7-2009; IN COMMERCE 2-7-2009.

3,962,205. STEWART-HAAS RACING, LLC, KANNAPOLIS, NC. SN 77-561,921. PUB. 7-7-2009, FILED 9-4-2008.

A large, stylized number '39' in a bold, italicized font with a thick black outline and a white fill. The numbers are slanted to the right.

THE MARK CONSISTS OF THE NUMBERS "39" WRITTEN IN A STYLIZED MANNER.

#### CLASS 5—PHARMACEUTICALS

FOR PAPER AIR FRESHENERS (U.S. CLS. 6, 18, 44, 46, 51 AND 52).

FIRST USE 7-1-2010; IN COMMERCE 7-1-2010.

**CLASS 6—METAL GOODS**

FOR METAL GOODS, NAMELY, MONEY BANKS, KEY CHAINS, KEY RINGS, KEY CLIPS, LOCK BOXES, COMMEMORATIVE COLLECTOR PLATES OF NON-PRECIOUS METAL, NON-LUMINOUS AND NON-MECHANICAL METAL SIGNS, LICENSE PLATES, COLLECTOR TINS SOLD EMPTY, DECORATIVE TINS SOLD EMPTY, HOLIDAY ORNAMENTS NOT BEING TREE ORNAMENTS, METAL KEY FOBS, PLAQUES AND PHOTO PLAQUES OF METAL; DESK ORNAMENTS OF METAL (U.S. CLS. 2, 12, 13, 14, 23, 25 AND 50).

FIRST USE 8-13-2010; IN COMMERCE 8-13-2010.

**CLASS 9—ELECTRICAL AND SCIENTIFIC APPARATUS**

FOR PRE-RECORDED AUDIO, VIDEO, COMPUTER AND LASER DISCS FEATURING RACING THEMES; PRE-RECORDED AUDIO, VIDEO, COMPUTER AND LASER DISCS FEATURING SPORTS AND MUSIC; PRE-RECORDED AUDIO AND VIDEO CASSETTES, PRE-RECORDED AUDIO AND VIDEO TAPES, PRE-RECORDED COMPACT DISCS, AND PRE-RECORDED COMPUTER DISCS FEATURING SPORTS AND MUSIC; COMPUTER ACCESSORIES, NAMELY, COMPUTER MICE, COMPUTER MOUSE PADS, COMPUTER DISC CASES, COMPUTER CARRYING CASES AND KEYBOARD WRIST PADS FOR COMPUTER USERS; COMPUTER SOFTWARE FOR STORING, RECEIVING, RETRIEVING, DISPLAYING, ANALYZING AND PROCESSING INFORMATION, DATA, STATISTICS AND TRIVIA RELATING TO SPORTS AND MUSIC; COMPUTER SOFTWARE FOR USE AS A SCREEN SAVER FEATURING SPORTS AND MUSIC; VIDEO GAME COMPUTER SOFTWARE; VIDEO GAME CARTRIDGES; VIDEO GAME MACHINES FOR USE WITH A TELEVISION; RADIOS; TELEPHONES; WALKIE-TALKIES; BINOCULARS; SUNGLASSES, EYEGGLASS CASES; DECORATIVE MAGNETS; AND CELLULAR TELEPHONE CARRYING CASES; SLOT MACHINES; COMPUTER GAME CARTRIDGES; MAGNETICALLY ENCODED CREDIT, DEBIT AND GIFT CARDS; MAGNETICALLY ENCODED TELEPHONE CALLING CARDS (U.S. CLS. 21, 23, 26, 36 AND 38).

FIRST USE 8-17-2010; IN COMMERCE 8-17-2010.

**CLASS 12—VEHICLES**

FOR LICENSE PLATE FRAMES, LICENSE PLATE HOLDERS; VISOR COVERS FOR CAR WINDSHIELD VISORS, AUTOMOBILE WINDSHIELD SUNSHADES AND AUTOMOBILE MUD FLAPS; AUTOMOBILE STRUCTURAL PARTS, NAMELY, REPLICA CAR AND TRUCK SIDE PORTIONS OF PLASTIC, REPLICA CAR AND TRUCK FRONT END PORTIONS OF PLASTIC, REPLICA HOODS OF PLASTIC, AND REPLICA TRUNK LIDS OF PLASTIC (U.S. CLS. 19, 21, 23, 31, 35 AND 44).

FIRST USE 8-16-2010; IN COMMERCE 8-16-2010.

**CLASS 14—JEWELRY**

FOR JEWELRY AND ACCESSORIES TO BE MARKETED AS GOODS ASSOCIATED WITH A STOCK CAR RACING TEAM, NAMELY, EARRINGS, NECKLACES, BRACELETS, BROOCHES, ANKLETS, FINGER RINGS, AND TOE RINGS, OF PRECIOUS METAL; WATCHES, CLOCKS AND WALL CLOCKS, TRADING CARDS MADE OF PRECIOUS METALS; JEWELRY, NAMELY, CHARMS FOR CHARM BRACELETS, EARRINGS, NECKLACES, PENDANTS, LAPEL PINS, RINGS, TIE FASTENERS, TIE CLASPS, WATCH BANDS; NON-MONETARY COINS OF PRECIOUS METAL (U.S. CLS. 2, 27, 28 AND 50).

FIRST USE 8-16-2010; IN COMMERCE 8-16-2010.

**CLASS 16—PAPER GOODS AND PRINTED MATTER**

FOR PRINTED MATERIAL, NAMELY, BROCHURES, MAGAZINES, NEWSLETTERS, PAMPHLETS, SOUVENIR PROGRAMS, STATISTICAL RECORD SHEETS AND BOOKS, ALL FEATURING SPORTS AND MUSIC; COMMEMORATIVE STAMP SHEETS; NOTE CARDS, MEMO PADS, NOTE PADS, FOLDERS, ADDRESS BOOKS, PAINTINGS, BINDERS, BOOKS FEATURING RACING THEMES, BUMPER STICKERS, CALENDARS, CARDBOARD BOXES, COLORING BOOKS, COMMEMORATIVE SHEETS OF TRADING CARDS, CREDIT CARDS WITHOUT MAGNETIC CODING, DECALS, ERASERS, FRAMED PHOTOGRAPHS, MOUNTED AND UNMOUNTED PHOTOGRAPHS, ART PRINTS, PHOTOGRAPHIC PRINTS, LIMITED EDITION PICTORIAL PRINTS, LITHOGRAPHIC PRINTS, PAPER MAGAZINE COVERS, BOOK COVERS, DECALS FOR MODEL CARS, PAPER NAPKINS, NOTEBOOKS, PAPER PENNANTS, PAPER BANNERS, PENCILS, PENS, PAPER IDENTIFICATION TAGS, DAILY PLANNERS, STATIONERY, STATIONERY-TYPE PORTFOLIOS, PLACE MATS MADE OF PAPER, POST CARDS, POSTERS, STATIC DECALS, STICKERS, PAPER TABLE LINEN, TRADING CARDS, FRAMED TRADING CARDS, WINDOW DECALS, SUBJECT NOTEBOOKS NOT WIRE-BOUND; METAL MONEY CLIPS; MONEY CLIPS OF PRECIOUS METAL MARKETED AS GOODS ASSOCIATED WITH A STOCK CAR RACING TEAM; TRADING CARDS MADE OF NON-PRECIOUS METAL; METAL POSTERS; MONEY CLIPS (U.S. CLS. 2, 5, 22, 23, 29, 37, 38 AND 50).

FIRST USE 1-1-2010; IN COMMERCE 1-1-2010.

**CLASS 18—LEATHER GOODS**

FOR LUGGAGE AND RELATED ITEMS TO BE MARKETED AS GOODS ASSOCIATED WITH A STOCK CAR RACING TEAM, NAMELY, LUGGAGE, ATHLETIC BAGS, SHOE BAGS FOR TRAVEL, OVERNIGHT BAGS, BACK PACKS, FANNY PACKS, WAIST PACKS, DIAPER BAGS, DUFFEL BAGS, TOTE BAGS, BOOK BAGS, TRAVEL BAGS, ALL PURPOSE SPORTS BAGS, GYM BAGS, GARMENT BAGS FOR TRAVEL, HANDBAGS, PURSES, TOILETRY CASES SOLD EMPTY, COSMETIC CASES SOLD EMPTY, TRUNKS, BRIFCASES, AT-TACHE CASES, SUITCASES, KNAPSACKS, BUSINESS CARD CASES, KEY CASES, BILLFOLDS, WALLETS, LUGGAGE TAGS, BELT BAGS, AND UMBRELLAS; LEATHER PET COLLARS, FABRIC PET COLLARS, FABRIC PET LEASHES, SPORTSWEAR CLOTHING FOR DOGS, LEATHER PHOTO KEY CHAINS (U.S. CLS. 1, 2, 3, 22 AND 41).

FIRST USE 8-17-2010; IN COMMERCE 8-17-2010.

**CLASS 20—FURNITURE AND ARTICLES NOT OTHERWISE CLASSIFIED**

FOR PET CUSHIONS, WRITING TABLES, NON-METAL KEY RINGS; NON-METAL AND NON-LEATHER KEY CHAINS; PLASTIC PHOTO KEY CHAINS; KEY FOBS, NOT OF METAL; PHOTO PLAQUES OF PLASTIC AND WOOD; PLAQUES OF PLASTIC AND WOOD; NON-METAL BOTTLE CAPS HAVING A RACING THEME, PICTURE FRAMES, FURNITURE FOR ADULTS, FURNITURE FOR CHILDREN; WOODEN PLAQUES; CHAIRS; PORTABLE FOLDING CHAIRS; NON-METAL NOVELTY LICENSE PLATES; PLASTIC LICENSE PLATES; SEAT CUSHIONS; CUSHIONS; PORTABLE BEDS FOR DOGS; DESK ORNAMENTS OF PLASTER, PLASTIC AND WOOD; DECORATIVE WINDOW ORNAMENTS OF PLASTIC, ACRYLIC AND VINYL; MAGNETIC VINYL DECORATIVE EMBLEMS; PLASTIC PENNANTS AND PLASTIC BANNERS; FIGURINES AND SCULPTURES MADE OF PLASTIC; FIGURINES AND SCULPTURES MADE OF ACRYLIC; WIND CHIMES; MEMORABILIA DISPLAY FRAMES OF PLASTIC AND ACRYLIC; DECORATIVE BOXES MADE OF PLASTIC AND ACRYLIC FOR DIECAST MINIATURE AUTOMOBILES; BASEBALLS AND SPORTS SCENES (U.S. CLS. 2, 13, 22, 25, 32 AND 50).

FIRST USE 1-1-2009; IN COMMERCE 1-1-2009.

**CLASS 21—HOUSEWARES AND GLASS**

FOR HOUSEWARES, NAMELY, SHOT GLASSES, PLATES, DRINKING GLASSES, CUPS, MUGS AND DRINKING STEINS, COMMEMORATIVE COLLECTOR PLATES, COFFEE CUPS, MUGS IN THE SHAPE OF HELMETS, JUICE CUPS AND PET FEEDING DISHES; GLASS, NAMELY, GLASS ETCHED BY ACID; PAPER CUPS; PLASTIC COASTERS; COASTERS NOT MADE OF PAPER OR CLOTH; BOTTLE OPENERS; HOUSEHOLD CONTAINERS FOR FOOD, NAMELY, RUBBER, PLASTIC AND FOAM INSULATING FOOD CONTAINERS; PORTABLE BEVERAGE COOLERS, THERMAL INSULATED COOLER BAGS FOR BEVERAGES, INSULATED PORTABLE SPORTS COOLERS, THERMAL INSULATED CONTAINERS FOR CAN BEVERAGES, PLASTIC SPORTS BOTTLES SOLD EMPTY, PLASTIC WATER BOTTLES SOLD EMPTY, NON-METAL HELMET PIGGY BANKS, MEAL TRAYS, LUNCH BOXES, TRASH CANS, AND WASTEPAPER BASKETS; DECORATIVE BOXES MADE OF CERAMIC; FIGURINES AND SCULPTURES MADE OF CHINA, PORCELAIN, EARTHENWARE, GLASS, CRYSTAL, TERRA COTTA AND CERAMIC; MINIATURE FUEL CANS SOLD EMPTY; PLAQUES AND PHOTO PLAQUES OF CHINA, CRYSTAL, EARTHENWARE, GLASS, PORCELAIN AND TERRA COTTA; DESK ORNAMENTS OF CHINA, CRYSTAL, EARTHENWARE, GLASS, PORCELAIN AND TERRA COTTA (U.S. CLS. 2, 13, 23, 29, 30, 33, 40 AND 50).

FIRST USE 1-1-2010; IN COMMERCE 1-1-2010.

#### CLASS 24—FABRICS

FOR AFGHANS, DECORATIVE BED LINEN, BED BLANKETS, BLANKETS FOR BED AND OUTDOOR USE, TABLE CLOTHS MADE OF CLOTH, BED SHEETS, PILLOWCASES, TOWELS, COTTON FABRIC, CLOTH FLAGS, CLOTH PENNANTS, CLOTH BANNERS, AND FABRIC TABLE LINEN (U.S. CLS. 42 AND 50).

FIRST USE 1-1-2010; IN COMMERCE 1-1-2010.

#### CLASS 25—CLOTHING

FOR CLOTHING MARKETED AS GOODS ASSOCIATED WITH A STOCK CAR RACING TEAM, NAMELY, CLOTHING BELTS, SUSPENDERS, HEAD BANDS, WRIST BANDS, LEATHER JACKETS, LEATHER CAPS, SHORTS WITH BEVERAGE HOLDING LOOPS, CLOTH BIBS, BOXER SHORTS, BUTTON DOWN COLLAR SHIRTS, CREW NECK SHIRTS, FASHION SHIRTS, GOLF SHIRTS, SOCKS WITH TRACTION GRIPPING SOLES, HATS, CAPS, INFANT SHIRTS, JACKETS, JERSEYS, NECKTIES, PANTS, SPORT SHIRTS, POLO SHIRTS, PULLOVER SHIRTS, RUGBY SHIRTS, SHOES, FOOTWEAR, SPORT SHORTS, SHORTS, SOCKS, HOSIERY, SUNSUITS, DRESSES, SKIRTS, SWEATERS, LONG PANTS, SWEATPANTS, SWEATSHIRTS, SWEATSUITS, WARM-UP SUITS, T-SHIRTS, TANK TOPS, TANK TOP DRESSES, BATHING SUITS, TOBOGGAN-TYPE KNIT CAPS, PANTS, TROUSERS, TURTLENECK SHIRTS, VISORS, COATS, GLOVES, SCARVES, BANDANAS, WIND-RESISTANT SUITS, RAINCOATS, PONCHOS, PAJAMAS, NIGHT SHIRTS, NIGHT GOWNS AND ROBES; MASQUERADE COSTUMES, NAMELY, REPLICAS DRIVER SUITS, REPLICAS DRIVER HELMETS AND BASEBALL UNIFORMS; AND INFANT WEAR, SLEEP AND PLAY SETS FEATURING INFANT CLOTHING FOR USE AS SLEEPWEAR OR PLAYWEAR, AND CLOTH BABY BIBS NOT OF PAPER; HAT BANDS (U.S. CLS. 22 AND 39).

FIRST USE 1-1-2009; IN COMMERCE 1-1-2009.

#### CLASS 26—FANCY GOODS

FOR FANCY GOODS, NAMELY, HAT PINS; ORNAMENTAL NOVELTY PINS NOT OF PRECIOUS METAL; ZIPPER PULLS, SHOE LACES, BELT BUCKLES NOT OF PRECIOUS METAL; HAT PINS OF PRECIOUS METAL MARKETED AS GOODS ASSOCIATED WITH A STOCK CAR RACING TEAM (U.S. CLS. 37, 39, 40, 42 AND 50).

FIRST USE 2-1-2010; IN COMMERCE 2-1-2010.

#### CLASS 27—FLOOR COVERINGS

FOR FLOOR MATS FOR AUTOMOTIVE VEHICLES (U.S. CLS. 19, 20, 37, 42 AND 50).

FIRST USE 2-4-2010; IN COMMERCE 2-4-2010.

#### CLASS 28—TOYS AND SPORTING GOODS

FOR MINIATURE TOYS, NAMELY, AUTOMOBILES, AUTOMOBILE HOODS, AIRPLANES, TRUCKS, BOATS, MOTORCYCLES AND ALL-TERRAIN VEHICLES; RADIO-CONTROLLED TOY CARS, AIRPLANES, TRUCKS, BOATS, MOTORCYCLES AND ALL-TERRAIN VEHICLES; TOY MODEL AUTOMOBILES, AIRPLANES, TRUCKS, BOATS, MOTORCYCLES AND ALL-TERRAIN VEHICLES; AUTOMOBILE, AIRPLANE, TRUCK, BOAT, MOTORCYCLE, AND ALL-TERRAIN VEHICLE TOY BANKS; TOY SLOT TRACK CARS AND TRUCKS; TOY PEDAL STOCK CARS AND TRUCKS; SPORTS BALLS, NAMELY, BASEBALLS, BASKETBALLS, FOOTBALLS, BEACH BALLS, TENNIS BALLS, VOLLEYBALLS, SOCCER BALLS AND GOLF BALLS; GOLF BAGS, BASEBALL TABLE TOP GAMES; SPORTS BOARD GAMES; DOLLS; STUFFED TOYS; STUFFED TOY ANIMALS; STUFFED TOY CARS AND TRUCKS; TOY ACTION FIGURES; CHRISTMAS TREE ORNAMENTS; BALLOONS, BASEBALL BATS; MINIATURE BASEBALL BATS; INFLATABLE BASEBALL BATS; REPLICAS BATTING HELMETS; MINIATURE BATTING HELMETS; MINIATURE RACING HELMETS; YO-YOS; STAND ALONE AND HAND-HELD VIDEO GAME MACHINES; PLAYING CARDS; MINIATURE CARS MADE OF PAPER; HAND-HELD UNITS FOR PLAYING ELECTRONIC GAMES; TOY REPLICAS CAR AND TRUCK SIDE PORTIONS OF PLASTIC, TOY REPLICAS CAR AND TRUCK FRONT END PORTIONS MADE OF PLASTIC, TOY REPLICAS HOODS OF PLASTIC, TOY REPLICAS TRUNK LIDS OF PLASTIC; TOY BANKS, TOY TRACTOR/TRAILERS OF METAL AND PLASTIC, TOY CARS OF PLASTIC AND METAL, TOY VEHICLE HAULERS, TOY MODEL CARS AND RELATED ACCESSORIES SOLD AS A UNIT, BABY RATTLES, TOY TRUCKS, WOODEN TOY CARS, MINIATURE TOY HELMETS, DIECAST TOY CARS, AND DIECAST TOY VEHICLE HAULERS; METAL BASEBALL HOLDERS; HOLIDAY TREE ORNAMENTS (U.S. CLS. 22, 23, 38 AND 50).

FIRST USE 1-1-2010; IN COMMERCE 1-1-2010.

#### CLASS 35—ADVERTISING AND BUSINESS

FOR ADVERTISING SERVICES, NAMELY, PROVIDING ADVERTISING SPACE ON AN AUTOMOBILE PARTICIPATING IN STOCK CAR EVENTS (U.S. CLS. 100, 101 AND 102).

FIRST USE 2-7-2009; IN COMMERCE 2-7-2009.

#### CLASS 41—EDUCATION AND ENTERTAINMENT

FOR ENTERTAINMENT SERVICES IN THE NATURE OF PARTICIPATING IN PROFESSIONAL AUTOMOBILE RACES AND AUTO RACING EXHIBITIONS; ENTERTAINMENT SERVICES IN THE NATURE OF BASEBALL GAMES AND RELATED EXHIBITIONS; ENTERTAINMENT SERVICES IN THE NATURE OF LIVE MUSICAL CONCERTS; ENTERTAINMENT, NAMELY, LIVE PERFORMANCES BY A MUSICAL BAND; ENTERTAINMENT IN THE NATURE OF VISUAL AND AUDIO PERFORMANCES, AND MUSICAL, VARIETY, NEWS AND COMEDY SHOWS (U.S. CLS. 100, 101 AND 107).

FIRST USE 2-7-2009; IN COMMERCE 2-7-2009.

3,962,210. SPRUCE NATURALS, LLC, RENO, NV. SN 77-566,870. PUB. 1-27-2009, FILED 9-10-2008.

MONTEBELLO ESTABLISHED 1388

THE MARK CONSISTS OF STANDARD CHARACTERS WITHOUT CLAIM TO ANY PARTICULAR FONT, STYLE, SIZE, OR COLOR.

OWNER OF U.S. REG. NO. 2,181,478.



NO CLAIM IS MADE TO THE EXCLUSIVE RIGHT TO USE "ESTABLISHED 1388", APART FROM THE MARK AS SHOWN.

THE FOREIGN WORDING IN THE MARK TRANSLATES INTO ENGLISH AS BEAUTIFUL MOUNTAIN.

#### **CLASS 29—MEATS AND PROCESSED FOODS**

FOR OLIVE OIL (U.S. CL. 46).  
FIRST USE 1-25-2006; IN COMMERCE 1-25-2006.

#### **CLASS 30—STAPLE FOODS**

FOR PASTA; PASTA SAUCE; RICE AND VINEGAR (U.S. CL. 46).  
FIRST USE 6-30-1997; IN COMMERCE 6-1-1998.

3,962,213. ALEXANDRIA REAL ESTATE EQUITIES, INC., PASADENA, CA. SN 77-573,818. PUB. 1-19-2010, FILED 9-18-2008.

## **CLEAN COLLABORATION**

THE MARK CONSISTS OF STANDARD CHARACTERS WITHOUT CLAIM TO ANY PARTICULAR FONT, STYLE, SIZE, OR COLOR.

#### **CLASS 35—ADVERTISING AND BUSINESS**

FOR BUSINESS ADMINISTRATION SERVICES, NAMELY, OPERATION OF BUSINESSES FOR OTHERS AND PROVIDING START UP SUPPORT FOR BUSINESSES OF OTHERS; BUSINESS MANAGEMENT AND CONSULTATION; BUSINESS MANAGEMENT, NAMELY, BUSINESS INCUBATOR SERVICES; RENTAL AND LEASING OF OFFICE MACHINERY AND EQUIPMENT; BUSINESS NETWORKING SERVICES; OPERATION AND ADMINISTRATION OF TELECOMMUNICATION SYSTEMS AND NETWORKS FOR OTHERS (U.S. CLS. 100, 101 AND 102).  
FIRST USE 9-0-2008; IN COMMERCE 9-0-2008.

#### **CLASS 36—INSURANCE AND FINANCIAL**

FOR FINANCIAL SERVICES, NAMELY, FINANCIAL CONSULTATION, FINANCIAL ANALYSIS, FINANCIAL PLANNING, FINANCIAL MANAGEMENT, VENTURE CAPITAL SERVICES, NAMELY, PROVIDING DEBT AND EQUITY CAPITAL, AND TANGIBLE AND INTANGIBLE ASSET FINANCING, BUSINESS INCUBATOR SERVICES, NAMELY, PROVIDING EQUITY AND DEBT FINANCING TO EMERGING AND START-UP COMPANIES, REAL ESTATE SERVICES, NAMELY, REAL ESTATE BROKERAGE, ACQUISITION, RENTAL OF OFFICE, RESEARCH AND LABORATORY PROPERTIES, LEASING, AND MANAGEMENT SERVICES, INVESTMENT MANAGEMENT SERVICES, PROPERTY MANAGEMENT SERVICES, NAMELY, REAL ESTATE MANAGEMENT (U.S. CLS. 100, 101 AND 102).  
FIRST USE 9-0-2008; IN COMMERCE 9-0-2008.

#### **CLASS 37—CONSTRUCTION AND REPAIR**

FOR REAL ESTATE DEVELOPMENT; REAL ESTATE MAINTENANCE, NAMELY, MAINTENANCE OF BUILDINGS, OFFICES, AND RESEARCH FACILITIES; BUILDING CONSTRUCTION AND REPAIR; MAINTENANCE AND REPAIR OF ELECTRICAL SYSTEMS, HEATING AND AIR CONDITIONING SYSTEMS AND PLUMBING SYSTEMS, ALL IN THE FIELD OF REAL ESTATE (U.S. CLS. 100, 103 AND 106).  
FIRST USE 9-0-2008; IN COMMERCE 9-0-2008.

#### **CLASS 38—COMMUNICATION**

FOR PROVIDING AN ONLINE FORUM FOR COMPANIES TO FORM VIRTUAL COMMUNITIES AND SPACES; PROVIDING AN ONLINE FORUM FOR COMPANIES TO OPERATE AND MANAGE VIRTUAL OFFICE, LABORATORY AND RESEARCH SPACES; PROVIDE AN ONLINE FORUM FOR COMPANIES TO SHOWCASE, DISPLAY, DEMONSTRATE AND PROMOTE NEW AND INNOVATIVE IDEAS AND TECHNOLOGIES, PRODUCTS AND SERVICES; PROVIDING ONLINE FORUMS FOR TRANSMISSION OF MESSAGES AMONG USERS IN THE SCIENTIFIC, RESEARCH AND TECHNOLOGY FIELDS; COMMUNICATION SERVICES, NAMELY, TRANSMISSION OF VOICE, AUDIO, VISUAL IMAGES AND DATA BY TELECOMMUNICATIONS NETWORKS, WIRELESS COMMUNICATION NETWORKS, THE INTERNET, INFORMATION SERVICES NETWORKS AND DATA NETWORKS (U.S. CLS. 100, 101 AND 104).  
FIRST USE 9-0-2008; IN COMMERCE 9-0-2008.

#### **CLASS 41—EDUCATION AND ENTERTAINMENT**

FOR EDUCATIONAL AND TRAINING SERVICES, NAMELY, CONDUCTING CLASSES, SEMINARS, CONFERENCES, EXHIBITIONS AND WORKSHOPS IN THE FIELDS OF BUSINESS MANAGEMENT, BUSINESS DEVELOPMENT, SCIENCE, TECHNOLOGY, INFORMATION NETWORKING AND INFORMATION MANAGEMENT; PROVIDING ONLINE NEWSLETTERS IN THE FIELDS OF BUSINESS MANAGEMENT, BUSINESS DEVELOPMENT, SCIENCE, TECHNOLOGY, INFORMATION NETWORKING AND INFORMATION MANAGEMENT; ORGANIZING AND CONDUCTING ENTERTAINMENT EXHIBITIONS AND SPECIAL EVENTS FOR BUSINESSES, NAMELY, SOCIAL GATHERINGS AND EDUCATIONAL CONFERENCES (U.S. CLS. 100, 101 AND 107).  
FIRST USE 9-0-2008; IN COMMERCE 9-0-2008.

#### **CLASS 42—SCIENTIFIC AND COMPUTER SERVICES**

FOR ARCHITECTURAL DESIGN; ENGINEERING; RENTAL AND LEASING OF COMPUTERS; COMPUTER SERVICES, NAMELY, CREATING AN ONLINE COMMUNITY FOR USERS TO FORM VIRTUAL COMMUNITIES; DEVELOPMENT OF COMPUTER INFORMATION NETWORKS FOR OTHERS (U.S. CLS. 100 AND 101).  
FIRST USE 9-0-2008; IN COMMERCE 9-0-2008.

3,962,214. HYPE-IP LIMITED, GIBRALTAR, GIBRALTAR. SN 77-576,490. PUB. 8-3-2010, FILED 9-23-2008.

# HYPE

THE MARK CONSISTS OF STANDARD CHARACTERS WITHOUT CLAIM TO ANY PARTICULAR FONT, STYLE, SIZE, OR COLOR.



**CLASS 5—PHARMACEUTICALS**

FOR PHARMACEUTICAL PREPARATIONS FOR THE TREATMENT AND PREVENTION OF TIREDNESS AND FATIGUE; VITAMIN PREPARATIONS; ORAL GLUCOSE SPRAY FOR USE IN RAISING BLOOD GLUCOSE LEVEL, ENERGY LEVEL, WEIGHT MANAGEMENT; NUTRITIONAL AND FOOD SUPPLEMENTS, NAMELY, ORAL SPRAY FOR BOOSTING ENERGY, ORALLY INGESTED GEL FOR BOOSTING ENERGY, ENERGY BOOSTING BARS FOR USE AS MEAL SUBSTITUTE, ENERGY BOOSTING SHOTS, AND VITAMIN FORTIFIED DRINKS (U.S. CLS. 6, 18, 44, 46, 51 AND 52).

FIRST USE 2-1-2009; IN COMMERCE 2-1-2009.

**CLASS 32—LIGHT BEVERAGES**

FOR NON ALCOHOLIC BEVERAGES, NAMELY, CARBONATED BEVERAGES; FRUIT DRINKS AND FRUIT JUICES; SYRUPS AND OTHER PREPARATIONS FOR MAKING NON ALCOHOLIC BEVERAGES; ENERGY DRINKS, SPORTS DRINKS AND DRINKING WATER WITH VITAMINS (U.S. CLS. 45, 46 AND 48).

FIRST USE 12-1-2000; IN COMMERCE 12-1-2000.

3,962,216. RSM MCGLADREY, INC., BLOOMINGTON, MN. AND MCGLADREY & PULLEN, LLP, BLOOMINGTON, MN. SN 77-581,318. PUB. 8-31-2010, FILED 9-29-2008.

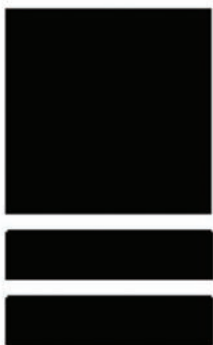

THE MARK CONSISTS OF A SQUARE OVER TWO RECTANGLES.

**CLASS 9—ELECTRICAL AND SCIENTIFIC APPARATUS**

FOR COMPUTER SOFTWARE FOR USE IN PERFORMING BUSINESS ADMINISTRATION FUNCTIONS; COMPUTER SOFTWARE FOR USE IN MANAGING CORPORATE HUMAN RESOURCES FUNCTIONS; COMPUTER SOFTWARE FOR USE IN MANAGING CORPORATE HUMAN RESOURCES PROCESSES; COMPUTER SOFTWARE FOR USE IN THE MANAGEMENT OF FINANCIAL TRANSACTIONS AND FINANCIAL PLANNING; COMPUTER SOFTWARE FOR USE IN PERFORMING BOOKKEEPING; COMPUTER SOFTWARE FOR USE IN CONDUCTING AND MANAGING CORPORATE AUDITS; COMPUTER SOFTWARE FOR USE IN CONDUCTING AND MANAGING FINANCIAL AUDITS; COMPUTER SOFTWARE FOR USE IN CONDUCTING AND MANAGING INVENTORY AUDITS; COMPUTER SOFTWARE FOR USE IN PROVIDING ACCOUNTING SERVICES; COMPUTER SOFTWARE FOR USE IN CONDUCTING TAX ANALYSIS; COMPUTER SOFTWARE FOR USE IN THE FACILITATION OF PROPER PLANNING FOR THE DESIGN, DEVELOPMENT, IMPLEMENTATION AND MAINTENANCE OF COMPUTER AND INFORMATION SYSTEMS (U.S. CLS. 21, 23, 26, 36 AND 38).

FIRST USE 6-3-2010; IN COMMERCE 6-3-2010.

**CLASS 35—ADVERTISING AND BUSINESS**

FOR ACCOUNTING SERVICES; ACCOUNT AND BUSINESS AUDITING SERVICES; BUSINESS ADMINISTRATION SERVICES; TAX PREPARATION; TAX ADVISORY SERVICES, NAMELY, CONSULTATION SERVICES; BOOKKEEPING SERVICES; BUSINESS MANAGEMENT CONSULTING SERVICES; GOVERNMENT MANAGEMENT CONSULTING SERVICES, NAMELY, PROVIDING INFORMATION IN THE FIELD OF GOVERNMENT AFFAIRS; ADVICE RELATING TO THE ORGANIZATION AND MANAGEMENT OF BUSINESS, NAMELY, ASSISTING AND ADVISING OTHERS ON THE ORGANIZATION AND MANAGEMENT OF BUSINESSES OR BUSINESS MANAGEMENT OF TRADING FUNCTIONS OF COMMERCIAL OR INDUSTRIAL COMPANIES; ECONOMIC FORECASTING AND ANALYSIS, NAMELY, ECONOMIC RESEARCH IN THE ATTAINMENT OF BENEFITS, BUSINESS INTERRUPTION AND LOSS DETERMINATION FOR COST ASSESSMENT SERVICES; EMPLOYMENT COUNSELING AND RECRUITING; HUMAN RESOURCES MANAGEMENT CONSULTING SERVICES; PERSONNEL PLACEMENT AND RECRUITMENT SERVICES (U.S. CLS. 100, 101 AND 102).

FIRST USE 6-3-2010; IN COMMERCE 6-3-2010.

**CLASS 36—INSURANCE AND FINANCIAL**

FOR INSURANCE CONSULTATION AND ADVISORY SERVICES; FINANCIAL PLANNING, CONSULTING AND MANAGEMENT SERVICES; INSURANCE CONSULTATION, NAMELY, PROVIDING ADVICE RELATING TO INSURANCE ISSUES; ACTUARIAL SERVICES; FINANCIAL RESEARCH, NAMELY, RESEARCH IN THE ATTAINMENT OF INSURANCE AND EMPLOYEE BENEFITS; REAL ESTATE INVESTMENT SERVICES; FINANCING SERVICES; INDIVIDUAL RETIREMENT ACCOUNT SERVICES; GENERAL SECURITIES BROKERAGE AND INVESTMENT BANKING SERVICES; FINANCIAL PLANNING AND INVESTMENT ADVISORY AND MANAGEMENT SERVICES; CONSULTING SERVICES IN THE FIELD OF EMPLOYEE BENEFITS CONCERNING INSURANCE, FINANCE AND FINANCIAL COMPENSATION PROGRAMS; ADVICE RELATING TO THE ORGANIZATION AND MANAGEMENT OF BUSINESS, NAMELY, ASSISTING AND ADVISING OTHERS ON MANAGEMENT OF FINANCIAL TRADING FUNCTIONS OF COMMERCIAL OR INDUSTRIAL COMPANIES (U.S. CLS. 100, 101 AND 102).

FIRST USE 6-3-2010; IN COMMERCE 6-3-2010.

**CLASS 42—SCIENTIFIC AND COMPUTER SERVICES**

FOR CUSTOM DESIGN AND DEVELOPMENT OF COMPUTER HARDWARE, SOFTWARE AND COMPUTER SYSTEMS FOR OTHERS; CONSULTING SERVICES IN THE FIELD OF COMPUTER BASED INFORMATION SYSTEMS FOR BUSINESSES AND GOVERNMENT; CONSULTING SERVICES IN THE FIELD OF IDENTIFICATION, PRIORITIZATION, ANALYSIS, DESIGN, DEVELOPMENT AND IMPLEMENTATION OF COMPUTER-BASED INFORMATION SYSTEMS FOR INSURANCE AND OTHER FINANCIAL SERVICES BUSINESSES AND OTHER INDUSTRIES; TECHNICAL CONSULTING SERVICES AND ASSISTANCE WITH COMPUTER-BASED INFORMATION SYSTEMS AND COMPONENTS THEREOF; COMPUTER ASSURANCE SERVICES RELATING TO THE DEVELOPMENT OF SECURITY SYSTEMS AND CONTINGENCY PLANNING FOR INFORMATION SYSTEMS (U.S. CLS. 100 AND 101).

FIRST USE 6-3-2010; IN COMMERCE 6-3-2010.

**CLASS 45—PERSONAL AND LEGAL SERVICES**

FOR LITIGATION SUPPORT IN ECONOMICS, ACCOUNTING AND FINANCE, NAMELY, INVESTIGATIVE AUDITS AND FINANCIAL ANALYSES; TAX ADVISORY SERVICES, NAMELY, TAX COMPLIANCE CONSULTING RELATING TO COMPLIANCE WITH FEDERAL, STATE, AND FOREIGN TAX LAWS AND REGULATIONS (U.S. CLS. 100 AND 101).

FIRST USE 6-3-2010; IN COMMERCE 6-3-2010.

3,962,219. DAKOTA FLUID POWER, INC., SIOUX FALLS, SD. SN 77-587,491. PUB. 10-26-2010, FILED 10-7-2008.

3,962,220. RAYMOND JAMES FINANCIAL, INC., ST. PETERSBURG, FL. SN 77-588,449. PUB. 9-1-2009, FILED 10-8-2008.



## EAGLE FUND SERVICES

NO CLAIM IS MADE TO THE EXCLUSIVE RIGHT TO USE "MOBILE", APART FROM THE MARK AS SHOWN.

THE COLOR(S) BLACK, BLUE AND WHITE IS/ARE CLAIMED AS A FEATURE OF THE MARK.

THE MARK CONSISTS OF STYLIZED LETTERS "M", "B", "I", "L", AND "E", WITH A SPACE SEPARATING APPROXIMATELY THE TOP THIRD FROM APPROXIMATELY THE BOTTOM THIRD OF EACH LETTER. THE TOP PORTION OF EACH LETTER IS BLUE AND THE BOTTOM PORTION IS BLACK. THE LETTER "O" IS ALSO STYLIZED, CONSISTING OF A THICK, WHITE OUTER BORDER, WITH THE INTERIOR EDGE OF THE WHITE BORDER A DARK BLUE. THE INTERNAL OF THE LETTER "O" IS COLORED BLUE, WITH A LIGHTER SHADE OF BLUE ON THE TOP HALF AND A DARKER SHADE OF BLUE ON THE BOTTOM HALF. THE INTERNAL OF THE LETTER "O" ALSO CONSISTS OF A TRIANGULAR IMAGE WITH A WHITE DOT AT EACH TERMINAL OF THE IMAGE AND INWARD ARCHING LINES CONNECTING THE DOTS. THE TOPMOST DOT OF THE IMAGE IS SURROUNDED BY THREE CONCENTRIC CIRCLES, WITH THE INNERMOST CIRCLE BEING THE SMALLEST, THE MIDDLE CIRCLE BEING THE SECOND LARGEST, AND THE OUTERMOST CIRCLE BEING THE LARGEST. THE IMAGE IN THE LETTER "O" IS CENTERED WITHIN THE INTERNAL OF THE LETTER, TAKING INTO ACCOUNT THE IMAGE AS A WHOLE. FOLLOWING THE LETTERS "M", "O", "B", "I", "L", AND "E", ARE THE LETTERS "S", "T", "A", AND "R", WHICH ARE CAPITALIZED BLOCK LETTERS THAT ARE SMALLER IN SCALE TO THE PRECEDING LETTERS. ALL OF THE LETTERS ("M O B I L E S T A" AND "R") ARE UNDERSHADED SO AS TO APPEAR THREE-Dimensionally OFF THE PAGE. THREE BLUE OVAL RINGS, ORIGINATING FROM THE LETTER "O", STRETCH ACROSS THE MARK, WITH THE INNERMOST RING EXTENDING TO THE LETTER "S"; THE SECOND RING EXTENDING TO THE LETTER "A"; AND THE LAST RING EXTENDING SLIGHTLY PAST THE LAST LETTER OF THE MARK, OR THE LETTER "R". AT THEIR ORIGIN, ALL RINGS ARE THIN IN DIAMETER, BUT INCREASE HORIZONTALLY IN DIAMETER AS EACH RING EXTENDS TO THE RIGHT OF THE MARK.

### CLASS 35—ADVERTISING AND BUSINESS

FOR COMMERCIAL AND INDUSTRIAL MONITORING SERVICES, NAMELY, TRACKING, LOCATING AND MONITORING THE GEOGRAPHIC LOCATION OF VEHICLES, MACHINERY, ELECTRONIC EQUIPMENT AND ENGINES (U.S. CLS. 100, 101 AND 102).  
FIRST USE 1-1-2008; IN COMMERCE 1-1-2008.

### CLASS 42—SCIENTIFIC AND COMPUTER SERVICES

FOR COMPUTER SERVICES, NAMELY, ELECTRONICALLY GATHERING, ANALYZING AND FORMATTING DATA TO TRACK, LOCATE, MONITOR AND LOG OPERATIONS AND PERFORMANCE OF ELECTRONIC EQUIPMENT AND ENGINE FUNCTIONS FOR COMMERCIAL AND INDUSTRIAL PURPOSES (U.S. CLS. 100 AND 101).  
FIRST USE 1-1-2008; IN COMMERCE 1-1-2008.

THE MARK CONSISTS OF STANDARD CHARACTERS WITHOUT CLAIM TO ANY PARTICULAR FONT, STYLE, SIZE, OR COLOR.

OWNER OF U.S. REG. NO. 2,738,117.

NO CLAIM IS MADE TO THE EXCLUSIVE RIGHT TO USE "FUND SERVICES", APART FROM THE MARK AS SHOWN.

### CLASS 35—ADVERTISING AND BUSINESS

FOR MAINTAINING RECORDS OF INVESTMENTS, ACCOUNT BALANCES AND TRANSACTIONS; FUND ACCOUNTING SERVICES; AND COMPLIANCE SERVICES RELATING TO INVESTMENTS, NAMELY, ACCOUNTING, RECORD KEEPING, AND REGULATORY REPORTING OF INFORMATION RELATING TO INVESTMENTS (U.S. CLS. 100, 101 AND 102).  
FIRST USE 11-1-2008; IN COMMERCE 11-1-2008.

### CLASS 36—INSURANCE AND FINANCIAL

FOR INVESTMENT VALUATION SERVICES (U.S. CLS. 100, 101 AND 102).  
FIRST USE 11-1-2008; IN COMMERCE 11-1-2008.

3,962,222. ALLIANT TECHSYSTEMS INC., MINNEAPOLIS, MN. SN 77-590,522. PUB. 7-6-2010, FILED 10-10-2008.

# NITREX

THE MARK CONSISTS OF STANDARD CHARACTERS WITHOUT CLAIM TO ANY PARTICULAR FONT, STYLE, SIZE, OR COLOR.

### CLASS 9—ELECTRICAL AND SCIENTIFIC APPARATUS

FOR FIREARM OPTICS ACCESSORIES FOR GUN AND RIFLE SCOPES, NAMELY, A LENS DISPLAY PROTECTOR TO PROVIDE SHADE FROM SUNLIGHT (U.S. CLS. 21, 23, 26, 36 AND 38).  
FIRST USE 11-0-2007; IN COMMERCE 4-0-2008.

### CLASS 21—HOUSEWARES AND GLASS

FOR FIREARM OPTIC ACCESSORIES FOR GUN AND RIFLE SCOPES, NAMELY, ANTI-FOG CLEANING CLOTHS, LENS CLEANING PEN (U.S. CLS. 2, 13, 23, 29, 30, 33, 40 AND 50).  
FIRST USE 11-0-2007; IN COMMERCE 4-0-2008.

3,962,224. KIWI SPORT PRE SCHOOL LIMITED, MANUKAU, AUCKLAND, NEW ZEALAND. SN 77-594,625. PUB. 11-23-2010, FILED 10-16-2008.

## KIWICARE

THE MARK CONSISTS OF STANDARD CHARACTERS WITHOUT CLAIM TO ANY PARTICULAR FONT, STYLE, SIZE, OR COLOR.

PRIORITY CLAIMED UNDER SEC. 44(D) ON NEW ZEALAND APPLICATION NO. 797693, FILED 10-16-2008, REG. NO. 797693, DATED 10-16-2008, EXPIRES 10-16-2018.

OWNER OF NEW ZEALAND REG. NO. 640242, DATED 6-22-2001, RENEWED AS REG. NO. 640242, DATED 6-22-2008, EXPIRES 6-22-2018.

### CLASS 35—ADVERTISING AND BUSINESS

FOR (BASED ON 44(E)) ASSISTANCE, ADVISORY SERVICES AND CONSULTANCY WITH REGARD TO BUSINESS PLANNING, BUSINESS ANALYSIS, BUSINESS MANAGEMENT, AND BUSINESS ORGANIZATION (U.S. CLS. 100, 101 AND 102).

### CLASS 41—EDUCATION AND ENTERTAINMENT

FOR (BASED ON USE IN COMMERCE) AND (BASED ON 44(E)) CHILDREN'S EDUCATIONAL SERVICES, NAMELY, PROVIDING ACADEMIC PERFORMANCE EVALUATION, GUIDANCE AND MONITORING FOR CHILDREN PRE-KINDERGARTEN THROUGH GRADE 12 VIA THE INTERNET (U.S. CLS. 100, 101 AND 107).

FIRST USE 6-22-2001; IN COMMERCE 6-22-2009.

### CLASS 43—HOTEL AND RESTAURANT SERVICES

FOR (BASED ON 44(E)) CHILD CARE SERVICES (U.S. CLS. 100 AND 101).

3,962,226. CREATURE CONTROL, LLC, FORMERLY ADVANCED CREATURE CONTROL, GREGORY, MI. SN 77-597,464. PUB. 11-10-2009, FILED 10-21-2008.



NO CLAIM IS MADE TO THE EXCLUSIVE RIGHT TO USE "CREATURE CONTROL", APART FROM THE MARK AS SHOWN.

THE MARK CONSISTS OF THE WORDING "CREATURE CONTROL" WITH A SMALL MAMMAL SLIGHTLY OVERLAPPING THE LAST LETTER OF THE WORD "CONTROL".

### CLASS 37—CONSTRUCTION AND REPAIR

FOR BUILDING CONSTRUCTION, REMODELING AND REPAIR; FUMIGATING; INSECTICIDE SPRAYING; PEST CONTROL AND EXTERMINATION OTHER THAN FOR AGRICULTURAL PURPOSES (U.S. CLS. 100, 103 AND 106).

FIRST USE 9-1-2007; IN COMMERCE 3-8-2011.

### CLASS 39—TRANSPORTATION AND STORAGE

FOR ANIMAL REMOVAL SERVICES (U.S. CLS. 100 AND 105).

FIRST USE 9-1-2007; IN COMMERCE 3-8-2011.

3,962,227. COMFORT LIFE PRODUCTS, LLC, GIG HARBOR, WA. SN 77-602,175. PUB. 6-23-2009, FILED 10-28-2008.

## SUPPLE SPINE

THE MARK CONSISTS OF STANDARD CHARACTERS WITHOUT CLAIM TO ANY PARTICULAR FONT, STYLE, SIZE, OR COLOR.

NO CLAIM IS MADE TO THE EXCLUSIVE RIGHT TO USE "SPINE", APART FROM THE MARK AS SHOWN.

### CLASS 10—MEDICAL APPARATUS

FOR APPARATUS FOR PHYSICAL TRAINING FOR MEDICAL USE (U.S. CLS. 26, 39 AND 44).

FIRST USE 10-0-2010; IN COMMERCE 10-0-2010.

### CLASS 28—TOYS AND SPORTING GOODS

FOR MANUALLY-OPERATED EXERCISE EQUIPMENT, NAMELY, APPARATUS USED FOR THE SPINE (U.S. CLS. 22, 23, 38 AND 50).

FIRST USE 10-0-2010; IN COMMERCE 10-0-2010.

3,962,231. QUALMAN, ERIK, CAMBRIDGE, MA. SN 77-621,080. PUB. 8-4-2009, FILED 11-24-2008.

## Socialnomics

THE MARK CONSISTS OF STANDARD CHARACTERS WITHOUT CLAIM TO ANY PARTICULAR FONT, STYLE, SIZE, OR COLOR.

### CLASS 9—ELECTRICAL AND SCIENTIFIC APPARATUS

FOR DOWNLOADABLE MP3 FILES, MP3 RECORDINGS, ON-LINE DISCUSSION BOARDS, WEBCASTS AND PODCASTS FEATURING MUSIC, AUDIO BOOKS AND NEWS BROADCASTS (U.S. CLS. 21, 23, 26, 36 AND 38).

FIRST USE 9-1-2009; IN COMMERCE 9-1-2009.

### CLASS 16—PAPER GOODS AND PRINTED MATTER

FOR PUBLICATIONS, NAMELY, BOOKS, WHITE-PAPERS, RESEARCH PAPERS IN THE FIELDS OF BUSINESS, SOCIAL MEDIA, ONLINE MEDIA, INTERNET (U.S. CLS. 2, 5, 22, 23, 29, 37, 38 AND 50).

FIRST USE 9-1-2009; IN COMMERCE 9-1-2009.

3,962,236. GREENCORE COMPOSITES INC., TORONTO, CANADA. SN 77-623,153. PUB. 11-3-2009, FILED 11-28-2008.

# NCELL

THE MARK CONSISTS OF STANDARD CHARACTERS WITHOUT CLAIM TO ANY PARTICULAR FONT, STYLE, SIZE, OR COLOR.

## CLASS 1—CHEMICALS

FOR GENERAL PURPOSE THERMOPLASTIC RESINS CONTAINING NATURAL FIBER FOR USE IN THE MANUFACTURE OF AUTOMATION PARTS, AUTOMOTIVE PARTS, AEROSPACE PARTS, AEROSPACE STRUCTURAL BODIES, FURNITURE, CONSTRUCTION SUPPLIES, THERMOSETS, INSTRUMENT HOUSINGS, COMMUNICATION DEVICE HOUSINGS, CIRCUIT BOARDS, TELEPHONES, CLOCK RADIOS, TUBS AND CONTAINERS, SPORTING EQUIPMENT, HOUSEHOLD APPLIANCES, TOYS AND TOOL HANDLES (U.S. CLS. 1, 5, 6, 10, 26 AND 46).

FIRST USE 7-31-2008; IN COMMERCE 7-31-2008.

## CLASS 17—RUBBER GOODS

FOR A GENERAL PURPOSE FIBER/THERMOPLASTIC MATERIAL IN PELLET FORM FOR USE IN THE FURTHER MANUFACTURE OF AUTOMATION PARTS, AUTOMOTIVE PARTS, AEROSPACE PARTS, AEROSPACE STRUCTURAL BODIES, FURNITURE, CONSTRUCTION SUPPLIES, THERMOSETS, INSTRUMENT HOUSINGS, COMMUNICATION DEVICE HOUSINGS, CIRCUIT BOARDS, TELEPHONES, CLOCK RADIOS, TUBS AND CONTAINERS, SPORTING EQUIPMENT, HOUSEHOLD APPLIANCES, TOYS AND TOOL HANDLES (U.S. CLS. 1, 5, 12, 13, 35 AND 50).

FIRST USE 7-31-2008; IN COMMERCE 7-31-2008.

3,962,238. MASCHINENBAU KITZ GMBH, 53844 TROIS-DORF, FED REP GERMANY. SN 77-624,437. PUB. 6-8-2010, FILED 12-2-2008.



OWNER OF U.S. REG. NO. 2,852,272.

NO CLAIM IS MADE TO THE EXCLUSIVE RIGHT TO USE "TECHNOLOGY GROUP", APART FROM THE MARK AS SHOWN.

THE MARK CONSISTS OF THE LETTERS "MK TECHNOLOGY GROUP".

## CLASS 6—METAL GOODS

FOR BUILDING MATERIALS OF METAL, NAMELY, TUBES AND PROFILES; METAL JUNCTIONS FOR PIPES; METAL JUNCTIONS FOR PROFILES; METAL INTERIOR WALL PARTITIONS; WIRE FENCES AND METAL FENCE POSTS LATTICES; METAL BUILDING MATERIALS IN THE NATURE OF PROTECTIVE COVER AND LINING ELEMENTS OF METAL, NAMELY, ALUMINUM SHEETS, STEEL SHEETS, METAL FOIL, BARRIER GRIDS, ALUMINUM AND STEEL WIRE SCREENS, FOLDING DOORS, VERTICAL LIFT DOORS, AND SLIDING DOORS; METAL MANIFOLDS FOR PIPES AND PROFILES; METAL COLLARS FOR FASTENING PIPES; METAL BALL JOINTS FOR PROFILES AND SOCKETS FOR PIPES AND PROFILES; METAL SHIMS FOR PIPES AND PROFILES; METAL JOINT SHIMS; METAL ANGLE SHIMS; METAL CROSS SHIMS; METAL PLATES FOR FURTHER MANUFACTURE; METAL SUPPORT LEGS FOR METAL FRAMES; METAL STAIRCASES, HANDRAILS AND SCAFFOLD PLATFORMS MADE OF METAL; METAL CONSTRUCTION ELEMENTS FOR THE MANUFACTURING OF MACHINE PARTS FOR FURTHER MANUFACTURE, NAMELY, CONSTRUCTION PROFILES OF ALUMINUM, COVER AND BORDER PROFILES, JOINT PLATES, JOINT LATCHES, SPECIALITY SCREWS OF STEEL, T-JOINT AND JOINT PLATES OF ALUMINUM; METAL MOUNTING RAILS AND CORRESPONDING FITTING MATERIALS OF METAL, NAMELY, BRACKETS, FLANGES, SCREWS, RING SCREWS, NUTS, PINS, WASHERS, SLEEVES, CLAMPS, SUPPORTING ANGLE PIECES, CONNECTING PIECES FOR PROFILES, FASTENERS, BOLTS, ANCHORS, DOWELS, LATCHES, SOCKETS FOR PROFILES, T-SLOT LATCHES, HINGES, LOCKS, DOOR STOPS, ROLLERS FOR PALLET RUN-OUTS OF CONVEYOR PLANTS; METAL COUPLINGS AND METAL PIPE CONNECTORS FOR PRESSURIZED AIR AND FLUIDS; METAL CABLE CLAMPS AND METAL CABLEWAYS; PORTABLE METAL BUILDINGS (U.S. CLS. 2, 12, 13, 14, 23, 25 AND 50).

FIRST USE 1-27-2011; IN COMMERCE 1-27-2011.

## CLASS 7—MACHINERY

FOR MACHINES, NAMELY, DIE STAMPING MACHINES, DRILLING MACHINES, MILLING MACHINES FOR THE PLASTICS INDUSTRY AND THE AUTOMOTIVE INDUSTRY; DIE CUTTING MACHINES; CONE-BELT CONVEYORS, BELT CONVEYORS, ROUND-BELT CONVEYORS, CHAIN CONVEYORS AND BELTS FOR CONVEYORS; ROLLER CONVEYORS, ANGLE TRANSPOSERS FOR CONVEYOR MECHANISMS; MACHINE PARTS FOR THE MANUFACTURING OF CONVEYORS, NAMELY, CARRIAGES WITH ROLLERS MOVEABLE ON PROFILES FOR LINEAR MOTION, GUIDE CRADLES FOR TRADES; MACHINE PARTS, NAMELY, HYDRAULIC, PNEUMATIC AND ELECTRIC DRIVES FOR FOLDING, VERTICAL LIFT AND SLIDING DOORS; PARTS OF MACHINES, NAMELY, HANDWHEELS MADE OF PLASTIC FOR SPINDLES; STANDS OF METAL FOR MACHINES (U.S. CLS. 13, 19, 21, 23, 31, 34 AND 35).

FIRST USE 1-27-2011; IN COMMERCE 1-27-2011.

## CLASS 17—RUBBER GOODS

FOR GENERAL PURPOSE SHOCK ABSORBING RUBBER BUFFERS FOR USES ON MACHINERY; NON-METAL JUNCTIONS FOR METAL PIPES AND METAL PROFILES (U.S. CLS. 1, 5, 12, 13, 35 AND 50).

FIRST USE 1-27-2011; IN COMMERCE 1-27-2011.

## CLASS 19—NON-METALLIC BUILDING MATERIALS

FOR NON-METAL BUILDING MATERIALS, NAMELY, PROFILES, SEALING AND LOCKING PROFILES, SLIDING PROFILES, PROFILES MADE OF FOAM AND PROFILES FILLED WITH FOAM; NON-METAL BUILDING MATERIALS, NAMELY, PLATES FOR FACADE AND WALL CLADDING; PLASTIC COVERS AND END CAPS FOR NON-METAL PROFILES FOR USE AS A BUILDING MATERIAL (U.S. CLS. 1, 12, 33 AND 50).

FIRST USE 1-27-2011; IN COMMERCE 1-27-2011.



**CLASS 20—FURNITURE AND ARTICLES NOT OTHERWISE CLASSIFIED**

FOR ROTARY TABLES; NON-METAL SHIMS AND JOINT SHIMS FOR METAL PIPES AND METAL PROFILES; TABLE FOR MACHINES; FURNITURE, DESKS, OFFICE FURNITURE, INDUSTRIAL WORKPLACE FURNITURE; RACKS, NAMELY, DISPLAY RACKS, STORAGE RACKS, MAGAZINE RACKS; PLASTIC DOOR HANDLES; FURNITURE FOR INDUSTRIAL WORKSTATIONS WITH MATERIAL ASSEMBLING; FURNITURE CASTERS MADE OF NON-METAL PLASTICS, GLASS OR WOOD; NON-METAL SHIMS AND JOINT SHIMS FOR PIPES AND PROFILES (U.S. CLS. 2, 13, 22, 25, 32 AND 50).

FIRST USE 1-27-2011; IN COMMERCE 1-27-2011.

**CLASS 37—CONSTRUCTION AND REPAIR**

FOR REPAIR AND MAINTENANCE OF CONVEYOR PLANTS AND EQUIPMENT, NAMELY, CONVEYORS, LINEAR MOTION CARRIAGES, PNEUMATICS, ENCLOSURES, WORKSTATIONS, AND MACHINERY (U.S. CLS. 100, 103 AND 106).

FIRST USE 1-27-2011; IN COMMERCE 1-27-2011.

**CLASS 40—MATERIAL TREATMENT**

FOR METAL TREATING (U.S. CLS. 100, 103 AND 106).

FIRST USE 1-27-2011; IN COMMERCE 1-27-2011.

**CLASS 42—SCIENTIFIC AND COMPUTER SERVICES**

FOR ENGINEERING AND PRODUCT DEVELOPMENT FOR OTHERS IN THE FIELD OF MECHANICAL CONVEYANCING AND HANDLING AND MACHINE CONSTRUCTION; COMPUTER PROGRAMMING FOR OTHERS (U.S. CLS. 100 AND 101).

FIRST USE 1-27-2011; IN COMMERCE 1-27-2011.

3,962,241. BUSINESS PARTNER FRANCHISING, LLC, SOUTHURY, CT. SN 77-631,236. PUB. 9-8-2009, FILED 12-11-2008.



OWNER OF U.S. REG. NOS. 3,429,422 AND 3,544,990.  
NO CLAIM IS MADE TO THE EXCLUSIVE RIGHT TO USE "BUSINESS PARTNER MARKETING COACH", APART FROM THE MARK AS SHOWN.

THE MARK CONSISTS OF A COMBINED LOWER CASE "B" AND "P" OUTLINED IN A RECTANGLE HAVING ROUNDED CORNERS WITH THE LITERAL ELEMENTS "BUSINESS PARTNER MARKETING COACH" ON THE RIGHT SIDE OF THE RECTANGLE.

**CLASS 35—ADVERTISING AND BUSINESS**

FOR BUSINESS MARKETING SERVICES; BUSINESS MARKETING CONSULTING SERVICES; DISTRIBUTORSHIPS IN THE FIELD OF PROMOTIONAL PRODUCTS AND SPECIALTY ADVERTISING GOODS FOR OTHERS; FRANCHISING SERVICES, NAMELY, CONSULTATION AND ASSISTANCE IN BUSINESS MANAGEMENT, ORGANIZATION AND PROMOTION; OPERATION OF A BUSINESS FOR OTHERS, NAMELY, COPYING AND PRINTING CENTERS; COPYING DOCUMENTS FOR OTHERS; PRODUCTION OF TELEVISION COMMERCIALS (U.S. CLS. 100, 101 AND 102).

FIRST USE 3-7-2011; IN COMMERCE 3-7-2011.

**CLASS 40—MATERIAL TREATMENT**

FOR EMBROIDERY AND SCREEN PRINTING OF CLOTHING FOR OTHERS; MANUFACTURING OF SIGNS AND BANNERS FOR OTHERS; MANUFACTURING OF TRADE SHOW DISPLAYS FOR OTHERS; MANUFACTURING OF PROMOTIONAL PRODUCTS AND SPECIALTY ADVERTISING GOODS FOR OTHERS (U.S. CLS. 100, 103 AND 106).

FIRST USE 3-7-2011; IN COMMERCE 3-7-2011.

**CLASS 41—EDUCATION AND ENTERTAINMENT**

FOR BUSINESS COACHING SERVICES, NAMELY, TRAINING IN THE FIELD OF BUSINESS DEVELOPMENT; BUSINESS COACHING SERVICES, NAMELY, TRAINING IN THE FIELD OF FRANCHISING AND SEARCHING FOR AND SELECTION OF FRANCHISE OPPORTUNITIES; PRODUCTION OF VIDEO CASSETTES AND VIDEO DISCS FOR OTHERS (U.S. CLS. 100, 101 AND 107).

FIRST USE 3-7-2011; IN COMMERCE 3-7-2011.

**CLASS 42—SCIENTIFIC AND COMPUTER SERVICES**

FOR GRAPHIC DESIGN SERVICES; CREATING AND DESIGNING WEB SITES FOR OTHERS; DESIGN AND DEVELOPMENT OF MULTI-MEDIA PRODUCTS; DESIGN OF MULTI-MEDIA OF MULTI-MEDIA PRODUCTS (U.S. CLS. 100 AND 101).

FIRST USE 3-7-2011; IN COMMERCE 3-7-2011.

3,962,243. AVG TECHNOLOGIES CZ, S.R.O., BRNO, CZECH REPUBLIC. SN 77-632,865. PUB. 6-2-2009, FILED 12-15-2008.

**AVG IDENTITY PROTECTION**

THE MARK CONSISTS OF STANDARD CHARACTERS WITHOUT CLAIM TO ANY PARTICULAR FONT, STYLE, SIZE, OR COLOR.

OWNER OF U.S. REG. NO. 3,122,712.

NO CLAIM IS MADE TO THE EXCLUSIVE RIGHT TO USE "IDENTITY PROTECTION", APART FROM THE MARK AS SHOWN.

**CLASS 9—ELECTRICAL AND SCIENTIFIC APPARATUS**

FOR COMPUTER SOFTWARE AND PROGRAMS FOR SECURITY PROTECTION AND ANTI-VIRUS PROTECTION, IN THE FIELD OF COMPUTERS; ELECTRONIC, MAGNETIC AND OPTICAL MEDIA, NAMELY, CDS AND DVDS CONTAINING INFORMATION FOR SECURITY AND ANTI-VIRUS PROTECTION; MULTI-MEDIA SOFTWARE RECORDED ON CD-ROMS FEATURING INFORMATION ON SECURITY AND ANTI-VIRUS PROTECTION (U.S. CLS. 21, 23, 26, 36 AND 38).

FIRST USE 3-2-2009; IN COMMERCE 3-2-2009.



**CLASS 42—SCIENTIFIC AND COMPUTER SERVICES**

FOR PRODUCT DEVELOPMENT, NAMELY, DEVELOPMENT OF SOFTWARE PROGRAMS FOR OTHERS; CONSULTANCY SERVICES IN THE FIELDS OF COMPUTER SOFTWARE AND HARDWARE, COMPUTER HARDWARE AND SOFTWARE INSTALLATIONS, UPDATING SOFTWARE, COMPUTER HARDWARE AND SOFTWARE LEASING, CONSULTANCY SERVICES IN THE FIELDS OF COPYING DATA, RENEWAL AND RESTORATION OF COMPUTER SOFTWARE, REGENERATION OF COMPUTER DATA AND SOFTWARE, AND COMPUTER SYSTEM ANALYSIS; CONSULTANCY SERVICES IN THE FIELDS OF TRANSFERRING DATA OR DOCUMENTS FROM PHYSICAL MEDIA TO ELECTRONIC MEDIA, CONVERSIONS OF COMPUTER DATA AND PROGRAMS, AND LEASING OF COMPUTERS; CONSULTANCY IN THE FIELD OF COMPUTER HARDWARE; MAINTENANCE OF COMPUTER SOFTWARE (U.S. CLS. 100 AND 101).

FIRST USE 3-2-2009; IN COMMERCE 3-2-2009.

3,962,246. BAMBOOSERO, LLC, LA SELVA BEACH, CA. SN 77-635,497. PUB. 7-27-2010, FILED 12-17-2008.

**BAMBOOSERO**

THE MARK CONSISTS OF STANDARD CHARACTERS WITHOUT CLAIM TO ANY PARTICULAR FONT, STYLE, SIZE, OR COLOR.

THE WORDING "BAMBOOSERO" HAS NO MEANING IN A FOREIGN LANGUAGE.

**CLASS 12—VEHICLES**

FOR GOODS MADE IN WHOLE OR SUBSTANTIAL PART FROM BAMBOO, NAMELY, BICYCLE FRAMES (U.S. CLS. 19, 21, 23, 31, 35 AND 44).

FIRST USE 3-0-2008; IN COMMERCE 3-0-2008.

**CLASS 25—CLOTHING**

FOR CLOTHING, NAMELY, SHIRTS (U.S. CLS. 22 AND 39).

FIRST USE 8-0-2008; IN COMMERCE 8-0-2008.

3,962,250. CONKLIN, GREGORY J., SEBASTOPOL, CA. SN 77-639,053. PUB. 12-29-2009, FILED 12-23-2008.

**Patient Terrier**

THE MARK CONSISTS OF STANDARD CHARACTERS WITHOUT CLAIM TO ANY PARTICULAR FONT, STYLE, SIZE, OR COLOR.

**CLASS 31—NATURAL AGRICULTURAL PRODUCTS**

FOR FRESH WINE GRAPES (U.S. CLS. 1 AND 46).

FIRST USE 8-4-2008; IN COMMERCE 10-1-2008.

**CLASS 33—WINES AND SPIRITS**

FOR GRAPE WINE; NATURAL SPARKLING WINES; PORT WINES; RED WINE; RED WINES; SPARKLING FRUIT WINE; SPARKLING GRAPE WINE; SPARKLING WINES; SWEET WINES; TABLE WINES; WHITE WINE; WINES; WINES AND FORTIFIED WINES; WINES AND LIQUEURS; WINES AND SPARKLING WINES (U.S. CLS. 47 AND 49).

FIRST USE 5-1-2009; IN COMMERCE 5-1-2009.

3,962,253. CARNIVAL CORPORATION, MIAMI, FL. SN 77-645,226. PUB. 11-24-2009, FILED 1-7-2009.

**FUNVILLE**

THE MARK CONSISTS OF STANDARD CHARACTERS WITHOUT CLAIM TO ANY PARTICULAR FONT, STYLE, SIZE, OR COLOR.

**CLASS 39—TRANSPORTATION AND STORAGE**

FOR CRUISE SHIP SERVICES; TRAVEL AGENCY SERVICES, NAMELY, MAKING RESERVATIONS AND BOOKINGS FOR TRANSPORTATION; ARRANGING TRAVEL TOURS (U.S. CLS. 100 AND 105).

FIRST USE 12-31-2009; IN COMMERCE 12-31-2009.

**CLASS 41—EDUCATION AND ENTERTAINMENT**

FOR ENTERTAINMENT SERVICES, NAMELY, ORGANIZING AND CONDUCTING SPORTING EVENTS IN THE NATURE OF CARD GAMES, CONTESTS IN THE NATURE OF SCAVENGER HUNTS, DANCE CONTESTS, PARTIES, AND VIDEO GAME COMPETITIONS FOR CHILDREN OF ALL AGES; DISCOTHEQUES; ENTERTAINMENT IN THE NATURE OF DANCE PERFORMANCES; ENTERTAINMENT IN THE NATURE OF WATER SLIDE RIDES; PROVIDING FACILITIES FOR RECREATION ACTIVITIES; PROVIDING AMUSEMENT FACILITIES (U.S. CLS. 100, 101 AND 107).

FIRST USE 12-31-2009; IN COMMERCE 12-31-2009.

3,962,254. BLOUNT, INC., PORTLAND, OR. SN 77-649,468. PUB. 10-6-2009, FILED 1-14-2009.

**POWERSHARP**

THE MARK CONSISTS OF STANDARD CHARACTERS WITHOUT CLAIM TO ANY PARTICULAR FONT, STYLE, SIZE, OR COLOR.

**CLASS 7—MACHINERY**

FOR SAW CHAIN AND GUIDE BARS FOR CHAIN SAWS (U.S. CLS. 13, 19, 21, 23, 31, 34 AND 35).

FIRST USE 5-0-2010; IN COMMERCE 5-0-2010.

**CLASS 8—HAND TOOLS**

FOR HAND TOOLS, NAMELY, SAW CHAIN SHARPENING STONES FOR CHAIN SAWS (U.S. CLS. 23, 28 AND 44).

FIRST USE 5-0-2010; IN COMMERCE 5-0-2010.

3,962,259. AUTOSALES, INCORPORATED, TALLMADGE, OH. SN 77-654,094. PUB. 12-8-2009, FILED 1-22-2009.



OWNER OF U.S. REG. NOS. 1,741,692, 2,528,907, AND OTHERS.

NO CLAIM IS MADE TO THE EXCLUSIVE RIGHT TO USE "RACING EQUIPMENT", APART FROM THE MARK AS SHOWN.

THE MARK CONSISTS OF THE WORDS "RACING EQUIPMENT" UNDERNEATH THE WORD "SUMMIT".

**CLASS 9—ELECTRICAL AND SCIENTIFIC APPARATUS**

FOR EDUCATION AND ENTERTAINMENT VIDEOS RELATED TO AUTOMOTIVE PRODUCTS AND INSTALLATIONS, FEATURE VEHICLES, AND EVENTS (U.S. CLS. 21, 23, 26, 36 AND 38).

FIRST USE 7-29-2009; IN COMMERCE 7-29-2009.

**CLASS 41—EDUCATION AND ENTERTAINMENT**

FOR EDUCATION AND ENTERTAINMENT SERVICES, NAMELY, PRODUCING AND DISPLAYING ENTERTAINMENT AND EDUCATION VIDEOS ABOUT AUTOMOTIVE PRODUCTS AND THEIR INSTALLATION, FEATURE VEHICLES AND EVENTS VIA A WEBSITE (U.S. CLS. 100, 101 AND 107).

FIRST USE 7-29-2009; IN COMMERCE 7-29-2009.

3,962,260. AUTOSALES, INCORPORATED, TALLMADGE, OH. SN 77-654,109. PUB. 12-8-2009, FILED 1-22-2009.

**TRICK FLOW**

THE MARK CONSISTS OF STANDARD CHARACTERS WITHOUT CLAIM TO ANY PARTICULAR FONT, STYLE, SIZE, OR COLOR.

OWNER OF U.S. REG. NOS. 1,887,752, 2,681,311, AND OTHERS.

**CLASS 9—ELECTRICAL AND SCIENTIFIC APPARATUS**

FOR EDUCATION AND ENTERTAINMENT VIDEOS RELATED TO AUTOMOTIVE PRODUCTS AND INSTALLATIONS, FEATURE VEHICLES, EVENTS (U.S. CLS. 21, 23, 26, 36 AND 38).

FIRST USE 7-29-2009; IN COMMERCE 7-29-2009.

**CLASS 41—EDUCATION AND ENTERTAINMENT**

FOR EDUCATION AND ENTERTAINMENT SERVICES, NAMELY, PRODUCING AND DISPLAYING ENTERTAINMENT AND EDUCATION VIDEOS ABOUT AUTOMOTIVE PRODUCTS AND THEIR INSTALLATION, FEATURE VEHICLES AND EVENTS VIA A WEBSITE (U.S. CLS. 100, 101 AND 107).

FIRST USE 7-29-2009; IN COMMERCE 7-29-2009.

3,962,261. IMPORT EXPORT INTERNATIONAL, WATERFORD, MI. SN 77-654,348. PUB. 5-5-2009, FILED 1-22-2009.

**ALWALI**

THE MARK CONSISTS OF STANDARD CHARACTERS WITHOUT CLAIM TO ANY PARTICULAR FONT, STYLE, SIZE, OR COLOR.

**CLASS 29—MEATS AND PROCESSED FOODS**

FOR PICKLES; CANNED FRUITS AND VEGETABLES; GLAZED FRUITS; FRUITS PASTE; ROASTED NUTS; JELLIES, JAMS; SESAME PASTE; MEAT; POTATO CHIPS; PROCESSED BEANS; HUMMUS CHICK PEA PASTE; FROZEN VEGETABLES; TAHINI; OLIVE OILS; PROCESSED OLIVES; PROCESSED NUTS (U.S. CL. 46).

FIRST USE 1-22-2009; IN COMMERCE 1-22-2009.

**CLASS 30—STAPLE FOODS**

FOR PROCESSED GRAINS; SPICES; SALAD DRESSING; TORTILLA CHIPS; COFFEE; CANDY; PROCESSED CEREALS; TEA; MUSTARD; KETCHUP; MAYONNAISE; COOKIES; VINEGAR; SAUCES; HONEY (U.S. CL. 46).

FIRST USE 1-22-2009; IN COMMERCE 1-22-2009.

3,962,266. THE INSTITUTE OF ELECTRICAL AND ELECTRONICS ENGINEERS, INC., AKA IEEE, PISCATAWAY, NJ. SN 77-658,631. PUB. 6-23-2009, FILED 1-28-2009.



OWNER OF U.S. REG. NOS. 773,206, 1,770,511, AND OTHERS.

NO CLAIM IS MADE TO THE EXCLUSIVE RIGHT TO USE "TECHNOLOGY MANAGEMENT", APART FROM

THE MARK AS SHOWN.

THE MARK CONSISTS OF THE LETTERS "IEEE" APPEARING WITHIN THE DESIGN OF A GLOBE COMPRISED OF LATITUDINAL AND LONGITUDINAL LINES. THE GLOBE IS SURROUNDED BY THE WORDS "TECHNOLOGY MANAGEMENT" CONTAINED WITHIN A SEMI-CIRCLE SHAPED LIKE THE LETTER "C". SMALL DIAMOND SHAPES APPEAR ON EITHER SIDE OF THE LETTERS "IEEE".

#### **CLASS 16—PAPER GOODS AND PRINTED MATTER**

FOR PUBLICATIONS, NAMELY, MAGAZINES AND JOURNALS IN THE FIELDS OF MANAGEMENT THEORY AND PRACTICE FOR THE TECHNOLOGY PROFESSION (U.S. CLS. 2, 5, 22, 23, 29, 37, 38 AND 50).

FIRST USE 3-1-2009; IN COMMERCE 3-1-2009.

#### **CLASS 41—EDUCATION AND ENTERTAINMENT**

FOR EDUCATIONAL SERVICES, NAMELY, CONDUCTING CONFERENCES, SEMINARS AND WORKSHOPS IN THE FIELD OF MANAGEMENT THEORY AND PRACTICE FOR THE TECHNOLOGY PROFESSION AND DISTRIBUTION OF COURSE MATERIAL IN CONNECTION THEREWITH (U.S. CLS. 100, 101 AND 107).

FIRST USE 3-10-2011; IN COMMERCE 3-10-2011.

---

3,962,268. MOLON LAVE, LLC, CHICAGO, IL. SN 77-661,417. PUB. 6-2-2009, FILED 2-2-2009.

## **JAVA BREEZE**

THE MARK CONSISTS OF STANDARD CHARACTERS WITHOUT CLAIM TO ANY PARTICULAR FONT, STYLE, SIZE, OR COLOR.

NO CLAIM IS MADE TO THE EXCLUSIVE RIGHT TO USE "JAVA" FOR INTERNATIONAL CLASS 030, APART FROM THE MARK AS SHOWN.

#### **CLASS 30—STAPLE FOODS**

FOR COFFEE; TEA (U.S. CL. 46).  
FIRST USE 2-1-2010; IN COMMERCE 2-1-2010.

#### **CLASS 39—TRANSPORTATION AND STORAGE**

FOR DISTRIBUTION SERVICES, NAMELY, DELIVERY OF COFFEE AND TEA (U.S. CLS. 100 AND 105).  
FIRST USE 2-1-2010; IN COMMERCE 2-1-2010.

3,962,281. NEURALTUS PHARMACEUTICALS, INC., PALO ALTO, CA. SN 77-667,012. PUB. 9-29-2009, FILED 2-10-2009.

#### **NEURALTUS PHARMACEUTICALS**

THE MARK CONSISTS OF STANDARD CHARACTERS WITHOUT CLAIM TO ANY PARTICULAR FONT, STYLE, SIZE, OR COLOR.

NO CLAIM IS MADE TO THE EXCLUSIVE RIGHT TO USE "PHARMACEUTICALS", APART FROM THE MARK AS SHOWN.

#### **CLASS 5—PHARMACEUTICALS**

FOR PHARMACEUTICAL PREPARATIONS FOR THE PREVENTION AND TREATMENT OF NEURODEGENERATIVE DISEASES AND OTHER NEUROLOGICAL DISORDERS; PHARMACEUTICAL PREPARATIONS FOR THE PREVENTION AND TREATMENT OF LYSOSOMAL STORAGE DISEASES (U.S. CLS. 6, 18, 44, 46, 51 AND 52).

FIRST USE 3-23-2011; IN COMMERCE 3-23-2011.

#### **CLASS 42—SCIENTIFIC AND COMPUTER SERVICES**

FOR PHARMACEUTICAL DRUG RESEARCH AND DEVELOPMENT SERVICES (U.S. CLS. 100 AND 101).  
FIRST USE 6-14-2010; IN COMMERCE 6-14-2010.

---

3,962,282. ULTRA LEARNING SYSTEMS, LLC, PHOENIX, AZ. SN 77-667,128. PUB. 1-5-2010, FILED 2-10-2009.

## **MINDABILITY**

THE MARK CONSISTS OF STANDARD CHARACTERS WITHOUT CLAIM TO ANY PARTICULAR FONT, STYLE, SIZE, OR COLOR.

#### **CLASS 44—MEDICAL, BEAUTY AND AGRICULTURAL SERVICES**

FOR PROVIDING WELLNESS SERVICES, NAMELY, SELF-HELP PERSONAL ASSESSMENTS, PERSONALIZED ROUTINES, AND COUNSELING; PROVIDING ONLINE INFORMATION IN THE FIELD OF LIFESTYLE WELLNESS COUNSELING; PROVIDING COUNSELING IN THE FIELD OF LIFESTYLE WELLNESS (U.S. CLS. 100 AND 101).

FIRST USE 2-15-2009; IN COMMERCE 2-15-2009.

**CLASS 45—PERSONAL AND LEGAL SERVICES**

FOR PROVIDING ON-LINE INFORMATION IN THE FIELD OF SELF-HELP SUBJECT MATTERS; PROVIDING ON-LINE INFORMATION IN THE FIELD OF PERSONAL LIFESTYLE COUNSELING, SELF-HELP, AND PERSONAL EMPOWERMENT SUBJECT MATTERS; PROVIDING INFORMATION IN THE FIELD OF SELF-HELP SUBJECT MATTERS (U.S. CLS. 100 AND 101).

FIRST USE 2-15-2009; IN COMMERCE 2-15-2009.

3,962,293. GANEDEN BIOTECH, INC., MAYFIELD HEIGHTS, OH. SN 77-677,109. PUB. 7-20-2010, FILED 2-24-2009.



OWNER OF U.S. REG. NOS. 2,403,460 AND 3,591,766.

NO CLAIM IS MADE TO THE EXCLUSIVE RIGHT TO USE "PROBIOTIC" AND "DIGESTIVE & IMMUNE HEALTH", APART FROM THE MARK AS SHOWN.

THE MARK CONSISTS OF THE WORDS "GANEDEN BC30 PROBIOTIC" STACKED VERTICALLY IN THE CENTER OF A CIRCLE WITH THE WORDS "POWERED BY" ON THE TOP PORTION OF THE CIRCLE AND THE WORDS "DIGESTIVE & IMMUNE HEALTH" ON THE BOTTOM PORTION OF THE CIRCLE.

**CLASS 1—CHEMICALS**

FOR BACTERIA USED IN THE MANUFACTURE OF FOODS AND NUTRITIONAL SUPPLEMENTS (U.S. CLS. 1, 5, 6, 10, 26 AND 46).

FIRST USE 11-1-2010; IN COMMERCE 11-1-2010.

**CLASS 5—PHARMACEUTICALS**

FOR DIETARY AND NUTRITIONAL SUPPLEMENTS; NEUTRACEUTICALS FOR USE AS A DIETARY SUPPLEMENT (U.S. CLS. 6, 18, 44, 46, 51 AND 52).

FIRST USE 1-1-2009; IN COMMERCE 1-1-2009.

3,962,300. HUMICON LLC, HAUPPAUGE, NY. SN 77-679,369. PUB. 6-23-2009, FILED 2-26-2009.

# Rockchilde

THE MARK CONSISTS OF STANDARD CHARACTERS WITHOUT CLAIM TO ANY PARTICULAR FONT, STYLE,

SIZE, OR COLOR.

**CLASS 16—PAPER GOODS AND PRINTED MATTER**

FOR CIGAR BANDS (U.S. CLS. 2, 5, 22, 23, 29, 37, 38 AND 50).

FIRST USE 4-22-2009; IN COMMERCE 4-22-2009.

**CLASS 34—SMOKERS' ARTICLES**

FOR CIGAR BOXES; CIGARS (U.S. CLS. 2, 8, 9 AND 17).

FIRST USE 4-22-2009; IN COMMERCE 4-22-2009.

3,962,302. MISUMARU USA CORPORATION, FAIRFIELD, CA. SN 77-680,545. PUB. 6-23-2009, FILED 2-27-2009.

# Q2 TECHNOLOGY

THE MARK CONSISTS OF STANDARD CHARACTERS WITHOUT CLAIM TO ANY PARTICULAR FONT, STYLE, SIZE, OR COLOR.

NO CLAIM IS MADE TO THE EXCLUSIVE RIGHT TO USE "TECHNOLOGY", APART FROM THE MARK AS SHOWN.

**CLASS 18—LEATHER GOODS**

FOR MULTI-PURPOSE RESEALABLE BAGS AND CONTAINERS FOR TRAVEL, NAMELY, CLOTHING BAGS, GARMENT BAGS, ATHLETIC BAGS, BEACH BAGS, CARRY-ON BAGS, COSMETIC BAGS SOLD EMPTY, DIAPER BAGS, GYM BAGS, LUGGAGE, SUITCASES, TRAVEL TRUNKS, TRAVEL BAGS AND TOTE BAGS (U.S. CLS. 1, 2, 3, 22 AND 41).

FIRST USE 1-1-2009; IN COMMERCE 1-1-2009.

**CLASS 22—CORDAGE AND FIBERS**

FOR GARMENT BAGS FOR STORAGE; STORAGE BAGS FOR CLOTHING; EVACUATABLE RESEALABLE STORAGE BAG MADE OF NYLON AND POLYETHYLENE WITH A VALVE MADE OF POLYETHYLENE OR NYLON, AND A CLOSURE SYSTEM MADE OF PLASTIC FOR STORAGE OF CLOTHING AND HOUSEHOLD ITEMS (U.S. CLS. 1, 2, 7, 19, 22, 42 AND 50).

FIRST USE 1-1-2009; IN COMMERCE 1-1-2009.

3,962,319. CITATIONSHARES HOLDING LLC, GREENWICH, CT. SN 77-689,580. PUB. 9-7-2010, FILED 3-12-2009.

# CITATIONAIR

THE MARK CONSISTS OF STANDARD CHARACTERS WITHOUT CLAIM TO ANY PARTICULAR FONT, STYLE, SIZE, OR COLOR.

**CLASS 35—ADVERTISING AND BUSINESS**

FOR AIRCRAFT OWNERSHIP AND MANAGEMENT SERVICES, NAMELY, ARRANGING AND COORDINATING THE PURCHASE AND SALE OF AIRCRAFT BY MULTIPLE OWNERS FOR SOLE OR JOINT OWNERSHIP OF THE AIRCRAFT; MANAGING AIRCRAFT OWNERSHIP FOR OTHERS (U.S. CLS. 100, 101 AND 102).

FIRST USE 10-9-2009; IN COMMERCE 10-9-2009.

**CLASS 36—INSURANCE AND FINANCIAL**

FOR FORMATION, BROKERAGE, AND MANAGEMENT OF TIME SHARE INTERESTS IN AIRCRAFT BY MULTIPLE USERS FOR SOLE OR JOINT OWNERSHIP; OFFERING AIRCRAFT FRACTIONAL OWNERSHIP PROGRAMS TO OTHERS (U.S. CLS. 100, 101 AND 102).

FIRST USE 10-9-2009; IN COMMERCE 10-9-2009.

**CLASS 39—TRANSPORTATION AND STORAGE**

FOR RESERVATION AND BOOKING SERVICES OF AIRCRAFT USE FOR TRAVEL (U.S. CLS. 100 AND 105).

FIRST USE 10-9-2009; IN COMMERCE 10-9-2009.

3,962,321. SAFETY INNOVATIONS, LLC, NEW BERLIN, WI. SN 77-690,564. PUB. 8-24-2010, FILED 3-13-2009.



THE COLOR(S) BLACK, WHITE, YELLOW AND GRAY IS/ARE CLAIMED AS A FEATURE OF THE MARK.

THE MARK CONSISTS OF THE WORDS "WORK SAFE" IN WHITE AND OUTLINED IN BLACK. BETWEEN THE TERMS "WORK" AND "SAFE" ARE THE LETTERS "WS" IN BLACK AND ARRANGED VERTICALLY TO FORM AN ARROWHEAD. THE ARROWHEAD IS OUTLINED IN BLACK AND FILLED WITH YELLOW. THE ENTIRE GRAPHIC IS OUTLINED IN GRAY.

**CLASS 6—METAL GOODS**

FOR METAL COMPONENT PARTS FOR FALL PROTECTION SYSTEM, NAMELY, METAL LADDER BRACKETS, METAL GUARD RAILS, METAL GUARD RAIL BRACKETS, METAL CARRIAGES, METAL LADDER RUNG HOOKS, AND METAL GUARD RAIL END STOPS (U.S. CLS. 2, 12, 13, 14, 23, 25 AND 50).

FIRST USE 6-1-2010; IN COMMERCE 6-3-2010.

**CLASS 9—ELECTRICAL AND SCIENTIFIC APPARATUS**

FOR SAFETY EQUIPMENT FOR FALL PROTECTION SOLD AS A UNIT COMPRISED OF METAL LADDER BRACKETS, METAL GUARD RAILS, METAL GUARD RAIL BRACKETS, METAL CARRIAGES, METAL LADDER RUNG HOOKS, METAL GUARD RAIL END STOPS, AND PARTS AND FITTINGS THEREFOR (U.S. CLS. 21, 23, 26, 36 AND 38).

FIRST USE 6-1-2010; IN COMMERCE 6-3-2010.

3,962,327. LEACHCO, INC., ADA, OK. SN 77-696,313. PUB. 7-21-2009, FILED 3-21-2009.

**BELLY BUMPER**

THE MARK CONSISTS OF STANDARD CHARACTERS WITHOUT CLAIM TO ANY PARTICULAR FONT, STYLE, SIZE, OR COLOR.

**CLASS 10—MEDICAL APPARATUS**

FOR BODY PILLOWS FOR THERAPEUTIC AND MEDICAL PURPOSES, THERAPEUTIC BODY PILLOWS FOR PRE AND POST SURGICAL OR MEDICAL CARE, THERAPEUTIC BODY PILLOWS FOR USE BY PREGNANT WOMEN AND NURSING MOTHERS (U.S. CLS. 26, 39 AND 44).

FIRST USE 3-2-2011; IN COMMERCE 3-2-2011.

**CLASS 20—FURNITURE AND ARTICLES NOT OTHERWISE CLASSIFIED**

FOR MATERNITY PILLOWS, BODY PILLOWS (U.S. CLS. 2, 13, 22, 25, 32 AND 50).

FIRST USE 3-2-2011; IN COMMERCE 3-2-2011.

3,962,329. GEVICAR S.A., BARCELONA, SPAIN. SN 77-696,505. PUB. 1-19-2010, FILED 3-23-2009.



THE MARK CONSISTS OF THE WORD "GEVICAR" IN STYLIZED LETTERS ON TOP OF A LONG HORIZONTAL LINE AND TOWARD THE RIGHT.

THE WORDING "GEVICAR" HAS NO MEANING IN A FOREIGN LANGUAGE.

**CLASS 39—TRANSPORTATION AND STORAGE**

FOR RENTAL OF HIGH END AND LUXURY CARS; HIGH END AND LUXURY TRAVEL ARRANGEMENTS; ORGANIZATION OF EXCURSIONS IN LUXURY CARS; ORGANIZATION AND BOOKING OF TRANSPORTATION DURING THE HOLIDAYS (U.S. CLS. 100 AND 105).

FIRST USE 12-31-1988; IN COMMERCE 12-15-2009.



**CLASS 41—EDUCATION AND ENTERTAINMENT**

FOR EDUCATION IN THE NATURE OF SEMINARS AND SYMPOSIUMS IN THE FIELD OF LUXURY CARS; PROVIDING DRIVING LESSONS; ENTERTAINMENT IN THE NATURE OF LUXURY CAR EXHIBITIONS; ENTERTAINMENT SERVICES, NAMELY, CONDUCTING PARTIES; ENTERTAINMENT IN THE NATURE OF A LUXURY CARS CLUB IN THE NATURE OF ARRANGING, ORGANIZING AND HOSTING SOCIAL EVENTS, GET-TOGETHERS AND PARTIES FOR CLUB MEMBERS; ORGANIZING COMMUNITY SPORTING AND CULTURAL EVENTS (U.S. CLS. 100, 101 AND 107).  
FIRST USE 12-31-1988; IN COMMERCE 12-15-2009.

3,962,332. PROTEA BIOSCIENCES, INC., MORGANTOWN, WV. SN 77-697,420. PUB. 8-4-2009, FILED 3-24-2009.

**LAESI**

THE MARK CONSISTS OF STANDARD CHARACTERS WITHOUT CLAIM TO ANY PARTICULAR FONT, STYLE, SIZE, OR COLOR.

**CLASS 9—ELECTRICAL AND SCIENTIFIC APPARATUS**

FOR MASS SPECTROMETRY DEVICES (U.S. CLS. 21, 23, 26, 36 AND 38).  
FIRST USE 11-5-2010; IN COMMERCE 11-5-2010.

**CLASS 42—SCIENTIFIC AND COMPUTER SERVICES**

FOR MASS SPECTROMETRY SERVICES (U.S. CLS. 100 AND 101).  
FIRST USE 1-1-2011; IN COMMERCE 1-1-2011.

3,962,334. ZOELLER PUMP COMPANY, LOUISVILLE, KY. SN 77-699,610. PUB. 3-2-2010, FILED 3-26-2009.



THE MARK CONSISTS OF CIRCULAR DESIGN MARK.

**CLASS 7—MACHINERY**

FOR SUMP, SEWAGE, AND DRAIN PUMPS (U.S. CLS. 13, 19, 21, 23, 31, 34 AND 35).  
FIRST USE 3-29-2011; IN COMMERCE 3-29-2011.

**CLASS 9—ELECTRICAL AND SCIENTIFIC APPARATUS**

FOR ELECTRONIC WARNING ALARMS FOR DETECTING WATER (U.S. CLS. 21, 23, 26, 36 AND 38).  
FIRST USE 3-29-2011; IN COMMERCE 3-29-2011.

**CLASS 11—ENVIRONMENTAL CONTROL APPARATUS**

FOR INSTALLATIONS FOR THE TREATMENT OF WATER, WASTE WATER AND SEWAGE, NAMELY, REVERSE OSMOSIS FILTRATION UNITS, WATER NEUTRALIZATION UNITS, ULTRAVIOLET STERILIZATION UNITS, WATER SOFTENING UNITS, IRON FILTRATION UNITS, UPFLOW NEUTRALIZING UNITS AND REPLACEMENT PARTS AND FITTINGS THEREFOR; MEDIA FOR FILTRATION AND BIOLOGICAL TREATMENT OF WATER, WASTE WATER, AND SEWAGE, NAMELY, CARTRIDGE FILTRATION UNITS AND FILTERS (U.S. CLS. 13, 21, 23, 31 AND 34).  
FIRST USE 3-29-2011; IN COMMERCE 3-29-2011.

**CLASS 19—NON-METALLIC BUILDING MATERIALS**

FOR SUMP BASINS, NAMELY, NON-METAL IN-GROUND SEWAGE AND WATER RUN-OFF BASINS (U.S. CLS. 1, 12, 33 AND 50).  
FIRST USE 3-29-2011; IN COMMERCE 3-29-2011.

3,962,343. ANGEL ON A LEASH, INC., NEW YORK, NY. SN 77-706,679. PUB. 12-15-2009, FILED 4-3-2009.



THE COLOR(S) BLACK, YELLOW AND PURPLE IS/ARE CLAIMED AS A FEATURE OF THE MARK.

THE MARK CONSISTS OF A PURPLE DOG OUTLINED IN BLACK WEARING A HEART-SHAPED YELLOW TAG ON ITS NECK WITH A BLACK NOSE, BLACK EYES AND WITH THE BLACK STYLIZED LETTERING "ANGEL ON A LEASH" APPEARING BESIDE THE DOG.

**CLASS 35—ADVERTISING AND BUSINESS**

FOR PROMOTING PUBLIC AWARENESS OF OR INTEREST IN THE ROLE OF THE HUMAN-ANIMAL BOND AS THERAPEUTIC (U.S. CLS. 100, 101 AND 102).  
FIRST USE 1-1-2009; IN COMMERCE 1-1-2009.

**CLASS 44—MEDICAL, BEAUTY AND AGRICULTURAL SERVICES**

FOR PROVIDING ANIMAL THERAPY FOR PEOPLE IN THE NATURE OF COMPANIONSHIP AND SUPPORT TO CONTRIBUTE TO THE EMOTIONAL AND PHYSICAL WELL-BEING OF THOSE IN HEALTH CARE FACILITIES, SCHOOLS, REHABILITATION, HOSPICE, EXTENDED CARE, AND CORRECTIONAL FACILITIES (U.S. CLS. 100 AND 101).  
FIRST USE 1-1-2009; IN COMMERCE 1-1-2009.

3,962,353. RELATIONSHIP TOOLBOX LLC, STAMFORD, CT. SN 77-714,331. PUB. 6-29-2010, FILED 4-15-2009.

## RELATIONSHIP TOOLBOX

THE MARK CONSISTS OF STANDARD CHARACTERS WITHOUT CLAIM TO ANY PARTICULAR FONT, STYLE, SIZE, OR COLOR.

NO CLAIM IS MADE TO THE EXCLUSIVE RIGHT TO USE "RELATIONSHIP", APART FROM THE MARK AS SHOWN.

### CLASS 9—ELECTRICAL AND SCIENTIFIC APPARATUS

FOR PRE-RECORDED CDS FEATURING INSTRUCTION AND INFORMATION IN THE FIELD OF PERSONAL AND MARITAL RELATIONSHIPS, ACCOMPANIED BY PRINTED TEACHING MATERIALS IN THE FORM OF AN EDUCATIONAL WORKBOOK, ALL SOLD AS A KIT (U.S. CLS. 21, 23, 26, 36 AND 38).  
FIRST USE 3-10-2010; IN COMMERCE 3-10-2010.

### CLASS 41—EDUCATION AND ENTERTAINMENT

FOR PUBLICATION OF AN E-ZINE; PROVIDING ONLINE NONDOWNLOADABLE E-ZINES IN THE FIELD OF PERSONAL AND MARITAL RELATIONSHIPS; EDUCATIONAL SERVICES, NAMELY, CONDUCTING WORKSHOPS AND SEMINARS IN THE FIELD OF PERSONAL AND MARITAL RELATIONSHIPS AND DISTRIBUTION OF TRAINING MATERIAL IN CONNECTION THEREWITH; LIFE COACHING SERVICES IN THE FIELD OF PERSONAL AND MARITAL RELATIONSHIPS; PERSONAL COACHING SERVICES IN THE FIELD OF PERSONAL AND MARITAL RELATIONSHIPS (U.S. CLS. 100, 101 AND 107).  
FIRST USE 4-16-2009; IN COMMERCE 4-16-2009.

### CLASS 45—PERSONAL AND LEGAL SERVICES

FOR PROVIDING A WEB SITE FEATURING INFORMATION ON LOVE, ROMANCE AND INTERPERSONAL RELATIONSHIPS (U.S. CLS. 100 AND 101).  
FIRST USE 4-16-2009; IN COMMERCE 4-16-2009.

3,962,356. CORE INTELLECTUAL PROPERTIES HOLDINGS, LLC, GOODYEAR, AZ. SN 77-717,313. PUB. 4-6-2010, FILED 4-20-2009.



OWNER OF U.S. REG. NOS. 2,682,104 AND 3,341,826.

NO CLAIM IS MADE TO THE EXCLUSIVE RIGHT TO USE "GLOBAL ORGANICS GROUP INTEGRATED LIFE SCIENCES", APART FROM THE MARK AS SHOWN.

THE COLOR(S) PURPLE AND GREEN IS/ARE CLAIMED AS A FEATURE OF THE MARK.

THE MARK CONSISTS OF THE STYLIZED LETTERS "GO" HAVING STYLIZED GLOBES WITH LATITUDE AND LONGITUDE LINES CONTAINED THEREIN, THE "G"

BEING PURPLE WITH A PALER PURPLE INTERIOR, AND THE "O" BEING GREEN WITH A PALER GREEN INTERIOR. THE STYLIZED PHRASE "THE GLOBAL ORGANICS GROUP INTEGRATED LIFE SCIENCES" APPEARS TO THE RIGHT OF THE LETTERS "GO", ON FOUR SEPARATE LINES, WITH THE WORDING APPEARING IN PURPLE WITH THE EXCEPTION OF THE WORD "ORGANICS", WHICH APPEARS IN GREEN.

### CLASS 1—CHEMICALS

FOR ORGANIC FERTILIZERS; ORGANIC FERTILIZERS FOR AGRICULTURAL USE; ORGANIC FERTILIZERS FOR DOMESTIC USE; ORGANIC NATURAL FERTILIZERS; ORGANIC NON-CHEMICAL BIO-FERTILIZERS (U.S. CLS. 1, 5, 6, 10, 26 AND 46).

FIRST USE 10-0-2007; IN COMMERCE 10-0-2007.

### CLASS 5—PHARMACEUTICALS

FOR ORGANIC NUTRACEUTICALS FOR USE AS A DIETARY SUPPLEMENT; ORGANIC NUTRITIONAL SUPPLEMENTS (U.S. CLS. 6, 18, 44, 46, 51 AND 52).

FIRST USE 10-0-2007; IN COMMERCE 10-0-2007.

3,962,357. RED'S GARDEN CENTER, INC., DBA RED'S, NORTHBROOK, IL. SN 77-718,544. PUB. 3-9-2010, FILED 4-21-2009.



NO CLAIM IS MADE TO THE EXCLUSIVE RIGHT TO USE "MIX", "WEED FREE", "RICH IN MINERALS", "ALL-PURPOSE", "PREMIUM" AND "40 QT/ 44L", APART FROM THE MARK AS SHOWN.

THE COLOR(S) RED, GREEN, YELLOW-GREEN, YELLOW-BROWN, LIGHT BROWN, BLUE, WHITE, YELLOW, BROWN, ORANGE, PEACH, GRAY AND BLACK IS/ARE CLAIMED AS A FEATURE OF THE MARK.

THE MARK CONSISTS OF DESIGN OF A FARM BOY WEARING BLUE OVERALLS, BROWN SHOES, A RED AND WHITE CHECKED SHIRT, AND A YELLOW AND BROWN STRAW HAT AND HE HAS ORANGE HAIR, ROSY RED CHEEKS, AND PEACH SKIN. HIS FEATURES ARE OTHERWISE OUTLINED IN BLACK. HE IS PULLING A RED WAGON WITH GRAY TIRES WITH THE WORDS "REDS" WRITTEN ON THE SIDE OF THE WAGON IN BLACK. INSIDE THE WAGON IS A TREE WITH A BROWN TRUNK AND GREEN LEAVES, A RED COLORED BUG INSIDE AN ORANGE POT. THE BOY IS PULLING THE WAGON OVER LIGHT BROWN DIRT WITH A FEW BLADES OF YELLOW-GREEN GRASS. THE DIRT IS YELLOW-BROWNISH WITH A LITTLE GREEN. ABOVE THE DESIGN OF THE BOY AND THE WAGON APPEARS THE WORDING "REDS" IN RED WITH THE TAIL OF THE "S" FORMING A LEAF AND THE WORDING "MAGIC MIX" IN GREEN. BENEATH THE DESIGN OF THE BOY AND WAGON APPEARS THE GREEN WORDING "OVER 40 YEARS AND STILL GROWING. . ." FOLLOWED BY RED LEAF. BENEATH THAT IS THE GREEN WORDING "WEED FREE" "RICH IN MINERALS" "ALL-PURPOSE" "PREMIUM". TO THE RIGHT OF

THE DESIGN IS A SECOND DESIGN, CONSISTING OF THE SAME BOY IN THE SAME COLOR SCHEME WALKING ON GRASS THAT IS SHADED GREEN TO YELLOW GREEN. THE BOY IS CARRYING A GARDEN SHOVEL SHADED IN BLACK. IN FRONT OF THE BOY APPEARS THE WORDING "REDS" IN RED WITH THE TAIL OF THE "S" FORMING A LEAF. BEHIND THE BOY IS THE GREEN WORDING "MAGIC MIX 40 QT/ 44L". A MIRROR IMAGE OF THIS DESIGN IS FOUND ON THE LEFT PORTION OF THE MARK.

#### CLASS 1—CHEMICALS

FOR FERTILIZER; COMPOST (U.S. CLS. 1, 5, 6, 10, 26 AND 46).

FIRST USE 5-1-2010; IN COMMERCE 5-1-2010.

#### CLASS 31—NATURAL AGRICULTURAL PRODUCTS

FOR TOP SOIL; PEAT MOSS; GRASS SEED (U.S. CLS. 1 AND 46).

FIRST USE 5-1-2010; IN COMMERCE 5-1-2010.

---

3,962,361. COLE, BARRY, WICHITA, KS. SN 77-720,078. PUB. 8-25-2009, FILED 4-22-2009.

## TEA PARTY PATRIOT

THE MARK CONSISTS OF STANDARD CHARACTERS WITHOUT CLAIM TO ANY PARTICULAR FONT, STYLE, SIZE, OR COLOR.

#### CLASS 6—METAL GOODS

FOR METAL LICENSE PLATES; METAL NOVELTY LICENSE PLATES (U.S. CLS. 2, 12, 13, 14, 23, 25 AND 50).

FIRST USE 1-10-2011; IN COMMERCE 1-10-2011.

#### CLASS 12—VEHICLES

FOR LICENSE PLATE FRAMES; LICENSE PLATE HOLDERS; NOVELTY LICENSE PLATE FRAMES; NOVELTY LICENSE PLATE HOLDERS (U.S. CLS. 19, 21, 23, 31, 35 AND 44).

FIRST USE 1-17-2011; IN COMMERCE 1-17-2011.

#### CLASS 14—JEWELRY

FOR JEWELRY (U.S. CLS. 2, 27, 28 AND 50).

FIRST USE 9-10-2010; IN COMMERCE 9-10-2010.

#### CLASS 24—FABRICS

FOR CLOTH BANNERS (U.S. CLS. 42 AND 50).

FIRST USE 1-10-2011; IN COMMERCE 1-10-2011.

#### CLASS 25—CLOTHING

FOR BANDANAS; CAPS; JACKETS; SHIRTS; TOPS; WEARABLE GARMENTS AND CLOTHING, NAMELY, SHIRTS; WRAPS (U.S. CLS. 22 AND 39).

FIRST USE 1-27-2010; IN COMMERCE 7-27-2010.

3,962,364. SUBLIMINAL PRODUCTIONS, AURORA, CO. SN 77-721,311. PUB. 9-1-2009, FILED 4-23-2009.

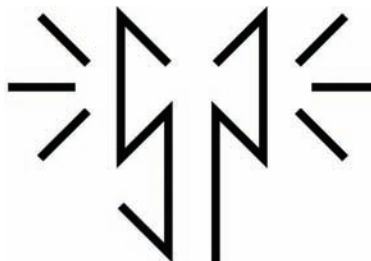

THE MARK CONSISTS OF ENGLISH LETTERS "S" AND "P" SHAPED LIKE SPEAKERS WITH 3 STRAIGHT LINES ON EACH SIDE WHICH REPRESENT SOUND WAVES COMING FROM THE SPEAKERS.

#### CLASS 9—ELECTRICAL AND SCIENTIFIC APPARATUS

FOR DIGITAL MUSIC DOWNLOADABLE FROM THE INTERNET; DOWNLOADABLE MP3 FILES, MP3 RECORDINGS, DOWNLOADABLE MUSICAL SOUND RECORDINGS; MUSICAL SOUND RECORDINGS (U.S. CLS. 21, 23, 26, 36 AND 38).

FIRST USE 6-14-2009; IN COMMERCE 6-14-2009.

#### CLASS 41—EDUCATION AND ENTERTAINMENT

FOR MUSIC COMPOSITION FOR OTHERS; MUSIC PRODUCTION SERVICES; PROVIDING AN INTERNET WEBSITE PORTAL IN THE FIELD OF MUSIC (U.S. CLS. 100, 101 AND 107).

FIRST USE 6-14-2009; IN COMMERCE 6-14-2009.

---

3,962,369. DR. SLEEPGOOD, INC., OAK PARK, CA. SN 77-728,736. PUB. 11-30-2010, FILED 5-4-2009.

## DR. SLEEPGOOD

THE MARK CONSISTS OF STANDARD CHARACTERS WITHOUT CLAIM TO ANY PARTICULAR FONT, STYLE, SIZE, OR COLOR.

#### CLASS 9—ELECTRICAL AND SCIENTIFIC APPARATUS

FOR DOWNLOADABLE ELECTRONIC PUBLICATIONS IN THE NATURE OF BOOKS, INCLUDING ELECTRONIC BOOKS, AND NEWSLETTERS ALL ON THE SUBJECT OF SLEEP DISORDERS FOR PERSONS SUFFERING THEREFROM (U.S. CLS. 21, 23, 26, 36 AND 38).

FIRST USE 7-1-2009; IN COMMERCE 7-1-2009.

**CLASS 41—EDUCATION AND ENTERTAINMENT**

FOR EDUCATIONAL SERVICES, NAMELY, CONDUCTING CLASSES, WORKSHOPS, SEMINARS AND CONFERENCES ON THE SUBJECT OF SLEEP DISORDERS FOR PERSONS SUFFERING THEREFROM; PROVIDING ON-LINE NON-DOWNLOADABLE PUBLICATIONS IN THE NATURE OF BOOKS, INCLUDING ELECTRONIC BOOKS, AND NEWSLETTERS ALL ON THE SUBJECT OF SLEEP DISORDERS FOR PERSONS SUFFERING THEREFROM (U.S. CLS. 100, 101 AND 107).

FIRST USE 7-1-2009; IN COMMERCE 7-1-2009.

3,962,371. MERIDIAN TELECOM, INC., NEWPORT BEACH, CA. SN 77-732,378. PUB. 2-2-2010, FILED 5-8-2009.

**GENREADY**

THE MARK CONSISTS OF STANDARD CHARACTERS WITHOUT CLAIM TO ANY PARTICULAR FONT, STYLE, SIZE, OR COLOR.

**CLASS 37—CONSTRUCTION AND REPAIR**

FOR CONSTRUCTION, INSTALLATION, MAINTENANCE AND REFUELING OF AUXILIARY POWER UNITS FOR WIRELESS ANTENNA SITES (U.S. CLS. 100, 103 AND 106).

FIRST USE 2-9-2010; IN COMMERCE 2-9-2010.

**CLASS 42—SCIENTIFIC AND COMPUTER SERVICES**

FOR CONSULTING SERVICES, NAMELY, PROJECT MANAGEMENT AND LAND USE PLANNING FOR THE PURPOSE OF INSTALLING AUXILIARY POWER UNITS AT WIRELESS ANTENNA SITES; ENGINEERING SERVICES IN THE FIELD OF AUXILIARY POWER UNITS AT WIRELESS ANTENNA SITES (U.S. CLS. 100 AND 101).

FIRST USE 2-9-2010; IN COMMERCE 2-9-2010.

**CLASS 45—PERSONAL AND LEGAL SERVICES**

FOR PERMITTING, NAMELY, OBTAINING ENVIRONMENTAL, DESIGN, ZONING AND OTHER GOVERNMENTAL PERMITS FOR PURPOSES OF INSTALLING AUXILIARY POWER UNITS AT WIRELESS ANTENNA SITES (U.S. CLS. 100 AND 101).

FIRST USE 2-9-2010; IN COMMERCE 2-9-2010.

3,962,372. ENERGY CURTAILMENT SPECIALISTS, INC., BUFFALO, NY. SN 77-733,127. PUB. 6-29-2010, FILED 5-8-2009.

**BIDURENERGY.COM**

THE MARK CONSISTS OF STANDARD CHARACTERS WITHOUT CLAIM TO ANY PARTICULAR FONT, STYLE,

SIZE, OR COLOR.

**CLASS 35—ADVERTISING AND BUSINESS**

FOR ARRANGING AND CONDUCTING AUCTIONS IN THE FIELD OF ENERGY DISTRIBUTION; ON-LINE AUCTION SERVICES; CONNECTING BUYERS AND SELLERS OF ENERGY; PROVIDING A WEB SITE WHEREBY BUYERS OF GOODS OR SERVICES LOCATE AND RECEIVE QUOTATIONS FROM MULTIPLE COMPETITIVE SOURCES AND SELLERS OF GOODS OR SERVICES IDENTIFY AND BID ON MULTIPLE NEW SALES OPPORTUNITIES; INFOMEDIARY SERVICES, NAMELY, FACILITATING TRANSACTIONS BETWEEN BUYERS AND SELLERS THROUGH PROVIDING BUYERS WITH INFORMATION ABOUT SELLERS, GOODS, AND/OR SERVICES; CONSULTATION IN THE FIELD OF ENERGY EFFICIENCY; ENERGY AUDITING; ENERGY MANAGEMENT SERVICES, NAMELY, PROVIDING A SERVICE THAT ALLOWS CUSTOMERS TO PURCHASE ENERGY, NAMELY, ELECTRICITY, NATURAL GAS AND RENEWABLE ENERGY, AT A FIXED PRICE; ENERGY PRICE COMPARISON SERVICES; ENERGY USAGE MANAGEMENT; ENERGY USAGE MANAGEMENT INFORMATION SERVICES; INFORMATION IN THE FIELD OF ENERGY EFFICIENCY; UTILITY BILL MANAGEMENT SERVICES, NAMELY, TRACKING, REPORTING, ANALYZING AND DELIVERING ENERGY INFORMATION IN THE FORM OF UTILITY BILLS AND UTILITY METER DATA RATE SCHEDULES; PROVIDING COMPARISON SHOPPING INFORMATION BY MEANS OF A GLOBAL COMPUTER NETWORK (U.S. CLS. 100, 101 AND 102).

FIRST USE 9-20-2009; IN COMMERCE 9-20-2009.

**CLASS 36—INSURANCE AND FINANCIAL**

FOR BROKERAGE OF ENERGY, NAMELY, GAS AND ELECTRICITY; CONSULTANCY CONCERNING FINANCING OF ENERGY PROJECTS; ENERGY BROKERAGE SERVICES; DISTRIBUTION OF ENERGY (U.S. CLS. 100, 101 AND 102).

FIRST USE 9-20-2009; IN COMMERCE 9-20-2009.

3,962,376. BUSINESS FOR SOCIAL RESPONSIBILITY, SAN FRANCISCO, CA. SN 77-735,422. PUB. 12-22-2009, FILED 5-12-2009.



**BSR**

The Business of a Better World

OWNER OF U.S. REG. NOS. 2,097,680, 3,206,137, AND 3,324,153.

THE MARK CONSISTS OF A DESIGN OF VARIOUS CIRCLES AND DOTS IN A CIRCULAR FORMAT WITH THE LETTERS "BSR" TO THE RIGHT AND BELOW IT THE WORDS "THE BUSINESS OF A BETTER WORLD".

**CLASS 35—ADVERTISING AND BUSINESS**

FOR CONSULTING SERVICES IN THE FIELD OF SOCIALLY RESPONSIBLE BUSINESS PRACTICES; BUSINESS SERVICES, NAMELY, ORGANIZING, PLANNING, CONVENING AND MANAGING EVENTS IN THE FIELD OF SOCIALLY RESPONSIBLE BUSINESS PRACTICES; BUSINESS NETWORKING SERVICES, NAMELY, CREATING AND FACILITATING NETWORKS BETWEEN COMPANY REPRESENTATIVES; BUSINESS SERVICES, NAMELY, PROVIDING INFORMATION IN THE FIELD OF SOCIALLY RESPONSIBLE BUSINESS PRACTICES AND PROVIDING TECHNICAL ASSISTANCE IN THE ESTABLISHMENT AND OPERATION OF BUSINESSES THAT ENGAGE IN SOCIALLY RESPONSIBLE BUSINESSES PRACTICES; ASSOCIATION SERVICES, NAMELY, PROMOTING SOCIALLY RESPONSIBLE BUSINESS PRACTICES BY IDENTIFYING AND PROMOTING BUSINESS POLICIES AND PRACTICES THAT BENEFIT EMPLOYEES, COMMUNITIES, THE ECONOMY, THE ENVIRONMENT AND THE COMMERCIAL HEALTH OF THE BUSINESS AND BY COORDINATING BUSINESSES, THE PUBLIC SECTOR AND PUBLIC INTEREST ORGANIZATIONS IN THEIR EFFORTS TO PROMOTE SOCIALLY RESPONSIBLE BUSINESS PRACTICES (U.S. CLS. 100, 101 AND 102).

FIRST USE 6-7-2009; IN COMMERCE 6-7-2009.

**CLASS 41—EDUCATION AND ENTERTAINMENT**

FOR EDUCATIONAL SERVICES, NAMELY, CONDUCTING CONFERENCES, SEMINARS AND OTHER INSTRUCTIONAL PROGRAMS IN THE FIELD OF SOCIALLY RESPONSIBLE BUSINESS PRACTICES AND DISTRIBUTING COURSE MATERIAL IN CONNECTION THEREWITH (U.S. CLS. 100, 101 AND 107).

FIRST USE 6-7-2009; IN COMMERCE 6-7-2009.

3,962,382. CARDIODX, INC., PALO ALTO, CA. SN 77-742,694. PUB. 4-13-2010, FILED 5-21-2009.



THE MARK CONSISTS OF "CORUS" WITH DOTS OVER THE LETTER "S".

**CLASS 5—PHARMACEUTICALS**

FOR DIAGNOSTIC MEDICAL REAGENTS, CHEMICALS AND BIOLOGICAL MATERIALS BOTH AS SPATIALLY DEFINED ARRAYS AND SOLUTIONS OR REAGENTS FOR MEDICAL USE IN DIAGNOSING, MONITORING, AND PREDICTING DISEASES AND FOR MEASURING OR PREDICTING RESPONSE TO THERAPY OF CARDIAC AND VASCULAR DISEASES (U.S. CLS. 6, 18, 44, 46, 51 AND 52).

FIRST USE 6-15-2009; IN COMMERCE 6-15-2009.

**CLASS 10—MEDICAL APPARATUS**

FOR MEDICAL APPARATUS AND INSTRUMENTS FOR USE IN CARDIAC AND VASCULAR PROGNOSTIC, THERAPEUTIC, AND DIAGNOSTIC TESTING, NAMELY, DIAGNOSTIC TESTS OR TEST KITS COMPRISED OF BLOOD AND TISSUE COLLECTION APPARATUS AND BIOLOGICAL SAMPLE SHIPMENT APPARATUS FOR USE IN BIOLOGICAL SAMPLE COLLECTION AND STORAGE FOR MEDICAL LABORATORY USE, NAMELY, FOR USE IN ANALYSIS OF GENE EXPRESSION, GENETICS, SINGLE NUCLEOTIDE POLYMORPHISM, HAPLOTYPES, PROTEINS, AND OTHER ANALYTES IN BIOLOGICAL SAMPLES, FOR THE DIAGNOSIS OF DISEASES, FOR THE MONITORING AND PREDICTION OF DISEASE INCIDENCE AND PROGRESSION, AND FOR DETERMINING DRUG RESPONSES (U.S. CLS. 26, 39 AND 44).

FIRST USE 6-15-2009; IN COMMERCE 6-15-2009.

**CLASS 44—MEDICAL, BEAUTY AND AGRICULTURAL SERVICES**

FOR MEDICAL SERVICES, NAMELY, CARDIAC AND VASCULAR THERAPEUTIC, PROGNOSTIC, AND DIAGNOSTIC TESTING SERVICES (U.S. CLS. 100 AND 101).

FIRST USE 6-15-2009; IN COMMERCE 6-15-2009.

3,962,385. LOVELACE RESPIRATORY RESEARCH INSTITUTE, ALBUQUERQUE, NM. SN 77-744,706. PUB. 4-27-2010, FILED 5-26-2009.

# ALIVE

THE MARK CONSISTS OF STANDARD CHARACTERS WITHOUT CLAIM TO ANY PARTICULAR FONT, STYLE, SIZE, OR COLOR.

**CLASS 1—CHEMICALS**

FOR CELLS NAMELY, CULTURED AND CRYOPRESERVED PRIMARY MAMMALIAN CELLS, NAMELY, HEPATOCYTES; AND TISSUE FRACTIONS FOR USE IN SCIENTIFIC AND RESEARCH PURPOSES; CRYOPRESERVED CELLS; CELLS IN CULTURE; AND CELL COMPONENTS FROM NORMAL AND CANCEROUS CELLS FOR SCIENTIFIC AND RESEARCH PURPOSE USE (U.S. CLS. 1, 5, 6, 10, 26 AND 46).

FIRST USE 10-1-2009; IN COMMERCE 10-1-2009.

**CLASS 35—ADVERTISING AND BUSINESS**

FOR RETAIL DISTRIBUTORSHIP SERVICES IN THE FIELD OF CELLS AND CELL BY-PRODUCTS AND BIOLOGICS (U.S. CLS. 100, 101 AND 102).

FIRST USE 10-21-2009; IN COMMERCE 10-21-2009.

**CLASS 42—SCIENTIFIC AND COMPUTER SERVICES**

FOR RESEARCH AND DEVELOPMENT FOR OTHERS OF IN-VITRO TESTING OF THERAPEUTIC AGENTS FOR HEPATITIS C AND ANALYSIS OF THE PHARMACOLOGY, METABOLISM AND TOXICITY OF INDUSTRIAL AND PHARMACEUTICAL AGENTS IN PRIMARY MAMMALIAN CELLS INCLUDING HEPATOCYTES AND RESPIRATORY TRACT EPITHELIAL CELLS (U.S. CLS. 100 AND 101).

FIRST USE 3-1-2011; IN COMMERCE 3-1-2011.



3,962,386. FILER ENTERPRISES LLC, PLYMOUTH, MN. SN 77-745,325. PUB. 6-29-2010, FILED 5-27-2009.

## GRAND CRAZY

THE MARK CONSISTS OF STANDARD CHARACTERS WITHOUT CLAIM TO ANY PARTICULAR FONT, STYLE, SIZE, OR COLOR.

### CLASS 16—PAPER GOODS AND PRINTED MATTER

FOR PRINTED NEWSLETTERS FEATURING SUBJECTS OF INTEREST TO GRANDPARENTS, NAMELY, BIRTH AND NAME ANNOUNCEMENTS, NOTICE OF CELEBRATIONS, GIFT ACKNOWLEDGMENTS, WAYS TO STAY CONNECTED WITH GRANDCHILDREN, AGE APPROPRIATE GIFTS FOR GRANDCHILDREN, AGE APPROPRIATE ACTIVITIES WITH GRANDCHILDREN, WAYS TO CELEBRATE AND NURTURE THE RELATIONSHIPS A NEW GRANDCHILD CREATES BETWEEN FAMILY MEMBERS, TECHNOLOGY AND SOCIAL NETWORKING FOR GRANDPARENTS, CELEBRITY GRANDPARENTS, FAMILY ACTIVITIES, CHILDREN'S SAFETY, CHILDREN'S ENTERTAINMENT AND FAMILY TRAVEL; GREETING CARDS; BUMPER STICKERS (U.S. CLS. 2, 5, 22, 23, 29, 37, 38 AND 50).

FIRST USE 11-15-2009; IN COMMERCE 11-15-2009.

### CLASS 25—CLOTHING

FOR MEN'S AND WOMEN'S CLOTHING, NAMELY, SHIRTS, T-SHIRTS, APRONS, HATS, SWEATSHIRTS, AND JACKETS; CHILDREN AND INFANT'S CLOTHING, NAMELY, JACKETS, SHIRTS, T-SHIRTS, SWEATSHIRTS, UNDERWEAR, ONE-PIECE UNDERWEAR, ONE-PIECE SLEEP SET, HATS, CAPS AND VISORS (U.S. CLS. 22 AND 39).

FIRST USE 11-8-2008; IN COMMERCE 11-8-2008.

### CLASS 35—ADVERTISING AND BUSINESS

FOR RETAIL STORE SERVICES FEATURING CUSTOMIZED AND NON-CUSTOMIZED GIFT BASKETS, CLOTHING, HEADWEAR, BEVERAGeware, APRONS, MAGNETS, BUTTONS, MESSENGER BAGS, MOUSE PADS, CANVAS BAGS, ORNAMENTS, PLUSH TOYS, PILLOWS, CLOCKS, BOOKS, JOURNALS, COMPACT DISCS, MAGNETS, FRAMED PRINTS, GREETING CARDS, JOURNALS, LICENSE PLATE FRAMES, POSTER PRINTS, STICKERS, AND POSTERS; COMPUTERIZED ONLINE RETAIL STORES FEATURING CUSTOMIZED AND NON-CUSTOMIZED GIFT BASKETS, CLOTHING, HEADWEAR, BEVERAGeware, APRONS, PETWEAR, MAGNETS, BUTTONS, MESSENGER BAGS, MOUSE PADS, CANVAS BAGS, ORNAMENTS, CALENDARS, PLUSH TOYS, PILLOWS, CLOCKS, BOOKS, COMPACT DISCS, FRAMED PRINTS, GREETING CARDS, JOURNALS, LICENSE PLATE FRAMES, CALENDAR PRINTS, POSTER PRINTS, POSTCARDS, STICKERS AND POSTERS (U.S. CLS. 100, 101 AND 102).

FIRST USE 11-8-2008; IN COMMERCE 11-8-2008.

### CLASS 40—MATERIAL TREATMENT

FOR PRINTING SERVICES, NAMELY, CUSTOM IMPRINTING OF CLOTHING, SIGNS, BUMPER STICKERS, COFFEE MUGS, MOUSE PADS, AND SPECIALTY ITEMS; CUSTOM EMBROIDERY SERVICES, NAMELY, CUSTOM EMBROIDERY OF CLOTHING, HATS, BLANKETS AND PILLOWS (U.S. CLS. 100, 103 AND 106).

FIRST USE 1-0-2010; IN COMMERCE 1-0-2010.

### CLASS 41—EDUCATION AND ENTERTAINMENT

FOR PROVIDING ONLINE NEWSLETTERS REGARDING SUBJECTS OF INTEREST TO GRANDPARENTS, NAMELY, BIRTH AND NAME ANNOUNCEMENTS, PICTURES OF GRANDCHILDREN, STORIES RELATING TO GRANDPARENTING, NOTICE OF CELEBRATIONS, GIFT ACKNOWLEDGMENTS, WAYS TO STAY CONNECTED WITH GRANDCHILDREN, AGE APPROPRIATE GIFTS FOR GRANDCHILDREN, AGE APPROPRIATE ACTIVITIES WITH GRANDCHILDREN, WAYS TO CELEBRATE AND NURTURE THE RELATIONSHIPS A NEW GRANDCHILD CREATES BETWEEN FAMILY MEMBERS, TECHNOLOGY AND SOCIAL NETWORKING FOR GRANDPARENTS, CELEBRITY GRANDPARENTS, FAMILY ACTIVITIES, CHILDREN'S SAFETY, CHILDREN'S ENTERTAINMENT AND FAMILY TRAVEL; PROVIDING MEMBERSHIP CLUB AND SOCIAL CLUB SERVICES, NAMELY, ARRANGING, ORGANIZING AND HOSTING SOCIAL EVENTS, GET-TOGETHERS, AND PARTIES FOR CLUB MEMBERS (U.S. CLS. 100, 101 AND 107).

FIRST USE 11-15-2009; IN COMMERCE 11-15-2009.

3,962,390. INSPIRATION BEVERAGE COMPANY, LLC, LAKEWOOD, CO. SN 77-751,589. PUB. 1-19-2010, FILED 6-3-2009.

## BING ME

THE MARK CONSISTS OF STANDARD CHARACTERS WITHOUT CLAIM TO ANY PARTICULAR FONT, STYLE, SIZE, OR COLOR.

OWNER OF U.S. REG. NO. 3,562,803.

NO CLAIM IS MADE TO THE EXCLUSIVE RIGHT TO USE "BING", APART FROM THE MARK AS SHOWN.

### CLASS 25—CLOTHING

FOR CLOTHING, NAMELY, SHIRTS AND CAPS (U.S. CLS. 22 AND 39).

FIRST USE 4-8-2011; IN COMMERCE 4-8-2011.

### CLASS 32—LIGHT BEVERAGES

FOR ENERGY DRINKS, SPORTS DRINKS, SOFT DRINKS, AND NON-ALCOHOLIC BEVERAGES CONTAINING FRUIT JUICES (U.S. CLS. 45, 46 AND 48).

FIRST USE 8-28-2006; IN COMMERCE 9-17-2006.

3,962,391. INSPIRATION BEVERAGE COMPANY, LLC, LAKEWOOD, CO. SN 77-751,602. PUB. 1-19-2010, FILED 6-3-2009.

## GET BINGED

THE MARK CONSISTS OF STANDARD CHARACTERS WITHOUT CLAIM TO ANY PARTICULAR FONT, STYLE, SIZE, OR COLOR.

OWNER OF U.S. REG. NO. 3,562,803.

**CLASS 25—CLOTHING**

FOR CLOTHING, NAMELY, SHIRTS AND CAPS (U.S. CLS. 22 AND 39).  
FIRST USE 4-8-2011; IN COMMERCE 4-8-2011.

**CLASS 32—LIGHT BEVERAGES**

FOR ENERGY DRINKS, SPORTS DRINKS, SOFT DRINKS, AND NON-ALCOHOLIC BEVERAGES CONTAINING FRUIT JUICES (U.S. CLS. 45, 46 AND 48).  
FIRST USE 8-28-2006; IN COMMERCE 9-17-2006.

3,962,393. INSPIRATION BEVERAGE COMPANY, LLC, LAKEWOOD, CO. SN 77-751,820. PUB. 1-19-2010, FILED 6-4-2009.

# BING IT

THE MARK CONSISTS OF STANDARD CHARACTERS WITHOUT CLAIM TO ANY PARTICULAR FONT, STYLE, SIZE, OR COLOR.

OWNER OF U.S. REG. NO. 3,562,803.

NO CLAIM IS MADE TO THE EXCLUSIVE RIGHT TO USE "BING", APART FROM THE MARK AS SHOWN.

**CLASS 25—CLOTHING**

FOR CLOTHING, NAMELY, SHIRTS AND CAPS (U.S. CLS. 22 AND 39).  
FIRST USE 4-8-2011; IN COMMERCE 4-8-2011.

**CLASS 32—LIGHT BEVERAGES**

FOR ENERGY DRINKS, SPORTS DRINKS, SOFT DRINKS, AND NON-ALCOHOLIC BEVERAGES CONTAINING FRUIT JUICES (U.S. CLS. 45, 46 AND 48).  
FIRST USE 6-3-2009; IN COMMERCE 6-3-2009.

3,962,397. COOPER TECHNOLOGIES COMPANY, HOUSTON, TX. SN 77-755,542. PUB. 1-12-2010, FILED 6-9-2009.



NO CLAIM IS MADE TO THE EXCLUSIVE RIGHT TO USE "LED TECHNOLOGY", APART FROM THE MARK AS SHOWN.

THE MARK CONSISTS OF THE WORDING "LED TECHNOLOGY" WITH TWO ROWS OF CIRCLES, ALL WITHIN CONCENTRIC OVALS.

**CLASS 9—ELECTRICAL AND SCIENTIFIC APPARATUS**

FOR ILLUMINATED EXIT SIGNS; EMERGENCY WARNING LIGHTS; MOTION SENSITIVE SECURITY LIGHTS; AND PARTS AND FITTINGS OF THE AFOREMENTIONED GOODS (U.S. CLS. 21, 23, 26, 36 AND 38).  
FIRST USE 9-30-2009; IN COMMERCE 9-30-2009.

**CLASS 11—ENVIRONMENTAL CONTROL APPARATUS**

FOR LED (LIGHT EMITTING DIODE) ELECTRIC LIGHTING FIXTURES FOR INDOOR AND OUTDOOR LIGHTING APPLICATIONS, NAMELY, FLOODLIGHTS, ELECTRIC LIGHTING FIXTURES WITH MOTION DETECTION NOT FOR SECURITY PURPOSES AND TRACK LIGHTS, ALL FOR USE IN DISPLAY, COMMERCIAL, INDUSTRIAL, RESIDENTIAL, AND ARCHITECTURAL ACCENT LIGHTING APPLICATIONS; FLUORESCENT ELECTRIC LIGHTING FIXTURES, NAMELY, TROFFER LIGHTS, STRIP LIGHTS IN THE NATURE OF NARROW LIGHTING FIXTURES CONSISTING OF LONG TUBE LIGHT OR LIGHTS THAT PROVIDE ILLUMINATION, WRAPPED LIGHTS IN THE NATURE OF LIGHTING FIXTURES WITH WRAP AROUND LENS THAT WRAP AROUND A LOW PROFILE HOUSING, AND SHOP LIGHTS IN THE NATURE OF SUSPENDED LONG TUBE LIGHTING FIXTURE WITH REFLECTORS TO ILLUMINATE A WORK AREA, ALL FOR USE IN DISPLAY, COMMERCIAL, INDUSTRIAL, RESIDENTIAL, AND ARCHITECTURAL ACCENT LIGHTING APPLICATIONS; WORKLIGHTS IN THE NATURE OF LIGHTING FIXTURES USED TO ILLUMINATE WORK AREAS; FLASHLIGHTS; ELECTRIC STICK LIGHTS IN THE NATURE OF SINGLE TUBE LIGHTING FIXTURES BOTH CORDED AND CORDLESS WITH HOOK FOR USE IN WORK AREAS; UTILITY LIGHTS IN THE NATURE OF LIGHTING FIXTURE FOR USE IN WORK AREAS; AND PARTS AND FITTINGS OF THE AFOREMENTIONED GOODS (U.S. CLS. 13, 21, 23, 31 AND 34).

FIRST USE 9-30-2009; IN COMMERCE 9-30-2009.

3,962,412. DICOTA GMBH, BIETIGHEIM-BISSINGEN, FED REP GERMANY. SN 77-762,995. PUB. 11-24-2009, FILED 6-18-2009.

# BASE xx

THE MARK CONSISTS OF STANDARD CHARACTERS WITHOUT CLAIM TO ANY PARTICULAR FONT, STYLE, SIZE, OR COLOR.

OWNER OF U.S. REG. NO. 3,520,736.

**CLASS 9—ELECTRICAL AND SCIENTIFIC APPARATUS**

FOR CELLULAR PHONE PLUG ADAPTORS, CONNECTING AND MOUNTING OR HOLDING STRAPS FOR CELLULAR PHONES; COMPUTER BAGS, CASES; CARRYING CASES FOR CELL PHONES; NOTEBOOK COMPUTERS; LAPTOP COMPUTERS; NOTEPAD COMPUTERS; ELECTRONIC DIARIES, POCKET CALCULATORS; PRINTERS; AUDIO CABLES, POWER SUPPLIES; BLANK FLOPPY COMPUTER DISCS; PLUG IN CONNECTORS; BATTERIES AND TELEPHONES; MAGNETICALLY ENCODED CREDIT CARDS (U.S. CLS. 21, 23, 26, 36 AND 38).

FIRST USE 1-2-2000; IN COMMERCE 6-30-2010.

**CLASS 18—LEATHER GOODS**

FOR ATTACHE CASES, PURSES, BRIEFCASES AND WALLETS ADAPTED FOR CONTAINING ELECTRONIC DEVICES; BAGS, NAMELY, CARRY ON BAGS, BOOK BAGS, DUFFLE BAGS, TRUNKS, SUIT CASES, ATTACHE CASES, VALISES, PURSES, RUCKSACKS, TRAVELING BAGS, BRIEFCASES, WALLETS AND CREDIT CARD CASES MADE OF LEATHER AND TEXTILES, WITH OR WITHOUT WOOD, METAL OR PLASTIC SIDE POCKETS, OUTER POCKETS, HANDLES, GRIPS AND CARRYING STRAPS; STRAPS FOR CARRYING CASES; POUCHES AND BAGS SOLD EMPTY FOR ATTACHMENT TO BACKPACKS; GARMENT BAGS FOR TRAVEL (U.S. CLS. 1, 2, 3, 22 AND 41).

FIRST USE 1-2-2000; IN COMMERCE 12-12-2010.

3,962,413. MUSIC INTELLIGENCE PROJECT, LLC, OLD LYME, CT. SN 77-765,026. PUB. 11-3-2009, FILED 6-22-2009.

**THE TUNEABLES**

THE MARK CONSISTS OF STANDARD CHARACTERS WITHOUT CLAIM TO ANY PARTICULAR FONT, STYLE, SIZE, OR COLOR.

**CLASS 9—ELECTRICAL AND SCIENTIFIC APPARATUS**

FOR CHILDREN'S EDUCATIONAL MUSIC CDS AND DVDS; CHILDREN'S EDUCATIONAL SOFTWARE (U.S. CLS. 21, 23, 26, 36 AND 38).

FIRST USE 2-13-2011; IN COMMERCE 2-13-2011.

**CLASS 41—EDUCATION AND ENTERTAINMENT**

FOR PRODUCTION OF DVDS, CDS AND TELEVISION PROGRAMS FEATURING MUSIC EDUCATION; EDUCATIONAL SERVICES, NAMELY, CONDUCTING CLASSES AND WORKSHOPS IN THE FIELD OF MUSIC AND DISTRIBUTION OF COURSE MATERIAL IN CONNECTION THEREWITH; PROVIDING A WEBSITE FEATURING EDUCATION AND ENTERTAINMENT FOR CHILDREN (U.S. CLS. 100, 101 AND 107).

FIRST USE 2-11-2011; IN COMMERCE 2-11-2011.

3,962,414. EUROCRAFT INDUSTRIES, INC., LARGO, FL. SN 77-765,796. PUB. 6-1-2010, FILED 6-23-2009.

**ECO-STAR**

THE MARK CONSISTS OF STANDARD CHARACTERS WITHOUT CLAIM TO ANY PARTICULAR FONT, STYLE, SIZE, OR COLOR.

**CLASS 6—METAL GOODS**

FOR TILT AND TURN METAL WINDOWS AND METAL SLIDING GLASS DOORS (U.S. CLS. 2, 12, 13, 14, 23, 25 AND 50).

FIRST USE 6-30-2007; IN COMMERCE 6-30-2007.

**CLASS 19—NON-METALLIC BUILDING MATERIALS**

FOR TILT AND TURN NON-METAL WINDOWS AND NON-METAL SLIDING GLASS DOORS (U.S. CLS. 1, 12, 33 AND 50).

FIRST USE 6-30-2007; IN COMMERCE 6-30-2007.

3,962,428. BAYER AKTIENGESELLSCHAFT, 51373 LEVERKUSEN, FED REP GERMANY. SN 77-773,758. PUB. 10-27-2009, FILED 7-2-2009.

**VOTIVO**

THE MARK CONSISTS OF STANDARD CHARACTERS WITHOUT CLAIM TO ANY PARTICULAR FONT, STYLE, SIZE, OR COLOR.

**CLASS 1—CHEMICALS**

FOR CHEMICAL PREPARATIONS FOR USE IN AGRICULTURE, HORTICULTURE; CHEMICAL PREPARATIONS FOR THE TREATMENT OF SEEDS (U.S. CLS. 1, 5, 6, 10, 26 AND 46).

FIRST USE 9-7-2010; IN COMMERCE 9-7-2010.

**CLASS 5—PHARMACEUTICALS**

FOR PREPARATIONS FOR DESTROYING VERMIN; INSECTICIDES (U.S. CLS. 6, 18, 44, 46, 51 AND 52).

FIRST USE 9-7-2010; IN COMMERCE 9-7-2010.

3,962,437. CHATEAU INTERIORS - CALIFORNIA, IRVINE, CA. SN 77-777,411. PUB. 12-29-2009, FILED 7-9-2009.

**STUDIO CHATEAU**

THE MARK CONSISTS OF STANDARD CHARACTERS WITHOUT CLAIM TO ANY PARTICULAR FONT, STYLE, SIZE, OR COLOR.

NO CLAIM IS MADE TO THE EXCLUSIVE RIGHT TO USE "STUDIO", APART FROM THE MARK AS SHOWN.

**CLASS 9—ELECTRICAL AND SCIENTIFIC APPARATUS**

FOR COMPUTER SOFTWARE TO ALLOW SELECTION AND ORDERING OF INTERIOR DESIGN PRODUCTS AND SERVICES FOR NEW HOMEBUYERS (U.S. CLS. 21, 23, 26, 36 AND 38).

FIRST USE 8-1-2009; IN COMMERCE 8-1-2009.

**CLASS 42—SCIENTIFIC AND COMPUTER SERVICES**

FOR SOFTWARE AS A SERVICES (SAAS) SERVICES, NAMELY, HOSTING SOFTWARE FOR USE BY OTHERS FOR USE IN THE SELECTION AND ORDERING OF INTERIOR DESIGN PRODUCTS AND SERVICES FOR NEW HOMEBUYERS; AND INTERIOR DESIGN SERVICES FOR NEW HOMEBUYERS (U.S. CLS. 100 AND 101).

FIRST USE 8-1-2009; IN COMMERCE 8-1-2009.



3,962,439. CHATEAU INTERIORS - CALIFORNIA, IRVINE, CA. SN 77-777,495. PUB. 12-29-2009, FILED 7-9-2009.



NO CLAIM IS MADE TO THE EXCLUSIVE RIGHT TO USE "STUDIO" AND "DESIGN", APART FROM THE MARK AS SHOWN.

THE MARK CONSISTS OF THE WORDS "STUDIO CHATEAU" IN LOWER CASE LETTERS WITH STARS TRAILING UPWARD FROM THE "O" IN "STUDIO" FOLLOWED BY THE PHRASE "THE MAGIC OF DESIGN" IN LOWER CASE LETTERS POSITIONED UNDERNEATH THE WORLD "CHATEAU".

**CLASS 9—ELECTRICAL AND SCIENTIFIC APPARATUS**

FOR COMPUTER SOFTWARE TO ALLOW SELECTION AND ORDERING OF INTERIOR DESIGN PRODUCTS AND SERVICES FOR NEW HOMEBUYERS (U.S. CLS. 21, 23, 26, 36 AND 38).

FIRST USE 8-1-2009; IN COMMERCE 8-1-2009.

**CLASS 42—SCIENTIFIC AND COMPUTER SERVICES**

FOR SOFTWARE AS A SERVICE (SAAS) SERVICES, NAMELY, HOSTING SOFTWARE FOR USE BY OTHERS FOR USE IN THE SELECTION AND ORDERING OF INTERIOR DESIGN PRODUCTS AND SERVICES FOR NEW HOMEBUYERS; AND INTERIOR DESIGN SERVICES FOR NEW HOMEBUYERS (U.S. CLS. 100 AND 101).

FIRST USE 8-1-2009; IN COMMERCE 8-1-2009.

3,962,449. ORE ORIGINALS, INC., LONG BEACH, CA. SN 77-782,194. PUB. 6-29-2010, FILED 7-15-2009.



OWNER OF U.S. REG. NOS. 3,690,658, 3,690,728, AND 3,690,733.

THE MARK CONSISTS OF THE DESIGN OF A BABY WITH TOOTH, HAIR AND STAR.

**CLASS 18—LEATHER GOODS**

FOR DIAPER BAGS, TOTE BAGS AND PLASTIC AND CLOTH POUCHES FOR INFANT ACCESSORIES (U.S. CLS. 1, 2, 3, 22 AND 41).

FIRST USE 1-1-2009; IN COMMERCE 1-1-2009.

**CLASS 21—HOUSEWARES AND GLASS**

FOR PLATES AND MUGS; NYLON BOXES FOR STORAGE OF PERSONAL ITEMS (U.S. CLS. 2, 13, 23, 29, 30, 33, 40 AND 50).

FIRST USE 1-31-2005; IN COMMERCE 1-31-2005.



3,962,458. THE HEALTH COMPANY, LONDON LTD, TA BEAMING BABY, TOTNES, UNITED KINGDOM. SN 77-785,639. PUB. 8-31-2010, FILED 7-21-2009.

**Beaming Baby**

THE MARK CONSISTS OF STANDARD CHARACTERS WITHOUT CLAIM TO ANY PARTICULAR FONT, STYLE, SIZE, OR COLOR.

PRIORITY CLAIMED UNDER SEC. 44(D) ON UNITED KINGDOM APPLICATION NO. 2519601, FILED 6-26-2009, REG. NO. 008436719, DATED 2-1-2010, EXPIRES 7-20-2019.

NO CLAIM IS MADE TO THE EXCLUSIVE RIGHT TO USE "BABY" , APART FROM THE MARK AS SHOWN.

**CLASS 3—COSMETICS AND CLEANING PREPARATIONS**

FOR (BASED ON USE IN COMMERCE) BABY LOTION; BABY OIL; BABY OILS; BABY SHAMPOO; BABY WIPES; BATH FOAM; BATH FOAMS; BATH GEL; BATH GELS; BODY LOTION; BODY LOTIONS; BODY OIL; BODY OILS; BUBBLE BATH; CLOTHS OR TISSUES IMPREGNATED WITH A SKIN CLEANSER; COSMETIC CREAMS FOR SKIN CARE; COSMETIC OILS; COSMETIC OILS FOR THE EPIDERMIS; FACE AND BODY CREAMS; FACE AND BODY LOTIONS; FACIAL CLEANSERS; FACIAL LOTION; FACIAL WASHES; HAIR CARE PREPARATIONS; HAIR CLEANING PREPARATIONS; HAIR SHAMPOO; HAIR SHAMPOOS AND CONDITIONERS; HAND CREAM; HAND CREAMS; HAND LOTIONS; HAND SOAPS; IMPREGNATED CLEANING CLOTHS; IMPREGNATED CLEANING PADS IMPREGNATED WITH TOILET PREPARATIONS; LIQUID BATH SOAPS; LIQUID SOAP; LIQUID SOAPS; LIQUID SOAPS FOR HANDS AND FACE; LIQUID SOAPS FOR HANDS, FACE AND BODY; LOTIONS FOR FACE AND BODY CARE; NON-MEDICATED BATH PREPARATIONS; NON-MEDICATED BUBBLE BATH PREPARATIONS; NON-MEDICATED DIAPER RASH OINTMENTS AND LOTIONS; NON-MEDICATED PREPARATIONS ALL FOR THE CARE OF SKIN, HAIR AND SCALP; NON-MEDICATED SKIN CARE PREPARATIONS; NON-MEDICATED SKIN CARE PREPARATIONS, NAMELY, CREAMS, LOTIONS, GELS, TONERS, CLEANSERS AND PEELS; NON-MEDICATED SKIN CREAMS; NON-MEDICATED TOILETRIES; PRE-MOISTENED COSMETIC WIPES; SCENTED BODY LOTIONS AND CREAMS; SHAMPOO-CONDITIONERS; SHAMPOOS; SHAMPOOS FOR BABIES; SHOWER AND BATH FOAM; SHOWER AND BATH GEL; SKIN AND BODY TOPICAL LOTIONS, CREAMS AND OILS FOR COSMETIC USE; SKIN CLEANSERS; SKIN CLEANSING CREAM; SKIN CLEANSING LOTION; SKIN CONDITIONERS; SKIN CONDITIONING CREAMS FOR COSMETIC PURPOSES; SKIN CREAM; SKIN CREAMS; SKIN CREAMS IN LIQUID AND IN SOLID FORM; SKIN CREAMS IN LIQUID AND SOLID; SKIN CREAMS IN LIQUID AND SOLID FORM; SKIN LOTION; SKIN LOTIONS; SKIN MOISTURIZER; TISSUES IMPREGNATED WITH COSMETIC LOTIONS; WIPES IMPREGNATED WITH A SKIN CLEANSER; 3-IN-1 HAIR CONDITIONERS; 3-IN-1 HAIR SHAMPOOS; AFTER SUN CREAMS; AFTER-SUN GELS; AFTER-SUN LOTIONS; AFTER-SUN MILKS; AFTER-SUN OILS; ALL PURPOSE CLEANING PREPARATIONS; ALL PURPOSE COTTON SWABS FOR PERSONAL USE; ALL-PURPOSE CLEANERS; ALMOND SOAPS; ALOE VERA GEL FOR COSMETIC PURPOSES; ANTIPERSPIRANTS AND DEODORANTS FOR PERSONAL USE; ANTIPERSPIRANTS FOR PERSONAL USE; AROMATHERAPY BODY CARE PRODUCTS, NAMELY, BODY LOTION, SHOWER GEL, CUTICLE CREAM, SHAMPOO, CONDITIONER, NON-MEDICATED LIP BALM, SOAP, BODY POLISH, BODY AND FOOT SCRUB AND NON-MEDICATED FOOT CREAM; AROMATHERAPY CREAMS; AROMATHERAPY EVAPORATING SHOWER BALLS; AROMATHERAPY LOTIONS; AROMATHERAPY OIL; AROMATHERAPY OILS; AROMATHERAPY PILLOWS COMPRISING POTPOURRI IN FABRIC CONTAINERS; AROMATHERAPY PILLOWS THAT MAY BE USED TO FRESHEN CLOTHING OR LAY OVER THE EYES; AROMATHERAPY SPRAYS; BABY HAIR CONDITIONER; BABY POWDER; BABY POWDERS; BAR SOAP; BATH AND SHOWER GELS AND SALTS NOT FOR MEDICAL PURPOSES; BATH CREAM; BATH HERBS; BATH LOTION; BATH MILKS; BATH OIL; BATH OILS; BATH OILS AND BATH SALTS; BATH OILS FOR COSMETIC PURPOSES; BATH PEARLS; BATH POWDER; BATH SALTS; BATH SALTS; BATH SOAPS; BATH SOAPS IN LIQUID, SOLID OR GEL FORM; BATHING LOTIONS; BEAUTY CREAMS; BEAUTY CREAMS FOR BODY CARE; BEAUTY GELS; BEAUTY LOTIONS; BEAUTY MASKS; BEAUTY MILKS; BODY AND BEAUTY CARE COSMETICS; BODY BUTTER; BODY CREAM; BODY CREAM SOAP; BODY CREAMS; BODY EMULSIONS; BODY MILK; BODY MILKS; BODY POWDER; BODY SPLASH; BODY SPRAYS; BODY WASHES; CAKES OF TOILET SOAP; CLEANSING MILK; COCOA BUTTER FOR COSMETIC PURPOSES; COLD CREAM; COLD CREAMS; COSMETIC CREAMS; COSMETIC MILKS; COSMETIC OLIVE OIL FOR THE FACE AND BODY; COSMETIC PADS; COSMETIC PREPARATIONS; COSMETIC PREPARATIONS AGAINST SUNBURN; COSMETIC PREPARATIONS FOR BODY CARE; COSMETIC SUN-PROTECTING PREPARATIONS; COSMETIC SUN-TANNING PREPARATIONS; COSMETIC SUNTAN LO-

TIONS; COSMETIC SUNTAN PREPARATIONS; COSMETICS; COSMETICS AND COSMETIC PREPARATIONS; COSMETICS AND MAKE-UP; COSMETICS IN GENERAL, INCLUDING PERFUMES; COSMETICS IN THE FORM OF MILKS, LOTIONS AND EMULSIONS; COTTON BALLS FOR COSMETIC PURPOSES; COTTON BUDS FOR COSMETIC PURPOSES; COTTON FOR COSMETIC PURPOSES; COTTON PUFFS FOR COSMETIC PURPOSES; COTTON STICKS FOR COSMETIC PURPOSES; COTTON SWABS FOR COSMETIC PURPOSES; COTTON WOOL AND COTTON STICKS FOR COSMETIC PURPOSES; COTTON WOOL FOR COSMETIC PURPOSES; CREAM SOAPS; DEODORANT FOR PERSONAL USE; DEODORANT SOAP; DEODORANTS AND ANTIPERSPIRANTS; DEODORANTS AND ANTIPERSPIRANTS FOR PERSONAL USE; DEODORANTS FOR BODY CARE; FACE AND BODY BEAUTY CREAMS; FACE CREAMS; FACIAL CLEANSING MILK; FACIAL CREAM; FACIAL CREAMS; FACIAL EMULSIONS; FOAM CLEANING PREPARATIONS; HAIR CONDITIONER; HAIR CONDITIONERS; HAIR CONDITIONERS FOR BABIES; IMPREGNATED CLEANING PADS IMPREGNATED WITH COSMETICS; IMPREGNATED CLEANING, DUSTING OR POLISHING CLOTHS; IMPREGNATED CLOTHS FOR POLISHING; IMPREGNATED PAPER TISSUES FOR CLEANING DISHWARE; NON-MEDICATED SUN CARE PREPARATIONS; PERSONAL DEODORANTS; PRE-MOISTENED COSMETIC TISSUES; PRE-MOISTENED COSMETIC TOWELETTES; PRE-MOISTENED TOWELETTES IMPREGNATED WITH DISHWASHING DETERGENT; SACHETS; SHOWER CREAMS; SHOWER GEL; SHOWER GELS; SKIN EMOLLIENTS; SKIN MOISTURIZER MASKS; SKIN SOAP; SOAPS FOR BODY CARE; SOAPS FOR PERSONAL USE; SPF SUNBLOCK TOWELETTES; SUN BLOCK; SUN BLOCK PREPARATIONS; SUN CARE LOTIONS; SUN CREAMS; SUN SCREEN; SUN SCREEN PREPARATIONS; SUN TAN GEL; SUN TAN LOTION; SUN TAN OIL; SUN-BLOCK LOTIONS; SUN-TANNING OILS; SUN-TANNING OILS AND LOTIONS; SUN-TANNING PREPARATIONS; SUNSCREEN CREAM; SUNSCREEN CREAMS; SUNTAN CREAMS; SUNTAN OILS FOR COSMETIC PURPOSES; SUNTANNING PREPARATIONS; (BASED ON 44(D) PRIORITY APPLICATION) 3-IN-1 HAIR SHAMPOOS; AFTER SUN CREAMS; AFTER-SUN GELS; AFTER-SUN LOTIONS; AFTER-SUN MILKS; AFTER-SUN OILS; ALL PURPOSE CLEANING PREPARATIONS; ALL PURPOSE COTTON SWABS FOR PERSONAL USE; ALL-PURPOSE CLEANERS; ALMOND SOAPS; ALOE VERA GEL FOR COSMETIC PURPOSES; ANTIPERSPIRANTS AND DEODORANTS FOR PERSONAL USE; ANTIPERSPIRANTS FOR PERSONAL USE; AROMATHERAPY BODY CARE PRODUCTS, NAMELY, BODY LOTION, SHOWER GEL, CUTICLE CREAM, SHAMPOO, CONDITIONER, NON-MEDICATED LIP BALM, SOAP, BODY POLISH, BODY AND FOOT SCRUB AND NON-MEDICATED FOOT CREAM; AROMATHERAPY CREAMS; AROMATHERAPY EVAPORATING SHOWER BALLS; AROMATHERAPY LOTIONS; AROMATHERAPY OIL; AROMATHERAPY OILS; AROMATHERAPY PILLOWS COMPRISING POTPOURRI IN FABRIC CONTAINERS; AROMATHERAPY PILLOWS THAT MAY BE USED TO FRESHEN CLOTHING OR LAY OVER THE EYES; AROMATHERAPY SPRAYS; BABY HAIR CONDITIONER; BABY POWDER; BABY POWDERS; BAR SOAP; BATH AND SHOWER GELS AND SALTS NOT FOR MEDICAL PURPOSES; BATH CREAM; BATH HERBS; BATH LOTION; BATH MILKS; BATH OIL; BATH OILS; BATH OILS AND BATH SALTS; BATH OILS FOR COSMETIC PURPOSES; BATH PEARLS; BATH POWDER; BATH SALTS; BATH SALTS; BATH SOAPS; BATH SOAPS IN LIQUID, SOLID OR GEL FORM; BATHING LOTIONS; BEAUTY CREAMS; BEAUTY CREAMS FOR BODY CARE; BEAUTY GELS; BEAUTY LOTIONS; BEAUTY MASKS; BEAUTY MILKS; BODY AND BEAUTY CARE COSMETICS; BODY BUTTER; BODY CREAM; BODY CREAM SOAP; BODY CREAMS; BODY EMULSIONS; BODY LOTION; BODY LOTIONS; BODY MILK; BODY MILKS; BODY OIL; BODY OILS; BODY POWDER; BODY SPLASH; BODY SPRAYS; BODY WASHES; BUBBLE BATH; CAKES OF TOILET SOAP; CLEANSING MILK; CLOTHS OR TISSUES IMPREGNATED WITH A SKIN CLEANSER; COLD CREAM; COLD CREAMS; COSMETIC CREAMS; COSMETIC CREAMS FOR SKIN CARE; COSMETIC OILS; COSMETIC OILS FOR THE EPIDERMIS; COSMETIC OLIVE OIL FOR THE FACE AND BODY; COSMETIC PADS; COSMETIC PREPARATIONS; COSMETIC PREPARATIONS AGAINST SUNBURN; COSMETIC PREPARATIONS FOR BODY CARE; COSMETIC SUN-PROTECTING PREPARATIONS; COS-



METIC SUN-TANNING PREPARATIONS; COSMETIC SUNTAN LOTIONS; COSMETIC SUNTAN PREPARATIONS; COSMETICS; COSMETICS AND COSMETIC PREPARATIONS; COSMETICS AND MAKE-UP; COSMETICS IN GENERAL, INCLUDING PERFUMES; COSMETICS IN THE FORM OF MILKS, LOTIONS AND EMULSIONS; COTTON STICKS FOR COSMETIC PURPOSES; COTTON SWABS FOR COSMETIC PURPOSES; COTTON WOOL AND COTTON STICKS FOR COSMETIC PURPOSES; COTTON WOOL FOR COSMETIC PURPOSES; CREAM SOAPS; DEODORANT FOR PERSONAL USE; DEODORANT SOAP; DEODORANTS AND ANTIPERSPIRANTS; DEODORANTS AND ANTIPERSPIRANTS FOR PERSONAL USE; DEODORANTS FOR BODY CARE; FACE AND BODY BEAUTY CREAMS; FACE AND BODY CREAMS; FACE AND BODY LOTIONS; FACE CREAMS; FACIAL CLEANSERS; FACIAL CLEANSING MILK; FACIAL CREAM; FACIAL CREAMS; FACIAL EMULSIONS; FACIAL LOTION; FACIAL WASHES; FOAM CLEANING PREPARATIONS; HAIR SHAMPOO; HAND CREAM; HAND CREAMS; HAND LOTIONS; HAND SOAPS; IMPREGNATED CLEANING CLOTHS; IMPREGNATED CLEANING PADS IMPREGNATED WITH TOILET PREPARATIONS; IMPREGNATED CLEANING CLOTHS; IMPREGNATED PAPER TISSUES FOR CLEANING DISHWARE; LIQUID BATH SOAPS; LIQUID SOAP; LIQUID SOAPS; LIQUID SOAPS FOR HANDS AND FACE; LIQUID SOAPS FOR HANDS, FACE AND BODY; LOTIONS FOR FACE AND BODY CARE; NON-MEDICATED BATH PREPARATIONS; NON-MEDICATED BUBBLE BATH PREPARATIONS; NON-MEDICATED PREPARATIONS ALL FOR THE CARE OF SKIN; NON-MEDICATED SKIN CARE PREPARATIONS; NON-MEDICATED SKIN CARE PREPARATIONS, NAMELY, CREAMS, LOTIONS, GELS, TONERS, CLEANERS AND PEELS; NON-MEDICATED SKIN CREAMS; NON-MEDICATED TOILETRIES; PERSONAL DEODORANTS; PRE-MOISTENED TOWELETES IMPREGNATED WITH DISHWASHING DETERGENT; SCENTED BODY LOTIONS AND CREAMS; SHAMPOOS; SHAMPOOS FOR BABIES; SHOWER AND BATH FOAM; SHOWER AND BATH GEL; SHOWER CREAMS; SHOWER GEL; SHOWER GELS; SKIN AND BODY TOPICAL LOTIONS, CREAMS AND OILS FOR COSMETIC USE; SKIN CLEANSERS; SKIN CLEANSING CREAM; SKIN CLEANSING LOTION; SKIN CONDITIONERS; SKIN CONDITIONING CREAMS FOR COSMETIC PURPOSES; SKIN CREAM; SKIN CREAMS; SKIN CREAMS IN LIQUID AND IN SOLID FORM; SKIN CREAMS IN LIQUID AND SOLID; SKIN CREAMS IN LIQUID AND SOLID FORM; SKIN EMOLLIENTS; SKIN LOTION; SKIN LOTIONS; SKIN MOISTURIZER; SKIN MOISTURIZER MASKS; SKIN SOAP; SOAPS FOR BODY CARE; SOAPS FOR PERSONAL USE; SPF SUNBLOCK TOWELETES; SUN BLOCK; SUN BLOCK PREPARATIONS; SUN CARE LOTIONS; SUN CREAMS; SUN SCREEN; SUN SCREEN PREPARATIONS; SUN TAN GEL; SUN TAN LOTION; SUN TAN OIL; SUN-BLOCK LOTIONS; SUN-TANNING OILS; SUN-TANNING OILS AND LOTIONS; SUN-TANNING PREPARATIONS; SUNSCREEN CREAM; SUNSCREEN CREAMS; SUNTAN CREAMS; SUNTAN OILS FOR COSMETIC PURPOSES; SUNTANNING PREPARATIONS; TISSUES IMPREGNATED WITH COSMETIC LOTIONS; WIPES IMPREGNATED WITH A SKIN CLEANSER (U.S. CLS. 1, 4, 6, 50, 51 AND 52).

FIRST USE 1-9-1999; IN COMMERCE 1-9-2000.

### CLASS 5—PHARMACEUTICALS

FOR (BASED ON USE IN COMMERCE) BABY FOOD; BABY FOODS; BREAST PADS; BREAST-NURSING PADS; CEDAR WOOD FOR USE AS AN INSECT REPELLENT; FOOD FOR BABIES; FOOD FOR INFANTS; INSECT REPELLENT IN CANDLE FORM; INSECT REPELLENT IN THE NATURE OF A LAMP OIL; INSECT REPELLENTS; INSECT-REPELLENTS; MEDICATED PRE-MOISTENED TISSUES; MEDICATED PRE-MOISTENED TOWELETES; MEDICATED PRE-MOISTENED WIPES; NURSING PADS; POWDERED MILK FOR BABIES; SANITARY NAPKINS; SANITARY PADS; SANITARY PANTIES; SANITARY TOWELS; SANITIZING WIPES; (BASED ON 44(D) PRIORITY APPLICA-

TION) BABY FOOD; BABY FOODS; BREAST PADS; BREAST-NURSING PADS; CEDAR WOOD FOR USE AS AN INSECT REPELLENT; FOOD FOR BABIES; FOOD FOR INFANTS; INSECT REPELLENT IN CANDLE FORM; INSECT REPELLENT IN THE NATURE OF A LAMP OIL; INSECT REPELLENTS; INSECT-REPELLENTS; MEDICATED PRE-MOISTENED TISSUES; MEDICATED PRE-MOISTENED TOWELETES; NURSING PADS; POWDERED MILK FOR BABIES; SANITARY NAPKINS; SANITARY PADS; SANITARY PANTIES; SANITARY TOWELS (U.S. CLS. 6, 18, 44, 46, 51 AND 52).

FIRST USE 1-9-1999; IN COMMERCE 1-9-2000.

### CLASS 16—PAPER GOODS AND PRINTED MATTER

FOR (BASED ON USE IN COMMERCE) CELLULOSE WIPERS; CELLULOSE WIPES; PLASTIC BAGS FOR DISPOSABLE DIAPERS; PLASTIC DISPOSABLE DIAPER BAGS; PLASTIC GARBAGE BAGS; PLASTIC OR PAPER BAGS FOR HOUSEHOLD USE; BABIES' DIAPERS OF PAPER; BABY BOOKS; DISPOSABLE DIAPERS; DISPOSABLE NAPKINS; DISPOSABLE NAPPIES; DISPOSABLE PADS FOR DIAPER CHANGING; DISPOSABLE SWIM PANTS FOR CHILDREN AND INFANTS; DISPOSABLE TRAINING PANTS; DISPOSABLE WIPES NOT IMPREGNATED WITH CHEMICALS OR COMPOUNDS; PAPER BABY BIBS; PAPER DIAPERS; PAPER LINERS FOR DIAPERS; PAPER NAPKINS; TISSUE PAPER; TOILET PAPER; TOILET TISSUE; (BASED ON 44(D) PRIORITY APPLICATION) BABIES' DIAPERS OF PAPER; DISPOSABLE DIAPERS; DISPOSABLE NAPKINS; DISPOSABLE NAPPIES; DISPOSABLE TRAINING PANTS; PAPER DIAPERS; PAPER NAPKINS; PLASTIC BAGS FOR DISPOSABLE DIAPERS; PLASTIC DISPOSABLE DIAPER BAGS; PLASTIC GARBAGE BAGS; PLASTIC OR PAPER BAGS FOR HOUSEHOLD USE; TOILET PAPER (U.S. CLS. 2, 5, 22, 23, 29, 37, 38 AND 50).

FIRST USE 1-9-1999; IN COMMERCE 1-9-2000.

### CLASS 25—CLOTHING

FOR (BASED ON USE IN COMMERCE) BABY BIBS NOT OF PAPER; BABY BODYSUITS; BABY BOTTOMS; BABY BUNTING; BABY DOLL PYJAMAS; BABY LAYETTES FOR CLOTHING; BABY TOPS; BATH SLIPPERS; BATHING COSTUMES; BATHING SUITS; BATHING TRUNKS; BATHROBES; BEACH COVER-UPS; BEACH COVERUPS; BEACH FOOTWEAR; BEACH SHOES; BEACHWEAR; BEANIES; BED JACKETS; BELTS; BELTS FOR CLOTHING; BIB OVERALLS; BIB SHORTS; BIBS NOT OF CLOTH OR PAPER; BIBS NOT OF PAPER; BODY SHIRTS; BODY SUITS; BONNETS; BOOTIES; BOOTS; BOTTOMS; BRAS; BRASSIERES; BRIEFS; BRIEFS; CANVAS SHOES; CARDIGANS; CARGO PANTS; CHILDREN'S AND INFANT'S APPAREL, NAMELY, JUMPERS, OVERALL SLEEPWEAR, PAJAMAS, ROMPERS AND ONE-PIECE GARMENTS; CHILDREN'S AND INFANTS' CLOTH BIBS; CHILDREN'S CLOTH EATING BIBS; CHILDREN'S HEADWEAR; CLOTH BIBS; CLOTH DIAPERS; CLOTHING, NAMELY, MATERNITY BANDS; CLOTHING, NAMELY, WRAP-AROUNDS; COATS; COATS MADE OF COTTON; COATS OF DENIM; CULOTTES; DENIMS; DISPOSABLE SLIPPERS; DISPOSABLE UNDERWEAR; DRESSES; DRESSES THAT MAY ALSO BE USED AS TOWELS; DRESSING GOWNS; DRESSING GOWNS AND BATH ROBES; DUNGAREES; FOOTWEAR; GLOVES; GLOVES AS CLOTHING; GOWNS; HATS; HATS FOR INFANTS, BABIES, TODDLERS AND CHILDREN; HEAD WEAR; HEADWEAR; HOODED PULLOVERS; HOODED SWEAT SHIRTS; INFANT AND TODDLER ONE PIECE CLOTHING; INFANT CLOTH DIAPERS; INFANT DIAPER COVERS; INFANT SLEEPERS; INFANT WEAR; INFANTS' SHOES AND BOOTS; INFANTS' TROUSERS; INFANTWEAR; JACKETS; JACKETS AND SOCKS; JEANS; JUMPERS; JUMPSUITS; KNICKERS; KNITTED CAPS; KNITTED GLOVES; LAYETTES; LEGGINGS; LEISURE SHOES; LONG SLEEVED VESTS; MATERNITY LINGERIE; MATERNITY SLEEPWEAR; MITTENS; MUFFLERS; MUFFLERS; MUFFS; NIGHT GOWNS; NIGHT SHIRTS; NIGHTDRESSES; NIGHTGOWNS; NIGHTIES; NIGHTWEAR; NON-DISPOSABLE CLOTH TRAINING PANTS; ONE PIECE GARMENT FOR INFANTS AND TODDLERS; ONE-PIECE PLAY SUITS; OPEN-NECKED SHIRTS; OUTDOOR GLOVES; OUT-

DOOR MITTENS; OUTER JACKETS; PAJAMA BOTTOMS; PAJAMAS; PANTIES; PANTIES, SHORTS AND BRIEFS; PANTS; PLASTIC BABY BIBS; PLAY SUITS; ROMPERS; SHIRTS; SHIRTS AND SHORT-SLEEVED SHIRTS; SHIRTS FOR INFANTS, BABIES, TODDLERS AND CHILDREN; SHOES; SHORT SETS; SHORT TROUSERS; SHORT-SLEEVED OR LONG-SLEEVED T-SHIRTS; SHORT-SLEEVED SHIRTS; SHORTS; SKIRT SUITS; SKIRTS; SKORTS; SLEEPING GARMENTS; SLEEPWEAR; SLIPPERS; SLIPS; SMALL HATS; SMOCKS; SOCKS AND STOCKINGS; SWADDLING CLOTHES; T-SHIRTS; TEDDIES; TEE SHIRTS; TEXTILE DIAPERS; TEXTILE NAPPIES; TROUSERS; (BASED ON 44(D) PRIORITY APPLICATION) BABY BIBS NOT OF PAPER; BABY BODYSUITS; BABY BOTTOMS; BABY BUNTING; BABY DOLL PYJAMAS; BABY LAYETTES FOR CLOTHING; BABY TOPS; BATH SLIPPERS; BATHING COSTUMES; BATHING SUITS; BATHING TRUNKS; BATHROBES; BEACH COVER-UPS; BEACH COVERUPS; BEACH FOOTWEAR; BEACH SHOES; BEACHWEAR; BEANIES; BED JACKETS; BELTS; BELTS FOR CLOTHING; BIB OVERALLS; BIB SHORTS; BIBS NOT OF CLOTH OR PAPER; BIBS NOT OF PAPER; BODY SHIRTS; BODY SUITS; BONNETS; BOOTIES; BOOTS; BOTTOMS; BRAS; BRASSIERES; BRIEFS; BRIEFS; CANVAS SHOES; CARDIGANS; CARGO PANTS; CHILDREN'S AND INFANT'S APPAREL, NAMELY, JUMPERS, OVERALL SLEEPWEAR, PAJAMAS, ROMPERS AND ONE-PIECE GARMENTS; CHILDREN'S AND INFANTS' CLOTH BIBS; CHILDREN'S CLOTH EATING BIBS; CHILDREN'S HEADWEAR; CLOTH BIBS; CLOTH DIAPERS; CLOTHING, NAMELY, MATERNITY BANDS; CLOTHING, NAMELY, WRAP-AROUNDS; COATS; COATS MADE OF COTTON; COATS OF DENIM; CULOTTES; DENIMS; DISPOSABLE SLIPPERS; DISPOSABLE UNDERWEAR; DRESSES; DRESSES THAT MAY ALSO BE USED AS TOWELS; DRESSING GOWNS; DRESSING GOWNS AND BATH ROBES; DUNGAREES; FOOTWEAR; GLOVES; GLOVES AS CLOTHING; GOWNS; HATS; HATS FOR INFANTS, BABIES, TODDLERS AND CHILDREN; HEAD WEAR; HEADWEAR; HOODED PULLOVERS; HOODED SWEAT SHIRTS; INFANT AND TODDLER ONE PIECE CLOTHING; INFANT CLOTH DIAPERS; INFANT DIAPER COVERS; INFANT SLEEPERS; INFANT WEAR; INFANTS' SHOES AND BOOTS; INFANTS' TROUSERS; INFANTWEAR; JACKETS; JACKETS AND SOCKS; JEANS; JUMPERS; JUMPSUITS; KNICKERS; KNITTED CAPS; KNITTED GLOVES; LAYETTES; LEGGINGS; LEISURE SHOES; LONG SLEEVED VESTS; MATERNITY LINGERIE; MATERNITY SLEEPWEAR; MITTENS; MUFFLERS; MUFFLERS; MUFFS; NIGHT GOWNS; NIGHT SHIRTS; NIGHTDRESSES; NIGHTGOWNS; NIGHTTIES; NIGHTWEAR; NON-DISPOSABLE CLOTH TRAINING PANTS; ONE PIECE GARMENT FOR INFANTS AND TODDLERS; ONE-PIECE PLAY SUITS; OPEN-NECKED SHIRTS; OUTDOOR GLOVES; OUTDOOR MITTENS; OUTER JACKETS; PAJAMA BOTTOMS; PAJAMAS; PANTIES; PANTIES, SHORTS AND BRIEFS; PANTS; PLASTIC BABY BIBS; PLAY SUITS; ROMPERS; SHIRTS; SHIRTS AND SHORT-SLEEVED SHIRTS; SHIRTS FOR INFANTS, BABIES, TODDLERS AND CHILDREN; SHOES; SHORT SETS; SHORT TROUSERS; SHORT-SLEEVED OR LONG-SLEEVED T-SHIRTS; SHORT-SLEEVED SHIRTS; SHORTS; SKIRT SUITS; SKIRTS; SKORTS; SLEEPING GARMENTS; SLEEPWEAR; SLIPPERS; SLIPS; SMALL HATS; SMOCKS; SOCKS; SOCKS AND STOCKINGS; SWADDLING CLOTHES; T-SHIRTS; TEDDIES; TEE SHIRTS; TEXTILE DIAPERS; TEXTILE NAPPIES; TROUSERS (U.S. CLS. 22 AND 39).

FIRST USE 1-9-1999; IN COMMERCE 1-9-2000.

3,962,459. POSTITOS INC., LOS ANGELES, CA. SN 77-785,722. PUB. 1-12-2010, FILED 7-21-2009.

# POSTITOS

THE MARK CONSISTS OF STANDARD CHARACTERS

WITHOUT CLAIM TO ANY PARTICULAR FONT, STYLE, SIZE, OR COLOR.

THE WORDING "POSTITOS" HAS NO MEANING IN A FOREIGN LANGUAGE.

## CLASS 35—ADVERTISING AND BUSINESS

FOR ADVERTISING AND INFORMATION DISTRIBUTION SERVICES, NAMELY, PROVIDING CLASSIFIED ADVERTISING SPACE VIA THE GLOBAL COMPUTER NETWORK; PROVIDING CONSUMER PRODUCT AND SERVICE INFORMATION VIA THE INTERNET; PROMOTING THE GOODS AND SERVICES OF OTHERS OVER THE INTERNET; PROVIDING AN ONLINE BUSINESS INFORMATION DIRECTORY ON THE INTERNET; COMPUTERIZED DATABASE MANAGEMENT; PROMOTING AND ADVERTISING INFORMATION ABOUT THE PROFESSIONAL SERVICES OF OTHERS; PROVIDING ON-LINE COMPUTER DATABASES AND ON-LINE SEARCHABLE DATABASES FEATURING CLASSIFIED LISTINGS AND WANT ADS; PROVIDING ON-LINE COMPUTER DATABASES AND ON-LINE SEARCHABLE DATABASES FEATURING INFORMATION, CLASSIFIED LISTINGS AND ANNOUNCEMENTS ABOUT EMPLOYMENT INFORMATION AND RESUMES, JOB OPENINGS, VOLUNTEER INFORMATION AND VOLUNTEER OPPORTUNITIES THROUGH COMMUNITY AND CHARITABLE ORGANIZATIONS AND BUSINESSES, INFORMATION ABOUT COMMUNITY SERVICE PROGRAMS, INFORMATION ABOUT POLITICS, BUSINESS EVENTS, AND BUSINESS MEETINGS; CLASSIFIED LISTINGS FOR RENTALS OF A WIDE-VARIETY OF CONSUMER AND BUSINESS GOODS; COMPUTER SERVICES, NAMELY, PROVIDING ON-LINE COMPUTER DATABASES AND ON-LINE SEARCHABLE DATABASES FEATURING CONSUMER INFORMATION ON A WIDE VARIETY OF TOPICS OF GENERAL INTEREST TO THE CONSUMING PUBLIC (U.S. CLS. 100, 101 AND 102).

FIRST USE 10-1-2008; IN COMMERCE 8-13-2009.

## CLASS 38—COMMUNICATION

FOR PROVIDING ONLINE INTERACTIVE BULLETIN BOARDS FOR TRANSMISSION OF MESSAGES AMONG COMPUTER USERS CONCERNING CLASSIFIED LISTINGS AND LISTINGS FOR ANNOUNCEMENTS, EVENTS, CLASSES, MEETINGS, ACTIVITIES, HOUSING, REAL ESTATE, ROOMMATES, RENTALS, FOR SALE ADVERTISEMENTS, WANT ADS, EMPLOYMENT, RESUMES, VOLUNTEERISM, SERVICES, COMMUNITY, PERSONALS, POLITICS, FAMILY, ARTS AND INFORMATION ON A WIDE VARIETY OF TOPICS OF GENERAL INTEREST TO THE PUBLIC; PROVIDING ON-LINE FORUMS AND DISCUSSION GROUPS FOR TRANSMISSION OF MESSAGES AMONG COMPUTER USERS CONCERNING HEALTH, FAMILY, ARTS, POLITICS, LEISURE, ROMANCE, WORK, AND INFORMATION ON A WIDE VARIETY OF TOPICS OF GENERAL INTEREST TO THE PUBLIC; ELECTRONIC MAIL SERVICES; ELECTRONIC MAIL SUBSCRIPTION SERVICES; AND ELECTRONIC TRANSMISSION OF MESSAGES, DATA AND IMAGES; AUDIO AND VIDEO BROADCASTING SERVICES OVER THE INTERNET OR OTHER COMMUNICATIONS NETWORK, NAMELY, ELECTRONICALLY TRANSMITTING INFORMATION, AUDIO, AND VIDEO CLIPS; PROVIDING ACCESS TO INFORMATION, AUDIO, AND VIDEO VIA WEBSITES, ONLINE FORUMS, CHAT ROOMS, LIST SERVICE AND BLOGS OVER THE INTERNET; PROVIDING ON-LINE CHAT ROOMS AND ELECTRONIC BULLETIN BOARDS FOR TRANSMISSION OF MESSAGES AMONG USERS IN THE FIELD OF GENERAL INTEREST (U.S. CLS. 100, 101 AND 104).

FIRST USE 10-1-2008; IN COMMERCE 8-13-2009.

3,962,462. VICAR OPERATING, INC., LOS ANGELES, CA.  
SN 77-786,995. PUB. 7-20-2010, FILED 7-22-2009.

## SOUND-EKLIN

THE MARK CONSISTS OF STANDARD CHARACTERS WITHOUT CLAIM TO ANY PARTICULAR FONT, STYLE, SIZE, OR COLOR.

OWNER OF U.S. REG. NOS. 2,975,821 AND 3,528,170.

### CLASS 9—ELECTRICAL AND SCIENTIFIC APPARATUS

FOR DIGITAL MEDICAL AND VETERINARY IMAGE STORAGE DEVICES, NAMELY, COMPUTER WORKSTATIONS COMPRISING A HARD DRIVE, APPARATUS FOR RECORDING, TRANSMISSION OR REPRODUCTION OF IMAGES, CENTRAL PROCESSING UNIT FOR PROCESSING INFORMATION, DATA, OR IMAGES, AND PRELOADED COMPUTER SOFTWARE FOR DIGITAL MEDICAL IMAGE PROCESSING AND MANAGEMENT; COMPUTER HARD DRIVES FOR STORAGE OF DIGITAL MEDICAL AND VETERINARY IMAGES; BLANK MAGNETIC AND OPTICAL AND MAGNETO-OPTICAL DATA AND DIGITAL AND OPTICAL DATA CARRIERS FOR STORING MEDICAL IMAGES; CD AND DVD BURNERS FOR STORING DIGITAL MEDICAL AND VETERINARY IMAGES; MONITORS FOR DIGITAL IMAGE PRESENTATION; DIGITAL IMAGE GENERATORS AND PROCESSORS; DIGITAL IMAGE PANELS; X-RAY PANEL SENSORS; X-RAY SENSORS; MAGNETIC AND OPTICAL IMAGE STORAGE DEVICES FOR STORING MEDICAL IMAGES; AND COMPUTER WORKSTATIONS WITH PRE-LOADED SOFTWARE FOR DIGITAL RADIOGRAPHY IMAGE PROCESSING AND IMAGE MANAGEMENT; X-RAY GENERATORS; IMAGE PROCESSORS, NAMELY, DIGITAL IMAGE PROCESSING SOFTWARE; MAGNETIC AND OPTICAL IMAGE STORAGE DEVICES FOR STORING MEDICAL IMAGES; SOFTWARE FOR USE IN CAPTURING RADIOGRAPHIC IMAGES ONTO STORAGE MEDIA; COMPUTER WORKSTATION WITH PRELOADED SOFTWARE FOR DIGITAL RADIOGRAPHY IMAGE PROCESSING AND IMAGE MANAGEMENT; MAGNETIC AND OPTICAL IMAGE STORAGE DEVICES, NAMELY, COMPUTER SERVERS AND NETWORK-ATTACHED-STORAGE (NAS) DEVICES FOR STORING MEDICAL IMAGES (U.S. CLS. 21, 23, 26, 36 AND 38).

FIRST USE 7-0-2009; IN COMMERCE 7-0-2009.

### CLASS 10—MEDICAL APPARATUS

FOR MEDICAL IMAGE GENERATORS, NAMELY, X-RAY GENERATORS; MEDICAL IMAGE PROCESSORS; DIGITAL RADIOGRAPHY SYSTEMS FOR VETERINARY AND HUMAN MEDICAL USES, NAMELY, X-RAY MACHINES, X-RAY HEADS, X-RAY PANEL SENSORS, X-RAY PANEL CASES AND X-RAY GRIDS, TUNNELS AND BUMPERS; ULTRASOUND EQUIPMENT AND SYSTEMS, NAMELY, VETERINARY ULTRASOUND APPARATUS (U.S. CLS. 26, 39 AND 44).

FIRST USE 7-0-2009; IN COMMERCE 7-0-2009.

### CLASS 39—TRANSPORTATION AND STORAGE

FOR STORAGE OF ELECTRONIC MEDIA, NAMELY, DIGITAL IMAGES AND RELATED DATA TEXT IN THE MEDICAL AND VETERINARY FIELDS; STORAGE SERVICES FOR ARCHIVING RADIOGRAPHIC IMAGES, PATIENT AND OWNER DATA (U.S. CLS. 100 AND 105).

FIRST USE 7-0-2009; IN COMMERCE 7-0-2009.

### CLASS 41—EDUCATION AND ENTERTAINMENT

FOR TRAINING, EDUCATION SERVICES, NAMELY, ON-SITE TUTORING, COURSES, WET LABS AND SEMINARS IN THE FIELD OF ULTRASOUND, RADIOGRAPHY, COMPUTED TOMOGRAPHY, RADIATION ONCOLOGY, AND MAGNETIC RESONANCE IMAGING (U.S. CLS. 100, 101 AND 107).

FIRST USE 7-0-2009; IN COMMERCE 7-0-2009.

### CLASS 42—SCIENTIFIC AND COMPUTER SERVICES

FOR UPLOADING, RETRIEVING, AND SHARING DIGITAL IMAGES AND RELATED DATA AND TEXT IN THE MEDICAL AND VETERINARY FIELDS VIA A WEB SITE, DIRECT LINK, DICOM QUERY, OR THE LIKE; SUPPORT SERVICES, NAMELY, REPAIRING AND UPDATING SOFTWARE FOR OTHERS IN THE FIELD OF ULTRASOUND, RADIOGRAPHY, COMPUTED TOMOGRAPHY, RADIATION ONCOLOGY, AND MAGNETIC RESONANCE IMAGING; TECHNICAL SUPPORT SERVICES, NAMELY, TROUBLESHOOTING AND PROVIDING TECHNICAL ADVICE IN THE FIELD OF ULTRASOUND, RADIOGRAPHY, COMPUTED TOMOGRAPHY, RADIATION ONCOLOGY AND MAGNETIC RESONANCE IMAGING EQUIPMENT AND RELATED COMPUTER SOFTWARE (U.S. CLS. 100 AND 101).

FIRST USE 7-0-2009; IN COMMERCE 7-0-2009.

3,962,463. VICAR OPERATING, INC., LOS ANGELES, CA.  
SN 77-787,043. PUB. 7-20-2010, FILED 7-22-2009.



OWNER OF U.S. REG. NOS. 2,975,821 AND 3,528,170.

THE MARK CONSISTS OF THE WORDS "SOUND-EKLIN" IN LOWER CASE STYLIZED FONT SEPARATED BY A HYPHEN AND ENCLOSED IN A SWOOSH DEVICE ON BOTH SIDES WHICH SHAPES AN OVAL AROUND THE WORDS.

**CLASS 9—ELECTRICAL AND SCIENTIFIC APPARATUS**

FOR DIGITAL MEDICAL AND VETERINARY IMAGE STORAGE DEVICES, NAMELY, COMPUTER WORKSTATIONS COMPRISING A HARD DRIVE, APPARATUS FOR RECORDING, TRANSMISSION OR REPRODUCTION OF IMAGES, CENTRAL PROCESSING UNIT FOR PROCESSING INFORMATION, DATA, OR IMAGES, AND PRELOADED COMPUTER SOFTWARE FOR DIGITAL MEDICAL IMAGE PROCESSING AND MANAGEMENT; COMPUTER HARD DRIVES FOR STORAGE OF DIGITAL MEDICAL AND VETERINARY IMAGES; BLANK MAGNETIC AND OPTICAL AND MAGNETO-OPTICAL DATA AND DIGITAL AND OPTICAL DATA CARRIERS FOR STORING MEDICAL IMAGES; CD AND DVD BURNERS FOR STORING DIGITAL MEDICAL AND VETERINARY IMAGES; MONITORS FOR DIGITAL IMAGE PRESENTATION; DIGITAL IMAGE GENERATORS AND PROCESSORS; DIGITAL IMAGE PANELS; X-RAY PANEL SENSORS; X-RAY SENSORS; MAGNETIC AND OPTICAL IMAGE STORAGE DEVICES FOR STORING MEDICAL IMAGES; AND COMPUTER WORKSTATIONS WITH PRE-LOADED SOFTWARE FOR DIGITAL RADIOGRAPHY IMAGE PROCESSING AND IMAGE MANAGEMENT; X-RAY GENERATORS; IMAGE PROCESSORS, NAMELY, DIGITAL IMAGE PROCESSING SOFTWARE; MAGNETIC AND OPTICAL IMAGE STORAGE DEVICES FOR STORING MEDICAL IMAGES; SOFTWARE FOR USE IN CAPTURING RADIOGRAPHIC IMAGES ONTO STORAGE MEDIA; COMPUTER WORKSTATION WITH PRELOADED SOFTWARE FOR DIGITAL RADIOGRAPHY IMAGE PROCESSING AND IMAGE MANAGEMENT; MAGNETIC AND OPTICAL IMAGE STORAGE DEVICES, NAMELY, COMPUTER SERVERS AND NETWORK-ATTACHED-STORAGE (NAS) DEVICES FOR STORING MEDICAL IMAGES (U.S. CLS. 21, 23, 26, 36 AND 38).

FIRST USE 7-0-2009; IN COMMERCE 7-0-2009.

**CLASS 42—SCIENTIFIC AND COMPUTER SERVICES**

FOR UPLOADING, RETRIEVING, AND SHARING DIGITAL IMAGES AND RELATED DATA AND TEXT IN THE MEDICAL AND VETERINARY FIELDS VIA A WEB SITE, DIRECT LINK, DICOM QUERY, OR THE LIKE; SUPPORT SERVICES, NAMELY, REPAIRING AND UPDATING SOFTWARE FOR OTHERS IN THE FIELD OF ULTRASOUND, RADIOGRAPHY, COMPUTED TOMOGRAPHY, RADIATION ONCOLOGY, AND MAGNETIC RESONANCE IMAGING; TECHNICAL SUPPORT SERVICES, NAMELY, TROUBLESHOOTING AND PROVIDING TECHNICAL ADVICE IN THE FIELD OF ULTRASOUND, RADIOGRAPHY, COMPUTED TOMOGRAPHY, RADIATION ONCOLOGY AND MAGNETIC RESONANCE IMAGING EQUIPMENT AND RELATED COMPUTER SOFTWARE (U.S. CLS. 100 AND 101).

FIRST USE 7-0-2009; IN COMMERCE 7-0-2009.

3,962,464. VICAR OPERATING, INC., LOS ANGELES, CA.  
SN 77-787,912. PUB. 7-20-2010, FILED 7-23-2009.

**CLASS 10—MEDICAL APPARATUS**

FOR MEDICAL IMAGE GENERATORS, NAMELY, X-RAY GENERATORS; MEDICAL IMAGE PROCESSORS; DIGITAL RADIOGRAPHY SYSTEMS FOR VETERINARY AND HUMAN MEDICAL USES, NAMELY, X-RAY MACHINES, X-RAY HEADS, X-RAY PANEL SENSORS, X-RAY PANEL CASES AND X-RAY GRIDS, TUNNELS AND BUMPERS; ULTRASOUND EQUIPMENT AND SYSTEMS, NAMELY, VETERINARY ULTRASOUND APPARATUS (U.S. CLS. 26, 39 AND 44).

FIRST USE 7-0-2009; IN COMMERCE 7-0-2009.

**CLASS 39—TRANSPORTATION AND STORAGE**

FOR STORAGE OF ELECTRONIC MEDIA, NAMELY, DIGITAL IMAGES AND RELATED DATA TEXT IN THE MEDICAL AND VETERINARY FIELDS; STORAGE SERVICES FOR ARCHIVING RADIOGRAPHIC IMAGES, PATIENT AND OWNER DATA (U.S. CLS. 100 AND 105).

FIRST USE 7-0-2009; IN COMMERCE 7-0-2009.

**CLASS 41—EDUCATION AND ENTERTAINMENT**

FOR TRAINING, EDUCATION SERVICES, NAMELY, ON-SITE TUTORING, COURSES, WET LABS AND SEMINARS IN THE FIELD OF ULTRASOUND, RADIOGRAPHY, COMPUTED TOMOGRAPHY, RADIATION ONCOLOGY, AND MAGNETIC RESONANCE IMAGING (U.S. CLS. 100, 101 AND 107).

FIRST USE 7-0-2009; IN COMMERCE 7-0-2009.



OWNER OF U.S. REG. NOS. 2,975,821 AND 3,528,170.  
THE COLOR(S) BLUE AND GRAY IS/ARE CLAIMED AS A FEATURE OF THE MARK.

THE MARK CONSISTS OF THE WORDS "SOUND-EKLIN" IN LOWER CASE STYLIZED FONT SEPARATED BY A HYPHEN AND ENCLOSED IN A SWOOSH DEVICE ON BOTH SIDES WHICH SHAPES AN OVAL AROUND THE WORDS. THE WORD "SOUND" IS BLUE AND THE DOT OVER THE LETTER "I" IN "EKLIN" IS BLUE. THE WORD "EKLIN" AND THE HYPHEN ARE GRAY. THE SWOOSH DEVICE ON BOTH SIDES OF THE WORDS IS GRAY AND BLUE.



**CLASS 9—ELECTRICAL AND SCIENTIFIC APPARATUS**

FOR DIGITAL MEDICAL AND VETERINARY IMAGE STORAGE DEVICES, NAMELY, COMPUTER WORKSTATIONS COMPRISING A HARD DRIVE, APPARATUS FOR RECORDING, TRANSMISSION OR REPRODUCTION OF IMAGES, CENTRAL PROCESSING UNIT FOR PROCESSING INFORMATION, DATA, OR IMAGES, AND PRELOADED COMPUTER SOFTWARE FOR DIGITAL MEDICAL IMAGE PROCESSING AND MANAGEMENT; COMPUTER HARD DRIVES FOR STORAGE OF DIGITAL MEDICAL AND VETERINARY IMAGES; BLANK MAGNETIC AND OPTICAL AND MAGNETO-OPTICAL DATA AND DIGITAL AND OPTICAL DATA CARRIERS FOR STORING MEDICAL IMAGES; CD AND DVD BURNERS FOR STORING DIGITAL MEDICAL AND VETERINARY IMAGES; MONITORS FOR DIGITAL IMAGE PRESENTATION; DIGITAL IMAGE GENERATORS AND PROCESSORS; DIGITAL IMAGE PANELS; X-RAY PANEL SENSORS; X-RAY SENSORS; MAGNETIC AND OPTICAL IMAGE STORAGE DEVICES FOR STORING MEDICAL IMAGES; AND COMPUTER WORKSTATIONS WITH PRE-LOADED SOFTWARE FOR DIGITAL RADIOGRAPHY IMAGE PROCESSING AND IMAGE MANAGEMENT; X-RAY GENERATORS; IMAGE PROCESSORS, NAMELY, DIGITAL IMAGE PROCESSING SOFTWARE; MAGNETIC AND OPTICAL IMAGE STORAGE DEVICES FOR STORING MEDICAL IMAGES; SOFTWARE FOR USE IN CAPTURING RADIOGRAPHIC IMAGES ONTO STORAGE MEDIA; COMPUTER WORKSTATION WITH PRELOADED SOFTWARE FOR DIGITAL RADIOGRAPHY IMAGE PROCESSING AND IMAGE MANAGEMENT; MAGNETIC AND OPTICAL IMAGE STORAGE DEVICES, NAMELY, COMPUTER SERVERS AND NETWORK-ATTACHED-STORAGE (NAS) DEVICES FOR STORING MEDICAL IMAGES (U.S. CLS. 21, 23, 26, 36 AND 38).

FIRST USE 7-0-2009; IN COMMERCE 7-0-2009.

**CLASS 10—MEDICAL APPARATUS**

FOR MEDICAL IMAGE GENERATORS, NAMELY, X-RAY GENERATORS; MEDICAL IMAGE PROCESSORS; DIGITAL RADIOGRAPHY SYSTEMS FOR VETERINARY AND HUMAN MEDICAL USES, NAMELY, X-RAY MACHINES, X-RAY HEADS, X-RAY PANEL SENSORS, X-RAY PANEL CASES AND X-RAY GRIDS, TUNNELS AND BUMPERS; ULTRASOUND EQUIPMENT AND SYSTEMS, NAMELY, VETERINARY ULTRASOUND APPARATUS (U.S. CLS. 26, 39 AND 44).

FIRST USE 7-0-2009; IN COMMERCE 7-0-2009.

**CLASS 39—TRANSPORTATION AND STORAGE**

FOR STORAGE OF ELECTRONIC MEDIA, NAMELY, DIGITAL IMAGES AND RELATED DATA TEXT IN THE MEDICAL AND VETERINARY FIELDS; STORAGE SERVICES FOR ARCHIVING RADIOGRAPHIC IMAGES, PATIENT AND OWNER DATA (U.S. CLS. 100 AND 105).

FIRST USE 7-0-2009; IN COMMERCE 7-0-2009.

**CLASS 41—EDUCATION AND ENTERTAINMENT**

FOR TRAINING, EDUCATION SERVICES, NAMELY, ON-SITE TUTORING, COURSES, WET LABS AND SEMINARS IN THE FIELD OF ULTRASOUND, RADIOGRAPHY, COMPUTED TOMOGRAPHY, RADIATION ONCOLOGY, AND MAGNETIC RESONANCE IMAGING (U.S. CLS. 100, 101 AND 107).

FIRST USE 7-0-2009; IN COMMERCE 7-0-2009.

**CLASS 42—SCIENTIFIC AND COMPUTER SERVICES**

FOR UPLOADING, RETRIEVING, AND SHARING DIGITAL IMAGES AND RELATED DATA AND TEXT IN THE MEDICAL AND VETERINARY FIELDS VIA A WEB SITE, DIRECT LINK, DICOM QUERY, OR THE LIKE; SUPPORT SERVICES, NAMELY, REPAIRING AND UPDATING SOFTWARE FOR OTHERS IN THE FIELD OF ULTRASOUND, RADIOGRAPHY, COMPUTED TOMOGRAPHY, RADIATION ONCOLOGY, AND MAGNETIC RESONANCE IMAGING; TECHNICAL SUPPORT SERVICES, NAMELY, TROUBLESHOOTING AND PROVIDING TECHNICAL ADVICE IN THE FIELD OF ULTRASOUND, RADIOGRAPHY, COMPUTED TOMOGRAPHY, RADIATION ONCOLOGY AND MAGNETIC RESONANCE IMAGING EQUIPMENT AND RELATED COMPUTER SOFTWARE (U.S. CLS. 100 AND 101).

FIRST USE 7-0-2009; IN COMMERCE 7-0-2009.

---

3,962,470. TEXTRON INNOVATIONS INC., PROVIDENCE, RI. SN 77-790,346. PUB. 6-1-2010, FILED 7-27-2009.

**GREENLEE UTILITY**

THE MARK CONSISTS OF STANDARD CHARACTERS WITHOUT CLAIM TO ANY PARTICULAR FONT, STYLE, SIZE, OR COLOR.

OWNER OF U.S. REG. NOS. 514,729 AND 1,734,296.

NO CLAIM IS MADE TO THE EXCLUSIVE RIGHT TO USE "UTILITY", APART FROM THE MARK AS SHOWN.

SEC. 2(F).

**CLASS 7—MACHINERY**

FOR HYDRAULIC WATER PUMPS FOR WATER REMOVAL; HYDRAULIC POWER UNITS FOR OPERATION OF HYDRAULICALLY POWERED TOOLS; HYDRAULIC PRESSURE BOOSTERS; BATTERY-POWERED POWER TOOLS, NAMELY, CRIMPERS, HYDRAULICALLY-OPERATED TOOLS, NAMELY, IMPACT WRENCHES, PRUNERS, DRILLS, HAMMER DRILLS, ROTARY HAMMER DRILLS, CHAIN SAWS, CIRCULAR SAWS, CRIMPERS, PAVING BREAKERS, SIGN POST DRIVERS, SIGN POST PULLERS, POLE TAMPERS, POST PULLERS AND GROUND ROD BREAKERS (U.S. CLS. 13, 19, 21, 23, 31, 34 AND 35).

FIRST USE 9-30-2009; IN COMMERCE 3-31-2010.

**CLASS 9—ELECTRICAL AND SCIENTIFIC APPARATUS**

FOR CONTROL VALVES FOR REGULATING THE FLOW OF LIQUIDS (U.S. CLS. 21, 23, 26, 36 AND 38).

FIRST USE 9-30-2009; IN COMMERCE 10-31-2009.



3,962,472. LEITH, KATHERINE HENRIETTA, COLUMBIA, SC. SN 77-790,524. PUB. 12-15-2009, FILED 7-27-2009.



NO CLAIM IS MADE TO THE EXCLUSIVE RIGHT TO USE "HANDMADE KNITS AND WARES", APART FROM THE MARK AS SHOWN.

THE NAME "JULIALELE" DOES NOT IDENTIFY A LIVING INDIVIDUAL.

THE COLOR(S) GRAY, RED AND YELLOW IS/ARE CLAIMED AS A FEATURE OF THE MARK.

THE MARK CONSISTS OF A GRAY BACKGROUND RECTANGLE, THE WORDING "JULIALELE" IN RED, AND THE WORDING "HANDMADE KNITS AND WARES" IN YELLOW.

#### CLASS 18—LEATHER GOODS

FOR CLOTHING ACCESSORIES THAT HAVE BEEN KNITTED, CROCHETED, OR SEWN BY HAND, AND INTENDED FOR USE BY ADULTS, CHILDREN, AND BABIES, NAMELY, PURSES AND HAND BAGS (U.S. CLS. 1, 2, 3, 22 AND 41).

FIRST USE 9-1-2009; IN COMMERCE 1-1-2010.

#### CLASS 25—CLOTHING

FOR CLOTHING THAT HAS BEEN KNITTED, CROCHETED, OR SEWN BY HAND, INTENDED FOR WEAR BY ADULTS, CHILDREN, OR BABIES, NAMELY, SHIRTS, SWEATERS, TANK TOPS, SKIRTS, PANTS, SHORTS, DRESSES, JUMPERS, CARDIGANS, COATS, JACKETS, SCARVES, MITTENS, GLOVES, ARM WARMERS, NECK WARMERS, SHRUGS, WRAPS, CAPES, CAPS, HATS, SOCKS, BELTS, APRONS, AND HEAD BANDS (U.S. CLS. 22 AND 39).

FIRST USE 9-1-2009; IN COMMERCE 1-1-2010.

3,962,482. HOLDING SOPREMA, STRASBOURG CEDEX, FRANCE. SN 77-795,647. PUB. 9-14-2010, FILED 8-3-2009.

# RESISTOSEAL

THE MARK CONSISTS OF STANDARD CHARACTERS WITHOUT CLAIM TO ANY PARTICULAR FONT, STYLE, SIZE, OR COLOR.

OWNER OF CANADA REG. NO. TMA749073, DATED 9-30-2009, EXPIRES 9-30-2024.

#### CLASS 2—PAINTS

FOR ASPHALT-BASED ALUMINUM PAINT (U.S. CLS. 6, 11 AND 16).

FIRST USE 11-4-2008; IN COMMERCE 2-9-2011.

#### CLASS 3—COSMETICS AND CLEANING PREPARATIONS

FOR CLEANING PREPARATIONS FOR OIL SPOT, DIRT AND GREASE CLEANING; DEGREASING PREPARATIONS NOT USED IN MANUFACTURING PROCESSES FOR ASPHALT AND CONCRETE SURFACES (U.S. CLS. 1, 4, 6, 50, 51 AND 52).

FIRST USE 11-4-2008; IN COMMERCE 2-9-2011.

#### CLASS 19—NON-METALLIC BUILDING MATERIALS

FOR PRODUCTS FOR THE MAINTENANCE, REPAIRS AND PROTECTION OF ASPHALT SURFACES, NAMELY, LEVELING AND CRACK FILLER, LEVELING PATCH, RUBBERIZED CRACK FILLER, LIQUID CRACK FILLER, POT HOLE PATCH AND ASPHALT REPAIR IN THE NATURE OF ASPHALT PATCHING COMPOUND MADE OF ASPHALT, RUBBER, OR BITUMEN BASE; OIL SPOT PRIMER, ASPHALT SEALER; ASPHALT BASED PRODUCTS, NAMELY, PLASTIC CEMENT, NON FIBROUS AND FIBROUS COATINGS FOR USE ON ASPHALT SURFACES, ADHESIVE CEMENT IN THE NATURE OF MASTIC ADHESIVE FOR ASPHALT SURFACES, FOUNDATION COATING, PRIMER, CONTRACTOR PLASTIC CEMENT, WINTER PLASTIC CEMENT, ASPHALT SEALER, AND PATCHING MATERIALS, NAMELY, CONCRETE SEALERS (U.S. CLS. 1, 12, 33 AND 50).

FIRST USE 11-4-2008; IN COMMERCE 2-9-2011.

3,962,483. HOLDING SOPREMA, 67100 STRASBOURG CEDEX, FRANCE. SN 77-795,719. PUB. 9-14-2010, FILED 8-3-2009.



OWNER OF CANADA REG. NO. TMA749076, DATED 9-30-2009, EXPIRES 9-30-2024.

THE MARK CONSISTS OF THE WORDING "RESISTOSEAL" OVERLAYING A DESIGN ELEMENT OF A CHECK MARK OVERLAYING A CIRCLE. THE "O" IN THE MARK IS IN THE FORM OF A WATER DROPLET. ALL THE WORDING AND DESIGN ARE OUTLINED.

#### CLASS 2—PAINTS

FOR ASPHALT-BASED ALUMINUM PAINT (U.S. CLS. 6, 11 AND 16).

FIRST USE 11-4-2008; IN COMMERCE 2-9-2011.

#### CLASS 3—COSMETICS AND CLEANING PREPARATIONS

FOR CLEANING PREPARATIONS FOR OIL SPOT, DIRT AND GREASE CLEANING; DEGREASING PREPARATIONS NOT USED IN MANUFACTURING PROCESSES FOR ASPHALT AND CONCRETE SURFACES (U.S. CLS. 1, 4, 6, 50, 51 AND 52).

FIRST USE 11-4-2008; IN COMMERCE 2-9-2011.

**CLASS 19—NON-METALLIC BUILDING MATERIALS**

FOR PRODUCTS FOR THE MAINTENANCE, REPAIRS AND PROTECTION OF ASPHALT SURFACES, NAMELY, LEVELING AND CRACK FILLER, LEVELING PATCH, RUBBERIZED CRACK FILLER, LIQUID CRACK FILLER, POTHOLE PATCH AND ASPHALT REPAIR IN THE NATURE OF ASPHALT PATCHING COMPOUND MADE OF ASPHALT, RUBBER, OR BITUMEN BASE; OIL SPOT PRIMER, ASPHALT SEALER; ASPHALT BASED PRODUCTS, NAMELY, PLASTIC CEMENT, NON FIBROUS AND FIBROUS COATINGS FOR USE ON ASPHALT SURFACES, ADHESIVE CEMENT IN THE NATURE OF MASTIC ADHESIVE FOR ASPHALT SURFACES, FOUNDATION COATING, PRIMER, CONTRACTOR PLASTIC CEMENT, WINTER PLASTIC CEMENT, ASPHALT SEALER, AND PATCHING MATERIALS, NAMELY, CONCRETE SEALERS (U.S. CLS. 1, 12, 33 AND 50).

FIRST USE 11-4-2008; IN COMMERCE 2-9-2011.

WITHOUT CLAIM TO ANY PARTICULAR FONT, STYLE, SIZE, OR COLOR.

**CLASS 11—ENVIRONMENTAL CONTROL APPARATUS**

FOR REFRIGERATION EQUIPMENT, NAMELY, BEVERAGE COOLING UNITS AND TABLES WITH BUILT-IN BEVERAGE COOLING UNITS (U.S. CLS. 13, 21, 23, 31 AND 34).

FIRST USE 2-9-2011; IN COMMERCE 2-9-2011.

**CLASS 28—TOYS AND SPORTING GOODS**

FOR GAMING TABLES; BEER PONG TABLES (U.S. CLS. 22, 23, 38 AND 50).

FIRST USE 2-9-2011; IN COMMERCE 2-9-2011.

3,962,489. SQUARE, INC., SAN FRANCISCO, CA. SN 77-798,170. PUB. 6-29-2010, FILED 8-5-2009.

SQUARE

THE MARK CONSISTS OF STANDARD CHARACTERS WITHOUT CLAIM TO ANY PARTICULAR FONT, STYLE, SIZE, OR COLOR.

**CLASS 35—ADVERTISING AND BUSINESS**

FOR RECONCILING CREDIT CARD, DEBIT CARD, AND GIFT CARD ACCOUNTS TRANSACTIONS VIA A GLOBAL COMPUTER NETWORK (U.S. CLS. 100, 101 AND 102).

FIRST USE 7-0-2009; IN COMMERCE 7-0-2009.

**CLASS 36—INSURANCE AND FINANCIAL**

FOR RECONCILING, NAMELY, PROCESSING CREDIT CARD, DEBIT CARD, AND GIFT CARD TRANSACTIONS VIA A GLOBAL COMPUTER NETWORK (U.S. CLS. 100, 101 AND 102).

FIRST USE 7-0-2009; IN COMMERCE 7-0-2009.

**CLASS 38—COMMUNICATION**

FOR PROVIDING ELECTRONIC TRANSMISSION OF CREDIT CARD, DEBIT CARD, AND GIFT CARD TRANSACTION DATA, NAMELY, CHARGES (U.S. CLS. 100, 101 AND 104).

FIRST USE 7-0-2009; IN COMMERCE 7-0-2009.

3,962,491. BIG DOGG PONG LLC, DBA BD PONG, WARREN, NJ. SN 77-798,914. PUB. 6-29-2010, FILED 8-6-2009.

JUST CHILLIN'

THE MARK CONSISTS OF STANDARD CHARACTERS

3,962,492. UNITED STATES DEPARTMENT OF HOMELAND SECURITY, WASHINGTON, DC. SN 77-799,459. PUB. 6-15-2010, FILED 8-7-2009.



NO CLAIM IS MADE TO THE EXCLUSIVE RIGHT TO USE "U.S. COAST GUARD", APART FROM THE MARK AS SHOWN.

THE MARK CONSISTS OF THE WORDS "U.S. COAST GUARD" IN BOLD CAPITAL LETTERS WITH THE WORDS "BORN READY" APPEARING IN SLIGHTLY SMALLER STYLIZED CAPITAL LETTERS DIRECTLY BENEATH THE MIDPOINT TO THE END OF THE WORDS "COAST GUARD". THE WORDS "BORN READY" ANGLE SLIGHTLY UP FROM LEFT TO RIGHT AND LOOK LIKE THEY WERE APPLIED WITH SPRAY PAINT THROUGH A STENCIL. DIRECTLY ABOVE THE WORDS "U.S. COAST GUARD" THE WORDS "877.NOW.USCG" AND "GOCOASTGUARD.COM" APPEAR IN THE SAME BUT SLIGHTLY SMALLER FONT. THERE IS A SMALL VERTICAL LINE BETWEEN THE TWO. ALL LETTERS ARE CAPITALIZED "GOCOASTGUARD.COM" IS IN ITALICS AND THE LETTERS "O", "OAST" AND "UARD" ARE ALL IN SMALLER CAPITAL LETTERS.

**CLASS 35—ADVERTISING AND BUSINESS**

FOR PROVIDING CAREER INFORMATION ABOUT JOB OPPORTUNITIES IN THE UNITED STATES COAST GUARD, INCLUDING MISSIONS IN THE FIELDS OF SEARCH AND RESCUE, MARINE ENVIRONMENTAL PROTECTION, MARINE SAFETY, AND DRUG INTERDICTION (U.S. CLS. 100, 101 AND 102).

FIRST USE 12-18-2008; IN COMMERCE 12-18-2008.

**CLASS 41—EDUCATION AND ENTERTAINMENT**

FOR EDUCATIONAL SERVICES, NAMELY, CONDUCTING EDUCATIONAL PROGRAMS ABOUT THE TYPES MISSIONS ENGAGED IN BY THE UNITED STATES COAST GUARD, INCLUDING SEARCH AND RESCUE, MARINE ENVIRONMENTAL PROTECTION, MARINE SAFETY, AND DRUG INTERDICTION MISSIONS (U.S. CLS. 100, 101 AND 107).

FIRST USE 12-18-2008; IN COMMERCE 12-18-2008.

3,962,495. BIG TIME HOLDINGS, INC., ROME, GA. SN 77-799,950. PUB. 8-31-2010, FILED 8-7-2009.

3,962,500. GSM (OPERATIONS) PTY LTD, BURLEIGH HEADS QLD, AUSTRALIA. SN 77-800,438. PUB. 7-20-2010, FILED 8-9-2009.

## MEDIC'S CHOICE

THE MARK CONSISTS OF STANDARD CHARACTERS WITHOUT CLAIM TO ANY PARTICULAR FONT, STYLE, SIZE, OR COLOR.

NO CLAIM IS MADE TO THE EXCLUSIVE RIGHT TO USE "MEDIC'S", APART FROM THE MARK AS SHOWN.

### CLASS 9—ELECTRICAL AND SCIENTIFIC APPARATUS

FOR PROTECTIVE GLOVES FOR INDUSTRIAL USE, DISPOSABLE LATEX GLOVES FOR LABORATORY USE, AND DISPOSABLE PLASTIC GLOVES FOR LABORATORY USE (U.S. CLS. 21, 23, 26, 36 AND 38).  
FIRST USE 2-23-2011; IN COMMERCE 2-23-2011.

### CLASS 10—MEDICAL APPARATUS

FOR GLOVES FOR MEDICAL USE, LATEX MEDICAL GLOVES (U.S. CLS. 26, 39 AND 44).  
FIRST USE 2-23-2011; IN COMMERCE 2-23-2011.

### CLASS 21—HOUSEWARES AND GLASS

FOR DISPOSABLE LATEX GLOVES FOR GENERAL USE, HOUSEHOLD GLOVES FOR GENERAL USE; VINYL AND NON-VINYL HOUSEHOLD GLOVES, LATEX AND NON-LATEX HOUSEHOLD GLOVES, WORK GLOVES, AND NEOPRENE HOUSEHOLD AND WORK GLOVES AND GARDENING GLOVES (U.S. CLS. 2, 13, 23, 29, 30, 33, 40 AND 50).  
FIRST USE 2-23-2011; IN COMMERCE 2-23-2011.

3,962,499. CYBEX INTERNATIONAL, INC., MEDWAY, MA. SN 77-800,356. PUB. 1-5-2010, FILED 8-9-2009.

## BRAVO

THE MARK CONSISTS OF STANDARD CHARACTERS WITHOUT CLAIM TO ANY PARTICULAR FONT, STYLE, SIZE, OR COLOR.

### CLASS 10—MEDICAL APPARATUS

FOR WEIGHT LIFTING APPARATUS USED FOR PHYSICAL THERAPY (U.S. CLS. 26, 39 AND 44).  
FIRST USE 12-0-2009; IN COMMERCE 12-0-2009.

### CLASS 28—TOYS AND SPORTING GOODS

FOR WEIGHT LIFTING MACHINES (U.S. CLS. 22, 23, 38 AND 50).  
FIRST USE 12-0-2009; IN COMMERCE 12-0-2009.

## ART OF SHAPING

THE MARK CONSISTS OF STANDARD CHARACTERS WITHOUT CLAIM TO ANY PARTICULAR FONT, STYLE, SIZE, OR COLOR.

NO CLAIM IS MADE TO THE EXCLUSIVE RIGHT TO USE "SHAPING" FOR INTERNATIONAL CLASS 41, APART FROM THE MARK AS SHOWN.

### CLASS 25—CLOTHING

FOR CLOTHING, NAMELY, T-SHIRTS (U.S. CLS. 22 AND 39).  
FIRST USE 8-0-2008; IN COMMERCE 8-0-2008.

### CLASS 41—EDUCATION AND ENTERTAINMENT

FOR ENTERTAINMENT SERVICES, NAMELY, ORGANIZATION OF EXHIBITIONS AND SHOWCASES FOR CULTURAL OR ENTERTAINMENT PURPOSES RELATING TO MANUFACTURING, BUILDING OR SHAPING SURFBOARDS AND COMPETITIONS RELATING TO MANUFACTURING, BUILDING OR SHAPING SURFBOARDS (U.S. CLS. 100, 101 AND 107).  
FIRST USE 8-0-2008; IN COMMERCE 8-0-2008.

3,962,513. YORK COLLEGE OF PENNSYLVANIA, YORK, PA. SN 77-804,089. PUB. 7-27-2010, FILED 8-13-2009.



THE MARK CONSISTS OF THE LETTERS "Y" AND "C" WITH A SPARTAN WARRIOR PARTIALLY SUPERIMPOSED OVER THE TOP OF THE LETTERS.

### CLASS 25—CLOTHING

FOR CLOTHING, NAMELY, SHIRTS, PANTS, SWEATSHIRTS (U.S. CLS. 22 AND 39).  
FIRST USE 6-9-2004; IN COMMERCE 6-9-2004.

### CLASS 41—EDUCATION AND ENTERTAINMENT

FOR ENTERTAINMENT IN THE FORM OF LIVE SPORTING EVENTS (U.S. CLS. 100, 101 AND 107).  
FIRST USE 6-9-2004; IN COMMERCE 6-9-2004.

3,962,514. CROWNBRIDGE GROUP, LLC, ATLANTA, GA.  
SN 77-804,092. PUB. 7-20-2010, FILED 8-13-2009.

## CROWNBRIDGE

THE MARK CONSISTS OF STANDARD CHARACTERS WITHOUT CLAIM TO ANY PARTICULAR FONT, STYLE, SIZE, OR COLOR.

### CLASS 35—ADVERTISING AND BUSINESS

FOR TAX SERVICES, NAMELY, TAX ADVISORY SERVICES, TAX PLANNING SERVICES, TAX FILING SERVICES, AND TAX LIEN MANAGEMENT SERVICES, OUTSOURCING SERVICES, CONSULTING SERVICES IN THE AREAS OF BUSINESS PROCESS IMPROVEMENT, COST/PROFITABILITY IMPROVEMENT, BUSINESS OPERATIONS IMPROVEMENT, AND BUSINESS RISK MANAGEMENT; PROCURING OF CONTRACTS FOR THE PURCHASE AND SALE OF GOODS (U.S. CLS. 100, 101 AND 102).

FIRST USE 4-29-2009; IN COMMERCE 4-29-2009.

### CLASS 36—INSURANCE AND FINANCIAL

FOR FINANCIAL SERVICES, NAMELY, PAYROLL TAX DEBITING SERVICES, REAL ESTATE TAX APPRAISALS, TAX PAYMENT PROCESSING SERVICES, FINANCIAL VALUATION SERVICES (U.S. CLS. 100, 101 AND 102).

FIRST USE 4-29-2009; IN COMMERCE 4-29-2009.

### CLASS 42—SCIENTIFIC AND COMPUTER SERVICES

FOR ELECTRONIC LEGAL DISCOVERY CONSULTING SERVICES (U.S. CLS. 100 AND 101).

FIRST USE 4-29-2009; IN COMMERCE 4-29-2009.

### CLASS 45—PERSONAL AND LEGAL SERVICES

FOR LITIGATION SUPPORT SERVICES, LEGAL SERVICES, NAMELY, PROCESS SERVING, INTELLECTUAL PROPERTY LEGAL SERVICES, LEGAL DOCUMENT REVIEW SERVICES (U.S. CLS. 100 AND 101).

FIRST USE 4-29-2009; IN COMMERCE 4-29-2009.

3,962,515. CROWNBRIDGE GROUP, LLC, ATLANTA, GA.  
SN 77-804,098. PUB. 7-20-2010, FILED 8-13-2009.



THE MARK CONSISTS OF THE WORD "CROWNBRIDGE" BELOW THE DESIGN OF A CROWN WITHIN A SOLID CIRCLE IN THE MIDDLE OF AN ARC STRETCHING FROM THE "R" TO THE "E".

### CLASS 35—ADVERTISING AND BUSINESS

FOR TAX SERVICES, NAMELY, TAX ADVISORY SERVICES, TAX PLANNING SERVICES, TAX FILING SERVICES, AND TAX LIEN MANAGEMENT SERVICES, OUTSOURCING SERVICES, CONSULTING SERVICES IN THE AREAS OF BUSINESS PROCESS IMPROVEMENT, COST/PROFITABILITY IMPROVEMENT, BUSINESS OPERATIONS IMPROVEMENT, AND BUSINESS RISK MANAGEMENT; PROCURING OF CONTRACTS FOR THE PURCHASE AND SALE OF GOODS (U.S. CLS. 100, 101 AND 102).

FIRST USE 4-29-2009; IN COMMERCE 4-29-2009.

### CLASS 36—INSURANCE AND FINANCIAL

FOR FINANCIAL SERVICES, NAMELY, PAYROLL TAX DEBITING SERVICES, REAL ESTATE TAX APPRAISALS, TAX PAYMENT PROCESSING SERVICES, FINANCIAL VALUATION SERVICES (U.S. CLS. 100, 101 AND 102).

FIRST USE 4-29-2009; IN COMMERCE 4-29-2009.

### CLASS 42—SCIENTIFIC AND COMPUTER SERVICES

FOR ELECTRONIC LEGAL DISCOVERY CONSULTING SERVICES (U.S. CLS. 100 AND 101).

FIRST USE 4-29-2009; IN COMMERCE 4-29-2009.

### CLASS 45—PERSONAL AND LEGAL SERVICES

FOR LITIGATION SUPPORT SERVICES, LEGAL SERVICES, NAMELY, PROCESS SERVING, INTELLECTUAL PROPERTY LEGAL SERVICES, LEGAL DOCUMENT REVIEW SERVICES (U.S. CLS. 100 AND 101).

FIRST USE 4-29-2009; IN COMMERCE 4-29-2009.

3,962,516. WESTERN NEW YORK PUBLIC BROADCASTING ASSOCIATION, BUFFALO, NY. SN 77-804,491. PUB. 7-6-2010, FILED 8-13-2009.

## THINKBRIGHT AND WELL

THE MARK CONSISTS OF STANDARD CHARACTERS WITHOUT CLAIM TO ANY PARTICULAR FONT, STYLE, SIZE, OR COLOR.

OWNER OF U.S. REG. NO. 3,298,449.

### CLASS 16—PAPER GOODS AND PRINTED MATTER

FOR PRINTED INSTRUCTIONAL, EDUCATIONAL, AND TEACHING MATERIALS IN THE FIELD OF HEALTH AND WELLNESS AND TRAINING FOR EDUCATORS (U.S. CLS. 2, 5, 22, 23, 29, 37, 38 AND 50).

FIRST USE 10-1-2009; IN COMMERCE 10-1-2009.

### CLASS 38—COMMUNICATION

FOR TELEVISION BROADCASTING; DIGITAL MULTICASTING; BROADCASTING PROGRAMS VIA THE INTERNET; VIDEO BROADCASTING; STREAMING OF AUDIO AND VIDEO MATERIAL ON THE INTERNET; PROVIDING A WEB SITE THAT FEATURES STREAMING OF AUDIO AND VIDEO MATERIAL ON THE INTERNET (U.S. CLS. 100, 101 AND 104).

FIRST USE 10-1-2009; IN COMMERCE 10-1-2009.

**CLASS 41—EDUCATION AND ENTERTAINMENT**

FOR EDUCATION SERVICES, NAMELY, CONDUCTING SEMINARS, CONFERENCES, AND WORKSHOPS IN THE FIELD OF HEALTH AND WELLNESS AND TRAINING FOR EDUCATORS (U.S. CLS. 100, 101 AND 107).

FIRST USE 10-1-2009; IN COMMERCE 10-1-2009.

**CLASS 42—SCIENTIFIC AND COMPUTER SERVICES**

FOR PROVIDING TEMPORARY USE OF NON-DOWNLOADABLE EDUCATIONAL SOFTWARE VIA THE INTERNET (U.S. CLS. 100 AND 101).

FIRST USE 10-1-2009; IN COMMERCE 10-1-2009.

3,962,518. WERX, LLC, DBA SEASONFIVE, PARK CITY, UT. SN 77-805,243. PUB. 7-20-2010, FILED 8-14-2009.



THE MARK CONSISTS OF THE COMBINATION OF THE LETTER "S", AND THE NUMBER "5", TO CREATE ONE SYMBOL.

**CLASS 18—LEATHER GOODS**

FOR ALL PURPOSE SPORT BAGS; ALL-PURPOSE ATHLETIC BAGS; ALL-PURPOSE CARRYING BAGS; ATHLETIC BAGS; BACKPACKS; BACKPACKS; BACKPACKS, BOOK BAGS, SPORTS BAGS, WALLETS AND HANDBAGS; BAGS AND HOLDALLS FOR SPORTS CLOTHING; BAGS FOR SPORTS; BOOK BAGS; CARRY-ALL BAGS; CARRYING CASES; DRY BAGS; DUFFEL BAGS; DUFFEL BAGS FOR TRAVEL; DUFFLE BAGS; ; GYM BAGS; HIKING BAGS; LEATHER BAGS AND WALLETS; LEATHER BAGS, SUITCASES AND WALLETS; LUGGAGE; LUGGAGE LABEL HOLDERS; LUGGAGE TAGS; MESSENGER BAGS; MILITARY DUFFLE BAGS, TOTE BAGS, SHOULDER BAGS AND BACKPACKS; OVERNIGHT BAGS; SHOULDER BAGS; SMALL BACKPACKS; SPORT BAGS; SPORTS BAGS; SPORTSMAN'S HUNTING BAGS; TOILETRY BAGS SOLD EMPTY; TRAVEL BAGS; TRAVELING BAGS; WHEELED BAGS; WHEELED DUFFLE BAGS (U.S. CLS. 1, 2, 3, 22 AND 41).

FIRST USE 2-5-2010; IN COMMERCE 2-5-2010.

**CLASS 25—CLOTHING**

FOR ANKLE SOCKS; ATHLETIC APPAREL, NAMELY, SHIRTS, PANTS, JACKETS, FOOTWEAR, HATS AND CAPS, ATHLETIC UNIFORMS; ATHLETIC SHOES; BANDANAS; BEACH SHOES; BOARD SHORTS; BOXER SHORTS; CANVAS SHOES; CARGO PANTS; DENIMS; DOWN JACKETS; GLOVES; SHIRTS AND SKIRTS; GYM SHORTS; HATS; HEADGEAR, NAMELY, HATS, CAPS, BEANIES, HEADBANDS; HOODED SWEAT SHIRTS; JACKETS AND SOCKS; KNIT SHIRTS; LEISURE SHOES; LONG-SLEEVED SHIRTS; MEN'S SOCKS; MOISTURE-WICKING SPORTS PANTS; MOISTURE-WICKING SPORTS SHIRTS; OUTDOOR GLOVES; OUTDOOR MITTENS; PANTS; POLO SHIRTS; RAIN JACKETS; RAIN-PROOF JACKETS; SANDALS; SANDALS AND BEACH SHOES; SHELL JACKETS; SHIRTS; SHIRTS AND SHORT-SLEEVED SHIRTS; SHORT-SLEEVED OR LONG-SLEEVED T-SHIRTS; SHORT-SLEEVED SHIRTS; SHORTS; SKI GLOVES; SKI JACKETS; SKI PANTS; SKIRTS AND DRESSES; SNOW PANTS; SNOWBOARD GLOVES; SNOWBOARD PANTS; SOCKS; SPORT SHIRTS; SURF WEAR; SWEAT SHIRTS; SWEAT SHORTS; SWEATERS; SWIM TRUNKS; SWIM WEAR; SWIM WEAR FOR GENTLEMEN AND LADIES; T-SHIRTS; THERMAL SOCKS; TRAINING SHOES; TRAVEL CLOTHING CONTAINED IN A PACKAGE COMPRISING REVERSIBLE JACKETS, PANTS, SKIRTS; WATERPROOF JACKETS AND PANTS; WETSUITS; WIND RESISTANT JACKETS; WIND SHIRTS (U.S. CLS. 22 AND 39).

FIRST USE 11-1-2009; IN COMMERCE 11-1-2009.

3,962,519. KALEIDOSCOPE 3D LIMITED, AUCKLAND, NEW ZEALAND. SN 77-805,633. PUB. 7-20-2010, FILED 8-17-2009.

# Luvitorshuvit

THE MARK CONSISTS OF STANDARD CHARACTERS WITHOUT CLAIM TO ANY PARTICULAR FONT, STYLE, SIZE, OR COLOR.

OWNER OF NEW ZEALAND REG. NO. 811939, DATED 9-1-2009, EXPIRES 9-1-2019.

OWNER OF NEW ZEALAND REG. NO. 810981, DATED 8-13-2009, EXPIRES 8-13-2019.

**CLASS 35—ADVERTISING AND BUSINESS**

FOR (BASED ON 44(E)) ADVERTISING AND COMMERCIAL INFORMATION SERVICES, VIA THE INTERNET; ADVERTISING SERVICES, NAMELY, PROMOTING PROPERTIES FOR SALE BY OWNER VIA THE INTERNET; ADVERTISING VIA ELECTRONIC MEDIA AND SPECIFICALLY THE INTERNET; ADVICE AND INFORMATION ABOUT CUSTOMER SERVICES AND PRODUCT MANAGEMENT AND PRICES ON INTERNET SITES IN CONNECTION WITH PURCHASES MADE OVER THE INTERNET; AN INTERACTIVE WEB SITE FOR USERS TO REVIEW AND RATE INTERNET CONTENT, PEOPLE, COMPANIES, PRODUCTS AND/OR SERVICES UTILIZING A SOFTWARE APPLICATION TO AWARD POINTS WHEREBY WEB SITE USERS ARE ELIGIBLE TO EXCHANGE POINTS EARNED FOR PROMOTIONAL ITEMS CONSISTING OF COUPONS, REBATES, DISCOUNTS OR SPECIAL OFFERINGS ON GOODS AND/OR SERVICE PROVIDED BY WEB SITE SPONSORS; COMPILATION OF ADVERTISEMENTS FOR USE AS WEB PAGES ON THE INTERNET; CONSULTING SERVICES IN THE FIELD OF INTERNET MARKETING; DESIGN OF INTERNET ADVERTISING; DISSEMINATION OF ADVERTISING FOR OTHERS VIA AN ON-LINE COMMUNICATIONS NETWORK ON THE INTERNET; DISSEMINATION OF ADVERTISING FOR OTHERS VIA THE INTERNET; FACILITATING THE EXCHANGE OF NEEDED INFORMATION FOR FINAN-



CIAL COMPENSATION VIA THE INTERNET; INFORMATION, ADVISORY AND CONSULTANCY SERVICES RELATING TO BUSINESS AND MANAGEMENT OR BUSINESS ADMINISTRATION, INCLUDING SUCH SERVICES PROVIDED ON LINE OR VIA THE INTERNET; INTERNET ADVERTISING SERVICES; MANAGEMENT OF ADVERTISING THROUGH A COMMAND AND CONTROL CENTER FOR BOTH MOVIE THEATRE ON-SCREEN ADVERTISING AND OVER THE INTERNET; MARKET MANIPULATION, RESEARCH AND ANALYSIS, WHETHER OR NOT VIA THE INTERNET; PROMOTING THE GOODS AND SERVICES OF OTHERS BY MEANS OF DISTRIBUTING ADVERTISING ON THE INTERNET; PROVIDING A SEARCHABLE ON-LINE ADVERTISING WEBSITE AND GUIDE FEATURING THE GOODS AND SERVICES OF OTHER VENDORS VIA THE INTERNET; PROVIDING A SEARCHABLE ONLINE ADVERTISING GUIDE FEATURING THE GOODS AND SERVICES OF OTHER ON-LINE VENDORS ON THE INTERNET; PROVIDING ADVERTISING SERVICE TO DISTRIBUTE ADVERTISEMENTS FOR DISPLAY ON INTERNET, NAMELY, IN WEBSITES, SOCIAL CONVERSATIONS OVER THE INTERNET, EMAILS, MICROBLOGS, BLOGS, ELECTRONIC MESSAGES, INSTANT MESSAGES, TEXT MESSAGES, MULTIMEDIA MESSAGES, SOCIAL NETWORKS, STATUS UPDATES, FORUMS, ELECTRONIC BULLETIN BOARDS.; PROVIDING AN INTERNET WEBSITE PORTAL FEATURING LINKS TO MUSIC-RELATED MERCHANDISE FOR RETAIL PURPOSES; PROVIDING AN ON-LINE COMMERCIAL INFORMATION DIRECTORY ON THE INTERNET; PROVIDING AND RENTAL OF ADVERTISING SPACE ON THE INTERNET; PROVIDING CONSUMER PRODUCT INFORMATION VIA THE INTERNET; PROVIDING INFORMATION IN THE FIELD OF MARKETING AND ON-LINE MARKETING MEDIA VIA THE INTERNET; PROVIDING INFORMATION PERTAINING TO PROCUREMENT, BUYING, SELLING AND TENDERING INFORMATION AND OPPORTUNITIES RELATING TO GOODS, SERVICES, AND CONSTRUCTION VIA COMPUTER, COMPUTER NETWORKS, TELEPHONE, THE INTERNET OR ELECTRONIC MAIL; SUBSCRIPTION TO A TELEMATICS, TELEPHONE OR COMPUTER SERVICE; THE BRINGING TOGETHER, FOR THE BENEFIT OF OTHERS, OF A VARIETY OF GOODS AND SERVICES, ENABLING CUSTOMERS TO CONVENIENTLY VIEW AND PURCHASE THOSE GOODS AND SERVICES FROM AN INTERNET WEB SITE PARTICULARLY SPECIALIZING IN THE MARKETING OF THE SALE OF GOODS AND SERVICES OF OTHERS (U.S. CLS. 100, 101 AND 102).

### **CLASS 38—COMMUNICATION**

FOR (BASED ON 44(E)) AUDIO AND VIDEO BROADCASTING SERVICES OVER THE INTERNET; BROADCASTING OF VIDEO AND AUDIO PROGRAMMING OVER THE INTERNET; BROADCASTING SERVICES AND PROVISION OF TELECOMMUNICATION ACCESS TO VIDEO AND AUDIO CONTENT PROVIDED VIA A VIDEO-ON-DEMAND SERVICE VIA THE INTERNET; COMMUNICATION SERVICES, NAMELY, TRANSMISSION OF VOICE, AUDIO, VISUAL IMAGES AND DATA BY TELECOMMUNICATIONS NETWORKS, WIRELESS COMMUNICATION NETWORKS, THE INTERNET, INFORMATION SERVICES NETWORKS AND DATA NETWORKS; COMMUNICATIONS SERVICES, NAMELY, TRANSMITTING STREAMED SOUND AND AUDIOVISUAL RECORDINGS VIA THE INTERNET; INTERNET BROADCASTING SERVICES; INTERNET RADIO BROADCASTING SERVICES; PROVIDING ACCESS TO DIGITAL MUSIC WEBSITES ON THE INTERNET; PROVIDING CHAT LINES UTILISING THE INTERNET; PROVIDING INTERNET CHATROOMS; STREAMING OF AUDIO MATERIAL ON THE INTERNET; STREAMING OF VIDEO MATERIAL ON THE INTERNET; VIDEO BROADCASTING SERVICES OVER THE INTERNET OR

OTHER COMMUNICATIONS NETWORK FEATURING THE UPLOADED, POSTED AND TAGGED VIDEOS OF OTHERS; VIDEO BROADCASTING SERVICES OVER THE INTERNET OR OTHER COMMUNICATIONS NETWORK, NAMELY, SHOWING, DISPLAYING, AND ELECTRONICALLY TRANSMITTING VIDEO CLIPS; VIDEO BROADCASTING SERVICES VIA THE INTERNET; VIDEO STREAMING SERVICES VIA THE INTERNET, FEATURING INDEPENDENT FILMS AND MOVIES; VIDEO-ON-DEMAND TRANSMISSION SERVICES VIA THE INTERNET (U.S. CLS. 100, 101 AND 104).

### **CLASS 41—EDUCATION AND ENTERTAINMENT**

FOR (BASED ON 44(E)) ENTERTAINMENT, NAMELY, A CONTINUING VARIETY SHOW BROADCAST OVER THE INTERNET FEATURING VIDEOS IN THE FIELD OF ART, BOOKS, FASHION, FILM, GAMES, MUSIC, PEOPLE, PLACES, PRODUCTS, SPORTS, OR TV SHOWS; PRODUCTION OF VISUAL EFFECTS FOR VIDEOS, DVDS, TELEVISION AND FOR INTERNET WEB SITES; PROVIDING AN INTERNET NEWS PORTAL FEATURING LINKS TO NEWS STORIES AND ARTICLES IN THE FIELD OF CURRENT EVENTS; PROVIDING AN INTERNET WEBSITE PORTAL FEATURING LINKS TO MUSICAL ARTIST WEBSITES AND MUSIC PERFORMANCE TICKET INFORMATION; PROVIDING AN INTERNET WEBSITE PORTAL IN THE FIELD OF ENTERTAINMENT, CULTURAL AND SPORTING EVENTS; PROVIDING AN INTERNET WEBSITE PORTAL IN THE FIELD OF MUSIC; PROVISION OF INFORMATION RELATING TO ELECTRONIC COMPUTER GAMES PROVIDED VIA THE INTERNET; RENTAL OF PRE-RECORDED VIDEOS THAT MAY BE DOWNLOADED FROM AN INTERNET WEB SITE (U.S. CLS. 100, 101 AND 107).

### **CLASS 45—PERSONAL AND LEGAL SERVICES**

FOR INTERNET BASED SOCIAL NETWORKING, INTRODUCTION, AND DATING SERVICES; INTERNET-BASED DATING, SOCIAL INTRODUCTION AND SOCIAL NETWORKING SERVICES (U.S. CLS. 100 AND 101).

FIRST USE 11-13-2009; IN COMMERCE 11-13-2009.

---

3,962,520. MEATHEAD MOVERS, INC., SAN LUIS OBISPO, CA. SN 77-806,297. PUB. 7-13-2010, FILED 8-17-2009.

### **NATIONALLY RECOGNIZED LOCALLY FOCUSED**

THE MARK CONSISTS OF STANDARD CHARACTERS WITHOUT CLAIM TO ANY PARTICULAR FONT, STYLE, SIZE, OR COLOR.

### **CLASS 35—ADVERTISING AND BUSINESS**

FOR MOVING AND RELOCATION SERVICES, NAMELY, PLANNING AND PROJECT OVERSIGHT OF HOME MOVING FOR OTHERS (U.S. CLS. 100, 101 AND 102).

FIRST USE 1-1-1998; IN COMMERCE 1-1-1998.

**CLASS 39—TRANSPORTATION AND STORAGE**

FOR PACKING AND UNPACKING OF HOUSEHOLD GOODS; COMMERCIAL AND RESIDENTIAL MOVING VAN AND FURNITURE MOVING SERVICES; DELIVERY OF GOODS BY TRUCK; ON-SITE LOADING AND UNLOADING OF FREIGHT ONTO AND OFF OF TRUCKS; PACKING OF HOUSEHOLD GOODS FOR STORAGE AND TRANSPORTATION (U.S. CLS. 100 AND 105).

FIRST USE 1-1-1998; IN COMMERCE 1-1-1998.

3,962,521. MEATHEAD MOVERS, INC., SAN LUIS OBISPO, CA. SN 77-806,304. PUB. 7-13-2010, FILED 8-17-2009.

**PRINCESS PACKERS**

THE MARK CONSISTS OF STANDARD CHARACTERS WITHOUT CLAIM TO ANY PARTICULAR FONT, STYLE, SIZE, OR COLOR.

NO CLAIM IS MADE TO THE EXCLUSIVE RIGHT TO USE "PACKERS", APART FROM THE MARK AS SHOWN.

**CLASS 35—ADVERTISING AND BUSINESS**

FOR MOVING AND RELOCATION SERVICES, NAMELY, PLANNING AND PROJECT OVERSIGHT OF HOME MOVING FOR OTHERS (U.S. CLS. 100, 101 AND 102).

FIRST USE 1-0-2010; IN COMMERCE 1-0-2010.

**CLASS 39—TRANSPORTATION AND STORAGE**

FOR PACKING AND UNPACKING OF HOUSEHOLD GOODS; COMMERCIAL AND RESIDENTIAL MOVING VAN AND FURNITURE MOVING SERVICES; DELIVERY OF GOODS BY TRUCK; ON-SITE LOADING AND UNLOADING OF FREIGHT ONTO AND OFF OF TRUCKS; PACKING OF HOUSEHOLD GOODS FOR STORAGE AND TRANSPORTATION (U.S. CLS. 100 AND 105).

FIRST USE 1-0-2010; IN COMMERCE 1-0-2010.

3,962,529. SABOGAL, ELKIN CAMILO, DBA MUSELKO, METHUEN, MA. SN 77-807,763. PUB. 6-8-2010, FILED 8-19-2009.

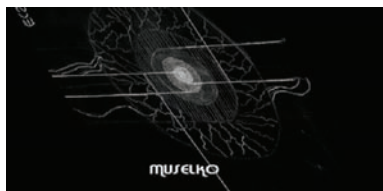

THE MARK CONSISTS OF THE WORD "MUSELKO" IN STYLIZED FONT AT THE BOTTOM CENTER, THE LETTERING "EC" AND AN INCOMPLETE INFINITE SIGN AT THE TOP LEFT, AND THE FOLLOWING DESIGN IN THE CENTER: A DESIGN CONSISTING OF SIX CONCENTRIC CIRCLES WITH THE INNER TWO HIGHLY SHADED, THE THIRD AND FOURTH WITH LESS SHADING, THE FIFTH WITH DIAGONAL LINES RUNNING THROUGH THE CIRCLE, AND THE SIXTH WITH SQUIGGLY LINES RUN-

NING THROUGH THE CIRCLE; FOUR HORIZONTAL AND TWO VERTICAL LINES INTERSECT AT VARIOUS POINTS OF THE CIRCLES, AND SIX SQUIGGLY LINES PROTRUDE FROM THE SIDES OF THE OUTER CIRCLE.

THE WORDING "MUSELKO" HAS NO MEANING IN A FOREIGN LANGUAGE.

**CLASS 41—EDUCATION AND ENTERTAINMENT**

FOR MULTIMEDIA ENTERTAINMENT SERVICES IN THE NATURE OF RECORDING, PRODUCTION AND POST-PRODUCTION SERVICES IN THE FIELDS OF MUSIC, VIDEO AND FILMS (U.S. CLS. 100, 101 AND 107).

FIRST USE 9-9-2009; IN COMMERCE 9-9-2009.

**CLASS 42—SCIENTIFIC AND COMPUTER SERVICES**

FOR RESEARCH AND DEVELOPMENT OF NEW PRODUCTS (U.S. CLS. 100 AND 101).

FIRST USE 9-9-2009; IN COMMERCE 9-9-2009.

3,962,531. MEATHEAD MOVERS, INC., SAN LUIS OBISPO, CA. SN 77-808,142. PUB. 7-13-2010, FILED 8-19-2009.

**PROTECTING WHAT'S WORTH KEEPING**

THE MARK CONSISTS OF STANDARD CHARACTERS WITHOUT CLAIM TO ANY PARTICULAR FONT, STYLE, SIZE, OR COLOR.

**CLASS 35—ADVERTISING AND BUSINESS**

FOR MOVING AND RELOCATION SERVICES, NAMELY, PLANNING AND PROJECT OVERSIGHT OF HOME MOVING FOR OTHERS (U.S. CLS. 100, 101 AND 102).

FIRST USE 8-19-2009; IN COMMERCE 8-19-2009.

**CLASS 39—TRANSPORTATION AND STORAGE**

FOR PACKING AND UNPACKING OF HOUSEHOLD GOODS; COMMERCIAL AND RESIDENTIAL MOVING VAN AND FURNITURE MOVING SERVICES; DELIVERY OF GOODS BY TRUCK; ON-SITE LOADING AND UNLOADING OF FREIGHT ONTO AND OFF OF TRUCKS; PACKING OF HOUSEHOLD GOODS FOR STORAGE AND TRANSPORTATION (U.S. CLS. 100 AND 105).

FIRST USE 8-19-2009; IN COMMERCE 8-19-2009.

3,962,537. METRO INDUSTRIES, INC., WILKES-BARRE, PA. SN 77-811,073. PUB. 7-20-2010, FILED 8-24-2009.

**SMARTWALL G3**

THE MARK CONSISTS OF STANDARD CHARACTERS

WITHOUT CLAIM TO ANY PARTICULAR FONT, STYLE, SIZE, OR COLOR.  
OWNER OF U.S. REG. NOS. 2,366,558 AND 3,262,286.

#### **CLASS 6—METAL GOODS**

FOR SHELVING SYSTEM ACCESSORIES, NAMELY, METAL BINS, METAL HOOKS AND METAL WALL TRACKS (U.S. CLS. 2, 12, 13, 14, 23, 25 AND 50).  
FIRST USE 8-31-2009; IN COMMERCE 8-31-2009.

#### **CLASS 20—FURNITURE AND ARTICLES NOT OTHERWISE CLASSIFIED**

FOR SHELVING SYSTEM COMPRISED OF SHELVES, VERTICAL UPRIGHTS, HORIZONTAL TUBULAR SUPPORTS, WIRE SHELF BRACKETS, SHELF COLLAR PLUGS, GRIDS, GRID DIRECT MOUNTING BRACKETS, FOLD DOWN WORK SURFACES ALL SOLD AS A UNIT; SHELVING SYSTEM ACCESSORIES, NAMELY, NON-METAL BINS, NON-METAL BIN HOLDERS AND NON-METAL WALL TRACKS; AND, SHELVING SYSTEM ACCESSORIES, NAMELY, BEVERAGE CAN RACKS; AND (U.S. CLS. 2, 13, 22, 25, 32 AND 50).  
FIRST USE 8-31-2009; IN COMMERCE 8-31-2009.

#### **CLASS 21—HOUSEWARES AND GLASS**

FOR SHELVING SYSTEM ACCESSORIES, NAMELY, STEAM PAN HOLDERS AND GRID MOUNTED SPICE RACKS (U.S. CLS. 2, 13, 23, 29, 30, 33, 40 AND 50).  
FIRST USE 8-31-2009; IN COMMERCE 8-31-2009.

3,962,538. SUPERMEDIA LLC, DFW AIRPORT, TX. SN 77-111,134. PUB. 10-12-2010, FILED 8-24-2009.



THE MARK CONSISTS OF THE WORD "SUPERMEDIA" IN STYLIZED FONT AND A SHIELD DESIGN.

#### **CLASS 9—ELECTRICAL AND SCIENTIFIC APPARATUS**

FOR SOFTWARE FOR MAXIMIZING THE ACQUISITION AND MANAGEMENT OF TRAFFIC THROUGH WEBSITES, TRACKING AND ANALYZING ONLINE CUSTOMER PURCHASING AND CLICK STREAM, MANAGING EMAIL MARKETING CAMPAIGNS AND USER'S MANUALS SUPPLIED THEREWITH; ELECTRONIC PUBLICATIONS, NAMELY, TELEPHONE DIRECTORIES, BUSINESS TELEPHONE LISTINGS, RESIDENTIAL TELEPHONE LISTINGS, BUSINESS DIRECTORIES, CITY DIRECTORIES, RESTAURANT DIRECTORIES, AND SHOPPING DIRECTORIES RECORDED ON ELECTRONIC RECORDING MEDIA, INCLUDING CD-ROM AND DVD (U.S. CLS. 21, 23, 26, 36 AND 38).  
FIRST USE 1-0-2010; IN COMMERCE 1-0-2010.

#### **CLASS 16—PAPER GOODS AND PRINTED MATTER**

FOR PRINTED PUBLICATIONS, NAMELY, TELEPHONE DIRECTORIES, LOCAL SERVICE AND ACTIVITY GUIDES, BUSINESS DIRECTORIES AND CITY DIRECTORIES; PRINTED GUIDES, NAMELY, RESTAURANT GUIDES AND SHOPPING GUIDES; COUPON BOOKS; PUBLICATIONS, NAMELY, BUSINESS LISTING/PROFILE DIRECTORIES; POSTCARDS THAT PROMOTE THE GOODS AND SERVICES OF OTHERS (U.S. CLS. 2, 5, 22, 23, 29, 37, 38 AND 50).  
FIRST USE 1-0-2010; IN COMMERCE 1-0-2010.

#### **CLASS 35—ADVERTISING AND BUSINESS**

FOR ADVERTISING SERVICES, NAMELY, PROMOTING THE GOODS AND SERVICES OF OTHERS BY MEANS OF TELEPHONE DIRECTORIES; DISSEMINATION OF ADVERTISING FOR OTHERS VIA THE INTERNET; PREPARING ADVERTISING FOR OTHERS; ELECTRONIC TELEPHONE DIRECTORY SERVICES, NAMELY, ONLINE TELEPHONE DIRECTORY INFORMATION; PROVIDING QUALITY ASSURANCE OF PERFORMANCE OF SERVICES OF OTHERS ADVERTISED IN TELEPHONE DIRECTORIES AND ELECTRONIC TELEPHONE DIRECTORIES; ADVERTISING AND PROMOTING THE SERVICES OF OTHERS THROUGH A PROGRAM ASSURING SATISFACTORY PERFORMANCE OF ADVERTISED SERVICES; TELEPHONE DIRECTORY INFORMATION SERVICES AND ELECTRONIC TELEPHONE DIRECTORY INFORMATION SERVICES FEATURING ASSURANCE OF SATISFACTORY PERFORMANCE OF ADVERTISED SERVICES; ADVERTISING AND PROMOTING THE GOODS AND SERVICES OF OTHERS FEATURING A PROGRAM RELEASING LIABILITY FOR PAYMENT OF ACCOUNTS OWED IN THE EVENT OF BUSINESS CLOSURE; EXCHANGE SERVICES, NAMELY, AN INTERACTIVE WEB SITE FOR USERS TO BUY AND SELL GOODS AND SERVICES; PROVIDING A WEBSITE FOR SELLING AND BUYING AUTOMOBILES, WHICH ALSO CONTAINS INFORMATION ON AUTOMOBILE SALES AND PROVIDES LINKS TO INFORMATION ON AUTOMOBILE SALES; SEARCH ENGINE MARKETING SERVICES; SEARCH ENGINE OPTIMIZATION SERVICES, NAMELY, PROMOTING THE GOODS AND SERVICES OF OTHERS THROUGH SEARCH ENGINE REFERRAL TRAFFIC ANALYSIS AND REPORTING, AND MARKETING SERVICES REGARDING THE OPTIMIZATION OF SEARCH ENGINES FOR MARKETING PURPOSES AND ANALYZING, REPORTING AND TRACKING SERVICES IN RELATION THERETO; ONLINE RETAIL STORE SERVICES FEATURING BOOKS, PRINTED GUIDES, GUIDES ON CD-ROM, PRINTED TELEPHONE AND BUSINESS DIRECTORIES, AND TELEPHONE AND BUSINESS DIRECTORIES ON CD-ROM; ADVERTISING SERVICES, NAMELY, PROMOTING THE GOODS AND SERVICES OF OTHERS VIA THE PREPARATION AND SALE OF ADVERTISEMENTS AND LISTINGS AND CONSULTING SERVICES RELATED THERETO, AND PLACING SUCH ADVERTISEMENTS AND LISTINGS IN PUBLICATIONS AND ELECTRONIC INFORMATION AND TRANSMISSION SERVICES, PROVISION OF INTERACTIVE, ON-LINE, YELLOW-PAGES-LIKE BUSINESS DIRECTORY AND SHOPPERS' INFORMATION GUIDE BY MEANS OF A WEB SITE ON A MULTI-USER GLOBAL COMPUTER INFORMATION NETWORK; ADVERTISING SERVICES, NAMELY, TRACKING AND MONITORING THE EFFECTIVENESS OF AN INTERNET ADVERTISING CAMPAIGN BY AUTOMATICALLY TRACING TELEPHONE CALLS BACK TO A SPECIFIC ADVERTISING SOURCE ON THE INTERNET; PROVIDING INFORMATION ABOUT NAMES OF INDIVIDUALS AND BUSINESSES, INDIVIDUAL'S AND BUSINESSES ADDRESSES AND TELEPHONE AND ELECTRONIC MAIL ADDRESS DIRECTORIES VIA GLOBAL COMPUTER NETWORKS; PROVIDING ON-LINE DIRECTORY PERSONAL AND BUSINESS INFORMATION SERVICES ALSO FEATURING HYPERLINKS TO OTHER WEB SITES; BUSINESS INFORMATION SERVICES; COMMERCIAL INFORMATION SERVICES, NAMELY, ADVERTISEMENT MANAGEMENT BY PROVIDING REPORTS, ADVERTISEMENT TARGETING, AND MANAGEMENT OF ELECTRONICALLY STORED ADVERTISING, FOR USE ON THE GLOBAL COMPUTER NETWORK; PROMOTING THE GOODS AND SERVICES OF OTHERS BY

PREPARING AND PLACING ON-LINE ADVERTISEMENTS ON A NETWORK OF WEB PAGES ON THE GLOBAL COMPUTER NETWORK, AS WELL AS VIA E-MAIL; CONSULTING IN THE FIELD OF ON-LINE ADVERTISING; BUSINESS MARKETING SERVICES, NAMELY, PROVIDING ONLINE SEARCH MARKETING TECHNOLOGY AND SERVICES FOR MANAGING PAY-PER-CLICK CAMPAIGNS; PAY PER CALL ADVERTISING SERVICES; PROVIDING A WEB SITE CONTAINING INFORMATION ON THE AUTO INDUSTRY AND THE PURCHASE AND SALE OF AUTOMOBILES, LINKS TO AUTO INDUSTRY SOCIAL NETWORKING AND BLOGGING SITES AND AN ON-LINE FACILITY FOR USERS TO POST COMMENTS RELATING TO AUTOMOBILES AND THE AUTO INDUSTRY; COMPUTER SERVICES, NAMELY, PROVIDING DATABASES FEATURING GENERAL AND LOCAL NEWS AND INFORMATION OF INTEREST TO SPECIFIC GEOGRAPHIC AREAS, NAMELY, DIRECTORY INFORMATION FOR RESTAURANTS, AND COUPONS (U.S. CLS. 100, 101 AND 102).

FIRST USE 1-0-2010; IN COMMERCE 1-0-2010.

#### **CLASS 36—INSURANCE AND FINANCIAL**

FOR PROVIDING A WEBSITE WHICH PROVIDES INFORMATION ON AUTOMOBILE INSURANCE AND FINANCING, AND PROVIDES LINKS TO INFORMATION ON AUTOMOBILE INSURANCE AND FINANCING (U.S. CLS. 100, 101 AND 102).

FIRST USE 1-0-2010; IN COMMERCE 1-0-2010.

#### **CLASS 38—COMMUNICATION**

FOR PROVIDING E-MAIL SERVICES (U.S. CLS. 100, 101 AND 104).

FIRST USE 1-0-2010; IN COMMERCE 1-0-2010.

#### **CLASS 39—TRANSPORTATION AND STORAGE**

FOR PROVIDING A WEB SITE ON A GLOBAL COMMUNICATIONS NETWORK FEATURING MAPS AND ROUTE DIRECTIONS (U.S. CLS. 100 AND 105).

FIRST USE 1-0-2010; IN COMMERCE 1-0-2010.

#### **CLASS 41—EDUCATION AND ENTERTAINMENT**

FOR PUBLISHING DIRECTORIES AND GUIDES, NAMELY, TELEPHONE DIRECTORIES, BUSINESS DIRECTORIES, BUSINESS TELEPHONE LISTINGS, RESIDENTIAL TELEPHONE LISTINGS, CITY DIRECTORIES, RESTAURANT GUIDES AND SHOPPING GUIDES; COMPUTER SERVICES, NAMELY, PROVIDING DATABASES FEATURING GENERAL AND LOCAL NEWS AND INFORMATION OF INTEREST TO SPECIFIC GEOGRAPHIC AREAS, NAMELY, MOVIES, CULTURAL EVENTS, FESTIVALS AND ATTRACTIONS (U.S. CLS. 100, 101 AND 107).

FIRST USE 1-0-2010; IN COMMERCE 1-0-2010.

#### **CLASS 42—SCIENTIFIC AND COMPUTER SERVICES**

FOR COMPUTER SERVICES, NAMELY, ANALYZING AND REPORTING ON THE PERFORMANCE OF WEB SITES OF OTHERS; COMPUTER SERVICES, NAMELY, PROVIDING SEARCH ENGINES FOR OBTAINING DATA ON THE INTERNET; COMPUTER SERVICES, NAMELY, PROVIDING DATABASES FEATURING GENERAL AND LOCAL NEWS AND INFORMATION OF INTEREST TO SPECIFIC GEOGRAPHIC AREAS, NAMELY, WEATHER; DESIGNING, DEVELOPING, MANAGING, MAINTAINING AND HOSTING WEB SITES FOR OTHERS (U.S. CLS. 100 AND 101).

FIRST USE 1-0-2010; IN COMMERCE 1-0-2010.

3,962,539. SUPERMEDIA LLC, DFW AIRPORT, TX. SN 77-811,149. PUB. 10-12-2010, FILED 8-24-2009.



THE COLOR(S) ORANGE AND BLACK IS/ARE CLAIMED AS A FEATURE OF THE MARK.

THE MARK CONSISTS OF THE WORD "SUPERMEDIA" IN STYLIZED FONT AND A SHIELD DESIGN. THE WORD "SUPERMEDIA" IS BLACK AND THE OUTLINE OF THE SHIELD DESIGN WHICH IS BEHIND THE LETTERS "UPE" IS ORANGE.

#### **CLASS 9—ELECTRICAL AND SCIENTIFIC APPARATUS**

FOR SOFTWARE FOR MAXIMIZING THE ACQUISITION AND MANAGEMENT OF TRAFFIC THROUGH WEBSITES, TRACKING AND ANALYZING ONLINE CUSTOMER PURCHASING AND CLICK STREAM, MANAGING EMAIL MARKETING CAMPAIGNS AND USER'S MANUALS SUPPLIED THEREWITH; ELECTRONIC PUBLICATIONS, NAMELY, TELEPHONE DIRECTORIES, BUSINESS TELEPHONE LISTINGS, RESIDENTIAL TELEPHONE LISTINGS, BUSINESS DIRECTORIES, CITY DIRECTORIES, RESTAURANT DIRECTORIES, AND SHOPPING DIRECTORIES RECORDED ON ELECTRONIC RECORDING MEDIA, INCLUDING CD-ROM AND DVD (U.S. CLS. 21, 23, 26, 36 AND 38).

FIRST USE 1-0-2010; IN COMMERCE 1-0-2010.

#### **CLASS 16—PAPER GOODS AND PRINTED MATTER**

FOR PRINTED PUBLICATIONS, NAMELY, TELEPHONE DIRECTORIES, LOCAL SERVICE AND ACTIVITY GUIDES, BUSINESS DIRECTORIES AND CITY DIRECTORIES; PRINTED GUIDES, NAMELY, RESTAURANT GUIDES AND SHOPPING GUIDES; COUPON BOOKS; PUBLICATIONS, NAMELY, BUSINESS LISTING/PROFILE DIRECTORIES; POSTCARDS THAT PROMOTE THE GOODS AND SERVICES OF OTHERS (U.S. CLS. 2, 5, 22, 23, 29, 37, 38 AND 50).

FIRST USE 1-0-2010; IN COMMERCE 1-0-2010.

#### **CLASS 35—ADVERTISING AND BUSINESS**

FOR ADVERTISING SERVICES, NAMELY, PROMOTING THE GOODS AND SERVICES OF OTHERS BY MEANS OF TELEPHONE DIRECTORIES; DISSEMINATION OF ADVERTISING FOR OTHERS VIA THE INTERNET; PREPARING ADVERTISING FOR OTHERS; ELECTRONIC TELEPHONE DIRECTORY SERVICES, NAMELY, ONLINE TELEPHONE DIRECTORY INFORMATION; PROVIDING QUALITY ASSURANCE OF PERFORMANCE OF SERVICES OF OTHERS ADVERTISED IN TELEPHONE DIRECTORIES AND ELECTRONIC TELEPHONE DIRECTORIES; ADVERTISING AND PROMOTING THE SERVICES OF OTHERS THROUGH A PROGRAM ASSURING SATISFACTORY PERFORMANCE OF ADVERTISED SERVICES; TELEPHONE DIRECTORY INFORMATION SERVICES AND ELECTRONIC TELEPHONE DIRECTORY INFORMATION SERVICES FEATURING ASSURANCE OF SATISFACTORY PERFORMANCE OF ADVERTISED SERVICES; ADVERTISING AND PROMOTING THE GOODS AND SERVICES OF OTHERS FEATURING A PROGRAM RELEASING LIABILITY FOR PAYMENT OF ACCOUNTS OWED IN THE EVENT OF BUSINESS CLOSURE; EXCHANGE SERVICES, NAMELY, AN INTERACTIVE WEB SITE FOR USERS TO BUY AND SELL GOODS AND SERVICES; PROVIDING A WEBSITE FOR SELLING AND BUYING AUTOMOBILES, WHICH ALSO CONTAINS INFORMATION ON AUTOMOBILE SALES AND PROVIDES LINKS TO INFORMATION ON AUTOMOBILE SALES; SEARCH ENGINE MARKETING



SERVICES; SEARCH ENGINE OPTIMIZATION SERVICES, NAMELY, PROMOTING THE GOODS AND SERVICES OF OTHERS THROUGH SEARCH ENGINE REFERRAL TRAFFIC ANALYSIS AND REPORTING, AND MARKETING SERVICES REGARDING THE OPTIMIZATION OF SEARCH ENGINES FOR MARKETING PURPOSES AND ANALYZING, REPORTING AND TRACKING SERVICES IN RELATION THERETO; ON-LINE RETAIL STORE SERVICES FEATURING BOOKS, PRINTED GUIDES, GUIDES ON CD-ROM, PRINTED TELEPHONE AND BUSINESS DIRECTORIES, AND TELEPHONE AND BUSINESS DIRECTORIES ON CD-ROM; ADVERTISING SERVICES, NAMELY, PROMOTING THE GOODS AND SERVICES OF OTHERS VIA THE PREPARATION AND SALE OF ADVERTISEMENTS AND LISTINGS AND CONSULTING SERVICES RELATED THERETO, AND PLACING SUCH ADVERTISEMENTS AND LISTINGS IN PUBLICATIONS AND ELECTRONIC INFORMATION AND TRANSMISSION SERVICES, PROVISION OF INTERACTIVE, ON-LINE, YELLOW-PAGES-LIKE BUSINESS DIRECTORY AND SHOPPERS' INFORMATION GUIDE BY MEANS OF A WEB SITE ON A MULTI-USER GLOBAL COMPUTER INFORMATION NETWORK; ADVERTISING SERVICES, NAMELY, TRACKING AND MONITORING THE EFFECTIVENESS OF AN INTERNET ADVERTISING CAMPAIGN BY AUTOMATICALLY TRACING TELEPHONE CALLS BACK TO A SPECIFIC ADVERTISING SOURCE ON THE INTERNET; PROVIDING INFORMATION ABOUT NAMES OF INDIVIDUALS AND BUSINESSES, INDIVIDUAL'S AND BUSINESSES ADDRESSES AND TELEPHONE AND ELECTRONIC MAIL ADDRESS DIRECTORIES VIA GLOBAL COMPUTER NETWORKS; PROVIDING ON-LINE DIRECTORY PERSONAL AND BUSINESS INFORMATION SERVICES ALSO FEATURING HYPERLINKS TO OTHER WEB SITES; BUSINESS INFORMATION SERVICES; COMMERCIAL INFORMATION SERVICES, NAMELY, ADVERTISEMENT MANAGEMENT BY PROVIDING REPORTS, ADVERTISEMENT TARGETING, AND MANAGEMENT OF ELECTRONICALLY STORED ADVERTISING; FOR USE ON THE GLOBAL COMPUTER NETWORK; PROMOTING THE GOODS AND SERVICES OF OTHERS BY PREPARING AND PLACING ON-LINE ADVERTISEMENTS ON A NETWORK OF WEB PAGES ON THE GLOBAL COMPUTER NETWORK, AS WELL AS VIA E-MAIL; CONSULTING IN THE FIELD OF ON-LINE ADVERTISING; BUSINESS MARKETING SERVICES, NAMELY, PROVIDING ONLINE SEARCH MARKETING TECHNOLOGY AND SERVICES FOR MANAGING PAY-PER-CLICK CAMPAIGNS; PAY PER CALL ADVERTISING SERVICES; PROVIDING A WEB SITE CONTAINING INFORMATION ON THE AUTO INDUSTRY AND THE PURCHASE AND SALE OF AUTOMOBILES, LINKS TO AUTO INDUSTRY SOCIAL NETWORKING AND BLOGGING SITES AND AN ON-LINE FACILITY FOR USERS TO POST COMMENTS RELATING TO AUTOMOBILES AND THE AUTO INDUSTRY; COMPUTER SERVICES, NAMELY, PROVIDING DATABASES FEATURING GENERAL AND LOCAL NEWS AND INFORMATION OF INTEREST TO SPECIFIC GEOGRAPHIC AREAS, NAMELY, DIRECTORY INFORMATION FOR RESTAURANTS, AND COUPONS (U.S. CLS. 100, 101 AND 102).

FIRST USE 1-0-2010; IN COMMERCE 1-0-2010.

#### **CLASS 36—INSURANCE AND FINANCIAL**

FOR PROVIDING A WEBSITE WHICH PROVIDES INFORMATION ON AUTOMOBILE INSURANCE AND FINANCING, AND PROVIDES LINKS TO INFORMATION ON AUTOMOBILE INSURANCE AND FINANCING (U.S. CLS. 100, 101 AND 102).

FIRST USE 1-0-2010; IN COMMERCE 1-0-2010.

#### **CLASS 38—COMMUNICATION**

FOR PROVIDING E-MAIL SERVICES (U.S. CLS. 100, 101 AND 104).

FIRST USE 1-0-2010; IN COMMERCE 1-0-2010.

#### **CLASS 39—TRANSPORTATION AND STORAGE**

FOR PROVIDING A WEB SITE ON A GLOBAL COMMUNICATIONS NETWORK FEATURING MAPS AND ROUTE DIRECTIONS (U.S. CLS. 100 AND 105).

FIRST USE 1-0-2010; IN COMMERCE 1-0-2010.

#### **CLASS 41—EDUCATION AND ENTERTAINMENT**

FOR PUBLISHING DIRECTORIES AND GUIDES, NAMELY, TELEPHONE DIRECTORIES, BUSINESS DIRECTORIES, BUSINESS TELEPHONE LISTINGS, RESIDENTIAL TELEPHONE LISTINGS, CITY DIRECTORIES, RESTAURANT GUIDES AND SHOPPING GUIDES; COMPUTER SERVICES, NAMELY, PROVIDING DATABASES FEATURING GENERAL AND LOCAL NEWS AND INFORMATION OF INTEREST TO SPECIFIC GEOGRAPHIC AREAS, NAMELY, MOVIES, CULTURAL EVENTS, FESTIVALS AND ATTRACTIONS (U.S. CLS. 100, 101 AND 107).

FIRST USE 1-0-2010; IN COMMERCE 1-0-2010.

#### **CLASS 42—SCIENTIFIC AND COMPUTER SERVICES**

FOR COMPUTER SERVICES, NAMELY, ANALYZING AND REPORTING ON THE PERFORMANCE OF WEB SITES OF OTHERS; COMPUTER SERVICES, NAMELY, PROVIDING SEARCH ENGINES FOR OBTAINING DATA ON THE INTERNET; COMPUTER SERVICES, NAMELY, PROVIDING DATABASES FEATURING GENERAL AND LOCAL NEWS AND INFORMATION OF INTEREST TO SPECIFIC GEOGRAPHIC AREAS, NAMELY, WEATHER; DESIGNING, DEVELOPING, MANAGING, MAINTAINING AND HOSTING WEB SITES FOR OTHERS (U.S. CLS. 100 AND 101).

FIRST USE 1-0-2010; IN COMMERCE 1-0-2010.

#### **CLASS 45—PERSONAL AND LEGAL SERVICES**

FOR REGISTRATION OF DOMAIN NAMES FOR IDENTIFICATION OF USERS ON THE INTERNET (U.S. CLS. 100 AND 101).

FIRST USE 1-0-2010; IN COMMERCE 1-0-2010.

---

3,962,547. AMBIENT CORPORATION, NEWTON, MA. SN 77-814,039. PUB. 8-3-2010, FILED 8-27-2009.

### **COMMUNICATIONS FOR A SMARTER GRID**

THE MARK CONSISTS OF STANDARD CHARACTERS WITHOUT CLAIM TO ANY PARTICULAR FONT, STYLE, SIZE, OR COLOR.

NO CLAIM IS MADE TO THE EXCLUSIVE RIGHT TO USE "GRID", APART FROM THE MARK AS SHOWN.



**CLASS 9—ELECTRICAL AND SCIENTIFIC APPARATUS**

FOR ELECTRONIC SYSTEMS COMPRISED OF ELECTRONIC DISPLAY UNITS, COMPUTER HARDWARE, ELECTRONIC TRANSMITTERS AND RECEIVERS FOR MONITORING AND CONTROLLING UTILITY CONSUMPTION; COMPUTER SOFTWARE FOR MONITORING AND CONTROLLING UTILITY CONSUMPTION, NAMELY, ELECTRICITY, WATER, AND GAS CONSUMPTION; MICRO-PROCESSOR BASED HARDWARE AND SOFTWARE USED TO MONITOR ELECTRICAL DISTRIBUTION; COMMUNICATIONS SOFTWARE FOR CONNECTING COMPUTER NETWORK USERS TO ENERGY TRANSMISSION AND POWER DISTRIBUTION MEASURING DEVICES; COMPUTER SOFTWARE AND HARDWARE FOR TRACKING ENERGY USAGE; COMPUTER SOFTWARE FOR ADMINISTRATION OF COMPUTER NETWORKS; ELECTRICAL ENERGY UTILIZATION METERING DEVICES COMPLETE WITH RELATED SOFTWARE; COMPUTER HARDWARE AND SOFTWARE FOR FACILITATING THE DELIVERY OF ELECTRICITY FROM SUPPLIERS TO CONSUMERS (U.S. CLS. 21, 23, 26, 36 AND 38).

FIRST USE 8-0-2009; IN COMMERCE 8-0-2009.

**CLASS 42—SCIENTIFIC AND COMPUTER SERVICES**

FOR AUTOMATIC UTILITY METER READING SERVICES, NAMELY, ELECTRIC POWER QUALITY MONITORING THROUGH METER DATA MANAGEMENT AND ANALYSIS FEATURING REAL-TIME FAULT DETECTION AND ISOLATION OF AN ABNORMAL CONDITION PRESENT IN A POWER SYSTEM (U.S. CLS. 100 AND 101).

FIRST USE 8-0-2009; IN COMMERCE 8-0-2009.

3,962,552. GUIDESTAR CLINICAL TRIALS MANAGEMENT, LLC, MIRAMARBEACH, FL. SN 77-816,230. PUB. 6-1-2010, FILED 8-31-2009.

# GUIDESTAR

THE MARK CONSISTS OF STANDARD CHARACTERS WITHOUT CLAIM TO ANY PARTICULAR FONT, STYLE, SIZE, OR COLOR.

**CLASS 35—ADVERTISING AND BUSINESS**

FOR BUSINESS MANAGEMENT, NAMELY, ADMINISTRATION OF MEDICAL RESEARCH AND CLINICAL TRIALS (U.S. CLS. 100, 101 AND 102).

FIRST USE 8-11-2009; IN COMMERCE 8-11-2009.

**CLASS 41—EDUCATION AND ENTERTAINMENT**

FOR EDUCATIONAL SERVICES, NAMELY, CONDUCTING SEMINARS AND CLASSES IN THE FIELD OF OPERATIONS AND ADMINISTRATION OF CLINICAL TRIALS AND MEDICAL RESEARCH IN THE FIELD OF MEDICINE AND MEDICAL TREATMENTS (U.S. CLS. 100, 101 AND 107).

FIRST USE 8-11-2009; IN COMMERCE 8-11-2009.

**CLASS 42—SCIENTIFIC AND COMPUTER SERVICES**

FOR CONSULTATION SERVICES IN THE FIELD OF MEDICAL RESEARCH AND CLINICAL TRIALS (U.S. CLS. 100 AND 101).

FIRST USE 8-11-2009; IN COMMERCE 8-11-2009.

3,962,582. LAB ARMOR, INC., SAN ANTONIO, TX. SN 77-824,594. PUB. 8-10-2010, FILED 9-11-2009.

# LAB ARMOR

THE MARK CONSISTS OF STANDARD CHARACTERS WITHOUT CLAIM TO ANY PARTICULAR FONT, STYLE, SIZE, OR COLOR.

NO CLAIM IS MADE TO THE EXCLUSIVE RIGHT TO USE "LAB", APART FROM THE MARK AS SHOWN.

**CLASS 6—METAL GOODS**

FOR ALUMINUM BEADS FOR CONTROLLING AND RETAINING HEAT (U.S. CLS. 2, 12, 13, 14, 23, 25 AND 50).

FIRST USE 10-1-2009; IN COMMERCE 10-1-2009.

**CLASS 9—ELECTRICAL AND SCIENTIFIC APPARATUS**

FOR LABORATORY EQUIPMENT, NAMELY, ELECTRIC LABORATORY BATHS AND ELECTRIC LABORATORY BATH HEATERS (U.S. CLS. 21, 23, 26, 36 AND 38).

FIRST USE 6-1-2010; IN COMMERCE 6-1-2010.

3,962,585. DANJAQ, LLC, SANTA MONICA, CA. SN 77-825,206. PUB. 8-10-2010, FILED 9-11-2009.

# YOUNG BOND

THE MARK CONSISTS OF STANDARD CHARACTERS WITHOUT CLAIM TO ANY PARTICULAR FONT, STYLE, SIZE, OR COLOR.

OWNER OF U.S. REG. NO. 1,737,876.

**CLASS 9—ELECTRICAL AND SCIENTIFIC APPARATUS**

FOR ELECTRONIC PUBLICATIONS, NAMELY, BOOKS AND BOOKLETS FEATURING FICTIONAL STORIES AND CHARACTERS RECORDED ON COMPUTER MEDIA; ELECTRONIC PUBLICATIONS, NAMELY, COMIC BOOKS AND COMIC STRIPS FEATURING FICTIONAL STORIES AND CHARACTERS RECORDED ON COMPUTER MEDIA; AUDIO BOOKS ON CASSETTE, COMPACT DISC, COMPUTER DISC, AND IN DIGITAL FILE FORMAT FEATURING FICTIONAL STORIES AND CHARACTERS; DOWNLOADABLE ELECTRONIC PUBLICATIONS IN THE NATURE OF BOOKS AND BOOKLETS IN THE FIELD OF FICTIONAL STORIES AND CHARACTERS; PRERECORDED AUDIO CASSETTES, CARTRIDGES, AND COMPUTER AUDIO FILES FEATURING FICTIONAL STORIES AND CHARACTERS AND ADVERTISEMENTS (U.S. CLS. 21, 23, 26, 36 AND 38).

FIRST USE 4-11-2006; IN COMMERCE 4-11-2006.

**CLASS 16—PAPER GOODS AND PRINTED MATTER**

FOR PRINTED MATTER, NAMELY, A SERIES OF BOOKS IN THE FIELD OF ACTION ADVENTURE FICTION, COMIC BOOKS IN THE FIELD OF ACTION ADVENTURE FICTION; COMIC STRIPS (U.S. CLS. 2, 5, 22, 23, 29, 37, 38 AND 50).

FIRST USE 4-27-2005; IN COMMERCE 4-27-2005.

**CLASS 41—EDUCATION AND ENTERTAINMENT**

FOR ENTERTAINMENT SERVICES, NAMELY, PROVIDING ON-LINE COMPUTER GAMES; PROVIDING A WEB SITE FEATURING GAMES, FICTIONAL CHARACTER TRIVIA, CONTESTS, PHOTOGRAPHS, AND OTHER MULTIMEDIA MATERIALS; PUBLISHING OF SOUND RECORDINGS, IMAGES, TEXT, SOFTWARE, INFORMATION AND DATA FEATURING FICTIONAL STORIES AND CHARACTERS, VIA GLOBAL COMPUTER NETWORKS; PUBLISHING OF BOOKS AND MAGAZINES, AND PUBLISHING OF ELECTRONIC PUBLICATIONS (U.S. CLS. 100, 101 AND 107).

FIRST USE 3-20-2005; IN COMMERCE 3-20-2005.

3,962,590. KABUSHIKI KAISHA BANDAI, TOKYO, JAPAN. SN 77-827,085. PUB. 8-24-2010, FILED 9-15-2009.

# Battle Spirits

THE MARK CONSISTS OF STANDARD CHARACTERS WITHOUT CLAIM TO ANY PARTICULAR FONT, STYLE, SIZE, OR COLOR.

OWNER OF U.S. REG. NO. 2,804,731.

**CLASS 16—PAPER GOODS AND PRINTED MATTER**

FOR TRADING CARDS AND TRADING CARD ACCESSORIES, NAMELY, CARRYING CASES FOR STORING TRADING CARDS AND CARDBOARD BOXES FOR STORING TRADING CARDS (U.S. CLS. 2, 5, 22, 23, 29, 37, 38 AND 50).

FIRST USE 8-14-2009; IN COMMERCE 8-14-2009.

**CLASS 28—TOYS AND SPORTING GOODS**

FOR CARD GAMES; PLAYING CARDS; TRADING CARD GAMES; ACCESSORIES FOR TRADING CARD GAMES, NAMELY, GAME MATS FOR USE IN CONNECTION WITH PLAYING CARD GAMES; GAMING EQUIPMENT IN THE NATURE OF CHIPS FOR USE IN CONNECTION WITH CARD GAMES; AND CASES FOR HOLDING TRADING CARD GAMES (U.S. CLS. 22, 23, 38 AND 50).

FIRST USE 8-14-2009; IN COMMERCE 8-14-2009.

**CLASS 41—EDUCATION AND ENTERTAINMENT**

FOR ENTERTAINMENT SERVICES, NAMELY, ORGANIZING CARD GAME EVENTS IN THE NATURE OF CARD GAME TOURNAMENTS, ONLINE INFORMATION RELATING TO CARD GAMES AND COMPUTER GAMES, ORGANIZATION OF ONLINE GAME EVENTS IN THE NATURE OF ONLINE CARD GAME TOURNAMENTS (U.S. CLS. 100, 101 AND 107).

FIRST USE 9-15-2009; IN COMMERCE 9-15-2009.

3,962,594. TAIWAN FU HSING INDUSTRIAL CO., LTD., KAOHSIUNG COUNTY, TAIWAN. SN 77-828,524. PUB. 7-20-2010, FILED 9-17-2009.

# iKey

THE MARK CONSISTS OF STANDARD CHARACTERS WITHOUT CLAIM TO ANY PARTICULAR FONT, STYLE, SIZE, OR COLOR.

**CLASS 6—METAL GOODS**

FOR ACCESSORIES OF METAL FOR DOOR USE IN BUILDINGS, NAMELY, DOOR STOPS OF METAL, DOORJAMBS OF METAL, DOOR TRIMS OF METAL; METAL LOCKS FOR DOORS USED IN BUILDINGS; KEYS MADE OF METAL FOR LOCKS USED IN BUILDINGS; NON-ELECTRIC METAL LOCKS FOR DOOR USE IN BUILDINGS; METAL LATCHES; ROUND HANDLES MADE OF METAL FOR DOORS USED IN BUILDINGS; FLAT HANDLE BARS MADE OF METAL FOR DOORS USED IN BUILDINGS; HANDLE BAR OF METAL FOR DOOR USE IN BUILDINGS; METAL CYLINDRICAL LOCK FOR DOORS IN BUILDINGS; METAL KEY BLANKS FOR DOORS IN BUILDINGS; METAL KEY RINGS FOR DOORS IN BUILDINGS; METAL KEY LOOPS FOR DOORS IN BUILDINGS; METAL KNOBS FOR DOORS IN BUILDINGS; paneled door made of metal; non-electronic combination locks for use in doors in buildings (U.S. CLS. 2, 12, 13, 14, 23, 25 AND 50).

FIRST USE 1-20-2011; IN COMMERCE 1-20-2011.

**CLASS 9—ELECTRICAL AND SCIENTIFIC APPARATUS**

FOR ELECTRIC LOCKS FOR DOORS IN BUILDINGS; ELECTRONIC LOCKS FOR DOORS IN BUILDINGS; ELECTRIC ANTI-THEFT LOCK FOR DOORS IN BUILDINGS; ELECTRONIC COMBINATION LOCKS FOR DOORS IN BUILDINGS (U.S. CLS. 21, 23, 26, 36 AND 38).

FIRST USE 1-20-2011; IN COMMERCE 1-20-2011.

3,962,598. BEVERLY KAYE & ASSOCIATES, INC., DBA CAREER SERVICES INTERNATIONAL, SCRANTON, PA. SN 77-829,877. PUB. 6-29-2010, FILED 9-18-2009.

### SELF POWERED CAREERISTS

THE MARK CONSISTS OF STANDARD CHARACTERS WITHOUT CLAIM TO ANY PARTICULAR FONT, STYLE, SIZE, OR COLOR.

NO CLAIM IS MADE TO THE EXCLUSIVE RIGHT TO USE "CAREERISTS", APART FROM THE MARK AS SHOWN.

### CLASS 16—PAPER GOODS AND PRINTED MATTER

FOR PRINTED EDUCATIONAL MATERIALS IN THE FIELD OF CAREER DEVELOPMENT, ASSESSMENT, PLANNING OR IMPROVEMENT (U.S. CLS. 2, 5, 22, 23, 29, 37, 38 AND 50).

FIRST USE 6-30-2010; IN COMMERCE 6-30-2010.

### CLASS 35—ADVERTISING AND BUSINESS

FOR PROVIDING ONLINE CONTENT FEATURING CONSULTING SERVICES IN THE FIELD OF CAREER DEVELOPMENT, ASSESSMENT, PLANNING OR IMPROVEMENT (U.S. CLS. 100, 101 AND 102).

FIRST USE 6-30-2010; IN COMMERCE 6-30-2010.

3,962,599. BEVERLY KAYE & ASSOCIATES, INC., DBA CAREER SYSTEMS INTERNATIONAL, SCRANTON, PA. SN 77-829,887. PUB. 6-29-2010, FILED 9-18-2009.

### CAREER POWER 3.0

THE MARK CONSISTS OF STANDARD CHARACTERS WITHOUT CLAIM TO ANY PARTICULAR FONT, STYLE, SIZE, OR COLOR.

NO CLAIM IS MADE TO THE EXCLUSIVE RIGHT TO USE "CAREER", APART FROM THE MARK AS SHOWN.

### CLASS 16—PAPER GOODS AND PRINTED MATTER

FOR PRINTED EDUCATIONAL MATERIALS IN THE FIELD OF CAREER DEVELOPMENT, ASSESSMENT, PLANNING OR IMPROVEMENT (U.S. CLS. 2, 5, 22, 23, 29, 37, 38 AND 50).

FIRST USE 6-30-2010; IN COMMERCE 6-30-2010.

### CLASS 35—ADVERTISING AND BUSINESS

FOR PROVIDING ONLINE CONTENT FEATURING CONSULTING SERVICES IN THE FIELD OF CAREER DEVELOPMENT, ASSESSMENT, PLANNING OR IMPROVEMENT (U.S. CLS. 100, 101 AND 102).

FIRST USE 6-30-2010; IN COMMERCE 6-30-2010.

### CLASS 41—EDUCATION AND ENTERTAINMENT

FOR EDUCATION SERVICES, NAMELY, PROVIDING LIVE AND ON-LINE CLASSES, SEMINARS OR WORKSHOPS IN THE FIELD OF CAREER DEVELOPMENT, ASSESSMENT, PLANNING OR IMPROVEMENT (U.S. CLS. 100, 101 AND 107).

FIRST USE 6-30-2010; IN COMMERCE 6-30-2010.

3,962,600. BEVERLY KAYE & ASSOCIATES, INC., DBA CAREER SERVICES INTERNATIONAL, SCRANTON, PA. SN 77-829,990. PUB. 6-29-2010, FILED 9-18-2009.

### SELF POWERED CAREERS

THE MARK CONSISTS OF STANDARD CHARACTERS WITHOUT CLAIM TO ANY PARTICULAR FONT, STYLE, SIZE, OR COLOR.

NO CLAIM IS MADE TO THE EXCLUSIVE RIGHT TO USE "CAREERS", APART FROM THE MARK AS SHOWN.

### CLASS 16—PAPER GOODS AND PRINTED MATTER

FOR PRINTED EDUCATIONAL MATERIALS IN THE FIELD OF CAREER DEVELOPMENT, ASSESSMENT, PLANNING OR IMPROVEMENT (U.S. CLS. 2, 5, 22, 23, 29, 37, 38 AND 50).

FIRST USE 6-30-2010; IN COMMERCE 6-30-2010.

### CLASS 35—ADVERTISING AND BUSINESS

FOR PROVIDING ONLINE CONTENT FEATURING CONSULTING SERVICES IN THE FIELD OF CAREER DEVELOPMENT, ASSESSMENT, PLANNING OR IMPROVEMENT (U.S. CLS. 100, 101 AND 102).

FIRST USE 6-30-2010; IN COMMERCE 6-30-2010.

3,962,604. GOOGLE INC., MOUNTAIN VIEW, CA. SN 77-831,323. PUB. 8-3-2010, FILED 9-21-2009.

### GOOGLE SIDEWIKI

THE MARK CONSISTS OF STANDARD CHARACTERS WITHOUT CLAIM TO ANY PARTICULAR FONT, STYLE, SIZE, OR COLOR.

### CLASS 9—ELECTRICAL AND SCIENTIFIC APPARATUS

FOR COMPUTER SOFTWARE TO ENABLE UPLOADING, POSTING, SHOWING, DISPLAYING, TAGGING, BLOGGING, SHARING OR OTHERWISE PROVIDING ELECTRONIC MEDIA OR INFORMATION OVER THE INTERNET OR OTHER COMMUNICATIONS NETWORK (U.S. CLS. 21, 23, 26, 36 AND 38).

FIRST USE 9-0-2009; IN COMMERCE 9-0-2009.

**CLASS 41—EDUCATION AND ENTERTAINMENT**

FOR ELECTRONIC PUBLISHING SERVICES, NAMELY, PUBLICATION OF TEXT AND GRAPHIC WORKS OF OTHERS ON-LINE FEATURING INFORMATION IN THE FIELD OF GENERAL INTEREST; PROVIDING BLOGS ONLINE FEATURING INFORMATION IN THE FIELD OF GENERAL INTEREST (U.S. CLS. 100, 101 AND 107).

FIRST USE 9-0-2009; IN COMMERCE 9-0-2009.

**CLASS 42—SCIENTIFIC AND COMPUTER SERVICES**

FOR HOSTING OF DIGITAL CONTENT ON THE INTERNET; APPLICATION SERVICE PROVIDER (ASP) SERVICES FEATURING SOFTWARE TO ENABLE UPLOADING, POSTING, SHOWING, DISPLAYING, TAGGING, BLOGGING, SHARING OR OTHERWISE PROVIDING ELECTRONIC MEDIA OR INFORMATION OVER THE INTERNET OR OTHER COMMUNICATIONS NETWORK (U.S. CLS. 100 AND 101).

FIRST USE 9-0-2009; IN COMMERCE 9-0-2009.

3,962,609. NATIONAL PUBLISHING AND TECHNOLOGY, INC., BONITA SPRINGS, FL. SN 77-831,877. PUB. 8-3-2010, FILED 9-22-2009.

# SICMS

THE MARK CONSISTS OF STANDARD CHARACTERS WITHOUT CLAIM TO ANY PARTICULAR FONT, STYLE, SIZE, OR COLOR.

**CLASS 9—ELECTRICAL AND SCIENTIFIC APPARATUS**

FOR COMPUTER SOFTWARE FOR COMPILING CUSTOMIZED BUSINESS OPERATING POLICIES AND PROCEDURES FROM A PROPRIETARY DATA BASE; DOWNLOADABLE ELECTRONIC PUBLICATIONS IN THE NATURE OF BOOKS, MANUALS, HANDBOOKS, CHECKSHEETS AND TESTS REGARDING BUSINESS OPERATING POLICIES AND PROCEDURES COMPILED FROM A PROPRIETARY DATA BASE; ELECTRONIC PUBLICATIONS IN THE NATURE OF BOOKS, MANUALS, HANDBOOKS, CHECKSHEETS AND TESTS REGARDING BUSINESS OPERATING POLICIES AND PROCEDURES COMPILED FROM A PROPRIETARY DATA BASE (U.S. CLS. 21, 23, 26, 36 AND 38).

FIRST USE 1-12-2011; IN COMMERCE 1-12-2011.

**CLASS 41—EDUCATION AND ENTERTAINMENT**

FOR PROVIDING ON-LINE NON-DOWNLOADABLE PUBLICATIONS IN THE NATURE OF BOOKS, MANUALS, HANDBOOKS, CHECKSHEETS AND TESTS REGARDING BUSINESS OPERATING POLICIES AND PROCEDURES COMPILED FROM A PROPRIETARY DATA BASE (U.S. CLS. 100, 101 AND 107).

FIRST USE 1-12-2011; IN COMMERCE 1-12-2011.

3,962,614. DISCUS DENTAL, LLC, CULVER CITY, CA. SN 77-833,571. PUB. 8-3-2010, FILED 9-23-2009.

# DISCUS

THE MARK CONSISTS OF STANDARD CHARACTERS WITHOUT CLAIM TO ANY PARTICULAR FONT, STYLE, SIZE, OR COLOR.

OWNER OF U.S. REG. NOS. 2,127,164, 2,431,601, AND OTHERS.

**CLASS 3—COSMETICS AND CLEANING PREPARATIONS**

FOR DENTAL PRODUCTS, NAMELY, COSMETIC TOOTH WHITENER, DENTIFRICES, BLEACHING PREPARATIONS AND TOOTH WHITENING KITS FOR COSMETIC PURPOSES, DENTAL BLEACHING GEL (U.S. CLS. 1, 4, 6, 50, 51 AND 52).

FIRST USE 9-21-2009; IN COMMERCE 9-21-2009.

**CLASS 5—PHARMACEUTICALS**

FOR DENTAL PRODUCTS, NAMELY, DENTAL COMPOSITE MATERIALS, DENTAL IMPRESSION MATERIALS, MEDICATED TOOTHPASTE, MEDICATED MOUTHWASH AND MEDICATED DENTAL RINSE, MEDICATED BREATH FRESHENERS, DENTAL WAXES AND COMPOUNDS FOR USE IN ENDODONTIC PROCEDURES, DENTAL POLISH, DENTAL PROPHY PASTE; DENTAL RESTORATION COMPOUNDS FOR TISSUE PROTECTION, FIXING MATERIALS FOR USE WITH A CURING LIGHT FOR DENTAL CROWNS, BRIDGES AND OTHER PROSTHESES FOR DENTAL AND OTHER ORAL PROPHYLAXIS PURPOSES; MATERIALS FOR USE WITH A CURING LIGHT FOR DENTAL FILLINGS AND FOR SEALING PURPOSES (U.S. CLS. 6, 18, 44, 46, 51 AND 52).

FIRST USE 9-21-2009; IN COMMERCE 9-21-2009.

**CLASS 9—ELECTRICAL AND SCIENTIFIC APPARATUS**

FOR EDUCATIONAL DVDS IN THE FIELD OF DENTISTRY (U.S. CLS. 21, 23, 26, 36 AND 38).

FIRST USE 3-25-2010; IN COMMERCE 3-25-2010.

**CLASS 10—MEDICAL APPARATUS**

FOR DENTAL INSTRUMENTS, NAMELY, DENTAL DRILLS, HANDPIECES, ULTRASONIC SCALERS, TONGUE SCRAPERS, CURING DENTAL BITE TRAYS AND DENTAL IMPRESSION TRAYS, INTRA-ORAL DENTAL LIGHTS, DENTAL CURING LIGHTS AND LASERS FOR DENTAL USE; PROPHY ANGLES THAT ARE DISPOSABLE OR REUSABLE OR RECYCLABLE; DENTAL INSTRUMENTS THAT CAN BE USED IN ENDODONTIC THERAPY, NAMELY, MICROASPIRATORS, ROOT CANAL FILES AND INSTRUMENTS USED TO SHAVE THE INSIDE OF A ROOT CANAL; DENTAL DEVICES THAT EXPAND THE MOUTH, NAMELY, LIP AND CHEEK RETRACTORS (U.S. CLS. 26, 39 AND 44).

FIRST USE 9-21-2009; IN COMMERCE 9-21-2009.

**CLASS 16—PAPER GOODS AND PRINTED MATTER**

FOR PRINTED EDUCATIONAL COURSE MATERIALS IN THE FIELD OF DENTISTRY; EDUCATIONAL KITS, COMPRISED OF PRINTED EDUCATIONAL BOOKS, BOOKLETS, LEAFLETS, AND COURSE MATERIALS, AND AN EDUCATIONAL DVD, ALL SOLD AS A UNIT IN THE FIELD OF DENTISTRY; AND PRINTED ART REPRODUCTIONS (U.S. CLS. 2, 5, 22, 23, 29, 37, 38 AND 50).

FIRST USE 9-21-2009; IN COMMERCE 9-21-2009.

**CLASS 35—ADVERTISING AND BUSINESS**

FOR COMPUTERIZED ON-LINE ORDERING SERVICES AND RETAIL STORE SERVICES, ALL IN THE FIELD OF DENTAL SUPPLIES AND EQUIPMENT (U.S. CLS. 100, 101 AND 102).

FIRST USE 9-21-2009; IN COMMERCE 9-21-2009.

**CLASS 41—EDUCATION AND ENTERTAINMENT**

FOR DEVELOPMENT AND DISSEMINATION OF EDUCATIONAL MATERIALS OF OTHERS IN THE FIELD OF DENTISTRY; EDUCATIONAL SERVICES, NAMELY, CONDUCTING SEMINARS, CONFERENCES AND WORKSHOPS IN THE FIELD OF DENTISTRY; ARRANGING AND CONDUCTING SEMINARS, PROFESSIONAL WORKSHOPS AND TRAINING COURSES IN THE FIELD OF DENTISTRY; PROVIDING CONTINUING DENTAL EDUCATION SERVICES, NAMELY, PROVIDING LIVE AND ON-LINE CONTINUING PROFESSIONAL EDUCATION SEMINARS, CONFERENCES, CLASSES, COURSES AND WORKSHOPS IN THE FIELD OF DENTISTRY, AND DISTRIBUTING COURSE MATERIALS IN CONNECTION THEREWITH (U.S. CLS. 100, 101 AND 107).

FIRST USE 3-4-2010; IN COMMERCE 3-4-2010.

3,962,624. A&E TELEVISION NETWORKS, LLC, NEW YORK, NY. SN 77-840,486. PUB. 7-27-2010, FILED 10-2-2009.

**AMERICAN PICKERS**

THE MARK CONSISTS OF STANDARD CHARACTERS WITHOUT CLAIM TO ANY PARTICULAR FONT, STYLE, SIZE, OR COLOR.

NO CLAIM IS MADE TO THE EXCLUSIVE RIGHT TO USE "AMERICAN", APART FROM THE MARK AS SHOWN.

**CLASS 9—ELECTRICAL AND SCIENTIFIC APPARATUS**

FOR MULTIMEDIA GOODS, NAMELY, PRERECORDED DIGITAL VIDEO DISCS AND DVDS FEATURING STORIES ABOUT ANTIQUES, COLLECTABLES AND TREASURES; DIGITAL MEDIA, NAMELY, DOWNLOADABLE AUDIO AND VIDEO FILES FEATURING STORIES ABOUT ANTIQUES, COLLECTABLES AND TREASURES; DOWNLOADABLE WEBCASTS FEATURING STORIES ABOUT ANTIQUES, COLLECTABLES AND TREASURES (U.S. CLS. 21, 23, 26, 36 AND 38).

FIRST USE 1-19-2010; IN COMMERCE 1-19-2010.

**CLASS 41—EDUCATION AND ENTERTAINMENT**

FOR ENTERTAINMENT SERVICES, NAMELY, A MULTIMEDIA PROGRAM SERIES FEATURING STORIES ABOUT ANTIQUES, COLLECTABLES AND TREASURES DISTRIBUTED VIA VARIOUS PLATFORMS ACROSS MULTIPLE FORMS OF TRANSMISSION MEDIA; ENTERTAINMENT SERVICES, NAMELY, PROVIDING INFORMATION ON ANTIQUES, COLLECTABLES AND TREASURES (U.S. CLS. 100, 101 AND 107).

FIRST USE 1-18-2010; IN COMMERCE 1-18-2010.

3,962,625. DANJAQ, LLC, SANTA MONICA, CA. SN 77-840,605. PUB. 8-10-2010, FILED 10-2-2009.



OWNER OF U.S. REG. NO. 1,737,876.

THE MARK CONSISTS OF A STYLIZED RIFLE SCOPE TARGET DESIGN INCLUDING A CENTRAL SOLID CIRCLE, SYMMETRICALLY SURROUNDED BY A SOLID, THICK RING, WHICH IS SURROUNDED BY A RING OF BROKEN ARCS AND HAVING SOLID-LINE CROSS-HAIRS THAT EXTEND BEYOND THE ARCS. A ROUND-CORNERED RECTANGLE, CANTED SLIGHTLY RIGHTWARD, EXTENDS TO THE RIGHT FROM THE CENTRAL SOLID CIRCLE AND INCLUDES THE WORDS "YOUNG BOND".

**CLASS 9—ELECTRICAL AND SCIENTIFIC APPARATUS**

FOR ELECTRONIC PUBLICATIONS, NAMELY, BOOKS AND BOOKLETS FEATURING FICTIONAL STORIES AND CHARACTERS RECORDED ON COMPUTER MEDIA; ELECTRONIC PUBLICATIONS, NAMELY, COMIC BOOKS AND COMIC STRIPS FEATURING FICTIONAL STORIES AND CHARACTERS RECORDED ON COMPUTER MEDIA; AUDIO BOOKS ON CASSETTE, COMPACT DISC, COMPUTER DISC, AND IN DIGITAL FILE FORMAT FEATURING FICTIONAL STORIES AND CHARACTERS; DOWNLOADABLE ELECTRONIC PUBLICATIONS IN THE NATURE OF BOOKS AND BOOKLETS IN THE FIELD OF FICTIONAL STORIES AND CHARACTERS; PRERECORDED AUDIO CASSETTES, CARTRIDGES, AND COMPUTER AUDIO FILES FEATURING FICTIONAL STORIES AND CHARACTERS AND ADVERTISEMENTS (U.S. CLS. 21, 23, 26, 36 AND 38).

FIRST USE 4-11-2006; IN COMMERCE 4-11-2006.

**CLASS 16—PAPER GOODS AND PRINTED MATTER**

FOR PRINTED MATTER, NAMELY, A SERIES OF BOOKS IN THE FIELD OF ACTION ADVENTURE FICTION, COMIC BOOKS IN THE FIELD OF ACTION ADVENTURE FICTION; COMIC STRIPS (U.S. CLS. 2, 5, 22, 23, 29, 37, 38 AND 50).

FIRST USE 4-27-2005; IN COMMERCE 4-27-2005.



**CLASS 41—EDUCATION AND ENTERTAINMENT**

FOR ENTERTAINMENT SERVICES, NAMELY, PROVIDING ON-LINE COMPUTER GAMES; PROVIDING A WEB SITE FEATURING GAMES, FICTIONAL CHARACTER TRIVIA, CONTESTS, PHOTOGRAPHS, AND OTHER MULTIMEDIA MATERIALS; PUBLISHING OF SOUND RECORDINGS, IMAGES, TEXT, SOFTWARE, INFORMATION AND DATA FEATURING FICTIONAL STORIES AND CHARACTERS, VIA GLOBAL COMPUTER NETWORKS; PUBLISHING OF BOOKS AND MAGAZINES, AND PUBLISHING OF ELECTRONIC PUBLICATIONS (U.S. CLS. 100, 101 AND 107).

FIRST USE 3-20-2005; IN COMMERCE 3-20-2005.

**CLASS 9—ELECTRICAL AND SCIENTIFIC APPARATUS**

FOR ELECTRONIC PUBLICATIONS, NAMELY, E-BOOKS IN THE FIELD OF RELIGION, FAITH, AND SPIRITUALITY, RECORDED ON COMPUTER MEDIA (U.S. CLS. 21, 23, 26, 36 AND 38).

FIRST USE 1-0-2010; IN COMMERCE 1-0-2010.

**CLASS 16—PAPER GOODS AND PRINTED MATTER**

FOR PUBLICATIONS, NAMELY, BOOKS IN THE FIELD OF RELIGION, FAITH, AND SPIRITUALITY (U.S. CLS. 2, 5, 22, 23, 29, 37, 38 AND 50).

FIRST USE 1-0-2010; IN COMMERCE 1-0-2010.

3,962,698. EMSEAL JOINT SYSTEMS LTD, WESTBOROUGH, MA. SN 77-863,826. PUB. 2-16-2010, FILED 11-3-2009.

3,962,715. SAGEL, GAIL, WESTPORT, CT. SN 77-872,032. PUB. 8-3-2010, FILED 11-13-2009.

# SecuritySeal

THE MARK CONSISTS OF STANDARD CHARACTERS WITHOUT CLAIM TO ANY PARTICULAR FONT, STYLE, SIZE, OR COLOR.

**CLASS 17—RUBBER GOODS**

FOR ELASTOMERIC EXPANSION AND CONTRACTION JOINT SEALS FOR USE IN BUILDING, BRIDGES, ROADWAYS, PARKING STRUCTURES AND OPEN-AIR STRUCTURES (U.S. CLS. 1, 5, 12, 13, 35 AND 50).

FIRST USE 1-1-2010; IN COMMERCE 7-30-2010.

**CLASS 19—NON-METALLIC BUILDING MATERIALS**

FOR NON-METAL EXPANSION JOINTS FOR FLOORS AND WALLS (U.S. CLS. 1, 12, 33 AND 50).

FIRST USE 1-1-2010; IN COMMERCE 7-30-2010.

3,962,702. INI-ABASI, ANIEKAN, AKA ELISHA GOODMAN, WINDSOR, ONTARIO, CANADA. SN 77-865,746. PUB. 7-13-2010, FILED 11-5-2009.



NO CLAIM IS MADE TO THE EXCLUSIVE RIGHT TO USE "PRAYER", APART FROM THE MARK AS SHOWN.

THE MARK CONSISTS OF THE WORDS "PRAYER COOKBOOK" WITH TWO PRAYING HANDS PLACED NEXT TO THE WORD "PRAYER", ALL OF WHICH IS WITHIN AN OVAL.

# FACES BEAUTIFUL

THE MARK CONSISTS OF STANDARD CHARACTERS WITHOUT CLAIM TO ANY PARTICULAR FONT, STYLE, SIZE, OR COLOR.

**CLASS 3—COSMETICS AND CLEANING PREPARATIONS**

FOR COSMETICS; NON-MEDICATED SKIN CARE PREPARATIONS; HAIR CARE PREPARATIONS (U.S. CLS. 1, 4, 6, 50, 51 AND 52).

FIRST USE 1-0-2009; IN COMMERCE 1-0-2009.

**CLASS 35—ADVERTISING AND BUSINESS**

FOR RETAIL STORE SERVICES FEATURING COSMETIC AND HAIR CARE PRODUCTS (U.S. CLS. 100, 101 AND 102).

FIRST USE 1-0-2010; IN COMMERCE 1-0-2010.

**CLASS 44—MEDICAL, BEAUTY AND AGRICULTURAL SERVICES**

FOR COSMETIC SKIN CARE SERVICES; HAIR SALON SERVICES; SERVICES OF A MAKE-UP ARTIST (U.S. CLS. 100 AND 101).

FIRST USE 1-0-2010; IN COMMERCE 1-0-2010.

3,962,716. MICROSOFT CORPORATION, REDMOND, WA. SN 77-872,539. PUB. 8-17-2010, FILED 11-13-2009.

# RIBBON HERO

THE MARK CONSISTS OF STANDARD CHARACTERS WITHOUT CLAIM TO ANY PARTICULAR FONT, STYLE, SIZE, OR COLOR.

**CLASS 9—ELECTRICAL AND SCIENTIFIC APPARATUS**

FOR COMPUTER SOFTWARE FOR TRAINING USERS TO USE BUSINESS APPLICATION SOFTWARE; AND COMPUTER GAME SOFTWARE FOR USE IN COMPUTER USER TRAINING (U.S. CLS. 21, 23, 26, 36 AND 38).  
FIRST USE 1-19-2010; IN COMMERCE 1-19-2010.

**CLASS 41—EDUCATION AND ENTERTAINMENT**

FOR PROVIDING ONLINE TRAINING IN THE NATURE OF TUTORIALS AND "HOW TO" DEMONSTRATIONS IN THE FIELD OF BUSINESS APPLICATION SOFTWARE; EDUCATIONAL SERVICES, NAMELY, PROVIDING TRAINING AND ONLINE EDUCATIONAL MATERIALS FOR TRAINING IN THE FIELD OF BUSINESS APPLICATION SOFTWARE; ENTERTAINMENT IN THE NATURE OF COMPETITIONS IN THE FIELD OF BUSINESS APPLICATION SOFTWARE USER SKILLS; AND PROVIDING RECOGNITION AND INCENTIVES BY THE WAY OF AWARDS AND CONTESTS TO DEMONSTRATE EXCELLENCE IN THE FIELD OF BUSINESS APPLICATION SOFTWARE USER SKILLS (U.S. CLS. 100, 101 AND 107).  
FIRST USE 1-19-2010; IN COMMERCE 1-19-2010.

---

3,962,717. MILLIGAN, JOSEPH JAMES, OAKDALE, MN. SN 77-872,913. PUB. 4-20-2010, FILED 11-15-2009.

# Shadowcraft

THE MARK CONSISTS OF STANDARD CHARACTERS WITHOUT CLAIM TO ANY PARTICULAR FONT, STYLE, SIZE, OR COLOR.

**CLASS 9—ELECTRICAL AND SCIENTIFIC APPARATUS**

FOR AUDIO RECORDINGS FEATURING MUSIC; DOWNLOADABLE MUSIC VIA THE INTERNET AND WIRELESS DEVICES; SOUND RECORDINGS FEATURING MUSIC; VIDEO RECORDINGS FEATURING MUSIC; AUDIO TAPES FEATURING MUSIC; COMPACT DISCS FEATURING MUSIC; DIGITAL MUSIC DOWNLOADABLE FROM THE INTERNET; DOWNLOADABLE MP3 FILES, MP3 RECORDINGS, ON-LINE DISCUSSION BOARDS, WEBCASTS, WEBINARS AND PODCASTS FEATURING MUSIC, AUDIO BOOKS AND NEWS BROADCASTS; DOWNLOADABLE MUSICAL SOUND RECORDINGS; DOWNLOADABLE RING TONES, GRAPHICS AND MUSIC VIA A GLOBAL COMPUTER NETWORK AND WIRELESS DEVICES; DOWNLOADABLE VIDEO RECORDINGS FEATURING MUSIC; MUSIC RECORDINGS SOLD AS A KIT WITH A MASK; MUSICAL SOUND RECORDINGS; MUSICAL VIDEO RECORDINGS; PRERECORDED VIDEO TAPES FEATURING MUSIC (U.S. CLS. 21, 23, 26, 36 AND 38).  
FIRST USE 3-30-2004; IN COMMERCE 3-30-2004.

**CLASS 41—EDUCATION AND ENTERTAINMENT**

FOR ENTERTAINMENT SERVICES, NAMELY, PROVIDING A WEB SITE FEATURING MUSICAL PERFORMANCES, MUSICAL VIDEOS, RELATED FILM CLIPS, PHOTOGRAPHS, AND OTHER MULTIMEDIA MATERIALS FEATURING MUSIC; ENTERTAINMENT SERVICES, NAMELY, PROVIDING A WEB SITE FEATURING PHOTOGRAPHIC AND PROSE PRESENTATIONS FEATURING MUSIC; ENTERTAINMENT SERVICES, NAMELY, PROVIDING A WEB SITE FEATURING PHOTOGRAPHIC, AUDIO, VIDEO AND PROSE PRESENTATIONS FEATURING MUSIC; ENTERTAINMENT SERVICES, NAMELY, PROVIDING A WEB SITE FEATURING PHOTOGRAPHIC, VIDEO AND PROSE PRESENTATIONS FEATURING MUSIC; COMPOSITION OF MUSIC FOR OTHERS; CONSULTATION AND ADVICE REGARDING MUSICAL SELECTIONS AND ARRANGEMENTS FOR SOUND RECORDINGS AND LIVE PERFORMANCES; ENTERTAINMENT IN THE NATURE OF LASER SHOWS; ENTERTAINMENT IN THE NATURE OF LIGHT SHOWS; ENTERTAINMENT IN THE NATURE OF LIVE PERFORMANCES BY A MUSICAL BAND; ENTERTAINMENT SERVICES IN THE NATURE OF DEVELOPMENT, CREATION, PRODUCTION AND POST-PRODUCTION SERVICES OF MULTIMEDIA CONTENT; ENTERTAINMENT SERVICES IN THE NATURE OF LIVE MUSICAL PERFORMANCES; ENTERTAINMENT SERVICES, NAMELY, AN ON-LINE ACTIVITY WHERE YOU CREATE YOUR OWN MUSIC VIDEOS; ENTERTAINMENT SERVICES, NAMELY, NON-DOWNLOADABLE RINGTONES, PRE-RECORDED MUSIC, VIDEO AND GRAPHICS PRESENTED TO MOBILE COMMUNICATIONS DEVICES VIA A GLOBAL COMPUTER NETWORK AND WIRELESS NETWORKS; ENTERTAINMENT SERVICES, NAMELY, PROVIDING NON-DOWNLOADABLE PLAYBACK OF MUSIC VIA GLOBAL COMMUNICATIONS NETWORKS; ENTERTAINMENT SERVICES, NAMELY, PROVIDING ONLINE, NON-DOWNLOADABLE VIRTUAL MUSICAL SOUND RECORDINGS FOR USE IN VIRTUAL ENVIRONMENTS CREATED FOR ENTERTAINMENT PURPOSES; ENTERTAINMENT, NAMELY, LIGHTING PRODUCTION; ENTERTAINMENT, NAMELY, LIVE MUSIC CONCERTS; ENTERTAINMENT, NAMELY, LIVE PERFORMANCES BY A MUSICAL BAND; ENTERTAINMENT, NAMELY, LIVE PERFORMANCES BY MUSICAL BANDS; ENTERTAINMENT, NAMELY, LIVE PERFORMANCES BY ROCK GROUPS; ENTERTAINMENT, NAMELY, PREPARATION OF SPECIAL EFFECTS; MUSIC COMPOSITION AND TRANSCRIPTION FOR OTHERS; MUSIC COMPOSITION FOR OTHERS; MUSIC PRODUCTION SERVICES; MUSIC TRANSCRIPTION FOR OTHERS; MUSIC VIDEO PRODUCTION; POST-PRODUCTION EDITING SERVICES IN THE FIELD OF MUSIC, VIDEOS AND FILM; PRODUCTION OF MUSICAL SOUND RECORDING; PRODUCTION OF SOUND AND MUSIC VIDEO RECORDINGS; PROVIDING AN INTERNET WEBSITE PORTAL FEATURING LINKS TO MUSICAL ARTIST WEBSITES AND MUSIC PERFORMANCE TICKET INFORMATION; PROVISION OF INFORMATION RELATING TO LIVE PERFORMANCES, ROAD SHOWS, LIVE STAGE EVENTS, THEATRICAL PERFORMANCES, LIVE MUSIC CONCERTS AND AUDIENCE PARTICIPATION IN SUCH EVENTS; RADIO ENTERTAINMENT SERVICES, NAMELY, RADIO PROGRAMS FEATURING PERFORMANCES BY A MUSICAL BAND (U.S. CLS. 100, 101 AND 107).  
FIRST USE 3-30-2004; IN COMMERCE 3-30-2004.

---

3,962,725. NIKE, INC., BEAVERTON, OR. SN 77-877,978. PUB. 7-6-2010, FILED 11-20-2009.

# LUNARLON

THE MARK CONSISTS OF STANDARD CHARACTERS WITHOUT CLAIM TO ANY PARTICULAR FONT, STYLE, SIZE, OR COLOR.

**CLASS 17—RUBBER GOODS**

FOR PADDING AND CUSHIONING MATERIALS OF PLASTIC USED IN FOOTWEAR (U.S. CLS. 1, 5, 12, 13, 35 AND 50).

FIRST USE 4-0-2010; IN COMMERCE 4-0-2010.

**CLASS 25—CLOTHING**

FOR FOOTWEAR (U.S. CLS. 22 AND 39).

FIRST USE 4-0-2010; IN COMMERCE 4-0-2010.

3,962,728. ARMARK AUTHENTICATION TECHNOLOGIES, LLC, GLEN ROCK, PA. SN 77-879,923. PUB. 6-1-2010, FILED 11-24-2009.

ARmicron

THE MARK CONSISTS OF STANDARD CHARACTERS WITHOUT CLAIM TO ANY PARTICULAR FONT, STYLE, SIZE, OR COLOR.

**CLASS 1—CHEMICALS**

FOR CHEMICAL SUBSTANCES, NAMELY, POLYMER BASED MICROSTRUCTURES, NAMELY, MICROSCOPIC FIBERS, MICRO-NEEDLES AND MICRO SPHERES FOR USE IN THE MANUFACTURE OF PHARMACEUTICAL PREPARATIONS AND MEDICAL DEVICES (U.S. CLS. 1, 5, 6, 10, 26 AND 46).

FIRST USE 2-25-2011; IN COMMERCE 2-25-2011.

**CLASS 5—PHARMACEUTICALS**

FOR PHARMACEUTICAL PREPARATIONS, NAMELY, A DRUG DELIVERY SYSTEM COMPRISED OF POLYMER BASED MICROSTRUCTURES, NAMELY, MICROSCOPIC FIBERS, MICRO-NEEDLES AND MICRO SPHERES FOR USE AS A CARRIER OF PHARMACEUTICALS AND FOR USE AS A CARRIER FOR CONTRAST MEDIA FOR MEDICAL IMAGING (U.S. CLS. 6, 18, 44, 46, 51 AND 52).

FIRST USE 2-25-2011; IN COMMERCE 2-25-2011.

**CLASS 10—MEDICAL APPARATUS**

FOR POLYMER BASED MICROSTRUCTURES, NAMELY, MICROSCOPIC FIBERS, MICRO-NEEDLES AND MICRO SPHERES SOLD AS AN INTEGRAL COMPONENT OF MEDICAL STENTS AND OTHER IMPLANTABLE MEDICAL DEVICES (U.S. CLS. 26, 39 AND 44).

FIRST USE 2-25-2011; IN COMMERCE 2-25-2011.

**CLASS 17—RUBBER GOODS**

FOR POLYMER BASED MICROSTRUCTURES, NAMELY, MICROSCOPIC FIBERS, MICRO-NEEDLES AND MICRO SPHERES FOR USE IN THE MANUFACTURE OF IMPLANTABLE MEDICAL DEVICES (U.S. CLS. 1, 5, 12, 13, 35 AND 50).

FIRST USE 2-25-2011; IN COMMERCE 2-25-2011.

3,962,746. KNOWLEDGE INFUSION, LLC, MINNEAPOLIS, MN. SN 77-885,556. PUB. 6-8-2010, FILED 12-3-2009.

**KNOWLEDGE INFUSION**

THE MARK CONSISTS OF STANDARD CHARACTERS WITHOUT CLAIM TO ANY PARTICULAR FONT, STYLE, SIZE, OR COLOR.

OWNER OF U.S. REG. NO. 3,903,443.

**CLASS 9—ELECTRICAL AND SCIENTIFIC APPARATUS**

FOR DOWNLOADABLE AUDIO FILES, MULTIMEDIA FILES, TEXT FILES, E-MAILS, WRITTEN DOCUMENTS, AUDIO MATERIAL, VIDEO MATERIAL AND GAMES FEATURING INFORMATION IN THE FORM OF DOWNLOADABLE SHORT EDUCATIONAL/TRAINING COMMUNICATIONS IN THE FIELD OF HUMAN RESOURCE DEVELOPMENT FOR THE PROMOTION OF EMPLOYEE RETENTION, CAREER GROWTH AND INCREASED PRODUCTIVITY FOR EMPLOYEES AND EMPLOYERS, NAMELY, INFORMATION RELATING TO DEVELOPING TALENT STRATEGIES INTEGRATING TECHNOLOGY AND BUSINESS STRATEGIES, TALENT ACQUISITION, TALENT MANAGEMENT, TALENT INTELLIGENCE, SOCIAL COLLABORATION AND EMERGING SOLUTIONS, VENDOR SELECTION, PROGRAM MANAGEMENT OF TALENT ACQUISITION PROJECTS (U.S. CLS. 21, 23, 26, 36 AND 38).

FIRST USE 1-0-2005; IN COMMERCE 1-0-2005.

**CLASS 35—ADVERTISING AND BUSINESS**

FOR HUMAN RESOURCES CONSULTING SERVICES, NAMELY, PROVIDING ADVICE, COUNSELING, AND EXPERTISE IN DEVELOPING TALENT STRATEGIES INTEGRATING TECHNOLOGY AND BUSINESS STRATEGIES, TALENT ACQUISITION, TALENT MANAGEMENT, TALENT INTELLIGENCE, SOCIAL COLLABORATION AND EMERGING SOLUTIONS, VENDOR SELECTION, PROGRAM MANAGEMENT OF TALENT ACQUISITION PROJECTS; ONLINE HUMAN RESOURCES CONSULTING SERVICES, NAMELY, PROVIDING INFORMATION ON DEVELOPING TALENT STRATEGIES INTEGRATING TECHNOLOGY AND BUSINESS STRATEGIES, TALENT ACQUISITION, TALENT MANAGEMENT, TALENT INTELLIGENCE, SOCIAL COLLABORATION AND EMERGING SOLUTIONS, VENDOR SELECTION, PROGRAM MANAGEMENT OF TALENT ACQUISITION PROJECTS, HUMAN RESOURCES BEST PRACTICES, AND HUMAN RESOURCES DATA; ONLINE HUMAN RESOURCES CONSULTING SERVICES, NAMELY, PROVIDING INTERACTIVE CONSULTING AND COMPANY-SPECIFIC COLLABORATION WITH INDUSTRY CONSULTANTS AND EXECUTIVES (U.S. CLS. 100, 101 AND 102).

FIRST USE 1-0-2005; IN COMMERCE 1-0-2005.

**CLASS 41—EDUCATION AND ENTERTAINMENT**

FOR INSTRUCTIONAL AND EDUCATIONAL SERVICES, NAMELY, CONDUCTING SEMINARS, WORKSHOPS, AND WEBINARS RELATING TO DEVELOPING TALENT STRATEGIES INTEGRATING TECHNOLOGY AND BUSINESS STRATEGIES, TALENT ACQUISITION, TALENT MANAGEMENT, TALENT INTELLIGENCE, SOCIAL COLLABORATION AND EMERGING SOLUTIONS, VENDOR SELECTION, PROGRAM MANAGEMENT OF TALENT ACQUISITION PROJECTS (U.S. CLS. 100, 101 AND 107).

FIRST USE 1-0-2005; IN COMMERCE 1-0-2005.

3,962,750. BRITTON, BEVERLY L., DBA ALIGNBETWEEN, TAMPA, FL. SN 77-887,016. PUB. 4-27-2010, FILED 12-5-2009.



THE MARK CONSISTS OF A PERFECT SQUARE BISECTED VERTICALLY AND WITH EQUALLY SIZED CIRCLES IN THE UPPER LEFT AND LOWER RIGHT CORNERS, WITH THE CIRCLES REPRESENTING A LOWERCASE "A" AND "B".

**CLASS 16—PAPER GOODS AND PRINTED MATTER**

FOR PRINTED MATTER, NAMELY, PHOTOGRAPHIC PRINTS; WORKS OF ART, NAMELY, DIGITALLY PRODUCED PHOTOGRAPHIC PRINTS PRINTED ONTO GICLEE CANVAS (U.S. CLS. 2, 5, 22, 23, 29, 37, 38 AND 50).

FIRST USE 2-1-2010; IN COMMERCE 2-1-2010.

**CLASS 35—ADVERTISING AND BUSINESS**

FOR ONLINE RETAIL STORE SERVICES FEATURING ORIGINAL PHOTOGRAPHIC ARTWORK AND VISUAL ART (U.S. CLS. 100, 101 AND 102).

FIRST USE 2-1-2010; IN COMMERCE 7-10-2010.

3,962,751. HARVEST GIFTS INC., NIAGARA-ON-THE-LAKE, CANADA. SN 77-887,291. PUB. 5-18-2010, FILED 12-7-2009.

**SOAP & WATER EVERYDAY**

THE MARK CONSISTS OF STANDARD CHARACTERS WITHOUT CLAIM TO ANY PARTICULAR FONT, STYLE, SIZE, OR COLOR.

NO CLAIM IS MADE TO THE EXCLUSIVE RIGHT TO USE "SOAP & WATER", APART FROM THE MARK AS SHOWN.

**CLASS 3—COSMETICS AND CLEANING PREPARATIONS**

FOR BODY CARE PRODUCTS, NAMELY, SOAP, BODY LOTION, HAND LOTION, BODY CREAM, BODY WASH, SHOWER GEL, BATH FOAM, BODY SPLASH, AND ANTIPERSPIRANT; COSMETICS, NAMELY, PERFUME; FRAGRANCED LINEN AND IRONING WATER (U.S. CLS. 1, 4, 6, 50, 51 AND 52).

FIRST USE 2-28-2010; IN COMMERCE 11-3-2010.

**CLASS 24—FABRICS**

FOR HOUSEHOLD LINEN, NAMELY, BATH TOWELS (U.S. CLS. 42 AND 50).

FIRST USE 5-30-2010; IN COMMERCE 11-3-2010.

**CLASS 25—CLOTHING**

FOR CLOTHING, NAMELY, SLEEPWEAR, LOUNGEWEAR, BATH ROBES AND SPA ROBES; FOOTWEAR, NAMELY, CASUAL, EVENING, AND SLIPPERS (U.S. CLS. 22 AND 39).

FIRST USE 8-30-2010; IN COMMERCE 11-3-2010.

3,962,753. FLOYD, SKEREN & KELLY, LLP, CALABASAS, CA. SN 77-887,819. PUB. 9-14-2010, FILED 12-7-2009.

**FSKLAW**

THE MARK CONSISTS OF STANDARD CHARACTERS WITHOUT CLAIM TO ANY PARTICULAR FONT, STYLE, SIZE, OR COLOR.

**CLASS 36—INSURANCE AND FINANCIAL**

FOR PROVIDING INFORMATION IN THE FIELD OF WORKERS' COMPENSATION (U.S. CLS. 100, 101 AND 102).

FIRST USE 3-14-2011; IN COMMERCE 3-14-2011.

**CLASS 45—PERSONAL AND LEGAL SERVICES**

FOR LEGAL SERVICES (U.S. CLS. 100 AND 101).

FIRST USE 3-14-2011; IN COMMERCE 3-14-2011.

3,962,760. L. PERRIGO COMPANY, ALLEGAN, MI. SN 77-888,522. PUB. 10-5-2010, FILED 12-8-2009.

**GOOD SENSE**

THE MARK CONSISTS OF STANDARD CHARACTERS WITHOUT CLAIM TO ANY PARTICULAR FONT, STYLE, SIZE, OR COLOR.

OWNER OF U.S. REG. NOS. 1,763,914, 3,129,568, AND OTHERS.

**CLASS 3—COSMETICS AND CLEANING PREPARATIONS**

FOR EMERY BOARDS (U.S. CLS. 1, 4, 6, 50, 51 AND 52).

FIRST USE 3-24-2011; IN COMMERCE 3-24-2011.

**CLASS 8—HAND TOOLS**

FOR NAIL IMPLEMENTS, NAMELY, NAIL FILES, NAIL CLIPPERS, SMALL SCISSORS, AND CUTICLE STICKS (U.S. CLS. 23, 28 AND 44).

FIRST USE 3-24-2011; IN COMMERCE 3-24-2011.

3,962,761. MUSIC CHOICE, HORSHAM, PA. SN 77-888,768.  
PUB. 11-30-2010, FILED 12-8-2009.

# SWRV

THE MARK CONSISTS OF STANDARD CHARACTERS WITHOUT CLAIM TO ANY PARTICULAR FONT, STYLE, SIZE, OR COLOR.

#### CLASS 35—ADVERTISING AND BUSINESS

FOR ADVERTISING, PROMOTIONAL, AND MARKETING SERVICES, NAMELY, PROMOTING AND MARKETING THE GOODS AND SERVICES OF OTHERS VIA DIGITAL AND ANALOG COMMUNICATIONS NETWORKS AND DEVICES; PROVIDING VOTING AND PUBLIC OPINION POLLING VIA DIGITAL AND ANALOG COMMUNICATIONS NETWORKS AND DEVICES (U.S. CLS. 100, 101 AND 102).

FIRST USE 2-10-2010; IN COMMERCE 2-10-2010.

#### CLASS 38—COMMUNICATION

FOR COMMUNICATION SERVICES, NAMELY, TRANSMISSION OF AUDIO, VIDEO IMAGES, PHOTOGRAPHS, TEXT MESSAGES, USER GENERATED CONTENT, INFORMATION AND NEWS VIA DIGITAL AND ANALOG COMMUNICATIONS NETWORKS AND DEVICES; BROADCASTING PROGRAMS AND CONTENT VIA DIGITAL AND ANALOG COMMUNICATIONS NETWORKS AND DEVICES IN THE FIELD OF MUSIC, MUSICAL ENTERTAINMENT, MUSIC-RELATED NEWS AND INFORMATION, USER-GENERATED, AND POP-CULTURE RELATED CONTENT; STREAMING OF AUDIO AND VIDEO MATERIAL VIA DIGITAL AND ANALOG COMMUNICATIONS NETWORKS AND DEVICES (U.S. CLS. 100, 101 AND 104).

FIRST USE 2-10-2010; IN COMMERCE 2-10-2010.

3,962,762. HUMBLE ENDEAVORS, LLC, SCOTTSDALE, AZ.  
SN 77-888,796. PUB. 10-12-2010, FILED 12-8-2009.

# HUMBLE SEED

THE MARK CONSISTS OF STANDARD CHARACTERS WITHOUT CLAIM TO ANY PARTICULAR FONT, STYLE, SIZE, OR COLOR.

NO CLAIM IS MADE TO THE EXCLUSIVE RIGHT TO USE "SEED", APART FROM THE MARK AS SHOWN.

#### CLASS 31—NATURAL AGRICULTURAL PRODUCTS

FOR PLANT SEEDS (U.S. CLS. 1 AND 46).  
FIRST USE 4-15-2010; IN COMMERCE 4-15-2010.

#### CLASS 35—ADVERTISING AND BUSINESS

FOR ONLINE RETAIL STORE SERVICES FEATURING PLANT SEEDS (U.S. CLS. 100, 101 AND 102).  
FIRST USE 4-15-2010; IN COMMERCE 4-15-2010.

3,962,763. HUMBLE ENDEAVORS, LLC, SCOTTSDALE, AZ.  
SN 77-888,842. PUB. 10-12-2010, FILED 12-8-2009.

# SEED THAT FEEDS

THE MARK CONSISTS OF STANDARD CHARACTERS WITHOUT CLAIM TO ANY PARTICULAR FONT, STYLE, SIZE, OR COLOR.

NO CLAIM IS MADE TO THE EXCLUSIVE RIGHT TO USE "SEED", APART FROM THE MARK AS SHOWN.

#### CLASS 31—NATURAL AGRICULTURAL PRODUCTS

FOR PLANT SEEDS (U.S. CLS. 1 AND 46).  
FIRST USE 4-15-2010; IN COMMERCE 4-15-2010.

#### CLASS 35—ADVERTISING AND BUSINESS

FOR ONLINE RETAIL STORE SERVICES FEATURING PLANT SEEDS (U.S. CLS. 100, 101 AND 102).  
FIRST USE 4-15-2010; IN COMMERCE 4-15-2010.

3,962,766. JIMENEZURIBE, GLORIA, DOUGLSTON, NY.  
SN 77-889,350. PUB. 5-4-2010, FILED 12-9-2009.



THE MARKS CONSISTS OF THE UNITARY TERM, "K9BLISS", IN STYLIZED FORM WITH THE NUMBER "9" AND THE WORD "BLISS" INTEGRATED WITH THE DESIGN OF THE LETTER K, AND THE DESIGN OF FOUR DOGS, A LABRADOR RETRIEVER, A BULLDOG, A BOSTON TERRIER, AND A YORKSHIRE TERRIER, INSIDE THE NUMBER "9".

#### CLASS 16—PAPER GOODS AND PRINTED MATTER

FOR BOOKMARKS; CALENDARS; GREETING CARDS; POSTCARDS (U.S. CLS. 2, 5, 22, 23, 29, 37, 38 AND 50).  
FIRST USE 1-1-2010; IN COMMERCE 1-1-2010.

#### CLASS 25—CLOTHING

FOR TEE SHIRTS (U.S. CLS. 22 AND 39).  
FIRST USE 1-1-2010; IN COMMERCE 1-1-2010.



3,962,773. SUNBEAM PRODUCTS, INC., BOCA RATON, FL.  
SN 77-892,917. PUB. 8-24-2010, FILED 12-14-2009.



OWNER OF U.S. REG. NOS. 1,253,660, 1,797,566, AND 2,743,458.

THE MARK CONSISTS OF THE LITERAL ELEMENT "BIONAIRE" PRECEDED BY A SWIRL ELEMENT PARTIALLY ENCIRCLED BY A CRESCENT ELEMENT WHICH TOGETHER CREATE A WHIRLWIND DESIGN.

#### CLASS 7—MACHINERY

FOR ELECTRICAL APPLIANCES, NAMELY, ELECTRIC STEAM CLEANING MACHINES FOR STEAMING HARD SURFACES (U.S. CLS. 13, 19, 21, 23, 31, 34 AND 35).

FIRST USE 7-21-2010; IN COMMERCE 7-21-2010.

#### CLASS 9—ELECTRICAL AND SCIENTIFIC APPARATUS

FOR ELECTRICAL APPLIANCES, NAMELY, ELECTRIC STEAMERS FOR STEAMING FABRICS (U.S. CLS. 21, 23, 26, 36 AND 38).

FIRST USE 1-29-2010; IN COMMERCE 1-29-2010.

3,962,776. 8X8, INC., SUNNYVALE, CA. SN 77-893,832. PUB. 10-12-2010, FILED 12-15-2009.

#### 8X8 VIRTUAL OFFICE PRO

THE MARK CONSISTS OF STANDARD CHARACTERS WITHOUT CLAIM TO ANY PARTICULAR FONT, STYLE, SIZE, OR COLOR.

OWNER OF U.S. REG. NOS. 3,008,225, 3,035,318, AND OTHERS.

NO CLAIM IS MADE TO THE EXCLUSIVE RIGHT TO USE "VIRTUAL OFFICE", APART FROM THE MARK AS SHOWN.

#### CLASS 9—ELECTRICAL AND SCIENTIFIC APPARATUS

FOR COMPUTER SOFTWARE THAT ENABLES TELECONFERENCING VIA WIDE-AREA DATA NETWORKING, VIDEO COMMUNICATIONS, VOICE COMMUNICATIONS, VOICE-OVER INTERNET PROTOCOL COMMUNICATIONS, VIDEO-OVER INTERNET PROTOCOL COMMUNICATIONS, ONLINE COMMUNICATIONS, VOICE-OVER-DIGITAL-SUBSCRIBER LINE COMMUNICATIONS, VIDEO-OVER-DIGITAL-SUBSCRIBER LINE COMMUNICATIONS, VOICE MAIL, VIDEO MAIL, CALL FORWARDING, CALLER ID, CALL WAITING, 3-WAY CALLING, CONFERENCING, CUSTOMIZED PHONE NUMBER DIRECTORIES, CALL ROUTING SERVICES, VOICE-OVER DIGITAL LINE COMMUNICATIONS, ONLINE CALL MANAGEMENT CONTROL, WEB AND AUDIO CONFERENCING, CALL RECORDING AND STORAGE, AND INTERNET FAX (U.S. CLS. 21, 23, 26, 36 AND 38).

FIRST USE 1-20-2010; IN COMMERCE 1-20-2010.

#### CLASS 38—COMMUNICATION

FOR INTERNET TELEPHONY SERVICES; STREAMING OF AUDIO AND VIDEO MATERIAL ON THE INTERNET; LOCAL AND LONG DISTANCE TELEPHONE SERVICES; VOICE MAIL SERVICES; VIDEO MAIL SERVICES, NAMELY, THE TRANSMISSION OF VIDEO MESSAGES OVER ELECTRONIC MEDIA; CALL FORWARDING SERVICES; CALLER ID SERVICES; CALL WAITING SERVICES; 3-WAY CALLING SERVICES; TELEPHONE CONFERENCING SERVICES; TELEPHONY CALL ROUTING SERVICES; ONLINE CALL MANAGEMENT CONTROL SERVICES; WEB AND AUDIO CONFERENCING SERVICES; CALL RECORDING AND STORAGE SERVICES; AND INTERNET FAX SERVICES (U.S. CLS. 100, 101 AND 104).

FIRST USE 1-20-2010; IN COMMERCE 1-20-2010.

#### CLASS 42—SCIENTIFIC AND COMPUTER SERVICES

FOR TECHNICAL SUPPORT SERVICES, NAMELY, TROUBLESHOOTING IN THE NATURE OF DIAGNOSING COMPUTER HARDWARE AND SOFTWARE PROBLEMS FOR WEB-BASED CUSTOMERS, AND COMPUTER SOFTWARE INSTALLATION AND MAINTENANCE (U.S. CLS. 100 AND 101).

FIRST USE 1-20-2010; IN COMMERCE 1-20-2010.

3,962,780. PERDUE HOLDINGS, INC., WILMINGTON, DE.  
SN 77-894,665. PUB. 8-31-2010, FILED 12-16-2009.



OWNER OF U.S. REG. NOS. 1,326,205, 2,402,409, AND OTHERS.

THE MARK CONSISTS OF THE TERM "PERDUE" UNDERLINED IN A RECTANGLE DESIGN WITH "IT'S HIP TO BE FIT!" IN STYLIZED LETTERING.

#### CLASS 41—EDUCATION AND ENTERTAINMENT

FOR EDUCATIONAL SERVICES, NAMELY, AN EMPLOYEE PERSONAL HEALTH PROGRAM IN THE NATURE OF CONDUCTING CLASSES DESIGNED TO IMPROVE THE OVERALL HEALTH OF EMPLOYEES; PROVIDING NEWSLETTERS DESIGNED TO IMPROVE THE OVERALL HEALTH OF EMPLOYEES IN THE FIELD OF AN EMPLOYEE PERSONAL HEALTH PROGRAM FOR FITNESS, HEALTH, AND ACTIVE LIFESTYLE VIA EMAIL (U.S. CLS. 100, 101 AND 107).

FIRST USE 8-0-2010; IN COMMERCE 8-0-2010.

#### CLASS 44—MEDICAL, BEAUTY AND AGRICULTURAL SERVICES

FOR PROVIDING INFORMATION IN THE FIELD OF IMPROVING HEALTH; PROVIDING HEALTH INFORMATION (U.S. CLS. 100 AND 101).

FIRST USE 5-0-2010; IN COMMERCE 5-0-2010.

3,962,811. KEITH A. KENNEALLY, SOUTH SAN FRANCISCO, CA. SN 77-904,247. PUB. 6-8-2010, FILED 1-4-2010.

3,962,813. WASHINGTON TENNIS & EDUCATION FOUNDATION, WASHINGTON, DC. SN 77-905,047. PUB. 11-9-2010, FILED 1-5-2010.

## JET POD

THE MARK CONSISTS OF STANDARD CHARACTERS WITHOUT CLAIM TO ANY PARTICULAR FONT, STYLE, SIZE, OR COLOR.

NO CLAIM IS MADE TO THE EXCLUSIVE RIGHT TO USE "JET", APART FROM THE MARK AS SHOWN.

### CLASS 11—ENVIRONMENTAL CONTROL APPARATUS

FOR REFRIGERATED SHIPPING CONTAINER USED TO PACKAGE AND STORE PERISHABLE GOODS DURING TRANSPORT BY GROUND, AIR OR SEA SO AS TO PRESERVE THE TEMPERATURE OF, AND PREVENT HEAT DAMAGE AND CHILL INJURY TO, THE GOODS WHILE IN TRANSIT; APPARATUS FOR REFRIGERATION, NAMELY, FOOD AND BEVERAGE CHILLING UNITS USED TO PACKAGE AND STORE PERISHABLE GOODS DURING TRANSPORT BY GROUND, AIR OR SEA SO AS TO PRESERVE THE TEMPERATURE OF, AND PREVENT HEAT DAMAGE AND CHILL INJURY TO, THE GOODS WHILE IN TRANSIT, BUT SPECIFICALLY EXCLUDING (1) SELF-CONTAINED TEMPERATURE CONTROL REFRIGERATION UNITS ADAPTED CONNECTION TO INDUSTRIAL ENCLOSURES SUCH AS TRANSPORT VEHICLES, LOCKER CABINETS AND THE LIKE; (2) METAL CONTAINERS FOR THE STORAGE AND TRANSPORTATION OF GOODS; AND (3) PAPER AND CARDBOARD PACKING BOXES (U.S. CLS. 13, 21, 23, 31 AND 34).

FIRST USE 9-1-2010; IN COMMERCE 9-1-2010.

### CLASS 20—FURNITURE AND ARTICLES NOT OTHERWISE CLASSIFIED

FOR NON-METAL AND NON-PAPER INSULATED SHIPPING CONTAINERS FOR TRANSPORTING FROZEN OR PERISHABLE GOODS; PLASTIC CONTAINERS FOR COMMERCIAL AND INDUSTRIAL USE, NAMELY, THERMAL INSULATED CONTAINERS TO PRESERVE THE TEMPERATURE OF, AND PREVENT HEAT DAMAGE AND CHILL INJURY TO, PERISHABLE FOODS AND BEVERAGES, BUT SPECIFICALLY EXCLUDING (1) METAL CONTAINERS FOR THE STORAGE AND TRANSPORTATION OF GOODS; AND (2) PAPER AND CARDBOARD PACKING BOXES (U.S. CLS. 2, 13, 22, 25, 32 AND 50).

FIRST USE 9-1-2010; IN COMMERCE 9-1-2010.

### CLASS 39—TRANSPORTATION AND STORAGE

FOR TRANSPORT OF PERISHABLE GOODS BY GROUND, AIR OR SEA SO AS TO PRESERVE THE TEMPERATURE OF, AND PREVENT HEAT DAMAGE AND CHILL INJURY TO, THE GOODS WHILE IN TRANSIT; STORAGE OF PERISHABLE GOODS TO PRESERVE THE TEMPERATURE OF, AND PREVENT HEAT DAMAGE AND CHILL INJURY TO, THE GOODS BUT SPECIFICALLY EXCLUDING STORAGE AND MOVING SERVICES, NAMELY, RENTAL, STORAGE, DELIVERY AND PICK UP OF PORTABLE STORAGE CONTAINERS (U.S. CLS. 100 AND 105).

FIRST USE 3-28-2011; IN COMMERCE 3-28-2011.

## ADVANTAGE KIDS

THE MARK CONSISTS OF STANDARD CHARACTERS WITHOUT CLAIM TO ANY PARTICULAR FONT, STYLE, SIZE, OR COLOR.

NO CLAIM IS MADE TO THE EXCLUSIVE RIGHT TO USE "KIDS", APART FROM THE MARK AS SHOWN.

### CLASS 9—ELECTRICAL AND SCIENTIFIC APPARATUS

FOR DOWNLOADABLE ELECTRONIC NEWSLETTERS IN THE FIELD OF PROMOTING THE WELL-BEING OF CHILDREN THROUGH TENNIS, EDUCATION, AND COMMUNITY-BUILDING ACTIVITIES; DOWNLOADABLE ELECTRONIC NEWSLETTERS DELIVERED BY EMAIL IN THE FIELD OF PROMOTING THE WELL-BEING OF CHILDREN THROUGH TENNIS, EDUCATION, AND COMMUNITY-BUILDING ACTIVITIES (U.S. CLS. 21, 23, 26, 36 AND 38).

FIRST USE 12-31-2005; IN COMMERCE 12-31-2005.

### CLASS 16—PAPER GOODS AND PRINTED MATTER

FOR NEWSLETTERS IN THE FIELD OF PROMOTING THE WELL-BEING OF CHILDREN THROUGH TENNIS, EDUCATION, AND COMMUNITY-BUILDING ACTIVITIES (U.S. CLS. 2, 5, 22, 23, 29, 37, 38 AND 50).

FIRST USE 12-31-1997; IN COMMERCE 12-31-1997.

### CLASS 36—INSURANCE AND FINANCIAL

FOR CHARITABLE FUND RAISING SERVICES, NAMELY, ELEEMOSYNARY SERVICES IN THE FIELD OF COLLECTION, MANAGEMENT, AND DISBURSEMENT OF MONEY IN CONNECTION WITH PROGRAMS AND FACILITIES FOR CHILDREN (U.S. CLS. 100, 101 AND 102).

FIRST USE 12-31-1997; IN COMMERCE 12-31-1997.

### CLASS 41—EDUCATION AND ENTERTAINMENT

FOR ON-LINE ELECTRONIC NEWSLETTERS DELIVERED BY EMAIL IN THE FIELD OF PROMOTING THE WELL-BEING OF CHILDREN THROUGH TENNIS, EDUCATION, AND COMMUNITY-BUILDING ACTIVITIES; PROVIDING NEWSLETTERS IN THE FIELD OF PROMOTING THE WELL-BEING OF CHILDREN THROUGH TENNIS, EDUCATION, AND COMMUNITY-BUILDING ACTIVITIES BY EMAIL; PROVIDING ON-LINE NEWSLETTERS IN THE FIELD OF PROMOTING THE WELL-BEING OF CHILDREN THROUGH TENNIS, EDUCATION, AND COMMUNITY-BUILDING ACTIVITIES (U.S. CLS. 100, 101 AND 107).

FIRST USE 1-21-2010; IN COMMERCE 1-21-2010.

3,962,822. MEDCO HEALTH SOLUTIONS, INC., FRANKLIN LAKES, NJ. SN 77-907,820. PUB. 9-21-2010, FILED 1-8-2010.

### MAKING MEDICINE SMARTER

THE MARK CONSISTS OF STANDARD CHARACTERS WITHOUT CLAIM TO ANY PARTICULAR FONT, STYLE, SIZE, OR COLOR.

#### CLASS 35—ADVERTISING AND BUSINESS

FOR DRUG UTILIZATION REVIEW SERVICES; MAIL ORDER AND ON-LINE RETAIL PHARMACY SERVICES (U.S. CLS. 100, 101 AND 102).  
FIRST USE 5-26-2010; IN COMMERCE 5-26-2010.

#### CLASS 36—INSURANCE AND FINANCIAL

FOR PHARMACY BENEFIT MANAGEMENT SERVICES; ADMINISTERING AND UNDERWRITING OF A MEDICARE PRESCRIPTION DRUG BENEFIT PLAN; PHARMACY BENEFIT MANAGEMENT SERVICES, NAMELY, ADMINISTRATION OF PHARMACY BENEFIT PLANS (U.S. CLS. 100, 101 AND 102).  
FIRST USE 10-1-2010; IN COMMERCE 10-1-2010.

#### CLASS 44—MEDICAL, BEAUTY AND AGRICULTURAL SERVICES

FOR HEALTHCARE SERVICES, NAMELY, WELLNESS AND DISEASE MANAGEMENT SERVICES; MEDICARE PRESCRIPTION DRUG COVERAGE PLAN SERVICES, NAMELY, COMPLEX CASE MANAGEMENT SERVICES IN THE NATURE OF PROVIDING CONSULTATION SERVICES TO PATIENTS WITH CHRONIC CONDITIONS REGARDING MEDICATION COMPLIANCE, AND PROVIDING INFORMATION REGARDING HEALTH ISSUES REGARDING CHRONIC CONDITIONS, DISEASE MANAGEMENT AND PROVIDING INFORMATION REGARDING HEALTH ISSUES REGARDING CHRONIC CONDITIONS; PROVIDING INFORMATION IN THE FIELDS OF HEALTHCARE, PHARMACEUTICALS AND PHARMACOGENOMICS (U.S. CLS. 100 AND 101).  
FIRST USE 9-30-2010; IN COMMERCE 9-30-2010.

3,962,829. SMITH, RONNIE G., CYPRESS, TX. SN 77-909,523. PUB. 5-25-2010, FILED 1-11-2010.

# G2EODE

THE MARK CONSISTS OF STANDARD CHARACTERS WITHOUT CLAIM TO ANY PARTICULAR FONT, STYLE, SIZE, OR COLOR.

#### CLASS 35—ADVERTISING AND BUSINESS

FOR ECONOMIC CONSULTING AND INFORMATION FOR THE INDUSTRIAL AND COMMERCIAL SECTORS FOR PLANNING, ORGANIZING, MONITORING AND CARRYING OUT UNIQUE AND COMPLEX PROJECTS IN DIFFERENT SECTORS OF ONE OR SEVERAL COMPANIES (U.S. CLS. 100, 101 AND 102).  
FIRST USE 2-10-2010; IN COMMERCE 3-12-2010.

#### CLASS 37—CONSTRUCTION AND REPAIR

FOR OIL AND GAS DRILLING (U.S. CLS. 100, 103 AND 106).  
FIRST USE 2-10-2010; IN COMMERCE 3-12-2010.

#### CLASS 42—SCIENTIFIC AND COMPUTER SERVICES

FOR ENGINEERING; GEOPHYSICAL EXPLORATION FOR THE OIL, GAS AND MINING INDUSTRIES; OIL AND GAS WELL DRILLING SERVICES, NAMELY, PROVIDING MEASUREMENTS AND DOWNHOLE TELEMETRY WHILE DRILLING (U.S. CLS. 100 AND 101).  
FIRST USE 2-10-2010; IN COMMERCE 3-15-2010.

3,962,845. OVERLAKE SERVICE LEAGUE, BELLEVUE, WA. SN 77-914,760. PUB. 8-10-2010, FILED 1-19-2010.

# BELLEVUE LIFSPRING

THE MARK CONSISTS OF STANDARD CHARACTERS WITHOUT CLAIM TO ANY PARTICULAR FONT, STYLE, SIZE, OR COLOR.

NO CLAIM IS MADE TO THE EXCLUSIVE RIGHT TO USE "BELLEVUE", APART FROM THE MARK AS SHOWN.

#### CLASS 35—ADVERTISING AND BUSINESS

FOR CHARITABLE SERVICES, NAMELY, ORGANIZING AND CONDUCTING VOLUNTEER AND COMMUNITY SERVICE PROJECTS IN THE FIELDS OF SOCIAL SERVICES AND HUMAN SERVICES; RETAIL STORE SERVICES FEATURING A VARIETY OF GOODS OF OTHERS (U.S. CLS. 100, 101 AND 102).  
FIRST USE 2-12-2011; IN COMMERCE 2-12-2011.

#### CLASS 36—INSURANCE AND FINANCIAL

FOR CHARITABLE FUNDRAISING SERVICES FOR SOCIAL SERVICES, HUMAN SERVICES, FOOD, CLOTHING, HOUSING, EDUCATION, AND FINANCIAL ASSISTANCE PROGRAMS; CHARITABLE SERVICES, NAMELY, PROVIDING FINANCIAL ASSISTANCE TO MEET THE PHYSICAL, SOCIAL AND EDUCATIONAL REQUIREMENTS OF PERSONS IN NEED; CHARITABLE SERVICES, NAMELY, PROVIDING FINANCIAL ASSISTANCE TO NEEDY PERSONS (U.S. CLS. 100, 101 AND 102).  
FIRST USE 2-12-2011; IN COMMERCE 2-12-2011.

3,962,850. FOREST LABORATORIES, INC., NEW YORK, NY. SN 77-915,729. PUB. 9-21-2010, FILED 1-20-2010.



THE MARK CONSISTS OF A CIRCULAR DESIGN FORMED BY AN INTERLOCKING SWIRL.

#### CLASS 16—PAPER GOODS AND PRINTED MATTER

FOR PRINTED MATTER, NAMELY, BROCHURES, PAMPHLETS, POSTERS, NEWSLETTERS, PROMOTIONAL MATERIALS, NAMELY, BROCHURES AND PAMPHLETS, AND PRINTED PATIENT EDUCATIONAL MATERIALS, ALL CONCERNING THE TREATMENT OF BACTERIAL INFECTIONS (U.S. CLS. 2, 5, 22, 23, 29, 37, 38 AND 50).

FIRST USE 12-13-2010; IN COMMERCE 12-13-2010.

#### CLASS 44—MEDICAL, BEAUTY AND AGRICULTURAL SERVICES

FOR MEDICAL INFORMATION SERVICES, NAMELY, PROVIDING HEALTH INFORMATION IN THE FIELD OF BACTERIAL INFECTIONS VIA A GLOBAL COMPUTER NETWORK (U.S. CLS. 100 AND 101).

FIRST USE 11-2-2010; IN COMMERCE 11-2-2010.

3,962,851. CENTRAL METAL FABRICATORS, INC., FARMINGDALE, NJ. SN 77-916,200. PUB. 8-24-2010, FILED 1-20-2010.

1NZU4

THE MARK CONSISTS OF STANDARD CHARACTERS WITHOUT CLAIM TO ANY PARTICULAR FONT, STYLE, SIZE, OR COLOR.

#### CLASS 40—MATERIAL TREATMENT

FOR MACHINING PARTS FOR OTHERS; WELDING; METAL FABRICATION AND FINISHING SERVICES; ASSEMBLING MACHINE PARTS FOR OTHERS (U.S. CLS. 100, 103 AND 106).

FIRST USE 3-14-2011; IN COMMERCE 3-14-2011.

#### CLASS 42—SCIENTIFIC AND COMPUTER SERVICES

FOR MACHINE PART DESIGN SERVICES (U.S. CLS. 100 AND 101).

FIRST USE 3-14-2011; IN COMMERCE 3-14-2011.

3,962,860. EAST SIDE ENTREES, INC., WOODBURY, NY. SN 77-918,242. PUB. 7-27-2010, FILED 1-22-2010.



NO CLAIM IS MADE TO THE EXCLUSIVE RIGHT TO USE "FOODS", APART FROM THE MARK AS SHOWN.

THE MARK CONSISTS OF THE WORDS "E-S FOODS" IN STYLIZED CAPITAL LETTERS, WITH THE WORDS "NOURISHING OUR FUTURE" IN STYLIZED LOWER CASE LETTERING UNDERNEATH, AND ABOVE ALL THE LETTERING, FOUR STYLIZED FIGURES OF CHILDREN, TOUCHING HANDS.

#### CLASS 29—MEATS AND PROCESSED FOODS

FOR PREPACKAGED SHELF-STABLE MEAL KITS CONSISTING PRIMARILY OF MEAT, POULTRY, FISH, CHEESE, OR PEANUT BUTTER AND JELLY, WITH FRUIT JUICE AND NUTRITIOUS SNACKS, NAMELY, ROASTED SOYBEANS, SEED SNACKS, CEREAL BAR, SNACK BAR, SNACK CRACKERS, OR DRIED OR CANNED FRUIT; PREPACKAGED SHELF-STABLE MEAL KITS CONSISTING PRIMARILY OF MEAT, POULTRY, CHEESE, OR PEANUT BUTTER AND JELLY, WITH FRUIT JUICE, MILK, AND NUTRITIOUS SNACKS, NAMELY, ROASTED SOYBEANS, SEED SNACKS, DRIED OR CANNED FRUIT, AND SNACK CRACKERS; SOUPS; MILK; CHEESE SNACKS, NAMELY, CHEESE STICKS, STRING CHEESE, AND CHEESE SLICES; PREPACKAGED FROZEN BREAKFAST MEAL KITS CONSISTING PRIMARILY OF CHEESE WITH CANNED OR DRIED FRUIT, AND NUTRITIOUS SNACKS, NAMELY, CEREAL BAR, SNACK BAR, OR SNACK CRACKERS; ALL OF THE ABOVE FOR USE IN SCHOOL FOOD SERVICE PROGRAMS, BEFORE- AND AFTER-SCHOOL FOOD SERVICE PROGRAMS, AND COMMUNITY GROUP AND SUMMER CAMP FEEDING PROGRAMS FOR CHILDREN AND TEENS (U.S. CL. 46).

FIRST USE 2-0-2010; IN COMMERCE 2-0-2010.

#### CLASS 30—STAPLE FOODS

FOR PREPACKAGED SHELF-STABLE BREAKFAST MEAL KITS CONSISTING PRIMARILY OF CEREAL, WITH FRUIT JUICE AND NUTRITIOUS SNACKS, NAMELY, CEREAL BAR, SNACK BAR, OR SNACK CRACKERS; PREPACKAGED SHELF-STABLE BREAKFAST MEAL KITS CONSISTING PRIMARILY OF CEREAL, WITH MILK, FRUIT JUICE, AND NUTRITIOUS SNACKS, NAMELY, CEREAL BAR, SNACK BAR, OR SNACK CRACKERS; PREPACKAGED FROZEN BREAKFAST MEAL KITS CONSISTING OF MUFFINS, BREADS, BUNS, PANCAKES, OR FRENCH TOAST; PREPARED FROZEN ENTREES CONSISTING PRIMARILY OF PASTA; PREPACKAGED FROZEN MEAL KITS CONSISTING PRIMARILY OF MEAT, POULTRY, CHEESE, OR PEANUT BUTTER AND JELLY SANDWICHES, WITH NUTRITIOUS SNACKS, NAMELY, SUNFLOWER SEEDS, ROASTED SOYBEANS, OR SNACK CRACKERS, AND DRIED OR CANNED FRUIT; FROZEN CHEESE SAUCE; SHELF-STABLE PROCESSED CHEESE SAUCE; FROZEN DOUGH-ENROBED FOODS CONSISTING OF A DOUGH-BASED WRAPPER WITH FILLING CONSISTING PRIMARILY OF CHEESE, MEAT, OR EGG; SNACK CRACKERS; ALL OF THE ABOVE FOR USE IN SCHOOL FOOD SERVICE PROGRAMS, BEFORE- AND AFTER-SCHOOL FOOD SERVICE PROGRAMS, AND COMMUNITY GROUP AND SUMMER CAMP FEEDING PROGRAMS FOR CHILDREN AND TEENS (U.S. CL. 46).

FIRST USE 2-0-2010; IN COMMERCE 2-0-2010.

3,962,866. VIRGIN MOBILE USA, L.P., OVERLAND PARK, KS. SN 77-919,485. PUB. 7-27-2010, FILED 1-25-2010.

## COMMON CENTS MOBILE

THE MARK CONSISTS OF STANDARD CHARACTERS WITHOUT CLAIM TO ANY PARTICULAR FONT, STYLE, SIZE, OR COLOR.

NO CLAIM IS MADE TO THE EXCLUSIVE RIGHT TO USE "MOBILE", APART FROM THE MARK AS SHOWN.

### CLASS 9—ELECTRICAL AND SCIENTIFIC APPARATUS

FOR MOBILE TELEPHONES, TELEPHONES AND MODEMS, AND ACCESSORIES THEREFOR, NAMELY, BATTERIES, BATTERY CHARGERS, ELECTRIC CIGARETTE LIGHTER ADAPTERS FOR LAND VEHICLES, HANDS-FREE HEADSETS FOR TELEPHONES, CARRYING CASES FOR CELL PHONES AND CARRYING CASES FOR CELLPHONES, NAMELY, CARRYING CASES THAT CLIP TO AN INDIVIDUAL'S BELT (U.S. CLS. 21, 23, 26, 36 AND 38).  
FIRST USE 5-12-2010; IN COMMERCE 5-12-2010.

### CLASS 35—ADVERTISING AND BUSINESS

FOR TELEPHONE DIRECTORY ASSISTANCE SERVICES (U.S. CLS. 100, 101 AND 102).  
FIRST USE 5-12-2010; IN COMMERCE 5-12-2010.

### CLASS 38—COMMUNICATION

FOR TELECOMMUNICATIONS SERVICES, NAMELY, TRANSMISSION OF VOICE, DATA, IMAGES, AUDIO, VIDEO AND INFORMATION VIA TELEPHONE OR THE INTERNET; TELECOMMUNICATION SERVICES, NAMELY, PERSONAL COMMUNICATION SERVICES; ELECTRONIC MAIL SERVICES; TRANSMISSION OF NEWS AND TRANSMISSION OF INFORMATION FOR OTHERS VIA TELEPHONE, INCLUDING THE INTERNET (U.S. CLS. 100, 101 AND 104).  
FIRST USE 5-12-2010; IN COMMERCE 5-12-2010.

3,962,868. UNION LABOR WORKS, INC., NEW FAIRFIELD, CT. SN 77-919,889. PUB. 12-21-2010, FILED 1-25-2010.

## UNION LABOR WORKS

THE MARK CONSISTS OF STANDARD CHARACTERS WITHOUT CLAIM TO ANY PARTICULAR FONT, STYLE, SIZE, OR COLOR.

### CLASS 35—ADVERTISING AND BUSINESS

FOR ADVERTISING AGENCY, ADVERTISING, MARKETING AND MEDIA BUYING, NAMELY, PURCHASING BROADCAST TELEVISION, CABLE TELEVISION, PRINT, RADIO, ONLINE AND OUTDOOR ADVERTISING (U.S. CLS. 100, 101 AND 102).  
FIRST USE 1-3-2007; IN COMMERCE 1-27-2010.

### CLASS 42—SCIENTIFIC AND COMPUTER SERVICES

FOR WEBSITE DEVELOPMENT AND DESIGN AND WEB HOSTING SERVICES (U.S. CLS. 100 AND 101).  
FIRST USE 1-3-2007; IN COMMERCE 1-27-2010.

3,962,872. EARTHLUST LLC, SAN FRANCISCO, CA. SN 77-920,760. PUB. 6-15-2010, FILED 1-26-2010.

birds&bees

THE MARK CONSISTS OF THE TERM "BIRDS" FOLLOWED BY AN AMPERSAND FOLLOWED BY THE TERM "BEES".

### CLASS 10—MEDICAL APPARATUS

FOR BABY BOTTLE NIPPLES; BABY BOTTLES; FEEDING BOTTLES (U.S. CLS. 26, 39 AND 44).  
FIRST USE 3-31-2010; IN COMMERCE 3-31-2010.

### CLASS 21—HOUSEWARES AND GLASS

FOR TRAINING CUPS FOR BABIES AND CHILDREN (U.S. CLS. 2, 13, 23, 29, 30, 33, 40 AND 50).  
FIRST USE 3-31-2010; IN COMMERCE 3-31-2010.

3,962,882. RATIONAL INTELLECTUAL HOLDINGS LIMITED, DOUGLAS, ISLE OF MAN. SN 77-922,311. PUB. 6-15-2010, FILED 1-28-2010.

NAPT

THE MARK CONSISTS OF STANDARD CHARACTERS WITHOUT CLAIM TO ANY PARTICULAR FONT, STYLE, SIZE, OR COLOR.

### CLASS 9—ELECTRICAL AND SCIENTIFIC APPARATUS

FOR DOWNLOADABLE COMPUTER CARD GAME SOFTWARE (U.S. CLS. 21, 23, 26, 36 AND 38).  
FIRST USE 2-1-2010; IN COMMERCE 2-1-2010.

### CLASS 41—EDUCATION AND ENTERTAINMENT

FOR ON-LINE ENTERTAINMENT IN THE NATURE OF CARD GAMES AND CARD GAMES TOURNAMENTS AND COMPETITIONS; CASINO ON-LINE SERVICES FEATURING INTERACTIVE MULTI-PLAYER CARD GAMES; ORGANIZATION OF AND ADMINISTRATION OF CARD GAMES AND CONTESTS, INTERACTIVE ON-LINE CARD GAMES AND CARD GAME CONTESTS; PROVIDING NEWSLETTERS VIA E-MAIL IN THE FIELD OF ON-LINE AND OFF-LINE CARD GAMES (U.S. CLS. 100, 101 AND 107).  
FIRST USE 2-1-2010; IN COMMERCE 2-1-2010.



3,962,883. RATIONAL INTELLECTUAL HOLDINGS LIMITED, DOUGLAS, ISLE OF MAN. SN 77-922,317. PUB. 6-15-2010, FILED 1-28-2010.



NO CLAIM IS MADE TO THE EXCLUSIVE RIGHT TO USE "NORTH AMERICAN POKER TOUR", APART FROM THE MARK AS SHOWN.

THE MARK CONSISTS OF THE LETTERS "NAPT" IN A STYLIZED FONT TO THE RIGHT OF WHICH IS A PLAYING CARD DEPICTING A STAR CENTERED WITHIN A SPADE. "NAPT" AND THE PLAYING CARD ARE WITHIN A RHOMBOID. BENEATH THE RHOMBOID ARE THE WORDS "NORTH AMERICAN POKER TOUR" IN A STYLIZED FONT.

#### CLASS 9—ELECTRICAL AND SCIENTIFIC APPARATUS

FOR DOWNLOADABLE COMPUTER CARD GAME SOFTWARE (U.S. CLS. 21, 23, 26, 36 AND 38).  
FIRST USE 2-1-2010; IN COMMERCE 2-1-2010.

#### CLASS 41—EDUCATION AND ENTERTAINMENT

FOR ON-LINE ENTERTAINMENT IN THE NATURE OF CARD GAMES AND CARD GAME TOURNAMENTS AND COMPETITIONS; CASINO ON-LINE SERVICES FEATURING INTERACTIVE MULTI-PLAYER CARD GAMES; ORGANIZATION OF AND ADMINISTRATION OF CARD GAMES AND CONTESTS, INTERACTIVE ON-LINE CARD GAMES AND CARD GAME CONTESTS; PROVIDING NEWSLETTERS VIA E-MAIL IN THE FIELD OF ON-LINE AND OFF-LINE CARD GAMES (U.S. CLS. 100, 101 AND 107).

FIRST USE 2-1-2010; IN COMMERCE 2-1-2010.

3,962,890. LUMINESS LP, STAFFORD,, TX. SN 77-925,571. PUB. 7-20-2010, FILED 2-2-2010.

## LUMINESS TAN

THE MARK CONSISTS OF STANDARD CHARACTERS WITHOUT CLAIM TO ANY PARTICULAR FONT, STYLE, SIZE, OR COLOR.

OWNER OF U.S. REG. NOS. 3,442,016 AND 3,781,522.

NO CLAIM IS MADE TO THE EXCLUSIVE RIGHT TO USE "TAN", APART FROM THE MARK AS SHOWN.

#### CLASS 3—COSMETICS AND CLEANING PREPARATIONS

FOR COSMETICS, NAMELY, MAKEUP, INDOOR SUN-TANNING PREPARATIONS; SELF-TANNING PREPARATIONS; SUN-TANNING PREPARATIONS (U.S. CLS. 1, 4, 6, 50, 51 AND 52).

FIRST USE 2-28-2009; IN COMMERCE 2-28-2009.

#### CLASS 7—MACHINERY

FOR MAKEUP APPLICATION SYSTEM CONSISTING OF AN AIRBRUSH AND COMPRESSOR (U.S. CLS. 13, 19, 21, 23, 31, 34 AND 35).

FIRST USE 2-28-2009; IN COMMERCE 2-28-2009.

3,962,893. NS412, LLC, GARLAND, TX. SN 77-926,185. PUB. 6-22-2010, FILED 2-2-2010.

## TRUE THIN

THE MARK CONSISTS OF STANDARD CHARACTERS WITHOUT CLAIM TO ANY PARTICULAR FONT, STYLE, SIZE, OR COLOR.

#### CLASS 29—MEATS AND PROCESSED FOODS

FOR PACKAGED PROCESSED NUTS (U.S. CL. 46).  
FIRST USE 1-10-2011; IN COMMERCE 1-10-2011.

#### CLASS 30—STAPLE FOODS

FOR POPCORN (U.S. CL. 46).  
FIRST USE 1-10-2011; IN COMMERCE 1-10-2011.

#### CLASS 32—LIGHT BEVERAGES

FOR BOTTLED SPRING WATER (U.S. CLS. 45, 46 AND 48).  
FIRST USE 2-14-2011; IN COMMERCE 2-14-2011.

#### CLASS 38—COMMUNICATION

FOR PROVIDING ONLINE FACILITIES FOR REAL-TIME INTERACTION AND ELECTRONIC TRANSMISSION OF MESSAGES AMONG COMPUTER USERS IN THE FIELD OF NUTRITION AND WEIGHT MANAGEMENT; ONLINE VIDEO AND AUDIO BROADCASTING IN THE FIELD OF NUTRITION AND WEIGHT MANAGEMENT (U.S. CLS. 100, 101 AND 104).

FIRST USE 12-1-2010; IN COMMERCE 12-1-2010.

#### CLASS 41—EDUCATION AND ENTERTAINMENT

FOR EDUCATIONAL SERVICES, NAMELY, CONDUCTING CLASSES AND SEMINARS IN THE FIELD OF NUTRITION AND WEIGHT MANAGEMENT AND DISTRIBUTING COURSE MATERIALS THEREWITH (U.S. CLS. 100, 101 AND 107).

FIRST USE 12-1-2010; IN COMMERCE 12-1-2010.

3,962,902. WORSHIP TOOLBOX, INC., LAS VEGAS, NV. SN 77-928,173. PUB. 6-22-2010, FILED 2-4-2010.

## Worship Toolbox

THE MARK CONSISTS OF STANDARD CHARACTERS WITHOUT CLAIM TO ANY PARTICULAR FONT, STYLE,

SIZE, OR COLOR.

NO CLAIM IS MADE TO THE EXCLUSIVE RIGHT TO USE "WORSHIP", APART FROM THE MARK AS SHOWN.

#### **CLASS 9—ELECTRICAL AND SCIENTIFIC APPARATUS**

FOR AUDIO AND VIDEO RECORDINGS FEATURING INSTRUCTIONAL GUIDES ON CREATING, PRODUCING AND USING MUSIC IN A CHURCH OR RELIGIOUS SETTING; AUDIO RECORDINGS FEATURING INSTRUCTIONAL GUIDES ON CREATING, PRODUCING AND USING MUSIC IN A CHURCH OR RELIGIOUS SETTING; SOUND RECORDINGS FEATURING INSTRUCTIONAL GUIDES ON CREATING, PRODUCING AND USING MUSIC IN A CHURCH OR RELIGIOUS SETTING; VIDEO RECORDINGS FEATURING INSTRUCTIONAL GUIDES ON CREATING, PRODUCING AND USING MUSIC IN A CHURCH OR RELIGIOUS SETTING (U.S. CLS. 21, 23, 26, 36 AND 38).

FIRST USE 2-1-2011; IN COMMERCE 2-1-2011.

#### **CLASS 16—PAPER GOODS AND PRINTED MATTER**

FOR PRINTED INSTRUCTIONAL, EDUCATIONAL, AND TEACHING MATERIALS IN THE FIELD OF CREATING, PRODUCING AND USING MUSIC IN A CHURCH OR RELIGIOUS SETTING (U.S. CLS. 2, 5, 22, 23, 29, 37, 38 AND 50).

FIRST USE 2-1-2011; IN COMMERCE 2-1-2011.

3,962,909. ICIM CORPORATION, DBA PLANET TELECOM, NEW ALBANY, IN. SN 77-930,153. PUB. 7-20-2010, FILED 2-8-2010.

# INDATUS

THE MARK CONSISTS OF STANDARD CHARACTERS WITHOUT CLAIM TO ANY PARTICULAR FONT, STYLE, SIZE, OR COLOR.

#### **CLASS 35—ADVERTISING AND BUSINESS**

FOR RETAIL STORE SERVICES FEATURING BUSINESS TELEPHONE SYSTEMS, COMMUNICATIONS SERVERS, SECURITY AND VIDEO SURVEILLANCE EQUIPMENT, ELECTRONIC BUILDING ACCESS SECURITY SYSTEMS, AND TELECOMMUNICATIONS AND DATA NETWORKING INFRASTRUCTURE, NAMELY, CABLING, WIRING AND CONNECTORS; TELEPHONE MARKETING SERVICES, NAMELY, PRODUCING CUSTOMIZED RECORDED MESSAGES TO BE PLAYED TO ON-HOLD TELEPHONE CALLERS (U.S. CLS. 100, 101 AND 102).

FIRST USE 5-1-2010; IN COMMERCE 5-1-2010.

#### **CLASS 37—CONSTRUCTION AND REPAIR**

FOR INSTALLATION OF TELECOMMUNICATIONS AND DATA NETWORKING INFRASTRUCTURE; TELECOMMUNICATIONS NETWORK MANAGEMENT SERVICES, NAMELY, INSTALLATION OF TELECOMMUNICATION SYSTEMS AND NETWORKS FOR OTHERS (U.S. CLS. 100, 103 AND 106).

FIRST USE 5-1-2010; IN COMMERCE 5-1-2010.

#### **CLASS 38—COMMUNICATION**

FOR TELECOMMUNICATION SERVICES, NAMELY, AUTOMATED CALL PROCESSING, RECORDING AND TRACKING SERVICES; AUTOMATED TELEPHONE VOICE MESSAGING AND NOTIFICATION SERVICES; VOICE OVER INTERNET PROTOCOL (VOIP) SERVICES; TELECOMMUNICATIONS NETWORK MANAGEMENT SERVICES, NAMELY, ADMINISTRATION OF TELECOMMUNICATION SYSTEMS AND NETWORKS FOR OTHERS (U.S. CLS. 100, 101 AND 104).

FIRST USE 5-1-2010; IN COMMERCE 5-1-2010.

#### **CLASS 42—SCIENTIFIC AND COMPUTER SERVICES**

FOR PROVIDING TEMPORARY USE OF NON-DOWNLOADABLE SOFTWARE IN THE FIELD OF VOICE AND DATA COMMUNICATIONS; CUSTOM SOFTWARE DEVELOPMENT IN THE FIELD OF VOICE AND DATA COMMUNICATIONS; DESIGN OF TELECOMMUNICATIONS AND DATA NETWORKING INFRASTRUCTURE; TELECOMMUNICATIONS NETWORK MANAGEMENT SERVICES, NAMELY, DESIGN OF TELECOMMUNICATION SYSTEMS AND NETWORKS FOR OTHERS (U.S. CLS. 100 AND 101).

FIRST USE 5-1-2010; IN COMMERCE 5-1-2010.

3,962,910. ICIM CORPORATION, DBA PLANET TELECOM, NEW ALBANY, IN. SN 77-930,156. PUB. 7-20-2010, FILED 2-8-2010.

# DATA INSPIRED

THE MARK CONSISTS OF STANDARD CHARACTERS WITHOUT CLAIM TO ANY PARTICULAR FONT, STYLE, SIZE, OR COLOR.

NO CLAIM IS MADE TO THE EXCLUSIVE RIGHT TO USE "DATA", APART FROM THE MARK AS SHOWN.

#### **CLASS 35—ADVERTISING AND BUSINESS**

FOR RETAIL STORE SERVICES FEATURING BUSINESS TELEPHONE SYSTEMS, COMMUNICATIONS SERVERS, SECURITY AND VIDEO SURVEILLANCE EQUIPMENT, ELECTRONIC BUILDING ACCESS SECURITY SYSTEMS, AND TELECOMMUNICATIONS AND DATA NETWORKING INFRASTRUCTURE, NAMELY, CABLING, WIRING AND CONNECTORS; TELEPHONE MARKETING SERVICES, NAMELY, PRODUCING CUSTOMIZED RECORDED MESSAGES TO BE PLAYED TO ON-HOLD TELEPHONE CALLERS (U.S. CLS. 100, 101 AND 102).

FIRST USE 5-0-2010; IN COMMERCE 5-0-2010.

#### **CLASS 37—CONSTRUCTION AND REPAIR**

FOR INSTALLATION OF TELECOMMUNICATIONS AND DATA NETWORKING INFRASTRUCTURE; TELECOMMUNICATIONS NETWORK MANAGEMENT SERVICES, NAMELY, INSTALLATION OF TELECOMMUNICATION SYSTEMS AND NETWORKS FOR OTHERS (U.S. CLS. 100, 103 AND 106).

FIRST USE 5-0-2010; IN COMMERCE 5-0-2010.

**CLASS 38—COMMUNICATION**

FOR TELECOMMUNICATION SERVICES, NAMELY, AUTOMATED CALL PROCESSING, RECORDING AND TRACKING SERVICES; AUTOMATED TELEPHONE VOICE MESSAGING AND NOTIFICATION SERVICES; VOICE OVER INTERNET PROTOCOL (VOIP) SERVICES; TELECOMMUNICATIONS NETWORK MANAGEMENT SERVICES, NAMELY, ADMINISTRATION OF TELECOMMUNICATION SYSTEMS AND NETWORKS FOR OTHERS (U.S. CLS. 100, 101 AND 104).

FIRST USE 5-0-2010; IN COMMERCE 5-0-2010.

**CLASS 42—SCIENTIFIC AND COMPUTER SERVICES**

FOR PROVIDING TEMPORARY USE OF NON-DOWNLOADABLE SOFTWARE IN THE FIELD OF VOICE AND DATA COMMUNICATIONS; CUSTOM SOFTWARE DEVELOPMENT IN THE FIELD OF VOICE AND DATA COMMUNICATIONS; DESIGN OF TELECOMMUNICATIONS AND DATA NETWORKING INFRASTRUCTURE; TELECOMMUNICATIONS NETWORK MANAGEMENT SERVICES, NAMELY, DESIGN OF TELECOMMUNICATION SYSTEMS AND NETWORKS FOR OTHERS (U.S. CLS. 100 AND 101).

FIRST USE 5-0-2010; IN COMMERCE 5-0-2010.

3,962,914. ROCLAND WINE IMPORTS, SAN FRANCISCO, CA. SN 77-931,061. PUB. 6-29-2010, FILED 2-9-2010.

# TIGHT ASS

THE MARK CONSISTS OF STANDARD CHARACTERS WITHOUT CLAIM TO ANY PARTICULAR FONT, STYLE, SIZE, OR COLOR.

**CLASS 32—LIGHT BEVERAGES**

FOR BEER (U.S. CLS. 45, 46 AND 48).  
FIRST USE 2-1-2011; IN COMMERCE 2-1-2011.

**CLASS 33—WINES AND SPIRITS**

FOR DISTILLED SPIRITS; WINE (U.S. CLS. 47 AND 49).  
FIRST USE 2-1-2011; IN COMMERCE 2-1-2011.

3,962,918. GRAEBEL RELOCATION SERVICES WORLDWIDE, INC., AURORA, CO. SN 77-931,939. PUB. 8-10-2010, FILED 2-9-2010.

GRAEBEL EXPRESS RELOCATION  
SERVICES

THE MARK CONSISTS OF STANDARD CHARACTERS WITHOUT CLAIM TO ANY PARTICULAR FONT, STYLE, SIZE, OR COLOR.

OWNER OF U.S. REG. NO. 2,848,765.

NO CLAIM IS MADE TO THE EXCLUSIVE RIGHT TO USE "EXPRESS RELOCATION SERVICES", APART FROM THE MARK AS SHOWN.

**CLASS 35—ADVERTISING AND BUSINESS**

FOR PERSONNEL AND EMPLOYEE RELOCATION SERVICES (U.S. CLS. 100, 101 AND 102).  
FIRST USE 2-0-2011; IN COMMERCE 2-0-2011.

**CLASS 39—TRANSPORTATION AND STORAGE**

FOR RELOCATION PACKING, CRATING AND WAREHOUSING SERVICES AND TRANSPORT SERVICES, NAMELY, LOCAL, INTERSTATE AND INTERNATIONAL MOVING SERVICES (U.S. CLS. 100 AND 105).

FIRST USE 2-0-2011; IN COMMERCE 2-0-2011.

3,962,923. MR. IDEA, INC., ATTLEBORO, MA. SN 77-932,776.  
PUB. 7-13-2010, FILED 2-10-2010.

## GAME DAY RAINGEAR

THE MARK CONSISTS OF STANDARD CHARACTERS WITHOUT CLAIM TO ANY PARTICULAR FONT, STYLE, SIZE, OR COLOR.

NO CLAIM IS MADE TO THE EXCLUSIVE RIGHT TO USE "RAINGEAR", APART FROM THE MARK AS SHOWN.

**CLASS 18—LEATHER GOODS**

FOR UMBRELLAS (U.S. CLS. 1, 2, 3, 22 AND 41).  
FIRST USE 1-1-2010; IN COMMERCE 1-1-2010.

**CLASS 25—CLOTHING**

FOR RAINWEAR AND PONCHOS (U.S. CLS. 22 AND 39).  
FIRST USE 9-1-2010; IN COMMERCE 9-1-2010.

3,962,933. LYFEPUBLICATIONS, BALTIMORE, MD. SN 77-935,219. PUB. 8-3-2010, FILED 2-13-2010.



NO CLAIM IS MADE TO THE EXCLUSIVE RIGHT TO USE "PUBLICATIONS", APART FROM THE MARK AS SHOWN.

THE COLOR(S) FUCHSIA PINK, GRAY, AND BLACK. IS/ ARE CLAIMED AS A FEATURE OF THE MARK.

THE MARK CONSISTS OF A FUCHSIA AND GRAY INCOMPLETE CIRCULAR DESIGN RESEMBLING A PAINT SPLASH, TO THE LEFT OF THE TERMS "LYE" IN FUCHSIA IN ALL CAPS AND "PUBLICATIONS" IN BLACK LOWERCASE LETTERS.

**CLASS 35—ADVERTISING AND BUSINESS**

FOR PROMOTIONAL SERVICES, NAMELY, LAUNCH PARTIES TO INTRODUCE A NEW BOOK, AUTHOR, BOOK PUBLISHER OR RETAILER (U.S. CLS. 100, 101 AND 102).

FIRST USE 10-1-2010; IN COMMERCE 10-1-2010.

**CLASS 41—EDUCATION AND ENTERTAINMENT**

FOR BOOK PUBLISHING (U.S. CLS. 100, 101 AND 107).  
FIRST USE 10-1-2010; IN COMMERCE 10-1-2010.

3,962,935. NOBLE WAR PRIZE, INC., SOUTHAMPTON, NY. SN 77-935,270. PUB. 7-13-2010, FILED 2-13-2010.

**WASHINGTON DC GLOBAL  
WARMING SNOW JOB**

THE MARK CONSISTS OF STANDARD CHARACTERS WITHOUT CLAIM TO ANY PARTICULAR FONT, STYLE, SIZE, OR COLOR.

**CLASS 25—CLOTHING**

FOR T-SHIRTS (U.S. CLS. 22 AND 39).  
FIRST USE 2-13-2010; IN COMMERCE 7-23-2010.

**CLASS 28—TOYS AND SPORTING GOODS**

FOR TOY SNOW GLOBES (U.S. CLS. 22, 23, 38 AND 50).  
FIRST USE 2-13-2010; IN COMMERCE 7-23-2010.

3,962,940. ACCURO MEDICAL PRODUCTS LLC, DENVER, CO. SN 77-935,878. PUB. 6-29-2010, FILED 2-15-2010.

**WoundPro**

THE MARK CONSISTS OF STANDARD CHARACTERS WITHOUT CLAIM TO ANY PARTICULAR FONT, STYLE, SIZE, OR COLOR.

**CLASS 5—PHARMACEUTICALS**

FOR WOUND DRESSINGS (U.S. CLS. 6, 18, 44, 46, 51 AND 52).  
FIRST USE 9-30-2010; IN COMMERCE 9-30-2010.

**CLASS 10—MEDICAL APPARATUS**

FOR MEDICAL COMPRESSION STOCKINGS AND TIGHTS; WOUND DRAINAGE APPARATUS; WOUND SUCTION APPARATUS (U.S. CLS. 26, 39 AND 44).  
FIRST USE 9-30-2010; IN COMMERCE 9-30-2010.

3,962,944. ICIM CORPORATION, DBA PLANET TELECOM, NEW ALBANY, IN. SN 77-936,240. PUB. 7-20-2010, FILED 2-16-2010.



THE MARK CONSISTS OF THE TERM "INDATUS" PRECEDED BY A STYLIZED RENDITION OF THREE VERTICAL BARS WHERE THE FIRST BAR REPRESENTS THE LETTER "I".

**CLASS 35—ADVERTISING AND BUSINESS**

FOR RETAIL STORE SERVICES FEATURING BUSINESS TELEPHONE SYSTEMS, COMMUNICATIONS SERVERS, SECURITY AND VIDEO SURVEILLANCE EQUIPMENT, ELECTRONIC BUILDING ACCESS SECURITY SYSTEMS, AND TELECOMMUNICATIONS AND DATA NETWORKING INFRASTRUCTURE, NAMELY, CABLING, WIRING AND CONNECTORS; TELEPHONE MARKETING SERVICES, NAMELY, PRODUCING CUSTOMIZED RECORDED MESSAGES TO BE PLAYED TO ON-HOLD TELEPHONE CALLERS (U.S. CLS. 100, 101 AND 102).

FIRST USE 5-1-2010; IN COMMERCE 5-1-2010.

**CLASS 37—CONSTRUCTION AND REPAIR**

FOR INSTALLATION OF TELECOMMUNICATIONS AND DATA NETWORKING INFRASTRUCTURE; TELECOMMUNICATIONS NETWORK MANAGEMENT SERVICES, NAMELY, INSTALLATION OF TELECOMMUNICATION SYSTEMS AND NETWORKS FOR OTHERS (U.S. CLS. 100, 103 AND 106).

FIRST USE 5-1-2010; IN COMMERCE 5-1-2010.

**CLASS 38—COMMUNICATION**

FOR TELECOMMUNICATION SERVICES, NAMELY, AUTOMATED CALL PROCESSING, RECORDING AND TRACKING SERVICES; AUTOMATED TELEPHONE VOICE MESSAGING AND NOTIFICATION SERVICES; VOICE OVER INTERNET PROTOCOL (VOIP) SERVICES; TELECOMMUNICATIONS NETWORK MANAGEMENT SERVICES, NAMELY, ADMINISTRATION OF TELECOMMUNICATION SYSTEMS AND NETWORKS FOR OTHERS (U.S. CLS. 100, 101 AND 104).

FIRST USE 5-1-2010; IN COMMERCE 5-1-2010.

**CLASS 42—SCIENTIFIC AND COMPUTER SERVICES**

FOR PROVIDING TEMPORARY USE OF NON-DOWNLOADABLE SOFTWARE IN THE FIELD OF VOICE AND DATA COMMUNICATIONS; CUSTOM SOFTWARE DEVELOPMENT IN THE FIELD OF VOICE AND DATA COMMUNICATIONS; DESIGN OF TELECOMMUNICATIONS AND DATA NETWORKING INFRASTRUCTURE; TELECOMMUNICATIONS NETWORK MANAGEMENT SERVICES, NAMELY, DESIGN OF TELECOMMUNICATION SYSTEMS AND NETWORKS FOR OTHERS (U.S. CLS. 100 AND 101).

FIRST USE 5-1-2010; IN COMMERCE 5-1-2010.

3,962,945. ICIM CORPORATION, DBA PLANET TELECOM, NEW ALBANY, IN. SN 77-936,241. PUB. 7-20-2010, FILED 2-16-2010.

3,962,955. VIRGIN MOBILE USA, L.P., OVERLAND PARK, KS. SN 77-938,053. PUB. 7-27-2010, FILED 2-17-2010.



THE MARK CONSISTS OF A STYLIZED RENDITION OF THREE VERTICAL BARS WHERE THE FIRST BAR REPRESENTS THE LETTER "I".

#### **CLASS 35—ADVERTISING AND BUSINESS**

FOR RETAIL STORE SERVICES FEATURING BUSINESS TELEPHONE SYSTEMS, COMMUNICATIONS SERVERS, SECURITY AND VIDEO SURVEILLANCE EQUIPMENT, ELECTRONIC BUILDING ACCESS SECURITY SYSTEMS, AND TELECOMMUNICATIONS AND DATA NETWORKING INFRASTRUCTURE, NAMELY, CABLING, WIRING AND CONNECTORS; TELEPHONE MARKETING SERVICES, NAMELY, PRODUCING CUSTOMIZED RECORDED MESSAGES TO BE PLAYED TO ON-HOLD TELEPHONE CALLERS (U.S. CLS. 100, 101 AND 102).

FIRST USE 5-1-2010; IN COMMERCE 5-1-2010.

#### **CLASS 37—CONSTRUCTION AND REPAIR**

FOR INSTALLATION OF TELECOMMUNICATIONS AND DATA NETWORKING INFRASTRUCTURE; TELECOMMUNICATIONS NETWORK MANAGEMENT SERVICES, NAMELY, INSTALLATION OF TELECOMMUNICATION SYSTEMS AND NETWORKS FOR OTHERS (U.S. CLS. 100, 103 AND 106).

FIRST USE 5-1-2010; IN COMMERCE 5-1-2010.

#### **CLASS 38—COMMUNICATION**

FOR TELECOMMUNICATION SERVICES, NAMELY, AUTOMATED CALL PROCESSING, RECORDING AND TRACKING SERVICES; AUTOMATED TELEPHONE VOICE MESSAGING AND NOTIFICATION SERVICES; VOICE OVER INTERNET PROTOCOL (VOIP) SERVICES; TELECOMMUNICATIONS NETWORK MANAGEMENT SERVICES, NAMELY, ADMINISTRATION OF TELECOMMUNICATION SYSTEMS AND NETWORKS FOR OTHERS (U.S. CLS. 100, 101 AND 104).

FIRST USE 5-1-2010; IN COMMERCE 5-1-2010.

#### **CLASS 42—SCIENTIFIC AND COMPUTER SERVICES**

FOR PROVIDING TEMPORARY USE OF NON-DOWNLOADABLE SOFTWARE IN THE FIELD OF VOICE AND DATA COMMUNICATIONS; CUSTOM SOFTWARE DEVELOPMENT IN THE FIELD OF VOICE AND DATA COMMUNICATIONS; DESIGN OF TELECOMMUNICATIONS AND DATA NETWORKING INFRASTRUCTURE; TELECOMMUNICATIONS NETWORK MANAGEMENT SERVICES, NAMELY, DESIGN OF TELECOMMUNICATION SYSTEMS AND NETWORKS FOR OTHERS (U.S. CLS. 100 AND 101).

FIRST USE 5-1-2010; IN COMMERCE 5-1-2010.



NO CLAIM IS MADE TO THE EXCLUSIVE RIGHT TO USE "MOBILE", APART FROM THE MARK AS SHOWN.

THE MARK CONSISTS OF A STYLIZED LETTER "C", THE UPPER AND LOWER PORTIONS OF WHICH ARE SHADED WITH THE WORDS "COMMON CENTS MOBILE" APPEARING TO THE RIGHT OF THE STYLIZED LETTER "C".

#### **CLASS 9—ELECTRICAL AND SCIENTIFIC APPARATUS**

FOR MOBILE TELEPHONES, TELEPHONES AND MODEMS, AND ACCESSORIES THEREFOR, NAMELY, BATTERIES, BATTERY CHARGERS, ELECTRIC CIGARETTE LIGHTER ADAPTERS FOR LAND VEHICLES, HANDS-FREE HEADSETS FOR MOBILE TELEPHONES, CARRYING CASES FOR MOBILE TELEPHONES AND CARRYING CASES FOR MOBILE TELEPHONES, NAMELY, CARRYING CASES THAT CLIP TO AN INDIVIDUAL'S BELT (U.S. CLS. 21, 23, 26, 36 AND 38).

FIRST USE 5-12-2010; IN COMMERCE 5-12-2010.

#### **CLASS 35—ADVERTISING AND BUSINESS**

FOR TELEPHONE DIRECTORY ASSISTANCE SERVICES (U.S. CLS. 100, 101 AND 102).

FIRST USE 5-12-2010; IN COMMERCE 5-12-2010.

#### **CLASS 38—COMMUNICATION**

FOR TELECOMMUNICATIONS SERVICES, NAMELY, TRANSMISSION OF VOICE, DATA, IMAGES, AUDIO, VIDEO AND INFORMATION VIA TELEPHONE OR THE INTERNET; TELECOMMUNICATION SERVICES, NAMELY, PERSONAL COMMUNICATION SERVICES; ELECTRONIC MAIL SERVICES; TRANSMISSION OF NEWS AND TRANSMISSION OF INFORMATION FOR OTHERS VIA TELEPHONE, INCLUDING THE INTERNET (U.S. CLS. 100, 101 AND 104).

FIRST USE 5-12-2010; IN COMMERCE 5-12-2010.

3,963,024. BLAKE AUSTIN COLLEGE, VACAVILLE, CA. SN 77-947,194. PUB. 7-27-2010, FILED 3-1-2010.

#### **BLAKE AUSTIN BEAUTY EMPORIUM**

THE MARK CONSISTS OF STANDARD CHARACTERS WITHOUT CLAIM TO ANY PARTICULAR FONT, STYLE, SIZE, OR COLOR.

NO CLAIM IS MADE TO THE EXCLUSIVE RIGHT TO USE "BEAUTY EMPORIUM", APART FROM THE MARK AS SHOWN.

THE NAME "BLAKE AUSTIN" IDENTIFIES A LIVING INDIVIDUAL WHOSE CONSENT IS OF RECORD.



**CLASS 35—ADVERTISING AND BUSINESS**

FOR RETAIL STORE SERVICES FEATURING PREPARATIONS FOR BEAUTY AND BODY CARE, COSMETICS, PERFUMERY, EYEGLASSES, FINERIES, COSTUME JEWELRY, WATCHES, BAGS, HANDBAGS, CLOTHING, FOOTWEAR AND HEADGEAR (U.S. CLS. 100, 101 AND 102).

FIRST USE 11-27-2010; IN COMMERCE 11-27-2010.

**CLASS 44—MEDICAL, BEAUTY AND AGRICULTURAL SERVICES**

FOR SALON, SKIN AND SPA SERVICES, NAMELY, COSMETOLOGY SERVICES, HAIR CUTTING, STYLING, COLOR AND TREATMENT SERVICES; MANICURES AND PEDICURES; AND ESTHETICS SERVICES, NAMELY, FACIALS, SKIN TREATMENTS AND SKIN CARE THERAPIES, MASSAGE, HAIR REMOVAL AND COSMETIC SERVICES (U.S. CLS. 100 AND 101).

FIRST USE 11-27-2010; IN COMMERCE 11-27-2010.

---

3,963,031. THOMAS JEFFERSON UNIVERSITY, PHILADELPHIA, PA. SN 77-948,380. PUB. 6-22-2010, FILED 3-2-2010.

**SKILLS2CARE**

THE MARK CONSISTS OF STANDARD CHARACTERS WITHOUT CLAIM TO ANY PARTICULAR FONT, STYLE, SIZE, OR COLOR.

**CLASS 16—PAPER GOODS AND PRINTED MATTER**

FOR PRINTED EDUCATIONAL MATERIALS, ALL IN THE FIELDS OF MEDICINE AND HEALTHCARE (U.S. CLS. 2, 5, 22, 23, 29, 37, 38 AND 50).

FIRST USE 2-0-2010; IN COMMERCE 2-0-2010.

**CLASS 41—EDUCATION AND ENTERTAINMENT**

FOR PROVIDING CONTINUING EDUCATION SEMINARS, CLASSES, AND COURSES OF INSTRUCTION FOR HEALTH CARE PROFESSIONALS, AND PROVIDING SEMINARS, CLASSES, AND COURSES OF INSTRUCTION IN THE FIELD OF COMMUNITY HEALTH CARE EDUCATION (U.S. CLS. 100, 101 AND 107).

FIRST USE 2-0-2010; IN COMMERCE 2-0-2010.

**CLASS 44—MEDICAL, BEAUTY AND AGRICULTURAL SERVICES**

FOR HEALTH CARE SERVICES (U.S. CLS. 100 AND 101).

FIRST USE 8-0-2010; IN COMMERCE 8-0-2010.

3,963,041. JONMOR INVESTMENTS, INC., WILMINGTON, DE. SN 77-949,721. PUB. 7-27-2010, FILED 3-3-2010.



OWNER OF U.S. REG. NOS. 1,054,792, 2,897,136, AND OTHERS.

NO CLAIM IS MADE TO THE EXCLUSIVE RIGHT TO USE "SINCE 1827", APART FROM THE MARK AS SHOWN.

THE NAME(S), PORTRAIT(S), AND/OR SIGNATURE(S) SHOWN IN THE MARK DOES NOT IDENTIFY A PARTICULAR LIVING INDIVIDUAL.

THE COLOR(S) RED, BLACK, AND WHITE IS/ARE CLAIMED AS A FEATURE OF THE MARK.

THE MARK CONSISTS OF THE WORDS, "JOHN MORRELL" IN WHITE SCRIPT, OUTLINED IN RED AND BLACK, WITH A RED BACKGROUND, OUTLINED IN BLACK, HAVING A RED HEART-LIKE DESIGN, OUTLINED IN WHITE AND BLACK, TO THE LEFT OF THE WORD "JOHN". BELOW THE WORDS, "JOHN MORRELL" ARE THE WORDS, "SINCE 1827" IN SMALL, WHITE SCRIPT, OUTLINED IN BLACK.

**CLASS 29—MEATS AND PROCESSED FOODS**

FOR MEATS; HAM; BACON; PORK; LUNCH MEAT; SAUSAGE; HOT DOGS; TURKEY; BOLOGNA (U.S. CL. 46).

FIRST USE 12-0-2005; IN COMMERCE 12-0-2005.

**CLASS 43—HOTEL AND RESTAURANT SERVICES**

FOR PROVIDING INFORMATION IN THE FIELD OF RECIPES AND COOKING INFORMATION (U.S. CLS. 100 AND 101).

FIRST USE 12-0-2005; IN COMMERCE 12-0-2005.

---

3,963,063. CONSOLIDATED PROPERTY HOLDINGS, INC., LAS VEGAS, NV. SN 77-951,789. PUB. 9-28-2010, FILED 3-5-2010.

**MYSTIC PASSAGE**

THE MARK CONSISTS OF STANDARD CHARACTERS WITHOUT CLAIM TO ANY PARTICULAR FONT, STYLE, SIZE, OR COLOR.

**CLASS 4—LUBRICANTS AND FUELS**

FOR CANDLES (U.S. CLS. 1, 6 AND 15).  
FIRST USE 12-22-2010; IN COMMERCE 12-22-2010.

**CLASS 11—ENVIRONMENTAL CONTROL APPARATUS**

FOR LAMPS, REED DIFFUSERS FOR SCENTED OIL (U.S. CLS. 13, 21, 23, 31 AND 34).  
FIRST USE 11-5-2010; IN COMMERCE 11-5-2010.

**CLASS 20—FURNITURE AND ARTICLES NOT OTHERWISE CLASSIFIED**

FOR DECORATIVE PILLOWS, ART AND PICTURE FRAMES, WALL DECOR IN THE NATURE OF WOOD PLAQUES AND MIRRORS WITH MOLDED FRAMES, DECORATIVE PAINTED BOXES MADE OF WOOD (U.S. CLS. 2, 13, 22, 25, 32 AND 50).

FIRST USE 12-21-2010; IN COMMERCE 12-21-2010.

**CLASS 21—HOUSEWARES AND GLASS**

FOR CANDLE HOLDERS, VASES, DECORATIVE PAINTED BOXES MADE OF CERAMICS, BATH ACCESSORIES, NAMELY, LOTION PUMPS, COTTON BALL BOXES, TOOTH BRUSH HOLDERS, AND SOAP DISHES (U.S. CLS. 2, 13, 23, 29, 30, 33, 40 AND 50).

FIRST USE 7-1-2010; IN COMMERCE 7-1-2010.

**CLASS 24—FABRICS**

FOR BEDDING, NAMELY, COMFORTER SETS, TABLE LINENS (U.S. CLS. 42 AND 50).

FIRST USE 10-10-2010; IN COMMERCE 10-10-2010.

**CLASS 27—FLOOR COVERINGS**

FOR RUGS, DOORMATS (U.S. CLS. 19, 20, 37, 42 AND 50).

FIRST USE 9-11-2010; IN COMMERCE 9-11-2010.

---

3,963,090. MONTGOMERY JR., STEVEN L., CHARLOTTE, NC. SN 77-954,700. PUB. 8-3-2010, FILED 3-9-2010.



THE MARK CONSISTS OF A STYLIZED DEPICTION OF BOTH A MENORAH AND A TREE.

**CLASS 9—ELECTRICAL AND SCIENTIFIC APPARATUS**

FOR DOWNLOADABLE ELECTRONIC PUBLICATIONS, NAMELY, BOOKS, MAGAZINES, AND NEWSLETTERS FEATURING ANTHROPOLOGY, HISTORY, SCIENCE AND RELIGION; ELECTRONIC PUBLICATIONS, NAMELY, BOOKS, MAGAZINES, AND NEWSLETTERS FEATURING ANTHROPOLOGY, HISTORY, SCIENCE AND RELIGION RECORDED ON COMPUTER MEDIA; PRERECORDED CDS, DVDS, AUDIO CASSETTES, RECORD ALBUMS, AND VIDEOTAPES, ALL FEATURING ANTHROPOLOGY, HISTORY, SCIENCE AND RELIGION (U.S. CLS. 21, 23, 26, 36 AND 38).

FIRST USE 3-27-2011; IN COMMERCE 3-27-2011.

**CLASS 14—JEWELRY**

FOR JEWELRY CONSISTING OF LEATHER, PLASTIC, PRECIOUS AND SEMI-PRECIOUS METALS, PRECIOUS AND SEMI-PRECIOUS GEMSTONES, OR PRECIOUS AND SEMI-PRECIOUS STONES, NAMELY, BRACELETS, BROACHES, EARRINGS, CLOCKS AND WATCHES, CUFF LINKS AND TIE CLIPS, INSIGNIAS, JEWEL CHAINS, PENDANTS, AMULETS, PRECIOUS METAL KEY CHAINS, LAPEL PINS, MEDALLIONS, NECK CHAINS, NECKLACES, RINGS, AND TIMEPIECES (U.S. CLS. 2, 27, 28 AND 50).

FIRST USE 1-15-2011; IN COMMERCE 2-1-2011.

**CLASS 16—PAPER GOODS AND PRINTED MATTER**

FOR PUBLICATIONS, NAMELY, BOOKS, MAGAZINES AND NEWSLETTERS FEATURING ANTHROPOLOGY, HISTORY, SCIENCE AND RELIGION; PAPER ADVERTISING SIGNS AND PAMPHLETS FEATURING ANTHROPOLOGY, HISTORY, SCIENCE, AND RELIGION; INFORMATIONAL FLYERS FEATURING ANTHROPOLOGY, HISTORY, SCIENCE, AND RELIGION; COLORING BOOKS; MOUNTED AND UNMOUNTED PHOTOGRAPHS; POSTERS; POSTCARDS; COVERS OF PAPER FOR CDS, CASSETTE TAPES, AND BOOKS; CALENDARS AND GREETING CARDS; BUSINESS CARDS AND OFFICE STATIONERY (U.S. CLS. 2, 5, 22, 23, 29, 37, 38 AND 50).

FIRST USE 3-24-2011; IN COMMERCE 3-24-2011.

**CLASS 25—CLOTHING**

FOR MEN'S, WOMEN'S, AND CHILDREN'S CLOTHING, NAMELY, BANDANAS, BELTS, BODY LINEN, CAPS AND HATS, CLOAKS, COATS, HEAVY COATS, JACKETS, HEAVY JACKETS, PARKAS, POLO SHIRTS, PULLOVERS, HOODED PULLOVERS, SCARVES, SHAWLS, SHORT-SLEEVED AND LONG-SLEEVED T-SHIRTS, SKULL CAPS, SWEAT SHIRTS, HOODED SWEAT SHIRTS, SWEATERS, TALLITOT, TZITZIT IN THE NATURE OF A VEST HOLDING TASSELS, UNIFORMS, AND VESTS (U.S. CLS. 22 AND 39).

FIRST USE 12-9-2010; IN COMMERCE 12-9-2010.

---

3,963,094. SOLSTICE LIVING SOLUTIONS, INC., SCOTTSDALE, AZ. SN 77-955,312. PUB. 7-13-2010, FILED 3-10-2010.



NO CLAIM IS MADE TO THE EXCLUSIVE RIGHT TO USE "LIVING SOLUTIONS", APART FROM THE MARK AS SHOWN.

THE COLOR(S) BLUE AND GRAY IS/ARE CLAIMED AS A FEATURE OF THE MARK.

THE MARK CONSISTS OF THE WORD "SOLSTICE" IN BLUE STACKED ON TOP OF THE WORDS "LIVING SOLUTIONS" IN GRAY, EXCEPT FOR THE LETTERS "I," WHICH ARE IN BLUE AND CONSIST OF MIRRORED GEOMETRIC FIGURES, EACH REPRESENTING A PERSON.

**CLASS 44—MEDICAL, BEAUTY AND AGRICULTURAL SERVICES**

FOR MEDICAL SERVICES FOR RESIDENTS IN PRIVATE HOMES AND SENIOR LIVING FACILITIES; MEDICAL ASSISTANCE SERVICES, NAMELY, PROVIDING ASSISTANCE WITH DAILY LIVING ACTIVITIES TO RESIDENTS IN SENIOR LIVING FACILITIES (U.S. CLS. 100 AND 101).

FIRST USE 12-1-2010; IN COMMERCE 12-1-2010.

**CLASS 45—PERSONAL AND LEGAL SERVICES**

FOR IN-HOME SUPPORT SERVICES TO SENIOR PERSONS, NAMELY, GERIATRIC CARE MANAGEMENT SERVICES AND PERSONAL AFFAIRS MANAGEMENT SERVICES IN THE NATURE OF THE COORDINATION OF NECESSARY SERVICES AND CARE FOR OLDER INDIVIDUALS (U.S. CLS. 100 AND 101).

FIRST USE 12-1-2010; IN COMMERCE 12-1-2010.

3,963,103. DANSKO, LLC, WEST GROVE, PA. SN 77-956,080. PUB. 8-3-2010, FILED 3-10-2010.

# DANSKO

THE MARK CONSISTS OF STANDARD CHARACTERS WITHOUT CLAIM TO ANY PARTICULAR FONT, STYLE, SIZE, OR COLOR.

OWNER OF U.S. REG. NOS. 3,264,216, 3,265,196, AND OTHERS.

**CLASS 10—MEDICAL APPARATUS**

FOR MEDICAL WEARING APPAREL, NAMELY, SCRUB PANTS; MEDICAL WEARING APPAREL, NAMELY, SCRUB TOPS (U.S. CLS. 26, 39 AND 44).

FIRST USE 2-17-2011; IN COMMERCE 2-17-2011.

**CLASS 25—CLOTHING**

FOR SCRUBS NOT FOR MEDICAL PURPOSES (U.S. CLS. 22 AND 39).

FIRST USE 2-17-2011; IN COMMERCE 2-17-2011.

3,963,149. MUNCHKIN, INC., NORTH HILLS, CA. SN 77-960,991. PUB. 8-3-2010, FILED 3-17-2010.

# LOFT

THE MARK CONSISTS OF STANDARD CHARACTERS WITHOUT CLAIM TO ANY PARTICULAR FONT, STYLE, SIZE, OR COLOR.

**CLASS 6—METAL GOODS**

FOR METAL SAFETY GATES FOR BABIES, CHILDREN, AND PETS (U.S. CLS. 2, 12, 13, 14, 23, 25 AND 50).

FIRST USE 1-24-2011; IN COMMERCE 2-28-2011.

**CLASS 20—FURNITURE AND ARTICLES NOT OTHERWISE CLASSIFIED**

FOR NON-METAL SAFETY GATES FOR BABIES, CHILDREN, AND PETS (U.S. CLS. 2, 13, 22, 25, 32 AND 50).

FIRST USE 1-24-2011; IN COMMERCE 2-28-2011.

3,963,174. THE TEACHING COMPANY, LLC, CHANTILLY, VA. SN 77-963,099. PUB. 8-10-2010, FILED 3-19-2010.



OWNER OF U.S. REG. NOS. 1,859,109 AND 3,033,618. THE MARK CONSISTS OF A TORCH DESIGN.

**CLASS 9—ELECTRICAL AND SCIENTIFIC APPARATUS**

FOR PRERECORDED CDS AND DVDS ON THE SUBJECTS OF SOCIAL SCIENCES, PSYCHOLOGY, HISTORY, LAW, LITERATURE, FINE ARTS, COSMOLOGY, PHYSICAL SCIENCE, BIOLOGICAL SCIENCE, PHILOSOPHY, THEOLOGY, LINGUISTICS, RELIGION, MATHEMATICS, MUSIC AND PERFORMING ARTS (U.S. CLS. 21, 23, 26, 36 AND 38).

FIRST USE 6-0-2010; IN COMMERCE 6-0-2010.

**CLASS 16—PAPER GOODS AND PRINTED MATTER**

FOR PRINTED EDUCATIONAL MATERIALS ON THE SUBJECTS OF SOCIAL SCIENCES, PSYCHOLOGY, HISTORY, LAW, LITERATURE, FINE ARTS, COSMOLOGY, PHYSICAL SCIENCE, BIOLOGICAL SCIENCE, PHILOSOPHY, THEOLOGY, LINGUISTICS, RELIGION, MATHEMATICS, MUSIC AND PERFORMING ARTS (U.S. CLS. 2, 5, 22, 23, 29, 37, 38 AND 50).

FIRST USE 6-0-2010; IN COMMERCE 6-0-2010.

**CLASS 35—ADVERTISING AND BUSINESS**

FOR MAIL ORDER CATALOG SERVICES AND ONLINE RETAIL STORE SERVICES FEATURING PRERECORDED VIDEOTAPES, AUDIOTAPES, CDS AND DVDS OF NONCREDIT COURSES IN SOCIAL SCIENCES, PSYCHOLOGY, HISTORY, LAW, LITERATURE, FINE ARTS, COSMOLOGY, PHYSICAL SCIENCE, BIOLOGICAL SCIENCE, PHILOSOPHY, THEOLOGY, LINGUISTICS, RELIGION, MATHEMATICS, MUSIC AND PERFORMING ARTS (U.S. CLS. 100, 101 AND 102).

FIRST USE 6-0-2010; IN COMMERCE 6-0-2010.

3,963,194. LEAK IT OUT, INC., LAS VEGAS, NV. SN 77-965,381. PUB. 8-10-2010, FILED 3-22-2010.

## LEAK IT OUT

THE MARK CONSISTS OF STANDARD CHARACTERS WITHOUT CLAIM TO ANY PARTICULAR FONT, STYLE, SIZE, OR COLOR.

### CLASS 35—ADVERTISING AND BUSINESS

FOR ADVERTISING ON THE INTERNET FOR OTHERS; PROVIDING ADVERTISING AND ADVERTISEMENT SERVICES (U.S. CLS. 100, 101 AND 102).  
FIRST USE 11-10-2010; IN COMMERCE 11-10-2010.

### CLASS 42—SCIENTIFIC AND COMPUTER SERVICES

FOR APPLICATION SERVICE PROVIDER (ASP) FEATURING SOFTWARE FOR USE IN ENABLING UP-LOADING, POSTING, SHOWING, DISPLAYING, TAGGING, BLOGGING, SHARING OR OTHERWISE PROVIDING ELECTRONIC MEDIA OR INFORMATION OVER THE INTERNET OR OTHER COMMUNICATIONS NETWORK (U.S. CLS. 100 AND 101).  
FIRST USE 5-1-2010; IN COMMERCE 5-1-2010.

### CLASS 45—PERSONAL AND LEGAL SERVICES

FOR INTERNET-BASED SOCIAL NETWORKING SERVICES (U.S. CLS. 100 AND 101).  
FIRST USE 5-1-2010; IN COMMERCE 5-1-2010.

3,963,195. LEAK IT OUT, INC., LAS VEGAS, NV. SN 77-965,385. PUB. 8-10-2010, FILED 3-22-2010.

## LIO

THE MARK CONSISTS OF STANDARD CHARACTERS WITHOUT CLAIM TO ANY PARTICULAR FONT, STYLE, SIZE, OR COLOR.

### CLASS 35—ADVERTISING AND BUSINESS

FOR ADVERTISING ON THE INTERNET FOR OTHERS; PROVIDING ADVERTISING AND ADVERTISEMENT SERVICES (U.S. CLS. 100, 101 AND 102).  
FIRST USE 11-10-2010; IN COMMERCE 11-10-2010.

### CLASS 42—SCIENTIFIC AND COMPUTER SERVICES

FOR APPLICATION SERVICE PROVIDER (ASP) FEATURING SOFTWARE FOR USE IN ENABLING UP-LOADING, POSTING, SHOWING, DISPLAYING, TAGGING, BLOGGING, SHARING OR OTHERWISE PROVIDING ELECTRONIC MEDIA OR INFORMATION OVER THE INTERNET OR OTHER COMMUNICATIONS NETWORK (U.S. CLS. 100 AND 101).  
FIRST USE 5-1-2010; IN COMMERCE 5-1-2010.

### CLASS 45—PERSONAL AND LEGAL SERVICES

FOR INTERNET-BASED SOCIAL NETWORKING SERVICES (U.S. CLS. 100 AND 101).  
FIRST USE 5-1-2010; IN COMMERCE 5-1-2010.

3,963,203. IMERGENT, INC., OREM, UT. SN 77-966,343. PUB. 8-10-2010, FILED 3-23-2010.

## CREXENDO

THE MARK CONSISTS OF STANDARD CHARACTERS WITHOUT CLAIM TO ANY PARTICULAR FONT, STYLE, SIZE, OR COLOR.

### CLASS 35—ADVERTISING AND BUSINESS

FOR BUSINESS MARKETING SERVICES (U.S. CLS. 100, 101 AND 102).  
FIRST USE 11-5-2009; IN COMMERCE 11-5-2009.

### CLASS 41—EDUCATION AND ENTERTAINMENT

FOR BUSINESS TRAINING; EDUCATION SERVICES, NAMELY, PROVIDING WORKSHOPS IN THE FIELD OF ELECTRONIC COMMERCE (U.S. CLS. 100, 101 AND 107).  
FIRST USE 12-1-2009; IN COMMERCE 12-1-2009.

### CLASS 42—SCIENTIFIC AND COMPUTER SERVICES

FOR COMPUTER SERVICES, NAMELY, SEARCH ENGINE OPTIMIZATION; DESIGN, CREATION, HOSTING, MAINTENANCE OF WEBSITES FOR OTHERS (U.S. CLS. 100 AND 101).  
FIRST USE 11-5-2009; IN COMMERCE 11-5-2009.

3,963,205. THE HEREAFTER INC., SISTER BAY, WI. SN 77-966,599. PUB. 8-10-2010, FILED 3-23-2010.

## THE-HEREAFTER

THE MARK CONSISTS OF STANDARD CHARACTERS WITHOUT CLAIM TO ANY PARTICULAR FONT, STYLE, SIZE, OR COLOR.

### CLASS 9—ELECTRICAL AND SCIENTIFIC APPARATUS

FOR SOFTWARE FOR PROCESSING IMAGES, TEXT, AUDIO, AND VIDEO INFORMATION RELATING TO FAMILY HISTORIES AND MEMORIALS (U.S. CLS. 21, 23, 26, 36 AND 38).  
FIRST USE 3-29-2011; IN COMMERCE 3-29-2011.

**CLASS 39—TRANSPORTATION AND STORAGE**

FOR ELECTRONIC STORAGE OF IMAGES, TEXT, AUDIO, AND VIDEO INFORMATION RELATING TO FAMILY HISTORIES AND MEMORIALS (U.S. CLS. 100 AND 105).

FIRST USE 3-29-2011; IN COMMERCE 3-29-2011.

**CLASS 44—MEDICAL, BEAUTY AND AGRICULTURAL SERVICES**

FOR PSYCHOTHERAPY SERVICES (U.S. CLS. 100 AND 101).

FIRST USE 1-19-2010; IN COMMERCE 1-19-2010.

3,963,211. SMITTY'S SUPPLY, INC., ROSELAND, LA. SN 77-967,012. PUB. 8-3-2010, FILED 3-24-2010.

3,963,219. DIAGNOSTIC DEVICES, INC., CHARLOTTE, NC. SN 77-967,923. PUB. 8-10-2010, FILED 3-24-2010.

# TRISTAR

THE MARK CONSISTS OF STANDARD CHARACTERS WITHOUT CLAIM TO ANY PARTICULAR FONT, STYLE, SIZE, OR COLOR.

**CLASS 1—CHEMICALS**

FOR HYDRAULIC FLUID (U.S. CLS. 1, 5, 6, 10, 26 AND 46).

FIRST USE 12-22-2010; IN COMMERCE 12-22-2010.

**CLASS 4—LUBRICANTS AND FUELS**

FOR GEAR OILS; HYDRAULIC OILS (U.S. CLS. 1, 6 AND 15).

FIRST USE 12-22-2010; IN COMMERCE 12-22-2010.

3,963,216. GRACE AND GROWTH COUNSELING CENTER, INC., SANDY SPRINGS, GA. SN 77-967,550. PUB. 11-9-2010, FILED 3-24-2010.



NO CLAIM IS MADE TO THE EXCLUSIVE RIGHT TO USE "COUNSELING CENTER", APART FROM THE MARK AS SHOWN.

THE MARK CONSISTS OF A TREE SUPERIMPOSED OVER A SUN, WITH FOUR HUMAN FIGURES UNDER THE TREE BRANCHES ON THE LEFT AND TWO HUMAN FIGURES UNDER THE TREE BRANCHES ON THE RIGHT, WITH THE WORDS "GRACE AND GROWTH" ABOVE A STRAIGHT LINE RUNNING UNDER THE FIGURES' FEET AND THE BASE OF THE TREE AND THE WORDS "COUNSELING CENTER" BELOW THE LINE, ALL TO THE RIGHT OF THE TREE TRUNK.

**CLASS 41—EDUCATION AND ENTERTAINMENT**

FOR EDUCATIONAL SEMINARS FOR MENTAL HEALTH PROFESSIONALS AND CLERGY REGARDING TREATMENT AND CAREGIVING TECHNIQUES AND OTHER TOPICS OF CONCERN RELEVANT TO AIDING INDIVIDUALS AND FAMILIES EXPERIENCING STRESS OR PERSONAL TRAUMA (U.S. CLS. 100, 101 AND 107).

FIRST USE 8-28-2010; IN COMMERCE 8-28-2010.

# PRODIGY CHOICE

THE MARK CONSISTS OF STANDARD CHARACTERS WITHOUT CLAIM TO ANY PARTICULAR FONT, STYLE, SIZE, OR COLOR.

**CLASS 5—PHARMACEUTICALS**

FOR MEDICAL DIAGNOSTIC TEST STRIPS FOR DETERMINING THE LEVELS OF GLUCOSE IN BLOOD (U.S. CLS. 6, 18, 44, 46, 51 AND 52).

FIRST USE 6-1-2010; IN COMMERCE 6-1-2010.

**CLASS 10—MEDICAL APPARATUS**

FOR BLOOD GLUCOSE METERS (U.S. CLS. 26, 39 AND 44).

FIRST USE 6-1-2010; IN COMMERCE 6-1-2010.

3,963,220. DIAGNOSTIC DEVICES, INC., CHARLOTTE, NC. SN 77-967,924. PUB. 8-10-2010, FILED 3-24-2010.

# PRODIGY PREFERRED

THE MARK CONSISTS OF STANDARD CHARACTERS WITHOUT CLAIM TO ANY PARTICULAR FONT, STYLE, SIZE, OR COLOR.

**CLASS 5—PHARMACEUTICALS**

FOR MEDICAL DIAGNOSTIC TEST STRIPS FOR DETERMINING THE LEVELS OF GLUCOSE IN BLOOD (U.S. CLS. 6, 18, 44, 46, 51 AND 52).

FIRST USE 4-9-2010; IN COMMERCE 4-9-2010.

**CLASS 10—MEDICAL APPARATUS**

FOR BLOOD GLUCOSE METERS (U.S. CLS. 26, 39 AND 44).

FIRST USE 4-9-2010; IN COMMERCE 4-9-2010.



3,963,232. PAUL MCKENNA, LONDON W84LY, UNITED KINGDOM. SN 77-980,155. PUB. 4-7-2009, FILED 5-12-2008.

3,963,241. PORTICO ACQUISITION, LLC, NEW YORK, NY. SN 77-981,578. PUB. 6-3-2008, FILED 7-17-2007.

## I CAN MAKE YOU RICH

THE MARK CONSISTS OF STANDARD CHARACTERS WITHOUT CLAIM TO ANY PARTICULAR FONT, STYLE, SIZE, OR COLOR.

### CLASS 9—ELECTRICAL AND SCIENTIFIC APPARATUS

FOR SOUND RECORDINGS IN THE FORM OF CDS ON THE SUBJECT OF PERSONAL DEVELOPMENT AND IMPROVEMENT, NAMELY, BEAUTY AND PHYSICAL APPEARANCE, SOCIAL SKILLS, HEALTH AND WEALTH, HYPNOTHERAPY, AND NEURO-LINGUISTIC PROGRAMMING (NLP) (U.S. CLS. 21, 23, 26, 36 AND 38).

FIRST USE 3-16-2008; IN COMMERCE 3-16-2008.

### CLASS 16—PAPER GOODS AND PRINTED MATTER

FOR BOOKS ON THE SUBJECT OF PERSONAL DEVELOPMENT AND IMPROVEMENT, NAMELY, BEAUTY AND PHYSICAL APPEARANCE, SOCIAL SKILLS, HEALTH AND WEALTH, HYPNOTHERAPY, AND NEURO-LINGUISTIC PROGRAMMING (NLP) (U.S. CLS. 2, 5, 22, 23, 29, 37, 38 AND 50).

FIRST USE 3-16-2008; IN COMMERCE 3-16-2008.

---

3,963,236. WISECRACKER LLC, PETALUMA, CA. SN 77-981,309. PUB. 5-4-2010, FILED 12-7-2009.

## WISECRACKER

THE MARK CONSISTS OF STANDARD CHARACTERS WITHOUT CLAIM TO ANY PARTICULAR FONT, STYLE, SIZE, OR COLOR.

### CLASS 9—ELECTRICAL AND SCIENTIFIC APPARATUS

FOR LEATHER LAPTOP COMPUTER BAGS (U.S. CLS. 21, 23, 26, 36 AND 38).

FIRST USE 10-18-2010; IN COMMERCE 10-18-2010.

### CLASS 18—LEATHER GOODS

FOR LUGGAGE, LEATHER BRIEFCASES, AND WALLET (U.S. CLS. 1, 2, 3, 22 AND 41).

FIRST USE 10-18-2010; IN COMMERCE 10-18-2010.

## PORTICO

THE MARK CONSISTS OF STANDARD CHARACTERS WITHOUT CLAIM TO ANY PARTICULAR FONT, STYLE, SIZE, OR COLOR.

OWNER OF U.S. REG. NO. 2,641,451.

### CLASS 3—COSMETICS AND CLEANING PREPARATIONS

FOR COSMETIC ACCESSORIES, NAMELY, COTTON BALLS, COTTON BUDS, COTTON PUFFS, COTTON STICKS, COTTON SWABS; AROMATHERAPY CREAMS, LOTIONS AND OILS; SHAMPOOS; SHAMPOO-CONDITIONERS; HAIR CONDITIONERS; FACIAL CLEANSERS; LIP BALM; TONING LOTION AND MIST, FOR THE FACE, BODY AND HANDS; SUGAR SCRUB; BODY BUTTER (U.S. CLS. 1, 4, 6, 50, 51 AND 52).

FIRST USE 12-31-2002; IN COMMERCE 12-31-2002.

### CLASS 20—FURNITURE AND ARTICLES NOT OTHERWISE CLASSIFIED

FOR PILLOWS (U.S. CLS. 2, 13, 22, 25, 32 AND 50).

FIRST USE 9-30-2010; IN COMMERCE 9-30-2010.

### CLASS 21—HOUSEWARES AND GLASS

FOR SHOE POLISHING MITTS (U.S. CLS. 2, 13, 23, 29, 30, 33, 40 AND 50).

FIRST USE 12-31-2002; IN COMMERCE 12-31-2002.

### CLASS 24—FABRICS

FOR BED PADS; FEATHER BEDS; BATH LINENS; BATH TOWELS; BLANKETS, NAMELY, BED BLANKETS; MATTRESS PADS; MATTRESS COVERS (U.S. CLS. 42 AND 50).

FIRST USE 2-1-2010; IN COMMERCE 2-1-2010.

### CLASS 25—CLOTHING

FOR SHOWER CAPS (U.S. CLS. 22 AND 39).

FIRST USE 1-31-2011; IN COMMERCE 1-31-2011.

### CLASS 27—FLOOR COVERINGS

FOR BATH MATS (U.S. CLS. 19, 20, 37, 42 AND 50).

FIRST USE 2-1-2010; IN COMMERCE 2-1-2010.

---

3,963,242. PORTICO ACQUISITION, LLC, NEW YORK, NY. SN 77-981,579. PUB. 6-3-2008, FILED 7-17-2007.

portico

OWNER OF U.S. REG. NO. 2,641,451.

**CLASS 3—COSMETICS AND CLEANING PREPARATIONS**

FOR COSMETIC ACCESSORIES, NAMELY, COTTON BALLS, COTTON BUDDS, COTTON PUFFS, COTTON STICKS, COTTON SWABS; AROMATHERAPY CREAMS, LOTIONS AND OILS; SHAMPOOS; SHAMPOO-CONDITIONERS; HAIR CONDITIONERS; FACIAL CLEANSERS; LIP BALM; TONING LOTION AND MIST, FOR THE FACE, BODY AND HANDS; SUGAR SCRUB; BODY BUTTER; NON-MEDICATED BATH SALTS, SKIN SOAP, BODY LOTION (U.S. CLS. 1, 4, 6, 50, 51 AND 52).  
FIRST USE 12-31-2002; IN COMMERCE 12-31-2002.

**CLASS 20—FURNITURE AND ARTICLES NOT OTHERWISE CLASSIFIED**

FOR PILLOWS (U.S. CLS. 2, 13, 22, 25, 32 AND 50).  
FIRST USE 9-30-2010; IN COMMERCE 9-30-2010.

**CLASS 21—HOUSEWARES AND GLASS**

FOR SHOE POLISHING MITTS (U.S. CLS. 2, 13, 23, 29, 30, 33, 40 AND 50).  
FIRST USE 12-31-2002; IN COMMERCE 12-31-2002.

**CLASS 24—FABRICS**

FOR BED PADS; FEATHER BEDS; BED LINENS; BATH LINENS; BATH TOWELS; BLANKETS, NAMELY, BED BLANKETS, MATTRESS PADS; MATTRESS COVERS (U.S. CLS. 42 AND 50).  
FIRST USE 2-1-2010; IN COMMERCE 2-1-2010.

**CLASS 25—CLOTHING**

FOR ROBES AND SHOWER CAPS (U.S. CLS. 22 AND 39).  
FIRST USE 1-31-2011; IN COMMERCE 1-31-2011.

**CLASS 27—FLOOR COVERINGS**

FOR BATH MATS (U.S. CLS. 19, 20, 37, 42 AND 50).  
FIRST USE 2-1-2010; IN COMMERCE 2-1-2010.

3,963,247. TATA SONS LIMITED, MUMBAI, INDIA. SN 77-981,642. PUB. 4-22-2008, FILED 10-19-2006.

**TATA**

THE MARK CONSISTS OF STANDARD CHARACTERS WITHOUT CLAIM TO ANY PARTICULAR FONT, STYLE, SIZE, OR COLOR.

OWNER OF U.S. REG. NOS. 2,814,916, 2,929,070, AND OTHERS.

**CLASS 36—INSURANCE AND FINANCIAL**

FOR TELEPHONE CALLING CARD SERVICES (U.S. CLS. 100, 101 AND 102).  
FIRST USE 12-31-2005; IN COMMERCE 12-31-2005.

**CLASS 38—COMMUNICATION**

FOR TELECOMMUNICATIONS SERVICES, NAMELY, PROVIDING LONG DISTANCE TRANSMISSION OF VOICE, VIDEO AND DATA VIA A FIBER OPTIC NETWORK; PROVIDING MULTIPLE USE ACCESS TO A GLOBAL COMPUTER NETWORK; SATELLITE COMMUNICATIONS; VOICE OVER INTERNET PROTOCOL SERVICES; ELECTRONIC MESSAGE COLLECTION, PROCESSING AND TRANSMISSION SERVICES (U.S. CLS. 100, 101 AND 104).

FIRST USE 12-31-2004; IN COMMERCE 12-31-2004.

3,963,248. HAYWARD INDUSTRIES, INC., ELIZABETH, NJ. SN 77-981,656. PUB. 5-26-2009, FILED 8-21-2008.

**AQUA CONNECT**

THE MARK CONSISTS OF STANDARD CHARACTERS WITHOUT CLAIM TO ANY PARTICULAR FONT, STYLE, SIZE, OR COLOR.

NO CLAIM IS MADE TO THE EXCLUSIVE RIGHT TO USE "AQUA", APART FROM THE MARK AS SHOWN.

**CLASS 9—ELECTRICAL AND SCIENTIFIC APPARATUS**

FOR REMOTE CONTROL UNITS, NAMELY, WIRELESS CONTROLS ACCESSIBLE VIA GLOBAL AND LOCAL COMPUTER NETWORKS, FOR CONTROLLING WATER MANAGEMENT AND TREATMENT SYSTEMS CONSISTING OF TIMERS, CHLORINATORS, HEATERS, PUMPS, AND ACTUATORS OF SWIMMING POOLS, SPAS, HOT TUBS, WHIRLPOOLS, WATER FEATURES AND OTHER RECREATIONAL BODIES OF WATER (U.S. CLS. 21, 23, 26, 36 AND 38).

FIRST USE 7-0-2008; IN COMMERCE 5-3-2010.

**CLASS 42—SCIENTIFIC AND COMPUTER SERVICES**

FOR PROVIDING A COMPUTER WEBSITE FEATURING ON-LINE NON-DOWNLOADABLE SOFTWARE FOR USE IN ACCESSING AND/OR RECEIVING INFORMATION CONCERNING THE STATUS OF, AND TO ISSUE INSTRUCTIONS TO, WATER MANAGEMENT AND TREATMENT SYSTEMS CONSISTING OF TIMERS, CHLORINATORS, HEATERS, PUMPS, AND ACTUATORS OF SWIMMING POOLS, SPAS, HOT TUBS, WHIRLPOOLS, WATER FEATURES AND OTHER RECREATIONAL BODIES OF WATER; TECHNICAL SUPPORT SERVICES, NAMELY, DIAGNOSIS OF WATER MANAGEMENT AND TREATMENT SYSTEMS FOR SWIMMING POOLS, SPAS, HOT TUBS, WHIRLPOOLS, WATER FEATURES AND OTHER RECREATIONAL BODIES OF WATER (U.S. CLS. 100 AND 101).

FIRST USE 7-0-2008; IN COMMERCE 6-0-2010.

3,963,249. RELIANT ENERGY RETAIL HOLDINGS, LLC, HOUSTON, TX. SN 77-981,657. PUB. 8-31-2010, FILED 9-17-2009.

## RELIANT RENEWABLES

THE MARK CONSISTS OF STANDARD CHARACTERS WITHOUT CLAIM TO ANY PARTICULAR FONT, STYLE, SIZE, OR COLOR.

NO CLAIM IS MADE TO THE EXCLUSIVE RIGHT TO USE "RENEWABLES", APART FROM THE MARK AS SHOWN.

### CLASS 35—ADVERTISING AND BUSINESS

FOR ENERGY MANAGEMENT SERVICES, NAMELY, PROVIDING A SERVICE THAT ALLOWS CUSTOMERS TO PURCHASE ENERGY, NAMELY, ELECTRICITY, RENEWABLE ENERGY AS WELL AS RENEWABLE ENERGY CREDITS; CONSULTATION IN THE FIELD OF ENERGY EFFICIENCY (U.S. CLS. 100, 101 AND 102).  
FIRST USE 2-1-2011; IN COMMERCE 2-11-2011.

### CLASS 36—INSURANCE AND FINANCIAL

FOR ENERGY BROKERAGE SERVICES; ELECTRICITY BROKERAGE, NAMELY, THE BROKERAGE OF ELECTRIC SOLAR, WIND, BIO MASS OR NUCLEAR POWER (U.S. CLS. 100, 101 AND 102).  
FIRST USE 2-1-2011; IN COMMERCE 2-1-2011.

3,963,253. XCEL ENERGY INC., MINNEAPOLIS, MN. SN 77-981,665. PUB. 12-30-2008, FILED 4-10-2008.

## RESPONSIBLE BY NATURE

THE MARK CONSISTS OF STANDARD CHARACTERS WITHOUT CLAIM TO ANY PARTICULAR FONT, STYLE, SIZE, OR COLOR.

### CLASS 35—ADVERTISING AND BUSINESS

FOR BILLING SERVICES, INCLUDING STRUCTURED FLAT RATE PRICING OPTIONS FOR UTILITY BILL PAYMENT; BUSINESS RELOCATION SERVICES, NAMELY, ALLOWING INDIVIDUALS WHO ARE MOVING TO TRANSFER HOME SERVICES TO THE NEW LOCATION BY CONTACTING MULTIPLE THIRD PARTY VENDORS THROUGH A CONSUMER SERVICE REPRESENTATIVE IN ORDER TO FACILITATE THEIR MOVE; PUBLIC GAS AND ELECTRIC UTILITY ENERGY MANAGEMENT CONSULTATION FOR COMMERCIAL AND INDUSTRIAL CUSTOMERS, NAMELY, CONSULTATION CONCERNING ALTERNATIVE FUEL AND ENERGY BACK-UP PROGRAMS, LOAD BALANCING PROGRAMS, ENERGY SUPPLY MANAGEMENT AND ENERGY CONSERVATION PROGRAMS; PROMOTING THE GOODS AND SERVICES OF OTHERS THROUGH THE ADMINISTRATION OF AIR CONDITIONING REBATE PROGRAMS AND ENERGY SAVING REBATE PROGRAMS; ACCOUNTING SERVICES RELATED TO ENERGY USE; UTILITY BILLING SERVICES IN THE NATURE OF UTILITY BILL DIRECT PAYMENT SERVICES, ELECTRONIC BILLING FOR UTILITY BILLS; ELECTRIC UTILITY SERVICES IN THE NATURE OF OFFERING INCENTIVE PRICING FOR CONTROLLED USE OF ELECTRICITY DURING SPECIFIC HOURS; ENERGY CONSERVATION CONSULTATION, CONSULTATION IN THE FIELD OF ENERGY USE AND REGARDING ENERGY EFFICIENT APPLIANCES SUCH AS AIR CONDITIONING AND FURNACES; PROMOTING PUBLIC AWARENESS OF THE NEED FOR ENERGY CONSERVATION AND EFFICIENT ELECTRICITY UTILIZATION BY BUSINESSES THROUGH ENERGY AUDITS AND CONSULTATION IN THE EFFECTS OF ENERGY EFFICIENT LIGHTING, ENERGY EFFICIENT AIR CONDITIONING, ENERGY EFFICIENT REFRIGERATION, ENERGY EFFICIENT MOTORS AND CONTROLS, WINDOW GLAZING, AND ENERGY CONSERVATION AND HOME ENERGY AUDITS; PROMOTING PUBLIC AWARENESS OF THE NEED FOR APPLIANCE REBATES, ENERGY EFFICIENT LIGHTING FOR HOMES, AIR CONDITIONING LOAD CONTROL, APPLIANCE RECYCLING, AND SPECIAL TIME-OF-DAY RATES; CONSULTATION AND ANALYSIS REGARDING ENERGY EFFICIENCY AND CUSTOMER'S USAGE MANAGEMENT OF ELECTRIC AND GAS UTILITY SERVICES, NAMELY, ENERGY USE ANALYSIS, ENERGY PROFILING AND MONITORING, CONTROLLING ENERGY COSTS AND USAGE; ADMINISTERING ENERGY EFFICIENCY AND ENERGY USAGE MANAGEMENT PROGRAMS, NAMELY, ENERGY LOAD CONTROL PROGRAMS, ENERGY SCHEDULING PROGRAMS, AND ENERGY RATE ANALYSIS SERVICES; PROVISION OF INFORMATION IN THE FIELD OF ENERGY USAGE MANAGEMENT DISTRIBUTED THROUGH THE INTERNET (U.S. CLS. 100, 101 AND 102).

FIRST USE 11-0-2008; IN COMMERCE 11-0-2008.

### CLASS 36—INSURANCE AND FINANCIAL

FOR BILL PAYMENT SERVICES; AUTOMATIC PAYMENT SERVICES, INCLUDING, AUTOMATIC PAYMENT DEDUCTIONS FOR UTILITY BILLS (U.S. CLS. 100, 101 AND 102).

FIRST USE 11-0-2008; IN COMMERCE 11-0-2008.

### CLASS 39—TRANSPORTATION AND STORAGE

FOR PUBLIC UTILITY SERVICES IN THE NATURE OF ELECTRICITY AND NATURAL GAS TRANSMISSION; TRANSMISSION OF NATURAL GAS AND LIQUEFIED NATURAL GAS THROUGH PIPELINE; STORAGE OF NATURAL GAS AND LIQUEFIED NATURAL GAS; PROVISION OF INFORMATION IN THE FIELD OF ENERGY TRANSMISSION DISTRIBUTED THROUGH THE INTERNET (U.S. CLS. 100 AND 105).

FIRST USE 11-0-2008; IN COMMERCE 11-0-2008.

### CLASS 41—EDUCATION AND ENTERTAINMENT

FOR EDUCATIONAL SERVICES, NAMELY, CONDUCTING LIVE AND ONLINE CLASSES, SEMINARS, WORKSHOPS, AND CONFERENCES IN THE FIELDS OF ENERGY, THE ENVIRONMENT, AND THE CONSERVATION OF RESOURCES, AND DISTRIBUTING COURSE MATERIALS IN CONNECTION THEREWITH (U.S. CLS. 100, 101 AND 107).

FIRST USE 0-0-2009; IN COMMERCE 0-0-2009.

#### **CLASS 42—SCIENTIFIC AND COMPUTER SERVICES**

FOR AUTOMATED ENERGY SERVICES, NAMELY, REMOTE MONITORING AND THERMOSTATIC CONTROL OF ENERGY UTILIZATION; IN-PERSON TROUBLESHOOTING SPECIAL POWER SUPPLY REQUIREMENTS FOR CUSTOMERS HAVING SENSITIVE ELECTRONIC EQUIPMENT AND ASSESSING POWER SUPPLY REQUIREMENTS AND PROBLEMS FOR SENSITIVE ELECTRONIC EQUIPMENT (U.S. CLS. 100 AND 101).

FIRST USE 11-0-2008; IN COMMERCE 11-0-2008.

---

3,963,259. ARTISTIC PRODUCTS, LLC, HAUPPAUGE, NY. SN 77-981,710. PUB. 8-3-2010, FILED 3-6-2009.

## **EARTH SMART OFFICE**

THE MARK CONSISTS OF STANDARD CHARACTERS WITHOUT CLAIM TO ANY PARTICULAR FONT, STYLE, SIZE, OR COLOR.

OWNER OF U.S. REG. NO. 3,796,487.

NO CLAIM IS MADE TO THE EXCLUSIVE RIGHT TO USE "OFFICE", APART FROM THE MARK AS SHOWN.

#### **CLASS 16—PAPER GOODS AND PRINTED MATTER**

FOR BLACKBOARDS, DRAWING BOARDS AND EASELS; CHALK BOARDS FOR SCHOOL AND HOME USE; CLIP BOARDS; CLIPS FOR LETTERS; DRY ERASE WRITING BOARDS AND WRITING SURFACES; LETTER OPENERS; LETTER RACKS; PICTURE FRAMING MAT BOARDS; DESK FILE TRAYS, DESK STANDS AND HOLDERS FOR PENS, PENCILS, AND INK, DIRECTORY BOARDS, DOCUMENT FILE TRAYS, FILE TRAYS, LAP BOARDS FOR READING AND WRITING, LETTER HOLDERS, LETTER TRAYS, MEMORANDUM BOARDS, PEN AND PENCIL TRAYS, NOT MADE OF PAPER, CARDBOARD OR RECYCLED PAPER (U.S. CLS. 2, 5, 22, 23, 29, 37, 38 AND 50).

FIRST USE 1-1-2010; IN COMMERCE 1-1-2010.

#### **CLASS 20—FURNITURE AND ARTICLES NOT OTHERWISE CLASSIFIED**

FOR BULLETIN BOARDS; FOOT RESTS; PICTURE AND PHOTOGRAPH FRAMES; PICTURE FRAMES; PLAQUES OF BAMBOO; WALL PLAQUES MADE OF PLASTIC OR WOOD (U.S. CLS. 2, 13, 22, 25, 32 AND 50).

FIRST USE 9-1-2010; IN COMMERCE 9-1-2010.

3,963,260. ALDI INC., BATAVIA, IL. SN 77-981,730. PUB. 2-2-2010, FILED 10-29-2009.

## **BOULDER**

THE MARK CONSISTS OF STANDARD CHARACTERS WITHOUT CLAIM TO ANY PARTICULAR FONT, STYLE, SIZE, OR COLOR.

OWNER OF U.S. REG. NO. 3,225,945.

#### **CLASS 6—METAL GOODS**

FOR ALUMINUM FOIL (U.S. CLS. 2, 12, 13, 14, 23, 25 AND 50).

FIRST USE 5-13-2010; IN COMMERCE 5-13-2010.

#### **CLASS 16—PAPER GOODS AND PRINTED MATTER**

FOR PLASTIC WRAP, PLASTIC FOOD STORAGE BAGS FOR HOUSEHOLD USE (U.S. CLS. 2, 5, 22, 23, 29, 37, 38 AND 50).

FIRST USE 10-26-2010; IN COMMERCE 10-26-2010.

---

3,963,261. THE BOPPY COMPANY, LLC, GOLDEN, CO. SN 77-981,744. PUB. 8-31-2010, FILED 12-11-2009.

## **SLIDELINE**

THE MARK CONSISTS OF STANDARD CHARACTERS WITHOUT CLAIM TO ANY PARTICULAR FONT, STYLE, SIZE, OR COLOR.

#### **CLASS 24—FABRICS**

FOR A TOY ATTACHMENT SYSTEM COMPRISED OF A SLIDER CLIP AND TRACK USED TO ATTACH TOYS TO PUT THEM WITHIN REACH OF A BABY FOR THE PURPOSE OF STIMULATION AND ENTERTAINMENT, SOLD AS AN INTEGRAL PART OF FABRIC SLIPCOVERS FOR PILLOWS (U.S. CLS. 42 AND 50).

FIRST USE 12-10-2010; IN COMMERCE 12-10-2010.

#### **CLASS 28—TOYS AND SPORTING GOODS**

FOR A TOY ATTACHMENT SYSTEM COMPRISED OF A SLIDER CLIP AND TRACK USED TO ATTACH TOYS TO PUT THEM WITHIN REACH OF A BABY FOR THE PURPOSE OF STIMULATION AND ENTERTAINMENT, SOLD AS AN INTEGRAL PART OF PLAY GYMS FOR BABIES AND PLAY MATS FOR BABIES (U.S. CLS. 22, 23, 38 AND 50).

FIRST USE 11-30-2010; IN COMMERCE 11-30-2010.

3,963,262. INTREXON CORPORATION, BLACKSBURG, VA.  
SN 77-981,745. PUB. 12-9-2008, FILED 2-22-2008.

### RHEOSWITCH THERAPEUTIC SYSTEM

THE MARK CONSISTS OF STANDARD CHARACTERS WITHOUT CLAIM TO ANY PARTICULAR FONT, STYLE, SIZE, OR COLOR.

OWNER OF U.S. REG. NO. 2,925,677.

NO CLAIM IS MADE TO THE EXCLUSIVE RIGHT TO USE "THERAPEUTIC SYSTEM", APART FROM THE MARK AS SHOWN.

#### CLASS 1—CHEMICALS

FOR CHEMICALS, NAMELY, CHEMICALS FOR USE IN INDUSTRY AND SCIENCE, CHEMICALS FOR USE IN BIOCHEMICAL AND CHEMICAL INDUSTRY, CHEMICALS FOR USE IN AGRICULTURE, CHEMICALS FOR USE IN BIOTECHNOLOGICAL PRODUCT DEVELOPMENT, CHEMICALS FOR USE IN BIOTECHNOLOGICAL MANUFACTURING PROCESSES, CHEMICAL PREPARATIONS FOR SCIENTIFIC PURPOSES, CHEMICAL REAGENTS FOR NON-MEDICAL PURPOSES (U.S. CLS. 1, 5, 6, 10, 26 AND 46).

FIRST USE 8-0-2010; IN COMMERCE 8-0-2010.

#### CLASS 5—PHARMACEUTICALS

FOR CHEMICALS PREPARATIONS FOR MEDICAL AND VETERINARY PURPOSES; BIOCHEMICALS PREPARATIONS FOR MEDICAL AND VETERINARY PURPOSES; CHEMICAL REAGENTS FOR MEDICAL AND VETERINARY PURPOSES (U.S. CLS. 6, 18, 44, 46, 51 AND 52).

FIRST USE 8-0-2010; IN COMMERCE 8-0-2010.

3,963,263. GEN-PROBE INCORPORATED, SAN DIEGO, CA.  
SN 77-981,748. PUB. 9-15-2009, FILED 5-8-2009.

### PANTHER

THE MARK CONSISTS OF STANDARD CHARACTERS WITHOUT CLAIM TO ANY PARTICULAR FONT, STYLE, SIZE, OR COLOR.

#### CLASS 9—ELECTRICAL AND SCIENTIFIC APPARATUS

FOR COMPUTER SOFTWARE FOR THE OPERATION OF AN AUTOMATED IN VITRO DIAGNOSTIC SPECIMEN TEST ANALYZER; COMPUTER SOFTWARE FOR THE ORGANIZATION, ANALYSIS AND REPORTING OF IN VITRO DIAGNOSTIC SPECIMEN TEST DATA, NAMELY, DATA PROCESSING SOFTWARE; ELECTRONIC PUBLICATIONS, NAMELY, INSTRUMENT AND SOFTWARE MANUALS, AND QUICK REFERENCE GUIDES RECORDED ON COMPUTER MEDIA; AUTOMATED IN VITRO DIAGNOSTIC INSTRUMENT, AND PARTS THEREFOR, FOR THE DETECTION AND ASSAY OF NUCLEIC ACIDS IN TEST SAMPLES, ALL FOR LABORATORY USE (U.S. CLS. 21, 23, 26, 36 AND 38).

FIRST USE 11-4-2010; IN COMMERCE 12-17-2010.

#### CLASS 10—MEDICAL APPARATUS

FOR AUTOMATED IN VITRO DIAGNOSTIC SPECIMEN ANALYZER INSTRUMENT, AND PARTS THEREFOR, FOR THE DETECTION AND ASSAY OF ANALYTES IN BIOLOGICAL SPECIMENS FOR MEDICAL DIAGNOSTIC USE (U.S. CLS. 26, 39 AND 44).

FIRST USE 11-4-2010; IN COMMERCE 12-17-2010.

3,963,271. BELLATOR SPORT WORLDWIDE LLC, CHICAGO, IL. SN 77-981,772. PUB. 11-23-2010, FILED 12-21-2009.

### WHERE FIGHTERS BECOME WARRIORS, AND WARRIORS BECOME LEGENDS

THE MARK CONSISTS OF STANDARD CHARACTERS WITHOUT CLAIM TO ANY PARTICULAR FONT, STYLE, SIZE, OR COLOR.

#### CLASS 16—PAPER GOODS AND PRINTED MATTER

FOR POSTERS (U.S. CLS. 2, 5, 22, 23, 29, 37, 38 AND 50).

FIRST USE 4-0-2009; IN COMMERCE 4-0-2009.

#### CLASS 25—CLOTHING

FOR ATHLETIC CLOTHING, NAMELY, SHIRTS (U.S. CLS. 22 AND 39).

FIRST USE 4-0-2009; IN COMMERCE 4-0-2009.

#### CLASS 35—ADVERTISING AND BUSINESS

FOR PROMOTING, SPONSORING, ADVERTISING AND MARKETING OF MIXED MARTIAL ARTS FIGHTING EVENTS (U.S. CLS. 100, 101 AND 102).

FIRST USE 4-0-2009; IN COMMERCE 4-0-2009.

#### CLASS 41—EDUCATION AND ENTERTAINMENT

FOR ENTERTAINMENT SERVICES, NAMELY, ORGANIZING AND CONDUCTING MIXED MARTIAL ARTS COMPETITIONS AND EVENTS AND PERSONAL APPEARANCES BY MIXED MARTIAL ARTS COMPETITORS, FOR DISTRIBUTION BY MEANS OF CABLE, BROADCAST, INTERNET, SATELLITE AND OTHER BROADCAST MEDIA; ENTERTAINMENT, NAMELY, CONDUCTING AND PRODUCING LIVE STAGE SHOWS AND PERFORMANCES FEATURING MIXED MARTIAL ARTS (U.S. CLS. 100, 101 AND 107).

FIRST USE 4-0-2009; IN COMMERCE 4-0-2009.

3,963,272. PROTEUS BIOMEDICAL, INC., REDWOOD CITY, CA. SN 77-981,774. PUB. 8-3-2010, FILED 3-2-2007.

### PROTEUS

THE MARK CONSISTS OF STANDARD CHARACTERS WITHOUT CLAIM TO ANY PARTICULAR FONT, STYLE, SIZE, OR COLOR.



**CLASS 5—PHARMACEUTICALS**

FOR INGESTIBLE MEDICATED AND PHARMACEUTICALS, NAMELY, DIAGNOSTIC AND THERAPEUTIC PREPARATIONS FOR MEDICAL PURPOSES BOTH PRESCRIPTION AND OVER-THE-COUNTER, FOR USE IN CONNECTION WITH HUMANS AND ANIMALS, TO GATHER DATA ON PATIENT STATUS AND CONDITION, TO MONITOR PATIENT CONDITION, PATIENT ADHERENCE TO TREATMENT REGIMENS, EFFICACY OF TREATMENT, AND TO ENABLE PERSONALIZED THERAPY FOR THE PURPOSE OF MAXIMIZING PATIENT OUTCOME IN THE DIAGNOSIS, THERAPEUTIC TREATMENT, AND MANAGEMENT OF CANCERS, CHRONIC PAIN, SKIN DISEASE, DISEASES OF THE EAR, NOSE, AND THROAT, INFECTIOUS DISEASE, PSYCHIATRIC DISORDERS, AND DISEASES OF THE CARDIOVASCULAR, RESPIRATORY, METABOLIC, IMMUNE, CENTRAL NERVOUS, ENDOCRINE, GLANDULAR, MUSCULOSKELETAL, DIGESTIVE, EXCRETORY, AND REPRODUCTIVE SYSTEMS (U.S. CLS. 6, 18, 44, 46, 51 AND 52).

FIRST USE 1-18-2008; IN COMMERCE 1-18-2008.

**CLASS 9—ELECTRICAL AND SCIENTIFIC APPARATUS**

FOR DATA CENTRAL PROCESSING UNITS FOR PROCESSING PHARMACEUTICAL OR DEVICE COMPLIANCE DATA, PHARMACEUTICAL ADMINISTRATION DATA, DEVICE ACTIVATION DATA OR PHYSIOLOGICAL RESPONSE DATA; DATABASE COMPUTER SOFTWARE FOR USE WITH MEDICAL DEVICES FOR MONITORING ADMINISTRATION OF PHARMACEUTICAL COMPOSITIONS, DEVICE ACTIVATION OR PHYSIOLOGICAL RESPONSES (U.S. CLS. 21, 23, 26, 36 AND 38).

FIRST USE 1-18-2008; IN COMMERCE 1-18-2008.

**CLASS 10—MEDICAL APPARATUS**

FOR CONDUCTANCE CONTROL DEVICES FOR USE WITH MEDICAL DEVICES FOR USE IN ADMINISTRATION OF PHARMACEUTICAL COMPOSITIONS, NAMELY, SYRINGES, CATHETERS, IV BAGS, INFUSION PUMPS FOR USE WITH IV BAGS, IMPLANTABLE AND TOPICAL FLUID DELIVERY PORTS, DIALYSIS MACHINES, INHALERS, NEBULIZERS FOR RESPIRATION THERAPY; MEDICAL MONITORING DEVICES FOR USE IN THE ADMINISTRATION OF PHARMACEUTICAL COMPOSITIONS AND FOR USE WITH MEDICAL DEVICES IN THE NATURE OF SYRINGES, CATHETERS, IV BAGS, INFUSION PUMPS FOR USE WITH IV BAGS, IMPLANTABLE AND TOPICAL FLUID DELIVERY PORTS, DIALYSIS MACHINES, INHALERS, NEBULIZERS FOR RESPIRATION THERAPY; IMPLANTABLE ELECTRICAL STIMULATION DEVICES, NAMELY, PACEMAKERS, IMPLANTABLE CARDIOVERTER-DEFIBRILLATORS; TRANSCUTANEOUS AND IMPLANTABLE ELECTROTHERAPY DEVICES, NAMELY, NEUROLOGICAL ELECTROSTIMULATION DEVICES, MUSCULOSKELETAL ELECTROSTIMULATION DEVICES, RESPIRATORY ELECTROSTIMULATION DEVICES, GASTRO-INTESTINAL ELECTROSTIMULATION DEVICES AND ELECTRICAL STIMULATION DEVICES FOR USE IN STIMULATING THE CARDIOVASCULAR, RESPIRATORY, METABOLIC, IMMUNE, CENTRAL NERVOUS, ENDOCRINE, GLANDULAR, MUSCULOSKELETAL, DIGESTIVE, EXCRETORY, AND REPRODUCTIVE SYSTEMS; IMPLANTABLE PHYSIOLOGICAL MEDICAL MONITORING DEVICES, NAMELY, HEART, GASTRO-INTESTINAL, RESPIRATORY AND NEUROLOGICAL MONITORING DEVICES (U.S. CLS. 26, 39 AND 44).

FIRST USE 1-18-2008; IN COMMERCE 1-18-2008.

**CLASS 41—EDUCATION AND ENTERTAINMENT**

FOR TRAINING AND TEACHING IN THE FIELD OF PREVENTION, DIAGNOSIS AND TREATMENT OF MEDICAL CONDITIONS (U.S. CLS. 100, 101 AND 107).

FIRST USE 4-12-2010; IN COMMERCE 4-12-2010.

**CLASS 42—SCIENTIFIC AND COMPUTER SERVICES**

FOR TECHNICAL CONSULTANCY IN THE FIELD OF THE DESIGN AND DEVELOPMENT OF MEDICAL DEVICES AND SURGICAL EQUIPMENT; MEDICAL RESEARCH IN THE FIELD OF MEDICAL AND SURGICAL APPARATUS, APPLIANCES, INSTRUMENTS, THERAPIES AND DRUGS; MEDICAL AND SCIENTIFIC RESEARCH IN THE FIELD OF CLINICAL TRIAL SERVICES; COMPUTER SOFTWARE DESIGN FOR OTHERS, COMPUTER PROGRAMMING FOR OTHERS, AND UPDATING OF COMPUTER SOFTWARE; MAINTENANCE OF COMPUTER SOFTWARE (U.S. CLS. 100 AND 101).

FIRST USE 4-12-2010; IN COMMERCE 4-12-2010.

**CLASS 44—MEDICAL, BEAUTY AND AGRICULTURAL SERVICES**

FOR MEDICAL CONSULTATION AND PROFESSIONAL MEDICAL CONSULTATION IN THE FIELD OF MEDICAL AND SURGICAL EQUIPMENT, APPARATUS, APPLIANCES AND INSTRUMENTS, MEDICAL CARE, MEDICAL THERAPY AND SURGERY; PROVIDING HEALTH AND MEDICAL INFORMATION ABOUT MEDICAL DISORDERS; INFORMATION SERVICES, NAMELY, PROVIDING MEDICAL INFORMATION TO CHRONICALLY ILL PATIENTS; INFORMATION SERVICES RELATING TO MEDICAL SERVICES VIA A GLOBAL COMPUTER NETWORK, NAMELY, PROVIDING MEDICAL CONSULTANCY AND ADVISORY SERVICES VIA A GLOBAL COMPUTER NETWORK (U.S. CLS. 100 AND 101).

FIRST USE 4-12-2010; IN COMMERCE 4-12-2010.

3,963,275. JABBAWOCKEEZ, LLC, LOS ANGELES, CA. SN 77-981,802. PUB. 7-14-2009, FILED 6-26-2008.

**JABB  
AWOC  
KEEZ**  
A Figment of your Imagination

THE MARK CONSISTS OF THE WORD "JABBAWOCKEEZ" APPEARING AS "JABB", "AWOC", "KEEZ" ON THREE SEPARATE LINES IN LARGE FONT, FOLLOWED BY THE WORDS "A FIGMENT OF YOUR IMAGINATION" APPEARING IN A SMALLER FONT ON THE FOURTH LINE.

**CLASS 18—LEATHER GOODS**

FOR ATHLETIC BAGS, BACKPACKS, BEACH BAGS, BOOK BAGS, GYM BAGS, TOTE BAGS, KNAPSACKS, UMBRELLAS (U.S. CLS. 1, 2, 3, 22 AND 41).

FIRST USE 0-0-2003; IN COMMERCE 8-0-2010.

**CLASS 25—CLOTHING**

FOR CLOTHING FOR MEN, WOMEN AND CHILDREN, NAMELY, SHIRTS, T-SHIRTS, SWEATSHIRTS, TANK TOPS, JACKETS, HATS, CAPS, SLEEPWEAR, AND MASQUERADE AND HALLOWEEN COSTUMES AND MASKS SOLD IN CONNECTION THEREWITH (U.S. CLS. 22 AND 39).

FIRST USE 0-0-2003; IN COMMERCE 1-0-2008.

3,963,280. EMERGO (CYPRUS) LIMITED, NICOSIA, CYPRUS. SN 78-309,252. PUB. 4-13-2010, FILED 10-3-2003.

## EMERGOMED

PRIORITY CLAIMED UNDER SEC. 44(D) ON ERPNTY TM OFC APPLICATION NO. 3344901, FILED 9-10-2003.

### CLASS 35—ADVERTISING AND BUSINESS

FOR ADVERTISING AND PUBLICITY SERVICES; MARKET RESEARCH AND ANALYSIS; BUSINESS CONSULTATION SERVICES IN THE NATURE OF RENDERING ADVICE TO ENTERPRISES REGARDING BUSINESS ORGANIZATION; BUSINESS-ECONOMIC CONSULTANCY; BUSINESS CONSULTATION SERVICES AND PURCHASING AGENT SERVICES IN THE FIELD OF MERGERS, TAKE-OVERS, INVESTMENTS, DISINVESTMENTS, FINANCINGS AND SHARE HOLDINGS WITH REGARD TO ENTERPRISES; MEDIATION OF TRADE BUSINESS FOR THIRD PARTIES; BUSINESS MANAGEMENT SERVICES, NAMELY, INTERIM AND BUSINESS PROJECT MANAGEMENT, AS WELL AS CONDUCTING RESEARCH AND CONSULTATION SERVICES IN THESE FIELDS; EMPLOYMENT HIRING, RECRUITING, PLACEMENT, STAFFING AND CAREER NETWORKING SERVICES; BUSINESS CONSULTATION SERVICES FOR DRAWING UP BUSINESS PLANS; INVENTORY CONTROL AND BUSINESS MANAGEMENT OF COMPANIES AND ORGANIZATIONS, EITHER OR NOT ON INTERIM OR PROJECT BASIS; PROFESSIONAL CONSULTATION IN THE BUSINESS FIELD; PREPARING BUSINESS EXPERTS' REPORTS (U.S. CLS. 100, 101 AND 102).

FIRST USE 2-21-2003; IN COMMERCE 2-21-2003.

### CLASS 36—INSURANCE AND FINANCIAL

FOR FINANCIAL SERVICES, NAMELY, FINANCIAL ANALYSIS, CONSULTATION AND MANAGEMENT; CAPITAL INVESTMENT CONSULTATION AND MANAGEMENT AND INVESTMENT CONSULTATION AND MANAGEMENT; FINANCIAL RESEARCH AND CONSULTANCY IN THE FIELD OF FINANCINGS AND SHARE HOLDING; SECURITIZATION SERVICES, NAMELY, GUARANTEERING LOANS; REAL ESTATE BROKERAGE (U.S. CLS. 100, 101 AND 102).

FIRST USE 2-21-2003; IN COMMERCE 2-21-2003.

3,963,282. AMERIKAL NUTRACEUTICAL CORPORATION, MISSION VIEJO, CA. SN 78-455,933. PUB. 8-10-2010, FILED 7-23-2004.

## INTENZ

THE MARK CONSISTS OF STANDARD CHARACTERS WITHOUT CLAIM TO ANY PARTICULAR FONT, STYLE, SIZE, OR COLOR.

### CLASS 3—COSMETICS AND CLEANING PREPARATIONS

FOR COSMETICS AND BEAUTY PRODUCTS, NAMELY, SKIN CREAMS, FACIAL MASKS, AND SKIN MASKS (U.S. CLS. 1, 4, 6, 50, 51 AND 52).

FIRST USE 3-22-2004; IN COMMERCE 3-22-2004.

### CLASS 5—PHARMACEUTICALS

FOR VITAMINS, HERBAL SUPPLEMENTS, MINERAL SUPPLEMENTS AND NUTRITIONAL SUPPLEMENTS (U.S. CLS. 6, 18, 44, 46, 51 AND 52).

FIRST USE 8-1-2003; IN COMMERCE 8-1-2003.

3,963,286. LIFESTYLE UHREN GMBH, ECHING, FED REP GERMANY. SN 78-590,645. PUB. 7-17-2007, FILED 3-18-2005.

## MONOMANIA

THE MARK CONSISTS OF STANDARD CHARACTERS WITHOUT CLAIM TO ANY PARTICULAR FONT, STYLE, SIZE, OR COLOR.

OWNER OF FED REP GERMANY REG. NO. 30306700, DATED 3-31-2003, EXPIRES 2-28-2013.

### CLASS 14—JEWELRY

FOR WROUGHT PRECIOUS METALS, NAMELY, GOLD, SILVER, PLATINUM, COPPER, AND TITANIUM; WROUGHT PRECIOUS METAL ALLOYS; JEWELRY; PRECIOUS STONES (U.S. CLS. 2, 27, 28 AND 50).

FIRST USE 11-0-2001; IN COMMERCE 11-0-2001.

### CLASS 34—SMOKERS' ARTICLES

FOR ARTICLES FOR SMOKERS NOT OF PRECIOUS METALS, NAMELY, CIGARETTE LIGHTERS (U.S. CLS. 2, 8, 9 AND 17).

FIRST USE 11-0-2001; IN COMMERCE 11-0-2001.

3,963,292. CHACE, COLLIN CLAY, RIVERSIDE, RI. SN 78-857,458. PUB. 2-26-2008, FILED 4-10-2006.

## Juha

THE MARK CONSISTS OF STANDARD CHARACTERS WITHOUT CLAIM TO ANY PARTICULAR FONT, STYLE, SIZE, OR COLOR.

**CLASS 9—ELECTRICAL AND SCIENTIFIC APPARATUS**

FOR A SERIES OF PHONOGRAPHIC RECORDS, MOTION PICTURE FILMS, VIDEO RECORDINGS IN THE NATURE OF MUSIC VIDEOS, DVDS, CDS, AND AUDIO TAPES FEATURING PERFORMANCES OF MUSIC AND VISUAL PERFORMANCES (U.S. CLS. 21, 23, 26, 36 AND 38).

FIRST USE 12-31-2010; IN COMMERCE 12-31-2010.

**CLASS 41—EDUCATION AND ENTERTAINMENT**

FOR ENTERTAINMENT IN THE NATURE OF LIVE VISUAL AND AUDIO PERFORMANCES, NAMELY, MUSIC, SONGS PERFORMED BY A MUSICAL BAND AND LIVE THEATRICAL PERFORMANCES; PRESENTATION OF LIVE SHOWS AND MUSICAL PERFORMANCES; LIVE PERFORMANCES BY PROFESSIONAL ACTORS AND MUSICIANS (U.S. CLS. 100, 101 AND 107).

FIRST USE 6-25-1999; IN COMMERCE 6-25-1999.

3,963,299. YELLOWPAGES.COM, LLC, GLENDALE, CA. SN 78-936,435. PUB. 2-26-2008, FILED 7-24-2006.



NO CLAIM IS MADE TO THE EXCLUSIVE RIGHT TO USE ".COM", APART FROM THE MARK AS SHOWN.

THE MARK CONSISTS OF AN IMAGE OF WALKING FINGERS PRECEDING ".COM".

**CLASS 35—ADVERTISING AND BUSINESS**

FOR PROVIDING ADVERTISEMENT SERVICES FOR OTHERS VIA A GLOBAL COMPUTER NETWORK, NAMELY, THE DISSEMINATION OF ADVERTISING FOR OTHERS VIA THE INTERNET; PROVIDING AN ON-LINE COMMERCIAL INFORMATION DIRECTORY ON THE INTERNET; PROVIDING ONLINE TELEPHONE DIRECTORY INFORMATION (U.S. CLS. 100, 101 AND 102).

FIRST USE 12-1-2005; IN COMMERCE 1-1-2006.

3,963,298. BRILLIANCE AUDIO, INC., GRAND HAVEN, MI. SN 78-933,884. PUB. 3-6-2007, FILED 7-20-2006.

BRILLIANCE AUDIO

THE MARK CONSISTS OF STANDARD CHARACTERS WITHOUT CLAIM TO ANY PARTICULAR FONT, STYLE, SIZE, OR COLOR.

OWNER OF U.S. REG. NOS. 1,919,390 AND 2,957,571.

NO CLAIM IS MADE TO THE EXCLUSIVE RIGHT TO USE "AUDIO", APART FROM THE MARK AS SHOWN.

**CLASS 41—EDUCATION AND ENTERTAINMENT**

FOR PROVIDING AN ON-LINE INTERACTIVE DATABASE FEATURING ENTERTAINMENT INFORMATION IN THE FIELDS OF LIVE MUSICAL PERFORMANCES, LIVE THEATRICAL PERFORMANCES, LIVE DRAMATIC PERFORMANCES, MOTION PICTURE FILMS AND SPORTING EVENTS, NAMELY, FOOTBALL, BASEBALL, BASKETBALL, TENNIS, SWIMMING AND MOTOR SPORTS EVENTS (U.S. CLS. 100, 101 AND 107).

FIRST USE 10-0-2007; IN COMMERCE 10-0-2007.

**CLASS 9—ELECTRICAL AND SCIENTIFIC APPARATUS**

FOR PUBLICATIONS AND ELECTRONIC PUBLICATIONS, NAMELY, AUDIBLY RENDERED BOOKS FEATURING LITERARY WORKS RECORDED ON TAPES, CASSETTES, DIGITAL DISCS, COMPACT DISCS, OPTICAL DISCS, MP3 DISCS, AND COMPUTER-READABLE MEDIA; DOWNLOADABLE ELECTRONIC PUBLICATIONS IN THE NATURE OF AUDIBLY RENDERED BOOKS FEATURING SOUNDS, TEXT, MUSIC, AND SPOKEN WORD CONTENT FOR LITERARY WORKS (U.S. CLS. 21, 23, 26, 36 AND 38).

FIRST USE 1-1-1999; IN COMMERCE 1-1-1999.

3,963,320. AUDIOMACHINE, BEVERLY HILLS, CA. SN 85-003,725. PUB. 8-31-2010, FILED 3-31-2010.

**CLASS 41—EDUCATION AND ENTERTAINMENT**

FOR PUBLISHING AND ELECTRONIC PUBLISHING SERVICES, NAMELY, PUBLICATION OF TEXT AND GRAPHIC WORKS OF OTHERS ON TAPES, CASSETTES, DIGITAL DISCS, COMPACT DISCS, OPTICAL DISCS, MP3 DISCS, AND COMPUTER-READABLE MEDIA AND ON-LINE, FEATURING SOUNDS, TEXT, MUSIC, AND SPOKEN WORD CONTENT FOR LITERARY WORKS (U.S. CLS. 100, 101 AND 107).

FIRST USE 9-1-1998; IN COMMERCE 9-1-1998.

THE MARK CONSISTS OF TWO MACHINE-LIKE GEARS WITH SPEAKERS POSITIONED ABOVE THE WORD "AUDIOMACHINE", WITH A PLUG STRETCHING FROM THE LARGER, UPPERMOST GEAR/SPEAKER TO THE "I" IN AUDIO, SERVING AS THE DOT OF SUCH LETTER. ALTHOUGH IT IS ONE WORD, "AUDIO" IS BOLDED FONT AND "MACHINE" IS REGULAR FONT.

**CLASS 9—ELECTRICAL AND SCIENTIFIC APPARATUS**

FOR AUDIO AND VIDEO RECORDINGS FEATURING MUSIC AND ARTISTIC PERFORMANCES; COMPACT DISCS FEATURING MUSIC AND SOUND DESIGN; DIGITAL MUSIC DOWNLOADABLE FROM THE INTERNET; DOWNLOADABLE MP3 FILES AND MP3 RECORDINGS FEATURING MUSIC AND SOUND DESIGN; DOWNLOADABLE MUSICAL SOUND RECORDINGS; DOWNLOADABLE MUSIC VIA THE INTERNET AND WIRELESS DEVICES; MUSICAL SOUND RECORDINGS; SERIES OF MUSICAL SOUND RECORDINGS; SOUND RECORDINGS FEATURING MUSIC AND SOUND DESIGN; VISUAL RECORDINGS AND AUDIO-VISUAL RECORDINGS FEATURING MUSIC AND ANIMATION (U.S. CLS. 21, 23, 26, 36 AND 38).  
FIRST USE 8-5-2005; IN COMMERCE 8-5-2005.

**CLASS 25—CLOTHING**

FOR BANDANAS; BELTS FOR CLOTHING; CAPS; CLOTH BIBS; COATS; EYESHADES; HEAD WEAR; HEADBANDS; HOODED SWEAT SHIRTS; HOODS; INFANT AND TODDLER ONE PIECE CLOTHING; JACKETS; JERSEYS; PANTS; POLO SHIRTS; SHIRTS; SHOES; SHORT SETS; SHORTS; SKIRTS; SOCKS; SWEAT BANDS; SWEAT JACKETS; SWEAT PANTS; SWEAT SHIRTS; SWEAT SHORTS; SWEAT SUITS; T-SHIRTS; TANK TOPS; TIES; TOPS; UNDERWEAR; WRAPS (U.S. CLS. 22 AND 39).  
FIRST USE 1-10-2011; IN COMMERCE 1-10-2011.

**CLASS 41—EDUCATION AND ENTERTAINMENT**

FOR COMPOSITION OF MUSIC FOR OTHERS; ENTERTAINMENT SERVICES IN THE NATURE OF DEVELOPMENT, CREATION, PRODUCTION AND POST-PRODUCTION SERVICES OF MULTIMEDIA ENTERTAINMENT CONTENT; ENTERTAINMENT SERVICES IN THE NATURE OF RECORDING, PRODUCTION AND POST-PRODUCTION SERVICES IN THE FIELDS OF MUSIC; ENTERTAINMENT SERVICES, NAMELY, PROVIDING A WEB SITE FEATURING NON-DOWNLOADABLE MUSICAL PERFORMANCES, MUSICAL VIDEOS, RELATED FILM CLIPS, PHOTOGRAPHS, AND OTHER MULTIMEDIA MATERIALS FEATURING MUSIC AND SOUND DESIGN; MULTIMEDIA ENTERTAINMENT SERVICES IN THE NATURE OF RECORDING, PRODUCTION AND POST-PRODUCTION SERVICES IN THE FIELDS OF MUSIC, VIDEO, AND FILMS; MUSIC COMPOSITION AND TRANSCRIPTION FOR OTHERS; MUSIC PRODUCTION SERVICES; MUSIC PUBLISHING SERVICES; MUSIC SELECTION SERVICES FOR USE IN TELEVISION, FILM, RADIO AND VIDEO GAMES; PRODUCTION OF MUSICAL SOUND RECORDING; PRODUCTION OF SOUND RECORDINGS; PROVIDING AN INTERNET WEBSITE PORTAL IN THE FIELD OF MUSIC (U.S. CLS. 100, 101 AND 107).  
FIRST USE 8-5-2005; IN COMMERCE 8-5-2005.

3,963,326. CONSTRUCTION RISK SOLUTIONS, LLC, HUNT VALLEY, MD. SN 85-004,918. PUB. 8-24-2010, FILED 4-2-2010.



THE MARK CONSISTS OF THE LETTERS "CRS", A TRIANGULAR SHAPED AREA BELOW THE LETTER "R" AND HORIZONTAL LINES ABOVE AND BELOW THE LETTERS.

**CLASS 35—ADVERTISING AND BUSINESS**

FOR BUSINESS CONSULTING SERVICES, NAMELY, MANAGEMENT CONSULTING AND RISK MANAGEMENT IN THE FIELD OF CONSTRUCTION (U.S. CLS. 100, 101 AND 102).  
FIRST USE 12-15-2006; IN COMMERCE 12-15-2006.

**CLASS 36—INSURANCE AND FINANCIAL**

FOR INSURANCE SERVICES, NAMELY, PROVIDING ADVICE IN CONNECTION WITH RISK MANAGEMENT, SAFETY, LOSS CONTROL, CLAIMS MANAGEMENT AND SURETY IN THE FIELD OF CONSTRUCTION; INSURANCE BROKERAGE SERVICES IN THE FIELD OF CONSTRUCTION (U.S. CLS. 100, 101 AND 102).  
FIRST USE 12-15-2006; IN COMMERCE 12-15-2006.

3,963,345. PARKMOBILE USA, INC., ATLANTA, GA. SN 85-007,317. PUB. 8-17-2010, FILED 4-6-2010.

**DIGITAL PARKING**

THE MARK CONSISTS OF STANDARD CHARACTERS WITHOUT CLAIM TO ANY PARTICULAR FONT, STYLE, SIZE, OR COLOR.

NO CLAIM IS MADE TO THE EXCLUSIVE RIGHT TO USE "PARKING", APART FROM THE MARK AS SHOWN.

**CLASS 36—INSURANCE AND FINANCIAL**

FOR PAYMENT SERVICES, NAMELY, BILL PAYMENT SERVICES USING ON-LINE SYSTEMS, THE INTERNET, PDAS OR MOBILE PHONES; FINANCIAL TRANSACTIONS SERVICES, NAMELY, PROVIDING SECURE COMMERCIAL TRANSACTIONS AND PAYMENT OPTIONS USING A MOBILE DEVICE AT A POINT OF SALE; FINANCIAL AFFAIRS SERVICES, NAMELY, FINANCIAL CONSULTATION; AND ELECTRONIC FUNDS TRANSFERS (U.S. CLS. 100, 101 AND 102).  
FIRST USE 4-12-2010; IN COMMERCE 4-12-2010.

**CLASS 42—SCIENTIFIC AND COMPUTER SERVICES**

FOR APPLICATION SERVICE PROVIDER (ASP) FEATURING SOFTWARE FOR USE IN PROCESSING PARKING TRANSACTIONS; APPLICATION SERVICE PROVIDER (ASP) FEATURING SOFTWARE FOR USE AS AN ELECTRONIC PLATFORM THAT ACCOMMODATES PARKING TRANSACTIONS IN A MOBILE PHONE, PDA, AND WEB-BASED ENVIRONMENT (U.S. CLS. 100 AND 101).  
FIRST USE 4-12-2010; IN COMMERCE 4-12-2010.

3,963,358. HILL'S PET NUTRITION, INC., TOPEKA, KS. SN 85-009,561. PUB. 7-27-2010, FILED 4-8-2010.

3,963,391. THE BUCKLE, INC., KEARNEY, NE. SN 85-017,352. PUB. 9-21-2010, FILED 4-19-2010.



THE MARK CONSISTS OF A STETHOSCOPE INSIDE A BEAKER WITHIN A SHADED CIRCLE SURROUNDED BY A BROKEN CIRCLE.

**CLASS 5—PHARMACEUTICALS**

FOR DIETARY ANIMAL FOOD FOR CATS AND DOGS (U.S. CLS. 6, 18, 44, 46, 51 AND 52).  
FIRST USE 5-1-2010; IN COMMERCE 5-10-2010.

**CLASS 31—NATURAL AGRICULTURAL PRODUCTS**

FOR PET FOOD (U.S. CLS. 1 AND 46).  
FIRST USE 5-1-2010; IN COMMERCE 5-1-2010.

3,963,388. STANDARD & POOR'S FINANCIAL SERVICES LLC, NEW YORK, NY. SN 85-017,012. PUB. 7-13-2010, FILED 4-19-2010.

R2P

THE MARK CONSISTS OF STANDARD CHARACTERS WITHOUT CLAIM TO ANY PARTICULAR FONT, STYLE, SIZE, OR COLOR.

**CLASS 36—INSURANCE AND FINANCIAL**

FOR FINANCIAL SERVICES IN THE NATURE OF ASSESSING THE RISK PROFILE OF A SPECIFIC SECURITY ON A PEER GROUP COMPARISON BASIS AND PROVIDING QUALITATIVE RESEARCH OPINIONS THAT INTERPRET THE RISK PROFILE OF A SPECIFIC SECURITY ON A PEER GROUP COMPARISON BASIS (U.S. CLS. 100, 101 AND 102).  
FIRST USE 8-2-2010; IN COMMERCE 8-2-2010.

**CLASS 42—SCIENTIFIC AND COMPUTER SERVICES**

FOR PROVIDING NON-DOWNLOADABLE COMPUTER SOFTWARE VIA A WEB SITE THAT ASSESSES THE RISK PROFILE OF A SPECIFIC SECURITY ON A PEER GROUP COMPARISON BASIS (U.S. CLS. 100 AND 101).  
FIRST USE 8-2-2010; IN COMMERCE 8-2-2010.

DAYTRIP

THE MARK CONSISTS OF STANDARD CHARACTERS WITHOUT CLAIM TO ANY PARTICULAR FONT, STYLE, SIZE, OR COLOR.

OWNER OF U.S. REG. NO. 3,752,011.

**CLASS 14—JEWELRY**

FOR BRACELETS; EARRINGS; JEWELRY; NECKLACES (U.S. CLS. 2, 27, 28 AND 50).  
FIRST USE 9-2-2010; IN COMMERCE 9-2-2010.

**CLASS 25—CLOTHING**

FOR BELTS; BELTS FOR CLOTHING; BELTS MADE OF LEATHER; BELTS MADE OUT OF CLOTH; BELTS OF TEXTILE; CAPS; HATS (U.S. CLS. 22 AND 39).  
FIRST USE 7-2-2010; IN COMMERCE 7-2-2010.

3,963,393. ARCHITECTURAL COMPUTER SERVICES, INC., SALT LAKE CITY, UT. SN 85-018,024. PUB. 8-17-2010, FILED 4-20-2010.



OWNER OF U.S. REG. NO. 3,147,384.

THE MARK CONSISTS OF A CHEVRON DESIGN.

**CLASS 9—ELECTRICAL AND SCIENTIFIC APPARATUS**

FOR COMPUTER SOFTWARE FOR USE IN PRODUCING SPECIFICATIONS FOR ARCHITECTURAL, ENGINEERING, OR CONSTRUCTION PROJECTS (U.S. CLS. 21, 23, 26, 36 AND 38).  
FIRST USE 6-24-2008; IN COMMERCE 1-13-2009.



**CLASS 42—SCIENTIFIC AND COMPUTER SERVICES**

FOR DEVELOPING OF VOLUNTARY STANDARDS FOR BUILDING PRODUCTS USED IN THE CONSTRUCTION INDUSTRY, NAMELY, DEVELOPMENT OF PROPRIETARY SPECIFICATIONS FOR BUILDING CONSTRUCTION PRODUCTS; RESEARCH AND DEVELOPMENT AND CONSULTATION RELATED THERETO IN THE FIELD OF BUILDING PRODUCTS USED IN THE CONSTRUCTION INDUSTRY, NAMELY, CONSULTING WITH, ADVISING, AND ASSISTING MANUFACTURERS, ARCHITECTS, AND CONTRACTORS IN DEVELOPING AND INTERPRETING SPECIFICATIONS FOR BUILDING PRODUCTS USED IN THE CONSTRUCTION INDUSTRY (U.S. CLS. 100 AND 101).

FIRST USE 6-24-2008; IN COMMERCE 1-13-2009.

3,963,409. INTERNATIONAL PAPER COMPANY, MEMPHIS, TN. SN 85-022,714. PUB. 9-7-2010, FILED 4-26-2010.

HEALTHY BUILDINGS. HEALTHY PEOPLE.

THE MARK CONSISTS OF STANDARD CHARACTERS WITHOUT CLAIM TO ANY PARTICULAR FONT, STYLE, SIZE, OR COLOR.

**CLASS 35—ADVERTISING AND BUSINESS**

FOR WHOLESALE AND RETAIL STORE SERVICES IN THE FIELD OF FACILITY SUPPLIES, NAMELY, CLEANING AND JANITORIAL PRODUCTS; DISTRIBUTORSHIP SERVICES IN THE FIELD OF FACILITY SUPPLIES, NAMELY, CLEANING AND JANITORIAL PRODUCTS (U.S. CLS. 100, 101 AND 102).

FIRST USE 5-31-2010; IN COMMERCE 5-31-2010.

**CLASS 39—TRANSPORTATION AND STORAGE**

FOR DELIVERY OF FACILITY SUPPLIES, NAMELY, CLEANING AND JANITORIAL PRODUCTS BY TRUCK; WAREHOUSING SERVICES FOR FACILITY SUPPLIES, NAMELY, CLEANING AND JANITORIAL PRODUCTS; PACKAGING OF FACILITY SUPPLIES, NAMELY, CLEANING AND JANITORIAL PRODUCTS OF OTHERS FOR TRANSPORTATION (U.S. CLS. 100 AND 105).

FIRST USE 5-31-2010; IN COMMERCE 5-31-2010.

3,963,428. PROMARK BRANDS INC., MERIDIAN, ID. SN 85-027,013. PUB. 9-21-2010, FILED 4-30-2010.

57

THE MARK CONSISTS OF STANDARD CHARACTERS WITHOUT CLAIM TO ANY PARTICULAR FONT, STYLE, SIZE, OR COLOR.

OWNER OF U.S. REG. NOS. 61,051, 1,122,910, AND OTHERS.

**CLASS 14—JEWELRY**

FOR LAPEL PINS (U.S. CLS. 2, 27, 28 AND 50).  
FIRST USE 5-1-2003; IN COMMERCE 5-1-2003.

**CLASS 20—FURNITURE AND ARTICLES NOT OTHERWISE CLASSIFIED**

FOR PLASTIC CLIPS FOR SEALING BAGS; NON-METAL AND NON-LEATHER KEY CHAINS (U.S. CLS. 2, 13, 22, 25, 32 AND 50).

FIRST USE 12-31-2004; IN COMMERCE 12-31-2004.

**CLASS 21—HOUSEWARES AND GLASS**

FOR MUGS; STATUES OF CRYSTAL; THERMAL INSULATED WRAP FOR CANS TO KEEP THE CONTENTS COLD OR HOT (U.S. CLS. 2, 13, 23, 29, 30, 33, 40 AND 50).

FIRST USE 7-31-2003; IN COMMERCE 7-31-2003.

**CLASS 24—FABRICS**

FOR BLANKET THROWS (U.S. CLS. 42 AND 50).  
FIRST USE 3-31-2005; IN COMMERCE 3-31-2005.

**CLASS 25—CLOTHING**

FOR BASEBALL CAPS; SHIRTS; SOCKS; T-SHIRTS (U.S. CLS. 22 AND 39).

FIRST USE 1-1-1984; IN COMMERCE 1-1-1984.

**CLASS 26—FANCY GOODS**

FOR SHOE CHARMS; SHOELACES; THIMBLES (U.S. CLS. 37, 39, 40, 42 AND 50).

FIRST USE 12-31-2003; IN COMMERCE 12-31-2003.

**CLASS 28—TOYS AND SPORTING GOODS**

FOR BASEBALLS; GOLF BALLS; GOLF CLUB COVERS; STUFFED TOY ANIMALS; TOY TRAINS AND ACCESSORIES THEREFOR; TOY WHISTLES (U.S. CLS. 22, 23, 38 AND 50).

FIRST USE 5-31-2003; IN COMMERCE 5-31-2003.

3,963,430. ANCHOR WALL SYSTEMS, INC., MINNETONKA, MN. SN 85-027,811. PUB. 8-3-2010, FILED 4-30-2010.



OWNER OF U.S. REG. NOS. 1,877,641, 2,710,177, AND 3,768,829.

THE MARK CONSISTS OF THE LETTER "A" WITH AN ANCHOR AT THE BOTTOM OF ONE SIDE OF THE LETTER.

**CLASS 19—NON-METALLIC BUILDING MATERIALS**

FOR CONCRETE WALL BLOCKS; CONCRETE SLABS; CONCRETE PAVERS; CONCRETE BUILDING MATERIALS, NAMELY, BLOCKS AND VENEERS (U.S. CLS. 1, 12, 33 AND 50).

FIRST USE 2-0-2011; IN COMMERCE 2-0-2011.

**CLASS 42—SCIENTIFIC AND COMPUTER SERVICES**

FOR DESIGN ENGINEERING SERVICES RELATING TO MODULAR CONCRETE RETAINING WALLS (U.S. CLS. 100 AND 101).

FIRST USE 1-0-2011; IN COMMERCE 1-0-2011.

3,963,435. TRUST RISK MANAGEMENT SERVICES, INC., ROCKVILLE, MD. SN 85-029,327. PUB. 11-2-2010, FILED 5-4-2010.



NO CLAIM IS MADE TO THE EXCLUSIVE RIGHT TO USE "RISK MANAGEMENT SERVICES", APART FROM THE MARK AS SHOWN.

THE MARK CONSISTS OF THE LETTERS "TRMS" ABOVE THE WORDS "TRUST RISK MANAGEMENT SERVICES" INSIDE OF A PARTIAL OVAL.

**CLASS 35—ADVERTISING AND BUSINESS**

FOR BUSINESS ADMINISTRATION AND MANAGEMENT IN THE FIELD OF INSURANCE SERVICES; ASSISTING WITH THE FORMATION, NEGOTIATION, AND MANAGEMENT OF CONTRACTS ON BEHALF OF INSURERS; AND BUSINESS RISK MANAGEMENT SERVICES (U.S. CLS. 100, 101 AND 102).

FIRST USE 5-7-2010; IN COMMERCE 5-7-2010.

**CLASS 36—INSURANCE AND FINANCIAL**

FOR INSURANCE BROKERAGE AND UNDERWRITING SERVICES FOR ALL TYPES OF INSURANCE; INSURANCE ADMINISTRATION (U.S. CLS. 100, 101 AND 102).

FIRST USE 5-7-2010; IN COMMERCE 5-7-2010.

3,963,437. AMERICAN CAR CARE CENTERS, INC., MEMPHIS, TN. SN 85-029,681. PUB. 12-14-2010, FILED 5-4-2010.



NO CLAIM IS MADE TO THE EXCLUSIVE RIGHT TO USE "ECO EXPRESS TIRE CENTERS", APART FROM THE

MARK AS SHOWN.

THE COLOR(S) WHITE, BLACK, GREEN, AND OLIVE IS/ ARE CLAIMED AS A FEATURE OF THE MARK.

THE MARK CONSISTS OF THE WORD "ECO" ABOVE THE WORD "EXPRESS" IN WHITE WITH BLACK EDGES, BORDERED BY GREEN, BORDERED BY WHITE, POSITIONED ABOVE THE WORDS "TIRE CENTERS" IN OLIVE, AND POSITIONED BELOW A GREEN GLOBE DESIGN OUTLINED IN WHITE AND INCORPORATING OPPOSING BLACK GEOMETRIC FIGURES OUTLINED IN WHITE AND LATITUDINAL AND LONGITUDINAL LINES APPEARING IN OLIVE, THE WORDING AND GLOBE DESIGN SUPERIMPOSED ON AN INCOMPLETE GREEN OVAL SURROUNDED BY AN INCOMPLETE OLIVE OVAL.

**CLASS 35—ADVERTISING AND BUSINESS**

FOR RETAIL TIRE STORE SERVICES FOR AUTOMOBILES AND LIGHT TRUCKS (U.S. CLS. 100, 101 AND 102).

FIRST USE 10-4-2010; IN COMMERCE 10-4-2010.

**CLASS 37—CONSTRUCTION AND REPAIR**

FOR REPAIR AND MAINTENANCE SERVICES FOR AUTOMOBILES AND LIGHT TRUCKS (U.S. CLS. 100, 103 AND 106).

FIRST USE 10-4-2010; IN COMMERCE 10-4-2010.

3,963,441. JOSEPH & EDNA JOSEPHSON INSTITUTE OF ETHICS, LOS ANGELES, CA. SN 85-030,023. PUB. 11-16-2010, FILED 5-4-2010.

LOGRANDO LA VICTORIA CON  
HONOR

THE MARK CONSISTS OF STANDARD CHARACTERS WITHOUT CLAIM TO ANY PARTICULAR FONT, STYLE, SIZE, OR COLOR.

OWNER OF U.S. REG. NOS. 2,880,000 AND 2,891,644.

THE ENGLISH TRANSLATION OF "LOGRANDO LA VICTORIA CON HONOR" IN THE MARK IS "ACHIEVING THE VICTORY WITH HONOR".

**CLASS 16—PAPER GOODS AND PRINTED MATTER**

FOR BOOKS FEATURING TRAINING MATERIALS AND EDUCATIONAL CURRICULUM IN THE FIELD OF SPORTS ETHICS AND SPORTSMANSHIP (U.S. CLS. 2, 5, 22, 23, 29, 37, 38 AND 50).

FIRST USE 4-25-2010; IN COMMERCE 4-25-2010.

**CLASS 20—FURNITURE AND ARTICLES NOT OTHERWISE CLASSIFIED**

FOR VINYL BANNERS (U.S. CLS. 2, 13, 22, 25, 32 AND 50).

FIRST USE 6-28-2010; IN COMMERCE 6-28-2010.

3,963,442. JOSEPH & EDNA JOSEPHSON INSTITUTE OF ETHICS, LOS ANGELES, CA. SN 85-030,043. PUB. 11-16-2010, FILED 5-4-2010.

## TUS VALORES CUENTAN

THE MARK CONSISTS OF STANDARD CHARACTERS WITHOUT CLAIM TO ANY PARTICULAR FONT, STYLE, SIZE, OR COLOR.

THE ENGLISH TRANSLATION OF "TUS VALORES CUENTAN" IN THE MARK IS "YOUR VALUES COUNT".

### CLASS 16—PAPER GOODS AND PRINTED MATTER

FOR BOOKS FEATURING TRAINING MATERIALS AND EDUCATIONAL CURRICULUM IN THE FIELD OF ETHICAL VALUES; POSTERS; STICKERS; PENCILS; PENS AND BUMPER STICKERS (U.S. CLS. 2, 5, 22, 23, 29, 37, 38 AND 50).

FIRST USE 3-1-2010; IN COMMERCE 3-1-2010.

### CLASS 20—FURNITURE AND ARTICLES NOT OTHERWISE CLASSIFIED

FOR VINYL BANNERS (U.S. CLS. 2, 13, 22, 25, 32 AND 50).

FIRST USE 9-1-2010; IN COMMERCE 9-10-2010.

### CLASS 25—CLOTHING

FOR CLOTHING, NAMELY, T-SHIRTS, HATS (U.S. CLS. 22 AND 39).

FIRST USE 9-1-2010; IN COMMERCE 9-1-2010.

3,963,492. QUALITY NEON SIGN COMPANY, DBA HARBINGER, JACKSONVILLE, FL. SN 85-042,842. PUB. 10-26-2010, FILED 5-19-2010.

## HARBINGER

THE MARK CONSISTS OF STANDARD CHARACTERS WITHOUT CLAIM TO ANY PARTICULAR FONT, STYLE, SIZE, OR COLOR.

### CLASS 9—ELECTRICAL AND SCIENTIFIC APPARATUS

FOR NON-LUMINOUS AND NON-MECHANICAL METAL SIGNS; BACKLIT SIGNS; ELECTRIC SIGNS; ELECTRONIC LED SIGNS; LUMINOUS SIGNS; LUMINOUS VARIABLE/DYNAMIC SIGNS USING LIGHT EMITTING DIODES AND ELECTRONIC CONTROLLERS TO PRODUCE REAL-TIME AND PROGRAMMABLE MESSAGES AND INFORMATION DISPLAYS; MECHANICAL SIGNS; NEON SIGNS; ELECTRONIC ADVERTISEMENT BOARDS FEATURING A NEON LAMP; LIGHT EMITTING DIODE (LED) DISPLAYS; ELECTRIC LUMINESCENT DISPLAY PANELS; ELECTRONIC DISPLAYS, NAMELY, DIGITAL SIGNAGE (U.S. CLS. 21, 23, 26, 36 AND 38).

FIRST USE 5-1-2010; IN COMMERCE 5-1-2010.

### CLASS 37—CONSTRUCTION AND REPAIR

FOR INSTALLATION, MAINTENANCE AND REPAIR OF MECHANICAL, NON-MECHANICAL, LUMINOUS AND NON-LUMINOUS SIGNS AND SIGNAGE; CONSULTATION IN THE FIELD OF INSTALLATION, MAINTENANCE AND REPAIR OF MECHANICAL, NON-MECHANICAL, LUMINOUS AND NON-LUMINOUS SIGNS AND SIGNAGE (U.S. CLS. 100, 103 AND 106).

FIRST USE 5-1-2010; IN COMMERCE 5-1-2010.

### CLASS 40—MATERIAL TREATMENT

FOR FABRICATION, NAMELY, CUSTOM MANUFACTURING OF MECHANICAL, NON-MECHANICAL, LUMINOUS AND NON-LUMINOUS SIGNS AND SIGNAGE TO THE ORDER AND SPECIFICATION OF OTHERS; CONSULTATION IN THE FIELD OF CUSTOM MANUFACTURING OF MECHANICAL, NON-MECHANICAL, LUMINOUS AND NON-LUMINOUS SIGNS AND SIGNAGE TO THE ORDER AND SPECIFICATION OF OTHERS (U.S. CLS. 100, 103 AND 106).

FIRST USE 5-1-2010; IN COMMERCE 5-1-2010.

3,963,502. LIFE RESET BUTTON, LLC, MERRITT ISLAND, FL. SN 85-045,100. PUB. 9-7-2010, FILED 5-21-2010.



THE MARK CONSISTS OF THE GRAPHIC DEPICTION OF THE INTERNATIONAL POWER SYMBOL WITHIN WHICH APPEARS A SMILEY FACE.

### CLASS 41—EDUCATION AND ENTERTAINMENT

FOR PROVIDING ON-LINE MAGAZINES IN THE FIELD OF INSPIRATION AND CHANGE FOR THE BETTER; ON-LINE JOURNALS, NAMELY, BLOGS FEATURING INSPIRATION AND HOW TO CHANGE FOR THE BETTER; ENTERTAINMENT AND EDUCATIONAL SERVICES, NAMELY, A CONTINUING PROGRAM ABOUT INSPIRATION AND HOW TO CHANGE FOR THE BETTER ACCESSIBLE BY RADIO, TELEVISION, SATELLITE, AUDIO, VIDEO AND COMPUTER NETWORKS; PROVIDING INDIVIDUAL AND GROUP COACHING AND LEARNING FORUMS IN THE FIELD OF INSPIRATION AND CHANGE FOR THE BETTER (U.S. CLS. 100, 101 AND 107).

FIRST USE 5-28-2010; IN COMMERCE 1-19-2011.

### CLASS 45—PERSONAL AND LEGAL SERVICES

FOR ON-LINE SOCIAL NETWORKING SERVICES (U.S. CLS. 100 AND 101).

FIRST USE 5-28-2010; IN COMMERCE 1-19-2011.

3,963,510. HAIM, ALBERT M., DBA ALBERT M. HAIM, POTOMAC, MD. SN 85-047,142. PUB. 10-26-2010, FILED 5-25-2010.

# TINIPAW

THE MARK CONSISTS OF STANDARD CHARACTERS WITHOUT CLAIM TO ANY PARTICULAR FONT, STYLE, SIZE, OR COLOR.

## CLASS 28—TOYS AND SPORTING GOODS

FOR PET TOYS (U.S. CLS. 22, 23, 38 AND 50).  
FIRST USE 4-23-2010; IN COMMERCE 3-13-2011.

## CLASS 35—ADVERTISING AND BUSINESS

FOR COMPUTERIZED ONLINE WHOLESALE AND RETAIL STORE SERVICES FEATURING PET TOYS (U.S. CLS. 100, 101 AND 102).  
FIRST USE 4-23-2010; IN COMMERCE 3-2-2011.

3,963,520. THE ACTIVE NETWORK, INC., SAN DIEGO, CA. SN 85-049,074. PUB. 11-9-2010, FILED 5-27-2010.



THE MARK CONSISTS OF THE STYLIZED HEAD AND ARMS OF A PERSON REACHING UP AND ENCOMPASSING THE LOWER LEFT LEG OF AN "X" WHEREIN THE HEAD IS REPRESENTED BY A SOLID SPHERE CENTERED WITHIN THE ARC OF A CRESCENT REPRESENTING THE ARMS OUTSTRETCHED.

## CLASS 25—CLOTHING

FOR CLOTHING, NAMELY, T-SHIRTS, TANK TOPS, SWEATSHIRTS, JACKETS, SHORTS, PANTS, CAPS, AND VISORS; CLOTHING FOR ATHLETIC USE, NAMELY, JERSEYS, TRIATHLON TOPS, TRIATHLON SHORTS, CYCLING SHORTS, BIB SHORTS, AND COMPRESSION SHORTS (U.S. CLS. 22 AND 39).  
FIRST USE 11-1-2009; IN COMMERCE 11-1-2009.

## CLASS 41—EDUCATION AND ENTERTAINMENT

FOR PROVIDING ASSISTANCE, PERSONAL TRAINING, AND PHYSICAL FITNESS CONSULTATION TO CORPORATE CLIENTS TO HELP THEIR EMPLOYEES MAKE PHYSICAL FITNESS, STRENGTH, CONDITIONING, AND EXERCISE ALTERATIONS IN THEIR DAILY LIVING; PROVIDING ASSISTANCE, PERSONAL TRAINING, AND PHYSICAL FITNESS CONSULTATION TO INDIVIDUALS TO HELP THEM MAKE PHYSICAL FITNESS, STRENGTH, CONDITIONING, AND EXERCISE IMPROVEMENT IN THEIR DAILY LIVING; AND PROVIDING A WEB SITE FEATURING INFORMATION ON EXERCISE AND FITNESS, ONLINE SPORTS AND FITNESS TRAINING AND TRAINING ADVICE, AND THE RECORDING OF TRAINING AND WORKOUTS (U.S. CLS. 100, 101 AND 107).  
FIRST USE 11-1-2009; IN COMMERCE 11-1-2009.

## CLASS 44—MEDICAL, BEAUTY AND AGRICULTURAL SERVICES

FOR PROVIDING ASSISTANCE AND CONSULTATION TO CORPORATE CLIENTS TO HELP THEIR EMPLOYEES MAKE HEALTH, WELLNESS AND NUTRITIONAL ALTERATIONS IN THEIR DAILY LIVING; PROVIDING ASSISTANCE AND CONSULTATION TO INDIVIDUALS TO HELP THEM MAKE HEALTH AND WELLNESS IMPROVEMENT IN THEIR DAILY LIVING (U.S. CLS. 100 AND 101).  
FIRST USE 11-1-2009; IN COMMERCE 11-1-2009.

3,963,521. NORTHERN TOOL & EQUIPMENT COMPANY, INC., BURNSVILLE, MN. SN 85-049,287. PUB. 11-23-2010, FILED 5-27-2010.

# Klutch

THE MARK CONSISTS OF STANDARD CHARACTERS WITHOUT CLAIM TO ANY PARTICULAR FONT, STYLE, SIZE, OR COLOR.

## CLASS 7—MACHINERY

FOR TABLE SAWS; ELECTRIC SHEARS; POWER-OPERATED POLISHERS; POWER DRILL DRIVERS; POWER TOOL ACCESSORIES, NAMELY, TOOL STANDS (U.S. CLS. 13, 19, 21, 23, 31, 34 AND 35).  
FIRST USE 10-31-2010; IN COMMERCE 10-31-2010.

## CLASS 8—HAND TOOLS

FOR HAND TOOLS, NAMELY, DENT PULLERS (U.S. CLS. 23, 28 AND 44).  
FIRST USE 8-31-2010; IN COMMERCE 8-31-2010.

3,963,546. SEARS BRANDS, LLC, HOFFMAN ESTATES, IL. SN 85-059,892. PUB. 9-28-2010, FILED 6-10-2010.

3,963,577. SHALEE PRODUCTIONS LLC, AGOURA HILLS, CA. SN 85-068,521. PUB. 11-16-2010, FILED 6-22-2010.

## SEARS FIT CLUB

THE MARK CONSISTS OF STANDARD CHARACTERS WITHOUT CLAIM TO ANY PARTICULAR FONT, STYLE, SIZE, OR COLOR.

NO CLAIM IS MADE TO THE EXCLUSIVE RIGHT TO USE "FIT CLUB", APART FROM THE MARK AS SHOWN.

### CLASS 41—EDUCATION AND ENTERTAINMENT

FOR PROVIDING A WEBSITE FEATURING INFORMATION ON EXERCISE AND FITNESS; PROVIDING INFORMATION IN THE FIELD OF EXERCISE AND FITNESS (U.S. CLS. 100, 101 AND 107).

FIRST USE 3-0-2010; IN COMMERCE 3-0-2010.

### CLASS 44—MEDICAL, BEAUTY AND AGRICULTURAL SERVICES

FOR PROVIDING A WEBSITE FEATURING INFORMATION ON HEALTH AND NUTRITION; PROVIDING INFORMATION IN THE FIELD OF HEALTH AND NUTRITION (U.S. CLS. 100 AND 101).

FIRST USE 3-0-2010; IN COMMERCE 3-0-2010.

3,963,570. GRANICRETE INTERNATIONAL, INC, PHOENIX, AZ. SN 85-066,785. PUB. 11-16-2010, FILED 6-18-2010.

## What's In Your Portfolio?

THE MARK CONSISTS OF STANDARD CHARACTERS WITHOUT CLAIM TO ANY PARTICULAR FONT, STYLE, SIZE, OR COLOR.

### CLASS 35—ADVERTISING AND BUSINESS

FOR WHOLESALE DISTRIBUTORSHIPS FEATURING DECORATIVE CONCRETE MATERIALS, NAMELY, COLORANTS, SEALERS, OVERLAY TEXTURES, AND PLASTERES (U.S. CLS. 100, 101 AND 102).

FIRST USE 4-1-2010; IN COMMERCE 2-10-2011.

### CLASS 40—MATERIAL TREATMENT

FOR MANUFACTURING SERVICES FOR OTHERS IN THE FIELD OF OTHERS IN THE FIELD OF DECORATIVE CONCRETE MATERIALS, NAMELY, COLORANTS, SEALERS, OVERLAY TEXTURES, AND PLASTERES (U.S. CLS. 100, 103 AND 106).

FIRST USE 4-1-2010; IN COMMERCE 2-10-2011.

## Shalee

THE MARK CONSISTS OF STANDARD CHARACTERS WITHOUT CLAIM TO ANY PARTICULAR FONT, STYLE, SIZE, OR COLOR.

### CLASS 9—ELECTRICAL AND SCIENTIFIC APPARATUS

FOR DIGITAL MATERIALS, NAMELY, CDS, DVDS, DOWNLOADABLE AUDIO AND VIDEO FILES FEATURING MUSIC (U.S. CLS. 21, 23, 26, 36 AND 38).

FIRST USE 6-7-2009; IN COMMERCE 4-1-2010.

### CLASS 41—EDUCATION AND ENTERTAINMENT

FOR ENTERTAINMENT SERVICES IN THE NATURE OF LIVE MUSICAL PERFORMANCES (U.S. CLS. 100, 101 AND 107).

FIRST USE 6-7-2009; IN COMMERCE 4-1-2010.

3,963,588. LIVE IN WONDER LLC, HENDERSON, NV. SN 85-070,071. PUB. 11-23-2010, FILED 6-23-2010.



THE MARK CONSISTS OF A PERSON WITH A ROUND, CIRCLE AS THE HEAD; AN UPWARD ARCHED LINE AS THE ARMS; AND A DOWNWARD ARCHED LINE AS THE LEGS. THE STYLIZED TEXT "LIVE IN WONDER" APPEARS ON THE MIDDLE.

### CLASS 25—CLOTHING

FOR T-SHIRTS (U.S. CLS. 22 AND 39).

FIRST USE 2-28-2008; IN COMMERCE 2-28-2008.

### CLASS 41—EDUCATION AND ENTERTAINMENT

FOR ENTERTAINMENT SERVICES, NAMELY, PROVIDING A WEB SITE FEATURING PHOTOGRAPHIC, AUDIO, VIDEO AND PROSE PRESENTATIONS FEATURING MUSIC, COMEDY AND DRAMA THROUGH WISDOM, HUMOR AND INSPIRATION (U.S. CLS. 100, 101 AND 107).

FIRST USE 9-30-2009; IN COMMERCE 9-30-2009.



3,963,621. AFTERSCHOOL BUDDY, INC., ALLISON PARK, PA. SN 85-076,803. PUB. 12-7-2010, FILED 7-2-2010.

3,963,642. BOUTIQUE CUPCAKE COMPANY, LLC, NORTH POTOMAC, MD. SN 85-084,337. PUB. 12-21-2010, FILED 7-14-2010.

## JAKE POODLES

THE MARK CONSISTS OF STANDARD CHARACTERS WITHOUT CLAIM TO ANY PARTICULAR FONT, STYLE, SIZE, OR COLOR.

### CLASS 9—ELECTRICAL AND SCIENTIFIC APPARATUS

FOR DIGITAL MATERIALS CONTAINING CHILDREN'S ENTERTAINMENT AND EDUCATION, NAMELY, CDS, DVDS, AND DOWNLOADABLE AUDIO AND VIDEO FILES; COMPUTER SOFTWARE FOR USE WITH CHILDREN'S ENTERTAINMENT AND EDUCATION, NAMELY, VIDEO GAMES AND COMPUTER SCREEN SAVER SOFTWARE AND MOUSE PADS; SUNGLASSES AND CASES FOR SPECTACLES AND SUNGLASSES; ELECTRONIC DEVICES CASES, NAMELY, LAPTOP CASES, CELL PHONE CASES AND PORTABLE MEDIA PLAYER CASES (U.S. CLS. 21, 23, 26, 36 AND 38).  
FIRST USE 11-7-2009; IN COMMERCE 11-7-2009.

### CLASS 25—CLOTHING

FOR CLOTHING, NAMELY, SHIRTS, SHORTS, PANTS, DRESSES, PONCHOS, COATS, BATHING SUITS, APRONS, PARKAS, SHOES AND GLOVES; RAIN GEAR, NAMELY, BOOTS, COATS, SLICKERS, SUITS AND TROUSERS; HEADGEAR, NAMELY, HATS, CAPS AND BANDANAS; BABY CLOTHING, NAMELY, CLOTH BIBS AND PAJAMAS; HALLOWEEN COSTUMES AND COSTUME MASKS SOLD AS A UNIT (U.S. CLS. 22 AND 39).  
FIRST USE 11-7-2009; IN COMMERCE 11-7-2009.

### CLASS 28—TOYS AND SPORTING GOODS

FOR TOYS FOR CHILDREN AND PETS, NAMELY, PLUSH TOYS, TOY FIGURES, DOLLS, COLLECTIBLES, NAMELY, SNOW GLOBES, HOLIDAY AND SEASONAL ORNAMENTS, NAMELY, CHRISTMAS TREE ORNAMENTS, COLLECTIBLE TOY FIGURES, BATH TOYS, INFLATABLE TOYS, MUSICAL TOYS, RADIO CONTROLLED TOY VEHICLES, SANDBOX AND BEACH TOYS, SQUEEZE TOYS, BOARD GAMES, PUPPETS AND HAND PUPPETS AND BALLOONS; COSTUME MASKS (U.S. CLS. 22, 23, 38 AND 50).  
FIRST USE 11-7-2009; IN COMMERCE 11-7-2009.

### CLASS 41—EDUCATION AND ENTERTAINMENT

FOR ENTERTAINMENT AND EDUCATIONAL SERVICES, NAMELY, PRODUCTION AND PROVISION OF ON-GOING CHILDREN'S PROGRAMS VIA BROADCAST CABLE, VIA VIDEO ON-DEMAND, SATELLITE TV AND THE INTERNET AND PROGRAMMING, NAMELY, THE SCHEDULING THEREOF; PRODUCTION AND PROVISION OF CHILDREN'S MOVIES (U.S. CLS. 100, 101 AND 107).  
FIRST USE 7-0-2010; IN COMMERCE 7-0-2010.

## LILLY MAGILLY'S

THE MARK CONSISTS OF STANDARD CHARACTERS WITHOUT CLAIM TO ANY PARTICULAR FONT, STYLE, SIZE, OR COLOR.

THE NAME(S), PORTRAIT(S), AND/OR SIGNATURE(S) SHOWN IN THE MARK DOES NOT IDENTIFY A PARTICULAR LIVING INDIVIDUAL.

### CLASS 30—STAPLE FOODS

FOR BAKERY GOODS; BAKERY DESSERTS; CUPCAKES; COOKIES; SWEETS; CANDY (U.S. CL. 46).  
FIRST USE 10-1-2010; IN COMMERCE 10-1-2010.

### CLASS 35—ADVERTISING AND BUSINESS

FOR RETAIL BAKERY SHOP; TAKE-OUT BAKERY SERVICES; RETAIL GIFT SHOP (U.S. CLS. 100, 101 AND 102).  
FIRST USE 10-1-2010; IN COMMERCE 10-1-2010.

3,963,651. CITIGROUP INC., NEW YORK, NY. SN 85-086,225. PUB. 12-28-2010, FILED 7-16-2010.

## CITI POND

THE MARK CONSISTS OF STANDARD CHARACTERS WITHOUT CLAIM TO ANY PARTICULAR FONT, STYLE, SIZE, OR COLOR.

OWNER OF U.S. REG. NOS. 3,635,724, 3,661,460, AND OTHERS.

### CLASS 36—INSURANCE AND FINANCIAL

FOR FINANCIAL SPONSORSHIP OF SPORTS, RECREATIONAL, CULTURAL AND ENTERTAINMENT EVENTS (U.S. CLS. 100, 101 AND 102).  
FIRST USE 10-28-2010; IN COMMERCE 10-28-2010.

### CLASS 41—EDUCATION AND ENTERTAINMENT

FOR ORGANIZING SPORTS, RECREATIONAL, CULTURAL AND ENTERTAINMENT EVENTS FOR PUBLIC EXHIBITION (U.S. CLS. 100, 101 AND 107).  
FIRST USE 10-28-2010; IN COMMERCE 10-28-2010.

3,963,693. L18 HOLDINGS, INC., NEW YORK, NY. SN 85-105,785. PUB. 1-25-2011, FILED 8-12-2010.

Lot18

THE MARK CONSISTS OF STANDARD CHARACTERS WITHOUT CLAIM TO ANY PARTICULAR FONT, STYLE, SIZE, OR COLOR.

**CLASS 35—ADVERTISING AND BUSINESS**

FOR ADVERTISING SERVICES, NAMELY, PROMOTING THE FOOD AND WINE OF OTHERS; PROVIDING A WEBSITE WHERE USERS CAN POST RATINGS, REVIEWS AND RECOMMENDATIONS ON RESTAURANTS, FOOD AND WINE FOR COMMERCIAL PURPOSES (U.S. CLS. 100, 101 AND 102).  
FIRST USE 10-12-2010; IN COMMERCE 10-12-2010.

**CLASS 43—HOTEL AND RESTAURANT SERVICES**

FOR PROVIDING A WEB SITE WHERE USERS CAN POST RATINGS, REVIEWS AND RECOMMENDATIONS ON WINES FOR WINE APPRECIATION PURPOSES; PROVIDING INFORMATION ABOUT WINE CHARACTERISTICS; SOMMELIER SERVICES, NAMELY, PROVIDING ADVICE ON WINE AND WINE AND FOOD PAIRING (U.S. CLS. 100 AND 101).  
FIRST USE 10-12-2010; IN COMMERCE 10-12-2010.

3,963,694. L18 HOLDINGS, INC., NEW YORK, NY. SN 85-105,809. PUB. 1-25-2011, FILED 8-12-2010.

Lot18

THE MARK CONSISTS OF THE WORD "LOT18" IN STYLIZED FONT.

**CLASS 35—ADVERTISING AND BUSINESS**

FOR ADVERTISING SERVICES, NAMELY, PROMOTING THE FOOD AND WINE OF OTHERS; PROVIDING A WEBSITE WHERE USERS CAN POST RATINGS, REVIEWS AND RECOMMENDATIONS ON RESTAURANTS, FOOD AND WINE FOR COMMERCIAL PURPOSES (U.S. CLS. 100, 101 AND 102).  
FIRST USE 10-12-2010; IN COMMERCE 10-12-2010.

**CLASS 43—HOTEL AND RESTAURANT SERVICES**

FOR PROVIDING A WEB SITE WHERE USERS CAN POST RATINGS, REVIEWS AND RECOMMENDATIONS ON WINES FOR WINE APPRECIATION PURPOSES; PROVIDING INFORMATION ABOUT WINE CHARACTERISTICS; SOMMELIER SERVICES, NAMELY, PROVIDING ADVICE ON WINE AND WINE AND FOOD PAIRING (U.S. CLS. 100 AND 101).  
FIRST USE 10-12-2010; IN COMMERCE 10-12-2010.

3,963,705. GEOFFREY, LLC, WAYNE, NJ. SN 85-120,630. PUB. 1-11-2011, FILED 9-1-2010.

B IS FOR BEAR

THE MARK CONSISTS OF STANDARD CHARACTERS WITHOUT CLAIM TO ANY PARTICULAR FONT, STYLE, SIZE, OR COLOR.

**CLASS 12—VEHICLES**

FOR BABY GEAR, NAMELY, STROLLERS AND CARSEATS (U.S. CLS. 19, 21, 23, 31, 35 AND 44).  
FIRST USE 11-10-2010; IN COMMERCE 11-10-2010.

**CLASS 20—FURNITURE AND ARTICLES NOT OTHERWISE CLASSIFIED**

FOR BABY GEAR, NAMELY, HIGHCHAIRS (U.S. CLS. 2, 13, 22, 25, 32 AND 50).  
FIRST USE 11-10-2010; IN COMMERCE 11-10-2010.

3,963,722. S. C. JOHNSON & SON, INC., RACINE, WI. SN 85-975,145. PUB. 11-30-2010, FILED 6-30-2010.

LISTOS PARA LA PRIMAVERA

THE MARK CONSISTS OF STANDARD CHARACTERS WITHOUT CLAIM TO ANY PARTICULAR FONT, STYLE, SIZE, OR COLOR.

THE ENGLISH TRANSLATION OF "LISTOS PARA LA PRIMAVERA" IN THE MARK IS "WE ARE READY FOR THE SPRING".

**CLASS 4—LUBRICANTS AND FUELS**

FOR CANDLES (U.S. CLS. 1, 6 AND 15).  
FIRST USE 2-11-2011; IN COMMERCE 2-11-2011.

**CLASS 5—PHARMACEUTICALS**

FOR AIR FRESHENERS (U.S. CLS. 6, 18, 44, 46, 51 AND 52).  
FIRST USE 1-19-2011; IN COMMERCE 1-19-2011.

## SECTION 2.— INTERNATIONAL CLASSIFICATION

The short titles associated below with the international class numbers are terms designed merely for quick identification and are not an official part of the international classification. The full names of international classes are given in section 6.1 of the trademark rules of practice.

The designation "U.S. Cl." appearing in this section refers to the U.S. class in effect prior to Sep. 1, 1973 rather than the international class which applies to applications filed on or after that date. For adoption of international classification see notice in the OFFICIAL GAZETTE of Jun. 26, 1973 (911 O.G. TM 210).

### Application in one class

#### CLASS 1—CHEMICALS

3,962,000. PILOTS POINT, LLC, BELLEAIR BLUFFS, FL. SN 76-704,064. PUB. 11-23-2010, FILED 8-9-2010.

# PILOTS POINT

THE MARK CONSISTS OF STANDARD CHARACTERS WITHOUT CLAIM TO ANY PARTICULAR FONT, STYLE, SIZE, OR COLOR.

FOR BIOMEDICAL COMPOUNDS, NAMELY, SUBSTRATES CONTAINING PEPTIDES, VITAMINS, INDICATORS, AND ENERGY CONTAINING REAGENTS FOR USE IN DETECTING THE PRESENCE OR ABSENCE OF TARGET MICROBES, NAMELY, VANCOMYCIN RESISTANT ENTEROCOCCUS, MRSA, MSSA, E COLI, OR STREPTOCOCCUS B IN BIOLOGICAL SAMPLE SPECIMENS, FOOD SAMPLE SPECIMENS, NATURAL SAMPLE SPECIMENS, OR ENVIRONMENTAL SAMPLE SPECIMENS ALL FOR USE IN EPIDEMIOLOGY SURVEILLANCE, FOR CLINICAL, RESEARCH, OR MEDICAL LABORATORY USE (U.S. CLS. 1, 5, 6, 10, 26 AND 46).

FIRST USE 8-0-2010; IN COMMERCE 8-0-2010.

3,962,080. CHAMNESS TECHNOLOGY, INC., BLAIRSBURG, IA. SN 77-282,440. PUB. 4-22-2008, FILED 9-18-2007.

# CHAMNESS SOIL BUILDER

THE MARK CONSISTS OF STANDARD CHARACTERS WITHOUT CLAIM TO ANY PARTICULAR FONT, STYLE, SIZE, OR COLOR.

NO CLAIM IS MADE TO THE EXCLUSIVE RIGHT TO USE "SOIL BUILDER", APART FROM THE MARK AS SHOWN.

FOR ORGANIC SOIL CONDITIONER FOR AGRICULTURAL USE (U.S. CLS. 1, 5, 6, 10, 26 AND 46).

FIRST USE 3-16-2011; IN COMMERCE 3-16-2011.

#### CLASS 1—(Continued).

3,962,081. TETRAVITAE BIOSCIENCE, INC., CHICAGO, IL. SN 77-289,305. PUB. 1-22-2008, FILED 9-26-2007.

# TETRAVITAE

THE MARK CONSISTS OF STANDARD CHARACTERS WITHOUT CLAIM TO ANY PARTICULAR FONT, STYLE, SIZE, OR COLOR.

FOR CHEMICALS FOR INDUSTRIAL PURPOSES; UNPROCESSED PLASTICS, NAMELY, POLYMERS MADE FROM ORGANIC MATERIALS FOR INDUSTRIAL USE (U.S. CLS. 1, 5, 6, 10, 26 AND 46).

FIRST USE 9-30-2010; IN COMMERCE 9-30-2010.

3,962,082. TROY CORPORATION, FLORHAM PARK, NJ. SN 77-293,569. PUB. 4-8-2008, FILED 10-2-2007.

# THE GOLD STANDARD FOR PERFORMANCE

THE MARK CONSISTS OF STANDARD CHARACTERS WITHOUT CLAIM TO ANY PARTICULAR FONT, STYLE, SIZE, OR COLOR.

FOR CHEMICALS FOR INDUSTRIAL PURPOSES; CHEMICALS FOR USE IN THE MANUFACTURE OF PAINTS, PAINT STAINS, WOOD PRESERVATIVES, COATINGS, INKS, CAULKS, ADHESIVES, METAL WORKING FLUIDS, AND POLYMERIC MATERIALS; WETTING AGENTS FOR USE IN THE MANUFACTURE OF PAINTS (U.S. CLS. 1, 5, 6, 10, 26 AND 46).

FIRST USE 6-9-2010; IN COMMERCE 6-9-2010.

**CLASS 1—(Continued).**

3,962,093. DANISCO A/S, COPENHAGEN, DENMARK. SN 77-328,269. PUB. 4-15-2008, FILED 11-13-2007.

**DULCADEN**

THE MARK CONSISTS OF STANDARD CHARACTERS WITHOUT CLAIM TO ANY PARTICULAR FONT, STYLE, SIZE, OR COLOR.

FOR ARTIFICIAL CHEMICAL SWEETENERS FOR USE IN THE MANUFACTURE OF FOOD AND BEVERAGES AND PHARMACEUTICALS (U.S. CLS. 1, 5, 6, 10, 26 AND 46).

FIRST USE 1-3-2011; IN COMMERCE 1-3-2011.

3,962,410. TRINA SOLAR LIMITED, GRAND CAYMAN KY11111, CAYMAN ISLANDS. SN 77-762,624. PUB. 12-22-2009, FILED 6-18-2009.



THE COLOR(S) YELLOW, ORANGE AND GREEN IS/ARE CLAIMED AS A FEATURE OF THE MARK.

THE MARK CONSISTS OF THE FOLLOWING: A RISING SUN IN THE COLORS YELLOW AND ORANGE POSITIONED TO THE LEFT OF THE LITERAL ELEMENT "YOUSOLAR" WHICH IS PRESENTED IN GREEN. THE SUN DESIGN ELEMENT AND THE LITERAL ELEMENT "YOUSOLAR" ARE BOTH UNDERLINED WITH A SINGLE, CURVED LINE, ALSO PRESENTED IN THE COLOR GREEN.

FOR POLYCRYSTALLINE SILICON FOR USE IN THE SOLAR CELL INDUSTRY (U.S. CLS. 1, 5, 6, 10, 26 AND 46).

FIRST USE 1-1-2008; IN COMMERCE 7-21-2009.

3,962,958. FISHER SCIENTIFIC COMPANY L.L.C., PITTSBURGH, PA. SN 77-939,780. PUB. 8-3-2010, FILED 2-19-2010.

**CELLPURE**

THE MARK CONSISTS OF STANDARD CHARACTERS WITHOUT CLAIM TO ANY PARTICULAR FONT, STYLE, SIZE, OR COLOR.

FOR CHEMICALS, NAMELY, BUFFERS AND BUFFERED AQUEOUS SOLUTIONS USED IN GROWING CELLS FOR SCIENTIFIC AND RESEARCH PURPOSES (U.S. CLS. 1, 5, 6, 10, 26 AND 46).

FIRST USE 10-1-2010; IN COMMERCE 10-1-2010.

**CLASS 1—(Continued).**

3,963,039. BEACON ADHESIVES CORPORATION, NEW YORK, NY. SN 77-949,545. PUB. 7-27-2010, FILED 3-3-2010.

**FOAM TAC**

THE MARK CONSISTS OF STANDARD CHARACTERS WITHOUT CLAIM TO ANY PARTICULAR FONT, STYLE, SIZE, OR COLOR.

FOR ADHESIVES AND GLUE FOR INDUSTRIAL AND COMMERCIAL USE (U.S. CLS. 1, 5, 6, 10, 26 AND 46).

FIRST USE 1-1-2011; IN COMMERCE 1-1-2011.

3,963,040. BEACON ADHESIVES CORPORATION, NEW YORK, NY. SN 77-949,552. PUB. 7-27-2010, FILED 3-3-2010.

**QUICK GRAB**

THE MARK CONSISTS OF STANDARD CHARACTERS WITHOUT CLAIM TO ANY PARTICULAR FONT, STYLE, SIZE, OR COLOR.

FOR ADHESIVES AND GLUE FOR INDUSTRIAL AND COMMERCIAL USE (U.S. CLS. 1, 5, 6, 10, 26 AND 46).

FIRST USE 1-1-2011; IN COMMERCE 1-1-2011.

3,963,078. CARGILL, INCORPORATED, WAYZATA,, MN. SN 77-953,970. PUB. 7-13-2010, FILED 3-9-2010.

**VERXAN**

THE MARK CONSISTS OF STANDARD CHARACTERS WITHOUT CLAIM TO ANY PARTICULAR FONT, STYLE, SIZE, OR COLOR.

FOR XANTHAN GUM FOR INDUSTRIAL PURPOSES (U.S. CLS. 1, 5, 6, 10, 26 AND 46).

FIRST USE 3-15-2005; IN COMMERCE 3-15-2005.

**CLASS 1—(Continued).**

3,963,096. MERCEDES MEDICAL, INC., SARASOTA, FL. SN 77-955,497. PUB. 8-31-2010, FILED 3-10-2010.

**HENRY'S WONDER WAX**

THE MARK CONSISTS OF STANDARD CHARACTERS WITHOUT CLAIM TO ANY PARTICULAR FONT, STYLE, SIZE, OR COLOR.

NO CLAIM IS MADE TO THE EXCLUSIVE RIGHT TO USE "WAX", APART FROM THE MARK AS SHOWN.

FOR PARAFFIN WAX USED AS AN INFILTRATION AND EMBEDDING MEDIUM FOR CLINICAL LABORATORY OR MEDICAL LABORATORY USE; PARAFFIN WAX FOR USE IN HISTOLOGY APPLICATIONS TO PREPARE TISSUE IN CLINICAL LABORATORY SITUATIONS (U.S. CLS. 1, 5, 6, 10, 26 AND 46).

FIRST USE 9-0-2010; IN COMMERCE 9-0-2010.

---

3,963,105. ADVANCED TECHNOLOGY MATERIALS, INC., DANBURY, CT. SN 77-956,185. PUB. 7-27-2010, FILED 3-11-2010.

**PLANARCLEAN**

THE MARK CONSISTS OF STANDARD CHARACTERS WITHOUT CLAIM TO ANY PARTICULAR FONT, STYLE, SIZE, OR COLOR.

FOR CHEMICAL COMPOSITIONS FOR USE IN REMOVING MICROELECTRONICS MANUFACTURING FABRICATION MATERIALS FROM MICROELECTRONIC PRODUCTS SUCH AS WAFERS (U.S. CLS. 1, 5, 6, 10, 26 AND 46).

FIRST USE 12-3-2010; IN COMMERCE 12-3-2010.

---

3,963,208. BG CHEMICAL, LP, DALLAS, TX. SN 77-966,672. PUB. 8-10-2010, FILED 3-23-2010.

**GreenGuard**

THE MARK CONSISTS OF STANDARD CHARACTERS WITHOUT CLAIM TO ANY PARTICULAR FONT, STYLE, SIZE, OR COLOR.

FOR CHEMICAL PRODUCTS USED IN INDUSTRY, NAMELY, CHEMICALS FOR USE AS ASPHALT RELEASE AGENTS TO FACILITATE CLEANING OF ASPHALT TRANSPORT VEHICLES (U.S. CLS. 1, 5, 6, 10, 26 AND 46).

FIRST USE 3-10-2010; IN COMMERCE 3-10-2010.

**CLASS 1—(Continued).**

3,963,233. CELL SIGNALING TECHNOLOGY, INC., DANVERS, MA. SN 77-980,609. PUB. 6-30-2009, FILED 4-6-2009.

**XP**

THE MARK CONSISTS OF STANDARD CHARACTERS WITHOUT CLAIM TO ANY PARTICULAR FONT, STYLE, SIZE, OR COLOR.

FOR BIOCHEMICAL REAGENTS COMMONLY KNOWN AS PROBES, FOR DETECTING AND ANALYZING MOLECULES IN PROTEIN OR NUCLEOTIDE ARRAYS; CHEMICAL REAGENTS FOR NON-MEDICAL PURPOSES; REAGENTS FOR RESEARCH PURPOSES; REAGENTS FOR SCIENTIFIC OR MEDICAL RESEARCH USE; REAGENTS FOR USE IN SCIENTIFIC APPARATUS FOR CHEMICAL OR BIOLOGICAL ANALYSIS (U.S. CLS. 1, 5, 6, 10, 26 AND 46).

FIRST USE 7-19-2009; IN COMMERCE 7-31-2009.

---

3,963,279. BAYER CROPSCIENCE LP, RESEARCH TRIANGLE PARK, NC. SN 78-169,200. PUB. 12-30-2003, FILED 9-30-2002.

**PRECISE**

FOR BINDING AGENTS AND APPEARANCE ENHANCERS USED IN THE MANUFACTURE OF SEED CONDITIONERS TO IMPROVE SEED PLANTABILITY, ENHANCE APPEARANCE AND REDUCE DUST (U.S. CLS. 1, 5, 6, 10, 26 AND 46).

FIRST USE 2-29-2004; IN COMMERCE 2-29-2004.

---

3,963,355. NORTH AMERICAN SALT COMPANY, KANSAS CITY, MO. SN 85-009,174. PUB. 7-13-2010, FILED 4-8-2010.

**SURE PAWS**

THE MARK CONSISTS OF STANDARD CHARACTERS WITHOUT CLAIM TO ANY PARTICULAR FONT, STYLE, SIZE, OR COLOR.

FOR DE-ICING AND ICE PREVENTION PREPARATION FOR ROADWAYS, SIDEWALKS AND OTHER PAVED SURFACES (U.S. CLS. 1, 5, 6, 10, 26 AND 46).

FIRST USE 9-22-2010; IN COMMERCE 9-22-2010.



**CLASS 1—(Continued).**

3,963,429. S B INDUSTRIES, LLC, MYSTIC, CT. SN 85-027,118. PUB. 9-14-2010, FILED 4-30-2010.

# PB 111J

THE MARK CONSISTS OF STANDARD CHARACTERS WITHOUT CLAIM TO ANY PARTICULAR FONT, STYLE, SIZE, OR COLOR.

NO CLAIM IS MADE TO THE EXCLUSIVE RIGHT TO USE "PB", APART FROM THE MARK AS SHOWN.

FOR POLYMER BASED CHEMICAL COMPOSITION FOR USE IN HARDENING THE SAND BASE OF A SWIMMING POOL; POLYMER BASED CHEMICAL COMPOSITION COATING FOR USE IN HARDENING THE SAND BASE OF A SWIMMING POOL; POLYMER-BASED LIQUID CHEMICAL COMPOSITION FOR HARDENING SAND (U.S. CLS. 1, 5, 6, 10, 26 AND 46).

FIRST USE 5-31-2010; IN COMMERCE 5-31-2010.

3,963,500. YANTAI VALIANT FINE CHEMICALS CO., LTD., YANTAI, SHANDONG, CHINA. SN 85-044,906. PUB. 10-12-2010, FILED 5-21-2010.

# Valiant

THE MARK CONSISTS OF THE WORD "VALIANT" IN STYLIZED FONT, WHICH HAS NO SIGNIFICANCE IN THE RELEVANT TRADE OR INDUSTRY OR AS APPLIED TO THE GOODS LISTED IN THE APPLICATION, NO GEOGRAPHICAL SIGNIFICANCE.

FOR CHEMICALS INTERMEDIATES IN PHARMACEUTICALS; ACTIVE CHEMICAL INGREDIENTS AND SOLVENTS FOR USE IN THE MANUFACTURE OF INSECTICIDES; ACTIVE CHEMICAL INGREDIENTS FOR USE IN THE MANUFACTURE OF PHARMACEUTICALS FOR TREATING DISEASES CAUSED BY BACTERIAL INFECTION OR MICROBE INFECTION; ACTIVE CHEMICAL INGREDIENTS FOR USE IN THE MANUFACTURE OF ANTIBIOTIC DRUGS; ADJUVANT FOR USE WITH AGRICULTURAL CHEMICALS; CATALYSTS FOR USE IN THE MANUFACTURE OF INDUSTRIAL CHEMICALS; CHEMICAL PREPARATIONS FOR SCIENTIFIC PURPOSES; CHEMICAL PRESERVATIVES FOR USE IN THE PRODUCTION OF A WIDE VARIETY OF CHEMICALS; CHEMICAL REAGENTS FOR NON-MEDICAL PURPOSES; CHEMICALS FOR USE IN INDUSTRY AND SCIENCE; CHEMICALS, NAMELY, BUFFER AND STANDARD SOLUTIONS USED IN ANALYTICAL CHEMISTRY; CHEMICALS, NAMELY, UV LIGHT STABILIZERS FOR USE IN ENGINEERING PLASTICS; INDUSTRIAL CHEMICALS; PERFLUORINATED CHEMICAL COMPOUNDS PREPARED SYNTHETICALLY FOR USE IN THE MANUFACTURE OF COSMETICS AND PHARMACEUTICALS; SPECIALTY CHEMICALS, NAMELY, CHEMICAL ADDITIVES FOR GENERAL INDUSTRIAL USE IN THE MANUFACTURE OF A WIDE VARIETY OF GOODS; SPECIALTY CHEMICALS, NAMELY, CHEMICAL ADDITIVES FOR USE IN THE MANUFACTURE OF FABRICS AND OF SURFACES OF A WIDE VARIETY OF MANUFACTURED PRODUCTS, FOR HEALTH AND SAFETY RELATED PURPOSES (U.S. CLS. 1, 5, 6, 10, 26 AND 46). FIRST USE 9-9-1999; IN COMMERCE 12-10-1999.

**CLASS 1—(Continued).**

3,963,563. DAN MAR CO., ARLINGTON, TX. SN 85-064,787. PUB. 11-2-2010, FILED 6-16-2010.

# Flako

THE MARK CONSISTS OF STANDARD CHARACTERS WITHOUT CLAIM TO ANY PARTICULAR FONT, STYLE, SIZE, OR COLOR.

FOR ANTIMICROBIAL SPRAY FOR INDUSTRIAL USE THAT KILLS BACTERIA ON THE SURFACE OF FOOD (U.S. CLS. 1, 5, 6, 10, 26 AND 46).

FIRST USE 6-11-2010; IN COMMERCE 6-11-2010.

3,963,612. KALLE GMBH, 65203 WIESBADEN, FED REP GERMANY. SN 85-075,121. PUB. 11-30-2010, FILED 6-30-2010.

# NaloCoat

THE MARK CONSISTS OF STANDARD CHARACTERS WITHOUT CLAIM TO ANY PARTICULAR FONT, STYLE, SIZE, OR COLOR.

OWNER OF U.S. REG. NOS. 3,348,894, 3,843,469, AND OTHERS.

FOR NON-NUTRITIVE MIXTURE OF COLLAGEN PROTEIN AND WATER FOR FORMING AN EDIBLE CASING ON FOOD PRODUCTS IN FOOD PROCESSING (U.S. CLS. 1, 5, 6, 10, 26 AND 46).

FIRST USE 3-4-2011; IN COMMERCE 3-4-2011.

3,963,672. ISP INVESTMENTS INC., WILMINGTON, DE. SN 85-095,646. PUB. 12-21-2010, FILED 7-29-2010.

# FLEXIDONE

THE MARK CONSISTS OF STANDARD CHARACTERS WITHOUT CLAIM TO ANY PARTICULAR FONT, STYLE, SIZE, OR COLOR.

FOR VINYL LACTAM PLASTICIZER FOR USE IN PVC AND OTHER RESINS (U.S. CLS. 1, 5, 6, 10, 26 AND 46).

FIRST USE 7-31-2010; IN COMMERCE 7-31-2010.

**CLASS 2—PAINTS**

**CLASS 2—(Continued).**

3,961,970. CANON KABUSHIKI KAISHA, TOKYO, JAPAN.  
SN 76-685,717. PUB. 5-13-2008, FILED 1-11-2008.

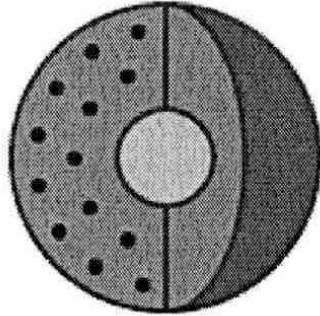

THE MARK CONSISTS OF A DESIGN WHICH DEPICTS A SPHERE WITH A CUT OUT SEGMENT, A VISIBLE AXIS AND SMALL DOTS.

FOR TONER, TONER CARTRIDGE (U.S. CLS. 6, 11 AND 16).

FIRST USE 9-30-2010; IN COMMERCE 9-30-2010.

3,962,191. SHERWIN-WILLIAMS COMPANY, THE, CLEVELAND, OH. SN 77-547,786. PUB. 12-23-2008, FILED 8-15-2008.

**SMART MARK**

THE MARK CONSISTS OF STANDARD CHARACTERS WITHOUT CLAIM TO ANY PARTICULAR FONT, STYLE, SIZE, OR COLOR.

NO CLAIM IS MADE TO THE EXCLUSIVE RIGHT TO USE "MARK", APART FROM THE MARK AS SHOWN.

FOR THERMOPLASTIC PAINT MATERIALS FOR USE IN MARKING ROAD SURFACES (U.S. CLS. 6, 11 AND 16).

FIRST USE 12-18-2009; IN COMMERCE 12-18-2009.

**CLASS 2—(Continued).**

3,962,278. DIGITEK COMPUTER PRODUCTS, INC., DULLES, VA. SN 77-665,149. PUB. 1-5-2010, FILED 2-6-2009.

**EXPRESSION**

THE MARK CONSISTS OF STANDARD CHARACTERS WITHOUT CLAIM TO ANY PARTICULAR FONT, STYLE, SIZE, OR COLOR.

FOR FILLED TONER CARTRIDGES (U.S. CLS. 6, 11 AND 16).

FIRST USE 1-1-2009; IN COMMERCE 1-1-2009.

3,962,485. SUN CHEMICAL CORPORATION, PARSIPPANY, NJ. SN 77-796,446. PUB. 7-27-2010, FILED 8-4-2009.

**SUNLIT**

THE MARK CONSISTS OF STANDARD CHARACTERS WITHOUT CLAIM TO ANY PARTICULAR FONT, STYLE, SIZE, OR COLOR.

FOR PRINTING INKS (U.S. CLS. 6, 11 AND 16).

FIRST USE 9-1-2009; IN COMMERCE 9-1-2009.

3,962,486. SUN CHEMICAL CORPORATION, PARSIPPANY, NJ. SN 77-796,452. PUB. 7-27-2010, FILED 8-4-2009.

**SUNPAK**

THE MARK CONSISTS OF STANDARD CHARACTERS WITHOUT CLAIM TO ANY PARTICULAR FONT, STYLE, SIZE, OR COLOR.

THE WORDING "SUNPAK" HAS NO MEANING IN A FOREIGN LANGUAGE.

FOR PRINTING INKS (U.S. CLS. 6, 11 AND 16).

FIRST USE 9-1-2009; IN COMMERCE 9-1-2009.

**CLASS 2—(Continued).**

3,962,550. SUN CHEMICAL CORPORATION, PARSIPPANY, NJ. SN 77-816,063. PUB. 8-3-2010, FILED 8-31-2009.

**SPECTRAFLEX**

THE MARK CONSISTS OF STANDARD CHARACTERS WITHOUT CLAIM TO ANY PARTICULAR FONT, STYLE, SIZE, OR COLOR.

OWNER OF U.S. REG. NO. 1,684,972.  
THE WORDING "SPECTRAFLEX" HAS NO MEANING IN A FOREIGN LANGUAGE.  
FOR INORGANIC PIGMENTS; PEARLESCENT PIGMENTS (U.S. CLS. 6, 11 AND 16).  
FIRST USE 1-31-2009; IN COMMERCE 1-31-2009.

3,962,616. MODERN MASTERS, INC., SUN VALLEY, CA. SN 77-835,389. PUB. 3-16-2010, FILED 9-25-2009.

**CABINET TRANSFORMATIONS**

THE MARK CONSISTS OF STANDARD CHARACTERS WITHOUT CLAIM TO ANY PARTICULAR FONT, STYLE, SIZE, OR COLOR.

NO CLAIM IS MADE TO THE EXCLUSIVE RIGHT TO USE "CABINET", APART FROM THE MARK AS SHOWN.

FOR COATINGS FOR INTERIOR USE, NAMELY, FAUX COATINGS AND CLEAR WOOD FINISHES (U.S. CLS. 6, 11 AND 16).

FIRST USE 11-30-2010; IN COMMERCE 11-30-2010.

3,962,674. UNITED ASPHALT COMPANY, CEDARBROOK, NJ. SN 77-857,312. PUB. 5-18-2010, FILED 10-26-2009.

**Armour Proof Coatings**

THE MARK CONSISTS OF STANDARD CHARACTERS WITHOUT CLAIM TO ANY PARTICULAR FONT, STYLE, SIZE, OR COLOR.

NO CLAIM IS MADE TO THE EXCLUSIVE RIGHT TO USE "COATINGS", APART FROM THE MARK AS SHOWN.

FOR ANTICORROSIVE PAINTS (U.S. CLS. 6, 11 AND 16).

FIRST USE 11-20-2009; IN COMMERCE 3-1-2010.

**CLASS 2—(Continued).**

3,963,000. MOHAWK CARPET DISTRIBUTION, INC., CALHOUN, GA. SN 77-944,493. PUB. 7-27-2010, FILED 2-25-2010.

**ARMORMAX**

THE MARK CONSISTS OF STANDARD CHARACTERS WITHOUT CLAIM TO ANY PARTICULAR FONT, STYLE, SIZE, OR COLOR.

FOR POLYURETHANE COATINGS FOR HARDWOOD FLOOR (U.S. CLS. 6, 11 AND 16).

FIRST USE 2-28-2010; IN COMMERCE 2-28-2010.

3,963,575. PPG ARCHITECTURAL FINISHES, INC., PITTSBURGH, PA. SN 85-068,393. PUB. 1-11-2011, FILED 6-22-2010.

**PPG PITTSBURGH PAINTS**

THE MARK CONSISTS OF STANDARD CHARACTERS WITHOUT CLAIM TO ANY PARTICULAR FONT, STYLE, SIZE, OR COLOR.

OWNER OF U.S. REG. NOS. 1,544,089, 3,262,062, AND OTHERS.

NO CLAIM IS MADE TO THE EXCLUSIVE RIGHT TO USE "PAINTS", APART FROM THE MARK AS SHOWN.

SEC. 2(F) AS TO "PITTSBURGH".

FOR COATING COMPOSITIONS IN THE NATURE OF PAINT FOR ARCHITECTURAL APPLICATIONS (U.S. CLS. 6, 11 AND 16).

FIRST USE 5-31-2009; IN COMMERCE 5-31-2009.

3,963,608. AMERICAN ART CLAY CO., INC., INDIANAPOLIS, IN. SN 85-074,047. PUB. 11-30-2010, FILED 6-29-2010.

**TEACHER'S PALETTE**

THE MARK CONSISTS OF STANDARD CHARACTERS WITHOUT CLAIM TO ANY PARTICULAR FONT, STYLE, SIZE, OR COLOR.

FOR GLAZES (U.S. CLS. 6, 11 AND 16).

FIRST USE 10-15-2010; IN COMMERCE 10-15-2010.

**CLASS 3—COSMETICS AND CLEANING PREPARATIONS**

**CLASS 3—(Continued).**

3,962,051. LEGACY TECHNOLOGIES, SAINT FRANCISVILLE, LA. SN 77-216,888. PUB. 1-1-2008, FILED 6-27-2007.

**ORGANOMEDIX**

THE MARK CONSISTS OF STANDARD CHARACTERS WITHOUT CLAIM TO ANY PARTICULAR FONT, STYLE, SIZE, OR COLOR.

FOR ORGANIC AND ORGANICALLY DERIVED PERSONAL HEALTHCARE PRODUCTS, NAMELY, HAIR SHAMPOOS AND CONDITIONERS; BODY WASHES AND SKIN LOTIONS; SKIN CLEANSERS, EXFOLIANTS, AND MOISTURIZERS; AND ANTI-WRINKLE SKIN CREAMS, NON-MEDICATED ANTI-WRINKLE SKIN LOTIONS AND SERUMS (U.S. CLS. 1, 4, 6, 50, 51 AND 52).

FIRST USE 10-1-2010; IN COMMERCE 3-1-2011.

3,962,061. SODASHI PTY LTD., NORTH FREMANTLE, AUSTRALIA. SN 77-225,622. PUB. 12-18-2007, FILED 7-10-2007.

**SAMADARA**

THE MARK CONSISTS OF STANDARD CHARACTERS WITHOUT CLAIM TO ANY PARTICULAR FONT, STYLE, SIZE, OR COLOR.

FOR FACIAL CREAMS; COSMETIC CREAMS; FACE CREAMS FOR COSMETIC USE; NON-MEDICATED SKIN CARE PREPARATIONS; SKIN CREAMS; BEAUTY CARE COSMETICS; BEAUTY CARE PREPARATIONS (U.S. CLS. 1, 4, 6, 50, 51 AND 52).

FIRST USE 1-10-2011; IN COMMERCE 1-10-2011.

3,962,186. MANZIONE, JOHN JOSEPH, BAY SHORE, NY. SN 77-543,218. PUB. 12-30-2008, FILED 8-10-2008.

**Chic & Pretty**

THE MARK CONSISTS OF STANDARD CHARACTERS WITHOUT CLAIM TO ANY PARTICULAR FONT, STYLE, SIZE, OR COLOR.

FOR COSMETICS AND MAKEUP, NON-MEDICATED SKIN CARE PREPARATIONS, HAIR CARE PREPARATIONS, NAIL CARE PREPARATIONS, ARTIFICIAL NAILS, NON-MEDICATED TOILETRIES AND PERFUMERY (U.S. CLS. 1, 4, 6, 50, 51 AND 52).

FIRST USE 1-1-2011; IN COMMERCE 1-1-2011.

**CLASS 3—(Continued).**

3,962,195. LINNELL SKIN CARE, INC, FORT LAUDERDALE, FL. SN 77-551,031. PUB. 1-20-2009, FILED 8-19-2008.

**JOON**

THE MARK CONSISTS OF STANDARD CHARACTERS WITHOUT CLAIM TO ANY PARTICULAR FONT, STYLE, SIZE, OR COLOR.

FOR NON-MEDICATED SKIN CARE PREPARATIONS FOR PRE-TEENS TO YOUNG ADULTS; COSMETICS AND MAKE-UP FOR PRE-TEENS TO YOUNG ADULTS (U.S. CLS. 1, 4, 6, 50, 51 AND 52).

FIRST USE 11-1-2010; IN COMMERCE 11-1-2010.

3,962,310. LORIT LLC, LAS VEGAS, NV. SN 77-685,589. PUB. 7-7-2009, FILED 3-6-2009.

**SEVIN NYNE**

THE MARK CONSISTS OF STANDARD CHARACTERS WITHOUT CLAIM TO ANY PARTICULAR FONT, STYLE, SIZE, OR COLOR.

FOR SELF-TANNING PREPARATIONS (U.S. CLS. 1, 4, 6, 50, 51 AND 52).

FIRST USE 3-1-2011; IN COMMERCE 3-1-2011.

3,962,335. BENOSTAN INTERNATIONAL, LTD., NEW YORK, NY. SN 77-699,637. PUB. 8-4-2009, FILED 3-26-2009.

**BENOSTAN LABORATORIES**

THE MARK CONSISTS OF STANDARD CHARACTERS WITHOUT CLAIM TO ANY PARTICULAR FONT, STYLE, SIZE, OR COLOR.

OWNER OF U.S. REG. NO. 2,242,432.

NO CLAIM IS MADE TO THE EXCLUSIVE RIGHT TO USE "LABORATORIES", APART FROM THE MARK AS SHOWN.

THE ENGLISH TRANSLATION OF THE WORD "BENOSTAN" IN THE MARK IS "WELL-BEING".

FOR HOUSE MARK FOR COSMETICS (U.S. CLS. 1, 4, 6, 50, 51 AND 52).

FIRST USE 0-0-2010; IN COMMERCE 0-0-2010.

**CLASS 3—(Continued).**

3,962,444. COLGATE-PALMOLIVE COMPANY, NEW YORK, NY. SN 77-780,844. PUB. 4-20-2010, FILED 7-14-2009.

**WOWERFUL**

THE MARK CONSISTS OF STANDARD CHARACTERS WITHOUT CLAIM TO ANY PARTICULAR FONT, STYLE, SIZE, OR COLOR.

FOR PERSONAL CARE PRODUCTS, NAMELY, SKIN CLEANSING PREPARATIONS (U.S. CLS. 1, 4, 6, 50, 51 AND 52).

FIRST USE 5-20-2010; IN COMMERCE 5-20-2010.

3,962,477. GEORGE, PHILIP B., WESTBURY, NY. SN 77-793,048. PUB. 12-29-2009, FILED 7-30-2009.

**ONE HUMAN**

THE MARK CONSISTS OF STANDARD CHARACTERS WITHOUT CLAIM TO ANY PARTICULAR FONT, STYLE, SIZE, OR COLOR.

FOR NON-MEDICATED SKIN CARE AND SKIN TREATMENT PREPARATIONS, NAMELY, SKIN CLEANSERS, SKIN LOTIONS, SKIN CREAMS, SKIN MASKS, EXFOLIANTS, SKIN MOISTURIZERS, SKIN TONERS, FACIAL SCRUBS, SHAVING CREAMS, SHAVING GELS, SHAVING FOAM (U.S. CLS. 1, 4, 6, 50, 51 AND 52).

FIRST USE 12-0-2010; IN COMMERCE 12-0-2010.

3,962,484. JOHNSON & JOHNSON, NEW BRUNSWICK, NJ. SN 77-796,351. PUB. 12-22-2009, FILED 8-4-2009.

**COOL HEAT LISTERINE**

THE MARK CONSISTS OF STANDARD CHARACTERS WITHOUT CLAIM TO ANY PARTICULAR FONT, STYLE, SIZE, OR COLOR.

OWNER OF U.S. REG. NOS. 85,150, 3,218,073, AND 3,218,074.

FOR NON-MEDICATED BREATH FRESHENERS, NAMELY, ORAL CARE STRIPS (U.S. CLS. 1, 4, 6, 50, 51 AND 52).

FIRST USE 12-4-2009; IN COMMERCE 12-4-2009.

**CLASS 3—(Continued).**

3,962,536. SUPRE, INC., DALLAS, TX. SN 77-810,434. PUB. 7-27-2010, FILED 8-21-2009.

**Supre Tan**

THE MARK CONSISTS OF STANDARD CHARACTERS WITHOUT CLAIM TO ANY PARTICULAR FONT, STYLE, SIZE, OR COLOR.

OWNER OF U.S. REG. NO. 1,969,818.

NO CLAIM IS MADE TO THE EXCLUSIVE RIGHT TO USE "TAN", APART FROM THE MARK AS SHOWN.

FOR SKIN CARE PRODUCTS, NAMELY, INDOOR AND OUTDOOR SUN TANNING PREPARATIONS, SUNLESS TANNING PREPARATIONS, BATH AND SHOWER GELS AND SKIN MOISTURIZERS (U.S. CLS. 1, 4, 6, 50, 51 AND 52).

FIRST USE 8-21-2009; IN COMMERCE 8-21-2009.

3,962,548. BUBBLES, INC., VIENNA, VA. SN 77-814,835. PUB. 7-20-2010, FILED 8-28-2009.

**ANCIENT SERUM**

THE MARK CONSISTS OF STANDARD CHARACTERS WITHOUT CLAIM TO ANY PARTICULAR FONT, STYLE, SIZE, OR COLOR.

NO CLAIM IS MADE TO THE EXCLUSIVE RIGHT TO USE "SERUM", APART FROM THE MARK AS SHOWN.

FOR HAIR CARE PRODUCTS, NAMELY, SHAMPOOS, CONDITIONERS AND STYLING PREPARATIONS AND SKIN CREAMS AND BODY LOTIONS (U.S. CLS. 1, 4, 6, 50, 51 AND 52).

FIRST USE 10-1-2009; IN COMMERCE 10-1-2009.

3,962,581. LISA ASHLEY, INC., THOUSAND OAKS, CA. SN 77-824,225. PUB. 2-9-2010, FILED 9-10-2009.

**LISA ASHLEY L.A. GIRLFRIEND**

THE MARK CONSISTS OF STANDARD CHARACTERS WITHOUT CLAIM TO ANY PARTICULAR FONT, STYLE, SIZE, OR COLOR.



**CLASS 3—(Continued).**

THE NAME(S), PORTRAIT(S), AND/OR SIGNATURE(S) SHOWN IN THE MARK IDENTIFIES "LISA ASHLEY", WHOSE CONSENT(S) TO REGISTER IS MADE OF RECORD.

FOR SKIN CLEANSER, SKIN MOISTURIZER, NON-MEDICATED SKIN BLEMISH TREATMENT CREAM AND TINTED LIP BALM (U.S. CLS. 1, 4, 6, 50, 51 AND 52).

FIRST USE 9-22-2010; IN COMMERCE 9-22-2010.

3,962,591. HENKEL AG & CO. KGAA, DUESSELDORF, FED REP GERMANY. SN 77-827,604. PUB. 8-10-2010, FILED 9-16-2009.

**MICROGRIP TECHNOLOGY**

THE MARK CONSISTS OF STANDARD CHARACTERS WITHOUT CLAIM TO ANY PARTICULAR FONT, STYLE, SIZE, OR COLOR.

NO CLAIM IS MADE TO THE EXCLUSIVE RIGHT TO USE "TECHNOLOGY", APART FROM THE MARK AS SHOWN.

FOR HAIR STYLING PREPARATIONS (U.S. CLS. 1, 4, 6, 50, 51 AND 52).

FIRST USE 5-5-2010; IN COMMERCE 5-5-2010.

3,962,610. SIGNAL INVESTMENT & MANAGEMENT CO., WILMINGTON, DE. SN 77-832,423. PUB. 1-5-2010, FILED 9-22-2009.

**WATER ARMOR**

THE MARK CONSISTS OF STANDARD CHARACTERS WITHOUT CLAIM TO ANY PARTICULAR FONT, STYLE, SIZE, OR COLOR.

FOR SUN SCREEN PREPARATIONS; SUN BLOCK PREPARATIONS; CHEMICAL INGREDIENTS WHICH ENHANCE SUN SCREEN PROTECTION, SOLD AS AN INTEGRAL COMPONENT OF SUN BLOCKS AND SUN SCREENS (U.S. CLS. 1, 4, 6, 50, 51 AND 52).

FIRST USE 11-1-2010; IN COMMERCE 11-1-2010.

3,962,637. REVLO CONSUMER PRODUCTS CORPORATION, NEW YORK, NY. SN 77-845,096. PUB. 6-1-2010, FILED 10-9-2009.

**BLEMISHEAL TECHNOLOGY**

THE MARK CONSISTS OF STANDARD CHARACTERS WITHOUT CLAIM TO ANY PARTICULAR FONT, STYLE, SIZE, OR COLOR.

**CLASS 3—(Continued).**

NO CLAIM IS MADE TO THE EXCLUSIVE RIGHT TO USE "BLEMISH HEAL", APART FROM THE MARK AS SHOWN.

FOR COSMETICS; MAKE-UP (U.S. CLS. 1, 4, 6, 50, 51 AND 52).

FIRST USE 2-7-2011; IN COMMERCE 2-7-2011.

3,962,640. YZY INC, MIAMI, FL. SN 77-846,376. PUB. 2-16-2010, FILED 10-12-2009.

**ARDOR**

THE MARK CONSISTS OF STANDARD CHARACTERS WITHOUT CLAIM TO ANY PARTICULAR FONT, STYLE, SIZE, OR COLOR.

FOR COLOGNES, PERFUMES AND COSMETICS; EAU DE TOILETTE AND EAU DE COLOGNE; PERFUMES AND COLOGNES; PERFUMES, AFTERSHAVES AND COLOGNES (U.S. CLS. 1, 4, 6, 50, 51 AND 52).

FIRST USE 2-15-2011; IN COMMERCE 2-15-2011.

3,962,642. AMOREPACIFIC CORPORATION, SEOUL, REPUBLIC OF KOREA. SN 77-847,373. PUB. 8-3-2010, FILED 10-13-2009.

**SULWHASOO**

THE MARK CONSISTS OF STANDARD CHARACTERS WITHOUT CLAIM TO ANY PARTICULAR FONT, STYLE, SIZE, OR COLOR.

OWNER OF U.S. REG. NO. 2,764,970.

THE WORDING "SULWHASOO" HAS NO MEANING IN A FOREIGN LANGUAGE.

FOR SKIN LOTIONS, FOUNDATION CREAMS, EYE CREAMS; COSMETIC NOURISHING CREAMS; COSMETIC SKIN FRESHENERS; MAKE-UP POWDER; COSMETICS; COSMETIC CREAMS FOR SKIN CARE; SHAMPOOS; DENTIFRICES (U.S. CLS. 1, 4, 6, 50, 51 AND 52).

FIRST USE 5-1-1997; IN COMMERCE 10-31-2009.

3,962,654. TOBI B. GREENE, NEW YORK, NY. SN 77-851,246. PUB. 5-25-2010, FILED 10-18-2009.

**MD.Organix**

NO CLAIM IS MADE TO THE EXCLUSIVE RIGHT TO USE "ORGANICS", APART FROM THE MARK AS SHOWN.

**CLASS 3—(Continued).**

THE MARK CONSISTS OF THE WORDING "M.D. ORGANIX", WITH THE WORD "ORGANIX" STIPPLED AND THE LETTER "X" AS A MODIFICATION OF A BREAST CANCER RIBBON.

FOR AFTER SUN CREAMS; ANTI-AGING CREAM; ANTI-WRINKLE CREAMS; AROMATHERAPY BODY CARE PRODUCTS, NAMELY, BODY LOTION, SHOWER GEL, CUTICLE CREAM, SHAMPOO, CONDITIONER, NON-MEDICATED LIP BALM, SOAP, BODY POLISH, BODY AND FOOT SCRUB AND NON-MEDICATED FOOT CREAM; BEAUTY CREAMS; BEAUTY CREAMS FOR BODY CARE; BODY CREAM; BODY CREAM SOAP; BODY CREAMS; CLEANSING CREAMS; COSMETIC CREAMS; COSMETIC CREAMS FOR SKIN CARE; COSMETIC PREPARATIONS, NAMELY, FIRMING CREAMS; EXFOLIANT CREAMS; EYE CREAM; FACE AND BODY BEAUTY CREAMS; FACE AND BODY CREAMS; FACE CREAMS; FACE CREAMS FOR COSMETIC USE; FACIAL CREAM; FACIAL CREAMS; HAND CREAM; HAND CREAMS; LIP CREAM; MASSAGE CREAMS; MOISTURIZING CREAMS; NATURAL COCOA BUTTER BASED PERSONAL CARE PRODUCTS, NAMELY, BODY LOTION, SHOWER GEL, SOAP, BODY POLISH, BODY AND FOOT SCRUB AND NON-MEDICATED SKIN CREAMS; NIGHT CREAM; NON-MEDICATED FOOT CREAM; NON-MEDICATED SKIN CARE PREPARATIONS, NAMELY, CREAMS, LOTIONS, GELS, TONERS, CLEANSERS AND PEELS; NON-MEDICATED SKIN CREAMS; SCENTED BODY LOTIONS AND CREAMS; SKIN CLEANSING CREAM; SKIN CONDITIONING CREAMS FOR COSMETIC PURPOSES; SKIN CREAM; SKIN CREAMS; SKIN CREAMS IN LIQUID AND IN SOLID FORM; SKIN CREAMS IN LIQUID AND SOLID; SKIN CREAMS IN LIQUID AND SOLID FORM; SUNSCREEN CREAM; SUNSCREEN CREAMS; VANISHING CREAM; ALL OF THE FOREGOING MADE IN SUBSTANTIAL PART OF ORGANIC MATERIALS (U.S. CLS. 1, 4, 6, 50, 51 AND 52).

FIRST USE 2-15-2011; IN COMMERCE 2-15-2011.

---

3,962,668. BRAMTON COMPANY, THE, IRVING, TX. SN 77-855,748. PUB. 9-21-2010, FILED 10-23-2009.

**PAW SAFE**

THE MARK CONSISTS OF STANDARD CHARACTERS WITHOUT CLAIM TO ANY PARTICULAR FONT, STYLE, SIZE, OR COLOR.

FOR CLEANING PREPARATIONS, NAMELY, FLOOR CLEANER, WINDOW CLEANER, MULTI-SURFACE CLEANER, TUB AND TILE CLEANER, TOILET CLEANER AND A TOY AND DISH CLEANER (U.S. CLS. 1, 4, 6, 50, 51 AND 52).

FIRST USE 3-1-2010; IN COMMERCE 3-1-2010.

**CLASS 3—(Continued).**

3,962,714. L'OREAL USA CREATIVE, INC., NEW YORK, NY. SN 77-871,905. PUB. 2-2-2010, FILED 11-13-2009.

**BUTTER WHIP COIL CREAM**

THE MARK CONSISTS OF STANDARD CHARACTERS WITHOUT CLAIM TO ANY PARTICULAR FONT, STYLE, SIZE, OR COLOR.

NO CLAIM IS MADE TO THE EXCLUSIVE RIGHT TO USE "BUTTER" AND "COIL CREAM", APART FROM THE MARK AS SHOWN.

FOR HAIR CARE PREPARATION (U.S. CLS. 1, 4, 6, 50, 51 AND 52).

FIRST USE 12-1-2010; IN COMMERCE 12-1-2010.

---

3,962,730. L'OREAL USA CREATIVE, INC., NEW YORK, NY. SN 77-882,228. PUB. 2-2-2010, FILED 11-30-2009.

**BEACH CLAY**

THE MARK CONSISTS OF STANDARD CHARACTERS WITHOUT CLAIM TO ANY PARTICULAR FONT, STYLE, SIZE, OR COLOR.

OWNER OF U.S. REG. NOS. 3,293,892 AND 3,424,381.

NO CLAIM IS MADE TO THE EXCLUSIVE RIGHT TO USE "CLAY", APART FROM THE MARK AS SHOWN.

FOR HAIR STYLING PREPARATION (U.S. CLS. 1, 4, 6, 50, 51 AND 52).

FIRST USE 3-1-2011; IN COMMERCE 3-1-2011.

---

3,962,733. ZIBA IP HOLDINGS, LLC, ARTESIA, CA. SN 77-882,555. PUB. 8-17-2010, FILED 11-30-2009.

**SUMITA BEAUTY**

THE MARK CONSISTS OF STANDARD CHARACTERS WITHOUT CLAIM TO ANY PARTICULAR FONT, STYLE, SIZE, OR COLOR.

OWNER OF U.S. REG. NO. 3,248,462.

**CLASS 3—(Continued).**

NO CLAIM IS MADE TO THE EXCLUSIVE RIGHT TO USE "BEAUTY", APART FROM THE MARK AS SHOWN.

FOR BEAUTY SALON PRODUCTS, NAMELY, NON-MEDICATED TOILETRIES, COSMETICS, FRAGRANCES, AND BEAUTY PREPARATIONS, NAMELY, MAKEUP KITS COMPRISED OF FOUNDATION MAKEUP, EYESHADOWS, EYE LINER PENCILS, LIPSTICK, EYE MAKEUP, FACIAL MAKEUP, FOUNDATION MAKEUP, LIPSTICK, AND ARTIFICIAL EYELASHES; FACE PACKS, NAMELY, FACIAL BEAUTY MASKS, THEATRICAL MAKEUP, NAIL POLISH, FOUNDATION MAKE UP, FACE POWDER, MASCARA, LIP GLOSS, EYELINER, BLUSH, ROUGE, EYE SHADOW, EYEBROW PENCIL; NAIL CARE PREPARATIONS, NAMELY, NAIL HARDENER, NAIL CONDITIONER, NAIL POLISH BASECOAT AND TOPCOAT, NAIL POLISH REMOVER, NAIL CREAM, NAIL ENAMEL, AND FALSE NAILS; HAIR AND BODY SHAMPOO, HAIR CONDITIONER, HAIR MOUSSE, SCALP CONDITIONER, HAIR RINSES, HAIR GEL, SKIN CLEANSING CREAM, FACIAL, HAND AND BODY CREAMS, LOTIONS AND MOISTURIZERS, BUBBLE BATH, BATH OIL, BATH SALTS, BATH AND BODY GELS, SHOWER GEL, BATH AND BABY POWDER, FACIAL SCRUBS, FACIAL BEAUTY MASKS, TALCUM POWDER, PERFUME, COLOGNE, TOILET WATER, AFTER SHAVE, SHAVING CREAM, SHAVING BALM, SHAVING GEL, BAR BODY SOAP, LIQUID BODY SOAP, DEODORANT SOAP, BODY OIL, BREATH FRESHENER; HAIR BLEACHING PREPARATIONS, HAIR LIGHTENERS, EYE CREAM, NIGHT CREAM, HAIR LOTIONS, SKIN TONERS, TOOTH GEL, MOUTHWASH, TOOTHPASTE, NON-MEDICATED LIP BALM, MASSAGE OIL, PRE-MOISTENED COSMETIC TOWELETTES, SUN BLOCK, AND SUNSCREEN CREAMS AND LOTIONS (U.S. CLS. 1, 4, 6, 50, 51 AND 52).

FIRST USE 12-15-2010; IN COMMERCE 12-15-2010.

3,962,743. DURGA, GARY, TA SUPERVATIONS LLC, MARLBORO, NJ. SN 77-884,727. PUB. 10-19-2010, FILED 12-2-2009.

**MIGHTY BLAST**

THE MARK CONSISTS OF STANDARD CHARACTERS WITHOUT CLAIM TO ANY PARTICULAR FONT, STYLE, SIZE, OR COLOR.

FOR ALL PURPOSE CLEANING PREPARATIONS; BIOTECHNOLOGICAL CHEMICAL AND SPRAY CLEANERS FOR INDUSTRIAL AND HOUSEHOLD APPLICATIONS SUCH AS STAIN REMOVAL, ODOR ELIMINATION, AND BIOREMEDIATION OF MANY TYPES OF ORGANIC AND HYDROCARBON-BASED MATERIALS; BIOTECHNOLOGICAL CLEANING SOLUTION FOR ELIMINATING ODORS, BREAKING DOWN ORGANICS, AND REMOVING STAINS; CLEANING AGENTS FOR CLEANING SURFACES; DISPOSABLE WIPES IMPREGNATED WITH CLEANSING CHEMICALS OR COMPOUNDS FOR HOUSEHOLD PURPOSES; GLASS CLEANING PREPARATIONS; HOUSEHOLD CLEANING PREPARATIONS; IMPREGNATED CLEANING CLOTHS; LIMESTONE REMOVING PREPARATION FOR USE ON HOUSEHOLD APPARATUS (U.S. CLS. 1, 4, 6, 50, 51 AND 52).

FIRST USE 10-19-2010; IN COMMERCE 10-19-2010.

**CLASS 3—(Continued).**

3,962,747. COY PRODUCTS, LLC, MERCER ISLAND, WA. SN 77-885,618. PUB. 10-12-2010, FILED 12-3-2009.

**COY**

THE MARK CONSISTS OF STANDARD CHARACTERS WITHOUT CLAIM TO ANY PARTICULAR FONT, STYLE, SIZE, OR COLOR.

FOR SHAMPOOS; CONDITIONERS; HAIR STYLING CREAMS AND SPRAYS (U.S. CLS. 1, 4, 6, 50, 51 AND 52). FIRST USE 11-0-2009; IN COMMERCE 11-0-2009.

3,962,764. L'OREAL USA CREATIVE, INC., NEW YORK, NY. SN 77-888,845. PUB. 2-9-2010, FILED 12-8-2009.

**THERMO GLIDE**

THE MARK CONSISTS OF STANDARD CHARACTERS WITHOUT CLAIM TO ANY PARTICULAR FONT, STYLE, SIZE, OR COLOR.

FOR HAIR STYLING PREPARATION (U.S. CLS. 1, 4, 6, 50, 51 AND 52). FIRST USE 8-0-2010; IN COMMERCE 8-0-2010.

3,962,765. MC CONNELL, GLORIA J, BOCA RATON, FL. SN 77-889,337. PUB. 5-11-2010, FILED 12-9-2009.

**Stem Cellutrition**

THE MARK CONSISTS OF STANDARD CHARACTERS WITHOUT CLAIM TO ANY PARTICULAR FONT, STYLE, SIZE, OR COLOR.

NO CLAIM IS MADE TO THE EXCLUSIVE RIGHT TO USE "STEM", APART FROM THE MARK AS SHOWN.

FOR BEAUTY CREAMS FOR BODY CARE; BEAUTY LOTIONS; BEAUTY SERUMS; BODY AND BEAUTY CARE COSMETICS; COSMETIC CREAMS FOR SKIN CARE (U.S. CLS. 1, 4, 6, 50, 51 AND 52).

FIRST USE 3-23-2010; IN COMMERCE 3-23-2010.

**CLASS 3—(Continued).**

3,962,791. STILLMAN, ALLISON, DBA ROMANCING THE DIVINE, OJAI, CA. SN 77-898,626. PUB. 5-18-2010, FILED 12-21-2009.



THE COLOR(S) RED, BLUE, GREEN, PINK IS/ARE CLAIMED AS A FEATURE OF THE MARK.

THE MARK CONSISTS OF THE WORDING "ROMANCING THE DIVINE" IN THE COLOR BLUE AND THE DESIGN ELEMENT OF RED AND PINK ROSES WITH GREEN LEAVES AND STEMS.

FOR AROMATHERAPY OILS (U.S. CLS. 1, 4, 6, 50, 51 AND 52).

FIRST USE 6-1-2009; IN COMMERCE 1-1-2010.

3,962,805. PHYSICIANS FORMULA, INC., AZUSA, CA. SN 77-903,148. PUB. 4-27-2010, FILED 12-30-2009.

**CASHMERE WEAR**

THE MARK CONSISTS OF STANDARD CHARACTERS WITHOUT CLAIM TO ANY PARTICULAR FONT, STYLE, SIZE, OR COLOR.

OWNER OF U.S. REG. NOS. 3,164,117 AND 3,454,574. FOR COSMETICS (U.S. CLS. 1, 4, 6, 50, 51 AND 52). FIRST USE 11-23-2010; IN COMMERCE 11-23-2010.

3,962,806. PHYSICIANS FORMULA, INC., AZUSA, CA. SN 77-903,165. PUB. 6-29-2010, FILED 12-30-2009.

**HAPPY BOOSTER**

THE MARK CONSISTS OF STANDARD CHARACTERS WITHOUT CLAIM TO ANY PARTICULAR FONT, STYLE, SIZE, OR COLOR.

OWNER OF U.S. REG. NO. 3,737,835. FOR COSMETICS (U.S. CLS. 1, 4, 6, 50, 51 AND 52). FIRST USE 12-6-2010; IN COMMERCE 12-6-2010.

**CLASS 3—(Continued).**

3,962,812. L'OREAL USA CREATIVE, INC., NEW YORK, NY. SN 77-904,565. PUB. 3-30-2010, FILED 1-4-2010.

**FEATHER WHIPPED CURL CREAM**

THE MARK CONSISTS OF STANDARD CHARACTERS WITHOUT CLAIM TO ANY PARTICULAR FONT, STYLE, SIZE, OR COLOR.

OWNER OF U.S. REG. NOS. 2,760,406 AND 3,373,586.

NO CLAIM IS MADE TO THE EXCLUSIVE RIGHT TO USE "CURL CREAM", APART FROM THE MARK AS SHOWN.

FOR HAIR STYLING PREPARATION (U.S. CLS. 1, 4, 6, 50, 51 AND 52).

FIRST USE 12-0-2010; IN COMMERCE 12-0-2010.

3,962,856. STEPHANIE GIORDANO, BROOKFIELD, WI. SN 77-917,512. PUB. 7-13-2010, FILED 1-22-2010.

**CHILLY WINTER CHEEKS**

THE MARK CONSISTS OF STANDARD CHARACTERS WITHOUT CLAIM TO ANY PARTICULAR FONT, STYLE, SIZE, OR COLOR.

FOR SUNSCREEN LOTIONS; NON-MEDICATED MOISTURIZING LOTIONS FOR THE SKIN (U.S. CLS. 1, 4, 6, 50, 51 AND 52).

FIRST USE 3-2-2011; IN COMMERCE 3-2-2011.

3,962,911. STRENGTH OF NATURE, LLC, SAVANNAH, GA. SN 77-930,163. PUB. 8-3-2010, FILED 2-8-2010.

**OLIVE MIRACLE**

THE MARK CONSISTS OF STANDARD CHARACTERS WITHOUT CLAIM TO ANY PARTICULAR FONT, STYLE, SIZE, OR COLOR.

NO CLAIM IS MADE TO THE EXCLUSIVE RIGHT TO USE "OLIVE", APART FROM THE MARK AS SHOWN.

FOR HAIR CARE PREPARATIONS CONTAINING OLIVE OIL (U.S. CLS. 1, 4, 6, 50, 51 AND 52).

FIRST USE 5-14-2010; IN COMMERCE 5-14-2010.

**CLASS 3—(Continued).**

3,962,977. ESSENTIALLY BASIC, LLC, MIDWAY, UT. SN 77-942,621. PUB. 7-20-2010, FILED 2-23-2010.

## barefoot butter

THE MARK CONSISTS OF STANDARD CHARACTERS WITHOUT CLAIM TO ANY PARTICULAR FONT, STYLE, SIZE, OR COLOR.

NO CLAIM IS MADE TO THE EXCLUSIVE RIGHT TO USE "BUTTER", APART FROM THE MARK AS SHOWN, FOR NON-MEDICATED CREAM FOR DRY CRACKED HEELS (U.S. CLS. 1, 4, 6, 50, 51 AND 52).  
FIRST USE 3-1-2010; IN COMMERCE 4-1-2010.

---

3,963,067. JHONY USA INC., NEW YORK, NY. SN 77-952,262. PUB. 8-3-2010, FILED 3-5-2010.

## 100% SEXY COUTURE

THE MARK CONSISTS OF STANDARD CHARACTERS WITHOUT CLAIM TO ANY PARTICULAR FONT, STYLE, SIZE, OR COLOR.

OWNER OF U.S. REG. NO. 3,773,308.  
FOR FRAGRANCES AND PERFUMERY; FRAGRANCES FOR PERSONAL USE; PERFUME (U.S. CLS. 1, 4, 6, 50, 51 AND 52).  
FIRST USE 3-28-2011; IN COMMERCE 3-28-2011.

---

3,963,068. JHONY USA INC., NEW YORK, NY. SN 77-952,268. PUB. 7-27-2010, FILED 3-5-2010.

## STARLUXE

THE MARK CONSISTS OF STANDARD CHARACTERS WITHOUT CLAIM TO ANY PARTICULAR FONT, STYLE, SIZE, OR COLOR.

FOR FRAGRANCES AND PERFUMERY; FRAGRANCES FOR PERSONAL USE; PERFUME (U.S. CLS. 1, 4, 6, 50, 51 AND 52).  
FIRST USE 9-0-2010; IN COMMERCE 9-0-2010.

**CLASS 3—(Continued).**

3,963,072. CHOTARD, SYLVIE DELPY, EUGENE, OR. SN 77-952,968. PUB. 8-3-2010, FILED 3-8-2010.

## Syllaya

THE MARK CONSISTS OF STANDARD CHARACTERS WITHOUT CLAIM TO ANY PARTICULAR FONT, STYLE, SIZE, OR COLOR.

FOR AROMATHERAPY OIL; COSMETIC PREPARATIONS FOR BODY CARE; COSMETIC PREPARATIONS FOR SKIN RENEWAL; ESSENTIAL OILS FOR PERSONAL USE (U.S. CLS. 1, 4, 6, 50, 51 AND 52).  
FIRST USE 2-28-2011; IN COMMERCE 2-28-2011.

---

3,963,127. ADVANCED INGREDIENTS, INC., CAPITOLA, CA. SN 77-959,365. PUB. 8-3-2010, FILED 3-15-2010.

## FRUITSOURCE

THE MARK CONSISTS OF STANDARD CHARACTERS WITHOUT CLAIM TO ANY PARTICULAR FONT, STYLE, SIZE, OR COLOR.

OWNER OF U.S. REG. NO. 1,795,173.  
FOR COSMETICS (U.S. CLS. 1, 4, 6, 50, 51 AND 52).  
FIRST USE 3-22-2011; IN COMMERCE 3-22-2011.

---

3,963,300. COTY DEUTSCHLAND GMBH, MAINZ, FED REP GERMANY. SN 78-943,988. PUB. 2-20-2007, FILED 8-3-2006.

## TRULY PINK

THE MARK CONSISTS OF STANDARD CHARACTERS WITHOUT CLAIM TO ANY PARTICULAR FONT, STYLE, SIZE, OR COLOR.

NO CLAIM IS MADE TO THE EXCLUSIVE RIGHT TO USE "PINK", APART FROM THE MARK AS SHOWN.  
FOR PERFUMERY, NAMELY, PERFUME, COLOGNE, SCENTED SOAPS, EAU DE TOILETTE; BEAUTY CARE PREPARATIONS, NAMELY, SKIN AND BODY CREAMS, LOTIONS, CLEANSERS, TONERS AND MOISTURIZERS; BODY WASH, SHOWER GEL AND BUBBLE BATH (U.S. CLS. 1, 4, 6, 50, 51 AND 52).  
FIRST USE 1-1-2007; IN COMMERCE 1-1-2007.



**CLASS 3—(Continued).**

3,963,317. THE PROCTER & GAMBLE COMPANY, CINCINNATI, OH. SN 85-003,000. PUB. 8-10-2010, FILED 3-31-2010.

**PLAYMAKER**

THE MARK CONSISTS OF STANDARD CHARACTERS WITHOUT CLAIM TO ANY PARTICULAR FONT, STYLE, SIZE, OR COLOR.

FOR BODY WASH; ANTIPERSPIRANTS AND DEODORANTS (U.S. CLS. 1, 4, 6, 50, 51 AND 52).  
FIRST USE 2-14-2011; IN COMMERCE 2-14-2011.

3,963,325. KERALAGE LLC, MONROE, NY. SN 85-004,663. PUB. 8-24-2010, FILED 4-1-2010.

**HEALTHY HAIR BEGINS HERE**

THE MARK CONSISTS OF STANDARD CHARACTERS WITHOUT CLAIM TO ANY PARTICULAR FONT, STYLE, SIZE, OR COLOR.

FOR HAIR CARE PREPARATIONS; NON-MEDICATED HAIR TREATMENT PREPARATIONS FOR COSMETIC PURPOSES (U.S. CLS. 1, 4, 6, 50, 51 AND 52).  
FIRST USE 2-28-2011; IN COMMERCE 2-28-2011.

3,963,367. MARTIN, RICARDOS.B, DBA INFUSION ESSENTIALS, MARIETTA, GA. SN 85-011,212. PUB. 9-7-2010, FILED 4-10-2010.

**InFusion Essentials**

THE MARK CONSISTS OF STANDARD CHARACTERS WITHOUT CLAIM TO ANY PARTICULAR FONT, STYLE, SIZE, OR COLOR.

FOR FACE AND BODY CREAMS; FACE AND BODY LOTIONS; HAIR CARE LOTIONS; HAIR CARE PREPARATIONS; HAIR OILS; HAIR SHAMPOOS AND CONDITIONERS (U.S. CLS. 1, 4, 6, 50, 51 AND 52).  
FIRST USE 2-11-2011; IN COMMERCE 2-18-2011.

**CLASS 3—(Continued).**

3,963,417. RENPURE, L.L.C., EDINA, MN. SN 85-025,221. PUB. 9-28-2010, FILED 4-28-2010.

**MY FOXY HAIR NEEDS FIXING!**

THE MARK CONSISTS OF STANDARD CHARACTERS WITHOUT CLAIM TO ANY PARTICULAR FONT, STYLE, SIZE, OR COLOR.

FOR HAIR CARE PREPARATIONS; HAIR SHAMPOOS AND CONDITIONERS (U.S. CLS. 1, 4, 6, 50, 51 AND 52).  
FIRST USE 12-15-2010; IN COMMERCE 12-15-2010.

3,963,418. RENPURE, L.L.C., EDINA, MN. SN 85-025,227. PUB. 9-28-2010, FILED 4-28-2010.

**MY STYLIN' HAIR NEEDS STRENGTH!**

THE MARK CONSISTS OF STANDARD CHARACTERS WITHOUT CLAIM TO ANY PARTICULAR FONT, STYLE, SIZE, OR COLOR.

FOR HAIR CARE PREPARATIONS; HAIR SHAMPOOS AND CONDITIONERS (U.S. CLS. 1, 4, 6, 50, 51 AND 52).  
FIRST USE 12-15-2010; IN COMMERCE 12-15-2010.

3,963,419. RENPURE, L.L.C., EDINA, MN. SN 85-025,238. PUB. 9-28-2010, FILED 4-28-2010.

**MY SAVVY HAIR NEEDS SLEEK!**

THE MARK CONSISTS OF STANDARD CHARACTERS WITHOUT CLAIM TO ANY PARTICULAR FONT, STYLE, SIZE, OR COLOR.

FOR HAIR CARE PREPARATIONS; HAIR SHAMPOOS AND CONDITIONERS (U.S. CLS. 1, 4, 6, 50, 51 AND 52).  
FIRST USE 12-15-2010; IN COMMERCE 12-15-2010.

**CLASS 3—(Continued).**

3,963,446. COTY GERMANY GMBH, MAINZ, FED REP GERMANY. SN 85-032,104. PUB. 9-21-2010, FILED 5-6-2010.

## PLAY IT SEXY

THE MARK CONSISTS OF STANDARD CHARACTERS WITHOUT CLAIM TO ANY PARTICULAR FONT, STYLE, SIZE, OR COLOR.

FOR COSMETICS, PERFUMERY, ESSENTIAL OLS, SOAPS (U.S. CLS. 1, 4, 6, 50, 51 AND 52).

FIRST USE 1-31-2011; IN COMMERCE 1-31-2011.

---

3,963,511. HE, BING RONG, MARKHAM, ONTARIO, CANADA. SN 85-047,349. PUB. 11-16-2010, FILED 5-25-2010.

la bornita  
switzerland element

NO CLAIM IS MADE TO THE EXCLUSIVE RIGHT TO USE "SWITZERLAND", APART FROM THE MARK AS SHOWN.

THE ENGLISH TRANSLATION OF "LA BORNITA" IN THE MARK IS "BORNITE".

FOR SKIN CARE PRODUCTS, NAMELY, COSMETIC CREAMS FOR SKIN CARE, BODY LOTIONS, SKIN MOISTURIZER, SKIN TONERS, ASTRINGENTS FOR COSMETIC PURPOSES, SKIN CLEANSING CREAM, SKIN CLEANSING LOTION, BAR SOAP, LIQUID SOAP, SHOWER AND BATH GEL, FOUNDATIONS, BLUSH, FACE POWDER, FACIAL CONCEALER, EYE LINER, EYEBROW PENCILS, EYE SHADOWS, MASCARAS, LIPSTICKS, LIP LINER, NAIL ENAMELS, PERFUME, DEODORANTS AND ANTIPERSPIRANTS (U.S. CLS. 1, 4, 6, 50, 51 AND 52).

FIRST USE 11-25-2009; IN COMMERCE 11-25-2009.

**CLASS 3—(Continued).**

3,963,534. ORIAKU, NKECHINYERE, BUFFALO, NY. AND EGWU, CHETACHI, FT. LAUDERDALE, NY. AND EGWU, ADELE, RIVERDALE, NY. SN 85-054,460. PUB. 10-26-2010, FILED 6-3-2010.



NO CLAIM IS MADE TO THE EXCLUSIVE RIGHT TO USE "GOLDEN LIQUID BATH SOAP", APART FROM THE MARK AS SHOWN.

THE COLOR(S) GOLD, BLACK, YELLOW, BROWN, CREAM, WHITE, GREEN AND TAN IS/ARE CLAIMED AS A FEATURE OF THE MARK.

THE MARK CONSISTS OF THE WORDING "GOLDEN" IN THE COLOR GOLD AND "LIQUID BATH SOAP BY U.C.A.N" ALL IN THE COLOR BLACK ON A YELLOW BAND. BEHIND THE YELLOW BAND APPEARS A BROWN WOODEN BOWL, A CREAM COLORED STONE, AND A WHITE TWISTED TOWEL ON A GREEN LEAF FEATURING DROPS OF WATER ALL LAYING UPON A TAN COLORED MAT.

FOR BATH SOAPS IN LIQUID, SOLID OR GEL FORM (U.S. CLS. 1, 4, 6, 50, 51 AND 52).

FIRST USE 6-1-2010; IN COMMERCE 8-1-2010.

---

3,963,548. UNICO INTERNATIONAL TRADING CORP., BOCA RATON, FL. SN 85-060,198. PUB. 11-16-2010, FILED 6-11-2010.

## NOZ-EEZ

THE MARK CONSISTS OF STANDARD CHARACTERS WITHOUT CLAIM TO ANY PARTICULAR FONT, STYLE, SIZE, OR COLOR.

FOR DISPOSABLE WIPES IMPREGNATED WITH CLEANSING CHEMICALS OR COMPOUNDS FOR PERSONAL HYGIENE AND NASAL CARE (U.S. CLS. 1, 4, 6, 50, 51 AND 52).

FIRST USE 1-18-2011; IN COMMERCE 1-18-2011.

**CLASS 3—(Continued).**

3,963,549. UNICO INTERNATIONAL TRADING CORP., BOCA RATON, FL. SN 85-060,201. PUB. 11-16-2010, FILED 6-11-2010.

**OUCH-EEZ**

THE MARK CONSISTS OF STANDARD CHARACTERS WITHOUT CLAIM TO ANY PARTICULAR FONT, STYLE, SIZE, OR COLOR.

FOR DISPOSABLE WIPES IMPREGNATED WITH CLEANSING CHEMICALS OR COMPOUNDS FOR PERSONAL HYGIENE (U.S. CLS. 1, 4, 6, 50, 51 AND 52).  
FIRST USE 1-18-2011; IN COMMERCE 1-18-2011.

**CLASS 3—(Continued).**

3,963,552. ORLY INTERNATIONAL, INC., VAN NUYS, CA. SN 85-060,346. PUB. 11-30-2010, FILED 6-11-2010.

**SNAP DRY**

THE MARK CONSISTS OF STANDARD CHARACTERS WITHOUT CLAIM TO ANY PARTICULAR FONT, STYLE, SIZE, OR COLOR.

OWNER OF U.S. REG. NO. 1,697,306.  
NO CLAIM IS MADE TO THE EXCLUSIVE RIGHT TO USE "DRY", APART FROM THE MARK AS SHOWN.  
FOR NAIL CARE PREPARATIONS (U.S. CLS. 1, 4, 6, 50, 51 AND 52).  
FIRST USE 12-22-2010; IN COMMERCE 12-22-2010.

3,963,550. ORLY INTERNATIONAL, INC., VAN NUYS, CA. SN 85-060,324. PUB. 11-30-2010, FILED 6-11-2010.

**POLISH BOND**

THE MARK CONSISTS OF STANDARD CHARACTERS WITHOUT CLAIM TO ANY PARTICULAR FONT, STYLE, SIZE, OR COLOR.

NO CLAIM IS MADE TO THE EXCLUSIVE RIGHT TO USE "POLISH", APART FROM THE MARK AS SHOWN.  
FOR NAIL CARE PREPARATIONS, EXCLUDING ADHESIVES FOR ARTIFICIAL NAILS (U.S. CLS. 1, 4, 6, 50, 51 AND 52).  
FIRST USE 12-22-2010; IN COMMERCE 12-22-2010.

3,963,553. ORLY INTERNATIONAL, INC., VAN NUYS, CA. SN 85-060,361. PUB. 11-9-2010, FILED 6-11-2010.

**BOTTOM TOP**

THE MARK CONSISTS OF STANDARD CHARACTERS WITHOUT CLAIM TO ANY PARTICULAR FONT, STYLE, SIZE, OR COLOR.

OWNER OF U.S. REG. NO. 2,886,184.  
FOR NAIL CARE PREPARATIONS (U.S. CLS. 1, 4, 6, 50, 51 AND 52).  
FIRST USE 12-22-2010; IN COMMERCE 12-22-2010.

3,963,551. ORLY INTERNATIONAL, INC., VAN NUYS, CA. SN 85-060,329. PUB. 11-30-2010, FILED 6-11-2010.

**CHIP GUARD**

THE MARK CONSISTS OF STANDARD CHARACTERS WITHOUT CLAIM TO ANY PARTICULAR FONT, STYLE, SIZE, OR COLOR.

NO CLAIM IS MADE TO THE EXCLUSIVE RIGHT TO USE "CHIP", APART FROM THE MARK AS SHOWN.  
FOR NAIL CARE PREPARATIONS (U.S. CLS. 1, 4, 6, 50, 51 AND 52).  
FIRST USE 12-22-2010; IN COMMERCE 12-22-2010.

3,963,554. ORLY INTERNATIONAL, INC., VAN NUYS, CA. SN 85-060,374. PUB. 11-30-2010, FILED 6-11-2010.

**COLOR CARE**

THE MARK CONSISTS OF STANDARD CHARACTERS WITHOUT CLAIM TO ANY PARTICULAR FONT, STYLE, SIZE, OR COLOR.

NO CLAIM IS MADE TO THE EXCLUSIVE RIGHT TO USE "COLOR", APART FROM THE MARK AS SHOWN.  
FOR NAIL CARE PREPARATIONS (U.S. CLS. 1, 4, 6, 50, 51 AND 52).  
FIRST USE 12-22-2010; IN COMMERCE 12-22-2010.

**CLASS 3—(Continued).**

3,963,593. L'OREAL USA CREATIVE, INC., NEW YORK, NY. SN 85-071,439. PUB. 8-24-2010, FILED 6-25-2010.

**HEALTHY-GLOSS 5**

THE MARK CONSISTS OF STANDARD CHARACTERS WITHOUT CLAIM TO ANY PARTICULAR FONT, STYLE, SIZE, OR COLOR.

NO CLAIM IS MADE TO THE EXCLUSIVE RIGHT TO USE "HEALTHY GLOSS", APART FROM THE MARK AS SHOWN.

FOR HAIR CARE PREPARATIONS, NON-MEDICATED HAIR TREATMENT PREPARATIONS AND HAIR RELAXERS (U.S. CLS. 1, 4, 6, 50, 51 AND 52).

FIRST USE 1-0-2011; IN COMMERCE 1-0-2011.

3,963,610. ORLY INTERNATIONAL, INC., VAN NUYS, CA. SN 85-074,582. PUB. 11-9-2010, FILED 6-30-2010.

**GROW AID**

THE MARK CONSISTS OF STANDARD CHARACTERS WITHOUT CLAIM TO ANY PARTICULAR FONT, STYLE, SIZE, OR COLOR.

FOR NAIL CARE PREPARATIONS (U.S. CLS. 1, 4, 6, 50, 51 AND 52).

FIRST USE 12-22-2010; IN COMMERCE 12-22-2010.

3,963,614. SEAWEED BATH CO., LLC, THE, AUSTIN, TX. SN 85-076,450. PUB. 10-19-2010, FILED 7-1-2010.



NO CLAIM IS MADE TO THE EXCLUSIVE RIGHT TO USE "THE SEAWEED BATH CO." AND "FIGHTING FLAKING AND SCALING SKIN NATURALLY", APART FROM THE MARK AS SHOWN.

THE MARK CONSISTS OF THE DESIGN OF A PLANT UNDER WATER IN A RECTANGLE BOX WITH A BORDER AND WORDS ABOVE "THE SEAWEED BATH CO. FIGHTING FLAKING AND SCALING SKIN NATURALLY".

FOR NON-MEDICATED SKIN CARE PREPARATIONS (U.S. CLS. 1, 4, 6, 50, 51 AND 52).

FIRST USE 7-1-2010; IN COMMERCE 9-1-2010.

**CLASS 3—(Continued).**

3,963,636. EVOLVED NOVELTIES, INC., DBA EVOLVED NOVELTIES, CANOGA PARK, CA. SN 85-082,408. PUB. 12-28-2010, FILED 7-12-2010.

**SMART CLEANER**

THE MARK CONSISTS OF STANDARD CHARACTERS WITHOUT CLAIM TO ANY PARTICULAR FONT, STYLE, SIZE, OR COLOR.

NO CLAIM IS MADE TO THE EXCLUSIVE RIGHT TO USE "CLEANER", APART FROM THE MARK AS SHOWN.

FOR LIQUID FOR CLEANING ADULT SEXUAL AID PRODUCTS, NAMELY, DILDOS AND PHALLIC-SHAPED VIBRATORS (U.S. CLS. 1, 4, 6, 50, 51 AND 52).

FIRST USE 12-29-2010; IN COMMERCE 12-29-2010.

3,963,638. ALTERNA HOLDINGS CORP., CENTURY CITY, CA. SN 85-083,719. PUB. 12-21-2010, FILED 7-13-2010.

**STYLING COCKTAILS**

THE MARK CONSISTS OF STANDARD CHARACTERS WITHOUT CLAIM TO ANY PARTICULAR FONT, STYLE, SIZE, OR COLOR.

NO CLAIM IS MADE TO THE EXCLUSIVE RIGHT TO USE "STYLING", APART FROM THE MARK AS SHOWN.

FOR HAIR CARE PREPARATIONS (U.S. CLS. 1, 4, 6, 50, 51 AND 52).

FIRST USE 10-29-2010; IN COMMERCE 10-29-2010.

3,963,691. SISQUOC HEALTHCARE, INC., NEWPORT BEACH, CA. SN 85-105,467. PUB. 1-25-2011, FILED 8-11-2010.

**EPIBRIGHT**

THE MARK CONSISTS OF STANDARD CHARACTERS WITHOUT CLAIM TO ANY PARTICULAR FONT, STYLE, SIZE, OR COLOR.

FOR SKIN LIGHTENING CREAMS (U.S. CLS. 1, 4, 6, 50, 51 AND 52).

FIRST USE 1-1-2011; IN COMMERCE 1-1-2011.

**CLASS 3—(Continued).**

3,963,702. UNICO INTERNATIONAL TRADING CORP., BOCA RATON, FL. SN 85-113,378. PUB. 11-16-2010, FILED 8-23-2010.

## FEVER-EEZ

THE MARK CONSISTS OF STANDARD CHARACTERS WITHOUT CLAIM TO ANY PARTICULAR FONT, STYLE, SIZE, OR COLOR.

FOR NON-MEDICATED DISPOSABLE WIPES IMPREGNATED WITH CLEANSING CHEMICALS OR COMPOUNDS FOR PERSONAL HYGIENE USED TO PRODUCE A COOLING EFFECT IN RELIEF OF BODY HEAT (U.S. CLS. 1, 4, 6, 50, 51 AND 52).

FIRST USE 1-18-2011; IN COMMERCE 1-18-2011.

**CLASS 3—(Continued).**

3,963,713. DIAMOND WIPES INTERNATIONAL, CHINO, CA. SN 85-133,348. PUB. 2-1-2011, FILED 9-20-2010.

## handynaps

THE MARK CONSISTS OF STANDARD CHARACTERS WITHOUT CLAIM TO ANY PARTICULAR FONT, STYLE, SIZE, OR COLOR.

FOR DISPOSABLE WIPES IMPREGNATED WITH CLEANSING CHEMICALS OR COMPOUNDS FOR PERSONAL HYGIENE; DISPOSABLE WIPES IMPREGNATED WITH CLEANSING COMPOUNDS FOR USE ON SKIN; WIPES IMPREGNATED WITH A SKIN CLEANSER (U.S. CLS. 1, 4, 6, 50, 51 AND 52).

FIRST USE 5-13-2010; IN COMMERCE 5-13-2010.

3,963,711. COLGATE-PALMOLIVE COMPANY, NEW YORK, NY. SN 85-129,908. PUB. 1-11-2011, FILED 9-15-2010.

## SPEARMINT BLAST

THE MARK CONSISTS OF STANDARD CHARACTERS WITHOUT CLAIM TO ANY PARTICULAR FONT, STYLE, SIZE, OR COLOR.

OWNER OF U.S. REG. NO. 2,705,467.

NO CLAIM IS MADE TO THE EXCLUSIVE RIGHT TO USE "SPEARMINT", APART FROM THE MARK AS SHOWN.

FOR TOOTHPASTE (U.S. CLS. 1, 4, 6, 50, 51 AND 52).  
FIRST USE 2-7-2011; IN COMMERCE 2-7-2011.

3,963,721. PACIFIC WORLD CORPORATION, LAKE FOREST, CA. SN 85-975,129. PUB. 9-28-2010, FILED 5-6-2010.

## GEOGIRL

THE MARK CONSISTS OF STANDARD CHARACTERS WITHOUT CLAIM TO ANY PARTICULAR FONT, STYLE, SIZE, OR COLOR.

FOR FACE POWDER; TINTED MOISTURIZER FOR THE FACE; CONCEALER FOR THE FACE; FACIAL SHIMMER POWDER; EYEBROW GEL (U.S. CLS. 1, 4, 6, 50, 51 AND 52).

FIRST USE 2-0-2011; IN COMMERCE 2-0-2011.

3,963,712. COLGATE-PALMOLIVE COMPANY, NEW YORK, NY. SN 85-129,914. PUB. 1-11-2011, FILED 9-15-2010.

## EFFERVESCENT MINT

THE MARK CONSISTS OF STANDARD CHARACTERS WITHOUT CLAIM TO ANY PARTICULAR FONT, STYLE, SIZE, OR COLOR.

NO CLAIM IS MADE TO THE EXCLUSIVE RIGHT TO USE "MINT", APART FROM THE MARK AS SHOWN.

FOR TOOTHPASTE (U.S. CLS. 1, 4, 6, 50, 51 AND 52).  
FIRST USE 2-7-2011; IN COMMERCE 2-7-2011.

**CLASS 4—LUBRICANTS AND FUELS**

3,962,159. SOL BRANDS, INC., WILDEY, ST. MICHAEL, BARBADOS. SN 77-494,096. PUB. 12-2-2008, FILED 6-9-2008.

## SOL

THE MARK CONSISTS OF STANDARD CHARACTERS WITHOUT CLAIM TO ANY PARTICULAR FONT, STYLE, SIZE, OR COLOR.

THE FOREIGN WORDING IN THE MARK TRANSLATES INTO ENGLISH AS "SUN".

FOR FUELS, AUTOMOTIVE LUBRICANTS AND INDUSTRIAL LUBRICANTS (U.S. CLS. 1, 6 AND 15).

FIRST USE 4-15-2008; IN COMMERCE 4-15-2008.



**CLASS 4—(Continued).**

3,963,622. ROYAL OAK ENTERPRISES, LLC, ROSWELL, GA. SN 85-076,875. PUB. 12-7-2010, FILED 7-2-2010.

**HICKORY RIVER**

THE MARK CONSISTS OF STANDARD CHARACTERS WITHOUT CLAIM TO ANY PARTICULAR FONT, STYLE, SIZE, OR COLOR.

FOR CHARCOAL BRIQUETTES COMPOSED IN SUBSTANTIAL PART OF HICKORY (U.S. CLS. 1, 6 AND 15). FIRST USE 3-16-2011; IN COMMERCE 3-16-2011.

---

3,963,637. AN ORGANIC WICK, LLC, DBA ORGANIC WICK OR AN ORGANIC WICK, GOLDEN, CO. SN 85-083,172. PUB. 12-14-2010, FILED 7-13-2010.



THE MARK CONSISTS OF A STYLIZED STRIPED HONEY BEE IN PROFILE ABOVE THREE TEAR SHAPES, BOTH TO THE LEFT OF THE LITERAL ELEMENT "ORGANICWICK" IN LOWER CASE LETTERS, WITH THE LETTERS "WICK" IN ITALICS.

FOR SOLID FIRE STARTERS (U.S. CLS. 1, 6 AND 15). FIRST USE 2-15-2011; IN COMMERCE 2-15-2011.

---

3,963,646. SOS NOVELTIES, INC., PASADENA, CA. SN 85-085,037. PUB. 12-21-2010, FILED 7-15-2010.

**SOS**

THE MARK CONSISTS OF STANDARD CHARACTERS WITHOUT CLAIM TO ANY PARTICULAR FONT, STYLE, SIZE, OR COLOR.

FOR CANDLES (U.S. CLS. 1, 6 AND 15). FIRST USE 11-15-2010; IN COMMERCE 11-15-2010.

**CLASS 5—PHARMACEUTICALS****CLASS 5—(Continued).**

3,961,963. CONSEAL INTERNATIONAL INCORPORATED, NORWOOD, MA. SN 76-661,565. PUB. 2-12-2008, FILED 6-14-2006.

**NANOSIL**

THE MARK CONSISTS OF STANDARD CHARACTERS WITHOUT CLAIM TO ANY PARTICULAR FONT, STYLE, SIZE, OR COLOR.

FOR FOOD SUPPLEMENTS, NAMELY, DIETARY FOOD SUPPLEMENTS FOR HUMAN CONSUMPTION, NUTRITIONAL MEAL REPLACEMENT SUPPLEMENTS, NUTRITIONAL DRINK MIXES FOR USE AS MEAL REPLACEMENTS, NUTRACEUTICALS FOR USE AS DIETARY SUPPLEMENTS, NUTRITIONAL ADDITIVES FOR USE IN FOODS, DIETARY CAPSULES IN THE NATURE OF A DIETARY SUPPLEMENT, NUTRITIONAL PILLS IN THE NATURE OF A NUTRITIONAL SUPPLEMENT, FOOD FOR MEDICALLY RESTRICTED DIETS, MINERAL NUTRITIONAL SUPPLEMENTS, NUTRITIONAL ADDITIVES FOR USE IN FOODS AND DIETARY SUPPLEMENTS FOR HUMAN CONSUMPTION, MEAL REPLACEMENT SUPPLEMENTS AND SHAKES, POWDERED NUTRITIONAL SUPPLEMENT DRINK MIXES, AND VITAMIN AND MINERAL PREPARATIONS FOR USE AS NUTRITIONAL INGREDIENTS FOR USE IN DIETARY SUPPLEMENTS (U.S. CLS. 6, 18, 44, 46, 51 AND 52).

FIRST USE 4-0-2005; IN COMMERCE 5-0-2005.

---

3,961,966. VITAMINS USA.COM, INC., DALLAS, TX. SN 76-679,054. PUB. 12-4-2007, FILED 6-29-2007.

**NeuroVantage**

THE MARK CONSISTS OF STANDARD CHARACTERS WITHOUT CLAIM TO ANY PARTICULAR FONT, STYLE, SIZE, OR COLOR.

FOR DIETARY SUPPLEMENTS (U.S. CLS. 6, 18, 44, 46, 51 AND 52). FIRST USE 7-22-2010; IN COMMERCE 7-22-2010.

**CLASS 5—(Continued).**

3,962,007. PERNIX THERAPEUTICS, LLC, GONZALES, LA. SN 77-034,634. PUB. 5-8-2007, FILED 11-1-2006.

**NODOLOR**

THE MARK CONSISTS OF STANDARD CHARACTERS WITHOUT CLAIM TO ANY PARTICULAR FONT, STYLE, SIZE, OR COLOR.

FOR PHARMACEUTICAL PREPARATION USED AS AN ANTIHISTAMINE; PHARMACEUTICAL PREPARATION FOR PAIN RELIEF; PHARMACEUTICAL PREPARATION FOR TREATING UPPER RESPIRATORY DISEASES AND ASTHMA (U.S. CLS. 6, 18, 44, 46, 51 AND 52).

FIRST USE 7-29-2010; IN COMMERCE 7-29-2010.

3,962,019. EISAI R&D MANAGEMENT CO., LTD., TOKYO, JAPAN. SN 77-097,283. PUB. 12-4-2007, FILED 2-1-2007.

**HALAVEN**

THE MARK CONSISTS OF STANDARD CHARACTERS WITHOUT CLAIM TO ANY PARTICULAR FONT, STYLE, SIZE, OR COLOR.

FOR PHARMACEUTICAL PREPARATIONS AND SUBSTANCES FOR THE TREATMENT OF ONCOLOGICAL DISEASES (U.S. CLS. 6, 18, 44, 46, 51 AND 52).

FIRST USE 11-17-2010; IN COMMERCE 11-17-2010.

3,962,044. LUSTBERG, A. MICHAEL, SANTA ROSA, CA. SN 77-207,819. PUB. 11-27-2007, FILED 6-15-2007.

**HEALTHY LIVING STARTS FROM  
THE INSIDE**

THE MARK CONSISTS OF STANDARD CHARACTERS WITHOUT CLAIM TO ANY PARTICULAR FONT, STYLE, SIZE, OR COLOR.

FOR VITAMIN AND MINERAL SUPPLEMENTS (U.S. CLS. 6, 18, 44, 46, 51 AND 52).

FIRST USE 11-24-2010; IN COMMERCE 11-27-2010.

**CLASS 5—(Continued).**

3,962,100. THERATECHNOLOGIES, INC., ST-LAURENT, CANADA. SN 77-343,258. PUB. 12-7-2010, FILED 12-4-2007.

**EGRIFTA**

THE MARK CONSISTS OF STANDARD CHARACTERS WITHOUT CLAIM TO ANY PARTICULAR FONT, STYLE, SIZE, OR COLOR.

PRIORITY CLAIMED UNDER SEC. 44(D) ON CANADA APPLICATION NO. 1350032, FILED 6-4-2007.

FOR PHARMACEUTICAL PREPARATIONS FOR THE TREATMENT OF LIPODYSTROPHY, OBESITY, WASTING, GROWTH HORMONE DEFICIENCY, COGNITIVE IMPAIRMENT AND TRAUMATIC BRAIN INJURY; PHARMACEUTICAL PREPARATIONS FOR THE TREATMENT OF MALNUTRITION, FOR THE IMPROVEMENT OF IMMUNE FUNCTION, AND FOR THE IMPROVEMENT OF BONE MINERAL DENSITY (U.S. CLS. 6, 18, 44, 46, 51 AND 52).

FIRST USE 12-27-2010; IN COMMERCE 12-27-2010.

3,962,161. BIOMIMETIC THERAPEUTICS, INC., FRANKLIN, TN. SN 77-502,316. PUB. 8-24-2010, FILED 6-18-2008.

**AUGMENT**

THE MARK CONSISTS OF STANDARD CHARACTERS WITHOUT CLAIM TO ANY PARTICULAR FONT, STYLE, SIZE, OR COLOR.

FOR BIOLOGIC PREPARATIONS FOR USE IN ORTHOPEDIC THERAPIES TO STIMULATE AND REGENERATE BONES, TENDONS, CARTILAGE AND LIGAMENTS (U.S. CLS. 6, 18, 44, 46, 51 AND 52).

FIRST USE 3-2-2011; IN COMMERCE 3-2-2011.

3,962,212. SCHERING-PLOUGH HEALTHCARE PRODUCTS, INC., MEMPHIS, TN. SN 77-571,785. PUB. 1-20-2009, FILED 9-17-2008.

**NEATPAX**

THE MARK CONSISTS OF STANDARD CHARACTERS WITHOUT CLAIM TO ANY PARTICULAR FONT, STYLE, SIZE, OR COLOR.

FOR LAXATIVES (U.S. CLS. 6, 18, 44, 46, 51 AND 52).

FIRST USE 11-12-2010; IN COMMERCE 11-12-2010.

**CLASS 5—(Continued).**

3,962,285. CANADIAN PACIFIC PHYTOPLANKTON, LTD., NANAIMO, CANADA. SN 77-670,446. PUB. 6-16-2009, FILED 2-13-2009.

**CELLANKTON**

THE MARK CONSISTS OF STANDARD CHARACTERS WITHOUT CLAIM TO ANY PARTICULAR FONT, STYLE, SIZE, OR COLOR.

FOR DIETARY AND NUTRITIONAL SUPPLEMENTS (U.S. CLS. 6, 18, 44, 46, 51 AND 52).  
FIRST USE 6-9-2010; IN COMMERCE 6-9-2010.

---

3,962,304. CYTOSPORT, INC., BENICIA, CA. SN 77-682,185. PUB. 8-4-2009, FILED 3-3-2009.

**MONSTER STACK**

THE MARK CONSISTS OF STANDARD CHARACTERS WITHOUT CLAIM TO ANY PARTICULAR FONT, STYLE, SIZE, OR COLOR.

OWNER OF U.S. REG. NO. 2,904,119.  
NO CLAIM IS MADE TO THE EXCLUSIVE RIGHT TO USE "STACK", APART FROM THE MARK AS SHOWN.  
FOR DIETARY AND NUTRITIONAL SUPPLEMENTS, EXCLUDING READY TO DRINK BEVERAGES; DIETARY AND NUTRITIONAL SUPPLEMENT DRINK MIXES, EXCLUDING READY TO DRINK BEVERAGES (U.S. CLS. 6, 18, 44, 46, 51 AND 52).  
FIRST USE 5-6-2009; IN COMMERCE 5-6-2009.

---

3,962,305. CYTOSPORT, INC., BENICIA, CA. SN 77-682,353. PUB. 8-4-2009, FILED 3-3-2009.

**MONSTER PUMP**

THE MARK CONSISTS OF STANDARD CHARACTERS WITHOUT CLAIM TO ANY PARTICULAR FONT, STYLE, SIZE, OR COLOR.

OWNER OF U.S. REG. NO. 2,904,119.  
FOR DIETARY AND NUTRITIONAL SUPPLEMENTS, EXCLUDING READY TO DRINK BEVERAGES; DIETARY SUPPLEMENT DRINK MIXES, EXCLUDING READY TO DRINK BEVERAGES (U.S. CLS. 6, 18, 44, 46, 51 AND 52).  
FIRST USE 5-12-2009; IN COMMERCE 5-12-2009.

**CLASS 5—(Continued).**

3,962,306. CYTOSPORT, INC., BENICIA, CA. SN 77-682,408. PUB. 8-4-2009, FILED 3-3-2009.

**MONSTER MAIZE**

THE MARK CONSISTS OF STANDARD CHARACTERS WITHOUT CLAIM TO ANY PARTICULAR FONT, STYLE, SIZE, OR COLOR.

OWNER OF U.S. REG. NO. 2,904,119.  
NO CLAIM IS MADE TO THE EXCLUSIVE RIGHT TO USE "MAIZE", APART FROM THE MARK AS SHOWN.  
FOR DIETARY AND NUTRITIONAL SUPPLEMENTS, EXCLUDING READY TO DRINK BEVERAGES (U.S. CLS. 6, 18, 44, 46, 51 AND 52).  
FIRST USE 5-12-2009; IN COMMERCE 5-12-2009.

---

3,962,307. CYTOSPORT, INC., BENICIA, CA. SN 77-682,447. PUB. 8-4-2009, FILED 3-3-2009.

**MONSTER AMINO**

THE MARK CONSISTS OF STANDARD CHARACTERS WITHOUT CLAIM TO ANY PARTICULAR FONT, STYLE, SIZE, OR COLOR.

OWNER OF U.S. REG. NO. 2,904,119.  
NO CLAIM IS MADE TO THE EXCLUSIVE RIGHT TO USE "AMINO", APART FROM THE MARK AS SHOWN.  
FOR DIETARY AND NUTRITIONAL SUPPLEMENTS, EXCLUDING READY TO DRINK BEVERAGES; DIETARY SUPPLEMENT DRINK MIXES, EXCLUDING READY TO DRINK BEVERAGES (U.S. CLS. 6, 18, 44, 46, 51 AND 52).  
FIRST USE 5-28-2009; IN COMMERCE 5-28-2009.

---

3,962,381. FMC CORPORATION, PHILADELPHIA, PA. SN 77-741,869. PUB. 9-29-2009, FILED 5-21-2009.

**STALLION**

THE MARK CONSISTS OF STANDARD CHARACTERS WITHOUT CLAIM TO ANY PARTICULAR FONT, STYLE, SIZE, OR COLOR.

FOR PREPARATIONS FOR THE DESTRUCTION OF VERMIN, PESTICIDES FOR AGRICULTURAL USE (U.S. CLS. 6, 18, 44, 46, 51 AND 52).  
FIRST USE 2-25-2011; IN COMMERCE 2-25-2011.

**CLASS 5—(Continued).**

3,962,394. JENNIFER YOAKUM, LONGVIEW, TX. AND HAL WITT, LONGVIEW, TX. SN 77-753,376. PUB. 1-19-2010, FILED 6-5-2009.

**SUPERSYNC**

THE MARK CONSISTS OF STANDARD CHARACTERS WITHOUT CLAIM TO ANY PARTICULAR FONT, STYLE, SIZE, OR COLOR.

FOR VETERINARY PREPARATIONS FOR ESTRUS SYNCHRONIZATION (U.S. CLS. 6, 18, 44, 46, 51 AND 52). FIRST USE 12-31-2010; IN COMMERCE 12-31-2010.

3,962,407. ADVANCED BIONUTRITIONALS, L.L.C., ATLANTA, GA. SN 77-761,125. PUB. 11-3-2009, FILED 6-16-2009.

**REDULOXIN**

THE MARK CONSISTS OF STANDARD CHARACTERS WITHOUT CLAIM TO ANY PARTICULAR FONT, STYLE, SIZE, OR COLOR.

FOR DIETARY SUPPLEMENTS FOR HUMAN CONSUMPTION TO REDUCE INFLAMMATION (U.S. CLS. 6, 18, 44, 46, 51 AND 52). FIRST USE 8-13-2009; IN COMMERCE 8-13-2009.

3,962,435. DNA NATURE RESEARCH, INC., HENDERSON, NC. SN 77-775,664. PUB. 11-24-2009, FILED 7-7-2009.

**TurboRESX**

THE MARK CONSISTS OF STANDARD CHARACTERS WITHOUT CLAIM TO ANY PARTICULAR FONT, STYLE, SIZE, OR COLOR.

FOR DIETARY AND NUTRITIONAL SUPPLEMENTS (U.S. CLS. 6, 18, 44, 46, 51 AND 52). FIRST USE 11-20-2009; IN COMMERCE 11-20-2009.

**CLASS 5—(Continued).**

3,962,490. BASF CORPORATION, FLORHAM PARK, NJ. SN 77-798,868. PUB. 11-10-2009, FILED 8-6-2009.

**MOZART**

THE MARK CONSISTS OF STANDARD CHARACTERS WITHOUT CLAIM TO ANY PARTICULAR FONT, STYLE, SIZE, OR COLOR.

FOR FUNGICIDES, PESTICIDES (U.S. CLS. 6, 18, 44, 46, 51 AND 52). FIRST USE 2-15-2011; IN COMMERCE 2-15-2011.

3,962,564. S2 SYNERGY LLC, DBA POO-POURRI, DALLAS, TX. SN 77-820,246. PUB. 2-2-2010, FILED 9-4-2009.

**Loo~Pourri**

THE MARK CONSISTS OF STANDARD CHARACTERS WITHOUT CLAIM TO ANY PARTICULAR FONT, STYLE, SIZE, OR COLOR.

FOR AIR DEODORIZER; AIR FRESHENER SPRAYS; AIR FRESHENERS (U.S. CLS. 6, 18, 44, 46, 51 AND 52). FIRST USE 1-10-2010; IN COMMERCE 1-10-2010.

3,962,577. ADDS PHARMACEUTICALS, LLC, SUNNYVALE, CA. SN 77-823,653. PUB. 2-9-2010, FILED 9-10-2009.



THE COLOR(S) DARK GREEN, GREEN, LIGHT GREEN, YELLOW-GREEN, WHITE, LIGHT BLUE, BLUE AND DARK BLUE IS/ARE CLAIMED AS A FEATURE OF THE MARK.

THE MARK CONSISTS OF "AQUA" DISPLAYED IN LIGHT BLUE, BLUE AND DARK BLUE LETTERS WITH WHITE OUTLINING AND DARK GREEN SHADOWING.

**CLASS 5—(Continued).**

BEGINNING FROM THE LEFT-HAND SIDE OF "AQUA", THE COLORS DARKEN FROM LIGHT BLUE, BLUE, TO DARK BLUE ON THE RIGHT-HAND SIDE. THE TERM "AQUA" OVERLAPS A CIRCLE MADE UP OF FOUR CIRCULAR RINGS. BEGINNING FROM THE OUTER EDGE, THE OUTER RING IS DISPLAYED IN DARK GREEN, THE NEXT RING IS DISPLAYED IN GREEN, THE NEXT RING IS DISPLAYED IN LIGHT GREEN, AND THE INNER MOST RING IS DISPLAYED IN YELLOW-GREEN.

FOR NUTRITIONAL SUPPLEMENTS; VITAMINS; MINERAL SUPPLEMENTS; NUTRITIONAL SUPPLEMENTS CONTAINING FISH OILS; DIETARY SUPPLEMENTS (U.S. CLS. 6, 18, 44, 46, 51 AND 52).

FIRST USE 1-25-2011; IN COMMERCE 1-25-2011.

---

3,962,595. 2TOMS, LLC, DUBLIN, NH. SN 77-828,858. PUB. 2-9-2010, FILED 9-17-2009.

## ButtShield

THE MARK CONSISTS OF STANDARD CHARACTERS WITHOUT CLAIM TO ANY PARTICULAR FONT, STYLE, SIZE, OR COLOR.

FOR RUBBING COMPOUND FOR MEDICAL AND/OR THERAPEUTIC USE; SKIN LUBRICANTS FOR ATHLETES TO PREVENT SKIN CHAFFING (U.S. CLS. 6, 18, 44, 46, 51 AND 52).

FIRST USE 11-15-2010; IN COMMERCE 12-1-2010.

---

3,962,619. MISHRA, ALLAN, MENLO PARK, CA. SN 77-836,195. PUB. 8-3-2010, FILED 9-28-2009.

## VITAKINE

THE MARK CONSISTS OF STANDARD CHARACTERS WITHOUT CLAIM TO ANY PARTICULAR FONT, STYLE, SIZE, OR COLOR.

FOR PLATELET RICH BLOOD PLASMA; PHARMACEUTICAL PREPARATIONS FOR TREATMENT AND PREVENTION OF TENDON AND MUSCLE INJURIES AND DISORDERS, SKIN DISORDERS AND DISEASES, CARDIAC DISORDERS AND DISEASES, BRAIN DISORDERS AND DISEASES, AND SPORTS RELATED INJURIES, AND FOR PROMOTION OF KNEE CARTILAGE REGENERATION; MEDICAMENTS FOR PROMOTING RECOVERY FROM TENDON AND MUSCLE INJURIES AND DISORDERS, SKIN DISORDERS, CARDIAC DISORDERS AND DISEASES, BRAIN DISORDERS AND DISEASES AND SPORTS RELATED INJURIES, AND TO HELP ASSIST WITH THE REGENERATION OF LIGAMENT AND TENDON FIBERS (U.S. CLS. 6, 18, 44, 46, 51 AND 52).

FIRST USE 1-6-2010; IN COMMERCE 1-6-2010.

**CLASS 5—(Continued).**

3,962,647. MORELES, SELOMITH RAMIREZ, IRAPUATO, MEXICO. SN 77-849,900. PUB. 9-7-2010, FILED 10-15-2009.



THE MARK CONSISTS OF THE WORDING "RIVIERE" ABOVE A DESIGN COMPRISED OF A WAVE.

THE ENGLISH TRANSLATION OF "RIVIERE" IN THE MARK IS "RIVER".

FOR DIETARY AND NUTRITIONAL SUPPLEMENTS (U.S. CLS. 6, 18, 44, 46, 51 AND 52).

FIRST USE 1-2-2006; IN COMMERCE 10-5-2008.

---

3,962,672. RAINBOW LIGHT NUTRITIONAL SYSTEMS, INC., SANTA CRUZ, CA. SN 77-857,215. PUB. 3-30-2010, FILED 10-26-2009.

## Probiolicious

THE MARK CONSISTS OF STANDARD CHARACTERS WITHOUT CLAIM TO ANY PARTICULAR FONT, STYLE, SIZE, OR COLOR.

FOR DIETARY AND NUTRITIONAL SUPPLEMENTS; VITAMINS (U.S. CLS. 6, 18, 44, 46, 51 AND 52).

FIRST USE 2-9-2011; IN COMMERCE 2-9-2011.



**CLASS 5—(Continued).**

3,962,696. ALVAREZ, SALVADOR, SAN DIEGO, CA. SN 77-863,072. PUB. 4-6-2010, FILED 11-2-2009.

## Plantimex

THE MARK CONSISTS OF STANDARD CHARACTERS WITHOUT CLAIM TO ANY PARTICULAR FONT, STYLE, SIZE, OR COLOR.

FOR CALCIUM SUPPLEMENTS; DIETARY AND NUTRITIONAL SUPPLEMENTS; DIETARY BEVERAGE SUPPLEMENTS FOR HUMAN CONSUMPTION IN LIQUID AND DRY MIX FORM FOR THERAPEUTIC PURPOSES; DIETARY FOOD SUPPLEMENTS; DIETARY SUPPLEMENT FOR ELIMINATING TOXINS FROM THE INTESTINAL TRACT; DIETARY SUPPLEMENTAL DRINKS; DIETARY SUPPLEMENTAL DRINKS IN THE NATURE OF VITAMIN AND MINERAL BEVERAGES; DIETARY SUPPLEMENTS; DIETARY SUPPLEMENTS FOR ANIMALS; DIETARY SUPPLEMENTS FOR CONTROLLING CHOLESTEROL; DIETARY SUPPLEMENTS FOR HUMAN CONSUMPTION; FOOD SUPPLEMENTS; FOOD SUPPLEMENTS, NAMELY, ANTI-OXIDANTS; GROUND FLAXSEED FIBER FOR USE AS A DIETARY SUPPLEMENT; HEALTH FOOD SUPPLEMENTS; HERBAL SUPPLEMENTS; HOMEOPATHIC SUPPLEMENTS; LECITHIN FOR USE AS A DIETARY SUPPLEMENT; LIQUID NUTRITIONAL SUPPLEMENT; MEAL REPLACEMENT AND DIETARY SUPPLEMENT DRINK MIXES; MINERAL FOOD SUPPLEMENTS; MINERAL NUTRITIONAL SUPPLEMENTS; MINERAL SUPPLEMENTS; NATURAL HERBAL SUPPLEMENTS; NATURAL SUPPLEMENTS FOR TREATING DEPRESSION AND ANXIETY; NATURAL SUPPLEMENTS FOR TREATING ERECTILE DYSFUNCTION; NUTRACEUTICALS FOR USE AS A DIETARY SUPPLEMENT; NUTRITIONAL SUPPLEMENTS; NUTRITIONAL SUPPLEMENTS IN LOTION FORM SOLD AS A COMPONENT OF NUTRITIONAL SKIN CARE PRODUCTS; POWDERED FRUIT-FLAVORED DIETARY SUPPLEMENT DRINK MIX; POWDERED NUTRITIONAL SUPPLEMENT DRINK MIX; PROTEIN SUPPLEMENTS; VITAMIN AND MINERAL SUPPLEMENTS; VITAMIN SUPPLEMENT IN TABLET FORM FOR USE IN MAKING AN EFFERVESCENT BEVERAGE WHEN ADDED TO WATER; VITAMIN SUPPLEMENTS; WEIGHT MANAGEMENT SUPPLEMENTS (U.S. CLS. 6, 18, 44, 46, 51 AND 52).  
FIRST USE 1-1-2009; IN COMMERCE 1-1-2009.

3,962,700. ADVANCED BIOLOGICS LLC, LADERA RANCH, CA. SN 77-864,335. PUB. 5-25-2010, FILED 11-3-2009.

## OSSEOGEN

THE MARK CONSISTS OF STANDARD CHARACTERS WITHOUT CLAIM TO ANY PARTICULAR FONT, STYLE, SIZE, OR COLOR.

FOR ORTHOBIOLOGIC MATERIAL DERIVED FROM HUMAN ALLOGRAFT BONE AND TISSUE (U.S. CLS. 6, 18, 44, 46, 51 AND 52).  
FIRST USE 10-1-2010; IN COMMERCE 1-13-2011.

**CLASS 5—(Continued).**

3,962,708. ALFA VITAMINS LABORATORIES INC., DORAL, FL. SN 77-869,578. PUB. 8-24-2010, FILED 11-10-2009.

## ALFA 369

THE MARK CONSISTS OF STANDARD CHARACTERS WITHOUT CLAIM TO ANY PARTICULAR FONT, STYLE, SIZE, OR COLOR.

NO CLAIM IS MADE TO THE EXCLUSIVE RIGHT TO USE "369", APART FROM THE MARK AS SHOWN.

FOR DIETARY AND NUTRITIONAL SUPPLEMENTS (U.S. CLS. 6, 18, 44, 46, 51 AND 52).

FIRST USE 9-0-2010; IN COMMERCE 9-0-2010.

3,962,774. DR. REDDY'S LABORATORIES, INC., BRIDGEWATER, NJ. SN 77-893,754. PUB. 5-4-2010, FILED 12-15-2009.

## OMP20

THE MARK CONSISTS OF STANDARD CHARACTERS WITHOUT CLAIM TO ANY PARTICULAR FONT, STYLE, SIZE, OR COLOR.

FOR PHARMACEUTICAL PREPARATIONS AND SUBSTANCES FOR THE TREATMENT OF GASTRO-INTESTINAL DISEASES (U.S. CLS. 6, 18, 44, 46, 51 AND 52).

FIRST USE 12-10-2009; IN COMMERCE 12-10-2009.

3,962,775. FLUTRENDS INTERNATIONAL, LLC, DBA FLUTRENDS INTERNATIONAL, LLC, DENVER, CO. SN 77-893,766. PUB. 5-4-2010, FILED 12-15-2009.

## FLUNADA

THE MARK CONSISTS OF STANDARD CHARACTERS WITHOUT CLAIM TO ANY PARTICULAR FONT, STYLE, SIZE, OR COLOR.

FOR ANTI-VIRAL NOSE AND THROAT SPRAY (U.S. CLS. 6, 18, 44, 46, 51 AND 52).

FIRST USE 12-15-2009; IN COMMERCE 2-4-2011.

**CLASS 5—(Continued).**

3,962,795. MATERIALS SCIENCE TECHNOLOGY INC., CONROE, TX. SN 77-899,622. PUB. 8-24-2010, FILED 12-22-2009.

# NOVUS

THE MARK CONSISTS OF STANDARD CHARACTERS WITHOUT CLAIM TO ANY PARTICULAR FONT, STYLE, SIZE, OR COLOR.  
FOR DENTURE LINER (U.S. CLS. 6, 18, 44, 46, 51 AND 52).  
FIRST USE 7-15-2010; IN COMMERCE 12-15-2010.

3,962,836. PAGE, RODNEY K., WILLOWS, CA. SN 77-912,054. PUB. 7-13-2010, FILED 1-14-2010.

# RANGER'S REMEDY

THE MARK CONSISTS OF STANDARD CHARACTERS WITHOUT CLAIM TO ANY PARTICULAR FONT, STYLE, SIZE, OR COLOR.  
NO CLAIM IS MADE TO THE EXCLUSIVE RIGHT TO USE "REMEDY", APART FROM THE MARK AS SHOWN.  
FOR MEDICINAL CREAMS FOR SKIN CARE (U.S. CLS. 6, 18, 44, 46, 51 AND 52).  
FIRST USE 8-1-2010; IN COMMERCE 8-1-2010.

3,962,855. NOVARTIS AG, BASEL, SWITZERLAND. SN 77-916,878. PUB. 6-22-2010, FILED 1-21-2010.

# THERAFLU MAX-D

THE MARK CONSISTS OF STANDARD CHARACTERS WITHOUT CLAIM TO ANY PARTICULAR FONT, STYLE, SIZE, OR COLOR.  
OWNER OF U.S. REG. NOS. 1,452,879, 3,550,152, AND OTHERS.  
FOR COUGH, COLD, FLU AND ALLERGY TREATMENT PREPARATIONS (U.S. CLS. 6, 18, 44, 46, 51 AND 52).  
FIRST USE 7-31-2010; IN COMMERCE 7-31-2010.

**CLASS 5—(Continued).**

3,962,869. BREMBOS, THEODORE J., POINT PLEASANT, NJ. SN 77-920,211. PUB. 7-6-2010, FILED 1-26-2010.

NJIT  
New Jersey International  
Trading Company

THE MARK CONSISTS OF STANDARD CHARACTERS WITHOUT CLAIM TO ANY PARTICULAR FONT, STYLE, SIZE, OR COLOR.  
NO CLAIM IS MADE TO THE EXCLUSIVE RIGHT TO USE "NEW JERSEY INTERNATIONAL TRADING COMPANY", APART FROM THE MARK AS SHOWN.  
FOR DIETARY FOOD SUPPLEMENTS (U.S. CLS. 6, 18, 44, 46, 51 AND 52).  
FIRST USE 9-15-2010; IN COMMERCE 9-15-2010.

3,962,871. HANSEN, LYNN, DECLO, ID. SN 77-920,697. PUB. 6-15-2010, FILED 1-26-2010.

# NITROLYTES

THE MARK CONSISTS OF STANDARD CHARACTERS WITHOUT CLAIM TO ANY PARTICULAR FONT, STYLE, SIZE, OR COLOR.  
FOR NUTRITIONAL SUPPLEMENT (U.S. CLS. 6, 18, 44, 46, 51 AND 52).  
FIRST USE 1-24-2011; IN COMMERCE 1-24-2011.

3,962,873. IDT DENTAL GROUP, LLC, TEANECK, NJ. SN 77-920,920. PUB. 11-23-2010, FILED 1-27-2010.



NO CLAIM IS MADE TO THE EXCLUSIVE RIGHT TO USE "BIOCOMPATIBLE ZIRCONIA", APART FROM THE MARK AS SHOWN.

THE COLOR(S) BLUE, WHITE, LIGHT GREY IS/ARE CLAIMED AS A FEATURE OF THE MARK.

THE MARK CONSISTS OF THE WORD "XENON" IS SURROUNDED WITH A BLUE SQUARE AROUND THE WHITE LETTER "X" AND A BLUE AND WHITE LETTERING OF "ENON". THE WORDING "BIOCOMPATIBLE ZIRCONIA" IS LIGHT GRAY.

FOR ALL CERAMIC ZIRCONIUM DENTAL RESTORATION COMPOUNDS (U.S. CLS. 6, 18, 44, 46, 51 AND 52).  
FIRST USE 12-1-2010; IN COMMERCE 1-20-2011.

**CLASS 5—(Continued).**

3,962,942. EL-GEN LLC, DBA ALIMENTAL SCIENCE, BOHEMIA, NY. SN 77-936,229. PUB. 5-18-2010, FILED 2-16-2010.

# RadioShield

THE MARK CONSISTS OF STANDARD CHARACTERS WITHOUT CLAIM TO ANY PARTICULAR FONT, STYLE, SIZE, OR COLOR.  
FOR DIETARY AND NUTRITIONAL SUPPLEMENTS (U.S. CLS. 6, 18, 44, 46, 51 AND 52).  
FIRST USE 12-8-2010; IN COMMERCE 12-8-2010.

**CLASS 5—(Continued).**

3,962,994. QN LABS, LLC, ROUND ROCK, TX. SN 77-944,029. PUB. 7-20-2010, FILED 2-24-2010.

# QUIDDITY NUTRITION CENTER

THE MARK CONSISTS OF STANDARD CHARACTERS WITHOUT CLAIM TO ANY PARTICULAR FONT, STYLE, SIZE, OR COLOR.  
NO CLAIM IS MADE TO THE EXCLUSIVE RIGHT TO USE "NUTRITION CENTER", APART FROM THE MARK AS SHOWN.  
FOR DIETARY AND NUTRITIONAL SUPPLEMENTS (U.S. CLS. 6, 18, 44, 46, 51 AND 52).  
FIRST USE 2-24-2010; IN COMMERCE 2-24-2010.

3,962,963. LUNADA BIOMEDICAL, LOS ANGELES, CA. SN 77-940,929. PUB. 7-20-2010, FILED 2-21-2010.

# Ambioptin

THE MARK CONSISTS OF STANDARD CHARACTERS WITHOUT CLAIM TO ANY PARTICULAR FONT, STYLE, SIZE, OR COLOR.  
FOR DIETARY SUPPLEMENTS (U.S. CLS. 6, 18, 44, 46, 51 AND 52).  
FIRST USE 8-1-2010; IN COMMERCE 8-1-2010.

3,963,007. CRESCENDO THERAPEUTICS LLC, SAN DIEGO, CA. SN 77-945,009. PUB. 7-20-2010, FILED 2-25-2010.

# HYBRISIL

THE MARK CONSISTS OF STANDARD CHARACTERS WITHOUT CLAIM TO ANY PARTICULAR FONT, STYLE, SIZE, OR COLOR.  
FOR MEDICATED SKIN PREPARATION FOR TREATMENT AND MANAGEMENT OF SKIN AND SCAR TISSUE (U.S. CLS. 6, 18, 44, 46, 51 AND 52).  
FIRST USE 5-20-2010; IN COMMERCE 5-20-2010.

3,962,984. VOLUNTARY PURCHASING GROUPS, INC., BONHAM, TX. SN 77-943,273. PUB. 7-20-2010, FILED 2-24-2010.

# DOUBLE PLAY

THE MARK CONSISTS OF STANDARD CHARACTERS WITHOUT CLAIM TO ANY PARTICULAR FONT, STYLE, SIZE, OR COLOR.  
FOR HERBICIDES (U.S. CLS. 6, 18, 44, 46, 51 AND 52).  
FIRST USE 9-28-2010; IN COMMERCE 9-28-2010.

3,963,128. ADVANCED INGREDIENTS, INC., CAPITOLA, CA. SN 77-959,381. PUB. 8-3-2010, FILED 3-15-2010.

# FRUITSOURCE

THE MARK CONSISTS OF STANDARD CHARACTERS WITHOUT CLAIM TO ANY PARTICULAR FONT, STYLE, SIZE, OR COLOR.  
OWNER OF U.S. REG. NO. 1,795,173.  
FOR DIETARY SUPPLEMENTS; NUTRACEUTICALS FOR USE AS A DIETARY SUPPLEMENT (U.S. CLS. 6, 18, 44, 46, 51 AND 52).  
FIRST USE 3-21-2011; IN COMMERCE 3-21-2011.

**CLASS 5—(Continued).**

3,963,146. GARCIA, JOSE LUIS, CARACAS, VENEZUELA.  
SN 77-960,833. PUB. 8-10-2010, FILED 3-17-2010.

# Valtrum

THE MARK CONSISTS OF STANDARD CHARACTERS WITHOUT CLAIM TO ANY PARTICULAR FONT, STYLE, SIZE, OR COLOR.  
FOR ANTI-INFLAMMATORIES (U.S. CLS. 6, 18, 44, 46, 51 AND 52).  
FIRST USE 11-1-2010; IN COMMERCE 11-1-2010.

3,963,151. METABOLAB, LLC, BEVERLY HILLS, CA. SN 77-961,102. PUB. 8-3-2010, FILED 3-17-2010.

# FIT

THE MARK CONSISTS OF STANDARD CHARACTERS WITHOUT CLAIM TO ANY PARTICULAR FONT, STYLE, SIZE, OR COLOR.  
FOR APPETITE SUPPRESSANTS; DIETARY AND NUTRITIONAL SUPPLEMENTS; DIETARY SUPPLEMENTAL DRINKS; DIETARY SUPPLEMENTS; FOOD SUPPLEMENTS; MEAL REPLACEMENT DRINKS; MEAL REPLACEMENT SHAKES; MEAL REPLACEMENT SNACKS; NUTRITIONAL DRINKS USED FOR MEAL REPLACEMENT; NUTRITIONAL SHAKES FOR USE AS A MEAL SUBSTITUTE; NUTRITIONAL SUPPLEMENTS; PROTEIN SUPPLEMENTS; WEIGHT MANAGEMENT SUPPLEMENTS (U.S. CLS. 6, 18, 44, 46, 51 AND 52).  
FIRST USE 1-28-2011; IN COMMERCE 1-28-2011.

3,963,157. LABRADA BODYBUILDING NUTRITION, INC., HOUSTON, TX. SN 77-961,478. PUB. 8-3-2010, FILED 3-17-2010.

# POWER CARB

THE MARK CONSISTS OF STANDARD CHARACTERS WITHOUT CLAIM TO ANY PARTICULAR FONT, STYLE, SIZE, OR COLOR.  
NO CLAIM IS MADE TO THE EXCLUSIVE RIGHT TO USE "CARB", APART FROM THE MARK AS SHOWN.  
FOR NUTRITIONAL SUPPLEMENTS (U.S. CLS. 6, 18, 44, 46, 51 AND 52).  
FIRST USE 5-28-2010; IN COMMERCE 5-28-2010.

**CLASS 5—(Continued).**

3,963,304. S. C. JOHNSON & SON, INC., RACINE, WI. SN 78-981,457. PUB. 8-24-2010, FILED 1-29-2003.

# BUG-OFF

OWNER OF U.S. REG. NO. 3,303,024.  
FOR INSECT REPELLENTS (U.S. CLS. 6, 18, 44, 46, 51 AND 52).  
FIRST USE 3-29-2010; IN COMMERCE 3-29-2010.

3,963,308. PAINFREE-PERIOD, SANDPOINT, ID. SN 85-000,611. PUB. 8-17-2010, FILED 3-29-2010.



**Painfree-PERIOD**  
*Natural menstrual cramp relief*  
*"Let Nature Heal"*

NO CLAIM IS MADE TO THE EXCLUSIVE RIGHT TO USE "PAINFREE - PERIOD NATURAL MENSTRUAL CRAMP RELIEF", APART FROM THE MARK AS SHOWN. THE COLOR(S) BLACK, BLUE, RED, AND YELLOW IS/ ARE CLAIMED AS A FEATURE OF THE MARK.

THE MARK CONSISTS OF A DESIGN OF A BUTTERFLY ABOVE THE STYLIZED WORDING "PAINFREE - PERIOD NATURAL MENSTRUAL CRAMP RELIEF "LET NATURE HEAL." THE WORDING "PERIOD" IS IN RED AND THE REST OF THE WORDING IS IN BLACK. THE OUTER PART OF THE BUTTERFLY WINGS ARE BLACK WITH BLUE AND YELLOW DETAILING. THE INNER PART OF THE WINGS ARE IN SHADES OF BLUE WITH BLACK VEINS. THERE ARE TWO RED DOTS ON THE LEFT WING AND TWO RED DOTS ON THE RIGHT WING. THE HEAD AND CHEST ARE BLACK, WITH BLACK ANTENNAS, BLUE EYES, BLUE SPOTS ON THE UPPER CHEST, AND A YELLOW OVAL ON THE CHEST. THE LOWER BODY, WHICH EXTENDS FROM BELOW THE OVAL, TO WHERE THE WINGS COME TOGETHER AT THE BOTTOM OF THE BUTTERFLY, IS IN SHADES OF BLUE.

FOR MENSTRUAL SYMPTOM TREATMENT PREPARATIONS (U.S. CLS. 6, 18, 44, 46, 51 AND 52).  
FIRST USE 7-2-2010; IN COMMERCE 7-2-2010.

**CLASS 5—(Continued).**

3,963,334. MONSANTO TECHNOLOGY LLC, ST. LOUIS, MO.  
SN 85-006,242. PUB. 8-31-2010, FILED 4-5-2010.

**WARRANT**

THE MARK CONSISTS OF STANDARD CHARACTERS WITHOUT CLAIM TO ANY PARTICULAR FONT, STYLE, SIZE, OR COLOR.

FOR HERBICIDES FOR AGRICULTURAL USE; HERBICIDES FOR DOMESTIC USE (U.S. CLS. 6, 18, 44, 46, 51 AND 52).

FIRST USE 9-30-2010; IN COMMERCE 9-30-2010.

**CLASS 5—(Continued).**

3,963,497. IMAGENETIX, SAN DIEGO, CA. SN 85-044,485.  
PUB. 10-19-2010, FILED 5-21-2010.

**QUCEL**

THE MARK CONSISTS OF STANDARD CHARACTERS WITHOUT CLAIM TO ANY PARTICULAR FONT, STYLE, SIZE, OR COLOR.

FOR DIETARY SUPPLEMENTS (U.S. CLS. 6, 18, 44, 46, 51 AND 52).

FIRST USE 6-8-2010; IN COMMERCE 6-8-2010.

3,963,436. VALUEVISION MEDIA, INC., EDEN PRAIRIE, MN. SN 85-029,507. PUB. 8-10-2010, FILED 5-4-2010.

**VIVANTAGE**

THE MARK CONSISTS OF STANDARD CHARACTERS WITHOUT CLAIM TO ANY PARTICULAR FONT, STYLE, SIZE, OR COLOR.

FOR DIETARY AND NUTRITIONAL SUPPLEMENTS; DIETARY SUPPLEMENTS; FOOD SUPPLEMENTS; HERBAL SUPPLEMENTS; NUTRACEUTICALS FOR USE AS A DIETARY SUPPLEMENT; NUTRITIONAL SUPPLEMENTS; PROTEIN SUPPLEMENTS; VITAMIN AND MINERAL SUPPLEMENTS; VITAMIN PREPARATIONS; VITAMIN SUPPLEMENTS; VITAMINS (U.S. CLS. 6, 18, 44, 46, 51 AND 52).

FIRST USE 9-13-2010; IN COMMERCE 9-13-2010.

3,963,499. MONSANTO TECHNOLOGY LLC, ST. LOUIS, MO.  
SN 85-044,758. PUB. 8-31-2010, FILED 5-21-2010.

**TRIPLEFLEX**

THE MARK CONSISTS OF STANDARD CHARACTERS WITHOUT CLAIM TO ANY PARTICULAR FONT, STYLE, SIZE, OR COLOR.

FOR AGRICULTURAL HERBICIDE (U.S. CLS. 6, 18, 44, 46, 51 AND 52).

FIRST USE 8-13-2010; IN COMMERCE 8-13-2010.

3,963,473. DAVE PHARMACEUTICALS (DP), INC, HOUSTON, TX. SN 85-037,598. PUB. 11-30-2010, FILED 5-13-2010.

**SECRET WEAPON**

THE MARK CONSISTS OF STANDARD CHARACTERS WITHOUT CLAIM TO ANY PARTICULAR FONT, STYLE, SIZE, OR COLOR.

FOR DIETARY AND NUTRITIONAL SUPPLEMENTS (U.S. CLS. 6, 18, 44, 46, 51 AND 52).

FIRST USE 3-19-2010; IN COMMERCE 5-20-2010.

3,963,545. VORTEX, INC., KETCHUM, ID. SN 85-059,830.  
PUB. 11-9-2010, FILED 6-10-2010.

**SKINNY CHIA**

THE MARK CONSISTS OF STANDARD CHARACTERS WITHOUT CLAIM TO ANY PARTICULAR FONT, STYLE, SIZE, OR COLOR.

NO CLAIM IS MADE TO THE EXCLUSIVE RIGHT TO USE "CHIA", APART FROM THE MARK AS SHOWN.

FOR LOW FAT WHOLE GRAIN FIBER DIETARY FOOD SUPPLEMENT CONTAINING CHIA CONSUMED BY MIXING WITH WATER (U.S. CLS. 6, 18, 44, 46, 51 AND 52).

FIRST USE 12-14-2010; IN COMMERCE 12-14-2010.



**CLASS 5—(Continued).**

3,963,579. WEIGHT WATCHERS INTERNATIONAL, INC., NEW YORK, NY. SN 85-068,801. PUB. 11-16-2010, FILED 6-22-2010.



THE COLOR(S) LIGHT BLUE AND WHITE IS/ARE CLAIMED AS A FEATURE OF THE MARK.

THE MARK CONSISTS OF THE NUMBER "2" AND THE WORDING "POINTSPLUS" WITH A PLUS SIGN IN A CIRCLE AND THE WORD "VALUE" ALL IN WHITE, AND ALL WITHIN A DIAMOND SHAPE WITH ROUNDED CORNERS WITH A LIGHT BLUE BACKGROUND.

FOR DIETARY DRINK MIX FOR USE AS A MEAL REPLACEMENT (U.S. CLS. 6, 18, 44, 46, 51 AND 52).  
FIRST USE 1-1-2011; IN COMMERCE 1-1-2011.

3,963,585. GREEN MEADOWS FORAGE, LLC, GAYVILLE, SD. SN 85-069,686. PUB. 11-16-2010, FILED 6-23-2010.

## Natural Fill

THE MARK CONSISTS OF STANDARD CHARACTERS WITHOUT CLAIM TO ANY PARTICULAR FONT, STYLE, SIZE, OR COLOR.

NO CLAIM IS MADE TO THE EXCLUSIVE RIGHT TO USE "NATURAL", APART FROM THE MARK AS SHOWN.  
FOR ANIMAL FEED SUPPLEMENTS (U.S. CLS. 6, 18, 44, 46, 51 AND 52).

FIRST USE 11-5-2010; IN COMMERCE 11-5-2010.

**CLASS 5—(Continued).**

3,963,632. T & J BIOMEDICAL, OSPREY, FL. SN 85-081,468. PUB. 11-30-2010, FILED 7-9-2010.

## Universal Foundation Formula N-2

THE MARK CONSISTS OF STANDARD CHARACTERS WITHOUT CLAIM TO ANY PARTICULAR FONT, STYLE, SIZE, OR COLOR.

NO CLAIM IS MADE TO THE EXCLUSIVE RIGHT TO USE "FORMULA N-2", APART FROM THE MARK AS SHOWN.

FOR DIETARY AND NUTRITIONAL SUPPLEMENTS (U.S. CLS. 6, 18, 44, 46, 51 AND 52).  
FIRST USE 9-27-2010; IN COMMERCE 9-27-2010.

3,963,634. T & J BIOMEDICAL, OSPREY, FL. SN 85-081,490. PUB. 11-30-2010, FILED 7-9-2010.

## Universal Foundation Formula N-3

THE MARK CONSISTS OF STANDARD CHARACTERS WITHOUT CLAIM TO ANY PARTICULAR FONT, STYLE, SIZE, OR COLOR.

NO CLAIM IS MADE TO THE EXCLUSIVE RIGHT TO USE "FORMULA N-3", APART FROM THE MARK AS SHOWN.

FOR DIETARY AND NUTRITIONAL SUPPLEMENTS (U.S. CLS. 6, 18, 44, 46, 51 AND 52).  
FIRST USE 1-15-2011; IN COMMERCE 1-24-2011.

3,963,648. ARYSTA LIFESCIENCE NORTH AMERICA, LLC, CARY, NC. SN 85-085,921. PUB. 12-28-2010, FILED 7-15-2010.

THE MARK CONSISTS OF SINGLE-LEAF DESIGN AND STEM WITH THE WORD "RAZE".

FOR HERBICIDES FOR COMMERCIAL AGRICULTURAL AND HORTICULTURAL USE (U.S. CLS. 6, 18, 44, 46, 51 AND 52).

FIRST USE 11-0-2010; IN COMMERCE 11-0-2010.

**CLASS 5—(Continued).**

3,963,676. NATURMED INC., CAMP VERDE, AZ. SN 85-097,168. PUB. 1-18-2011, FILED 7-30-2010.

## L-MINERATE528

THE MARK CONSISTS OF STANDARD CHARACTERS WITHOUT CLAIM TO ANY PARTICULAR FONT, STYLE, SIZE, OR COLOR.

FOR DIETARY SUPPLEMENTS; MINERAL NUTRITIONAL SUPPLEMENTS (U.S. CLS. 6, 18, 44, 46, 51 AND 52).

FIRST USE 8-30-2010; IN COMMERCE 8-30-2010.

3,963,685. PREVENTIVE BEVERAGES, LLC, HAVERFORD, PA. SN 85-101,313. PUB. 1-18-2011, FILED 8-5-2010.

## EVR

THE MARK CONSISTS OF STANDARD CHARACTERS WITHOUT CLAIM TO ANY PARTICULAR FONT, STYLE, SIZE, OR COLOR.

FOR NUTRITIONALLY FORTIFIED BEVERAGES (U.S. CLS. 6, 18, 44, 46, 51 AND 52).

FIRST USE 8-0-2010; IN COMMERCE 8-0-2010.

3,963,686. PREVENTIVE BEVERAGES, LLC, HAVERFORD, PA. SN 85-101,316. PUB. 1-4-2011, FILED 8-5-2010.

## EVR

THE MARK CONSISTS OF STANDARD CHARACTERS WITHOUT CLAIM TO ANY PARTICULAR FONT, STYLE, SIZE, OR COLOR.

FOR NUTRITIONALLY FORTIFIED BEVERAGES WITH FRUIT FLAVOR (U.S. CLS. 6, 18, 44, 46, 51 AND 52).

FIRST USE 8-0-2010; IN COMMERCE 8-0-2010.

**CLASS 6—METAL GOODS****CLASS 6—(Continued).**

3,962,125. ORIGIN POINT BRANDS, LLC, CHARLESTON, SC. SN 77-408,862. PUB. 1-13-2009, FILED 2-28-2008.

## IRONCRAFT

THE MARK CONSISTS OF STANDARD CHARACTERS WITHOUT CLAIM TO ANY PARTICULAR FONT, STYLE, SIZE, OR COLOR.

FOR METAL FENCE POSTS; METAL FENCE RAIL CLAMPS; METAL FENCING PANELS; METAL FENCING STAYS; METAL GATES AND FENCING; METAL GATES AND FENCING PANELS; METAL WIRE FENCING; WIRE FENCES (U.S. CLS. 2, 12, 13, 14, 23, 25 AND 50).

FIRST USE 1-29-2010; IN COMMERCE 1-29-2010.

3,962,140. WILLIAMS SCOTSMAN, INC., BALTIMORE, MD. SN 77-440,973. PUB. 1-6-2009, FILED 4-5-2008.



OWNER OF U.S. REG. NOS. 2,454,889, 2,475,259, AND 3,160,920.

THE NAME "WILLIAMS SCOTSMAN" DOES NOT IDENTIFY A LIVING INDIVIDUAL.

THE MARK CONSISTS OF THE WORDS "GOSPACE BY WILLIAMS SCOTSMAN" WITH AN ARROW NEXT TO THE WORD "GOSPACE" AND A STEP DESIGN STARTING UNDER THE WORD "GOSPACE" AND CONTINUING UNDER THE WORDS "WILLIAMS SCOTSMAN".

FOR PORTABLE METAL STORAGE CONTAINERS THAT CAN BE FUNCTIONAL AS GROUND-LEVEL OFFICE SPACE, STORAGE SPACE, OR A COMBINATION OF OFFICE AND STORAGE SPACE (U.S. CLS. 2, 12, 13, 14, 23, 25 AND 50).

FIRST USE 12-0-2007; IN COMMERCE 3-14-2011.

3,962,228. DAB DOOR COMPANY, INC., HIALEAH GARDENS, FL. SN 77-615,562. PUB. 6-30-2009, FILED 11-17-2008.

## PREVENT A DISASTER WITH THE HURRICANE MASTER

THE MARK CONSISTS OF STANDARD CHARACTERS WITHOUT CLAIM TO ANY PARTICULAR FONT, STYLE, SIZE, OR COLOR.

OWNER OF U.S. REG. NO. 2,882,966.  
FOR METAL GARAGE DOORS (U.S. CLS. 2, 12, 13, 14, 23, 25 AND 50).

FIRST USE 8-17-2007; IN COMMERCE 8-29-2007.

**CLASS 6—(Continued).**

3,962,583. LAB ARMOR, INC., SAN ANTONIO, TX. SN 77-824,601. PUB. 8-10-2010, FILED 9-11-2009.

**BATH ARMOR**

THE MARK CONSISTS OF STANDARD CHARACTERS WITHOUT CLAIM TO ANY PARTICULAR FONT, STYLE, SIZE, OR COLOR.

NO CLAIM IS MADE TO THE EXCLUSIVE RIGHT TO USE "BATH", APART FROM THE MARK AS SHOWN.

FOR ALUMINUM BEADS FOR CONTROLLING AND RETAINING HEAT (U.S. CLS. 2, 12, 13, 14, 23, 25 AND 50).

FIRST USE 10-1-2009; IN COMMERCE 10-1-2009.

**CLASS 6—(Continued).**

3,962,680. THE METRAFLEX COMPANY, CHICAGO, IL. SN 77-858,009. PUB. 9-28-2010, FILED 10-27-2009.

**UFLEX**

THE MARK CONSISTS OF STANDARD CHARACTERS WITHOUT CLAIM TO ANY PARTICULAR FONT, STYLE, SIZE, OR COLOR.

FOR METAL EXPANSION JOINTS FOR PIPING AND DUCTING (U.S. CLS. 2, 12, 13, 14, 23, 25 AND 50).

FIRST USE 12-22-2010; IN COMMERCE 12-22-2010.

3,962,843. RESOLVE SPECIALTY PRODUCTS LLC, MENASHA, WI. SN 77-914,028. PUB. 6-1-2010, FILED 1-18-2010.

3,962,621. UNITED STATES METAL POWDERS INC., FLEMINGTON, NJ. SN 77-837,029. PUB. 6-15-2010, FILED 9-29-2009.



THE MARK CONSISTS OF THE LETTERS "USM" WITH A STYLIZED EAGLE DESIGN.

FOR NON-FERROUS METAL POWDERS USED IN MANUFACTURING (U.S. CLS. 2, 12, 13, 14, 23, 25 AND 50).

FIRST USE 2-3-2011; IN COMMERCE 2-3-2011.

**KLAMP-IT**

THE MARK CONSISTS OF STANDARD CHARACTERS WITHOUT CLAIM TO ANY PARTICULAR FONT, STYLE, SIZE, OR COLOR.

FOR CANTILEVERED BRACKETS OF METAL; METAL CLAMPS (U.S. CLS. 2, 12, 13, 14, 23, 25 AND 50).

FIRST USE 2-1-2010; IN COMMERCE 5-1-2010.

3,962,919. NEUMANN, DONALD J., PLYMOUTH, MN. SN 77-931,977. PUB. 6-22-2010, FILED 2-9-2010.

**FurFinders**

THE MARK CONSISTS OF STANDARD CHARACTERS WITHOUT CLAIM TO ANY PARTICULAR FONT, STYLE, SIZE, OR COLOR.

FOR METAL PET TAGS (U.S. CLS. 2, 12, 13, 14, 23, 25 AND 50).

FIRST USE 10-23-2009; IN COMMERCE 10-23-2009.

**CLASS 6—(Continued).**

3,962,920. YOUNGDO IND. CO., LTD., BUSAN, REPUBLIC OF KOREA. SN 77-932,184. PUB. 6-29-2010, FILED 2-9-2010.



OWNER OF U.S. REG. NO. 2,493,880.  
 THE MARK CONSISTS OF THE HIGHLY STYLIZED LETTERS "YD".  
 FOR MANUALLY OPERATED METAL CYLINDER VALVES FOR GASES (U.S. CLS. 2, 12, 13, 14, 23, 25 AND 50).  
 FIRST USE 1-1-2010; IN COMMERCE 1-1-2010.

3,962,950. LUXE LINK LLC, SANTA MONICA, CA. SN 77-937,007. PUB. 7-6-2010, FILED 2-16-2010.

PURSE ON THE FLOOR MONEY  
 OUT THE DOOR

THE MARK CONSISTS OF STANDARD CHARACTERS WITHOUT CLAIM TO ANY PARTICULAR FONT, STYLE, SIZE, OR COLOR.  
 FOR CASE, BAG AND ACCESSORY HOLDER, NAMELY, A METAL HOOK USED TO SECURELY HOLD A PURSE, HANDBAG, BRIEFCASE, GARMENT OR FASHION ACCESSORY OR OTHER OBJECT WITH A STRAP OR LOOP, TO A TABLE, COUNTER TOP OR OTHER SIMILAR SURFACE FOR CONVENIENCE AND SECURITY PURPOSES (U.S. CLS. 2, 12, 13, 14, 23, 25 AND 50).  
 FIRST USE 3-10-2010; IN COMMERCE 3-10-2010.

**CLASS 6—(Continued).**

3,963,172. EUROTA CORPORATION, TAIPEI, TAIWAN. SN 77-962,909. PUB. 11-2-2010, FILED 3-19-2010.



THE MARK CONSISTS OF A STYLIZED LETTER "M".  
 FOR PIPE VALVES OF METAL NOT BEING PARTS OF MACHINES; PIPES OF METAL; METAL VALVES NOT BEING PARTS OF MACHINES; METAL TUBING; STEEL TUBES; PIPEWORK OF METAL; CASINGS OF METAL FOR OILWELLS; METAL GATE VALVES, METAL GLOBE VALVES, METAL CHECK VALVES, METAL GAS COCKS, NOT BEING PARTS OF MACHINES (U.S. CLS. 2, 12, 13, 14, 23, 25 AND 50).  
 FIRST USE 1-16-2010; IN COMMERCE 9-16-2010.

3,963,190. MACLEAN POWER, L.L.C., FRANKLIN PARK, IL. SN 77-964,997. PUB. 8-10-2010, FILED 3-22-2010.

CabinetPile

THE MARK CONSISTS OF STANDARD CHARACTERS WITHOUT CLAIM TO ANY PARTICULAR FONT, STYLE, SIZE, OR COLOR.  
 FOR FABRICATED METAL HOUSING ELEMENTS SOLD AS COMPONENT PARTS OF PILES (U.S. CLS. 2, 12, 13, 14, 23, 25 AND 50).  
 FIRST USE 2-0-2010; IN COMMERCE 4-0-2010.

3,963,302. NUCOR CORPORATION, CHARLOTTE, NC. SN 78-964,007. PUB. 6-30-2009, FILED 8-30-2006.

NUCOR VISE LOCK

THE MARK CONSISTS OF STANDARD CHARACTERS WITHOUT CLAIM TO ANY PARTICULAR FONT, STYLE, SIZE, OR COLOR.  
 NO CLAIM IS MADE TO THE EXCLUSIVE RIGHT TO USE "LOCK", APART FROM THE MARK AS SHOWN.  
 FOR METAL ROOFING PANELS; METAL ROOFING PURLINS AND METAL RAKE ANGLES; METAL FASTENERS FOR USE WITH METAL ROOFING PANELS, PURLINS AND RAKE ANGLES, NAMELY, SCREWS, PANEL CLIPS, RAKE CLIPS, BACKUP PLATES, METAL EAVE PLATES (U.S. CLS. 2, 12, 13, 14, 23, 25 AND 50).  
 FIRST USE 11-0-2010; IN COMMERCE 11-0-2010.

**CLASS 6—(Continued).**

3,963,303. NUCOR CORPORATION, CHARLOTTE, NC. SN 78-964,029. PUB. 6-30-2009, FILED 8-30-2006.

**NUCOR VISE LOCK 360**

THE MARK CONSISTS OF STANDARD CHARACTERS WITHOUT CLAIM TO ANY PARTICULAR FONT, STYLE, SIZE, OR COLOR.

NO CLAIM IS MADE TO THE EXCLUSIVE RIGHT TO USE "LOCK", APART FROM THE MARK AS SHOWN.

FOR METAL ROOFING PANELS; METAL ROOFING PURLINS AND METAL RAKE ANGLES; METAL FASTENERS FOR USE WITH METAL ROOFING PANELS, PURLINS AND RAKE ANGLES, NAMELY, SCREWS, PANEL CLIPS, RAKE CLIPS, BACKUP PLATES, METAL EAVE PLATES (U.S. CLS. 2, 12, 13, 14, 23, 25 AND 50).

FIRST USE 11-0-2010; IN COMMERCE 11-0-2010.

3,963,396. GALE, KENNETH A., OCEANSIDE, CA. SN 85-018,791. PUB. 9-21-2010, FILED 4-20-2010.

**MyMedInfoCARD** 

NO CLAIM IS MADE TO THE EXCLUSIVE RIGHT TO USE "MYMEDINFOCARD", APART FROM THE MARK AS SHOWN.

THE MARK CONSISTS OF THE WORDS "MYMEDINFOCARD" FOLLOWED BY A HEART MONITOR LINE.

FOR CUSTOM ENGRAVED METAL MEDICAL INFORMATION IDENTIFICATION CARDS, TAGS, BRACELETS AND NECKLACES, NOT MAGNETICALLY ENCODED AND NOT TO FUNCTION AS JEWELRY (U.S. CLS. 2, 12, 13, 14, 23, 25 AND 50).

FIRST USE 1-24-2011; IN COMMERCE 1-24-2011.

**CLASS 7—MACHINERY**

3,961,998. SMARTPOOL, INC., LAKEWOOD, NJ. SN 76-703,598. PUB. 11-30-2010, FILED 6-30-2010.

**DIRECT COMMAND**

THE MARK CONSISTS OF STANDARD CHARACTERS WITHOUT CLAIM TO ANY PARTICULAR FONT, STYLE, SIZE, OR COLOR.

FOR REMOTE CONTROLLABLE ROBOTIC POOL CLEANERS (U.S. CLS. 13, 19, 21, 23, 31, 34 AND 35).

FIRST USE 11-27-2010; IN COMMERCE 11-27-2010.

**CLASS 7—(Continued).**

3,962,110. AKTIEBOLAGET ELECTROLUX, SE 105-45 STOCKHOLM, SWEDEN. SN 77-378,368. PUB. 7-21-2009, FILED 1-23-2008.



NO CLAIM IS MADE TO THE EXCLUSIVE RIGHT TO USE "WASH" AND "CONTROL", APART FROM THE MARK AS SHOWN.

THE MARK CONSISTS OF "WASH . SAFE CONTROL" LOCATED IN BETWEEN TWO HORIZONTAL LINES. THE TOP LINE IS BROKEN BY TWO CENTRALLY LOCATED CIRCLES. ONE CIRCLE IS INSIDE THE OTHER.

FOR DISHWASHERS; PARTS OF DISHWASHERS, NAMELY, BASKETS; GLASSWARE WASHING MACHINES (U.S. CLS. 13, 19, 21, 23, 31, 34 AND 35).

FIRST USE 4-30-2008; IN COMMERCE 4-30-2008.

3,962,143. VORTECH ENGINEERING, INC., CHANNEL ISLANDS, CA. SN 77-461,268. PUB. 9-30-2008, FILED 4-29-2008.

**SAFE BOOST**

THE MARK CONSISTS OF STANDARD CHARACTERS WITHOUT CLAIM TO ANY PARTICULAR FONT, STYLE, SIZE, OR COLOR.

NO CLAIM IS MADE TO THE EXCLUSIVE RIGHT TO USE "BOOST", APART FROM THE MARK AS SHOWN.

FOR SUPERCHARGERS AND SUPERCHARGER KITS COMPRISED OF A SUPERCHARGER, MOUNTING BRACKETS, PULLEYS, TUBING, HOSES, AND INSTALLATION HARDWARE, SOLD AS A KIT (U.S. CLS. 13, 19, 21, 23, 31, 34 AND 35).

FIRST USE 1-13-2011; IN COMMERCE 1-13-2011.

3,962,204. MULCAHY, DAVID NATHANIEL SEBASTIAN, DBA WORLDSTOVE, TORTONA, ITALY. SN 77-561,359. PUB. 2-10-2009, FILED 9-3-2008.

**WORLDSTOVE.COM**

THE MARK CONSISTS OF STANDARD CHARACTERS WITHOUT CLAIM TO ANY PARTICULAR FONT, STYLE, SIZE, OR COLOR.

FOR GASIFIERS (U.S. CLS. 13, 19, 21, 23, 31, 34 AND 35).

FIRST USE 12-0-2006; IN COMMERCE 9-8-2008.



**CLASS 7—(Continued).**

3,962,264. GRANITE CITY TOOL COMPANY, WAITE PARK, MN. SN 77-655,491. PUB. 5-5-2009, FILED 1-23-2009.

# RIVAL

THE MARK CONSISTS OF STANDARD CHARACTERS WITHOUT CLAIM TO ANY PARTICULAR FONT, STYLE, SIZE, OR COLOR.

FOR CORE DRILLING BITS; POWER SAW BLADES; POWER TOOLS, NAMELY, DIAMOND TIPPED BLADES FOR POWER SAWS (U.S. CLS. 13, 19, 21, 23, 31, 34 AND 35).

FIRST USE 4-20-2009; IN COMMERCE 6-30-2009.

---

3,962,313. DRESSER, INC., ADDISON, TX. SN 77-687,227. PUB. 7-7-2009, FILED 3-10-2009.

# 275GL

THE MARK CONSISTS OF STANDARD CHARACTERS WITHOUT CLAIM TO ANY PARTICULAR FONT, STYLE, SIZE, OR COLOR.

FOR GASEOUS FUELED INTERNAL COMBUSTION ENGINES FOR USE ON INDUSTRIAL EQUIPMENT (U.S. CLS. 13, 19, 21, 23, 31, 34 AND 35).

FIRST USE 3-22-2011; IN COMMERCE 3-22-2011.

---

3,962,354. VORTEX VENTURES, INC., HOUSTON, TX. SN 77-716,196. PUB. 3-23-2010, FILED 4-17-2009.

# VORTEX MIXMATE

THE MARK CONSISTS OF STANDARD CHARACTERS WITHOUT CLAIM TO ANY PARTICULAR FONT, STYLE, SIZE, OR COLOR.

FOR EQUIPMENT, NAMELY, MACHINES FOR MIXING AND BLENDING MUD (U.S. CLS. 13, 19, 21, 23, 31, 34 AND 35).

FIRST USE 12-0-2010; IN COMMERCE 12-16-2010.

**CLASS 7—(Continued).**

3,962,368. DUNN-RITE PRODUCTS, INC., ELWOOD, IN. SN 77-728,008. PUB. 9-15-2009, FILED 5-4-2009.

# HYDRO-NET

THE MARK CONSISTS OF STANDARD CHARACTERS WITHOUT CLAIM TO ANY PARTICULAR FONT, STYLE, SIZE, OR COLOR.

FOR POWERED FLOTATION DEVICE IN THE NATURE OF AN AUTOMATIC SWIMMING POOL CLEANER FOR COLLECTING SWIMMING POOL DEBRIS (U.S. CLS. 13, 19, 21, 23, 31, 34 AND 35).

FIRST USE 3-4-2011; IN COMMERCE 3-4-2011.

---

3,962,415. SEARS BRANDS, LLC, HOFFMAN ESTATES, IL. SN 77-767,881. PUB. 6-22-2010, FILED 6-25-2009.



THE COLOR(S) WHITE AND BLUE IS/ARE CLAIMED AS A FEATURE OF THE MARK.

THE MARK CONSISTS OF A STYLIZED BLUE AND WHITE HAND OUTLINED IN BLACK WITH A WHITE DROP OF WATER CENTERED IN THE PALM. THE COLOR BLACK IN THE DRAWING ONLY REPRESENTS OUTLINING AND IS NOT PART OF THE MARK.

FOR LCD PANELS SOLD AS COMPONENT PARTS OF CLOTHES WASHING MACHINES FEATURING WASHING CYCLE OPTIONS TO ENSURE A GENTLE WASH CYCLE FOR DELICATE LOADS (U.S. CLS. 13, 19, 21, 23, 31, 34 AND 35).

FIRST USE 1-0-2011; IN COMMERCE 1-0-2011.

**CLASS 7—(Continued).**

3,962,416. SEARS BRANDS, LLC, HOFFMAN ESTATES, IL.  
SN 77-767,896. PUB. 6-22-2010, FILED 6-25-2009.



THE COLOR(S) WHITE AND BLUE IS/ARE CLAIMED AS A FEATURE OF THE MARK.

THE MARK CONSISTS OF A WHITE AND BLUE SQUARE OUTLINED IN BLACK, WITH A WHITE CIRCLE AND THREE WAVY WHITE LINES INSIDE THE SQUARE. THE COLOR BLACK IN THE DRAWING ONLY REPRESENTS OUTLINING AND IS NOT PART OF THE MARK.

FOR LCD PANELS SOLD AS COMPONENT PARTS OF CLOTHES WASHING MACHINES FEATURING WASHING CYCLE OPTIONS TO CLEAN AND SANITIZE THE INSIDE DRUM OF THE WASHER (U.S. CLS. 13, 19, 21, 23, 31, 34 AND 35).

FIRST USE 1-0-2011; IN COMMERCE 1-0-2011.

3,962,436. ENVIRONMENTAL TILLAGE SYSTEMS, INC.,  
FARIBAULT, MN. SN 77-777,392. PUB. 12-8-2009, FILED  
7-9-2009.

**SEED WARRIOR**

THE MARK CONSISTS OF STANDARD CHARACTERS WITHOUT CLAIM TO ANY PARTICULAR FONT, STYLE, SIZE, OR COLOR.

OWNER OF U.S. REG. NOS. 3,288,837 AND 3,433,179.

NO CLAIM IS MADE TO THE EXCLUSIVE RIGHT TO USE "SEED", APART FROM THE MARK AS SHOWN.

FOR AGRICULTURAL EQUIPMENT, NAMELY, PLANTER BARS WHICH CONTAIN ROW UNITS FOR PLANTING SEEDS AND PLANTER CARTS (U.S. CLS. 13, 19, 21, 23, 31, 34 AND 35).

FIRST USE 7-22-2009; IN COMMERCE 7-22-2009.

**CLASS 7—(Continued).**

3,962,623. GOLDNER, SANDOR, BROOKLYN, NY. AND  
GOLDNER, NORMAN, BROOKLYN, NY. SN 77-839,404.  
PUB. 9-21-2010, FILED 10-1-2009.

**TAAK Tools**

THE MARK CONSISTS OF STANDARD CHARACTERS WITHOUT CLAIM TO ANY PARTICULAR FONT, STYLE, SIZE, OR COLOR.

NO CLAIM IS MADE TO THE EXCLUSIVE RIGHT TO USE "TOOLS", APART FROM THE MARK AS SHOWN.

THE WORDING "TAAK" HAS NO MEANING IN A FOREIGN LANGUAGE.

FOR ELECTRIC TOOLS, NAMELY, ELECTRIC NAIL GUNS, ELECTRIC STAPLE GUNS, AIR POWERED RIVET HAMMERS (U.S. CLS. 13, 19, 21, 23, 31, 34 AND 35).

FIRST USE 1-5-2011; IN COMMERCE 1-5-2011.

3,962,634. PARK, KWANG SU, GYEONGGI-DO, REPUBLIC  
OF KOREA. SN 77-844,146. PUB. 8-10-2010, FILED 10-8-  
2009.

**SEED WARRIOR**

THE MARK CONSISTS OF THE WORD "SPIDER" IN CAPITAL LETTERS WITH THE DOT IN THE LETTER "I" REPLACED WITH A CIRCULAR SPIDER WEB DESIGN. THE WORDS "CREATE YOUR STYLE" IN INITIAL CAPITAL LETTERS UNDER AND TO THE RIGHT SIDE OF THE WORD "SPIDER".

FOR ELECTRIC YARN WRAPPER, NAMELY, ELECTRIC YARN WINDING MACHINE FOR MANUFACTURE OF ACCESSORY MADE OF YARN; ELECTRIC FIBER WRAPPER, NAMELY, ELECTRIC FIBER WINDING MACHINE FOR MANUFACTURE OF ACCESSORY MADE OF FIBER (U.S. CLS. 13, 19, 21, 23, 31, 34 AND 35).

FIRST USE 6-3-2010; IN COMMERCE 9-1-2010.

**CLASS 7—(Continued).**

3,962,726. SINGLETON EQUIPMENT, LLC, LIVINGSTON, LA. SN 77-878,316. PUB. 6-8-2010, FILED 11-22-2009.

## Valve Master

THE MARK CONSISTS OF STANDARD CHARACTERS WITHOUT CLAIM TO ANY PARTICULAR FONT, STYLE, SIZE, OR COLOR.

NO CLAIM IS MADE TO THE EXCLUSIVE RIGHT TO USE "VALVE", APART FROM THE MARK AS SHOWN.

FOR MACHINES, NAMELY, VALVE EXERCISERS, ALSO KNOWN AS VALVE ACTUATORS, USED TO OPEN AND CLOSE MUNICIPAL, INDUSTRIAL AND OTHER FLUIDS VALVES, WHICH CAN BE POWERED BY PNEUMATIC OR HYDRAULIC POWER SOURCES (U.S. CLS. 13, 19, 21, 23, 31, 34 AND 35).

FIRST USE 2-17-2011; IN COMMERCE 2-17-2011.

3,962,748. CARRIER CORPORATION, FARMINGTON, CT. SN 77-886,357. PUB. 4-20-2010, FILED 12-4-2009.

## FUELWISE

THE MARK CONSISTS OF STANDARD CHARACTERS WITHOUT CLAIM TO ANY PARTICULAR FONT, STYLE, SIZE, OR COLOR.

FOR GENERATOR SETS COMPRISED OF A MOTOR AND GENERATOR AND USED FOR POWERING REFRIGERATION UNITS PROVIDING HEATED OR COOLED AIR TO A CARGO CONTAINER (U.S. CLS. 13, 19, 21, 23, 31, 34 AND 35).

FIRST USE 11-30-2010; IN COMMERCE 11-30-2010.

3,962,790. NOOR UL MUSHTAQ, JAMMU & KASHMIR, INDIA. SN 77-897,658. PUB. 8-3-2010, FILED S.R. 12-20-2009; AM. P.R. 6-4-2010.



The logo for MUFFEER consists of the word "MUFFEER" in a bold, serif font. The letters "M", "U", "F", "E", "E", and "R" are in blue, while the letter "F" is in red. The text is flanked by two thick, horizontal blue lines, one above and one below.

PRIORITY CLAIMED UNDER SEC. 44(D) ON INDIA APPLICATION NO. 01889070, FILED 11-26-2009.

THE COLOR(S) RED AND BLUE IS/ARE CLAIMED AS A FEATURE OF THE MARK.

THE MARK CONSISTS OF THE WORDING "MUFFEER" IN BETWEEN TWO BLUE HORIZONTAL LINES. THE LETTER "F" IS IN THE COLOR RED AND THE REST OF THE WORDING IS IN THE COLOR BLUE.

**CLASS 7—(Continued).**

THE WORDING "MUFEER" HAS NO MEANING IN A FOREIGN LANGUAGE.

FOR DOMESTIC ELECTRIC MACHINES FOR HOUSEHOLD PURPOSES, NAMELY, CLOTHES WASHING MACHINES, CLOTHES WASHER COMBINED WITH A CLOTHES DRYER, DISHWASHERS, ELECTRIC FOOD MIXERS, FOOD BLENDERS, JUICERS, FOOD PROCESSORS, FOOD SLICERS AND SHREDDERS, WHISKS, COFFEE GRINDERS, CAN OPENERS, KNIFE SHARPENERS, AERATED BEVERAGE MAKING MACHINES, GARBAGE DISPOSALS; ELECTRIC CLOTHING PRESSING MACHINES FOR COMMERCIAL DRY CLEANING AND LAUNDRY PURPOSES (U.S. CLS. 13, 19, 21, 23, 31, 34 AND 35).

FIRST USE 4-17-2009; IN COMMERCE 5-28-2008.

3,962,906. ALCO INDUSTRIES, INC., NORRISTOWN, PA. SN 77-929,251. PUB. 6-29-2010, FILED 2-5-2010.

## PROTECTOR

THE MARK CONSISTS OF STANDARD CHARACTERS WITHOUT CLAIM TO ANY PARTICULAR FONT, STYLE, SIZE, OR COLOR.

FOR MECHANICAL SEALS (U.S. CLS. 13, 19, 21, 23, 31, 34 AND 35).

FIRST USE 2-24-2011; IN COMMERCE 2-24-2011.

**CLASS 7—(Continued).**

3,962,985. ISTOBAL, S.A., L'ALCUDIA, VALENCIA, SPAIN.  
SN 77-943,473. PUB. 7-20-2010, FILED 2-24-2010.

# M'NEX

THE MARK CONSISTS OF STANDARD CHARACTERS WITHOUT CLAIM TO ANY PARTICULAR FONT, STYLE, SIZE, OR COLOR.

FOR AIR SUCTION MACHINES; AUTOMOTIVE SERVICE EQUIPMENT, NAMELY, BRAKE FLUSHING MACHINES; CAR LIFTS; CONVEYORS; ELECTRIC WASHING MACHINES FOR INDUSTRIAL PURPOSES; ELECTRIC WAX-POLISHING MACHINES FOR INDUSTRIAL PURPOSES; ELEVATING OR LIFTING WORK PLATFORMS; ELEVATING WORK PLATFORMS; ELEVATORS; HIGH-PRESSURE PUMPS FOR WASHING APPLIANCES AND INSTALLATIONS; HYDRAULIC JACKS; HYDRAULIC LIFT TABLES; LUBRICATING PUMPS; LUBRICATION MACHINES; MACHINES FOR BLAST CLEANING A SURFACE; MACHINES FOR CLEANING SURFACES USING HIGH PRESSURE WATER; MECHANICAL AND HYDRAULIC LIFTS; PAINTING MACHINES; PNEUMATICALLY OPERATED TIRE INFLATION MACHINE; POWER JACKS; POWER-OPERATED LIFTS FOR MOVING, PARKING AND STORING LAND VEHICLES; POWER-OPERATED LUBRICANT DISPENSERS FOR MACHINES; POWER-OPERATED TIRE MOUNTING MACHINES; POWERED TIRE CHANGER MACHINES FOR LAND VEHICLES; PRESSURE WASHING MACHINES; SPRAY PAINT SYSTEMS COMPRISED OF PUMPS, PUMP CONTROLLERS, NOZZLES, TUBING AND VALVES; STEAM CLEANING MACHINES; VACUUM CLEANERS; VEHICLE WASHING INSTALLATIONS; VEHICLE WASHING MACHINES (U.S. CLS. 13, 19, 21, 23, 31, 34 AND 35).

FIRST USE 9-14-2010; IN COMMERCE 2-25-2011.

3,963,177. L&P PROPERTY MANAGEMENT COMPANY,  
SOUTH GATE, CA. SN 77-963,470. PUB. 8-3-2010, FILED  
3-19-2010.

# SAFELATCH

THE MARK CONSISTS OF STANDARD CHARACTERS WITHOUT CLAIM TO ANY PARTICULAR FONT, STYLE, SIZE, OR COLOR.

FOR WIRE TYING AND WIRE STRAPPING MACHINES AND COMPONENTS THEREFOR (U.S. CLS. 13, 19, 21, 23, 31, 34 AND 35).

FIRST USE 7-23-2010; IN COMMERCE 7-23-2010.

**CLASS 7—(Continued).**

3,963,188. YANGZHOU GELIBAO POWER MACHINE COMPANY LIMITED, YANGZHOU CITY, JIANGSU, CHINA.  
SN 77-964,902. PUB. 8-10-2010, FILED 3-22-2010.

# JUROTHER

THE MARK CONSISTS OF THE STYLIZED WORD "JUROTHER".

FOR AGRICULTURAL MACHINES, NAMELY, CULTIVATORS, HARVESTORS, DISC HARROWS, SEEDERS; AGRICULTURAL PLANTING MACHINES, NAMELY, TREE PLANTING MACHINES; TREE STUMP PLANTING MACHINES; WOODWORKING MACHINE, NAMELY, WOODWORKING SAW-TOOTH SETTING MACHINES, WOOD SPLITTING MACHINES; LAWN MOWERS; TURF REMOVING PLOUGHS; AGRICULTURAL IMPLEMENTS, NAMELY, SEED DRILLS, HARVESTORS, INCORPORATORS; DRILLING MACHINES, NAMELY, LAWN DRILLING MACHINES; ELECTRIC PUMPS; CAKE-FODDER CRUSHING MACHINES; DISINTEGRATORS; LAWN COMBING MACHINES (U.S. CLS. 13, 19, 21, 23, 31, 34 AND 35).

FIRST USE 8-0-2010; IN COMMERCE 8-0-2010.

3,963,201. GREENSGROOMER WORLDWIDE, INC., INDIANAPOLIS, IN. SN 77-966,025. PUB. 8-17-2010, FILED 3-23-2010.

# GreensGrader

"The KillerTiller"

OWNER OF U.S. REG. NOS. 2,453,712, 2,605,142, AND 3,372,778.

THE MARK CONSISTS OF A HORIZONTAL LINE UNDER THE STYLIZED WORDING "GREENSGRADER" ALL OF WHICH IS LOCATED ABOVE THE STYLIZED WORDING "THE KILLERTILLER" WHICH APPEARS IN QUOTATION MARKS.

FOR A TOWABLE IMPLEMENT FOR SOIL GRADING AND FOR PICKING UP TRASH AND LITTER (U.S. CLS. 13, 19, 21, 23, 31, 34 AND 35).

FIRST USE 2-2-2011; IN COMMERCE 2-2-2011.

3,963,204. TRI-STATE PUMP, INC., FARMINGDALE, NJ. SN 77-966,356. PUB. 12-28-2010, FILED 3-23-2010.

# CHUGGER PUMP

THE MARK CONSISTS OF STANDARD CHARACTERS WITHOUT CLAIM TO ANY PARTICULAR FONT, STYLE, SIZE, OR COLOR.

**CLASS 7—(Continued).**

NO CLAIM IS MADE TO THE EXCLUSIVE RIGHT TO USE "PUMP", APART FROM THE MARK AS SHOWN.

FOR ELECTRIC PUMPS; PARTS FOR ELECTRIC PUMPS; PUMPHEADS FOR ELECTRIC PUMPS, HEADS FOR ELECTRIC PUMPS (U.S. CLS. 13, 19, 21, 23, 31, 34 AND 35).

FIRST USE 6-10-2010; IN COMMERCE 6-10-2010.

3,963,273. MELLER EQUIPAMENTOS E TECNOLOGIA INDUSTRIA E COMERCIO LTDA., ESPIRITO SANTO, BRAZIL. SN 77-981,777. PUB. 7-15-2008, FILED 6-27-2007.



THE COLOR(S) RED AND BLACK IS/ARE CLAIMED AS A FEATURE OF THE MARK.

THE COLOR(S) BLACK APPEARS IN THE WORDING "MELLER" AND THE COLOR RED APPEARS IN THE OVAL.

FOR ELECTRIC FOOD PROCESSORS (U.S. CLS. 13, 19, 21, 23, 31, 34 AND 35).

FIRST USE 6-1-2005; IN COMMERCE 6-1-2005.

3,963,291. RAYTHEON COMPANY, WALTHAM, MA. SN 78-847,100. PUB. 1-1-2008, FILED 3-27-2006.

# SARCOS

THE MARK CONSISTS OF STANDARD CHARACTERS WITHOUT CLAIM TO ANY PARTICULAR FONT, STYLE, SIZE, OR COLOR.

OWNER OF U.S. REG. NO. 1,953,225.

FOR SERVO-VALVES; INDUSTRIAL ROBOTS FOR USE IN TRANSPORTING AND MOVING OBJECTS AND PERFORMING INSPECTIONS AND OTHER USEFUL TASKS IN AN INDUSTRIAL SETTING; HYDRAULIC VALVE ACTUATORS; LINEAR ACTUATORS; PNEUMATIC VALVE ACTUATORS; ELECTRIC, MAGNETIC MOTORS FOR MACHINES; MINIATURE VACUUM PUMPS; INVERTED VANE VACUUM PUMPS; MOLECULAR DRAG VACUUM PUMPS; ROBOTS IN THE SHAPE OF ARMS AND HANDS AND FOR GRASPING FOR INDUSTRIAL USE; TWIST/BEND ELECTRIC ACTUATORS; ADVANCED ROBOTIC SYSTEMS CONSISTING OF ROBOTS FOR INDUSTRIAL PURPOSES AND PLATE-BASED COVERS FOR INDUSTRIAL ROBOTS; FLUID DELIVERY SYSTEMS CONSISTING OF VALVES, NAMELY, SERVO-VALVES, MULTIPLE VALVE SYSTEMS, PUMPS, MANIFOLDS AND ACTUATORS (U.S. CLS. 13, 19, 21, 23, 31, 34 AND 35).

FIRST USE 4-12-2005; IN COMMERCE 4-12-2005.

**CLASS 7—(Continued).**

3,963,366. PROTEAM, INC., BOISE, ID. SN 85-010,869. PUB. 9-7-2010, FILED 4-9-2010.

# PROGUARD

THE MARK CONSISTS OF STANDARD CHARACTERS WITHOUT CLAIM TO ANY PARTICULAR FONT, STYLE, SIZE, OR COLOR.

FOR VACUUM CLEANERS AND REPLACEMENT PARTS THEREFOR; ACCESSORIES FOR VACUUM CLEANERS, NAMELY, BRUSHES, HOSES, NOZZLES, FILTERS, AND VACUUM CLEANER BAGS (U.S. CLS. 13, 19, 21, 23, 31, 34 AND 35).

FIRST USE 11-10-2010; IN COMMERCE 11-10-2010.

3,963,398. ROBERT BOSCH TOOL CORPORATION, MOUNT PROSPECT, IL. SN 85-019,123. PUB. 9-21-2010, FILED 4-21-2010.

# DREMEL TRIO

THE MARK CONSISTS OF STANDARD CHARACTERS WITHOUT CLAIM TO ANY PARTICULAR FONT, STYLE, SIZE, OR COLOR.

FOR POWER TOOLS, NAMELY, A MULTI-PURPOSE SPIRAL ACTION TOOL THAT IS USED TO CUT, SAND AND ROUT (U.S. CLS. 13, 19, 21, 23, 31, 34 AND 35).

FIRST USE 4-0-2010; IN COMMERCE 4-0-2010.

3,963,411. LEE, ROBERT H, III, BIRMINGHAM, AL. SN 85-023,299. PUB. 9-14-2010, FILED 4-26-2010.

# SANITIZIT

THE MARK CONSISTS OF STANDARD CHARACTERS WITHOUT CLAIM TO ANY PARTICULAR FONT, STYLE, SIZE, OR COLOR.

FOR SPRAYING MACHINES (U.S. CLS. 13, 19, 21, 23, 31, 34 AND 35).

FIRST USE 4-15-2010; IN COMMERCE 11-15-2010.



**CLASS 7—(Continued).**

3,963,526. MWASE, ERNEST, WEST DENE, SOUTH AFRICA.  
SN 85-051,110. PUB. 10-26-2010, FILED 5-31-2010.

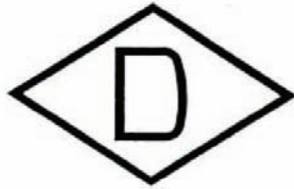

THE MARK CONSISTS OF A DIAMOND WITH A LETTER "D" INSIDE THE DIAMOND.  
FOR SEWING MACHINES AND PARTS THEREOF FOR CONSUMERS (U.S. CLS. 13, 19, 21, 23, 31, 34 AND 35).

FIRST USE 1-1-1895; IN COMMERCE 1-1-1895.

---

3,963,589. GIBERSON ENTERPRISES, LLC, SHAMONG, NJ.  
SN 85-070,653. PUB. 12-21-2010, FILED 6-24-2010.

**ECO-CRUSHER**

THE MARK CONSISTS OF STANDARD CHARACTERS WITHOUT CLAIM TO ANY PARTICULAR FONT, STYLE, SIZE, OR COLOR.

FOR CONSTRUCTION MATERIAL AND NATURAL AGGREGATE RECYCLING AND PROCESSING ATTACHMENTS FOR CONSTRUCTION EQUIPMENT, NAMELY, ROCK, STONE, PAVERS, CONCRETE, CONCRETE WASHOUT, BRICK, ASPHALT, CINDER BLOCK, CLAY, DIRT, SAND, ROOTS, GRASS CLUMPS AND TRASH (U.S. CLS. 13, 19, 21, 23, 31, 34 AND 35).

FIRST USE 8-0-2005; IN COMMERCE 8-0-2005.

---

3,963,650. MARQUIP, LLC, PHILLIPS, WI. SN 85-086,169.  
PUB. 12-21-2010, FILED 7-16-2010.

**SOFT TOUCH**

THE MARK CONSISTS OF STANDARD CHARACTERS WITHOUT CLAIM TO ANY PARTICULAR FONT, STYLE, SIZE, OR COLOR.

FOR GLUE MACHINES FOR THE MANUFACTURE OF CORRUGATED PAPERBOARD (U.S. CLS. 13, 19, 21, 23, 31, 34 AND 35).

FIRST USE 2-28-2010; IN COMMERCE 3-5-2011.

**CLASS 7—(Continued).**

3,963,696. BAILAIR, LLC, BEND, OR. SN 85-106,244. PUB. 2-1-2011, FILED 8-12-2010.

**ROCKET AIR**

THE MARK CONSISTS OF STANDARD CHARACTERS WITHOUT CLAIM TO ANY PARTICULAR FONT, STYLE, SIZE, OR COLOR.

NO CLAIM IS MADE TO THE EXCLUSIVE RIGHT TO USE "AIR", APART FROM THE MARK AS SHOWN.

FOR IRRIGATION PURGING SYSTEMS COMPRISED OF AIR BLOWERS AND AIR COMPRESSORS; IRRIGATION PURGING SYSTEMS COMPRISED PRIMARILY OF AIR BLOWERS; IRRIGATION PURGING SYSTEMS COMPRISED PRIMARILY OF AIR COMPRESSORS (U.S. CLS. 13, 19, 21, 23, 31, 34 AND 35).

FIRST USE 9-12-2010; IN COMMERCE 9-12-2010.

**CLASS 8—HAND TOOLS**

---

3,962,440. THE GILLETTE COMPANY, BOSTON, MA. SN 77-778,122. PUB. 1-5-2010, FILED 7-10-2009.



OWNER OF U.S. REG. NO. 3,686,982.

THE MARK CONSISTS OF A STYLIZED LETTER "G".  
FOR RAZORS AND RAZOR BLADES; DISPENSERS, CASSETTES, HOLDERS, AND CARTRIDGES, ALL CONTAINING RAZOR BLADES; AND STRUCTURAL PARTS THEREFOR (U.S. CLS. 23, 28 AND 44).

FIRST USE 2-28-2010; IN COMMERCE 2-28-2010.

**CLASS 8—(Continued).**

3,962,474. GLOBAL TV CONCEPTS, DEERFIELD BEACH, FL. SN 77-791,139. PUB. 7-6-2010, FILED 7-28-2009.



NO CLAIM IS MADE TO THE EXCLUSIVE RIGHT TO USE "CUTTER", APART FROM THE MARK AS SHOWN.

THE MARK CONSISTS OF THE WORDING "AIR CUTTER" SUPERIMPOSED ON AN A-FRAME AND A CIRCLE DESIGN IN THE NATURE OF TWO CONCENTRIC CIRCLES CONNECTED BY SHORT LINES. THE A-FRAME IS REPRESENTED BY TWO BARS WITH GRADUATED SHADING SLANTED TOWARD EACH OTHER AT THE TOP OF THE CIRCLE DESIGN AND BISECTED BY A CURVED HORIZONTAL LINE.

FOR HAIR CUTTING DEVICES IN THE NATURE OF ELECTRIC HAIR CLIPPERS (U.S. CLS. 23, 28 AND 44).  
FIRST USE 6-21-2010; IN COMMERCE 6-21-2010.

3,962,481. ZARRO EMIDIO, ROYAL OAK, MI. SN 77-794,631. PUB. 12-29-2009, FILED 7-31-2009.

**LIPSANDS**

THE MARK CONSISTS OF STANDARD CHARACTERS WITHOUT CLAIM TO ANY PARTICULAR FONT, STYLE, SIZE, OR COLOR.

FOR NAIL FILES (U.S. CLS. 23, 28 AND 44).  
FIRST USE 9-30-2010; IN COMMERCE 12-31-2010.

3,962,922. THE GILLETTE COMPANY, BOSTON, MA. SN 77-932,660. PUB. 11-30-2010, FILED 2-10-2010.

**VENUS PROSKIN**

THE MARK CONSISTS OF STANDARD CHARACTERS WITHOUT CLAIM TO ANY PARTICULAR FONT, STYLE, SIZE, OR COLOR.

**CLASS 8—(Continued).**

OWNER OF U.S. REG. NOS. 2,488,308, 2,892,008, AND OTHERS.

FOR RAZORS AND RAZOR BLADES; DISPENSERS, CASSETTES, HOLDERS AND CARTRIDGES ALL SPECIFICALLY DESIGNED FOR AND CONTAINING RAZOR BLADES, AND STRUCTURAL PARTS THEREFOR (U.S. CLS. 23, 28 AND 44).

FIRST USE 1-17-2011; IN COMMERCE 1-17-2011.

3,963,048. YOCOM, GARY, STANFORD, KY. SN 77-950,449. PUB. 7-27-2010, FILED 3-4-2010.

**Guardian Angel**

THE MARK CONSISTS OF STANDARD CHARACTERS WITHOUT CLAIM TO ANY PARTICULAR FONT, STYLE, SIZE, OR COLOR.

FOR POCKET KNIVES (U.S. CLS. 23, 28 AND 44).  
FIRST USE 12-10-2009; IN COMMERCE 12-10-2009.

3,963,369. ANDIS COMPANY, STURTEVANT, WI. SN 85-011,503. PUB. 7-13-2010, FILED 4-12-2010.

**VERSATRIM**

THE MARK CONSISTS OF STANDARD CHARACTERS WITHOUT CLAIM TO ANY PARTICULAR FONT, STYLE, SIZE, OR COLOR.

FOR ELECTRIC MUSTACHE AND BEARD TRIMMERS (U.S. CLS. 23, 28 AND 44).  
FIRST USE 7-13-2010; IN COMMERCE 7-13-2010.

3,963,562. MEYER INTELLECTUAL PROPERTIES LIMITED, KOWLOON, HONGKONG, CHINA. SN 85-064,571. PUB. 11-16-2010, FILED 6-16-2010.

**Fujimaru**

THE MARK CONSISTS OF STANDARD CHARACTERS WITHOUT CLAIM TO ANY PARTICULAR FONT, STYLE, SIZE, OR COLOR.

OWNER OF U.S. REG. NO. 1,519,722.  
FOR CUTLERY (U.S. CLS. 23, 28 AND 44).  
FIRST USE 1-2-2011; IN COMMERCE 1-15-2011.

**CLASS 8—(Continued).**

3,963,643. BUD K WORLDWIDE, INC., MOULTRIE, GA. SN 85-084,394. PUB. 10-19-2010, FILED 7-14-2010.

**SPEED DEMON**

THE MARK CONSISTS OF STANDARD CHARACTERS WITHOUT CLAIM TO ANY PARTICULAR FONT, STYLE, SIZE, OR COLOR.

FOR KNIVES, NAMELY, POCKET KNIVES, SPORT KNIVES AND HUNTING KNIVES (U.S. CLS. 23, 28 AND 44).

FIRST USE 2-14-2011; IN COMMERCE 2-14-2011.

**CLASS 9—ELECTRICAL AND SCIENTIFIC APPARATUS**

3,961,961. HEARST COMMUNICATIONS, INC, NEW YORK, NY. SN 76-387,276. PUB. 6-9-2009, FILED 3-26-2002.

**SEVENTEEN**

OWNER OF U.S. REG. NOS. 411,294, 2,523,413, AND OTHERS.

FOR CD-ROMS CONTAINING MUSICAL SOUND RECORDINGS; COMPUTER ACCESSORIES, NAMELY, COMPUTER MOUSE PADS, AND KEYBOARD WRIST PADS (U.S. CLS. 21, 23, 26, 36 AND 38).

FIRST USE 3-1-2011; IN COMMERCE 3-1-2011.

3,961,964. AMAYA GAMING GROUP INC., POINTE-CLAIRE, QUEBEC, CANADA. SN 76-663,104. PUB. 8-11-2009, FILED 7-14-2006.



PRIORITY CLAIMED UNDER SEC. 44(D) ON CANADA APPLICATION NO. 1,298,717, FILED 4-21-2006, REG. NO. TMA741775, DATED 6-10-2009, EXPIRES 6-10-2024.

NO CLAIM IS MADE TO THE EXCLUSIVE RIGHT TO USE "POKER", APART FROM THE MARK AS SHOWN.

THE MARK REPRESENTS THE WORD "POKER" AND "MATE", LOCATED UNDER THE SENTENCE "PLAY TO PERFECTION!". IN STYLIZED LETTERS, SURROUNDED BY A RECTANGLE. THE "O" IN THE WORD "POKER" HAS A DIAMOND INSCRIBED THEREIN. THE "A" IN THE WORD "MATE" IS REPRESENTED BY A SYMBOL FOR A SPADE, COMMONLY FOUND ON PLAYING CARDS.

FOR COMPUTERIZED VIDEO GAME TABLES, NAMELY, A COMPUTERIZED POKER GAME TABLE; COMPUTERIZED VIDEO GAME TABLE FOR MULTI-GAMING PURPOSES (U.S. CLS. 21, 23, 26, 36 AND 38).

FIRST USE 4-30-2007; IN COMMERCE 9-30-2010.

**CLASS 9—(Continued).**

3,961,971. HACH COMPANY, LOVELAND, CO. SN 76-686,998. PUB. 6-24-2008, FILED 2-21-2008.

**FASTCHEK PRO**

THE MARK CONSISTS OF STANDARD CHARACTERS WITHOUT CLAIM TO ANY PARTICULAR FONT, STYLE, SIZE, OR COLOR.

OWNER OF U.S. REG. NO. 3,095,501.

FOR DIGITAL METERS THAT MEASURE THE CHEMICAL CONSTITUENTS AND PARAMETERS OF POOL AND SPA WATER BY READING REAGENT STRIP CHEMICAL TEST PAPER; COMPUTER SOFTWARE USED FOR ANALYSIS OF POOL AND SPA WATER (U.S. CLS. 21, 23, 26, 36 AND 38).

FIRST USE 2-18-2011; IN COMMERCE 2-18-2011.

3,961,980. YAMAHA CORPORATION, SHIZUOKA, JAPAN. SN 76-698,498. PUB. 8-3-2010, FILED 7-17-2009.



THE COLOR(S) LIGHT BLUE AND BLACK IS/ARE CLAIMED AS A FEATURE OF THE MARK.

THE MARK CONSISTS OF THE WORDING "YAIED" IN BLACK LETTERING, WITH THE LETTER "A" APPEARING IN CAPITAL LETTERING AND THE REMAINING CHARACTERS APPEARING IN LOWER-CASE LETTERING, AND WITH THE "I" INSIDE A DESIGN OF A TRANSMITTER SIGNAL THAT APPEARS IN LIGHT BLUE.

FOR APPARATUS FOR RECORDING, TRANSMISSION AND REPRODUCTION OF SOUND OR IMAGES; MICROPHONES; HEADPHONES, EARPHONES; AMPLIFIERS; AUDIO MIXERS; ELECTRONIC SOUND MIXING APPARATUS; AUDIO RECEIVERS; AMPLIFIERS FOR MUSICAL INSTRUMENTS; ELECTRIC AND ELECTRONIC SOUND EFFECTORS FOR MUSICAL INSTRUMENTS; REMOTE CONTROLLERS FOR AUDIO AND VIDEO APPARATUS; WIRELESS AUDIO SIGNAL SERVERS AND RECEIVERS FOR NETWORKS; MULTI-ROOM WIRELESS AUDIO SERVERS COMPRISING OPTICAL DISC DRIVES, HARD DISC DRIVES, TUNERS AND COMPRESSED MUSIC ENCODERS AND PLAYERS; WIRELESS AUDIO RECEIVERS COMPRISING AMPLIFIERS, COMPRESSED AUDIO PLAYERS AND SPEAKERS; KARAOKE PLAYERS; WIRELESS MUSIC SYSTEM ENCOMPASSING A WIRELESS TRANSMITTER, TRANSMITTER CRADLE AND SPEAKER, AND REMOTE CONTROLLERS THEREFOR SOLD TOGETHER AS A UNIT OR SEPARATELY; WIRELESS AUDIO SIGNAL TRANSMITTERS; DOCK SPEAKERS FOR MOBILE AUDIO PLAYERS; PERSONAL COMPUTERS; OPTICAL DISC DRIVES; HARD DISK DRIVES; LARGE SCALE INTEGRATION CHIPS; HARDWARE, SOFTWARE AND PROGRAMS FOR COMPUTER GAMES; HARDWARE AND SOFTWARE FOR VIDEO GAMES; PRE-RECORDED DISCS FEATURING MUSIC AND CINEMATOGRAPHIC FILMS; DOWNLOADABLE ELECTRONIC MUSIC; METRONOMES (U.S. CLS. 21, 23, 26, 36 AND 38).

FIRST USE 12-31-2008; IN COMMERCE 8-31-2009.

**CLASS 9—(Continued).**

3,961,996. OHARARP LLC, DAYTON, OH. SN 76-703,095.  
PUB. 11-23-2010, FILED 5-24-2010.



THE COLOR(S) BLACK, BLUE, AND WHITE IS/ARE CLAIMED AS A FEATURE OF THE MARK.

THE MARK CONSISTS OF THE TERM "TRIPLOGIK" WITH A RECTANGULAR BACKGROUND CARRIER. THE TERM "TRIP" IS IN WHITE WITH THE DOT OVER THE "I" IN BLUE, AND THE TERM "LOGIK" IS IN BLUE WITH THE DOT OVER THE "I" IN WHITE. THE BACKGROUND CARRIER IS BLACK.

FOR GPS NAVIGATION DEVICE FOR RECORDING AND TRACKING TRIPS (U.S. CLS. 21, 23, 26, 36 AND 38).

FIRST USE 12-1-2009; IN COMMERCE 12-1-2009.

**CLASS 9—(Continued).**

3,962,012. SDI TECHNOLOGIES INC., RAHWAY, NJ. SN 77-060,011. PUB. 12-25-2007, FILED 12-8-2006.

# IHOME

THE MARK CONSISTS OF STANDARD CHARACTERS WITHOUT CLAIM TO ANY PARTICULAR FONT, STYLE, SIZE, OR COLOR.

FOR ELECTRONIC PRODUCTS, NAMELY, RADIOS; AUDIO, VIDEO AND COMMUNICATIONS PRODUCTS, NAMELY, CHARGERS; CELL PHONE ACCESSORIES, NAMELY, PROTECTIVE CARRYING CASES (U.S. CLS. 21, 23, 26, 36 AND 38).

FIRST USE 12-0-2004; IN COMMERCE 12-0-2004.

3,962,020. MAD DOGG ATHLETICS, INC., VENICE, CA. SN 77-099,689. PUB. 2-19-2008, FILED 2-5-2007.

# SPIN FITNESS

THE MARK CONSISTS OF STANDARD CHARACTERS WITHOUT CLAIM TO ANY PARTICULAR FONT, STYLE, SIZE, OR COLOR.

OWNER OF U.S. REG. NOS. 2,173,202, 2,475,595, AND OTHERS.

NO CLAIM IS MADE TO THE EXCLUSIVE RIGHT TO USE "FITNESS", APART FROM THE MARK AS SHOWN.

FOR PRERECORDED AUDIO AND VIDEO RECORDINGS, NAMELY, CDS, DVDS, FEATURING INSTRUCTION IN THE FIELD OF HEALTH AND EXERCISE (U.S. CLS. 21, 23, 26, 36 AND 38).

FIRST USE 3-12-2009; IN COMMERCE 3-12-2009.

3,961,999. J.A. WOOLLAM CO., INC., LINCOLN, NE. SN 76-703,770. PUB. 1-18-2011, FILED 7-12-2010.

# T-SOLAR

THE MARK CONSISTS OF STANDARD CHARACTERS WITHOUT CLAIM TO ANY PARTICULAR FONT, STYLE, SIZE, OR COLOR.

FOR ELLIPSOMETERS, POLARIMETERS AND REFLECTOMETERS WHICH UTILIZE ELECTROMAGNETIC RADIATION FOR INVESTIGATING SAMPLES CONSISTING OF SUBSTRATES HAVING ROUGH OR TEXTURED SURFACES WITH OR WITHOUT SURFACE LAYERS (U.S. CLS. 21, 23, 26, 36 AND 38).

FIRST USE 11-21-2008; IN COMMERCE 11-21-2008.

3,962,035. GROUP COMRAP CORP. DE C.V., COL. GRANJAS MODERNAS, MEXICO. SN 77-147,952. PUB. 6-8-2010, FILED 4-3-2007.



THE COLOR(S) BLUE AND WHITE IS/ARE CLAIMED AS A FEATURE OF THE MARK.

**CLASS 9—(Continued).**

THE MARK CONSISTS OF THE LETTER "M" TO THE LEFT OF THE WORD "MITZU", IN STYLIZED FORM. ALL ELEMENTS OF THE MARK APPEAR IN THE COLORS BLUE AND WHITE, WITH WHITE USED TO SHOW SHADING FROM DARKER TO LIGHTER BLUE.

FOR TWEETERS; SPEAKERS; PROFESSIONAL AUDIO SPEAKERS; MULTIMEDIA SPEAKERS; MID-RANGE STEREO SPEAKERS; WOOFER STEREO SPEAKERS; MICROPHONES; MICROPHONES FOR CB RADIOS; WIRELESS MICROPHONES; CD PLAYERS; AMPLIFIERS, CAR AMPLIFIERS, GUITAR AMPLIFIERS, AND PUBLIC ADDRESS SPEAKER AMPLIFIERS; ANTENNAS, CAR ANTENNAS, AND ANTENNAS FOR UHF/VHF SIGNALS USED IN TELEVISIONS, DIGITAL TELEVISIONS, FM RADIO, PERSONAL STEREO, CAR STEREO, HEADPHONES, AND WIRELESS HEADPHONES; COMPUTER ACCESSORIES, NAMELY, COMPUTER MOUSE, COMPUTER KEYBOARDS, COMPUTER MONITORS; ANTI-INTRUSION ALARMS AND BURGLAR ALARMS FOR WINDOWS AND DOORS; VEHICLE BREAKDOWN WARNING LAMPS; CALL BELLS, SIGNAL BELLS, ELECTRONIC WARNING BELLS; MULTIMETERS; ELECTRIC POWERED SOLDERING IRONS; MULTIMEDIA PROJECTORS, MOVIE PROJECTORS, LCD PROJECTORS USED TO DISPLAY ADVERTISEMENTS, CINEMATOGRAPHIC PROJECTORS, AND PICTURE PROJECTORS (U.S. CLS. 21, 23, 26, 36 AND 38).

FIRST USE 8-3-1992; IN COMMERCE 10-18-2003.

3,962,039. UNIVERSITY OF NEW HAMPSHIRE, DURHAM, NH. SN 77-162,449. PUB. 12-11-2007, FILED 4-21-2007.

**RIGHTSCHECK**

THE MARK CONSISTS OF STANDARD CHARACTERS WITHOUT CLAIM TO ANY PARTICULAR FONT, STYLE, SIZE, OR COLOR.

FOR WEB-BASED SOFTWARE THAT LINKS UNIFORM COMMERCIAL CODE DATABASES MAINTAINED BY INDIVIDUAL STATES AS WELL AS THE UNITED STATES PATENT AND TRADEMARK OFFICE DATABASES IN A HIGHLY SECURE ENVIRONMENT, ALLOWING USERS TO VISIT ONE WEBSITE FOR EASY ACCESS TO INFORMATION REGARDING INTELLECTUAL PROPERTY ASSIGNMENTS, LIENS AND SECURITY INTERESTS (U.S. CLS. 21, 23, 26, 36 AND 38).

FIRST USE 1-1-2011; IN COMMERCE 1-1-2011.

3,962,041. KONICA MINOLTA BUSINESS SOLUTIONS U.S.A., INC., RAMSEY, NJ. SN 77-167,368. PUB. 4-22-2008, FILED 4-27-2007.

**BIZHUB VCARE**

THE MARK CONSISTS OF STANDARD CHARACTERS WITHOUT CLAIM TO ANY PARTICULAR FONT, STYLE, SIZE, OR COLOR.

**CLASS 9—(Continued).**

OWNER OF U.S. REG. NO. 3,075,546.

FOR COMPUTER SOFTWARE, NAMELY, SOFTWARE FOR REMOTELY SERVICING PRINTERS, COPYING MACHINES, FACSIMILE MACHINES, SCANNERS, AND MULTI-FUNCTIONAL OFFICE DEVICES (U.S. CLS. 21, 23, 26, 36 AND 38).

FIRST USE 1-17-2007; IN COMMERCE 1-17-2007.

3,962,047. SOUTHWIRE COMPANY, CARROLLTON, GA. SN 77-215,594. PUB. 1-1-2008, FILED 6-26-2007.

**EFC ENVIROCLAD**

THE MARK CONSISTS OF STANDARD CHARACTERS WITHOUT CLAIM TO ANY PARTICULAR FONT, STYLE, SIZE, OR COLOR.

FOR ELECTRICAL WIRE AND CABLE (U.S. CLS. 21, 23, 26, 36 AND 38).

FIRST USE 5-0-2010; IN COMMERCE 5-0-2010.

3,962,049. PROCON INC., KNOXVILLE, TN. SN 77-215,849. PUB. 12-25-2007, FILED 6-26-2007.



THE COLOR(S) BLACK AND BLUE IS/ARE CLAIMED AS A FEATURE OF THE MARK.

THE MARK CONSISTS OF THE WORD "PROCON" IN BLACK BLOCK LETTERS IN FRONT OF A STYLIZED BLUE ELLIPSE.

FOR WIRELESS DEVICES FOR NAVIGATION AND COMMUNICATION, NAMELY, PORTABLE TRACKING UNITS THAT COMBINE GPS AND CELLULAR TECHNOLOGIES FOR DETERMINING LOCATION INFORMATION AND COMMUNICATING THE LOCATION INFORMATION; INSTALLED VEHICLE TRACKING DEVICES FOR AUTO THEFT RECOVERY; DEVICES FOR WIRELESS RADIO TRANSMISSION; MOBILE COMPUTING AND OPERATING PLATFORMS CONSISTING OF DATA TRANSCEIVERS, WIRELESS NETWORKS AND GATEWAYS FOR COLLECTION AND MANAGEMENT OF DATA; TELEMATICS APPARATUS, NAMELY, WIRELESS INTERNET DEVICES WHICH PROVIDE TELEMATIC SERVICES AND HAVE A CELLULAR TELEPHONE FUNCTION (U.S. CLS. 21, 23, 26, 36 AND 38).

FIRST USE 9-17-2010; IN COMMERCE 9-17-2010.



**CLASS 9—(Continued).**

3,962,050. ZVON ENTERTAINMENT, L.L.C., ALAMO, CA. SN 77-215,884. PUB. 1-22-2008, FILED 6-26-2007.

**YULIANNA**

THE MARK CONSISTS OF STANDARD CHARACTERS WITHOUT CLAIM TO ANY PARTICULAR FONT, STYLE, SIZE, OR COLOR.

THE NAME(S), PORTRAIT(S), AND/OR SIGNATURE(S) SHOWN IN THE MARK IDENTIFIES THE STAGE NAME OF YULIYA VLADIMIROVNA ZINOVIEVA, A LIVING INDIVIDUAL, WHOSE CONSENT(S) TO REGISTER IS MADE OF RECORD.

FOR AUDIO RECORDINGS FEATURING MUSIC; AUDIO TAPES FEATURING MUSIC; DOWNLOADABLE MUSICAL SOUND RECORDINGS; DOWNLOADABLE RING TONES, GRAPHICS AND MUSIC VIA A GLOBAL COMPUTER NETWORK AND WIRELESS DEVICES; MUSICAL SOUND RECORDINGS; MUSICAL VIDEO RECORDINGS; PRE-RECORDED CDS, VIDEO TAPES, LASER DISKS AND DVDS FEATURING MUSIC AND VISUAL IMAGES; PRERECORDED DIGITAL VIDEO DISKS FEATURING MUSIC AND VISUAL IMAGES; PRERECORDED VIDEO CASSETTES FEATURING MUSIC; SOUND RECORDINGS FEATURING MUSIC; VIDEO RECORDINGS FEATURING MUSIC AND VISUAL IMAGES (U.S. CLS. 21, 23, 26, 36 AND 38).

FIRST USE 6-1-2007; IN COMMERCE 2-1-2008.

---

3,962,057. SPIELO MANUFACTURING ULC, MONCTON, NEW BRUNSWICK, CANADA. SN 77-222,762. PUB. 1-1-2008, FILED 7-5-2007.

**TREASURES OF OLYMPUS**

THE MARK CONSISTS OF STANDARD CHARACTERS WITHOUT CLAIM TO ANY PARTICULAR FONT, STYLE, SIZE, OR COLOR.

FOR RECONFIGURABLE CASINO AND LOTTERY GAMING EQUIPMENT, NAMELY, SLOT MACHINES AND VIDEO LOTTERY TERMINALS AND OPERATIONAL COMPUTER GAME SOFTWARE THEREFOR (U.S. CLS. 21, 23, 26, 36 AND 38).

FIRST USE 4-30-2010; IN COMMERCE 4-30-2010.

**CLASS 9—(Continued).**

3,962,066. TRIQUINT SEMICONDUCTOR, INC., HILLSBORO, OR. SN 77-237,974. PUB. 7-1-2008, FILED 7-25-2007.

**CURB TO CARPORT**

THE MARK CONSISTS OF STANDARD CHARACTERS WITHOUT CLAIM TO ANY PARTICULAR FONT, STYLE, SIZE, OR COLOR.

FOR ELECTRONIC COMPONENTS AND MODULES FOR RECEIVING AND TRANSMITTING VOICE, VIDEO, DATA AND INFORMATION VIA TELECOMMUNICATION AND WIRELESS SIGNALS, NAMELY, TRANSMITTER AND RECEIVER COMMUNICATION MODULES (U.S. CLS. 21, 23, 26, 36 AND 38).

FIRST USE 9-21-2008; IN COMMERCE 9-21-2008.

---

3,962,069. HID GLOBAL CORPORATION, IRVINE, CA. SN 77-244,926. PUB. 6-17-2008, FILED 8-1-2007.

**IDIRECTOR**

THE MARK CONSISTS OF STANDARD CHARACTERS WITHOUT CLAIM TO ANY PARTICULAR FONT, STYLE, SIZE, OR COLOR.

FOR COMPUTER SOFTWARE PLATFORMS FOR LOADING DATA ONTO SMARTCARDS USED FOR PHYSICAL ACCESS CONTROL TO SECURED AREAS, PERSONNEL TIME AND ATTENDANCE, IDENTITY CREDENTIALING, LOGICAL ACCESS TO SECURED COMPUTERS, ACCESS AUTHORIZATION TO OFFICE EQUIPMENT AND MANUFACTURING MACHINERY, EQUIPMENT AND MATERIAL CHECK-OUT, AND SECURITY PATROL MONITORING (U.S. CLS. 21, 23, 26, 36 AND 38).

FIRST USE 8-31-2007; IN COMMERCE 8-31-2007.

---

3,962,085. OCULIS LABS, INC., OWINGS MILLS, MD. SN 77-296,924. PUB. 2-17-2009, FILED 10-5-2007.

**OCULIS LABS**

THE MARK CONSISTS OF STANDARD CHARACTERS WITHOUT CLAIM TO ANY PARTICULAR FONT, STYLE, SIZE, OR COLOR.

**CLASS 9—(Continued).**

NO CLAIM IS MADE TO THE EXCLUSIVE RIGHT TO USE "LABS", APART FROM THE MARK AS SHOWN.

FOR COMPUTER HARDWARE AND SOFTWARE, NAMELY, A COMPUTER SYSTEM COMPOSED OF A HARDWARE COMPONENT AND A SOFTWARE COMPONENT FOR KEEPING INFORMATION DISPLAYED ON COMPUTER MONITORS VISUALLY SECURE AND PRIVATE, TO BE USED IN THE FIELD OF COMPUTER INFORMATION SECURITY AND PRIVACY, EXCLUDING SOFTWARE AND PROFESSIONAL SERVICES USED FOR DATA VISUALIZATION AND INFORMATION ANALYSIS (U.S. CLS. 21, 23, 26, 36 AND 38).

FIRST USE 2-9-2010; IN COMMERCE 2-17-2010.

---

3,962,088. LANDACORP, INC., LOUISVILLE, KY. SN 77-301,944. PUB. 6-24-2008, FILED 10-11-2007.

## CareAffiliate

THE MARK CONSISTS OF STANDARD CHARACTERS WITHOUT CLAIM TO ANY PARTICULAR FONT, STYLE, SIZE, OR COLOR.

FOR COMPUTER SOFTWARE FOR USE IN THE ADMINISTRATION AND MANAGEMENT OF HEALTH CARE PLANS AND PAYMENTS IN THE HEALTHCARE INDUSTRY; WEB-BASED DOWNLOADABLE MEDICAL MANAGEMENT SOFTWARE THAT PERFORMS ADMINISTRATIVE AND CARE-PLANNING FUNCTIONS FOR MANAGED CARE ORGANIZATIONS AND OTHER ENTITIES THAT ADMINISTER HEALTHCARE PLANS AND PAYMENTS TO MEMBER POPULATIONS IN THE MEDICAL FIELD; WEB-BASED DOWNLOADABLE COMPUTER SOFTWARE APPLICATION THAT ALLOWS MANAGED CARE STAFF, PROVIDERS AND MEMBERS TO SUBMIT AND EXCHANGE MEDICAL REQUESTS, INQUIRIES, AND MESSAGES OVER THE INTERNET IN THE MEDICAL FIELD; WEB-BASED DOWNLOADABLE COMPUTER SOFTWARE APPLICATION THAT ALLOWS FOR THE CALCULATING OF CLINICAL INDICATORS FOR DEFINED POPULATIONS IN THE MEDICAL FIELD (U.S. CLS. 21, 23, 26, 36 AND 38).

FIRST USE 10-12-2009; IN COMMERCE 10-12-2009.

---

3,962,090. SWANSON, BRYON, HIGHLANDS RANCH, CO. SN 77-309,577. PUB. 4-15-2008, FILED 10-22-2007.

## GREENBAR

THE MARK CONSISTS OF STANDARD CHARACTERS WITHOUT CLAIM TO ANY PARTICULAR FONT, STYLE, SIZE, OR COLOR.

FOR COMPUTER SOFTWARE FOR FINANCIAL MODELING IN THE FIELD OF FINANCIAL SERVICES (U.S. CLS. 21, 23, 26, 36 AND 38).

FIRST USE 3-4-2011; IN COMMERCE 3-4-2011.

**CLASS 9—(Continued).**

3,962,130. HACH COMPANY, LOVELAND, CO. SN 77-423,507. PUB. 6-24-2008, FILED 3-17-2008.

## FASTCHEK

THE MARK CONSISTS OF STANDARD CHARACTERS WITHOUT CLAIM TO ANY PARTICULAR FONT, STYLE, SIZE, OR COLOR.

OWNER OF U.S. REG. NO. 3,095,501.

FOR DIGITAL METERS THAT MEASURE THE CHEMICAL CONSTITUENTS AND PARAMETERS OF POOL AND SPA WATER BY READING REAGENT STRIP CHEMICAL TEST PAPER (U.S. CLS. 21, 23, 26, 36 AND 38).

FIRST USE 2-18-2011; IN COMMERCE 2-18-2011.

---

3,962,131. MOTOROLA TRADEMARK HOLDINGS, LLC, LIBERTYVILLE, IL. SN 77-424,108. PUB. 7-22-2008, FILED 3-17-2008.

## ADVENTURE

THE MARK CONSISTS OF STANDARD CHARACTERS WITHOUT CLAIM TO ANY PARTICULAR FONT, STYLE, SIZE, OR COLOR.

FOR TELEPHONES, CELLULAR TELEPHONES, ELECTRONIC MESSAGE DEVICES IN THE NATURE OF PORTABLE TELECOMMUNICATION INSTANT MESSAGING DEVICES; HANDHELD GAME DEVICE IN THE NATURE OF HAND-HELD UNITS FOR PLAYING ELECTRONIC GAMES FOR USE WITH EXTERNAL DISPLAY SCREEN OR MONITOR, BATTERIES, BATTERY CHARGERS AND POWER ADAPTERS (U.S. CLS. 21, 23, 26, 36 AND 38).

FIRST USE 7-6-2008; IN COMMERCE 7-6-2008.

---

3,962,136. FURIOUS ROSE PRODUCTIONS, INC., NEW YORK, NY. SN 77-434,499. PUB. 2-3-2009, FILED 3-28-2008.

## Lisa Loeb

THE MARK CONSISTS OF STANDARD CHARACTERS WITHOUT CLAIM TO ANY PARTICULAR FONT, STYLE, SIZE, OR COLOR.

**CLASS 9—(Continued).**

THE NAME "LISA LOEB" IDENTIFIES A LIVING INDIVIDUAL WHOSE CONSENT IS OF RECORD.

FOR AUDIO AND VIDEO RECORDINGS FEATURING THE PERFORMANCES OF A MUSICAL ARTIST; DOWNLOADABLE MUSICAL SOUND RECORDINGS; MUSICAL SOUND RECORDINGS; PRE-RECORDED DIGITAL MEDIA FEATURING THE PERFORMANCES OF A MUSICAL ARTIST; EYEGLASS CASES; EYEGLASS FRAMES; EYEGLASS LENSES; EYEGLASSES; SUNGLASSES (U.S. CLS. 21, 23, 26, 36 AND 38).

FIRST USE 3-0-1992; IN COMMERCE 3-0-1992.

**CLASS 9—(Continued).**

3,962,150. BAE SYSTEMS INFORMATION AND ELECTRONIC SYSTEMS INTEGRATION INC., NASHUA, NH. SN 77-478,246. PUB. 12-16-2008, FILED 5-19-2008.

## CHECK-12

THE MARK CONSISTS OF STANDARD CHARACTERS WITHOUT CLAIM TO ANY PARTICULAR FONT, STYLE, SIZE, OR COLOR.

FOR DAY, NIGHT AND ALL-WEATHER FORWARD VIEWING SYSTEM THAT IS EMBEDDED IN THE FRONT LAMP FIXTURES OF TACTICAL WHEELED VEHICLES AND GROUND COMBAT VEHICLES BEING COMPRISED PRIMARILY OF EMBEDDED FRONT VIEW CAMERAS, CAMERA MOUNTING DEVICES, LENS COVER MECHANISM, POWER CONDITIONING CIRCUITRY, ELECTRICAL CONNECTORS, AND ELECTRONIC SWITCHES, AND ALSO COMPRISED OF FRONT, PARK AND TURN LAMP HOUSING, FRONT, PARK AND TURN LAMP LED LAMPS, AND WIRING HARNESES, ALL FOR OPERATION OF THE VIEWING SYSTEM AND GENERATION OF CAPTURED IMAGES FOR DISPLAY TO THE VEHICLE CREW MEMBERS (U.S. CLS. 21, 23, 26, 36 AND 38).

FIRST USE 5-31-2007; IN COMMERCE 5-31-2007.

3,962,148. COKEM INTERNATIONAL, LTD., PLYMOUTH, MN. SN 77-465,996. PUB. 12-8-2009, FILED 5-5-2008.

## FUN FACTORY

THE MARK CONSISTS OF STANDARD CHARACTERS WITHOUT CLAIM TO ANY PARTICULAR FONT, STYLE, SIZE, OR COLOR.

FOR VIDEO GAMES, NAMELY, VIDEO GAME SOFTWARE, VIDEO GAME CARTRIDGES AND DISCS; VIDEO GAME ACCESSORIES, NAMELY, VIDEO GAME CONSOLES FOR USE WITH AN EXTERNAL DISPLAY SCREEN OR MONITOR, VIDEO GAME CONTROLLERS, VIDEO GAME INTERACTIVE CONTROL FLOOR PADS; PROTECTIVE VIDEO GAME CARRYING CASES SPECIALLY ADAPTED FOR VIDEO GAME SOFTWARE, VIDEO GAME CARTRIDGES AND DISCS, VIDEO GAME ACCESSORIES, NAMELY, VIDEO GAME CONSOLES FOR USE WITH AN EXTERNAL DISPLAY SCREEN OR MONITOR, VIDEO GAME CONTROLLERS, VIDEO GAME INTERACTIVE CONTROL FLOOR PADS (U.S. CLS. 21, 23, 26, 36 AND 38).

FIRST USE 5-31-2008; IN COMMERCE 5-31-2008.

3,962,157. UNDERGROUND SYSTEMS, INC., ARMONK, NY. SN 77-486,481. PUB. 6-16-2009, FILED 5-29-2008.

## PD2

THE MARK CONSISTS OF STANDARD CHARACTERS WITHOUT CLAIM TO ANY PARTICULAR FONT, STYLE, SIZE, OR COLOR.

FOR SENSING AND POWER RATING MEASURING DEVICES FOR USE WITH OVERHEAD HIGH VOLTAGE TRANSMISSION LINES (U.S. CLS. 21, 23, 26, 36 AND 38).

FIRST USE 11-30-2003; IN COMMERCE 11-30-2003.

**CLASS 9—(Continued).**

3,962,163. BOWENS, DANIEL MACEO, SEWELL, NJ. SN 77-502,766. PUB. 2-10-2009, FILED 6-19-2008.



NO CLAIM IS MADE TO THE EXCLUSIVE RIGHT TO USE "RECORDS", APART FROM THE MARK AS SHOWN. THE MARK CONSISTS OF THE WORDS "I AM YOU", REPRESENTED BY THE LOWERCASE LETTER "I" WITH THE WORD "AM" WRITTEN INSIDE THE LETTER "I". BOTH THE WORDS "I" AND "AM" ARE WRITTEN INSIDE AND ABOVE THE LOWERCASE LETTER "U". THE WORD "RECORDS" IS UNDERNEATH THE LETTER "U".

FOR AUDIO RECORDINGS FEATURING MUSIC (U.S. CLS. 21, 23, 26, 36 AND 38).

FIRST USE 6-15-2009; IN COMMERCE 7-15-2009.

---

3,962,166. PHYSIK INSTRUMENTE (PI) GMBH & CO. KG, KARLSRUHE, FED REP GERMANY. SN 77-505,666. PUB. 7-7-2009, FILED 6-23-2008.

**PICMA**

THE MARK CONSISTS OF STANDARD CHARACTERS WITHOUT CLAIM TO ANY PARTICULAR FONT, STYLE, SIZE, OR COLOR.

FOR SCIENTIFIC APPARATUS AND INSTRUMENTS, NAMELY, PRECISION MICROPOSITIONING APPARATUS; PIEZOELECTRIC MULTILAYER ACTUATORS (U.S. CLS. 21, 23, 26, 36 AND 38).

FIRST USE 3-31-2003; IN COMMERCE 3-31-2003.

**CLASS 9—(Continued).**

3,962,170. EXTREME REALITY LTD., HERZELIYA PI-TUACH, ISRAEL. SN 77-514,197. PUB. 12-1-2009, FILED 7-3-2008.

**XTR3D**

THE MARK CONSISTS OF STANDARD CHARACTERS WITHOUT CLAIM TO ANY PARTICULAR FONT, STYLE, SIZE, OR COLOR.

FOR HUMAN MACHINE INTERFACE USED BY A USER FOR INTERFACING WITH A COMPUTING DEVICE; HUMAN MACHINE INTERFACE USED BY A USER FOR INTERFACING WITH A COMPUTING PLATFORM; HUMAN MACHINE INTERFACE WITH A CAMERA IN A VIDEO ACQUISITION SYSTEM FOR A COMPUTING DEVICE; HUMAN MACHINE INTERFACE WITH A CAMERA IN A VIDEO ACQUISITION SYSTEM FOR A COMPUTING PLATFORM; HUMAN MACHINE INTERFACE WITH IMAGE PROCESSING CIRCUITS; HUMAN MACHINE INTERFACE WITH IMAGE IDENTIFICATION TRACKING CIRCUITRY; HUMAN MACHINE INTERFACE WITH IMAGE ELEMENT TRACKING CIRCUITRY; HUMAN MACHINE INTERFACE USED BY A GAMING DEVICE FOR IMAGE BASED INTERFACING; HUMAN MACHINE INTERFACE USED BY A GAMING PLATFORM FOR IMAGE BASED INTERFACING; HUMAN MACHINE INTERFACE USED BY A GAMING DEVICE FOR CAMERA BASED INTERFACING; HUMAN MACHINE INTERFACE USED BY A GAMING PLATFORM FOR CAMERA BASED INTERFACING; COMPUTER GAME SOFTWARE AND COMPUTER GAME PROGRAMS ENABLING USERS TO PLAY GAMES USING A CAMERA BASED INTERFACE; COMPUTER INTERFACE BOARD, COMPUTER GAME SOFTWARE AND COMPUTER GAME INTERFACE SOFTWARE FOR USE WITH COMPUTING DEVICES, NAMELY, PERSONAL COMPUTERS AND SET-TOP BOXES; COMPUTER SOFTWARE AND COMPUTER SOFTWARE PROGRAMS FOR USE IN ENABLING USERS WITH COMPUTING DEVICES TO SIMULTANEOUSLY ACCESS DATABASES AND GLOBAL COMPUTER NETWORKS; COMPUTER GAME DISCS; INTERACTIVE MULTIMEDIA COMPUTER GAME PROGRAM; DOWNLOADABLE GRAPHICS AND MUSIC VIA GLOBAL COMPUTER NETWORK AND WIRELESS DEVICES; COMPUTER APPLICATION SOFTWARE FOR USE IN COMPUTING DEVICES; COMPUTER APPLICATION SOFTWARE FOR ROBOTICS, ROBOT VISION, MACHINE VISION, ARTIFICIAL INTELLIGENCE, MOTION CAPTURE APPLICATION, ALL FOR USE IN COMPUTER GAMES, NAMELY, 3D GAMES (U.S. CLS. 21, 23, 26, 36 AND 38).

FIRST USE 5-11-2005; IN COMMERCE 10-24-2008.

---

3,962,181. ANALOG DEVICES, INC., NORWOOD, MA. SN 77-538,046. PUB. 2-8-2011, FILED 8-4-2008.

**EZ-BOARD**

THE MARK CONSISTS OF STANDARD CHARACTERS WITHOUT CLAIM TO ANY PARTICULAR FONT, STYLE, SIZE, OR COLOR.

**CLASS 9—(Continued).**

OWNER OF U.S. REG. NOS. 2,600,198 AND 2,965,206.  
 FOR CIRCUIT BOARDS CONTAINING HARDWARE  
 AND SOFTWARE ALL FOR USE IN THE MANUFACTURING OF ELECTRONIC DEVICES (U.S. CLS. 21, 23, 26, 36 AND 38).  
 FIRST USE 11-0-2008; IN COMMERCE 11-0-2008.

3,962,189. COMPREHENSIVE NEUROSCIENCE, INC., BRADENTON, FL. SN 77-547,413. PUB. 7-21-2009, FILED 8-14-2008.



OWNER OF U.S. REG. NOS. 3,449,533, 3,449,534, AND 3,449,535.

NO CLAIM IS MADE TO THE EXCLUSIVE RIGHT TO USE "CNS COMPREHENSIVE NEUROSCIENCE", APART FROM THE MARK AS SHOWN.

THE MARK CONSISTS OF A RECTANGLE PARTIALLY SHADED WITH WAVY AND CURVED BARS AND LINES AND THE WORDING "CNS COMPREHENSIVE NEUROSCIENCE".

FOR COMPUTER SOFTWARE FOR ANALYSIS OF DATA IN THE FIELD OF MEDICINE, HEALTH, CLINICAL RESEARCH AND PHARMACEUTICAL PREPARATIONS; COMPUTER SOFTWARE FOR PRESENTATION OF DATA IN THE FIELD OF MEDICINE, HEALTH, CLINICAL RESEARCH AND PHARMACEUTICAL PREPARATIONS (U.S. CLS. 21, 23, 26, 36 AND 38).  
 FIRST USE 5-15-2006; IN COMMERCE 5-15-2006.

3,962,208. TEKNOVUS, INC., PETALUMA, CA. SN 77-565,704. PUB. 8-4-2009, FILED 9-9-2008.

# TEKNOVUS

THE MARK CONSISTS OF STANDARD CHARACTERS WITHOUT CLAIM TO ANY PARTICULAR FONT, STYLE, SIZE, OR COLOR.

OWNER OF U.S. REG. NO. 3,191,573.  
 THE WORDING "TEKNOVUS" HAS NO MEANING IN A FOREIGN LANGUAGE.

FOR COMPUTER SOFTWARE, FIRMWARE AND EMBEDDED SOFTWARE FOR PROGRAMMING, OPERATING, MANAGING, MONITORING AND CONTROLLING MICROPROCESSORS, SEMICONDUCTORS, MICROCHIPS AND INTEGRATED CIRCUITS USED IN BROADBAND ACCESS NETWORKING, OPTICAL COMMUNICATIONS AND WIRELINE COMMUNICATIONS (U.S. CLS. 21, 23, 26, 36 AND 38).  
 FIRST USE 4-29-2003; IN COMMERCE 4-29-2003.

**CLASS 9—(Continued).**

3,962,211. CENTER FOR ECOLITERACY, BERKELEY, CA. SN 77-569,776. PUB. 6-2-2009, FILED 9-15-2008.

## SMART BY NATURE

THE MARK CONSISTS OF STANDARD CHARACTERS WITHOUT CLAIM TO ANY PARTICULAR FONT, STYLE, SIZE, OR COLOR.

FOR DOWNLOADABLE TEXT FILES AND WRITTEN DOCUMENTS RELATED TO SCHOOLING FOR SUSTAINABILITY (U.S. CLS. 21, 23, 26, 36 AND 38).

FIRST USE 10-16-2008; IN COMMERCE 10-16-2008.

3,962,229. ARISTOCRAT TECHNOLOGIES AUSTRALIA PTY LTD, NORTH RYDE, NSW, AUSTRALIA. SN 77-617,563. PUB. 3-2-2010, FILED 11-19-2008.

## DESERT MAGIC

THE MARK CONSISTS OF STANDARD CHARACTERS WITHOUT CLAIM TO ANY PARTICULAR FONT, STYLE, SIZE, OR COLOR.

PRIORITY CLAIMED UNDER SEC. 44(D) ON AUSTRALIA APPLICATION NO. 1244414, FILED 6-4-2008, REG. NO. 1244414, DATED 6-4-2008, EXPIRES 6-4-2018.

FOR ELECTRONIC GAMING MACHINES, NAMELY, DEVICES WHICH ACCEPT A WAGER (U.S. CLS. 21, 23, 26, 36 AND 38).

FIRST USE 9-9-2010; IN COMMERCE 9-9-2010.

3,962,242. IGT, RENO, NV. SN 77-632,375. PUB. 4-14-2009, FILED 12-12-2008.

## LILY OF THE VALLEY

THE MARK CONSISTS OF STANDARD CHARACTERS WITHOUT CLAIM TO ANY PARTICULAR FONT, STYLE, SIZE, OR COLOR.

FOR GAMING MACHINES, NAMELY, DEVICES WHICH ACCEPT A WAGER (U.S. CLS. 21, 23, 26, 36 AND 38).

FIRST USE 1-20-2011; IN COMMERCE 1-20-2011.



**CLASS 9—(Continued).**

3,962,247. BROADCAST TOOLS, INC., SEDRO WOOLLEY, WA. SN 77-636,411. PUB. 9-15-2009, FILED 12-18-2008.

**SILENCE SENTINEL**

THE MARK CONSISTS OF STANDARD CHARACTERS WITHOUT CLAIM TO ANY PARTICULAR FONT, STYLE, SIZE, OR COLOR.

NO CLAIM IS MADE TO THE EXCLUSIVE RIGHT TO USE "SILENCE", APART FROM THE MARK AS SHOWN.

FOR ELECTRONIC DEVICE, NAMELY, COMPUTER HARDWARE USED AS A WEB BASED DUAL CHANNEL STEREO AUDIO SILENCE MONITOR WHICH ALERTS THE USER WHEN THERE IS A LOSS OF AUDIO VIA EMAIL (U.S. CLS. 21, 23, 26, 36 AND 38).

FIRST USE 3-8-2011; IN COMMERCE 3-8-2011.

**CLASS 9—(Continued).**

3,962,301. JQL ELECTRONICS INC, DEARFIELD, IL. SN 77-680,369. PUB. 6-23-2009, FILED 2-27-2009.



3,962,249. DWYER INSTRUMENTS, INC., MICHIGAN CITY, IN. SN 77-638,757. PUB. 6-9-2009, FILED 12-23-2008.



OWNER OF U.S. REG. NOS. 942,339, 946,287, AND 2,184,408.

NO CLAIM IS MADE TO THE EXCLUSIVE RIGHT TO USE "DP", APART FROM THE MARK AS SHOWN.

THE MARK CONSISTS OF THE WORD "DWYER" AND LETTERS "DP" IN A STYLIZED FONT, THE WORD "MAG" IN A DIFFERENT FONT, AND THE LETTERS "DW" AND "ER" IN THE WORD "DWYER" ARE UNDERSCORED.

FOR PRESSURE GAGES (U.S. CLS. 21, 23, 26, 36 AND 38).

FIRST USE 2-24-2011; IN COMMERCE 2-24-2011.

THE COLOR(S) ORANGE AND GREY IS/ARE CLAIMED AS A FEATURE OF THE MARK.

THE MARK CONSISTS OF THE LETTERS "JQL" IN ORANGE ON A GREY SQUARE.

FOR AUTOMATIC SWITCHING APPARATUS; ELECTRICAL COMPONENTS IN THE NATURE OF ELECTRIC CONTACTORS; ELECTRICAL COMPONENTS IN THE NATURE OF PROTECTION RELAYS; ELECTRICAL TRANSFORMERS; ELECTRONIC AND OPTICAL COMMUNICATIONS INSTRUMENTS AND COMPONENTS, NAMELY, CABLE TELEVISION TRANSMITTERS; ELECTRONIC AND OPTICAL COMMUNICATIONS INSTRUMENTS AND COMPONENTS, NAMELY, COMMUNICATION LINK TESTERS FOR TESTING COMMUNICATION LINKS; ELECTRONIC AND OPTICAL COMMUNICATIONS INSTRUMENTS AND COMPONENTS, NAMELY, DIGITAL TRANSMITTERS; ELECTRONIC AND OPTICAL COMMUNICATIONS INSTRUMENTS AND COMPONENTS, NAMELY, OPTICAL DATA LINKS; ELECTRONIC AND OPTICAL COMMUNICATIONS INSTRUMENTS AND COMPONENTS, NAMELY, OPTICAL RECEIVERS; ELECTRONIC AND OPTICAL COMMUNICATIONS INSTRUMENTS AND COMPONENTS, NAMELY, OPTICAL TRANSCIEVERS; ELECTRONIC AND OPTICAL COMMUNICATIONS INSTRUMENTS AND COMPONENTS, NAMELY, OPTICAL TRANSMITTERS; ELECTRONIC COMPONENTS FOR COMPUTERS; ELECTRONIC TEST AND MEASUREMENT DEVICES FOR USE IN THE FIELDS OF NETWORKS AND TELECOMMUNICATIONS, NAMELY, INSTRUMENTATION USED TO TEST AND CERTIFY NEW AND EXISTING DATA AND VOICE COMMUNICATION CABLE AND COAXIAL CABLE; INTEGRATED CIRCUIT CARDS AND COMPONENTS; SIGNAL BAND SEPARATORS FOR USE IN TELECOMMUNICATIONS APPLICATIONS; TELECOMMUNICATION CABLES; TELECOMMUNICATION SWITCHES; TELECOMMUNICATIONS CABLES; TELECOMMUNICATIONS TRANSMITTERS; ALL OF THE FOREGOING FOR USE ONLY IN INDUSTRIAL WIRELESS EQUIPMENTS (U.S. CLS. 21, 23, 26, 36 AND 38).

FIRST USE 1-10-2010; IN COMMERCE 1-10-2010.

3,962,277. IGT, RENO, NV. SN 77-665,018. PUB. 5-19-2009, FILED 2-6-2009.

**ANCIENT ARCADIA**

THE MARK CONSISTS OF STANDARD CHARACTERS WITHOUT CLAIM TO ANY PARTICULAR FONT, STYLE, SIZE, OR COLOR.

FOR GAMING MACHINES, NAMELY, DEVICES WHICH ACCEPT A WAGER (U.S. CLS. 21, 23, 26, 36 AND 38).

FIRST USE 1-31-2011; IN COMMERCE 1-31-2011.

**CLASS 9—(Continued).**

3,962,311. SMSC EUROPE GMBH, KARLSRUHE, FED REP GERMANY. SN 77-685,694. PUB. 7-14-2009, FILED 3-6-2009.

**STRESSNIC**

THE MARK CONSISTS OF STANDARD CHARACTERS WITHOUT CLAIM TO ANY PARTICULAR FONT, STYLE, SIZE, OR COLOR.

FOR COMPUTER HARDWARE AND ELECTRONIC COMPUTER LOADS COMPONENTS FOR GENERATING NETWORK LOADS FOR TESTING LAN (LOCAL AREA NETWORK) TRAFFIC AND LEVELS OF DATA EXCHANGE BETWEEN NETWORK NODES; SOFTWARE FOR GENERATING NETWORK LOADS FOR TESTING LAN (LOCAL AREA NETWORK) TRAFFIC AND LEVELS OF DATA EXCHANGE BETWEEN NETWORK NODES (U.S. CLS. 21, 23, 26, 36 AND 38).

FIRST USE 5-0-2009; IN COMMERCE 5-0-2009.

3,962,315. WORLD HUNTING GROUP ENTERPRISES, INC., CANTON, IL. SN 77-688,494. PUB. 1-12-2010, FILED 3-11-2009.

**Lethal Flight**

THE MARK CONSISTS OF STANDARD CHARACTERS, WITHOUT CLAIM TO ANY PARTICULAR FONT, STYLE, SIZE OR COLOR.

FOR DIGITAL MATERIALS, NAMELY, DVDS FEATURING OUTDOOR SPORTS, NAMELY, HUNTING AND FISHING (U.S. CLS. 21, 23, 26, 36 AND 38).

FIRST USE 11-1-1999; IN COMMERCE 11-1-1999.

3,962,323. ANTON/BAUER, INC., SHELTON, CT. SN 77-692,798. PUB. 3-2-2010, FILED 3-17-2009.

**CAMBIO**

THE MARK CONSISTS OF STANDARD CHARACTERS WITHOUT CLAIM TO ANY PARTICULAR FONT, STYLE, SIZE, OR COLOR.

THE ENGLISH TRANSLATION OF THE WORD "CAMBIO" IN THE MARK IS CHANGE.

FOR BAGS, LUGGAGE, TRIPODS AND SUPPORT EQUIPMENT, NAMELY, LIGHT AND FLASH STANDS AND MONPODS, AND ACCESSORIES, NAMELY, REFLECTORS AND BATTERIES, ALL FOR CAMERA AND OTHER IMAGE GATHERING AND RECORDING DEVICES (U.S. CLS. 21, 23, 26, 36 AND 38).

FIRST USE 4-0-2010; IN COMMERCE 4-0-2010.

**CLASS 9—(Continued).**

3,962,328. DOXWOX, LLC, FAIRFAX, VA. SN 77-696,421. PUB. 3-23-2010, FILED 3-22-2009.

**DOXWOX**

THE MARK CONSISTS OF STANDARD CHARACTERS WITHOUT CLAIM TO ANY PARTICULAR FONT, STYLE, SIZE, OR COLOR.

FOR SOFTWARE FOR FILE SHARING, INSTANT MESSAGING, VOICE COMMUNICATIONS, VIDEO CONFERENCING, AND MULTI-MODAL COMMUNICATIONS (U.S. CLS. 21, 23, 26, 36 AND 38).

FIRST USE 1-16-2011; IN COMMERCE 1-16-2011.

3,962,333. ERIC JACOBSON, MENASHA, WI. SN 77-699,485. PUB. 2-16-2010, FILED 3-26-2009.

**BILOXI BACON**

THE MARK CONSISTS OF STANDARD CHARACTERS WITHOUT CLAIM TO ANY PARTICULAR FONT, STYLE, SIZE, OR COLOR.

FOR ELECTRONIC CASINO GAMING MACHINES, NAMELY, ELECTRONIC SLOT AND BINGO MACHINES; ELECTRONIC GAMBLING GAME MACHINES; GAME SOFTWARE, NAMELY, GAMBLING AND CASINO SOFTWARE (U.S. CLS. 21, 23, 26, 36 AND 38).

FIRST USE 8-10-2010; IN COMMERCE 9-7-2010.

3,962,336. SIMONIZ USA, INC., BOLTON, CT. SN 77-700,707. PUB. 8-10-2010, FILED 3-27-2009.

**IF IT'S GREEN, MY HANDS  
ARE CLEAN!**

THE MARK CONSISTS OF STANDARD CHARACTERS WITHOUT CLAIM TO ANY PARTICULAR FONT, STYLE, SIZE, OR COLOR.

FOR HAND WASHING MONITORING SYSTEM COMPRISED OF SENSORS, TIMERS AND INDICATOR LIGHTS, AND SOAP DISPENSERS HAVING ELECTRONIC SIGNAL-EMITTING DEVICES (U.S. CLS. 21, 23, 26, 36 AND 38).

FIRST USE 7-18-2008; IN COMMERCE 3-17-2011.

**CLASS 9—(Continued).**

3,962,346. KRAFT FOODS GLOBAL BRANDS LLC, NORTH-FIELD, IL. SN 77-710,319. PUB. 7-21-2009, FILED 4-9-2009.

# DIJI-TOUCH

THE MARK CONSISTS OF STANDARD CHARACTERS WITHOUT CLAIM TO ANY PARTICULAR FONT, STYLE, SIZE, OR COLOR.

FOR VENDING MACHINES FOR FOODS AND BEVERAGES (U.S. CLS. 21, 23, 26, 36 AND 38).

FIRST USE 2-28-2010; IN COMMERCE 2-28-2010.

3,962,350. COLUMBIA LIGHTING PROPERTIES, INC., WILMINGTON, DE. SN 77-712,726. PUB. 2-2-2010, FILED 4-13-2009.

# A+CLASS

THE MARK CONSISTS OF STANDARD CHARACTERS WITHOUT CLAIM TO ANY PARTICULAR FONT, STYLE, SIZE, OR COLOR.

FOR LIGHTING APPARATUS, NAMELY, LIGHTING CONTROL PANELS AND LIGHTING CONTROL SYSTEMS FOR LIGHTING COMPRISING BALLASTS, PASSIVE INFRARED AND ULTRASONIC OCCUPANCY SENSORS, PHOTOVOLTAIC CELLS AND MODULES FOR USE IN DETECTING THE PRESENCE OF DAYLIGHT, ELECTRICAL CONNECTORS, LIGHTING CONTROL PANELS, AND THE ASSOCIATED PLUG AND PLAY COLOR CODED LOW VOLTAGE WIRING, HIGH VOLTAGE WIRING AND ANY OTHER COMPONENT OR DEVICE EMPLOYED WITH THE ABOVE DESCRIBED EQUIPMENT FOR RELAYING CONTROL SIGNALS FROM ONE DEVICE TO ANOTHER OVER A POWER LINE CONNECTION, AND LIGHTING CONTROL SOFTWARE (U.S. CLS. 21, 23, 26, 36 AND 38).

FIRST USE 8-26-2010; IN COMMERCE 8-26-2010.

**CLASS 9—(Continued).**

3,962,352. UNIVERSITY OF WEST FLORIDA, PENSACOLA, FL. SN 77-714,144. PUB. 8-18-2009, FILED 4-15-2009.

# TELLUS POINT

THE MARK CONSISTS OF STANDARD CHARACTERS WITHOUT CLAIM TO ANY PARTICULAR FONT, STYLE, SIZE, OR COLOR.

FOR DOWNLOADABLE MULTIMEDIA FILE CONTAINING ARTWORK, TEXT, AUDIO, VIDEO, GAMES, AND INTERNET WEB LINKS RELATING TO THE HISTORY OF SPECIFIC GEOGRAPHIC AREAS (U.S. CLS. 21, 23, 26, 36 AND 38).

FIRST USE 8-1-2010; IN COMMERCE 8-1-2010.

3,962,358. TOBIAS, CHRISTINE M, DBA ENVIROMONSTER, DOWNERS GROVE, IL. AND PARKINSON, DAVID R, DBA ENVIROMONSTER, DOWNERS GROVE, IL. AND MACARUS, JORDAN D, DBA ENVIROMONSTER, WESTMONT, IL. SN 77-718,806. PUB. 3-2-2010, FILED 4-21-2009.

# EnviroMonster

THE MARK CONSISTS OF STANDARD CHARACTERS WITHOUT CLAIM TO ANY PARTICULAR FONT, STYLE, SIZE, OR COLOR.

FOR DIGITAL MEDIA, NAMELY, DOWNLOADABLE VIDEO, MUSIC AND GRAPHIC FILES AS WELL AS ARTICLES AND NEWSLETTERS FEATURING CONSERVATION AND ENVIRONMENTAL SUSTAINABILITY (U.S. CLS. 21, 23, 26, 36 AND 38).

FIRST USE 1-1-2007; IN COMMERCE 1-1-2007.

3,962,396. IGT, RENO, NV. SN 77-753,637. PUB. 10-20-2009, FILED 6-5-2009.

# MAGIC WISH

THE MARK CONSISTS OF STANDARD CHARACTERS WITHOUT CLAIM TO ANY PARTICULAR FONT, STYLE, SIZE, OR COLOR.

OWNER OF U.S. REG. NO. 2,973,652.  
FOR GAMING MACHINES, NAMELY, DEVICES WHICH ACCEPT A WAGER (U.S. CLS. 21, 23, 26, 36 AND 38).

FIRST USE 2-15-2011; IN COMMERCE 2-15-2011.

**CLASS 9—(Continued).**

3,962,398. COMPONEXX CORP., SUNRISE, FL. SN 77-757,025. PUB. 10-27-2009, FILED 6-11-2009.

**ComponexX Get Connected!**

THE MARK CONSISTS OF STANDARD CHARACTERS WITHOUT CLAIM TO ANY PARTICULAR FONT, STYLE, SIZE, OR COLOR.

FOR AUDIO AMPLIFIERS; AUDIO CABLES; AUDIO ELECTRONIC COMPONENTS, NAMELY, SURROUND SOUND SYSTEMS; AUDIO EQUIPMENT FOR VEHICLES, NAMELY, STEREOs, SPEAKERS, AMPLIFIERS, EQUALIZERS, CROSSOVERS AND SPEAKER HOUSINGS; CABLE CONNECTORS; CABLE TELEVISION CONVERTERS; CABLES FOR ELECTRICAL AND OPTICAL SIGNAL TRANSMISSION SYSTEMS; CABLES FOR ELECTRICAL OR OPTICAL SIGNAL TRANSMISSION; CABLES FOR OPTICAL SIGNAL TRANSMISSION; CABLES, ELECTRIC; COAXIAL CABLES; COAXIAL CABLES INCORPORATING FILTERS; COMPUTER CABLES; CONNECTING ELECTRICAL CABLES; CONNECTION CABLES; CONSUMER ELECTRONIC PRODUCTS, NAMELY, AUDIO AMPLIFIERS, AUDIO SPEAKERS, AUDIO RECEIVERS, ELECTRICAL AUDIO AND SPEAKER CABLES AND CONNECTORS, HOME THEATER SYSTEMS, AUDIO DECODERS, VIDEO DECODERS, SPEAKERS, POWER CONVERSION DEVICES, POWER CONVERTERS, AND POWER INVERTERS; DISTRIBUTION AMPLIFIERS FOR AUDIO AND VIDEO SIGNALS; ELECTRIC CABLES; ELECTRIC CABLES AND WIRES; ELECTRIC CABLES, WIRES, CONDUCTORS AND CONNECTION FITTINGS THEREFOR; ELECTRIC WIRE AND CABLE; ELECTRICAL AND OPTICAL CABLES; ELECTRICAL CABLES; ELECTRICAL CABLES AND CORDSETS; ELECTRICAL CABLES FOR MUSICAL INSTRUMENTS; ELECTRICAL CABLES FOR USE IN CONNECTIONS; ELECTRICAL CABLES WITH INTEGRATED FITTINGS, NAMELY, CORDSETS; ELECTRONIC CABLES; ELECTRONIC INTERCONNECTERS FOR AUDIO AND VIDEO SIGNALS; ELECTRONIC SWITCHERS FOR AUDIO AND VIDEO SIGNALS; ETHERNET CABLES; EXTENSION CABLES; FIBER OPTIC CABLES; FIBRE-OPTIC CABLES; GUITAR CABLES; HOME THEATER SYSTEMS COMPRISING AUDIO VIDEO CABLES; JUMPER CABLES; MICROPHONE CABLES; MODEM CABLES; OPTICAL CABLES; OPTICAL FIBER CABLES; OPTICAL FIBERS SOLD AS A COMPONENT OF FIBER OPTICAL CABLES; POWER CABLES; PRINTER CABLES; PUBLIC ADDRESS (PA) AND SOUND SYSTEM ACCESSORIES, NAMELY, MICROPHONE STANDS, SPEAKER STANDS, MICROPHONE CABLES, SPEAKER CABLES, SPEAKER BOXES AND SOUND MIXERS; RADIO RELAY CABLES; RECEIVERS FOR ANALOG DIGITAL CONVERSION; STEREO CABLES; TELECOMMUNICATION CABLES; TELECOMMUNICATIONS AND DATA NETWORKING HARDWARE, NAMELY, DEVICES FOR TRANSPORTING AND AGGREGATING VOICE, DATA, AND VIDEO COMMUNICATIONS ACROSS MULTIPLE NETWORK INFRASTRUCTURES AND COMMUNICATIONS PROTOCOLS; TELECOMMUNICATIONS CABLES; TELEVISION AND VIDEO CONVERTERS; THREADED CABLE CONNECTORS OF METAL; TRANSMITTERS AND RECEIVERS FOR AUDIO AND VIDEO SIGNALS FOR TRANSMISSION OVER TWISTED PAIR CABLES; USB CABLES; VIDEO CABLES; VIDEO RECEIVERS (U.S. CLS. 21, 23, 26, 36 AND 38).

FIRST USE 4-1-2011; IN COMMERCE 4-1-2011.

**CLASS 9—(Continued).**

3,962,405. STIFEL, NICOLAUS & COMPANY, INC., ST. LOUIS, MO. SN 77-759,420. PUB. 12-29-2009, FILED 6-15-2009.

**INFOLINX**

THE MARK CONSISTS OF STANDARD CHARACTERS WITHOUT CLAIM TO ANY PARTICULAR FONT, STYLE, SIZE, OR COLOR.

FOR COMPUTER SOFTWARE FOR USE IN INFORMATION AND DATA CAPTURE, INFORMATION ORGANIZATION AND PROCESSING, FINANCIAL ANALYSIS, PROXY VOTING AND PROXY VOTE TABULATION, COMMON STOCK REGISTRATION AND TABULATION OF STOCK PURCHASES, AND REPORTING IN THE FIELD OF INITIAL PUBLIC OFFERINGS OF COMMON STOCK WHEN CONVERTING FROM A MUTUAL TO A MUTUAL HOLDING COMPANY OR A STOCK COMPANY (U.S. CLS. 21, 23, 26, 36 AND 38).

FIRST USE 11-13-2009; IN COMMERCE 11-13-2009.

3,962,408. REVLON CONSUMER PRODUCTS CORPORATION, NEW YORK, NY. SN 77-761,605. PUB. 9-8-2009, FILED 6-17-2009.

**SMOOTHSTAY**

THE MARK CONSISTS OF STANDARD CHARACTERS WITHOUT CLAIM TO ANY PARTICULAR FONT, STYLE, SIZE, OR COLOR.

FOR ELECTRIC HAIR STRAIGHTENER (U.S. CLS. 21, 23, 26, 36 AND 38).

FIRST USE 2-28-2010; IN COMMERCE 2-28-2010.

**CLASS 9—(Continued).**

3,962,418. ACCRETIVE HEALTH, INC., CHICAGO, IL. SN 77-768,576. PUB. 8-24-2010, FILED 6-25-2009.

# AHtoScribe

THE MARK CONSISTS OF STANDARD CHARACTERS WITHOUT CLAIM TO ANY PARTICULAR FONT, STYLE, SIZE, OR COLOR.

FOR COMPUTER SOFTWARE FOR USE BY MEDICAL TRANSCRIPTIONISTS, PHYSICIANS AND OTHER MEDICAL PROFESSIONALS IN THE CONVERSION AND TRANSCRIPTION OF MEDICAL DICTATION, THE MANAGEMENT OF MEDICAL RECORDS AND BILLING INFORMATION, AND THE ELECTRONIC DISTRIBUTION IN THE NATURE OF PROVIDING TRANSCRIBED REPORTS TO HOSPITAL INFORMATION CENTERS VIA REAL-TIME, MESSAGE-BASED COMPUTER INTERFACES OR VIA DOWNLOADING DATA FILES IN THE NATURE OF ELECTRONIC MEDICAL RECORDS (EMR), MEDICAL CLAIM CODES, AND MEDICAL CLAIMS SUBMISSIONS (U.S. CLS. 21, 23, 26, 36 AND 38).

FIRST USE 8-0-2009; IN COMMERCE 8-0-2009.

---

3,962,430. BLOW UP RECORDS LIMITED, LONDON, ENGLAND. SN 77-774,262. PUB. 7-6-2010, FILED 7-3-2009.

# BLOW UP

THE MARK CONSISTS OF STANDARD CHARACTERS WITHOUT CLAIM TO ANY PARTICULAR FONT, STYLE, SIZE, OR COLOR.

OWNER OF U.S. REG. NO. 2,796,423.  
FOR MUSICAL SOUND RECORDINGS; PHONOGRAPH RECORDS FEATURING MUSIC; DOWNLOADABLE MUSICAL SOUND RECORDINGS; DIGITAL MUSIC DOWNLOADABLE FROM THE INTERNET (U.S. CLS. 21, 23, 26, 36 AND 38).

FIRST USE 5-0-1994; IN COMMERCE 10-0-1996.

**CLASS 9—(Continued).**

3,962,443. VENTIS CORPORATION, CARSON CITY, NV. SN 77-780,742. PUB. 12-8-2009, FILED 7-14-2009.

# LightFighter

THE MARK CONSISTS OF STANDARD CHARACTERS WITHOUT CLAIM TO ANY PARTICULAR FONT, STYLE, SIZE, OR COLOR.

FOR LIGHTWEIGHT HIGH PERFORMANCE ULTRA-WIDEBAND ANTENNAS (U.S. CLS. 21, 23, 26, 36 AND 38).

FIRST USE 1-3-2010; IN COMMERCE 1-3-2010.

---

3,962,446. EPPENDORF AG, HAMBURG, FED REP GERMANY. SN 77-781,327. PUB. 7-27-2010, FILED 7-15-2009.

# Eppendorf Eporator

THE MARK CONSISTS OF STANDARD CHARACTERS WITHOUT CLAIM TO ANY PARTICULAR FONT, STYLE, SIZE, OR COLOR.

OWNER OF U.S. REG. NOS. 1,404,655, 2,452,949, AND 3,187,659.

FOR ELECTRICAL AND SCIENTIFIC APPARATUS USED FOR TRANSPORTING DNA AND OTHER MOLECULES INTO BACTERIA AND YEAST CELLS BY HIGH VOLTAGE PULSES (U.S. CLS. 21, 23, 26, 36 AND 38).

FIRST USE 1-24-2011; IN COMMERCE 1-24-2011.

---

3,962,467. IGT, RENO, NV. SN 77-790,027. PUB. 12-15-2009, FILED 7-27-2009.

# SUPER STACKS

THE MARK CONSISTS OF STANDARD CHARACTERS WITHOUT CLAIM TO ANY PARTICULAR FONT, STYLE, SIZE, OR COLOR.

FOR A FEATURE OF GAMING MACHINES, NAMELY, DEVICES WHICH ACCEPT A WAGER (U.S. CLS. 21, 23, 26, 36 AND 38).

FIRST USE 1-31-2011; IN COMMERCE 1-31-2011.



**CLASS 9—(Continued).**

3,962,471. WMS GAMING INC., WAUKEGAN, IL. SN 77-790,416. PUB. 12-22-2009, FILED 7-27-2009.

**CLASS 9—(Continued).**

3,962,511. WMS GAMING INC., WAUKEGAN, IL. SN 77-803,758. PUB. 12-22-2009, FILED 8-13-2009.

**WINNERS SHARE**

THE MARK CONSISTS OF STANDARD CHARACTERS WITHOUT CLAIM TO ANY PARTICULAR FONT, STYLE, SIZE, OR COLOR.

FOR COMPONENTS FOR GAMING MACHINES THAT GENERATE OR DISPLAY WAGER OUTCOMES, NAMELY, CONTROLLERS, DISPLAYS, BUTTON PANELS, BOLSTERS, ELECTRICAL WIRING, AND COMPUTER HARDWARE AND SOFTWARE ASSOCIATED THEREWITH; GAMING MACHINES, NAMELY, DEVICES WHICH ACCEPT A WAGER; GAMING SOFTWARE THAT GENERATES OR DISPLAYS WAGER OUTCOMES OF GAMING MACHINES (U.S. CLS. 21, 23, 26, 36 AND 38).

FIRST USE 11-17-2009; IN COMMERCE 11-17-2009.

**LUXURIOUS LIFE**

THE MARK CONSISTS OF STANDARD CHARACTERS WITHOUT CLAIM TO ANY PARTICULAR FONT, STYLE, SIZE, OR COLOR.

OWNER OF U.S. REG. NO. 2,317,146.  
FOR COMPONENTS FOR GAMING MACHINES THAT GENERATE OR DISPLAY WAGER OUTCOMES, NAMELY, CONTROLLERS, DISPLAYS, BUTTON PANELS, BOLSTERS, ELECTRICAL WIRING, AND COMPUTER HARDWARE AND SOFTWARE ASSOCIATED THEREWITH; GAMING MACHINES, NAMELY, DEVICES WHICH ACCEPT A WAGER; GAMING SOFTWARE THAT GENERATES OR DISPLAYS WAGER OUTCOMES OF GAMING MACHINES (U.S. CLS. 21, 23, 26, 36 AND 38).

FIRST USE 11-17-2009; IN COMMERCE 11-17-2009.

3,962,473. IGT, RENO, NV. SN 77-790,688. PUB. 12-15-2009, FILED 7-27-2009.

**CAPISTRANO**

THE MARK CONSISTS OF STANDARD CHARACTERS WITHOUT CLAIM TO ANY PARTICULAR FONT, STYLE, SIZE, OR COLOR.

FOR GAMING MACHINES, NAMELY, DEVICES WHICH ACCEPT A WAGER (U.S. CLS. 21, 23, 26, 36 AND 38).

FIRST USE 2-15-2011; IN COMMERCE 2-15-2011.

3,962,512. WMS GAMING INC., WAUKEGAN, IL. SN 77-803,762. PUB. 12-22-2009, FILED 8-13-2009.

**PRIZES OF PARADISE**

3,962,487. PROVENTUS GLOBAL HOLDINGS, LLC, PARKTON, MD. SN 77-796,586. PUB. 12-29-2009, FILED 8-4-2009.

**MANPOINTS**

THE MARK CONSISTS OF STANDARD CHARACTERS WITHOUT CLAIM TO ANY PARTICULAR FONT, STYLE, SIZE, OR COLOR.

FOR COMPUTER APPLICATION SOFTWARE FOR MOBILE PHONES (U.S. CLS. 21, 23, 26, 36 AND 38).

FIRST USE 9-18-2009; IN COMMERCE 9-18-2009.

THE MARK CONSISTS OF STANDARD CHARACTERS WITHOUT CLAIM TO ANY PARTICULAR FONT, STYLE, SIZE, OR COLOR.

FOR COMPONENTS FOR GAMING MACHINES THAT GENERATE OR DISPLAY WAGER OUTCOMES, NAMELY, CONTROLLERS, DISPLAYS, BUTTON PANELS, BOLSTERS, ELECTRICAL WIRING, AND COMPUTER HARDWARE AND SOFTWARE ASSOCIATED THEREWITH; GAMING MACHINES, NAMELY, DEVICES WHICH ACCEPT A WAGER; GAMING SOFTWARE THAT GENERATES OR DISPLAYS WAGER OUTCOMES OF GAMING MACHINES (U.S. CLS. 21, 23, 26, 36 AND 38).

FIRST USE 11-17-2009; IN COMMERCE 11-17-2009.

**CLASS 9—(Continued).**

3,962,551. ENCORE SOFTWARE, INC., EL SEGUNDA, CA. SN 77-816,215. PUB. 8-10-2010, FILED 8-31-2009.

**CLASS 9—(Continued).**

3,962,556. WMS GAMING INC., WAUKEGAN, IL. SN 77-817,208. PUB. 12-29-2009, FILED 9-1-2009.

**PRECISIONPOINT**

THE MARK CONSISTS OF STANDARD CHARACTERS WITHOUT CLAIM TO ANY PARTICULAR FONT, STYLE, SIZE, OR COLOR.

FOR SOFTWARE TOOL, NAMELY, A GRAPHICAL USER INTERFACE TO PRECISELY ENTER COORDINATES IN COMPUTER-ASSISTED DRAFTING SOFTWARE FOR HOME DESIGN, ADDITION IMPROVEMENT, AND MODELING (U.S. CLS. 21, 23, 26, 36 AND 38).

FIRST USE 3-17-2010; IN COMMERCE 3-17-2010.

**SEA TALES**

THE MARK CONSISTS OF STANDARD CHARACTERS WITHOUT CLAIM TO ANY PARTICULAR FONT, STYLE, SIZE, OR COLOR.

FOR COMPONENTS FOR GAMING MACHINES THAT GENERATE OR DISPLAY WAGER OUTCOMES, NAMELY, CONTROLLERS, DISPLAYS, BUTTON PANELS, BOLSTERS, ELECTRICAL WIRING, AND COMPUTER HARDWARE AND SOFTWARE ASSOCIATED THEREWITH; GAMING MACHINES, NAMELY, DEVICES WHICH ACCEPT A WAGER; GAMING SOFTWARE THAT GENERATES OR DISPLAYS WAGER OUTCOMES OF GAMING MACHINES (U.S. CLS. 21, 23, 26, 36 AND 38).

FIRST USE 11-16-2010; IN COMMERCE 11-16-2010.

3,962,553. ARISTOCRAT TECHNOLOGIES AUSTRALIA, PTY LTD, NORTH RYDE, NSW, AUSTRALIA. SN 77-816,379. PUB. 8-3-2010, FILED 8-31-2009.

3,962,557. WMS GAMING INC., WAUKEGAN, IL. SN 77-817,209. PUB. 12-29-2009, FILED 9-1-2009.

**ALOHA PARADISE**

THE MARK CONSISTS OF STANDARD CHARACTERS WITHOUT CLAIM TO ANY PARTICULAR FONT, STYLE, SIZE, OR COLOR.

OWNER OF AUSTRALIA REG. NO. 1289115, DATED 3-12-2009, EXPIRES 3-12-2019.

FOR GAMING MACHINES, NAMELY, DEVICES WHICH ACCEPT A WAGER (U.S. CLS. 21, 23, 26, 36 AND 38).

FIRST USE 7-1-2010; IN COMMERCE 7-1-2010.

**WINTER WOLF**

THE MARK CONSISTS OF STANDARD CHARACTERS WITHOUT CLAIM TO ANY PARTICULAR FONT, STYLE, SIZE, OR COLOR.

FOR COMPONENTS FOR GAMING MACHINES THAT GENERATE OR DISPLAY WAGER OUTCOMES, NAMELY, CONTROLLERS, DISPLAYS, BUTTON PANELS, BOLSTERS, ELECTRICAL WIRING, AND COMPUTER HARDWARE AND SOFTWARE ASSOCIATED THEREWITH; GAMING MACHINES, NAMELY, DEVICES WHICH ACCEPT A WAGER; GAMING SOFTWARE THAT GENERATES OR DISPLAYS WAGER OUTCOMES OF GAMING MACHINES (U.S. CLS. 21, 23, 26, 36 AND 38).

FIRST USE 11-16-2010; IN COMMERCE 11-16-2010.

**CLASS 9—(Continued).**

3,962,558. WMS GAMING INC., WAUKEGAN, IL. SN 77-817,214. PUB. 12-29-2009, FILED 9-1-2009.

# ZANZIBAR

THE MARK CONSISTS OF STANDARD CHARACTERS WITHOUT CLAIM TO ANY PARTICULAR FONT, STYLE, SIZE, OR COLOR.

FOR COMPONENTS FOR GAMING MACHINES THAT GENERATE OR DISPLAY WAGER OUTCOMES, NAMELY, CONTROLLERS, DISPLAYS, BUTTON PANELS, BOLSTERS, ELECTRICAL WIRING, AND COMPUTER HARDWARE AND SOFTWARE ASSOCIATED THEREWITH; GAMING MACHINES, NAMELY, DEVICES WHICH ACCEPT A WAGER; GAMING SOFTWARE THAT GENERATES OR DISPLAYS WAGER OUTCOMES OF GAMING MACHINES (U.S. CLS. 21, 23, 26, 36 AND 38).

FIRST USE 11-16-2010; IN COMMERCE 11-16-2010.

3,962,570. MRK FINE ARTS, LLC, NEW CANAAN, CT. SN 77-822,491. PUB. 8-17-2010, FILED 9-9-2009.



THE MARK CONSISTS OF THE LETTER "M" STYLIZED. FOR SOFTWARE THAT DEPICTS A VISUAL REPRESENTATION OF A LOCKET AND INPUTS DATA ASSOCIATED THEREWITH, NAMELY, TEXT DATA AND IMAGE DATA FOR OVERLAY ON THE VISUAL REPRESENTATION OF THE LOCKET (U.S. CLS. 21, 23, 26, 36 AND 38).

FIRST USE 10-31-2009; IN COMMERCE 10-31-2009.

3,962,574. NAMCO BANDAI GAMES AMERICA INC., SANTA CLARA, CA. SN 77-823,217. PUB. 12-8-2009, FILED 9-9-2009.

# ENSLAVED

THE MARK CONSISTS OF STANDARD CHARACTERS WITHOUT CLAIM TO ANY PARTICULAR FONT, STYLE, SIZE, OR COLOR.

FOR COMPUTER GAME PROGRAMS; COMPUTER GAME SOFTWARE; DOWNLOADABLE COMPUTER GAME SOFTWARE; VIDEO GAME DISCS; AND VIDEO GAME SOFTWARE (U.S. CLS. 21, 23, 26, 36 AND 38).

FIRST USE 10-5-2010; IN COMMERCE 10-5-2010.

**CLASS 9—(Continued).**

3,962,592. ILSCO CORPORATION, DBA FTZ INDUSTRIES, CINCINNATI, OH. SN 77-827,630. PUB. 8-24-2010, FILED 9-16-2009.

# ECO-MAX

THE MARK CONSISTS OF STANDARD CHARACTERS WITHOUT CLAIM TO ANY PARTICULAR FONT, STYLE, SIZE, OR COLOR.

FOR BATTERY TERMINAL CONNECTOR CLAMPS (U.S. CLS. 21, 23, 26, 36 AND 38).

FIRST USE 1-26-2010; IN COMMERCE 1-26-2010.

3,962,593. RED.COM, INC., LAKE FOREST, CA. SN 77-828,105. PUB. 1-12-2010, FILED 9-16-2009.

# REDVOLT

THE MARK CONSISTS OF STANDARD CHARACTERS WITHOUT CLAIM TO ANY PARTICULAR FONT, STYLE, SIZE, OR COLOR.

FOR CAMERA BATTERIES AND BATTERY PACKS (U.S. CLS. 21, 23, 26, 36 AND 38).

FIRST USE 2-10-2011; IN COMMERCE 2-10-2011.

3,962,618. JNS DATA SYSTEMS, LLC., LA, CA. SN 77-835,597. PUB. 8-17-2010, FILED 9-25-2009.

# MySongApp

THE MARK CONSISTS OF STANDARD CHARACTERS WITHOUT CLAIM TO ANY PARTICULAR FONT, STYLE, SIZE, OR COLOR.

FOR COMPUTER HARDWARE AND COMPUTER SOFTWARE PROGRAMS FOR THE INTEGRATION OF TEXT, AUDIO, GRAPHICS, STILL IMAGES AND MOVING PICTURES INTO AN INTERACTIVE DELIVERY FOR MULTIMEDIA APPLICATIONS (U.S. CLS. 21, 23, 26, 36 AND 38).

FIRST USE 1-1-2011; IN COMMERCE 1-1-2011.

**CLASS 9—(Continued).**

3,962,644. PNY TECHNOLOGIES, INC., PARSIPPANY, NJ. SN 77-849,301. PUB. 12-28-2010, FILED 10-15-2009.



NO CLAIM IS MADE TO THE EXCLUSIVE RIGHT TO USE "POWER EFFICIENT" AND "AS MUCH AS 30% LESS POWER CONSUMPTION THAN THE STANDARD 9800 GT", APART FROM THE MARK AS SHOWN.

THE MARK CONSISTS OF STYLIZED LETTERS "PE" WITH A STYLIZED DESIGN ELEMENT OF DASHED LINE ABOVE THE LETTERS "PE" PROJECTING FROM THE LETTER "P" TOWARDS THE END OF THE LETTER "E" IN A DOWNWARD SLOPE AND THE LETTER "PE" APPEARING ABOVE THE WORDS "POWER EFFICIENT" ALL WITHIN A RECTANGLE AND THE WORDS "AS MUCH AS 30% LESS POWER CONSUMPTION THAN THE STANDARD 9800 GT" APPEARS WITHIN THE LOWER PORTION OF ANOTHER RECTANGLE THAT APPEARS BEHIND AND SLIGHTLY LOWER THAN THE FIRST RECTANGLE.

FOR COMPUTER GRAPHIC CARDS (U.S. CLS. 21, 23, 26, 36 AND 38).

FIRST USE 9-0-2009; IN COMMERCE 9-0-2009.

3,962,652. FLORES, STEVE, REDMOND, WA. SN 77-851,128. PUB. 3-23-2010, FILED 10-17-2009.

**ALPHA SQUAD**

THE MARK CONSISTS OF STANDARD CHARACTERS WITHOUT CLAIM TO ANY PARTICULAR FONT, STYLE, SIZE, OR COLOR.

FOR COMPUTER GAME SOFTWARE; ELECTRONIC GAME SOFTWARE; GAME SOFTWARE; INTERACTIVE GAME SOFTWARE; VIDEO GAME SOFTWARE (U.S. CLS. 21, 23, 26, 36 AND 38).

FIRST USE 8-0-2010; IN COMMERCE 8-0-2010.

**CLASS 9—(Continued).**

3,962,673. STREET LAW, INC., SILVER SPRING, MD. SN 77-857,254. PUB. 7-20-2010, FILED 10-26-2009.

**BREAKFAST WITH A LEGEND**

THE MARK CONSISTS OF STANDARD CHARACTERS WITHOUT CLAIM TO ANY PARTICULAR FONT, STYLE, SIZE, OR COLOR.

FOR DOWNLOADABLE ELECTRONIC PUBLICATIONS IN THE NATURE OF TRAINING MANUALS IN THE FIELD OF ORGANIZING, CONDUCTING, AND EVALUATING PROGRAMS FEATURING EDUCATIONAL AND MOTIVATIONAL SPEAKERS, AND EDUCATIONAL LESSON PLANS IN THE FIELDS OF LAW AND DISPUTE RESOLUTION; DOWNLOADABLE PRINTING FONTS; DOWNLOADABLE IMAGE AND TEXT FILES USED FOR MAKING CERTIFICATES, EVALUATION FORMS, BLANK JOURNALS, BOOKMARKS, NAME BADGES, AND STICKERS; DOWNLOADABLE TEXT FILES USED FOR MAKING LEGAL AGREEMENTS (U.S. CLS. 21, 23, 26, 36 AND 38).

FIRST USE 12-1-2009; IN COMMERCE 11-30-2010.

3,962,685. MCELROY, JAMES RANDALL, SHOBNIER, IL. SN 77-859,361. PUB. 3-2-2010, FILED 10-28-2009.

**Cop Out**

THE MARK CONSISTS OF STANDARD CHARACTERS WITHOUT CLAIM TO ANY PARTICULAR FONT, STYLE, SIZE, OR COLOR.

FOR ELECTRONIC TIMERS; TIMERS (U.S. CLS. 21, 23, 26, 36 AND 38).

FIRST USE 6-5-2007; IN COMMERCE 2-14-2010.

3,962,693. MICROSOFT CORPORATION, REDMOND, WA. SN 77-861,827. PUB. 2-2-2010, FILED 10-30-2009.

**BACKSTAGE**

THE MARK CONSISTS OF STANDARD CHARACTERS WITHOUT CLAIM TO ANY PARTICULAR FONT, STYLE, SIZE, OR COLOR.

FOR COMPUTER SOFTWARE, NAMELY, A BUSINESS PRODUCTIVITY PROGRAM FEATURE PROVIDING A DASHBOARD FOR MANAGEMENT, NAVIGATION, ACCESS, STORAGE, AND SHARING OF DOCUMENTS AND FILES (U.S. CLS. 21, 23, 26, 36 AND 38).

FIRST USE 11-18-2009; IN COMMERCE 11-18-2009.

**CLASS 9—(Continued).**

3,962,694. POWERTECH INDUSTRIAL CO., LTD., TAIPEI HSIEN, TAIWAN. SN 77-862,046. PUB. 7-20-2010, FILED 10-31-2009.

## X3 MOV

THE MARK CONSISTS OF STANDARD CHARACTERS WITHOUT CLAIM TO ANY PARTICULAR FONT, STYLE, SIZE, OR COLOR.

FOR POWER SUPPLIES; MOBILE PHONE BATTERY CHARGERS; MOBILE PHONE BATTERY CHARGER STATIONS; BATTERY CHARGERS; UNIVERSAL POWER SUPPLIES; POWER SAVING ADAPTERS; ELECTRIC STORAGE BATTERIES; UNINTERRUPTIBLE POWER SUPPLIES; AC/DC CONVERTERS; POWER SOURCE STABLE ADAPTERS; ELECTRIC WIRES; REMOTE CONTROLLER FOR ELECTRICAL OUTLET; ELECTRIC AUTOMATIC TIME SWITCHES; ELECTRIC PLUGS; ELECTRIC SOCKETS; POWER WIRES; VOLTAGE SURGE ABSORBERS; RAILWAY TRAFFIC SAFETY APPLIANCES, NAMELY, SENSORS AND DETECTOR UNITS FOR USE IN CONTROLLING THE ACTUATION AND OPERATION OF RAILWAY SAFETY APPARATUS AND EQUIPMENT; ELECTRIC STARTER CABLE FOR MOTORS; VOLTAGE SURGE PROTECTORS (U.S. CLS. 21, 23, 26, 36 AND 38).  
FIRST USE 1-7-2010; IN COMMERCE 1-7-2010.

---

3,962,695. BLACK DOG TECHNOLOGY LLC, LAS VEGAS, NV. SN 77-862,121. PUB. 4-13-2010, FILED 10-31-2009.

## Proposal Navigator

THE MARK CONSISTS OF STANDARD CHARACTERS WITHOUT CLAIM TO ANY PARTICULAR FONT, STYLE, SIZE, OR COLOR.

NO CLAIM IS MADE TO THE EXCLUSIVE RIGHT TO USE "PROPOSAL", APART FROM THE MARK AS SHOWN. FOR COMPUTER PROGRAMMES FOR DOCUMENT MANAGEMENT (U.S. CLS. 21, 23, 26, 36 AND 38).  
FIRST USE 3-1-2011; IN COMMERCE 3-1-2011.

**CLASS 9—(Continued).**

3,962,727. PACKER, LYNN, NORTH SALT LAKE, UT. SN 77-879,293. PUB. 4-6-2010, FILED 11-23-2009.

## V-Chassis

THE MARK CONSISTS OF STANDARD CHARACTERS WITHOUT CLAIM TO ANY PARTICULAR FONT, STYLE, SIZE, OR COLOR.

FOR BOXES SPECIALLY ADAPTED FOR AUDIO/VIDEO EQUIPMENT FOR THE RECORDING AND LIVE STREAMING OF EVENTS SUCH AS LECTURES, TRAINING SESSIONS AND LEGAL DEPOSITIONS (U.S. CLS. 21, 23, 26, 36 AND 38).

FIRST USE 4-20-2009; IN COMMERCE 4-20-2009.

---

3,962,754. APRICORN, POWAY, CA. SN 77-888,201. PUB. 5-4-2010, FILED 12-8-2009.

## NetDock

THE MARK CONSISTS OF STANDARD CHARACTERS WITHOUT CLAIM TO ANY PARTICULAR FONT, STYLE, SIZE, OR COLOR.

FOR COMPUTER HARDWARE AND COMPUTER PERIPHERALS (U.S. CLS. 21, 23, 26, 36 AND 38).  
FIRST USE 7-28-2010; IN COMMERCE 9-1-2010.

---

3,962,757. JWING ELECTRONICS CORP., PORT WASHINGTON, NY. SN 77-888,368. PUB. 5-18-2010, FILED 12-8-2009.

## Emoticon Dock

THE MARK CONSISTS OF STANDARD CHARACTERS WITHOUT CLAIM TO ANY PARTICULAR FONT, STYLE, SIZE, OR COLOR.



**CLASS 9—(Continued).**

NO CLAIM IS MADE TO THE EXCLUSIVE RIGHT TO USE "DOCK", APART FROM THE MARK AS SHOWN.

FOR ABDOMINAL BELTS CONTAINING BUILT-IN SPEAKERS FOR PURPOSES OF TRANSMITTING MUSIC/SOUNDS/EDUCATIONAL MATERIAL TO A FETUS AND BUILT-IN POCKETS IN WHICH TO CARRY AUDIO TRANSMITTERS; AUDIO AMPLIFIERS; AUDIO AND VIDEO CASSETTE RECORDERS; AUDIO CABLES; AUDIO CASSETTE AND CD PLAYERS; AUDIO CASSETTE DECKS FOR AUTOMOBILES; AUDIO CASSETTE PLAYERS; AUDIO CASSETTE RECORDERS; AUDIO CIRCUIT BOARDS; AUDIO ELECTRONIC COMPONENTS, NAMELY, SURROUND SOUND SYSTEMS; AUDIO EQUIPMENT FOR VEHICLES, NAMELY, STEREOs, SPEAKERS, AMPLIFIERS, EQUALIZERS, CROSSOVERS AND SPEAKER HOUSINGS; AUDIO EQUIPMENT FOR VEHICLES, NAMELY, SUBWOOFERS; AUDIO HEADPHONES; AUDIO MIXERS; AUDIO PROCESSING EQUIPMENT, NAMELY, LIMITERS AND COMPRESSORS; AUDIO RECORDERS; AUDIO SPEAKER ENCLOSURES; AUDIO SPEAKERS; AUDIO SPEAKERS THAT MAY BE ATTACHED WITH ADHESIVE TO THE ABDOMINAL AREA OF PREGNANT WOMEN FOR THE PURPOSE OF TRANSMITTING MUSIC/SOUNDS TO THE FETUS, NOT FOR MEDICAL PURPOSES; AUDIO TAPE RECORDERS; AUDIO TAPES FEATURING MUSIC; AUDIO-VIDEO RECEIVERS; BLANK AUDIO CASSETTES; BLANK AUDIO TAPES; BLANK DIGITAL AUDIO TAPES; BOXES SPECIALLY ADAPTED FOR HOUSING AUDIO EQUIPMENT; COMPUTER HARDWARE AND COMPUTER SOFTWARE PROGRAMS FOR THE INTEGRATION OF TEXT, AUDIO, GRAPHICS, STILL IMAGES AND MOVING PICTURES INTO AN INTERACTIVE DELIVERY FOR MULTIMEDIA APPLICATIONS; COMPUTER HARDWARE FOR COMMUNICATING AUDIO, VIDEO AND DATA BETWEEN COMPUTERS VIA A GLOBAL COMPUTER NETWORK, WIDE-AREA COMPUTER NETWORKS, AND PEER-TO-PEER COMPUTER NETWORKS; COMPUTER SOFTWARE FOR MANIPULATING DIGITAL AUDIO INFORMATION FOR USE IN AUDIO MEDIA APPLICATIONS; COMPUTER SOFTWARE FOR USE IN THE ENCRYPTION AND DECRYPTION OF DIGITAL FILES, INCLUDING AUDIO, VIDEO, TEXT, BINARY, STILL IMAGES, GRAPHICS AND MULTIMEDIA FILES; COMPUTER SOFTWARE FOR USE IN THE SAFEGUARDING OF DIGITAL FILES, INCLUDING AUDIO, VIDEO, TEXT, BINARY, STILL IMAGES, GRAPHICS AND MULTIMEDIA FILES (U.S. CLS. 21, 23, 26, 36 AND 38).

FIRST USE 12-22-2009; IN COMMERCE 12-22-2009.

3,962,767. OPTRONIC TECHNOLOGIES, INC., WATSONVILLE, CA. SN 77-889,592. PUB. 5-4-2010, FILED 12-9-2009.

# FUNSCOPE

THE MARK CONSISTS OF STANDARD CHARACTERS WITHOUT CLAIM TO ANY PARTICULAR FONT, STYLE, SIZE, OR COLOR.

FOR TELESCOPES (U.S. CLS. 21, 23, 26, 36 AND 38).  
FIRST USE 8-9-2010; IN COMMERCE 8-9-2010.

**CLASS 9—(Continued).**

3,962,779. PERDUE HOLDINGS, INC., WILMINGTON, DE. SN 77-894,613. PUB. 8-31-2010, FILED 12-16-2009.



OWNER OF U.S. REG. NOS. 1,326,205, 2,311,032, AND 2,402,409.

THE MARK CONSISTS OF THE TERM "PERDUE" UNDERLINED IN A RECTANGLE DESIGN WITH "IT'S HIP TO BE FIT!" IN STYLIZED LETTERING.

FOR DOWNLOADABLE ELECTRONIC NEWSLETTERS AND BROCHURES IN THE FIELD OF HEALTH (U.S. CLS. 21, 23, 26, 36 AND 38).

FIRST USE 8-0-2010; IN COMMERCE 8-0-2010.

3,962,785. AVVASI INC., WATERLOO, ONTARIO, CANADA. SN 77-896,483. PUB. 7-13-2010, FILED 12-18-2009.

# AVVASI Q-VUE

THE MARK CONSISTS OF STANDARD CHARACTERS WITHOUT CLAIM TO ANY PARTICULAR FONT, STYLE, SIZE, OR COLOR.

PRIORITY CLAIMED UNDER SEC. 44(D) ON CANADA APPLICATION NO. 1,460,984, FILED 11-30-2009.

THE WORDING "AVVASI Q-VUE" HAS NO MEANING IN A FOREIGN LANGUAGE.

FOR SOFTWARE AND COMPUTER HARDWARE FOR MONITORING A CUSTOMER USER'S QUALITY OF EXPERIENCE IN WIRED AND WIRELESS CARRIER NETWORKS, FOR USE WITHIN MULTIMEDIA TRAFFIC AND OTHER TYPES OF ELECTRONIC TRAFFIC (U.S. CLS. 21, 23, 26, 36 AND 38).

FIRST USE 5-0-2010; IN COMMERCE 5-0-2010.

**CLASS 9—(Continued).**

3,962,786. OLYMPUS CORPORATION, TOKYO, JAPAN. SN 77-897,010. PUB. 3-23-2010, FILED 12-18-2009.



THE MARK CONSISTS OF THE STYLIZED LETTERS "E-P".

FOR CAMERAS, DIGITAL CAMERAS, AND PARTS AND ACCESSORIES THEREFOR, NAMELY, INTERCHANGEABLE LENSES, EXTENSION AND CONVERSION LENSES, LENS FILTERS, MOUNT ADAPTERS (U.S. CLS. 21, 23, 26, 36 AND 38).

FIRST USE 6-16-2009; IN COMMERCE 6-16-2009.

3,962,804. TOMTOM INTERNATIONAL B.V., AMSTERDAM, NETHERLANDS. SN 77-902,954. PUB. 8-17-2010, FILED 12-30-2009.

## TOMTOM EASE

THE MARK CONSISTS OF STANDARD CHARACTERS WITHOUT CLAIM TO ANY PARTICULAR FONT, STYLE, SIZE, OR COLOR.

OWNER OF U.S. REG. NOS. 3,389,061, 3,606,082, AND OTHERS.

FOR COMPUTER HARDWARE AND SOFTWARE FOR USE WITH NAVIGATION SYSTEMS, ROUTE PLANNERS, ELECTRONIC MAPS AND DIGITAL DICTIONARIES FOR NAVIGATION AND TRANSLATION PURPOSES; SOFTWARE FOR USE WITH SATELLITE AND GPS NAVIGATION SYSTEMS FOR NAVIGATION PURPOSES; SOFTWARE FOR TRAVEL INFORMATION SYSTEMS FOR THE PROVISION AND RENDERING OF TRAVEL ADVICE AND INFORMATION CONCERNING SERVICE STATIONS, CAR PARKS, RESTAURANTS, CAR DEALERS AND OTHER TRAVEL AND TRANSPORT RELATED INFORMATION; SOFTWARE TO BE USED FOR VIEWING ELECTRONIC MAPS; DOWNLOADABLE ELECTRONIC MAPS; SOFTWARE FOR OPERATING ROUTE PLANNERS; ROUTE PLANNERS IN THE NATURE OF HAND-HELD PERSONAL COMPUTERS; SOFTWARE FOR OPERATING ELECTRONIC DIGITAL DICTIONARIES; LOCATION, ORIENTATION, AND NAVIGATION SENSORS, TRANSMITTERS, ACTUATORS, CAMERAS AND GLOBAL POSITIONING SYSTEMS, NAMELY, GPS CONSISTING OF COMPUTERS, COMPUTER SOFTWARE, TRANSMITTERS, GPS AND SATELLITE RECEIVERS, NETWORK INTERFACE DEVICES, CONNECTION CABLES AND PARTS AND FITTINGS THEREOF; SATELLITE AND RADIO TRANSMISSION PROCESSORS AND RECEIVERS; TELECOMMUNICATIONS INSTALLATIONS, NETWORKS AND APPARATUS, NAMELY, MOUNTING RACKS FOR TELECOMMUNICATIONS HARDWARE, TELECOMMUNICATIONS SWITCHES; COMPUTER TERMINALS, ALL IN PARTICULAR TO BE USED WITH NAVIGATION SYSTEMS, ROUTE PLANNERS AND DIGITAL MAPS; AUDIO AND VIDEO APPARATUS, NAMELY, AUDIO AND VIDEO RECEIVERS AND PROCESSORS; HAND HELD PERSONAL COMPUTERS (U.S. CLS. 21, 23, 26, 36 AND 38).

FIRST USE 5-1-2010; IN COMMERCE 5-1-2010.

**CLASS 9—(Continued).**

3,962,814. DE MARTINEZ, EMANUELE, DORAL, FL. SN 77-905,195. PUB. 7-6-2010, FILED 1-5-2010.



THE MARK CONSISTS OF STANDARD CHARACTERS WITHOUT CLAIM TO ANY PARTICULAR FONT, STYLE, SIZE, OR COLOR.

FOR COMPUTER BAGS; COMPUTER EQUIPMENT, NAMELY, WIRELESS CARDS; COMPUTER KEYBOARDS; COMPUTER MOUSE (U.S. CLS. 21, 23, 26, 36 AND 38).

FIRST USE 11-17-2010; IN COMMERCE 11-17-2010.

3,962,826. BRIGHT IDEAS, INC, AGOURA HILLS, CA. SN 77-908,963. PUB. 6-1-2010, FILED 1-11-2010.

## Flexsmart

THE MARK CONSISTS OF STANDARD CHARACTERS WITHOUT CLAIM TO ANY PARTICULAR FONT, STYLE, SIZE, OR COLOR.

FOR FM TRANSMITTER/CAR CRADLE FOR SMART PHONES (U.S. CLS. 21, 23, 26, 36 AND 38).

FIRST USE 1-1-2010; IN COMMERCE 1-1-2010.

3,962,827. BRIGHT IDEAS, INC, AGOURA HILLS, CA. SN 77-908,985. PUB. 6-1-2010, FILED 1-11-2010.

## TruCell

THE MARK CONSISTS OF STANDARD CHARACTERS WITHOUT CLAIM TO ANY PARTICULAR FONT, STYLE, SIZE, OR COLOR.

FOR BATTERIES (U.S. CLS. 21, 23, 26, 36 AND 38).

FIRST USE 1-1-2010; IN COMMERCE 1-1-2010.

**CLASS 9—(Continued).**

3,962,849. SAVANH, BOBBY B, PORTLAND, OR. SN 77-915,404. PUB. 6-22-2010, FILED 1-19-2010.



NO CLAIM IS MADE TO THE EXCLUSIVE RIGHT TO USE "GROW", APART FROM THE MARK AS SHOWN.

THE MARK CONSISTS OF TWO WORDS "GROW" AND "KING" WITH THE "O" IN "GROW" SHADED IN AND A THREE PRONGED CROWN POSITIONED ABOVE THE LETTERS "ING" IN "KING".

FOR FLUORESCENT LAMP BALLAST FOR ELECTRIC LIGHTS; LIGHTING BALLASTS (U.S. CLS. 21, 23, 26, 36 AND 38).

FIRST USE 4-15-2010; IN COMMERCE 4-15-2010.

**CLASS 9—(Continued).**

3,962,858. JACK HSU, ALEXANDRIA, VA. SN 77-917,899. PUB. 6-8-2010, FILED 1-22-2010.

**SHAGDRIVE**

THE MARK CONSISTS OF STANDARD CHARACTERS WITHOUT CLAIM TO ANY PARTICULAR FONT, STYLE, SIZE, OR COLOR.

FOR COMPUTER STORAGE DEVICES, NAMELY, FLASH DRIVES FOR SAFE AND SECURE INTERNET USE (U.S. CLS. 21, 23, 26, 36 AND 38).

FIRST USE 9-0-2009; IN COMMERCE 9-0-2009.

3,962,874. MULTIMEDIA GAMES, INC., AUSTIN, TX. SN 77-921,025. PUB. 6-15-2010, FILED 1-27-2010.

**SIDE ACTION**

THE MARK CONSISTS OF STANDARD CHARACTERS WITHOUT CLAIM TO ANY PARTICULAR FONT, STYLE, SIZE, OR COLOR.

FOR A FEATURE OF GAMING MACHINES, NAMELY, DEVICES THAT ACCEPT A WAGER (U.S. CLS. 21, 23, 26, 36 AND 38).

FIRST USE 11-16-2010; IN COMMERCE 11-16-2010.

3,962,875. MULTIMEDIA GAMES, INC., AUSTIN, TX. SN 77-921,077. PUB. 6-15-2010, FILED 1-27-2010.

**iClooly**

THE MARK CONSISTS OF STANDARD CHARACTERS WITHOUT CLAIM TO ANY PARTICULAR FONT, STYLE, SIZE, OR COLOR.

THE WORDING "CLOOLY" HAS NO MEANING IN A FOREIGN LANGUAGE.

FOR ELECTRIC COMMUNICATION APPARATUS, AND ITS COMPONENTS AND ACCESSORIES, NAMELY, CASES AND STANDS FOR MOBILE PHONES, MP3 PLAYERS, PDAS AND PERSONAL COMPUTERS; ELECTRONIC APPLICATION APPARATUS, AND ITS COMPONENTS AND ACCESSORIES, NAMELY, ACCESSORIES FOR MOBILE PHONES, MP3 PLAYERS, PDAS AND PERSONAL COMPUTERS, NAMELY, CHARGERS, DESK STANDS, SPEAKERS AND FLASH MEMORY CARDS (U.S. CLS. 21, 23, 26, 36 AND 38).

FIRST USE 7-13-2008; IN COMMERCE 7-13-2008.

**WESTERN WILDS**

THE MARK CONSISTS OF STANDARD CHARACTERS WITHOUT CLAIM TO ANY PARTICULAR FONT, STYLE, SIZE, OR COLOR.

FOR GAMING MACHINES INCLUDING SLOT MACHINES OR VIDEO LOTTERY TERMINALS; GAMING MACHINES THAT GENERATE OR DISPLAY WAGER OUTCOMES (U.S. CLS. 21, 23, 26, 36 AND 38).

FIRST USE 11-16-2010; IN COMMERCE 11-16-2010.

**CLASS 9—(Continued).**

3,962,876. MULTIMEDIA GAMES, INC., AUSTIN, TX. SN 77-921,193. PUB. 6-29-2010, FILED 1-27-2010.

**SMOKIN' HOT ANGELS**

THE MARK CONSISTS OF STANDARD CHARACTERS WITHOUT CLAIM TO ANY PARTICULAR FONT, STYLE, SIZE, OR COLOR.

OWNER OF U.S. REG. NOS. 2,211,720, 3,346,081, AND OTHERS.

FOR GAMING MACHINES THAT GENERATE OR DISPLAY WAGER OUTCOMES; GAMING MACHINES, NAMELY, ELECTRONIC SLOT AND BINGO MACHINES (U.S. CLS. 21, 23, 26, 36 AND 38).

FIRST USE 11-16-2010; IN COMMERCE 11-16-2010.

3,962,885. BARTON, ALAN, MARLAND, OK. SN 77-923,291. PUB. 7-13-2010, FILED 1-29-2010.



NO CLAIM IS MADE TO THE EXCLUSIVE RIGHT TO USE "TRAIL CAM VISOR", APART FROM THE MARK AS SHOWN.

THE COLOR(S) ORANGE, WHITE, AND GREY IS/ARE CLAIMED AS A FEATURE OF THE MARK.

THE MARK CONSISTS OF THE FOLLOWING: THE WORDING "TRAIL CAM" AND THE OUTLINE OF THE DESIGN FEATURE APPEAR IN GREY. THE WORD "VISOR" AND THE INNER PORTION OF THE DESIGN APPEAR IN ORANGE. THE BACKGROUND BEHIND THE WORDING APPEARS IN WHITE.

FOR ENVIRONMENTAL ENCLOSURES, NAMELY, STRUCTURES SPECIALLY ADAPTED TO HOLD AND PROTECT CAMERAS FROM OUTDOOR ELEMENTS AND TAMPERING; MOUNTING DEVICES FOR CAMERAS AND MONITORS (U.S. CLS. 21, 23, 26, 36 AND 38).

FIRST USE 5-4-2010; IN COMMERCE 5-4-2010.

**CLASS 9—(Continued).**

3,962,912. CALLPOD, INC., CHICAGO, IL. SN 77-930,343. PUB. 6-22-2010, FILED 2-8-2010.

**fueltank maestro**

THE MARK CONSISTS OF STANDARD CHARACTERS WITHOUT CLAIM TO ANY PARTICULAR FONT, STYLE, SIZE, OR COLOR.

OWNER OF U.S. REG. NO. 3,562,387.

FOR DEVICE BATTERY CHARGERS, NAMELY, BATTERY OPERATED DEVICES THAT CHARGE MULTIPLE ELECTRONIC DEVICES AT ONCE (U.S. CLS. 21, 23, 26, 36 AND 38).

FIRST USE 10-10-2010; IN COMMERCE 10-10-2010.

3,962,927. CARIBBEAN ELECTRONICS ENTERPRISES, INC., MIAMI, FL. SN 77-933,605. PUB. 6-29-2010, FILED 2-11-2010.

**soundbarrier**

OWNER OF U.S. REG. NOS. 2,828,979, 3,021,517, AND OTHERS.

THE MARK CONSISTS OF THE STYLIZED WORD "SOUNDBARRIER".

FOR AUDIO AMPLIFIERS; AUDIO CASSETTE AND CD PLAYERS; AUDIO ELECTRONIC COMPONENTS, NAMELY, SURROUND SOUND SYSTEMS; AUDIO EQUIPMENT FOR VEHICLES, NAMELY, STEREOS, SPEAKERS, AMPLIFIERS, EQUALIZERS, CROSSOVERS AND SPEAKER HOUSINGS; AUDIO EQUIPMENT FOR VEHICLES, NAMELY, SUBWOOFERS; AUDIO MIXERS; AUDIO SPEAKER ENCLOSURES; AUDIO SPEAKERS; CD PLAYERS; DIGITAL SIGNAL PROCESSORS; ELECTRONIC PRODUCTS FOR THE MANIPULATION OF THE FREQUENCY, TIME, AND AMPLITUDE CHARACTERISTICS OF AUDIO SIGNALS, NAMELY, AUDIO PROCESSORS; LOUD SPEAKER SYSTEMS; LOUD SPEAKERS; MOBILE RADIOS; MP3 PLAYERS; PERSONAL STEREOS; PORTABLE RADIOS; RADIO RECEIVERS AND RADIO SIGNAL TUNERS; RADIO RECEIVERS AND TRANSMITTERS; RADIOS; RADIOS FOR VEHICLES; SIGNAL PROCESSORS; SPEAKER ENCLOSURES; STANDS SPECIALLY ADAPTED FOR STEREOS AND AUDIO SPEAKERS; STEREO AMPLIFIERS; STEREO CABLES; STEREO RECEIVERS; STEREO TUNERS (U.S. CLS. 21, 23, 26, 36 AND 38).

FIRST USE 0-0-2002; IN COMMERCE 0-0-2004.

**CLASS 9—(Continued).**

3,962,932. GIGAMON LLC, MILPITAS, CA. SN 77-935,149. PUB. 7-6-2010, FILED 2-12-2010.



OWNER OF U.S. REG. NOS. 3,416,717 AND 3,777,143.  
THE MARK CONSISTS OF THE LETTER "G" FORMED BY CURVED LINES WRAPPED AROUND EACH OTHER, EACH SHAPED FROM A NARROW POINTED END TO A WIDER END, OVER THE TERM, "GIGAMON" IN STYLIZED FORM.  
FOR COMPUTER NETWORK ACCESS SWITCHES; SOFTWARE FOR USE IN OPERATING COMPUTER NETWORK SWITCHES (U.S. CLS. 21, 23, 26, 36 AND 38).  
FIRST USE 11-23-2010; IN COMMERCE 11-23-2010.

3,962,936. OHIO ASSOCIATED ENTERPRISES, LLC, PAINESVILLE, OH. SN 77-935,643. PUB. 8-31-2010, FILED 2-15-2010.

**VPX PLUS**

THE MARK CONSISTS OF STANDARD CHARACTERS WITHOUT CLAIM TO ANY PARTICULAR FONT, STYLE, SIZE, OR COLOR.  
NO CLAIM IS MADE TO THE EXCLUSIVE RIGHT TO USE "VPX", APART FROM THE MARK AS SHOWN.  
FOR HIGH SPEED ELECTRICAL CABLES WITH ELECTRICAL CONNECTORS FOR ROUTING SIGNALS OFF THE BACKPLANE IN COMPUTER SYSTEMS, AND POSITIONING AND RETAINING SHROUDS AND HOLD DOWN RAILS (U.S. CLS. 21, 23, 26, 36 AND 38).  
FIRST USE 11-0-2009; IN COMMERCE 11-0-2009.

**CLASS 9—(Continued).**

3,962,937. CREATIVE DISTRIBUTION SOLUTIONS, PORT ALLEGANY, PA. SN 77-935,656. PUB. 7-6-2010, FILED 2-15-2010.

**Turn N' Style**

THE MARK CONSISTS OF STANDARD CHARACTERS WITHOUT CLAIM TO ANY PARTICULAR FONT, STYLE, SIZE, OR COLOR.  
FOR ROTATABLE POWER AND STORAGE UNIT FOR SUPPLYING POWER TO AND ORGANIZING WIRES AND CORDS OF HANDHELD EQUIPMENT AND TOOLS (U.S. CLS. 21, 23, 26, 36 AND 38).  
FIRST USE 11-3-2009; IN COMMERCE 1-14-2011.

3,962,939. OHIO ASSOCIATED ENTERPRISES, LLC, PAINESVILLE, OH. SN 77-935,675. PUB. 8-31-2010, FILED 2-15-2010.



THE MARK CONSISTS OF THE LETTERS "VPX" AND THE WORD "PLUS" IN AN ARROW DESIGN.  
FOR HIGH SPEED ELECTRICAL CABLES WITH ELECTRICAL CONNECTORS FOR ROUTING SIGNALS OFF THE BACKPLANE IN COMPUTER SYSTEMS, AND POSITIONING AND RETAINING SHROUDS AND HOLD DOWN RAILS (U.S. CLS. 21, 23, 26, 36 AND 38).  
FIRST USE 11-0-2009; IN COMMERCE 11-0-2009.

3,962,948. LG ELECTRONICS INC., SEOUL, REPUBLIC OF KOREA. SN 77-936,861. PUB. 6-29-2010, FILED 2-16-2010.

**MYSTIQUE**

THE MARK CONSISTS OF STANDARD CHARACTERS WITHOUT CLAIM TO ANY PARTICULAR FONT, STYLE, SIZE, OR COLOR.  
FOR MOBILE PHONES (U.S. CLS. 21, 23, 26, 36 AND 38).  
FIRST USE 4-9-2010; IN COMMERCE 4-9-2010.



**CLASS 9—(Continued).**

3,962,968. PRESTIGE GAMING LLC, ANADARKO, OK. SN 77-941,802. PUB. 7-20-2010, FILED 2-22-2010.

**PLAYERS TOUCH**

THE MARK CONSISTS OF STANDARD CHARACTERS WITHOUT CLAIM TO ANY PARTICULAR FONT, STYLE, SIZE, OR COLOR.

FOR GAMING DEVICES, NAMELY, GAMING MACHINES, SLOT MACHINES, MULTI-GAME SLOT MACHINES AND BINGO MACHINES (U.S. CLS. 21, 23, 26, 36 AND 38).

FIRST USE 12-1-2010; IN COMMERCE 12-1-2010.

3,962,978. JAMES CARIDI, GAINESVILLE, FL. AND MICHAEL J. MAIMONE, ISLAND PARK, NY. SN 77-942,649. PUB. 7-20-2010, FILED 2-23-2010.

**DO YOU MISS ME YET?**

THE MARK CONSISTS OF STANDARD CHARACTERS WITHOUT CLAIM TO ANY PARTICULAR FONT, STYLE, SIZE, OR COLOR.

FOR MAGNETS (U.S. CLS. 21, 23, 26, 36 AND 38).  
FIRST USE 1-0-2011; IN COMMERCE 1-0-2011.

3,962,981. TITAN PET PRODUCTS, INC., RALEIGH, NC. SN 77-942,894. PUB. 7-13-2010, FILED 2-23-2010.

**SAFETY STATION**

THE MARK CONSISTS OF STANDARD CHARACTERS WITHOUT CLAIM TO ANY PARTICULAR FONT, STYLE, SIZE, OR COLOR.

NO CLAIM IS MADE TO THE EXCLUSIVE RIGHT TO USE "SAFETY", APART FROM THE MARK AS SHOWN.

FOR A WIRELESS, ELECTRONIC ANIMAL CONFINEMENT SYSTEM COMPRISED OF TRANSMITTERS AND RECEIVERS (U.S. CLS. 21, 23, 26, 36 AND 38).

FIRST USE 3-25-2011; IN COMMERCE 3-25-2011.

**CLASS 9—(Continued).**

3,963,016. MEDECO SECURITY LOCKS, INC., SALEM, VA. SN 77-946,113. PUB. 7-20-2010, FILED 2-26-2010.

**NEXGEN XT**

THE MARK CONSISTS OF STANDARD CHARACTERS WITHOUT CLAIM TO ANY PARTICULAR FONT, STYLE, SIZE, OR COLOR.

OWNER OF U.S. REG. NOS. 2,269,370 AND 2,650,669.  
FOR ELECTRO-MECHANICAL CYLINDER LOCKS AND KEYS THEREFOR (U.S. CLS. 21, 23, 26, 36 AND 38).  
FIRST USE 7-15-2010; IN COMMERCE 7-15-2010.

3,963,019. MERCHSOURCE, LLC, FOOTHILL RANCH, CA. SN 77-946,384. PUB. 7-27-2010, FILED 2-26-2010.

**LIGHTBLAST**

THE MARK CONSISTS OF STANDARD CHARACTERS WITHOUT CLAIM TO ANY PARTICULAR FONT, STYLE, SIZE, OR COLOR.

FOR MULTIMEDIA PROJECTOR (U.S. CLS. 21, 23, 26, 36 AND 38).  
FIRST USE 3-1-2010; IN COMMERCE 3-1-2010.

3,963,032. HONEYWELL INTERNATIONAL INC., MORRISTOWN, NJ. SN 77-948,464. PUB. 12-28-2010, FILED 3-2-2010.

**FAAST FIRE ALARM  
ASPIRATION SENSING  
TECHNOLOGY**

THE MARK CONSISTS OF STANDARD CHARACTERS WITHOUT CLAIM TO ANY PARTICULAR FONT, STYLE, SIZE, OR COLOR.

NO CLAIM IS MADE TO THE EXCLUSIVE RIGHT TO USE "FIRE ALARM ASPIRATION SENSING TECHNOLOGY", APART FROM THE MARK AS SHOWN.

FOR ASPIRATION SMOKE DETECTORS; SMOKE ALARMS; FIRE ALARMS; HOME AND BUILDING SAFETY MICROPROCESSOR BASED HARDWARE AND SOFTWARE FOR THE DETECTION OF SMOKE AND OTHER ENVIRONMENTAL HAZARDS; ELECTRICAL AND ELECTRONIC WIRING AND ELECTRICAL AND ELECTRONIC CONNECTORS AND CONNECTOR HOUSINGS FOR SMOKE AND FIRE DETECTORS; FIRE AND SMOKE DETECTION SENSORS (U.S. CLS. 21, 23, 26, 36 AND 38).

FIRST USE 6-7-2010; IN COMMERCE 9-13-2010.

**CLASS 9—(Continued).**

3,963,042. OUTSPARK, INC., SAN FRANCISCO, CA. SN 77-949,902. PUB. 7-20-2010, FILED 3-3-2010.

## DIVINE SOULS

THE MARK CONSISTS OF STANDARD CHARACTERS WITHOUT CLAIM TO ANY PARTICULAR FONT, STYLE, SIZE, OR COLOR.

FOR COMPUTER GAME SOFTWARE (U.S. CLS. 21, 23, 26, 36 AND 38).

FIRST USE 12-14-2010; IN COMMERCE 12-14-2010.

3,963,049. INFUSINO, SUSAN, SCHAUMBERG, IL. SN 77-950,459. PUB. 8-3-2010, FILED 3-4-2010.



NO CLAIM IS MADE TO THE EXCLUSIVE RIGHT TO USE "REMOTE WRAPS", APART FROM THE MARK AS SHOWN.

THE MARK CONSISTS OF THE LITERAL ELEMENT "REMOTE WRAPS" IN WHICH THE "O" IS A STYLIZED REMOTE CONTROL.

FOR PROTECTIVE COVERS SPECIALLY ADAPTED FOR PERSONAL ELECTRONIC DEVICES; PROTECTIVE COVERS AND CASES FOR REMOTE CONTROL DEVICES AND HAND HELD ELECTRONIC DEVICES (U.S. CLS. 21, 23, 26, 36 AND 38).

FIRST USE 3-7-2011; IN COMMERCE 3-7-2011.

3,963,059. BOEING MANAGEMENT COMPANY, SEAL BEACH, CA. SN 77-951,635. PUB. 8-17-2010, FILED 3-5-2010.

## VSOC SENTINEL

THE MARK CONSISTS OF STANDARD CHARACTERS WITHOUT CLAIM TO ANY PARTICULAR FONT, STYLE, SIZE, OR COLOR.

**CLASS 9—(Continued).**

OWNER OF U.S. REG. NOS. 2,821,152 AND 2,823,121.

FOR COMPUTER SOFTWARE FOR SENSOR MANAGEMENT IN THE FIELDS OF ALARMS, COMPUTER AIDED DISPATCH, ASSET TRACKING, VIDEO SURVEILLANCE, AND SENSOR INTEGRATION FOR USE IN THREAT RECOGNITION, ANALYSIS, COLLABORATION AND RESPONSE COORDINATION FOR USE IN HOMELAND SECURITY AND PROTECTION OF MILITARY, CIVIL, AND COMMERCIAL ASSETS (U.S. CLS. 21, 23, 26, 36 AND 38).

FIRST USE 7-0-2010; IN COMMERCE 7-0-2010.

3,963,065. TIMEWIRE TECHNOLOGIES, LLC, PURCELLVILLE, VA. SN 77-952,064. PUB. 7-27-2010, FILED 3-5-2010.

## TIMEWIRE

THE MARK CONSISTS OF STANDARD CHARACTERS WITHOUT CLAIM TO ANY PARTICULAR FONT, STYLE, SIZE, OR COLOR.

FOR COMPUTER SOFTWARE AND HARDWARE FOR USE IN OPTIMIZING, ENHANCING, MONITORING, ACCELERATING, SECURING, AND MANAGING COMPUTER NETWORKS AND APPLICATIONS (U.S. CLS. 21, 23, 26, 36 AND 38).

FIRST USE 9-2-2010; IN COMMERCE 10-24-2010.

3,963,073. SIXNET, LLC, BALLSTON LAKE, NY. SN 77-953,173. PUB. 8-10-2010, FILED 3-8-2010.

## MobilityPro

THE MARK CONSISTS OF STANDARD CHARACTERS WITHOUT CLAIM TO ANY PARTICULAR FONT, STYLE, SIZE, OR COLOR.

FOR WIRELESS MODEMS; GATEWAY ROUTERS IN THE NATURE OF COMPUTER CONTROL HARDWARE (U.S. CLS. 21, 23, 26, 36 AND 38).

FIRST USE 5-15-2010; IN COMMERCE 5-15-2010.

**CLASS 9—(Continued).**

3,963,074. SIXNET, LLC, BALLSTON LAKE, NY. SN 77-953,289. PUB. 8-3-2010, FILED 3-8-2010.

# EnterprisePro

THE MARK CONSISTS OF STANDARD CHARACTERS WITHOUT CLAIM TO ANY PARTICULAR FONT, STYLE, SIZE, OR COLOR.

FOR WIRELESS MODEMS; GATEWAY ROUTERS IN THE NATURE OF COMPUTER CONTROL HARDWARE (U.S. CLS. 21, 23, 26, 36 AND 38).

FIRST USE 5-15-2010; IN COMMERCE 5-15-2010.

**CLASS 9—(Continued).**

3,963,086. POWERARC, INC., SHREWSBURY, MO. SN 77-954,442. PUB. 8-3-2010, FILED 3-9-2010.

# VOLT

THE MARK CONSISTS OF STANDARD CHARACTERS WITHOUT CLAIM TO ANY PARTICULAR FONT, STYLE, SIZE, OR COLOR.

FOR SIGNAL LIGHT MECHANISMS USED ON EMERGENCY AND SERVICE VEHICLES, SUCH AS POLICE CARS, FIRE DEPARTMENT VEHICLES AND ROAD DEPARTMENT TRUCKS, FOR THE PURPOSE OF ATTRACTING ATTENTION (U.S. CLS. 21, 23, 26, 36 AND 38).

FIRST USE 1-31-2011; IN COMMERCE 1-31-2011.

3,963,075. SIXNET, LLC, BALLSTON LAKE, NY. SN 77-953,850. PUB. 8-3-2010, FILED 3-9-2010.

# IndustrialPro

THE MARK CONSISTS OF STANDARD CHARACTERS WITHOUT CLAIM TO ANY PARTICULAR FONT, STYLE, SIZE, OR COLOR.

FOR WIRELESS MODEMS; GATEWAY ROUTERS IN THE NATURE OF COMPUTER CONTROL HARDWARE (U.S. CLS. 21, 23, 26, 36 AND 38).

FIRST USE 5-15-2010; IN COMMERCE 5-15-2010.

3,963,087. POWERARC, INC., SHREWSBURY, MO. SN 77-954,448. PUB. 8-3-2010, FILED 3-9-2010.

# AMP

THE MARK CONSISTS OF STANDARD CHARACTERS WITHOUT CLAIM TO ANY PARTICULAR FONT, STYLE, SIZE, OR COLOR.

FOR SIGNAL LIGHT MECHANISMS USED ON EMERGENCY AND SERVICE VEHICLES, SUCH AS POLICE CARS, FIRE DEPARTMENT VEHICLES AND ROAD DEPARTMENT TRUCKS, FOR THE PURPOSE OF ATTRACTING ATTENTION (U.S. CLS. 21, 23, 26, 36 AND 38).

FIRST USE 1-31-2011; IN COMMERCE 1-31-2011.

3,963,076. SIXNET, LLC, BALLSTON LAKE, NY. SN 77-953,854. PUB. 8-3-2010, FILED 3-9-2010.

# QuicKonnnect

THE MARK CONSISTS OF STANDARD CHARACTERS WITHOUT CLAIM TO ANY PARTICULAR FONT, STYLE, SIZE, OR COLOR.

FOR WIRELESS MODEMS; GATEWAY ROUTERS IN THE NATURE OF COMPUTER CONTROL HARDWARE (U.S. CLS. 21, 23, 26, 36 AND 38).

FIRST USE 5-15-2010; IN COMMERCE 5-15-2010.

3,963,100. AT BOX TECHNOLOGY, INC., IRVINE, CA. SN 77-955,972. PUB. 8-3-2010, FILED 3-10-2010.

# GreenView

THE MARK CONSISTS OF STANDARD CHARACTERS WITHOUT CLAIM TO ANY PARTICULAR FONT, STYLE, SIZE, OR COLOR.

FOR COMPUTER HARDWARE AND COMPUTER PERIPHERAL DEVICES; COMPUTER HARDWARE AND PERIPHERAL DEVICES; COMPUTER PERIPHERALS (U.S. CLS. 21, 23, 26, 36 AND 38).

FIRST USE 3-9-2010; IN COMMERCE 3-11-2010.

**CLASS 9—(Continued).**

3,963,104. AINSWORTH GAME TECHNOLOGY LIMITED, NEWINGTON, AUSTRALIA. SN 77-956,134. PUB. 7-27-2010, FILED 3-11-2010.

## Magic Dreams

THE MARK CONSISTS OF STANDARD CHARACTERS WITHOUT CLAIM TO ANY PARTICULAR FONT, STYLE, SIZE, OR COLOR.

FOR COMPUTER SOFTWARE AND FIRMWARE FOR GAMES OF CHANCE ON ANY COMPUTERIZED PLATFORM, INCLUDING DEDICATED GAMING CONSOLES, VIDEO BASED SLOT MACHINES, REEL BASED SLOT MACHINES, AND VIDEO LOTTERY TERMINALS (U.S. CLS. 21, 23, 26, 36 AND 38).  
FIRST USE 2-18-2011; IN COMMERCE 2-18-2011.

**CLASS 9—(Continued).**

3,963,110. TREPSI, S.A. DE C.V., HUIXQUILUCAN, MEXICO. SN 77-956,919. PUB. 8-3-2010, FILED 3-11-2010.



THE COLOR(S) MEDIUM BLUE, DARK BLUE, YELLOW, BEIGE, WHITE, AND BLACK IS/ARE CLAIMED AS A FEATURE OF THE MARK.

THE MARK CONSISTS OF STANDING BIRD WITH WINGS OUTSTRETCHED IN A MEDIUM SHADE OF BLUE WITH INNER WING FEATHERS IN DARKER BLUE, YELLOW BEAK WITH BEIGE INSIDE MOUTH, YELLOW FEET, WHITE, BLUE AND BLACK RIMMED EYES.

FOR CHILDREN'S DVDS AND CDS FEATURING EDUCATIONAL SONGS, VIDEOS AND MUSIC (U.S. CLS. 21, 23, 26, 36 AND 38).

FIRST USE 1-31-2003; IN COMMERCE 1-31-2003.

3,963,106. LUMLUX LIGHTING (SUZHOU) INC., SUZHOU, CHINA. SN 77-956,234. PUB. 8-17-2010, FILED 3-11-2010.



THE MARK CONSISTS OF THE WORDING "LUM LUX" ON A RECTANGULAR BACKGROUND.

FOR AUTOMATIC SWITCHING APPARATUS; ELECTRIC LIGHT DIMMERS; ELECTRONIC REGULATING AND CONTROL DEVICES FOR THE OPERATION OF LIGHT EMITTING DIODES; ILLUMINATION REGULATORS; INDUCTION VOLTAGE REGULATORS; POWER INVERTERS; POWER SUPPLIES; RECTIFIERS; VOLTAGE STABILIZING POWER SUPPLY (U.S. CLS. 21, 23, 26, 36 AND 38).

FIRST USE 2-3-2008; IN COMMERCE 5-4-2009.

3,963,119. ADVION BIOSYSTEMS, INC., ITHACA, NY. SN 77-957,664. PUB. 9-21-2010, FILED 3-12-2010.

## LESA

THE MARK CONSISTS OF STANDARD CHARACTERS WITHOUT CLAIM TO ANY PARTICULAR FONT, STYLE, SIZE, OR COLOR.

FOR COMPUTER SOFTWARE FOR LABORATORY USE FOR OPERATING AUTOMATED ELECTROSPRAY INSTRUMENTS THAT DELIVER SAMPLES FROM CHEMICAL OR BIOLOGICAL SURFACES TO A MASS SPECTROMETER FOR ANALYSIS USING CHIP-BASED INFUSION; LABORATORY EQUIPMENT, NAMELY, SAMPLE PLATES AND SOLVENT RESERVOIRS FOR USE WITH THE FOREGOING; NONE OF THE FOREGOING INCLUDE PRODUCTS FOR DETECTING CHEMICAL AND/OR BIOLOGICAL SURFACE CONTAMINANTS IN FIELD APPLICATIONS FOR MILITARY, HOMELAND DEFENSE, EMERGENCY RESPONSE AND ENVIRONMENTAL PROTECTION PURPOSES (U.S. CLS. 21, 23, 26, 36 AND 38).

FIRST USE 6-30-2010; IN COMMERCE 6-30-2010.

**CLASS 9—(Continued).**

3,963,125. SOLARWORLD AG, BONN, FED REP GERMANY.  
SN 77-958,918. PUB. 8-3-2010, FILED 3-15-2010.



THE COLOR(S) YELLOW AND BLACK IS/ARE CLAIMED AS A FEATURE OF THE MARK.

THE MARK CONSISTS OF THE WORDS "SUN AT WORK" IN BLACK FONT CENTERED INSIDE A YELLOW TRIANGLE WITH A SINGLE BLACK LINE BORDER.

FOR ELECTRICAL APPARATUS AND INSTRUMENTS FOR THE GENERATION OF ELECTRICAL ENERGY FROM PHOTOVOLTAIC AND SOLAR SOURCES, NAMELY, PHOTOVOLTAIC SOLAR MODULES, SILICON WAFERS AND OTHER SOLAR PANELS (U.S. CLS. 21, 23, 26, 36 AND 38).

FIRST USE 3-0-2010; IN COMMERCE 3-0-2010.

3,963,132. GIGA-BYTE TECHNOLOGY CO., LTD., HSINTIEN, TAIWAN. SN 77-959,654. PUB. 1-11-2011, FILED 3-16-2010.



THE MARK CONSISTS OF THE WORD "TURBO 3D", WITH THE WORD "TURBO" UNDERLINED AND AN EIGHTPOINT STAR AT THE BOTTOM RIGHT EDGE OF THE LETTER "D". THE ENTIRE WORD MARK IS CONTAINED IN A RECTANGULAR DESIGN WITH ROUNDED EDGES, A THIN BORDER, AND A HORIZONTAL LINE SPLITTING THE DESIGN INTO A LIGHTLY SHADED UPPER HALF AND DARKLY SHADED LOWER HALF. THE WORD "TURBO3D" AND THE UNDERLINING ALL HAVE A SHADOW BEHIND THEM AND THEY ARE ALL CUT HORIZONTALLY BY A LINE THAT CREATES A LIGHTER SHADED TOP HALF AND DARKER SHADED BOTTOM HALF.

FOR MOTHERBOARDS (U.S. CLS. 21, 23, 26, 36 AND 38).

FIRST USE 4-1-2010; IN COMMERCE 4-1-2010.

**CLASS 9—(Continued).**

3,963,164. ITRENEW INC., NEWARK, CA. SN 77-961,729.  
PUB. 8-3-2010, FILED 3-17-2010.

## TERAWIPE

THE MARK CONSISTS OF STANDARD CHARACTERS WITHOUT CLAIM TO ANY PARTICULAR FONT, STYLE, SIZE, OR COLOR.

FOR COMPUTER SOFTWARE FOR ERASING DATA FROM COMPUTER DISKS AND HARD DRIVES (U.S. CLS. 21, 23, 26, 36 AND 38).

FIRST USE 2-0-2011; IN COMMERCE 2-0-2011.

3,963,182. OTTER PRODUCTS, LLC, FORT COLLINS, CO. SN 77-963,864. PUB. 9-7-2010, FILED 3-19-2010.

## COMMUTER SERIES

THE MARK CONSISTS OF STANDARD CHARACTERS WITHOUT CLAIM TO ANY PARTICULAR FONT, STYLE, SIZE, OR COLOR.

OWNER OF U.S. REG. NO. 3,791,317.

NO CLAIM IS MADE TO THE EXCLUSIVE RIGHT TO USE "SERIES", APART FROM THE MARK AS SHOWN.

FOR PROTECTIVE CASES FOR HANDHELD ELECTRONIC DEVICES, NAMELY, MULTIFUNCTIONAL MOBILE PHONES, PORTABLE MUSIC PLAYERS, PORTABLE VIDEO PLAYERS AND COMPUTERS (U.S. CLS. 21, 23, 26, 36 AND 38).

FIRST USE 7-29-2009; IN COMMERCE 7-29-2009.

3,963,192. PETROGLYPH GAMES, INC., LAS VEGAS, NV. SN 77-965,329. PUB. 8-10-2010, FILED 3-22-2010.

## GUARDIANS OF GRAXIA

THE MARK CONSISTS OF STANDARD CHARACTERS WITHOUT CLAIM TO ANY PARTICULAR FONT, STYLE, SIZE, OR COLOR.

FOR VIDEO GAME SOFTWARE; COMPUTER GAME SOFTWARE AND INSTRUCTION MANUALS SOLD THEREWITH; ELECTRONIC GAME PROGRAMS (U.S. CLS. 21, 23, 26, 36 AND 38).

FIRST USE 2-1-2011; IN COMMERCE 2-1-2011.



**CLASS 9—(Continued).**

3,963,196. U.S. VISION, INC., GLENDORA, NJ. SN 77-965,599.  
PUB. 8-10-2010, FILED 3-23-2010.

**BLUESURF**

THE MARK CONSISTS OF STANDARD CHARACTERS WITHOUT CLAIM TO ANY PARTICULAR FONT, STYLE, SIZE, OR COLOR.

FOR CASES FOR EYEGLASSES AND SUNGLASSES; EYEWEAR; EYEWEAR ACCESSORIES, NAMELY, STRAPS, NECK CORDS AND HEAD STRAPS WHICH RESTRAIN EYEWEAR FROM MOVEMENT ON A WEARER; SUNGLASSES (U.S. CLS. 21, 23, 26, 36 AND 38).

FIRST USE 1-3-2011; IN COMMERCE 1-3-2011.

**CLASS 9—(Continued).**

3,963,218. ASSA ABLOY AB, SE-107 23 STOCKHOLM, SWEDEN. SN 77-967,827. PUB. 7-27-2010, FILED 3-24-2010.

**VERICLASS**

THE MARK CONSISTS OF STANDARD CHARACTERS WITHOUT CLAIM TO ANY PARTICULAR FONT, STYLE, SIZE, OR COLOR.

FOR PRINTED CIRCUIT BOARDS WITH EMBEDDED ANTENNAS AND RF RECEIVERS FOR USE IN IDENTIFICATION CARD READERS; PRINTED CIRCUIT BOARDS FOR USE IN IDENTIFICATION CARD READERS; CHIPSETS FOR USE IN IDENTIFICATION CARD READERS (U.S. CLS. 21, 23, 26, 36 AND 38).

FIRST USE 1-31-2011; IN COMMERCE 1-31-2011.

3,963,207. SAMSUNG ELECTRONICS CO., LTD., SUWON-SI, GYEONGGI-DO, REPUBLIC OF KOREA. SN 77-966,634.  
PUB. 8-10-2010, FILED 3-23-2010.

**SAMSUNG ACCLAIM**

THE MARK CONSISTS OF STANDARD CHARACTERS WITHOUT CLAIM TO ANY PARTICULAR FONT, STYLE, SIZE, OR COLOR.

OWNER OF U.S. REG. NOS. 2,882,774, 3,713,355, AND OTHERS.

THE ENGLISH TRANSLATION OF "SAMSUNG" IN THE MARK IS "THREE STARS".

FOR MOBILE PHONES; SMARTPHONES (U.S. CLS. 21, 23, 26, 36 AND 38).

FIRST USE 7-2-2010; IN COMMERCE 7-2-2010.

3,963,226. WELCOME CO., LTD., HSI CHIH, TAIPEI HSIEN, TAIWAN. SN 77-969,287. PUB. 8-17-2010, FILED 3-26-2010.



THE MARK CONSISTS OF TWO INTERCONNECTED TRIANGLE RINGS ABOVE THE STYLIZED WORD "MODCON".

FOR MECHANICAL SEALING DEVICES, NAMELY, SEALERS WHICH SEAL PLASTIC BAGS BY THE APPLICATION OF ELECTRICALLY GENERATED HEAT, AND WHICH MAY BE PROVIDED WITH A BAG OPENER, AND WHICH ARE SOLD TO CONSUMERS FOR DOMESTIC USE (U.S. CLS. 21, 23, 26, 36 AND 38).

FIRST USE 3-0-2010; IN COMMERCE 3-0-2010.

3,963,217. ASSA ABLOY AB, SE-107 23 STOCKHOLM, SWEDEN. SN 77-967,824. PUB. 7-27-2010, FILED 3-24-2010.

**IDENTICLASS**

THE MARK CONSISTS OF STANDARD CHARACTERS WITHOUT CLAIM TO ANY PARTICULAR FONT, STYLE, SIZE, OR COLOR.

FOR PRINTED CIRCUIT BOARDS WITH EMBEDDED ANTENNAS AND RF RECEIVERS FOR USE IN IDENTIFICATION CARD READERS; PRINTED CIRCUIT BOARDS FOR USE IN IDENTIFICATION CARD READERS; CHIPSETS FOR USE IN IDENTIFICATION CARD READERS (U.S. CLS. 21, 23, 26, 36 AND 38).

FIRST USE 11-24-2010; IN COMMERCE 11-24-2010.

3,963,227. WELCOME CO., LTD., HSI CHIH, TAIPEI HSIEN, TAIWAN. SN 77-969,298. PUB. 8-17-2010, FILED 3-26-2010.

**MODCON**

THE MARK CONSISTS OF STANDARD CHARACTERS WITHOUT CLAIM TO ANY PARTICULAR FONT, STYLE, SIZE, OR COLOR.

FOR MECHANICAL SEALING DEVICES, NAMELY, SEALERS WHICH SEAL PLASTIC BAGS BY THE APPLICATION OF ELECTRICALLY GENERATED HEAT, AND WHICH MAY BE PROVIDED WITH A BAG OPENER, AND WHICH ARE SOLD TO CONSUMERS FOR DOMESTIC USE (U.S. CLS. 21, 23, 26, 36 AND 38).

FIRST USE 3-0-2010; IN COMMERCE 3-0-2010.

**CLASS 9—(Continued).**

3,963,235. TATE, INCORPORATED, ALEXANDRIA, VA. SN 77-981,186. PUB. 5-4-2010, FILED 10-16-2009.

TATE, INCORPORATED

THE MARK CONSISTS OF STANDARD CHARACTERS WITHOUT CLAIM TO ANY PARTICULAR FONT, STYLE, SIZE, OR COLOR.

OWNER OF U.S. REG. NO. 2,951,012.

NO CLAIM IS MADE TO THE EXCLUSIVE RIGHT TO USE "INCORPORATED", APART FROM THE MARK AS SHOWN.

SEC. 2(F).

FOR COMPUTER SOFTWARE THAT ALLOWS THE DISSEMINATION OF TRAINING AND EDUCATIONAL MATERIAL FOR MOBILE AND DISTANCE LEARNING TECHNOLOGY FOR THE STATUS AND TRACKING OF ALL VEHICLE TYPES IN LOCAL ENVIRONMENTS (U.S. CLS. 21, 23, 26, 36 AND 38).

FIRST USE 11-1-2009; IN COMMERCE 11-1-2009.

3,963,250. AGILENT TECHNOLOGIES, INC., SANTA CLARA, CA. SN 77-981,661. PUB. 12-15-2009, FILED 2-27-2009.

1290 INFINITY

THE MARK CONSISTS OF STANDARD CHARACTERS WITHOUT CLAIM TO ANY PARTICULAR FONT, STYLE, SIZE, OR COLOR.

FOR ULTRA HIGH PRESSURE LIQUID CHROMATOGRAPHY (UHPLC) EQUIPMENT COMPRISING CHROMATOGRAPHIC COLUMNS, CARTRIDGES, PUMPS, SEPARATION DEVICES IN SINGLE AND MULTI-WELL FORMATS, DETECTORS, INJECTORS, FILTERS, AND AUTOSAMPLERS; LABORATORY OPERATING SYSTEMS COMPRISING OF COMPUTER HARDWARE AND COMPUTER SOFTWARE FOR USE IN CONNECTION WITH ULTRA HIGH PRESSURE LIQUID CHROMATOGRAPHY SYSTEMS (UHPLC) (U.S. CLS. 21, 23, 26, 36 AND 38).

FIRST USE 4-29-2009; IN COMMERCE 4-29-2009.

**CLASS 9—(Continued).**

3,963,251. AGILENT TECHNOLOGIES, INC., SANTA CLARA, CA. SN 77-981,662. PUB. 12-15-2009, FILED 2-27-2009.

AGILENT 1290 INFINITY

THE MARK CONSISTS OF STANDARD CHARACTERS WITHOUT CLAIM TO ANY PARTICULAR FONT, STYLE, SIZE, OR COLOR.

OWNER OF U.S. REG. NOS. 2,461,406, 2,643,345, AND OTHERS.

FOR ULTRA HIGH PRESSURE LIQUID CHROMATOGRAPHY (UHPLC) EQUIPMENT COMPRISING CHROMATOGRAPHIC COLUMNS, CARTRIDGES, PUMPS, SEPARATION DEVICES IN SINGLE AND MULTI-WELL FORMATS, DETECTORS, INJECTORS, FILTERS, AND AUTOSAMPLERS; LABORATORY OPERATING SYSTEMS COMPRISING OF COMPUTER HARDWARE AND COMPUTER SOFTWARE FOR USE IN CONNECTION WITH ULTRA HIGH PRESSURE LIQUID CHROMATOGRAPHY SYSTEMS (UHPLC) (U.S. CLS. 21, 23, 26, 36 AND 38).

FIRST USE 4-29-2009; IN COMMERCE 4-29-2009.

3,963,254. PERFECT TACT LIMITED, DBA/ TRAXON TECHNOLOGIES LTD, SHATIN, HONG KONG. SN 77-981,673. PUB. 3-24-2009, FILED 2-26-2008.

TX CONNECT

THE MARK CONSISTS OF STANDARD CHARACTERS WITHOUT CLAIM TO ANY PARTICULAR FONT, STYLE, SIZE, OR COLOR.

NO CLAIM IS MADE TO THE EXCLUSIVE RIGHT TO USE "CONNECT", APART FROM THE MARK AS SHOWN.

FOR ELECTRICAL APPARATUS AND EQUIPMENT, NAMELY, ELECTRIC CABLES FOR USE WITH INTERFACE UNITS FOR LIGHTING (U.S. CLS. 21, 23, 26, 36 AND 38).

FIRST USE 12-10-2010; IN COMMERCE 12-10-2010.

**CLASS 9—(Continued).**

3,963,255. PENGU CORPORATION, LAURENS, IA. SN 77-981,674. PUB. 6-29-2010, FILED 11-25-2009.

**REVTRAK**

THE MARK CONSISTS OF STANDARD CHARACTERS WITHOUT CLAIM TO ANY PARTICULAR FONT, STYLE, SIZE, OR COLOR.

FOR CONSTRUCTION, UTILITY, AND AGRICULTURAL EQUIPMENT ATTACHMENTS, NAMELY, ELECTRONIC TORQUE MONITORS FOR ANCHOR AND AUGER DRIVES (U.S. CLS. 21, 23, 26, 36 AND 38). FIRST USE 10-29-2010; IN COMMERCE 10-29-2010.

3,963,257. CONTINENTAL AUTOMOTIVE SYSTEMS US, INC., AUBURN HILLS, MI. SN 77-981,695. PUB. 8-17-2010, FILED 3-26-2010.

**REDI-SENSOR**

THE MARK CONSISTS OF STANDARD CHARACTERS WITHOUT CLAIM TO ANY PARTICULAR FONT, STYLE, SIZE, OR COLOR.

FOR PRESSURE SENSORS (U.S. CLS. 21, 23, 26, 36 AND 38). FIRST USE 1-25-2011; IN COMMERCE 1-25-2011.

3,963,258. WEATHERHOLT & ASSOCIATES, LLC, ANCHORAGE, AK. SN 77-981,698. PUB. 5-11-2010, FILED 4-20-2009.



THE MARK CONSISTS OF THE LITERAL ELEMENT "GETTING DOWN TO BUSINESS" AND A DESIGN ELEMENT CONSISTING OF THE GRAPHIC STYLIZED REPRESENTATION OF A DOLLAR SIGN SUPERIMPOSED UPON A RECTANGULAR BACKGROUND WHOSE CORNERS ARE ROUNDED, AND WHEREIN THE WORD "GETTING" IS LOCATED ABOVE THE WORD "DOWN TO" WHICH ARE LOCATED ABOVE THE WORD "BUSINESS", AND WHEREIN FURTHER, THE LITERAL ELEMENT IS LOCATED TO THE RIGHT OF THE DESIGN ELEMENT.

FOR DOWNLOADABLE ELECTRONIC NEWSLETTERS IN THE FIELD OF BUSINESS MANAGEMENT TOPICS ON ACCOUNTING, FINANCE, MARKETING, HUMAN RESOURCES, LEADERSHIP (U.S. CLS. 21, 23, 26, 36 AND 38).

FIRST USE 5-19-2009; IN COMMERCE 5-19-2009.

**CLASS 9—(Continued).**

3,963,281. KH TECHNOLOGY CORPORATION, GEORGE TOWN, CAYMAN ISLANDS. SN 78-349,861. PUB. 7-21-2009, FILED 1-9-2004.

**INSTANT THEATRE**

THE MARK CONSISTS OF STANDARD CHARACTERS WITHOUT CLAIM TO ANY PARTICULAR FONT, STYLE, SIZE, OR COLOR.

PRIORITY CLAIMED UNDER SEC. 44(D) ON ERPNTY TM OFC APPLICATION NO. 003261146, FILED 7-9-2003, REG. NO. 003261146, DATED 11-7-2007, EXPIRES 9-7-2013.

FOR APPARATUS FOR THE RECORDAL, TRANSMISSION, PROCESSING, RECEPTION AND REPRODUCTION OF SOUND, NAMELY, SURROUND AUDIO SPEAKERS AND SUBWOOFERS; ELECTRICAL AND ELECTRONIC APPARATUS, NAMELY, A DVD PLAYER FOR USE WITH TELEVISION SETS AND VIDEO UNITS; AUDIO LOUDSPEAKERS; ELECTRICAL AND ELECTRONIC DIGITAL PROCESSORS; PRE-RECORDED MEDIA, NAMELY, DVD, DVD-RW, DVD+RW, CD, CDR/RW, MP3 ENCODED CD, CARRYING RECORDED SOUNDS; BLANK MEDIA, NAMELY, DVD, DVD-RW, DVD+RW, CD, CDR/RW, FOR RECORDAL OF SOUNDS; PARTS AND FITTINGS FOR ALL THE AFORESAID GOODS, NAMELY, TELEVISION AND COMPONENT-VIDEO CABLES FEATURING THREE A/V INPUTS, ONE OPTICAL DIGITAL INPUT AND OUTPUT, S-VIDEO AND PROGRESSIVE-SCAN COMPONENT-VIDEO OUTPUTS; BUT EACH OF THE ABOVE NOT INCLUDING PROJECTION SCREENS AND PARTS AND ACCESSORIES THEREFOR OR OTHER GOODS ANCILLARY THERETO (U.S. CLS. 21, 23, 26, 36 AND 38). FIRST USE 4-0-2004; IN COMMERCE 4-0-2004.

3,963,290. BIOVIGILANT SYSTEMS, INC., TUCSON, AZ. SN 78-827,624. PUB. 10-31-2006, FILED 3-2-2006.

**IMD-L**

THE MARK CONSISTS OF STANDARD CHARACTERS WITHOUT CLAIM TO ANY PARTICULAR FONT, STYLE, SIZE, OR COLOR.

FOR ELECTRICAL AND OPTICAL INSTRUMENTS FOR MONITORING AND TESTING AIR AND WATER FOR DETECTING MICROBIAL CONTAMINATION, FOR AGRICULTURE, CONSUMER, GOVERNMENTAL, MILITARY, HOMELAND SECURITY, RETAIL, TRANSPORTATION, ENTERTAINMENT, FOOD, LODGING, EDUCATION AND HEALTHCARE INDUSTRIES, FOR LABORATORY APPLICATIONS, FOOD PROCESSING MANUFACTURING AND OPTICAL DEVICE MANUFACTURING, AND FOR PHARMACEUTICAL AND MEDICAL DEVICE MANUFACTURING INDUSTRIES (U.S. CLS. 21, 23, 26, 36 AND 38).

FIRST USE 2-25-2011; IN COMMERCE 2-25-2011.

**CLASS 9—(Continued).**

3,963,314. LEVITON MANUFACTURING CO., INC., MELVILLE, NY. SN 85-001,687. PUB. 7-20-2010, FILED 3-30-2010.

# WETGUARD

THE MARK CONSISTS OF STANDARD CHARACTERS WITHOUT CLAIM TO ANY PARTICULAR FONT, STYLE, SIZE, OR COLOR.

OWNER OF U.S. REG. NO. 2,895,023.  
FOR ELECTRICAL PLUGS, CONNECTORS, RECEPTACLES AND COVERS FOR SAME (U.S. CLS. 21, 23, 26, 36 AND 38).

FIRST USE 7-29-2010; IN COMMERCE 7-29-2010.

3,963,331. ACCELERATED TECHNOLOGY LABORATORIES, INC., WEST END, NC. SN 85-005,787. PUB. 8-24-2010, FILED 4-3-2010.

# SeqNFind

THE MARK CONSISTS OF THE STYLIZED WORD MARK "SEQNFIND", USING CAPITAL LETTERS FOR "S", "N" AND "F", LOWERCASE LETTERING "EQ" AND "IND" ALL IN HAETTENSCHWEILER FONT.

FOR COMPUTER HARDWARE AND SOFTWARE FOR PROCESSING, ANALYZING AND ORGANIZING SEQUENCE BASED DATA (U.S. CLS. 21, 23, 26, 36 AND 38).

FIRST USE 3-16-2010; IN COMMERCE 4-20-2010.

3,963,337. PULSAFEEDER, INC., ROCHESTER, NY. SN 85-006,637. PUB. 1-4-2011, FILED 4-5-2010.

# PULSABLUE

THE MARK CONSISTS OF STANDARD CHARACTERS WITHOUT CLAIM TO ANY PARTICULAR FONT, STYLE, SIZE, OR COLOR.

**CLASS 9—(Continued).**

OWNER OF U.S. REG. NOS. 902,588, 1,054,688, AND 1,532,768.

FOR CHEMICAL SUPPLY CONTROLLER FOR USE IN MONITORING AND TREATING WATER IN COOLING TOWER AND BOILER APPLICATIONS, NAMELY, AN ELECTRONIC CONTROLLER FOR MONITORING CONDUCTIVITY PH AND OTHER CHEMICAL LEVELS IN WATER AND ACTIVATING CHEMICAL DISPENSING PUMPS TO ADJUST CHEMICAL CONTENT IN THE WATER (U.S. CLS. 21, 23, 26, 36 AND 38).

FIRST USE 6-24-2010; IN COMMERCE 6-24-2010.

3,963,338. DATAMEER INC., SAN MATEO, CA. SN 85-006,701. PUB. 8-31-2010, FILED 4-5-2010.

# Datameer

THE MARK CONSISTS OF STANDARD CHARACTERS WITHOUT CLAIM TO ANY PARTICULAR FONT, STYLE, SIZE, OR COLOR.

FOR COMPUTER SOFTWARE FOR DATA MANAGEMENT AND ANALYTICS (U.S. CLS. 21, 23, 26, 36 AND 38).

FIRST USE 4-5-2010; IN COMMERCE 4-5-2010.

3,963,346. WGBH EDUCATIONAL FOUNDATION, BOSTON, MA. SN 85-007,319. PUB. 7-20-2010, FILED 4-6-2010.

# Rough Cut

THE MARK CONSISTS OF STANDARD CHARACTERS WITHOUT CLAIM TO ANY PARTICULAR FONT, STYLE, SIZE, OR COLOR.

FOR DOWNLOADABLE PODCASTS IN THE FIELD OF WOOD WORKING (U.S. CLS. 21, 23, 26, 36 AND 38).

FIRST USE 10-31-2010; IN COMMERCE 10-31-2010.

**CLASS 9—(Continued).**

3,963,354. TOURNAMENT ONE CORP, AKA T1 GAMING, T1, TOC, STAMFORD, CT. SN 85-008,852. PUB. 7-27-2010, FILED 4-7-2010.

**KENOTAINMENT**

THE MARK CONSISTS OF STANDARD CHARACTERS WITHOUT CLAIM TO ANY PARTICULAR FONT, STYLE, SIZE, OR COLOR.

FOR COMPUTER GAME SOFTWARE DOWNLOADABLE FROM A GLOBAL COMPUTER NETWORK; COMPUTER GAME SOFTWARE FOR GAMING MACHINES INCLUDING SLOT MACHINES OR VIDEO LOTTERY TERMINALS; DOWNLOADABLE COMPUTER GAME PROGRAMS; DOWNLOADABLE COMPUTER GAME SOFTWARE VIA A GLOBAL COMPUTER NETWORK AND WIRELESS DEVICES; DOWNLOADABLE ELECTRONIC GAMES VIA THE INTERNET AND WIRELESS DEVICES; ELECTRONIC GAME SOFTWARE FOR CELLULAR TELEPHONES; ELECTRONIC GAME SOFTWARE FOR HANDHELD ELECTRONIC DEVICES; ELECTRONIC GAME SOFTWARE FOR WIRELESS DEVICES (U.S. CLS. 21, 23, 26, 36 AND 38).  
FIRST USE 4-7-2010; IN COMMERCE 11-30-2010.

3,963,372. COVENANT EYES, INC., OWOSSO, MI. SN 85-011,926. PUB. 12-14-2010, FILED 4-12-2010.



OWNER OF U.S. REG. NOS. 3,430,825 AND 3,434,966.  
THE MARK CONSISTS OF AN EYE DESIGN.

FOR COMPUTER SOFTWARE AND DOWNLOADABLE COMPUTER SOFTWARE FOR MONITORING AND RECORDING INTERNET USAGE AND FILTERING INTERNET CONTENT; COMPUTER APPLICATION SOFTWARE FOR MOBILE PHONES, NAMELY, INTERNET-USE ACCOUNTABILITY SOFTWARE FOR SMART PHONES, CELL PHONES AND PDAS; COMPUTER OPERATING SYSTEMS; COMPUTER PROGRAMS AND DOWNLOADABLE COMPUTER PROGRAMS FOR MONITORING ALL URLS IN ALL PROTOCOLS ACCESSED ON OPERATING SYSTEMS, SCORING THE URLS, WEBSITE PAGES, AND SOURCE CODE FOR OBJECTIONABLE CONTENT, AND RECORDING AND COMPILING THIS INFORMATION FOR CUSTOMERS; AGE-BASED DYNAMIC INTERNET CONTENT FILTERING SOFTWARE AND DOWNLOADABLE SOFTWARE THAT BLOCKS OBJECTIONABLE CONTENT BASED ON REAL-TIME SCANNING AND SCORING; WEB BROWSING SOFTWARE FOR USING THE INTERNET AND THE WORLDWIDE WEB (U.S. CLS. 21, 23, 26, 36 AND 38).  
FIRST USE 9-28-2010; IN COMMERCE 9-28-2010.

**CLASS 9—(Continued).**

3,963,379. SPARTAN MOTORS, INC., CHARLOTTE, MI. SN 85-013,930. PUB. 9-7-2010, FILED 4-14-2010.

**TRANSFORMER**

THE MARK CONSISTS OF STANDARD CHARACTERS WITHOUT CLAIM TO ANY PARTICULAR FONT, STYLE, SIZE, OR COLOR.

FOR FIRE ENGINES; FIRE TRUCKS (U.S. CLS. 21, 23, 26, 36 AND 38).  
FIRST USE 4-23-2010; IN COMMERCE 4-23-2010.

3,963,380. ELIJAH LIST PUBLICATIONS, LLC, AKA THE ELIJAH LIST, ALBANY, OR. SN 85-014,021. PUB. 9-7-2010, FILED 4-14-2010.

**ElijahSounds**

THE MARK CONSISTS OF STANDARD CHARACTERS WITHOUT CLAIM TO ANY PARTICULAR FONT, STYLE, SIZE, OR COLOR.

FOR COMPACT DISCS FEATURING MUSIC; DIGITAL MUSIC DOWNLOADABLE FROM THE INTERNET; DOWNLOADABLE MP3 FILES, MP3 RECORDINGS, ONLINE DISCUSSION BOARDS, WEBCASTS, WEBINARS AND PODCASTS FEATURING MUSIC, AUDIO BOOKS AND NEWS BROADCASTS; DOWNLOADABLE MUSICAL SOUND RECORDINGS; MUSICAL SOUND RECORDINGS; SOUND RECORDINGS FEATURING MUSIC (U.S. CLS. 21, 23, 26, 36 AND 38).  
FIRST USE 4-15-2010; IN COMMERCE 4-15-2010.

3,963,381. SAMSUNG ELECTRONICS CO., LTD., SUWON-SI, GYEONGGI-DO, REPUBLIC OF KOREA. SN 85-014,235. PUB. 8-17-2010, FILED 4-14-2010.

**SAMSUNG GEM**

THE MARK CONSISTS OF STANDARD CHARACTERS WITHOUT CLAIM TO ANY PARTICULAR FONT, STYLE, SIZE, OR COLOR.

OWNER OF U.S. REG. NOS. 2,882,774, 3,713,355, AND OTHERS.

THE ENGLISH TRANSLATION OF "SAMSUNG" IN THE MARK IS "THREE STARS".

FOR MOBILE PHONES; SMARTPHONES (U.S. CLS. 21, 23, 26, 36 AND 38).  
FIRST USE 1-19-2011; IN COMMERCE 1-19-2011.



**CLASS 9—(Continued).**

3,963,406. BITLAB, PARK RIDGE, IL. SN 85-022,143. PUB. 9-28-2010, FILED 4-23-2010.

# Base3z

THE MARK CONSISTS OF STANDARD CHARACTERS WITHOUT CLAIM TO ANY PARTICULAR FONT, STYLE, SIZE, OR COLOR.

FOR DECODER SOFTWARE; ENCODING AND DECODING APPARATUS; ENCODING AND DECODING APPARATUS AND INSTRUMENTS (U.S. CLS. 21, 23, 26, 36 AND 38).

FIRST USE 4-28-2010; IN COMMERCE 4-28-2010.

---

3,963,433. SAMSUNG ELECTRONICS CO., LTD., SUWON-SI, GYEONGGI-DO, REPUBLIC OF KOREA. SN 85-028,674. PUB. 8-24-2010, FILED 5-3-2010.

# SAMSUNG FOCUS

THE MARK CONSISTS OF STANDARD CHARACTERS WITHOUT CLAIM TO ANY PARTICULAR FONT, STYLE, SIZE, OR COLOR.

OWNER OF U.S. REG. NOS. 2,882,774, 3,713,355, AND OTHERS.

THE ENGLISH TRANSLATION OF "SAMSUNG" IN THE MARK IS "THREE STARS".

FOR MOBILE PHONES; SMARTPHONES (U.S. CLS. 21, 23, 26, 36 AND 38).

FIRST USE 11-4-2010; IN COMMERCE 11-4-2010.

---

3,963,434. ZEENYX SOFTWARE, INC., HOPKINTON, MA. SN 85-029,008. PUB. 10-5-2010, FILED 5-3-2010.

# Zee

THE MARK CONSISTS OF STANDARD CHARACTERS WITHOUT CLAIM TO ANY PARTICULAR FONT, STYLE, SIZE, OR COLOR.

FOR COMPUTER SOFTWARE DEVELOPMENT TOOLS (U.S. CLS. 21, 23, 26, 36 AND 38).

FIRST USE 4-1-2010; IN COMMERCE 10-1-2010.

**CLASS 9—(Continued).**

3,963,440. ICONIC TSUNAMI, LLC, SMYRNA, DE. SN 85-029,755. PUB. 9-28-2010, FILED 5-4-2010.



THE MARK CONSISTS OF A STICK-FIGURE DRAWING OF A PERSON.

FOR ACCESSORIES FOR MONITORS, NAMELY, FRAMES FOR ATTACHMENT TO COMPUTER MONITORS (U.S. CLS. 21, 23, 26, 36 AND 38).

FIRST USE 2-0-2010; IN COMMERCE 4-0-2010.

---

3,963,454. SEAGATE TECHNOLOGY LLC, SCOTTS VALLEY, CA. SN 85-035,594. PUB. 8-3-2010, FILED 5-11-2010.

# SEAGATE SMARTALIGN

THE MARK CONSISTS OF STANDARD CHARACTERS WITHOUT CLAIM TO ANY PARTICULAR FONT, STYLE, SIZE, OR COLOR.

OWNER OF U.S. REG. NOS. 1,269,032, 3,632,745, AND OTHERS.

FOR COMPUTER MEMORY HARDWARE; HARD DISK DRIVES; COMPUTER FIRMWARE FOR DATA STORAGE, DATA RETRIEVAL, DATA ACCESS, DATA BACKUP, DATA REPLICATION, DATA AVAILABILITY, DATA RECOVERY, DATA TRANSLATION AND DATA CONVERSION (U.S. CLS. 21, 23, 26, 36 AND 38).

FIRST USE 10-12-2010; IN COMMERCE 10-12-2010.

**CLASS 9—(Continued).**

3,963,463. POCKET SOFT, INC., HOUSTON, TX. SN 85-036,581. PUB. 10-12-2010, FILED 5-12-2010.

**UNTHREAD**

THE MARK CONSISTS OF STANDARD CHARACTERS WITHOUT CLAIM TO ANY PARTICULAR FONT, STYLE, SIZE, OR COLOR.

FOR COMPUTER SOFTWARE, NAMELY, A PARALLEL TASK APPLICATION PROGRAMMING INTERFACE (API) FOR CPU-BOUND APPLICATIONS (U.S. CLS. 21, 23, 26, 36 AND 38).

FIRST USE 5-3-2010; IN COMMERCE 5-3-2010.

**CLASS 9—(Continued).**

3,963,488. BATTERIES PLUS, LLC, HARTLAND, WI. SN 85-042,399. PUB. 10-5-2010, FILED 5-19-2010.

**CONTENDER**

THE MARK CONSISTS OF STANDARD CHARACTERS WITHOUT CLAIM TO ANY PARTICULAR FONT, STYLE, SIZE, OR COLOR.

FOR BATTERIES (U.S. CLS. 21, 23, 26, 36 AND 38).

FIRST USE 2-15-2011; IN COMMERCE 2-15-2011.

3,963,480. DOCUNOWLEDGE, LLC, DAWSONVILLE, GA. SN 85-039,168. PUB. 11-9-2010, FILED 5-14-2010.

**DocuNOWledge**  
Extracting knowledge from  
documents - NOW!

THE MARK CONSISTS OF STANDARD CHARACTERS WITHOUT CLAIM TO ANY PARTICULAR FONT, STYLE, SIZE, OR COLOR.

FOR COMPUTER DATABASE MANAGEMENT SOFTWARE FOR USE IN GAINING RELEVANT KNOWLEDGE FROM LARGE SETS OF DOCUMENTS THROUGH UNDERSTANDING OF IMPORTANT CONCEPTS (U.S. CLS. 21, 23, 26, 36 AND 38).

FIRST USE 3-1-2011; IN COMMERCE 3-1-2011.

3,963,507. CUSTOM SOFTWARE MANAGEMENT LLC, NEW YORK, NY. SN 85-046,195. PUB. 10-19-2010, FILED 5-24-2010.

**REPORT GUARD**

THE MARK CONSISTS OF STANDARD CHARACTERS WITHOUT CLAIM TO ANY PARTICULAR FONT, STYLE, SIZE, OR COLOR.

FOR COMPUTER SOFTWARE FOR SECURING EMAIL ATTACHMENTS THAT MAY BE DOWNLOADED FROM A GLOBAL COMPUTER NETWORK (U.S. CLS. 21, 23, 26, 36 AND 38).

FIRST USE 9-1-2009; IN COMMERCE 9-1-2009.

3,963,486. LOVATO, JR., MD, ALFRED A. ALBUQUERQUE, NM. SN 85-040,848. PUB. 10-26-2010, FILED 5-17-2010.

**Eye Candy Optical Boutique**

THE MARK CONSISTS OF STANDARD CHARACTERS WITHOUT CLAIM TO ANY PARTICULAR FONT, STYLE, SIZE, OR COLOR.

NO CLAIM IS MADE TO THE EXCLUSIVE RIGHT TO USE "OPTICAL BOUTIQUE", APART FROM THE MARK AS SHOWN.

FOR OPTICAL FRAMES; OPTICAL GLASSES (U.S. CLS. 21, 23, 26, 36 AND 38).

FIRST USE 5-20-2010; IN COMMERCE 5-20-2010.

3,963,508. DSR, INC., KINGSBURG, CA. SN 85-046,688. PUB. 12-14-2010, FILED 5-24-2010.

**HEARAID**

THE MARK CONSISTS OF STANDARD CHARACTERS WITHOUT CLAIM TO ANY PARTICULAR FONT, STYLE, SIZE, OR COLOR.

FOR SOUND AMPLIFIERS FOR PERSONAL USE (U.S. CLS. 21, 23, 26, 36 AND 38).

FIRST USE 8-21-2009; IN COMMERCE 8-21-2009.

**CLASS 9—(Continued).**

3,963,547. POMDEVICES, LLC, DBA POMDEVICES, LLC, DURHAM, NC. SN 85-059,977. PUB. 11-9-2010, FILED 6-10-2010.

# SONAMBA

THE MARK CONSISTS OF STANDARD CHARACTERS WITHOUT CLAIM TO ANY PARTICULAR FONT, STYLE, SIZE, OR COLOR.

FOR ELECTRONIC DEVICES FOR ASSISTING CARE GIVING FOR SENIORS OR PEOPLE NEEDING ASSISTANCE COMPRISED OF SENSORS FOR DETERMINING STATUS OF PERSON AND APPARATUS FOR SENDING ELECTRONIC ALERTS TO CARE GIVERS (U.S. CLS. 21, 23, 26, 36 AND 38).

FIRST USE 9-29-2010; IN COMMERCE 11-22-2010.

---

3,963,567. JUBILEE DIAMOND INSTRUMENT LTD., SAN PO KONG, KOWLOON, HONG KONG. SN 85-065,212. PUB. 12-7-2010, FILED 6-17-2010.

# Gemlogis

THE MARK CONSISTS OF THE STYLIZED WORDING "GEMLOGIS" TO THE LEFT OF A DESIGN CONSISTING OF FOUR CONNECTING DIAMOND SHAPES AT RIGHT ANGLES TO EACH OTHER

FOR GEMOLOGICAL INSTRUMENTS, NAMELY, SCALES, PRECISION WEIGHING BALANCES, DIGITAL MEASURING CALIPERS, OPTICAL MEASURING APPARATUS, NAMELY, IMAGE PATTERN RECOGNITION AND IMAGE DIMENSION MEASUREMENT APPARATUS, DIAMOND COLORIMETERS, ELECTRICAL CONDUCTIVITY METERS, HEAT CONDUCTIVITY METERS, MICROSCOPES, REFRACTOMETERS; SPECTROGRAPH APPARATUS, BATTERY CHARGERS (U.S. CLS. 21, 23, 26, 36 AND 38).

FIRST USE 1-21-2011; IN COMMERCE 1-21-2011.

**CLASS 9—(Continued).**

3,963,569. HONEY FARMS, INC., WORCESTER, MA. SN 85-066,049. PUB. 11-23-2010, FILED 6-18-2010.



THE COLOR(S) RED, YELLOW AND ORANGE IS/ARE CLAIMED AS A FEATURE OF THE MARK.

THE MARK CONSISTS OF A YELLOW OUTLINE OF A CIRCLE CONTAINING AN ORANGE INTERIOR WITH A DOLLAR SIGN "\$" THAT IS TILTED TO THE LEFT AND THE WORDS "HONEY MONEY" IN RED SUPERIMPOSED ACROSS THE INTERIOR OF THE CIRCLE WITH A SLANT IN THE SAME DIRECTION AS THE DOLLAR SIGN.

FOR MAGNETIC CODED CARDS, NAMELY, CARDS FOR USE BY CUSTOMERS IN CUSTOMER LOYALTY PROGRAM FOR PURCHASES OF CONVENIENCE STORE MERCHANDISE (U.S. CLS. 21, 23, 26, 36 AND 38).

FIRST USE 3-24-2011; IN COMMERCE 3-24-2011.

---

3,963,572. ADAPTIVE SOUND TECHNOLOGIES, INC., CAMPBELL, CA. SN 85-067,777. PUB. 11-30-2010, FILED 6-21-2010.

# Adaptive Sound

THE MARK CONSISTS OF STANDARD CHARACTERS WITHOUT CLAIM TO ANY PARTICULAR FONT, STYLE, SIZE, OR COLOR.

NO CLAIM IS MADE TO THE EXCLUSIVE RIGHT TO USE "SOUND", APART FROM THE MARK AS SHOWN.

FOR APPARATUS FOR RECORDING, TRANSMISSION OR REPRODUCTION OF SOUND (U.S. CLS. 21, 23, 26, 36 AND 38).

FIRST USE 11-18-2010; IN COMMERCE 11-18-2010.

**CLASS 9—(Continued).**

3,963,582. NAVICO, INC., TULSA, OK. SN 85-068,852. PUB. 11-16-2010, FILED 6-22-2010.

**CLASS 9—(Continued).**

3,963,591. AUDIO TECHNOLOGY OF NEW YORK INC., BROOKLYN, NY. SN 85-071,088. PUB. 10-19-2010, FILED 6-24-2010.

**SONICHUB**

**IVIBE**

THE MARK CONSISTS OF STANDARD CHARACTERS WITHOUT CLAIM TO ANY PARTICULAR FONT, STYLE, SIZE, OR COLOR.

FOR MARINE AUDIO SERVER SYSTEM, COMPRISING AMPLIFIERS, SPEAKERS, DOCKING STATION, CONNECTORS AND CABLES, AND INSTRUCTION MANUALS (U.S. CLS. 21, 23, 26, 36 AND 38).

FIRST USE 8-24-2010; IN COMMERCE 8-24-2010.

THE MARK CONSISTS OF STANDARD CHARACTERS WITHOUT CLAIM TO ANY PARTICULAR FONT, STYLE, SIZE, OR COLOR.

FOR COMPUTER HARDWARE AND PERIPHERAL DEVICES, NAMELY, COMPUTER KEYBOARDS, COMPUTER WEBCAMS, NOTEBOOK COMPUTER COOLING PADS, HEADSETS FOR USE WITH COMPUTERS, COMPUTER MICE, COMPUTER KEYPADS, COMPUTER KEYBOARD CONTROLLERS, WIRELESS COMPUTER MICE, WRIST RESTS FOR COMPUTER MOUSE USERS, MOUSE PADS, COMPUTER PERIPHERALS (U.S. CLS. 21, 23, 26, 36 AND 38).

FIRST USE 11-12-2010; IN COMMERCE 1-3-2011.

3,963,583. CASCADE MICROTECH, INC., PORTLAND, OR. SN 85-068,975. PUB. 11-16-2010, FILED 6-22-2010.

3,963,592. AUDIO TECHNOLOGY OF NEW YORK INC., BROOKLYN, NY. SN 85-071,091. PUB. 10-19-2010, FILED 6-24-2010.



**IFLOW**

THE MARK CONSISTS OF A PARTIAL PYRAMID INSIDE A CIRCLE.

FOR PROBES, PROBE STATIONS, SOCKETS, AND THEIR COMPONENTS AND ACCESSORIES, FOR TESTING INTEGRATED CIRCUITS; COMPUTER SOFTWARE FOR TESTING INTEGRATED CIRCUITS AND CALIBRATING PROBES, PROBE STATIONS AND SOCKETS (U.S. CLS. 21, 23, 26, 36 AND 38).

FIRST USE 12-0-2010; IN COMMERCE 12-0-2010.

THE MARK CONSISTS OF STANDARD CHARACTERS WITHOUT CLAIM TO ANY PARTICULAR FONT, STYLE, SIZE, OR COLOR.

FOR COMPUTER HARDWARE AND PERIPHERAL DEVICES, NAMELY, COMPUTER KEYBOARDS, COMPUTER WEBCAMS, NOTEBOOK COMPUTER COOLING PADS, HEADSETS FOR USE WITH COMPUTERS, COMPUTER MICE, COMPUTER KEYPADS, COMPUTER KEYBOARD CONTROLLERS, WIRELESS COMPUTER MICE, WRIST RESTS FOR COMPUTER MOUSE USERS, MOUSE PADS, COMPUTER PERIPHERALS (U.S. CLS. 21, 23, 26, 36 AND 38).

FIRST USE 11-12-2010; IN COMMERCE 2-14-2011.

**CLASS 9—(Continued).**

3,963,597. CHATSWORTH PRODUCTS, INC., WESTLAKE VILLAGE, CA. SN 85-072,561. PUB. 11-30-2010, FILED 6-28-2010.

**GLOBALFRAME**

THE MARK CONSISTS OF STANDARD CHARACTERS WITHOUT CLAIM TO ANY PARTICULAR FONT, STYLE, SIZE, OR COLOR.

FOR ELECTRICAL EQUIPMENT CABINETS FOR HOUSING ELECTRICAL COMPUTER, COMPUTER DATA STORAGE AND COMPUTER NETWORK EQUIPMENT COMPONENTS FOR USE IN COMPUTER NETWORKS, DATA CENTERS AND COMPUTER ROOM ENVIRONMENT (U.S. CLS. 21, 23, 26, 36 AND 38).

FIRST USE 12-15-2010; IN COMMERCE 12-15-2010.

**CLASS 9—(Continued).**

3,963,681. IOTO CORP., CHICAGO, IL. SN 85-099,910. PUB. 1-18-2011, FILED 8-4-2010.

**iSpoil**

THE MARK CONSISTS OF STANDARD CHARACTERS WITHOUT CLAIM TO ANY PARTICULAR FONT, STYLE, SIZE, OR COLOR.

FOR DOWNLOADABLE SOFTWARE IN THE NATURE OF A MOBILE APPLICATION FOR PHONES, SMARTPHONES, COMPUTERS, PDAS FOR DETERMINING EXPIRATION DATES OF FOOD, PROVIDING HEALTH AND WELLNESS INFORMATION; COMPUTER APPLICATION SOFTWARE FOR DETERMINING NUTRITIONAL FACTS, DETERMINING EXPIRATION DATES OF FOOD; PROVIDING HEALTH AND WELLNESS INFORMATION, NAMELY, SOFTWARE FOR PHONES, SMARTPHONES, COMPUTERS, PDAS FOR DETERMINING NUTRITIONAL FACTS, DETERMINING EXPIRATION DATES OF FOOD, PROVIDING HEALTH AND WELLNESS INFORMATION (U.S. CLS. 21, 23, 26, 36 AND 38).

FIRST USE 3-15-2011; IN COMMERCE 3-15-2011.

3,963,628. NEWER TECHNOLOGY, INC., WOODSTOCK, IL. SN 85-080,282. PUB. 10-26-2010, FILED 7-8-2010.

**STORADRIVE**

THE MARK CONSISTS OF STANDARD CHARACTERS WITHOUT CLAIM TO ANY PARTICULAR FONT, STYLE, SIZE, OR COLOR.

FOR ENCLOSURES FOR PROTECTING, STORING, AND ORGANIZING COMPUTER DATA STORAGE DEVICES, SUCH AS HARD DRIVES AND SOLID STATE DRIVES (U.S. CLS. 21, 23, 26, 36 AND 38).

FIRST USE 5-5-2010; IN COMMERCE 5-5-2010.

3,963,706. NIKON CORPORATION, TOKYO, JAPAN. SN 85-120,886. PUB. 1-25-2011, FILED 9-1-2010.

**Bolt XR**

THE MARK CONSISTS OF THE STYLIZED WORD "BOLT", FOLLOWED BY THE STYLIZED LETTERS "XR". A STYLIZED CROSSBOW DESIGN FORMED BY THE LETTERS "L" AND "T" IN THE WORD "BOLT" AND LETTER "X", AND AN ARROW DESIGN.

FOR CROSSBOW SCOPES (U.S. CLS. 21, 23, 26, 36 AND 38).

FIRST USE 3-10-2011; IN COMMERCE 3-10-2011.



**CLASS 9—(Continued).**

3,963,718. M4 GROUP, LLC, CRESTED BUTTE, CO. SN 85-151,495. PUB. 2-1-2011, FILED 10-13-2010.

THE MARK CONSISTS OF THE STYLIZED TEXT "MOBANU" WITH THREE CIRCLES ON THE TOP.

FOR WEIGHT LOSS PROGRAM KITS COMPRISED OF DVDS, A SELF-GUIDED HYPNOSIS CD, BOOKLETS, HEART-RATE MONITOR, BODY TAPE MEASURE TO ALLOW YOU TO MEASURE WAIST SIZE AND OTHER MEASUREMENTS, MULTI-VITAMINS, AND A BLOOD SUGAR CONTROLLER, PACKAGED TOGETHER AS A UNIT (U.S. CLS. 21, 23, 26, 36 AND 38).

FIRST USE 8-1-2010; IN COMMERCE 3-14-2011.

**CLASS 10—MEDICAL APPARATUS**

3,961,979. WILLIAMS, MICHAEL O. D.D.S., GULFPORT, MS. SN 76-697,827. PUB. 10-27-2009, FILED 6-9-2009.

THE MARK CONSISTS OF STANDARD CHARACTERS WITHOUT CLAIM TO ANY PARTICULAR FONT, STYLE, SIZE, OR COLOR.

OWNER OF U.S. REG. NOS. 2,115,358, 3,470,124, AND OTHERS.

FOR ORTHODONTIC APPLIANCE (U.S. CLS. 26, 39 AND 44).

FIRST USE 3-24-2006; IN COMMERCE 11-27-2006.

3,961,994. GALT MEDICAL CORP., GARLAND, TX. SN 76-702,091. PUB. 9-21-2010, FILED 3-15-2010.

THE MARK CONSISTS OF STANDARD CHARACTERS WITHOUT CLAIM TO ANY PARTICULAR FONT, STYLE, SIZE, OR COLOR.

OWNER OF U.S. REG. NOS. 3,645,323 AND 3,712,391.

FOR MEDICAL GUIDEWIRE THAT IS EITHER A STAINLESS STEEL OR NITINOL WIRE THAT GUIDES THROUGH THE SUBCUTANEOUS TRACT IN THE VASCULAR SYSTEM FOR PLACEMENT OF SHEATHS AND CATHETERS (U.S. CLS. 26, 39 AND 44).

FIRST USE 10-15-2010; IN COMMERCE 10-15-2010.

**CLASS 10—(Continued).**

3,962,054. HANSEN MEDICAL, INC., MOUNTAIN VIEW, CA. SN 77-219,754. PUB. 12-11-2007, FILED 6-29-2007.

THE MARK CONSISTS OF STANDARD CHARACTERS WITHOUT CLAIM TO ANY PARTICULAR FONT, STYLE, SIZE, OR COLOR.

NO CLAIM IS MADE TO THE EXCLUSIVE RIGHT TO USE "TECHNOLOGY", APART FROM THE MARK AS SHOWN.

FOR ROBOTIC CATHETERS; SURGICAL ROBOTS FOR USE IN THE HUMAN BODY (U.S. CLS. 26, 39 AND 44).

FIRST USE 5-2-2008; IN COMMERCE 5-2-2008.

3,962,077. ENTRIGUE SURGICAL, INC., SAN ANTONIO, TX. SN 77-268,602. PUB. 12-9-2008, FILED 8-30-2007.

THE MARK CONSISTS OF STANDARD CHARACTERS WITHOUT CLAIM TO ANY PARTICULAR FONT, STYLE, SIZE, OR COLOR.

FOR SURGICAL INSTRUMENTS AND APPARATUS; SURGICAL STAPLES; SURGICAL IMPLANTS COMPRISING ARTIFICIAL MATERIALS; NON-LIVING TISSUE IMPLANTS, NAMELY, BONE IMPLANTS, CARTILAGE IMPLANTS, SOFT TISSUE IMPLANTS, AND HARD TISSUE IMPLANTS DERIVED FROM NON-HUMAN SPECIES (U.S. CLS. 26, 39 AND 44).

FIRST USE 2-25-2011; IN COMMERCE 2-25-2011.

**CLASS 10—(Continued).**

3,962,099. CYTORI THERAPEUTICS, INC., SAN DIEGO, CA. SN 77-339,793. PUB. 6-24-2008, FILED 11-29-2007.

## WHERE INFINITE POSSIBILITIES MEET

THE MARK CONSISTS OF STANDARD CHARACTERS WITHOUT CLAIM TO ANY PARTICULAR FONT, STYLE, SIZE, OR COLOR.

FOR MEDICAL APPARATUS, INSTRUMENTS AND ARTICLES, NAMELY, MEDICAL INSTRUMENTS FOR PROCESSING, CONCENTRATING, AND IMPLANTING CELLS AND CELLULAR COMPOSITIONS; MEDICAL INSTRUMENTS FOR TISSUE, CELL, CELLULAR COMPONENT AND STEM CELL EXTRACTION, PROCESSING AND APPLICATION; TISSUE AND CELL SEPARATION AND PURIFICATION DEVICES, NAMELY, DEVICES USED FOR THE ISOLATION OF CELLS AND CELLULAR COMPONENTS WITHIN ADIPOSE TISSUE FOR MEDICAL USE; TISSUE AND CELL PROCESSING DEVICES, NAMELY, DEVICES USED FOR THE COLLECTION AND STORAGE OF ADIPOSE TISSUE AND ADIPOSE TISSUE DERIVED CELLS FOR MEDICAL USE; MEDICAL DEVICES FOR POSITIONING AND SECURING THE BONE AND SOFT TISSUE IMPLANTS (U.S. CLS. 26, 39 AND 44).

FIRST USE 3-0-2008; IN COMMERCE 3-0-2008.

3,962,115. CARTICEPT MEDICAL, INC., FORMERLY WINDWARD MEDICAL, INC., ALPHARETTA, GA. SN 77-390,693. PUB. 7-15-2008, FILED 2-6-2008.

## CARTICEPT

THE MARK CONSISTS OF STANDARD CHARACTERS WITHOUT CLAIM TO ANY PARTICULAR FONT, STYLE, SIZE, OR COLOR.

FOR MEDICAL APPARATUS, NAMELY, INFUSION AND INJECTION DEVICES FOR ADMINISTERING DRUGS AND FLUIDS FOR MEDICAL USE; ARTIFICIAL CARTILAGE; ORTHOPEDIC JOINT IMPLANTS; SUBSTITUTES FOR BONES, CARTILAGE, LIGAMENTS, AND TENDONS; ARTIFICIAL SUBSTITUTES FOR JOINT TISSUE (U.S. CLS. 26, 39 AND 44).

FIRST USE 1-12-2011; IN COMMERCE 1-12-2011.

**CLASS 10—(Continued).**

3,962,122. CASCADE DAFO, INC., FERNDALE, WA. SN 77-405,543. PUB. 1-12-2010, FILED 2-25-2008.

## LEAP FROG

THE MARK CONSISTS OF STANDARD CHARACTERS WITHOUT CLAIM TO ANY PARTICULAR FONT, STYLE, SIZE, OR COLOR.

FOR ANKLE FOOT ORTHOTICS; ORTHOTIC DEVICES FOR FEET, ANKLES, LEGS; AND LOWER LIMB ORTHOSES (U.S. CLS. 26, 39 AND 44).

FIRST USE 1-15-2008; IN COMMERCE 1-15-2008.

3,962,316. BAYLIS MEDICAL COMPANY INC., SAINT-LAURENT, QC, CANADA. SN 77-688,516. PUB. 7-14-2009, FILED 3-11-2009.

## THORACOOOL

THE MARK CONSISTS OF STANDARD CHARACTERS WITHOUT CLAIM TO ANY PARTICULAR FONT, STYLE, SIZE, OR COLOR.

FOR ELECTRONIC STIMULATOR FOR USE IN THE SPINE OR SURROUNDING REGIONS, INCLUDING THE THORACIC SPINE; HIGH FREQUENCY ELECTROMAGNETIC THERAPY APPARATUS; MEDICAL INSTRUMENTS FOR USE IN RADIO FREQUENCY ABLATION; SURGICAL INSTRUMENTS FOR USE IN THE SPINE OR SURROUNDING REGIONS, INCLUDING THE THORACIC SPINE; SURGICAL INSTRUMENTS, NAMELY, CANNULAE, PROBES AND SHEATHS (U.S. CLS. 26, 39 AND 44).

FIRST USE 6-5-2009; IN COMMERCE 6-5-2009.

**CLASS 10—(Continued).**

3,962,524. ELECTROCORE LLC, MORRIS PLAINS, NJ. SN 77-806,685. PUB. 6-22-2010, FILED 8-18-2009.

**ELECTROCORE**

THE MARK CONSISTS OF STANDARD CHARACTERS WITHOUT CLAIM TO ANY PARTICULAR FONT, STYLE, SIZE, OR COLOR.

FOR MEDICAL DEVICES, NAMELY, NERVE AND MUSCLE TISSUE STIMULATORS; MEDICAL DEVICES FOR TREATING BREATHING AILMENTS, NAMELY, ASTHMA AND BRONCHIAL CONSTRICTION, GASTRIC MOTILITY, GASTRIC AILMENTS, AND CIRCULATORY AILMENTS, THE FOREGOING TREATMENT ACCOMPLISHED BY ELECTRICALLY STIMULATING AND MODULATING NERVE AND MUSCLE TISSUE (U.S. CLS. 26, 39 AND 44).

FIRST USE 1-20-2009; IN COMMERCE 1-20-2009.

**CLASS 10—(Continued).**

3,962,589. VIVEBIO, LLC, NORCROSS, GA. SN 77-826,439. PUB. 3-23-2010, FILED 9-15-2009.

**A HAND IN LIFE**

THE MARK CONSISTS OF STANDARD CHARACTERS WITHOUT CLAIM TO ANY PARTICULAR FONT, STYLE, SIZE, OR COLOR.

FOR MEDICAL SPECIMEN CONTAINERS FOR STORAGE AND TRANSPORTATION OF BIOLOGICAL SPECIMENS, AND KITS FOR COLLECTION AND PRESERVATION OF BIOLOGICAL SPECIMENS COMPRISING THE MEDICAL SPECIMEN CONTAINERS AND REAGENTS (U.S. CLS. 26, 39 AND 44).

FIRST USE 11-2-2009; IN COMMERCE 11-2-2009.

3,962,643. PRESBIBIO, LLC, LOS ANGELES, CA. SN 77-847,851. PUB. 7-13-2010, FILED 10-13-2009.

**PRESBIA**

THE MARK CONSISTS OF STANDARD CHARACTERS WITHOUT CLAIM TO ANY PARTICULAR FONT, STYLE, SIZE, OR COLOR.

THE WORDING "PRESBIA" HAS NO MEANING IN A FOREIGN LANGUAGE.

FOR OCULAR IMPLANTS; INTRAOCULAR LENSES; OPHTHALMIC LENSES; MEDICAL AND SURGICAL APPARATUS AND INSTRUMENTS FOR USE IN OPHTHALMIC SURGERY; OPHTHALMIC PRODUCTS, NAMELY, LENSES FOR SURGICAL IMPLANTATION; OPTOMETRIC INSTRUMENTS, NAMELY, INSTRUMENTS FOR LOCATING GROOVES, ENGRAVINGS AND OTHER INDICIA ON OPHTHALMIC LENSES, INSTRUMENTS FOR MEASURING THE DIAMETER OF OPHTHALMIC LENSES, AND INSTRUMENTS FOR LOCATING THE OPTICAL CENTER OF OPHTHALMIC LENSES; OPHTHALMIC MEDICAL AND SURGICAL APPARATUS, NAMELY, A DEVICE FOR INSERTING OCULAR IMPLANTS AND LENSES INTO EYES; OPHTHALMIC MEDICAL AND SURGICAL APPARATUS, NAMELY, A DEVICE FOR HOLDING OCULAR IMPLANTS AND LENSES DURING TRANSPORT, TESTING, AND IMPLANTATION (U.S. CLS. 26, 39 AND 44).

FIRST USE 10-0-2009; IN COMMERCE 1-13-2011.

3,962,578. EVENT MEDICAL INC., SAN CLEMENTE, CA. SN 77-823,654. PUB. 2-2-2010, FILED 9-10-2009.

**CLININET**

THE MARK CONSISTS OF STANDARD CHARACTERS WITHOUT CLAIM TO ANY PARTICULAR FONT, STYLE, SIZE, OR COLOR.

FOR MEDICAL APPARATUS AND INSTRUMENTS FOR MONITORING OXYMETORY, GAS ANALYSIS, VITAL SIGNS, BLOOD PROPERTIES AND RESPIRATORY EVENTS AND SYSTEM THAT TRANSMITS DATA THROUGH THE INTERNET; MEDICAL DEVICES FOR MONITORING OXYMETORY, GAS ANALYSIS, VITAL SIGNS, BLOOD PROPERTIES AND RESPIRATORY EVENTS AND SYSTEM THAT TRANSMITS DATA THROUGH THE INTERNET (U.S. CLS. 26, 39 AND 44).

FIRST USE 5-3-2010; IN COMMERCE 5-3-2010.

**CLASS 10—(Continued).**

3,962,682. BISCHOFF, KAREN, SUGAR HILL, GA. SN 77-858,218. PUB. 7-27-2010, FILED 10-27-2009.

**HANDI-CUFF**

THE MARK CONSISTS OF STANDARD CHARACTERS WITHOUT CLAIM TO ANY PARTICULAR FONT, STYLE, SIZE, OR COLOR.

FOR MEDICAL DEVICES AND APPARATUS TO AID PERSONS WITH QUADRIPLÉGIA, ARTHRITIS, FINGER AMPUTATIONS AND OTHER NERVE RELATED DISORDERS, NAMELY, WEARABLE CUFFS WHICH ASSIST IN HOLDING AND USING WRITING IMPLEMENTS, EATING UTENSILS, PERSONAL HYGIENE PRODUCTS AND A VARIETY OF OTHER OBJECTS (U.S. CLS. 26, 39 AND 44).

FIRST USE 7-29-1986; IN COMMERCE 1-15-1987.

3,962,724. PRE HOLDING, INC., MIDLOTHIAN, VA. SN 77-877,145. PUB. 5-11-2010, FILED 11-20-2009.

**VIOS**

THE MARK CONSISTS OF STANDARD CHARACTERS WITHOUT CLAIM TO ANY PARTICULAR FONT, STYLE, SIZE, OR COLOR.

THE WORDING "VIOS" HAS NO MEANING IN A FOREIGN LANGUAGE.

FOR MEDICAL DEVICES, NAMELY, NEBULIZERS FOR RESPIRATION THERAPY AND INHALATION DEVICES PROVIDED EMPTY, FOR USE WITH PHARMACEUTICALS; EXCLUDING USE IN CONNECTION WITH MEDICAL DEVICES RELATING TO ELECTRO-SURGERY, VESSEL SEALING/THERMOFUSION, APC AND WATERJET SURGERY (U.S. CLS. 26, 39 AND 44).

FIRST USE 8-31-2009; IN COMMERCE 2-28-2010.

3,962,781. CAUTION WEAR CORP., NASHUA, NH. SN 77-895,487. PUB. 5-11-2010, FILED 12-17-2009.

**Wild Rose**

THE MARK CONSISTS OF STANDARD CHARACTERS WITHOUT CLAIM TO ANY PARTICULAR FONT, STYLE, SIZE, OR COLOR.

FOR CONDOMS (U.S. CLS. 26, 39 AND 44).

FIRST USE 11-28-2010; IN COMMERCE 11-28-2010.

**CLASS 10—(Continued).**

3,962,798. INTEGRATED PAIN MANAGEMENT, S.C., CHICAGO, IL. SN 77-900,655. PUB. 7-6-2010, FILED 12-23-2009.

**TX360**

THE MARK CONSISTS OF STANDARD CHARACTERS WITHOUT CLAIM TO ANY PARTICULAR FONT, STYLE, SIZE, OR COLOR.

FOR DRUG DELIVERY DEVICES FOR NASAL USE, NAMELY, NASAL SPRAY APPLICATORS SOLD EMPTY (U.S. CLS. 26, 39 AND 44).

FIRST USE 1-1-2011; IN COMMERCE 1-1-2011.

3,962,887. MERCHSOURCE, LLC, FOOTHILL RANCH, CA. SN 77-924,082. PUB. 7-20-2010, FILED 1-29-2010.

**SARAH PEYTON**

THE MARK CONSISTS OF STANDARD CHARACTERS WITHOUT CLAIM TO ANY PARTICULAR FONT, STYLE, SIZE, OR COLOR.

OWNER OF U.S. REG. NOS. 3,493,282, 3,603,089, AND 3,732,533.

THE NAME(S), PORTRAIT(S), AND/OR SIGNATURE(S) SHOWN IN THE MARK DOES NOT IDENTIFY A PARTICULAR LIVING INDIVIDUAL.

FOR ELECTRIC AND NON-ELECTRIC MECHANICAL MASSAGERS, NAMELY, FOOT, NECK, BACK AND SPOT MASSAGERS (U.S. CLS. 26, 39 AND 44).

FIRST USE 1-31-2010; IN COMMERCE 1-31-2010.

3,963,029. ORTHO TECHNOLOGY, INC., TAMPA, FL. SN 77-948,286. PUB. 8-3-2010, FILED 3-2-2010.

**SPIDER SCREW**

THE MARK CONSISTS OF STANDARD CHARACTERS WITHOUT CLAIM TO ANY PARTICULAR FONT, STYLE, SIZE, OR COLOR.

NO CLAIM IS MADE TO THE EXCLUSIVE RIGHT TO USE "SCREW", APART FROM THE MARK AS SHOWN.

FOR BONE SCREW FOR ORTHODONTIC APPLIANCE (U.S. CLS. 26, 39 AND 44).

FIRST USE 7-1-2009; IN COMMERCE 7-1-2009.

**CLASS 10—(Continued).**

3,963,054. KCI LICENSING, INC., SAN ANTONIO, TX. SN 77-951,301. PUB. 7-27-2010, FILED 3-5-2010.

**SKIN IQ**

THE MARK CONSISTS OF STANDARD CHARACTERS WITHOUT CLAIM TO ANY PARTICULAR FONT, STYLE, SIZE, OR COLOR.

FOR MATTRESS OVERLAYS IN THE NATURE OF PADS, MATTRESS CUSHIONS, AND COVERS FOR MATTRESS PADS AND CUSHIONS ALL FOR THERAPEUTIC PURPOSES, AND COMPONENT PARTS FOR ALL THE AFORESAID GOODS (U.S. CLS. 26, 39 AND 44).

FIRST USE 10-10-2010; IN COMMERCE 10-10-2010.

3,963,118. PINOOK USA, LLC, ORLANDO, FL. SN 77-957,583. PUB. 11-23-2010, FILED 3-12-2010.

**NANO MASSAGER**

THE MARK CONSISTS OF STANDARD CHARACTERS WITHOUT CLAIM TO ANY PARTICULAR FONT, STYLE, SIZE, OR COLOR.

NO CLAIM IS MADE TO THE EXCLUSIVE RIGHT TO USE "MASSAGER", APART FROM THE MARK AS SHOWN. FOR MASSAGE APPARATUS (U.S. CLS. 26, 39 AND 44).

FIRST USE 2-16-2011; IN COMMERCE 2-16-2011.

3,963,185. EZ SURGICAL LTD., YOKENAM 20692, ISRAEL. SN 77-964,451. PUB. 8-10-2010, FILED 3-22-2010.

**A-LAP**

THE MARK CONSISTS OF STANDARD CHARACTERS WITHOUT CLAIM TO ANY PARTICULAR FONT, STYLE, SIZE, OR COLOR.

FOR SURGICAL RETRACTORS AND ASSOCIATED ENTRY PORTS FOR LAPAROSCOPIC USE (U.S. CLS. 26, 39 AND 44).

FIRST USE 2-1-2009; IN COMMERCE 2-1-2009.

**CLASS 10—(Continued).**

3,963,209. DIAGNOSTIC DEVICES, INC., CHARLOTTE, NC. SN 77-966,702. PUB. 8-10-2010, FILED 3-23-2010.

**COUNT-A-DOSE**

THE MARK CONSISTS OF STANDARD CHARACTERS WITHOUT CLAIM TO ANY PARTICULAR FONT, STYLE, SIZE, OR COLOR.

FOR INJECTORS FOR MEDICAL SYRINGES, AND ASSEMBLIES SOLD THEREWITH (U.S. CLS. 26, 39 AND 44).

FIRST USE 4-6-2010; IN COMMERCE 4-6-2010.

3,963,210. DIAGNOSTIC DEVICES, INC., CHARLOTTE, NC. SN 77-966,703. PUB. 8-10-2010, FILED 3-23-2010.

**PRODIGY COUNT-A-DOSE**

THE MARK CONSISTS OF STANDARD CHARACTERS WITHOUT CLAIM TO ANY PARTICULAR FONT, STYLE, SIZE, OR COLOR.

FOR INJECTORS FOR MEDICAL SYRINGES, AND ASSEMBLIES SOLD THEREWITH (U.S. CLS. 26, 39 AND 44).

FIRST USE 4-6-2010; IN COMMERCE 4-6-2010.

3,963,243. MICELL TECHNOLOGIES, INC., DURHAM, NC. SN 77-981,595. PUB. 12-2-2008, FILED 7-11-2008.

**MISTENT**

THE MARK CONSISTS OF STANDARD CHARACTERS WITHOUT CLAIM TO ANY PARTICULAR FONT, STYLE, SIZE, OR COLOR.

FOR MEDICAL AND SURGICAL DEVICES, APPARATUS AND INSTRUMENTS, NAMELY, DRUG-ELUTING STENTS (U.S. CLS. 26, 39 AND 44).

FIRST USE 11-16-2010; IN COMMERCE 11-16-2010.



**CLASS 10—(Continued).**

3,963,284. WORLD HEART CORPORATION, SALT LAKE CITY, UT. SN 78-571,469. PUB. 7-22-2008, FILED 2-21-2005.

PediaFlow

THE MARK CONSISTS OF STANDARD CHARACTERS WITHOUT CLAIM TO ANY PARTICULAR FONT, STYLE, SIZE, OR COLOR.

FOR MEDICAL DEVICE, NAMELY, BLOOD PUMP FOR ASSISTING OR REPLACING THE HEART IN CARDIAC PATIENTS (U.S. CLS. 26, 39 AND 44). FIRST USE 2-2-2008; IN COMMERCE 2-2-2008.

**CLASS 10—(Continued).**

3,963,330. PLAYBOY ENTERPRISES INTERNATIONAL, INC., CHICAGO, IL. SN 85-005,414. PUB. 8-24-2010, FILED 4-2-2010.



OWNER OF U.S. REG. NOS. 643,926, 3,128,038, AND OTHERS.

THE MARK CONSISTS OF RABBIT HEAD DESIGN. FOR CONDOMS (U.S. CLS. 26, 39 AND 44). FIRST USE 9-0-2010; IN COMMERCE 9-0-2010.

3,963,404. MEDISIM LTD., NEVE ILAN, ISRAEL. SN 85-021,487. PUB. 7-27-2010, FILED 4-23-2010.

MOTHER'S TOUCH

THE MARK CONSISTS OF STANDARD CHARACTERS WITHOUT CLAIM TO ANY PARTICULAR FONT, STYLE, SIZE, OR COLOR.

FOR THERMOMETERS FOR MEDICAL USE (U.S. CLS. 26, 39 AND 44). FIRST USE 10-31-2010; IN COMMERCE 1-6-2011.

3,963,307. BOSTON SCIENTIFIC SCIMED, INC., MAPLE GROVE, MN. SN 85-000,240. PUB. 8-10-2010, FILED 3-28-2010.

JOURNEY

THE MARK CONSISTS OF STANDARD CHARACTERS WITHOUT CLAIM TO ANY PARTICULAR FONT, STYLE, SIZE, OR COLOR.

FOR MEDICAL GUIDEWIRES (U.S. CLS. 26, 39 AND 44). FIRST USE 10-4-2010; IN COMMERCE 10-4-2010.

3,963,461. PARENTING TIP OF THE WEEK, LLC, HUNTERVILLE, NC. SN 85-036,207. PUB. 10-12-2010, FILED 5-12-2010.

CUBBIE CUP

THE MARK CONSISTS OF STANDARD CHARACTERS WITHOUT CLAIM TO ANY PARTICULAR FONT, STYLE, SIZE, OR COLOR.

NO CLAIM IS MADE TO THE EXCLUSIVE RIGHT TO USE "CUP", APART FROM THE MARK AS SHOWN. FOR CUPS ADAPTED FOR FEEDING BABIES AND CHILDREN (U.S. CLS. 26, 39 AND 44). FIRST USE 5-1-2010; IN COMMERCE 5-1-2010.

**CLASS 10—(Continued).**

3,963,542. MIRACLE STRETCH, LLC, SAN FRANCISCO, CA. SN 85-059,006. PUB. 11-23-2010, FILED 6-9-2010.

## Piri-Stretcher

THE MARK CONSISTS OF STANDARD CHARACTERS WITHOUT CLAIM TO ANY PARTICULAR FONT, STYLE, SIZE, OR COLOR.

FOR MANUALLY-OPERATED EXERCISE EQUIPMENT FOR PHYSICAL THERAPY PURPOSES (U.S. CLS. 26, 39 AND 44).

FIRST USE 7-1-2009; IN COMMERCE 11-1-2010.

3,963,630. PALOMAR MEDICAL TECHNOLOGIES, INC., BURLINGTON, MA. SN 85-081,020. PUB. 1-11-2011, FILED 7-9-2010.

PROVEN BY DERMATOLOGISTS.  
PERFECTED FOR YOU.

THE MARK CONSISTS OF STANDARD CHARACTERS WITHOUT CLAIM TO ANY PARTICULAR FONT, STYLE, SIZE, OR COLOR.

NO CLAIM IS MADE TO THE EXCLUSIVE RIGHT TO USE "DERMATOLOGISTS", APART FROM THE MARK AS SHOWN.

FOR LIGHT-BASED DEVICES FOR MEDICAL, DERMATOLOGICAL, AND COSMETIC TREATMENT OF THE BODY (U.S. CLS. 26, 39 AND 44).

FIRST USE 12-27-2010; IN COMMERCE 12-27-2010.

3,963,658. DR. THOMAS C. WHITE, SIOUX FALLS, SD. SN 85-088,691. PUB. 1-11-2011, FILED 7-20-2010.

## ASSIST

THE MARK CONSISTS OF STANDARD CHARACTERS WITHOUT CLAIM TO ANY PARTICULAR FONT, STYLE, SIZE, OR COLOR.

FOR GLAUCOMA SHUNTS (U.S. CLS. 26, 39 AND 44). FIRST USE 10-26-2010; IN COMMERCE 10-26-2010.

**CLASS 10—(Continued).**

3,963,670. IZI MEDICAL PRODUCTS, LLC, BALTIMORE, MD. SN 85-094,585. PUB. 1-11-2011, FILED 7-28-2010.

## CARECUSHION

THE MARK CONSISTS OF STANDARD CHARACTERS WITHOUT CLAIM TO ANY PARTICULAR FONT, STYLE, SIZE, OR COLOR.

FOR COVERS FOR COMPRESSION SURFACES OF A MAMMOGRAPHY DEVICE (U.S. CLS. 26, 39 AND 44).

FIRST USE 11-1-2010; IN COMMERCE 11-11-2010.

3,963,697. ELIKING TECH & ENTERPRISES, LAS VEGAS, NV. SN 85-107,252. PUB. 12-28-2010, FILED 8-13-2010.

## IPRO MASSAGER

THE MARK CONSISTS OF STANDARD CHARACTERS WITHOUT CLAIM TO ANY PARTICULAR FONT, STYLE, SIZE, OR COLOR.

NO CLAIM IS MADE TO THE EXCLUSIVE RIGHT TO USE "MASSAGER", APART FROM THE MARK AS SHOWN.

FOR ELECTRIC MASSAGE APPLIANCES, NAMELY, ELECTRIC VIBRATING MASSAGER; MESSAGE APPARATUS (U.S. CLS. 26, 39 AND 44).

FIRST USE 8-1-2009; IN COMMERCE 8-1-2009.

**CLASS 11—ENVIRONMENTAL CONTROL APPARATUS**

3,961,989. ICARUS ENERGY, LLC., FAIRFIELD, CT. SN 76-701,003. PUB. 10-12-2010, FILED 12-28-2009.



NO CLAIM IS MADE TO THE EXCLUSIVE RIGHT TO USE "ENERGY LLC", APART FROM THE MARK AS SHOWN.

THE COLOR(S) GOLD, GREY, LIGHT GREY, DARK GREY AND WHITE IS/ARE CLAIMED AS A FEATURE OF THE MARK.

THE MARK CONSISTS OF "ICARUS ENERGY, LLC IT'S TIME!" THE MARK CONSISTS OF THE WORDING "ICARUS ENERGY, "LLC IT'S TIME!" IN STYLIZED LETTERING WRITTEN ON TWO LINES. A CIRCLE AP-

**CLASS 11—(Continued).**

PEARS ABOVE THE WORDING "ICARUS ENERGY, LLC IT'S TIME!" A COMPUTER MOTHER BOARD PATTERN APPEARS INSIDE THE CIRCLE. A BORDER APPEARS AROUND THE CIRCLE. A GRADIENT APPEARS IN THE BORDER STARTING GREY AT THE BOTTOM AND FADING LIGHT GREY AT THE TOP. AN ARROW APPEARS WRAPPING AROUND THE CIRCLE AND BORDER. A SHINE APPEARS INSIDE THE CIRCLE, BORDER AND ARROW. A SHADOW APPEARS IN THE ARROW, BORDER AND UNDERNEATH THE BORDER. A GRADIENT APPEARS IN THE WORDING "ICARUS ENERGY, "LLC IT'S TIME!" STARTING GOLD AT THE TOP AND FADING LIGHTER GOLD AT THE TOP. THE COLOR GOLD APPEARS IN THE WORDING "ICARUS ENERGY, LLC", CIRCLE, ARROW AND SHADOW UNDER THE BORDER. THE COLOR GREY APPEARS IN THE WORDING "IT'S TIME!" PATTERN AND BORDER AND SHADOW UNDERNEATH THE BORDER. THE COLOR LIGHT GREY APPEARS IN THE GRADIENT OF THE BORDER. THE COLOR DARK GREY APPEARS IN THE SHADOW OF THE ARROW AND BORDER. THE COLOR WHITE APPEARS IN THE SHINE.

FOR SOLAR COLLECTORS (U.S. CLS. 13, 21, 23, 31 AND 34).

FIRST USE 12-1-2009; IN COMMERCE 2-1-2010.

3,962,102. AIR TECH EQUIPMENT LTD., NEW BRUNSWICK, CANADA. SN 77-354,560. PUB. 6-24-2008, FILED 12-18-2007.

**HUMIFRESH**

THE MARK CONSISTS OF STANDARD CHARACTERS WITHOUT CLAIM TO ANY PARTICULAR FONT, STYLE, SIZE, OR COLOR.

FOR ENERGY RECOVERY VENTILATOR; AIR QUALITY EQUIPMENT AND AIR VENTILATOR EQUIPMENT, NAMELY, DEHUMIDIFIERS, AIR CLEANING AND PURIFYING UNITS FOR SUPPLYING FRESH AIR, VENTILATION UNITS FOR THE REMOVAL OF STALE AIR, HUMIDITY CONTROL DEVICES IN THE NATURE OF DEHUMIDIFIERS, EXHAUST VENTILATION SYSTEMS FEATURING VENTILATORS AND VENTILATING EXHAUST FANS, AND CIRCULATING ELECTRIC FANS (U.S. CLS. 13, 21, 23, 31 AND 34).

FIRST USE 2-28-2011; IN COMMERCE 2-28-2011.

3,962,128. BSH BOSCH UND SIEMENS HAUSGERAETE GMBH, MUNICH, FED REP GERMANY. SN 77-412,584. PUB. 7-20-2010, FILED 3-4-2008.

**Silk Silver**

THE MARK CONSISTS OF STANDARD CHARACTERS WITHOUT CLAIM TO ANY PARTICULAR FONT, STYLE, SIZE, OR COLOR.

**CLASS 11—(Continued).**

PRIORITY CLAIMED UNDER SEC. 44(D) ON FED REP GERMANY APPLICATION NO. 30758039.3/0, FILED 9-5-2007.

FOR TEMPERATURE-CONTROLLED MULTI-BEVERAGE DISPENSERS, AND COMPONENTS THEREOF (U.S. CLS. 13, 21, 23, 31 AND 34).

FIRST USE 7-1-2008; IN COMMERCE 7-1-2008.

3,962,133. FERGUSON ENTERPRISES, INC., NEWPORT NEWS, VA. SN 77-425,152. PUB. 6-24-2008, FILED 3-18-2008.

**EDENTON**

THE MARK CONSISTS OF STANDARD CHARACTERS WITHOUT CLAIM TO ANY PARTICULAR FONT, STYLE, SIZE, OR COLOR.

FOR PLUMBING FIXTURES, NAMELY, SINKS, PED-ESTAL SINKS, BATH TUBS, FAUCETS AND TOILETS (U.S. CLS. 13, 21, 23, 31 AND 34).

FIRST USE 6-30-2010; IN COMMERCE 6-30-2010.

3,962,312. SELKIRK CORPORATION, RICHARDSON, TX. SN 77-686,182. PUB. 1-26-2010, FILED 3-9-2009.

**METALBEST**

THE MARK CONSISTS OF STANDARD CHARACTERS WITHOUT CLAIM TO ANY PARTICULAR FONT, STYLE, SIZE, OR COLOR.

FOR FLUES, CHIMNEY AND VENT PIPES FOR HEATING AND VENTILATION AND FITTINGS THEREOF, NAMELY, CLAMPS, T-PIECES, CONNECTORS, REDUCERS, DRIP CAPS, PRESSURE REDUCER VALVES, SAFETY VALVES, ELBOW JOINTS, TEE JOINTS, ADAPTORS, REDUCING COUPLINGS AND DRIP CAPS, ALL FOR THE AFORESAID PIPES AND FLUES; COMBINED EXHAUST AND AIR TUBES FOR USE IN CONNECTION WITH HEATING AND VENTILATION APPARATUS AND INSTALLATIONS; FURNACES; FIREPLACES; CHIMNEYS AND CHIMNEY CAPS; CHIMNEY LINERS; SOLID FUEL CHIMNEYS, ALL THE AFORESAID GOODS MADE WHOLLY OR PRINCIPALLY OF METAL (U.S. CLS. 13, 21, 23, 31 AND 34).

FIRST USE 7-1-2009; IN COMMERCE 7-1-2009.

**CLASS 11—(Continued).**

3,962,324. PRISTINA CAPITAL PARTNERS, LLC, MIDLAND PARK, NJ. SN 77-693,041. PUB. 7-20-2010, FILED 3-17-2009.

# AXENIKA

THE MARK CONSISTS OF STANDARD CHARACTERS WITHOUT CLAIM TO ANY PARTICULAR FONT, STYLE, SIZE, OR COLOR.

THE WORDING "AXENIKA" HAS NO MEANING IN A FOREIGN LANGUAGE.

FOR WATER PURIFICATION AND FILTRATION APPARATUS FOR DOMESTIC AND COMMERCIAL USE (U.S. CLS. 13, 21, 23, 31 AND 34).

FIRST USE 6-8-2010; IN COMMERCE 6-8-2010.

**CLASS 11—(Continued).**

3,962,400. FERGUSON ENTERPRISES, INC., NEWPORT NEWS, VA. SN 77-759,093. PUB. 10-27-2009, FILED 6-13-2009.

# ALLEDONIA

THE MARK CONSISTS OF STANDARD CHARACTERS WITHOUT CLAIM TO ANY PARTICULAR FONT, STYLE, SIZE, OR COLOR.

FOR PLUMBING FIXTURES, NAMELY, SINKS, PED-ESTAL SINKS, BATH TUBS, BATH TUB JETS, WHIRL-POOL BATHS, BATH INSTALLATIONS; FAUCETS AND FAUCET SPRAYERS; TOILETS AND BIDETS; DRAIN STRUCTURES FOR USE IN SPAS, STEAM ROOMS AND BATHS; SITZ BATHS; SPOUTS FOR AFFIXING ON WALLS FOR BATHS, BASINS, BIDETS; SHOWERS, SHOWER HEADS, HAND HELD SHOWER HEADS, HAND SHOWERS, HAND HELD SHOWERS, SHOWER SPRAYERS, SHOWER HEAD SPRAYERS, SHOWER MIXERS, SHOWER AND BATH CUBICLES, SHOWER BASES, SHOWER CONTROL FITTINGS, NAMELY, ESCUTCHEONS, SHOWER DOORS, SHOWER ENCLOSURES, SHOWER FAUCET EXTENSIONS, SHOWER PANELS, SHOWER SURROUNDS, SHOWER TRAYS, SHOWER TUBS; ELECTRIC TOWEL WARMERS, IN-DOOR ELECTRIC LIGHTING FIXTURES AND CEILING FANS (U.S. CLS. 13, 21, 23, 31 AND 34).

FIRST USE 9-30-2010; IN COMMERCE 9-30-2010.

3,962,401. FERGUSON ENTERPRISES, INC., NEWPORT NEWS, VA. SN 77-759,141. PUB. 11-3-2009, FILED 6-14-2009.

3,962,380. DART INDUSTRIES INC., ORLANDO, FL. SN 77-741,779. PUB. 9-29-2009, FILED 5-21-2009.

# TUPPERWARE

THE MARK CONSISTS OF STANDARD CHARACTERS WITHOUT CLAIM TO ANY PARTICULAR FONT, STYLE, SIZE, OR COLOR.

OWNER OF U.S. REG. NOS. 633,394, 991,025, AND OTHERS.

FOR WATER FILTRATION PITCHERS SOLD EMPTY; WATER FILTERS (U.S. CLS. 13, 21, 23, 31 AND 34).

FIRST USE 1-1-2011; IN COMMERCE 1-1-2011.

# BRIDGEHURST

THE MARK CONSISTS OF STANDARD CHARACTERS WITHOUT CLAIM TO ANY PARTICULAR FONT, STYLE, SIZE, OR COLOR.

FOR PLUMBING FIXTURES, NAMELY, SINKS, PED-ESTAL SINKS, BATH TUBS, BATH TUB JETS, WHIRL-POOL BATHS, BATH INSTALLATIONS; FAUCETS AND FAUCET SPRAYERS; TOILETS AND BIDETS; DRAIN STRUCTURES FOR USE IN SPAS, STEAM ROOMS AND BATHS; SITZ BATHS; SPOUTS FOR AFFIXING ON WALLS FOR BATHS, BASINS, BIDETS; SHOWERS, SHOWER HEADS, HAND HELD SHOWER HEADS, HAND SHOWERS, HAND HELD SHOWERS, SHOWER SPRAYERS, SHOWER HEAD SPRAYERS, SHOWER MIXERS, SHOWER AND BATH CUBICLES, SHOWER BASES, SHOWER CONTROL FITTINGS, NAMELY, ESCUTCHEONS, SHOWER DOORS, SHOWER ENCLOSURES, SHOWER FAUCET EXTENSIONS, SHOWER PANELS, SHOWER SURROUNDS, SHOWER TRAYS, SHOWER TUBS; ELECTRIC TOWEL WARMERS, IN-DOOR ELECTRIC LIGHTING FIXTURES AND CEILING FANS (U.S. CLS. 13, 21, 23, 31 AND 34).

FIRST USE 10-31-2008; IN COMMERCE 10-31-2008.

**CLASS 11—(Continued).**

3,962,402. FERGUSON ENTERPRISES, INC., NEWPORT NEWS, VA. SN 77-759,149. PUB. 11-3-2009, FILED 6-14-2009.

**GALATIA**

THE MARK CONSISTS OF STANDARD CHARACTERS WITHOUT CLAIM TO ANY PARTICULAR FONT, STYLE, SIZE, OR COLOR.

FOR PLUMBING FIXTURES, NAMELY, SINKS, PED-ESTAL SINKS, BATH TUBS, BATH TUB JETS, WHIRL-POOL BATHS, BATH INSTALLATIONS; FAUCETS AND FAUCET SPRAYERS; TOILETS AND BIDETS; DRAIN STRUCTURES FOR USE IN SPAS, STEAM ROOMS AND BATHS; SITZ BATHS; SPOUTS FOR AFFIXING ON WALLS FOR BATHS, BASINS, BIDETS; SHOWERS, SHOWER HEADS, HAND HELD SHOWER HEADS, HAND SHOWERS, HAND HELD SHOWERS, SHOWER SPRAYERS, SHOWER HEAD SPRAYERS, SHOWER MIXERS, SHOWER AND BATH CUBICLES, SHOWER BASES, SHOWER CONTROL FITTINGS, NAMELY, ESCUTCHEONS, SHOWER DOORS, SHOWER ENCLOSURES, SHOWER FAUCET EXTENSIONS, SHOWER PANELS, SHOWER SURROUNDS, SHOWER TRAYS, SHOWER TUBS; ELECTRIC TOWEL WARMERS, IN-DOOR ELECTRIC LIGHTING FIXTURES AND CEILING FANS (U.S. CLS. 13, 21, 23, 31 AND 34).

FIRST USE 2-28-2010; IN COMMERCE 2-28-2010.

**CLASS 11—(Continued).**

3,962,404. FERGUSON ENTERPRISES, INC., NEWPORT NEWS, VA. SN 77-759,201. PUB. 11-10-2009, FILED 6-14-2009.

**PROVINCETOWN**

THE MARK CONSISTS OF STANDARD CHARACTERS WITHOUT CLAIM TO ANY PARTICULAR FONT, STYLE, SIZE, OR COLOR.

FOR PLUMBING FIXTURES, NAMELY, SINKS, PED-ESTAL SINKS, BATH TUBS, BATH TUB JETS, WHIRL-POOL BATHS, BATH INSTALLATIONS; FAUCETS AND FAUCET SPRAYERS; TOILETS AND BIDETS; DRAIN STRUCTURES FOR USE IN SPAS, STEAM ROOMS AND BATHS; SITZ BATHS; SPOUTS FOR AFFIXING ON WALLS FOR BATHS, BASINS, BIDETS; SHOWERS, SHOWER HEADS, HAND HELD SHOWER HEADS, HAND SHOWERS, HAND HELD SHOWERS, SHOWER SPRAYERS, SHOWER HEAD SPRAYERS, SHOWER MIXERS, SHOWER AND BATH CUBICLES, SHOWER BASES, SHOWER CONTROL FITTINGS, NAMELY, ESCUTCHEONS, SHOWER DOORS, SHOWER ENCLOSURES, SHOWER FAUCET EXTENSIONS, SHOWER PANELS, SHOWER SURROUNDS, SHOWER TRAYS, SHOWER TUBS; ELECTRIC TOWEL WARMERS, IN-DOOR ELECTRIC LIGHTING FIXTURES AND CEILING FANS (U.S. CLS. 13, 21, 23, 31 AND 34).

FIRST USE 9-30-2010; IN COMMERCE 9-30-2010.

3,962,403. FERGUSON ENTERPRISES, INC., NEWPORT NEWS, VA. SN 77-759,200. PUB. 11-10-2009, FILED 6-14-2009.

**PRESIDIO**

THE MARK CONSISTS OF STANDARD CHARACTERS WITHOUT CLAIM TO ANY PARTICULAR FONT, STYLE, SIZE, OR COLOR.

FOR PLUMBING FIXTURES, NAMELY, SINKS, PED-ESTAL SINKS, BATH TUBS, BATH TUB JETS, WHIRL-POOL BATHS, BATH INSTALLATIONS; FAUCETS AND FAUCET SPRAYERS; TOILETS AND BIDETS; DRAIN STRUCTURES FOR USE IN SPAS, STEAM ROOMS AND BATHS; SITZ BATHS; SPOUTS FOR AFFIXING ON WALLS FOR BATHS, BASINS, BIDETS; SHOWERS, SHOWER HEADS, HAND HELD SHOWER HEADS, HAND SHOWERS, HAND HELD SHOWERS, SHOWER SPRAYERS, SHOWER HEAD SPRAYERS, SHOWER MIXERS, SHOWER AND BATH CUBICLES, SHOWER BASES, SHOWER CONTROL FITTINGS, NAMELY, ESCUTCHEONS, SHOWER DOORS, SHOWER ENCLOSURES, SHOWER FAUCET EXTENSIONS, SHOWER PANELS, SHOWER SURROUNDS, SHOWER TRAYS, SHOWER TUBS; ELECTRIC TOWEL WARMERS, IN-DOOR ELECTRIC LIGHTING FIXTURES AND CEILING FANS (U.S. CLS. 13, 21, 23, 31 AND 34).

FIRST USE 9-30-2010; IN COMMERCE 9-30-2010.

3,962,411. TRINA SOLAR LIMITED, GRAND CAYMAN KY1-1111, CAYMAN ISLANDS. SN 77-762,628. PUB. 12-29-2009, FILED 6-18-2009.



THE COLOR(S) YELLOW, ORANGE AND GREEN IS/ARE CLAIMED AS A FEATURE OF THE MARK.

THE MARK CONSISTS OF THE FOLLOWING: A RISING SUN IN THE COLORS YELLOW AND ORANGE POSITIONED TO THE LEFT OF THE LITERAL ELEMENT "YOUSOLAR" WHICH IS PRESENTED IN GREEN, THE SUN DESIGN ELEMENT AND THE LITERAL ELEMENT "YOUSOLAR" ARE BOTH UNDERLINED WITH A SINGLE, CURVED LINE, ALSO PRESENTED IN THE COLOR GREEN.

FOR SOLAR LIGHT FIXTURES, NAMELY, INDOOR AND OUTDOOR SOLAR POWERED LIGHTING UNITS AND FIXTURES; SOLAR WATER HEATERS; SUN LAMPS; STREET LAMPS; SOLAR COLLECTORS; SOLAR THERMAL INSTALLATIONS, NAMELY, SOLAR THERMAL MODULES; AIR CLEANING UNITS CONTAINING AN AIR FILTER, ULTRAVIOLET LIGHTS AND A PHOTOCATALYTIC FILTER; ENERGY STORAGE PLANTS; POWER PLANTS; LIGHT PANELS FOR VEHICLES, NAMELY, LAND VEHICLES; SOLAR HEAT COLLECTION PANELS (U.S. CLS. 13, 21, 23, 31 AND 34).

FIRST USE 1-1-2008; IN COMMERCE 7-21-2009.



**CLASS 11—(Continued).**

3,962,479. HYDRANAUTICS, INC., OCEANSIDE, CA. SN 77-794,325. PUB. 3-23-2010, FILED 7-31-2009.

**HYDRABLOCK**

THE MARK CONSISTS OF STANDARD CHARACTERS WITHOUT CLAIM TO ANY PARTICULAR FONT, STYLE, SIZE, OR COLOR.

FOR REVERSE OSMOSIS, NANOFILTRATION, AND ULTRAFILTRATION MEMBRANES; FEEDSPACERS FOR REVERSE OSMOSIS, NANOFILTRATION, AND ULTRAFILTRATION MEMBRANES; ALL OF THE FOREGOING FOR COMMERCIAL AND INDUSTRIAL USE (U.S. CLS. 13, 21, 23, 31 AND 34).

FIRST USE 12-27-2010; IN COMMERCE 12-27-2010.

3,962,532. ECOWATER SYSTEMS LLC, WOODBURY, MN. SN 77-809,428. PUB. 1-19-2010, FILED 8-20-2009.



The logo for IntelliSoft2 features the word "IntelliSoft2" in a stylized, italicized font. The "i" in "Intelli" has a dot that is a raindrop. The "2" is superscripted. A semi-circle curves around the bottom and right side of the text.

OWNER OF U.S. REG. NOS. 3,314,054 AND 3,314,238. THE MARK CONSISTS OF THE WORD "INTELLISOFT2". THE DOT OF THE "I" IS A RAINDROP AND THERE IS A SEMI-CIRCLE CURVING AROUND THE WORD "SOFT". FOR WATER SOFTENING UNITS (U.S. CLS. 13, 21, 23, 31 AND 34).

FIRST USE 1-17-2011; IN COMMERCE 1-17-2011.

3,962,562. CONAIR CORPORATION, STAMFORD, CT. SN 77-818,525. PUB. 1-5-2010, FILED 9-2-2009.

**TORINO**

THE MARK CONSISTS OF STANDARD CHARACTERS WITHOUT CLAIM TO ANY PARTICULAR FONT, STYLE, SIZE, OR COLOR.

FOR HAND-HELD ELECTRIC HAIR DRYERS (U.S. CLS. 13, 21, 23, 31 AND 34).

FIRST USE 2-1-2010; IN COMMERCE 2-1-2010.

**CLASS 11—(Continued).**

3,962,656. THE RARING CORPORATION, VANCOUVER, WA. SN 77-851,771. PUB. 3-30-2010, FILED 10-19-2009.

**AEROLIFE**

THE MARK CONSISTS OF STANDARD CHARACTERS WITHOUT CLAIM TO ANY PARTICULAR FONT, STYLE, SIZE, OR COLOR.

FOR IRRIGATION AND NUTRIENT SYSTEMS FOR PLANT CULTIVATION AND HUSBANDRY COMPRISED OF PUMPS, NOZZLES, VALVES, RESERVOIRS, FLOW CONTROLS, AND POTS (U.S. CLS. 13, 21, 23, 31 AND 34).

FIRST USE 1-0-2010; IN COMMERCE 1-0-2010.

3,962,697. BARTCO LIGHTING, INC., HUNTINGTON BEACH, CA. SN 77-863,755. PUB. 10-19-2010, FILED 11-3-2009.

**SLIDE-A-LIGHT**

THE MARK CONSISTS OF STANDARD CHARACTERS WITHOUT CLAIM TO ANY PARTICULAR FONT, STYLE, SIZE, OR COLOR.

FOR LIGHTING FIXTURES FOR ILLUMINATION (U.S. CLS. 13, 21, 23, 31 AND 34).

FIRST USE 5-12-2010; IN COMMERCE 5-12-2010.

3,962,777. MERCHSOURCE, LLC, FOOTHILL RANCH, CA. SN 77-893,933. PUB. 7-20-2010, FILED 12-15-2009.

**SARAH PEYTON**

THE MARK CONSISTS OF STANDARD CHARACTERS WITHOUT CLAIM TO ANY PARTICULAR FONT, STYLE, SIZE, OR COLOR.

OWNER OF U.S. REG. NOS. 3,493,282, 3,603,089, AND 3,732,533.

THE NAME(S), PORTRAIT(S), AND/OR SIGNATURE(S) SHOWN IN THE MARK DOES NOT IDENTIFY A PARTICULAR LIVING INDIVIDUAL.

FOR INDOOR AND OUTDOOR LIGHTING FIXTURES; SOLAR LIGHT FIXTURES, NAMELY, INDOOR AND OUTDOOR SOLAR POWERED LIGHTING UNITS AND FIXTURES (U.S. CLS. 13, 21, 23, 31 AND 34).

FIRST USE 1-31-2010; IN COMMERCE 1-31-2010.

**CLASS 11—(Continued).**

3,962,778. MERCHSOURCE, LLC, FOOTHILL RANCH, CA. SN 77-893,935. PUB. 7-20-2010, FILED 12-15-2009.



OWNER OF U.S. REG. NOS. 3,493,282, 3,603,089, AND 3,732,533.

THE NAME(S), PORTRAIT(S), AND/OR SIGNATURE(S) SHOWN IN THE MARK DOES NOT IDENTIFY A PARTICULAR LIVING INDIVIDUAL.

THE MARK CONSISTS OF A WAVY GRAPHICAL DESIGN WITH THE WORDS "SARAH PEYTON" OVERLAYING THE TOP PORTION OF THE WAVY GRAPHICAL DESIGN.

FOR INDOOR AND OUTDOOR LIGHTING FIXTURES; SOLAR LIGHT FIXTURES, NAMELY, INDOOR AND OUTDOOR SOLAR POWERED LIGHTING UNITS AND FIXTURES (U.S. CLS. 13, 21, 23, 31 AND 34).

FIRST USE 1-31-2010; IN COMMERCE 1-31-2010.

3,962,847. SAVANH, BOBBY B, PORTLAND, OR. SN 77-915,389. PUB. 6-8-2010, FILED 1-19-2010.

## G-WING

THE MARK CONSISTS OF STANDARD CHARACTERS WITHOUT CLAIM TO ANY PARTICULAR FONT, STYLE, SIZE, OR COLOR.

FOR ELECTRIC LIGHTING FIXTURES; LIGHT REFLECTORS (U.S. CLS. 13, 21, 23, 31 AND 34).

FIRST USE 5-2-2010; IN COMMERCE 5-2-2010.

3,962,848. SAVANH, BOBBY B, PORTLAND, OR. SN 77-915,390. PUB. 6-8-2010, FILED 1-19-2010.

## HEAVY HITTER

THE MARK CONSISTS OF STANDARD CHARACTERS WITHOUT CLAIM TO ANY PARTICULAR FONT, STYLE, SIZE, OR COLOR.

FOR ELECTRIC LIGHTING FIXTURES; LIGHT REFLECTORS (U.S. CLS. 13, 21, 23, 31 AND 34).

FIRST USE 4-15-2010; IN COMMERCE 4-15-2010.

**CLASS 11—(Continued).**

3,962,878. DELAWARE CAPITAL FORMATION, INC., WILMINGTON, DE. SN 77-921,648. PUB. 6-8-2010, FILED 1-27-2010.

## LASERH2O

THE MARK CONSISTS OF STANDARD CHARACTERS WITHOUT CLAIM TO ANY PARTICULAR FONT, STYLE, SIZE, OR COLOR.

FOR WATER CONDITIONING EQUIPMENT FOR USE WITH COMMERCIAL MACHINES TO WASH MOTOR VEHICLES (U.S. CLS. 13, 21, 23, 31 AND 34).

FIRST USE 5-12-2010; IN COMMERCE 5-12-2010.

3,962,907. CHET WILLS, INDIANAPOLIS, IN. SN 77-929,922. PUB. 8-24-2010, FILED 2-7-2010.

## BEST SEEN GRILLS

THE MARK CONSISTS OF STANDARD CHARACTERS WITHOUT CLAIM TO ANY PARTICULAR FONT, STYLE, SIZE, OR COLOR.

NO CLAIM IS MADE TO THE EXCLUSIVE RIGHT TO USE "GRILLS", APART FROM THE MARK AS SHOWN.

FOR ELECTRIC OUTDOOR GRILLS; FOLDING PORTABLE CHARCOAL, PROPANE AND GAS FIRED BARBECUES, STOVES, AND GRILLS (U.S. CLS. 13, 21, 23, 31 AND 34).

FIRST USE 1-1-2010; IN COMMERCE 9-1-2010.

3,962,913. WORLD DRYER CORPORATION, BERKELEY, IL. SN 77-930,659. PUB. 7-13-2010, FILED 2-8-2010.



OWNER OF U.S. REG. NOS. 646,029, 2,578,255, AND OTHERS.

NO CLAIM IS MADE TO THE EXCLUSIVE RIGHT TO USE "DRYER", APART FROM THE MARK AS SHOWN.

THE COLOR(S) RED, GREEN, BLACK, AND GRAY IS/ARE CLAIMED AS A FEATURE OF THE MARK.

**CLASS 11—(Continued).**

THE MARK CONSISTS OF A CIRCULAR DESIGN COMPRISING THE HIGHLY STYLIZED LETTERS "W" AND "D" IN RED, THE WORDS "WORLD DRYER" IN BLACK BELOW THE CIRCULAR DESIGN, THE WORDS "SMART-DRI" IN GRAY AND A GREEN LIGHT BULB WITH CHECKMARK AND LEAF DESIGN ENCLOSED WITHIN THE BULB.

FOR STATIONARY HAND, FACE, AND HAIR ELECTRIC DRYERS FOR COMMON COMMERCIAL USE (U.S. CLS. 13, 21, 23, 31 AND 34).

FIRST USE 6-0-2010; IN COMMERCE 6-0-2010.

3,962,995. WGI INNOVATIONS, LTD., GRAND PRAIRIE, TX. SN 77-944,115. PUB. 8-3-2010, FILED 2-24-2010.

**MOONSHINE**

THE MARK CONSISTS OF STANDARD CHARACTERS WITHOUT CLAIM TO ANY PARTICULAR FONT, STYLE, SIZE, OR COLOR.

FOR AUTOMATICALLY OPERATED ELECTRIC LIGHTING APPARATUS FOR USE WITH ANIMAL FEEDERS (U.S. CLS. 13, 21, 23, 31 AND 34).

FIRST USE 3-1-2010; IN COMMERCE 3-1-2010.

3,963,077. MTI WHIRLPOOLS, INC., SUGAR HILL, GA. SN 77-953,916. PUB. 8-3-2010, FILED 3-9-2010.

**PARISIAN**

THE MARK CONSISTS OF STANDARD CHARACTERS WITHOUT CLAIM TO ANY PARTICULAR FONT, STYLE, SIZE, OR COLOR.

FOR BATHTUBS (U.S. CLS. 13, 21, 23, 31 AND 34).

FIRST USE 3-18-2011; IN COMMERCE 3-18-2011.

3,963,277. HEPA CORPORATION, ANAHEIM, CA. SN 78-029,282. PUB. 10-19-2010, FILED 10-5-2000.

**HEPA-STEALTH**

FOR HIGH EFFICIENCY PARTICULATE AIR FILTERS FOR INDUSTRIAL USE (U.S. CLS. 13, 21, 23, 31 AND 34).

FIRST USE 2-11-2011; IN COMMERCE 2-11-2011.

**CLASS 11—(Continued).**

3,963,312. KOHLER CO., KOHLER, WI. SN 85-001,205. PUB. 1-4-2011, FILED 3-29-2010.

**LATTIS**

THE MARK CONSISTS OF STANDARD CHARACTERS WITHOUT CLAIM TO ANY PARTICULAR FONT, STYLE, SIZE, OR COLOR.

THE ENGLISH TRANSLATION OF "LATTIS" IN THE MARK IS "LATHING" OR "LATH-WORK".

FOR SHOWER DOORS (U.S. CLS. 13, 21, 23, 31 AND 34).

FIRST USE 3-31-2010; IN COMMERCE 3-31-2010.

3,963,323. SOCIETE DES PRODUITS NESTLE S.A., 1800 VEVEY, SWITZERLAND. SN 85-004,420. PUB. 8-10-2010, FILED 4-1-2010.

**PICCOLO**

THE MARK CONSISTS OF STANDARD CHARACTERS WITHOUT CLAIM TO ANY PARTICULAR FONT, STYLE, SIZE, OR COLOR.

FOR ELECTRIC COFFEE, COCOA, AND CAPPUCCINO MAKERS; ELECTRIC COFFEE MAKING MACHINES; PARTS AND FITTINGS FOR ALL OF THE AFORESAID GOODS (U.S. CLS. 13, 21, 23, 31 AND 34).

FIRST USE 10-30-2010; IN COMMERCE 10-30-2010.

3,963,352. ADVANCED ILLUMINATION, INC., ROCHESTER, VT. SN 85-008,405. PUB. 9-7-2010, FILED 4-7-2010.

**SOLIDESCENT**

THE MARK CONSISTS OF STANDARD CHARACTERS WITHOUT CLAIM TO ANY PARTICULAR FONT, STYLE, SIZE, OR COLOR.

FOR LIGHT EMITTING DIODE (LED) LIGHT BULBS AND FIXTURES (U.S. CLS. 13, 21, 23, 31 AND 34).

FIRST USE 3-21-2011; IN COMMERCE 3-21-2011.

**CLASS 11—(Continued).**

3,963,365. ALLMAX INTERNATIONAL CORP., TORTOLA, BR. VIRGIN ISLANDS. SN 85-010,851. PUB. 12-7-2010, FILED 4-9-2010.

# ALLMAX

THE MARK CONSISTS OF STANDARD CHARACTERS WITHOUT CLAIM TO ANY PARTICULAR FONT, STYLE, SIZE, OR COLOR.

FOR BATH TUBS; SAUNA BATH INSTALLATIONS; TOILET SEATS; WATER CLOSETS; TOILET BOWLS; WATER FLUSHING INSTALLATIONS, NAMELY, FLUSH LEVERS; SHOWERS; WATER FLUSHING APPARATUS COMPRISED OF FLUSH LEVERS AND FLUSH-METER VALVES; PURIFICATION INSTALLATIONS FOR SEWAGE; ELECTRIC HAND DRYING APPARATUS FOR WASHROOMS; TOUCHLESS HAND DRYING APPARATUS FOR WASHROOMS; SHOWER CUBICLES; STERILIZERS; SINKS; PORTABLE TOILETS; DISPOSABLE STERILIZATION POUCHES, NOT FOR MEDICAL USE; BIDETS; WHIRLPOOL-JETS; FOUNTAINS, NAMELY, DRINKING FOUNTAINS AND WATER FOUNTAINS; MIXER FAUCETS FOR WATER PIPES; HYDRANTS; WATER FILTERING APPARATUS; PLUMBING FITTINGS, NAMELY, SHOWER AND TUB CONTROL VALVES; WATERING MACHINES FOR AGRICULTURAL PURPOSES (U.S. CLS. 13, 21, 23, 31 AND 34).

FIRST USE 3-31-2010; IN COMMERCE 3-31-2010.

3,963,370. RUUD LIGHTING, INC., RACINE, WI. SN 85-011,562. PUB. 8-17-2010, FILED 4-12-2010.

# ESSENTIA

THE MARK CONSISTS OF STANDARD CHARACTERS WITHOUT CLAIM TO ANY PARTICULAR FONT, STYLE, SIZE, OR COLOR.

FOR INDOOR LIGHTING FIXTURES, NAMELY, DOWNLIGHTS, ADJUSTABLE LIGHTS, WALL-WASH LIGHTING, UNDER CABINET LIGHTING, COVE LIGHTING AND LINEAR LIGHTING (U.S. CLS. 13, 21, 23, 31 AND 34).

FIRST USE 6-3-2010; IN COMMERCE 6-3-2010.

**CLASS 11—(Continued).**

3,963,576. FEDERAL SIGNAL CORPORATION, OAK BROOK, IL. SN 85-068,469. PUB. 11-16-2010, FILED 6-22-2010.

# VALOR

THE MARK CONSISTS OF STANDARD CHARACTERS WITHOUT CLAIM TO ANY PARTICULAR FONT, STYLE, SIZE, OR COLOR.

FOR LIGHT BARS FOR VEHICLES, NAMELY, EMERGENCY AND LAW ENFORCEMENT VEHICLES (U.S. CLS. 13, 21, 23, 31 AND 34).

FIRST USE 12-9-2010; IN COMMERCE 12-9-2010.

3,963,635. HPL, L.L.C., GILBERT, AZ. SN 85-081,729. PUB. 12-7-2010, FILED 7-9-2010.



OWNER OF U.S. REG. NO. 3,558,216.

THE MARK CONSISTS OF A CROSS IN THE MIDDLE OF A CIRCLE WITH THE WORDS "DRY-ALL" INSIDE THE CROSS.

FOR DEHUMIDIFIERS (U.S. CLS. 13, 21, 23, 31 AND 34).

FIRST USE 4-1-2010; IN COMMERCE 4-1-2010.

**CLASS 12—VEHICLES**

3,961,992. HOLLEY PERFORMANCE PRODUCTS, INC., BOWLING GREEN, KY. SN 76-701,705. PUB. 7-27-2010, FILED 2-19-2010.

# HOLLEY EFI

THE MARK CONSISTS OF STANDARD CHARACTERS WITHOUT CLAIM TO ANY PARTICULAR FONT, STYLE, SIZE, OR COLOR.

**CLASS 12—(Continued).**

OWNER OF U.S. REG. NOS. 188,941, 2,023,526, AND OTHERS.

NO CLAIM IS MADE TO THE EXCLUSIVE RIGHT TO USE "EFI", APART FROM THE MARK AS SHOWN.

SEC. 2(F) AS TO "HOLLEY".

FOR STRUCTURAL PARTS FOR AUTOMOBILES, NAMELY, IGNITION SYSTEM MOUNTING BRACKETS AND INSTRUCTIONAL MANUALS FOR USE THEREWITH SOLD AS A UNIT (U.S. CLS. 19, 21, 23, 31, 35 AND 44).

FIRST USE 4-0-2010; IN COMMERCE 4-0-2010.

---

3,962,406. EARLE, DAVID, WATSONVILLE, CA. SN 77-760,256. PUB. 8-10-2010, FILED 6-15-2009.

# Turn

THE MARK CONSISTS OF STANDARD CHARACTERS WITHOUT CLAIM TO ANY PARTICULAR FONT, STYLE, SIZE, OR COLOR.

FOR BICYCLES; BICYCLE PARTS, NAMELY, BICYCLE FRAMES AND FRAME PARTS, NAMELY, HANDLE BAR STEMS, HANDLEBARS, FRONT AND REAR DERAILLEURS, GEAR SHIFTERS, CRANKS, BICYCLE PEDALS, WHEEL HUBS, WHEEL RIMS AND TIRES (U.S. CLS. 19, 21, 23, 31, 35 AND 44).

FIRST USE 3-16-2011; IN COMMERCE 3-16-2011.

---

3,962,454. CUSTOM WHEEL HOUSE LLC, LONG BEACH, CA. SN 77-784,465. PUB. 12-15-2009, FILED 7-20-2009.

**METHOD RACING WHEELS**

THE MARK CONSISTS OF STANDARD CHARACTERS WITHOUT CLAIM TO ANY PARTICULAR FONT, STYLE, SIZE, OR COLOR.

NO CLAIM IS MADE TO THE EXCLUSIVE RIGHT TO USE "RACING WHEELS", APART FROM THE MARK AS SHOWN.

FOR VEHICLE WHEELS (U.S. CLS. 19, 21, 23, 31, 35 AND 44).

FIRST USE 1-0-2010; IN COMMERCE 1-0-2010.

**CLASS 12—(Continued).**

3,962,455. CUSTOM WHEEL HOUSE LLC, LONG BEACH, CA. SN 77-784,466. PUB. 12-15-2009, FILED 7-20-2009.

**METHOD RACING**

THE MARK CONSISTS OF STANDARD CHARACTERS WITHOUT CLAIM TO ANY PARTICULAR FONT, STYLE, SIZE, OR COLOR.

NO CLAIM IS MADE TO THE EXCLUSIVE RIGHT TO USE "RACING", APART FROM THE MARK AS SHOWN.

FOR VEHICLE WHEELS (U.S. CLS. 19, 21, 23, 31, 35 AND 44).

FIRST USE 1-0-2010; IN COMMERCE 1-0-2010.

---

3,962,456. CUSTOM WHEEL HOUSE LLC, LONG BEACH, CA. SN 77-784,468. PUB. 12-15-2009, FILED 7-20-2009.

**METHOD FORGED**

THE MARK CONSISTS OF STANDARD CHARACTERS WITHOUT CLAIM TO ANY PARTICULAR FONT, STYLE, SIZE, OR COLOR.

NO CLAIM IS MADE TO THE EXCLUSIVE RIGHT TO USE "FORGED", APART FROM THE MARK AS SHOWN.

FOR VEHICLE WHEELS (U.S. CLS. 19, 21, 23, 31, 35 AND 44).

FIRST USE 3-0-2010; IN COMMERCE 3-0-2010.

---

3,962,517. ADVANCE AUTO INNOVATIONS, LLC, ROANOKE, VA. SN 77-804,869. PUB. 1-12-2010, FILED 8-14-2009.



OWNER OF U.S. REG. NOS. 1,650,703, 3,093,058, AND OTHERS.

NO CLAIM IS MADE TO THE EXCLUSIVE RIGHT TO USE "IMPORT", APART FROM THE MARK AS SHOWN.

THE MARK CONSISTS OF THE TERM "WEAREVER" WITH THE FIRST "R" OF "WEAREVER" STYLIZED WITHIN AN INCOMPLETE CAPSULE WITH A MAP OF THE WORLD AT THE RIGHT END OF THE CAPSULE AND THE TERM "IMPORT" BENEATH AND TO THE RIGHT OF THE TERM "WEAREVER".

FOR AUTOMOTIVE BRAKE COMPONENTS, NAMELY, BRAKE DISCS, BRAKE ROTORS, BRAKE PADS, BRAKE DRUMS AND BRAKE SHOES (U.S. CLS. 19, 21, 23, 31, 35 AND 44).

FIRST USE 1-0-2010; IN COMMERCE 1-0-2010.



**CLASS 12—(Continued).**

3,962,810. MORELLI, GERARD A., BEAVERTON, OR. SN 77-903,760. PUB. 8-3-2010, FILED 12-31-2009.



NO CLAIM IS MADE TO THE EXCLUSIVE RIGHT TO USE "SAILING CO", APART FROM THE MARK AS SHOWN.

THE MARK CONSISTS OF TWO CONCENTRIC CIRCLES CONTAINING A SAIL OVER THREE STYLIZED WAVES. THE WORDS "PACIFIC WIND" ARE WRITTEN ON A BANNER ACROSS THE CIRCLE WITH THE WORDS "SAILING CO" BELOW THE BANNER.

FOR BOATS AND STRUCTURAL PARTS THEREFOR (U.S. CLS. 19, 21, 23, 31, 35 AND 44).  
FIRST USE 12-31-2009; IN COMMERCE 3-24-2011.

3,962,817. ELECTRIC MOBILITY CORPORATION, DBA THE RASCAL COMPANY, SEWELL, NJ. SN 77-906,009. PUB. 5-25-2010, FILED 1-6-2010.

## Rascal WeGo

THE MARK CONSISTS OF STANDARD CHARACTERS WITHOUT CLAIM TO ANY PARTICULAR FONT, STYLE, SIZE, OR COLOR.

OWNER OF U.S. REG. NOS. 3,117,254, 3,334,063, AND 3,334,293.

FOR MOTORISED WHEELCHAIRS FOR THE DISABLED AND THOSE WITH MOBILITY DIFFICULTIES (U.S. CLS. 19, 21, 23, 31, 35 AND 44).

FIRST USE 10-22-2009; IN COMMERCE 11-5-2009.

**CLASS 12—(Continued).**

3,962,861. GOOD EARTH ENERGY CONSERVATION, INC., FORT WORTH, TX. SN 77-918,286. PUB. 6-15-2010, FILED 1-22-2010.

## FIREFLY

THE MARK CONSISTS OF STANDARD CHARACTERS WITHOUT CLAIM TO ANY PARTICULAR FONT, STYLE, SIZE, OR COLOR.

FOR ELECTRIC UTILITY VEHICLES (U.S. CLS. 19, 21, 23, 31, 35 AND 44).

FIRST USE 4-4-2011; IN COMMERCE 4-4-2011.

3,962,999. EXTANG CORPORATION, ANN ARBOR, MI. SN 77-944,472. PUB. 7-20-2010, FILED 2-25-2010.

## WeatherTop

THE MARK CONSISTS OF STANDARD CHARACTERS WITHOUT CLAIM TO ANY PARTICULAR FONT, STYLE, SIZE, OR COLOR.

FOR FITTED COVERS FOR VEHICLES (U.S. CLS. 19, 21, 23, 31, 35 AND 44).

FIRST USE 2-18-2010; IN COMMERCE 3-16-2010.

3,963,017. GEAR GATOR PRODUCTS, LLC, BUENA VISTA, VA. SN 77-946,308. PUB. 7-27-2010, FILED 2-26-2010.

## A CARGO HAULIN', LIFESTYLE CHANGIN', ATV REVOLUTION!

THE MARK CONSISTS OF STANDARD CHARACTERS WITHOUT CLAIM TO ANY PARTICULAR FONT, STYLE, SIZE, OR COLOR.

FOR ATV CARGO RACKS; ATV CANOPIES; CARGO STORAGE BASKETS ESPECIALLY ADAPTED FOR USE ON ATVS (U.S. CLS. 19, 21, 23, 31, 35 AND 44).

FIRST USE 11-29-2010; IN COMMERCE 11-29-2010.

**CLASS 12—(Continued).**

3,963,034. WEBER ENTERPRISES, LLC, DBA WEBER BUILT PRODUCT DESIGN AND DEVELOPMENT, WHITE-WATER, CO. SN 77-948,858. PUB. 7-27-2010, FILED 3-2-2010.

## SIDEJACKER

THE MARK CONSISTS OF STANDARD CHARACTERS WITHOUT CLAIM TO ANY PARTICULAR FONT, STYLE, SIZE, OR COLOR.

FOR TRAILER HITCHING ACCESSORY IN THE NATURE OF A RETENTIVE LATERAL TRAILER HITCHING DEVICE, TO ASSIST A TOWING VEHICLE OPERATOR IN RETENTIVELY MOVING TO AND HOLDING A TRAILER IN A LATERAL POSITION TO FACILITATE PROPER TRAILER COUPLER TO VEHICLE TOW BALL ALIGNMENT (U.S. CLS. 19, 21, 23, 31, 35 AND 44).

FIRST USE 3-2-2010; IN COMMERCE 6-30-2010.

---

3,963,165. TRICO PRODUCTS CORPORATION, ROCHESTER HILLS, MI. SN 77-961,929. PUB. 7-20-2010, FILED 3-18-2010.

## DUAL-SHIELD

THE MARK CONSISTS OF STANDARD CHARACTERS WITHOUT CLAIM TO ANY PARTICULAR FONT, STYLE, SIZE, OR COLOR.

FOR WINDSHIELD WIPER BLADES FOR VEHICLES (U.S. CLS. 19, 21, 23, 31, 35 AND 44).

FIRST USE 9-16-2010; IN COMMERCE 9-16-2010.

---

3,963,168. TRICO PRODUCTS CORPORATION, ROCHESTER HILLS, MI. SN 77-961,984. PUB. 7-20-2010, FILED 3-18-2010.

## ENGINEERED BY TRICO

THE MARK CONSISTS OF STANDARD CHARACTERS WITHOUT CLAIM TO ANY PARTICULAR FONT, STYLE, SIZE, OR COLOR.

OWNER OF U.S. REG. NOS. 167,037, 2,292,526, AND OTHERS.

FOR WINDSHIELD WIPER BLADES FOR VEHICLES (U.S. CLS. 19, 21, 23, 31, 35 AND 44).

FIRST USE 9-16-2010; IN COMMERCE 9-16-2010.

**CLASS 12—(Continued).**

3,963,301. K-2 CORPORATION, SEATTLE, WA. SN 78-951,329. PUB. 12-11-2007, FILED 8-14-2006.



OWNER OF U.S. REG. NOS. 1,817,410, 3,171,129, AND OTHERS.

THE MARK CONSISTS OF A DESIGN OF A STYLIZED TRIANGLE FORMED BY THE LETTER AND NUMERAL "K2".

FOR LAND VEHICLES, ALL-TERRAIN VEHICLES (U.S. CLS. 19, 21, 23, 31, 35 AND 44).

FIRST USE 11-0-1997; IN COMMERCE 11-0-1997.

---

3,963,403. LEXANI HOLDINGS, INC., CORONA, CA. SN 85-021,040. PUB. 9-21-2010, FILED 4-22-2010.

## SNYPER

THE MARK CONSISTS OF STANDARD CHARACTERS WITHOUT CLAIM TO ANY PARTICULAR FONT, STYLE, SIZE, OR COLOR.

FOR LAND VEHICLES AND STRUCTURAL PARTS THEREFOR (U.S. CLS. 19, 21, 23, 31, 35 AND 44).

FIRST USE 1-1-2011; IN COMMERCE 1-1-2011.

---

3,963,415. SPECIALIZED BICYCLE COMPONENTS, INC., MORGAN HILL, CA. SN 85-024,451. PUB. 12-7-2010, FILED 4-27-2010.

## CAMBER

THE MARK CONSISTS OF STANDARD CHARACTERS WITHOUT CLAIM TO ANY PARTICULAR FONT, STYLE, SIZE, OR COLOR.

FOR BICYCLES AND BICYCLE FRAMES (U.S. CLS. 19, 21, 23, 31, 35 AND 44).

FIRST USE 6-26-2010; IN COMMERCE 7-20-2010.

**CLASS 13—FIREARMS**

3,962,841. PROGRESSIVE OUTDOORS, LLC, ADDISON, TX.  
SN 77-912,836. PUB. 6-1-2010, FILED 1-15-2010.



NO CLAIM IS MADE TO THE EXCLUSIVE RIGHT TO USE "WATERFOWL PRO", APART FROM THE MARK AS SHOWN.

THE MARK CONSISTS OF A DUCK HEAD INSIDE OF A CIRCLE, WINGS ON OUTSIDE OF THE CIRCLE, THE WORDS "WATERFOWL" AND "PRO" CENTERED BELOW THE CIRCLE, WITH "PRO" WITHIN AN OVAL.

FOR BANDOLIERS FOR HOLDING CARTRIDGES OR AMMUNITION CASES; CARTRIDGE BELTS; GUN AND RIFLE CASES; GUN BELTS; GUN CASES (U.S. CLS. 2 AND 9).

FIRST USE 3-28-2011; IN COMMERCE 3-28-2011.

**CLASS 14—JEWELRY**

3,962,030. LIDA KULUMCULUK SANAYI VE TICARET LTD., NURUOSMANIYE - ISTANBUL, TURKEY. SN 77-129,333. PUB. 5-20-2008, FILED 3-13-2007.

# LIDA

THE MARK CONSISTS OF STANDARD CHARACTERS WITHOUT CLAIM TO ANY PARTICULAR FONT, STYLE, SIZE, OR COLOR.

THE NAME(S), PORTRAIT(S), AND/OR SIGNATURE(S) SHOWN IN THE MARK DOES NOT IDENTIFY A PARTICULAR LIVING INDIVIDUAL.

FOR PRECIOUS STONES (U.S. CLS. 2, 27, 28 AND 50).  
FIRST USE 8-0-2008; IN COMMERCE 8-0-2008.

**CLASS 14—(Continued).**

3,962,561. 143 DESIGNS, LLC, LOS ALTOS HILLS, CA. SN 77-818,477. PUB. 12-22-2009, FILED 9-2-2009.

**LOVE'S INSTANT MESSAGE**

THE MARK CONSISTS OF STANDARD CHARACTERS WITHOUT CLAIM TO ANY PARTICULAR FONT, STYLE, SIZE, OR COLOR.

FOR JEWELRY, NAMELY, PENDANTS, EARRINGS, BRACELETS (U.S. CLS. 2, 27, 28 AND 50).

FIRST USE 11-16-2010; IN COMMERCE 11-16-2010.

3,962,617. TAGLIAMONTE, NINO, VICENZA, ITALY. SN 77-835,563. PUB. 9-28-2010, FILED 9-25-2009.

**Tagliamonte Designs**

THE MARK CONSISTS OF STANDARD CHARACTERS WITHOUT CLAIM TO ANY PARTICULAR FONT, STYLE, SIZE, OR COLOR.

NO CLAIM IS MADE TO THE EXCLUSIVE RIGHT TO USE "DESIGNS", APART FROM THE MARK AS SHOWN.

FOR JEWELRY (U.S. CLS. 2, 27, 28 AND 50).

FIRST USE 2-21-2011; IN COMMERCE 2-21-2011.

3,962,723. JACQUIE AICHE, INC, LOS ANGELES, CA. SN 77-876,787. PUB. 4-20-2010, FILED 11-19-2009.

**BLESSLEV**

THE MARK CONSISTS OF STANDARD CHARACTERS WITHOUT CLAIM TO ANY PARTICULAR FONT, STYLE, SIZE, OR COLOR.

FOR JEWELRY (U.S. CLS. 2, 27, 28 AND 50).

FIRST USE 11-1-2009; IN COMMERCE 11-1-2009.

**CLASS 14—(Continued).**

3,962,737. DAY, LAWRENCE JAMES, GRAND BLANC, MI. SN 77-883,667. PUB. 4-27-2010, FILED 12-1-2009.

# PACE PAL

THE MARK CONSISTS OF STANDARD CHARACTERS WITHOUT CLAIM TO ANY PARTICULAR FONT, STYLE, SIZE, OR COLOR.  
FOR CLOCKS (U.S. CLS. 2, 27, 28 AND 50).  
FIRST USE 1-1-2010; IN COMMERCE 1-1-2011.

**CLASS 14—(Continued).**

3,963,121. HANSEN, KIMBERLY RAE, CASPER, WY. SN 77-958,429. PUB. 8-3-2010, FILED 3-13-2010.

# FRACTALICIOUS

THE MARK CONSISTS OF STANDARD CHARACTERS WITHOUT CLAIM TO ANY PARTICULAR FONT, STYLE, SIZE, OR COLOR.  
FOR WATCHES; JEWELRY (U.S. CLS. 2, 27, 28 AND 50).  
FIRST USE 11-1-2009; IN COMMERCE 3-8-2010.

3,962,989. M&E INNOVATIVE SOLUTIONS LLC, LEE'S SUMMIT, MO. SN 77-943,575. PUB. 7-20-2010, FILED 2-24-2010.

# SHADEMATES

THE MARK CONSISTS OF STANDARD CHARACTERS WITHOUT CLAIM TO ANY PARTICULAR FONT, STYLE, SIZE, OR COLOR.  
FOR CHARM THAT IS MECHANICALLY ATTACHED TO THE ARM OF A PAIR OF SUNGLASSES OR EYEGLASSES (U.S. CLS. 2, 27, 28 AND 50).  
FIRST USE 2-20-2011; IN COMMERCE 2-25-2011.

3,963,148. MBM COMPANY, INC., CHICAGO, IL. SN 77-960,963. PUB. 8-10-2010, FILED 3-17-2010.

# LIFECARVED

THE MARK CONSISTS OF STANDARD CHARACTERS WITHOUT CLAIM TO ANY PARTICULAR FONT, STYLE, SIZE, OR COLOR.  
FOR JEWELRY (U.S. CLS. 2, 27, 28 AND 50).  
FIRST USE 3-15-2011; IN COMMERCE 3-15-2011.

3,963,113. HARRIS, JOHN E, VACAVILLE, CA. SN 77-957,225. PUB. 8-3-2010, FILED 3-11-2010.

# FTK

THE MARK CONSISTS OF STANDARD CHARACTERS WITHOUT CLAIM TO ANY PARTICULAR FONT, STYLE, SIZE, OR COLOR.  
FOR BRACELETS; EARRINGS; JEWELRY; NECKLACES; RINGS; RUBBER OR SILICON WRISTBANDS IN THE NATURE OF A BRACELET (U.S. CLS. 2, 27, 28 AND 50).  
FIRST USE 2-0-2011; IN COMMERCE 2-0-2011.

3,963,170. DAGNABIT! LLC, ATLANTA, GA. SN 77-962,177. PUB. 8-24-2010, FILED 3-18-2010.



THE COLOR(S) BLACK, WHITE AND BURGUNDY IS/ ARE CLAIMED AS A FEATURE OF THE MARK.

**CLASS 14—(Continued).**

THE MARK CONSISTS OF THE WORD "EYE" ENTIRELY IN BLACK WITH EXAGGERATED LOOPS AT THE BOTTOM OF THE 2 "E'S" AND A MORE EXAGGERATED LOOP AT THE BOTTOM OF THE "Y" WITH A BLACK PAIR OF EYE GLASSES "HANGING" FROM THE LOOP IN THE "Y" AND WITH THE WORD "CATCHERS" IN WHITE ON A BURGUNDY BACKGROUND DIRECTLY UNDER ALL OF THE WORD "EYE" EXCEPT THE BOTTOM PART OF THE "Y".

FOR JEWELRY THAT WILL HOLD EYEGLASSES (U.S. CLS. 2, 27, 28 AND 50).

FIRST USE 4-1-2010; IN COMMERCE 5-1-2010.

---

3,963,171. 212, LLC, EDEN PRAIRIE, MN. SN 77-962,301. PUB. 8-3-2010, FILED 3-18-2010.

# VERADO

THE MARK CONSISTS OF STANDARD CHARACTERS WITHOUT CLAIM TO ANY PARTICULAR FONT, STYLE, SIZE, OR COLOR.

FOR JEWELRY (U.S. CLS. 2, 27, 28 AND 50).

FIRST USE 5-0-2010; IN COMMERCE 5-0-2010.

---

3,963,270. DISTRICT OF COLUMBIA FIRE & EMERGENCY MEDICAL SERVICES DEPARTMENT, WASHINGTON, DC. SN 77-981,770. PUB. 7-27-2010, FILED 3-1-2010.

# DISTRICT OF COLUMBIA FIRE & EMS DEPARTMENT

THE MARK CONSISTS OF STANDARD CHARACTERS WITHOUT CLAIM TO ANY PARTICULAR FONT, STYLE, SIZE, OR COLOR.

NO CLAIM IS MADE TO THE EXCLUSIVE RIGHT TO USE "DISTRICT OF COLUMBIA", APART FROM THE MARK AS SHOWN.

FOR LAPEL PINS (U.S. CLS. 2, 27, 28 AND 50).

FIRST USE 12-0-2004; IN COMMERCE 12-0-2004.

**CLASS 14—(Continued).**

3,963,328. LINDA JOHNSON, MOLINE, IL. SN 85-005,272. PUB. 8-24-2010, FILED 4-2-2010.

# GAGALOVE

THE MARK CONSISTS OF STANDARD CHARACTERS WITHOUT CLAIM TO ANY PARTICULAR FONT, STYLE, SIZE, OR COLOR.

FOR BRACELETS; BROACHES; CHARMS; JEWELRY (U.S. CLS. 2, 27, 28 AND 50).

FIRST USE 1-1-2010; IN COMMERCE 9-1-2010.

---

3,963,356. PEARL, SANDRA SELLERS, NEW YORK, NY. SN 85-009,335. PUB. 9-7-2010, FILED 4-8-2010.

# KATHERINE HOYLE

THE MARK CONSISTS OF STANDARD CHARACTERS WITHOUT CLAIM TO ANY PARTICULAR FONT, STYLE, SIZE, OR COLOR.

THE NAME "KATHERINE HOYLE" DOES NOT IDENTIFY A LIVING INDIVIDUAL.

FOR JEWELRY (U.S. CLS. 2, 27, 28 AND 50).

FIRST USE 1-18-2011; IN COMMERCE 1-18-2011.

---

3,963,357. MOVADO LLC, WILMINGTON, DE. SN 85-009,517. PUB. 8-31-2010, FILED 4-8-2010.

# SERIO

THE MARK CONSISTS OF STANDARD CHARACTERS WITHOUT CLAIM TO ANY PARTICULAR FONT, STYLE, SIZE, OR COLOR.

OWNER OF U.S. REG. NO. 2,680,619.

THE ENGLISH TRANSLATION OF THE WORD "SERIO" IN THE MARK IS "SERIOUS".

FOR HOROLOGICAL AND CHRONOMETRIC INSTRUMENTS (U.S. CLS. 2, 27, 28 AND 50).

FIRST USE 6-30-2010; IN COMMERCE 6-30-2010.



**CLASS 14—(Continued).**

3,963,361. IP HOLDINGS UNLTD LLC, NEW YORK, NY. SN 85-010,172. PUB. 8-31-2010, FILED 4-9-2010.

# MARC ECKO

THE MARK CONSISTS OF STANDARD CHARACTERS WITHOUT CLAIM TO ANY PARTICULAR FONT, STYLE, SIZE, OR COLOR.

OWNER OF U.S. REG. NOS. 2,927,076, 3,341,002, AND OTHERS.

THE NAME(S), PORTRAIT(S), AND/OR SIGNATURE(S) SHOWN IN THE MARK IDENTIFIES A LIVING INDIVIDUAL, WHOSE CONSENT(S) TO REGISTER IS MADE OF RECORD.

FOR JEWELRY (U.S. CLS. 2, 27, 28 AND 50).  
FIRST USE 3-1-2011; IN COMMERCE 3-1-2011.

---

3,963,495. K WEBER COMMUNICATIONS LLC, CUERO, TX. SN 85-043,085. PUB. 10-19-2010, FILED 5-19-2010.



THE MARK CONSISTS OF THE NUMBER "8800" TO THE RIGHT OF A CIRCLE CONTAINING TWO SHAPES OF A GENERALLY END-POINTED OBLONG NATURE AND A THIRD SHAPE HAVING ONE POINTED END.

FOR COSTUME JEWELRY; GEMSTONE JEWELRY; GEMSTONES; JEWELRY; JEWELRY AND IMITATION JEWELRY; JEWELRY WATCHES; PEARLS; PRECIOUS GEMSTONES; SEMI-PRECIOUS GEMSTONES; WATCHES AND JEWELRY; WATCHES, CLOCKS, JEWELRY AND IMITATION JEWELRY (U.S. CLS. 2, 27, 28 AND 50).

FIRST USE 11-4-2010; IN COMMERCE 11-4-2010.

**CLASS 14—(Continued).**

3,963,602. LORD GRIFFON LLC, LOS ANGELES, CA. SN 85-073,360. PUB. 12-14-2010, FILED 6-28-2010.



THE MARK CONSISTS OF A SHIELD CONTAINING A GRIFFIN STANDING ON HIS HIND LEGS WITH A SHIELD COVERING HIS LEFT HAND AND CLUTCHING A STAFF WITH FLAG IN HIS EXTENDED RIGHT HAND.

FOR JEWELRY, NAMELY, AMULETS, BRACELETS, BROOCHES, JEWELRY CHAINS, WATCH CHAINS, TIE CLIPS, CUFF LINKS, DIAMONDS, EARRINGS, GOLD THREAD JEWELRY, JEWELRY CASES, KEY RINGS OF PRECIOUS METAL, JEWELRY MEDALLIONS, MEDALS, JEWELRY NECKLACES, OLIVINE, ORNAMENTAL PINS, JEWELRY PEARLS, TIE PINS, PRECIOUS METALS, PRECIOUS STONES, SEMI-PRECIOUS STONES, SILVER ORNAMENTS, SILVER THREAD, SPUN SILVER, STRAPS FOR WRISTWATCHES, WATCH BANDS, WORKS OF ART OF PRECIOUS METAL (U.S. CLS. 2, 27, 28 AND 50).

FIRST USE 7-2-2010; IN COMMERCE 7-2-2010.

---

3,963,673. KIMAYA USA, INC., SECAUCUS, NJ. SN 85-096,210. PUB. 1-11-2011, FILED 7-29-2010.

# iDiGi

THE MARK CONSISTS OF STANDARD CHARACTERS WITHOUT CLAIM TO ANY PARTICULAR FONT, STYLE, SIZE, OR COLOR.

FOR WATCHES (U.S. CLS. 2, 27, 28 AND 50).  
FIRST USE 11-1-2010; IN COMMERCE 11-1-2010.

**CLASS 14—(Continued).**

3,963,674. KIMAYA USA, INC, SECAUCUS, NJ. SN 85-096,219. PUB. 1-11-2011, FILED 7-29-2010.

# TRUCE

THE MARK CONSISTS OF STANDARD CHARACTERS WITHOUT CLAIM TO ANY PARTICULAR FONT, STYLE, SIZE, OR COLOR.

FOR WATCHES (U.S. CLS. 2, 27, 28 AND 50).  
FIRST USE 11-15-2010; IN COMMERCE 11-15-2010.

3,963,720. SMITH, GREGG, BEND, OR. AND SMITH, SHARON, BEND, OR. AND SMITH BRYNNE, SCOTTSDALE, AZ. SN 85-975,127. PUB. 8-24-2010, FILED 4-2-2010.

# 831

THE MARK CONSISTS OF STANDARD CHARACTERS WITHOUT CLAIM TO ANY PARTICULAR FONT, STYLE, SIZE, OR COLOR.

FOR JEWELRY (U.S. CLS. 2, 27, 28 AND 50).  
FIRST USE 8-14-2010; IN COMMERCE 8-14-2010.

**CLASS 15—MUSICAL INSTRUMENTS**

3,961,997. CHAPMAN, CRAIG D, RANCHO CORDOVA, CA. SN 76-703,271. PUB. 11-2-2010, FILED 6-7-2010.



NO CLAIM IS MADE TO THE EXCLUSIVE RIGHT TO USE "DRUMS", APART FROM THE MARK AS SHOWN. THE COLOR(S) BLUE, BLACK, GOLD AND GRAY IS/ARE CLAIMED AS A FEATURE OF THE MARK.

**CLASS 15—(Continued).**

THE MARK CONSISTS OF THE FOLLOWING: THE TERM "B.C. DRUMS" IN THE COLOR BLUE WITH BLACK BORDERING AND GRAY PERIODS FOLLOWING THE LETTERS "B." AND "C.", AND A DESIGN INCORPORATED INTO THE WORD "DRUMS" CONSISTING OF GOLD CYMBALS AND GRAY DRUM HEADS.

FOR CUSTOM BUILT MUSICAL DRUMS AND HARDWARE THEREFOR (U.S. CLS. 2, 21 AND 36).  
FIRST USE 11-18-2010; IN COMMERCE 11-18-2010.

3,962,070. YAMAHA CORPORATION OF AMERICA, BUENA PARK, CA. SN 77-246,282. PUB. 2-12-2008, FILED 8-3-2007.

# ROGERS DYNA-SONIC

THE MARK CONSISTS OF STANDARD CHARACTERS WITHOUT CLAIM TO ANY PARTICULAR FONT, STYLE, SIZE, OR COLOR.

THE NAME(S), PORTRAIT(S), AND/OR SIGNATURE(S) SHOWN IN THE MARK DOES NOT IDENTIFY A PARTICULAR LIVING INDIVIDUAL.

FOR MUSICAL INSTRUMENTS, NAMELY, SNARE DRUMS (U.S. CLS. 2, 21 AND 36).  
FIRST USE 2-28-2011; IN COMMERCE 2-28-2011.

3,962,788. TAYLOR-LISTUG, INC., EL CAJON, CA. SN 77-897,301. PUB. 10-12-2010, FILED 12-18-2009.

# GS

THE MARK CONSISTS OF STANDARD CHARACTERS WITHOUT CLAIM TO ANY PARTICULAR FONT, STYLE, SIZE, OR COLOR.

FOR MUSICAL INSTRUMENTS, NAMELY, GUITARS; AND CARRYING CASES FOR MUSICAL INSTRUMENTS (U.S. CLS. 2, 21 AND 36).

FIRST USE 0-0-2006; IN COMMERCE 0-0-2006.

3,962,789. TAYLOR-LISTUG, INC., EL CAJON, CA. SN 77-897,319. PUB. 10-12-2010, FILED 12-18-2009.

# GS MINI

THE MARK CONSISTS OF STANDARD CHARACTERS WITHOUT CLAIM TO ANY PARTICULAR FONT, STYLE, SIZE, OR COLOR.

**CLASS 15—(Continued).**

NO CLAIM IS MADE TO THE EXCLUSIVE RIGHT TO USE "MINI", APART FROM THE MARK AS SHOWN.

FOR MUSICAL INSTRUMENTS, NAMELY, GUITARS; AND CARRYING CASES FOR MUSICAL INSTRUMENTS (U.S. CLS. 2, 21 AND 36).

FIRST USE 6-0-2010; IN COMMERCE 6-0-2010.

3,963,315. LIU, SU-JUN, IRVINE, CA. SN 85-002,587. PUB. 8-24-2010, FILED 3-31-2010.



THE MARK CONSISTS OF THE WORD "ATHENA" AND A DESIGN OF AN OWL.

FOR SAXOPHONES; MOUTHPIECES FOR MUSICAL INSTRUMENTS; MOUTHPIECE LIGATURES; CASES FOR MUSICAL INSTRUMENTS; THUMB RESTS FOR MUSICAL INSTRUMENTS; STRAPS FOR MUSICAL INSTRUMENTS; SWAB AND PAD SAVER FOR SAXOPHONES; STANDS FOR MUSICAL INSTRUMENTS; PLUGS FOR CONVERTING OPEN HOLE FLUTES TO CLOSED HOLE FLUTES (U.S. CLS. 2, 21 AND 36).

FIRST USE 9-1-2010; IN COMMERCE 9-1-2010.

**CLASS 16—PAPER GOODS AND PRINTED MATTER**

3,961,991. SHALOM INTERNATIONAL CORP., PERTH AMBOY, NJ. SN 76-701,619. PUB. 6-29-2010, FILED 2-16-2010.

# DESIGNS BY PRISCILLA

THE MARK CONSISTS OF STANDARD CHARACTERS WITHOUT CLAIM TO ANY PARTICULAR FONT, STYLE, SIZE, OR COLOR.

NO CLAIM IS MADE TO THE EXCLUSIVE RIGHT TO USE "DESIGNS", APART FROM THE MARK AS SHOWN.

FOR PENS, PAPER GIFT BAGS, PAPER GIFT WRAP BOWS, PAPER GIFT WRAP, TISSUE PAPER, STATIONERY, NOTE CARDS, BLANK JOURNALS, NOTEBOOKS, DIARIES, ADDRESS BOOKS, PHOTOGRAPH ALBUMS, PAPER GIFT BOXES, AND STICKERS (U.S. CLS. 2, 5, 22, 23, 29, 37, 38 AND 50).

FIRST USE 1-0-2010; IN COMMERCE 1-0-2010.

**CLASS 16—(Continued).**

3,962,024. SIHL GMBH, DÜREN, FED REP GERMANY. SN 77-108,478. PUB. 7-29-2008, FILED 2-15-2007.



THE MARK CONSISTS OF THE WORDS "SIHL ENDURO" IN A SOLD RECTANGLE WITH AN "E" DESIGN.

FOR PLASTIC FILM LAMINATED PAPER FOR PRINTING PURPOSES; ENVELOPE PAPERS AND LAMINATED PAPERS; LABEL PAPER; LAMINATED PAPER; PAPER; LAMINATED PAPER SHEETS FOR WRITING, PRINTING, AND MARKING; LAMINATED PAPERS FOR USE IN THE MANUFACTURE OF ENVELOPES AND SACKS; LAMINATED PAPERS FOR USE IN THE PRINTING INDUSTRY; LAMINATED PAPER FOR WRAPPING AND PACKAGING; PLASTIC-LAMINATED PAPER; PRINTING PAPERS; REEL PAPER FOR PRINTERS; SYNTHETIC PAPER; UNPRINTED PAPER (U.S. CLS. 2, 5, 22, 23, 29, 37, 38 AND 50).

FIRST USE 1-3-2011; IN COMMERCE 1-3-2011.

3,962,034. FELD, CAROLE, WASHINGTON, DC. SN 77-145,504. PUB. 11-6-2007, FILED 3-31-2007.

**COLLEGE OF STRIPTEASE**

THE MARK CONSISTS OF STANDARD CHARACTERS WITHOUT CLAIM TO ANY PARTICULAR FONT, STYLE, SIZE, OR COLOR.

FOR PRINTED MATERIALS, NAMELY, BOOKS CONCERNING ENTERTAINMENT IN THE FIELD OF SINGING, DANCING AND PERFORMING AND INSTRUCTIONAL MATERIAL IN THE FIELD OF DANCE AND PERFORMANCE ARTS, PENS, STATIONERY, STICKERS, AND POSTCARDS (U.S. CLS. 2, 5, 22, 23, 29, 37, 38 AND 50).

FIRST USE 12-21-2010; IN COMMERCE 12-21-2010.

**CLASS 16—(Continued).**

3,962,101. PIDILITE INDUSTRIES LIMITED, MUMBAI, INDIA. SN 77-345,418. PUB. 7-22-2008, FILED 12-6-2007.

# FEVICOL

THE MARK CONSISTS OF STANDARD CHARACTERS WITHOUT CLAIM TO ANY PARTICULAR FONT, STYLE, SIZE, OR COLOR.

FOR ADHESIVES USED FOR STATIONERY AND HOUSEHOLD PURPOSES, NAMELY, FABRIC GLUE (U.S. CLS. 2, 5, 22, 23, 29, 37, 38 AND 50).

FIRST USE 12-31-1959; IN COMMERCE 10-0-2010.

3,962,105. RODALE INC., EMMAUS, PA. SN 77-371,063. PUB. 12-9-2008, FILED 1-14-2008.

## BUY THIS NOT THAT

THE MARK CONSISTS OF STANDARD CHARACTERS WITHOUT CLAIM TO ANY PARTICULAR FONT, STYLE, SIZE, OR COLOR.

OWNER OF U.S. REG. NOS. 3,033,225, 3,492,564, AND OTHERS.

FOR MAGAZINE COLUMN, FEATURE OR SECTION IN THE FIELD OF CONSUMER VALUES, SHOPPING AND PURCHASE OPTIONS, COMPARATIVE PRICING AND PRODUCT AND SERVICE REVIEWS AND RATINGS (U.S. CLS. 2, 5, 22, 23, 29, 37, 38 AND 50).

FIRST USE 4-1-2006; IN COMMERCE 4-1-2006.

3,962,106. RODALE INC., EMMAUS, PA. SN 77-371,098. PUB. 12-2-2008, FILED 1-14-2008.

## SAY THIS NOT THAT

THE MARK CONSISTS OF STANDARD CHARACTERS WITHOUT CLAIM TO ANY PARTICULAR FONT, STYLE, SIZE, OR COLOR.

OWNER OF U.S. REG. NO. 3,033,225.

FOR MAGAZINE COLUMN FEATURE OR SECTION IN THE FIELD OF THE ART OF NEGOTIATION, SOCIAL AND BUSINESS COMMUNICATION AND CONVERSATION (U.S. CLS. 2, 5, 22, 23, 29, 37, 38 AND 50).

FIRST USE 6-1-2008; IN COMMERCE 6-1-2008.

**CLASS 16—(Continued).**

3,962,138. WILLIAMS, MIDGE, EAST SANDWICH, MA. SN 77-435,912. PUB. 8-19-2008, FILED 3-31-2008.

# PLANIT RECOVERY

THE MARK CONSISTS OF STANDARD CHARACTERS WITHOUT CLAIM TO ANY PARTICULAR FONT, STYLE, SIZE, OR COLOR.

NO CLAIM IS MADE TO THE EXCLUSIVE RIGHT TO USE "RECOVERY", APART FROM THE MARK AS SHOWN.

FOR EDUCATIONAL PUBLICATIONS, NAMELY, EDUCATIONAL LEARNING CARDS, FLASH CARDS, ACTIVITY CARDS, WORKBOOKS, TEXTBOOKS, ACTIVITY BOOKS, STORY BOOKS, PUZZLE BOOKS, PRINTED PUZZLES, TEACHER GUIDES, MANUALS, POSTERS, EDUCATIONAL CARD GAMES AND EDUCATIONAL BOOKLETS IN THE FIELD OF HEALTH AND RECOVERY (U.S. CLS. 2, 5, 22, 23, 29, 37, 38 AND 50).

FIRST USE 3-30-2011; IN COMMERCE 3-30-2011.

3,962,151. DI CARLO, ALFONSO, ALLENTOWN, PA. SN 77-478,363. PUB. 5-19-2009, FILED 5-19-2008.



THE COLOR(S) RED, BLUE, LIGHT BLUE, ORANGE, YELLOW, PURPLE, GREEN, LIGHT GREEN, FUCHSIA, WHITE AND BLACK IS/ARE CLAIMED AS A FEATURE OF THE MARK.

THE MARK CONSISTS OF THE WORD "WYN" WITH THE LETTER "Y" BEING SLIGHTLY LARGER AND CENTERED BETWEEN THE LETTERS "W" AND "N", AND WITH A PLURALITY OF COLORED PENS OR MARKERS BEING ARRANGED TO FORM THE LETTERS. THE COLOR BLACK FORMS THE OUTLINE OF THE LETTERS IN THE WORD "WYN", THE COLORS RED, BLUE, ORANGE, YELLOW AND PURPLE WITH WHITE SHADING ARE USED TO COLOR THE LETTER "W", THE COLORS GREEN, YELLOW, ORANGE, AND BLUE WITH WHITE SHADING ARE USED TO COLOR THE LETTER "Y", AND THE COLORS GREEN, BLUE, RED, ORANGE, PURPLE AND FUCHSIA WITH WHITE SHADING ARE USED TO COLOR THE LETTER "N".

FOR EDUCATIONAL BOOKS FEATURING MEANS FOR TEACHING CHILDREN IN WRITING THEIR NAME (U.S. CLS. 2, 5, 22, 23, 29, 37, 38 AND 50).

FIRST USE 2-4-2011; IN COMMERCE 2-9-2011.

**CLASS 16—(Continued).**

3,962,153. MUTASIAN MEDIA, LLC, PALM BEACH GARDENS, FL. SN 77-481,364. PUB. 12-1-2009, FILED 5-22-2008.

# CHADWICK

THE MARK CONSISTS OF STANDARD CHARACTERS WITHOUT CLAIM TO ANY PARTICULAR FONT, STYLE, SIZE, OR COLOR.

FOR BOOKS IN THE FIELD OF CHILDREN'S THEMES FEATURING CARTOONS; CHILDREN'S BOOKS FEATURING WHIMSICAL CARTOON CHARACTERS; PLAYER'S GUIDE BOOKS RELATING TO CHILDREN'S CARTOON CHARACTERS IN THE FIELD OF VIDEO, TRADING CARDS, AND FANTASY GAMES; PAPER INSTRUCTIONAL AND TEACHING MATERIALS, PRINTED PUBLICATIONS, NAMELY, MAGAZINES OR JOURNALS, LEAFLETS, BROCHURES AND POSTERS, ALL IN THE FIELD OF CHILDREN'S THEMES AND ALL RELATING TO CHILDREN'S CARTOON CHARACTERS; PRINTED MATTER AND PUBLICATIONS, NAMELY, ADDRESS BOOKS, BOOK COVERS, BOOKMARKS, BOOKPLATES AND CALENDARS HAVING A CHILDREN'S THEME; CHILDREN'S BOOKS; COLORING AND CHILDREN'S ACTIVITY BOOKS; COMIC BOOKS; MAGAZINES REGARDING VIDEO GAMES OR ONLINE GAMES; MAGNETIC WRITING SLATES, MEMO BOARDS MADE OF PAPER OR CARDBOARD OR WHITEBOARD, NEWSPAPER CARTOONS, PAPER BANNERS, PAPER PARTY DECORATIONS MOUNTABLE ON DOORS, PAPER NAPKINS, PAPER PARTY FAVORS, PAPER PLACE MATS, PAPER TABLE COVERS ALL IN THE FIELD OF CHILDREN'S THEMES; PAPERBACK BOOKS IN THE FIELD OF CHILDREN'S THEMES, GIFT WRAPPING PAPER, GREETING CARDS, INVITATION CARDS, IRON-ON TRANSFERS ALL HAVING CHILDREN'S THEMES; PICTURE STORYBOOKS, POSTCARDS, TRADING CARDS, POSTERS, THREE-RING BINDERS, RUBBER STAMPS, SCOREBOOKS, SCRAPBOOKS AND STAMP COLLECTOR BOOKS, STATIONERY-TYPE PORTFOLIOS, STICKER ALBUMS, STICKERS ALL HAVING CHILDREN'S THEMES; PENCIL BOXES, PENCIL SHARPENERS, PENCILS, PENS; STAPLERS; ARTIST BRUSHES, ARTISTS PASTELS, ART AND CRAFT PAINT KITS, CRAYONS; DECORATIVE FIGURES ATTACHABLE TO PENCILS; DRAWING RULERS; ERASERS, FELT-TIP MARKERS; AND GIFT BOXES (U.S. CLS. 2, 5, 22, 23, 29, 37, 38 AND 50).

FIRST USE 3-17-2009; IN COMMERCE 9-10-2009.

**CLASS 16—(Continued).**

3,962,154. MUTASIAN MEDIA, LLC, PALM BEACH GARDENS, FL. SN 77-481,667. PUB. 4-14-2009, FILED 5-22-2008.



THE MARK CONSISTS OF A WHIMSICAL CHARACTER IN THE SHAPE OF A COMBINATION WOLF AND BIRD.

FOR BOOKS IN THE FIELD OF CHILDREN'S THEMES FEATURING CARTOONS; CHILDREN'S BOOKS FEATURING WHIMSICAL CARTOON CHARACTERS; PLAYER'S GUIDE BOOKS RELATING TO CHILDREN'S CARTOON CHARACTERS IN THE FIELD OF VIDEO, TRADING CARDS, AND FANTASY GAMES; PAPER INSTRUCTIONAL AND TEACHING MATERIALS, PRINTED PUBLICATIONS, NAMELY, MAGAZINES OR JOURNALS, LEAFLETS, BROCHURES AND POSTERS, ALL IN THE FIELD OF CHILDREN'S THEMES AND ALL RELATING TO CHILDREN'S CARTOON CHARACTERS; PRINTED MATTER AND PUBLICATIONS, NAMELY, ADDRESS BOOKS, BOOK COVERS, BOOKMARKS, BOOKPLATES; CALENDARS; CHILDREN'S BOOKS; COLORING AND CHILDREN'S ACTIVITY BOOKS; COMIC BOOKS; MAGAZINES REGARDING VIDEO GAMES OR ONLINE GAMES; MAGNETIC WRITING SLATES, MEMO BOARDS MADE OF PAPER OR CARDBOARD OR WHITEBOARD, MEMO PADS, NEWSPAPER CARTOONS, NOTE PADS, NOTEBOOKS, PAPER BANNERS, PAPER PARTY DECORATIONS MOUNTABLE ON DOORS, PAPER NAPKINS, PAPER PARTY FAVORS, PAPER PLACE MATS, PAPER TABLE COVERS, PAPERBACK BOOKS IN THE FIELD OF CHILDREN'S THEMES, GIFT WRAPPING PAPER, GREETING CARDS, INVITATION CARDS, IRON-ON TRANSFERS; PICTURE STORYBOOKS, POSTCARDS, TRADING CARDS, POSTERS, THREE-RING BINDERS, RUBBER STAMPS, SCOREBOOKS, SCRAPBOOKS AND STAMP COLLECTOR BOOKS, SCRATCH PADS, STATIONERY, STATIONERY-TYPE PORTFOLIOS, STICKER ALBUMS, STICKERS; PENCIL BOXES, PENCIL SHARPENERS, PENCILS, PENS; STAPLERS; ARTIST BRUSHES, ARTISTS PASTELS, ART AND CRAFT PAINT KITS, CRAYONS; DECORATIVE FIGURES ATTACHABLE TO PENCILS; DRAWING RULERS; ERASERS, FELT-TIP MARKERS; AND GIFT BOXES (U.S. CLS. 2, 5, 22, 23, 29, 37, 38 AND 50).

FIRST USE 3-17-2009; IN COMMERCE 9-10-2009.



**CLASS 16—(Continued).**

3,962,155. MUTASIAN MEDIA, LLC, PALM BEACH GARDENS, FL. SN 77-481,686. PUB. 4-14-2009, FILED 5-22-2008.



THE MARK CONSISTS OF A WHIMSICAL CHARACTER IN THE SHAPE OF A COMBINATION OF AT LEAST AN OCTOPUS, PRAYING MANTIS, AND BAT.

FOR BOOKS IN THE FIELD OF CHILDREN'S THEMES FEATURING CARTOONS; CHILDREN'S BOOKS FEATURING WHIMSICAL CARTOON CHARACTERS; PLAYER'S GUIDE BOOKS RELATING TO CHILDREN'S CARTOON CHARACTERS IN THE FIELD OF VIDEO, TRADING CARDS, AND FANTASY GAMES; PAPER INSTRUCTIONAL AND TEACHING MATERIALS, PRINTED PUBLICATIONS, NAMELY, MAGAZINES OR JOURNALS, LEAFLETS, BROCHURES AND POSTERS, ALL IN THE FIELD OF CHILDREN'S THEMES AND ALL RELATING TO CHILDREN'S CARTOON CHARACTERS; PRINTED MATTER AND PUBLICATIONS, NAMELY, ADDRESS BOOKS, BOOK COVERS, BOOKMARKS, BOOKPLATES; CALENDARS; CHILDREN'S BOOKS; COLORING AND CHILDREN'S ACTIVITY BOOKS; COMIC BOOKS; MAGAZINES REGARDING VIDEO GAMES OR ONLINE GAMES; MAGNETIC WRITING SLATES, MEMO BOARDS MADE OF PAPER OR CARDBOARD OR WHITEBOARD, MEMO PADS, NEWSPAPER CARTOONS, NOTE PADS, NOTEBOOKS, PAPER BANNERS, PAPER PARTY DECORATIONS MOUNTABLE ON DOORS, PAPER NAPKINS, PAPER PARTY FAVORS, PAPER PLACE MATS, PAPER TABLE COVERS, PAPERBACK BOOKS IN THE FIELD OF CHILDREN'S THEMES, GIFT WRAPPING PAPER, GREETING CARDS, INVITATION CARDS, IRON-ON TRANSFERS; PICTURE STORYBOOKS, POSTCARDS, TRADING CARDS, POSTERS, THREE-RING BINDERS, RUBBER STAMPS, SCOREBOOKS, SCRAPBOOKS AND STAMP COLLECTOR BOOKS, SCRATCH PADS, STATIONERY, STATIONERY-TYPE PORTFOLIOS, STICKER ALBUMS, STICKERS; PENCIL BOXES, PENCIL SHARPENERS, PENCILS, PENS; STAPLERS; ARTIST BRUSHES, ARTISTS PASTELS, ART AND CRAFT PAINT KITS, CRAYONS; DECORATIVE FIGURES ATTACHABLE TO PENCILS; DRAWING RULERS; ERASERS, FELT-TIP MARKERS; AND GIFT BOXES (U.S. CLS. 2, 5, 22, 23, 29, 37, 38 AND 50).

FIRST USE 3-17-2009; IN COMMERCE 9-10-2009.

**CLASS 16—(Continued).**

3,962,184. APA - THE ENGINEERED WOOD ASSOCIATION, TACOMA, WA. SN 77-538,898. PUB. 7-20-2010, FILED 8-5-2008.

**APA SYSTEM REPORT**

THE MARK CONSISTS OF STANDARD CHARACTERS WITHOUT CLAIM TO ANY PARTICULAR FONT, STYLE, SIZE, OR COLOR.

NO CLAIM IS MADE TO THE EXCLUSIVE RIGHT TO USE "SYSTEM REPORT", APART FROM THE MARK AS SHOWN.

FOR PRINTED MATTER, NAMELY, INFORMATIONAL BULLETINS, REPORTS, BROCHURES, GUIDES AND PAMPHLETS IN THE FIELD OF BUILDING DESIGN AND CONSTRUCTION (U.S. CLS. 2, 5, 22, 23, 29, 37, 38 AND 50).

FIRST USE 1-0-2010; IN COMMERCE 1-0-2010.

3,962,271. SIMAS, CAROLINE H., CHARLOTTE, NC. SN 77-663,079. PUB. 12-8-2009, FILED 2-4-2009.

**MULTIPLE BLESSINGS**

THE MARK CONSISTS OF STANDARD CHARACTERS WITHOUT CLAIM TO ANY PARTICULAR FONT, STYLE, SIZE, OR COLOR.

FOR ANNOUNCEMENT CARDS; BLANK NOTE CARDS; BUSINESS CARD PAPER; CARDS BEARING UNIVERSAL GREETINGS; CARDS, NAMELY, INSPIRATIONAL AND SCRIPTURE BASED GREETING CARDS; CHRISTMAS CARDS; CORRESPONDENCE CARDS; GIFT CARDS; GREETING CARDS; GREETING CARDS HAVING A CHRISTIAN MESSAGE; GREETINGS CARDS AND POSTCARDS; HOLIDAY CARDS; INDEX CARDS; INVITATION CARDS; MOTIVATIONAL CARDS; MUSICAL GREETING CARDS; NOTE CARDS; OCCASION CARDS; OFFICE PAPER STATIONERY; OFFICE STATIONERY; PAPER STATIONERY; POSTCARDS AND GREETING CARDS; STATIONERY; STATIONERY BOXES; STATIONERY CASES; STATIONERY WRITING PAPER AND ENVELOPES; STICKERS; PENCIL ORNAMENTS; PLACE CARDS; PRINTED GREETING CARDS WITH ELECTRONIC INFORMATION STORED THEREIN; STATIONERY-TYPE PORTFOLIOS (U.S. CLS. 2, 5, 22, 23, 29, 37, 38 AND 50).

FIRST USE 1-15-2009; IN COMMERCE 1-15-2009.

**CLASS 16—(Continued).**

3,962,279. GREEN, JAMES M., HOUSTON, TX. SN 77-665,490. PUB. 6-16-2009, FILED 2-6-2009.

**GOT CHILD?**

THE MARK CONSISTS OF STANDARD CHARACTERS WITHOUT CLAIM TO ANY PARTICULAR FONT, STYLE, SIZE, OR COLOR.

NO CLAIM IS MADE TO THE EXCLUSIVE RIGHT TO USE "CHILD", APART FROM THE MARK AS SHOWN.

FOR PAMPHLETS, BOOKLETS, HAND-OUTS, MANUALS, STICKERS, DECALS AND TRANSFERS IN THE FIELD OF CHILD SAFETY AWARENESS (U.S. CLS. 2, 5, 22, 23, 29, 37, 38 AND 50).

FIRST USE 9-2-2010; IN COMMERCE 9-2-2010.

3,962,322. BIGDIFBOOKS.COM, LLC, CHICAGO, IL. SN 77-690,577. PUB. 7-14-2009, FILED 3-13-2009.

**BigDifBooks.com**

THE MARK CONSISTS OF STANDARD CHARACTERS WITHOUT CLAIM TO ANY PARTICULAR FONT, STYLE, SIZE, OR COLOR.

FOR CHILDREN'S BOOKS (U.S. CLS. 2, 5, 22, 23, 29, 37, 38 AND 50).

FIRST USE 3-24-2011; IN COMMERCE 3-24-2011.

3,962,373. CIRCLE OF FRIENDS MINISTRIES, INC., SUGARCREEK, OH. SN 77-733,935. PUB. 8-25-2009, FILED 5-11-2009.

**MACCHIATO MOMENTS**

THE MARK CONSISTS OF STANDARD CHARACTERS WITHOUT CLAIM TO ANY PARTICULAR FONT, STYLE, SIZE, OR COLOR.

FOR A SERIES OF BOOKS AND WRITTEN ARTICLES IN THE FIELD OF INSPIRATION, FAITH AND FRIENDSHIP; CALENDARS; GIFT WRAP PAPER; GREETING CARDS HAVING A CHRISTIAN MESSAGE; NOTE PADS; STATIONERY (U.S. CLS. 2, 5, 22, 23, 29, 37, 38 AND 50).

FIRST USE 1-15-2010; IN COMMERCE 1-15-2010.

**CLASS 16—(Continued).**

3,962,425. TY GALLANDER, DBA THINKING OUT OF A BOX, ROCKWALL, TX. SN 77-771,034. PUB. 9-14-2010, FILED 6-30-2009.

**Mind Missions**

THE MARK CONSISTS OF STANDARD CHARACTERS WITHOUT CLAIM TO ANY PARTICULAR FONT, STYLE, SIZE, OR COLOR.

FOR CHILDREN'S INTERACTIVE EDUCATIONAL BOOKS; EDUCATIONAL AND LEARNING PUBLICATIONS, NAMELY, BOOKLETS AND FLASH CARDS ON A VARIETY OF EDUCATIONAL DISCIPLINES IN PRE-SCHOOL THROUGH EIGHTH GRADE; EDUCATIONAL BOOKS FEATURING CREATIVE PROBLEM SOLVING; EDUCATIONAL PUBLICATIONS, NAMELY, BOOKS, HAND-OUTS, WORKBOOKS, JOURNALS, PLAYBOOKS, WORKSHEETS AND CARDS IN THE FIELD OF RIGHT-BRAIN FITNESS; EDUCATIONAL PUBLICATIONS, NAMELY, EDUCATIONAL LEARNING CARDS, FLASH CARDS, ACTIVITY CARDS, WORKBOOKS, TEXTBOOKS, ACTIVITY BOOKS, STORY BOOKS, PUZZLE BOOKS, PRINTED PUZZLES, TEACHER GUIDES, MANUALS, POSTERS AND EDUCATIONAL BOOKLETS IN THE FIELD OF CREATIVE PROBLEM SOLVING; EDUCATIONAL PUBLICATIONS, NAMELY, TRAINING MANUALS IN THE FIELD OF CREATIVE PROBLEM SOLVING; EDUCATIONAL PUBLICATIONS, NAMELY, CHILD LEARNING MATERIALS IN THE FIELDS OF CREATIVE PROBLEM SOLVING; PACKAGED KITS COMPRISING PRINTED INSTRUCTIONAL, EDUCATIONAL, AND TEACHING MATERIALS FOR EDUCATIONAL ACTIVITIES IN THE FIELD OF CREATIVE PROBLEM SOLVING; PRINTED EDUCATIONAL MATERIAL, NAMELY, TEACHING TILES; PRINTED EDUCATIONAL MATERIALS IN THE FIELD OF CREATIVE PROBLEM SOLVING; PRINTED INSTRUCTIONAL, EDUCATIONAL, AND TEACHING MATERIALS IN THE FIELD OF CREATIVE PROBLEM SOLVING (U.S. CLS. 2, 5, 22, 23, 29, 37, 38 AND 50).

FIRST USE 10-26-2009; IN COMMERCE 10-26-2009.

3,962,460. MADARAS GALLERY, INC., DBA MADARAS GALLERY, TUCSON, AZ. SN 77-786,187. PUB. 6-29-2010, FILED 7-21-2009.

**KITTY HUMBUG**

THE MARK CONSISTS OF STANDARD CHARACTERS WITHOUT CLAIM TO ANY PARTICULAR FONT, STYLE, SIZE, OR COLOR.

THE NAME(S), PORTRAIT(S), AND/OR SIGNATURE(S) SHOWN IN THE MARK DOES NOT IDENTIFY A PARTICULAR LIVING INDIVIDUAL.

FOR PAPER GOODS AND PRINTED MATTER, NAMELY, ARTWORK MADE FROM CUSTOM MANUFACTURED PAPER, POSTERS, POST CARDS, GREETING CARDS, CALENDARS, PERSONAL ORGANIZERS, BLANK PERSONAL JOURNALS, NOTEBOOKS, NOTE PADS, CHILDREN'S BOOKS, CHILDREN'S MAGAZINES, CHILDREN'S ACTIVITY BOOKS AND COLORING BOOKS (U.S. CLS. 2, 5, 22, 23, 29, 37, 38 AND 50).

FIRST USE 8-15-2009; IN COMMERCE 8-26-2009.

**CLASS 16—(Continued).**

3,962,476. HOLMBERG COMPANY, INC., MINNEAPOLIS, MN. SN 77-792,023. PUB. 4-13-2010, FILED 7-29-2009.



NO CLAIM IS MADE TO THE EXCLUSIVE RIGHT TO USE "PRINT MEDIA", APART FROM THE MARK AS SHOWN.

THE MARK CONSISTS OF A STYLIZED DEPICTION OF AN OPEN BOOK WITH THE RIGHT PAGE SLIGHTLY RAISED TO REVEAL A THIRD PAGE BEHIND IT. ON TOP OF THE OPEN BOOK IS A DEPICTION OF A FEATHER OVER THE STYLIZED WORD "MAZINA" WHICH IS OVER THE STYLIZED WORDS "PRINT MEDIA".

FOR PAPER PAGES INCORPORATING A BENDABLE, REINFORCED HINGE MADE OF PLASTIC FILM FOR USE IN ALBUMS, BOOKS, AND BUSINESS DOCUMENTS; END LEAF PAPER SHEETS FOR USE IN ALBUMS, BOOKS, AND BUSINESS DOCUMENTS; FLY PAPER SHEETS FOR USE IN ALBUMS, BOOKS, AND BUSINESS DOCUMENTS; SPECIALTY PAPER PRODUCTS, NAMELY, HEAVY WEIGHT REPORT COVER PAPER, CLEAR AND TRANSLUCENT PLASTIC REPORT COVER MATERIAL AND LAMINATED TONER RECEPTIVE COVER MATERIALS FOR USE IN ALBUMS, BOOKS, AND BUSINESS DOCUMENTS (U.S. CLS. 2, 5, 22, 23, 29, 37, 38 AND 50).

FIRST USE 12-7-2009; IN COMMERCE 8-4-2010.

**CLASS 16—(Continued).**

3,962,528. BLACK EDUCATIONAL EVENTS, LLC, COLLEYVILLE, TX. SN 77-807,592. PUB. 1-12-2010, FILED 8-18-2009.



NO CLAIM IS MADE TO THE EXCLUSIVE RIGHT TO USE "HBCU", APART FROM THE MARK AS SHOWN.

THE COLOR(S) RED, WHITE AND YELLOW IS/ARE CLAIMED AS A FEATURE OF THE MARK.

THE MARK CONSISTS OF THE WORDING "HBCU TODAY" IN STYLIZED LETTERS, WHERE "HBCU" APPEARS IN RED LETTERING OUTLINED IN THE COLORS YELLOW, THEN WHITE, THEN RED, WHERE "TODAY" APPEARS IN RED LETTERING WITH HORIZONTAL BARS ABOVE AND BELOW THE WORDING "TODAY", WHERE THE BARS APPEAR IN THE COLOR YELLOW WITH RED OUTLINING.

FOR GENERAL FEATURES MAGAZINE, BROCHURES AND BOOKLETS ABOUT COLLEGE ADMISSION, NEWSLETTERS IN THE FIELD OF EDUCATION AND COLLEGE LIFE (U.S. CLS. 2, 5, 22, 23, 29, 37, 38 AND 50).

FIRST USE 9-30-2009; IN COMMERCE 9-30-2009.

3,962,571. P. H. GLATFELTER COMPANY, YORK, PA. SN 77-822,592. PUB. 8-3-2010, FILED 9-9-2009.

**SCIOTO LEDGER**

THE MARK CONSISTS OF STANDARD CHARACTERS WITHOUT CLAIM TO ANY PARTICULAR FONT, STYLE, SIZE, OR COLOR.

NO CLAIM IS MADE TO THE EXCLUSIVE RIGHT TO USE "LEDGER", APART FROM THE MARK AS SHOWN.

FOR UNCOATED PRINTING PAPER (U.S. CLS. 2, 5, 22, 23, 29, 37, 38 AND 50).

FIRST USE 3-1-2009; IN COMMERCE 3-1-2009.

**HBCU TODAY**

3,962,572. P. H. GLATFELTER COMPANY, YORK, PA. SN 77-822,600. PUB. 8-3-2010, FILED 9-9-2009.

THE MARK CONSISTS OF STANDARD CHARACTERS WITHOUT CLAIM TO ANY PARTICULAR FONT, STYLE, SIZE, OR COLOR.

NO CLAIM IS MADE TO THE EXCLUSIVE RIGHT TO USE "HBCU", APART FROM THE MARK AS SHOWN.

FOR GENERAL FEATURES MAGAZINE, BROCHURES AND BOOKLETS ABOUT COLLEGE ADMISSION, NEWSLETTERS IN THE FIELD OF EDUCATION AND COLLEGE LIFE (U.S. CLS. 2, 5, 22, 23, 29, 37, 38 AND 50).

FIRST USE 9-30-2009; IN COMMERCE 9-30-2009.

**TIFFIN TAG**

THE MARK CONSISTS OF STANDARD CHARACTERS WITHOUT CLAIM TO ANY PARTICULAR FONT, STYLE, SIZE, OR COLOR.

**CLASS 16—(Continued).**

NO CLAIM IS MADE TO THE EXCLUSIVE RIGHT TO USE "TAG", APART FROM THE MARK AS SHOWN.  
FOR UNCOATED PRINTING PAPER (U.S. CLS. 2, 5, 22, 23, 29, 37, 38 AND 50).  
FIRST USE 3-1-2009; IN COMMERCE 3-1-2009.

**CLASS 16—(Continued).**

3,962,660. SHAPIRO, NANCY B., OLNEY, MD. SN 77-852,781.  
PUB. 8-3-2010, FILED 10-20-2009.

## CUE STICKS

3,962,573. P. H. GLATFELTER COMPANY, YORK, PA. SN 77-822,611. PUB. 8-3-2010, FILED 9-9-2009.

THE MARK CONSISTS OF STANDARD CHARACTERS WITHOUT CLAIM TO ANY PARTICULAR FONT, STYLE, SIZE, OR COLOR.

FOR TEMPORARY TATTOOS, STICKERS, BLANK CARDS, BLANK JOURNAL BOOKS, NOTE CARDS, BLANK OR PARTIALLY BLANK PRINTED PAPER LABELS, BLANK OR PARTIALLY PRINTED POSTCARDS, PAPER NOTEBOOKS, BUMPER STICKERS, CALENDARS, CHILDREN'S WALL STICKERS AND MURALS, FRAMED ART PRINTS, FRAMED GRAPHIC ART REPRODUCTIONS, PAPER BADGES AND STATIONERY (U.S. CLS. 2, 5, 22, 23, 29, 37, 38 AND 50).  
FIRST USE 11-30-2009; IN COMMERCE 2-22-2010.

## WORTHINGTON INDEX

THE MARK CONSISTS OF STANDARD CHARACTERS WITHOUT CLAIM TO ANY PARTICULAR FONT, STYLE, SIZE, OR COLOR.

NO CLAIM IS MADE TO THE EXCLUSIVE RIGHT TO USE "INDEX", APART FROM THE MARK AS SHOWN.  
FOR UNCOATED PRINTING PAPER (U.S. CLS. 2, 5, 22, 23, 29, 37, 38 AND 50).  
FIRST USE 3-1-2009; IN COMMERCE 3-1-2009.

3,962,665. SHANNON BELL, MARY, DBA LOVING GIFTS FROM HEAVEN, MIDDLETOWN, MD. SN 77-854,837. PUB. 4-27-2010, FILED 10-22-2009.

## Loving Gifts From Heaven

THE MARK CONSISTS OF STANDARD CHARACTERS WITHOUT CLAIM TO ANY PARTICULAR FONT, STYLE, SIZE, OR COLOR.

FOR A SERIES OF BOOKS, WRITTEN ARTICLES, HANDOUTS AND WORKSHEETS IN THE FIELD OF SPIRITUALITY (U.S. CLS. 2, 5, 22, 23, 29, 37, 38 AND 50).  
FIRST USE 1-1-2010; IN COMMERCE 1-1-2010.

3,962,603. WINDROSE GROUP, LLC, GREENWOOD VILLAGE, CO. SN 77-831,277. PUB. 8-3-2010, FILED 9-21-2009.

## NOVEL BRIEFS

THE MARK CONSISTS OF STANDARD CHARACTERS WITHOUT CLAIM TO ANY PARTICULAR FONT, STYLE, SIZE, OR COLOR.

FOR CUSTOMIZABLE JOURNALS AND BOOKMARKS (U.S. CLS. 2, 5, 22, 23, 29, 37, 38 AND 50).  
FIRST USE 3-22-2011; IN COMMERCE 3-22-2011.

3,962,707. BLESSED FOOTSTEPS, INC., DBA BLESSED FOOTSTEPS, INC., POWDER SPRINGS, GA. SN 77-867,783. PUB. 6-1-2010, FILED 11-8-2009.



NO CLAIM IS MADE TO THE EXCLUSIVE RIGHT TO USE "INC.", APART FROM THE MARK AS SHOWN.

**CLASS 16—(Continued).**

THE MARK CONSISTS OF STYLIZED LETTERS.  
FOR NON-FICTION BOOKS ON A VARIETY OF TOPICS; SERIES OF FICTION BOOKS (U.S. CLS. 2, 5, 22, 23, 29, 37, 38 AND 50).  
FIRST USE 1-15-2011; IN COMMERCE 1-15-2011.

**MILITARY KIDS SPEAK**

THE MARK CONSISTS OF STANDARD CHARACTERS WITHOUT CLAIM TO ANY PARTICULAR FONT, STYLE, SIZE, OR COLOR.

NO CLAIM IS MADE TO THE EXCLUSIVE RIGHT TO USE "MILITARY KIDS", APART FROM THE MARK AS SHOWN.

FOR SERIES OF NON-FICTION BOOKS IN THE FIELD OF LIFE AS A CHILD WHO HAS A PARENT IN THE MILITARY (U.S. CLS. 2, 5, 22, 23, 29, 37, 38 AND 50).  
FIRST USE 12-20-2010; IN COMMERCE 12-20-2010.

3,962,825. UNIVERSITY OF MARYLAND UNIVERSITY COLLEGE, ADELPHI, MD. SN 77-908,786. PUB. 5-25-2010, FILED 1-11-2010.

**UMUC Teachers Press**

THE MARK CONSISTS OF STANDARD CHARACTERS WITHOUT CLAIM TO ANY PARTICULAR FONT, STYLE, SIZE, OR COLOR.

OWNER OF U.S. REG. NOS. 2,255,012 AND 2,433,389.

NO CLAIM IS MADE TO THE EXCLUSIVE RIGHT TO USE "TEACHERS PRESS", APART FROM THE MARK AS SHOWN.

FOR EDUCATIONAL PUBLICATIONS, NAMELY, BOOKS, JOURNALS, AND PRINTED INSTRUCTIONAL, EDUCATIONAL, AND TEACHING MATERIALS IN THE FIELDS OF TEACHER EDUCATION, HIGHER EDUCATION, AND ONLINE LEARNING (U.S. CLS. 2, 5, 22, 23, 29, 37, 38 AND 50).  
FIRST USE 1-1-2009; IN COMMERCE 1-1-2009.

**CLASS 16—(Continued).**

3,962,837. IBASIS, INC., BURLINGTON, MA. SN 77-912,315. PUB. 11-2-2010, FILED 1-14-2010.

**EU AMO BRASIL**

THE MARK CONSISTS OF STANDARD CHARACTERS WITHOUT CLAIM TO ANY PARTICULAR FONT, STYLE, SIZE, OR COLOR.

NO CLAIM IS MADE TO THE EXCLUSIVE RIGHT TO USE "BRASIL", APART FROM THE MARK AS SHOWN.

THE ENGLISH TRANSLATION OF "EU AMO BRASIL" IN THE MARK IS "I LOVE BRAZIL".

FOR PRE-PAID TELEPHONE CALLING CARDS, NOT MAGNETICALLY ENCODED; TELEPHONE CALLING CARDS, NOT MAGNETICALLY ENCODED (U.S. CLS. 2, 5, 22, 23, 29, 37, 38 AND 50).  
FIRST USE 3-1-2011; IN COMMERCE 3-1-2011.

3,962,840. A WELL BALANCED HOME, LLC, DBA THE BARF BOUTIQUE, SEATTLE, WA. SN 77-912,481. PUB. 6-1-2010, FILED 1-15-2010.

**The Barf Boutique bags  
that make you laugh,  
giggle & smile**

THE MARK CONSISTS OF STANDARD CHARACTERS WITHOUT CLAIM TO ANY PARTICULAR FONT, STYLE, SIZE, OR COLOR.

OWNER OF U.S. REG. NO. 3,750,425.

NO CLAIM IS MADE TO THE EXCLUSIVE RIGHT TO USE "BARF" AND "BAG", APART FROM THE MARK AS SHOWN.

FOR LEAK RESISTANT PAPER AND PLASTIC BAGS USED AS SICKNESS RECEPTACLES, WHICH MAY OR MAY NOT FEATURE ARTWORK, DESIGNS, AND/OR WORDS (U.S. CLS. 2, 5, 22, 23, 29, 37, 38 AND 50).  
FIRST USE 2-7-2011; IN COMMERCE 2-7-2011.

3,962,952. PROFESSIONAL DISPOSABLES INTERNATIONAL, INC., ORANGEBURG, NY. SN 77-937,719. PUB. 7-13-2010, FILED 2-17-2010.

**SANI-TAG**

THE MARK CONSISTS OF STANDARD CHARACTERS WITHOUT CLAIM TO ANY PARTICULAR FONT, STYLE, SIZE, OR COLOR.



**CLASS 16—(Continued).**

OWNER OF U.S. REG. NOS. 2,565,754, 3,573,276, AND OTHERS.

FOR STICKERS FOR LABELING EQUIPMENT; PLASTIC STICKERS FOR LABELING EQUIPMENT (U.S. CLS. 2, 5, 22, 23, 29, 37, 38 AND 50).

FIRST USE 3-4-2011; IN COMMERCE 3-4-2011.

**CLASS 16—(Continued).**

3,963,022. AUGUST, JENN, LOS GATOS, CA. SN 77-946,985. PUB. 7-27-2010, FILED 3-1-2010.

---

**Remove Your Blocks So Your  
Business Rocks**

3,962,971. PFEIFFER, LAURENCE, COBLESKILL, NY. SN 77-941,886. PUB. 8-10-2010, FILED 2-22-2010.

THE MARK CONSISTS OF STANDARD CHARACTERS WITHOUT CLAIM TO ANY PARTICULAR FONT, STYLE, SIZE, OR COLOR.

FOR BOOKS IN THE FIELD OF BUSINESS MOTIVATION AND HYPNOTHERAPY (U.S. CLS. 2, 5, 22, 23, 29, 37, 38 AND 50).

FIRST USE 2-0-2011; IN COMMERCE 2-0-2011.

---

**WORDS OF WISDOM**

3,963,081. DOYLE, MANON, DUBLIN, OH. SN 77-954,157. PUB. 8-3-2010, FILED 3-9-2010.

THE MARK CONSISTS OF STANDARD CHARACTERS WITHOUT CLAIM TO ANY PARTICULAR FONT, STYLE, SIZE, OR COLOR.

FOR PUBLICATIONS, NAMELY, A SERIES OF NON-FICTION INSTRUCTIONAL BOOKS, GUIDES, MANUALS, AND CATALOGS IN THE FIELDS OF LAW, ECONOMICS, MEDICINE, DENTISTRY, VETERINARY MEDICINE, NURSING, EDUCATION, ACCOUNTING, FINANCE, AND ARCHITECTURE (U.S. CLS. 2, 5, 22, 23, 29, 37, 38 AND 50).

FIRST USE 10-27-2009; IN COMMERCE 3-29-2011.



**SISTERS OF THE SUN**

THE MARK CONSISTS OF A CIRCLE CONTAINING A HEART WITH AN OVERLAPPING QUARTER-CIRCULAR BAND IN REVERSE NEGATIVE WITH SMALL, POINTED SUNRAYS. THE CIRCLE CONTAINING THE HEART HAS 4 LINES OF VARIOUS LENGTHS COMING FROM EACH SIDE AND THE TOP AND BOTTOM OF THE CIRCLE.

FOR ART PRINTS; GREETINGS CARDS AND POSTCARDS; NOTEBOOKS; PAINTINGS IN MIXED MEDIA (U.S. CLS. 2, 5, 22, 23, 29, 37, 38 AND 50).

FIRST USE 9-0-2010; IN COMMERCE 9-0-2010.

3,963,011. RITZ CAMERA & IMAGE, L.L.C., BELTSVILLE, MD. SN 77-945,551. PUB. 7-13-2010, FILED 2-26-2010.

---

**RITZPIX POCKETPIX**

3,963,108. PET VALU CANADA INC., MARKHAM, ONTARIO, CANADA. SN 77-956,551. PUB. 8-31-2010, FILED 3-11-2010.

---

**PET VALU COMPANION**

THE MARK CONSISTS OF STANDARD CHARACTERS WITHOUT CLAIM TO ANY PARTICULAR FONT, STYLE, SIZE, OR COLOR.

OWNER OF U.S. REG. NOS. 1,594,588, 2,704,028, AND OTHERS.

FOR PHOTO BOOKS (U.S. CLS. 2, 5, 22, 23, 29, 37, 38 AND 50).

FIRST USE 4-15-2010; IN COMMERCE 4-15-2010.

THE MARK CONSISTS OF STANDARD CHARACTERS WITHOUT CLAIM TO ANY PARTICULAR FONT, STYLE, SIZE, OR COLOR.

OWNER OF U.S. REG. NOS. 1,563,967, 1,980,978, AND OTHERS.

NO CLAIM IS MADE TO THE EXCLUSIVE RIGHT TO USE "PET", APART FROM THE MARK AS SHOWN.

FOR MAGAZINES AND BULLETINS PUBLISHED PERIODICALLY IN THE FIELD OF PETS AND PET OWNERSHIP (U.S. CLS. 2, 5, 22, 23, 29, 37, 38 AND 50).

FIRST USE 4-30-2010; IN COMMERCE 4-30-2010.

**CLASS 16—(Continued).**

3,963,111. TREPSI, S.A. DE C.V., HUIXQUILUCAN, MEXICO.  
SN 77-956,930. PUB. 8-3-2010, FILED 3-11-2010.



THE COLOR(S) MEDIUM BLUE, DARK BLUE, YELLOW, BEIGE, WHITE, AND BLACK IS/ARE CLAIMED AS A FEATURE OF THE MARK.

THE MARK CONSISTS OF STANDING BIRD WITH WINGS OUTSTRETCHED IN A MEDIUM SHADE OF BLUE WITH INNER WING FEATHERS IN DARKER BLUE, YELLOW BEAK WITH BEIGE INSIDE MOUTH, YELLOW FEET, WHITE, BLUE AND BLACK RIMMED EYES.

FOR PRINTED GOODS AND PUBLICATIONS, NAMELY, CHILDREN'S BOOKS, CHILDREN'S EDUCATIONAL BOOKS AND MAGAZINES, PAPER PARTY FAVORS, PAPER TABLECLOTHS, PAPER INVITATIONS, THANK YOU NOTES, NOTEBOOKS; SCHOOL SUPPLIES, NAMELY, PENS, PENCILS, FOLDERS, MEMO PADS AND STICKERS (U.S. CLS. 2, 5, 22, 23, 29, 37, 38 AND 50).

FIRST USE 1-31-2003; IN COMMERCE 1-31-2003.

3,963,114. HARRIS, JOHN E, VACAVILLE, CA. SN 77-957,226.  
PUB. 8-3-2010, FILED 3-11-2010.

# FTK

THE MARK CONSISTS OF STANDARD CHARACTERS WITHOUT CLAIM TO ANY PARTICULAR FONT, STYLE, SIZE, OR COLOR.

FOR BOXES OF PAPER; BOXES OF PAPER OR CARDBOARD; ENVELOPES FOR STATIONERY USE; OFFICE PAPER STATIONERY; OFFICE STATIONERY; PAPER STATIONERY; STATIONERY; STATIONERY BOXES; STATIONERY FOLDERS; STATIONERY WRITING PAPER AND ENVELOPES; STICKERS (U.S. CLS. 2, 5, 22, 23, 29, 37, 38 AND 50).

FIRST USE 2-0-2011; IN COMMERCE 2-0-2011.

**CLASS 16—(Continued).**

3,963,115. HARRIS, JOHN E, VACAVILLE, CA. SN 77-957,230.  
PUB. 8-3-2010, FILED 3-11-2010.

## FOR THE KINGDOM

THE MARK CONSISTS OF STANDARD CHARACTERS WITHOUT CLAIM TO ANY PARTICULAR FONT, STYLE, SIZE, OR COLOR.

FOR BOXES OF PAPER; BOXES OF PAPER OR CARDBOARD; ENVELOPES FOR STATIONERY USE; OFFICE PAPER STATIONERY; OFFICE STATIONERY; PAPER STATIONERY; STATIONERY; STATIONERY BOXES; STATIONERY FOLDERS; STATIONERY WRITING PAPER AND ENVELOPES; STICKERS (U.S. CLS. 2, 5, 22, 23, 29, 37, 38 AND 50).

FIRST USE 2-0-2011; IN COMMERCE 2-0-2011.

3,963,147. BARRISTO ENTERPRISES, INC., CHICAGO, IL.  
SN 77-960,910. PUB. 8-10-2010, FILED 3-17-2010.

## SUREFLEX

THE MARK CONSISTS OF STANDARD CHARACTERS WITHOUT CLAIM TO ANY PARTICULAR FONT, STYLE, SIZE, OR COLOR.

OWNER OF U.S. REG. NOS. 1,446,311, 2,386,258, AND 3,045,139.

FOR MULTI-PURPOSE ADHESIVE FOR HARD PLASTICS, METALS, WOOD, TILE, GLASS, CHINA, FABRIC AND CERAMICS FOR STATIONERY OR HOUSEHOLD PURPOSES (U.S. CLS. 2, 5, 22, 23, 29, 37, 38 AND 50).

FIRST USE 4-15-2010; IN COMMERCE 4-15-2010.

**CLASS 16—(Continued).**

3,963,169. ALLEN, THOMAS L., DBA FRIENDLY GREETINGS, INC., WINTER GARDEN, FL. SN 77-962,134. PUB. 8-10-2010, FILED 3-18-2010.

## Friendly Kritters

THE MARK CONSISTS OF STANDARD CHARACTERS WITHOUT CLAIM TO ANY PARTICULAR FONT, STYLE, SIZE, OR COLOR.

FOR ADDRESS BOOKS; ADDRESS BOOKS AND DIARIES; APPOINTMENT BOOKS; BABY BOOKS; BIRTHDAY BOOKS; BOOK COVERS; BOOK MARKERS; BOOK MARKS; BOOK-COVER PAPER; BRAG BOOKS; CHILDREN'S ACTIVITY BOOKS; CHILDREN'S BOOKS; CHILDREN'S INTERACTIVE EDUCATIONAL BOOKS; COLORING BOOKS; DATE BOOKS; EDUCATIONAL PUBLICATIONS, NAMELY, BOOKS, HAND-OUTS, WORKBOOKS, JOURNALS, PLAYBOOKS, WORKSHEETS AND CARDS IN THE FIELD OF RIGHT-BRAIN FITNESS; MEMORANDUM BOOKS; MEMORY BOOKS; NOTE BOOKS; PERSONALIZED COLORING BOOKS FOR CHILDREN; PICTURE BOOKS; PRINTED MATERIALS, NAMELY, NOVELS AND SERIES OF FICTION BOOKS AND SHORT STORIES FEATURING SCENES AND CHARACTERS BASED ON VIDEO GAMES; PRINTED MATTER, NAMELY, NEWSPAPERS, PHOTOGRAPHS, MAGAZINES, BOOKS, PRINTED PERIODICALS, NEWSLETTERS, AND BROCHURES ALL IN THE FIELDS OF SECURITIES, OPTIONS AND OTHER FINANCIAL INSTRUMENTS; PROTECTIVE COVERS FOR BOOKS; RELIGIOUS BOOKS; SCHOOL SUPPLY KITS CONTAINING VARIOUS COMBINATIONS OF SELECTED SCHOOL SUPPLIES, NAMELY, WRITING INSTRUMENTS, PENS, PENCILS, MECHANICAL PENCILS, ERASERS, MARKERS, CRAYONS, HIGHLIGHTER PENS, FOLDERS, NOTEBOOKS, PAPER, PROTRACTORS, PAPER CLIPS, PENCIL SHARPENERS, WRITING GRIPS, GLUE AND BOOK MARKS; SCRAP BOOKS; SKETCH BOOKS; STORY BOOKS; WEDDING BOOKS (U.S. CLS. 2, 5, 22, 23, 29, 37, 38 AND 50).

FIRST USE 1-1-1990; IN COMMERCE 1-1-1990.

3,963,181. RA, MAXWEALTH, AKA RA, MAX, LANCASTER, CA. SN 77-963,691. PUB. 8-10-2010, FILED 3-19-2010.

## Cosmic Faith

THE MARK CONSISTS OF STANDARD CHARACTERS WITHOUT CLAIM TO ANY PARTICULAR FONT, STYLE, SIZE, OR COLOR.

NO CLAIM IS MADE TO THE EXCLUSIVE RIGHT TO USE "FAITH", APART FROM THE MARK AS SHOWN.

FOR RELIGIOUS BOOKS (U.S. CLS. 2, 5, 22, 23, 29, 37, 38 AND 50).

FIRST USE 7-1-2010; IN COMMERCE 7-1-2010.

**CLASS 16—(Continued).**

3,963,239. DISNEY ENTERPRISES, INC., BURBANK, CA. SN 77-981,573. PUB. 7-27-2010, FILED 10-9-2009.

## MAD HATTER

THE MARK CONSISTS OF STANDARD CHARACTERS WITHOUT CLAIM TO ANY PARTICULAR FONT, STYLE, SIZE, OR COLOR.

FOR A SERIES OF FICTION BOOKS; APPLIQUÉS IN THE FORM OF DECALS; ART PRINTS; ARTS AND CRAFT PAINT KITS; BOOKS FEATURING STORIES, GAMES AND ACTIVITIES FOR CHILDREN; CALENDARS; CHILDREN'S ACTIVITY BOOKS; COMIC BOOKS; DECALS; PAPER NAPKINS; PAPERWEIGHTS; PHOTOGRAPH ALBUMS; PICTURE BOOKS; RECIPE BOOKS; STAPLERS; STICKERS (U.S. CLS. 2, 5, 22, 23, 29, 37, 38 AND 50).

FIRST USE 7-1-2008; IN COMMERCE 7-1-2008.

3,963,274. SELLARS ABSORBENT MATERIALS, INC., MILWAUKEE, WI. SN 77-981,801. PUB. 8-24-2010, FILED 3-10-2009.



NO CLAIM IS MADE TO THE EXCLUSIVE RIGHT TO USE "GREEN", APART FROM THE MARK AS SHOWN.

THE COLOR(S) GREEN, BLACK, YELLOW, AND TAN IS/ARE CLAIMED AS A FEATURE OF THE MARK.

THE MARK CONSISTS OF THE WORD "GREEN" IN GREEN WITH A BLACK BORDER AND THE LETTER "X" IN BLACK WITH A GREEN BORDER, WITH A YELLOW SUN OVER THE WORD "GREEN", ALL WITH A TAN BACKGROUND.

FOR PAPER TOWELS COMPRISED OF WOOD PULP AND BINDING AGENTS (U.S. CLS. 2, 5, 22, 23, 29, 37, 38 AND 50).

FIRST USE 6-19-2009; IN COMMERCE 6-19-2009.

**CLASS 16—(Continued).**

3,963,327. BEECON LEARNING, LLC, DALLAS, TX. SN 85-004,968. PUB. 11-23-2010, FILED 4-2-2010.

# KINDERKIT

THE MARK CONSISTS OF STANDARD CHARACTERS WITHOUT CLAIM TO ANY PARTICULAR FONT, STYLE, SIZE, OR COLOR.

FOR EDUCATIONAL KITS CONTAINING PRINTED EDUCATIONAL AND TEACHING MATERIALS, STICKERS, POSTERS, NOTE PADS, BOOKS, PUZZLES, GAMES, PUPPETS, MANIPULATIVES, AND TOYS SOLD AS A UNIT FOR USE IN TEACHING YOUNG CHILDREN COGNITIVE AREAS SUCH AS SCIENCE, MATH, PHONICS, READING, AND LANGUAGE SKILLS (U.S. CLS. 2, 5, 22, 23, 29, 37, 38 AND 50).

FIRST USE 5-13-2010; IN COMMERCE 5-13-2010.

3,963,360. THE BRAMTON COMPANY, IRVING, TX. SN 85-009,793. PUB. 8-31-2010, FILED 4-8-2010.

# ECO-CARE

THE MARK CONSISTS OF STANDARD CHARACTERS WITHOUT CLAIM TO ANY PARTICULAR FONT, STYLE, SIZE, OR COLOR.

FOR ENVIRONMENTALLY FRIENDLY, DISPOSABLE HOUSETRAINING PADS MADE OF RECYCLED MATERIAL FOR USE IN TRAINING DOGS (U.S. CLS. 2, 5, 22, 23, 29, 37, 38 AND 50).

FIRST USE 3-1-2010; IN COMMERCE 3-1-2010.

3,963,368. RA, MAXWEALTH, AKA RA, MAX, LANCASTER, CA. SN 85-011,404. PUB. 8-10-2010, FILED 4-12-2010.

# Crystal Ball

THE MARK CONSISTS OF STANDARD CHARACTERS WITHOUT CLAIM TO ANY PARTICULAR FONT, STYLE, SIZE, OR COLOR.

FOR BOOKS IN THE FIELD OF ASTROLOGY (U.S. CLS. 2, 5, 22, 23, 29, 37, 38 AND 50).

FIRST USE 7-1-2010; IN COMMERCE 7-1-2010.

**CLASS 16—(Continued).**

3,963,477. DILL-SCHMIDT, JANICE, VALENCIA, CA. SN 85-038,196. PUB. 10-19-2010, FILED 5-13-2010.

# Flip It

THE MARK CONSISTS OF STANDARD CHARACTERS WITHOUT CLAIM TO ANY PARTICULAR FONT, STYLE, SIZE, OR COLOR.

FOR OFFICE DESK CARDS IN THE NATURE OF PRINTED INFORMATIONAL CARDS ATTACHED TO A STAND FOR THE PURPOSE OF SWITCHING PRINTED CARDS THAT INDICATE THE REASON WHY THE DESK'S OCCUPANT IS NOT AT THEIR DESK (U.S. CLS. 2, 5, 22, 23, 29, 37, 38 AND 50).

FIRST USE 7-31-2010; IN COMMERCE 12-14-2010.

3,963,485. ABELMANN, JERYL J, ALAMO, CA. SN 85-040,791. PUB. 10-19-2010, FILED 5-17-2010.



THE COLOR(S) BLACK IS/ARE CLAIMED AS A FEATURE OF THE MARK.

THE MARK CONSISTS OF THE DANCING MOMMY WHICH IS A BLACK SILHOUETTE SHOWING A WOMAN FLIPPING A PANCAKE WITH A SPATULA.

FOR A SERIES OF BOOKS, WRITTEN ARTICLES, HANDOUTS AND WORKSHEETS IN THE FIELD OF COOKING CHILDREN; APPOINTMENT BOOKS; AUTOGRAPH BOOKS; BABY BOOKS; BIRTHDAY BOOKS; BLANK JOURNAL BOOKS; BOOK COVERS; BOOK MARKERS; BOOK MARKS; BOOK PLATES; BOOK-COVER PAPER; BOOKS IN THE FIELD OF COOKING CHILDREN; CHILDREN'S ACTIVITY BOOKS; CHILDREN'S BOOKS; CHILDREN'S INTERACTIVE EDUCATIONAL BOOKS; CHILDREN'S STORYBOOKS; CHILDREN'S WALL STICKERS AND MURALS; CHILDREN'S ARTS AND CRAFTS PAPER KITS; COFFEE TABLE BOOKS FEATURING CHILDREN COOKING; COLORING BOOKS; COMIC BOOKS; COMMEMORATIVE BOOKS FEATURING CHILDREN COOKING; COMPOSITION BOOKS; COOK BOOKS; EDUCATIONAL BOOKS FEATURING CHILDREN COOKING; EDUCATIONAL KITS SOLD AS A UNIT IN THE FIELD OF CHILDREN COOKING CONSISTING PRIMARILY OF EDUCATIONAL BOOKS, FLASH CARDS AND WORKSHEETS, AND ALSO INCLUDING AN EDUCATIONAL DVD; EDUCATIONAL PUBLICATIONS, NAMELY, BOOKS, HAND-OUTS, WORKBOOKS, JOURNALS, PLAYBOOKS, WORKSHEETS AND CARDS IN THE FIELD OF RIGHT-BRAIN FITNESS; EDUCATIONAL PUBLICATIONS, NAMELY, BOOKS IN THE FIELDS OF

**CLASS 16—(Continued).**

CHILDREN COOKING; FLIP BOOKS; GIFT BOOKS FEATURING CHILDREN COOKING; GIFT SETS CONSISTING OF A BOOK IN THE FIELD OF COOKING CHILDREN AND ALSO INCLUDING A BLANKET; MANUSCRIPT BOOKS; MEMORY BOOKS; PAINTING SETS FOR CHILDREN; PERSONALIZED COLORING BOOKS FOR CHILDREN; PICTURE BOOKS; POCKET MEMORANDUM BOOKS; PRINTED MATERIALS, NAMELY, NOVELS AND SERIES OF FICTION BOOKS AND SHORT STORIES FEATURING SCENES AND CHARACTERS BASED ON VIDEO GAMES; PRINTED MATTER, NAMELY, NEWSPAPERS, PHOTOGRAPHS, MAGAZINES, BOOKS, PRINTED PERIODICALS, NEWSLETTERS, AND BROCHURES ALL IN THE FIELDS OF SECURITIES, OPTIONS AND OTHER FINANCIAL INSTRUMENTS; PRINTED MUSIC BOOKS; PROTECTIVE COVERS FOR SHEETS OR PAPER AND PAGES OF BOOKS AND THE LIKE; PUBLICATIONS, NAMELY, BOOKS IN THE FIELDS OF CHILDREN COOKING; RECIPE BOOKS; REFERENCE BOOKS IN THE FIELD OF COOKING CHILDREN; RESOURCE BOOKS IN THE FIELD OF CHILDREN COOKING; SCHOOL SUPPLY KITS CONTAINING VARIOUS COMBINATIONS OF SELECTED SCHOOL SUPPLIES, NAMELY, WRITING INSTRUMENTS, PENS, PENCILS, MECHANICAL PENCILS, ERASERS, MARKERS, CRAYONS, HIGHLIGHTER PENS, FOLDERS, NOTEBOOKS, PAPER, PROTRACTORS, PAPER CLIPS, PENCIL SHARPENERS, WRITING GRIPS, GLUE AND BOOK MARKS; SCHOOL WRITING BOOKS; SCRAP BOOKS; SERIES OF FICTION BOOKS; SERIES OF FICTION WORKS, NAMELY, NOVELS AND BOOKS; SERIES OF NON-FICTION BOOKS IN THE FIELD OF CHILDREN COOKING; SKETCH BOOKS; SONG BOOKS; STORY BOOKS; TALKING CHILDREN'S BOOKS; WIREBOUND BOOKS (U.S. CLS. 2, 5, 22, 23, 29, 37, 38 AND 50).

FIRST USE 3-1-2008; IN COMMERCE 3-1-2008.

3,963,503. POWERPLAY STRATEGIES INCORPORATED, SURREY, BC, CANADA. SN 85-045,299. PUB. 10-19-2010, FILED 5-21-2010.

**CIA CARING IN ACTION**

THE MARK CONSISTS OF STANDARD CHARACTERS WITHOUT CLAIM TO ANY PARTICULAR FONT, STYLE, SIZE, OR COLOR.

PRIORITY CLAIMED UNDER SEC. 44(D) ON CANADA APPLICATION NO. 1463810, FILED 12-22-2009.

FOR PRINTED EDUCATIONAL MATERIALS, NAMELY, TEACHER MANUALS WHICH INCLUDE LESSON PLANS, ACTIVITY SHEETS, PLANNING TOOLS AND EVALUATIONS, TO EDUCATE K-12 STUDENTS IN THE DEVELOPMENT SOCIAL RESPONSIBILITY, DEVELOPMENT OF THE LANGUAGE ARTS, NAMELY, THE SKILLS OF READING, WRITING AND ORAL COMMUNICATION, SUPPORTING THE COMMUNITY THROUGH ACTS OF CARING, SETTING GOALS, IMPLEMENTING ACTION PLANS, BUILDING SELF-CONFIDENCE, DEVELOPMENT OF PROBLEM SOLVING SKILLS, UTILIZING CREATIVE THINKING AND DEVELOPING LEADERSHIP (U.S. CLS. 2, 5, 22, 23, 29, 37, 38 AND 50).

FIRST USE 12-31-2010; IN COMMERCE 12-31-2010.

**CLASS 16—(Continued).**

3,963,522. SOMETRICS, INC., EL SEGUNDO, CA. SN 85-049,649. PUB. 11-23-2010, FILED 5-27-2010.

**GAME COINS**

THE MARK CONSISTS OF STANDARD CHARACTERS WITHOUT CLAIM TO ANY PARTICULAR FONT, STYLE, SIZE, OR COLOR.

NO CLAIM IS MADE TO THE EXCLUSIVE RIGHT TO USE "GAME", APART FROM THE MARK AS SHOWN.

FOR PREPAID CARDS FOR VIRTUAL CURRENCY AND NON-MONETARY CREDITS AND POINTS FOR USE BY MEMBERS OF ON-LINE VIRTUAL COMMUNITIES (U.S. CLS. 2, 5, 22, 23, 29, 37, 38 AND 50).

FIRST USE 6-15-2010; IN COMMERCE 6-15-2010.

3,963,543. SAMMONS III, JOHN F, FORT WORTH, TX. SN 85-059,280. PUB. 11-2-2010, FILED 6-10-2010.

**ECO-CORRECT**

THE MARK CONSISTS OF STANDARD CHARACTERS WITHOUT CLAIM TO ANY PARTICULAR FONT, STYLE, SIZE, OR COLOR.

FOR ADVERTISING SIGNS OF PAPER OR CARDBOARD; BIODEGRADABLE PAPER PULP-BASED TO-GO CONTAINERS FOR FOOD; BOTTLE WRAPPERS OF CARDBOARD OR PAPER; BOXES OF CARDBOARD OR PAPER; BOXES OF PAPER; BOXES OF PAPER OR CARDBOARD; CARDBOARD; CARDBOARD BACKING FOR BINDING BOOKS; CARDBOARD BOXES; CARDBOARD CAKE BOXES; CARDBOARD CARRIERS FOR FOOD AND BEVERAGES; CARDBOARD CARTONS; CARDBOARD CONTAINERS; CARDBOARD HANG TAGS; CARDBOARD MADE FROM PAPER MULBERRY (SENKASI); CARDBOARD MAILING TUBES; CARDBOARD PACKAGING; CARDBOARD PACKAGING BOXES IN COLLAPSIBLE FORM; CARDBOARD PACKAGING BOXES IN MADE-UP FORM; CARDBOARD SIGNBOARDS; CARDBOARD TUBES; COASTERS OF PAPER; COLLAPSIBLE BOXES OF PAPER; COLLAPSIBLE CARDBOARD BOXES; COMPOSTABLE AND BIODEGRADABLE PAPER PULP-BASED TO-GO CONTAINERS FOR FOOD; CONSTRUCTION PAPER; CONTAINERS FOR ICE MADE OF PAPER OR CARDBOARD; CONTAINERS FOR STORAGE OR TRANSPORT MADE OF PAPER OR CARDBOARD; COPIER PAPER; COPY PAPER; COPYING PAPER; CORRUGATED BOARD; CORRUGATED BOARD AND PAPER CONTAINERS; CORRUGATED BOXES; CORRUGATED CARDBOARD; CORRUGATED CARDBOARD BOXES; CORRUGATED CONTAINERS; CORRUGATED PAPER; CORRUGATED PAPER PANELS LAMINATED WITH BLEACHED WHITE PAPER PRIMARILY FOR APPLICATION OF PRINTED MEDIA FOR FURTHER USE IN SIGNAGE APPLICATIONS; CORRUGATED PAPER PANELS LAMINATED WITH KRAFT LINERBOARD PRIMARILY FOR LAMINATION WITH DECORATIVE OVERLAYS FOR FURTHER USE IN THE CONSTRUCTION OF WALL PARTITIONS, ROOM DIVIDERS, DESKTOPS AND TABLETOPS; CORRUGATED RECORD STORAGE BOXES; CRAFT PAPER; DISPOSABLE PAPER SHEETS FOR PERSONAL HYGIENIC USE IN THE NATURE OF DISPOSABLE HEADREST COVERS NOT



**CLASS 16—(Continued).**

FOR MEDICAL USE; DRAWING PAPER; EMBROIDERY DESIGN PATTERNS; ENVELOPE PAPER; FACE TOWELS OF PAPER; FLUTING PAPER; FREE-STANDING AND WALL-MOUNTED PAPER AND CARDBOARD BOXES FOR DEPOSITING A WRITTEN MESSAGE OR PRAYER WISHING A LOVED ONE WELL, FOR USE IN HOSPITALS, ELDER CARE RESIDENCES, SCHOOLS, AND INSTITUTIONS FOR CHILDREN WITH SPECIAL NEEDS; GARBAGE BAGS OF PAPER; GIFT BOXES MADE OF CARDBOARD; GIFT WRAP PAPER EMBEDDED WITH WILDFLOWER SEEDS; GIFT WRAPPING PAPER; GROCERY PAPER; HAND TOWELS OF PAPER; HANDPAINTED PAPER WINE BOTTLE LABELS; HAT BOXES OF CARDBOARD; HYGIENIC PAPER; INDUSTRIAL PACKAGING CONTAINERS OF PAPER; INSULATED SHIPPING CONTAINERS FOR TRANSPORTING FROZEN MATERIALS MADE OF PAPER OR CARDBOARD; KRAFT PAPER; LABEL PAPER; LAMINATED PAPER; LAMINATED PAPERS TO BE AFFIXED TO THE SURFACE OF FURNITURE; LINERBOARD FOR CORRUGATED CARDBOARD; LINING PAPER; MULCH PAPER; NAPKIN PAPER; OILPROOF PAPER; PACKAGING AND CONTAINERS COMPRISED OF STARCH-BASED MATERIALS IN THE NATURE OF A PAPER SUBSTITUTE FOR FOOD, BEVERAGES AND CONSUMER PRODUCTS; PACKAGING CONTAINERS OF PAPER; PACKAGING MATERIALS MADE FROM MINERAL-BASED PAPER SUBSTITUTES; PACKAGING MATERIALS MADE OF RECYCLED PAPER; PACKING CARDBOARD; PACKING CARDBOARD CONTAINERS; PACKING PAPER; PAINT TRAY LINERS OF PAPER OR PLASTIC; PAPER; PAPER AND CARDBOARD; PAPER BADGES; PAPER BAGS; PAPER BAGS AND SACKS; PAPER BAGS FOR PACKAGING; PAPER BANNERS; PAPER BOARD; PAPER BOARDS; PAPER BOWS FOR GIFT WRAP; PAPER BOXES; PAPER BOXES FOR STORING GREETING CARDS; PAPER CLOSURES FOR CONTAINERS; PAPER CLOSURES FOR SEALING CONTAINERS; PAPER CONTAINERS; PAPER FOR BAGS AND SACKS; PAPER FOR USE IN MAKING SIGNS; PAPER FOR USE IN THE GRAPHIC ARTS INDUSTRY; PAPER FOR WRAPPING AND PACKAGING; PAPER GARBAGE BAGS; PAPER HAND-TOWELS; PAPER HANDKERCHIEFS; PAPER HANDTOWELS; PAPER IDENTIFICATION TAGS; PAPER KNIVES; PAPER MACHE; PAPER MATS; PAPER NAME BADGES; PAPER NAPKINS; PAPER NOTE TABLETS; PAPER NOTEBOOKS; PAPER PACKAGING AND CONTAINERS FOR FOOD AND BEVERAGES COMPRISED OF MATERIALS DESIGNED TO LESSEN ADVERSE EFFECTS ON THE ENVIRONMENT; PAPER PLACE MATS; PAPER POUCHES FOR PACKAGING; PAPER PRODUCTS, NAMELY, PAPER TUBES; PAPER PRODUCTS, NAMELY, PAPER TUBES AND PAPER CORES; PAPER RACKS; PAPER REFUSE BAGS; PAPER SHOPPING BAGS; PAPER TABLE CLOTHS; PAPER TABLE LINENS; PAPER TABLECLOTHS; PAPER TAKE-OUT CARTONS FOR FOOD; PAPER TISSUES; PAPER TISSUES FOR COSMETIC USE; PAPER TOILET BOWL LINERS; PAPER TOWELS; PAPER TRAY COVERS; PAPER WINE GIFT BAGS; PAPERBOARD; PAPERS FOR HOUSEHOLD AND INDUSTRIAL USE; PICTURE MOUNTS OF CARDBOARD; PLACARDS OF PAPER OR CARDBOARD; PLACE MATS OF PAPER; PLASTIC BAGS IN THE SHAPE OF TUBES FOR THE STORAGE AND DISPOSAL OF WASTE, INCLUDING SANITARY WASTE SUCH AS DIAPERS AND NAPPIES, FEMININE HYGIENE PRO-

**CLASS 16—(Continued).**

DUCTS AND INCONTINENCE PRODUCTS; PLASTIC OR PAPER BAGS FOR HOUSEHOLD USE; POSTCARD PAPER; PRINTED ADVERTISING BOARDS OF PAPER OR CARDBOARD; PRINTED PAPER SIGNS; PRINTING PAPER; RECYCLED BOND PAPER; RECYCLED PAPER; RIBBONS AND BANDS MADE OF PAPER AND CARDBOARD FOR USE ON FLORAL CONTAINERS; RUBBISH BAGS (MADE OF PAPER OR PLASTIC MATERIALS); SAFETY PAPER; SEMI-PROCESSED PAPER; TABLE CLOTHS OF PAPER; TABLE LINENS OF PAPER; TABLE MATS OF PAPER; TABLE NAPKINS OF PAPER; TISSUE PAPER; TISSUES OF PAPER FOR REMOVING MAKE-UP; TOILET PAPER; TOILET SEAT COVER PAPER; TOILET TRAINING TARGETS MADE OF PAPER; TRADING CARD DISCS OF PAPER OR CARDBOARD; TYPEWRITER PAPER; UNPRINTED PAPER; WOOD PULP PAPER; WORKS OF ART MADE FROM CUSTOM MANUFACTURED PAPER; WRAPPING PAPER; WRITING PAPER; WRITING PAPER HOLDERS; WRITING PAPER PADS (U.S. CLS. 2, 5, 22, 23, 29, 37, 38 AND 50).

FIRST USE 6-18-2010; IN COMMERCE 1-10-2011.

3,963,668. HANSEN BEVERAGE COMPANY, CORONA, CA. SN 85-094,343. PUB. 12-28-2010, FILED 7-28-2010.



THE MARK CONSISTS OF A STYLIZED LETTER "M" IN THE FORM OF A CLAW.

FOR STICKERS; STICKER KITS COMPRISING STICKERS AND DECALS; DECALS; POSTERS (U.S. CLS. 2, 5, 22, 23, 29, 37, 38 AND 50).

FIRST USE 1-0-2004; IN COMMERCE 1-0-2004.

3,963,703. GEPCO INC., KENNESAW, GA. SN 85-113,530. PUB. 2-8-2011, FILED 8-23-2010.

## Pickup'N Flush

THE MARK CONSISTS OF STANDARD CHARACTERS WITHOUT CLAIM TO ANY PARTICULAR FONT, STYLE, SIZE, OR COLOR.

FOR PLASTIC BAGS FOR DISPOSING OF PET WASTE (U.S. CLS. 2, 5, 22, 23, 29, 37, 38 AND 50).

FIRST USE 4-2-2011; IN COMMERCE 4-2-2011.

**CLASS 16—(Continued).**

3,963,707. INVENT FOR LIFE, INC., GRANADA HILLS, CA. SN 85-123,473. PUB. 2-8-2011, FILED 9-5-2010.



THE COLOR(S) GREEN AND GRAY IS/ARE CLAIMED AS A FEATURE OF THE MARK.

THE MARK CONSISTS OF A SET OF THREE INTER-MESHED GEAR TEETH FOLLOWED BY THE NAME OF THE COMPANY "INVENT FOR LIFE" AND THE COMPANY MOTTO "A LIFETIME OF CREATIVITY AND INGENUITY". THE FIRST GEAR CONTAINS THE LETTER "I" AT THE HUB OF THE GEAR. THE SECOND GEAR CONTAINS THE NUMBER "4" AT THE HUB OF THE GEAR. THE THIRD GEAR CONTAINS THE LETTER "L" AT THE HUB OF THE GEAR. ALL OF THE GEARS ARE IN A GRAY COLOR. THE THREE LETTERS IN THE HUBS OF THE GEARS ARE GREEN IN COLOR. THE WORDING "INVENT FOR LIFE" IS IN THE COLOR GREEN. THE WORDING "A LIFETIME OF CREATIVITY AND INGENUITY" IS IN THE COLOR GRAY.

FOR EDUCATIONAL PUBLICATIONS, NAMELY, EDUCATIONAL LEARNING CARDS, FLASH CARDS, ACTIVITY CARDS, WORKBOOKS, TEXTBOOKS, ACTIVITY BOOKS, STORY BOOKS, PUZZLE BOOKS, PRINTED PUZZLES, TEACHER GUIDES, MANUALS, POSTERS AND EDUCATIONAL BOOKLETS IN THE FIELD OF PROBLEM SOLVING AND INVENTION; PRINTED TEACHING ACTIVITY GUIDES IN THE FIELD OF PROBLEM SOLVING AND INVENTION (U.S. CLS. 2, 5, 22, 23, 29, 37, 38 AND 50).

FIRST USE 9-1-2010; IN COMMERCE 1-12-2011.

**CLASS 17—RUBBER GOODS**

3,962,084. AMPAC HOLDINGS, LLC, CINCINNATI, OH. SN 77-296,516. PUB. 4-1-2008, FILED 10-4-2007.

## APEX 9000

THE MARK CONSISTS OF STANDARD CHARACTERS WITHOUT CLAIM TO ANY PARTICULAR FONT, STYLE, SIZE, OR COLOR.

FOR PLASTIC FILMS USED TO MANUFACTURE PACKAGING MATERIALS, BAGS AND LABELS (U.S. CLS. 1, 5, 12, 13, 35 AND 50).

FIRST USE 10-13-2010; IN COMMERCE 10-13-2010.

**CLASS 17—(Continued).**

3,962,223. PREGIS INNOVATIVE PACKAGING INC., DEER-FIELD, IL. SN 77-592,644. PUB. 3-3-2009, FILED 10-14-2008.

## ASTRO-FOAM RENEW

THE MARK CONSISTS OF STANDARD CHARACTERS WITHOUT CLAIM TO ANY PARTICULAR FONT, STYLE, SIZE, OR COLOR.

OWNER OF U.S. REG. NO. 3,299,721.

FOR FOAM PLASTIC PACKAGING MATERIAL SOLD IN ROLL AND SHEET FORM (U.S. CLS. 1, 5, 12, 13, 35 AND 50).

FIRST USE 10-1-2008; IN COMMERCE 10-1-2008.

3,962,276. TRANSCO INC., CHICAGO, IL. SN 77-664,944. PUB. 6-2-2009, FILED 2-6-2009.

## RAPIDRAP

THE MARK CONSISTS OF STANDARD CHARACTERS WITHOUT CLAIM TO ANY PARTICULAR FONT, STYLE, SIZE, OR COLOR.

FOR NON-METAL BLANKET INSULATION USED TO ENCASE VESSELS, GENERATORS, TURBINES, ENGINES, PUMPS, REACTORS, TOP HEADS, BOTTOM HEADS, FANS, BLOWERS, FLANGES, VALVES, EXHAUSTS, COMPRESSORS, EXCHANGERS, HEADERS, TANKS, DRYERS, HOPPERS, PIPES, T-JOINTS, AND ELBOWS, IN POWER GENERATING STATIONS, STEAM AND GAS TURBINES, NUCLEAR FACILITIES, AND HEAT RETENTION APPLICATIONS (U.S. CLS. 1, 5, 12, 13, 35 AND 50).

FIRST USE 11-17-1987; IN COMMERCE 11-17-1987.

3,962,422. UNITED PLASTICS CORPORATION, MOUNT AIRY, NC. SN 77-770,223. PUB. 9-29-2009, FILED 6-29-2009.

## DB-4-WALLS

THE MARK CONSISTS OF STANDARD CHARACTERS WITHOUT CLAIM TO ANY PARTICULAR FONT, STYLE, SIZE, OR COLOR.

OWNER OF U.S. REG. NO. 3,509,689.

FOR ACOUSTICAL PANELS FOR BUILDINGS (U.S. CLS. 1, 5, 12, 13, 35 AND 50).

FIRST USE 1-17-2011; IN COMMERCE 1-17-2011.

**CLASS 17—(Continued).**

3,962,889. ABT FOAM, LLC, TROUTMAN, NC. SN 77-925,026. PUB. 11-23-2010, FILED 2-1-2010.

**ADVANCED WRAP**

THE MARK CONSISTS OF STANDARD CHARACTERS WITHOUT CLAIM TO ANY PARTICULAR FONT, STYLE, SIZE, OR COLOR.

NO CLAIM IS MADE TO THE EXCLUSIVE RIGHT TO USE "WRAP", APART FROM THE MARK AS SHOWN.

FOR FOAM SHEETING FOR USE AS BUILDING INSULATION AND SHEATHING, NAMELY, LAMINATED EPS (EXPANDED POLYSTYRENE) INSULATION (U.S. CLS. 1, 5, 12, 13, 35 AND 50).

FIRST USE 5-19-2010; IN COMMERCE 5-19-2010.

3,962,926. EVA-GLORY INDUSTRIAL CO., LTD., TAI-CHUNG COUNTY, TAIWAN. SN 77-933,385. PUB. 10-12-2010, FILED 2-11-2010.



THE COLOR(S) BLUE, GREEN, WHITE IS/ARE CLAIMED AS A FEATURE OF THE MARK.

THE MARK CONSISTS OF THE LETTERS "DE-COTO". THE LETTERS "DE-COT" ARE IN BLUE, FOLLOWED BY THE LETTER "O" REPRESENTED BY A GREEN SPHERE WITH WHITE LINES. ABOVE THE LETTERS IS A GREEN LEAF, WITH A WHITE VEIN.

FOR FOAMS, FOAM BOARDS, SHOCK ABSORBING PLASTIC BUFFERS, SHEETS OF FOAM FABRIC, CUSHIONING OF PLASTIC IN THE NATURE OF STUFFING, PLASTIC STRIPS AND RUBBER STRIPS, ALL FOR SHOCK-ABSORBING, CUSHIONING AND PACKING USED IN VARIOUS MANUFACTURING INDUSTRIES; SHOCK ABSORBING FOAM BUFFERS, SHOCK ABSORBING RUBBER BUFFERS, SHOCK ABSORBING PLASTIC BUFFERS, ALL FOR USE AS A PACKING MATERIAL (U.S. CLS. 1, 5, 12, 13, 35 AND 50).

FIRST USE 2-10-2010; IN COMMERCE 3-2-2010.

3,963,212. HOBBY LOBBY STORES, INC., OKLAHOMA CITY, OK. SN 77-967,044. PUB. 1-25-2011, FILED 3-24-2010.

**SIMPLY TACKY**

THE MARK CONSISTS OF STANDARD CHARACTERS WITHOUT CLAIM TO ANY PARTICULAR FONT, STYLE, SIZE, OR COLOR.

**CLASS 17—(Continued).**

NO CLAIM IS MADE TO THE EXCLUSIVE RIGHT TO USE "TACKY", APART FROM THE MARK AS SHOWN.

FOR NON-PERMANENT ADHESIVE PUTTY (U.S. CLS. 1, 5, 12, 13, 35 AND 50).

FIRST USE 7-2-2010; IN COMMERCE 7-2-2010.

3,963,214. AAA KITCHEN & BATH DISTRIBUTOR, INC., PHILADELPHIA, PA. SN 77-967,447. PUB. 8-24-2010, FILED 3-24-2010.



NO CLAIM IS MADE TO THE EXCLUSIVE RIGHT TO USE "PAD", APART FROM THE MARK AS SHOWN.

THE COLOR(S) WHITE, LIGHT BLUE, AND SILVER OR GREY IS/ARE CLAIMED AS A FEATURE OF THE MARK.

THE MARK CONSISTS OF A RECTANGULAR REGION PRINCIPALLY BOUNDED IN LIGHT BLUE WITH A LEFT-HAND SIDE CONSISTING OF A LIGHT BLUE RECTANGULAR REGION (INTEGRAL TO THE LIGHT-BLUE BOUNDARY OF THE LARGER RECTANGULAR REGION) WITH WHITE REGIONS REPRESENTING SHEETS OR LAYERS BEING INTERLEAVED INTO THE LOWER BOUNDARY OF THE RIGHT-HAND PORTION OF THE RECTANGULAR REGION, AND WHERE THE RIGHT-HAND PORTION OF THE RECTANGULAR REGION CONSISTS OF THE WORD "SILENT" IN LOWER-CASE GREY LETTERING ABOVE THE WORD "PAD" IN LIGHT BLUE UPPER-CASE LETTERING WITH BOTH WORDS SET ON A WHITE BACKGROUND WITH A LIGHT-BLUE SEMICIRCULAR BORDER TO THE RIGHT.

FOR SOUND ABSORBING FLOORING UNDERLAYMENT; PADS TO BE PLACED UNDER HARDWOOD OR LAMINATE FLOORING TO REDUCE SOUND (U.S. CLS. 1, 5, 12, 13, 35 AND 50).

FIRST USE 7-1-2010; IN COMMERCE 7-1-2010.

3,963,336. BERRY PLASTICS CORPORATION, EVANSVILLE, IN. SN 85-006,472. PUB. 8-31-2010, FILED 4-5-2010.

**DUCTSHIELD**

NO CLAIM IS MADE TO THE EXCLUSIVE RIGHT TO USE "DUCTSHIELD", APART FROM THE MARK AS SHOWN.

**CLASS 17—(Continued).**

THE MARK CONSISTS OF THE WORD "DUCTSHIELD" WITH A SHIELD SHAPE INSIDE THE "D" AT THE END OF "DUCTSHIELD".

FOR ADHESIVE FILM TAPE FOR SURFACE PROTECTION ON DUCTS AND OTHER SURFACES (U.S. CLS. 1, 5, 12, 13, 35 AND 50).

FIRST USE 4-1-2010; IN COMMERCE 4-1-2010.

**CLASS 17—(Continued).**

3,963,664. QSPAC INDUSTRIES, INC., CERRITOS, CA. SN 85-093,202. PUB. 1-11-2011, FILED 7-26-2010.

**JUST PRINT**

3,963,387. ILLINOIS TOOL WORKS INC., GLENVIEW, IL. SN 85-015,180. PUB. 8-3-2010, FILED 4-15-2010.

**SYN-TEX**

THE MARK CONSISTS OF STANDARD CHARACTERS WITHOUT CLAIM TO ANY PARTICULAR FONT, STYLE, SIZE, OR COLOR.

FOR DUNNAGE BAGS; PACKING PADDING OF PLASTIC FOR SHIPPING CONTAINERS; PACKING PADDING OF RUBBER FOR SHIPPING CONTAINERS (U.S. CLS. 1, 5, 12, 13, 35 AND 50).

FIRST USE 0-0-1990; IN COMMERCE 0-0-1990.

THE MARK CONSISTS OF STANDARD CHARACTERS WITHOUT CLAIM TO ANY PARTICULAR FONT, STYLE, SIZE, OR COLOR.

FOR ADHESIVE TAPE THAT CAN BE PRINTED DIRECTLY ON THE NON-ADHESIVE SIDE FOR COMMERCIAL AND INDUSTRIAL USE (U.S. CLS. 1, 5, 12, 13, 35 AND 50).

FIRST USE 9-13-2010; IN COMMERCE 9-13-2010.

**CLASS 18—LEATHER GOODS**

3,962,183. GREEN GARMENTO, LLC, THE, LOS ANGELES, CA. SN 77-538,810. PUB. 5-5-2009, FILED 8-4-2008.

**The Green Garmento**

THE MARK CONSISTS OF STANDARD CHARACTERS WITHOUT CLAIM TO ANY PARTICULAR FONT, STYLE, SIZE, OR COLOR.

NO CLAIM IS MADE TO THE EXCLUSIVE RIGHT TO USE "GREEN", APART FROM THE MARK AS SHOWN.

FOR GARMENT BAG FOR TRAVEL THAT CAN ALSO BE USED AS A DUFFLE BAG AND LAUNDRY BAG (U.S. CLS. 1, 2, 3, 22 AND 41).

FIRST USE 8-8-2008; IN COMMERCE 8-8-2008.

3,963,530. HONEYWELL INTERNATIONAL INC., MORRISTOWN, NJ. SN 85-053,506. PUB. 11-2-2010, FILED 6-3-2010.

**HYDROBLOCK**

THE MARK CONSISTS OF STANDARD CHARACTERS WITHOUT CLAIM TO ANY PARTICULAR FONT, STYLE, SIZE, OR COLOR.

FOR FLUORINE-CONTAINING PLASTICS IN THE FORM OF PELLETS, POWDER, SHEETS AND FILMS FOR COMMERCIAL AND INDUSTRIAL USE (U.S. CLS. 1, 5, 12, 13, 35 AND 50).

FIRST USE 1-27-2011; IN COMMERCE 1-27-2011.

3,962,194. BELEAF LIMITED LIABILITY COMPANY, MANASQUAN, NJ. SN 77-549,802. PUB. 1-13-2009, FILED 8-18-2008.

**STITCHED WITH PURPOSE**

THE MARK CONSISTS OF STANDARD CHARACTERS WITHOUT CLAIM TO ANY PARTICULAR FONT, STYLE, SIZE, OR COLOR.

FOR ALL-PURPOSE CARRYING BAGS (U.S. CLS. 1, 2, 3, 22 AND 41).

FIRST USE 5-1-2009; IN COMMERCE 5-1-2009.

**CLASS 18—(Continued).**

3,962,201. KHT JOINT VENTURE, LLC, CHARLESTON, SC. SN 77-555,068. PUB. 8-18-2009, FILED 8-25-2008.



**CHRISTOPHE HARBOUR**  
ST. KITTS

NO CLAIM IS MADE TO THE EXCLUSIVE RIGHT TO USE "ST. KITTS", APART FROM THE MARK AS SHOWN.

THE MARK CONSISTS OF A STYLIZED DEPICTION OF FOUR MALTESE CROSSES CONNECTED TO FORM A DESIGN RESEMBLING A COMPASS ROSE ABOVE THE WORDS "CHRISTOPHE HARBOUR ST. KITTS".

FOR UMBRELLAS, BEACH BAGS (U.S. CLS. 1, 2, 3, 22 AND 41).

FIRST USE 5-27-2008; IN COMMERCE 5-27-2008.

3,962,245. STINGR SOLUTIONS LLC, ORLANDO, FL. SN 77-633,971. PUB. 4-14-2009, FILED 12-16-2008.



THE MARK CONSISTS OF A STYLIZED UMBRELLA BETWEEN THE TEXTS "GR" AND "P2".

FOR UMBRELLAS AND PARASOLS (U.S. CLS. 1, 2, 3, 22 AND 41).

FIRST USE 3-3-2011; IN COMMERCE 3-3-2011.

3,962,267. THIAM, ALIAUNE, ATLANTA, GA. SN 77-660,672. PUB. 12-15-2009, FILED 1-30-2009.

**ALIAUNE**

THE MARK CONSISTS OF STANDARD CHARACTERS WITHOUT CLAIM TO ANY PARTICULAR FONT, STYLE, SIZE, OR COLOR.

FOR BAGS, NAMELY, SHOULDER BAGS, ATHLETIC BAGS, BOOK BAGS, GYM BAGS, SCHOOL BAGS, TRAVEL BAGS, TOTE BAGS; WALLETS; BACKPACKS; DUFFEL BAGS; PURSES; BRIEFCASES; LUGGAGE AND TRUNKS; GARMENT BAGS FOR TRAVEL (U.S. CLS. 1, 2, 3, 22 AND 41).

FIRST USE 6-30-2009; IN COMMERCE 12-16-2010.

**CLASS 18—(Continued).**

3,962,387. PEDERSEN, CHERYL, SIMSBURY, CT. SN 77-745,821. PUB. 10-6-2009, FILED 5-27-2009.

**FURBITZ**

THE MARK CONSISTS OF STANDARD CHARACTERS WITHOUT CLAIM TO ANY PARTICULAR FONT, STYLE, SIZE, OR COLOR.

FOR PET COLLAR AND LEASH ACCESSORIES, NAMELY, SMALL DECORATIVE OBJECTS SPECIALLY ADAPTED FOR ATTACHING TO PET LEASHES AND COLLARS, CHARMS ATTACHABLE TO LEASHES AND COLLARS (U.S. CLS. 1, 2, 3, 22 AND 41).

FIRST USE 2-1-2011; IN COMMERCE 2-1-2011.

3,962,852. GENRE & MODE, INC., BOZEMAN, MT. SN 77-916,398. PUB. 6-22-2010, FILED 1-20-2010.

**REDD LABEL**

THE MARK CONSISTS OF STANDARD CHARACTERS WITHOUT CLAIM TO ANY PARTICULAR FONT, STYLE, SIZE, OR COLOR.

NO CLAIM IS MADE TO THE EXCLUSIVE RIGHT TO USE "LABEL", APART FROM THE MARK AS SHOWN.

FOR LEATHER BAGS AND POUCHES SPECIALLY ADAPTED FOR HOLDING DIABETES SUPPLIES; NON-LEATHER BAGS AND POUCHES SPECIALLY ADAPTED FOR HOLDING DIABETES SUPPLIES; WEARABLE STRAP-ON POUCHES WHICH ARE WORN AROUND THE WAIST AND ARE SPECIALLY ADAPTED FOR HOLDING AN INSULIN PUMP (U.S. CLS. 1, 2, 3, 22 AND 41).

FIRST USE 1-21-2011; IN COMMERCE 1-21-2011.

3,962,957. LUMISOURCE, INC., ELK GROVE VILLAGE, IL. SN 77-939,703. PUB. 7-13-2010, FILED 2-19-2010.

**GLOBRELLA**

THE MARK CONSISTS OF STANDARD CHARACTERS WITHOUT CLAIM TO ANY PARTICULAR FONT, STYLE, SIZE, OR COLOR.

FOR UMBRELLAS (U.S. CLS. 1, 2, 3, 22 AND 41).

FIRST USE 8-17-2010; IN COMMERCE 8-17-2010.



**CLASS 18—(Continued).**

3,963,229. PRL USA HOLDINGS, INC., WILMINGTON, DE.  
SN 77-969,581. PUB. 7-27-2010, FILED 3-26-2010.

**RL TARTAN COLLECTION**

THE MARK CONSISTS OF STANDARD CHARACTERS WITHOUT CLAIM TO ANY PARTICULAR FONT, STYLE, SIZE, OR COLOR.

OWNER OF U.S. REG. NOS. 2,312,818, 2,468,133, AND 3,525,323.

NO CLAIM IS MADE TO THE EXCLUSIVE RIGHT TO USE "TARTAN COLLECTION", APART FROM THE MARK AS SHOWN.

FOR BAGS, NAMELY, HANDBAGS, DUFFLE BAGS, BRIEFCASES, TOTE BAGS, COSMETIC BAGS SOLD EMPTY (U.S. CLS. 1, 2, 3, 22 AND 41).

FIRST USE 6-0-2010; IN COMMERCE 6-0-2010.

3,963,230. PRL USA HOLDINGS, INC., WILMINGTON, DE.  
SN 77-969,584. PUB. 7-27-2010, FILED 3-26-2010.

**RALPH LAUREN TARTAN COLLECTION**

THE MARK CONSISTS OF STANDARD CHARACTERS WITHOUT CLAIM TO ANY PARTICULAR FONT, STYLE, SIZE, OR COLOR.

OWNER OF U.S. REG. NOS. 1,664,241, 3,305,576, AND OTHERS.

NO CLAIM IS MADE TO THE EXCLUSIVE RIGHT TO USE "TARTAN COLLECTION", APART FROM THE MARK AS SHOWN.

THE NAME(S), PORTRAIT(S), AND/OR SIGNATURE(S) SHOWN IN THE MARK IDENTIFIES "RALPH LAUREN", WHOSE CONSENT(S) TO REGISTER IS MADE OF RECORD.

FOR BAGS, NAMELY, HANDBAGS, DUFFLE BAGS, BRIEFCASES, TOTE BAGS, COSMETIC BAGS SOLD EMPTY (U.S. CLS. 1, 2, 3, 22 AND 41).

FIRST USE 6-0-2010; IN COMMERCE 6-0-2010.

3,963,377. TOP'S HANDBAGS, DBA ALYSSA, EMPERIA,  
VERNON, CA. SN 85-012,208. PUB. 9-14-2010, FILED 4-12-2010.

**Bellaluca**

THE MARK CONSISTS OF STANDARD CHARACTERS WITHOUT CLAIM TO ANY PARTICULAR FONT, STYLE, SIZE, OR COLOR.

**CLASS 18—(Continued).**

THE WORDING "BELLALUCA" HAS NO MEANING IN A FOREIGN LANGUAGE.

FOR EVENING HANDBAGS; FASHION HANDBAGS; HANDBAGS FOR LADIES; HANDBAGS, PURSES AND WALLETS (U.S. CLS. 1, 2, 3, 22 AND 41).

FIRST USE 1-1-2011; IN COMMERCE 1-1-2011.

3,963,457. ASICS CORPORATION, CHUO-KU, KOBE, JAPAN. SN 85-035,909. PUB. 8-17-2010, FILED 5-11-2010.

**HUDDLE**

THE MARK CONSISTS OF STANDARD CHARACTERS WITHOUT CLAIM TO ANY PARTICULAR FONT, STYLE, SIZE, OR COLOR.

FOR DUFFLE BAGS (U.S. CLS. 1, 2, 3, 22 AND 41).  
FIRST USE 5-27-2010; IN COMMERCE 5-27-2010.

3,963,669. HANSEN BEVERAGE COMPANY, CORONA, CA.  
SN 85-094,364. PUB. 12-28-2010, FILED 7-28-2010.



THE MARK CONSISTS OF A STYLIZED LETTER "M" IN THE FORM OF A CLAW.

FOR ALL PURPOSE SPORT BAGS; ALL-PURPOSE CARRYING BAGS; BACKPACKS; DUFFEL BAGS (U.S. CLS. 1, 2, 3, 22 AND 41).

FIRST USE 5-24-2002; IN COMMERCE 6-30-2002.

**CLASS 19—NON-METALLIC BUILDING MATERIALS**

**CLASS 19—(Continued).**

3,961,982. EROSION PREVENTION PRODUCTS, LLC, HOUSTON, TX. SN 76-699,025. PUB. 6-22-2010, FILED 8-17-2009.

**CHANNEL LOCK V-LOCK**

THE MARK CONSISTS OF STANDARD CHARACTERS WITHOUT CLAIM TO ANY PARTICULAR FONT, STYLE, SIZE, OR COLOR.

OWNER OF U.S. REG. NO. 2,213,362.  
FOR VERTICAL INTERLOCKING CONCRETE BLOCKS USED FOR EROSION CONTROL MATS (U.S. CLS. 1, 12, 33 AND 50).

FIRST USE 6-17-2009; IN COMMERCE 7-18-2009.

3,962,037. THOR TECH, INC., JACKSON CENTER, OH. SN 77-154,847. PUB. 12-4-2007, FILED 4-12-2007.

**PERFECT COTTAGE**

THE MARK CONSISTS OF STANDARD CHARACTERS WITHOUT CLAIM TO ANY PARTICULAR FONT, STYLE, SIZE, OR COLOR.

NO CLAIM IS MADE TO THE EXCLUSIVE RIGHT TO USE "COTTAGE", APART FROM THE MARK AS SHOWN.  
FOR MANUFACTURED HOUSING, NAMELY, TRANSPORTABLE HOMES AND PARK MODEL HOMES (U.S. CLS. 1, 12, 33 AND 50).

FIRST USE 0-0-2006; IN COMMERCE 0-0-2006.

3,962,097. JOHN JOSEPH AUGUST, VOLCANO, HI. SN 77-335,856. PUB. 4-29-2008, FILED 11-22-2007.

**Interock**

THE MARK CONSISTS OF STANDARD CHARACTERS WITHOUT CLAIM TO ANY PARTICULAR FONT, STYLE, SIZE, OR COLOR.

FOR CONCRETE RETAINING WALLS (U.S. CLS. 1, 12, 33 AND 50).

FIRST USE 2-3-2011; IN COMMERCE 2-3-2011.

**CLASS 19—(Continued).**

3,962,158. MARINE FLOATS CORPORATION, TACOMA, WA. SN 77-492,113. PUB. 5-19-2009, FILED 6-5-2008.

**ENVIROCRETE**

THE MARK CONSISTS OF STANDARD CHARACTERS WITHOUT CLAIM TO ANY PARTICULAR FONT, STYLE, SIZE, OR COLOR.

FOR NON-METAL FLOATING DOCKS AND PIERS; NON-METAL COMPONENTS USED IN THE CONSTRUCTION OF NON-METAL FLOATING DOCKS, NAMELY, RAMPS AND FLOATS FOR DOCKS; PREFABRICATED NON-METAL BUILDINGS, NAMELY, MARINAS AND BOAT HOUSES (U.S. CLS. 1, 12, 33 AND 50).

FIRST USE 11-27-2009; IN COMMERCE 11-27-2009.

3,962,318. MAGBACKER, LLC, BRUNSWICK, GA. SN 77-689,356. PUB. 7-14-2009, FILED 3-12-2009.

**MagTemp**

THE MARK CONSISTS OF STANDARD CHARACTERS WITHOUT CLAIM TO ANY PARTICULAR FONT, STYLE, SIZE, OR COLOR.

FOR CONSTRUCTION BOARDS COMPOSED OF MAGNESIUM (U.S. CLS. 1, 12, 33 AND 50).

FIRST USE 1-16-2011; IN COMMERCE 1-16-2011.

3,962,488. PORCELANOSA GRUPO A.I.E., VILA-REAL (CASTELLÓN), SPAIN. SN 77-796,734. PUB. 12-29-2009, FILED 8-4-2009.

**CLI-KER****Automatic Installation System**

NO CLAIM IS MADE TO THE EXCLUSIVE RIGHT TO USE "AUTOMATIC INSTALLATION SYSTEM", APART FROM THE MARK AS SHOWN.

THE MARK CONSISTS OF "CLI-KER" IN UPPER CASE LETTERS ON TOP OF THE WORDS "AUTOMATIC INSTALLATION SYSTEM" IN SMALL FONT.

FOR NON-METAL BUILDING MATERIALS, NAMELY, CERAMIC FLOOR TILES, CERAMIC WALL TILES AND PAVING TILES (U.S. CLS. 1, 12, 33 AND 50).

FIRST USE 4-9-2009; IN COMMERCE 9-16-2010.

**CLASS 19—(Continued).**

3,962,769. VERTI-CRETE, SANDY, UT. SN 77-890,314. PUB. 6-8-2010, FILED 12-10-2009.



OWNER OF U.S. REG. NOS. 2,871,145 AND 3,249,045.  
NO CLAIM IS MADE TO THE EXCLUSIVE RIGHT TO USE "BLOCK", APART FROM THE MARK AS SHOWN.

THE MARK CONSISTS OF THE WORDING "VERTI-BLOCK" IN ALL CAPITAL LETTERS AND A LETTER "V" DESIGN. THE LETTER "V" IS LARGE AND APPEARS BEHIND THE TERM "BLOCK"; THE TERM "VERTI" APPEARS IN A SMALLER FONT ABOVE THE TERM "BLOCK" AND IS PLACED IN THE SPACE WITHIN THE UPPER MOST PORTION OF THE LETTER "V". THE TERM "BLOCK" IS BOUNDED BY A SLIGHTLY ANGLED TOP AND BOTTOM LINE.

FOR RETAINING WALL SYSTEMS CONSISTING OF ENGINEERED HOLLOW CEMENT BLOCKS (U.S. CLS. 1, 12, 33 AND 50).

FIRST USE 11-1-2010; IN COMMERCE 11-1-2010.

3,963,283. MARTIN MARIETTA MATERIALS, INC., RALEIGH, NC. SN 78-529,842. PUB. 1-16-2007, FILED 12-9-2004.



NO CLAIM IS MADE TO THE EXCLUSIVE RIGHT TO USE "MATERIALS", APART FROM THE MARK AS SHOWN.

THE NAME(S), PORTRAIT(S), AND/OR SIGNATURE(S) SHOWN IN THE MARK DOES NOT IDENTIFY A PARTICULAR LIVING INDIVIDUAL.

THE COLOR(S) BLACK AND BLUE ARE CLAIMED AS A FEATURE OF THE MARK.

THE COLOR BLACK APPEARS IN THE WORDING PORTION OF THE MARK; AND THE COLOR BLUE APPEARS IN THE DESIGN ELEMENT COMPRISING A DOUBLE HORIZONTAL LINE AND STYLIZED LETTER "M".

FOR BUILDING MATERIALS, NAMELY, CONSTRUCTION AGGREGATES COMPOSED OF SAND AND ROCK, CRUSHED STONE, SAND AND GRAVEL USED TO BUILD THE ROADS, SIDEWALKS AND BUILDING AND STRUCTURAL FOUNDATIONS; AGGREGATE BUILDING MATERIALS, NAMELY, ASPHALT AND READY MIXED CONCRETE (U.S. CLS. 1, 12, 33 AND 50).

FIRST USE 0-0-1995; IN COMMERCE 0-0-1995.

**CLASS 20—FURNITURE AND ARTICLES NOT OTHERWISE CLASSIFIED****CLASS 20—(Continued).**

3,962,014. KOHLER CO., KOHLER, WI. SN 77-078,007. PUB. 5-13-2008, FILED 1-8-2007.

**SEA SPARES**

THE MARK CONSISTS OF STANDARD CHARACTERS WITHOUT CLAIM TO ANY PARTICULAR FONT, STYLE, SIZE, OR COLOR.

FOR NON-METAL UTILITY BOXES, FOR HOUSING SERVICING, MAINTENANCE AND REPLACEMENT MARINE GENERATOR PARTS (U.S. CLS. 2, 13, 22, 25, 32 AND 50).

FIRST USE 3-31-1996; IN COMMERCE 3-31-1996.

3,962,480. NATURE'S PILLOWS INC., TREVOSE, PA. SN 77-794,338. PUB. 8-3-2010, FILED 7-31-2009.

**SOBAKAWA CLOUD PILLOW**

THE MARK CONSISTS OF STANDARD CHARACTERS WITHOUT CLAIM TO ANY PARTICULAR FONT, STYLE, SIZE, OR COLOR.

OWNER OF U.S. REG. NO. 2,224,901.  
NO CLAIM IS MADE TO THE EXCLUSIVE RIGHT TO USE "PILLOW", APART FROM THE MARK AS SHOWN.

THE ENGLISH TRANSLATION OF "SOBAKAWA" IS "BUCKWHEAT".

SEC. 2(F) AS TO "SOBAKAWA".

FOR PILLOWS (U.S. CLS. 2, 13, 22, 25, 32 AND 50).

FIRST USE 10-29-2009; IN COMMERCE 10-29-2009.

3,962,560. REAGAN HAYES, INC., LOS ANGELES, CA. SN 77-818,452. PUB. 1-26-2010, FILED 9-2-2009.

**Youthful Elegance**

THE MARK CONSISTS OF STANDARD CHARACTERS WITHOUT CLAIM TO ANY PARTICULAR FONT, STYLE, SIZE, OR COLOR.

FOR FURNITURE (U.S. CLS. 2, 13, 22, 25, 32 AND 50).  
FIRST USE 9-2-2009; IN COMMERCE 9-2-2009.

**CLASS 20—(Continued).**

3,962,587. AMERICAN WOODMARK CORPORATION, WINCHESTER, VA. SN 77-825,705. PUB. 2-9-2010, FILED 9-14-2009.

**WAYPOINT LIVING SPACES**

THE MARK CONSISTS OF STANDARD CHARACTERS WITHOUT CLAIM TO ANY PARTICULAR FONT, STYLE, SIZE, OR COLOR.

FOR KITCHEN CABINETS AND BATHROOM CABINETS (U.S. CLS. 2, 13, 22, 25, 32 AND 50).  
FIRST USE 11-17-2009; IN COMMERCE 2-1-2010.

---

3,962,588. AMERICAN WOODMARK CORPORATION, WINCHESTER, VA. SN 77-825,706. PUB. 2-9-2010, FILED 9-14-2009.

**WAYPOINT**

THE MARK CONSISTS OF STANDARD CHARACTERS WITHOUT CLAIM TO ANY PARTICULAR FONT, STYLE, SIZE, OR COLOR.

FOR KITCHEN CABINETS AND BATHROOM CABINETS (U.S. CLS. 2, 13, 22, 25, 32 AND 50).  
FIRST USE 11-17-2009; IN COMMERCE 4-1-2010.

---

3,962,622. JSJ FURNITURE CORPORATION, GRAND HAVEN, MI. SN 77-839,169. PUB. 9-7-2010, FILED 10-1-2009.

**Z SERIES**

THE MARK CONSISTS OF STANDARD CHARACTERS WITHOUT CLAIM TO ANY PARTICULAR FONT, STYLE, SIZE, OR COLOR.

OWNER OF U.S. REG. NO. 2,597,447.  
NO CLAIM IS MADE TO THE EXCLUSIVE RIGHT TO USE "SERIES", APART FROM THE MARK AS SHOWN.  
FOR OFFICE FURNITURE (U.S. CLS. 2, 13, 22, 25, 32 AND 50).  
FIRST USE 4-26-2010; IN COMMERCE 4-26-2010.

**CLASS 20—(Continued).**

3,962,629. COMFORT REVOLUTION, LLC, EATONTOWN, NJ. SN 77-842,104. PUB. 8-3-2010, FILED 10-6-2009.

**SLEEP ESSENTIALS**

THE MARK CONSISTS OF STANDARD CHARACTERS WITHOUT CLAIM TO ANY PARTICULAR FONT, STYLE, SIZE, OR COLOR.

NO CLAIM IS MADE TO THE EXCLUSIVE RIGHT TO USE "SLEEP", APART FROM THE MARK AS SHOWN.  
FOR MATTRESSES; MATTRESS AND BED FOUNDATIONS (U.S. CLS. 2, 13, 22, 25, 32 AND 50).  
FIRST USE 2-15-2010; IN COMMERCE 2-15-2010.

---

3,962,659. HUF COR, INC., JANESVILLE, WI. SN 77-852,457. PUB. 4-13-2010, FILED 10-20-2009.

**FLEXTACT**

THE MARK CONSISTS OF STANDARD CHARACTERS WITHOUT CLAIM TO ANY PARTICULAR FONT, STYLE, SIZE, OR COLOR.

FOR MOVEABLE WALL PARTITIONS (U.S. CLS. 2, 13, 22, 25, 32 AND 50).  
FIRST USE 9-0-2010; IN COMMERCE 9-0-2010.

---

3,962,718. NAS VENTURES LLC, WHITE PLAINS, NY. SN 77-873,242. PUB. 4-20-2010, FILED 11-16-2009.



NO CLAIM IS MADE TO THE EXCLUSIVE RIGHT TO USE "PILLOW", APART FROM THE MARK AS SHOWN.

THE COLOR(S) BLUE AND GRAY IS/ARE CLAIMED AS A FEATURE OF THE MARK.

THE MARK CONSISTS OF THE STYLIZED WORDS "POLAR" IN BLUE AND "PILLOW" IN GRAY, IN ALL LOWER-CASE LETTERS, WITH MIRROR-IMAGE REFLECTIONS OF THE WORDS BELOW THE WORDS, AND WITH A BLUE DEGREE SYMBOL IN THE UPPER RIGHT CORNER OF THE WORD "PILLOW".

FOR PILLOWS HAVING A THERMAL PACK AND FLOW RETARDANT GEL CONTAINING COOLING FEATURE (U.S. CLS. 2, 13, 22, 25, 32 AND 50).  
FIRST USE 3-18-2011; IN COMMERCE 3-18-2011.

**CLASS 20—(Continued).**

3,962,799. ANDERSON GREGORY H, EAGAN, MN. SN 77-900,706. PUB. 5-18-2010, FILED 12-24-2009.

# HelmetHeads

THE MARK CONSISTS OF STANDARD CHARACTERS WITHOUT CLAIM TO ANY PARTICULAR FONT, STYLE, SIZE, OR COLOR.

FOR DISPLAY CASES; DISPLAY STANDS; HAT STANDS (U.S. CLS. 2, 13, 22, 25, 32 AND 50).

FIRST USE 11-13-2010; IN COMMERCE 11-13-2010.

3,962,816. ORIGINAL IDEAS, INC., LA QUINTA, CA. SN 77-905,854. PUB. 5-25-2010, FILED 1-6-2010.

# BEST OF TIMES

THE MARK CONSISTS OF STANDARD CHARACTERS WITHOUT CLAIM TO ANY PARTICULAR FONT, STYLE, SIZE, OR COLOR.

FOR FURNITURE, NAMELY, FOLDABLE BEVERAGE BARS (U.S. CLS. 2, 13, 22, 25, 32 AND 50).

FIRST USE 10-1-2010; IN COMMERCE 1-11-2011.

3,962,997. SMILE SANGYO CO., LTD., OSAKA, JAPAN. SN 77-944,424. PUB. 7-20-2010, FILED 2-25-2010.



THE MARK CONSISTS OF THE LETTER "S" IN A STYLIZED FORM.

FOR PLASTIC STORAGE CONTAINERS FOR COMMERCIAL OR INDUSTRIAL USE (U.S. CLS. 2, 13, 22, 25, 32 AND 50).

FIRST USE 1-17-2008; IN COMMERCE 3-2-2011.

**CLASS 20—(Continued).**

3,963,009. POPPACK LLC, SAN FRANCISCO, CA. SN 77-945,422. PUB. 8-3-2010, FILED 2-25-2010.

# JUST FOR THE FUN OF IT

THE MARK CONSISTS OF STANDARD CHARACTERS WITHOUT CLAIM TO ANY PARTICULAR FONT, STYLE, SIZE, OR COLOR.

FOR PLASTIC CONTAINERS FOR PACKAGING CONSUMER FOOD PRODUCTS AND INDUSTRIAL AND COMMERCIAL NON-FOOD PRODUCTS FEATURING A PRESSURE SENSITIVE OPENING DEVICE (U.S. CLS. 2, 13, 22, 25, 32 AND 50).

FIRST USE 10-31-2010; IN COMMERCE 10-31-2010.

3,963,085. JAMIE WALLACE, ROUND ROCK, TX. SN 77-954,408. PUB. 8-10-2010, FILED 3-9-2010.

# STRAW-LUTION

THE MARK CONSISTS OF STANDARD CHARACTERS WITHOUT CLAIM TO ANY PARTICULAR FONT, STYLE, SIZE, OR COLOR.

FOR STRAWS FOR DRINKING BEVERAGES AND SOFT FOODS (U.S. CLS. 2, 13, 22, 25, 32 AND 50).

FIRST USE 3-26-2010; IN COMMERCE 3-26-2010.

3,963,088. JAMIE WALLACE, ROUND ROCK, TX. SN 77-954,459. PUB. 8-10-2010, FILED 3-9-2010.

# THE STRAW THAT GOES IN, BUT DOESN'T COME OUT!

THE MARK CONSISTS OF STANDARD CHARACTERS WITHOUT CLAIM TO ANY PARTICULAR FONT, STYLE, SIZE, OR COLOR.

FOR STRAWS FOR DRINKING BEVERAGES AND SOFT FOODS (U.S. CLS. 2, 13, 22, 25, 32 AND 50).

FIRST USE 3-26-2010; IN COMMERCE 3-26-2010.



**CLASS 20—(Continued).**

3,963,089. ENRIQUEZ, JESUS R., TUCSON, AZ. SN 77-954,554. PUB. 7-27-2010, FILED 3-9-2010.

## LAST RIDES

THE MARK CONSISTS OF STANDARD CHARACTERS WITHOUT CLAIM TO ANY PARTICULAR FONT, STYLE, SIZE, OR COLOR.  
FOR FUNERARY URNS (U.S. CLS. 2, 13, 22, 25, 32 AND 50).

FIRST USE 11-30-2010; IN COMMERCE 11-30-2010.

3,963,102. BICKHAM, MICHAEL, OVERLAND, KS. SN 77-956,058. PUB. 8-3-2010, FILED 3-10-2010.

## PetablePets

THE MARK CONSISTS OF STANDARD CHARACTERS WITHOUT CLAIM TO ANY PARTICULAR FONT, STYLE, SIZE, OR COLOR.

FOR PLASTIC SIGNS (U.S. CLS. 2, 13, 22, 25, 32 AND 50).

FIRST USE 0-0-2010; IN COMMERCE 0-0-2010.

3,963,215. SIMPLISSE, INC., ST. LOUIS, MO. SN 77-967,528. PUB. 8-17-2010, FILED 3-24-2010.

## GIA

THE MARK CONSISTS OF STANDARD CHARACTERS WITHOUT CLAIM TO ANY PARTICULAR FONT, STYLE, SIZE, OR COLOR.

FOR MATERNITY PILLOWS (U.S. CLS. 2, 13, 22, 25, 32 AND 50).

FIRST USE 11-8-2010; IN COMMERCE 11-8-2010.

**CLASS 20—(Continued).**

3,963,231. PARTYDRAGON LIMITED, CENTRAL, HONG KONG. SN 77-979,294. PUB. 6-23-2009, FILED 8-29-2008.

## PARTY DRAGON

THE MARK CONSISTS OF STANDARD CHARACTERS WITHOUT CLAIM TO ANY PARTICULAR FONT, STYLE, SIZE, OR COLOR.

NO CLAIM IS MADE TO THE EXCLUSIVE RIGHT TO USE "PARTY", APART FROM THE MARK AS SHOWN.

FOR PARTY FAVORS IN THE NATURE OF CHEMICALLY-ACTIVATED LIGHT STICKS SOLD AS INTEGRAL COMPONENTS OF DRINKING STRAWS (U.S. CLS. 2, 13, 22, 25, 32 AND 50).

FIRST USE 3-30-2009; IN COMMERCE 3-30-2009.

3,963,237. THE BRADFORD EXCHANGE, LTD., NILES, IL. SN 77-981,505. PUB. 12-4-2007, FILED 11-27-2006.

## RHODES STUDIOS

THE MARK CONSISTS OF STANDARD CHARACTERS WITHOUT CLAIM TO ANY PARTICULAR FONT, STYLE, SIZE, OR COLOR.

OWNER OF U.S. REG. NO. 1,472,327.

NO CLAIM IS MADE TO THE EXCLUSIVE RIGHT TO USE "STUDIOS", APART FROM THE MARK AS SHOWN.

FOR ART OBJECTS, NAMELY, FIGURES, FIGURINES, SCULPTURES AND PLAQUES MADE OF COLD CAST RESIN, PLASTIC OR WOOD OR OF ANY COMBINATION OF THE FOREGOING (U.S. CLS. 2, 13, 22, 25, 32 AND 50).

FIRST USE 7-30-2010; IN COMMERCE 7-30-2010.

3,963,450. KORB, ALAN D, DBA TUFF FURNITURE, BELMONT, NH. SN 85-033,697. PUB. 11-23-2010, FILED 5-8-2010.



NO CLAIM IS MADE TO THE EXCLUSIVE RIGHT TO USE "GENUINE" AND "FURNITURE ORIGINAL", APART FROM THE MARK AS SHOWN.

**CLASS 20—(Continued).**

THE COLOR(S) YELLOW AND NAVY BLUE IS/ARE CLAIMED AS A FEATURE OF THE MARK.

THE MARK CONSISTS OF THE WORDING "GENUINE TUFF FURNITURE ORIGINAL" IN NAVY BLUE SUPERIMPOSED ON A YELLOW OVAL OUTLINED IN NAVY BLUE.

FOR FURNITURE FOR HOUSE, OFFICE AND GARDEN (U.S. CLS. 2, 13, 22, 25, 32 AND 50).

FIRST USE 10-27-2010; IN COMMERCE 10-27-2010.

3,963,596. FURNETCHA LLC, BOSTON, MA. SN 85-072,351. PUB. 11-23-2010, FILED 6-26-2010.

---

## FURNETCHA

THE MARK CONSISTS OF STANDARD CHARACTERS WITHOUT CLAIM TO ANY PARTICULAR FONT, STYLE, SIZE, OR COLOR.

FOR FURNITURE, CABINETS (U.S. CLS. 2, 13, 22, 25, 32 AND 50).

FIRST USE 3-13-2011; IN COMMERCE 3-13-2011.

3,963,682. CARPIN MANUFACTURING, INC., WATERBURY, CT. SN 85-100,407. PUB. 1-18-2011, FILED 8-4-2010.

---

## SOLO GLIDE

THE MARK CONSISTS OF STANDARD CHARACTERS WITHOUT CLAIM TO ANY PARTICULAR FONT, STYLE, SIZE, OR COLOR.

OWNER OF U.S. REG. NOS. 3,259,280 AND 3,759,245.

NO CLAIM IS MADE TO THE EXCLUSIVE RIGHT TO USE "GLIDE", APART FROM THE MARK AS SHOWN.

FOR FURNITURE PARTS, NAMELY, GLIDES (U.S. CLS. 2, 13, 22, 25, 32 AND 50).

FIRST USE 7-16-2010; IN COMMERCE 7-16-2010.

**CLASS 20—(Continued).**

3,963,709. CARLSBAD SAFETY PRODUCTS, LLC, CARLSBAD, CA. SN 85-126,219. PUB. 1-25-2011, FILED 9-9-2010.

## PINCH-NOT

THE MARK CONSISTS OF STANDARD CHARACTERS WITHOUT CLAIM TO ANY PARTICULAR FONT, STYLE, SIZE, OR COLOR.

FOR CHILD SAFETY PRODUCTS MADE PRIMARILY OF NON-METAL TO PREVENT PINCHING OF FINGERS BETWEEN A DOOR JAMB AND A HINGED DOOR IN THE NATURE OF DOOR SAFETY SHIELDS AND DOOR SAFETY BLOCKS (U.S. CLS. 2, 13, 22, 25, 32 AND 50).

FIRST USE 9-1-2010; IN COMMERCE 2-1-2011.

**CLASS 21—HOUSEWARES AND GLASS**

3,962,055. W.I.N.O.S., INC., BOONE, NC. SN 77-220,768. PUB. 12-11-2007, FILED 7-2-2007.

## LIQUID SANITY

THE MARK CONSISTS OF STANDARD CHARACTERS WITHOUT CLAIM TO ANY PARTICULAR FONT, STYLE, SIZE, OR COLOR.

FOR COFFEE CUPS AND MUGS; THERMAL INSULATED BAGS FOR FOOD OR BEVERAGES; THERMAL INSULATED CONTAINERS FOR FOOD OR BEVERAGE; THERMAL INSULATED WRAP FOR CANS TO KEEP THE CONTENTS COLD OR HOT (U.S. CLS. 2, 13, 23, 29, 30, 33, 40 AND 50).

FIRST USE 6-30-2009; IN COMMERCE 6-30-2009.

3,962,111. AHOLD LICENSING SARL, GENEVA, SWITZERLAND. SN 77-379,253. PUB. 6-24-2008, FILED 1-24-2008.



THE COLOR(S) YELLOW, ORANGE, PURPLE AND GREEN IS/ARE CLAIMED AS A FEATURE OF THE MARK.

THE MARK CONSISTS OF FOUR WEDGE DESIGNS, DEPICTED IN FOUR DIFFERENT COLORS IN VARYING SIZES AND DEGREES OF ROTATION. THE YELLOW

**CLASS 21—(Continued).**

WEDGE IS LARGEST AND PORTRAYED AS HORIZONTAL. THE ORANGE WEDGE IS SMALLER THAN THE YELLOW, AND APPEARS AT AN APPROXIMATELY 45 DEGREE ANGLE. THE PURPLE WEDGE IS SMALLER THAN THE ORANGE, AND IS PORTRAYED AS VERTICAL. THE GREEN WEDGE IS SMALLEST, AND APPEARS AT AN APPROXIMATELY 135 DEGREE ANGLE; I.E., BOTH THE ORANGE AND PURPLE WEDGES ARE DISPOSED APPROXIMATELY 45 DEGREES FROM THE YELLOW WEDGE.

FOR PAPER CUPS, PLASTIC CUPS, FOAM CUPS, PAPER PLATES, PLASTIC PLATES, FOAM PLATES, PAPER BOWLS, PLASTIC BOWLS, FOAM BOWLS, PLASTIC DRINKING GLASSES, TUMBLERS AND MUGS (U.S. CLS. 2, 13, 23, 29, 30, 33, 40 AND 50).

FIRST USE 2-0-2010; IN COMMERCE 2-0-2010.

**CLASS 21—(Continued).**

3,962,218. ONWARD MULTI-CORP INC., WATERLOO, CANADA. SN 77-582,733. PUB. 12-1-2009, FILED 9-30-2008.



THE MARK CONSISTS OF THE WORD "FIREWORKS" WITH TWO PARALLEL WAVED LINES ABOVE THE LETTER "E" OF THE WORD "FIREWORKS".

FOR UTENSILS FOR BARBECUES AND GRILLS, NAMELY, FORKS, TONGS, TURNERS; COOKING UTENSILS, NAMELY, NON-ELECTRIC GRILLS; WOOD COOKING PLANKS FOR USE IN GRILLING; COOKING UTENSILS, NAMELY, WIRE BASKETS; HOUSEHOLD UTENSILS, NAMELY, SPATULAS; TOPPERS, NAMELY, PERFORATED PLATES THAT ARE PLACED ON TOP OF A GRILL FOR PURPOSES OF COOKING FOOD AT REDUCED HEAT; COOKING UTENSILS, NAMELY, ROASTING RACKS; BASTING BRUSHES; BARBECUE AND GRILL CLEANING BRUSHES; SCRAPING BRUSHES; HOUSEHOLD GLOVES FOR GENERAL USE; RUBBER HOUSEHOLD GLOVES; NON-ELECTRIC GRIDDLES (U.S. CLS. 2, 13, 23, 29, 30, 33, 40 AND 50).

FIRST USE 6-15-2010; IN COMMERCE 8-18-2010.

3,962,192. TURTLE WAX, INC., WILLOWBROOK, IL. SN 77-548,167. PUB. 8-3-2010, FILED 8-15-2008.

**ICE**

3,962,525. GLOBAL CONCEPTS LIMITED, INC., DBA GLOBAL TV CONCEPTS, LTD., DEERFIELD BEACH, FL. SN 77-807,212. PUB. 12-22-2009, FILED 8-18-2009.

**BIG TOP**

THE MARK CONSISTS OF STANDARD CHARACTERS WITHOUT CLAIM TO ANY PARTICULAR FONT, STYLE, SIZE, OR COLOR.

OWNER OF U.S. REG. NO. 3,442,359.

FOR APPLICATORS FOR THE APPLICATION OF CLEANING, POLISHING, WAXING, PROTECTING AND RESTORING PREPARATIONS (NOT INCLUDING PAINT PRODUCTS), FOR INTERIOR AND EXTERIOR VEHICLE SURFACES, NAMELY, SPONGES, CLOTHS, AND CHAMOIS CLOTHS FOR DRYING AND POLISHING PAINTED SURFACES; CLEANING MITTS OF FABRIC; CLEANING CLOTHS, NAMELY, WOVEN, NON-WOVEN AND KNITTED CLEANING CLOTHS (U.S. CLS. 2, 13, 23, 29, 30, 33, 40 AND 50).

FIRST USE 1-27-2009; IN COMMERCE 1-27-2009.

THE MARK CONSISTS OF STANDARD CHARACTERS WITHOUT CLAIM TO ANY PARTICULAR FONT, STYLE, SIZE, OR COLOR.

FOR BAKEWARE, NAMELY, BAKING DISHES, PANS, SHEETS AND MOLDS (U.S. CLS. 2, 13, 23, 29, 30, 33, 40 AND 50).

FIRST USE 9-1-2010; IN COMMERCE 9-1-2010.

**CLASS 21—(Continued).**

3,962,601. NEW PENDULUM CORP., WILMINGTON, DE. SN 77-830,745. PUB. 8-3-2010, FILED 9-21-2009.

**ROUGH TASK**

THE MARK CONSISTS OF STANDARD CHARACTERS WITHOUT CLAIM TO ANY PARTICULAR FONT, STYLE, SIZE, OR COLOR.

FOR ABSORBENT CLEANING CLOTHS, TEXTILE WIPES, RAGS, AND TOWELS FOR INDUSTRIAL AND COMMERCIAL USE (U.S. CLS. 2, 13, 23, 29, 30, 33, 40 AND 50).

FIRST USE 1-1-2010; IN COMMERCE 1-26-2010.

**CLASS 21—(Continued).**

3,962,722. GOODWEST INDUSTRIES, INC., WARMINSTER, PA. SN 77-876,149. PUB. 6-15-2010, FILED 11-19-2009.



NO CLAIM IS MADE TO THE EXCLUSIVE RIGHT TO USE "CREAM MACHINE", APART FROM THE MARK AS SHOWN.

THE MARK CONSISTS OF A STYLIZED DRAWING SHOWING A RADIANT SUN IN THE SKY OVER ROLLING HILLS ON WHICH TWO COWS GRAZE. WHERE THE SUN CONSISTS OF A 3-D VIEW OF A NOZZLE OR OPENING THROUGH WHICH MILK OR CREAM APPEARS TO BE FLOWING STRAIGHT OUT AT THE VIEWER, OVER WHICH THE WORDS "THE CREAM MACHINE" ARE SUPERIMPOSED IN A STYLIZED FONT, AND WHERE ALTERNATING LIGHTER AND DARKER RAYS RADIATE OUT FROM THE SUN OPENING ABOVE-DESCRIBED.

FOR CONCESSION DISPENSING EQUIPMENT, NAMELY, BEVERAGE, SWEETENER AND CREAMER DISPENSING PUMPS (U.S. CLS. 2, 13, 23, 29, 30, 33, 40 AND 50).

FIRST USE 1-1-2010; IN COMMERCE 1-1-2010.

3,962,686. DISNEY ENTERPRISES, INC., BURBANK, CA. SN 77-859,374. PUB. 8-31-2010, FILED 10-28-2009.

**TRON LEGACY**

THE MARK CONSISTS OF STANDARD CHARACTERS WITHOUT CLAIM TO ANY PARTICULAR FONT, STYLE, SIZE, OR COLOR.

FOR BEVERAGeware: DECORATIVE GLASS NOT FOR BUILDING; SPORTS BOTTLES SOLD EMPTY (U.S. CLS. 2, 13, 23, 29, 30, 33, 40 AND 50).

FIRST USE 10-31-2010; IN COMMERCE 10-31-2010.

3,962,821. SYRACUSE CHINA COMPANY, TOLEDO, OH. SN 77-907,591. PUB. 5-25-2010, FILED 1-8-2010.

**RESONATE**

3,962,719. THE LIBMAN COMPANY, ARCOLA, IL. SN 77-873,935. PUB. 4-20-2010, FILED 11-17-2009.

**GRIPSTRIPS**

THE MARK CONSISTS OF STANDARD CHARACTERS WITHOUT CLAIM TO ANY PARTICULAR FONT, STYLE, SIZE, OR COLOR.

FOR MOPS (U.S. CLS. 2, 13, 23, 29, 30, 33, 40 AND 50).

FIRST USE 12-21-2009; IN COMMERCE 12-21-2009.

THE MARK CONSISTS OF STANDARD CHARACTERS WITHOUT CLAIM TO ANY PARTICULAR FONT, STYLE, SIZE, OR COLOR.

FOR DINNERWARE (U.S. CLS. 2, 13, 23, 29, 30, 33, 40 AND 50).

FIRST USE 9-30-2010; IN COMMERCE 9-30-2010.

**CLASS 21—(Continued).**

3,962,931. VEZINA, MARGUERITE A., MARCO ISLAND, FL. SN 77-934,776. PUB. 8-24-2010, FILED 2-12-2010.

**POLY-DOWELS**

THE MARK CONSISTS OF STANDARD CHARACTERS WITHOUT CLAIM TO ANY PARTICULAR FONT, STYLE, SIZE, OR COLOR.

FOR CAKE SUPPORTS IN THE NATURE OF PLASTIC INTERIOR PILLARS FOR USE IN MULTI-TIERED CAKES (U.S. CLS. 2, 13, 23, 29, 30, 33, 40 AND 50).

FIRST USE 1-19-2010; IN COMMERCE 1-19-2010.

3,962,987. NUTTO, LLC, CHICAGO, IL. SN 77-943,549. PUB. 7-27-2010, FILED 2-24-2010.



THE COLOR(S) PERIWINKLE, BRIGHT PINK AND GREEN IS/ARE CLAIMED AS A FEATURE OF THE MARK. THE MARK CONSISTS OF THE LETTERS "N" AND "TT" WHICH APPEAR IN PERIWINKLE, THE LETTER "U" WHICH APPEARS IN BRIGHT PINK AND THE LETTER "O" IS AN IMAGE OF A BABY'S SMILING FACE WHICH APPEARS IN GREEN.

FOR NON-ELECTRIC HEATERS FOR FEEDING BOTTLES (U.S. CLS. 2, 13, 23, 29, 30, 33, 40 AND 50).

FIRST USE 6-10-2009; IN COMMERCE 3-1-2010.

3,962,992. NUTTO, LLC, CHICAGO, IL. SN 77-943,644. PUB. 7-27-2010, FILED 2-24-2010.

**nutto**

THE MARK CONSISTS OF STANDARD CHARACTERS WITHOUT CLAIM TO ANY PARTICULAR FONT, STYLE, SIZE, OR COLOR.

FOR NON-ELECTRIC HEATERS FOR FEEDING BOTTLES (U.S. CLS. 2, 13, 23, 29, 30, 33, 40 AND 50).

FIRST USE 6-10-2009; IN COMMERCE 3-1-2010.

**CLASS 21—(Continued).**

3,962,993. NUTTO, LLC, CHICAGO, IL. SN 77-943,688. PUB. 7-27-2010, FILED 2-24-2010.

**Simple Solutions for the Madness of Motherhood**

THE MARK CONSISTS OF STANDARD CHARACTERS WITHOUT CLAIM TO ANY PARTICULAR FONT, STYLE, SIZE, OR COLOR.

FOR NON-ELECTRIC HEATERS FOR FEEDING BOTTLES (U.S. CLS. 2, 13, 23, 29, 30, 33, 40 AND 50).

FIRST USE 6-10-2009; IN COMMERCE 3-1-2010.

3,963,002. KAYTEE PRODUCTS INCORPORATED, CHILTON, WI. SN 77-944,523. PUB. 7-13-2010, FILED 2-25-2010.

**HABITAT DEFINED**

THE MARK CONSISTS OF STANDARD CHARACTERS WITHOUT CLAIM TO ANY PARTICULAR FONT, STYLE, SIZE, OR COLOR.

NO CLAIM IS MADE TO THE EXCLUSIVE RIGHT TO USE "HABITAT", APART FROM THE MARK AS SHOWN.

FOR ANIMAL HOUSING IN THE NATURE OF CAGES FOR SMALL HOUSEHOLD PETS AND DOMESTIC BIRDS MADE OF PLASTIC BASES AND METAL WIRES (U.S. CLS. 2, 13, 23, 29, 30, 33, 40 AND 50).

FIRST USE 9-0-2008; IN COMMERCE 9-0-2008.

3,963,003. WATER CADDY GOLF, LLC, BELLEVUE, NE. SN 77-944,569. PUB. 7-20-2010, FILED 2-25-2010.



THE MARK CONSISTS OF A SHIELD WITH TWO SLANTED STRIPES AND A WATER DROP. TO THE RIGHT THERE IS THE STYLIZED TEXT "HYDRACADDY".

FOR PERSONAL FLUID HYDRATION SYSTEM COMPRISING A FLUID RESERVOIR, A DELIVERY TUBE, A MOUTHPIECE AND A REMOVABLE CARRYING PACK FOR USE ON GOLF BAGS (U.S. CLS. 2, 13, 23, 29, 30, 33, 40 AND 50).

FIRST USE 8-14-2010; IN COMMERCE 1-28-2011.



**CLASS 21—(Continued).**

3,963,036. STEWART, THOMAS R., PHILADELPHIA, PA. SN 77-949,131. PUB. 8-3-2010, FILED 3-3-2010.



THE MARK CONSISTS OF AN ARROW FORMING THE LETTER "C" THEN UNDERSCORING THE WORDING "SALSABOL".

FOR BOWLS, NAMELY, SERVING BOWLS FOR CONDIMENTS ESPECIALLY SALSA (U.S. CLS. 2, 13, 23, 29, 30, 33, 40 AND 50).

FIRST USE 3-1-2010; IN COMMERCE 3-1-2010.

3,963,055. WILD BIRDS UNLIMITED, INC, CARMEL, IN. SN 77-951,392. PUB. 8-10-2010, FILED 3-5-2010.

ECOCLEAN

THE MARK CONSISTS OF STANDARD CHARACTERS WITHOUT CLAIM TO ANY PARTICULAR FONT, STYLE, SIZE, OR COLOR.

FOR SMALL ANIMAL FEEDERS (U.S. CLS. 2, 13, 23, 29, 30, 33, 40 AND 50).

FIRST USE 3-30-2010; IN COMMERCE 3-30-2010.

3,963,161. REXAIR LLC, TROY, MI. SN 77-961,599. PUB. 8-3-2010, FILED 3-17-2010.

RAINBOW

THE MARK CONSISTS OF STANDARD CHARACTERS WITHOUT CLAIM TO ANY PARTICULAR FONT, STYLE, SIZE, OR COLOR.

OWNER OF U.S. REG. NOS. 993,728, 3,756,153, AND 3,759,325.

FOR COOKWARE, NAMELY, POTS AND PANS (U.S. CLS. 2, 13, 23, 29, 30, 33, 40 AND 50).

FIRST USE 4-0-1996; IN COMMERCE 5-29-2010.

**CLASS 21—(Continued).**

3,963,162. REXAIR LLC, TROY, MI. SN 77-961,618. PUB. 8-10-2010, FILED 3-17-2010.



OWNER OF U.S. REG. NOS. 993,728 AND 3,756,153.

THE MARK CONSISTS OF THE WORD "RAINBOW" WITH THE TAIL OF THE LETTER "R" FORMING A DROP OVER THE LETTER "I".

FOR COOKWARE, NAMELY, POTS AND PANS (U.S. CLS. 2, 13, 23, 29, 30, 33, 40 AND 50).

FIRST USE 5-29-2010; IN COMMERCE 5-29-2010.

3,963,163. REXAIR LLC, TROY, MI. SN 77-961,630. PUB. 8-10-2010, FILED 3-17-2010.



THE MARK CONSISTS OF THE LETTER "R" IN A STYLIZED FONT APPEARING WITHIN A DESIGN THAT CONSISTS OF A SWIRL THAT ENDS IN A DROP.

FOR COOKWARE, NAMELY, POTS AND PANS (U.S. CLS. 2, 13, 23, 29, 30, 33, 40 AND 50).

FIRST USE 5-29-2010; IN COMMERCE 5-29-2010.

3,963,184. FUSIONBRANDS INC, NAPLES, NY. SN 77-964,256. PUB. 8-10-2010, FILED 3-21-2010.

eggcradle

THE MARK CONSISTS OF STANDARD CHARACTERS WITHOUT CLAIM TO ANY PARTICULAR FONT, STYLE, SIZE, OR COLOR.

FOR HOUSEHOLD UTENSILS, NAMELY, A SPOON SHAPED MINIATURE SERVING DISH WITH HANDLE THAT HOLDS SMALL PORTIONS OF FOOD AND CAN BE SET ON A SERVING PLATTER; SERVING SPOONS (U.S. CLS. 2, 13, 23, 29, 30, 33, 40 AND 50).

FIRST USE 1-1-2011; IN COMMERCE 1-1-2011.

**CLASS 21—(Continued).**

3,963,200. CHARCOAL COMPANION INCORPORATED, DBA THE COMPANION GROUP, EMERYVILLE, CA. SN 77-965,984. PUB. 8-10-2010, FILED 3-23-2010.

**MOISTLY ROASTED**

THE MARK CONSISTS OF STANDARD CHARACTERS WITHOUT CLAIM TO ANY PARTICULAR FONT, STYLE, SIZE, OR COLOR.

OWNER OF U.S. REG. NO. 3,759,205.

FOR COOKING ACCESSORIES, NAMELY, CONTAINERS FOR HOUSEHOLD USE, FOR HOLDING LIQUIDS IN OVEN OR GRILL FOR ADDING MOISTURE TO THE FOOD BEING COOKED (U.S. CLS. 2, 13, 23, 29, 30, 33, 40 AND 50).

FIRST USE 10-0-2010; IN COMMERCE 10-0-2010.

3,963,246. PACTIV CORPORATION, LAKE FOREST, IL. SN 77-981,631. PUB. 6-30-2009, FILED 2-4-2009.

**HEFTY**

THE MARK CONSISTS OF STANDARD CHARACTERS WITHOUT CLAIM TO ANY PARTICULAR FONT, STYLE, SIZE, OR COLOR.

OWNER OF U.S. REG. NOS. 854,403, 2,887,745, AND OTHERS.

FOR GENERAL PURPOSE STORAGE BINS FOR HOUSEHOLD USE, NAMELY, INDOOR HOUSEHOLD STORAGE PRODUCTS DESIGNED AND MARKETED FOR CLOSETS, BEDROOMS, BATHROOMS, FAMILY ROOMS, LAUNDRY, BASEMENTS, OR HOME OFFICE (U.S. CLS. 2, 13, 23, 29, 30, 33, 40 AND 50).

FIRST USE 2-1-2011; IN COMMERCE 2-1-2011.

3,963,382. MILLER, CHARLA, GRAND ISLAND, NE. SN 85-014,425. PUB. 9-21-2010, FILED 4-15-2010.

**DOGGONE CLEAN PAWS**

THE MARK CONSISTS OF STANDARD CHARACTERS WITHOUT CLAIM TO ANY PARTICULAR FONT, STYLE, SIZE, OR COLOR.

**CLASS 21—(Continued).**

NO CLAIM IS MADE TO THE EXCLUSIVE RIGHT TO USE "CLEAN PAWS", APART FROM THE MARK AS SHOWN.

FOR DOG PAW WASHING AND DRYING DEVICE, NAMELY, A PORTABLE SET OF TRAYS INTO WHICH DOG PAWS ARE PLACED (U.S. CLS. 2, 13, 23, 29, 30, 33, 40 AND 50).

FIRST USE 8-31-2010; IN COMMERCE 9-30-2010.

3,963,565. BRUSHPOINT INNOVATIONS INC, KING CITY, CANADA. SN 85-065,051. PUB. 1-4-2011, FILED 6-17-2010.

**BRUSHPOINT CLINICAL CARE**

THE MARK CONSISTS OF STANDARD CHARACTERS WITHOUT CLAIM TO ANY PARTICULAR FONT, STYLE, SIZE, OR COLOR.

OWNER OF U.S. REG. NO. 3,306,005.

FOR ELECTRICAL TOOTHBRUSHES (U.S. CLS. 2, 13, 23, 29, 30, 33, 40 AND 50).

FIRST USE 9-23-2010; IN COMMERCE 9-23-2010.

**CLASS 22—CORDAGE AND FIBERS**

3,962,534. WEIL NOMINEES PTY LTD, PRAHRAN VIC, AUSTRALIA. SN 77-809,707. PUB. 7-20-2010, FILED 8-21-2009.



NO CLAIM IS MADE TO THE EXCLUSIVE RIGHT TO USE "MICROCLOUD ULTRA SOFT COMFORT", APART FROM THE MARK AS SHOWN.

THE MARK CONSISTS OF THE WORD "MICROCLOUD" APPEARING AGAINST AN IMAGE OF A CLOUD WITH THE WORDS "ULTRA SOFT COMFORT" WRITTEN BELOW.

FOR PADDING AND STUFFING MATERIALS NOT OF RUBBER, PAPER OR PLASTIC (U.S. CLS. 1, 2, 7, 19, 22, 42 AND 50).

FIRST USE 1-1-2009; IN COMMERCE 1-1-2009.

**CLASS 24—FABRICS**

**CLASS 24—(Continued).**

3,962,010. IDEA NUOVA, INC., NEW YORK, NY. SN 77-045,694. PUB. 12-11-2007, FILED 11-16-2006.

AMERICAN KIDS HOME DIVISION

THE MARK CONSISTS OF STANDARD CHARACTERS WITHOUT CLAIM TO ANY PARTICULAR FONT, STYLE, SIZE, OR COLOR.

NO CLAIM IS MADE TO THE EXCLUSIVE RIGHT TO USE "KIDS HOME DIVISION", APART FROM THE MARK AS SHOWN.

FOR BEDDING, NAMELY, BLANKETS, QUILTS, COVERLETS, BLANKET THROWS, BED SKIRTS, BED CURTAINS, DUST RUFFLES, PILLOW SHAMS, PILLOW CASES, SHEET AND SHEET SETS, DUVETS, COMFORTER AND BLANKET COVERS, AND BED CANOPIES; WINDOW TREATMENTS, NAMELY, FABRIC VALANCES, CURTAINS, DRAPERIES, PANELS, SWAGS AND TIE-BACKS (U.S. CLS. 42 AND 50).

FIRST USE 2-28-2011; IN COMMERCE 2-28-2011.

3,962,175. STANDARD TEXTILE CO., INC., CINCINNATI, OH. SN 77-527,189. PUB. 12-21-2010, FILED 7-21-2008.

LUXSOFT

THE MARK CONSISTS OF STANDARD CHARACTERS WITHOUT CLAIM TO ANY PARTICULAR FONT, STYLE, SIZE, OR COLOR.

FOR BED BLANKETS (U.S. CLS. 42 AND 50).  
FIRST USE 8-0-2008; IN COMMERCE 8-0-2008.

3,962,535. WEIL NOMINEES PTY LTD, PRAHRAN VIC, AUSTRALIA. SN 77-809,708. PUB. 6-29-2010, FILED 8-21-2009.

**durasoft**  
seriously hi performance fabric

NO CLAIM IS MADE TO THE EXCLUSIVE RIGHT TO USE "HIGH PERFORMANCE FABRIC", APART FROM THE MARK AS SHOWN.

THE MARK CONSISTS OF THE WORDS "DURASOFT" APPEARING IN STYLIZED FONT WITH THE WORDS "SERIOUSLY HI PERFORMANCE FABRIC" WRITTEN IN SMALLER STYLIZED FONT UNDERNEATH.

FOR BED COVERS; PET BLANKETS; PILLOW CASES; PILLOW COVERS (U.S. CLS. 42 AND 50).  
FIRST USE 1-1-2009; IN COMMERCE 1-1-2009.

**CLASS 24—(Continued).**

3,962,657. EZNAP INC., RENO, NV. SN 77-852,227. PUB. 4-13-2010, FILED 10-19-2009.

EZNAP

THE MARK CONSISTS OF STANDARD CHARACTERS WITHOUT CLAIM TO ANY PARTICULAR FONT, STYLE, SIZE, OR COLOR.

FOR CHILDREN'S BLANKETS (U.S. CLS. 42 AND 50).  
FIRST USE 10-0-2009; IN COMMERCE 10-0-2009.

3,962,683. NATIONAL ALLERGY SUPPLY, INC., DULUTH, GA. SN 77-858,570. PUB. 8-10-2010, FILED 10-27-2009.

MICRENZA

THE MARK CONSISTS OF STANDARD CHARACTERS WITHOUT CLAIM TO ANY PARTICULAR FONT, STYLE, SIZE, OR COLOR.

FOR TEXTILE FABRIC FOR USE IN BEDDING PRODUCTS FOR FILTERING ALLERGENS (U.S. CLS. 42 AND 50).

FIRST USE 11-0-2009; IN COMMERCE 11-0-2009.

3,962,741. MY BIG IDEAS, LLC, FAIRFIELD, NJ. SN 77-884,616. PUB. 8-3-2010, FILED 12-2-2009.

TIME TOWEL

THE MARK CONSISTS OF STANDARD CHARACTERS WITHOUT CLAIM TO ANY PARTICULAR FONT, STYLE, SIZE, OR COLOR.

NO CLAIM IS MADE TO THE EXCLUSIVE RIGHT TO USE "TOWEL", APART FROM THE MARK AS SHOWN.  
FOR BEACH TOWELS (U.S. CLS. 42 AND 50).  
FIRST USE 5-1-2010; IN COMMERCE 5-10-2010.

**CLASS 24—(Continued).**

3,962,867. COMFORT HOME OUTLET CORP., POMONA, CA. SN 77-919,551. PUB. 8-10-2010, FILED 1-25-2010.

**COMFORT HOME**

THE MARK CONSISTS OF STANDARD CHARACTERS WITHOUT CLAIM TO ANY PARTICULAR FONT, STYLE, SIZE, OR COLOR.

NO CLAIM IS MADE TO THE EXCLUSIVE RIGHT TO USE "HOME", APART FROM THE MARK AS SHOWN.

FOR BED BLANKETS, BED LINENS, BED SHEETS, BED SPREADS, COMFORTERS, QUILTS, DUVET COVERS, BLANKETS, NAMELY, LAP BLANKETS, DECORATING BLANKETS, PILLOWCASES, CURTAINS, UNFITTED FURNITURE COVERS MADE OF FABRIC, KITCHEN TOWELS, TOWELS AND WASH CLOTHS (U.S. CLS. 42 AND 50).

FIRST USE 7-0-2010; IN COMMERCE 7-0-2010.

3,963,139. MMI-IPCO,LLC, LAWRENCE, MA. SN 77-960,295. PUB. 8-10-2010, FILED 3-16-2010.

**POWER SHIELD FR**

THE MARK CONSISTS OF STANDARD CHARACTERS WITHOUT CLAIM TO ANY PARTICULAR FONT, STYLE, SIZE, OR COLOR.

OWNER OF U.S. REG. NOS. 2,629,230, 3,540,731, AND 3,683,498.

NO CLAIM IS MADE TO THE EXCLUSIVE RIGHT TO USE "FR", APART FROM THE MARK AS SHOWN.

FOR FLAME RESISTANT TEXTILE FABRICS FOR USE IN THE MANUFACTURE OF CLOTHING, HOME FURNISHINGS, UPHOLSTERY, FURNITURE, HOUSEWARES FURNISHINGS, CARPETS, FLOOR COVERINGS, WALL COVERINGS, CURTAINS, FURNITURE COVERS, BLANKETS, PILLOWS, BED LINENS, BATH LINENS, AND KITCHEN LINENS; FLAME RESISTANT TEXTILE FABRICS FOR USE IN THE MANUFACTURE OF HOUSEWARES, NAMELY, FURNITURE AND FURNISHINGS; FLAME RESISTANT TEXTILES FOR USE IN THE MANUFACTURE OF CARPETS AND FLOOR COVERINGS; FLAME RESISTANT TEXTILES, NAMELY, CURTAINS (U.S. CLS. 42 AND 50).

FIRST USE 3-16-2010; IN COMMERCE 3-16-2010.

**CLASS 24—(Continued).**

3,963,228. KADENA INDUSTRIES COMPANY, LTD., HANG-ZHOU, CHINA. SN 77-969,436. PUB. 8-17-2010, FILED 3-26-2010.

**NANO MAX**

THE MARK CONSISTS OF STANDARD CHARACTERS WITHOUT CLAIM TO ANY PARTICULAR FONT, STYLE, SIZE, OR COLOR.

FOR FABRICS FOR THE MANUFACTURE OF GARMENTS, APPAREL, GLOVES AND BOOTS (U.S. CLS. 42 AND 50).

FIRST USE 11-19-2010; IN COMMERCE 11-19-2010.

3,963,395. GOLDEN MILLS, LLC, CHATSWORTH, CA. SN 85-018,423. PUB. 9-21-2010, FILED 4-20-2010.

**GOLDEN TREASURE**

THE MARK CONSISTS OF STANDARD CHARACTERS WITHOUT CLAIM TO ANY PARTICULAR FONT, STYLE, SIZE, OR COLOR.

OWNER OF U.S. REG. NOS. 3,030,484, 3,463,201, AND 3,493,495.

FOR TOWELS (U.S. CLS. 42 AND 50).

FIRST USE 9-30-2010; IN COMMERCE 9-30-2010.

3,963,710. MULLEN, JEFFREY M., LAKELAND, TN. SN 85-129,073. PUB. 1-11-2011, FILED 9-14-2010.

**THE MULLY**

THE MARK CONSISTS OF STANDARD CHARACTERS WITHOUT CLAIM TO ANY PARTICULAR FONT, STYLE, SIZE, OR COLOR.

FOR SPORT TOWELS (U.S. CLS. 42 AND 50).

FIRST USE 1-27-2011; IN COMMERCE 1-27-2011.

**CLASS 25—CLOTHING**

**CLASS 25—(Continued).**

3,961,977. TAYLOR, PAUL C., JR., NOVELTY, OH. SN 76-691,938. PUB. 1-20-2009, FILED 8-8-2008.

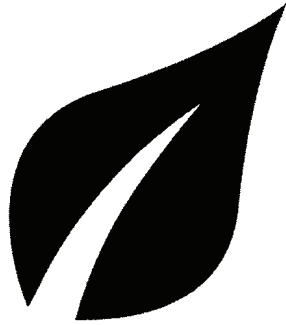

OWNER OF U.S. REG. NO. 3,158,444.  
THE MARK CONSISTS OF A LEAF DESIGN FEATURING AN OPEN AREA AT THE BASE OF THE LEAF AND NARROWING AS IT EXTENDS UPWARD INTO THE LEAF FOR CLOTHING AND OUTERWEAR FOR CHILDREN, NAMELY, COVERALLS, OVERALLS, PANTS, SHORTS, BELTS, SHIRTS, T-SHIRTS, SWEATSHIRTS, UNDERWEAR, SLEEPWEAR, VESTS, HATS, GLOVES, FOOTWEAR, AND JACKETS (U.S. CLS. 22 AND 39).  
FIRST USE 2-4-2011; IN COMMERCE 2-4-2011.

3,961,978. SOON, LIM OK, GANGDONG-GU, SEOUL, REPUBLIC OF KOREA. SN 76-695,908. PUB. 8-10-2010, FILED 2-23-2009.

PRIORITY CLAIMED UNDER SEC. 44(D) ON REPUBLIC OF KOREA APPLICATION NO. 40-2008-0058, FILED 12-17-2008.

THE MARK CONSISTS OF THE WORD "NARZIO" APPEARING IN STYLIZED TEXT WITH A CURVED LINE EXTENDING FROM THE LETTER "N" TO THE DESIGN OF A BUTTERFLY APPEARING OVER THE LETTER "O".

FOR SHOE SOLES; SHOES; MOUNTAINEERING BOOTS; WINTER BOOTS; INNER SOLES; SOLES FOR FOOTWEAR; FOOTWEAR UPPERS; HEEL PIECES FOR BOOTS; NON-SLIPPING SOLE TREADS FOR BOOTS; TIPS FOR FOOTWEAR; WALKING SHOES; OVERSHOES (U.S. CLS. 22 AND 39).

FIRST USE 6-15-2008; IN COMMERCE 1-10-2009.

**CLASS 25—(Continued).**

3,962,008. BIG SHOES PRODUCTIONS, INC., SEATTLE, WA. SN 77-036,283. PUB. 12-11-2007, FILED 11-3-2006.

# D'S T'S

THE MARK CONSISTS OF STANDARD CHARACTERS WITHOUT CLAIM TO ANY PARTICULAR FONT, STYLE, SIZE, OR COLOR.

NO CLAIM IS MADE TO THE EXCLUSIVE RIGHT TO USE "T'S", APART FROM THE MARK AS SHOWN.

FOR CLOTHING, NAMELY, T-SHIRTS (U.S. CLS. 22 AND 39).

FIRST USE 2-6-2009; IN COMMERCE 2-6-2009.

3,962,015. RETAIL ROYALTY COMPANY, LAS VEGAS, NV. SN 77-078,353. PUB. 3-17-2009, FILED 1-8-2007.

# 06

THE MARK CONSISTS OF STANDARD CHARACTERS WITHOUT CLAIM TO ANY PARTICULAR FONT, STYLE, SIZE, OR COLOR.

FOR WEARING APPAREL, CLOTHING, AND CLOTHING ACCESSORIES, NAMELY, BOTTOMS, TOPS (U.S. CLS. 22 AND 39).

FIRST USE 7-0-2009; IN COMMERCE 7-0-2009.

3,962,016. THE RACHEL LAMB PROJECT, LLC, BEDFORD, TX. SN 77-082,054. PUB. 1-8-2008, FILED 1-12-2007.

# RED INK

THE MARK CONSISTS OF STANDARD CHARACTERS WITHOUT CLAIM TO ANY PARTICULAR FONT, STYLE, SIZE, OR COLOR.

FOR CLOTHING, NAMELY, MEN'S AND WOMEN'S SHORT SLEEVE T-SHIRTS (U.S. CLS. 22 AND 39).

FIRST USE 3-11-2011; IN COMMERCE 3-11-2011.



**CLASS 25—(Continued).**

3,962,023. EDITFASHION LLC, NEW YORK, NY. SN 77-107,514. PUB. 1-8-2008, FILED 2-14-2007.

**EDIT**

THE MARK CONSISTS OF STANDARD CHARACTERS WITHOUT CLAIM TO ANY PARTICULAR FONT, STYLE, SIZE, OR COLOR.

FOR SWEATERS (U.S. CLS. 22 AND 39).  
FIRST USE 10-0-2010; IN COMMERCE 10-0-2010.

3,962,108. ANDREW FEZZA, LTD., WESTON, CT. SN 77-374,195. PUB. 1-20-2009, FILED 1-17-2008.

**FEZ**

THE MARK CONSISTS OF STANDARD CHARACTERS WITHOUT CLAIM TO ANY PARTICULAR FONT, STYLE, SIZE, OR COLOR.

FOR MEN'S WEARING APPAREL, NAMELY, SUITS, PANTS, SPORT JACKETS, SPORT COATS, JACKETS, DRESS PANTS, CASUAL PANTS (U.S. CLS. 22 AND 39).  
FIRST USE 2-15-2011; IN COMMERCE 2-15-2011.

3,962,116. NUERA GROUP INC., EL MONTE, CA. SN 77-393,243. PUB. 11-10-2009, FILED 2-10-2008.

**SOLEADO**

THE MARK CONSISTS OF STANDARD CHARACTERS WITHOUT CLAIM TO ANY PARTICULAR FONT, STYLE, SIZE, OR COLOR.

THE ENGLISH TRANSLATION OF THE WORD "SOLEADO" IN THE MARK IS SUNNY.

FOR SHOES; GOLF SHOES; LEATHER SHOES; RUNNING SHOES; WORK SHOES AND BOOTS; ATHLETIC SHOES; CANVAS SHOES; FOOTWEAR FOR MEN; FOOTWEAR FOR MEN AND WOMEN (U.S. CLS. 22 AND 39).

FIRST USE 6-1-2010; IN COMMERCE 6-1-2010.

**CLASS 25—(Continued).**

3,962,127. SENGSTAKEN ENTERPRISES, INC., OXNARD, CA. SN 77-410,261. PUB. 7-15-2008, FILED 2-29-2008.

**TWO TREES**

THE MARK CONSISTS OF STANDARD CHARACTERS WITHOUT CLAIM TO ANY PARTICULAR FONT, STYLE, SIZE, OR COLOR.

FOR CLOTHING, NAMELY, T-SHIRTS, SWEAT-SHIRTS AND JACKETS (U.S. CLS. 22 AND 39).  
FIRST USE 4-7-2011; IN COMMERCE 4-7-2011.

3,962,132. RICH, JOHN, NASHVILLE, TN. SN 77-424,533. PUB. 7-29-2008, FILED 3-18-2008.

**REDNECK RIVIERA**

THE MARK CONSISTS OF STANDARD CHARACTERS WITHOUT CLAIM TO ANY PARTICULAR FONT, STYLE, SIZE, OR COLOR.

FOR SHIRTS (U.S. CLS. 22 AND 39).  
FIRST USE 3-7-2011; IN COMMERCE 3-7-2011.

3,962,135. INTERNATIONAL MERCHANDISING INC. SDN BHD (CO#645198-T), SELANGOR DARUL EHSAN, MALAYSIA. SN 77-433,286. PUB. 9-7-2010, FILED 3-27-2008.

**EDRY**

THE MARK CONSISTS OF STANDARD CHARACTERS WITHOUT CLAIM TO ANY PARTICULAR FONT, STYLE, SIZE, OR COLOR.

FOR ATHLETIC CLOTHING AND CASUAL CLOTHING, NAMELY, OUTDOOR JACKETS, SWEATERS, PULLOVERS, T-SHIRTS, PANTS, SKIRTS, DRESSES, BLAZERS, BLOUSES, SHORTS, CULOTTES, SWEAT TOPS, SWEAT BOTTOMS, JOGGING SUITS, TWIN SETS, JERSEYS, TANK TOPS; GOLFWEAR, NAMELY, PANTS, OUTDOOR JACKETS, SWEATERS, GOLF SHIRTS, SOCKS, SHORTS AND HATS; WORKWEAR, NAMELY, OVERALLS, PANTS, SHIRTS, OUTDOOR JACKETS, SOCKS, SHORTS, PULLOVERS; UNIFORMWEAR, NAMELY, MEDICAL UNIFORMS, FOOD SERVICE UNIFORMS (U.S. CLS. 22 AND 39).

FIRST USE 0-0-2002; IN COMMERCE 0-0-2002.

**CLASS 25—(Continued).**

3,962,141. SISCO TEXTILES N.V., WILLEMSTAD, CURA-CAO, NETHERLANDS ANTILLES. SN 77-449,611. PUB. 7-29-2008, FILED 4-16-2008.

# ECO'NEILL

THE MARK CONSISTS OF STANDARD CHARACTERS WITHOUT CLAIM TO ANY PARTICULAR FONT, STYLE, SIZE, OR COLOR.

FOR CLOTHING, NAMELY, SHIRTS, TANK TOPS, SHORTS, BELTS, SWIM WEAR, SWEAT SUITS, HATS, AND FOOT WEAR (U.S. CLS. 22 AND 39).

FIRST USE 3-0-2010; IN COMMERCE 8-25-2010.

3,962,160. GALAXY BRAND MANAGEMENT CORP., WILDWOOD, FL. SN 77-497,697. PUB. 11-4-2008, FILED 6-12-2008.

# Spare Your Pair

THE MARK CONSISTS OF STANDARD CHARACTERS WITHOUT CLAIM TO ANY PARTICULAR FONT, STYLE, SIZE, OR COLOR.

FOR BLAZERS; BLOUSES; CAMISOLES; CARDIGANS; DRESSES; HALTER TOPS; JEANS; JUMPSUITS; KNIT SHIRTS; MINISKIRTS; OVERALLS; PANTS; PANTSUITS; POLO SHIRTS; SHORTS; SKIRTS; SLACKS; SPORT COATS; SPORT SHIRTS; SWEAT PANTS; SWEAT SHIRTS; SWEAT SHORTS; SWEAT SUITS; SWEATERS; T-SHIRTS; TANK TOPS; TANK-TOPS; TROUSERS; VESTS (U.S. CLS. 22 AND 39).

FIRST USE 2-1-2009; IN COMMERCE 2-1-2009.

3,962,172. HELLA GOOD, LLC, MILPITAS, CA. SN 77-521,271. PUB. 11-11-2008, FILED 7-14-2008.



THE MARK CONSISTS OF A STYLIZED CIRCLE WITH 2

**CLASS 25—(Continued).**

OUTLINES, AND A CALLIGRAPHY LOOKING LETTER "H". THE FIRST STROKE OF THE CAPITAL LETTER "H" STARTS AT 9 O'CLOCK, THEN CONTINUES TO 1 O'CLOCK, THEN ENDS A LITTLE PAST 7 O'CLOCK. THE 2ND STROKE STARTS AT 2 O'CLOCK AND ENDS AT 6 O'CLOCK. THE FINAL MIDDLE/CONNECTING STROKE STARTS AT 9 O'CLOCK AND MOVES HORIZONTALLY JUST ABOVE 3 O'CLOCK. AT 4 O'CLOCK, TO THE RIGHT OF THE LETTER "H" AND WITHIN THE CIRCLE IS A STAR THAT IS TILTED TO THE RIGHT SLIGHTLY.

FOR HATS; JACKETS; PANTS; SHIRTS; SHOES; SWEATERS (U.S. CLS. 22 AND 39).

FIRST USE 1-1-2008; IN COMMERCE 8-12-2010.

3,962,178. BROWN, JAKE, OCEANSIDE, CA. SN 77-532,144. PUB. 12-30-2008, FILED 7-26-2008.

# LACED

THE MARK CONSISTS OF STANDARD CHARACTERS WITHOUT CLAIM TO ANY PARTICULAR FONT, STYLE, SIZE, OR COLOR.

FOR A-SHIRTS; ATHLETIC APPAREL, NAMELY, SHIRTS, PANTS, JACKETS, FOOTWEAR, HATS AND CAPS, ATHLETIC FOOTWEAR; ATHLETIC SHOES; BEACH SHOES; BUTTON-FRONT ALOHA SHIRTS; CAMP SHIRTS; CANVAS SHOES; DECK-SHOES; DRESS SHIRTS; GOLF SHIRTS; HAT BANDS; HATS; HOODED SWEAT SHIRTS; KNIT SHIRTS; LEATHER SHOES; LONG-SLEEVED SHIRTS; OPEN-NECKED SHIRTS; PIQUE SHIRTS; POLO SHIRTS; SHORT-SLEEVED OR LONG-SLEEVED T-SHIRTS; SHORT-SLEEVED SHIRTS; SKI AND SNOWBOARD SHOES AND PARTS THEREOF; SMALL HATS; SPORT SHIRTS; SPORTS SHIRTS; SPORTS SHIRTS WITH SHORT SLEEVES; SWEAT SHIRTS; T-SHIRTS; TEE SHIRTS; TENNIS SHOES (U.S. CLS. 22 AND 39).

FIRST USE 7-20-2010; IN COMMERCE 7-20-2010.

3,962,200. MOORE, SAMUEL, OLD HICKORY, TX. SN 77-555,039. PUB. 1-13-2009, FILED 8-25-2008.

# Bow-Up

THE MARK CONSISTS OF STANDARD CHARACTERS WITHOUT CLAIM TO ANY PARTICULAR FONT, STYLE, SIZE, OR COLOR.

FOR CLOTHING, NAMELY, SHIRTS, T-SHIRTS, SWEATSHIRTS, JACKETS, SHORTS, PANTS, HATS, CAPS (U.S. CLS. 22 AND 39).

FIRST USE 10-18-2009; IN COMMERCE 10-18-2009.

**CLASS 25—(Continued).**

3,962,221. IMAGEWEAR APPAREL CORP., WILMINGTON, DE. SN 77-589,237. PUB. 12-30-2008, FILED 10-9-2008.

**THERMA BASE**

THE MARK CONSISTS OF STANDARD CHARACTERS WITHOUT CLAIM TO ANY PARTICULAR FONT, STYLE, SIZE, OR COLOR.

FOR SPORTS CLOTHING, NAMELY, JACKETS, COATS, SWEATSHIRTS, JERSEYS; TEAM UNIFORMS (U.S. CLS. 22 AND 39).

FIRST USE 6-24-2008; IN COMMERCE 6-24-2008.

---

3,962,255. MAIDENFORM, INC., ISELIN, NJ. SN 77-649,681. PUB. 8-10-2010, FILED 1-14-2009.

**THE INSTANT BUST MAKEOVER**

THE MARK CONSISTS OF STANDARD CHARACTERS WITHOUT CLAIM TO ANY PARTICULAR FONT, STYLE, SIZE, OR COLOR.

NO CLAIM IS MADE TO THE EXCLUSIVE RIGHT TO USE "BUST", APART FROM THE MARK AS SHOWN.

FOR FOUNDATION GARMENTS; BRASSIERES; WOMEN'S INTIMATE APPAREL, NAMELY, WOMEN'S UNDERGARMENTS, BUSTIERS, BANDEAUX, CORSETS AND CORSELETTES (U.S. CLS. 22 AND 39).

FIRST USE 8-0-2008; IN COMMERCE 3-0-2009.

---

3,962,256. CHRISTY FRANK MIRACLES, LLC, SCOTTSDALE, AZ. SN 77-650,485. PUB. 1-12-2010, FILED 1-15-2009.



OWNER OF U.S. REG. NO. 3,493,238.

THE MARK CONSISTS OF THE WORD "ROCKHEART" SUPERIMPOSED OVER CURVILINEAR EMBELLISHMENTS WITH A HEART SHAPE SUPERIMPOSED WITHIN THE WORD "ROCKHEART".

FOR CLOTHING, NAMELY, SCARVES AND SHIRTS (U.S. CLS. 22 AND 39).

FIRST USE 1-1-2009; IN COMMERCE 1-1-2009.

**CLASS 25—(Continued).**

3,962,265. ALATAS, TARIQ, LOS ANGELES, CA. SN 77-657,083. PUB. 6-9-2009, FILED 1-26-2009.

**UNDERLAB SYSTEMS**

THE MARK CONSISTS OF STANDARD CHARACTERS WITHOUT CLAIM TO ANY PARTICULAR FONT, STYLE, SIZE, OR COLOR.

NO CLAIM IS MADE TO THE EXCLUSIVE RIGHT TO USE "SYSTEMS", APART FROM THE MARK AS SHOWN.

FOR CLOTHING, NAMELY, PANTS, SHIRTS, COATS, JACKETS, SWEATERS, SWEATSHIRTS, SWEATPANTS, SHORTS, TOPS, BOTTOMS, AND HEADWEAR (U.S. CLS. 22 AND 39).

FIRST USE 10-0-2010; IN COMMERCE 10-0-2010.

---

3,962,284. STEVEN M. SHRIVER, CEDAR RAPIDS, IA. SN 77-669,605. PUB. 6-9-2009, FILED 2-12-2009.

**NOT FROM HERE**

THE MARK CONSISTS OF STANDARD CHARACTERS WITHOUT CLAIM TO ANY PARTICULAR FONT, STYLE, SIZE, OR COLOR.

FOR SHORT-SLEEVED OR LONG-SLEEVED T-SHIRTS (U.S. CLS. 22 AND 39).

FIRST USE 2-28-2011; IN COMMERCE 2-28-2011.

**CLASS 25—(Continued).**

3,962,295. FINZCORP, INC., LAS VEGAS, NV. SN 77-677,424.  
PUB. 6-30-2009, FILED 2-24-2009.



THE MARK CONSISTS OF THE HEAD AND SHOULDERS OF A WOMAN WEARING A HOODED JACKET BEARING A STAR ON THE HOOD. THE WORDS "KREATED KOCKY" APPEAR UNDERNEATH THE WOMAN AND THERE IS A STAR REPLACING THE LETTER "O" IN "KOCKY".

FOR BEANIES; BOXER SHORTS; BRAS; BRIEFS; CLOTHING FOR ATHLETIC USE, NAMELY, PADDED SHORTS; DRESSES; GLOVES; GYM SHORTS; HAT BANDS; HATS; JACKETS; JEANS; JERSEYS; LEGGINGS; NECK BANDS; PANTS; SHIRTS; SHORTS; SPORTS BRA; SPORTS BRAS; SPORTS JERSEYS; SWEAT BANDS; SWEAT JACKETS; SWEAT PANTS; SWEAT SHIRTS; SWEAT SHORTS; SWIM CAPS; SWIM TRUNKS; SWIM WEAR; SWIM WEAR FOR GENTLEMEN AND LADIES; SWIMWEAR; T-SHIRTS; THERMAL UNDERWEAR; TRAVEL CLOTHING CONTAINED IN A PACKAGE COMPRISING REVERSIBLE JACKETS, PANTS, SKIRTS, TOPS AND A BELT OR SCARF; UNDERWEAR; UNDERWEAR, NAMELY, BOY SHORTS; VESTS; WRIST BANDS (U.S. CLS. 22 AND 39).

FIRST USE 9-22-2010; IN COMMERCE 9-22-2010.

**CLASS 25—(Continued).**

3,962,296. FINZCORP, INC., LAS VEGAS, NV. SN 77-677,427.  
PUB. 6-30-2009, FILED 2-24-2009.



THE MARK CONSISTS OF THE HEAD AND SHOULDERS OF A MAN WEARING A HOODED JACKET BEARING A STAR ON THE HOOD. THERE IS A SOLID HORIZONTAL LINE BENEATH THE MAN'S IMAGE AND THE WORDS "KREATED KOCKY" APPEAR UNDERNEATH THE LINE WITH A STAR OVERLAYING THE LETTER "O" IN "KOCKY".

FOR BEANIES; BOXER SHORTS; BRAS; BRIEFS; CLOTHING FOR ATHLETIC USE, NAMELY, PADDED SHORTS; DRESSES; GLOVES; GYM SHORTS; HAT BANDS; HATS; JACKETS; JEANS; JERSEYS; LEGGINGS; NECK BANDS; PANTS; SHIRTS; SHORTS; SPORTS BRA; SPORTS BRAS; SPORTS JERSEYS; SWEAT BANDS; SWEAT JACKETS; SWEAT PANTS; SWEAT SHIRTS; SWEAT SHORTS; SWIM CAPS; SWIM TRUNKS; SWIM WEAR; SWIM WEAR FOR GENTLEMEN AND LADIES; SWIMWEAR; T-SHIRTS; THERMAL UNDERWEAR; TRAVEL CLOTHING CONTAINED IN A PACKAGE COMPRISING REVERSIBLE JACKETS, PANTS, SKIRTS, TOPS AND A BELT OR SCARF; UNDERWEAR; UNDERWEAR, NAMELY, BOY SHORTS; VESTS; WRIST BANDS (U.S. CLS. 22 AND 39).

FIRST USE 9-22-2010; IN COMMERCE 9-22-2010.

3,962,342. THE ROB NELSON COMPANY, VANCOUVER, WA. SN 77-705,364. PUB. 8-4-2009, FILED 4-2-2009.

**BIG LEAGUE CHEW**

THE MARK CONSISTS OF STANDARD CHARACTERS WITHOUT CLAIM TO ANY PARTICULAR FONT, STYLE, SIZE, OR COLOR.

OWNER OF U.S. REG. NOS. 1,254,665 AND 1,262,578.  
FOR CAPS; HATS; JACKETS; POLO SHIRTS; SWEAT PANTS; SWEAT SHIRTS; T-SHIRTS (U.S. CLS. 22 AND 39).

FIRST USE 2-0-2011; IN COMMERCE 2-0-2011.

**CLASS 25—(Continued).**

3,962,345. OAK HALL INDUSTRIES, LP, DBA OAK HALL CAP & GOWN/CE WARD/BENTLEY & SIMON, SALEM, VA. SN 77-709,737. PUB. 3-2-2010, FILED 4-8-2009.

**GREENWEAVER**

THE MARK CONSISTS OF STANDARD CHARACTERS WITHOUT CLAIM TO ANY PARTICULAR FONT, STYLE, SIZE, OR COLOR.

FOR GRADUATION GOWNS (U.S. CLS. 22 AND 39).  
FIRST USE 4-21-2009; IN COMMERCE 4-21-2009.

3,962,348. SCHOR, EDWARD, TORRINGTON, CT. SN 77-712,367. PUB. 8-10-2010, FILED 4-13-2009.



NO CLAIM IS MADE TO THE EXCLUSIVE RIGHT TO USE "SOCK STRAP" AND "CALF STRAP", APART FROM THE MARK AS SHOWN.

THE MARK CONSISTS OF THE STYLIZED WORDING "SOCK STRAP IT'S THE SOLUTION CALF STRAP" IN A RECTANGLE WITH A CHECKERED BORDER AND THE DESIGN OF A MUSTACHIOED MAN WEARING A HAT AND HOLDING A GARTER WHILE SEATED ON A CHAIR WITH PANT LEGS RAISED SHOWING ONE OF TWO CALF LENGTH SOCKS CRUMPLED AT THE ANKLE, AND IN THE FOREGROUND TWO LEGS EACH WITH A CALF LENGTH SOCK, ONE WITH A STRIPE AND THE TERMS "SOCK STRAP" AND THE OTHER CRUMPLED AT THE ANKLE.

FOR ANKLE GARTERS; GARTERS (U.S. CLS. 22 AND 39).  
FIRST USE 7-22-2010; IN COMMERCE 7-22-2010.

**CLASS 25—(Continued).**

3,962,349. SCHOR, EDWARD, TORRINGTON, CT. SN 77-712,409. PUB. 7-27-2010, FILED 4-13-2009.



NO CLAIM IS MADE TO THE EXCLUSIVE RIGHT TO USE "SOCK" AND "KNEE-HIGH STRAP", APART FROM THE MARK AS SHOWN.

THE MARK CONSISTS OF THE STYLIZED WORDING "SOCK STRAPETTE IT'S THE SOLUTION KNEE HIGH STRAP" IN A RECTANGLE WITH A CHECKERED BORDER AND THE DESIGN OF A SEATED WOMAN WITH CROSSED LEGS WEARING CALF LENGTH SOCKS, ONE OF WHICH IS CRUMPLED AT THE ANKLE. IN THE FOREGROUND ON EACH SIDE OF THE SEATED WOMAN IS A LEG, EACH OF WHICH IS WEARING A CALF LENGTH SOCK, ONE OF WHICH IS CRUMPLED AT THE ANKLE.

FOR ANKLE GARTERS; GARTERS (U.S. CLS. 22 AND 39).  
FIRST USE 7-22-2010; IN COMMERCE 7-22-2010.

3,962,367. KENNETH COLE PRODUCTIONS (LIC), INC., NEW YORK, NY. SN 77-725,693. PUB. 3-2-2010, FILED 4-30-2009.

**-KENNETH COLE NEW YORK  
EXCLUSIVE 9-2-5 TECHNOLOGY**

THE MARK CONSISTS OF STANDARD CHARACTERS WITHOUT CLAIM TO ANY PARTICULAR FONT, STYLE, SIZE, OR COLOR.

OWNER OF U.S. REG. NOS. 1,372,672, 2,179,237, AND OTHERS.

NO CLAIM IS MADE TO THE EXCLUSIVE RIGHT TO USE "NEW YORK" AND "EXCLUSIVE" AND "TECHNOLOGY", APART FROM THE MARK AS SHOWN.

THE NAME(S), PORTRAIT(S), AND/OR SIGNATURE(S) SHOWN IN THE MARK IDENTIFIES "KENNETH COLE", WHOSE CONSENT(S) TO REGISTER IS MADE OF RECORD.

FOR FOOTWEAR (U.S. CLS. 22 AND 39).  
FIRST USE 8-7-2009; IN COMMERCE 8-7-2009.



**CLASS 25—(Continued).**

3,962,377. WILSON-PASTOR, BRITTA, ENCINITAS, CA. SN 77-736,458. PUB. 4-13-2010, FILED 5-13-2009.



THE COLOR(S) BLUE, PURPLE, AND FUCHSIA IS/ARE CLAIMED AS A FEATURE OF THE MARK.

THE MARK CONSISTS OF STYLIZED WORDS "BRITTAWEAR" IN BLUE COLOR WITH A PURPLE AND FUCHSIA COLORED FLOWER ABOVE THE "I" IN "BRITTA", WITH THE WORDS "CLEAN" "NATURAL" "CLASSIC" IN FUCHSIA COLOR ON THE SECOND LINE OF THE LOGO.

FOR JAPANESE SLEEPING ROBES (NEMAKI); ROBES; BOARD SHORTS; CAPS; CHILDREN'S HEADWEAR; DRESSES; DRESSING GOWNS; FOOTWEAR FOR WOMEN; KNIT SHIRTS; NIGHT GOWNS; PANTS; SHIRTS; SHORTS; SKIRTS; SKIRTS AND DRESSES; SOCKS; T-SHIRTS (U.S. CLS. 22 AND 39).

FIRST USE 8-1-2005; IN COMMERCE 8-1-2005.

**CLASS 25—(Continued).**

3,962,383. KENNETH COLE PRODUCTIONS (LIC), LLC, NEW YORK, NY. SN 77-742,863. PUB. 8-18-2009, FILED 5-22-2009.

KENNETH COLE SELECT

THE MARK CONSISTS OF STANDARD CHARACTERS WITHOUT CLAIM TO ANY PARTICULAR FONT, STYLE, SIZE, OR COLOR.

OWNER OF U.S. REG. NOS. 1,372,672, 1,999,096, AND OTHERS.

NO CLAIM IS MADE TO THE EXCLUSIVE RIGHT TO USE "SELECT", APART FROM THE MARK AS SHOWN.

THE NAME(S), PORTRAIT(S), AND/OR SIGNATURE(S) SHOWN IN THE MARK IDENTIFIES "KENNETH COLE", WHOSE CONSENT(S) TO REGISTER IS MADE OF RECORD.

FOR SUITS, JACKETS, PANTS (U.S. CLS. 22 AND 39). FIRST USE 4-14-2009; IN COMMERCE 4-14-2009.

3,962,378. SPINELLI, JAMES, DEVON, PA. SN 77-738,001. PUB. 12-8-2009, FILED 5-15-2009.



THE MARK CONSISTS OF THE STYLIZED LETTER "C". INSIDE THE LETTER "C" IS THE PEACE SYMBOL. FOR HATS; JACKETS; SHIRTS (U.S. CLS. 22 AND 39). FIRST USE 1-1-2011; IN COMMERCE 1-1-2011.

3,962,388. WM. B. COLEMAN CO., INC., HARAHAN, LA. SN 77-747,518. PUB. 11-23-2010, FILED 5-29-2009.

AMÉLLINE

THE MARK CONSISTS OF STANDARD CHARACTERS WITHOUT CLAIM TO ANY PARTICULAR FONT, STYLE, SIZE, OR COLOR.

THE NAME(S), PORTRAIT(S), AND/OR SIGNATURE(S) SHOWN IN THE MARK DOES NOT IDENTIFY A PARTICULAR LIVING INDIVIDUAL.

THE WORDING "AMÉLLINE" HAS NO MEANING IN A FOREIGN LANGUAGE.

FOR BELTS FOR CLOTHING; CAPRI PANTS; DENIMS; DRESS SHIRTS; DRESSES; HALTER TOPS; HATS; JACKETS; KNIT SHIRTS; LADIES' SUITS; LONG-SLEEVED SHIRTS; LOUNGE PANTS; OPEN-NECKED SHIRTS; PANTS; POLO SHIRTS; SCARVES; SHORT-SLEEVED OR LONG-SLEEVED T-SHIRTS; SHORT-SLEEVED SHIRTS; SHORTS; SKIRT SUITS; SKIRTS; SPORT SHIRTS; TANK TOPS; TOPS; TURTLE NECK SHIRTS (U.S. CLS. 22 AND 39).

FIRST USE 5-9-2009; IN COMMERCE 7-13-2009.

**CLASS 25—(Continued).**

3,962,389. THORP DIRECT SALES, INC., DORAVILLE, GA. SN 77-750,965. PUB. 1-12-2010, FILED 6-3-2009.

# FLEX RIDE

THE MARK CONSISTS OF STANDARD CHARACTERS WITHOUT CLAIM TO ANY PARTICULAR FONT, STYLE, SIZE, OR COLOR.

NO CLAIM IS MADE TO THE EXCLUSIVE RIGHT TO USE "FLEX", APART FROM THE MARK AS SHOWN.

FOR FOOTWEAR, EXCLUDING WINTER SPORTS FOOTWEAR (U.S. CLS. 22 AND 39).

FIRST USE 8-1-2010; IN COMMERCE 8-1-2010.

3,962,399. GRISALES CRISTINA, NORTH BERGEN, NJ. SN 77-759,059. PUB. 3-30-2010, FILED 6-13-2009.



NO CLAIM IS MADE TO THE EXCLUSIVE RIGHT TO USE "BABY GEAR", APART FROM THE MARK AS SHOWN.

THE COLOR(S) PURPLE (PANTONE 267C), GREEN (PANTONE 370C) AND WHITE IS/ARE CLAIMED AS A FEATURE OF THE MARK.

THE MARK CONSISTS OF THE STYLIZED WORDING "GLOBAL BABY GEAR" WITH THE WORD "GLOBAL" IN PURPLE (PANTONE 267C), THE WORD "BABY" IN WHITE COLOR WITH A BORDER AND SHADOW IN PURPLE (PANTONE 267C), THE WORD "GEAR" IN GREEN (PANTONE 370C), AND A SILHOUETTE OF A BABY IN PURPLE (PANTONE 267C) DEPICTED BETWEEN THE WORDS "GLOBAL" AND "GEAR".

FOR BABY TOPS; DRESSES; INFANT AND TODDLER ONE PIECE CLOTHING; ONE PIECE GARMENT FOR INFANTS AND TODDLERS; ROMPERS; SHORT SETS (U.S. CLS. 22 AND 39).

FIRST USE 11-22-2010; IN COMMERCE 11-22-2010.

3,962,424. RICHARD SEAN GARBER, CORONA, CA. SN 77-770,913. PUB. 11-24-2009, FILED 6-30-2009.

# SOUL DESTINATION

THE COLOR(S) BLACK, WHITE AND RED IS/ARE CLAIMED AS A FEATURE OF THE MARK.

**CLASS 25—(Continued).**

THE MARK CONSISTS OF THE FULLY CAPITALIZED WORD "SOUL" PRINTED IN WHITE WITH A BLACK OUTLINE AROUND EACH LETTER; BELOW IT TO THE LOWER RIGHT, BEGINNING BENEATH THE "O", IS THE WORD "DESTINATION" PRINTED IN BLACK, WITH ALL LETTERS CAPITALIZED EXCEPT THE TWO "T'S"; A HAZY RED HALO SURROUNDS THE SECOND "T" WHICH IS WHITE WITH A BLACK OUTLINE.

FOR APPAREL, NAMELY, T-SHIRTS, CAPS, HATS, BUTTON-DOWN SHIRTS, POLO SHIRTS (U.S. CLS. 22 AND 39).

FIRST USE 8-15-2010; IN COMMERCE 2-14-2011.

3,962,445. ROBERT P. NICKELL, TORRANCE, CA. SN 77-781,222. PUB. 12-8-2009, FILED 7-15-2009.

# I'M THE DADDY

THE MARK CONSISTS OF STANDARD CHARACTERS WITHOUT CLAIM TO ANY PARTICULAR FONT, STYLE, SIZE, OR COLOR.

FOR ATHLETIC APPAREL, NAMELY, SHIRTS, PANTS, HATS AND CAPS; BASEBALL CAPS; SCRUBS NOT FOR MEDICAL PURPOSES; SHIRTS (U.S. CLS. 22 AND 39).

FIRST USE 3-31-2010; IN COMMERCE 3-31-2010.

3,962,461. MADARAS GALLERY, INC., DBA MADARAS GALLERY, TUCSON, AZ. SN 77-786,238. PUB. 6-29-2010, FILED 7-21-2009.

# KITTY HUMBUG

THE MARK CONSISTS OF STANDARD CHARACTERS WITHOUT CLAIM TO ANY PARTICULAR FONT, STYLE, SIZE, OR COLOR.

THE NAME(S), PORTRAIT(S), AND/OR SIGNATURE(S) SHOWN IN THE MARK DOES NOT IDENTIFY A PARTICULAR LIVING INDIVIDUAL.

FOR APPAREL, NAMELY, T-SHIRTS, SWEATSHIRTS (U.S. CLS. 22 AND 39).

FIRST USE 8-15-2009; IN COMMERCE 9-24-2009.

**CLASS 25—(Continued).**

3,962,466. ROGER D. POPA, DBA PETOSKEY PETE'S, TRAVERSE CITY, MI. SN 77-789,289. PUB. 7-20-2010, FILED 7-24-2009.



THE COLOR(S) BLACK AND WHITE IS/ARE CLAIMED AS A FEATURE OF THE MARK.

THE MARK CONSISTS OF THE WORD "NORTH" SURROUNDED BY WHITE, A BLACK BORDER AND A WHITE BORDER.

FOR BOTTOMS; GOLF SHIRTS; HATS; HOODED SWEAT SHIRTS; JOGGING PANTS; LONG-SLEEVED SHIRTS; LOUNGE PANTS; PANTS; PIQUE SHIRTS; POLO SHIRTS; SHIRTS; SHIRTS AND SHORT-SLEEVED SHIRTS; SHIRTS FOR INFANTS, BABIES, TODDLERS AND CHILDREN; SHORT-SLEEVED OR LONG-SLEEVED T-SHIRTS; SHORT-SLEEVED SHIRTS; SPORT SHIRTS; SWEAT PANTS; SWEAT SHIRTS; T-SHIRTS; TEE SHIRTS; TOPS; YOGA PANTS; ATHLETIC APPAREL, NAMELY, SHIRTS, PANTS, JACKETS, FOOTWEAR, HATS AND CAPS, ATHLETIC UNIFORMS; CAPRI PANTS; CARGO PANTS; DRESS SHIRTS; FLEECE VESTS; KNIT SHIRTS; MOISTURE-WICKING SPORTS SHIRTS; RUGBY SHIRTS; WIND PANTS; WIND SHIRTS (U.S. CLS. 22 AND 39).

FIRST USE 6-1-2008; IN COMMERCE 6-15-2009.

3,962,478. ROBERT P. NICKELL, TORRANCE, CA. SN 77-793,337. PUB. 12-8-2009, FILED 7-30-2009.

**DADDYSCRUBS**

THE MARK CONSISTS OF STANDARD CHARACTERS WITHOUT CLAIM TO ANY PARTICULAR FONT, STYLE, SIZE, OR COLOR.

FOR ATHLETIC APPAREL, NAMELY, SHIRTS, PANTS, HATS AND CAPS; BASEBALL CAPS; SCRUBS NOT FOR MEDICAL PURPOSES; SHIRTS (U.S. CLS. 22 AND 39).

FIRST USE 3-31-2010; IN COMMERCE 3-31-2010.

**CLASS 25—(Continued).**

3,962,496. JEAN ELLEN SEDLMAYR MACMILLAN, HONOLULU, HI. SN 77-800,190. PUB. 1-12-2010, FILED 8-7-2009.



THE MARK CONSISTS OF A GRAPHIC OF A HOT AIR BALLOON MADE OF STONE WITH THE WORDS "THE STONE BALLOON" APPEARING WITHIN THE BALLOON AND A MARIONETTE CHARACTER IN THE BASKET BELOW THE BALLOON.

FOR GOLF SHIRTS; HATS; HEADGEAR, NAMELY, HATS, CAPS, BASEBALL CAPS, AND STRAW HATS; KNIT SHIRTS; LONG-SLEEVED SHIRTS; POLO SHIRTS; SHIRTS; SHIRTS AND SHORT-SLEEVED SHIRTS; SHORT-SLEEVED OR LONG-SLEEVED T-SHIRTS; SHORT-SLEEVED SHIRTS; SPORT SHIRTS; T-SHIRTS (U.S. CLS. 22 AND 39).

FIRST USE 12-20-2009; IN COMMERCE 3-29-2011.

3,962,505. COLUMBIA INSURANCE COMPANY, OMAHA, NE. SN 77-802,156. PUB. 12-29-2009, FILED 8-11-2009.



THE MARK CONSISTS OF A DESIGN FEATURING THE WORDING "COVE" IN STYLIZED LETTERS AT THE BOTTOM OF A SEMI CIRCLE; WITHIN THE SEMI-CIRCLE, AND ABOVE THE WORD "COVE" APPEARS A STYLIZED LANDSCAPE FEATURING EVERGREEN TREES; MOUNTAINS, AND A RIVER.

FOR FOOTWEAR (U.S. CLS. 22 AND 39).

FIRST USE 7-31-2009; IN COMMERCE 7-31-2009.

**CLASS 25—(Continued).**

3,962,533. FAVAZZA, MATTHEW S., GLOUCESTER, MA. AND FAVAZZA, CHRISTOPHER P., GLOUCESTER, MA. AND FAVAZZA, PETER A., GLOUCESTER, MA. SN 77-809,455. PUB. 7-13-2010, FILED 8-20-2009.



THE COLOR(S) BLACK, WHITE, AND GRAY IS/ARE CLAIMED AS A FEATURE OF THE MARK.

THE MARK CONSISTS OF A DESIGN OF A PAIR OF BLACK GLASSES WITH A WHITE TAPE DESIGN WRAPPED AROUND BRIDGE OF GLASSES WITH COMPANY NAME "KAR BEN" WITH AN UMLAUT ABOVE THE "A" AND THE "E" PRESENTED BACKWARDS. THE INSIDE DESIGN OF THE GLASSES CONTAINS GRAY.

FOR ATHLETIC APPAREL, NAMELY, SHIRTS, PANTS, JACKETS, FOOTWEAR, HATS AND CAPS, ATHLETIC UNIFORMS; BODY SHIRTS; DRESS SHIRTS; HOODED SWEAT SHIRTS; KNIT SHIRTS; LONG-SLEEVED SHIRTS; NIGHT SHIRTS; OPEN-NECKED SHIRTS; OVER SHIRTS; PIQUE SHIRTS; POLO SHIRTS; RUGBY SHIRTS; SCIENTIFIC AND TECHNOLOGICAL APPAREL, NAMELY, SHIRTS, PANTS, JACKETS, FOOTWEAR, HATS AND CAPS, UNIFORMS; SHIRT FRONTS; SHIRTS; SHIRTS AND SHORT-SLEEVED SHIRTS; SHIRTS FOR INFANTS, BABIES, TODDLERS AND CHILDREN; SHIRTS FOR SUITS; SHORT-SLEEVED OR LONG-SLEEVED T-SHIRTS; SHORT-SLEEVED SHIRTS; SLEEP SHIRTS; SPORT SHIRTS; SPORTS SHIRTS; SPORTS SHIRTS WITH SHORT SLEEVES; SWEAT SHIRTS; T-SHIRTS; TEE SHIRTS; TURTLE NECK SHIRTS; WEARABLE GARMENTS AND CLOTHING, NAMELY, SHIRTS; WIND SHIRTS; YOGA SHIRTS (U.S. CLS. 22 AND 39).

FIRST USE 10-1-2009; IN COMMERCE 10-23-2009.

3,962,541. WILLIAMS, MICHAEL DEWAYNE, HOLLAND, MO. SN 77-811,297. PUB. 2-9-2010, FILED 8-24-2009.

**SOUTH FORTY CLOTHING CO.**

THE MARK CONSISTS OF STANDARD CHARACTERS WITHOUT CLAIM TO ANY PARTICULAR FONT, STYLE, SIZE, OR COLOR.

**CLASS 25—(Continued).**

NO CLAIM IS MADE TO THE EXCLUSIVE RIGHT TO USE "CLOTHING CO.", APART FROM THE MARK AS SHOWN. FOR CLOTHING, NAMELY, T-SHIRTS, SWEATSHIRTS, HOODED SWEATSHIRTS, HOODED PULL-OVERS, JACKETS, PANTS, AND BANDANAS; HEADGEAR, NAMELY, HATS, CAPS, AND TOBOGGAN HATS; FOOTWEAR, NAMELY, SHOES, SLIPPERS, AND BOOTS (U.S. CLS. 22 AND 39).

FIRST USE 10-18-2009; IN COMMERCE 11-5-2009.

3,962,542. BOTTOMS UP GROUP, LLC, THE, MT. PLEASANT, SC. SN 77-811,604. PUB. 1-19-2010, FILED 8-24-2009.

**The Cutey Booty**

THE MARK CONSISTS OF STANDARD CHARACTERS WITHOUT CLAIM TO ANY PARTICULAR FONT, STYLE, SIZE, OR COLOR.

FOR BABY BOTTOMS; BLOOMERS; BOXER BRIEFS; BOXER SHORTS; INFANT DIAPER COVERS; NON-DISPOSABLE CLOTH TRAINING PANTS; PANTIES, SHORTS AND BRIEFS; UNDERWEAR, NAMELY, BOY SHORTS (U.S. CLS. 22 AND 39).

FIRST USE 1-21-2010; IN COMMERCE 1-21-2010.

3,962,586. J.B.S. LTD., NEW YORK, NY. SN 77-825,286. PUB. 2-2-2010, FILED 9-11-2009.

**PRELUDE**

THE MARK CONSISTS OF STANDARD CHARACTERS WITHOUT CLAIM TO ANY PARTICULAR FONT, STYLE, SIZE, OR COLOR.

FOR CLOTHING, NAMELY, WOMEN'S DRESSES, PANTS, SKIRTS, TOPS, PANT SETS, NAMELY, PANTS AND SHIRTS, SKIRT SETS, NAMELY, SKIRTS AND SHIRTS (U.S. CLS. 22 AND 39).

FIRST USE 11-30-2009; IN COMMERCE 12-15-2009.

**CLASS 25—(Continued).**

3,962,612. CHEEKS FOOTWEAR INTERNATIONAL, LLC, ST. PETERSBURG, FL. SN 77-833,270. PUB. 8-3-2010, FILED 9-23-2009.



OWNER OF U.S. REG. NO. 2,935,389.  
NO CLAIM IS MADE TO THE EXCLUSIVE RIGHT TO USE "FIT BODY", APART FROM THE MARK AS SHOWN.  
THE MARK CONSISTS OF THE STYLIZED WORDS "CHEEKS FIT BODY" WITH A SET OF FOOTPRINTS NEXT TO THE WORDS.  
FOR FOOTWEAR, NAMELY, EXERCISE, ATHLETIC, AND FASHION SHOES (U.S. CLS. 22 AND 39).  
FIRST USE 4-7-2010; IN COMMERCE 4-7-2010.

3,962,626. KOTABISH, CHING, DBA PINK AUBERGINE, STATEN ISLAND, NY. SN 77-840,996. PUB. 5-4-2010, FILED 10-4-2009.



THE COLOR(S) PURPLE, YELLOW, ORANGE AND GREEN IS/ARE CLAIMED AS A FEATURE OF THE MARK.  
THE MARK CONSISTS OF YELLOW CHESTED PURPLE FROG SITTING ON GREEN LILY PAD SURROUNDED BY GREEN WATER RIPPLES AND ORANGE FLOWERS. THE ORANGE WORDS "YUTOPIA" UNDER LILY PAD.  
FOR INFANT AND TODDLER ONE PIECE CLOTHING; JERSEYS; KNIT SHIRTS; T-SHIRTS; TEE SHIRTS (U.S. CLS. 22 AND 39).  
FIRST USE 3-15-2011; IN COMMERCE 3-15-2011.

**CLASS 25—(Continued).**

3,962,628. VALENCIA, ROSARIO, VICTORVILLE, CA. SN 77-841,885. PUB. 8-10-2010, FILED 10-5-2009.



"XIVA" DOES NOT IDENTIFY A LIVING INDIVIDUAL.  
THE MARK CONSISTS OF THE WORDING "XIVA" FEATURING A DESIGN IN THE NATURE OF TWO TRIANGLES INVERSE TO EACH OTHER OVER THE LETTER "X".  
THE WORDING "XIVA" HAS NO MEANING IN A FOREIGN LANGUAGE.  
FOR CAPS; JACKETS; PANTS; SHORTS; SWEAT SHIRTS; T-SHIRTS (U.S. CLS. 22 AND 39).  
FIRST USE 2-14-2011; IN COMMERCE 2-14-2011.

3,962,635. ESTES, CINDY, BELMONT, MA. SN 77-844,197. PUB. 3-9-2010, FILED 10-8-2009.



THE MARK CONSISTS OF THE STYLIZED TEXT "SEAM" WITH A LINE IN THE MIDDLE.  
FOR INFANT, TODDLER, CHILDREN, AND PRE-TEEN APPAREL, NAMELY, SHIRTS, SKIRTS, PANTS, JACKETS, COATS, SWEAT SHIRTS, BATHING SUITS, HEADBANDS, AND HATS (U.S. CLS. 22 AND 39).  
FIRST USE 12-1-2009; IN COMMERCE 5-20-2010.



**CLASS 25—(Continued).**

3,962,638. TRIPLETT, JOSEPH DAVID, LAS VEGAS, NV. SN 77-846,155. PUB. 3-16-2010, FILED 10-11-2009.



NO CLAIM IS MADE TO THE EXCLUSIVE RIGHT TO USE "GU", APART FROM THE MARK AS SHOWN.

THE COLOR(S) RED AND BLACK IS/ARE CLAIMED AS A FEATURE OF THE MARK.

THE MARK CONSISTS OF THE STYLIZED LETTERS "IGU" IN BLACK WITH A RED HEART DESIGN OUTLINED IN BLACK APPEARING TO THE RIGHT OF THE "I" AND ABOVE THE "U".

FOR ATHLETIC APPAREL, NAMELY, SHIRTS, PANTS, JACKETS, FOOTWEAR, HATS AND CAPS, ATHLETIC UNIFORMS; CLOTHING FOR ATHLETIC USE, NAMELY, PADDED SHORTS; PANTS; SHIRTS; SHIRTS FOR INFANTS, BABIES, TODDLERS AND CHILDREN; SHORTS; SPORTS SHIRTS; T-SHIRTS; UNDERWEAR (U.S. CLS. 22 AND 39).

FIRST USE 6-1-1996; IN COMMERCE 2-8-2011.

3,962,646. ANDIS WINES, LLC, SUTTER CREEK, CA. SN 77-849,826. PUB. 6-15-2010, FILED 10-15-2009.

## ANDIS WINES

THE MARK CONSISTS OF STANDARD CHARACTERS WITHOUT CLAIM TO ANY PARTICULAR FONT, STYLE, SIZE, OR COLOR.

NO CLAIM IS MADE TO THE EXCLUSIVE RIGHT TO USE "WINES", APART FROM THE MARK AS SHOWN.

FOR T-SHIRTS, SHIRTS AND HEADWEAR (U.S. CLS. 22 AND 39).

FIRST USE 3-13-2011; IN COMMERCE 3-13-2011.

**CLASS 25—(Continued).**

3,962,796. ANGELA BOON, PONCA CITY, OK. SN 77-899,886. PUB. 5-18-2010, FILED 12-23-2009.

## No Nips No Slips NipAway

THE MARK CONSISTS OF STANDARD CHARACTERS WITHOUT CLAIM TO ANY PARTICULAR FONT, STYLE, SIZE, OR COLOR.

FOR FOAM BRA CUP INSERT ACTING AS A NIPPLE SHIELD (U.S. CLS. 22 AND 39).

FIRST USE 11-1-2008; IN COMMERCE 11-1-2008.

3,962,807. SHANGHAI CREATOR APPAREL & ACCESSORIES CO., LTD., SHANGHAI, CHINA. SN 77-903,265. PUB. 5-18-2010, FILED 12-31-2009.

## Autason

THE MARK CONSISTS OF THE WORDING "AUTASON". THE WORDING "AUTASON" HAS NO MEANING IN A FOREIGN LANGUAGE.

FOR SHIRTS; JERSEYS (CLOTHING); PARTS OF CLOTHING, NAMELY, GUSSETS FOR TIGHTS; GUSSETS FOR STOCKINGS, GUSSETS FOR BATHING SUITS; GUSSETS FOR UNDERWEAR, GUSSETS FOR LEOTARDS AND GUSSETS FOR FOOTLETS; SHORT SETS (CLOTHING); TRAVEL CLOTHING CONTAINED IN A PACKAGE COMPRISING REVERSIBLE JACKETS, PANTS, SKIRTS, TOPS AND A BELT OR SCARF; TROUSERS; JACKETS (CLOTHING); T-SHIRTS; UNDERPANTS; DUST COATS; BABY LAYETTES FOR CLOTHING; LAYETTES; BATHING SUITS; SWIMWEAR; WATERPROOF CLOTHING; WATERPROOF JACKETS AND PANTS; DANCE COSTUMES; SHOES; HATS; HOSIERY; GLOVES (CLOTHING); GLOVES AS CLOTHING; NECKTIES; TIES (CLOTHING); SCARFS; BELTS (CLOTHING); WEDDING GOWN (U.S. CLS. 22 AND 39).

FIRST USE 9-20-1997; IN COMMERCE 3-1-2010.

3,962,809. BILL ELLIOTT RACING LLC, DAWSONVILLE, GA. SN 77-903,647. PUB. 6-15-2010, FILED 12-31-2009.

## BILL ELLIOTT

THE MARK CONSISTS OF STANDARD CHARACTERS WITHOUT CLAIM TO ANY PARTICULAR FONT, STYLE, SIZE, OR COLOR.

**CLASS 25—(Continued).**

THE NAME "BILL ELLIOTT" IDENTIFIES A LIVING INDIVIDUAL WHOSE CONSENT IS OF RECORD.

SEC. 2(F).  
FOR HATS; JACKETS; SHIRTS; WEARABLE GARMENTS AND CLOTHING, NAMELY, SHIRTS (U.S. CLS. 22 AND 39).

FIRST USE 1-1-1986; IN COMMERCE 1-1-1986.

**CLASS 25—(Continued).**

3,962,888. BEIJING KAIZE FASHION TECH LTD., BEIJING CITY,, CHINA. SN 77-924,471. PUB. 6-29-2010, FILED 1-31-2010.

3,962,846. WEST COAST NOVELTY CORPORATION, ALAMEDA, CA. SN 77-914,928. PUB. 6-8-2010, FILED 1-19-2010.



THE MARK CONSISTS OF THE WORDS "AMERICAN CROWN COZIE" WITH THE TERM "AMERICAN" ABOVE "CROWN" AND A STYLIZED DRAWING OF A CROWN ABOVE THE "C" IN "CROWN" AND TO THE LEFT OF "AMERICAN".

FOR WEARABLE BLANKETS IN THE NATURE OF BLANKETS WITH SLEEVES (U.S. CLS. 22 AND 39).

FIRST USE 8-16-2010; IN COMMERCE 8-16-2010.



OWNER OF U.S. REG. NO. 3,779,338.  
THE MARK CONSISTS OF A CURVE LINE ON TOP OF THE WORDING "HONGBOND".

FOR CLOTHES, NAMELY, MEN'S SUIT, JACKETS; SHIRTS; PANTS; WAISTCOATS; DRESSES; FOOTWEAR; NECKTIES; POCKET SQUARES; BELTS (CLOTHING) (U.S. CLS. 22 AND 39).

FIRST USE 3-2-2009; IN COMMERCE 2-15-2010.

3,962,854. JOHN A. BROWN, FAIRBURN, GA. SN 77-916,774. PUB. 6-29-2010, FILED 1-21-2010.



NO CLAIM IS MADE TO THE EXCLUSIVE RIGHT TO USE "APPAREL", APART FROM THE MARK AS SHOWN.

THE MARK CONSISTS OF THE WORDS "ICE GIRL" WITH A LINE DRAWING OF A GIRL SITTING WITH HER LEGS THROUGH THE "G" AND HER HAIR BLOWING; BELOW ARE THE WORDS "AUTHENTIC APPAREL".

FOR APPAREL FOR DANCERS, NAMELY, TEE SHIRTS, SWEATSHIRTS, PANTS, LEGGINGS, SHORTS AND JACKETS; ATHLETIC APPAREL, NAMELY, SHIRTS, PANTS, JACKETS, FOOTWEAR, HATS AND CAPS, ATHLETIC UNIFORMS; DENIMS (U.S. CLS. 22 AND 39).

FIRST USE 8-10-2009; IN COMMERCE 9-1-2009.

3,962,903. YU JIANG NING, STOCKTON, CA. SN 77-928,566. PUB. 7-27-2010, FILED 2-4-2010.



THE MARK CONSISTS OF STANDARD CHARACTERS WITHOUT CLAIM TO ANY PARTICULAR FONT, STYLE, SIZE, OR COLOR.

THE WORDING "MEIJIADA" HAS NO MEANING IN A FOREIGN LANGUAGE.

FOR HATS; JEANS; OVER SHIRTS; POLO SHIRTS; SHIRTS; SOCKS; SPORT SHIRTS; T-SHIRTS; UNDERWEAR (U.S. CLS. 22 AND 39).

FIRST USE 1-10-2011; IN COMMERCE 1-10-2011.

**CLASS 25—(Continued).**

3,962,928. TOMLINSON, SHELLIE R., LAKE PROVIDENCE, LA. SN 77-933,702. PUB. 7-6-2010, FILED 2-11-2010.



THE MARK CONSISTS OF A BIRD WITH A NECKLACE AND THE WORDS, "SOUTHERN" ABOVE AND "PEARLS" BELOW.

FOR CLOTHING, NAMELY, T-SHIRTS AND CAPS (U.S. CLS. 22 AND 39).  
FIRST USE 5-31-2010; IN COMMERCE 5-31-2010.

**CLASS 25—(Continued).**

3,962,951. MCGUIRE, DAYMIAN LEE, OAKWOOD, OH. SN 77-937,163. PUB. 7-13-2010, FILED 2-16-2010.



THE MARK CONSISTS OF THE STYLIZED WORDING "JUSTBEFLY.COM" WITH A LINE EXTENDING FROM THE PERIOD BEFORE "COM" TO THE PERIOD ABOVE THE LETTER "J".

FOR ATHLETIC APPAREL, NAMELY, SHIRTS, PANTS, JACKETS, FOOTWEAR, HATS AND CAPS, ATHLETIC UNIFORMS (U.S. CLS. 22 AND 39).  
FIRST USE 10-10-2009; IN COMMERCE 1-1-2011.

3,962,954. CONRAD, ROBERT A, SPRING, TX. SN 77-937,992. PUB. 7-13-2010, FILED 2-17-2010.

Don't blame me I voted for  
Jesus!

THE MARK CONSISTS OF STANDARD CHARACTERS WITHOUT CLAIM TO ANY PARTICULAR FONT, STYLE, SIZE, OR COLOR.

FOR ATHLETIC APPAREL, NAMELY, SHIRTS, PANTS, JACKETS, FOOTWEAR, HATS AND CAPS, ATHLETIC UNIFORMS, GOLF SHIRTS, WRISTBANDS, TEE SHIRTS (U.S. CLS. 22 AND 39).  
FIRST USE 6-11-2010; IN COMMERCE 6-11-2010.

3,962,929. POWERS, NATHAN, COSTA MESA, CA. SN 77-934,439. PUB. 7-6-2010, FILED 2-12-2010.



THE MARK COMPRISES THE WORDS "SACRIFICE & HONOR" WITH THE STYLIZED LETTERS "SH" OVERLAPPING A CREST DESIGN.

FOR CLOTHING AND ATHLETIC APPAREL, NAMELY, SHIRTS, SHORTS, PANTS, SWEATSHIRTS, HEAD BANDS, HATS, AND TANKS TOPS (U.S. CLS. 22 AND 39).  
FIRST USE 4-1-2010; IN COMMERCE 4-1-2010.

3,962,959. MARK NICKERSON, BOISE, ID. SN 77-939,901. PUB. 7-20-2010, FILED 2-19-2010.



**KOKOBLU**

THE MARK CONSISTS OF A STYLIZED GORILLA AND THE WORD "KOKOBLU" UNDERNEATH.

**CLASS 25—(Continued).**

THE WORDING "KOKOBLU" HAS NO MEANING IN A FOREIGN LANGUAGE.

FOR BOARD SHORTS; BODY SHIRTS; DENIMS; HATS; JACKETS; POLO SHIRTS; SWEATERS; TANK TOPS (U.S. CLS. 22 AND 39).

FIRST USE 7-4-2010; IN COMMERCE 7-4-2010.

**CLASS 25—(Continued).**

NO CLAIM IS MADE TO THE EXCLUSIVE RIGHT TO USE "INDUSTRIES", APART FROM THE MARK AS SHOWN.

FOR CLOTHING, NAMELY, SHIRTS, PANTS, SHORTS, SOCKS, HEADWEAR, SHOES AND JACKETS (U.S. CLS. 22 AND 39).

FIRST USE 11-1-2010; IN COMMERCE 11-1-2010.

3,962,962. JAV-JR LLC, LONG ISLAND CITY, NY. SN 77-940,526. PUB. 7-27-2010, FILED 2-19-2010.

3,962,988. NATURALLY COOL, FAIRFIELD, CT. AND WOLF, PAMELA M., FAIRFIELD, CT. SN 77-943,552. PUB. 8-31-2010, FILED 2-24-2010.

# SQUISHEE

# PAMELA VACHERON

THE MARK CONSISTS OF STANDARD CHARACTERS WITHOUT CLAIM TO ANY PARTICULAR FONT, STYLE, SIZE, OR COLOR.

OWNER OF U.S. REG. NOS. 1,998,394, 3,177,347, AND OTHERS.

FOR VISORS AND CAPS (U.S. CLS. 22 AND 39).  
FIRST USE 11-30-2003; IN COMMERCE 11-30-2003.

THE MARK CONSISTS OF STANDARD CHARACTERS WITHOUT CLAIM TO ANY PARTICULAR FONT, STYLE, SIZE, OR COLOR.

THE NAME "PAMELA VACHERON" DOES NOT IDENTIFY A LIVING INDIVIDUAL.

FOR SLEEPWEAR (U.S. CLS. 22 AND 39).  
FIRST USE 6-10-2010; IN COMMERCE 6-10-2010.

3,962,965. CABALLERO, CO., YAKIMA, WA. SN 77-941,449. PUB. 7-20-2010, FILED 2-22-2010.

3,963,004. DICKSON, MATTHEW T., AURORA, CO. SN 77-944,684. PUB. 7-13-2010, FILED 2-25-2010.

# ADMIRABLE

# What's your energy drink?

THE MARK CONSISTS OF STANDARD CHARACTERS WITHOUT CLAIM TO ANY PARTICULAR FONT, STYLE, SIZE, OR COLOR.

FOR APPAREL, NAMELY, JEANS, PANTS, SHIRTS, VESTS, TIES, SUITS, JACKETS, HEADWEAR, AND FOOTWEAR (U.S. CLS. 22 AND 39).

FIRST USE 2-1-2010; IN COMMERCE 5-7-2010.

THE MARK CONSISTS OF STANDARD CHARACTERS WITHOUT CLAIM TO ANY PARTICULAR FONT, STYLE, SIZE, OR COLOR.

FOR ATHLETIC APPAREL, NAMELY, SHIRTS (U.S. CLS. 22 AND 39).

FIRST USE 1-18-2011; IN COMMERCE 1-18-2011.

3,962,972. STEPHENS, JASON T., BAKERSFIELD, CA. SN 77-941,892. PUB. 7-20-2010, FILED 2-22-2010.

3,963,010. WOO, SANG K., LOS ANGELES, CA. SN 77-945,450. PUB. 7-20-2010, FILED 2-25-2010.

# LEWD INDUSTRIES

# URBAN DAY

THE MARK CONSISTS OF STANDARD CHARACTERS WITHOUT CLAIM TO ANY PARTICULAR FONT, STYLE, SIZE, OR COLOR.

THE MARK CONSISTS OF STANDARD CHARACTERS WITHOUT CLAIM TO ANY PARTICULAR FONT, STYLE, SIZE, OR COLOR.

FOR CLOTHING, NAMELY, T-SHIRTS, TOPS, SHORTS, SKIRTS, SWEATERS, SWEAT-SHIRTS, SWEAT-PANTS, DRESSES, JACKETS, PANTS, JEANS, DENIMS, AND COATS; HATS (U.S. CLS. 22 AND 39).

FIRST USE 2-28-2011; IN COMMERCE 2-28-2011.

**CLASS 25—(Continued).**

3,963,020. AUGSTEIN ENTERPRISE GROUP USA, SAN FRANCISCO, CA. SN 77-946,648. PUB. 7-27-2010, FILED 2-27-2010.

# Tali Regal

THE MARK CONSISTS OF STANDARD CHARACTERS WITHOUT CLAIM TO ANY PARTICULAR FONT, STYLE, SIZE, OR COLOR.

FOR BOTTOMS; CLOTHING, NAMELY, KHAKIS; FOULARDS; JACKETS; JERSEYS; SHIRTS; SHORT SETS; SHOULDER WRAPS; SHOULDER WRAPS FOR CLOTHING; TOPS; WEARABLE GARMENTS AND CLOTHING, NAMELY, SHIRTS; WRAPS, ADULT NOVELTY GAG CLOTHING ITEM, NAMELY, SOCKS; BABY LAYETTES FOR CLOTHING; BELTS; BELTS FOR CLOTHING; BELTS MADE OUT OF CLOTH; BIBS NOT OF CLOTH OR PAPER; CHILDREN'S AND INFANTS' CLOTH BIBS; CHILDREN'S CLOTH EATING BIBS; CLOTH BIBS; CLOTH BIBS FOR ADULT DINERS; CLOTHING FOR ATHLETIC USE, NAMELY, PADDED ELBOW COMPRESSION SLEEVES BEING PART OF AN ATHLETIC GARMENT; CLOTHING FOR ATHLETIC USE, NAMELY, PADDED PANTS; CLOTHING FOR ATHLETIC USE, NAMELY, PADDED SHIRTS; CLOTHING FOR ATHLETIC USE, NAMELY, PADDED SHORTS; CLOTHING FOR WEAR IN JUDO PRACTICES; CLOTHING FOR WEAR IN WRESTLING GAMES; CLOTHING ITEMS, NAMELY, ADHESIVE POCKETS THAT MAY BE AFFIXED DIRECTLY TO THE BODY AS A DECORATIVE PIECE OF CLOTHING WITH UTILITY; CLOTHING ITEMS, NAMELY, ADHESIVE POCKETS THAT MAY BE AFFIXED DIRECTLY TO THE INSIDE OF CLOTHING FOR STORAGE AND SAFEKEEPING OF PERSONAL ITEMS; CLOTHING, NAMELY, ARM WARMERS; CLOTHING, NAMELY, BASE LAYERS; CLOTHING, NAMELY, FOLK COSTUMES; CLOTHING, NAMELY, HAND-WARMERS; CLOTHING, NAMELY, KNEE WARMERS; CLOTHING, NAMELY, MATERNITY BANDS; CLOTHING, NAMELY, NECK TUBES; CLOTHING, NAMELY, THOBES; CLOTHING, NAMELY, WRAP-AROUNDS; CORSETS; DUSTERS; EYESHADES; GLOVES AS CLOTHING; HEADBANDS FOR CLOTHING; HOODS; INFANT AND TODDLER ONE PIECE CLOTHING; LEATHER BELTS; MANTLES; MUFFLERS; NON-DISPOSABLE CLOTH TRAINING PANTS; PAPER HATS FOR USE AS CLOTHING ITEMS; PARTS OF CLOTHING, NAMELY, GUSSETS FOR TIGHTS, GUSSETS FOR STOCKINGS, GUSSETS FOR BATHING SUITS, GUSSETS FOR UNDERWEAR, GUSSETS FOR LEOTARDS AND GUSSETS FOR FOOTLETS; PARTS OF CLOTHING, NAMELY, UNDERARM GUSSETS; PARTY HATS; PERSPIRATION ABSORBENT UNDERWEAR CLOTHING; POCKET SQUARES; SWADDLING CLOTHES; TIES; TRAVEL CLOTHING CONTAINED IN A PACKAGE COMPRISING REVERSIBLE JACKETS, PANTS, SKIRTS, TOPS AND A BELT OR SCARF; TRIATHLON CLOTHING, NAMELY, TRIATHLON TIGHTS, TRIATHLON SHORTS, TRIATHLON SINGLETTS, TRIATHLON SHIRTS, TRIATHLON SUITS; UNDERARM CLOTHING SHIELDS (U.S. CLS. 22 AND 39). FIRST USE 5-19-2009; IN COMMERCE 5-19-2009.

**CLASS 25—(Continued).**

3,963,026. HATER PRUUF, INC., EASTON, PA. SN 77-948,004. PUB. 7-27-2010, FILED 3-2-2010.

# Hater Pruuf

THE MARK CONSISTS OF STANDARD CHARACTERS WITHOUT CLAIM TO ANY PARTICULAR FONT, STYLE, SIZE, OR COLOR.

OWNER OF U.S. REG. NO. 2,971,549.  
FOR BEANIES; CAPS; HATS; HEADBANDS; JEANS; PANTS; ROBES; SHIRTS; SHORTS; SOCKS; T-SHIRTS; HOODED SWEAT SHIRTS; SKIRTS; SWEATERS; UNDERWEAR (U.S. CLS. 22 AND 39).  
FIRST USE 1-1-2005; IN COMMERCE 1-1-2005.

3,963,037. SILVERMAN, SARAH, EAST HAMPTON, NY. SN 77-949,399. PUB. 8-3-2010, FILED 3-3-2010.

# SARAH LEORA

THE MARK CONSISTS OF STANDARD CHARACTERS WITHOUT CLAIM TO ANY PARTICULAR FONT, STYLE, SIZE, OR COLOR.

THE NAME(S), PORTRAIT(S), AND/OR SIGNATURE(S) SHOWN IN THE MARK IDENTIFIES SARAH SILVERMAN, WHOSE CONSENT(S) TO REGISTER IS MADE OF RECORD.

FOR CLOTHING, NAMELY, DRESSES, SKIRTS AND GOWNS (U.S. CLS. 22 AND 39).  
FIRST USE 8-10-2010; IN COMMERCE 11-15-2010.

3,963,061. SHEPARD, SANDRA HOUGH, CHICO, CA. SN 77-951,667. PUB. 7-27-2010, FILED 3-5-2010.

# SKINNIN' & GRINNIN'

THE MARK CONSISTS OF STANDARD CHARACTERS WITHOUT CLAIM TO ANY PARTICULAR FONT, STYLE, SIZE, OR COLOR.

FOR HATS; JACKETS; SHIRTS; SWEAT SHIRTS (U.S. CLS. 22 AND 39).  
FIRST USE 9-30-2010; IN COMMERCE 9-30-2010.



**CLASS 25—(Continued).**

3,963,097. POUND, PATRICIA WESCOAT, NEW YORK, NY. SN 77-955,527. PUB. 8-10-2010, FILED 3-10-2010.



THE MARK CONSISTS OF THE LETTERS "HHN", CONNECTED AND STYLIZED.

FOR CLOTHING, NAMELY, JACKETS, VESTS, STOCKINGS, SWEATERS, HOODED JACKETS, SWEAT-SHIRTS, CARDIGANS, PONCHOS, SCARVES, HATS, GLOVES, SHIRTS, BOLERO SHIRTS (U.S. CLS. 22 AND 39).

FIRST USE 7-9-2010; IN COMMERCE 7-9-2010.

3,963,122. SHIMANO INC., SAKAI CITY, OSAKA, JAPAN. SN 77-958,567. PUB. 7-27-2010, FILED 3-14-2010.

## HYPER REPEL

THE MARK CONSISTS OF STANDARD CHARACTERS WITHOUT CLAIM TO ANY PARTICULAR FONT, STYLE, SIZE, OR COLOR.

FOR CLOTHING, NAMELY, TOPS, BOTTOMS, PANTS; CLOTHING FOR CYCLISTS, NAMELY, TOPS, BOTTOMS, PANTS; CLOTHING FOR FISHING, NAMELY, TOPS, BOTTOMS, PANTS; CLOTHING FOR ROWING, NAMELY, TOPS, BOTTOMS, PANTS; JACKETS; RAIN SUITS; RAIN COATS (U.S. CLS. 22 AND 39).

FIRST USE 12-31-1998; IN COMMERCE 11-16-2010.

3,963,133. POINT 3 BASKETBALL, LLC, ATLANTA, GA. SN 77-959,784. PUB. 8-3-2010, FILED 3-16-2010.

## POINT 3

THE MARK CONSISTS OF STANDARD CHARACTERS WITHOUT CLAIM TO ANY PARTICULAR FONT, STYLE, SIZE, OR COLOR.

FOR ATHLETIC APPAREL, NAMELY, SHIRTS, PANTS, JACKETS, FOOTWEAR, HATS AND CAPS, ATHLETIC UNIFORMS (U.S. CLS. 22 AND 39).

FIRST USE 6-1-2010; IN COMMERCE 11-1-2010.

**CLASS 25—(Continued).**

3,963,140. MMI-IPCO, LLC, LAWRENCE, MA. SN 77-960,370. PUB. 8-10-2010, FILED 3-16-2010.

## POWER SHIELD FR

THE MARK CONSISTS OF STANDARD CHARACTERS WITHOUT CLAIM TO ANY PARTICULAR FONT, STYLE, SIZE, OR COLOR.

OWNER OF U.S. REG. NOS. 2,629,230, 3,540,731, AND 3,683,498.

NO CLAIM IS MADE TO THE EXCLUSIVE RIGHT TO USE "FR", APART FROM THE MARK AS SHOWN.

FOR FLAME RESISTANT TEXTILE FABRIC PIECE GOODS SOLD AS A COMPONENT OF CLOTHING, NAMELY, COATS, JACKETS, PARKAS, RAINCOATS, PULLOVERS, SHIRTS, SPORTS JERSEYS, TROUSERS, PANTS, DRESSES, SKIRTS, PAJAMAS, UNDERCLOTHING, SCARVES, SHAWLS, GLOVES, MITTENS, HEADWEAR, NAMELY, HATS, CAPS, HEADBANDS, AND VISORS, FOOTWEAR, NAMELY, SPORT AND LEISURE SHOES, SLIPPERS, SOCKS, TIGHTS, STOCKINGS, AND HOSIERY (U.S. CLS. 22 AND 39).

FIRST USE 3-16-2010; IN COMMERCE 3-16-2010.

3,963,141. ASICS CORPORATION, CHUO-KU, KOBE, JAPAN. SN 77-960,372. PUB. 8-10-2010, FILED 3-16-2010.

## GEL-LETHAL

THE MARK CONSISTS OF STANDARD CHARACTERS WITHOUT CLAIM TO ANY PARTICULAR FONT, STYLE, SIZE, OR COLOR.

OWNER OF U.S. REG. NOS. 1,877,669, 3,770,691, AND OTHERS.

FOR FOOTWEAR (U.S. CLS. 22 AND 39).

FIRST USE 5-27-2010; IN COMMERCE 5-27-2010.

3,963,158. ISLAND WORLD APPAREL, LOS ALAMITOS, CA. SN 77-961,555. PUB. 8-3-2010, FILED 3-17-2010.

## ISLAND LOVE

THE MARK CONSISTS OF STANDARD CHARACTERS WITHOUT CLAIM TO ANY PARTICULAR FONT, STYLE, SIZE, OR COLOR.

FOR SWIMWEAR (U.S. CLS. 22 AND 39).

FIRST USE 12-1-2010; IN COMMERCE 12-1-2010.

**CLASS 25—(Continued).**

3,963,189. KUCUHEAD INC, SHERMAN OAKS, CA. SN 77-964,949. PUB. 8-10-2010, FILED 3-22-2010.



THE COLOR(S) BLACK, RED AND WHITE IS/ARE CLAIMED AS A FEATURE OF THE MARK.

THE MARK CONSISTS OF A GRAPHICAL DEPICTION OF A HEAD AND FACE IN THE COLOR WHITE WITH RED HAIR ALL ABOVE THE WORD "KUCUHEAD" WRITTEN IN THE COLOR WHITE ALL OF WHICH IS ON A BLACK BACKGROUND.

THE WORDING "KUCUHEAD" HAS NO MEANING IN A FOREIGN LANGUAGE.

FOR ANKLE SOCKS; ATHLETIC FOOTWEAR; ATHLETIC SHOES; BEACH SHOES; BELTS; BERMUDA SHORTS; BOARD SHORTS; BOXER SHORTS; DENIMS; DRESS SHIRTS; GOLF SHIRTS; GOLF SHORTS; GYM PANTS; GYM SHORTS; HATS; JACKETS; JEANS; JOGGING PANTS; POLO SHIRTS; RUNNING SHOES; SHIRTS; SHOES; SHORT-SLEEVED OR LONG-SLEEVED T-SHIRTS; SKIRTS AND DRESSES; SOCKS; SPORT SHIRTS; SPORTS JACKETS; SWEAT SHIRTS; SWIMSUITS; T-SHIRTS; THERMAL SOCKS; TRACK JACKETS; UNDERWEAR (U.S. CLS. 22 AND 39).

FIRST USE 0-0-2010; IN COMMERCE 3-0-2011.

3,963,206. SEA FEAR, LARGO, FL. SN 77-966,624. PUB. 8-10-2010, FILED 3-23-2010.

## Sea Fear

THE MARK CONSISTS OF STANDARD CHARACTERS WITHOUT CLAIM TO ANY PARTICULAR FONT, STYLE, SIZE, OR COLOR.

FOR HATS; HOODED SWEAT SHIRTS; JACKETS; POLO SHIRTS; SHORT-SLEEVED OR LONG-SLEEVED T-SHIRTS; SLEEPWEAR; T-SHIRTS; TANK TOPS; VI-SORS (U.S. CLS. 22 AND 39).

FIRST USE 3-8-2010; IN COMMERCE 4-24-2010.

**CLASS 25—(Continued).**

3,963,264. GARAN SERVICES CORP., NEW YORK, NY. SN 77-981,761. PUB. 8-3-2010, FILED 9-21-2009.



THE COLOR(S) BROWN, DARK BROWN, TAN, BLACK, WHITE, PINK, YELLOW, AND GREEN IS/ARE CLAIMED AS A FEATURE OF THE MARK.

THE MARK CONSISTS OF A TAN AND BROWN KANGAROO WITH DARK BROWN FEET, NOSE, AND EYEBROWS; DARK BROWN, BLACK AND WHITE EYES; AND PINK EARS AND BOW; HOLDING A GREEN, YELLOW, AND PINK FLOWER.

FOR SWEATERS, JEANS, BATHING SUITS, SWIMWEAR, SLEEPWEAR, LEOTARDS, TIGHTS, ROMPERS, UNDERWEAR, HOSIERY, OUTERWEAR, NAMELY, COATS, JACKETS, SCARVES; HEADWEAR, NAMELY, HATS, EARMUFFS, SKI MASKS; GLOVES, BELTS, SOCKS (U.S. CLS. 22 AND 39).

FIRST USE 4-0-2009; IN COMMERCE 4-0-2009.

3,963,265. GARAN SERVICES CORP., NEW YORK, NY. SN 77-981,763. PUB. 8-3-2010, FILED 9-21-2009.



THE COLOR(S) GREY, DARK GREY, BLACK, WHITE, BLUE AND PINK IS/ARE CLAIMED AS A FEATURE OF THE MARK.

THE MARK CONSISTS OF A GREY, DARK GREY, AND WHITE KOALA BEAR WITH A BLACK NOSE, PINK MOUTH, PINK BOWS, PINK PADS ON ITS HANDS, AND BLUE, BLACK, AND WHITE EYES.

FOR SWEATERS, JEANS, BATHING SUITS, SWIMWEAR, SLEEPWEAR, LEOTARDS, TIGHTS, ROMPERS, UNDERWEAR, HOSIERY, OUTERWEAR, NAMELY, COATS, JACKETS, SCARVES; HEADWEAR, NAMELY, HATS, EARMUFFS, SKI MASKS; GLOVES, BELTS, SOCKS (U.S. CLS. 22 AND 39).

FIRST USE 4-0-2009; IN COMMERCE 4-0-2009.

**CLASS 25—(Continued).**

3,963,266. GARAN SERVICES CORP., NEW YORK, NY. SN 77-981,764. PUB. 8-3-2010, FILED 9-21-2009.



THE COLOR(S) DARK GREY, BLACK, WHITE, BLUE, PURPLE, GREEN, PINK AND YELLOW IS/ARE CLAIMED AS A FEATURE OF THE MARK.

THE MARK CONSISTS OF A GRAY, DARK GREY, AND WHITE BABY KOALA BEAR WITH A BLACK NOSE, PINK MOUTH, PINK PADS ON ITS FEET, AND BLACK, WHITE, AND BLUE EYES HOLDING A PINK, GREEN, YELLOW, PURPLE AND WHITE BOOK WITH A PINK HEART ON ONE SIDE AND A BLUE, YELLOW, BLACK AND WHITE BIRD ON A YELLOW CIRCLE ON THE OTHER SIDE.

FOR SWEATERS, JEANS, BATHING SUITS, SWIMWEAR, SLEEPWEAR, LEOTARDS, TIGHTS, ROMPERS, UNDERWEAR, HOSIERY, OUTERWEAR, NAMELY, COATS, JACKETS, SCARVES; HEADWEAR, NAMELY, HATS, EARMUFFS, SKI MASKS; GLOVES, BELTS, SOCKS (U.S. CLS. 22 AND 39).

FIRST USE 6-0-2009; IN COMMERCE 6-0-2009.

3,963,267. GARAN SERVICES CORP., NEW YORK, NY. SN 77-981,765. PUB. 8-3-2010, FILED 9-21-2009.



THE COLOR(S) GREY, LIGHT BROWN, WHITE, BLACK AND PINK IS/ARE CLAIMED AS A FEATURE OF THE MARK.

**CLASS 25—(Continued).**

THE MARK CONSISTS OF A GRAY AND WHITE COYOTE WITH A BLACK NOSE, BLACK EYEBROWS, A PINK MOUTH, AND LIGHT BROWN, WHITE AND BLACK EYES HOLDING A LIGHT BROWN AND BLACK HOCKEY STICK.

FOR SWEATERS, JEANS, BATHING SUITS, SWIMWEAR, SLEEPWEAR, LEOTARDS, TIGHTS, ROMPERS, UNDERWEAR, HOSIERY, OUTERWEAR, NAMELY, COATS, JACKETS, SCARVES; HEADWEAR, NAMELY, HATS, EARMUFFS, SKI MASKS; GLOVES, BELTS, SOCKS (U.S. CLS. 22 AND 39).

FIRST USE 4-0-2009; IN COMMERCE 4-0-2009.

3,963,268. GARAN SERVICES CORP., NEW YORK, NY. SN 77-981,766. PUB. 8-3-2010, FILED 9-21-2009.



THE COLOR(S) GREY, DARK GREY, BLACK, WHITE, TAN, YELLOW, RED, PINK, AND GREEN IS/ARE CLAIMED AS A FEATURE OF THE MARK.

THE MARK CONSISTS OF A GREY, DARK GREY, AND WHITE BABY COYOTE WITH BLACK EYEBROWS AND NOSE, A PINK MOUTH, AND TAN, BLACK, AND WHITE EYES USING FINGER-PAINTS TO PAINT A YELLOW AND RED FACE ON A WHITE PIECE OF PAPER. THE PAINTS TO THE LEFT OF THE PAPER ARE RED, YELLOW, AND GREEN AND ARE IN WHITE CONTAINERS.

FOR CLOTHING, NAMELY, TOPS AND BOTTOMS, SWEATERS, SWEATSHIRTS, PANTS, JEANS, SWEATPANTS, SHORTS, LEGGINGS, CAPRIS, BATHING SUITS, SWIMWEAR, SLEEPWEAR, LEOTARDS, TIGHTS, ROMPERS, UNDERWEAR, HOSIERY, DRESSES, HOODS, CREEPERS; OUTERWEAR, NAMELY, COATS, JACKETS, SCARVES; HEADWEAR, NAMELY, HATS, EARMUFFS, SKI MASKS; GLOVES, BELTS, SOCKS; AND FOOTWEAR, NAMELY, SHOES, BOOTS, SANDALS, SNEAKERS (U.S. CLS. 22 AND 39).

FIRST USE 6-0-2010; IN COMMERCE 6-0-2010.

**CLASS 25—(Continued).**

3,963,269. GARAN SERVICES CORP., NEW YORK, NY. SN 77-981,767. PUB. 8-3-2010, FILED 9-21-2009.



THE COLOR(S) GREY, PINK, BLACK, WHITE, BLUE, RED AND YELLOW IS/ARE CLAIMED AS A FEATURE OF THE MARK.

THE MARK CONSISTS OF A GREY ELEPHANT WITH PINK EARS, A PINK MOUTH, WHITE NAILS ON ITS FEET, AND BLUE, WHITE AND BLACK EYES WEARING WHITE AND RED ELBOW PADS AND HOLDING A RED, WHITE, YELLOW AND GREY SKATEBOARD.

FOR SWEATERS, JEANS, BATHING SUITS, SWIMWEAR, SLEEPWEAR, LEOTARDS, TIGHTS, ROMPERS, UNDERWEAR, HOSIERY, OUTERWEAR, NAMELY, COATS, JACKETS, SCARVES; HEADWEAR, NAMELY, HATS, EARMUFFS, SKI MASKS; GLOVES, BELTS, SOCKS (U.S. CLS. 22 AND 39).

FIRST USE 4-0-2009; IN COMMERCE 4-0-2009.

3,963,295. GURU DENIM INC., VERNON, CA. SN 78-918,258. PUB. 12-18-2007, FILED 6-27-2006.

**TRUE RELIGION**

THE MARK CONSISTS OF STANDARD CHARACTERS WITHOUT CLAIM TO ANY PARTICULAR FONT, STYLE, SIZE, OR COLOR.

OWNER OF U.S. REG. NOS. 2,761,793 AND 2,917,187. FOR LOUNGEWEAR, APPAREL AND OUTERWEAR, NAMELY, BLAZERS, DUNGAREES, OVERALLS, SWEATERS, TROUSERS (U.S. CLS. 22 AND 39).

FIRST USE 7-1-2005; IN COMMERCE 9-1-2005.

**CLASS 25—(Continued).**

3,963,297. TWIN CITY KNITTING COMPANY, INC., CONOVER, NC. SN 78-933,710. PUB. 11-10-2009, FILED 7-20-2006.



OWNER OF U.S. REG. NOS. 2,215,249 AND 2,504,102. NO CLAIM IS MADE TO THE EXCLUSIVE RIGHT TO USE "SERIES", APART FROM THE MARK AS SHOWN.

THE COLOR(S) RED AND BROWN IS/ARE CLAIMED AS A FEATURE OF THE MARK.

THE MARK CONSISTS OF THE COLOR RED APPEARS IN THE WORDING "SLOG SERIES" AND IN THE CIRCLES. THE COLOR BROWN APPEARS IN THE BAR ABOVE THE WORDS "SLOG SERIES". THE MARK APPEARS ON A TRANSPARENT BACKGROUND AND NO OTHER COLOR IS CLAIMED AS PART OF THE MARK.

FOR SOCKS (U.S. CLS. 22 AND 39).

FIRST USE 0-0-2006; IN COMMERCE 0-0-2006.

3,963,310. JUAN MARTINEZ, ATWATER, CA. SN 85-001,125. PUB. 6-15-2010, FILED 3-29-2010.



NO CLAIM IS MADE TO THE EXCLUSIVE RIGHT TO USE "MMA WEAR", APART FROM THE MARK AS SHOWN.

THE MARK CONSISTS OF A MARTIAL ARTIST WITH GLOVES MAKING A CAPITAL "F" FOR THE WORD "FINISHED" IN A STYLIZED WRITING SIMILAR TO A MEDIEVAL ILLUMINATED MANUSCRIPT, WITH THE WORDS "MMA WEAR" UNDERNEATH.

FOR ATHLETIC FOOTWEAR; CLOTHING FOR ATHLETIC USE, NAMELY, PADDED PANTS; CLOTHING FOR ATHLETIC USE, NAMELY, PADDED SHIRTS; CLOTHING FOR ATHLETIC USE, NAMELY, PADDED SHORTS; CLOTHING FOR WEAR IN JUDO PRACTICES; CLOTHING FOR WEAR IN WRESTLING GAMES; GLOVES AS CLOTHING; HEADGEAR, NAMELY, HATS, CAPS (U.S. CLS. 22 AND 39).

FIRST USE 9-16-2010; IN COMMERCE 9-16-2010.

**CLASS 25—(Continued).**

3,963,324. JAY A. HUMINSKY, PLANO, TX. SN 85-004,655.  
PUB. 9-21-2010, FILED 4-1-2010.

## Duck Pirate

THE MARK CONSISTS OF STANDARD CHARACTERS WITHOUT CLAIM TO ANY PARTICULAR FONT, STYLE, SIZE, OR COLOR.

NO CLAIM IS MADE TO THE EXCLUSIVE RIGHT TO USE "DUCK PIRATE", APART FROM THE MARK AS SHOWN.

FOR HEADGEAR, NAMELY, BALL CAPS, BEANIES AND HOODS FOR HUNTING AND OUTDOOR ACTIVITIES (U.S. CLS. 22 AND 39).

FIRST USE 1-1-2010; IN COMMERCE 11-15-2010.

---

3,963,347. SUMMERBELL, CEDRIC, RIO RANCHO, NM. SN 85-007,778. PUB. 8-31-2010, FILED 4-6-2010.

## Rotten Retro

THE MARK CONSISTS OF STANDARD CHARACTERS WITHOUT CLAIM TO ANY PARTICULAR FONT, STYLE, SIZE, OR COLOR.

NO CLAIM IS MADE TO THE EXCLUSIVE RIGHT TO USE "RETRO", APART FROM THE MARK AS SHOWN.

FOR HATS; HOODED SWEAT SHIRTS; SHIRTS; SWEAT SHIRTS (U.S. CLS. 22 AND 39).

FIRST USE 5-1-2009; IN COMMERCE 8-1-2010.

---

3,963,350. CANADELLE LIMITED PARTNERSHIP, MONTREAL, QUEBEC, CANADA. SN 85-008,071. PUB. 9-7-2010, FILED 4-7-2010.

## COMMITMENT-PHOBE

THE MARK CONSISTS OF STANDARD CHARACTERS WITHOUT CLAIM TO ANY PARTICULAR FONT, STYLE, SIZE, OR COLOR.

FOR BRAS (U.S. CLS. 22 AND 39).

FIRST USE 9-15-2010; IN COMMERCE 9-15-2010.

**CLASS 25—(Continued).**

3,963,363. VICTORIA'S SECRET STORES BRAND MANAGEMENT, INC., REYNOLDSBURG, OH. SN 85-010,523. PUB. 8-31-2010, FILED 4-9-2010.



OWNER OF U.S. REG. NOS. 3,455,138, 3,702,059, AND OTHERS.

NO CLAIM IS MADE TO THE EXCLUSIVE RIGHT TO USE "SPORT", APART FROM THE MARK AS SHOWN.

THE MARK CONSISTS OF "VICTORIA'S SECRET VSX SEXY SPORT" AND SEVEN VERTICAL STRIPES.

FOR CLOTHING, NAMELY, BRAS, BRA TOPS, CAMISOLES, HALTER TOPS, TANK TOPS, CAPRIS, PANTS, SHORTS, JOGGING PANTS, TIGHTS (U.S. CLS. 22 AND 39).

FIRST USE 6-30-2010; IN COMMERCE 6-30-2010.

---

3,963,389. PAUL MAGGARD, WESTON, FL. SN 85-017,098. PUB. 9-28-2010, FILED 4-19-2010.



THE COLOR(S) GREEN, BLUE, PINK, RED, WHITE AND SILVER IS/ARE CLAIMED AS A FEATURE OF THE MARK.

THE MARK CONSISTS OF A DESIGN OF AN ALIEN MAN WITH A GREEN BODY, PINK CHEST, AND PINK TONGUE, WEARING SILVER AND BLUE GLASSES, RED JACKET, WHITE AND BLUE SHIRT, BLUE PANTS, AND SILVER AND WHITE SHOES.

FOR CLOTHING, NAMELY, HATS, CAPS, FOOTWEAR, PANTS, AND SHIRTS (U.S. CLS. 22 AND 39).

FIRST USE 5-1-2010; IN COMMERCE 5-1-2010.



**CLASS 25—(Continued).**

3,963,392. BIG BOSS ENTERPRISES, INC., NEW YORK, NY.  
SN 85-018,005. PUB. 9-21-2010, FILED 4-20-2010.

# JAVINO

THE MARK CONSISTS OF STANDARD CHARACTERS WITHOUT CLAIM TO ANY PARTICULAR FONT, STYLE, SIZE, OR COLOR.

FOR MEN'S AND BOYS' WEARING APPAREL, NAMELY, JACKETS, COATS, VESTS, SUITS, PANTS, JEANS, SHORTS, SHIRTS, JERSEYS, SWEATERS, TRACK SUITS AND SWEAT SUITS (U.S. CLS. 22 AND 39).

FIRST USE 11-10-2010; IN COMMERCE 11-10-2010.

3,963,408. BATSON, JEFF, ROBERT, BRUNSWICK, MD. SN  
85-022,677. PUB. 9-28-2010, FILED 4-26-2010.



THE MARK CONSISTS OF A CIRCULAR BORDER RULE LINE WITH A VERTICAL RULE LINE SPLITTING THE CIRCLE IN TWO EQUAL HALVES, WITH TWO CURVED RULE LINES STEMMING FROM THE VERTICAL LINE OPPOSITE EACH OTHER AND ATTACHING TO THE CIRCULAR BORDER RULE. BELOW THE DESIGN ELEMENT IS THE STYLIZED WORDING "PIECE".

FOR WEARABLE GARMENTS AND CLOTHING, NAMELY, SHIRTS (U.S. CLS. 22 AND 39).

FIRST USE 11-15-2007; IN COMMERCE 11-15-2007.

**CLASS 25—(Continued).**

3,963,412. SOCIETY CLOTHING COMPANY LLC, BOSTON, MA. SN 85-023,785. PUB. 9-28-2010, FILED 4-27-2010.



THE MARK CONSISTS OF A STYLIZED BICYCLE. FOR CLOTHING, NAMELY, JACKETS, PANTS, DENIM PANTS, SHIRTS, T-SHIRTS, SWEATERS, HOODED SWEAT SHIRTS, SHORTS, HEADWEAR, HATS, AND BELTS (U.S. CLS. 22 AND 39).

FIRST USE 10-28-2010; IN COMMERCE 10-28-2010.

3,963,420. POSI-TS LLC, TELFORD, PA. SN 85-025,548. PUB.  
9-28-2010, FILED 4-28-2010.



THE MARK CONSISTS OF PERSON WITH WAVY HAIR SITTING IN BOAT HOLDING A PADDLE, WITH WAVY WATER UNDER THE BOAT.

FOR WOMEN'S, MEN'S, BOYS AND GIRLS WEARING APPAREL, NAMELY, SHIRTS AND T-SHIRTS (U.S. CLS. 22 AND 39).

FIRST USE 2-28-2010; IN COMMERCE 2-28-2010.

**CLASS 25—(Continued).**

3,963,424. UNITED FOOTBALL LEAGUE, LLC, NEW YORK, NY. SN 85-026,018. PUB. 7-27-2010, FILED 4-29-2010.

**NIGHTHAWKS**

THE MARK CONSISTS OF STANDARD CHARACTERS WITHOUT CLAIM TO ANY PARTICULAR FONT, STYLE, SIZE, OR COLOR.

FOR MEN'S, WOMEN'S AND CHILDREN'S CLOTHING AND FOOTWEAR, NAMELY, COACHES CAPS, WOOL HATS, BASEBALL CAPS, VISORS, EAR MUFFS, BELTS, WRISTBANDS, T-SHIRTS, TANK TOPS, PAJAMAS, GOLF SHIRTS, SWEATERS, SWEATSHIRTS, JACKETS, NECKTIES, CLOTH BIBS, JERSEYS, NIGHT SHIRTS, COATS, ROBES, RAINCOATS, PARKAS, SCARVES, MITTENS, APRONS, LEATHER JACKETS, SHORTS, SWEAT PANTS, PANTS, SOCKS, FLEECE PULLOVERS, TURTLENECKS, GLOVES, KNIT CAPS, PONCHOS ALL USED TO PROMOTE A PROFESSIONAL FOOTBALL TEAM (U.S. CLS. 22 AND 39).

FIRST USE 9-24-2010; IN COMMERCE 9-24-2010.

3,963,425. UNITED FOOTBALL LEAGUE, LLC, NEW YORK, NY. SN 85-026,021. PUB. 7-27-2010, FILED 4-29-2010.

**OMAHA NIGHTHAWKS**

THE MARK CONSISTS OF STANDARD CHARACTERS WITHOUT CLAIM TO ANY PARTICULAR FONT, STYLE, SIZE, OR COLOR.

NO CLAIM IS MADE TO THE EXCLUSIVE RIGHT TO USE "OMAHA", APART FROM THE MARK AS SHOWN.

FOR MEN'S, WOMEN'S AND CHILDREN'S CLOTHING AND FOOTWEAR, NAMELY, COACHES CAPS, WOOL HATS, BASEBALL CAPS, VISORS, EAR MUFFS, BELTS, WRISTBANDS, T-SHIRTS, TANK TOPS, PAJAMAS, GOLF SHIRTS, SWEATERS, SWEATSHIRTS, JACKETS, NECKTIES, CLOTH BIBS, JERSEYS, NIGHT SHIRTS, COATS, ROBES, RAINCOATS, PARKAS, SCARVES, MITTENS, APRONS, LEATHER JACKETS, SHORTS, SWEAT PANTS, PANTS, SOCKS, FLEECE PULLOVERS, TURTLENECKS, GLOVES, KNIT CAPS, PONCHOS ALL USED TO PROMOTE A PROFESSIONAL FOOTBALL TEAM (U.S. CLS. 22 AND 39).

FIRST USE 9-24-2010; IN COMMERCE 9-24-2010.

**CLASS 25—(Continued).**

3,963,455. ASICS CORPORATION, CHUO-KU, KOBE, JAPAN. SN 85-035,703. PUB. 8-17-2010, FILED 5-11-2010.

**GEL-TOUR LYTE**

THE MARK CONSISTS OF STANDARD CHARACTERS WITHOUT CLAIM TO ANY PARTICULAR FONT, STYLE, SIZE, OR COLOR.

OWNER OF U.S. REG. NOS. 1,877,669, 2,230,692, AND OTHERS.

NO CLAIM IS MADE TO THE EXCLUSIVE RIGHT TO USE "LIGHT", APART FROM THE MARK AS SHOWN.

FOR FOOTWEAR (U.S. CLS. 22 AND 39).

FIRST USE 5-27-2010; IN COMMERCE 5-27-2010.

3,963,456. ASICS CORPORATION, CHUO-KU, KOBE, JAPAN. SN 85-035,901. PUB. 8-10-2010, FILED 5-11-2010.

**COURT DIVA**

THE MARK CONSISTS OF STANDARD CHARACTERS WITHOUT CLAIM TO ANY PARTICULAR FONT, STYLE, SIZE, OR COLOR.

FOR ATHLETIC APPAREL, NAMELY, JERSEYS (U.S. CLS. 22 AND 39).

FIRST USE 5-27-2010; IN COMMERCE 5-27-2010.

3,963,458. ASICS CORPORATION, CHUO-KU, KOBE, JAPAN. SN 85-035,912. PUB. 8-17-2010, FILED 5-11-2010.

**INTERVAL**

THE MARK CONSISTS OF STANDARD CHARACTERS WITHOUT CLAIM TO ANY PARTICULAR FONT, STYLE, SIZE, OR COLOR.

FOR ATHLETIC APPAREL, NAMELY, SINGLET AND SHORTS (U.S. CLS. 22 AND 39).

FIRST USE 5-27-2010; IN COMMERCE 5-27-2010.

**CLASS 25—(Continued).**

3,963,459. ASICS CORPORATION, CHUO-KU, KOBE, JAPAN. SN 85-035,918. PUB. 8-10-2010, FILED 5-11-2010.

**PIRANHA**

THE MARK CONSISTS OF STANDARD CHARACTERS WITHOUT CLAIM TO ANY PARTICULAR FONT, STYLE, SIZE, OR COLOR.

OWNER OF U.S. REG. NO. 3,435,056.  
FOR ATHLETIC APPAREL, NAMELY, POLO SHIRTS (U.S. CLS. 22 AND 39).  
FIRST USE 5-27-2010; IN COMMERCE 5-27-2010.

**CLASS 25—(Continued).**

3,963,465. ASICS CORPORATION, CHUO-KU, KOBE, JAPAN. SN 85-036,622. PUB. 8-10-2010, FILED 5-12-2010.

**GEL-REPRISAL**

THE MARK CONSISTS OF STANDARD CHARACTERS WITHOUT CLAIM TO ANY PARTICULAR FONT, STYLE, SIZE, OR COLOR.

OWNER OF U.S. REG. NOS. 1,877,669, 2,230,692, AND OTHERS.  
FOR FOOTWEAR (U.S. CLS. 22 AND 39).  
FIRST USE 5-27-2010; IN COMMERCE 5-27-2010.

3,963,462. HBI BRANDED APPAREL ENTERPRISES, LLC, WINSTON-SALEM, NC. SN 85-036,365. PUB. 10-5-2010, FILED 5-12-2010.

**ELEGANT-U**

THE MARK CONSISTS OF STANDARD CHARACTERS WITHOUT CLAIM TO ANY PARTICULAR FONT, STYLE, SIZE, OR COLOR.

FOR BRAS (U.S. CLS. 22 AND 39).  
FIRST USE 3-15-2011; IN COMMERCE 3-15-2011.

3,963,466. ASICS CORPORATION, CHUO-KU, KOBE, JAPAN. SN 85-036,638. PUB. 8-17-2010, FILED 5-12-2010.

**GEL-SAYURI**

THE MARK CONSISTS OF STANDARD CHARACTERS WITHOUT CLAIM TO ANY PARTICULAR FONT, STYLE, SIZE, OR COLOR.

OWNER OF U.S. REG. NOS. 1,877,669, 2,230,692, AND OTHERS.  
FOR FOOTWEAR (U.S. CLS. 22 AND 39).  
FIRST USE 5-27-2010; IN COMMERCE 5-27-2010.

3,963,464. ASICS CORPORATION, CHUO-KU, KOBE, JAPAN. SN 85-036,604. PUB. 8-10-2010, FILED 5-12-2010.

**GEL-ADVANTAGE**

THE MARK CONSISTS OF STANDARD CHARACTERS WITHOUT CLAIM TO ANY PARTICULAR FONT, STYLE, SIZE, OR COLOR.

OWNER OF U.S. REG. NOS. 1,877,669, 2,230,692, AND OTHERS.  
FOR FOOTWEAR (U.S. CLS. 22 AND 39).  
FIRST USE 5-27-2010; IN COMMERCE 5-27-2010.

3,963,467. ASICS CORPORATION, CHUO-KU, KOBE, JAPAN. SN 85-036,662. PUB. 8-10-2010, FILED 5-12-2010.

**GEL-UPSHOT**

THE MARK CONSISTS OF STANDARD CHARACTERS WITHOUT CLAIM TO ANY PARTICULAR FONT, STYLE, SIZE, OR COLOR.

OWNER OF U.S. REG. NOS. 1,877,669, 2,230,692, AND OTHERS.  
FOR FOOTWEAR (U.S. CLS. 22 AND 39).  
FIRST USE 5-27-2010; IN COMMERCE 5-27-2010.

**CLASS 25—(Continued).**

3,963,468. ASICS CORPORATION, CHUO-KU, KOBE, JAPAN. SN 85-036,672. PUB. 8-10-2010, FILED 5-12-2010.

**GEL-UPSTART**

THE MARK CONSISTS OF STANDARD CHARACTERS WITHOUT CLAIM TO ANY PARTICULAR FONT, STYLE, SIZE, OR COLOR.

OWNER OF U.S. REG. NOS. 1,877,669, 2,230,692, AND OTHERS.

FOR FOOTWEAR (U.S. CLS. 22 AND 39).  
FIRST USE 5-27-2010; IN COMMERCE 5-27-2010.

3,963,469. ASICS CORPORATION, CHUO-KU, KOBE, JAPAN. SN 85-036,688. PUB. 8-10-2010, FILED 5-12-2010.

**GEL-FINITE**

THE MARK CONSISTS OF STANDARD CHARACTERS WITHOUT CLAIM TO ANY PARTICULAR FONT, STYLE, SIZE, OR COLOR.

OWNER OF U.S. REG. NOS. 1,877,669, 2,230,692, AND OTHERS.

FOR FOOTWEAR (U.S. CLS. 22 AND 39).  
FIRST USE 5-27-2010; IN COMMERCE 5-27-2010.

3,963,470. ASICS CORPORATION, CHUO-KU, KOBE, JAPAN. SN 85-036,725. PUB. 8-10-2010, FILED 5-12-2010.

**GEL-UPTEMPO**

THE MARK CONSISTS OF STANDARD CHARACTERS WITHOUT CLAIM TO ANY PARTICULAR FONT, STYLE, SIZE, OR COLOR.

OWNER OF U.S. REG. NOS. 1,877,669, 2,230,692, AND OTHERS.

FOR FOOTWEAR (U.S. CLS. 22 AND 39).  
FIRST USE 5-27-2010; IN COMMERCE 5-27-2010.

**CLASS 25—(Continued).**

3,963,472. ASICS CORPORATION, CHUO-KU, KOBE, JAPAN. SN 85-037,195. PUB. 8-17-2010, FILED 5-13-2010.

**GEL-LINKSMASTER**

THE MARK CONSISTS OF STANDARD CHARACTERS WITHOUT CLAIM TO ANY PARTICULAR FONT, STYLE, SIZE, OR COLOR.

OWNER OF U.S. REG. NOS. 1,877,669, 2,230,692, AND OTHERS.

FOR FOOTWEAR (U.S. CLS. 22 AND 39).  
FIRST USE 5-27-2010; IN COMMERCE 5-27-2010.

3,963,476. WORLDWIDE DISTRIBUTORS, KENT, WA. SN 85-037,970. PUB. 10-19-2010, FILED 5-13-2010.

**REED**

THE MARK CONSISTS OF STANDARD CHARACTERS WITHOUT CLAIM TO ANY PARTICULAR FONT, STYLE, SIZE, OR COLOR.

FOR WADERS AND AQUATIC FOOTWEAR FOR FISHING AND SPORTING ACTIVITIES (U.S. CLS. 22 AND 39).

FIRST USE 7-28-2010; IN COMMERCE 7-28-2010.

3,963,482. WINTER BEE, INC., LOS ANGELES, CA. SN 85-040,376. PUB. 1-4-2011, FILED 5-17-2010.



NO CLAIM IS MADE TO THE EXCLUSIVE RIGHT TO USE "LA", APART FROM THE MARK AS SHOWN.

**CLASS 25—(Continued).**

THE MARK CONSISTS OF A SHADED CIRCLE WITH THE WORDING "LA SPEEDY" CONTAINED THEREIN.

FOR CLOTHING FOR MEN, WOMEN, AND CHILDREN, NAMELY, SHIRTS, T-SHIRTS, SWEATSHIRTS, SWEATERS, TOPS, TANK TOPS, TIGHTS, ROMPERS, PANTS, BOTTOMS, SWEATPANTS, SHORTS, TROUSERS, SKIRTS, DRESSES, BLOUSES, HALTERS, UNIFORMS, SUITS, JOGGING SUITS, WARM-UP SUITS, BLAZERS, BATHING SUITS, COATS, JACKETS, VESTS, RAINWEAR, JUMPERS, CARDIGANS, UNDERGARMENTS, LINGERIE, CORSETS, CAMISOLES, BUSTIER, BRAS, UNDERSHIRTS, BOXER SHORTS, PAJAMAS, HOSIERY, SOCKS, STOCKINGS, NIGHTGOWNS, ROBES, HEADBANDS, WRISTBANDS, HATS, CAPS, VISORS, SCARVES, MUFFLERS, GLOVES, BELTS, AND SUSPENDERS (U.S. CLS. 22 AND 39).

FIRST USE 1-4-2011; IN COMMERCE 1-4-2011.

**CLASS 25—(Continued).**

THE MARK CONSISTS OF THE WORD "ASTIS" IN STYLIZED GREEN FONT WITH A STYLIZED BLUE SNOWFLAKE APPEARING AS THE DOT OF THE LETTER "I". THE COLOR WHITE REPRESENTS TRANSPARENT BACKGROUND AND IS NOT CLAIMED AS A FEATURE OF THE MARK.

THE ENGLISH TRANSLATION OF "ASTIS" IN THE MARK IS "MITTENS".

FOR MITTENS; OUTDOOR MITTENS; SNOWBOARD MITTENS (U.S. CLS. 22 AND 39).

FIRST USE 7-15-2010; IN COMMERCE 10-5-2010.

3,963,494. FRANCO, FRANCISCO JAVIER, RIVERSIDE, CA. SN 85-043,069. PUB. 10-19-2010, FILED 5-19-2010.

# Nc'mon valoR

THE MARK CONSISTS OF STANDARD CHARACTERS WITHOUT CLAIM TO ANY PARTICULAR FONT, STYLE, SIZE, OR COLOR.

FOR A-SHIRTS; APPAREL FOR DANCERS, NAMELY, TEE SHIRTS, SWEATSHIRTS, PANTS, LEGGINGS, SHORTS AND JACKETS; ATHLETIC APPAREL, NAMELY, SHIRTS, PANTS, JACKETS, FOOTWEAR, HATS AND CAPS, ATHLETIC UNIFORMS; BODY SHIRTS; HOODED SWEAT SHIRTS; HUNTING SHIRTS; LONG-SLEEVED SHIRTS; POLO SHIRTS; SHIRTS; SHIRTS AND SHORT-SLEEVED SHIRTS; SHORT-SLEEVED OR LONG-SLEEVED T-SHIRTS; SPORT SHIRTS; SPORTS SHIRTS; SPORTS SHIRTS WITH SHORT SLEEVES; SWEAT SHIRTS; T-SHIRTS (U.S. CLS. 22 AND 39).

FIRST USE 3-10-2011; IN COMMERCE 3-10-2011.

3,963,571. HARRIS II, JOHN HENRY, BELCAMP, MD. SN 85-067,436. PUB. 11-23-2010, FILED 6-21-2010.



3,963,505. NANTEEKA GLOVES, SAN FRANCISCO, CA. SN 85-045,504. PUB. 11-30-2010, FILED 5-21-2010.

NO CLAIM IS MADE TO THE EXCLUSIVE RIGHT TO USE "ASTIS", APART FROM THE MARK AS SHOWN.  
THE COLOR(S) GREEN AND BLUE IS/ARE CLAIMED AS A FEATURE OF THE MARK.

NO CLAIM IS MADE TO THE EXCLUSIVE RIGHT TO USE "ATHLETICS LLC", APART FROM THE MARK AS SHOWN.

THE MARK CONSISTS OF A HUMAN HEART INSIDE A CIRCLE WITH THE STYLIZED TEXT "H.E.A.R.T ATHLETICS LLC".

FOR HATS; HOODED SWEAT SHIRTS; SHORT-SLEEVED OR LONG-SLEEVED T-SHIRTS; SHORTS; SWEAT PANTS; SWEAT SHIRTS (U.S. CLS. 22 AND 39).  
FIRST USE 2-16-2011; IN COMMERCE 2-16-2011.



**CLASS 25—(Continued).**

3,963,594. JOAN ELAINE CASELLA, NEW YORK, NY. SN 85-072,025. PUB. 11-23-2010, FILED 6-25-2010.

**Bleeker & McDougal**

THE MARK CONSISTS OF STANDARD CHARACTERS WITHOUT CLAIM TO ANY PARTICULAR FONT, STYLE, SIZE, OR COLOR.

FOR BLOUSES; BODY SHIRTS; BODY SUITS; CAMOUFLAGE PANTS; CAMP SHIRTS; CAPRI PANTS; CAPRIS; CARGO PANTS; CROP TOPS; DENIMS; DRESS SHIRTS; DRESSES; GAUCHOS; GOLF PANTS, SHIRTS AND SKIRTS; HALTER TOPS; HEAD SCARVES; HOODED SWEAT SHIRTS; JUMPSUITS; KNIT SHIRTS; LADIES' SUITS; LEATHER PANTS; LEATHER SKIRTS; LEGGINGS; LONG-SLEEVED SHIRTS; LOUNGE PANTS; MEN'S SUITS, WOMEN'S SUITS; PANTS; POLO KNIT TOPS; POLO SHIRTS; ROMPERS; SCARVES; SHIRTS AND SHORT-SLEEVED SHIRTS; SHORT-SLEEVED OR LONG-SLEEVED T-SHIRTS; SILK SCARVES; SKIRT SUITS; SKIRTS; SKIRTS AND DRESSES; STRETCH PANTS; SWEAT PANTS; SWEAT SHIRTS; SWEAT SUITS; T-SHIRTS; TANK TOPS; TANK-TOPS; TEE SHIRTS; TOPS; TRAVEL CLOTHING CONTAINED IN A PACKAGE COMPRISING REVERSIBLE JACKETS, PANTS, SKIRTS, TOPS AND A BELT OR SCARF; TUBE TOPS; TURTLE NECK SHIRTS; WOMEN'S TOPS, NAMELY, CAMIS; YOGA PANTS; YOGA SHIRTS (U.S. CLS. 22 AND 39).

FIRST USE 8-30-2010; IN COMMERCE 8-30-2010.

3,963,640. LEIDELMEYER, HEATHER, MAGNOLIA, TX. SN 85-084,188. PUB. 12-14-2010, FILED 7-14-2010.

**Can't Stop Awesome**

THE MARK CONSISTS OF STANDARD CHARACTERS WITHOUT CLAIM TO ANY PARTICULAR FONT, STYLE, SIZE, OR COLOR.

FOR APRONS; HATS; JACKETS; SWEAT SHIRTS; T-SHIRTS (U.S. CLS. 22 AND 39).

FIRST USE 11-13-2010; IN COMMERCE 11-13-2010.

**CLASS 25—(Continued).**

3,963,641. ELAN-POLO, INC., NASHVILLE, TN. SN 85-084,289. PUB. 12-28-2010, FILED 7-14-2010.

**CREVO**

THE MARK CONSISTS OF STANDARD CHARACTERS WITHOUT CLAIM TO ANY PARTICULAR FONT, STYLE, SIZE, OR COLOR.

FOR FOOTWEAR (U.S. CLS. 22 AND 39).  
FIRST USE 2-24-2011; IN COMMERCE 2-24-2011.

3,963,647. GARNER, KATIE, SPANISH FORK, UT. SN 85-085,672. PUB. 12-14-2010, FILED 7-15-2010.

**OH KATY**

THE MARK CONSISTS OF STANDARD CHARACTERS WITHOUT CLAIM TO ANY PARTICULAR FONT, STYLE, SIZE, OR COLOR.

FOR CLOTH DIAPERS (U.S. CLS. 22 AND 39).  
FIRST USE 2-18-2011; IN COMMERCE 2-18-2011.

3,963,657. UNSPOKEN, LLC, WEST HOLLYWOOD, CA. SN 85-088,346. PUB. 12-14-2010, FILED 7-20-2010.

**UNSPOKEN**

THE MARK CONSISTS OF STANDARD CHARACTERS WITHOUT CLAIM TO ANY PARTICULAR FONT, STYLE, SIZE, OR COLOR.

FOR BRAS, PANTIES, SLEEPWEAR, SWEAT PANTS, T-SHIRTS, BATHING SUITS, TANK TOPS, BATHROBES, NIGHT GOWNS, NEGLIGEEES, PANTS, SLIPS, SLIPPERS, BUSTIERS, CORSETS, TEDDIES, HOSIERY, BODY SUITS, GARTER BELTS, WAIST CINCHERS, STOCKINGS, ROBES, SARONGS, WRAPS, SLIPPERS AND SOCKS (U.S. CLS. 22 AND 39).

FIRST USE 4-1-2011; IN COMMERCE 4-1-2011.

**CLASS 25—(Continued).**

3,963,666. DEER STAGS CONCEPTS INC., NEW YORK, NY. SN 85-094,286. PUB. 1-11-2011, FILED 7-27-2010.

Get a gym-free workout.  
Really.

THE MARK CONSISTS OF STANDARD CHARACTERS WITHOUT CLAIM TO ANY PARTICULAR FONT, STYLE, SIZE, OR COLOR.  
FOR FOOTWEAR (U.S. CLS. 22 AND 39).  
FIRST USE 9-27-2010; IN COMMERCE 9-27-2010.

---

3,963,675. GOELLER, STEVEN H, MIDDLE RIVER, MD. SN 85-096,631. PUB. 1-11-2011, FILED 7-30-2010.

It's A Wonderful Thing

THE MARK CONSISTS OF STANDARD CHARACTERS WITHOUT CLAIM TO ANY PARTICULAR FONT, STYLE, SIZE, OR COLOR.  
FOR APPAREL FOR DANCERS, NAMELY, TEE SHIRTS, SWEATSHIRTS, PANTS, LEGGINGS, SHORTS AND JACKETS; ATHLETIC APPAREL, NAMELY, SHIRTS, PANTS, JACKETS, FOOTWEAR, HATS AND CAPS, ATHLETIC UNIFORMS; BASEBALL CAPS AND HATS; BUTTON DOWN SHIRTS; FISHING SHIRTS; GOLF PANTS, SHIRTS AND SKIRTS; GOLF SHIRTS; HATS; HOODED SWEAT SHIRTS; KNIT SHIRTS; POLO SHIRTS; T-SHIRTS; TEE SHIRTS; TURTLE NECK SHIRTS (U.S. CLS. 22 AND 39).  
FIRST USE 5-1-2008; IN COMMERCE 5-1-2008.

---

3,963,689. ELAN-POLO, INC., NASHVILLE, TN. SN 85-103,782. PUB. 12-28-2010, FILED 8-10-2010.

CREATE.EVOLVE.LIVE

THE MARK CONSISTS OF STANDARD CHARACTERS WITHOUT CLAIM TO ANY PARTICULAR FONT, STYLE, SIZE, OR COLOR.  
FOR FOOTWEAR (U.S. CLS. 22 AND 39).  
FIRST USE 2-28-2011; IN COMMERCE 2-28-2011.

**CLASS 25—(Continued).**

3,963,701. ELAN-POLO, INC., NASHVILLE, TN. SN 85-111,131. PUB. 12-28-2010, FILED 8-19-2010.



THE MARK CONSISTS OF A FANCIFUL LETTER E WITH A NEARLY-HORIZONTAL ACCENT MARK ABOVE THE E.  
FOR FOOTWEAR (U.S. CLS. 22 AND 39).  
FIRST USE 2-28-2011; IN COMMERCE 2-28-2011.

---

3,963,704. MARY JANE PARRISH, MIRAMAR BEACH, FL. SN 85-117,292. PUB. 2-8-2011, FILED 8-27-2010.

SKITE

THE MARK CONSISTS OF STANDARD CHARACTERS WITHOUT CLAIM TO ANY PARTICULAR FONT, STYLE, SIZE, OR COLOR.  
FOR APPAREL FOR DANCERS, NAMELY, TEE SHIRTS, SWEATSHIRTS, PANTS, LEGGINGS, SHORTS AND JACKETS (U.S. CLS. 22 AND 39).  
FIRST USE 3-24-2011; IN COMMERCE 3-24-2011.

**CLASS 26—FANCY GOODS**

**CLASS 26—(Continued).**

3,962,991. M & E INNOVATIVE SOLUTIONS LLC, LEE'S SUMMIT, MO. SN 77-943,601. PUB. 7-20-2010, FILED 2-24-2010.

**HOODMATES**

THE MARK CONSISTS OF STANDARD CHARACTERS WITHOUT CLAIM TO ANY PARTICULAR FONT, STYLE, SIZE, OR COLOR.

FOR CHARM THAT IS MECHANICALLY ATTACHED TO THE DRAWSTRING OF A HOODED SWEATSHIRT OR JACKET (U.S. CLS. 37, 39, 40, 42 AND 50).

FIRST USE 2-20-2011; IN COMMERCE 2-25-2011.

**CLASS 27—(Continued).**

3,963,005. MOHAWK CARPET DISTRIBUTION, INC., CALHOUN, GA. SN 77-944,753. PUB. 8-24-2010, FILED 2-25-2010.

**MOHAWK FLOOR GUARD**

THE MARK CONSISTS OF STANDARD CHARACTERS WITHOUT CLAIM TO ANY PARTICULAR FONT, STYLE, SIZE, OR COLOR.

OWNER OF U.S. REG. NOS. 1,099,660, 3,248,171, AND OTHERS.

NO CLAIM IS MADE TO THE EXCLUSIVE RIGHT TO USE "FLOOR", APART FROM THE MARK AS SHOWN.

FOR PROTECTIVE FLOOR COVERINGS (U.S. CLS. 19, 20, 37, 42 AND 50).

FIRST USE 2-27-2010; IN COMMERCE 2-27-2010.

3,963,351. TELEBRANDS CORP., FAIRFIELD, NJ. SN 85-008,355. PUB. 9-7-2010, FILED 4-7-2010.

**1 SECOND NEEDLE**

THE MARK CONSISTS OF STANDARD CHARACTERS WITHOUT CLAIM TO ANY PARTICULAR FONT, STYLE, SIZE, OR COLOR.

NO CLAIM IS MADE TO THE EXCLUSIVE RIGHT TO USE "NEEDLE", APART FROM THE MARK AS SHOWN.

FOR SEWING NEEDLE (U.S. CLS. 37, 39, 40, 42 AND 50).

FIRST USE 7-29-2010; IN COMMERCE 7-29-2010.

**CLASS 28—TOYS AND SPORTING GOODS**

3,961,981. BLIP, LLC, MINNETONKA, MN. SN 76-698,646. PUB. 8-3-2010, FILED 7-27-2009.

**SURPRIZE INSIDE**

FOR TOY GAME SET IN THE NATURE OF A DISPENSER OF PLASTIC TOY EGGS OR GLOBES CONTAINING CHILDREN'S TOY FIGURES, DOLLS AND ACCESSORIES THEREFOR; PLAYSETS FOR DISPENSING PLASTIC TOY EGGS OR GLOBES CONTAINING CHILDREN'S TOY FIGURES, DOLLS AND ACCESSORIES THEREFOR; NOVELTY TOYS IN THE NATURE OF PLASTIC EGGS OR GLOBES CONTAINING CHILDREN'S TOY FIGURES, DOLLS AND ACCESSORIES THEREFOR (U.S. CLS. 22, 23, 38 AND 50).

FIRST USE 7-17-2009; IN COMMERCE 7-17-2009.

**CLASS 27—FLOOR COVERINGS**

3,963,001. MOHAWK CARPET DISTRIBUTION, INC., CALHOUN, GA. SN 77-944,504. PUB. 7-20-2010, FILED 2-25-2010.

**EVERYDAY COMFORT**

THE MARK CONSISTS OF STANDARD CHARACTERS WITHOUT CLAIM TO ANY PARTICULAR FONT, STYLE, SIZE, OR COLOR.

FOR CARPETS (U.S. CLS. 19, 20, 37, 42 AND 50).

FIRST USE 10-2-2010; IN COMMERCE 10-2-2010.

3,962,025. GABBACADABRA LLC, SHERMAN OAKS, CA. SN 77-115,250. PUB. 1-8-2008, FILED 2-23-2007.

**PLEX**

THE MARK CONSISTS OF STANDARD CHARACTERS WITHOUT CLAIM TO ANY PARTICULAR FONT, STYLE, SIZE, OR COLOR.

FOR TOYS AND SPORTING GOODS, NAMELY, PLAY FIGURES AND ACCESSORIES THEREFOR, ACTION FIGURES AND ACCESSORIES THEREFOR, TOY FIGURES, PLUSH TOYS, BOARD GAMES, DOMINOES, JIGSAW PUZZLES, TOY VEHICLES AND ACCESSORIES THEREFOR, TOY CONSTRUCTION BLOCKS, MUSICAL TOYS, BEACH BALLS, AND PLAYING CARDS (U.S. CLS. 22, 23, 38 AND 50).

FIRST USE 8-31-2008; IN COMMERCE 8-31-2008.

**CLASS 28—(Continued).**

3,962,026. GABBACADABRA LLC, SHERMAN OAKS, CA. SN 77-115,312. PUB. 1-29-2008, FILED 2-23-2007.

# MUNO

THE MARK CONSISTS OF STANDARD CHARACTERS WITHOUT CLAIM TO ANY PARTICULAR FONT, STYLE, SIZE, OR COLOR.

FOR TOYS AND SPORTING GOODS, NAMELY, PLAY FIGURES AND ACCESSORIES THEREFOR, ACTION FIGURES AND ACCESSORIES THEREFOR, TOY FIGURES, PLUSH TOYS, DOMINOES, JIGSAW PUZZLES, TOY VEHICLES AND ACCESSORIES THEREFOR, TOY CONSTRUCTION BLOCKS, MUSICAL TOYS, BEACH BALLS, AND PLAYING CARDS (U.S. CLS. 22, 23, 38 AND 50).

FIRST USE 8-31-2008; IN COMMERCE 8-31-2008.

3,962,027. GABBACADABRA LLC, SHERMAN OAKS, CA. SN 77-115,324. PUB. 1-8-2008, FILED 2-23-2007.

# FOOFA

THE MARK CONSISTS OF STANDARD CHARACTERS WITHOUT CLAIM TO ANY PARTICULAR FONT, STYLE, SIZE, OR COLOR.

FOR TOYS AND SPORTING GOODS, NAMELY, PLAY FIGURES AND ACCESSORIES THEREFOR, ACTION FIGURES AND ACCESSORIES THEREFOR, TOY FIGURES, PLUSH TOYS, DOMINOES, JIGSAW PUZZLES, TOY VEHICLES AND ACCESSORIES THEREFOR, TOY CONSTRUCTION BLOCKS, MUSICAL TOYS, BEACH BALLS, AND PLAYING CARDS (U.S. CLS. 22, 23, 38 AND 50).

FIRST USE 8-31-2008; IN COMMERCE 8-31-2008.

3,962,031. CHANTAL, MARK ANTHONY, GOFFSTOWN, NH. SN 77-131,507. PUB. 9-18-2007, FILED 3-15-2007.

# MIRROR TEE

THE MARK CONSISTS OF STANDARD CHARACTERS WITHOUT CLAIM TO ANY PARTICULAR FONT, STYLE, SIZE, OR COLOR.

**CLASS 28—(Continued).**

NO CLAIM IS MADE TO THE EXCLUSIVE RIGHT TO USE "TEE", APART FROM THE MARK AS SHOWN.

FOR IMPROVED SYNTHETIC GOLF TEE WHICH HAS A SUBSTANTIALLY UNIFORM TRANSVERSE CROSS SECTIONAL WALL THICKNESS ALONG THE ENTIRE LENGTH THEREOF FROM A BALL SUPPORTING END TO A TAPERED END (U.S. CLS. 22, 23, 38 AND 50).

FIRST USE 10-15-2009; IN COMMERCE 11-1-2009.

3,962,052. CROCODILES NOT WATERLILIES ENTERTAINMENT, LLC, SAN FRANCISCO, CA. SN 77-219,664. PUB. 12-25-2007, FILED 6-29-2007.

# CROCPOND

THE MARK CONSISTS OF STANDARD CHARACTERS WITHOUT CLAIM TO ANY PARTICULAR FONT, STYLE, SIZE, OR COLOR.

FOR ACTION FIGURES, DOLLS AND PLAYSETS THEREFOR, PLUSH TOYS AND BOARDGAMES (U.S. CLS. 22, 23, 38 AND 50).

FIRST USE 10-0-2008; IN COMMERCE 10-0-2008.

3,962,060. CONSTABLE, JAMES E, BELMONT, MA. SN 77-225,332. PUB. 10-14-2008, FILED 7-9-2007.

# SHOREDITCH

THE MARK CONSISTS OF STANDARD CHARACTERS WITHOUT CLAIM TO ANY PARTICULAR FONT, STYLE, SIZE, OR COLOR.

FOR SPORTING GOODS, NAMELY, BASEBALLS, BASEBALL GLOVES, BASEBALL BATTING GLOVES, BASEBALL BATS, SOFTBALLS, SOFTBALL GLOVES, SOFTBALL BATS; ATHLETIC EQUIPMENT, NAMELY, BASEBALLS, BASEBALL GLOVES, BASEBALL BATTING GLOVES, BASEBALL BATS, SOFTBALLS, SOFTBALL GLOVES, SOFTBALL BATS (U.S. CLS. 22, 23, 38 AND 50).

FIRST USE 3-9-2011; IN COMMERCE 3-9-2011.

**CLASS 28—(Continued).**

3,962,071. PERFECT PUSHUP, LLC, MILL VALLEY, CA. SN 77-248,156. PUB. 2-5-2008, FILED 8-6-2007.

**PERFECT.WORKOUT**

THE MARK CONSISTS OF STANDARD CHARACTERS WITHOUT CLAIM TO ANY PARTICULAR FONT, STYLE, SIZE, OR COLOR.

NO CLAIM IS MADE TO THE EXCLUSIVE RIGHT TO USE "WORKOUT", APART FROM THE MARK AS SHOWN. FOR MANUALLY-OPERATED EXERCISE EQUIPMENT (U.S. CLS. 22, 23, 38 AND 50).

FIRST USE 2-1-2011; IN COMMERCE 2-1-2011.

3,962,083. MATTEL, INC., EL SEGUNDO, CA. SN 77-293,587. PUB. 7-8-2008, FILED 10-2-2007.

**SNAKE MEN**

THE MARK CONSISTS OF STANDARD CHARACTERS WITHOUT CLAIM TO ANY PARTICULAR FONT, STYLE, SIZE, OR COLOR.

FOR TOY ACTION FIGURES AND ACCESSORIES THEREFOR (U.S. CLS. 22, 23, 38 AND 50).

FIRST USE 3-15-2011; IN COMMERCE 3-15-2011.

3,962,109. METZ, JOHN RICHARD, SONOMA, CA. SN 77-376,839. PUB. 6-3-2008, FILED 1-21-2008.

**CROSS  CHECKS**

THE COLOR(S) BLUE, YELLOW, VIOLET, RED, BLACK, WHITE, AND GREY IS/ARE CLAIMED AS A FEATURE OF THE MARK.

THE MARK CONSISTS OF A SQUARE BETWEEN THE TWO WORDS "CROSS CHECKS" THE SQUARE IS DIVIDED EQUALLY INTO FOUR SMALLER WHITE AND GRAY SQUARES IN A CHECKERBOARD PATTERN. A SMALL CIRCLE IS SUPERIMPOSED ON THE CENTER OF THE LARGE SQUARE AND IS DIVIDED INTO FOUR PIE SHAPED SEGMENTS WHICH ARE COLORED (CLOCK-WISE) BLUE, YELLOW, VIOLET AND RED.

FOR BOARD GAMES (U.S. CLS. 22, 23, 38 AND 50). FIRST USE 8-26-2008; IN COMMERCE 2-25-2011.

**CLASS 28—(Continued).**

3,962,142. MASTERGRIP, INC., IRVING, TX. SN 77-451,165. PUB. 8-5-2008, FILED 4-17-2008.

**OUTRIGGER**

THE MARK CONSISTS OF STANDARD CHARACTERS WITHOUT CLAIM TO ANY PARTICULAR FONT, STYLE, SIZE, OR COLOR.

FOR GOLF CLUBS (U.S. CLS. 22, 23, 38 AND 50). FIRST USE 2-25-2011; IN COMMERCE 2-25-2011.

3,962,203. Z'BAG, LLC., NEW YORK, NY. SN 77-556,910. PUB. 7-28-2009, FILED 8-27-2008.

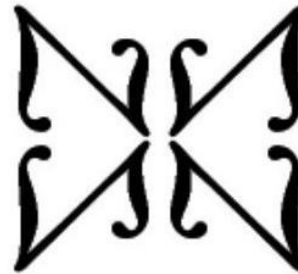

THE MARK CONSISTS OF A BUTTERFLY FORMED BY MIRRORED IMAGES OF THE LETTER Z.

FOR GOLF ACCESSORY POUCHES SPECIFICALLY DESIGNED FOR CARRYING SPORTS ACCESSORIES AND EQUIPMENT, NAMELY, GOLF BALL MARKERS, GOLF TEES, SCORE CARDS, PENCILS, PENS, GOLF BALLS, GOLF CLUBS, GOLF GLOVES, GOLF DIVOT TOOLS, GOLF CLUB HEAD COVERS, GOLF PUTTING AIDS AND GOLF SWING TRAINING AIDS (U.S. CLS. 22, 23, 38 AND 50).

FIRST USE 3-9-2011; IN COMMERCE 3-9-2011.

3,962,258. LANDSCAPE STRUCTURES, INC., DELANO, MN. SN 77-653,670. PUB. 3-30-2010, FILED 1-21-2009.

**WEE POD**

THE MARK CONSISTS OF STANDARD CHARACTERS WITHOUT CLAIM TO ANY PARTICULAR FONT, STYLE, SIZE, OR COLOR.

OWNER OF U.S. REG. NOS. 3,481,286, 3,485,588, AND 3,595,330.

FOR PLAYGROUND EQUIPMENT, NAMELY, CLIMBING UNITS (U.S. CLS. 22, 23, 38 AND 50).

FIRST USE 2-1-2011; IN COMMERCE 2-1-2011.



**CLASS 28—(Continued).**

3,962,299. PLYO SYSTEMS, LLC, COLORADO SPRINGS, CO.  
SN 77-679,203. PUB. 1-12-2010, FILED 2-26-2009.

**Pneubounder**

THE MARK CONSISTS OF STANDARD CHARACTERS  
WITHOUT CLAIM TO ANY PARTICULAR FONT, STYLE,  
SIZE, OR COLOR.

FOR EXERCISE MACHINES (U.S. CLS. 22, 23, 38 AND  
50).  
FIRST USE 3-1-2008; IN COMMERCE 11-11-2009.

3,962,370. BORG UNLIMITED INC., MONTEREY PARK, CA.  
SN 77-730,322. PUB. 2-9-2010, FILED 5-6-2009.

**CATCH-ALL**

THE MARK CONSISTS OF STANDARD CHARACTERS  
WITHOUT CLAIM TO ANY PARTICULAR FONT, STYLE,  
SIZE, OR COLOR.

FOR SPORTING EQUIPMENT, NAMELY, A PAD FOR  
USE IN FOOTBALL AND SPECIALLY ADAPTED FOR  
FOOTBALL CATCHING DRILLS; A TRAINING VEST  
SPECIALLY ADAPTED FOR FOOTBALL CATCHING  
DRILLS (U.S. CLS. 22, 23, 38 AND 50).

FIRST USE 7-23-2009; IN COMMERCE 7-23-2009.

3,962,498. CYBEX INTERNATIONAL, INC., MEDWAY, MA.  
SN 77-800,353. PUB. 1-5-2010, FILED 8-9-2009.

**NOTHING BURNS FASTER.  
NOTHING.**

THE MARK CONSISTS OF STANDARD CHARACTERS  
WITHOUT CLAIM TO ANY PARTICULAR FONT, STYLE,  
SIZE, OR COLOR.

FOR EXERCISE AND FITNESS EQUIPMENT,  
NAMELY, TOTAL AND LOWER BODY CARDIOVASCULAR  
CONDITIONING MACHINES (U.S. CLS. 22, 23, 38  
AND 50).

FIRST USE 12-0-2009; IN COMMERCE 12-0-2009.

**CLASS 28—(Continued).**

3,962,554. TOY STATE INDUSTRIAL LTD., TSIMSHATSUI,  
KOWLOON, HONG KONG. SN 77-816,714. PUB. 8-3-2010,  
FILED 8-31-2009.

**SPORT TRAILER**

THE MARK CONSISTS OF STANDARD CHARACTERS  
WITHOUT CLAIM TO ANY PARTICULAR FONT, STYLE,  
SIZE, OR COLOR.

NO CLAIM IS MADE TO THE EXCLUSIVE RIGHT TO  
USE "TRAILER", APART FROM THE MARK AS SHOWN.  
FOR TOY VEHICLES (U.S. CLS. 22, 23, 38 AND 50).  
FIRST USE 9-12-2010; IN COMMERCE 9-12-2010.

3,962,565. PURE FISHING, INC., COLUMBIA, SC. SN 77-  
820,570. PUB. 7-20-2010, FILED 9-4-2009.

**VENDETTA**

THE MARK CONSISTS OF STANDARD CHARACTERS  
WITHOUT CLAIM TO ANY PARTICULAR FONT, STYLE,  
SIZE, OR COLOR.

FOR FISHING RODS (U.S. CLS. 22, 23, 38 AND 50).  
FIRST USE 5-0-2009; IN COMMERCE 8-0-2009.

3,962,566. PURE FISHING, INC., COLUMBIA, SC. SN 77-  
820,571. PUB. 7-20-2010, FILED 9-4-2009.

**VENGEANCE**

THE MARK CONSISTS OF STANDARD CHARACTERS  
WITHOUT CLAIM TO ANY PARTICULAR FONT, STYLE,  
SIZE, OR COLOR.

FOR FISHING RODS (U.S. CLS. 22, 23, 38 AND 50).  
FIRST USE 5-0-2009; IN COMMERCE 8-0-2009.

**CLASS 28—(Continued).**

3,962,576. HARDWICK, APRIL, NEW YORK, NY. SN 77-823,318. PUB. 2-2-2010, FILED 9-9-2009.

**ECO BELLA**

THE MARK CONSISTS OF STANDARD CHARACTERS WITHOUT CLAIM TO ANY PARTICULAR FONT, STYLE, SIZE, OR COLOR.

NO CLAIM IS MADE TO THE EXCLUSIVE RIGHT TO USE "ECO", APART FROM THE MARK AS SHOWN.

THE ENGLISH TRANSLATION OF THE WORD "BELLA" IN THE MARK IS BEAUTIFUL.

FOR PET TOYS (U.S. CLS. 22, 23, 38 AND 50).  
FIRST USE 8-12-2010; IN COMMERCE 10-8-2010.

3,962,606. TOY STATE INDUSTRIAL LTD., TSIMSHATSUI, KOWLOON, HONG KONG. SN 77-831,698. PUB. 7-27-2010, FILED 9-22-2009.

**ROAD RIPPERS RACING**

THE MARK CONSISTS OF STANDARD CHARACTERS WITHOUT CLAIM TO ANY PARTICULAR FONT, STYLE, SIZE, OR COLOR.

OWNER OF U.S. REG. NOS. 2,360,841 AND 3,317,546.

NO CLAIM IS MADE TO THE EXCLUSIVE RIGHT TO USE "RACING", APART FROM THE MARK AS SHOWN.

FOR TOY VEHICLES (U.S. CLS. 22, 23, 38 AND 50).  
FIRST USE 9-14-2010; IN COMMERCE 9-14-2010.

3,962,607. TOY STATE INDUSTRIAL LTD., TSIMSHATSUI, KOWLOON, HONG KONG. SN 77-831,700. PUB. 7-27-2010, FILED 9-22-2009.

**SECRET SERVICE**

THE MARK CONSISTS OF STANDARD CHARACTERS WITHOUT CLAIM TO ANY PARTICULAR FONT, STYLE, SIZE, OR COLOR.

FOR TOY VEHICLES (U.S. CLS. 22, 23, 38 AND 50).  
FIRST USE 9-14-2010; IN COMMERCE 9-14-2010.

**CLASS 28—(Continued).**

3,962,608. TOY STATE INDUSTRIAL LTD., TSIMSHATSUI, KOWLOON, HONG KONG. SN 77-831,703. PUB. 7-27-2010, FILED 9-22-2009.

**MOBILE COMMAND**

THE MARK CONSISTS OF STANDARD CHARACTERS WITHOUT CLAIM TO ANY PARTICULAR FONT, STYLE, SIZE, OR COLOR.

FOR TOY VEHICLES (U.S. CLS. 22, 23, 38 AND 50).  
FIRST USE 9-14-2010; IN COMMERCE 9-14-2010.

3,962,661. IMPERIAL TOY, LLC, NORTH HILLS, CA. SN 77-853,158. PUB. 9-28-2010, FILED 10-20-2009.

**3-D TIVITIES**

THE MARK CONSISTS OF STANDARD CHARACTERS WITHOUT CLAIM TO ANY PARTICULAR FONT, STYLE, SIZE, OR COLOR.

NO CLAIM IS MADE TO THE EXCLUSIVE RIGHT TO USE "3-D", APART FROM THE MARK AS SHOWN.

FOR TOYS AND GAMES, NAMELY, CHILDREN'S ART ACTIVITY TOYS; TOYS, NAMELY, BUBBLE TOYS AND ACCESSORIES AND PARTS THEREFOR; TOYS AND GAMES INVOLVING OPTICAL ILLUSIONS AND THE PROJECTION OF IMAGES, NAMELY, ART KITS COMPRISING SPECIAL VIEWING EYEGLASSES, MARKERS, STICKERS AND ONE OR MORE OF THE FOLLOWING: POSTERS, SHIRTS, BLANK DIARIES, BRACELETS, MOBILES, PACKAGED AND SOLD TOGETHER AS A UNIT (U.S. CLS. 22, 23, 38 AND 50).

FIRST USE 3-22-2010; IN COMMERCE 3-22-2010.

3,962,662. MEGA BRANDS INTERNATIONAL, LUXEMBOURG, ZUG BRANCH, ZUG, SWITZERLAND. SN 77-853,593. PUB. 9-21-2010, FILED 10-21-2009.

**BATTLE STRIKERS**

THE MARK CONSISTS OF STANDARD CHARACTERS WITHOUT CLAIM TO ANY PARTICULAR FONT, STYLE, SIZE, OR COLOR.

OWNER OF U.S. REG. NOS. 3,732,598 AND 3,732,600.

FOR TOYS, NAMELY, SPINNING TOPS, MAGNETIC CONTROLLABLE SPINNING TOPS, AND ACCESSORIES FOR USE THEREWITH, NAMELY, TOP LAUNCHERS, TOP CONTROLLERS AND ARENAS FOR SPINNING TOP (U.S. CLS. 22, 23, 38 AND 50).

FIRST USE 5-12-2009; IN COMMERCE 5-12-2009.

**CLASS 28—(Continued).**

3,962,687. DISNEY ENTERPRISES, INC., BURBANK, CA. SN 77-859,420. PUB. 8-31-2010, FILED 10-28-2009.

**TRON LEGACY**

THE MARK CONSISTS OF STANDARD CHARACTERS WITHOUT CLAIM TO ANY PARTICULAR FONT, STYLE, SIZE, OR COLOR.

FOR ACTION SKILL GAMES; ACTION FIGURES AND ACCESSORIES THEREFOR; BALLOONS; COLLECTABLE TOY FIGURES; DISC TOSS TOYS; DOLL PLAYSETS; ELECTRIC ACTION TOYS; TOY ACTION FIGURES AND ACCESSORIES THEREFOR; TOY VEHICLES; TOY FIGURES; TOY WEAPONS (U.S. CLS. 22, 23, 38 AND 50).

FIRST USE 10-10-2010; IN COMMERCE 10-10-2010.

3,962,713. MATTEL, INC., EL SEGUNDO, CA. SN 77-871,563. PUB. 10-5-2010, FILED 11-12-2009.

**SKIP-BO MOD**

THE MARK CONSISTS OF STANDARD CHARACTERS WITHOUT CLAIM TO ANY PARTICULAR FONT, STYLE, SIZE, OR COLOR.

OWNER OF U.S. REG. NOS. 1,260,110, 2,019,660, AND 3,745,221.

FOR TOYS, GAMES AND PLAYTHINGS, NAMELY, CARD GAMES (U.S. CLS. 22, 23, 38 AND 50).

FIRST USE 10-12-2010; IN COMMERCE 10-12-2010.

3,962,720. CALLAWAY GOLF COMPANY, CARLSBAD, CA. SN 77-875,265. PUB. 4-6-2010, FILED 11-18-2009.

**X RAZR**

THE MARK CONSISTS OF STANDARD CHARACTERS WITHOUT CLAIM TO ANY PARTICULAR FONT, STYLE, SIZE, OR COLOR.

FOR GOLF CLUBS (U.S. CLS. 22, 23, 38 AND 50).  
FIRST USE 7-16-2010; IN COMMERCE 7-16-2010.

**CLASS 28—(Continued).**

3,962,738. MATTEL, INC., EL SEGUNDO, CA. SN 77-884,038. PUB. 8-24-2010, FILED 12-2-2009.

**SWEET SPEEDSTERS**

THE MARK CONSISTS OF STANDARD CHARACTERS WITHOUT CLAIM TO ANY PARTICULAR FONT, STYLE, SIZE, OR COLOR.

OWNER OF U.S. REG. NO. 3,623,785.  
FOR TOYS, GAMES AND PLAYTHINGS, NAMELY, TOY VEHICLES, TOY VEHICLE PLAYSETS, TOY BALLS, AND ACCESSORIES FOR ALL OF THE FOREGOING (U.S. CLS. 22, 23, 38 AND 50).

FIRST USE 10-13-2010; IN COMMERCE 10-13-2010.

3,962,739. MATTEL, INC., EL SEGUNDO, CA. SN 77-884,040. PUB. 8-24-2010, FILED 12-2-2009.

**RESCUE RACERS**

THE MARK CONSISTS OF STANDARD CHARACTERS WITHOUT CLAIM TO ANY PARTICULAR FONT, STYLE, SIZE, OR COLOR.

OWNER OF U.S. REG. NO. 3,724,323.  
FOR TOYS, GAMES AND PLAYTHINGS, NAMELY, TOY VEHICLES, TOY VEHICLE PLAYSETS, TOY BALLS, AND ACCESSORIES FOR ALL OF THE FOREGOING (U.S. CLS. 22, 23, 38 AND 50).

FIRST USE 3-15-2011; IN COMMERCE 3-15-2011.

3,962,740. TOY STATE INDUSTRIAL LTD., TSIMSHATSUI, KOWLOON, HONG KONG. SN 77-884,243. PUB. 7-27-2010, FILED 12-2-2009.



THE MARK CONSISTS OF THE WORDS "TOUGH TRACKS THE FEEL OF REAL" INSIDE THE STYLIZED REPRESENTATION OF VEHICLE TREADS.

FOR TOY VEHICLES (U.S. CLS. 22, 23, 38 AND 50).  
FIRST USE 11-13-2010; IN COMMERCE 11-13-2010.

**CLASS 28—(Continued).**

3,962,752. OUTHCUNIS, BRETT, DBA NINE POINTS ENTERTAINMENT, ONSET, MA. SN 77-887,363. PUB. 5-11-2010, FILED 12-7-2009.

# OOCH

THE MARK CONSISTS OF STANDARD CHARACTERS WITHOUT CLAIM TO ANY PARTICULAR FONT, STYLE, SIZE, OR COLOR.

FOR SPINNING TOPS; TOY HOLSTERS; YO-YOS (U.S. CLS. 22, 23, 38 AND 50).

FIRST USE 7-7-2010; IN COMMERCE 7-7-2010.

**CLASS 28—(Continued).**

3,962,862. BURGOS, ERLINDA, DBA HILEA ENTERPRISES, GLENDALE, CA. SN 77-918,935. PUB. 6-8-2010, FILED 1-25-2010.

# word brainiac

THE MARK CONSISTS OF STANDARD CHARACTERS WITHOUT CLAIM TO ANY PARTICULAR FONT, STYLE, SIZE, OR COLOR.

NO CLAIM IS MADE TO THE EXCLUSIVE RIGHT TO USE "WORD", APART FROM THE MARK AS SHOWN.

FOR CARD GAMES; EDUCATIONAL CARD GAMES (U.S. CLS. 22, 23, 38 AND 50).

FIRST USE 1-1-2011; IN COMMERCE 1-1-2011.

3,962,819. THANE INTERNATIONAL, INC., LA QUINTA, CA. SN 77-907,125. PUB. 5-25-2010, FILED 1-7-2010.

# TOTAL FLEX

THE MARK CONSISTS OF STANDARD CHARACTERS WITHOUT CLAIM TO ANY PARTICULAR FONT, STYLE, SIZE, OR COLOR.

FOR EXERCISE MACHINES AND ACCESSORIES THEREFOR (U.S. CLS. 22, 23, 38 AND 50).

FIRST USE 12-10-2010; IN COMMERCE 1-20-2011.

3,962,863. MATTEL, INC., EL SEGUNDO, CA. SN 77-919,055. PUB. 9-28-2010, FILED 1-25-2010.

# CHARMAINE KING

THE MARK CONSISTS OF STANDARD CHARACTERS WITHOUT CLAIM TO ANY PARTICULAR FONT, STYLE, SIZE, OR COLOR.

THE NAME(S), PORTRAIT(S), AND/OR SIGNATURE(S) SHOWN IN THE MARK DOES NOT IDENTIFY A PARTICULAR LIVING INDIVIDUAL.

FOR TOYS, GAMES AND PLAYTHINGS, NAMELY, DOLLS, DOLL CLOTHING AND DOLL ACCESSORIES (U.S. CLS. 22, 23, 38 AND 50).

FIRST USE 8-4-2010; IN COMMERCE 8-4-2010.

3,962,820. BARETZ, SUSIE, HIGHLAND PARK, IL. SN 77-907,230. PUB. 11-30-2010, FILED 1-7-2010.

# ENLITE

THE MARK CONSISTS OF STANDARD CHARACTERS WITHOUT CLAIM TO ANY PARTICULAR FONT, STYLE, SIZE, OR COLOR.

FOR MAGNETIC PUZZLES (U.S. CLS. 22, 23, 38 AND 50).

FIRST USE 2-28-2011; IN COMMERCE 2-28-2011.

3,962,870. MOLOR PRODUCTS COMPANY, OSWEGO, IL. SN 77-920,448. PUB. 9-7-2010, FILED 1-26-2010.

# Flatball

THE MARK CONSISTS OF STANDARD CHARACTERS WITHOUT CLAIM TO ANY PARTICULAR FONT, STYLE, SIZE, OR COLOR.

FOR GOLF TRAINING EQUIPMENT USED TO IMPROVE A GOLF SWING, NAMELY, PROJECTILE DEVICES TO BE HIT WITH A GOLF CLUB (U.S. CLS. 22, 23, 38 AND 50).

FIRST USE 1-12-2011; IN COMMERCE 1-27-2011.

**CLASS 28—(Continued).**

3,962,891. FITNESS BRANDS, INC., AUSTIN, TX. SN 77-925,676. PUB. 6-15-2010, FILED 2-2-2010.

**POWER DISK**

THE MARK CONSISTS OF STANDARD CHARACTERS WITHOUT CLAIM TO ANY PARTICULAR FONT, STYLE, SIZE, OR COLOR.

NO CLAIM IS MADE TO THE EXCLUSIVE RIGHT TO USE "DISK", APART FROM THE MARK AS SHOWN.

FOR MANUALLY-OPERATED EXERCISE EQUIPMENT; EXERCISE EQUIPMENT, NAMELY, ABDOMINAL EXERCISE MACHINES (U.S. CLS. 22, 23, 38 AND 50).

FIRST USE 2-15-2010; IN COMMERCE 2-15-2010.

**CLASS 28—(Continued).**

3,962,941. HASTY JR, WILTON HERBERT, DBA INTERPERSONAL COMMUNICATIONS COMPANY, WHITNEY, TX. SN 77-936,087. PUB. 7-13-2010, FILED 2-15-2010.

**INTROSPECTION**

THE MARK CONSISTS OF STANDARD CHARACTERS WITHOUT CLAIM TO ANY PARTICULAR FONT, STYLE, SIZE, OR COLOR.

FOR BOARD GAMES (U.S. CLS. 22, 23, 38 AND 50).

FIRST USE 9-1-2010; IN COMMERCE 2-1-2011.

3,962,925. EENIE MEENIE MINEY MOE, PARKER, CO. SN 77-932,915. PUB. 7-27-2010, FILED 2-10-2010.



THE COLOR(S) RED, ORANGE, LIGHT BLUE, PINK, WHITE AND BLACK IS/ARE CLAIMED AS A FEATURE OF THE MARK.

THE MARK CONSISTS OF A CIRCULAR MARK WITH A BLACK OUTER RING CONTAINING THE WORDS "EENIE MEENIE MINEY MOE" IN WHITE, WITH A WHITE SMALL STAR ON EITHER END OF THE WORDING. THE INNER CIRCLE IS WHITE, CONTAINING A STYLIZED DEPICTION OF AN ORANGE CAT WITH BLACK STRIPES AND PINK INNER EARS, WEARING A RED CONE HAT, AND HOLDING A LIGHT BLUE PACKAGE WITH A RED RIBBON.

FOR PAPER PARTY HATS; PARTY FAVORS IN THE NATURE OF CRACKERS AND NOISEMAKERS; PLASTIC PARTY HATS (U.S. CLS. 22, 23, 38 AND 50).

FIRST USE 10-15-2010; IN COMMERCE 10-15-2010.

3,962,960. SECURA INC., NAPERVILLE, IL. SN 77-940,121. PUB. 9-7-2010, FILED 2-19-2010.



THE MARK CONSISTS OF THE WORDS "RUNNING TWISTER" IN WHITE STYLIZED LETTERING ON TWO LINES WITHIN A SHADED OVAL WITH A WHITE FRAME AND A SINGLE LINE PERIPHERY. CENTERED WITHIN THE DARK OVAL ARE THE WORDS OF THE MARK. THE DESIGN COMPONENT OF THE MARK HAS A STYLIZED WHITE FIGURE, ARMS OUTSTRETCHED, APPEARING TO EXTEND UPWARD FROM THE FIRST "N" IN "RUNNING" AND TWO CURVED MOTION LINES ABOVE AND TO THE RIGHT OF "RUNNING" AND BELOW AND TO THE LEFT OF "TWISTER".

FOR EXERCISE MACHINES; MANUALLY OPERATED EXERCISE EQUIPMENT; MANUALLY OPERATED EXERCISE EQUIPMENT FOR PHYSICAL FITNESS PURPOSES; TRAMPOLINES (U.S. CLS. 22, 23, 38 AND 50).

FIRST USE 10-28-2010; IN COMMERCE 10-28-2010.



**CLASS 28—(Continued).**

3,963,018. RHODE ISLAND NOVELTY, INC., CUMBERLAND, RI. SN 77-946,323. PUB. 7-13-2010, FILED 2-26-2010.

BRINGING YOU A WORLD OF FUN

THE MARK CONSISTS OF STANDARD CHARACTERS WITHOUT CLAIM TO ANY PARTICULAR FONT, STYLE, SIZE, OR COLOR.

FOR TOYS AND NOVELTY ITEMS, NAMELY, STUFFED ANIMALS, PUPPETS, MODELED PLASTIC TOY FIGURINES, ACTION FIGURES, REPLICAS OF ANIMALS, VEHICLES, WEAPONS, ELECTRONICS AND INSECTS, PUZZLES, BOARD GAMES, DICE GAMES, INFLATABLE RIDE-ON TOYS, PARTY FAVORS IN THE NATURE OF SMALL TOYS, AND TOY VEHICLES (U.S. CLS. 22, 23, 38 AND 50).

FIRST USE 2-3-2009; IN COMMERCE 2-3-2009.

3,963,025. LUVMAT, WESTMINSTER, CO. SN 77-947,584. PUB. 7-27-2010, FILED 3-1-2010.

LuvMat

THE MARK CONSISTS OF STANDARD CHARACTERS WITHOUT CLAIM TO ANY PARTICULAR FONT, STYLE, SIZE, OR COLOR.

FOR YOGA MATS (U.S. CLS. 22, 23, 38 AND 50).  
FIRST USE 5-17-2010; IN COMMERCE 3-15-2011.

3,963,028. MILLER, CAROLE HANNA, PUNTA GORDA, FL. SN 77-948,158. PUB. 11-16-2010, FILED 3-2-2010.

SCOTHPOTTLE KIDS

THE MARK CONSISTS OF STANDARD CHARACTERS WITHOUT CLAIM TO ANY PARTICULAR FONT, STYLE, SIZE, OR COLOR.

NO CLAIM IS MADE TO THE EXCLUSIVE RIGHT TO USE "KIDS", APART FROM THE MARK AS SHOWN.  
FOR DOLLS (U.S. CLS. 22, 23, 38 AND 50).  
FIRST USE 3-17-2011; IN COMMERCE 3-17-2011.

**CLASS 28—(Continued).**

3,963,082. BALL, BOUNCE & SPORT, INC., ASHLAND, OH. SN 77-954,188. PUB. 8-3-2010, FILED 3-9-2010.

BOZAGGA

THE MARK CONSISTS OF STANDARD CHARACTERS WITHOUT CLAIM TO ANY PARTICULAR FONT, STYLE, SIZE, OR COLOR.

FOR BALLS OF ALL KINDS (U.S. CLS. 22, 23, 38 AND 50).  
FIRST USE 3-1-2011; IN COMMERCE 3-1-2011.

3,963,092. POSEY, DANIEL L, KINGSLAND, TX. SN 77-954,850. PUB. 8-3-2010, FILED 3-9-2010.

Talking With Paws

THE MARK CONSISTS OF STANDARD CHARACTERS WITHOUT CLAIM TO ANY PARTICULAR FONT, STYLE, SIZE, OR COLOR.

FOR PET TOYS (U.S. CLS. 22, 23, 38 AND 50).  
FIRST USE 1-1-2011; IN COMMERCE 2-1-2011.

3,963,095. MOORE III, WILLIAM E., VALDOSTA, GA. SN 77-955,406. PUB. 8-3-2010, FILED 3-10-2010.

DEERCON

THE MARK CONSISTS OF STANDARD CHARACTERS WITHOUT CLAIM TO ANY PARTICULAR FONT, STYLE, SIZE, OR COLOR.

FOR HUNTING EQUIPMENT, NAMELY, SCENT DISPENSER FOR ATTRACTING OR REPELLING ANIMALS (U.S. CLS. 22, 23, 38 AND 50).  
FIRST USE 5-26-2010; IN COMMERCE 5-26-2010.

**CLASS 28—(Continued).**

3,963,145. PATCH PRODUCTS, INC., BELOIT, WI. SN 77-960,787. PUB. 8-3-2010, FILED 3-17-2010.

**MAKE-A-SAURUS**

THE MARK CONSISTS OF STANDARD CHARACTERS WITHOUT CLAIM TO ANY PARTICULAR FONT, STYLE, SIZE, OR COLOR.

FOR CHILDREN'S MULTIPLE ACTIVITY TOYS; GO GAMES; JIGSAW AND MANIPULATIVE PUZZLES; MANIPULATIVE GAMES; MEMORY GAMES; PLAYSETS FOR MAGNETIC TOYS AND ANIMATED CHARACTERS, ANIMATED SCENES, AND MAGNETIC ACTIVITY SETS; PUZZLE GAMES; PUZZLES (U.S. CLS. 22, 23, 38 AND 50).

FIRST USE 7-20-2010; IN COMMERCE 7-20-2010.

---

3,963,153. BORDER CROSSING LABS, DAVISON, MI. SN 77-961,193. PUB. 8-3-2010, FILED 3-17-2010.

**CONQUEST**

THE MARK CONSISTS OF STANDARD CHARACTERS WITHOUT CLAIM TO ANY PARTICULAR FONT, STYLE, SIZE, OR COLOR.

FOR ANIMAL ATTRACTANT SCENTS; SCENT DISPENSERS FOR ATTRACTING ANIMALS; AND HUNTING BLINDS (U.S. CLS. 22, 23, 38 AND 50).

FIRST USE 1-1-2011; IN COMMERCE 1-1-2011.

---

3,963,198. ZCEPT, THOUSAND OAKS, CA. SN 77-965,944. PUB. 9-7-2010, FILED 3-23-2010.

**ZCEPT**

THE MARK CONSISTS OF STANDARD CHARACTERS WITHOUT CLAIM TO ANY PARTICULAR FONT, STYLE, SIZE, OR COLOR.

FOR GOLF TRAINING DEVICES, NAMELY, APPARATUS FOR IMPROVING THE BALL STRIKING CAPABILITY OF A GOLFER (U.S. CLS. 22, 23, 38 AND 50).

FIRST USE 9-1-2009; IN COMMERCE 9-1-2009.

**CLASS 28—(Continued).**

3,963,252. CEPIA, LLC, ST. LOUIS, MO. SN 77-981,664. PUB. 7-20-2010, FILED 1-15-2010.

**ZHUZHU**

THE MARK CONSISTS OF STANDARD CHARACTERS WITHOUT CLAIM TO ANY PARTICULAR FONT, STYLE, SIZE, OR COLOR.

FOR BATTERY OPERATED ACTION TOYS; ELECTRONIC ACTION TOYS; FANTASY CHARACTER TOYS; MODELED PLASTIC TOY FIGURINES; MOLDED TOY FIGURES; NON-ELECTRONIC TOY VEHICLES; PLASTIC CHARACTER TOYS; PLUSH TOYS; REMOTE CONTROL TOYS, NAMELY, MOTORIZED PLUSH ANIMALS; STUFFED AND PLUSH TOYS; STUFFED TOY ANIMALS; STUFFED TOYS; TALKING ELECTRONIC PRESS-DOWN TOY; TALKING TOYS; TOY ACTION FIGURES; TOY ACTION FIGURES AND ACCESSORIES THEREFOR; TOY BUILDING STRUCTURES AND TOY VEHICLE TRACKS; TOY BUILDINGS AND ACCESSORIES THEREFOR; TOY VEHICLE TRACK SETS AND ROADWAYS AND ACCESSORIES THEREFOR; TOY VEHICLES; TOY, NAMELY, BATTERY-POWERED COMPUTER GAME WITH LCD SCREEN WHICH FEATURES ANIMATION AND SOUND EFFECTS; PAPER PARTY HATS (U.S. CLS. 22, 23, 38 AND 50).

FIRST USE 8-0-2009; IN COMMERCE 8-0-2009.

---

3,963,256. UNDER ARMOUR, INC., BALTIMORE, MD. SN 77-981,684. PUB. 5-25-2010, FILED 3-1-2010.

**ARMOUR**

THE MARK CONSISTS OF STANDARD CHARACTERS WITHOUT CLAIM TO ANY PARTICULAR FONT, STYLE, SIZE, OR COLOR.

OWNER OF U.S. REG. NOS. 3,392,904, 3,720,012, AND OTHERS.

FOR KNEE PADS FOR ATHLETIC USE (U.S. CLS. 22, 23, 38 AND 50).

FIRST USE 5-24-2010; IN COMMERCE 5-24-2010.

**CLASS 28—(Continued).**

3,963,288. 3M COMPANY, ST. PAUL, MN. SN 78-667,546. PUB. 4-6-2010, FILED 7-11-2005.

**MOMENTUM**

THE MARK CONSISTS OF STANDARD CHARACTERS WITHOUT CLAIM TO ANY PARTICULAR FONT, STYLE, SIZE, OR COLOR.

FOR FISHING RODS AND FISHING REELS (U.S. CLS. 22, 23, 38 AND 50).

FIRST USE 12-31-2009; IN COMMERCE 12-31-2009.

---

3,963,316. MACKEY, JR., JAMES F., TEWKSBURY, MA. SN 85-002,776. PUB. 8-31-2010, FILED 3-31-2010.

**RAVAGE NOCKS**

THE MARK CONSISTS OF STANDARD CHARACTERS WITHOUT CLAIM TO ANY PARTICULAR FONT, STYLE, SIZE, OR COLOR.

NO CLAIM IS MADE TO THE EXCLUSIVE RIGHT TO USE "NOCKS", APART FROM THE MARK AS SHOWN.

FOR HUNTING ACCESSORIES, NAMELY, ARCHERY EQUIPMENT IN THE NATURE OF REAR DEPLOYABLE CUTTING DEVICES AND VANES MOUNTABLE AT THE AFT END OF A HUNTING ARROW (U.S. CLS. 22, 23, 38 AND 50).

FIRST USE 3-21-2011; IN COMMERCE 3-21-2011.

---

3,963,438. MATTEL, INC., EL SEGUNDO, CA. SN 85-029,739. PUB. 9-28-2010, FILED 5-4-2010.

**SISTERS' SLEEPTIME!**

THE MARK CONSISTS OF STANDARD CHARACTERS WITHOUT CLAIM TO ANY PARTICULAR FONT, STYLE, SIZE, OR COLOR.

OWNER OF U.S. REG. NOS. 3,122,750 AND 3,253,351.  
FOR DOLLS, DOLL CLOTHING AND DOLL ACCESSORIES; DOLL FURNITURE PLAYSETS AND ACCESSORIES THEREFOR (U.S. CLS. 22, 23, 38 AND 50).  
FIRST USE 11-1-2010; IN COMMERCE 11-1-2010.

**CLASS 28—(Continued).**

3,963,439. MATTEL, INC., EL SEGUNDO, CA. SN 85-029,742. PUB. 9-28-2010, FILED 5-4-2010.

**SISTERS SKATE!**

THE MARK CONSISTS OF STANDARD CHARACTERS WITHOUT CLAIM TO ANY PARTICULAR FONT, STYLE, SIZE, OR COLOR.

OWNER OF U.S. REG. NOS. 3,122,750 AND 3,253,351.  
NO CLAIM IS MADE TO THE EXCLUSIVE RIGHT TO USE "SKATE", APART FROM THE MARK AS SHOWN.  
FOR DOLLS, DOLL CLOTHING AND DOLL ACCESSORIES (U.S. CLS. 22, 23, 38 AND 50).  
FIRST USE 9-29-2010; IN COMMERCE 9-29-2010.

---

3,963,498. MATTEL, INC., EL SEGUNDO, CA. SN 85-044,711. PUB. 10-5-2010, FILED 5-21-2010.

**SISTERS SKATEBOARD!**

THE MARK CONSISTS OF STANDARD CHARACTERS WITHOUT CLAIM TO ANY PARTICULAR FONT, STYLE, SIZE, OR COLOR.

OWNER OF U.S. REG. NOS. 3,122,750 AND 3,253,351.  
NO CLAIM IS MADE TO THE EXCLUSIVE RIGHT TO USE "SKATEBOARD", APART FROM THE MARK AS SHOWN.

FOR DOLLS, DOLL CLOTHING AND DOLL ACCESSORIES (U.S. CLS. 22, 23, 38 AND 50).  
FIRST USE 9-29-2010; IN COMMERCE 9-29-2010.

---

3,963,506. SRI SPORTS LIMITED, KOBE-SHI, HYOGO, JAPAN. SN 85-046,099. PUB. 10-19-2010, FILED 5-24-2010.

**C.KUA**

THE MARK CONSISTS OF STANDARD CHARACTERS WITHOUT CLAIM TO ANY PARTICULAR FONT, STYLE, SIZE, OR COLOR.

FOR GOLF CLUB SHAFTS (U.S. CLS. 22, 23, 38 AND 50).  
FIRST USE 8-3-2010; IN COMMERCE 8-3-2010.

**CLASS 28—(Continued).**

3,963,556. RAMP SPORTS, LLC, PARK CITY, UT. SN 85-060,725. PUB. 11-9-2010, FILED 6-11-2010.

**CLASS 28—(Continued).**

3,963,561. MATTEL, INC., EL SEGUNDO, CA. SN 85-064,550. PUB. 11-16-2010, FILED 6-16-2010.

**PEACEPIPE**

THE MARK CONSISTS OF STANDARD CHARACTERS WITHOUT CLAIM TO ANY PARTICULAR FONT, STYLE, SIZE, OR COLOR.  
FOR SKIS; SNOWBOARDS (U.S. CLS. 22, 23, 38 AND 50).  
FIRST USE 12-10-2010; IN COMMERCE 12-10-2010.

**BUBBLE-MATIC**

THE MARK CONSISTS OF STANDARD CHARACTERS WITHOUT CLAIM TO ANY PARTICULAR FONT, STYLE, SIZE, OR COLOR.  
FOR TOY VEHICLE PLAYSETS AND ACCESSORIES THEREFOR (U.S. CLS. 22, 23, 38 AND 50).  
FIRST USE 1-10-2011; IN COMMERCE 1-20-2011.

3,963,557. RAMP SPORTS, LLC, PARK CITY, UT. SN 85-060,750. PUB. 11-9-2010, FILED 6-11-2010.

3,963,568. SCHOLASTIC INC., NEW YORK, NY. SN 85-065,227. PUB. 11-16-2010, FILED 6-17-2010.

**WOODPECKER**

THE MARK CONSISTS OF STANDARD CHARACTERS WITHOUT CLAIM TO ANY PARTICULAR FONT, STYLE, SIZE, OR COLOR.  
FOR SKIS; SNOWBOARDS (U.S. CLS. 22, 23, 38 AND 50).  
FIRST USE 12-10-2010; IN COMMERCE 12-10-2010.



THE MARK CONSISTS OF THE WORDS "FLY GUY" IN STYLIZED LETTERING.  
FOR PLUSH TOYS BASED ON A SERIES OF BOOKS FOR CHILDREN (U.S. CLS. 22, 23, 38 AND 50).  
FIRST USE 8-0-2010; IN COMMERCE 8-0-2010.

3,963,558. RAMP SPORTS, LLC, PARK CITY, UT. SN 85-061,746. PUB. 11-9-2010, FILED 6-14-2010.

3,963,616. ROOFTOP GROUP USA, INC., MISSION VIEJO, CA. SN 85-076,590. PUB. 11-30-2010, FILED 7-1-2010.

**CORK**

THE MARK CONSISTS OF STANDARD CHARACTERS WITHOUT CLAIM TO ANY PARTICULAR FONT, STYLE, SIZE, OR COLOR.  
FOR SKIS; SNOWBOARDS (U.S. CLS. 22, 23, 38 AND 50).  
FIRST USE 12-10-2010; IN COMMERCE 12-10-2010.

**GYROPTER**

THE MARK CONSISTS OF STANDARD CHARACTERS WITHOUT CLAIM TO ANY PARTICULAR FONT, STYLE, SIZE, OR COLOR.  
FOR TOY VEHICLES (U.S. CLS. 22, 23, 38 AND 50).  
FIRST USE 2-15-2010; IN COMMERCE 2-15-2010.

**CLASS 28—(Continued).**

3,963,633. CEPIA, LLC, ST. LOUIS, MO. SN 85-081,485. PUB. 9-7-2010, FILED 7-9-2010.

**ZHUZHU PUPPIES**

THE MARK CONSISTS OF STANDARD CHARACTERS WITHOUT CLAIM TO ANY PARTICULAR FONT, STYLE, SIZE, OR COLOR.

OWNER OF U.S. REG. NOS. 3,808,405 AND 3,808,406.

NO CLAIM IS MADE TO THE EXCLUSIVE RIGHT TO USE "PUPPIES", APART FROM THE MARK AS SHOWN.

FOR BATTERY OPERATED ACTION TOYS AND ACCESSORIES THEREFOR; ELECTRONIC ACTION TOYS AND ACCESSORIES THEREFOR; FANTASY CHARACTER TOYS AND ACCESSORIES THEREFOR; MODELED PLASTIC TOY FIGURINES AND OBJECTS AND ACCESSORIES THEREFOR; MOLDED TOY FIGURES AND OBJECTS AND ACCESSORIES THEREFOR; NON-ELECTRONIC TOY VEHICLES; PLASTIC CHARACTER TOYS AND ACCESSORIES THEREFOR; PLUSH TOYS AND ACCESSORIES THEREFOR; MOTORIZED PLUSH TOYS AND ACCESSORIES THEREFOR; MOTORIZED PLUSH ANIMALS AND ACCESSORIES THEREFOR; STUFFED AND PLUSH TOYS AND ACCESSORIES THEREFOR; STUFFED TOYS AND ACCESSORIES THEREFOR; STUFFED ANIMALS AND ACCESSORIES THEREFOR; TALKING ELECTRONIC PRESS-DOWN TOYS AND ACCESSORIES THEREFOR; TALKING TOYS AND ACCESSORIES THEREFOR; TOY ACTION FIGURES AND ACCESSORIES THEREFOR; TOY BUILDING STRUCTURES; TOY PLAY SETS; TOY VEHICLE TRACKS; TOY VEHICLES (U.S. CLS. 22, 23, 38 AND 50).

FIRST USE 3-14-2011; IN COMMERCE 3-14-2011.

---

3,963,645. MAHAR MANUFACTURING CORP., DBA FIESTA CONCESSION CORP., VERNON, CA. SN 85-084,618. PUB. 12-14-2010, FILED 7-14-2010.



THE MARK CONSISTS OF THE DESIGN OF A HEART WITH THE WORD "LOVE" GOING THROUGH THE MIDDLE OF THE HEART. DIRECTLY ABOVE AND TO THE LEFT OF THE HEART IS THE WORD "GOTTA". DIRECTLY BELOW AND TO THE RIGHT OF THE HEART IS THE WORD "ME". THROUGHOUT THE HEART ARE SPIKES WHICH EXTEND OUTWARD.

FOR STUFFED PLUSH TOYS (U.S. CLS. 22, 23, 38 AND 50).

FIRST USE 11-1-2010; IN COMMERCE 11-1-2010.

**CLASS 28—(Continued).**

3,963,663. ROOFTOP GROUP USA, INC., MISSION VIEJO, CA. SN 85-092,069. PUB. 11-30-2010, FILED 7-23-2010.

**HELIHAULER**

THE MARK CONSISTS OF STANDARD CHARACTERS WITHOUT CLAIM TO ANY PARTICULAR FONT, STYLE, SIZE, OR COLOR.

FOR TOY VEHICLES (U.S. CLS. 22, 23, 38 AND 50).  
FIRST USE 5-12-2010; IN COMMERCE 5-12-2010.

---

3,963,677. SIMPLYFUN, LLC, BELLEVUE, WA. SN 85-098,218. PUB. 1-11-2011, FILED 8-2-2010.

**LET'S JET**

THE MARK CONSISTS OF STANDARD CHARACTERS WITHOUT CLAIM TO ANY PARTICULAR FONT, STYLE, SIZE, OR COLOR.

FOR BOARD GAMES; EDUCATIONAL GAMES, NAMELY, A GEOGRAPHY GAME CONSISTING OF A BOARD, CARDS, AND PAWNS (U.S. CLS. 22, 23, 38 AND 50).

FIRST USE 12-1-2010; IN COMMERCE 12-1-2010.

---

3,963,708. MAHAR MANUFACTURING CORP., DBA FIESTA CONCESSION CORP., VERNON, CA. SN 85-125,884. PUB. 12-14-2010, FILED 9-9-2010.

**HENNATUDE**

THE MARK CONSISTS OF STANDARD CHARACTERS WITHOUT CLAIM TO ANY PARTICULAR FONT, STYLE, SIZE, OR COLOR.

FOR STUFFED PLUSH TOYS (U.S. CLS. 22, 23, 38 AND 50).

FIRST USE 1-6-2011; IN COMMERCE 1-6-2011.



**CLASS 28—(Continued).**

3,963,716. SIMPLYFUN, LLC, BELLEVUE, WA. SN 85-146,183. PUB. 1-11-2011, FILED 10-6-2010.

**CLOVER LEAP**

THE MARK CONSISTS OF STANDARD CHARACTERS WITHOUT CLAIM TO ANY PARTICULAR FONT, STYLE, SIZE, OR COLOR.

FOR BOARD GAMES; EDUCATIONAL GAMES, NAMELY, A BOARD GAME WITH DICE, PAWNS AND WORD TILES (U.S. CLS. 22, 23, 38 AND 50).

FIRST USE 1-20-2011; IN COMMERCE 1-20-2011.

---

3,963,719. BRIAN, DBA GREENERGY GAME, BALTIMORE, MD. SN 85-975,118. PUB. 8-24-2010, FILED 4-1-2010.

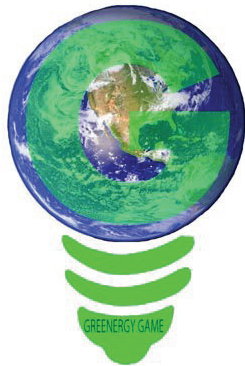

NO CLAIM IS MADE TO THE EXCLUSIVE RIGHT TO USE "GAME", APART FROM THE MARK AS SHOWN.

THE COLOR(S) BLUE, GREEN, AND WHITE IS/ARE CLAIMED AS A FEATURE OF THE MARK.

THE MARK CONSISTS OF THE FOLLOWING A STYLIZED LIGHT BULB FEATURING A GLOBE WITH BLUE WATER, WHITE CLOUDS AND GREEN LAND CONTINENTS. A GREEN LETTER "G" IS SUPERIMPOSED ON THE GLOBE. THE TWIST PORTION OF THE LIGHT BULB IS IN GREEN AND FEATURES THE WORDING "GREENERGY" IN A DARKER SHADE OF GREEN.

FOR BOARD GAMES (U.S. CLS. 22, 23, 38 AND 50). FIRST USE 2-1-2011; IN COMMERCE 2-1-2011.

**CLASS 28—(Continued).**

3,963,724. CEPIA, LLC, ST. LOUIS, MS. SN 85-975,154. PUB. 10-5-2010, FILED 4-9-2010.

**ZHU-NIVERSE**

THE MARK CONSISTS OF STANDARD CHARACTERS WITHOUT CLAIM TO ANY PARTICULAR FONT, STYLE, SIZE, OR COLOR.

OWNER OF U.S. REG. NOS. 3,808,405 AND 3,808,406.

FOR BATTERY OPERATED ACTION TOYS; ELECTRONIC ACTION TOYS; FANTASY CHARACTER TOYS; MODELED PLASTIC TOY FIGURINES; MOLDED TOY FIGURES; MUSICAL TOYS; NON-ELECTRONIC TOY VEHICLES; PLASTIC CHARACTER TOYS; PLUSH TOYS; RADIO CONTROLLED TOY VEHICLES; REMOTE CONTROL TOYS, NAMELY, MOTORIZED PLUSH ANIMALS; STUFFED AND PLUSH TOYS; STUFFED TOY ANIMALS; STUFFED TOY BEARS; STUFFED TOYS; TALKING ELECTRONIC PRESS-DOWN TOY; TALKING TOYS; TOY ACTION FIGURES; TOY ACTION FIGURES AND ACCESSORIES THEREFOR; TOY BUILDING STRUCTURES AND TOY VEHICLE TRACKS; TOY BUILDINGS AND ACCESSORIES THEREFOR; TOY CONSTRUCTION SETS; TOY VEHICLE TRACK SETS AND ROADWAYS AND ACCESSORIES THEREFOR; TOY VEHICLES; TOY, NAMELY, BATTERY-POWERED COMPUTER GAME WITH LCD SCREEN WHICH FEATURES ANIMATION AND SOUND EFFECTS; PAPER PARTY HATS (U.S. CLS. 22, 23, 38 AND 50).

FIRST USE 12-0-2010; IN COMMERCE 12-0-2010.

**CLASS 29—MEATS AND PROCESSED FOODS**

3,961,990. WIN SCHULER FOODS, INC, SOUTHFIELD, MI. SN 76-701,443. PUB. 7-27-2010, FILED 2-1-2010.

**LIA MARIE'S**

THE MARK CONSISTS OF STANDARD CHARACTERS WITHOUT CLAIM TO ANY PARTICULAR FONT, STYLE, SIZE, OR COLOR.

"LIA MARIE" IDENTIFIES A LIVING INDIVIDUAL WHOSE CONSENT IS OF RECORD.

FOR FOOD SPREADS, NAMELY, DAIRY-BASED SPREADS, BUTTER-BASED SPREADS, OIL-BASED SPREADS, HERB-BASED SPREADS, AND VEGETABLE-BASED SPREADS (U.S. CL. 46).

FIRST USE 3-7-2011; IN COMMERCE 3-7-2011.

**CLASS 29—(Continued).**

3,962,124. JIANG, RODERICK, MR., VICTORIA, BC, CANADA. SN 77-407,872. PUB. 7-15-2008, FILED 2-27-2008.



NO CLAIM IS MADE TO THE EXCLUSIVE RIGHT TO USE "THAI", APART FROM THE MARK AS SHOWN.

THE MARK CONSISTS OF THE WORDS "LITTLE THAI" IN A STYLIZED FONT WITH AN IMAGE OF A CHILI PEPPER SITUATED OVER THE LETTERS "H" AND "A" AND AN IMAGE OF AN ONION SITUATED OVER THE LETTER "I".

FOR PRE-COOKED READY-TO EAT MEALS AND PREPARED, READY-TO COOK MEALS, BOTH CONSISTING PRIMARILY OF MEAT, SEAFOOD, POULTRY, VEGETABLES OR TOFU (U.S. CL. 46).

FIRST USE 2-17-2011; IN COMMERCE 4-4-2011.

3,962,252. LA REYNERA, LLC, HOUSTON, TX. SN 77-644,382. PUB. 8-4-2009, FILED 1-6-2009.



THE MARK CONSISTS OF A PLATE, A STACK OF TORTILLAS ATOP THE PLATE, A FIVE-POINTED CROWN WITH A DIAMOND ATOP EACH OF THE FIVE POINTS, A GAP IN BETWEEN THE BOTTOM OF THE CROWN AND THE TOP OF THE TORTILLAS, AND THE LETTERS SPELLING "REYNAROST" IN UPPER CASE INSIDE THE CROWN.

THE WORDING "REYNAROST" HAS NO MEANING IN A FOREIGN LANGUAGE.

FOR BEEF; BEEF STEW; CHICKEN; PORK; PROCESSED MEAT, NAMELY, SLOW COOKED PORK, MEXICAN BEEF BARBECUE, NAMELY, SPICY BARBECUED BEEF, SLOW COOKED LAMB, ROTISSERIE CHICKEN, AND BEEF TRIPE; SOUPS (U.S. CL. 46).

FIRST USE 12-30-2009; IN COMMERCE 9-16-2010.

**CLASS 29—(Continued).**

3,962,579. HUDSON CONSULTING & MANAGEMENT, LLC, MIAMI, FL. SN 77-823,796. PUB. 7-13-2010, FILED 9-10-2009.

**MISTER CHOPSTIK EXPRESS**

THE MARK CONSISTS OF STANDARD CHARACTERS WITHOUT CLAIM TO ANY PARTICULAR FONT, STYLE, SIZE, OR COLOR.

FOR FROZEN MEALS CONSISTING PRIMARILY OF MEAT, FISH, POULTRY, VEGETABLES AND ALSO CONTAINING RICE (U.S. CL. 46).

FIRST USE 12-22-2010; IN COMMERCE 1-19-2011.

3,962,705. JAMBA JUICE COMPANY, EMERYVILLE, CA. SN 77-867,059. PUB. 6-1-2010, FILED 11-6-2009.



OWNER OF U.S. REG. NOS. 2,209,377, 3,651,041, AND OTHERS.

THE MARK CONSISTS OF A DESIGN OF A WHIRL. FOR TRAIL MIX CONSISTING PRIMARILY OF PROCESSED NUTS, SEEDS, DRIED FRUIT AND ALSO INCLUDING CHOCOLATE (U.S. CL. 46).

FIRST USE 3-15-2011; IN COMMERCE 3-15-2011.

3,962,706. JAMBA JUICE COMPANY, EMERYVILLE, CA. SN 77-867,063. PUB. 6-1-2010, FILED 11-6-2009.

# JAMBA

THE MARK CONSISTS OF STANDARD CHARACTERS WITHOUT CLAIM TO ANY PARTICULAR FONT, STYLE, SIZE, OR COLOR.

**CLASS 29—(Continued).**

OWNER OF U.S. REG. NOS. 2,526,399, 3,367,108, AND OTHERS.

FOR TRAIL MIX CONSISTING PRIMARILY OF PROCESSED NUTS, SEEDS, DRIED FRUIT AND ALSO INCLUDING CHOCOLATE (U.S. CL. 46).

FIRST USE 3-15-2011; IN COMMERCE 3-15-2011.

---

3,962,709. CALIFRESH OF CALIFORNIA, LLC, SANGER, CA. SN 77-870,091. PUB. 5-4-2010, FILED 11-11-2009.



THE COLOR(S) DARK GREEN, GREEN, LIGHT GREEN, BLACK, BLUE, WHITE, BEIGE, YELLOW, RED AND BROWN IS/ARE CLAIMED AS A FEATURE OF THE MARK.

THE MARK CONSISTS OF A LIGHT GREEN CHICKPEA OUTLINED WITH DARK GREEN AND WITH GREEN SHADING. THE CHICKPEA HAS BLUE, BLACK AND WHITE EYES. THE CHICKPEA IS WEARING A BEIGE MEXICAN STYLE HAT THAT HAS YELLOW DETAIL AND BLUE OUTLINE ON THE BRIM, AND RED AND GREEN DETAIL AROUND THE CENTER OF THE HAT. THE TOP AND BOTTOM OF THE HAT ARE OUTLINED IN BROWN.

FOR BEAN DIP; DIP MIXES; DIPS; PROCESSED BEANS; SNACK DIPS; SNACK FOOD DIPS (U.S. CL. 46). FIRST USE 1-1-2010; IN COMMERCE 7-1-2010.

---

3,962,710. CALIFRESH OF CALIFORNIA, LLC, SANGER, CA. SN 77-870,183. PUB. 4-20-2010, FILED 11-11-2009.



THE COLOR(S) DARK GREEN, LIGHT GREEN, BLACK, BLUE, WHITE, RED, GRAY AND BROWN IS/ARE CLAIMED AS A FEATURE OF THE MARK.

**CLASS 29—(Continued).**

THE MARK CONSISTS OF A LIGHT GREEN CHICKPEA OUTLINED WITH DARK GREEN AND WITH GREEN SHADING. THE CHICKPEA HAS BLUE, BLACK AND WHITE EYES. THE CHICKPEA IS WEARING A RED SCARF. THERE ARE TWO GRAY LINES UNDERNEATH THE CHICKPEA. THE CHICKPEA IS WEARING A BLACK ITALIAN GONDOLIER HAT THAT IS TRIMMED IN RED AND BROWN. THERE IS A BLUE RIBBON AROUND THE CENTER OF THE HAT.

FOR BEAN DIP; DIP MIXES; DIPS; PROCESSED BEANS; SNACK DIPS; SNACK FOOD DIPS (U.S. CL. 46). FIRST USE 7-1-2010; IN COMMERCE 7-1-2010.

---

3,962,771. HERBST ANDY, DBA RACE NUTS, COPPEROPOLIS, CA. SN 77-891,432. PUB. 5-4-2010, FILED 12-11-2009.

# Race Nuts

THE MARK CONSISTS OF STANDARD CHARACTERS WITHOUT CLAIM TO ANY PARTICULAR FONT, STYLE, SIZE, OR COLOR.

NO CLAIM IS MADE TO THE EXCLUSIVE RIGHT TO USE "NUTS", APART FROM THE MARK AS SHOWN.

FOR ROASTED NUTS; SNACK MIX CONSISTING OF DEHYDRATED FRUIT AND PROCESSED NUTS; SNACK MIX CONSISTING OF PRIMARILY OF PROCESSED NUTS, SEEDS, DRIED FRUIT AND ALSO INCLUDING CHOCOLATE; SNACK MIX CONSISTING OF WASABI PEAS, PROCESSED NUTS, DEHYDRATED FRUIT AND/OR RAISINS; SNACK MIX CONSISTING PRIMARILY OF PROCESSED FRUITS, PROCESSED NUTS AND/OR RAISINS; TRAIL MIX CONSISTING PRIMARILY OF PROCESSED NUTS, SEEDS, DRIED FRUIT AND ALSO INCLUDING CHOCOLATE (U.S. CL. 46).

FIRST USE 3-1-2011; IN COMMERCE 3-1-2011.

---

3,962,880. GOODKIND ORGANICS, LLC, ARCATA, CA. SN 77-922,140. PUB. 6-15-2010, FILED 1-28-2010.

# GOODKIND

THE MARK CONSISTS OF STANDARD CHARACTERS WITHOUT CLAIM TO ANY PARTICULAR FONT, STYLE, SIZE, OR COLOR.

FOR DAIRY BASED CREAMER AND NON-DAIRY CREAMER (U.S. CL. 46).

FIRST USE 1-26-2011; IN COMMERCE 1-26-2011.

**CLASS 29—(Continued).**

3,962,899. CHEA, JAMES, HYATTSVILLE, MD. SN 77-927,549.  
PUB. 7-27-2010, FILED 2-3-2010.



THE MARK CONSISTS OF THE WORDING "NORTH-STAR" IN CAPITALIZED LETTERS WITH THE LETTERS "N" AND "S" SLIGHTLY LARGER THAN THE OTHER LETTERS, AND THE STYLIZED DESIGN OF A STAR HAVING A CURVED TAIL. THE CURVED TAIL OF THE STAR IS IN THE FORM OF A PARTIAL OVAL BEGINNING BELOW THE LETTER "N" AND ENDING AT THE STAR ABOVE THE LETTERS "S" AND "R".

FOR CHEESE; COMPOTES; EDIBLE OILS AND FATS; EGGS; FROZEN FRUITS; FROZEN VEGETABLES; JELLIES AND JAMS; MEAT EXTRACTS; MEAT, FISH, POULTRY AND GAME; MILK; MILK PRODUCTS EXCLUDING ICE CREAM, ICE MILK AND FROZEN YOGURT; PRESERVED, DRIED AND COOKED FRUIT AND VEGETABLES (U.S. CL. 46).

FIRST USE 10-1-2010; IN COMMERCE 10-1-2010.

3,962,901. ALDI INC., BATAVIA, IL. SN 77-928,096. PUB. 7-13-2010, FILED 2-4-2010.



OWNER OF U.S. REG. NO. 3,764,427.  
NO CLAIM IS MADE TO THE EXCLUSIVE RIGHT TO USE "WILD CAUGHT", APART FROM THE MARK AS SHOWN.

THE MARK CONSISTS OF A STYLIZED FISH DESIGN AND THE WORDS "WILD CAUGHT".  
FOR SEAFOOD THAT IS WILD CAUGHT (U.S. CL. 46).  
FIRST USE 2-8-2011; IN COMMERCE 2-8-2011.

**CLASS 29—(Continued).**

3,962,905. ROTEM INC., SKOKIE, IL. SN 77-929,238. PUB. 7-27-2010, FILED 2-5-2010.

**TOMER KOSHER FOODS**

THE MARK CONSISTS OF STANDARD CHARACTERS WITHOUT CLAIM TO ANY PARTICULAR FONT, STYLE, SIZE, OR COLOR.

NO CLAIM IS MADE TO THE EXCLUSIVE RIGHT TO USE "KOSHER FOODS", APART FROM THE MARK AS SHOWN.

FOR KOSHER MEAT (U.S. CL. 46).  
FIRST USE 8-31-2010; IN COMMERCE 1-11-2011.

3,963,091. ROTEM INC., SKOKIE, IL. SN 77-954,791. PUB. 7-20-2010, FILED 3-9-2010.



NO CLAIM IS MADE TO THE EXCLUSIVE RIGHT TO USE "KOSHER FOODS", APART FROM THE MARK AS SHOWN.

THE MARK CONSISTS OF A PALM TREE WHICH FORMS THE LETTER "T" FOLLOWED BY THE LETTERS "OMER" ATOP THE WORDING "KOSHER FOODS" AND ALL INSIDE A PRIZE RIBBON.

FOR KOSHER MEAT (U.S. CL. 46).  
FIRST USE 8-31-2010; IN COMMERCE 1-11-2011.

3,963,166. LINK SNACKS, INC., MINONG, WI. SN 77-961,940.  
PUB. 8-10-2010, FILED 3-18-2010.

**JACK LINK'S CLASSICS**

THE MARK CONSISTS OF STANDARD CHARACTERS WITHOUT CLAIM TO ANY PARTICULAR FONT, STYLE, SIZE, OR COLOR.

OWNER OF U.S. REG. NOS. 1,910,274, 3,123,509, AND OTHERS.

**CLASS 29—(Continued).**

NO CLAIM IS MADE TO THE EXCLUSIVE RIGHT TO USE "CLASSICS", APART FROM THE MARK AS SHOWN.  
 THE NAME "JACK LINK" IDENTIFIES A LIVING INDIVIDUAL WHOSE CONSENT IS OF RECORD.  
 FOR MEAT SNACKS (U.S. CL. 46).  
 FIRST USE 3-7-2011; IN COMMERCE 3-7-2011.

---

3,963,173. KIND, LLC, NEW YORK, NY. SN 77-962,923. PUB. 7-27-2010, FILED 3-19-2010.

IT'S USUALLY THE NUTS THAT  
 CHANGE THE WORLD

THE MARK CONSISTS OF STANDARD CHARACTERS WITHOUT CLAIM TO ANY PARTICULAR FONT, STYLE, SIZE, OR COLOR.  
 FOR HEALTHY SNACKS, NAMELY, NUT AND SEED BASED SNACK BARS; PROCESSED FRUIT-AND NUT-BASED FOOD BARS, NUT BASED SNACK FOOD BARS, FRUIT BASED SNACK FOOD BARS ALSO CONTAINING NUTS, GRAINS, CEREALS AND DRIED FRUIT (U.S. CL. 46).  
 FIRST USE 3-20-2010; IN COMMERCE 3-15-2011.

---

3,963,223. A&B FAMOUS GEFILTE FISH INC., PATERSON, NJ. SN 77-968,869. PUB. 8-17-2010, FILED 3-25-2010.

Main Menu

THE MARK CONSISTS OF STANDARD CHARACTERS WITHOUT CLAIM TO ANY PARTICULAR FONT, STYLE, SIZE, OR COLOR.  
 FOR PREPACKAGED FROZEN CHICKEN AND MEAT LOAF; FROZEN VEGETABLE PATTIES; FRENCH FRIES (U.S. CL. 46).  
 FIRST USE 10-1-2010; IN COMMERCE 10-1-2010.

---

3,963,376. WHITEWAVE SERVICES, INC., DALLAS, TX. SN 85-012,051. PUB. 9-7-2010, FILED 4-12-2010.

CHOOSE WISELY, DRINK  
 HAPPILY

THE MARK CONSISTS OF STANDARD CHARACTERS WITHOUT CLAIM TO ANY PARTICULAR FONT, STYLE, SIZE, OR COLOR.  
 FOR NUT-BASED MILK (U.S. CL. 46).  
 FIRST USE 4-0-2010; IN COMMERCE 7-0-2010.

**CLASS 29—(Continued).**

3,963,532. HARDEE'S FOOD SYSTEMS, INC., ST. LOUIS, MO. SN 85-054,231. PUB. 1-25-2011, FILED 6-3-2010.

THERE'S NOTHING FRESH  
 ABOUT PRE-COOKED CHICKEN

THE MARK CONSISTS OF STANDARD CHARACTERS WITHOUT CLAIM TO ANY PARTICULAR FONT, STYLE, SIZE, OR COLOR.  
 FOR CHICKEN (U.S. CL. 46).  
 FIRST USE 11-30-2010; IN COMMERCE 11-30-2010.

---

3,963,533. HARDEE'S FOOD SYSTEMS, INC., ST. LOUIS, MO. SN 85-054,235. PUB. 1-25-2011, FILED 6-3-2010.

BECAUSE THERE'S NOTHING  
 FRESH ABOUT PRE-COOKED  
 CHICKEN

THE MARK CONSISTS OF STANDARD CHARACTERS WITHOUT CLAIM TO ANY PARTICULAR FONT, STYLE, SIZE, OR COLOR.  
 FOR CHICKEN (U.S. CL. 46).  
 FIRST USE 11-30-2010; IN COMMERCE 11-30-2010.

---

3,963,580. WEIGHT WATCHERS INTERNATIONAL, INC., NEW YORK, NY. SN 85-068,826. PUB. 11-16-2010, FILED 6-22-2010.



THE COLOR(S) LIGHT BLUE AND WHITE IS/ARE CLAIMED AS A FEATURE OF THE MARK.



**CLASS 29—(Continued).**

THE MARK CONSISTS OF THE NUMBER "2" AND THE WORDING "POINTSPLUS" WITH A PLUS SIGN IN A CIRCLE AND THE WORD "VALUE" ALL IN WHITE, AND ALL WITHIN A DIAMOND SHAPE WITH ROUNDED CORNERS WITH A LIGHT BLUE BACKGROUND.

FOR FROZEN AND PREPARED CHILLED MEALS CONSISTING PRIMARILY OF MEAT, FISH, POULTRY OR VEGETABLES; FROZEN VEGETABLES; FROZEN MEAT ALTERNATIVE PRODUCTS; DRINKING YOGURT; YOGURT; CHEESE; CHEESE SPREADS; SOUPS (U.S. CL. 46).

FIRST USE 3-0-2011; IN COMMERCE 3-0-2011.

3,963,584. WEIGHT WATCHERS INTERNATIONAL, INC., NEW YORK, NY. SN 85-069,324. PUB. 11-30-2010, FILED 6-23-2010.



OWNER OF U.S. REG. NOS. 2,139,767 AND 3,346,918.  
THE MARK CONSISTS OF THE NUMBER "7" AND THE WORDING "POINTSPLUS" WITH A PLUS SIGN IN A CIRCLE AND THE WORD "VALUE". ALL WITHIN A SHADED DIAMOND SHAPE WITH ROUNDED CORNERS.  
FOR FROZEN AND PREPARED CHILLED MEALS CONSISTING PRIMARILY OF MEAT, FISH, POULTRY OR VEGETABLES; FROZEN VEGETABLES; FROZEN MEAT ALTERNATIVE PRODUCTS; DRINKING YOGURT; YOGURT; CHEESE; CHEESE SPREADS; SOUPS (U.S. CL. 46).

FIRST USE 3-1-2011; IN COMMERCE 3-1-2011.

3,963,644. BUNGE OILS, INC., ST. LOUIS, MO. SN 85-084,577. PUB. 12-7-2010, FILED 7-14-2010.

**ECLIPSE**

THE MARK CONSISTS OF STANDARD CHARACTERS WITHOUT CLAIM TO ANY PARTICULAR FONT, STYLE, SIZE, OR COLOR.

FOR EDIBLE FATS; EDIBLE OILS; MARGARINE (U.S. CL. 46).

FIRST USE 10-1-2010; IN COMMERCE 10-1-2010.

**CLASS 29—(Continued).**

3,963,660. FRITO-LAY NORTH AMERICA, INC., PLANO, TX. SN 85-089,803. PUB. 11-16-2010, FILED 7-21-2010.

**DIP CREATIONS**

THE MARK CONSISTS OF STANDARD CHARACTERS WITHOUT CLAIM TO ANY PARTICULAR FONT, STYLE, SIZE, OR COLOR.

NO CLAIM IS MADE TO THE EXCLUSIVE RIGHT TO USE "DIP", APART FROM THE MARK AS SHOWN.

FOR DIP MIXES (U.S. CL. 46).

FIRST USE 2-0-2011; IN COMMERCE 2-0-2011.

3,963,661. TOMALES BAY FOODS CORP., POINT REYES STATION, CA. SN 85-090,253. PUB. 1-4-2011, FILED 7-22-2010.

**BUCKAROO**

THE MARK CONSISTS OF STANDARD CHARACTERS WITHOUT CLAIM TO ANY PARTICULAR FONT, STYLE, SIZE, OR COLOR.

FOR CHEESE (U.S. CL. 46).

FIRST USE 8-4-2010; IN COMMERCE 8-4-2010.

3,963,679. MAYA OVERSEAS FOODS, INC., MASPETH, NY. SN 85-099,256. PUB. 1-18-2011, FILED 8-3-2010.

**FISHKA**

THE MARK CONSISTS OF STANDARD CHARACTERS WITHOUT CLAIM TO ANY PARTICULAR FONT, STYLE, SIZE, OR COLOR.

FOR FROZEN AND PREPARED MEALS CONSISTING PRIMARILY OF FISH AND SEAFOOD (U.S. CL. 46).

FIRST USE 12-31-2007; IN COMMERCE 12-31-2007.

**CLASS 29—(Continued).**

3,963,723. OCEAN DIRECT, LLC, HAWTHORNE, CA. SN 85-975,147. PUB. 11-9-2010, FILED 6-1-2010.

**WILDWOOD FARMS**

THE MARK CONSISTS OF STANDARD CHARACTERS WITHOUT CLAIM TO ANY PARTICULAR FONT, STYLE, SIZE, OR COLOR.

NO CLAIM IS MADE TO THE EXCLUSIVE RIGHT TO USE "FARMS", APART FROM THE MARK AS SHOWN.

FOR LIQUID FROZEN WHOLE EGGS, LIQUID FROZEN EGG WHITES, LIQUID FROZEN EGG YOLKS, LIQUID FROZEN SCRAMBLED EGG MIX, LIQUID FROZEN LOW FAT/LOW CHOLESTEROL EGG MIX, LIQUID FROZEN NO FAT/NO CHOLESTEROL EGG MIX, EXTENDED SHELF LIFE REFRIGERATED LIQUID WHOLE EGGS, EXTENDED SHELF LIFE REFRIGERATED LIQUID SCRAMBLED EGG MIX, EXTENDED SHELF LIFE REFRIGERATED LIQUID EGG WHITES, EXTENDED SHELF LIFE REFRIGERATED LIQUID EGG YOLKS, EXTENDED SHELF LIFE REFRIGERATED LIQUID LOW FAT/LOW CHOLESTEROL EGG MIX, EXTENDED SHELF LIFE REFRIGERATED LIQUID NO FAT/NO CHOLESTEROL EGG MIX, PRE-COOKED HARD COOKED EGGS, PRE-COOKED OMELETS, PRE-COOKED SCRAMBLED EGGS, PRE-COOKED EGG PATTIES, PRE-COOKED FRITTATA, ORGANIC LIQUID EGGS, CAGE FREE LIQUID EGGS, BREAKFAST EGG BOWLS COMPRISING EGGS AND A COMBINATION OF CHEESE, BACON, SAUSAGE OR HAM, BREAKFAST POTATOES CONSISTING OF WEDGES, CUBED, OR SHOE-STRING STYLE HASH BROWNS (U.S. CL. 46).

FIRST USE 4-1-2011; IN COMMERCE 4-1-2011.

**CLASS 30—STAPLE FOODS**

3,961,969. GRAND FOOD COMPANY, HOUSTON, TX. SN 76-683,631. PUB. 7-29-2008, FILED 11-5-2007.



THE MARK CONSISTS OF THE WORDING "DIAMOND CREEK" ON A DIAMOND SHAPED DESIGN. VARIOUS TREES, PLANTS, AND A STREAM APPEAR WITHIN THE DIAMOND DESIGN.

FOR TEA AND HONEY (U.S. CL. 46).  
FIRST USE 12-21-2010; IN COMMERCE 12-21-2010.

**CLASS 30—(Continued).**

3,962,003. GRAINDROPS LLC, ATLANTA, GA. SN 77-017,398. PUB. 3-18-2008, FILED 10-10-2006.

**GRAINDROPS**

THE MARK CONSISTS OF STANDARD CHARACTERS WITHOUT CLAIM TO ANY PARTICULAR FONT, STYLE, SIZE, OR COLOR.

FOR GRAIN-BASED BEVERAGES (U.S. CL. 46).  
FIRST USE 1-0-2010; IN COMMERCE 1-0-2010.

3,962,038. ZWIENER, WOLFGANG, NEW YORK, NY. SN 77-155,272. PUB. 12-4-2007, FILED 4-12-2007.

**WOLFGANG'S STEAKHOUSE BY  
WOLFGANG ZWIENER**

THE MARK CONSISTS OF STANDARD CHARACTERS WITHOUT CLAIM TO ANY PARTICULAR FONT, STYLE, SIZE, OR COLOR.

NO CLAIM IS MADE TO THE EXCLUSIVE RIGHT TO USE "STEAKHOUSE", APART FROM THE MARK AS SHOWN.

FOR STEAK SAUCES (U.S. CL. 46).  
FIRST USE 2-0-2009; IN COMMERCE 2-0-2009.

3,962,120. VAMBERI, GABOR, LEESBURG, VA. SN 77-402,072. PUB. 7-8-2008, FILED 2-20-2008.

**VEGELATO**

THE MARK CONSISTS OF STANDARD CHARACTERS WITHOUT CLAIM TO ANY PARTICULAR FONT, STYLE, SIZE, OR COLOR.

FOR SOFT FROZEN SNACKS IN THE NATURE OF GELATO CONSISTING PRIMARILY OF VEGETABLE, MEAT, FISH, POULTRY AND DAIRY PRODUCTS (U.S. CL. 46).

FIRST USE 3-14-2011; IN COMMERCE 3-14-2011.

**CLASS 30—(Continued).**

3,962,320. RESTREPO GUTIERREZ, SANTIAGO, BOGOTÁ, COLOMBIA. SN 77-689,888. PUB. 6-16-2009, FILED 3-12-2009.

**CLASS 30—(Continued).**

3,962,508. DIPPIN' DOTS, INC., PADUCAH, KY. SN 77-803,158. PUB. 12-1-2009, FILED 8-12-2009.

## POWER FRUITS

THE MARK CONSISTS OF STANDARD CHARACTERS WITHOUT CLAIM TO ANY PARTICULAR FONT, STYLE, SIZE, OR COLOR.

NO CLAIM IS MADE TO THE EXCLUSIVE RIGHT TO USE "FRUITS", APART FROM THE MARK AS SHOWN.

FOR CEREAL BASED ENERGY BARS; GRANOLA-BASED SNACK BARS; READY TO EAT, CEREAL DERIVED FOOD BARS (U.S. CL. 46).

FIRST USE 12-20-2005; IN COMMERCE 12-31-2008.

## SMACK PACK

THE MARK CONSISTS OF STANDARD CHARACTERS WITHOUT CLAIM TO ANY PARTICULAR FONT, STYLE, SIZE, OR COLOR.

FOR ICE CREAM, FROZEN YOGURT AND FROZEN FLAVORED ICE (U.S. CL. 46).

FIRST USE 4-1-2010; IN COMMERCE 4-1-2010.

3,962,347. GOOSE VALLEY NATURAL FOODS, LLC, BOSTON, MA. SN 77-711,397. PUB. 4-6-2010, FILED 4-10-2009.

## FUSION

THE MARK CONSISTS OF STANDARD CHARACTERS WITHOUT CLAIM TO ANY PARTICULAR FONT, STYLE, SIZE, OR COLOR.

FOR NATURAL FOOD PRODUCTS, NAMELY, WILD RICE; WILD RICE, BROWN RICE, RED RICE, AND SEASONING MIX COMBINED IN UNITARY PACKAGES; PACKAGED MEAL MIXES CONSISTING PRIMARILY OF WILD RICE, BROWN RICE, RED RICE, RICE, PROCESSED BULGUR WHEAT, BUCKWHEAT GROATS, PROCESSED CEREAL MILLET, PROCESSED BARLEY, AND PROCESSED QUINOA (U.S. CL. 46).

FIRST USE 10-0-2009; IN COMMERCE 10-0-2009.

3,962,509. ORGANO GOLD ENTERPRISES INC., RICHMOND, B.C., CANADA. SN 77-803,387. PUB. 1-12-2010, FILED 8-12-2009.

## OrGano Gold

3,962,392. UNILEVER SUPPLY CHAIN, INC., CLINTON, CT. SN 77-751,749. PUB. 3-23-2010, FILED 6-4-2009.

## THE TASTE YOU LOVE SINCE 1920

THE MARK CONSISTS OF STANDARD CHARACTERS WITHOUT CLAIM TO ANY PARTICULAR FONT, STYLE, SIZE, OR COLOR.

NO CLAIM IS MADE TO THE EXCLUSIVE RIGHT TO USE "SINCE 1920", APART FROM THE MARK AS SHOWN.

FOR ICE CREAM, FROZEN CONFECTIONS (U.S. CL. 46).

FIRST USE 3-1-2009; IN COMMERCE 3-1-2009.

THE MARK CONSISTS OF STANDARD CHARACTERS WITHOUT CLAIM TO ANY PARTICULAR FONT, STYLE, SIZE, OR COLOR.

FOR INSTANT ORGANIC COFFEE CONTAINING ORGANIC MUSHROOMS AND ORGANIC MUSHROOM EXTRACTS; ORGANIC COFFEE MIXED WITH ORGANIC MUSHROOMS AND ORGANIC MUSHROOM EXTRACTS; ORGANIC TEA MIXED WITH ORGANIC MUSHROOMS AND ORGANIC MUSHROOM EXTRACTS; MIXES IN THE NATURE OF POWDERS USED IN THE PREPARATION OF ORGANIC COFFEE, ORGANIC TEA, AND ORGANIC COCOA BASED BEVERAGES (U.S. CL. 46).

FIRST USE 2-2-2009; IN COMMERCE 2-7-2011.

**CLASS 30—(Continued).**

3,962,546. MAPLE LEAF BAKERY, INC., DES PLAINES, IL. SN 77-813,193. PUB. 8-3-2010, FILED 8-26-2009.



NO CLAIM IS MADE TO THE EXCLUSIVE RIGHT TO USE "NEW YORK STYLE", APART FROM THE MARK AS SHOWN.

THE MARK CONSISTS OF AN IMAGE OF A BAGEL WITH THE WORDS "NEW YORK STYLE" AROUND THE TOP OF THE BAGEL AND "1880" BETWEEN TWO STAR SHAPES ROUNDED UNDERNEATH THE BOTTOM OF THE BAGEL, ALL INSIDE A CIRCLE.

FOR BAGELS (U.S. CL. 46).

FIRST USE 6-0-2010; IN COMMERCE 6-0-2010.

3,962,559. TWANG PARTNERS, LTD, SAN ANTONIO, TX. SN 77-817,332. PUB. 2-2-2010, FILED 9-1-2009.

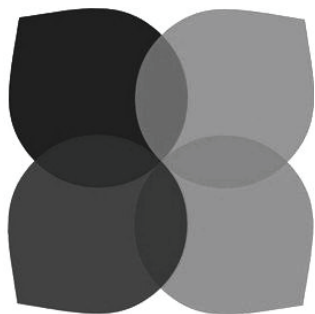

**fabflavors**

THE MARK CONSISTS OF A GEOMETRIC SHAPE COMPRISED OF FOUR OVERLAPPING CIRCULAR SHAPES, WITH OUTSIDE CORNERS THAT PROTRUDE FROM EACH CIRCLE; THE FOUR OVERLAPPING CIRCULAR SHAPES RESEMBLE FLOWER PETALS OR LEAVES.

FOR SPICES; SEASONINGS; SEASONING BLENDS; SUGAR BLENDS; SALT BLENDS; FLAVORED SALTS; SALT-BASED SPICES INTENDED FOR USE WITH BEER; CANDY, NAMELY, FLAVORED SUGAR (U.S. CL. 46).

FIRST USE 10-29-2010; IN COMMERCE 10-29-2010.

**CLASS 30—(Continued).**

3,962,633. BRIDGFORD FOODS CORPORATION, ANAHEIM, CA. SN 77-843,896. PUB. 9-14-2010, FILED 10-7-2009.

**BRIDGFORD READY TO EAT**

THE MARK CONSISTS OF STANDARD CHARACTERS WITHOUT CLAIM TO ANY PARTICULAR FONT, STYLE, SIZE, OR COLOR.

NO CLAIM IS MADE TO THE EXCLUSIVE RIGHT TO USE "READY TO EAT", APART FROM THE MARK AS SHOWN.

SEC. 2(F).

FOR SANDWICHES (U.S. CL. 46).

FIRST USE 1-0-2010; IN COMMERCE 1-0-2010.

3,962,636. SCHWAN'S IP, LLC, MARSHALL, MN. SN 77-844,772. PUB. 3-16-2010, FILED 10-8-2009.



OWNER OF U.S. REG. NOS. 1,190,169, 2,749,741, AND OTHERS.

NO CLAIM IS MADE TO THE EXCLUSIVE RIGHT TO USE "PIZZERIA STYLE", APART FROM THE MARK AS SHOWN.

THE MARK CONSISTS OF A BANNER WITH CHECKBOARD ON THE TOP AND BOTTOM OF THE BANNER AND THE WORDS "RED BARON PIZZERIA STYLE" INSIDE THE BANNER WITH A PICTURE OF A MALE BUST, WITH MUSTACHE, FLIGHT GOGGLES AND SCARF.

FOR PIZZA; OPEN FACED BREAKFAST SANDWICHES CONSISTING OF MEAT, CHEESE, EGGS, SAUCE AND/OR GRAVY AND/OR VEGETABLES (U.S. CL. 46).

FIRST USE 8-1-2010; IN COMMERCE 8-1-2010.

3,962,675. WM. WRIGLEY JR. COMPANY, CHICAGO, IL. SN 77-857,359. PUB. 8-10-2010, FILED 10-26-2009.

**PERFECT PEACH**

THE MARK CONSISTS OF STANDARD CHARACTERS WITHOUT CLAIM TO ANY PARTICULAR FONT, STYLE, SIZE, OR COLOR.

NO CLAIM IS MADE TO THE EXCLUSIVE RIGHT TO USE "PEACH", APART FROM THE MARK AS SHOWN.

FOR CHEWING GUM (U.S. CL. 46).

FIRST USE 5-0-2010; IN COMMERCE 5-0-2010.

**CLASS 30—(Continued).**

3,962,688. CJ GLOBAL, INC., NEW YORK, NY. SN 77-859,442.  
PUB. 4-13-2010, FILED 10-28-2009.

**RABBI MINTS**

THE MARK CONSISTS OF STANDARD CHARACTERS WITHOUT CLAIM TO ANY PARTICULAR FONT, STYLE, SIZE, OR COLOR.

NO CLAIM IS MADE TO THE EXCLUSIVE RIGHT TO USE "MINTS", APART FROM THE MARK AS SHOWN. FOR CANDY, NAMELY, MINTS (U.S. CL. 46).  
FIRST USE 3-0-2011; IN COMMERCE 3-0-2011.

3,962,808. CONAGRA FOODS RDM, INC., OMAHA, NE. SN 77-903,376. PUB. 8-10-2010, FILED 12-31-2009.

**POP UP BOWL**

THE MARK CONSISTS OF STANDARD CHARACTERS WITHOUT CLAIM TO ANY PARTICULAR FONT, STYLE, SIZE, OR COLOR.

NO CLAIM IS MADE TO THE EXCLUSIVE RIGHT TO USE "BOWL", APART FROM THE MARK AS SHOWN. FOR MICROWAVE POPCORN (U.S. CL. 46).  
FIRST USE 1-25-2011; IN COMMERCE 2-7-2011.

3,962,879. PORTAL GOURMET L.L.C., ATLANTA, GA. SN 77-921,853. PUB. 6-15-2010, FILED 1-27-2010.

**Portal Gourmet Sauce**

THE MARK CONSISTS OF STANDARD CHARACTERS WITHOUT CLAIM TO ANY PARTICULAR FONT, STYLE, SIZE, OR COLOR.

NO CLAIM IS MADE TO THE EXCLUSIVE RIGHT TO USE "GOURMET SAUCE", APART FROM THE MARK AS SHOWN.

FOR SALSA (U.S. CL. 46).  
FIRST USE 1-1-2010; IN COMMERCE 2-1-2010.

**CLASS 30—(Continued).**

3,962,983. NORTHERN SALES COMPANY INC., KENT, WA. SN 77-942,963. PUB. 7-13-2010, FILED 2-23-2010.

**NORTHERN PEAKS**

THE MARK CONSISTS OF STANDARD CHARACTERS WITHOUT CLAIM TO ANY PARTICULAR FONT, STYLE, SIZE, OR COLOR.

FOR COFFEE (U.S. CL. 46).  
FIRST USE 7-14-2010; IN COMMERCE 7-14-2010.

3,963,058. SAM'S PRODUCTS, INC., SOPHIA, NC. SN 77-951,583. PUB. 7-27-2010, FILED 3-5-2010.

**HIJOLE**

THE MARK CONSISTS OF STANDARD CHARACTERS WITHOUT CLAIM TO ANY PARTICULAR FONT, STYLE, SIZE, OR COLOR.

THE ENGLISH TRANSLATION OF "HIJOLE" IN THE MARK IS LOOSELY TRANSLATED AS "OK".

FOR COOKING SPICES, NAMELY, CUMIN, BLACK PEPPER, BAY LEAVES AND DRY CHILI (U.S. CL. 46).  
FIRST USE 11-11-2010; IN COMMERCE 11-24-2010.

3,963,101. YOUNGER BIOTECHNOLOGY CO., LTD., TAIPEI CITY, TAIWAN. SN 77-955,982. PUB. 10-19-2010, FILED 3-10-2010.



THE LIKENESS (OR, "PORTRAIT") IN THE MARK DOES NOT IDENTIFY A LIVING INDIVIDUAL.



**CLASS 30—(Continued).**

THE MARK CONSISTS OF THE BUST OF A WOMAN WEARING A CROWN SURROUNDED BY CONCENTRIC CIRCLES.

FOR COFFEE, COCOA POWDER, ROASTED COFFEE, ARTIFICIAL COFFEE, UNROASTED COFFEE, COFFEE BEANS, INSTANT COFFEE, COFFEE BEVERAGES WITH MILK, COCOA, COFFEE-BASED BEVERAGES (U.S. CL. 46).

FIRST USE 10-1-2006; IN COMMERCE 10-1-2006.

---

3,963,240. RYAN, OWEN, CHARLOTTE, NC. SN 77-981,575.  
PUB. 11-9-2010, FILED 9-19-2009.

**ANTIOXIDANT FARMS**

THE MARK CONSISTS OF STANDARD CHARACTERS WITHOUT CLAIM TO ANY PARTICULAR FONT, STYLE, SIZE, OR COLOR.

NO CLAIM IS MADE TO THE EXCLUSIVE RIGHT TO USE "ANTIOXIDANT", APART FROM THE MARK AS SHOWN.

FOR GRANOLA (U.S. CL. 46).  
FIRST USE 4-30-2010; IN COMMERCE 4-30-2010.

---

3,963,289. THE KROGER CO. OF MICHIGAN, NOVI, MI. SN 78-682,865. PUB. 8-3-2010, FILED 8-1-2005.

**KITCHEN CREATIONS**

THE MARK CONSISTS OF STANDARD CHARACTERS WITHOUT CLAIM TO ANY PARTICULAR FONT, STYLE, SIZE, OR COLOR.

FOR PACKAGED DINNER MIXES CONSISTING OF PASTA AND SEASONINGS (U.S. CL. 46).

FIRST USE 10-0-2006; IN COMMERCE 10-0-2006.

---

3,963,319. SYNGENTA PARTICIPATIONS AG, BASEL, SWITZERLAND. SN 85-003,202. PUB. 7-27-2010, FILED 3-31-2010.

**Nuspecialty**

THE MARK CONSISTS OF STANDARD CHARACTERS WITHOUT CLAIM TO ANY PARTICULAR FONT, STYLE, SIZE, OR COLOR.

FOR COFFEE, GREEN COFFEE (U.S. CL. 46).  
FIRST USE 1-1-2008; IN COMMERCE 1-1-2008.

**CLASS 30—(Continued).**

3,963,339. DISTRIBUIDORA DE ALIMENTOS NATURALES Y NUTRICIONALES, S.A. DE C.V., MEXICO, MEXICO. SN 85-006,735. PUB. 8-31-2010, FILED 4-5-2010.

**DULCE IDEA**

THE MARK CONSISTS OF STANDARD CHARACTERS WITHOUT CLAIM TO ANY PARTICULAR FONT, STYLE, SIZE, OR COLOR.

NO CLAIM IS MADE TO THE EXCLUSIVE RIGHT TO USE "DULCE", APART FROM THE MARK AS SHOWN.

THE ENGLISH TRANSLATION OF "DULCE" IN THE MARK IS "SWEET".

FOR CANDIES; CANDY; CANDY BARS; CANDY MINTS; CANDY SPRINKLES; CANDY WITH CARAMEL; CANDY WITH COCOA; CHOCOLATE CANDIES; CHOCOLATES AND CHOCOLATE BASED READY TO EAT CANDIES AND SNACKS; MEXICAN CANDY; SUGARLESS CANDIES; SWEETS (U.S. CL. 46).

FIRST USE 3-23-2011; IN COMMERCE 3-23-2011.

---

3,963,397. CRYSTAL RIVER ORGANICS LLC, CARBONDALE, CO. SN 85-018,936. PUB. 2-8-2011, FILED 4-21-2010.

**NOURISH YOUR BEING**

THE MARK CONSISTS OF STANDARD CHARACTERS WITHOUT CLAIM TO ANY PARTICULAR FONT, STYLE, SIZE, OR COLOR.

FOR CEREAL BASED SNACK BARS; CEREAL BASED HIGH PROTEIN SNACK BARS; CEREAL BASED HIGH ENERGY BARS NOT FOR USE AS A MEAL REPLACEMENT; CEREALS AND PREPARATIONS MADE FROM CEREALS, NAMELY, BREAKFAST CEREALS, PROCESSED CEREALS AND CEREAL BASED SNACK FOODS; SALAD DRESSINGS, CONDIMENTS, NAMELY, SALSAS, MARINADES; PREPARED AND PACKAGED READY TO EAT MEALS CONSISTING PRIMARILY OF PASTA OR RICE (U.S. CL. 46).

FIRST USE 3-1-2011; IN COMMERCE 3-1-2011.

---

3,963,399. CRYSTAL RIVER ORGANICS LLC, CARBONDALE, CO. SN 85-019,616. PUB. 2-8-2011, FILED 4-21-2010.

**DOC DAWA'S UNDRRESSING**

THE MARK CONSISTS OF STANDARD CHARACTERS WITHOUT CLAIM TO ANY PARTICULAR FONT, STYLE, SIZE, OR COLOR.

**CLASS 30—(Continued).**

THE NAME(S), PORTRAIT(S), AND/OR SIGNATURE(S) SHOWN IN THE MARK DOES NOT IDENTIFY A PARTICULAR LIVING INDIVIDUAL.

FOR CEREALS AND PREPARATIONS MADE FROM CEREALS, NAMELY, BREAKFAST CEREALS, PROCESSED CEREALS AND CEREAL BASED SNACK FOODS; SALAD DRESSINGS, CONDIMENTS, NAMELY, SALSAS, MARINADES; PREPARED AND PACKAGED READY TO EAT MEALS CONSISTING PRIMARILY OF PASTA OR RICE (U.S. CL. 46).

FIRST USE 3-1-2011; IN COMMERCE 3-1-2011.

**CLASS 30—(Continued).**

3,963,516. YILDIZ HOLDING A.S., USKUDAR, ISTANBUL, TURKEY. SN 85-047,982. PUB. 10-26-2010, FILED 5-26-2010.



THE COLOR(S) GREEN AND WHITE IS/ARE CLAIMED AS A FEATURE OF THE MARK.

THE MARK CONSISTS OF THE TERM "HALLEY" IN GREEN LETTERING ON A WHITE BACKGROUND. THE LETTER "Y" INCLUDES A TAIL HAVING A "STAR" AT THE END.

FOR BISCUITS (U.S. CL. 46).

FIRST USE 0-0-1989; IN COMMERCE 0-0-2003.

3,963,445. PATTY KING INC, DBA MAJESTY FOODS, HIALEAH, FL. SN 85-031,931. PUB. 10-5-2010, FILED 5-6-2010.

## Latin Delights

THE MARK CONSISTS OF STANDARD CHARACTERS WITHOUT CLAIM TO ANY PARTICULAR FONT, STYLE, SIZE, OR COLOR.

NO CLAIM IS MADE TO THE EXCLUSIVE RIGHT TO USE "LATIN", APART FROM THE MARK AS SHOWN.

FOR FROZEN FOODS, NAMELY, GRAIN AND BREAD BASED APPETIZERS, HORS D'OEUVRES, AND CANAPÉS (U.S. CL. 46).

FIRST USE 12-1-2010; IN COMMERCE 12-1-2010.

3,963,528. WM. WRIGLEY JR. COMPANY, CHICAGO, IL. SN 85-052,669. PUB. 8-31-2010, FILED 6-2-2010.

### CURIOSLY STRONG CURIOSLY SMALL

THE MARK CONSISTS OF STANDARD CHARACTERS WITHOUT CLAIM TO ANY PARTICULAR FONT, STYLE, SIZE, OR COLOR.

FOR CANDY MINTS (U.S. CL. 46).

FIRST USE 12-1-2010; IN COMMERCE 12-1-2010.

3,963,460. HERSHEY CHOCOLATE & CONFECTIONERY CORPORATION, WHEAT RIDGE, CO. SN 85-036,118. PUB. 10-5-2010, FILED 5-12-2010.

## BAKE SHARE AND WIN

THE MARK CONSISTS OF STANDARD CHARACTERS WITHOUT CLAIM TO ANY PARTICULAR FONT, STYLE, SIZE, OR COLOR.

FOR CANDY; CHOCOLATE; COCOA; CONFECTIONERY CHIPS FOR BAKING (U.S. CL. 46).

FIRST USE 9-1-2010; IN COMMERCE 9-1-2010.

3,963,541. FRITO-LAY NORTH AMERICA, INC., PLANO, TX. SN 85-058,796. PUB. 11-30-2010, FILED 6-9-2010.



OWNER OF U.S. REG. NOS. 1,775,391, 3,623,424, AND OTHERS.

NO CLAIM IS MADE TO THE EXCLUSIVE RIGHT TO USE "PRETZELS", "BRAND" AND "SINCE 1917", APART FROM THE MARK AS SHOWN.

**CLASS 30—(Continued).**

THE MARK CONSISTS OF THE WORDS "- THE GOLD STANDARD -" , "ROLD GOLD PRETZELS BRAND", AND "SINCE 1917". THE WORDS ARE CENTERED WITHIN THE LOGO FROM TOP TO BOTTOM. THERE ARE TWO STARS, ONE ON EITHER SIDE OF THE WORDS "ROLD GOLD". THERE ARE TWO WHEAT STALKS STARTING FROM THE BOTTOM OF THE LOGO AND BORDERING BOTH SIDES OF THE LOGO. THE OUTSIDE SHAPE OF THE LOGO IS A RECTANGLE WITH ROUNDED SIDES. THE WORDS "SINCE 1917" APPEAR IN A BOX.

FOR PRETZELS (U.S. CL. 46).  
FIRST USE 10-0-2010; IN COMMERCE 10-0-2010.

3,963,581. WEIGHT WATCHERS INTERNATIONAL, INC., NEW YORK, NY. SN 85-068,838. PUB. 11-30-2010, FILED 6-22-2010.



OWNER OF U.S. REG. NOS. 2,139,767 AND 3,346,918.  
THE COLOR(S) LIGHT BLUE AND WHITE IS/ARE CLAIMED AS A FEATURE OF THE MARK.

THE MARK CONSISTS OF THE NUMBER "2" AND THE WORDING "POINTSPLUS" WITH A PLUS SIGN IN A CIRCLE AND THE WORD "VALUE" ALL IN WHITE, AND ALL WITHIN A DIAMOND SHAPE WITH ROUNDED CORNERS WITH A LIGHT BLUE BACKGROUND.

FOR FROZEN MEALS CONSISTING PRIMARILY OF PASTA OR RICE; BAKERY PRODUCTS, NAMELY, BROWNIES, SNACK CAKES, COOKIES, AND MUFFINS; BREAD AND BUNS; BAGELS; ROLLS; CEREAL-BASED SNACK BARS; CHOCOLATE CANDIES; CANDY BARS; FLOUR-BASED CHIPS; PRETZELS; BAKED MULTI-GRAIN CHIPS; POPCORN; OATMEAL; FLAVORED AND SWEETENED GELATINS; PUDDINGS; FROZEN CONFECTIONS; ICE CREAM; FROZEN PIZZA; FROZEN PIZZA SNACKS; FROZEN HAND-HELD SANDWICHES (U.S. CL. 46).

FIRST USE 2-1-2011; IN COMMERCE 2-1-2011.

3,963,609. MOHAMED, MEDHAT, DIX HILLS, NY. SN 85-074,145. PUB. 12-7-2010, FILED 6-29-2010.

**TROPIC JOY SWEET DREAMS**

THE MARK CONSISTS OF STANDARD CHARACTERS WITHOUT CLAIM TO ANY PARTICULAR FONT, STYLE, SIZE, OR COLOR.

**CLASS 30—(Continued).**

OWNER OF U.S. REG. NO. 2,383,960.

FOR ICE CREAM, ICE CREAM NOVELTIES, FROZEN CONFECTIONS AND FROZEN DESSERTS CONSISTING OF FRUIT AND CREAM OR CREAM SUBSTITUTES (U.S. CL. 46).

FIRST USE 7-0-2010; IN COMMERCE 7-0-2010.

3,963,611. CORPORATIVO INTERNACIONAL MEXICANO, S. DE R.L. DE C.V., MEXICO CITY, MEXICO. SN 85-074,883. PUB. 11-16-2010, FILED 6-30-2010.

**DALE UN GIRO A TU DIA**

THE MARK CONSISTS OF STANDARD CHARACTERS WITHOUT CLAIM TO ANY PARTICULAR FONT, STYLE, SIZE, OR COLOR.

THE ENGLISH TRANSLATION OF "DALE UN GIRO A TU DIA" IN THE MARK IS GIVE A SPIN TO YOUR DAY.

FOR COOKIES (U.S. CL. 46).  
FIRST USE 11-30-2010; IN COMMERCE 11-30-2010.

3,963,653. YILDIZ HOLDING A.S., USKUDAR, ISTANBUL, TURKEY. SN 85-086,330. PUB. 10-26-2010, FILED 7-16-2010.



THE COLOR(S) YELLOW AND BLACK IS/ARE CLAIMED AS A FEATURE OF THE MARK.

THE MARK CONSISTS OF "ECE" IN STYLIZED LETTERING IN YELLOW WITH BLACK SHADING.

THE ENGLISH TRANSLATION OF "ECE" IN THE MARK IS "QUEEN".

FOR CHOCOLATE AND CHOCOLATES (U.S. CL. 46).  
FIRST USE 0-0-1991; IN COMMERCE 0-0-2003.

**CLASS 30—(Continued).**

3,963,683. SURKLE VENTURES, LLC, BROOKLYN, NY. SN 85-101,192. PUB. 1-25-2011, FILED 8-5-2010.

**TICKLE SAUCE**

THE MARK CONSISTS OF STANDARD CHARACTERS WITHOUT CLAIM TO ANY PARTICULAR FONT, STYLE, SIZE, OR COLOR.

NO CLAIM IS MADE TO THE EXCLUSIVE RIGHT TO USE "SAUCE", APART FROM THE MARK AS SHOWN.

FOR HOT SAUCE (U.S. CL. 46).  
FIRST USE 3-1-2011; IN COMMERCE 3-1-2011.

---

3,963,684. SURKLE VENTURES, LLC, BROOKLYN, NY. SN 85-101,201. PUB. 1-25-2011, FILED 8-5-2010.

**HABANERO TICKLE SAUCE**

THE MARK CONSISTS OF STANDARD CHARACTERS WITHOUT CLAIM TO ANY PARTICULAR FONT, STYLE, SIZE, OR COLOR.

NO CLAIM IS MADE TO THE EXCLUSIVE RIGHT TO USE "HABANERO" AND "SAUCE", APART FROM THE MARK AS SHOWN.

FOR HOT SAUCE (U.S. CL. 46).  
FIRST USE 3-1-2011; IN COMMERCE 3-1-2011.

---

3,963,725. GIVE BARS, LLC, SAN FRANCISCO, CA. SN 85-975,168. PUB. 9-7-2010, FILED 5-21-2010.

**TWO DEGREES**

THE MARK CONSISTS OF STANDARD CHARACTERS WITHOUT CLAIM TO ANY PARTICULAR FONT, STYLE, SIZE, OR COLOR.

FOR GRAIN-BASED SNACK FOODS, GRAIN-BASED FOOD BARS (U.S. CL. 46).  
FIRST USE 11-18-2010; IN COMMERCE 11-18-2010.

---

**CLASS 31—NATURAL AGRICULTURAL PRODUCTS**

**CLASS 31—(Continued).**

3,962,036. OCTAVE VINEYARD, LLC, WALLA WALLA, WA. SN 77-154,792. PUB. 10-9-2007, FILED 4-12-2007.

**OCTAVE**

THE MARK CONSISTS OF STANDARD CHARACTERS WITHOUT CLAIM TO ANY PARTICULAR FONT, STYLE, SIZE, OR COLOR.

FOR FRUITS, NAMELY, RAW UNPROCESSED GRAPES (U.S. CLS. 1 AND 46).  
FIRST USE 12-23-2010; IN COMMERCE 12-23-2010.

---

3,962,202. NORTH AMERICAN GREEN, INC., POSEYVILLE, IN. SN 77-555,813. PUB. 1-27-2009, FILED 8-26-2008.

**HYDRACM**

THE MARK CONSISTS OF STANDARD CHARACTERS WITHOUT CLAIM TO ANY PARTICULAR FONT, STYLE, SIZE, OR COLOR.

FOR SPRAY-ON MULCH FOR EROSION CONTROL (U.S. CLS. 1 AND 46).  
FIRST USE 7-0-2008; IN COMMERCE 7-0-2008.

---

3,962,240. CAMPOSOL S.A., LIMA, PERU. SN 77-630,620. PUB. 9-21-2010, FILED 12-10-2008.

**Green Delight**

THE MARK CONSISTS OF STANDARD CHARACTERS WITHOUT CLAIM TO ANY PARTICULAR FONT, STYLE, SIZE, OR COLOR.

NO CLAIM IS MADE TO THE EXCLUSIVE RIGHT TO USE "GREEN", APART FROM THE MARK AS SHOWN.

FOR FRESH WHITE AND GREEN ASPARAGUS AND FRESH PEPPERS IN THE NATURE OF RED PEPPER PIQUILLO (U.S. CLS. 1 AND 46).  
FIRST USE 3-9-2010; IN COMMERCE 3-9-2010.

**CLASS 31—(Continued).**

3,962,280. DISNEY ENTERPRISES, INC., BURBANK, CA. SN 77-666,694. PUB. 1-5-2010, FILED 2-9-2009.



THE MARK CONSISTS OF THE OUTLINE OF THREE INCOMPLETE INTERLOCKING CIRCLES WITH A CHECK MARK PLACED OVER THE CIRCLES.

FOR RAW FRUITS; FRESH FRUITS; UNPROCESSED FRUITS; RAW VEGETABLES; FRESH VEGETABLES; UNPROCESSED VEGETABLES (U.S. CLS. 1 AND 46).

FIRST USE 6-30-2009; IN COMMERCE 6-30-2009.

3,962,286. ELVA PRODUCE, LLC, NOGALES, AZ. SN 77-671,329. PUB. 1-12-2010, FILED 2-16-2009.

**FAMILY PRIDE**

THE MARK CONSISTS OF STANDARD CHARACTERS WITHOUT CLAIM TO ANY PARTICULAR FONT, STYLE, SIZE, OR COLOR.

FOR FRESH FRUITS AND VEGETABLES (U.S. CLS. 1 AND 46).

FIRST USE 5-0-2009; IN COMMERCE 5-0-2009.

3,962,468. C.I. UNION DE BANANEROS DE URABA, S.A. - UNIBAN, DBA C.I. UNIBAN S.A., MEDELLIN, COLOMBIA. SN 77-790,307. PUB. 6-22-2010, FILED 7-27-2009.



OWNER OF U.S. REG. NOS. 1,799,567, 3,131,777, AND OTHERS.

THE COLOR(S) BLACK, YELLOW AND WHITE IS/ARE CLAIMED AS A FEATURE OF THE MARK.

**CLASS 31—(Continued).**

THE MARK CONSISTS OF THE STYLIZED WORD "TURBANA" IN BLACK LETTERS AND THREE STYLIZED DEPICTIONS OF YELLOW BANANAS.

THE WORDING "TURBANA" HAS NO MEANING IN A FOREIGN LANGUAGE.

FOR FRESH BANANAS AND FRESH PLANTAINS (U.S. CLS. 1 AND 46).

FIRST USE 10-0-2009; IN COMMERCE 10-0-2009.

3,962,543. BROWNIE, THE PLAIN BROWN DOG LLC, EAST BRUNSWICK, NJ. SN 77-811,645. PUB. 5-11-2010, FILED 8-24-2009.



NO CLAIM IS MADE TO THE EXCLUSIVE RIGHT TO USE "DOG", APART FROM THE MARK AS SHOWN.

THE MARK CONSISTS OF A DRAWING OF A DOG'S FACE AND THE WORDS "BROWNIE THE PLAIN BROWN DOG" WITH A JAGGED HAND DRAWN SQUARE SURROUNDING THE IMAGE AND THE WORDING.

FOR DOG TREATS (U.S. CLS. 1 AND 46).

FIRST USE 1-28-2011; IN COMMERCE 1-28-2011.

3,962,663. JUPITER BONSAI, INC., JUPITER, FL. SN 77-853,625. PUB. 7-6-2010, FILED 10-21-2009.

**BonBoo**

THE MARK CONSISTS OF STANDARD CHARACTERS WITHOUT CLAIM TO ANY PARTICULAR FONT, STYLE, SIZE, OR COLOR.

FOR LIVE PLANTS (U.S. CLS. 1 AND 46).

FIRST USE 5-31-2010; IN COMMERCE 12-31-2010.



**CLASS 31—(Continued).**

3,962,803. PROVEN WINNERS NORTH AMERICA LLC, CAMPBELL, CA. SN 77-902,144. PUB. 5-25-2010, FILED 12-29-2009.

# DAISY MAY

THE MARK CONSISTS OF STANDARD CHARACTERS WITHOUT CLAIM TO ANY PARTICULAR FONT, STYLE, SIZE, OR COLOR.  
FOR LIVING PLANTS (U.S. CLS. 1 AND 46).  
FIRST USE 2-28-2011; IN COMMERCE 2-28-2011.

---

3,962,881. NEXT VEGETALES S.A. DE C.V., DEL MIGUEL HIDALGO, MEXICO. SN 77-922,238. PUB. 12-28-2010, FILED 1-28-2010.

# EVA

THE MARK CONSISTS OF STANDARD CHARACTERS WITHOUT CLAIM TO ANY PARTICULAR FONT, STYLE, SIZE, OR COLOR.  
OWNER OF MEXICO REG. NO. 873765, DATED 3-29-2005, EXPIRES 3-29-2015.  
FOR UNPROCESSED LETTUCE (U.S. CLS. 1 AND 46).  
FIRST USE 5-30-2007; IN COMMERCE 5-30-2007.

---

3,962,894. MIDWESTERN PET FOODS, INC., EVANSVILLE, IN. SN 77-926,592. PUB. 7-13-2010, FILED 2-3-2010.

# CHICKEN CATCCIATORI

THE MARK CONSISTS OF STANDARD CHARACTERS WITHOUT CLAIM TO ANY PARTICULAR FONT, STYLE, SIZE, OR COLOR.  
FOR CAT FOOD (U.S. CLS. 1 AND 46).  
FIRST USE 2-15-2011; IN COMMERCE 2-15-2011.

**CLASS 31—(Continued).**

3,962,896. CAROL SUE BLUEBERRY FARM, INC., HAMPSTEAD, NC. SN 77-926,910. PUB. 6-22-2010, FILED 2-3-2010.

# They taste like summertime!

THE MARK CONSISTS OF STANDARD CHARACTERS WITHOUT CLAIM TO ANY PARTICULAR FONT, STYLE, SIZE, OR COLOR.  
FOR FRESH BLUEBERRIES (U.S. CLS. 1 AND 46).  
FIRST USE 6-15-2010; IN COMMERCE 6-15-2010.

---

3,962,967. KAMLAR CORPORATION, ROCKY MOUNT, NC. SN 77-941,702. PUB. 7-20-2010, FILED 2-22-2010.

# SERPENTURF

THE MARK CONSISTS OF STANDARD CHARACTERS WITHOUT CLAIM TO ANY PARTICULAR FONT, STYLE, SIZE, OR COLOR.  
FOR WOOD CHIPS AND WOOD SHAVINGS USED FOR ANIMAL BEDDING AND ANIMAL LITTER (U.S. CLS. 1 AND 46).  
FIRST USE 12-8-2010; IN COMMERCE 12-8-2010.

---

3,963,098. KALMBACH FEEDS, INC., UPPER SANDUSKY, OH. SN 77-955,585. PUB. 6-29-2010, FILED 3-10-2010.

# OPTI-FERM ME

THE MARK CONSISTS OF STANDARD CHARACTERS WITHOUT CLAIM TO ANY PARTICULAR FONT, STYLE, SIZE, OR COLOR.  
OWNER OF U.S. REG. NO. 3,309,589.  
FOR NON-MEDICATED ADDITIVES FOR ANIMAL FEED (U.S. CLS. 1 AND 46).  
FIRST USE 2-2-2010; IN COMMERCE 3-3-2010.

**CLASS 31—(Continued).**

3,963,143. WAGGIN' TRAIN, LLC, ANDERSON, SC. SN 77-960,458. PUB. 8-3-2010, FILED 3-16-2010.

**PIGGY CURLS**

THE MARK CONSISTS OF STANDARD CHARACTERS WITHOUT CLAIM TO ANY PARTICULAR FONT, STYLE, SIZE, OR COLOR.

OWNER OF U.S. REG. NO. 3,759,169.  
NO CLAIM IS MADE TO THE EXCLUSIVE RIGHT TO USE "CURLS", APART FROM THE MARK AS SHOWN.  
FOR EDIBLE PET TREAT (U.S. CLS. 1 AND 46).  
FIRST USE 4-20-2010; IN COMMERCE 4-20-2010.

**CLASS 31—(Continued).**

3,963,540. CHURCH & DWIGHT CO., INC., PRINCETON, NJ. SN 85-058,466. PUB. 11-30-2010, FILED 6-9-2010.

**NATURAL ESSENTIALS**

THE MARK CONSISTS OF STANDARD CHARACTERS WITHOUT CLAIM TO ANY PARTICULAR FONT, STYLE, SIZE, OR COLOR.

OWNER OF U.S. REG. NOS. 3,562,415, 3,612,378, AND OTHERS.  
NO CLAIM IS MADE TO THE EXCLUSIVE RIGHT TO USE "NATURAL", APART FROM THE MARK AS SHOWN.  
FOR CAT LITTER (U.S. CLS. 1 AND 46).  
FIRST USE 12-10-2010; IN COMMERCE 12-10-2010.

3,963,329. GREENBRIER INTERNATIONAL, INC., CHESAPEAKE, VA. SN 85-005,294. PUB. 8-24-2010, FILED 4-2-2010.

**Greenbrier Kennel Club**

THE MARK CONSISTS OF STANDARD CHARACTERS WITHOUT CLAIM TO ANY PARTICULAR FONT, STYLE, SIZE, OR COLOR.

FOR CONSUMABLE PET CHEWS; PET FOOD (U.S. CLS. 1 AND 46).  
FIRST USE 8-1-2010; IN COMMERCE 8-1-2010.

3,963,586. TUCKER MILLING, LLC, GUNTERSVILLE, AL. SN 85-070,016. PUB. 11-23-2010, FILED 6-23-2010.

**SOLUTION HORSE FEED**

THE MARK CONSISTS OF STANDARD CHARACTERS WITHOUT CLAIM TO ANY PARTICULAR FONT, STYLE, SIZE, OR COLOR.

NO CLAIM IS MADE TO THE EXCLUSIVE RIGHT TO USE "HORSE FEED", APART FROM THE MARK AS SHOWN.  
FOR HORSE FEED (U.S. CLS. 1 AND 46).  
FIRST USE 8-28-2008; IN COMMERCE 8-28-2008.

3,963,527. ICC USA, INC., LOUISVILLE, KY. SN 85-051,833. PUB. 10-26-2010, FILED 6-1-2010.

**IMW50**

THE MARK CONSISTS OF STANDARD CHARACTERS WITHOUT CLAIM TO ANY PARTICULAR FONT, STYLE, SIZE, OR COLOR.

FOR ANIMAL FEED INGREDIENTS, NAMELY, YEAST-BASED ADDITIVES (U.S. CLS. 1 AND 46).  
FIRST USE 11-0-2010; IN COMMERCE 1-0-2011.

3,963,587. TUCKER MILLING, LLC, GUNTERSVILLE, AL. SN 85-070,019. PUB. 11-23-2010, FILED 6-23-2010.

**DEER MASTER**

THE MARK CONSISTS OF STANDARD CHARACTERS WITHOUT CLAIM TO ANY PARTICULAR FONT, STYLE, SIZE, OR COLOR.

NO CLAIM IS MADE TO THE EXCLUSIVE RIGHT TO USE "DEER", APART FROM THE MARK AS SHOWN.  
FOR DEER FEED (U.S. CLS. 1 AND 46).  
FIRST USE 3-25-2007; IN COMMERCE 3-25-2007.

**CLASS 31—(Continued).**

3,963,598. CANIDAE CORPORATION, SAN LUIS OBISPO, CA. SN 85-072,910. PUB. 11-16-2010, FILED 6-28-2010.

# PURE SKY

THE MARK CONSISTS OF STANDARD CHARACTERS WITHOUT CLAIM TO ANY PARTICULAR FONT, STYLE, SIZE, OR COLOR.  
FOR PET FOOD (U.S. CLS. 1 AND 46).  
FIRST USE 1-10-2011; IN COMMERCE 1-10-2011.

**CLASS 31—(Continued).**

3,963,601. CANIDAE CORPORATION, SAN LUIS OBISPO, CA. SN 85-072,945. PUB. 11-16-2010, FILED 6-28-2010.

# PURE SEA

THE MARK CONSISTS OF STANDARD CHARACTERS WITHOUT CLAIM TO ANY PARTICULAR FONT, STYLE, SIZE, OR COLOR.  
FOR PET FOOD (U.S. CLS. 1 AND 46).  
FIRST USE 1-12-2011; IN COMMERCE 1-12-2011.

3,963,599. CANIDAE CORPORATION, SAN LUIS OBISPO, CA. SN 85-072,921. PUB. 11-16-2010, FILED 6-28-2010.

# PURE LAND

THE MARK CONSISTS OF STANDARD CHARACTERS WITHOUT CLAIM TO ANY PARTICULAR FONT, STYLE, SIZE, OR COLOR.  
FOR PET FOOD (U.S. CLS. 1 AND 46).  
FIRST USE 1-10-2011; IN COMMERCE 1-10-2011.

**CLASS 32—LIGHT BEVERAGES**

3,961,983. BOONE BREWING COMPANY, LLC, BLOWING ROCK, NC. SN 76-699,159. PUB. 1-19-2010, FILED 8-25-2009.

# BOONDOGGLE

THE MARK CONSISTS OF STANDARD CHARACTERS WITHOUT CLAIM TO ANY PARTICULAR FONT, STYLE, SIZE, OR COLOR.  
FOR BEER (U.S. CLS. 45, 46 AND 48).  
FIRST USE 7-13-2010; IN COMMERCE 7-13-2010.

3,963,600. CANIDAE CORPORATION, SAN LUIS OBISPO, CA. SN 85-072,930. PUB. 11-16-2010, FILED 6-28-2010.

# PURE ELEMENTS

THE MARK CONSISTS OF STANDARD CHARACTERS WITHOUT CLAIM TO ANY PARTICULAR FONT, STYLE, SIZE, OR COLOR.  
FOR PET FOOD (U.S. CLS. 1 AND 46).  
FIRST USE 1-5-2011; IN COMMERCE 1-5-2011.

3,962,171. LATIBAER EHF, GARDABAER 210, ICELAND. SN 77-520,098. PUB. 12-2-2008, FILED 7-11-2008.

# LAZY TOWN

THE MARK CONSISTS OF STANDARD CHARACTERS WITHOUT CLAIM TO ANY PARTICULAR FONT, STYLE, SIZE, OR COLOR.  
FOR NON-ALCOHOLIC BEVERAGES, NAMELY, BOTTLED WATER (U.S. CLS. 45, 46 AND 48).  
FIRST USE 4-1-2010; IN COMMERCE 4-1-2010.

**CLASS 32—(Continued).**

3,962,292. DELMAR BREWING COMPANY, LLC, DELMAR, DE. SN 77-674,838. PUB. 8-3-2010, FILED 2-20-2009.



NO CLAIM IS MADE TO THE EXCLUSIVE RIGHT TO USE "CRAFT BREWING CO.", APART FROM THE MARK AS SHOWN.

THE MARK CONSISTS OF THE WORDS "EVOLUTION CRAFT BREWING CO." SITUATED ABOVE THE LETTERS "EVO", WHICH ARE ENCLOSED WITHIN A CIRCLE.

FOR BEER (U.S. CLS. 45, 46 AND 48).  
FIRST USE 4-23-2009; IN COMMERCE 4-23-2009.

**CLASS 32—(Continued).**

3,962,341. DELMAR BREWING COMPANY, LLC, DELMAR, DE. SN 77-704,257. PUB. 8-3-2010, FILED 4-1-2009.



NO CLAIM IS MADE TO THE EXCLUSIVE RIGHT TO USE "CRAFT BREWING CO." AND "PALE ALE", APART FROM THE MARK AS SHOWN.

THE MARK CONSISTS OF THE WORDS "EVOLUTION CRAFT BREWING CO." SITUATED ABOVE THE LETTERS "EVO", WHICH ARE ENCLOSED WITHIN A CIRCLE. A HOWLING WOLF IS SUPERIMPOSED OVER THE WORD "EVO", AND THE WORDS "PRIMAL PALE ALE" ARE SITUATED BENEATH THE WOLF.

FOR BEER (U.S. CLS. 45, 46 AND 48).  
FIRST USE 4-23-2009; IN COMMERCE 4-23-2009.

3,962,340. DELMAR BREWING COMPANY, LLC, DELMAR, DE. SN 77-704,075. PUB. 8-3-2010, FILED 4-1-2009.



NO CLAIM IS MADE TO THE EXCLUSIVE RIGHT TO USE "CRAFT BREWING CO." AND "A PORTER BREWED WITH 7 MALTS", APART FROM THE MARK AS SHOWN.

THE MARK CONSISTS OF THE WORDS "EVOLUTION CRAFT BREWING CO." SITUATED ABOVE THE LETTERS "EVO", WHICH ARE ENCLOSED WITHIN A CIRCLE. THE WORDS "LUCKY 7" ARE SITUATED BELOW THE CIRCLE, AND THE WORDS "A PORTER BREWED WITH 7 LUCKY MALTS" ARE SITUATED BENEATH THE WORDS "LUCKY 7". STALKS OF GRAINS ARE SITUATED IN THE RIGHT BOTTOM CORNER OF THE MARK.

FOR BEER (U.S. CLS. 45, 46 AND 48).  
FIRST USE 4-23-2009; IN COMMERCE 4-23-2009.

3,962,431. SARPES BEVERAGES, LLC, GOLDEN BEACH, FL. SN 77-774,695. PUB. 11-16-2010, FILED 7-6-2009.

**Drink to Dream**

THE MARK CONSISTS OF STANDARD CHARACTERS WITHOUT CLAIM TO ANY PARTICULAR FONT, STYLE, SIZE, OR COLOR.

NO CLAIM IS MADE TO THE EXCLUSIVE RIGHT TO USE "DRINK", APART FROM THE MARK AS SHOWN.

FOR NON-CARBONATED, WATER-BASED BEVERAGES CONTAINING DIETARY SUPPLEMENTS FOR SLEEP AND RELAXATION ENHANCEMENT PURPOSES (U.S. CLS. 45, 46 AND 48).

FIRST USE 8-1-2009; IN COMMERCE 8-1-2009.

**CLASS 32—(Continued).**

3,962,432. SARPES BEVERAGES, LLC, GOLDEN BEACH, FL. SN 77-774,711. PUB. 11-16-2010, FILED 7-6-2009.

Dream Responsibly

THE MARK CONSISTS OF STANDARD CHARACTERS WITHOUT CLAIM TO ANY PARTICULAR FONT, STYLE, SIZE, OR COLOR.

FOR NON-CARBONATED, WATER-BASED BEVERAGES CONTAINING DIETARY SUPPLEMENTS FOR SLEEP AND RELAXATION ENHANCEMENT PURPOSES (U.S. CLS. 45, 46 AND 48).

FIRST USE 9-1-2009; IN COMMERCE 9-1-2009.

3,962,503. SDM LTD., MINERAL WELLS, TX. SN 77-801,852. PUB. 9-21-2010, FILED 8-11-2009.

STERLING

THE MARK CONSISTS OF STANDARD CHARACTERS WITHOUT CLAIM TO ANY PARTICULAR FONT, STYLE, SIZE, OR COLOR.

FOR BOTTLED MINERAL WATER (U.S. CLS. 45, 46 AND 48).

FIRST USE 3-21-2011; IN COMMERCE 3-21-2011.

3,962,602. BOULEVARD BREWING ASSOCIATES LIMITED PARTNERSHIP, DBA BOULEVARD BREWING COMPANY, KANSAS CITY, MO. SN 77-831,206. PUB. 2-16-2010, FILED 9-21-2009.

HARVEST DANCE WHEAT WINE

THE MARK CONSISTS OF STANDARD CHARACTERS WITHOUT CLAIM TO ANY PARTICULAR FONT, STYLE, SIZE, OR COLOR.

NO CLAIM IS MADE TO THE EXCLUSIVE RIGHT TO USE "WHEAT WINE", APART FROM THE MARK AS SHOWN.

FOR BEER, ALE AND MALT LIQUOR (U.S. CLS. 45, 46 AND 48).

FIRST USE 11-1-2009; IN COMMERCE 11-1-2009.

**CLASS 32—(Continued).**

3,962,615. SAVE-A-LOT FOOD STORES, LTD., EARTH CITY, MO. SN 77-834,946. PUB. 12-29-2009, FILED 9-25-2009.

DETER'S

THE MARK CONSISTS OF STANDARD CHARACTERS WITHOUT CLAIM TO ANY PARTICULAR FONT, STYLE, SIZE, OR COLOR.

FOR SOFT DRINKS (U.S. CLS. 45, 46 AND 48).

FIRST USE 1-1-2011; IN COMMERCE 1-15-2011.

3,962,961. DR. BREINL LIFESCIENCE GMBH, FRANKFURT AM MAIN, FED REP GERMANY. SN 77-940,143. PUB. 7-27-2010, FILED 2-19-2010.

2B  
[to be]

THE MARK CONSISTS OF THE LETTERS "2B" ON THE TOP LINE AND THE WORDS "[TO BE]" CENTERED ON THE LINE BELOW.

FOR NON-ALCOHOLIC BEVERAGES, NAMELY, FRUIT-BASED BEVERAGES AND FRUIT-BASED BEVERAGES CONTAINING CAFFEINE (U.S. CLS. 45, 46 AND 48).

FIRST USE 8-26-2010; IN COMMERCE 8-26-2010.

3,963,130. FOUR PEAKS BREWING COMPANY, INC., TEMPE, AZ. SN 77-959,510. PUB. 8-3-2010, FILED 3-15-2010.

DOUBLE KNOT DOUBLE IPA

THE MARK CONSISTS OF STANDARD CHARACTERS WITHOUT CLAIM TO ANY PARTICULAR FONT, STYLE, SIZE, OR COLOR.

NO CLAIM IS MADE TO THE EXCLUSIVE RIGHT TO USE "IPA", APART FROM THE MARK AS SHOWN.

FOR BEER AND ALE (U.S. CLS. 45, 46 AND 48).

FIRST USE 1-13-2010; IN COMMERCE 1-13-2010.



**CLASS 32—(Continued).**

3,963,234. THE BOARD OF REGENTS OF THE UNIVERSITY OF TEXAS SYSTEM, AUSTIN, TX. SN 77-981,021. PUB. 4-13-2010, FILED 11-10-2009.

DRINK WATER. BLEED ORANGE.

THE MARK CONSISTS OF STANDARD CHARACTERS WITHOUT CLAIM TO ANY PARTICULAR FONT, STYLE, SIZE, OR COLOR.

NO CLAIM IS MADE TO THE EXCLUSIVE RIGHT TO USE "WATER", APART FROM THE MARK AS SHOWN.

FOR UNFLAVORED BOTTLED WATER (U.S. CLS. 45, 46 AND 48).

FIRST USE 8-25-2010; IN COMMERCE 8-25-2010.

3,963,375. WHITEWAVE SERVICES, INC., DALLAS, TX. SN 85-012,044. PUB. 9-7-2010, FILED 4-12-2010.

CHOOSE WISELY, DRINK  
HAPPILY

THE MARK CONSISTS OF STANDARD CHARACTERS WITHOUT CLAIM TO ANY PARTICULAR FONT, STYLE, SIZE, OR COLOR.

FOR COCONUT MILK (U.S. CLS. 45, 46 AND 48).

FIRST USE 8-0-2010; IN COMMERCE 12-0-2010.

3,963,481. EMERALD CITY BEER COMPANY, LLC, SEATTLE, WA. SN 85-039,368. PUB. 10-12-2010, FILED 5-14-2010.

Demand More From Your Beer

THE MARK CONSISTS OF STANDARD CHARACTERS WITHOUT CLAIM TO ANY PARTICULAR FONT, STYLE, SIZE, OR COLOR.

FOR BEER (U.S. CLS. 45, 46 AND 48).

FIRST USE 9-25-2010; IN COMMERCE 9-25-2010.

**CLASS 32—(Continued).**

3,963,501. SALTMARSH, III, THOMAS W., LONGWOOD, FL. SN 85-044,949. PUB. 10-19-2010, FILED 5-21-2010.

PERFECT ORANGE

THE MARK CONSISTS OF STANDARD CHARACTERS WITHOUT CLAIM TO ANY PARTICULAR FONT, STYLE, SIZE, OR COLOR.

NO CLAIM IS MADE TO THE EXCLUSIVE RIGHT TO USE "ORANGE", APART FROM THE MARK AS SHOWN.

FOR JUICES, NAMELY, ORANGE JUICE AND FRUIT JUICE BEVERAGES (U.S. CLS. 45, 46 AND 48).

FIRST USE 12-21-2010; IN COMMERCE 12-21-2010.

3,963,538. MAMMA CHIA, LLC, BONSALL, CA. SN 85-056,294. PUB. 11-16-2010, FILED 6-7-2010.



OWNER OF U.S. REG. NO. 3,845,269.

THE COLOR(S) PURPLE IS/ARE CLAIMED AS A FEATURE OF THE MARK.

THE MARK CONSISTS OF A PURPLE KNEELING GODDESS HOLDING A PURPLE SPRING OF CHIA SEEDS.

FOR FRUIT-FLAVORED BEVERAGES (U.S. CLS. 45, 46 AND 48).

FIRST USE 1-20-2010; IN COMMERCE 9-19-2010.

3,963,539. MAMMA CHIA, LLC, BONSALL, CA. SN 85-056,353. PUB. 11-9-2010, FILED 6-7-2010.

MAMMA CHIA

THE MARK CONSISTS OF STANDARD CHARACTERS WITHOUT CLAIM TO ANY PARTICULAR FONT, STYLE, SIZE, OR COLOR.

OWNER OF U.S. REG. NOS. 3,845,268 AND 3,845,269.

**CLASS 32—(Continued).**

NO CLAIM IS MADE TO THE EXCLUSIVE RIGHT TO USE "CHIA", APART FROM THE MARK AS SHOWN.  
 FOR FRUIT-FLAVORED BEVERAGES (U.S. CLS. 45, 46 AND 48).  
 FIRST USE 1-20-2010; IN COMMERCE 9-19-2010.

**CLASS 32—(Continued).**

3,963,604. BAXTER BREWING CO., LLC, AUBURN, ME. SN 85-073,553. PUB. 12-7-2010, FILED 6-29-2010.

3,963,559. MANUEL G. GOMEZ, SHIRLEY, NY. SN 85-063,996. PUB. 10-26-2010, FILED 6-16-2010.

## Heaven Quencher

THE MARK CONSISTS OF STANDARD CHARACTERS WITHOUT CLAIM TO ANY PARTICULAR FONT, STYLE, SIZE, OR COLOR.

NO CLAIM IS MADE TO THE EXCLUSIVE RIGHT TO USE "QUENCHER", APART FROM THE MARK AS SHOWN.

FOR BOTTLED DRINKING WATER; DRINKING WATER; DRINKING WATER WITH VITAMINS; DRINKING WATERS; ENERGY DRINKS; FRUIT DRINKS AND FRUIT JUICES; FRUIT DRINKS AND JUICES; FRUIT FLAVOURED DRINKS; FRUIT JUICES AND FRUIT DRINKS; SOFT DRINKS; SOFT DRINKS FLAVORED WITH TEA; SPORTS DRINKS; SPORTS DRINKS, NAMELY, ENERGY DRINKS; VEGETABLE DRINKS (U.S. CLS. 45, 46 AND 48).

FIRST USE 3-15-2010; IN COMMERCE 3-16-2010.

## STOWAWAY

THE MARK CONSISTS OF STANDARD CHARACTERS WITHOUT CLAIM TO ANY PARTICULAR FONT, STYLE, SIZE, OR COLOR.

FOR BEER (U.S. CLS. 45, 46 AND 48).  
 FIRST USE 2-1-2011; IN COMMERCE 2-1-2011.

3,963,605. BAXTER BREWING CO., LLC, AUBURN, ME. SN 85-073,559. PUB. 11-23-2010, FILED 6-29-2010.

3,963,603. BAXTER BREWING CO., LLC, AUBURN, ME. SN 85-073,547. PUB. 12-7-2010, FILED 6-29-2010.



**BAXTER**  
 Brewing Co.

## PAMOLA

THE MARK CONSISTS OF STANDARD CHARACTERS WITHOUT CLAIM TO ANY PARTICULAR FONT, STYLE, SIZE, OR COLOR.

FOR BEER (U.S. CLS. 45, 46 AND 48).  
 FIRST USE 1-21-2011; IN COMMERCE 1-21-2011.

NO CLAIM IS MADE TO THE EXCLUSIVE RIGHT TO USE "BREWING CO.", APART FROM THE MARK AS SHOWN.

THE TERM "BAXTER" DOES NOT IDENTIFY A LIVING INDIVIDUAL.

THE MARK CONSISTS OF THE HEAD OF A MOOSE WITH ANTLERS AND WINGS INSIDE A CIRCLE, WITH THE WORDS "BAXTER BREWING CO." UNDERNEATH.

FOR BEER (U.S. CLS. 45, 46 AND 48).  
 FIRST USE 1-21-2011; IN COMMERCE 1-21-2011.

**CLASS 32—(Continued).**

3,963,606. BAXTER BREWING CO., LLC, AUBURN, ME. SN 85-073,567. PUB. 1-11-2011, FILED 6-29-2010.



NO CLAIM IS MADE TO THE EXCLUSIVE RIGHT TO USE "EXTRA PALE ALE", APART FROM THE MARK AS SHOWN.

THE COLOR GRAY REPRESENTS SHADING AND IS NOT A PART OF THE MARK.

THE MARK CONSISTS OF AN IMAGE OF A HILL WITH A SETTING SUN TO THE FAR RIGHT AND THE WORDS "PAMOLA XTRA PALE ALE".

FOR BEER (U.S. CLS. 45, 46 AND 48).

FIRST USE 1-21-2011; IN COMMERCE 1-21-2011.

3,963,607. BAXTER BREWING CO., LLC, AUBURN, ME. SN 85-073,569. PUB. 12-7-2010, FILED 6-29-2010.



NO CLAIM IS MADE TO THE EXCLUSIVE RIGHT TO USE "I.P.A.", APART FROM THE MARK AS SHOWN.

THE MARK CONSISTS OF A STYLIZED IMAGE OF A SKULL AND CROSSBONES, WITH THE WORDS "STOWAWAY I.P.A.".

FOR BEER (U.S. CLS. 45, 46 AND 48).

FIRST USE 2-1-2011; IN COMMERCE 2-1-2011.

**CLASS 32—(Continued).**

3,963,687. ELLEN CURTIS, TEMPLETON, CA. SN 85-102,355. PUB. 1-18-2011, FILED 8-6-2010.

## Lavmonade

THE MARK CONSISTS OF STANDARD CHARACTERS WITHOUT CLAIM TO ANY PARTICULAR FONT, STYLE, SIZE, OR COLOR.

FOR LEMONADE; LEMONADES (U.S. CLS. 45, 46 AND 48).

FIRST USE 1-27-2010; IN COMMERCE 7-10-2010.

**CLASS 33—WINES AND SPIRITS**

3,961,995. NUESTRO VINO, LLC, HOPLAND, CA. SN 76-702,211. PUB. 8-10-2010, FILED 3-23-2010.

## NUESTRO VINO

THE MARK CONSISTS OF STANDARD CHARACTERS WITHOUT CLAIM TO ANY PARTICULAR FONT, STYLE, SIZE, OR COLOR.

NO CLAIM IS MADE TO THE EXCLUSIVE RIGHT TO USE "VINO", APART FROM THE MARK AS SHOWN.

THE ENGLISH TRANSLATION OF "NUESTRO VINO" IS "OUR WINE".

FOR WINE (U.S. CLS. 47 AND 49).

FIRST USE 3-31-2011; IN COMMERCE 3-31-2011.

3,962,001. BISON CAPITAL, VENICE, FL. SN 77-003,201. PUB. 12-4-2007, FILED 9-20-2006.

## TIGER'S MILK

THE MARK CONSISTS OF STANDARD CHARACTERS WITHOUT CLAIM TO ANY PARTICULAR FONT, STYLE, SIZE, OR COLOR.

NO CLAIM IS MADE TO THE EXCLUSIVE RIGHT TO USE "MILK", APART FROM THE MARK AS SHOWN.

FOR LIQUEUR (U.S. CLS. 47 AND 49).

FIRST USE 12-6-2010; IN COMMERCE 12-6-2010.

**CLASS 33—(Continued).**

3,962,177. CASEY FLAT ESTATES LLC, TIBURON, CA. SN 77-529,523. PUB. 12-9-2008, FILED 7-23-2008.

# CFR

THE MARK CONSISTS OF STANDARD CHARACTERS WITHOUT CLAIM TO ANY PARTICULAR FONT, STYLE, SIZE, OR COLOR.

FOR WINE (U.S. CLS. 47 AND 49).  
FIRST USE 12-8-2010; IN COMMERCE 12-8-2010.

---

3,962,287. FINKELSTEIN VINEYARDS, NAPA, CA. SN 77-671,458. PUB. 7-7-2009, FILED 2-16-2009.

# JUDD'S ENORMOUS WINE

THE MARK CONSISTS OF STANDARD CHARACTERS WITHOUT CLAIM TO ANY PARTICULAR FONT, STYLE, SIZE, OR COLOR.

OWNER OF U.S. REG. NOS. 2,109,230 AND 2,528,299.  
NO CLAIM IS MADE TO THE EXCLUSIVE RIGHT TO USE "WINE", APART FROM THE MARK AS SHOWN.  
FOR WINE (U.S. CLS. 47 AND 49).  
FIRST USE 3-28-2011; IN COMMERCE 3-28-2011.

---

3,962,384. ATHENS DISTRIBUTING, CHATTANOOGA, TN. SN 77-743,454. PUB. 9-29-2009, FILED 5-22-2009.

# 865 Spirits

THE MARK CONSISTS OF STANDARD CHARACTERS WITHOUT CLAIM TO ANY PARTICULAR FONT, STYLE, SIZE, OR COLOR.

NO CLAIM IS MADE TO THE EXCLUSIVE RIGHT TO USE "SPIRITS", APART FROM THE MARK AS SHOWN.  
FOR SPIRITS AND LIQUEURS (U.S. CLS. 47 AND 49).  
FIRST USE 5-22-2009; IN COMMERCE 8-24-2009.

**CLASS 33—(Continued).**

3,962,417. LA VERDOSA, S.L., MADRID, SPAIN. SN 77-768,423. PUB. 3-2-2010, FILED 6-25-2009.



# ARRAYÁN

THE NAME(S), PORTRAIT(S), AND/OR SIGNATURE(S) SHOWN IN THE MARK DOES NOT IDENTIFY A PARTICULAR LIVING INDIVIDUAL.

THE COLOR(S) BLACK, GRAY AND RED IS/ARE CLAIMED AS A FEATURE OF THE MARK.

THE MARK CONSISTS OF A REPRESENTATION OF THE FACE OF A MAN WITH A LEAF ON THE RIGHT SIDE AND A BRANCH OF GRAPES TO THE LEFT. ALL IN BLACK; A GRAY BACKGROUND BEHIND THE DESIGN ELEMENT; THE WORD "ARRAYAN" IS BELOW THIS DESIGN WRITTEN IN STYLIZED RED LETTERS.

THE WORDING "ARRAYAN" HAS NO MEANING IN A FOREIGN LANGUAGE.

FOR ALCOHOLIC BEVERAGES, EXCEPT BEERS (U.S. CLS. 47 AND 49).

FIRST USE 12-31-2007; IN COMMERCE 12-31-2007.

---

3,962,423. SAWYER JOHN & CO., INC., DBA CREEKSIDE VINEYARDS, COAL VALLEY, IL. SN 77-770,388. PUB. 12-22-2009, FILED 6-29-2009.

creekside  
vineyards



NO CLAIM IS MADE TO THE EXCLUSIVE RIGHT TO USE "VINEYARDS", APART FROM THE MARK AS SHOWN.

THE COLOR(S) PURPLE AND GREEN IS/ARE CLAIMED AS A FEATURE OF THE MARK.

**CLASS 33—(Continued).**

THE MARK CONSISTS OF A GREEN LETTER "C" WHICH APPEARS SIMILAR TO A WINE GLASS OVER A PURPLE LETTER "V" THAT ALSO ABSTRACTLY RESEMBLES A WINE GLASS. PURPLE BUBBLES, REPRESENTING WINE, FLOW FROM THE "C" INTO THE "V". THE WORDS "CREEKSIDE", IN GREEN LOWERCASE LETTERS, AND THE WORD "VINEYARDS", IN PURPLE LOWERCASE LETTERS, ARE INCLUDED. THE COLOR WHITE REPRESENTS BACKGROUND COLOR AND IS NOT PART OF THE MARK.

FOR FORTIFIED WINES; FRUIT WINE; GRAPE WINE; NATURAL SPARKLING WINES; PORT WINES; RED WINE; RED WINES; SPARKLING FRUIT WINE; SPARKLING GRAPE WINE; SPARKLING WINES; STRAWBERRY WINE; SWEET WINES; TABLE WINES; WHITE WINE; WINE; WINES; WINES AND FORTIFIED WINES; WINES AND SPARKLING WINES (U.S. CLS. 47 AND 49).

FIRST USE 6-1-2009; IN COMMERCE 6-1-2010.

---

3,962,563. AZAR DISTILLING, LLC, SAN ANTONIO, TX. SN 77-818,720. PUB. 11-24-2009, FILED 9-2-2009.

## AZAR CINCO

THE MARK CONSISTS OF STANDARD CHARACTERS WITHOUT CLAIM TO ANY PARTICULAR FONT, STYLE, SIZE, OR COLOR.

THE ENGLISH TRANSLATION OF "AZAR CINCO" IS "CHANCE FIVE".

FOR VODKA (U.S. CLS. 47 AND 49).

FIRST USE 3-14-2011; IN COMMERCE 3-14-2011.

---

3,962,756. F. L. NAVARRO LTD, DBA THE ARTISAN COLLECTION, BROOKLYN, NY. SN 77-888,320. PUB. 10-5-2010, FILED 12-8-2009.

## El Agosto

THE MARK CONSISTS OF STANDARD CHARACTERS WITHOUT CLAIM TO ANY PARTICULAR FONT, STYLE, SIZE, OR COLOR.

THE ENGLISH TRANSLATION OF "EL AGOSTO" IN THE MARK IS THE AUGUST. THE WORDING "EL AGOSTO" HAS NO MEANING IN A FOREIGN LANGUAGE.

FOR WINES (U.S. CLS. 47 AND 49).

FIRST USE 2-25-2011; IN COMMERCE 2-25-2011.

**CLASS 33—(Continued).**

3,962,835. DUCA DI SALAPARUTA S.P.A., MARSALA (TRAPANI), ITALY. SN 77-911,846. PUB. 8-24-2010, FILED 1-14-2010.

## CORVO FIORE

THE MARK CONSISTS OF STANDARD CHARACTERS WITHOUT CLAIM TO ANY PARTICULAR FONT, STYLE, SIZE, OR COLOR.

OWNER OF U.S. REG. NO. 532,892.

THE ENGLISH TRANSLATION OF "CORVO" IN THE MARK IS "CROW" OR "RAVEN" AND "FIORE" IS "FLOWER".

FOR ALCOHOLIC BEVERAGES, EXCEPT BEERS (U.S. CLS. 47 AND 49).

FIRST USE 4-0-2010; IN COMMERCE 4-0-2010.

---

3,962,904. RAMIREZ, HERNANDO JR, MIAMI, FL. AND METIN, SARA, MIAMI, FL. SN 77-928,989. PUB. 8-10-2010, FILED 2-5-2010.



NO CLAIM IS MADE TO THE EXCLUSIVE RIGHT TO USE "BOX", APART FROM THE MARK AS SHOWN.

THE WORDING "ART BOX" APPEARS THREE TIMES ON THE DRAWING WITHIN DIFFERENT RECTANGLE DESIGNS. THE BACKGROUND OF THE MARK IS COMPRISED OF VARIOUS RECTANGULAR AND SQUARE SHAPES, WHICH APPEAR IN A MONDRIAN STYLE.

FOR APERITIF WINES; APERITIFS WITH A WINE BASE; BRANDY SPIRITS; COOKING WINE; DISTILLED SPIRITS; DISTILLED SPIRITS OF GRAINS, GRAPES, CANE SUGAR, FRUITS; FORTIFIED WINES; FRUIT WINE; GRAPE WINE; NATURAL SPARKLING WINES; PORT WINES; POTABLE SPIRITS; PREPARED WINE COCKTAILS; RED WINE; RED WINES; SPARKLING FRUIT WINE; SPARKLING GRAPE WINE; SPARKLING WINES; SPIRITS; SPIRITS AND LIQUEURS; STILL WINE; SWEET WINES; TABLE WINES; WHITE WINE; WINE; WINE COOLERS; WINE PUNCH; WINE PUNCHES; WINE-BASED DRINKS; WINES; WINES AND FORTIFIED WINES; WINES AND LIQUEURS; WINES AND SPARKLING WINES (U.S. CLS. 47 AND 49).

FIRST USE 10-17-2010; IN COMMERCE 10-17-2010.



**CLASS 33—(Continued).**

3,962,917. BODEGA MONTE BALBANO S.A., BUENOS AIRES, ARGENTINA. SN 77-931,899. PUB. 7-13-2010, FILED 2-9-2010.

# SERBAL

THE MARK CONSISTS OF STANDARD CHARACTERS WITHOUT CLAIM TO ANY PARTICULAR FONT, STYLE, SIZE, OR COLOR.

THE ENGLISH TRANSLATION OF "SERBAL" IN THE MARK IS SERVICE TREE OR MOUNTAIN ASH. FOR ALCOHOLIC BEVERAGES EXCEPT BEERS (U.S. CLS. 47 AND 49).

FIRST USE 6-1-2010; IN COMMERCE 8-7-2010.

---

3,962,956. DESTILADORA DE LOS ALTOS S.A. DE C.V., ARANDAS, JALISCO, MEXICO. SN 77-939,385. PUB. 7-20-2010, FILED 2-18-2010.



OWNER OF U.S. REG. NO. 3,296,351.

NO CLAIM IS MADE TO THE EXCLUSIVE RIGHT TO USE "HACIENDA", APART FROM THE MARK AS SHOWN.

THE NAME(S), PORTRAIT(S), AND/OR SIGNATURE(S) SHOWN IN THE MARK IDENTIFIES "FELIX BAÑUELOS", WHOSE CONSENT(S) TO REGISTER IS MADE OF RECORD.

THE COLOR(S) BROWN, YELLOW, WHITE, GRAY AND GREEN IS/ARE CLAIMED AS A FEATURE OF THE MARK.

THE MARK CONSISTS OF ROUND SIGN WITH A "T" FORM ON TOP HAVING THE COLORS GREEN AND GRAY, AND BENEATH THE SIGN ARE THE WORDS "HACIENDA FELIX BAÑUELOS" IN STYLIZED BROWN LETTERS. THE DESIGN AND WORDING ARE ON A BACKGROUND OF VARIOUS SHADES OF YELLOW, WHITE, AND GRAY.

THE ENGLISH TRANSLATION OF "HACIENDA" IN THE MARK IS "RANCH".

FOR ALCOHOLIC BEVERAGES EXCEPT BEERS (U.S. CLS. 47 AND 49).

FIRST USE 1-15-2011; IN COMMERCE 1-15-2011.

**CLASS 33—(Continued).**

3,963,006. UNITED STATES DISTILLED PRODUCTS COMPANY, PRINCETON, MN. SN 77-944,870. PUB. 6-22-2010, FILED 2-25-2010.

# JONATHAN DRAKE

THE MARK CONSISTS OF STANDARD CHARACTERS WITHOUT CLAIM TO ANY PARTICULAR FONT, STYLE, SIZE, OR COLOR.

THE NAME(S), PORTRAIT(S), AND/OR SIGNATURE(S) SHOWN IN THE MARK DOES NOT IDENTIFY A PARTICULAR LIVING INDIVIDUAL.

FOR DISTILLED SPIRITS (U.S. CLS. 47 AND 49).

FIRST USE 11-3-2010; IN COMMERCE 11-3-2010.

---

3,963,014. RHODEN, MATTHEW B., FREEPORT, NY. SN 77-945,697. PUB. 7-27-2010, FILED 2-26-2010.



NO CLAIM IS MADE TO THE EXCLUSIVE RIGHT TO USE "RED", APART FROM THE MARK AS SHOWN.

THE MARK CONSISTS OF A PIRATE HAT ABOVE THE WORDING "REBELLEERS RED", WHICH IS ABOVE A SWIRL DESIGN.

FOR ALCOHOLIC PUNCHES; PREPARED ALCOHOLIC COCKTAIL; RUM (U.S. CLS. 47 AND 49).

FIRST USE 1-29-2011; IN COMMERCE 1-29-2011.

**CLASS 33—(Continued).**

3,963,033. ADLER FELS WINERY, LLC, SANTA ROSA, CA.  
SN 77-948,638. PUB. 7-27-2010, FILED 3-2-2010.

**EYE CANDY**

THE MARK CONSISTS OF STANDARD CHARACTERS  
WITHOUT CLAIM TO ANY PARTICULAR FONT, STYLE,  
SIZE, OR COLOR.

FOR WINE (U.S. CLS. 47 AND 49).  
FIRST USE 10-22-2010; IN COMMERCE 10-22-2010.

3,963,046. ROCLAND WINE IMPORTS, SAN FRANCISCO,  
CA. SN 77-950,087. PUB. 7-20-2010, FILED 3-3-2010.

**SWEET JESUS**

THE MARK CONSISTS OF STANDARD CHARACTERS  
WITHOUT CLAIM TO ANY PARTICULAR FONT, STYLE,  
SIZE, OR COLOR.

FOR DISTILLED SPIRITS (U.S. CLS. 47 AND 49).  
FIRST USE 2-1-2011; IN COMMERCE 2-1-2011.

3,963,117. EARLY TIMES DISTILLERS COMPANY, LOUIS-  
VILLE, KY. SN 77-957,428. PUB. 8-3-2010, FILED 3-12-2010.

**EARLY TIMES MAN DAY**

THE MARK CONSISTS OF STANDARD CHARACTERS  
WITHOUT CLAIM TO ANY PARTICULAR FONT, STYLE,  
SIZE, OR COLOR.

OWNER OF U.S. REG. NOS. 327,086, 2,066,568, AND  
OTHERS.  
FOR DISTILLED SPIRITS (U.S. CLS. 47 AND 49).  
FIRST USE 9-1-2010; IN COMMERCE 9-1-2010.

**CLASS 33—(Continued).**

3,963,131. LUCTOR INTERNATIONAL, L.L.C., ORLANDO,  
FL. SN 77-959,531. PUB. 7-27-2010, FILED 3-15-2010.

**COCKTAIL CREATIONS**

THE MARK CONSISTS OF STANDARD CHARACTERS  
WITHOUT CLAIM TO ANY PARTICULAR FONT, STYLE,  
SIZE, OR COLOR.

NO CLAIM IS MADE TO THE EXCLUSIVE RIGHT TO  
USE "COCKTAIL", APART FROM THE MARK AS SHOWN.  
FOR MULTI-BOTTLE CO-PACKS OF ALCOHOLIC  
BEVERAGES, NOT INCLUDING BEER (U.S. CLS. 47  
AND 49).

FIRST USE 4-26-2010; IN COMMERCE 4-26-2010.

3,963,159. SWANSON VINEYARDS AND WINERY, OAK-  
VILLE, CA. SN 77-961,577. PUB. 8-3-2010, FILED 3-17-2010.

**JUST MARRIED**

THE MARK CONSISTS OF STANDARD CHARACTERS  
WITHOUT CLAIM TO ANY PARTICULAR FONT, STYLE,  
SIZE, OR COLOR.

FOR WINE (U.S. CLS. 47 AND 49).  
FIRST USE 5-0-2010; IN COMMERCE 5-0-2010.

3,963,183. JACK CREEK CELLARS, INC., TEMPLETON, CA.  
SN 77-964,195. PUB. 8-10-2010, FILED 3-20-2010.

**CONCRETE BLONDE**

THE MARK CONSISTS OF STANDARD CHARACTERS  
WITHOUT CLAIM TO ANY PARTICULAR FONT, STYLE,  
SIZE, OR COLOR.

FOR WINE (U.S. CLS. 47 AND 49).  
FIRST USE 11-30-2010; IN COMMERCE 11-30-2010.

**CLASS 33—(Continued).**

3,963,221. DIAGEO NORTH AMERICA, INC., NORWALK, CT. SN 77-968,593. PUB. 7-27-2010, FILED 3-25-2010.



OWNER OF U.S. REG. NOS. 574,181, 2,992,605, AND OTHERS.

THE MARK CONSISTS OF A STYLIZED CROWN ABOVE A STYLIZED NUMBER "7". A SYMMETRIC SWIRL PATTERN AND CHERRY ARE EMBEDDED IN THE CROWN.

FOR ALCOHOLIC BEVERAGES EXCEPT BEERS (U.S. CLS. 47 AND 49).

FIRST USE 2-23-2011; IN COMMERCE 2-23-2011.

3,963,285. RIVER VALLEY VINEYARD, INC., DBA AUGUST HILL WINERY, UTICA, IL. SN 78-586,749. PUB. 8-24-2010, FILED 3-14-2005.

**AUGUST HILL WINERY**

THE MARK CONSISTS OF STANDARD CHARACTERS WITHOUT CLAIM TO ANY PARTICULAR FONT, STYLE, SIZE, OR COLOR.

NO CLAIM IS MADE TO THE EXCLUSIVE RIGHT TO USE "WINERY", APART FROM THE MARK AS SHOWN.

FOR ALCOHOLIC BEVERAGES, NAMELY, WINE (U.S. CLS. 47 AND 49).

FIRST USE 6-1-2005; IN COMMERCE 6-1-2005.

3,963,383. WAL-MART STORES, INC., BENTONVILLE, AR. SN 85-014,602. PUB. 7-27-2010, FILED 4-15-2010.

**CALLE AZUL**

THE MARK CONSISTS OF STANDARD CHARACTERS WITHOUT CLAIM TO ANY PARTICULAR FONT, STYLE, SIZE, OR COLOR.

**CLASS 33—(Continued).**

THE ENGLISH TRANSLATION OF "CALLE AZUL" IN THE MARK IS "BLUE STREET".

FOR ALCOHOLIC BEVERAGES EXCEPT BEERS (U.S. CLS. 47 AND 49).

FIRST USE 10-31-2010; IN COMMERCE 10-31-2010.

3,963,402. EARLY TIMES DISTILLERS COMPANY, LOUISVILLE, KY. SN 85-020,930. PUB. 8-3-2010, FILED 4-22-2010.

**EARLY TIMES 354 BOURBON**

THE MARK CONSISTS OF STANDARD CHARACTERS WITHOUT CLAIM TO ANY PARTICULAR FONT, STYLE, SIZE, OR COLOR.

OWNER OF U.S. REG. NOS. 327,086, 3,028,756, AND OTHERS.

NO CLAIM IS MADE TO THE EXCLUSIVE RIGHT TO USE "BOURBON", APART FROM THE MARK AS SHOWN.

FOR DISTILLED SPIRITS (U.S. CLS. 47 AND 49).

FIRST USE 2-23-2011; IN COMMERCE 2-23-2011.

3,963,564. MODERN SPIRITS LLC, MONROVIA, CA. SN 85-064,967. PUB. 11-16-2010, FILED 6-17-2010.

**IXA**

THE MARK CONSISTS OF STANDARD CHARACTERS WITHOUT CLAIM TO ANY PARTICULAR FONT, STYLE, SIZE, OR COLOR.

FOR SPIRITS (U.S. CLS. 47 AND 49).

FIRST USE 10-1-2010; IN COMMERCE 3-1-2010.

3,963,590. HEATHER WILLENS, PACIFIC PALISADES, CA. SN 85-070,783. PUB. 11-16-2010, FILED 6-24-2010.

**Dos Minas**

THE MARK CONSISTS OF STANDARD CHARACTERS WITHOUT CLAIM TO ANY PARTICULAR FONT, STYLE, SIZE, OR COLOR.

THE ENGLISH TRANSLATION OF THE WORD "DOS MINAS" IN THE MARK IS TWO CHICKS.

FOR STILL WINES (U.S. CLS. 47 AND 49).

FIRST USE 6-1-2010; IN COMMERCE 9-1-2010.

**CLASS 33—(Continued).**

3,963,595. C. MONDAVI & SONS, ST. HELENA, CA. SN 85-072,060. PUB. 11-23-2010, FILED 6-25-2010.



OWNER OF U.S. REG. NO. 1,588,776.  
NO CLAIM IS MADE TO THE EXCLUSIVE RIGHT TO USE "1861", APART FROM THE MARK AS SHOWN.  
THE MARK CONSISTS OF A STYLIZED ESTATE HOUSE DESIGN WITH THE NUMBERS "18" TO THE LEFT OF THE HOUSE AND THE NUMBERS "61" TO THE RIGHT OF THE HOUSE.

FOR WINE (U.S. CLS. 47 AND 49).  
FIRST USE 12-26-2010; IN COMMERCE 12-26-2010.

3,963,662. TANDEM WINES LLC, HEALDSBURG, CA. SN 85-090,614. PUB. 1-4-2011, FILED 7-22-2010.

## La Follette

THE MARK CONSISTS OF STANDARD CHARACTERS WITHOUT CLAIM TO ANY PARTICULAR FONT, STYLE, SIZE, OR COLOR.

THE ENGLISH TRANSLATION OF "LA FOLLETTE" IN THE MARK IS "CRAZY LITTLE GIRL".

FOR WINES (U.S. CLS. 47 AND 49).  
FIRST USE 7-31-2010; IN COMMERCE 8-19-2010.

3,963,665. THE SANDY BOTTOM ENTERPRISES, LLC, ANNAPOLIS, MD. SN 85-093,492. PUB. 1-11-2011, FILED 7-27-2010.

THE ONLY REASON TO GET OFF  
YOUR BOTTOM

THE MARK CONSISTS OF STANDARD CHARACTERS WITHOUT CLAIM TO ANY PARTICULAR FONT, STYLE, SIZE, OR COLOR.

FOR ALCOHOLIC BEVERAGES EXCEPT BEERS (U.S. CLS. 47 AND 49).

FIRST USE 9-2-2010; IN COMMERCE 1-10-2011.

**CLASS 34—SMOKERS' ARTICLES****CLASS 34—(Continued).**

3,962,584. PAD, LLC, CHICAGO, IL. SN 77-824,628. PUB. 8-3-2010, FILED 9-11-2009.

## TREND

THE MARK CONSISTS OF STANDARD CHARACTERS WITHOUT CLAIM TO ANY PARTICULAR FONT, STYLE, SIZE, OR COLOR.

FOR CIGARS (U.S. CLS. 2, 8, 9 AND 17).  
FIRST USE 10-0-2010; IN COMMERCE 10-0-2010.

3,962,648. INLIFE, LLC, IRVINE, CA. SN 77-850,100. PUB. 7-27-2010, FILED 10-16-2009.

## MARQUEE

THE MARK CONSISTS OF STANDARD CHARACTERS WITHOUT CLAIM TO ANY PARTICULAR FONT, STYLE, SIZE, OR COLOR.

FOR TOBACCO; ELECTRONIC SMOKING DEVICES; ELECTRONIC CIGARETTES; CIGARETTES CONTAINING TOBACCO SUBSTITUTES, NOT FOR MEDICAL PURPOSES; CIGARETTE TIPS; CIGARETTE FILTERS; CIGARETTE MOUTHPIECES; ELECTRONIC CIGARETTE NICOTINE CARTRIDGES (U.S. CLS. 2, 8, 9 AND 17).

FIRST USE 1-1-2009; IN COMMERCE 1-1-2009.

3,963,129. DNA DISTRIBUTORS, INC., ELGIN, IL. SN 77-959,417. PUB. 7-27-2010, FILED 3-15-2010.

## CIGALECTRIC

THE MARK CONSISTS OF STANDARD CHARACTERS WITHOUT CLAIM TO ANY PARTICULAR FONT, STYLE, SIZE, OR COLOR.

FOR ELECTRONIC SMOKELESS CIGARETTES FOR USE AS AN ALTERNATIVE TO TRADITIONAL CIGARETTES (U.S. CLS. 2, 8, 9 AND 17).

FIRST USE 3-16-2010; IN COMMERCE 3-16-2010.

**CLASS 34—(Continued).**

3,963,167. FAIRMONT HOLDINGS, INC., DANIA, FL. SN 77-961,958. PUB. 8-3-2010, FILED 3-18-2010.

**COPA DEL SOL**

THE MARK CONSISTS OF STANDARD CHARACTERS WITHOUT CLAIM TO ANY PARTICULAR FONT, STYLE, SIZE, OR COLOR.

THE ENGLISH TRANSLATION OF "COPA DEL SOL" IN THE MARK IS "CUP OF THE SUN".

FOR CIGARS, TOBACCO, CIGAR BOXES, CIGAR CUTTERS AND CIGAR TUBES (U.S. CLS. 2, 8, 9 AND 17).

FIRST USE 12-13-2010; IN COMMERCE 12-13-2010.

3,963,224. THOMPSON & CO. OF TAMPA, INC., TAMPA, FL. SN 77-969,243. PUB. 8-17-2010, FILED 3-26-2010.

**GOLDEN CLASS**

THE MARK CONSISTS OF STANDARD CHARACTERS WITHOUT CLAIM TO ANY PARTICULAR FONT, STYLE, SIZE, OR COLOR.

FOR CIGARS (U.S. CLS. 2, 8, 9 AND 17).

FIRST USE 12-1-2009; IN COMMERCE 12-1-2009.

3,963,225. THOMPSON & CO. OF TAMPA, INC., TAMPA, FL. SN 77-969,254. PUB. 8-17-2010, FILED 3-26-2010.

**NIMBUS**

THE MARK CONSISTS OF STANDARD CHARACTERS WITHOUT CLAIM TO ANY PARTICULAR FONT, STYLE, SIZE, OR COLOR.

FOR CIGARS (U.S. CLS. 2, 8, 9 AND 17).

FIRST USE 11-1-2009; IN COMMERCE 11-1-2009.

**CLASS 34—(Continued).**

3,963,305. K. HANSOTIA & CO., INC., MIAMI, FL. SN 85-000,092. PUB. 12-21-2010, FILED 3-27-2010.

**SAN MIGUEL**

THE MARK CONSISTS OF STANDARD CHARACTERS WITHOUT CLAIM TO ANY PARTICULAR FONT, STYLE, SIZE, OR COLOR.

THE ENGLISH TRANSLATION OF "SAN MIGUEL" IN THE MARK IS "SAINT MICHAEL".

FOR CIGARS (U.S. CLS. 2, 8, 9 AND 17).

FIRST USE 6-9-2009; IN COMMERCE 6-9-2009.

3,963,335. PATEL, RAKESH, BONITA SPRINGS, FL. SN 85-006,461. PUB. 8-3-2010, FILED 4-5-2010.

**CARGO**

THE MARK CONSISTS OF STANDARD CHARACTERS WITHOUT CLAIM TO ANY PARTICULAR FONT, STYLE, SIZE, OR COLOR.

FOR CIGARS (U.S. CLS. 2, 8, 9 AND 17).

FIRST USE 9-24-2010; IN COMMERCE 9-24-2010.

**SERVICE MARKS****CLASS 35—ADVERTISING AND BUSINESS**

3,962,022. PAWN AMERICA MINNESOTA, L.L.C., BURNSVILLE, MN. SN 77-107,438. PUB. 2-26-2008, FILED 2-14-2007.

**EXCHANGE STREET**

THE MARK CONSISTS OF STANDARD CHARACTERS WITHOUT CLAIM TO ANY PARTICULAR FONT, STYLE, SIZE, OR COLOR.



**CLASS 35—(Continued).**

NO CLAIM IS MADE TO THE EXCLUSIVE RIGHT TO USE "EXCHANGE", APART FROM THE MARK AS SHOWN.

FOR RETAIL DISCOUNT STORE SERVICES IN THE FIELD OF PRE-OWNED GOODS AND GENERAL MERCHANDISE, NAMELY, CLOTHING; RETAIL SHOPS FEATURING PRE-OWNED GOODS AND GENERAL MERCHANDISE, NAMELY, CLOTHING; RETAIL STORE SERVICES FEATURING PRE-OWNED GOODS AND GENERAL MERCHANDISE, NAMELY, CLOTHING; RETAIL STORES FEATURING PRE-OWNED GOODS AND GENERAL MERCHANDISE, NAMELY, CLOTHING (U.S. CLS. 100, 101 AND 102).

FIRST USE 3-23-2011; IN COMMERCE 3-23-2011.

3,962,029. PATTI, ANTHONY G., ALTA LOMA, CA. SN 77-127,625. PUB. 2-12-2008, FILED 3-9-2007.

**PET DYNAMICS**

THE MARK CONSISTS OF STANDARD CHARACTERS WITHOUT CLAIM TO ANY PARTICULAR FONT, STYLE, SIZE, OR COLOR.

NO CLAIM IS MADE TO THE EXCLUSIVE RIGHT TO USE "PET", APART FROM THE MARK AS SHOWN.

FOR ADVERTISING AGENCIES, NAMELY, PROMOTING THE GOODS AND SERVICES OF OTHERS; ADVERTISING AND ADVERTISEMENT SERVICES; ADVERTISING AND BUSINESS SERVICES, NAMELY, SECURING AIRTIME ON ALL FORMS OF MEDIA COMMUNICATIONS STATIONS, SYSTEMS, NETWORKS, AND SERVICES FOR THE PURPOSE OF PROMOTING THE GOODS AND SERVICES OF OTHERS; ADVERTISING AND COMMERCIAL INFORMATION SERVICES, VIA THE INTERNET; ADVERTISING AND MARKETING; ADVERTISING AND PUBLICITY SERVICES, NAMELY, PROMOTING THE GOODS, SERVICES, BRAND IDENTITY AND COMMERCIAL INFORMATION AND NEWS OF THIRD PARTIES THROUGH PRINT, AUDIO, VIDEO, DIGITAL AND ON-LINE MEDIUM; ADVERTISING SERVICES, NAMELY, PROMOTING AND MARKETING THE GOODS AND SERVICES OF OTHERS THROUGH ALL PUBLIC COMMUNICATION MEANS; ADVERTISING VIA ELECTRONIC MEDIA AND SPECIFICALLY THE INTERNET; ADVERTISING, MARKETING AND PROMOTION SERVICES; DISSEMINATION OF ADVERTISING FOR OTHERS VIA THE INTERNET; ON-LINE ADVERTISING AND MARKETING SERVICES; PROMOTING, ADVERTISING AND MARKETING OF THE ON-LINE WEBSITES OF OTHERS; PROMOTION, ADVERTISING AND MARKETING OF ON-LINE WEBSITES; PROVIDING A SEARCHABLE ONLINE ADVERTISING GUIDE FEATURING THE GOODS AND SERVICES OF OTHER ON-LINE VENDORS ON THE INTERNET; PROVIDING A WEB SITE THAT ENABLES USERS TO POST ITEMS FOR SALE THROUGH ON-LINE CLASSIFIED ADVERTISEMENTS; PROVIDING A WEB SITE WHICH FEATURES ADVERTISEMENTS FOR THE GOODS AND SERVICES OF OTHERS ON A GLOBAL COMPUTER NETWORK; PROVIDING AND RENTAL OF ADVERTISING SPACE ON THE INTERNET; PROVIDING SPACE AT A WEB SITE FOR THE ADVERTISEMENT OF THE GOODS AND SERVICES OF OTHERS; RENTAL OF ADVERTISING SPACE ON WEB SITES (U.S. CLS. 100, 101 AND 102).

FIRST USE 3-8-2011; IN COMMERCE 3-8-2011.

**CLASS 35—(Continued).**

3,962,073. CUMMINS INTELLECTUAL PROPERTY, INC., COLUMBUS, IN. SN 77-256,595. PUB. 1-15-2008, FILED 8-16-2007.

**POWERZONE**

THE MARK CONSISTS OF STANDARD CHARACTERS WITHOUT CLAIM TO ANY PARTICULAR FONT, STYLE, SIZE, OR COLOR.

FOR PROVIDING AN ONLINE COMPUTER DATABASE IN THE FIELD OF MANAGING INVENTORY, HANDLING, AND PROCESSING OF PURCHASE ORDERS RELATING TO ENGINES, GENERATORS, AND PARTS THEREOF (U.S. CLS. 100, 101 AND 102).

FIRST USE 4-8-2011; IN COMMERCE 4-8-2011.

3,962,078. NATIONAL BUSINESS TRAVEL ASSOCIATION, ALEXANDRIA, VA. SN 77-275,422. PUB. 3-4-2008, FILED 9-10-2007.

**GBTA**

THE MARK CONSISTS OF STANDARD CHARACTERS WITHOUT CLAIM TO ANY PARTICULAR FONT, STYLE, SIZE, OR COLOR.

FOR ASSOCIATION SERVICES, NAMELY, PROMOTING THE VALUE OF BUSINESS TRAVEL MANAGEMENT AND THE INTERESTS OF THE BUSINESS TRAVEL INDUSTRY; PROVIDING BUSINESS AND COMMERCIAL INFORMATION IN THE FIELD OF BUSINESS TRAVEL MANAGEMENT AND THE BUSINESS TRAVEL INDUSTRY VIA A WEB SITE ON GLOBAL COMPUTER NETWORKS; PROVIDING BUSINESS AND COMMERCIAL RESEARCH IN THE FIELD OF BUSINESS TRAVEL MANAGEMENT AND THE BUSINESS TRAVEL INDUSTRY; ARRANGING AND CONDUCTING TRADE SHOW EXHIBITIONS IN THE FIELD OF BUSINESS TRAVEL MANAGEMENT AND THE BUSINESS TRAVEL INDUSTRY; POLITICAL ACTION COMMITTEE SERVICES, NAMELY, PROMOTING THE INTERESTS OF BUSINESS TRAVEL MANAGERS IN THE FIELD OF POLITICS (U.S. CLS. 100, 101 AND 102).

FIRST USE 8-9-2010; IN COMMERCE 2-3-2011.

**CLASS 35—(Continued).**

3,962,104. HADI, ALTAF, MURPHY, TX. SN 77-370,474. PUB. 5-27-2008, FILED 1-14-2008.



THE COLOR(S) BLUE, GREEN, REDDISH TAN, ORANGE AND PURPLE IS/ARE CLAIMED AS A FEATURE OF THE MARK.

THE MARK CONSISTS OF: FIRST BLUE SET OF 4 STYLIZED LETTERS "DATA"; A SECOND GREEN STYLIZED LETTER "P" WITH EMBEDDED CURRENCY IMAGES; A THIRD REDDISH TAN STYLIZED LETTER "A"; A FOURTH ORANGE STYLIZED LETTER "Y"; A FIFTH PURPLE STYLIZED LETTER "S"; AND A SIXTH REDDISH TAN SET OF 20 STYLIZED LETTERS "THE INTERNET NOW PAYS".

FOR ADVERTISING AND COMMERCIAL INFORMATION SERVICES, VIA THE INTERNET; ON-LINE TRADING SERVICES IN WHICH SELLER POSTS PRODUCTS TO BE AUCTIONED AND BIDDING IS DONE VIA THE INTERNET; ADVERTISING SERVICES, NAMELY, PROMOTING PROPERTIES FOR SALE BY OWNER VIA THE INTERNET; ADVERTISING VIA ELECTRONIC MEDIA AND SPECIFICALLY THE INTERNET; ADVICE AND INFORMATION ABOUT CUSTOMER SERVICES AND PRODUCT MANAGEMENT AND PRICES ON INTERNET SITES IN CONNECTION WITH PURCHASES MADE OVER THE INTERNET; AN INTERACTIVE WEB SITE FOR USERS TO REVIEW AND RATE INTERNET CONTENT, PEOPLE, COMPANIES, PRODUCTS AND/OR SERVICES UTILIZING A SOFTWARE APPLICATION TO AWARD POINTS WHEREBY WEB SITE USERS ARE ELIGIBLE TO EXCHANGE POINTS EARNED FOR PROMOTIONAL ITEMS CONSISTING; OF COUPONS, REBATES, DISCOUNTS OR SPECIAL OFFERINGS ON GOODS AND/OR SERVICE PROVIDED BY WEB SITE SPONSORS; ELECTRONIC COMMERCE SERVICES, NAMELY, PROVIDING INFORMATION ABOUT PRODUCTS VIA TELECOMMUNICATION NETWORKS FOR ADVERTISING AND SALES PURPOSES; FACILITATING THE EXCHANGE OF NEEDED INFORMATION FOR FINANCIAL COMPENSATION VIA THE INTERNET; PROVIDING AN ON-LINE COMMERCIAL INFORMATION DIRECTORY ON THE INTERNET; DISSEMINATION OF ADVERTISING FOR OTHERS VIA THE INTERNET; MARKET MANIPULATION, RESEARCH AND ANALYSIS, WHETHER OR NOT VIA THE INTERNET; PROVIDING BUSINESS INFORMATION, ALSO VIA INTERNET, THE CABLE NETWORK OR OTHER FORMS OF DATA TRANSFER (U.S. CLS. 100, 101 AND 102).

FIRST USE 1-4-2008; IN COMMERCE 7-30-2010.

**CLASS 35—(Continued).**

3,962,107. DDB WORLDWIDE COMMUNICATIONS GROUP INC., NEW YORK, NY. SN 77-373,297. PUB. 12-23-2008, FILED 1-16-2008.

## Share Value

THE MARK CONSISTS OF STANDARD CHARACTERS WITHOUT CLAIM TO ANY PARTICULAR FONT, STYLE, SIZE, OR COLOR.

FOR ADVERTISING AGENCY SERVICES, MARKET RESEARCH SERVICES, AND BUSINESS AND MARKETING CONSULTING SERVICES (U.S. CLS. 100, 101 AND 102).

FIRST USE 7-1-2010; IN COMMERCE 7-1-2010.

---

3,962,169. A WELL BALANCED HOME, LLC, DBA THE BARF BOUTIQUE, SEATTLE, WA. SN 77-509,191. PUB. 11-4-2008, FILED 6-26-2008.

## The Barf Boutique

THE MARK CONSISTS OF STANDARD CHARACTERS WITHOUT CLAIM TO ANY PARTICULAR FONT, STYLE, SIZE, OR COLOR.

NO CLAIM IS MADE TO THE EXCLUSIVE RIGHT TO USE "BOUTIQUE", APART FROM THE MARK AS SHOWN. FOR ON-LINE RETAIL STORE SERVICES FEATURING PRODUCTS RELATED TO NAUSEA AND VOMITING (U.S. CLS. 100, 101 AND 102).

FIRST USE 10-1-2009; IN COMMERCE 10-1-2009.

---

3,962,182. GOODLOE, GWENDOLYN, PHOENIX, AZ. SN 77-538,778. PUB. 12-30-2008, FILED 8-4-2008.

## Women's Garden

THE MARK CONSISTS OF STANDARD CHARACTERS WITHOUT CLAIM TO ANY PARTICULAR FONT, STYLE, SIZE, OR COLOR.

FOR ON-LINE RETAIL STORE SERVICES FEATURING DOWNLOADABLE PRE-RECORDED MUSIC AND VIDEO (U.S. CLS. 100, 101 AND 102).

FIRST USE 3-19-2009; IN COMMERCE 2-12-2011.

**CLASS 35—(Continued).**

3,962,185. PANGANIBAN, NATHAN Y, SALINAS, CA. SN 77-542,003. PUB. 1-20-2009, FILED 8-7-2008.

**DIMES & DAMES**

THE MARK CONSISTS OF STANDARD CHARACTERS WITHOUT CLAIM TO ANY PARTICULAR FONT, STYLE, SIZE, OR COLOR.

FOR TALENT AGENCIES (U.S. CLS. 100, 101 AND 102).

FIRST USE 3-30-2010; IN COMMERCE 7-18-2010.

3,962,187. SEARCH AMERICA, INC., MINNEAPOLIS, MN. SN 77-546,826. PUB. 6-23-2009, FILED 8-14-2008.

**POP-UP**

THE MARK CONSISTS OF STANDARD CHARACTERS WITHOUT CLAIM TO ANY PARTICULAR FONT, STYLE, SIZE, OR COLOR.

FOR PROVIDING BUSINESS INFORMATION TO VERIFY CUSTOMER FINANCIAL AND DEMOGRAPHIC INFORMATION; BUSINESS INFORMATION MANAGEMENT SERVICES IN THE NATURE OF IDENTIFYING DISCREPANCIES WITH THE HEALTH CARE PROVIDERS AND/OR HEALTH CARE FACILITIES' CUSTOMER INFORMATION AND UPDATING THE HEALTH CARE PROVIDERS AND/OR HEALTH CARE FACILITIES INFORMATION SYSTEM WITH THE CUSTOMER'S UPDATED INFORMATION (U.S. CLS. 100, 101 AND 102).

FIRST USE 5-0-2008; IN COMMERCE 5-0-2008.

3,962,190. COMPREHENSIVE NEUROSCIENCE, INC., BRADENTON, FL. SN 77-547,419. PUB. 7-21-2009, FILED 8-14-2008.



OWNER OF U.S. REG. NOS. 3,449,533, 3,449,534, AND 3,449,535.

NO CLAIM IS MADE TO THE EXCLUSIVE RIGHT TO USE "CNS COMPREHENSIVE NEUROSCIENCE", APART FROM THE MARK AS SHOWN.

THE MARK CONSISTS OF A RECTANGLE PARTIALLY SHADED WITH WAVY AND CURVED BARS AND LINES AND THE WORDING "CNS COMPREHENSIVE NEUROSCIENCE".

FOR BUSINESS MANAGEMENT CONSULTING; COST MANAGEMENT FOR THE HEALTH BENEFIT PLANS OF OTHERS; PHARMACEUTICAL COST MANAGEMENT SERVICES AND DRUG UTILIZATION REVIEW SERVICES (U.S. CLS. 100, 101 AND 102).

FIRST USE 5-15-2006; IN COMMERCE 5-15-2006.

**CLASS 35—(Continued).**

3,962,207. BRANDERS.COM, INC., SAN MATEO, CA. SN 77-563,720. PUB. 2-3-2009, FILED 9-5-2008.

**BRANDERS**

THE MARK CONSISTS OF STANDARD CHARACTERS WITHOUT CLAIM TO ANY PARTICULAR FONT, STYLE, SIZE, OR COLOR.

FOR ON-LINE WHOLESALE AND RETAIL STORE SERVICES FEATURING PROMOTIONAL PRODUCTS AND GIFTS (U.S. CLS. 100, 101 AND 102).

FIRST USE 4-6-1999; IN COMMERCE 12-4-1999.

3,962,237. BUCZKOWSKI, MICHAEL, KINGSTON, IL. SN 77-623,210. PUB. 6-30-2009, FILED 11-28-2008.



NO CLAIM IS MADE TO THE EXCLUSIVE RIGHT TO USE "CHICAGO, IL", APART FROM THE MARK AS SHOWN.

THE COLOR(S) RED, WHITE AND BLACK IS/ARE CLAIMED AS A FEATURE OF THE MARK.

THE COLOR BLACK APPEARS IN THE SHADED BANNER DESIGNS AND THE OUTLINE OF THE ENGINE DESIGN. THE COLOR RED APPEARS IN THE WORDING "SLACKERS" AND "CHICAGO, IL" AND "CC" SUPERIMPOSED ON THE THREE BANNERS. THE COLOR WHITE APPEARS IN THE BODY OF THE ENGINE DESIGN AND IN THE BACKGROUND.

FOR CLUB SERVICES, NAMELY, PROMOTING THE INTERESTS OF HOT RODS, AUTOMOBILES (U.S. CLS. 100, 101 AND 102).

FIRST USE 9-1-2008; IN COMMERCE 12-1-2008.

**CLASS 35—(Continued).**

3,962,262. RDA STERLING HOLDINGS CORPORATION, JACKSONVILLE, FL. SN 77-655,362. PUB. 12-22-2009, FILED 1-23-2009.



NO CLAIM IS MADE TO THE EXCLUSIVE RIGHT TO USE "HOSPITAL" AND "PHYSICIAN" AND "PARTNERS", APART FROM THE MARK AS SHOWN.

THE MARK CONSISTS OF THREE CONCENTRIC PARTIAL CIRCLES WHERE THE TWO OUTERMOST PARTIAL CIRCLES ARE HALF CIRCLES FORMED ALONG A VERTICAL AXIS AND THE MOST INTERIOR PARTIAL CIRCLE IS A CRESCENT MOON SHAPE. TO THE RIGHT OF THE DESIGN ARE THE WORDS "HOSPITAL PHYSICIAN PARTNERS". UNDERNEATH THE DESIGN AND WORDING IS THE TERM "PARTNERING FOR RESULTS".

FOR RECRUITING AND STAFFING SERVICES IN THE HEALTHCARE INDUSTRY, BILLING SERVICES IN THE HEALTHCARE INDUSTRY, AND MANAGEMENT OF EMERGENCY DEPARTMENTS AND/OR HOSPITALIST PROGRAMS FOR HOSPITALS, NAMELY, BUSINESS MANAGEMENT (U.S. CLS. 100, 101 AND 102).

FIRST USE 4-6-2009; IN COMMERCE 4-6-2009.

**CLASS 35—(Continued).**

3,962,273. TASHUA HILL, LLC, CHICAGO, IL. SN 77-663,410. PUB. 9-15-2009, FILED 2-4-2009.

DIVERSITY BREEDS ACCEPTANCE

THE MARK CONSISTS OF STANDARD CHARACTERS WITHOUT CLAIM TO ANY PARTICULAR FONT, STYLE, SIZE, OR COLOR.

FOR BUSINESS CONSULTATION SERVICES; BUSINESS MARKETING SERVICES; CHARITABLE SERVICES, NAMELY, ORGANIZING AND CONDUCTING VOLUNTEER PROGRAMS AND COMMUNITY SERVICE PROJECTS; ADVERTISING, MARKETING AND PUBLICITY SERVICES; PUBLIC RELATIONS (U.S. CLS. 100, 101 AND 102).

FIRST USE 0-0-2009; IN COMMERCE 0-0-2009.

3,962,263. RDA STERLING HOLDINGS CORPORATION, JACKSONVILLE, FL. SN 77-655,382. PUB. 12-22-2009, FILED 1-23-2009.



NO CLAIM IS MADE TO THE EXCLUSIVE RIGHT TO USE "HOSPITAL" AND "PHYSICIAN" AND "PARTNERS", APART FROM THE MARK AS SHOWN.

THE MARK CONSISTS OF THREE CONCENTRIC PARTIAL CIRCLES WHERE THE TWO OUTERMOST PARTIAL CIRCLES ARE HALF CIRCLES FORMED ALONG A VERTICAL AXIS AND THE MOST INTERIOR PARTIAL CIRCLE IS A CRESCENT MOON SHAPE. TO THE RIGHT OF THE DESIGN, ARE THE WORDS "HOSPITAL PHYSICIAN PARTNERS".

FOR RECRUITING AND STAFFING SERVICES IN THE HEALTHCARE INDUSTRY, BILLING SERVICES IN THE HEALTHCARE INDUSTRY, AND MANAGEMENT OF EMERGENCY DEPARTMENTS AND/OR HOSPITALIST PROGRAMS FOR HOSPITALS, NAMELY, BUSINESS MANAGEMENT (U.S. CLS. 100, 101 AND 102).

FIRST USE 4-6-2009; IN COMMERCE 4-6-2009.

3,962,298. GASOLINE ALLEY CLASSICS, INC., BROKEN ARROW, OK. SN 77-679,173. PUB. 11-17-2009, FILED 2-26-2009.

IN RUST WE TRUST

THE MARK CONSISTS OF STANDARD CHARACTERS WITHOUT CLAIM TO ANY PARTICULAR FONT, STYLE, SIZE, OR COLOR.

FOR RETAIL STORE SERVICES FEATURING GOODS WITH AN AUTOMOTIVE THEME, NAMELY, NOVELTY ITEMS, AUTOMOTIVE MEMORABILIA, DISPLAY CASES, CLOCKS AND AUTOMOTIVE ACCESSORIES; ONLINE RETAIL STORE SERVICES FEATURING GOODS WITH AN AUTOMOTIVE THEME, NAMELY, NOVELTY ITEMS, AUTOMOTIVE MEMORABILIA, DISPLAY CASES, CLOCKS AND AUTOMOTIVE ACCESSORIES (U.S. CLS. 100, 101 AND 102).

FIRST USE 7-31-2010; IN COMMERCE 7-31-2010.

**CLASS 35—(Continued).**

3,962,308. VIRGIN HEALTHMILES, INC., FRAMINGHAM, MA. SN 77-684,242. PUB. 9-15-2009, FILED 3-5-2009.

**PAY FOR PREVENTION**

THE MARK CONSISTS OF STANDARD CHARACTERS WITHOUT CLAIM TO ANY PARTICULAR FONT, STYLE, SIZE, OR COLOR.

FOR CONDUCTING EMPLOYEE INCENTIVE AWARD PROGRAMS FOR OTHERS TO PROMOTE PERSONAL HEALTH, PHYSICAL FITNESS, AND PREVENTION OF MEDICAL CONDITIONS; CONDUCTING MEMBER INCENTIVE AWARD PROGRAMS FOR ORGANIZATIONS TO PROMOTE PERSONAL HEALTH, PHYSICAL FITNESS, AND PREVENTION OF MEDICAL CONDITIONS (U.S. CLS. 100, 101 AND 102).

FIRST USE 7-31-2009; IN COMMERCE 7-31-2009.

3,962,317. GILL ATHLETICS, INC., CHAMPAIGN, IL. SN 77-689,139. PUB. 6-30-2009, FILED 3-12-2009.

**LITANIA**

THE MARK CONSISTS OF STANDARD CHARACTERS WITHOUT CLAIM TO ANY PARTICULAR FONT, STYLE, SIZE, OR COLOR.

THE ENGLISH TRANSLATION OF "LITANIA" IN THE MARK IS "PRAYER" IN LATIN.

FOR WHOLESALE ORDERING SERVICES, RETAIL ORDERING AND STORE SERVICES, RETAIL CATALOG ORDERING, AND RETAIL ONLINE ORDERING SERVICES FEATURING SPORTING GOODS (U.S. CLS. 100, 101 AND 102).

FIRST USE 3-22-2011; IN COMMERCE 3-22-2011.

3,962,351. S. AUDIT GMBH WIRTSCHAFTSPRÜFUNGSSELLSCHAFT, KÖLN, FED REP GERMANY. SN 77-713,224. PUB. 3-2-2010, FILED 4-14-2009.



NO CLAIM IS MADE TO THE EXCLUSIVE RIGHT TO USE "AUDIT", APART FROM THE MARK AS SHOWN. THE COLOR(S) RED IS/ARE CLAIMED AS A FEATURE OF THE MARK.

**CLASS 35—(Continued).**

THE MARK CONSISTS OF THE FOLLOWING: A LETTER "S" IN A RED SQUARE IN WHICH THE SQUARE IS SPLIT BY THE DIAGONAL LINE WITH THE LEFT SIDE BEING A LIGHTER SHADE OF RED THAN THE RIGHT SIDE AND WITH A LINE CUT THROUGH PART OF THE BOTTOM OF THE SQUARE AND THE PERIOD IN THE MARK IS A SMALL RED SQUARE CUT OUT OF THE RIGHT SIDE OF THE LARGER SQUARE TO THE LEFT OF THE WORD "AUDIT" IN RED WITH RED UNDERLINE.

FOR BUSINESS AUDITING SERVICES IN THE FIELD OF INFORMATION ASSURANCE AND FINANCIAL STATEMENT AUDITING (U.S. CLS. 100, 101 AND 102). FIRST USE 8-2-2010; IN COMMERCE 8-2-2010.

3,962,365. BULLSBLOOD INC., TORONTO, ONTARIO, CANADA. SN 77-723,067. PUB. 1-26-2010, FILED 4-27-2009.



PRIORITY CLAIMED UNDER SEC. 44(D) ON CANADA APPLICATION NO. 1434346, FILED 4-14-2009.

NO CLAIM IS MADE TO THE EXCLUSIVE RIGHT TO USE "THE BULLDOG PROPER", APART FROM THE MARK AS SHOWN.

THE MARK CONSISTS OF A BULL'S HEAD INSIDE OF AN OVAL UNDER THE STYLIZED TEXT "THE BULLDOG PROPER".

FOR MAINTAINING A REGISTRY OF BREEDS IN THE FIELD OF PUREBRED DOGS, MAINTAINING A REGISTRY OF OWNERSHIP AND TRANSFER OF TITLE OF SUCH DOGS, AND ISSUING PEDIGREE CERTIFICATES (U.S. CLS. 100, 101 AND 102).

FIRST USE 3-21-2011; IN COMMERCE 3-21-2011.

3,962,419. COZMOFON INC., TORONTO, CANADA. SN 77-769,375. PUB. 10-12-2010, FILED 6-26-2009.

**CondosExtra**

THE MARK CONSISTS OF STANDARD CHARACTERS WITHOUT CLAIM TO ANY PARTICULAR FONT, STYLE, SIZE, OR COLOR.

FOR MATCHING CONSUMERS WITH REAL ESTATE PROFESSIONALS IN THE FIELD OF REAL ESTATE SERVICES VIA COMPUTER NETWORK; PROVIDING A DATABASE FEATURING REAL PROPERTY TAX INFORMATION; PROVIDING REAL ESTATE LEADS FOR PROSPECTIVE PURCHASERS; REAL ESTATE ADVERTISING SERVICES; REAL ESTATE MARKETING SERVICES IN THE FIELD OF CONDOMINIUMS (U.S. CLS. 100, 101 AND 102).

FIRST USE 2-3-2010; IN COMMERCE 2-3-2010.



**CLASS 35—(Continued).**

3,962,434. DREW - IRELAND LLC, BOSTON, MA. SN 77-774,940. PUB. 1-26-2010, FILED 7-6-2009.

**WEBPORT GLOBAL**

THE MARK CONSISTS OF STANDARD CHARACTERS WITHOUT CLAIM TO ANY PARTICULAR FONT, STYLE, SIZE, OR COLOR.

NO CLAIM IS MADE TO THE EXCLUSIVE RIGHT TO USE "GLOBAL", APART FROM THE MARK AS SHOWN.

FOR ASSOCIATION SERVICES, NAMELY, PROMOTING THE INTERESTS OF SMALL AND MEDIUM ENTERPRISES BY FOSTERING, MAINTAINING, AND EXPANDING MEMBERS' CAPABILITIES AND THEIR ACCESS TO RESOURCES AND POTENTIAL BUSINESS PARTNERS WITH REGARD TO THE DEVELOPMENT AND EXPANSION OF OPPORTUNITIES AND OPERATIONS IN INTERNATIONAL BUSINESS (U.S. CLS. 100, 101 AND 102).

FIRST USE 10-28-2010; IN COMMERCE 10-28-2010.

3,962,453. KATHLEEN TAYLOR, SAN DIEGO, CA. SN 77-782,850. PUB. 12-8-2009, FILED 7-16-2009.

**ATTAGIRL**

THE MARK CONSISTS OF STANDARD CHARACTERS WITHOUT CLAIM TO ANY PARTICULAR FONT, STYLE, SIZE, OR COLOR.

FOR ADVERTISING AND INFORMATION DISTRIBUTION SERVICES, NAMELY, PROMOTING THE GOODS AND SERVICES OF OTHERS OVER THE INTERNET (U.S. CLS. 100, 101 AND 102).

FIRST USE 1-20-2011; IN COMMERCE 1-20-2011.

3,962,465. HUNTER, KATHERIN, BROOKSVILLE, FL. SN 77-787,939. PUB. 7-20-2010, FILED 7-23-2009.

**The Earth's Cauldron**

THE MARK CONSISTS OF STANDARD CHARACTERS WITHOUT CLAIM TO ANY PARTICULAR FONT, STYLE, SIZE, OR COLOR.

FOR RETAIL STORES FEATURING HANDMADE GOODS, NAMELY, SOAPS, CANDLES, INCENSE, OILS, HERBS (U.S. CLS. 100, 101 AND 102).

FIRST USE 7-22-2000; IN COMMERCE 7-22-2000.

**CLASS 35—(Continued).**

3,962,493. BLACKWOOD ASSETS, INC., WILMINGTON, DE. SN 77-799,581. PUB. 7-6-2010, FILED 8-7-2009.

**A.C. MOORE** ARTS & CRAFTS

OWNER OF U.S. REG. NOS. 2,210,537, 3,645,372, AND OTHERS.

NO CLAIM IS MADE TO THE EXCLUSIVE RIGHT TO USE "ARTS & CRAFTS", APART FROM THE MARK AS SHOWN.

THE NAME(S), PORTRAIT(S), AND/OR SIGNATURE(S) SHOWN IN THE MARK DOES NOT IDENTIFY A PARTICULAR LIVING INDIVIDUAL.

THE MARK CONSISTS OF THE WORDS "A.C. MOORE" FOLLOWED BY THE WORDS "ARTS & CRAFTS". THE LETTER "M" CREATES AN UNDERScore FOR THE ELEMENT "A.C. MOORE".

FOR RETAIL STORE SERVICES IN THE FIELD OF ARTS AND CRAFTS (U.S. CLS. 100, 101 AND 102).

FIRST USE 3-31-2009; IN COMMERCE 3-31-2009.

3,962,502. HOT TOPIC, INC., CITY OF INDUSTRY, CA. SN 77-801,371. PUB. 6-29-2010, FILED 8-10-2009.



OWNER OF U.S. REG. NO. 3,842,625.

THE MARK CONSISTS OF TWO LARGE STYLIZED LETTERS "HT" FOLLOWED BY A PLUS SIGN AND STYLIZED NUMERAL ONE, HALF AS LARGE AS THE LETTERS AND TILTING UP TO THE RIGHT FROM A POSITION HALFWAY UP THE HEIGHT OF THE LETTERS.

FOR PROVIDING INCENTIVE AWARD PROGRAMS FOR CUSTOMERS THROUGH ISSUANCE AND PROCESSING OF LOYALTY POINTS FOR ON-LINE PURCHASES OF COMPANY'S GOODS AND SERVICES (U.S. CLS. 100, 101 AND 102).

FIRST USE 8-1-2009; IN COMMERCE 8-1-2009.

3,962,506. BISSMAN, BENJAMIN F, MANSFIELD, OH. SN 77-802,788. PUB. 1-12-2010, FILED 8-12-2009.

**CHUGZ**

THE MARK CONSISTS OF STANDARD CHARACTERS WITHOUT CLAIM TO ANY PARTICULAR FONT, STYLE, SIZE, OR COLOR.

FOR RETAIL STORE SERVICES FEATURING CONVENIENCE STORE ITEMS AND GASOLINE (U.S. CLS. 100, 101 AND 102).

FIRST USE 9-10-2008; IN COMMERCE 9-10-2008.

**CLASS 35—(Continued).**

3,962,507. THE NEUROMATRIX GROUP, LLC, ALPHARETTA, GA. SN 77-802,870. PUB. 7-27-2010, FILED 8-12-2009.

**NEUROLOGIC**

THE MARK CONSISTS OF STANDARD CHARACTERS WITHOUT CLAIM TO ANY PARTICULAR FONT, STYLE, SIZE, OR COLOR.

FOR BUSINESS ADVISORY SERVICES, CONSULTANCY AND INFORMATION; BUSINESS DEVELOPMENT CONSULTING SERVICES (U.S. CLS. 100, 101 AND 102).

FIRST USE 6-19-2006; IN COMMERCE 6-19-2006.

---

3,962,526. JOHNSON PRODUCTS COMPANY, INC., DALLAS, TX. SN 77-807,323. PUB. 12-15-2009, FILED 8-18-2009.

**NO EXCUSE! STOP THE ABUSE!**

THE MARK CONSISTS OF STANDARD CHARACTERS WITHOUT CLAIM TO ANY PARTICULAR FONT, STYLE, SIZE, OR COLOR.

FOR PROMOTING PUBLIC AWARENESS OF THE NEED TO ELIMINATE ABUSE AGAINST WOMEN (U.S. CLS. 100, 101 AND 102).

FIRST USE 8-1-2009; IN COMMERCE 8-1-2009.

---

3,962,580. CLODI L.L.C., CRYSTAL LAKE, IL. SN 77-824,118. PUB. 8-3-2010, FILED 9-10-2009.

**SWITCHING TO A GREENER TOMORROW**

THE MARK CONSISTS OF STANDARD CHARACTERS WITHOUT CLAIM TO ANY PARTICULAR FONT, STYLE, SIZE, OR COLOR.

FOR ADVERTISING IN BROCHURES IN THE FIELD OF ELECTRICAL PRODUCTS (U.S. CLS. 100, 101 AND 102).

FIRST USE 12-4-2009; IN COMMERCE 12-4-2009.

**CLASS 35—(Continued).**

3,962,596. FORTUNOFF BRANDS, LLC, GARDEN CITY, NY. SN 77-828,924. PUB. 7-13-2010, FILED 9-17-2009.

**FORTUNOFF BACKYARD STORE**

THE MARK CONSISTS OF STANDARD CHARACTERS WITHOUT CLAIM TO ANY PARTICULAR FONT, STYLE, SIZE, OR COLOR.

OWNER OF U.S. REG. NOS. 1,044,488, 1,420,819, AND 1,634,537.

NO CLAIM IS MADE TO THE EXCLUSIVE RIGHT TO USE "BACKYARD STORE", APART FROM THE MARK AS SHOWN.

FOR RETAIL AND ONLINE STORE SERVICES FEATURING OUTDOOR AND PATIO FURNITURE, OUTDOOR AND PATIO ACCESSORIES, OUTDOOR GRILLS AND HEATERS, OUTDOOR LIGHTING FIXTURES, PEST AND INSECT CONTROL DEVICES, MAILBOXES AND MAILBOX COVERS, DINNERWARE, TABLEWARE, BEVERAGeware, FLATWARE, UTENSILS, SERVING TRAYS, CANDLE HOLDERS, KITCHEN, TABLE AND BATH LINENS, BARBECUE ACCESSORIES, PICNIC ACCESSORIES, SWIMMING POOL ACCESSORIES, RUGS, FANS AND GARDEN DÉCOR (U.S. CLS. 100, 101 AND 102).

FIRST USE 3-0-2010; IN COMMERCE 3-0-2010.

---

3,962,605. CANTALEIR INTERNATIONAL, INC., HOFFMAN ESTATES, IL. SN 77-831,572. PUB. 7-27-2010, FILED 9-21-2009.

**CANTALEIR**

THE MARK CONSISTS OF STANDARD CHARACTERS WITHOUT CLAIM TO ANY PARTICULAR FONT, STYLE, SIZE, OR COLOR.

FOR BUSINESS CONSULTATION AND MANAGEMENT SERVICES IN THE FIELDS OF INNOVATION, TECHNOLOGY DEVELOPMENT, PRODUCT DEVELOPMENT, PROJECT MANAGEMENT AND REGULATORY AFFAIRS; BUSINESS DEVELOPMENT SERVICES, NAMELY, MARKETING AND PROVIDING REPRESENTATION SERVICES TO CLIENT COMPANIES FOR TECHNICAL SALES TO CLIENTS' CUSTOMERS IN THE FIELDS OF FOOD AND BEVERAGE INGREDIENTS AND PRODUCTS, DIETARY SUPPLEMENTS, OTC DRUGS, AND COSMETICS AND BODY CARE PRODUCTS (U.S. CLS. 100, 101 AND 102).

FIRST USE 5-19-2010; IN COMMERCE 5-24-2010.

**CLASS 35—(Continued).**

3,962,632. WINDWARD PROJECT MANAGEMENT LLC, ANNAPOLIS, MD. SN 77-843,107. PUB. 3-9-2010, FILED 10-7-2009.

## Windward Project Management

THE MARK CONSISTS OF STANDARD CHARACTERS WITHOUT CLAIM TO ANY PARTICULAR FONT, STYLE, SIZE, OR COLOR.

NO CLAIM IS MADE TO THE EXCLUSIVE RIGHT TO USE "PROJECT MANAGEMENT", APART FROM THE MARK AS SHOWN.

FOR BUSINESS MANAGEMENT CONSULTANCY AS WELL AS DEVELOPMENT OF PROCESSES FOR THE ANALYSIS AND THE IMPLEMENTATION OF STRATEGY PLANS AND MANAGEMENT PROJECTS (U.S. CLS. 100, 101 AND 102).

FIRST USE 7-1-2010; IN COMMERCE 7-1-2010.

**CLASS 35—(Continued).**

3,962,655. INLIFE, LLC, IRVINE, CA. SN 77-851,320. PUB. 8-3-2010, FILED 10-18-2009.

## Live inLife

THE MARK CONSISTS OF STANDARD CHARACTERS WITHOUT CLAIM TO ANY PARTICULAR FONT, STYLE, SIZE, OR COLOR.

FOR ADVERTISING, DIRECT MARKETING AND RETAIL MERCHANDISING SERVICES OF VARIOUS HEALTH RELATED GOODS, NAMELY, ELECTRONIC NICOTINE DELIVERY DEVICES, COFFEE, COSMETICS, CONSUMER ELECTRONICS, DIETARY AND FOOD SUPPLEMENTS, DOMESTIC WATER AND AIR TREATMENT SYSTEMS, CLEANERS, WAXES, POLISHES, SOAPS; CONDUCTING BUSINESS AND MARKET RESEARCH SURVEYS IN THE FIELD OF LIFESTYLE WELLNESS, NUTRITIONAL PRODUCTS AND HEALTHCARE; PROVIDING PRODUCT DEMONSTRATIONS IN THE FIELD OF NUTRITION AND LIFESTYLE WELLNESS; PROVIDING INFORMATION REGARDING CONSUMER PRODUCTS VIA A GLOBAL COMPUTERIZED INTERNET BASED NETWORK; COMPUTERIZED ONLINE RETAIL AND WHOLESALE STORE SERVICES AND DISTRIBUTORSHIPS IN THE FIELD OF ELECTRONIC NICOTINE DELIVERY DEVICES, COFFEE, COSMETICS, CONSUMER ELECTRONICS, DIETARY AND FOOD SUPPLEMENTS, DOMESTIC WATER AND AIR TREATMENT SYSTEMS, CLEANERS, WAXES, POLISHES, SOAPS; BUSINESS CONSULTATION IN THE NATURE OF RENDERING ASSISTANCE TO OTHERS IN CONNECTION WITH THE ESTABLISHMENT AND OPERATION OF DISTRIBUTORSHIPS IN THE FIELD OF ELECTRONIC NICOTINE DELIVERY DEVICES, COFFEE, COSMETICS, CONSUMER ELECTRONICS, DIETARY AND FOOD SUPPLEMENTS, DOMESTIC WATER AND AIR TREATMENT SYSTEMS, CLEANERS, WAXES, POLISHES, SOAPS; ASSOCIATION SERVICES, NAMELY, PROMOTING THE INTERESTS OF INDEPENDENT BUSINESS OWNERS (U.S. CLS. 100, 101 AND 102).

FIRST USE 9-27-2007; IN COMMERCE 7-1-2008.

3,962,645. JACKSON SPALDING, INC., ATLANTA, GA. SN 77-849,629. PUB. 7-13-2010, FILED 10-15-2009.

## JS EXCAVATION

THE MARK CONSISTS OF STANDARD CHARACTERS WITHOUT CLAIM TO ANY PARTICULAR FONT, STYLE, SIZE, OR COLOR.

FOR ADVERTISING AND MARKETING; BRANDING SERVICES, NAMELY, BRAND CREATION AND DEVELOPMENT FOR BUSINESSES AND NON-PROFIT ORGANIZATIONS; BRAND POSITIONING; MARKET RESEARCH AND CONSULTATION; PUBLIC RELATIONS; BUSINESS DEVELOPMENT CONSULTING SERVICES, NAMELY, DEVELOPMENT OF BUSINESS MISSION AND VISION STATEMENTS (U.S. CLS. 100, 101 AND 102).

FIRST USE 1-15-2009; IN COMMERCE 1-15-2009.

**CLASS 35—(Continued).**

3,962,658. MIL-SPEC MONKEY, INC., SAN JOSE, CA. SN 77-852,253. PUB. 9-7-2010, FILED 10-19-2009.



THE MARK CONSISTS OF A MONKEY FACE WEARING EAR PROTECTION.

FOR ON-LINE RETAILER STORE FEATURING CLOTHING, NAMELY, PATCHES, T-SHIRTS, HATS, BAGS AND POUCHES AND TACTICAL GEAR (U.S. CLS. 100, 101 AND 102).

FIRST USE 7-29-2010; IN COMMERCE 7-29-2010.

3,962,670. MINASSIAN, PATRICIA, LAGUNA NIGUEL, CA. SN 77-856,616. PUB. 4-6-2010, FILED 10-24-2009.

Position, Communicate,  
Persuade!

THE MARK CONSISTS OF STANDARD CHARACTERS WITHOUT CLAIM TO ANY PARTICULAR FONT, STYLE, SIZE, OR COLOR.

FOR ADVERTISING SERVICES, PUBLIC RELATIONS AND MARKETING SERVICES, NAMELY, PROMOTING AND MARKETING THE GOODS AND SERVICES OF OTHERS THROUGH ALL PUBLIC COMMUNICATION MEANS (U.S. CLS. 100, 101 AND 102).

FIRST USE 6-1-2009; IN COMMERCE 6-1-2009.

**CLASS 35—(Continued).**

3,962,671. MINASSIAN, PATRICIA, LAGUNA NIGUEL, CA. SN 77-856,622. PUB. 4-6-2010, FILED 10-24-2009.

Marketing Impact.  
Business Results.

THE MARK CONSISTS OF STANDARD CHARACTERS WITHOUT CLAIM TO ANY PARTICULAR FONT, STYLE, SIZE, OR COLOR.

FOR ADVERTISING SERVICES, PUBLIC RELATIONS AND MARKETING SERVICES, NAMELY, PROMOTING AND MARKETING THE GOODS AND SERVICES OF OTHERS THROUGH ALL PUBLIC COMMUNICATION MEANS (U.S. CLS. 100, 101 AND 102).

FIRST USE 6-1-2009; IN COMMERCE 6-1-2009.

3,962,676. LG ELECTRONICS INC., SEOUL, REPUBLIC OF KOREA. SN 77-857,565. PUB. 9-14-2010, FILED 10-26-2009.

Before you Text, Give it a  
Ponder

THE MARK CONSISTS OF STANDARD CHARACTERS WITHOUT CLAIM TO ANY PARTICULAR FONT, STYLE, SIZE, OR COLOR.

FOR PROMOTING PUBLIC AWARENESS OF PROPER TEXT MESSAGING BEHAVIOR (U.S. CLS. 100, 101 AND 102).

FIRST USE 12-1-2009; IN COMMERCE 12-1-2009.

3,962,681. J&L MARKETING, INC., LOUISVILLE, KY. SN 77-858,077. PUB. 8-17-2010, FILED 10-27-2009.

**BPRECISE**

THE MARK CONSISTS OF STANDARD CHARACTERS WITHOUT CLAIM TO ANY PARTICULAR FONT, STYLE, SIZE, OR COLOR.

FOR PROVIDING STATISTICAL ANALYSIS OF CUSTOMER DATABASES FOR BUSINESS PURPOSES THROUGH A SERIES OF PREDICTIVE MODELS THAT FORECAST THE PROPENSITY OF CUSTOMER BEHAVIOR; BUSINESS SERVICES, NAMELY, PROVIDING RECOMMENDATIONS FOR MARKETING DECISIONS AND SELECTING TARGET MARKETS FOR SPECIFIC CAMPAIGNS (U.S. CLS. 100, 101 AND 102).

FIRST USE 2-0-2010; IN COMMERCE 2-0-2010.

**CLASS 35—(Continued).**

3,962,684. LOVIN' SCOOPFUL, LLC, SEATTLE, WA. SN 77-859,254. PUB. 2-16-2010, FILED 10-28-2009.

## Lovin' List

THE MARK CONSISTS OF STANDARD CHARACTERS WITHOUT CLAIM TO ANY PARTICULAR FONT, STYLE, SIZE, OR COLOR.

FOR PROVIDING LISTINGS OF COMPANIES MAKING SIGNIFICANT CHARITABLE CONTRIBUTIONS TO SPECIFIC CAUSES (U.S. CLS. 100, 101 AND 102).

FIRST USE 6-13-2010; IN COMMERCE 6-13-2010.

---

3,962,690. HOMEGOODS, INC., FRAMINGHAM, MA. SN 77-860,376. PUB. 8-24-2010, FILED 10-29-2009.

## HOMEGOODS HAPPY HOUR

THE MARK CONSISTS OF STANDARD CHARACTERS WITHOUT CLAIM TO ANY PARTICULAR FONT, STYLE, SIZE, OR COLOR.

OWNER OF U.S. REG. NOS. 1,955,706 AND 2,692,830. FOR RETAIL DEPARTMENT STORE SERVICES (U.S. CLS. 100, 101 AND 102).

FIRST USE 2-17-2011; IN COMMERCE 2-17-2011.

---

3,962,691. TALBOT, JEFFREY, SAN MARINO, CA. SN 77-860,905. PUB. 8-24-2010, FILED 10-29-2009.



THE MARK CONSISTS OF THE WORDING "SUMMERPIE" IN OUTLINED STYLIZED FONT. A DESIGN ELEMENT CONSISTING OF FOUR STYLIZED WATERMELON WEDGES ABOVE A SHADED SEMI-CIRCLE APPEARS ABOVE THE WORDING.

FOR PROMOTING THE SALE AND CONSUMPTION OF WATERMELON (U.S. CLS. 100, 101 AND 102).

FIRST USE 10-21-2009; IN COMMERCE 10-21-2009.

**CLASS 35—(Continued).**

3,962,701. YIP, CHUNGHONG, MA ON SHAN, NT, HONG KONG. SN 77-865,491. PUB. 10-26-2010, FILED 11-5-2009.

## APFFI

THE MARK CONSISTS OF STANDARD CHARACTERS WITHOUT CLAIM TO ANY PARTICULAR FONT, STYLE, SIZE, OR COLOR.

FOR ADVERTISING AND BUSINESS SERVICES, NAMELY, PROVIDING AN ONLINE WEBSITES WHERE ADVERTISERS, MARKETERS, AND CONTENT PROVIDERS CAN INTERACT WITH USERS FOR ADVERTISING, BRANDING, AND PROMOTING KNOWLEDGE, PRODUCTS, AND SERVICES, AND TRADESHOWS, ON BEHALF OF THEMSELVES AND OTHERS, AND FOR EVALUATING AND RATING THE SAME, ALL THE FOREGOING RELEVANT TO HUMAN ACTIVITIES AFFECTING CLIMATE CHANGE AND RELATED FIELDS; ONLINE ADVERTISING VIA A COMPUTER COMMUNICATIONS NETWORK.; PROVIDING A WEB-BASED SYSTEM AND ONLINE PORTALS IN THE FIELD OF CONSUMER-TO-BUSINESS COMMERCE FOR CONSUMERS TO ENTER, MANAGE AND MODIFY THEIR CONSUMER PREFERENCE INFORMATION FOR USE BY MERCHANTS TO CREATE AND MANAGE OFFERS FOR DELIVERY TO CONSUMERS; PROVIDING ONLINE BUSINESS MANAGEMENT SERVICES INCLUDING ACCOUNTING, MARKETING, BUSINESS PROJECT MANAGEMENT, AND BUSINESS DEVELOPMENT (U.S. CLS. 100, 101 AND 102).

FIRST USE 10-0-2009; IN COMMERCE 2-0-2011.

---

3,962,712. INGRID S. TIGHE, BIRMINGHAM, MI. SN 77-871,297. PUB. 8-17-2010, FILED 11-12-2009.



NO CLAIM IS MADE TO THE EXCLUSIVE RIGHT TO USE "LEADERSHIP", APART FROM THE MARK AS SHOWN.

THE COLOR(S) BLACK, YELLOW AND PINK IS/ARE CLAIMED AS A FEATURE OF THE MARK.

THE MARK CONSISTS OF "SPARK" IN BLACK WITH THE WORD "LEADERSHIP" IN PINK BELOW WITH AN EIGHT POINTED STAR DESIGN AT THE END OF THE "K" IN "SPARK" IN YELLOW AND PINK.

FOR BUSINESS MANAGEMENT CONSULTATION IN THE FIELD OF EXECUTIVE AND LEADERSHIP DEVELOPMENT (U.S. CLS. 100, 101 AND 102).

FIRST USE 1-1-2011; IN COMMERCE 1-1-2011.



**CLASS 35—(Continued).**

3,962,731. ZIBA IP HOLDINGS, LLC, ARTESIA, CA. SN 77-882,506. PUB. 8-17-2010, FILED 11-30-2009.

**SUMITA BEAUTY**

THE MARK CONSISTS OF STANDARD CHARACTERS WITHOUT CLAIM TO ANY PARTICULAR FONT, STYLE, SIZE, OR COLOR.

OWNER OF U.S. REG. NO. 3,248,462.

NO CLAIM IS MADE TO THE EXCLUSIVE RIGHT TO USE "BEAUTY", APART FROM THE MARK AS SHOWN.

FOR FRANCHISE SERVICES, NAMELY, OFFERING BUSINESS MANAGEMENT ASSISTANCE IN THE ESTABLISHMENT AND OPERATION OF BEAUTY SALONS (U.S. CLS. 100, 101 AND 102).

FIRST USE 12-15-2010; IN COMMERCE 12-15-2010.

3,962,735. HUNTER, SHELLEY A, DANVILLE, CA. SN 77-882,839. PUB. 4-27-2010, FILED 12-1-2009.

**Gift Card Girlfriend**

THE MARK CONSISTS OF STANDARD CHARACTERS WITHOUT CLAIM TO ANY PARTICULAR FONT, STYLE, SIZE, OR COLOR.

NO CLAIM IS MADE TO THE EXCLUSIVE RIGHT TO USE "GIFT CARD", APART FROM THE MARK AS SHOWN.

FOR ADVERTISING SERVICES, NAMELY, PROMOTING THE GIFT CARDS OF OTHERS (U.S. CLS. 100, 101 AND 102).

FIRST USE 12-1-2009; IN COMMERCE 3-11-2010.

3,962,744. APPLESEED LLC, OLD GREENWICH, CT. SN 77-885,071. PUB. 10-12-2010, FILED 12-3-2009.

**APPLESEED FOOD FRONTIERS**

THE MARK CONSISTS OF STANDARD CHARACTERS WITHOUT CLAIM TO ANY PARTICULAR FONT, STYLE, SIZE, OR COLOR.

NO CLAIM IS MADE TO THE EXCLUSIVE RIGHT TO USE "FOOD", APART FROM THE MARK AS SHOWN.

FOR MARKETING AND BUSINESS CONSULTING SERVICES FOR PRODUCERS AND PURVEYORS OF GOOD FOOD AND LOCALLY-BASED FOOD PRODUCTS (U.S. CLS. 100, 101 AND 102).

FIRST USE 1-1-2010; IN COMMERCE 1-1-2010.

**CLASS 35—(Continued).**

3,962,784. ROGERS, PAMELA M, DBA RECKLESS WOMEN, CAPE CORAL, FL. SN 77-896,445. PUB. 5-11-2010, FILED 12-18-2009.

**Reckless Women**

THE MARK CONSISTS OF STANDARD CHARACTERS WITHOUT CLAIM TO ANY PARTICULAR FONT, STYLE, SIZE, OR COLOR.

FOR ON-LINE RETAIL STORE SERVICES FEATURING A WIDE VARIETY OF CONSUMER GOODS OF OTHERS (U.S. CLS. 100, 101 AND 102).

FIRST USE 1-1-2010; IN COMMERCE 1-1-2010.

3,962,793. RAMSELL HOLDING CORPORATION, OAKLAND, CA. SN 77-899,391. PUB. 7-13-2010, FILED 12-22-2009.



THE MARK CONSISTS OF A SQUARE TEXT BOX WITH THE WORD "HELP" IN IT. TO THE TOP RIGHT OF THE LARGE TEXT BOX THERE IS A SMALLER TEXT BOX WITH THE NUMBER "4" IN IT AND BELOW THAT A SMALLER TEXT BOX WITH THE LETTER "U" IN IT.

FOR PROVIDING A WEB BASED SYSTEM AND ON-LINE PORTAL FOR CONNECTING CITIZENS IN NEED WITH PUBLICLY FUNDED PRIVATE AND NON-PROFIT PROGRAMS (U.S. CLS. 100, 101 AND 102).

FIRST USE 5-1-2010; IN COMMERCE 5-1-2010.

**CLASS 35—(Continued).**

3,962,800. SOMERS, CANDACE L., DBA CRAZYMARE, HENDERSON, NV. SN 77-901,120. PUB. 9-28-2010, FILED 12-27-2009.

# Crazymare

THE MARK CONSISTS OF STANDARD CHARACTERS WITHOUT CLAIM TO ANY PARTICULAR FONT, STYLE, SIZE, OR COLOR.

FOR WHOLESALE AND RETAIL STORE SERVICES AND ON-LINE RETAIL AND WHOLESALE STORE SERVICES FEATURING WESTERN CLOTHING AND PRODUCTS (U.S. CLS. 100, 101 AND 102).

FIRST USE 12-4-2009; IN COMMERCE 12-4-2009.

**CLASS 35—(Continued).**

3,962,877. OPTELEC U.S., INC, CHELMSFORD, MA. SN 77-921,517. PUB. 12-14-2010, FILED 1-27-2010.



The logo for VisionZone features the word "VisionZone" in a sans-serif font. The "i" in "Vision" has a dot that is a small circle. Above the "o" in "Zone" is a curved line that starts above the "o" and ends above the "e". Below the "o" in "Zone" is a curved line that starts below the "o" and ends below the "e".

FOR BUSINESS SERVICES, NAMELY, ORGANIZING THIRD PARTY VENDORS AT EVENTS; RETAIL STORE SERVICES FEATURING MAGNIFICATION AIDS FOR THE VISUALLY IMPAIRED; ON-LINE RETAIL STORE SERVICES FEATURING MAGNIFICATION AIDS FOR THE VISUALLY IMPAIRED (U.S. CLS. 100, 101 AND 102).

FIRST USE 3-13-2010; IN COMMERCE 3-13-2010.

3,962,815. MYLIKES, INC., SAN FRANCISCO, CA. SN 77-905,446. PUB. 5-18-2010, FILED 1-5-2010.

# MYLIKES

THE MARK CONSISTS OF STANDARD CHARACTERS WITHOUT CLAIM TO ANY PARTICULAR FONT, STYLE, SIZE, OR COLOR.

FOR ADVERTISING AND BUSINESS SERVICES, NAMELY, PROVIDING AN ONLINE WEBSITE WHERE ADVERTISERS, MARKETERS, AND CONTENT PROVIDERS CAN INTERACT WITH USERS FOR ADVERTISING, BRANDING, AND PROMOTING KNOWLEDGE, PRODUCTS, AND SERVICES, AND TRADESHOWS, ON BEHALF OF THEMSELVES AND OTHERS, AND FOR EVALUATING AND RATING THE SAME, ALL THE FOREGOING RELEVANT TO HUMAN ACTIVITIES AFFECTING CLIMATE CHANGE AND RELATED FIELDS; ADVERTISING AND COMMERCIAL INFORMATION SERVICES, VIA THE INTERNET; ADVERTISING AND DIRECTORY SERVICES, NAMELY, PROMOTING THE SERVICES OF OTHERS BY PROVIDING A WEB PAGE FEATURING LINKS TO THE WEBSITES OF OTHERS; ADVERTISING AND MARKETING; ADVERTISING AND MARKETING SERVICES, NAMELY, PROMOTING THE GOODS AND SERVICES OF OTHERS; ADVERTISING AND PROMOTIONAL SERVICES; ADVERTISING AND PUBLICITY SERVICES; ADVERTISING ON THE INTERNET FOR OTHERS; ADVERTISING SERVICES, NAMELY, COST-PER-ACTION ON-LINE ADVERTISING; ADVERTISING SERVICES, NAMELY, PROMOTING PROPERTIES FOR SALE BY OWNER VIA THE INTERNET; ADVERTISING, INCLUDING ON-LINE ADVERTISING ON A COMPUTER NETWORK; PAY PER CLICK (PPC) ADVERTISING MANAGEMENT SERVICES (U.S. CLS. 100, 101 AND 102).

FIRST USE 1-5-2010; IN COMMERCE 1-5-2010.

3,962,908. ICIM CORPORATION, DBA PLANET TELECOM, NEW ALBANY, IN. SN 77-930,148. PUB. 7-20-2010, FILED 2-8-2010.

# CHAMBERBID

THE MARK CONSISTS OF STANDARD CHARACTERS WITHOUT CLAIM TO ANY PARTICULAR FONT, STYLE, SIZE, OR COLOR.

FOR PROVIDING AN ON-LINE MARKETPLACE TO CONTRIBUTE TO COMMERCIAL TRANSACTIONS BETWEEN DIFFERENT OPERATORS IN THE SALE OF PRODUCTS AND SERVICES, AND PROVIDING ON-LINE ADVERTISING SPACE FOR ASSOCIATED PRODUCTS AND SERVICES (U.S. CLS. 100, 101 AND 102).

FIRST USE 6-0-2010; IN COMMERCE 6-0-2010.

**CLASS 35—(Continued).**

3,962,915. FLORENCE CONVENTION AND VISITORS BUREAU, AKA PEE DEE TOURISM COMMISSION, FLORENCE, SC. SN 77-931,452. PUB. 6-1-2010, FILED 2-9-2010.

artastic

THE MARK CONSISTS OF STANDARD CHARACTERS WITHOUT CLAIM TO ANY PARTICULAR FONT, STYLE, SIZE, OR COLOR.

FOR CONVENTION AND VISITORS BUREAU SERVICES IN THE NATURE OF CHAMBER OF COMMERCE SERVICES, NAMELY, PROMOTING BUSINESS AND TOURISM IN THE NORTHEAST SOUTH CAROLINA AREA; CONVENTION AND VISITORS BUREAU SERVICES IN THE NATURE OF CHAMBER OF COMMERCE SERVICES, NAMELY, PROMOTING TOURISM, BUSINESS AND CONVENTIONS IN AND AROUND THE NORTHEAST SOUTH CAROLINA AREA (U.S. CLS. 100, 101 AND 102).

FIRST USE 1-20-2010; IN COMMERCE 1-20-2010.

---

3,962,943. ICIM CORPORATION, DBA PLANET TELECOM, NEW ALBANY, IN. SN 77-936,236. PUB. 7-20-2010, FILED 2-16-2010.



NO CLAIM IS MADE TO THE EXCLUSIVE RIGHT TO USE "BID" AND "OFFER", APART FROM THE MARK AS SHOWN.

THE MARK CONSISTS OF THE WORDS "CHAMBERBID" OVER THE PHRASE OFFER EASY, WHERE THE TERM "BID" APPEARS IN A STYLIZED RENDITION OF A PADDLE.

FOR PROVIDING AN ON-LINE MARKETPLACE TO CONTRIBUTE TO COMMERCIAL TRANSACTIONS BETWEEN DIFFERENT OPERATORS IN THE SALE OF PRODUCTS AND SERVICES, AND PROVIDING ON-LINE ADVERTISING SPACE FOR ASSOCIATED PRODUCTS AND SERVICES (U.S. CLS. 100, 101 AND 102).

FIRST USE 6-0-2010; IN COMMERCE 6-0-2010.

**CLASS 35—(Continued).**

3,962,946. O'NEAL INSURANCE SERVICES, UPPER MARLBORO, MD. SN 77-936,425. PUB. 7-20-2010, FILED 2-16-2010.

1-800-GOT-BAIL

THE MARK CONSISTS OF STANDARD CHARACTERS WITHOUT CLAIM TO ANY PARTICULAR FONT, STYLE, SIZE, OR COLOR.

NO CLAIM IS MADE TO THE EXCLUSIVE RIGHT TO USE "BAIL", APART FROM THE MARK AS SHOWN.

FOR ADVERTISEMENT AND PUBLICITY SERVICES BY TELEVISION, RADIO, MAIL; ADVERTISEMENT FOR OTHERS ON THE INTERNET; ADVERTISEMENT VIA MOBILE PHONE NETWORKS; ADVERTISING AGENCIES, NAMELY, PROMOTING THE GOODS AND SERVICES OF OTHERS; ADVERTISING AND ADVERTISEMENT SERVICES; ADVERTISING AND BUSINESS SERVICES, NAMELY, SECURING AIRTIME ON ALL FORMS OF MEDIA COMMUNICATIONS STATIONS, SYSTEMS, NETWORKS, AND SERVICES FOR THE PURPOSE OF PROMOTING THE GOODS AND SERVICES OF OTHERS; ADVERTISING AND COMMERCIAL INFORMATION SERVICES, VIA THE INTERNET; ADVERTISING AND DIRECTORY SERVICES, NAMELY, PROMOTING THE SERVICES OF OTHERS BY PROVIDING A WEB PAGE FEATURING LINKS TO THE WEBSITES OF OTHERS; ADVERTISING AND PUBLICITY SERVICES, NAMELY, PROMOTING THE GOODS, SERVICES, BRAND IDENTITY AND COMMERCIAL INFORMATION AND NEWS OF THIRD PARTIES THROUGH PRINT, AUDIO, VIDEO, DIGITAL AND ON-LINE MEDIUM; ADVERTISING BUSINESS ESPECIALLY IN THE FIELD OF TELEMATIC AND TELEPHONE NETWORKS; ADVERTISING BY TRANSMISSION OF ON-LINE PUBLICITY FOR THIRD PARTIES THROUGH ELECTRONIC COMMUNICATIONS NETWORKS; ADVERTISING ON THE INTERNET FOR OTHERS; ADVERTISING SERVICES, NAMELY, COST-PER-ACTION ON-LINE ADVERTISING; ADVERTISING SERVICES, NAMELY, PROMOTING AND MARKETING THE GOODS AND SERVICES OF OTHERS THROUGH ALL PUBLIC COMMUNICATION MEANS; ADVERTISING VIA ELECTRONIC MEDIA AND SPECIFICALLY THE INTERNET; ADVERTISING, INCLUDING ON-LINE ADVERTISING ON A COMPUTER NETWORK; ALL OF THE FORGOING IN THE FIELD OF PROVIDING ACCESS AND REFERRAL TO BAIL BOND SERVICES THROUGH A NETWORK OF BAIL BOND SERVICE PROVIDES (U.S. CLS. 100, 101 AND 102).

FIRST USE 2-14-2010; IN COMMERCE 2-14-2010.

**CLASS 35—(Continued).**

3,962,964. EDWARD D. SCHMIDT, SAN FRANCISCO, CA. SN 77-941,324. PUB. 10-26-2010, FILED 2-22-2010.

**BRATTY MODEL**

THE MARK CONSISTS OF STANDARD CHARACTERS WITHOUT CLAIM TO ANY PARTICULAR FONT, STYLE, SIZE, OR COLOR.

FOR ADVERTISING AND INFORMATION DISTRIBUTION SERVICES, NAMELY, PROVIDING CLASSIFIED ADVERTISING SPACE VIA THE INTERNET; PROMOTING THE GOODS AND SERVICES OF OTHERS OVER THE INTERNET (U.S. CLS. 100, 101 AND 102).

FIRST USE 1-15-2011; IN COMMERCE 1-15-2011.

3,962,979. NORDSTROM, INC., SEATTLE, WA. SN 77-942,736. PUB. 8-10-2010, FILED 2-23-2010.

**THE RACK**

THE MARK CONSISTS OF STANDARD CHARACTERS WITHOUT CLAIM TO ANY PARTICULAR FONT, STYLE, SIZE, OR COLOR.

OWNER OF U.S. REG. NOS. 1,409,938 AND 2,980,055.

FOR RETAIL STORE SERVICES, ONLINE RETAIL STORE SERVICES AND MAIL ORDER CATALOG SERVICES FEATURING APPAREL, FOOTWEAR, FASHION ACCESSORIES AND GIFTS (U.S. CLS. 100, 101 AND 102).

FIRST USE 0-0-1990; IN COMMERCE 0-0-1990.

3,962,996. AMANDA VARE, WYONG CREEK NSW, AUSTRALIA. SN 77-944,363. PUB. 7-27-2010, FILED 2-25-2010.



NO CLAIM IS MADE TO THE EXCLUSIVE RIGHT TO USE "EST. 2008" AND "T-SHIRTS", APART FROM THE MARK AS SHOWN.

THE MARK CONSISTS OF AN ELLIPSE WITH THE WORDS "EST.2008" IN SMALL STYLIZED FONT POSITIONED AT THE TOP AND THE WORD "GRITFX" IN LARGER STYLIZED FONT IN THE CENTRE OF THE ELLIPSE WITH THE WORD "T-SHIRTS" IN STYLIZED FONT IN A SMALLER RECTANGLE SITUATED AT THE BOTTOM OF THE ELLIPSE.

FOR ON-LINE RETAIL STORE SERVICES FEATURING T-SHIRTS AND T-SHIRT DESIGNS (U.S. CLS. 100, 101 AND 102).

FIRST USE 1-1-2010; IN COMMERCE 6-1-2010.

**CLASS 35—(Continued).**

3,963,008. GLOVER, SIMONE, DBA SIM 1 COMMUNICATIONS, BROOKLYN, NY. SN 77-945,372. PUB. 7-27-2010, FILED 2-25-2010.



NO CLAIM IS MADE TO THE EXCLUSIVE RIGHT TO USE "COMMUNICATIONS" AND "NEW YORK", APART FROM THE MARK AS SHOWN.

THE MARK CONSISTS OF THE WORDS "SIM 1 COMMUNICATIONS" WITH A DOT BETWEEN "SIM" AND "1" AND THE WORD "COMMUNICATIONS" UNDERNEATH, WITH A SWAN DESIGN WITH "NEW YORK" INSIDE THAT APPEARS BELOW THE WORD "COMMUNICATIONS"; AND THE WORDS, "S.W.A.N. SIM1 WILL ACHIEVE NOTORIETY" ARE UNDERNEATH THE SWAN DESIGN.

FOR ARRANGING PERSONAL APPEARANCES BY PERSONS WORKING IN THE FIELD OF FILM, MUSIC, TELEVISION, ENTERTAINMENT OR SPORT; BUSINESS CONSULTING, BUSINESS MANAGEMENT AND PROVIDING INFORMATION IN THE MUSIC BUSINESS FIELD; BUSINESS DEVELOPMENT CONSULTING SERVICES; BUSINESS ORGANIZATION AND MANAGEMENT CONSULTING; ENTERTAINMENT MARKETING SERVICES, NAMELY, MARKETING, PROMOTION AND ADVERTISING FOR INDEPENDENT RECORDING ARTISTS; MANAGEMENT OF PERFORMING ARTISTS; MANAGEMENT OF PROFESSIONAL ATHLETES; MODELING AGENCIES (U.S. CLS. 100, 101 AND 102).

FIRST USE 9-5-2006; IN COMMERCE 2-1-2010.

3,963,012. BORDO, SARA, SANTA MONICA, CA. SN 77-945,615. PUB. 7-27-2010, FILED 2-26-2010.

**WOMEN RISING**

THE MARK CONSISTS OF STANDARD CHARACTERS WITHOUT CLAIM TO ANY PARTICULAR FONT, STYLE, SIZE, OR COLOR.

NO CLAIM IS MADE TO THE EXCLUSIVE RIGHT TO USE "WOMEN", APART FROM THE MARK AS SHOWN.

FOR PROVIDING EMPLOYMENT COUNSELING INFORMATION ON HOW TO SUCCESSFULLY TRANSITION JOBS; PROVIDING A JOB-READINESS AND CAREER-DEVELOPMENT WEBSITE; PROVIDING CAREER INFORMATION; CAREER PLACEMENT AND CAREER INFORMATION SERVICES FOR YOUNG WOMEN; INTERNSHIP PLACEMENT SERVICES; JOB AND PERSONNEL PLACEMENT (U.S. CLS. 100, 101 AND 102).

FIRST USE 5-0-2010; IN COMMERCE 5-0-2010.

**CLASS 35—(Continued).**

3,963,038. EXCITE IT PARTNERS, LLC, PERRY HALL, MD. SN 77-949,440. PUB. 8-3-2010, FILED 3-3-2010.



**EXCITE**  
IT PARTNERS

NO CLAIM IS MADE TO THE EXCLUSIVE RIGHT TO USE "IT PARTNERS", APART FROM THE MARK AS SHOWN.

THE COLOR(S) BLUE, GREEN, AND BLACK IS/ARE CLAIMED AS A FEATURE OF THE MARK.

THE MARK CONSISTS OF THE WORD "EXCITE" IN BLUE LETTERING WITH THE EXCEPTION OF THE "X" WHICH IS IN A LARGER FONT AND WHICH USES THE COLOR GREEN FOR ITS LEFT SIDE EXTENSIONS AND ITS CENTRAL CROSSING POINT AND THE COLOR BLUE FOR ITS RIGHT SIDE EXTENSIONS. THE WORDING "IT PARTNERS" APPEARS BELOW "EXCITE" IN BLACK LETTERING. THE COLOR WHITE REPRESENTS BACKGROUND AND TRANSPARENT AREAS AND IS NOT PART OF THE MARK.

FOR PERSONNEL RECRUITMENT SERVICES AND EMPLOYMENT AGENCIES (U.S. CLS. 100, 101 AND 102). FIRST USE 3-1-2010; IN COMMERCE 3-1-2010.

3,963,051. BLUE & GREEN LLC, MINNEAPOLIS, MN. SN 77-950,747. PUB. 7-27-2010, FILED 3-4-2010.

**SUSTOLOGY**

THE MARK CONSISTS OF STANDARD CHARACTERS WITHOUT CLAIM TO ANY PARTICULAR FONT, STYLE, SIZE, OR COLOR.

FOR BUSINESS ADVISORY SERVICES IN THE FIELDS OF ARCHITECTURE, INTERIOR DESIGN AND URBAN PLANNING DESIGN; CONSULTING SERVICES IN THE FIELD OF ENERGY USAGE MANAGEMENT AND ENERGY EFFICIENCY; MANAGEMENT AND BUSINESS CONSULTING SERVICES IN THE FIELD OF WATER, ENERGY, TRANSPORTATION, CONSTRUCTION, REAL ESTATE DEVELOPMENT AND BUILDING PRODUCTS; ON-LINE BUYERS GUIDE SERVICE PROVIDING INFORMATION IN THE FIELD OF GREEN PRODUCTS; PROVIDING A WEB SITE FEATURING PRODUCT RATINGS OF THE CONSUMER GOODS AND SERVICES OF OTHERS IN THE FIELD OF WATER, ENERGY, TRANSPORTATION, CONSTRUCTION AND REAL ESTATE DEVELOPMENT; PROVIDING AN ON-LINE COMPUTER DATABASE FEATURING TRADE INFORMATION IN THE FIELD OF RENEWABLE AND ENERGY EFFICIENT PRODUCTS, GREEN ARCHITECTURE, INTERIOR DESIGN, COMMUNITY PLANNING AND INFRASTRUCTURE DEVELOPMENT (U.S. CLS. 100, 101 AND 102).

FIRST USE 2-15-2010; IN COMMERCE 3-30-2010.

**CLASS 35—(Continued).**

3,963,052. ANDERSON, ANN-CABELL BAUM, RALEIGH, NC. SN 77-950,773. PUB. 7-27-2010, FILED 3-4-2010.

**MYSCENE**

THE MARK CONSISTS OF STANDARD CHARACTERS WITHOUT CLAIM TO ANY PARTICULAR FONT, STYLE, SIZE, OR COLOR.

FOR ADVERTISING SERVICES, NAMELY, PROMOTING THE GOODS AND/OR SERVICES OF RESTAURANTS, CLUBS, BARS, COFFEE SHOPS, BANKS, LEGAL AND ACCOUNTING FIRMS, RETAIL STORES, AND RESIDENTIAL REAL ESTATE SERVICES THROUGH THE DISTRIBUTION OF ADVERTISING MATERIAL IN THE NATURE OF INFORMATION SHEETS, FLYERS, BROCHURES, MAPS, AND VIA A PROMOTIONAL WEBSITE FEATURING INFORMATION ABOUT THE BUSINESSES SUCH AS LOCATION, EVENTS, SPECIAL FEATURES, AND/OR DISCOUNTS (U.S. CLS. 100, 101 AND 102).

FIRST USE 6-1-2010; IN COMMERCE 6-1-2010.

3,963,123. HARRIS, NEIL I., BURNSVILLE, NC. SN 77-958,705. PUB. 8-31-2010, FILED 3-15-2010.

**XCARD**

THE MARK CONSISTS OF STANDARD CHARACTERS WITHOUT CLAIM TO ANY PARTICULAR FONT, STYLE, SIZE, OR COLOR.

FOR ADMINISTRATION, BILLING AND RECONCILIATION OF ACCOUNTS ON BEHALF OF OTHERS (U.S. CLS. 100, 101 AND 102).

FIRST USE 9-29-2009; IN COMMERCE 9-29-2009.

3,963,144. INDEPENDENT PURCHASING COMPANY (AUSTRALASIA) LTD., NORTH SYDNEY, AUSTRALIA. SN 77-960,638. PUB. 12-7-2010, FILED 3-16-2010.



**Unaterra**

THE MARK CONSISTS OF THE WORD "UNATERRA" WITH A GLOBE.



**CLASS 35—(Continued).**

THE ENGLISH TRANSLATION OF "UNATERRA" IN THE MARK IS AN "EARTH".

FOR PROCUREMENT, NAMELY, PURCHASING FOOD, NON-ALCOHOLIC DRINKS, PACKAGING, AND RESTAURANT EQUIPMENT FOR RESTAURANTS AND FOOD OUTLETS (U.S. CLS. 100, 101 AND 102).

FIRST USE 12-1-2004; IN COMMERCE 12-1-2004.

---

3,963,156. ADVANCE AUTO INNOVATIONS, LLC, ROANOKE, VA. SN 77-961,431. PUB. 8-3-2010, FILED 3-17-2010.

STOPPING POWER STARTS HERE.

THE MARK CONSISTS OF STANDARD CHARACTERS WITHOUT CLAIM TO ANY PARTICULAR FONT, STYLE, SIZE, OR COLOR.

FOR RETAIL AUTO PARTS STORE SERVICES; RETAIL AUTO PARTS STORE SERVICES FOR COMMERCIAL CUSTOMERS; ONLINE RETAIL AUTO PARTS STORE SERVICES; ONLINE RETAIL AUTO PARTS STORE SERVICES FOR COMMERCIAL CUSTOMERS (U.S. CLS. 100, 101 AND 102).

FIRST USE 5-0-2010; IN COMMERCE 5-0-2010.

---

3,963,175. VALTREND, LLC, EAGLE, ID. SN 77-963,217. PUB. 8-10-2010, FILED 3-19-2010.

**VALTREND**

THE MARK CONSISTS OF STANDARD CHARACTERS WITHOUT CLAIM TO ANY PARTICULAR FONT, STYLE, SIZE, OR COLOR.

FOR BUSINESS MANAGEMENT CONSULTING AND ADVISORY SERVICES (U.S. CLS. 100, 101 AND 102).

FIRST USE 8-1-2010; IN COMMERCE 8-1-2010.

**CLASS 35—(Continued).**

3,963,202. INCENERGY, LLC, AUSTIN, TX. SN 77-966,229. PUB. 8-10-2010, FILED 3-23-2010.

**INCENERGY**

THE MARK CONSISTS OF STANDARD CHARACTERS WITHOUT CLAIM TO ANY PARTICULAR FONT, STYLE, SIZE, OR COLOR.

FOR ENERGY USAGE MANAGEMENT INFORMATION SERVICES (U.S. CLS. 100, 101 AND 102).

FIRST USE 5-15-2010; IN COMMERCE 5-15-2010.

---

3,963,213. PATTON, BRANDY, ALBUQUERQUE, NM. SN 77-967,089. PUB. 8-17-2010, FILED 3-24-2010.

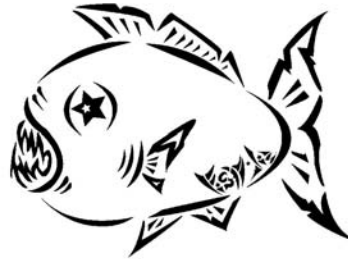

THE MARK CONSISTS OF A FISH AND THE STYLIZED TEXT "FISH\*JIZ" ALONG THE BOTTOM REAR PORTION OF THE FISH.

FOR RETAIL STORE SERVICES FEATURING CLOTHING, SKATEBOARDS, SNOWBOARDS, HATS, AND BACKPACKS (U.S. CLS. 100, 101 AND 102).

FIRST USE 1-1-2010; IN COMMERCE 1-10-2011.

---

3,963,244. LINKEDIN CORPORATION, MOUNTAIN VIEW, CA. SN 77-981,606. PUB. 6-22-2010, FILED 7-16-2009.

**LINKEDIN**

THE MARK CONSISTS OF STANDARD CHARACTERS WITHOUT CLAIM TO ANY PARTICULAR FONT, STYLE, SIZE, OR COLOR.

**CLASS 35—(Continued).**

OWNER OF U.S. REG. NOS. 3,074,241, 3,074,242, AND 3,303,349.

FOR ADVERTISING AND MARKETING SERVICES, NAMELY, PROMOTING GOODS AND SERVICES FOR BUSINESSES; PROVIDING AN ONLINE SEARCHABLE DATABASE FEATURING EMPLOYMENT AND CAREER OPPORTUNITIES AND BUSINESS, EMPLOYMENT AND PROFESSIONAL QUERIES AND ANSWERS; JOB PLACEMENT SERVICES, HUMAN RESOURCES CONSULTING SERVICES; BUSINESS RESEARCH AND SURVEY SERVICES; PROMOTING THE GOODS AND SERVICES OF OTHERS VIA A GLOBAL COMPUTER NETWORK; ADVERTISING, MARKETING AND PROMOTIONAL SERVICES RELATED TO ALL INDUSTRIES FOR THE PURPOSE OF FACILITATING NETWORKING AND SOCIALIZING OPPORTUNITIES FOR BUSINESS PURPOSES; CHARITABLE SERVICES, NAMELY, PROMOTING PUBLIC AWARENESS ABOUT COMMUNITY SERVICE; PROVIDING ONLINE CAREER NETWORKING SERVICES AND INFORMATION IN THE FIELDS OF EMPLOYMENT, RECRUITMENT, JOB RESOURCES, AND JOB LISTINGS; PERSONNEL RECRUITMENT AND PLACEMENT SERVICES; ELECTRONIC COMMERCE SERVICES, NAMELY, PROVIDING INFORMATION ABOUT PRODUCTS AND SERVICES VIA TELECOMMUNICATION NETWORKS FOR ADVERTISING AND SALES PURPOSES; PROVIDING NETWORKING OPPORTUNITIES FOR INDIVIDUALS SEEKING EMPLOYMENT; ON-LINE PROFESSIONAL NETWORKING OPPORTUNITIES; PROVIDING ONLINE COMPUTER DATABASES AND ONLINE SEARCHABLE DATABASES IN THE FIELDS OF BUSINESS AND PROFESSIONAL NETWORKING (U.S. CLS. 100, 101 AND 102).

FIRST USE 7-0-2008; IN COMMERCE 7-0-2008.

3,963,278. GIRONDI, RITA A. DR., CAMP HILL, PA. SN 78-126,766. PUB. 10-27-2009, FILED 5-7-2002.

**STARS**

FOR COMPILATION AND SYSTEMIZATION OF INFORMATION INTO COMPUTER DATABASES IN THE FIELD OF WRITTEN STUDENT RECORDS, NAMELY, GRADES, ATTENDANCE, FINANCIAL AID ACCOUNTS, STUDENT TRANSCRIPTS, GRADE POINT AVERAGE, AND RELATED STUDENT ENROLLMENT DATA (U.S. CLS. 100, 101 AND 102).

FIRST USE 4-12-2002; IN COMMERCE 4-12-2002.

**CLASS 35—(Continued).**

3,963,296. MYCAREERNETWORK.COM, LLC, LOUISVILLE, KY. SN 78-928,901. PUB. 2-27-2007, FILED 7-13-2006.

**LOUISVILLEWORKS.COM**

THE MARK CONSISTS OF STANDARD CHARACTERS WITHOUT CLAIM TO ANY PARTICULAR FONT, STYLE, SIZE, OR COLOR.

FOR PROVIDING ON-LINE PERSONNEL RECRUITMENT, PERSONNEL MANAGEMENT INFORMATION AND JOB SEARCH INFORMATION SERVICES; PROVIDING AN INTERACTIVE COMPUTER DATABASE FEATURING RECRUITMENT AND EMPLOYMENT INFORMATION, CAREER INFORMATION AND RESOURCES, RESUME POSTING, RESUME TRANSMITTAL AND COMMUNICATION OF RESPONSES THERETO VIA A GLOBAL COMPUTER NETWORK (U.S. CLS. 100, 101 AND 102).

FIRST USE 8-31-2000; IN COMMERCE 8-31-2000.

3,963,332. IMPACTRX, INC., MT. LAUREL, NJ. SN 85-006,137. PUB. 8-3-2010, FILED 4-5-2010.

**ImpactData**

THE MARK CONSISTS OF STANDARD CHARACTERS WITHOUT CLAIM TO ANY PARTICULAR FONT, STYLE, SIZE, OR COLOR.

FOR COLLECTION OF PATIENT DATA FROM PHYSICIANS IN ORDER TO PROVIDE TO PHARMACEUTICAL MANUFACTURERS BUSINESS INFORMATION IN THE FIELD OF PHARMACEUTICALS, NAMELY, INFORMATION ON PRODUCT VOLUME AND MARKETING ACTIVITIES (U.S. CLS. 100, 101 AND 102).

FIRST USE 5-7-2010; IN COMMERCE 5-7-2010.

3,963,340. GRASSLAND OUTFITTERS, LLC, ROANOKE, VA. SN 85-006,832. PUB. 8-31-2010, FILED 4-5-2010.

**Grassland Outfitters**

THE MARK CONSISTS OF STANDARD CHARACTERS WITHOUT CLAIM TO ANY PARTICULAR FONT, STYLE, SIZE, OR COLOR.

NO CLAIM IS MADE TO THE EXCLUSIVE RIGHT TO USE "OUTFITTERS", APART FROM THE MARK AS SHOWN.

FOR RETAIL SPORTING GOODS STORES (U.S. CLS. 100, 101 AND 102).

FIRST USE 2-1-2009; IN COMMERCE 2-1-2011.

**CLASS 35—(Continued).**

3,963,341. GRASSLAND OUTFITTERS, LLC, ROANOKE, VA. SN 85-006,838. PUB. 8-17-2010, FILED 4-5-2010.



NO CLAIM IS MADE TO THE EXCLUSIVE RIGHT TO USE "OUTFITTERS" AND "HUNT" AND "CALL", APART FROM THE MARK AS SHOWN.

THE MARK CONSISTS OF A DESIGN OF A SILHOUETTE OF A HUNTER ON ONE KNEE IN THE GRASS, WITH BIRD CALL HELD TO MOUTH WITH HAND, CAP, AND GUN, ALL WITH THE TERMS "GRASSLAND OUTFITTERS" ABOVE THE TERMS "HUNT.CALL.KILL." TO THE LEFT OF THE DESIGN ELEMENT.

FOR RETAIL SPORTING GOODS STORES (U.S. CLS. 100, 101 AND 102).

FIRST USE 11-1-2009; IN COMMERCE 2-1-2011.

3,963,342. GRASSLAND OUTFITTERS, LLC, ROANOKE, VA. SN 85-006,842. PUB. 8-17-2010, FILED 4-5-2010.



THE MARK CONSISTS OF A SILHOUETTE OF A HUNTER ON ONE KNEE IN THE GRASS WITH BIRD CALL HELD IN MOUTH BY HAND, CAP, AND GUN.

FOR RETAIL SPORTING GOODS STORES (U.S. CLS. 100, 101 AND 102).

FIRST USE 11-1-2009; IN COMMERCE 2-1-2011.

**CLASS 35—(Continued).**

3,963,362. SURRY COUNTY ECONOMIC DEVELOPMENT AND TOURISM, DOBSON, NC. SN 85-010,420. PUB. 9-7-2010, FILED 4-9-2010.

Art & Soul  
Of The Yadkin Valley

NO CLAIM IS MADE TO THE EXCLUSIVE RIGHT TO USE "YADKIN VALLEY", APART FROM THE MARK AS SHOWN.

THE MARK CONSISTS OF THE STYLIZED WORDING "ART & SOUL OF THE YADKIN VALLEY".

FOR PROMOTING RECREATION AND TOURISM IN SURRY COUNTY, NORTH CAROLINA (U.S. CLS. 100, 101 AND 102).

FIRST USE 7-1-2009; IN COMMERCE 7-1-2009.

3,963,374. CAREERBUILDER, LLC, CHICAGO, IL. SN 85-011,977. PUB. 10-5-2010, FILED 4-12-2010.

**MIRACLEWORKERS**

THE MARK CONSISTS OF STANDARD CHARACTERS WITHOUT CLAIM TO ANY PARTICULAR FONT, STYLE, SIZE, OR COLOR.

FOR PERSONNEL RECRUITMENT SERVICES VIA THE GLOBAL COMPUTER NETWORK; PROVIDING INFORMATION VIA THE GLOBAL COMPUTER NETWORK IN THE FIELDS OF PERSONNEL RECRUITMENT, PERSONNEL MANAGEMENT, EMPLOYMENT RECRUITING, CAREER PLACEMENT AND RESOURCES FOR ASSISTING PROSPECTIVE EMPLOYEES IN THE NATURE OF EMPLOYMENT LISTINGS AND RESUME PREPARATION INFORMATION (U.S. CLS. 100, 101 AND 102).

FIRST USE 5-11-2010; IN COMMERCE 5-11-2010.

**CLASS 35—(Continued).**

3,963,413. THINKPETS, INC., SANTA MONICA, CA. SN 85-024,282. PUB. 12-14-2010, FILED 4-27-2010.

# THINKPETS

THE MARK CONSISTS OF STANDARD CHARACTERS WITHOUT CLAIM TO ANY PARTICULAR FONT, STYLE, SIZE, OR COLOR.

FOR BUSINESS MARKETING AND ADVERTISING AND MARKETING SERVICES ON BEHALF OF VETERINARIANS; CONSULTING SERVICES FOR VETERINARIANS IN THE FIELDS OF PRACTICE MARKETING, BUSINESS MANAGEMENT AND PRACTICE MANAGEMENT (U.S. CLS. 100, 101 AND 102).  
FIRST USE 1-14-2011; IN COMMERCE 1-14-2011.

---

3,963,431. THE RUGGED BEAR COMPANY, NORWOOD, MA. SN 85-028,436. PUB. 10-5-2010, FILED 5-3-2010.

# LIVE LIFE RUGGED

THE MARK CONSISTS OF STANDARD CHARACTERS WITHOUT CLAIM TO ANY PARTICULAR FONT, STYLE, SIZE, OR COLOR.

OWNER OF U.S. REG. NOS. 1,435,781 AND 2,995,811.  
FOR RETAIL STORE SERVICES FEATURING APPAREL AND ACCESSORIES; ONLINE RETAIL STORE SERVICES FEATURING APPAREL AND ACCESSORIES (U.S. CLS. 100, 101 AND 102).  
FIRST USE 6-0-2010; IN COMMERCE 6-0-2010.

---

3,963,474. UNITED AUBURN INDIAN COMMUNITY, LINCOLN, CA. SN 85-037,843. PUB. 8-3-2010, FILED 5-13-2010.

# THUNDER VALLEY CASINO RESORT

THE MARK CONSISTS OF STANDARD CHARACTERS WITHOUT CLAIM TO ANY PARTICULAR FONT, STYLE, SIZE, OR COLOR.

OWNER OF U.S. REG. NOS. 2,872,370 AND 2,872,371.  
NO CLAIM IS MADE TO THE EXCLUSIVE RIGHT TO USE "CASINO RESORT", APART FROM THE MARK AS SHOWN.

FOR RETAIL GIFT SHOPS; RETAIL STORE SERVICES FEATURING A WIDE VARIETY OF CONSUMER GOODS OF OTHERS; RETAIL STORE SERVICES FEATURING CLOTHING AND SOUVENIRS (U.S. CLS. 100, 101 AND 102).

FIRST USE 7-1-2010; IN COMMERCE 7-1-2010.

**CLASS 35—(Continued).**

3,963,475. UNITED AUBURN INDIAN COMMUNITY, LINCOLN, CA. SN 85-037,899. PUB. 8-3-2010, FILED 5-13-2010.



OWNER OF U.S. REG. NOS. 2,872,370 AND 2,872,371.  
NO CLAIM IS MADE TO THE EXCLUSIVE RIGHT TO USE "CASINO" "RESORT", APART FROM THE MARK AS SHOWN.

THE MARK CONSISTS OF FIVE UPWARD POINTING ARROWS THE BASES OF WHICH FORM AN INVERTED "V" ALL OF WHICH IS A REPRESENTATION OF TREES UPON A MOUNTAIN PEAK WHICH IS OVER THE STYLIZED LETTER "T" WHICH IS OVER A STYLIZED REPRESENTATION OF A VALLEY ALL OF WHICH IS OVER THE STYLIZED WORDS "THUNDER VALLEY" WHICH IS OVER THE STYLIZED WORDS "CASINO RESORT" WHERE THE WORD "CASINO" AND THE WORD "RESORT" ARE SEPARATED BY A BULLET POINT.

FOR RETAIL GIFT SHOPS; RETAIL STORE SERVICES FEATURING A WIDE VARIETY OF CONSUMER GOODS OF OTHERS; RETAIL STORE SERVICES FEATURING CLOTHING AND SOUVENIRS (U.S. CLS. 100, 101 AND 102).

FIRST USE 7-1-2010; IN COMMERCE 7-1-2010.

---

3,963,478. HERO USA, INC., FONTANA, CA. SN 85-038,492. PUB. 10-12-2010, FILED 5-14-2010.

# ACCESS HOME

NO CLAIM IS MADE TO THE EXCLUSIVE RIGHT TO USE "HOME", APART FROM THE MARK AS SHOWN.

THE MARK CONSISTS OF "ACCESS HOME" IN CAPITAL STYLIZED LETTERS.

FOR ON-LINE RETAIL STORE SERVICES FEATURING HOME FURNISHINGS AND DECORATIVE ACCESSORIES; RETAIL STORE SERVICES FEATURING HOME FURNISHINGS AND DECORATIVE ACCESSORIES (U.S. CLS. 100, 101 AND 102).

FIRST USE 12-0-2010; IN COMMERCE 12-0-2010.

**CLASS 35—(Continued).**

3,963,479. HERO USA, INC., FONTANA, CA. SN 85-038,500.  
PUB. 10-12-2010, FILED 5-14-2010.



NO CLAIM IS MADE TO THE EXCLUSIVE RIGHT TO USE "USA INC. GARDEN FURNITURE", APART FROM THE MARK AS SHOWN.

THE COLOR(S) RED, BLUE, BLACK, AND CREAM IS/ARE CLAIMED AS A FEATURE OF THE MARK.

THE MARK CONSISTS OF BLACK OUTLINED, RED AND CREAM STRIPED UMBRELLA; "HERO USA INC." IN RED LETTERS; "GARDEN FURNITURE" BELOW IN BLUE.

FOR WHOLESALE AND RETAIL STORE SERVICES FEATURING PATIO FURNITURE (U.S. CLS. 100, 101 AND 102).

FIRST USE 12-0-2010; IN COMMERCE 12-0-2010.

**CLASS 35—(Continued).**

3,963,484. PERALTA, MADAY, MIAMI, FL. SN 85-040,452.  
PUB. 10-19-2010, FILED 5-17-2010.

# PEARHIGH

THE MARK CONSISTS OF STANDARD CHARACTERS WITHOUT CLAIM TO ANY PARTICULAR FONT, STYLE, SIZE, OR COLOR.

FOR RETAIL STORES FEATURING HOUSEHOLD GOODS AND FURNITURE (U.S. CLS. 100, 101 AND 102).  
FIRST USE 12-27-2010; IN COMMERCE 12-27-2010.

3,963,487. T.G.I.C. IMPORTERS, INC., WOODLAND HILLS, CA. SN 85-042,037. PUB. 10-19-2010, FILED 5-18-2010.

## TITAN WINE & SPIRITS CO.

THE MARK CONSISTS OF STANDARD CHARACTERS WITHOUT CLAIM TO ANY PARTICULAR FONT, STYLE, SIZE, OR COLOR.

NO CLAIM IS MADE TO THE EXCLUSIVE RIGHT TO USE "WINE & SPIRITS CO.", APART FROM THE MARK AS SHOWN.

FOR IMPORT AGENCY SERVICES IN THE FIELD OF ALCOHOLIC BEVERAGES; WHOLESALE DISTRIBUTORSHIPS FEATURING ALCOHOLIC BEVERAGES (U.S. CLS. 100, 101 AND 102).

FIRST USE 1-0-2011; IN COMMERCE 1-0-2011.

3,963,483. PERALTA, MADAY, MIAMI, FL. SN 85-040,444.  
PUB. 10-19-2010, FILED 5-17-2010.



THE MARK CONSISTS OF THE OUTLINE OF A PEAR SHAPE WITH 4 SEPARATE RECTANGULAR DESIGNS FORMING THE BACKGROUND ON WHICH THE OUTLINE IS SET.

FOR RETAIL STORES FEATURING HOUSEHOLD GOODS AND FURNITURE (U.S. CLS. 100, 101 AND 102).  
FIRST USE 12-27-2010; IN COMMERCE 12-27-2010.

3,963,519. CROSS-CONTINENTAL SOLUTIONS INC., VANCOUVER, BC, CANADA. SN 85-049,012. PUB. 1-25-2011, FILED 5-27-2010.



NO CLAIM IS MADE TO THE EXCLUSIVE RIGHT TO USE "CROSS CONTINENTAL", APART FROM THE MARK AS SHOWN.

THE COLOR(S) BLUE IS/ARE CLAIMED AS A FEATURE OF THE MARK.



**CLASS 35—(Continued).**

THE MARK CONSISTS OF THE DESIGN OF A FLYING BIRD AND STRIPES GOING AROUND A GLOBE. TO THE RIGHT OF THE DESIGN IS THE STYLIZED WORD "CROSS" WHERE THE LETTER "O" IS A GLOBE ABOVE THE STYLIZED WORD "CONTINENTAL". THE MARK IS IN SHADES OF BLUE.

FOR ADMINISTERING STUDY ABROAD PROGRAMS FOR COLLEGE STUDENTS; CHARITABLE SERVICES, NAMELY, ORGANIZING AND CONDUCTING VOLUNTEER PROGRAMS AND COMMUNITY SERVICE PROJECTS; INTERNSHIP PLACEMENT SERVICES; TRAVEL MANAGEMENT (U.S. CLS. 100, 101 AND 102).

FIRST USE 10-16-2010; IN COMMERCE 3-25-2011.

---

3,963,523. UGO ENTERTAINMENT, INC., NEW YORK, NY. SN 85-050,114. PUB. 10-26-2010, FILED 5-28-2010.



OWNER OF U.S. REG. NOS. 2,450,661, 2,562,837, AND OTHERS.

THE MARK CONSISTS OF THE CAPITAL LETTERS "U", "G", AND "O" SURROUNDED BY A BLACK OUTLINE AND OVERLAPPING AT THE INTERSECTION OF THE LETTERS "U" AND "G" AND THE INTERSECTION OF "G" AND "O".

FOR ADVERTISING AND MARKETING SERVICES, NAMELY, PROMOTING THE GOODS AND SERVICES OF OTHERS (U.S. CLS. 100, 101 AND 102).

FIRST USE 4-22-2010; IN COMMERCE 4-22-2010.

---

3,963,531. FRAGMENTS, INC., NEW YORK, NY. SN 85-053,665. PUB. 11-2-2010, FILED 6-3-2010.

**THE TREND STARTS HERE**

THE MARK CONSISTS OF STANDARD CHARACTERS WITHOUT CLAIM TO ANY PARTICULAR FONT, STYLE, SIZE, OR COLOR.

FOR RETAIL STORE SERVICES FEATURING JEWELRY (U.S. CLS. 100, 101 AND 102).

FIRST USE 1-13-2011; IN COMMERCE 1-13-2011.

**CLASS 35—(Continued).**

3,963,535. GMA INC., DBA BMD FULL SERVICE DIRECT MARKETING, ALEXANDRIA, VA. SN 85-054,698. PUB. 11-30-2010, FILED 6-4-2010.

**LIGHTNINGPM 24/7 POLITICAL MESSAGING**

THE MARK CONSISTS OF STANDARD CHARACTERS WITHOUT CLAIM TO ANY PARTICULAR FONT, STYLE, SIZE, OR COLOR.

OWNER OF U.S. REG. NO. 3,393,696.

NO CLAIM IS MADE TO THE EXCLUSIVE RIGHT TO USE "24/7 POLITICAL MESSAGING", APART FROM THE MARK AS SHOWN.

FOR DIRECT MAIL CONSULTING SERVICES TARGETED TO NON-PROFIT ORGANIZATIONS, CAMPAIGNS FOR PUBLIC OFFICE AND INDIVIDUALS SEEKING ELECTED OFFICE (U.S. CLS. 100, 101 AND 102).

FIRST USE 2-3-2011; IN COMMERCE 2-3-2011.

---

3,963,555. ECOSOURCE, LLC, ARNOLD, MD. SN 85-060,619. PUB. 11-9-2010, FILED 6-11-2010.



NO CLAIM IS MADE TO THE EXCLUSIVE RIGHT TO USE "WASTE", APART FROM THE MARK AS SHOWN.

THE COLOR(S) GREEN AND GRAY IS/ARE CLAIMED AS A FEATURE OF THE MARK.

THE MARK CONSISTS OF THREE GREEN LEAVES IN A TRIANGULAR SHAPE, THE WORD "WASTE" IN GREEN AND THE WORD "STRATEGIES" IN GRAY. THE COLOR WHITE REPRESENTS BACKGROUND AND IS NOT A PART OF THE MARK.

FOR OUTSOURCING TO CUSTOMERS OF MANAGEMENT AND STAFF IN ORDER TO HANDLE SOLID WASTE, RECEIVING WASTE FROM JANITORIAL STAFF AND THE LIKE, AND PROVIDING THE CUSTOMER WITH EFFICIENT TRANSFER TO WASTE DISPOSAL COMPANIES (U.S. CLS. 100, 101 AND 102).

FIRST USE 7-1-2010; IN COMMERCE 7-1-2010.

**CLASS 35—(Continued).**

3,963,618. DD APARTMENTS, LLC, DBA DEEP DISCOUNT APARTMENTS, BETHESDA, MD. SN 85-076,776. PUB. 1-18-2011, FILED 7-2-2010.



NO CLAIM IS MADE TO THE EXCLUSIVE RIGHT TO USE "DEEP DISCOUNT APARTMENTS.COM", APART FROM THE MARK AS SHOWN.

THE COLOR(S) BLACK, WHITE, DARK RED AND LIGHT RED IS/ARE CLAIMED AS A FEATURE OF THE MARK.

THE MARK CONSISTS OF THE WORD, "DEEP" IN BLACK BUBBLE LETTERS OUTLINED IN WHITE AND DARK RED; THE WORD ABOVE THE WORD "DISCOUNT" ON A LIGHT RED TAG IN WHITE BUBBLE LETTERS OUTLINED IN DARK RED; THE TAG HAS A DARK RED RIBBON FLOWING THROUGH A ROUND HOLE; ABOVE THE WORD, "APARTMENTS" IN BLACK BUBBLE LETTERS OUTLINED IN WHITE AND DARK RED FOLLOWED BY ".COM" IN LOWERCASE DARK RED LETTERS.

FOR PROVIDING A SEARCHABLE ONLINE ADVERTISING WEBSITE AND INFORMATIONAL GUIDE FEATURING THE GOODS AND SERVICES OF OTHER VENDORS VIA THE INTERNET IN THE FIELD OF APARTMENT RENTALS; PROVIDING AN INTERACTIVE REAL ESTATE WEBSITE WHICH PROMOTES HOUSING AND APARTMENT PROPERTIES THROUGH OFFERING PROSPECTIVE TENANTS VIDEO WALK THROUGH, PROPERTY DESCRIPTIONS, TEXT, PRICE, LOCATION, MAPS AND OTHER INFORMATION THAT WOULD BE INFLUENTIAL TO A PROSPECTIVE TENANT IN MAKING A RENTAL DECISION (U.S. CLS. 100, 101 AND 102).

FIRST USE 7-1-2010; IN COMMERCE 9-17-2010.

3,963,624. SYNCOPOLIS, INC., ST. LOUIS, MO. SN 85-078,446. PUB. 12-7-2010, FILED 7-6-2010.

## SYNCOPOLIS

THE MARK CONSISTS OF STANDARD CHARACTERS WITHOUT CLAIM TO ANY PARTICULAR FONT, STYLE, SIZE, OR COLOR.

FOR PROVIDING A WEBSITE FOR FILTERED RECOMMENDATIONS FOR HOTELS, RESTAURANTS, ATTRACTIONS, AND EVENTS FOR A GEOGRAPHIC AREA BY NOMINATIONS FROM SUBSCRIBERS IN THE GEOGRAPHIC AREA FOR COMMERCIAL PURPOSES (U.S. CLS. 100, 101 AND 102).

FIRST USE 5-30-2010; IN COMMERCE 10-29-2010.

**CLASS 35—(Continued).**

3,963,626. INFINITY CONSULTANT GROUP LLC, KANSAS CITY, MO. SN 85-079,625. PUB. 12-7-2010, FILED 7-7-2010.

## C(MP)<sup>3</sup>

THE MARK CONSISTS OF THE LETTER "C" AND THE LETTERS "M" AND "P" ENCLOSED IN PARENTHESES WITH THE EXPONENT "3".

FOR EMPLOYMENT HIRING, RECRUITING, PLACEMENT, STAFFING AND CAREER NETWORKING SERVICES (U.S. CLS. 100, 101 AND 102).

FIRST USE 10-8-2010; IN COMMERCE 10-8-2010.

3,963,652. ACTIVIENT, WINDERMERE, FL. SN 85-086,264. PUB. 12-21-2010, FILED 7-16-2010.

## Activient

THE MARK CONSISTS OF STANDARD CHARACTERS WITHOUT CLAIM TO ANY PARTICULAR FONT, STYLE, SIZE, OR COLOR.

FOR BUSINESS CONSULTATION (U.S. CLS. 100, 101 AND 102).

FIRST USE 7-16-2010; IN COMMERCE 3-7-2011.

3,963,654. STRATEGIC MARKETING AND PLANNING, INC., AKA STRATEGIC MARKETING AND MAILING, CHAMPAIGN, IL. SN 85-086,506. PUB. 1-4-2011, FILED 7-16-2010.

## SMMartTools

THE MARK CONSISTS OF STANDARD CHARACTERS WITHOUT CLAIM TO ANY PARTICULAR FONT, STYLE, SIZE, OR COLOR.

FOR DIRECT MAIL ADVERTISING SERVICES; DIRECT MARKETING; DIRECT MARKETING ADVERTISING FOR OTHERS; DIRECT MARKETING CONSULTING SERVICES (U.S. CLS. 100, 101 AND 102).

FIRST USE 3-1-2011; IN COMMERCE 3-1-2011.

**CLASS 35—(Continued).**

3,963,656. ARNOLD LUMBER, CO., WEST KINGSTON, RI. SN 85-087,413. PUB. 12-21-2010, FILED 7-19-2010.

**WIN VISION**

THE MARK CONSISTS OF STANDARD CHARACTERS WITHOUT CLAIM TO ANY PARTICULAR FONT, STYLE, SIZE, OR COLOR.

FOR RETAIL SERVICES BY DIRECT SOLICITATION BY SALES AGENTS IN THE FIELD OF WINDOWS (U.S. CLS. 100, 101 AND 102).

FIRST USE 6-1-2010; IN COMMERCE 6-1-2010.

3,963,659. NFSP MARKETING, LLC, MONTGOMERY, AL. SN 85-089,250. PUB. 1-11-2011, FILED 7-21-2010.

**NFSP Marketing**

THE MARK CONSISTS OF STANDARD CHARACTERS WITHOUT CLAIM TO ANY PARTICULAR FONT, STYLE, SIZE, OR COLOR.

NO CLAIM IS MADE TO THE EXCLUSIVE RIGHT TO USE "MARKETING", APART FROM THE MARK AS SHOWN.

FOR PROVIDING INTERNET MARKETING AND ADVERTISING FOR PRODUCTS IN THE FOOD SERVICE INDUSTRY (U.S. CLS. 100, 101 AND 102).

FIRST USE 2-2-2011; IN COMMERCE 2-2-2011.

3,963,688. ROSENBERG, MICHAEL, NEW MILFORD, NJ. SN 85-102,451. PUB. 1-18-2011, FILED 8-6-2010.

**SHUFFLEDOG**

THE MARK CONSISTS OF STANDARD CHARACTERS WITHOUT CLAIM TO ANY PARTICULAR FONT, STYLE, SIZE, OR COLOR.

FOR ON-LINE RETAIL STORE SERVICES FEATURING A WIDE VARIETY OF CONSUMER GOODS OF OTHERS (U.S. CLS. 100, 101 AND 102).

FIRST USE 11-1-2010; IN COMMERCE 11-1-2010.

**CLASS 35—(Continued).**

3,963,700. LORD & TAYLOR LLC, NEW YORK, NY. SN 85-109,354. PUB. 1-4-2011, FILED 8-17-2010.

**BRINGING STYLE HOME**

THE MARK CONSISTS OF STANDARD CHARACTERS WITHOUT CLAIM TO ANY PARTICULAR FONT, STYLE, SIZE, OR COLOR.

FOR RETAIL STORE SERVICES FEATURING FURNITURE, HOME FURNISHINGS, LAMPS, BEDDING, TOWELS, HOME TEXTILES, PILLOWS, MATTRESS PADS AND RUGS (U.S. CLS. 100, 101 AND 102).

FIRST USE 11-4-2010; IN COMMERCE 11-4-2010.

**CLASS 36—INSURANCE AND FINANCIAL**

3,961,967. SECURITIES AMERICA ADVISORS, INC., LAVISTA, NE. SN 76-679,215. PUB. 4-15-2008, FILED 7-9-2007.

ROI PROFILE - THE NEW RELIABILITY OF INCOME PROFILE

THE MARK CONSISTS OF STANDARD CHARACTERS WITHOUT CLAIM TO ANY PARTICULAR FONT, STYLE, SIZE, OR COLOR.

NO CLAIM IS MADE TO THE EXCLUSIVE RIGHT TO USE "ROI PROFILE" AND "RELIABILITY OF INCOME PROFILE", APART FROM THE MARK AS SHOWN.

FOR FINANCIAL PLANNING AND INVESTMENT ADVISORY SERVICES (U.S. CLS. 100, 101 AND 102).

FIRST USE 5-15-2007; IN COMMERCE 5-15-2007.

3,961,968. SECURITIES AMERICA ADVISORS, INC., LAVISTA, NE. SN 76-679,216. PUB. 4-15-2008, FILED 7-9-2007.

**NEXTPHASE**

THE MARK CONSISTS OF STANDARD CHARACTERS WITHOUT CLAIM TO ANY PARTICULAR FONT, STYLE, SIZE, OR COLOR.

FOR FINANCIAL PLANNING AND INVESTMENT ADVISORY SERVICES (U.S. CLS. 100, 101 AND 102).

FIRST USE 7-0-2009; IN COMMERCE 7-0-2009.

**CLASS 36—(Continued).**

3,962,042. VCAP HOLDINGS, AUSTIN, TX. SN 77-191,536. PUB. 4-29-2008, FILED 5-28-2007.



FOR ADVICE RELATING TO INVESTMENTS; AGENCIES FOR COMMODITY FUTURES TRADING; BROKERAGE HOUSES IN THE FIELD OF STOCKS, COMMODITIES, AND FUTURES; CASH AND FOREIGN EXCHANGE TRANSACTIONS; COMMODITY BROKERAGE; COMMODITY INVESTMENT ADVICE; EQUITY CAPITAL INVESTMENT; FINANCIAL PLANNING; FINANCIAL PORTFOLIO MANAGEMENT; FINANCIAL SERVICES, NAMELY, ASSISTING OTHERS WITH THE COMPLETION OF FINANCIAL TRANSACTIONS FOR STOCKS, BONDS, SECURITIES AND EQUITIES; FINANCIAL SERVICES, NAMELY, PROVIDING INFORMATION IN THE FIELDS OF FOREIGN CURRENCY, COMMODITIES, FINANCIAL DERIVATIVES, INTEREST RATE PRODUCTS, AND EQUITIES VIA THE INTERNET AND INTRANET SYSTEMS; FINANCIAL SERVICES, NAMELY, PROVIDING FOR THE EXCHANGE OF FOREIGN CURRENCY, COMMODITIES, FINANCIAL DERIVATIVES, INTEREST RATE PRODUCTS, AND EQUITIES VIA THE INTERNET AND INTRANET SYSTEMS; HEDGE FUND INVESTMENT SERVICES; INVESTMENT ADVICE; INVESTMENT BROKERAGE; INVESTMENT OF FUNDS FOR OTHERS; MANAGEMENT OF A CAPITAL INVESTMENT FUND; MANAGEMENT OF PORTFOLIOS COMPRISING SECURITIES; MANAGEMENT OF PORTFOLIOS OF TRANSFERABLE SECURITIES; AGENCIES FOR BROKERAGE OF SECURITIES TRADING IN OVERSEAS SECURITIES MARKETS AND OF TRANSACTIONS ON COMMISSION OF OVERSEAS MARKET SECURITIES FUTURES; AUTOMATED SECURITIES BROKERAGE; INVESTMENT ADVISORY SERVICES; SECURITIES TRADING AND INVESTING SERVICES FOR OTHERS VIA THE INTERNET; SECURITY BROKERAGE (U.S. CLS. 100, 101 AND 102).

FIRST USE 9-15-2004; IN COMMERCE 9-15-2004.

3,962,092. TRUMARK FINANCIAL CREDIT UNION, TREVISO, PA. SN 77-320,916. PUB. 3-4-2008, FILED 11-4-2007.



OWNER OF U.S. REG. NOS. 3,082,473 AND 3,241,971. THE MARK CONSISTS OF THE WORDS "TRUMARK DIRECT" WITH A PAIR OF ARCS EMANATING FROM THE LETTER "M" AND EXTENDING OVER THE LETTERS "ARK", AN ARROW CROSSING THE LETTER "T", AND AN UNDERLINE.

FOR CREDIT UNION SERVICES (U.S. CLS. 100, 101 AND 102).

FIRST USE 2-10-2011; IN COMMERCE 2-10-2011.

**CLASS 36—(Continued).**

3,962,095. SHAREBUILDER CORPORATION, SEATTLE, WA. SN 77-331,697. PUB. 4-22-2008, FILED 11-16-2007.



OWNER OF U.S. REG. NOS. 2,488,646, 3,041,327, AND OTHERS.

THE COLOR(S) ORANGE AND DARK BLUE IS/ARE CLAIMED AS A FEATURE OF THE MARK.

THE MARK CONSISTS OF THE WORD "SHAREBUILDER" IN A STYLIZED FONT, WITH THE LETTERS "BUILD" IN UPPER CASE, THE REMAINING LETTERS IN LOWER CASE, THE COMPONENT "SHARE" IN ORANGE, AND THE COMPONENT "BUILDER" IN DARK BLUE.

FOR BROKERAGE IN THE FIELD OF STOCKS, BONDS AND FUNDS; BROKERAGE OF SHARES OR STOCKS AND OTHER SECURITIES; INVESTMENT BROKERAGE (U.S. CLS. 100, 101 AND 102).

FIRST USE 11-0-2007; IN COMMERCE 11-0-2007.

3,962,123. ESPLANADE CAPITAL LLC, BOSTON, MA. SN 77-407,233. PUB. 7-15-2008, FILED 2-27-2008.



THE MARK CONSISTS OF STANDARD CHARACTERS WITHOUT CLAIM TO ANY PARTICULAR FONT, STYLE, SIZE, OR COLOR.

OWNER OF U.S. REG. NO. 2,567,943.

FOR FINANCIAL INVESTMENT SERVICES IN THE FIELDS OF BONDS (U.S. CLS. 100, 101 AND 102).

FIRST USE 9-30-2008; IN COMMERCE 9-30-2008.

3,962,156. RAYMOND JAMES FINANCIAL, INC., ST. PETERSBURG, FL. SN 77-483,330. PUB. 9-9-2008, FILED 5-26-2008.



THE MARK CONSISTS OF STANDARD CHARACTERS WITHOUT CLAIM TO ANY PARTICULAR FONT, STYLE, SIZE, OR COLOR.

OWNER OF U.S. REG. NO. 2,738,117.

NO CLAIM IS MADE TO THE EXCLUSIVE RIGHT TO USE "FUND DISTRIBUTORS", APART FROM THE MARK AS SHOWN.

FOR MUTUAL FUNDS BROKERAGE SERVICES (U.S. CLS. 100, 101 AND 102).

FIRST USE 11-1-2008; IN COMMERCE 11-1-2008.

**CLASS 36—(Continued).**

3,962,196. NATIONAL FOUNDATION FOR CREDIT COUNSELING, INC., WASHINGTON, DC. SN 77-552,198. PUB. 7-7-2009, FILED 8-21-2008.

**COUNSELING HELP NOW**

THE MARK CONSISTS OF STANDARD CHARACTERS WITHOUT CLAIM TO ANY PARTICULAR FONT, STYLE, SIZE, OR COLOR.

NO CLAIM IS MADE TO THE EXCLUSIVE RIGHT TO USE "COUNSELING", APART FROM THE MARK AS SHOWN.

FOR CREDIT AND DEBT COUNSELING SERVICES, FINANCIAL COUNSELING SERVICES; PROVIDING A DATABASE FEATURING INFORMATION REGARDING CREDIT, DEBT, AND FINANCIAL COUNSELORS, AND CREDIT, DEBT, AND FINANCIAL COUNSELING SERVICES (U.S. CLS. 100, 101 AND 102).

FIRST USE 10-27-2010; IN COMMERCE 10-27-2010.

---

3,962,235. TRAVELERS INDEMNITY COMPANY, THE, HARTFORD, CT. SN 77-622,419. PUB. 4-6-2010, FILED 11-26-2008.

**CUSTOMCOMP**

THE MARK CONSISTS OF STANDARD CHARACTERS WITHOUT CLAIM TO ANY PARTICULAR FONT, STYLE, SIZE, OR COLOR.

FOR INSURANCE UNDERWRITING SERVICES, AND INSURANCE CLAIMS PROCESSING AND ADMINISTRATION SERVICES, NAMELY, IN THE FIELD OF WORKERS COMPENSATION (U.S. CLS. 100, 101 AND 102).

FIRST USE 2-24-2009; IN COMMERCE 2-24-2009.

---

3,962,272. ENCOMPASS COMMUNICATIONS, LLC, LONGVIEW, TX. SN 77-663,093. PUB. 5-26-2009, FILED 2-4-2009.

**Entourage**

THE MARK CONSISTS OF STANDARD CHARACTERS WITHOUT CLAIM TO ANY PARTICULAR FONT, STYLE, SIZE, OR COLOR.

FOR PRE-PAID PURCHASE CARD SERVICES, NAMELY, PROCESSING ELECTRONIC PAYMENTS MADE THROUGH PREPAID CARDS (U.S. CLS. 100, 101 AND 102).

FIRST USE 1-3-2011; IN COMMERCE 1-3-2011.

**CLASS 36—(Continued).**

3,962,275. NIKKO ASSET MANAGEMENT CO., LTD., TOKYO 107-6242, JAPAN. SN 77-664,814. PUB. 12-8-2009, FILED 2-6-2009.

**WORLD SERIES FUND PLATFORM**

THE MARK CONSISTS OF STANDARD CHARACTERS WITHOUT CLAIM TO ANY PARTICULAR FONT, STYLE, SIZE, OR COLOR.

NO CLAIM IS MADE TO THE EXCLUSIVE RIGHT TO USE "FUND PLATFORM", APART FROM THE MARK AS SHOWN.

FOR FINANCIAL SERVICES, NAMELY, INVESTMENT SERVICES FOR FOREIGN EXCHANGE, EQUITY, COMMODITY, DEBT, FUTURE, AND EXOTIC MARKETS FOR BOTH INSTITUTIONAL AND INDIVIDUAL CLIENTS; FINANCIAL ADVISORY AND MANAGEMENT SERVICES, NAMELY, INVESTMENT STRATEGIES FOR ASSET MANAGEMENT AND ALLOCATION, PORTFOLIO CONSTRUCTION, AND DEVELOPMENT OF CUSTOMIZED INVESTMENT OBJECTIVES AND POLICIES; FINANCIAL ADVISORY SERVICES, NAMELY, SELECTION AND EVALUATION OF FUND MANAGERS AND THEIR RESPECTIVE INVESTMENT STRATEGIES; AND FINANCIAL INVESTMENT SERVICES, NAMELY, A FUND PLATFORM FOR RETAIL AND INSTITUTIONAL INVESTORS; ALL OF THE FOREGOING NOT RELATING TO SPORTS OR A SPORTS TEAM (U.S. CLS. 100, 101 AND 102).

FIRST USE 7-31-2010; IN COMMERCE 7-31-2010.

---

3,962,294. MOUNTAIN PACIFIC INSTITUTE, LLC, BELLEVUE, WA. SN 77-677,385. PUB. 8-3-2010, FILED 2-24-2009.

**WEALTH PRESERVATION UNIT**

THE MARK CONSISTS OF STANDARD CHARACTERS WITHOUT CLAIM TO ANY PARTICULAR FONT, STYLE, SIZE, OR COLOR.

NO CLAIM IS MADE TO THE EXCLUSIVE RIGHT TO USE "WEALTH PRESERVATION", APART FROM THE MARK AS SHOWN.

FOR FINANCIAL SERVICES, NAMELY, ADVISORY, ANALYTIC, BENCHMARKING AND UNIT OF ACCOUNT SERVICES, NAMELY, PROVIDING A MECHANISM TO HEDGE CURRENCY AND INFLATION RISKS USING A PROPRIETARY UNIT OF MEASURE CALCULATED BASED ON THE VALUE OF THE UNDERLYING COMPONENTS CONSISTING OF DEVELOPED MARKET CURRENCIES, DEVELOPING MARKET CURRENCIES AND COMMODITIES (U.S. CLS. 100, 101 AND 102).

FIRST USE 3-1-2011; IN COMMERCE 3-10-2011.



**CLASS 36—(Continued).**

3,962,338. 21ST CENTURY INSURANCE AND FINANCIAL SERVICES, INC., WILMINGTON, DE. SN 77-703,416. PUB. 6-30-2009, FILED 3-31-2009.

**21st AUTO PAY**

THE MARK CONSISTS OF STANDARD CHARACTERS WITHOUT CLAIM TO ANY PARTICULAR FONT, STYLE, SIZE, OR COLOR.

OWNER OF U.S. REG. NO. 3,038,442.

NO CLAIM IS MADE TO THE EXCLUSIVE RIGHT TO USE "AUTO PAY", APART FROM THE MARK AS SHOWN.

FOR ELECTRONIC PROCESSING OF INSURANCE CLAIMS AND PAYMENT DATA (U.S. CLS. 100, 101 AND 102).

FIRST USE 10-0-2010; IN COMMERCE 10-0-2010.

3,962,339. PRIDEROCK CAPITAL PARTNERS, LLC, AKA PRCP, WEST PALM BEACH, FL. SN 77-703,991. PUB. 8-4-2009, FILED 4-1-2009.

**PRCP**

THE MARK CONSISTS OF STANDARD CHARACTERS WITHOUT CLAIM TO ANY PARTICULAR FONT, STYLE, SIZE, OR COLOR.

FOR REAL ESTATE FINANCING SERVICES; REAL ESTATE INVESTMENT; REAL ESTATE INVESTMENT SERVICES IN THE NATURE OF PURCHASING AND SELLING OF REAL ESTATE FOR OTHERS; REAL ESTATE MANAGEMENT (U.S. CLS. 100, 101 AND 102).

FIRST USE 7-21-2008; IN COMMERCE 7-21-2008.

**CLASS 36—(Continued).**

3,962,355. TF CORNERSTONE INC., NEW YORK, NY. SN 77-716,258. PUB. 6-15-2010, FILED 4-17-2009.

**TF Cornerstone**

THE MARK CONSISTS OF STANDARD CHARACTERS WITHOUT CLAIM TO ANY PARTICULAR FONT, STYLE, SIZE, OR COLOR.

FOR PROVIDING INFORMATION IN THE FIELD OF REAL ESTATE VIA THE INTERNET; REAL ESTATE BROKERAGE; REAL ESTATE MANAGEMENT; REAL ESTATE RENTAL SERVICES, NAMELY, RENTAL OF RESIDENTIAL HOUSING; REAL ESTATE SERVICE, NAMELY, RENTAL PROPERTY MANAGEMENT; REAL ESTATE SERVICES, NAMELY, CONDOMINIUM MANAGEMENT SERVICES; REAL ESTATE SERVICES, NAMELY, PROPERTY MANAGEMENT SERVICES FOR CONDOMINIUM ASSOCIATIONS, HOMEOWNER ASSOCIATIONS AND APARTMENT BUILDINGS; REAL ESTATE SERVICES, NAMELY, RENTAL, BROKERAGE, LEASING AND MANAGEMENT OF RESIDENTIAL PROPERTY (U.S. CLS. 100, 101 AND 102).

FIRST USE 9-26-2009; IN COMMERCE 9-26-2009.

3,962,366. STEP5 VENTURE PARTNERS GP, LLC, EAST PALO ALTO, CA. SN 77-725,623. PUB. 3-30-2010, FILED 4-30-2009.

**JAVELIN VENTURE PARTNERS**

THE MARK CONSISTS OF STANDARD CHARACTERS WITHOUT CLAIM TO ANY PARTICULAR FONT, STYLE, SIZE, OR COLOR.

NO CLAIM IS MADE TO THE EXCLUSIVE RIGHT TO USE "VENTURE PARTNERS", APART FROM THE MARK AS SHOWN.

FOR VENTURE CAPITAL SERVICES, NAMELY, PROVIDING FINANCING TO EMERGING AND START-UP COMPANIES (U.S. CLS. 100, 101 AND 102).

FIRST USE 4-17-2009; IN COMMERCE 4-17-2009.

3,962,421. NEUBERGER BERMAN GROUP LLC, NEW YORK, NY. SN 77-770,080. PUB. 11-24-2009, FILED 6-29-2009.

**THE CROSSROADS GROUP**

THE MARK CONSISTS OF STANDARD CHARACTERS WITHOUT CLAIM TO ANY PARTICULAR FONT, STYLE, SIZE, OR COLOR.

**CLASS 36—(Continued).**

OWNER OF U.S. REG. NOS. 2,214,154 AND 2,706,229.  
 NO CLAIM IS MADE TO THE EXCLUSIVE RIGHT TO USE "GROUP", APART FROM THE MARK AS SHOWN.  
 FOR INVESTMENT ADVISORY SERVICES AND INVESTMENT MANAGEMENT SERVICES (U.S. CLS. 100, 101 AND 102).  
 FIRST USE 1-4-2011; IN COMMERCE 1-4-2011.

---

3,962,450. SQUAWKSPOT, INC., DALLAS, TX. SN 77-782,362.  
 PUB. 12-8-2009, FILED 7-16-2009.

## MarketChorus

THE MARK CONSISTS OF STANDARD CHARACTERS WITHOUT CLAIM TO ANY PARTICULAR FONT, STYLE, SIZE, OR COLOR.

FOR PROVIDING STOCK MARKET INFORMATION, NAMELY, RESEARCHING, TEXT CLASSIFYING, RANKING AND FORECASTING PUBLICATIONS, ARTICLES AND OTHER BUSINESS DOCUMENTS THAT ARE RELATED TO FINANCIAL INSTRUMENTS (U.S. CLS. 100, 101 AND 102).

FIRST USE 2-8-2011; IN COMMERCE 2-8-2011.

---

3,962,494. STATE FARM MUTUAL AUTOMOBILE INSURANCE COMPANY, BLOOMINGTON, IL. SN 77-799,855.  
 PUB. 6-22-2010, FILED 8-7-2009.

## Discount Double Check

THE MARK CONSISTS OF STANDARD CHARACTERS WITHOUT CLAIM TO ANY PARTICULAR FONT, STYLE, SIZE, OR COLOR.

NO CLAIM IS MADE TO THE EXCLUSIVE RIGHT TO USE "DISCOUNT", APART FROM THE MARK AS SHOWN.

FOR UNDERWRITING AUTO, HOMEOWNERS, LIFE AND FIRE INSURANCE; SERVICING, NAMELY, INSURANCE ADMINISTRATION IN THE FIELDS OF AUTO, HOMEOWNERS, LIFE AND FIRE INSURANCE; BANKING AND MUTUAL FUND INVESTMENTS AND FINANCIAL ANALYSIS AND CONSULTATION (U.S. CLS. 100, 101 AND 102).

FIRST USE 9-28-2010; IN COMMERCE 9-29-2010.

**CLASS 36—(Continued).**

3,962,530. WILMINGTON TRUST COMPANY, WILMINGTON, DE. SN 77-807,835. PUB. 12-8-2009, FILED 8-19-2009.



THE MARK CONSISTS OF THE WORDS "RQX" INSIDE A RECTANGULAR DESIGN WITH THE WORDING "PLAN" UNDERNEATH.

FOR BANKING SERVICES; FINANCIAL SERVICES, NAMELY, MORTGAGE LENDING, COMMERCIAL, RETAIL AND CONSUMER LOANS, ISSUANCE OF CREDIT CARDS AND DEBIT CARDS; AND INVESTMENT AND FIDUCIARY SERVICES, NAMELY, TRUST ADMINISTRATION, INVESTMENT CONSULTATION, AND STOCK BROKERAGE SERVICES (U.S. CLS. 100, 101 AND 102).

FIRST USE 10-15-2010; IN COMMERCE 10-15-2010.

---

3,962,540. THE RESIDUAL WEALTH SYSTEM INC., PLANTATION, FL. SN 77-811,162. PUB. 4-6-2010, FILED 8-24-2009.

## RESIDUAL WEALTH SYSTEM

THE MARK CONSISTS OF STANDARD CHARACTERS WITHOUT CLAIM TO ANY PARTICULAR FONT, STYLE, SIZE, OR COLOR.

NO CLAIM IS MADE TO THE EXCLUSIVE RIGHT TO USE "SYSTEM", APART FROM THE MARK AS SHOWN.

FOR CREDIT CARD TRANSACTION PROCESSING SERVICES (U.S. CLS. 100, 101 AND 102).

FIRST USE 11-1-2010; IN COMMERCE 11-1-2010.

**CLASS 36—(Continued).**

3,962,568. TERRADIME, LLC, PITTSBURGH, PA. SN 77-821,126. PUB. 7-20-2010, FILED 9-6-2009.

## TERRADIME

THE MARK CONSISTS OF STANDARD CHARACTERS WITHOUT CLAIM TO ANY PARTICULAR FONT, STYLE, SIZE, OR COLOR.

FOR APARTMENT HOUSE MANAGEMENT; ASSESSMENT AND MANAGEMENT OF REAL ESTATE; CLASSIFIED REAL ESTATE LISTINGS OF APARTMENT RENTALS AND HOUSING RENTALS; COMMERCIAL AND RESIDENTIAL REAL ESTATE AGENCY SERVICES; FINANCIAL INVESTMENT IN THE FIELD OF REAL ESTATE AND INFORMATION TECHNOLOGY; FINANCIAL VALUATION OF PERSONAL PROPERTY AND REAL ESTATE; FINANCING OF REAL ESTATE DEVELOPMENT PROJECTS; LEASE OF REAL ESTATE; LEASING OF REAL ESTATE; LEASING OF REAL PROPERTY; MANAGEMENT OF APARTMENTS; MANAGEMENT OF BUILDINGS; PROVIDING A DATABASE OF RESIDENTIAL REAL ESTATE LISTINGS WITHIN NEIGHBORHOODS AND COMMUNITIES SPECIFICALLY IDENTIFIED BY USERS; PROVIDING REAL ESTATE LISTINGS AND REAL ESTATE INFORMATION VIA THE INTERNET; PROVIDING REAL ESTATE LISTINGS VIA THE INTERNET; REAL ESTATE ACQUISITION SERVICES; REAL ESTATE CONSULTANCY; REAL ESTATE INVESTMENT; REAL ESTATE MANAGEMENT CONSULTATION; REAL ESTATE MANAGEMENT SERVICES; REAL ESTATE RENTAL SERVICES, NAMELY, RENTAL OF RESIDENTIAL HOUSING; REAL ESTATE SERVICE, NAMELY, RENTAL PROPERTY MANAGEMENT; REAL ESTATE SERVICES, NAMELY, CONDOMINIUM MANAGEMENT SERVICES; REAL ESTATE SERVICES, NAMELY, PROPERTY MANAGEMENT SERVICES FOR CONDOMINIUM ASSOCIATIONS, HOMEOWNER ASSOCIATIONS AND APARTMENT BUILDINGS; REAL ESTATE SERVICES, NAMELY, RENTAL, BROKERAGE, LEASING AND MANAGEMENT OF COMMERCIAL PROPERTY, OFFICES AND OFFICE SPACE (U.S. CLS. 100, 101 AND 102).

FIRST USE 10-1-2009; IN COMMERCE 11-1-2009.

3,962,664. ROYAL BANK OF CANADA, MONTREAL, CANADA. SN 77-854,419. PUB. 8-17-2010, FILED 10-21-2009.

## RBC TRAVELPROTECTOR

THE MARK CONSISTS OF STANDARD CHARACTERS WITHOUT CLAIM TO ANY PARTICULAR FONT, STYLE, SIZE, OR COLOR.

OWNER OF U.S. REG. NOS. 2,463,205, 3,616,966, AND OTHERS.

FOR TRAVEL RELATED INSURANCE SERVICES, NAMELY, THE ADMINISTRATION OF TRIP CANCELLATION AND TRIP INTERRUPTION INSURANCE, TRAVEL DELAY INSURANCE, BAGGAGE LOSS AND BAGGAGE DELAY INSURANCE, FLIGHT ACCIDENT INSURANCE, HEALTH AND DENTAL INSURANCE; INSURANCE CLAIMS ADMINISTRATION; INSURANCE CLAIMS PROCESSING (U.S. CLS. 100, 101 AND 102).

FIRST USE 10-0-2010; IN COMMERCE 10-0-2010.

**CLASS 36—(Continued).**

3,962,669. AMERICAN FAMILY LIFE ASSURANCE COMPANY OF COLUMBUS, COLUMBUS, GA. SN 77-856,062. PUB. 7-27-2010, FILED 10-23-2009.

## AFLAC SMARTCLAIM

THE MARK CONSISTS OF STANDARD CHARACTERS WITHOUT CLAIM TO ANY PARTICULAR FONT, STYLE, SIZE, OR COLOR.

FOR INSURANCE UNDERWRITING SERVICES FOR ALL TYPES OF INSURANCE (U.S. CLS. 100, 101 AND 102).

FIRST USE 10-30-2009; IN COMMERCE 10-30-2009.

3,962,677. COLE CAPITAL ADVISORS, INC., PHOENIX, AZ. SN 77-857,628. PUB. 3-30-2010, FILED 10-26-2009.

## THE LANDLORD OF WHERE AMERICA WORKS

THE MARK CONSISTS OF STANDARD CHARACTERS WITHOUT CLAIM TO ANY PARTICULAR FONT, STYLE, SIZE, OR COLOR.

FOR FINANCIAL AND INVESTMENT SERVICES, NAMELY, INVESTMENT MANAGEMENT OF FUNDS; INVESTMENT SERVICES, NAMELY, ASSET ACQUISITION AND MANAGEMENT OF INVESTMENT PROPERTY; REAL ESTATE MANAGEMENT OF TRUST FUND PROPERTIES; MANAGING RETAIL INVESTMENT PROPERTY AND REAL ESTATE INVESTMENT TRUST (REIT) FUNDS ASSOCIATED WITH RETAIL INVESTMENT PROPERTY (U.S. CLS. 100, 101 AND 102).

FIRST USE 1-3-2011; IN COMMERCE 1-3-2011.

**CLASS 36—(Continued).**

3,962,678. COLE CAPITAL ADVISORS, INC., PHOENIX, AZ.  
SN 77-857,640. PUB. 3-30-2010, FILED 10-26-2009.

**THE LANDLORD OF WHERE  
AMERICA LIVES**

THE MARK CONSISTS OF STANDARD CHARACTERS WITHOUT CLAIM TO ANY PARTICULAR FONT, STYLE, SIZE, OR COLOR.

FOR FINANCIAL AND INVESTMENT SERVICES, NAMELY, INVESTMENT MANAGEMENT OF FUNDS; INVESTMENT SERVICES, NAMELY, ASSET ACQUISITION AND MANAGEMENT OF INVESTMENT PROPERTY; REAL ESTATE MANAGEMENT OF TRUST FUND PROPERTIES; MANAGING RETAIL INVESTMENT PROPERTY AND REAL ESTATE INVESTMENT TRUST (REIT) FUNDS ASSOCIATED WITH RETAIL INVESTMENT PROPERTY (U.S. CLS. 100, 101 AND 102).  
FIRST USE 1-3-2011; IN COMMERCE 1-3-2011.

3,962,679. COLE CAPITAL ADVISORS, INC., PHOENIX, AZ.  
SN 77-857,647. PUB. 3-30-2010, FILED 10-26-2009.

**THE LANDLORD OF WHERE  
AMERICA VACATIONS**

THE MARK CONSISTS OF STANDARD CHARACTERS WITHOUT CLAIM TO ANY PARTICULAR FONT, STYLE, SIZE, OR COLOR.

FOR FINANCIAL AND INVESTMENT SERVICES, NAMELY, INVESTMENT MANAGEMENT OF FUNDS; INVESTMENT SERVICES, NAMELY, ASSET ACQUISITION AND MANAGEMENT OF INVESTMENT PROPERTY; REAL ESTATE MANAGEMENT OF TRUST FUND PROPERTIES; MANAGING INVESTMENT PROPERTY AND REAL ESTATE INVESTMENT TRUST (REIT) FUNDS ASSOCIATED WITH INVESTMENT PROPERTY (U.S. CLS. 100, 101 AND 102).  
FIRST USE 1-3-2011; IN COMMERCE 1-3-2011.

3,962,758. AMERICAN INTERNATIONAL GROUP, INC., NEW YORK, NY. SN 77-888,379. PUB. 10-26-2010, FILED 12-8-2009.

**THE NATIONAL LIFE AND  
ACCIDENT INSURANCE CO.**

THE MARK CONSISTS OF STANDARD CHARACTERS WITHOUT CLAIM TO ANY PARTICULAR FONT, STYLE, SIZE, OR COLOR.

OWNER OF U.S. REG. NO. 547,329.

**CLASS 36—(Continued).**

NO CLAIM IS MADE TO THE EXCLUSIVE RIGHT TO USE "LIFE AND ACCIDENT INSURANCE CO.", APART FROM THE MARK AS SHOWN.

SEC. 2(F).

FOR INSURANCE UNDERWRITING IN THE FIELD OF LIFE, ACCIDENT AND HEALTH (U.S. CLS. 100, 101 AND 102).

FIRST USE 2-11-2011; IN COMMERCE 2-11-2011.

3,962,759. AMERICAN INTERNATIONAL GROUP, INC., NEW YORK, NY. SN 77-888,381. PUB. 10-26-2010, FILED 12-8-2009.

**THE NATIONAL LIFE AND  
ACCIDENT INSURANCE COMPANY**

THE MARK CONSISTS OF STANDARD CHARACTERS WITHOUT CLAIM TO ANY PARTICULAR FONT, STYLE, SIZE, OR COLOR.

OWNER OF U.S. REG. NO. 547,329.

NO CLAIM IS MADE TO THE EXCLUSIVE RIGHT TO USE "LIFE AND ACCIDENT INSURANCE COMPANY", APART FROM THE MARK AS SHOWN.

SEC. 2(F).

FOR INSURANCE UNDERWRITING IN THE FIELD OF LIFE, ACCIDENT AND HEALTH (U.S. CLS. 100, 101 AND 102).

FIRST USE 2-11-2011; IN COMMERCE 2-11-2011.

3,962,787. CHICAGO CLIMATE EXCHANGE, INC., CHICAGO, IL. SN 77-897,108. PUB. 8-24-2010, FILED 12-18-2009.

**SFI**

THE MARK CONSISTS OF STANDARD CHARACTERS WITHOUT CLAIM TO ANY PARTICULAR FONT, STYLE, SIZE, OR COLOR.

OWNER OF U.S. REG. NO. 3,392,856.

FOR COMMODITY, DERIVATIVES AND FUTURES EXCHANGE SERVICES AND FINANCIAL INSTRUMENTS THAT FACILITATE THE COMMODITIZATION OF AND TRADING OF ENVIRONMENTAL PRODUCTS, SERVICES AND RESOURCES, POLLUTANTS, EMISSIONS ALLOWANCES AND OFFSETS BETWEEN BUSINESS AND OTHER MARKET PARTICIPANTS; FINANCIAL CLEARING SERVICES, NAMELY, THE CLEARING AND SETTLEMENT OF TRADING TRANSACTIONS IN FINANCIAL MARKETS (U.S. CLS. 100, 101 AND 102).

FIRST USE 11-1-2004; IN COMMERCE 11-1-2004.

**CLASS 36—(Continued).**

3,962,792. TCF FINANCIAL CORPORATION, WAYZATA, MN. SN 77-898,656. PUB. 7-13-2010, FILED 12-21-2009.

**TCF CONVENIENCE CHECKING**

THE MARK CONSISTS OF STANDARD CHARACTERS WITHOUT CLAIM TO ANY PARTICULAR FONT, STYLE, SIZE, OR COLOR.

OWNER OF U.S. REG. NOS. 1,054,475, 3,454,849, AND OTHERS.

NO CLAIM IS MADE TO THE EXCLUSIVE RIGHT TO USE "CHECKING", APART FROM THE MARK AS SHOWN.

FOR BANKING AND RELATED FINANCIAL SERVICES, NAMELY, PROVIDING BANK ACCOUNT INFORMATION BY PHONE, PROVIDING ELECTRONIC PROCESSING OF ELECTRONIC FUNDS TRANSFER, ACH, CREDIT CARD, DEBIT CARD, ELECTRONIC CHECKS AND ELECTRONIC PAYMENTS, ISSUANCE OF BANK CHECKS, CHECK CASHING, CHECK PROCESSING, CHECK VERIFICATION, BILL PAYMENT SERVICES AND AUTOMATED COIN COUNTING, SORTING AND CONVERTING; CREDIT AND DEBIT CARD SERVICES; FINANCIAL SERVICES, NAMELY, CHECKING, SAVINGS, AND MONEY MARKET ACCOUNTS; BANKING SERVICES, NAMELY, PROVIDING AUTOMATED TELLER MACHINES OPERATED WITH A DATA CARD; FINANCIAL SERVICES FOR PERSONAL AND BUSINESS USE, NAMELY, ON-LINE BANKING AND RELATED FINANCIAL SERVICES, NAMELY, PROVIDING BANK ACCOUNT INFORMATION, BILL PAYMENT SERVICES AND ELECTRONIC PROCESSING OF ELECTRONIC FUNDS TRANSFER, ACH, CREDIT CARD, DEBIT CARD, ELECTRONIC CHECKS AND ELECTRONIC PAYMENTS; MOBILE BANKING, NAMELY, BANKING SERVICES PROVIDED VIA MOBILE TELECOMMUNICATION DEVICES (U.S. CLS. 100, 101 AND 102).

FIRST USE 1-5-2010; IN COMMERCE 1-19-2010.

3,962,794. GREAT AMERICAN INSURANCE COMPANY, CINCINNATI, OH. SN 77-899,560. PUB. 8-31-2010, FILED 12-22-2009.

# BIZDP

THE MARK CONSISTS OF STANDARD CHARACTERS WITHOUT CLAIM TO ANY PARTICULAR FONT, STYLE, SIZE, OR COLOR.

FOR INSURANCE SERVICES, NAMELY, INSURANCE UNDERWRITING AND INSURANCE ADMINISTRATION IN THE FIELD OF DEBT CANCELLATION, DEBT SUSPENSION AND DEBT PROTECTION (U.S. CLS. 100, 101 AND 102).

FIRST USE 8-16-2010; IN COMMERCE 8-16-2010.

**CLASS 36—(Continued).**

3,962,823. MUNICH REINSURANCE AMERICA, INC., PRINCETON, NJ. SN 77-908,162. PUB. 12-7-2010, FILED 1-8-2010.

**MUNICH RE STOP LOSS**

THE MARK CONSISTS OF STANDARD CHARACTERS WITHOUT CLAIM TO ANY PARTICULAR FONT, STYLE, SIZE, OR COLOR.

OWNER OF U.S. REG. NOS. 2,857,243 AND 3,747,881.

NO CLAIM IS MADE TO THE EXCLUSIVE RIGHT TO USE "RE STOP LOSS, INC.", APART FROM THE MARK AS SHOWN.

SEC. 2(F) AS TO "MUNICH".

FOR STOPLOSS INSURANCE, NAMELY, ACCIDENT INSURANCE UNDERWRITING, INSURANCE CLAIM ADMINISTRATION AND INSURANCE CLAIM PROCESSING (U.S. CLS. 100, 101 AND 102).

FIRST USE 4-15-2010; IN COMMERCE 4-15-2010.

3,962,842. TCF FINANCIAL CORPORATION, WAYZATA, MN. SN 77-913,345. PUB. 7-13-2010, FILED 1-15-2010.

**TCF STUDENT CHECKING**

THE MARK CONSISTS OF STANDARD CHARACTERS WITHOUT CLAIM TO ANY PARTICULAR FONT, STYLE, SIZE, OR COLOR.

OWNER OF U.S. REG. NOS. 1,054,475, 3,454,849, AND OTHERS.

NO CLAIM IS MADE TO THE EXCLUSIVE RIGHT TO USE "STUDENT CHECKING", APART FROM THE MARK AS SHOWN.

FOR BANKING AND RELATED FINANCIAL SERVICES, NAMELY, PROVIDING BANK ACCOUNT INFORMATION BY PHONE, PROVIDING ELECTRONIC PROCESSING OF ELECTRONIC FUNDS TRANSFER, ACH, CREDIT CARD, DEBIT CARD, ELECTRONIC CHECKS AND ELECTRONIC PAYMENTS, ISSUANCE OF BANK CHECKS, CHECK CASHING, CHECK PROCESSING, CHECK VERIFICATION, BILL PAYMENT SERVICES AND AUTOMATED COIN COUNTING, SORTING AND CONVERTING; CREDIT AND DEBIT CARD SERVICES; FINANCIAL SERVICES, NAMELY, CHECKING, SAVINGS, AND MONEY MARKET ACCOUNTS; BANKING SERVICES, NAMELY, PROVIDING AUTOMATED TELLER MACHINES OPERATED WITH A DATA CARD; FINANCIAL SERVICES FOR PERSONAL AND BUSINESS USE, NAMELY, ON-LINE BANKING AND RELATED FINANCIAL SERVICES, NAMELY, PROVIDING BANK ACCOUNT INFORMATION, BILL PAYMENT SERVICES AND ELECTRONIC PROCESSING OF ELECTRONIC FUNDS TRANSFER, ACH, CREDIT CARD, DEBIT CARD, ELECTRONIC CHECKS AND ELECTRONIC PAYMENTS; MOBILE BANKING, NAMELY, BANKING SERVICES PROVIDED VIA MOBILE TELECOMMUNICATION DEVICES (U.S. CLS. 100, 101 AND 102).

FIRST USE 1-5-2010; IN COMMERCE 1-19-2010.



**CLASS 36—(Continued).**

3,962,857. PAUL C. LANDIG, OMRO, WI. SN 77-917,717. PUB. 6-8-2010, FILED 1-22-2010.

**Great White Enterprises**

THE MARK CONSISTS OF STANDARD CHARACTERS WITHOUT CLAIM TO ANY PARTICULAR FONT, STYLE, SIZE, OR COLOR.

NO CLAIM IS MADE TO THE EXCLUSIVE RIGHT TO USE "ENTERPRISES", APART FROM THE MARK AS SHOWN.

FOR REAL ESTATE BROKERAGE (U.S. CLS. 100, 101 AND 102).

FIRST USE 1-25-2010; IN COMMERCE 10-11-2010.

---

3,962,865. FORD MOTOR COMPANY, DEARBORN, MI. SN 77-919,480. PUB. 11-2-2010, FILED 1-25-2010.

**FMCC RATE ADVISOR**

THE MARK CONSISTS OF STANDARD CHARACTERS WITHOUT CLAIM TO ANY PARTICULAR FONT, STYLE, SIZE, OR COLOR.

NO CLAIM IS MADE TO THE EXCLUSIVE RIGHT TO USE "RATE ADVISOR", APART FROM THE MARK AS SHOWN.

FOR AUTOMOBILE FINANCING SERVICES (U.S. CLS. 100, 101 AND 102).

FIRST USE 8-23-2010; IN COMMERCE 8-23-2010.

---

3,962,884. TRILLIUM ASSET MANAGEMENT CORPORATION, BOSTON, MA. SN 77-923,168. PUB. 7-13-2010, FILED 1-29-2010.

**ESG PLUS**

THE MARK CONSISTS OF STANDARD CHARACTERS WITHOUT CLAIM TO ANY PARTICULAR FONT, STYLE, SIZE, OR COLOR.

NO CLAIM IS MADE TO THE EXCLUSIVE RIGHT TO USE "ESG", APART FROM THE MARK AS SHOWN.

FOR FINANCIAL SERVICES, NAMELY, FINANCIAL ASSET MANAGEMENT AND INVESTMENT ADVISORY SERVICES (U.S. CLS. 100, 101 AND 102).

FIRST USE 3-2-2011; IN COMMERCE 3-2-2011.

**CLASS 36—(Continued).**

3,962,916. DEUTSCHE BANK SECURITIES, INC., NEW YORK, NY. SN 77-931,891. PUB. 7-6-2010, FILED 2-9-2010.

**SUPERX**

THE MARK CONSISTS OF STANDARD CHARACTERS WITHOUT CLAIM TO ANY PARTICULAR FONT, STYLE, SIZE, OR COLOR.

FOR PROVIDING ELECTRONIC FINANCIAL TRADING SERVICES FOR THE EXECUTION OF SECURITIES VIA ELECTRONIC AND VOICE NETWORKS; PROVIDING INVESTMENT AND FINANCIAL ADVICE BY MEANS OF A GLOBAL COMPUTER NETWORK; FINANCIAL SERVICES, NAMELY, PROVIDING INVESTMENT MANAGEMENT SERVICES VIA THE INTERNET; PROVIDING INFORMATION IN THE FIELD OF SECURITIES TRADING VIA THE INTERNET (U.S. CLS. 100, 101 AND 102).

FIRST USE 2-22-2009; IN COMMERCE 2-22-2009.

---

3,962,947. THE VOLATILITY EXCHANGE CORPORATION, GILLETTE, NJ. SN 77-936,807. PUB. 10-26-2010, FILED 2-16-2010.

**VOLCONTRACT**

THE MARK CONSISTS OF STANDARD CHARACTERS WITHOUT CLAIM TO ANY PARTICULAR FONT, STYLE, SIZE, OR COLOR.

OWNER OF U.S. REG. NO. 3,757,442.

FOR FINANCIAL RISK MANAGEMENT (U.S. CLS. 100, 101 AND 102).

FIRST USE 12-21-2010; IN COMMERCE 12-21-2010.

---

3,962,973. WE PAY DOUBLE, LLC, CEDAR RAPIDS, IA. SN 77-942,069. PUB. 7-20-2010, FILED 2-23-2010.

**THE GOLD ESTATE**

THE MARK CONSISTS OF STANDARD CHARACTERS WITHOUT CLAIM TO ANY PARTICULAR FONT, STYLE, SIZE, OR COLOR.

NO CLAIM IS MADE TO THE EXCLUSIVE RIGHT TO USE "GOLD", APART FROM THE MARK AS SHOWN.

FOR PROVIDING EXCHANGE SERVICES FOR GOLD INTO CASH (U.S. CLS. 100, 101 AND 102).

FIRST USE 12-14-2009; IN COMMERCE 12-14-2009.

**CLASS 36—(Continued).**

3,962,974. WE PAY DOUBLE, LLC, CEDAR RAPIDS, IA. SN 77-942,070. PUB. 7-20-2010, FILED 2-23-2010.

**SOPHIA GOLD**

THE MARK CONSISTS OF STANDARD CHARACTERS WITHOUT CLAIM TO ANY PARTICULAR FONT, STYLE, SIZE, OR COLOR.

NO CLAIM IS MADE TO THE EXCLUSIVE RIGHT TO USE "GOLD", APART FROM THE MARK AS SHOWN.

THE NAME "SOPHIA GOLD" DOES NOT IDENTIFY A LIVING INDIVIDUAL.

FOR PROVIDING EXCHANGE SERVICES FOR GOLD INTO CASH (U.S. CLS. 100, 101 AND 102).

FIRST USE 12-14-2009; IN COMMERCE 12-14-2009.

3,962,976. INTEGRITY MUTUAL INSURANCE COMPANY, APPLETON, WI. SN 77-942,503. PUB. 7-20-2010, FILED 2-23-2010.



**Integrity**  
Insurance

OWNER OF U.S. REG. NOS. 3,134,629, 3,134,630, AND 3,609,584.

NO CLAIM IS MADE TO THE EXCLUSIVE RIGHT TO USE "INSURANCE", APART FROM THE MARK AS SHOWN.

THE MARK CONSISTS OF THE WORDING "INTEGRITY INSURANCE" IN STYLIZED FONT AND THE STYLIZED DESIGN OF THREE OVERLAPPING OVALS.

FOR INSURANCE UNDERWRITING IN THE FIELD OF PROPERTY, CASUALTY, HOME, AUTO, MOTORCYCLES AND BUSINESS (U.S. CLS. 100, 101 AND 102).

FIRST USE 9-29-2010; IN COMMERCE 9-29-2010.

**CLASS 36—(Continued).**

3,962,982. BLACKROCK INSTITUTIONAL TRUST COMPANY, N.A., SAN FRANCISCO, CA. SN 77-942,914. PUB. 7-27-2010, FILED 2-23-2010.

**KEEP EVOLVING**

THE MARK CONSISTS OF STANDARD CHARACTERS WITHOUT CLAIM TO ANY PARTICULAR FONT, STYLE, SIZE, OR COLOR.

FOR BANKING SERVICES, MUTUAL FUND INVESTMENT ADVISORY SERVICES, INVESTMENT MANAGEMENT SERVICES AND FINANCIAL MANAGEMENT SERVICES IN THE NATURE OF POOLED INVESTMENT FUNDS (U.S. CLS. 100, 101 AND 102).

FIRST USE 4-1-2010; IN COMMERCE 4-1-2010.

3,963,023. TRILLIUM ASSET MANAGEMENT CORPORATION, BOSTON, MA. SN 77-947,115. PUB. 7-27-2010, FILED 3-1-2010.

**INVESTING FOR A SUSTAINABLE WORLD**

THE MARK CONSISTS OF STANDARD CHARACTERS WITHOUT CLAIM TO ANY PARTICULAR FONT, STYLE, SIZE, OR COLOR.

OWNER OF U.S. REG. NOS. 2,319,465 AND 2,335,480.

FOR FINANCIAL SERVICES, NAMELY, FINANCIAL ASSET MANAGEMENT AND INVESTMENT ADVISORY SERVICES (U.S. CLS. 100, 101 AND 102).

FIRST USE 2-28-2011; IN COMMERCE 2-28-2011.

3,963,027. CITIZENS FINANCIAL GROUP, INC., PROVIDENCE, RI. SN 77-948,053. PUB. 6-29-2010, FILED 3-2-2010.

**GOOD BANKING IS GOOD CITIZENSHIP**

THE MARK CONSISTS OF STANDARD CHARACTERS WITHOUT CLAIM TO ANY PARTICULAR FONT, STYLE, SIZE, OR COLOR.

FOR BANKING SERVICES (U.S. CLS. 100, 101 AND 102).

FIRST USE 5-12-2010; IN COMMERCE 5-12-2010.

**CLASS 36—(Continued).**

3,963,057. YESKE BUIE INC., SAN FRANCISCO, CA. SN 77-951,531. PUB. 7-27-2010, FILED 3-5-2010.

IT'S ABOUT THE SIZE OF  
YOUR LIFE, NOT THE SIZE OF  
YOUR WALLET

THE MARK CONSISTS OF STANDARD CHARACTERS WITHOUT CLAIM TO ANY PARTICULAR FONT, STYLE, SIZE, OR COLOR.

FOR FINANCIAL PLANNING AND INVESTMENT MANAGEMENT SERVICES (U.S. CLS. 100, 101 AND 102). FIRST USE 9-24-2010; IN COMMERCE 9-24-2010.

3,963,062. CALLAHAN FINANCIAL PLANNING COMPANY, OMAHA, NE. SN 77-951,690. PUB. 8-3-2010, FILED 3-5-2010.



NO CLAIM IS MADE TO THE EXCLUSIVE RIGHT TO USE "FINANCIAL PLANNING", APART FROM THE MARK AS SHOWN.

THE COLOR(S) RED, GREY AND BLACK IS/ARE CLAIMED AS A FEATURE OF THE MARK.

THE MARK CONSISTS OF SIX RED FORWARD AND SLANTED 3D SQUARES WITH GREY SHADOWS BENEATH. THE MARK ALSO CONSISTS OF THE WORD "CALLAHAN" IN RED WITH THE WORDS "FINANCIAL PLANNING" BELOW IN BLACK.

FOR FINANCIAL PLANNING; INVESTMENT MANAGEMENT (U.S. CLS. 100, 101 AND 102). FIRST USE 9-24-2010; IN COMMERCE 9-24-2010.

3,963,071. THE DEPOSITORY TRUST AND CLEARING CORPORATION, NEW YORK, NY. SN 77-952,338. PUB. 7-20-2010, FILED 3-5-2010.

OMNI/SERV

THE MARK CONSISTS OF STANDARD CHARACTERS WITHOUT CLAIM TO ANY PARTICULAR FONT, STYLE, SIZE, OR COLOR.

FOR PROVIDING FINANCIAL INFORMATION, NAMELY, PROVIDING TRANSACTIONAL SETTLEMENT AND COMMERCIAL TRANSACTION INFORMATION RELATING TO MUTUAL FUNDS FOR THE PURPOSE OF ENSURING TRANSPARENCY IN THE SUB-ACCOUNTS OF AN OMNIBUS ACCOUNT (U.S. CLS. 100, 101 AND 102).

FIRST USE 12-0-2010; IN COMMERCE 12-0-2010.

**CLASS 36—(Continued).**

3,963,099. THE CHARITY STRIPE, NORTHBROOK, IL. SN 77-955,677. PUB. 8-3-2010, FILED 3-10-2010.

BATTER UP

THE MARK CONSISTS OF STANDARD CHARACTERS WITHOUT CLAIM TO ANY PARTICULAR FONT, STYLE, SIZE, OR COLOR.

FOR CHARITABLE FUND RAISING SERVICES (U.S. CLS. 100, 101 AND 102). FIRST USE 12-20-2009; IN COMMERCE 1-26-2010.

3,963,126. TELUS CORPORATION, EDMONTON, ALBERTA, CANADA. SN 77-958,976. PUB. 8-10-2010, FILED 3-15-2010.



OWNER OF U.S. REG. NOS. 3,543,607 AND 3,613,014. THE MARK CONSISTS OF THE WORD "TELUS" WITH THE LETTER "T" WRITTEN IN A DISTINCTIVE SCRIPT BESIDE IT.

FOR FINANCIAL SPONSORSHIP OF ATHLETIC AND SPORTING EVENTS (U.S. CLS. 100, 101 AND 102). FIRST USE 12-26-2010; IN COMMERCE 12-26-2010.

3,963,135. WESTAR ENERGY, INC., TOPEKA, KS. SN 77-960,104. PUB. 8-3-2010, FILED 3-16-2010.

SIMPLESAVINGS

THE MARK CONSISTS OF STANDARD CHARACTERS WITHOUT CLAIM TO ANY PARTICULAR FONT, STYLE, SIZE, OR COLOR.

FOR FACILITATING AND ARRANGING FOR THE FINANCING OF ENERGY EFFICIENCY IMPROVEMENTS TO RESIDENTIAL AND COMMERCIAL STRUCTURES; COLLECTION OF DEBTS (U.S. CLS. 100, 101 AND 102).

FIRST USE 2-3-2011; IN COMMERCE 2-3-2011.

**CLASS 36—(Continued).**

3,963,137. HYATT CORPORATION, CHICAGO, IL. SN 77-960,208. PUB. 8-17-2010, FILED 3-16-2010.



OWNER OF U.S. REG. NOS. 945,384, 3,518,272, AND OTHERS.

THE MARK CONSISTS OF THE STYLIZED WORD "HYATT" WITH AN EXTENDED LETTER "A" WITH AN ARCH ACROSS THE MIDDLE.

FOR CREDIT CARD SERVICES (U.S. CLS. 100, 101 AND 102).

FIRST USE 9-2-2010; IN COMMERCE 9-2-2010.

---

3,963,155. MCKENZIE RIVER CORPORATION, SAN FRANCISCO, CA. SN 77-961,408. PUB. 8-3-2010, FILED 3-17-2010.



THE MARK CONSISTS OF SILHOUETTE OF A FISH WITH FUR ON THE TOP OF ITS BODY AND AN EYE IN THE SHAPE OF A HALF MOON.

FOR CHARITABLE FUNDRAISING SERVICES; PHILANTHROPIC SERVICES CONCERNING MONETARY DONATIONS (U.S. CLS. 100, 101 AND 102).

FIRST USE 4-12-2010; IN COMMERCE 4-12-2010.

**CLASS 36—(Continued).**

3,963,176. XIPWIRE, INC., PHILADELPHIA, PA. SN 77-963,326. PUB. 8-10-2010, FILED 3-19-2010.



THE MARK CONSISTS OF STANDARD CHARACTERS WITHOUT CLAIM TO ANY PARTICULAR FONT, STYLE, SIZE, OR COLOR.

FOR FUNDRAISING SERVICES FOR NON-PROFIT ORGANIZATIONS, CHARITIES, EDUCATIONAL INSTITUTIONS, AND POLITICAL CAMPAIGNS, NAMELY, PROVIDING A SYSTEM FOR PLEDGING MONETARY DONATIONS VIA A MOBILE TELECOMMUNICATIONS NETWORK AND/OR A GLOBAL COMPUTER NETWORK; PROVIDING AN INTERNET WEBSITE THROUGH WHICH A MONETARY DONATION MAY BE MADE TO NON-PROFIT ORGANIZATIONS, CHARITIES, EDUCATIONAL INSTITUTIONS, AND POLITICAL CAMPAIGNS; RECEIVING PLEDGES FROM INDIVIDUALS TO MAKE MONETARY DONATIONS TO NON-PROFIT ORGANIZATIONS, CHARITIES, EDUCATIONAL INSTITUTIONS, AND POLITICAL CAMPAIGNS VIA A MOBILE TELECOMMUNICATIONS NETWORK AND/OR A GLOBAL COMPUTER NETWORK; ELECTRONIC COMMERCE PAYMENT SERVICES, NAMELY, DISTRIBUTING MONETARY DONATIONS TO ESTABLISHED ELECTRONIC ACCOUNTS FOR NON-PROFIT ORGANIZATIONS, CHARITIES, EDUCATIONAL INSTITUTIONS, AND POLITICAL CAMPAIGNS (U.S. CLS. 100, 101 AND 102).

FIRST USE 2-1-2010; IN COMMERCE 2-1-2010.

---

3,963,199. MAZDA MOTOR OF AMERICA, INC., IRVINE, CA. SN 77-965,979. PUB. 8-17-2010, FILED 3-23-2010.



THE MARK CONSISTS OF STANDARD CHARACTERS WITHOUT CLAIM TO ANY PARTICULAR FONT, STYLE, SIZE, OR COLOR.

OWNER OF U.S. REG. NOS. 2,542,939, 3,635,320, AND OTHERS.

NO CLAIM IS MADE TO THE EXCLUSIVE RIGHT TO USE "CAPITAL SERVICES", APART FROM THE MARK AS SHOWN.

FOR FINANCING RELATING TO AUTOMOBILES; FINANCING SERVICES (U.S. CLS. 100, 101 AND 102).

FIRST USE 0-0-2010; IN COMMERCE 0-0-2010.

**CLASS 36—(Continued).**

3,963,311. FIFTH THIRD BANCORP, CINCINNATI, OH. SN 85-001,129. PUB. 7-27-2010, FILED 3-29-2010.

**REVLINK EXPRESS**

THE MARK CONSISTS OF STANDARD CHARACTERS WITHOUT CLAIM TO ANY PARTICULAR FONT, STYLE, SIZE, OR COLOR.

NO CLAIM IS MADE TO THE EXCLUSIVE RIGHT TO USE "EXPRESS", APART FROM THE MARK AS SHOWN.

FOR FINANCIAL MANAGEMENT SERVICES FOR THE HEALTHCARE INDUSTRY (U.S. CLS. 100, 101 AND 102).

FIRST USE 8-0-2009; IN COMMERCE 8-0-2009.

---

3,963,343. CITIZENS FINANCIAL GROUP, INC., PROVIDENCE, RI. SN 85-007,127. PUB. 6-29-2010, FILED 4-6-2010.

**CHARTER ONE U**

THE MARK CONSISTS OF STANDARD CHARACTERS WITHOUT CLAIM TO ANY PARTICULAR FONT, STYLE, SIZE, OR COLOR.

OWNER OF U.S. REG. NOS. 1,748,834, 2,450,402, AND OTHERS.

FOR STUDENT LOAN SERVICES (U.S. CLS. 100, 101 AND 102).

FIRST USE 8-1-2010; IN COMMERCE 8-1-2010.

---

3,963,344. CITIZENS FINANCIAL GROUP, INC., PROVIDENCE, RI. SN 85-007,145. PUB. 6-29-2010, FILED 4-6-2010.

**CITIZENS U**

THE MARK CONSISTS OF STANDARD CHARACTERS WITHOUT CLAIM TO ANY PARTICULAR FONT, STYLE, SIZE, OR COLOR.

OWNER OF U.S. REG. NOS. 2,482,203, 2,668,486, AND OTHERS.

FOR STUDENT LOAN SERVICES (U.S. CLS. 100, 101 AND 102).

FIRST USE 8-1-2010; IN COMMERCE 8-1-2010.

**CLASS 36—(Continued).**

3,963,349. CITIZENS COMMUNITY BANK, SOUTH HILL, VA. SN 85-008,060. PUB. 12-14-2010, FILED 4-7-2010.



NO CLAIM IS MADE TO THE EXCLUSIVE RIGHT TO USE COMMUNITY BANK, APART FROM THE MARK AS SHOWN.

THE COLOR(S) TEAL IS/ARE CLAIMED AS A FEATURE OF THE MARK.

THE MARK CONSISTS OF THE LETTERS "CCB" IN TEAL OVER TOP OF THE WORDS "CITIZENS COMMUNITY BANK" IN BLACK LETTERING, WITH A LINE BELOW THE LETTERS "CCB" AND ABOVE THE WORDS "CITIZENS COMMUNITY BANK".

FOR BANKING SERVICES; ATM BANKING SERVICES; ON-LINE BANKING SERVICES; FINANCIAL SERVICES, NAMELY, ELECTRONIC REMOTE CHECK DEPOSIT SERVICES; COMMERCIAL LENDING SERVICES; CONSUMER LENDING SERVICES; BILL PAYMENT SERVICES PROVIDED THROUGH A WEBSITE; MORTGAGE LENDING; CREDIT CARD AND DEBIT CARD SERVICES; SAFE DEPOSIT BOX SERVICES; TRAVELERS' CHECK ISSUANCE (U.S. CLS. 100, 101 AND 102).

FIRST USE 5-1-2010; IN COMMERCE 5-1-2010.

---

3,963,449. TRAVELERS INDEMNITY COMPANY, THE, HARTFORD, CT. SN 85-032,725. PUB. 10-5-2010, FILED 5-7-2010.

**MEDFIRST**

THE MARK CONSISTS OF STANDARD CHARACTERS WITHOUT CLAIM TO ANY PARTICULAR FONT, STYLE, SIZE, OR COLOR.

FOR PROPERTY AND CASUALTY INSURANCE UNDERWRITING, CLAIM PROCESSING, AND CLAIM ADMINISTRATION SERVICES (U.S. CLS. 100, 101 AND 102).

FIRST USE 7-1-2010; IN COMMERCE 7-1-2010.



**CLASS 36—(Continued).**

3,963,496. COLONIAL PENN LIFE INSURANCE COMPANY, PHILADELPHIA, PA. SN 85-044,025. PUB. 10-12-2010, FILED 5-20-2010.



OWNER OF U.S. REG. NO. 3,796,012.  
NO CLAIM IS MADE TO THE EXCLUSIVE RIGHT TO USE "FAMILY" AND "PROGRAM", APART FROM THE MARK AS SHOWN.

THE COLOR(S) RED, BLUE, GRAY, WHITE AND BLACK IS/ARE CLAIMED AS A FEATURE OF THE MARK.

THE MARK CONSISTS OF THE COLORS RED, BLUE, GRAY, WHITE AND BLACK, WITH THE COLOR RED APPEARING IN THE WORD "FAMILY" AND THE FLAG DESIGN; THE COLOR BLUE APPEARING IN THE WORDING "PROTECTOR PROGRAM" AND THE FLAG AND ONE OF THE PERSONS OF THE DESIGN; THE COLOR GRAY APPEARING IN TWO OF THE PERSONS OF THE DESIGN; THE COLOR WHITE APPEARING IN THE FLAG DESIGN; AND THE COLOR BLACK APPEARING IN THE WORDING "CARING FOR THOSE YOU LOVE".

FOR LIFE INSURANCE UNDERWRITING AND ADMINISTRATION SERVICES (U.S. CLS. 100, 101 AND 102).  
FIRST USE 3-28-2011; IN COMMERCE 3-28-2011.

3,963,514. ZESTCASH, INC., LOS ANGELES, CA. SN 85-047,793. PUB. 10-26-2010, FILED 5-25-2010.

# ZESTCASH

THE MARK CONSISTS OF STANDARD CHARACTERS WITHOUT CLAIM TO ANY PARTICULAR FONT, STYLE, SIZE, OR COLOR.

FOR BANKING SERVICES; ON-LINE BANKING SERVICES (U.S. CLS. 100, 101 AND 102).  
FIRST USE 10-15-2010; IN COMMERCE 10-15-2010.

**CLASS 36—(Continued).**

3,963,525. MICHAEL BRUCE BELLUOMINI, MILL VALLEY, CA. SN 85-050,715. PUB. 10-26-2010, FILED 5-28-2010.

# FIT FOR EQUALITY

THE MARK CONSISTS OF STANDARD CHARACTERS WITHOUT CLAIM TO ANY PARTICULAR FONT, STYLE, SIZE, OR COLOR.

FOR CHARITABLE FUND RAISING SERVICES BY MEANS OF SPORTS EVENTS (U.S. CLS. 100, 101 AND 102).

FIRST USE 10-4-2010; IN COMMERCE 1-30-2011.

3,963,544. MAZDA MOTOR OF AMERICA, INC., IRVINE, CA. SN 85-059,735. PUB. 8-17-2010, FILED 6-10-2010.



OWNER OF U.S. REG. NOS. 2,542,939, 3,635,320, AND OTHERS.

NO CLAIM IS MADE TO THE EXCLUSIVE RIGHT TO USE "CAPITAL SERVICES", APART FROM THE MARK AS SHOWN.

THE MARK CONSISTS OF THE WORDING "MAZDA CAPITAL SERVICES" AND THE DESIGN OF A FLATTENED OVAL SHAPE CONTAINING A DESIGN SUGGESTING A PAIR OF WINGS.

FOR FINANCING RELATING TO AUTOMOBILES; FINANCING SERVICES (U.S. CLS. 100, 101 AND 102).

FIRST USE 0-0-2010; IN COMMERCE 0-0-2010.

3,963,613. ANGUS, DALE C, DBA GOLDEN EGG ANALYTICS, LLC, BRENTWOOD, CA. SN 85-075,602. PUB. 12-21-2010, FILED 7-1-2010.

# MyTrendAlert

THE MARK CONSISTS OF STANDARD CHARACTERS WITHOUT CLAIM TO ANY PARTICULAR FONT, STYLE, SIZE, OR COLOR.

FOR INFORMATION, ADVISORY, CONSULTANCY AND RESEARCH SERVICES RELATING TO FINANCE AND INVESTMENTS (U.S. CLS. 100, 101 AND 102).  
FIRST USE 7-1-2010; IN COMMERCE 9-15-2010.

**CLASS 36—(Continued).**

3,963,625. AMPLIFY FEDERAL CREDIT UNION, AUSTIN, TX. SN 85-078,467. PUB. 12-7-2010, FILED 7-6-2010.



THE MARK CONSISTS OF THE WORD "AMPLIFY" WITH SOUND WAVES EMANATING FROM THE LETTER "M" AND A PICTURE OF A CAR WITH A PRICE TAG ATTACHED IN THE CENTER OF THE LETTER "O" IN "SHOPPER".

FOR CREDIT UNION SERVICES (U.S. CLS. 100, 101 AND 102).

FIRST USE 7-6-2010; IN COMMERCE 7-6-2010.

3,963,627. KALEIDOSCOPE MARKETING GROUP LLC, MT. PLEASANT, SC. SN 85-079,703. PUB. 11-2-2010, FILED 7-7-2010.

## GOECO! THE ULTIMATE ECO-FUNDRAISER

THE MARK CONSISTS OF STANDARD CHARACTERS WITHOUT CLAIM TO ANY PARTICULAR FONT, STYLE, SIZE, OR COLOR.

FOR FUNDRAISING SERVICES, NAMELY, ORGANIZING FUNDRAISERS FOR SCHOOLS AND OTHER GROUPS (U.S. CLS. 100, 101 AND 102).

FIRST USE 8-1-2010; IN COMMERCE 8-1-2010.

3,963,639. NEW YORK COMMUNITY BANCORP, INC., WESTBURY, NY. SN 85-084,069. PUB. 12-28-2010, FILED 7-14-2010.



OWNER OF U.S. REG. NOS. 3,094,697, 3,438,828, AND OTHERS.

NO CLAIM IS MADE TO THE EXCLUSIVE RIGHT TO USE "MORTGAGE COMPANY, LLC", APART FROM THE MARK AS SHOWN.

THE MARK CONSISTS OF THE LETTERS "NYCB" STAGGERED INSIDE A RECTANGLE WITH THE WORDING "NYCB MORTGAGE COMPANY, LLC" TO THE RIGHT OF THE RECTANGULAR DESIGN.

FOR MORTGAGE BANKING SERVICES; MORTGAGE LENDING SERVICES (U.S. CLS. 100, 101 AND 102).

FIRST USE 1-3-2011; IN COMMERCE 1-3-2011.

**CLASS 36—(Continued).**

3,963,692. RAYMOND JAMES FINANCIAL, INC., ST. PETERSBURG, FL. SN 85-105,760. PUB. 1-25-2011, FILED 8-12-2010.

## LIFE WELL PLANNED

THE MARK CONSISTS OF STANDARD CHARACTERS WITHOUT CLAIM TO ANY PARTICULAR FONT, STYLE, SIZE, OR COLOR.

FOR FINANCIAL SERVICES, NAMELY, FINANCIAL PLANNING, FINANCIAL CONSULTING, ASSET MANAGEMENT AND INVESTMENT BROKERAGE SERVICES (U.S. CLS. 100, 101 AND 102).

FIRST USE 10-11-2010; IN COMMERCE 10-11-2010.

**CLASS 37—CONSTRUCTION AND REPAIR**

3,962,288. JEZOWSKI & MARKEL CONTRACTORS, INC., ORANGE, CA. SN 77-672,412. PUB. 1-5-2010, FILED 2-17-2009.

## AGGRETOP

THE MARK CONSISTS OF STANDARD CHARACTERS WITHOUT CLAIM TO ANY PARTICULAR FONT, STYLE, SIZE, OR COLOR.

FOR CEMENTITIOUS TERRAZZO PAVING SERVICES, PAD PREPARATION, DECK CONSTRUCTION AND CEMENTITIOUS FLOORING INSTALLATION SERVICES (U.S. CLS. 100, 103 AND 106).

FIRST USE 4-0-2010; IN COMMERCE 4-0-2010.

3,962,303. ORKIN EXPANSION, INC., WILMINGTON, DE. SN 77-681,345. PUB. 6-23-2009, FILED 3-2-2009.

## PESTS WANT IN. ORKIN KEEPS THEM OUT.

THE MARK CONSISTS OF STANDARD CHARACTERS WITHOUT CLAIM TO ANY PARTICULAR FONT, STYLE, SIZE, OR COLOR.

FOR PEST CONTROL SERVICES (U.S. CLS. 100, 103 AND 106).

FIRST USE 2-11-2011; IN COMMERCE 2-11-2011.

**CLASS 37—(Continued).**

3,962,362. ORKIN EXPANSION, INC., WILMINGTON, DE. SN 77-720,772. PUB. 7-13-2010, FILED 4-23-2009.



NO CLAIM IS MADE TO THE EXCLUSIVE RIGHT TO USE "PEST" AND "411", APART FROM THE MARK AS SHOWN.

THE MARK CONSISTS OF THE WORD "ORKIN" ABOVE THE WORD "PEST", TO THE RIGHT IS A MAGNIFYING GLASS WITH AN ANT UNDER THE GLASS, TO THE RIGHT OF THE MAGNIFYING GLASS IS THE NUMBER "411".

FOR PEST CONTROL; PROVIDING INFORMATION TO ASSIST CUSTOMERS IN IDENTIFICATION OF PESTS AND THEIR THREATS (U.S. CLS. 100, 103 AND 106).

FIRST USE 9-16-2009; IN COMMERCE 9-16-2009.

3,962,363. ORKIN EXPANSION, INC., WILMINGTON, DE. SN 77-720,822. PUB. 7-13-2010, FILED 4-23-2009.

**ORKIN PEST 411**

THE MARK CONSISTS OF STANDARD CHARACTERS WITHOUT CLAIM TO ANY PARTICULAR FONT, STYLE, SIZE, OR COLOR.

NO CLAIM IS MADE TO THE EXCLUSIVE RIGHT TO USE "PEST" AND "411", APART FROM THE MARK AS SHOWN.

FOR PEST CONTROL; PROVIDING INFORMATION TO ASSIST CUSTOMERS IN IDENTIFICATION OF PESTS AND THEIR THREATS (U.S. CLS. 100, 103 AND 106).

FIRST USE 4-15-2009; IN COMMERCE 4-15-2009.

3,962,375. VM PRODUCTS, BEDFORD, TX. SN 77-734,694. PUB. 3-23-2010, FILED 5-12-2009.



NO CLAIM IS MADE TO THE EXCLUSIVE RIGHT TO USE "FLY BAIT STATION", APART FROM THE MARK AS SHOWN.

**CLASS 37—(Continued).**

THE COLOR(S) BLUE, BLACK AND WHITE. IS/ARE CLAIMED AS A FEATURE OF THE MARK.

THE MARK CONSISTS OF BLUE LETTERS SPELLING OUT "FLY BAIT STATION" ACROSS THE BOTTOM, BOLD BLUE LETTERS "FBS" AND THE NUMBER "1" OUTLINED IN BLACK IN THE MIDDLE, AND A BLACK AND BLUE FLY AT THE TOP.

FOR PEST CONTROL INFORMATION SERVICES (U.S. CLS. 100, 103 AND 106).

FIRST USE 6-20-2006; IN COMMERCE 6-20-2006.

3,962,420. RICHARD WELSH, YUCCA VALLEY, CA. SN 77-769,711. PUB. 12-15-2009, FILED 6-27-2009.



NO CLAIM IS MADE TO THE EXCLUSIVE RIGHT TO USE "LEAK", APART FROM THE MARK AS SHOWN.

THE COLOR(S) BLUE AND BLACK IS/ARE CLAIMED AS A FEATURE OF THE MARK.

THE MARK CONSISTS OF THE LETTERS "L" AND "P" APPEARING IN BLUE AND OUTLINED IN BLACK WITH THE TERM "LEAK" APPEARING IN BLACK TO THE RIGHT OF THE TOP PORTION OF THE "L" AND THE TERM "POINT" APPEARING IN BLACK TO THE RIGHT OF THE BOTTOM PORTION OF THE "P".

FOR PLUMBING SERVICES, NAMELY, LEAK LOCATION SERVICES IN POOLS, SPAS, PIPE SYSTEMS, OTHER WATER FEATURES, SEWER, WATER, AND GAS PIPING SYSTEMS AND UTILITIES; PLUMBING SERVICES; PLUMBING CONTRACTOR SERVICES; REPAIR OR MAINTENANCE OF GAS WATER HEATERS; INSTALLATION, MAINTENANCE AND REPAIR OF PIPE SYSTEMS, SEWER LINES, WATER LINES, GAS LINES AND UTILITY SYSTEMS (U.S. CLS. 100, 103 AND 106).

FIRST USE 2-28-2010; IN COMMERCE 2-28-2010.

3,962,447. GUTERMAXX, L.P., HOUSTON, TX. SN 77-781,773. PUB. 12-8-2009, FILED 7-15-2009.

**THE LAST GUTTER YOU'LL  
EVER NEED**

THE MARK CONSISTS OF STANDARD CHARACTERS WITHOUT CLAIM TO ANY PARTICULAR FONT, STYLE, SIZE, OR COLOR.

FOR INSTALLATION OF METAL ROOF GUTTERS (U.S. CLS. 100, 103 AND 106).

FIRST USE 7-7-2009; IN COMMERCE 7-7-2009.

**CLASS 37—(Continued).**

3,962,448. GUTERMAXX, L.P., HOUSTON, TX. SN 77-781,778.  
PUB. 12-8-2009, FILED 7-15-2009.

**THE LAST GUTTER YOU'LL  
EVER BUY**

THE MARK CONSISTS OF STANDARD CHARACTERS  
WITHOUT CLAIM TO ANY PARTICULAR FONT, STYLE,  
SIZE, OR COLOR.

FOR INSTALLATION OF METAL ROOF GUTTERS  
(U.S. CLS. 100, 103 AND 106).

FIRST USE 8-4-2009; IN COMMERCE 8-4-2009.

3,962,801. ZIGMO, LLC, GLEN ALLEN, VA. SN 77-901,648.  
PUB. 5-18-2010, FILED 12-28-2009.

**ZIGMO**

THE MARK CONSISTS OF STANDARD CHARACTERS  
WITHOUT CLAIM TO ANY PARTICULAR FONT, STYLE,  
SIZE, OR COLOR.

FOR INSTALLATION, MAINTENANCE, AND REPAIR  
OF COMPUTER HARDWARE AND CONSUMER ELECTRONICS  
IN THE FIELD OF MULTIMEDIA, DATA COMMUNICATIONS,  
COMPUTING, TELECOMMUNICATIONS, SECURITY SYSTEMS,  
HOME AUTOMATION, AUTOMOTIVE ELECTRONICS, AND  
APPLIANCES (U.S. CLS. 100, 103 AND 106).

FIRST USE 1-6-2010; IN COMMERCE 1-6-2010.

3,962,949. PAUL DAVIS RESTORATION, INC., JACKSONVILLE, FL. SN 77-936,997. PUB. 8-31-2010, FILED 2-16-2010.

**PAUL DAVIS**

THE MARK CONSISTS OF STANDARD CHARACTERS  
WITHOUT CLAIM TO ANY PARTICULAR FONT, STYLE,  
SIZE, OR COLOR.

OWNER OF U.S. REG. NOS. 2,530,592, 2,598,729, AND  
3,673,765.

**CLASS 37—(Continued).**

THE NAME(S), PORTRAIT(S), AND/OR SIGNATURE(S)  
SHOWN IN THE MARK IDENTIFIES "PAUL DAVIS",  
WHOSE CONSENT(S) TO REGISTER IS MADE OF RECORD.

FOR PROVIDING RESTORATION, RECONSTRUCTION,  
REMODELING AND EMERGENCY REPAIR SERVICES FOR  
COMMERCIAL AND RESIDENTIAL BUILDINGS AFTER  
LOSSES; PROVIDING RESTORATION, RECONSTRUCTION,  
REMODELING AND EMERGENCY REPAIR SERVICES FOR  
COMMERCIAL AND RESIDENTIAL BUILDINGS TO  
MITIGATE DAMAGES AFTER LOSSES; DRYING AND  
CLEANING OF RESIDENTIAL AND COMMERCIAL  
BUILDINGS, STRUCTURES AND CONTENTS DAMAGED  
BY LOSSES (U.S. CLS. 100, 103 AND 106).

FIRST USE 11-0-2010; IN COMMERCE 11-0-2010.

3,962,998. INSPIRON, INC., BROOKLYN, NY. SN 77-944,450.  
PUB. 7-27-2010, FILED 2-26-2010.

**INSPIRON**

THE MARK CONSISTS OF STANDARD CHARACTERS  
WITHOUT CLAIM TO ANY PARTICULAR FONT, STYLE,  
SIZE, OR COLOR.

FOR BUILDING CONSTRUCTION SUPERVISION,  
MANAGEMENT AND CONSULTATION; GENERAL  
CONSTRUCTION CONTRACTING; CONSTRUCTION  
PLANNING (U.S. CLS. 100, 103 AND 106).

FIRST USE 8-0-2010; IN COMMERCE 8-0-2010.

3,963,109. ANCHOR LOANS, INC., CALABASAS, CA. SN 77-956,756. PUB. 8-3-2010, FILED 3-11-2010.

**ANCHOR HOMES**

THE MARK CONSISTS OF STANDARD CHARACTERS  
WITHOUT CLAIM TO ANY PARTICULAR FONT, STYLE,  
SIZE, OR COLOR.

NO CLAIM IS MADE TO THE EXCLUSIVE RIGHT TO  
USE "HOMES", APART FROM THE MARK AS SHOWN.

FOR HOUSING SERVICES, NAMELY, REPAIR,  
IMPROVEMENT, AND CONSTRUCTION OF RESIDENTIAL  
REAL PROPERTY; RESIDENTIAL AND BUILDING  
CONSTRUCTION CONSULTING; GENERAL CONTRACTING  
OF CONSTRUCTION SERVICES AND CONSTRUCTION  
AND REPAIR OF LUXURY AND CUSTOM RESIDENTIAL  
BUILDINGS; CONSTRUCTION OF LUXURY AND CUSTOM  
RESIDENTIAL HOMES; RESIDENTIAL REAL ESTATE  
DEVELOPMENT SERVICES; LUXURY AND CUSTOM HOME  
REMODELING SERVICES (U.S. CLS. 100, 103 AND 106).

FIRST USE 1-31-2010; IN COMMERCE 1-31-2010.

**CLASS 37—(Continued).**

3,963,116. SIDNEY, WILLIAM, GREENWOOD, CA. AND ALKIRE, JEFF, GREENWOOD, CA. SN 77-957,380. PUB. 8-3-2010, FILED 3-12-2010.



THE COLOR(S) PURPLE, YELLOW, BLACK, GRAY, WHITE, AND GREEN IS/ARE CLAIMED AS A FEATURE OF THE MARK.

THE MARK CONSISTS OF STYLIZED CAT DESIGN APPEARING WHITE AND OUTLINED IN BLACK WITH GRAY HAIR, A BLACK AND WHITE NOSE, BLACK WHISKERS AND WHITE AND GRAY EARS WEARING PURPLE AND BLACK SUNGLASSES, A GREEN SHIRT, A PURPLE TIE AND A BLACK AND PURPLE COAT WITH BLACK AND WHITE BUTTONS WHILE HOLDING A BLACK AND YELLOW SAXOPHONE AND LEANING AGAINST A PURPLE, YELLOW AND WHITE DRUM WITH BLACK STANDS SUPERIMPOSED OVER A GRAY CIRCLE.

FOR REPAIR OR MAINTENANCE OF MUSICAL INSTRUMENTS (U.S. CLS. 100, 103 AND 106).  
FIRST USE 10-12-2010; IN COMMERCE 10-12-2010.

3,963,293. RED DEVELOPMENT, LLC, KANSAS CITY, MO. SN 78-893,786. PUB. 10-10-2006, FILED 5-26-2006.



FOR REAL ESTATE DEVELOPMENT AND SITE SELECTION; CONSTRUCTION SERVICES, NAMELY, CONSTRUCTION PLANNING AND BUILDING; CONSTRUCTION CONSULTING FOR COMMERCIAL, RESIDENTIAL, EDUCATIONAL, NON-PROFIT, AND MEDICAL FACILITIES AND FOR PUBLIC ACCESS LANDS (U.S. CLS. 100, 103 AND 106).  
FIRST USE 8-1-2009; IN COMMERCE 8-1-2009.

**CLASS 37—(Continued).**

3,963,529. GOTTABECLEAN, INC., RALEIGH, NC. SN 85-052,812. PUB. 11-2-2010, FILED 6-2-2010.

## Gotta Be Clean

THE MARK CONSISTS OF STANDARD CHARACTERS WITHOUT CLAIM TO ANY PARTICULAR FONT, STYLE, SIZE, OR COLOR.

NO CLAIM IS MADE TO THE EXCLUSIVE RIGHT TO USE "CLEAN", APART FROM THE MARK AS SHOWN.

FOR CLEANING OF RESIDENTIAL HOUSES (U.S. CLS. 100, 103 AND 106).

FIRST USE 6-21-2009; IN COMMERCE 7-3-2009.

**CLASS 38—COMMUNICATION**

3,962,011. NOSVA LP, DBA EXIT MOBILE, LAS VEGAS, NV. SN 77-053,175. PUB. 12-25-2007, FILED 11-29-2006.

## EXIT MOBILE

THE MARK CONSISTS OF STANDARD CHARACTERS WITHOUT CLAIM TO ANY PARTICULAR FONT, STYLE, SIZE, OR COLOR.

NO CLAIM IS MADE TO THE EXCLUSIVE RIGHT TO USE "MOBILE", APART FROM THE MARK AS SHOWN.

FOR TELECOMMUNICATIONS SERVICES, NAMELY, PROVIDING MOBILE TELEPHONE COMMUNICATIONS AND MOBILE TELEPHONE CALLING PLANS (U.S. CLS. 100, 101 AND 104).

FIRST USE 4-0-2007; IN COMMERCE 4-0-2007.

3,962,062. WEC HOLDINGS, LLC, LAS VEGAS, NV. SN 77-227,649. PUB. 1-15-2008, FILED 7-12-2007.

## WEC WREKAGE

THE MARK CONSISTS OF STANDARD CHARACTERS WITHOUT CLAIM TO ANY PARTICULAR FONT, STYLE, SIZE, OR COLOR.

FOR VIDEO-ON-DEMAND TRANSMISSION SERVICES (U.S. CLS. 100, 101 AND 104).

FIRST USE 6-3-2007; IN COMMERCE 6-3-2007.



**CLASS 38—(Continued).**

3,962,146. T-MOBILE USA, INC., BELLEVUE, WA. SN 77-464,834. PUB. 9-30-2008, FILED 5-2-2008.

**NEVER ALLOWED**

THE MARK CONSISTS OF STANDARD CHARACTERS WITHOUT CLAIM TO ANY PARTICULAR FONT, STYLE, SIZE, OR COLOR.

FOR TELECOMMUNICATIONS SERVICES, NAMELY, WIRELESS VOICE AND DATA TRANSMISSION, TWO WAY WIRELESS TRANSMISSION OF EMAIL AND TEXT BETWEEN WIRELESS TELECOMMUNICATION TERMINALS AND COMPUTERS, AND PROVIDING MULTIPLE-USER ACCESS TO A GLOBAL COMPUTER NETWORK (U.S. CLS. 100, 101 AND 104).  
FIRST USE 7-31-2008; IN COMMERCE 7-31-2008.

---

3,962,232. BEST THINKING, INC., CARY, NC. SN 77-621,276. PUB. 4-7-2009, FILED 11-25-2008.

**WHERE DO YOU DO YOUR BEST THINKING?**

THE MARK CONSISTS OF STANDARD CHARACTERS WITHOUT CLAIM TO ANY PARTICULAR FONT, STYLE, SIZE, OR COLOR.

FOR PROVIDING AN ONLINE FORUM FOR TRANSMISSION OF MESSAGES AMONG COMPUTER USERS CONCERNING ARTS AND ENTERTAINMENT, BUSINESS AND FINANCE, COMPUTERS AND TECHNOLOGY, EDUCATION, ENGINEERING, HISTORY, LAW, LIFESTYLE, MEDICINE, NEWS AND POLITICS, SCIENCE, SOCIETY AND THE HUMANITIES (U.S. CLS. 100, 101 AND 104).  
FIRST USE 6-17-2010; IN COMMERCE 6-17-2010.

**CLASS 38—(Continued).**

3,962,233. BEST THINKING, INC., CARY, NC. SN 77-621,358. PUB. 4-7-2009, FILED 11-25-2008.

**WHAT ARE YOU THINKING?**

THE MARK CONSISTS OF STANDARD CHARACTERS WITHOUT CLAIM TO ANY PARTICULAR FONT, STYLE, SIZE, OR COLOR.

FOR PROVIDING AN ONLINE FORUM FOR TRANSMISSION OF MESSAGES AMONG COMPUTER USERS CONCERNING ARTS AND ENTERTAINMENT, BUSINESS AND FINANCE, COMPUTERS AND TECHNOLOGY, EDUCATION, ENGINEERING, HISTORY, LAW, LIFESTYLE, MEDICINE, NEWS AND POLITICS, SCIENCE, SOCIETY AND THE HUMANITIES (U.S. CLS. 100, 101 AND 104).  
FIRST USE 6-17-2010; IN COMMERCE 6-17-2010.

---

3,962,274. ROWDY ORBIT IPTV, LLC, MARTINSBURG, WV. SN 77-664,692. PUB. 6-9-2009, FILED 2-5-2009.

**ROWDY ORBIT**

THE MARK CONSISTS OF STANDARD CHARACTERS WITHOUT CLAIM TO ANY PARTICULAR FONT, STYLE, SIZE, OR COLOR.

FOR AUDIO AND VIDEO BROADCASTING SERVICES OVER THE INTERNET OR OTHER COMMUNICATIONS NETWORK, NAMELY, SHOWING, DISPLAYING, AND ELECTRONICALLY TRANSMITTING INFORMATION, AUDIO, AND VIDEO CLIPS; AUDIO AND VIDEO BROADCASTING SERVICES OVER THE INTERNET OR OTHER COMMUNICATIONS NETWORK FEATURING THE UPLOADED, POSTED, AND TAGGED AUDIO AND VIDEOS OF OTHERS (U.S. CLS. 100, 101 AND 104).  
FIRST USE 4-6-2011; IN COMMERCE 4-6-2011.

---

3,962,523. BLACK EDUCATIONAL EVENTS, LLC, COLLEYVILLE, TX. SN 77-806,524. PUB. 1-12-2010, FILED 8-17-2009.

**HBCU TODAY**

THE MARK CONSISTS OF STANDARD CHARACTERS WITHOUT CLAIM TO ANY PARTICULAR FONT, STYLE, SIZE, OR COLOR.

**CLASS 38—(Continued).**

NO CLAIM IS MADE TO THE EXCLUSIVE RIGHT TO USE "HBCU", APART FROM THE MARK AS SHOWN.

FOR BROADCASTING OF VIDEO AND AUDIO PROGRAMMING OVER THE INTERNET (U.S. CLS. 100, 101 AND 104).

FIRST USE 9-30-2009; IN COMMERCE 9-30-2009.

**CLASS 38—(Continued).**

3,963,489. LNO S.A., GENEVA, SWITZERLAND. SN 85-042,605. PUB. 10-19-2010, FILED 5-19-2010.

**OFFICIAL.FM**

3,962,772. FEDTECHSERVICES, LLC, AKA FTS, TAMPA, FL. SN 77-891,800. PUB. 5-11-2010, FILED 12-11-2009.

THE MARK CONSISTS OF STANDARD CHARACTERS WITHOUT CLAIM TO ANY PARTICULAR FONT, STYLE, SIZE, OR COLOR.

FOR DELIVERY OF DIGITAL MUSIC BY ELECTRONIC TRANSMISSION; PROVIDING ACCESS TO DIGITAL MUSIC WEBSITES ON THE INTERNET; INTERNET RADIO SERVICES, NAMELY, TRANSMISSION OF AUDIO MATERIAL VIA THE INTERNET (U.S. CLS. 100, 101 AND 104).

FIRST USE 7-31-2010; IN COMMERCE 7-31-2010.



3,963,512. STAGEIT CORP., LOS ANGELES, CA. SN 85-047,379. PUB. 10-26-2010, FILED 5-25-2010.

NO CLAIM IS MADE TO THE EXCLUSIVE RIGHT TO USE "TNMA" AND "THEATER NETWORK MANAGEMENT ARCHITECTURE", APART FROM THE MARK AS SHOWN.

THE COLOR(S) LIGHT BROWN, DARK BROWN, BLACK AND WHITE IS/ARE CLAIMED AS A FEATURE OF THE MARK.

THE MARK CONSISTS OF THE WORDING "THEATER NETWORK MANAGEMENT ARCHITECTURE" WITH "THEATER" APPEARING IN BLACK, "NETWORK" APPEARING IN LIGHT BROWN, "MANAGEMENT" APPEARING IN BLACK, AND "ARCHITECTURE" APPEARING IN LIGHT BROWN; THREE LIGHT BROWN STARS APPEAR ON THE LEFT AND RIGHT OF THE WORD "ARCHITECTURE"; A STYLIZED EAGLE APPEARS WITH A BLACK BODY, LIGHT BROWN WINGS OUTLINED IN BLACK, LIGHT BROWN TAIL FEATHERS OUTLINED IN DARK BROWN AND A WHITE HEAD OUTLINED IN BLACK; AN OVAL APPEARS OVER THE EAGLE WITH A BLACK BACKGROUND, AN A DARK BROWN OUTLINE; THE LETTERS "TNMA" APPEAR ON THE BLACK OVAL, WITH THE LETTER "T" IN LIGHT BROWN WITH A WHITE OUTLINE, THE LETTER "N" IN WHITE, THE LETTER "M" IN LIGHT BROWN WITH A WHITE OUTLINE, AND THE LETTER "A" IN WHITE.

FOR TELECOMMUNICATIONS CONSULTATION (U.S. CLS. 100, 101 AND 104).

FIRST USE 12-11-2009; IN COMMERCE 12-11-2009.

**A FRONT ROW SEAT TO A BACKSTAGE EXPERIENCE**

THE MARK CONSISTS OF STANDARD CHARACTERS WITHOUT CLAIM TO ANY PARTICULAR FONT, STYLE, SIZE, OR COLOR.

FOR AUDIO AND VIDEO BROADCASTING SERVICES OVER THE INTERNET; COMMUNICATIONS SERVICES, NAMELY, TRANSMITTING STREAMED SOUND AND AUDIOVISUAL RECORDINGS VIA THE INTERNET; ELECTRONIC TRANSMISSION AND STREAMING OF DIGITAL MEDIA CONTENT FOR OTHERS VIA GLOBAL AND LOCAL COMPUTER NETWORKS; INTERACTIVE DELIVERY OF VIDEO OVER DIGITAL NETWORKS; STREAMING OF AUDIO MATERIAL ON THE INTERNET; STREAMING OF AUDIO, VISUAL AND AUDIOVISUAL MATERIAL VIA A GLOBAL COMPUTER NETWORK; STREAMING OF VIDEO MATERIAL ON THE INTERNET; VIDEO BROADCASTING (U.S. CLS. 100, 101 AND 104).

FIRST USE 1-1-2009; IN COMMERCE 9-1-2010.

**CLASS 38—(Continued).**

3,963,524. T-MOBILE USA, INC., BELLEVUE, WA. SN 85-050,399. PUB. 10-26-2010, FILED 5-28-2010.

# WebPak

THE MARK CONSISTS OF STANDARD CHARACTERS WITHOUT CLAIM TO ANY PARTICULAR FONT, STYLE, SIZE, OR COLOR.

FOR TELECOMMUNICATIONS SERVICES, NAMELY, WIRELESS VOICE AND DATA TRANSMISSION, TWO WAY WIRELESS TRANSMISSION OF EMAIL AND TEXT BETWEEN WIRELESS TELECOMMUNICATIONS TERMINALS AND COMPUTERS, AND PROVISION OF ACCESS TO THE INTERNET (U.S. CLS. 100, 101 AND 104).

FIRST USE 9-13-2010; IN COMMERCE 9-13-2010.

**CLASS 39—TRANSPORTATION AND STORAGE**

3,962,112. HOTELS.COM, L.P., DALLAS, TX. SN 77-380,836. PUB. 1-19-2010, FILED 1-25-2008.



OWNER OF U.S. REG. NOS. 2,918,738, 3,015,723, AND 3,337,609.

THE MARK CONSISTS OF THE WORDS "HOTELS.COM" WITH TRIANGLES ON THE BOTTOM AND TOP OF THE "O" IN HOTELS. THE WORDS "HOTELS.COM" AND THE TRIANGLES APPEAR IN THE BOTTOM HALF OF A CONTRASTING COLORED RECTANGLE. THE RECTANGLE HAS ROUNDED CORNERS.

SEC. 2(F) AS TO "HOTELS.COM".

FOR TRAVEL AGENCY SERVICES, NAMELY, MAKING RESERVATIONS AND BOOKINGS FOR TRANSPORTATION AND PROVIDING INFORMATION CONCERNING TRAVEL AND PROVIDING TRAVEL INFORMATION OVER COMPUTER NETWORKS AND GLOBAL COMMUNICATION NETWORKS (U.S. CLS. 100 AND 105).

FIRST USE 2-11-2008; IN COMMERCE 2-11-2008.

**CLASS 39—(Continued).**

3,962,126. HOTELS.COM, L.P., DALLAS, TX. SN 77-410,176. PUB. 1-19-2010, FILED 2-29-2008.



OWNER OF U.S. REG. NOS. 2,918,738, 3,015,723, AND 3,337,609.

THE MARK CONSISTS OF THE WORDS "HOTELS.COM" WITH TRIANGLES ON THE BOTTOM AND TOP OF THE "O" IN HOTELS. THE WORDS "HOTELS.COM" AND THE TRIANGLES APPEAR IN THE BOTTOM HALF OF A CONTRASTING COLORED RECTANGLE. THE RECTANGLE HAS ROUNDED CORNERS.

SEC. 2(F) AS TO "HOTELS.COM".

FOR TRAVEL AGENCY SERVICES, NAMELY, MAKING RESERVATIONS AND BOOKINGS FOR TRANSPORTATION AND PROVIDING INFORMATION CONCERNING TRAVEL AND PROVIDING TRAVEL INFORMATION OVER COMPUTER NETWORKS, GLOBAL COMMUNICATION NETWORKS AND MOBILE NETWORKS (U.S. CLS. 100 AND 105).

FIRST USE 2-11-2008; IN COMMERCE 2-11-2008.

3,963,294. NEW HOLLAND PUBLISHING (SOUTH AFRICA) (PROPRIETARY) LIMITED, CAPE TOWN, SOUTH AFRICA. SN 78-908,836. PUB. 4-20-2010, FILED 6-15-2006.

# GLOBETROTTER

THE MARK CONSISTS OF STANDARD CHARACTERS WITHOUT CLAIM TO ANY PARTICULAR FONT, STYLE, SIZE, OR COLOR.

FOR PROVIDING INFORMATION ABOUT TRAVEL, TOURISM AND TRAVEL ROUTES (U.S. CLS. 100 AND 105).

FIRST USE 3-1-1996; IN COMMERCE 3-1-1996.

**CLASS 39—(Continued).**

3,963,444. CITATIONSHARES MANAGEMENT, LLC, GREENWICH, CT. SN 85-030,846. PUB. 10-5-2010, FILED 5-5-2010.

## PrivateConnect

THE MARK CONSISTS OF STANDARD CHARACTERS WITHOUT CLAIM TO ANY PARTICULAR FONT, STYLE, SIZE, OR COLOR.

FOR AIR TRANSPORTATION SERVICES; PASSENGER GROUND TRANSPORTATION SERVICES BETWEEN AIRPORTS, EXCLUDING VEHICLE RENTAL SERVICES; ARRANGING, COORDINATING AND CONTROLLING TRANSFER AND TRANSIT OF PASSENGERS AND THEIR LUGGAGE; ARRANGING AND COORDINATING GROUND TRANSPORTATION SERVICES OF PEOPLE AND GOODS FOR OTHERS, EXCLUDING VEHICLE RENTAL SERVICES; PROVIDING A WEBSITE FEATURING INFORMATION ON TRAVEL; PROVIDE A WEBSITE FOR THE ARRANGEMENT AND BOOKING OF TRAVEL SERVICES, NAMELY, TRANSPORTATION, EXCLUDING VEHICLE RENTAL SERVICES (U.S. CLS. 100 AND 105).

FIRST USE 6-14-2010; IN COMMERCE 6-14-2010.

3,963,715. DELTA AIR LINES, INC., ATLANTA, GA. SN 85-142,253. PUB. 2-1-2011, FILED 9-30-2010.

## AWARD BUILDER

THE MARK CONSISTS OF STANDARD CHARACTERS WITHOUT CLAIM TO ANY PARTICULAR FONT, STYLE, SIZE, OR COLOR.

NO CLAIM IS MADE TO THE EXCLUSIVE RIGHT TO USE "AWARD", APART FROM THE MARK AS SHOWN.

FOR AIR TRANSPORTATION SERVICES FEATURING A FREQUENT FLYER BONUS PROGRAM (U.S. CLS. 100 AND 105).

FIRST USE 9-30-2010; IN COMMERCE 9-30-2010.

**CLASS 40—MATERIAL TREATMENT****CLASS 40—(Continued).**

3,962,009. ARMORWORKS ENTERPRISES, LLC, CHANDLER, AZ. SN 77-043,929. PUB. 11-27-2007, FILED 11-14-2006.

## ARMOR UP

THE MARK CONSISTS OF STANDARD CHARACTERS WITHOUT CLAIM TO ANY PARTICULAR FONT, STYLE, SIZE, OR COLOR.

NO CLAIM IS MADE TO THE EXCLUSIVE RIGHT TO USE "ARMOR", APART FROM THE MARK AS SHOWN.

FOR CONTRACT MANUFACTURING IN THE FIELD OF BALLISTICS (U.S. CLS. 100, 103 AND 106).

FIRST USE 4-24-2006; IN COMMERCE 4-24-2006.

3,962,119. DKRW WIND LLC, HOUSTON, TX. SN 77-399,297. PUB. 6-10-2008, FILED 2-18-2008.



THE COLOR(S) BLUE, GREEN AND BLUE/GREY IS/ARE CLAIMED AS A FEATURE OF THE MARK.

THE MARK CONSISTS OF A TURBINE OR PROPELLER DESIGN CONSISTING OF ONE BLUE BLADE, ONE GREEN BLADE AND ONE BLUE/GREY BLADE.

FOR PRODUCTION OF ENERGY (U.S. CLS. 100, 103 AND 106).

FIRST USE 12-20-2007; IN COMMERCE 12-20-2007.

**CLASS 40—(Continued).**

3,962,244. INNOVATION SPECIALTIES, CULVER CITY, CA. SN 77-633,460. PUB. 6-23-2009, FILED 12-15-2008.

**BRANDBAND**

THE MARK CONSISTS OF STANDARD CHARACTERS WITHOUT CLAIM TO ANY PARTICULAR FONT, STYLE, SIZE, OR COLOR.

FOR CUSTOM MANUFACTURE OF BANGLE BRACELETS FEATURING COMPANY LOGOS FOR OTHERS (U.S. CLS. 100, 103 AND 106).

FIRST USE 6-21-2010; IN COMMERCE 6-21-2010.

---

3,962,337. CI METAL FABRICATION, LLC, SAINT LOUIS, MO. SN 77-703,279. PUB. 8-10-2010, FILED 3-31-2009.

**CI METAL FABRICATION**

THE MARK CONSISTS OF STANDARD CHARACTERS WITHOUT CLAIM TO ANY PARTICULAR FONT, STYLE, SIZE, OR COLOR.

NO CLAIM IS MADE TO THE EXCLUSIVE RIGHT TO USE "METAL FABRICATION", APART FROM THE MARK AS SHOWN.

FOR METAL FABRICATION OF VARIOUS MATERIALS, NAMELY, LIGHT AND HEAVY GAUGE METALS, CARBON STEEL, STAINLESS STEEL, ALUMINUM, COPPER, CONVENTIONAL PIPE STOCK, ROLLED PLATE AND SHEET STEEL (U.S. CLS. 100, 103 AND 106).

FIRST USE 4-1-2009; IN COMMERCE 4-1-2009.

---

3,962,426. VITRUVIAN EXPLORATION, LLC, THE WOODLANDS, TX. SN 77-772,753. PUB. 5-25-2010, FILED 7-1-2009.

**VITRUVIAN EXPLORATION**

THE MARK CONSISTS OF STANDARD CHARACTERS WITHOUT CLAIM TO ANY PARTICULAR FONT, STYLE, SIZE, OR COLOR.

FOR PRODUCTION OF OIL AND NATURAL GAS; GREENHOUSE GAS EMISSION REDUCTION SERVICES FOR THE MINING INDUSTRY UTILIZING SUBSURFACE DRILLING PROCESSES FOR THE REMOVAL AND CAPTURE OF NATURAL GAS (U.S. CLS. 100, 103 AND 106).

FIRST USE 10-0-2009; IN COMMERCE 10-0-2009.

**CLASS 40—(Continued).**

3,962,631. VENTURA FOODS, LLC, BREA, CA. SN 77-842,887. PUB. 8-10-2010, FILED 10-6-2009.

**PURE PRODUCING USEFUL  
RENEWABLE ENERGY**

THE MARK CONSISTS OF STANDARD CHARACTERS WITHOUT CLAIM TO ANY PARTICULAR FONT, STYLE, SIZE, OR COLOR.

NO CLAIM IS MADE TO THE EXCLUSIVE RIGHT TO USE "PRODUCING USEFUL RENEWABLE ENERGY", APART FROM THE MARK AS SHOWN.

FOR RECYCLING OF WASTE VEGETABLE OIL INTO RENEWABLE FUEL AS PART OF GREEN CAMPAIGN WHERE PARTICIPATING RESTAURANTS SAVE USED COOKING OIL SO IT CAN BE RECYCLED INTO RENEWABLE ENERGY (U.S. CLS. 100, 103 AND 106).

FIRST USE 9-0-2009; IN COMMERCE 9-0-2009.

---

3,962,650. MODERNE GLASS COMPANY, INC., ALIQUIPPA, PA. SN 77-850,617. PUB. 3-23-2010, FILED 10-16-2009.

**IF IT CAN BE PUT ON  
GLASS... WE DO IT.**

THE MARK CONSISTS OF STANDARD CHARACTERS WITHOUT CLAIM TO ANY PARTICULAR FONT, STYLE, SIZE, OR COLOR.

FOR PRINTING FOR OTHERS ON SUBSTRATES (U.S. CLS. 100, 103 AND 106).

FIRST USE 3-3-2010; IN COMMERCE 3-30-2010.

---

3,962,833. GREENE, TWEED OF DELAWARE, INC., WILMINGTON, DE. SN 77-910,607. PUB. 5-11-2010, FILED 1-13-2010.

**HyFusion**

THE MARK CONSISTS OF STANDARD CHARACTERS WITHOUT CLAIM TO ANY PARTICULAR FONT, STYLE, SIZE, OR COLOR.

FOR COMPRESSION MOLDING OF THERMOPLASTIC COMPOSITE MATERIALS; CUSTOM MANUFACTURE OF THERMOPLASTIC PARTS TO THE ORDER AND SPECIFICATION OF OTHERS; MOLDING SERVICES, NAMELY, CREATING CUSTOM MOLDED THERMOPLASTIC SHAPES AND PARTS THROUGH COMPRESSION MOLDING (U.S. CLS. 100, 103 AND 106).

FIRST USE 10-0-2010; IN COMMERCE 10-0-2010.



**CLASS 40—(Continued).**

3,962,834. RCI HOLDINGS, L.L.C., BELTSVILLE, MD. SN 77-910,791. PUB. 12-21-2010, FILED 1-13-2010.

## PhotoLife Imaging

THE MARK CONSISTS OF STANDARD CHARACTERS WITHOUT CLAIM TO ANY PARTICULAR FONT, STYLE, SIZE, OR COLOR.

NO CLAIM IS MADE TO THE EXCLUSIVE RIGHT TO USE "IMAGING", APART FROM THE MARK AS SHOWN.

FOR DIGITAL IMAGE PROCESSING SERVICES, NAMELY, PHOTOGRAPHIC ENLARGING; CREATION OF CUSTOM PHOTO BOOKS, PHOTO GREETING CARDS, AND PHOTO CALENDARS BASED ON IMAGES PROVIDED BY THE CUSTOMER; CUSTOM IMPRINTING OF DIGITAL PHOTOGRAPHIC IMAGES ONTO PHOTO GIFTS, NAMELY, CLOTHING, JEWELRY, BELT BUCKLES, PURSES, TOTE BAGS, SPORTING EQUIPMENT, HOUSEWARES, LUGGAGE TAGS, KEY CHAINS, MOUSE PADS, CARD CASES, CHECKBOOK COVERS, PENCIL HOLDERS, PAPER WEIGHTS, PET COLLARS, PET DISHES, PET FOOD MATS, ORNAMENTS AND KEEPSAKES, CANDY AND COOKIES, PLAYING CARDS, PUZZLES, AND TEDDY BEARS (U.S. CLS. 100, 103 AND 106).

FIRST USE 1-19-2010; IN COMMERCE 1-19-2010.

3,963,030. THE PENN STATE RESEARCH FOUNDATION, UNIVERSITY PARK, PA. SN 77-948,305. PUB. 8-24-2010, FILED 3-2-2010.

## REDI INDEX

THE MARK CONSISTS OF STANDARD CHARACTERS WITHOUT CLAIM TO ANY PARTICULAR FONT, STYLE, SIZE, OR COLOR.

NO CLAIM IS MADE TO THE EXCLUSIVE RIGHT TO USE "INDEX", APART FROM THE MARK AS SHOWN.

FOR PROVIDING AN ONLINE COMPUTER DATABASE IN THE FIELD OF WASTE MANAGEMENT, NAMELY, A DATABASE FEATURING INFORMATION RELATING TO VARIOUS TYPES OF WASTE MANAGEMENT PROGRAMS AND INDICATING WASTE REMEDIATION EFFECTIVENESS THROUGH RESPONSE AND DIVERSION COMPARISONS OF WASTE STREAM MATERIALS DISPOSED OF BY A NUMBER OF PROCESSES, NAMELY, RECYCLING, REUSE, COMPOSTING, WASTE TO ENERGY, RETURN POLICIES, AND SANITARY DRAIN DISCHARGE (U.S. CLS. 100, 103 AND 106).

FIRST USE 3-28-2011; IN COMMERCE 3-28-2011.

**CLASS 40—(Continued).**

3,963,309. VITACAP LABS, LLC, FARMINGDALE, NY. SN 85-000,648. PUB. 8-3-2010, FILED 3-29-2010.

## YOUR ANSWER TO PRIVATE LABEL VITAMIN MANUFACTURING

THE MARK CONSISTS OF STANDARD CHARACTERS WITHOUT CLAIM TO ANY PARTICULAR FONT, STYLE, SIZE, OR COLOR.

FOR MANUFACTURING SERVICES FOR OTHERS IN THE FIELD OF VITAMIN, DIETARY, BODYBUILDING AND ENERGY SUPPLEMENTS (U.S. CLS. 100, 103 AND 106).

FIRST USE 5-17-2010; IN COMMERCE 5-17-2010.

3,963,451. INTERNATIONAL PAPER PRODUCTS CORPORATION, WESTFIELD, MA. SN 85-033,887. PUB. 12-28-2010, FILED 5-10-2010.

**YOUR TRASH IS NOT WASTE**



OWNER OF U.S. REG. NOS. 3,229,149, 3,274,896, AND 3,498,544.

NO CLAIM IS MADE TO THE EXCLUSIVE RIGHT TO USE THE RECYCLING SYMBOL, APART FROM THE MARK AS SHOWN.

THE MARK CONSISTS OF A GRAPHIC PORTION OF THREE IMAGES UNIFORM IN SIZE AND SHAPE. SET EQUIDISTANCE APART AND DEPICTED IN A HORIZONTAL PLACE. FROM LEFT TO RIGHT, THE FIRST IMAGE CONSISTS OF THE WORD "LANDFILL" IN BLOCK LETTERS ENCIRCLED BY A PROHIBITIVE SYMBOL. THE SECOND IMAGE CONSISTS OF THE WORD "INCINERATE" IN BLOCK LETTERS ENCIRCLED BY A PROHIBITIVE SYMBOL. THE THIRD IMAGE IS A COMPOSITE GRAPHIC CONSISTING OF THE OUTLINE OF A DECIDUOUS TREE, AND SUPERIMPOSED ON THE TREE, A RECYCLING SYMBOL, SAID TREE BEING ENTIRELY WITHIN A TRIANGLE, THE UPPER CASE LETTERS "IPP", APPEARING DIRECTLY ABOVE THE GRAPHIC PORTION OF THE MARK ARE THE WORDS "YOUR TRASH IS NOT WASTE" IN BLOCK LETTERS WITH "IS NOT" DEPICTED IN AN ITALICIZED FONT. APPEARING DIRECTLY BELOW THE GRAPHIC IS THE URL "WWW.IPPBIOMASSFUEL.COM."

FOR CONVERSION OF RECYCLABLE RAW MATERIALS INTO BIOMASS AND ENVIRONMENTALLY FRIENDLY CUBES (U.S. CLS. 100, 103 AND 106).

FIRST USE 12-1-2010; IN COMMERCE 12-1-2010.

**CLASS 40—(Continued).**

3,963,560. EFT SOURCE, INC., NASHVILLE, TN. SN 85-064,263. PUB. 11-16-2010, FILED 6-16-2010.

# Card@Once

THE MARK CONSISTS OF STANDARD CHARACTERS WITHOUT CLAIM TO ANY PARTICULAR FONT, STYLE, SIZE, OR COLOR.

FOR CUSTOM MANUFACTURE OF PERSONALIZED FINANCIAL TRANSACTION CARDS (U.S. CLS. 100, 103 AND 106).

FIRST USE 7-15-2010; IN COMMERCE 7-15-2010.

---

3,963,714. REPUBLIC SERVICES, INC., PHOENIX, AZ. SN 85-140,377. PUB. 12-21-2010, FILED 9-28-2010.

GOOD FOR OUR PLANET. GOOD  
FOR YOUR BUSINESS.

THE MARK CONSISTS OF STANDARD CHARACTERS WITHOUT CLAIM TO ANY PARTICULAR FONT, STYLE, SIZE, OR COLOR.

FOR RECYCLING SERVICES (U.S. CLS. 100, 103 AND 106).

FIRST USE 1-0-2011; IN COMMERCE 1-0-2011.

**CLASS 41—EDUCATION AND ENTERTAINMENT**

3,961,988. HAAS OUTDOORS, INC., WEST POINT, MS. SN 76-700,935. PUB. 5-11-2010, FILED 12-22-2009.

# FIST FULL OF DIRT

THE MARK CONSISTS OF STANDARD CHARACTERS WITHOUT CLAIM TO ANY PARTICULAR FONT, STYLE, SIZE, OR COLOR.

FOR ENTERTAINMENT IN THE NATURE OF ONGOING TELEVISION PROGRAMS FEATURING HUNTING AND OUTDOORS MATERIAL (U.S. CLS. 100, 101 AND 107).

FIRST USE 12-28-2009; IN COMMERCE 12-28-2009.

**CLASS 41—(Continued).**

3,962,048. ZVON ENTERTAINMENT, L.L.C., ALAMO, CA. SN 77-215,803. PUB. 1-22-2008, FILED 6-26-2007.

# YULIANNA

THE MARK CONSISTS OF STANDARD CHARACTERS WITHOUT CLAIM TO ANY PARTICULAR FONT, STYLE, SIZE, OR COLOR.

THE NAME(S), PORTRAIT(S), AND/OR SIGNATURE(S) SHOWN IN THE MARK IDENTIFIES THE STAGE NAME OF YULIYA VLADIMIROVNA ZINOVIEVA, A LIVING INDIVIDUAL, WHOSE CONSENT(S) TO REGISTER IS MADE OF RECORD.

FOR ENTERTAINMENT IN THE NATURE OF LIVE PERFORMANCES BY A PROFESSIONAL ENTERTAINER; ENTERTAINMENT SERVICES, NAMELY, LIVE, TELEVISED AND MOVIE APPEARANCES BY A PROFESSIONAL ENTERTAINER; ENTERTAINMENT SERVICES, NAMELY, PERSONAL APPEARANCES BY A PROFESSIONAL ENTERTAINER (U.S. CLS. 100, 101 AND 107).

FIRST USE 6-1-2007; IN COMMERCE 2-1-2008.

---

3,962,056. MACK, CHRISTOPHER R., DBA 8B MARKETING & MEDIA, NEW YORK, NY. SN 77-221,826. PUB. 12-25-2007, FILED 7-3-2007.

# HIP-HOP AND HARDBALL

THE MARK CONSISTS OF STANDARD CHARACTERS WITHOUT CLAIM TO ANY PARTICULAR FONT, STYLE, SIZE, OR COLOR.

NO CLAIM IS MADE TO THE EXCLUSIVE RIGHT TO USE "HARDBALL", APART FROM THE MARK AS SHOWN.

FOR ORGANIZING COMMUNITY SPORTING AND CULTURAL EVENTS; ORGANIZING EXHIBITIONS FOR SPORTING, CULTURAL AND ENTERTAINMENT PURPOSES.; AMATEUR YOUTH SPORTS SERVICES, NAMELY, ORGANIZING, PROVIDING AND MANAGING YOUTH SPORTS ACTIVITIES; ENCOURAGING AMATEUR SPORTS AND PHYSICAL EDUCATION BY ORGANIZING, PROMOTING, SPONSORING, SANCTIONING, CONDUCTING, ADMINISTERING, REGULATING AND GOVERNING AMATEUR ATHLETIC PROGRAMS AND ACTIVITIES (U.S. CLS. 100, 101 AND 107).

FIRST USE 3-17-2011; IN COMMERCE 3-17-2011.

**CLASS 41—(Continued).**

3,962,064. MATTOCKS, NORMAN, CHESTERFIELD, MI. SN 77-233,434. PUB. 1-1-2008, FILED 7-19-2007.

# GOT IT!

THE MARK CONSISTS OF STANDARD CHARACTERS WITHOUT CLAIM TO ANY PARTICULAR FONT, STYLE, SIZE, OR COLOR.

FOR EDUCATIONAL AND ENTERTAINMENT SERVICES, NAMELY, PROVIDING MOTIVATIONAL AND EDUCATIONAL SPEAKERS (U.S. CLS. 100, 101 AND 107).

FIRST USE 3-17-2011; IN COMMERCE 3-20-2011.

3,962,091. MR. WILLS, INC., TORONTO, CANADA. SN 77-317,113. PUB. 1-27-2009, FILED 10-30-2007.

# ESTATETHERAPY

THE MARK CONSISTS OF STANDARD CHARACTERS WITHOUT CLAIM TO ANY PARTICULAR FONT, STYLE, SIZE, OR COLOR.

OWNER OF CANADA REG. NO. TMA675428, DATED 10-23-2006, EXPIRES 10-23-2021.

FOR EDUCATIONAL SERVICES, NAMELY, PROVIDING SEMINARS, TEACHING, AND COURSES AT THE COLLEGE, POST-GRADUATE, ADULT CONTINUING-EDUCATION, LEGAL CONTINUING-EDUCATION LEVEL, ALL RELATING TO ESTATES AND ESTATE PLANNING, WILLS, ESTATE ADMINISTRATION AND LITIGATION; PUBLICATION OF BOOKS AND PUBLISHING OF ELECTRONIC PUBLICATIONS, NAMELY, BOOKS CONTAINING INFORMATION PERTAINING TO WILLS, ESTATES, ESTATE PLANNING ADMINISTRATION AND LITIGATION; ELECTRONIC PUBLISHING SERVICES, NAMELY, PUBLICATION OF TEXT AND GRAPHIC WORKS OF OTHERS ON PRE-RECORDED TAPES AND COMPACT DISCS, ALL PERTAINING TO ESTATES, WILLS, ADMINISTRATION AND LITIGATION (U.S. CLS. 100, 101 AND 107).

FIRST USE 11-12-2007; IN COMMERCE 11-12-2007.

**CLASS 41—(Continued).**

3,962,094. LAVENDER, JAY, LOS ANGELES, CA. SN 77-331,075. PUB. 12-8-2009, FILED 11-15-2007.

# 1to300

THE MARK CONSISTS OF STANDARD CHARACTERS WITHOUT CLAIM TO ANY PARTICULAR FONT, STYLE, SIZE, OR COLOR.

FOR ENTERTAINMENT SERVICES, NAMELY, THE PRODUCTION AND DISTRIBUTION OF BROADCAST TELEVISION EPISODES SPECIALLY MADE FOR VIEWING ON A MOBILE TELEPHONE SCREEN AND OF SHORT DURATION, EPISODES OF A TELEVISION SHOW THAT AIRS INITIALLY AS AN INTERNET DOWNLOAD OR STREAM, SHORT TELEVISION PROGRAMS AND FILMS IN THE GENRES OF COMEDY, ROMANCE, DRAMA, MYSTERY, THRILLERS, INTERNATIONAL CULTURAL EVENTS, ACTION, AND MUSIC AND CONCERTS VIA MULTI-SATELLITE, AUDIO, AND VIDEO MEDIA; PROVIDING PODCASTS IN THE FIELD OF COMEDY, ROMANCE, DRAMA, MYSTERY, THRILLERS, INTERNATIONAL CULTURAL EVENTS, ACTION, AND MUSIC AND CONCERTS (U.S. CLS. 100, 101 AND 107).

FIRST USE 4-7-2008; IN COMMERCE 2-22-2011.

3,962,096. KCP TECHNOLOGIES, INC., EMERYVILLE, CA. SN 77-334,751. PUB. 11-18-2008, FILED 11-20-2007.

# SKETCHPAD LESSONLINK

THE MARK CONSISTS OF STANDARD CHARACTERS WITHOUT CLAIM TO ANY PARTICULAR FONT, STYLE, SIZE, OR COLOR.

OWNER OF U.S. REG. NO. 2,094,130.

FOR EDUCATIONAL SERVICES, NAMELY, PROVIDING AN ONLINE WEBSITE FOR EDUCATORS TO CREATE LESSONS AND LESSON PLANS, TO GRADE, ANALYZE AND EVALUATE STUDENT PERFORMANCE, AND TO ALLOW STUDENTS TO ACCESS AND TAKE LESSONS AND LESSONS PLANS; EDUCATIONAL SERVICES, NAMELY, PROVIDING ONLINE COURSES AND WORKSHOPS ON THE SUBJECTS OF MATHEMATICS, GEOMETRY, AND MATHEMATICAL VISUALIZATION, DATA ANALYSIS AND STATISTICS, AND TEACHING INSTRUCTION IN SUCH SUBJECTS; EDUCATIONAL SERVICES, NAMELY, PROVIDING PROFESSIONAL DEVELOPMENT CLASSES AND WORKSHOPS FOR TEACHERS IN ALL LEVELS OF EDUCATION IN THE FIELDS OF MATHEMATICS, GEOMETRY, MATHEMATICAL VISUALIZATION, DATA ANALYSIS AND STATISTICS (U.S. CLS. 100, 101 AND 107).

FIRST USE 4-1-2008; IN COMMERCE 4-1-2008.

**CLASS 41—(Continued).**

3,962,134. ANGLERS INTERNATIONAL RESOURCES LLC, PALATINE, IL. SN 77-425,935. PUB. 4-14-2009, FILED 3-19-2008.

# Fishingurus

THE MARK CONSISTS OF STANDARD CHARACTERS WITHOUT CLAIM TO ANY PARTICULAR FONT, STYLE, SIZE, OR COLOR.

FOR FISHING GUIDE SERVICES (U.S. CLS. 100, 101 AND 107).

FIRST USE 12-0-2008; IN COMMERCE 12-0-2008.

3,962,162. TONOKA HEALTH ENTERPRISES, THOUSAND OAKS, CA. SN 77-502,671. PUB. 11-11-2008, FILED 6-19-2008.

# LifestyleDNA

THE MARK CONSISTS OF STANDARD CHARACTERS WITHOUT CLAIM TO ANY PARTICULAR FONT, STYLE, SIZE, OR COLOR.

FOR EDUCATION SERVICES, NAMELY, PROVIDING LIVE AND ON-LINE CLASSES, SEMINARS, AND WORKSHOPS IN THE FIELD OF HEALTH AND WELLNESS (U.S. CLS. 100, 101 AND 107).

FIRST USE 1-1-2009; IN COMMERCE 2-24-2011.

3,962,176. WOLSTENHOLME, MICHAEL, GRANADA HILLS, CA. SN 77-527,222. PUB. 9-22-2009, FILED 7-21-2008.

# Michael Tinholme

THE MARK CONSISTS OF STANDARD CHARACTERS WITHOUT CLAIM TO ANY PARTICULAR FONT, STYLE, SIZE, OR COLOR.

THE NAME(S), PORTRAIT(S), AND/OR SIGNATURE(S) SHOWN IN THE MARK IDENTIFIES "MICHAEL WOLSTENHOLME", WHOSE CONSENT(S) TO REGISTER IS MADE OF RECORD.

FOR ENTERTAINMENT IN THE NATURE OF LIVE PERFORMANCES BY MUSICAL ARTIST; ENTERTAINMENT, NAMELY, LIVE MUSIC CONCERTS; SONG WRITING SERVICES (U.S. CLS. 100, 101 AND 107).

FIRST USE 9-15-2009; IN COMMERCE 11-1-2009.

**CLASS 41—(Continued).**

3,962,188. COMPREHENSIVE NEUROSCIENCE, INC., BRADENTON, FL. SN 77-547,401. PUB. 6-30-2009, FILED 8-14-2008.



OWNER OF U.S. REG. NOS. 3,449,533, 3,449,534, AND 3,449,535.

NO CLAIM IS MADE TO THE EXCLUSIVE RIGHT TO USE "CNS COMPREHENSIVE NEUROSCIENCE", APART FROM THE MARK AS SHOWN.

THE MARK CONSISTS OF A RECTANGLE PARTIALLY SHADED WITH WAVY AND CURVED BARS AND LINES AND THE WORDING "CNS COMPREHENSIVE NEUROSCIENCE".

FOR EDUCATION SERVICES, NAMELY, SEMINARS IN THE FIELD OF CONTINUING MEDICAL EDUCATION (U.S. CLS. 100, 101 AND 107).

FIRST USE 5-15-2006; IN COMMERCE 5-15-2006.

3,962,198. WMS GAMING INC., WAUKEGAN, IL. SN 77-553,679. PUB. 1-13-2009, FILED 8-22-2008.

# FREEDOMPORT

THE MARK CONSISTS OF STANDARD CHARACTERS WITHOUT CLAIM TO ANY PARTICULAR FONT, STYLE, SIZE, OR COLOR.

FOR ENTERTAINMENT SERVICES, NAMELY, PROVIDING GAMING CONTENT VIA SERVERS TO NETWORKED GAMING MACHINES THAT GENERATE OR DISPLAY WAGER OUTCOMES (U.S. CLS. 100, 101 AND 107).

FIRST USE 11-18-2008; IN COMMERCE 11-18-2008.

3,962,215. ELECTRONIC ARTS INC., REDWOOD CITY, CA. SN 77-577,013. PUB. 12-8-2009, FILED 9-23-2008.



OWNER OF U.S. REG. NOS. 2,407,266, 2,855,873, AND OTHERS.

**CLASS 41—(Continued).**

THE MARK CONSISTS OF THE WORDING "THE SIMS" IN STYLIZED FONT.

FOR ENTERTAINMENT SERVICES, NAMELY, PROVIDING NEWS AND INFORMATION REGARDING INTERACTIVE VIDEO GAME SOFTWARE, INTERACTIVE VIDEO GAME SOFTWARE AND INTERACTIVE COMPUTER GAMES AND INTERACTIVE VIDEO GAMES, VIA ELECTRONIC, WIRELESS AND COMPUTER NETWORKS (U.S. CLS. 100, 101 AND 107).

FIRST USE 3-31-2008; IN COMMERCE 3-31-2008.

---

3,962,225. THRIVING CHURCHES INTERNATIONAL, INC., MINDEN, NV. SN 77-596,553. PUB. 6-23-2009, FILED 10-20-2008.

**THRIVING CHURCHES NETWORK**

THE MARK CONSISTS OF STANDARD CHARACTERS WITHOUT CLAIM TO ANY PARTICULAR FONT, STYLE, SIZE, OR COLOR.

NO CLAIM IS MADE TO THE EXCLUSIVE RIGHT TO USE "CHURCHES NETWORK", APART FROM THE MARK AS SHOWN.

FOR EDUCATIONAL SERVICES, NAMELY, PROVIDING CLASSES, SEMINARS AND WORKSHOPS IN THE FIELD OF CHURCH GROWTH AND DEVELOPMENT (U.S. CLS. 100, 101 AND 107).

FIRST USE 5-28-2010; IN COMMERCE 5-28-2010.

---

3,962,230. THE MARIN INSTITUTE, AKA MARIN INSTITUTE, SAN RAFAEL, CA. SN 77-620,140. PUB. 7-20-2010, FILED 11-22-2008.

**FREE The BOWL**

THE MARK CONSISTS OF STANDARD CHARACTERS WITHOUT CLAIM TO ANY PARTICULAR FONT, STYLE, SIZE, OR COLOR.

FOR ENTERTAINMENT SERVICES, NAMELY, CONDUCTING CONTESTS (U.S. CLS. 100, 101 AND 107).

FIRST USE 10-19-2007; IN COMMERCE 10-19-2007.

**CLASS 41—(Continued).**

3,962,290. TV2MORO, INC., PASADENA, CA. SN 77-673,658. PUB. 1-5-2010, FILED 2-19-2009.

 The logo for TV2MORO features the letters "TV" in a simple sans-serif font, followed by a stylized number "2" that is larger and more decorative, and then the letters "MORO" in a simple sans-serif font.

THE MARK CONSISTS OF THE LETTERS AND NUMBER "TV2MORO", WITH "TV" AND "MORO" IN CAPITALIZED LETTERING AND A STYLIZED NUMBER "2" BETWEEN "TV" AND "MORO".

FOR ENTERTAINMENT SERVICES IN THE NATURE OF ONGOING INTERNET PROTOCOL TELEVISION (IPTV) PROGRAMS IN THE FIELDS OF CURRENT EVENT REPORTING, NEWS, ENTERTAINMENT, SPORTS, COMEDY, DRAMA, MUSIC, AND MUSIC VIDEOS; PROVIDING INTERACTIVE ONLINE GAMES; PROVIDING ONLINE INFORMATION VIA A GLOBAL COMPUTER NETWORK ON THE ENTERTAINMENT SUBJECTS OF MOTION PICTURES, TELEVISION PROGRAMMING, CURRENT EVENT REPORTING, NEWS, ENTERTAINMENT, SPORTS, COMEDY, DRAMA, VIDEOS, MUSIC VIDEOS AND MUSIC; PROVIDING A WEB SITE FEATURING INTERACTIVE PROGRAMMING GUIDES IN THE ENTERTAINMENT FIELDS OF MOTION PICTURES, TELEVISION PROGRAMMING, CURRENT EVENT REPORTING, NEWS, ENTERTAINMENT, SPORTS, COMEDY, DRAMA, VIDEOS, AND MUSIC TAILORED TO VIEWER'S PROGRAMMING PREFERENCES; ELECTRONIC PUBLISHING SERVICES, NAMELY, PUBLICATION OF TEXT, GRAPHICS, PHOTOGRAPHS, IMAGES, AND AUDIO-VISUAL WORKS OF OTHERS ONLINE FOR STREAMING OR DOWNLOADING, AND ON CDS, DVDS, MUSIC VIDEO INTERACTIVE DISCS (MVIS), AND PODCASTS, FEATURING CURRENT EVENT REPORTING, NEWS, ENTERTAINMENT, SPORTS, COMEDY, DRAMA, MUSIC, AND MUSIC VIDEOS; PRODUCTION AND RENTAL OF PRE-RECORDED AUDIO-VISUAL WORKS, NAMELY, MOTION PICTURES, TELEVISION PROGRAMS, VIDEOS, MUSIC VIDEOS, AND MUSIC (U.S. CLS. 100, 101 AND 107).

FIRST USE 4-1-2009; IN COMMERCE 4-1-2009.

---

3,962,291. SALON DEVELOPMENT, INC., DBA SALON DEVELOPMENT CORPORATION, ST. PAUL, MN. SN 77-674,057. PUB. 6-16-2009, FILED 2-19-2009.

**Top 20**

THE MARK CONSISTS OF STANDARD CHARACTERS WITHOUT CLAIM TO ANY PARTICULAR FONT, STYLE, SIZE, OR COLOR.

FOR EDUCATIONAL SERVICES, NAMELY, PROVIDING CLASSES, SEMINARS AND WORKSHOPS IN THE FIELDS OF COSMETOLOGY, ESTHIOLOGY, MASSAGE THERAPY, HAIR CARE, BODY AND SKIN CARE, SPA THERAPY, SALON AND SPA MANAGEMENT AND CLIENT RELATIONS AND DISTRIBUTION OF COURSE MATERIAL AND WRITTEN CURRICULUM IN CONNECTION THEREWITH (U.S. CLS. 100, 101 AND 107).

FIRST USE 1-17-2011; IN COMMERCE 1-17-2011.



**CLASS 41—(Continued).**

3,962,297. CSTV NETWORKS INC., DBA CBS COLLEGE SPORTS NETWORK, NEW YORK, NY. SN 77-678,121. PUB. 6-23-2009, FILED 2-25-2009.



NO CLAIM IS MADE TO THE EXCLUSIVE RIGHT TO USE "COLLEGE ACTION SPORTS CHAMPIONSHIPS", APART FROM THE MARK AS SHOWN.

THE MARK CONSISTS OF THE WORDS "THEALT-GAMES" WITH THE WORDS "COLLEGE ACTION SPORTS CHAMPIONSHIPS" BELOW AND TWO MOUNTAINS WITH STRAIGHT LINES BELOW.

FOR ENTERTAINMENT SERVICES, NAMELY, AN ON-GOING TELEVISION SERIES FEATURING LIVE COLLEGIATE SPORTING EVENTS AND MUSIC FESTIVALS RENDERED THROUGH THE MEDIA OF TELEVISION, CABLE, SATELLITE, RADIO, TELEPHONE AND BROADBAND SYSTEMS VIA THE INTERNET, AND PORTABLE AND WIRELESS COMMUNICATION DEVICES (U.S. CLS. 100, 101 AND 107).

FIRST USE 2-25-2009; IN COMMERCE 2-25-2009.

---

3,962,330. RETRO TELEVISION, INC., CHATTANOOGA, TN. SN 77-697,073. PUB. 7-21-2009, FILED 3-23-2009.

## RETRO TV

THE MARK CONSISTS OF STANDARD CHARACTERS WITHOUT CLAIM TO ANY PARTICULAR FONT, STYLE, SIZE, OR COLOR.

NO CLAIM IS MADE TO THE EXCLUSIVE RIGHT TO USE "TV", APART FROM THE MARK AS SHOWN.

FOR TELEVISION PROGRAMMING SERVICES (U.S. CLS. 100, 101 AND 107).

FIRST USE 6-30-2009; IN COMMERCE 6-30-2009.

**CLASS 41—(Continued).**

3,962,409. TAR PRODUCTIONS, INC., SOLANA BEACH, CA. SN 77-762,233. PUB. 6-1-2010, FILED 6-17-2009.

## On A Rail

THE MARK CONSISTS OF STANDARD CHARACTERS WITHOUT CLAIM TO ANY PARTICULAR FONT, STYLE, SIZE, OR COLOR.

FOR DISTRIBUTION OF TELEVISION PROGRAMMING TO CABLE TELEVISION SYSTEMS; EDITING OF RADIO AND TELEVISION PROGRAMMES; ENTERTAINMENT AND EDUCATION SERVICES IN THE NATURE OF A SERIES OF SHORT SHOWS FEATURING ATHLETES TRAVELING VIA RAILROAD DISTRIBUTED TO MOBILE HANDSETS, WHICH MAY INCLUDE VIDEO, TEXT, PHOTOS, ILLUSTRATIONS OR HYPERTEXT; ENTERTAINMENT IN THE NATURE OF ON-GOING TELEVISION PROGRAMS IN THE FIELD OF ACTION SPORTS AND TOURISM; ENTERTAINMENT SERVICES IN THE NATURE OF AN ON-GOING REALITY BASED TELEVISION PROGRAM; ENTERTAINMENT SERVICES IN THE NATURE OF ON-GOING TELEVISION PROGRAMS IN THE FIELD OF CHILDREN'S ENTERTAINMENT; ENTERTAINMENT SERVICES, NAMELY, PROVIDING A TELEVISION PROGRAM IN THE FIELD OF SPORTS AND TOURISM VIA A GLOBAL COMPUTER NETWORK; PRODUCTION OF CABLE TELEVISION PROGRAMS; PRODUCTION OF TELEVISION PROGRAMS; TELEVISION PROGRAM SYNDICATION; TELEVISION PROGRAMMING; TELEVISION SHOW PRODUCTION (U.S. CLS. 100, 101 AND 107).

FIRST USE 8-1-2008; IN COMMERCE 3-24-2009.

---

3,962,433. DAVIS, CHARLES "JIGGS", ALAMEDA, CA. SN 77-774,724. PUB. 6-15-2010, FILED 7-6-2009.

## OWL'S CLUB

THE MARK CONSISTS OF STANDARD CHARACTERS WITHOUT CLAIM TO ANY PARTICULAR FONT, STYLE, SIZE, OR COLOR.

NO CLAIM IS MADE TO THE EXCLUSIVE RIGHT TO USE "CLUB", APART FROM THE MARK AS SHOWN.

FOR ENTERTAINMENT SERVICES PROVIDED THROUGH A WINE CLUB, NAMELY, WINE TASTINGS (U.S. CLS. 100, 101 AND 107).

FIRST USE 11-14-2010; IN COMMERCE 11-14-2010.

**CLASS 41—(Continued).**

3,962,442. KING, JANELLE, CHARLES TOWN, WV. AND WILLIAMS, DENA, CHARLES TOWN, WV. AND CEASER, SANYEA, CHICAGO, IL. AND EDWARDS, WHITNEY, CHARLES TOWN, WV. SN 77-780,572. PUB. 3-30-2010, FILED 7-14-2009.



NO CLAIM IS MADE TO THE EXCLUSIVE RIGHT TO USE "EST. 2006", APART FROM THE MARK AS SHOWN.

THE MARK CONSISTS OF THE STYLIZED LETTERS, WORD, AND NUMBERS "CQ COGNQUILA EST. 2006". TO THE RIGHT OF THE LETTERS "C" AND "Q" IS AN IMAGE OF A CITY SKYLINE.

FOR ENTERTAINMENT SERVICES, NAMELY, CONDUCTING PARTIES (U.S. CLS. 100, 101 AND 107).  
FIRST USE 7-20-2009; IN COMMERCE 7-30-2009.

3,962,457. NATIONAL HISPANIC COUNCIL ON AGING, AKA NHCOA, WASHINGTON, DC. SN 77-784,521. PUB. 2-16-2010, FILED 7-20-2009.



NO CLAIM IS MADE TO THE EXCLUSIVE RIGHT TO USE "NATIONAL HISPANIC COUNCIL ON AGING", APART FROM THE MARK AS SHOWN.

THE COLOR(S) BLUE AND RED IS/ARE CLAIMED AS A FEATURE OF THE MARK.

THE MARK CONSISTS OF THE ACRONYM "NHCOA" IN BLUE WITH A HORIZONTAL RED LINE APPEARING ABOVE AND BELOW THE WORDING "NATIONAL HISPANIC COUNCIL ON AGING".

FOR EDUCATIONAL SERVICES, NAMELY, CONDUCTING SEMINARS, CONFERENCES, WORKSHOPS IN THE FIELD OF OLDER ADULTS AND DISTRIBUTION OF TRAINING MATERIAL IN CONNECTION THEREWITH (U.S. CLS. 100, 101 AND 107).  
FIRST USE 5-1-2006; IN COMMERCE 5-1-2006.

**CLASS 41—(Continued).**

3,962,497. CYBEX INTERNATIONAL, INC., MEDWAY, MA. SN 77-800,350. PUB. 1-5-2010, FILED 8-9-2009.

**SWEET SPOT**

THE MARK CONSISTS OF STANDARD CHARACTERS WITHOUT CLAIM TO ANY PARTICULAR FONT, STYLE, SIZE, OR COLOR.

FOR PROVIDING FITNESS AND EXERCISE FACILITIES (U.S. CLS. 100, 101 AND 107).

FIRST USE 8-0-2009; IN COMMERCE 8-0-2009.

3,962,501. THE CHICAGO HIGH SCHOOL FOR THE ARTS, CHICAGO, IL. SN 77-800,970. PUB. 7-6-2010, FILED 8-10-2009.

**FOR THE ARTS + MINDS OF CHICAGO**

THE MARK CONSISTS OF STANDARD CHARACTERS WITHOUT CLAIM TO ANY PARTICULAR FONT, STYLE, SIZE, OR COLOR.

NO CLAIM IS MADE TO THE EXCLUSIVE RIGHT TO USE "CHICAGO", APART FROM THE MARK AS SHOWN.

FOR EDUCATIONAL SERVICES, NAMELY, PROVIDING COURSES OF INSTRUCTION AT THE SECONDARY AND COLLEGE PREPARATORY LEVELS, NAMELY, PROVIDING CLASSES AND WORKSHOPS IN THE FIELDS OF PERFORMING AND VISUAL ARTS, MUSIC, DANCE, THEATRE, ILLUSTRATION AND DESIGN; ENTERTAINMENT SERVICES, NAMELY, ARRANGING AND CONDUCTING MUSICALS, THEATRICALS, DANCE PERFORMANCES AND PERFORMING ARTS PRESENTATIONS (U.S. CLS. 100, 101 AND 107).

FIRST USE 9-1-2009; IN COMMERCE 9-1-2009.

3,962,545. THE INK WELL FOUNDATION, INC., NEW YORK, NY. SN 77-812,382. PUB. 8-3-2010, FILED 8-25-2009.

**The Ink Well Foundation**

THE MARK CONSISTS OF STANDARD CHARACTERS WITHOUT CLAIM TO ANY PARTICULAR FONT, STYLE, SIZE, OR COLOR.

**CLASS 41—(Continued).**

NO CLAIM IS MADE TO THE EXCLUSIVE RIGHT TO USE "FOUNDATION", APART FROM THE MARK AS SHOWN.

FOR CHILDREN'S ENTERTAINMENT SERVICES, NAMELY, ARRANGING, ORGANIZING, AND CONDUCTING SOCIAL GATHERINGS WHERE PARTICIPANTS ENGAGE IN ART-RELATED ACTIVITIES (U.S. CLS. 100, 101 AND 107).

FIRST USE 11-30-2005; IN COMMERCE 12-10-2010.

3,962,569. ENVIRONOMICS COMMUNICATIONS, INC., SCHAUMBURG, IL. SN 77-821,442. PUB. 8-3-2010, FILED 9-8-2009.

## GREEN\$ENSE

THE MARK CONSISTS OF STANDARD CHARACTERS WITHOUT CLAIM TO ANY PARTICULAR FONT, STYLE, SIZE, OR COLOR.

FOR ENTERTAINMENT SERVICES, NAMELY, AN ON-GOING SERIES FEATURING NEWS AND COMMENTARY PROVIDED THROUGH WEBCASTS, RADIO BROADCASTS AND PODCASTS (U.S. CLS. 100, 101 AND 107).

FIRST USE 9-26-2009; IN COMMERCE 9-26-2009.

3,962,630. CARTER, DEBRA, BRADENTON, FL. SN 77-842,321. PUB. 12-21-2010, FILED 10-6-2009.

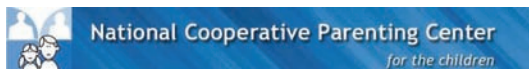

NO CLAIM IS MADE TO THE EXCLUSIVE RIGHT TO USE "NATIONAL COOPERATIVE PARENTING CENTER FOR THE CHILDREN", APART FROM THE MARK AS SHOWN.

THE COLOR(S) BLUE, BLACK AND WHITE IS/ARE CLAIMED AS A FEATURE OF THE MARK.

THE MARK CONSISTS OF THE PHRASE "NATIONAL COOPERATIVE PARENTING CENTER FOR THE CHILDREN" IN WHITE ON A DARK BLUE BACKGROUND. TO THE LEFT OF THE WORDING IS THE OUTLINE OF A MAN AND WOMAN IN WHITE AND A BOY AND GIRL IN WHITE OUTLINED IN BLACK BELOW, ALL ON A LIGHT BLUE BACKGROUND.

FOR EDUCATION SERVICES, NAMELY, PROVIDING TRAINING AND CONTINUING EDUCATION FOR LEGAL, MENTAL HEALTH AND LAY PERSONS IN THE FIELD OF PARENTING COORDINATION, CHILDREN'S ISSUES, PARENTING PLAN DEVELOPMENT, CHILD AND FAMILY MENTAL HEALTH AND THE FAMILY LAW PROCESS (U.S. CLS. 100, 101 AND 107).

FIRST USE 1-1-2009; IN COMMERCE 1-1-2009.

**CLASS 41—(Continued).**

3,962,666. AMERICAN PSYCHOLOGICAL ASSOCIATION PRACTICE ORGANIZATION, WASHINGTON, DC. SN 77-855,040. PUB. 7-13-2010, FILED 10-22-2009.

NO CLAIM IS MADE TO THE EXCLUSIVE RIGHT TO USE "PRACTICE", APART FROM THE MARK AS SHOWN.

THE MARK CONSISTS OF THE WORDS "PRACTICE CENTRAL" SEPARATED BY A DESIGN OF THE GREEK LETTER PSI WITHIN A CIRCLE CONSISTING OF HORIZONTAL LINES.

FOR PROVIDING A WEBSITE FEATURING CONTINUING EDUCATION COURSES IN THE FIELD OF PROFESSIONAL PSYCHOLOGY AND NON-DOWNLOADABLE FACT SHEETS AND INFORMATIONAL GUIDELINES IN THE FIELD OF PROFESSIONAL PSYCHOLOGY IN CONNECTION THEREWITH; EDUCATIONAL SERVICES, NAMELY, CONTINUING EDUCATION COURSES IN THE FIELD OF PROFESSIONAL PSYCHOLOGY (U.S. CLS. 100, 101 AND 107).

FIRST USE 12-15-2009; IN COMMERCE 12-15-2009.

3,962,667. CLASSIC KIDS PHOTOGRAPHY, LLC, AKA CLASSIC KIDS, WINNETKA, IL. SN 77-855,342. PUB. 3-30-2010, FILED 10-22-2009.



NO CLAIM IS MADE TO THE EXCLUSIVE RIGHT TO USE "TEEN", APART FROM THE MARK AS SHOWN.

THE MARK CONSISTS OF LOWERCASE LETTERS OF "CK" IN BLACK/WHITE ON BLACK/ WHITE BACKGROUND WITH CORRESPONDING BORDER; "CK" IS ABOVE THE WORD "TEEN", WHICH IS SHOWN IN BLACK/ WHITE BELOW "CK" AND ON BLACK/ WHITE BACKGROUND WITH THE CORRESPONDING BORDER.

FOR PORTRAIT PHOTOGRAPHY (U.S. CLS. 100, 101 AND 107).

FIRST USE 10-1-2010; IN COMMERCE 10-1-2010.

**CLASS 41—(Continued).**

3,962,689. DISNEY ENTERPRISES, INC., BURBANK, CA. SN 77-859,443. PUB. 8-31-2010, FILED 10-28-2009.

**TRON LEGACY**

THE MARK CONSISTS OF STANDARD CHARACTERS WITHOUT CLAIM TO ANY PARTICULAR FONT, STYLE, SIZE, OR COLOR.

FOR PRODUCTION, PRESENTATION, DISTRIBUTION OF MOTION PICTURE FILMS; PRODUCTION AND PRESENTATION OF SOUND AND VISUAL RECORDINGS; PRODUCTION OF ANIMATED ENTERTAINMENT SHOWS AND INTERACTIVE PROGRAMS FOR DISTRIBUTION VIA AUDIO AND VISUAL MEDIA, AND ELECTRONIC MEANS; PRODUCTION AND PROVISION OF ENTERTAINMENT NEWS AND ENTERTAINMENT INFORMATION VIA COMMUNICATION AND COMPUTER NETWORKS; AMUSEMENT PARK AND THEME PARK SERVICES; EDUCATIONAL AND ENTERTAINMENT SERVICES RENDERED IN OR RELATING TO THEME PARKS, NAMELY, LIVE STAGE SHOWS, LIVE AMUSEMENT PARK SHOWS, LIVE PERFORMANCES BY COSTUMED CHARACTERS, AND PRESENTATION OF LIVE THEATRICAL PERFORMANCES; PRESENTATION OF LIVE STAGE SHOWS; PRESENTATION OF LIVE SHOW PERFORMANCES; THEATER PRODUCTIONS; ENTERTAINER SERVICES, NAMELY, LIVE APPEARANCES BY A PROFESSIONAL ENTERTAINER (U.S. CLS. 100, 101 AND 107).

FIRST USE 10-31-2010; IN COMMERCE 10-31-2010.

3,962,721. FRIDAY JONES PUBLISHING, DENVER, CO. SN 77-875,670. PUB. 4-20-2010, FILED 11-18-2009.

**Wag Your Tale**

THE MARK CONSISTS OF STANDARD CHARACTERS WITHOUT CLAIM TO ANY PARTICULAR FONT, STYLE, SIZE, OR COLOR.

FOR BOOK PUBLISHING (U.S. CLS. 100, 101 AND 107).  
FIRST USE 5-1-2010; IN COMMERCE 5-1-2010.

**CLASS 41—(Continued).**

3,962,736. THE TENNIS CHANNEL, INC., SANTA MONICA, CA. SN 77-883,435. PUB. 4-6-2010, FILED 12-1-2009.

**COMMUNITY SURFACE**

THE MARK CONSISTS OF STANDARD CHARACTERS WITHOUT CLAIM TO ANY PARTICULAR FONT, STYLE, SIZE, OR COLOR.

FOR ENTERTAINMENT IN THE NATURE OF AN ONGOING TELEVISION SHOW FEATURING TENNIS BROADCAST OVER TELEVISION, SATELLITE, AUDIO, VIDEO MEDIA AND THE INTERNET (U.S. CLS. 100, 101 AND 107).

FIRST USE 9-13-2010; IN COMMERCE 9-13-2010.

3,962,742. WEINER, KRISTEN, DBA DEAFHOOD YOGA, WALNUT CREEK, CA. SN 77-884,696. PUB. 11-30-2010, FILED 12-2-2009.



NO CLAIM IS MADE TO THE EXCLUSIVE RIGHT TO USE "YOGA", APART FROM THE MARK AS SHOWN.

THE MARK CONSISTS OF THE WORDS "DEAFHOOD YOGA" FLANKED ON EACH SIDE BY THE DESIGN OF AN OPEN HAND WITH THE THUMB TOUCHING A FINGER AT THEIR RESPECTIVE TIPS.

FOR EDUCATION SERVICES, NAMELY, PROVIDING CLASSES, TEACHING AND TRAINING IN THE FIELD OF YOGA; INFORMATION ON EDUCATION SERVICES IN THE FIELD OF YOGA; WORKSHOP SERVICES IN THE FIELD OF YOGA (U.S. CLS. 100, 101 AND 107).

FIRST USE 2-26-2009; IN COMMERCE 3-1-2009.

3,962,745. SCIENCE & TECH CMO, INC., DENVER, CO. SN 77-885,498. PUB. 5-18-2010, FILED 12-3-2009.

**DSST PUBLIC SCHOOLS**

THE MARK CONSISTS OF STANDARD CHARACTERS WITHOUT CLAIM TO ANY PARTICULAR FONT, STYLE, SIZE, OR COLOR.

**CLASS 41—(Continued).**

NO CLAIM IS MADE TO THE EXCLUSIVE RIGHT TO USE "PUBLIC SCHOOLS", APART FROM THE MARK AS SHOWN.

FOR EDUCATIONAL SERVICES, NAMELY, PROVIDING COURSES OF INSTRUCTION AT THE MIDDLE SCHOOL AND HIGH SCHOOL LEVELS AND DISTRIBUTING COURSE MATERIALS IN CONNECTION THEREWITH; EDUCATIONAL SERVICES FOR CHARTER SCHOOLS, NAMELY, DEVELOPMENT AND DISSEMINATION OF EDUCATIONAL MATERIALS IN THE FIELD OF MIDDLE AND HIGH SCHOOL EDUCATION; CURRICULUM DEVELOPMENT IN THE FIELD OF MIDDLE AND HIGH SCHOOL EDUCATION (U.S. CLS. 100, 101 AND 107).

FIRST USE 11-19-2010; IN COMMERCE 11-19-2010.

---

3,962,802. SCOTT FREEDMAN, VENICE, CA. SN 77-902,142. PUB. 5-11-2010, FILED 12-29-2009.

**XTP**

THE MARK CONSISTS OF STANDARD CHARACTERS WITHOUT CLAIM TO ANY PARTICULAR FONT, STYLE, SIZE, OR COLOR.

FOR ENTERTAINMENT IN THE NATURE OF TENNIS TOURNAMENTS (U.S. CLS. 100, 101 AND 107).  
FIRST USE 4-1-2011; IN COMMERCE 4-1-2011.

---

3,962,838. WASTE MANAGEMENT, INC., HOUSTON, TX. SN 77-912,326. PUB. 5-25-2010, FILED 1-14-2010.

**OCEANOPOLIS**

THE MARK CONSISTS OF STANDARD CHARACTERS WITHOUT CLAIM TO ANY PARTICULAR FONT, STYLE, SIZE, OR COLOR.

FOR ENTERTAINMENT SERVICES, NAMELY, PROVIDING ON-LINE COMPUTER GAMES (U.S. CLS. 100, 101 AND 107).  
FIRST USE 1-19-2011; IN COMMERCE 1-19-2011.

**CLASS 41—(Continued).**

3,962,844. BRIGHT HORIZONS FAMILY SOLUTIONS LLC, WATERTOWN, MA. SN 77-914,411. PUB. 11-9-2010, FILED 1-19-2010.



THE MARK CONSISTS OF A STYLIZED DEPICTION OF A HUMAN FORM WITH ITS ARMS RAISED ABOVE ITS HEAD. THE RAISED ARMS APPEAR TO BE REACHING UP TOWARD A STYLIZED GLOBE.

FOR EDUCATION SERVICES, NAMELY, PROVIDING COURSES OF INSTRUCTION FOR INFANTS, TODDLERS, AND CHILDREN AT THE PRESCHOOL AND PRIMARY LEVEL, AND DISTRIBUTION OF COURSE MATERIALS IN CONNECTION THEREWITH; EDUCATION SERVICES IN THE NATURE OF EARLY CHILDHOOD INSTRUCTION AND PROVIDING COURSES OF INSTRUCTION FOR SCHOOL-AGED CHILDREN AT THE PRESCHOOL, PRIMARY, AND SECONDARY LEVEL, AND DISTRIBUTION OF COURSE MATERIALS IN CONNECTION THEREWITH; INFORMATION ON EDUCATION; PROVIDING INFORMATION ABOUT CHILDHOOD EDUCATION AND RELATED CURRICULA VIA A WEBSITE AND VIA E-MAIL (U.S. CLS. 100, 101 AND 107).

FIRST USE 6-30-2000; IN COMMERCE 6-30-2000.

---

3,962,864. INTERNET TESTING SYSTEMS, LLC, BALTIMORE, MD. SN 77-919,093. PUB. 6-15-2010, FILED 1-25-2010.

**Promise Math**

THE MARK CONSISTS OF STANDARD CHARACTERS WITHOUT CLAIM TO ANY PARTICULAR FONT, STYLE, SIZE, OR COLOR.

NO CLAIM IS MADE TO THE EXCLUSIVE RIGHT TO USE "MATH", APART FROM THE MARK AS SHOWN.

FOR PROVIDING AN INTERACTIVE WEB SITE FEATURING EDUCATIONAL INFORMATION AND TEST QUESTIONS IN THE FIELD OF MATHEMATICS (U.S. CLS. 100, 101 AND 107).

FIRST USE 12-8-2010; IN COMMERCE 1-31-2011.



**CLASS 41—(Continued).**

3,962,892. NATURALLY SLIM, INC., GARLAND, TX. SN 77-926,123. PUB. 6-22-2010, FILED 2-2-2010.

IT'S NOT WHAT YOU EAT, BUT  
WHEN AND HOW

THE MARK CONSISTS OF STANDARD CHARACTERS WITHOUT CLAIM TO ANY PARTICULAR FONT, STYLE, SIZE, OR COLOR.

FOR EDUCATIONAL SERVICES, NAMELY, CONDUCTING CLASSES AND SEMINARS IN THE FIELD OF NUTRITION AND WEIGHT MANAGEMENT AND DISTRIBUTING COURSE MATERIALS THEREWITH (U.S. CLS. 100, 101 AND 107).

FIRST USE 1-5-2011; IN COMMERCE 1-5-2011.

3,962,921. HARD ROCK CAFE INTERNATIONAL (USA), INC., ORLANDO, FL. SN 77-932,551. PUB. 8-10-2010, FILED 2-10-2010.

HARD ROCK AT THE FALLS

THE MARK CONSISTS OF STANDARD CHARACTERS WITHOUT CLAIM TO ANY PARTICULAR FONT, STYLE, SIZE, OR COLOR.

OWNER OF U.S. REG. NOS. 2,349,579, 2,478,328, AND OTHERS.

NO CLAIM IS MADE TO THE EXCLUSIVE RIGHT TO USE "THE FALLS", APART FROM THE MARK AS SHOWN. FOR ENTERTAINMENT, NAMELY, LIVE MUSIC CONCERTS (U.S. CLS. 100, 101 AND 107).

FIRST USE 7-1-2010; IN COMMERCE 7-1-2010.

3,962,930. HORST, MARY GARVEY, DBA MINDBODY VISIONS, SANTA FE, NM. SN 77-934,698. PUB. 6-29-2010, FILED 2-12-2010.

Positive Pairing into  
Sacred Union

THE MARK CONSISTS OF STANDARD CHARACTERS WITHOUT CLAIM TO ANY PARTICULAR FONT, STYLE, SIZE, OR COLOR.

FOR CONDUCTING RELATIONSHIP SEMINARS FOR COUPLES WHO ARE IN A MARRIED, ENGAGED, OR LIKE RELATIONSHIP (U.S. CLS. 100, 101 AND 107).

FIRST USE 8-4-2010; IN COMMERCE 8-4-2010.

**CLASS 41—(Continued).**

3,962,953. YES! MEDIAWORKS LLC, WESTBOROUGH, MA. SN 77-937,884. PUB. 7-13-2010, FILED 2-17-2010.

YES!

THE MARK CONSISTS OF STANDARD CHARACTERS WITHOUT CLAIM TO ANY PARTICULAR FONT, STYLE, SIZE, OR COLOR.

FOR ANIMATION PRODUCTION SERVICES; AUDIO AND VIDEO RECORDING SERVICES; AUDIO RECORDING AND PRODUCTION; DIGITAL VIDEO, AUDIO, AND MULTIMEDIA PUBLISHING SERVICES; ENTERTAINMENT MEDIA PRODUCTION SERVICES FOR MOTION PICTURES, TELEVISION AND INTERNET; ENTERTAINMENT SERVICES IN THE NATURE OF CREATION, DEVELOPMENT, AND PRODUCTION OF TELEVISION PROGRAMMING; ENTERTAINMENT SERVICES IN THE NATURE OF DEVELOPMENT, CREATION, PRODUCTION AND POST-PRODUCTION SERVICES OF MULTIMEDIA ENTERTAINMENT CONTENT; ENTERTAINMENT SERVICES, NAMELY, MULTIMEDIA PRODUCTION SERVICES; ENTERTAINMENT SERVICES, NAMELY, PRODUCTION OF SPECIAL EFFECTS INCLUDING MODEL-MAKING SERVICES, COMPUTER-GENERATED IMAGERY AND COMPUTER-GENERATED GRAPHICS FOR THE PRODUCTION OF MOTION PICTURES, VIDEOS, AND MOVIE TRAILERS; FILM AND VIDEO FILM PRODUCTION; FILM AND VIDEO PRODUCTION; FILM AND VIDEO PRODUCTION CONSULTING SERVICES; FILM AND VIDEO TAPE FILM PRODUCTION; FILM DISTRIBUTION; FILM EDITING; FILM PRODUCTION; MEDIA PRODUCTION SERVICES, NAMELY, VIDEO AND FILM PRODUCTION; MULTIMEDIA ENTERTAINMENT SERVICES IN THE NATURE OF DEVELOPMENT, PRODUCTION AND POST-PRODUCTION SERVICES IN THE FIELDS OF VIDEO AND FILMS; MULTIMEDIA ENTERTAINMENT SERVICES IN THE NATURE OF RECORDING, PRODUCTION AND POST-PRODUCTION SERVICES IN THE FIELDS OF MUSIC, VIDEO, AND FILMS; MULTIMEDIA ENTERTAINMENT SOFTWARE PRODUCTION SERVICES; OPERATION OF ROBOTIC CAMERAS, VIDEO EQUIPMENT AND/OR AUDIO EQUIPMENT FOR PRODUCTION OF INTERNET TELECONFERENCING, TELECONFERENCING OR TELEVISION PROGRAMS; OPERATION OF VIDEO EQUIPMENT OR AUDIO EQUIPMENT ETC. FOR PRODUCTION OF RADIO OR TELEVISION PROGRAMS; PHOTOGRAPHIC AND VIDEO SERVICES, NAMELY, PHOTOGRAPHIC AND VIDEO CAPTURE; PHOTOGRAPHIC COMPOSITION FOR OTHERS; PHOTOGRAPHIC COMPUTER IMAGING; POST-PRODUCTION EDITING SERVICES IN THE FIELD OF MUSIC, VIDEOS AND FILM; PRODUCTION AND DISTRIBUTION OF TELEVISION SHOWS AND MOVIES; PRODUCTION OF AUDIO RECORDING; PRODUCTION OF CABLE TELEVISION PROGRAMS; PRODUCTION OF CLOSED CAPTION TELEVISION PROGRAMS; PRODUCTION OF FILMS; PRODUCTION OF SOUND AND MUSIC VIDEO RECORDINGS; PRODUCTION OF VIDEO AND CREATION OF VISUAL EFFECTS FOR OTHERS FOR USE IN DVDS, TELEVISION PROGRAMS AND ON WEB SITES; PRODUCTION OF VIDEO CASSETTES; PRODUCTION OF VIDEO DISCS AND TAPES; PRODUCTION OF VIDEO DISCS FOR OTHERS; PRODUCTION OF VISUAL EFFECTS FOR VIDEOS, DVDS, TELEVISION AND FOR INTERNET WEB SITES; SPECIAL EFFECTS ANIMATION SERVICES FOR FILM AND VIDEO; TELEVISION, VIDEO AND MOVIE FILMING SERVICES; VIDEO EDITING; VIDEO MASTERING SERVICES; VIDEO PRODUCTION SERVICES; VIDEO RECORDING OF PERSONAL GENEALOGICAL DOCUMENTARIES; VIDEO RECORDING SERVICES; VIDEO TAPE EDITING; VIDEO TAPE FILM PRODUCTION; VIDEO TAPE RECORDING FOR OTHERS; VIDEOTAPE PRODUCTION (U.S. CLS. 100, 101 AND 107).

FIRST USE 4-1-2009; IN COMMERCE 4-1-2009.

**CLASS 41—(Continued).**

3,962,966. CONNECTED, LLC, BIRMINGHAM, AL. SN 77-941,513. PUB. 7-13-2010, FILED 2-22-2010.

## FIRSTMATE

THE MARK CONSISTS OF STANDARD CHARACTERS WITHOUT CLAIM TO ANY PARTICULAR FONT, STYLE, SIZE, OR COLOR.

FOR PROVIDING INFORMATION ON RECREATIONAL FISHING (U.S. CLS. 100, 101 AND 107).  
FIRST USE 4-5-2010; IN COMMERCE 4-5-2010.

3,962,975. SLIM & FIT FRANCHISE, LLC, CONCORD, OH. SN 77-942,181. PUB. 7-6-2010, FILED 2-23-2010.

## Jaime Brenkus' Fitness FUSION

THE MARK CONSISTS OF STANDARD CHARACTERS WITHOUT CLAIM TO ANY PARTICULAR FONT, STYLE, SIZE, OR COLOR.

NO CLAIM IS MADE TO THE EXCLUSIVE RIGHT TO USE "FITNESS", APART FROM THE MARK AS SHOWN.

THE NAME "JAIME BRENKUS" IDENTIFIES A LIVING INDIVIDUAL WHOSE CONSENT IS OF RECORD.

FOR PROVIDING ASSISTANCE, PERSONAL TRAINING AND PHYSICAL FITNESS CONSULTATION TO CORPORATE CLIENTS TO HELP THEIR EMPLOYEES MAKE PHYSICAL FITNESS, STRENGTH, CONDITIONING, AND EXERCISE ALTERATIONS IN THEIR DAILY LIVING (U.S. CLS. 100, 101 AND 107).

FIRST USE 8-31-2010; IN COMMERCE 8-31-2010.

3,962,980. DUE VOCI LLC, BURBANK, CA. SN 77-942,864. PUB. 8-10-2010, FILED 2-23-2010.

## DUE VOCI

THE MARK CONSISTS OF STANDARD CHARACTERS WITHOUT CLAIM TO ANY PARTICULAR FONT, STYLE, SIZE, OR COLOR.

**CLASS 41—(Continued).**

THE ENGLISH TRANSLATION OF "DUE VOCI" IN THE MARK IS "TWO VOICES".

FOR ENTERTAINMENT SERVICES, NAMELY, LIVE PERFORMANCES BY A MUSIC PERFORMER OR GROUP, PROVIDING A WEB SITE FEATURING ENTERTAINMENT INFORMATION AND PERFORMANCES, RELATING TO MUSIC, AND MUSICAL ARTISTS, MUSICAL VIDEOS, FILM CLIPS, PHOTOGRAPHS AND OTHER MULTIMEDIA MATERIALS ALL RELATED TO MUSICAL ENTERTAINMENT (U.S. CLS. 100, 101 AND 107).

FIRST USE 3-18-2010; IN COMMERCE 3-18-2010.

3,962,990. BUSINESS LEGACY, INC., ALLEN, TX. SN 77-943,597. PUB. 7-20-2010, FILED 2-24-2010.

## INVESTOR PEACE

THE MARK CONSISTS OF STANDARD CHARACTERS WITHOUT CLAIM TO ANY PARTICULAR FONT, STYLE, SIZE, OR COLOR.

NO CLAIM IS MADE TO THE EXCLUSIVE RIGHT TO USE "INVESTOR", APART FROM THE MARK AS SHOWN.

FOR PROVIDING AN ON-GOING RADIO PROGRAM FEATURING FINANCIAL PLANNING AND INVESTMENT ADVISORY SERVICES (U.S. CLS. 100, 101 AND 107).

FIRST USE 1-20-2010; IN COMMERCE 7-1-2010.

3,963,013. BORDO, SARA, SANTA MONICA, CA. SN 77-945,617. PUB. 7-27-2010, FILED 2-26-2010.

## WOMEN RISING

THE MARK CONSISTS OF STANDARD CHARACTERS WITHOUT CLAIM TO ANY PARTICULAR FONT, STYLE, SIZE, OR COLOR.

NO CLAIM IS MADE TO THE EXCLUSIVE RIGHT TO USE "WOMEN", APART FROM THE MARK AS SHOWN.

FOR EDUCATIONAL SERVICES, NAMELY, HOSTING COURSES AND CONDUCTING PROGRAMS TO EDUCATE WOMEN WITH RESPECT TO PROFESSIONAL DEVELOPMENT, JOB SEARCHING, RESUME CREATION, AND BUSINESS PROSPECTS; CAREER COUNSELING; EDUCATION SERVICES, NAMELY, PROVIDING CLASSES, SEMINARS, WORKSHOPS, TUTORING, AND MENTORING IN THE FIELD OF PROFESSIONAL DEVELOPMENT, JOB SEARCHING, RESUME CREATION, AND BUSINESS PROSPECTS (U.S. CLS. 100, 101 AND 107).

FIRST USE 5-0-2010; IN COMMERCE 5-0-2010.

**CLASS 41—(Continued).**

3,963,021. 20/20 MARKETING LLC, SOUTH ST. PAUL, MN.  
SN 77-946,841. PUB. 7-27-2010, FILED 2-28-2010.



THE MARK CONSISTS OF LETTERS "PICKPOINTZ". THE "PICKPOINTZ" LETTERING IS POSITIONED UNDER A SEMI-CIRCLE OF CONCENTRIC CIRCLES.

FOR ENTERTAINMENT SERVICES, NAMELY, ON-LINE ELECTRONIC GAMES PROVIDED VIA MOBILE TELEPHONES, COMPUTERS AND COMPUTER AND TELECOMMUNICATIONS NETWORKS, IN THE FIELD OF SPORTING EVENTS; PROVIDING AN ONLINE ELECTRONIC GAME FOR GUESSING FINAL RESULTS FOR LIVE SPORTING EVENTS THAT AWARDS POINTS FOR ACCURATELY PREDICTING SCORE RESULTS, STATISTICS ON SPORTING EVENTS, ATHLETES, AND SPORTS TEAMS AND RECORDS THE POINTS AWARDED WHICH CAN BE REDEEMED FOR PRIZES (U.S. CLS. 100, 101 AND 107).

FIRST USE 8-19-2010; IN COMMERCE 8-19-2010.

3,963,043. OUTSPARK, INC., SAN FRANCISCO, CA. SN 77-949,903. PUB. 7-20-2010, FILED 3-3-2010.

**DIVINE SOULS**

THE MARK CONSISTS OF STANDARD CHARACTERS WITHOUT CLAIM TO ANY PARTICULAR FONT, STYLE, SIZE, OR COLOR.

FOR ENTERTAINMENT SERVICES, NAMELY, PROVIDING AN ON-LINE COMPUTER GAME (U.S. CLS. 100, 101 AND 107).

FIRST USE 12-14-2010; IN COMMERCE 12-14-2010.

3,963,047. BSA BUSINESS SOFTWARE ALLIANCE, INC., WASHINGTON, DC. SN 77-950,222. PUB. 8-24-2010, FILED 3-4-2010.



OWNER OF U.S. REG. NOS. 2,887,539, 2,887,540, AND 2,991,766.

NO CLAIM IS MADE TO THE EXCLUSIVE RIGHT TO USE "SAM", APART FROM THE MARK AS SHOWN.

**CLASS 41—(Continued).**

THE MARK CONSISTS OF TWO PARALLEL CURVED HORIZONTAL LINES AND A SINGLE CURVED VERTICAL LINE WITH THE WORDS "SAM ADVANTAGE" STACKED TO THE RIGHT OF THE DESIGN.

FOR EDUCATIONAL SERVICES, NAMELY, PROVIDING AN ONLINE COURSE IN THE FIELD OF DATABASE MANAGEMENT AND DISTRIBUTION, SECURITY, LICENSING AND ANTI-PIRACY PROTECTION CONTROL OF THIRD PARTY SOFTWARE AND DATA FILES AND DISTRIBUTION OF COURSE MATERIAL IN CONNECTION THEREWITH (U.S. CLS. 100, 101 AND 107).

FIRST USE 8-19-2010; IN COMMERCE 8-19-2010.

3,963,064. TERM OF ART PRODUCTIONS LLC, MINNEAPOLIS, MN. SN 77-951,934. PUB. 7-27-2010, FILED 3-5-2010.

**TERM OF ART**

THE MARK CONSISTS OF STANDARD CHARACTERS WITHOUT CLAIM TO ANY PARTICULAR FONT, STYLE, SIZE, OR COLOR.

FOR FILM AND VIDEO PRODUCTION; MULTIMEDIA ENTERTAINMENT SERVICES IN THE NATURE OF DEVELOPMENT, PRODUCTION AND POST-PRODUCTION SERVICES IN THE FIELDS OF VIDEO AND FILMS; PRODUCTION AND DISTRIBUTION OF MOTION PICTURES (U.S. CLS. 100, 101 AND 107).

FIRST USE 5-1-2010; IN COMMERCE 5-1-2010.

3,963,066. KNOWLEDGE ADVENTURE, INC., TORRANCE, CA. SN 77-952,195. PUB. 7-27-2010, FILED 3-5-2010.

**adventure.com**

THE MARK CONSISTS OF STANDARD CHARACTERS WITHOUT CLAIM TO ANY PARTICULAR FONT, STYLE, SIZE, OR COLOR.

FOR ENTERTAINMENT SERVICES, NAMELY, PROVIDING BRAIN TRAINING GAMES ON-LINE AND IN MOBILE WIRELESS FORM; ENTERTAINMENT SERVICES, NAMELY, PROVIDING ON-LINE COMPUTER GAMES; ENTERTAINMENT SERVICES, NAMELY, PROVIDING ONLINE ELECTRONIC GAMES; ENTERTAINMENT SERVICES, NAMELY, PROVIDING TEMPORARY USE OF NON-DOWNLOADABLE COMPUTER LEARNING GAMES; ENTERTAINMENT SERVICES, NAMELY, PROVIDING TEMPORARY USE OF NON-DOWNLOADABLE ELECTRONIC GAMES; ENTERTAINMENT SERVICES, NAMELY, PROVIDING TEMPORARY USE OF NON-DOWNLOADABLE INTERACTIVE GAMES (U.S. CLS. 100, 101 AND 107).

FIRST USE 7-2-2009; IN COMMERCE 11-1-2010.

**CLASS 41—(Continued).**

3,963,069. THOMAS, DWAYNE, PENNSAUKEN, NJ. SN 77-952,286. PUB. 7-20-2010, FILED 3-5-2010.

**LYVE KRATES**

THE MARK CONSISTS OF STANDARD CHARACTERS WITHOUT CLAIM TO ANY PARTICULAR FONT, STYLE, SIZE, OR COLOR.

FOR MUSIC PRODUCTION SERVICES (U.S. CLS. 100, 101 AND 107).

FIRST USE 10-1-2010; IN COMMERCE 11-13-2010.

---

3,963,079. LYNN, JACKSON, SHULTZ & LEBRUN, P.C., SIOUX FALLS, SD. SN 77-954,151. PUB. 8-3-2010, FILED 3-9-2010.

**LEGACYOLOGY**

THE MARK CONSISTS OF STANDARD CHARACTERS WITHOUT CLAIM TO ANY PARTICULAR FONT, STYLE, SIZE, OR COLOR.

FOR ON-LINE JOURNALS, NAMELY, BLOGS FEATURING TOPICS ON ESTATE, BUSINESS AND ASSET PROTECTION PLANNING (U.S. CLS. 100, 101 AND 107).

FIRST USE 10-28-2010; IN COMMERCE 10-28-2010.

---

3,963,080. NEW YORK RESTORATION PROJECT, NEW YORK, NY. SN 77-954,156. PUB. 8-3-2010, FILED 3-9-2010.

**NATURE IN MY NEIGHBORHOOD**

THE MARK CONSISTS OF STANDARD CHARACTERS WITHOUT CLAIM TO ANY PARTICULAR FONT, STYLE, SIZE, OR COLOR.

NO CLAIM IS MADE TO THE EXCLUSIVE RIGHT TO USE "NATURE", APART FROM THE MARK AS SHOWN.

FOR EDUCATIONAL SERVICES, NAMELY, CONDUCTING FORUMS AND WORKSHOPS FEATURING PROGRAMS AND STRATEGIES FOR GETTING CHILDREN INTERESTED IN NATURE AND THE ENVIRONMENT AND DISTRIBUTING COURSE MATERIAL IN CONNECTION THEREWITH; SUMMER CAMPS (U.S. CLS. 100, 101 AND 107).

FIRST USE 10-31-2008; IN COMMERCE 10-31-2008.

**CLASS 41—(Continued).**

3,963,093. UNITED FOOTBALL LEAGUE, LLC, NEW YORK, NY. SN 77-955,300. PUB. 8-3-2010, FILED 3-10-2010.

**COLONIALS**

THE MARK CONSISTS OF STANDARD CHARACTERS WITHOUT CLAIM TO ANY PARTICULAR FONT, STYLE, SIZE, OR COLOR.

FOR ENTERTAINMENT SERVICES IN THE FORM OF PROFESSIONAL FOOTBALL GAMES AND EXHIBITIONS (U.S. CLS. 100, 101 AND 107).

FIRST USE 9-18-2010; IN COMMERCE 9-18-2010.

---

3,963,107. LANDO & ANASTASI, LLP, CAMBRIDGE, MA. SN 77-956,322. PUB. 8-10-2010, FILED 3-11-2010.

**THE ORDINARY OBSERVER**

THE MARK CONSISTS OF STANDARD CHARACTERS WITHOUT CLAIM TO ANY PARTICULAR FONT, STYLE, SIZE, OR COLOR.

FOR ONLINE BLOG FEATURING COMMENTARY AND INFORMATION IN THE FIELD OF INTELLECTUAL PROPERTY LAW; AN ONLINE BLOG FEATURING COMMENTARY AND INFORMATION REGARDING LEGAL DECISIONS RELATING TO INTELLECTUAL PROPERTY LAW (U.S. CLS. 100, 101 AND 107).

FIRST USE 3-25-2010; IN COMMERCE 3-25-2010.

---

3,963,112. TREPSI, S.A. DE C.V., HUIXQUILUCAN, MEXICO. SN 77-956,944. PUB. 8-3-2010, FILED 3-11-2010.



THE COLOR(S) MEDIUM BLUE, DARK BLUE, YELLOW, BEIGE, WHITE, AND BLACK IS/ARE CLAIMED AS A FEATURE OF THE MARK.

**CLASS 41—(Continued).**

THE MARK CONSISTS OF STANDING BIRD WITH WINGS OUTSTRETCHED IN A MEDIUM SHADE OF BLUE WITH INNER WING FEATHERS IN DARKER BLUE, YELLOW BEAK WITH BEIGE INSIDE MOUTH, YELLOW FEET, WHITE, BLUE AND BLACK RIMMED EYES.

FOR EDUCATIONAL PROGRAMS, NAMELY, PRE-SCHOOL AND KINDERGARTENS; PROVIDING FACILITIES FOR PRE-SCHOOL AND AFTER-SCHOOL ACTIVITIES (U.S. CLS. 100, 101 AND 107).

FIRST USE 1-31-2003; IN COMMERCE 1-31-2003.

3,963,120. WILLIAMS, LEBARRON, NORFOLK, VA. SN 77-958,322. PUB. 8-17-2010, FILED 3-13-2010.



NO CLAIM IS MADE TO THE EXCLUSIVE RIGHT TO USE "SEIDO-RYU" AND "GOSHIN-JITSU", APART FROM THE MARK AS SHOWN.

THE COLOR(S) RED, BLUE, BLACK, AND WHITE IS/ARE CLAIMED AS A FEATURE OF THE MARK.

THE MARK CONSISTS OF A RED INNER CIRCLE WITH BLACK FISH SYMBOL, BLUE REED ON EACH SIDE OF RED CIRCLE, WHITE BACKGROUND, BLUE REED ON BOTH SIDES OF RED CIRCLE, "SEIDO-RYU" IN BLUE LETTERING ABOVE RED CIRCLE, "GOSHIN-JITSU" IN BLUE LETTERING BELOW RED CIRCLE, AND BLACK OUTER CIRCLE.

THE ENGLISH TRANSLATION OF THE WORDS "SEIDO-RYU GOSHIN-JITSU" IN THE MARK IS PURE WAY SELF-DEFENSE SYSTEM.

FOR MARTIAL ARTS INSTRUCTION; OPERATING OF MARTIAL ARTS' SCHOOLS; PROVIDING A WEB SITE FEATURING NON-DOWNLOADABLE INSTRUCTIONAL VIDEOS IN THE FIELD OF MARTIAL ARTS (U.S. CLS. 100, 101 AND 107).

FIRST USE 10-15-2010; IN COMMERCE 10-15-2010.

3,963,134. NEXT STEP PUBLISHING, INC., VICTOR, NY. SN 77-959,947. PUB. 9-28-2010, FILED 3-16-2010.

# NextStepU

THE MARK CONSISTS OF STANDARD CHARACTERS WITHOUT CLAIM TO ANY PARTICULAR FONT, STYLE, SIZE, OR COLOR.

**CLASS 41—(Continued).**

OWNER OF U.S. REG. NOS. 3,280,875, 3,336,432, AND OTHERS.

FOR PROVIDING A WEB SITE THAT FEATURES INFORMATION ON ATTENDING COLLEGES AND UNIVERSITIES WITH AN EMPHASIS ON PROSPECTIVE STUDENTS; PROVIDING A WEB SITE THAT FEATURES INFORMATION ABOUT ONLINE HIGHER EDUCATION RESOURCES; PROVIDING A WEB SITE THAT FEATURES INFORMATION ON COLLEGE PLANNING AND CAREER PLANNING, NAMELY, EDUCATIONAL CAREER PLANNING; INFORMATION ABOUT EDUCATION (U.S. CLS. 100, 101 AND 107).

FIRST USE 4-0-2010; IN COMMERCE 4-0-2010.

3,963,150. SCRATCH MUSIC GROUP, INC., NEW YORK, NY. SN 77-960,998. PUB. 10-12-2010, FILED 3-17-2010.

## SCRATCH EVENTS

THE MARK CONSISTS OF STANDARD CHARACTERS WITHOUT CLAIM TO ANY PARTICULAR FONT, STYLE, SIZE, OR COLOR.

OWNER OF U.S. REG. NOS. 2,943,147, 3,142,529, AND OTHERS.

NO CLAIM IS MADE TO THE EXCLUSIVE RIGHT TO USE "EVENTS", APART FROM THE MARK AS SHOWN.

FOR DISC JOCKEYS FOR PARTIES AND SPECIAL EVENTS; MASTER OF CEREMONY SERVICES FOR PARTIES AND SPECIAL EVENTS; MUSICIANS FOR PARTIES AND SPECIAL EVENTS; SPECIAL EVENT, COORDINATION AND CONSULTATION SERVICES; EDUCATION SERVICES, NAMELY, PROVIDING WORKSHOPS IN THE FIELD OF DISC JOCKEYING; RENTAL OF AUDIOVISUAL EQUIPMENT (U.S. CLS. 100, 101 AND 107).

FIRST USE 8-8-2006; IN COMMERCE 8-8-2006.

3,963,154. SOARINGWORDS, INC., NEW YORK, NY. SN 77-961,366. PUB. 8-3-2010, FILED 3-17-2010.

## SOARINGSCRAPBOOKS

THE MARK CONSISTS OF STANDARD CHARACTERS WITHOUT CLAIM TO ANY PARTICULAR FONT, STYLE, SIZE, OR COLOR.

OWNER OF U.S. REG. NOS. 3,407,806, 3,407,808, AND OTHERS.

FOR CHARITABLE SERVICES, NAMELY, PROVIDING A WEBSITE FEATURING SCRAPBOOKS AND OTHER ARTS AND CRAFTS FOR CHILDREN WITH SERIOUS ILLNESS AND THEIR FAMILY AND FRIENDS (U.S. CLS. 100, 101 AND 107).

FIRST USE 8-13-2010; IN COMMERCE 8-13-2010.



**CLASS 41—(Continued).**

3,963,179. MAJOR LEAGUE LACROSSE LLC, BOSTON, MA. SN 77-963,572. PUB. 8-10-2010, FILED 3-19-2010.

**CHESAPEAKE BAYHAWKS**

THE MARK CONSISTS OF STANDARD CHARACTERS WITHOUT CLAIM TO ANY PARTICULAR FONT, STYLE, SIZE, OR COLOR.

OWNER OF U.S. REG. NOS. 3,179,650, 3,472,886, AND OTHERS.

NO CLAIM IS MADE TO THE EXCLUSIVE RIGHT TO USE "CHESAPEAKE", APART FROM THE MARK AS SHOWN.

FOR ENTERTAINMENT IN THE NATURE OF LACROSSE GAMES, COMPETITIONS AND TOURNAMENTS; ENTERTAINMENT, NAMELY, PARTICIPATION IN LACROSSE GAMES AND COMPETITIONS; CONDUCTING ENTERTAINMENT EXHIBITIONS IN THE NATURE OF LACROSSE GAMES AND COMPETITIONS; ORGANIZING EXHIBITIONS FOR THE SPORT OF LACROSSE; PROVIDING FACILITIES FOR LACROSSE TOURNAMENTS; ARRANGING AND CONDUCTING ATHLETIC COMPETITIONS; ENTERTAINMENT IN THE NATURE ON-GOING TELEVISION PROGRAMS IN THE FIELD OF SPORTING EVENTS; ENTERTAINMENT, NAMELY, A CONTINUING SPORTS EVENT SHOW DISTRIBUTED OVER TELEVISION, SATELLITE, AUDIO AND VIDEO MEDIA; ENTERTAINMENT SERVICES, NAMELY, PROVIDING A CONTINUING TELEVISION PROGRAM FEATURING SPORTING EVENTS VIA A GLOBAL COMPUTER NETWORK; ENTERTAINMENT SERVICES, NAMELY, PROVIDING A WEB SITE FEATURING INFORMATION PERTAINING TO LACROSSE GOODS AND SERVICES (U.S. CLS. 100, 101 AND 107).

FIRST USE 1-0-2010; IN COMMERCE 1-0-2010.

3,963,180. MAJOR LEAGUE LACROSSE LLC, BOSTON, MA. SN 77-963,614. PUB. 8-10-2010, FILED 3-19-2010.



OWNER OF U.S. REG. NOS. 3,179,650, 3,472,886, AND OTHERS.

NO CLAIM IS MADE TO THE EXCLUSIVE RIGHT TO USE "CHESAPEAKE", APART FROM THE MARK AS SHOWN.

**CLASS 41—(Continued).**

THE MARK CONSISTS OF A FANCIFUL DESIGN OF A HAWK WHICH APPEARS ABOVE THE WORDING "CHESAPEAKE BAYHAWKS".

FOR ENTERTAINMENT IN THE NATURE OF LACROSSE GAMES, COMPETITIONS AND TOURNAMENTS; ENTERTAINMENT, NAMELY, PARTICIPATION IN LACROSSE GAMES AND COMPETITIONS; CONDUCTING ENTERTAINMENT EXHIBITIONS IN THE NATURE OF LACROSSE GAMES AND COMPETITIONS; ORGANIZING EXHIBITIONS FOR THE SPORT OF LACROSSE; PROVIDING FACILITIES FOR LACROSSE TOURNAMENTS; ARRANGING AND CONDUCTING ATHLETIC COMPETITIONS; ENTERTAINMENT IN THE NATURE ON-GOING TELEVISION PROGRAMS IN THE FIELD OF SPORTING EVENTS; ENTERTAINMENT, NAMELY, A CONTINUING SPORTS EVENT SHOW DISTRIBUTED OVER TELEVISION, SATELLITE, AUDIO AND VIDEO MEDIA; ENTERTAINMENT SERVICES, NAMELY, PROVIDING A CONTINUING TELEVISION PROGRAM FEATURING SPORTING EVENTS VIA A GLOBAL COMPUTER NETWORK; ENTERTAINMENT SERVICES, NAMELY, PROVIDING A WEB SITE FEATURING INFORMATION PERTAINING TO LACROSSE GOODS AND SERVICES (U.S. CLS. 100, 101 AND 107).

FIRST USE 1-0-2010; IN COMMERCE 1-0-2010.

3,963,197. U BETTER SING!, INC., AUSTIN, TX. SN 77-965,712. PUB. 8-10-2010, FILED 3-23-2010.

**U BETTER Sing!**

THE MARK CONSISTS OF STANDARD CHARACTERS WITHOUT CLAIM TO ANY PARTICULAR FONT, STYLE, SIZE, OR COLOR.

FOR ENTERTAINMENT SERVICES IN THE NATURE OF DEVELOPMENT, CREATION, PRODUCTION AND POST-PRODUCTION SERVICES OF MULTIMEDIA ENTERTAINMENT CONTENT; ENTERTAINMENT SERVICES, NAMELY, PROVIDING WEBCASTS IN THE FIELD OF MUSICAL EDUCATION; PROVIDING A WEBSITE FEATURING EDUCATION AND ENTERTAINMENT FOR CHILDREN; PROVIDING ADVICE AND INFORMATION IN THE FIELD OF EDUCATIONAL AND ENTERTAINMENT ACTIVITIES AND EVENTS FOR CHILDREN (U.S. CLS. 100, 101 AND 107).

FIRST USE 11-30-2010; IN COMMERCE 11-30-2010.

3,963,245. ADVANCE MAGAZINE PUBLISHERS INC., NEW YORK, NY. SN 77-981,619. PUB. 5-18-2010, FILED 6-17-2009.

**OPERATION DREAM DRESS**

THE MARK CONSISTS OF STANDARD CHARACTERS WITHOUT CLAIM TO ANY PARTICULAR FONT, STYLE, SIZE, OR COLOR.

**CLASS 41—(Continued).**

NO CLAIM IS MADE TO THE EXCLUSIVE RIGHT TO USE "DRESS", APART FROM THE MARK AS SHOWN.

FOR ARRANGING, ORGANIZING AND CONDUCTING CONTESTS AND COMPETITIONS THAT CONCERN DRESS DESIGN (U.S. CLS. 100, 101 AND 107).  
FIRST USE 3-1-2009; IN COMMERCE 3-1-2009.

---

3,963,276. PLAYBOY ENTERPRISES INTERNATIONAL, INC., CHICAGO, IL. SN 77-981,813. PUB. 1-13-2009, FILED 8-22-2008.

**THE GAMER NEXT DOOR**

THE MARK CONSISTS OF STANDARD CHARACTERS WITHOUT CLAIM TO ANY PARTICULAR FONT, STYLE, SIZE, OR COLOR.

FOR ENTERTAINMENT SERVICES, NAMELY, PROVIDING ON-LINE REVIEWS OF VIDEO GAMES; ENTERTAINMENT SERVICES, NAMELY, PROVIDING VIDEOS ON-LINE FEATURING A FEMALE HOST CONDUCTING INTERVIEWS IN THE FIELDS OF GAMING, PREVIEWING VIDEO GAMES, TESTING VIDEO GAMES AND REVIEWING VIDEO GAMES; ON-LINE JOURNALS, NAMELY, BLOGS FEATURING GAMING AND ENTERTAINMENT TOPICS (U.S. CLS. 100, 101 AND 107).  
FIRST USE 8-25-2009; IN COMMERCE 8-25-2009.

---

3,963,287. SMART SALES SOLUTIONS LLC, BEND, OR. SN 78-599,102. PUB. 12-22-2009, FILED 3-31-2005.



THE MARK CONSISTS OF THE WORDS "SMART SALES SOLUTIONS" APPEARS AS FOLLOWS: THE WORD "SMART" IS CENTERED, ON TOP OF THE OTHER 2 WORDS, "SALES SOLUTIONS". SALES SOLUTIONS APPEARS WITH NO SPACES BETWEEN THEM. ALL WORDS ARE ENCIRCLED BY A THIN BLACK LINE, IN THE SHAPE OF A HORIZONTAL OVAL. BEHIND THE WORDS IS A DESIGN OF A LINE SWOOPING TOWARD THE UPPER RIGHT CORNER, IMMEDIATELY OUTSIDE THE OVAL IS A STAR.

FOR PERSONAL COACHING AND BUSINESS TRAINING SERVICES IN THE FIELD OF SALES (U.S. CLS. 100, 101 AND 107).  
FIRST USE 6-29-2004; IN COMMERCE 6-29-2004.

**CLASS 41—(Continued).**

3,963,318. PERIO HEALTH PROFESSIONALS, PLLC, HOUSTON, TX. SN 85-003,194. PUB. 8-24-2010, FILED 3-31-2010.

**PERIO HEALTH INSTITUTE  
JAPAN**

THE MARK CONSISTS OF STANDARD CHARACTERS WITHOUT CLAIM TO ANY PARTICULAR FONT, STYLE, SIZE, OR COLOR.

OWNER OF U.S. REG. NOS. 3,323,760 AND 3,323,761.  
NO CLAIM IS MADE TO THE EXCLUSIVE RIGHT TO USE "HEALTH INSTITUTE JAPAN", APART FROM THE MARK AS SHOWN.

FOR EDUCATIONAL SERVICES, NAMELY, SEMINARS IN THE FIELD OF DENTISTRY, PERIODONTAL HEALTH AND DISEASE, AND ORAL SURGERY (U.S. CLS. 100, 101 AND 107).  
FIRST USE 1-5-2010; IN COMMERCE 1-5-2010.

---

3,963,321. LILLYPAD PRODUCTIONS, LLC, FLORENCE, SC. SN 85-003,833. PUB. 9-7-2010, FILED 4-1-2010.

**Country Fried Rock**

THE MARK CONSISTS OF STANDARD CHARACTERS WITHOUT CLAIM TO ANY PARTICULAR FONT, STYLE, SIZE, OR COLOR.

NO CLAIM IS MADE TO THE EXCLUSIVE RIGHT TO USE "ROCK", APART FROM THE MARK AS SHOWN.

FOR ENTERTAINMENT SERVICES, NAMELY, PROVIDING A SERIES OF RADIO SHOWS FEATURING MUSIC AND INTERVIEWS WITH MUSICAL COMPOSERS AND PERFORMERS FOR RADIO BROADCAST AND DIGITAL STREAMING (U.S. CLS. 100, 101 AND 107).

FIRST USE 4-30-2010; IN COMMERCE 10-28-2010.

---

3,963,353. UNITED FOOTBALL LEAGUE, LLC, NEW YORK, NY. SN 85-008,847. PUB. 7-27-2010, FILED 4-7-2010.

**MOUNTAIN LIONS**

THE MARK CONSISTS OF STANDARD CHARACTERS WITHOUT CLAIM TO ANY PARTICULAR FONT, STYLE, SIZE, OR COLOR.

FOR ENTERTAINMENT SERVICES IN THE FORM OF PROFESSIONAL FOOTBALL GAMES AND EXHIBITIONS (U.S. CLS. 100, 101 AND 107).  
FIRST USE 9-18-2010; IN COMMERCE 9-18-2010.

**CLASS 41—(Continued).**

3,963,371. LIFE RESET BUTTON, LLC, MERRITT ISLAND, FL. SN 85-011,733. PUB. 9-7-2010, FILED 4-12-2010.

## LIFE RESET BUTTON

THE MARK CONSISTS OF STANDARD CHARACTERS WITHOUT CLAIM TO ANY PARTICULAR FONT, STYLE, SIZE, OR COLOR.

FOR PROVIDING ON-LINE MAGAZINES IN THE FIELD OF INSPIRATION AND CHANGE FOR THE BETTER; ON-LINE JOURNALS, NAMELY, BLOGS FEATURING INSPIRATION AND HOW TO CHANGE FOR THE BETTER; ENTERTAINMENT AND EDUCATIONAL SERVICES, NAMELY, A CONTINUING PROGRAM ABOUT INSPIRATION AND HOW TO CHANGE FOR THE BETTER ACCESSIBLE BY RADIO, TELEVISION, SATELLITE, AUDIO, VIDEO AND COMPUTER NETWORKS; PROVIDING INDIVIDUAL AND GROUP COACHING AND LEARNING FORUMS IN THE FIELD OF INSPIRATION AND CHANGE FOR THE BETTER (U.S. CLS. 100, 101 AND 107).

FIRST USE 5-28-2010; IN COMMERCE 1-19-2011.

---

3,963,384. UNIVISION COMMUNICATIONS INC., LOS ANGELES, CA. SN 85-015,048. PUB. 9-7-2010, FILED 4-15-2010.

## EL PESO DEL MATRIMONIO

THE MARK CONSISTS OF STANDARD CHARACTERS WITHOUT CLAIM TO ANY PARTICULAR FONT, STYLE, SIZE, OR COLOR.

THE ENGLISH TRANSLATION OF "EL PESO DEL MATRIMONIO" IN THE MARK IS "THE WEIGHT OF MARRIAGE".

FOR ENTERTAINMENT SERVICES, NAMELY, AN ONGOING TELEVISION REALITY PROGRAM CONCERNING WEIGHT LOSS AND RE-KINDLING OF ROMANCE FOR MARRIED COUPLES (U.S. CLS. 100, 101 AND 107).

FIRST USE 2-3-2011; IN COMMERCE 2-3-2011.

**CLASS 41—(Continued).**

3,963,385. BRINKER INTERNATIONAL PAYROLL COMPANY, L.P., DALLAS, TX. SN 85-015,098. PUB. 9-7-2010, FILED 4-15-2010.



OWNER OF U.S. REG. NOS. 1,690,466 AND 1,724,412.

THE MARK CONSISTS OF A GRID LINED GLOBE DESIGN ENCIRCLED BY AN OUTER RING. A FLAGPOLE WITH A FLAG THAT CONTAINS THE WORD "BRINKER" IN A FANCIFUL FONT RISES FROM THE OUTER RING. RANDOM STAR DESIGNS ARE DEPICTED ON THE GLOBE, THE OUTER RING AND THE FLAG. THE WORD "NATION" IN A FANCIFUL FONT IS POSITIONED UNDER THE FLAG.

FOR BUSINESS TRAINING IN THE FIELD OF FOOD PREPARATION, RESTAURANT OPERATIONS AND RETAIL RESTAURANT MANAGEMENT (U.S. CLS. 100, 101 AND 107).

FIRST USE 8-24-2009; IN COMMERCE 9-1-2009.

---

3,963,386. BRINKER INTERNATIONAL PAYROLL COMPANY, L.P., DALLAS, TX. SN 85-015,117. PUB. 9-7-2010, FILED 4-15-2010.

## BRINKER NATION

THE MARK CONSISTS OF STANDARD CHARACTERS WITHOUT CLAIM TO ANY PARTICULAR FONT, STYLE, SIZE, OR COLOR.

OWNER OF U.S. REG. NOS. 1,690,466 AND 1,724,412.

FOR BUSINESS TRAINING IN THE FIELD OF FOOD PREPARATION, RESTAURANT OPERATIONS AND RETAIL RESTAURANT MANAGEMENT (U.S. CLS. 100, 101 AND 107).

FIRST USE 8-24-2009; IN COMMERCE 9-1-2009.

**CLASS 41—(Continued).**

3,963,400. CRYSTAL RIVER ORGANICS LLC, CARBONDALE, CO. SN 85-019,630. PUB. 2-8-2011, FILED 4-21-2010.

**NUDE WEIGHT MANAGEMENT**

THE MARK CONSISTS OF STANDARD CHARACTERS WITHOUT CLAIM TO ANY PARTICULAR FONT, STYLE, SIZE, OR COLOR.

NO CLAIM IS MADE TO THE EXCLUSIVE RIGHT TO USE "WEIGHT MANAGEMENT", APART FROM THE MARK AS SHOWN.

FOR PROVIDING WEIGHT LOSS PROGRAM SERVICES (U.S. CLS. 100, 101 AND 107).  
FIRST USE 4-1-2011; IN COMMERCE 4-1-2011.

3,963,405. WARRICK, MERCEDES, LAS VEGAS, NV. SN 85-021,666. PUB. 8-31-2010, FILED 4-23-2010.

**The Intuitive CEO**

THE MARK CONSISTS OF STANDARD CHARACTERS WITHOUT CLAIM TO ANY PARTICULAR FONT, STYLE, SIZE, OR COLOR.

NO CLAIM IS MADE TO THE EXCLUSIVE RIGHT TO USE "CEO", APART FROM THE MARK AS SHOWN.

FOR EDUCATIONAL SERVICES, NAMELY, CONDUCTING SEMINARS, WORKSHOPS, CONFERENCES, TELECONFERENCES AND ONLINE SEMINARS IN THE FIELD OF BUSINESS BUILDING, MARKETING, LEADERSHIP DEVELOPMENT AND PERSONAL LIFESTYLE AND DISTRIBUTING TRAINING MATERIAL IN CONNECTION THEREWITH (U.S. CLS. 100, 101 AND 107).  
FIRST USE 10-1-2010; IN COMMERCE 10-1-2010.

3,963,416. NATIONAL ASSOCIATION FOR STOCK CAR AUTO RACING, INC., DAYTONA BEACH, FL. SN 85-025,177. PUB. 7-27-2010, FILED 4-28-2010.



OWNER OF U.S. REG. NOS. 1,973,218, 2,026,304, AND OTHERS.

NO CLAIM IS MADE TO THE EXCLUSIVE RIGHT TO USE "HOSPITALITY", APART FROM THE MARK AS SHOWN.

**CLASS 41—(Continued).**

THE MARK CONSISTS OF SLANTED BARS IN ASCENDING ORDER AND THE WORDING, "NASCAR FUEL FOR HOSPITALITY", ALL ENCLOSED IN A SLANTED RECTANGLE.

FOR HOSPITALITY SERVICES, NAMELY, ORGANIZING AND PLANNING PARTIES FOR MOTORSPORTS RACING EVENTS (U.S. CLS. 100, 101 AND 107).  
FIRST USE 8-12-2010; IN COMMERCE 8-12-2010.

3,963,423. UNITED FOOTBALL LEAGUE, LLC, NEW YORK, NY. SN 85-026,011. PUB. 7-27-2010, FILED 4-29-2010.

**NIGHTHAWKS**

THE MARK CONSISTS OF STANDARD CHARACTERS WITHOUT CLAIM TO ANY PARTICULAR FONT, STYLE, SIZE, OR COLOR.

FOR ENTERTAINMENT SERVICES IN THE FORM OF PROFESSIONAL FOOTBALL GAMES AND EXHIBITIONS (U.S. CLS. 100, 101 AND 107).  
FIRST USE 9-24-2010; IN COMMERCE 9-24-2010.

3,963,426. UNITED FOOTBALL LEAGUE, LLC, NEW YORK, NY. SN 85-026,028. PUB. 7-27-2010, FILED 4-29-2010.

**OMAHA NIGHTHAWKS**

THE MARK CONSISTS OF STANDARD CHARACTERS WITHOUT CLAIM TO ANY PARTICULAR FONT, STYLE, SIZE, OR COLOR.

NO CLAIM IS MADE TO THE EXCLUSIVE RIGHT TO USE "OMAHA", APART FROM THE MARK AS SHOWN.

FOR ENTERTAINMENT SERVICES IN THE FORM OF PROFESSIONAL FOOTBALL GAMES AND EXHIBITIONS (U.S. CLS. 100, 101 AND 107).  
FIRST USE 9-24-2010; IN COMMERCE 9-24-2010.

3,963,443. MPVM, LLC, BURBANK, CA. SN 85-030,308. PUB. 10-5-2010, FILED 5-4-2010.



THE MARK CONSISTS OF A STYLIZED TENT WITH A PENNANT-TYPE FLAG ON TOP ADJACENT TO THE WORDS, "CURIOUS CIRCUS".

FOR MULTIMEDIA PUBLISHING OF BOOKS, MAGAZINES, JOURNALS, SOFTWARE, GAMES, MUSIC, AND ELECTRONIC PUBLICATIONS (U.S. CLS. 100, 101 AND 107).  
FIRST USE 5-5-2010; IN COMMERCE 8-19-2010.

**CLASS 41—(Continued).**

3,963,447. PERIO HEALTH PROFESSIONALS, PLLC, HOUSTON, TX. SN 85-032,557. PUB. 8-24-2010, FILED 5-7-2010.

**PERIO HEALTH INSTITUTE**

THE MARK CONSISTS OF STANDARD CHARACTERS WITHOUT CLAIM TO ANY PARTICULAR FONT, STYLE, SIZE, OR COLOR.

OWNER OF U.S. REG. NOS. 3,323,760 AND 3,323,761.

NO CLAIM IS MADE TO THE EXCLUSIVE RIGHT TO USE "HEALTH INSTITUTE", APART FROM THE MARK AS SHOWN.

FOR EDUCATIONAL SERVICES, NAMELY, SEMINARS IN THE FIELD OF DENTISTRY, PERIODONTAL HEALTH AND DISEASE, ORAL SURGERY, AND ORAL AND DENTAL IMPLANTS (U.S. CLS. 100, 101 AND 107).  
FIRST USE 9-18-2010; IN COMMERCE 9-18-2010.

3,963,453. BAHLEDA, ANDREW, ROYAL OAK, MI. SN 85-034,790. PUB. 12-21-2010, FILED 5-10-2010.

**Epiphany Catalyst**

THE MARK CONSISTS OF STANDARD CHARACTERS WITHOUT CLAIM TO ANY PARTICULAR FONT, STYLE, SIZE, OR COLOR.

FOR EDUCATIONAL AND ENTERTAINMENT SERVICES, NAMELY, PROVIDING MOTIVATIONAL AND EDUCATIONAL SPEAKERS IN THE FIELD OF SELF- AND PERSONAL IMPROVEMENT, PROVIDED VIA SEMINARS, WORKSHOPS, PERSONAL MENTORING AND TUTORING SESSIONS; EDUCATIONAL AND ENTERTAINMENT SERVICES, NAMELY, PROVIDING A WEBSITE FEATURING INFORMATION ABOUT MOTIVATIONAL AND EDUCATIONAL SPEAKERS IN THE FIELD OF SELF- AND PERSONAL IMPROVEMENT (U.S. CLS. 100, 101 AND 107).

FIRST USE 12-10-2010; IN COMMERCE 12-10-2010.

3,963,471. UNIVISION COMMUNICATIONS INC., LOS ANGELES, CA. SN 85-036,954. PUB. 9-7-2010, FILED 5-12-2010.

**ARRASA CON TODO**

THE MARK CONSISTS OF STANDARD CHARACTERS WITHOUT CLAIM TO ANY PARTICULAR FONT, STYLE, SIZE, OR COLOR.

**CLASS 41—(Continued).**

THE ENGLISH TRANSLATION OF "ARRASA CON TODO" IN THE MARK IS "TAKE IT ALL".

FOR ENTERTAINMENT SERVICES, NAMELY, AN ONGOING REALITY TELEVISION PROGRAM FEATURING GAMES AND CONTESTS (U.S. CLS. 100, 101 AND 107).

FIRST USE 2-19-2011; IN COMMERCE 2-19-2011.

3,963,490. LNO S.A., GENEVA, SWITZERLAND. SN 85-042,611. PUB. 10-19-2010, FILED 5-19-2010.

**OFFICIAL.FM**

THE MARK CONSISTS OF STANDARD CHARACTERS WITHOUT CLAIM TO ANY PARTICULAR FONT, STYLE, SIZE, OR COLOR.

FOR ENTERTAINMENT SERVICES, NAMELY, PROVIDING ON-LINE REVIEWS OF MUSIC, PROVIDING NONDOWNLOADABLE PRERECORDED MUSIC, INFORMATION IN THE FIELD OF MUSIC AND COMMENTARY AND ARTICLES ABOUT MUSIC; PROVIDING AN INTERNET WEBSITE PORTAL FEATURING LINKS TO MUSIC ARTIST WEBSITES; PROVISION OF INFORMATION RELATING TO MUSIC; ENTERTAINMENT SERVICES, NAMELY, NON-DOWNLOADABLE RINGTONES, PRE-RECORDED MUSIC, AND GRAPHICS PRESENTED TO MOBILE COMMUNICATIONS DEVICES VIA A GLOBAL COMPUTER NETWORK AND WIRELESS NETWORKS; ONLINE JOURNALS, NAMELY, BLOGS FEATURING INFORMATION ABOUT MUSIC; ONLINE PUBLICATION IN THE NATURE OF A NEWSLETTER IN THE FIELD OF MUSIC (U.S. CLS. 100, 101 AND 107).

FIRST USE 7-31-2010; IN COMMERCE 7-31-2010.

3,963,504. BOB BAIN PRODUCTIONS, INC., SANTA MONICA, CA. SN 85-045,426. PUB. 10-19-2010, FILED 5-21-2010.

**THE ACA's**

THE MARK CONSISTS OF STANDARD CHARACTERS WITHOUT CLAIM TO ANY PARTICULAR FONT, STYLE, SIZE, OR COLOR.

FOR ENTERTAINMENT SERVICES, NAMELY, PROVIDING AN ANNUAL AWARD PROGRAM FOR PRESENTATION OF AWARDS IN RECOGNITION OF TALENT, MILESTONES AND ACHIEVEMENTS IN THE MUSIC INDUSTRY (U.S. CLS. 100, 101 AND 107).

FIRST USE 12-10-2006; IN COMMERCE 12-10-2006.



**CLASS 41—(Continued).**

3,963,515. PINTO, GEORGE, SCHILLER PARK, IL. SN 85-047,866. PUB. 11-2-2010, FILED 5-26-2010.

**KILLWAVE**

THE MARK CONSISTS OF STANDARD CHARACTERS WITHOUT CLAIM TO ANY PARTICULAR FONT, STYLE, SIZE, OR COLOR.

FOR ENTERTAINMENT IN THE NATURE OF VISUAL AND AUDIO PERFORMANCES BY A MUSICAL BAND AND LIVE PERFORMANCES BY A MUSICAL BAND (U.S. CLS. 100, 101 AND 107).

FIRST USE 4-1-2010; IN COMMERCE 7-1-2010.

---

3,963,536. A.R. BIEL, INC. DBA BOOKS OF DISCOVERY, BOULDER, CO. SN 85-056,090. PUB. 11-9-2010, FILED 6-7-2010.

**e-XPLORE**

THE MARK CONSISTS OF STANDARD CHARACTERS WITHOUT CLAIM TO ANY PARTICULAR FONT, STYLE, SIZE, OR COLOR.

FOR PROVIDING A WEB SITE THAT FEATURES INFORMATION ABOUT ONLINE HIGHER EDUCATION RESOURCES (U.S. CLS. 100, 101 AND 107).

FIRST USE 10-1-2010; IN COMMERCE 10-1-2010.

---

3,963,566. THE CARTOON NETWORK, INC., ATLANTA, GA. SN 85-065,056. PUB. 10-5-2010, FILED 6-17-2010.

**GETTING IN IS THE EASY PART**

THE MARK CONSISTS OF STANDARD CHARACTERS WITHOUT CLAIM TO ANY PARTICULAR FONT, STYLE, SIZE, OR COLOR.

FOR ENTERTAINMENT SERVICES, NAMELY, A MULTIMEDIA PROGRAM SERIES FEATURING COMEDY, ACTION AND ADVENTURE DISTRIBUTED VIA VARIOUS PLATFORMS ACROSS MULTIPLE FORMS OF TRANSMISSION MEDIA (U.S. CLS. 100, 101 AND 107).

FIRST USE 10-19-2010; IN COMMERCE 10-19-2010.

**CLASS 41—(Continued).**

3,963,573. NATIONAL ASSOCIATION OF STATE BOARDS OF ACCOUNTANCY, INC., NASHVILLE, TN. SN 85-067,991. PUB. 12-14-2010, FILED 6-21-2010.

**LEARNING MARKET**

THE MARK CONSISTS OF STANDARD CHARACTERS WITHOUT CLAIM TO ANY PARTICULAR FONT, STYLE, SIZE, OR COLOR.

NO CLAIM IS MADE TO THE EXCLUSIVE RIGHT TO USE "LEARNING", APART FROM THE MARK AS SHOWN.

FOR PROVIDING AN ONLINE RESOURCE FOR PROFESSIONALS TO SEARCH FOR CONTINUING EDUCATION COURSES THAT MEET THE REQUIREMENTS NECESSARY TO MAINTAIN PROFESSIONAL LICENSES AND FOR LEARNING PROVIDERS WHO PROVIDE CONTINUING EDUCATION COURSES TO LIST AVAILABLE CONTINUING EDUCATION COURSES AND TO LEARN ABOUT THE NATIONAL REGISTRY OF CPE PROVIDERS APPLICATION PROCESS (U.S. CLS. 100, 101 AND 107).

FIRST USE 9-28-2010; IN COMMERCE 9-28-2010.

---

3,963,574. NATIONAL ASSOCIATION OF STATE BOARDS OF ACCOUNTANCY, INC., NASHVILLE, TN. SN 85-067,998. PUB. 12-14-2010, FILED 6-21-2010.



NO CLAIM IS MADE TO THE EXCLUSIVE RIGHT TO USE "LEARNING", APART FROM THE MARK AS SHOWN.

THE MARK CONSISTS OF THE LETTERS "LM" IN A BOX TO THE LEFT OF THE WORDS "LEARNING MARKET".

FOR PROVIDING AN ONLINE RESOURCE FOR PROFESSIONALS TO SEARCH FOR CONTINUING EDUCATION COURSES THAT MEET THE REQUIREMENTS NECESSARY TO MAINTAIN PROFESSIONAL LICENSES AND FOR LEARNING PROVIDERS WHO PROVIDE CONTINUING EDUCATION COURSES TO LIST AVAILABLE CONTINUING EDUCATION COURSES AND TO LEARN ABOUT THE NATIONAL REGISTRY OF CPE PROVIDERS APPLICATION PROCESS (U.S. CLS. 100, 101 AND 107).

FIRST USE 9-28-2010; IN COMMERCE 9-28-2010.

**CLASS 41—(Continued).**

3,963,615. COHEN, DAVE, DOYLESTOWN, PA. SN 85-076,573. PUB. 1-11-2011, FILED 7-1-2010.



NO CLAIM IS MADE TO THE EXCLUSIVE RIGHT TO USE "STRENGTH & WELLNESS", APART FROM THE MARK AS SHOWN.

THE MARK CONSISTS OF THE STYLIZED TEXT "NXT LEVEL STRENGTH & WELLNESS". THE TERMS "NXT LEVEL" APPEARS ABOVE THE TERMS "STRENGTH & WELLNESS". THE FONT OF THE LETTERS "NXT" IS LARGER THAN THE OTHER WORDING. THE TOP LEFT STEM OF THE LETTER "X" EXTENDS TO THE LEFT OVER THE LETTER "N" AND THE BOTTOM RIGHT STEM OF THE LETTER "X" EXTENDS TO THE RIGHT UNDER THE LETTER "T" AND THE TERM "LEVEL".

FOR PROVIDING INFORMATION IN THE FIELD OF CONCEPTS OF FITNESS; PERSONAL FITNESS TRAINING SERVICES AND CONSULTANCY; HEALTH CLUB SERVICES, NAMELY, PROVIDING INSTRUCTION AND EQUIPMENT IN THE FIELD OF PHYSICAL EXERCISE (U.S. CLS. 100, 101 AND 107).

FIRST USE 6-1-2010; IN COMMERCE 6-1-2010.

**CLASS 41—(Continued).**

3,963,678. HYPERVOCAL, LLC, WASHINGTON, DC. SN 85-099,228. PUB. 1-18-2011, FILED 8-3-2010.

# hypervocal

THE MARK CONSISTS OF STANDARD CHARACTERS WITHOUT CLAIM TO ANY PARTICULAR FONT, STYLE, SIZE, OR COLOR.

FOR NEWS REPORTER SERVICES IN THE NATURE OF NEWS ANALYSIS AND NEWS COMMENTARY; ON-LINE JOURNALS, NAMELY, BLOGS FEATURING NEWS, POLITICS, ENTERTAINMENT, VIDEOS, COMMENTARY, SPORTS, CULTURE, CELEBRITY, AND CURRENT EVENTS; PROVIDING A WEBSITE FEATURING ENTERTAINMENT INFORMATION; PROVIDING AN INTERNET NEWS PORTAL FEATURING LINKS TO NEWS STORIES AND ARTICLES IN THE FIELD OF CURRENT EVENTS (U.S. CLS. 100, 101 AND 107).

FIRST USE 4-15-2010; IN COMMERCE 5-1-2010.

3,963,680. FLURTY LLC, CHICAGO, IL. SN 85-099,372. PUB. 1-18-2011, FILED 8-3-2010.

# FLURTY

THE MARK CONSISTS OF STANDARD CHARACTERS WITHOUT CLAIM TO ANY PARTICULAR FONT, STYLE, SIZE, OR COLOR.

FOR ENTERTAINMENT SERVICES, NAMELY, PROVIDING ON-LINE COMPUTER GAMES (U.S. CLS. 100, 101 AND 107).

FIRST USE 12-10-2010; IN COMMERCE 12-10-2010.

3,963,617. UY, REGINALD, TINLEY PARK, IL. AND KUBACZYK, KRISTOPHER, TINLEY PARK, IL. AND SNEE III, JOHN, TINLEY PARK, IL. SN 85-076,624. PUB. 11-30-2010, FILED 7-1-2010.

# FCL

3,963,690. GANZ, WOODBRIDGE, ONT, CANADA. SN 85-104,875. PUB. 1-11-2011, FILED 8-11-2010.

# KINZAPEDIA

THE MARK CONSISTS OF STANDARD CHARACTERS WITHOUT CLAIM TO ANY PARTICULAR FONT, STYLE, SIZE, OR COLOR.

FOR ORGANIZATION OF SPORTS ACTIVITIES AND EVENTS IN THE NATURE OF PROFESSIONAL FLICKERBALL (U.S. CLS. 100, 101 AND 107).

FIRST USE 2-1-2010; IN COMMERCE 7-1-2010.

THE MARK CONSISTS OF STANDARD CHARACTERS WITHOUT CLAIM TO ANY PARTICULAR FONT, STYLE, SIZE, OR COLOR.

**CLASS 41—(Continued).**

OWNER OF U.S. REG. NOS. 3,015,923, 3,222,635, AND OTHERS.

FOR ENTERTAINMENT SERVICES, NAMELY, PROVIDING A WEBSITE FEATURING ONLINE INTERACTIVE STORIES FOR CHILDREN, ONLINE INTERACTIVE AND EDUCATIONAL COMPUTER GAMES PLAYED OVER COMPUTER NETWORKS AND GLOBAL COMMUNICATION NETWORKS; PROVIDING A WEBSITE FEATURING INFORMATION ABOUT FICTIONAL CHARACTERS FEATURED IN THESE ONLINE INTERACTIVE STORIES AND GAMES (U.S. CLS. 100, 101 AND 107).

FIRST USE 10-19-2010; IN COMMERCE 10-19-2010.

---

3,963,726. WINTER PARK RECREATIONAL ASSOCIATION, WINTER PARK, CO. SN 85-975,194. PUB. 8-3-2010, FILED 4-8-2010.

## DARK TERRITORY

THE MARK CONSISTS OF STANDARD CHARACTERS WITHOUT CLAIM TO ANY PARTICULAR FONT, STYLE, SIZE, OR COLOR.

FOR ENTERTAINMENT SERVICES IN THE NATURE OF A SKI AND SNOWBOARD TERRAIN PARK; ORGANIZING AND CONDUCTING SKI AND SNOWBOARD EXHIBITIONS AND COMPETITIONS (U.S. CLS. 100, 101 AND 107).

FIRST USE 11-0-2009; IN COMMERCE 11-0-2009.

**CLASS 42—SCIENTIFIC AND COMPUTER SERVICES**

3,961,993. PHILIP R. BERGER & ASSOCIATES, INC, WARRENDALE, PA. SN 76-701,788. PUB. 7-13-2010, FILED 2-24-2010.

## Re:mote

THE MARK CONSISTS OF STANDARD CHARACTERS WITHOUT CLAIM TO ANY PARTICULAR FONT, STYLE, SIZE, OR COLOR.

FOR SCIENTIFIC DATA COLLECTION USING SEISMOGRAPHS, DATA LOGGERS, WEATHER LOGGERS, WEATHER STATIONS AND CRACK MONITORS TO GATHER AND RECORD ACOUSTIC SOUNDS, GROUND VIBRATIONS, AIR EFFECTS FROM BLASTING, WEATHER CONDITIONS, AND STRUCTURAL RESPONSES (U.S. CLS. 100 AND 101).

FIRST USE 1-29-2010; IN COMMERCE 1-29-2010.

**CLASS 42—(Continued).**

3,962,079. TECHNOIMAGING, L.L.C., SALT LAKE CITY, UT. SN 77-277,630. PUB. 5-13-2008, FILED 9-12-2007.

## MEMRS

THE MARK CONSISTS OF STANDARD CHARACTERS WITHOUT CLAIM TO ANY PARTICULAR FONT, STYLE, SIZE, OR COLOR.

FOR GEOPHYSICAL EXPLORATION FOR THE OIL, GAS, AND MINING INDUSTRIES, AND CONSULTATION RELATED THERETO (U.S. CLS. 100 AND 101).

FIRST USE 8-10-2010; IN COMMERCE 8-10-2010.

---

3,962,152. DEL PALMA ORTHOPEDICS, LLC, COLUMBIA CITY, IN. SN 77-481,274. PUB. 3-3-2009, FILED 5-22-2008.

## ADVANCING TODAY'S TECHNIQUES WITH TOMORROW'S TECHNOLOGY

THE MARK CONSISTS OF STANDARD CHARACTERS WITHOUT CLAIM TO ANY PARTICULAR FONT, STYLE, SIZE, OR COLOR.

FOR RESEARCH, DEVELOPMENT AND TESTING IN THE FIELD OF MEDICAL DEVICES (U.S. CLS. 100 AND 101).

FIRST USE 10-7-2010; IN COMMERCE 10-7-2010.

---

3,962,206. KOLO LLC, HARTFORD, CT. SN 77-562,053. PUB. 6-2-2009, FILED 9-4-2008.

## ALBUM BAR

THE MARK CONSISTS OF STANDARD CHARACTERS WITHOUT CLAIM TO ANY PARTICULAR FONT, STYLE, SIZE, OR COLOR.

NO CLAIM IS MADE TO THE EXCLUSIVE RIGHT TO USE "ALBUM", APART FROM THE MARK AS SHOWN.

FOR PROVIDING DESIGN SERVICES FOR OTHERS IN THE FIELD OF CREATING AN ALBUM OF DIGITAL IMAGES OR PHOTOGRAPHS; PROVIDING ON-LINE NON-DOWNLOADABLE SOFTWARE FOR CREATING AN ALBUM OF DIGITAL IMAGES OR PHOTOGRAPHS (U.S. CLS. 100 AND 101).

FIRST USE 2-1-2011; IN COMMERCE 2-1-2011.

**CLASS 42—(Continued).**

3,962,217. UNIVERSAL SERIAL BUS IMPLEMENTERS FORUM, INC., BEAVERTON, OR. SN 77-582,731. PUB. 1-6-2009, FILED 9-30-2008.



THE MARK CONSISTS OF "SS" FOLLOWED BY AN ARROW DESIGN.

FOR DESIGN AND TESTING OF USB COMPATIBLE PRODUCTS FOR THIRD PARTIES, NAMELY, USB COMPATIBLE COMPUTERS, ELECTRONIC AND TELECOMMUNICATION PRODUCTS (U.S. CLS. 100 AND 101).

FIRST USE 3-0-2011; IN COMMERCE 3-0-2011.

---

3,962,239. BARBARA ST. CLAIR JONES, TAMPA, FL. SN 77-626,481. PUB. 7-14-2009, FILED 12-4-2008.

# Zyacom

THE MARK CONSISTS OF STANDARD CHARACTERS WITHOUT CLAIM TO ANY PARTICULAR FONT, STYLE, SIZE, OR COLOR.

FOR HOSTING AN ONLINE COMMUNITY WEBSITE FEATURING EXPERTS IN A WIDE RANGE OF FIELDS THAT ENABLES USERS TO SEEK ADVICE AND BE EDUCATED BY ONE OF THE SITE'S EXPERTS IN A PARTICULAR SUBJECT MATTER (U.S. CLS. 100 AND 101).

FIRST USE 4-1-2011; IN COMMERCE 4-1-2011.

---

3,962,248. VYMED CORPORATION, GERMANTOWN, MD. SN 77-638,030. PUB. 4-28-2009, FILED 12-22-2008.

# VYMED

THE MARK CONSISTS OF STANDARD CHARACTERS WITHOUT CLAIM TO ANY PARTICULAR FONT, STYLE, SIZE, OR COLOR.

FOR PHARMACEUTICAL DRUG DEVELOPMENT SERVICES; MEDICAL AND SCIENTIFIC RESEARCH IN THE FIELD OF PHARMACEUTICALS; PHARMACEUTICAL RESEARCH AND DEVELOPMENT AND CONSULTATION RELATED THERETO; SCIENTIFIC INVESTIGATIONS FOR MEDICAL PURPOSES (U.S. CLS. 100 AND 101).

FIRST USE 6-7-2010; IN COMMERCE 6-7-2010.

**CLASS 42—(Continued).**

3,962,257. SARGENTO FOODS, INC., PLYMOUTH, WI. SN 77-652,209. PUB. 7-6-2010, FILED 1-19-2009.

## SARGENTO IDEA CENTER

THE MARK CONSISTS OF STANDARD CHARACTERS WITHOUT CLAIM TO ANY PARTICULAR FONT, STYLE, SIZE, OR COLOR.

OWNER OF U.S. REG. NOS. 2,782,725, 3,004,932, AND OTHERS.

NO CLAIM IS MADE TO THE EXCLUSIVE RIGHT TO USE "CENTER", APART FROM THE MARK AS SHOWN.

THE ENGLISH TRANSLATION OF "SARGENTO" IN THE MARK IS "SERGEANT".

FOR DEVELOPMENT SERVICES FOR OTHERS IN THE FIELD OF FOOD PRODUCTS, NAMELY, CUSTOMIZED FOOD INGREDIENT, MEALS, MIXES, APPETIZERS, AND SNACK FOOD DEVELOPMENT SERVICES FOR RETAILERS, RESTAURANTS AND FOOD DISTRIBUTORS, INCLUDING BUT NOT LIMITED TO PREPACKAGED, FROZEN AND REFRIGERATED MEALS, SAUCES, MIXES, SNACKS, APPETIZERS, FLAVORINGS, INGREDIENTS, AND SOUPS (U.S. CLS. 100 AND 101).

FIRST USE 5-0-2009; IN COMMERCE 5-0-2009.

---

3,962,289. DAVID B.I. ANTLER, NEW YORK, NY. SN 77-672,852. PUB. 6-16-2009, FILED 2-18-2009.

## CYCHOLOGY

THE MARK CONSISTS OF STANDARD CHARACTERS WITHOUT CLAIM TO ANY PARTICULAR FONT, STYLE, SIZE, OR COLOR.

FOR WEB SITE, WEB APPLICATION, MOBILE SITE AND MOBILE APPLICATION DESIGN, DEVELOPMENT, CREATION AND CONSULTATION FOR OTHERS (U.S. CLS. 100 AND 101).

FIRST USE 4-0-2010; IN COMMERCE 4-0-2010.

---

3,962,309. BOEING MANAGEMENT COMPANY, SEAL BEACH, CA. SN 77-684,271. PUB. 1-12-2010, FILED 3-5-2009.

## 787 DREAMLINER

THE MARK CONSISTS OF STANDARD CHARACTERS WITHOUT CLAIM TO ANY PARTICULAR FONT, STYLE, SIZE, OR COLOR.

**CLASS 42—(Continued).**

OWNER OF U.S. REG. NOS. 3,532,353, 3,532,725, AND 3,558,964.  
FOR CUSTOM DESIGN OF AIRCRAFT (U.S. CLS. 100 AND 101).  
FIRST USE 2-0-2007; IN COMMERCE 2-0-2007.

---

3,962,314. SUCCESSION CAPITAL FINANCIAL SYSTEMS, L.L.C., TUCSON, AZ. SN 77-687,906. PUB. 1-26-2010, FILED 3-10-2009.

## LEGACYTRAX

THE MARK CONSISTS OF STANDARD CHARACTERS WITHOUT CLAIM TO ANY PARTICULAR FONT, STYLE, SIZE, OR COLOR.  
FOR DESIGN AND DEVELOPMENT OF AN ON-LINE COMPUTER SYSTEM TO INTEGRATE LIFE INSURANCE AND FINANCIAL PLANNING (U.S. CLS. 100 AND 101).  
FIRST USE 9-7-2010; IN COMMERCE 9-7-2010.

---

3,962,374. GENERAL DATATECH, L.P., DALLAS, TX. SN 77-734,305. PUB. 4-20-2010, FILED 5-11-2009.



THE COLOR(S) GOLD AND SILVER-WHITE IS/ARE CLAIMED AS A FEATURE OF THE MARK.  
THE MARK CONSISTS OF BLOCKED LETTERS "GDT". THE "G" IS PRESENTED IN UPPER CASE FONT IN GOLD TYPEFACE. THE LETTERS "D" AND "T" ARE PRESENTED IN UPPER CASE FONT IN SILVER-WHITE SHADED TYPEFACE.  
FOR ENGINEERING IN THE FIELD OF VOICE AND DATA COMMUNICATIONS, NETWORKS, AND COMMUNICATIONS INFRASTRUCTURES; CONSULTING IN THE FIELD OF TELECOMMUNICATIONS TECHNOLOGY RELATED TO VOICE AND DATA COMMUNICATIONS, NETWORKS, AND COMMUNICATIONS INFRASTRUCTURES; DESIGN OF EQUIPMENT, COMPUTER SOFTWARE, COMPUTER HARDWARE FOR VOICE AND DATA COMMUNICATIONS, NETWORKS, AND COMMUNICATIONS INFRASTRUCTURES; TECHNICAL SUPPORT SERVICES, NAMELY, TECHNICAL ADVICE RELATED TO THE INSTALLATION OF COMPUTER SOFTWARE, TROUBLE SHOOTING OF COMPUTER SOFTWARE PROBLEMS, AND MONITORING OF NETWORK SYSTEMS, IN THE FIELD OF VOICE AND DATA COMMUNICATIONS, NETWORKS, AND COMMUNICATIONS INFRASTRUCTURES (U.S. CLS. 100 AND 101).  
FIRST USE 11-17-2009; IN COMMERCE 11-17-2009.

**CLASS 42—(Continued).**

3,962,427. VITRUVIAN EXPLORATION, LLC, THE WOODLANDS, TX. SN 77-772,765. PUB. 5-18-2010, FILED 7-1-2009.

## VITRUVIAN EXPLORATION

THE MARK CONSISTS OF STANDARD CHARACTERS WITHOUT CLAIM TO ANY PARTICULAR FONT, STYLE, SIZE, OR COLOR.  
NO CLAIM IS MADE TO THE EXCLUSIVE RIGHT TO USE "EXPLORATION", APART FROM THE MARK AS SHOWN.  
FOR EXPLORATION OF OIL AND NATURAL GAS RESOURCES; RESEARCH AND DEVELOPMENT OF TECHNOLOGY RELATED TO THE DRILLING AND RECOVERY OF OIL AND NATURAL GAS (U.S. CLS. 100 AND 101).  
FIRST USE 10-0-2009; IN COMMERCE 10-0-2009.

---

3,962,452. KATHLEEN TAYLOR, SAN DIEGO, CA. SN 77-782,821. PUB. 12-8-2009, FILED 7-16-2009.

## ATTAGIRL

THE MARK CONSISTS OF STANDARD CHARACTERS WITHOUT CLAIM TO ANY PARTICULAR FONT, STYLE, SIZE, OR COLOR.  
FOR CUSTOMIZED WEB PAGES FEATURING USER-DEFINED INFORMATION, PERSONAL PROFILES AND INFORMATION (U.S. CLS. 100 AND 101).  
FIRST USE 1-20-2011; IN COMMERCE 1-20-2011.

---

3,962,469. COLLECTIVE BIAS, LLC, SOUTHFIELD, MI. SN 77-790,342. PUB. 7-13-2010, FILED 7-27-2009.

## THE WISDOM OF CONNECTED CROWDS

THE MARK CONSISTS OF STANDARD CHARACTERS WITHOUT CLAIM TO ANY PARTICULAR FONT, STYLE, SIZE, OR COLOR.  
FOR COMPUTER SERVICES, NAMELY, CREATING AN ONLINE COMMUNITY FOR REGISTERED USERS TO PARTICIPATE IN DISCUSSIONS, GET FEEDBACK FROM THEIR PEERS, FORM VIRTUAL COMMUNITIES, AND ENGAGE IN SOCIAL NETWORKING; HOSTING AN ONLINE COMMUNITY WEBSITE FEATURING SOCIAL NETWORKING, VIRTUAL COMMUNITIES AND PEER DISCUSSIONS (U.S. CLS. 100 AND 101).  
FIRST USE 7-0-2009; IN COMMERCE 7-0-2009.



**CLASS 42—(Continued).**

3,962,475. BRAINCELLS INC., SAN DIEGO, CA. SN 77-791,742. PUB. 12-29-2009, FILED 7-28-2009.

# BCI

THE MARK CONSISTS OF STANDARD CHARACTERS WITHOUT CLAIM TO ANY PARTICULAR FONT, STYLE, SIZE, OR COLOR.

FOR PHARMACEUTICAL RESEARCH AND DEVELOPMENT SERVICES, NAMELY, ASSAY DEVELOPMENT, COMPOUND SCREENING, COMPOUND AND CHEMICAL IDENTIFICATION, DRUG TARGET IDENTIFICATION AND CHARACTERIZATION, PERFORMANCE OF HUMAN CLINICAL TRIALS (U.S. CLS. 100 AND 101).

FIRST USE 11-29-2004; IN COMMERCE 11-29-2004.

---

3,962,510. STERN, ROBERT A, MONROE TOWNSHIP, NJ. SN 77-803,392. PUB. 2-16-2010, FILED 8-12-2009.

# KidnectU

THE MARK CONSISTS OF STANDARD CHARACTERS WITHOUT CLAIM TO ANY PARTICULAR FONT, STYLE, SIZE, OR COLOR.

FOR APPLICATION SERVICE PROVIDER (ASP) FEATURING SOFTWARE THAT CREATES INTERACTIVE TO-DO LISTS TO BE USED BY PARENTS AND SITTEES ON MOBILE DEVICES (U.S. CLS. 100 AND 101).

FIRST USE 10-23-2009; IN COMMERCE 10-23-2009.

---

3,962,544. STEP FORWARD GROUP, LLC, LOS ANGELES, CA. SN 77-812,305. PUB. 7-20-2010, FILED 8-25-2009.

# CHROMOZONEXX

THE MARK CONSISTS OF STANDARD CHARACTERS WITHOUT CLAIM TO ANY PARTICULAR FONT, STYLE, SIZE, OR COLOR.

FOR PROVIDING A COMMUNITY WEB SITE FOR WOMEN THAT GIVES COMPUTER USERS THE ABILITY TO UPLOAD AND SHARE USER-GENERATED VIDEOS, STORIES, DIARIES, ESSAYS, AND ARTICLES ON A WIDE-VARIETY OF TOPICS AND SUBJECTS (U.S. CLS. 100 AND 101).

FIRST USE 9-30-2009; IN COMMERCE 9-30-2009.

**CLASS 42—(Continued).**

3,962,555. LOGISTICS MANAGEMENT INSTITUTE, MCLEAN, VA. SN 77-816,977. PUB. 12-8-2009, FILED 8-31-2009.

# LMI-CLICKE

THE MARK CONSISTS OF STANDARD CHARACTERS WITHOUT CLAIM TO ANY PARTICULAR FONT, STYLE, SIZE, OR COLOR.

OWNER OF U.S. REG. NOS. 943,428, 3,270,756, AND OTHERS.

FOR PROVIDING AN ON-LINE COMPUTER DATABASE IN THE FIELD OF WEATHER AND CLIMATE INFORMATION; PROVIDING SCIENTIFIC INFORMATION IN THE FIELD OF CLIMATE CHANGE (U.S. CLS. 100 AND 101).

FIRST USE 12-0-2010; IN COMMERCE 12-0-2010.

---

3,962,611. MICROSOFT CORPORATION, REDMOND, WA. SN 77-832,555. PUB. 10-5-2010, FILED 9-22-2009.

# WEBSITESPARK

THE MARK CONSISTS OF STANDARD CHARACTERS WITHOUT CLAIM TO ANY PARTICULAR FONT, STYLE, SIZE, OR COLOR.

FOR PROVIDING ONLINE INFORMATION CONCERNING THE DESIGN, DEVELOPMENT AND IMPLEMENTATION OF SOFTWARE; PROVIDING A WEBSITE THAT GIVES DESIGNERS, DEVELOPERS AND HOSTS OF SITES ON COMPUTER NETWORKS THE ABILITY TO DOWNLOAD COMPUTER SOFTWARE IN THE FIELD OF WEBSITE DESIGN, WEBSITE AND SOFTWARE DEVELOPMENT TOOLS; AND PROVIDING A WEBSITE FOR DESIGNERS, DEVELOPERS AND HOSTS OF SITES ON COMPUTER NETWORKS TO OBTAIN TECHNICAL SUPPORT INFORMATION CONCERNING COMPUTER SOFTWARE, THE DIAGNOSING OF COMPUTER HARDWARE SYSTEM PROBLEMS, WEBSITE AND SOFTWARE APPLICATION DEVELOPMENT, DEPLOYMENT AND MANAGEMENT (U.S. CLS. 100 AND 101).

FIRST USE 9-24-2009; IN COMMERCE 9-24-2009.

**CLASS 42—(Continued).**

3,962,613. VIVOTECH, INC., SANTA CLARA, CA. SN 77-833,382. PUB. 9-21-2010, FILED 9-23-2009.

# mPromotion

THE MARK CONSISTS OF STANDARD CHARACTERS WITHOUT CLAIM TO ANY PARTICULAR FONT, STYLE, SIZE, OR COLOR.

FOR PROVIDING ON-LINE NON-DOWNLOADABLE SOFTWARE THAT ALLOWS BUSINESSES TO PREPARE AND PROVISION USER-SELECTED CONTENT TO MOBILE DEVICES THROUGH SECURE AND AUTHENTICATED OVER-THE-AIR (OTA) OR IP NETWORKS AND ENABLES BUSINESSES TO DELIVER TARGETED MARKETING CONTENT IN THE FORM OF COUPONS, PROMOTIONS, REWARDS AND OFFERS TO MOBILE DEVICES BY ALLOWING MOBILE USERS TO DYNAMICALLY SELECT CONTENT SUCH AS COUPONS AND PROMOTIONS, PAYMENT CARDS, PRE-PAID CARDS, GIFT AND LOYALTY CARDS, TRANSIT CARDS AND EVENT TICKETS FROM SMART-TAGS, PRINT MEDIA OR MOBILE/WEB BROWSER BY TAPPING AGAINST SMART-TAGS, SCANNING CODES FROM PRINT/ON-LINE MEDIA, USER-ENTERED CODE ON MOBILE DEVICE OR ACCESSING FROM MOBILE/WEB BROWSER (U.S. CLS. 100 AND 101).

FIRST USE 9-23-2009; IN COMMERCE 9-23-2009.

3,962,620. DEVELOPMENT SEED, WASHINGTON, DC. SN 77-836,269. PUB. 7-13-2010, FILED 9-28-2009.

# MapBox

THE MARK CONSISTS OF STANDARD CHARACTERS WITHOUT CLAIM TO ANY PARTICULAR FONT, STYLE, SIZE, OR COLOR.

FOR CLOUD COMPUTING FEATURING SOFTWARE FOR USE IN CUSTOM MAPPING; PROVIDING ON-LINE NON-DOWNLOADABLE SOFTWARE FOR CUSTOM MAPPING; SOFTWARE AS A SERVICE (SAAS) SERVICES FEATURING SOFTWARE IN THE FIELD OF CUSTOM MAPPING (U.S. CLS. 100 AND 101).

FIRST USE 4-1-2009; IN COMMERCE 5-4-2009.

**CLASS 42—(Continued).**

3,962,639. VANTIUM CAPITAL, INC., IRVING, TX. SN 77-846,204. PUB. 8-24-2010, FILED 10-11-2009.

# VELOCITY

THE MARK CONSISTS OF STANDARD CHARACTERS WITHOUT CLAIM TO ANY PARTICULAR FONT, STYLE, SIZE, OR COLOR.

FOR PROVIDING ONLINE NON-DOWNLOADABLE SOFTWARE FOR ANALYZING LOANS FOR USE WITH LOAN SERVICING (U.S. CLS. 100 AND 101).

FIRST USE 7-0-2009; IN COMMERCE 7-0-2009.

3,962,649. FICKLE PASSION PRODUCTIONS, INC., MURPHY, OR. SN 77-850,440. PUB. 2-2-2010, FILED 10-16-2009.

# BRAINSTORMS IN MOTION

THE MARK CONSISTS OF STANDARD CHARACTERS WITHOUT CLAIM TO ANY PARTICULAR FONT, STYLE, SIZE, OR COLOR.

FOR COMPUTER HARDWARE AND SOFTWARE DESIGN; COMPUTER SERVICES, NAMELY, DESIGNING AND IMPLEMENTING NETWORK WEB PAGES FOR OTHERS; CREATING, DESIGNING AND MAINTAINING WEB SITES; DESIGN AND DEVELOPMENT OF COMPUTER SOFTWARE; DESIGN OF HOMEPAGES AND WEBSITES; DESIGNING AND DEVELOPING WEB-PAGES ON THE INTERNET (U.S. CLS. 100 AND 101).

FIRST USE 10-1-2009; IN COMMERCE 6-1-2010.

3,962,651. AMERICAN INSTITUTE OF TOXICOLOGY, INC., INDIANAPOLIS, IN. SN 77-850,705. PUB. 6-29-2010, FILED 10-16-2009.

# GOOD SCIENCE. GOOD DECISIONS. GOOD PRACTICE.

THE MARK CONSISTS OF STANDARD CHARACTERS WITHOUT CLAIM TO ANY PARTICULAR FONT, STYLE, SIZE, OR COLOR.

FOR MATERIALS TESTING AND EVALUATION, NAMELY, PROVIDING EVALUATION TESTING FOR PHARMACEUTICAL, BIOPHARMACEUTICAL AND CHEMICAL CONCENTRATIONS AND COMPOSITIONS (U.S. CLS. 100 AND 101).

FIRST USE 10-0-2009; IN COMMERCE 10-0-2009.

**CLASS 42—(Continued).**

3,962,653. FLORES, STEVE, REDMOND, WA. SN 77-851,132.  
PUB. 3-30-2010, FILED 10-17-2009.

**DRAGON DIVIDE**

THE MARK CONSISTS OF STANDARD CHARACTERS WITHOUT CLAIM TO ANY PARTICULAR FONT, STYLE, SIZE, OR COLOR.

FOR DESIGNING AND DEVELOPING COMPUTER GAME SOFTWARE AND VIDEO GAME SOFTWARE FOR USE WITH COMPUTERS, VIDEO GAME PROGRAM SYSTEMS AND COMPUTER NETWORKS (U.S. CLS. 100 AND 101).

FIRST USE 8-0-2010; IN COMMERCE 8-0-2010.

---

3,962,699. FICKLE PASSION PRODUCTIONS, INC., MURPHY, OR. SN 77-863,828. PUB. 2-9-2010, FILED 11-3-2009.



NO CLAIM IS MADE TO THE EXCLUSIVE RIGHT TO USE "PRODUCTIONS, INC.", APART FROM THE MARK AS SHOWN.

THE MARK CONSISTS OF AN IMAGE OF A LADYBUG, WITH CURVED LINES AT THE REAR AND ON EACH SIDE OF THE HEAD AND SHOULDERS OF THE LADYBUG TO DEPICT MOTION. THE LADYBUG'S ANTENNAE ARE JAGGED TO DEPICT THE ACTIVE ENERGY DISCHARGE OF A LIGHTNING BOLT. TO THE RIGHT OF THE IMAGE IS THE LITERAL ELEMENT OF THE MARK, CONSISTING OF THE STYLIZED INITIALS "FPP", DIRECTLY ABOVE THE PHRASE "FICKLE PASSION PRODUCTIONS, INC.", DIRECTLY ABOVE THE PHRASE "BRAINSTORMS IN MOTION". THE LEFT ANTENNAE OF THE LADYBUG IS CONNECTED TO THE LETTER "F" IN "FPP", RESULTING IN THE DEPICTION OF A SPARK TO SIMULATE THE TRANSFER OF ELECTRICITY OR ENERGY.

FOR COMPUTER HARDWARE AND SOFTWARE DESIGN; COMPUTER SERVICES, NAMELY, DESIGNING AND IMPLEMENTING NETWORK WEB PAGES FOR OTHERS; CREATING, DESIGNING AND MAINTAINING WEB SITES; DESIGN AND DEVELOPMENT OF COMPUTER SOFTWARE; DESIGN OF HOMEPAGES AND WEBSITES; DESIGNING AND DEVELOPING WEB-PAGES ON THE INTERNET (U.S. CLS. 100 AND 101).

FIRST USE 10-6-2010; IN COMMERCE 10-6-2010.

**CLASS 42—(Continued).**

3,962,703. SHIFT4 CORPORATION, LAS VEGAS, NV. SN 77-865,827. PUB. 9-21-2010, FILED 11-5-2009.

**TOKENSTORE**

THE MARK CONSISTS OF STANDARD CHARACTERS WITHOUT CLAIM TO ANY PARTICULAR FONT, STYLE, SIZE, OR COLOR.

FOR COMPUTER SERVICES, NAMELY, PROVIDING ON-LINE SECURITY SERVICES FOR PROCESSING ELECTRONIC PAYMENT TRANSACTIONS BY REPLACING CARDHOLDER PAYMENT DATA WITH A UNIQUE IDENTIFIER ASSOCIATED WITH AN ELECTRONIC PAYMENT TRANSACTION AND ENABLING MERCHANTS TO PROCESS AN ELECTRONIC PAYMENT TRANSACTION USING THE UNIQUE IDENTIFIER (U.S. CLS. 100 AND 101).

FIRST USE 4-0-2010; IN COMMERCE 4-0-2010.

---

3,962,704. STOREFLIX, LLC, MASON, OH. SN 77-866,646.  
PUB. 4-13-2010, FILED 11-6-2009.

**Storeflex**

THE MARK CONSISTS OF STANDARD CHARACTERS WITHOUT CLAIM TO ANY PARTICULAR FONT, STYLE, SIZE, OR COLOR.

FOR APPLICATION SERVICE PROVIDER (ASP) FEATURING SOFTWARE FOR USE IN TAKING PHOTOGRAPHS AND VIDEOS WITH A CELL PHONE OR OTHER HANDHELD DIGITAL DEVICE AND STORING SUCH PHOTOGRAPHS AND VIDEOS OR EMAILING SUCH PHOTOGRAPHS OR VIDEOS TO THIRD PARTIES (U.S. CLS. 100 AND 101).

FIRST USE 11-30-2010; IN COMMERCE 11-30-2010.

**CLASS 42—(Continued).**

3,962,711. FICKLE PASSION PRODUCTIONS, INC., MURPHY, OR. SN 77-870,242. PUB. 2-9-2010, FILED 11-11-2009.



THE MARK CONSISTS OF AN IMAGE OF A LADYBUG, WITH CURVED LINES AT THE REAR AND ON EACH SIDE OF THE HEAD AND SHOULDERS OF THE LADYBUG TO DEPICT MOTION. THE LADYBUG'S ANTENNAE ARE JAGGED TO DEPICT THE ACTIVE ENERGY DISCHARGE OF A LIGHTNING BOLT.

FOR COMPUTER HARDWARE AND SOFTWARE DESIGN; COMPUTER SERVICES, NAMELY, DESIGNING AND IMPLEMENTING NETWORK WEB PAGES FOR OTHERS; CREATING, DESIGNING AND MAINTAINING WEB SITES; DESIGN AND DEVELOPMENT OF COMPUTER SOFTWARE; DESIGN OF HOMEPAGES AND WEBSITES; DESIGNING AND DEVELOPING WEB-PAGES ON THE INTERNET (U.S. CLS. 100 AND 101).

FIRST USE 10-6-2010; IN COMMERCE 10-6-2010.

3,962,734. RSUPPORT CO. LTD., SEOUL, REPUBLIC OF KOREA. SN 77-882,596. PUB. 4-27-2010, FILED 11-30-2009.

## Carbonless Support

THE MARK CONSISTS OF STANDARD CHARACTERS WITHOUT CLAIM TO ANY PARTICULAR FONT, STYLE, SIZE, OR COLOR.

NO CLAIM IS MADE TO THE EXCLUSIVE RIGHT TO USE "SUPPORT", APART FROM THE MARK AS SHOWN.

FOR APPLICATION SERVICE PROVIDER (ASP) FEATURING SOFTWARE FOR USE IN REMOTE SUPPORT OF COMPUTER APPLICATIONS AND ACCESS TO THE INTERNET; APPLICATION SERVICE PROVIDER (ASP), NAMELY, HOSTING COMPUTER SOFTWARE APPLICATIONS OF OTHERS; ALL THE AFOREMENTIONED SERVICES EXCLUDE DATA BACK-UP SERVICES AND RELATED SOFTWARE (U.S. CLS. 100 AND 101).

FIRST USE 2-24-2010; IN COMMERCE 2-24-2010.

**CLASS 42—(Continued).**

3,962,782. CREATIVE TESTING SOLUTIONS, SCOTTSDALE, AZ. SN 77-895,544. PUB. 7-6-2010, FILED 12-17-2009.

## CREATIVE TESTING SOLUTIONS

THE MARK CONSISTS OF STANDARD CHARACTERS WITHOUT CLAIM TO ANY PARTICULAR FONT, STYLE, SIZE, OR COLOR.

NO CLAIM IS MADE TO THE EXCLUSIVE RIGHT TO USE "TESTING", APART FROM THE MARK AS SHOWN.

FOR MEDICAL LABORATORY SERVICES, NAMELY, TESTING OF BLOOD DONOR SAMPLES (U.S. CLS. 100 AND 101).

FIRST USE 1-1-2010; IN COMMERCE 1-1-2010.

3,962,783. CREATIVE TESTING SOLUTIONS, SCOTTSDALE, AZ. SN 77-895,553. PUB. 7-6-2010, FILED 12-17-2009.



NO CLAIM IS MADE TO THE EXCLUSIVE RIGHT TO USE "TESTING", APART FROM THE MARK AS SHOWN.

THE MARK CONSISTS OF THE WORDING "CREATIVE TESTING SOLUTIONS" WITH SHADED OBLONG DESIGNS ABOVE THE WORDING.

FOR MEDICAL LABORATORY SERVICES, NAMELY, TESTING OF BLOOD DONOR SAMPLES (U.S. CLS. 100 AND 101).

FIRST USE 1-1-2010; IN COMMERCE 1-1-2010.

3,962,886. CONSTELLATION ENERGY GROUP, INC., BALTIMORE, MD. SN 77-923,864. PUB. 7-20-2010, FILED 1-29-2010.

## VIRTUWATT ENERGY MANAGER

THE MARK CONSISTS OF STANDARD CHARACTERS WITHOUT CLAIM TO ANY PARTICULAR FONT, STYLE, SIZE, OR COLOR.

**CLASS 42—(Continued).**

NO CLAIM IS MADE TO THE EXCLUSIVE RIGHT TO USE "ENERGY MANAGER", APART FROM THE MARK AS SHOWN.

FOR PROVIDING TEMPORARY USE OF ONLINE NON-DOWNLOADABLE SOFTWARE FOR AUTOMATED LOAD CONTROL AND DEMAND RESPONSE PROGRAMS; PROVIDING TEMPORARY USE OF ONLINE NON-DOWNLOADABLE SOFTWARE FOR USE IN PROVIDING ENERGY PRICING AND USAGE INFORMATION, MONITORING ENERGY USAGE AND SUPPLY, MANAGING AND REDUCING ENERGY LOAD AND USAGE, ENERGY AUDITING, AND PROVIDING CUSTOMIZED REPORTS RELATED THERETO (U.S. CLS. 100 AND 101).

FIRST USE 5-0-2010; IN COMMERCE 5-0-2010.

---

3,962,895. ALLIANT TECHSYSTEMS INC., MINNEAPOLIS, MN. SN 77-926,715. PUB. 6-15-2010, FILED 2-3-2010.



THE MARK CONSISTS OF STANDARD CHARACTERS WITHOUT CLAIM TO ANY PARTICULAR FONT, STYLE, SIZE, OR COLOR.

FOR PROVIDING INFORMATION SERVICES IN THE FIELD OF SYSTEMS ENGINEERING, NAMELY, ANALYZING MATERIALS AND SYSTEMS FOR INEFFICIENCIES AND PROVIDING INFORMATION AS TO THE FINDINGS (U.S. CLS. 100 AND 101).

FIRST USE 3-30-2010; IN COMMERCE 3-30-2010.

---

3,962,900. SERVICEBENCH, INC., STERLING, VA. SN 77-927,808. PUB. 7-13-2010, FILED 2-4-2010.

**SERVICEBENCH MOBILE**

THE MARK CONSISTS OF STANDARD CHARACTERS WITHOUT CLAIM TO ANY PARTICULAR FONT, STYLE, SIZE, OR COLOR.

OWNER OF U.S. REG. NO. 2,901,988.

NO CLAIM IS MADE TO THE EXCLUSIVE RIGHT TO USE "MOBILE", APART FROM THE MARK AS SHOWN.

FOR SOFTWARE AS A SERVICE (SAAS) SERVICES FEATURING SOFTWARE FOR USE IN SCHEDULING AND MANAGEMENT OF SERVICE CALLS, DISPATCH OF SERVICE PERSONNEL, ORDERING, DELIVERING, AND TRACKING OF PARTS, MANAGEMENT OF WARRANTY CLAIMS AND EXTENDED SERVICE AGREEMENTS, AND COMMUNICATION BETWEEN AND AMONG MANUFACTURERS, WARRANTY ADMINISTRATORS, REPAIR TECHNICIANS, AND PARTS FACILITIES TO ADDRESS CUSTOMERS' REPAIR AND SERVICE NEEDS (U.S. CLS. 100 AND 101).

FIRST USE 9-15-2009; IN COMMERCE 9-15-2009.

**CLASS 42—(Continued).**

3,962,924. NEARVERSE INC., HUNTINGDON VALLEY, PA. SN 77-932,796. PUB. 8-3-2010, FILED 2-10-2010.



THE MARK CONSISTS OF STANDARD CHARACTERS WITHOUT CLAIM TO ANY PARTICULAR FONT, STYLE, SIZE, OR COLOR.

FOR CREATING WIRELESS NETWORKS AND WIRELESS COMMUNICATIONS SYSTEMS, NAMELY, DESIGN AND DEVELOPMENT OF WIRELESS NETWORKS AND WIRELESS COMMUNICATIONS SYSTEMS FOR OTHERS; COMPUTER TECHNICAL SUPPORT SERVICES, NAMELY, MONITORING WIRELESS NETWORKS AND WIRELESS COMMUNICATIONS SYSTEMS TO ENHANCE THEIR PERFORMANCE; COMPUTER SERVICES, NAMELY, CREATING AN ON-LINE COMMUNITY FOR REGISTERED USERS TO PARTICIPATE IN DISCUSSIONS, GET FEEDBACK FROM THEIR PEERS, FORM VIRTUAL COMMUNITIES, AND ENGAGE IN SOCIAL NETWORKING FEATURING GAMES, GROUPS, VIDEO, PHOTOS, BLOGS, FORUMS, AND POLLS; COMPUTER SOFTWARE DEVELOPMENT IN THE FIELD OF MOBILE COMMUNICATIONS; DESIGN AND DEVELOPMENT OF WIRELESS COMMUNICATION SYSTEMS FOR OTHERS (U.S. CLS. 100 AND 101).

FIRST USE 12-1-2008; IN COMMERCE 6-1-2009.

---

3,962,969. REES ASSOCIATES, INC., OKLAHOMA CITY, OK. SN 77-941,807. PUB. 7-27-2010, FILED 2-22-2010.



OWNER OF U.S. REG. NOS. 3,025,443 AND 3,025,445.

THE MARK CONSISTS OF THE WORDS "REES" AND "EARTH" WITH A LOGO BETWEEN THE WORDS COMPRISED OF A SERIES OF ANGLED LINES INTERSECTED BY A SPHERE.

FOR ARCHITECTURAL SERVICES (U.S. CLS. 100 AND 101).

FIRST USE 4-10-2010; IN COMMERCE 4-10-2010.

---

3,962,970. REES ASSOCIATES, INC., OKLAHOMA CITY, OK. SN 77-941,823. PUB. 7-20-2010, FILED 2-22-2010.



THE MARK CONSISTS OF STANDARD CHARACTERS WITHOUT CLAIM TO ANY PARTICULAR FONT, STYLE, SIZE, OR COLOR.



**CLASS 42—(Continued).**

OWNER OF U.S. REG. NOS. 3,025,443 AND 3,025,445.  
FOR ARCHITECTURAL SERVICES (U.S. CLS. 100  
AND 101).  
FIRST USE 4-10-2010; IN COMMERCE 4-10-2010.

3,963,050. INFORMATICA 64, S.L.U., 28932 MOSTOLES  
MADRID, SPAIN. SN 77-950,611. PUB. 7-27-2010, FILED 3-  
4-2010.



NO CLAIM IS MADE TO THE EXCLUSIVE RIGHT TO  
USE "PROTECTOR", APART FROM THE MARK AS  
SHOWN.

THE MARK CONSISTS OF THE WORD "METASHIELD"  
IN CAPITAL LETTERS WITH A LEFT ANGLED BRACKET  
BEFORE THE LETTER "M" AND RIGHT ANGLED BRACK-  
ET AFTER THE LETTER "D". THE WORD "PROTECTOR"  
IS BENEATH "METASHIELD" IN A STYLIZED FONT. A  
DESIGN OF A SHIELD SITS BELOW THE WORDS "META-  
SHIELD PROTECTOR" AND CONTAINS A LEFT AND  
RIGHT ANGLED BRACKET INSIDE.

FOR COMPUTER SERVICES, NAMELY, COMPUTER  
VIRUS PROTECTION SERVICES; RESEARCH, DEVEL-  
OPMENT, DESIGN AND UPGRADING OF COMPUTER  
SOFTWARE; DESIGN AND DEVELOPMENT OF COM-  
PUTER HARDWARE AND SOFTWARE; COMPUTER  
AND COMPUTER SOFTWARE RENTAL; COMPUTER  
SYSTEMS ANALYSIS; DATA RECOVERY SERVICES;  
CONVERSION OF DATA OR DOCUMENTS FROM  
PHYSICAL TO ELECTRONIC MEDIA; COMPUTER  
SOFTWARE DEVELOPMENT; INSTALLATION OF  
COMPUTER SOFTWARE; COMPUTER SOFTWARE DES-  
IGN; COMPUTER PROGRAMMING AND MAINTEN-  
ANCE OF COMPUTER SOFTWARE (U.S. CLS. 100  
AND 101).

FIRST USE 1-8-2010; IN COMMERCE 1-8-2010.

3,963,060. BLOSSOM BUCKET, INC., NORTH LAWRENCE,  
OH. SN 77-951,654. PUB. 7-13-2010, FILED 3-5-2010.

## BUCKETEER

THE MARK CONSISTS OF STANDARD CHARACTERS  
WITHOUT CLAIM TO ANY PARTICULAR FONT, STYLE,  
SIZE, OR COLOR.

FOR COMPUTER SERVICES, NAMELY, CREATING  
AN ONLINE COMMUNITY FOR USERS TO PARTICI-  
PATE IN DISCUSSIONS AND TO GET FEEDBACK  
FROM PEERS AND MANUFACTURERS RELATING TO  
THE SALE, DISTRIBUTION AND USE OF HOME-DEC-  
ORATING PRODUCTS (U.S. CLS. 100 AND 101).  
FIRST USE 3-4-2011; IN COMMERCE 3-4-2011.

**CLASS 42—(Continued).**

3,963,124. MEADWESTVACO CORPORATION, RICHMOND,  
VA. SN 77-958,884. PUB. 8-3-2010, FILED 3-15-2010.

## MPACT

THE MARK CONSISTS OF STANDARD CHARACTERS  
WITHOUT CLAIM TO ANY PARTICULAR FONT, STYLE,  
SIZE, OR COLOR.

FOR RESEARCH AND DEVELOPMENT OF NEW  
PRODUCTS IN THE FIELD OF DISPENSING SOLU-  
TIONS (U.S. CLS. 100 AND 101).

FIRST USE 12-1-2010; IN COMMERCE 12-1-2010.

3,963,186. ASSOCIATED MATERIALS, LLC, DBA ALSIDE,  
CUYAHOGA FALLS, OH. SN 77-964,647. PUB. 9-21-2010,  
FILED 3-22-2010.

## FRAMEWORKS

THE MARK CONSISTS OF STANDARD CHARACTERS  
WITHOUT CLAIM TO ANY PARTICULAR FONT, STYLE,  
SIZE, OR COLOR.

FOR CONSULTATION IN THE FIELD OF COLOR  
ANALYSIS FOR PURPOSES OF INTERIOR AND EX-  
TERIOR DESIGN, NAMELY, COLOR MATCHING VIN-  
YL WINDOW AND DOOR FRAMES WITH  
WOODGRAIN AND COLOR LAMINATES (U.S. CLS.  
100 AND 101).

FIRST USE 6-1-2010; IN COMMERCE 6-1-2010.

3,963,191. UNITED STATES DEPARTMENT OF HOME-  
LAND SECURITY, WASHINGTON, DC. SN 77-965,128.  
PUB. 7-27-2010, FILED 3-22-2010.

## NBTCC

THE MARK CONSISTS OF STANDARD CHARACTERS  
WITHOUT CLAIM TO ANY PARTICULAR FONT, STYLE,  
SIZE, OR COLOR.

FOR RESEARCH AND DEVELOPMENT AND CON-  
SULTATION RELATED THERETO IN THE FIELD OF  
BIOLOGICAL AGENTS AND OTHER ORGANISMS,  
AND THREATS ASSOCIATED WITH SAME, ANALYSIS  
OF BIOLOGICAL THREATS, AND COUNTERMEA-  
SURES (U.S. CLS. 100 AND 101).  
FIRST USE 7-31-2010; IN COMMERCE 7-31-2010.

**CLASS 42—(Continued).**

3,963,238. POZEN INC., CHAPEL HILL, NC. SN 77-981,566.  
PUB. 4-20-2010, FILED 11-13-2009.

TRANSFORMING MEDICINE.  
TRANSFORMING LIVES.

THE MARK CONSISTS OF STANDARD CHARACTERS WITHOUT CLAIM TO ANY PARTICULAR FONT, STYLE, SIZE, OR COLOR.

FOR RESEARCH AND DEVELOPMENT OF NEW PRODUCTS; RESEARCH AND DEVELOPMENT OF PHARMACEUTICAL PREPARATIONS AND MEDICINES (U.S. CLS. 100 AND 101).

FIRST USE 11-0-2009; IN COMMERCE 11-0-2009.

---

3,963,306. GRAND ROUND TABLE, PHILADELPHIA, PA.  
SN 85-000,235. PUB. 8-24-2010, FILED 3-28-2010.

grand round table

THE MARK CONSISTS OF STANDARD CHARACTERS WITHOUT CLAIM TO ANY PARTICULAR FONT, STYLE, SIZE, OR COLOR.

NO CLAIM IS MADE TO THE EXCLUSIVE RIGHT TO USE "ROUND TABLE", APART FROM THE MARK AS SHOWN.

FOR COMPUTER SERVICES, NAMELY, HOSTING ON-LINE WEB FACILITIES FOR OTHERS FOR ORGANIZING AND CONDUCTING ONLINE MEETINGS, GATHERINGS, AND INTERACTIVE DISCUSSIONS; COMPUTER SERVICES, NAMELY, PROVIDING A WEB-BASED SYSTEM AND ONLINE PORTAL FEATURING ON-LINE NON-DOWNLOADABLE SOFTWARE THAT ENABLES USERS TO ACCESS TRAINING, EDUCATION, TESTING AND CERTIFICATION MATERIALS IN THE FIELD OF MEDICINE; HOSTING AN ONLINE WEBSITE FEATURING MEDICAL CONTENT; PROVIDING A WEB SITE THAT GIVES MULTIPLE COMPUTER USERS SIMULTANEOUSLY THE ABILITY TO UPLOAD, CREATE AND EDIT DOCUMENTS, PRINTED PUBLICATIONS, ONLINE PUBLICATIONS, PHOTOGRAPHS, PRODUCT PACKAGING AND ADVERTISEMENTS; PROVIDING AN ONLINE NETWORK SERVICE THAT ENABLES USERS TO SHARE DATA IN THE FIELD OF MEDICINE; PROVIDING AN ONLINE WEBSITE FOR CREATING AND HOSTING MICRO WEBSITES FOR BUSINESSES (U.S. CLS. 100 AND 101).

FIRST USE 4-1-2010; IN COMMERCE 1-1-2011.

**CLASS 42—(Continued).**

3,963,364. OZBURN-HESSEY LOGISTICS, LLC, BRENTWOOD, TN. SN 85-010,828. PUB. 8-31-2010, FILED 4-9-2010.

E-FOCUS

THE MARK CONSISTS OF STANDARD CHARACTERS WITHOUT CLAIM TO ANY PARTICULAR FONT, STYLE, SIZE, OR COLOR.

FOR PROVIDING A WEBSITE THAT GIVES USERS THE ABILITY TO TRACK SHIPMENT OF GOODS; PROVIDING A WEBSITE THAT GIVES USERS THE ABILITY TO TRACK INTERNATIONAL SHIPMENTS; PROVIDING A WEBSITE THAT GIVES USERS THE ABILITY TO MANAGE LOGISTICS (U.S. CLS. 100 AND 101).

FIRST USE 3-0-2010; IN COMMERCE 3-0-2010.

---

3,963,432. TACTYON, FAIRMONT, WV. SN 85-028,537. PUB. 10-5-2010, FILED 5-3-2010.

TACTYON

THE MARK CONSISTS OF STANDARD CHARACTERS WITHOUT CLAIM TO ANY PARTICULAR FONT, STYLE, SIZE, OR COLOR.

FOR DESIGN AND DEVELOPMENT OF COMPUTER SOFTWARE; DESIGN AND DEVELOPMENT OF NETWORKS; DESIGN FOR OTHERS IN THE FIELD OF COMPUTER NETWORKS, SOFTWARE, ENGINEERING, SCIENTIFIC RESEARCH, INFORMATION TECHNOLOGY, COMPUTER SCIENCE, ELECTRONICS ENGINEERING; SOFTWARE DESIGN AND DEVELOPMENT (U.S. CLS. 100 AND 101).

FIRST USE 5-3-2010; IN COMMERCE 5-3-2010.

**CLASS 42—(Continued).**

3,963,491. LNO S.A., GENEVA, SWITZERLAND. SN 85-042,619. PUB. 10-19-2010, FILED 5-19-2010.

# OFFICIAL.FM

THE MARK CONSISTS OF STANDARD CHARACTERS WITHOUT CLAIM TO ANY PARTICULAR FONT, STYLE, SIZE, OR COLOR.

FOR COMPUTER SERVICES, NAMELY, UPLOADING MUSIC TO THE INTERNET FOR OTHERS; COMPUTER SERVICES, NAMELY, HOSTING ON-LINE WEB FACILITIES FOR OTHERS TO SHOWCASE SONGWRITING AND MUSICAL TALENTS AND FOR FACILITATING AND CONDUCTING ONLINE CONNECTIONS, COLLABORATIONS, AND INTERACTIVE DISCUSSIONS ABOUT SONGWRITING AND MUSIC; PROVIDING A WEBSITE ALLOWING USERS TO UPLOAD AND DOWNLOAD MUSIC; PROVIDING A WEBSITE THAT GIVES USERS THE ABILITY TO PURCHASE DOWNLOADABLE MUSIC; HOSTING OF DIGITAL CONTENT ON THE INTERNET (U.S. CLS. 100 AND 101).

FIRST USE 7-31-2010; IN COMMERCE 7-31-2010.

**CLASS 42—(Continued).**

3,963,620. ADP, INC., ROSELAND, NJ. SN 85-076,802. PUB. 12-7-2010, FILED 7-2-2010.

## ADP INVOICE - PROFESSIONAL EDITION

THE MARK CONSISTS OF STANDARD CHARACTERS WITHOUT CLAIM TO ANY PARTICULAR FONT, STYLE, SIZE, OR COLOR.

NO CLAIM IS MADE TO THE EXCLUSIVE RIGHT TO USE "INVOICE" AND "PROFESSIONAL EDITION", APART FROM THE MARK AS SHOWN.

FOR PROVIDING A SECURE ELECTRONIC ONLINE SYSTEM FEATURING TECHNOLOGY WHICH ALLOWS SUBSCRIBING USERS TO SUBMIT AND TRACK VENDOR INVOICES ELECTRONICALLY, NAMELY, ALLOWING FOR SCANNING, AUTOMATED ROUTING, CODING AND APPROVAL PROCESS, AUTOMATED SUPPLIER ON-BOARDING, AND A SUPPLIER PORTAL (U.S. CLS. 100 AND 101).

FIRST USE 7-3-2010; IN COMMERCE 7-3-2010.

3,963,619. ADP, INC., ROSELAND, NJ. SN 85-076,799. PUB. 12-7-2010, FILED 7-2-2010.

## ADP INVOICE - ENTERPRISE EDITION

THE MARK CONSISTS OF STANDARD CHARACTERS WITHOUT CLAIM TO ANY PARTICULAR FONT, STYLE, SIZE, OR COLOR.

NO CLAIM IS MADE TO THE EXCLUSIVE RIGHT TO USE "INVOICE" AND "ENTERPRISE EDITION", APART FROM THE MARK AS SHOWN.

FOR PROVIDING A SECURE ELECTRONIC ONLINE SYSTEM FEATURING TECHNOLOGY WHICH ALLOWS SUBSCRIBING USERS TO SUBMIT AND TRACK VENDOR INVOICES ELECTRONICALLY, NAMELY, ALLOWING FOR EARLY PAYMENT DISCOUNTS, AUTOMATIC PRICE CHECKING, LINE ITEM DETAIL, REAL TIME VISIBILITY OF CORPORATE SPEND, SCANNING, AUTOMATED ROUTING, CODING AND APPROVAL PROCESS, AUTOMATED SUPPLIER ON-BOARDING, AND A SUPPLIER PORTAL (U.S. CLS. 100 AND 101).

FIRST USE 7-3-2010; IN COMMERCE 7-3-2010.

3,963,623. NEUMAN, MIRANDA, ALPHARETTA, GA. SN 85-078,382. PUB. 12-28-2010, FILED 7-6-2010.



NO CLAIM IS MADE TO THE EXCLUSIVE RIGHT TO USE "PRO", APART FROM THE MARK AS SHOWN.

THE COLOR(S) BLUE, GOLD, WHITE, AND BLACK IS/ARE CLAIMED AS A FEATURE OF THE MARK.

THE MARK CONSISTS OF THE WORD "iASK" WRITTEN IN WHITE FONT WITH A BLACK SHADOW IN A BLUE SPLASH FOLLOWED BY THE WORD "PRO" WRITTEN IN GOLD WITH BLACK SHADOW.

FOR DESIGN, CREATION, HOSTING AND MAINTENANCE OF INTERNET SITES FOR THIRD PARTIES (U.S. CLS. 100 AND 101).

FIRST USE 4-1-2009; IN COMMERCE 6-2-2010.

**CLASS 42—(Continued).**

3,963,667. MORAN REGENERATIVE MEDICINE (MRM), LLC, SAN DIEGO, CA. SN 85-094,297. PUB. 1-11-2011, FILED 7-27-2010.



THE MARK CONSISTS OF VARIOUS SIZED HEXAGONS ARRANGED TO THE LEFT OF THE TEXT "MRM" AND ABOVE THE TEXT "REGENERATING LIFE. REBUILDING HEALTH.". THE HEXAGONS SYMBOLIZE THE FIRST PART OF THE SLOGAN (REGENERATING LIFE).

FOR PHARMACEUTICAL DRUG DEVELOPMENT SERVICES; RESEARCH AND DEVELOPMENT IN THE PHARMACEUTICAL AND BIOTECHNOLOGY FIELDS (U.S. CLS. 100 AND 101).

FIRST USE 12-9-2010; IN COMMERCE 12-9-2010.

3,963,695. IO DATA CENTERS, LLC, PHOENIX, AZ. SN 85-106,044. PUB. 12-28-2010, FILED 8-12-2010.

**i/o PORTAL**

THE MARK CONSISTS OF STANDARD CHARACTERS WITHOUT CLAIM TO ANY PARTICULAR FONT, STYLE, SIZE, OR COLOR.

OWNER OF U.S. REG. NOS. 3,414,361, 3,827,956, AND 3,844,294.

NO CLAIM IS MADE TO THE EXCLUSIVE RIGHT TO USE "PORTAL", APART FROM THE MARK AS SHOWN.

FOR COMPUTER SERVICES, NAMELY, HOSTING AN ONLINE WEBSITE FOR CUSTOMERS TO REMOTELY MONITOR AND MANAGE THEIR DATA CENTER AND COLLOCATION SERVICES (U.S. CLS. 100 AND 101).

FIRST USE 11-6-2010; IN COMMERCE 11-6-2010.

**CLASS 42—(Continued).**

3,963,698. ACADEMICMERIT, LLC, PORTLAND, ME. SN 85-108,880. PUB. 2-8-2011, FILED 8-17-2010.



THE MARK CONSISTS OF A STYLIZED LETTER "A" ABOVE THE NUMBER "21" ABOVE A STYLIZED DEPICTION OF A COMPUTER MOUSE, ALL TO THE LEFT OF THE PHRASE "ASSESSMENTS21".

FOR PROVIDING ON-LINE NON-DOWNLOADABLE EDUCATIONAL SOFTWARE FEATURING INSTRUCTION IN VOCABULARY, READING COMPREHENSION, AND WRITING (U.S. CLS. 100 AND 101).

FIRST USE 4-7-2011; IN COMMERCE 4-7-2011.

3,963,699. ACADEMICMERIT, LLC, PORTLAND, ME. SN 85-108,881. PUB. 2-8-2011, FILED 8-17-2010.

**ASSESSMENTS21**

THE MARK CONSISTS OF STANDARD CHARACTERS WITHOUT CLAIM TO ANY PARTICULAR FONT, STYLE, SIZE, OR COLOR.

FOR PROVIDING ON-LINE NON-DOWNLOADABLE EDUCATIONAL SOFTWARE FEATURING INSTRUCTION IN VOCABULARY, READING COMPREHENSION, AND WRITING (U.S. CLS. 100 AND 101).

FIRST USE 9-30-2010; IN COMMERCE 9-30-2010.

**CLASS 43—HOTEL AND RESTAURANT SERVICES**

3,961,987. CORDIN-BLITSTEIN, CHRIS, BURR RIDGE, IL. SN 76-699,913. PUB. 4-27-2010, FILED 10-16-2009.

**VACANT 2 VEGETABLES**

THE MARK CONSISTS OF STANDARD CHARACTERS WITHOUT CLAIM TO ANY PARTICULAR FONT, STYLE, SIZE, OR COLOR.

FOR CHARITABLE SERVICES, NAMELY, PROVIDING FOOD TO NEEDY PERSONS BY DEVELOPMENT OF VACANT PROPERTY TO GROW VEGETABLES (U.S. CLS. 100 AND 101).

FIRST USE 10-1-2009; IN COMMERCE 10-1-2009.

**CLASS 43—(Continued).**

3,962,043. 835 AVENUE OF THE AMERICAS, L.P., NEW YORK, NY. SN 77-204,176. PUB. 11-16-2010, FILED 6-12-2007.

# EVENTI

THE MARK CONSISTS OF STANDARD CHARACTERS WITHOUT CLAIM TO ANY PARTICULAR FONT, STYLE, SIZE, OR COLOR.  
FOR HOTEL SERVICES (U.S. CLS. 100 AND 101).  
FIRST USE 5-14-2010; IN COMMERCE 5-14-2010.

**CLASS 43—(Continued).**

3,962,234. ATLANTA GSPOTS, L.L.C., ATLANTA, GA. SN 77-622,172. PUB. 6-16-2009, FILED 11-26-2008.

# ATLANTA GSPOTS

THE MARK CONSISTS OF STANDARD CHARACTERS WITHOUT CLAIM TO ANY PARTICULAR FONT, STYLE, SIZE, OR COLOR.  
NO CLAIM IS MADE TO THE EXCLUSIVE RIGHT TO USE "ATLANTA", APART FROM THE MARK AS SHOWN, FOR PROVIDING ON-LINE REVIEWS OF RESTAURANTS AND BARS (U.S. CLS. 100 AND 101).  
FIRST USE 2-28-2010; IN COMMERCE 2-28-2010.

3,962,117. MEGA MART CO., LTD., SEOUL, REPUBLIC OF KOREA. SN 77-397,359. PUB. 10-27-2009, FILED 2-14-2008.

# MEGAMART

THE MARK CONSISTS OF STANDARD CHARACTERS WITHOUT CLAIM TO ANY PARTICULAR FONT, STYLE, SIZE, OR COLOR.  
FOR RESTAURANT SERVICES (U.S. CLS. 100 AND 101).  
FIRST USE 2-28-2011; IN COMMERCE 2-28-2011.

3,962,251. 5STONES HOLDINGS, LLC, VIENNA, VA. SN 77-640,294. PUB. 4-28-2009, FILED 12-28-2008.

3,962,193. IL LUGANO, LLC, FORT LAUDERDALE, FL. SN 77-549,092. PUB. 1-26-2010, FILED 8-18-2008.

# DA CAMPO

THE MARK CONSISTS OF STANDARD CHARACTERS WITHOUT CLAIM TO ANY PARTICULAR FONT, STYLE, SIZE, OR COLOR.  
THE ENGLISH TRANSLATION OF "DA CAMPO" IN THE MARK IS "FROM FIELDS".  
FOR RESTAURANT AND BAR SERVICES (U.S. CLS. 100 AND 101).  
FIRST USE 4-9-2009; IN COMMERCE 4-9-2009.



THE MARK CONSISTS OF A FLAME.  
FOR RESTAURANT, BAR, AND COCKTAIL LOUNGE SERVICES (U.S. CLS. 100 AND 101).  
FIRST USE 2-27-2011; IN COMMERCE 2-27-2011.



**CLASS 43—(Continued).**

3,962,283. 5STONES HOLDINGS, LLC, VIENNA, VA. SN 77-667,916. PUB. 4-28-2009, FILED 2-11-2009.



THE MARK CONSISTS OF A FLAME DESIGN ABOVE THE WORDING "STONE'S COVE" AND "KITBAR", WITH ALL OF THE ABOVE APPEARING ON A CIRCULAR BACKGROUND.

FOR RESTAURANT, BAR AND COCKTAIL LOUNGE SERVICES (U.S. CLS. 100 AND 101).

FIRST USE 2-27-2011; IN COMMERCE 2-27-2011.

3,962,331. SAM MEINER, ORLANDO, FL. SN 77-697,303. PUB. 12-29-2009, FILED 3-23-2009.

## Que Rico Subs

THE MARK CONSISTS OF STANDARD CHARACTERS WITHOUT CLAIM TO ANY PARTICULAR FONT, STYLE, SIZE, OR COLOR.

NO CLAIM IS MADE TO THE EXCLUSIVE RIGHT TO USE "SUBS", APART FROM THE MARK AS SHOWN.

THE ENGLISH TRANSLATION OF THE WORD "QUE RICO" IN THE MARK IS SO TASTY OR HOW RICH.

FOR FAST-FOOD RESTAURANTS (U.S. CLS. 100 AND 101).

FIRST USE 8-9-2010; IN COMMERCE 8-9-2010.

**CLASS 43—(Continued).**

3,962,359. DELYSE INC., RENO, NV. SN 77-718,989. PUB. 4-6-2010, FILED 4-21-2009.

## GREEN SKY

THE MARK CONSISTS OF STANDARD CHARACTERS WITHOUT CLAIM TO ANY PARTICULAR FONT, STYLE, SIZE, OR COLOR.

FOR CATERING SERVICES FOR AIRLINES (U.S. CLS. 100 AND 101).

FIRST USE 4-1-2009; IN COMMERCE 4-1-2009.

3,962,429. THE KESSLER ENTERPRISE, INC., ORLANDO, FL. SN 77-773,787. PUB. 11-24-2009, FILED 7-2-2009.

## Inspiring Places Intuitive Service Exuberant Guests

THE MARK CONSISTS OF STANDARD CHARACTERS WITHOUT CLAIM TO ANY PARTICULAR FONT, STYLE, SIZE, OR COLOR.

OWNER OF U.S. REG. NO. 3,082,549.  
FOR HOTEL AND RESTAURANT SERVICES (U.S. CLS. 100 AND 101).

FIRST USE 6-1-2010; IN COMMERCE 6-1-2010.

3,962,504. 76 WEST LLC, PHILADELPHIA, PA. SN 77-802,098. PUB. 7-13-2010, FILED 8-11-2009.



THE MARK CONSISTS OF THE WORD "SAMPAN" OVER THREE BRUSHSTROKE IMAGES.

FOR RESTAURANT SERVICES (U.S. CLS. 100 AND 101).

FIRST USE 12-9-2009; IN COMMERCE 12-18-2009.

**CLASS 43—(Continued).**

3,962,567. FLORES, RAYMON, TUCSON, AZ. SN 77-820,726.  
PUB. 8-24-2010, FILED 9-4-2009.

# SIR VEZA'S

THE MARK CONSISTS OF STANDARD CHARACTERS WITHOUT CLAIM TO ANY PARTICULAR FONT, STYLE, SIZE, OR COLOR.

THE NAME "SIR VEZA" DOES NOT IDENTIFY A LIVING INDIVIDUAL.

FOR BAR AND RESTAURANT SERVICES (U.S. CLS. 100 AND 101).

FIRST USE 4-19-2009; IN COMMERCE 4-19-2009.

**CLASS 43—(Continued).**

3,962,627. ROCK BACK PIZZA, INC., CHATTAHOOCHEE HILLS, GA. SN 77-841,624. PUB. 4-13-2010, FILED 10-5-2009.

# Rock Back Pizza

THE MARK CONSISTS OF STANDARD CHARACTERS WITHOUT CLAIM TO ANY PARTICULAR FONT, STYLE, SIZE, OR COLOR.

NO CLAIM IS MADE TO THE EXCLUSIVE RIGHT TO USE "PIZZA", APART FROM THE MARK AS SHOWN.

FOR BAR AND RESTAURANT SERVICES (U.S. CLS. 100 AND 101).

FIRST USE 1-3-2011; IN COMMERCE 1-3-2011.

3,962,575. COSMC FORCES INC, SAINT ALBANS, NY. SN 77-823,267. PUB. 7-27-2010, FILED 9-9-2009.

# Fat Pat's Barbeque Shack

THE MARK CONSISTS OF STANDARD CHARACTERS WITHOUT CLAIM TO ANY PARTICULAR FONT, STYLE, SIZE, OR COLOR.

NO CLAIM IS MADE TO THE EXCLUSIVE RIGHT TO USE "BARBEQUE SHACK", APART FROM THE MARK AS SHOWN.

THE NAME "PATRICK MCLEAN" IDENTIFIES A LIVING INDIVIDUAL WHOSE CONSENT IS OF RECORD.

FOR RESTAURANT SERVICES (U.S. CLS. 100 AND 101).

FIRST USE 3-1-2011; IN COMMERCE 3-7-2011.

3,962,749. COOKHOUSE LLC, SAN FRANCISCO, CA. SN 77-886,775. PUB. 10-19-2010, FILED 12-4-2009.

# COOKHOUSE

THE MARK CONSISTS OF STANDARD CHARACTERS WITHOUT CLAIM TO ANY PARTICULAR FONT, STYLE, SIZE, OR COLOR.

FOR PROVIDING SOCIAL MEETING FACILITIES (U.S. CLS. 100 AND 101).

FIRST USE 2-14-2011; IN COMMERCE 2-14-2011.

3,962,597. SANDRA L. BLANKFIELD INC, DBA BRANCH-WATER TAVERN, HOUSTON, TX. SN 77-829,765. PUB. 1-19-2010, FILED 9-18-2009.

# BRANCH WATER

THE MARK CONSISTS OF STANDARD CHARACTERS WITHOUT CLAIM TO ANY PARTICULAR FONT, STYLE, SIZE, OR COLOR.

FOR BAR AND RESTAURANT SERVICES (U.S. CLS. 100 AND 101).

FIRST USE 10-7-2009; IN COMMERCE 10-7-2009.

3,962,770. BT LEWIS ENTERPRISES, INC., LOS ANGELES, CA. SN 77-890,831. PUB. 7-20-2010, FILED 12-10-2009.



NO CLAIM IS MADE TO THE EXCLUSIVE RIGHT TO USE "SALAD" AND "CUSTOM GREENS", APART FROM THE MARK AS SHOWN.

**CLASS 43—(Continued).**

THE MARK CONSISTS OF STYLIZED GREENS AND A SALAD BOWL ABOVE THE LITERAL ELEMENTS "SIMPLY SALAD CUSTOM GREENS". A LEAF REPLACES THE DOT ABOVE THE LETTER "I" IN "SIMPLY".

FOR RESTAURANT SERVICES; RESTAURANTS (U.S. CLS. 100 AND 101).

FIRST USE 3-1-2011; IN COMMERCE 3-1-2011.

---

3,962,934. HEIRLOOM HOSPITALITY GROUP, LLC, ASHEVILLE, NC. SN 77-935,247. PUB. 6-29-2010, FILED 2-13-2010.

CÚRATE

THE MARK CONSISTS OF STANDARD CHARACTERS WITHOUT CLAIM TO ANY PARTICULAR FONT, STYLE, SIZE, OR COLOR.

FOR RESTAURANT, BAR AND CATERING SERVICES (U.S. CLS. 100 AND 101).

FIRST USE 1-1-2011; IN COMMERCE 3-4-2011.

---

3,962,938. THE KESSLER ENTERPRISE, INC., ORLANDO, FL. SN 77-935,663. PUB. 7-13-2010, FILED 2-15-2010.

BOHEMIAN HOTEL CELEBRATION

THE MARK CONSISTS OF STANDARD CHARACTERS WITHOUT CLAIM TO ANY PARTICULAR FONT, STYLE, SIZE, OR COLOR.

OWNER OF U.S. REG. NOS. 2,324,739, 3,699,745, AND OTHERS.

NO CLAIM IS MADE TO THE EXCLUSIVE RIGHT TO USE "HOTEL", APART FROM THE MARK AS SHOWN.

FOR HOTEL, RESTAURANT AND BAR SERVICES (U.S. CLS. 100 AND 101).

FIRST USE 5-13-2010; IN COMMERCE 5-13-2010.

**CLASS 43—(Continued).**

3,963,015. HLT DOMESTIC IP LLC, MCLEAN, VA. SN 77-945,720. PUB. 7-20-2010, FILED 2-26-2010.



THE MARK CONSISTS OF A DESIGN OF A TREE NEXT TO THE LETTER "D".

FOR RENTAL OF TEMPORARY ACCOMMODATION, NAMELY, HOTEL ROOMS; RESERVATIONS FOR TEMPORARY ACCOMMODATION, NAMELY, HOTEL ROOMS; HOTEL, MOTEL, BAR, CAFE, RESTAURANT, BANQUETING AND CATERING SERVICES; RENTAL OF ROOMS FOR HOLDING FUNCTIONS, CONFERENCES, CONVENTIONS, EXHIBITIONS, SEMINARS AND MEETINGS (U.S. CLS. 100 AND 101).

FIRST USE 2-1-2011; IN COMMERCE 2-1-2011.

---

3,963,070. AMERICAN BLUE RIBBON HOLDINGS, LLC, DENVER, CO. SN 77-952,316. PUB. 1-25-2011, FILED 3-5-2010.

THE INNCREDBLE V.I.B.

THE MARK CONSISTS OF STANDARD CHARACTERS WITHOUT CLAIM TO ANY PARTICULAR FONT, STYLE, SIZE, OR COLOR.

FOR RESTAURANT SERVICES; BREAKFASTS (U.S. CLS. 100 AND 101).

FIRST USE 11-10-2009; IN COMMERCE 11-10-2009.

---

3,963,138. HYATT CORPORATION, CHICAGO, IL. SN 77-960,222. PUB. 7-27-2010, FILED 3-16-2010.

JAPENGO

THE MARK CONSISTS OF STANDARD CHARACTERS WITHOUT CLAIM TO ANY PARTICULAR FONT, STYLE, SIZE, OR COLOR.

OWNER OF U.S. REG. NO. 2,647,681.

**CLASS 43—(Continued).**

THE WORDING "JAPENGO" HAS NO MEANING IN A FOREIGN LANGUAGE.

FOR RESTAURANT AND BAR SERVICES (U.S. CLS. 100 AND 101).

FIRST USE 12-16-2010; IN COMMERCE 12-16-2010.

**CLASS 43—(Continued).**

3,963,222. MARRIOTT INTERNATIONAL, INC., BETHESDA, MD. SN 77-968,772. PUB. 8-17-2010, FILED 3-25-2010.

**TOTS TRAVEL TOO**

3,963,160. BETHESDA FOUNDATION, COLORADO SPRINGS, CO. SN 77-961,583. PUB. 8-31-2010, FILED 3-17-2010.

THE MARK CONSISTS OF STANDARD CHARACTERS WITHOUT CLAIM TO ANY PARTICULAR FONT, STYLE, SIZE, OR COLOR.

FOR HOTEL SERVICES (U.S. CLS. 100 AND 101).  
FIRST USE 5-25-2010; IN COMMERCE 5-25-2010.

**Bethesda Senior Living  
Community**

3,963,313. INKAN GROUP, LLC., TORRANCE, CA. SN 85-001,263. PUB. 12-7-2010, FILED 3-29-2010.

THE MARK CONSISTS OF STANDARD CHARACTERS WITHOUT CLAIM TO ANY PARTICULAR FONT, STYLE, SIZE, OR COLOR.

OWNER OF U.S. REG. NOS. 2,695,385 AND 3,231,093.

NO CLAIM IS MADE TO THE EXCLUSIVE RIGHT TO USE "SENIOR LIVING COMMUNITY", APART FROM THE MARK AS SHOWN.

FOR PROVIDING ASSISTED LIVING FACILITIES FOR THE ELDERLY (U.S. CLS. 100 AND 101).

FIRST USE 3-1-2011; IN COMMERCE 3-1-2011.

**INKA WASI**

THE MARK CONSISTS OF STANDARD CHARACTERS WITHOUT CLAIM TO ANY PARTICULAR FONT, STYLE, SIZE, OR COLOR.

THE ENGLISH TRANSLATION OF "WASI" IS HOUSE.  
FOR RESTAURANT, CARRY-OUT FOOD AND BAR SERVICES (U.S. CLS. 100 AND 101).

FIRST USE 5-1-2010; IN COMMERCE 5-1-2010.

3,963,178. SCHNABEL RESTAURANTS, LLC, NAVARRE, OH. SN 77-963,508. PUB. 8-24-2010, FILED 3-19-2010.

**BURGERS HERE**

3,963,359. CENZOPRANO, PAUL, HUNTINGTON STATION, NY. SN 85-009,778. PUB. 8-31-2010, FILED 4-8-2010.

**BUILT FOR FOOD**

THE MARK CONSISTS OF STANDARD CHARACTERS WITHOUT CLAIM TO ANY PARTICULAR FONT, STYLE, SIZE, OR COLOR.

NO CLAIM IS MADE TO THE EXCLUSIVE RIGHT TO USE "BURGERS", APART FROM THE MARK AS SHOWN.

FOR RESTAURANT SERVICES (U.S. CLS. 100 AND 101).

FIRST USE 2-16-2011; IN COMMERCE 2-16-2011.

THE MARK CONSISTS OF STANDARD CHARACTERS WITHOUT CLAIM TO ANY PARTICULAR FONT, STYLE, SIZE, OR COLOR.

NO CLAIM IS MADE TO THE EXCLUSIVE RIGHT TO USE "FOOD", APART FROM THE MARK AS SHOWN.

FOR PROVISION OF ONLINE NEWS, INFORMATION AND COMMENTARY ON A WIDE VARIETY OF TOPICS RELATING TO THE RESTAURANT, FOOD AND BEVERAGE INDUSTRIES AND THE RESTAURANT AND FOOD EQUIPMENT INDUSTRIES (U.S. CLS. 100 AND 101).

FIRST USE 4-8-2011; IN COMMERCE 4-8-2011.

**CLASS 43—(Continued).**

3,963,378. CPO HOSPITALITY L.L.C., SKOKIE, IL. SN 85-013,748. PUB. 8-10-2010, FILED 4-14-2010.

**VISIBILITY BAR**

THE MARK CONSISTS OF STANDARD CHARACTERS WITHOUT CLAIM TO ANY PARTICULAR FONT, STYLE, SIZE, OR COLOR.

NO CLAIM IS MADE TO THE EXCLUSIVE RIGHT TO USE "BAR", APART FROM THE MARK AS SHOWN.

FOR BAR AND RESTAURANT SERVICES (U.S. CLS. 100 AND 101).

FIRST USE 5-3-2010; IN COMMERCE 5-3-2010.

3,963,390. GINGERINE, LLC, SOUTHLAKE, TX. SN 85-017,336. PUB. 9-21-2010, FILED 4-19-2010.

**GINGERINE**

THE MARK CONSISTS OF STANDARD CHARACTERS WITHOUT CLAIM TO ANY PARTICULAR FONT, STYLE, SIZE, OR COLOR.

FOR RESTAURANT SERVICES (U.S. CLS. 100 AND 101).

FIRST USE 10-1-2010; IN COMMERCE 10-1-2010.

3,963,401. ARORA, ASHOK, NORFOLK, VA. SN 85-020,523. PUB. 9-28-2010, FILED 4-22-2010.

**Lehja**

THE MARK CONSISTS OF STANDARD CHARACTERS WITHOUT CLAIM TO ANY PARTICULAR FONT, STYLE, SIZE, OR COLOR.

THE ENGLISH TRANSLATION OF THE WORD "LEHJA" IN THE MARK IS "ACCENT".

FOR RESTAURANT SERVICES (U.S. CLS. 100 AND 101).

FIRST USE 2-1-2010; IN COMMERCE 2-1-2010.

**CLASS 43—(Continued).**

3,963,422. NATIONAL ASSOCIATION FOR STOCK CAR AUTO RACING, INC., DAYTONA BEACH, FL. SN 85-025,930. PUB. 7-27-2010, FILED 4-29-2010.



OWNER OF U.S. REG. NOS. 2,420,020, 3,347,992, AND OTHERS.

NO CLAIM IS MADE TO THE EXCLUSIVE RIGHT TO USE "RV RESORTS", APART FROM THE MARK AS SHOWN.

THE MARK CONSISTS OF THE WORDING "NASCAR" LOCATED INSIDE A RECTANGLE FEATURING SLANTED BARS FOLLOWED BY THE WORDING "RV RESORTS" BELOW, ALL OF WHICH ARE SUPERIMPOSED UPON THREE CONCENTRIC OVALS.

FOR PROVIDING TEMPORARY RECREATIONAL VEHICLE (RV) SITE FACILITIES; RESORT LODGING SERVICES (U.S. CLS. 100 AND 101).

FIRST USE 12-16-2010; IN COMMERCE 12-16-2010.

3,963,448. COLUMBIA CONSULTANTS, LLC, NEW YORK, NY. AND DANUCHT ENTERTAINMENT, LLC, NEW YORK, NY. SN 85-032,682. PUB. 10-12-2010, FILED 5-7-2010.

**THE DARBY**

THE MARK CONSISTS OF STANDARD CHARACTERS WITHOUT CLAIM TO ANY PARTICULAR FONT, STYLE, SIZE, OR COLOR.

FOR COCKTAIL LOUNGE SERVICES; RESTAURANT SERVICES (U.S. CLS. 100 AND 101).

FIRST USE 9-4-2010; IN COMMERCE 9-4-2010.

3,963,452. SCHNABEL RESTAURANTS, LLC, NAVARRE, OH. SN 85-034,137. PUB. 8-24-2010, FILED 5-10-2010.

**SCHNAB'S BURGERS HERE**

THE MARK CONSISTS OF STANDARD CHARACTERS WITHOUT CLAIM TO ANY PARTICULAR FONT, STYLE, SIZE, OR COLOR.

NO CLAIM IS MADE TO THE EXCLUSIVE RIGHT TO USE "BURGERS", APART FROM THE MARK AS SHOWN.

FOR RESTAURANT SERVICES (U.S. CLS. 100 AND 101).

FIRST USE 2-16-2011; IN COMMERCE 2-16-2011.



**CLASS 43—(Continued).**

3,963,509. MCCAIN, MARILYN MICHELLE, BURBANK, CA. SN 85-047,004. PUB. 10-26-2010, FILED 5-25-2010.



NO CLAIM IS MADE TO THE EXCLUSIVE RIGHT TO USE "NAP STATION", APART FROM THE MARK AS SHOWN.

THE MARK CONSISTS OF IN BANK GOTHIC PRINT THE WORDS "THE NAP STATION" FOLLOWED DIRECTLY BY STICK FIGURE LAYING ON A BED COVERED BY A BLANKET WITH AN AIRPLANE SILHOUETTE ABOVE THE HEAD.

FOR PROVIDING TEMPORARY ACCOMMODATION (U.S. CLS. 100 AND 101).

FIRST USE 5-5-2010; IN COMMERCE 6-1-2010.

3,963,717. CARLSON, INC., MINNEAPOLIS, MN. SN 85-147,640. PUB. 12-14-2010, FILED 10-7-2010.

## CLUB CARLSON

THE MARK CONSISTS OF STANDARD CHARACTERS WITHOUT CLAIM TO ANY PARTICULAR FONT, STYLE, SIZE, OR COLOR.

NO CLAIM IS MADE TO THE EXCLUSIVE RIGHT TO USE "CLUB", APART FROM THE MARK AS SHOWN.

FOR HOTEL SERVICES FEATURING AN INCENTIVE PROGRAM PROVIDING SPECIAL GUEST SERVICES, AMENITIES AND AWARDS TO MEMBERS (U.S. CLS. 100 AND 101).

FIRST USE 3-31-2011; IN COMMERCE 3-31-2011.

**CLASS 44—MEDICAL, BEAUTY AND AGRICULTURAL SERVICES**

**CLASS 44—(Continued).**

3,962,040. CENTER FOR INTEGRATED MEDICINE, P.A., HOUSTON, TX. SN 77-166,210. PUB. 9-18-2007, FILED 4-26-2007.



NO CLAIM IS MADE TO THE EXCLUSIVE RIGHT TO USE "EARLY DETECTION DISEASE MANAGEMENT" AND "MEDICAL CENTER", APART FROM THE MARK AS SHOWN.

THE COLOR(S) BLUE AND WHITE IS/ARE CLAIMED AS A FEATURE OF THE MARK.

THE MARK CONSISTS OF THE STYLIZED LETTERING "CI" IN THE COLOR BLUE AND WHITE AND BLUE BORDERING, WHERE THE DESIGN OF A CADUCEUS APPEARS IN BETWEEN THE "C" AND "I" IN THE COLORS BLUE PARTIALLY OUTLINED IN WHITE, WITH THE STYLIZED WORDING "MEDICAL CENTER" APPEARING BELOW IN THE COLOR BLUE ON A BANNER DESIGN IN THE COLOR WHITE OUTLINED IN BLUE, ALL AFORESAID ELEMENTS ON A CIRCLE WITH BLUE BACKGROUND COLOR; A CONCENTRIC CIRCLE BORDERING THE CENTER CIRCLE IN THE COLOR BLUE WITH WHITE DOTS LINING BOTH EDGES OF THE OUTER CIRCLE, WHERE THE WORDING "EARLY DETECTION DISEASE MANAGEMENT" APPEARS IN STYLIZED LETTERS IN THE COLOR WHITE; CURVED OUTSIDE AND UNDERNEATH THE BOTTOM HALF OF THE CIRCLE APPEARS THE WORDING "LIFE IS UNCERTAIN. INCREASE YOUR ODDS WITH EARLY DETECTION." IN STYLIZED LETTERS IN THE COLOR BLUE.

FOR MEDICAL SERVICES (U.S. CLS. 100 AND 101).

FIRST USE 1-1-2008; IN COMMERCE 1-1-2008.

3,962,113. QUANTUM SOFT, LLC, LAS VEGAS, NV. SN 77-386,738. PUB. 6-23-2009, FILED 2-1-2008.

## SPA CLICK

THE MARK CONSISTS OF STANDARD CHARACTERS WITHOUT CLAIM TO ANY PARTICULAR FONT, STYLE, SIZE, OR COLOR.

NO CLAIM IS MADE TO THE EXCLUSIVE RIGHT TO USE "SPA", APART FROM THE MARK AS SHOWN.

FOR ONLINE RESERVATION SERVICES IN THE FIELD OF PHYSICAL AND BEAUTY TREATMENTS AT HEALTH SPAS AND RESORTS; ONLINE HEALTH SPA RESERVATION SERVICES FOR PHYSICAL AND BEAUTY TREATMENTS (U.S. CLS. 100 AND 101).

FIRST USE 7-0-2010; IN COMMERCE 7-0-2010.

**CLASS 44—(Continued).**

3,962,121. CROWN CLINIC, P.A., CHARLOTTE, NC. SN 77-403,878. PUB. 7-21-2009, FILED 2-22-2008.

THE DOCTOR WILL SEE YOU NOW

THE MARK CONSISTS OF STANDARD CHARACTERS WITHOUT CLAIM TO ANY PARTICULAR FONT, STYLE, SIZE, OR COLOR.  
FOR MEDICAL SERVICES (U.S. CLS. 100 AND 101).  
FIRST USE 9-30-2008; IN COMMERCE 9-30-2008.

3,962,209. PREVAIL HEALTH SOLUTIONS, AKA PREVAIL, CHICAGO, IL. SN 77-565,770. PUB. 1-27-2009, FILED 9-9-2008.

**Prevail**

THE MARK CONSISTS OF STANDARD CHARACTERS WITHOUT CLAIM TO ANY PARTICULAR FONT, STYLE, SIZE, OR COLOR.

FOR CONSULTING SERVICES IN THE FIELD OF MENTAL HEALTH AND WELLNESS BUT EXPRESSLY EXCLUDING INCONTINENCE; HEALTH CARE SERVICES, NAMELY, PROVIDING A DATABASE IN THE FIELD OF MENTAL HEALTH INFORMATION AND FEATURING INPUTTING AND COLLECTION OF DATA AND INFORMATION ALL FOR TREATMENT AND DIAGNOSTIC PURPOSES, BUT EXPRESSLY EXCLUDING INFORMATION AND DATA RELATED TO INCONTINENCE; MAINTAINING FILES AND RECORDS CONCERNING THE MEDICAL CONDITION OF INDIVIDUALS BUT EXPRESSLY EXCLUDING INFORMATION ABOUT INCONTINENCE; MENTAL HEALTH SERVICES; PROVIDING HEALTH CARE INFORMATION BY TELEPHONE AND THE INTERNET BUT EXPRESSLY EXCLUDING INFORMATION ABOUT INCONTINENCE; PROVIDING ON-LINE MEDICAL RECORD ANALYSIS SERVICES DESIGNED TO PROVIDE PATIENTS WITH CUSTOM TAILORED INFORMATION ABOUT THE RANGE OF POSSIBLE DIAGNOSES AND THERAPIES ASSOCIATED WITH A DEFINED SET OF SYMPTOMS, EXCLUDING INCONTINENCE; PROVIDING WELLNESS SERVICES, NAMELY, PERSONAL ASSESSMENTS, PERSONALIZED ROUTINES, MAINTENANCE SCHEDULES, BUT EXPRESSLY EXCLUDING WELLNESS SERVICES RELATED TO INCONTINENCE (U.S. CLS. 100 AND 101).  
FIRST USE 5-1-2008; IN COMMERCE 1-10-2011.

**CLASS 44—(Continued).**

3,962,269. JKRLHB, LLC, BEVERLY HILLS, CA. SN 77-661,453. PUB. 12-8-2009, FILED 2-2-2009.

**A HEALTHIER, HAPPIER  
FUTURE FOR OUR KIDS**

THE MARK CONSISTS OF STANDARD CHARACTERS WITHOUT CLAIM TO ANY PARTICULAR FONT, STYLE, SIZE, OR COLOR.

FOR PROVIDING WEIGHT LOSS PROGRAM SERVICES AND NUTRITION COUNSELING SERVICES (U.S. CLS. 100 AND 101).

FIRST USE 7-1-2010; IN COMMERCE 7-1-2010.

3,962,326. ATLANTIC EYE INSTITUTE, P.A., JACKSONVILLE BEACH, FL. SN 77-695,065. PUB. 6-1-2010, FILED 3-19-2009.

**THE EYE GUYS**

THE MARK CONSISTS OF STANDARD CHARACTERS WITHOUT CLAIM TO ANY PARTICULAR FONT, STYLE, SIZE, OR COLOR.

NO CLAIM IS MADE TO THE EXCLUSIVE RIGHT TO USE "EYE", APART FROM THE MARK AS SHOWN.

FOR COSMETIC AND PLASTIC SURGERY; EYE-GLASS FITTING; FITTING OF CONTACT LENSES; FITTING OF OPTICAL LENSES; LASER AND INTENSE PULSE LIGHT SKIN ENHANCEMENT PROCEDURES; LASER VISION CORRECTION SERVICES; LASER VISION SURGERY SERVICES; NON-INVASIVE COSMETIC MEDICAL PROCEDURES; OPHTHALMOLOGY SERVICES; OPTOMETRY SERVICES; TREATMENT OF EYE DISEASES AND CONDITIONS (U.S. CLS. 100 AND 101).  
FIRST USE 6-30-2002; IN COMMERCE 7-31-2007.

3,962,344. HUMANA INC., LOUISVILLE, KY. SN 77-708,660. PUB. 1-11-2011, FILED 4-7-2009.

**RIGHTSOURCERX SPECIALTY**

THE MARK CONSISTS OF STANDARD CHARACTERS WITHOUT CLAIM TO ANY PARTICULAR FONT, STYLE, SIZE, OR COLOR.

OWNER OF U.S. REG. NOS. 3,308,985 AND 3,308,995.

**CLASS 44—(Continued).**

NO CLAIM IS MADE TO THE EXCLUSIVE RIGHT TO USE "SPECIALTY", APART FROM THE MARK AS SHOWN.

FOR THERAPEUTIC PHARMACEUTICAL SERVICES, NAMELY, THE DEVELOPMENT AND MANAGEMENT OF COMPREHENSIVE PHARMACEUTICAL PROGRAMS COMPRISING DRUG THERAPY AND PHYSICAL SUPPORT SERVICES IN THE NATURE OF PROVIDING CONSULTATION IN THE DISPENSING OF PHARMACEUTICALS FOR PERSONS WITH CHRONIC HEALTH ISSUES (U.S. CLS. 100 AND 101).

FIRST USE 6-30-2009; IN COMMERCE 6-30-2009.

3,962,379. MX USA, INC., JENKINTOWN, PA. SN 77-739,423.  
PUB. 4-13-2010, FILED 5-18-2009.



The logo for TridentUSA Health Services features the word "TridentUSA" in a large, serif font. Above the letter "i" in "Trident" is a stylized trident symbol with a star above it. Below "TridentUSA" are the words "HEALTH SERVICES" in a smaller, all-caps, sans-serif font.

NO CLAIM IS MADE TO THE EXCLUSIVE RIGHT TO USE "HEALTH SERVICES", APART FROM THE MARK AS SHOWN.

THE MARK CONSISTS OF THE WORDS "TRIDENTUSA HEALTH SERVICES" WITH A STAR AND TWO WAVY LINES OVER THE LETTERS "DE" IN "TRIDENT".

FOR MOBILE MEDICAL IMAGING SERVICES (U.S. CLS. 100 AND 101).

FIRST USE 3-4-2011; IN COMMERCE 3-4-2011.

3,962,438. TECHNOVINEYARD, INC., NEWCASTLE, CA. SN 77-777,428. PUB. 12-1-2009, FILED 7-9-2009.

## The Vineyard Wizard

THE MARK CONSISTS OF STANDARD CHARACTERS WITHOUT CLAIM TO ANY PARTICULAR FONT, STYLE, SIZE, OR COLOR.

NO CLAIM IS MADE TO THE EXCLUSIVE RIGHT TO USE "VINEYARD", APART FROM THE MARK AS SHOWN.

FOR VINEYARD AND WINERY SERVICES, NAMELY, THE CULTIVATION OF GRAPES FOR OTHERS; VITICULTURE SERVICES, NAMELY, GRAPE GROWING AND CULTIVATION OF GRAPES FOR OTHERS (U.S. CLS. 100 AND 101).

FIRST USE 6-1-2010; IN COMMERCE 12-1-2010.

**CLASS 44—(Continued).**

3,962,441. UHS OF DELAWARE, INC., KING OF PRUSSIA, PA. SN 77-779,696. PUB. 4-27-2010, FILED 7-13-2009.



OWNER OF U.S. REG. NO. 3,731,405.

NO CLAIM IS MADE TO THE EXCLUSIVE RIGHT TO USE "CARDIOVASCULAR CENTER" AND "MEDICAL CENTER", APART FROM THE MARK AS SHOWN.

THE MARK CONSISTS OF A HEART-SHAPED SUN ABOVE A MOUNTAIN SILHOUETTE, WITH THREE RAYS EXTENDING FROM EACH SIDE OF THE SUN, WITH THE WORDS "SOUTHWEST CARDIOVASCULAR CENTER" BELOW THE SILHOUETTE AND ABOVE A LINE. BELOW THE LINE ARE THE WORDS "INLAND VALLEY MEDICAL CENTER RANCHO SPRINGS MEDICAL CENTER".

SEC. 2(F) AS TO "SOUTHWEST".

FOR MEDICAL AND HEALTH CARE SERVICES; CARDIOVASCULAR-RELATED HEALTH CARE SERVICES (U.S. CLS. 100 AND 101).

FIRST USE 2-20-2011; IN COMMERCE 2-20-2011.

3,962,527. AUREON LABORATORIES, INC., YONKERS, NY. SN 77-807,473. PUB. 7-27-2010, FILED 8-18-2009.

## AUREON POST-OP PX

THE MARK CONSISTS OF STANDARD CHARACTERS WITHOUT CLAIM TO ANY PARTICULAR FONT, STYLE, SIZE, OR COLOR.

OWNER OF U.S. REG. NOS. 3,190,310, 3,336,564, AND OTHERS.

NO CLAIM IS MADE TO THE EXCLUSIVE RIGHT TO USE "POST-OP PX", APART FROM THE MARK AS SHOWN.

FOR MEDICAL TESTING SERVICES THAT UTILIZE A PATIENT'S CLINICAL, MOLECULAR AND MORPHOMETRIC INFORMATION FOR PREDICTING THE PROBABILITY OF CLINICAL FAILURE POST PROSTATECTOMY OR BIOPSY IN THE ABSENCE OF OTHER TREATMENT AND PREDICTING A PATIENT'S PROGRESSION OF DISEASE AND PROVIDING INFORMATION USEFUL TO A DOCTOR IN PRESCRIBING A RECOMMENDED THERAPY (U.S. CLS. 100 AND 101).

FIRST USE 6-12-2010; IN COMMERCE 6-12-2010.

**CLASS 44—(Continued).**

3,962,732. ZIBA IP HOLDINGS, LLC, ARTESIA, CA. SN 77-882,535. PUB. 8-17-2010, FILED 11-30-2009.

**SUMITA BEAUTY**

THE MARK CONSISTS OF STANDARD CHARACTERS WITHOUT CLAIM TO ANY PARTICULAR FONT, STYLE, SIZE, OR COLOR.

OWNER OF U.S. REG. NO. 3,248,462.

NO CLAIM IS MADE TO THE EXCLUSIVE RIGHT TO USE "BEAUTY", APART FROM THE MARK AS SHOWN.

FOR BEAUTY SALON SERVICES, NAMELY, HYGIENIC AND BEAUTY CARE AND HAIR SALON SERVICES, NAMELY, SKIN CARE TREATMENTS, HAIR CARE TREATMENTS, HAIR CUTTING, HAIR STYLING, TATTOO, MEHNDI AND HENNA SERVICES, PERSONAL CARE TREATMENTS, NAMELY, EYEBROW AND FACIAL THREADING, WAXING, AND MAKE UP, FACIAL AND BODY COSMETIC TREATMENTS, PROVIDING INFORMATION ABOUT BEAUTY, BEAUTY CONSULTATION, HAIR CONSULTATION (U.S. CLS. 100 AND 101).

FIRST USE 12-15-2010; IN COMMERCE 12-15-2010.

---

3,962,797. ALLINA HEALTH SYSTEM, MINNEAPOLIS, MN. SN 77-899,956. PUB. 8-3-2010, FILED 12-23-2009.

**PENNY GEORGE**

THE MARK CONSISTS OF STANDARD CHARACTERS WITHOUT CLAIM TO ANY PARTICULAR FONT, STYLE, SIZE, OR COLOR.

THE NAME(S), PORTRAIT(S), AND/OR SIGNATURE(S) SHOWN IN THE MARK IDENTIFIES "PENNY GEORGE", WHOSE CONSENT(S) TO REGISTER IS MADE OF RECORD.

FOR MEDICAL SERVICES; HEALTH CARE SERVICES; PROVIDING INFORMATION AND ADVICE IN THE FIELD OF INTEGRATIVE MEDICINE; ACUPUNCTURE; STRESS REDUCTION THERAPY; COUNSELING IN THE FIELD OF HEALTH, NUTRITION AND LIFE STYLE WELLNESS (U.S. CLS. 100 AND 101).

FIRST USE 0-0-2003; IN COMMERCE 0-0-2003.

**CLASS 44—(Continued).**

3,962,839. COFINO, REBECCA, MIAMI SPRINGS, FL. SN 77-912,426. PUB. 6-1-2010, FILED 1-14-2010.

**mamaguru**

THE MARK CONSISTS OF STANDARD CHARACTERS WITHOUT CLAIM TO ANY PARTICULAR FONT, STYLE, SIZE, OR COLOR.

FOR PROVIDING A WEBSITE FEATURING CONTENT REGARDING HEALTHY LIVING AND LIFE-STYLE WELLNESS (U.S. CLS. 100 AND 101).

FIRST USE 6-1-2010; IN COMMERCE 8-1-2010.

---

3,962,859. MEDTRONIC MINIMED, INC., NORTHRIDGE, CA. SN 77-918,039. PUB. 6-8-2010, FILED 1-22-2010.

**LENNY**

THE MARK CONSISTS OF STANDARD CHARACTERS WITHOUT CLAIM TO ANY PARTICULAR FONT, STYLE, SIZE, OR COLOR.

FOR PROVIDING INFORMATION ABOUT DIABETES AND TREATMENT OPTIONS TO CHILDREN (U.S. CLS. 100 AND 101).

FIRST USE 8-9-2010; IN COMMERCE 8-9-2010.

---

3,963,035. EVER AFTER FARM, INC., EL DORADO, KS. SN 77-949,051. PUB. 7-27-2010, FILED 3-3-2010.



NO CLAIM IS MADE TO THE EXCLUSIVE RIGHT TO USE "FARM", APART FROM THE MARK AS SHOWN.

THE MARK CONSISTS OF A STYLIZED IMAGE OF A HORSE IMMEDIATELY ABOVE THE WORDS "EVER AFTER FARM".

FOR BREEDING AND STUD SERVICES FOR HORSES (U.S. CLS. 100 AND 101).

FIRST USE 12-31-2010; IN COMMERCE 12-31-2010.

**CLASS 44—(Continued).**

3,963,044. A G CONSULTING, LLC, SAN JUAN CAPISTRANO, CA. SN 77-950,030. PUB. 7-27-2010, FILED 3-3-2010.

EVERY CHILD DESERVES A  
HEALTHY START

THE MARK CONSISTS OF STANDARD CHARACTERS WITHOUT CLAIM TO ANY PARTICULAR FONT, STYLE, SIZE, OR COLOR.

FOR PROVIDING HEALTHY LIFESTYLE AND NUTRITION SERVICES, NAMELY, CONSULTING SERVICES IN NUTRITION FOR SCHOOLS AND SCHOOL CHILDREN AND LIFESTYLE WELLNESS (U.S. CLS. 100 AND 101).

FIRST USE 1-7-2010; IN COMMERCE 1-7-2010.

---

3,963,045. A G CONSULTING, LLC, SAN JUAN CAPISTRANO, CA. SN 77-950,037. PUB. 7-27-2010, FILED 3-3-2010.

EVERY CHILD IS MY CHILD

THE MARK CONSISTS OF STANDARD CHARACTERS WITHOUT CLAIM TO ANY PARTICULAR FONT, STYLE, SIZE, OR COLOR.

FOR PROVIDING HEALTHY LIFESTYLE AND NUTRITION SERVICES, NAMELY, CONSULTING SERVICES IN NUTRITION FOR SCHOOLS AND SCHOOL CHILDREN AND LIFESTYLE WELLNESS (U.S. CLS. 100 AND 101).

FIRST USE 1-7-2010; IN COMMERCE 1-7-2010.

---

3,963,053. COAN, KIMBERLY, DBA MEAL MOMMY, MISSOURI CITY, TX. SN 77-950,971. PUB. 8-3-2010, FILED 3-4-2010.

MEAL MOMMY

THE MARK CONSISTS OF STANDARD CHARACTERS WITHOUT CLAIM TO ANY PARTICULAR FONT, STYLE, SIZE, OR COLOR.

NO CLAIM IS MADE TO THE EXCLUSIVE RIGHT TO USE "MEAL", APART FROM THE MARK AS SHOWN.

FOR PROVIDING A WEBSITE FOR PROVIDING NUTRITIONAL AND DIETARY GUIDANCE FOR USERS AFFECTED BY TYPE ONE DIABETES, IN THE NATURE OF DELIVERING RECIPES AND GROCERY LISTS AND ORGANIZING MEAL PLANS BASED ON THE USERS' TYPE ONE DIABETES NEEDS (U.S. CLS. 100 AND 101).

FIRST USE 4-1-2010; IN COMMERCE 4-1-2010.

**CLASS 44—(Continued).**

3,963,056. CIECAL RC, INC., CHULA VISTA, CA. SN 77-951,466. PUB. 7-27-2010, FILED 3-5-2010.

DATADOC

THE MARK CONSISTS OF STANDARD CHARACTERS WITHOUT CLAIM TO ANY PARTICULAR FONT, STYLE, SIZE, OR COLOR.

FOR MAINTAINING PERSONAL MEDICAL HISTORY RECORDS AND FILES (U.S. CLS. 100 AND 101).

FIRST USE 3-5-2010; IN COMMERCE 3-5-2010.

---

3,963,083. WELLNESS CENTERS OF AMERICA, INC., DULUTH, GA. SN 77-954,279. PUB. 8-3-2010, FILED 3-9-2010.

*A*lifetime

THE MARK CONSISTS OF THE WORDING "4ALIFETIME" WITH THE NUMBER "4" AND THE LETTER "A" FORMING A STYLIZED ARROW.

FOR WEIGHT AND WELLNESS MANAGEMENT UNDER A DOCTOR'S CARE, WEIGHT REDUCTION DIET PLANNING SUPERVISION AND CHIROPRACTIC SERVICES (U.S. CLS. 100 AND 101).

FIRST USE 4-16-2010; IN COMMERCE 4-16-2010.

---

3,963,084. WELLNESS CENTERS OF AMERICA, INC., DULUTH, GA. SN 77-954,305. PUB. 8-3-2010, FILED 3-9-2010.

4 A LIFETIME

THE MARK CONSISTS OF STANDARD CHARACTERS WITHOUT CLAIM TO ANY PARTICULAR FONT, STYLE, SIZE, OR COLOR.

FOR WEIGHT AND WELLNESS MANAGEMENT UNDER A DOCTOR'S CARE, WEIGHT REDUCTION DIET PLANNING SUPERVISION AND CHIROPRACTIC SERVICES (U.S. CLS. 100 AND 101).

FIRST USE 4-16-2010; IN COMMERCE 4-16-2010.



**CLASS 44—(Continued).**

3,963,142. SHARP HEALTHCARE, SAN DIEGO, CA. SN 77-960,374. PUB. 8-10-2010, FILED 3-16-2010.

MYSHARP

THE MARK CONSISTS OF STANDARD CHARACTERS WITHOUT CLAIM TO ANY PARTICULAR FONT, STYLE, SIZE, OR COLOR.

OWNER OF U.S. REG. NOS. 1,802,451, 2,246,251, AND OTHERS.

FOR HEALTH CARE (U.S. CLS. 100 AND 101).  
FIRST USE 8-1-2003; IN COMMERCE 8-1-2003.

**CLASS 44—(Continued).**

3,963,187. DESIGNING DENTAL SMILES, PLLC, MERRICK, NY. SN 77-964,770. PUB. 8-10-2010, FILED 3-22-2010.

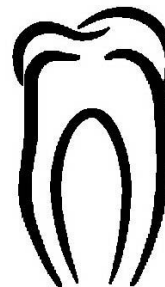

THE MARK CONSISTS OF AN ABSTRACT IMAGE OF A TOOTH.

FOR DENTISTRY; PROVIDING NEWS AND INFORMATION IN THE FIELD OF DENTISTRY (U.S. CLS. 100 AND 101).

FIRST USE 2-23-2010; IN COMMERCE 2-23-2010.

3,963,193. LIVING FOR LIFE MD, LLC, SALT LAKE CITY, UT. SN 77-965,331. PUB. 8-3-2010, FILED 3-22-2010.

PHYSICIAN FOR LIVING

THE MARK CONSISTS OF STANDARD CHARACTERS WITHOUT CLAIM TO ANY PARTICULAR FONT, STYLE, SIZE, OR COLOR.

NO CLAIM IS MADE TO THE EXCLUSIVE RIGHT TO USE "PHYSICIAN", APART FROM THE MARK AS SHOWN. FOR PROVIDING WEIGHT LOSS PROGRAM SERVICES; WEIGHT REDUCTION DIET PLANNING AND SUPERVISION (U.S. CLS. 100 AND 101).

FIRST USE 6-1-2010; IN COMMERCE 6-1-2010.

3,963,152. MONTFORD HALL, ASHEVILLE, NC. SN 77-961,140. PUB. 10-19-2010, FILED 3-17-2010.

INSPIRING RECOVERY

THE MARK CONSISTS OF STANDARD CHARACTERS WITHOUT CLAIM TO ANY PARTICULAR FONT, STYLE, SIZE, OR COLOR.

NO CLAIM IS MADE TO THE EXCLUSIVE RIGHT TO USE "RECOVERY", APART FROM THE MARK AS SHOWN.

FOR MENTAL HEALTH AND SUBSTANCE ABUSE TREATMENT SERVICES, REHABILITATION OF DRUG AND ALCOHOL ADDICTED PATIENTS, AND BEHAVIORAL HEALTH SERVICES, NAMELY, MENTAL HEALTH SERVICES (U.S. CLS. 100 AND 101).

FIRST USE 6-30-2010; IN COMMERCE 6-30-2010.

3,963,333. ST. DOMINIC JACKSON MEMORIAL HOSPITAL, JACKSON, MS. SN 85-006,187. PUB. 8-31-2010, FILED 4-5-2010.

Living the Mission

THE MARK CONSISTS OF STANDARD CHARACTERS WITHOUT CLAIM TO ANY PARTICULAR FONT, STYLE, SIZE, OR COLOR.

FOR MEDICAL SERVICES (U.S. CLS. 100 AND 101).  
FIRST USE 12-1-2010; IN COMMERCE 12-1-2010.

**CLASS 44—(Continued).**

3,963,373. HILARY J. CHOLHAN, MD, ROCHESTER, NY. SN 85-011,950. PUB. 9-14-2010, FILED 4-12-2010.



THE MARK CONSISTS OF A STYLISTIC "Y" OVERLAID WITH A CONTRASTING ARCUATE EDGED TRIANGLE HAVING A DEPENDING STEM.

FOR HEALTH CARE SERVICES, NAMELY, THE COMPREHENSIVE, DIAGNOSTIC AND THERAPEUTIC CARE FOR WOMEN WITH GENERAL GYNECOLOGIC DISORDERS, PELVIC FLOOR DYSFUNCTION, INCLUDING PELVIC ORGAN PROLAPSE AND LOWER URINARY TRACT CONDITIONS (U.S. CLS. 100 AND 101).

FIRST USE 4-1-2010; IN COMMERCE 4-1-2010.

3,963,407. NULINE PHARMACEUTICALS INC., GLENDALE, CA. SN 85-022,283. PUB. 10-5-2010, FILED 4-23-2010.

**NULINE PHARMACEUTICALS**

THE MARK CONSISTS OF STANDARD CHARACTERS WITHOUT CLAIM TO ANY PARTICULAR FONT, STYLE, SIZE, OR COLOR.

NO CLAIM IS MADE TO THE EXCLUSIVE RIGHT TO USE "PHARMACEUTICALS", APART FROM THE MARK AS SHOWN.

FOR PHARMACEUTICAL SERVICES, NAMELY, DISPENSING OF PHARMACEUTICALS FOR PHYSICIANS' PATIENTS WITHIN THE PHYSICIANS' OFFICES (U.S. CLS. 100 AND 101).

FIRST USE 7-13-2010; IN COMMERCE 7-13-2010.

3,963,421. ANDRE H. BRUNI, BATON ROUGE, LA. SN 85-025,553. PUB. 10-5-2010, FILED 4-28-2010.

**Sensible Dental**

THE MARK CONSISTS OF STANDARD CHARACTERS WITHOUT CLAIM TO ANY PARTICULAR FONT, STYLE, SIZE, OR COLOR.

**CLASS 44—(Continued).**

NO CLAIM IS MADE TO THE EXCLUSIVE RIGHT TO USE "DENTAL", APART FROM THE MARK AS SHOWN.

FOR COSMETIC DENTISTRY; DENTISTRY (U.S. CLS. 100 AND 101).

FIRST USE 11-29-2010; IN COMMERCE 11-29-2010.

3,963,493. METRO INFECTIOUS DISEASE CONSULTANTS, L.L.C., HINSDALE, IL. SN 85-042,969. PUB. 10-26-2010, FILED 5-19-2010.

**METRO INFUSION CENTER**

THE MARK CONSISTS OF STANDARD CHARACTERS WITHOUT CLAIM TO ANY PARTICULAR FONT, STYLE, SIZE, OR COLOR.

NO CLAIM IS MADE TO THE EXCLUSIVE RIGHT TO USE "INFUSION CENTER", APART FROM THE MARK AS SHOWN.

FOR MEDICAL SERVICES; PERFORMING DIAGNOSIS OF DISEASES; MEDICAL TESTING FOR DIAGNOSTIC OR TREATMENT PURPOSES; TREATMENT OF INFECTIONS WITH ORAL AND INTRAVENOUS MEDICATIONS; MEDICAL SERVICES, NAMELY, PROVIDING INFUSION THERAPY SERVICES; NURSING SERVICES; INFUSION MANAGEMENT, NAMELY, ADMINISTERING OF INTRAVENOUS DRUGS, FOOD AND HYDRATION THROUGH INFUSION THERAPY (U.S. CLS. 100 AND 101).

FIRST USE 10-17-2002; IN COMMERCE 8-0-2004.

3,963,513. WMWC, LLC, LAS VEGAS, NV. SN 85-047,621. PUB. 10-26-2010, FILED 5-25-2010.

**WhyDiet? Weight Management  
& Wellness Center**

THE MARK CONSISTS OF STANDARD CHARACTERS WITHOUT CLAIM TO ANY PARTICULAR FONT, STYLE, SIZE, OR COLOR.

NO CLAIM IS MADE TO THE EXCLUSIVE RIGHT TO USE "WEIGHT MANAGEMENT & WELLNESS CENTER", APART FROM THE MARK AS SHOWN.

FOR WEIGHT MANAGEMENT SERVICES, NAMELY, PROVIDING WEIGHT LOSS AND/OR WEIGHT MAINTENANCE PROGRAMS (U.S. CLS. 100 AND 101).

FIRST USE 1-3-2011; IN COMMERCE 1-3-2011.

**CLASS 44—(Continued).**

3,963,518. UNITED AUBURN INDIAN COMMUNITY, LINCOLN, CA. SN 85-048,696. PUB. 7-27-2010, FILED 5-26-2010.

**SPA AT THUNDER VALLEY**

THE MARK CONSISTS OF STANDARD CHARACTERS WITHOUT CLAIM TO ANY PARTICULAR FONT, STYLE, SIZE, OR COLOR.

NO CLAIM IS MADE TO THE EXCLUSIVE RIGHT TO USE "SPA", APART FROM THE MARK AS SHOWN.

FOR COSMETICIAN SERVICES; DAY SPA SERVICES, NAMELY, NAIL CARE, MANICURES, PEDICURES AND NAIL ENHANCEMENTS; HEALTH SPA SERVICES FOR HEALTH AND WELLNESS OF THE BODY AND SPIRIT, NAMELY, PROVIDING MASSAGE, FACIAL AND BODY TREATMENT SERVICES, COSMETIC BODY CARE SERVICES (U.S. CLS. 100 AND 101).

FIRST USE 7-1-2010; IN COMMERCE 7-1-2010.

---

3,963,649. MELANIE M. KATES, M.D., P.C., PENFIELD, NY. SN 85-086,138. PUB. 12-14-2010, FILED 7-16-2010.

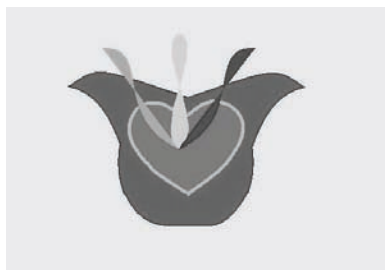

THE MARK CONSISTS OF A TULIP SHAPE WITH A HEART INSIDE. THREE WAVY LINES EXTEND FROM THE HEART UP THROUGH AND PAST THE OUTSIDE EDGE OF THE TULIP SHAPE.

FOR MEDICAL SERVICES, NAMELY, INTEGRATIVE INTERNAL MEDICINE AND ENERGY THERAPY (U.S. CLS. 100 AND 101).

FIRST USE 7-19-2010; IN COMMERCE 7-19-2010.

**CLASS 44—(Continued).**

3,963,655. HEART & VASCULAR INSTITUTE PLLC, DETROIT, MI. SN 85-087,412. PUB. 1-4-2011, FILED 7-19-2010.



NO CLAIM IS MADE TO THE EXCLUSIVE RIGHT TO USE "HEART & VASCULAR INSTITUTE", "CARDIOVASCULAR" AND THE CADUCEUS SYMBOL, APART FROM THE MARK AS SHOWN.

THE MARK CONSISTS OF A CIRCLE WITH A SECOND THINNER-LINED CIRCLE INSIDE WITH A THICKER DARK LINED CIRCLE INSIDE CONTAINING A DOT THEN THE WORDS "HEART & VASCULAR INSTITUTE" FOLLOWED BY A DOT THEN THE WORDS "CARDIOVASCULAR EXCELLENCE" WITH A CIRCLE INSIDE DIVIDED INTO 4 QUADRANTS WITH AN X AND BEGINNING ON THE LEFT THERE IS AN OPEN BOOK IN THE LEFT QUADRANT, A HEART MUSCLE IN THE TOP QUADRANT, A CADUCEUS (SERPENT AND STAFF) MEDICAL SYMBOL IN THE RIGHT QUADRANT AND A HUMAN OUTLINE WITH THE VASCULAR SYSTEM DISPLAYED IN THE BOTTOM QUADRANT.

FOR MEDICAL SERVICES, NAMELY, HEART AND VASCULAR TREATMENT, CONSULTANCY AND SURGERY (U.S. CLS. 100 AND 101).

FIRST USE 7-19-2010; IN COMMERCE 7-19-2010.

---

3,963,671. VIRTUA HEALTH, INC., MARLTON, NJ. SN 85-095,482. PUB. 12-7-2010, FILED 7-29-2010.

**EXUBERAN**

THE MARK CONSISTS OF STANDARD CHARACTERS WITHOUT CLAIM TO ANY PARTICULAR FONT, STYLE, SIZE, OR COLOR.

FOR HEALTH CARE SERVICES (U.S. CLS. 100 AND 101).

FIRST USE 10-7-2010; IN COMMERCE 10-15-2010.

---

**CLASS 45—PERSONAL AND LEGAL SERVICES**

**CLASS 45—(Continued).**

3,962,270. IT'S JUST LUNCH INTERNATIONAL LLC, PALM DESERT, CA. SN 77-662,686. PUB. 5-26-2009, FILED 2-3-2009.

## IT'S SIMPLY LUNCH

THE MARK CONSISTS OF STANDARD CHARACTERS WITHOUT CLAIM TO ANY PARTICULAR FONT, STYLE, SIZE, OR COLOR.

OWNER OF U.S. REG. NO. 1,821,901.  
FOR DATING SERVICES (U.S. CLS. 100 AND 101).  
FIRST USE 7-0-2009; IN COMMERCE 12-0-2010.

---

3,962,325. PERFECT 10, INC., BEVERLY HILLS, CA. SN 77-693,234. PUB. 7-14-2009, FILED 3-17-2009.

## Perfect 10

THE MARK CONSISTS OF STANDARD CHARACTERS WITHOUT CLAIM TO ANY PARTICULAR FONT, STYLE, SIZE, OR COLOR.

FOR COMPUTER DATING SERVICES; DATING SERVICES; DATING SERVICES, NAMELY, PROVIDING AN ON-LINE COMPUTER DATABASE FEATURING SINGLE PEOPLE INTERESTED IN MEETING OTHER SINGLE PEOPLE; INTERNET BASED SOCIAL NETWORKING, INTRODUCTION, AND DATING SERVICES; INTERNET-BASED DATING, SOCIAL INTRODUCTION AND SOCIAL NETWORKING SERVICES; MARRIAGE PARTNER INTRODUCTION OR DATING SERVICES; MATCHMAKING SERVICES; PROVIDING A WEB SITE FEATURING INFORMATION AND CONTENT IN THE FIELDS OF PERSONAL RELATIONSHIPS, DATING AND FASHION; SOCIAL INTRODUCTION AGENCIES; VIDEO DATING SERVICES; WEB SITE SERVICES FEATURING ON-LINE DATING CLUB (U.S. CLS. 100 AND 101).

FIRST USE 8-25-1997; IN COMMERCE 8-25-1997.

**CLASS 45—(Continued).**

3,962,360. KIKINI LIMITED, SAN DIEGO, CA. SN 77-719,415. PUB. 10-6-2009, FILED 4-22-2009.

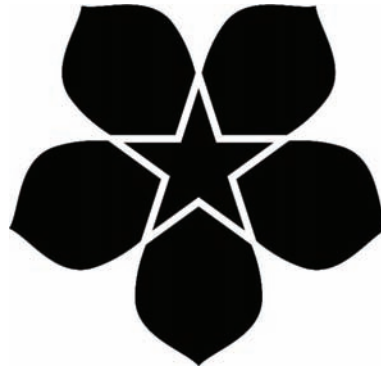

THE MARK CONSISTS OF A STAR WITHIN THE PETALS OF A FLOWER.

FOR COMPUTER DATING SERVICES; DATING SERVICES, NAMELY, PROVIDING AN ON-LINE COMPUTER DATABASE FEATURING SINGLE PEOPLE INTERESTED IN MEETING OTHER SINGLE PEOPLE; INTERNET-BASED DATING, SOCIAL INTRODUCTION AND SOCIAL NETWORKING SERVICES; PROVIDING A WEB SITE FEATURING INFORMATION AND CONTENT IN THE FIELDS OF PERSONAL RELATIONSHIPS, DATING AND FASHION; PROVIDING AN INTERACTIVE WEB SITE FOR PERSONS TO LOCATE OTHER INDIVIDUALS WITH SIMILAR INTERESTS TO PARTICIPATE WITH THEM IN, OR ACCOMPANY THEM TO, EVENTS AND ACTIVITIES (U.S. CLS. 100 AND 101).

FIRST USE 9-28-2010; IN COMMERCE 9-28-2010.

---

3,962,451. KATHLEEN TAYLOR, SAN DIEGO, CA. SN 77-782,814. PUB. 12-8-2009, FILED 7-16-2009.

## ATTAGIRL

THE MARK CONSISTS OF STANDARD CHARACTERS WITHOUT CLAIM TO ANY PARTICULAR FONT, STYLE, SIZE, OR COLOR.

FOR ONLINE SOCIAL NETWORKING SERVICES (U.S. CLS. 100 AND 101).

FIRST USE 1-20-2011; IN COMMERCE 1-20-2011.

**CLASS 45—(Continued).**

3,962,549. OHIO STATE BAR ASSOCIATION, COLUMBUS, OH. SN 77-815,914. PUB. 7-27-2010, FILED 8-29-2009.

# OHIODOCS

THE MARK CONSISTS OF STANDARD CHARACTERS WITHOUT CLAIM TO ANY PARTICULAR FONT, STYLE, SIZE, OR COLOR.

FOR PROVIDING A COMPUTER DATABASE OF ELECTRONIC LEGAL FORMS FOR USE IN THE PRACTICE OF LAW (U.S. CLS. 100 AND 101).

FIRST USE 2-8-2011; IN COMMERCE 2-8-2011.

---

3,962,641. BARBARA JOHANSEN NEWMAN, NEEDHAM, MA. SN 77-847,238. PUB. 8-10-2010, FILED 10-13-2009.

# REALLY REALLY RETRO

THE MARK CONSISTS OF STANDARD CHARACTERS WITHOUT CLAIM TO ANY PARTICULAR FONT, STYLE, SIZE, OR COLOR.

NO CLAIM IS MADE TO THE EXCLUSIVE RIGHT TO USE "RETRO", APART FROM THE MARK AS SHOWN.

FOR LICENSING OF GRAPHIC DESIGNS (U.S. CLS. 100 AND 101).

FIRST USE 5-17-2009; IN COMMERCE 3-10-2011.

---

3,962,692. DONALD CREADORE, NEW YORK, NY. SN 77-861,769. PUB. 9-14-2010, FILED 10-30-2009.

# PYROESQ

THE MARK CONSISTS OF STANDARD CHARACTERS WITHOUT CLAIM TO ANY PARTICULAR FONT, STYLE, SIZE, OR COLOR.

FOR LEGAL SERVICES (U.S. CLS. 100 AND 101).

FIRST USE 1-1-2005; IN COMMERCE 11-1-2010.

**CLASS 45—(Continued).**

3,962,729. MIKAYELYAN, GRIGORI, GLENDALE, CA. SN 77-881,224. PUB. 8-3-2010, FILED 11-25-2009.



NO CLAIM IS MADE TO THE EXCLUSIVE RIGHT TO USE "LINKED", APART FROM THE MARK AS SHOWN.

THE COLOR(S) PINK AND BLUE IS/ARE CLAIMED AS A FEATURE OF THE MARK.

THE MARK CONSISTS OF THE LETTER "D" CAPITALIZED IN PINK AND TURNED BACKWARDS, IN FRONT OF THE WORD "LINKED" THAT IS LOWER CASE IN BLUE.

FOR ON-LINE SOCIAL NETWORKING SERVICES (U.S. CLS. 100 AND 101).

FIRST USE 2-28-2011; IN COMMERCE 2-28-2011.

---

3,962,768. ART U TRADE LLC, TUCSON, AZ. SN 77-889,594. PUB. 8-31-2010, FILED 12-9-2009.



THE COLOR(S) BLACK AND RED IS/ARE CLAIMED AS A FEATURE OF THE MARK.

THE MARK CONSISTS OF THE FOLLOWING: THE WORDING "ART U TRADE" IN BLACK AND TWO RED TRIANGLES ON EITHER SIDE OF THE WORD "U".

FOR ON LINE SOCIAL NETWORKING SERVICES PROVIDED THROUGH AN ART COMMUNITY WEB SITE (U.S. CLS. 100 AND 101).

FIRST USE 12-1-2009; IN COMMERCE 12-1-2009.

---

3,962,818. COMMITTED U, SEBASTOPOL, CA. SN 77-906,515. PUB. 5-25-2010, FILED 1-6-2010.

# COMMITTED U

THE MARK CONSISTS OF STANDARD CHARACTERS WITHOUT CLAIM TO ANY PARTICULAR FONT, STYLE, SIZE, OR COLOR.

FOR PERSONAL GROWTH AND MOTIVATION CONSULTING SERVICES (U.S. CLS. 100 AND 101).

FIRST USE 2-23-2009; IN COMMERCE 2-23-2009.



**CLASS 45—(Continued).**

3,962,824. BRAINSTORMS, INC., SANTA FE, NM. SN 77-908,562. PUB. 4-27-2010, FILED 1-10-2010.

**CLASS 45—(Continued).**

3,962,830. BIG HAIR & PINK GUITARS, NEW YORK, NY. SN 77-909,658. PUB. 5-25-2010, FILED 1-12-2010.

**DIABETES WARRIORS**

THE MARK CONSISTS OF STANDARD CHARACTERS WITHOUT CLAIM TO ANY PARTICULAR FONT, STYLE, SIZE, OR COLOR.

NO CLAIM IS MADE TO THE EXCLUSIVE RIGHT TO USE "DIABETES", APART FROM THE MARK AS SHOWN. FOR ORGANIZING AND CONDUCTING SUPPORT GROUPS IN THE FIELDS OF HEALTH, WELLNESS AND DISEASE PREVENTION (U.S. CLS. 100 AND 101). FIRST USE 1-7-2011; IN COMMERCE 1-7-2011.

**BECAUSE SUICIDE IS JUST SO FINAL**

THE MARK CONSISTS OF STANDARD CHARACTERS WITHOUT CLAIM TO ANY PARTICULAR FONT, STYLE, SIZE, OR COLOR.

FOR COMPUTER DATING SERVICES; DATING SERVICES; DATING SERVICES, NAMELY, PROVIDING AN ON-LINE COMPUTER DATABASE FEATURING SINGLE PEOPLE INTERESTED IN MEETING OTHER SINGLE PEOPLE; INTERNET BASED SOCIAL NETWORKING, INTRODUCTION, AND DATING SERVICES; INTERNET-BASED DATING, SOCIAL INTRODUCTION AND SOCIAL NETWORKING SERVICES; MARRIAGE PARTNER INTRODUCTION OR DATING SERVICES; PROVIDING A WEB SITE FEATURING INFORMATION AND CONTENT IN THE FIELDS OF PERSONAL RELATIONSHIPS, DATING AND FASHION; PROVIDING ON-LINE COMPUTER DATABASES AND ON-LINE SEARCHABLE DATABASES IN THE FIELD OF SOCIAL NETWORKING; WEB SITE SERVICES FEATURING ON-LINE DATING CLUB (U.S. CLS. 100 AND 101). FIRST USE 3-31-2011; IN COMMERCE 3-31-2011.

3,962,828. BIG HAIR & PINK GUITARS, LLC, NEW YORK, NY. SN 77-909,189. PUB. 5-25-2010, FILED 1-11-2010.

3,962,831. BIG HAIR & PINK GUITARS, NEW YORK, NY. SN 77-909,662. PUB. 5-25-2010, FILED 1-12-2010.

**JADED LOVERS**

THE MARK CONSISTS OF STANDARD CHARACTERS WITHOUT CLAIM TO ANY PARTICULAR FONT, STYLE, SIZE, OR COLOR.

FOR DATING SERVICES, NAMELY, PROVIDING AN ON-LINE COMPUTER DATABASE FEATURING SINGLE PEOPLE INTERESTED IN MEETING OTHER SINGLE PEOPLE; INTERNET BASED SOCIAL NETWORKING, INTRODUCTION, AND DATING SERVICES; INTERNET-BASED DATING, SOCIAL INTRODUCTION AND SOCIAL NETWORKING SERVICES; MARRIAGE PARTNER INTRODUCTION OR DATING SERVICES; PROVIDING ON-LINE COMPUTER DATABASES AND ON-LINE SEARCHABLE DATABASES IN THE FIELD OF SOCIAL NETWORKING; WEB SITE SERVICES FEATURING ON-LINE DATING CLUB (U.S. CLS. 100 AND 101).

FIRST USE 3-31-2011; IN COMMERCE 3-31-2011.

**100% ACTUAL PEOPLE. NO ROBOTS, NO FALSE MEMBERS**

THE MARK CONSISTS OF STANDARD CHARACTERS WITHOUT CLAIM TO ANY PARTICULAR FONT, STYLE, SIZE, OR COLOR.

FOR COMPUTER DATING SERVICES; COMPUTER SECURITY SERVICES IN THE NATURE OF PROVIDING AN INTERNET TRUST CENTER, NAMELY, COMPUTER SECURITY ASSURANCE AND ADMINISTRATION OF DIGITAL KEYS AND DIGITAL CERTIFICATES; DATING SERVICES; DATING SERVICES, NAMELY, PROVIDING AN ON-LINE COMPUTER DATABASE FEATURING SINGLE PEOPLE INTERESTED IN MEETING OTHER SINGLE PEOPLE; INTERNET BASED SOCIAL NETWORKING, INTRODUCTION, AND DATING SERVICES; INTERNET-BASED DATING, SOCIAL INTRODUCTION AND SOCIAL NETWORKING SERVICES; MARRIAGE PARTNER INTRODUCTION OR DATING SERVICES; PROVIDING ON-LINE COMPUTER DATABASES AND ON-LINE SEARCHABLE DATABASES IN THE FIELD OF SOCIAL NETWORKING; WEB SITE SERVICES FEATURING ON-LINE DATING CLUB (U.S. CLS. 100 AND 101). FIRST USE 3-31-2011; IN COMMERCE 3-31-2011.

**CLASS 45—(Continued).**

3,962,832. BIG HAIR & PINK GUITARS, NEW YORK, NY. SN 77-909,669. PUB. 5-25-2010, FILED 1-12-2010.

**THIS SITE CONTAINS NO  
PHONY MEMBERS**

THE MARK CONSISTS OF STANDARD CHARACTERS WITHOUT CLAIM TO ANY PARTICULAR FONT, STYLE, SIZE, OR COLOR.

FOR COMPUTER DATING SERVICES; COMPUTER SECURITY SERVICES IN THE NATURE OF PROVIDING AN INTERNET TRUST CENTER, NAMELY, COMPUTER SECURITY ASSURANCE AND ADMINISTRATION OF DIGITAL KEYS AND DIGITAL CERTIFICATES; DATING SERVICES; DATING SERVICES, NAMELY, PROVIDING AN ON-LINE COMPUTER DATABASE FEATURING SINGLE PEOPLE INTERESTED IN MEETING OTHER SINGLE PEOPLE; INTERNET BASED SOCIAL NETWORKING, INTRODUCTION, AND DATING SERVICES; INTERNET-BASED DATING, SOCIAL INTRODUCTION AND SOCIAL NETWORKING SERVICES; MARRIAGE PARTNER INTRODUCTION OR DATING SERVICES; ON-LINE IDENTITY RELIABILITY INVESTIGATION IN THE FIELD OF ON-LINE DATING AND CLAIMS MADE ABOUT AGE, GENDER; PROVIDING A WEB SITE FEATURING INFORMATION AND CONTENT IN THE FIELDS OF PERSONAL RELATIONSHIPS, DATING AND FASHION; PROVIDING ON-LINE COMPUTER DATABASES AND ON-LINE SEARCHABLE DATABASES IN THE FIELD OF SOCIAL NETWORKING; VIDEO DATING SERVICES; WEB SITE SERVICES FEATURING ON-LINE DATING CLUB (U.S. CLS. 100 AND 101).

FIRST USE 3-31-2011; IN COMMERCE 3-31-2011.

3,962,897. ADIB NASLE, POWAY, CA. SN 77-927,054. PUB. 6-22-2010, FILED 2-3-2010.

**XENDEE**

THE MARK CONSISTS OF STANDARD CHARACTERS WITHOUT CLAIM TO ANY PARTICULAR FONT, STYLE, SIZE, OR COLOR.

FOR INTERNET-BASED SOCIAL NETWORKING SERVICES (U.S. CLS. 100 AND 101).

FIRST USE 8-1-2010; IN COMMERCE 8-1-2010.

**CLASS 45—(Continued).**

3,962,898. ADIB NASLE, POWAY, CA. SN 77-927,084. PUB. 6-22-2010, FILED 2-3-2010.

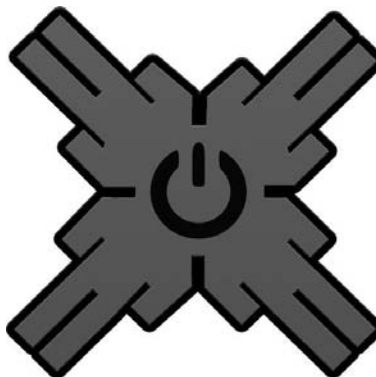

THE MARK CONSISTS OF A STYLIZED LOGO OF PEOPLE PUTTING THEIR HEADS TOGETHER AND COLLABORATING. A SINGLE HEAD WITH A POWER THERE IS THE INTERNATIONAL POWER ON/OFF ICON IN THE CENTER WHERE THE HEADS COME TOGETHER.

FOR ON-LINE SOCIAL NETWORKING SERVICES (U.S. CLS. 100 AND 101).

FIRST USE 8-1-2010; IN COMMERCE 8-1-2010.

3,962,986. TWO'S COMPANY RELATIONSHIPS BY DESIGN, LLC, ALPHARETTA, GA. SN 77-943,523. PUB. 7-20-2010, FILED 2-24-2010.

**TWO'S COMPANY  
RELATIONSHIPS BY DESIGN**

THE MARK CONSISTS OF STANDARD CHARACTERS WITHOUT CLAIM TO ANY PARTICULAR FONT, STYLE, SIZE, OR COLOR.

OWNER OF U.S. REG. NO. 2,336,506.

FOR DATING SERVICES (U.S. CLS. 100 AND 101).

FIRST USE 2-18-2010; IN COMMERCE 10-1-2010.

3,963,136. BINH NGUYEN, DBA INTELLECTUAL GARDEN, RENO, NV. SN 77-960,190. PUB. 7-27-2010, FILED 3-16-2010.

**Patent Pipeline**

THE MARK CONSISTS OF STANDARD CHARACTERS WITHOUT CLAIM TO ANY PARTICULAR FONT, STYLE, SIZE, OR COLOR.

**CLASS 45—(Continued).**

NO CLAIM IS MADE TO THE EXCLUSIVE RIGHT TO USE "PATENT", APART FROM THE MARK AS SHOWN.

FOR PATENT AGENT SERVICES; PATENT AND INTELLECTUAL PROPERTY CONSULTATION; PATENT LICENSING; PROVIDING A WEB SITE FEATURING INFORMATION ABOUT PATENTS AND PATENT APPLICATIONS; PROVIDING AN ONLINE SEARCHABLE DATABASE IN THE FIELD OF PATENT APPLICATIONS (U.S. CLS. 100 AND 101).

FIRST USE 10-1-2010; IN COMMERCE 10-1-2010.

3,963,322. CONNECTICUT ATTORNEYS TITLE INSURANCE COMPANY, ROCKY HILL, CT. SN 85-003,864. PUB. 8-24-2010, FILED 4-1-2010.

**RESPA RELIEF**

THE MARK CONSISTS OF STANDARD CHARACTERS WITHOUT CLAIM TO ANY PARTICULAR FONT, STYLE, SIZE, OR COLOR.

NO CLAIM IS MADE TO THE EXCLUSIVE RIGHT TO USE "RESPA", APART FROM THE MARK AS SHOWN.

FOR LEGAL CONSULTATION REGARDING REAL PROPERTY LAW (U.S. CLS. 100 AND 101).

FIRST USE 12-11-2009; IN COMMERCE 12-11-2009.

3,963,348. HOME INSTEAD, INC., OMAHA, NE. SN 85-008,025. PUB. 9-7-2010, FILED 4-7-2010.

**50-50 RULE**

THE MARK CONSISTS OF STANDARD CHARACTERS WITHOUT CLAIM TO ANY PARTICULAR FONT, STYLE, SIZE, OR COLOR.

OWNER OF U.S. REG. NOS. 3,691,159 AND 3,691,160.

FOR PROVIDING EMOTIONAL SUPPORT AND RESOURCES FEATURING OPEN FORUM DISCUSSIONS BETWEEN SIBLINGS ABOUT CARING FOR THEIR AGING PARENTS AND SHARING RESPONSIBILITIES EQUALLY IN THE FIELD OF PROVIDING CARE TO PARENTS AND THE ELDERLY AND VARIOUS OTHER SENIOR TOPICS; PROVIDING ONLINE INFORMATION RELATING TO DISCUSSIONS BETWEEN SIBLINGS WITH ABOUT CARING FOR THEIR AGING PARENTS AND SHARING RESPONSIBILITIES EQUALLY AND PERSONAL SERVICES (U.S. CLS. 100 AND 101).

FIRST USE 2-1-2011; IN COMMERCE 2-1-2011.

**CLASS 45—(Continued).**

3,963,394. LANGFORD, MICHAEL, LOUISVILLE, KY. SN 85-018,103. PUB. 9-21-2010, FILED 4-20-2010.

**SIT4US**

THE MARK CONSISTS OF STANDARD CHARACTERS WITHOUT CLAIM TO ANY PARTICULAR FONT, STYLE, SIZE, OR COLOR.

FOR BABYSITTING SERVICES (U.S. CLS. 100 AND 101).

FIRST USE 6-0-2010; IN COMMERCE 6-0-2010.

3,963,410. AIRBED & BREAKFAST, INC., SAN FRANCISCO, CA. SN 85-023,226. PUB. 9-28-2010, FILED 4-26-2010.

**AIRBNB**

THE MARK CONSISTS OF STANDARD CHARACTERS WITHOUT CLAIM TO ANY PARTICULAR FONT, STYLE, SIZE, OR COLOR.

FOR PROVIDING A SOCIAL NETWORKING WEB SITE FOR ENTERTAINMENT PURPOSES (U.S. CLS. 100 AND 101).

FIRST USE 3-4-2009; IN COMMERCE 3-4-2009.

3,963,427. LIFE RESET BUTTON, LLC, MERRITT ISLAND, FL. SN 85-026,604. PUB. 9-7-2010, FILED 4-29-2010.

**LIFE RESET BUTTON**

THE MARK CONSISTS OF STANDARD CHARACTERS WITHOUT CLAIM TO ANY PARTICULAR FONT, STYLE, SIZE, OR COLOR.

FOR ON-LINE SOCIAL NETWORKING SERVICES (U.S. CLS. 100 AND 101).

FIRST USE 5-28-2010; IN COMMERCE 1-19-2011.

**CLASS 45—(Continued).**

3,963,517. LBB ENTERPRISES, LLC, DBA IDIGYA, HENDERSON, NV. SN 85-048,380. PUB. 10-26-2010, FILED 5-26-2010.

# IDIGYA

THE MARK CONSISTS OF STANDARD CHARACTERS WITHOUT CLAIM TO ANY PARTICULAR FONT, STYLE, SIZE, OR COLOR.

FOR INTERNET BASED SOCIAL NETWORKING, INTRODUCTION, AND DATING SERVICES (U.S. CLS. 100 AND 101).

FIRST USE 5-26-2010; IN COMMERCE 6-1-2010.

**CLASS 45—(Continued).**

3,963,629. TRUSTEES OF THE PWC BUSINESS TRUST, THE, NEW YORK, NY. SN 85-080,749. PUB. 10-12-2010, FILED 7-8-2010.



OWNER OF U.S. REG. NOS. 2,579,070, 2,591,914, AND OTHERS.

THE MARK CONSISTS OF THE LETTERS "PWC" IN A STYLIZED FORM.

FOR ADVICE AND CONSULTANCY ON ENVIRONMENTAL REGULATORY MATTERS; ANALYSIS OF DATA, POLICY AND PROCESS, AND PROVISION OF BUSINESS MANAGEMENT ADVICE AND ASSISTANCE TO ENSURE COMPLIANCE WITH PUBLIC SECTOR PROCUREMENT LAWS AND REGULATIONS; CONSULTATION IN THE FIELD OF DATA THEFT AND IDENTITY THEFT; CONSULTING SERVICES IN THE FIELD OF PRIVACY AND SECURITY LAWS, REGULATIONS, AND REQUIREMENTS; CONSULTING SERVICES IN THE FIELD OF LISTING AND TRACKING OF FOREIGN AND DOMESTIC GOVERNMENT REGULATORY REQUIREMENTS, FOR OBTAINING PERMITS AND REGULATORY COMPLIANCE; INTELLECTUAL PROPERTY CONSULTATION; LITIGATION SUPPORT SERVICES; PROVIDING INFORMATION ABOUT INTELLECTUAL AND INDUSTRIAL PROPERTY RIGHTS; REGULATORY COMPLIANCE SERVICES, NAMELY, REVIEWING STANDARDS AND PRACTICES TO ASSIST CLIENTS WITH COMPLIANCE WITH GOVERNMENTAL LAWS, REGULATIONS AND RULES IN THE FIELDS OF BANKING AND CAPITAL MARKETS, INSURANCE, ASSET MANAGEMENT, TAX, ACCOUNTING, AUDITING, FINANCIAL SERVICES, EXPORT CONTROLS AND CUSTOMS, FOOD SAFETY, MEDICAL DEVICES, ANTI-BRIBERY AND CORRUPTION, PHARMACEUTICALS AND LIFE SCIENCES, EMPLOYEE BENEFITS, CLIMATE CHANGE, UTILITIES, ENERGY, HEALTH CARE, TELECOMMUNICATIONS, DATA PRIVACY, AUTOMOTIVE, AND HOSPITALITY AND LEISURE; SECURITY SERVICES, NAMELY, PROVIDING SECURITY ASSESSMENTS OF PHYSICAL LOCATIONS, INFORMATION SYSTEMS, AND WORKING ENVIRONMENTS; EXPERT WITNESS SERVICES IN THE FIELDS OF SECURITIES, FORENSIC ACCOUNTING, INTELLECTUAL PROPERTY, CYBER CRIMES, INFORMATION TECHNOLOGY, LEGAL DAMAGES ASSESSMENT, COMPLEX BUSINESS DISPUTES, CONSTRUCTION DISPUTES, HEALTHCARE FRAUD AND DISPUTES; ARBITRATION SERVICES; LITIGATION AND DISPUTE RESOLUTION SUPPORT SERVICES; PROVISION OF INFORMATION ON-LINE PERTAINING TO ALL OF THE ABOVE (U.S. CLS. 100 AND 101).

FIRST USE 9-16-2010; IN COMMERCE 9-16-2010.

3,963,537. P & L SAFETY, LLC, BRECKSVILLE, OH. SN 85-056,199. PUB. 1-4-2011, FILED 6-7-2010.

# P & L SAFETY, LLC

THE MARK CONSISTS OF STANDARD CHARACTERS WITHOUT CLAIM TO ANY PARTICULAR FONT, STYLE, SIZE, OR COLOR.

NO CLAIM IS MADE TO THE EXCLUSIVE RIGHT TO USE "SAFETY, LLC", APART FROM THE MARK AS SHOWN.

FOR CONSULTING IN THE FIELD OF WORKPLACE SAFETY (U.S. CLS. 100 AND 101).

FIRST USE 3-10-2010; IN COMMERCE 12-15-2010.

3,963,578. DIGAAI WORLD, INC., JAMAICA PLAIN, MA. SN 85-068,760. PUB. 11-16-2010, FILED 6-22-2010.

# Digaai

THE MARK CONSISTS OF STANDARD CHARACTERS WITHOUT CLAIM TO ANY PARTICULAR FONT, STYLE, SIZE, OR COLOR.

THE ENGLISH TRANSLATION OF "DIGAAI" IN THE MARK IS "WHAT'S HAPPENING?", A TERM IN BRAZILIAN SLANG.

FOR ON-LINE SOCIAL NETWORKING SERVICES (U.S. CLS. 100 AND 101).

FIRST USE 1-1-2011; IN COMMERCE 1-1-2011.

**CLASS 45—(Continued).**

3,963,631. TRUSTEES OF THE PWC BUSINESS TRUST, THE, NEW YORK, NY. SN 85-081,134. PUB. 10-12-2010, FILED 7-9-2010.



OWNER OF U.S. REG. NOS. 2,579,070, 2,591,914, AND OTHERS.

THE COLOR(S) BLACK, DARK BURGUNDY, DARK RED, BROWN, DARK ORANGE, ORANGE, LIGHT ORANGE, PINK, RED, YELLOW AND BEIGE IS/ARE CLAIMED AS A FEATURE OF THE MARK.

THE MARK CONSISTS OF THE WORDING "PWC" IN

**CLASS 45—(Continued).**

BLACK BELOW A GEOMETRIC DESIGN FORMED BY A SERIES OF FIVE OVERLAPPING SQUARES AND RECTANGLES CONNECTED IN THE BOTTOM LEFT CORNER TO A SINGLE SHORT RECTANGLE. THE COLORS USED WITHIN THE SYMBOL ARE DARK BURGUNDY, DARK RED, BROWN, DARK ORANGE, ORANGE, LIGHT ORANGE, PINK, RED, YELLOW, AND BEIGE. THE DARK BURGUNDY COLOR ALSO APPEARS IN THE SHORT SINGLE RECTANGLE THAT DOES NOT OVERLAP ANY OF THE OTHER SHAPES.

FOR ADVICE AND CONSULTANCY ON ENVIRONMENTAL REGULATORY MATTERS; ANALYSIS OF DATA, POLICY AND PROCESS, AND PROVISION OF BUSINESS MANAGEMENT ADVICE AND ASSISTANCE TO ENSURE COMPLIANCE WITH PUBLIC SECTOR PROCUREMENT LAWS AND REGULATIONS; CONSULTATION IN THE FIELD OF DATA THEFT AND IDENTITY THEFT; CONSULTING SERVICES IN THE FIELD OF PRIVACY AND SECURITY LAWS, REGULATIONS, AND REQUIREMENTS; CONSULTING SERVICES IN THE FIELD OF LISTING AND TRACKING OF FOREIGN AND DOMESTIC GOVERNMENT REGULATORY REQUIREMENTS, FOR OBTAINING PERMITS AND REGULATORY COMPLIANCE; INTELLECTUAL PROPERTY CONSULTATION; LITIGATION SUPPORT SERVICES; PROVIDING INFORMATION ABOUT INTELLECTUAL AND INDUSTRIAL PROPERTY RIGHTS; REGULATORY COMPLIANCE SERVICES, NAMELY, REVIEWING STANDARDS AND PRACTICES TO ASSIST CLIENTS WITH COMPLIANCE WITH GOVERNMENTAL LAWS, REGULATIONS AND RULES IN THE FIELDS OF BANKING AND CAPITAL MARKETS, INSURANCE, ASSET MANAGEMENT, TAX, ACCOUNTING, AUDITING, FINANCIAL SERVICES, EXPORT CONTROLS AND CUSTOMS, FOOD SAFETY, MEDICAL DEVICES, ANTI-BRIBERY AND CORRUPTION, PHARMACEUTICALS AND LIFE SCIENCES, EMPLOYEE BENEFITS, CLIMATE CHANGE, UTILITIES, ENERGY, HEALTH CARE, TELECOMMUNICATIONS, DATA PRIVACY, AUTOMOTIVE, AND HOSPITALITY AND LEISURE; SECURITY SERVICES, NAMELY, PROVIDING SECURITY ASSESSMENTS OF PHYSICAL LOCATIONS, INFORMATION SYSTEMS, AND WORKING ENVIRONMENTS; EXPERT WITNESS SERVICES IN THE FIELDS OF SECURITIES, FORENSIC ACCOUNTING, INTELLECTUAL PROPERTY, CYBER CRIMES, INFORMATION TECHNOLOGY, LEGAL DAMAGES ASSESSMENT, COMPLEX BUSINESS DISPUTES, CONSTRUCTION DISPUTES, HEALTHCARE FRAUD AND DISPUTES; ARBITRATION SERVICES; LITIGATION AND DISPUTE RESOLUTION SUPPORT SERVICES; PROVISION OF INFORMATION ON-LINE PERTAINING TO ALL OF THE ABOVE (U.S. CLS. 100 AND 101).

FIRST USE 9-16-2010; IN COMMERCE 9-16-2010.

\* \* \* \* \*



PRIOR UNITED STATES CLASSIFICATION

APPLICATION IN ONE CLASS

COLLECTIVE MEMBERSHIP MARKS

CERTIFICATION MARKS

**CLASS 200—COLLECTIVE MEMBERSHIP**

**CLASS B—SERVICES**

3,963,414. PINNER, PATRICIA, DBA THE BELIEVE TEAM, ASHEVILLE, NC. SN 85-024,339. PUB. 10-5-2010, FILED 4-27-2010.

3,962,395. SOUTH JERSEY PARALEGAL ASSOCIATION, HADDONFIELD, NJ. SN 77-753,522. PUB. 10-20-2009, FILED 6-5-2009.

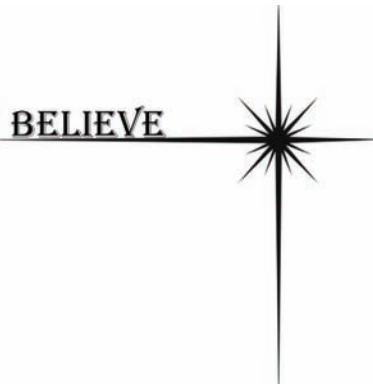

NJCP

THE MARK CONSISTS OF A STAR WITH SIXTEEN RAYS OF VARYING LENGTHS EXTENDING OUTWARDLY FROM THE CENTER. FOUR OF THE RAYS ARE NOTABLY LONGER THAN THE OTHER RAYS, FORMING A CROSS. THE WORD "BELIEVE" IS LOCATED ABOVE AND TOWARDS THE END OF THE LEFT ARM OF THE CROSS.

FOR INDICATING MEMBERSHIP IN AN ATHLETIC ASSOCIATION; TO INDICATE MEMBERSHIP IN A TRIATHLON ASSOCIATION; AND TO INDICATE MEMBERSHIP IN AN ASSOCIATION OF FEMALE ATHLETES (U.S. CL. 200).

FIRST USE 2-15-2011; IN COMMERCE 2-15-2011.

THE MARK CONSISTS OF STANDARD CHARACTERS WITHOUT CLAIM TO ANY PARTICULAR FONT, STYLE, SIZE, OR COLOR.

THE CERTIFICATION MARK, AS USED BY AUTHORIZED PERSONS, CERTIFIES THAT THE PERSON(S) USING THE MARK HAS BEEN CERTIFIED BY THE SOUTH JERSEY PARALEGAL ASSOCIATION AND HAS MET CERTAIN CRITERIA WHICH PROVIDE A BENCHMARK TO DETERMINE QUALIFIED INDIVIDUALS WHO ARE COMPETENT TO PROVIDE PARALEGAL SERVICES UNDER THE SUPERVISION OF AN ATTORNEY.

FOR PARALEGAL SERVICES (U.S. CL. B).  
FIRST USE 12-15-2010; IN COMMERCE 12-15-2010.

\* \* \* \* \*

# SUPPLEMENTAL REGISTER

These registrations are not subject to opposition.

## SECTION 1.— INTERNATIONAL CLASSIFICATION

The short titles associated below with the international class numbers are terms designed merely for quick identification and are not an official part of the international classification. The full names of international classes are given in section 6.1 of the trademark rules of practice.

The designation "U.S. Cl." appearing in this section refers to the U.S. class in effect prior to Sep. 1, 1973 rather than the international class which applies to applications filed on or after that date. For adoption of international classification see notice in the OFFICIAL GAZETTE of Jun. 26, 1973 (911 O.G. TM 210).

### Application in more than one class

3,963,731. SCHNEIDER NATIONAL, INC., GREENBAY, WI.  
SN 77-707,254. FILED P.R. 4-6-2009; AM. S.R. 4-8-2011.

#### CLASS 39—TRANSPORTATION AND STORAGE

FOR FREIGHT TRANSPORTATION CONSULTATION IN THE FIELD OF FREIGHT TRANSPORTATION BY TRUCK, RAIL, AIR AND OCEAN, NAMELY, ASSISTING OTHERS IN THE SELECTION OF FREIGHT CARRIERS; TRANSPORTATION AND SHIPPING SERVICES, NAMELY, THE TRANSPORTATION AND SHIPPING OF GOODS BY AIR, ROAD, RAIL AND SEA; TRANSLOADING AND DISTRIBUTION SERVICES, NAMELY, DELIVERY OF GOODS, NAMELY, CONSUMER PRODUCTS, MANUFACTURED PARTS, FOOD, CLOTHING, RAW MATERIALS, PHARMACEUTICALS, CLOTHING AND TEXTILES, BUILDING MATERIALS, PAPER PRODUCTS, TOYS, LIQUIDS, BEVERAGES, FUEL, GLASS, COMPUTERS, AND APPLIANCES; WAREHOUSING AND DRAY SERVICES, FREIGHT BROKERAGE, FREIGHT FORWARDING SERVICES, NAMELY, PACKING ARTICLES FOR TRANSPORTATION, TRANSPORTING OF GOODS, TRANSLOADING, FREIGHT FORWARDING AND STORAGE OF GOODS BY TRUCK, RAIL, AIR OR SEA; WAREHOUSING SERVICES, NAMELY, DISTRIBUTION OF CONSUMER GOODS, MANUFACTURING GOODS, CONSUMER ELECTRONICS, PAPER PRODUCTS, AUTOMOTIVE PARTS, GROCERY, BEVERAGES AND BEVERAGE WARE, BUILDING MATERIALS, BULK/SPECIALTY GOODS, CHEMICALS, FUELS, NAMELY, DIESEL, GASOLINE AND BIO BLENDS AND RETAIL GOODS; DISTRIBUTION SERVICES, NAMELY, DELIVERY OF FOOD, CLOTHING, RAW MATERIALS, PHARMACEUTICALS, TEXTILES, BUILDING MATERIALS, PAPER PRODUCTS, TOYS, LIQUIDS, BEVERAGES, FUEL, GLASS, COMPUTERS, AND APPLIANCES (U.S. CLS. 100 AND 105).

FIRST USE 4-24-2008; IN COMMERCE 4-24-2008.

## Schneider Logistics

THE MARK CONSISTS OF STANDARD CHARACTERS WITHOUT CLAIM TO ANY PARTICULAR FONT, STYLE, SIZE, OR COLOR.

OWNER OF U.S. REG. NOS. 1,352,131, 2,409,128, AND OTHERS.

NO CLAIM IS MADE TO THE EXCLUSIVE RIGHT TO USE "LOGISTICS", APART FROM THE MARK AS SHOWN.

#### CLASS 35—ADVERTISING AND BUSINESS

FOR TRANSPORTATION LOGISTICS AND MANAGEMENT SERVICES, NAMELY, ARRANGING FOR THE TRANSPORTATION OF THE GOODS OF OTHERS; TRANSPORTATION LOGISTICS SERVICES, NAMELY, PLANNING AND SCHEDULING SHIPMENTS FOR USERS OF TRANSPORTATION SERVICES; BUSINESS MANAGEMENT SERVICES, NAMELY, MANAGING LOGISTICS, REVERSE LOGISTICS FOR OTHERS; BUSINESS MANAGEMENT SERVICES, NAMELY, SUPPLY CHAIN LOGISTICS IN THE FIELD OF FREIGHT TRANSPORTATION OF GOODS BY TRUCK, RAIL, AIR AND SEA (U.S. CLS. 100, 101 AND 102).

FIRST USE 4-24-2008; IN COMMERCE 4-24-2008.

3,963,732. SCHNEIDER INTERNATIONAL, INC., GREENBAY, WI. SN 77-707,261. FILED P.R. 4-6-2009; AM. S.R. 4-8-2011.



OWNER OF U.S. REG. NOS. 1,352,131, 2,409,128, AND OTHERS.

NO CLAIM IS MADE TO THE EXCLUSIVE RIGHT TO USE "LOGISTICS", APART FROM THE MARK AS SHOWN.

THE COLOR(S) ORANGE AND WHITE IS/ARE CLAIMED AS A FEATURE OF THE MARK.

THE MARK CONSISTS OF THE WORD "SCHNEIDER" IN ORANGE WITH THE "N" BEING EXTENDED UNDERNEATH AS TO CREATE AN UNDERLINE WITH THE WORD "LOGISTICS" IN WHITE IN THE UNDERLINE.

**CLASS 35—ADVERTISING AND BUSINESS**

FOR TRANSPORTATION LOGISTICS AND MANAGEMENT SERVICES, NAMELY, ARRANGING FOR THE TRANSPORTATION OF THE GOODS OF OTHERS; TRANSPORTATION LOGISTICS SERVICES, NAMELY, PLANNING AND SCHEDULING SHIPMENTS FOR USERS OF TRANSPORTATION SERVICES; BUSINESS MANAGEMENT SERVICES, NAMELY, MANAGING LOGISTICS, REVERSE LOGISTICS FOR OTHERS; BUSINESS MANAGEMENT SERVICES, NAMELY, SUPPLY CHAIN LOGISTICS IN THE FIELD OF FREIGHT TRANSPORTATION OF GOODS BY TRUCK, RAIL, AIR AND SEA (U.S. CLS. 100, 101 AND 102).

FIRST USE 4-24-2008; IN COMMERCE 4-24-2008.

**CLASS 39—TRANSPORTATION AND STORAGE**

FOR FREIGHT TRANSPORTATION CONSULTATION IN THE FIELD OF FREIGHT TRANSPORTATION BY TRUCK, RAIL, AIR AND OCEAN, NAMELY, ASSISTING OTHERS IN THE SELECTION OF FREIGHT CARRIERS; TRANSPORTATION AND SHIPPING SERVICES, NAMELY, THE TRANSPORTATION AND SHIPPING OF GOODS BY AIR, ROAD, RAIL AND SEA; TRANSLOADING AND DISTRIBUTION SERVICES, NAMELY, DELIVERY OF GOODS, NAMELY, CONSUMER PRODUCTS, MANUFACTURED PARTS, FOOD, CLOTHING, RAW MATERIALS, PHARMACEUTICALS, CLOTHING AND TEXTILES, BUILDING MATERIALS, PAPER PRODUCTS, TOYS, LIQUIDS, BEVERAGES, FUEL, GLASS, COMPUTERS, AND APPLIANCES; WAREHOUSING AND DRAY SERVICES, FREIGHT BROKERAGE, FREIGHT FORWARDING SERVICES, NAMELY, PACKING ARTICLES FOR TRANSPORTATION, TRANSPORTING OF GOODS, TRANSLOADING, FREIGHT FORWARDING AND STORAGE OF GOODS BY TRUCK, RAIL, AIR OR SEA; WAREHOUSING SERVICES, NAMELY, DISTRIBUTION OF CONSUMER GOODS, MANUFACTURING GOODS, CONSUMER ELECTRONICS, PAPER PRODUCTS, AUTOMOTIVE PARTS, GROCERY, BEVERAGES AND BEVERAGE WARE, BUILDING MATERIALS, BULK/SPECIALTY GOODS, CHEMICALS, FUELS, NAMELY, DIESEL, GASOLINE AND BIO BLENDS AND RETAIL GOODS; DISTRIBUTION SERVICES, NAMELY, DELIVERY OF FOOD, CLOTHING, RAW MATERIALS, PHARMACEUTICALS, TEXTILES, BUILDING MATERIALS, PAPER PRODUCTS, TOYS, LIQUIDS, BEVERAGES, FUEL, GLASS, COMPUTERS, AND APPLIANCES (U.S. CLS. 100 AND 105).

FIRST USE 4-24-2008; IN COMMERCE 4-24-2008.  
3,963,739. U.S. EDUCATION CORPORATION, MISSION VIEJO, CA. SN 77-815,590. FILED P.R. 8-28-2009; AM. S.R. 4-8-2011.

**CARRINGTON COLLEGE**

THE MARK CONSISTS OF STANDARD CHARACTERS WITHOUT CLAIM TO ANY PARTICULAR FONT, STYLE, SIZE, OR COLOR.

NO CLAIM IS MADE TO THE EXCLUSIVE RIGHT TO USE "COLLEGE", APART FROM THE MARK AS SHOWN.

**CLASS 9—ELECTRICAL AND SCIENTIFIC APPARATUS**

FOR PRERECORDED INSTRUCTIONAL AUDIO AND VIDEO TAPES, CD-ROMS, AND DVDS FEATURING COLLEGE LEVEL CURRICULUM AND RECORDED COURSES OF INSTRUCTION (U.S. CLS. 21, 23, 26, 36 AND 38).

FIRST USE 7-1-2010; IN COMMERCE 7-1-2010.

**CLASS 35—ADVERTISING AND BUSINESS**

FOR PROVIDING JOB PLACEMENT ASSISTANCE FOR STUDENTS AND GRADUATES; CAREER PLACEMENT SERVICES (U.S. CLS. 100, 101 AND 102).

FIRST USE 7-1-2010; IN COMMERCE 7-1-2010.

**CLASS 36—INSURANCE AND FINANCIAL**

FOR PROVIDING FINANCIAL AID AND EXTENSION OF CREDIT TO STUDENTS, NAMELY, EDUCATIONAL GRANTS TO STUDENTS AND EDUCATIONAL LOANS TO STUDENTS (U.S. CLS. 100, 101 AND 102).

FIRST USE 7-1-2010; IN COMMERCE 7-1-2010.

**CLASS 41—EDUCATION AND ENTERTAINMENT**

FOR EDUCATIONAL SERVICES, NAMELY, PROVIDING COURSES OF INSTRUCTION AT THE COLLEGE LEVEL (U.S. CLS. 100, 101 AND 107).

FIRST USE 7-1-2010; IN COMMERCE 7-1-2010.

3,963,741. INTERNATIONAL FINANCIAL REPORTING STANDARDS FOUNDATION, WILMINGTON, DE. SN 77-829,441. FILED P.R. 9-18-2009; AM. S.R. 4-13-2011.

**IFRS for SMEs**

THE MARK CONSISTS OF STANDARD CHARACTERS WITHOUT CLAIM TO ANY PARTICULAR FONT, STYLE, SIZE, OR COLOR.

OWNER OF U.S. REG. NOS. 3,383,689 AND 3,871,660.

**CLASS 9—ELECTRICAL AND SCIENTIFIC APPARATUS**

FOR DOWNLOADABLE ELECTRONIC PUBLICATIONS, NAMELY, GRAPHS, PERIODICAL NEWSLETTERS, PAMPHLETS, AND WRITTEN ARTICLES ALL PERTAINING TO ACCOUNTING STANDARDS (U.S. CLS. 21, 23, 26, 36 AND 38).

FIRST USE 7-9-2009; IN COMMERCE 7-9-2009.

**CLASS 16—PAPER GOODS AND PRINTED MATTER**

FOR BOOKS FEATURING ACCOUNTING STANDARDS AND PRINCIPLES; AND PRINTED FORMS, WRITTEN ARTICLES, GRAPHS, PERIODICAL NEWSLETTERS AND PAMPHLETS ALL PERTAINING TO ACCOUNTING STANDARDS AND PRINCIPLES (U.S. CLS. 2, 5, 22, 23, 29, 37, 38 AND 50).

FIRST USE 7-9-2009; IN COMMERCE 7-9-2009.

3,963,755. COMPLETE CURRICULUM, LLC, GIBRALTAR, MI. SN 77-903,116. FILED P.R. 12-30-2009; AM. S.R. 4-4-2011.

3,963,757. VOCOLLECT, INC., PITTSBURGH, PA. SN 77-909,544. FILED 1-11-2010.

## COMPLETE CURRICULUM

THE MARK CONSISTS OF STANDARD CHARACTERS WITHOUT CLAIM TO ANY PARTICULAR FONT, STYLE, SIZE, OR COLOR.

### CLASS 9—ELECTRICAL AND SCIENTIFIC APPARATUS

FOR DOWNLOADABLE TEXTBOOKS, BOOKS, AND CUSTOMIZABLE TEXTBOOKS IN THE FIELD OF MATHEMATICS, HISTORY, ENGLISH, SCIENCE, GOVERNMENT, ECONOMICS, ART, COMMUNICATION AND COLLABORATION VIA COMMUNICATION NETWORKS, ETHICS, RESEARCH STRATEGIES, EVALUATION OF INFORMATION SOURCES, LIBRARY SCIENCE, THE CULTURAL IMPACT OF TECHNOLOGICAL ADVANCEMENTS, CRITICAL THINKING, PROBLEM SOLVING, CONSTRUCTING KNOWLEDGE, DECISION MAKING, HOW TO SELECT A CAREER AND JOB TRAINING (U.S. CLS. 21, 23, 26, 36 AND 38).  
FIRST USE 2-0-2010; IN COMMERCE 2-0-2010.

### CLASS 41—EDUCATION AND ENTERTAINMENT

FOR PROVIDING AN INTERACTIVE WEBSITE FEATURING NON-DOWNLOADABLE EDUCATION MATERIALS FOR THE PURPOSE OF ACADEMIC STUDY IN THE ACADEMIC FIELDS OF MATHEMATICS, HISTORY, ENGLISH, SCIENCE, GOVERNMENT, ECONOMICS, ART, COMMUNICATION AND COLLABORATION VIA COMMUNICATION NETWORKS, ETHICS, RESEARCH STRATEGIES, EVALUATION OF INFORMATION SOURCES, LIBRARY SCIENCE, THE CULTURAL IMPACT OF TECHNOLOGICAL ADVANCEMENTS, CRITICAL THINKING, PROBLEM SOLVING, CONSTRUCTING KNOWLEDGE, DECISION MAKING, HOW TO SELECT A CAREER AND JOB TRAINING (U.S. CLS. 100, 101 AND 107).  
FIRST USE 2-0-2010; IN COMMERCE 2-0-2010.

### CLASS 42—SCIENTIFIC AND COMPUTER SERVICES

FOR PROVIDING A WEBSITE THAT ENABLES USERS TO DOWNLOAD TEXTBOOKS, BOOKS, AND CUSTOMIZABLE TEXTBOOKS IN THE FIELDS OF MATHEMATICS, HISTORY, ENGLISH, SCIENCE, GOVERNMENT, ECONOMICS, ART, COMMUNICATION AND COLLABORATION VIA COMMUNICATION NETWORKS, ETHICS, RESEARCH STRATEGIES, EVALUATION OF INFORMATION SOURCES, LIBRARY SCIENCE, THE CULTURAL IMPACT OF TECHNOLOGICAL ADVANCEMENTS, CRITICAL THINKING, PROBLEM SOLVING, CONSTRUCTING KNOWLEDGE, DECISION MAKING, HOW TO SELECT A CAREER AND JOB TRAINING; PROVIDING TEMPORARY USE OF ONLINE, NON-DOWNLOADABLE SOFTWARE THAT ENABLES USERS TO MANAGE A COLLECTION OF ELECTRONIC TEXTBOOKS AND RECEIVE UPDATES TO THAT COLLECTION FROM OTHER USERS OF THE SOFTWARE (U.S. CLS. 100 AND 101).  
FIRST USE 2-0-2010; IN COMMERCE 2-0-2010.

## VOICEINTERFACE OBJECTS

THE MARK CONSISTS OF STANDARD CHARACTERS WITHOUT CLAIM TO ANY PARTICULAR FONT, STYLE, SIZE, OR COLOR.

### CLASS 9—ELECTRICAL AND SCIENTIFIC APPARATUS

FOR SOFTWARE FOR CREATING VOICE APPLICATIONS WITH VOICE OR SPEECH FUNCTIONALITY USED IN PERFORMING WAREHOUSE MANAGEMENT FUNCTIONS (U.S. CLS. 21, 23, 26, 36 AND 38).  
FIRST USE 7-30-2009; IN COMMERCE 7-30-2009.

### CLASS 42—SCIENTIFIC AND COMPUTER SERVICES

FOR DESIGN, DEVELOPMENT, CONSULTING, AND IMPLEMENTATION SERVICES FOR SOFTWARE, HARDWARE, AND TECHNOLOGY SOLUTIONS FOR SPEECH OR VOICE GENERATION AND RECOGNITION FOR USE WITH WEARABLE WIRELESS COMPUTER TERMINALS (U.S. CLS. 100 AND 101).  
FIRST USE 7-30-2009; IN COMMERCE 7-30-2009.

3,963,761. FRESH HEALTHY VENDING LLC, VERNON HILLS, IL. SN 77-945,947. FILED P.R. 2-26-2010; AM. S.R. 2-22-2011.

## FRESH HEALTHY VENDING

THE MARK CONSISTS OF STANDARD CHARACTERS WITHOUT CLAIM TO ANY PARTICULAR FONT, STYLE, SIZE, OR COLOR.

NO CLAIM IS MADE TO THE EXCLUSIVE RIGHT TO USE "VENDING", APART FROM THE MARK AS SHOWN.

### CLASS 9—ELECTRICAL AND SCIENTIFIC APPARATUS

FOR VENDING MACHINES (U.S. CLS. 21, 23, 26, 36 AND 38).  
FIRST USE 7-15-2010; IN COMMERCE 7-15-2010.

### CLASS 35—ADVERTISING AND BUSINESS

FOR VENDING MACHINE SERVICES; VENDING MACHINE FRANCHISE SERVICES, NAMELY OFFERING BUSINESS MANAGEMENT ASSISTANCE IN THE ESTABLISHMENT AND OPERATION OF VENDING MACHINES; VENDING MACHINE SERVICES FEATURING SNACKS AND BEVERAGES (U.S. CLS. 100, 101 AND 102).  
FIRST USE 5-15-2010; IN COMMERCE 5-15-2010.

3,963,762. BOOK TRUST, FORT COLLINS, CO. SN 77-951,976.  
FILED P.R. 3-5-2010; AM. S.R. 4-11-2011.

## BOOK TRUST

THE MARK CONSISTS OF STANDARD CHARACTERS WITHOUT CLAIM TO ANY PARTICULAR FONT, STYLE, SIZE, OR COLOR.

NO CLAIM IS MADE TO THE EXCLUSIVE RIGHT TO USE "TRUST", APART FROM THE MARK AS SHOWN.

### CLASS 35—ADVERTISING AND BUSINESS

FOR CHARITABLE SERVICES FOR CHILDREN AND FAMILIES, NAMELY, PROMOTING PUBLIC AWARENESS OF THE NEED FOR READING BOOKS AND FOR LITERACY PROGRAMS FOR CHILDREN AND FAMILIES; CHARITABLE SERVICES, NAMELY, PROMOTING PUBLIC AWARENESS OF THE NEED TO ASSIST INDIVIDUALS, TEACHERS, SCHOOLS, AND OTHER INSTITUTIONS TO FOSTER READING THROUGHOUT CLASSROOMS AND HOMES (U.S. CLS. 100, 101 AND 102).

FIRST USE 12-31-2000; IN COMMERCE 12-31-2001.

### CLASS 36—INSURANCE AND FINANCIAL

FOR CHARITABLE FUND RAISING SERVICES FOR PROVIDING FUNDS FOR SERVICES AND PROGRAMS THAT ENRICH LITERACY FOR CHILDREN AND FAMILIES IN NEED, SERVICES THAT EXPAND OPPORTUNITIES FOR UNDERPRIVILEGED FOR CHILDREN AND FAMILIES TO CHOOSE, OWN AND DELIGHT IN BOOKS, SERVICES THAT EXPAND OPPORTUNITIES FOR UNDERPRIVILEGED FOR CHILDREN AND FAMILIES TO SHOP FOR BOOKS OF THEIR OWN CHOICE, AND SERVICES TO ASSIST FOR CHILDREN AND FAMILIES IN GROWING, TREASURED LIBRARIES OF BOOKS (U.S. CLS. 100, 101 AND 102).

FIRST USE 12-31-2000; IN COMMERCE 12-31-2001.

### CLASS 41—EDUCATION AND ENTERTAINMENT

FOR CHARITABLE SERVICES, NAMELY, PROVIDING BOOKS TO PEOPLE; PROVIDING EDUCATION INFORMATION IN THE FIELD OF LITERACY PROGRAMS FOR CHILDREN AND FAMILIES (U.S. CLS. 100, 101 AND 107).

FIRST USE 12-31-2000; IN COMMERCE 12-31-2001.  
3,963,778. SIALIX, INC., FORMERLY GC-FREE, INC., VISTA, CA. SN 85-030,620. FILED P.R. 5-5-2010; AM. S.R. 2-16-2011.

## Gc-Free

THE MARK CONSISTS OF STANDARD CHARACTERS WITHOUT CLAIM TO ANY PARTICULAR FONT, STYLE, SIZE, OR COLOR.

### CLASS 1—CHEMICALS

FOR BIOCHEMICALS, NAMELY, MONOCLONAL ANTIBODIES FOR IN VITRO SCIENTIFIC OR RESEARCH USE; DIAGNOSTIC KITS CONSISTING PRIMARILY OF MONOCLONAL ANTIBODIES, BUFFERS, AND REAGENTS TO MONITOR TOXICITY OF DRUGS; LABORATORY CHEMICALS, NAMELY, AN ANTIBODY REAGENT USED FOR THE DETECTION OF ANTIGENS IN CELL AND TISSUE ANALYSIS FOR IN VITRO DIAGNOSTIC USE (U.S. CLS. 1, 5, 6, 10, 26 AND 46).

FIRST USE 11-13-2006; IN COMMERCE 11-13-2006.

### CLASS 5—PHARMACEUTICALS

FOR DIAGNOSTIC KITS CONSISTING PRIMARILY OF MONOCLONAL ANTIBODIES, BUFFERS, AND REAGENTS FOR USE IN DISEASE TESTING (U.S. CLS. 6, 18, 44, 46, 51 AND 52).

FIRST USE 11-13-2006; IN COMMERCE 11-13-2006.

3,963,783. REGATTA RESEARCH & MONEY MANAGEMENT, LLC., METARIE, LA. SN 85-039,699. FILED P.R. 5-16-2010; AM. S.R. 2-28-2011.

## Your Financial Coaches

THE MARK CONSISTS OF STANDARD CHARACTERS WITHOUT CLAIM TO ANY PARTICULAR FONT, STYLE, SIZE, OR COLOR.

NO CLAIM IS MADE TO THE EXCLUSIVE RIGHT TO USE "FINANCIAL", APART FROM THE MARK AS SHOWN.

### CLASS 16—PAPER GOODS AND PRINTED MATTER

FOR A SERIES OF EDUCATIONAL PRINTED MATERIALS SPECIFICALLY FOR PROFESSIONALS WHO HAVE ATTAINED A LEVEL OF EXPERTISE IN THE FINANCIAL PROFESSION, CERTIFIED PUBLIC ACCOUNTANTS, FINANCIAL ADVISORS, AND ATTORNEYS, COVERING THE TOPICS OF PORTFOLIO MANAGEMENT, STOCK MARKET RESEARCH, AND INVESTMENT VEHICLES AND TECHNIQUES (U.S. CLS. 2, 5, 22, 23, 29, 37, 38 AND 50).

FIRST USE 5-1-2009; IN COMMERCE 5-1-2009.

### CLASS 41—EDUCATION AND ENTERTAINMENT

FOR EDUCATIONAL SERVICES SPECIFICALLY FOR PROFESSIONALS WHO HAVE ATTAINED A LEVEL OF EXPERTISE IN THE FINANCIAL PROFESSION, CERTIFIED PUBLIC ACCOUNTANTS, FINANCIAL ADVISORS, AND ATTORNEYS, NAMELY, DEVELOPING, ARRANGING, AND CONDUCTING EDUCATIONAL CONFERENCES, CONTINUING EDUCATION SEMINARS, AND PROVIDING COURSES OF INSTRUCTION ALL IN THE FIELDS OF PORTFOLIO MANAGEMENT, STOCK MARKET RESEARCH, AND INVESTMENT VEHICLES AND TECHNIQUES AND DISTRIBUTION OF PRINTED MATERIALS IN CONNECTION THEREWITH IN HARD COPY OR ELECTRIC FORMAT ON THE SAME TOPICS (U.S. CLS. 100, 101 AND 107).

FIRST USE 5-1-2009; IN COMMERCE 5-1-2009.



3,963,786. ASSOCIATED MATERIAL HANDLING INDUSTRIES, INC., ADDISON, IL. SN 85-042,737. FILED P.R. 5-19-2010; AM. S.R. 2-25-2011.

## ASSOCIATED INTEGRATED SUPPLY CHAIN SOLUTIONS

THE MARK CONSISTS OF STANDARD CHARACTERS WITHOUT CLAIM TO ANY PARTICULAR FONT, STYLE, SIZE, OR COLOR.

NO CLAIM IS MADE TO THE EXCLUSIVE RIGHT TO USE "SUPPLY CHAIN SOLUTIONS", APART FROM THE MARK AS SHOWN.

### CLASS 35—ADVERTISING AND BUSINESS

FOR DISTRIBUTORSHIP SERVICES IN THE FIELD OF, MATERIAL HANDLING EQUIPMENT, NAMELY, DOCK LIFT TRUCKS, WAREHOUSE LIFT TRUCKS, WALKIE HIGH AND LOW LIFTS, HAND PALLET JACKS AND BATTERY CHANGERS AND PARTS THEREFOR; DISTRIBUTORSHIP SERVICES IN THE FIELD OF, MATERIAL HANDLING SYSTEMS, NAMELY, HORIZONTAL CAROUSELS, CONVEYOR SYSTEMS, INSERTER / EXTRACTOR DEVICES, MULTI LEVEL PICK MODULES, CONVEYOR SYSTEMS, PICK-TO-LIGHT SYSTEMS, PALLET CONVEYOR SYSTEMS, STRUCTURAL STEEL WAREHOUSE RACKS, ROLLED FRAME WAREHOUSE RACKS, AUTOMATED STORAGE AND RETRIEVAL SYSTEMS (ASRS) COMPRISED OF AUTOMATED SHELVES, RACKS, BINS AND CONTAINERS, WAREHOUSE MANAGEMENT SYSTEMS, AUTOMATED GUIDED VEHICLE INDUSTRIAL ROBOTS FOR USE IN MATERIAL HANDLING, VERTICAL LIFT MODULES, SHELVES AND MEZZANINES (U.S. CLS. 100, 101 AND 102).

FIRST USE 8-31-2010; IN COMMERCE 8-31-2010.

### CLASS 37—CONSTRUCTION AND REPAIR

FOR REPAIR AND MAINTENANCE SERVICES FOR MATERIAL HANDLING EQUIPMENT AND MATERIAL HANDLING SYSTEMS; FLEET MANAGEMENT SERVICES FOR REPAIR AND MAINTENANCE OF MATERIAL HANDLING EQUIPMENT (U.S. CLS. 100, 103 AND 106).

FIRST USE 8-31-2010; IN COMMERCE 8-31-2010.

### CLASS 39—TRANSPORTATION AND STORAGE

FOR EQUIPMENT RENTAL SERVICES, NAMELY, RENTAL OF MATERIAL HANDLING EQUIPMENT, NAMELY, DOCK LIFT TRUCKS, WAREHOUSE LIFT TRUCKS, WALKIE HIGH AND LOW LIFTS, HAND PALLET JACKS AND BATTERY CHANGERS AND PARTS THEREFOR; RENTAL OF MATERIAL HANDLING SYSTEMS, NAMELY, RENTAL OF HORIZONTAL CAROUSELS, CONVEYOR SYSTEMS, INSERTER / EXTRACTOR DEVICES, MULTI LEVEL PICK MODULES, CONVEYOR SYSTEMS, PICK-TO-LIGHT SYSTEMS, PALLET CONVEYOR SYSTEMS, STRUCTURAL STEEL WAREHOUSE RACKS, ROLLED FRAME WAREHOUSE RACKS, AUTOMATED STORAGE AND RETRIEVAL SYSTEMS (ASRS) COMPRISED OF AUTOMATED SHELVES, RACKS, BINS AND CONTAINERS, WAREHOUSE MANAGEMENT SYSTEMS, AUTOMATED GUIDED VEHICLE INDUSTRIAL ROBOTS FOR USE IN MATERIAL HANDLING, VERTICAL LIFT MODULES, SHELVES AND MEZZANINES (U.S. CLS. 100 AND 105).

FIRST USE 8-31-2010; IN COMMERCE 8-31-2010.

### CLASS 41—EDUCATION AND ENTERTAINMENT

FOR EDUCATIONAL SERVICES, NAMELY, PROVIDING TECHNICAL AND SAFETY TRAINING IN THE USE AND OPERATION OF MATERIAL HANDLING EQUIPMENT (U.S. CLS. 100, 101 AND 107).

FIRST USE 8-31-2010; IN COMMERCE 8-31-2010.

### CLASS 42—SCIENTIFIC AND COMPUTER SERVICES

FOR DESIGN, ENGINEERING AND CONSULTATION SERVICES AND INSTALLATION OF INTEGRATED MATERIAL HANDLING SYSTEMS FOR A WIDE RANGE OF DISTRIBUTION AND MANUFACTURING APPLICATIONS (U.S. CLS. 100 AND 101).

FIRST USE 8-31-2010; IN COMMERCE 8-31-2010.

3,963,794. CRC CONCRETE RAISING OF AMERICA, NEW BERLIN, WI. SN 85-050,363. FILED P.R. 5-28-2010; AM. S.R. 3-9-2011.

## CONCRETE GRINDING & RAISING SOLUTIONS

THE MARK CONSISTS OF STANDARD CHARACTERS WITHOUT CLAIM TO ANY PARTICULAR FONT, STYLE, SIZE, OR COLOR.

OWNER OF U.S. REG. NOS. 2,697,661, 2,795,775, AND 3,011,732.

NO CLAIM IS MADE TO THE EXCLUSIVE RIGHT TO USE "CONCRETE GRINDING AND RAISING", APART FROM THE MARK AS SHOWN.

### CLASS 37—CONSTRUCTION AND REPAIR

FOR MAINTENANCE AND REPAIR OF FIXED CONCRETE SLABS AND FOUNDATIONS; DEMOLITION OF CONCRETE SLABS AND FOUNDATIONS IN BUILDINGS; CONSTRUCTION AND REPAIR SERVICES IN THE NATURE OF RAISING AND LEVELING CONCRETE FOUNDATIONS AND SLABS (U.S. CLS. 100, 103 AND 106).

FIRST USE 3-5-2011; IN COMMERCE 3-5-2011.

### CLASS 40—MATERIAL TREATMENT

FOR DEMOLITION OF CONCRETE SLABS THAT ARE NOT PART OF BUILDINGS; GRINDING CONCRETE ROADWAYS AND WALKWAYS TO REDUCE HAZARDS (U.S. CLS. 100, 103 AND 106).

FIRST USE 3-8-2011; IN COMMERCE 3-8-2011.

3,963,796. PAQUETTE, REBECCA, LUDLOW, MA. SN 85-052,693. FILED P.R. 6-2-2010; AM. S.R. 3-25-2011.

# APPLETON

THE MARK CONSISTS OF STANDARD CHARACTERS WITHOUT CLAIM TO ANY PARTICULAR FONT, STYLE, SIZE, OR COLOR.

## CLASS 35—ADVERTISING AND BUSINESS

FOR PERSONNEL PLACEMENT AND RECRUITMENT; EMPLOYMENT AGENCY SERVICES; PERSONNEL MANAGEMENT; CONSULTING SERVICES IN THE FIELD OF HUMAN RESOURCES (U.S. CLS. 100, 101 AND 102).

FIRST USE 12-14-2010; IN COMMERCE 1-7-2011.

## CLASS 44—MEDICAL, BEAUTY AND AGRICULTURAL SERVICES

FOR HOME HEALTH CARE SERVICES; NURSING CARE; PHYSICAL THERAPY; NURSING CARE, NAMELY, INCONTINENCE CARE (U.S. CLS. 100 AND 101).

FIRST USE 12-14-2010; IN COMMERCE 1-7-2011.

## CLASS 45—PERSONAL AND LEGAL SERVICES

FOR PERSONAL CARE ASSISTANCE IN THE ACTIVITIES OF DAILY LIVING FOR MENTALLY OR PHYSICALLY CHALLENGED PEOPLE, SUCH AS COMPANIONSHIP, BATHING, SHOWERING, DRESSING, GROOMING, PERSONAL MOBILITY, PERSONAL MOBILITY ASSISTANCE TO AID TOILETING, ASSISTANCE WITH FEEDING, AND RUNNING ERRANDS (U.S. CLS. 100 AND 101).

FIRST USE 12-14-2010; IN COMMERCE 1-7-2011.

3,963,802. BESPOKE CORPORATION, BELMONT, MA. SN 85-058,609. FILED P.R. 6-9-2010; AM. S.R. 3-21-2011.

# BESPOKE

THE MARK CONSISTS OF STANDARD CHARACTERS WITHOUT CLAIM TO ANY PARTICULAR FONT, STYLE, SIZE, OR COLOR.

## CLASS 37—CONSTRUCTION AND REPAIR

FOR RESIDENTIAL HOME CONSTRUCTION SERVICES (U.S. CLS. 100, 103 AND 106).

FIRST USE 9-8-2009; IN COMMERCE 9-8-2009.

## CLASS 42—SCIENTIFIC AND COMPUTER SERVICES

FOR ARCHITECTURAL AND ENGINEERING SERVICES IN CONNECTION WITH RESIDENTIAL HOME CONSTRUCTION (U.S. CLS. 100 AND 101).

FIRST USE 9-8-2009; IN COMMERCE 9-8-2009.

3,963,803. MOBILE SCRIPTS, LLC, CORAL GABLES, FL. SN 85-058,951. FILED P.R. 6-9-2010; AM. S.R. 4-4-2011.

# Mobile Scripts

THE MARK CONSISTS OF STANDARD CHARACTERS WITHOUT CLAIM TO ANY PARTICULAR FONT, STYLE, SIZE, OR COLOR.

## CLASS 35—ADVERTISING AND BUSINESS

FOR RETAIL PHARMACY STORE SERVICES; MAIL ORDER PHARMACY SERVICES (U.S. CLS. 100, 101 AND 102).

FIRST USE 6-7-2010; IN COMMERCE 6-7-2010.

## CLASS 39—TRANSPORTATION AND STORAGE

FOR DELIVERY OF PRESCRIPTION AND NON-PRESCRIPTION MEDICINES; DELIVERY OF PHARMACEUTICAL PREPARATIONS; SERVICES IN THE NATURE OF PICKING UP PRESCRIPTIONS (U.S. CLS. 100 AND 105).

FIRST USE 6-7-2010; IN COMMERCE 6-7-2010.

## CLASS 44—MEDICAL, BEAUTY AND AGRICULTURAL SERVICES

FOR PHARMACISTS' SERVICES TO MAKE UP PRESCRIPTIONS; PRESCRIPTION REFILL REMINDER SERVICES; ONLINE INFORMATION WITH RESPECT TO PRESCRIPTION SERVICES (U.S. CLS. 100 AND 101).

FIRST USE 6-7-2010; IN COMMERCE 6-7-2010.

3,963,809. THE SENATORS (RET.) FIRM, LLP, SANTA ANA, CA. SN 85-063,453. FILED P.R. 6-15-2010; AM. S.R. 3-24-2011.

# THE SENATORS (RET.) FIRM

THE MARK CONSISTS OF STANDARD CHARACTERS WITHOUT CLAIM TO ANY PARTICULAR FONT, STYLE, SIZE, OR COLOR.

NO CLAIM IS MADE TO THE EXCLUSIVE RIGHT TO USE "FIRM", APART FROM THE MARK AS SHOWN.

**CLASS 35—ADVERTISING AND BUSINESS**

FOR POLITICAL CONSULTANCY; AND COMMERCIAL LOBBYING SERVICES (U.S. CLS. 100, 101 AND 102).

FIRST USE 6-1-2010; IN COMMERCE 6-1-2010.

**CLASS 45—PERSONAL AND LEGAL SERVICES**

FOR LEGAL SERVICES (U.S. CLS. 100 AND 101).  
FIRST USE 6-1-2010; IN COMMERCE 6-1-2010.

**CLASS 16—PAPER GOODS AND PRINTED MATTER**

FOR SYNDICATED NEWSPAPER COLUMNS DEALING WITH CONFLICT RESOLUTION (U.S. CLS. 2, 5, 22, 23, 29, 37, 38 AND 50).

FIRST USE 12-4-2000; IN COMMERCE 12-4-2000.

**CLASS 41—EDUCATION AND ENTERTAINMENT**

FOR PROVIDING AN ONLINE MONTHLY COLUMN IN THE FIELD OF CONFLICT RESOLUTION (U.S. CLS. 100, 101 AND 107).

FIRST USE 12-4-2000; IN COMMERCE 12-4-2000.

3,963,816. BOWTIE, INC., IRVINE, CA. SN 85-074,941. FILED P.R. 6-30-2010; AM. S.R. 4-7-2011.

**CANNING & PRESERVING**

THE MARK CONSISTS OF STANDARD CHARACTERS WITHOUT CLAIM TO ANY PARTICULAR FONT, STYLE, SIZE, OR COLOR.

**CLASS 16—PAPER GOODS AND PRINTED MATTER**

FOR MAGAZINES IN THE FIELD OF FOOD, COOKING, FOOD PREPARATION AND PRESERVATION, HEALTH, NUTRITION AND GARDENING (U.S. CLS. 2, 5, 22, 23, 29, 37, 38 AND 50).

FIRST USE 2-0-2010; IN COMMERCE 2-0-2010.

**CLASS 40—MATERIAL TREATMENT**

FOR PROVIDING ONLINE INFORMATION REGARDING FOOD PRESERVATION AND FOOD CANNING, AND THE COOLING OF FOOD FOR PRESERVATION PURPOSES (U.S. CLS. 100, 103 AND 106).

FIRST USE 4-0-2010; IN COMMERCE 4-0-2010.

3,963,857. AUTOMOTIVE SOURCING TECHNOLOGIES, LLC, OAKBROOK, IL. SN 85-173,126. FILED P.R. 11-10-2010; AM. S.R. 3-26-2011.

**AUTOMOTIVE SOCIAL MEDIA MANAGEMENT**

THE MARK CONSISTS OF STANDARD CHARACTERS WITHOUT CLAIM TO ANY PARTICULAR FONT, STYLE, SIZE, OR COLOR.

**CLASS 35—ADVERTISING AND BUSINESS**

FOR ONLINE MONITORING SERVICES USING COMPUTER SOFTWARE TO AUTOMATICALLY MONITOR INTERNET WEB SITES FOR CUSTOMER-CREATED TOPICS AND TO CAPTURE RELEVANT CONTENT ON THOSE TOPICS, AND SUMMARIZING THE RELEVANT CONTENT TO OTHERS FOR BUSINESS PURPOSES; ONLINE MONITORING SERVICES USING COMPUTER SOFTWARE TO AUTOMATICALLY MONITOR INTERNET WEB SITES FOR CUSTOMER-CREATED CONTENT RELATING TO AUTOMOBILES, CAPTURE RELEVANT CUSTOMER-CREATED CONTENT, AND SUMMARIZING THE RELEVANT CUSTOMER-CREATED CONTENT TO OTHERS FOR BUSINESS PURPOSES IN THE FIELD OF AUTOMOBILE SALES; PROVIDING CAR SALES LEADS FOR OTHERS (U.S. CLS. 100, 101 AND 102).

FIRST USE 7-28-2010; IN COMMERCE 7-28-2010.

3,963,843. JANN BLACKSTONE-FORD, DBA JANN BLACKSTONE-FORD, DISCOVERY BAY, CA. SN 85-134,080. FILED P.R. 9-20-2010; AM. S.R. 3-23-2011.

**EX-ETIQUETTE**

THE MARK CONSISTS OF STANDARD CHARACTERS WITHOUT CLAIM TO ANY PARTICULAR FONT, STYLE, SIZE, OR COLOR.

OWNER OF U.S. REG. NOS. 3,175,717 AND 3,203,161.

**CLASS 42—SCIENTIFIC AND COMPUTER SERVICES**

FOR PROVIDING ON-LINE NON-DOWNLOADABLE COMPUTER PROGRAMS FOR USING THE INTERNET AND THE WORLD WIDE WEB FOR BUSINESS DEVELOPMENT PURPOSES; PROVIDING ON-LINE NON-DOWNLOADABLE COMPUTER PROGRAMS FOR USING THE INTERNET AND THE WORLD WIDE WEB FOR BUSINESS DEVELOPMENT PURPOSES IN THE FIELD OF AUTOMOBILE SALES; PROVIDING ON-LINE NON-DOWNLOADABLE COMPUTER PROGRAMS FOR USING SOCIAL MEDIA WEB SITES FOR BUSINESS DEVELOPMENT PURPOSES; PROVIDING ON-LINE NON-DOWNLOADABLE COMPUTER PROGRAMS FOR MONITORING WEB SITES AND CAPTURING RELEVANT CONTENT FROM THOSE WEBSITES FOR BUSINESS DEVELOPMENT PURPOSES; PROVIDING ON-LINE NON-DOWNLOADABLE COMPUTER PROGRAMS FOR MONITORING WEB SITES AND CAPTURING RELEVANT CONTENT FROM THOSE WEBSITES FOR BUSINESS DEVELOPMENT PURPOSES IN THE FIELD OF AUTOMOBILE SALES (U.S. CLS. 100 AND 101).  
FIRST USE 7-28-2010; IN COMMERCE 7-28-2010.

3,963,868. INDOOR SCIENCES, INC., CHICAGO, IL. SN 85-196,436. FILED P.R. 12-13-2010; AM. S.R. 3-22-2011.

**INDOOR SCIENCES**

THE MARK CONSISTS OF STANDARD CHARACTERS WITHOUT CLAIM TO ANY PARTICULAR FONT, STYLE, SIZE, OR COLOR.

**CLASS 35—ADVERTISING AND BUSINESS**

FOR BUSINESS CONSULTING SERVICES IN THE FIELD OF INDOOR AIR QUALITY, BUILDING SCIENCE AND GREEN BUILDING (U.S. CLS. 100, 101 AND 102).  
FIRST USE 1-29-2007; IN COMMERCE 2-26-2007.

**CLASS 41—EDUCATION AND ENTERTAINMENT**

FOR PROVIDING CONTINUING BUSINESS EDUCATION COURSES (U.S. CLS. 100, 101 AND 107).  
FIRST USE 1-29-2007; IN COMMERCE 2-26-2007.  
3,963,872. GREAT LAKES SERVICES, LLC, MADISON, WI. SN 85-201,558. FILED P.R. 12-20-2010; AM. S.R. 3-17-2011.



THE COLOR(S) BROWN, PINK, FUCHSIA AND OFF-WHITE IS/ARE CLAIMED AS A FEATURE OF THE MARK. THE MARK CONSISTS OF TRADE DRESS FOR THE

INTERIOR OF A SPA AND SALON THAT INCORPORATES A BROWN, PINK, FUCHSIA AND OFF-WHITE COLOR SCHEME DISPLAYED IN A MANNER EVOKING AN ICE CREAM THEME. THE COLOR BROWN APPEARS ON WALLS, FLOOR TILES, BENCH BACKS, CHAIR SEATS, AND TABLE, COUNTER AND BENCH BASES. THE COLOR PINK APPEARS ON WALL TILES, TABLE TOPS, COUNTERTOPS AND CHAIR SEATS. THE COLOR FUCHSIA APPEARS ON BENCH SEATS. THE COLOR OFF-WHITE APPEARS ON BENCH BASES. THE REPRESENTATION OF THE SPA AND SALON SHOWN IN DASHED OR BROKEN LINES IS INTENDED TO SHOW THE POSITION OF THE MARK AND IS NOT A PART OF THE MARK.

**CLASS 35—ADVERTISING AND BUSINESS**

FOR RETAIL STORE SERVICES FEATURING SPA AND BEAUTY PRODUCTS, CLOTHING AND APPAREL, JEWELRY, MAKEUP, PICTURE FRAMES AND HAIR ACCESSORIES (U.S. CLS. 100, 101 AND 102).  
FIRST USE 4-0-2007; IN COMMERCE 4-0-2007.

**CLASS 44—MEDICAL, BEAUTY AND AGRICULTURAL SERVICES**

FOR BEAUTY SPA SERVICES, NAMELY, MANICURES, PEDICURES AND FACIALS; HAIR SALON SERVICES (U.S. CLS. 100 AND 101).  
FIRST USE 4-0-2007; IN COMMERCE 4-0-2007.

3,963,882. CHRISTOPHER W. MCDONALD, KILLINGWORTH, CT. SN 85-211,835. FILED P.R. 1-6-2011; AM. S.R. 3-29-2011.

**killingsworth sound**

THE MARK CONSISTS OF STANDARD CHARACTERS WITHOUT CLAIM TO ANY PARTICULAR FONT, STYLE, SIZE, OR COLOR.

NO CLAIM IS MADE TO THE EXCLUSIVE RIGHT TO USE "SOUND", APART FROM THE MARK AS SHOWN.

**CLASS 9—ELECTRICAL AND SCIENTIFIC APPARATUS**

FOR DOWNLOADABLE MUSICAL SOUND RECORDINGS; MUSICAL SOUND RECORDINGS; PHONOGRAPH RECORDS FEATURING MUSIC; SERIES OF MUSICAL SOUND RECORDINGS (U.S. CLS. 21, 23, 26, 36 AND 38).  
FIRST USE 3-24-2010; IN COMMERCE 11-8-2010.

**CLASS 41—EDUCATION AND ENTERTAINMENT**

FOR MUSIC COMPOSITION AND TRANSCRIPTION FOR OTHERS; MUSIC COMPOSITION FOR OTHERS; MUSIC PRODUCTION SERVICES; MUSIC TRANSCRIPTION FOR OTHERS; POST-PRODUCTION EDITING SERVICES IN THE FIELD OF MUSIC, VIDEOS AND FILM; PRODUCTION OF MUSICAL SOUND RECORDING; PRODUCTION OF SOUND AND MUSIC VIDEO RECORDINGS; PROVIDING AN INTERNET WEBSITE PORTAL FEATURING LINKS TO MUSICAL ARTIST WEBSITES AND MUSIC PERFORMANCE TICKET INFORMATION (U.S. CLS. 100, 101 AND 107).  
FIRST USE 3-24-2010; IN COMMERCE 3-24-2010.

\* \* \* \* \*



## SECTION 2.— INTERNATIONAL CLASSIFICATION

The short titles associated below with the international class numbers are terms designed merely for quick identification and are not an official part of the international classification. The full names of international classes are given in section 6.1 of the trademark rules of practice.

The designation "U.S. Cl." appearing in this section refers to the U.S. class in effect prior to Sep. 1, 1973 rather than the international class which applies to applications filed on or after that date. For adoption of international classification see notice in the OFFICIAL GAZETTE of Jun. 26, 1973 (911 O.G. TM 210).

### Application in one class

#### CLASS 3—COSMETICS AND CLEANING PREPARATIONS

3,963,836. PHYSICIANS CARE ALLIANCE, LLC, SCOTTS-DALE, AZ. SN 85-109,623. FILED P.R. 8-17-2010; AM. S.R. 4-4-2011.

#### BRIGHTENING THERAPY

THE MARK CONSISTS OF STANDARD CHARACTERS WITHOUT CLAIM TO ANY PARTICULAR FONT, STYLE, SIZE, OR COLOR.

FOR NON-MEDICATED SKIN CARE PREPARATIONS (U.S. CLS. 1, 4, 6, 50, 51 AND 52).

FIRST USE 12-0-2008; IN COMMERCE 12-0-2008.

---

3,963,862. RETAIL CONCEPTS OF MINNESOTA, INC., WINDERMERE, FL. SN 85-184,477. FILED P.R. 11-24-2010; AM. S.R. 3-9-2011.



OWNER OF U.S. REG. NO. 2,274,018.  
THE MARK CONSISTS OF STYLIZED VINES WITH FLOWER PETALS.

FOR BEAUTY, TOILETRIES, AND COSMETIC PRODUCTS, NAMELY, SOLID AND LIQUID SOAPS, BODY BUTTER, MASSAGE OIL BARS, SHAMPOO BARS, FRESH FACIAL MASKS, BEAUTY MASKS, NON-MEDICATED LIP CARE PREPARATIONS, SPA WAXES FOR MASSAGING AND MOISTURIZING BODY, SKIN MOISTURIZERS, SHAVING CREAM, BODY SCRUBS, BODY PERFUME, BATH BOMBS PRIMARILY MADE OF BATH SALTS, BATH SALTS, BATH FOAM, LIQUID SHAMPOOS AND HAIR CONDITIONERS; GIFT BASKETS PRIMARILY OF SOLID AND LIQUID SOAPS, BODY BUTTER, SHAMPOO BARS AND BEAUTY MASKS (U.S. CLS. 1, 4, 6, 50, 51 AND 52).

FIRST USE 11-1-2006; IN COMMERCE 11-1-2006.

#### CLASS 5—PHARMACEUTICALS

3,963,754. KEN BYERS AND HAKAN JOHANSON, CLEARWATER, FL. SN 77-895,877. FILED P.R. 12-17-2009; AM. S.R. 3-11-2011.

#### CalCM

THE MARK CONSISTS OF STANDARD CHARACTERS WITHOUT CLAIM TO ANY PARTICULAR FONT, STYLE, SIZE, OR COLOR.

FOR DIETARY SUPPLEMENT DRINK MIX, NAMELY, INSTANT MINERAL BEVERAGE POWDER CONTAINING CALCIUM AND MAGNESIUM (U.S. CLS. 6, 18, 44, 46, 51 AND 52).

FIRST USE 12-17-2009; IN COMMERCE 12-17-2009.

---

3,963,791. UNIVERSITY OF RHODE ISLAND, DBA UNIVERSITY OF RHODE ISLAND, KINGSTON, RI. SN 85-048,167. FILED P.R. 5-26-2010; AM. S.R. 3-15-2011.

#### TICK BITE PATCH

THE MARK CONSISTS OF STANDARD CHARACTERS WITHOUT CLAIM TO ANY PARTICULAR FONT, STYLE, SIZE, OR COLOR.

NO CLAIM IS MADE TO THE EXCLUSIVE RIGHT TO USE "PATCH", APART FROM THE MARK AS SHOWN.

FOR TRANSDERMAL PATCHES FOR USE IN THE TREATMENT OF HUMANS TO EVOKE: A TICK-BORNE DISEASE IMMUNE RESPONSE, ACQUIRED TICK-BORNE DISEASE RESISTANCE, AND TICK-BORNE DISEASE TRANSMISSION BLOCKING EFFECTS (U.S. CLS. 6, 18, 44, 46, 51 AND 52).

FIRST USE 3-14-2011; IN COMMERCE 3-14-2011.

**CLASS 5—(Continued).**

3,963,827. PRIMARY INVESTMENTS GROUP LIMITED, ROAD TOWN, TORTOLA, BR.VIRGIN ISLANDS. SN 85-095,228. FILED P.R. 7-28-2010; AM. S.R. 3-23-2011.

**NORDIC CALAMARI HIGHER  
POTENCY OMEGA-3**

THE MARK CONSISTS OF STANDARD CHARACTERS WITHOUT CLAIM TO ANY PARTICULAR FONT, STYLE, SIZE, OR COLOR.

NO CLAIM IS MADE TO THE EXCLUSIVE RIGHT TO USE "OMEGA-3", APART FROM THE MARK AS SHOWN.

FOR DIETARY SUPPLEMENTS CONTAINING NORDIC CALAMARI AND OMEGA-3 FATTY ACIDS; FOOD SUPPLEMENTS CONTAINING NORDIC CALAMARI AND OMEGA-3 FATTY ACIDS SUPPLEMENTS; HERBAL SUPPLEMENTS CONTAINING NORDIC CALAMARI AND OMEGA-3 FATTY ACIDS; NUTRITIONAL SUPPLEMENTS CONTAINING NORDIC CALAMARI AND OMEGA-3 FATTY ACIDS; VITAMIN SUPPLEMENTS CONTAINING NORDIC CALAMARI AND OMEGA-3 FATTY ACIDS; MINERAL SUPPLEMENTS CONTAINING NORDIC CALAMARI AND OMEGA-3 FATTY ACIDS; MULTI-VITAMIN AND MINERAL SUPPLEMENTS CONTAINING NORDIC CALAMARI AND OMEGA-3 FATTY ACIDS (U.S. CLS. 6, 18, 44, 46, 51 AND 52).

FIRST USE 11-19-2010; IN COMMERCE 11-19-2010.

**CLASS 6—(Continued).**

3,963,759. SLSB, LLC, MADISON, IL. SN 77-930,433. FILED P.R. 2-8-2010; AM. S.R. 3-3-2011.



THE COLOR(S) ORANGE IS/ARE CLAIMED AS A FEATURE OF THE MARK.

THE MARK CONSISTS OF THE COLOR ORANGE AS APPLIED TO THE PACKAGING KEG. THE DOTTED OUTLINE OF THE KEG IS INTENDED TO SHOW THE POSITION OF THE MARK ONLY AND NO CLAIM IS MADE TO THE CONFIGURATION OF THE KEG.

FOR METAL STRUCTURAL BOLTS, NUTS AND WASHERS; METAL TC BOLT ASSEMBLIES CONSISTING OF BOLT, NUT AND WASHER (U.S. CLS. 2, 12, 13, 14, 23, 25 AND 50).

FIRST USE 8-4-2004; IN COMMERCE 8-4-2004.

3,963,858. ATLANTA ROD & MANUFACTURING, INC., LAVONIA, GA. SN 85-177,592. FILED P.R. 11-16-2010; AM. S.R. 3-23-2011.

**ATLROD**

THE MARK CONSISTS OF STANDARD CHARACTERS WITHOUT CLAIM TO ANY PARTICULAR FONT, STYLE, SIZE, OR COLOR.

FOR METAL FASTENERS AND HARDWARE, NAMELY, METAL BOLTS AND NUTS (U.S. CLS. 2, 12, 13, 14, 23, 25 AND 50).

FIRST USE 10-30-2009; IN COMMERCE 10-30-2009.

**CLASS 6—METAL GOODS**

3,963,743. ALCOA INC., PITTSBURGH, PA. SN 77-837,288. FILED P.R. 9-29-2009; AM. S.R. 3-31-2011.

**CLEARWALL**

THE MARK CONSISTS OF STANDARD CHARACTERS WITHOUT CLAIM TO ANY PARTICULAR FONT, STYLE, SIZE, OR COLOR.

FOR CURTAIN WALLS MADE PRIMARILY OF METAL (U.S. CLS. 2, 12, 13, 14, 23, 25 AND 50).

FIRST USE 6-0-2010; IN COMMERCE 12-2-2010.

**CLASS 7—MACHINERY**

**CLASS 7—(Continued).**

3,963,727. DENSO CORPORATION, KARIYA-CITY, AICHI-PREF. 448-8661, JAPAN. SN 76-691,127. FILED P.R. 7-9-2008; AM. S.R. 3-11-2011.

**Segment Conductor**

OWNER OF JAPAN REG. NO. 5204724, DATED 2-20-2009, EXPIRES 2-20-2019.

FOR MOTIVE POWER MACHINES FOR BOATS, AERO PLANES, LAWN MOWERS, AIR CUSHION VEHICLES; PARTS OF MOTIVE POWER MACHINES FOR LAND VEHICLES, NAMELY, ENGINE COMPONENTS, NAMELY, ENGINE VALVES AND PISTONS, FLUES FOR ENGINE BOILERS, FEEDING APPARATUS FOR ENGINE BOILERS, NAMELY, FEEDING PUMPS, KICK STARTERS FOR MOTORCYCLES, GREASE RINGS BEING PARTS OF MACHINES, PISTONS OF CYLINDERS, PISTON RINGS, BOILER TUBES AS PARTS OF MACHINES, CARBURETORS, SUPERCHARGERS AND SUPER HEATERS FOR VEHICLE ENGINES, CRANKCASES FOR MACHINES, CONNECTING RODS FOR MACHINES, CYLINDERS, SEALING JOINTS, CARBURETOR FEEDERS, AIR TURBINES, NOT FOR LAND VEHICLES, ANTI-POLLUTION DEVICES FOR MOTORS AND ENGINES, MUFFLERS FOR MOTORS AND ENGINES, SILENCERS FOR MOTORS AND ENGINES, FUEL ECONOMIZERS FOR MOTORS AND ENGINES, EXHAUST SYSTEM, NAMELY, EXHAUST PIPES FOR VEHICLES, ENGINE EXHAUST TIPS, EXHAUST MANIFOLD, EXHAUST MUFFLER, EXHAUST EMISSION CONTROL DEVICE, EXHAUST GAS RECIRCULATION SYSTEM, EXHAUST GAS CLEANING SYSTEM, EXHAUST GAS DESULFURIZER, COWLINGS, SEPARATORS, NAMELY, DUST SEPARATORS, CYCLONE SEPARATORS, CENTRIFUGAL SEPARATORS, OIL SEPARATORS, FUEL SEPARATORS, VAPOR SEPARATORS, CATALYTIC CONVERTERS, SPARKING PLUGS, STATORS BEING PARTS OF MACHINES, EXPANSION TANKS, DISTRIBUTORS FOR MOTORS AND ENGINES; IGNITION PARTS, NAMELY, CONDENSERS AND IGNITION COILS; SPARK PLUGS; GLOW PLUGS; ELECTRIC STARTERS FOR ENGINES; AIR CLEANERS; AIR FILTERS FOR VEHICLES MOTORS AND ENGINES; OIL FILTERS FOR ENGINE OILS AND TRANSMISSION OILS; FUEL FILTERS FOR MOTORS AND ENGINES; FUEL SEDIMENTERS AND CYCLONE SEPARATORS; FUEL INJECTION NOZZLES AND INJECTORS; ELECTRIC DIESEL INJECTION CONTROL APPARATUS, COMPRISED OF INJECTION PUMPS, NOZZLES, COMMON RAIL SYSTEMS AND FUEL INJECTORS; THROTTLE BODIES; VALVES AS MACHINE COMPONENTS; WATER VALVES; INTAKE AIR HEATING APPARATUS; FUEL PRESSURE REGULATORS FOR MOTORS AND ENGINES; DIESEL FUEL INJECTION TIMING CONTROL VALVES; EXHAUST GAS RECIRCULER FOR ENGINES; CHARCOAL CANISTERS WHICH ABSORB VAPORIZED FUEL LEAKED FROM FUEL TANK AND SEND SUCH ABSORBED FUEL TO ENGINE; EXHAUST MANIFOLDS FOR ENGINES; FUEL CUT VALVES FOR ENGINES; RADIATORS FOR MOTORS AND ENGINES; SILENCERS FOR MOTORS AND ENGINES; LUBRICATING OIL COOLERS; FANS FOR MACHINE ENGINES; IGNITION PARTS FOR INTERNAL COMBUSTION ENGINES, NAMELY, CONDENSERS; RECEIVERS, NAMELY, OIL RECEIVERS WHICH ARE PLACED IN ENGINES TO RECEIVE LEAKED OIL IN GAS; BEARINGS FOR TRANSMISSION SHAFTS BEING PARTS OF MACHINES; FAN BELTS FOR MACHINES; CARBURETORS FOR INTERNAL COMBUSTION ENGINES; PULLEYS BEING PARTS OF MACHINES; PRESSURE REDUCERS AND TORQUE CONVERTERS NOT FOR LAND VEHICLES; CATALYTIC CONVERTERS FOR MOTORS AND ENGINES; PNEUMATIC MACHINES, NAMELY, AIR PUMPS, CENTRIFUGAL PUMPS, COMPRESSED AIR PUMPS, EJECTORS, LUBRICATING PUMPS, PLUNGER PISTONS, PUMP DIAPHRAGMS, PUMPS FOR HEATING INSTALLATIONS, VACUUM PUMPS, PNEUMATIC PUMPS, RECIPROCATING PUMPS, ROTARY PUMPS, ROTARY VACUUM PUMPS, DIFFUSION PUMPS, AXIA FLOW PUMPS, MIXED

**CLASS 7—(Continued).**

FLOW PUMPS; COMPRESSORS, NAMELY, COMPRESSED AIR MACHINES, COMPRESSORS FOR REFRIGERATORS, AIR COMPRESSORS, ELECTRIC COMPRESSORS, GAS COMPRESSORS, CENTRIFUGAL COMPRESSORS, RECIPROCATING COMPRESSORS, AXIA FLOW COMPRESSORS, TURBOCOMPRESSORS (A PART OF TURBOCHARGERS FOR ENGINES); HYDRAULIC MACHINES, NAMELY, HYDRAULIC TORQUE CONVERTERS, HYDRAULIC CONTROLS FOR MACHINES, MOTORS AND ENGINES, PUMPS, NAMELY, PUMP DIAPHRAGMS, COMPRESSED AIR PUMPS, CENTRIFUGAL PUMPS, RECIPROCATING PUMPS, ROTARY PUMPS, ROTARY VACUUM PUMPS, DIFFUSION PUMPS, AXIAL FLOW PUMPS, MIXED FLOW PUMPS, LUBRICATING PUMPS, VACUUM PUMPS, EJECTORS, PLUNGER PISTONS, PUMPS FOR HEATING INSTALLATIONS, PNEUMATIC PUMPS, BLOWERS, BLOWING ENGINES, BELLOWS, CENTRIFUGAL BLOWERS, ROTARY BLOWERS, AXIAL FLOW BLOWERS, TURBO BLOWERS; DISH WASHING MACHINES FOR HOUSEHOLD PURPOSES; ELECTRIC WAX-POLISHING MACHINES FOR HOUSEHOLD PURPOSES; WASHING MACHINES FOR HOUSEHOLD PURPOSES; VACUUM CLEANERS FOR HOUSEHOLD PURPOSES; TRANSMISSIONS FOR MACHINES; STARTERS FOR MOTORS AND ENGINES; AC MOTORS AND DC MOTORS AND THEIR PARTS AND FITTINGS, NAMELY, ROTORS, STATORS, ROTOR COILS, STATOR CORES, SHAFTS, MAGNETS AND COOLING FANS; ALTERNATORS FOR LAND VEHICLES, ALTERNATORS NOT FOR LAND VEHICLES; STARTER ALTERNATOR; DYNAMOS; ALTERNATING CURRENT GENERATORS; DIRECT CURRENT GENERATORS; ALTERNATOR BRUSHES; DYNAMO BRUSHES; ELECTRICALLY OPERATED BRUSHES THAT ARE PART OF MACHINES (U.S. CLS. 13, 19, 21, 23, 31, 34 AND 35).

3,963,767. PRECISION, INC., PELLA, IA. SN 77-959,021. FILED P.R. 3-15-2010; AM. S.R. 3-28-2011.

**HERRINGBONE WING**

THE MARK CONSISTS OF STANDARD CHARACTERS WITHOUT CLAIM TO ANY PARTICULAR FONT, STYLE, SIZE, OR COLOR.

NO CLAIM IS MADE TO THE EXCLUSIVE RIGHT TO USE "WING", APART FROM THE MARK AS SHOWN.

FOR CONVEYOR COMPONENTS, NAMELY, PULLEYS (U.S. CLS. 13, 19, 21, 23, 31, 34 AND 35).

FIRST USE 10-15-2009; IN COMMERCE 10-15-2009.

**CLASS 7—(Continued).**

3,963,804. LANDOLL CORPORATION, MARYSVILLE, KS. SN 85-060,849. FILED P.R. 6-11-2010; AM. S.R. 3-28-2011.

# TILL 'N SEED

THE MARK CONSISTS OF STANDARD CHARACTERS WITHOUT CLAIM TO ANY PARTICULAR FONT, STYLE, SIZE, OR COLOR.

FOR AGRICULTURAL MACHINERY, NAMELY, TILLERS AND SEEDERS (U.S. CLS. 13, 19, 21, 23, 31, 34 AND 35).

FIRST USE 11-0-2010; IN COMMERCE 11-0-2010.

---

3,963,820. THE BLACK & DECKER CORPORATION, TOWSON, MD. SN 85-078,312. FILED P.R. 7-6-2010; AM. S.R. 3-9-2011.

# ClampSaw

THE MARK CONSISTS OF STANDARD CHARACTERS WITHOUT CLAIM TO ANY PARTICULAR FONT, STYLE, SIZE, OR COLOR.

FOR POWER-OPERATED SAWS (U.S. CLS. 13, 19, 21, 23, 31, 34 AND 35).

FIRST USE 10-1-2010; IN COMMERCE 10-1-2010.

---

**CLASS 9—ELECTRICAL AND SCIENTIFIC APPARATUS**

**CLASS 9—(Continued).**

3,963,734. NAVAJO MANUFACTURING COMPANY, DENVER, CO. SN 77-730,827. FILED P.R. 5-6-2009; AM. S.R. 3-14-2011.

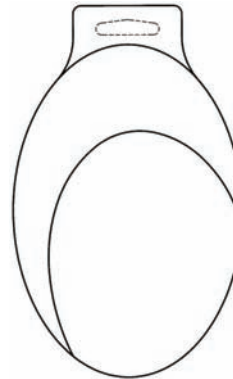

THE MARK CONSISTS OF AN OVAL SHAPED HANGER/BLISTER CARD CONFIGURATION PACKAGE DESIGN FOR THE GOODS ON WHICH APPEARS A PARTIAL OVAL DESIGN ON THE RIGHT SIDE AND EXTENDING TO THE BOTTOM. THE DOTTED LINES AT THE TOP FORM THE SLOTTED HOLE FROM WHICH THE PACKAGE HANGS, AND IS NOT PART OF THE MARK. THE SLOTTED HOLE IS ON AN OVERALL RECTANGULAR SHAPED TAB ON THE TOP OF THE BLISTER CARD.

FOR CELL PHONE AND MOBILE DEVICES ACCESSORIES, NAMELY, CHARGERS, CHARGER CONNECTION/PLUG ADAPTERS, CONVERTERS, HEADSETS, EARPHONES, BATTERIES, AND CELL PHONE CASES (U.S. CLS. 21, 23, 26, 36 AND 38).

FIRST USE 3-5-2009; IN COMMERCE 3-5-2009.

---

3,963,735. NAVAJO MANUFACTURING COMPANY, DENVER, CO. SN 77-730,837. FILED P.R. 5-6-2009; AM. S.R. 3-14-2011.

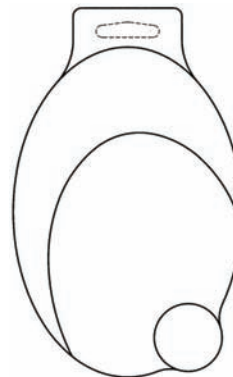

THE MARK CONSISTS OF AN OVAL SHAPED HANGER/

**CLASS 9—(Continued).**

BLISTER CARD CONFIGURATION PACKAGE DESIGN FOR THE GOODS ON WHICH APPEARS A PARTIAL OVAL DESIGN ON THE RIGHT SIDE AND EXTENDING TO THE BOTTOM; AND A SMALL CIRCLE APPEARS ON AND PROTRUDES FROM THE LOWER RIGHT SIDE OF THE OVAL. THE DOTTED LINES AT THE TOP FORM THE SLOTTED HOLE FROM WHICH THE PACKAGE HANGS, AND IS NOT PART OF THE MARK. THE SLOTTED HOLE IS ON AN OVERALL RECTANGULAR SHAPED TAB ON THE TOP OF THE BLISTER CARD.

FOR CELL PHONE AND MOBILE DEVICES ACCESSORIES, NAMELY, CHARGERS, CHARGER CONNECTION/PLUG ADAPTERS, CONVERTERS, HEADSETS, EARPHONES, BATTERIES, AND CELL PHONE CASES (U.S. CLS. 21, 23, 26, 36 AND 38).

FIRST USE 3-5-2009; IN COMMERCE 3-5-2009.

---

3,963,746. NELL, DOMINIKA, NOVE MISTO, CZECH REPUBLIC. SN 77-857,339. FILED P.R. 10-26-2009; AM. S.R. 21-2011.



NO CLAIM IS MADE TO THE EXCLUSIVE RIGHT TO USE "ALBUM", APART FROM THE MARK AS SHOWN. THE MARK CONSISTS OF THE WORD "ALBUM" IN BLACK DOTTED LETTERS.

FOR PORTABLE AND HANDHELD ELECTRONIC DEVICES FOR RECORDING, ORGANIZING, TRANSMITTING, MANIPULATING, AND REVIEWING MEDIA FILES; COMPUTER SOFTWARE FOR USE IN ORGANIZING, TRANSMITTING, MANIPULATING, AND REVIEWING MEDIA FILES ON PORTABLE AND HANDHELD ELECTRONIC DEVICES (U.S. CLS. 21, 23, 26, 36 AND 38).

FIRST USE 3-4-2008; IN COMMERCE 1-7-2009.

---

3,963,750. NIRVANIX, INC., SAN DIEGO, CA. SN 77-881,032. FILED P.R. 11-25-2009; AM. S.R. 3-15-2011.



THE MARK CONSISTS OF STANDARD CHARACTERS WITHOUT CLAIM TO ANY PARTICULAR FONT, STYLE, SIZE, OR COLOR.

**CLASS 9—(Continued).**

OWNER OF U.S. REG. NO. 3,590,956.

FOR COMPUTER SOFTWARE FOR THE COLLECTION, EDITING, ORGANIZING, MANAGING, MODIFYING, TRANSMISSION, STORAGE AND SHARING OF FILES, DATABASES, DATA, ELECTRONIC MEDIA, DIGITAL CONTENT, IMAGES, TEXT, MESSAGES, DOCUMENTS, AUDIO CONTENT AND VIDEO CONTENT; ELECTRONIC STORAGE SYSTEMS, NAMELY, BLANK ELECTRONIC AND DIGITAL STORAGE MEDIA, COMPUTER BACKUP AND COMPUTER STORAGE SYSTEMS WITH MULTIPLE REMOVABLE RAID CARTRIDGES, ELECTRONIC STORAGE SYSTEMS FEATURING RAID ARCHITECTURE, TAPE AND OPTICAL STORAGE, AND HIGH-SPEED STORAGE SUBSYSTEMS FOR STORAGE AND BACKUP OF ELECTRONIC DATA EITHER LOCALLY OR VIA A TELECOMMUNICATION NETWORK; COMPUTER SOFTWARE FOR CREATING ELECTRONIC DATABASES AND FOR USE IN THE COLLECTION, EDITING, ORGANIZING, MANAGING, MODIFYING, TRANSMISSION, STORAGE AND SHARING OF FILES, DATABASES, DATA, ELECTRONIC MEDIA, DIGITAL CONTENT, IMAGES, TEXT, MESSAGES, DOCUMENTS, AUDIO CONTENT AND VIDEO CONTENT; COMPUTER SOFTWARE FOR DATA PROCESSING, NAMELY, STUBBING, SEARCHING, CATEGORIZING, ENCRYPTION AND COMPRESSION OF DATA; COMPUTER HARDWARE AND NETWORK HARDWARE AND SERVERS, FOR THE COLLECTION, EDITING, ORGANIZING, MANAGING, MODIFYING, TRANSMISSION, STORAGE AND SHARING OF FILES, DATABASES, DATA, ELECTRONIC MEDIA, DIGITAL CONTENT, IMAGES, TEXT, MESSAGES, DOCUMENTS, AUDIO CONTENT AND VIDEO CONTENT (U.S. CLS. 21, 23, 26, 36 AND 38).

FIRST USE 6-30-2008; IN COMMERCE 6-30-2008.

---

3,963,764. SMARTPLUG SYSTEMS LLC, SEATTLE, WA. SN 77-954,710. FILED P.R. 3-9-2010; AM. S.R. 12-14-2010.



THE MARK CONSISTS OF STANDARD CHARACTERS WITHOUT CLAIM TO ANY PARTICULAR FONT, STYLE, SIZE, OR COLOR.

FOR WEATHERPROOF ELECTRICAL OUTLET SYSTEMS COMPOSED OF INTERLOCKING PLUGS AND SOCKET ELEMENTS (U.S. CLS. 21, 23, 26, 36 AND 38).

FIRST USE 6-14-2009; IN COMMERCE 6-14-2009.



**CLASS 9—(Continued).**

3,963,770. LAYERZERO POWER SYSTEMS, INC., SHAKER HEIGHTS, OH. SN 77-963,196. FILED P.R. 3-19-2010; AM. S.R. 3-25-2011.

# ePanel

THE MARK CONSISTS OF STANDARD CHARACTERS WITHOUT CLAIM TO ANY PARTICULAR FONT, STYLE, SIZE, OR COLOR.

FOR ELECTRICAL DISTRIBUTION PRODUCTS, NAMELY, CIRCUIT BREAKER PANEL BOARDS (U.S. CLS. 21, 23, 26, 36 AND 38).

FIRST USE 1-0-2010; IN COMMERCE 1-0-2010.

---

3,963,798. WORLDWIDE VAPOR, INC., HUNTINGTON BEACH, CA. SN 85-055,214. FILED P.R. 6-4-2010; AM. S.R. 2-25-2011.

# LEAKFINDER

THE MARK CONSISTS OF STANDARD CHARACTERS WITHOUT CLAIM TO ANY PARTICULAR FONT, STYLE, SIZE, OR COLOR.

FOR ELECTRICAL APPARATUS FOR TESTING A CLOSED FLUID SYSTEM OF A MOTOR VEHICLE FOR LEAKS (U.S. CLS. 21, 23, 26, 36 AND 38).

FIRST USE 12-0-2008; IN COMMERCE 12-0-2008.

---

3,963,805. N HOLDING AB, SOLLENTUNA, SWEDEN. SN 85-060,864. FILED P.R. 6-11-2010; AM. S.R. 3-14-2011.

# RED BATTERY

THE MARK CONSISTS OF STANDARD CHARACTERS WITHOUT CLAIM TO ANY PARTICULAR FONT, STYLE, SIZE, OR COLOR.

NO CLAIM IS MADE TO THE EXCLUSIVE RIGHT TO USE "BATTERY", APART FROM THE MARK AS SHOWN. FOR BATTERIES (U.S. CLS. 21, 23, 26, 36 AND 38). FIRST USE 2-28-2011; IN COMMERCE 2-28-2011.

**CLASS 9—(Continued).**

3,963,806. N HOLDING AB, SOLLENTUNA, SWEDEN. SN 85-060,869. FILED P.R. 6-11-2010; AM. S.R. 3-14-2011.

# SILVER BATTERY

THE MARK CONSISTS OF STANDARD CHARACTERS WITHOUT CLAIM TO ANY PARTICULAR FONT, STYLE, SIZE, OR COLOR.

NO CLAIM IS MADE TO THE EXCLUSIVE RIGHT TO USE "BATTERY", APART FROM THE MARK AS SHOWN. FOR BATTERIES (U.S. CLS. 21, 23, 26, 36 AND 38).

FIRST USE 1-31-2011; IN COMMERCE 1-31-2011.

---

3,963,810. ALFONSO, MARC, VANCOUVER, CHINA. SN 85-063,890. FILED P.R. 6-16-2010; AM. S.R. 3-23-2011.

# FSTOP WIRELESS

THE MARK CONSISTS OF STANDARD CHARACTERS WITHOUT CLAIM TO ANY PARTICULAR FONT, STYLE, SIZE, OR COLOR.

FOR COMPUTER HARDWARE AND COMPUTER SOFTWARE FOR WIRELESS CONTROL OF CAMERAS, REMOTE CONTROL OF CAMERAS, MOTOR CONTROL OF CAMERAS, CAMERA CONTROL, CAMERA LENS CONTROL, AND CAMERA FOLLOW FOCUS CONTROL, SAID COMPUTER HARDWARE AND SOFTWARE FOR USE WITH ELECTRONIC CAMERAS AND DIGITAL CAMERAS, WITH SAID COMPUTER HARDWARE AND SOFTWARE FOR USE BY PHOTOGRAPHERS, CINEMATOGRAPHERS, DIRECTORS, CAMERA ASSISTANTS, DIGITAL TECHNICIANS, FILM TECHNICIANS, VISUAL EFFECTS TECHNICIANS AND SPECIALTY CAMERA USERS; ANTENNAS, RECEIVERS FOR CAMERAS (U.S. CLS. 21, 23, 26, 36 AND 38).

FIRST USE 6-24-2009; IN COMMERCE 9-6-2009.

**CLASS 9—(Continued).**

3,963,826. ARUZE GAMING AMERICA, INC., LAS VEGAS, NV. SN 85-084,910. FILED P.R. 7-14-2010; AM. S.R. 3-22-2011.

**CHALLENGE FOR JACKPOT**

THE MARK CONSISTS OF STANDARD CHARACTERS WITHOUT CLAIM TO ANY PARTICULAR FONT, STYLE, SIZE, OR COLOR.

FOR COMPONENTS FOR GAMING MACHINES THAT GENERATE OR DISPLAY WAGER OUTCOMES, NAMELY, CONTROLLERS, DISPLAYS, BUTTON PANELS, BOLSTERS, ELECTRICAL WIRING, AND COMPUTER HARDWARE AND SOFTWARE ASSOCIATED THEREWITH; COMPUTER GAME SOFTWARE FOR GAMING MACHINES INCLUDING SLOT MACHINES OR VIDEO LOTTERY TERMINALS; COMPUTER SOFTWARE AND FIRMWARE FOR GAMES OF CHANCE ON ANY COMPUTERIZED PLATFORM, INCLUDING DEDICATED GAMING CONSOLES, VIDEO BASED SLOT MACHINES, REEL BASED SLOT MACHINES, AND VIDEO LOTTERY TERMINALS; ELECTRONIC COMPONENTS FOR SLOT MACHINES; ELECTRONIC GAMING MACHINES, NAMELY, DEVICES WHICH ACCEPT A WAGER; GAMING EQUIPMENT, NAMELY, SLOT MACHINES WITH OR WITHOUT VIDEO OUTPUT; GAMING MACHINES; GAMING MACHINES FEATURING A DEVICE THAT ACCEPTS WAGERS; GAMING MACHINES INCLUDING SLOT MACHINES OR VIDEO LOTTERY TERMINALS; GAMING MACHINES THAT GENERATE OR DISPLAY WAGER OUTCOMES; GAMING MACHINES, NAMELY, DEVICES WHICH ACCEPT A WAGER; GAMING SOFTWARE THAT GENERATES OR DISPLAYS WAGER OUTCOMES OF GAMING MACHINES; MACHINES FOR PLAYING GAMES OF CHANCE; SLOT MACHINES (U.S. CLS. 21, 23, 26, 36 AND 38).  
FIRST USE 11-0-2009; IN COMMERCE 11-0-2009.

**CLASS 10—MEDICAL APPARATUS**

3,963,740. OKAMOTO INDUSTRIES, INC., BUNKYO-KU, TOKYO, JAPAN. SN 77-817,559. FILED P.R. 9-1-2009; AM. S.R. 3-30-2011.



OWNER OF JAPAN REG. NO. 4823253, DATED 12-3-2004, EXPIRES 12-3-2014.  
THE COLOR(S) GREEN AND BLACK IS/ARE CLAIMED AS A FEATURE OF THE MARK.

**CLASS 10—(Continued).**

THE MARK CONSISTS OF THE COLOR BLACK APPLIED TO THE NUMBERS "003" AND THE COLOR GREEN APPLIED TO A CIRCLE WITHIN THE THICKNESS OF THE FIRST "0".

FOR CONDOM, OTHER CONTRACEPTIVES, NAMELY, PESSARIES AND INTRAUTERINE RINGS; TEETHING RINGS; ICE PILLOWS FOR MEDICAL PURPOSES; TRIANGULAR BANDAGES FOR MEDICAL PURPOSES IN THE NATURE OF COMPRESSION BANDAGES, ELASTIC BANDAGES, SUPPORT BANDAGES, BANDAGES FOR ANATOMICAL JOINTS, ORTHOPEDIC KNEE BANDAGES, AND ORTHOPEDIC SUPPORT BANDAGES; SUPPORTIVE BANDAGES; SURGICAL CATALOGS; FEEDING CUPS FOR MEDICAL USE; DROPPING PIPETTES FOR MEDICAL PURPOSES; PACIFIERS; ICE BAGS FOR MEDICAL PURPOSES; HOLDERS FOR ICE BAGS FOR MEDICAL PURPOSES; BABY BOTTLES; NURSING BOTTLES; COTTON SWABS FOR MEDICAL USE; RUBBER FINGER GUARD FOR MEDICAL USE; ARTIFICIAL TYMPANIC MEMBRANES; PROSTHETIC OR FILLING MATERIALS, NAMELY, ARTIFICIAL MATERIAL FOR USE IN THE REPLACEMENT OF BONES, NOT FOR DENTAL USE; PROSTHETIC AND FILLING MATERIALS, NAMELY, PUTTY FOR USE IN THE REPLACEMENT OF BONES, NOT FOR DENTAL USE; ESTHETIC MASSAGE APPARATUS FOR INDUSTRIAL PURPOSES; MEDICAL APPARATUS AND INSTRUMENTS, NAMELY, FOR TREATING CARDIOVASCULAR DISEASE, FOR MONITORING BLOOD PROPERTIES AND RESPIRATORY EVENTS, FOR USE IN POSITRON EMISSION TOMOGRAPHY, FOR DIAGNOSTIC RADIOPHARMACEUTICAL USE; ELECTRIC MASSAGE APPARATUS FOR HOUSEHOLD USE; GLOVES FOR MEDICAL USE; URINALS FOR MEDICAL PURPOSES; BED PANS; EAR PICKS (U.S. CLS. 26, 39 AND 44).

3,963,824. BLUE SKY SCRUBS, LLC, AUSTIN, TX. SN 85-084,818. FILED P.R. 7-14-2010; AM. S.R. 3-29-2011.

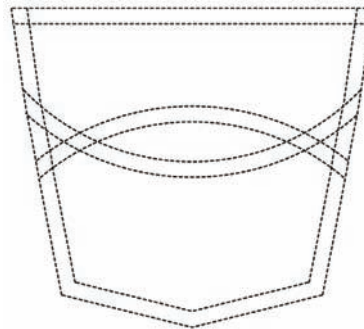

THE MARK CONSISTS OF A POCKET STITCH DESIGN WITH CURVED AND CROSSED STITCHING. THE BROKEN LINES IN THE DRAWING ARE A FEATURE OF THE MARK.  
FOR SURGICAL SCRUB SUITS (U.S. CLS. 26, 39 AND 44).  
FIRST USE 11-15-2007; IN COMMERCE 11-15-2007.

**CLASS 10—(Continued).**

3,963,825. BLUE SKY SCRUBS, LLC, AUSTIN, TX. SN 85-084,823. FILED P.R. 7-14-2010; AM. S.R. 3-29-2011.

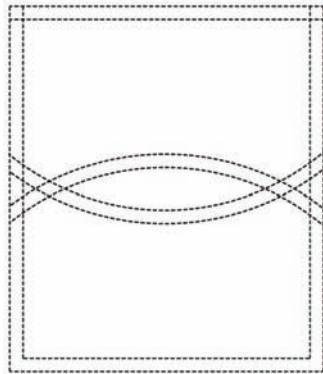

THE MARK CONSISTS OF A POCKET STITCH DESIGN WITH CURVED AND CROSSED STITCHING. THE BROKEN LINES IN THE DRAWING ARE A FEATURE OF THE MARK.

FOR SURGICAL SCRUB SUITS (U.S. CLS. 26, 39 AND 44).  
FIRST USE 11-15-2007; IN COMMERCE 11-15-2007.

3,963,837. OBP CORPORATION, LAWRENCE, MA. SN 85-110,147. FILED P.R. 8-18-2010; AM. S.R. 3-31-2011.

Office  
SPEC

NO CLAIM IS MADE TO THE EXCLUSIVE RIGHT TO USE "SPEC", APART FROM THE MARK AS SHOWN.

THE MARK CONSISTS OF THE STYLIZED TEXT "OFFICE SPEC" WITH A LINE IN THE MIDDLE.

FOR SPECULUMS (U.S. CLS. 26, 39 AND 44).  
FIRST USE 11-1-2009; IN COMMERCE 11-15-2009.

**CLASS 10—(Continued).**

3,963,856. RICHARD WOLF GMBH, KNITTLINGEN, FED REP GERMANY. SN 85-172,167. FILED P.R. 11-9-2010; AM. S.R. 3-29-2011.

# TIPcontrol

OWNER OF FED REP GERMANY REG. NO. 302008033329, DATED 2-12-2009, EXPIRES 11-10-2020.

FOR SURGICAL AND MEDICAL INSTRUMENTS FOR MEDICAL AND VETERINARY USE, NAMELY, SURGICAL INSTRUMENTS FOR GRIPPING, MILLING, CUTTING, HOLDING, PUNCHING, WORKING AND SPLITTING OF TISSUES, CARTILAGE AND BONES DURING ENDOSCOPIC SURGERY (U.S. CLS. 26, 39 AND 44).

3,963,865. ASCEND EAGLE, INC, AMERICAN CANYON, CA. SN 85-186,647. FILED P.R. 11-29-2010; AM. S.R. 3-8-2011.

# Red Nitrile

THE MARK CONSISTS OF STANDARD CHARACTERS WITHOUT CLAIM TO ANY PARTICULAR FONT, STYLE, SIZE, OR COLOR.

OWNER OF U.S. REG. NO. 3,915,296.  
NO CLAIM IS MADE TO THE EXCLUSIVE RIGHT TO USE "NITRILE", APART FROM THE MARK AS SHOWN.

FOR DENTAL GLOVES; MEDICAL EXAMINATION GLOVES; NITRILE GLOVES FOR MEDICAL USE (U.S. CLS. 26, 39 AND 44).

FIRST USE 1-1-2011; IN COMMERCE 1-1-2011.

3,963,867. TUPLER, JULIE, NEW YORK, NY. SN 85-195,803. FILED P.R. 12-11-2010; AM. S.R. 4-5-2011.

# DIASTASIS REHAB SPLINT

THE MARK CONSISTS OF STANDARD CHARACTERS WITHOUT CLAIM TO ANY PARTICULAR FONT, STYLE, SIZE, OR COLOR.

NO CLAIM IS MADE TO THE EXCLUSIVE RIGHT TO USE "SPLINT", APART FROM THE MARK AS SHOWN.

FOR ABDOMINAL SPLIT BINDER USED TO APPROXIMATE AND COMPRESS THE ABDOMINAL MUSCLES (U.S. CLS. 26, 39 AND 44).

FIRST USE 5-1-2009; IN COMMERCE 5-1-2009.

**CLASS 11—ENVIRONMENTAL CONTROL APPARATUS**

3,963,738. GWANGSUNG ELECTRIC INDUSTRY CO., LTD., INCHEON, REPUBLIC OF KOREA. SN 77-813,153. FILED P.R. 8-26-2009; AM. S.R. 1-7-2011.

**ACLEDS**

THE MARK CONSISTS OF STANDARD CHARACTERS WITHOUT CLAIM TO ANY PARTICULAR FONT, STYLE, SIZE, OR COLOR.

OWNER OF REPUBLIC OF KOREA REG. NO. 0741697, DATED 3-25-2008, EXPIRES 3-25-2018.

FOR LAMP SHADES; LAMPSHADE HOLDERS; LAMP HANGING SUPPORTS; LAMP CASINGS; LAMP REFLECTORS; LAMP GLASSES; STREET LAMPS; INCANDESCENT LIGHT BULBS; INCANDESCENT LAMPS; CHANDELIERS; SPOTLIGHTS; SAFETY LAMPS FOR USE UNDERGROUND; DECORATIVE LAMPS; ELECTRIC TORCHES FOR LIGHTING; CEILING LIGHTS; FAIRY LIGHTS FOR FESTIVE DECORATION; STANDARD LAMPS; SEARCHLIGHTS; FLASHLIGHTS (U.S. CLS. 13, 21, 23, 31 AND 34).

3,963,801. BEVOLO GAS & ELECTRIC LIGHTS, INC., NEW ORLEANS, LA. SN 85-057,598. FILED P.R. 6-8-2010; AM. S.R. 3-17-2011.

**Contemporary**

THE MARK CONSISTS OF STANDARD CHARACTERS WITHOUT CLAIM TO ANY PARTICULAR FONT, STYLE, SIZE, OR COLOR.

FOR LIGHTING FIXTURES (U.S. CLS. 13, 21, 23, 31 AND 34).

FIRST USE 5-1-2000; IN COMMERCE 11-1-2000.

**CLASS 12—VEHICLES**

3,963,730. FIAT GRUPPO AUTOMOBILES S.P.A., TORINO, ITALY. SN 77-666,325. FILED P.R. 2-9-2009; AM. S.R. 2-28-2011.

**MULTIJET**

THE MARK CONSISTS OF STANDARD CHARACTERS WITHOUT CLAIM TO ANY PARTICULAR FONT, STYLE, SIZE, OR COLOR.

OWNER OF ITALY REG. NO. 769283, DATED 1-18-1999, EXPIRES 1-25-2018.

FOR ENGINES FOR LAND VEHICLES (U.S. CLS. 19, 21, 23, 31, 35 AND 44).

**CLASS 12—(Continued).**

3,963,773. LOGAN, CHARLES W., MORIARTY, NM. SN 78-820,199. FILED P.R. 2-21-2006; AM. S.R. 3-31-2011.

**FASTBACK XTC**

THE MARK CONSISTS OF STANDARD CHARACTERS WITHOUT CLAIM TO ANY PARTICULAR FONT, STYLE, SIZE, OR COLOR.

NO CLAIM IS MADE TO THE EXCLUSIVE RIGHT TO USE "FASTBACK", APART FROM THE MARK AS SHOWN.

FOR INSIGNIA FOR VEHICLES, NAMELY, INSIGNIA FOR AUTOMOBILES AND CARS (U.S. CLS. 19, 21, 23, 31, 35 AND 44).

FIRST USE 3-13-2010; IN COMMERCE 3-13-2010.

**CLASS 13—FIREARMS**

3,963,834. WILLIAM BRICE, GILBERT, AZ. SN 85-107,672. FILED P.R. 8-14-2010; AM. S.R. 2-28-2011.

**BRICE MOUNT**

THE MARK CONSISTS OF STANDARD CHARACTERS WITHOUT CLAIM TO ANY PARTICULAR FONT, STYLE, SIZE, OR COLOR.

NO CLAIM IS MADE TO THE EXCLUSIVE RIGHT TO USE "MOUNT", APART FROM THE MARK AS SHOWN.

FOR AIR RIFLE MOUNTS; COMPONENT PARTS FOR AIR RIFLES; AIR RIFLE ATTACHMENTS, NAMELY, MOUNTS FOR ATTACHING ACCESSORIES, SUCH AS GUN SIGHTS, GUN SCOPES, TELESCOPIC SIGHTS, LASER SIGHTS, AIMING DEVICES, NIGHT VISION OPTICS, FLASHLIGHTS, OR OTHER TYPES OF TACTICAL EQUIPMENT, TO AIR GUNS; BASE FOR MOUNTING ANCILLARY EQUIPMENT TO AIR GUNS, NAMELY, FIREARM ATTACHMENTS, NAMELY, MOUNTS FOR ATTACHING ANCILLARY EQUIPMENT TO A FIREARM (U.S. CLS. 2 AND 9).

FIRST USE 8-25-2008; IN COMMERCE 8-25-2008.

**CLASS 16—PAPER GOODS AND PRINTED MATTER**

**CLASS 16—(Continued).**

3,963,758. DOLCE BLEU CORP., CAROLINA, PUERTO RICO. SN 77-928,343. FILED P.R. 2-4-2010; AM. S.R. 3-25-2011.



NO CLAIM IS MADE TO THE EXCLUSIVE RIGHT TO USE "REVISTA", APART FROM THE MARK AS SHOWN.

THE MARK CONSISTS OF THE WORDS "REVISTA FARMACIA DE COMUNIDAD" AND "INDUSTRIA FARMACEUTICA DE PUERTO RICO" IN SPECIAL AND STYLIZED LETTERS; THE LETTERS OF "REVISTA" AND "DE COMUNIDAD" ARE FORMED BY NEGATIVE SPACE PLACED RESPECTIVELY WITHIN THE TOP PART OF THE LETTER "F" AND WITHIN A RECTANGLE FORMED BY THE BOTTOM PART OF THE WORD "FARMACIA".

THE ENGLISH TRANSLATION OF "REVISTA FARMACIA DE COMUNIDAD INDUSTRIA FARMACEUTICA DE PUERTO RICO" IN THE MARK IS "COMMUNITY PHARMACY MAGAZINE PHARMACEUTICAL INDUSTRY OF PUERTO RICO".

FOR MAGAZINES IN THE FIELD OF HEALTH AND WELLNESS (U.S. CLS. 2, 5, 22, 23, 29, 37, 38 AND 50).

FIRST USE 5-1-2008; IN COMMERCE 5-1-2008.

---

3,963,765. UNITED AMERICAN INSURANCE COMPANY, MCKINNEY, TX. SN 77-955,163. FILED P.R. 3-10-2010; AM. S.R. 2-28-2011.

**MEMORIAL GUIDE**

THE MARK CONSISTS OF STANDARD CHARACTERS WITHOUT CLAIM TO ANY PARTICULAR FONT, STYLE, SIZE, OR COLOR.

NO CLAIM IS MADE TO THE EXCLUSIVE RIGHT TO USE "GUIDE", APART FROM THE MARK AS SHOWN.

FOR PLANNING REFERENCE IN THE NATURE OF A PAMPHLET FOR USE WITH END OF LIFE DECISIONS (U.S. CLS. 2, 5, 22, 23, 29, 37, 38 AND 50).

FIRST USE 0-0-1985; IN COMMERCE 0-0-1985.

**CLASS 16—(Continued).**

3,963,832. SOHO PUBLISHING COMPANY, NEW YORK, NY. SN 85-105,831. FILED P.R. 8-12-2010; AM. S.R. 4-11-2011.

**Knitopedia**

THE MARK CONSISTS OF STANDARD CHARACTERS WITHOUT CLAIM TO ANY PARTICULAR FONT, STYLE, SIZE, OR COLOR.

FOR REFERENCE BOOKS IN THE FIELD OF KNITTING, KNITTING SKILLS, KNITTING TECHNIQUES, KNITTING HISTORY AND KNITTING CRAFTS (U.S. CLS. 2, 5, 22, 23, 29, 37, 38 AND 50).

FIRST USE 1-21-2011; IN COMMERCE 1-21-2011.

---

3,963,859. HARRIS BAY TRADING CORPORATION, AKA HISTORIC PHOTO COMPANY, SAN FRANCISCO, CA. SN 85-178,446. FILED P.R. 11-16-2010; AM. S.R. 3-30-2011.

**HistoricPhotoCo.**

THE MARK CONSISTS OF STANDARD CHARACTERS WITHOUT CLAIM TO ANY PARTICULAR FONT, STYLE, SIZE, OR COLOR.

FOR POSTCARDS (U.S. CLS. 2, 5, 22, 23, 29, 37, 38 AND 50).

FIRST USE 10-2-2010; IN COMMERCE 10-2-2010.

**CLASS 18—LEATHER GOODS**

---

3,963,775. MCFADDEN, JOHN, EDEN PRAIRIE, MN. SN 85-016,971. FILED P.R. 4-19-2010; AM. S.R. 3-30-2011.

**CREWBAGTAG.COM**

THE MARK CONSISTS OF STANDARD CHARACTERS WITHOUT CLAIM TO ANY PARTICULAR FONT, STYLE, SIZE, OR COLOR.

FOR LUGGAGE TAGS CONTAINING METAL SHAPES THAT REFLECT X-RAYS IN AIRPORT X-RAY MACHINES FOR THE PURPOSE OF IDENTIFYING THE CONTENTS OF A BAG AS BELONGING TO A UNIFORMED AIRLINE FLIGHT CREW MEMBER (U.S. CLS. 1, 2, 3, 22 AND 41).

FIRST USE 7-0-2008; IN COMMERCE 7-0-2008.



**CLASS 18—(Continued).**

3,963,864. CUDLIE ACCESSORIES LLC, NEW YORK, NY. SN 85-184,583. FILED P.R. 11-24-2010; AM. S.R. 3-22-2011.

## Baby Sac

THE MARK CONSISTS OF STANDARD CHARACTERS WITHOUT CLAIM TO ANY PARTICULAR FONT, STYLE, SIZE, OR COLOR.

NO CLAIM IS MADE TO THE EXCLUSIVE RIGHT TO USE "SAC", APART FROM THE MARK AS SHOWN.

FOR DIAPER BAGS (U.S. CLS. 1, 2, 3, 22 AND 41).  
FIRST USE 12-1-2000; IN COMMERCE 12-1-2000.

**CLASS 20—(Continued).**

3,963,839. INDIGO ROOT, LLC, KIRKLAND, WA. SN 85-121,283. FILED P.R. 9-1-2010; AM. S.R. 3-29-2011.

## Candle Wrapps

THE MARK CONSISTS OF STANDARD CHARACTERS WITHOUT CLAIM TO ANY PARTICULAR FONT, STYLE, SIZE, OR COLOR.

FOR CANDLE HOLDERS IN THE NATURE OF DECORATIVE VINYL COVERINGS FOR PLACEMENT AROUND FLAMELESS CANDLES (U.S. CLS. 2, 13, 22, 25, 32 AND 50).

FIRST USE 6-10-2010; IN COMMERCE 6-18-2010.

**CLASS 20—FURNITURE AND ARTICLES NOT OTHERWISE CLASSIFIED**

3,963,747. STEGGERT, PETER F., BUFORD, GA. SN 77-875,424. FILED P.R. 11-18-2009; AM. S.R. 9-7-2010.

## Swedish Bath

THE MARK CONSISTS OF STANDARD CHARACTERS WITHOUT CLAIM TO ANY PARTICULAR FONT, STYLE, SIZE, OR COLOR.

NO CLAIM IS MADE TO THE EXCLUSIVE RIGHT TO USE "BATH", APART FROM THE MARK AS SHOWN.

FOR BATH PILLOWS (U.S. CLS. 2, 13, 22, 25, 32 AND 50).

FIRST USE 12-5-2003; IN COMMERCE 9-1-2009.

**CLASS 21—HOUSEWARES AND GLASS**

3,963,780. BEST BUY CONTAINERS, LLC, COSTA MESA, CA. SN 85-037,132. FILED P.R. 5-12-2010; AM. S.R. 2-15-2011.

## Camo Pots

THE MARK CONSISTS OF STANDARD CHARACTERS WITHOUT CLAIM TO ANY PARTICULAR FONT, STYLE, SIZE, OR COLOR.

NO CLAIM IS MADE TO THE EXCLUSIVE RIGHT TO USE "POTS", APART FROM THE MARK AS SHOWN.

FOR PLANT AND FLOWER POTS MADE OF FABRIC (U.S. CLS. 2, 13, 23, 29, 30, 33, 40 AND 50).

FIRST USE 4-15-2010; IN COMMERCE 4-15-2010.

3,963,771. CHRISTIAN & ASSOCIATES, INC., RALEIGH, NC. SN 77-963,602. FILED P.R. 3-19-2010; AM. S.R. 3-23-2011.

## MILL WOOD ART

THE MARK CONSISTS OF STANDARD CHARACTERS WITHOUT CLAIM TO ANY PARTICULAR FONT, STYLE, SIZE, OR COLOR.

NO CLAIM IS MADE TO THE EXCLUSIVE RIGHT TO USE "WOOD ART", APART FROM THE MARK AS SHOWN.

FOR WORKS OF ART MADE OF WOOD (U.S. CLS. 2, 13, 22, 25, 32 AND 50).

FIRST USE 8-0-2009; IN COMMERCE 8-0-2009.

3,963,793. EVRIHOLDER PRODUCTS LLC, ANAHEIM, CA. SN 85-050,284. FILED P.R. 5-28-2010; AM. S.R. 4-2-2011.

## SCENTED CINCH

THE MARK CONSISTS OF STANDARD CHARACTERS WITHOUT CLAIM TO ANY PARTICULAR FONT, STYLE, SIZE, OR COLOR.

FOR PLASTIC SCENTED TRASH BAG HOLDER FOR HOUSEHOLD USE (U.S. CLS. 2, 13, 23, 29, 30, 33, 40 AND 50).

FIRST USE 2-7-2011; IN COMMERCE 3-11-2011.

**CLASS 21—(Continued).**

3,963,844. TRANSFAR INTERNATIONAL CORP., TAIPEI, TAIWAN. SN 85-138,645. FILED P.R. 9-27-2010; AM. S.R. 4-11-2011.

## Shots Shooter

THE MARK CONSISTS OF STANDARD CHARACTERS WITHOUT CLAIM TO ANY PARTICULAR FONT, STYLE, SIZE, OR COLOR.  
FOR PORTABLE BEVERAGE DISPENSERS (U.S. CLS. 2, 13, 23, 29, 30, 33, 40 AND 50).  
FIRST USE 1-31-2009; IN COMMERCE 12-1-2010.

**CLASS 25—(Continued).**

3,963,799. TAHOE BOARD WORKS, LLC, RENO, NV. SN 85-055,610. FILED P.R. 6-5-2010; AM. S.R. 3-17-2011.

## PADDLE WITH A NEW PERSPECTIVE

THE MARK CONSISTS OF STANDARD CHARACTERS WITHOUT CLAIM TO ANY PARTICULAR FONT, STYLE, SIZE, OR COLOR.  
FOR RASH GUARDS; SHIRTS (U.S. CLS. 22 AND 39).  
FIRST USE 5-7-2009; IN COMMERCE 5-7-2009.

**CLASS 25—CLOTHING**

3,963,729. WHITE, SUSAN A., WASHINGTON, DC. SN 77-580,744. FILED P.R. 9-29-2008; AM. S.R. 2-25-2011.

## GOLDEN ANGEL

THE MARK CONSISTS OF STANDARD CHARACTERS WITHOUT CLAIM TO ANY PARTICULAR FONT, STYLE, SIZE, OR COLOR.  
FOR SHIRTS (U.S. CLS. 22 AND 39).  
FIRST USE 11-12-2009; IN COMMERCE 11-12-2009.

3,963,800. SMOKE ON AEROBATICS, L.L.C., HOUSTON, TX. SN 85-057,170. FILED P.R. 6-8-2010; AM. S.R. 3-25-2011.

## Enter the box if you dare

THE MARK CONSISTS OF STANDARD CHARACTERS WITHOUT CLAIM TO ANY PARTICULAR FONT, STYLE, SIZE, OR COLOR.  
FOR CLOTHING, NAMELY, SHIRTS, T-SHIRTS, TANK TOPS, HATS, AND CAPS (U.S. CLS. 22 AND 39).  
FIRST USE 3-1-2010; IN COMMERCE 5-18-2010.

3,963,790. LILLEHOFF, TROY, CENTENNIAL, CO. AND MOOK, MATT, CENTENNIAL, CO. SN 85-046,272. FILED P.R. 5-24-2010; AM. S.R. 4-11-2011.

## SCHEIZTY

THE MARK CONSISTS OF STANDARD CHARACTERS WITHOUT CLAIM TO ANY PARTICULAR FONT, STYLE, SIZE, OR COLOR.  
FOR HATS; JACKETS; PANTS; SHIRTS; SHOES (U.S. CLS. 22 AND 39).  
FIRST USE 1-1-2011; IN COMMERCE 1-1-2011.

3,963,813. AUSTIN, GRANT, OAKWOOD, GA. SN 85-068,208. FILED P.R. 6-22-2010; AM. S.R. 3-26-2011.

## ULTIMATE DANCE SHOES

THE MARK CONSISTS OF STANDARD CHARACTERS WITHOUT CLAIM TO ANY PARTICULAR FONT, STYLE, SIZE, OR COLOR.  
NO CLAIM IS MADE TO THE EXCLUSIVE RIGHT TO USE "SHOES", APART FROM THE MARK AS SHOWN.  
FOR CLOTHING, NAMELY, FOOTWEAR (U.S. CLS. 22 AND 39).  
FIRST USE 1-28-2007; IN COMMERCE 1-28-2007.

**CLASS 25—(Continued).**

3,963,842. SHOE BRANDING EUROPE BVBA, B-9700 OUDE-NAARDE, BELGIUM. SN 85-126,000. FILED 9-9-2010.

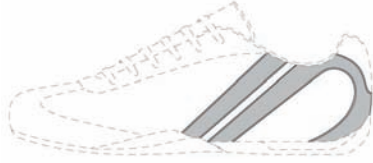

OWNER OF DENMARK REG. NO. VR200902252, DATED 8-19-2009, EXPIRES 8-19-2019.

THE MARK CONSISTS OF TWO PARALLEL LINES POSITIONED ON THE OUTSIDE SURFACE OF THE UPPER PART OF A SHOE; THE FIRST LINE RUNS FROM THE MIDDLE OF THE SOLE EDGE OF A SHOE AND SLOPES BACKWARDS TOWARDS THE INSTEP OF A SHOE; THE SECOND LINE RUNS PARALLEL WITH THE FIRST LINE AND CONTINUES IN A CURVE BACKWARDS ALONG THE COUNTER OF A SHOE TO THE HEEL OF A SHOE AND ENDS AT THE SOLE EDGE OF A SHOE; THE DOTTED LINE MARKS THE POSITION OF THE TRADEMARK AND DOES NOT FORM PART OF THE MARK.

FOR FOOTWEAR (U.S. CLS. 22 AND 39).

3,963,878. CROSIAR, TERESA, L., PONTIAC, IL. SN 85-209,188. FILED P.R. 1-3-2011; AM. S.R. 3-28-2011.



THE COLOR(S) BLACK AND RED IS/ARE CLAIMED AS A FEATURE OF THE MARK.

THE MARK CONSISTS OF THE WORDING "JUSTANORMALGIRL" IN BLACK UNDERNEATH A BLACK SMILEY FACE WITH BLACK DOTS FOR EYES, A BLACK MOUTH, AND A RED BOW OFFSET ON THE TOP OF HER HEAD WITH A BLACK PONY TAIL.

FOR CAP VISORS; HOODED SWEATSHIRTS; T-SHIRTS (U.S. CLS. 22 AND 39).

FIRST USE 11-1-2010; IN COMMERCE 11-26-2010.

**CLASS 27—FLOOR COVERINGS**

3,963,884. UNILIN FLOORING NC, LLC, CALHOUN, GA. SN 85-218,150. FILED P.R. 1-14-2011; AM. S.R. 3-18-2011.

**HIDEF COLOR FUSION  
TECHNOLOGY**

THE MARK CONSISTS OF STANDARD CHARACTERS WITHOUT CLAIM TO ANY PARTICULAR FONT, STYLE, SIZE, OR COLOR.

**CLASS 27—(Continued).**

NO CLAIM IS MADE TO THE EXCLUSIVE RIGHT TO USE "TECHNOLOGY", APART FROM THE MARK AS SHOWN. FOR FLOOR COVERINGS (U.S. CLS. 19, 20, 37, 42 AND 50).

FIRST USE 2-12-2011; IN COMMERCE 2-12-2011.

**CLASS 28—TOYS AND SPORTING GOODS**

3,963,787. MAKE IDEAS, INC., LA JOLLA, CA. SN 85-043,420. FILED 5-20-2010.

**BIONIC**

THE MARK CONSISTS OF STANDARD CHARACTERS WITHOUT CLAIM TO ANY PARTICULAR FONT, STYLE, SIZE, OR COLOR.

FOR PET TOYS (U.S. CLS. 22, 23, 38 AND 50).

FIRST USE 5-28-2008; IN COMMERCE 3-16-2011.

3,963,847. PRETTY UGLY LLC, EDISON, NJ. AND DAVID HORVATH, EDISON, NJ. AND SUN-MIN KIM, EDISON, NJ. SN 85-153,715. FILED P.R. 10-15-2010; AM. S.R. 3-30-2011.

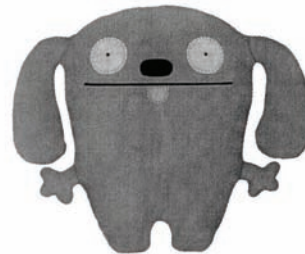

THE MARK CONSISTS OF A THREE-DIMENSIONAL CONFIGURATION OF A FIGURE WITH A CIRCULAR HEAD AND LONG EARS, CIRCULAR HAND-STITCHED EYES WITH A DOT IN THE CENTER, OVAL-SHAPED NOSE, A MOUTH FORMED BY A STRAIGHT LINE ACROSS MOST OF THE FACE AND ONE CURVED TOOTH HANGING DOWN FROM THE MOUTH, WITH A LOOSELY FORMED BODY, SHORT ARMS, HANDS WITH THREE FINGERS AND SHORT LEGS, WHICH IS NEITHER HUMAN NOR ANIMAL.

FOR STUFFED AND PLUSH TOYS (U.S. CLS. 22, 23, 38 AND 50).

FIRST USE 11-0-2009; IN COMMERCE 11-0-2009.

**CLASS 28—(Continued).**

3,963,848. PRETTY UGLY LLC, EDISON, NJ. AND DAVID HORVATH, EDISON, NJ. AND SUN-MIN KIM, EDISON, NJ. SN 85-153,724. FILED P.R. 10-15-2010; AM. S.R. 3-30-2011.



THE MARK CONSISTS OF A THREE-DIMENSIONAL CONFIGURATION OF A FIGURE WITH A CIRCULAR HEAD AND A POINTY TOP AND LOOSELY FORMED BODY, CIRCULAR HAND-STITCHED EYES WITH A DOT IN THE CENTER, OVAL-SHAPED NOSE, A MOUTH FORMED BY A STRAIGHT LINE ACROSS MOST OF THE FACE AND ONE CURVED TOOTH HANGING DOWN FROM THE MOUTH, SHORT ARMS AND SHORT LEGS, WHICH IS NEITHER HUMAN NOR ANIMAL.

FOR STUFFED AND PLUSH TOYS (U.S. CLS. 22, 23, 38 AND 50).

FIRST USE 8-31-2010; IN COMMERCE 8-31-2010.

**CLASS 29—MEATS AND PROCESSED FOODS**

3,963,763. CERTIFIED STEAK & SEAFOOD LLC, JACKSONVILLE, FL. SN 77-954,248. FILED P.R. 3-9-2010; AM. S.R. 3-7-2011.

CERTIFIED STEAK & SEAFOOD  
COMPANY, RESTAURANT  
QUALITY. INTERNET PRICES.

THE MARK CONSISTS OF STANDARD CHARACTERS WITHOUT CLAIM TO ANY PARTICULAR FONT, STYLE, SIZE, OR COLOR.

NO CLAIM IS MADE TO THE EXCLUSIVE RIGHT TO USE "CERTIFIED STEAK & SEAFOOD COMPANY", APART FROM THE MARK AS SHOWN.

FOR FRESH, FROZEN SEAFOOD AND MEAT PRODUCTS, NAMELY, FISH, SHELL FISH AND MEAT (U.S. CL. 46).

FIRST USE 2-8-2011; IN COMMERCE 2-8-2011.

**CLASS 29—(Continued).**

3,963,853. PLUMFUL FOODS, INC., HOUSTON, TX. SN 85-162,057. FILED P.R. 10-27-2010; AM. S.R. 4-6-2011.

**BURGER BLUE**

THE MARK CONSISTS OF STANDARD CHARACTERS WITHOUT CLAIM TO ANY PARTICULAR FONT, STYLE, SIZE, OR COLOR.

FOR CHEESE (U.S. CL. 46).

FIRST USE 1-18-2011; IN COMMERCE 1-18-2011.

3,963,854. PLUMFUL FOODS, INC., HOUSTON, TX. SN 85-162,062. FILED P.R. 10-27-2010; AM. S.R. 4-6-2011.

**PIZZA BLUE**

THE MARK CONSISTS OF STANDARD CHARACTERS WITHOUT CLAIM TO ANY PARTICULAR FONT, STYLE, SIZE, OR COLOR.

FOR CHEESE (U.S. CL. 46).

FIRST USE 1-25-2011; IN COMMERCE 1-25-2011.

**CLASS 30—STAPLE FOODS**

3,963,822. NADIA RODEN, NEW YORK, NY. SN 85-080,611. FILED P.R. 7-8-2010; AM. S.R. 3-14-2011.

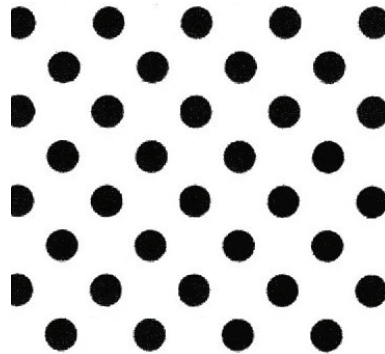

THE MARK CONSISTS OF POLKA DOTS.  
FOR ICE CREAM, FROZEN YOGURT, SORBET AND  
FROZEN CONFECTIONS (U.S. CL. 46).

FIRST USE 7-1-2010; IN COMMERCE 7-1-2010.

**CLASS 30—(Continued).**

3,963,833. NACIONAL DE ALIMENTOS Y HELADOS, S.A. DE C.V., SANTA CATARINA, N.L., MEXICO. SN 85-106,905. FILED P.R. 8-13-2010; AM. S.R. 4-7-2011.



THE MARK CONSISTS OF A SHAPE OF A FOOD PRODUCT RESEMBLING A BOW. FOR CORN-BASED SNACK FOODS (U.S. CL. 46). FIRST USE 4-5-2011; IN COMMERCE 4-5-2011.

3,963,849. SARRIS HOLDINGS, LLP, CANONSBURG, PA. SN 85-156,250. FILED P.R. 10-19-2010; AM. S.R. 2-22-2011.

**GRILLING FONDUE**

THE MARK CONSISTS OF STANDARD CHARACTERS WITHOUT CLAIM TO ANY PARTICULAR FONT, STYLE, SIZE, OR COLOR. NO CLAIM IS MADE TO THE EXCLUSIVE RIGHT TO USE "FONDUE", APART FROM THE MARK AS SHOWN. FOR CHOCOLATE FONDUE, PACKAGED FOR HEATING ON GRILL (U.S. CL. 46). FIRST USE 9-1-2010; IN COMMERCE 9-1-2010.

3,963,873. THE TOASTED NUT, LLC, ROSWELL, GA. SN 85-201,815. FILED P.R. 12-20-2010; AM. S.R. 4-4-2011.

**The Toasted Nut**

THE MARK CONSISTS OF STANDARD CHARACTERS WITHOUT CLAIM TO ANY PARTICULAR FONT, STYLE, SIZE, OR COLOR. NO CLAIM IS MADE TO THE EXCLUSIVE RIGHT TO USE "NUT", APART FROM THE MARK AS SHOWN. FOR COOKIES; GRANOLA SNACKS; PEANUT BRITTLE; TOFFEES (U.S. CL. 46). FIRST USE 1-2-2009; IN COMMERCE 7-0-2010.

**CLASS 31—NATURAL AGRICULTURAL PRODUCTS**

3,963,733. SUNSHINE MILLS, INC., RED BAY, AL. SN 77-725,699. FILED P.R. 4-30-2009; AM. S.R. 3-29-2011.

**VETERINARY SELECT**

THE MARK CONSISTS OF STANDARD CHARACTERS WITHOUT CLAIM TO ANY PARTICULAR FONT, STYLE, SIZE, OR COLOR.

OWNER OF U.S. REG. NO. 2,655,126. FOR EDIBLE PET TREATS; DOG FOOD; CAT FOOD (U.S. CLS. 1 AND 46). FIRST USE 1-31-2009; IN COMMERCE 1-31-2009.

3,963,851. BAKO SWEET, INC., BAKERSFIELD, CA. SN 85-161,237. FILED P.R. 10-26-2010; AM. S.R. 3-1-2011.

**Bako Sweet**

THE MARK CONSISTS OF STANDARD CHARACTERS WITHOUT CLAIM TO ANY PARTICULAR FONT, STYLE, SIZE, OR COLOR.

NO CLAIM IS MADE TO THE EXCLUSIVE RIGHT TO USE "SWEET", APART FROM THE MARK AS SHOWN. FOR FRESH FRUIT AND VEGETABLES (U.S. CLS. 1 AND 46).

FIRST USE 7-13-2010; IN COMMERCE 7-13-2010.

**CLASS 32—LIGHT BEVERAGES**

3,963,883. SHAPELLES ENTERPRISE INC., HARRISBURG, NC. SN 85-214,909. FILED P.R. 1-11-2011; AM. S.R. 1-10-2011.

**Natural Blendz**

THE MARK CONSISTS OF STANDARD CHARACTERS WITHOUT CLAIM TO ANY PARTICULAR FONT, STYLE, SIZE, OR COLOR.

FOR FRUIT JUICE AND SMOOTHIES MADE FROM PRIMARILY FRESH, NATURAL INGREDIENTS (U.S. CLS. 45, 46 AND 48).

FIRST USE 3-1-2009; IN COMMERCE 6-1-2010.

**CLASS 33—WINES AND SPIRITS**



**CLASS 33—(Continued).**

3,963,748. TEMPUS FUGIT, LLC, PETALUMA, CA. SN 77-879,310. FILED P.R. 11-23-2009; AM. S.R. 3-30-2011.

**ABBOTT'S BITTERS**

THE MARK CONSISTS OF STANDARD CHARACTERS WITHOUT CLAIM TO ANY PARTICULAR FONT, STYLE, SIZE, OR COLOR.

NO CLAIM IS MADE TO THE EXCLUSIVE RIGHT TO USE "BITTERS", APART FROM THE MARK AS SHOWN. FOR POTABLE SPIRITS (U.S. CLS. 47 AND 49). FIRST USE 3-28-2011; IN COMMERCE 3-28-2011.

---

3,963,795. MULLINEUX, CHRIS, DBA THE ROLLING STONE WINERY, RIEBEEK KASTEEL, SOUTH AFRICA. SN 85-051,699. FILED P.R. 6-1-2010; AM. S.R. 3-16-2011.

**MULLINEUX**

THE MARK CONSISTS OF STANDARD CHARACTERS WITHOUT CLAIM TO ANY PARTICULAR FONT, STYLE, SIZE, OR COLOR.

FOR WINE (U.S. CLS. 47 AND 49). FIRST USE 3-0-2009; IN COMMERCE 10-0-2010.

---

3,963,885. DRUM CIRCLE DISTILLING, LLC, SARASOTA, FL. SN 85-219,305. FILED 1-17-2011.

**Siesta Key Rum**

THE MARK CONSISTS OF STANDARD CHARACTERS WITHOUT CLAIM TO ANY PARTICULAR FONT, STYLE, SIZE, OR COLOR.

NO CLAIM IS MADE TO THE EXCLUSIVE RIGHT TO USE "RUM", APART FROM THE MARK AS SHOWN. FOR DISTILLED SPIRITS, NAMELY, RUM (U.S. CLS. 47 AND 49). FIRST USE 7-31-2008; IN COMMERCE 3-18-2010.

**SERVICE MARKS**

**CLASS 35—ADVERTISING AND BUSINESS**

**CLASS 35—(Continued).**

3,963,736. THE POWER OF PEACE LLC, CRARYVILLE, NY. SN 77-773,495. FILED P.R. 7-2-2009; AM. S.R. 9-11-2010.

**SOCIAL NET WORTH INDEX**

THE MARK CONSISTS OF STANDARD CHARACTERS WITHOUT CLAIM TO ANY PARTICULAR FONT, STYLE, SIZE, OR COLOR.

NO CLAIM IS MADE TO THE EXCLUSIVE RIGHT TO USE "INDEX", APART FROM THE MARK AS SHOWN. FOR PROVIDING A WEBSITE FEATURING INFORMATION ABOUT POLITICAL ISSUES PERTAINING TO GLOBAL SOCIAL ACTIVISM, HUMAN RIGHTS, ENVIRONMENTAL ISSUES, CULTURE AND GOVERNMENT (U.S. CLS. 100, 101 AND 102). FIRST USE 1-0-2008; IN COMMERCE 7-0-2009.

---

3,963,751. MARRERO PUBLISHING, INC., DBA ARIZONA COLLECTOR'S GUIDE, TUCSON, AZ. SN 77-882,533. FILED P.R. 11-30-2009; AM. S.R. 3-29-2011.



NO CLAIM IS MADE TO THE EXCLUSIVE RIGHT TO USE "VISITOR'S GUIDE", APART FROM THE MARK AS SHOWN.

THE MARK CONSISTS OF LOGO OF THE "TUBAC OFFICIAL VISITORS GUIDE" FOR TUBAC, AZ.

FOR PROVIDING ADVERTISING SPACE IN PERIODICALS, NEWSPAPERS AND MAGAZINES (U.S. CLS. 100, 101 AND 102).

FIRST USE 10-1-2009; IN COMMERCE 10-1-2009.

---

3,963,752. HELP ME SELL ME, LLC, ROSWELL, GA. SN 77-883,804. FILED P.R. 12-1-2009; AM. S.R. 3-18-2011.

**HUMAN CAPITAL BRANDING**

THE MARK CONSISTS OF STANDARD CHARACTERS WITHOUT CLAIM TO ANY PARTICULAR FONT, STYLE, SIZE, OR COLOR.

**CLASS 35—(Continued).**

NO CLAIM IS MADE TO THE EXCLUSIVE RIGHT TO USE "BRANDING", APART FROM THE MARK AS SHOWN.

FOR CONSULTATION SERVICES, NAMELY, ASSISTING BUSINESSES AND ORGANIZATIONS IN BRANDING AND PROMOTING THEMSELVES BY MEANS OF IDENTIFYING, DEFINING, AND PRESENTING THE TRAITS AND CHARACTERISTICS OF THEIR EMPLOYEES; CORPORATE IMAGE CONSULTING SERVICES; BUSINESS CONSULTATION SERVICES; BUSINESS MARKETING CONSULTATION SERVICES; CORPORATE MARKETING CONSULTING SERVICES (U.S. CLS. 100, 101 AND 102).

FIRST USE 3-1-2011; IN COMMERCE 3-1-2011.

---

3,963,768. FORSTER, CHRISTIAN, WESTON, FL. SN 77-961,195. FILED P.R. 3-17-2010; AM. S.R. 3-23-2011.

**DOCTORS BEST WEIGHT LOSS**

THE MARK CONSISTS OF STANDARD CHARACTERS WITHOUT CLAIM TO ANY PARTICULAR FONT, STYLE, SIZE, OR COLOR.

FOR ON-LINE RETAIL STORE SERVICES FEATURING WEIGHT LOSS PRODUCTS (U.S. CLS. 100, 101 AND 102).

FIRST USE 1-0-2009; IN COMMERCE 1-0-2009.

---

3,963,772. CALIFORNIAHOME TRADING LLC, THOUSAND OAKS, CA. SN 77-966,270. FILED P.R. 3-23-2010; AM. S.R. 3-30-2011.

**CaliforniaHomeTrading.com**

THE MARK CONSISTS OF STANDARD CHARACTERS WITHOUT CLAIM TO ANY PARTICULAR FONT, STYLE, SIZE, OR COLOR.

FOR ADVERTISING OF COMMERCIAL OR RESIDENTIAL REAL ESTATE; MATCHING CONSUMERS WITH REAL ESTATE PROFESSIONALS IN THE FIELD OF REAL ESTATE SERVICES VIA COMPUTER NETWORK (U.S. CLS. 100, 101 AND 102).

FIRST USE 1-1-2010; IN COMMERCE 1-1-2010.

**CLASS 35—(Continued).**

3,963,777. HESSING, FRANK, HOUSTON, TX. SN 85-025,579. FILED P.R. 4-28-2010; AM. S.R. 3-24-2011.

**MusiConsult**

THE MARK CONSISTS OF STANDARD CHARACTERS WITHOUT CLAIM TO ANY PARTICULAR FONT, STYLE, SIZE, OR COLOR.

FOR BUSINESS CONSULTING, BUSINESS MANAGEMENT AND PROVIDING INFORMATION IN THE MUSIC BUSINESS FIELD (U.S. CLS. 100, 101 AND 102).

FIRST USE 8-1-1998; IN COMMERCE 8-1-1998.

---

3,963,781. TOP CODERS, LLC, GILBERT, AZ. SN 85-039,627. FILED P.R. 5-16-2010; AM. S.R. 3-2-2011.

**Top Designers**

THE MARK CONSISTS OF STANDARD CHARACTERS WITHOUT CLAIM TO ANY PARTICULAR FONT, STYLE, SIZE, OR COLOR.

FOR OPERATING ON-LINE MARKETPLACES FOR SELLERS OF GOODS AND/OR SERVICES (U.S. CLS. 100, 101 AND 102).

FIRST USE 5-1-2010; IN COMMERCE 5-1-2010.

---

3,963,782. TOP CODERS, LLC, GILBERT, AZ. SN 85-039,629. FILED P.R. 5-16-2010; AM. S.R. 3-2-2011.

**Top Programmers**

THE MARK CONSISTS OF STANDARD CHARACTERS WITHOUT CLAIM TO ANY PARTICULAR FONT, STYLE, SIZE, OR COLOR.

FOR OPERATING ON-LINE MARKETPLACES FOR SELLERS OF GOODS AND/OR SERVICES (U.S. CLS. 100, 101 AND 102).

FIRST USE 5-1-2010; IN COMMERCE 5-1-2010.

**CLASS 35—(Continued).**

3,963,785. TOP CODERS, LLC, GILBERT, AZ. SN 85-041,216. FILED P.R. 5-18-2010; AM. S.R. 3-2-2011.

## Pro Contractors

THE MARK CONSISTS OF STANDARD CHARACTERS WITHOUT CLAIM TO ANY PARTICULAR FONT, STYLE, SIZE, OR COLOR.

FOR OPERATING ON-LINE MARKETPLACES FOR SELLERS OF GOODS AND/OR SERVICES (U.S. CLS. 100, 101 AND 102).

FIRST USE 5-18-2010; IN COMMERCE 5-18-2010.

---

3,963,807. GREEN YOUTH MOVEMENT, LLC, BEVERLY HILLS, CA. SN 85-062,718. FILED P.R. 6-14-2010; AM. S.R. 3-28-2011.

## Green Youth Movement

THE MARK CONSISTS OF STANDARD CHARACTERS WITHOUT CLAIM TO ANY PARTICULAR FONT, STYLE, SIZE, OR COLOR.

FOR CHARITABLE SERVICES, NAMELY, PROMOTING ENVIRONMENTAL AWARENESS TO CHILDREN (U.S. CLS. 100, 101 AND 102).

FIRST USE 9-1-2007; IN COMMERCE 9-1-2007.

---

3,963,808. OASIS INTERNATIONAL DEVELOPMENT CORP., COCONUT CREEK, FL. SN 85-063,230. FILED P.R. 6-15-2010; AM. S.R. 3-25-2011.

## ihospital

THE MARK CONSISTS OF STANDARD CHARACTERS WITHOUT CLAIM TO ANY PARTICULAR FONT, STYLE, SIZE, OR COLOR.

FOR MEDICAL REFERRAL SERVICE THAT ESTABLISHES A ONLINE VIDEO RELATIONSHIP BETWEEN A PATIENT AND DOCTOR IN ANOTHER COUNTRY AND A PHYSICIAN LOCATED IN THE USA (U.S. CLS. 100, 101 AND 102).

FIRST USE 5-21-2010; IN COMMERCE 5-21-2010.

**CLASS 35—(Continued).**

3,963,812. FOOD PROCESSING SUPPLIERS ASSOCIATION, MCLEAN, VA. SN 85-064,959. FILED P.R. 6-17-2010; AM. S.R. 3-21-2011.

## The Global Food Equipment and Technology Show

THE MARK CONSISTS OF STANDARD CHARACTERS WITHOUT CLAIM TO ANY PARTICULAR FONT, STYLE, SIZE, OR COLOR.

NO CLAIM IS MADE TO THE EXCLUSIVE RIGHT TO USE "SHOW", APART FROM THE MARK AS SHOWN.

FOR PROMOTING THE SALE OF FOOD, BEVERAGE, AND PHARMACEUTICAL PROCESSING EQUIPMENT, SUPPLIES, AND SERVICES BY MEANS OF AN ANNUAL EXHIBITION (U.S. CLS. 100, 101 AND 102).

FIRST USE 11-1-2010; IN COMMERCE 11-1-2010.

---

3,963,819. DD APARTMENTS, LLC, DBA DEEP DISCOUNT APARTMENTS, BETHESDA, MD. SN 85-076,741. FILED P.R. 7-2-2010; AM. S.R. 3-29-2011.

## DEEP DISCOUNT APARTMENTS

THE MARK CONSISTS OF STANDARD CHARACTERS WITHOUT CLAIM TO ANY PARTICULAR FONT, STYLE, SIZE, OR COLOR.

FOR PROVIDING A SEARCHABLE ONLINE ADVERTISING WEBSITE AND INFORMATIONAL GUIDE FEATURING THE GOODS AND SERVICES OF OTHER VENDORS VIA THE INTERNET IN THE FIELD OF APARTMENT RENTALS; PROVIDING AN INTERACTIVE REAL ESTATE WEBSITE WHICH PROMOTES HOUSING AND APARTMENT PROPERTIES THROUGH OFFERING PROSPECTIVE TENANTS VIDEO WALK THROUGHS, PROPERTY DESCRIPTIONS, TEXT, PRICE, LOCATION, MAPS AND OTHER INFORMATION THAT WOULD BE INFLUENTIAL TO A PROSPECTIVE TENANT IN MAKING A RENTAL DECISION (U.S. CLS. 100, 101 AND 102).

FIRST USE 7-1-2010; IN COMMERCE 9-17-2010.

---

3,963,846. CEO STRATEGY SUMMIT LLC, ATLANTA, GA. SN 85-148,941. FILED P.R. 10-8-2010; AM. S.R. 3-23-2011.

## CEO STRATEGY SUMMIT

THE MARK CONSISTS OF STANDARD CHARACTERS WITHOUT CLAIM TO ANY PARTICULAR FONT, STYLE, SIZE, OR COLOR.

**CLASS 35—(Continued).**

NO CLAIM IS MADE TO THE EXCLUSIVE RIGHT TO USE "SUMMIT", APART FROM THE MARK AS SHOWN.  
FOR ARRANGING AND CONDUCTING AN ANNUAL BUSINESS CONFERENCE (U.S. CLS. 100, 101 AND 102).  
FIRST USE 2-13-2002; IN COMMERCE 2-13-2002.

---

3,963,860. HERVOCHON, DEAN P., DBA THE GO TO GAY GUY, CHICAGO, IL. SN 85-179,508. FILED P.R. 11-17-2010; AM. S.R. 11-17-2010.

## Gay Guy Approved

THE MARK CONSISTS OF STANDARD CHARACTERS WITHOUT CLAIM TO ANY PARTICULAR FONT, STYLE, SIZE, OR COLOR.

FOR PROVIDING A WEB SITE FEATURING PRODUCT RATINGS OF THE CONSUMER GOODS AND SERVICES OF OTHERS IN THE FIELDS OF FASHION, BEAUTY, ENTERTAINING, HEALTH, HYGIENE, DECORATING, GIFT GIVING, FOOD AND BEVERAGES, DATING, HAIR, APPLIANCES, HOME GOODS, AUTOMOBILES, VACATION SERVICES AND PETS; PROVIDING A WEB SITE WHERE USERS CAN POST RATINGS, REVIEWS AND RECOMMENDATIONS ON PRODUCTS AND SERVICES FOR COMMERCIAL PURPOSES; ON-LINE RETAIL STORE SERVICES FEATURING CLOTHING, STICKERS, GIFTS, JEWELRY, COFFEE MUGS, GLASSWARE, HOME PRODUCTS, AND BATH PRODUCTS (U.S. CLS. 100, 101 AND 102).

FIRST USE 11-17-2010; IN COMMERCE 11-17-2010.

---

3,963,863. COMMERCIAL TEXTILES, INC., DBA BEST BUY UNIFORMS, HOMESTEAD, PA. SN 85-184,571. FILED P.R. 11-24-2010; AM. S.R. 3-29-2011.

## Best Buy Uniforms & Promos

THE MARK CONSISTS OF STANDARD CHARACTERS WITHOUT CLAIM TO ANY PARTICULAR FONT, STYLE, SIZE, OR COLOR.

NO CLAIM IS MADE TO THE EXCLUSIVE RIGHT TO USE "UNIFORMS AND PROMOS", APART FROM THE MARK AS SHOWN.

FOR WHOLESALE DISTRIBUTION OF CORPORATE, HEALTHCARE, HOSPITALITY, AND WORK UNIFORMS; RETAIL SERVICES FEATURING PROMOTIONAL PRODUCTS, NAMELY, MUGS, PENS, TOTE BAGS, UMBRELLAS, JACKETS, HATS, T-SHIRTS, POLO SHIRTS, TOWELS, TABLE SKIRTING, TABLE LINENS, AND INSTRUCTIONAL VIDEOS (U.S. CLS. 100, 101 AND 102).

FIRST USE 1-31-2008; IN COMMERCE 1-31-2008.

**CLASS 35—(Continued).**

3,963,870. MEMBERS MARKET, LLC., BYRON CENTER, MI. SN 85-200,148. FILED 12-16-2010.

## Members Market

THE MARK CONSISTS OF STANDARD CHARACTERS WITHOUT CLAIM TO ANY PARTICULAR FONT, STYLE, SIZE, OR COLOR.

NO CLAIM IS MADE TO THE EXCLUSIVE RIGHT TO USE "MARKET", APART FROM THE MARK AS SHOWN.

FOR PROVIDING A WEB SITE THAT FEATURES AN ON-LINE MARKET FOR USERS TO LIST OFFERED OR WANTED PERSONAL AND BUSINESS ASSETS AND SKILLS FOR HIRE, RENT, SALE OR AUCTION TRANSACTED ON THE BASIS OF PREDEFINED PERFORMANCE AND CLOSING TERMS AND CONDITIONS (U.S. CLS. 100, 101 AND 102).

FIRST USE 1-1-2010; IN COMMERCE 12-16-2010.

---

3,963,874. PREMIER GOODS LLC, MIAMI LAKES, FL. SN 85-203,208. FILED P.R. 12-21-2010; AM. S.R. 4-6-2011.

## Premier WatchShop

THE MARK CONSISTS OF STANDARD CHARACTERS WITHOUT CLAIM TO ANY PARTICULAR FONT, STYLE, SIZE, OR COLOR.

FOR ON-LINE RETAIL STORE SERVICES FEATURING WATCHES, PENS, WALLETS, BELTS, CUFFLINKS, AND ACCESSORIES (U.S. CLS. 100, 101 AND 102).

FIRST USE 8-28-2009; IN COMMERCE 8-28-2009.

---

3,963,876. MYVESTA FOUNDATION, INC., WASHINGTON, DC. SN 85-204,929. FILED P.R. 12-23-2010; AM. S.R. 4-4-2011.

## AMERICAN ASSOCIATION OF CREDIT COUNSELORS

THE MARK CONSISTS OF STANDARD CHARACTERS WITHOUT CLAIM TO ANY PARTICULAR FONT, STYLE, SIZE, OR COLOR.

**CLASS 35—(Continued).**

NO CLAIM IS MADE TO THE EXCLUSIVE RIGHT TO USE "ASSOCIATION", APART FROM THE MARK AS SHOWN.

FOR ASSOCIATION SERVICES, NAMELY, PROMOTING THE INTERESTS OF CONSUMER CREDIT COUNSELING AGENCIES, DEBT MANAGEMENT ORGANIZATIONS, CREDIT COUNSELORS, PERSONAL FINANCE EDUCATORS, CREDIT AND DEBT INFORMATION EDUCATORS, CREDIT COUNSELORS AND CONSUMER LAWYERS (U.S. CLS. 100, 101 AND 102).  
FIRST USE 11-13-2010; IN COMMERCE 11-13-2010.

3,963,879. SELL, JILL, SAGAMORE HILLS, OH. SN 85-209,408. FILED P.R. 1-3-2011; AM. S.R. 3-30-2011.

---

## International Gingerbread Society

THE MARK CONSISTS OF STANDARD CHARACTERS WITHOUT CLAIM TO ANY PARTICULAR FONT, STYLE, SIZE, OR COLOR.

NO CLAIM IS MADE TO THE EXCLUSIVE RIGHT TO USE "GINGERBREAD SOCIETY", APART FROM THE MARK AS SHOWN.

FOR PROMOTING THE AWARENESS AND THE INTERESTS OF GINGERBREAD ENTHUSIASTS (U.S. CLS. 100, 101 AND 102).

FIRST USE 11-1-1979; IN COMMERCE 1-1-2008.

3,963,880. INTERNATIONAL GROOVING & GRINDING ASSOC., INC., DBA IGGA, WEST COXSACKIE, NY. SN 85-209,799. FILED P.R. 1-4-2011; AM. S.R. 3-29-2011.

---

## Your Pavement Preservation Resource

THE MARK CONSISTS OF STANDARD CHARACTERS WITHOUT CLAIM TO ANY PARTICULAR FONT, STYLE, SIZE, OR COLOR.

NO CLAIM IS MADE TO THE EXCLUSIVE RIGHT TO USE "PAVEMENT PRESERVATION", APART FROM THE MARK AS SHOWN.

FOR ASSOCIATION SERVICES, NAMELY, PROMOTING THE INTERESTS OF THE CONCRETE PAVEMENT PRESERVATION INDUSTRY (U.S. CLS. 100, 101 AND 102).

FIRST USE 6-1-2010; IN COMMERCE 10-1-2010.

**CLASS 35—(Continued).**

3,963,886. WITS END HOLDINGS, BROOKFIELD, CT. SN 85-239,485. FILED P.R. 2-10-2011; AM. S.R. 3-28-2011.

## Who's Who in Architecture

THE MARK CONSISTS OF STANDARD CHARACTERS WITHOUT CLAIM TO ANY PARTICULAR FONT, STYLE, SIZE, OR COLOR.

OWNER OF U.S. REG. NOS. 3,607,987 AND 3,727,692.  
NO CLAIM IS MADE TO THE EXCLUSIVE RIGHT TO USE "WHO'S WHO", APART FROM THE MARK AS SHOWN.

FOR ON-LINE BUSINESS DIRECTORIES FEATURING ARCHITECTS (U.S. CLS. 100, 101 AND 102).  
FIRST USE 5-10-2008; IN COMMERCE 5-10-2008.

**CLASS 36—INSURANCE AND FINANCIAL**

3,963,749. MODERN WOODMEN OF AMERICA, ROCK ISLAND, IL. SN 77-879,834. FILED P.R. 11-24-2009; AM. S.R. 4-7-2010.

---

## FRATERNAL FINANCIAL

THE MARK CONSISTS OF STANDARD CHARACTERS WITHOUT CLAIM TO ANY PARTICULAR FONT, STYLE, SIZE, OR COLOR.

NO CLAIM IS MADE TO THE EXCLUSIVE RIGHT TO USE "FINANCIAL", APART FROM THE MARK AS SHOWN.

FOR INSURANCE SERVICES, NAMELY, UNDERWRITING, ISSUING AND ADMINISTRATION OF LIFE INSURANCE; ANNUITY UNDERWRITING; INVESTMENT MANAGEMENT OF AND DISTRIBUTION OF VARIABLE ANNUITIES; ISSUANCE AND ADMINISTRATION OF ANNUITIES; THE AFORESAID FINANCIAL SERVICES TO FOSTER ACTS OF FRATERNITY, CHARITY AND BENEVOLENCE BY AND AMONG ITS MEMBERS (U.S. CLS. 100, 101 AND 102).

FIRST USE 1-1-2008; IN COMMERCE 1-1-2008.

3,963,753. GKD INDEX PARTNERS, LLC, DALLAS, TX. SN 77-894,148. FILED P.R. 12-15-2009; AM. S.R. 3-27-2011.

---

## MLP ACCESS

THE MARK CONSISTS OF STANDARD CHARACTERS WITHOUT CLAIM TO ANY PARTICULAR FONT, STYLE, SIZE, OR COLOR.



**CLASS 36—(Continued).**

NO CLAIM IS MADE TO THE EXCLUSIVE RIGHT TO USE "MLP", APART FROM THE MARK AS SHOWN.

FOR FINANCIAL SERVICES, NAMELY, PROVIDING FINANCIAL ADVICE AND INVESTMENT MANAGEMENT IN THE FIELD OF MASTER LIMITED PARTNERSHIPS (U.S. CLS. 100, 101 AND 102).

FIRST USE 10-13-2009; IN COMMERCE 10-13-2009.

**CLASS 36—(Continued).**

3,963,815. EMIGRANT BANCORP., INC., NEW YORK, NY. SN 85-070,865. FILED P.R. 6-24-2010; AM. S.R. 3-23-2011.

**NEW YORK PRIVATE TRUST**

THE MARK CONSISTS OF STANDARD CHARACTERS WITHOUT CLAIM TO ANY PARTICULAR FONT, STYLE, SIZE, OR COLOR.

OWNER OF U.S. REG. NO. 3,022,254.

NO CLAIM IS MADE TO THE EXCLUSIVE RIGHT TO USE "PRIVATE TRUST", APART FROM THE MARK AS SHOWN.

FOR TRUST ADMINISTRATION SERVICES, NAMELY, INVESTMENT AND TRUST COMPANY SERVICES; FIDUCIARY SERVICES, NAMELY, FIDUCIARY REPRESENTATIVE SERVICES; CUSTODIAL SERVICES, NAMELY, FINANCIAL TRUST OPERATIONS (U.S. CLS. 100, 101 AND 102).

FIRST USE 2-4-2011; IN COMMERCE 2-4-2011.

3,963,797. ALLIANCE FOR VETERANS, LOS ANGELES, CA. SN 85-053,339. FILED P.R. 6-2-2010; AM. S.R. 3-18-2011.

**ALLIANCE FOR VETERANS**

THE MARK CONSISTS OF STANDARD CHARACTERS WITHOUT CLAIM TO ANY PARTICULAR FONT, STYLE, SIZE, OR COLOR.

FOR CHARITABLE FOUNDATION SERVICES, NAMELY, PROVIDING FUND RAISING ACTIVITIES TO SUPPORT U.S. MILITARY VETERANS AND THEIR FAMILIES; CHARITABLE SERVICES, NAMELY, ORGANIZING FUNDRAISING SERVICES AND EVENTS TO RAISE MONEY FOR U.S. MILITARY VETERANS AND THEIR FAMILIES; CHARITABLE FUNDRAISING SERVICES BY MEANS OF HOSTING TELETHONS TO RAISE MONEY FOR U.S. MILITARY VETERANS AND THEIR FAMILIES (U.S. CLS. 100, 101 AND 102).

FIRST USE 2-15-2009; IN COMMERCE 2-15-2009.

3,963,841. WISCONSIN REO REALTY INC., MILWAUKEE, WI. SN 85-125,579. FILED P.R. 9-9-2010; AM. S.R. 2-2-2011.

**WISCONSIN REO REALTY  
BANKOWNED FORECLOSURES  
PREFORECLOSURES SHORTSALES**

THE MARK CONSISTS OF STANDARD CHARACTERS WITHOUT CLAIM TO ANY PARTICULAR FONT, STYLE, SIZE, OR COLOR.

NO CLAIM IS MADE TO THE EXCLUSIVE RIGHT TO USE "REO REALTY" AND "BANKOWNED FORECLOSURES PREFORECLOSURES SHORTSALES", APART FROM THE MARK AS SHOWN.

FOR REAL ESTATE BROKERAGE (U.S. CLS. 100, 101 AND 102).

FIRST USE 8-31-2010; IN COMMERCE 8-31-2010.

3,963,814. KNIGHTSBRIDGE ADVISERS LLC, BARTLESVILLE, OK. SN 85-068,341. FILED P.R. 6-22-2010; AM. S.R. 4-7-2011.

**VENTURE PROXY FUND**

THE MARK CONSISTS OF STANDARD CHARACTERS WITHOUT CLAIM TO ANY PARTICULAR FONT, STYLE, SIZE, OR COLOR.

NO CLAIM IS MADE TO THE EXCLUSIVE RIGHT TO USE "FUND", APART FROM THE MARK AS SHOWN.

FOR FUNDS INVESTMENT, NAMELY, AN INVESTMENT FUND THAT TRACKS SELECTED INITIALLY VENTURE-BACKED, NOW PUBLIC, COMPANIES FROM IPO TO A SELECTED LATER STAGE USING PROCESS MODEL (U.S. CLS. 100, 101 AND 102).

FIRST USE 5-21-2010; IN COMMERCE 5-21-2010.

3,963,887. WHEN THEY COME BACK, LLC, TYLER, TX. SN 85-975,103. FILED P.R. 10-1-2010; AM. S.R. 3-22-2011.

**BOOT CAMPAIGN**

THE MARK CONSISTS OF STANDARD CHARACTERS WITHOUT CLAIM TO ANY PARTICULAR FONT, STYLE, SIZE, OR COLOR.

FOR CHARITABLE FUNDRAISING (U.S. CLS. 100, 101 AND 102).

FIRST USE 1-0-2010; IN COMMERCE 1-0-2010.

**CLASS 38—COMMUNICATION**

3,963,792. SSM HEALTH CARE OF OKLAHOMA, INC., OKLAHOMA CITY, OK. SN 85-048,295. FILED P.R. 5-26-2010; AM. S.R. 3-9-2011.

**SHARETHEPRAYER.TV**

THE MARK CONSISTS OF STANDARD CHARACTERS WITHOUT CLAIM TO ANY PARTICULAR FONT, STYLE, SIZE, OR COLOR.

FOR PROVIDING AN ONLINE FORUM FOR A USER TO ASK FOR A PRAYER OR TO PROVIDE A PRAYER IN A TIME OF SPIRITUAL NEED, FOR REGISTERED MEMBERS AND UNREGISTERED OPERATORS HAVING A FAMILY MEMBER, OR THEMSELVES, FACING AN ILLNESS OR OTHER SPIRITUALLY CHALLENGING EVENT FOR WHICH SHARING PRAYER WILL HELP EASE THEIR BURDEN (U.S. CLS. 100, 101 AND 104).

FIRST USE 12-1-2009; IN COMMERCE 12-1-2009.

**CLASS 39—TRANSPORTATION AND STORAGE**

3,963,728. INFORMATION MANAGEMENT SOLUTIONS, LLC, SAN ANTONIO, TX. SN 76-703,573. FILED P.R. 6-29-2010; AM. S.R. 3-11-2011.

**ONLINEFILECENTER**

THE MARK CONSISTS OF STANDARD CHARACTERS WITHOUT CLAIM TO ANY PARTICULAR FONT, STYLE, SIZE, OR COLOR.

FOR DOCUMENT MANAGEMENT SERVICES FOR OTHERS, NAMELY, ELECTRONIC STORAGE OF DOCUMENT IMAGES VIA THE INTERNET (U.S. CLS. 100 AND 105).

FIRST USE 11-0-2000; IN COMMERCE 11-0-2000.

3,963,788. CANADIAN NATIONAL RAILWAY COMPANY, MONTREAL, QUEBEC, CANADA. SN 85-045,150. FILED P.R. 5-21-2010; AM. S.R. 3-5-2011.

**NORTH AMERICAN RAILWAYS**

THE MARK CONSISTS OF STANDARD CHARACTERS WITHOUT CLAIM TO ANY PARTICULAR FONT, STYLE, SIZE, OR COLOR.

OWNER OF U.S. REG. NO. 3,074,993. FOR RAILWAY TRANSPORT (U.S. CLS. 100 AND 105). FIRST USE 1-1-2011; IN COMMERCE 1-1-2011.

**CLASS 39—(Continued).**

3,963,789. JETBOARDER PTY LTD, SYDNEY, AUSTRALIA. SN 85-045,937. FILED P.R. 5-24-2010; AM. S.R. 3-8-2011.

**JETBOARDER**

THE MARK CONSISTS OF STANDARD CHARACTERS WITHOUT CLAIM TO ANY PARTICULAR FONT, STYLE, SIZE, OR COLOR.

FOR RENTAL OF VEHICLES AND PRODUCTS FOR LOCOMOTION BY LAND, AIR OR WATER, NAMELY, MOTORIZED SURFBOARDS, KAYAK SMALL BOATS, JET PROPELLED STAND UP SURFBOARDS AND JET BOARDS FOR CONSUMERS, ATHLETES, FISHERMEN, SURFERS (U.S. CLS. 100 AND 105).

FIRST USE 10-22-2008; IN COMMERCE 5-8-2010.

3,963,881. MEDICAL FLIGHT SERVICES LLC, MESA, AZ. SN 85-211,794. FILED P.R. 1-6-2011; AM. S.R. 3-29-2011.

**MEDICAL FLIGHT SERVICES**

THE MARK CONSISTS OF STANDARD CHARACTERS WITHOUT CLAIM TO ANY PARTICULAR FONT, STYLE, SIZE, OR COLOR.

NO CLAIM IS MADE TO THE EXCLUSIVE RIGHT TO USE "FLIGHT SERVICES", APART FROM THE MARK AS SHOWN.

FOR AIR TRANSPORT; AIR TRANSPORT SERVICES; AMBULANCE TRANSPORT; TRANSPORTATION OF PASSENGERS AND/OR GOODS BY PRIVATE CHARTER JETS (U.S. CLS. 100 AND 105).

FIRST USE 8-2-2010; IN COMMERCE 8-2-2010.

**CLASS 41—EDUCATION AND ENTERTAINMENT**

**CLASS 41—(Continued).**

3,963,737. ALEXANDER, KENNETH C, DAYTON, NJ. SN 77-808,682. FILED P.R. 8-20-2009; AM. S.R. 3-12-2010.

## CERTIFIED GREEN ENERGY CONTRACTORS

THE MARK CONSISTS OF STANDARD CHARACTERS WITHOUT CLAIM TO ANY PARTICULAR FONT, STYLE, SIZE, OR COLOR.

FOR EDUCATIONAL SERVICES, NAMELY, PROVIDING TRAINING COURSES AND TRAINING PROGRAMS FOR TODAY'S CONTRACTORS IN THE FIELDS OF THE LATEST TECHNOLOGIES FOR GENERAL CONTRACTORS AND BUILDING CONSTRUCTION AND RENOVATION (U.S. CLS. 100, 101 AND 107). FIRST USE 12-17-2009; IN COMMERCE 12-17-2009.

---

3,963,742. ADVANCED LEARNING CENTERS, INC., DBA THE LEADERSHIP AND LEARNING CENTER, ENGLEWOOD, CO. SN 77-836,493. FILED P.R. 9-28-2009; AM. S.R. 6-23-2010.

## Implementation Audit

THE MARK CONSISTS OF STANDARD CHARACTERS WITHOUT CLAIM TO ANY PARTICULAR FONT, STYLE, SIZE, OR COLOR.

NO CLAIM IS MADE TO THE EXCLUSIVE RIGHT TO USE "AUDIT", APART FROM THE MARK AS SHOWN.

FOR ARRANGING AND CONDUCTING EDUCATIONAL CONFERENCES; CONSULTATION IN THE FIELD OF K-12 EDUCATIONAL SYSTEMS; EDUCATION SERVICES, NAMELY, PROVIDING CLASSES, SEMINARS, WORKSHOPS, TUTORING, AND MENTORING IN THE FIELD OF MIDDLE AND HIGH SCHOOL REFORM; EDUCATIONAL ASSESSMENT; EDUCATIONAL COURSE MONITORING, NAMELY, TRACKING STUDENT PERFORMANCE; EDUCATIONAL SERVICES, NAMELY, OFFERING OF ASSESSMENTS AND SURVEYS IN THE FIELD OF EDUCATOR TRAINING AND PERFORMANCE FOR THE PURPOSE OF IMPROVING TEACHING PROCEDURES; EDUCATIONAL SERVICES, NAMELY, THE OFFERING OF WEB BASED AND CLASSROOM TRAINING FOR CERTIFICATION OF TEACHERS AND CONTINUING EDUCATION FOR TEACHERS AND PRINCIPALS (U.S. CLS. 100, 101 AND 107).

FIRST USE 1-2-2009; IN COMMERCE 6-10-2009.

**CLASS 41—(Continued).**

3,963,745. ADVANCED LEARNING CENTERS, INC., DBA THE LEADERSHIP AND LEARNING CENTER, ENGLEWOOD, CO. SN 77-848,235. FILED P.R. 10-14-2009; AM. S.R. 6-23-2010.

## Implementation Review

THE MARK CONSISTS OF STANDARD CHARACTERS WITHOUT CLAIM TO ANY PARTICULAR FONT, STYLE, SIZE, OR COLOR.

NO CLAIM IS MADE TO THE EXCLUSIVE RIGHT TO USE "REVIEW", APART FROM THE MARK AS SHOWN.

FOR CONSULTATION IN THE FIELD OF K-12 EDUCATIONAL SYSTEMS; EDUCATION SERVICES, NAMELY, PROVIDING CLASSES, SEMINARS, WORKSHOPS, TUTORING, AND MENTORING IN THE FIELD OF MIDDLE AND HIGH SCHOOL REFORM; EDUCATIONAL ASSESSMENT; EDUCATIONAL RESEARCH; EDUCATIONAL SERVICES, NAMELY, A LEARNING AND INNOVATION CENTER FEATURING FULLY CUSTOMIZED LEADERSHIP, MOTIVATIONAL, EDUCATIONAL, AND BRAINSTORMING TRAINING; EDUCATIONAL SERVICES, NAMELY, DEVELOPING AND CONDUCTING TRAINING COURSES AND DISTRIBUTION OF TRAINING MATERIALS IN CONNECTION THEREWITH FOR SUBJECT MATTERS AS REQUESTED BY CUSTOMERS; EDUCATIONAL SERVICES, NAMELY, THE OFFERING OF WEB BASED AND CLASSROOM TRAINING FOR CERTIFICATION OF TEACHERS AND CONTINUING EDUCATION FOR TEACHERS AND PRINCIPALS; PROVIDING INFORMATION AND NEWS IN THE FIELD OF TEACHING METHODOLOGY AND EDUCATION (U.S. CLS. 100, 101 AND 107).

FIRST USE 1-2-2009; IN COMMERCE 6-1-2009.

---

3,963,756. WISCONSIN CHAMBER ORCHESTRA, INC., MADISON, WI. SN 77-905,786. FILED P.R. 1-6-2010; AM. S.R. 4-5-2011.

## WISCONSIN POPS

THE MARK CONSISTS OF STANDARD CHARACTERS WITHOUT CLAIM TO ANY PARTICULAR FONT, STYLE, SIZE, OR COLOR.

NO CLAIM IS MADE TO THE EXCLUSIVE RIGHT TO USE "POPS", APART FROM THE MARK AS SHOWN.

FOR ENTERTAINMENT, NAMELY, LIVE MUSICAL PERFORMANCES BY AN ORCHESTRA (U.S. CLS. 100, 101 AND 107).

FIRST USE 11-27-2010; IN COMMERCE 11-27-2010.

**CLASS 41—(Continued).**

3,963,760. MUSHIN NYC LLC, NEW YORK, NY. SN 77-932,471. FILED P.R. 2-10-2010; AM. S.R. 3-9-2011.

## MUSHIN MIXED MARTIAL ARTS

THE MARK CONSISTS OF STANDARD CHARACTERS WITHOUT CLAIM TO ANY PARTICULAR FONT, STYLE, SIZE, OR COLOR.

NO CLAIM IS MADE TO THE EXCLUSIVE RIGHT TO USE "MARTIAL ARTS", APART FROM THE MARK AS SHOWN.

FOR MARTIAL ARTS INSTRUCTION; PROVIDING FITNESS AND EXERCISE FACILITIES (U.S. CLS. 100, 101 AND 107).

FIRST USE 4-1-2010; IN COMMERCE 4-1-2010.

**CLASS 41—(Continued).**

3,963,769. GOLD COUNTRY WINE TOURS, INC., GRANADA HILLS, CA. SN 77-962,816. FILED P.R. 3-18-2010; AM. S.R. 3-31-2011.

## GOLD COUNTRY WINE TOURS

THE MARK CONSISTS OF STANDARD CHARACTERS WITHOUT CLAIM TO ANY PARTICULAR FONT, STYLE, SIZE, OR COLOR.

NO CLAIM IS MADE TO THE EXCLUSIVE RIGHT TO USE "WINE TOURS", APART FROM THE MARK AS SHOWN.

FOR ENTERTAINMENT SERVICES, NAMELY, WINE TASTINGS; GUIDED TOURS OF WINERIES (U.S. CLS. 100, 101 AND 107).

FIRST USE 2-0-2011; IN COMMERCE 2-0-2011.

3,963,766. ERIC FORBIS, ALEXANDRIA, VA. AND GABRIEL RIERA, ARLINGTON, VA. SN 77-958,379. FILED P.R. 3-13-2010; AM. S.R. 3-18-2011.

## BuddhaFest

THE MARK CONSISTS OF STANDARD CHARACTERS WITHOUT CLAIM TO ANY PARTICULAR FONT, STYLE, SIZE, OR COLOR.

FOR CONDUCTING ENTERTAINMENT EXHIBITIONS IN THE NATURE OF BUDDHIST RELIGION AND CULTURE, AND MEDITATION; ENTERTAINMENT IN THE NATURE OF BUDDHIST RELIGION AND CULTURE, AND MEDITATION; ENTERTAINMENT SERVICES, NAMELY, PLANNING AND CONDUCTING A SERIES OF FILM FESTIVALS; ORGANIZING COMMUNITY FESTIVALS FEATURING A VARIETY OF ACTIVITIES, NAMELY, ART EXHIBITIONS, HERITAGE MARKETS, ETHNIC DANCES, AND THE LIKE; ORGANIZING COMMUNITY FESTIVALS FEATURING A VARIETY OF ACTIVITIES, NAMELY, SPORTING EVENTS, ART EXHIBITIONS, FLEA MARKETS, ETHNIC DANCES AND THE LIKE (U.S. CLS. 100, 101 AND 107).

FIRST USE 10-15-2009; IN COMMERCE 10-15-2009.

3,963,776. DERRICK, DANIEL M, SAN FRANCISCO, CA. SN 85-017,457. FILED P.R. 4-19-2010; AM. S.R. 4-5-2011.

Ultimate Alliance Dance  
Company

THE MARK CONSISTS OF STANDARD CHARACTERS WITHOUT CLAIM TO ANY PARTICULAR FONT, STYLE, SIZE, OR COLOR.

NO CLAIM IS MADE TO THE EXCLUSIVE RIGHT TO USE "DANCE COMPANY", APART FROM THE MARK AS SHOWN.

FOR DANCE CLUB SERVICES; DANCE EVENTS; DANCE INSTRUCTION; DANCE INSTRUCTION FOR CHILDREN; DANCE RESERVATION SERVICES, NAMELY, ARRANGING FOR ADMISSION TO DANCE EVENTS; DANCE SCHOOLS; DANCE STUDIOS; EDUCATION SERVICES, NAMELY, PROVIDING CLASSES AND INSTRUCTION IN THE FIELD OF DANCE; ENTERTAINMENT AND EDUCATION SERVICES IN THE NATURE OF LIVE DANCE AND MUSICAL PERFORMANCES; ENTERTAINMENT IN THE NATURE OF DANCE PERFORMANCES; ENTERTAINMENT IN THE NATURE OF VISUAL AND AUDIO PERFORMANCES, NAMELY, MUSICAL BAND, ROCK GROUP, GYMNASTIC, DANCE, AND BALLET PERFORMANCES; ENTERTAINMENT SERVICES, NAMELY, DANCE EVENTS BY A RECORDING ARTIST (U.S. CLS. 100, 101 AND 107).

FIRST USE 2-26-2010; IN COMMERCE 2-26-2010.

**CLASS 41—(Continued).**

3,963,821. PHILIPPINE CULTURAL FOUNDATION, INC., TAMPA, FL. SN 85-079,043. FILED P.R. 7-7-2010; AM. S.R. 3-25-2011.

# PHILFEST

THE MARK CONSISTS OF STANDARD CHARACTERS WITHOUT CLAIM TO ANY PARTICULAR FONT, STYLE, SIZE, OR COLOR.

FOR EDUCATION AND ENTERTAINMENT SERVICES, NAMELY, A FESTIVAL FEATURING PHILIPPINE FOODS, ENTERTAINMENT, CULTURAL EXHIBITS, SINGING AND DANCING (U.S. CLS. 100, 101 AND 107).

FIRST USE 4-1-2008; IN COMMERCE 4-1-2008.

3,963,828. DENVER SCHOOL DISTRICT #1, DENVER, CO. SN 85-101,194. FILED P.R. 8-5-2010; AM. S.R. 3-23-2011.

## ADMINISTRATOR PORTAL

THE MARK CONSISTS OF STANDARD CHARACTERS WITHOUT CLAIM TO ANY PARTICULAR FONT, STYLE, SIZE, OR COLOR.

FOR CONSULTATION IN THE FIELD OF K-12 EDUCATIONAL SYSTEMS; EDUCATION SERVICES, NAMELY, PROVIDING METRICS AND INFORMATION FOR SCHOOL ADMINISTRATORS, STAFF, TEACHERS, PARENTS AND STUDENTS IN THE FIELD OF MEASURING AND ADDRESSING SCHOOL, TEACHER AND STUDENT PERFORMANCE; EDUCATIONAL RESEARCH SERVICES VIA INTERNET; EDUCATIONAL SERVICES, NAMELY, OFFERING OF ASSESSMENTS AND SURVEYS IN THE FIELD OF EDUCATOR TRAINING AND PERFORMANCE FOR THE PURPOSE OF IMPROVING TEACHING PROCEDURES (U.S. CLS. 100, 101 AND 107).

FIRST USE 1-1-2009; IN COMMERCE 1-1-2009.

**CLASS 41—(Continued).**

3,963,830. DENVER SCHOOL DISTRICT #1, DENVER, CO. SN 85-101,449. FILED P.R. 8-5-2010; AM. S.R. 3-23-2011.

## TEACHER PORTAL

THE MARK CONSISTS OF STANDARD CHARACTERS WITHOUT CLAIM TO ANY PARTICULAR FONT, STYLE, SIZE, OR COLOR.

FOR CONSULTATION IN THE FIELD OF K-12 EDUCATIONAL SYSTEMS; EDUCATION SERVICES, NAMELY, PROVIDING METRICS AND INFORMATION FOR SCHOOL ADMINISTRATORS, STAFF, TEACHERS, PARENTS AND STUDENTS IN THE FIELD OF MEASURING AND ADDRESSING SCHOOL, TEACHER AND STUDENT PERFORMANCE; EDUCATIONAL RESEARCH SERVICES VIA INTERNET; EDUCATIONAL SERVICES, NAMELY, OFFERING OF ASSESSMENTS AND SURVEYS IN THE FIELD OF EDUCATOR TRAINING AND PERFORMANCE FOR THE PURPOSE OF IMPROVING TEACHING PROCEDURES (U.S. CLS. 100, 101 AND 107).

FIRST USE 8-1-2009; IN COMMERCE 8-1-2009.

3,963,835. BALTIMORE RACING DEVELOPMENT, LLC, BALTIMORE, MD. SN 85-107,962. FILED P.R. 8-16-2010; AM. S.R. 4-1-2011.

## BALTIMORE GRAND PRIX

THE MARK CONSISTS OF STANDARD CHARACTERS WITHOUT CLAIM TO ANY PARTICULAR FONT, STYLE, SIZE, OR COLOR.

NO CLAIM IS MADE TO THE EXCLUSIVE RIGHT TO USE "GRAND PRIX", APART FROM THE MARK AS SHOWN.

FOR ENTERTAINMENT SERVICES, NAMELY, ORGANIZING AND CONDUCTING AN ANNUAL FESTIVAL OF AUTOMOBILE RACES (U.S. CLS. 100, 101 AND 107).

FIRST USE 12-10-2010; IN COMMERCE 12-10-2010.



**CLASS 41—(Continued).**

3,963,838. INTERNATIONAL KICKBALL FEDERATION, LLC, PARKLAND, FL. SN 85-111,915. FILED P.R. 8-20-2010; AM. S.R. 3-23-2011.

**THE OFFICIAL SANCTIONING  
BODY OF KICKBALL**

THE MARK CONSISTS OF STANDARD CHARACTERS WITHOUT CLAIM TO ANY PARTICULAR FONT, STYLE, SIZE, OR COLOR.

FOR EDUCATION AND ENTERTAINMENT SERVICES, NAMELY, RUNNING IN THE NATURE OF ORGANIZING, CONDUCTING AND ARRANGING KICKBALL LEAGUES; EDUCATION AND ENTERTAINMENT SERVICES, NAMELY, ENCOURAGING AMATEUR SPORTS BY SANCTIONING KICKBALL LEAGUES (U.S. CLS. 100, 101 AND 107).

FIRST USE 3-1-2010; IN COMMERCE 3-1-2010.

3,963,845. EVENT NAVIGATORS, LLC, GLADWYNE, PA. SN 85-147,350. FILED P.R. 10-7-2010; AM. S.R. 4-1-2011.



NO CLAIM IS MADE TO THE EXCLUSIVE RIGHT TO USE "FEST", APART FROM THE MARK AS SHOWN.

THE COLOR(S) BLUE AND WHITE IS/ARE CLAIMED AS A FEATURE OF THE MARK.

THE MARK CONSISTS OF BLUE CIRCLE WITH "SAKE FEST" IN WHITE STYLIZED LETTERS WITH A WHITE ACCENT MARK OVER THE "E" IN "SAKE".

FOR ORGANIZING COMMUNITY FESTIVALS FEATURING PRIMARILY BEVERAGE TASTINGS AND ALSO PROVIDING FOOD TASTINGS, FOOD AND BEVERAGE PAIRING INSTRUCTION AND LIVE ENTERTAINMENT (U.S. CLS. 100, 101 AND 107).

FIRST USE 1-0-2007; IN COMMERCE 1-0-2007.

**CLASS 41—(Continued).**

3,963,850. GAHAGAN, KEVIN E, LYNCHBURG, VA. SN 85-159,826. FILED P.R. 10-24-2010; AM. S.R. 3-28-2011.

**HIGHEST CLASS**

THE MARK CONSISTS OF STANDARD CHARACTERS WITHOUT CLAIM TO ANY PARTICULAR FONT, STYLE, SIZE, OR COLOR.

NO CLAIM IS MADE TO THE EXCLUSIVE RIGHT TO USE "ENTERTAINMENT", APART FROM THE MARK AS SHOWN.

FOR ENTERTAINMENT SERVICES IN THE NATURE OF DEVELOPMENT, CREATION, PRODUCTION AND POST-PRODUCTION SERVICES OF MULTIMEDIA ENTERTAINMENT CONTENT (U.S. CLS. 100, 101 AND 107).

FIRST USE 10-24-2010; IN COMMERCE 10-24-2010.

3,963,852. AMERICAN STRING TEACHERS ASSOCIATION, FAIRFAX, VA. SN 85-162,026. FILED P.R. 10-27-2010; AM. S.R. 3-23-2011.

**ECLECTIC STRINGS FESTIVAL**

THE MARK CONSISTS OF STANDARD CHARACTERS WITHOUT CLAIM TO ANY PARTICULAR FONT, STYLE, SIZE, OR COLOR.

OWNER OF U.S. REG. NOS. 2,987,363, 2,995,744, AND 3,076,229.

NO CLAIM IS MADE TO THE EXCLUSIVE RIGHT TO USE "FESTIVAL", APART FROM THE MARK AS SHOWN.

FOR EDUCATIONAL SERVICES, NAMELY, CONDUCTING PROGRAM EVENTS IN THE FIELD OF MUSIC FOR STRING AND ORCHESTRA STUDENTS (U.S. CLS. 100, 101 AND 107).

FIRST USE 3-19-2011; IN COMMERCE 3-19-2011.

3,963,861. THE AMERICAN ACADEMY OF DERMATOLOGY NURSE PRACTITIONERS, TAMPA, FL. SN 85-181,854. FILED P.R. 11-20-2010; AM. S.R. 3-9-2011.

**American Academy of  
Dermatology Nurse  
Practitioners**

THE MARK CONSISTS OF STANDARD CHARACTERS WITHOUT CLAIM TO ANY PARTICULAR FONT, STYLE, SIZE, OR COLOR.

FOR MEMBERSHIP CLUB SERVICES, NAMELY, PROVIDING TRAINING TO MEMBERS IN THE FIELD OF DERMATOLOGY (U.S. CLS. 100, 101 AND 107).

FIRST USE 3-11-2011; IN COMMERCE 3-11-2011.

**CLASS 41—(Continued).**

3,963,869. SANCHEZ, MATTHEW F., SANTA BARBARA, CA. SN 85-199,052. FILED P.R. 12-15-2010; AM. S.R. 4-7-2011.

## Hoods in the Woods

THE MARK CONSISTS OF STANDARD CHARACTERS WITHOUT CLAIM TO ANY PARTICULAR FONT, STYLE, SIZE, OR COLOR.

FOR EDUCATION SERVICES, NAMELY, PROVIDING MENTORING, TUTORING, CLASSES, SEMINARS AND WORKSHOPS IN THE FIELD OF PERSONAL IMPROVEMENT (U.S. CLS. 100, 101 AND 107).

FIRST USE 5-1-1992; IN COMMERCE 5-1-1992.

---

3,963,871. CRANIOSACRAL THERAPY ALLIANCE, THE, STRAFFORD, NH. SN 85-200,911. FILED P.R. 12-17-2010; AM. S.R. 3-25-2011.

## The Craniosacral Therapy Alliance

THE MARK CONSISTS OF STANDARD CHARACTERS WITHOUT CLAIM TO ANY PARTICULAR FONT, STYLE, SIZE, OR COLOR.

FOR EDUCATIONAL SERVICES, NAMELY, CONDUCTING SEMINARS IN THE FIELD OF CRANIOSACRAL THERAPY AND RELATED INTEGRATIVE MEDICINE TOPICS AND DISTRIBUTION OF TRAINING MATERIAL IN CONNECTION THEREWITH (U.S. CLS. 100, 101 AND 107).

FIRST USE 12-12-2009; IN COMMERCE 12-12-2009.

---

3,963,875. MMA SPORT FEDERATION, LAS VEGAS, NV. SN 85-203,411. FILED P.R. 12-21-2010; AM. S.R. 3-28-2011.



NO CLAIM IS MADE TO THE EXCLUSIVE RIGHT TO USE "MMA SPORT", APART FROM THE MARK AS SHOWN.

THE MARK CONSISTS OF A ROUND RECTANGULAR SHAPE WITH THE STYLIZED TEXT "MMA SPORT FEDERATION".

FOR ENTERTAINMENT IN THE NATURE OF COMPETITIONS IN THE FIELD OF MIXED MARTIAL ARTS; ENTERTAINMENT SERVICES, NAMELY, AN ONGOING SERIES FEATURING MIXED MARTIAL ARTS COMPETITIONS PROVIDED THROUGH TELEVISION (U.S. CLS. 100, 101 AND 107).

FIRST USE 12-10-2009; IN COMMERCE 12-10-2009.

**CLASS 42—SCIENTIFIC AND COMPUTER SERVICES**

3,963,779. JOSTENS, INC., MINNEAPOLIS, MN. SN 85-035,159. FILED P.R. 5-11-2010; AM. S.R. 3-30-2011.

## PERSONAL YEARBOOK PAGES

THE MARK CONSISTS OF STANDARD CHARACTERS WITHOUT CLAIM TO ANY PARTICULAR FONT, STYLE, SIZE, OR COLOR.

NO CLAIM IS MADE TO THE EXCLUSIVE RIGHT TO USE "PAGES", APART FROM THE MARK AS SHOWN.

FOR PROVIDING TEMPORARY USE OF A WEB-BASED SOFTWARE APPLICATION FOR CREATING CUSTOMIZED PAGES FOR YEARBOOKS; PROVIDING TEMPORARY USE OF ON-LINE NON-DOWNLOADABLE SOFTWARE FOR CREATING CUSTOMIZED PAGES FOR YEARBOOKS (U.S. CLS. 100 AND 101).

FIRST USE 2-3-2010; IN COMMERCE 2-3-2010.

---

3,963,829. DENVER SCHOOL DISTRICT #1, DENVER, CO. SN 85-101,412. FILED P.R. 8-5-2010; AM. S.R. 3-23-2011.

## ADMINISTRATOR PORTAL

THE MARK CONSISTS OF STANDARD CHARACTERS WITHOUT CLAIM TO ANY PARTICULAR FONT, STYLE, SIZE, OR COLOR.

FOR APPLICATION SERVICE PROVIDER (ASP) FEATURING SOFTWARE FOR USE BY SCHOOL ADMINISTRATORS, STAFF, TEACHERS, PARENTS AND STUDENTS IN MONITORING AND ANALYZING METRICS AND INFORMATION CONCERNING SCHOOL, STUDENT AND STAFF PERFORMANCE; COMPUTER SERVICE, NAMELY, ACTING AS AN APPLICATION SERVICE PROVIDER IN THE FIELD OF KNOWLEDGE MANAGEMENT TO HOST COMPUTER APPLICATION SOFTWARE FOR CREATING SEARCHABLE DATABASES OF INFORMATION AND DATA (U.S. CLS. 100 AND 101).

FIRST USE 1-1-2009; IN COMMERCE 1-1-2009.

**CLASS 42—(Continued).**

3,963,831. DENVER SCHOOL DISTRICT #1, DENVER, CO. SN 85-101,463. FILED P.R. 8-5-2010; AM. S.R. 3-23-2011.

**TEACHER PORTAL**

THE MARK CONSISTS OF STANDARD CHARACTERS WITHOUT CLAIM TO ANY PARTICULAR FONT, STYLE, SIZE, OR COLOR.

FOR APPLICATION SERVICE PROVIDER (ASP) FEATURING SOFTWARE FOR USE BY SCHOOL ADMINISTRATORS, STAFF, TEACHERS, PARENTS AND STUDENTS IN MONITORING AND ANALYZING METRICS AND INFORMATION CONCERNING SCHOOL, STUDENT AND STAFF PERFORMANCE; COMPUTER SERVICE, NAMELY, ACTING AS AN APPLICATION SERVICE PROVIDER IN THE FIELD OF KNOWLEDGE MANAGEMENT TO HOST COMPUTER APPLICATION SOFTWARE FOR CREATING SEARCHABLE DATABASES OF INFORMATION AND DATA (U.S. CLS. 100 AND 101).

FIRST USE 8-1-2009; IN COMMERCE 8-1-2009.

3,963,877. SUMMIT CATALOG CO, CENTENNIAL, CO. SN 85-205,400. FILED P.R. 12-23-2010; AM. S.R. 3-28-2011.

**On-Demand-Publishing**

THE MARK CONSISTS OF STANDARD CHARACTERS WITHOUT CLAIM TO ANY PARTICULAR FONT, STYLE, SIZE, OR COLOR.

FOR APPLICATION SERVICE PROVIDER (ASP) FEATURING SOFTWARE FOR USE FOR PRODUCING PUBLISHED MATERIAL; COMPUTER SOFTWARE DEVELOPMENT; PROVIDING TEMPORARY USE OF ONLINE NON-DOWNLOADABLE COMPUTER SOFTWARE FOR PRODUCING PUBLISHED MATERIAL (U.S. CLS. 100 AND 101).

FIRST USE 12-1-2009; IN COMMERCE 12-1-2009.

**CLASS 43—HOTEL AND RESTAURANT SERVICES****CLASS 43—(Continued).**

3,963,840. STRIMPLE, RANDALL L., WESTMINSTER, CO. SN 85-122,604. FILED P.R. 9-3-2010; AM. S.R. 4-5-2011.

**KARZ Drive In**

THE MARK CONSISTS OF STANDARD CHARACTERS WITHOUT CLAIM TO ANY PARTICULAR FONT, STYLE, SIZE, OR COLOR.

NO CLAIM IS MADE TO THE EXCLUSIVE RIGHT TO USE "DRIVE IN", APART FROM THE MARK AS SHOWN. FOR FAST-FOOD RESTAURANTS (U.S. CLS. 100 AND 101).

FIRST USE 10-26-2010; IN COMMERCE 10-26-2010.

3,963,855. PLACE OF HOPE FOUNDATION, INC., PALM BEACH GARDENS, FL. SN 85-162,575. FILED P.R. 10-27-2010; AM. S.R. 2-22-2011.

**A FAITH-BASED  
STATE-LICENSED CHILD  
WELFARE ORGANIZATION**

THE MARK CONSISTS OF STANDARD CHARACTERS WITHOUT CLAIM TO ANY PARTICULAR FONT, STYLE, SIZE, OR COLOR.

NO CLAIM IS MADE TO THE EXCLUSIVE RIGHT TO USE "STATE-LICENSED CHILD WELFARE ORGANIZATION", APART FROM THE MARK AS SHOWN.

FOR ARRANGING FOR HOUSING ACCOMMODATIONS USED TO PROVIDE A NURTURING AND STABLE COMMUNITY ENVIRONMENT FOR CHILDREN WHO HAVE BEEN VICTIMIZED BY ABUSE OR NEGLECT (U.S. CLS. 100 AND 101).

FIRST USE 0-0-2004; IN COMMERCE 0-0-2004.

3,963,866. OAKWOOD, INC., THE, DALTON, GA. SN 85-188,927. FILED 12-2-2010.

**Oakwood Cafe**

THE MARK CONSISTS OF STANDARD CHARACTERS WITHOUT CLAIM TO ANY PARTICULAR FONT, STYLE, SIZE, OR COLOR.

NO CLAIM IS MADE TO THE EXCLUSIVE RIGHT TO USE "CAFE", APART FROM THE MARK AS SHOWN.

FOR CAFE AND RESTAURANT SERVICES (U.S. CLS. 100 AND 101).

FIRST USE 10-6-2004; IN COMMERCE 10-6-2004.

**CLASS 44—MEDICAL, BEAUTY AND AGRICULTURAL SERVICES**

3,963,744. PHYTEL, INC., DALLAS, TX. SN 77-843,405. FILED P.R. 10-7-2009; AM. S.R. 2-18-2011.

**QUALITY CYCLE MANAGEMENT**

THE MARK CONSISTS OF STANDARD CHARACTERS WITHOUT CLAIM TO ANY PARTICULAR FONT, STYLE, SIZE, OR COLOR.

FOR HEALTHCARE SERVICES IN THE NATURE OF DISEASE MANAGEMENT PROGRAMS, NAMELY, TRACKING AND MEASURING PATIENT COMPLIANCE WITH PRESCRIBED TREATMENTS VIA PHONE, MAIL OR ELECTRONIC SYSTEMS AND ELECTRONIC COMMUNICATION, ALL IN THE COURSE OF DIAGNOSIS AND TREATMENT OF DISEASE (U.S. CLS. 100 AND 101).

FIRST USE 7-8-2010; IN COMMERCE 7-8-2010.

3,963,774. HAND CONSULTANTS PA, HOUSTON, TX. SN 85-012,244. FILED P.R. 4-12-2010; AM. S.R. 3-2-2011.

**MIGRAINE RELIEF CENTER**

THE MARK CONSISTS OF STANDARD CHARACTERS WITHOUT CLAIM TO ANY PARTICULAR FONT, STYLE, SIZE, OR COLOR.

NO CLAIM IS MADE TO THE EXCLUSIVE RIGHT TO USE "CENTER", APART FROM THE MARK AS SHOWN.

FOR MEDICAL SERVICES, NAMELY, SURGICAL AND MEDICAL SERVICES IN THE NATURE OF PROVIDING EVALUATION AND TREATMENT OF CAUSES OF MIGRAINE HEADACHES BY USING NOVEL AND INNOVATIVE SURGICAL AND CHEMICAL TREATMENTS USING OPHTHALMIC MUSCLE RELAXANTS AND PERIPHERAL NERVE DECOMPRESSION (U.S. CLS. 100 AND 101).

FIRST USE 3-1-2011; IN COMMERCE 3-1-2011.

3,963,784. HUNT, STEPHEN, ANGOLA, IN. SN 85-039,750. FILED P.R. 5-17-2010; AM. S.R. 3-1-2011.

**The Denture Doctor**

THE MARK CONSISTS OF STANDARD CHARACTERS WITHOUT CLAIM TO ANY PARTICULAR FONT, STYLE, SIZE, OR COLOR.

**CLASS 44—(Continued).**

NO CLAIM IS MADE TO THE EXCLUSIVE RIGHT TO USE "DOCTOR", APART FROM THE MARK AS SHOWN. FOR MEDICAL SERVICES, NAMELY, DENTISTRY (U.S. CLS. 100 AND 101).

FIRST USE 5-1-2010; IN COMMERCE 5-1-2010.

3,963,811. PRESSIMONE, JENNIFER H., CLERMONT, FL. SN 85-064,129. FILED P.R. 6-16-2010; AM. S.R. 2-21-2011.

**Olfactory Sensory Testing**

THE MARK CONSISTS OF STANDARD CHARACTERS WITHOUT CLAIM TO ANY PARTICULAR FONT, STYLE, SIZE, OR COLOR.

FOR AROMATHERAPY SERVICES (U.S. CLS. 100 AND 101).

FIRST USE 2-8-2003; IN COMMERCE 2-8-2003.

3,963,823. CUBIST PHARMACEUTICALS, INC., LEXINGTON, MA. SN 85-081,126. FILED P.R. 7-9-2010; AM. S.R. 3-23-2011.

**IDMEDS**

THE MARK CONSISTS OF STANDARD CHARACTERS WITHOUT CLAIM TO ANY PARTICULAR FONT, STYLE, SIZE, OR COLOR.

FOR MEDICAL AND HEALTH CARE INFORMATION SERVICES (U.S. CLS. 100 AND 101).

FIRST USE 1-31-2010; IN COMMERCE 1-31-2010.

**CLASS 45—PERSONAL AND LEGAL SERVICES**

3,963,817. CAP INDEX, INC., EXTON, PA. SN 85-076,074. FILED P.R. 7-1-2010; AM. S.R. 3-28-2011.

**CAPCONSULTING**

THE MARK CONSISTS OF STANDARD CHARACTERS WITHOUT CLAIM TO ANY PARTICULAR FONT, STYLE, SIZE, OR COLOR.

MAY 17, 2011

U.S. PATENT AND TRADEMARK OFFICE

TM 1669

**CLASS 45—(Continued).**

**CLASS 45—(Continued).**

3,963,818. CAP INDEX, INC., EXTON, PA. SN 85-076,088.  
FILED P.R. 7-1-2010; AM. S.R. 3-28-2011.

# CAPRisk

OWNER OF U.S. REG. NOS. 2,197,501 AND 2,939,613.  
FOR STATISTICAL ANALYSIS SERVICES FOR PREDICTING AND FORECASTING CRIMINAL VULNERABILITY; CONSULTATION SERVICES IN THE FIELD OF CRIME PREDICTION AND FORECASTING MODELS, PREVENTION AND REDUCTION; AND CRIME RISK ASSESSMENT SERVICES (U.S. CLS. 100 AND 101).  
FIRST USE 2-19-2011; IN COMMERCE 2-19-2011.

THE MARK CONSISTS OF STANDARD CHARACTERS WITHOUT CLAIM TO ANY PARTICULAR FONT, STYLE, SIZE, OR COLOR.

OWNER OF U.S. REG. NOS. 2,197,501 AND 2,939,613.  
FOR COMPILING AND PROVIDING CRIME OCCURRENCE DATA AND INFORMATION; CONSULTATION SERVICES IN THE FIELD OF CRIME PREDICTION AND FORECASTING MODELS, PREVENTION AND REDUCTION; AND CRIME RISK ASSESSMENT SERVICES (U.S. CLS. 100 AND 101).  
FIRST USE 2-28-1994; IN COMMERCE 2-28-1994.

\* \* \* \* \*



# TRADEMARK REGISTRATIONS RENEWED

The designation "U.S. Cl." appearing in this section refers to the U.S. class in effect prior to Sep. 1, 1973 rather than the international class which applies to applications filed on or after that date. For adoption of international classification see notice in the OFFICIAL GAZETTE of Jun. 26, 1973 (911 O.G. TM 210).

140,896.	NORIT. U.S. CL. 6. (INT. CL. 1). REG. 3-29-1921.	910,843.	CUSTOM 450. U.S. CL. 14. (INT. CL. 6). REG. 4-6-1971.
142,353.	WINCHESTER (STYLIZED). U.S. CL. 9. (INT. CLS. 13 AND 34). REG. 5-10-1921.	910,870.	ANGLER. U.S. CL. 29. (INT. CL. 21). REG. 4-6-1971.
381,836.	K AND DESIGN. U.S. CL. 26. (INT. CL. 9). REG. 10-8-1940.	910,883.	SMP AND DESIGN. U.S. CL. 32. (INT. CL. 20). REG. 4-6-1971.
384,795.	CASCOPHEN. U.S. CL. 5. (INT. CL. 1). REG. 2-4-1941.	910,903.	FLAIR. U.S. CL. 37. (INT. CL. 16). REG. 4-6-1971.
386,217.	BEAUTY COUNSELOR (STYLIZED). U.S. CL. 51. (INT. CL. 3). REG. 4-1-1941.	911,126.	SPECIAL ELECTRIC. U.S. CL. 6. (INT. CL. 5). REG. 4-13-1971.
386,520.	UNION (STYLIZED). U.S. CL. 23. (INT. CL. 7). REG. 4-15-1941.	911,189.	PLACE 'N PRESS. U.S. CL. 20. (INT. CL. 27). REG. 4-13-1971.
389,177.	PO-TA-DOH. U.S. CL. 46. (INT. CL. 30). REG. 7-29-1941.	911,254.	SKINNY. U.S. CL. 46. (INT. CLS. 29 AND 30). REG. 4-13-1971.
389,408.	CONDUCTEX (STYLIZED). U.S. CL. 6. (INT. CL. 1). REG. 8-5-1941.	911,683.	VIBRO-MAC. U.S. CL. 23. (INT. CL. 7). REG. 5-18-1971.
516,840.	CRANES (STYLIZED). U.S. CL. 37. (INT. CL. 16). REG. 10-25-1949.	912,427.	SAV-A-CAF (STYLIZED). U.S. CL. 18. (INT. CL. 5). REG. 6-8-1971.
531,217.	FLORCO (STYLIZED). U.S. CL. 1. (INT. CL. 4). REG. 9-26-1950.	912,720.	ELLIPTIPAR. U.S. CL. 21. (INT. CL. 11). REG. 6-8-1971.
534,964.	BALDT (STYLIZED). U.S. CL. 13. (INT. CL. 6). REG. 12-19-1950.	913,668.	HAVE A GOOD DAY. U.S. CL. 38. (INT. CL. 16). REG. 6-8-1971.
540,777.	MOTO DRIVE. U.S. CL. 23. (INT. CL. 7). REG. 4-10-1951.	916,632.	QUAD. U.S. CL. 21. (INT. CL. 9). REG. 7-20-1971.
540,853.	STAPLEX AND DESIGN. U.S. CL. 23. (INT. CL. 7). REG. 4-10-1951.	917,482.	POOL CUSHION. U.S. CL. 12. (INT. CL. 19). REG. 8-3-1971.
541,814.	ROTOBLAST (STYLIZED). U.S. CL. 23. (INT. CL. 7). REG. 5-1-1951.	918,534.	WIRE JOURNAL. U.S. CL. 38. (INT. CL. 16). REG. 8-17-1971.
544,208.	BOUND TO STAY BOUND (STYLIZED). U.S. CL. 106. (INT. CL. 40). REG. 6-19-1951.	918,964.	L'ALPINA AND DESIGN. U.S. CL. 39. (INT. CL. 25). REG. 8-24-1971.
544,931.	TROJAN (STYLIZED). INT. CL. 10. (U.S. CLS. 26, 39 AND 44). REG. 7-10-1951.	919,496.	THE JUG. U.S. CL. 46. (INT. CL. 30). REG. 8-31-1971.
547,029.	SOLA. U.S. CL. 21. (INT. CL. 9). REG. 8-28-1951.	920,146.	HURST. U.S. CL. 23. (INT. CL. 12). REG. 9-14-1971.
547,130.	ORAL B (STYLIZED). U.S. CL. 29. (INT. CL. 21). REG. 8-28-1951.	921,061.	AIDA. U.S. CL. 23. (INT. CLS. 6, 7, 8, 9, 11, 12, 16, 21 AND 28). REG. 9-28-1971.
547,942.	FORAL. U.S. CL. 6. (INT. CL. 1). REG. 9-11-1951.	921,403.	PHIFERGLASS. U.S. CL. 13. (INT. CL. 6). REG. 10-5-1971.
556,609.	HART'S (STYLIZED). U.S. CL. 46. (INT. CL. 30). REG. 3-25-1952.	924,017.	EXTERMITAL AND DESIGN. U.S. CL. 103. (INT. CL. 37). REG. 11-16-1971.
557,013.	FARMERS UNION. U.S. CL. 102. (INT. CL. 36). REG. 4-1-1952.	924,018.	E EXTERMITAL CHEMICALS EXTERMITAL TERMITE AND PEST CONTROL INCE 1936 AND DESIGN. U.S. CL. 103. (INT. CL. 37). REG. 11-16-1971.
706,598.	KORFUND AND DESIGN. U.S. CL. 23. (INT. CL. 7). REG. 11-1-1960.	925,621.	BROKER'S (STYLIZED). U.S. CL. 49. (INT. CL. 33). REG. 12-14-1971.
709,315.	"LUBE-ALIGN". U.S. CL. 23. (INT. CL. 7). REG. 1-3-1961.	928,907.	PYRELL. U.S. CL. 1. (INT. CL. 17). REG. 2-15-1972.
710,403.	D-TROL. U.S. CL. 6. (INT. CL. 5). REG. 1-31-1961.	930,423.	MACGREGOR (STYLIZED). U.S. CL. 22. (INT. CLS. 16, 18, 20, 22, 25 AND 28). REG. 3-7-1972.
713,296.	INA. U.S. CL. 102. (INT. CL. 36). REG. 3-28-1961.	930,955.	TARGON. U.S. CL. 52. (INT. CL. 1). REG. 3-14-1972.
713,769.	KL. U.S. CL. 13. (INT. CL. 31). REG. 4-11-1961.	931,895.	MISCELLANEOUS DESIGN. U.S. CL. 46. (INT. CLS. 1, 5, 29, 30, 31 AND 32). REG. 4-4-1972.
713,930.	PRAIRIE GOLD. INT. CL. 31. (U.S. CLS. 1 AND 46). REG. 4-11-1961.	932,277.	CALIFORNIA CONTRACTOR (STYLIZED). U.S. CL. 38. (INT. CL. 16). REG. 4-11-1972.
714,821.	E.Z.EST. U.S. CL. 52. (INT. CL. 3). REG. 5-2-1961.	1,148,478.	GROWISE AND DESIGN. INT. CL. 35. (U.S. CL. 101). REG. 3-17-1981.
715,035.	PENTAX. U.S. CL. 26. (INT. CL. 9). REG. 5-9-1961.	1,148,605.	GALBEX. INT. CL. 3. (U.S. CL. 6). REG. 3-24-1981.
715,627.	SPRAY CRAFT (STYLIZED). U.S. CL. 12. (INT. CL. 17). REG. 5-23-1961.	1,148,955.	MICROWARE. INT. CL. 21. (U.S. CL. 13). REG. 3-24-1981.
716,707.	SAKRETE. U.S. CL. 12. (INT. CL. 19). REG. 6-13-1961.	1,148,982.	SUN-SAN. INT. CL. 25. (U.S. CL. 39). REG. 3-24-1981.
718,714.	MISCELLANEOUS DESIGN. U.S. CL. 102. (INT. CL. 36). REG. 7-18-1961.	1,149,092.	PALOTES. INT. CL. 30. (U.S. CL. 46). REG. 3-24-1981.
720,765.	QUIK-SOLV. U.S. CL. 52. (INT. CL. 3). REG. 8-29-1961.	1,149,815.	CHIL-BYL. INT. CL. 17. (U.S. CL. 12). REG. 3-31-1981.
724,465.	CHAMPION. U.S. CL. 23. (INT. CL. 7). REG. 11-28-1961.	1,150,168.	TORO. INT. CL. 4. (U.S. CLS. 1, 6 AND 15). REG. 4-7-1981.
900,711.	SAUTER AND DESIGN. U.S. CL. 23. (INT. CL. 7). REG. 10-13-1970.	1,150,274.	COLONEL. INT. CL. 9. (U.S. CL. 21). REG. 4-7-1981.
901,753.	SAFE-PLAY. U.S. CL. 22. (INT. CL. 28). REG. 11-3-1970.	1,150,375.	COMPUSOFT PUBLISHING. INT. CL. 16. (U.S. CL. 38). REG. 4-7-1981.
906,647.	THERMAL-FLO. U.S. CL. 23. (INT. CL. 7). REG. 1-26-1971.		
910,553.	ANVILETS. U.S. CL. 13. (INT. CL. 6). REG. 3-30-1971.		

- 1,150,549. SUNSHINE AND DESIGN. INT. CL. 29. (U.S. CL. 46). REG. 4-7-1981.
- 1,150,576. JON DONAIRE. INT. CL. 30. (U.S. CL. 46). REG. 4-7-1981.
- 1,150,626. PRIFORM. INT. CL. 36. (U.S. CL. 102). REG. 4-7-1981.
- 1,150,631. CARTE BLANCHE (STYLIZED). INT. CL. 36. (U.S. CL. 102). REG. 4-7-1981.
- 1,150,717. FRESH FISH DAILY AND DESIGN. INT. CL. 42. (U.S. CL. 100). REG. 4-7-1981.
- 1,150,843. MIX-MIZER AND DESIGN. INT. CL. 9. (U.S. CL. 26). REG. 4-14-1981.
- 1,150,931. ROTOSTOKER. INT. CL. 11. (U.S. CL. 34). REG. 4-14-1981.
- 1,151,311. TRUSTWORTHY AND DESIGN. INT. CL. 42. (U.S. CL. 101). REG. 4-14-1981.
- 1,151,350. 1 AND DESIGN. INT. CLS. 1 AND 5. (U.S. CLS. 6 AND 18). REG. 4-21-1981.
- 1,152,583. BOUNCER. INT. CL. 30. (U.S. CL. 46). REG. 4-28-1981.
- 1,152,619. GROWISE. INT. CL. 35. (U.S. CL. 101). REG. 4-28-1981.
- 1,152,691. FREDBIRD. INT. CL. 41. (U.S. CL. 107). REG. 4-28-1981.
- 1,152,790. AWS. U.S. CL. 200. REG. 4-28-1981.
- 1,153,627. TIDY TANKS. INT. CL. 6. (U.S. CL. 2). REG. 5-12-1981.
- 1,153,742. SST. INT. CL. 9. (U.S. CL. 26). REG. 5-12-1981.
- 1,154,514. ZINCALUME. INT. CL. 6. (U.S. CL. 14). REG. 5-19-1981.
- 1,154,562. D (STYLIZED). INT. CL. 7. (U.S. CL. 23). REG. 5-19-1981.
- 1,154,629. HI-LUME. INT. CL. 9. (U.S. CLS. 21 AND 26). REG. 5-19-1981.
- 1,154,641. POWER ONE. INT. CL. 9. (U.S. CL. 21). REG. 5-19-1981.
- 1,154,873. FLUOROTREL. INT. CL. 17. (U.S. CL. 1). REG. 5-19-1981.
- 1,155,333. LENTON. INT. CL. 7. (U.S. CL. 23). REG. 5-26-1981.
- 1,155,834. ELITE MODEL MANAGEMENT. INT. CL. 35. (U.S. CL. 101). REG. 5-26-1981.
- 1,155,912. MIDLANDS AND DESIGN. INT. CL. 41. (U.S. CL. 107). REG. 5-26-1981.
- 1,156,275. FILTR-GARD. INT. CL. 11. (U.S. CL. 21). REG. 6-2-1981.
- 1,157,947. SUN STICK. INT. CL. 11. (U.S. CL. 21). REG. 6-23-1981.
- 1,158,504. MACHINE SHED. INT. CL. 42. (U.S. CL. 100). REG. 6-23-1981.
- 1,159,752. VOLVO (STYLIZED). INT. CL. 8. (U.S. CL. 23). REG. 7-7-1981.
- 1,160,101. LOCAL MOTION. INT. CLS. 25 AND 28. (U.S. CLS. 22 AND 39). REG. 7-7-1981.
- 1,161,629. PRATT BURNERD. INT. CL. 7. (U.S. CL. 23). REG. 7-21-1981.
- 1,164,977. AWS AND DESIGN. INT. CL. 41. (U.S. CL. 107). REG. 8-11-1981.
- 1,166,274. E C AND DESIGN. INT. CL. 9. (U.S. CL. 21). REG. 8-25-1981.
- 1,167,481. HILDEBRANDT. INT. CL. 28. (U.S. CL. 22). REG. 9-1-1981.
- 1,167,538. HI LITE (STYLIZED). INT. CL. 30. (U.S. CL. 46). REG. 9-1-1981.
- 1,167,804. WELCOME TO SCONYERS BAR-BQUE AND DESIGN. INT. CL. 42. (U.S. CL. 100). REG. 9-1-1981.
- 1,168,283. SILVERTIP. INT. CL. 13. (U.S. CL. 9). REG. 9-8-1981.
- 1,169,147. PARACUBE. INT. CL. 11. (U.S. CL. 34). REG. 9-15-1981.
- 1,178,030. AIR LINE PILOT. INT. CL. 16. (U.S. CL. 38). REG. 11-17-1981.
- 1,178,642. RUSS'. INT. CL. 42. (U.S. CL. 100). REG. 11-17-1981.
- 1,179,027. SKYLINE AND DESIGN. INT. CL. 12. (U.S. CLS. 19, 21, 23, 31, 35 AND 44). REG. 11-24-1981.
- 1,179,621. RUSS' AND DESIGN. INT. CL. 42. (U.S. CL. 100). REG. 11-24-1981.
- 1,183,010. TRANSGUARD. INT. CL. 22. (U.S. CL. 50). REG. 12-22-1981.
- 1,183,438. DENTEMP (STYLIZED). INT. CL. 5. (U.S. CL. 44). REG. 12-29-1981.
- 1,183,496. HUSKEE. INT. CLS. 7 AND 12. (U.S. CLS. 13, 19, 21, 23, 31, 34, 35 AND 44). REG. 12-29-1981.
- 1,183,727. FIBREEN. INT. CL. 16. (U.S. CL. 37). REG. 12-29-1981.
- 1,184,010. T-LOIN. INT. CL. 29. (U.S. CL. 46). REG. 12-29-1981.
- 1,184,609. SIL-TRAX. INT. CL. 10. (U.S. CL. 44). REG. 1-5-1982.
- 1,185,427. KERO-SUN. INT. CL. 6. (U.S. CL. 2). REG. 1-12-1982.
- 1,186,184. SCONYERS BAR-B QUE AND DESIGN. INT. CL. 42. (U.S. CL. 100). REG. 1-12-1982.
- 1,186,270. PERFECTOL. INT. CL. 1. (U.S. CL. 6). REG. 1-19-1982.
- 1,186,405. KERO-SUN AND DESIGN. INT. CL. 6. (U.S. CLS. 2 AND 13). REG. 1-19-1982.
- 1,189,944. AIRSTREAM. INT. CL. 12. (U.S. CL. 19). REG. 2-16-1982.
- 1,190,793. GEORGIE (STYLIZED). INT. CL. 26. (U.S. CL. 40). REG. 2-23-1982.
- 1,191,195. WEATHERPORT. INT. CL. 19. (U.S. CL. 12). REG. 3-2-1982.
- 1,191,789. RAPA. INT. CL. 29. (U.S. CL. 46). REG. 3-9-1982.
- 1,612,858. WINTER HEAT. INT. CL. 11. (U.S. CL. 34). REG. 9-11-1990.
- 1,613,730. GATOR ASSORTMENT AND DESIGN. INT. CL. 13. (U.S. CL. 9). REG. 9-18-1990.
- 1,615,385. CASTROL CYLTECH. INT. CL. 4. (U.S. CL. 15). REG. 10-2-1990.
- 1,616,702. CTI. INT. CLS. 16 AND 28. (U.S. CLS. 2, 37 AND 50). REG. 10-9-1990.
- 1,617,683. BEVERLY HILLS COUNTRY CLUB. INT. CL. 25. (U.S. CL. 39). REG. 10-16-1990.
- 1,617,723. TEE SHOTS. INT. CL. 25. (U.S. CL. 39). REG. 10-16-1990.
- 1,617,869. ODESSA CHUCK WAGON GANG. INT. CL. 35. (U.S. CLS. 100 AND 101). REG. 10-16-1990.
- 1,619,474. UNLIMITED SCISSORS. INT. CL. 8. (U.S. CL. 23). REG. 10-30-1990.
- 1,622,148. MIDIS. INT. CL. 42 ONLY. (U.S. CLS. 100, 101 AND 103). REG. 11-13-1990.
- 1,627,248. KING OF THE BEACH. INT. CL. 25. (U.S. CL. 39). REG. 12-11-1990.
- 1,636,633. ECOLO. INT. CL. 5 ONLY. (U.S. CL. 6). REG. 3-5-1991.
- 1,637,370. CRITIC-AID. INT. CL. 5. (U.S. CL. 18). REG. 3-12-1991.
- 1,638,273. COMBITHERM. INT. CL. 11. (U.S. CL. 34). REG. 3-19-1991.
- 1,638,435. BERNARDS. INT. CL. 20. (U.S. CL. 32). REG. 3-19-1991.
- 1,638,997. F.A.A.C.A.. INT. CL. 11. (U.S. CLS. 31 AND 34). REG. 3-26-1991.
- 1,639,223. HAWAII'S FAMOUS HULI-HULI SAUCE. INT. CL. 30. (U.S. CL. 46). REG. 3-26-1991.
- 1,639,350. EDITOR. INT. CL. 9. (U.S. CL. 26). REG. 3-26-1991.
- 1,639,499. LONGLIFE. INT. CL. 5. (U.S. CLS. 6 AND 18). REG. 4-2-1991.
- 1,639,500. ENERMAX. INT. CL. 5. (U.S. CL. 18). REG. 4-2-1991.
- 1,639,581. INTELLIKEY CORPORATION IK AND DESIGN. INT. CLS. 9 AND 42. (U.S. CLS. 21, 26 AND 100). REG. 4-2-1991.
- 1,639,594. OP. INT. CLS. 14, 18, 24, 25 AND 28 ONLY. (U.S. CLS. 1, 2, 3, 22, 23, 27, 28, 38, 39, 41, 42 AND 50). REG. 4-2-1991.
- 1,639,791. TREE STAND. INT. CL. 24. (U.S. CL. 42). REG. 4-2-1991.
- 1,639,810. SNO RIDER. INT. CL. 25. (U.S. CLS. 22 AND 39). REG. 4-2-1991.
- 1,639,853. LI'L MISS JENNY. INT. CL. 28. (U.S. CL. 22). REG. 4-2-1991.
- 1,639,915. RON CANITA CURAO ALAMBIQUE AND DESIGN. INT. CL. 33. (U.S. CL. 49). REG. 4-2-1991.
- 1,640,095. NOVASYN. INT. CL. 1. (U.S. CL. 6). REG. 4-9-1991.
- 1,640,119. ORION. INT. CL. 1. (U.S. CL. 6). REG. 4-9-1991.
- 1,640,205. PRINCETON. INT. CLS. 6, 14, 16, 18, 20, 21, 24, 25, 26, 28 AND 41 ONLY. (U.S. CLS. 1, 2, 3, 5, 12, 13, 14, 22, 23, 25, 27, 28, 29, 30, 32, 33, 37, 38, 39, 40, 41, 42, 50, 100, 101 AND 107). REG. 4-9-1991.
- 1,640,281. JAZZ CHANTS. INT. CL. 9. (U.S. CL. 36). REG. 4-9-1991.
- 1,640,291. MULTI-NET. INT. CL. 9. (U.S. CLS. 21 AND 26). REG. 4-9-1991.
- 1,640,323. VELOMITOR. INT. CL. 9. (U.S. CL. 26). REG. 4-9-1991.

- 1,640,357. SPLASHGUARD. INT. CL. 10. (U.S. CL. 44). REG. 4-9-1991.
- 1,640,359. REMSTAR. INT. CL. 10. (U.S. CL. 44). REG. 4-9-1991.
- 1,640,379. TM AND DESIGN. INT. CL. 12. (U.S. CL. 19). REG. 4-9-1991.
- 1,640,451. V ICS AND DESIGN. INT. CL. 16. (U.S. CLS. 2, 5, 22, 23, 29, 37, 38 AND 50). REG. 4-9-1991.
- 1,640,475. NEW YORK TECH. INT. CL. 16. (U.S. CL. 38). REG. 4-9-1991.
- 1,640,527. MICROGOURMET (STYLIZED). INT. CL. 21. (U.S. CL. 2). REG. 4-9-1991.
- 1,640,598. KNITMATES. INT. CL. 26. (U.S. CL. 40). REG. 4-9-1991.
- 1,640,626. AMERICAN HERITAGE. INT. CL. 29. (U.S. CL. 46). REG. 4-9-1991.
- 1,640,648. PATRICK'S PRIDE. INT. CL. 29. (U.S. CL. 46). REG. 4-9-1991.
- 1,640,700. SAUER'S AND DESIGN. INT. CL. 30. (U.S. CL. 46). REG. 4-9-1991.
- 1,640,873. MISCELLANEOUS DESIGN. INT. CL. 42. (U.S. CL. 100). REG. 4-9-1991.
- 1,640,907. BEAMLOK (STYLIZED). INT. CL. 9. (U.S. CLS. 21 AND 26). REG. 4-9-1991.
- 1,640,989. DALY'S. INT. CLS. 2, 3 AND 17. (U.S. CLS. 6, 16, 35 AND 52). REG. 4-16-1991.
- 1,641,000. PIERO GUIDI. INT. CL. 24 ONLY. (U.S. CLS. 42 AND 50). REG. 4-16-1991.
- 1,641,012. LABIOSAN. INT. CL. 5. (U.S. CL. 18). REG. 4-16-1991.
- 1,641,138. ENDURA. INT. CL. 9. (U.S. CL. 26). REG. 4-16-1991.
- 1,641,143. FLUOROMAX. INT. CL. 9. (U.S. CL. 26). REG. 4-16-1991.
- 1,641,355. TURTLE WAX. INT. CL. 25. (U.S. CL. 39). REG. 4-16-1991.
- 1,641,369. NEW YORK INSTITUTE OF TECHNOLOGY. INT. CL. 25. (U.S. CL. 39). REG. 4-16-1991.
- 1,641,509. ACRES. INT. CL. 35. (U.S. CLS. 100 AND 101). REG. 4-16-1991.
- 1,641,533. RIPARIUS AND DESIGN. INT. CL. 37 ONLY. (U.S. CLS. 100, 103 AND 106). REG. 4-16-1991.
- 1,641,568. PIEDMONT DISTRIBUTION CENTERS. INT. CL. 39. (U.S. CL. 105). REG. 4-16-1991.
- 1,641,652. ACCESS PLUS. INT. CL. 42. (U.S. CLS. 100 AND 101). REG. 4-16-1991.
- 1,642,368. CHEMRISK. INT. CL. 42. (U.S. CL. 100). REG. 4-23-1991.
- 1,642,376. DEFENDERS OF WILDLIFE. INT. CL. 42. (U.S. CL. 100). REG. 4-23-1991.
- 1,642,509. DABCO. INT. CL. 1. (U.S. CL. 6). REG. 4-30-1991.
- 1,642,734. IDITAROD. INT. CLS. 14, 21, 25 AND 26. (U.S. CLS. 2, 28, 33, 39 AND 40). REG. 4-30-1991.
- 1,642,874. MISCELLANEOUS DESIGN. INT. CL. 25. (U.S. CL. 39). REG. 4-30-1991.
- 1,642,980. MISCELLANEOUS DESIGN. INT. CL. 35. (U.S. CL. 101). REG. 4-30-1991.
- 1,642,994. RUN FOR THE ARTS AND DESIGN. INT. CL. 36. (U.S. CL. 102). REG. 4-30-1991.
- 1,643,467. GOLD'N HOT. INT. CLS. 9 AND 11. (U.S. CLS. 34 AND 44). REG. 5-7-1991.
- 1,644,359. CASSIS. INT. CL. 14. (U.S. CL. 28). REG. 5-14-1991.
- 1,644,563. PROSEED AND DESIGN. INT. CL. 31. (U.S. CLS. 1 AND 46). REG. 5-14-1991.
- 1,644,642. ROW. INT. CLS. 39 AND 41. (U.S. CLS. 105 AND 107). REG. 5-14-1991.
- 1,645,032. TOYOPUC. INT. CL. 9. (U.S. CL. 26). REG. 5-21-1991.
- 1,645,259. KERDI. INT. CL. 19. (U.S. CL. 12). REG. 5-21-1991.
- 1,645,639. CLARK. INT. CL. 42. (U.S. CL. 100). REG. 5-21-1991.
- 1,645,670. T.S. COUNTRY. INT. CL. 29. (U.S. CL. 46). REG. 5-21-1991.
- 1,645,975. MISCELLANEOUS DESIGN. INT. CLS. 16 AND 41. (U.S. CLS. 38 AND 107). REG. 5-28-1991.
- 1,646,007. RESTATEMENT OF THE LAW. INT. CL. 16. (U.S. CL. 38). REG. 5-28-1991.
- 1,646,022. MOSCHINO. INT. CL. 18. (U.S. CL. 3). REG. 5-28-1991.
- 1,646,023. CALIFORNIA INSTITUTE OF TECHNOLOGY 1891 AND DESIGN. INT. CL. 18. (U.S. CL. 41). REG. 5-28-1991.
- 1,647,052. S-T-O-R-A-G-E. INT. CL. 39. (U.S. CL. 105). REG. 6-4-1991.
- 1,647,398. BRIGHAM YOUNG UNIVERSITY. INT. CLS. 16, 25 AND 41. (U.S. CLS. 37, 38, 39 AND 107). REG. 6-11-1991.
- 1,647,684. (212) S-T-O-R-A-G-E. INT. CL. 39. (U.S. CL. 105). REG. 6-11-1991.
- 1,648,453. TRAVEL M.D.. INT. CL. 42. (U.S. CLS. 100 AND 105). REG. 6-18-1991.
- 1,648,517. MISCELLANEOUS DESIGN. INT. CL. 10. (U.S. CL. 44). REG. 6-18-1991.
- 1,648,557. FAST LANE. INT. CL. 28. (U.S. CL. 22). REG. 6-18-1991.
- 1,648,607. POLARITE. INT. CL. 1. (U.S. CLS. 1, 5, 6, 10, 26 AND 46). REG. 6-25-1991.
- 1,649,241. MISCELLANEOUS DESIGN. INT. CLS. 4 AND 34. (U.S. CLS. 2, 8, 9, 15 AND 17). REG. 7-2-1991.
- 1,649,415. BROADWAY. INT. CL. 12. (U.S. CL. 19). REG. 7-2-1991.
- 1,651,203. FERCOLA. INT. CL. 30. (U.S. CL. 46). REG. 7-16-1991.
- 1,651,248. MG 104. INT. CL. 1. (U.S. CL. 6). REG. 7-23-1991.
- 1,651,494. ADAIR. INT. CL. 19. (U.S. CL. 12). REG. 7-23-1991.
- 1,651,683. MAKING STRIDES. INT. CLS. 36 AND 42. (U.S. CLS. 100 AND 102). REG. 7-23-1991.
- 1,651,865. NSCAA AND DESIGN. U.S. CL. 200. REG. 7-23-1991.
- 1,652,825. CURIX. INT. CLS. 1 AND 9. (U.S. CLS. 1, 5, 6, 10, 26 AND 46). REG. 8-6-1991.
- 1,656,383. SINCE 1919 MCGLYNN'S BAKERY AND DESIGN. INT. CL. 30 ONLY. (U.S. CL. 46). REG. 9-10-1991.
- 1,656,746. RIGHT-TITE. INT. CL. 11. (U.S. CLS. 13 AND 50). REG. 9-10-1991.
- 1,657,712. PROM NITE. INT. CL. 42. (U.S. CLS. 100 AND 101). REG. 9-17-1991.
- 1,657,870. KNIVES ILLUSTRATED. INT. CL. 16. (U.S. CL. 38). REG. 9-17-1991.
- 1,658,819. EXIDE AND DESIGN. INT. CL. 9 ONLY. (U.S. CLS. 21, 23, 26, 36 AND 38). REG. 10-1-1991.
- 1,659,365. STRIPIT25. INT. CL. 3. (U.S. CL. 52). REG. 10-8-1991.
- 1,660,255. MISCELLANEOUS DESIGN. INT. CL. 3. (U.S. CL. 51). REG. 10-8-1991.
- 1,661,445. MECHTRIX. INT. CL. 7. (U.S. CL. 23). REG. 10-22-1991.
- 1,662,194. TALON SCREWS AND DESIGN. INT. CL. 6. (U.S. CLS. 2, 12, 13, 14, 23, 25 AND 50). REG. 10-29-1991.
- 1,662,434. BID-MASTER. INT. CL. 16. (U.S. CLS. 37 AND 38). REG. 10-29-1991.
- 1,662,906. CURV-RITE. INT. CL. 6. (U.S. CL. 13). REG. 10-29-1991.
- 1,663,642. BUSINESSCARES!. INT. CL. 36. (U.S. CLS. 100, 101 AND 102). REG. 11-5-1991.
- 1,663,894. PERMAPRINT. INT. CL. 2. (U.S. CL. 11). REG. 11-12-1991.
- 1,666,211. THE CRAB HOUSE AND DESIGN. INT. CL. 42. (U.S. CLS. 100 AND 101). REG. 11-26-1991.
- 1,666,635. HUSKY LINERS. INT. CL. 12. (U.S. CL. 19). REG. 12-3-1991.
- 1,666,962. LIVING CARE. INT. CL. 36. (U.S. CL. 102). REG. 12-3-1991.
- 1,666,987. AVIANCA EXPRESS. INT. CL. 39. (U.S. CL. 105). REG. 12-3-1991.
- 1,667,043. AQUATERRA. INT. CL. 42. (U.S. CLS. 100, 103 AND 106). REG. 12-3-1991.
- 1,671,646. QUICKPEN. INT. CL. 9. (U.S. CLS. 26 AND 38). REG. 1-14-1992.
- 1,674,767. E-CON. INT. CL. 6. (U.S. CL. 13). REG. 2-11-1992.
- 1,676,439. THE AREA'S LEADING JEWELER FOR VERY GOOD REASONS. INT. CL. 42. (U.S. CL. 101). REG. 2-18-1992.
- 1,676,517. BIOTICS. INT. CL. 5. (U.S. CLS. 6, 18, 44, 46, 51 AND 52). REG. 2-25-1992.
- 1,676,541. R-CON. INT. CL. 6. (U.S. CL. 13). REG. 2-25-1992.
- 1,677,804. BISTRO BEAN AND DESIGN. INT. CL. 31. (U.S. CL. 46). REG. 3-3-1992.
- 1,678,957. AXAREL. INT. CL. 3. (U.S. CL. 52). REG. 3-10-1992.
- 1,679,210. EW (STYLIZED). INT. CLS. 16, 25 AND 41 ONLY. (U.S. CLS. 38, 39 AND 107). REG. 3-17-1992.
- 1,679,351. OFF WALL STREET. INT. CL. 16. (U.S. CL. 38). REG. 3-17-1992.
- 1,679,634. DAILY 3 AND DESIGN. INT. CL. 36. (U.S. CLS. 100, 101 AND 102). REG. 3-17-1992.

- 1,680,601. MISCELLANEOUS DESIGN. INT. CL. 37. (U.S. CL. 103). REG. 3-24-1992.
- 1,681,040. WADIA (STYLIZED). INT. CL. 9. (U.S. CL. 21). REG. 3-31-1992.
- 1,681,754. ENDOVAC-BOVI (STYLIZED). INT. CL. 5. (U.S. CL. 18). REG. 4-7-1992.
- 1,682,322. CAREX. INT. CL. 3. (U.S. CL. 52). REG. 4-7-1992.
- 1,889,107. COPPER-CHEM. INT. CL. 1. (U.S. CL. 6). REG. 4-11-1995.
- 1,937,984. RIGHT RATE. INT. CL. 35. (U.S. CLS. 100, 101 AND 102). REG. 11-28-1995.
- 1,997,287. SNAP. INT. CL. 9. (U.S. CLS. 21, 23, 26, 36 AND 38). REG. 8-27-1996.
- 2,118,152. RAVENSWOOD. INT. CL. 25. (U.S. CLS. 22 AND 39). REG. 12-2-1997.
- 2,118,153. MISCELLANEOUS DESIGN. INT. CL. 25. (U.S. CLS. 22 AND 39). REG. 12-2-1997.
- 2,225,514. ADAPT HITCH BALL. INT. CL. 12. (U.S. CLS. 19, 21, 23, 31, 35 AND 44). REG. 2-23-1999.
- 2,314,104. ENDA. INT. CL. 9. (U.S. CLS. 21, 23, 26, 36 AND 38). REG. 2-1-2000.
- 2,341,677. GLASS ONION PRODUCTIONS. INT. CL. 41. (U.S. CLS. 100, 101 AND 107). REG. 4-11-2000.
- 2,342,664. DURACAST. INT. CL. 8. (U.S. CLS. 23, 28 AND 44). REG. 4-18-2000.
- 2,363,494. MISCELLANEOUS DESIGN. INT. CL. 25 ONLY. (U.S. CLS. 22 AND 39). REG. 7-4-2000.
- 2,382,389. CASINO NIAGARA AND DESIGN. INT. CL. 41. (U.S. CLS. 100, 101 AND 107). REG. 9-5-2000.
- 2,387,080. BAKER FIRST COMMERCIAL REAL ESTATE SERVICES. INT. CL. 36. (U.S. CLS. 100, 101 AND 102). REG. 9-19-2000.
- 2,389,609. MISCELLANEOUS DESIGN. INT. CL. 28. (U.S. CLS. 22, 23, 38 AND 50). REG. 9-26-2000.
- 2,390,066. MISCELLANEOUS DESIGN. INT. CL. 28. (U.S. CLS. 22, 23, 38 AND 50). REG. 9-26-2000.
- 2,390,716. PI AND DESIGN. INT. CLS. 9 AND 42. (U.S. CLS. 21, 23, 26, 36, 38, 100 AND 101). REG. 10-3-2000.
- 2,391,041. AFC AND DESIGN. INT. CL. 42. (U.S. CLS. 100 AND 101). REG. 10-3-2000.
- 2,391,195. YOUR FUTURE.OUR FOCUS.IOWA BANKS. INT. CL. 42. (U.S. CLS. 100 AND 101). REG. 10-3-2000.
- 2,391,774. MISCELLANEOUS DESIGN. INT. CL. 25. (U.S. CLS. 22 AND 39). REG. 10-3-2000.
- 2,392,392. LO-TORQ. INT. CL. 6. (U.S. CLS. 2, 12, 13, 14, 23, 25 AND 50). REG. 10-3-2000.
- 2,392,768. MOLECULAR BRAILLE. INT. CL. 42. (U.S. CLS. 100 AND 101). REG. 10-10-2000.
- 2,392,781. WILLOW. INT. CL. 35. (U.S. CLS. 100, 101 AND 102). REG. 10-10-2000.
- 2,393,145. ZEBRA STRIPES (STYLIZED). INT. CL. 37. (U.S. CLS. 100, 103 AND 106). REG. 10-10-2000.
- 2,393,263. SATI-BABI. INT. CL. 29. (U.S. CL. 46). REG. 10-10-2000.
- 2,393,421. WNET. INT. CL. 16. (U.S. CLS. 2, 5, 22, 23, 29, 37, 38 AND 50). REG. 10-10-2000.
- 2,393,422. WNET. INT. CL. 41. (U.S. CLS. 100, 101 AND 107). REG. 10-10-2000.
- 2,393,504. Ñ GENERATION. INT. CL. 25. (U.S. CLS. 22 AND 39). REG. 10-10-2000.
- 2,393,542. PORN STAR. INT. CL. 25. (U.S. CLS. 22 AND 39). REG. 10-10-2000.
- 2,393,759. WILLOW. INT. CL. 41. (U.S. CLS. 100, 101 AND 107). REG. 10-10-2000.
- 2,393,915. COMPLEX CU3. INT. CL. 5. (U.S. CLS. 6, 18, 44, 46, 51 AND 52). REG. 10-10-2000.
- 2,394,481. ASSETLEVERAGING. INT. CL. 36. (U.S. CLS. 100, 101 AND 102). REG. 10-10-2000.
- 2,394,944. MITCHELL BROTHERS O'FARRELL THEATRE. INT. CL. 41. (U.S. CLS. 100, 101 AND 107). REG. 10-17-2000.
- 2,395,768. MACAW. INT. CL. 9. (U.S. CLS. 21, 23, 26, 36 AND 38). REG. 10-17-2000.
- 2,395,870. CREDISWITCH. INT. CL. 36. (U.S. CLS. 100, 101 AND 102). REG. 10-17-2000.
- 2,396,264. GLACIAL PALACE. INT. CL. 41. (U.S. CLS. 100, 101 AND 107). REG. 10-17-2000.
- 2,396,300. TREASURES AT SEA. INT. CL. 35. (U.S. CLS. 100, 101 AND 102). REG. 10-17-2000.
- 2,396,821. WEBNURSERY. INT. CL. 42. (U.S. CLS. 100 AND 101). REG. 10-24-2000.
- 2,398,378. DESIGN HOUSE KITCHENS & APPLIANCES. INT. CL. 35. (U.S. CLS. 100, 101 AND 102). REG. 10-24-2000.
- 2,400,130. ADDISON WESLEY. INT. CL. 16. (U.S. CLS. 2, 5, 22, 23, 29, 37, 38 AND 50). REG. 10-31-2000.
- 2,400,166. SIMPLE LOGIC. INT. CL. 42. (U.S. CLS. 100 AND 101). REG. 10-31-2000.
- 2,401,640. SNAP-IN SNAP-OUT. INT. CL. 10. (U.S. CLS. 26, 39 AND 44). REG. 11-7-2000.
- 2,401,763. ARMY FOOTBALL. INT. CLS. 25 AND 41 ONLY. (U.S. CLS. 22, 39, 100, 101 AND 107). REG. 11-7-2000.
- 2,403,354. MILLENNIUM THEATER SYSTEM. INT. CL. 9. (U.S. CLS. 21, 23, 26, 36 AND 38). REG. 11-14-2000.
- 2,403,542. MINERAL ZONE. INT. CL. 14. (U.S. CLS. 2, 27, 28 AND 50). REG. 11-14-2000.
- 2,403,864. TEACHING FOR TOMORROW AND DESIGN. INT. CL. 42. (U.S. CLS. 100 AND 101). REG. 11-14-2000.
- 2,404,250. VIEWSONIC. INT. CL. 28. (U.S. CLS. 22, 23, 38 AND 50). REG. 11-14-2000.
- 2,404,448. PCW. INT. CL. 42. (U.S. CLS. 100 AND 101). REG. 11-14-2000.
- 2,405,428. SCARIB. INT. CL. 12. (U.S. CLS. 19, 21, 23, 31, 35 AND 44). REG. 11-21-2000.
- 2,406,032. BIO-STRONG. INT. CL. 3. (U.S. CLS. 1, 4, 6, 50, 51 AND 52). REG. 11-21-2000.
- 2,408,609. MISCELLANEOUS DESIGN. INT. CL. 11. (U.S. CLS. 13, 21, 23, 31 AND 34). REG. 11-28-2000.
- 2,410,460. HAWK'S CAY. INT. CLS. 39 AND 42. (U.S. CLS. 100, 101 AND 105). REG. 12-5-2000.
- 2,410,609. VIEWSONIC AND DESIGN. INT. CLS. 9, 14, 16, 18, 20 AND 25. (U.S. CLS. 1, 2, 3, 5, 13, 21, 22, 23, 25, 26, 27, 28, 29, 32, 36, 37, 38, 39, 41 AND 50). REG. 12-5-2000.
- 2,413,318. THE NEGRO LEAGUES. INT. CL. 35. (U.S. CLS. 100, 101 AND 102). REG. 12-12-2000.
- 2,416,268. CHARLOTTE RUSSE. INT. CL. 18. (U.S. CLS. 1, 2, 3, 22 AND 41). REG. 12-26-2000.
- 2,418,624. SKI-EQUIPMENT.COM AND DESIGN. INT. CL. 35. (U.S. CLS. 100, 101 AND 102). REG. 1-9-2001.
- 2,419,259. EASY GUN. INT. CL. 17. (U.S. CLS. 1, 5, 12, 13, 35 AND 50). REG. 1-9-2001.
- 2,421,755. DEEPDRILL. INT. CL. 40. (U.S. CLS. 100, 103 AND 106). REG. 1-16-2001.
- 2,423,212. BELANGER AND DESIGN. INT. CL. 7. (U.S. CLS. 13, 19, 21, 23, 31, 34 AND 35). REG. 1-23-2001.
- 2,423,356. COPY EFFECT INDEX. INT. CL. 35. (U.S. CLS. 100, 101 AND 102). REG. 1-23-2001.
- 2,425,651. SPABIZ. INT. CL. 9. (U.S. CLS. 21, 23, 26, 36 AND 38). REG. 1-30-2001.
- 2,426,046. ARCTIC SPAS AND DESIGN. INT. CL. 11. (U.S. CLS. 13, 21, 23, 31 AND 34). REG. 2-6-2001.
- 2,427,455. FREETAB. INT. CL. 35. (U.S. CLS. 100, 101 AND 102). REG. 2-6-2001.
- 2,428,383. MISCELLANEOUS DESIGN. INT. CL. 29. (U.S. CL. 46). REG. 2-13-2001.
- 2,428,757. CONTINUOUS CONTROL. INT. CLS. 3 AND 5. (U.S. CLS. 1, 4, 6, 18, 44, 46, 50, 51 AND 52). REG. 2-13-2001.
- 2,430,923. REJUVELAC. INT. CL. 32. (U.S. CLS. 45, 46 AND 48). REG. 2-27-2001.
- 2,431,552. ORA-KEEL. INT. CL. 5. (U.S. CLS. 6, 18, 44, 46, 51 AND 52). REG. 2-27-2001.
- 2,431,734. JAGRO. INT. CL. 39. (U.S. CLS. 100 AND 105). REG. 2-27-2001.
- 2,431,829. WEATHERIZING YOUR BUSINESS. INT. CL. 42. (U.S. CLS. 100 AND 101). REG. 2-27-2001.
- 2,433,040. MCGOUGH. INT. CL. 37. (U.S. CLS. 100, 103 AND 106). REG. 3-6-2001.
- 2,433,815. HOG WASH. INT. CL. 40. (U.S. CLS. 100, 103 AND 106). REG. 3-6-2001.
- 2,434,938. ZOYOX. INT. CL. 42. (U.S. CLS. 100 AND 101). REG. 3-13-2001.
- 2,435,250. LUBRI-PUMP, INC. (STYLIZED). INT. CL. 7. (U.S. CLS. 13, 19, 21, 23, 31, 34 AND 35). REG. 3-13-2001.
- 2,435,711. REY-ALIGN. INT. CL. 12. (U.S. CLS. 19, 21, 23, 31, 35 AND 44). REG. 3-13-2001.
- 2,436,421. D/3. INT. CL. 9. (U.S. CLS. 21, 23, 26, 36 AND 38). REG. 3-20-2001.
- 2,436,912. MISCELLANEOUS DESIGN. INT. CLS. 25 AND 41. (U.S. CLS. 22, 39, 100, 101 AND 107). REG. 3-20-2001.
- 2,437,028. LUBRI-PLUNGER. INT. CL. 7. (U.S. CLS. 13, 19, 21, 23, 31, 34 AND 35). REG. 3-20-2001.



- 2,437,695. BRONZE GUARD. INT. CL. 6. (U.S. CLS. 2, 12, 13, 14, 23, 25 AND 50). REG. 3-20-2001.
- 2,437,897. SERVICE PRO. INT. CLS. 8, 16, 20 AND 37. (U.S. CLS. 2, 5, 13, 22, 23, 25, 28, 29, 32, 37, 38, 44, 50, 100, 103 AND 106). REG. 3-27-2001.
- 2,438,222. BLUE MAN GROUP. INT. CLS. 9, 16 AND 25. (U.S. CLS. 2, 5, 21, 22, 23, 26, 29, 36, 37, 38, 39 AND 50). REG. 3-27-2001.
- 2,438,608. OPENING DOORS TO DISCOVERY. INT. CL. 42. (U.S. CLS. 100 AND 101). REG. 3-27-2001.
- 2,439,085. SHADOW HAWK. INT. CL. 35. (U.S. CLS. 100, 101 AND 102). REG. 3-27-2001.
- 2,439,143. AIR DOG. INT. CL. 28. (U.S. CLS. 22, 23, 38 AND 50). REG. 3-27-2001.
- 2,439,579. VAGINAL CONTRACEPTIVE FILM (STYLIZED). INT. CL. 5. (U.S. CLS. 6, 18, 44, 46, 51 AND 52). REG. 3-27-2001.
- 2,439,776. PEDALO. INT. CL. 10. (U.S. CLS. 26, 39 AND 44). REG. 4-3-2001.
- 2,439,903. CWCN. U.S. CL. B. REG. 4-3-2001.
- 2,440,040. MERRYBRITE. INT. CLS. 20 AND 28 ONLY. (U.S. CLS. 2, 13, 22, 23, 25, 32, 38 AND 50). REG. 4-3-2001.
- 2,440,217. FLOW-RITE AND DESIGN. INT. CL. 7. (U.S. CLS. 13, 19, 21, 23, 31, 34 AND 35). REG. 4-3-2001.
- 2,440,223. HUMS. INT. CL. 9. (U.S. CLS. 21, 23, 26, 36 AND 38). REG. 4-3-2001.
- 2,440,254. DARKSIDE. INT. CL. 35. (U.S. CLS. 100, 101 AND 102). REG. 4-3-2001.
- 2,440,289. MSI AND DESIGN. INT. CLS. 9, 40 AND 42. (U.S. CLS. 21, 23, 26, 36, 38, 100, 101, 103 AND 106). REG. 4-3-2001.
- 2,440,346. PULSE. INT. CL. 18. (U.S. CLS. 1, 2, 3, 22 AND 41). REG. 4-3-2001.
- 2,440,480. ADVISER INVESTMENT MANAGEMENT. INT. CL. 36. (U.S. CLS. 100, 101 AND 102). REG. 4-3-2001.
- 2,440,681. STARS OF THE STORM. INT. CL. 41. (U.S. CLS. 100, 101 AND 107). REG. 4-3-2001.
- 2,440,682. KBLX. INT. CL. 38. (U.S. CLS. 100, 101 AND 104). REG. 4-3-2001.
- 2,440,707. FOSTER'S DOWNEAST CLAMBAKE YORK HARBOR MAINE AND DESIGN. INT. CLS. 35 AND 42. (U.S. CLS. 100, 101 AND 102). REG. 4-3-2001.
- 2,440,798. OREO. INT. CL. 30. (U.S. CL. 46). REG. 4-3-2001.
- 2,440,897. JALANINO (STYLIZED). INT. CL. 21. (U.S. CLS. 2, 13, 23, 29, 30, 33, 40 AND 50). REG. 4-3-2001.
- 2,440,933. CLK AND DESIGN. INT. CL. 35. (U.S. CLS. 100, 101 AND 102). REG. 4-3-2001.
- 2,441,001. CAR SCHOOLING. INT. CL. 41. (U.S. CLS. 100, 101 AND 107). REG. 4-3-2001.
- 2,441,009. HEIDRA. INT. CL. 7. (U.S. CLS. 13, 19, 21, 23, 31, 34 AND 35). REG. 4-3-2001.
- 2,441,240. CIBC WORLD MARKETS. INT. CL. 36. (U.S. CLS. 100, 101 AND 102). REG. 4-3-2001.
- 2,441,257. PHYTOSORB. INT. CL. 5. (U.S. CLS. 6, 18, 44, 46, 51 AND 52). REG. 4-3-2001.
- 2,441,290. HORIZON. INT. CL. 7. (U.S. CLS. 13, 19, 21, 23, 31, 34 AND 35). REG. 4-3-2001.
- 2,441,303. AKAMAI. INT. CLS. 38 AND 42. (U.S. CLS. 100, 101 AND 104). REG. 4-3-2001.
- 2,441,521. WALLFLOWERS. INT. CL. 5. (U.S. CLS. 6, 18, 44, 46, 51 AND 52). REG. 4-3-2001.
- 2,441,555. TIP-TOP. INT. CL. 6. (U.S. CLS. 2, 12, 13, 14, 23, 25 AND 50). REG. 4-3-2001.
- 2,441,558. J JOHNSON INVESTMENT SERVICES AND DESIGN. INT. CL. 36. (U.S. CLS. 100, 101 AND 102). REG. 4-3-2001.
- 2,441,595. TIP-TOP SCREW MANUFACTURING INC. AND DESIGN. INT. CL. 6. (U.S. CLS. 2, 12, 13, 14, 23, 25 AND 50). REG. 4-3-2001.
- 2,441,628. MISCELLANEOUS DESIGN. INT. CL. 28. (U.S. CLS. 22, 23, 38 AND 50). REG. 4-3-2001.
- 2,441,647. KIT. INT. CL. 28. (U.S. CLS. 22, 23, 38 AND 50). REG. 4-3-2001.
- 2,441,666. POLYETHYLENE FILMS AND BAGS FOR INDUSTRY. INT. CL. 40. (U.S. CLS. 100, 103 AND 106). REG. 4-3-2001.
- 2,441,744. CALPHALON COMMERCIAL NONSTICK. INT. CL. 21. (U.S. CLS. 2, 13, 23, 29, 30, 33, 40 AND 50). REG. 4-10-2001.
- 2,441,758. "SURE WE CAN DO THAT". INT. CL. 40. (U.S. CLS. 100, 103 AND 106). REG. 4-10-2001.
- 2,441,805. ARCHIVE. INT. CL. 2. (U.S. CLS. 6, 11 AND 16). REG. 4-10-2001.
- 2,441,842. THE CATALOG PACKAGE SAMPLING PROGRAM. INT. CL. 35. (U.S. CLS. 100, 101 AND 102). REG. 4-10-2001.
- 2,441,851. MAXIFIX. INT. CL. 6 ONLY. (U.S. CLS. 2, 12, 13, 14, 23, 25 AND 50). REG. 4-10-2001.
- 2,441,854. STABLEEDGE. INT. CL. 19. (U.S. CLS. 1, 12, 33 AND 50). REG. 4-10-2001.
- 2,441,901. ORGANIZACAO E PROGRESSO AND DESIGN. INT. CL. 37. (U.S. CLS. 100, 103 AND 106). REG. 4-10-2001.
- 2,441,913. TXCN. INT. CL. 38. (U.S. CLS. 100, 101 AND 104). REG. 4-10-2001.
- 2,442,019. CALSOGEN. INT. CL. 1. (U.S. CLS. 1, 5, 6, 10, 26 AND 46). REG. 4-10-2001.
- 2,442,068. LIVING ASSISTANCE SERVICES VISITING ANGELS. INT. CL. 42. (U.S. CLS. 100 AND 101). REG. 4-10-2001.
- 2,442,116. LP. INT. CL. 9. (U.S. CLS. 21, 23, 26, 36 AND 38). REG. 4-10-2001.
- 2,442,125. STANLEY STEEMER. INT. CLS. 35 AND 37. (U.S. CLS. 100, 101, 102, 103 AND 106). REG. 4-10-2001.
- 2,442,328. SMARTSITE. INT. CL. 42. (U.S. CLS. 100 AND 101). REG. 4-10-2001.
- 2,442,349. MILLENNIUM MILLS. INT. CL. 27. (U.S. CLS. 19, 20, 37, 42 AND 50). REG. 4-10-2001.
- 2,442,393. LISA KLINE. INT. CL. 25. (U.S. CLS. 22 AND 39). REG. 4-10-2001.
- 2,442,402. BPPR POPULAR SECURITIES AND DESIGN. INT. CL. 36. (U.S. CLS. 100, 101 AND 102). REG. 4-10-2001.
- 2,442,417. DISCOVERY CREEK. INT. CL. 41. (U.S. CLS. 100, 101 AND 107). REG. 4-10-2001.
- 2,442,438. DRILSTORE. INT. CL. 20. (U.S. CLS. 2, 13, 22, 25, 32 AND 50). REG. 4-10-2001.
- 2,442,446. PROWL THE WEB KIMBANET AND DESIGN. INT. CL. 38. (U.S. CLS. 100, 101 AND 104). REG. 4-10-2001.
- 2,442,528. VISTAMART. INT. CL. 9. (U.S. CLS. 21, 23, 26, 36 AND 38). REG. 4-10-2001.
- 2,442,610. FUNDAMENTAL SOFTWARE. INT. CL. 9. (U.S. CLS. 21, 23, 26, 36 AND 38). REG. 4-10-2001.
- 2,442,613. CATERING BY DESIGN. INT. CL. 42. (U.S. CLS. 100 AND 101). REG. 4-10-2001.
- 2,442,635. NATURE'S WINDOW. INT. CL. 42. (U.S. CLS. 100 AND 101). REG. 4-10-2001.
- 2,442,636. A AND DESIGN. INT. CLS. 9 AND 16. (U.S. CLS. 2, 5, 21, 22, 23, 26, 29, 36, 37, 38 AND 50). REG. 4-10-2001.
- 2,442,677. SPECIAL SERVICE. INT. CL. 12. (U.S. CLS. 19, 21, 23, 31, 35 AND 44). REG. 4-10-2001.
- 2,442,724. W M WESTLAKE MEDICAL CENTER AND DESIGN. INT. CL. 36. (U.S. CLS. 100, 101 AND 102). REG. 4-10-2001.
- 2,442,767. EVENT DESIGN FROM CONCEPT TO COMPLETION. INT. CL. 41. (U.S. CLS. 100, 101 AND 107). REG. 4-10-2001.
- 2,442,784. CALDERA. INT. CL. 11. (U.S. CLS. 13, 21, 23, 31 AND 34). REG. 4-10-2001.
- 2,442,891. MISCELLANEOUS DESIGN. INT. CL. 12. (U.S. CLS. 19, 21, 23, 31, 35 AND 44). REG. 4-10-2001.
- 2,442,915. MARC BUCHANAN PELLE PELLE. INT. CLS. 6, 18, 20 AND 25. (U.S. CLS. 1, 2, 3, 12, 13, 14, 22, 23, 25, 32, 39, 41 AND 50). REG. 4-10-2001.
- 2,443,047. SERIOUS SPORTS SUPPLEMENTS. INT. CL. 5. (U.S. CLS. 6, 18, 44, 46, 51 AND 52). REG. 4-10-2001.
- 2,443,122. FANS' UNION. INT. CL. 41. (U.S. CLS. 100, 101 AND 107). REG. 4-10-2001.
- 2,443,163. KIRUNAL. INT. CL. 5. (U.S. CLS. 6, 18, 44, 46, 51 AND 52). REG. 4-10-2001.
- 2,443,184. HUGOTON ROYALTY TRUST. INT. CL. 36. (U.S. CLS. 100, 101 AND 102). REG. 4-10-2001.
- 2,443,273. FREETAB. INT. CL. 9. (U.S. CLS. 21, 23, 26, 36 AND 38). REG. 4-10-2001.
- 2,443,343. IATF AND DESIGN. INT. CL. 16. (U.S. CLS. 2, 5, 22, 23, 29, 37, 38 AND 50). REG. 4-10-2001.
- 2,443,360. TOTALLY TURTLE. INT. CL. 35. (U.S. CLS. 100, 101 AND 102). REG. 4-10-2001.
- 2,443,366. QUACKER BACKER. INT. CL. 25. (U.S. CLS. 22 AND 39). REG. 4-10-2001.
- 2,443,434. PROSIEVE. INT. CL. 1. (U.S. CLS. 1, 5, 6, 10, 26 AND 46). REG. 4-10-2001.



- 2,443,509. WALKING WORM. INT. CL. 28. (U.S. CLS. 22, 23, 38 AND 50). REG. 4-10-2001.
- 2,443,559. O2 SACRAL. INT. CL. 10. (U.S. CLS. 26, 39 AND 44). REG. 4-10-2001.
- 2,443,566. AMERICAN ACADEMY OF MINIMALLY INVASIVE SPINAL MEDICINE AND SURGERY. INT. CLS. 41 AND 42. (U.S. CLS. 100, 101 AND 107). REG. 4-10-2001.
- 2,443,588. DAMAGE CONTROL. INT. CL. 3. (U.S. CLS. 1, 4, 6, 50, 51 AND 52). REG. 4-10-2001.
- 2,443,626. DIVORCENET. INT. CL. 42. (U.S. CLS. 100 AND 101). REG. 4-17-2001.
- 2,443,680. NULLSOFT. INT. CL. 9. (U.S. CLS. 21, 23, 26, 36 AND 38). REG. 4-17-2001.
- 2,443,757. E-SEARCH. INT. CL. 35. (U.S. CLS. 100, 101 AND 102). REG. 4-17-2001.
- 2,443,813. CAMPO AZUL. INT. CL. 33. (U.S. CLS. 47 AND 49). REG. 4-17-2001.
- 2,443,837. KEINZ AND DESIGN. INT. CL. 25. (U.S. CLS. 22 AND 39). REG. 4-17-2001.
- 2,443,845. SCORCHIN' FORTUNE. INT. CL. 9. (U.S. CLS. 21, 23, 26, 36 AND 38). REG. 4-17-2001.
- 2,443,849. GEN-LINK SECURITY. INT. CL. 9. (U.S. CLS. 21, 23, 26, 36 AND 38). REG. 4-17-2001.
- 2,443,891. LBA HEALTH PLANS. INT. CL. 36. (U.S. CLS. 100, 101 AND 102). REG. 4-17-2001.
- 2,443,926. COMPACT DELTA. INT. CL. 10. (U.S. CLS. 26, 39 AND 44). REG. 4-17-2001.
- 2,443,945. WEATHER.COM. INT. CL. 18. (U.S. CLS. 1, 2, 3, 22 AND 41). REG. 4-17-2001.
- 2,443,974. RSI GEOPHYSICS FOR THE 21ST CENTURY RADAR SOLUTIONS INTERNATIONAL AND DESIGN. INT. CL. 42. (U.S. CLS. 100 AND 101). REG. 4-17-2001.
- 2,443,976. SPLASH OF MATH. INT. CL. 41. (U.S. CLS. 100, 101 AND 107). REG. 4-17-2001.
- 2,444,011. EVENT. INT. CL. 12. (U.S. CLS. 19, 21, 23, 31, 35 AND 44). REG. 4-17-2001.
- 2,444,013. SCOOP NYC. INT. CL. 35. (U.S. CLS. 100, 101 AND 102). REG. 4-17-2001.
- 2,444,090. SOLIDA. INT. CL. 7. (U.S. CLS. 13, 19, 21, 23, 31, 34 AND 35). REG. 4-17-2001.
- 2,444,124. E AND DESIGN. INT. CL. 39. (U.S. CLS. 100 AND 105). REG. 4-17-2001.
- 2,444,218. QUANTA. INT. CL. 30. (U.S. CL. 46). REG. 4-17-2001.
- 2,444,270. SUBAIR. INT. CLS. 7 AND 11. (U.S. CLS. 13, 19, 21, 23, 31, 34 AND 35). REG. 4-17-2001.
- 2,444,271. CAL-MISER. INT. CL. 11. (U.S. CLS. 13, 21, 23, 31 AND 34). REG. 4-17-2001.
- 2,444,294. PUPPETORIUM. INT. CL. 35. (U.S. CLS. 100, 101 AND 102). REG. 4-17-2001.
- 2,444,304. MISCELLANEOUS DESIGN. INT. CLS. 19 AND 31. (U.S. CLS. 1, 12, 33, 46 AND 50). REG. 4-17-2001.
- 2,444,397. ORBIS SAVING SIGHT WORLDWIDE AND DESIGN. INT. CL. 42. (U.S. CLS. 100 AND 101). REG. 4-17-2001.
- 2,444,422. UNICELL. INT. CL. 12. (U.S. CLS. 19, 21, 23, 31, 35 AND 44). REG. 4-17-2001.
- 2,444,433. CARBO-MIZER. INT. CL. 6. (U.S. CLS. 2, 12, 13, 14, 23, 25 AND 50). REG. 4-17-2001.
- 2,444,483. EVENTION. INT. CL. 41. (U.S. CLS. 100, 101 AND 107). REG. 4-17-2001.
- 2,444,525. ERMIC MAINTAINING YOUR WORLD AND DESIGN. INT. CL. 37. (U.S. CLS. 100, 103 AND 106). REG. 4-17-2001.
- 2,444,526. ERMIC MAINTAINING YOUR WORLD AND DESIGN. INT. CL. 42. (U.S. CLS. 100 AND 101). REG. 4-17-2001.
- 2,444,532. KLANWATCH. INT. CLS. 16 AND 42. (U.S. CLS. 2, 5, 22, 23, 29, 37, 38, 50, 100 AND 101). REG. 4-17-2001.
- 2,444,538. THINGS REMEMBERED. INT. CL. 35. (U.S. CLS. 100, 101 AND 102). REG. 4-17-2001.
- 2,444,574. TALKING STICK. INT. CL. 25. (U.S. CLS. 22 AND 39). REG. 4-17-2001.
- 2,444,576. TALKING STICK AND DESIGN. INT. CL. 25. (U.S. CLS. 22 AND 39). REG. 4-17-2001.
- 2,444,612. REVITADERM. INT. CL. 3. (U.S. CLS. 1, 4, 6, 50, 51 AND 52). REG. 4-17-2001.
- 2,444,691. CERMARK AND DESIGN. INT. CL. 2 ONLY. (U.S. CLS. 6, 11 AND 16 ONLY). REG. 4-17-2001.
- 2,444,717. IT NAVIGATOR. INT. CL. 35. (U.S. CLS. 100, 101 AND 102). REG. 4-17-2001.
- 2,444,722. QUANTUM. INT. CL. 12. (U.S. CLS. 19, 21, 23, 31, 35 AND 44). REG. 4-17-2001.
- 2,444,737. PLANTERS. INT. CL. 29. (U.S. CL. 46). REG. 4-17-2001.
- 2,444,758. OUTDOOR SPIRIT. INT. CL. 11. (U.S. CLS. 13, 21, 23, 31 AND 34). REG. 4-17-2001.
- 2,444,764. STERIZE. INT. CL. 10 ONLY. (U.S. CLS. 26, 39 AND 44). REG. 4-17-2001.
- 2,444,770. GOOD FOR BUSINESS, GOOD FOR THE BOTTOM LINE, GOOD FOR YOU. INT. CLS. 35 AND 39. (U.S. CLS. 100, 101, 102 AND 105). REG. 4-17-2001.
- 2,444,790. PRO-MATE SOAKER. INT. CL. 1. (U.S. CLS. 1, 5, 6, 10, 26 AND 46). REG. 4-17-2001.
- 2,444,796. DREAM SMILE. INT. CL. 42. (U.S. CLS. 100 AND 101). REG. 4-17-2001.
- 2,444,875. WORLD PANTRY. INT. CL. 35. (U.S. CLS. 100, 101 AND 102). REG. 4-17-2001.
- 2,444,923. AIRMASSEUR. INT. CL. 11. (U.S. CLS. 13, 21, 23, 31 AND 34). REG. 4-17-2001.
- 2,445,267. WAHOO RUN. INT. CL. 41. (U.S. CLS. 100, 101 AND 107). REG. 4-17-2001.
- 2,445,276. WAVERLY. INT. CLS. 20 AND 24. (U.S. CLS. 2, 13, 22, 25, 32, 42 AND 50). REG. 4-17-2001.
- 2,445,322. THE FUNCTIONAL MOVEMENT SCREEN. INT. CLS. 16 AND 41. (U.S. CLS. 2, 5, 22, 23, 29, 37, 38, 50, 100, 101 AND 107). REG. 4-17-2001.
- 2,445,406. BEANSTORE. INT. CLS. 9, 16 AND 42. (U.S. CLS. 2, 5, 21, 22, 23, 26, 29, 36, 37, 38, 50, 100 AND 101). REG. 4-24-2001.
- 2,445,487. NATIONAL COMMUNITY FOUNDATION. INT. CL. 36. (U.S. CLS. 100, 101 AND 102). REG. 4-24-2001.
- 2,445,678. WE CARE. WE RECYCLE. WE USE SAFETY-KLEEN ENVIRONMENTAL SERVICES. AND DESIGN. INT. CL. 42. (U.S. CLS. 100 AND 101). REG. 4-24-2001.
- 2,445,681. PRO-LINE AND DESIGN. INT. CL. 12. (U.S. CLS. 19, 21, 23, 31, 35 AND 44). REG. 4-24-2001.
- 2,445,795. STEPHEN MINISTRY. INT. CL. 41. (U.S. CLS. 100, 101 AND 107). REG. 4-24-2001.
- 2,446,062. RAINMAKER THINKING, INC.. INT. CLS. 35 AND 41. (U.S. CLS. 100, 101, 102 AND 107). REG. 4-24-2001.
- 2,446,107. INTERMEX AND DESIGN. INT. CL. 36. (U.S. CLS. 100, 101 AND 102). REG. 4-24-2001.
- 2,446,165. CLUB ABC TOURS. INT. CL. 35. (U.S. CLS. 100, 101 AND 102). REG. 4-24-2001.
- 2,446,169. CLUB ABC TOURS. INT. CL. 39. (U.S. CLS. 100 AND 105). REG. 4-24-2001.
- 2,446,348. JEFFERSON UNIVERSITY PHYSICIANS. INT. CL. 42. (U.S. CLS. 100 AND 101). REG. 4-24-2001.
- 2,446,370. PRIVACYGUARD. INT. CLS. 35 AND 36. (U.S. CLS. 100, 101 AND 102). REG. 4-24-2001.
- 2,446,417. CHEMPLEX. INT. CL. 9. (U.S. CLS. 21, 23, 26, 36 AND 38). REG. 4-24-2001.
- 2,446,427. FUTUREPLUS. INT. CL. 9. (U.S. CLS. 21, 23, 26, 36 AND 38). REG. 4-24-2001.
- 2,446,452. MISCELLANEOUS DESIGN. INT. CL. 29. (U.S. CL. 46). REG. 4-24-2001.
- 2,446,485. BIG OUTDOORS WITH CHIP HART AND DESIGN. INT. CL. 41. (U.S. CLS. 100, 101 AND 107). REG. 4-24-2001.
- 2,446,549. MISCELLANEOUS DESIGN. INT. CL. 36. (U.S. CLS. 100, 101 AND 102). REG. 4-24-2001.
- 2,446,619. SUNPOWER. INT. CL. 7. (U.S. CLS. 13, 19, 21, 23, 31, 34 AND 35). REG. 4-24-2001.
- 2,446,628. BLANC DE CHINE. INT. CL. 18. (U.S. CLS. 1, 2, 3, 22 AND 41). REG. 4-24-2001.
- 2,446,629. G AND DESIGN. INT. CLS. 16, 39, 41 AND 42 ONLY. (U.S. CLS. 2, 5, 22, 23, 29, 37, 38, 50, 100, 101, 105 AND 107). REG. 4-24-2001.
- 2,446,676. GECKO. INT. CL. 14. (U.S. CLS. 2, 27, 28 AND 50). REG. 4-24-2001.
- 2,446,678. SUCCESS IS A RESULT OF HARD WORK AND PATIENCE. INT. CL. 36. (U.S. CLS. 100, 101 AND 102). REG. 4-24-2001.
- 2,446,716. HEARTTOUCH. INT. CL. 9. (U.S. CLS. 21, 23, 26, 36 AND 38). REG. 4-24-2001.
- 2,446,740. UV ARMOR. INT. CL. 24. (U.S. CLS. 42 AND 50). REG. 4-24-2001.
- 2,446,792. AURORA. INT. CL. 17. (U.S. CLS. 1, 5, 12, 13, 35 AND 50). REG. 4-24-2001.
- 2,446,817. SWITCHMAN. INT. CL. 9. (U.S. CLS. 21, 23, 26, 36 AND 38). REG. 4-24-2001.

- 2,446,891. CCNA. INT. CL. 41. (U.S. CLS. 100, 101 AND 107). REG. 4-24-2001.
- 2,446,892. CCDP. INT. CL. 41. (U.S. CLS. 100, 101 AND 107). REG. 4-24-2001.
- 2,446,983. ALFAREX. INT. CL. 11. (U.S. CLS. 13, 21, 23, 31 AND 34). REG. 4-24-2001.
- 2,446,992. HAWK'S LANDING. INT. CL. 18. (U.S. CLS. 1, 2, 3, 22 AND 41). REG. 4-24-2001.
- 2,446,993. HAWK'S LANDING. INT. CL. 28. (U.S. CLS. 22, 23, 38 AND 50). REG. 4-24-2001.
- 2,446,994. HAWK'S LANDING. INT. CL. 25. (U.S. CLS. 22 AND 39). REG. 4-24-2001.
- 2,447,029. HAVMOR. INT. CL. 30. (U.S. CL. 46). REG. 4-24-2001.
- 2,447,041. BARDENAY. INT. CL. 33. (U.S. CLS. 47 AND 49). REG. 4-24-2001.
- 2,447,099. BABY HEDGEHOGS. INT. CL. 28. (U.S. CLS. 22, 23, 38 AND 50). REG. 4-24-2001.
- 2,447,170. CLASSIC. INT. CL. 28. (U.S. CLS. 22, 23, 38 AND 50). REG. 4-24-2001.
- 2,447,419. MISCELLANEOUS DESIGN. INT. CLS. 16, 36, 41 AND 42. (U.S. CLS. 2, 5, 22, 23, 29, 37, 38, 50, 100, 101, 102 AND 107). REG. 5-1-2001.
- 2,447,420. EVERSHEDES. INT. CLS. 16, 36, 41 AND 42. (U.S. CLS. 2, 5, 22, 23, 29, 37, 38, 50, 100, 101, 102 AND 107). REG. 5-1-2001.
- 2,447,467. CYBEROPTICS. INT. CL. 3. (U.S. CLS. 1, 4, 6, 50, 51 AND 52). REG. 5-1-2001.
- 2,447,511. EMPLOYMENT TELEVISION. INT. CL. 41. (U.S. CLS. 100, 101 AND 107). REG. 5-1-2001.
- 2,447,636. EONE AND DESIGN. INT. CL. 9. (U.S. CLS. 21, 23, 26, 36 AND 38). REG. 5-1-2001.
- 2,447,797. FEEDERS' ADVANTAGE. INT. CL. 35. (U.S. CLS. 100, 101 AND 102). REG. 5-1-2001.
- 2,447,831. RATH. INT. CLS. 1 AND 17. (U.S. CLS. 1, 5, 6, 10, 12, 13, 26, 35, 46 AND 50). REG. 5-1-2001.
- 2,447,978. EXCEL-FR. INT. CL. 9. (U.S. CLS. 21, 23, 26, 36 AND 38). REG. 5-1-2001.
- 2,448,035. OXFORD TEDDY BEAR UNIVERSITY. INT. CL. 25. (U.S. CLS. 22 AND 39). REG. 5-1-2001.
- 2,448,100. GRIP-RITE FAS'NERS AND DESIGN. INT. CL. 6. (U.S. CLS. 2, 12, 13, 14, 23, 25 AND 50). REG. 5-1-2001.
- 2,448,150. BAKER'S DELIGHT. INT. CL. 21. (U.S. CLS. 2, 13, 23, 29, 30, 33, 40 AND 50). REG. 5-1-2001.
- 2,448,179. T AND DESIGN. INT. CL. 41. (U.S. CLS. 100, 101 AND 107). REG. 5-1-2001.
- 2,448,180. THE TRIBUTE. INT. CL. 41. (U.S. CLS. 100, 101 AND 107). REG. 5-1-2001.
- 2,448,278. SERIOUS MEDICINE FOR SERIOUS GAS. INT. CL. 5. (U.S. CLS. 6, 18, 44, 46, 51 AND 52). REG. 5-1-2001.
- 2,448,308. ARCTIC BRICK. INT. CL. 1. (U.S. CLS. 1, 5, 6, 10, 26 AND 46). REG. 5-1-2001.
- 2,448,480. DISPATCHLOG. INT. CL. 9. (U.S. CLS. 21, 23, 26, 36 AND 38). REG. 5-1-2001.
- 2,448,685. FREEDOM PLAN. INT. CL. 36. (U.S. CLS. 100, 101 AND 102). REG. 5-8-2001.
- 2,448,782. CRIMESHIELD. INT. CL. 36. (U.S. CLS. 100, 101 AND 102). REG. 5-8-2001.
- 2,448,808. WELIGAN HUGSLEY AND DESIGN. INT. CL. 28. (U.S. CLS. 22, 23, 38 AND 50). REG. 5-8-2001.
- 2,448,809. WELIGAN HUGSLEY. INT. CL. 28. (U.S. CLS. 22, 23, 38 AND 50). REG. 5-8-2001.
- 2,449,010. MAKING A DIFFERENCE...WITH COMPASSION. INT. CL. 42. (U.S. CLS. 100 AND 101). REG. 5-8-2001.
- 2,449,211. LIGHTING FROM HOLLYWOOD. INT. CL. 25. (U.S. CLS. 22 AND 39). REG. 5-8-2001.
- 2,449,264. PENINO. INT. CL. 37. (U.S. CLS. 100, 103 AND 106). REG. 5-8-2001.
- 2,449,442. OGI AND DESIGN. INT. CL. 14. (U.S. CLS. 2, 27, 28 AND 50). REG. 5-8-2001.
- 2,449,589. ARC-ZONE.COM. INT. CL. 7. (U.S. CLS. 13, 19, 21, 23, 31, 34 AND 35). REG. 5-8-2001.
- 2,449,777. CHOICEHEALTH. INT. CL. 36. (U.S. CLS. 100, 101 AND 102). REG. 5-8-2001.
- 2,449,812. SOUND TRANSIT. INT. CL. 39. (U.S. CLS. 100 AND 105). REG. 5-8-2001.
- 2,449,820. SURE SHOT. INT. CL. 10. (U.S. CLS. 26, 39 AND 44). REG. 5-8-2001.
- 2,450,004. BUZZSPONGE. INT. CL. 35. (U.S. CLS. 100, 101 AND 102). REG. 5-8-2001.
- 2,450,057. CASHMINA. INT. CL. 24. (U.S. CLS. 42 AND 50). REG. 5-8-2001.
- 2,450,167. OSTEO-SITE. INT. CL. 10. (U.S. CLS. 26, 39 AND 44). REG. 5-8-2001.
- 2,450,412. SG. INT. CLS. 16, 36 AND 38 ONLY. (U.S. CLS. 2, 5, 22, 23, 29, 37, 38, 50, 100, 101, 102 AND 104). REG. 5-15-2001.
- 2,450,417. COTTO AND DESIGN. INT. CL. 19. (U.S. CLS. 1, 12, 33 AND 50). REG. 5-15-2001.
- 2,450,626. CRYSTAL ROCK. INT. CLS. 32, 35 AND 39. (U.S. CLS. 45, 46, 48, 100, 101, 102 AND 105). REG. 5-15-2001.
- 2,450,674. CHAMPIONS FOR CHARITY. INT. CL. 36. (U.S. CLS. 100, 101 AND 102). REG. 5-15-2001.
- 2,450,743. 4 BLEED NEW VITA SINCE 1983 AND DESIGN. INT. CL. 5. (U.S. CLS. 6, 18, 44, 46, 51 AND 52). REG. 5-15-2001.
- 2,450,744. DE STONE NEW VITA AND DESIGN. INT. CL. 5. (U.S. CLS. 6, 18, 44, 46, 51 AND 52). REG. 5-15-2001.
- 2,450,745. LUNG EASE NEW VITA SINCE 1983 AND DESIGN. INT. CL. 5. (U.S. CLS. 6, 18, 44, 46, 51 AND 52). REG. 5-15-2001.
- 2,450,746. HEART EASE NEW VITA SINCE 1983 AND DESIGN. INT. CL. 5. (U.S. CLS. 6, 18, 44, 46, 51 AND 52). REG. 5-15-2001.
- 2,450,748. 4 PROSTATE NEW VITA SINCE 1983 AND DESIGN. INT. CL. 5. (U.S. CLS. 6, 18, 44, 46, 51 AND 52). REG. 5-15-2001.
- 2,450,902. MICROMASSAGE MAGIC BY SOLIDEA. INT. CL. 25. (U.S. CLS. 22 AND 39). REG. 5-15-2001.
- 2,451,018. NOTS AND DESIGN. INT. CL. 39. (U.S. CLS. 100 AND 105). REG. 5-15-2001.
- 2,451,325. ESCAPE. INT. CL. 12. (U.S. CLS. 19, 21, 23, 31, 35 AND 44). REG. 5-15-2001.
- 2,451,752. TEINT NATUREL. INT. CL. 3. (U.S. CLS. 1, 4, 6, 50, 51 AND 52). REG. 5-15-2001.
- 2,451,997. YK AND DESIGN. INT. CL. 7. (U.S. CLS. 13, 19, 21, 23, 31, 34 AND 35). REG. 5-15-2001.
- 2,452,154. KIT KITTREDGE. INT. CL. 16. (U.S. CLS. 2, 5, 22, 23, 29, 37, 38 AND 50). REG. 5-15-2001.
- 2,452,211. AMERICAN GIRL PLACE. INT. CL. 41. (U.S. CLS. 100, 101 AND 107). REG. 5-15-2001.
- 2,452,635. PULSE. INT. CL. 36. (U.S. CLS. 100, 101 AND 102). REG. 5-22-2001.
- 2,452,638. PULSE PAY. INT. CL. 36. (U.S. CLS. 100, 101 AND 102). REG. 5-22-2001.
- 2,452,761. CREE AND DESIGN. INT. CL. 9. (U.S. CLS. 21, 23, 26, 36 AND 38). REG. 5-22-2001.
- 2,453,089. GODWIN PUMPS AND DESIGN. INT. CL. 7. (U.S. CLS. 13, 19, 21, 23, 31, 34 AND 35). REG. 5-22-2001.
- 2,453,090. SUB-PRIME. INT. CL. 7. (U.S. CLS. 13, 19, 21, 23, 31, 34 AND 35). REG. 5-22-2001.
- 2,453,154. "MONEY DOES GROW ON TREES". INT. CL. 36. (U.S. CLS. 100, 101 AND 102). REG. 5-22-2001.
- 2,453,155. TIMBERLEADS. INT. CL. 36. (U.S. CLS. 100, 101 AND 102). REG. 5-22-2001.
- 2,453,349. LEGACY. INT. CL. 36. (U.S. CLS. 100, 101 AND 102). REG. 5-22-2001.
- 2,453,515. BLADES - THE GRANULATOR SUPERSTORE. INT. CL. 35. (U.S. CLS. 100, 101 AND 102). REG. 5-22-2001.
- 2,453,933. CLOUD CHAMBER SCRUBBER. INT. CL. 11. (U.S. CLS. 13, 21, 23, 31 AND 34). REG. 5-22-2001.
- 2,454,111. TROPIMIX. INT. CL. 31. (U.S. CLS. 1 AND 46). REG. 5-22-2001.
- 2,454,165. CONNECTED. INT. CL. 25. (U.S. CLS. 22 AND 39). REG. 5-22-2001.
- 2,454,362. CENTRAL NATIONAL BANK (STYLIZED). INT. CL. 36. (U.S. CLS. 100, 101 AND 102). REG. 5-29-2001.
- 2,454,637. TONY STEWART. INT. CLS. 6, 9, 14, 16, 18, 19, 20, 21, 24, 25, 27, 28 AND 41 ONLY. (U.S. CLS. 1, 2, 3, 5, 12, 13, 14, 19, 20, 21, 22, 23, 25, 26, 27, 28, 29, 30, 32, 33, 36, 37, 38, 39, 40, 41, 42, 50, 100, 101 AND 107). REG. 5-29-2001.
- 2,454,648. WELCOME TO THE PLANET!. INT. CL. 35. (U.S. CLS. 100, 101 AND 102). REG. 5-29-2001.
- 2,454,653. HEALTH PLAN HAWAII AND DESIGN. INT. CL. 42. (U.S. CLS. 100 AND 101). REG. 5-29-2001.
- 2,454,851. KBA AND DESIGN. INT. CL. 7. (U.S. CLS. 13, 19, 21, 23, 31, 34 AND 35). REG. 5-29-2001.
- 2,455,043. LEARNING IN HARMONY WITH GOD'S WORD EST. 1973 PSALM 119:105 AND DESIGN. INT. CLS. 25 AND 41. (U.S. CLS. 22, 39, 100, 101 AND 107). REG. 5-29-2001.

- 2,455,208. R2K. INT. CL. 42. (U.S. CLS. 100 AND 101). REG. 5-29-2001.
- 2,455,355. SHOOTONLINE. INT. CL. 42. (U.S. CLS. 100 AND 101). REG. 5-29-2001.
- 2,455,361. PENNSWOOD. INT. CL. 8. (U.S. CLS. 23, 28 AND 44). REG. 5-29-2001.
- 2,455,406. JACK SPADE WARREN STREET NEW YORK. INT. CL. 18. (U.S. CLS. 1, 2, 3, 22 AND 41). REG. 5-29-2001.
- 2,455,641. GL GLYCON (STYLIZED). INT. CL. 7. (U.S. CLS. 13, 19, 21, 23, 31, 34 AND 35). REG. 5-29-2001.
- 2,455,954. TRUTH IN COLOR. INT. CL. 27. (U.S. CLS. 19, 20, 37, 42 AND 50). REG. 5-29-2001.
- 2,456,462. RIP TIDE. INT. CL. 12. (U.S. CLS. 19, 21, 23, 31, 35 AND 44). REG. 5-29-2001.
- 2,456,494. VIDEOVIEW. INT. CLS. 9 AND 42. (U.S. CLS. 21, 23, 26, 36, 38, 100 AND 101). REG. 5-29-2001.
- 2,456,712. PROTEIN BLAST. INT. CL. 5. (U.S. CLS. 6, 18, 44, 46, 51 AND 52). REG. 6-5-2001.
- 2,456,838. BED HEAD. INT. CL. 3. (U.S. CLS. 1, 4, 6, 50, 51 AND 52). REG. 6-5-2001.
- 2,456,871. CPM. INT. CL. 35. (U.S. CLS. 100, 101 AND 102). REG. 6-5-2001.
- 2,457,189. COMINA. INT. CL. 35. (U.S. CLS. 100, 101 AND 102). REG. 6-5-2001.
- 2,457,197. WET CALL. INT. CL. 10. (U.S. CLS. 26, 39 AND 44). REG. 6-5-2001.
- 2,457,391. KLARQUIST SPARKMAN. INT. CL. 42. (U.S. CLS. 100 AND 101). REG. 6-5-2001.
- 2,457,570. PARTYMAX. INT. CLS. 41 AND 42. (U.S. CLS. 100, 101 AND 107). REG. 6-5-2001.
- 2,458,322. SHORTCUTS. INT. CL. 16. (U.S. CLS. 2, 5, 22, 23, 29, 37, 38 AND 50). REG. 6-5-2001.
- 2,458,679. BOBBI. INT. CL. 3. (U.S. CLS. 1, 4, 6, 50, 51 AND 52). REG. 6-5-2001.
- 2,458,801. DES MOINES UNIVERSITY. INT. CLS. 25 AND 41. (U.S. CLS. 22, 39, 100, 101 AND 107). REG. 6-5-2001.
- 2,458,939. ULTRAVID. INT. CL. 9. (U.S. CLS. 21, 23, 26, 36 AND 38). REG. 6-12-2001.
- 2,459,049. PORTFOLIO. INT. CLS. 2 AND 16. (U.S. CLS. 2, 5, 6, 11, 16, 22, 23, 29, 37, 38 AND 50). REG. 6-12-2001.
- 2,459,099. ULTRADNS. INT. CLS. 38 AND 42. (U.S. CLS. 100, 101 AND 104). REG. 6-12-2001.
- 2,459,186. SAFEWAY. INT. CL. 31. (U.S. CLS. 1 AND 46). REG. 6-12-2001.
- 2,459,360. MVP (STYLIZED). INT. CLS. 7 AND 11. (U.S. CLS. 13, 19, 21, 23, 31, 34 AND 35). REG. 6-12-2001.
- 2,459,400. SMOVE (STYLIZED). INT. CL. 20. (U.S. CLS. 2, 13, 22, 25, 32 AND 50). REG. 6-12-2001.
- 2,459,724. AMY'S. INT. CLS. 29 AND 30. (U.S. CL. 46). REG. 6-12-2001.
- 2,460,033. XTREME COLOR. INT. CL. 3. (U.S. CLS. 1, 4, 6, 50, 51 AND 52). REG. 6-12-2001.
- 2,460,495. HIREPOTENTIAL. INT. CL. 35. (U.S. CLS. 100, 101 AND 102). REG. 6-12-2001.
- 2,461,018. ENKAGRID. INT. CL. 19. (U.S. CLS. 1, 12, 33 AND 50). REG. 6-19-2001.
- 2,461,372. MCCORMICK PLACE. INT. CL. 42. (U.S. CLS. 100 AND 101). REG. 6-19-2001.
- 2,461,373. ARIE CROWN THEATER. INT. CL. 41. (U.S. CLS. 100, 101 AND 107). REG. 6-19-2001.
- 2,461,450. ACRY LUX. INT. CL. 10. (U.S. CLS. 26, 39 AND 44). REG. 6-19-2001.
- 2,461,611. UNEXPECTED ORLANDO. INT. CL. 35. (U.S. CLS. 100, 101 AND 102). REG. 6-19-2001.
- 2,462,295. WORLDPANTRY.COM. INT. CL. 35. (U.S. CLS. 100, 101 AND 102). REG. 6-19-2001.
- 2,462,384. PHARMA KAVA. INT. CL. 5. (U.S. CLS. 6, 18, 44, 46, 51 AND 52). REG. 6-19-2001.
- 2,462,765. CARRIAGE HOUSE. INT. CL. 36. (U.S. CLS. 100, 101 AND 102). REG. 6-19-2001.
- 2,462,767. ENDURANCE. INT. CL. 7. (U.S. CLS. 13, 19, 21, 23, 31, 34 AND 35). REG. 6-19-2001.
- 2,462,798. APPLE STORE. INT. CL. 35. (U.S. CLS. 100, 101 AND 102). REG. 6-19-2001.
- 2,462,822. TEMPEST. INT. CL. 12. (U.S. CLS. 19, 21, 23, 31, 35 AND 44). REG. 6-19-2001.
- 2,462,825. INCREDIBLY LIFE-LIKE BABY. INT. CL. 28. (U.S. CLS. 22, 23, 38 AND 50). REG. 6-19-2001.
- 2,463,777. MISCELLANEOUS DESIGN. INT. CLS. 1 AND 30. (U.S. CLS. 1, 5, 6, 10, 26 AND 46). REG. 6-26-2001.
- 2,463,985. BRINGING DESIGN & BEAUTY TO CONCRETE. INT. CL. 37. (U.S. CLS. 100, 103 AND 106). REG. 6-26-2001.
- 2,464,095. DEKSTONE. INT. CL. 19. (U.S. CLS. 1, 12, 33 AND 50). REG. 6-26-2001.
- 2,464,853. BROLOS AND DESIGN. INT. CL. 29. (U.S. CL. 46). REG. 7-3-2001.
- 2,465,289. SHOPRITE STANDARD CHARACTER MARK. INT. CL. 35. (U.S. CLS. 100, 101 AND 102). REG. 7-3-2001.
- 2,465,630. AHR EXPO. INT. CL. 35. (U.S. CLS. 100, 101 AND 102). REG. 7-3-2001.
- 2,465,646. ALLCHEM. INT. CLS. 1, 35 AND 36. (U.S. CLS. 1, 5, 6, 10, 26, 46, 100, 101 AND 102). REG. 7-3-2001.
- 2,467,013. OLYMPIA. INT. CL. 13. (U.S. CLS. 2 AND 9). REG. 7-10-2001.
- 2,468,186. CALDERA. INT. CL. 9. (U.S. CLS. 21, 23, 26, 36 AND 38). REG. 7-10-2001.
- 2,468,575. APLASTIC ANEMIA & MDS INTERNATIONAL FOUNDATION, INC. INT. CL. 36. (U.S. CLS. 100, 101 AND 102). REG. 7-10-2001.
- 2,469,094. BREYER AND DESIGN. INT. CL. 28. (U.S. CLS. 22, 23, 38 AND 50). REG. 7-17-2001.
- 2,469,278. IVO. INT. CLS. 3 AND 5. (U.S. CLS. 1, 4, 6, 18, 44, 46, 50, 51 AND 52). REG. 7-17-2001.
- 2,469,352. HAWGER. INT. CL. 28. (U.S. CLS. 22, 23, 38 AND 50). REG. 7-17-2001.
- 2,469,886. WINNI - V. INT. CL. 5. (U.S. CLS. 6, 18, 44, 46, 51 AND 52). REG. 7-17-2001.
- 2,470,525. ELEARNS. INT. CL. 35. (U.S. CLS. 100, 101 AND 102). REG. 7-17-2001.
- 2,470,587. YARD MASTER. INT. CL. 9. (U.S. CLS. 21, 23, 26, 36 AND 38). REG. 7-17-2001.
- 2,471,544. MISCELLANEOUS DESIGN. INT. CL. 37. (U.S. CLS. 100, 103 AND 106). REG. 7-24-2001.
- 2,471,710. UNLOCK THE TRUTH. INT. CL. 42. (U.S. CLS. 100 AND 101). REG. 7-24-2001.
- 2,471,889. TOAST. INT. CL. 9. (U.S. CLS. 21, 23, 26, 36 AND 38). REG. 7-24-2001.
- 2,472,467. SOFT ON NATURE. INT. CL. 16. (U.S. CLS. 2, 5, 22, 23, 29, 37, 38 AND 50). REG. 7-24-2001.
- 2,472,468. SOFT ON NATURE, SOFT ON YOU. INT. CL. 16. (U.S. CLS. 2, 5, 22, 23, 29, 37, 38 AND 50). REG. 7-24-2001.
- 2,473,172. ONE DECK AT A TIME. INT. CL. 35. (U.S. CLS. 100, 101 AND 102). REG. 7-31-2001.
- 2,473,413. MOLE-RICHARDSON. INT. CL. 25. (U.S. CLS. 22 AND 39). REG. 7-31-2001.
- 2,473,487. THE BEST TASTING SMOOTHIE ON THE PLANET! AND DESIGN. INT. CLS. 32 AND 35. (U.S. CLS. 45, 46, 48, 100, 101 AND 102). REG. 7-31-2001.
- 2,473,691. TOTAL VIRX. INT. CL. 5. (U.S. CLS. 6, 18, 44, 46, 51 AND 52). REG. 7-31-2001.
- 2,474,089. KATHY CASEY FOOD STUDIOS. INT. CL. 42. (U.S. CLS. 100 AND 101). REG. 7-31-2001.
- 2,474,852. BIG CITY TAVERN. INT. CL. 42. (U.S. CLS. 100 AND 101). REG. 8-7-2001.
- 2,475,270. ICELENE. INT. CL. 17. (U.S. CLS. 1, 5, 12, 13, 35 AND 50). REG. 8-7-2001.
- 2,475,493. FOCUS ON THE FAMILY RADIO THEATRE. INT. CL. 41. (U.S. CLS. 100, 101 AND 107). REG. 8-7-2001.
- 2,475,639. TIMES TALKS. INT. CL. 41. (U.S. CLS. 100, 101 AND 107). REG. 8-7-2001.
- 2,476,637. CREST. INT. CL. 3. (U.S. CLS. 1, 4, 6, 50, 51 AND 52). REG. 8-7-2001.
- 2,476,951. MTP TECHNICAL MEDICAL PROMOTION GMBH AND DESIGN. INT. CL. 10 ONLY. (U.S. CLS. 26, 39 AND 44). REG. 8-14-2001.
- 2,477,948. FINANCIAL SECURITY. FOR LIFE. INT. CL. 42. (U.S. CLS. 100 AND 101). REG. 8-14-2001.
- 2,478,046. VDG AND DESIGN. INT. CL. 35. (U.S. CLS. 100, 101 AND 102). REG. 8-14-2001.
- 2,478,454. Z2. INT. CL. 10. (U.S. CLS. 26, 39 AND 44). REG. 8-14-2001.
- 2,479,699. NACHOS NAVIDAD.. INT. CL. 30. (U.S. CL. 46). REG. 8-21-2001.
- 2,480,076. GRAPH EXPO. INT. CL. 42. (U.S. CLS. 100 AND 101). REG. 8-21-2001.
- 2,480,662. AAS AND DESIGN. INT. CL. 1. (U.S. CLS. 1, 5, 6, 10, 26 AND 46). REG. 8-21-2001.
- 2,480,816. JOE NEMECHEK. INT. CLS. 16, 25 AND 41. (U.S. CLS. 2, 5, 22, 23, 29, 37, 38, 39, 50, 100, 101 AND 107). REG. 8-21-2001.

- 2,482,109. REDI-MEDIC. INT. CL. 5. (U.S. CLS. 6, 18, 44, 46, 51 AND 52). REG. 8-28-2001.
- 2,482,327. EGBAR. INT. CLS. 36 AND 42. (U.S. CLS. 100, 101 AND 102). REG. 8-28-2001.
- 2,483,170. TILECREST. INT. CL. 35. (U.S. CLS. 100, 101 AND 102). REG. 8-28-2001.
- 2,483,187. ALIFE. INT. CLS. 7 AND 16. (U.S. CLS. 2, 5, 13, 19, 21, 22, 23, 29, 31, 34, 35, 37, 38 AND 50). REG. 8-28-2001.
- 2,483,275. SMART CITY. INT. CL. 38. (U.S. CLS. 100, 101 AND 104). REG. 8-28-2001.
- 2,483,417. CELLU-SMOOTH. INT. CL. 5. (U.S. CLS. 6, 18, 44, 46, 51 AND 52). REG. 8-28-2001.
- 2,483,590. JEWELS & PEARLS. INT. CL. 12. (U.S. CLS. 19, 21, 23, 31, 35 AND 44). REG. 8-28-2001.
- 2,483,955. SALONBIZ. INT. CL. 9. (U.S. CLS. 21, 23, 26, 36 AND 38). REG. 8-28-2001.
- 2,484,822. AQUADEPOT. INT. CL. 11. (U.S. CLS. 13, 21, 23, 31 AND 34). REG. 9-4-2001.
- 2,485,941. ARMATECH. INT. CL. 40. (U.S. CLS. 100, 103 AND 106). REG. 9-4-2001.
- 2,485,995. EPICORE MSR. INT. CL. 6. (U.S. CLS. 2, 12, 13, 14, 23, 25 AND 50). REG. 9-4-2001.
- 2,486,021. WRECKS 4 RENT. INT. CL. 39. (U.S. CLS. 100 AND 105). REG. 9-4-2001.
- 2,487,023. SANOLITE. INT. CLS. 3, 5 AND 21. (U.S. CLS. 1, 2, 4, 6, 13, 18, 23, 29, 30, 33, 40, 44, 46, 50, 51 AND 52). REG. 9-11-2001.
- 2,487,383. PREGNACARE. INT. CL. 5. (U.S. CLS. 6, 18, 44, 46, 51 AND 52). REG. 9-11-2001.
- 2,487,770. TEDDYBERRY TALES. INT. CL. 16. (U.S. CLS. 2, 5, 22, 23, 29, 37, 38 AND 50). REG. 9-11-2001.
- 2,489,123. UNITED SITE SERVICES. INT. CL. 42. (U.S. CLS. 100 AND 101). REG. 9-11-2001.
- 2,489,473. EDGEAR. INT. CL. 9. (U.S. CLS. 21, 23, 26, 36 AND 38). REG. 9-11-2001.
- 2,489,632. SHIM-SUNG TRAINING. INT. CL. 41. (U.S. CLS. 100, 101 AND 107). REG. 9-11-2001.
- 2,490,032. COMPCOTE. INT. CL. 40. (U.S. CLS. 100, 103 AND 106). REG. 9-18-2001.
- 2,490,886. NEXTSUNDAY.COM. INT. CL. 42. (U.S. CLS. 100 AND 101). REG. 9-18-2001.
- 2,490,958. Q AND DESIGN. INT. CL. 16. (U.S. CLS. 2, 5, 22, 23, 29, 37, 38 AND 50). REG. 9-18-2001.
- 2,490,993. EMP. INT. CL. 25. (U.S. CLS. 22 AND 39). REG. 9-18-2001.
- 2,491,004. BELLING.COM. INT. CL. 42. (U.S. CLS. 100 AND 101). REG. 9-18-2001.
- 2,492,110. SANOLITE AND DESIGN. INT. CLS. 3, 5 AND 21. (U.S. CLS. 1, 2, 4, 6, 13, 18, 23, 29, 30, 33, 40, 44, 46, 50, 51 AND 52). REG. 9-25-2001.
- 2,492,169. CLOUDLITE STANDARD CHARACTER MARK. INT. CL. 18. (U.S. CLS. 1, 2, 3, 22 AND 41). REG. 9-25-2001.
- 2,492,652. SNEAKY PREVIEW. INT. CL. 9. (U.S. CLS. 21, 23, 26, 36 AND 38). REG. 9-25-2001.
- 2,493,188. OPTIFLOAT. INT. CL. 19. (U.S. CLS. 1, 12, 33 AND 50). REG. 9-25-2001.
- 2,493,461. CLIENTIZE. INT. CL. 35. (U.S. CLS. 100, 101 AND 102). REG. 9-25-2001.
- 2,493,601. THE ARNOLD GROUP. INT. CL. 42. (U.S. CLS. 100 AND 101). REG. 9-25-2001.
- 2,493,602. THE ARNOLD GROUP A HUMAN RESOURCE COMPANY. INT. CL. 42. (U.S. CLS. 100 AND 101). REG. 9-25-2001.
- 2,495,324. EXTRA SPACE STORAGE (STYLIZED). INT. CL. 39. (U.S. CLS. 100 AND 105). REG. 10-9-2001.
- 2,495,399. THOMAS A. EDISON. INT. CL. 11. (U.S. CLS. 13, 21, 23, 31 AND 34). REG. 10-9-2001.
- 2,495,897. ART OF THE WEST. INT. CL. 16. (U.S. CLS. 2, 5, 22, 23, 29, 37, 38 AND 50). REG. 10-9-2001.
- 2,496,231. BIOLAGE. INT. CL. 3. (U.S. CLS. 1, 4, 6, 50, 51 AND 52). REG. 10-9-2001.
- 2,498,251. SANDLER WORKS! (STYLIZED). INT. CL. 41. (U.S. CLS. 100, 101 AND 107). REG. 10-16-2001.
- 2,499,012. XANGOS. INT. CL. 30. (U.S. CL. 46). REG. 10-16-2001.
- 2,499,915. FANSTATION. INT. CL. 38. (U.S. CLS. 100, 101 AND 104). REG. 10-23-2001.
- 2,500,275. PROFIT FROM OUR EXPERIENCE. INT. CL. 36. (U.S. CLS. 100, 101 AND 102). REG. 10-23-2001.
- 2,500,545. UNCLE RAY'S ALWAYS MADE FRESH FROM NATURE'S BEST!. INT. CLS. 29 AND 30. (U.S. CL. 46). REG. 10-23-2001.
- 2,502,623. FRONTIER CAPITAL. INT. CL. 36. (U.S. CLS. 100, 101 AND 102). REG. 10-30-2001.
- 2,502,729. MARVIN THE MARTIAN. INT. CL. 41. (U.S. CLS. 100, 101 AND 107). REG. 10-30-2001.
- 2,503,744. MISCELLANEOUS DESIGN. INT. CL. 42. (U.S. CLS. 100 AND 101). REG. 11-6-2001.
- 2,504,580. WOTIF.COM. INT. CL. 42 ONLY. (U.S. CLS. 100 AND 101). REG. 11-6-2001.
- 2,504,806. RIVIERA. INT. CL. 14. (U.S. CLS. 2, 27, 28 AND 50). REG. 11-6-2001.
- 2,505,212. MONTEMAR. INT. CL. 33. (U.S. CLS. 47 AND 49). REG. 11-6-2001.
- 2,507,167. OHASHI. INT. CL. 6. (U.S. CLS. 2, 12, 13, 14, 23, 25 AND 50). REG. 11-13-2001.
- 2,509,222. BUSY KIDS. INT. CL. 16. (U.S. CLS. 2, 5, 22, 23, 29, 37, 38 AND 50). REG. 11-20-2001.
- 2,509,610. FACILITY OF MERIT. INT. CL. 41. (U.S. CLS. 100, 101 AND 107). REG. 11-20-2001.
- 2,509,662. PANDAT. INT. CL. 9. (U.S. CLS. 21, 23, 26, 36 AND 38). REG. 11-20-2001.
- 2,509,784. THE WATER HOG. INT. CL. 17. (U.S. CLS. 1, 5, 12, 13, 35 AND 50). REG. 11-20-2001.
- 2,510,341. XPLORER AND DESIGN. INT. CL. 9. (U.S. CLS. 21, 23, 26, 36 AND 38). REG. 11-20-2001.
- 2,510,418. PANAGO AND DESIGN. INT. CL. 30. (U.S. CL. 46). REG. 11-20-2001.
- 2,510,456. O AND DESIGN. INT. CL. 6. (U.S. CLS. 2, 12, 13, 14, 23, 25 AND 50). REG. 11-20-2001.
- 2,512,260. RIGATONI "D". INT. CL. 30. (U.S. CL. 46). REG. 11-27-2001.
- 2,512,684. MISCELLANEOUS DESIGN. INT. CL. 14. (U.S. CLS. 2, 27, 28 AND 50). REG. 11-27-2001.
- 2,514,454. SERVICECENTRAL. INT. CL. 9. (U.S. CLS. 21, 23, 26, 36 AND 38). REG. 12-4-2001.
- 2,515,252. S (STYLIZED). INT. CL. 42. (U.S. CLS. 100 AND 101). REG. 12-4-2001.
- 2,515,325. PERMASET. INT. CL. 19. (U.S. CLS. 1, 12, 33 AND 50). REG. 12-4-2001.
- 2,515,932. STUDY SEMINARS. INT. CL. 41. (U.S. CLS. 100, 101 AND 107). REG. 12-4-2001.
- 2,517,280. PANAGO AND DESIGN. INT. CL. 30. (U.S. CL. 46). REG. 12-11-2001.
- 2,517,370. POWER-ZONE. INT. CL. 9. (U.S. CLS. 21, 23, 26, 36 AND 38). REG. 12-11-2001.
- 2,517,838. RESTORE. INT. CL. 10. (U.S. CLS. 26, 39 AND 44). REG. 12-11-2001.
- 2,518,245. SIMPLEXITY. INT. CLS. 35 AND 42. (U.S. CLS. 100, 101 AND 102). REG. 12-11-2001.
- 2,518,542. WET WILLIE. INT. CL. 28. (U.S. CLS. 22, 23, 38 AND 50). REG. 12-11-2001.
- 2,521,254. RESPONSE. INT. CLS. 16 AND 21. (U.S. CLS. 2, 5, 13, 22, 23, 29, 30, 33, 37, 38, 40 AND 50). REG. 12-18-2001.
- 2,522,739. MISCELLANEOUS DESIGN. INT. CLS. 16, 41 AND 42. (U.S. CLS. 2, 5, 22, 23, 29, 37, 38, 50, 100, 101 AND 107). REG. 12-25-2001.
- 2,522,938. GEM SEAL. INT. CL. 19. (U.S. CLS. 1, 12, 33 AND 50). REG. 12-25-2001.
- 2,524,100. APR ASSOCIATION OF POSTCONSUMER PLASTIC RECYCLERS AND DESIGN. INT. CL. 42. (U.S. CLS. 100 AND 101). REG. 1-1-2002.
- 2,525,202. EASY START. INT. CL. 4. (U.S. CLS. 1, 6 AND 15). REG. 1-1-2002.
- 2,525,220. PANCHERO'S. INT. CL. 42. (U.S. CLS. 100 AND 101). REG. 1-1-2002.
- 2,528,222. MYERS-BRIGGS TYPE INDICATOR. INT. CL. 42. (U.S. CLS. 100 AND 101). REG. 1-8-2002.
- 2,528,223. MYERS-BRIGGS. INT. CL. 42. (U.S. CLS. 100 AND 101). REG. 1-8-2002.
- 2,528,803. MISCELLANEOUS DESIGN. INT. CL. 36. (U.S. CLS. 100, 101 AND 102). REG. 1-15-2002.
- 2,530,704. HEALTHCARE INSIGHTS. INT. CL. 36. (U.S. CLS. 100, 101 AND 102). REG. 1-15-2002.
- 2,531,656. TOTAL PROBIOTICS. INT. CL. 5. (U.S. CLS. 6, 18, 44, 46, 51 AND 52). REG. 1-22-2002.
- 2,531,968. ABRAZO ADOPTION ASSOCIATES. INT. CL. 42. (U.S. CLS. 100 AND 101). REG. 1-22-2002.
- 2,532,458. VIBRALERT. INT. CL. 9. (U.S. CLS. 21, 23, 26, 36 AND 38). REG. 1-22-2002.
- 2,533,702. HEALTH VITALS. INT. CL. 35. (U.S. CLS. 100, 101 AND 102). REG. 1-29-2002.
- 2,533,966. TRADEWINDS MARKETPLACE. INT. CL. 42. (U.S. CLS. 100 AND 101). REG. 1-29-2002.
- 2,534,700. BUG FREE. INT. CL. 3. (U.S. CLS. 1, 4, 6, 50, 51 AND 52). REG. 1-29-2002.



- 2,535,089. SUN VALLEY. INT. CLS. 3 AND 4. (U.S. CLS. 1, 4, 6, 15, 50, 51 AND 52). REG. 1-29-2002.
- 2,536,240. GOLF FOR KIDS AND DESIGN. INT. CL. 41. (U.S. CLS. 100, 101 AND 107). REG. 2-5-2002.
- 2,536,421. EVENTMASTER. INT. CL. 9. (U.S. CLS. 21, 23, 26, 36 AND 38). REG. 2-5-2002.
- 2,536,459. ROLLCALL. INT. CL. 9. (U.S. CLS. 21, 23, 26, 36 AND 38). REG. 2-5-2002.
- 2,536,518. ENERGY. PASSION. COMMITMENT. SHIRT-SLEEVES.. INT. CL. 42. (U.S. CLS. 100 AND 101). REG. 2-5-2002.
- 2,536,813. ZNP. INT. CL. 2. (U.S. CLS. 6, 11 AND 16). REG. 2-5-2002.
- 2,536,992. PAIROGEN. INT. CL. 32. (U.S. CLS. 45, 46 AND 48). REG. 2-5-2002.
- 2,537,155. ELEARNS.COM. INT. CL. 35. (U.S. CLS. 100, 101 AND 102). REG. 2-5-2002.
- 2,538,432. WINDOW WASHER. INT. CL. 9. (U.S. CLS. 21, 23, 26, 36 AND 38). REG. 2-12-2002.
- 2,538,919. COMMUTER CHECK AND DESIGN. INT. CL. 36. (U.S. CLS. 100, 101 AND 102). REG. 2-19-2002.
- 2,539,092. BLACKPLANET.COM. INT. CLS. 35, 38 AND 42. (U.S. CLS. 100, 101, 102 AND 104). REG. 2-19-2002.
- 2,540,956. AIR VALET AND DESIGN. INT. CL. 39. (U.S. CLS. 100 AND 105). REG. 2-19-2002.
- 2,541,160. LAIRD. INT. CL. 9. (U.S. CLS. 21, 23, 26, 36 AND 38). REG. 2-19-2002.
- 2,541,433. AMAZON. INT. CL. 30. (U.S. CL. 46). REG. 2-19-2002.
- 2,541,434. GORILLA MUNCH. INT. CL. 30. (U.S. CL. 46). REG. 2-19-2002.
- 2,541,669. POWER HOLD. INT. CL. 3. (U.S. CLS. 1, 4, 6, 50, 51 AND 52). REG. 2-19-2002.
- 2,541,770. SILT- SAVER STORM WATER FILTER & SAFETYGUARD AND DESIGN. INT. CL. 11. (U.S. CLS. 13, 21, 23, 31 AND 34). REG. 2-19-2002.
- 2,542,037. MINISTERIOS EN CONTACTO. INT. CL. 42. (U.S. CLS. 100 AND 101). REG. 2-26-2002.
- 2,542,985. FRASER FORBES COMPANY. INT. CL. 36. (U.S. CLS. 100, 101 AND 102). REG. 2-26-2002.
- 2,543,672. EN CONTACTO. INT. CL. 41. (U.S. CLS. 100, 101 AND 107). REG. 3-5-2002.
- 2,543,673. EN CONTACTO. INT. CL. 42. (U.S. CLS. 100 AND 101). REG. 3-5-2002.
- 2,543,741. PAYCHECKER. INT. CL. 9. (U.S. CLS. 21, 23, 26, 36 AND 38). REG. 3-5-2002.
- 2,543,921. NATURALAWN. INT. CLS. 37 AND 42. (U.S. CLS. 100, 101, 103 AND 106). REG. 3-5-2002.
- 2,544,346. BOSTONBEAN COFFEE COMPANY. INT. CLS. 30 AND 42. (U.S. CLS. 46, 100 AND 101). REG. 3-5-2002.
- 2,544,975. MISCELLANEOUS DESIGN. INT. CL. 41. (U.S. CLS. 100, 101 AND 107). REG. 3-5-2002.
- 2,545,013. BEST OF MONTEREY COUNTY. INT. CL. 35. (U.S. CLS. 100, 101 AND 102). REG. 3-5-2002.
- 2,545,145. MANGO. INT. CL. 12. (U.S. CLS. 19, 21, 23, 31, 35 AND 44). REG. 3-5-2002.
- 2,545,477. LOCKJAR. INT. CL. 7. (U.S. CLS. 13, 19, 21, 23, 31, 34 AND 35). REG. 3-5-2002.
- 2,545,554. MINISTERIOS EN CONTACTO. INT. CL. 41. (U.S. CLS. 100, 101 AND 107). REG. 3-12-2002.
- 2,545,778. CHANNELIX AND DESIGN. INT. CL. 35. (U.S. CLS. 100, 101 AND 102). REG. 3-12-2002.
- 2,546,820. MILLENNIUM SHAPED CHARGES AND DESIGN. INT. CL. 13. (U.S. CLS. 2 AND 9). REG. 3-12-2002.
- 2,547,030. RLPS AND DESIGN. INT. CL. 42. (U.S. CLS. 100 AND 101). REG. 3-12-2002.
- 2,547,560. THE CITY AND DESIGN. INT. CL. 25. (U.S. CLS. 22 AND 39). REG. 3-12-2002.
- 2,547,677. XM. INT. CL. 38. (U.S. CLS. 100, 101 AND 104). REG. 3-12-2002.
- 2,547,890. PROWL. INT. CL. 41. (U.S. CLS. 100, 101 AND 107). REG. 3-12-2002.
- 2,547,947. HALLOWEEN HEADQUARTERS. INT. CL. 35. (U.S. CLS. 100, 101 AND 102). REG. 3-12-2002.
- 2,547,948. LAIRD TELEMEDIA. INT. CL. 9. (U.S. CLS. 21, 23, 26, 36 AND 38). REG. 3-12-2002.
- 2,547,987. JUSTICE TALKING AND DESIGN. INT. CLS. 9 AND 42 ONLY. (U.S. CLS. 21, 23, 26, 36, 38, 100 AND 101). REG. 3-12-2002.
- 2,548,079. DOCAGENT/400 (STYLIZED). INT. CL. 9. (U.S. CLS. 21, 23, 26, 36 AND 38). REG. 3-12-2002.
- 2,548,587. SALVAGESALE. INT. CL. 35. (U.S. CLS. 100, 101 AND 102). REG. 3-12-2002.
- 2,548,976. CLEO'S. INT. CL. 35. (U.S. CLS. 100, 101 AND 102). REG. 3-19-2002.
- 2,549,334. M&M'S AND DESIGN. INT. CL. 30. (U.S. CL. 46). REG. 3-19-2002.
- 2,549,553. PROJECT GUTENBERG. INT. CL. 41. (U.S. CLS. 100, 101 AND 107). REG. 3-19-2002.
- 2,549,841. ARTIST OF THE RAILS. INT. CLS. 16 AND 42. (U.S. CLS. 2, 5, 22, 23, 29, 37, 38, 50, 100 AND 101). REG. 3-19-2002.
- 2,549,849. WILDIZE FOUNDATION AND DESIGN. INT. CLS. 16 AND 36. (U.S. CLS. 2, 5, 22, 23, 29, 37, 38, 50, 100, 101 AND 102). REG. 3-19-2002.
- 2,549,850. WILDIZE (STYLIZED). INT. CLS. 16 AND 36. (U.S. CLS. 2, 5, 22, 23, 29, 37, 38, 50, 100, 101 AND 102). REG. 3-19-2002.
- 2,550,056. EXCELGINATE. INT. CL. 5. (U.S. CLS. 6, 18, 44, 46, 51 AND 52). REG. 3-19-2002.
- 2,550,083. COZEN AND O'CONNOR. INT. CL. 42. (U.S. CLS. 100 AND 101). REG. 3-19-2002.
- 2,550,182. GRAVITY. INT. CL. 12. (U.S. CLS. 19, 21, 23, 31, 35 AND 44). REG. 3-19-2002.
- 2,550,692. FACWORLD. INT. CL. 36. (U.S. CLS. 100, 101 AND 102). REG. 3-19-2002.
- 2,551,609. JIANGHAI AND DESIGN. INT. CL. 9. (U.S. CLS. 21, 23, 26, 36 AND 38). REG. 3-26-2002.
- 2,552,420. ST ON CALL AND DESIGN. INT. CL. 42. (U.S. CLS. 100 AND 101). REG. 3-26-2002.
- 2,552,738. VDE + IMAGES. INT. CL. 9. (U.S. CLS. 21, 23, 26, 36 AND 38). REG. 3-26-2002.
- 2,552,976. MISCELLANEOUS DESIGN. INT. CL. 13. (U.S. CLS. 2 AND 9). REG. 3-26-2002.
- 2,553,791. LG (STYLIZED). INT. CL. 7. (U.S. CLS. 13, 19, 21, 23, 31, 34 AND 35). REG. 3-26-2002.
- 2,553,792. GRANT-O-MATIC. INT. CL. 7. (U.S. CLS. 13, 19, 21, 23, 31, 34 AND 35). REG. 3-26-2002.
- 2,554,951. SUPERBOAT. INT. CL. 12. (U.S. CLS. 19, 21, 23, 31, 35 AND 44). REG. 4-2-2002.
- 2,555,161. POSTAL PRESCRIPTION SERVICES. INT. CL. 35. (U.S. CLS. 100, 101 AND 102). REG. 4-2-2002.
- 2,555,327. INSTRUCTOR. INT. CL. 16. (U.S. CLS. 2, 5, 22, 23, 29, 37, 38 AND 50). REG. 4-2-2002.
- 2,555,438. NEPHROLOGY NEWS & ISSUES. INT. CL. 16. (U.S. CLS. 2, 5, 22, 23, 29, 37, 38 AND 50). REG. 4-2-2002.
- 2,555,686. HARVEY. INT. CL. 35. (U.S. CLS. 100, 101 AND 102). REG. 4-2-2002.
- 2,555,912. GENUINE COUNTERFEIT CUBAN. INT. CL. 34. (U.S. CLS. 2, 8, 9 AND 17). REG. 4-2-2002.
- 2,556,054. HUMMER SUMMER. INT. CL. 35. (U.S. CLS. 100, 101 AND 102). REG. 4-2-2002.
- 2,556,619. OVER-N-OUT. INT. CL. 5. (U.S. CLS. 6, 18, 44, 46, 51 AND 52). REG. 4-2-2002.
- 2,556,817. XM AND DESIGN. INT. CL. 38. (U.S. CLS. 100, 101 AND 104). REG. 4-2-2002.
- 2,556,935. PHX AND DESIGN. INT. CL. 25. (U.S. CLS. 22 AND 39). REG. 4-2-2002.
- 2,558,258. BLUFFS RUN. INT. CL. 41 ONLY. (U.S. CLS. 100, 101 AND 107). REG. 4-9-2002.
- 2,559,182. PAPERDIRECT. INT. CLS. 16 AND 35. (U.S. CLS. 2, 5, 22, 23, 29, 37, 38, 50, 100, 101 AND 102). REG. 4-9-2002.

\* \* \* \* \*



# TRADEMARK REGISTRATIONS CANCELED

The designation "U.S. Cl." appearing in this section refers to the U.S. class in effect prior to Sep. 1, 1973 rather than the international class which applies to applications filed on or after that date. For adoption of international classification see notice in the OFFICIAL GAZETTE of Jun. 26, 1973 (911 O.G. TM 210).

## SECTION 7(D)

- 1,273,766. MILKSHAKE (STYLIZED). INT. CL. 30. REG. 4-10-1984.  
2,891,687. THE BEDPLACE. INT. CL. 35. REG. 10-5-2004.  
3,176,531. OMAHA AK-SAR-BEN KNIGHTS AK AND DESIGN. INT. CL. 41. REG. 11-28-2006.  
3,180,126. OMAHA AK-SAR-BEN KNIGHTS STANDARD CHARACTER MARK. INT. CL. 41. REG. 12-5-2006.  
3,724,523. LORDANCER STANDARD CHARACTER MARK. INT. CL. 41. REG. 12-15-2009.  
3,829,023. AMERICAN WRINKLE STANDARD CHARACTER MARK. INT. CL. 25. REG. 8-3-2010.  
3,829,580. ESSE STANDARD CHARACTER MARK. INT. CL. 3. REG. 8-3-2010.  
3,829,625. NATURELLA STANDARD CHARACTER MARK. INT. CL. 5. REG. 8-3-2010.  
3,851,498. DECK BRITE STANDARD CHARACTER MARK. INT. CL. 3. REG. 9-21-2010.

## SECTION 8

- 723,146. DON. U.S. CL. 39. REG. 10-24-1961.  
773,362. ARC. U.S. CL. 100. REG. 7-14-1964.  
813,205. MEMBER THE UNITED STATES JAYCEES OFFICIALLY RECOGNIZED AFFILIATE ORGANIZATION AND DESIGN. U.S. CL. 200. REG. 8-16-1966.  
883,004. FELIPE II. U.S. CL. 49. REG. 12-23-1969.  
1,079,783. HUGGABLES. INT. CL. 10. REG. 12-20-1977.  
1,131,371. ANNE MARIE BERETTA AND DESIGN. INT. CL. 25. REG. 2-26-1980.  
1,139,234. SPERRY TOP-SIDER AND DESIGN. INT. CLS. 18, 25 AND 26. REG. 9-2-1980.  
1,608,667. PERFECT CHOICE. INT. CLS. 1, 3, 4, 5 AND 10. REG. 8-7-1990.  
1,612,117. LIGHTNING BUG AND DESIGN. INT. CLS. 24 AND 25. REG. 9-4-1990.  
1,639,594. OP. INT. CLS. 9, 16 AND 42 ONLY. REG. 4-2-1991.  
1,640,205. PRINCETON. INT. CL. 8 ONLY. REG. 4-9-1991.  
1,641,533. RIPARIUS AND DESIGN. INT. CLS. 36, 40 AND 42 ONLY. REG. 4-16-1991.  
1,679,210. EW (STYLIZED). INT. CL. 9 ONLY. REG. 3-17-1992.  
1,883,843. BALLANTINE INDIA PALE ALE. INT. CL. 32. REG. 3-14-1995.  
1,906,423. SUPERPACH. INT. CL. 10. REG. 7-18-1995.  
1,918,856. PHOENIX PHOTOFILE. INT. CL. 20. REG. 9-12-1995.  
1,939,225. CONTROLINE. INT. CL. 11. REG. 12-5-1995.  
1,947,963. THE CEO INSTITUTE PROVIDING A FORUM FORCO INTERACTION AND DEVELOPMENT AND DESIGN. INT. CL. 41. REG. 1-16-1996.  
1,962,286. LATITUDE. INT. CL. 9. REG. 3-12-1996.  
1,969,175. PROKOTE. INT. CL. 16. REG. 4-23-1996.  
2,016,006. TWINSTAR. INT. CL. 9. REG. 11-12-1996.  
2,020,921. 4 POINT 0 AND DESIGN. INT. CL. 25. REG. 12-3-1996.  
2,103,798. FRANKENSTEIN; THROUGH THE EYES OF THE MONSTER. INT. CL. 28. REG. 10-7-1997.  
2,149,877. COLOUR. INT. CL. 4. REG. 4-7-1998.  
2,175,314. THE IDEAL RETIREMENT ACCOUNT. INT. CL. 36. REG. 7-21-1998.  
2,363,494. MISCELLANEOUS DESIGN. INT. CLS. 9, 14 AND 18 ONLY. REG. 7-4-2000.  
2,382,018. METZELER MBS RADIAL. INT. CL. 12. REG. 9-5-2000.  
2,382,025. CARGANZA. INT. CL. 42. REG. 9-5-2000.  
2,382,030. DATALINK. INT. CL. 36. REG. 9-5-2000.  
2,382,037. INFOTRUST. INT. CLS. 35, 36 AND 42. REG. 9-5-2000.  
2,382,044. GO FOR THE GOLD. INT. CL. 30. REG. 9-5-2000.  
2,382,051. MINI PSEUDO. INT. CL. 5. REG. 9-5-2000.  
2,382,067. CITATION. INT. CLS. 20 AND 24. REG. 9-5-2000.  
2,382,089. SALON RESOURCE. INT. CLS. 35 AND 42. REG. 9-5-2000.  
2,382,103. ECOSYSTEM AQUARIUM (STYLIZED). INT. CL. 11. REG. 9-5-2000.  
2,382,110. THE BODY WRAP AND DESIGN. INT. CL. 25. REG. 9-5-2000.  
2,382,113. STENCIL-CRETE. INT. CL. 16. REG. 9-5-2000.  
2,382,124. ICE. INT. CL. 9. REG. 9-5-2000.  
2,382,128. LA CLOSERIE DES LILAS. INT. CL. 42. REG. 9-5-2000.  
2,382,130. COLGATE AND DESIGN. INT. CL. 3. REG. 9-5-2000.  
2,382,135. T P PRO - SERIES (STYLIZED). INT. CLS. 7 AND 12. REG. 9-5-2000.  
2,382,139. BRIKO (STYLIZED). INT. CLS. 9 AND 28. REG. 9-5-2000.  
2,382,162. REX RF EMISSIONS EXPERTS AN EDWARDS ANDKELCEY SERVICE AND DESIGN. INT. CL. 42. REG. 9-5-2000.  
2,382,188. MISCELLANEOUS DESIGN. INT. CLS. 16 AND 41. REG. 9-5-2000.  
2,382,195. CAREER STEP AND DESIGN. INT. CLS. 9, 16 AND 41. REG. 9-5-2000.  
2,382,213. PLANSCAPE. INT. CL. 36. REG. 9-5-2000.  
2,382,226. FEDPRO. INT. CL. 35. REG. 9-5-2000.  
2,382,227. HARLEM ROCKETS. INT. CL. 41. REG. 9-5-2000.  
2,382,237. TESTED QUALITY PRODUCED UNDER THE HIGHEST STANDARDS FOR FOOD SAFETY AND DESIGN. U.S. CL. A. REG. 9-5-2000.  
2,382,242. CONSERVATION ULTRACLEAR. INT. CL. 21. REG. 9-5-2000.  
2,382,248. HERITAGE QUEST (STYLIZED). INT. CL. 16. REG. 9-5-2000.  
2,382,250. UNIDRIVE. INT. CL. 7. REG. 9-5-2000.  
2,382,251. PEARL OF LIFE PUBLISHING. INT. CL. 16. REG. 9-5-2000.  
2,382,252. LUXMAC. INT. CL. 36. REG. 9-5-2000.  
2,382,256. LITTLE ORPHAN ANIMALS. INT. CLS. 16 AND 28. REG. 9-5-2000.  
2,382,266. FIRST HOPE BANK WE TURN HOPE INTO REALITY AND DESIGN. INT. CL. 36. REG. 9-5-2000.  
2,382,272. I MY INDEPENDENCE AND DESIGN. INT. CL. 21. REG. 9-5-2000.

- 2,382,273. ACTIVE CONTROL AND DESIGN. INT. CL. 9. REG. 9-5-2000.
- 2,382,304. BROADWATER PRINTING. INT. CL. 42. REG. 9-5-2000.
- 2,382,318. DISTINCTION. INT. CL. 19. REG. 9-5-2000.
- 2,382,344. MISCELLANEOUS DESIGN. INT. CL. 7. REG. 9-5-2000.
- 2,382,345. HEALTHQUEST. INT. CL. 9. REG. 9-5-2000.
- 2,382,348. SANDRA RICH (STYLIZED). INT. CL. 21. REG. 9-5-2000.
- 2,382,349. MISCELLANEOUS DESIGN. INT. CL. 36. REG. 9-5-2000.
- 2,382,350. TCU. INT. CL. 36. REG. 9-5-2000.
- 2,382,356. FABRICS FOR YOUR HOME. INT. CLS. 22, 24 AND 35. REG. 9-5-2000.
- 2,382,371. ARCH RIVAL. INT. CL. 12. REG. 9-5-2000.
- 2,382,377. THE GREATEST DETECTIVES IN THE WORLD CITY OF NEW YORK POLICE DETECTIVE DEA AND DESIGN. INT. CLS. 14, 16, 18, 21, 25, 26, 36 AND 42. REG. 9-5-2000.
- 2,382,390. LOCUS. INT. CL. 42. REG. 9-5-2000.
- 2,382,392. GENERAL LINE. INT. CL. 42. REG. 9-5-2000.
- 2,382,394. GWS AND DESIGN. INT. CL. 7. REG. 9-5-2000.
- 2,382,408. TOASTINI AND DESIGN. INT. CL. 30. REG. 9-5-2000.
- 2,382,418. ESDJCO AND DESIGN. INT. CL. 25. REG. 9-5-2000.
- 2,382,428. SOMATOM VOLUMEZOOM (STYLIZED). INT. CL. 10. REG. 9-5-2000.
- 2,382,433. THE ARLEE GROUP. INT. CLS. 20 AND 24. REG. 9-5-2000.
- 2,382,435. PRO GRIP AND DESIGN. INT. CL. 25. REG. 9-5-2000.
- 2,382,441. XENSTART. INT. CL. 9. REG. 9-5-2000.
- 2,382,443. GUY LAROCHE. INT. CL. 25. REG. 9-5-2000.
- 2,382,446. STANDARD & POOR'S EXCELLENCE INTEGRITY OBJECTIVITY SECURITY CIRCLE AND DESIGN. INT. CL. 36. REG. 9-5-2000.
- 2,382,453. DUPLOTECH. INT. CL. 7. REG. 9-5-2000.
- 2,382,462. W25. INT. CL. 3. REG. 9-5-2000.
- 2,382,479. SIRSEND. INT. CL. 35. REG. 9-5-2000.
- 2,382,482. REALSCAN. INT. CL. 9. REG. 9-5-2000.
- 2,382,483. MR POKER. INT. CL. 25. REG. 9-5-2000.
- 2,382,487. BABY FACE AND DESIGN. INT. CL. 42. REG. 9-5-2000.
- 2,382,495. ASPEN SPRINGS RANCH. INT. CLS. 36 AND 37. REG. 9-5-2000.
- 2,382,496. COLD CUT CITY WE DON'T MAKE SANDWICHES WE BUILD EM "HOME OF THE HERO" AND DESIGN. INT. CL. 42. REG. 9-5-2000.
- 2,382,515. LOBO SYSTEMS AND DESIGN. INT. CLS. 6 AND 20. REG. 9-5-2000.
- 2,382,516. TECUMSEH AND DESIGN. INT. CL. 7. REG. 9-5-2000.
- 2,382,517. ROCK YOUR SOUL. INT. CL. 9. REG. 9-5-2000.
- 2,382,535. SKY FINANCIAL GROUP AND DESIGN. INT. CL. 36. REG. 9-5-2000.
- 2,382,536. MISCELLANEOUS DESIGN. INT. CL. 36. REG. 9-5-2000.
- 2,382,537. COLORS BY MHNY. INT. CL. 25. REG. 9-5-2000.
- 2,382,539. STARLITE. INT. CL. 19. REG. 9-5-2000.
- 2,382,572. CORPWATCH RADIO. INT. CL. 41. REG. 9-5-2000.
- 2,382,581. JUDITH RIPKA 18 AND DESIGN. INT. CL. 14. REG. 9-5-2000.
- 2,382,585. MISCELLANEOUS DESIGN. INT. CL. 25. REG. 9-5-2000.
- 2,382,598. AXIS AND DESIGN. INT. CL. 10. REG. 9-5-2000.
- 2,382,614. S AND DESIGN. INT. CLS. 17 AND 19. REG. 9-5-2000.
- 2,382,618. LIGHTBRIDGE. INT. CLS. 35 AND 42. REG. 9-5-2000.
- 2,382,619. LIGHTBRIDGE AND DESIGN. INT. CL. 35. REG. 9-5-2000.
- 2,382,625. YIELDVIEW. INT. CL. 9. REG. 9-5-2000.
- 2,382,647. GRAPH 1000. INT. CL. 16. REG. 9-5-2000.
- 2,382,654. T RAT AND DESIGN. INT. CL. 25. REG. 9-5-2000.
- 2,382,656. LISTEN AMERICA WITH JERRY FALWELL. INT. CL. 41. REG. 9-5-2000.
- 2,382,666. TEQUIZA. INT. CL. 25. REG. 9-5-2000.
- 2,382,667. SPOTS ON THE SPOT. INT. CL. 42. REG. 9-5-2000.
- 2,382,675. FEEL THE BENEFIT OF COPPER. INT. CL. 14. REG. 9-5-2000.
- 2,382,676. NKG GOLFWEAR AND DESIGN. INT. CL. 25. REG. 9-5-2000.
- 2,382,678. RADIOLOGY SERVICE PARTNERS. INT. CL. 41. REG. 9-5-2000.
- 2,382,688. MONTANA RIVER RANCH COUNTRY INN AND DESIGN. INT. CL. 42. REG. 9-5-2000.
- 2,382,694. QUICKPICK. INT. CL. 16. REG. 9-5-2000.
- 2,382,701. ASHANTI FARM. INT. CL. 42. REG. 9-5-2000.
- 2,382,709. WILLWORK. INT. CLS. 37 AND 42. REG. 9-5-2000.
- 2,382,710. JIDECO (STYLIZED). INT. CLS. 9 AND 12. REG. 9-5-2000.
- 2,382,717. GATOR TANK AND DESIGN. INT. CL. 20. REG. 9-5-2000.
- 2,382,726. TIN ALLEY GRILL. INT. CL. 42. REG. 9-5-2000.
- 2,382,732. POSI-LOCK. INT. CL. 25. REG. 9-5-2000.
- 2,382,735. CHRISTIAN BERNARD AND DESIGN. INT. CL. 14. REG. 9-5-2000.
- 2,382,739. DR. DENT AND DESIGN. INT. CL. 37. REG. 9-5-2000.
- 2,382,740. KITCHEN TALK (STYLIZED). INT. CLS. 25 AND 42. REG. 9-5-2000.
- 2,382,750. LEGATO. INT. CLS. 9 AND 42. REG. 9-5-2000.
- 2,382,756. LEGATO NETWORKER. INT. CLS. 9 AND 42. REG. 9-5-2000.
- 2,382,768. THE FLYING BISCUIT CAFE AND DESIGN. INT. CL. 42. REG. 9-5-2000.
- 2,382,777. PARMOD. INT. CL. 2. REG. 9-5-2000.
- 2,382,779. MERASTAR. INT. CL. 36. REG. 9-5-2000.
- 2,382,792. INSTEAD O' BUTTER. INT. CL. 29. REG. 9-5-2000.
- 2,382,798. RIVERSIDE MILITARY ACADEMY MENS SANA INCORPORA SANO AND DESIGN. INT. CL. 41. REG. 9-5-2000.
- 2,382,805. PRESTIGE. INT. CL. 28. REG. 9-5-2000.
- 2,382,826. GENLINK. INT. CL. 9. REG. 9-5-2000.
- 2,382,827. DISCOVERY HEALTH CHANNEL AND DESIGN. INT. CLS. 38 AND 41. REG. 9-5-2000.
- 2,382,830. INDEXATOR. INT. CL. 7. REG. 9-5-2000.
- 2,382,832. SHOOT BACK BASKETBALL. INT. CL. 28. REG. 9-5-2000.
- 2,382,841. ECHOLINK. INT. CLS. 36 AND 42. REG. 9-5-2000.
- 2,382,855. LIFE'S AN ADVENTURE BE PREPARED. INT. CL. 35. REG. 9-5-2000.
- 2,382,860. BLACK KNIGHT. INT. CL. 19. REG. 9-5-2000.
- 2,382,867. TBC HERRINGTON'S TEDDY BEAR CLUB AND DESIGN. INT. CL. 25. REG. 9-5-2000.
- 2,382,880. BIG DAY OUT (STYLIZED). INT. CLS. 25 AND 41. REG. 9-5-2000.
- 2,382,881. MEG-A-VAT. INT. CLS. 6 AND 20. REG. 9-5-2000.
- 2,382,884. GROWING GOPHERS. INT. CL. 11. REG. 9-5-2000.
- 2,382,919. WE DO IT ALL WITH JUST ONE CALL. INT. CL. 37. REG. 9-5-2000.
- 2,382,951. SUN STOP R. INT. CL. 12. REG. 9-5-2000.
- 2,382,956. EARNINGSWHISPERS.COM. INT. CL. 36. REG. 9-5-2000.
- 2,382,963. GOOD RANCH. INT. CL. 29. REG. 9-5-2000.
- 2,382,970. DRY DOC VELVET COMPANY AND DESIGN. INT. CL. 5. REG. 9-5-2000.
- 2,382,972. DECISION DEMOGRAPHICS AND DESIGN. INT. CL. 35. REG. 9-5-2000.
- 2,382,973. WIN. INT. CL. 42. REG. 9-5-2000.
- 2,382,976. LIVE LONG - TRAVEL LIGHT (STYLIZED). INT. CL. 29. REG. 9-5-2000.
- 2,382,981. CHOICE OF THE WORLD'S TOP DX'ERS. INT. CL. 35. REG. 9-5-2000.
- 2,382,986. KARATE KID TRAINING VIDEOS. INT. CL. 9. REG. 9-5-2000.
- 2,382,996. CHILDREN'S HOSPITAL FOUNDATION AND DESIGN. INT. CL. 36. REG. 9-5-2000.
- 2,383,007. MISCELLANEOUS DESIGN. INT. CLS. 25 AND 34. REG. 9-5-2000.

- 2,383,008. BROOKS PHARMACY. INT. CL. 35. REG. 9-5-2000.
- 2,383,013. MISCELLANEOUS DESIGN. INT. CL. 42. REG. 9-5-2000.
- 2,383,022. M & M SOUL FOOD. INT. CL. 42. REG. 9-5-2000.
- 2,383,036. MOUNT LUCAS. INT. CL. 36. REG. 9-5-2000.
- 2,383,037. INNOVATORS IN VACUUM TECHNOLOGY. INT. CL. 7. REG. 9-5-2000.
- 2,383,040. NEW IMAGE. INT. CL. 9. REG. 9-5-2000.
- 2,383,056. CLEAR AND DESIGN. INT. CL. 42. REG. 9-5-2000.
- 2,383,057. DOLPHIN DATA. INT. CL. 35. REG. 9-5-2000.
- 2,383,064. HIDEAWAY.NET. INT. CL. 35. REG. 9-5-2000.
- 2,383,072. WILDLIFE SOLUTIONS AND DESIGN. INT. CL. 42. REG. 9-5-2000.
- 2,383,075. TV TED. INT. CL. 41. REG. 9-5-2000.
- 2,383,081. TDAGENCY. INT. CL. 35. REG. 9-5-2000.
- 2,383,085. GRAPHISTOCK. INT. CL. 42. REG. 9-5-2000.
- 2,383,086. CROSS TECHNOLOGY. INT. CL. 9. REG. 9-5-2000.
- 2,383,092. CORSAIR. INT. CL. 12. REG. 9-5-2000.
- 2,383,107. SIMPLY YOURS! (STYLIZED). INT. CL. 20. REG. 9-5-2000.
- 2,383,116. WHEN YOU WANT A VACATION THAT'S WORRY-FREE, ASK FOR IT BY NAME. INT. CL. 42. REG. 9-5-2000.
- 2,383,117. WHEN YOU WANT A VACATION THAT'S WORRY-FREE, ASK FOR IT BY NAME. INT. CL. 39. REG. 9-5-2000.
- 2,383,122. JT MONEY. INT. CL. 41. REG. 9-5-2000.
- 2,383,131. VANGUARD. INT. CL. 12. REG. 9-5-2000.
- 2,383,145. KIDPOWER. INT. CL. 28. REG. 9-5-2000.
- 2,383,146. D AND DESIGN. INT. CL. 35. REG. 9-5-2000.
- 2,383,154. CERIOUS2. INT. CL. 9. REG. 9-5-2000.
- 2,383,155. ICE ANGELS. INT. CL. 41. REG. 9-5-2000.
- 2,383,156. VANTAGE. INT. CL. 9. REG. 9-5-2000.
- 2,383,157. V VANTAGE (STYLIZED). INT. CL. 9. REG. 9-5-2000.
- 2,383,159. TRADITION. INT. CL. 16. REG. 9-5-2000.
- 2,383,177. SANTO TOURS. INT. CL. 39. REG. 9-5-2000.
- 2,383,179. PARENTING BEBE (STYLIZED). INT. CL. 16. REG. 9-5-2000.
- 2,383,185. FAST & EASY (STYLIZED). INT. CL. 16. REG. 9-5-2000.
- 2,383,190. MISCELLANEOUS DESIGN. INT. CL. 42. REG. 9-5-2000.
- 2,383,195. STAR IMAGES. INT. CL. 42. REG. 9-5-2000.
- 2,383,197. SILVER SPURS & COWBOYS. INT. CL. 9. REG. 9-5-2000.
- 2,383,213. HAMAT AND DESIGN. INT. CL. 11. REG. 9-5-2000.
- 2,383,215. XENOCRAFT AND DESIGN. INT. CL. 12. REG. 9-5-2000.
- 2,383,218. OPPORTUNITY PRICING. INT. CL. 36. REG. 9-5-2000.
- 2,383,220. EQUITY FLEX. INT. CL. 36. REG. 9-5-2000.
- 2,383,222. LASERLIFE. INT. CL. 7. REG. 9-5-2000.
- 2,383,239. MISCELLANEOUS DESIGN. INT. CL. 25. REG. 9-5-2000.
- 2,383,240. MISCELLANEOUS DESIGN. INT. CL. 14. REG. 9-5-2000.
- 2,383,248. MUSIC CITY COUNTRY CLUB. INT. CL. 25. REG. 9-5-2000.
- 2,383,252. THE LEAF PROJECT. INT. CL. 3. REG. 9-5-2000.
- 2,383,254. STORMAN'S AND DESIGN. INT. CL. 42. REG. 9-5-2000.
- 2,383,256. LES PETITES FERMIERES. INT. CL. 29. REG. 9-5-2000.
- 2,383,272. B BROOKWOOD TITLE AGENCY, L.L.C. AND DESIGN. INT. CL. 36. REG. 9-5-2000.
- 2,383,274. PROMETIC BIOSCIENCES, INC.. INT. CL. 42. REG. 9-5-2000.
- 2,383,276. BRYAN OIL AND DESIGN. INT. CLS. 4, 35, 40, 41 AND 42. REG. 9-5-2000.
- 2,383,278. BLUE VELVET. INT. CL. 5. REG. 9-5-2000.
- 2,383,284. DEMARCO MAX VAC CORPORATION AND DESIGN. INT. CL. 7. REG. 9-5-2000.
- 2,383,292. JOE PEROT. INT. CL. 25. REG. 9-5-2000.
- 2,383,301. APPETIZE. INT. CL. 16. REG. 9-5-2000.
- 2,383,305. SUBLIJET XL. INT. CL. 2. REG. 9-5-2000.
- 2,383,309. CROSSWAY. INT. CL. 9. REG. 9-5-2000.
- 2,383,325. PERSONAL SAVINGS. INT. CLS. 9 AND 16. REG. 9-5-2000.
- 2,383,332. COLORAMICS. INT. CL. 20. REG. 9-5-2000.
- 2,383,343. EXTRAS! FOR EDUCATION (STYLIZED). INT. CL. 42. REG. 9-5-2000.
- 2,383,351. DECO STONE. INT. CL. 21. REG. 9-5-2000.
- 2,383,352. FOCUSED ON GROWTH. INT. CL. 36. REG. 9-5-2000.
- 2,383,354. VITAL FACTORS. INT. CL. 5. REG. 9-5-2000.
- 2,383,355. HEARTLAND FLYER. INT. CL. 39. REG. 9-5-2000.
- 2,383,359. THE CATALOGUES. INT. CL. 35. REG. 9-5-2000.
- 2,383,360. SOLARSHIELD FITS OVER GLASSES AND DESIGN. INT. CL. 9. REG. 9-5-2000.
- 2,383,362. WORK SITE. INT. CL. 35. REG. 9-5-2000.
- 2,383,367. ROCKETWEAR. INT. CL. 25. REG. 9-5-2000.
- 2,383,370. INTERNAP AND DESIGN. INT. CL. 38. REG. 9-5-2000.
- 2,383,380. CONRAD AND DESIGN. INT. CL. 28. REG. 9-5-2000.
- 2,383,388. PHASER. INT. CL. 42. REG. 9-5-2000.
- 2,383,398. FRANCIS COPPOLA PRESENTS. INT. CL. 33. REG. 9-5-2000.
- 2,383,402. SWIFTER. INT. CL. 11. REG. 9-5-2000.
- 2,383,412. BRITES. INT. CL. 16. REG. 9-5-2000.
- 2,383,414. CHET BAKER. INT. CL. 9. REG. 9-5-2000.
- 2,383,415. TRUTRACK. INT. CL. 9. REG. 9-5-2000.
- 2,383,418. ARACCELERATOR MORE POWER TO MOVE PARTS AND DESIGN. INT. CL. 35. REG. 9-5-2000.
- 2,383,419. ARACCELERATOR. INT. CL. 35. REG. 9-5-2000.
- 2,383,422. INA. INT. CL. 42. REG. 9-5-2000.
- 2,383,425. GLAREMASTER. INT. CL. 9. REG. 9-5-2000.
- 2,383,430. NATURE'S QUEST. INT. CL. 31. REG. 9-5-2000.
- 2,383,432. ADOPTION... "A LOVING CHOICE FOR ALL CONCERNED" AND DESIGN. INT. CL. 42. REG. 9-5-2000.
- 2,383,437. WEAR US BE LUCKY AND DESIGN. INT. CL. 25. REG. 9-5-2000.
- 2,383,446. FREAKAZOID. INT. CL. 41. REG. 9-5-2000.
- 2,383,449. E (STYLIZED). INT. CL. 41. REG. 9-5-2000.
- 2,383,451. SIMPLY BETTER RESULTS. INT. CL. 9. REG. 9-5-2000.
- 2,383,468. ASTONCARESYSTEMS AND DESIGN. INT. CL. 42. REG. 9-5-2000.
- 2,383,471. LIVE BETTER RIDE MORE. INT. CL. 25. REG. 9-5-2000.
- 2,383,472. LOCLOOP. INT. CL. 24. REG. 9-5-2000.
- 2,383,479. ACSM HEALTH/FITNESS INSTRUCTOR. INT. CL. 41. REG. 9-5-2000.
- 2,383,484. DOWN ISLAND TRADERS SAINT THOMAS VIRGINISLANDS AND DESIGN. INT. CL. 18. REG. 9-5-2000.
- 2,383,487. DAYTONA. INT. CL. 9. REG. 9-5-2000.
- 2,383,491. LABPRO. INT. CL. 9. REG. 9-5-2000.
- 2,383,494. T.W.ISM. (STYLIZED). INT. CLS. 9 AND 25. REG. 9-5-2000.
- 2,383,495. MISCELLANEOUS DESIGN. INT. CLS. 1 AND 42. REG. 9-5-2000.
- 2,383,499. EAGLE 1. INT. CL. 9. REG. 9-5-2000.
- 2,383,501. KIDS AND DESIGN. INT. CL. 41. REG. 9-5-2000.
- 2,383,506. REMINISCENT. INT. CL. 5. REG. 9-5-2000.
- 2,383,508. LEGENDS FIELD. INT. CLS. 16 AND 25. REG. 9-5-2000.
- 2,383,512. INNOVATIVE CONCEPTS CORPORATION. INT. CLS. 8 AND 9. REG. 9-5-2000.
- 2,383,530. OLD MEXICO. INT. CL. 25. REG. 9-5-2000.
- 2,383,534. AT&T GLOBAL DIPLOMATIC SERVICE. INT. CL. 36. REG. 9-5-2000.
- 2,383,537. CONSUMERS CHOICE. INT. CL. 36. REG. 9-5-2000.
- 2,383,540. PARAMAX. INT. CL. 9. REG. 9-5-2000.
- 2,383,549. ANTHEM COUNTRY CLUB. INT. CL. 41. REG. 9-5-2000.
- 2,383,568. HEADRUSH. INT. CL. 9. REG. 9-5-2000.
- 2,383,569. POWER RANGERS IN SPACE. INT. CL. 28. REG. 9-5-2000.

- 2,383,570. HYDRO-PLUS. INT. CL. 3. REG. 9-5-2000.  
 2,383,575. FRESH CHOICE MASTERS CLUB. INT. CL. 42. REG. 9-5-2000.  
 2,383,578. KULU ATOLL. INT. CL. 25. REG. 9-5-2000.  
 2,383,583. GAP PAD VO. INT. CL. 9. REG. 9-5-2000.  
 2,383,584. GAP PAD VO SOFT. INT. CL. 9. REG. 9-5-2000.  
 2,383,592. TCG. INT. CL. 36. REG. 9-5-2000.  
 2,383,600. PRINCIPIA. INT. CL. 12. REG. 9-5-2000.  
 2,383,608. TITLEIST LAUNCH MONITOR. INT. CL. 28. REG. 9-5-2000.  
 2,383,619. BAND-AID PLASTIC BRAND ADHESIVE BANDAGES DURABLE PROTECTION JOHNSON & JOHNSON AND DESIGN. INT. CL. 5. REG. 9-5-2000.  
 2,383,620. BAND-AID SHEER BRAND ADHESIVE BANDAGES BREATHABLE PROTECTION JOHNSON & JOHNSON AND DESIGN. INT. CL. 5. REG. 9-5-2000.  
 2,383,625. PT-1 PHONE CARD. INT. CL. 16. REG. 9-5-2000.  
 2,383,635. PT1. INT. CL. 16. REG. 9-5-2000.  
 2,383,636. SCRUB DEVIL. INT. CL. 7. REG. 9-5-2000.  
 2,383,659. COMFORTHOLD. INT. CL. 24. REG. 9-5-2000.  
 2,383,678. POWERBOARD. INT. CL. 9. REG. 9-5-2000.  
 2,383,696. COMPASS ROSE PRESS AND DESIGN. INT. CL. 41. REG. 9-5-2000.  
 2,383,726. LET US SHOW YOU THE LIGHT. INT. CL. 11. REG. 9-5-2000.  
 2,383,728. SEIS X. INT. CL. 13. REG. 9-5-2000.  
 2,383,732. EXPEDIA. INT. CL. 16. REG. 9-5-2000.  
 2,383,741. DLU6. INT. CL. 7. REG. 9-5-2000.  
 2,383,758. MQINTEGRATOR. INT. CL. 9. REG. 9-5-2000.  
 2,383,759. HIGH WATER AND DESIGN. INT. CLS. 9 AND 42. REG. 9-5-2000.  
 2,383,765. CODE 69 (STYLIZED). INT. CL. 25. REG. 9-5-2000.  
 2,383,791. YESTERMUSIC. INT. CLS. 9 AND 35. REG. 9-5-2000.  
 2,383,792. AQUARIUS KIDS. INT. CL. 25. REG. 9-5-2000.  
 2,383,799. CENTURY OF FLIGHT. INT. CL. 36. REG. 9-5-2000.  
 2,383,800. SCREAMING WILD BERRY. INT. CL. 32. REG. 9-5-2000.  
 2,383,803. WALKAIR (STYLIZED). INT. CL. 9. REG. 9-5-2000.  
 2,383,805. DREAM. INT. CL. 31. REG. 9-5-2000.  
 2,383,824. WORLDKIDS. INT. CL. 42. REG. 9-5-2000.  
 2,383,828. CLUB ICEBREAKER. INT. CL. 42. REG. 9-5-2000.  
 2,383,831. CARDIOVATIONS AND DESIGN. INT. CL. 10. REG. 9-5-2000.  
 2,383,835. THE NEW TOOL LEADER. INT. CL. 35. REG. 9-5-2000.  
 2,383,845. HIRE VU. INT. CL. 42. REG. 9-5-2000.  
 2,383,853. INTEGRITY (STYLIZED). INT. CL. 5. REG. 9-5-2000.  
 2,383,854. SMARTTRANSIT. INT. CL. 9. REG. 9-5-2000.  
 2,383,880. SPEEDY WRENCH. INT. CL. 8. REG. 9-5-2000.  
 2,383,890. G (STYLIZED). INT. CL. 36. REG. 9-5-2000.  
 2,383,896. FIVE-TEN-SG.COM. INT. CL. 42. REG. 9-5-2000.  
 2,383,898. HUGGY. INT. CL. 20. REG. 9-5-2000.  
 2,383,899. AERIAL. INT. CL. 19. REG. 9-5-2000.  
 2,383,900. PEERLITE AERO. INT. CL. 11. REG. 9-5-2000.  
 2,383,905. MISCELLANEOUS DESIGN. INT. CL. 13. REG. 9-5-2000.  
 2,383,927. BLACK ANGUS BEEF A USDA CERTIFIED PREMIUM PROGRAM USDA CHOICE OR HIGHER AND DESIGN. INT. CL. 29. REG. 9-5-2000.  
 2,383,936. ELECTROVISION. INT. CL. 9. REG. 9-5-2000.  
 2,383,960. JOY SWEET DREAMS. INT. CL. 30. REG. 9-5-2000.  
 2,383,976. SMARTSET. INT. CL. 9. REG. 9-5-2000.  
 2,383,978. BANCROFT NEUROHEALTH. INT. CL. 42. REG. 9-5-2000.  
 2,383,983. IMMUDYNE COSMETIC SCIENTIFIC. INT. CL. 3. REG. 9-5-2000.  
 2,383,984. EFSEAM. INT. CL. 17. REG. 9-5-2000.  
 2,383,990. DBD AND DESIGN. INT. CL. 14. REG. 9-5-2000.  
 2,383,991. SOFT & EASY. INT. CL. 24. REG. 9-5-2000.  
 2,383,996. GET AND DESIGN. INT. CL. 36. REG. 9-5-2000.  
 2,383,998. VIGORLIX. INT. CL. 5. REG. 9-5-2000.  
 2,384,001. NEPTUNE'S PEARLS. INT. CL. 9. REG. 9-5-2000.  
 2,384,002. JOJO'S VENTURE. INT. CL. 9. REG. 9-5-2000.  
 2,384,009. FLORIDA POOL AND DESIGN. INT. CL. 28. REG. 9-5-2000.  
 2,384,010. WAVE AND DESIGN. INT. CL. 36. REG. 9-5-2000.  
 2,384,021. COMPLETE SMOOTHER. INT. CL. 3. REG. 9-5-2000.  
 2,384,023. DIRECTNET. INT. CL. 36. REG. 9-5-2000.  
 2,384,037. PLAY @ HOME (STYLIZED). INT. CLS. 35 AND 37. REG. 9-5-2000.  
 2,384,042. PRO STAINLESS. INT. CL. 8. REG. 9-5-2000.  
 2,384,044. MISCELLANEOUS DESIGN. INT. CL. 9. REG. 9-5-2000.  
 2,384,053. READING BY 9. INT. CL. 25. REG. 9-5-2000.  
 2,384,054. RUMBLEWEAR. INT. CL. 25. REG. 9-5-2000.  
 2,384,055. IRONMAN TRIATHLON. INT. CL. 3. REG. 9-5-2000.  
 2,384,060. DVXPLORE. INT. CL. 9. REG. 9-5-2000.  
 2,384,069. ARCHITEC(K). INT. CLS. 9 AND 36. REG. 9-5-2000.  
 2,384,071. FINALE. INT. CL. 28. REG. 9-5-2000.  
 2,384,076. CV CALC. INT. CL. 9. REG. 9-5-2000.  
 2,384,080. MEDI-CAT. INT. CL. 12. REG. 9-5-2000.  
 2,384,086. HEALING THE WOUNDS OF TIME. INT. CLS. 3 AND 5. REG. 9-5-2000.  
 2,384,088. 3% SOLUTION. INT. CL. 36. REG. 9-5-2000.  
 2,384,095. SERENADE. INT. CL. 20. REG. 9-5-2000.  
 2,384,100. FOLD-A-HOOP. INT. CL. 28. REG. 9-5-2000.  
 2,384,112. NAPE ON LINE. INT. CL. 36. REG. 9-5-2000.  
 2,384,113. BLIZZARD RIG. INT. CL. 28. REG. 9-5-2000.  
 2,384,121. QUADRAULIC. INT. CL. 7. REG. 9-5-2000.  
 2,384,124. INSIGHT FOR SALES STRATEGY. INT. CL. 9. REG. 9-5-2000.  
 2,384,131. DVXPERT. INT. CL. 9. REG. 9-5-2000.  
 2,384,139. MISCELLANEOUS DESIGN. INT. CL. 42. REG. 9-5-2000.  
 2,384,149. CAVENDISH PRESS ANN ARBOR (STYLIZED). INT. CL. 41. REG. 9-5-2000.  
 2,384,152. IMAGINUTRITION AND DESIGN. INT. CL. 42. REG. 9-5-2000.  
 2,384,160. DESERT EMPIRE. INT. CL. 21. REG. 9-5-2000.  
 2,384,170. CHECKMITE+ AND DESIGN. INT. CL. 5. REG. 9-5-2000.  
 2,384,174. MARSHFIELD PARK RIDGE. INT. CL. 19. REG. 9-5-2000.  
 2,384,176. ENCORE RECIPE. INT. CL. 30. REG. 9-5-2000.  
 2,384,178. ORION GENOMICS LLC AND DESIGN. INT. CL. 42. REG. 9-5-2000.  
 2,384,185. PENNCHOICE. INT. CL. 36. REG. 9-5-2000.  
 2,384,195. MOUNTAIN YELLER. INT. CL. 32. REG. 9-5-2000.  
 2,384,199. HEXIMAGE. INT. CL. 9. REG. 9-5-2000.  
 2,384,202. SINFUL. INT. CL. 3. REG. 9-5-2000.  
 2,384,210. TAKE YOUR CHILD TO VOTE DAY. INT. CLS. 25 AND 42. REG. 9-5-2000.  
 2,384,218. SPIDERDAWG. INT. CL. 41. REG. 9-5-2000.  
 2,384,224. SPLIT PERSONALITY. INT. CL. 3. REG. 9-5-2000.  
 2,384,228. LOGOCRETE. INT. CL. 40. REG. 9-5-2000.  
 2,384,238. COOL MACHINES. INT. CL. 28. REG. 9-5-2000.  
 2,384,251. DIVERWEST. INT. CL. 25. REG. 9-5-2000.  
 2,384,259. MISCELLANEOUS DESIGN. INT. CL. 35. REG. 9-5-2000.  
 2,384,267. KATE SPADE. INT. CL. 16. REG. 9-5-2000.  
 2,384,275. VIRTUAL FIXTURING. INT. CL. 42. REG. 9-5-2000.  
 2,384,286. DIVERTER HOOD. INT. CL. 7. REG. 9-5-2000.  
 2,384,288. MISCELLANEOUS DESIGN. INT. CL. 2. REG. 9-5-2000.  
 2,384,293. MODA SCAPA. INT. CL. 35. REG. 9-5-2000.  
 2,384,319. COMPREHENSIVE OPHTHALMOLOGY UPDATE. INT. CL. 16. REG. 9-5-2000.  
 2,384,321. WEALTH BUILDING FORMULA. INT. CLS. 35 AND 36. REG. 9-5-2000.  
 2,384,323. PRIMARY PAYROLL SKILLS. INT. CL. 16. REG. 9-5-2000.  
 2,384,327. FRACTIONAL JET LEASING. INT. CL. 42. REG. 9-5-2000.  
 2,384,341. BROW CORRECTOR. INT. CL. 3. REG. 9-5-2000.



- 2,384,342. OCEAN COUNTY EYE. INT. CL. 42. REG. 9-5-2000.
- 2,384,344. DUST SEAL. INT. CL. 16. REG. 9-5-2000.
- 2,384,347. CONVERSION AIR. INT. CL. 11. REG. 9-5-2000.
- 2,384,349. HISPANIC OPINION TRACKER. INT. CL. 35. REG. 9-5-2000.
- 2,384,351. SAFE & SOUND. INT. CL. 9. REG. 9-5-2000.
- 2,384,355. TEXAS PNEUMATIC MOBILE EXPRESS. INT. CL. 35. REG. 9-5-2000.
- 2,384,357. CORRECT & COVER AND DESIGN. INT. CL. 3. REG. 9-5-2000.
- 2,384,363. SKELETAL STRENGTH. INT. CL. 5. REG. 9-5-2000.
- 2,384,371. SELLING MADE EASY. INT. CL. 16. REG. 9-5-2000.
- 2,384,372. INFORMATICS ONLINE. INT. CL. 42. REG. 9-5-2000.
- 2,384,373. DRUGSAFETY.COM. INT. CL. 42. REG. 9-5-2000.
- 2,384,376. MASS SPEC SOURCE. INT. CL. 16. REG. 9-5-2000.
- 2,384,377. THE TAG THAT SHRINKS. INT. CL. 20. REG. 9-5-2000.
- 2,384,378. DIAMOND PAIRS. INT. CL. 14. REG. 9-5-2000.
- 2,384,390. VIRTUAL SAN FRANCISCO. INT. CL. 42. REG. 9-5-2000.
- 2,384,393. GUIAS PARA MEJORAR SU SALUD (STYLIZED). INT. CL. 16. REG. 9-5-2000.
- 2,388,927. AROMABUBBLES. INT. CL. 28. REG. 9-19-2000.
- 2,390,750. DONINI. INT. CL. 42. REG. 10-3-2000.
- 2,440,040. MERRYBRITE. INT. CLS. 16 AND 21 ONLY. REG. 4-3-2001.
- 2,441,851. MAXIFIX. INT. CL. 20 ONLY. REG. 4-10-2001.
- 2,444,691. CERMARK AND DESIGN. INT. CLS. 1, 21 AND 40 ONLY. REG. 4-17-2001.
- 2,446,629. G AND DESIGN. INT. CL. 35 ONLY. REG. 4-24-2001.
- 2,450,412. SG. INT. CL. 35 ONLY. REG. 5-15-2001.
- 2,457,295. POTENTIAL AT WORK. INT. CL. 42. REG. 6-5-2001.
- 2,498,472. YOU'VE GOT IT MAID! (STYLIZED). INT. CL. 37. REG. 10-16-2001.
- 2,504,580. WOTIF.COM. INT. CL. 39 ONLY. REG. 11-6-2001.
- 2,541,733. ROLL-OFF. INT. CL. 10. REG. 2-19-2002.
- 2,544,632. CINDERELLA CARPETS. INT. CL. 35. REG. 3-5-2002.
- 2,547,987. JUSTICE TALKING AND DESIGN. INT. CLS. 16, 25 AND 41 ONLY. REG. 3-12-2002.
- 2,548,383. READY-TO-BED. INT. CLS. 20, 24 AND 25. REG. 3-12-2002.
- 2,556,091. LIBRARY-RAK. INT. CL. 20. REG. 4-2-2002.
- 2,557,305. WHERE THE GROWTH IS. INT. CL. 36. REG. 4-2-2002.
- 2,558,258. BLUFFS RUN. INT. CL. 42 ONLY. REG. 4-9-2002.
- 2,562,987. TERMOUT. INT. CL. 5. REG. 4-23-2002.
- 2,572,754. MEDIAPOST. INT. CL. 35. REG. 5-28-2002.
- 2,579,742. P.P.T.. INT. CL. 41. REG. 6-11-2002.
- 2,609,889. TETRA TOPS TOMORROW'S TOY TODAY AND DESIGN. INT. CL. 28. REG. 8-20-2002.
- 2,610,645. ETHERWIND. INT. CL. 9. REG. 8-20-2002.
- 2,613,946. CATCH-UP LOGISTICS. INT. CLS. 35 AND 39. REG. 9-3-2002.
- 2,615,849. MAP COMPANION. INT. CL. 9. REG. 9-3-2002.
- 2,624,617. ARTVALE. INT. CL. 25. REG. 9-24-2002.
- 2,628,132. CRAFT CFD. INT. CL. 9. REG. 10-1-2002.
- 2,631,323. CRISP CFD. INT. CL. 9. REG. 10-8-2002.
- 2,639,504. VIDIPAX. INT. CL. 40. REG. 10-22-2002.
- 2,642,305. MPHASIS INTERACTIVE INTEGRATORS AND DESIGN. INT. CL. 42. REG. 10-29-2002.
- 2,643,523. WEBCOR TECHNOLOGIES. INT. CL. 37. REG. 10-29-2002.
- 2,644,621. OPINIONSCOPE. INT. CL. 35. REG. 10-29-2002.
- 2,644,625. ALWAYS AND EVERYWHERE. INT. CL. 41. REG. 10-29-2002.
- 2,646,056. MISCELLANEOUS DESIGN. INT. CLS. 9 AND 16. REG. 11-5-2002.
- 2,647,930. PLUS GROUP INC. AND DESIGN. INT. CL. 35. REG. 11-12-2002.
- 2,648,075. CLUSTERBALL AND DESIGN. INT. CL. 9. REG. 11-12-2002.
- 2,651,970. HOTSTROKES. INT. CL. 11. REG. 11-19-2002.
- 2,653,367. APT AND DESIGN. INT. CL. 9. REG. 11-26-2002.
- 2,654,808. PTI PERSONAL TRAINING INSTITUTE AND DESIGN. INT. CLS. 41 AND 42. REG. 11-26-2002.
- 2,659,249. ARCHITECTS OF DIGITAL BUSINESS. INT. CL. 42. REG. 12-10-2002.
- 2,670,280. SPIRITSINGLES.COM WHERE LIKE-MINDED PEOPLE MEET AND DESIGN. INT. CL. 42. REG. 12-31-2002.
- 2,672,528. COMICSRULE. INT. CL. 35. REG. 1-7-2003.
- 2,674,787. MISCELLANEOUS DESIGN. INT. CL. 11. REG. 1-14-2003.
- 2,679,936. HEALTH DETECT IT'S GOOD TO KNOW. A SERVICE OF CEDAR CREST EMERGICENTER AND DESIGN. INT. CL. 42. REG. 1-28-2003.
- 2,687,955. HIGH Q LASER (STYLIZED). INT. CLS. 9 AND 42. REG. 2-18-2003.
- 2,688,165. MC AND DESIGN. INT. CL. 41. REG. 2-18-2003.
- 2,696,763. HEIDI'S BRAIDED STRUDEL AND DESIGN. INT. CL. 30. REG. 3-11-2003.
- 2,710,120. FOUNDSCAN. INT. CLS. 9 AND 42. REG. 4-22-2003.
- 2,714,061. JUST LAWYERS. INT. CL. 42. REG. 5-6-2003.
- 2,717,541. COMMNAV. INT. CL. 9. REG. 5-20-2003.
- 2,717,619. UVO-CLEANER. INT. CL. 11. REG. 5-20-2003.
- 2,720,302. MOSAIC. INT. CLS. 35 AND 42. REG. 6-3-2003.
- 2,727,702. AIRSPASH. INT. CL. 9. REG. 6-17-2003.
- 2,738,790. AIR FLO AND DESIGN. INT. CL. 9. REG. 7-15-2003.
- 2,739,500. NEW YORK HARBOR ALE AND DESIGN. INT. CL. 32. REG. 7-22-2003.
- 2,742,685. LA BRASSERIE AND DESIGN. INT. CL. 33. REG. 7-29-2003.
- 2,744,106. BELIEVE IN WHAT YOU EAT. INT. CL. 29. REG. 7-29-2003.
- 2,746,600. CLUBGEM.COM. INT. CL. 35. REG. 8-5-2003.
- 2,749,181. MTRE AND DESIGN. INT. CL. 10. REG. 8-12-2003.
- 2,776,345. GET YO ACT TOGETHER. INT. CL. 41. REG. 10-21-2003.
- 2,777,216. OPTISIZE (STYLIZED). INT. CLS. 12 AND 42. REG. 10-28-2003.
- 2,777,602. CONSCIOUS CUISINE. INT. CLS. 41 AND 43. REG. 10-28-2003.
- 2,781,235. HOTTEST CHILE IN TOWN!. INT. CL. 42. REG. 11-11-2003.
- 2,785,548. ABB (STYLIZED). INT. CLS. 10, 14, 18, 20, 21, 25 AND 26 ONLY. REG. 11-25-2003.
- 2,795,484. ATLAS INVESTMENTS. INT. CL. 36. REG. 12-16-2003.
- 2,798,153. GENEMAPPER. INT. CL. 9. REG. 12-23-2003.
- 2,798,195. AMISTAR. INT. CL. 5. REG. 12-23-2003.
- 2,800,048. SPA RESORT CASINO PALM SPRINGS AND DESIGN. INT. CLS. 41, 43 AND 44. REG. 12-30-2003.
- 2,800,652. ROLF KAUKA'S FIX & FOXI AND DESIGN. INT. CL. 25. REG. 12-30-2003.
- 2,801,929. PORTFOLIO GUARD AND DESIGN. INT. CL. 36. REG. 1-6-2004.
- 2,814,415. CHICAGO SPORT AND SOCIAL CLUB AND DESIGN. INT. CL. 41. REG. 2-17-2004.
- 2,815,975. THINKATHON. INT. CL. 41. REG. 2-24-2004.
- 2,818,847. DUAL IMPEDANCE. INT. CL. 27 ONLY. REG. 3-2-2004.
- 2,821,945. BRITESMILE PROFESSIONAL TEETH WHITENING CENTERS. INT. CL. 42. REG. 3-16-2004.
- 2,826,266. F AND DESIGN. INT. CLS. 37 AND 40. REG. 3-23-2004.
- 2,826,485. ALWAYS IN GOOD TASTE, NATURALLY!. INT. CL. 29. REG. 3-23-2004.
- 2,836,574. THE GLORY BUGLES. INT. CL. 41. REG. 4-27-2004.
- 2,845,631. ARCH ARMOR BACK MIRROR AND DESIGN. INT. CL. 20. REG. 5-25-2004.
- 2,856,330. BIT BOWERS INFORMATION TECHNOLOGY AND DESIGN. INT. CL. 9. REG. 6-22-2004.
- 2,865,076. HOMEAVENUE AND DESIGN. INT. CL. 36. REG. 7-20-2004.



- 2,866,472. WHIMSICLAY. INT. CL. 21. REG. 7-27-2004.  
 2,871,427. WE MAKE YOUR RETIREMENT WORK FOR YOU. INT. CL. 36. REG. 8-10-2004.  
 2,873,885. BEANSTALK LOGOPROMOTIONS AND DESIGN. INT. CL. 40. REG. 8-17-2004.  
 2,874,478. SAFETY TURF INC AND DESIGN. INT. CL. 40. REG. 8-17-2004.  
 2,876,812. QWIKCAST. INT. CL. 9. REG. 8-24-2004.  
 2,880,560. MEMBERS FIRST. INT. CL. 36. REG. 9-7-2004.  
 2,880,561. COSMO PARIS. INT. CL. 25. REG. 9-7-2004.  
 2,880,564. TMXPRESS. INT. CL. 9. REG. 9-7-2004.  
 2,880,565. ANIMAL CRACKUPS. INT. CL. 9. REG. 9-7-2004.  
 2,880,567. SILGUARD. INT. CL. 16. REG. 9-7-2004.  
 2,880,569. IDESK AND DESIGN. INT. CLS. 9, 16, 35, 38, 41 AND 42. REG. 9-7-2004.  
 2,880,571. LEVVIAX. INT. CL. 5. REG. 9-7-2004.  
 2,880,573. ANDERSON CONSULTING, TRAINING & TESTING. INT. CLS. 41 AND 42. REG. 9-7-2004.  
 2,880,574. SPORT & SPINE AND DESIGN. INT. CL. 10. REG. 9-7-2004.  
 2,880,577. BROWN EYED GIRL DANIELLE BOURHIS AND DESIGN. INT. CL. 25. REG. 9-7-2004.  
 2,880,584. CONCERTFINDER. INT. CL. 35. REG. 9-7-2004.  
 2,880,585. BARFINDER. INT. CL. 35. REG. 9-7-2004.  
 2,880,586. CASELINK. INT. CL. 9. REG. 9-7-2004.  
 2,880,587. ISTOPHIT. INT. CLS. 35 AND 36. REG. 9-7-2004.  
 2,880,588. SCOUTING REPORT. INT. CL. 35. REG. 9-7-2004.  
 2,880,591. IAM.CA. INT. CLS. 32 AND 35. REG. 9-7-2004.  
 2,880,594. CROCODILE. INT. CL. 12. REG. 9-7-2004.  
 2,880,595. SHOP LIKE YOU WASH. INT. CL. 35. REG. 9-7-2004.  
 2,880,598. KIDS CREATIONS. INT. CL. 16. REG. 9-7-2004.  
 2,880,606. HOME EQUITY ADVANTAGE. INT. CL. 36. REG. 9-7-2004.  
 2,880,607. SPLIT SECOND. INT. CL. 3. REG. 9-7-2004.  
 2,880,610. EASY-LOCK. INT. CL. 19. REG. 9-7-2004.  
 2,880,611. KRONOPLY AND DESIGN. INT. CL. 19. REG. 9-7-2004.  
 2,880,615. PMOFFICE AND DESIGN. INT. CLS. 9 AND 42. REG. 9-7-2004.  
 2,880,617. ROUGE PULSE. INT. CL. 3. REG. 9-7-2004.  
 2,880,619. TD (STYLIZED). INT. CL. 39. REG. 9-7-2004.  
 2,880,620. SIEMENS MOBILE TRAVEL SOLUTIONS (STYLIZED). INT. CLS. 9, 35, 38, 39 AND 42. REG. 9-7-2004.  
 2,880,621. NEW LIFE MINISTRIES. INT. CLS. 35 AND 41. REG. 9-7-2004.  
 2,880,623. NETWORKS. INT. CL. 35. REG. 9-7-2004.  
 2,880,625. MEDICHEW. INT. CLS. 3, 5 AND 30. REG. 9-7-2004.  
 2,880,626. SLIMCHEW. INT. CLS. 3, 5 AND 30. REG. 9-7-2004.  
 2,880,628. MEASURE WHAT MATTERS. INT. CLS. 9 AND 42. REG. 9-7-2004.  
 2,880,629. BLUEMAGIC. INT. CL. 9. REG. 9-7-2004.  
 2,880,631. KOSE AND DESIGN. INT. CLS. 8 AND 21. REG. 9-7-2004.  
 2,880,633. PRO IDEE AND DESIGN. INT. CLS. 7, 8, 9, 11, 14, 18, 20, 21, 24, 25, 28, 35 AND 39. REG. 9-7-2004.  
 2,880,634. NATURE'S ICE. INT. CL. 21. REG. 9-7-2004.  
 2,880,635. DOT.SEX. INT. CL. 42. REG. 9-7-2004.  
 2,880,636. PURE 7. INT. CL. 25. REG. 9-7-2004.  
 2,880,637. SPOTCELL. INT. CL. 9. REG. 9-7-2004.  
 2,880,638. WHITEWASH. INT. CLS. 18 AND 25. REG. 9-7-2004.  
 2,880,639. EXCEED. INT. CL. 21. REG. 9-7-2004.  
 2,880,640. HOME MIX AND DESIGN. INT. CL. 9. REG. 9-7-2004.  
 2,880,641. MESA. INT. CL. 36. REG. 9-7-2004.  
 2,880,643. THE MOBILITY DEPOT AND DESIGN. INT. CL. 12. REG. 9-7-2004.  
 2,880,644. M \* SEVEN. INT. CL. 34. REG. 9-7-2004.  
 2,880,647. VALUE-UP. INT. CLS. 9, 12, 16 AND 37. REG. 9-7-2004.  
 2,880,648. POWER BY HAND AND DESIGN. INT. CLS. 38 AND 41. REG. 9-7-2004.  
 2,880,650. YACHTY GRAS AND DESIGN. INT. CL. 36. REG. 9-7-2004.  
 2,880,651. MISCELLANEOUS DESIGN. INT. CL. 42. REG. 9-7-2004.  
 2,880,652. MISCELLANEOUS DESIGN. INT. CL. 41. REG. 9-7-2004.  
 2,880,653. MISCELLANEOUS DESIGN. INT. CL. 18. REG. 9-7-2004.  
 2,880,654. TECNEC AND DESIGN. INT. CL. 9. REG. 9-7-2004.  
 2,880,656. TREEWISE THE ORGANIC EXPERTS AND DESIGN. INT. CL. 44. REG. 9-7-2004.  
 2,880,665. DIVINE. INT. CLS. 9, 35, 41 AND 42. REG. 9-7-2004.  
 2,880,671. SCRAPSITE. INT. CL. 35. REG. 9-7-2004.  
 2,880,673. HUNTINGTON. INT. CL. 25. REG. 9-7-2004.  
 2,880,674. HEALTHMARKET SMARTFUNDS. INT. CL. 36. REG. 9-7-2004.  
 2,880,677. DR. RATH'S DENTAL FORMULA. INT. CLS. 5, 30 AND 32. REG. 9-7-2004.  
 2,880,679. YOUTH UNIVERSITY. INT. CL. 41. REG. 9-7-2004.  
 2,880,681. LIFE SCIENCE CAREER ALLIANCE. INT. CLS. 16, 35 AND 41. REG. 9-7-2004.  
 2,880,683. BODY IN SOUL AND DESIGN. INT. CL. 44. REG. 9-7-2004.  
 2,880,684. ZURICH GLOBAL ENERGY GENERAL STORE. INT. CL. 36. REG. 9-7-2004.  
 2,880,685. MY AND DESIGN. INT. CLS. 9, 16, 35, 36, 38, 39 AND 43. REG. 9-7-2004.  
 2,880,686. MY AND DESIGN. INT. CLS. 9, 16, 35, 36, 38, 39 AND 43. REG. 9-7-2004.  
 2,880,688. THE BEST PATH. INT. CL. 41. REG. 9-7-2004.  
 2,880,689. SULTEX. INT. CL. 7. REG. 9-7-2004.  
 2,880,692. ENLISTED ASSOCIATION OF THE NATIONAL GUARD OF THE UNITED STATES AND DESIGN. U.S. CL. 200. REG. 9-7-2004.  
 2,880,693. FPT. INT. CL. 9. REG. 9-7-2004.  
 2,880,697. THE FILMMAKERS STUDIO. INT. CL. 41. REG. 9-7-2004.  
 2,880,699. BUKIETY. INT. CL. 35. REG. 9-7-2004.  
 2,880,701. SLOT MACHINE THEORY VISION & MISSION VALUES & CULTURE STRATEGY & BUSINESS MODEL AND DESIGN. INT. CLS. 16, 35 AND 41. REG. 9-7-2004.  
 2,880,704. YIELDIRECTOR. INT. CL. 9. REG. 9-7-2004.  
 2,880,706. INSCOPE. INT. CLS. 40 AND 42. REG. 9-7-2004.  
 2,880,707. SPIR COMMUNICATION. INT. CLS. 16, 35, 36, 38 AND 41. REG. 9-7-2004.  
 2,880,711. OMNIPHASE. INT. CL. 9. REG. 9-7-2004.  
 2,880,713. SCHAPER APARTMENT MY PLACE. INT. CLS. 3, 16, 36 AND 43. REG. 9-7-2004.  
 2,880,714. S AND DESIGN. INT. CLS. 9, 16, 35, 40 AND 42. REG. 9-7-2004.  
 2,880,717. RICCI ANDRIST. INT. CLS. 3, 18 AND 25. REG. 9-7-2004.  
 2,880,718. COSMOLLOID. INT. CL. 4. REG. 9-7-2004.  
 2,880,720. LEKOV (STYLIZED). INT. CLS. 6, 7 AND 9. REG. 9-7-2004.  
 2,880,723. VNT. INT. CLS. 7 AND 12. REG. 9-7-2004.  
 2,880,724. AETHOS (STYLIZED). INT. CLS. 7, 9, 11, 12 AND 37. REG. 9-7-2004.  
 2,880,725. GAME-ADS. INT. CL. 9. REG. 9-7-2004.  
 2,880,728. LIGHTHOUSE COMMUNICATIONS. INT. CLS. 38 AND 42. REG. 9-7-2004.  
 2,880,729. SAFEHARBOR EMPLOYER SERVICES. INT. CL. 35. REG. 9-7-2004.  
 2,880,730. SAFEHARBOR EMPLOYER SERVICES AND DESIGN. INT. CL. 35. REG. 9-7-2004.  
 2,880,731. MEETING THE KNOWLEDGE NEEDS OF BUSINESS PROFESSIONALS. INT. CL. 41. REG. 9-7-2004.  
 2,880,735. GRANPA MO'S SMOKE-N-THE BAG. INT. CL. 30. REG. 9-7-2004.  
 2,880,736. LITTLE LUXURIES AND DESIGN. INT. CL. 3. REG. 9-7-2004.  
 2,880,737. PROPOSAL KIT AND DESIGN. INT. CL. 9. REG. 9-7-2004.  
 2,880,740. INFOANYWHERE. INT. CL. 35. REG. 9-7-2004.

- 2,880,742. DIRECTORS' CUP STANDARD CHARACTER MARK. INT. CL. 41. REG. 9-7-2004.
- 2,880,743. COROMANDEL CUSINE OF INDIA AND DESIGN. INT. CL. 43. REG. 9-7-2004.
- 2,880,744. TANGO. INT. CL. 21. REG. 9-7-2004.
- 2,880,745. NORRAIL INC. AND DESIGN. INT. CL. 35. REG. 9-7-2004.
- 2,880,746. LAS GUANACAS TORTILLAS AUTENTICAS SALVADORENAS AUTHENTIC SALVADOREAN TORTILLAS AND DESIGN. INT. CL. 30. REG. 9-7-2004.
- 2,880,748. MATCHBOX HERO CITY AND DESIGN. INT. CL. 28. REG. 9-7-2004.
- 2,880,749. ATLANTA FALL GIFT & ACCESSORIES MARKET. INT. CL. 35. REG. 9-7-2004.
- 2,880,753. CÉLÉ AND DESIGN. INT. CLS. 3, 8 AND 44. REG. 9-7-2004.
- 2,880,756. IDENTITY AN AMERICAN IDENTITY COMPANY AND DESIGN. INT. CL. 25. REG. 9-7-2004.
- 2,880,760. CLEAR OBJECTIVE AND DESIGN. INT. CL. 9. REG. 9-7-2004.
- 2,880,762. CLUB SANTOS LAGUNA AND DESIGN. INT. CL. 28. REG. 9-7-2004.
- 2,880,765. TWD. INT. CLS. 35, 36 AND 41. REG. 9-7-2004.
- 2,880,766. S SPYGLASS INTEGRATION AND DESIGN. INT. CLS. 35, 38 AND 42. REG. 9-7-2004.
- 2,880,771. W AND DESIGN. INT. CLS. 35, 39, 40, 41, 44 AND 45. REG. 9-7-2004.
- 2,880,774. SCRUB'N SHINE. INT. CL. 21. REG. 9-7-2004.
- 2,880,778. REASSURE. INT. CL. 36. REG. 9-7-2004.
- 2,880,783. BREMEN AND DESIGN. INT. CL. 28. REG. 9-7-2004.
- 2,880,785. THE ART INSTITUTE ONLINE. INT. CL. 41. REG. 9-7-2004.
- 2,880,789. COLDSAFE PLUS (STYLIZED). INT. CL. 16. REG. 9-7-2004.
- 2,880,790. FAITH KIDZ. INT. CL. 16. REG. 9-7-2004.
- 2,880,791. PRN TODAY. INT. CLS. 16 AND 35. REG. 9-7-2004.
- 2,880,797. ECSTASM. INT. CLS. 3, 25 AND 33. REG. 9-7-2004.
- 2,880,798. SI WAREHOUSE AND DESIGN. INT. CL. 42. REG. 9-7-2004.
- 2,880,802. DD AQUAFICIENT. INT. CL. 7. REG. 9-7-2004.
- 2,880,804. KING LION AND DESIGN. INT. CLS. 29 AND 30. REG. 9-7-2004.
- 2,880,805. NECESSITY. INT. CL. 3. REG. 9-7-2004.
- 2,880,808. MISCELLANEOUS DESIGN. INT. CL. 41. REG. 9-7-2004.
- 2,880,809. TENSITROL. INT. CL. 9. REG. 9-7-2004.
- 2,880,811. J JOHNSON ASSET MANAGEMENT AND DESIGN. INT. CL. 36. REG. 9-7-2004.
- 2,880,813. DOWNTOWN ORLANDO EVERYONE'S DOWNTOWN AND DESIGN. INT. CL. 35. REG. 9-7-2004.
- 2,880,818. JASON. INT. CL. 12. REG. 9-7-2004.
- 2,880,819. AAF (STYLIZED). INT. CL. 6. REG. 9-7-2004.
- 2,880,820. NEWALK. INT. CLS. 10, 18 AND 25. REG. 9-7-2004.
- 2,880,821. SECURITY LENDING AND DESIGN. INT. CL. 36. REG. 9-7-2004.
- 2,880,823. CLAIMING THE LEGACY OF PERICLES. INT. CL. 41. REG. 9-7-2004.
- 2,880,829. CLOTH TOWEL REUSABLE LINT FREE AND DESIGN. INT. CL. 24. REG. 9-7-2004.
- 2,880,830. MASTER'S @ WORK / WHERE SUCCESS COMES TO YOU. INT. CL. 41. REG. 9-7-2004.
- 2,880,834. SHATIK (STYLIZED). INT. CL. 41. REG. 9-7-2004.
- 2,880,839. LTC LABYRINTH THEATER COMPANY AND DESIGN. INT. CLS. 25 AND 41. REG. 9-7-2004.
- 2,880,844. MICHELLE DEBORAH (STYLIZED). INT. CL. 25. REG. 9-7-2004.
- 2,880,850. EVERY SEASON - EVERY STYLE - EVERY HOME. INT. CL. 35. REG. 9-7-2004.
- 2,880,852. FASHION KIDS. INT. CL. 20. REG. 9-7-2004.
- 2,880,853. TRUCK PRIDE SERVICE EXPERTS. INT. CL. 37. REG. 9-7-2004.
- 2,880,855. ALLSPORT. INT. CL. 27. REG. 9-7-2004.
- 2,880,859. ECNORROT. INT. CL. 25. REG. 9-7-2004.
- 2,880,864. THERMA-LINX. INT. CL. 11. REG. 9-7-2004.
- 2,880,865. INI AND DESIGN. INT. CL. 25. REG. 9-7-2004.
- 2,880,870. FAT CATS ALL OUT FUN AND DESIGN. INT. CL. 41. REG. 9-7-2004.
- 2,880,874. IST AND DESIGN. INT. CL. 10. REG. 9-7-2004.
- 2,880,875. FUN SUN. INT. CL. 39. REG. 9-7-2004.
- 2,880,883. MISCELLANEOUS DESIGN. INT. CL. 30. REG. 9-7-2004.
- 2,880,884. MISCELLANEOUS DESIGN. INT. CL. 30. REG. 9-7-2004.
- 2,880,886. "DS 304 PLUS". INT. CL. 21. REG. 9-7-2004.
- 2,880,887. MEP AND DESIGN. INT. CLS. 11, 37 AND 42. REG. 9-7-2004.
- 2,880,888. MEP. INT. CLS. 11, 37 AND 42. REG. 9-7-2004.
- 2,880,889. T.U.F JEANSMITH (STYLIZED). INT. CL. 35. REG. 9-7-2004.
- 2,880,890. SWIVEL CLIP. INT. CL. 9. REG. 9-7-2004.
- 2,880,898. ULTIMA. INT. CL. 4. REG. 9-7-2004.
- 2,880,899. CURRENT CONCEPTS. INT. CL. 41. REG. 9-7-2004.
- 2,880,900. HARBOR GOURMET MAINE LOBSTER MEAT AND DESIGN. INT. CL. 29. REG. 9-7-2004.
- 2,880,901. ACCU. INT. CL. 35. REG. 9-7-2004.
- 2,880,902. LAVEDENT. INT. CL. 3. REG. 9-7-2004.
- 2,880,903. CU BIZSOURCE AND DESIGN. INT. CL. 36. REG. 9-7-2004.
- 2,880,907. Z.I.T.. INT. CL. 41. REG. 9-7-2004.
- 2,880,908. REFRIGERATOR RIGHTS. INT. CLS. 16 AND 35. REG. 9-7-2004.
- 2,880,909. WAYPOINT. INT. CL. 36. REG. 9-7-2004.
- 2,880,912. MAMSI CHILDREN'S FOUNDATION, INC. AND DESIGN. INT. CL. 36. REG. 9-7-2004.
- 2,880,914. POLY-E PLUS. INT. CL. 17. REG. 9-7-2004.
- 2,880,917. MISCELLANEOUS DESIGN. INT. CL. 35. REG. 9-7-2004.
- 2,880,918. PCGAS. INT. CL. 9. REG. 9-7-2004.
- 2,880,919. TRANS CONTINENTS. INT. CLS. 18 AND 25. REG. 9-7-2004.
- 2,880,920. THROUGH TIME AND SPACE MODERCO PARTITIONS AND DESIGN. INT. CL. 19. REG. 9-7-2004.
- 2,880,923. AAMC ASSOCIATION OF AMERICAN MEDICAL COLLEGES AND DESIGN. INT. CL. 35. REG. 9-7-2004.
- 2,880,924. FAMOUS AAMC FACULTY ADMINISTRATIVE MANAGEMENT ON-LINE USER SYSTEM AND DESIGN. INT. CL. 42. REG. 9-7-2004.
- 2,880,926. GLOBAL MAIL. INT. CLS. 16, 35 AND 39. REG. 9-7-2004.
- 2,880,927. CRYSTAL GEM. INT. CL. 28. REG. 9-7-2004.
- 2,880,930. THE BLACK SEA. INT. CL. 9. REG. 9-7-2004.
- 2,880,932. LATINO GEAR. INT. CL. 25. REG. 9-7-2004.
- 2,880,935. PERSHINGLINK AND DESIGN. INT. CL. 36. REG. 9-7-2004.
- 2,880,937. IPERSONAL. INT. CL. 42. REG. 9-7-2004.
- 2,880,938. THE NATURAL PHARMACIST AND DESIGN. INT. CLS. 41 AND 44. REG. 9-7-2004.
- 2,880,939. GOOD TO GO SOFTWARE AND DESIGN. INT. CL. 9. REG. 9-7-2004.
- 2,880,941. VETERINARY DIGEST. INT. CL. 16. REG. 9-7-2004.
- 2,880,942. SS AND DESIGN. INT. CL. 20. REG. 9-7-2004.
- 2,880,950. EXPRESSATM (STYLIZED). INT. CL. 36. REG. 9-7-2004.
- 2,880,953. ADVISOR (STYLIZED). INT. CL. 9. REG. 9-7-2004.
- 2,880,954. THE ALL-TERRAIN VACATION. INT. CL. 35. REG. 9-7-2004.
- 2,880,955. ENGINUITY. INT. CL. 42. REG. 9-7-2004.
- 2,880,957. WEXLER PACKAGING PRODUCTS "THE BANDING PEOPLE" AND DESIGN. INT. CL. 7. REG. 9-7-2004.
- 2,880,960. DESTINY. INT. CL. 12. REG. 9-7-2004.
- 2,880,961. SPATIALIZER STREAM FX. INT. CL. 9. REG. 9-7-2004.
- 2,880,962. SPATIALIZER N-2-2. INT. CL. 9. REG. 9-7-2004.
- 2,880,963. SPATIALIZER VSP-11. INT. CL. 9. REG. 9-7-2004.

- 2,880,964. D SINCE 1884 AND DESIGN. INT. CL. 36. REG. 9-7-2004.
- 2,880,965. LAKESHORE ATHLETIC CLUB AND DESIGN. INT. CL. 41. REG. 9-7-2004.
- 2,880,967. TRASHPAK. INT. CL. 16. REG. 9-7-2004.
- 2,880,971. DEDICATED TO YOUR SECURITY SINCE 1895. INT. CL. 36. REG. 9-7-2004.
- 2,880,972. RAPIDFIRE RETRIEVER. INT. CL. 9. REG. 9-7-2004.
- 2,880,973. POWER DROP. INT. CL. 28. REG. 9-7-2004.
- 2,880,975. INVESTED IN EVERY CORNER OF AMERICA. INT. CL. 36. REG. 9-7-2004.
- 2,880,976. BOTTOM LINE AND DESIGN. INT. CL. 35. REG. 9-7-2004.
- 2,880,978. FASHIONCENTERDALLAS MARCH 2004 AND DESIGN. INT. CL. 35. REG. 9-7-2004.
- 2,880,979. DOUGLAS FURNITURE OF CALIFORNIA, LLC. INT. CLS. 20, 35, 37 AND 40. REG. 9-7-2004.
- 2,880,980. DOUGLAS FURNITURE. INT. CLS. 20, 35, 37 AND 40. REG. 9-7-2004.
- 2,880,982. ALL-IN-ONE. INT. CL. 16. REG. 9-7-2004.
- 2,880,987. A TASTE FOR LIFE'S PLEASURES. INT. CL. 34. REG. 9-7-2004.
- 2,880,990. 3 HERMANOS AND DESIGN. INT. CL. 25. REG. 9-7-2004.
- 2,880,995. NPS. INT. CL. 36. REG. 9-7-2004.
- 2,880,997. BRINGING FAMILIES TOGETHER!. INT. CL. 43. REG. 9-7-2004.
- 2,880,999. WHIMSY. INT. CL. 40. REG. 9-7-2004.
- 2,881,001. ALLEN PRIME. INT. CL. 29. REG. 9-7-2004.
- 2,881,002. AUTOTRAC. INT. CL. 9. REG. 9-7-2004.
- 2,881,004. DUNCAN'S BAR-B-QUE GRIPS AND DESIGN. INT. CL. 24. REG. 9-7-2004.
- 2,881,005. MINUANO GENUINE STEERHIDE MADE IN BRAZIL AND DESIGN. INT. CL. 18. REG. 9-7-2004.
- 2,881,007. NASCAR FAN SHOP AND DESIGN. INT. CL. 35. REG. 9-7-2004.
- 2,881,009. DURATION. INT. CL. 9. REG. 9-7-2004.
- 2,881,011. PROTECTOR 9000. INT. CL. 7. REG. 9-7-2004.
- 2,881,012. LAWSOME. INT. CL. 42. REG. 9-7-2004.
- 2,881,015. TEACHER EFFECTIVENESS AND CLASSROOM HANDLING. INT. CL. 41. REG. 9-7-2004.
- 2,881,016. KUTA AND DESIGN. INT. CL. 25. REG. 9-7-2004.
- 2,881,017. JIGS ACE AND DESIGN. INT. CL. 28. REG. 9-7-2004.
- 2,881,018. JORDAN. INT. CL. 28. REG. 9-7-2004.
- 2,881,019. OAKWOOD SMOKEHOUSE & GRILL AND DESIGN. INT. CL. 43. REG. 9-7-2004.
- 2,881,021. DESIGN CENTER SYSTEMS AND DESIGN. INT. CL. 9. REG. 9-7-2004.
- 2,881,024. EZ SHANTY. INT. CL. 19. REG. 9-7-2004.
- 2,881,025. CHERISH. INT. CL. 3. REG. 9-7-2004.
- 2,881,027. TEAMS THAT WORK ! STANDARD CHARACTER MARK. INT. CL. 35. REG. 9-7-2004.
- 2,881,031. PRO SIZE. INT. CL. 9. REG. 9-7-2004.
- 2,881,033. UNDER THE STARS. INT. CL. 36. REG. 9-7-2004.
- 2,881,036. MAD FOR MARGUERITAS. INT. CL. 30. REG. 9-7-2004.
- 2,881,037. DUAL ENHANCER AND DESIGN. INT. CL. 5. REG. 9-7-2004.
- 2,881,041. NEW METHOD TECHNOLOGIES. INT. CL. 9. REG. 9-7-2004.
- 2,881,048. INTER/VENE. INT. CL. 24. REG. 9-7-2004.
- 2,881,049. MISCELLANEOUS DESIGN. INT. CLS. 7, 9, 40 AND 42. REG. 9-7-2004.
- 2,881,052. THE RIGHT BLEND OF INNOVATION AND TRADITIONAL REINSURANCE VALUES. INT. CL. 36. REG. 9-7-2004.
- 2,881,053. YOUR LEAD REINSURER. INT. CL. 36. REG. 9-7-2004.
- 2,881,054. IMERSEAL. INT. CLS. 1 AND 2. REG. 9-7-2004.
- 2,881,055. STAR—LEARNING. INT. CLS. 9 AND 42. REG. 9-7-2004.
- 2,881,057. STAR—FINANCE (STYLIZED). INT. CLS. 9 AND 42. REG. 9-7-2004.
- 2,881,059. BARE BOTTOMS AND DESIGN. INT. CL. 3. REG. 9-7-2004.
- 2,881,060. S-MAT. INT. CL. 9. REG. 9-7-2004.
- 2,881,062. MOCA. INT. CL. 12. REG. 9-7-2004.
- 2,881,065. LIFE-SIZES. INT. CL. 35. REG. 9-7-2004.
- 2,881,066. INNOVA BRASS INC. INT. CL. 35. REG. 9-7-2004.
- 2,881,068. MISCELLANEOUS DESIGN. INT. CL. 9. REG. 9-7-2004.
- 2,881,072. MISCELLANEOUS DESIGN. INT. CL. 35. REG. 9-7-2004.
- 2,881,075. INFAMOUS. INT. CL. 41. REG. 9-7-2004.
- 2,881,077. INSPECTION CONSULTING, INC. AND DESIGN. INT. CL. 42. REG. 9-7-2004.
- 2,881,078. EPIX UNIVERSITY. INT. CL. 41. REG. 9-7-2004.
- 2,881,082. EPC AND DESIGN. INT. CL. 40. REG. 9-7-2004.
- 2,881,083. EEOL (STYLIZED). INT. CL. 40. REG. 9-7-2004.
- 2,881,084. HELPING TO MAKE A DIFFERENCE. INT. CLS. 35 AND 41. REG. 9-7-2004.
- 2,881,085. DMI ENTERTAINMENT PROGRAMMING. INT. CL. 41. REG. 9-7-2004.
- 2,881,086. BOX OPTIX AND DESIGN. INT. CL. 9. REG. 9-7-2004.
- 2,881,089. LIVEWIRE STANDARD CHARACTER MARK. INT. CL. 41. REG. 9-7-2004.
- 2,881,091. LICKSTICK. INT. CL. 30. REG. 9-7-2004.
- 2,881,094. PHYSICIAN REFERENCE LIBRARY AND DESIGN. INT. CL. 9. REG. 9-7-2004.
- 2,881,095. ZWIMPFER PILE UP AND DESIGN. INT. CLS. 37 AND 42. REG. 9-7-2004.
- 2,881,098. THE SOCCER SOURCE. INT. CL. 16. REG. 9-7-2004.
- 2,881,100. RITTLING AND DESIGN. INT. CL. 11. REG. 9-7-2004.
- 2,881,103. MISCELLANEOUS DESIGN. INT. CL. 9. REG. 9-7-2004.
- 2,881,104. EAGLE TEST SYSTEMS AND DESIGN. INT. CL. 9. REG. 9-7-2004.
- 2,881,105. NO-REACT (STYLIZED). INT. CL. 10. REG. 9-7-2004.
- 2,881,107. ALERT COURIER. INT. CL. 39. REG. 9-7-2004.
- 2,881,108. BERKSHIRE HOUSE. INT. CL. 11. REG. 9-7-2004.
- 2,881,109. PHONE CANDY. INT. CL. 9. REG. 9-7-2004.
- 2,881,111. STILL NAIVE. INT. CL. 41. REG. 9-7-2004.
- 2,881,112. TERRA NOVA. INT. CL. 16. REG. 9-7-2004.
- 2,881,113. HYDROGLIDE. INT. CL. 7. REG. 9-7-2004.
- 2,881,115. THE BEST 1 PREPAID CALLING CARD. INT. CL. 16. REG. 9-7-2004.
- 2,881,116. STEEL HORSE CHOPPERS. INT. CL. 25. REG. 9-7-2004.
- 2,881,117. LONGSHOT AND DESIGN. INT. CL. 28. REG. 9-7-2004.
- 2,881,119. COCOQUIZ. INT. CL. 41. REG. 9-7-2004.
- 2,881,121. LONG SHOT. INT. CL. 28. REG. 9-7-2004.
- 2,881,123. PAUL BALDIN. INT. CL. 14. REG. 9-7-2004.
- 2,881,124. TWIGS AND DESIGN. INT. CL. 25. REG. 9-7-2004.
- 2,881,126. PREPMASERS. INT. CL. 35. REG. 9-7-2004.
- 2,881,127. H HELIPRO AND DESIGN. INT. CL. 37. REG. 9-7-2004.
- 2,881,128. STEP UP SPORTS. INT. CL. 41. REG. 9-7-2004.
- 2,881,129. HELIPRO. INT. CL. 37. REG. 9-7-2004.
- 2,881,131. WRENCHHEAD CENTRAL. INT. CL. 42. REG. 9-7-2004.
- 2,881,133. ART FOR WOMEN'S SAKE. INT. CL. 36. REG. 9-7-2004.
- 2,881,134. PERFECT SCULPTURE. INT. CL. 5. REG. 9-7-2004.
- 2,881,135. TWISTS AND TURNS. INT. CL. 16. REG. 9-7-2004.
- 2,881,136. CORNER CUBE. INT. CL. 38. REG. 9-7-2004.
- 2,881,141. BDRX (STYLIZED). INT. CL. 5. REG. 9-7-2004.
- 2,881,142. CAMPUS2000 AND DESIGN. INT. CL. 9. REG. 9-7-2004.
- 2,881,144. FIND YOUR TRUE VOICE... AND GROW YOUR BUSINESS. INT. CL. 41. REG. 9-7-2004.
- 2,881,146. SCATE. INT. CL. 41. REG. 9-7-2004.
- 2,881,147. VRROOM. INT. CL. 32. REG. 9-7-2004.
- 2,881,148. ACCOMMODATING. ACCURATE. ACCREDITED.. INT. CL. 44. REG. 9-7-2004.
- 2,881,149. MAT WITH MUSCLE! PIG AND DESIGN. INT. CL. 27. REG. 9-7-2004.
- 2,881,152. SUPRASAVER. INT. CL. 38. REG. 9-7-2004.

- 2,881,153. DEPRESSIONWORKROOM.COM. INT. CL. 44. REG. 9-7-2004.
- 2,881,156. LONY. INT. CL. 25. REG. 9-7-2004.
- 2,881,157. CRESCENT CITY. INT. CL. 43. REG. 9-7-2004.
- 2,881,161. SAMURAI. INT. CL. 3. REG. 9-7-2004.
- 2,881,162. MADTAP. INT. CL. 35. REG. 9-7-2004.
- 2,881,164. JUST LOVING CARS. INT. CL. 41. REG. 9-7-2004.
- 2,881,166. BIOPHEX. INT. CL. 35. REG. 9-7-2004.
- 2,881,168. WHITE MAN SURPRISE. INT. CL. 30. REG. 9-7-2004.
- 2,881,172. PROVIDING QUALITY WORKMANSHIP WITH EXTRAORDINARY SERVICE. INT. CL. 37. REG. 9-7-2004.
- 2,881,173. SHRIMPSAHOY. INT. CL. 29. REG. 9-7-2004.
- 2,881,174. STARFIRE. INT. CL. 9. REG. 9-7-2004.
- 2,881,176. EORIGINAL ECORE. INT. CLS. 9, 38 AND 39. REG. 9-7-2004.
- 2,881,180. WING MATE. INT. CL. 9. REG. 9-7-2004.
- 2,881,182. SADUSA. INT. CL. 14. REG. 9-7-2004.
- 2,881,184. MISCELLANEOUS DESIGN. INT. CL. 42. REG. 9-7-2004.
- 2,881,185. VEECE. INT. CL. 25. REG. 9-7-2004.
- 2,881,190. AISLE BY AISLE. INT. CL. 16. REG. 9-7-2004.
- 2,881,191. SPUDMASTER. INT. CL. 11. REG. 9-7-2004.
- 2,881,193. MISCELLANEOUS DESIGN. INT. CL. 35. REG. 9-7-2004.
- 2,881,198. HEALTHY EATING MADE EASIER. INT. CL. 41. REG. 9-7-2004.
- 2,881,199. DAIRY COUNCIL OF CALIFORNIA AND DESIGN. INT. CLS. 9, 16 AND 41. REG. 9-7-2004.
- 2,881,200. CHRONOPATH. INT. CL. 9. REG. 9-7-2004.
- 2,881,202. OPUS RED. INT. CL. 31. REG. 9-7-2004.
- 2,881,204. PROSPECTION AND DESIGN. INT. CLS. 35 AND 42. REG. 9-7-2004.
- 2,881,213. GREAT ESCAPES. INT. CL. 30. REG. 9-7-2004.
- 2,881,215. WWAC. INT. CL. 35. REG. 9-7-2004.
- 2,881,216. COLORS IN WHITE. INT. CL. 16. REG. 9-7-2004.
- 2,881,220. FCI FRANCORP CAPITAL, INC. AND DESIGN. INT. CL. 36. REG. 9-7-2004.
- 2,881,221. FRANCORP CAPITAL. INT. CL. 36. REG. 9-7-2004.
- 2,881,223. NEW YORK CITY TRANSIT. INT. CL. 28. REG. 9-7-2004.
- 2,881,225. FUNERAL CONSUMER GUARDIAN SOCIETY AND DESIGN. INT. CL. 45. REG. 9-7-2004.
- 2,881,227. DIRECT THE DECISION. WIN YOUR CASE.. INT. CL. 42. REG. 9-7-2004.
- 2,881,232. DARK HORSE PERFORMANCE. INT. CL. 37. REG. 9-7-2004.
- 2,881,236. XACT2FORM. INT. CL. 19. REG. 9-7-2004.
- 2,881,240. MELLON FORENSIC GROUP. INT. CLS. 41 AND 42. REG. 9-7-2004.
- 2,881,241. CCC (STYLIZED). INT. CLS. 9, 37, 40 AND 42. REG. 9-7-2004.
- 2,881,243. DEL SOL. INT. CL. 11. REG. 9-7-2004.
- 2,881,244. EXPANDING THE POWER OF ASSESSMENTS!. INT. CL. 41. REG. 9-7-2004.
- 2,881,247. CARGO-TEC. INT. CL. 6. REG. 9-7-2004.
- 2,881,248. ELEVATE. INT. CL. 41. REG. 9-7-2004.
- 2,881,253. MISCELLANEOUS DESIGN. INT. CLS. 30 AND 32. REG. 9-7-2004.
- 2,881,255. TERRAX. INT. CL. 9. REG. 9-7-2004.
- 2,881,257. FANTASYSWINGERS. INT. CLS. 38 AND 45. REG. 9-7-2004.
- 2,881,258. YOUR STREETS. OUR WATCH.. INT. CLS. 16 AND 45. REG. 9-7-2004.
- 2,881,259. SOL MATES AND DESIGN. INT. CL. 18. REG. 9-7-2004.
- 2,881,262. MORPHOSIS. INT. CL. 9. REG. 9-7-2004.
- 2,881,266. CEAA. INT. CL. 35. REG. 9-7-2004.
- 2,881,268. CUATRALBA (STYLIZED). INT. CL. 25. REG. 9-7-2004.
- 2,881,269. SHOTGUN FIREWORKS AND DESIGN. INT. CL. 13. REG. 9-7-2004.
- 2,881,272. NOTES HACK. INT. CL. 16. REG. 9-7-2004.
- 2,881,274. LEGENDS ACADEMY. INT. CL. 25. REG. 9-7-2004.
- 2,881,283. JACK JELLY. INT. CL. 5. REG. 9-7-2004.
- 2,881,284. GUN OIL. INT. CL. 5. REG. 9-7-2004.
- 2,881,289. ROYAL FILTH (STYLIZED). INT. CL. 25. REG. 9-7-2004.
- 2,881,290. NATIVE PALM AND DESIGN. INT. CL. 44. REG. 9-7-2004.
- 2,881,297. SONIA KASHUK (STYLIZED). INT. CLS. 3, 8, 18, 21 AND 24. REG. 9-7-2004.
- 2,881,298. J.LO BY JENNIFER LOPEZ AND DESIGN. INT. CLS. 14 AND 25. REG. 9-7-2004.
- 2,881,302. ICUC. INT. CLS. 35, 38 AND 42. REG. 9-7-2004.
- 2,881,305. TOGETHER WE GIVE, TOGETHER WE GROW. INT. CL. 41. REG. 9-7-2004.
- 2,881,306. S.T.A.T. TEAM NURSING STAFFING TODAY AND TOMORROW AND DESIGN. INT. CL. 35. REG. 9-7-2004.
- 2,881,307. ELASTIC GASKET. INT. CL. 9. REG. 9-7-2004.
- 2,881,308. BLUE BOOK OF COLLEGE ATHLETICS AND DESIGN. INT. CL. 16. REG. 9-7-2004.
- 2,881,311. FORTEC. INT. CL. 9. REG. 9-7-2004.
- 2,881,312. CHROMELL. INT. CL. 23. REG. 9-7-2004.
- 2,881,313. MPLATFORM. INT. CL. 9. REG. 9-7-2004.
- 2,881,315. ULTRATERA. INT. CLS. 9, 40 AND 42. REG. 9-7-2004.
- 2,881,316. JAMLADY. INT. CL. 29. REG. 9-7-2004.
- 2,881,320. TETRION. INT. CLS. 1 AND 19. REG. 9-7-2004.
- 2,881,321. KIDS FARM AND DESIGN. INT. CL. 9. REG. 9-7-2004.
- 2,881,322. GIRLS CAN TOO. INT. CL. 9. REG. 9-7-2004.
- 2,881,323. PINCH AND DESIGN. INT. CL. 41. REG. 9-7-2004.
- 2,881,324. TIWAK. INT. CLS. 9, 28, 41 AND 42. REG. 9-7-2004.
- 2,881,325. I-CAST. INT. CL. 36. REG. 9-7-2004.
- 2,881,326. VANTAGREN. INT. CL. 5. REG. 9-7-2004.
- 2,881,327. MBX. INT. CLS. 9 AND 42. REG. 9-7-2004.
- 2,881,329. OPTISON AND DESIGN. INT. CL. 5. REG. 9-7-2004.
- 2,881,333. 9:11 CONVERSATIONAL TIMEPIECE. INT. CL. 14. REG. 9-7-2004.
- 2,881,334. RIVER RIDGE AND DESIGN. INT. CL. 18. REG. 9-7-2004.
- 2,881,335. N NUMBERCRUNCHERS BUSINESS & FINANCIAL SERVICES AND DESIGN. INT. CL. 35. REG. 9-7-2004.
- 2,881,336. MISCELLANEOUS DESIGN. INT. CL. 31. REG. 9-7-2004.
- 2,881,338. A55. INT. CL. 9. REG. 9-7-2004.
- 2,881,339. JSKBEST. INT. CLS. 1 AND 11. REG. 9-7-2004.
- 2,881,341. COMWIN. INT. CLS. 9 AND 38. REG. 9-7-2004.
- 2,881,343. SHAW SC AND DESIGN. INT. CL. 27. REG. 9-7-2004.
- 2,881,344. GP &ME AND DESIGN. INT. CL. 21. REG. 9-7-2004.
- 2,881,345. WOW! CARD SERVICES. INT. CL. 9. REG. 9-7-2004.
- 2,881,346. WOW!. INT. CL. 9. REG. 9-7-2004.
- 2,881,347. CADDINFORMATICS. INT. CL. 42. REG. 9-7-2004.
- 2,881,351. LATINA. INT. CLS. 9 AND 41. REG. 9-7-2004.
- 2,881,354. CELL PHARM. INT. CLS. 5, 42 AND 44. REG. 9-7-2004.
- 2,881,356. U.S. DIGEST MAGAZINE AND DESIGN. INT. CL. 16. REG. 9-7-2004.
- 2,881,358. SILVERGOLF AND DESIGN. INT. CL. 14. REG. 9-7-2004.
- 2,881,359. SOLUX. INT. CL. 3. REG. 9-7-2004.
- 2,881,360. STIL GARDEN AND DESIGN. INT. CLS. 20, 21 AND 28. REG. 9-7-2004.
- 2,881,362. DOUBLE SHOT. INT. CL. 35. REG. 9-7-2004.
- 2,881,363. WORLD PRAYERNET. INT. CL. 45. REG. 9-7-2004.
- 2,881,364. KEYNOTE THE INTERNET PERFORMANCE AUTHORITY AND DESIGN. INT. CL. 42. REG. 9-7-2004.
- 2,881,365. ARMOR-KOTE. INT. CL. 19. REG. 9-7-2004.
- 2,881,369. CAMBRIAN. INT. CL. 29. REG. 9-7-2004.
- 2,881,370. 3 IN 1 AND DESIGN. INT. CL. 33. REG. 9-7-2004.
- 2,881,371. SERVICEMAGIC REAL ESTATE. INT. CL. 35. REG. 9-7-2004.



- 2,881,372. ROUGH HAND REPAIR AND DESIGN. INT. CL. 3. REG. 9-7-2004.
- 2,881,373. HARRIS READYLINE. INT. CL. 36. REG. 9-7-2004.
- 2,881,375. STUMBLING BUFFALO BROWN ALE AND DESIGN. INT. CL. 32. REG. 9-7-2004.
- 2,881,377. VARIFLEX (STYLIZED). INT. CL. 7. REG. 9-7-2004.
- 2,881,379. COME TO YOUR SENSES EVENTS. INT. CL. 41. REG. 9-7-2004.
- 2,881,380. ONE OF A KIND, NOT ONE OF A MILLION. INT. CL. 35. REG. 9-7-2004.
- 2,881,381. PEDIATRIC MANUAL OF CLINICAL DIETETICS. INT. CL. 16. REG. 9-7-2004.
- 2,881,382. SNAPTANK. INT. CL. 20. REG. 9-7-2004.
- 2,881,384. GALTES. INT. CL. 24. REG. 9-7-2004.
- 2,881,385. ENUNCIATE CONFERENCING. INT. CL. 38. REG. 9-7-2004.
- 2,881,386. OL' KENTUCKY STANDARD CHARACTER MARK. INT. CL. 34. REG. 9-7-2004.
- 2,881,387. QUIKSCRIBE TRANSCRIPTION SYSTEM AND DESIGN. INT. CL. 9. REG. 9-7-2004.
- 2,881,392. PREMIUM CIGAR COMPANY AND DESIGN. INT. CLS. 25, 34, 35 AND 40. REG. 9-7-2004.
- 2,881,393. XTRAMILE. INT. CLS. 36, 41 AND 42. REG. 9-7-2004.
- 2,881,394. CASCADE CUP. INT. CL. 41. REG. 9-7-2004.
- 2,881,395. MINDWORKS AND DESIGN. INT. CL. 42. REG. 9-7-2004.
- 2,881,397. NOTHING DISAPPEARS WITHOUT A TRACE. INT. CL. 42. REG. 9-7-2004.
- 2,881,401. RAMORA. INT. CLS. 2, 7, 9 AND 20. REG. 9-7-2004.
- 2,881,403. TEXAS PRIMARY READING INVENTORY. INT. CL. 9. REG. 9-7-2004.
- 2,881,404. TEXAS PRIMARY READING INVENTORY. INT. CL. 16. REG. 9-7-2004.
- 2,881,405. TEXAS PRIMARY READING INVENTORY. INT. CL. 41. REG. 9-7-2004.
- 2,881,407. CHASE FARMS, INC.. INT. CL. 29. REG. 9-7-2004.
- 2,881,408. COUNTRY'S MOST SHOCKING.... INT. CL. 41. REG. 9-7-2004.
- 2,881,409. TRISA. INT. CL. 3. REG. 9-7-2004.
- 2,881,414. FLEXLINE. INT. CL. 9. REG. 9-7-2004.
- 2,881,418. ABOUT NEW YORK. INT. CL. 39. REG. 9-7-2004.
- 2,881,419. SOL TEC AND DESIGN. INT. CLS. 38 AND 42. REG. 9-7-2004.
- 2,881,420. TURN KEY WINDOWS WINDOW SPECIALIST AND DESIGN. INT. CL. 37. REG. 9-7-2004.
- 2,881,422. IQ. INT. CL. 35. REG. 9-7-2004.
- 2,881,423. COLUMBIA RIVER NATURAL PET FOODS AND DESIGN. INT. CL. 31. REG. 9-7-2004.
- 2,881,425. DINO'S PIZZA ITALIAN BISTRO. INT. CL. 30. REG. 9-7-2004.
- 2,881,430. HYSTERICAL HISTORY OF NEW ORLEANS. INT. CL. 41. REG. 9-7-2004.
- 2,881,431. D AND DESIGN. INT. CLS. 36 AND 42. REG. 9-7-2004.
- 2,881,433. SPOILED ROTTEN SOAP. INT. CL. 3. REG. 9-7-2004.
- 2,881,434. DRIFT AWAY LLC AND DESIGN. INT. CL. 39. REG. 9-7-2004.
- 2,881,435. TUTOPATCH. INT. CL. 5. REG. 9-7-2004.
- 2,881,436. D DIVERSIFIED EXCHANGE CORPORATION AND DESIGN. INT. CL. 36. REG. 9-7-2004.
- 2,881,437. D AND DESIGN. INT. CL. 5. REG. 9-7-2004.
- 2,881,440. CRISTACER AND DESIGN. INT. CL. 19. REG. 9-7-2004.
- 2,881,442. ANDREA FONTEBASSO 1760 (STYLIZED). INT. CL. 21. REG. 9-7-2004.
- 2,881,444. GREAT FOOD, GREAT FUN, GREAT OPPORTUNITY!. INT. CL. 29. REG. 9-7-2004.
- 2,881,449. CHONGGA AND DESIGN. INT. CLS. 29 AND 30. REG. 9-7-2004.
- 2,881,450. WALLIS. INT. CL. 10. REG. 9-7-2004.
- 2,881,455. CVI. INT. CLS. 36 AND 42. REG. 9-7-2004.
- 2,881,456. STRONGBOX. INT. CL. 41. REG. 9-7-2004.
- 2,881,458. WWW.IXMATE.COM ...FOR SPORT ANALYSIS ...FÜR SPORTANALYSE ...PER L'ANALISI DELLO AND DESIGN. INT. CLS. 9, 38 AND 42. REG. 9-7-2004.
- 2,881,459. BOOTYHOG GEAR. INT. CL. 25. REG. 9-7-2004.
- 2,881,464. STANDARD COMMERCIAL TOBACCO CO., INC.. INT. CLS. 35 AND 40. REG. 9-7-2004.
- 2,881,466. BIO SCoured AND DESIGN. INT. CLS. 1, 24, 25 AND 41. REG. 9-7-2004.
- 2,881,469. 50'S AT THE HOP. INT. CL. 41. REG. 9-7-2004.
- 2,881,472. HW HARRY WINSTON THE CAPTIVE BRACELET. INT. CL. 14. REG. 9-7-2004.
- 2,881,474. MISCELLANEOUS DESIGN. INT. CL. 36. REG. 9-7-2004.
- 2,881,475. NATURAL. INT. CL. 25. REG. 9-7-2004.
- 2,881,477. HOLD UP. INT. CL. 18. REG. 9-7-2004.
- 2,881,478. RHEA. INT. CL. 9. REG. 9-7-2004.
- 2,881,483. SMARTDISK AND DESIGN. INT. CL. 9. REG. 9-7-2004.
- 2,881,485. WHAT TO READ NEXT. INT. CL. 16. REG. 9-7-2004.
- 2,881,486. IT'S A FRIEND THING. (STYLIZED). INT. CL. 25. REG. 9-7-2004.
- 2,881,488. START NOW!. INT. CL. 35. REG. 9-7-2004.
- 2,881,489. GAVILAN. INT. CL. 42. REG. 9-7-2004.
- 2,881,491. ELECTROTANK AND DESIGN. INT. CL. 9. REG. 9-7-2004.
- 2,881,492. ELECTROTANK. INT. CL. 9. REG. 9-7-2004.
- 2,881,493. STASYS. INT. CLS. 9, 35, 38, 39, 41 AND 42. REG. 9-7-2004.
- 2,881,494. MISCELLANEOUS DESIGN. INT. CL. 25. REG. 9-7-2004.
- 2,881,496. TRIBOARD. INT. CL. 19. REG. 9-7-2004.
- 2,881,497. QUEEN OF THE NILE. INT. CL. 14. REG. 9-7-2004.
- 2,881,498. ELBORNES. INT. CL. 42. REG. 9-7-2004.
- 2,881,499. REASONABLE ZONE (STYLIZED). INT. CL. 35. REG. 9-7-2004.
- 2,881,501. EDITIONES CLASSICAE. INT. CL. 9. REG. 9-7-2004.
- 2,881,502. CLEANS GLASS PLUS A WHOLE LOT MORE!. INT. CLS. 3 AND 21. REG. 9-7-2004.
- 2,881,503. MOBILE GOURMET SAVOR EVERY ADVENTURE.. INT. CLS. 8 AND 30. REG. 9-7-2004.
- 2,881,505. MCGUIRE AND DESIGN. INT. CLS. 6, 7 AND 19. REG. 9-7-2004.
- 2,881,507. VILANTO. INT. CL. 18. REG. 9-7-2004.
- 2,881,510. VOICEWISE. INT. CL. 9. REG. 9-7-2004.
- 2,881,513. BAIN DE LUXE LUXURY BODY WASH. INT. CL. 3. REG. 9-7-2004.
- 2,881,515. WAGON. INT. CLS. 12 AND 42. REG. 9-7-2004.
- 2,881,519. ONLINE OPTICAL OUTLET AND DESIGN. INT. CL. 35. REG. 9-7-2004.
- 2,881,520. SANDY'S. INT. CL. 25. REG. 9-7-2004.
- 2,881,521. MARKESTIL (STYLIZED). INT. CL. 20. REG. 9-7-2004.
- 2,881,522. PRO-BURN. INT. CLS. 9, 38 AND 41. REG. 9-7-2004.
- 2,881,530. MISCELLANEOUS DESIGN. INT. CL. 35. REG. 9-7-2004.
- 2,881,532. MISCELLANEOUS DESIGN. INT. CL. 5. REG. 9-7-2004.
- 2,881,533. MISCELLANEOUS DESIGN. INT. CL. 5. REG. 9-7-2004.
- 2,881,534. MISCELLANEOUS DESIGN. INT. CL. 5. REG. 9-7-2004.
- 2,881,536. "I DO" DESIGN. INT. CL. 42. REG. 9-7-2004.
- 2,881,537. GLIMPSO. INT. CLS. 35 AND 42. REG. 9-7-2004.
- 2,881,541. HUAHONG AND DESIGN. INT. CL. 14. REG. 9-7-2004.
- 2,881,542. NEIGHBORHOOD MARKETING INSTITUTE. INT. CLS. 35 AND 41. REG. 9-7-2004.
- 2,881,543. MYDATANET AND DESIGN. INT. CLS. 35 AND 41. REG. 9-7-2004.
- 2,881,545. TURFLEX. INT. CLS. 1, 17 AND 27. REG. 9-7-2004.
- 2,881,546. TROVITSKY PARK AND DESIGN. INT. CLS. 36 AND 37. REG. 9-7-2004.



- 2,881,547. KATESRIDGE AND DESIGN. INT. CLS. 36 AND 37. REG. 9-7-2004.
- 2,881,548. TROVITSKY PARK. INT. CLS. 36 AND 37. REG. 9-7-2004.
- 2,881,549. DCI. INT. CLS. 42 AND 43. REG. 9-7-2004.
- 2,881,550. WINGEAR. INT. CL. 35. REG. 9-7-2004.
- 2,881,551. EUROGEAR. INT. CL. 35. REG. 9-7-2004.
- 2,881,552. MOTORIL. INT. CL. 5. REG. 9-7-2004.
- 2,881,553. V THE VIDEO GAME BUYERS GUIDE AND DESIGN. INT. CL. 16. REG. 9-7-2004.
- 2,881,554. FORLOVEDE. INT. CL. 3. REG. 9-7-2004.
- 2,881,555. XY23. INT. CL. 3. REG. 9-7-2004.
- 2,881,556. SQ-II SERVICE QUESTIONNAIRE SECOND EDITION AND DESIGN. INT. CL. 35. REG. 9-7-2004.
- 2,881,557. CLICKDRIVER. INT. CL. 35. REG. 9-7-2004.
- 2,881,558. ISOTILES. INT. CLS. 9, 16 AND 28. REG. 9-7-2004.
- 2,881,559. DBMOTION. INT. CL. 9. REG. 9-7-2004.
- 2,881,560. THE ATLANTA MEDICAL GUIDE. INT. CL. 16. REG. 9-7-2004.
- 2,881,565. URBAN AUDIO WORKS. INT. CL. 9. REG. 9-7-2004.
- 2,881,567. NUVO BODY AND DESIGN. INT. CL. 5. REG. 9-7-2004.
- 2,881,568. BREEZYME. INT. CL. 1. REG. 9-7-2004.
- 2,881,571. MISCELLANEOUS DESIGN. INT. CL. 9. REG. 9-7-2004.
- 2,881,572. POP TIMER AND DESIGN. INT. CL. 30. REG. 9-7-2004.
- 2,881,575. TFOCA-III. INT. CL. 9. REG. 9-7-2004.
- 2,881,576. NICKELODEON ALL GROWN UP. INT. CL. 41. REG. 9-7-2004.
- 2,881,580. COOL DADDY'S DAIQUIRIS. INT. CLS. 25, 32 AND 43. REG. 9-7-2004.
- 2,881,581. CITI KNIGHTS. INT. CL. 25. REG. 9-7-2004.
- 2,881,583. PUTNAM LUMBER & EXPORT CO.. INT. CL. 35. REG. 9-7-2004.
- 2,881,586. DINNER & DREAMS AND DESIGN. INT. CLS. 41 AND 43. REG. 9-7-2004.
- 2,881,590. ZECUF. INT. CL. 5. REG. 9-7-2004.
- 2,881,591. BONACERA. INT. CL. 21. REG. 9-7-2004.
- 2,881,596. DREAM IT. SEE IT. BELIEVE IT.. INT. CL. 41. REG. 9-7-2004.
- 2,881,600. EXAM STANDARD CHARACTER MARK. INT. CL. 10. REG. 9-7-2004.
- 2,881,601. JCOMP. INT. CL. 9. REG. 9-7-2004.
- 2,881,602. NEXPOINT TECHNOLOGIES. INT. CL. 42. REG. 9-7-2004.
- 2,881,604. SIOP SHELTERED INSTRUCTION OBSERVATION PROTOCOL AND DESIGN. INT. CL. 41. REG. 9-7-2004.
- 2,881,606. FEEL LIKE A TRUE GOURMET!. INT. CLS. 35 AND 43. REG. 9-7-2004.
- 2,881,610. WILLIAMS CHICKEN STANDARD CHARACTER MARK. INT. CL. 35. REG. 9-7-2004.
- 2,881,611. EIG. INT. CL. 45. REG. 9-7-2004.
- 2,881,612. REDBALL. INT. CLS. 7 AND 9. REG. 9-7-2004.
- 2,881,613. MAMA'S HOT TAMALES. INT. CL. 30. REG. 9-7-2004.
- 2,881,614. DRINKMOR COFFEE. INT. CLS. 21, 25, 35 AND 43. REG. 9-7-2004.
- 2,881,618. DAD (STYLIZED). INT. CL. 35. REG. 9-7-2004.
- 2,881,619. LIGHTYEAR. INT. CLS. 9 AND 10. REG. 9-7-2004.
- 2,881,620. HOME ECONOMICS 101. INT. CL. 36. REG. 9-7-2004.
- 2,881,622. PLANETA BRASIL TOURISM. INT. CLS. 39 AND 43. REG. 9-7-2004.
- 2,881,624. TRES MONKEY THIS GARMENT IS DESIGNED TO FIT AND PERFORM FOR THE LONG LASTING U.S.A. AND DESIGN. INT. CL. 25. REG. 9-7-2004.
- 2,881,625. RED JAVELIN. INT. CL. 35. REG. 9-7-2004.
- 2,881,626. OLD FORESTER KENTUCKY STRAIGHT BOURBON WHISKY BIRTHDAY BOURBON AND DESIGN. INT. CL. 33. REG. 9-7-2004.
- 2,881,628. VADIUM TECHNOLOGY, INC. STANDARD CHARACTER MARK. INT. CL. 9. REG. 9-7-2004.
- 2,881,629. GLOBAL ARCH FINANCIAL AND DESIGN. INT. CL. 36. REG. 9-7-2004.
- 2,881,630. HANDY GIRLS AND DESIGN. INT. CL. 8. REG. 9-7-2004.
- 2,881,631. OIL GOBLER. INT. CL. 1. REG. 9-7-2004.
- 2,881,633. VYZO. INT. CL. 42. REG. 9-7-2004.
- 2,881,634. VYZO AND DESIGN. INT. CL. 42. REG. 9-7-2004.
- 2,881,635. PROVENCOURSE. INT. CL. 35. REG. 9-7-2004.
- 2,881,638. ROBOPRESENTER. INT. CL. 9. REG. 9-7-2004.
- 2,881,639. CROCKER UNCORKED. INT. CLS. 16 AND 36. REG. 9-7-2004.
- 2,881,641. SONRISA TOYS. INT. CL. 35. REG. 9-7-2004.
- 2,881,643. SHAPE-SHIFTER. INT. CL. 16. REG. 9-7-2004.
- 2,881,644. BAJA BEACH BUCKET. INT. CL. 29. REG. 9-7-2004.
- 2,881,645. REAL FINANCIAL CENTER. INT. CL. 36. REG. 9-7-2004.
- 2,881,647. RED ROCKS!. INT. CL. 3. REG. 9-7-2004.
- 2,881,649. BEND A BOARD. INT. CL. 19. REG. 9-7-2004.
- 2,881,650. BEND A BOARD (STYLIZED). INT. CL. 19. REG. 9-7-2004.
- 2,881,652. C. RICHARD HEARN. INT. CL. 36. REG. 9-7-2004.
- 2,881,653. YOUR MONEY YOUR DREAMS. INT. CL. 36. REG. 9-7-2004.
- 2,881,654. THE INTERSECTION OF FORTUNE AND MISFORTUNE. INT. CL. 36. REG. 9-7-2004.
- 2,881,656. MAREA. INT. CL. 12. REG. 9-7-2004.
- 2,881,658. H3 AND DESIGN. INT. CL. 16. REG. 9-7-2004.
- 2,881,660. SEATOWEL. INT. CL. 22. REG. 9-7-2004.
- 2,881,663. TYKINERB. INT. CL. 5. REG. 9-7-2004.
- 2,881,665. TRANZEMBRYO. INT. CL. 42. REG. 9-7-2004.
- 2,881,666. GEO FENCE CO.. INT. CL. 37. REG. 9-7-2004.
- 2,881,667. OLD DOG NEW TRICK CAFE. INT. CL. 43. REG. 9-7-2004.
- 2,881,668. SPOT. INT. CL. 1. REG. 9-7-2004.
- 2,881,671. CHEROKEE AND DESIGN. INT. CL. 12. REG. 9-7-2004.
- 2,881,672. THE ULTIMATE FIT JEAN (STYLIZED). INT. CL. 25. REG. 9-7-2004.
- 2,881,673. UTAH CARES AND DESIGN. INT. CL. 35. REG. 9-7-2004.
- 2,881,674. PSYCHIATRY RESIDENT IN-TRAINING EXAMINATION. INT. CLS. 35 AND 41. REG. 9-7-2004.
- 2,881,675. 6 FIGURES PAINLESS DENT REPAIR. INT. CL. 41. REG. 9-7-2004.
- 2,881,676. AK ADEE KAYE (STYLIZED). INT. CL. 14. REG. 9-7-2004.
- 2,881,680. CREDITBOOSTER. INT. CL. 9. REG. 9-7-2004.
- 2,881,681. WHERE RACING INNOVATION BECOMES REALITY. INT. CL. 35. REG. 9-7-2004.
- 2,881,682. THE SENSUAL WOMAN. INT. CL. 35. REG. 9-7-2004.
- 2,881,683. JUST SOLUTIONS. INT. CL. 42. REG. 9-7-2004.
- 2,881,684. LUXURIOUSITY. INT. CL. 9. REG. 9-7-2004.
- 2,881,685. XIRION (STYLIZED). INT. CL. 38. REG. 9-7-2004.
- 2,881,687. VACATION CASH. INT. CL. 35. REG. 9-7-2004.
- 2,881,688. IN YOUR POCKET. INT. CL. 28. REG. 9-7-2004.
- 2,881,690. NEOMICRO DEVELOPMENT & DESIGN AND DESIGN. INT. CL. 42. REG. 9-7-2004.
- 2,881,699. BLACK KROSS AND DESIGN. INT. CL. 15. REG. 9-7-2004.
- 2,881,701. GEARS AND DESIGN. INT. CLS. 9 AND 38. REG. 9-7-2004.
- 2,881,703. GOURMET CUSTARD - ALWAYS FRESH. ALL DAY, EVERY DAY. INT. CL. 35. REG. 9-7-2004.
- 2,881,704. WATCH DOCTORS. INT. CL. 37. REG. 9-7-2004.
- 2,881,712. EXALTING HIM NATIONAL TALENT SEARCH. INT. CL. 41. REG. 9-7-2004.
- 2,881,713. CONTINENTAL DIVIDE COLLECTION. INT. CL. 27. REG. 9-7-2004.
- 2,881,714. THE JUDY RIDE. INT. CL. 36. REG. 9-7-2004.
- 2,881,715. CHRISTIAN TODAY. INT. CL. 16. REG. 9-7-2004.
- 2,881,718. TAKE STEPS TO SPREAD THE WORD!. INT. CL. 25. REG. 9-7-2004.
- 2,881,719. DYNINET AND DESIGN. INT. CL. 42. REG. 9-7-2004.
- 2,881,721. TECHNOLOGY..... FOR CONVENIENCE. INT. CL. 9. REG. 9-7-2004.

- 2,881,725. PRO-FORMANCE 500 TRIKE. INT. CL. 12. REG. 9-7-2004.
- 2,881,728. ANNA WILLIAM AND DESIGN. INT. CL. 18. REG. 9-7-2004.
- 2,881,733. SOBE ELIXIR 3C AND DESIGN. INT. CL. 32. REG. 9-7-2004.
- 2,881,735. SHAREHOLDERS. INT. CL. 29. REG. 9-7-2004.
- 2,881,736. DIEHARD SILVER. INT. CL. 9. REG. 9-7-2004.
- 2,881,744. FPC-2M. INT. CL. 1. REG. 9-7-2004.
- 2,881,745. LIVE MECHANICS. INT. CL. 25. REG. 9-7-2004.
- 2,881,746. VITALITY. INT. CLS. 1 AND 35. REG. 9-7-2004.
- 2,881,748. STARMED AND DESIGN. INT. CL. 35. REG. 9-7-2004.
- 2,881,752. SCOREBUGS. INT. CL. 9. REG. 9-7-2004.
- 2,881,753. THE APPLESMITH ORIGINAL HANDCRAFTED DESIGNS AND DESIGN. INT. CLS. 4, 21 AND 35. REG. 9-7-2004.
- 2,881,755. PROTALK. INT. CL. 28. REG. 9-7-2004.
- 2,881,756. CARTOON NETWORK'S LAST BELL. INT. CL. 41. REG. 9-7-2004.
- 2,881,757. SAPHION AND DESIGN. INT. CL. 9. REG. 9-7-2004.
- 2,881,760. MISCELLANEOUS DESIGN. INT. CLS. 3 AND 41. REG. 9-7-2004.
- 2,881,761. ECCO RUBBERTECH AND DESIGN. INT. CL. 25. REG. 9-7-2004.
- 2,881,762. VP-RX. INT. CL. 5. REG. 9-7-2004.
- 2,881,763. CLICK & GO. INT. CL. 9. REG. 9-7-2004.
- 2,881,766. SCANPOST. INT. CL. 9. REG. 9-7-2004.
- 2,881,767. DIAMOND CUTTER. INT. CL. 41. REG. 9-7-2004.
- 2,881,770. BIGGER THAN BIG. INT. CL. 16. REG. 9-7-2004.
- 2,881,772. LUXLOFT. INT. CL. 20. REG. 9-7-2004.
- 2,881,773. STAY SALTY STAY FUNKY. INT. CLS. 29 AND 30. REG. 9-7-2004.
- 2,881,775. REXX. INT. CL. 14. REG. 9-7-2004.
- 2,881,776. PLANTOPIA. INT. CL. 16. REG. 9-7-2004.
- 2,881,781. DEERBOX. INT. CL. 28. REG. 9-7-2004.
- 2,881,783. TOMORROW'S MEDICINES FOR TODAY'S PROBLEMS. INT. CL. 42. REG. 9-7-2004.
- 2,881,784. CAR CARE GUYS. INT. CL. 37. REG. 9-7-2004.
- 2,881,785. SUSAN LANDAU DESIGNS. INT. CL. 14. REG. 9-7-2004.
- 2,881,786. SUGAR & SPICE. INT. CL. 14. REG. 9-7-2004.
- 2,881,788. J.D.I. INT. CL. 10. REG. 9-7-2004.
- 2,881,789. SACRED PROFANITIES AND DESIGN. INT. CL. 35. REG. 9-7-2004.
- 2,881,793. HEALTH AND BEAUTY, INSIDE AND OUT . . . INT. CL. 44. REG. 9-7-2004.
- 2,881,794. AKIBAOTAKU. INT. CL. 35. REG. 9-7-2004.
- 2,881,796. KITTEL. INT. CL. 6. REG. 9-7-2004.
- 2,881,799. "WHERE THERE'S SMOKE THERE'S FLAVOR!". INT. CL. 30. REG. 9-7-2004.
- 2,881,800. SERIOUS SHOPPING. INT. CL. 35. REG. 9-7-2004.
- 2,881,801. INTER-DRINKS. INT. CL. 35. REG. 9-7-2004.
- 2,881,802. PICHINCHA. INT. CL. 25. REG. 9-7-2004.
- 2,881,804. ETIQUETTE ESSENTIALS. INT. CL. 41. REG. 9-7-2004.
- 2,881,807. DEVELOPRENEURS. INT. CL. 35. REG. 9-7-2004.
- 2,881,808. SWIPE. INT. CL. 5. REG. 9-7-2004.
- 2,881,810. DELICIOUS CHOICES. INT. CL. 30. REG. 9-7-2004.
- 2,881,811. DAMAR. INT. CL. 35. REG. 9-7-2004.
- 2,881,813. DISPATCH1. INT. CL. 36. REG. 9-7-2004.
- 2,881,815. RESPONDER1. INT. CL. 36. REG. 9-7-2004.
- 2,881,816. WORK FOR THE EARTH. INT. CL. 36. REG. 9-7-2004.
- 2,881,817. GAMMAX AND DESIGN. INT. CL. 28. REG. 9-7-2004.
- 2,881,818. LECICAP. INT. CL. 5. REG. 9-7-2004.
- 2,881,824. REACTIONVIEW. INT. CL. 9. REG. 9-7-2004.
- 2,881,825. CHINA BOY. INT. CL. 30. REG. 9-7-2004.
- 2,881,826. DR. FITNESS. INT. CL. 41. REG. 9-7-2004.
- 2,881,830. PREFERRED MILES. INT. CL. 35. REG. 9-7-2004.
- 2,881,834. WASH & GO CAR WASH. INT. CL. 37. REG. 9-7-2004.
- 2,881,835. PRYDE. INT. CL. 41. REG. 9-7-2004.
- 2,881,836. WONDERGLOW. INT. CL. 11. REG. 9-7-2004.
- 2,881,837. EUROSUPREME. INT. CL. 29. REG. 9-7-2004.
- 2,881,838. NAMEX (STYLIZED). INT. CLS. 9 AND 42. REG. 9-7-2004.
- 2,881,839. THE LATIN BOX. INT. CL. 35. REG. 9-7-2004.
- 2,881,845. SPIRITED CULTURES. INT. CL. 41. REG. 9-7-2004.
- 2,881,847. KK AND DESIGN. INT. CL. 25. REG. 9-7-2004.
- 2,881,848. 4REL. INT. CL. 25. REG. 9-7-2004.
- 2,881,849. NIMARIV. INT. CL. 5. REG. 9-7-2004.
- 2,881,850. WORLDMEMBER. INT. CL. 35. REG. 9-7-2004.
- 2,881,852. ITM. INT. CL. 9. REG. 9-7-2004.
- 2,881,858. EASY UPS. INT. CL. 27. REG. 9-7-2004.
- 2,881,859. ICITY. INT. CL. 35. REG. 9-7-2004.
- 2,881,860. NELSLINGSHOT. INT. CL. 28. REG. 9-7-2004.
- 2,881,861. GORDON'S. INT. CLS. 10 AND 42. REG. 9-7-2004.
- 2,881,862. SAILOR BLUE. INT. CL. 29. REG. 9-7-2004.
- 2,881,863. SWEET LOVE. INT. CL. 5. REG. 9-7-2004.
- 2,881,865. DUALCOMP. INT. CL. 12. REG. 9-7-2004.
- 2,881,868. WE THE PEOPLE. INT. CL. 20. REG. 9-7-2004.
- 2,881,869. SLAPSTIX. INT. CL. 20. REG. 9-7-2004.
- 2,881,871. SWITCH 'EM UP. INT. CL. 28. REG. 9-7-2004.
- 2,881,874. MUDDERS & POTTERS HOUSE. INT. CL. 41. REG. 9-7-2004.
- 2,881,875. MISCELLANEOUS DESIGN. INT. CL. 41. REG. 9-7-2004.
- 2,881,877. NIGHTHAWK STANDARD CHARACTER MARK. INT. CL. 9. REG. 9-7-2004.
- 2,881,879. GOLF-TECH STANDARD CHARACTER MARK. INT. CL. 14. REG. 9-7-2004.
- 2,881,880. WAKE20 STANDARD CHARACTER MARK. INT. CLS. 16 AND 25. REG. 9-7-2004.
- 2,881,881. LINOVANE STANDARD CHARACTER MARK. INT. CL. 11. REG. 9-7-2004.
- 2,881,883. FASTRAK AND DESIGN. INT. CL. 35. REG. 9-7-2004.
- 2,881,884. TRUDOT STANDARD CHARACTER MARK. INT. CL. 1. REG. 9-7-2004.
- 2,881,885. NILAMBU STANDARD CHARACTER MARK. INT. CL. 41. REG. 9-7-2004.
- 2,881,886. NILAMBU A PERSONAL YOGA STUDIO AND DESIGN. INT. CL. 41. REG. 9-7-2004.
- 2,881,887. BAZOOMBAS! AND DESIGN. INT. CL. 43. REG. 9-7-2004.
- 2,881,889. SOUND LEARNING STANDARD CHARACTER MARK. INT. CL. 16. REG. 9-7-2004.
- 2,881,890. PH-RESPONSE STANDARD CHARACTER MARK. INT. CL. 10. REG. 9-7-2004.
- 2,881,891. MISCELLANEOUS DESIGN. INT. CL. 25. REG. 9-7-2004.
- 2,881,892. LUMITREND STANDARD CHARACTER MARK. INT. CL. 9. REG. 9-7-2004.
- 2,881,893. MAKE UP AMY STANDARD CHARACTER MARK. INT. CL. 28. REG. 9-7-2004.
- 2,881,897. ACUSTAT. INT. CL. 10. REG. 9-7-2004.
- 2,881,898. E-Z GRADER. INT. CL. 9. REG. 9-7-2004.
- 2,881,900. TSE AND DESIGN. INT. CL. 36. REG. 9-7-2004.
- 2,881,905. ROLLING WORKSHOP. INT. CLS. 6 AND 7. REG. 9-7-2004.
- 2,881,908. TAKARA. INT. CL. 32. REG. 9-7-2004.
- 2,881,909. WM GROUP OF FUNDS. INT. CL. 36. REG. 9-7-2004.
- 2,881,910. OPTOVAC. INT. CLS. 9 AND 37. REG. 9-7-2004.
- 2,881,911. IT'S IN TO BE OUT...OR IS IT THE OTHER WAY AROUND?. INT. CLS. 20 AND 35. REG. 9-7-2004.
- 2,881,912. BEE BEE BEAR B AND DESIGN. INT. CL. 25. REG. 9-7-2004.
- 2,881,914. GLOBALSTAR AND DESIGN. INT. CL. 38. REG. 9-7-2004.
- 2,881,915. THE CIVILIZED MALE. INT. CL. 16. REG. 9-7-2004.
- 2,881,916. JINGLE JELLS. INT. CL. 30. REG. 9-7-2004.
- 2,881,917. HOUSE OF BLUES AND DESIGN. INT. CL. 41. REG. 9-7-2004.
- 2,881,919. ECO. INT. CLS. 7 AND 9. REG. 9-7-2004.
- 2,881,923. E AND DESIGN. INT. CL. 37. REG. 9-7-2004.
- 2,881,925. SUNRISE REALTY. INT. CL. 36. REG. 9-7-2004.
- 2,881,929. EVESTING. INT. CL. 16. REG. 9-7-2004.
- 2,881,931. NOODLERY. INT. CL. 42. REG. 9-7-2004.

- 2,881,932. ALL-STAR BASEBALL. INT. CL. 28. REG. 9-7-2004.
- 2,881,934. JURIS. INT. CL. 9. REG. 9-7-2004.
- 2,881,940. FRONTWAVE (STYLIZED). INT. CL. 9. REG. 9-7-2004.
- 2,881,943. RANCHER. INT. CL. 28. REG. 9-7-2004.
- 2,881,945. CYBERSEAT. INT. CL. 9. REG. 9-7-2004.
- 2,881,946. PUTNAM TAX SMART FUNDS. INT. CL. 36. REG. 9-7-2004.
- 2,881,949. ORCHID NIGHT. INT. CL. 3. REG. 9-7-2004.
- 2,881,950. LIVEMANUALS. INT. CLS. 35, 36 AND 42. REG. 9-7-2004.
- 2,881,952. PRAIRIECOMM AND DESIGN. INT. CL. 9. REG. 9-7-2004.
- 2,881,955. LIBA. INT. CL. 17. REG. 9-7-2004.
- 2,881,958. EARTHFACE. INT. CLS. 9, 35 AND 42. REG. 9-7-2004.
- 2,881,961. MTV'S THE TOM GREEN SHOW MTV MUSIC TELEVISION AND DESIGN. INT. CL. 25. REG. 9-7-2004.
- 2,881,962. TRAININGLINK. INT. CLS. 41 AND 42. REG. 9-7-2004.
- 2,881,964. STRATEGIC START. INT. CLS. 35 AND 41. REG. 9-7-2004.
- 2,881,966. NOGGIN. INT. CL. 16. REG. 9-7-2004.
- 2,881,967. PAUL & JOE. INT. CLS. 3 AND 18. REG. 9-7-2004.
- 2,881,972. ISH WEAR. INT. CL. 25. REG. 9-7-2004.
- 2,881,975. RICHTREE. INT. CLS. 35 AND 42. REG. 9-7-2004.
- 2,881,978. EREP. INT. CL. 41. REG. 9-7-2004.
- 2,881,980. BLYS (STYLIZED). INT. CL. 5. REG. 9-7-2004.
- 2,881,982. COMFORTSMITH STANDARD CHARACTER MARK. INT. CL. 10. REG. 9-7-2004.
- 2,881,983. SPINAL TAP. INT. CL. 25. REG. 9-7-2004.
- 2,881,984. SPINAL TAP. INT. CL. 28. REG. 9-7-2004.
- 2,881,986. D-LOOP. INT. CL. 9. REG. 9-7-2004.
- 2,881,988. PILLY TIGER AND DESIGN. INT. CL. 16. REG. 9-7-2004.
- 2,881,989. BEAUTYIDEAS.COM. INT. CLS. 35 AND 42. REG. 9-7-2004.
- 2,881,990. SURF WITH THE GREATEST. INT. CLS. 35 AND 42. REG. 9-7-2004.
- 2,881,994. NTAS. INT. CL. 9. REG. 9-7-2004.
- 2,882,000. EXCLUSIVELY CAT (STYLIZED). INT. CL. 31. REG. 9-7-2004.
- 2,882,001. INTELLIGIRL SOFTWARE. INT. CLS. 9, 35 AND 41. REG. 9-7-2004.
- 2,882,002. THERIGHTEDUCATION. INT. CL. 41. REG. 9-7-2004.
- 2,882,004. ELVENWARE. INT. CL. 42. REG. 9-7-2004.
- 2,882,006. MEDPOINTS. INT. CL. 35. REG. 9-7-2004.
- 2,882,007. SOULSVILLE U.S.A.. INT. CLS. 9, 25, 35 AND 38. REG. 9-7-2004.
- 2,882,008. BARBARY COAST ADVENTURES. INT. CL. 42. REG. 9-7-2004.
- 2,882,010. EARTH ORIGINS AND DESIGN. INT. CL. 25. REG. 9-7-2004.
- 2,882,011. NWHRC. INT. CL. 16. REG. 9-7-2004.
- 2,882,012. OOPS. INT. CL. 36. REG. 9-7-2004.
- 2,882,014. ONE. INT. CL. 5. REG. 9-7-2004.
- 2,882,015. GLOBALGRUB STANDARD CHARACTER MARK. INT. CL. 42. REG. 9-7-2004.
- 2,882,017. HYDRO-IMPACT. INT. CL. 7. REG. 9-7-2004.
- 2,882,018. BUILDING SPEED. INT. CL. 35. REG. 9-7-2004.
- 2,882,019. BAG-ALONG LEASH. INT. CL. 18. REG. 9-7-2004.
- 2,882,021. CLUBKOSHER. INT. CL. 35. REG. 9-7-2004.
- 2,882,026. COFFEEISIT. INT. CL. 35. REG. 9-7-2004.
- 2,882,027. CHOCOLATEISIT. INT. CL. 35. REG. 9-7-2004.
- 2,882,029. THREE CROWNS FUNDING. INT. CL. 36. REG. 9-7-2004.
- 2,882,030. SPORANOX AND DESIGN. INT. CL. 5. REG. 9-7-2004.
- 2,882,033. SOLLEN TECHNOLOGIES. INT. CL. 42. REG. 9-7-2004.
- 2,882,036. C-TLIF. INT. CL. 10. REG. 9-7-2004.
- 2,882,039. ACCELA.COM. INT. CL. 35. REG. 9-7-2004.
- 2,882,040. HEARTYO'S. INT. CL. 30. REG. 9-7-2004.
- 2,882,041. ACURA AND DESIGN. INT. CL. 28. REG. 9-7-2004.
- 2,882,044. REMOTERISE. INT. CL. 7. REG. 9-7-2004.
- 2,882,045. THE EXECUTIVE EDUCATOR. INT. CL. 16. REG. 9-7-2004.
- 2,882,046. FACEFINDER. INT. CL. 9. REG. 9-7-2004.
- 2,882,047. V VECTOR AND DESIGN. INT. CLS. 9, 35 AND 42. REG. 9-7-2004.
- 2,882,048. EMPIRE GOLF. INT. CLS. 41 AND 42. REG. 9-7-2004.
- 2,882,053. IDINE PRIME. INT. CLS. 35, 36 AND 42. REG. 9-7-2004.
- 2,882,057. MISCELLANEOUS DESIGN. INT. CL. 30. REG. 9-7-2004.
- 2,882,058. FIND LADY. INT. CL. 35. REG. 9-7-2004.
- 2,882,059. LIZ CLAIBORNE HOME. INT. CLS. 20 AND 24. REG. 9-7-2004.
- 2,882,060. ANDROID 16. INT. CL. 28. REG. 9-7-2004.
- 2,882,061. KINGSHIP AND DESIGN. INT. CL. 37. REG. 9-7-2004.
- 2,882,062. BRUT ROYAL CHAMPAGNE POMMERY AND DESIGN. INT. CL. 33. REG. 9-7-2004.
- 2,882,063. CHAMPIONS AND DESIGN. INT. CLS. 41 AND 42. REG. 9-7-2004.
- 2,882,066. PRIME AND DESIGN. INT. CL. 36. REG. 9-7-2004.
- 2,882,067. WANTED 3FT 2FT 1 TED AND DESIGN. INT. CL. 28. REG. 9-7-2004.
- 2,882,068. EASI SOLUTIONS. INT. CL. 9. REG. 9-7-2004.
- 2,882,069. RACE RED. INT. CL. 4. REG. 9-7-2004.
- 2,882,070. SCANCOMMERCE. INT. CLS. 9, 35 AND 42. REG. 9-7-2004.
- 2,882,071. HEALTHETECH AND DESIGN. INT. CLS. 9, 10 AND 42. REG. 9-7-2004.
- 2,882,072. LEARNING DIVIDENDS. INT. CLS. 9, 16 AND 41. REG. 9-7-2004.
- 2,882,073. ELECTRAMEDICS MICROSYSTEMS. INT. CL. 42. REG. 9-7-2004.
- 2,882,074. MISCELLANEOUS DESIGN. INT. CLS. 38 AND 41. REG. 9-7-2004.
- 2,882,075. TUBOBEND AND DESIGN. INT. CLS. 7, 9, 37 AND 42. REG. 9-7-2004.
- 2,882,080. HYDRA PURE, INC. ULTRA PURE WATER THROUGH SCIENCE AND DESIGN. INT. CL. 11. REG. 9-7-2004.
- 2,882,081. SANTA NET AND DESIGN. INT. CL. 28. REG. 9-7-2004.
- 2,882,082. SPIRIT OF THE RAIN. INT. CLS. 15 AND 25. REG. 9-7-2004.
- 2,882,084. MISCELLANEOUS DESIGN. INT. CLS. 11 AND 24. REG. 9-7-2004.
- 2,882,088. OR NOIR. INT. CL. 30. REG. 9-7-2004.
- 2,882,091. COMPOSITE TIMED RELEASE. INT. CL. 1. REG. 9-7-2004.
- 2,882,093. COCCOACE (STYLIZED). INT. CL. 31. REG. 9-7-2004.
- 2,882,094. KICAP MANAGEMENT. INT. CL. 36. REG. 9-7-2004.
- 2,882,098. RAYPAX. INT. CL. 42. REG. 9-7-2004.
- 2,882,099. AUTO-TRACK. INT. CL. 37. REG. 9-7-2004.
- 2,882,102. MATREX PROVEN PATHWAYS FOR ENHANCED CARE AND DESIGN. INT. CL. 9. REG. 9-7-2004.
- 2,882,103. FUN POLICE. INT. CLS. 16, 20 AND 25. REG. 9-7-2004.
- 2,882,105. JO MALONE EXPRESS. INT. CL. 35. REG. 9-7-2004.
- 2,882,107. REMOTEVIEW BOX. INT. CL. 42. REG. 9-7-2004.
- 2,882,109. KAREN PEARSE. INT. CL. 42. REG. 9-7-2004.
- 2,882,111. AQUAKIDS (STYLIZED). INT. CL. 16. REG. 9-7-2004.
- 2,882,113. SER AND DESIGN. INT. CL. 42. REG. 9-7-2004.
- 2,882,114. FREEDOM OF IMPRESSION. INT. CLS. 7, 9, 11, 37, 41 AND 42. REG. 9-7-2004.
- 2,882,115. KOMORI FREEDOM OF IMPRESSION AND DESIGN. INT. CLS. 7, 9, 11, 37, 41 AND 42. REG. 9-7-2004.
- 2,882,116. 6A. INT. CLS. 9, 38 AND 42. REG. 9-7-2004.
- 2,882,117. U.S. SMOKELESS TOBACCO BRANDS INC.. INT. CL. 16. REG. 9-7-2004.

- 2,882,121. MONEYASSOC MONEY ASSOCIATION. INT. CLS. 35 AND 36. REG. 9-7-2004.
- 2,882,126. SANCTORUM THE SERENITY SOUND SPA (STYLIZED). INT. CL. 42. REG. 9-7-2004.
- 2,882,127. FASTPRODUCT. INT. CL. 42. REG. 9-7-2004.
- 2,882,129. CERTES FINANCIAL PROS L'ETOILE DU NORD CPAS, CMAS & MBAS ON CALL TRUTH & CERTAINTY AND DESIGN. INT. CL. 35. REG. 9-7-2004.
- 2,882,131. BE THE GIRL YOU WANNA BE. INT. CLS. 9, 21 AND 28. REG. 9-7-2004.
- 2,882,134. TAO OF LAW. INT. CL. 16. REG. 9-7-2004.
- 2,882,136. ORBSEAL TOTAL SEALANT MANAGEMENT AND DESIGN. INT. CLS. 35, 40 AND 42. REG. 9-7-2004.
- 2,882,137. VNN VOTER NEWS NETWORK OFFICIAL VOICE OF INDEPENDENT VOTERS AND DESIGN. INT. CL. 16. REG. 9-7-2004.
- 2,882,141. MISCELLANEOUS DESIGN. INT. CL. 16. REG. 9-7-2004.
- 2,882,142. BIOEXPRESS. INT. CL. 9. REG. 9-7-2004.
- 2,882,145. LIGHTHOUSE GRILLE. INT. CL. 42. REG. 9-7-2004.
- 2,882,147. ACQUADIAMONDS STANDARD CHARACTER MARK. INT. CL. 14. REG. 9-7-2004.
- 2,882,150. LATINAS. INT. CL. 25. REG. 9-7-2004.
- 2,882,156. SOLARSTOP. INT. CL. 25. REG. 9-7-2004.
- 2,882,159. SAFE HARBOR AND DESIGN. INT. CL. 42. REG. 9-7-2004.
- 2,882,162. SHOPMAP. INT. CL. 9. REG. 9-7-2004.
- 2,882,164. M AND DESIGN. INT. CL. 3. REG. 9-7-2004.
- 2,882,167. COMFORT STATION. INT. CL. 42. REG. 9-7-2004.
- 2,882,168. PALMAZ. INT. CL. 41. REG. 9-7-2004.
- 2,882,169. LUV A CUPS. INT. CL. 30. REG. 9-7-2004.
- 2,882,175. PUMPKING THE KING OF GHOSTS. INT. CL. 28. REG. 9-7-2004.
- 2,882,176. PURE ATLANTIC. INT. CLS. 14, 25, 28, 35 AND 41. REG. 9-7-2004.
- 2,882,177. GEARFRIED THE IRON KNIGHT. INT. CL. 28. REG. 9-7-2004.
- 2,882,178. ONTAP. INT. CLS. 35 AND 38. REG. 9-7-2004.
- 2,882,182. VM ZINC PLUS. INT. CL. 6. REG. 9-7-2004.
- 2,882,183. AB FUNDS TRUST. INT. CL. 36. REG. 9-7-2004.
- 2,882,184. ACROBAT AND DESIGN. INT. CL. 28. REG. 9-7-2004.
- 2,882,187. MISCELLANEOUS DESIGN. INT. CL. 33. REG. 9-7-2004.
- 2,882,191. 4 ETERNITY COLLECTION (STYLIZED). INT. CL. 14. REG. 9-7-2004.
- 2,882,193. CARENIC. INT. CL. 3. REG. 9-7-2004.
- 2,882,194. LIL J. INT. CL. 41. REG. 9-7-2004.
- 2,882,195. SILENT SCOPE EX AND DESIGN. INT. CL. 28. REG. 9-7-2004.
- 2,882,196. SPICEE. INT. CL. 28. REG. 9-7-2004.
- 2,882,200. UCS. INT. CL. 25. REG. 9-7-2004.
- 2,882,201. SSR. INT. CL. 9. REG. 9-7-2004.
- 2,882,202. HAPPINESS HAPPENS THROUGH MY MOUTH. INT. CL. 16. REG. 9-7-2004.
- 2,882,205. PROTURON. INT. CL. 1. REG. 9-7-2004.
- 2,882,207. COUNTDOWN TO ATHENS. INT. CL. 14. REG. 9-7-2004.
- 2,882,209. DOGGIE DIARY AND DESIGN. INT. CL. 16. REG. 9-7-2004.
- 2,882,213. ADVICE MANAGEMENT SOLUTIONS. INT. CLS. 36 AND 41. REG. 9-7-2004.
- 2,882,215. FIX6. INT. CLS. 35 AND 37. REG. 9-7-2004.
- 2,882,216. TUBEEZ. INT. CL. 25. REG. 9-7-2004.
- 2,882,220. BALANCIN. INT. CL. 7. REG. 9-7-2004.
- 2,882,221. CONSERVATION COCOA. INT. CL. 42. REG. 9-7-2004.
- 2,882,222. YOUBET.COM TOTALACCESS. INT. CL. 36. REG. 9-7-2004.
- 2,882,223. HENRY DUARTE. INT. CL. 35. REG. 9-7-2004.
- 2,882,226. ROYAL ROMANCE COLLECTION BY JANIG AND DESIGN. INT. CLS. 14, 15 AND 20. REG. 9-7-2004.
- 2,882,227. X'E BY XL. INT. CL. 35. REG. 9-7-2004.
- 2,882,229. 143 AND DESIGN. INT. CLS. 3, 16, 20 AND 30. REG. 9-7-2004.
- 2,882,232. ENVIROLIZER. INT. CL. 1. REG. 9-7-2004.
- 2,882,234. WILD TURKEY FREEDOM. INT. CL. 33. REG. 9-7-2004.
- 2,882,238. MYNEWHOME. INT. CLS. 36 AND 37. REG. 9-7-2004.
- 2,882,241. BOKIMICA AND DESIGN. INT. CL. 1. REG. 9-7-2004.
- 2,882,242. UNIVERSAL PLATINUM. INT. CL. 1. REG. 9-7-2004.
- 2,882,243. MONEYTRONIX AND DESIGN. INT. CL. 9. REG. 9-7-2004.
- 2,882,246. CARDIOSTRIDES. INT. CL. 25. REG. 9-7-2004.
- 2,882,247. SING ALONG SANTA. INT. CL. 41. REG. 9-7-2004.
- 2,882,253. GOVERNMAX. INT. CL. 42. REG. 9-7-2004.
- 2,882,255. EMPOWER PLANT. INT. CLS. 16 AND 41. REG. 9-7-2004.
- 2,882,257. DECOURTENAY. INT. CL. 35. REG. 9-7-2004.
- 2,882,258. MISCELLANEOUS DESIGN. INT. CL. 25. REG. 9-7-2004.
- 2,882,260. NUASIS. INT. CL. 9. REG. 9-7-2004.
- 2,882,263. MISCELLANEOUS DESIGN. INT. CL. 36. REG. 9-7-2004.
- 2,882,269. SPEAKFREELY. INT. CL. 9. REG. 9-7-2004.
- 2,882,271. RIVERBOAT RUMMY. INT. CLS. 28 AND 41. REG. 9-7-2004.
- 2,882,272. ACCESS INTEGRATED TECHNOLOGIES. INT. CLS. 38, 39 AND 42. REG. 9-7-2004.
- 2,882,274. VIRTUAL LIBRARY MIGUEL DE CERVANTES AND DESIGN. INT. CLS. 38 AND 41. REG. 9-7-2004.
- 2,882,276. ISSUEALERT. INT. CL. 38. REG. 9-7-2004.
- 2,882,277. HORSESTYLE.COM. INT. CL. 25. REG. 9-7-2004.
- 2,882,281. ONOVO. INT. CL. 25. REG. 9-7-2004.
- 2,882,282. UNIMAT. INT. CL. 7. REG. 9-7-2004.
- 2,882,285. SKINDULGENCE. INT. CL. 3. REG. 9-7-2004.
- 2,882,286. WARNER'S PURE BENEFITS. INT. CL. 25. REG. 9-7-2004.
- 2,882,287. SEEIDEAS. INT. CL. 16. REG. 9-7-2004.
- 2,882,290. THE SPACE FACTOR. INT. CL. 20. REG. 9-7-2004.
- 2,882,291. SINCE 1918 AND DESIGN. INT. CLS. 29 AND 30. REG. 9-7-2004.
- 2,882,295. ZAX AND DESIGN. INT. CL. 18. REG. 9-7-2004.
- 2,882,296. NETWORK REMARKETING. INT. CL. 35. REG. 9-7-2004.
- 2,882,297. LA MET. INT. CL. 14. REG. 9-7-2004.
- 2,882,299. OCEAN PACIFIC. INT. CL. 28. REG. 9-7-2004.
- 2,882,302. A L COMMONWEALTH ALUMINUM TUBE ENTERPRISES, LLC AND DESIGN. INT. CL. 40. REG. 9-7-2004.
- 2,882,309. DECISION WISDOM. INT. CL. 9. REG. 9-7-2004.
- 2,882,310. THE LEGACYMAKER JOURNAL. INT. CL. 9. REG. 9-7-2004.
- 2,882,315. RST. INT. CL. 11. REG. 9-7-2004.
- 2,882,316. BOW-WOWERS. INT. CL. 16. REG. 9-7-2004.
- 2,882,317. MISCELLANEOUS DESIGN. INT. CL. 41. REG. 9-7-2004.
- 2,882,318. MISCELLANEOUS DESIGN. INT. CL. 41. REG. 9-7-2004.
- 2,882,319. BUZZMARKETING. INT. CL. 35. REG. 9-7-2004.
- 2,882,321. ECONO-COOL (STYLIZED). INT. CL. 9. REG. 9-7-2004.
- 2,882,322. ECO COOL AND DESIGN. INT. CL. 9. REG. 9-7-2004.
- 2,882,323. DIGITAL LIBRARY MIGUEL DE CERVANTES AND DESIGN. INT. CLS. 38 AND 41. REG. 9-7-2004.
- 2,882,324. E E.LAND AND DESIGN. INT. CL. 25. REG. 9-7-2004.
- 2,882,325. RAMP RUNNER. INT. CL. 12. REG. 9-7-2004.
- 2,882,329. SAUCER ATTACK!. INT. CLS. 35, 40, 41 AND 42. REG. 9-7-2004.
- 2,882,330. SNAPPIN' BASHERS. INT. CL. 28. REG. 9-7-2004.
- 2,882,331. NEW YORK CUT. INT. CL. 34. REG. 9-7-2004.
- 2,882,336. VENASONIX. INT. CL. 10. REG. 9-7-2004.
- 2,882,337. TDSOFT. INT. CL. 9. REG. 9-7-2004.
- 2,882,338. 5 BAC. INT. CL. 25. REG. 9-7-2004.



- 2,882,340. BLASTERS. INT. CL. 30. REG. 9-7-2004.  
2,882,344. DOC ROCK AND DESIGN. INT. CL. 16. REG. 9-7-2004.  
2,882,345. PG.27 DRAPEFAST PAINT MASKING SYSTEM AND DESIGN. INT. CL. 17. REG. 9-7-2004.  
2,882,348. HITMAN GOLD AND DESIGN. INT. CL. 32. REG. 9-7-2004.  
2,882,351. FIRST TEA. INT. CL. 5. REG. 9-7-2004.  
2,882,352. TONI CREATIONS. INT. CL. 14. REG. 9-7-2004.  
2,882,354. MOMMY STYLE AND DESIGN. INT. CL. 41. REG. 9-7-2004.  
2,882,357. THE SOUP'S ON! PROJECT. INT. CL. 41. REG. 9-7-2004.  
2,882,362. UTOPIA FINANCIAL FITNESS. INT. CL. 36. REG. 9-7-2004.  
2,882,363. EXTENZA. INT. CLS. 35, 41, 42 AND 45. REG. 9-7-2004.  
2,882,366. WATER ANGELS. INT. CLS. 9 AND 41. REG. 9-7-2004.  
2,882,367. HIPPI HEARTS. INT. CL. 28. REG. 9-7-2004.  
2,882,369. SOFTTOP. INT. CLS. 9 AND 42. REG. 9-7-2004.  
2,882,371. STOPPAL PRODUCTIONS. INT. CL. 41. REG. 9-7-2004.  
2,882,373. SMART OUTDOOR PRODUCTS AND DESIGN. INT. CL. 9. REG. 9-7-2004.  
2,882,376. SALSA SAN RAMON. INT. CL. 30. REG. 9-7-2004.  
2,882,377. TEAM-SCOREBOARD!. INT. CL. 9. REG. 9-7-2004.  
2,882,378. PCT. INT. CL. 28. REG. 9-7-2004.  
2,882,381. JUAR TEA AND DESIGN. INT. CL. 30. REG. 9-7-2004.  
2,882,384. MISCELLANEOUS DESIGN. INT. CL. 17. REG. 9-7-2004.  
2,882,385. CD-HARDWARE. INT. CLS. 6, 7, 11 AND 19. REG. 9-7-2004.  
2,882,386. ICERA. INT. CL. 21. REG. 9-7-2004.  
2,882,388. PULL YOUR WEIGHT. INT. CL. 16. REG. 9-7-2004.  
2,882,391. VIRTUAL PROCTOR. INT. CL. 45. REG. 9-7-2004.  
2,882,394. TWIN HENS AND DESIGN. INT. CL. 30. REG. 9-7-2004.  
2,882,395. THE POWER OF THE COMPOSER. INT. CL. 42. REG. 9-7-2004.  
2,882,396. POLAR AIR. INT. CL. 21. REG. 9-7-2004.  
2,882,397. COLOR RELEASE. INT. CL. 3. REG. 9-7-2004.  
2,882,399. CHECKBOOK COUPONS. INT. CLS. 16 AND 35. REG. 9-7-2004.  
2,882,400. MID SOUTH CLUB. INT. CL. 35. REG. 9-7-2004.  
2,882,401. TERRA THERAPY AND DESIGN. INT. CL. 3. REG. 9-7-2004.  
2,882,403. RHODES AND DESIGN. INT. CLS. 7 AND 11. REG. 9-7-2004.  
2,882,406. SPIKE SERVER AND DESIGN. INT. CL. 9. REG. 9-7-2004.  
2,882,409. LOOK AT ME WHEN I'M TALKING TO YOU. INT. CL. 9. REG. 9-7-2004.  
2,882,410. THIN ICE. INT. CL. 30. REG. 9-7-2004.  
2,882,411. MIAMANNA AND DESIGN. INT. CL. 29. REG. 9-7-2004.  
2,882,414. EXEMPLAR CAPITAL MANAGEMENT. INT. CL. 36. REG. 9-7-2004.  
2,882,415. COMPETITIVE SPECTRUM. INT. CL. 42. REG. 9-7-2004.  
2,882,416. SAEGIS. INT. CLS. 5 AND 42. REG. 9-7-2004.  
2,882,417. MISCELLANEOUS DESIGN. INT. CL. 11. REG. 9-7-2004.  
2,882,418. MCK SARGUARD. INT. CL. 6. REG. 9-7-2004.  
2,882,419. EXIM. INT. CL. 28. REG. 9-7-2004.  
2,882,421. ENVIROLITE. INT. CL. 17. REG. 9-7-2004.  
2,882,423. CHOLESTECH GDX. INT. CLS. 5 AND 10. REG. 9-7-2004.  
2,882,424. NICO AND DESIGN. INT. CL. 16. REG. 9-7-2004.  
2,882,425. GUIDESTAR AND DESIGN. INT. CL. 39. REG. 9-7-2004.  
2,882,426. NASDAQ POWerview. INT. CLS. 36 AND 38. REG. 9-7-2004.  
2,882,431. SUNSET ARCH. INT. CL. 20. REG. 9-7-2004.  
2,882,433. MEMSDRYER. INT. CL. 11. REG. 9-7-2004.  
2,882,434. CHEER CHAMPS AND DESIGN. INT. CL. 41. REG. 9-7-2004.  
2,882,435. TEAS OF CEYLON AND DESIGN. INT. CL. 30. REG. 9-7-2004.  
2,882,437. MISCELLANEOUS DESIGN. INT. CL. 12. REG. 9-7-2004.  
2,882,439. ANCORA BY MARY ANN RESTIVO AND DESIGN. INT. CL. 25. REG. 9-7-2004.  
2,882,444. W.O.B AND DESIGN. INT. CL. 35. REG. 9-7-2004.  
2,882,446. M-BOX AND DESIGN. INT. CL. 11. REG. 9-7-2004.  
2,882,450. ANGEL FLUFFS. INT. CL. 30. REG. 9-7-2004.  
2,882,452. ELITE PROTECTIVE & INVESTIGATIVE SERVICES. INT. CL. 45. REG. 9-7-2004.  
2,882,453. SIL-O-FLEX. INT. CL. 10. REG. 9-7-2004.  
2,882,454. BENJAMIN FRANKLIN THE PUNCTUAL PLUMBER! (STYLIZED). INT. CL. 37. REG. 9-7-2004.  
2,882,455. NIRA. INT. CL. 41. REG. 9-7-2004.  
2,882,456. NATIONAL INITIATIVE FOR RHEUMATOID ARTHRITIS. INT. CL. 41. REG. 9-7-2004.  
2,882,457. DOUBLIN DUBLIN. INT. CL. 9. REG. 9-7-2004.  
2,882,458. SCOTTY THE SKATEBOARD AND DESIGN. INT. CL. 35. REG. 9-7-2004.  
2,882,459. THERMAFLEX. INT. CL. 17. REG. 9-7-2004.  
2,882,463. SAFE SHIELD. INT. CL. 7. REG. 9-7-2004.  
2,882,464. EXQUISITE XTREM AND DESIGN. INT. CL. 32. REG. 9-7-2004.  
2,882,465. FIELD TRAC. INT. CL. 9. REG. 9-7-2004.  
2,882,466. WE ARE ALL NEW YORKERS. INT. CL. 16. REG. 9-7-2004.  
2,882,470. E EMPIRE (STYLIZED). INT. CL. 35. REG. 9-7-2004.  
2,882,472. FIRST CRUSH. INT. CL. 25. REG. 9-7-2004.  
2,882,473. E BENK AND DESIGN. INT. CL. 9. REG. 9-7-2004.  
2,882,480. PULSE ONLINE AND DESIGN. INT. CL. 36. REG. 9-7-2004.  
2,882,482. SPEEDPASS. INT. CL. 14. REG. 9-7-2004.  
2,882,483. WX TECH. INT. CL. 25. REG. 9-7-2004.  
2,882,491. KNOWLEDGE BEYOND DOUBT. INT. CL. 41. REG. 9-7-2004.  
2,882,493. XAKTSOFT. INT. CL. 42. REG. 9-7-2004.  
2,882,495. THE FITTING ROOM. INT. CL. 35. REG. 9-7-2004.  
2,882,500. TRANSTAR. INT. CL. 36. REG. 9-7-2004.  
2,882,501. INKJETMART. INT. CL. 35. REG. 9-7-2004.  
2,882,502. INDURE. INT. CL. 17. REG. 9-7-2004.  
2,882,504. BIG BEN. INT. CL. 30. REG. 9-7-2004.  
2,882,505. DIYN AND DESIGN. INT. CL. 9. REG. 9-7-2004.  
2,882,507. PROKRT AND DESIGN. INT. CL. 25. REG. 9-7-2004.  
2,882,509. SAFETY SCRUBS. INT. CL. 10. REG. 9-7-2004.  
2,882,510. "THE ORIGINAL" NEW YORK MILKSHAKE COMPANY AND DESIGN. INT. CL. 43. REG. 9-7-2004.  
2,882,511. EVANSVILLE BLUECATS. INT. CL. 41. REG. 9-7-2004.  
2,882,513. SPARKLEWORKS. INT. CL. 28. REG. 9-7-2004.  
2,882,516. MISS TEEN AFRICAN AMERICAN. INT. CL. 41. REG. 9-7-2004.  
2,882,520. STRETCH RUN. INT. CL. 25. REG. 9-7-2004.  
2,882,525. OLLIE. INT. CL. 25. REG. 9-7-2004.  
2,882,526. BLOSSOM AND DESIGN. INT. CL. 14. REG. 9-7-2004.  
2,882,527. G W L G AND DESIGN. INT. CL. 25. REG. 9-7-2004.  
2,882,532. SELECTRX PHARMACY PPO AND DESIGN. INT. CL. 36. REG. 9-7-2004.  
2,882,534. LEXINGTON HORSEMEN. INT. CL. 41. REG. 9-7-2004.  
2,882,538. AB AND DESIGN. INT. CLS. 18 AND 25. REG. 9-7-2004.  
2,882,541. OUT-OF-SIGHT POWER JACK. INT. CL. 9. REG. 9-7-2004.  
2,882,545. G SPORT MR. GASKET PERFORMANCE GROUP (STYLIZED). INT. CLS. 7 AND 12. REG. 9-7-2004.  
2,882,546. G SPORT MR. GASKET PERFORMANCE GROUP AND DESIGN. INT. CLS. 12 AND 16. REG. 9-7-2004.



- 2,882,548. CUSTOM CRAFT WINDOW FASHIONS AND DESIGN. INT. CL. 20. REG. 9-7-2004.
- 2,882,551. EAGLE CHRISTIAN OUTLET. INT. CL. 35. REG. 9-7-2004.
- 2,882,552. BUCKNELL BISON AND DESIGN. INT. CL. 20. REG. 9-7-2004.
- 2,882,557. GYPSY AND DESIGN. INT. CL. 36. REG. 9-7-2004.
- 2,882,559. OUTROSPECTIVE RECORDS AND DESIGN. INT. CL. 41. REG. 9-7-2004.
- 2,882,560. MATRIX TNT SUPPLY CHAIN TECHNOLOGIES. INT. CL. 9. REG. 9-7-2004.
- 2,882,562. COFFEE DRIVEN. INT. CL. 35. REG. 9-7-2004.
- 2,882,563. ILA ST. CLAIRE AND DESIGN. INT. CL. 42. REG. 9-7-2004.
- 2,882,564. CRASH BAGS AND DESIGN. INT. CL. 18. REG. 9-7-2004.
- 2,882,565. MAKENOW. INT. CL. 42. REG. 9-7-2004.
- 2,882,566. SURFISTA. INT. CL. 25. REG. 9-7-2004.
- 2,882,569. TUTTI FRUITTI. INT. CL. 30. REG. 9-7-2004.
- 2,882,576. BUMPIT. INT. CL. 20. REG. 9-7-2004.
- 2,882,578. NPO. INT. CL. 9. REG. 9-7-2004.
- 2,882,579. BRANELLI. INT. CL. 25. REG. 9-7-2004.
- 2,882,581. CORNERSTONE OF LEAWOOD. INT. CLS. 35 AND 36. REG. 9-7-2004.
- 2,882,582. AA AMERICA'S ARMY AND DESIGN. INT. CL. 16. REG. 9-7-2004.
- 2,882,583. TEAM HEROES. INT. CL. 16. REG. 9-7-2004.
- 2,882,585. EVIGILANCE. INT. CL. 9. REG. 9-7-2004.
- 2,882,586. MEMORIAL TOUCH. INT. CLS. 31 AND 37. REG. 9-7-2004.
- 2,882,587. LENOX HRC. INT. CL. 7. REG. 9-7-2004.
- 2,882,589. CAROL'S ANGEL. INT. CL. 20. REG. 9-7-2004.
- 2,882,591. NV NATIONAL VALVE (STYLIZED). INT. CL. 6. REG. 9-7-2004.
- 2,882,593. MOVIKA. INT. CL. 10. REG. 9-7-2004.
- 2,882,595. RTS AND DESIGN. INT. CLS. 37 AND 42. REG. 9-7-2004.
- 2,882,598. FAST FIX AND DESIGN. INT. CL. 37. REG. 9-7-2004.
- 2,882,599. IOS. INT. CLS. 9, 11, 21 AND 26. REG. 9-7-2004.
- 2,882,600. COWBOY JANE. INT. CL. 41. REG. 9-7-2004.
- 2,882,604. MOTHERSHIP. INT. CL. 11. REG. 9-7-2004.
- 2,882,605. AT WEAR. INT. CL. 25. REG. 9-7-2004.
- 2,882,607. ROBORACE. INT. CL. 6. REG. 9-7-2004.
- 2,882,609. X-KAN. INT. CL. 9. REG. 9-7-2004.
- 2,882,610. MISCELLANEOUS DESIGN. INT. CL. 40. REG. 9-7-2004.
- 2,882,613. LIPWORX. INT. CL. 3. REG. 9-7-2004.
- 2,882,614. VISIBLY CLEAN. INT. CL. 3. REG. 9-7-2004.
- 2,882,617. CAMBAR. INT. CL. 16. REG. 9-7-2004.
- 2,882,621. MISCELLANEOUS DESIGN. INT. CL. 9. REG. 9-7-2004.
- 2,882,623. INTELLIGENTBPM. INT. CL. 16. REG. 9-7-2004.
- 2,882,624. THE POWER OF EVIDENCE. INT. CL. 41. REG. 9-7-2004.
- 2,882,625. AMERICAN GIRL TODAY AND DESIGN. INT. CL. 28. REG. 9-7-2004.
- 2,882,626. CAST OF THOUSANDS. INT. CL. 9. REG. 9-7-2004.
- 2,882,627. NEUROSURGERY TODAY. INT. CLS. 35 AND 44. REG. 9-7-2004.
- 2,882,628. SERENGETI. INT. CL. 30. REG. 9-7-2004.
- 2,882,630. COLOR SMASH. INT. CL. 3. REG. 9-7-2004.
- 2,882,631. PIERRE GOURMET. INT. CL. 35. REG. 9-7-2004.
- 2,882,637. KEYSTEEL. INT. CL. 9. REG. 9-7-2004.
- 2,882,640. NEXMAG AND DESIGN. INT. CL. 42. REG. 9-7-2004.
- 2,882,643. MORE THAN MAKEUP. INT. CL. 3. REG. 9-7-2004.
- 2,882,644. ALBUMPRINT. INT. CL. 16. REG. 9-7-2004.
- 2,882,645. TRUSTCORE INVESTMENTS, INC.. INT. CL. 36. REG. 9-7-2004.
- 2,882,646. COMFORT-FLEX. INT. CL. 11. REG. 9-7-2004.
- 2,882,647. SENSATION TOTALE. INT. CL. 3. REG. 9-7-2004.
- 2,882,649. IF IT DOESN'T STICK, IT JUST DOESN'T WORK. INT. CL. 1. REG. 9-7-2004.
- 2,882,651. INFINITY. INT. CL. 11. REG. 9-7-2004.
- 2,882,652. FAIRY BEARS. INT. CL. 28. REG. 9-7-2004.
- 2,882,653. AIM. INT. CL. 35. REG. 9-7-2004.
- 2,882,655. ASB AND DESIGN. INT. CL. 35. REG. 9-7-2004.
- 2,882,656. THE POWER BEHIND THE PROMISE. INT. CL. 39. REG. 9-7-2004.
- 2,882,660. COLOUR ON, SPLASH OFF. INT. CL. 3. REG. 9-7-2004.
- 2,882,662. BEAUTY STYLE. INT. CL. 3. REG. 9-7-2004.
- 2,882,666. DESIGNED TO PERFORM. DESIGNED TO LAST.. INT. CL. 9. REG. 9-7-2004.
- 2,882,669. INNOVATOR. INT. CL. 12. REG. 9-7-2004.
- 2,882,672. BY D:SIGN (STYLIZED). INT. CL. 9. REG. 9-7-2004.
- 2,882,673. WOODIES AND DESIGN. INT. CL. 43. REG. 9-7-2004.
- 2,882,674. BEACHCOMBER. INT. CL. 33. REG. 9-7-2004.
- 2,882,675. COMETRY. INT. CL. 41. REG. 9-7-2004.
- 2,882,676. CHATHAM POTTERY AND DESIGN. INT. CL. 21. REG. 9-7-2004.
- 2,882,677. PLEX4SECS. INT. CLS. 9 AND 42. REG. 9-7-2004.
- 2,882,678. HURON RIVER PRESS. INT. CL. 41. REG. 9-7-2004.
- 2,882,682. POCO LOCO PEANUTS. INT. CL. 29. REG. 9-7-2004.
- 2,882,683. INFIGUARD AND DESIGN. INT. CL. 42. REG. 9-7-2004.
- 2,882,687. INCEPTURE KNOWLEDGE CREATOR. INT. CL. 9. REG. 9-7-2004.
- 2,882,690. CRAZY GEAR (STYLIZED). INT. CL. 28. REG. 9-7-2004.
- 2,882,691. KOMAX AND DESIGN. INT. CL. 21. REG. 9-7-2004.
- 2,882,692. SARAH SIMON. INT. CL. 28. REG. 9-7-2004.
- 2,882,693. RHONDA RODRIGUEZ. INT. CL. 28. REG. 9-7-2004.
- 2,882,694. MAGENTA MORGAN. INT. CL. 28. REG. 9-7-2004.
- 2,882,695. LUCY LEE. INT. CL. 28. REG. 9-7-2004.
- 2,882,696. DEAN DARLING. INT. CL. 28. REG. 9-7-2004.
- 2,882,697. BRANDON BROWN. INT. CL. 28. REG. 9-7-2004.
- 2,882,698. ASHLEY ADAMS. INT. CL. 28. REG. 9-7-2004.
- 2,882,699. RAGING BULL. INT. CL. 7. REG. 9-7-2004.
- 2,882,700. HEARTS & ROMANCE. INT. CL. 14. REG. 9-7-2004.
- 2,882,701. MIMESHIELD AND DESIGN. INT. CL. 9. REG. 9-7-2004.
- 2,882,703. REMAIN INDEPENDENT BUT NOT FORGOTTEN. INT. CL. 36. REG. 9-7-2004.
- 2,882,704. J-ZOO. INT. CL. 28. REG. 9-7-2004.
- 2,882,706. HABITAT. INT. CL. 33. REG. 9-7-2004.
- 2,882,707. TENDERRRRRIFIC. INT. CL. 29. REG. 9-7-2004.
- 2,882,708. HAIRCUTS ETC. (STYLIZED). INT. CL. 44. REG. 9-7-2004.
- 2,882,709. PSECHECK. INT. CL. 36. REG. 9-7-2004.
- 2,882,718. HYPHEN SUPPLY. INT. CL. 35. REG. 9-7-2004.
- 2,882,724. GREAT SOUTH CATERING. INT. CL. 43. REG. 9-7-2004.
- 2,882,725. MIND YOUR MAKEUP. INT. CL. 44. REG. 9-7-2004.
- 2,882,726. THE PEEKABOO'S. INT. CL. 28. REG. 9-7-2004.
- 2,882,727. AIRS ATMOSPHERE. INT. CL. 42. REG. 9-7-2004.
- 2,882,729. JETVEE. INT. CL. 12. REG. 9-7-2004.
- 2,882,733. CALL@VANTAGE. INT. CL. 9. REG. 9-7-2004.
- 2,882,734. VISTA. INT. CL. 9. REG. 9-7-2004.
- 2,882,735. SENSORY STYLING. INT. CL. 35. REG. 9-7-2004.
- 2,882,736. SILENT WATCH DOG. INT. CLS. 6 AND 19. REG. 9-7-2004.
- 2,882,737. LETTER DEPOT AND DESIGN. INT. CL. 28. REG. 9-7-2004.
- 2,882,740. 5 MINUTES TO FABULOUS. INT. CL. 3. REG. 9-7-2004.
- 2,882,742. SMALL TREASURES. INT. CL. 18. REG. 9-7-2004.
- 2,882,745. PMT PACKAGING MACHINERY TECHNOLOGY. INT. CL. 16. REG. 9-7-2004.
- 2,882,749. MICHELLE'S OUTRAGEOUS MORSELS AND DESIGN. INT. CL. 30. REG. 9-7-2004.
- 2,882,751. MASTER LINE. INT. CLS. 8 AND 21. REG. 9-7-2004.
- 2,882,755. XENEREX. INT. CLS. 1 AND 42. REG. 9-7-2004.

- 2,882,762. ELIXENT. INT. CLS. 35 AND 42. REG. 9-7-2004.  
 2,882,763. MISCELLANEOUS DESIGN. INT. CL. 9. REG. 9-7-2004.  
 2,882,775. REALM OF THE CLAW AND DESIGN. INT. CLS. 16 AND 28. REG. 9-7-2004.  
 2,882,777. OXIDE. INT. CLS. 9, 25 AND 28. REG. 9-7-2004.  
 2,882,778. MEDICINES THAT MAKE A DIFFERENCE. INT. CL. 5. REG. 9-7-2004.  
 2,882,780. Y NOT B SAVED. INT. CL. 25. REG. 9-7-2004.  
 2,882,782. LASALLE BANK OPEN AND DESIGN. INT. CL. 25. REG. 9-7-2004.  
 2,882,784. NICKELODEON NATION. INT. CL. 41. REG. 9-7-2004.  
 2,882,785. OPERATE IT. INT. CL. 9. REG. 9-7-2004.  
 2,882,789. LIGHTNING DIRECT. INT. CL. 35. REG. 9-7-2004.  
 2,882,792. PAPERLESS POBOX.COM AND DESIGN. INT. CL. 40. REG. 9-7-2004.  
 2,882,793. AVON WELLNESS. INT. CL. 35. REG. 9-7-2004.  
 2,882,794. RAPID LINK. INT. CL. 36. REG. 9-7-2004.  
 2,882,795. WEB RESEARCH MADE EASY. INT. CLS. 9 AND 42. REG. 9-7-2004.  
 2,882,796. PRACTICA BIO AND DESIGN. INT. CL. 25. REG. 9-7-2004.  
 2,882,797. HILARIUM. INT. CL. 28. REG. 9-7-2004.  
 2,882,798. BREAKDOWN MANAGER (STYLIZED). INT. CL. 38. REG. 9-7-2004.  
 2,882,801. MISCELLANEOUS DESIGN. INT. CL. 35. REG. 9-7-2004.  
 2,882,804. LOVABLE. INT. CL. 20. REG. 9-7-2004.  
 2,882,805. APPLESEED. INT. CL. 35. REG. 9-7-2004.  
 2,882,806. BREW. INT. CLS. 38 AND 42. REG. 9-7-2004.  
 2,882,808. COLSTAR BEER 37 ML LOW ALCOHOL AUSTRALIA'S REFRESHING BEER NATURALLY BREWED IN AUSTRALIA BEER BIRRA BIER CERVEZA AND DESIGN. INT. CL. 32. REG. 9-7-2004.  
 2,882,809. RENACLEAN. INT. CL. 10. REG. 9-7-2004.  
 2,882,812. AEROBLACK. INT. CL. 17. REG. 9-7-2004.  
 2,882,813. TUNABLE PHOTONICS CORPORATION AND DESIGN. INT. CL. 9. REG. 9-7-2004.  
 2,882,814. TMIQ. INT. CLS. 9 AND 42. REG. 9-7-2004.  
 2,882,815. BLASCO MAKE-UP ACADEMY. INT. CL. 41. REG. 9-7-2004.  
 2,882,816. BLASCO SPECIAL MAKE-UP ACADEMY. INT. CL. 41. REG. 9-7-2004.  
 2,882,825. ACCUTEL PLUS. INT. CL. 38. REG. 9-7-2004.  
 2,882,828. LED VISION STANDARD CHARACTER MARK. INT. CL. 9. REG. 9-7-2004.  
 2,882,830. GUZZLE. INT. CL. 30. REG. 9-7-2004.  
 2,882,832. ORGANICBEAUTY. INT. CLS. 3 AND 42. REG. 9-7-2004.  
 2,882,833. BETTER THAN A HUSBAND. INT. CL. 37. REG. 9-7-2004.  
 2,882,834. JENSPORTS AND DESIGN. INT. CL. 28. REG. 9-7-2004.  
 2,882,835. SEATTLE SONICS AND DESIGN. INT. CL. 35. REG. 9-7-2004.  
 2,882,836. DOUBLEDUTCH LINKS AND DESIGN. INT. CL. 41. REG. 9-7-2004.  
 2,882,838. MISCELLANEOUS DESIGN. INT. CLS. 12 AND 42. REG. 9-7-2004.  
 2,882,839. INFRATONIC. INT. CL. 10. REG. 9-7-2004.  
 2,882,840. SOUNDMARK. INT. CL. 9. REG. 9-7-2004.  
 2,882,842. AUSTIN PRODUCTIONS. INT. CL. 41. REG. 9-7-2004.  
 2,882,843. SHO SHOT. INT. CL. 25. REG. 9-7-2004.  
 2,882,845. KILL THE GERMS. FEEL THE CLEAN.. INT. CL. 5. REG. 9-7-2004.  
 2,882,847. SUB-URBAN. INT. CL. 41. REG. 9-7-2004.  
 2,882,849. IMAGINAIL. INT. CLS. 3, 7 AND 42. REG. 9-7-2004.  
 2,882,850. THE ADHD ORIGINAL. OPTIMIZED.. INT. CL. 5. REG. 9-7-2004.  
 2,882,851. TONY'S FROSTED CRUNCH. INT. CL. 30. REG. 9-7-2004.  
 2,882,855. STRATSEC. INT. CL. 42. REG. 9-7-2004.  
 2,882,857. NEO JAVA. INT. CL. 30. REG. 9-7-2004.  
 2,882,866. 6.5 5 AND DESIGN. INT. CL. 43. REG. 9-7-2004.  
 2,882,870. DADA-EEEATTT. INT. CL. 16. REG. 9-7-2004.  
 2,882,871. PIDS. INT. CL. 9. REG. 9-7-2004.  
 2,882,872. PURMER. INT. CL. 29. REG. 9-7-2004.  
 2,882,873. ACTIVA SYSTEM. INT. CL. 5. REG. 9-7-2004.  
 2,882,874. ATFISS. INT. CL. 16. REG. 9-7-2004.  
 2,882,876. TRENDMAKER HOMES THE LEADER IN AFFORDABLE LUXURY AND DESIGN. INT. CLS. 36 AND 37. REG. 9-7-2004.  
 2,882,877. THE CURVY CHICK. INT. CLS. 16 AND 25. REG. 9-7-2004.  
 2,882,880. PRETTY PERFECT. INT. CL. 25. REG. 9-7-2004.  
 2,882,881. SMALLVILLE. INT. CL. 9. REG. 9-7-2004.  
 2,882,882. HARE RIDGE. INT. CL. 33. REG. 9-7-2004.  
 2,882,883. PRINCESS OF THE DANISH COURT. INT. CL. 28. REG. 9-7-2004.  
 2,882,884. HEDGE HOG 24. INT. CL. 7. REG. 9-7-2004.  
 2,882,886. BALANCE FOR LIFE PROCESS. INT. CL. 36. REG. 9-7-2004.  
 2,882,888. HALLMARK CHOCOLATIER. INT. CL. 30. REG. 9-7-2004.  
 2,882,890. MATRIXCURE. INT. CL. 2. REG. 9-7-2004.  
 2,882,893. RAMPAGE. INT. CL. 28. REG. 9-7-2004.  
 2,882,894. PIERRE & PALETTE. INT. CL. 16. REG. 9-7-2004.  
 2,882,895. STONEFUSION. INT. CL. 9. REG. 9-7-2004.  
 2,882,897. SPEEDY CALL. INT. CL. 9. REG. 9-7-2004.  
 2,882,898. SPEEDY NET. INT. CL. 38. REG. 9-7-2004.  
 2,882,902. VITAL VENTURE CAPITAL. INT. CL. 36. REG. 9-7-2004.  
 2,882,903. TAILOR'S SELECT. INT. CL. 20. REG. 9-7-2004.  
 2,882,907. SWIVLER. INT. CLS. 25 AND 28. REG. 9-7-2004.  
 2,882,909. VERSADUR. INT. CL. 12. REG. 9-7-2004.  
 2,882,910. SADDLE MOUNT. INT. CL. 20. REG. 9-7-2004.  
 2,882,912. LASERLOC. INT. CL. 7. REG. 9-7-2004.  
 2,882,914. VISUALREP - THE FARBER CONSULTING GROUP, INC. DESKTOP DIVISION AND DESIGN. INT. CL. 9. REG. 9-7-2004.  
 2,882,915. FEMTABS. INT. CL. 5. REG. 9-7-2004.  
 2,882,916. JUVENON ENERGY FORMULA. INT. CL. 5. REG. 9-7-2004.  
 2,882,917. BRUNETTE BRILLIANCE. INT. CL. 28. REG. 9-7-2004.  
 2,882,919. LITTLE SCHOLAR. INT. CL. 16. REG. 9-7-2004.  
 2,882,920. SIDEWINDER 150. INT. CL. 8. REG. 9-7-2004.  
 2,882,923. GRAND VALLEY STATE LAKERS AND DESIGN. INT. CLS. 25 AND 41. REG. 9-7-2004.  
 2,882,925. TENONATOR. INT. CL. 8. REG. 9-7-2004.  
 2,882,926. CULTURA. INT. CLS. 35, 42 AND 44. REG. 9-7-2004.  
 2,882,929. MINI-MANTLE. INT. CL. 20. REG. 9-7-2004.  
 2,882,931. IN INTELLECTUAL NUTRITION AND DESIGN. INT. CL. 44. REG. 9-7-2004.  
 2,882,932. AIRTRIX. INT. CL. 3. REG. 9-7-2004.  
 2,882,933. PHYTO-AROMATHERAPY SEASONAL CONCEPTS. INT. CLS. 3, 5 AND 11. REG. 9-7-2004.  
 2,882,934. PLUM CREEK. INT. CLS. 3 AND 4. REG. 9-7-2004.  
 2,882,935. BRAND EQUITY & AFFINITY MEASUREMENT (BEAM). INT. CL. 35. REG. 9-7-2004.  
 2,882,936. QUEON AND DESIGN. INT. CL. 9. REG. 9-7-2004.  
 2,882,939. BIOWEST. INT. CL. 35. REG. 9-7-2004.  
 2,882,940. SEXY FITS. INT. CL. 25. REG. 9-7-2004.  
 2,882,941. NEW IDEAS ARE YOUR BUSINESS. PROTECTING THEM IS OURS.. INT. CL. 42. REG. 9-7-2004.  
 2,882,943. MIND-A-MOMMY AND DESIGN. INT. CL. 16. REG. 9-7-2004.  
 2,882,944. AMEYE (STYLIZED). INT. CL. 9. REG. 9-7-2004.  
 2,882,945. ISLA DE LA TENTACION. INT. CL. 41. REG. 9-7-2004.  
 2,882,946. DOLLAR WAVE. INT. CL. 35. REG. 9-7-2004.  
 2,882,948. GREENWOOD. INT. CL. 28. REG. 9-7-2004.  
 2,882,949. RESINDIRECT AND DESIGN. INT. CL. 35. REG. 9-7-2004.  
 2,882,951. PIRANHA KILLER SUSHI. INT. CL. 43. REG. 9-7-2004.  
 2,882,953. CLEAR VIEW. INT. CL. 5. REG. 9-7-2004.  
 2,882,955. BARONESS VON LUXE. INT. CLS. 3 AND 4. REG. 9-7-2004.  
 2,882,956. SIESTA KEY. INT. CL. 25. REG. 9-7-2004.

- 2,882,959. DUNCAN COLORSHIELD. INT. CL. 40. REG. 9-7-2004.
- 2,882,963. AETHER TRAILERMAX. INT. CLS. 9 AND 38. REG. 9-7-2004.
- 2,882,964. ARENA. INT. CL. 10. REG. 9-7-2004.
- 2,882,967. QUICK BLOCK. INT. CL. 2. REG. 9-7-2004.
- 2,882,970. FRESH MINDER. INT. CL. 21. REG. 9-7-2004.
- 2,882,974. SKYBOX SECURITY (STYLIZED). INT. CL. 9. REG. 9-7-2004.
- 2,882,978. MEANTIME M T AND DESIGN. INT. CL. 25. REG. 9-7-2004.
- 2,882,979. REACH. INT. CL. 36. REG. 9-7-2004.
- 2,882,981. CRATE-A-SALE. INT. CL. 16. REG. 9-7-2004.
- 2,882,982. KECCI. INT. CL. 18. REG. 9-7-2004.
- 2,882,983. OBJECTIVE INVESTMENTS. INT. CL. 36. REG. 9-7-2004.
- 2,882,984. OFF THE MAP. INT. CLS. 9 AND 28. REG. 9-7-2004.
- 2,882,985. FUNDRAISING SOLUTIONS. INT. CL. 36. REG. 9-7-2004.
- 2,882,988. POINTCHARGER. INT. CL. 9. REG. 9-7-2004.
- 2,882,991. FOXFIRE. INT. CL. 43. REG. 9-7-2004.
- 2,882,993. TRUNAV. INT. CL. 9. REG. 9-7-2004.
- 2,882,995. RUB ME ALL OVER. INT. CL. 3. REG. 9-7-2004.
- 2,882,996. PS: RELIEF!. INT. CL. 5. REG. 9-7-2004.
- 2,882,997. CLEAN IT OUT. INT. CL. 3. REG. 9-7-2004.
- 2,882,998. FORTY WINKS. INT. CL. 3. REG. 9-7-2004.
- 2,882,999. MOULDWORKS. INT. CL. 9. REG. 9-7-2004.
- 2,883,001. FRENCH MILL STONE. INT. CL. 19. REG. 9-7-2004.
- 2,883,003. ALMP. INT. CL. 25. REG. 9-7-2004.
- 2,883,005. WHOLELIFE PAGES. INT. CLS. 16 AND 44. REG. 9-7-2004.
- 2,883,006. DISMS. INT. CL. 9. REG. 9-7-2004.
- 2,883,007. SIMPLE INVENTIONS. INT. CL. 42. REG. 9-7-2004.
- 2,883,014. ALLYOUCANPLAY. INT. CL. 41. REG. 9-7-2004.
- 2,883,017. EPI-VASC. INT. CL. 5. REG. 9-7-2004.
- 2,883,018. THE ORIGINAL CUPCAKE SHOT DRINK COMPANY. INT. CL. 32. REG. 9-7-2004.
- 2,883,019. WHAT'S BEHIND YOUR FACE?. INT. CL. 35. REG. 9-7-2004.
- 2,883,021. ANDREA YORK. INT. CL. 25. REG. 9-7-2004.
- 2,883,024. KLEENZ-IT. INT. CL. 3. REG. 9-7-2004.
- 2,883,026. NICOTINE FREE. SIMPLE AS 1-2-3. INT. CL. 34. REG. 9-7-2004.
- 2,883,030. BOBBY BLOOMS. INT. CL. 26. REG. 9-7-2004.
- 2,883,031. THERMALRHO. INT. CL. 1. REG. 9-7-2004.
- 2,883,032. PRO SE IPSO. INT. CL. 41. REG. 9-7-2004.
- 2,883,034. EASY TRAY AND DESIGN. INT. CL. 21. REG. 9-7-2004.
- 2,883,035. AHA! (STYLIZED). INT. CLS. 29 AND 30. REG. 9-7-2004.
- 2,883,036. DELIXUS. INT. CL. 9. REG. 9-7-2004.
- 2,883,038. ONE TOUCH. INT. CL. 9. REG. 9-7-2004.
- 2,883,041. BETTER-THAN-CHOCOLATE PRESS. INT. CL. 9. REG. 9-7-2004.
- 2,883,044. GONE FROM HOME. INT. CL. 35. REG. 9-7-2004.
- 2,883,045. SAMMIE SNOOZYHEAD. INT. CL. 28. REG. 9-7-2004.
- 2,883,046. CANDY CUPCAKE. INT. CL. 28. REG. 9-7-2004.
- 2,883,049. EXPERTANYTIME. INT. CL. 41. REG. 9-7-2004.
- 2,883,050. EXTREME RUSH. INT. CL. 41. REG. 9-7-2004.
- 2,883,053. ITC. INT. CL. 28. REG. 9-7-2004.
- 2,883,054. 7 HEAVENLY CHARDS ENDURANCE CHARITY TEMPERANCE PRUDENCE JUSTICE FAITH HOPE AND DESIGN. INT. CL. 33. REG. 9-7-2004.
- 2,883,057. WRAPZEL. INT. CL. 30. REG. 9-7-2004.
- 2,883,059. STRENFLEX. INT. CL. 16. REG. 9-7-2004.
- 2,883,060. EPISCOPOPOLY. INT. CL. 28. REG. 9-7-2004.
- 2,883,061. THE HOMEWORK ROOM. INT. CL. 41. REG. 9-7-2004.
- 2,883,064. SMOKIN' TIRE AND DESIGN. INT. CL. 25. REG. 9-7-2004.
- 2,883,066. THE FUTURE OF R/C. INT. CL. 28. REG. 9-7-2004.
- 2,883,067. EUROTECH. INT. CL. 20. REG. 9-7-2004.
- 2,883,069. RELPAX MIGRAINE REPORT. INT. CL. 16. REG. 9-7-2004.
- 2,883,073. OPENCELL. INT. CL. 9. REG. 9-7-2004.
- 2,883,074. N POWER AND DESIGN. INT. CLS. 35 AND 37. REG. 9-7-2004.
- 2,883,076. NATURE'S PREFERENCE. INT. CLS. 20 AND 24. REG. 9-7-2004.
- 2,883,078. ACUMEN. INT. CL. 9. REG. 9-7-2004.
- 2,883,079. WRISTPASS. INT. CL. 20. REG. 9-7-2004.
- 2,883,083. NET SAVVY. INT. CL. 43. REG. 9-7-2004.
- 2,883,084. FOR-HEAVEN'S-SAKE. INT. CL. 16. REG. 9-7-2004.
- 2,883,085. CIRQUAL. INT. CL. 11. REG. 9-7-2004.
- 2,883,086. HAMTARO LITTLE HAMSTERS BIG ADVENTURES AND DESIGN. INT. CL. 24. REG. 9-7-2004.
- 2,883,087. BORROWED LIGHT. INT. CL. 41. REG. 9-7-2004.
- 2,883,088. OAG TRAVEL PLANNER. INT. CLS. 9 AND 39. REG. 9-7-2004.
- 2,883,089. PRIMEPLUS. INT. CL. 29. REG. 9-7-2004.
- 2,883,090. DISCOVERIES FOR LIFE. INT. CL. 42. REG. 9-7-2004.
- 2,883,094. WIZPLC. INT. CL. 9. REG. 9-7-2004.
- 2,883,095. WIZSCHEDULER. INT. CL. 9. REG. 9-7-2004.
- 2,883,097. FOX RIDGE. INT. CL. 25. REG. 9-7-2004.
- 2,883,098. FIBROSTIK. INT. CL. 10. REG. 9-7-2004.
- 2,883,099. URBANOMIKS. INT. CL. 25. REG. 9-7-2004.
- 2,883,100. DSENTERPRISE (STYLIZED). INT. CL. 9. REG. 9-7-2004.
- 2,883,101. DSE (STYLIZED). INT. CL. 9. REG. 9-7-2004.
- 2,883,103. H C HEADMASTER CAMPUSWEAR AND DESIGN. INT. CL. 25. REG. 9-7-2004.
- 2,883,105. AM-DRAIN. INT. CL. 17. REG. 9-7-2004.
- 2,883,108. DIS-ORDER. INT. CL. 3. REG. 9-7-2004.
- 2,883,111. FAST TRACK. INT. CL. 21. REG. 9-7-2004.
- 2,883,112. WHAT A WIRELESS WORLD IT SHOULD BE. INT. CL. 38. REG. 9-7-2004.
- 2,883,115. IDMSC. INT. CL. 42. REG. 9-7-2004.
- 2,883,117. ULTRA PRIME. INT. CL. 19. REG. 9-7-2004.
- 2,883,118. GLACIS CAPITAL MANAGEMENT AND DESIGN. INT. CL. 36. REG. 9-7-2004.
- 2,883,119. 1% MIRACLE. INT. CL. 41. REG. 9-7-2004.
- 2,883,120. SECURE PROTECT NETWORK AND DESIGN. INT. CL. 42. REG. 9-7-2004.
- 2,883,122. PICCOLO. INT. CL. 21. REG. 9-7-2004.
- 2,883,125. SCRIBESMART. INT. CL. 9. REG. 9-7-2004.
- 2,883,126. PLANITACTION. INT. CL. 35. REG. 9-7-2004.
- 2,883,127. ULTIMATE JOURNEYS, LLC AND DESIGN. INT. CL. 39. REG. 9-7-2004.
- 2,883,128. ULTIMATE JOURNEYS, LLC AND DESIGN. INT. CL. 43. REG. 9-7-2004.
- 2,883,129. CAN AM. INT. CL. 12. REG. 9-7-2004.
- 2,883,130. 4X MADE EASY. INT. CL. 9. REG. 9-7-2004.
- 2,883,131. ONE CLICK. THAT'S QUICK. INT. CL. 36. REG. 9-7-2004.
- 2,883,132. DINITY KRISIS. INT. CL. 25. REG. 9-7-2004.
- 2,883,133. N.E.W. NUTRITIONALLY ENRICHED WATER. INT. CL. 32. REG. 9-7-2004.
- 2,883,134. MAKING TOMORROW'S MEMORIES BY CAPTURING TODAY'S HAPPINESS. INT. CL. 41. REG. 9-7-2004.
- 2,883,135. SKINGREDIENTS. INT. CL. 3. REG. 9-7-2004.
- 2,883,138. X-TRCT. INT. CL. 41. REG. 9-7-2004.
- 2,883,139. AMERICAN CRAFTSMAN WINDOWS AND DESIGN. INT. CL. 40. REG. 9-7-2004.
- 2,883,140. NEXTBOOK AND DESIGN. INT. CL. 41. REG. 9-7-2004.
- 2,883,141. ROCKSTARS HAVE KIDNAPPED MY SON. INT. CL. 41. REG. 9-7-2004.
- 2,883,142. GET FIT, ON ROUTE 66 AND DESIGN. INT. CL. 41. REG. 9-7-2004.
- 2,883,143. SEVEN IN THE MORNING. INT. CL. 30. REG. 9-7-2004.
- 2,883,145. SNEAKER DAY AND DESIGN. INT. CL. 36. REG. 9-7-2004.
- 2,883,146. SNEAKER DAY AND DESIGN. INT. CL. 41. REG. 9-7-2004.
- 2,883,147. KAEMPZIN. INT. CL. 3. REG. 9-7-2004.

- 2,883,148. SERVIAS. INT. CL. 9. REG. 9-7-2004.  
 2,883,150. SYNTAGE. INT. CL. 9. REG. 9-7-2004.  
 2,883,151. VOY. INT. CL. 36. REG. 9-7-2004.  
 2,883,152. VITAL CARD. INT. CL. 16. REG. 9-7-2004.  
 2,883,153. GRANOBELLO. INT. CL. 30. REG. 9-7-2004.  
 2,883,155. BRINGING LIFE TO YOUR IDEAS. INT. CL. 42. REG. 9-7-2004.  
 2,883,157. STRENGTH COMES FROM WITHIN. INT. CL. 35. REG. 9-7-2004.  
 2,883,161. SUSSEX. INT. CL. 11. REG. 9-7-2004.  
 2,883,163. FOUR4ALL. INT. CL. 30. REG. 9-7-2004.  
 2,883,165. SHOP TOWELS IN A BOX AND DESIGN. INT. CL. 16. REG. 9-7-2004.  
 2,883,166. PASTEURIZE THIS!. INT. CL. 29. REG. 9-7-2004.  
 2,883,167. VIRTUGATE. INT. CL. 45. REG. 9-7-2004.  
 2,883,168. VIRTUGREET. INT. CL. 45. REG. 9-7-2004.  
 2,883,169. DODGE POWER DAYS. INT. CL. 41. REG. 9-7-2004.  
 2,883,170. EMPOWERTEK. INT. CL. 42. REG. 9-7-2004.  
 2,883,171. OXYMAX. INT. CL. 3. REG. 9-7-2004.  
 2,883,175. COMPLETE ALL DAY. INT. CL. 3. REG. 9-7-2004.  
 2,883,176. ROCK ON!. INT. CL. 9. REG. 9-7-2004.  
 2,883,177. MEMORY ZONE. INT. CL. 20. REG. 9-7-2004.  
 2,883,180. THE IRISH SITTER. INT. CL. 44. REG. 9-7-2004.  
 2,883,181. CONTENTED CANINE. INT. CL. 3. REG. 9-7-2004.  
 2,883,182. BODY SURF. INT. CL. 3. REG. 9-7-2004.  
 2,883,183. PB N° GO AND DESIGN. INT. CL. 29. REG. 9-7-2004.  
 2,883,184. POWER SIGNS TREATMENT. INT. CL. 3. REG. 9-7-2004.  
 2,883,185. CHEF DAD. INT. CL. 30. REG. 9-7-2004.  
 2,883,187. SAFEVIEW AND DESIGN. INT. CL. 20. REG. 9-7-2004.  
 2,883,188. INSULEAN. INT. CL. 5. REG. 9-7-2004.  
 2,883,189. INTERNATIONAL SOIL TECHNOLOGIES, INC.. INT. CL. 40. REG. 9-7-2004.  
 2,883,190. ROBOTIC WARRIOR. INT. CL. 13. REG. 9-7-2004.  
 2,883,194. HYDRA-FLUSH. INT. CL. 3. REG. 9-7-2004.  
 2,883,195. TRU-TRIM. INT. CL. 16. REG. 9-7-2004.  
 2,883,196. NL ASSET BUILDER. INT. CL. 36. REG. 9-7-2004.  
 2,883,200. VOYTEK. INT. CL. 9. REG. 9-7-2004.  
 2,883,202. WORLD BLACK BELT. INT. CL. 25. REG. 9-7-2004.  
 2,883,204. EVAC+. INT. CL. 9. REG. 9-7-2004.  
 2,883,205. EARS TO YA. INT. CL. 25. REG. 9-7-2004.  
 2,883,207. NATURE SENT. INT. CL. 16. REG. 9-7-2004.  
 2,883,209. WAI KI KI KOOLER. INT. CL. 32. REG. 9-7-2004.  
 2,883,210. JUNGLE JAMMERS. INT. CL. 32. REG. 9-7-2004.  
 2,883,211. QURB. INT. CL. 9. REG. 9-7-2004.  
 2,883,212. NUMERATOR. INT. CL. 36. REG. 9-7-2004.  
 2,883,213. FRUITY JELLY. INT. CL. 3. REG. 9-7-2004.  
 2,883,214. NUTONES. INT. CL. 9. REG. 9-7-2004.  
 2,883,216. WATCHFUL NETWORK. INT. CL. 35. REG. 9-7-2004.  
 2,883,219. TI SUPER TOE. INT. CL. 25. REG. 9-7-2004.  
 2,883,220. STORYSHOP. INT. CL. 9. REG. 9-7-2004.  
 2,883,221. STORYMAKER. INT. CL. 9. REG. 9-7-2004.  
 2,883,223. FASHIONTACKLE. INT. CL. 14. REG. 9-7-2004.  
 2,883,229. SPICE MICE. INT. CL. 28. REG. 9-7-2004.  
 2,883,237. AQUI TE PRESTAMOS ATENCION. INT. CL. 36. REG. 9-7-2004.  
 2,883,238. TIMELESS RETREAT. INT. CL. 20. REG. 9-7-2004.  
 2,883,241. BAR 10 (STYLIZED). INT. CL. 43. REG. 9-7-2004.  
 2,883,242. CURIOMOUNT. INT. CL. 20. REG. 9-7-2004.  
 2,883,244. FRESH COMFORT. INT. CL. 21. REG. 9-7-2004.  
 2,883,246. NATURAL PURRZ. INT. CL. 31. REG. 9-7-2004.  
 2,883,247. POPPPSS. INT. CLS. 9, 16 AND 41. REG. 9-7-2004.  
 2,883,249. NANOLUX. INT. CL. 11. REG. 9-7-2004.  
 2,883,250. NEUBERGER BERMAN PLAN IQ. INT. CL. 36. REG. 9-7-2004.  
 2,883,251. PLAN IQ. INT. CL. 36. REG. 9-7-2004.  
 2,883,254. COMMUNITY MED 100. INT. CL. 36. REG. 9-7-2004.  
 2,883,255. MCASE. INT. CL. 9. REG. 9-7-2004.  
 2,883,256. KUUDUK. INT. CL. 28. REG. 9-7-2004.  
 2,883,257. NETHERFIELD. INT. CL. 20. REG. 9-7-2004.  
 2,883,260. FREEDOM BRAND. INT. CL. 25. REG. 9-7-2004.  
 2,883,266. THE EZ GOURMET (STYLIZED). INT. CL. 30. REG. 9-7-2004.  
 2,883,267. RODEO CHAMPIONS. INT. CL. 28. REG. 9-7-2004.  
 2,883,268. PYRA-MAT. INT. CL. 21. REG. 9-7-2004.  
 2,883,269. TM FACTORY. INT. CL. 9. REG. 9-7-2004.  
 2,883,270. MR. CLEAN AUTODRY CAR WASH. INT. CLS. 3, 11 AND 21. REG. 9-7-2004.  
 2,883,271. MR. CLEAN AUTODRY. INT. CLS. 3, 11 AND 21. REG. 9-7-2004.  
 2,883,272. MR. CLEAN. INT. CLS. 3, 11 AND 21. REG. 9-7-2004.  
 2,883,275. LIDROCK. INT. CL. 9. REG. 9-7-2004.  
 2,883,276. LIDROCK. INT. CL. 21. REG. 9-7-2004.  
 2,883,282. PAIN & STRESS RELEASER. INT. CL. 20. REG. 9-7-2004.  
 2,883,284. CEREUS. INT. CL. 5. REG. 9-7-2004.  
 2,883,285. SONOMA VILLA AND DESIGN. INT. CL. 21. REG. 9-7-2004.  
 2,883,295. ESCORTS AND DESIGN. INT. CLS. 16 AND 25. REG. 9-7-2004.  
 2,883,297. ALEXIS MUSELODY. INT. CL. 9. REG. 9-7-2004.  
 2,883,298. CLASSIC FILE. INT. CL. 20. REG. 9-7-2004.  
 2,883,299. MEGA FILE. INT. CL. 20. REG. 9-7-2004.  
 2,883,300. MARE & MAINTENANCE. INT. CL. 31. REG. 9-7-2004.  
 2,883,303. SPLENDOR OF SPRING. INT. CLS. 16 AND 26. REG. 9-7-2004.  
 2,883,306. NANCY'S PETITE SOUFFLÉ (STYLIZED). INT. CL. 30. REG. 9-7-2004.  
 2,883,308. GEOQUOTE. INT. CL. 42. REG. 9-7-2004.  
 2,883,309. FLEUR DE VIE. INT. CL. 3. REG. 9-7-2004.  
 2,883,312. TEMPSPAN. INT. CL. 5. REG. 9-7-2004.  
 2,883,314. THE SMOKING GUN. INT. CL. 41. REG. 9-7-2004.  
 2,883,318. THE BIG PEN. INT. CL. 41. REG. 9-7-2004.  
 2,883,320. BEYOND GOOD! BRAND. INT. CL. 29. REG. 9-7-2004.  
 2,883,321. CONTRACT J.A.C.K.. INT. CL. 9. REG. 9-7-2004.  
 2,883,322. EFX (STYLIZED). INT. CL. 9. REG. 9-7-2004.  
 2,883,326. POLARIS. INT. CL. 11. REG. 9-7-2004.  
 2,883,329. SCENTS-U-KNOW. INT. CL. 4. REG. 9-7-2004.  
 2,883,331. DURACOLOUR. INT. CL. 3. REG. 9-7-2004.  
 2,883,334. ORANGE BAY. INT. CL. 25. REG. 9-7-2004.  
 2,883,335. OUR SOURCE. YOUR SUPPLY.. INT. CL. 5. REG. 9-7-2004.  
 2,883,337. TEXAS PERFECT 10. INT. CL. 31. REG. 9-7-2004.  
 2,883,339. TECHCHECK. INT. CL. 35. REG. 9-7-2004.  
 2,883,341. SHINING KISSES. INT. CL. 3. REG. 9-7-2004.  
 2,883,343. ELEMENTS OF LIVING. INT. CL. 16. REG. 9-7-2004.  
 2,883,347. PRIME REWARDS CONNECTION. INT. CL. 16. REG. 9-7-2004.  
 2,883,351. FRONTIER. INT. CL. 25. REG. 9-7-2004.  
 2,883,353. SLOT MACHINE. INT. CL. 28. REG. 9-7-2004.  
 2,883,355. HOT FORGED. INT. CL. 28. REG. 9-7-2004.  
 2,883,356. ULTIMATE GOLD. INT. CL. 14. REG. 9-7-2004.  
 2,883,357. BERRIES AND CREAM MINT (STYLIZED). INT. CL. 31. REG. 9-7-2004.  
 2,883,358. VAIL LIVING. INT. CL. 16. REG. 9-7-2004.  
 2,883,359. AROMA DRYER. INT. CL. 11. REG. 9-7-2004.  
 2,883,360. PMONLINE. INT. CL. 42. REG. 9-7-2004.  
 2,883,361. EDUCATION FINANCE CENTER. INT. CLS. 16 AND 36. REG. 9-7-2004.  
 2,883,363. MISCELLANEOUS DESIGN. INT. CL. 11. REG. 9-7-2004.  
 2,883,365. NAPLES LIVING. INT. CL. 16. REG. 9-7-2004.  
 2,883,366. EXTRAORDINARY REWARDS. INT. CL. 36. REG. 9-7-2004.  
 2,883,368. INDIANAPOLIS COLLEGE. INT. CL. 41. REG. 9-7-2004.  
 2,883,369. UPSCALE SMALL SCALE DINING. INT. CL. 20. REG. 9-7-2004.  
 2,883,370. ONE-STEP WAX. INT. CL. 3. REG. 9-7-2004.  
 2,883,371. SECURITIZATION NEWS. INT. CLS. 16 AND 36. REG. 9-7-2004.  
 2,883,372. CHARLOTTESVILLE TROLLEY RENTALS. INT. CL. 39. REG. 9-7-2004.  
 2,883,374. SURETY AMERICA. INT. CL. 36. REG. 9-7-2004.  
 2,883,376. 1-800 US LEMON. INT. CL. 42. REG. 9-7-2004.



- 2,883,378. KENAI WILD. INT. CL. 29. REG. 9-7-2004.  
 2,883,379. THE PIPES REPORT. INT. CL. 16. REG. 9-7-2004.  
 2,883,380. PCS DATA LINK. INT. CL. 38. REG. 9-7-2004.  
 2,883,381. BEST COFFEE ON THE PLANET! (STYLIZED).  
 INT. CL. 30. REG. 9-7-2004.  
 2,883,386. DIVA AMOUR AND DESIGN. INT. CL. 25. REG.  
 9-7-2004.  
 2,883,388. PROFESSIONAL OFFICE BUILDING MANAGE-  
 MENT. INT. CL. 16. REG. 9-7-2004.  
 2,883,389. INTERNATIONAL BEAD SHOW STANDARD  
 CHARACTER MARK. INT. CL. 35. REG. 9-7-  
 2004.  
 2,883,390. ZOUK. INT. CL. 41. REG. 9-7-2004.  
 2,883,391. CREATIVE CELEBRATIONS. INT. CL. 41. REG.  
 9-7-2004.  
 2,883,392. PRIVATE MESSENGER. INT. CL. 42. REG. 9-7-  
 2004.  
 2,883,393. NOODLE CHRUNCH (STYLIZED). INT. CL. 30.  
 REG. 9-7-2004.  
 2,883,394. LEATHERETTES. INT. CL. 21. REG. 9-7-2004.  
 2,883,395. OOWARE. INT. CL. 9. REG. 9-7-2004.  
 2,883,396. ELDERSTORE. INT. CL. 35. REG. 9-7-2004.  
 2,883,397. 5 ESSENCE. INT. CL. 3. REG. 9-7-2004.  
 2,883,400. COLOR COORDINATES. INT. CL. 27. REG. 9-7-  
 2004.  
 2,883,401. DRIP ALERT. INT. CL. 10. REG. 9-7-2004.  
 2,883,402. SAVORY SAUCES, INC.. INT. CL. 30. REG. 9-7-  
 2004.  
 2,883,404. WWW.BIOPATENTLAW.COM. INT. CL. 42. REG.  
 9-7-2004.  
 2,883,406. PREMIUM SALARY REPORT. INT. CL. 35. REG.  
 9-7-2004.  
 2,883,407. SENIOR LIFE INSURANCE COMPANY AND  
 DESIGN. INT. CL. 36. REG. 9-7-2004.  
 2,883,408. INTERNATIONAL BONEFISHING SOCIETY.  
 INT. CLS. 25 AND 41. REG. 9-7-2004.  
 2,883,409. BEAUTIFUL SHAPING. INT. CL. 25. REG. 9-7-  
 2004.  
 2,883,410. INFERTILITY CENTER OF HOUSTON. INT. CL.  
 44. REG. 9-7-2004.  
 2,883,411. ALBUM DESIGNER. INT. CL. 9. REG. 9-7-2004.  
 2,883,414. WORLD'S FINEST TOYS. INT. CL. 16. REG. 9-7-  
 2004.  
 2,883,415. XPERTCMA. INT. CL. 9. REG. 9-7-2004.  
 2,883,416. SWEETN' JUICY. INT. CL. 31. REG. 9-7-2004.  
 2,883,418. COMPACT EQUIPMENT. INT. CL. 16. REG. 9-7-  
 2004.  
 2,883,419. SHIPWORKS. INT. CL. 37. REG. 9-7-2004.  
 2,883,420. ADAPT ADVANCEMENT COOPERATIVE AND  
 DESIGN. INT. CL. 25. REG. 9-7-2004.  
 2,883,422. \$100 MILLION DOLLAR CLUB. INT. CL. 36. REG.  
 9-7-2004.  
 2,883,423. GAY & LESBIAN COMMUNITY EXPO. INT. CL.  
 35. REG. 9-7-2004.  
 2,883,426. DETOXX BOX STANDARD CHARACTER  
 MARK. INT. CL. 5. REG. 9-7-2004.
- 2,883,427. CRYSTAL'S CHARMS STANDARD CHARAC-  
 TER MARK. INT. CL. 14. REG. 9-7-2004.  
 2,884,900. MISCELLANEOUS DESIGN. INT. CL. 31. REG. 9-  
 14-2004.  
 2,886,263. MRI MOBILE AND DESIGN. INT. CL. 44. REG. 9-  
 21-2004.  
 2,888,774. ONE BIG MAN & ONE BIG TRUCK AND DE-  
 SIGN. INT. CL. 39. REG. 9-28-2004.  
 2,890,385. PHOTOSENSUALIS. INT. CLS. 16 AND 41. REG.  
 9-28-2004.  
 2,891,317. COPYCO (STYLIZED). INT. CL. 35. REG. 10-5-  
 2004.  
 2,891,495. STARWOOD. INT. CLS. 35 AND 39 ONLY. REG.  
 10-5-2004.  
 2,893,431. ILLUMINATIONS. INT. CLS. 21 AND 35 ONLY.  
 REG. 10-12-2004.  
 2,895,278. ASTRONAUT PEOPLE WEAR. INT. CL. 18  
 ONLY. REG. 10-19-2004.  
 2,896,437. FUNCTIONAL INTEGRATED THERAPY. INT.  
 CLS. 9, 16 AND 44 ONLY. REG. 10-19-2004.  
 2,916,131. CORDYS. INT. CL. 38 ONLY. REG. 1-4-2005.  
 2,916,631. MAID OF THE MIST SINCE 1846 AND DESIGN.  
 INT. CLS. 26 AND 34 ONLY. REG. 1-4-2005.  
 2,938,419. MGM. INT. CL. 33 ONLY. REG. 4-5-2005.  
 2,938,549. CSD. INT. CLS. 9 AND 19 ONLY. REG. 4-5-2005.  
 2,938,756. STAND4. INT. CL. 35 ONLY. REG. 4-5-2005.  
 2,942,804. CHILDREN'S MUSEUM PITTSBURGH (STY-  
 LIZED). INT. CL. 28 ONLY. REG. 4-19-2005.  
 2,971,403. ULUDAG. INT. CL. 30 ONLY. REG. 7-19-2005.  
 3,043,076. RAFFAELLO DECOR STUCCO (STYLIZED).  
 INT. CL. 27 ONLY. REG. 1-17-2006.
- 
- SECTION 71**
- 
- 3,032,511. COLOMBIN STANDARD CHARACTER MARK.  
 INT. CLS. 6 AND 20 ONLY. REG. 12-20-2005.  
 3,055,709. HILDEGARD BRAUKMANN AND DESIGN.  
 INT. CLS. 3 AND 44 ONLY. REG. 1-31-2006.
- 
- INADVERTENTLY ISSUED REGISTRATION  
 NUMBERS**
- 
- 3,921,948. DEVICewise STANDARD CHARACTER  
 MARK. INT. CLS. 42 AND 45. REG. 2-22-2011.  
 RESTORED TO SN 77-930,283.

\* \* \* \* \*



# TRADEMARK REGISTRATIONS AMENDED, CORRECTED, ETC.

The designation "U.S. Cl." appearing in this section refers to the U.S. class in effect prior to Sep. 1, 1973 rather than the international class which applies to applications filed on or after that date. For adoption of international classification see notice in the OFFICIAL GAZETTE of Jun. 26, 1973 (911 O.G. TM 210).

Any change to the registration will be indicated at the bottom of each entry under ELEMENTS AMENDED, CORRECTED OR RESTRICTED. With the exception of changes to the goods and services, additions to the registration will appear in asterisks and deletions of the registration will appear in brackets. Elements which are only changed will be listed with no punctuation. As to the goods/services statement, amendments to the goods/services will appear in asterisks and deletions will appear in brackets. In addition if any change to the goods/services occurs, the element "Goods/Services" will be listed under ELEMENTS AMENDED, CORRECTED OR RESTRICTED.

542,990. REG. 5-29-1951. ORFEVRENERIE CHRISTOFLE (FRANCE CORPORATION) 9 RUE ROYALE, 75008 PARIS, FRANCE., SN 71-581,740. FILED 7-9-1949. PRINCIPAL REGISTER.



## Christofle

OWNER OF FRANCE REG. NO. 390319, DATED 12-16-1948.

INT. CLS. 8 AND 14/U.S. CL. 28

FOR GOLD AND STERLING SILVER FLATWARE AND HOLLOW WARE—NAMELY. BOWLS, TRAYS, SALT CELLARS, CASSEROLES, COVER DISHES, SAUCE DISHES, ICE CONTAINERS, COFFEE MAKING DEVICES, SALT AND PEPPER SHAKERS, GLASS HOLDERS, CUPS, COCKTAIL SHAKERS, TEA AND COFFEE POTS, PITCHERS, TEA AND COFFEE SETS, AND KNIVES, FORKS, AND SPOONS.

ELEMENTS AMENDED  
MARK

544,931. REG. 7-10-1951. CHURCH & DWIGHT CO., INC. (DELAWARE CORPORATION) 469 NORTH HARRISON STREET, LAW DEPARTMENT, PRINCETON, NJ, 08543, SN 71-599,358. FILED 6-17-1950. PRINCIPAL REGISTER.

# TROJAN

OWNER OF U.S. REG. NO. 429,472.  
INT. CL. 10/U.S. CLS. 26, 39 AND 44  
FOR [ PROPHYLACTIC MEMBRANOUS ARTICLES FOR THE PREVENTION OF CONTAGIOUS DISEASES ]  
\* CONDOMS \*  
FIRST USE 11-5-1946; IN COMMERCE 11-5-1946.

ELEMENTS AMENDED  
GOODS/SERVICES  
MARK  
U.S. CLASS(ES)

658,838. REG. 2-25-1958. HARVEST MANOR FARMS, LLC (DELAWARE LIMITED LIABILITY COMPANY) 8 ZANE GREY STREET, EL PASO, TX, 79906, SN 71-692,692. FILED 8-9-1955. PRINCIPAL REGISTER.

## ALL AMERICAN

INT. CLS. 1, 5, 29, 30, 31 AND 32/U.S. CL. 46

FOR [ PEANUT BUTTER, ] SALTED NUTS, SUNFLOWER SEEDS, ROASTED PEANUTS IN THE SHELL, AND NUT MEATS (VARIOUS).

FIRST USE 9-0-1949; IN COMMERCE 9-0-1949.

ELEMENTS AMENDED  
MARK

713,930. REG. 4-11-1961. CORN PRODUCTS INTERNATIONAL, INC. (DELAWARE CORPORATION) 5 WESTBROOK CORPORATE CENTER, WESTCHESTER, IL, 60154, SN 72-095,253. FILED 4-18-1960. PRINCIPAL REGISTER.

## PRAIRIE GOLD

INT. CL. 31/U.S. CLS. 1 AND 46

FOR GLUTEN FEEDS FOR POULTRY, HOGS, CATTLE AND HORSES, AND GLUTEN MEAL USED AS AN INGREDIENT OF FEEDS FOR POULTRY, HOGS, CATTLE AND HORSES.

FIRST USE 2-15-1960; IN COMMERCE 2-15-1960.

ELEMENTS AMENDED  
\*OWNER NAME\*  
\*OWNER ADDRESS\*  
\*CITIZENSHIP\*  
\*ENTITY\*  
GOODS/SERVICES  
U.S. CLASS(ES)  
DATE OF FIRST USE  
DATE OF FIRST USE IN COMMERCE

1,186,958. REG. 1-19-1982. CAESARS WORLD, INC. (FLORIDA CORPORATION) ONE CAESARS PALACE DRIVE, LAS VEGAS, NV, 89109, SN 73-297,472. FILED 2-17-1981. PRINCIPAL REGISTER.

**CAESARS**

OWNER OF U.S. REG. NOS. 1,036,401, 1,066,436 AND OTHERS.  
INT. CL. 28/U.S. CL. 22  
FOR DICE.  
FIRST USE 11-30-1979; IN COMMERCE 11-30-1979.

ELEMENTS AMENDED  
MARK

1,439,497. REG. 5-12-1987. NEW ECONOMY FUND (MASSACHUSETTS BUSINESS TRUST) ATTN: DAVID M. GIVNER, 333 SOUTH HOPE STREET, 55TH FLOOR, LOS ANGELES, CA, 90071, SN 73-619,771. FILED 9-15-1986. PRINCIPAL REGISTER.

**NEW ECONOMY FUND**

NO CLAIM IS MADE TO THE EXCLUSIVE RIGHT TO USE "FUND", APART FROM THE MARK AS SHOWN.  
INT. CL. 36/U.S. CL. 102  
FOR MUTUAL FUND INVESTMENT SERVICES.  
FIRST USE 5-17-1983; IN COMMERCE 5-17-1983.

ELEMENTS CORRECTED  
OWNER ADDRESS  
ENTITY

1,640,451. REG. 4-9-1991. INTERNATIONAL CHURCHILL SOCIETY (ILLINOIS NOT-FOR-PROFIT CORPORATION) 200 WEST MADISON STREET, SUITE 1700, CHICAGO, IL, 60606, SN 74-043,106. FILED 3-27-1990. PRINCIPAL REGISTER.



INT. CL. 16/U.S. CLS. 2, 5, 22, 23, 29, 37, 38 AND 50  
FOR PRINTS AND PUBLICATIONS, NAMELY, MAGAZINES [, HANDBOOKS, BOOKS AND BOOKLETS ] DEALING WITH THE LIFE AND ACCOMPLISHMENTS OF SIR WINSTON CHURCHILL.  
FIRST USE 5-15-1988; IN COMMERCE 5-15-1988.

ELEMENTS CORRECTED  
OWNER NAME  
OWNER ADDRESS

ENTITY

2,115,253. REG. 11-25-1997. INOVA DIAGNOSTICS, INC. (CALIFORNIA CORPORATION) 9900 OLD GROVE ROAD, SAN DIEGO, CA, 92131, SN 75-085,406. FILED 4-1-1996. PRINCIPAL REGISTER.

**QUANTA LITE**

NO CLAIM IS MADE TO THE EXCLUSIVE RIGHT TO USE "LITE", APART FROM THE MARK AS SHOWN.  
INT. CL. 1/U.S. CLS. 1

FOR CHEMICAL PRODUCTS FOR SCIENTIFIC PURPOSES, NAMELY, IN VITRO DIAGNOSTIC TEST REAGENTS AND CONTROL STANDARDS FOR MEDICAL RESEARCH USE.

FIRST USE 5-0-1988; IN COMMERCE 5-0-1988.

INT. CL. 5/U.S. CLS. 6, 18, 44, 46, 51 AND 52

FOR PHARMACEUTICAL [ AND VETERINARY ] PRODUCTS, NAMELY, IN VITRO TEST REAGENTS AND CONTROL STANDARDS FOR MEDICAL DIAGNOSTIC USE.

FIRST USE 5-0-1988; IN COMMERCE 5-0-1988.

INT. CL. 10/U.S. CLS. 26, 39 AND 44

FOR KITS AND COMPONENTS FOR MEDICAL DIAGNOSTICS USE, NAMELY, [ ELECTRONIC SYSTEMS COMPRISING PLATE READERS, STRIP READERS, DATA PROCESSORS, DATA REDUCTION SOFTWARE AND FLUID HANDLERS; GELS, GEL PLATES, MOUNTING MEDIA, WELL SLIDES, COVERSLIPS, WELL SLIDE HOLDERS, ] MICROWELLS [, SLIDE MASKS, CONTROL STANDARDS MOUNTED ON SLIDES, ] AND REAGENT VIALS [, DEMONSTRATION SLIDE SETS WITH PROTOCOLS ].

FIRST USE 5-0-1988; IN COMMERCE 5-0-1988.

ELEMENTS AMENDED  
GOODS/SERVICES  
OWNER ADDRESS

2,115,254. REG. 11-25-1997. INOVA DIAGNOSTICS, INC. (CALIFORNIA CORPORATION) 9900 OLD GROVE ROAD, SAN DIEGO, CA, 92131, SN 75-085,407. FILED 4-1-1996. PRINCIPAL REGISTER.

**INOVA**

INT. CL. 1/U.S. CLS. 1

FOR CHEMICAL PRODUCTS FOR SCIENTIFIC PURPOSES, NAMELY, IN VITRO DIAGNOSTIC TEST REAGENTS AND CONTROL STANDARDS FOR MEDICAL RESEARCH USE.

FIRST USE 2-0-1988; IN COMMERCE 2-0-1988.

INT. CL. 5/U.S. CLS. 6, 18, 44, 46, 51 AND 52

FOR PHARMACEUTICAL [ AND VETERINARY ] PRODUCTS, NAMELY, IN VITRO TEST REAGENTS AND CONTROL STANDARDS FOR MEDICAL DIAGNOSTIC USE.

FIRST USE 2-0-1988; IN COMMERCE 2-0-1988.

INT. CL. 10/U.S. CLS. 26, 39 AND 44

FOR KITS AND COMPONENTS FOR MEDICAL DIAGNOSTICS USE, NAMELY, ELECTRONIC SYSTEMS COMPRISING PLATE READERS, STRIP READERS, DATA PROCESSORS, DATA REDUCTION SOFTWARE AND FLUID HANDLERS; GELS, GEL PLATES, MOUNTING MEDIA, WELL SLIDES, COVERSLIPS, WELL SLIDE HOLDERS, MICROWELLS, SLIDE MASKS, CONTROL STANDARDS MOUNTED ON SLIDES, REAGENT VIALS, AND DEMONSTRATION SLIDE SETS WITH PROTOCOLS.

FIRST USE 2-0-1988; IN COMMERCE 2-0-1988.

ELEMENTS AMENDED  
GOODS/SERVICES  
OWNER ADDRESS

2,330,826. REG. 3-21-2000. BODYPOINT, INC. (WASHINGTON CORPORATION) 558 FIRST AVE S, SUITE 300, SEATTLE, WA, 98104, SN 75-452,655. FILED 3-18-1998. PRINCIPAL REGISTER.



INT. CL. 12/U.S. CLS. 19, 21, 23, 31, 35 AND 44

FOR WHEELCHAIR APPARATUS AND ACCESSORIES, NAMELY, HIP BELTS, CENTER-PULL HIP BELTS, REAR-PULL HIP BELTS, BUCKLES, SIDE-RELEASE BUCKLES, PUSH-BUTTON BUCKLES, CAM BUCKLES, BELT KITS, LAMINATED HIP BELT PAD, HIP BELT MOUNTING CLAMPS, SHOULDER HARNESSSES, SHOULDER HARNESS STRAP KITS CONSISTING PRIMARILY OF ACCESSORY STRAPS, CHEST BELTS, JOYSTICK MIDLINE MOUNTS, JOYSTICK MIDLINE MOUNTING KITS CONSISTING PRIMARILY OF SHAFT AND BRACKETS, JOYSTICK ARMS, JOYSTICK MOUNTING CLAMPS, JOYSTICK HANDLES, [ JOYSTICK TRAY MOUNTING KIT CONSISTING PRIMARILY OF TRAY MOUNTING CHANNELS, ] STRAPS AND BRACKETS, SEAT LATCHES AND CATCHES AND KITS CONTAINING SAME.

FIRST USE 11-0-1993; IN COMMERCE 11-0-1993.

ELEMENTS AMENDED  
MARK

2,440,037. REG. 4-3-2001. GETTY IMAGES (US), INC. (NEW YORK CORPORATION) 601 NORTH 34TH STREET, SEATTLE, WA, 98103, SN 75-701,666. FILED 5-10-1999. PRINCIPAL REGISTER.

**ALLSPORT**

THE MARK CONSISTS OF STANDARD CHARACTERS WITHOUT CLAIM TO ANY PARTICULAR FONT, STYLE, SIZE, OR COLOR.

INT. CL. 42/U.S. CLS. 100 AND 101

FOR PROVIDING ON-LINE COMPUTER DATABASES IN THE FIELD OF PHOTOGRAPHY AND GRAPHIC DESIGN, NAMELY, DATABASES FEATURING STOCK PHOTOGRAPHS, ARCHIVAL PHOTOGRAPHS, ART ILLUSTRATIONS AND GRAPHIC DESIGNS VIA COMPUTER NETWORKS AND GLOBAL COMMUNICATION NETWORKS; COMPUTER SERVICES, NAMELY, PROVIDING A SEARCH ENGINE FOR OBTAINING PHOTOGRAPHS, ART ILLUSTRATIONS, AND GRAPHIC DESIGNS ON COMPUTER NETWORKS AND GLOBAL COMMUNICATION NETWORKS.

FIRST USE 11-0-1996; IN COMMERCE 11-0-1996.

ELEMENTS AMENDED  
MARK

2,442,724. REG. 4-10-2001. WESTLAKE MEDICAL OF AUSTIN, LTD. (TEXAS LIMITED PARTNERSHIP) 5656 BEE CAVES ROAD, SUITE 200, AUSTIN, TX, 78746, SN 76-032,725. FILED 4-24-2000. PRINCIPAL REGISTER.



WESTLAKE MEDICAL  
CENTER

NO CLAIM IS MADE TO THE EXCLUSIVE RIGHT TO USE "MEDICAL CENTER", APART FROM THE MARK AS SHOWN.

INT. CL. 36/U.S. CLS. 100, 101 AND 102

FOR REAL ESTATE AND PROPERTY MANAGEMENT SERVICES..

FIRST USE 8-31-1999; IN COMMERCE 8-31-1999.

ELEMENTS CORRECTED  
OWNER NAME

2,447,797. REG. 5-1-2001. FEEDERS' ADVANTAGE, L.L.C. (IDAHO LIMITED LIABILITY COMPANY) 651 S. STRATFORD DRIVE, SUITE 100, MERIDIAN, ID, 83642, SN 76-009,098. FILED 3-24-2000. PRINCIPAL REGISTER.

**FEEDERS' ADVANTAGE**

INT. CL. 35/U.S. CLS. 100, 101 AND 102

FOR PURCHASING SERVICES IN THE FIELD OF VETERINARY SUPPLIES FEATURING ANIMAL CARE AND GROOMING PRODUCTS, ANIMAL NUTRITIONAL SUPPLEMENTS AND MEDICATION.

FIRST USE 10-1-1996; IN COMMERCE 10-1-1996.

ELEMENTS CORRECTED  
ENTITY

2,465,289. REG. 7-3-2001. WAKEFERN FOOD CORP. (NEW JERSEY CORPORATION) 5000 RIVERSIDE DRIVE, KEASBEY, NJ, 08832, SN 75-874,423. FILED 12-17-1999. PRINCIPAL REGISTER.

# SHOPRITE

THE MARK CONSISTS OF STANDARD CHARACTERS WITHOUT CLAIM TO ANY PARTICULAR FONT, STYLE, SIZE, OR COLOR.

OWNER OF U.S. REG. NOS. 1,530,270, 1,867,239 AND OTHERS.

INT. CL. 35/U.S. CLS. 100, 101 AND 102

FOR WHOLESALE DISTRIBUTORSHIP SERVICES FOR GROCERY [AND DEPARTMENT STORES;] RETAIL SUPERMARKET SERVICES; RETAIL DRUG STORE SERVICES; RETAIL PHOTOGRAPHY STORE SERVICES; RETAIL LIQUOR STORE SERVICES; AND RETAIL VIDEO CASSETTE STORE SERVICES; RETAIL LAWN AND GARDEN STORE SERVICES.

FIRST USE 0-0-1976; IN COMMERCE 0-0-1976.

ELEMENTS AMENDED  
MARK

2,487,276. REG. 9-11-2001. AVENUES IN LEATHER, INC. (NEW JERSEY CORPORATION) 750 HOPE ROAD, TINTON FALLS, NJ, 07724, SN 76-084,406. FILED 7-7-2000. PRINCIPAL REGISTER.

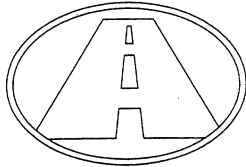

OWNER OF U.S. REG. NO. 1,887,167.

INT. CL. 18/U.S. CLS. 1, 2, 3, 22 AND 41

FOR BRIEFCASE TYPE PORTFOLIOS; ATTACHE CASES TRAVELING BAGS; TOTE BAGS; SOFT LUGGAGE; PILOT CASES AND OVERNIGHT BUSINESS CASES.

FIRST USE 7-1-1998; IN COMMERCE 7-1-1998.

ELEMENTS CORRECTED  
CITIZENSHIP

2,492,169. REG. 9-25-2001. SKYWAY LUGGAGE COMPANY (WASHINGTON CORPORATION) THIRTY WALL STREET, SEATTLE, WA, 98121, SN 75-937,263. FILED 3-7-2000. PRINCIPAL REGISTER.

# CLOUDLITE

THE MARK CONSISTS OF STANDARD CHARACTERS WITHOUT CLAIM TO ANY PARTICULAR FONT, STYLE, SIZE, OR COLOR.

OWNER OF U.S. REG. NO. 724,658.

INT. CL. 18/U.S. CLS. 1, 2, 3, 22 AND 41

FOR LUGGAGE.

FIRST USE 2-26-2000; IN COMMERCE 2-26-2000.

ELEMENTS AMENDED  
MARK

2,500,803. REG. 10-23-2001. CARDIOM, LLC (MINNESOTA LIMITED LIABILITY COMPANY) 7980 CENTURY BOULEVARD, CHANHASSEN, MN, 55317, SN 75-736,158. FILED 6-24-1999. PRINCIPAL REGISTER.

# TELESCALE

INT. CL. 10/U.S. CLS. 26, 39 AND 44

FOR SCALE AND MONITORING DEVICE FOR CARDIOVASCULAR PATIENTS WHICH TAKES MEASUREMENTS OF WEIGHT AND OTHER PHYSICAL CRITERIA AND TRANSMITS THE INFORMATION TO DOCTOR'S OFFICE VIA TELEPHONIC OR ELECTRONIC MEANS.

FIRST USE 10-0-1998; IN COMMERCE 11-0-1998.

ELEMENTS CORRECTED  
ENTITY

2,512,267. REG. 11-27-2001. TEMPLE UNIVERSITY - OF THE COMMONWEALTH SYSTEM OF HIGHER EDUCATION (PENNSYLVANIA NON-PROFIT CORPORATION) 1330 POLETT WALK, SUITE 300, PHILADELPHIA, PA, 19122, SN 76-122,280. FILED 9-5-2000. PRINCIPAL REGISTER.

# OWLINK

INT. CL. 41/U.S. CLS. 100, 101 AND 107

FOR INTERNET WEBSITE FEATURING OFFICIAL STUDENT RECORDS AND INFORMATION ON COURSES OF INSTRUCTION AT THE UNIVERSITY LEVEL.

FIRST USE 4-6-1998; IN COMMERCE 4-6-1998.

ELEMENTS CORRECTED  
ENTITY

2,664,033. REG. 12-17-2002. WELLPET LLC (DELAWARE LIMITED LIABILITY COMPANY) 200 AMES POND DRIVE, TEWKSBURY, MA, 018761274, SN 76-083,840. FILED 7-6-2000. PRINCIPAL REGISTER.

# WELLBARS

THE MARK CONSISTS OF STANDARD CHARACTERS WITHOUT CLAIM TO ANY PARTICULAR FONT, STYLE, SIZE, OR COLOR.

INT. CL. 31/U.S. CLS. 1 AND 46

FOR PET FOOD AND PET TREATS.

FIRST USE 7-0-2000; IN COMMERCE 7-0-2001.

ELEMENTS AMENDED  
MARK

2,708,988. REG. 4-22-2003. COUSINS SUBMARINES, INC. (WISCONSIN CORPORATION) N83 W13400 LEON ROAD, MENOMONEE FALLS, WI, 53051, SN 76-392,076. FILED 4-8-2002. PRINCIPAL REGISTER.



OWNER OF U.S. REG. NOS. 1,705,595, 2,539,428 AND OTHERS.

NO CLAIM IS MADE TO THE EXCLUSIVE RIGHT TO USE "SUBS", APART FROM THE MARK AS SHOWN.

INT. CL. 30/U.S. CL. 46

FOR SANDWICHES, PASTA SALAD, BREAD AND COOKIES.

FIRST USE 9-0-1991; IN COMMERCE 9-0-1991. INT. CL. 43/U.S. CLS. 100 AND 101

FOR RESTAURANT SERVICES, CATERING SERVICES, CARRY-OUT SERVICES AND CONTRACT FOOD SERVICES.

FIRST USE 9-0-1991; IN COMMERCE 9-0-1991.

ELEMENTS AMENDED  
MARK

2,719,069. REG. 5-27-2003. NATIONAL RAILROAD PASSENGER CORPORATION (D.C. CORPORATION) 60 MASSACHUSETTS AVE, N.E., WASHINGTON, DC, 20002, SN 76-425,294. FILED 6-21-2002. PRINCIPAL REGISTER.



OWNER OF U.S. REG. NOS. 960,643, 2,465,363 AND OTHERS.

INT. CL. 28/U.S. CLS. 22, 23, 38 AND 50

FOR TOYS, GAMES, AND PLAYTHINGS, NAMELY, PLUSH TOYS, STUFFED TOYS, TOY MODEL TRAINS, TOY MODEL TRAIN SETS, BOARD GAMES, GAME SETS COMPRISED OF JACKS, PICK-UP STICKS, AND MARBLES, JIGSAW PUZZLES, FOOTBALLS, BASKETBALLS, VOLLEYBALLS, GOLF BALLS AND GOLF TEES, GOLF DIVOT FIXERS, GOLF SETS COMPRISED OF GOLF BALLS, GOLF TEES, AND GOLF DIVOT FIXERS, AND CHRISTMAS TREE ORNAMENTS.

FIRST USE 0-0-1985; IN COMMERCE 0-0-1985.

ELEMENTS AMENDED  
MARK

2,778,441. REG. 10-28-2003. INTERDESIGN, INC. (OHIO CORPORATION) 30725 SOLON INDUSTRIAL PARKWAY, SOLON, OH, 441394331, SN 76-367,072. FILED 2-5-2002. PRINCIPAL REGISTER.

**RESIPREME**

INT. CL. 1/U.S. CLS. 1

FOR [ SYNTHETIC RESINS FOR USE IN THE MANUFACTURE OF MOLDING COMPOUNDS; ] SYNTHETIC RESINS FOR USE IN THE MANUFACTURE OF PLASTIC MOLDING COMPOUNDS USED TO MAKE PLASTIC ARTICLES, NAMELY, [ BOXES, NAMELY, PLASTIC BOXES. ] HOOKS, NAMELY, [ NON-METAL CLOTHES HOOKS, CONTAINER CLOSURES OF PLASTIC, DIVIDERS FOR DRAWER, DRAWER ORGANIZERS, HAMPERS, PLASTIC LIDS, PLASTIC KNOBS, KNOBS, CD RACKS, HAND HELD MIRRORS, PICTURE FRAMES, PLATE RACKS, PLASTIC STORAGE CONTAINERS, TRAVEL CONTAINERS FOR BATHROOM ACCESSORIES, PLASTIC TUBS, HOOKS, NAMELY, ] NON-METAL HOOKS HAVING SECURING DEVICES COMPOSED OF [ MAGNETICS, ] ADHESIVES OR SUCTION CUPS, SELF ADHESIVE HOOKS, NON-METAL OVER-THE-DOOR HOOKS, NON-METAL OVER-THE-DOOR RACKS, [ DRAWERS, CONTAINERS FOR DRAWERS, ] BASKETS, NAMELY, PLASTIC BASKETS, WASTE BASKETS, SUCTION BASKETS, STORAGE TOTES, [ TRAVEL BAGS FOR BATHROOM ACCESSORIES, ] SUCTION CORNER SHELVES, HOLDERS FOR CONNECTION TO WALLS AND BATHROOM FIXTURES FOR HOLDING BATHROOM ACCESSORIES, [ BRUSHES, NAMELY, CLOTHES BRUSHES, DISHWASHING BRUSHES, DUSTING BRUSHES, FLOOR BRUSHES, POT CLEANING BRUSHES, SCRAPING BRUSHES, SCRUBBING BRUSHES AND TOILET BRUSHES, ] HOLDERS, NAMELY, [ NAPKIN HOLDERS, SERVIETTE HOLDERS, ] SOAP HOLDERS, SCRUBBER AND SPONGE HOLDERS, [ TOILET TISSUE HOLDERS, ] TOWEL HOLDERS, TOWEL RINGS, PAPER HOLDERS, PAPER TOWEL HOLDERS, HOLDERS FOR BATHROOM ACCESSORIES, NAMELY, TOOTHBRUSHES, COMBS AND RAZORS, [ TRIVETS, BOXES FOR DISPENSING PAPER TOWELS, BOTTLES SOLD EMPTY, ] CANS, NAMELY, NON-METAL CANS, TRASH CANS, [ COVERED CANS AND CANS SOLD EMPTY, ] BEVERAGE WARE, SHOWER CADDIES, SQUEEGEES, [ PLASTIC DECORATIVE PLATES FOR SWITCHES AND RECEPTACLES, ACCENT TABLES, ] SHELVES, [ ETAGERES, CARTS, ] [ PLASTIC MOLDING COMPOUNDS FOR USE IN PLASTIC EXTRUSION OPERATIONS; ] PLASTIC MOLDING COMPOUNDS FOR USE IN THE MANUFACTURE OF MOLDED PLASTIC ARTICLES; [ PLASTIC MOLDING COMPOUNDS FOR USE IN THE MANUFACTURE OF PLASTIC SHEETS AND FILMS; POLYMER BEADS FOR USE IN MANUFACTURING; THERMOSETTING PLASTIC REFRACTORY MATERIALS ].

FIRST USE 11-9-2001; IN COMMERCE 11-9-2001.

ELEMENTS CORRECTED  
GOODS/SERVICES

2,783,516. REG. 11-18-2003. HUN B.V., THE (NETHERLANDS PRIVATE LIMITED LIABILITY COMPANY) P.O. BOX 66, 1693 ZH, WERVERSHOOF, NETHERLANDS., SN 76-025,442. FILED 4-14-2000. PRINCIPAL REGISTER.

**THE HUN'S**

INT. CL. 35/U.S. CLS. 100, 101 AND 102

FOR [ ON-LINE ORDERING SERVICES FEATURING GREETING CARDS; ] ON-LINE RETAIL STORE SERVICES FEATURING ADULT VIDEOS, TOYS, BOOKS, DOLLS, NOVELTIES, JEWELRY, OILS AND CREAMS FOR PERSONAL USE, GIFTS AND SEXUAL AIDS; PROMOTING THE GOODS AND SERVICES OF OTHERS BY PLACING ADVERTISEMENTS IN AN ELECTRONIC COMMUNICATIONS NETWORK.

FIRST USE 5-0-1995; IN COMMERCE 5-0-1995.

ELEMENTS AMENDED  
OWNER ADDRESS



2,818,847. REG. 3-2-2004. ENTWICKLUNGSGESELLSCHAFT FÜR AKUSTIK (EFA) MIT BESCHRÄNKTER HAFTUNG (FED REP GERMANY CORPORATION) BRAUCKSTRASSE 51, WITTEN, FED REP GERMANY, 58454, SN 76-397,149. FILED 4-17-2002. PRINCIPAL REGISTER.

## DUAL IMPEDANCE

OWNER OF FED REP GERMANY REG. NO. 30152521, DATED 10-22-2001, EXPIRES 8-31-2011.

INT. CL. 12/U.S. CLS. 19, 21, 23, 31, 35 AND 44  
FOR STRUCTURAL PARTS FOR AUTOMOBILES, NAMELY, [ TEXTILE WHEEL ARCH SHIELDS, UNDER-SIDE SHIELDS, INTERIOR ROOF LINERS, SIDE LINING, ] [ TRUCK ] \* TRUNK \* FLOOR LININGS, [ INTERIOR REAR SHELVES, ] AND TRUNK [ COVER AND ] SIDE LINERS.

FIRST USE ; IN COMMERCE .

INT. CL. 17/U.S. CLS. 1, 5, 12, 13, 35 AND 50  
FOR INSULATION FOR AUTOMOBILES, NAMELY, [ HOOD INSULATION, BULKHEAD EXTERIOR INSULATION, ] BULKHEAD INTERIOR INSULATION [ FRONT FLOOR INSULATION, MIDDLE FLOOR INSULATION, BULKHEAD TOP INSULATION AND SEAT WELL INSULATION ] .

FIRST USE ; IN COMMERCE .

INT. CL. 27/U.S. CLS. 19, 20, 37, 42 AND 50  
FOR [ FLOOR MATS FOR VEHICLES, AND CARPETS ] .

FIRST USE ; IN COMMERCE .

ELEMENTS CORRECTED  
GOODS/SERVICES

2,830,128. REG. 4-6-2004. INFRASTRUCTURED: FITNESS INSIDE & OUT, LLC (MARYLAND LIMITED LIABILITY COMPANY) 3720 FARRAGUT AVENUE, KENSINGTON, MD, 20895, SN 78-240,165. FILED 4-21-2003. PRINCIPAL REGISTER.

## INFRASTRUCTURED

INT. CL. 41/U.S. CLS. 100, 101 AND 107

FOR PHYSICAL FITNESS INSTRUCTION SERVICES, NAMELY, CLASSES, WORKSHOPS, PERSONAL TRAINING AND CONSULTATION, FEATURING FITNESS BIOMECHANICS, NEUROMUSCULAR RE-EDUCATION AND KINESIOLOGICAL ASSESSMENT.

FIRST USE 5-1-2002; IN COMMERCE 5-1-2002.

ELEMENTS CORRECTED  
ENTITY

2,866,735. REG. 7-27-2004. DRUG TEST, INC. (DELAWARE CORPORATION) 12600 NORTHBOROUGH DRIVE, SUITE 300, HOUSTON, TX, 77067, SN 78-253,541. FILED 5-23-2003. PRINCIPAL REGISTER.

## DISA

OWNER OF U.S. REG. NO. 1,744,892.  
INT. CL. 39/U.S. CLS. 100 AND 105  
FOR ELECTRONIC STORAGE AND RETRIEVAL OF EMPLOYEE AND EMPLOYMENT DATA.  
FIRST USE 9-30-1989; IN COMMERCE 9-30-1989.  
INT. CL. 44/U.S. CLS. 100 AND 101

FOR DRUG AND ALCOHOL TESTING FOR SUBSTANCE ABUSE; COUNSELING FOR DRUG REHABILITATION AND SUBSTANCE ABUSE.

FIRST USE 9-30-1989; IN COMMERCE 9-30-1989.

INT. CL. 45/U.S. CLS. 100 AND 101  
FOR PRE-EMPLOYMENT AND EMPLOYMENT BACKGROUND SCREENING.

FIRST USE 12-27-2002; IN COMMERCE 12-27-2002.

ELEMENTS CORRECTED  
OWNER NAME  
OWNER ADDRESS

2,884,139. REG. 9-14-2004. THE INSPIRATIONAL NETWORK, INC. (NORTH CAROLINA NON-PROFIT CORPORATION) 3000 WORLDREACH DRIVE, INDIAN LAND, SC, 29707, SN 78-224,693. FILED 3-12-2003. PRINCIPAL REGISTER.

## CHRISTIAN ARTIST TALENT SEARCH

SEC. 2(F).

INT. CL. 41/U.S. CLS. 100, 101 AND 107  
FOR ENTERTAINMENT SERVICES, NAMELY, CONDUCTING A MUSICAL TALENT CONTEST.  
FIRST USE 4-0-2002; IN COMMERCE 4-0-2002.

ELEMENTS CORRECTED  
OWNER NAME  
ENTITY

2,896,050. REG. 10-19-2004. GOODRICH CORPORATION (NEW YORK CORPORATION) 2730 WEST TYVOLA ROAD FOUR COLISEUM CENT, CHARLOTTE, NC, 282174578, SN 76-218,196. FILED 3-2-2001. PRINCIPAL REGISTER.



The logo for Goodrich, featuring the word "GOODRICH" in a bold, sans-serif font. Above the letters "O", "O", and "I" are three slanted, parallel lines that sweep upwards and to the right, suggesting motion or a winged design.

OWNER OF U.S. REG. NOS. 64,996, 1,423,775 AND OTHERS.  
INT. CL. 12/U.S. CLS. 19, 21, 23, 31, 35 AND 44

FOR NACELLE SYSTEMS FOR AEROSPACE VEHICLES COMPRISING ENGINE COWLING AND RELATED NACELLE COMPONENTS, NAMELY, THRUST REVERSERS AND EXHAUST NOZZLES; PYLON SYSTEMS FOR AEROSPACE VEHICLES COMPRISING THE STRUCTURAL MOUNTS AND FAIRINGS THAT ATTACH THE POWERPLANT TO THE WING OR FUSELAGE OF AN AEROSPACE VEHICLE; LANDING GEAR FOR AEROSPACE VEHICLES; WHEELS AND BRAKES FOR AEROSPACE VEHICLES; [INFLATABLE SEAT] BELTS FOR AEROSPACE AND LAND VEHICLES; SEAT BELTS FOR AEROSPACE AND LAND VEHICLES; STRUCTURAL PANELS FOR AEROSPACE VEHICLES; CREW SEATS FOR AEROSPACE VEHICLES; TAIL-CONES FOR AEROSPACE VEHICLE AUXILIARY POWER UNITS; EXO-STRUCTURE FAIRINGS FOR MARINE VEHICLES; VEHICLE WHEEL SUSPENSION SYSTEMS FOR LAND VEHICLES, AND COMPONENTS THEREFOR; ROTOR [AND PROPELLER] BLADES FOR AEROSPACE VEHICLES; WINDSHIELD WIPER AND/

OR WASHER SYSTEMS COMPRISING WIPER ARMS, BLADES, MOTORS, CONTROLS, FLUID RESERVOIRS AND PUMPS; AEROSPACE VEHICLE PARTS, NAMELY, BRAKE DISKS, FRICTION DISKS, CLUTCH PLATES, FUEL NOZZLE SHROUDS, ENGINE FLAPS SEALS; CONTROL SURFACES FOR LAND AND AEROSPACE VEHICLES, NAMELY, THE MOVABLE SURFACES OF AEROSPACE VEHICLES THAT HELP CONTROL MOVEMENT OF THE VEHICLE; STRUCTURAL PARTS, NAMELY, ROCKET NOSE CONES AND INTERIOR AND AIRFRAME COMPOSITE STRUCTURES FOR USE IN AEROSPACE VEHICLES.

FIRST USE 6-1-2001; IN COMMERCE 6-1-2001.

ELEMENTS CORRECTED  
CITIZENSHIP

2,912,325. REG. 12-21-2004. CREATIVE CLOSETS, LTD. (PENNSYLVANIA BUSINESS CORPORATION) 7248 PENN DRIVE, ALLENTOWN, PA, 18106, SN 76-539,227. FILED 8-22-2003. PRINCIPAL REGISTER.

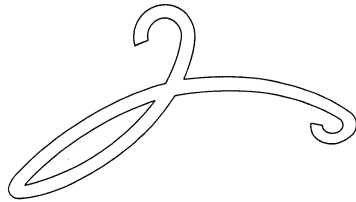

INT. CL. 42/U.S. CLS. 100 AND 101  
FOR CUSTOM DESIGN OF CLOSETS AND OTHER INTERIOR SPACES IN RESIDENTIAL AND COMMERCIAL BUILDINGS.

FIRST USE 6-1-2003; IN COMMERCE 6-1-2003.

ELEMENTS CORRECTED  
OWNER ADDRESS  
ENTITY

2,921,460. REG. 1-25-2005. CARDIOM, LLC (MINNESOTA LIMITED LIABILITY COMPANY) 7980 CENTURY BLVD., CHANHASSEN, MN, 55317, SN 78-153,327. FILED 8-12-2002. PRINCIPAL REGISTER.

### OMNIVISOR

OWNER OF U.S. REG. NO. 2,505,169.  
INT. CL. 9/U.S. CLS. 21, 23, 26, 36 AND 38  
FOR COMPUTER HARDWARE AND SOFTWARE USED FOR DISEASE MANAGEMENT, NAMELY, RECEIVING INFORMATION ABOUT PATIENTS' DAILY VITAL SIGNS AND SYMPTOMS, MANAGING ELECTRONIC MEDICAL RECORDS, REMOTELY MONITORING AN INTERACTIVE DATABASE OF PATIENT DATA, AND GENERATING REPORTS FOR HEALTHCARE PROFESSIONALS.

FIRST USE 8-1-2002; IN COMMERCE 8-1-2002.

ELEMENTS CORRECTED  
ENTITY

2,931,853. REG. 3-8-2005. LF, LLC (DELAWARE LIMITED LIABILITY COMPANY) P.O. BOX 39, MOUNT MOURNE, NC, 28123, SN 78-255,260. FILED 5-28-2003. PRINCIPAL REGISTER.

### GARDEN TREASURES

OWNER OF U.S. REG. NO. 2,697,298.  
NO CLAIM IS MADE TO THE EXCLUSIVE RIGHT TO USE "GARDEN", APART FROM THE MARK AS SHOWN.  
INT. CL. 11/U.S. CLS. 13, 21, 23, 31 AND 34

FOR OUTDOOR PATIO AND GARDEN HEATERS, NAMELY, CHIMENEAS, FIREPLACES, FIRE PITS AND FIRE RINGS.

FIRST USE 3-31-2003; IN COMMERCE 3-31-2003.  
INT. CL. 21/U.S. CLS. 2, 13, 23, 29, 30, 33, 40 AND 50

FOR BIRD HOUSES; BIRD FEEDERS AND ACCESSORIES THEREFOR, NAMELY, SQUIRREL BAFFLES AND SEED CATCHERS; SQUIRREL FEEDERS.

FIRST USE 3-31-2003; IN COMMERCE 3-31-2003.  
INT. CL. 31/U.S. CLS. 1 AND 46

FOR WILD BIRD FEED; SUNFLOWER SEED FOR BIRDS; BIRD FEED CONTAINING SUET; SQUIRREL FOOD; UNPROCESSED CORN ON THE COB FOR USE WITH SQUIRREL FEEDERS.

FIRST USE 3-31-2003; IN COMMERCE 3-31-2003.

ELEMENTS CORRECTED  
ENTITY

2,931,854. REG. 3-8-2005. LF, LLC (DELAWARE LIMITED LIABILITY COMPANY) P.O. BOX 39, MOUNT MOURNE, NC, 28123, SN 78-255,271. FILED 5-28-2003. PRINCIPAL REGISTER.



INT. CL. 11/U.S. CLS. 13, 21, 23, 31 AND 34  
FOR OUTDOOR PATIO AND GARDEN HEATERS, NAMELY, CHIMENEAS, FIREPLACES, FIRE PITS AND FIRE RINGS.

FIRST USE 3-31-2003; IN COMMERCE 3-31-2003.  
INT. CL. 21/U.S. CLS. 2, 13, 23, 29, 30, 33, 40 AND 50

FOR BIRD HOUSES; BIRD FEEDERS AND ACCESSORIES THEREFOR, NAMELY, SQUIRREL BAFFLES AND SEED CATCHERS; SQUIRREL FEEDERS.

FIRST USE 3-31-2003; IN COMMERCE 3-31-2003.  
INT. CL. 31/U.S. CLS. 1 AND 46

FOR WILD BIRD FEED; SUNFLOWER SEED FOR BIRDS; BIRD FEED CONTAINING SUET; SQUIRREL FOOD; UNPROCESSED CORN ON THE COB FOR USE WITH SQUIRREL FEEDERS.

FIRST USE 3-31-2003; IN COMMERCE 3-31-2003.

ELEMENTS CORRECTED  
ENTITY

2,941,356. REG. 4-19-2005. RIGHTNOW TECHNOLOGIES, INC. (DELAWARE CORPORATION) 136 ENTERPRISE BLVD., BOZEMAN, MT, 59718, SN 76-574,649. FILED 2-9-2004. PRINCIPAL REGISTER.

FOR CONSULTING SERVICES IN THE FIELD OF INTERPERSONAL RELATIONSHIPS IN CONNECTION WITH TRUST BUILDING AND BETRAYAL.  
FIRST USE 6-15-1999; IN COMMERCE 6-15-1999.

ELEMENTS AMENDED  
OWNER NAME

## RIGHTNOW

THE MARK CONSISTS OF STANDARD CHARACTERS WITHOUT CLAIM TO ANY PARTICULAR FONT, STYLE, SIZE, OR COLOR.

OWNER OF U.S. REG. NOS. 2,332,767 AND 2,484,836.  
INT. CL. 9/U.S. CLS. 21, 23, 26, 36 AND 38  
FOR CUSTOMER RELATIONSHIP MANAGEMENT SOFTWARE.  
FIRST USE 4-23-1997; IN COMMERCE 4-23-1997.

ELEMENTS CORRECTED  
OWNER ADDRESS  
CITIZENSHIP

2,950,983. REG. 5-17-2005. THE REINA TRUST BUILDING INSTITUTE, INC. (VERMONT CORPORATION) 560 BLACK BEAR RUN, STOWE, VT, 05672, SN 76-546,119. FILED 9-22-2003. PRINCIPAL REGISTER.

## THE REINA CUSTOMER TRUST SCALE

OWNER OF U.S. REG. NO. 2,706,331.  
NO CLAIM IS MADE TO THE EXCLUSIVE RIGHT TO USE "CUSTOMER TRUST SCALE", APART FROM THE MARK AS SHOWN.

REINA TRANSLATES TO QUEEN IN ENGLISH.  
INT. CL. 45/U.S. CLS. 100 AND 101  
FOR CONSULTING SERVICES IN THE FIELD OF INTERPERSONAL RELATIONSHIPS IN CONNECTION WITH TRUST BUILDING AND BETRAYAL.  
FIRST USE 1-15-2001; IN COMMERCE 1-15-2001.

ELEMENTS AMENDED  
OWNER NAME

2,959,081. REG. 6-7-2005. THE REINA TRUST BUILDING INSTITUTE, INC. (VERMONT CORPORATION) 560 BLACK BEAR RUN, STOWE, VT, 05672, SN 76-546,123. FILED 9-22-2003. PRINCIPAL REGISTER.

## THE REINA LEADERSHIP TRUST SCALE

OWNER OF U.S. REG. NO. 2,706,331.  
NO CLAIM IS MADE TO THE EXCLUSIVE RIGHT TO USE "LEADERSHIP TRUST SCALE", APART FROM THE MARK AS SHOWN.  
REINA TRANSLATES TO QUEEN IN ENGLISH.  
INT. CL. 45/U.S. CLS. 100 AND 101

2,963,788. REG. 6-28-2005. TEXAS STAR NUT AND FOOD COMPANY, INC. (TEXAS CORPORATION) 206 MARKET AVENUE, BOERNE, TX, 78006, SN 76-588,827. FILED 4-22-2004. PRINCIPAL REGISTER.

## TEXAS STAR NUT & FOOD COMPANY

THE MARK CONSISTS OF STANDARD CHARACTERS WITHOUT CLAIM TO ANY PARTICULAR FONT, STYLE, SIZE, OR COLOR.

NO CLAIM IS MADE TO THE EXCLUSIVE RIGHT TO USE "TEXAS" AND "NUT & FOOD COMPANY", APART FROM THE MARK AS SHOWN.

INT. CL. 29/U.S. CL. 46  
FOR PROCESSED NUTS, EDIBLE SEEDS AND DRIED FRUIT.  
FIRST USE 9-0-2001; IN COMMERCE 9-0-2001.

ELEMENTS CORRECTED  
MARK

2,968,159. REG. 7-12-2005. NU ORBIT MEDIA INCORPORATED (INDIANA CORPORATION) 101 EAST 2ND STREET, SEYMOUR, IN, 47274, SN 78-177,519. FILED 10-23-2002. PRINCIPAL REGISTER.

## NUORBIT MEDIA

THE MARK CONSISTS OF STANDARD CHARACTERS WITHOUT CLAIM TO ANY PARTICULAR FONT, STYLE, SIZE, OR COLOR.

NO CLAIM IS MADE TO THE EXCLUSIVE RIGHT TO USE "MEDIA", APART FROM THE MARK AS SHOWN.

INT. CL. 35/U.S. CLS. 100, 101 AND 102  
FOR ADVERTISING SERVICES, NAMELY DISSEMINATION OF ADVERTISING FOR OTHERS VIA INTERNET WEB SITES; DEVELOPMENT OF INTERACTIVE ADVERTISING PRESENTATIONS FOR OTHERS VIA THE INTERNET; AND CONTEST AND PROMOTIONAL CAMPAIGNS FOR BUSINESSES.

FIRST USE 6-30-2003; IN COMMERCE 6-30-2003.  
INT. CL. 42/U.S. CLS. 100 AND 101  
FOR COMPUTER SOFTWARE DEVELOPMENT SERVICES, NAMELY THE DESIGN AND DEVELOPMENT OF INTERNET WEB SITES AND MULTIMEDIA APPLICATIONS.

FIRST USE 6-30-2003; IN COMMERCE 6-30-2003.

ELEMENTS AMENDED  
MARK

2,969,195. REG. 7-19-2005. DECORE-ATIVE SPECIALTIES (CALIFORNIA CORPORATION) 2772 SOUTH PECK ROAD, MONROVIA, CA, 91016, SN 76-511,899. FILED 5-1-2003. PRINCIPAL REGISTER.

*Deco Lam*

INT. CL. 20/U.S. CLS. 2, 13, 22, 25, 32 AND 50  
FOR CABINETS AND DRAWERS.  
FIRST USE 12-1-2002; IN COMMERCE 12-1-2002.

ELEMENTS AMENDED  
MARK

2,982,800. REG. 8-9-2005. ADRIANNA PAPELL L.L.C. (NEW YORK LIMITED LIABILITY COMPANY) 512 SEVENTH AVENUE, 8TH FLOOR, NEW YORK, NY, 10018, SN 76-597,469. FILED 6-14-2004. PRINCIPAL REGISTER.

**PAPELL STUDIO**

OWNER OF U.S. REG. NOS. 1,309,081 AND 2,043,707.  
INT. CL. 25/U.S. CLS. 22 AND 39  
FOR WOMEN'S CLOTHING, NAMELY, SKIRTS,  
DRESSES, PANTS, JACKETS, BLOUSES, SCARVES,  
PONCHOS, VESTS AND SWEATERS.  
FIRST USE 12-15-2003; IN COMMERCE 12-15-2003.

ELEMENTS CORRECTED  
CITIZENSHIP

2,992,530. REG. 9-6-2005. AGS JUBILEE LLC (DELAWARE LIMITED LIABILITY COMPANY) 23215 NE GREENS CROSSING ROAD, REDMOND, WA, 98053, SN 78-453,093. FILED 7-19-2004. PRINCIPAL REGISTER.

  
**Jubilee**  
AT HAWKS PRAIRIE

NO CLAIM IS MADE TO THE EXCLUSIVE RIGHT TO USE "AT HAWKS PRAIRIE", APART FROM THE MARK AS SHOWN.

THE MARK CONSISTS OF STYLIZED WORD JUBILEE AND STYLIZED FLAG CONSISTING OF THREE FIVE-POINT STARS AND THREE BANNER LIKE SECTIONS OF THE FLAG.

INT. CL. 37/U.S. CLS. 100, 103 AND 106

FOR CONSTRUCTION SERVICES, NAMELY PLANNING, LAYING OUT, AND CONSTRUCTION OF RESIDENTIAL ACTIVE ADULT COMMUNITIES.  
FIRST USE 7-30-2003; IN COMMERCE 7-30-2003.

ELEMENTS CORRECTED  
ENTITY

3,007,079. REG. 10-18-2005. COSMO U.S.A. INC. (WASHINGTON CORPORATION), DBA INTERNATIONAL CROSS-CULTURAL COMMITTEE, 600 108TH AVENUE NE, SUITE 543, BELLEVUE, WA, 98004, SN 76-584,435. FILED 4-2-2004. PRINCIPAL REGISTER.

**IBP**

THE MARK CONSISTS OF STANDARD CHARACTERS WITHOUT CLAIM TO ANY PARTICULAR FONT, STYLE, SIZE, OR COLOR.

INT. CL. 41/U.S. CLS. 100, 101 AND 107

FOR ADMINISTRATION OF EXAMINATIONS TO IDENTIFY STUDENT CANDIDATES, MOSTLY JAPANESE STUDENTS, TO PARTICIPATE IN FOREIGN EXCHANGE PROGRAMS; ADMINISTRATION OF ORIENTATION SEMINARS TO PREPARE STUDENTS FOR FOREIGN EXCHANGE PROGRAMS; SPONSORING, DEVELOPING, AND CARRYING OUT INTERNATIONAL FOREIGN EXCHANGE PROGRAMS, INCLUDING SELECTION OF SCHOOLS, SELECTION OF COMPANIES TO PROVIDE INTERNSHIP PROGRAMS FOR STUDENTS.

FIRST USE 9-0-1989; IN COMMERCE 9-0-1989.

ELEMENTS CORRECTED  
OWNER NAME

3,013,789. REG. 11-8-2005. SANDERS CANDY FACTORY, INC. (CALIFORNIA CORPORATION) 5051 CALMVIEW AVENUE, BALDWIN PARK, CA, 91706, SN 78-197,000. FILED 12-20-2002. PRINCIPAL REGISTER.

**TIMOTHY'S CONFECTIONS**

THE MARK CONSISTS OF STANDARD CHARACTERS WITHOUT CLAIM TO ANY PARTICULAR FONT, STYLE, SIZE, OR COLOR.

NO CLAIM IS MADE TO THE EXCLUSIVE RIGHT TO USE "CONFECTIONS", APART FROM THE MARK AS SHOWN.

INT. CL. 30/U.S. CL. 46

FOR CANDY.

FIRST USE 11-29-2004; IN COMMERCE 11-29-2004.

ELEMENTS AMENDED  
MARK

3,033,485. REG. 12-27-2005. W.E. BASSETT COMPANY, THE (CONNECTICUT CORPORATION) 100 TRAP FALLS ROAD EXTENSION, SHELTON, CT, 06484, SN 76-568,834. FILED 1-8-2004. PRINCIPAL REGISTER.

# TRIM

THE MARK CONSISTS OF STANDARD CHARACTERS WITHOUT CLAIM TO ANY PARTICULAR FONT, STYLE, SIZE, OR COLOR.

OWNER OF U.S. REG. NOS. 614,895, 903,941 AND OTHERS.

INT. CL. 8/U.S. CLS. 23, 28 AND 44

FOR BATTERY OPERATED EYELASH CURLERS.

FIRST USE 8-22-2003; IN COMMERCE 8-22-2003.

ELEMENTS CORRECTED  
OWNER NAME

3,043,659. REG. 1-17-2006. COSMO U.S.A. INC. (WASHINGTON CORPORATION), DBA INTERNATIONAL CROSS-CULTURAL COMMITTEE, 600 108TH AVENUE NE, SUITE 543, BELLEVUE, WA, 98004, SN 76-595,373. FILED 6-3-2004. PRINCIPAL REGISTER.

## INTERNATIONAL BUSINESS PROFESSIONS

THE MARK CONSISTS OF STANDARD CHARACTERS WITHOUT CLAIM TO ANY PARTICULAR FONT, STYLE, SIZE, OR COLOR.

SEC. 2(F).

INT. CL. 41/U.S. CLS. 100, 101 AND 107

FOR EDUCATIONAL SERVICES, NAMELY, ADMINISTRATION OF EXAMINATIONS TO IDENTIFY STUDENT CANDIDATES, MOSTLY JAPANESE STUDENTS, TO PARTICIPATE IN FOREIGN EXCHANGE PROGRAMS; ADMINISTRATION OF ORIENTATION SEMINARS TO PREPARE STUDENTS FOR FOREIGN EXCHANGE PROGRAMS.

FIRST USE 9-0-1989; IN COMMERCE 9-0-1989.

ELEMENTS CORRECTED  
OWNER NAME

3,061,615. REG. 2-28-2006. PROGRESSIVE TECHNOLOGIES, LLC (COLORADO LIMITED LIABILITY COMPANY) 112 E. SPRUCE STREET, MITCHELL, SD, 57301, SN 76-586,485. FILED 4-12-2004. PRINCIPAL REGISTER.

# TOOL TREE

OWNER OF U.S. REG. NO. 2,849,437.  
INT. CL. 6/U.S. CLS. 2, 12, 13, 14, 23, 25 AND 50

FOR FREE-STANDING AND ATTACHED METAL TOOL STORAGE HOLDER PRIMARILY FOR GARDEN TOOLS AND IMPLEMENTS WITH ELONGATED HANDLES.

FIRST USE 5-6-2000; IN COMMERCE 5-6-2000.

ELEMENTS CORRECTED  
ENTITY

3,093,943. REG. 5-16-2006. HARRIS CONNECT, LLC (DELAWARE LIMITED LIABILITY COMPANY) 1400-A CROSSWAYS BLVD., CHESAPEAKE, VA, 23320, SN 78-359,880. FILED 1-30-2004. PRINCIPAL REGISTER.

## HARRIS CONNECT

THE MARK CONSISTS OF STANDARD CHARACTERS WITHOUT CLAIM TO ANY PARTICULAR FONT, STYLE, SIZE, OR COLOR.

NO CLAIM IS MADE TO THE EXCLUSIVE RIGHT TO USE CONNECT, APART FROM THE MARK AS SHOWN.

INT. CL. 35/U.S. CLS. 100, 101 AND 102

FOR PROVIDING ON-LINE COMPUTER DATABASES FEATURING ALUMNI, ASSOCIATION, FRATERNITY AND MEMBERSHIP DIRECTORIES; DATABASE MANAGEMENT \*, NAMELY, DATABASE MANAGEMENT FOR FOR-PROFIT AND NOT-FOR-PROFIT AFFINITY GROUPS, INCLUDING ALUMNI AND OTHER MEMBERSHIP ASSOCIATIONS, AND FOR EDUCATIONAL, CHARITABLE AND OTHER NOT-FOR-PROFIT AND NON-PROFIT ORGANIZATIONS\*; PROVIDING ALUMNI AND MEMBERSHIP DIRECTORY INFORMATION VIA A GLOBAL COMPUTER NETWORK.

FIRST USE 9-2-2005; IN COMMERCE 9-2-2005.

ELEMENTS AMENDED  
GOODS/SERVICES

3,196,826. REG. 1-9-2007. HARRIS CONNECT, LLC (DELAWARE LIMITED LIABILITY COMPANY) 1400-A CROSSWAYS BLVD., CHESAPEAKE, VA, 23320, SN 78-845,065. FILED 3-24-2006. PRINCIPAL REGISTER.



The logo for HARRIS CONNECT features the words "HARRIS" and "CONNECT" in a bold, sans-serif font. Between the two words is a stylized graphic consisting of several small, shaded circles arranged in a semi-circular arc, with a vertical bar element to the right of the circles.

OWNER OF U.S. REG. NO. 3,093,943.  
THE MARK CONSISTS OF WORDS "HARRIS CONNECT" DIVIDED BY A DESIGN OF SHADED CIRCLES AND SQUARES.

AS TO "CONNECT".

INT. CL. 35/U.S. CLS. 100, 101 AND 102



FOR PROVIDING ON-LINE COMPUTER DATABASES FEATURING ALUMNI, ASSOCIATION, FRATERNITY, AND MEMBERSHIP DIRECTORIES; DATABASE MANAGEMENT\*, NAMELY, DATABASE MANAGEMENT FOR FOR-PROFIT AND NOT-FOR-PROFIT AFFINITY GROUPS, INCLUDING ALUMNI AND OTHER MEMBERSHIP ASSOCIATIONS, AND FOR EDUCATIONAL, CHARITABLE AND OTHER NOT-FOR-PROFIT AND NON-PROFIT ORGANIZATIONS; PROVIDING ALUMNI AND MEMBERSHIP DIRECTORY INFORMATION VIA A GLOBAL COMPUTER NETWORK\*; PROVIDING ALUMNI AND MEMBERSHIP DIRECTORY INFORMATION VIA A GLOBAL COMPUTER NETWORK.

FIRST USE 9-2-2005; IN COMMERCE 9-2-2005.

ELEMENTS AMENDED  
GOODS/SERVICES

---

3,359,644. REG. 12-25-2007. CASH AMERICA INTERNATIONAL, INC. (TEXAS CORPORATION) 1600 W. 7TH STREET, FORT WORTH, TX, 76102, SN 78-833,972. FILED 3-9-2006. PRINCIPAL REGISTER.

## NATIONAL JEWELRY LIQUIDATION CENTER

THE MARK CONSISTS OF STANDARD CHARACTERS WITHOUT CLAIM TO ANY PARTICULAR FONT, STYLE, SIZE, OR COLOR.

NO CLAIM IS MADE TO THE EXCLUSIVE RIGHT TO USE "JEWELRY LIQUIDATION CENTER", APART FROM THE MARK AS SHOWN.

INT. CL. 35/U.S. CLS. 100, 101 AND 102

FOR RETAIL STORE SERVICES FEATURING JEWELRY.

FIRST USE 5-1-2003; IN COMMERCE 7-1-2003.

ELEMENTS AMENDED  
MARK  
DISCLAIMER

---

3,379,401. REG. 2-5-2008. MEDIA RECOVERY, INC. (NEVADA CORPORATION) 1111 W. MOCKINGBIRD LANE, DALLAS, TX, 75247, SN 78-723,703. FILED 9-29-2005. PRINCIPAL REGISTER.

## EQUIPMANAGER

THE MARK CONSISTS OF STANDARD CHARACTERS WITHOUT CLAIM TO ANY PARTICULAR FONT, STYLE, SIZE, OR COLOR.

INT. CL. 9/U.S. CLS. 21, 23, 26, 36 AND 38

FOR COMPUTER SOFTWARE FOR MONITORING IMPACTS, LOCATION, TEMPERATURE, PRESSURE, ENGINE SPEED AND USAGE OF FLEET VEHICLES AND MATERIAL HANDLING EQUIPMENT, NAMELY, FORKLIFTS, EARTH MOVERS, BAGGAGE TRUCKS AND CARGO TRUCKS AND FOR CONTROLLING ACCESS TO THE FLEET VEHICLES AND MATERIAL HANDLING EQUIPMENT; ELECTRONIC APPARATUS FOR MONITORING IMPACTS, LOCATION, TEMPERATURE, PRESSURE, ENGINE SPEED AND USAGE OF FLEET VEHICLES AND MATERIAL HANDLING EQUIPMENT, NAMELY, FORKLIFTS, EARTH MOVERS, BAGGAGE TRUCKS AND CARGO TRUCKS AND FOR CONTROLLING ACCESS TO THE FLEET VEHICLES AND MATERIAL HANDLING EQUIPMENT.

FIRST USE 9-6-2006; IN COMMERCE 9-6-2006.

ELEMENTS CORRECTED  
CITIZENSHIP

---

3,380,879. REG. 2-12-2008. DORAL BRANDS, INC. (FLORIDA CORPORATION) 18090 COLLINS AVENUE, SUITE T17-213, SUNNY ISLES, FL, 33160, SN 77-199,738. FILED 6-6-2007. PRINCIPAL REGISTER.

## FIRENZE

THE MARK CONSISTS OF STANDARD CHARACTERS WITHOUT CLAIM TO ANY PARTICULAR FONT, STYLE, SIZE, OR COLOR.

THE FOREIGN WORDING IN THE MARK TRANSLATES INTO ENGLISH AS FLORENCE.

INT. CL. 34/U.S. CLS. 2, 8, 9 AND 17

FOR CIGARETTES.

FIRST USE 9-6-2006; IN COMMERCE 9-6-2006.

ELEMENTS CORRECTED  
CITIZENSHIP

---

3,420,472. REG. 4-29-2008. MEDIA RECOVERY, INC. (NEVADA CORPORATION) 1111 W. MOCKINGBIRD LANE, SUITE 1050, DALLAS, TX, 75247, SN 78-865,821. FILED 4-20-2006. PRINCIPAL REGISTER.

## SHOCKWATCH USAGE MANAGER

THE MARK CONSISTS OF STANDARD CHARACTERS WITHOUT CLAIM TO ANY PARTICULAR FONT, STYLE, SIZE, OR COLOR.

OWNER OF U.S. REG. NO. 1,101,993.

NO CLAIM IS MADE TO THE EXCLUSIVE RIGHT TO USE "USAGE MANAGER", APART FROM THE MARK AS SHOWN.

INT. CL. 9/U.S. CLS. 21, 23, 26, 36 AND 38

FOR DEVICES COMPRISING A PROCESSOR, AN EVENT RECORDER, A WIRELESS COMMUNICATIONS DEVICE, USER SOFTWARE AND FIRMWARE, SUCH DEVICES BEING FOR THE PURPOSES OF MONITORING OPERATION OF INDUSTRIAL VEHICLES, NAMELY, USAGE, LOW BATTERY VOLTAGE, KEY SWITCH TIME, MOTOR TIME AND DRIVE MOTOR TIME.

FIRST USE 10-2-2006; IN COMMERCE 10-2-2006.

ELEMENTS CORRECTED  
CITIZENSHIP

3,420,473. REG. 4-29-2008. MEDIA RECOVERY, INC. (NEVADA CORPORATION) 1111 W. MOCKINGBIRD LANE, SUITE 1050, DALLAS, TX, 75247, SN 78-865,832. FILED 4-20-2006. PRINCIPAL REGISTER.

### SHOCKWATCH IMPACT MANAGER

THE MARK CONSISTS OF STANDARD CHARACTERS WITHOUT CLAIM TO ANY PARTICULAR FONT, STYLE, SIZE, OR COLOR.

OWNER OF U.S. REG. NO. 1,101,993.

NO CLAIM IS MADE TO THE EXCLUSIVE RIGHT TO USE "IMPACT MANAGER", APART FROM THE MARK AS SHOWN.

INT. CL. 9/U.S. CLS. 21, 23, 26, 36 AND 38

FOR DEVICE COMPRISED OF A PROCESSOR, A USER ADJUSTABLE IMPACT SENSOR, AN EVENT RECORDER, A WIRELESS COMMUNICATIONS DEVICE, USER SOFTWARE AND FIRMWARE, SUCH DEVICE BEING FOR THE PURPOSE OF MONITORING AND LIMITING OPERATION OF INDUSTRIAL VEHICLES, NAMELY, IMPACT DETECTION AND RECORDING, ACCESS CONTROL, OPERATION CERTIFICATION TRACKING, VOLTAGE MONITORING, AND VEHICLE ACTIVITY AND MAINTENANCE ALERTS.

FIRST USE 8-15-2006; IN COMMERCE 8-15-2006.

ELEMENTS CORRECTED  
CITIZENSHIP

3,427,703. REG. 5-13-2008. MEDIA RECOVERY, INC. (NEVADA CORPORATION) SUITE 1050, 1111 W. MOCKINGBIRD LANE, DALLAS, TX, 75247, SN 77-095,683. FILED 1-31-2007. PRINCIPAL REGISTER.

### STARTMANAGER

THE MARK CONSISTS OF STANDARD CHARACTERS WITHOUT CLAIM TO ANY PARTICULAR FONT, STYLE, SIZE, OR COLOR.

INT. CL. 9/U.S. CLS. 21, 23, 26, 36 AND 38

FOR ACCESS CONTROL SYSTEMS FOR EQUIPMENT HANDLING VEHICLES.

FIRST USE 8-21-2007; IN COMMERCE 8-21-2007.

ELEMENTS CORRECTED  
CITIZENSHIP

3,464,452. REG. 7-8-2008. LORICK, LEON (UNITED STATES INDIVIDUAL) 376 MARLBORO ROAD, ENGLEWOOD, NJ, 07631, SN 78-925,578. FILED 7-10-2006. PRINCIPAL REGISTER.

### S.I.B Entertainment

THE MARK CONSISTS OF STANDARD CHARACTERS WITHOUT CLAIM TO ANY PARTICULAR FONT, STYLE, SIZE, OR COLOR.

NO CLAIM IS MADE TO THE EXCLUSIVE RIGHT TO USE "ENTERTAINMENT", APART FROM THE MARK AS SHOWN.

INT. CL. 41/U.S. CLS. 100, 101 AND 107

FOR ENTERTAINMENT SERVICES, NAMELY, MUSICAL COMPOSITION SERVICES FOR OTHERS; MUSIC PRODUCTION SERVICES; RECORD MASTER PRODUCTION; RECORDING ARTIST SERVICES IN THE NATURE OF WRITING MUSIC FOR OTHERS.

FIRST USE 10-11-2007; IN COMMERCE 10-11-2007.

ELEMENTS CORRECTED  
OWNER NAME

3,608,010. REG. 4-14-2009. ARTHREX, INC. (DELAWARE CORPORATION) 1370 CREEKSIDE BLVD., NAPLES, FL, 34108, SN 78-453,843. FILED S.R. 7-21-2004; AM. P.R. 7-9-2007. PRINCIPAL REGISTER.

### iBalance

THE MARK CONSISTS OF STANDARD CHARACTERS WITHOUT CLAIM TO ANY PARTICULAR FONT, STYLE, SIZE, OR COLOR.

INT. CL. 10/U.S. CLS. 26, 39 AND 44

FOR SURGICAL SYSTEM FOR ADJUSTING THE ORIENTATION OF A BONE ASSOCIATED WITH A JOINT, CONSISTING OF SAWS AND SAW GUIDES FOR CUTTING A BONE, JACKS FOR OPENING A WEDGE-SHAPED VOID IN THE BONE SO AS TO ADJUST THE ORIENTATION OF THE BONE, AND A WEDGE-SHAPED IMPLANT FOR DISPOSITION IN THE WEDGE-SHAPED VOID SO AS TO MAINTAIN THE ADJUSTED ORIENTATION OF THE BONE.

FIRST USE 8-22-2008; IN COMMERCE 8-22-2008.

ELEMENTS CORRECTED  
REGISTER  
AMENDED REGISTER

3,671,206. REG. 8-18-2009. TABLETOPS UNLIMITED, INC. (CALIFORNIA CORPORATION) 23000 SOUTH AVALON BOULEVARD, CARSON, CA, 90745, SN 77-565,070. FILED P.R. 9-8-2008; AM. S.R. 6-15-2009. SUPPLEMENTAL REGISTER.

3,733,998. REG. 1-5-2010. NANA PATRICIA MCPEAK (UNITED STATES INDIVIDUAL) 100 ROCK LANE, EL DORADO HILLS, CA, 95762, SN 77-751,249. FILED 6-3-2009. PRINCIPAL REGISTER.

**ASIAN FUSION TOOLS FOR PROFESSIONAL COOKS**

**HiFiManna**

THE MARK CONSISTS OF STANDARD CHARACTERS WITHOUT CLAIM TO ANY PARTICULAR FONT, STYLE, SIZE, OR COLOR.

INT. CL. 21/U.S. CLS. 2, 13, 23, 29, 30, 33, 40 AND 50 FOR COOKWARE, NAMELY, WOKS, STIR FRY PANS, STEAMERS, NON-ELECTRIC RICE COOKERS; CHOPSTICKS; KITCHEN PREP TOOLS, NAMELY, SKIMMERS.

FIRST USE 3-31-2009; IN COMMERCE 3-31-2009.

ELEMENTS CORRECTED  
OWNER NAME

THE MARK CONSISTS OF STANDARD CHARACTERS WITHOUT CLAIM TO ANY PARTICULAR FONT, STYLE, SIZE, OR COLOR.

INT. CL. 5/U.S. CLS. 6, 18, 44, 46, 51 AND 52 FOR DIETARY AND NUTRITIONAL SUPPLEMENTS.

FIRST USE 3-1-2009; IN COMMERCE 3-1-2009.

ELEMENTS CORRECTED  
OWNER NAME

3,694,811. REG. 10-13-2009. EUGENIO COLLAVINI VITICOLTORI S.P.A. (ITALY CORPORATION) LOC. GRAMOLIANO, VIA DELLA RIBOLLA GIALLA N.2, CORNO DI ROSSAZZO (UDINE), ITALY, 33040, SN 77-555,090. FILED 8-25-2008. PRINCIPAL REGISTER.

3,760,041. REG. 3-16-2010. CINCO CORPORATION (PHILIPPINES CORPORATION) 869 KATARUNGAN STREET, PLAINVIEW, MANDALUYONG, PHILIPPINES, 1550, SN 77-668,072. FILED 2-11-2009. PRINCIPAL REGISTER.



OWNER OF U.S. REG. NOS. 1,722,294, 2,104,914 AND 2,183,298.

THE STIPPLING IS A FEATURE OF THE MARK AND DOES NOT INDICATE COLOR.

THE NAME(S), PORTRAIT(S), AND/OR SIGNATURE(S) SHOWN IN THE MARK DOES NOT IDENTIFY A PARTICULAR LIVING INDIVIDUAL.

THE MARK CONSISTS OF THE WORDS "VILLA CANLUNGO" AND "CORNO ROSAZZO" IN AN ELLIPTICAL LABEL SURROUNDING A SMALL DOG; THE WORDS "EUGENIO COLLAVINI" APPEARS IN A TAG APPENDED BELOW THE LABEL.

THE FOREIGN WORDING IN THE MARK TRANSLATES INTO ENGLISH AS VILLA OF THE LONG DOG.

INT. CL. 33/U.S. CLS. 47 AND 49

FOR WINES.

FIRST USE 12-31-2007; IN COMMERCE 12-31-2007.

ELEMENTS CORRECTED  
OWNER ADDRESS

OWNER OF PHILIPPINES REG. NO. 42001007962, DATED 3-26-2007.

NO CLAIM IS MADE TO THE EXCLUSIVE RIGHT TO USE "POTATO", APART FROM THE MARK AS SHOWN.

THE COLOR(S) YELLOW, GREEN, BROWN, BLACK AND WHITE IS/ARE CLAIMED AS A FEATURE OF THE MARK.

THE MARK CONSISTS OF A BROWN POTATO WITH ARMS AND LEGS THAT IS OUTLINED IN BLACK, YELLOW AND GREEN AND HAS BLACK SPECKS AND A BLACK SMILE AND BLACK AND WHITE EYES. THE POTATO APPEARS BETWEEN THE WORDS "POTATO" AND "CORNER", WHICH ARE BOTH IN YELLOW COLOR, AND APPEAR INSIDE A LONG, GREEN OBLONG OVAL.

INT. CL. 43/U.S. CLS. 100 AND 101

FOR RESTAURANT AND CATERING SERVICES.

FIRST USE ; IN COMMERCE .

ELEMENTS AMENDED  
OWNER ADDRESS  
MARK

3,783,356. REG. 5-4-2010. SUMMIT ENTERTAINMENT, LLC (DELAWARE LIMITED LIABILITY COMPANY) 1630 STEWART STREET, SUITE 201, SANTA MONICA, CA, 90404, SN 77-671,090. FILED 2-16-2009. PRINCIPAL REGISTER.

**TEAM JACOB**

THE MARK CONSISTS OF STANDARD CHARACTERS WITHOUT CLAIM TO ANY PARTICULAR FONT, STYLE, SIZE, OR COLOR.

INT. CL. 20/U.S. CLS. 2, 13, 22, 25, 32 AND 50

FOR [ BEACH CHAIRS, CAT SCRATCHING POSTS, CORKS FOR BOTTLES, PLASTIC DECORATIVE WALL PLAQUES, DIRECTOR'S CHAIRS, PET BEDS, BAR STOOLS, PICTURE FRAMES, PLASTIC BOXES, PLASTIC NOVELTY LICENSE PLATES, WIND CHIMES, PLASTIC BAG CLIPS AND WOOD BOXES; ] PLASTIC KEY CHAINS.

FIRST USE 9-0-2008; IN COMMERCE 9-0-2008.

ELEMENTS CORRECTED  
GOODS/SERVICES

3,831,155. REG. 8-10-2010. 3PD, INC. (GEORGIA CORPORATION) SUITE 100, 1851 WEST OAK PARKWAY, MARIETTA, GA, 30062, SN 77-894,626. FILED 12-16-2009. PRINCIPAL REGISTER.

THE MARK CONSISTS OF THE NUMBER "3" ADJACENT TO THE LETTERS "P" AND "D" IN STYLIZED FONT. THE LETTER "D" IS STRETCHED TO COVER THE BACKGROUND OF THE LETTER "P".

INT. CL. 37/U.S. CLS. 100, 103 AND 106

FOR \* FACILITATING THE \* INSTALLATION OF APPLIANCES, FURNITURE AND ELECTRONICS.

FIRST USE 8-0-2006; IN COMMERCE 8-0-2006.

INT. CL. 39/U.S. CLS. 100 AND 105

FOR LOGISTICS AND REVERSE LOGISTICS SERVICES, NAMELY, STORAGE, CROSS-DOCKING, \* AND FACILITATING OF \* TRANSPORTATION AND DELIVERY OF FREIGHT FOR OTHERS BY [ AIR, RAIL, SHIP OR ] TRUCK.

FIRST USE 8-0-2006; IN COMMERCE 8-0-2006.

ELEMENTS AMENDED  
GOODS/SERVICES

3,832,687. REG. 8-10-2010. YOUNG, RONALD ALEXANDER (SCOT) (UNITED KINGDOM INDIVIDUAL) 95 MUSHROOM GREEN, DUDLEY WOOD, WEST MIDLANDS, UNITED KINGDOM, DY20EE, SN 77-681,759. FILED 3-2-2009. PRINCIPAL REGISTER.

OWNER OF U.S. REG. NO. 3,289,404.

THE MARK CONSISTS OF THE LETTERS "SYR" IN STYLIZED FONT WITH THE UPPER LEFT PORTION OF THE "Y" DEPICTING A TEAR DROP SHAPE.

INT. CL. 3/U.S. CLS. 1, 4, 6, 50, 51 AND 52

FOR CLEANING, POLISHING, SCOURING AND ABRASIVE PREPARATIONS; DETERGENTS; ALL FOR USE IN PROFESSIONAL AND INDUSTRIAL CLEANING.

FIRST USE 1-0-1995; IN COMMERCE 1-0-1995.

INT. CL. 12/U.S. CLS. 19, 21, 23, 31, 35 AND 44

FOR TROLLEYS; TROLLEYS FOR CARRYING CLEANING UTENSILS AND APPARATUS; JANITORIAL TROLLEYS.

FIRST USE 1-15-2010; IN COMMERCE 1-15-2010.

INT. CL. 21/U.S. CLS. 2, 13, 23, 29, 30, 33, 40 AND 50

FOR MOPS, SPONGES AND CLOTHS FOR CLEANING PURPOSES; BUCKETS, BUCKETS INCORPORATING MOP WRINGERS AND BUCKETS INCORPORATING CASTORS; DUSTERS, MOP HEADS, MOP HOLDERS; WINDOW AND FLOOR SCRAPPERS AND WIPERS, NAMELY, WINDOW AND FLOOR CLEANERS IN THE NATURE OF SQUEEGEES, SCRUBBERS, NAMELY, SCRUB BRUSHES AND ABRASIVE PADS, A COMBINATION SQUEEGEE AND SCRUBBER, AND SCRAPPERS FOR HOUSEHOLD PURPOSES; NON-ELECTRIC CARPET SWEEPERS, NON-ELECTRIC FLOOR SWEEPERS, BROOMS, SCOURING PADS, SCRUBBING BRUSHES; BOTTLES SOLD EMPTY INCORPORATING NON-ELECTRIC SPRAYING APPARATUS; DUSTBINS, REFUSE BINS, WASTE PAPER BINS, LITTER AND WASTE SCOOPS; SPONGE HOLDERS AND SPONGE WRINGERS; AND PARTS AND FITTINGS FOR ALL THE AFORESAID GOODS.

FIRST USE 1-0-1995; IN COMMERCE 1-0-1995.

ELEMENTS CORRECTED

\*GOODS/SERVICES\*

\*INTERNATIONAL CLASS(ES)\*

DATE OF FIRST USE

DATE OF FIRST USE IN COMMERCE

3,840,435. REG. 8-31-2010. SANDEL MEDICAL INDUSTRIES L.L.C. (DELAWARE LIMITED LIABILITY COMPANY) 19736 DEARBORN STREET, CHATSWORTH, CA, 91311, SN 77-875,841. FILED 11-18-2009. PRINCIPAL REGISTER.

**Safety means NEVER having  
to say you're sorry.**

THE MARK CONSISTS OF STANDARD CHARACTERS WITHOUT CLAIM TO ANY PARTICULAR FONT, STYLE, SIZE, OR COLOR.

INT. CL. 10/U.S. CLS. 26, 39 AND 44

FOR SURGICAL SUPPLIES AND EQUIPMENT USED IN AN OPERATING ROOM, NAMELY, SURGICAL SKIN MARKING PENS; SURGICAL AND MEDICAL APPARATUS AND INSTRUMENTS FOR USE IN GENERAL SURGERY; SURGICAL SUPPLY KITS CONSISTING PRIMARILY OF SKIN MARKING PENS, AND CUPS FOR DISPENSING MEDICINE AND CONTAINING SURGICAL LABELS; SURGICAL SCALPELS.

FIRST USE 11-15-2005; IN COMMERCE 11-15-2005.

ELEMENTS CORRECTED  
CITIZENSHIP

3,844,436. REG. 9-7-2010. BROOKS SHOPPING CENTERS, LLC (NEW YORK LIMITED LIABILITY COMPANY) 8000 MALL WALK DRIVE, YONKERS, NY, 10704, SN 77-913,078. FILED 1-15-2010. PRINCIPAL REGISTER.

## CROSS COUNTY SHOPPING CENTER

THE MARK CONSISTS OF STANDARD CHARACTERS WITHOUT CLAIM TO ANY PARTICULAR FONT, STYLE, SIZE, OR COLOR.

NO CLAIM IS MADE TO THE EXCLUSIVE RIGHT TO USE "SHOPPING CENTER", APART FROM THE MARK AS SHOWN.

AS TO "CROSS COUNTY".

INT. CL. 35/U.S. CLS. 100, 101 AND 102

FOR ADVERTISING SERVICES FOR SHOPPING CENTER TENANTS.

FIRST USE 10-10-1962; IN COMMERCE 10-10-1962.

INT. CL. 36/U.S. CLS. 100, 101 AND 102

FOR SHOPPING CENTER SERVICES, NAMELY, RENTAL OF SHOPPING CENTER SPACE; REAL ESTATE MANAGEMENT.

FIRST USE 10-10-1962; IN COMMERCE 10-10-1962.

ELEMENTS CORRECTED  
OWNER NAME

3,851,157. REG. 9-21-2010. CAMAIR LLC (ILLINOIS LIMITED LIABILITY COMPANY) 4500 WEST 47TH STREET, CHICAGO, IL, 60632, SN 77-757,003. FILED 6-11-2009. PRINCIPAL REGISTER.

## BLACKHAWK

THE MARK CONSISTS OF STANDARD CHARACTERS WITHOUT CLAIM TO ANY PARTICULAR FONT, STYLE, SIZE, OR COLOR.

INT. CL. 11/U.S. CLS. 13, 21, 23, 31 AND 34

FOR ELECTRIC FANS; PORTABLE ELECTRIC FANS; ELECTRIC FANS FOR PERSONAL USE [; ELECTRIC RADIANT HEATERS; ELECTRIC SPACE HEATERS; PORTABLE ELECTRIC HEATERS AND OIL-FILLED ELECTRIC HEATERS].

FIRST USE 6-2-2010; IN COMMERCE 6-2-2010.

ELEMENTS CORRECTED  
GOODS/SERVICES

3,852,783. REG. 9-28-2010. BROOKS SHOPPING CENTERS, LLC (NEW YORK LIMITED LIABILITY COMPANY) 8000 MALL WALK DRIVE, YONKERS, NY, 10704, SN 77-913,090. FILED 1-15-2010. PRINCIPAL REGISTER.



NO CLAIM IS MADE TO THE EXCLUSIVE RIGHT TO USE "CROSS COUNTY SHOPPING CENTER", APART FROM THE MARK AS SHOWN.

THE MARK CONSISTS OF A LARGE SQUARE ENCLOSING A SMALL OUTLINED SQUARE, SITUATED OFF-CENTER TOWARDS THE UPPER LEFT PORTION OF THE LARGE SQUARE. EXTENDING FROM EACH SIDE OF THE SMALL SQUARE IS A LINE THAT REACHES THE NEAREST PARALLEL EDGE OF THE LARGE SQUARE. THESE LINES CREATE THE IMAGE OF FOUR HEXAGONAL SHAPES SURROUNDING THE SMALL SQUARE. TO THE RIGHT OF THE SQUARE DESIGN ARE THE WORDS "CROSS COUNTY SHOPPING CENTER".

INT. CL. 35/U.S. CLS. 100, 101 AND 102

FOR ADVERTISING SERVICES FOR SHOPPING CENTER TENANTS.

FIRST USE 4-16-2008; IN COMMERCE 4-16-2008.

INT. CL. 36/U.S. CLS. 100, 101 AND 102

FOR SHOPPING CENTER SERVICES, NAMELY, RENTAL OF SHOPPING CENTER SPACE; REAL ESTATE MANAGEMENT.

FIRST USE 4-16-2008; IN COMMERCE 4-16-2008.

ELEMENTS CORRECTED  
OWNER NAME

3,856,884. REG. 10-5-2010. TIETO OYJ (FINLAND CORPORATION) AKU KORHOSEN TIE 2-6, FI-00440 HELSINKI, FINLAND., SN 79-071,057. FILED 4-8-2009. PRINCIPAL REGISTER.

## KNOWLEDGE.PASSION.RESULTS.

PRIORITY DATE OF 11-21-2008 IS CLAIMED.

OWNER OF INTERNATIONAL REGISTRATION 1008106 DATED 4-8-2009, EXPIRES 4-8-2019.

INT. CL. 9/U.S. CLS. 21, 23, 26, 36 AND 38

FOR DATA PROCESSING EQUIPMENT AND COMPUTERS; DATA COLLECTION AND DISTRIBUTION NETWORKS, NAMELY, NETWORK SERVERS FOR LOCAL AREA NETWORKS, WIDE AREA NETWORKS AND GLOBAL COMMUNICATION NETWORKS; COMPUTER SOFTWARE, NAMELY, SOFTWARE FOR MANAGEMENT, COLLECTION, EDITING, ORGANIZING, MODIFYING, BOOK MARKING, TRANSMISSION, STORAGE AND SHARING OF DATA AND INFORMATION USED IN INFORMATION, CONTROL, OPERATIVE, ADMINISTRATIVE, BUSINESS, EMBEDDED, SELF-SERVICE AND MANAGEMENT SYSTEMS; DOWNLOADABLE ELECTRONIC PUBLICATIONS, NAMELY, ELECTRONICALLY READABLE TECHNICAL AND USER MANUALS IN THE FIELD OF COMPUTER SYSTEMS.

INT. CL. 16/U.S. CLS. 2, 5, 22, 23, 29, 37, 38 AND 50

FOR PAPER AND CARDBOARD; PRINTED MATTER, NAMELY, MAGAZINES AND BOOKS IN THE FIELD OF COMPUTER SYSTEMS AND COMPUTER PROGRAMMING; BOOKBINDING MATERIAL; PHOTOGRAPHS; STATIONERY; ADHESIVES FOR STATIONERY OR HOUSEHOLD PURPOSES; PRINTED INSTRUCTIONAL AND TEACHING MATERIAL IN THE FIELD OF COMPUTER SYSTEMS AND COMPUTER PROGRAMMING; PRINTED TECHNICAL AND USER MANUALS IN THE FIELD OF COMPUTER OPERATING SYSTEMS; PRINTED TEACHING MATERIAL FOR COMPUTER USERS AND PROFESSIONALS IN THE FIELD OF COMPUTER PROGRAMS AND SYSTEMS.

INT. CL. 35/U.S. CLS. 100, 101 AND 102



FOR ADVERTISING; BUSINESS MANAGEMENT; BUSINESS ADMINISTRATION; OFFICE FUNCTIONS; BUSINESS CONSULTANCY; COMPILATION AND SYSTEMIZATION OF INFORMATION INTO COMPUTER DATABASES; COMPUTERISED DATA PROCESSING IN THE NATURE OF VERIFICATION AND FILE MANAGEMENT SERVICES; COMPUTERIZED AND CENTRAL FILE MANAGEMENT AND BUSINESS FILE MANAGEMENT; DATABASE MANAGEMENT SERVICES.

INT. CL. 37/U.S. CLS. 100, 103 AND 106

FOR INSTALLATION, REPAIR AND MAINTENANCE OF COMPUTER HARDWARE.

INT. CL. 38/U.S. CLS. 100, 101 AND 104

FOR TELECOMMUNICATION ACCESS SERVICES; PROVIDING MULTIPLE-USER ACCESS TO A GLOBAL AND LOCAL COMPUTER INFORMATION NETWORK VIA A GLOBAL COMPUTER NETWORK; PROVIDING MULTIPLE-USER ACCESS TO COMPUTER DATABASES VIA A GLOBAL COMPUTER NETWORK; PROVIDING ACCESS TO A COMPUTER DATABASE VIA A GLOBAL COMPUTER NETWORK; TRANSMISSION OF INFORMATION BETWEEN COMPUTERS, WORKSTATIONS AND WIRELESS DEVICES .

INT. CL. 41/U.S. CLS. 100, 101 AND 107

FOR PROVIDING OF TRAINING IN THE FIELD OF INFORMATION TECHNOLOGY; EDUCATIONAL SERVICES, NAMELY, ARRANGING EDUCATIONAL CLASSES, EDUCATIONAL SEMINARS, EDUCATIONAL CONFERENCES AND EDUCATIONAL WORKSHOPS IN THE FIELD OF INFORMATION TECHNOLOGY; OFFERING PROFESSIONAL COACHING SERVICES IN THE FIELD OF INFORMATION TECHNOLOGY.

INT. CL. 42/U.S. CLS. 100 AND 101

FOR SCIENTIFIC RESEARCH, PRODUCT RESEARCH, DESIGN FOR OTHERS AND TECHNOLOGICAL CONSULTATION IN THE FIELD OF INFORMATION TECHNOLOGY; INDUSTRIAL RESEARCH AND TECHNICAL ANALYSIS IN THE FIELD OF INFORMATION TECHNOLOGY; DESIGN AND DEVELOPMENT OF COMPUTER HARDWARE AND SOFTWARE; COMPUTER PROGRAMMING; MAINTENANCE AND UPDATING OF COMPUTER SOFTWARE; COMPUTER SYSTEM ANALYSIS, NAMELY, MONITORING THE COMPUTER SYSTEMS OF OTHERS FOR TECHNICAL PURPOSES AND PROVIDING BACK-UP COMPUTER SOFTWARE; RENTAL OF COMPUTER HARDWARE AND SOFTWARE; WEB SITE HOSTING SERVICES.

INT. CL. 45/U.S. CLS. 100 AND 101

FOR COMPUTER SOFTWARE LICENSING; MANAGEMENT OF COPYRIGHT RELATING TO COMPUTER SOFTWARE; SECURITY SERVICES RELATING TO COMPUTERISED DATA, NAMELY, MONITORING OF COMPUTER SYSTEMS FOR SECURITY PURPOSES.

ELEMENTS CORRECTED  
ENTITY

3,866,894. REG. 10-26-2010. RINCON JIMENEZ ENTERPRISES LLC (FLORIDA LIMITED LIABILITY COMPANY) SUITE 2103, 175 SW 7TH STREET, MIAMI, FL. 33130, SN 77-954,894. FILED 3-9-2010. PRINCIPAL REGISTER.

## THE ORCHID BOUTIQUE

THE MARK CONSISTS OF STANDARD CHARACTERS WITHOUT CLAIM TO ANY PARTICULAR FONT, STYLE, SIZE, OR COLOR.

NO CLAIM IS MADE TO THE EXCLUSIVE RIGHT TO USE "BOUTIQUE", APART FROM THE MARK AS SHOWN.  
INT. CL. 35/U.S. CLS. 100, 101 AND 102

FOR ON-LINE RETAIL STORE SERVICES FEATURING DESIGNER SWIMWEAR, JEWELRY, AND HANDBAGS.

FIRST USE 6-1-2007; IN COMMERCE 6-1-2007.

ELEMENTS CORRECTED  
OWNER NAME

3,871,194. REG. 11-2-2010. EWM BRAND HOLDINGS, LLC (NEVADA LIMITED LIABILITY COMPANY) 6301 RIVERSIDE DR., IRVING, TX. 75039, SN 77-743,931. FILED 5-25-2009. PRINCIPAL REGISTER.



## THE STUDIOS AT LAS COLINAS

NO CLAIM IS MADE TO THE EXCLUSIVE RIGHT TO USE "STUDIOS AT LAS COLINAS", APART FROM THE MARK AS SHOWN.

THE MARK CONSISTS OF A STAR IMAGE COMPOSED OF A FILM REEL MATERIAL FOLLOWED IMMEDIATELY BY THE TERMS "THE STUDIOS AT LAS COLINAS".

INT. CL. 41/U.S. CLS. 100, 101 AND 107

FOR MOVIE STUDIOS; OPERATING OF FILM STUDIOS.

FIRST USE 2-1-1982; IN COMMERCE 2-1-1982.

ELEMENTS CORRECTED  
OWNER NAME  
CITIZENSHIP

3,884,373. REG. 11-30-2010. NATURAL SWEET VENTURES, LLC (DELAWARE LIMITED LIABILITY COMPANY) 8016 HWY. 90A, P.O. BOX 9, SUGAR LAND, TX. 77478, SN 77-966,159. FILED 3-23-2010. PRINCIPAL REGISTER.



THE MARK CONSISTS OF THE WORD "STEVIAACANE" TO THE RIGHT OF THE WORD IS AN IMAGE THAT REPRESENTS LEAVES, GRASS AND A STALK.

INT. CL. 30/U.S. CL. 46

FOR NATURAL SWEETENER; FLAVOR ENHANCER USED IN FOOD AND BEVERAGE PRODUCTS.

FIRST USE 3-0-2010; IN COMMERCE 7-19-2010.

ELEMENTS CORRECTED  
CITIZENSHIP

3,884,824. REG. 12-7-2010. ENBALA POWER NETWORKS INC. (CANADA CORPORATION) 360 BAY STREET, SUITE 401, TORONTO, ON M5H 2V6, CANADA., SN 77-779,979. FILED 7-13-2009. PRINCIPAL REGISTER.

3,893,720. REG. 12-21-2010. SANDEL MEDICAL INDUSTRIES L.L.C. (DELAWARE LIMITED LIABILITY COMPANY) 19736 DEARBORN STREET, CHATSWORTH, CA, 91311, SN 85-031,784. FILED 5-6-2010. PRINCIPAL REGISTER.

SMARTER BUILDINGS MAKE A  
SMARTER GRID

CHANGE-A-BLADE

THE MARK CONSISTS OF STANDARD CHARACTERS WITHOUT CLAIM TO ANY PARTICULAR FONT, STYLE, SIZE, OR COLOR.

THE MARK CONSISTS OF STANDARD CHARACTERS WITHOUT CLAIM TO ANY PARTICULAR FONT, STYLE, SIZE, OR COLOR.

OWNER OF CANADA REG. NO. TMA769167, DATED 6-8-2010, EXPIRES 6-8-2020.

INT. CL. 10/U.S. CLS. 26, 39 AND 44

INT. CL. 37/U.S. CLS. 100, 103 AND 106

FOR SCALPEL HANDLES.

FOR INSTALLING AND MAINTAINING ENERGY CONTROL SYSTEMS FOR USE IN COMMERCIAL, RESIDENTIAL AND INDUSTRIAL BUILDINGS.

FIRST USE 2-28-2007; IN COMMERCE 2-28-2007.

INT. CL. 42/U.S. CLS. 100 AND 101

FOR DESIGNING ENERGY CONTROL SYSTEMS FOR USE IN COMMERCIAL, RESIDENTIAL, AND INDUSTRIAL BUILDINGS.

ELEMENTS CORRECTED  
CITIZENSHIP

ELEMENTS CORRECTED  
OWNER NAME  
OWNER ADDRESS

3,898,752. REG. 1-4-2011. CONSERVATION FOUNDATION OF THE GULF COAST, INC. (FLORIDA NON-PROFIT CORPORATION), FORMERLY SARASOTA CONSERVATION FOUNDATION, INC., P.O. BOX 902, OSPREY, FL, 34229, SN 77-875,376. FILED 11-18-2009. PRINCIPAL REGISTER.

3,888,601. REG. 12-14-2010. SUGATSUNE KOGYO CO., LTD. (JAPAN CORPORATION) 1-8-11 HIGASHIKANDA, CHIOYDA-KU, TOKYO, JAPAN., SN 77-803,886. FILED 8-13-2009. PRINCIPAL REGISTER.



SLS-ELAN

CONSERVATION  
FOUNDATION  
*of the Gulf Coast*

THE MARK CONSISTS OF STANDARD CHARACTERS WITHOUT CLAIM TO ANY PARTICULAR FONT, STYLE, SIZE, OR COLOR.

NO CLAIM IS MADE TO THE EXCLUSIVE RIGHT TO USE "CONSERVATION FOUNDATION OF THE GULF COAST", APART FROM THE MARK AS SHOWN.

PRIORITY CLAIMED UNDER SEC. 44(D) ON JAPAN APPLICATION NO. 2009-010855, FILED 2-18-2009, REG. NO. 5250504, DATED 7-24-2009, EXPIRES 2-18-2019.

THE COLOR(S) GREEN, BLUE, AND BLACK IS/ARE CLAIMED AS A FEATURE OF THE MARK.

INT. CL. 6/U.S. CLS. 2, 12, 13, 14, 23, 25 AND 50

FOR METAL HINGES; HINGES PRIMARILY FORMED OF METAL FOR USE AS DOWN STAYS IN GUIDING AND LIMITING OPENING AND CLOSING MOVEMENT OF FLIPPER DOORS; HINGES PRIMARILY FORMED OF METAL IN THE NATURE OF ROTARY DAMPERS; HINGES PRIMARILY FORMED OF METAL FOR FACILITATING OPENING AND CLOSING OF DOORS.

THE MARK CONSISTS OF A MANGROVE CONSISTING OF BLUE BRANCHES WITH LEAVES OF GREEN WITH BLUE EDGES. UNDERNEATH THE MANGROVE ARE THREE GREEN WAVES. UNDERNEATH THIS IMAGE ARE THE STYLIZED LETTERS "CONSERVATION FOUNDATION OF THE GULF COAST" IN BLACK.

INT. CL. 35/U.S. CLS. 100, 101 AND 102

FOR PROMOTING PUBLIC AWARENESS OF ENVIRONMENTAL ISSUES AND INITIATIVES.  
FIRST USE 9-17-2009; IN COMMERCE 9-17-2009.

ELEMENTS CORRECTED  
OWNER ADDRESS

ELEMENTS CORRECTED  
OWNER NAME

3,906,392. REG. 1-18-2011. CONSERVATION FOUNDATION OF THE GULF COAST, INC. (FLORIDA NON-PROFIT CORPORATION), FORMERLY SARASOTA CONSERVATION FOUNDATION, INC., P.O. BOX 902, OSPREY, FL, 34229, SN 77-875,273. FILED 11-18-2009. PRINCIPAL REGISTER.



NO CLAIM IS MADE TO THE EXCLUSIVE RIGHT TO USE "SARASOTA CONSERVATION FOUNDATION", APART FROM THE MARK AS SHOWN.

THE COLOR(S) GREEN, BLUE, BLACK IS/ARE CLAIMED AS A FEATURE OF THE MARK.

THE MARK CONSISTS OF MANGROVE CONSISTING OF BLUE BRANCHES WITH LEAVES OF GREEN WITH BLUE EDGES. UNDERNEATH THE MANGROVE ARE THREE GREEN WAVES. UNDERNEATH THIS IMAGE ARE THE STYLIZED LETTERS "SARASOTA CONSERVATION FOUNDATION" IN BLACK

INT. CL. 35/U.S. CLS. 100, 101 AND 102

FOR PROMOTING PUBLIC AWARENESS OF ENVIRONMENTAL ISSUES AND INITIATIVES.

FIRST USE 8-4-2003; IN COMMERCE 8-4-2003.

ELEMENTS CORRECTED  
OWNER NAME

3,911,346. REG. 1-25-2011. LAIRD NORTON TYEE TRUST COMPANY (WASHINGTON CORPORATION) 801 SECOND AVENUE, SUITE 1600, SEATTLE, WA, 98104, SN 77-104,956. FILED 2-12-2007. PRINCIPAL REGISTER.

# REGENU

THE MARK CONSISTS OF STANDARD CHARACTERS WITHOUT CLAIM TO ANY PARTICULAR FONT, STYLE, SIZE, OR COLOR.

INT. CL. 41/U.S. CLS. 100, 101 AND 107

FOR [ EDUCATIONAL SERVICES, NAMELY, ] PROVIDING [ CLASSES, ] SEMINARS, AND WORKSHOPS IN THE FIELD OF FINANCES \* FOR MARKETING OF WEALTH MANAGEMENT SERVICES AND PROVIDING PERSONAL PLANNING FOR SUCCESSFUL LIFE TRANSITIONS, ALL FOR NON-STUDENT WEALTH MANAGEMENT CLIENTS, PROSPECTIVE CLIENTS AND REFERRAL SOURCES OTHER THAN AS PART OF A COURSE OF UNIVERSITY STUDY FOR DEGREE CREDIT \*

FIRST USE 11-3-2009; IN COMMERCE 9-15-2010.

ELEMENTS AMENDED  
GOODS/SERVICES

3,916,300. REG. 2-8-2011. KABUSHIKI KAISHA MEIDENSHA; (MEIDENSHA CORPORATION) (JAPAN CORPORATION) 1-1, OSAKI 2-CHOME, SHINAGAWA-KU; TOKYO 141-0032, JAPAN., SN 79-081,518. FILED 3-18-2010. PRINCIPAL REGISTER.

# EVREVO

PRIORITY DATE OF 1-22-2010 IS CLAIMED.

OWNER OF INTERNATIONAL REGISTRATION 1035820 DATED 3-18-2010, EXPIRES 3-18-2020.

THE MARK CONSISTS OF THE WORDING "EVREVO" IN A STYLIZED FORMAT, WITH THE LETTERS "EV" APPEARING IN A BOLDER FONT THAN THE LETTERS "REVO".

THE WORDING "EVREVO" HAS NO MEANING IN A FOREIGN LANGUAGE.

INT. CL. 9/U.S. CLS. 21, 23, 26, 36 AND 38

FOR AUTOMATIC TESTING EQUIPMENT FOR MOTOR VEHICLE PERFORMANCE, NAMELY, TRANSMISSION TESTING, DIFFERENTIAL GEAR TESTING, BRAKE TESTING, ENGINE TESTING, TIRE TESTING AND TRANSFER TESTING EQUIPMENT; DYNAMOMETERS; ACCELEROMETERS; VIBRATION METERS; NOISEMETERS; SPEED INDICATORS; ELECTRIC AND MAGNETIC METERS AND TESTERS FOR DETECTING MOTOR EFFICIENCY, INVERTER EFFICIENCY, BATTERY EFFICIENCY, VIBRATION AND NOISE; FREQUENCY METERS; COMPUTER SOFTWARE FOR AUTOMATIC TESTING EQUIPMENTS FOR MOTOR VEHICLE PERFORMANCE; COMPUTERS FOR AUTOMATIC TESTING EQUIPMENTS FOR MOTOR VEHICLE PERFORMANCE.

FIRST USE ; IN COMMERCE .

ELEMENTS CORRECTED  
GOODS/SERVICES

3,916,347. REG. 2-8-2011. FASCINUM S.R.O. (CZECH REPUBLIC LIMITED LIABILITY COMPANY) JEDLOVA 851/11, CZ-637 00 BRNO, JUNDROV, CZECH REPUBLIC., SN 79-085,395. FILED 2-25-2010. PRINCIPAL REGISTER.



# FASCINUM

PRIORITY DATE OF 9-22-2009 IS CLAIMED.

OWNER OF INTERNATIONAL REGISTRATION 1045934 DATED 2-25-2010, EXPIRES 2-25-2020.

THE MARK CONSISTS OF THE WORD "FASCINUM" UNDERNEATH A CASTLE DESIGN.

INT. CL. 25/U.S. CLS. 22 AND 39

FOR MEN'S, WOMEN'S AND CHILDREN'S CLOTHES, NAMELY, BLOUSES, DRESSES, SUITS, TROUSERS, SKIRTS, SHIRTS, VESTS, OVERCOATS, COATS, PELISSES, JACKETS, TURTLE NECK SHIRTS, SWEATERS, PULLOVERS; CLOTHES FOR PREGNANT WOMEN, NAMELY, BLOUSES, DRESSES, SUITS, TROUSERS, SKIRTS, SHIRTS, VESTS, OVERCOATS, COATS, PELISSES, JACKETS, TURTLE NECK SHIRTS, SWEATERS, PULLOVERS; CLOTHING FOR LEISURE AND SPORT TIME, NAMELY, BLOUSES, DRESSES, SUITS, TROUSERS, SKIRTS, SHIRTS, VESTS, OVERCOATS, COATS, PELISSES, JACKETS, TURTLE NECK SHIRTS, SWEATERS, PULLOVERS; BATHING SUITS AND BEACHWEAR, SHORTS, TRAINING SUITS, TRACKSUITS, SWEAT SHIRTS, WIND-JACKETS, SPORTS JACKETS, COMBINATIONS; MEN'S, WOMEN'S AND CHILDREN'S UNDERWEAR; MATERNITY UNDERWEAR; NIGHT SHIRTS; PAJAMAS, DRESSING GOWNS AND BATH ROBES, OVERALLS, TEDDIES, [ SLIPS, ] SHORTS, BOXER SHORTS, PETTICOATS, [ PANTIES, BRAS-

SIERES, ] CORSETS, CAMISOLES, [ GARTERS, ] SING-LETS, WAISTCOATS, UNDER GARMENTS, [ COTTON AND ELASTIC T-SHIRTS ] [, LEGGINGS, SOCKS, HOSIERY ]; LEOTARDS AND TIGHTS FOR [ WOMEN, ] MEN [ AND CHILDREN OF NYLON, COTTON OR OTHER TEXTILE FIBERS ]; UNIFORMS, APRONS, COVERALLS, JEANS; CLOTHING OF LEATHER, NAMELY, COATS, HATS, HEADWEAR, JACKETS, PANTS, SHIRTS, SKIRTS, VESTS, SUITS, TROUSERS OF LEATHER; LEATHER SHOES; LEATHER SLIPPERS; CLOTHING OF FUR, NAMELY, CLOAKS, COATS, JACKETS, HATS, MUFFS, STOLE, GLOVES; [ LAY-ETTES; BIBS NOT OF PAPER ]; [ INFANT CLOTH DIAPERS; TIES, NECKTIES, BOW TIES, BRACES, SHAWLS, ] SCARVES, GLOVES; HEADGEAR OF ALL SORTS INCLUDED IN THIS CLASS, NAMELY, HATS, CAPS, SKULL CAPS, HEADBANDS, BERETS, CAP PEAKS, [ BATHING CAPS, EAR MUFFS ]; ALL KINDS OF MEN'S, WOMEN'S AND CHILDREN'S FOOTWEAR, HOME AND SPORTS SHOES, SNEAKERS, FIELD BOOTS, BOOTS, MOCCASINS, WALKING SHOES, BED-ROOM SLIPPERS, SHOES, SLIPPERS; MUFFLERS, SANDALS, BELTS.

FIRST USE ; IN COMMERCE .

ELEMENTS CORRECTED  
GOODS/SERVICES

3,918,442. REG. 2-15-2011. CANTERBURY LIMITED (UNI-  
TED KINGDOM LIMITED COMPANY (LTD.)) HOLLINS-  
BROOK WAY, PILSWORTH, BURY, LANCASHIRE,  
UNITED KINGDOM, BL9 8RR, SN 77-613,095. FILED 11-  
12-2008. PRINCIPAL REGISTER.

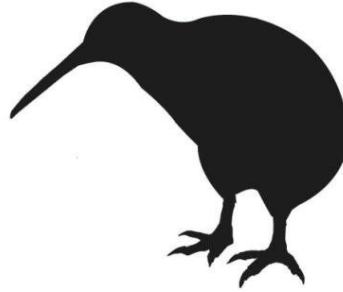

3,918,427. REG. 2-15-2011. HUFNAGEL, ZORKA (UNITED  
STATES INDIVIDUAL), AKA HUFNAGEL, Z., P.O. BOX  
164, PULTNEYVILLE, NY, 14538, SN 77-518,526. FILED 7-9-  
2008. PRINCIPAL REGISTER.

# SOULWALK

THE MARK CONSISTS OF STANDARD CHARACTERS  
WITHOUT CLAIM TO ANY PARTICULAR FONT, STYLE,  
SIZE, OR COLOR.

INT. CL. 41/U.S. CLS. 100, 101 AND 107

FOR PROVIDING ASSISTANCE, PERSONAL TRAIN-  
ING AND PHYSICAL FITNESS CONSULTATION TO  
INDIVIDUALS TO HELP THEM MAKE PHYSICAL  
FITNESS, STRENGTH, CONDITIONING, AND EXER-  
CISE IMPROVEMENT IN THEIR DAILY LIVING FOR  
THE PURPOSE OF IMPROVING MIND, BODY, AND  
SPIRIT WELLNESS.

FIRST USE 12-31-1998; IN COMMERCE 1-7-1999.

ELEMENTS AMENDED  
DATE OF FIRST USE  
DATE OF FIRST USE IN COMMERCE

OWNER OF ERPN CMNTY TM OFC REG. NO. 007390503,  
DATED 6-16-2009, EXPIRES 11-13-2018.

THE MARK CONSISTS OF THE SILHOUETTE OF A KIWI  
BIRD.

INT. CL. 25/U.S. CLS. 22 AND 39

FOR SPORTS SHORTS; JERSEYS; SWEATERS; PULL-  
OVERS; T-SHIRTS; RUGBY JERSEYS; SHORTS; FLEECE  
TOPS; KNIT TOPS; FLEECE BOTTOMS; KNIT BOT-  
TOMS; FLEECE JACKETS; RAIN JACKETS; LEISURE  
JACKETS; STADIUM JACKETS; COATS; SWEAT SUITS;  
SWEAT PANTS; JOGGING SUITS; POLO SHIRTS; RAIN  
PANTS; HATS; CAPS; SCARVES; SOCKS; SHIRTS;  
PANTS; DRESSES; SKIRTS; BLOUSES; SUITS; HOSIERY;  
UNDERGARMENTS; TRACKSUITS; TRACK PANTS;  
TRACK JACKETS; SLACKS; CLOTHING FOR CHIL-  
DREN, NAMELY, CHILDREN'S HEADWEAR, SWEA-  
TERS, PANTS, SHIRTS, T-SHIRTS, SHORTS, DRESSES,  
SKIRTS, HOSIERY, UNDERGARMENTS, SOCKS,  
FLEECE TOPS, KNIT TOPS, FLEECE BOTTOMS, KNIT  
BOTTOMS, TRACKSUITS, TRACK PANTS, SLACKS;  
TROUSERS; OVERCOATS; CLOTHING FOR BABIES,  
NAMELY, BABIES' HEADWEAR, SWEATERS, PANTS,  
SHIRTS, T-SHIRTS, SHORTS, DRESSES, SKIRTS, HOSI-  
ERY, UNDERGARMENTS, SOCKS, FLEECE TOPS, KNIT  
TOPS, FLEECE BOTTOMS, KNIT BOTTOMS, TRACK-  
SUITS, TRACK PANTS, SLACKS; JACKETS; JUMPERS;  
PARKAS; BODY SUITS; UNDERWEAR; UNDERPANTS;  
UNDERSHIRTS; SWEAT SHORTS; UNIFORMS FOR  
EXERCISE, NAMELY, ATHLETIC UNIFORM; VESTS;  
TANK TOPS; LEGGINGS; BANDANAS; HEADBANDS;  
WINTER GLOVES; MITTENS; WATERPROOF CLOTH-  
ING, NAMELY JACKETS, TROUSERS, OVER TRU-  
SERS, HATS AND GLOVES; RAINWEAR.

INT. CL. 35/U.S. CLS. 100, 101 AND 102

FOR RETAIL STORE SERVICES IN THE FIELD OF  
CLOTHING, HEADGEAR, HATS, CAPS, RUGBY BOOTS,  
SPORTING APPARATUS FOR PLAYING RUGBY,  
SPORTS APPAREL, PROTECTIVE CLOTHING, RUGBY  
HEADGEAR, UNDERGARMENTS, BAGS, SPORTING  
ARTICLES, RUGBY GEAR, AND RUGBY BALLS.

FIRST USE ; IN COMMERCE .

ELEMENTS CORRECTED  
OWNER ADDRESS  
CITIZENSHIP  
ENTITY



3,919,055. REG. 2-15-2011. KUHN S.A. (FRANCE SOCIÉTÉ ANONYME) 4 IMPASSE DES FABRIQUES, F-67700 SAVERNE, FRANCE., SN 79-081,327. FILED 2-9-2010. PRINCIPAL REGISTER.

# MYKUH N

PRIORITY DATE OF 8-19-2009 IS CLAIMED.  
OWNER OF INTERNATIONAL REGISTRATION 1035413 DATED 2-9-2010, EXPIRES 2-9-2020.  
OWNER OF U.S. REG. NOS. 1,177,826, 3,499,440 AND OTHERS.

THE WORDING "MYKUH N" HAS NO MEANING IN A FOREIGN LANGUAGE.

INT. CL. 35/U.S. CLS. 100, 101 AND 102

FOR ADVERTISING; BUSINESS MANAGEMENT; ADVICE AND INFORMATION CONCERNING COMMERCIAL BUSINESS INFORMATION; ONLINE ADVERTISING ON A COMPUTER NETWORK; PUBLIC RELATIONS; RETAIL STORE SERVICES FEATURING AGRICULTURAL MACHINES; ELECTRONIC COMMERCE SERVICES, NAMELY, PROVIDING INFORMATION ABOUT PRODUCTS VIA TELECOMMUNICATION NETWORKS FOR ADVERTISING AND SALES PURPOSES.

FIRST USE ; IN COMMERCE .

INT. CL. 38/U.S. CLS. 100, 101 AND 104

FOR ONLINE ELECTRONIC DATA TRANSMISSION; TELECOMMUNICATIONS BY E-MAIL; COMMUNICATION BY COMPUTER TERMINALS; TRANSMISSION OF INFORMATION, IMAGES AND SOUND VIA THE INTERNET; DATA TRANSMISSION VIA THE INTERNET; PROVISION OF DISCUSSION FORUMS IN THE NATURE OF ONLINE CHAT ROOMS AND ELECTRONIC BULLETIN BOARDS FOR TRANSMISSION OF MESSAGES AMONG USERS IN THE FIELD OF AGRICULTURAL MACHINERY ON THE INTERNET; COMPUTER AIDED TRANSMISSION OF MESSAGES AND IMAGES.

FIRST USE ; IN COMMERCE .

INT. CL. 41/U.S. CLS. 100, 101 AND 107

FOR EDUCATION SERVICES, NAMELY, PROVIDING LIVE AND ON-LINE SEMINARS OR WORKSHOPS IN THE FIELD OF AGRICULTURAL MACHINERY; PROVIDING OF TRAINING SERVICES IN THE FIELD OF AGRICULTURAL MACHINERY; TEACHING IN THE FIELD OF AGRICULTURAL MACHINERY; ARRANGING AND CONDUCTING OF EDUCATIONAL CONFERENCES IN THE NATURE OF SYMPOSIUMS IN THE FIELD OF AGRICULTURAL MACHINERY; ARRANGING AND CONDUCTING OF TRAINING WORKSHOPS IN THE FIELD OF AGRICULTURAL MACHINERY.

FIRST USE ; IN COMMERCE .

ELEMENTS CORRECTED  
TRANSLATION OF MARK

3,920,196. REG. 2-15-2011. PORTUCEL - EMPRESA PRODUTORA DE PASTA EPAPEL, S.A. (PORTUGAL CORPORATION) MITRENA - APARTADO 55, 2901-861 SETUBAL, PORTUGAL., SN 77-544,259. FILED 8-11-2008. PRINCIPAL REGISTER.

MULTIOFFICE - STRESS FREE  
PAPER

THE MARK CONSISTS OF STANDARD CHARACTERS WITHOUT CLAIM TO ANY PARTICULAR FONT, STYLE, SIZE, OR COLOR.

NO CLAIM IS MADE TO THE EXCLUSIVE RIGHT TO USE "PAPER", APART FROM THE MARK AS SHOWN.  
INT. CL. 16/U.S. CLS. 2, 5, 22, 23, 29, 37, 38 AND 50

FOR PAPER, NAMELY, PAPER FOR PHOTOCOPIING AND FOR LASER, INKJET AND OFFSET PRINTERS; ENVELOPES; PAPER FOR PLOTTERS.

FIRST USE 3-11-2008; IN COMMERCE 3-23-2008.

ELEMENTS CORRECTED  
OWNER NAME

3,921,557. REG. 2-22-2011. ARYSTA LIFESCIENCE EUROPE (FRANCE CORPORATION) BP617 - ZA DE COURTABOEUF, VILLEBON SUR YVETTE, FRANCE, 91140, SN 77-632,990. FILED 12-15-2008. PRINCIPAL REGISTER.



THE MARK CONSISTS OF STANDARD CHARACTERS WITHOUT CLAIM TO ANY PARTICULAR FONT, STYLE, SIZE, OR COLOR.

OWNER OF ERPN CMNTY TM OFC REG. NO. 007222508, DATED 6-5-2009, EXPIRES 9-10-2018.

INT. CL. 1/U.S. CLS. 1

FOR VETERINARY DIAGNOSTIC KIT, COMPRISED OF IMMUNOCHROMATOGRAPHY, ENZYME-LINKED IMMUNOSORBENT ASSAY, CULTURE MEDIUM, AND TRAY ATTACHED WELLS FOR VETERINARY RESEARCH PURPOSES.

FIRST USE ; IN COMMERCE .

INT. CL. 5/U.S. CLS. 6, 18, 44, 46, 51 AND 52

FOR CHEMICAL REAGENTS FOR VETERINARY USE.

FIRST USE ; IN COMMERCE .

INT. CL. 10/U.S. CLS. 26, 39 AND 44

FOR VETERINARY APPARATUS AND INSTRUMENTS, NAMELY, INTERNAL MEDICINE AND SURGICAL INSTRUMENTS FOR VETERINARY USE.

FIRST USE ; IN COMMERCE .

ELEMENTS CORRECTED  
OWNER NAME

3,922,137. REG. 2-22-2011. HOLOPACK VERPACKUNGSTECHNIK GMBH (FED REP GERMANY GMBH) BAHNHOFSTR., 74429 SULZBACH-LAUFEN, FED REP GERMANY., SN 79-075,462. FILED 7-31-2009. PRINCIPAL REGISTER.



PRIORITY DATE OF 4-16-2009 IS CLAIMED.  
OWNER OF INTERNATIONAL REGISTRATION 1019760 DATED 7-31-2009, EXPIRES 7-31-2019.



THE MARK CONSISTS OF THE DESIGNATION "HOLO-PACK" IN STYLIZED FORM WITH THE DESIGNATION "HOLO" OVER THE DESIGNATION "PACK" JOINED BY THE LETTER "H" WITH AN INCOMPLETE QUADRILATERAL AS A CARRIER FOR THE WORDING.

INT. CL. 37/U.S. CLS. 100, 103 AND 106

FOR INSTALLATION, MAINTENANCE AND REPAIR OF CONTAINER FILLING SYSTEMS, OF MACHINES FOR PROCESSING THERMOPLASTIC MATERIALS AND OF MACHINES FOR MANUFACTURING FILMS AND SEALING CONTAINERS MADE OF PLASTIC; INSTALLATION, REPAIR AND MAINTENANCE OF BLOW MOLDING MACHINES, FILLING MACHINES AND SEALING MACHINES AND BLOW-FILL-SEAL MACHINES; INSTALLATION, REPAIR AND MAINTENANCE OF MACHINES FOR PREPARING PLASTIC MATERIALS AND PLASTICS COMPOUNDING MACHINES, AND MACHINES FOR LOADING PALLETES, UNLOADING PALLETES, PACKING AND UNPACKING A CASE, SORTING, CLEANING, INSPECTING, FILLING, SEALING, LABELING AND PACKAGING.

FIRST USE ; IN COMMERCE .

INT. CL. 39/U.S. CLS. 100 AND 105

FOR PACKAGING OF LIQUID AND PASTY GOODS, NAMELY, FILLING OF PLASTIC CONTAINER PRODUCTS WITH FLUID MEDIA OF ALL KINDS; PACKAGING OF LIQUID AND PASTRY GOODS IN BLOW-FILL-SEAL MACHINES; PACKAGING OF LIQUIDS, GELS, SUSPENSIONS AND OTHER SUBSTANCES, PACKAGING SAME IN PLASTIC CONTAINERS IN BLOW-FILL-SEAL MACHINES AND OTHER PACKAGING MACHINES, PACKING THE FILLED CONTAINERS.

FIRST USE ; IN COMMERCE .

INT. CL. 42/U.S. CLS. 100 AND 101

FOR TECHNICAL CONSULTING, DEVELOPMENT AND RESEARCH, INCLUDING ENGINEERING SERVICES, IN THE FIELDS OF CONTAINER FILLING SYSTEMS, FILLING MACHINES FOR CONTAINERS, ASEPTIC FILLING MACHINES FOR CONTAINERS, BLOW MOLDING MACHINES FOR MANUFACTURING PLASTIC CONTAINERS MADE OF INJECTION MOLDED THERMOPLASTIC BLANKS, MACHINES FOR MANUFACTURING AMPULES, BAGS, CANS, BOXES AND CONTAINERS, INJECTION MOLDING MACHINES, INJECTION BLOW MOLDING MACHINES, EXTRUSION BLOW MOLDING MACHINES, STRETCH BLOW MOLDING MACHINES, BLOW MOLDING MACHINES FOR PRODUCING HOLLOW BODIES MADE OF SYNTHETIC PLASTIC MATERIAL AND CONTAINERS, BLOW-FILL-SEAL MACHINES, MACHINES FOR PROCESSING THERMOPLASTICS AND FOR MANUFACTURING PLASTIC PRODUCTS AND FILMS MADE OF PLASTIC, FILLING MACHINES AND SEALING MACHINES, MACHINES FOR PREPARING PLASTIC MATERIALS, PLASTIC COMPOUNDING MACHINES, CONTAINER WASHING MACHINES, ALIGNERS, CONVEYORS FOR CONTAINER FILLING SYSTEMS, POSITIONING AND ALIGNING MACHINES FOR CONTAINERS, LOCKING AND SEALING MACHINES FOR CONTAINERS, AUTOMATIC ACCUMULATION TABLES FOR CONTAINERS, BUFFERING DEVICES, PACKAGING AND PACKING MACHINES, ERECTORS FOR PLASTIC BOTTLES AND PLASTIC CONTAINERS, DEVICES FOR LOADING AND UNLOADING PALLETES, INDUSTRIAL ROBOTS, LABELING MACHINES, SYSTEMS FOR HANDLING FLUIDS OF ANY KIND, MIXERS, HOMOGENIZING MACHINES, AGITATING MACHINES, SATURATORS, METHODS FOR MAKING AND PACKAGING LIQUIDS, GELS, SUSPENSIONS AND OTHER SUBSTANCES, CONTAINER SHAPES FOR PACKAGING LIQUIDS, GELS, SUSPENSIONS AND OTHER SUBSTANCES, QUALITY CONTROL PROCEDURES FOR MAKING AND PACKAGING LIQUIDS, GELS, SUSPENSIONS AND OTHER SUBSTANCES, AND QUALIFICATION AND VALIDATION OF MAKING AND PACKAGING LIQUIDS, GELS, SUSPENSIONS AND OTHER SUBSTANCES.

FIRST USE ; IN COMMERCE .

ELEMENTS CORRECTED  
GOODS/SERVICES

3,923,387. REG. 2-22-2011. BRANDSTORM, INC. (CALIFORNIA CORPORATION) 10853 VENICE BLVD., SUITE 2, LOS ANGELES, CA, 90034, SN 77-144,620. FILED 3-30-2007. PRINCIPAL REGISTER.

## GOJILANIA

THE MARK CONSISTS OF STANDARD CHARACTERS WITHOUT CLAIM TO ANY PARTICULAR FONT, STYLE, SIZE, OR COLOR.

INT. CL. 29/U.S. CL. 46

FOR DRIED FRUIT MIXES; DRIED FRUITS; FROZEN FRUITS; FRUIT-BASED FOOD BEVERAGE; FRUIT-BASED SNACK FOOD; FRUITS, NAMELY, DRIED, CANNED, PRESERVED, PROCESSED GOJI BERRIES; PROCESSED FRUITS; SNACK MIX CONSISTING PRIMARILY OF PROCESSED FRUITS, PROCESSED NUTS.

FIRST USE 10-0-2006; IN COMMERCE 10-0-2006.

INT. CL. 32/U.S. CLS. 45, 46 AND 48

FOR FRUIT BEVERAGES; FRUIT DRINKS; FRUIT JUICES; FRUIT JUICES, NAMELY, GOJI BERRY JUICE; NON-ALCOHOLIC BEVERAGES CONTAINING FRUIT JUICES; NON-ALCOHOLIC BEVERAGES WITH TEA FLAVOR; NON-ALCOHOLIC FRUIT JUICE BEVERAGES.

FIRST USE 10-0-2006; IN COMMERCE 10-0-2006.

ELEMENTS CORRECTED  
OWNER NAME

3,926,410. REG. 3-1-2011. NEO FOODS PVT. LTD. (INDIA CORPORATION) NITON, E BLOCK, GROUND FLOOR, #11, PALACE ROAD, VASANTH NAGAR, BANGALORE, INDIA, 560052, SN 77-754,925. FILED 6-9-2009. PRINCIPAL REGISTER.

## Nirvana Farms

THE MARK CONSISTS OF STANDARD CHARACTERS WITHOUT CLAIM TO ANY PARTICULAR FONT, STYLE, SIZE, OR COLOR.

NO CLAIM IS MADE TO THE EXCLUSIVE RIGHT TO USE "FARMS", APART FROM THE MARK AS SHOWN.

INT. CL. 29/U.S. CL. 46

FOR CANNED OR BOTTLED VEGETABLES; CANNED VEGETABLES; PICKLED JALAPENOS; PICKLED VEGETABLES; PICKLES; PRESERVED FRUIT AND VEGETABLES; PROCESSED PEPPERS; VEGETABLES, NAMELY, CANNED PICKLES, PEPPERS, JALAPENOS, GHERKINS, AND CORNICHONS.

FIRST USE 3-12-2010; IN COMMERCE 3-12-2010.

ELEMENTS CORRECTED  
OWNER ADDRESS

3,926,666. REG. 3-1-2011. CROSS VETPHARM GROUP LIMITED (IRELAND LIMITED COMPANY (LTD.)) BROOMHILL ROAD, TALLAGHT, DUBLIN 24, IRELAND, IRELAND., SN 77-881,517. FILED 11-27-2009. PRINCIPAL REGISTER.



NO CLAIM IS MADE TO THE EXCLUSIVE RIGHT TO USE THE REPRESENTATION OF THE VETERINARY CADUCEUS DESIGN CONSISTING OF THE CADUCEUS AND THE LETTER "V", APART FROM THE MARK AS SHOWN.

THE COLOR(S) RED, BLACK AND WHITE IS/ARE CLAIMED AS A FEATURE OF THE MARK.

THE MARK CONSISTS OF A VERTICAL RECTANGLE OVERLAID BY A BROKEN CIRCLE, ALL OUTLINED IN THE COLOR BLACK WITH A WHITE INTERIOR. THERE IS A RED CIRCLE IN THE VERY CENTER OF THE BROKEN CIRCLE WITH A WHITE "V" SHAPE WITH A WHITE SERPENT AND STAFF DESIGN IN THE CENTER OF THE RED CIRCLE. THE WHITE BETWEEN THE BROKEN PART OF THE CIRCLE AND BEHIND THE MARK IS BACKGROUND AREA WHICH IS NOT A PART OF THE MARK.

INT. CL. 5/U.S. CLS. 6, 18, 44, 46, 51 AND 52

FOR VETERINARY PHARMACEUTICAL PREPARATIONS AND SUBSTANCES, NAMELY, ANTIBIOTIC AND ANTIBACTERIAL INJECTABLES, ANTIBACTERIAL ORAL LIQUIDS, ANTIBACTERIAL ORAL POWDERS, ANTIBACTERIAL TABLETS, ANTHELMINTHICS, ENDECTOCIDES, PHARMACEUTICAL PREPARATIONS FOR THE PREVENTION AND TREATMENT OF DISORDERS OF THE AUTONOMIC NERVOUS SYSTEM, HORMONES, STEROIDS, PROSTAGLANDINS, NON STEROIDAL ANTI-INFLAMMATORIES, TRANQUILIZERS, ANTI-INFLAMMATORIES, ANESTHETICS FOR SURGICAL AND NON-SURGICAL USE, ANTIHISTAMINES, TOPICAL PREPARATIONS FOR THE TREATMENT OF SKIN DISEASES, OPHTHALMIC PREPARATIONS, DIGESTIVE DISORDER PREPARATIONS, ELECTROLYTES FOR REHYDRATION, INTRAMAMMARY PREPARATIONS FOR THE TREATMENT AND PREVENTION OF BACTERIAL INFECTIONS, NUTRITIONAL SUPPLEMENTS, VITAMIN INJECTABLES, INJECTABLE MINERAL SUPPLEMENTS, ELECTROLYTE INJECTABLES, MEDICATED ANIMAL FEED, ANTISEPTICS, DISINFECTANTS FOR HYGIENIC PURPOSES, PARASITICIDES FOR MEDICAL USE, ECTOPARASITICIDES FOR MEDICAL USE, INSECTICIDES, PESTICIDES, AND SURGICAL AND HYGIENE PREPARATIONS, NAMELY, ANTISEPTICS FOR USE IN SURGERY, SURGICAL DISINFECTING HAND SCRUBS, AND TEAT DIPS.

FIRST USE 0-0-1971; IN COMMERCE 0-0-1989.

ELEMENTS CORRECTED  
DATE OF FIRST USE

3,928,882. REG. 3-8-2011. NAME RITE, L.L.C. (DELAWARE LIMITED LIABILITY COMPANY) 27710 JEFFERSON AVENUE, SUITE 105, TEMECULA, CA, 92590, SN 77-414,379. FILED 3-5-2008. PRINCIPAL REGISTER.

## OFFICE EXPERT

THE MARK CONSISTS OF STANDARD CHARACTERS WITHOUT CLAIM TO ANY PARTICULAR FONT, STYLE, SIZE, OR COLOR.

NO CLAIM IS MADE TO THE EXCLUSIVE RIGHT TO USE "OFFICE", APART FROM THE MARK AS SHOWN.

INT. CL. 9/U.S. CLS. 21, 23, 26, 36 AND 38

FOR CALCULATORS, COMPUTER PRINTERS, SURGE PROTECTORS, BACKPACKS ESPECIALLY ADAPTED FOR HOLDING LAPTOPS, AND MESSENGER BAGS ESPECIALLY ADAPTED FOR HOLDING LAPTOPS; GRADUATED RULERS; ELECTRONIC PERSONAL ORGANIZERS AND PLANNERS.

FIRST USE 11-13-2007; IN COMMERCE 11-13-2007.

INT. CL. 18/U.S. CLS. 1, 2, 3, 22 AND 41

FOR SCHOOL BAGS, SCHOOL BOOK BAGS, SCHOOL KNAPSACKS, AND MESSENGER BAGS.

FIRST USE 11-13-2007; IN COMMERCE 11-13-2007.

ELEMENTS CORRECTED  
MARK

3,929,006. REG. 3-8-2011. WIND RIVER TOBACCO COMPANY, LLC (WYOMING LIMITED LIABILITY COMPANY) P.O. BOX 4600, JACKSON, WY, 83001, SN 77-621,740. FILED 11-25-2008. PRINCIPAL REGISTER.

## BLACK MOUNTAIN

THE MARK CONSISTS OF STANDARD CHARACTERS WITHOUT CLAIM TO ANY PARTICULAR FONT, STYLE, SIZE, OR COLOR.

INT. CL. 34/U.S. CLS. 2, 8, 9 AND 17

FOR CHEWING TOBACCO; SMOKELESS TOBACCO.

FIRST USE 9-14-2010; IN COMMERCE 9-14-2010.

ELEMENTS CORRECTED  
OWNER NAME

3,929,123. REG. 3-8-2011. AGC FLAT GLASS NORTH AMERICA, INC. (DELAWARE CORPORATION) SUITE 400, 11175 CICERO DR., ALPHARETTA, GA, 30022, SN 77-706,377. FILED 4-3-2009. PRINCIPAL REGISTER.

## COMFORT E-PS

THE MARK CONSISTS OF STANDARD CHARACTERS WITHOUT CLAIM TO ANY PARTICULAR FONT, STYLE, SIZE, OR COLOR.

OWNER OF U.S. REG. NOS. 1,144,185 AND 2,061,224.

INT. CL. 2/U.S. CLS. 6, 11 AND 16

FOR SURFACE TREATMENT COMPOSITIONS FOR APPLICATION TO GLASS SUBSTRATES, NAMELY, EMISSIVITY CONTROLLING COATINGS APPLIED TO GLASS.  
FIRST USE 10-6-2009; IN COMMERCE 10-6-2009.

ELEMENTS CORRECTED  
MARK

3,932,028. REG. 3-15-2011. WASTE MANAGEMENT, INC. (DELAWARE CORPORATION) 1001 FANNIN, SUITE 4000, HOUSTON, TX, 77002. SN 77-846,231. FILED 10-11-2009. PRINCIPAL REGISTER.



OWNER OF U.S. REG. NO. 3,677,065.  
THE MARK CONSISTS OF THE WORD "GREENOPOLIS" WITHIN A RECTANGLE FORMED BY TWO ARROWS, AND A PLURALITY OF VERTICAL LINES APPEARING ABOVE THE WORD "GREENOPOLIS".  
INT. CL. 40/U.S. CLS. 100, 103 AND 106  
FOR RECYCLING AND WASTE TREATMENT SERVICES; SORTING OF WASTE AND RECYCLABLE MATERIALS; AND RESOURCE RECOVERY, NAMELY, SORTING WASTE AND RECYCLABLE MATERIALS.  
FIRST USE 1-18-2011; IN COMMERCE 1-18-0211.

ELEMENTS CORRECTED  
DESCRIPTION OF MARK

3,933,287. REG. 3-22-2011. KXH, INC. (TEXAS CORPORATION) POST OFFICE BOX 4350, MISSION, TX, 78573, SN 77-757,516. FILED 6-11-2009. PRINCIPAL REGISTER.

**FLASH/GUARD**

THE MARK CONSISTS OF STANDARD CHARACTERS WITHOUT CLAIM TO ANY PARTICULAR FONT, STYLE, SIZE, OR COLOR.  
INT. CL. 10/U.S. CLS. 26, 39 AND 44  
FOR STERILIZATION UNITS FOR MEDICAL INSTRUMENTS; STERILIZATION UNITS FOR MEDICAL PURPOSES.  
FIRST USE 6-5-1984; IN COMMERCE 10-1-1984.

ELEMENTS CORRECTED  
OWNER ADDRESS

3,935,381. REG. 3-22-2011. EARTH DAY NEW YORK (NEW YORK CORPORATION) 201 EAST 42ND STREET, #3200, NEW YORK, NY, 10017, SN 77-886,155. FILED 12-4-2009. PRINCIPAL REGISTER.



THE MARK CONSISTS OF A GLOBE WITH A HAND PRINT OVER THE GLOBE TO THE LEFT OF THE LETTER "E" WITH A LINE ABOVE AND BELOW THE "E" AND THE WORD "DAY".  
INT. CL. 35/U.S. CLS. 100, 101 AND 102  
FOR PROMOTING PUBLIC AWARENESS OF ENVIRONMENTAL ISSUES AND POTENTIAL SOLUTIONS.  
FIRST USE 1-20-2010; IN COMMERCE 1-20-2010.

ELEMENTS CORRECTED  
OWNER ADDRESS

3,935,382. REG. 3-22-2011. EARTH DAY NEW YORK (NEW YORK CORPORATION) 201 EAST 42ND STREET, #3200, NEW YORK, NY, 10017, SN 77-886,187. FILED 12-4-2009. PRINCIPAL REGISTER.

**I A M E**

THE MARK CONSISTS OF STANDARD CHARACTERS WITHOUT CLAIM TO ANY PARTICULAR FONT, STYLE, SIZE, OR COLOR.  
INT. CL. 35/U.S. CLS. 100, 101 AND 102  
FOR PROMOTING PUBLIC AWARENESS OF ENVIRONMENTAL ISSUES AND POTENTIAL SOLUTIONS.  
FIRST USE 1-20-2010; IN COMMERCE 1-20-2010.

ELEMENTS CORRECTED  
OWNER ADDRESS

3,936,651. REG. 3-29-2011. INOVA DIAGNOSTICS, INC. (CALIFORNIA CORPORATION) 9900 OLD GROVE ROAD, SAN DIEGO, CA, 92131, SN 77-967,657. FILED 3-24-2010. PRINCIPAL REGISTER.

**OMP Plus**

THE MARK CONSISTS OF STANDARD CHARACTERS WITHOUT CLAIM TO ANY PARTICULAR FONT, STYLE, SIZE, OR COLOR.  
NO CLAIM IS MADE TO THE EXCLUSIVE RIGHT TO USE "OMP", APART FROM THE MARK AS SHOWN.  
INT. CL. 1/U.S. CLS. 1

FOR CHEMICAL PREPARATIONS FOR SCIENTIFIC PURPOSES, NAMELY, IN VITRO DIAGNOSTIC TEST REAGENTS AND CONTROL STANDARDS FOR MEDICAL RESEARCH USE.

FIRST USE 11-11-2008; IN COMMERCE 11-11-2008.  
INT. CL. 5/U.S. CLS. 6, 18, 44, 46, 51 AND 52

FOR DIAGNOSTIC PREPARATIONS FOR MEDICAL [ AND VETERINARY ] USE, NAMELY, IN VITRO TEST REAGENTS AND CONTROL STANDARDS FOR MEDICAL DIAGNOSTIC USE.

FIRST USE 11-11-2008; IN COMMERCE 11-11-2008.  
INT. CL. 10/U.S. CLS. 26, 39 AND 44

FOR APPARATUS FOR CLINICAL MEDICAL DIAGNOSIS IN THE NATURE OF KITS AND COMPONENTS FOR MEDICAL DIAGNOSTICS USE, NAMELY, [ ELECTRONIC SYSTEMS COMPRISING PLATE READERS, STRIP READERS, DATA PROCESSORS, DATA REDUCTION SOFTWARE AND FLUID HANDLERS, GELS, GEL PLATES, MOUNTING MEDIA, WELL SLIDES, COVERSLIPS, WELL SLIDE HOLDERS, ] MICROWELLS [ , SLIDE MASKS, CONTROL STANDARDS MOUNTED ON SLIDES, ] \*AND\* REAGENT VIALS [ , AND DEMONSTRATION SLIDE SETS WITH PROTOCOLS ] .

FIRST USE 11-11-2008; IN COMMERCE 11-11-2008.

ELEMENTS AMENDED  
GOODS/SERVICES

3,937,086. REG. 3-29-2011. GLOVER, MAURICE L. (UNITED STATES INDIVIDUAL), DBA ALAVICI, 1959 W 17TH ST., JACKSONVILLE, FL, 32209, SN 85-046,739. FILED 5-24-2010. PRINCIPAL REGISTER.

# ALAVICI

THE MARK CONSISTS OF STANDARD CHARACTERS WITHOUT CLAIM TO ANY PARTICULAR FONT, STYLE, SIZE, OR COLOR.

INT. CL. 9/U.S. CLS. 21, 23, 26, 36 AND 38

FOR EYEWEAR AND EYEWEAR ACCESSORIES, NAMELY, STRAPS AND CASES.

FIRST USE 12-9-2008; IN COMMERCE 12-9-2008.

ELEMENTS CORRECTED  
OWNER NAME

3,937,935. REG. 3-29-2011. PURA VIDA CREATE GOOD, INC. (WASHINGTON CORPORATION) 936 N. 34TH STREET, SUITE 206, SEATTLE, WA, 98103, SN 85-097,956. FILED 8-2-2010. PRINCIPAL REGISTER.

# BISHOPS BLEND

THE MARK CONSISTS OF STANDARD CHARACTERS WITHOUT CLAIM TO ANY PARTICULAR FONT, STYLE, SIZE, OR COLOR.

NO CLAIM IS MADE TO THE EXCLUSIVE RIGHT TO USE "BLEND", APART FROM THE MARK AS SHOWN.

INT. CL. 30/U.S. CL. 46

FOR COFFEE; TEA.

FIRST USE 3-31-2002; IN COMMERCE 3-31-2002.

ELEMENTS CORRECTED  
OWNER NAME

CITIZENSHIP

3,939,362. REG. 4-5-2011. KOA SPEER ELECTRONICS, INC. (DELAWARE CORPORATION) 199 BOLIVAR DRIVE, BRADFORD, PA, 16701, SN 76-701,494. FILED 2-5-2010. PRINCIPAL REGISTER.

# KSE

THE MARK CONSISTS OF STANDARD CHARACTERS WITHOUT CLAIM TO ANY PARTICULAR FONT, STYLE, SIZE, OR COLOR.

INT. CL. 9/U.S. CLS. 21, 23, 26, 36 AND 38

FOR FIXED RESISTOR NETWORKS, POTENTIOMETERS, CIRCUIT PROTECTORS, CAPACITORS, THERMISTORS.

FIRST USE 4-0-1980; IN COMMERCE 4-0-1980.

ELEMENTS CORRECTED  
CITIZENSHIP

3,940,093. REG. 4-5-2011. TEDD CYCLE, INC. (NEW YORK CORPORATION) 9 SCOBIE DRIVE, NEWBURGH, NY, 12550, SN 85-006,387. FILED 4-5-2010. PRINCIPAL REGISTER.

# WYATT GATLING

THE MARK CONSISTS OF STANDARD CHARACTERS WITHOUT CLAIM TO ANY PARTICULAR FONT, STYLE, SIZE, OR COLOR.

THE NAME(S), PORTRAIT(S), AND/OR SIGNATURE(S) SHOWN IN THE MARK DOES NOT IDENTIFY A PARTICULAR LIVING INDIVIDUAL.

INT. CL. 7/U.S. CLS. 13, 19, 21, 23, 31, 34 AND 35

FOR MOTORCYCLE COMPONENTS, NAMELY, EXHAUST PIPE EXTENSION TIPS FOR ATTACHMENT TO AN EXHAUST PIPE AND OIL TANKS; BAFFLE RING SETS SPECIALLY ADAPTED FOR USE INSIDE A MOTORCYCLE EXHAUST PIPE TO CREATE A BACK PRESSURE IN THE EXHAUST PIPE COMPRISED OF BAFFLE ELEMENTS AND BARS OR TUBES WITH HOLES AND PIPE BRACKETS BEING COMPONENTS OF THE MOTORCYCLE EXHAUST SYSTEM.

FIRST USE 12-31-2004; IN COMMERCE 12-31-2007.

INT. CL. 11/U.S. CLS. 13, 21, 23, 31 AND 34

FOR MOTORCYCLE COMPONENTS, NAMELY, LIGHT BULBS.

FIRST USE 12-31-2004; IN COMMERCE 12-31-2007.

ELEMENTS CORRECTED  
DATE OF FIRST USE  
DATE OF FIRST USE IN COMMERCE  
[GOODS/SERVICES]  
[INTERNATIONAL CLASS(ES)]

3,940,104. REG. 4-5-2011. TEDD CYCLE, INC. (NEW YORK CORPORATION) 9 SCOBIE DRIVE, NEWBURGH, NY, 12550, SN 85-013,541. FILED 4-14-2010. PRINCIPAL REGISTER.



THE STIPPLING IS FOR SHADING PURPOSES ONLY. THE NAME(S), PORTRAIT(S), AND/OR SIGNATURE(S) SHOWN IN THE MARK DOES NOT IDENTIFY A PARTICULAR LIVING INDIVIDUAL.

THE MARK CONSISTS OF A BLACK OUTER BORDER OUTLINING THE SHAPE OF THE LITERAL ELEMENT "WYATT GATLING" INSIDE THE BORDER. A WHITE NON-SHADED LINE FOLLOWS THE CONTOUR OF THE BORDER INSIDE AND SPACED FROM THE OUTER BORDER. STIPPLING INSIDE THE BORDER REPRESENTS SHADING NOT BEING CLAIMED, WITH "WYATT GATLING" IN STYLIZED LETTERS INSIDE THE WHITE NON-SHADED LINE.

INT. CL. 7/U.S. CLS. 13, 19, 21, 23, 31, 34 AND 35

FOR MOTORCYCLE COMPONENTS, NAMELY, EXHAUST PIPE EXTENSION TIPS FOR ATTACHMENT TO AN EXHAUST PIPE AND OIL TANKS; BAFFLE RING SETS SPECIALLY ADAPTED FOR USE INSIDE A MOTORCYCLE EXHAUST PIPE TO CREATE A BACK PRESSURE IN THE EXHAUST PIPE COMPRISED OF BAFFLE ELEMENTS AND BARS OR TUBES WITH HOLES AND PIPE BRACKETS BEING COMPONENTS OF THE MOTORCYCLE EXHAUST SYSTEM.

FIRST USE 12-31-2004; IN COMMERCE 12-31-2007.

INT. CL. 11/U.S. CLS. 13, 21, 23, 31 AND 34

FOR MOTORCYCLE COMPONENTS, NAMELY, LIGHT BULBS.

FIRST USE 12-31-2004; IN COMMERCE 12-31-2007.

ELEMENTS CORRECTED  
 DATE OF FIRST USE  
 DATE OF FIRST USE IN COMMERCE  
 [GOODS/SERVICES]  
 [INTERNATIONAL CLASS(ES)]

3,940,356. REG. 4-5-2011. CHAMPIONSHIP, INC. (TEXAS CORPORATION) 523 OLD COURSE DRIVE, FRIENDSWOOD, TX, 77546, SN 85-088,558. FILED 7-20-2010. PRINCIPAL REGISTER.

# BADLANDS 94.7 FM

THE MARK CONSISTS OF STANDARD CHARACTERS WITHOUT CLAIM TO ANY PARTICULAR FONT, STYLE, SIZE, OR COLOR.

NO CLAIM IS MADE TO THE EXCLUSIVE RIGHT TO USE "94.7 FM", APART FROM THE MARK AS SHOWN. INT. CL. 38/U.S. CLS. 100, 101 AND 104 FOR RADIO BROADCASTING. FIRST USE 1-1-2000; IN COMMERCE 1-1-2000.

ELEMENTS CORRECTED  
 OWNER NAME  
 OWNER ADDRESS

3,942,014. REG. 4-5-2011. DARLINGTON COOKIE COMPANY (INDIANA CORPORATION) 802 MULBERRY STREET, SUITE B2, NOBLESVILLE, IN, 46060, SN 77-981,141. FILED 10-9-2008. PRINCIPAL REGISTER.

# APPLEWAYS

THE MARK CONSISTS OF STANDARD CHARACTERS WITHOUT CLAIM TO ANY PARTICULAR FONT, STYLE, SIZE, OR COLOR.

INT. CL. 30/U.S. CL. 46

FOR GRANOLA-BASED SNACK BARS; COOKIES; CEREAL-BASED SNACK BARS.

FIRST USE 11-9-2010; IN COMMERCE 11-9-2010.

ELEMENTS CORRECTED  
 OWNER NAME  
 OWNER ADDRESS

3,943,086. REG. 4-12-2011. NUTRIQUINE, NAAMLOZE VENNOTSCHAP (BELGIUM NV/NAAMLOZE VENNOTSCHAP) INDUSTRIEPARK 11B, B-9031 DRONGEN, BELGIUM,, SN 79-080,448. FILED 1-27-2010. PRINCIPAL REGISTER.

# SUPERFORCE

THE MARK CONSISTS OF STANDARD CHARACTERS WITHOUT CLAIM TO ANY PARTICULAR FONT, STYLE, SIZE, OR COLOR.

PRIORITY DATE OF 12-23-2009 IS CLAIMED.

OWNER OF INTERNATIONAL REGISTRATION 1032922 DATED 1-27-2010, EXPIRES 1-27-2020.

INT. CL. 5/U.S. CLS. 6, 18, 44, 46, 51 AND 52

FOR MINERAL FOOD SUPPLEMENTS FOR MEDICAL USE; FOOD SUPPLEMENTS FOR VETERINARY USE; VITAMIN PREPARATIONS [; PREPARATIONS FOR DESTROYING VERMIN; FUNGICIDES; HERBICIDES ].

FIRST USE ; IN COMMERCE .

ELEMENTS CORRECTED  
 GOODS/SERVICES



# TRADEMARK REGISTRATIONS—NEW CERTIFICATES

New Certificates issued under section 7(d) of the Trademark Act of 1946 for the unexpired term of the original registrations.

146,810. MARMITE. U.S. CL. 46. MARMITE FOOD EXTRACT CO., LIMITED, THE, LONDON, ENGLAND. REG. 9-20-1921. NEW CERT. SEC. 7(D) TO UNILEVER PLC, WIRRAL, MERSEYSIDE, ENGLAND.

3,160,519. COUNTERSTORM STANDARD CHARACTER MARK. INT. CL. 9. COUNTERSTORM, INC., NEW YORK, NY. REG. 10-17-2006. NEW CERT. SEC. 7(D) TO REGISTRANT.

1,353,454. LONSDALE. INT. CL. 25. LONSDALE BELTS & DENIMS LIMITED, SOUTHPORT, ENGLAND. REG. 8-6-1985. NEW CERT. SEC. 7(D) TO REGISTRANT.

3,390,371. TRUSTED THIN CLIENT STANDARD CHARACTER MARK. INT. CL. 9. TRUSTED COMPUTER SOLUTIONS, INC., HERNDON, VA. REG. 2-26-2008. NEW CERT. SEC. 7(D) TO REGISTRANT.

2,622,125. ELEMEX. INT. CL. 7. DAVCO MANUFACTURING, LLC, SALINE, MI. REG. 9-17-2002. NEW CERT. SEC. 7(D) TO REGISTRANT.

3,737,417. SECURITY BLANKET STANDARD CHARACTER MARK. INT. CL. 9. TRUSTED COMPUTER SOLUTIONS, INC., HERNDON, VA. REG. 1-12-2010. NEW CERT. SEC. 7(D) TO REGISTRANT.

\* \* \* \* \*

This page is intentionally blank

# INDEX OF REGISTRANTS

MAY 17, 2011

(Registered; Renewed; Canceled; Amended, Corrected, etc.; New Certificates; 12c Publications.)

The designation "U.S. Cl." appearing in this section refers to the U.S. class in effect prior to Sep. 1, 1973 rather than the international class which applies to applications filed on or after that date. For adoption of international classification see notice in the OFFICIAL GAZETTE of Jun. 26, 1973 (911 O.G. TM 210).

- A & A RESEARCH AND DEVELOPMENT W.L.L. (HOLDING), MANAMA, BAHRAIN:  
3,960,268, PUB. 3-1-2011. INT. CL. 5.  
3,960,269, PUB. 3-1-2011. INT. CL. 5.
- A G CONSULTING, LLC, SAN JUAN CAPISTRANO, CA:  
3,963,044, INT. CL. 44.  
3,963,045, INT. CL. 44.
- A J WALTER AVIATION LTD, WEST SUSSEX, UNITED KINGDOM:  
3,960,368, PUB. 3-1-2011. MULTIPLE CLASS, INT. CLS. 7, 9 AND 12.
- A LOT MOORE PRODUCTIONS, LLC, TOMS RIVER, NJ:  
2,883,003, CANC. INT. CL. 25.
- A WELL BALANCED HOME, LLC, SEATTLE, WA, DBA THE BARF BOUTIQUE:  
3,962,169, INT. CL. 35.  
3,962,840, INT. CL. 16.
- A.C. MILAN S.P.A., ITALY:  
3,960,660, PUB. 3-1-2011. MULTIPLE CLASS, INT. CLS. 3, 6, 8, 9, 14, 15, 16, 18, 20, 24, 25, 28, 30, 32, 35, 38, 41, 42 AND 45.
- A.R. BIEL, INC, BOULDER, CO, DBA BOOKS OF DISCOVERY:  
3,963,536, INT. CL. 41.
- A.W. BENNETT ENT., INC., EUGENE, OR, DBA WESTERN SHELTER SYSTEMS:  
2,881,382, CANC. INT. CL. 20.
- A&A MERCHANDISING, INC., TORRANCE, CA:  
3,961,159, PUB. 3-1-2011. INT. CL. 18.
- A&B FAMOUS GEFILTE FISH INC., PATERSON, NJ:  
3,963,223, INT. CL. 29.
- A&E TELEVISION NETWORKS, LLC, NEW YORK, NY:  
3,962,624, MULTIPLE CLASS, INT. CLS. 9 AND 41.
- AAA KITCHEN & BATH DISTRIBUTOR, INC., PHILADELPHIA, PA:  
3,963,214, INT. CL. 17.
- AAB MIDWIFERY, P.C., FORT WORTH, TX:  
3,960,927, PUB. 3-1-2011. INT. CL. 44.
- AALNEX, INC., IRVINE, CA:  
3,961,392, PUB. 3-1-2011. INT. CL. 5.
- AARHUUS STIFTSBOGTRYKKERIE, AKTIESELSKAB, DK-8270 HOJBJERG, DENMARK:  
2,880,714, CANC. MULTIPLE CLASS, INT. CLS. 9, 16, 35, 40 AND 42.
- AARON D. STERNBERG, VANCOUVER, WA AND NOAH ULLMAN, VANCOUVER, WA:  
2,738,790, CANC. INT. CL. 9.
- AARTING IP HOLDER LLC, BROOKLYN, NY:  
3,961,435, PUB. 3-1-2011. MULTIPLE CLASS, INT. CLS. 20, 35 AND 42.
- AASTRA TECHNOLOGIES LIMITED, CONCORD, ONTARIO, CANADA:  
3,960,378, PUB. 3-1-2011. INT. CL. 9.
- ABB ASEA BROWN BOVERI LTD, CH-8050 ZURICH, SWITZERLAND:  
2,785,548, CANC. MULTIPLE CLASS, INT. CLS. 10, 14, 18, 20, 21, 25 AND 26.
- ABB AUTOMATION TECHNOLOGIES MANAGEMENT LTD, CH-8050 ZURICH, SWITZERLAND:  
2,882,785, CANC. INT. CL. 9.
- ABBOTT PRODUCTS GMBH, HANNOVER, FED REP GERMANY:  
2,881,552, CANC. INT. CL. 5.
- ABBOTT SPINE, BORDEAUX, FRANCE:  
2,881,450, CANC. INT. CL. 10.
- ABELMANN, JERYL J, ALAMO, CA:  
3,963,485, INT. CL. 16.
- ABENER ENERGIA S.A., 41018-SEVILLA, SPAIN:  
3,960,542, PUB. 3-1-2011. MULTIPLE CLASS, INT. CLS. 37 AND 42.
- ABEYSEKARA, JAYARANJAN, ANAHEIM HILLS, CA:  
3,961,148, PUB. 3-1-2011. INT. CL. 30.
- ABILITY BEYOND DISABILITY, INC., BETHEL, CT:  
3,961,930, PUB. 3-1-2011. INT. CL. 35.
- ABL IP HOLDING LLC, CONYERS, GA:  
2,383,900, CANC. INT. CL. 11.
- ABM ITALIA S.P.A., ORMELLE FRAZIONE RONCADELLE (TREVISO), ITALY:  
2,881,360, CANC. MULTIPLE CLASS, INT. CLS. 20, 21 AND 28.
- ABRAZO ADOPTION ASSOCIATES, SAN ANTONIO, TX:  
2,531,968, REN. 4-14-11. INT. CL. 42.
- ABSENTE LLC, PALM COAST, FL:  
3,961,203, PUB. 3-1-2011. INT. CL. 33.
- ABSOLUTE COLD GMBH, D-38106 BRAUNSCHWEIG, FED REP GERMANY:  
2,880,789, CANC. INT. CL. 16.
- ABT FOAM, LLC, TROUTMAN, NC:  
3,962,889, INT. CL. 17.
- ACADEMICMERIT, LLC, PORTLAND, ME:  
3,963,698, INT. CL. 42.  
3,963,699, INT. CL. 42.
- ACCELA, INC., SOUTH SAN FRANCISCO, CA:  
2,882,018, CANC. INT. CL. 35.  
2,882,039, CANC. INT. CL. 35.
- ACCELERATED TECHNOLOGY LABORATORIES, INC., WEST END, NC:  
3,963,331, INT. CL. 9.
- ACCELRY'S SOFTWARE INC., SAN DIEGO, CA:  
2,383,154, CANC. INT. CL. 9.
- ACCO BRANDS CORPORATION, LINCOLNSHIRE, IL:  
2,383,425, CANC. INT. CL. 9.
- ACCREDO HEALTH GROUP, INC., MEMPHIS, TN:  
2,448,808, REN. 4-11-11. INT. CL. 28.  
2,448,809, REN. 4-11-11. INT. CL. 28.
- ACCRETIVE HEALTH, INC., CHICAGO, IL:  
3,962,418, INT. CL. 9.
- ACCURO MEDICAL PRODUCTS LLC, DENVER, CO:  
3,962,940, MULTIPLE CLASS, INT. CLS. 5 AND 10.
- ACCUTRANS, COVINGTON, WA:  
3,961,317, PUB. 3-1-2011. INT. CL. 35.
- ACE - APPLIED COGNITIVE ENGINEERING, LTD., HOD HASHARON, ISRAEL:  
3,960,469, PUB. 3-1-2011. INT. CL. 9.
- ACME SCALE CO., VILLA PARK, IL, DBA ACME SCALE SYSTEMS, INC.:  
3,960,375, PUB. 3-1-2011. MULTIPLE CLASS, INT. CLS. 35, 37 AND 42.
- ACO, INC., OKLAHOMA CITY, OK:  
2,440,897, REN. 4-11-11. INT. CL. 21.

- ACOUSTIC SOLUTIONS LIMITED, NORTHAMPTON, NN7 4PS, UNITED KINGDOM:  
2,880,640, CANC. INT. CL. 9.
- ACS DATA SEARCH, LLC, OVERLAND PARK, KS:  
2,471,710, REN. 4-11-11. INT. CL. 42.
- ACS MARKETING, L.P., DALLAS, TX:  
2,856,330, CANC. INT. CL. 9.
- ACT COSMETICS GMBH, FED REP GERMANY:  
3,960,810, PUB. 3-1-2011. MULTIPLE CLASS, INT. CLS. 3, 5 AND 21.
- ACTEGA KELSTAR, INC, CINNAMINSON, NJ:  
3,961,379, PUB. 3-1-2011. INT. CL. 1.
- ACTINVER, S.A. DE C.V. SOCIEDAD OPERADORA DE SOCIEDADES DE INVERSION, SANTA FE, MEXICO D.F., MEXICO:  
3,960,336, PUB. 8-17-2010. MULTIPLE CLASS, INT. CLS. 35 AND 36.
- ACTIVIENT, WINDERMERE, FL:  
3,963,652, INT. CL. 35.
- ACUSHNET COMPANY, FAIRHAVEN, MA:  
2,383,608, CANC. INT. CL. 28.
- AD-TECH MEDICAL INSTRUMENT CORPORATION, RACINE, WI:  
1,648,517, REN. 4-14-11. INT. CL. 10.
- ADAIR GROUP, LLC, ATLANTA, GA:  
2,882,520, CANC. INT. CL. 25.
- ADAMS, KEN, FALLBROOK, CA:  
2,881,880, CANC. MULTIPLE CLASS, INT. CLS. 16 AND 25.
- ADAPTIVE SOUND TECHNOLOGIES, INC., CAMPBELL, CA:  
3,963,572, INT. CL. 9.
- ADDS PHARMACEUTICALS, LLC, SUNNYVALE, CA:  
3,962,577, INT. CL. 5.
- ADIB NASLE, POWAY, CA:  
3,962,897, INT. CL. 45.  
3,962,898, INT. CL. 45.
- ADLER FELS WINERY, LLC, SANTA ROSA, CA:  
3,963,033, INT. CL. 33.
- ADLER TRAINING, ASTORIA, NY:  
3,961,886, PUB. 3-1-2011. MULTIPLE CLASS, INT. CLS. 41 AND 44.
- ADLY, INC., BEVERLY HILLS, CA:  
3,961,740, PUB. 3-1-2011. INT. CL. 35.
- ADMUNDSON, RICHARD, NEW YORK, NY:  
3,960,852, PUB. 3-1-2011. INT. CL. 25.
- ADOPT A SCHOOL PROGRAM, THE, BOULDER, CO:  
2,383,343, CANC. INT. CL. 42.
- ADP, INC., ROSELAND, NJ:  
3,963,619, INT. CL. 42.  
3,963,620, INT. CL. 42.
- ADRIANNA PAPELL L.L.C., NEW YORK, NY:  
2,982,800, COR. INT. CL. 25.
- ADT SERVICES AG, SCHAFFHAUSEN, SWITZERLAND,  
ADT SERVICES AG, SCHAFFHAUSEN, SWITZERLAND:  
2,456,494, REN. 4-8-11. MULTIPLE CLASS, INT. CLS. 9 AND 42.
- ADTRACTION, INC., LANGHORNE, PA:  
2,880,725, CANC. INT. CL. 9.
- ADULT SOURCE MEDIA, INC., CHATSWORTH, CA:  
3,961,302, PUB. 3-1-2011. INT. CL. 9.
- ADVANCE AUTO INNOVATIONS, LLC, ROANOKE, VA:  
3,961,539, PUB. 3-1-2011. MULTIPLE CLASS, INT. CLS. 35, 37, 40 AND 42.  
3,962,517, INT. CL. 12.  
3,963,156, INT. CL. 35.
- ADVANCE MAGAZINE PUBLISHERS INC, NEW YORK, NY:  
3,960,247, PUB. 3-1-2011. INT. CL. 36.
- ADVANCE MAGAZINE PUBLISHERS INC., NEW YORK, NY:  
3,960,245, PUB. 3-1-2011. INT. CL. 41.  
3,961,931, PUB. 3-1-2011. INT. CL. 9.  
3,963,245, INT. CL. 41.
- ADVANCED ADHESIVE SYSTEMS, INC., NEWINGTON, CT:  
2,480,662, REN. 4-14-11. INT. CL. 1.
- ADVANCED ARCHITECTURAL FRAMES, STANTON, CA:  
2,880,819, CANC. INT. CL. 6.
- ADVANCED BIOLOGICS LLC, LADERA RANCH, CA:  
3,962,700, INT. CL. 5.
- ADVANCED BIONUTRITIONALS, L.L.C., ATLANTA, GA:  
3,962,407, INT. CL. 5.
- ADVANCED FORECASTING CORPORATION, BILLINGS, MT:  
2,391,041, REN. 4-14-11. INT. CL. 42.
- ADVANCED FUSION, LLC, SAN ANTONIO, TX:  
3,960,497, PUB. 3-1-2011. INT. CL. 5.
- ADVANCED ILLUMINATION, INC., ROCHESTER, VT:  
3,963,352, INT. CL. 11.
- ADVANCED INGREDIENTS, INC., CAPITOLA, CA:  
3,963,127, INT. CL. 3.  
3,963,128, INT. CL. 5.
- ADVANCED LEARNING CENTERS, INC., ENGLEWOOD, CO, DBA THE LEADERSHIP AND LEARNING CENTER:  
3,963,742, INT. CL. 41.  
3,963,745, INT. CL. 41.
- ADVANCED MOTION TECHNOLOGIES, ASHTON, MD:  
2,881,945, CANC. INT. CL. 9.
- ADVANCED PRODUCTIVITY SOFTWARE, INC., ATLANTA, GA:  
2,536,459, REN. 4-11-11. INT. CL. 9.
- ADVANCED RAIL CONCEPTS, LLC, SNOHOMISH, WA:  
3,961,844, PUB. 3-1-2011. INT. CL. 7.  
3,961,847, PUB. 3-1-2011. INT. CL. 7.
- ADVANCED SURFACE SYSTEMS LLC, ALCOA, TN, AKA AKA ASSI:  
3,960,477, PUB. 3-1-2011. INT. CL. 19.
- ADVANCED TECHNOLOGY MATERIALS, INC., DANBURY, CT:  
3,963,105, INT. CL. 1.
- ADVENTURE FOREST LLC, ROCKVILLE, MD:  
3,960,240, PUB. 3-1-2011. INT. CL. 41.
- ADVENTURE TOURS USA, INC., MILWAUKEE, WI:  
2,383,177, CANC. INT. CL. 39.
- ADVION BIOSYSTEMS, INC., ITHACA, NY:  
3,963,119, INT. CL. 9.
- ADVISER INVESTMENT MANAGEMENT, INC., NEWTON, MA:  
2,440,480, REN. 4-11-11. INT. CL. 36.
- AEROFLOT RUSSIAN AIRLINES, NEW YORK, NY:  
3,961,792, PUB. 3-1-2011. INT. CL. 39.
- AEROLENZ LLC, SANTA FE, NM:  
3,961,494, PUB. 3-1-2011. INT. CL. 19.
- AEROSPACE PRODUCTS INTERNATIONAL, INC., MEMPHIS, TN:  
2,384,347, CANC. INT. CL. 11.
- AEROVIAS DEL CONTINENTE AMERICANO S.A. AVIANCA, BARRANQUILLA, ATLANTICO, COLOMBIA:  
1,666,987, REN. 4-14-11. INT. CL. 39.
- AERVOE INDUSTRIES, INC., GARDNERVILLE, NV, E-ZEST PRODUCTS CO., INC., OAKLAND, CA:  
714,821, REN. 4-11-11. U.S. CL. 52 (INT. CL. 3).
- AEU MEDIA GROUP, LLC, PALM SPRINGS, CA:  
3,960,475, PUB. 3-1-2011. INT. CL. 35.
- AFFINION PUBLISHING, LLC, LAS VEGAS, NV:  
2,446,370, REN. 4-11-11. MULTIPLE CLASS, INT. CLS. 35 AND 36.
- AFFINITY PETCARE S.A., BARCELONA, SPAIN:  
3,961,410, PUB. 3-1-2011. INT. CL. 31.
- AFHAMI, REZA, SACRAMENTO, CA:  
2,382,251, CANC. INT. CL. 16.
- AFTER MARKET ACCESSORIES GROUP, LLC, RENO, NV:  
3,961,179, PUB. 3-1-2011. INT. CL. 12.
- AFTERMARKET AUTO PARTS ALLIANCE, INC., SAN ANTONIO, TX:  
3,961,224, PUB. 3-1-2011. INT. CL. 35.  
3,961,225, PUB. 3-1-2011. INT. CL. 35.  
3,961,789, PUB. 3-1-2011. INT. CL. 37.
- AFTERSCHOOL BUDDY, INC., ALLISON PARK, PA:  
3,963,621, MULTIPLE CLASS, INT. CLS. 9, 25, 28 AND 41.
- AGBO, PETE, CULVER CITY, CA:  
2,882,281, CANC. INT. CL. 25.

AGC FLAT GLASS NORTH AMERICA, INC., ALPHARETTA, GA:  
3,929,123, COR. INT. CL. 2.

AGENCIA ESPAÑOLA DE PROTECCION DE DATOS, SPAIN:  
3,960,748, PUB. 3-1-2011. MULTIPLE CLASS, INT. CLS. 35, 41 AND 45.

AGFA HEALTHCARE NV, MORTSEL, BELGIUM:  
1,652,825, REN. 4-8-11. MULTIPLE CLASS, INT. CLS. 1 AND 9.

AGHA JUICE, LLC, CARROLLTON, TX:  
3,961,839, PUB. 3-1-2011. INT. CL. 43.

AGILE WEB SOLUTIONS, INC., ST. THOMAS, ONTARIO, CANADA:  
3,960,422, PUB. 3-1-2011. INT. CL. 9.

AGILENT TECHNOLOGIES, INC., SANTA CLARA, CA:  
3,963,250, INT. CL. 9.  
3,963,251, INT. CL. 9.

AGL RESOURCES INC., ATLANTA, GA:  
3,960,486, PUB. 3-1-2011. INT. CL. 39.

AGRI LABORATORIES, LTD., ST. JOSEPH, MO:  
3,961,234, PUB. 3-1-2011. INT. CL. 5.

AGUA CALIENTE BAND OF CAHUILLA INDIANS, PALM SPRINGS, CA:  
2,800,048, CANC. MULTIPLE CLASS, INT. CLS. 41, 43 AND 44.

AHLERS, JURGEN, TUCKER, GA:  
2,882,126, CANC. INT. CL. 42.

AHMANN, DOUGLAS, WOODBURY, MN:  
3,961,658, PUB. 3-1-2011. INT. CL. 30.

AHOLD LICENSING SARL, GENEVA, SWITZERLAND:  
3,962,111, INT. CL. 21.

AHRENS, JASON T., TUKWILA, WA AND CHURCHILL, SARAJEAN E, TUKWILA, WA:  
3,962,114, MULTIPLE CLASS, INT. CLS. 9 AND 41.

AHS HOSPITAL CORP., MORRISTOWN, NJ, MORRISTOWN MEMORIAL HOSPITAL, MORRISTOWN, NJ:  
1,648,453, REN. 4-12-11. INT. CL. 42.

AIDA ENGINEERING, LTD., SAGAMIHARA CITY, KANAGAWA PREF., JAPAN:  
921,061, REN. 4-8-11. U.S. CL. 23 (INT. CLS. 6, 7, 8, 9, 11, 12, 16, 21 AND 28).

AINSWORTH GAME TECHNOLOGY LIMITED, NEWINGTON, AUSTRALIA:  
3,963,104, INT. CL. 9.

AIR LINE PILOTS ASSOCIATION INT'L, WASHINGTON, DC:  
1,178,030, REN. 4-14-11. INT. CL. 16.

AIR PRODUCTS AND CHEMICALS, INC., ALLENTOWN, PA:  
1,642,509, REN. 4-12-11. INT. CL. 1.

AIR TECH EQUIPMENT LTD., NEW BRUNSWICK, CANADA:  
3,962,102, INT. CL. 11.

AIRBED & BREAKFAST, INC., SAN FRANCISCO, CA:  
3,963,410, INT. CL. 45.

AIRHOLE FACEMASKS INC., VANCOUVER, CANADA:  
3,960,991, PUB. 3-1-2011. INT. CL. 25.

AIRS HUMAN CAPITAL SOLUTIONS, INC., WHITE RIVER JUNCTION, VT:  
2,882,727, CANC. INT. CL. 42.

AIRSPASH, INC., FAIRFIELD, NJ:  
2,727,702, CANC. INT. CL. 9.

AJINOMOTO CO., INC., CHUO-KU, TOKYO, JAPAN:  
3,960,611, PUB. 3-1-2011. INT. CL. 29.

AK-SAR-BEN/CALGARY HOCKEY, INC., OMAHA, NE:  
3,176,531, CANC. INT. CL. 41.  
3,180,126, CANC. INT. CL. 41.

AKAMAI TECHNOLOGIES, INC., CAMBRIDGE, MA, AKAMAI TECHNOLOGIES, INC., CAMBRIDGE, MA:  
2,441,303, REN. 4-8-11. MULTIPLE CLASS, INT. CLS. 38 AND 42.

AKITA, INC., WILMINGTON, DE:  
3,961,905, PUB. 3-1-2011. INT. CL. 40.

AKSEL GROUP, INC, SAN FRANCISCO, CA:  
3,961,124, PUB. 3-1-2011. INT. CL. 25.

AKTIEBOLAGET ELECTROLUX, STOCKHOLM, SWEDEN:  
3,961,139, PUB. 3-1-2011. INT. CL. 7.  
3,961,140, PUB. 3-1-2011. INT. CL. 7.

AKTIEBOLAGET ELECTROLUX, SE 105-45 STOCKHOLM, SWEDEN:  
3,962,110, INT. CL. 7.

ALATAS, TARIQ, LOS ANGELES, CA:  
3,962,265, INT. CL. 25.

ALBERICO LEMME, ITALY:  
3,960,741, PUB. 3-1-2011. INT. CL. 44.

ALBERT HANDTMANN ELTEKA GMBH & CO. KG, FED REP GERMANY:  
3,960,833, PUB. 3-1-2011. MULTIPLE CLASS, INT. CLS. 1, 7 AND 17.

ALBRECHT KRESSE, 10405 BERLIN, FED REP GERMANY:  
3,960,659, PUB. 3-1-2011. MULTIPLE CLASS, INT. CLS. 35, 39 AND 41.

ALCO INDUSTRIES, INC., NORRISTOWN, PA:  
3,962,906, INT. CL. 7.

ALCOA INC., PITTSBURGH, PA:  
3,963,743, INT. CL. 6.

ALDI INC., BATAVIA, IL:  
3,962,901, INT. CL. 29.  
3,963,260, MULTIPLE CLASS, INT. CLS. 6 AND 16.

ALEXANDER DOLL COMPANY, NEW YORK, NY:  
2,882,726, CANC. INT. CL. 28.

ALEXANDER, KENNETH C, DAYTON, NJ:  
3,963,737, INT. CL. 41.

ALEXANDRA SELECTION, F-75008 PARIS, FRANCE:  
3,960,638, PUB. 3-1-2011. MULTIPLE CLASS, INT. CLS. 9, 14, 18 AND 26.

ALEXANDRIA REAL ESTATE EQUITIES, INC., PASADENA, CA:  
3,962,213, MULTIPLE CLASS, INT. CLS. 35, 36, 37, 38, 41 AND 42.

ALEXIS BROTHERS, INC., SARASOTA, FL:  
2,882,258, CANC. INT. CL. 25.

ALEXIS PRODUCTIONS, LLC., LAS VEGAS, NV:  
2,883,297, CANC. INT. CL. 9.

ALFA LAVAL CORPORATE AB, LUND, SWEDEN, ALFA LAVAL THERMAL INC., RICHMOND, VA:  
2,446,983, REN. 4-12-11. INT. CL. 11.

ALFA VITAMINS LABORATORIES INC., DORAL, FL:  
3,962,708, INT. CL. 5.

ALFELD, BEVERLY, CRYSTAL LAKE, IL AND ALFELD, TIMOTHY, CRYSTAL LAKE, IL AND ALFELD, KIMBERLY, CRYSTAL LAKE, IL:  
2,881,316, CANC. INT. CL. 29.

ALFONSO, MARC, VANCOUVER, CHINA:  
3,963,810, INT. CL. 9.

ALFORD BUSINESS INC., TORTOLA, BR.VIRGIN ISLANDS:  
3,960,990, PUB. 11-23-2010. INT. CL. 32.

ALGENOL BIOFUELS INC., BONITA SPRINGS, FL:  
3,961,673, PUB. 3-1-2011. MULTIPLE CLASS, INT. CLS. 40, 42 AND 44.

ALIBABA GROUP HOLDING LIMITED, GRAND CAYMAN, CAYMAN ISLANDS:  
3,960,397, PUB. 3-1-2011. MULTIPLE CLASS, INT. CLS. 9, 35, 36, 38, 39, 41 AND 42.  
3,960,466, PUB. 3-1-2011. MULTIPLE CLASS, INT. CLS. 9, 35, 38 AND 42.

ALIBRIS, INC., EMERYVILLE, CA:  
3,960,998, PUB. 3-1-2011. MULTIPLE CLASS, INT. CLS. 35 AND 42.

ALL AMERICAN NUT CO., INC., DOWNEY, CA TO HARVEST MANOR FARMS, LLC, EL PASO, TX:  
658,838, AM. U.S. CL. 46.

ALLCHEM INDUSTRIES HOLDING CORPORATION, GAINESVILLE, FL:  
2,465,646, REN. 4-12-11. MULTIPLE CLASS, INT. CLS. 1, 35 AND 36.

ALLEGED MEDIA, INC., CULVER CITY, CA:  
3,961,819, PUB. 3-1-2011. INT. CL. 38.

ALLEN SYSTEMS GROUP, INC., NAPLES, FL:  
3,961,756, PUB. 3-1-2011. INT. CL. 9.



- ALLEN, THOMAS L., WINTER GARDEN, FL, DBA FRIENDLY GREETINGS, INC.:  
3,963,169, INT. CL. 16.
- ALLIANCE FOR SMALL BUSINESS, FORT WORTH, TX:  
2,882,655, CANC. INT. CL. 35.
- ALLIANCE FOR VETERANS, LOS ANGELES, CA:  
3,963,797, INT. CL. 36.
- ALLIANCE RUBBER COMPANY, HOT SPRINGS, AR:  
2,383,412, CANC. INT. CL. 16.
- ALLIANT AVIATION, LLC, THREE RIVERS, MI:  
2,880,960, CANC. INT. CL. 12.
- ALLIANT TECHSYSTEMS INC., MINNEAPOLIS, MN:  
3,962,222, MULTIPLE CLASS, INT. CLS. 9 AND 21.  
3,962,895, INT. CL. 42.
- ALLINA HEALTH SYSTEM, MINNEAPOLIS, MN:  
3,962,797, INT. CL. 44.
- ALLMAX INTERNATIONAL CORP., TORTOLA, BR. VIRGIN ISLANDS:  
3,963,365, INT. CL. 11.
- ALLPRO CORPORATION, BRANDON, FL:  
2,419,259, REN. 4-12-11, INT. CL. 17.
- ALLSEATING CORPORATION, MISSISSAUGA, CANADA:  
3,960,285, PUB. 3-1-2011, INT. CL. 20.
- ALLSTATE ENTERPRISES, LLC, NORTHBROOK, IL:  
2,882,215, CANC. MULTIPLE CLASS, INT. CLS. 35 AND 37.
- ALLTRADE INC., LONG BEACH, CA:  
2,383,880, CANC. INT. CL. 8.
- ALMADA, ANTHONY, LAGUNA NIGUEL, CA:  
2,384,152, CANC. INT. CL. 42.
- ALMOST FAMOUS, MIAMI, FL:  
3,962,144, MULTIPLE CLASS, INT. CLS. 41 AND 45.
- ALPHA PSI OMEGA, WICHITA, KS:  
3,961,229, PUB. 3-1-2011, INT. CL. 41.
- ALS CANADA LTD., NORTH VANCOUVER, B.C., CANADA:  
3,961,244, PUB. 3-1-2011, INT. CL. 42.
- ALTA VIA CONSULTING, LLC, KNOXVILLE, TN:  
3,961,962, MULTIPLE CLASS, INT. CLS. 35, 41 AND 42.
- ALTERA LAW GROUP, L.L.C., MINNEAPOLIS, MN:  
3,961,465, PUB. 3-1-2011, INT. CL. 45.
- ALTERNA HOLDINGS CORP., CENTURY CITY, CA:  
3,963,638, INT. CL. 3.
- ALTERNA-JF LLC, WHIPPANY, NJ:  
3,961,466, PUB. 3-1-2011, INT. CL. 5.
- ALTO SHAAM, INC., MENOMONEE FALLS, WI:  
1,638,273, REN. 4-12-11, INT. CL. 11.
- ALVAREZ, SALVADOR, SAN DIEGO, CA:  
3,962,696, INT. CL. 5.
- ALWAYS PRESENTABLE MUSIC & ENTERTAINMENT COMPANY INC., NEW YORK, NY:  
3,961,859, PUB. 3-1-2011, INT. CL. 41.
- ALWAYS SUMMER TAN, INC., CARY, NC:  
2,880,805, CANC. INT. CL. 3.
- AMANDA VARE, WYONG CREEK NSW, AUSTRALIA:  
3,962,996, INT. CL. 35.
- AMAYA GAMING GROUP INC., POINTE-CLAIRE, QUEBEC, CANADA:  
3,961,964, INT. CL. 9.
- AMAZING BOOKS LLC, PLAYA DEL REY, CA:  
3,961,291, PUB. 3-1-2011, INT. CL. 9.
- AMBIENT CORPORATION, NEWTON, MA:  
3,962,547, MULTIPLE CLASS, INT. CLS. 9 AND 42.
- AMC, INC., ATLANTA, GA:  
2,880,749, CANC. INT. CL. 35.
- AMEREX CORPORATION, TRUSSVILLE, AL:  
3,961,365, PUB. 3-1-2011, INT. CL. 9.
- AMERICA TECHNOLOGICA, INC., CONCORD, CA:  
2,883,036, CANC. INT. CL. 9.
- AMERICA'S PROMISE - THE ALLIANCE FOR YOUTH, INC., WASHINGTON, DC:  
2,882,388, CANC. INT. CL. 16.
- AMERICAL CORPORATION, HENDERSON, NC:  
2,882,216, CANC. INT. CL. 25.
- AMERICAN ACADEMY OF MINIMALLY INVASIVE SPINAL MEDICINE AND SURGERY, THOUSAND OAKS, CA:  
2,443,566, REN. 4-12-11, MULTIPLE CLASS, INT. CLS. 41 AND 42.
- AMERICAN AEROGEL CORPORATION, ROCHESTER, NY:  
2,882,812, CANC. INT. CL. 17.
- AMERICAN ARBITRATION ASSOCIATION, NEW YORK, NY:  
1,645,975, REN. 4-11-11, MULTIPLE CLASS, INT. CLS. 16 AND 41.
- AMERICAN ART CLAY CO., INC., INDIANAPOLIS, IN:  
3,963,608, INT. CL. 2.
- AMERICAN ASSOCIATION OF NEUROLOGICAL SURGEONS, ROLLING MEADOWS, IL:  
2,882,627, CANC. MULTIPLE CLASS, INT. CLS. 35 AND 44.
- AMERICAN ASSOCIATION OF PROFESSIONAL EYE CARE SPECIALISTS, P.C., VIRGINIA BEACH, VA:  
2,383,388, CANC. INT. CL. 42.
- AMERICAN ASSOCIATION OF PROFESSIONAL LANDMEN, FORT WORTH, TX:  
2,384,112, CANC. INT. CL. 36.
- AMERICAN ASSOCIATION OF STATE COLLEGES AND UNIVERSITIES, WASHINGTON, DC:  
3,961,347, PUB. 3-1-2011, INT. CL. 41.
- AMERICAN BIBLE SOCIETY, NEW YORK, NY:  
2,882,763, CANC. INT. CL. 9.
- AMERICAN BLUE RIBBON HOLDINGS, LLC, DENVER, CO:  
3,963,070, INT. CL. 43.
- AMERICAN CANCER SOCIETY, INC., ATLANTA, GA:  
1,651,683, REN. 4-8-11, MULTIPLE CLASS, INT. CLS. 36 AND 42.
- AMERICAN CAR CARE CENTERS, INC., MEMPHIS, TN:  
2,448,685, REN. 4-8-11, INT. CL. 36.  
3,963,437, MULTIPLE CLASS, INT. CLS. 35 AND 37.
- AMERICAN COLEMAN, LLC, TELLURIDE, CO:  
2,384,080, CANC. INT. CL. 12.
- AMERICAN COLLEGE OF SPORTS MEDICINE, INC., INDIANAPOLIS, IN:  
2,383,479, CANC. INT. CL. 41.
- AMERICAN COMMUNITY MUTUAL INSURANCE CO., LIVONIA, MI:  
2,883,254, CANC. INT. CL. 36.
- AMERICAN COUNCIL OF LIFE INSURERS, INC., WASHINGTON, DC:  
2,477,948, REN. 4-9-11, INT. CL. 42.
- AMERICAN DIETETIC ASSOCIATION, CHICAGO, IL:  
2,881,381, CANC. INT. CL. 16.
- AMERICAN FAMILY LIFE ASSURANCE COMPANY OF COLUMBUS, COLUMBUS, GA:  
3,962,669, INT. CL. 36.
- AMERICAN FLOOR INC., DAVIE, FL:  
2,383,899, CANC. INT. CL. 19.
- AMERICAN GIRL, LLC, EL SEGUNDO, CA:  
2,441,647, REN. 4-12-11, INT. CL. 28.  
2,452,154, REN. 4-12-11, INT. CL. 16.  
2,452,211, REN. 4-8-11, INT. CL. 41.  
2,882,625, CANC. INT. CL. 28.
- AMERICAN GRIP INCORPORATED, SUN VALLEY, CA:  
2,882,920, CANC. INT. CL. 8.
- AMERICAN INSTITUTE OF TOXICOLOGY, INC., INDIANAPOLIS, IN:  
3,962,651, INT. CL. 42.
- AMERICAN INTERNATIONAL GROUP, INC., NEW YORK, NY:  
2,882,794, CANC. INT. CL. 36.  
3,962,758, INT. CL. 36.  
3,962,759, INT. CL. 36.
- AMERICAN KEY FOOD PRODUCTS, LLC, CLOSTER, NJ:  
2,880,804, CANC. MULTIPLE CLASS, INT. CLS. 29 AND 30.
- AMERICAN LAW INSTITUTE, PHILADELPHIA, PA:  
1,646,007, REN. 4-13-11, INT. CL. 16.
- AMERICAN MARINE HOLDINGS, LLC, HOMOSASSA, FL:  
2,445,681, REN. 4-13-11, INT. CL. 12.
- AMERICAN MODERN INSURANCE COMPANY, INC., AMELIA, OH:  
3,961,037, PUB. 3-1-2011, INT. CL. 36.

AMERICAN MODERN INSURANCE GROUP, INC., AMELIA, OH:  
3,961,036, PUB. 3-1-2011. INT. CL. 36.

AMERICAN PAYROLL INSTITUTE, NEW YORK, NY:  
2,384,323, CANC. INT. CL. 16.

AMERICAN PIPE & PLASTICS, INC., BINGHAMTON, NY:  
2,883,105, CANC. INT. CL. 17.

AMERICAN PROMOTIONAL EVENTS, INC., FLORENCE, AL, DBA TNT FIREWORKS:  
3,961,448, PUB. 3-1-2011. INT. CL. 13.  
3,961,506, PUB. 3-1-2011. INT. CL. 13.  
3,961,588, PUB. 3-1-2011. INT. CL. 13.  
3,961,590, PUB. 3-1-2011. INT. CL. 13.

AMERICAN PSYCHOLOGICAL ASSOCIATION PRACTICE ORGANIZATION, WASHINGTON, DC:  
3,962,666, INT. CL. 41.

AMERICAN PUBLIC POWER ASSOCIATION, WASHINGTON, DC:  
3,961,943, PUB. 3-1-2011. MULTIPLE CLASS, INT. CLS. 16, 35 AND 44.

AMERICAN RECREATION PRODUCTS, INC., ST. LOUIS, MO:  
2,446,740, REN. 4-8-11. INT. CL. 24.

AMERICAN SCHOOL OF CORRESPONDENCE, LANSING, IL, AKA AMERICAN SCHOOL:  
3,960,445, PUB. 3-1-2011. INT. CL. 41.

AMERICAN SOCIETY FOR NUTRITION, BETHESDA, MD:  
3,960,556, PUB. 3-1-2011. MULTIPLE CLASS, INT. CLS. 16 AND 41.

AMERICAN SOCIETY OF COMPOSERS, AUTHORS & PUBLISHERS, NEW YORK, NY:  
2,882,395, CANC. INT. CL. 42.

AMERICAN STRING TEACHERS ASSOCIATION, FAIRFAX, VA:  
3,963,852, INT. CL. 41.

AMERICAN SURGICAL INSTRUMENTS CORPORATION, WESTMONT, IL:  
1,906,423, CANC. INT. CL. 10.

AMERICAN TELECONFERENCING SERVICES, LTD., ATLANTA, GA:  
2,881,385, CANC. INT. CL. 38.

AMERICAN TREBLE, LLC, WARNER ROBINS, GA:  
3,961,741, PUB. 3-1-2011. INT. CL. 41.

AMERICAN WATERCOLOR SOCIETY, NEW YORK, NY:  
1,152,790, REN. 4-14-11. U.S. CL. 200.  
1,164,977, REN. 4-12-11. INT. CL. 41.

AMERICAN WOODMARK CORPORATION, WINCHESTER, VA:  
3,962,587, INT. CL. 20.  
3,962,588, INT. CL. 20.

AMERICANA INTERNATIONAL LIMITED, MANCHESTER, UNITED KINGDOM:  
3,960,630, PUB. 3-1-2011. MULTIPLE CLASS, INT. CLS. 18 AND 25.

AMERIKAL NUTRACEUTICAL CORPORATION, MISSION VIEJO, CA:  
3,963,282, MULTIPLE CLASS, INT. CLS. 3 AND 5.

AMERIPARK, LLC, ATLANTA, GA:  
2,540,956, REN. 4-13-11. INT. CL. 39.

AMESCUA, GERARDO, PUEBLA, MEXICO:  
3,961,949, PUB. 3-1-2011. INT. CL. 10.

AMIXIMA CORP., MISSISSAUGA, ONTARIO, CANADA:  
2,883,014, CANC. INT. CL. 41.

AMOREPACIFIC CORPORATION, SEOUL, REPUBLIC OF KOREA:  
3,962,642, INT. CL. 3.

AMPAC HOLDINGS, LLC, CINCINNATI, OH:  
3,962,084, INT. CL. 17.

AMPLIFY FEDERAL CREDIT UNION, AUSTIN, TX:  
3,963,625, INT. CL. 36.

AMY'S KITCHEN, INC., SANTA ROSA, CA:  
2,459,724, REN. 4-13-11. MULTIPLE CLASS, INT. CLS. 29 AND 30.

AN ORGANIC WICK, LLC, GOLDEN, CO, DBA ORGANIC WICK OR AN ORGANIC WICK:  
3,963,637, INT. CL. 4.

ANALOG DEVICES, INC., NORWOOD, MA:  
3,962,181, INT. CL. 9.

ANASTASIA LTD., TEL-AVIV 66538, ISRAEL:  
2,383,792, CANC. INT. CL. 25.

ANAT, LLC, LONG ISLAND CITY, NY:  
3,961,127, PUB. 3-1-2011. INT. CL. 39.

ANCHOR LOANS, INC., CALABASAS, CA:  
3,963,109, INT. CL. 37.

ANCHOR WALL SYSTEMS, INC., MINNETONKA, MN:  
3,963,430, MULTIPLE CLASS, INT. CLS. 19 AND 42.

ANDA & MASHA LLC, NEW YORK, NY:  
3,961,601, PUB. 3-1-2011. MULTIPLE CLASS, INT. CLS. 25 AND 45.

ANDERSON GREGORY H, EAGAN, MN:  
3,962,799, INT. CL. 20.

ANDERSON INTERNATIONAL FOODS, INC., LOS ANGELES, CA:  
2,383,256, CANC. INT. CL. 29.

ANDERSON UNIVERSITY, INC., ANDERSON, IN, DBA COVENANT PRODUCTIONS:  
3,960,311, PUB. 3-1-2011. INT. CL. 41.

ANDERSON, ANN-CABELL BAUM, RALEIGH, NC:  
3,963,052, INT. CL. 35.

ANDIS COMPANY, STURTEVANT, WI:  
3,963,369, INT. CL. 8.

ANDIS WINES, LLC, SUTTER CREEK, CA:  
3,962,646, INT. CL. 25.

ANDRADE, MERWIN, NEW YORK, NY AND MINTZ, PETER, NEW YORK, NY:  
2,881,289, CANC. INT. CL. 25.

ANDRE H. BRUNI, BATON ROUGE, LA:  
3,963,421, INT. CL. 44.

ANDREA BECKER DESIGN, MORRISTOWN, NJ:  
2,882,538, CANC. MULTIPLE CLASS, INT. CLS. 18 AND 25.

ANDREA ELECTRONICS CORPORATION, BOHEMIA, NY:  
2,384,351, CANC. INT. CL. 9.

ANDREW FEZZA, LTD., WESTON, CT:  
3,962,108, INT. CL. 25.

ANDY LI, CITY OF INDUSTRY, CA:  
3,961,098, PUB. 1-25-2011. INT. CL. 5.

ANGEL ON A LEASH, INC., NEW YORK, NY:  
3,962,343, MULTIPLE CLASS, INT. CLS. 35 AND 44.

ANGELA BOON, PONCA CITY, OK:  
3,962,796, INT. CL. 25.

ANGLERS INTERNATIONAL RESOURCES LLC, PALATINE, IL:  
3,962,134, INT. CL. 41.

ANGUS, DALE C, BRENTWOOD, CA, DBA GOLDEN EGG ANALYTICS, LLC:  
3,963,613, INT. CL. 36.

ANHEUSER-BUSCH, INCORPORATED, ST. LOUIS, MO:  
2,382,666, CANC. INT. CL. 25.

ANIMOBILE, INC., GLENDALE, CA:  
2,882,074, CANC. MULTIPLE CLASS, INT. CLS. 38 AND 41.

ANNA WILLIAM, LLC, WINDHAM, NH:  
2,881,728, CANC. INT. CL. 18.

ANNENBERG PUBLIC POLICY CENTER, THE TRUSTEES OF THE UNIVERSITY OF PENNSYLVANIA, PHILADELPHIA, PA:  
2,547,987, REN. 4-13-11. MULTIPLE CLASS, INT. CLS. 9 AND 42.  
2,547,987, CANC. MULTIPLE CLASS, INT. CLS. 16, 25 AND 41.

ANNIE'S ENTERPRISES, INC., NORTH CALAIS, VT:  
2,882,569, CANC. INT. CL. 30.

ANNUITY BOARD OF THE SOUTHERN BAPTIST CONVENTION, DALLAS, TX:  
2,882,183, CANC. INT. CL. 36.

ANSTAETT, TIM, COLUMBUS, OH:  
3,961,818, PUB. 3-1-2011. INT. CL. 41.

ANTHONY & SONS ITALIAN BAKERY, INC., DENVER, NJ:  
3,961,236, PUB. 3-1-2011. MULTIPLE CLASS, INT. CLS. 35 AND 43.  
3,961,238, PUB. 3-1-2011. MULTIPLE CLASS, INT. CLS. 35 AND 43.

- ANTHONY TESSELAAR PLANTS PTY LTD., SILVAN, VICTORIA, AUSTRALIA TO ANTHONY TESSELAAR PLANTS PTY LTD., SILVAN, VICTORIA, AUSTRALIA: 2,383,805, CANC. INT. CL. 31.
- ANTON/BAUER, INC., SHELTON, CT: 3,962,323, INT. CL. 9.
- ANVIL INTERNATIONAL, LP, ATLANTA, GA, ANVIL PRODUCTS, INC., ALLISON PARK, PA: 910,553, REN. 4-8-11, U.S. CL. 13 (INT. CL. 6).
- AOL INC., DULLES, VA, AMERICA ONLINE, INC., DULLES, VA: 2,443,680, REN. 4-11-11, INT. CL. 9.
- APA - THE ENGINEERED WOOD ASSOCIATION, TACOMA, WA: 3,962,184, INT. CL. 16.
- APCO WORLDWIDE, INC., WASHINGTON, DC: 3,961,281, PUB. 3-1-2011, INT. CL. 35.
- APEX BRANDS, INC., APEX, NC: 2,342,664, REN. 4-11-11, INT. CL. 8.
- APLASTIC ANEMIA & MDS INTERNATIONAL FOUNDATION, INC., ROCKVILLE, MD: 2,468,575, REN. 4-11-11, INT. CL. 36.
- APOTHECUS PHARMACEUTICAL CORP., OYSTER BAY, NY: 2,439,579, REN. 4-14-11, INT. CL. 5.
- APPLE INC., CUPERTINO, CA: 2,462,798, REN. 4-11-11, INT. CL. 35.  
2,490,958, REN. 4-14-11, INT. CL. 16.  
2,882,805, CANC. INT. CL. 35.
- APPLEGATE FARMS, LLC, BRIDGEWATER, NJ: 2,744,106, CANC. INT. CL. 29.
- APPLERA CORPORATION, FOSTER CITY, CA: 2,798,153, CANC. INT. CL. 9.
- APPLESEED LLC, OLD GREENWICH, CT: 3,962,744, INT. CL. 35.
- APPLICATIONS TECHNOLOGY, INC., MCLEAN, VA: 3,961,355, PUB. 3-1-2011, INT. CL. 9.
- APPLIED MATERIALS, INC., SANTA CLARA, CA: 1,641,138, REN. 4-12-11, INT. CL. 9.
- APPLIED PREDICTIVE TECHNOLOGIES, ARLINGTON, VA: 2,653,367, CANC. INT. CL. 9.
- APPLIED RESEARCH ASSOCIATES, INC., ALBUQUERQUE, NM: 3,962,017, MULTIPLE CLASS, INT. CLS. 9, 41 AND 42.  
3,962,018, MULTIPLE CLASS, INT. CLS. 9, 41 AND 42.
- APPLIED SEISMIC RESEARCH CORPORATION, PLANO, TX: 2,882,017, CANC. INT. CL. 7.
- APRICORN, POWAY, CA: 3,962,754, INT. CL. 9.
- ARA SERVICES CORPORATION, FAIRFAX, VA: 2,383,418, CANC. INT. CL. 35.  
2,383,419, CANC. INT. CL. 35.
- ARASH AGHAKHANI D.D.S, INC., LOS ANGELES, CA: 3,961,557, PUB. 3-1-2011, INT. CL. 44.
- ARBOR-NOMICS TURF, INC., NORCROSS, GA: 3,961,058, PUB. 3-1-2011, INT. CL. 44.
- ARBORSCAPE LLC, ANN ARBOR, MI: 3,961,216, PUB. 3-1-2011, INT. CL. 44.
- ARCH ALUMINUM & GLASS, LLC, TAMARAC, FL: 2,845,631, CANC. INT. CL. 20.
- ARCHITECTURAL COMPUTER SERVICES, INC., SALT LAKE CITY, UT: 3,963,393, MULTIPLE CLASS, INT. CLS. 9 AND 42.
- ARCHULETA, RICKY JOSEPH, DENVER, CO AND ARCHULETA, MERCEDES MARIE, DENVER, CO: 2,881,351, CANC. MULTIPLE CLASS, INT. CLS. 9 AND 41.
- ARCTIC PAPER KOSTRZYN S.A., KOSTRZYN ODRQ, POLAND: 3,960,262, PUB. 3-1-2011, INT. CL. 16.
- ARDENTSKY, LLC, POTOMAC, MD: 3,960,558, PUB. 3-1-2011, MULTIPLE CLASS, INT. CLS. 9, 35 AND 42.
- ARDIRE, JOSEPH R. III, PLEASANTON, CA: 2,883,132, CANC. INT. CL. 25.
- ARES PROTECTION, S.A., 38270 PRIMARETTE, FRANCE: 2,881,955, CANC. INT. CL. 17.
- ARES TRADING S.A., AUBONNE CH 1170, SWITZERLAND: 3,960,589, PUB. 3-1-2011, MULTIPLE CLASS, INT. CLS. 5, 10, 41 AND 44.
- ARIE AND IDA CROWN MEMORIAL, CHICAGO, IL: 3,961,078, PUB. 3-1-2011, INT. CL. 36.
- ARISE VIRTUAL SOLUTIONS, INC., MIRAMAR, FL: 2,392,781, REN. 4-13-11, INT. CL. 35.  
2,393,759, REN. 4-13-11, INT. CL. 41.
- ARISTOCRAT TECHNOLOGIES AUSTRALIA PTY LIMITED, NORTH RYDE, NSW, AUSTRALIA: 2,443,845, REN. 4-12-11, INT. CL. 9.
- ARISTOCRAT TECHNOLOGIES AUSTRALIA PTY LTD, NORTH RYDE, NSW, AUSTRALIA: 3,962,229, INT. CL. 9.
- ARISTOCRAT TECHNOLOGIES AUSTRALIA, PTY LTD, NORTH RYDE, NSW, AUSTRALIA: 3,962,553, INT. CL. 9.
- ARISTOCRAT TECHNOLOGIES PTY LTD, NORTH RYDE, NSW, AUSTRALIA: 3,960,940, PUB. 3-1-2011, INT. CL. 9.  
3,960,941, PUB. 3-1-2011, INT. CL. 9.  
3,960,942, PUB. 3-1-2011, INT. CL. 9.  
3,960,943, PUB. 3-1-2011, INT. CL. 9.
- ARIZONA BOARD OF REGENTS, FOR AND ON BEHALF OF ARIZONA STATE UNIVERSITY, TEMPE, AZ: 3,960,580, PUB. 3-1-2011, INT. CL. 16.  
3,960,581, PUB. 3-1-2011, INT. CL. 43.
- ARLEE HOME FASHIONS, INC., NEW YORK, NY: 2,382,433, CANC. MULTIPLE CLASS, INT. CLS. 20 AND 24.
- ARLON, INC., WHITE PLAINS, NY: 3,961,196, PUB. 3-1-2011, MULTIPLE CLASS, INT. CLS. 16, 17 AND 42.  
3,961,197, PUB. 3-1-2011, MULTIPLE CLASS, INT. CLS. 1 AND 17.
- ARMANDO ÁLVAREZ, S.A., TORRELAVEGA (SANTANDER, SPAIN: 3,961,267, PUB. 3-1-2011, INT. CL. 17.
- ARMARK AUTHENTICATION TECHNOLOGIES, LLC, GLEN ROCK, PA: 3,962,728, MULTIPLE CLASS, INT. CLS. 1, 5, 10 AND 17.
- ARMORWORKS ENTERPRISES, LLC, CHANDLER, AZ: 3,962,009, INT. CL. 40.
- ARNOLD & ASSOCIATES OF WICHITA, INC., WICHITA, KS: 2,493,601, REN. 4-12-11, INT. CL. 42.  
2,493,602, REN. 4-14-11, INT. CL. 42.
- ARNOLD LUMBER, CO., WEST KINGSTON, RI: 3,963,656, INT. CL. 35.
- ARNOLD PALMER ENTERPRISES, INC., CLEVELAND, OH, PALMER, ARNOLD D., CLEVELAND, OH: 1,642,980, REN. 4-8-11, INT. CL. 35.
- AROMA RX, INC., LOS ALAMOS, CA: 2,388,927, CANC. INT. CL. 28.
- AROMATHERAPY OF ROME, THE, TAYLOR, TX: 2,149,877, CANC. INT. CL. 4.
- AROOGA'S GRILLE HOUSE & SPORTS BAR HOLDINGS, LP, HARRISBURG, PA: 3,961,104, PUB. 3-1-2011, INT. CL. 32.
- ARORA, ASHOK, NORFOLK, VA: 3,963,401, INT. CL. 43.
- ARORA, KABEER, MIAMI, FL, TA KABACCHA INC: 3,961,262, PUB. 3-1-2011, INT. CL. 25.
- ARROCERA TUCAPEL S.A.I.C., TUCAPEL 3140, CHILE: 2,505,212, REN. 4-8-11, INT. CL. 33.
- ARROW-INTECHRA LLC, MELVILLE, NY: 2,881,082, CANC. INT. CL. 40.  
2,881,083, CANC. INT. CL. 40.
- ART CART NYC LTD., NEW YORK, NY: 3,961,326, PUB. 3-1-2011, MULTIPLE CLASS, INT. CLS. 35 AND 41.
- ART U TRADE LLC, TUCSON, AZ: 3,962,768, INT. CL. 45.
- ARTHUR J. GALLAGHER & CO., ITASCA, IL: 3,960,540, PUB. 3-1-2011, INT. CL. 36.

ARTISTIC PRODUCTS, LLC, HAUPPAUGE, NY:  
3,963,259, MULTIPLE CLASS, INT. CLS. 16 AND 20.

ARTURO SALICE S.P.A., 22060 NOVEDRATE COMO, ITALY:  
2,459,400. REN. 4-8-11. INT. CL. 20.

ARUZE GAMING AMERICA, INC., LAS VEGAS, NV:  
3,963,826, INT. CL. 9.

ARYSTA LIFESCIENCE EUROPE, VILLEBON SUR YVETTE, FRANCE:  
3,921,557, COR. MULTIPLE CLASS, INT. CLS. 1, 5 AND 10.

ARYSTA LIFESCIENCE NORTH AMERICA, LLC, CARY, NC:  
3,963,648, INT. CL. 5.

ASAHI SEIKO CO., LTD., TOKYO 107-0062, JAPAN:  
2,882,243, CANC. INT. CL. 9.

ASARCO LLC, TUCSON, AZ:  
2,382,482, CANC. INT. CL. 9.

ASCEND EAGLE, INC, AMERICAN CANYON, CA:  
3,963,865, INT. CL. 10.

ASHANTI FARM, INC., GORDONSVILLE, VA:  
2,382,701, CANC. INT. CL. 42.

ASHOKA THE GREAT, INC, ARTESIA, CA, DBA ASHOKA THE GREAT:  
3,961,637, PUB. 3-1-2011. INT. CL. 43.

ASICS CORPORATION, CHUO-KU, KOBE, JAPAN:  
3,963,141, INT. CL. 25.  
3,963,455, INT. CL. 25.  
3,963,456, INT. CL. 25.  
3,963,457, INT. CL. 18.  
3,963,458, INT. CL. 25.  
3,963,459, INT. CL. 25.  
3,963,464, INT. CL. 25.  
3,963,465, INT. CL. 25.  
3,963,466, INT. CL. 25.  
3,963,467, INT. CL. 25.  
3,963,468, INT. CL. 25.  
3,963,469, INT. CL. 25.  
3,963,470, INT. CL. 25.  
3,963,472, INT. CL. 25.

ASPEN HILL RACQUET CLUB LIMITED PARTNERSHIP, SILVER SPRING, MD:  
2,544,975. REN. 4-8-11. INT. CL. 41.

ASPIDE MEDICAL, 42350 LA TALAUDIERE, FRANCE:  
3,961,067, PUB. 3-1-2011. INT. CL. 10.

ASSA ABLOY AB, SE-107 23 STOCKHOLM, SWEDEN:  
3,963,217, INT. CL. 9.  
3,963,218, INT. CL. 9.

ASSETNATION, INC., HOUSTON, TX:  
2,548,587. REN. 4-14-11. INT. CL. 35.

ASSOCIATED FOOD STORES, INC., SALT LAKE CITY, UT:  
3,961,460, PUB. 3-1-2011. INT. CL. 30.

ASSOCIATED HEALTHCARE SYSTEMS, INC., AMHERST, NY, DBA C-PAP XPRESS:  
3,961,057, PUB. 3-1-2011. INT. CL. 35.

ASSOCIATED MATERIAL HANDLING INDUSTRIES, INC., ADDISON, IL:  
3,963,786, MULTIPLE CLASS, INT. CLS. 35, 37, 39, 41 AND 42.

ASSOCIATED MATERIALS, LLC, CUYAHOGA FALLS, OH, DBA ALSIDE:  
3,963,186, INT. CL. 42.

ASSOCIATION COMPANY, INTERNATIONAL, THE, YORK HARBOR, ME:  
2,882,985, CANC. INT. CL. 36.

ASSOCIATION HEADQUARTERS, INC., MT. LAUREL, NJ:  
3,960,325, PUB. 3-1-2011. MULTIPLE CLASS, INT. CLS. 35, 36 AND 42.

ASSOCIATION OF AMERICAN MEDICAL COLLEGES, WASHINGTON, DC:  
2,880,923, CANC. INT. CL. 35.  
2,880,924, CANC. INT. CL. 42.

ASSOCIATION OF POSTCONSUMER PLASTIC RECYCLERS, WASHINGTON, DC:  
2,524,100. REN. 4-9-11. INT. CL. 42.

ASSURITY LIFE INSURANCE COMPANY, LINCOLN, NE:  
2,880,971, CANC. INT. CL. 36.

AT & S AUSTRIA TECHNOLOGIE & SYSTEMTECHNIK AKTIENGESELLSCHAFT, AUSTRIA:  
3,960,776, PUB. 3-1-2011. MULTIPLE CLASS, INT. CLS. 9 AND 42.

AT BOX TECHNOLOGY, INC., IRVINE, CA:  
3,963,100, INT. CL. 9.

AT&T CORP., DAYTONA BEACH, FL TO INTERNATIONAL SPEEDWAY, INC., DAYTONA BEACH, FL:  
2,383,487, CANC. INT. CL. 9.

AT&T INTELLECTUAL PROPERTY II, L.P., RENO, NV:  
2,383,534, CANC. INT. CL. 36.

ATE MY HEART INC., LOS ANGELES, CA:  
3,960,468, PUB. 3-1-2011. MULTIPLE CLASS, INT. CLS. 9, 16, 25, 35, 38 AND 41.

ATHENS DISTRIBUTING, CHATTANOOGA, TN:  
3,962,384, INT. CL. 33.

ATHLETIC BIRTH CERTIFICATE, INC., LEESBURG, FL:  
3,961,385, PUB. 3-1-2011. INT. CL. 16.

ATHLETIC BUSINESS PUBLICATIONS, INC., MADISON, WI:  
2,509,610. REN. 4-8-11. INT. CL. 41.

ATLANTA GSPOTS, L.L.C., ATLANTA, GA:  
3,962,234, INT. CL. 43.

ATLANTA ROD & MANUFACTURING, INC., LAVONIA, GA:  
3,963,858, INT. CL. 6.

ATLANTIC EYE INSTITUTE, P.A., JACKSONVILLE BEACH, FL:  
3,962,326, INT. CL. 44.

ATLANTIC RESEARCH CORPORATION, ALEXANDRIA, VA:  
773,362, CANC. U.S. CL. 100.

ATLAS ADVISERS, INC., SAN LEANDRO, CA:  
2,795,484, CANC. INT. CL. 36.

ATTACK! MARKETING AND PROMOTIONS, LLC, SAN FRANCISCO, CA:  
3,961,371, PUB. 3-1-2011. INT. CL. 35.

AUDIO TECHNOLOGY OF NEW YORK INC., BROOKLYN, NY:  
3,963,591, INT. CL. 9.  
3,963,592, INT. CL. 9.

AUDIOMACHINE, BEVERLY HILLS, CA:  
3,963,320, MULTIPLE CLASS, INT. CLS. 9, 25 AND 41.

AUGSTEIN ENTERPRISE GROUP USA, SAN FRANCISCO, CA:  
3,963,020, INT. CL. 25.

AUGUST RUEGGERBERG GMBH & CO. KG, MARIENHEIDE, FED REP GERMANY:  
3,961,662, PUB. 3-1-2011. INT. CL. 7.  
3,961,748, PUB. 3-1-2011. INT. CL. 7.

AUGUST, JENN, LOS GATOS, CA:  
3,963,022, INT. CL. 16.

AUGUSTCORP, KAYSVILLE, UT:  
2,444,294. REN. 4-13-11. INT. CL. 35.

AUREON LABORATORIES, INC., YONKERS, NY:  
3,962,527, INT. CL. 44.

AUSTIN BAZAAR INCORPORATED, PFLUGERVILLE, TX:  
3,960,879, PUB. 9-7-2010. INT. CL. 15.

AUSTIN, GRANT, OAKWOOD, GA:  
3,963,813, INT. CL. 25.

AUSTIN, JONATHAN, MALIBU, CA:  
2,882,842, CANC. INT. CL. 41.

AUSTRALIAN BREWING CORPORATION PTY LTD, LITTLE RIVER, AUSTRALIA:  
2,882,808, CANC. INT. CL. 32.

AUSTRALIAN GOLD, INC., INDIANAPOLIS, IN:  
2,384,202, CANC. INT. CL. 3.

AUTHORIZE.NET HOLDINGS, INC., MARLBOROUGH, MA:  
2,382,618, CANC. MULTIPLE CLASS, INT. CLS. 35 AND 42.  
2,382,619, CANC. INT. CL. 35.

AUTO MILL SUPPLY COMPANY LTD., LIN-KOU TAIPEI, TAIWAN:  
2,882,437, CANC. INT. CL. 12.

AUTOMEDX, INC., GERMANTOWN, MD:  
3,960,270, PUB. 3-1-2011. INT. CL. 10.

- AUTOMOTIVE INDUSTRY ACTION GROUP, SOUTH-FIELD, MN:  
2,443,343. REN. 4-11-11. INT. CL. 16.
- AUTOMOTIVE SOURCING TECHNOLOGIES, LLC, OAK-BROOK, IL:  
3,963,857, MULTIPLE CLASS, INT. CLS. 35 AND 42.
- AUTOSALES, INCORPORATED, TALLMADGE, OH:  
3,962,259, MULTIPLE CLASS, INT. CLS. 9 AND 41.  
3,962,260, MULTIPLE CLASS, INT. CLS. 9 AND 41.
- AUTOZONE PARTS, INC., MEMPHIS, TN:  
3,960,460, PUB. 3-1-2011. MULTIPLE CLASS, INT. CLS. 7, 9 AND 12.
- AVAILIGENT, INC., SAN JOSE, CA:  
2,881,009, CANC. INT. CL. 9.
- AVARIA HEALTH & BEAUTY CORP., ONTARIO, N2L 5V4, CANADA:  
3,962,139, MULTIPLE CLASS, INT. CLS. 3 AND 5.
- AVCO CORPORATION, WILLIAMSPORT, PA:  
3,960,452, PUB. 3-1-2011. INT. CL. 7.
- AVEMCO INSURANCE COMPANY, FREDERICK, MD:  
2,383,799, CANC. INT. CL. 36.
- AVENTIS PHARMA S.A., 92800 PUTEAUX, FRANCE:  
2,880,571, CANC. INT. CL. 5.
- AVENUES IN LEATHER, INC., TINTON FALLS, NJ:  
2,442,636. REN. 4-12-11. MULTIPLE CLASS, INT. CLS. 9 AND 16.  
2,487,276, COR. INT. CL. 18.
- AVG TECHNOLOGIES CZ, S.R.O., BRNO, CZECH REPUBLIC:  
3,962,243, MULTIPLE CLASS, INT. CLS. 9 AND 42.
- AVICI SYSTEMS, INC., NORTH BILLERICA, MA:  
2,882,201, CANC. INT. CL. 9.
- AVOCADO GROWERS' ASSOCIATION, TAURANGA, NEW ZEALAND:  
2,881,336, CANC. INT. CL. 31.
- AVON PRODUCTS, INC., NEW YORK, NY:  
2,880,607, CANC. INT. CL. 3.  
2,882,793, CANC. INT. CL. 35.
- AVVASI INC., WATERLOO, ONTARIO, CANADA:  
3,962,785, INT. CL. 9.
- AWI LICENSING COMPANY, WILMINGTON, DE, ARM-STRONG CORK COMPANY, LANCASTER, PA:  
911,189. REN. 4-8-11. U.S. CL. 20 (INT. CL. 27).
- AWKWARD FAMILY, LLC, LOS ANGELES, CA:  
3,961,532, PUB. 3-1-2011. INT. CL. 41.
- AWS TRUEPOWER, LLC, ALBANY, NY:  
3,960,983, PUB. 3-1-2011. INT. CL. 35.
- AXA, FRANCE:  
3,960,835, PUB. 3-1-2011. MULTIPLE CLASS, INT. CLS. 35, 36, 37, 38, 39, 41, 43 AND 45.
- AXEDA SYSTEMS INC., MALVERN, PA:  
2,883,094, CANC. INT. CL. 9.  
2,883,095, CANC. INT. CL. 9.
- AZAR DISTILLING, LLC, SAN ANTONIO, TX:  
3,962,563, INT. CL. 33.
- AZIENDA AGRICOLA RICCI LUCA, ITALY:  
3,960,816, PUB. 3-1-2011. INT. CL. 33.
- AZUMA FOODS INTERNATIONAL INC. USA, HAYWARD, CA, AKA AFI:  
3,961,739, PUB. 3-1-2011. INT. CL. 29.
- AZUR PHARMA INTERNATIONAL II LIMITED, HAMILTON, BERMUDA:  
2,882,915, CANC. INT. CL. 5.
- A9.COM, INC., PALO ALTO, CA:  
2,881,557, CANC. INT. CL. 35.
- B&M RACING & PERFORMANCE PRODUCTS INC., CHATSWORTH, CA, HURST PERFORMANCE, INC., WARMINSTER, PA:  
920,146. REN. 4-8-11. U.S. CL. 23 (INT. CL. 12).
- B-CALM, LLC, ANKENY, IA:  
3,960,605, PUB. 3-1-2011. INT. CL. 9.
- B-CYCLE, LLC, WATERLOO, WI:  
3,960,369, PUB. 3-1-2011. MULTIPLE CLASS, INT. CLS. 12, 35 AND 39.
- B-PACK, FRANCE:  
3,960,656, PUB. 3-1-2011. MULTIPLE CLASS, INT. CLS. 9 AND 42.
- BABAKNIA, ARI, NEWPORT BEACH, CA:  
2,882,040, CANC. INT. CL. 30.
- BABYCOMFYNOSE, LLC, LONGMONT, CO:  
3,961,409, PUB. 3-1-2011. INT. CL. 10.
- BADAMA TECHNOLOGY (H.K.) CO., LTD., HONG KONG, HONG KONG:  
2,882,944, CANC. INT. CL. 9.
- BADGER METER, INC., MILWAUKEE, WI:  
3,961,060, PUB. 3-1-2011. INT. CL. 42.
- BADIA HAND TO SHOULDER, LLC, MIAMI, FL:  
3,960,972, PUB. 3-1-2011. INT. CL. 44.
- BAE SYSTEMS INFORMATION AND ELECTRONIC SYSTEMS INTEGRATION INC., NASHUA, NH:  
3,962,150, INT. CL. 9.
- BAHLEDA, ANDREW, ROYAL OAK, MI:  
3,963,453, INT. CL. 41.
- BAILAIR, LLC, BEND, OR:  
3,963,696, INT. CL. 7.
- BAKER FIRST COMMERCIAL REAL ESTATE SERVICES, INC., OKLAHOMA CITY, OK:  
2,387,080. REN. 4-11-11. INT. CL. 36.
- BAKER, SYLVIA SCHEPPS, PLANO, TX:  
2,882,366, CANC. MULTIPLE CLASS, INT. CLS. 9 AND 41.
- BAKO SWEET, INC., BAKERSFIELD, CA:  
3,963,851, INT. CL. 31.
- BALL, BOUNCE & SPORT, INC., ASHLAND, OH:  
3,963,082, INT. CL. 28.
- BALTIMORE BEND VINEYARD, LLC, WAVERLY, MO:  
3,961,678, PUB. 3-1-2011. INT. CL. 33.
- BALTIMORE ORIOLES LIMITED PARTNERSHIP, BALTIMORE, MD:  
1,642,874. REN. 4-12-11. INT. CL. 25.
- BALTIMORE RACING DEVELOPMENT, LLC, BALTIMORE, MD:  
3,963,835, INT. CL. 41.
- BAMBENEK, GREGORY, DULUTH, MN:  
3,961,794, PUB. 3-1-2011. INT. CL. 9.
- BAMBOOSERO, LLC, LA SELVA BEACH, CA:  
3,962,246, MULTIPLE CLASS, INT. CLS. 12 AND 25.
- BANCROFT NEUROHEALTH A NEW JERSEY NONPROFIT CORP., HADDONFIELD, NJ TO BANCROFT NEUROHEALTH A NEW JERSEY NONPROFIT CORP., HADDONFIELD, NJ:  
2,383,978, CANC. INT. CL. 42.
- BANDAÏ S.A., FRANCE:  
3,960,755, PUB. 3-1-2011. INT. CL. 28.
- BANK OF AMERICA CORPORATION, CHARLOTTE, NC:  
2,384,023, CANC. INT. CL. 36.  
2,882,782, CANC. INT. CL. 25.
- BANNISTER, THOMAS E, NEW YORK, NY:  
3,961,047, PUB. 1-4-2011. INT. CL. 41.
- BANZI, INC., MANHATTAN BEACH, CA:  
2,882,557, CANC. INT. CL. 36.
- BARBARA JOHANSEN NEWMAN, NEEDHAM, MA:  
3,962,641, INT. CL. 45.
- BARBARA ST. CLAIR JONES, TAMPA, FL:  
3,962,239, INT. CL. 42.
- BARBER-COLMAN COMPANY, LOVES PARK, IL TO INVENSYS BUILDING SYSTEMS, INC., LOVES PARK, IL:  
1,939,225, CANC. INT. CL. 11.
- BARCANA, INC., CERRITOS, CA:  
2,382,805, CANC. INT. CL. 28.
- BARD ACCESS SYSTEMS, INC., SALT LAKE CITY, UT:  
2,882,453, CANC. INT. CL. 10.
- BARETZ, SUSIE, HIGHLAND PARK, IL:  
3,962,820, INT. CL. 28.
- BARJAN LLC, ROCK ISLAND, IL:  
3,961,480, PUB. 3-1-2011. INT. CL. 9.  
3,961,706, PUB. 3-1-2011. INT. CL. 16.
- BARLETTA, GIULIO, JOSLIN, AUSTRALIA AND BALLESTRIN, ROGER, JOSLIN, AUSTRALIA:  
2,881,370, CANC. INT. CL. 33.
- BAROMETER INC., ST. PAUL, MN:  
3,961,450, PUB. 3-1-2011. MULTIPLE CLASS, INT. CLS. 9 AND 42.
- BARRIER SYSTEMS, INC., VACAVILLE, CA:  
3,961,984, MULTIPLE CLASS, INT. CLS. 6 AND 12.



BARRISTO ENTERPRISES, INC., CHICAGO, IL:  
3,963,147, INT. CL. 16.

BARRY CALLEBAUT AG, ZURICH, SWITZERLAND:  
2,882,088, CANC. INT. CL. 30.

BARRY CALLEBAUT AG, SWITZERLAND:  
3,960,756, PUB. 3-1-2011. MULTIPLE CLASS, INT. CLS. 41 AND 43.

BARTCO LIGHTING, INC., HUNTINGTON BEACH, CA:  
3,962,697, INT. CL. 11.

BARTON, ALAN, MARLAND, OK:  
3,962,885, INT. CL. 9.

BASE CORP., EDMONTON, CANADA:  
3,960,303, PUB. 3-1-2011. INT. CL. 42.

BASF CATALYSTS LLC, ISELIN, NJ:  
531,217, REN. 4-11-11. U.S. CL. 1 (INT. CL. 4).

BASF CORPORATION, FLORHAM PARK, NJ:  
3,962,490, INT. CL. 5.

BASSETT FURNITURE INDUSTRIES, INC., BASSETT, VA:  
2,383,107, CANC. INT. CL. 20.

BASTIANON, LYNN, SANTA ROSA, CA:  
3,961,972, MULTIPLE CLASS, INT. CLS. 16 AND 33.

BATESVILLE SERVICES, INC., BATESVILLE, IN:  
2,883,242, CANC. INT. CL. 20.

BATH & BODY WORKS BRAND MANAGEMENT, INC., REYNOLDSBURG, OH:  
2,441,521, REN. 4-8-11. INT. CL. 5.

BATRUS HOLLWEG INTERNATIONAL, PLANO, TX:  
2,881,556, CANC. INT. CL. 35.

BATSON, JEFF, ROBERT, BRUNSWICK, MD:  
3,963,408, INT. CL. 25.

BATTERIES PLUS, LLC, HARTLAND, WI:  
3,963,488, INT. CL. 9.

BAUMGARTEN'S, ATLANTA, GA:  
2,883,079, CANC. INT. CL. 20.

BAXTER BREWING CO., LLC, AUBURN, ME:  
3,963,603, INT. CL. 32.  
3,963,604, INT. CL. 32.  
3,963,605, INT. CL. 32.  
3,963,606, INT. CL. 32.  
3,963,607, INT. CL. 32.

BAXTER INTERNATIONAL INC., DEERFIELD, IL:  
2,882,964, CANC. INT. CL. 10.

BAY STATE MILLING COMPANY, QUINCY, MA:  
1,152,583, REN. 4-11-11. INT. CL. 30.

BAYER AKTIENGESELLSCHAFT, 51373 LEVERKUSEN, FED REP GERMANY:  
3,962,428, MULTIPLE CLASS, INT. CLS. 1 AND 5.

BAYER CROPSCIENCE LP, RESEARCH TRIANGLE PARK, NC:  
3,963,279, INT. CL. 1.

BAYER HEALTHCARE LLC, PITTSBURGH, PA:  
2,384,170, CANC. INT. CL. 5.

BAYLIS MEDICAL COMPANY INC., SAINT-LAURENT, QC, CANADA:  
3,962,316, INT. CL. 10.

BBY SOLUTIONS, INC., RICHFIELD, MN:  
2,883,339, CANC. INT. CL. 35.

BCG RESOURCES, INC., AKRON, OH:  
3,961,342, PUB. 3-1-2011. INT. CL. 45.

BEACON ADHESIVES CORPORATION, NEW YORK, NY:  
3,963,039, INT. CL. 1.  
3,963,040, INT. CL. 1.

BEAM ASSOCIATES LLC, LYNDHURST, NJ:  
3,961,679, PUB. 3-1-2011. INT. CL. 10.  
3,961,682, PUB. 3-1-2011. INT. CL. 10.

BEATTY, PATRICIA C., BETHESDA, MD:  
2,883,180, CANC. INT. CL. 44.

BEAUTIFUL BROWN GIRL, INC, RED OAK, GA:  
3,961,416, PUB. 3-1-2011. INT. CL. 35.

BEAUTY SYSTEMS GROUP LLC, DENTON, TX:  
2,382,089, CANC. MULTIPLE CLASS, INT. CLS. 35 AND 42.

BEBOOK, FRANCE:  
3,960,645, PUB. 8-31-2010. MULTIPLE CLASS, INT. CLS. 9, 16, 35, 38, 39, 41 AND 42.

BECKETT MEDIA LLC, DALLAS, TX, MCMULLEN PUBLISHING, INC., ANAHEIM, CA:  
1,657,870, REN. 4-13-11. INT. CL. 16.

BECTON, DICKINSON AND COMPANY, FRANKLIN LAKES, NJ:  
1,153,742, REN. 4-13-11. INT. CL. 9.

BEDDA HEDDA HAIR, LTD., WEST HEMPSTEAD, NY, NY:  
3,961,449, PUB. 3-1-2011. INT. CL. 3.  
3,961,454, PUB. 3-1-2011. INT. CL. 3.

BEDESSEE IMPORTS LTD., TORONTO, ONTARIO, CANADA:  
3,961,070, PUB. 1-25-2011. MULTIPLE CLASS, INT. CLS. 5 AND 30.

BEECON LEARNING, LLC, DALLAS, TX:  
3,963,327, INT. CL. 16.

BEELE ENGINEERING B.V., 7122 NZ AALTEN, NETHERLANDS:  
2,938,549, CANC. MULTIPLE CLASS, INT. CLS. 9 AND 19.

BEER.COM INC., TORONTO, ONTARIO, CANADA:  
2,880,584, CANC. INT. CL. 35.

BEHIND THE BLUE LINE, WINSTON-SALEM, NC:  
3,961,299, PUB. 3-1-2011. INT. CL. 35.

BEHR GMBH & CO., D-70469 STUTTGART, FED REP GERMANY:  
2,880,724, CANC. MULTIPLE CLASS, INT. CLS. 7, 9, 11, 12 AND 37.

BEHR INDUSTRY GMBH & CO. KG, 70469 STUTTGART, FED REP GERMANY:  
3,960,742, PUB. 3-1-2011. MULTIPLE CLASS, INT. CLS. 12 AND 37.

BEIERSDORF AG, FED REP GERMANY:  
3,960,713, PUB. 3-1-2011. MULTIPLE CLASS, INT. CLS. 1 AND 3.

BEIJING KAIZE FASHION TECH LTD., BEIJING CITY,, CHINA:  
3,962,888, INT. CL. 25.

BELANGER, INC., NORTHVILLE, MI:  
2,423,212, REN. 4-8-11. INT. CL. 7.

BELEAF LIMITED LIABILITY COMPANY, MANASQUAN, NJ:  
3,962,194, INT. CL. 18.

BELL CANADA, MONTREAL, QUEBEC, CANADA:  
2,882,825, CANC. INT. CL. 38.

BELLA & ARIEL, LTD, NEW YORK, NY:  
2,882,495, CANC. INT. CL. 35.

BELLA FLOR, LLC, NEWARK, DE:  
3,829,625, CANC. INT. CL. 5.

BELLATOR SPORT WORLDWIDE LLC, CHICAGO, IL:  
3,963,271, MULTIPLE CLASS, INT. CLS. 16, 25, 35 AND 41.

BELLING, MARK, MILWAUKEE, WI:  
2,491,004, REN. 4-14-11. INT. CL. 42.

BEN SHERMAN GROUP LIMITED, LURGAN, NORTHERN IRELAND:  
3,961,585, PUB. 3-1-2011. INT. CL. 25.

BENCH TREE GROUP, LLC, GEORGETOWN, TX:  
3,961,770, PUB. 3-1-2011. INT. CL. 42.

BENJAMIN MEDIA, INC., PENINSULA, OH:  
2,883,418, CANC. INT. CL. 16.

BENNETT AUTO SUPPLY, INC., POMPANO BEACH, FL:  
3,961,157, PUB. 3-1-2011. INT. CL. 35.

BENOSTAN INTERNATIONAL, LTD., NEW YORK, NY:  
3,962,335, INT. CL. 3.

BENTHIEN, HOLGER WALTER, BREMEN, FED REP GERMANY:  
2,881,591, CANC. INT. CL. 21.

BENTLY NEVADA, INC., MINDEN, NV:  
1,640,323, REN. 4-9-11. INT. CL. 9.

BERETTA, ANNE MARIE JULIETTE BOUSQUET, 75116 PARIS, FRANCE:  
1,131,371, CANC. INT. CL. 25.

BERG, PAUL G, SCOTTSDALE, AZ:  
3,961,870, PUB. 3-1-2011. INT. CL. 9.

BERGAN, LLC, MIAMI, OK:  
2,882,742, CANC. INT. CL. 18.

BERGER BUILDING PRODUCTS, INC., FEASTERVILLE, PA:  
2,437,695, REN. 4-9-11. INT. CL. 6.

BERGQUIST COMPANY, THE, CHANHASSEN, MN:  
2,383,583, CANC. INT. CL. 9.

- BERGQUIST COMPANY, THE, MINNEAPOLIS, MN:  
2,383,584, CANC. INT. CL. 9.
- BERGSMA, JODY, BELLINGHAM, WA:  
2,882,652, CANC. INT. CL. 28.
- BERNARDS, INC., GREENSBORO, NC:  
1,638,435, REN. 4-13-11. INT. CL. 20.
- BERNTSEN, KIRSTEN L, SAN JUAN BAUTISTA, CA:  
3,961,374, PUB. 3-1-2011. INT. CL. 16.
- BEROL CORPORATION, ATLANTA, GA, GILLETTE COMPANY, THE, BOSTON, MA, DBA PAPER MATE CO.:  
910,903, REN. 4-8-11. U.S. CL. 37 (INT. CL. 16).
- BERRY PLASTICS CORPORATION, EVANSVILLE, IN:  
3,963,336, INT. CL. 17.
- BERRYHILL, MARK N., BOSTON, MA, DBA UNCONVENTIONAL PARTNERS LLC:  
3,961,150, PUB. 3-1-2011. INT. CL. 41.
- BESPOKE CORPORATION, BELMONT, MA:  
3,963,802, MULTIPLE CLASS, INT. CLS. 37 AND 42.
- BEST BUY CONTAINERS, LLC, COSTA MESA, CA:  
3,963,780, INT. CL. 21.
- BEST THINKING, INC., CARY, NC:  
3,962,232, INT. CL. 38.  
3,962,233, INT. CL. 38.
- BETH ISRAEL DEACONESS MEDICAL CENTER, INC., BOSTON, MA:  
3,961,758, PUB. 3-1-2011. INT. CL. 44.
- BETHESDA FOUNDATION, COLORADO SPRINGS, CO:  
3,963,160, INT. CL. 43.
- BETHUNE-COOKMAN UNIVERSITY INC., DAYTONA BEACH, FL:  
3,961,380, PUB. 3-1-2011. MULTIPLE CLASS, INT. CLS. 9, 16, 24, 25, 28 AND 41.
- BETULA SCHUH GMBH, LINZ 53545, FED REP GERMANY:  
2,880,820, CANC. MULTIPLE CLASS, INT. CLS. 10, 18 AND 25.
- BEVERLY KAYE & ASSOCIATES, INC., SCRANTON, PA, DBA CAREER SERVICES INTERNATIONAL:  
3,962,598, MULTIPLE CLASS, INT. CLS. 16 AND 35.
- BEVERLY KAYE & ASSOCIATES, INC., SCRANTON, PA, DBA CAREER SYSTEMS INTERNATIONAL:  
3,962,599, MULTIPLE CLASS, INT. CLS. 16, 35 AND 41.
- BEVERLY KAYE & ASSOCIATES, INC., SCRANTON, PA, DBA CAREER SERVICES INTERNATIONAL:  
3,962,600, MULTIPLE CLASS, INT. CLS. 16 AND 35.
- BEVOLO GAS & ELECTRIC LIGHTS, INC., NEW ORLEANS, LA:  
3,963,801, INT. CL. 11.
- BEYONDTRUST SOFTWARE, INC., AGOURA HILLS, CA:  
3,960,866, PUB. 3-1-2011. INT. CL. 9.
- BG CHEMICAL, LP, DALLAS, TX:  
3,963,208, INT. CL. 1.
- BG DOOR INTERNATIONAL V.O.F., NL-3991 CT HOUTEN, NETHERLANDS:  
3,960,778, PUB. 3-1-2011. INT. CL. 6.
- BH/NV HAWK'S CAY PROPERTY HOLDINGS, LLC, DUCK KEY, FL:  
2,410,460, REN. 4-11-11. MULTIPLE CLASS, INT. CLS. 39 AND 42.
- BIBBY SCIENTIFIC LIMITED, STAFFORDSHIRE, UNITED KINGDOM:  
3,960,407, PUB. 3-1-2011. MULTIPLE CLASS, INT. CLS. 7 AND 9.
- BICKHAM, MICHAEL, OVERLAND, KS:  
3,963,102, INT. CL. 20.
- BICO AUSTRALIA PTY LIMITED, CHATSWOOD NSW, AUSTRALIA:  
3,960,622, PUB. 12-4-2007. MULTIPLE CLASS, INT. CLS. 9, 14 AND 25.
- BIE MEDIA, LLC, DENVER, CO:  
2,447,511, REN. 4-8-11. INT. CL. 41.
- BIG BANG, 38920 CROLLES, FRANCE:  
2,883,363, CANC. INT. CL. 11.
- BIG BOSS ENTERPRISES, INC., NEW YORK, NY:  
3,963,392, INT. CL. 25.
- BIG BROTHER SPORTSWEAR, INC., MOONACHIE, NJ:  
2,882,338, CANC. INT. CL. 25.
- BIG DOGG PONG LLC, WARREN, NJ, DBA BD PONG:  
3,962,491, MULTIPLE CLASS, INT. CLS. 11 AND 28.
- BIG FILMS PTY LIMITED, SURRY HILLS, NEW SOUTH WALES, 2010, AUSTRALIA:  
2,382,880, CANC. MULTIPLE CLASS, INT. CLS. 25 AND 41.
- BIG HAIR & PINK GUITARS, NEW YORK, NY:  
3,962,830, INT. CL. 45.  
3,962,831, INT. CL. 45.  
3,962,832, INT. CL. 45.
- BIG HAIR & PINK GUITARS, LLC, NEW YORK, NY:  
3,962,828, INT. CL. 45.
- BIG SHOES PRODUCTIONS, INC., SEATTLE, WA:  
3,962,008, INT. CL. 25.
- BIG TIME ENTERPRISES, INC., SEATTLE, WA:  
2,880,939, CANC. INT. CL. 9.
- BIG TIME HOLDINGS, INC., ROME, GA:  
3,962,495, MULTIPLE CLASS, INT. CLS. 9, 10 AND 21.
- BIG TIME RESTAURANT GROUP CORP., WEST PALM BEACH, FL:  
2,474,852, REN. 4-12-11. INT. CL. 42.
- BIG WARDROBE LIMITED, HARROGATE N. YORKSHIRE, UNITED KINGDOM:  
3,960,387, PUB. 3-1-2011. INT. CL. 35.
- BIGDIFBOOKS.COM, LLC, CHICAGO, IL:  
3,962,322, INT. CL. 16.
- BILL ELLIOTT RACING LLC, DAWSONVILLE, GA:  
3,962,809, INT. CL. 25.
- BILL FOSTER'S DOWN EAST CLAMBAKE, INC., YORK HARBOR, ME, DBA FOSTER'S DOWNEAST CLAMBAKE:  
2,440,707, REN. 4-11-11. MULTIPLE CLASS, INT. CLS. 35 AND 42.
- BILL THE BUTCHER, INC., SEATTLE, WA:  
3,960,851, PUB. 3-1-2011. INT. CL. 35.
- BINH NGUYEN, RENO, NV, DBA INTELLECTUAL GARDEN:  
3,963,136, INT. CL. 45.
- BIOCOMPANY S.P.A., 56029 S. CROCE SULL'ARNO, PI, ITALY:  
2,882,241, CANC. INT. CL. 1.
- BIOFARMA, FRANCE:  
3,960,749, PUB. 3-1-2011. INT. CL. 5.
- BIOMET, INC., WARSAW, IN:  
2,883,078, CANC. INT. CL. 9.  
2,883,098, CANC. INT. CL. 10.
- BIOMIMETIC THERAPEUTICS, INC., FRANKLIN, TN:  
3,962,161, INT. CL. 5.
- BIOMÉRIEUX, INC., DURHAM, NC:  
3,962,173, MULTIPLE CLASS, INT. CLS. 1, 5, 9 AND 10.
- BIORESPONSE, L.L.C., BOULDER, CO:  
2,441,257, REN. 4-12-11. INT. CL. 5.
- BIOTAGE AB, SE-753 18 UPPSALA, SWEDEN:  
2,883,150, CANC. INT. CL. 9.
- BIOTICS RESEARCH CORPORATION, ROSENBERG, TX:  
1,676,517, REN. 4-8-11. INT. CL. 5.
- BIOVIGILANT SYSTEMS, INC., TUCSON, AZ:  
3,963,290, INT. CL. 9.
- BIRD, BENJAMIN, VIENNA, VA:  
3,961,687, PUB. 3-1-2011. INT. CL. 41.
- BISCHOFF, KAREN, SUGAR HILL, GA:  
3,962,682, INT. CL. 10.
- BISON CAPITAL, VENICE, FL:  
3,962,001, INT. CL. 33.
- BISSMAN, BENJAMIN F, MANSFIELD, OH:  
3,962,506, INT. CL. 35.
- BITCHROOM, INC., NAPLES, FL:  
3,961,212, PUB. 3-1-2011. INT. CL. 38.  
3,961,215, PUB. 3-1-2011. INT. CL. 38.
- BITLAB, PARK RIDGE, IL:  
3,963,406, INT. CL. 9.
- BJORK, BRYCE, MINNEAPOLIS, MN:  
3,960,569, PUB. 3-1-2011. INT. CL. 39.
- BLACK & DECKER CORPORATION, THE, TOWSON, MD:  
2,882,884, CANC. INT. CL. 7.
- BLACK DOG TECHNOLOGY LLC, LAS VEGAS, NV:  
3,962,695, INT. CL. 9.

BLACK EDUCATIONAL EVENTS, LLC, COLLEYVILLE, TX:  
 3,962,522, INT. CL. 16.  
 3,962,523, INT. CL. 38.  
 3,962,528, INT. CL. 16.

BLACKBURN, BRIAN, ORLANDO, FL:  
 2,883,188, CANC. INT. CL. 5.

BLACKROCK INSTITUTIONAL TRUST COMPANY, N.A., SAN FRANCISCO, CA:  
 3,962,982, INT. CL. 36.

BLACKWOOD ASSETS, INC., WILMINGTON, DE:  
 2,883,303, CANC. MULTIPLE CLASS, INT. CLS. 16 AND 26.  
 3,962,493, INT. CL. 35.

BLADES COMPANY, INC., ELK GROVE VILLAGE, IL:  
 2,453,515, REN. 4-14-11, INT. CL. 35.

BLAINE BROOKE PHOTOGRAPHY, INC., LOUISVILLE, KY:  
 2,882,466, CANC. INT. CL. 16.

BLAINE LABORATORIES, INC., SANTA FE SPRINGS, CA:  
 2,444,612, REN. 4-8-11, INT. CL. 3.

BLAKE AUSTIN COLLEGE, VACAVILLE, CA:  
 3,963,024, MULTIPLE CLASS, INT. CLS. 35 AND 44.

BLAKEY, COLLEEN BANKS, FORT LAUDERDALE, FL, DBA RAINCHECK SOLUTIONS, INC.:  
 3,961,565, PUB. 3-1-2011, INT. CL. 35.

BLASCO, JOSEPH D., ORLANDO, FL:  
 2,882,815, CANC. INT. CL. 41.  
 2,882,816, CANC. INT. CL. 41.

BLASKEY, GUY, LONDON, UNITED KINGDOM, DBA POOCH AND MUTT:  
 3,961,403, PUB. 3-1-2011, INT. CL. 5.  
 3,961,639, PUB. 3-1-2011, INT. CL. 5.

BLASTMASTER MANAGEMENT PTY LTD, SOUTH AUSTRALIA, AUSTRALIA:  
 3,960,396, PUB. 3-1-2011, INT. CL. 7.  
 3,960,398, PUB. 3-1-2011, INT. CL. 7.

BLESSED FOOTSTEPS, INC., POWDER SPRINGS, GA, DBA BLESSED FOOTSTEPS, INC.:  
 3,962,707, INT. CL. 16.

BLIP, LLC, MINNETONKA, MN:  
 3,961,981, INT. CL. 28.

BLITZ-CORPORATION LTD, UNITED KINGDOM:  
 3,960,673, PUB. 3-1-2011, MULTIPLE CLASS, INT. CLS. 9, 25 AND 28.

BLOCK DRUG COMPANY, INC., WEST TRENTON, NJ:  
 2,448,278, REN. 4-13-11, INT. CL. 5.

BLOCKER RANCH INC., ESTACADA, OR:  
 2,883,205, CANC. INT. CL. 25.

BLOSSOM BUCKET, INC., NORTH LAWRENCE, OH:  
 3,963,060, INT. CL. 42.

BLOUNT, INC., PORTLAND, OR:  
 3,962,254, MULTIPLE CLASS, INT. CLS. 7 AND 8.

BLOW UP RECORDS LIMITED, LONDON, ENGLAND:  
 3,962,430, INT. CL. 9.

BLS ENTERPRISES, INC., ITASCA, IL:  
 3,961,105, PUB. 3-1-2011, INT. CL. 12.

BLU PRINT ENTERTAINMENT, INC., MULLICA HILL, NJ:  
 3,960,227, PUB. 3-1-2011, INT. CL. 35.

BLUE & GREEN LLC, MINNEAPOLIS, MN:  
 3,963,051, INT. CL. 35.

BLUE HORIZON IDEAS LIMITED, WINCHESTER, ENGLAND:  
 3,960,355, PUB. 3-1-2011, MULTIPLE CLASS, INT. CLS. 3, 9 AND 17.

BLUE MAN PRODUCTIONS, LLC, NEW YORK, NY:  
 2,438,222, REN. 4-12-11, MULTIPLE CLASS, INT. CLS. 9, 16 AND 25.

BLUE SKY SCRUBS, LLC, AUSTIN, TX:  
 3,963,824, INT. CL. 10.  
 3,963,825, INT. CL. 10.

BLUE SPIDER ANALYTICS, INC, KING GEORGE, VA:  
 3,961,340, PUB. 3-1-2011, INT. CL. 9.  
 3,961,341, PUB. 3-1-2011, INT. CL. 9.

BLUE SPRUCE FARM, INC., JACKSON, NJ:  
 3,961,324, PUB. 3-1-2011, INT. CL. 41.

BLUE TECH, INC., LA JOLLA, CA:  
 3,961,064, PUB. 3-1-2011, MULTIPLE CLASS, INT. CLS. 9 AND 42.

BLUE WATER ENTERTAINMENT, INC., MARINA DEL REY, CA:  
 3,960,434, PUB. 3-1-2011, INT. CL. 25.

BLUEBEARDS INC., EXTON, PA:  
 3,961,411, PUB. 3-1-2011, INT. CL. 3.

BLUEFLY, INC., NEW YORK, NY:  
 2,384,259, CANC. INT. CL. 35.

BLUESCOPE STEEL LIMITED, MELBOURNE, VIC 3000, AUSTRALIA:  
 1,154,514, REN. 4-13-11, INT. CL. 6.

BLUESTEM BRANDS, INC., EDEN PRAIRIE, MN:  
 2,444,758, REN. 4-11-11, INT. CL. 11.

BLUM, KENNETH L, OWINGS MILLS, MD:  
 3,961,795, PUB. 3-1-2011, INT. CL. 29.

BNC RESTAURANTS II, INC., CLERMONT, FL:  
 2,881,019, CANC. INT. CL. 43.

BNL ENTERTAINMENT INC., TORONTO, ONTARIO, CANADA:  
 3,960,439, PUB. 3-1-2011, MULTIPLE CLASS, INT. CLS. 9 AND 41.

BNSF RAILWAY COMPANY, FORT WORTH, TX:  
 1,641,509, REN. 4-12-11, INT. CL. 35.

BOARD OF REGENTS OF THE UNIVERSITY SYSTEM OF GEORGIA, ATLANTA, GA:  
 3,961,942, PUB. 3-1-2011, MULTIPLE CLASS, INT. CLS. 6 AND 41.

BOB BAIN PRODUCTIONS, INC., SANTA MONICA, CA:  
 3,963,504, INT. CL. 41.

BOB EVANS FARMS, INC., COLUMBUS, OH:  
 3,961,671, PUB. 3-1-2011, INT. CL. 30.

BOBBI BROWN PROFESSIONAL COSMETICS, INC., NEW YORK, NY:  
 2,458,679, REN. 4-13-11, INT. CL. 3.

BOCOMO BAY INC., COLUMBIA, MO:  
 3,961,145, PUB. 3-1-2011, INT. CL. 3.

BODEGA MONTE BALBANO S.A., BUENOS AIRES, ARGENTINA:  
 3,962,917, INT. CL. 33.

BODEGAS OSBORNE, S.A.U., CADIZ, SPAIN:  
 883,004, CANC. U.S. CL. 49.

BODILY, KERRY D., WHITE SALMON, WA:  
 2,883,415, CANC. INT. CL. 9.

BODY DYNAMICS, INC., CARMEL, IN:  
 2,382,051, CANC. INT. CL. 5.

BODYBIO, INC, MILLVILLE, NJ:  
 2,443,163, REN. 4-12-11, INT. CL. 5.

BODYPOINT, INC., SEATTLE, WA:  
 2,330,826, AM. INT. CL. 12.

BOEHLKE, RAIMAR, FED REP GERMANY:  
 3,960,641, PUB. 3-1-2011, MULTIPLE CLASS, INT. CLS. 9, 35, 38, 41, 42 AND 44.

BOEHRINGER INGELHEIM INTERNATIONAL GMBH, INGELHEIM, FED REP GERMANY:  
 3,961,084, PUB. 3-1-2011, MULTIPLE CLASS, INT. CLS. 38, 41 AND 42.

BOEHRINGER INGELHEIM INTERNATIONAL GMBH, 55218 INGELHEIM, FED REP GERMANY:  
 3,961,866, PUB. 3-1-2011, INT. CL. 5.

BOEHRINGER INGELHEIM PHARMA GMBH & CO. KG, INGELHEIM AM RHEIN, FED REP GERMANY:  
 2,881,849, CANC. INT. CL. 5.

BOEHRINGER INGELHEIM PHARMACEUTICALS, INC., RIDGEFIELD, CT:  
 3,961,880, PUB. 3-1-2011, MULTIPLE CLASS, INT. CLS. 35 AND 44.

BOEING MANAGEMENT COMPANY, SEAL BEACH, CA:  
 3,960,984, PUB. 3-1-2011, INT. CL. 25.  
 3,960,985, PUB. 3-1-2011, INT. CL. 25.  
 3,962,309, INT. CL. 42.  
 3,963,059, INT. CL. 9.

BOLDT ENTERTAINMENT, INC., MINNEAPOLIS, MN:  
 2,882,196, CANC. INT. CL. 28.

BOLLORE, COMMUNE D'ERGUE GABERIC, FRANCE:  
 2,382,585, CANC. INT. CL. 25.

BOMAG AMERICAS, INC., KEWANEE, IL:  
 2,882,282, CANC. INT. CL. 7.

- BOMBARDIER CAPITAL RAIL INC. (SUCCESSOR BY MERGER TO NORRAIL, INC.), JACKSONVILLE, FL: 2,880,745, CANC. INT. CL. 35.
- BOND LABORATORIES, INC., OMAHA, NE: 3,961,644, PUB. 3-1-2011. INT. CL. 5. 3,961,647, PUB. 3-1-2011. INT. CL. 5.
- BONSAL AMERICAN, INC., CHARLOTTE, NC: 2,515,325, REN. 4-12-11. INT. CL. 19. 2,522,938, REN. 4-13-11. INT. CL. 19.
- BOOK TRUST, FORT COLLINS, CO: 3,963,762, MULTIPLE CLASS, INT. CLS. 35, 36 AND 41.
- BOONE BREWING COMPANY, LLC, BLOWING ROCK, NC: 3,961,983, INT. CL. 32.
- BORDER CROSSING LABS, DAVISON, MI: 3,963,153, INT. CL. 28.
- BORDO, SARA, SANTA MONICA, CA: 3,963,012, INT. CL. 35. 3,963,013, INT. CL. 41.
- BORG HOLDINGS INC, TEMPE, AZ: 3,961,294, PUB. 3-1-2011. INT. CL. 43.
- BORG UNLIMITED INC., MONTEREY PARK, CA: 3,962,370, INT. CL. 28.
- BORROWED LIGHT, BELLINGHAM, WA: 2,883,087, CANC. INT. CL. 41.
- BOSTON CONSULTING GROUP, INC., THE, BOSTON, MA: 2,444,717, REN. 4-13-11. INT. CL. 35.
- BOSTON SCIENTIFIC SCIMED, INC., MAPLE GROVE, MN: 2,541,733, CANC. INT. CL. 10. 3,963,307, INT. CL. 10.
- BOSTONBEAN COFFEE COMPANY, INC., WOBURN, MA: 2,544,346, REN. 4-11-11. MULTIPLE CLASS, INT. CLS. 30 AND 42.
- BOTTOMS UP GROUP, LLC, THE, MT. PLEASANT, SC: 3,962,542, INT. CL. 25.
- BOULDIN CORPORATION, MCMINNVILLE, TN: 3,961,985, MULTIPLE CLASS, INT. CLS. 7 AND 40.
- BOULEVARD BREWING ASSOCIATES LIMITED PARTNERSHIP, KANSAS CITY, MO, DBA BOULEVARD BREWING COMPANY: 3,962,602, INT. CL. 32.
- BOUND TO STAY BOUND BOOKS, INC., JACKSONVILLE, IL: 544,208, REN. 4-8-11. U.S. CL. 106 (INT. CL. 40).
- BOUTIQUE CUPCAKE COMPANY, LLC, NORTH POTOMAC, MD: 3,963,642, MULTIPLE CLASS, INT. CLS. 30 AND 35.
- BOWEN, BRUCE M., NORTH KINGSTOWN, RI: 2,882,833, CANC. INT. CL. 37.
- BOWENS, DANIEL MACEO, SEWELL, NJ: 3,962,163, INT. CL. 9.
- BOWERS STUDIO INC., GRANVILLE, OH: 2,882,316, CANC. INT. CL. 16.
- BOWTIE, INC., IRVINE, CA: 3,960,416, PUB. 3-1-2011. INT. CL. 35. 3,963,816, MULTIPLE CLASS, INT. CLS. 16 AND 40.
- BR CONSULTING, INC., SEDONA, AZ: 2,489,632, REN. 4-12-11. INT. CL. 41.
- BRACKEN, FRANCES, SCOTTSDALE, AZ: 2,881,862, CANC. INT. CL. 29.
- BRADFORD CAPITAL PARTNERS, PITTSBURGH, PA: 3,961,486, PUB. 3-1-2011. INT. CL. 41.
- BRADLEY, DARRELL C., LYNCHBURG, VA: 3,960,455, PUB. 3-1-2011. INT. CL. 25.
- BRAINCELLS INC., SAN DIEGO, CA: 3,962,475, INT. CL. 42.
- BRAINSTORMS, INC., SANTA FE, NM: 3,962,824, INT. CL. 45.
- BRAMTON COMPANY, THE, IRVING, TX: 3,962,668, INT. CL. 3.
- BRAND NAME CONNOISSEURS, CORP., WEST PALM BEACH, FL, DBA BNC CORP.: 2,881,386, CANC. INT. CL. 34.
- BRAND NEW MARKETING & DESIGN, INC., CHESTER, NJ: 3,960,482, PUB. 3-1-2011. INT. CL. 28.
- BRAND PROGRESSIONS, LLC, VERNON, CA: 2,881,745, CANC. INT. CL. 25.
- BRANDERS.COM, INC., SAN MATEO, CA: 3,962,207, INT. CL. 35.
- BRANDSTORM, INC., LOS ANGELES, CA: 3,923,387, COR. MULTIPLE CLASS, INT. CLS. 29 AND 32.
- BRANNIAN, PAULA DAY, SIMI VALLEY, CA: 2,881,335, CANC. INT. CL. 35.
- BRAVOLUTION S.P.A., BERGAMO, ITALY: 3,960,286, PUB. 3-1-2011. MULTIPLE CLASS, INT. CLS. 9, 35, 38, 41 AND 42.
- BREAD CRUMBS, NEW YORK, NY: 3,961,623, PUB. 3-1-2011. INT. CL. 41.
- BREMBOS, THEODORE J., POINT PLEASANT, NJ: 3,962,869, INT. CL. 5.
- BREMEN COMPANY, INC., BOYDS, MD: 2,880,783, CANC. INT. CL. 28.
- BREWER EDUCATIONAL RESOURCES, INC., MCKINNEY, TX: 3,961,230, PUB. 3-1-2011. INT. CL. 35.
- BRIAN, BALTIMORE, MD, DBA GREENENERGY GAME: 3,963,719, INT. CL. 28.
- BRIAN KENDALL, LTD., COLUMBUS, OH: 2,883,064, CANC. INT. CL. 25.
- BRIDGESTONE CORPORATION, CHUO-KU, TOKYO, JAPAN: 3,960,909, PUB. 3-1-2011. INT. CL. 39.
- BRIDGESTONE/FIRESTONE NORTH AMERICAN TIRE, LLC, NASHVILLE, TN: 2,882,798, CANC. INT. CL. 38.
- BRIDGFORD FOODS CORPORATION, ANAHEIM, CA: 3,962,633, INT. CL. 30.
- BRIGHAM YOUNG UNIVERSITY, PROVO, UT: 1,647,398, REN. 4-9-11. MULTIPLE CLASS, INT. CLS. 16, 25 AND 41.
- BRIGHT HORIZONS FAMILY SOLUTIONS LLC, WATERTOWN, MA: 3,962,844, INT. CL. 41.
- BRIGHT IDEAS, INC, AGOURA HILLS, CA: 3,962,826, INT. CL. 9. 3,962,827, INT. CL. 9.
- BRILLIANCE AUDIO, INC., GRAND HAVEN, MI: 3,963,298, MULTIPLE CLASS, INT. CLS. 9 AND 41.
- BRINKER INTERNATIONAL PAYROLL COMPANY, L.P., DALLAS, TX: 2,503,744, REN. 4-11-11. INT. CL. 42. 2,512,260, REN. 4-11-11. INT. CL. 30. 3,963,385, INT. CL. 41. 3,963,386, INT. CL. 41.
- BRITTON, BEVERLY L., TAMPA, FL, DBA ALIGNBETWEEN: 3,962,750, MULTIPLE CLASS, INT. CLS. 16 AND 35.
- BROADCAST TOOLS, INC., SEDRO WOOLLEY, WA: 3,962,247, INT. CL. 9.
- BROADSOFT, INC., GAITHERSBURG, MD: 3,961,780, PUB. 3-1-2011. INT. CL. 42.
- BRODIE, ADJOWAH, OAKLAND, CA, DBA THE WEEK-END STORE: 3,960,297, PUB. 3-1-2011. INT. CL. 14.
- BROKERAGEAMERICA, INC., NEW YORK, NY: 2,882,263, CANC. INT. CL. 36.
- BROMINE COMPOUNDS LTD., ISRAEL: 3,960,829, PUB. 3-1-2011. INT. CL. 1.
- BROOKS ENTERTAINMENT INC., CORONADO, CA: 3,961,290, PUB. 3-1-2011. INT. CL. 9.
- BROOKS SHOPPING CENTERS, LLC, YONKERS, NY: 3,844,436, COR. MULTIPLE CLASS, INT. CLS. 35 AND 36. 3,852,783, COR. MULTIPLE CLASS, INT. CLS. 35 AND 36.
- BROOKWOOD TITLE AGENCY, LLC, BROOKLYN, NY: 2,383,272, CANC. INT. CL. 36.
- BROWN EYED GIRL, INC., SAN FRANCISCO, CA: 2,880,577, CANC. INT. CL. 25.
- BROWN, CHRISTOPHER, TARZANA, CA: 3,961,776, PUB. 3-1-2011. INT. CL. 42.
- BROWN, JAKE, OCEANSIDE, CA: 3,962,178, INT. CL. 25.



BROWN, TIA MONIQUE, EWING TWP., NJ:  
2,384,210, CANC. MULTIPLE CLASS, INT. CLS. 25 AND 42.

BROWNEE, THE PLAIN BROWN DOG LLC, EAST BRUNSWICK, NJ:  
3,962,543, INT. CL. 31.

BROWNSTONE PUBLISHERS, INC., NEW YORK, NY:  
2,883,388, CANC. INT. CL. 16.

BRUCE K. KOELLER, INC., LONE TREE, CO:  
3,961,491, PUB. 3-1-2011. INT. CL. 43.

BRUSHPOINT INNOVATIONS INC, KING CITY, CANADA:  
3,963,565, INT. CL. 21.

BRYAN N. HADLEY, ROUND ROCK, TX:  
3,961,827, PUB. 3-1-2011. INT. CL. 41.

BRYAN OIL OF GEORGIA, LLC, PEMBROKE, GA:  
2,383,276, CANC. MULTIPLE CLASS, INT. CLS. 4, 35, 40, 41 AND 42.

BSA BUSINESS SOFTWARE ALLIANCE, INC., WASHINGTON, DC:  
3,963,047, INT. CL. 41.

BSH BOSCH UND SIEMENS HAUSGERAETE GMBH, MUNICH, FED REP GERMANY:  
3,962,128, INT. CL. 11.

BT LEWIS ENTERPRISES, INC., LOS ANGELES, CA:  
3,962,770, INT. CL. 43.

BUBBAQUE'S, LLC, BRANDON, FL:  
3,961,932, PUB. 3-1-2011. MULTIPLE CLASS, INT. CLS. 30, 35 AND 43.

BUBBLES, INC., VIENNA, VA:  
3,962,548, INT. CL. 3.

BUCHANAN, LEONARD E, ALAMOGORDO, NM, DBA PROBLEMS SOLUTIONS INNOVATIONS:  
3,961,177, PUB. 3-1-2011. INT. CL. 41.

BUCKNELL UNIVERSITY, LEWISBURG, PA:  
2,882,552, CANC. INT. CL. 20.

BUCKNER & COMPANY, INC., DALLAS, TX:  
3,960,244, PUB. 3-1-2011. INT. CL. 35.

BU CZKOWSKI, MICHAEL, KINGSTON, IL:  
3,962,237, INT. CL. 35.

BUD K WORLDWIDE, INC., MOULTRIE, GA:  
3,963,643, INT. CL. 8.

BUDGET RENT A CAR SYSTEM, INC., PARSIPPANY, NJ:  
3,961,569, PUB. 3-1-2011. INT. CL. 35.

BUENA VIDA SOCIAL CLUB, INC., MIAMI LAKES, FL:  
3,960,593, PUB. 3-1-2011. INT. CL. 41.

BUI, PHUONG B, RENTON, WA, DBA NGHIA NIPPERS USA:  
3,961,693, PUB. 3-1-2011. INT. CL. 8.

BUILD-A-BEAR RETAIL MANAGEMENT, INC., ST. LOUIS, MO:  
3,961,956, PUB. 3-1-2011. INT. CL. 28.

BUILT FOR MAN LLC, SEATTLE, WA:  
3,961,128, PUB. 3-1-2011. INT. CL. 25.

BUKIETY, INC., CHICAGO, IL:  
2,880,699, CANC. INT. CL. 35.

BULK TANK INC., PARK HILLS, MO:  
3,960,850, PUB. 3-1-2011. INT. CL. 7.

BULLSBLOOD INC., TORONTO, ONTARIO, CANADA:  
3,962,365, INT. CL. 35.

BUNDY AMERICAN, LLC, LAUREL, MD:  
2,486,021, REN. 4-11-11. INT. CL. 39.

BUNGE OILS, INC., ST. LOUIS, MO:  
3,963,644, INT. CL. 29.

BUNTING BEARINGS, LLC, HOLLAND, OH, BRONZE BEARINGS, INC., CHICAGO, IL:  
709,315, REN. 4-11-11. U.S. CL. 23 (INT. CL. 7).

BURGOS, ERLINDA, GLENDALE, CA, DBA HILEA ENTERPRISES:  
3,962,862, INT. CL. 28.

BURNETTE FOODS, INC., ELK RAPIDS, MI, FORMERLY ELK RAPIDS PACKING CO.:

3,961,126, PUB. 3-1-2011. MULTIPLE CLASS, INT. CLS. 29 AND 32.

BURNS, RONALD, SEDONA, AZ AND BURNS, BUFF, SEDONA, AZ:  
2,382,256, CANC. MULTIPLE CLASS, INT. CLS. 16 AND 28.

BURRUS, SWAN, IV, BRENTWOOD, TN:  
2,882,621, CANC. INT. CL. 9.

BURTIN POLYMER LABORATORIES, INC., CARTERSVILLE, GA:  
3,961,668, PUB. 3-1-2011. INT. CL. 2.

BUSHMAN, JEFFREY, HALEIWA, HI:  
3,960,307, PUB. 1-25-2011. INT. CL. 25.

BUSINESS FOR SOCIAL RESPONSIBILITY, SAN FRANCISCO, CA:  
3,962,376, MULTIPLE CLASS, INT. CLS. 35 AND 41.

BUSINESS LEGACY, INC., ALLEN, TX:  
3,962,990, INT. CL. 41.

BUSINESS PARTNER FRANCHISING, LLC, SOUTHURDY, CT:  
3,962,241, MULTIPLE CLASS, INT. CLS. 35, 40, 41 AND 42.

BUSINESS RESOURCE SOFTWARE, INC., AUSTIN, TX:  
2,384,124, CANC. INT. CL. 9.

BYD:SIGN CORPORATION, TOKYO 104-0045, JAPAN:  
2,882,672, CANC. INT. CL. 9.

BÖHLER WELDING GROUP NORDIC AB, SWEDEN:  
3,960,689, PUB. 3-1-2011. MULTIPLE CLASS, INT. CLS. 6 AND 9.

C D LISTENING BAR, INC., IRVINE, CA, DBA SUPER D:  
2,882,559, CANC. INT. CL. 41.

C FOR YOU APPAREL GROUP INC., SEATTLE, WA:  
3,961,615, PUB. 3-1-2011. INT. CL. 25.

C. F. SAUER COMPANY, THE, RICHMOND, VA:  
1,640,700, REN. 4-9-11. INT. CL. 30.

C. HUMPHREY & ASSOCIATES, P.A., MIAMI, FL:  
3,961,278, PUB. 3-1-2011. INT. CL. 45.

C. MONDAVI & SONS, ST. HELENA, CA:  
3,963,595, INT. CL. 33.

C.D. MEYER, INC., FAIRFIELD, NJ:  
3,961,583, PUB. 3-1-2011. INT. CL. 9.

C.I. BANACOL, S.A., MEDELLIN, COLOMBIA:  
3,960,961, PUB. 3-1-2011. INT. CL. 31.

C.I. CASTRO & CO., INC., SAN ANTONIO, TX:  
3,960,637, PUB. 3-1-2011. INT. CL. 25.

C.I. UNION DE BANANEROS DE URABA, S.A. - UNIBAN, MEDELLIN, COLOMBIA, DBA C.I. UNIBAN S.A.:

3,962,468, INT. CL. 31.

CABALLERO, CO., YAKIMA, WA:  
3,962,965, INT. CL. 25.

CABRALES SOCIEDAD ANONIMA, PROVINCE OF BUENOS AIRES, ARGENTINA:  
2,882,504, CANC. INT. CL. 30.

CAESARS LICENSE COMPANY, LLC, LAS VEGAS, NV:  
2,558,258, REN. 4-12-11. INT. CL. 41.

2,558,258, CANC. INT. CL. 42.

CAESARS WORLD, INC., LAS VEGAS, NV:  
1,186,958, AM. INT. CL. 28.

CAFFE D'AMORE, INC., MONROVIA, CA:  
3,961,012, PUB. 3-1-2011. INT. CL. 32.

CALDERA ENGINEERING, L.C., PROVO, UT:  
2,468,186, REN. 4-8-11. INT. CL. 9.

CALI, DEBORAH K, NAPA, CA:  
3,960,335, PUB. 3-1-2011. INT. CL. 36.

CALIFORNIA EMERGING TECHNOLOGY FUND, SAN FRANCISCO, CA:  
3,961,009, PUB. 3-1-2011. MULTIPLE CLASS, INT. CLS. 35 AND 41.

3,961,010, PUB. 3-1-2011. MULTIPLE CLASS, INT. CLS. 35 AND 41.

CALIFORNIA INSTITUTE OF TECHNOLOGY, PASADENA, CA:  
1,646,023, REN. 4-12-11. INT. CL. 18.

3,961,858, PUB. 3-1-2011. INT. CL. 9.

CALIFORNIA MILK PROCESSOR BOARD, SAN CLEMENTE, CA:  
2,883,157, CANC. INT. CL. 35.

CALIFORNIAHOME TRADING LLC, THOUSAND OAKS, CA:  
3,963,772, INT. CL. 35.

CALIFRESH OF CALIFORNIA, LLC, SANGER, CA:  
3,962,709, INT. CL. 29.

3,962,710, INT. CL. 29.



- CALLAHAN FINANCIAL PLANNING COMPANY, OMAHA, NE:  
3,963,062, INT. CL. 36.
- CALLAWAY GOLF COMPANY, CARLSBAD, CA:  
3,962,720, INT. CL. 28.
- CALLPOD, INC., CHICAGO, IL:  
3,962,912, INT. CL. 9.
- CALPHALON CORPORATION, ATLANTA, GA:  
2,441,744, REN. 4-9-11, INT. CL. 21.
- CALPITO, CHRISTOPHER LAWRENCE, IMPERIAL BEACH, CA:  
3,961,965, MULTIPLE CLASS, INT. CLS. 30 AND 32.
- CALVERT, CHARLES S., SANTA CRUZ, CA:  
2,882,004, CANC. INT. CL. 42.
- CALZIFICIO PINELLI S.R.L., CASTEL GOFFREDO (MAN-TOVA), ITALY:  
2,450,902, REN. 4-8-11, INT. CL. 25.
- CAMAIR LLC, CHICAGO, IL:  
3,851,157, COR. INT. CL. 11.
- CAMPAGNA, DENNIS, SAN FRANCISCO, CA:  
2,430,923, REN. 4-9-11, INT. CL. 32.
- CAMPBELL, EWAN MALCOLM, WAIHI, NEW ZEALAND:  
2,881,369, CANC. INT. CL. 29.
- CAMPOSOL S.A., LIMA, PERU:  
3,962,240, INT. CL. 31.
- CAMPUS MANAGEMENT CORP, BOCA RATON, FL:  
2,881,142, CANC. INT. CL. 9.
- CANA-PACIFIC RIBBONS, INC., FERNDALE, WA:  
2,882,501, CANC. INT. CL. 35.
- CANADELLE LIMITED PARTNERSHIP, MONTREAL, QUEBEC, CANADA:  
3,963,350, INT. CL. 25.
- CANADIAN GENERAL-TOWER LIMITED, CAMBRIDGE, ONTARIO, CANADA:  
3,960,533, PUB. 3-1-2011, INT. CL. 24.
- CANADIAN IMPERIAL BANK OF COMMERCE, TORONTO, ONTARIO, CANADA:  
2,441,240, REN. 4-8-11, INT. CL. 36.
- CANADIAN NATIONAL RAILWAY COMPANY, MONTREAL, QUEBEC, CANADA:  
3,963,788, INT. CL. 39.
- CANADIAN PACIFIC PHYTOPLANKTON, LTD., NANAIMO, CANADA:  
3,962,285, INT. CL. 5.
- CANHOO(USA) INC, FLUSHING, NY:  
3,960,225, PUB. 3-1-2011, INT. CL. 44.
- CANIDAE CORPORATION, SAN LUIS OBISPO, CA:  
3,963,598, INT. CL. 31.  
3,963,599, INT. CL. 31.  
3,963,600, INT. CL. 31.  
3,963,601, INT. CL. 31.
- CANON KABUSHIKI KAISHA, TOKYO, JAPAN:  
3,961,970, INT. CL. 2.
- CANTALEIR INTERNATIONAL, INC., HOFFMAN ESTATES, IL:  
3,962,605, INT. CL. 35.
- CANTERBURY LIMITED, AUCKLAND, NEW ZEALAND:  
3,918,442, COR. MULTIPLE CLASS, INT. CLS. 25 AND 35.
- CANTINE RIUNITE & CIV - SOCIETA COOPERATIVA AGRICOLA, 42040 CAMPEGINE, ITALY:  
3,960,609, PUB. 8-17-2010, INT. CL. 33.
- CANYON BICYCLES GMBH, KOBLENZ, FED REP GERMANY:  
2,777,216, CANC. MULTIPLE CLASS, INT. CLS. 12 AND 42.
- CAP INDEX, INC., EXTON, PA:  
3,963,817, INT. CL. 45.  
3,963,818, INT. CL. 45.
- CAPACITY COVERAGE COMPANY OF NEW JERSEY, INC., MAHWAH, NJ:  
3,961,754, PUB. 3-1-2011, INT. CL. 36.
- CAPE COMPUTING CORP., HALETHORPE, MD:  
2,881,241, CANC. MULTIPLE CLASS, INT. CLS. 9, 37, 40 AND 42.
- CAPSTRAT, INC., RALEIGH, NC:  
3,960,610, PUB. 3-1-2011, MULTIPLE CLASS, INT. CLS. 35 AND 42.
- CAPTIVE OCEAN REEF ENTERPRISES, IRVINE, CA:  
2,382,103, CANC. INT. CL. 11.
- CAR FORT INC., LOS ANGELES, CA:  
3,961,330, PUB. 3-1-2011, INT. CL. 1.
- CAR SOUND EXHAUST SYSTEM, INC., RANCHO SANTA MARGARITA, CA:  
3,961,306, PUB. 3-1-2011, INT. CL. 7.  
3,961,311, PUB. 3-1-2011, INT. CL. 7.  
3,961,312, PUB. 3-1-2011, INT. CL. 7.  
3,961,315, PUB. 3-1-2011, INT. CL. 7.
- CARAVELLE INTERNATIONAL, LLC, SCHUYLKILL HAVEN, PA:  
2,509,784, REN. 4-13-11, INT. CL. 17.  
2,882,736, CANC. MULTIPLE CLASS, INT. CLS. 6 AND 19.
- CARBON TRADE EXCHANGE PTY LTD, SOUTHPORT QLD 4215, AUSTRALIA:  
3,960,865, PUB. 3-1-2011, INT. CL. 36.
- CARDINAL HEALTH ALLIANCE, LLC, MUNCIE, IN:  
2,882,532, CANC. INT. CL. 36.
- CARDINAL WILLIAM H. KEELER, ROMAN CATHOLIC ARCHBISHOP OF BALTIMORE, A CORPORATION SOLE, BALTIMORE, MD:  
2,881,363, CANC. INT. CL. 45.
- CARDIOCOM, LLC, EXCELSIOR, MN:  
2,500,803, COR. INT. CL. 10.
- CARDIOCOM, LLC, CHANHASSEN, MN:  
2,921,460, COR. INT. CL. 9.
- CARDIODX, INC., PALO ALTO, CA:  
3,962,382, MULTIPLE CLASS, INT. CLS. 5, 10 AND 44.
- CARDWELL, LA VONNDA, SAN ANTONIO, TX:  
2,382,483, CANC. INT. CL. 25.
- CAREER STEP, INC., PROVO, UT:  
2,382,195, CANC. MULTIPLE CLASS, INT. CLS. 9, 16 AND 41.
- CAREERBUILDER, LLC, CHICAGO, IL:  
3,963,374, INT. CL. 35.
- CARGILL, INCORPORATED, WAYZATA, MN:  
3,961,957, PUB. 3-1-2011, INT. CL. 29.  
3,961,958, PUB. 3-1-2011, INT. CL. 31.
- CARGILL, INCORPORATED, WAYZATA, MN:  
3,963,078, INT. CL. 1.
- CARGOTEC PATENTER AB, SE-341 81 LJUNGBY, SWEDEN:  
3,960,651, PUB. 3-1-2011, MULTIPLE CLASS, INT. CLS. 6, 9, 12, 19 AND 42.
- CARIBBEAN ELECTRONICS ENTERPRISES, INC., MIAMI, FL:  
3,962,927, INT. CL. 9.
- CARLSBAD SAFETY PRODUCTS, LLC, CARLSBAD, CA:  
3,963,709, INT. CL. 20.
- CARLSON, INC., MINNEAPOLIS, MN:  
3,963,717, INT. CL. 43.
- CARNIVAL CORPORATION, MIAMI, FL:  
3,962,253, MULTIPLE CLASS, INT. CLS. 39 AND 41.
- CAROL SUE BLUEBERRY FARM, INC., HAMPSTEAD, NC:  
3,962,896, INT. CL. 31.
- CARPIN MANUFACTURING, INC., WATERBURY, CT:  
3,963,682, INT. CL. 20.
- CARRIER CORPORATION, FARMINGTON, CT:  
3,962,748, INT. CL. 7.
- CARSAFE LLC, ST. CHARLES, MO:  
3,961,295, PUB. 3-1-2011, INT. CL. 36.
- CARSON SALES COMPANY, INC., PHOENIX, AZ:  
1,662,194, REN. 4-11-11, INT. CL. 6.
- CARTER, DEBRA, BRADENTON, FL:  
3,962,630, INT. CL. 41.
- CARTICEPT MEDICAL, INC., ALPHARETTA, GA, FORMERLY WINDWARD MEDICAL, INC.:  
3,962,115, INT. CL. 10.
- CASABELLA HOLDINGS LLC, BLAUVELT, NY:  
2,880,774, CANC. INT. CL. 21.
- CASARINI, ANNA, ITALY:  
3,960,671, PUB. 3-1-2011, MULTIPLE CLASS, INT. CLS. 9, 12 AND 25.
- CASCADE DAFO, INC., FERNDALE, WA:  
3,962,122, INT. CL. 10.

CASCADE MICROTECH, INC., PORTLAND, OR:  
3,963,583, INT. CL. 9.

CASEY FLAT ESTATES LLC, TIBURON, CA:  
3,962,177, INT. CL. 33.

CASH AMERICA INTERNATIONAL, INC., FORT WORTH, TX:  
3,359,644, AM. INT. CL. 35.

CASHCO, INC., ELLSWORTH, KS:  
2,384,076, CANC. INT. CL. 9.

CASSANDRA METZGER, WASHINGTON, DC:  
2,881,886, CANC. INT. CL. 41.

CASTROL LIMITED, SWINDON, WILTSHIRE, UNITED KINGDOM:  
1,615,385, REN. 4-8-11, INT. CL. 4.  
3,960,483, PUB. 3-1-2011, INT. CL. 4.

CAUTION WEAR CORP., NASHUA, NH:  
3,962,781, INT. CL. 10.

CAVALIER INC, NORFOLK, VA:  
2,881,011, CANC. INT. CL. 7.

CBORD GROUP, INC., THE, NEW YORK, NY:  
2,536,421, REN. 4-11-11, INT. CL. 9.

CBS STUDIOS, INC., STUDIO CITY, CA:  
3,961,732, PUB. 3-1-2011, INT. CL. 25.

CEDAR KNOLL VINEYARDS, INC., SAN ANTONIO, TX:  
2,882,168, CANC. INT. CL. 41.

CEEVEE NORTH AMERICA, LLC, MT. PLEASANT, SC:  
2,882,729, CANC. INT. CL. 12.

CELESTE FOOTWEAR, MIAMI, FL, TA CELESTE FOOTWEAR:  
3,961,185, PUB. 3-1-2011, INT. CL. 25.

CELL SIGNALING TECHNOLOGY, INC., DANVERS, MA:  
3,963,233, INT. CL. 1.

CELLIER DE SAINT LOUIS, BRIGNOLES, FRANCE:  
2,742,685, CANC. INT. CL. 33.

CELLNET COMMUNICATIONS LLC, MADISON HEIGHTS, MI:  
1,937,984, REN. 4-12-11, INT. CL. 35.

CEM SERVICE GROUP, INC., THE, OTTSVILLE, PA:  
2,383,013, CANC. INT. CL. 42.

CENDRES+MÉTAUX HOLDING SA, CH-2501 BIEL/BIENNE, SWITZERLAND:  
3,960,699, PUB. 3-1-2011, INT. CL. 5.

CENGAGE LEARNING, INC., STAMFORD, CT:  
2,383,185, CANC. INT. CL. 16.

CENTER FOR CULTURAL AND TECHNICAL INTERCHANGE BETWEEN EAST AND WEST, INC., HONOLULU, HI:  
1,679,210, REN. 4-13-11, MULTIPLE CLASS, INT. CLS. 16, 25 AND 41.  
1,679,210, CANC. INT. CL. 9.

CENTER FOR ECOLITERACY, BERKELEY, CA:  
3,962,211, INT. CL. 9.

CENTER FOR INTEGRATED MEDICINE, P.A., HOUSTON, TX:  
3,962,040, INT. CL. 44.

CENTEX CORPORATION, DALLAS, TX:  
2,882,238, CANC. MULTIPLE CLASS, INT. CLS. 36 AND 37.

CENTRAL METAL FABRICATORS, INC., FARMINGDALE, NJ:  
3,962,851, MULTIPLE CLASS, INT. CLS. 40 AND 42.

CENTRAL NATIONAL BANK OF ALVA, THE, ALVA, OK:  
2,454,362, REN. 4-14-11, INT. CL. 36.

CENTRAL PUGET SOUND REGIONAL TRANSIT AUTHORITY, SEATTLE, WA, DBA SOUND TRANSIT:  
2,449,812, REN. 4-11-11, INT. CL. 39.

CENTURY CONSULTANTS, LTD., LAKEWOOD, NJ:  
2,881,055, CANC. MULTIPLE CLASS, INT. CLS. 9 AND 42.  
2,881,057, CANC. MULTIPLE CLASS, INT. CLS. 9 AND 42.

CENZOPRANO, PAUL, HUNTINGTON STATION, NY:  
3,963,359, INT. CL. 43.

CEO INSTITUTE, INC., THE, DALLAS, TX:  
1,947,963, CANC. INT. CL. 41.

CEO STRATEGY SUMMIT LLC, ATLANTA, GA:  
3,963,846, INT. CL. 35.

CEPIA, LLC, ST. LOUIS, MO:  
3,963,252, INT. CL. 28.  
3,963,633, INT. CL. 28.

CEPIA, LLC, ST. LOUIS, MS:  
3,963,724, INT. CL. 28.

CERES NANOSCIENCES, LLLP, MANASSASS, VA:  
3,960,444, PUB. 3-1-2011, INT. CL. 1.

CERNER INNOVATION, INC., OVERLAND PARK, KS:  
2,384,372, CANC. INT. CL. 42.  
2,384,373, CANC. INT. CL. 42.

CERTES FINANCIAL PROS, INC., ST. LOUIS PARTK, MN:  
2,882,129, CANC. INT. CL. 35.

CERTIFIED STEAK & SEAFOOD LLC, JACKSONVILLE, FL:  
3,963,763, INT. CL. 29.

CFP EUROPE B.V., 3404LH IJSSELSTEIN, NETHERLANDS:  
3,960,624, PUB. 8-3-2010, MULTIPLE CLASS, INT. CLS. 18, 25 AND 28.

CGI INFORMATION SYSTEMS AND MANAGEMENT CONSULTANTS INC., TORONTO, ON M5L 1A9, CANADA:  
3,961,503, PUB. 3-1-2011, INT. CL. 9.

CHACE, COLLIN CLAY, RIVERSIDE, RI:  
3,963,292, MULTIPLE CLASS, INT. CLS. 9 AND 41.

CHALACO CORPORATION, THE, OAKLAND, CA:  
2,883,035, CANC. MULTIPLE CLASS, INT. CLS. 29 AND 30.

CHALLENGE MACHINERY COMPANY, THE, NORTON SHORES, MI:  
724,465, REN. 4-13-11, U.S. CL. 23 (INT. CL. 7).

CHAMBER OF COMMERCE OF HUNTSVILLE/MADISON COUNTY, INC., HUNTSVILLE, AL:  
3,961,530, PUB. 3-1-2011, INT. CL. 35.

CHAMNESS TECHNOLOGY, INC., BLAIRSBURG, IA:  
3,962,080, INT. CL. 1.

CHAMPIONSHIP BULL RIDING, INC., FORT WORTH, TX:  
3,961,081, PUB. 1-25-2011, INT. CL. 41.

CHAMPIONSHIP, INC., FRIENDSWOOD, TX:  
3,940,356, COR. INT. CL. 38.

CHANCE PUBLICATIONS N.V., NETHERLANDS:  
3,960,672, PUB. 3-1-2011, INT. CL. 35.

CHANG CHUN PETROCHEMICAL CO., LTD., TAIPEI, TAIWAN:  
3,961,050, PUB. 3-1-2011, INT. CL. 1.

CHANG LEE, ORANGE, CA:  
3,961,578, PUB. 3-1-2011, INT. CL. 43.

CHANGE FOR CLIMATE LLC, WEST HOLLYWOOD, CA, DBA CARBONPIG:  
3,961,358, PUB. 3-1-2011, INT. CL. 42.

CHANSON WATER USA, INC., LAGUNA HILLS, CA:  
3,961,814, PUB. 3-1-2011, INT. CL. 3.

CHANTAL, MARK ANTHONY, GOFFSTOWN, NH:  
3,962,031, INT. CL. 28.

CHAPMAN, CRAIG D, RANCHO CORDOVA, CA:  
3,961,997, INT. CL. 15.

CHARCOAL COMPANION INCORPORATED, EMERYVILLE, CA, DBA THE COMPANION GROUP:  
3,963,200, INT. CL. 21.

CHARITY TRUCKS LTD., VANCOUVER, BC, CANADA:  
3,960,420, PUB. 3-1-2011, INT. CL. 35.

CHARLES FLORA CONSUMER PRODUCTS, LLC., LOS ANGELES, CA:  
2,882,630, CANC. INT. CL. 3.

CHARLES W. MERRIAM & SON, INC., SCHENECTADY, NY, DBA THE MERRIAM AGENCY:  
3,961,027, PUB. 3-1-2011, INT. CL. 36.

CHARLOTTE RUSSE MERCHANDISING, INC., SAN DIEGO, CA:  
2,416,268, REN. 4-9-11, INT. CL. 18.

CHARLOTTESVILLE TROLLEY RENTALS, LLC, CHARLOTTESVILLE, VA:  
2,883,372, CANC. INT. CL. 39.

CHART INC., GARFIELD HEIGHTS, OH, CHART INC., GARFIELD HEIGHTS, OH:  
2,444,433, REN. 4-13-11, INT. CL. 6.

CHASE FARMS, INC., WALKERVILLE, MI:  
2,881,407, CANC. INT. CL. 29.

- CHATEAU INTERIORS - CALIFORNIA, IRVINE, CA:  
3,962,437, MULTIPLE CLASS, INT. CLS. 9 AND 42.  
3,962,439, MULTIPLE CLASS, INT. CLS. 9 AND 42.
- CHATHAMPOTTERY, S.CHATHAM, MA:  
2,882,676, CANC. INT. CL. 21.
- CHATSWORTH PRODUCTS, INC., WESTLAKE VILLAGE, CA:  
3,963,597, INT. CL. 9.
- CHEA, JAMES, HYATTSVILLE, MD:  
3,962,899, INT. CL. 29.
- CHEAPSKATES STORES, INC., MARS, PA:  
2,882,946, CANC. INT. CL. 35.
- CHEEKS FOOTWEAR INTERNATIONAL, LLC, ST. PETERSBURG, FL:  
3,962,612, INT. CL. 25.
- CHEMISCHE WERKE KLUTHE GMBH, FED REP GERMANY:  
3,960,644, PUB. 3-1-2011. MULTIPLE CLASS, INT. CLS. 1, 3 AND 4.
- CHEMPLEX INDUSTRIES, INC., PALM CITY, FL:  
2,446,417, REN. 4-13-11. INT. CL. 9.
- CHEMRISK LLP, SAN FRANCISCO, CA, PAUSTENBACH, DENNIS J., WOODSIDE, CA:  
1,642,368, REN. 4-14-11. INT. CL. 42.
- CHERRY, JOHN R., III, NASHVILLE, TN:  
3,960,412, PUB. 3-1-2011. INT. CL. 45.
- CHESAPEAKE GROUP INC., THE, LOS ANGELES, CA:  
2,492,652, REN. 4-13-11. INT. CL. 9.
- CHESTERFIELD TOM THUMB DAY CARE & KINDERGARTEN #2, CHICAGO, IL:  
3,960,612, PUB. 3-1-2011. INT. CL. 43.
- CHET BAKER ENTERPRISES LLC, TULSA, OK:  
2,383,414, CANC. INT. CL. 9.
- CHET WILLS, INDIANAPOLIS, IN:  
3,962,907, INT. CL. 11.
- CHIASSON, JAMES P., BURLINGTON, VT:  
2,882,948, CANC. INT. CL. 28.
- CHICAGO CLIMATE EXCHANGE, INC., CHICAGO, IL:  
3,962,787, INT. CL. 36.
- CHICAGO CULTURAL MILE ASSOCIATION, INC., CHICAGO, IL:  
3,961,307, PUB. 3-1-2011. MULTIPLE CLASS, INT. CLS. 35 AND 41.
- CHILDREN'S APPAREL MANUFACTURERS ASSOCIATION, MONTREAL (QUÉBEC) H3X 2T8, CANADA:  
2,880,598, CANC. INT. CL. 16.
- CHILDREN'S HOSPITAL AND HEALTH SYSTEM, INC., MILWAUKEE, WI:  
2,382,996, CANC. INT. CL. 36.
- CHILDREN'S MUSEUM OF PITTSBURGH, THE, PITTSBURGH, PA:  
2,942,804, CANC. INT. CL. 28.
- CHINA ROAD, LTD., SEATTLE, WA:  
3,960,974, PUB. 3-1-2011. INT. CL. 39.
- CHISHOLM, BRETT J, HOUSTON, TX:  
3,961,391, PUB. 3-1-2011. INT. CL. 36.
- CHOLESTECH CORPORATION, HAYWARD, CA:  
2,882,423, CANC. MULTIPLE CLASS, INT. CLS. 5 AND 10.
- CHOMP, INC., EL SEGUNDO, CA:  
3,960,261, PUB. 3-1-2011. INT. CL. 25.
- CHORION RIGHTS LIMITED, LONDON, UNITED KINGDOM:  
3,960,260, PUB. 11-23-2010. MULTIPLE CLASS, INT. CLS. 9, 16, 25, 28, 38 AND 41.
- CHOTARD, SYLVIE DELPY, EUGENE, OR:  
3,963,072, INT. CL. 3.
- CHRIS & CAROL APPAREL, INC., LOS ANGELES, CA, DBA CHRIS & CAROL APPAREL:  
3,961,616, PUB. 3-1-2011. INT. CL. 35.
- CHRIS & CAROL APPAREL, INC., LOS ANGELES, CA:  
3,961,772, PUB. 3-1-2011. INT. CL. 25.
- CHRIST INTERNATIONAL CENTER, MT. VERNON, NY:  
3,961,830, PUB. 3-1-2011. INT. CL. 41.  
3,961,832, PUB. 3-1-2011. INT. CL. 45.
- CHRISTENSEN O'CONNOR JOHNSON KINDNESS PLLC, SEATTLE, WA:  
2,882,941, CANC. INT. CL. 42.
- CHRISTHOMAS CORPORATION, IRVINE, CA:  
2,882,589, CANC. INT. CL. 20.
- CHRISTIAN & ASSOCIATES, INC., RALEIGH, NC:  
3,963,771, INT. CL. 20.
- CHRISTIAN BERNARD DIFFUSION, 75002 PARIS, FRANCE:  
2,382,735, CANC. INT. CL. 14.
- CHRISTIAN BUSINESSCARES FOUNDATION, CLEVELAND, OH:  
1,663,642, REN. 4-8-11. INT. CL. 36.
- CHRISTINA AMERICA INC., MONTREAL, QUEBEC, CANADA TO CHRISTINA AMERICA INC., MONTREAL, QUEBEC, CANADA:  
2,382,110, CANC. INT. CL. 25.
- CHRISTOPHER W. MCDONALD, KILLINGWORTH, CT:  
3,963,882, MULTIPLE CLASS, INT. CLS. 9 AND 41.
- CHRISTY FRANK MIRACLES, LLC, SCOTTSDALE, AZ:  
3,962,256, INT. CL. 25.
- CHRONOPATH, INC, ENGLISHTOWN, NJ:  
2,881,200, CANC. INT. CL. 9.
- CHRYSLER LLC, AUBURN HILLS, MI:  
2,883,169, CANC. INT. CL. 41.
- CHURCH & DWIGHT CO., INC., PRINCETON, NJ, YOUNGS RUBBER CORPORATION, NEW YORK, NY:  
544,931, REN. 4-8-11. U.S. CL. 10 (INT. CL. 10).
- CHURCH & DWIGHT CO., INC., PRINCETON, NJ:  
3,963,540, INT. CL. 31.
- CHURCH LANE COFFEE COMPANY, ATLANTA, GA, DBA DRINKMOR COFFEE COMPANY:  
2,881,614, CANC. MULTIPLE CLASS, INT. CLS. 21, 25, 35 AND 43.
- CHURCHILL, CARLY, SAN MARCOS, CA, DBA CARLY'S CLOSET:  
3,961,648, PUB. 3-1-2011. INT. CL. 14.
- CHURCHILLS FURNITURE, INC., SARASOTA, FL:  
2,881,380, CANC. INT. CL. 35.
- CI METAL FABRICATION, LLC, SAINT LOUIS, MO:  
3,962,337, INT. CL. 40.
- CIANO, JOHN A., PEABODY, MA, DBA J. C. GOURMET IMPORT CORP.:  
2,382,408, CANC. INT. CL. 30.
- CIECAL RC, INC., CHULA VISTA, CA:  
3,963,056, INT. CL. 44.
- CINCINNATI BELL TELEPHONE COMPANY LLC, CINCINNATI, OH:  
2,880,623, CANC. INT. CL. 35.
- CINCO CORPORATION, PLAINVIEW, MANDALUYONG, PHILIPPINES:  
3,760,041, AM. INT. CL. 43.
- CINDERELLA SHOWCASE, SALINAS, CA:  
2,544,632, CANC. INT. CL. 35.
- CINEDIGM DIGITAL CINEMA CORP., MORRISTOWN, NJ:  
2,882,272, CANC. MULTIPLE CLASS, INT. CLS. 38, 39 AND 42.
- CINEMA 7 INC., SAN FRANCISCO, CA:  
2,394,944, REN. 4-11-11. INT. CL. 41.
- CIRCLE ENVIRONMENTAL, INC., COLUMBIA, SC:  
2,881,816, CANC. INT. CL. 36.
- CIRCLE OF FRIENDS MINISTRIES, INC., SUGARCREEK, OH:  
3,962,373, INT. CL. 16.
- CISCO TECHNOLOGY, INC., SAN JOSE, CA:  
2,446,891, REN. 4-9-11. INT. CL. 41.  
2,446,892, REN. 4-9-11. INT. CL. 41.
- CITATIONSHARES HOLDING LLC, GREENWICH, CT:  
3,962,319, MULTIPLE CLASS, INT. CLS. 35, 36 AND 39.
- CITATIONSHARES MANAGEMENT, LLC, GREENWICH, CT:  
3,963,444, INT. CL. 39.
- CITI TRENDS, INC., SAVANNAH, GA:  
2,881,581, CANC. INT. CL. 25.
- CITIGROUP INC., NEW YORK, NY:  
3,963,651, MULTIPLE CLASS, INT. CLS. 36 AND 41.
- CITIZENS COMMUNITY BANK, SOUTH HILL, VA:  
3,963,349, INT. CL. 36.

CITIZENS FINANCIAL GROUP, INC., PROVIDENCE, RI:  
3,963,027, INT. CL. 36.  
3,963,343, INT. CL. 36.  
3,963,344, INT. CL. 36.

CITOC, HOUSTON, TX:  
3,961,357, PUB. 3-1-2011. INT. CL. 35.

CITY OF GROVER BEACH, GROVER BEACH, CA:  
3,961,625, PUB. 3-1-2011. INT. CL. 35.  
3,961,627, PUB. 3-1-2011. INT. CL. 35.

CITY SPROUTS, ST. LOUIS, MO:  
3,961,735, PUB. 3-1-2011. INT. CL. 35.

CJ CHEILJEDANG CORPORATION, SEOUL, REPUBLIC OF KOREA:  
3,960,267, PUB. 3-1-2011. INT. CL. 31.

CJ GLOBAL, INC., NEW YORK, NY:  
3,962,688, INT. CL. 30.

CJC APPAREL, INC., SCRANTON, PA:  
2,882,483, CANC. INT. CL. 25.

CKF6 HOLDINGS, LLC, BOSTON, MA, BRUNSWICK CORPORATION, CHICAGO, IL:  
930,423. REN. 4-9-11. U.S. CL. 22 (INT. CLS. 16, 18, 20, 22, 25 AND 28).

CLARIANT AG, CH-4132 MUTTENZ, SWITZERLAND:  
2,442,019. REN. 4-12-11. INT. CL. 1.

CLARK REALTY MANAGEMENT, LLC, ARLINGTON, VA:  
3,960,979, PUB. 3-1-2011. INT. CL. 35.

CLARK RESEARCH AND DEVELOPMENT, INC., FOLSOM, LA:  
1,645,639. REN. 4-8-11. INT. CL. 42.

CLASSIC KIDS PHOTOGRAPHY, LLC, WINNETKA, IL, AKA CLASSIC KIDS:  
3,962,667, INT. CL. 41.

CLASSIC PRODUCTS, INC., PIQUA, OH:  
2,882,384, CANC. INT. CL. 17.

CLEAN EARTH SYSTEMS, INC., TAMPA, FL:  
3,960,602, PUB. 3-1-2011. INT. CL. 16.

CLEANOFFER, INC., SAN FRANCISCO, CA:  
3,960,888, PUB. 3-1-2011. INT. CL. 36.

CLEANWAY INDUSTRIES, INC., WESATHMAPTON BEACH, NY:  
3,960,512, PUB. 3-1-2011. INT. CL. 37.

CLEAR CARBON INNOVATIONS LLC, GAINESVILLE, FL:  
3,960,607, PUB. 3-1-2011. INT. CL. 42.  
3,960,608, PUB. 3-1-2011. INT. CL. 42.

CLEAR CHANNEL INTANGIBLES, INC., SAN ANTONIO, TX:  
2,883,044, CANC. INT. CL. 35.

CLEAR MEDIA PARTNERS, INC., ATHENS, GA:  
3,960,288, PUB. 3-1-2011. INT. CL. 38.

CLEAR OBJECTIVE PTY LTD., BOWEN HILLS QLD 4006, AUSTRALIA:  
2,880,760, CANC. INT. CL. 9.

CLEARVIEW MEDIA LLC, BIRMINGHAM, AL:  
2,880,791, CANC. MULTIPLE CLASS, INT. CLS. 16 AND 35.

CLEO'S ENTERPRISES, INC., LAS VEGAS, NV:  
2,548,976. REN. 4-8-11. INT. CL. 35.

CLEVERSAFE, INC., CHICAGO, IL:  
3,960,282, PUB. 3-1-2011. INT. CL. 9.

CLICK SALES INC., BOISE, ID:  
3,960,318, PUB. 7-14-2009. INT. CL. 42.

CLIENTIZE.COM, INC., BOCA RATON, FL:  
2,493,461. REN. 4-8-11. INT. CL. 35.

CLIFF WILLIAMS, ANN ARBOR, MI:  
3,961,109, PUB. 3-1-2011. INT. CL. 40.

CLINTON, LISA, NEW YORK, NY:  
2,383,155, CANC. INT. CL. 41.

CLOCK TOWER PRESS, LLC, ANN ARBOR, MI:  
2,882,678, CANC. INT. CL. 41.

CLOCKWORK IP, LLC, SARASOTA, FL:  
2,882,454, CANC. INT. CL. 37.

CLODI L.L.C., CRYSTAL LAKE, IL:  
3,962,580, INT. CL. 35.

CLOVERDALE FOODS COMPANY, MANDAN, ND:  
1,645,670. REN. 4-13-11. INT. CL. 29.

CLUB COFFEE COMPANY INC., TORONTO, ONTARIO, CANADA:  
3,960,409, PUB. 3-1-2011. INT. CL. 30.

CLUB GASTRONOMICO MILLESIME, S.L., ARAVACA 28023 MADRID, SPAIN:  
3,960,385, PUB. 3-1-2011. INT. CL. 41.

CMI-SCHNEIBLE COMPANY, HOLLY, MI:  
2,556,091, CANC. INT. CL. 20.

CMS INDUSTRIES, LTD., SASKATOON, SASKATCHEWAN, CANADA:  
2,482,109. REN. 4-11-11. INT. CL. 5.

CNL HOLDINGS, INC., ORLANDO, FL:  
2,880,975, CANC. INT. CL. 36.

CNL INTELLECTUAL PROPERTIES, INC., ORLANDO, FL:  
3,962,028, MULTIPLE CLASS, INT. CLS. 35 AND 36.

CNXN LLC, SHAKER HEIGHTS, OH:  
3,961,600, PUB. 3-1-2011. INT. CL. 25.

COALITION OF EXCLUSIVE AGENT ASSOCIATIONS, INC., BALTIMORE, MD:  
2,881,266, CANC. INT. CL. 35.

COAN, KIMBERLY, MISSOURI CITY, TX, DBA MEAL MOMMY:  
3,963,053, INT. CL. 44.

COBBIN, KEITH J., CHARLOTTE, NC AND OLIVER-COBBIN, RACHEL, CHARLOTTE, NC:  
2,882,516, CANC. INT. CL. 41.

COBRA ELECTRONICS CORPORATION, CHICAGO, IL:  
2,532,458. REN. 4-8-11. INT. CL. 9.

CODA RESOURCES, LTD., BROOKLYN, NY:  
3,961,248, PUB. 3-1-2011. INT. CL. 6.

COFINO, REBECCA, MIAMI SPRINGS, FL:  
3,962,839, INT. CL. 44.

COGHLAN FINANCIAL GROUP, INC., SAN DIEGO, CA:  
2,871,427, CANC. INT. CL. 36.

COHEN, ALAN M., LOS ANGELES, CA:  
2,883,260, CANC. INT. CL. 25.

COHEN, DAVE, DOYLESTOWN, PA:  
3,963,615, INT. CL. 41.

COKEM INTERNATIONAL, LTD., PLYMOUTH, MN:  
3,962,148, INT. CL. 9.

COLAPINTO, FRANK, CORONA, CA:  
2,881,868, CANC. INT. CL. 20.  
2,881,869, CANC. INT. CL. 20.

COLBOND B.V., ARNHEM, NETHERLANDS:  
2,461,018. REN. 4-8-11. INT. CL. 19.

COLD CUT GOURMET CORP., BRONX, NY:  
2,382,496, CANC. INT. CL. 42.

COLE CAPITAL ADVISORS, INC., PHOENIX, AZ:  
3,962,677, INT. CL. 36.  
3,962,678, INT. CL. 36.  
3,962,679, INT. CL. 36.

COLE, BARRY, WICHITA, KS:  
3,962,361, MULTIPLE CLASS, INT. CLS. 6, 12, 14, 24 AND 25.

COLE, CARLTON J., RED BANK, NJ:  
3,961,543, PUB. 3-1-2011. INT. CL. 44.

COLEMAN CABLE, INC., WAUKEGAN, IL:  
2,470,587. REN. 4-9-11. INT. CL. 9.

COLGATE-PALMOLIVE COMPANY, NEW YORK, NY:  
720,765. REN. 4-8-11. U.S. CL. 52 (INT. CL. 3).  
2,382,130, CANC. INT. CL. 3.  
3,962,444, INT. CL. 3.  
3,963,711, INT. CL. 3.  
3,963,712, INT. CL. 3.

COLLECTIONS 2000, INC., CARLSBAD, CA:  
2,396,300. REN. 4-8-11. INT. CL. 35.

COLLECTIVE BIAS, LLC, SOUTHFIELD, MI:  
3,962,469, INT. CL. 42.

COLLINS, MICHAEL T., BOCA RATON, FL:  
3,960,524, PUB. 3-1-2011. INT. CL. 11.

COLOMBIN & FIGLIO S.P.A., ITALY:  
3,032,511.

COLOMER, ANNA GRIMALDI, SAN JUAN, PUERTO RICO:  
2,403,864. REN. 4-14-11. INT. CL. 42.

COLONIAL PENN LIFE INSURANCE COMPANY, PHILADELPHIA, PA:  
3,963,496, INT. CL. 36.

COLOPLAST A/S, HUMLEBAEK, DENMARK:  
1,637,370. REN. 4-13-11. INT. CL. 5.

COLOR GUILD ASSOCIATES, INC., BRANDON, FL:  
2,881,216, CANC. INT. CL. 16.

- COLORADO BOXED BEEF CO., AUBURNDALE, FL:  
3,961,611, PUB. 3-1-2011. INT. CL. 29.
- COLORAMICS, LLC, HILLARD, OH:  
2,383,332, CANC. INT. CL. 20.
- COLUMBIA CONSULTANTS, LLC, NEW YORK, NY AND DANUCHT ENTERTAINMENT, LLC, NEW YORK, NY:  
3,963,448, INT. CL. 43.
- COLUMBIA INSURANCE COMPANY, OMAHA, NE:  
2,881,343, CANC. INT. CL. 27.  
2,883,400, CANC. INT. CL. 27.  
3,962,505, INT. CL. 25.
- COLUMBIA LIGHTING PROPERTIES, INC., WILMINGTON, DE:  
3,962,350, INT. CL. 9.
- COLUMBIA RIVER NATURAL PET FOODS, INC., CAMAS, WA:  
2,881,423, CANC. INT. CL. 31.
- COLUMBIAN CHEMICALS COMPANY, MARIETTA, GA, BINNEY & SMITH COMPANY, NEW YORK, NY:  
389,408, REN. 4-11-11. U.S. CL. 6 (INT. CL. 1).
- COLUMBIAN HOME PRODUCTS, LLC, TERRE HAUTE, IN:  
1,619,474, REN. 4-9-11. INT. CL. 8.
- COLUMBUS, KEZMIT, ELLENWOOD, GA:  
3,961,790, PUB. 3-1-2011. INT. CL. 25.
- COMBAT CORNER LLC, WEST ALLIS, WI, DBA COMBAT CORNER PROFESSIONAL:  
3,961,362, PUB. 3-1-2011. INT. CL. 28.
- COMBE INCORPORATED, WHITE PLAINS, NY, J.B. WILLIAMS COMPANY INC., WHITE PLAINS, NY:  
2,541,669, REN. 4-13-11. INT. CL. 3.
- COMBISEP, INC., AMES, IA:  
2,881,031, CANC. INT. CL. 9.
- COMBUSTION RESEARCH AND FLOW TECHNOLOGY, INC., DUBLIN, PA:  
2,628,132, CANC. INT. CL. 9.  
2,631,323, CANC. INT. CL. 9.
- COMFORT HOME OUTLET CORP., POMONA, CA:  
3,962,867, INT. CL. 24.
- COMFORT LIFE PRODUCTS, LLC, GIG HARBOR, WA:  
3,962,227, MULTIPLE CLASS, INT. CLS. 10 AND 28.
- COMFORT REVOLUTION, LLC, EATONTOWN, NJ:  
3,962,629, INT. CL. 20.
- COMFORTEX CORPORATION, WATERVLIET, NY:  
2,384,095, CANC. INT. CL. 20.
- COMFORTSMITH, LLC, GREENSBORO, GA:  
2,881,982, CANC. INT. CL. 10.
- COMFY COUCH COMPANY, COLUMBUS, OH:  
3,961,926, PUB. 3-1-2011. INT. CL. 39.
- COMINA, INC., WELLESLEY, MA:  
2,457,189, REN. 4-8-11. INT. CL. 35.
- COMMAND INFORMATION, INC., ALEXANDRIA, VA:  
3,960,877, PUB. 3-1-2011. INT. CL. 9.
- COMMANDITAIRE VENNOOTSCHAP HOEFIJZERFABRIEK—WERKMAN & CO., NETHERLANDS:  
3,960,777, PUB. 3-1-2011. MULTIPLE CLASS, INT. CLS. 6, 8 AND 35.
- COMMERCIAL TEXTILES, INC., HOMESTEAD, PA, DBA BEST BUY UNIFORMS:  
3,963,863, INT. CL. 35.
- COMMITTED U, SEBASTOPOL, CA:  
3,962,818, INT. CL. 45.
- COMMITTEE ON ADVANCED TUITION PAYMENT, OLYMPIA, WA:  
2,383,996, CANC. INT. CL. 36.
- COMMON CENSUS, INC., WESTBROOK, MA, COMMON CENSUS, INC., WESTBROOK, MA:  
2,543,741, REN. 4-11-11. INT. CL. 9.
- COMMONWEALTH ALUMINUM TUBE ENTERPRISES, LLC, LOUISVILLE, KY:  
2,882,302, CANC. INT. CL. 40.
- COMMUNITY CONNECT INC., NEW YORK, NY:  
2,539,092, REN. 4-12-11. MULTIPLE CLASS, INT. CLS. 35, 38 AND 42.
- COMMUNITY MARKETING, INC., SAN FRANCISCO, CA:  
2,883,423, CANC. INT. CL. 35.
- COMMUTER CHECK SERVICES CORPORATION, WATERTOWN, MA:  
2,538,919, REN. 4-8-11. INT. CL. 36.
- COMPASSLEARNING, INC., SAN DIEGO, CA:  
2,882,317, CANC. INT. CL. 41.  
2,882,318, CANC. INT. CL. 41.
- COMPCOTE INTERNATIONAL, INC., ELMHURST, IL:  
2,490,032, REN. 4-11-11. INT. CL. 40.
- COMPLETE COLLECTION SERVICES, INC., ALEXANDRIA, CA:  
3,961,552, PUB. 3-1-2011. INT. CL. 36.
- COMPLETE CURRICULUM, LLC, GIBRALTAR, MI:  
3,963,755, MULTIPLE CLASS, INT. CLS. 9, 41 AND 42.
- COMPLIANT HEALTHCARE TECHNOLOGIES, LLC, RALEIGH, NC:  
3,961,164, PUB. 3-1-2011. INT. CL. 42.
- COMPONENT HARDWARE GROUP, INC., LAKEWOOD, NJ:  
3,961,501, PUB. 3-1-2011. INT. CL. 11.
- COMPONEXX CORP., SUNRISE, FL:  
3,962,398, INT. CL. 9.
- COMPREHENSIVE HEALTH SERVICES, INC., RESTON, VA:  
2,440,223, REN. 4-8-11. INT. CL. 9.
- COMPREHENSIVE NEUROSCIENCE, INC., BRADENTON, FL:  
3,962,188, INT. CL. 41.  
3,962,189, INT. CL. 9.  
3,962,190, INT. CL. 35.
- COMPRESSOR ENGINEERING CORPORATION, HOUSTON, TX:  
2,880,573, CANC. MULTIPLE CLASS, INT. CLS. 41 AND 42.
- COMPUTER SCIENCES CORPORATION, EL SEGUNDO, CA:  
2,882,068, CANC. INT. CL. 9.
- COMPUTERSHARE TRUST COMPANY OF CANADA, MONTREAL, CANADA:  
3,960,305, PUB. 3-1-2011. INT. CL. 19.
- COMPUTHERM, LLC, MADISON, WI:  
2,509,662, REN. 4-9-11. INT. CL. 9.
- COMPUWARE CORPORATION, DETROIT, MI:  
3,961,793, PUB. 3-1-2011. INT. CL. 42.  
3,961,879, PUB. 3-1-2011. INT. CL. 9.
- COMTECH SOLUTIONS, INC., SALT LAKE CITY, UT:  
2,883,392, CANC. INT. CL. 42.
- CONAGRA FOODS RDM, INC., OMAHA, NE:  
2,382,976, CANC. INT. CL. 29.  
3,962,808, INT. CL. 30.
- CONAIR CORPORATION, STAMFORD, CT:  
2,883,394, CANC. INT. CL. 21.  
3,960,263, PUB. 3-1-2011. INT. CL. 18.  
3,962,562, INT. CL. 11.
- CONCORD CAMERA CORP., HOLLYWOOD, FL:  
2,881,763, CANC. INT. CL. 9.
- CONCORD MUSIC GROUP, INC., BERKELEY, CA:  
2,882,007, CANC. MULTIPLE CLASS, INT. CLS. 9, 25, 35 AND 38.
- CONCRETE DREAM, INC., SPRUCE PINE, AL:  
3,960,314, PUB. 3-1-2011. MULTIPLE CLASS, INT. CLS. 25 AND 28.
- CONCRETE TECHNOLOGY INCORPORATED, LARGO, FL:  
2,463,985, REN. 4-9-11. INT. CL. 37.
- CONCUR TECHNOLOGIES, INC., REDMOND, WA:  
3,962,068, MULTIPLE CLASS, INT. CLS. 41 AND 42.
- CONIMAR CORPORATION, OCALA, FL:  
2,383,351, CANC. INT. CL. 21.
- CONKLIN, GREGORY J., SEBASTOPOL, CA:  
3,962,250, MULTIPLE CLASS, INT. CLS. 31 AND 33.
- CONMED CORPORATION, UTICA, NY:  
1,079,783, CANC. INT. CL. 10.
- CONMED ENDOSCOPIC TECHNOLOGIES, INC., UTICA, NY:  
2,449,820, REN. 4-13-11. INT. CL. 10.
- CONNANCE, INC., WALTHAM, MA:  
3,961,168, PUB. 3-1-2011. INT. CL. 42.
- CONNECTED APPAREL COMPANY, LLC, LOS ANGELES, CA:  
2,454,165, REN. 4-13-11. INT. CL. 25.



CONNECTED CREATIVES, INC., VENICE, CA:  
3,960,986, PUB. 3-1-2011. INT. CL. 35.

CONNECTED PLANET SOLUTIONS, LTD., TEL AVIV 63504, ISRAEL:  
3,961,101, PUB. 3-1-2011. INT. CL. 35.

CONNECTED, LLC, BIRMINGHAM, AL:  
3,962,966, INT. CL. 41.

CONNECTICUT ATTORNEYS TITLE INSURANCE COMPANY, ROCKY HILL, CT:  
3,963,322, INT. CL. 45.

CONNECTOR SET LIMITED PARTNERSHIP, HATFIELD, PA:  
2,384,238, CANC. INT. CL. 28.

CONNOR, MICHAEL P., BROCKTON, MA:  
2,883,119, CANC. INT. CL. 41.

CONRAD GMBH, D-90562 KALCHREUTH, FED REP GERMANY:  
2,383,380, CANC. INT. CL. 28.

CONRAD, ROBERT A, SPRING, TX:  
3,962,954, INT. CL. 25.

CONSCIOUSLY CREATIVE LLC, DENVER, CO:  
3,961,845, PUB. 3-1-2011. INT. CL. 9.

CONSEAL INTERNATIONAL INCORPORATED, NORWOOD, MA:  
3,961,963, INT. CL. 5.

CONSERVATION FOUNDATION OF THE GULF COAST, INC., OSPREY, FL, FORMERLY SARASOTA CONSERVATION FOUNDATION, INC.:  
3,898,752, COR. INT. CL. 35.  
3,906,392, COR. INT. CL. 35.

CONSERVATION INTERNATIONAL FOUNDATION, WASHINGTON, DC:  
2,882,221, CANC. INT. CL. 42.

CONSOLIDATED DISTRIBUTORS INC, BKLYN, NY:  
3,961,068, PUB. 11-23-2010. INT. CL. 25.

CONSOLIDATED PROPERTY HOLDINGS, INC., LAS VEGAS, NV:  
3,963,063, MULTIPLE CLASS, INT. CLS. 4, 11, 20, 21, 24 AND 27.

CONSTABLE, JAMES E, BELMONT, MA:  
3,962,060, INT. CL. 28.

CONSTELLATION BRANDS, INC., VICTOR, NY:  
2,882,674, CANC. INT. CL. 33.

CONSTELLATION ENERGY GROUP, INC., BALTIMORE, MD:  
3,962,886, INT. CL. 42.

CONSTRUCTION RISK SOLUTIONS, LLC, HUNT VALLEY, MD:  
3,963,326, MULTIPLE CLASS, INT. CLS. 35 AND 36.

CONSUMERS CHOICE CREDIT UNION, SAGINAW, MI:  
2,383,537, CANC. INT. CL. 36.

CONTINENTAL AUTOMOTIVE SYSTEMS US, INC., AUBURN HILLS, MI:  
3,963,257, INT. CL. 9.

CONTROL SOLUTIONS LLC, AURORA, IL:  
3,960,621, PUB. 5-19-2009. INT. CL. 9.

CONWELL ENTERPRISES, INC., ELMIRA, NY:  
3,960,520, PUB. 3-1-2011. INT. CL. 14.

COOK INLET SALMON BRAND, INC., SOLDOTNA, AK:  
2,883,378, CANC. INT. CL. 29.

COOK MEDICAL TECHNOLOGIES LLC, BLOOMINGTON, IN:  
2,450,167, REN. 4-13-11. INT. CL. 10.

COOK, GRACE, ST. CLAIR SHORES, MI:  
2,881,059, CANC. INT. CL. 3.

COOKHOUSE LLC, SAN FRANCISCO, CA:  
3,962,749, INT. CL. 43.

COOPER TECHNOLOGIES COMPANY, HOUSTON, TX:  
3,961,540, PUB. 3-1-2011. INT. CL. 9.  
3,962,397, MULTIPLE CLASS, INT. CLS. 9 AND 11.

COOPER US, INC., HOUSTON, TX:  
2,495,399, REN. 4-14-11. INT. CL. 11.

COOPER, GARY, ATLANTA, GA:  
3,961,472, PUB. 3-1-2011. INT. CL. 35.

COPYCO, INC., FULLERTON, CA:  
2,891,317, CANC. INT. CL. 35.

COR DEVELOPMENT, LLC, KANSAS CITY, MO:  
2,882,581, CANC. MULTIPLE CLASS, INT. CLS. 35 AND 36.

CORDIN-BLITSTEIN, CHRIS, BURR RIDGE, IL:  
3,961,987, INT. CL. 43.

CORDIS CORPORATION, MIAMI LAKES, FL:  
2,882,336, CANC. INT. CL. 10.

CORDYS SOFTWARE B.V., 3882 RH PUTTEN, NETHERLANDS:  
2,916,131, CANC. INT. CL. 38.

CORE INTELLECTUAL PROPERTIES HOLDINGS, LLC, GOODYEAR, AZ:  
3,962,356, MULTIPLE CLASS, INT. CLS. 1 AND 5.

COREPARTNERS, INC, FREDERICK, MD:  
3,961,755, PUB. 3-1-2011. INT. CL. 9.

CORN PRODUCTS INTERNATIONAL, INC., WESTCHESTER, IL:  
713,930, REN. 4-13-11. U.S. CL. 31 (INT. CL. 31).  
713,930, AM. U.S. CL. 31.

CORNERSTONE PHOTOGRAPHY, INC., ALGONQUIN, IL:  
3,961,171, PUB. 3-1-2011. INT. CL. 41.

CORNFIELDS, INC., WAUKEGAN, IL, MEAD JOHNSON & COMPANY, EVANSVILLE, IN:  
911,254, REN. 4-14-11. U.S. CL. 46 (INT. CLS. 29 AND 30).

CORPORATIVO INTERNACIONAL MEXICANO, S. DE R.L. DE C.V., MEXICO CITY, MEXICO:  
3,963,611, INT. CL. 30.

CORPRO SYSTEMS LIMITED, WHITECAIRNS, UNITED KINGDOM:  
3,960,887, PUB. 3-1-2011. MULTIPLE CLASS, INT. CLS. 7 AND 9.

CORR WIRELESS COMMUNICATIONS, LLC, ONEONTA, AL:  
2,883,112, CANC. INT. CL. 38.

COSENTINO, RALPH R., NORTH OLMSTED, OH:  
2,882,894, CANC. INT. CL. 16.

COSMC FORCES INC, SAINT ALBANS, NY:  
3,962,575, INT. CL. 43.

COSMETIC PHYSICIANS, P.C., WASHINGTON, DC:  
2,882,926, CANC. MULTIPLE CLASS, INT. CLS. 35, 42 AND 44.

COSMO PARIS, 13685 AUBAGNE, FRANCE:  
2,880,561, CANC. INT. CL. 25.

COSMO U.S.A. INC., BELLEVUE, WA, DBA INTERNATIONAL CROSS-CULTURAL COMMITTEE:  
3,007,079, COR. INT. CL. 41.  
3,043,659, COR. INT. CL. 41.

COSTCO WHOLESALE MEMBERSHIP, INC., ISSAQUAH, WA FROM THE PRICE COMPANY, ISSAQUAH, WA:  
3,960,218, PUB. 3-1-2011. INT. CL. 37.

COSTRECOVERY USA, INC., DAYTON, OH:  
2,881,813, CANC. INT. CL. 36.  
2,881,815, CANC. INT. CL. 36.

COSWORTH ELECTRONICS LIMITED, NORTHAMPTONSHIRE, UNITED KINGDOM:  
2,390,716, REN. 4-8-11. MULTIPLE CLASS, INT. CLS. 9 AND 42.

COTT BEVERAGES INC., TAMPA, FL:  
2,384,195, CANC. INT. CL. 32.

COTY DEUTSCHLAND GMBH, MAINZ, FED REP GERMANY:  
3,963,300, INT. CL. 3.

COTY GERMANY GMBH, MAINZ, FED REP GERMANY:  
3,963,446, INT. CL. 3.

COUNSELOR HOLDING, INC., FRIDLEY, MN:  
2,500,275, REN. 4-11-11. INT. CL. 36.

COUNTER REVOLUTION INC, LEOMINSTER, MA:  
3,960,337, PUB. 3-1-2011. INT. CL. 40.

COUNTRY MUSIC TELEVISION, INC., NASHVILLE, TN:  
2,881,408, CANC. INT. CL. 41.

COURTNEY, RONALD S., B-7000 MONS, BELGIUM:  
2,882,257, CANC. INT. CL. 35.

COURTROOM TELEVISION NETWORK LLC, NEW YORK, NY:  
2,883,314, CANC. INT. CL. 41.

COUSINS SUBMARINES, INC., MENOMONEE FALLS, WI:  
2,708,988, AM. MULTIPLE CLASS, INT. CLS. 30 AND 43.

COVENANT EYES, INC., OWOSSO, MI:  
3,963,372, INT. CL. 9.

- COVENANT HARBOR BIBLE CAMP AND RETREAT CENTER, INC., LAKE GENEVA, WI:  
2,536,240. REN. 4-9-11. INT. CL. 41.
- COVINO & COMPANY, INC., TARRYTOWN, NY:  
2,382,252. CANC. INT. CL. 36.
- COWARD, JAMES H., AUGUSTA, GA:  
2,383,215. CANC. INT. CL. 12.
- COWBELL GAMES BUNCH, LOS ANGELES, CA:  
3,960,349. PUB. 3-1-2011. INT. CL. 9.
- COX, MARK R., DOVER, MA:  
2,882,127. CANC. INT. CL. 42.
- COY PRODUCTS, LLC, MERCER ISLAND, WA:  
3,962,747. INT. CL. 3.
- COYNE BEAHM, INC., GREENSBORO, NC:  
2,882,277. CANC. INT. CL. 25.
- COZEN O'CONNOR, P.C., PHILADELPHIA, PA:  
2,550,083. REN. 4-9-11. INT. CL. 42.
- COZMOFON INC., TORONTO, CANADA:  
3,962,419. INT. CL. 35.
- CPO HOSPITALITY L.L.C., SKOKIE, IL:  
3,963,378. INT. CL. 43.
- CRANE & CO., INC., DALTON, MA:  
516,840. REN. 4-13-11. U.S. CL. 37 (INT. CL. 16).
- CRANIOSACRAL THERAPY ALLIANCE, THE, STRAFFORD, NH:  
3,963,871. INT. CL. 41.
- CRASH BAGS, INC., DALLAS, TX:  
2,882,564. CANC. INT. CL. 18.
- CRAWFORD & COMPANY, ATLANTA, GA:  
2,882,066. CANC. INT. CL. 36.
- CRAYOLA PROPERTIES, INC., EASTON, PA:  
2,459,049. REN. 4-13-11. MULTIPLE CLASS, INT. CLS. 2 AND 16.
- CRC CONCRETE RAISING OF AMERICA, NEW BERLIN, WI:  
3,963,794. MULTIPLE CLASS, INT. CLS. 37 AND 40.
- CREATINGWILL.COM LLC, WILMINGTON, DE:  
3,961,617. PUB. 3-1-2011. MULTIPLE CLASS, INT. CLS. 42 AND 45.
- 3,961,618. PUB. 3-1-2011. MULTIPLE CLASS, INT. CLS. 42 AND 45.
- CREATIVE BIOCHEMICAL, INCORPORATED, KENTFIELD, CA, DBA TRUE NORTH MAGNETICS:  
3,960,847. PUB. 3-1-2011. INT. CL. 10.
- CREATIVE CLOSETS, LTD., ALLENTOWN, PA:  
2,912,325. COR. INT. CL. 42.
- CREATIVE DISTRIBUTION SOLUTIONS, PORT ALLEGANY, PA:  
3,962,937. INT. CL. 9.
- CREATIVE SPORT CONCEPTS, INC., ST. PETERSBURG, FL:  
3,960,885. PUB. 3-1-2011. INT. CL. 27.
- CREATIVE TESTING SOLUTIONS, SCOTTSDALE, AZ:  
3,962,782. INT. CL. 42.
- 3,962,783. INT. CL. 42.
- CREATURE CONTROL, LLC, GREGORY, MI, FORMERLY ADVANCED CREATURE CONTROL:  
3,962,226. MULTIPLE CLASS, INT. CLS. 37 AND 39.
- CREE, INC., DURHAM, NC, CREE, INC., DURHAM, NC:  
2,452,761. REN. 4-11-11. INT. CL. 9.
- CREO INC., BURNABY BC, CANADA:  
2,882,162. CANC. INT. CL. 9.
- CRESCENDO THERAPEUTICS LLC, SAN DIEGO, CA:  
3,963,007. INT. CL. 5.
- CRESCENT CITY BEIGNETS, INC., HOUSTON, TX:  
2,881,157. CANC. INT. CL. 43.
- CRIBIS CORPORATION, TAMPA, FL:  
2,882,656. CANC. INT. CL. 39.
- CRIF CORPORATION, TAMPA, FL:  
2,395,870. REN. 4-8-11. INT. CL. 36.
- CRIMSON AV, LLC., SCHILLER PARK, IL:  
3,961,270. PUB. 3-1-2011. INT. CL. 6.
- CRIST, WAYNE W., SAN ANTONIO, TX AND AKROMIS, GREG, SAN ANTONIO, TX:  
2,881,164. CANC. INT. CL. 41.
- CRISTAL CERAMICAS, S.A., ONDA (CASTELLON), SPAIN:  
2,881,440. CANC. INT. CL. 19.
- CROCKER ART MUSEUM ASSOCIATION, SACRAMENTO, CA:  
2,881,639. CANC. MULTIPLE CLASS, INT. CLS. 16 AND 36.
- CROCODILE TECHNOLOGY (UK) LIMITED, LONDON, UNITED KINGDOM:  
2,880,594. CANC. INT. CL. 12.
- CROCODILES NOT WATERLILIES ENTERTAINMENT, LLC, SAN FRANCISCO, CA:  
3,962,052. INT. CL. 28.
- CROISSANT ETC. CORPORATION, GREENDALE, WI:  
2,696,763. CANC. INT. CL. 30.
- CROOSTER CORP, NEW YORK, NY:  
3,961,857. PUB. 3-1-2011. INT. CL. 42.
- CROSIAR, TERESA, L., PONTIAC, IL:  
3,963,878. INT. CL. 25.
- CROSS TREAD INDUSTRIES, INC., HINSDALE, IL:  
2,442,891. REN. 4-14-11. INT. CL. 12.
- CROSS VETPHARM GROUP LIMITED, DUBLIN 24, IRELAND, IRELAND:  
3,926,666. COR. INT. CL. 5.
- CROSS-CONTINENTAL SOLUTIONS INC., VANCOUVER, BC, CANADA:  
3,963,519. INT. CL. 35.
- CROSSING CARE, LLC, RADNOR, PA:  
2,881,141. CANC. INT. CL. 5.
- CROSSWAY MINISTRIES, INC., WALNUT, MS:  
2,383,309. CANC. INT. CL. 9.
- CROWLEY TAR PRODUCTS COMPANY, INC., NEW YORK, NY:  
2,881,365. CANC. INT. CL. 19.
- CROWN CAP (1987) LTD., WINNIPEG, MANITOBA, CANADA:  
3,962,074. MULTIPLE CLASS, INT. CLS. 25, 35 AND 40.
- 3,962,075. MULTIPLE CLASS, INT. CLS. 25, 35 AND 40.
- 3,962,076. MULTIPLE CLASS, INT. CLS. 25, 35 AND 40.
- CROWN CASTLE INTERNATIONAL CORP., HOUSTON, TX:  
2,883,073. CANC. INT. CL. 9.
- CROWN CLINIC, P.A., CHARLOTTE, NC:  
3,962,121. INT. CL. 44.
- CROWN TRAVEL SERVICE, INC., BLOOMFIELD, NJ:  
2,446,165. REN. 4-14-11. INT. CL. 35.
- 2,446,169. REN. 4-14-11. INT. CL. 39.
- CROWNBRIDGE GROUP, LLC, ATLANTA, GA:  
3,962,514. MULTIPLE CLASS, INT. CLS. 35, 36, 42 AND 45.
- 3,962,515. MULTIPLE CLASS, INT. CLS. 35, 36, 42 AND 45.
- CRS HOLDINGS, INC., WILMINGTON, DE:  
910,843. REN. 4-8-11. U.S. CL. 14 (INT. CL. 6).
- CRUZ, ANA MARLENE, WHEATON, MD:  
2,880,746. CANC. INT. CL. 30.
- CRYSTAL RIVER ORGANICS LLC, CARBONDALE, CO:  
3,963,397. INT. CL. 30.
- 3,963,399. INT. CL. 30.
- 3,963,400. INT. CL. 41.
- CRYSTAL ROCK LLC, WATERTOWN, CT:  
2,450,626. REN. 4-14-11. MULTIPLE CLASS, INT. CLS. 32, 35 AND 39.
- CSAL CANADA-STATES-AFRICA-LINE INC., MONTREAL, QUEBEC, CANADA:  
3,961,575. PUB. 3-1-2011. INT. CL. 39.
- CSTV NETWORKS INC., NEW YORK, NY, DBA CBS COLLEGE SPORTS NETWORK:  
3,962,297. INT. CL. 41.
- CTB, INC., MILFORD, IN:  
2,382,250. CANC. INT. CL. 7.
- CTI INDUSTRIES CORPORATION, BARRINGTON, IL:  
1,616,702. REN. 4-8-11. MULTIPLE CLASS, INT. CLS. 16 AND 28.
- CU BIZSOURCE, LLC, MADISON, WI:  
2,880,903. CANC. INT. CL. 36.
- CUA IRENE L., ROSEMEAD, CA:  
2,450,746. REN. 4-13-11. INT. CL. 5.

CUA, IRENE L., ROSEMEAD, CA:  
 2,450,743, REN. 4-13-11. INT. CL. 5.  
 2,450,744, REN. 4-13-11. INT. CL. 5.  
 2,450,745, REN. 4-13-11. INT. CL. 5.  
 2,450,748, REN. 4-13-11. INT. CL. 5.

CUADRA, ERIC ARTURO, VANCOUVER, CANADA:  
 2,882,843, CANC. INT. CL. 25.

CUBICLE DECOR, LLC, LOUISVILLE, KY:  
 2,881,530, CANC. INT. CL. 35.

CUBIST PHARMACEUTICALS, INC., LEXINGTON, MA:  
 3,963,823, INT. CL. 44.

CUDLIE ACCESSORIES LLC, NEW YORK, NY:  
 3,963,864, INT. CL. 18.

CUEVAS, HATTI A JR., LAKE RONKONKOMA, NY AND  
 SCHAEFER, DONALD E., LAKE RONKONKOMA, NY  
 AND FAULKNER, RANDALL, FARMINGVILLE, NY:  
 2,882,847, CANC. INT. CL. 41.

CULINARY BUSINESS ACADEMY LLC, ALBUQUERQUE,  
 NM:  
 3,960,550, PUB. 3-1-2011. INT. CL. 9.  
 3,960,551, PUB. 3-1-2011. INT. CL. 9.

CUMBERLAND PACKING CORP., BROOKLYN, NY:  
 2,463,777, REN. 4-8-11. MULTIPLE CLASS, INT. CLS. 1  
 AND 30.

CUMMING, KEITH M., WELLAND, ON, CANADA:  
 3,961,471, PUB. 3-1-2011. INT. CL. 21.

CUMMINS INTELLECTUAL PROPERTY, INC., COLUM-  
 BUS, IN:  
 3,962,073, INT. CL. 35.

CUMMINS NPOWER LLC, WHITE BEAR LAKE, MN:  
 2,883,074, CANC. MULTIPLE CLASS, INT. CLS. 35 AND  
 37.

CUNNINGHAM, BELINDA ANNA, HOUSTON, TX, DBA  
 CUNNINGHAM ENTERPRISES AND CUNNINGHAM,  
 LARA, HOUSTON, TX:  
 3,960,425, PUB. 3-1-2011. INT. CL. 41.

CURRENT LIMITED, WATFORD, HERTS WD18 7SB, UNI-  
 TED KINGDOM:  
 2,882,121, CANC. MULTIPLE CLASS, INT. CLS. 35 AND  
 36.

CURRENT USA, INC., NORTH MANKATO, MN, CURRENT  
 USA, INC., NORTH MANKATO, MN:  
 2,559,182, REN. 4-14-11. MULTIPLE CLASS, INT. CLS. 16  
 AND 35.

CURRIER, DEBORAH K., CLERMONT, FL, DBA THE  
 ORIGINAL CUPCAKE SHOT DRINK COMPANY:  
 2,883,018, CANC. INT. CL. 32.

CURRY, C. ARNOLD, SOUTHFIELD, MI:  
 2,882,073, CANC. INT. CL. 42.

CURSOR OY, FI-48600 KOTKA, FINLAND:  
 3,960,718, PUB. 3-1-2011. INT. CL. 7.

CURV-RITE, INC., WAYLAND, MI:  
 1,662,906, REN. 4-13-11. INT. CL. 6.

CURVY CHICK INC., THE, NORTH PALM BEACH, FL:  
 2,882,877, CANC. MULTIPLE CLASS, INT. CLS. 16 AND  
 25.

CUSTOM SOFTWARE MANAGEMENT LLC, NEW YORK,  
 NY:  
 3,963,507, INT. CL. 9.

CUSTOM WHEEL HOUSE LLC, LONG BEACH, CA:  
 3,962,454, INT. CL. 12.  
 3,962,455, INT. CL. 12.  
 3,962,456, INT. CL. 12.

CUTE BRANDS INC, FRESH MEADOWS, NY:  
 3,961,871, PUB. 3-1-2011. INT. CL. 25.

CUTLER, PAUL, NIAGARA FALLS, NY:  
 2,431,552, REN. 4-8-11. INT. CL. 5.

CV PRODUCTS INC., THOMASVILLE, NC:  
 2,881,681, CANC. INT. CL. 35.

CVS PHARMACY, INC., WOONSOCKET, RI:  
 2,440,040, REN. 4-8-11. MULTIPLE CLASS, INT. CLS. 20  
 AND 28.  
 2,440,040, CANC. MULTIPLE CLASS, INT. CLS. 16 AND  
 21.

CYBEX INTERNATIONAL, INC., MEDWAY, MA:  
 3,962,497, INT. CL. 41.  
 3,962,498, INT. CL. 28.  
 3,962,499, MULTIPLE CLASS, INT. CLS. 10 AND 28.

CYTORI THERAPEUTICS, INC., SAN DIEGO, CA:  
 3,962,099, INT. CL. 10.

CYTOSPORT, INC., BENICIA, CA:  
 3,962,304, INT. CL. 5.  
 3,962,305, INT. CL. 5.  
 3,962,306, INT. CL. 5.  
 3,962,307, INT. CL. 5.

D & K GROUP, INC., ELK GROVE VILLAGE, IL:  
 3,960,317, PUB. 3-1-2011. INT. CL. 17.

D S I ENTERPRISES, INC., PROVO, UT:  
 2,880,870, CANC. INT. CL. 41.

D SQUARED ASSESSMENTS, INC., HAZLET, NJ:  
 2,881,244, CANC. INT. CL. 41.

D-GENERATION, INC., DAYTONA BEACH, FL:  
 3,960,299, PUB. 3-1-2011. INT. CL. 16.  
 3,960,978, PUB. 3-1-2011. INT. CL. 14.  
 3,961,141, PUB. 3-1-2011. INT. CL. 44.  
 3,961,240, PUB. 3-1-2011. INT. CL. 2.  
 3,961,710, PUB. 3-1-2011. INT. CL. 32.  
 3,961,711, PUB. 3-1-2011. INT. CL. 23.  
 3,961,712, PUB. 3-1-2011. INT. CL. 34.

D'AGUANNO, JOE, PEORIA, AZ:  
 2,881,682, CANC. INT. CL. 35.

DAB DOOR COMPANY, INC., HIALEAH GARDENS, FL:  
 3,962,228, INT. CL. 6.

DABISH, ROB, WARREN, MI:  
 3,961,337, PUB. 3-1-2011. INT. CL. 38.

DAC N SAC INC., CAMPBELL, CA:  
 2,881,784, CANC. INT. CL. 37.

DAESANG FNF CORPORATION, SEOUL, REPUBLIC OF  
 KOREA:  
 2,881,449, CANC. MULTIPLE CLASS, INT. CLS. 29 AND  
 30.

DAGNABIT! LLC, ATLANTA, GA:  
 3,963,170, INT. CL. 14.

DAIMLER AG, STUTTGART, FED REP GERMANY:  
 2,880,723, CANC. MULTIPLE CLASS, INT. CLS. 7 AND  
 12.

DAIRY COUNCIL OF CALIFORNIA, SACRAMENTO, CA:  
 2,881,198, CANC. INT. CL. 41.  
 2,881,199, CANC. MULTIPLE CLASS, INT. CLS. 9, 16  
 AND 41.

DAKOTA FLUID POWER, INC., SIOUX FALLS, SD:  
 3,962,219, MULTIPLE CLASS, INT. CLS. 35 AND 42.

DALLAS COUNTY COMMUNITY COLLEGE DISTRICT,  
 DALLAS, TX:  
 3,961,198, PUB. 3-1-2011. INT. CL. 36.

DALLAS PROJECT HOLDINGS LIMITED, BRIDGETOWN,  
 BARBADOS:  
 2,881,635, CANC. INT. CL. 35.

DALTILE DISTRIBUTION, INC., CALHOUN, GA:  
 3,961,900, PUB. 3-1-2011. INT. CL. 19.

DALY'S, INC., SEATTLE, WA:  
 1,640,989, REN. 4-13-11. MULTIPLE CLASS, INT. CLS. 2,  
 3 AND 17.

DAM FIREWORKS LTD, YANKTON, SD:  
 3,961,356, PUB. 3-1-2011. INT. CL. 35.

DAMAR STAFFING SOLUTIONS, INC., CLEVELAND, OH:  
 2,881,811, CANC. INT. CL. 35.

DAN MAR CO., ARLINGTON, TX:  
 3,963,563, INT. CL. 1.

DAN-DEE INTERNATIONAL LIMITED, JERSEY CITY, NJ:  
 2,447,170, REN. 4-13-11. INT. CL. 28.

DANISCO A/S, COPENHAGEN, DENMARK:  
 3,962,093, INT. CL. 1.

DANJAO, LLC, SANTA MONICA, CA:  
 3,962,585, MULTIPLE CLASS, INT. CLS. 9, 16 AND 41.  
 3,962,625, MULTIPLE CLASS, INT. CLS. 9, 16 AND 41.

DANSKO, LLC, WEST GROVE, PA:  
 3,963,103, MULTIPLE CLASS, INT. CLS. 10 AND 25.

DARKSIDE MOTORING, INC., CHATSWORTH, CA:  
 2,440,254, REN. 4-12-11. INT. CL. 35.

DARLINGTON COOKIE COMPANY, NOBLESVILLE, IN:  
 3,942,014, COR. INT. CL. 30.

DARPHARMA, INC., CHAPEL HILL, NC:  
 2,881,783, CANC. INT. CL. 42.

DART INDUSTRIES INC., ORLANDO, FL:  
 3,962,380, INT. CL. 11.

- DAS DISTRIBUTORS, PALMYRA, PA:  
2,455,361. REN. 4-14-11. INT. CL. 8.
- DATAIUM, LLC, NASHVILLE, TN:  
3,960,423, PUB. 3-1-2011. INT. CL. 9.
- DATAMEER INC., SAN MATEO, CA:  
3,963,338, INT. CL. 9.
- DATCCI CORP, AVENTURA, FL:  
3,961,422, PUB. 3-1-2011. INT. CL. 35.  
3,961,423, PUB. 3-1-2011. INT. CL. 35.
- DAVCO TECHNOLOGY, LLC, SALINE, MI:  
2,622,125 NEW CERT. 5-17-2011. INT. CL. 7.
- DAVE PHARMACEUTICALS (DP), INC, HOUSTON, TX:  
3,963,473, INT. CL. 5.
- DAVE WILSON NURSERY INC., HICKMAN, CA:  
3,961,359, PUB. 3-1-2011. INT. CL. 44.
- DAVID B.I. ANTLER, NEW YORK, NY:  
3,962,289, INT. CL. 42.
- DAVID BRIZER, NYACK, NY, DBA DAVID BRIZER, M.D.,  
PLLC:  
3,960,508, PUB. 3-1-2011. INT. CL. 44.
- DAVID C COOK, COLORADO SPRINGS, CO:  
2,880,790, CANC. INT. CL. 16.
- DAVID DAVID LONDON LIMITED, UNITED KINGDOM:  
3,960,793, PUB. 3-1-2011. INT. CL. 25.
- DAVID DAWES NEE II FOUNDATION, NEW YORK, NY,  
DBA THE DAVE NEE FOUNDATION:  
3,960,931, PUB. 3-1-2011. MULTIPLE CLASS, INT. CLS. 36  
AND 41.  
3,960,932, PUB. 3-1-2011. MULTIPLE CLASS, INT. CLS. 36  
AND 41.
- DAVID M. BURWEN, MOUNTAIN VIEW, CA, DBA VEN-  
TURE DEVELOPMENT GROUP:  
2,478,046. REN. 4-8-11. INT. CL. 35.
- DAVID ROULIN, SWITZERLAND:  
3,960,685, PUB. 3-1-2011. INT. CL. 35.
- DAVIS, CHARLES "JIGGS", ALAMEDA, CA:  
3,962,433, INT. CL. 41.
- DAVIS, SILVIA D., HOUSTON, TX, DBA BULLARD INTER-  
NATIONAL:  
3,961,332, PUB. 3-1-2011. INT. CL. 2.
- DAWN ENERGY LIMITED, CAMBRIDGE, UNITED KING-  
DOM:  
3,960,459, PUB. 3-1-2011. MULTIPLE CLASS, INT. CLS.  
35, 36, 40 AND 42.
- DAWS MANUFACTURING CO., INC., PENSACOLA, FL:  
2,444,722. REN. 4-11-11. INT. CL. 12.
- DAY, LAWRENCE JAMES, GRAND BLANC, MI:  
3,962,737, INT. CL. 14.
- DAYWIND, INC., HENDERSONVILLE, TN:  
2,881,712, CANC. INT. CL. 41.
- DBGRX INC., MIAMI, FL, DBA COINMOGUL.COM:  
3,960,954, PUB. 3-1-2011. INT. CL. 14.
- DC COMICS, NEW YORK, NY:  
2,882,881, CANC. INT. CL. 9.
- DCA BUSINESS MEDIA LLC, WESTPORT, CT:  
2,455,355. REN. 4-11-11. INT. CL. 42.
- DD APARTMENTS, LLC, BETHESDA, MD, DBA DEEP  
DISCOUNT APARTMENTS:  
3,963,618, INT. CL. 35.  
3,963,819, INT. CL. 35.
- DDB WORLDWIDE COMMUNICATIONS GROUP INC.,  
NEW YORK, NY:  
3,962,107, INT. CL. 35.
- DE ASIS ISLA TRIANA, FRANCISCO, MEXICO, D.F.,  
MEXICO:  
2,883,414, CANC. INT. CL. 16.
- DE BEERS LV LTD, LONDON, UNITED KINGDOM:  
2,881,497, CANC. INT. CL. 14.
- DE FATIS LTD, SURREY, UNITED KINGDOM:  
2,881,760, CANC. MULTIPLE CLASS, INT. CLS. 3 AND  
41.
- DE MARTINEZ, EMANUELE, DORAL, FL:  
3,962,814, INT. CL. 9.
- DE NINA, BERNI, SAN JOSE, CA:  
3,961,656, PUB. 3-1-2011. INT. CL. 41.
- DEALFLOW MEDIA, INC., SYOSSET, NY:  
2,883,379, CANC. INT. CL. 16.
- DEANGELO, STEPHEN ROWAN, BERKELEY, CA:  
2,881,789, CANC. INT. CL. 35.
- DEBREY, DREW S., ROCK ISLAND, IL:  
2,444,271. REN. 4-9-11. INT. CL. 11.
- DEBRUYN PRODUCE COMPANY, WESLACO, TX:  
3,960,864, PUB. 3-1-2011. INT. CL. 39.
- DECHANT, SANDRA M., BROOKFIELD, WI:  
2,881,098, CANC. INT. CL. 16.
- DECISION WISDOM, LLC, FAIRFIELD, CT:  
2,882,309, CANC. INT. CL. 9.
- DECLEMENTE, WILLIAM J., HALLANDALE BEACH, FL:  
2,382,986, CANC. INT. CL. 9.
- DECORE-ATIVE SPECIALTIES, MONROVIA, CA:  
2,969,195, AM. INT. CL. 20.
- DEEKS AND COMPANY, INCORPORATED, STONE  
MOUNTAIN, GA:  
2,383,146, CANC. INT. CL. 35.
- DEEPAK, ADARSH, HAMPTON, VA, DBA TAKSHASHILA  
UNIVERSITY:  
3,961,083, PUB. 3-1-2011. INT. CL. 41.
- DEER STAGS CONCEPTS INC., NEW YORK, NY:  
3,963,666, INT. CL. 25.
- DEERBOX, INC., PICTURE ROCKS, PA:  
2,881,781, CANC. INT. CL. 28.
- DEES COMMUNICATIONS, INC., MONTGOMERY, AL:  
2,881,308, CANC. INT. CL. 16.
- DEFENDERS OF WILDLIFE, WASHINGTON, DC:  
1,642,376. REN. 4-12-11. INT. CL. 42.
- DEFIANCE U.S.A., INC., LOS ANGELES, CA:  
2,895,278, CANC. INT. CL. 18.
- DEFIANTE FARMACEUTICA, S.A., FUNCHAL - MA-  
DEIRA, PORTUGAL:  
2,383,056, CANC. INT. CL. 42.
- DEHART CAPITAL, LLC, COLLIERVILLE, TN:  
2,880,964, CANC. INT. CL. 36.
- DEL PALMA ORTHOPEDICS, LLC, COLUMBIA CITY, IN:  
3,962,152, INT. CL. 42.
- DELAWARE CAPITAL FORMATION, INC., WILMINGTON,  
DE:  
3,962,878, INT. CL. 11.
- DELICIOUS CHOICES INC, LINCOLN, NE:  
2,881,810, CANC. INT. CL. 30.
- DELL INC., ROUND ROCK, TX:  
1,962,286, CANC. INT. CL. 9.
- DELMAR BREWING COMPANY, LLC, DELMAR, DE:  
3,962,292, INT. CL. 32.  
3,962,340, INT. CL. 32.  
3,962,341, INT. CL. 32.
- DELTA AIR LINES, INC., ATLANTA, GA:  
3,963,715, INT. CL. 39.
- DELTA INDUSTRIAL SERVICES INC, DELTA JUNCTION,  
AK:  
3,961,052, PUB. 3-1-2011. INT. CL. 19.
- DELTA T ENGINEERING, LLC, METUCHEN, NJ:  
3,960,890, PUB. 3-1-2011. INT. CL. 9.
- DELVILLE, PHILIPPE, 1180 BRUSSELS, BELGIUM:  
2,880,797, CANC. MULTIPLE CLASS, INT. CLS. 3, 25  
AND 33.
- DELYSE INC., RENO, NV:  
3,962,359, INT. CL. 43.
- DEMAND MANAGEMENT, INC., CLAYTON, MO:  
2,883,100, CANC. INT. CL. 9.  
2,883,101, CANC. INT. CL. 9.
- DEMARCO MAXVAC CORPORATION, MCHENRY, IL:  
2,383,284, CANC. INT. CL. 7.
- DENIM PROJECT LLC, NEW YORK, NY:  
3,960,357, PUB. 1-25-2011. INT. CL. 25.
- DENIMEX, S.A. DE C.V., NAUCALPAN DE JUAREZ,  
MEXICO:  
2,383,530, CANC. INT. CL. 25.
- DENSO CORPORATION, KARIYA-CITY, AICHI-PREF. 448-  
8661, JAPAN:  
3,963,727, INT. CL. 7.
- DENT WIZARD INTERNATIONAL CORPORATION,  
BRIDGETON, MO:  
3,961,152, PUB. 3-1-2011. INT. CL. 36.

DENTAL MANUFACTURING S.P.A., BADIA POLESINE (ROVIGO), ITALY:  
2,461,450. REN. 4-12-11. INT. CL. 10.

DENTAL PRO, LLC, WESTCHESTER, IL:  
3,961,111. PUB. 3-1-2011. INT. CL. 40.

DENVER SCHOOL DISTRICT #1, DENVER, CO:  
3,963,828, INT. CL. 41.  
3,963,829, INT. CL. 42.  
3,963,830, INT. CL. 41.  
3,963,831, INT. CL. 42.

DEPARTMENT OF DEVELOPMENT OF STATE OF OHIO, COLUMBUS, OH:  
3,960,309. PUB. 3-1-2011. INT. CL. 35.

DEPARTMENT OF THE ARMY, WEST POINT, NY:  
2,401,763. REN. 4-13-11. MULTIPLE CLASS, INT. CLS. 25 AND 41.

DEPARTMENT OF THE ARMY, ARLINGTON, VA:  
2,882,582. CANC. INT. CL. 16.

DEPRESSION WORKROOM, LLC, MIAMI, FL:  
2,881,153. CANC. INT. CL. 44.

DEPUY ORTHOPAEDICS, INC., WARSAW, IN:  
2,517,838. REN. 4-13-11. INT. CL. 10.

DERRICK, DANIEL M., SAN FRANCISCO, CA:  
3,963,776. INT. CL. 41.

DES MOINES UNIVERSITY OSTEOPATHIC MEDICAL CENTER., DES MOINES, IA:  
2,458,801. REN. 4-12-11. MULTIPLE CLASS, INT. CLS. 25 AND 41.

DESIGN CENTER SOLUTIONS, INC., SAUSALITO, CA:  
2,881,021. CANC. INT. CL. 9.

DESIGN HOUSE KITCHENS & APPLIANCES, L.L.C., SAVAGE, MD:  
2,398,378. REN. 4-9-11. INT. CL. 35.

DESIGNING DENTAL SMILES, PLLC, MERRICK, NY:  
3,963,187. INT. CL. 44.

DESOBEAU, MARC, RIVERDALE, UT:  
2,549,841. REN. 4-11-11. MULTIPLE CLASS, INT. CLS. 16 AND 42.

DESTILADORA DE LOS ALTOS S.A. DE C.V., ARANDAS, JALISCO, MEXICO:  
3,962,956. INT. CL. 33.

DETECTIVES' ENDOWMENT ASSOCIATION, NEW YORK, NY:  
2,382,377. CANC. MULTIPLE CLASS, INT. CLS. 14, 16, 18, 21, 25, 26, 36 AND 42.

DETOXIFY, LLC, SCOTTSDALE, AZ:  
3,961,183. PUB. 3-1-2011. INT. CL. 5.

DETROIT STOKER COMPANY, MONROE, MI:  
1,150,931. REN. 4-11-11. INT. CL. 11.

DEUTSCHE BANK SECURITIES, INC., NEW YORK, NY:  
3,962,916. INT. CL. 36.

DEUTSCHE POST AG, 53113 BONN, FED REP GERMANY:  
2,880,926. CANC. MULTIPLE CLASS, INT. CLS. 16, 35 AND 39.

DEVELOPMENT SEED, WASHINGTON, DC:  
3,962,620. INT. CL. 42.

DEVELOPNEURS, LLC, ELKHART, IN:  
2,881,807. CANC. INT. CL. 35.

DEVICWISE STRATEGIES, INC., GOLDEN, CO:  
3,921,948. CANC. IIRN. RESTORED TO S.N. 77-930,283.

DFO, LLC., SPARTANBURG, SC:  
2,881,173. CANC. INT. CL. 29.

DHANRAJ IMPORTS, INC., RIVERSIDE, CA, DBA DHANRAJ IMPORTS, INC.:  
3,961,846. PUB. 3-1-2011. INT. CL. 34.

DI CARLO, ALFONSO, ALLENTOWN, PA:  
3,962,151. INT. CL. 16.

DIACO INTERNATIONAL, NEW YORK, NY:  
2,882,700. CANC. INT. CL. 14.

DIAGENIC ASA, NORWAY:  
3,960,826. PUB. 3-1-2011. MULTIPLE CLASS, INT. CLS. 10, 35 AND 44.

DIAGEO NORTH AMERICA, INC., NORWALK, CT:  
3,963,221. INT. CL. 33.

DIAGNOSTIC DEVICES, INC., CHARLOTTE, NC:  
3,963,209. INT. CL. 10.  
3,963,210. INT. CL. 10.  
3,963,219. MULTIPLE CLASS, INT. CLS. 5 AND 10.  
3,963,220. MULTIPLE CLASS, INT. CLS. 5 AND 10.

DIAMOND CUTTER, LLC, PHILADELPHIA, PA:  
2,881,767. CANC. INT. CL. 41.

DIAMOND PAIRS, LTD., NEW YORK, NY:  
2,384,378. CANC. INT. CL. 14.

DIAMOND WIPES INTERNATIONAL, CHINO, CA:  
3,963,713. INT. CL. 3.

DIAPHONICS INC., HALIFAX, NOVA SCOTIA, CANADA:  
2,882,406. CANC. INT. CL. 9.

DICKSON, MATTHEW T., AURORA, CO:  
3,963,004. INT. CL. 25.

DICOTA GMBH, BIETIGHEIM-BISSINGEN, FED REP GERMANY:  
3,962,412. MULTIPLE CLASS, INT. CLS. 9 AND 18.

DIFRANCESCO, JOSEPH, LONGWOOD, FL AND DIFRANCESCO, BERNADETTE, LONGWOOD, FL:  
2,383,075. CANC. INT. CL. 41.

DIGAAI WORLD, INC., JAMAICA PLAIN, MA:  
3,963,578. INT. CL. 45.

DIGICERT, INC., LINDON, UT:  
3,961,174. PUB. 3-1-2011. MULTIPLE CLASS, INT. CLS. 18, 21, 25 AND 45.

DIGITAL DESIGNS, INC., MONROE, NC:  
2,548,079. REN. 4-9-11. INT. CL. 9.

DIGITAL INTERACTIVE STREAMS, INC., JACKSONVILLE, FL:  
2,883,006. CANC. INT. CL. 9.

DIGITAL NEXUS TECHNOLOGIES, INC., FOOTHILL RANCH, CA:  
3,961,724. PUB. 3-1-2011. INT. CL. 9.

DIGITEK COMPUTER PRODUCTS, INC., DULLES, VA:  
3,962,278. INT. CL. 2.

DILL-SCHMIDT, JANICE, VALENCIA, CA:  
3,963,477. INT. CL. 16.

DIMENSION ONE SPAS, INC., VISTA, CA:  
2,881,243. CANC. INT. CL. 11.

DINERS CLUB INTERNATIONAL LTD., RIVERWOODS, IL, CARTE BLANCHE CORPORATION, LOS ANGELES, CA:  
1,150,631. REN. 4-8-11. INT. CL. 36.

DINO'S ITALIAN BISTRO, INC., SHAVERTOWN, PA, DBA DINO'S PIZZA ITALIAN BISTRO:  
2,881,425. CANC. INT. CL. 30.

DIOPTRICS MEDICAL PRODUCTS, INC., SAN LUIS OBISPO, CA:  
2,383,360. CANC. INT. CL. 9.

DIPPIN' DOTS, INC., PADUCAH, KY:  
3,962,508. INT. CL. 30.

DIPTI SONI & AJIT SHAH PARTNERSHIP, THE, SCHAUMBURG, IL:  
2,447,029. REN. 4-13-11. INT. CL. 30.

DIRECT HOLDINGS AMERICAS INC., FAIRFAX, VA:  
3,961,193. PUB. 3-1-2011. INT. CL. 16.

DIRECTED DECISIONS, INC., CLEVELAND, OH:  
2,881,227. CANC. INT. CL. 42.

DISABLED WORKERS FOUNDATION OF CANADA, VICTORIA, BRITISH COLUMBIA, CANADA:  
2,883,115. CANC. INT. CL. 42.

DISC MARKETING, INC., PASADENA, CA:  
2,881,085. CANC. INT. CL. 41.

DISCOVERY COMMUNICATIONS, INC., SILVER SPRING, MD:  
3,960,627. PUB. 5-9-2006. INT. CL. 41.

DISCOVERY COMMUNICATIONS, LLC, SILVER SPRING, MD:  
2,382,827. CANC. MULTIPLE CLASS, INT. CLS. 38 AND 41.

DISCOVERY CREEK CHILDREN'S MUSEUM OF WASHINGTON, WASHINGTON, DC:  
2,442,417. REN. 4-12-11. INT. CL. 41.

DISCUS DENTAL, LLC, CULVER CITY, CA:  
2,821,945. CANC. INT. CL. 42.  
3,962,614. MULTIPLE CLASS, INT. CLS. 3, 5, 9, 10, 16, 35 AND 41.



- DISNEY ENTERPRISES, INC., BURBANK, CA:  
2,882,164, CANC. INT. CL. 3.  
3,962,280, INT. CL. 31.  
3,962,686, INT. CL. 21.  
3,962,687, INT. CL. 28.  
3,962,689, INT. CL. 41.  
3,963,239, INT. CL. 16.
- DISORDERLY KIDS, LLC, COMMERCE, CA:  
3,960,616, PUB. 3-1-2011. INT. CL. 25.  
3,960,617, PUB. 3-1-2011. INT. CL. 25.  
3,960,618, PUB. 3-1-2011. INT. CL. 25.
- DISPO-BUD MARKETING, BARKAN, ISRAEL, DBA DISPOBUD:  
3,961,707, PUB. 3-1-2011. INT. CL. 24.
- DISTRIBUIDORA DE ALIMENTOS NATURALES Y NUTRICIONALES, S.A. DE C.V., MEXICO, MEXICO:  
3,963,339, INT. CL. 30.
- DISTRIBUTION AMERICA, INC., CHARLOTTE, NC:  
1,151,311, REN. 4-8-11. INT. CL. 42.  
2,456,871, REN. 4-8-11. INT. CL. 35.
- DISTRIBUTION TECHNOLOGY, INC., CHARLOTTE, NC:  
1,641,568, REN. 4-13-11. INT. CL. 39.
- DISTRICT OF COLUMBIA FIRE & EMERGENCY MEDICAL SERVICES DEPARTMENT, WASHINGTON, DC:  
3,963,270, INT. CL. 14.
- DIVER, JEFFREY A., ETNA, NY:  
2,384,218, CANC. INT. CL. 41.
- DIVERSAFIRE EVERETT, LLC, BRENTWOOD, TN:  
2,383,159, CANC. INT. CL. 16.
- DIVERSEY, INC., STURTEVANT, WI, DU BOIS CO. INC, THE, CINCINNATI, OH:  
710,403, REN. 4-9-11. U.S. CL. 6 (INT. CL. 5).
- DIVERSIFIED DATA PROCESSING & CONSULTING, INC., FERNDALE, MI, DBA DIVDAT:  
3,960,534, PUB. 3-1-2011. MULTIPLE CLASS, INT. CLS. 35 AND 36.
- DIVERSIFIED ENDEAVORS INC., LAGO VISTA, TX:  
3,961,099, PUB. 3-1-2011. INT. CL. 9.
- DIVERSIFIED HOLDING CORPORATION, LONG BEACH, CA:  
2,881,431, CANC. MULTIPLE CLASS, INT. CLS. 36 AND 42.  
2,881,436, CANC. INT. CL. 36.
- DIVERWEST CORPORATION, LAKE FOREST, CA:  
2,384,251, CANC. INT. CL. 25.
- DIVINE HEALING SOCIETY, INC., LAS VEGAS, NV:  
3,961,855, PUB. 3-1-2011. INT. CL. 3.
- DIVINE INNOVATIONS, LLC, KNOXVILLE, TN:  
3,961,408, PUB. 3-1-2011. INT. CL. 21.  
3,961,654, PUB. 3-1-2011. INT. CL. 21.
- DIXIE CONSUMER PRODUCTS LLC, ATLANTA, GA:  
2,882,970, CANC. INT. CL. 21.
- DIXON, JACQUELYN D, AUBURN, AL:  
3,961,388, PUB. 3-1-2011. INT. CL. 41.
- DIYN OPTOELECTRONICS CO., LTD., KWEISHAN, TAOYUAN SHIEN, TAIWAN:  
2,882,505, CANC. INT. CL. 9.
- DKRW WIND LLC, HOUSTON, TX:  
3,962,119, INT. CL. 40.
- DLH A/S, DK-2630 TAASTRUP, DENMARK:  
2,881,236, CANC. INT. CL. 19.
- DMC2 DEGUSSA METALS CATALYSTS CERDEC CORPORATION, WASHINGTON, PA TO FERRO CORPORATION, CLEVELAND, OH:  
2,444,691, CANC. MULTIPLE CLASS, INT. CLS. 1, 21 AND 40.
- DNA DISTRIBUTORS, INC., ELGIN, IL:  
3,963,129, INT. CL. 34.
- DNA NATURE RESEARCH, INC., HENDERSON, NC:  
3,962,435, INT. CL. 5.
- DOCUNOWLEDGE, LLC, DAWSONVILLE, GA:  
3,963,480, INT. CL. 9.
- DOGOPOULOS, JAMES, R., HUDSON, NH:  
2,881,719, CANC. INT. CL. 42.
- DOLCE BLEU CORP., CAROLINA, PUERTO RICO:  
3,963,758, INT. CL. 16.
- DOLPHIN DATA, EL MONTE, CA:  
2,383,057, CANC. INT. CL. 35.
- DOMESTICATIONS, LLC, WEEHAWKEN, NJ, HANOVER BRANDS, INC., WEEHAWKEN, NJ:  
2,450,057, REN. 4-9-11. INT. CL. 24.
- DOMINO PRINTING SCIENCES, PLC, CAMBRIDGE CB3 8TU, UNITED KINGDOM:  
1,639,350, REN. 4-8-11. INT. CL. 9.
- DOMPE FARMACEUTICI S.P.A., 20122 MILAN, ITALY:  
2,881,437, CANC. INT. CL. 5.
- DON'S COME BACK, LLC, BLACKWOOD, NJ:  
3,960,224, PUB. 3-1-2011. INT. CL. 3.
- DONALD CREADORE, NEW YORK, NY:  
3,962,692, INT. CL. 45.
- DONALD V. WATKINS, P.C., BIRMINGHAM, AL:  
2,882,137, CANC. INT. CL. 16.
- DONNA S FOSTER, EUGENE, OR, DBA STRAPWORKS:  
3,961,066, PUB. 3-1-2011. INT. CL. 22.
- DONORTREE, LLC, JACKSON, MS:  
3,961,364, PUB. 3-1-2011. INT. CL. 36.
- DOORAE GLOBAL INDUSTRIES CORPORATION, LOS ANGELES, CA:  
2,880,883, CANC. INT. CL. 30.  
2,880,884, CANC. INT. CL. 30.
- DOOSAN CORPORATION, YOUNGDEUNGPO-KU, SEOUL, REPUBLIC OF KOREA:  
2,882,193, CANC. INT. CL. 3.
- DORAL BRANDS, INC., SUNNY ISLES, FL:  
3,380,879, COR. INT. CL. 34.
- DORNIER MEDTECH AMERICA, INC., KENNESAW, GA:  
2,443,926, REN. 4-8-11. INT. CL. 10.
- DORTCH, THOMAS W., JR., ATLANTA, GA:  
2,880,765, CANC. MULTIPLE CLASS, INT. CLS. 35, 36 AND 41.
- DOUGLAS FURNITURE OF CALIFORNIA, LLC, REDONDO BEACH, CA:  
2,880,979, CANC. MULTIPLE CLASS, INT. CLS. 20, 35, 37 AND 40.  
2,880,980, CANC. MULTIPLE CLASS, INT. CLS. 20, 35, 37 AND 40.
- DOWN ISLAND TRADERS, INC., ST. THOMAS, BR. VIRGIN ISLANDS:  
2,383,484, CANC. INT. CL. 18.
- DOWNTOWN DEVELOPMENT BOARD, ORLANDO, FL:  
2,880,813, CANC. INT. CL. 35.
- DOXWOX, LLC, FAIRFAX, VA:  
3,962,328, INT. CL. 9.
- DOYLE, MANON, DUBLIN, OH:  
3,963,081, INT. CL. 16.
- DR PEPPER/SEVEN UP, INC., PLANO, TX:  
2,883,166, CANC. INT. CL. 29.
- DR. BREINL LIFESCIENCE GMBH, FRANKFURT AM MAIN, FED REP GERMANY:  
3,962,961, INT. CL. 32.
- DR. CLARK RESEARCH ASSOCIATION, SAN DIEGO, CA:  
3,960,566, PUB. 3-1-2011. MULTIPLE CLASS, INT. CLS. 5, 10 AND 35.  
3,960,567, PUB. 3-1-2011. MULTIPLE CLASS, INT. CLS. 5, 10 AND 35.  
3,960,572, PUB. 3-1-2011. INT. CL. 11.
- DR. FRANK ARNOLD, SWITZERLAND:  
3,960,780, PUB. 3-1-2011. MULTIPLE CLASS, INT. CLS. 16, 35 AND 41.
- DR. MED. MATTHIAS RATH, SOUTH AFRICA:  
3,960,709, PUB. 3-1-2011. MULTIPLE CLASS, INT. CLS. 5 AND 29.
- DR. REDDY'S LABORATORIES, INC., BRIDGEWATER, NJ:  
3,962,774, INT. CL. 5.
- DR. SLEEPGOOD, INC., OAK PARK, CA:  
3,962,369, MULTIPLE CLASS, INT. CLS. 9 AND 41.
- DR. SLICK CO., BELGRADE, MT:  
3,960,614, PUB. 3-1-2011. INT. CL. 8.  
3,960,615, PUB. 3-1-2011. INT. CL. 8.
- DR. SUWELACK SKIN & HEALTH CARE AG, FED REP GERMANY:  
3,960,667, PUB. 3-1-2011. MULTIPLE CLASS, INT. CLS. 1 AND 5.
- DR. THOMAS C. WHITE, SIOUX FALLS, SD:  
3,963,658, INT. CL. 10.

DRAKE INTERNATIONAL INC., TORONTO, ONTARIO, CANADA:  
3,961,762, PUB. 3-1-2011. MULTIPLE CLASS, INT. CLS. 35 AND 41.

DRAZGA, EDWARD A., MEDFORD, NJ:  
1,659,365. REN. 4-14-11. INT. CL. 3.

DRESSER, INC., ADDISON, TX:  
2,383,540, CANC. INT. CL. 9.  
3,962,313, INT. CL. 7.

DREW - IRELAND LLC, BOSTON, MA:  
3,962,434, INT. CL. 35.

DREW'S LLC, CHESTER, VT:  
3,961,293, PUB. 3-1-2011. INT. CL. 30.

DRIFT-AWAY, LLC, MUSKEGON, MI:  
2,881,434, CANC. INT. CL. 39.

DRINKS INTERNATIONAL MANAGEMENT, INC., CORAL SPRINGS, FL:  
2,881,801, CANC. INT. CL. 35.

DRIP ALERT, INC., MIAMI, FL:  
2,883,401, CANC. INT. CL. 10.

DROSSAPHARM AG, SWITZERLAND:  
3,960,820, PUB. 3-1-2011. INT. CL. 5.

DRUG TEST, INC., HOUSTON, TX:  
2,866,735, COR. MULTIPLE CLASS, INT. CLS. 39, 44 AND 45.

DRUGSTORE.COM, INC., BELLEVUE, WA:  
2,881,513, CANC. INT. CL. 3.

DRUM CIRCLE DISTILLING, LLC, SARASOTA, FL:  
3,963,885, INT. CL. 33.

DRY DOC VELVET COMPANY, INC., BROWNSBURG, IN:  
2,382,970, CANC. INT. CL. 5.

DSR, INC., KINGSBURG, CA:  
3,963,508, INT. CL. 9.

DTL, INC., PALM SPRINGS, CA:  
2,882,996, CANC. INT. CL. 5.

DTS LICENSING LIMITED, CLARE, IRELAND:  
2,880,961, CANC. INT. CL. 9.  
2,880,962, CANC. INT. CL. 9.  
2,880,963, CANC. INT. CL. 9.

DUAL MACHINE CORPORATION, INDIANAPOLIS, IN, KLINCHER LOCKNUT CORPORATION, INDIANAPOLIS, IN:  
713,769. REN. 4-9-11. U.S. CL. 13 (INT. CL. 31).

DUBUQUE RACING ASSOCIATION, LTD., DUBUQUE, IA:  
2,881,305, CANC. INT. CL. 41.

DUCA DI SALAPARUTA S.P.A., MARSALA (TRAPANI), ITALY:  
3,962,835, INT. CL. 33.

DUCANE R & D PTY LTD, SANDY BAY, TAS, AUSTRALIA:  
3,960,328, PUB. 3-1-2011. INT. CL. 11.

DUE VOCI LLC, BURBANK, CA:  
3,962,980, INT. CL. 41.

DUERR AND TIERNEY, LTD., MINNETONKA, MN:  
2,495,897. REN. 4-13-11. INT. CL. 16.

DUMORE CORPORATION, MAUSTON, WI:  
1,154,562. REN. 4-9-11. INT. CL. 7.

DUNCAN GALVANIZING CORPORATION, EVERETT, MA:  
2,882,959, CANC. INT. CL. 40.

DUNCAN, DAVID, SANTA CLARITA, CA:  
2,881,004, CANC. INT. CL. 24.

DUNDEE CORPORATION, TORONTO, ONTARIO, CANADA:  
3,960,626, PUB. 3-1-2011. MULTIPLE CLASS, INT. CLS. 9 AND 36.

DUNLOP SPORTS GROUP AMERICAS INC., WESTMINSTER, SC:  
2,384,071, CANC. INT. CL. 28.

DUNN-RITE PRODUCTS, INC., ELWOOD, IN:  
3,962,368, INT. CL. 7.

DUOTECH SALES, LLC, BLOOMINGDALE, IL:  
2,881,631, CANC. INT. CL. 1.

DUPLO USA CORPORATION, SANTA ANA, CA:  
2,382,453, CANC. INT. CL. 7.

DURGA, GARY, MARLBORO, NJ, TA SUPERVATIONS LLC:  
3,962,743, INT. CL. 3.

DUSZA, STEVEN WAYNE, DONIPHAN, MO:  
3,961,640, PUB. 3-1-2011. INT. CL. 28.

DWYER INSTRUMENTS, INC., MICHIGAN CITY, IN:  
3,962,249, INT. CL. 9.

DX/DY VOICE PROCESSING, INC., SPOKANE, WA:  
2,881,136, CANC. INT. CL. 38.

DYNACRAFT BSC, INC., AMERICAN CANYON, CA:  
2,456,462. REN. 4-13-11. INT. CL. 12.  
2,483,590. REN. 4-9-11. INT. CL. 12.  
3,961,441, PUB. 3-1-2011. INT. CL. 12.  
3,961,808, PUB. 3-1-2011. INT. CL. 12.  
3,961,862, PUB. 3-1-2011. INT. CL. 12.  
3,961,887, PUB. 3-1-2011. INT. CL. 12.  
3,961,888, PUB. 3-1-2011. INT. CL. 12.  
3,961,889, PUB. 3-1-2011. INT. CL. 12.  
3,961,906, PUB. 3-1-2011. INT. CL. 12.

DYNO NOBEL INC., SALT LAKE CITY, UT:  
2,383,728, CANC. INT. CL. 13.

D5 FASHION VOF, AMSTELVEEN, NETHERLANDS:  
2,882,978, CANC. INT. CL. 25.

E. F. JOHNSON COMPANY, WASECA, MN:  
1,640,291. REN. 4-12-11. INT. CL. 9.

E. LAND LTD., SEOUL, REPUBLIC OF KOREA:  
2,882,324, CANC. INT. CL. 25.

E. LAND WORLD LTD., SEOUL, REPUBLIC OF KOREA:  
2,881,912, CANC. INT. CL. 25.

E. REMY MARTIN & C<sup>o</sup>, COGNAC, FRANCE:  
3,960,690, PUB. 3-1-2011. INT. CL. 33.

E.W. BRANDT & SONS, INC., WAPATO, WA:  
2,883,416, CANC. INT. CL. 31.

E! ENTERTAINMENT TELEVISION, INC., LOS ANGELES, CA:  
2,881,075, CANC. INT. CL. 41.

E&O INC., MINNEAPOLIS, MN, DBA TRANSBIKE SYSTEMS:  
2,882,838, CANC. MULTIPLE CLASS, INT. CLS. 12 AND 42.

E-BENK TECH. CO., LTD., TAIPEI HSIEN, TAIWAN:  
2,882,473, CANC. INT. CL. 9.

E-LYTE INC, MILLVILLE, NJ:  
2,883,426, CANC. INT. CL. 5.

E-ONE MOLI ENERGY CORP., SHANHUA TOWNSHIP, TAINAN COUNTY 741, TAIWAN:  
2,447,636. REN. 4-13-11. INT. CL. 9.

E-RATE MANAGEMENT PROFESSIONALS ASSOCIATION, INC., ADA, OK:  
3,961,211, PUB. 3-1-2011. U.S. CL. 200.

E-SIM LTD., JERUSALEM 91450, ISRAEL:  
2,881,950, CANC. MULTIPLE CLASS, INT. CLS. 35, 36 AND 42.

EAGLE IMPORTS, INC., WANAMASSA, NJ:  
3,961,653, PUB. 3-1-2011. MULTIPLE CLASS, INT. CLS. 13 AND 25.

EAGLE RESEARCH CORPORATION, SCOTT DEPOT, WV:  
2,880,918, CANC. INT. CL. 9.

EAGLE TEST SYSTEMS, INC., NORTH READING, MA:  
2,881,103, CANC. INT. CL. 9.  
2,881,104, CANC. INT. CL. 9.

EARLE, DAVID, WATSONVILLE, CA:  
3,962,406, INT. CL. 12.

EARLY ALZHEIMER'S FOUNDATION, INC., NEW YORK, NY:  
3,962,149, MULTIPLE CLASS, INT. CLS. 9, 16, 36, 41 AND 44.

EARLY TIMES DISTILLERS COMPANY, LOUISVILLE, KY:  
2,881,626, CANC. INT. CL. 33.  
3,963,117, INT. CL. 33.  
3,963,402, INT. CL. 33.

EARTH DAY NEW YORK, NEW YORK, NY:  
3,935,381, COR. INT. CL. 35.  
3,935,382, COR. INT. CL. 35.

EARTHLUST LLC, SAN FRANCISCO, CA:  
3,962,872, MULTIPLE CLASS, INT. CLS. 10 AND 21.

EAST HEAVEN CO., LTD., JAPAN:  
3,960,815, PUB. 3-1-2011. INT. CL. 43.

EAST SIDE ENTREES, INC., WOODBURY, NY:  
3,962,860, MULTIPLE CLASS, INT. CLS. 29 AND 30.

EASTMAN CHEMICAL COMPANY, KINGSPORT, TN:  
2,881,489, CANC. INT. CL. 42.

- EASY KARAOKE LIMITED, HERTFORDSHIRE, WATFORD WD18 9SB, UNITED KINGDOM:  
2,881,522, CANC. MULTIPLE CLASS, INT. CLS. 9, 38 AND 41.
- EASY TRAY, LLC, NORTH CHARLESTON, SC:  
2,883,034, CANC. INT. CL. 21.
- EASYMAIL INTERACTIVE, INC., CINCINNATI, OH, DBA EMI ONLINE RESEARCH SOLUTIONS:  
3,961,582, PUB. 3-1-2011. INT. CL. 35.
- EAZYPOWER CORPORATION, CHICAGO, IL:  
2,442,438. REN. 4-12-11. INT. CL. 20.
- EBSCO INDUSTRIES, INC., BIRMINGHAM, AL:  
2,555,438. REN. 4-8-11. INT. CL. 16.  
3,961,305, PUB. 3-1-2011. INT. CL. 28.
- ECCO HEATING PRODUCTS LTD., EDMONTON, ALBERTA, CANADA:  
3,961,129, PUB. 3-1-2011. INT. CL. 6.
- ECCO SKO A/S, DK-6261 BREDEBRO, DENMARK:  
2,881,761, CANC. INT. CL. 25.
- ECNORROT, L.L.C., ASHBURN, VA:  
2,880,859, CANC. INT. CL. 25.
- ECOLINK, INC., STONE MOUNTAIN, GA:  
2,383,252, CANC. INT. CL. 3.
- ECOLO ODOR CONTROL TECHNOLOGIES INC., TORONTO, ONTARIO, CANADA, ECOLO ODOR CONTROL SYSTEMS INC., MISSISSAUGA, ONTARIO, CANADA:  
1,636,633. REN. 4-8-11. INT. CL. 5.
- ECOMIS LTD, PINNER, UNITED KINGDOM:  
2,881,838, CANC. MULTIPLE CLASS, INT. CLS. 9 AND 42.
- ECOMMERCE INDUSTRIES, INC., LEESBURG, VA:  
2,882,377, CANC. INT. CL. 9.
- ECOSOURCE, LLC, ARNOLD, MD:  
3,963,555, INT. CL. 35.
- ECOWATER SYSTEMS LLC, WOODBURY, MN:  
3,962,532, INT. CL. 11.
- EDGENICS, INC., EDISON, NJ:  
2,882,391, CANC. INT. CL. 45.
- EDITFASHION LLC, NEW YORK, NY:  
3,962,023, INT. CL. 25.
- EDMONDS FAMILY MEDICINE CLINIC, PS, EDMONDS, WA:  
3,961,612, PUB. 3-1-2011. INT. CL. 44.  
3,961,613, PUB. 3-1-2011. INT. CL. 44.
- EDROVER INC., STEVENSON RANCH, CA:  
3,961,645, PUB. 3-1-2011. INT. CL. 9.
- EDUCATION CENTER, INC., THE, GREENSBORO, NC:  
2,509,222. REN. 4-9-11. INT. CL. 16.
- EDUCATION MANAGEMENT LLC, PITTSBURGH, PA:  
2,880,785, CANC. INT. CL. 41.
- EDUCATIONDYNAMICS, LLC, HOBOKEN, NJ:  
2,470,525. REN. 4-8-11. INT. CL. 35.  
2,537,155. REN. 4-8-11. INT. CL. 35.
- EDWARD D. SCHMIDT, SAN FRANCISCO, CA:  
3,962,964, INT. CL. 35.
- EDWARD INTERNATIONAL USA, INC., ARCADIA, CA:  
2,881,037, CANC. INT. CL. 5.
- EDWARDS AND KELCEY, INC., MORRISTOWN, NJ:  
2,382,162, CANC. INT. CL. 42.
- EDWARDS LIFESCIENCES AG, ST. PREX, SWITZERLAND:  
2,383,831, CANC. INT. CL. 10.
- EDWARDS, JON SCOTT, VENICE, CA:  
2,881,699, CANC. INT. CL. 15.
- EENIE MEENIE MINEY MOE, PARKER, CO:  
3,962,925, INT. CL. 28.
- EFFIE WORLDWIDE, INC., NEW YORK, NY:  
2,383,449, CANC. INT. CL. 41.
- EFT SOURCE, INC., NASHVILLE, TN:  
3,963,560, INT. CL. 40.
- EFTEC NORTH AMERICA LLC, TROY, MI:  
2,383,984, CANC. INT. CL. 17.
- EGGERSMANN, KARLGÜNTNER, MARIENFELD, FED REP GERMANY:  
3,960,441, PUB. 3-1-2011. MULTIPLE CLASS, INT. CLS. 6, 7, 11, 37, 40 AND 42.
- EHELP CORPORATION, SAN DIEGO, CA:  
2,881,638, CANC. INT. CL. 9.
- EHLER, SHELLY, LADERA RANCH, CA:  
3,961,054, PUB. 3-1-2011. INT. CL. 24.
- EHLERS, SHAWN, NEW YORK, NY:  
3,961,760, PUB. 3-1-2011. INT. CL. 41.
- EICHHORN, ANDREW, CARMEL, NY AND GUKELBERGER, TODD, CARMEL, NY:  
3,961,580, PUB. 3-1-2011. INT. CL. 9.
- EIMCO WATER TECHNOLOGIES, LLC, SALT LAKE CITY, UT:  
2,882,446, CANC. INT. CL. 11.
- EISAI R&D MANAGEMENT CO., LTD., TOKYO, JAPAN:  
3,962,019, INT. CL. 5.
- EL ENCANTO, INC., ALBUQUERQUE, NM:  
3,960,577, PUB. 3-1-2011. INT. CL. 30.
- EL-GEN LLC, BOHEMIA, NY, DBA ALIMENTAL SCIENCE:  
3,962,942, INT. CL. 5.
- ELAN PHARMA INTERNATIONAL LIMITED, SHANNON, COUNTY CLARE, IRELAND:  
2,881,326, CANC. INT. CL. 5.
- ELAN-POLO, INC., NASHVILLE, TN:  
3,963,641, INT. CL. 25.  
3,963,689, INT. CL. 25.  
3,963,701, INT. CL. 25.
- ELATINFOOD, L.L.C., DALLAS, TX:  
3,960,313, PUB. 3-1-2011. MULTIPLE CLASS, INT. CLS. 30, 35 AND 43.
- ELBORNE MITCHELL, LONDON, UNITED KINGDOM:  
2,881,498, CANC. INT. CL. 42.
- ELECTRIC MOBILITY CORPORATION, SEWELL, NJ, DBA THE RASCAL COMPANY:  
3,962,817, INT. CL. 12.
- ELECTROCORE LLC, MORRIS PLAINS, NJ:  
3,962,524, INT. CL. 10.
- ELECTRONIC ARTS INC., REDWOOD CITY, CA:  
3,962,215, INT. CL. 41.
- ELECTRONIC CONCEPTS INC., EATONTOWN, NJ:  
1,166,274. REN. 4-13-11. INT. CL. 9.
- ELECTROTANK, INC., RALEIGH, NC:  
2,881,491, CANC. INT. CL. 9.  
2,881,492, CANC. INT. CL. 9.
- ELF MAGIC, LLC, ATLANTA, GA:  
3,961,691, PUB. 3-1-2011. INT. CL. 28.  
3,961,692, PUB. 3-1-2011. INT. CL. 28.
- ELI'S CHEESECAKE COMPANY, THE, CHICAGO, IL, ELI'S CHEESECAKE COMPANY, THE, CHICAGO, IL:  
2,443,360. REN. 4-12-11. INT. CL. 35.
- ELIJAH LIST PUBLICATIONS, LLC, ALBANY, OR, AKA THE ELIJAH LIST:  
3,963,380, INT. CL. 9.
- ELIKING TECH & ENTERPRISES, LAS VEGAS, NV:  
3,963,697, INT. CL. 10.
- ELIOT HOTEL, INC., BOSTON, MA:  
3,961,860, PUB. 3-1-2011. INT. CL. 43.
- ELIPSE SOFTWARE CORPORATION, RALEIGH, NC:  
3,961,797, PUB. 3-1-2011. INT. CL. 9.
- ELITE CARE MANAGEMENT GROUP, LLC., PORTLAND, OR:  
3,961,589, PUB. 3-1-2011. INT. CL. 44.
- ELITE MODEL MANAGEMENT CORPORATION, NEW YORK, NY:  
1,155,834. REN. 4-13-11. INT. CL. 35.
- ELITE PROTECTIVE & INVESTIGATIVE SERVICES GROUP, INC., ANAHEIM, CA:  
2,882,452, CANC. INT. CL. 45.
- ELITE SPORTING EVENTS, INC., HOT SPRINGS, AR:  
3,961,869, PUB. 3-1-2011. INT. CL. 41.
- ELKHORN TECHNICAL RESOURCES, INC., LAKEWOOD, CO, DBA ELKHORN HEATING & AIR CONDITIONING, INC.:  
3,961,106, PUB. 3-1-2011. INT. CL. 37.
- ELKHORN TECHNICAL RESOURCES, INC., LAKEWOOD, CO, DBA ELKHORN ELECTRIC, INC.:  
3,961,786, PUB. 3-1-2011. INT. CL. 37.
- ELLEN CURTIS, TEMPLETON, CA:  
3,963,687, INT. CL. 32.
- ELLIOTT & PAGE LIMITED, TORONTO, ONTARIO, CANADA:  
3,960,636, PUB. 3-1-2011. MULTIPLE CLASS, INT. CLS. 35

- AND 36.
- ELMASSIAN, DIKRAN A., MONROVIA, CA, DBA DHARMA JEWELRY DESIGNS AND DEVES, ANTONIS, MONROVIA, CA, DBA DHARMA JEWELRY DESIGNS:  
3,960,531, PUB. 3-1-2011. INT. CL. 14.
- ELSTER NV/SA, BELGIUM:  
3,960,694, PUB. 3-1-2011. INT. CL. 9.  
3,960,695, PUB. 3-1-2011. INT. CL. 9.  
3,960,696, PUB. 3-1-2011. INT. CL. 9.  
3,960,697, PUB. 3-1-2011. INT. CL. 9.  
3,960,698, PUB. 3-1-2011. INT. CL. 9.
- ELVA PRODUCE, LLC, NOGALES, AZ:  
3,962,286, INT. CL. 31.
- ELYSEE SCIENTIFIC COSMETICS, INC., MADISON, WI:  
2,881,949, CANC. INT. CL. 3.
- EMANATION, INC., NEW ORLEANS, LA:  
2,881,688, CANC. INT. CL. 28.
- EMC CORPORATION, HOPKINTON, MA:  
2,382,750, CANC. MULTIPLE CLASS, INT. CLS. 9 AND 42.
- EMC CORPORATION, HOPKINTON, MO:  
2,382,756, CANC. MULTIPLE CLASS, INT. CLS. 9 AND 42.
- EMCO CHEMICAL DISTRIBUTORS, INC., NORTH CHICAGO, IL:  
3,962,067, MULTIPLE CLASS, INT. CLS. 39, 40 AND 42.
- EMCO WHEATON CORP., OAKVILLE (ONTARIO), CANADA:  
3,960,295, PUB. 3-1-2011. INT. CL. 6.
- EMERALD CITY BEER COMPANY, LLC, SEATTLE, WA:  
3,963,481, INT. CL. 32.
- EMERGE MEDICAL, INC., DENVER, CO:  
3,961,032, PUB. 3-1-2011. INT. CL. 10.
- EMERGO (CYPRUS) LIMITED, NICOSIA, CYPRUS:  
3,963,280, MULTIPLE CLASS, INT. CLS. 35 AND 36.
- EMERSONCADE HOLDINGS, LLC, LAKEWOOD, CO:  
2,881,474, CANC. INT. CL. 36.
- EMI (IP) LIMITED, UNITED KINGDOM:  
3,960,795, PUB. 3-1-2011. MULTIPLE CLASS, INT. CLS. 9, 16, 18, 25, 38, 41 AND 42.
- EMIFINANCIAL CORPORATION, WALNUT PARK, CA:  
2,880,950, CANC. INT. CL. 36.
- EMIGRANT BANCORP., INC., NEW YORK, NY:  
3,963,815, INT. CL. 36.
- EMILY, BURSON, M, SANTA MONICA, CA:  
2,882,931, CANC. INT. CL. 44.
- EMMIS PUBLISHING, L.P., INDIANAPOLIS, IN:  
2,881,560, CANC. INT. CL. 16.  
3,961,951, PUB. 3-1-2011. MULTIPLE CLASS, INT. CLS. 16 AND 41.
- EMONT, GEORGE, D., LOUISVILLE, KY:  
2,882,902, CANC. INT. CL. 36.
- EMPIRE FORD, INC., SPOKANE, WA:  
2,882,470, CANC. INT. CL. 35.
- EMPIRE GOLF MANAGEMENT LLC, NEW CITY, NY:  
2,882,048, CANC. MULTIPLE CLASS, INT. CLS. 41 AND 42.
- EMPLOYEE RELOCATION COUNCIL, INC., WASHINGTON, D.C., DC:  
3,960,437, PUB. 3-1-2011. U.S. CL. B.  
3,960,438, PUB. 3-1-2011. U.S. CL. B.
- EMPOWERTEK LLC, ROCHESTER, NY:  
2,883,170, CANC. INT. CL. 42.
- EMSEAL JOINT SYSTEMS LTD, WESTBOROUGH, MA:  
3,962,698, MULTIPLE CLASS, INT. CLS. 17 AND 19.
- EMU AMERICA'S, LLC, BRIDGEPORT, CT:  
2,881,911, CANC. MULTIPLE CLASS, INT. CLS. 20 AND 35.
- ENCOMPASS COMMUNICATIONS, LLC, LONGVIEW, TX:  
3,962,272, INT. CL. 36.
- ENCORE SOFTWARE, INC., EL SEGUNDA, CA:  
3,962,551, INT. CL. 9.
- ENERDRINKS NOROESTE, S.L., 15705 SANTIAGO DE COMPOSTELA (A CORUNA), SPAIN:  
2,882,464, CANC. INT. CL. 32.
- ENERGY CURTAILMENT SPECIALISTS, INC., BUFFALO, NY:  
3,962,372, MULTIPLE CLASS, INT. CLS. 35 AND 36.
- ENGENIUS, INC., LIVONIA, MI:  
2,383,854, CANC. INT. CL. 9.
- ENLISTED ASSOCIATION OF THE NATIONAL GUARD OF THE UNITED STATES, ALEXANDRIA, VA:  
2,880,692, CANC. U.S. CL. 200.
- ENRIQUEZ, JESUS R., TUCSON, AZ:  
3,963,089, INT. CL. 20.
- ENSEO, INC., RICHARDSON, TX:  
3,961,643, PUB. 3-1-2011. INT. CL. 9.
- ENSOL, L.L.C., BETHANY, OK:  
2,433,815, REN. 4-9-11. INT. CL. 40.
- ENTERPRISE HOLDINGS, INC., ST. LOUIS, MO:  
3,961,701, PUB. 3-1-2011. INT. CL. 39.
- ENTRIGUE SURGICAL, INC., SAN ANTONIO, TX:  
3,962,077, INT. CL. 10.
- ENTWICKLUNGSGESELLSCHAFT FUR AKUSTIK (EFA) MIT BESCHRANKTER HAFTUNG, WITTEN, FED REP GERMANY:  
2,818,847, CANC. INT. CL. 27.
- ENVI NETWORKS, INC., ANDOVER, MA:  
3,960,327, PUB. 3-1-2011. INT. CL. 42.
- ENVIRON SKIN CARE (PROPRIETARY) LIMITED, WESTERN CAPE, SOUTH AFRICA:  
3,960,634, PUB. 3-1-2011. INT. CL. 3.
- ENVIRON-OPW, INC., HAMILTON, OH:  
2,882,421, CANC. INT. CL. 17.  
2,882,459, CANC. INT. CL. 17.
- ENVIRONMENTAL TILLAGE SYSTEMS, INC., FARBULT, MN:  
3,962,436, INT. CL. 7.
- ENVIRONOMICS COMMUNICATIONS, INC., SCHAUMBURG, IL:  
3,962,569, INT. CL. 41.
- EORIGINAL, INC., BALTIMORE, MD:  
2,881,176, CANC. MULTIPLE CLASS, INT. CLS. 9, 38 AND 39.
- EP&A ENVIROTAC, INC., LA QUINTA, CA:  
3,961,630, PUB. 3-1-2011. INT. CL. 1.
- EPALS, INC., HERNDON, VA:  
3,961,178, PUB. 3-1-2011. INT. CL. 35.
- EPIC METALS CORPORATION, RANKIN, PA:  
2,485,995, REN. 4-14-11. INT. CL. 6.
- EPIMED INTERNATIONAL, INC., JOHNSTOWN, NY:  
3,961,541, PUB. 3-1-2011. INT. CL. 10.
- EPIX HOLDINGS CORPORATION, NEW YORK, NY:  
2,881,078, CANC. INT. CL. 41.
- EPPENDORF AG, HAMBURG, FED REP GERMANY:  
3,962,446, INT. CL. 9.
- EQUITRAC CORPORATION, CORAL GABLES, FL:  
2,881,766, CANC. INT. CL. 9.
- ERBAK-ULUDAG MESRUBAT VE GIDA SANAYI ANONIM SIRKETI, BURSA, TURKEY:  
2,971,403, CANC. INT. CL. 30.
- ERIC BRENTON SADREAMELI, LEXINGTON, SC, DBA MR. B'S AUTHENTIC BOTTLENECK SLIDES:  
3,960,342, PUB. 3-1-2011. INT. CL. 15.
- ERIC FORBIS, ALEXANDRIA, VA AND GABRIEL RIERA, ARLINGTON, VA:  
3,963,766, INT. CL. 41.
- ERIC JACOBSON, MENASHA, WI:  
3,962,333, INT. CL. 9.
- ERIC MARAIS, FONTENAY SOUS BOIS, FRANCE:  
3,961,014, PUB. 3-1-2011. INT. CL. 9.
- ERICO INTERNATIONAL CORPORATION, SOLON, OH, ERICO PRODUCTS, INC., SOLON, OH:  
1,155,333, REN. 4-9-11. INT. CL. 7.
- ERIK'S DELICAFE, INC., SANTA CRUZ, CA:  
3,961,781, PUB. 3-1-2011. INT. CL. 30.
- ERM II, L.P., CHATTANOOGA, TN:  
2,444,525, REN. 4-14-11. INT. CL. 37.  
2,444,526, REN. 4-14-11. INT. CL. 42.
- ERNEMANN DESIGN GMBH, 12247 BERLIN, FED REP GERMANY:  
3,960,737, PUB. 3-1-2011. INT. CL. 25.
- EROSION PREVENTION PRODUCTS, LLC, HOUSTON, TX:  
3,961,982, INT. CL. 19.
- ESAYIAN, DEBORAH, RIVERSIDE, IL:  
2,883,060, CANC. INT. CL. 28.



- ESE INC., BROOKLYN, NY:  
3,960,504, PUB. 3-1-2011. INT. CL. 24.
- ESHOP CONSULTING INC., ORLANDO, FL:  
2,881,800, CANC. INT. CL. 35.
- ESPINO, PAUL, LOS ANGELES, CA:  
3,961,246, PUB. 3-1-2011. INT. CL. 25.
- ESPLANADE CAPITAL LLC, BOSTON, MA:  
3,962,123, INT. CL. 36.
- ESSENTIALLY BASIC, LLC, MIDWAY, UT:  
3,962,977, INT. CL. 3.
- ESSEX P.B. & R. CORP., ST. LOUIS, MO:  
2,883,204, CANC. INT. CL. 9.
- ESSEX TECHNOLOGY GROUP, INC., NASHVILLE, TN:  
3,961,518, PUB. 3-1-2011. INT. CL. 35.
- ESSILOR INTERNATIONAL (COMPAGNIE GENERALE D'OPTIQUE), FRANCE:  
3,960,720, PUB. 3-1-2011. MULTIPLE CLASS, INT. CLS. 9 AND 40.
- ESTES, CINDY, BELMONT, MA:  
3,962,635, INT. CL. 25.
- ESTILOS MODERNOS DEL BAJIO, S.A. DE C.V., GUANAJUATO C.P., MEXICO:  
2,880,990, CANC. INT. CL. 25.
- ETHICON ENDO-SURGERY, INC., CINCINNATI, OH:  
2,880,706, CANC. MULTIPLE CLASS, INT. CLS. 40 AND 42.
- ETHNIC TOPS, FREMONT, CA, CA:  
3,960,960, PUB. 3-1-2011. INT. CL. 25.
- ETHNOMEDICINE PRESERVATION PROJECT, BOULDER, CO:  
3,961,074, PUB. 3-1-2011. INT. CL. 5.
- ETI GIDA; SANAYI VE TICARET ANONIM SIRKETI, TURKEY:  
3,960,681, PUB. 3-1-2011. INT. CL. 30.
- EUGENIO COLLAVINI VITICOLTORI S.P.A., CORNO DI ROSSAZZO, ITALY:  
3,694,811, COR. INT. CL. 33.
- EUREKA SPRINGS CITY ADVERTISING AND PROMOTIONS COMMISSION, EUREKA SPRINGS, AR:  
3,960,905, PUB. 3-1-2011. U.S. CL. B.
- EURESCOM-EUROPEAN INSTITUTE; FOR RESEARCH AND STRATEGIC STUDIES; IN TELECOMMUNICATION-GMBH, 6900 HEIDELBERG 1, FED REP GERMANY:  
3,960,642, PUB. 3-1-2011. MULTIPLE CLASS, INT. CLS. 9, 38 AND 42.
- EURISKO CORPORATION, TARZANA, CA:  
2,881,397, CANC. INT. CL. 42.
- EURO SOURCE GOURMET, LLC, CEDAR GROVE, NJ:  
2,881,193, CANC. INT. CL. 35.
- EUROBUBBLIES, INC., ASHLAND, MA:  
2,881,837, CANC. INT. CL. 29.
- EUROCRAFT INDUSTRIES, INC., LARGO, FL:  
3,962,414, MULTIPLE CLASS, INT. CLS. 6 AND 19.
- EUROGENTEC S.A., B-4102 SERAING, BELGIUM:  
3,960,662, PUB. 3-1-2011. INT. CL. 1.
- EUROTA CORPORATION, TAIPEI, TAIWAN:  
3,963,172, INT. CL. 6.
- EUROTALK LIMITED, UNITED KINGDOM:  
3,960,808, PUB. 11-23-2010. INT. CL. 9.
- EUROTECH WHEELS, LLC, SAN DIEGO, CA:  
3,960,491, PUB. 1-25-2011. INT. CL. 12.
- EVA-GLORY INDUSTRIAL CO., LTD., TAICHUNG COUNTY, TAIWAN:  
3,962,926, INT. CL. 17.
- EVENT MEDICAL INC., SAN CLEMENTE, CA:  
3,962,578, INT. CL. 10.
- EVENT NAVIGATORS, LLC, GLADWYNE, PA:  
3,963,845, INT. CL. 41.
- EVENTION, INC., GLEN ROCK, NJ:  
2,442,767, REN. 4-12-11. INT. CL. 41.  
2,444,483, REN. 4-12-11. INT. CL. 41.
- EVER AFTER FARM, INC., EL DORADO, KS:  
3,963,035, INT. CL. 44.
- EVER FRESH FRUIT COMPANY, SANDY, OR:  
2,383,430, CANC. INT. CL. 31.
- EVERETT, JOHN NICHOLAS, LUTTERWORTH, LEICESTERSHIRE, UNITED KINGDOM:  
2,881,558, CANC. MULTIPLE CLASS, INT. CLS. 9, 16 AND 28.
- EVERFAST, INC., KENNETT SQUARE, PA:  
2,382,356, CANC. MULTIPLE CLASS, INT. CLS. 22, 24 AND 35.
- EVERSHEDS LEGAL SERVICES LIMITED, LONDON EC4V 4JL, UNITED KINGDOM:  
2,447,419, REN. 4-13-11. MULTIPLE CLASS, INT. CLS. 16, 36, 41 AND 42.  
2,447,420, REN. 4-13-11. MULTIPLE CLASS, INT. CLS. 16, 36, 41 AND 42.
- EVERYTHING CABINS, LLC, KNOXVILLE, TN:  
3,961,336, PUB. 3-1-2011. INT. CL. 35.
- EVERYTHING GREEN HYDROPONICS, LLC, RENO, NV:  
3,960,964, PUB. 3-1-2011. MULTIPLE CLASS, INT. CLS. 11 AND 35.
- EVOLVED NOVELTIES, INC., CANOGA PARK, CA, DBA EVOLVED NOVELTIES:  
3,963,636, INT. CL. 3.
- EVONIK DEGUSSA GMBH, FED REP GERMANY:  
3,960,757, PUB. 3-1-2011. MULTIPLE CLASS, INT. CLS. 1, 2, 9, 10, 11, 19, 21 AND 40.
- EVRIHOLDER PRODUCTS LLC, ANAHEIM, CA:  
3,963,793, INT. CL. 21.
- EWM BRAND HOLDINGS, LLC, IRVING, TX:  
3,871,194, COR. INT. CL. 41.
- EXACT CHANGE ONLY CORPORATION, NEW YORK, NY:  
2,882,472, CANC. INT. CL. 25.
- EXCITE IT PARTNERS, LLC, PERRY HALL, MD:  
3,963,038, INT. CL. 35.
- EXCLUSIVELY PET, INC., MILWAUKEE, WI:  
2,882,000, CANC. INT. CL. 31.
- EXECUTIVE FUSION, INC., NEWPORT NEWS, VA:  
3,960,509, PUB. 3-1-2011. INT. CL. 16.
- EXEMPLAR CAPITAL MANAGEMENT, LLC, NEW YORK, NY:  
2,882,414, CANC. INT. CL. 36.
- EXIDE TECHNOLOGIES, MILTON, GA, EXIDE CORPORATION, READING, PA:  
1,658,819, REN. 4-13-11. INT. CL. 9.
- EXMARK MANUFACTURING COMPANY INCORPORATED, BEATRICE, NE:  
3,961,899, PUB. 3-1-2011. INT. CL. 7.
- EXPEDIA, INC., REDMOND, WA TO EXPEDIA, INC., REDMOND, WA:  
2,383,732, CANC. INT. CL. 16.
- EXPERIENCE LEARNING COMMUNITY, SEATTLE, WA, EXPERIENCE LEARNING COMMUNITY, SEATTLE, WA:  
2,490,993, REN. 4-8-11. INT. CL. 25.
- EXPLORIA PRODUCTIONS, LLC, HARTFORD, CT:  
2,881,094, CANC. INT. CL. 9.
- EXPOMIX CORPORATION, BARRINGTON, IL:  
2,881,668, CANC. INT. CL. 1.
- EXPRESION Y COMUNICACION EDITORES S.A., BOGOTA, COLOMBIA:  
2,882,424, CANC. INT. CL. 16.
- EXPRESS, LLC, COLUMBUS, OH:  
2,882,940, CANC. INT. CL. 25.
- EXTANG CORPORATION, ANN ARBOR, MI:  
3,962,999, INT. CL. 12.
- EXTERMITAL TERMITE SERVICE OF DAYTON, INC., DAYTON, OH, EXTERMITAL CHEMICALS, INC., DAYTON, OH:  
924,017, REN. 4-11-11. U.S. CL. 103 (INT. CL. 37).  
924,018, REN. 4-11-11. U.S. CL. 103 (INT. CL. 37).
- EXTRA SPACE STORAGE LLC, SALT LAKE CITY, UT:  
2,495,324, REN. 4-11-11. INT. CL. 39.
- EXTRASTRENGTH INTERNATIONAL, SANTA CRUZ, CA:  
2,382,418, CANC. INT. CL. 25.
- EXTREME REALITY LTD., HERZELIYA PITUACH, ISRAEL:  
3,962,170, INT. CL. 9.
- EXTRUSION LLC, ALPHARETTA, GA:  
2,882,576, CANC. INT. CL. 20.
- EXXON MOBIL CORPORATION, IRVING, TX:  
3,960,414, PUB. 3-1-2011. MULTIPLE CLASS, INT. CLS. 4



AND 35.  
 EXXONMOBIL OIL CORPORATION, IRVING, TX:  
 2,882,482, CANC. INT. CL. 14.  
 EYE CAN HEAR, LLC, TAMPA, FL:  
 3,961,195, PUB. 3-1-2011. INT. CL. 44.  
 3,961,702, PUB. 3-1-2011. INT. CL. 44.  
 EYE Q EYEWEAR CORPORATION, HOLLISTON, MA:  
 2,881,262, CANC. INT. CL. 9.  
 EYEFIVE, INC., VAN NUYS, CA:  
 2,881,762, CANC. INT. CL. 5.  
 EYGN LIMITED, NASSAU, BAHAMAS:  
 2,882,213, CANC. MULTIPLE CLASS, INT. CLS. 36 AND 41.  
 EZ SURGICAL LTD., YOKENAM 20692, ISRAEL:  
 3,963,185, INT. CL. 10.  
 EZNAP INC., RENO, NV:  
 3,962,657, INT. CL. 24.  
 E3 PERFORMANCE GROUP, LLC, CROSS PLAINS, TN:  
 3,961,517, PUB. 3-1-2011. INT. CL. 35.  
 E4 BEVERAGES LLC, ADELL, WI:  
 3,961,652, PUB. 3-1-2011. INT. CL. 32.  
 F ONE SARL, LATTES, FRANCE:  
 3,961,883, PUB. 3-1-2011. MULTIPLE CLASS, INT. CLS. 9, 12, 18, 22, 25 AND 28.  
 F. L. NAVARRO LTD, BROOKLYN, NY, DBA THE ARTISAN COLLECTION:  
 3,962,756, INT. CL. 33.  
 F. SCHUMACHER & CO., NEW YORK, NY:  
 2,881,858, CANC. INT. CL. 27.  
 F.B.T. ENTERPRISES, INC., ROME, GA:  
 3,961,708, PUB. 3-1-2011. INT. CL. 12.  
 FABRICA DE APARATOS DE AIRE ACONDICIONADO (F.A.A.C.A.), CARACAS, VENEZUELA:  
 1,638,997, REN. 4-12-11. INT. CL. 11.  
 FACADE, INC., HOUSTON, TX:  
 2,882,643, CANC. INT. CL. 3.  
 FACONNABLE SAS, NICE, FRANCE:  
 2,882,147, CANC. INT. CL. 14.  
 FADNER MEDIA ENTERPRISES LLC, WESTPORT, CT, DBA MEDIAPOST COMMUNICATIONS:  
 2,572,754, CANC. INT. CL. 35.  
 FAIRMONT HOLDINGS, INC., DANIA, FL:  
 3,963,167, INT. CL. 34.  
 FALT FISHERIES, INC., OMAHA, NE:  
 1,150,717, REN. 4-12-11. INT. CL. 42.  
 FANBOX, INC., SAN DIEGO, CA:  
 3,960,505, PUB. 3-1-2011. MULTIPLE CLASS, INT. CLS. 38, 41, 42 AND 45.  
 FARLEY, AFTON, EL SEGUNDO, CA, DBA RED WAGON BABY:  
 3,960,480, PUB. 3-1-2011. INT. CL. 25.  
 FARMERS EDUCATIONAL AND COOPERATIVE UNION OF AMERICA, WASHINGTON, DC:  
 557,013, REN. 4-12-11. U.S. CL. 102 (INT. CL. 36).  
 FARMS AND FAMILIES OF NORTH AMERICA INC., SASKATOON, SASKATCHEWAN, CANADA:  
 3,960,383, PUB. 3-1-2011. MULTIPLE CLASS, INT. CLS. 1, 5 AND 31.  
 FARROW & BALL HOLDINGS LIMITED, DORSET, ENGLAND:  
 2,441,805, REN. 4-11-11. INT. CL. 2.  
 FASCINUM S.R.O., CZECH REPUBLIC:  
 3,916,347, COR. INT. CL. 25.  
 FAST INDUSTRIES, LTD., FORT LAUDERDALE, FL:  
 2,882,014, CANC. INT. CL. 5.  
 FASTEC INDUSTRIAL CORP., JOHNSON CITY, TN:  
 2,881,247, CANC. INT. CL. 6.  
 FAVAZZA, MATTHEW S., GLOUCESTER, MA AND FAVAZZA, CHRISTOPHER P., GLOUCESTER, MA AND FAVAZZA, PETER A., GLOUCESTER, MA:  
 3,962,533, INT. CL. 25.  
 FAY, MATTHEW M., CINCINNATI, OH, DBA YOTTA-QUEST:  
 3,961,508, PUB. 3-1-2011. INT. CL. 35.  
 FEAGINS, JOHN PATRICK, LAREDO, TX:  
 2,881,641, CANC. INT. CL. 35.  
 FEDERAL SIGNAL CORPORATION, OAK BROOK, IL:  
 3,963,576, INT. CL. 11.  
 FEDERATED AUTO PARTS DISTRIBUTORS, INC., STAUNTON, VA:  
 3,960,235, PUB. 3-1-2011. INT. CL. 12.  
 FEDPRO INCORPORATED, NEW MARKET, MD:  
 2,382,226, CANC. INT. CL. 35.  
 FEDTECHSERVICES, LLC, TAMPA, FL, AKA FTS:  
 3,962,772, INT. CL. 38.  
 FEED PRODUCTS NORTH, INC., MAPLEWOOD, MN:  
 3,961,837, PUB. 3-1-2011. INT. CL. 5.  
 FEEDBACK TRAYER, S.L., POZUELO DE ALARCON (MADRID), SPAIN:  
 3,960,767, PUB. 3-1-2011. INT. CL. 5.  
 FEEDERS' ADVANTAGE, L.L.C., MERIDIAN, ID:  
 2,447,797, REN. 4-14-11. INT. CL. 35.  
 FEEDERS' ADVANTAGE, L.L.C., NAMPA, ID:  
 2,447,797, COR. INT. CL. 35.  
 FELD, CAROLE, WASHINGTON, DC:  
 3,962,034, INT. CL. 16.  
 FENG SHENG SHOES INDUSTRY CO., LTD., TAICHUNG HSIEN, TAIWAN:  
 2,882,507, CANC. INT. CL. 25.  
 FERGUSON ENTERPRISES, INC., NEWPORT NEWS, VA:  
 3,961,226, PUB. 3-1-2011. INT. CL. 41.  
 3,961,227, PUB. 3-1-2011. INT. CL. 41.  
 3,961,884, PUB. 3-1-2011. INT. CL. 35.  
 3,961,885, PUB. 3-1-2011. INT. CL. 35.  
 3,962,133, INT. CL. 11.  
 3,962,400, INT. CL. 11.  
 3,962,401, INT. CL. 11.  
 3,962,402, INT. CL. 11.  
 3,962,403, INT. CL. 11.  
 3,962,404, INT. CL. 11.  
 FERRAILOLO, FRANK A., DES PLAINES, IL:  
 2,881,323, CANC. INT. CL. 41.  
 FERRARA PAN CANDY CO., INC., FOREST PARK, IL:  
 1,651,203, REN. 4-11-11. INT. CL. 30.  
 FERRO CORPORATION, CLEVELAND, OH, DMC2 DEGUS-SA METALS CATALYSTS CERDEC CORPORATION, WASHINGTON, PA:  
 2,444,691, REN. 4-13-11. INT. CL. 2.  
 FERTIN PHARMA A/S, 7120 VEJLE ØST, DENMARK:  
 2,880,625, CANC. MULTIPLE CLASS, INT. CLS. 3, 5 AND 30.  
 2,880,626, CANC. MULTIPLE CLASS, INT. CLS. 3, 5 AND 30.  
 FETCH TECHNOLOGIES, EL SEGUNDO, CA:  
 3,962,168, MULTIPLE CLASS, INT. CLS. 9 AND 42.  
 FIAT AUTO S.P.A., TORINO, ITALY:  
 2,881,656, CANC. INT. CL. 12.  
 FIAT GRUPPO AUTOMOBILES S.P.A., TORINO, ITALY:  
 3,963,730, INT. CL. 12.  
 FIBER SYSTEMS INTERNATIONAL, ALLEN, TX:  
 2,881,575, CANC. INT. CL. 9.  
 FIBRE-METAL PRODUCTS CO., THE, CONCORDVILLE, PA:  
 2,383,040, CANC. INT. CL. 9.  
 FICKLE PASSION PRODUCTIONS, INC., MURPHY, OR:  
 3,962,649, INT. CL. 42.  
 3,962,699, INT. CL. 42.  
 3,962,711, INT. CL. 42.  
 FIELD CRAFTS, INC., HONOR, MI:  
 3,961,649, PUB. 3-1-2011. INT. CL. 25.  
 3,961,651, PUB. 3-1-2011. INT. CL. 16.  
 FIFTH AVENUE OF LONG ISLAND REALTY ASSOCIATES, MANHASSET, NY:  
 2,450,674, REN. 4-8-11. INT. CL. 36.  
 FIFTH THIRD BANCORP, CINCINNATI, OH:  
 3,963,311, INT. CL. 36.  
 FIGHTERGIRLS.COM, LLC, LAGUNA HILLS, CA:  
 3,961,459, PUB. 3-1-2011. INT. CL. 25.  
 FIGUEROA, KIRK, WESTBURY, NY:  
 2,881,089, CANC. INT. CL. 41.  
 FIITOTECH COMPANY LIMITED, ZHONGZHENG TAIPEI CITY, TAIWAN:  
 3,960,503, PUB. 3-1-2011. MULTIPLE CLASS, INT. CLS. 9, 35, 41 AND 42.  
 FIKI, MORAD, HISHAM, HOUSTON, TX:  
 2,883,138, CANC. INT. CL. 41.

- FILER ENTERPRISES LLC, PLYMOUTH, MN:  
3,962,386, MULTIPLE CLASS, INT. CLS. 16, 25, 35, 40 AND 41.
- FILTRATE PTY. LTD., SUBIACO, WA, AUSTRALIA:  
3,960,353, PUB. 3-1-2011. MULTIPLE CLASS, INT. CLS. 9 AND 25.
- FIMEX TECHNOLOGIES SA, LYSS, SWITZERLAND:  
2,881,458, CANC. MULTIPLE CLASS, INT. CLS. 9, 38 AND 42.
- FINKELSTEIN VINEYARDS, NAPA, CA:  
3,962,287, INT. CL. 33.
- FINKELSTEIN, ADAM, PORT WASHINGTON, NY:  
3,962,059, MULTIPLE CLASS, INT. CLS. 38, 39 AND 42.
- FINZCORP, INC., LAS VEGAS, NV:  
3,962,295, INT. CL. 25.  
3,962,296, INT. CL. 25.
- FIRMENICH SA, GENEVA, SWITZERLAND:  
1,148,605. REN. 4-14-11. INT. CL. 3.
- FIRST AMERICAN FINANCIAL CORPORATION, SANTA ANA, CA:  
2,383,499, CANC. INT. CL. 9.
- FIRST CORPORATION S.R.L., I-17041 ALTARE(SV), ITALY:  
3,960,769, PUB. 3-1-2011. INT. CL. 19.
- FIRST DATA CORPORATION, GREENWOOD VILLAGE, CO:  
3,962,145, MULTIPLE CLASS, INT. CLS. 9, 38 AND 42.
- FIRST HOPE BANK, HOPE, NJ:  
2,382,266, CANC. INT. CL. 36.
- FIRST NATIONAL BANK OF OMAHA, OMAHA, NE:  
2,880,606, CANC. INT. CL. 36.
- FIRST ONE LENDING CORPORATION, SAN JUAN CAPISTRANO, CA:  
2,881,680, CANC. INT. CL. 9.
- FIRST ORION CORP., QUINCY, MA, DBA FIRST ORION:  
3,960,391, PUB. 3-1-2011. MULTIPLE CLASS, INT. CLS. 35 AND 38.
- FIRST QUALITY PRODUCTS, INC., GREAT NECK, NY:  
2,882,873, CANC. INT. CL. 5.
- FISHER SCIENTIFIC COMPANY L.L.C., PITTSBURGH, PA:  
3,962,958, INT. CL. 1.
- FISHERING SERVICE LIMITED, RUSSIAN FED.:  
3,960,724, PUB. 3-1-2011. INT. CL. 22.
- FITNESS BRANDS, INC., AUSTIN, TX:  
3,962,891, INT. CL. 28.
- FITPASS NETWORK LLC, SAN DIEGO, CA:  
3,960,495, PUB. 3-1-2011. MULTIPLE CLASS, INT. CLS. 35 AND 41.
- FITZSIMONS REDEVELOPMENT AUTHORITY, AURORA, CO:  
2,882,939, CANC. INT. CL. 35.
- FIVES STEIN, FRANCE:  
3,960,775, PUB. 3-1-2011. MULTIPLE CLASS, INT. CLS. 7, 11 AND 40.
- FIXED NOISE, INC., LOS ANGELES, CA, DBA FIXED NOISE, INC. AND ARDALAN, JOANNA, LOS ANGELES, CA:  
3,960,331, PUB. 3-1-2011. INT. CL. 9.
- FKC.COM LTD., HONG KONG, HONG KONG:  
3,960,861, PUB. 3-1-2011. INT. CL. 35.
- FLAT EARTH BREWING COMPANY, ST. PAUL, MN:  
3,961,051, PUB. 1-25-2011. INT. CL. 32.
- FLAT-OUT EVENTS, LLC, NEWPORT NEWS, VA:  
3,961,200, PUB. 3-1-2011. INT. CL. 25.
- FLAVIA DIAMANTI, ITALY:  
3,960,728, PUB. 3-1-2011. INT. CL. 14.
- FLINT GROUP INCORPORATED, PLYMOUTH, MI, JAMES RIVER II, INC., OAKLAND, CA:  
1,663,894. REN. 4-12-11. INT. CL. 2.
- FLINT GROUP INCORPORATED, PLYMOUTH, MI:  
2,882,890, CANC. INT. CL. 2.
- FLIP, LLC, ATLANTA, GA:  
3,961,363, PUB. 3-1-2011. INT. CL. 43.
- FLOOR USA, INC., CITY OF INDUSTRY, CA:  
3,960,928, PUB. 3-1-2011. INT. CL. 35.
- FLORENCE CONVENTION AND VISITORS BUREAU, FLORENCE, SC, AKA PEE DEE TOURISM COMMISSION:  
3,962,915, INT. CL. 35.
- FLORES, RAYMON, TUCSON, AZ:  
3,962,567, INT. CL. 43.
- FLORES, STEVE, REDMOND, WA:  
3,962,652, INT. CL. 9.  
3,962,653, INT. CL. 42.
- FLORIDA POOL PRODUCTS, INC., CLEARWATER, FL:  
2,384,009, CANC. INT. CL. 28.
- FLOWARE SYSTEM SOLUTIONS LTD., OR YEHUDA 60250, ISRAEL:  
2,383,803, CANC. INT. CL. 9.
- FLOWENERGY, L.L.C., WOODINVILLE, WA:  
3,960,347, PUB. 3-1-2011. MULTIPLE CLASS, INT. CLS. 35 AND 42.
- FLOYD, SKEREN & KELLY, LLP, CALABASAS, CA:  
3,962,753, MULTIPLE CLASS, INT. CLS. 36 AND 45.
- FLURTY LLC, CHICAGO, IL:  
3,963,680, INT. CL. 41.
- FLUTRENDS INTERNATIONAL, LLC, DENVER, CO, DBA FLUTRENDS INTERNATIONAL, LLC:  
3,962,775, INT. CL. 5.
- FLYING BISCUIT FRANCHISING, INC., ATLANTA, GA:  
2,382,768, CANC. INT. CL. 42.
- FMC CORPORATION, PHILADELPHIA, PA:  
2,882,205, CANC. INT. CL. 1.  
3,962,381, INT. CL. 5.
- FNF INTELLECTUAL PROPERTY HOLDINGS, INC., JACKSONVILLE, FL:  
3,960,956, PUB. 3-1-2011. INT. CL. 36.  
3,960,981, PUB. 3-1-2011. INT. CL. 36.
- FOAMEX INNOVATIONS OPERATING COMPANY, MEDIA, PA. SCOTT PAPER COMPANY, DELAWARE COUNTY, PA:  
928,907. REN. 4-8-11. U.S. CL. 1 (INT. CL. 17).
- FOCUS ON THE FAMILY, COLORADO SPRINGS, CO:  
2,475,493. REN. 4-8-11. INT. CL. 41.
- FOLKS, INC., NORCROSS, GA:  
2,882,724, CANC. INT. CL. 43.
- FOLKSAMERICA REINSURANCE COMPANY, NEW YORK, NY:  
2,881,052, CANC. INT. CL. 36.  
2,881,053, CANC. INT. CL. 36.
- FONG, PETER SUI LUN, MONTEREY PARK, CA:  
2,882,081, CANC. INT. CL. 28.
- FOOD CIRCUS SUPERMARKETS, INC., MIDDLETOWN, NJ:  
3,961,019, PUB. 3-1-2011. INT. CL. 35.
- FOOD PROCESSING SUPPLIERS ASSOCIATION, MCLEAN, VA:  
3,963,812, INT. CL. 35.
- FOONBERG, JAY, BEVERLY HILLS, CA:  
2,384,327, CANC. INT. CL. 42.
- FOOTSTAR CORPORATION, MAHWAH, NJ:  
2,383,362, CANC. INT. CL. 35.
- FOOTWEAR UNLIMITED INC., FENTON, MO:  
2,882,150, CANC. INT. CL. 25.
- FORCE FLOW, CONCORD, CA:  
2,383,086, CANC. INT. CL. 9.
- FORD MOTOR COMPANY, DEARBORN, MI:  
2,451,325. REN. 4-13-11. INT. CL. 12.  
2,882,840, CANC. INT. CL. 9.  
3,962,865, INT. CL. 36.
- FOREIGN TRADE SERVICE CORPORATION, THE, PRINCETON JUNCTION, NJ, DBA FOREIGN TRADE SERVICE:  
3,960,436, PUB. 3-1-2011. INT. CL. 42.
- FOREST LABORATORIES, INC., NEW YORK, NY:  
3,962,850, MULTIPLE CLASS, INT. CLS. 16 AND 44.
- FOREST WOOD FIBER PRODUCTS, INC., LAKE ELSINORE, CA:  
3,961,113, PUB. 3-1-2011. INT. CL. 31.  
3,961,114, PUB. 3-1-2011. INT. CL. 31.  
3,961,115, PUB. 3-1-2011. INT. CL. 31.
- FOREVER FAMILY DESIGNS, LLC, CORVALLIS, OR:  
3,961,728, PUB. 3-1-2011. INT. CL. 42.
- FORSTER, CHRISTIAN, WESTON, FL:  
3,963,768, INT. CL. 35.
- FORTIFIBER CORPORATION, FENLEY, NV:  
1,183,727. REN. 4-13-11. INT. CL. 16.

FORTITUDE SKIS, INC., ARVADA, CO, DBA FORTITUDE SKIS, INC.:  
3,960,856, PUB. 3-1-2011. INT. CL. 28.

FORTUNOFF BRANDS, LLC, GARDEN CITY, NY:  
3,962,596, INT. CL. 35.

FORWARD, ANDREW W., PACIFICA, CA, DBA HORSE PRESENCE AND BROWN, JUDE, PACIFICA, CA, DBA HORSE PRESENCE:  
3,961,377, PUB. 3-1-2011. INT. CL. 35.

FOUR PEAKS BREWING COMPANY, INC., TEMPE, AZ:  
3,963,130, INT. CL. 32.

FOUR-T CORPORATION, OMAHA, NE:  
2,882,551, CANC. INT. CL. 35.

FOVEA APPAREL BOUTIQUE, LLC, ATLANTA, GA, DBA FOVEA:  
3,961,071, PUB. 3-1-2011. INT. CL. 41.

FOX BROADCASTING COMPANY, LOS ANGELES, CA:  
2,882,945, CANC. INT. CL. 41.

FOX CULINARY LLC, TUCSON, AZ:  
3,961,210, PUB. 3-1-2011. INT. CL. 30.

FOXFIRE GRILL, LLC, CHAPIN, SC:  
2,882,991, CANC. INT. CL. 43.

FRAGMENTS, INC., NEW YORK, NY:  
3,963,531, INT. CL. 35.

FRANCHISE LOGISTICS, L.L.C., GREENSBORO, NC:  
3,961,801, PUB. 3-1-2011. INT. CL. 35.

FRANCISCAN VINEYARDS, INC., ST. HELENA, CA:  
2,118,152, REN. 4-12-11. INT. CL. 25.  
2,118,153, REN. 4-12-11. INT. CL. 25.

FRANCO, FRANCISCO JAVIER, RIVERSIDE, CA:  
3,963,494, INT. CL. 25.

FRANCORP, INC., OLYMPIA FIELDS, IL:  
2,881,220, CANC. INT. CL. 36.  
2,881,221, CANC. INT. CL. 36.

FRANK BRUNCKHORST CO., L.L.C., BROOKLYN, NY:  
3,961,736, PUB. 3-1-2011. INT. CL. 29.

FRANK LEE ASSOCIATES, INC., APTOS, CA:  
2,880,701, CANC. MULTIPLE CLASS, INT. CLS. 16, 35 AND 41.

FRANK, BARBARA, GREAT FALLS, VA:  
2,882,344, CANC. INT. CL. 16.

FRASER FORBES COMPANY, LLC, MCLEAN, VA:  
2,542,985, REN. 4-12-11. INT. CL. 36.

FRASER, JOHN, PALM SPRINGS, CA:  
2,881,372, CANC. INT. CL. 3.

FRASER, SCOTT S., DEL MAR, CA, DBA EMPOWERED PRODUCTS:  
2,881,283, CANC. INT. CL. 5.  
2,881,284, CANC. INT. CL. 5.

FRC BALANCE LLC, SCOTTSDALE, AZ:  
3,961,181, PUB. 3-1-2011. INT. CL. 43.

FRED PERRY (HOLDINGS) LIMITED, UNITED KINGDOM:  
3,960,770, PUB. 3-1-2011. INT. CL. 18.

FREEDOM COMMUNICATIONS, INC., SANTA ANA, CA, DBA THE ORANGE COUNTY REGISTER:  
3,962,118, MULTIPLE CLASS, INT. CLS. 16, 35, 36 AND 41.

FREEDOM URGENT CARE, PLLC, HARKER HEIGHTS, TX:  
3,961,744, PUB. 3-1-2011. INT. CL. 44.

FRENCH MILL STONE, INC., ATHENS, AL:  
2,883,001, CANC. INT. CL. 19.

FRESCA FARMS LC, MIAMI, FL:  
2,881,202, CANC. INT. CL. 31.

FRESH CHOICE, LLC, NEWARK, CA:  
2,383,575, CANC. INT. CL. 42.

FRESH EXPRESS INCORPORATED, SALINAS, CA:  
3,960,880, PUB. 3-1-2011. INT. CL. 35.  
3,960,881, PUB. 3-1-2011. INT. CL. 35.

FRESH HEALTHY VENDING LLC, VERNON HILLS, IL:  
3,963,761, MULTIPLE CLASS, INT. CLS. 9 AND 35.

FRESH LIFELINES FOR YOUTH, INC., SAN JOSE, CA:  
3,961,596, PUB. 3-1-2011. MULTIPLE CLASS, INT. CLS. 35 AND 36.

FREUDENBERG HOUSEHOLD PRODUCTS INC., LAVAL (QUEBEC), CANADA:  
2,880,744, CANC. INT. CL. 21.

FREUDENBERG HOUSEHOLD PRODUCTS LP, AURORA, IL:  
910,870, REN. 4-8-11. U.S. CL. 29 (INT. CL. 21).  
2,883,244, CANC. INT. CL. 21.

FREUNDLICH-HALL, SONDRÁ, OAKLAND, CA:  
2,881,379, CANC. INT. CL. 41.

FREY MEDICAL TECHNOLOGIES AG, SWITZERLAND:  
3,960,663, PUB. 3-1-2011. MULTIPLE CLASS, INT. CLS. 3, 14, 18, 20, 21 AND 25.  
3,960,664, PUB. 3-1-2011. MULTIPLE CLASS, INT. CLS. 3, 14, 18, 20, 21 AND 25.

FRIDAY JONES PUBLISHING, DENVER, CO:  
3,962,721, INT. CL. 41.

FRIEND, RACHEL ANN, LAS VEGAS, NV:  
3,960,555, PUB. 3-1-2011. INT. CL. 16.

FRISINA, GARY A., FRANKLIN, TN:  
2,882,015, CANC. INT. CL. 42.

FRITO-LAY NORTH AMERICA, INC., PLANO, TX:  
3,963,541, INT. CL. 30.  
3,963,660, INT. CL. 29.

FRONTIER CAPITAL, LLC, CHARLOTTE, NC:  
2,502,623, REN. 4-12-11. INT. CL. 36.

FRYMIRE ENGINEERING CO., INC, DALLAS, TX:  
2,826,266, CANC. MULTIPLE CLASS, INT. CLS. 37 AND 40.

FTS SYSTEMS LLC, FLINT, MI:  
2,883,085, CANC. INT. CL. 11.

FU AN SHI XIN WANG; DIAN JI YOU XIAN GONG SI, FU'AN CITY, FUJIAN PROVINCE, CHINA:  
3,960,764, PUB. 3-1-2011. INT. CL. 7.

FU, TRON Y., CHAMPAIGN, IL:  
2,881,419, CANC. MULTIPLE CLASS, INT. CLS. 38 AND 42.

FUCHS, ANDREAS, SOUTHPORT, CT, DBA CREATIVE CINEMA:  
3,961,327, PUB. 3-1-2011. INT. CL. 41.  
3,961,328, PUB. 3-1-2011. INT. CL. 41.

FUGRO N.V., NETHERLANDS:  
3,960,716, PUB. 3-1-2011. MULTIPLE CLASS, INT. CLS. 9, 35, 41 AND 42.

FUN SUN VACATIONS. LTD., EDMONTON, ALBERTA, CANADA:  
2,880,875, CANC. INT. CL. 39.

FUNDAMENTAL SOFTWARE, INC., ARBUCKLE, CA:  
2,442,610, REN. 4-12-11. INT. CL. 9.

FUNDRAISING SOLUTIONS, INC., FAIR OAKS, CA:  
2,883,266, CANC. INT. CL. 30.

FUNERAL CONSUMER GUARDIAN SOCIETY, RICHARDSON, TX:  
2,881,225, CANC. INT. CL. 45.

FUNK-TIONAL ENTERPRISES, LLC, NEW YORK, NY:  
3,960,413, PUB. 3-1-2011. INT. CL. 25.

FUR PEACE RANCH, INC., POMEROY, OH:  
3,961,192, PUB. 3-1-2011. INT. CL. 41.

FURIOUS ROSE PRODUCTIONS, INC., NEW YORK, NY:  
3,962,136, INT. CL. 9.

FURMAN GREGORY LLC, BOSTON, MA, DBA FURMAN GREGORY DEPTULA:  
3,961,297, PUB. 3-1-2011. INT. CL. 45.

FURNETCHA LLC, BOSTON, MA:  
3,963,596, INT. CL. 20.

FURRY FRIENDS INC, PEYTON, CO:  
3,961,170, PUB. 3-1-2011. INT. CL. 31.

FUSION BEADS, INC., SEATTLE, WA:  
3,960,562, PUB. 3-1-2011. MULTIPLE CLASS, INT. CLS. 35 AND 41.

FUSIONBRANDS INC, NAPLES, NY:  
3,963,184, INT. CL. 21.

FUTUREPLUS SYSTEMS CORPORATION, BEDFORD, NH:  
2,446,427, REN. 4-14-11. INT. CL. 9.

FX LUMINAIRE, INC., SAN DIEGO, CA:  
2,881,255, CANC. INT. CL. 9.

G & P INDUSTRIAL CO. LIMITED, KOWLOON, HONG KONG:  
3,961,634, PUB. 3-1-2011. INT. CL. 28.  
3,961,636, PUB. 3-1-2011. INT. CL. 28.

- G. POHL-BOSKAMP GMBH & CO. KG, 25551 HOHENLOCKSTEDT, FED REP GERMANY:  
3,960,863, PUB. 2-1-2011. INT. CL. 5.
- G.B. 500, INC., NAPLES, FL:  
2,522,739. REN. 4-11-11. MULTIPLE CLASS, INT. CLS. 16, 41 AND 42.
- G.W.R. MEDICAL, INC., CHADDS FORD, PA:  
2,443,559. REN. 4-12-11. INT. CL. 10.
- G-PAC, INC., WILMINGTON, NC:  
2,882,099, CANC. INT. CL. 37.
- GABBACADABRA LLC, SHERMAN OAKS, CA:  
3,962,025, INT. CL. 28.  
3,962,026, INT. CL. 28.  
3,962,027, INT. CL. 28.
- GAHAGAN, KEVIN E, LYNCHBURG, VA:  
3,963,850, INT. CL. 41.
- GALAXY BRAND MANAGEMENT CORP., WILDWOOD, FL:  
3,962,160, INT. CL. 25.
- GALE, KENNETH A., OCEANSIDE, CA:  
3,963,396, INT. CL. 6.
- GALLAGHER, RICHARD J., BOSSIER CITY, LA:  
2,882,598, CANC. INT. CL. 37.
- GALT MEDICAL CORP., GARLAND, TX:  
3,961,420, PUB. 3-1-2011. INT. CL. 10.  
3,961,994, INT. CL. 10.
- GALTES SRL, SCHIO (VI), ITALY:  
2,881,384, CANC. INT. CL. 24.
- GANEDEN BIOTECH, INC., MAYFIELD HEIGHTS, OH:  
3,962,293, MULTIPLE CLASS, INT. CLS. 1 AND 5.
- GANNETT FLEMING INC., CAMP HILL, PA:  
2,881,701, CANC. MULTIPLE CLASS, INT. CLS. 9 AND 38.
- GANZ, WOODBRIDGE, ONT, CANADA:  
3,963,690, INT. CL. 41.
- GARAN SERVICES CORP., NEW YORK, NY:  
3,963,264, INT. CL. 25.  
3,963,265, INT. CL. 25.  
3,963,266, INT. CL. 25.  
3,963,267, INT. CL. 25.  
3,963,268, INT. CL. 25.  
3,963,269, INT. CL. 25.
- GARCIA, JOSE LUIS, CARACAS, VENEZUELA:  
3,963,146, INT. CL. 5.
- GARDWELL MANUFACTURING CORPORATION, WAMPUM, PA:  
2,382,860, CANC. INT. CL. 19.
- GARNER, KATIE, SPANISH FORK, UT:  
3,963,647, INT. CL. 25.
- GARRITY, MATTHEW, NEW YORK, NY:  
3,960,547, PUB. 3-1-2011. INT. CL. 35.
- GARYSON NOMINEES PTY LTD (AS TRUSTEE FOR THE LISA BURKE FAMILY TRUST), AUSTRALIA:  
3,960,785, PUB. 3-1-2011. INT. CL. 25.
- GASOLINE ALLEY CLASSICS, INC., BROKEN ARROW, OK:  
3,962,298, INT. CL. 35.
- GATX CORPORATION, CHICAGO, IL:  
3,961,898, PUB. 3-1-2011. INT. CL. 39.
- GAYLON, ALISA F., CHICAGO, IL, DBA PAJAMACHEF-NET BY GAYLON FUENTE RESTAURANT CONCEPTS, LLC AND FUENTE, JOHN B., CHICAGO, IL, DBA PAJAMACHEF-NET BY GAYLON FUENTE RESTAURANT CONCEPTS, LLC:  
3,961,095, PUB. 3-1-2011. INT. CL. 43.
- GBS, INC., ANAHEIM, CA:  
3,960,554, PUB. 3-1-2011. MULTIPLE CLASS, INT. CLS. 20 AND 24.
- GCA SERVICES GROUP, INC., CLEVELAND, OH:  
3,960,501, PUB. 3-1-2011. MULTIPLE CLASS, INT. CLS. 35, 37, 39, 41 AND 44.  
3,960,502, PUB. 3-1-2011. MULTIPLE CLASS, INT. CLS. 35, 37, 39, 41 AND 44.
- GE HEALTHCARE AS, OSLO, NORWAY:  
2,881,329, CANC. INT. CL. 5.
- GEAR GATOR PRODUCTS, LLC, BUENA VISTA, VA:  
3,963,017, INT. CL. 12.
- GECKO TRADING COMPANY, INC., MAKAWAO, HI:  
2,446,676. REN. 4-11-11. INT. CL. 14.
- GEDDES, ANNE, SYDNEY, AUSTRALIA:  
2,447,099. REN. 4-9-11. INT. CL. 28.
- GELAGRI BRETAGNE, FRANCE:  
3,960,670, PUB. 3-1-2011. MULTIPLE CLASS, INT. CLS. 29, 30 AND 31.
- GELFAND, ALAN "OLLIE", HOLLYWOOD, FL:  
2,882,525, CANC. INT. CL. 25.
- GEN-PROBE INCORPORATED, SAN DIEGO, CA:  
3,963,263, MULTIPLE CLASS, INT. CLS. 9 AND 10.
- GENERAC POWER SYSTEMS INC., WAUKESHA, WI:  
2,382,826, CANC. INT. CL. 9.
- GENERAL DATATECH, L.P., DALLAS, TX:  
3,962,374, INT. CL. 42.
- GENERAL ELECTRIC COMPANY, SCHENECTADY, NY:  
1,156,275. REN. 4-11-11. INT. CL. 11.
- GENERAL LINE, SARATOGA, CA:  
2,382,392, CANC. INT. CL. 42.
- GENERAL RE CORPORATION, STAMFORD, CT:  
2,550,692. REN. 4-13-11. INT. CL. 36.
- GENERAL SHALE BRICK, INC., JOHNSON CITY, TN, ARRIS CRAFT CORPORATION, CAMBRIDGE, ONTARIO N3H 4S8, CANADA:  
1,651,494. REN. 4-11-11. INT. CL. 19.
- GENESIS HEALTH INSTITUTE, P.L.L.C., BIRMINGHAM, MI:  
3,961,595, PUB. 3-1-2011. INT. CL. 44.
- GENFLEX ROOFING SYSTEMS, LLC, INDIANAPOLIS, IN:  
2,881,875, CANC. INT. CL. 41.
- GENIUS KIDS DEVELOPMENT, INC., FREMONT, CA:  
3,961,018, PUB. 3-1-2011. INT. CL. 41.
- GENRE & MODE, INC., BOZEMAN, MT:  
3,962,852, INT. CL. 18.
- GENUINE GEM INC., LOS ANGELES, CA:  
3,961,406, PUB. 3-1-2011. MULTIPLE CLASS, INT. CLS. 14 AND 25.
- GEO BROTHERS FENCE COMPANY, LYNN, MA:  
2,881,666, CANC. INT. CL. 37.
- GEOFFREY, LLC, WAYNE, NJ:  
1,612,117, CANC. MULTIPLE CLASS, INT. CLS. 24 AND 25.  
1,648,557. REN. 4-8-11. INT. CL. 28.  
2,382,832, CANC. INT. CL. 28.  
3,963,705, MULTIPLE CLASS, INT. CLS. 12 AND 20.
- GEOLOGIC SOLUTIONS, INC., BEVERLY HILLS, CA:  
2,882,963, CANC. MULTIPLE CLASS, INT. CLS. 9 AND 38.
- GEONOVA LLC, MOUNTVILLE, PA:  
2,881,112, CANC. INT. CL. 16.
- GEORGE C. MATTESON CO., INC., BLUE SPRINGS, MO, DBA GEMACO:  
2,880,927, CANC. INT. CL. 28.
- GEORGE, PHILIP B., WESTBURY, NY:  
3,962,477, INT. CL. 3.
- GEORGIA CORPORATE FEDERAL CREDIT UNION, DULUTH, GA:  
3,961,256, PUB. 3-1-2011. INT. CL. 42.
- GEORGIA-PACIFIC CONSUMER PRODUCTS LP, ATLANTA, GA, JAMES RIVER II, INC., OAKLAND, CA:  
1,682,322. REN. 4-12-11. INT. CL. 3.
- GEORGIA-PACIFIC CONSUMER PRODUCTS LP, ATLANTA, GA:  
2,472,467. REN. 4-12-11. INT. CL. 16.  
2,472,468. REN. 4-9-11. INT. CL. 16.
- GEORGIA-PACIFIC CORPORATION, ATLANTA, GA:  
1,969,175, CANC. INT. CL. 16.
- GEOS CORPORATION, TOKYO 102-0083, JAPAN:  
2,446,629. REN. 4-13-11. MULTIPLE CLASS, INT. CLS. 16, 39, 41 AND 42.  
2,446,629, CANC. INT. CL. 35.
- GEPCO INC., KENNESAW, GA:  
3,963,703, INT. CL. 16.
- GERALDTON FISHERMEN'S CO-OPERATIVE LTD., GERALDTON, WESTERN AUSTRALIA 6531, AUSTRALIA:  
2,464,853. REN. 4-12-11. INT. CL. 29.



GERLING-KONZERN ALLGEMEINE VERSICHERUNGS-AG, 50597 COLOGNE, FED REP GERMANY:  
2,383,890, CANC. INT. CL. 36.

GERRESHEIMER GLASS INC., VINELAND, NJ, KIMBLE GLASS COMPANY, VINELAND, NJ:  
381,836. REN. 4-12-11. U.S. CL. 26 (INT. CL. 9).

GESSWORKS, INC., MENTOR, OH:  
2,882,701, CANC. INT. CL. 9.

GETTY IMAGES (US), INC., SEATTLE, WA:  
2,440,037, AM. INT. CL. 42.

GEVICAR S.A., BARCELONA, SPAIN:  
3,962,329, MULTIPLE CLASS, INT. CLS. 39 AND 41.

GFD FABRICS, INC., GREENSBORO, NC:  
2,383,472, CANC. INT. CL. 24.

GIANPERO PEDRINI&ME S.R.L., BRESCIA, ITALY:  
2,881,344, CANC. INT. CL. 21.

GIANT KILLER PRODUCTIONS, INC., NOLENSVILLE, TN:  
3,961,214, PUB. 3-1-2011. INT. CL. 41.

GIBERSON ENTERPRISES, LLC, SHAMONG, NJ:  
3,963,589, INT. CL. 7.

GIFFORD, JACILYN, LODI, CA AND KRAMER, KENNETH, LODI, CA:  
3,961,481, PUB. 3-1-2011. INT. CL. 30.

GIGA-BYTE TECHNOLOGY CO., LTD., HSIN-TIEN, TAIWAN:  
3,963,132, INT. CL. 9.

GIGAMON LLC, MILPITAS, CA:  
3,962,932, INT. CL. 9.

GILBO, DARYL, MISSOURI, TX:  
2,881,848, CANC. INT. CL. 25.

GILBERTI, INC., PALM BEACH GARDENS, FL:  
2,882,325, CANC. INT. CL. 12.

GILL ATHLETICS, INC., CHAMPAIGN, IL:  
3,962,317, INT. CL. 35.

GILSON SAS, F-95400 VILLIERS LE BEL, FRANCE:  
3,960,734, PUB. 3-1-2011. INT. CL. 9.

GILSTON, JACK DAVID, LONDON, UNITED KINGDOM:  
3,961,865, PUB. 3-1-2011. INT. CL. 18.

GINGERINE, LLC, SOUTHLAKE, TX:  
3,963,390, INT. CL. 43.

GINZBURG, ROBERT, DELRAY BEACH, FL:  
2,882,058, CANC. INT. CL. 35.

GIRONDI, RITA A. DR., CAMP HILL, PA:  
3,963,278, INT. CL. 35.

GISH, ANN, NEW YORK, NY:  
2,548,383, CANC. MULTIPLE CLASS, INT. CLS. 20, 24 AND 25.

GIVAUDAN SA, 1214 VERNIER, SWITZERLAND:  
2,882,735, CANC. INT. CL. 35.

GIVE BARS, LLC, SAN FRANCISCO, CA:  
3,963,725, INT. CL. 30.

GKD INDEX PARTNERS, LLC, DALLAS, TX:  
3,963,753, INT. CL. 36.

GLACIER INVESTMENTS, LLC, TULSA, OK, DBA GLACIER CONFECTION:  
3,960,966, PUB. 3-1-2011. INT. CL. 30.

GLACIS CAPITAL MANAGEMENT, LLC, NEW YORK, NY:  
2,883,118, CANC. INT. CL. 36.

GLAXO GROUP LIMITED, GREENFORD, MIDDLESEX, UNITED KINGDOM:  
3,961,346, PUB. 3-1-2011. INT. CL. 5.  
3,961,348, PUB. 3-1-2011. INT. CL. 5.  
3,961,349, PUB. 3-1-2011. INT. CL. 5.  
3,961,350, PUB. 3-1-2011. INT. CL. 5.  
3,961,351, PUB. 3-1-2011. INT. CL. 5.  
3,961,745, PUB. 3-1-2011. INT. CL. 5.  
3,961,746, PUB. 3-1-2011. INT. CL. 5.

GLEN ELLYN INDUSTRIES, LLC, GLEN ELLYN, IL:  
2,880,967, CANC. INT. CL. 16.

GLENN S. SUPLEE TRUST, BRYN MAWR, PA, BOSTON METALS COMPANY, THE, CHESTER, PA:  
534,964. REN. 4-12-11. U.S. CL. 13 (INT. CL. 6).

GLIMPSON, LLC, BEND, OR:  
2,881,537, CANC. MULTIPLE CLASS, INT. CLS. 35 AND 42.

GLOBAL ARCH FINANCIAL LLC, NORTH BERGEN, NJ:  
2,881,629, CANC. INT. CL. 36.

GLOBAL BLUE HOLDINGS AB, SE-431 23 MÖLN DAL, SWEDEN:  
3,960,680, PUB. 3-1-2011. MULTIPLE CLASS, INT. CLS. 9, 16, 35 AND 36.

GLOBAL CONCEPTS LIMITED, INC., DEERFIELD BEACH, FL, DBA GLOBAL TV CONCEPTS, LTD.:  
3,962,525, INT. CL. 21.

GLOBAL HEALTHCARE EXCHANGE, LLC, LOUISVILLE, CO:  
3,961,029, PUB. 3-1-2011. MULTIPLE CLASS, INT. CLS. 35 AND 42.

GLOBAL NAME SERVICES LLP, WILMINGTON, DE:  
3,961,520, PUB. 3-1-2011. INT. CL. 45.

GLOBAL POSITIVE, LLC, DANVILLE, CA:  
3,961,167, PUB. 3-1-2011. INT. CL. 45.

GLOBAL PUMP COMPANY, L.L.C., DAVISON, MI:  
3,961,251, PUB. 3-1-2011. INT. CL. 7.

GLOBAL REFUND HOLDINGS AB, MOELNDAL, SWEDEN:  
3,960,400, PUB. 3-1-2011. MULTIPLE CLASS, INT. CLS. 9, 36 AND 38.

GLOBAL SAFETY; SOLUTIONS & MANAGEMENT PTY LTD, AUSTRALIA:  
3,960,762, PUB. 3-1-2011. INT. CL. 9.

GLOBAL TV CONCEPTS, DEERFIELD BEACH, FL:  
3,962,474, INT. CL. 8.

GLOBALFORCE NETWORK INC., VANCOUVER, CANADA:  
3,960,278, PUB. 3-1-2011. INT. CL. 35.

GLOBALPASS, INC, MIAMI, FL:  
2,881,830, CANC. INT. CL. 35.

GLOBALQUEST, LLC, HOPEWELL, NJ:  
2,882,134, CANC. INT. CL. 16.

GLOBALSTAR, L.P., NEW YORK, NY:  
2,881,914, CANC. INT. CL. 38.

GLOBALT, INC., ATLANTA, GA:  
2,557,305, CANC. INT. CL. 36.

GLOCON, INC., PARSIPPANY, NJ:  
2,383,402, CANC. INT. CL. 11.

GLOVER, MAURICE L., JACKSONVILLE, FL, DBA ALAVICI:  
3,937,086, COR. INT. CL. 9.

GLOVER, SIMONE, BROOKLYN, NY, DBA SIM 1 COMMUNICATIONS:  
3,963,008, INT. CL. 35.

GLYCON CORP., TECUMSEH, MI:  
2,455,641. REN. 4-13-11. INT. CL. 7.

GMA INC., ALEXANDRIA, VA, DBA BMD FULL SERVICE DIRECT MARKETING:  
3,963,535, INT. CL. 35.

GMYL, L.P., NAPA, CA:  
2,383,398, CANC. INT. CL. 33.

GODWIN PUMPS OF AMERICA, INC., BRIDGEPORT, NJ:  
2,441,009. REN. 4-8-11. INT. CL. 7.  
2,453,089. REN. 4-11-11. INT. CL. 7.  
2,453,090. REN. 4-11-11. INT. CL. 7.

GOELLER, STEVEN H, MIDDLE RIVER, MD:  
3,963,675, INT. CL. 25.

GOLAD, ADAR, HATTEM, NETHERLANDS:  
3,960,980, PUB. 11-16-2010. INT. CL. 28.

GOLD COUNTRY WINE TOURS, INC., GRANADA HILLS, CA:  
3,963,769, INT. CL. 41.

GOLD N CONNECTION LLC, POMPANO BEACH, FL:  
3,961,321, PUB. 3-1-2011. INT. CL. 36.

GOLDEN KEY FUTURA, INC., MONTROSE, CO:  
2,880,973, CANC. INT. CL. 28.

GOLDEN MILLS, LLC, CHATSWORTH, CA:  
3,963,395, INT. CL. 24.

GOLDEN STATE WARRIORS, LLC, OAKLAND, CA:  
2,547,560. REN. 4-8-11. INT. CL. 25.

GOLDNER, SANDOR, BROOKLYN, NY AND GOLDNER, NORMAN, BROOKLYN, NY:  
3,962,623, INT. CL. 7.

GOLISANO CHILDREN'S MUSEUM OF NAPLES, INC., NAPLES, FL:  
3,961,322, PUB. 3-1-2011. INT. CL. 41.



- GOLTENBODT PRAZSISIONSWERKZEUG- UND MASCHINENFABRIK GMBH & CO., D-71229 LEONBERG (HFINGEN), FED REP GERMANY:  
2,382,394, CANC. INT. CL. 7.
- GONZALES, LISAMARIE, ESCONDIDO, CA AND MILLER, ANDREW J., ESCONDIDO, CA AND TAYLOR, ELAINE H., ESCONDIDO, CA, DBA ROTTIE LOVE/MIXED PLANET:  
2,881,259, CANC. INT. CL. 18.
- GONZALEZ, GERARDO ESPINOSA, GUADALAJARA, JALISCO, MEXICO:  
2,383,292, CANC. INT. CL. 25.
- GOOD EARTH ENERGY CONSERVATION, INC., FORT WORTH, TX:  
3,962,861, INT. CL. 12.
- GOOD EGG CLUB LLC, ALBUQUERQUE, NM:  
3,961,638, PUB. 3-1-2011. INT. CL. 42.
- GOOD FOR THE GOOSE PRODUCTS, LLC, INDIANAPOLIS, IN:  
3,961,607, PUB. 3-1-2011. INT. CL. 3.
- GOOD LIFE 101 INC., BRONX, NY:  
2,883,284, CANC. INT. CL. 5.
- GOOD SOURCE SOLUTIONS, INC., CARLSBAD, CA:  
2,382,963, CANC. INT. CL. 29.
- GOODE-LITTHCUT ENTERPRISES LLC, BOSTON, MA:  
2,881,934, CANC. INT. CL. 9.
- GOODKIND ORGANICS, LLC, ARCATA, CA:  
3,962,880, INT. CL. 29.
- GOODLOE, GWENDOLYN, PHOENIX, AZ:  
3,962,182, INT. CL. 35.
- GOODRICH CORPORATION, CHARLOTTE, NC TO B.F.GOODRICH COMPANY, THE, CHARLOTTE, NC:  
2,896,050, COR. INT. CL. 12.
- GOODSPEED, JOHN, ANNAPOLIS, MD:  
2,881,302, CANC. MULTIPLE CLASS, INT. CLS. 35, 38 AND 42.
- GOODSTEIN & ASSOCIATES, LLC, FORT WASHINGTON, PA:  
3,961,824, PUB. 3-1-2011. INT. CL. 36.
- GOODWEST INDUSTRIES, INC., WARMINSTER, PA:  
3,962,722, INT. CL. 21.
- GOOGLE INC., MOUNTAIN VIEW, CA:  
3,962,604, MULTIPLE CLASS, INT. CLS. 9, 41 AND 42.
- GOOSE VALLEY NATURAL FOODS, LLC, BOSTON, MA:  
3,962,347, INT. CL. 30.
- GORANT CHOCOLATIER, LLC, WOOSTER, OH:  
3,961,092, PUB. 1-25-2011. INT. CL. 30.
- GORDON FOOD SERVICE, INC., GRAND RAPIDS, MI:  
2,383,927, CANC. INT. CL. 29.
- GORDON, NIKITA K., STONEBROOK VILLAGE, NY:  
2,382,676, CANC. INT. CL. 25.
- GORDON'S HEARING AID LAB, INC., HARRISBURG, PA:  
2,881,861, CANC. MULTIPLE CLASS, INT. CLS. 10 AND 42.
- GOSPEL MUSIC CHANNEL, LLC, ATLANTA, GA:  
3,960,237, PUB. 3-1-2011. INT. CL. 41.
- GOSS INTERNATIONAL CORPORATION, DURHAM, NH:  
2,880,809, CANC. INT. CL. 9.
- GOTHIC CABINET CRAFT INC., MASPETH, NY:  
3,960,426, PUB. 3-1-2011. INT. CL. 20.  
3,960,427, PUB. 3-1-2011. INT. CL. 20.  
3,960,428, PUB. 3-1-2011. INT. CL. 20.
- GOTTABECLEAN, INC., RALEIGH, NC:  
3,963,529, INT. CL. 37.
- GRACE AND GROWTH COUNSELING CENTER, INC., SANDY SPRINGS, GA:  
3,963,216, MULTIPLE CLASS, INT. CLS. 41 AND 44.
- GRACIE AND MO, LLC, DALLAS, TX:  
3,960,442, PUB. 3-1-2011. INT. CL. 16.
- GRAEBEL RELOCATION SERVICES WORLDWIDE, INC., AURORA, CO:  
3,962,918, MULTIPLE CLASS, INT. CLS. 35 AND 39.
- GRAFTON INTERNATIONAL LIMITED, STRAFFORDSHIRE WS14 ODJ, UNITED KINGDOM:  
2,880,753, CANC. MULTIPLE CLASS, INT. CLS. 3, 8 AND 44.
- GRAHAM WEBB INTERNATIONAL, INC., CARLSBAD, CA:  
2,384,224, CANC. INT. CL. 3.
- GRAINDROPS LLC, ATLANTA, GA:  
3,962,003, INT. CL. 30.
- GRAND FOOD COMPANY, HOUSTON, TX:  
3,961,969, INT. CL. 30.
- GRAND RAPIDS REAL ESTATE, GRAND RAPIDS, MI:  
2,881,325, CANC. INT. CL. 36.
- GRAND RAPIDS/KENT COUNTY CONVENTION & VISITORS BUREAU, GRAND RAPIDS, MI:  
3,961,368, PUB. 3-1-2011. INT. CL. 35.  
3,961,370, PUB. 3-1-2011. INT. CL. 35.
- GRAND ROUND TABLE, PHILADELPHIA, PA:  
3,963,306, INT. CL. 42.
- GRAND STREAM ENTERPRISE, INC., PARKLAND, FL:  
3,960,992, PUB. 12-14-2010. INT. CL. 3.
- GRAND VALLEY STATE UNIVERSITY, ALLENDALE, MI:  
2,882,923, CANC. MULTIPLE CLASS, INT. CLS. 25 AND 41.
- GRANDPOINT BANK, LOS ANGELES, CA:  
3,961,474, PUB. 3-1-2011. INT. CL. 36.
- GRANICRETE INTERNATIONAL, INC, PHOENIX, AZ:  
3,963,570, MULTIPLE CLASS, INT. CLS. 35 AND 40.
- GRANITE CITY TOOL COMPANY, WAITE PARK, MN:  
3,962,264, INT. CL. 7.
- GRANT, ALYSSA N., HUNTINGTON BEACH, CA:  
2,883,030, CANC. INT. CL. 26.
- GRAPHITE DESIGN INTERNATIONAL INC., SAN DIEGO, CA:  
3,961,720, PUB. 3-1-2011. INT. CL. 28.  
3,961,721, PUB. 3-1-2011. INT. CL. 28.  
3,961,722, PUB. 3-1-2011. INT. CL. 28.
- GRASSEL, ANN J., FOREST KNOLLS, CA:  
2,383,678, CANC. INT. CL. 9.
- GRASSLAND OUTFITTERS, LLC, ROANOKE, VA:  
3,963,340, INT. CL. 35.  
3,963,341, INT. CL. 35.  
3,963,342, INT. CL. 35.
- GRAVITY INTERACTIVE, INC., MARINA DEL REY, CA:  
3,961,849, PUB. 3-1-2011. INT. CL. 41.
- GRAY-DENIHAN, STEPHANIE, FONTANA, CA:  
2,881,433, CANC. INT. CL. 3.
- GRAY, DOUGLAS MERVYN, TOOWOOMBA, QUEENSLAND, 4350, AUSTRALIA AND HOLLOWAY, DAVID WILLIAM, TOOWOOMBA, QUEENSLAND, 4350, AUSTRALIA:  
2,562,987, CANC. INT. CL. 5.
- GRAYSON COOK, EARL, CHATHAM, VA:  
2,445,322, REN. 4-14-11. MULTIPLE CLASS, INT. CLS. 16 AND 41.
- GREAT AMERICAN INSURANCE COMPANY, CINCINNATI, OH:  
3,962,794, INT. CL. 36.
- GREAT LAKES REAL ESTATE, INC., YOUNGSTOWN, NY:  
3,961,725, PUB. 3-1-2011. INT. CL. 36.
- GREAT LAKES SERVICES, LLC, MADISON, WI:  
3,963,872, MULTIPLE CLASS, INT. CLS. 35 AND 44.
- GREAT WALL ADVERTISING LLC, GULFPORT, FL:  
3,960,854, PUB. 3-1-2011. INT. CL. 35.
- GREATBANC, INC., CHICAGO, IL:  
3,960,324, PUB. 3-1-2011. INT. CL. 36.
- GREATER GRACE TEMPLE OF THE APOSTOLIC FAITH, DETROIT, MI:  
2,688,165, CANC. INT. CL. 41.
- GREATER IRVING - LAS COLINAS CHAMBER OF COMMERCE, IRVING, TX:  
2,881,859, CANC. INT. CL. 35.
- GREEN GARMENTO, LLC, THE, LOS ANGELES, CA:  
3,962,183, INT. CL. 18.
- GREEN MEADOWS FORAGE, LLC, GAYVILLE, SD:  
3,963,585, INT. CL. 5.
- GREEN YOUTH MOVEMENT, LLC, BEVERLY HILLS, CA:  
3,963,807, INT. CL. 35.
- GREEN, JAMES M., HOUSTON, TX:  
3,962,279, INT. CL. 16.
- GREENBRIER INTERNATIONAL, INC., CHESAPEAKE, VA:  
3,963,329, INT. CL. 31.
- GREENCORE COMPOSITES INC., TORONTO, CANADA:  
3,962,236, MULTIPLE CLASS, INT. CLS. 1 AND 17.

GREENE, TWEED OF DELAWARE, INC., WILMINGTON, DE:  
3,962,833, INT. CL. 40.

GREENLANDS FARM, LLC, BOLIVIA, NC, DBA WHIFF WHIMS:  
3,960,912, PUB. 3-1-2011. INT. CL. 3.  
3,960,913, PUB. 3-1-2011. INT. CL. 3.

GREENSGROOMER WORLDWIDE, INC., INDIANAPOLIS, IN:  
3,963,201, INT. CL. 7.

GREYSON INTERNATIONAL, INC., BOCA RATON, FL:  
2,443,588. REN. 4-14-11. INT. CL. 3.

GRIFFITHS, WENDY, NEW YORK, NY:  
3,961,202, PUB. 3-1-2011. INT. CL. 9.

GRISALES CRISTINA, NORTH BERGEN, NJ:  
3,962,399, INT. CL. 25.

GRLC LLC, MADISON HEIGHTS, MI, DBA VALLEY TOWING SYSTEMS:  
2,225,514. REN. 4-12-11. INT. CL. 12.

GRO GROUP, INC., WALTHAM, MA:  
1,148,478. REN. 4-11-11. INT. CL. 35.

GRO GROUP, INC., BEDFORD, MA:  
1,152,619. REN. 4-11-11. INT. CL. 35.

GROOVE EQUIPMENT LTD., HONG KONG, HONG KONG:  
3,960,952, PUB. 3-1-2011. INT. CL. 28.

GROUP COMRAP CORP. DE C.V., COL. GRANJAS MODERNAS, MEXICO:  
3,962,035, INT. CL. 9.

GROWSEED AKTIENGESELLSCHAFT, 9490 VADUZ, LIECHTENSTEIN:  
2,881,572, CANC. INT. CL. 30.

GRUPO BIMBO, S.A. B. DE C.V., MEXICO CITY, DF, MEXICO:  
3,960,265, PUB. 3-1-2011. INT. CL. 29.

GRUPO P.I. MABE, S.A. DE C.V., PUEBLA, C.P., 72230, MEXICO:  
2,882,111, CANC. INT. CL. 16.

GSI GROUP CORPORATION, BILLERICA, MA:  
2,883,125, CANC. INT. CL. 9.

GSLE SUBCO L.L.C., CHARLOTTE, NC:  
2,383,415, CANC. INT. CL. 9.  
2,881,414, CANC. INT. CL. 9.

GSM (OPERATIONS) PTY LTD, BURLEIGH HEADS QLD, AUSTRALIA:  
3,962,500, MULTIPLE CLASS, INT. CLS. 25 AND 41.

GT MERCHANDISING & LICENSING LLC, NEW YORK, NY:  
2,882,740, CANC. INT. CL. 3.

GTJ ENTERPRISES, INC., MONSEY, NY, DBA AMERICAN NUTRITION CONSULTANTS:  
3,961,438, PUB. 3-1-2011. INT. CL. 5.

GUANGXI GOLDEN THROAT CO., LTD., GUANGXI, CHINA:  
3,960,513, PUB. 3-1-2011. MULTIPLE CLASS, INT. CLS. 5 AND 30.

GUANGZHOU HONGLI OPTO-ELECTRONIC CO., LTD., GUANGZHOU CITY, GUANGDON PROVINCE, CHINA:  
3,960,786, PUB. 3-1-2011. MULTIPLE CLASS, INT. CLS. 9 AND 11.

GUIDESPARK, INC., LOS ALTOS, CA:  
3,960,527, PUB. 3-1-2011. MULTIPLE CLASS, INT. CLS. 36 AND 41.

GUIDESTAR CLINICAL TRIALS MANAGEMENT, LLC, MIRAMARBEACH, FL:  
3,962,552, MULTIPLE CLASS, INT. CLS. 35, 41 AND 42.

GULF COAST FIREWORKS, INC., OVERLAND PARK, KS:  
1,613,730. REN. 4-11-11. INT. CL. 13.

GURU DENIM INC., VERNON, CA:  
3,963,295, INT. CL. 25.

GUSTARE, LLC, CHATHAM, MA:  
3,961,003, PUB. 3-1-2011. MULTIPLE CLASS, INT. CLS. 29 AND 30.

GUTERMAXX, L.P., HOUSTON, TX:  
3,962,447, INT. CL. 37.  
3,962,448, INT. CL. 37.

GUYS WHO LOVE GOD, LLC, GLEN BURNIE, MD:  
2,882,527, CANC. INT. CL. 25.

GWANGSUNG ELECTRIC INDUSTRY CO., LTD., INCHEON, REPUBLIC OF KOREA:  
3,963,738, INT. CL. 11.

GYANN, JOHN, WOODRIDGE, IL:  
2,883,129, CANC. INT. CL. 12.

GYRUS ACMI, INC., SOUTHBOROUGH, MA:  
2,401,640. REN. 4-8-11. INT. CL. 10.

H & H MEDICAL, INC., JEFFERSON HILLS, PA:  
2,882,509, CANC. INT. CL. 10.

H. E. BUTT GROCERY COMPANY, SAN ANTONIO, TX:  
2,880,595, CANC. INT. CL. 35.

H.B. FULLER CONSTRUCTION PRODUCTS INC., SAINT PAUL, MN, CHILDERS PRODUCTS COMPANY, INC., CLEVELAND, OH:  
1,149,815. REN. 4-8-11. INT. CL. 17.

H.E.L.P. CORP, INC., HOUMA, LA:  
3,960,891, PUB. 3-1-2011. INT. CL. 16.

HÄFELE GMBH & CO. KG, D-72202 NAGOLD, FED REP GERMANY:  
3,960,281, PUB. 11-23-2010. MULTIPLE CLASS, INT. CLS. 6, 9, 20 AND 21.

HAAKE, MARY JANE, PORTLAND, OR:  
2,881,808, CANC. INT. CL. 5.

HAAS OUTDOORS, INC., WEST POINT, MS:  
1,639,791. REN. 4-12-11. INT. CL. 24.  
3,961,988, INT. CL. 41.

HABANA HARLEM, LLC, BROOKLYN, NY:  
3,961,763, PUB. 3-1-2011. INT. CL. 41.

HACH COMPANY, LOVELAND, CO:  
3,961,971, INT. CL. 9.  
3,962,130, INT. CL. 9.

HADI, ALTAFA, MURPHY, TX:  
3,962,104, INT. CL. 35.

HAFELE GMBH & CO., D-72202 NAGOLD, FED REP GERMANY:  
2,441,851. REN. 4-8-11. INT. CL. 6.  
2,441,851, CANC. INT. CL. 20.

HAGAN, WILLIAM J. II, ELCO, GA AND MOSHER, NANCY B., ELCO, GA:  
2,881,915, CANC. INT. CL. 16.

HAGEMEYER NORTH AMERICA, INC., ALPHARETTA, GA:  
2,882,617, CANC. INT. CL. 16.

HAHN, FREDERICK W., JR., KANSAS CITY, MO:  
2,382,272, CANC. INT. CL. 21.

HAI FENG FEED CO., LTD, CHANGHUA COUNTY 510, TAIWAN:  
2,483,187. REN. 4-11-11. MULTIPLE CLASS, INT. CLS. 7 AND 16.

HAIM, ALBERT M., POTOMAC, MD, DBA ALBERT M. HAIM:  
3,963,510, MULTIPLE CLASS, INT. CLS. 28 AND 35.

HAKUBA PHOTO INDUSTRY CO., LTD., CHIYODA-KU, TOKYO, JAPAN:  
2,384,044, CANC. INT. CL. 9.

HALE FIREWORKS, LLC, BUFFALO, MO:  
2,881,269, CANC. INT. CL. 13.

HALFBRICK STUDIOS PTY LTD, AUSTRALIA:  
3,960,787, PUB. 3-1-2011. INT. CL. 9.

HALL, CATHERINE M., SAN DIEGO, CA:  
2,882,943, CANC. INT. CL. 16.

HALLIBURTON ENERGY SERVICES, INC., CARROLLTON, TX:  
930,955. REN. 4-8-11. U.S. CL. 52 (INT. CL. 1).

HALLIBURTON ENERGY SERVICES, INC., HOUSTON, TX:  
2,545,477. REN. 4-8-11. INT. CL. 7.

HALLIBURTON ENERGY SERVICES, INC., CARROLLTON, TX:  
2,546,820. REN. 4-8-11. INT. CL. 13.

HALLMARK LICENSING, INC., KANSAS CITY, MO:  
2,882,888, CANC. INT. CL. 30.

HAMAN, GERALD, CHICAGO, IL:  
2,815,975, CANC. INT. CL. 41.

HAMER, RUDY, NEW YORK, NY:  
2,484,822. REN. 4-8-11. INT. CL. 11.

HAND CONSULTANTS PA, HOUSTON, TX:  
3,963,774, INT. CL. 44.

- HANDY GIRLS, INC., LAS VEGAS, NV:  
2,881,630, CANC. INT. CL. 8.
- HANLIN, GARY L., DEARBORN HEIGHTS, MI:  
2,443,837, REN. 4-9-11. INT. CL. 25.
- HANNAN SPECIALTIES, INC., CARMICHAEL, CA:  
3,960,399, PUB. 3-1-2011. INT. CL. 20.
- HANSA METALLWERKE AG, FED REP GERMANY:  
3,960,715, PUB. 3-1-2011. MULTIPLE CLASS, INT. CLS.  
11, 20 AND 21.  
3,960,736, PUB. 3-1-2011. MULTIPLE CLASS, INT. CLS.  
11, 20 AND 21.
- HANSEN BEVERAGE COMPANY, CORONA, CA:  
3,963,668, INT. CL. 16.  
3,963,669, INT. CL. 18.
- HANSEN MEDICAL, INC., MOUNTAIN VIEW, CA:  
3,962,054, INT. CL. 10.
- HANSEN WEATHER-PORT CORP., DELTA, CO:  
1,191,195, REN. 4-13-11. INT. CL. 19.
- HANSEN, KIMBERLY RAE, CASPER, WY:  
3,963,121, INT. CL. 14.
- HANSEN, LYNN, DECLO, ID:  
3,962,871, INT. CL. 5.
- HAPPYNEURON INC., MOUNTAIN VIEW, CA:  
3,960,536, PUB. 3-1-2011. INT. CL. 42.
- HARD ROCK CAFE INTERNATIONAL (USA), INC., ORLANDO, FL:  
3,962,921, INT. CL. 41.
- HARDEE'S FOOD SYSTEMS, INC., ST. LOUIS, MO:  
3,963,532, INT. CL. 29.  
3,963,533, INT. CL. 29.
- HARDINGE, INC., ELMIRA, NY:  
2,881,113, CANC. INT. CL. 7.
- HARDOUIN, JASON E., SAN JOSE, CA AND MILLER, JERRY L., SAN JOSE, CA AND PESSOA, CESAR J., SAN JOSE, CA:  
3,960,384, PUB. 3-1-2011. INT. CL. 9.
- HARDWICK, APRIL, NEW YORK, NY:  
3,962,576, INT. CL. 28.
- HARLEM FURNITURE, INC., LOMBARD, IL:  
2,891,687, CANC. INT. CL. 35.
- HARLEM ROCKETS CORP., DERBY, KS:  
2,382,227, CANC. INT. CL. 41.
- HARMAN INTERNATIONAL INDUSTRIES, INCORPORATED, NORTHRIDGE, CA:  
3,960,292, PUB. 3-1-2011. MULTIPLE CLASS, INT. CLS. 9 AND 40.
- HARNISCHFEGER TECHNOLOGIES, INC., WILMINGTON, DE:  
3,961,941, PUB. 3-1-2011. INT. CL. 7.
- HARRIS BAY TRADING CORPORATION, SAN FRANCISCO, CA, AKA HISTORIC PHOTO COMPANY:  
3,963,859, INT. CL. 16.
- HARRIS CONNECT, LLC, CHESAPEAKE, VA:  
3,093,943, AM. INT. CL. 35.  
3,196,826, AM. INT. CL. 35.
- HARRIS II, JOHN HENRY, BELCAMP, MD:  
3,963,571, INT. CL. 25.
- HARRIS TRUST & SAVINGS BANK, CHICAGO, IL:  
2,881,373, CANC. INT. CL. 36.
- HARRIS, JEFF, WASHINGTON, PA:  
2,458,322, REN. 4-8-11. INT. CL. 16.
- HARRIS, JOHN E, VACAVILLE, CA:  
3,963,113, INT. CL. 14.  
3,963,114, INT. CL. 16.  
3,963,115, INT. CL. 16.
- HARRIS, NEIL I., BURNSVILLE, NC:  
3,963,123, INT. CL. 35.
- HARRY WINSTON SA (SOCIETE ANONYME HARRY WINSTON), GENEVA, SWITZERLAND:  
2,881,472, CANC. INT. CL. 14.
- HART PHYSICAL THERAPY, LLC, LAS VEGAS, NV:  
3,961,444, PUB. 3-1-2011. INT. CL. 44.
- HART, CHIP, CINCINNATI, OH:  
2,446,485, REN. 4-12-11. INT. CL. 41.
- HART, MICHAEL S, URBANA, IL:  
2,549,553, REN. 4-12-11. INT. CL. 41.
- HARTFORD FIRE INSURANCE COMPANY, HARTFORD, CT:  
2,448,782, REN. 4-14-11. INT. CL. 36.  
3,961,920, PUB. 3-1-2011. INT. CL. 36.
- HARVARD DRUG GROUP, LLC, LIVONIA, MI:  
3,960,344, PUB. 3-1-2011. INT. CL. 44.
- HARVEST GIFTS INC., NIAGARA-ON-THE-LAKE, CANADA:  
3,962,751, MULTIPLE CLASS, INT. CLS. 3, 24 AND 25.
- HARVEY RESEARCH, INC., FAIRPORT, NY:  
2,555,686, REN. 4-11-11. INT. CL. 35.
- HARVEY, MARVIN, TAMPA, FL:  
3,960,875, PUB. 9-28-2010. INT. CL. 41.
- HASBRO, INC., PAWTUCKET, RI:  
2,384,113, CANC. INT. CL. 28.  
2,882,513, CANC. INT. CL. 28.  
2,882,692, CANC. INT. CL. 28.  
2,882,693, CANC. INT. CL. 28.  
2,882,694, CANC. INT. CL. 28.  
2,882,695, CANC. INT. CL. 28.  
2,882,696, CANC. INT. CL. 28.  
2,882,697, CANC. INT. CL. 28.  
2,882,698, CANC. INT. CL. 28.
- HASCO I.A. LIMITED, ST. CHARLES, MO:  
2,396,821, REN. 4-12-11. INT. CL. 42.
- HASSAN, RICHARD, ESCONDIDO, CA:  
3,961,674, PUB. 3-1-2011. INT. CL. 43.
- HASTENS SANGAR AB, S-731 23 KOPING, SWEDEN:  
2,382,067, CANC. MULTIPLE CLASS, INT. CLS. 20 AND 24.
- HASTY JR, WILTON HERBERT, WHITNEY, TX, DBA INTERPERSONAL COMMUNICATIONS COMPANY:  
3,962,941, INT. CL. 28.
- HASTY, PAUL, FORT WORTH, TX:  
3,960,560, PUB. 3-1-2011. INT. CL. 9.
- HATER PRUUF, INC., EASTON, PA:  
3,963,026, INT. CL. 25.
- HAUGH, KELLY, A, KANSAS CITY, MO:  
2,882,857, CANC. INT. CL. 30.
- HAVEESP, INC., KINGWOOD, TX:  
2,881,990, CANC. MULTIPLE CLASS, INT. CLS. 35 AND 42.
- HAVILAND CHINA CORPORATION, PALATINE, IL:  
2,883,329, CANC. INT. CL. 4.
- HAWAII MEDICAL SERVICE ASSOCIATION, HONOLULU, HI:  
2,454,653, REN. 4-13-11. INT. CL. 42.
- HAX TECHNOLOGIES, LLC, NORTH RICHLAND HILLS, TX:  
3,960,944, PUB. 3-1-2011. INT. CL. 9.
- HAYES, PETER, LOS ANGELES, CA AND BEEN, ROBERT, LOS ANGELES, CA:  
3,960,448, PUB. 3-1-2011. INT. CL. 41.
- HAYNES AND BOONE, LLP, DALLAS, TX:  
3,961,175, PUB. 3-1-2011. INT. CL. 39.
- HAYWARD INDUSTRIES, INC., ELIZABETH, NJ:  
3,963,248, MULTIPLE CLASS, INT. CLS. 9 AND 42.
- HBI BRANDED APPAREL ENTERPRISES, LLC, WINSTON-SALEM, NC:  
2,883,409, CANC. INT. CL. 25.  
3,963,462, INT. CL. 25.
- HDR ENGINEERING, INC., OMAHA, NE:  
2,882,415, CANC. INT. CL. 42.
- HE, BING RONG, MARKHAM, ONTARIO, CANADA:  
3,963,511, INT. CL. 3.
- HEADMASTER, INC., SANTA ANA, CA:  
2,883,103, CANC. INT. CL. 25.
- HEALTH & DISABILITY ADVOCATES, CHICAGO, IL:  
3,960,500, PUB. 3-1-2011. MULTIPLE CLASS, INT. CLS. 35 AND 36.
- HEALTH CARE AUTHORITY OF THE CITY OF HUNTSVILLE, ALABAMA, THE, HUNTSVILLE, AL, DBA HUNTSVILLE HOSPITAL SYSTEM:  
2,382,487, CANC. INT. CL. 42.
- HEALTH CARE SUCCESS OY, FI-00250 HELSINKI, FINLAND:  
3,960,916, PUB. 3-1-2011. INT. CL. 9.

HEALTH ENHANCEMENT SYSTEMS, MIDLAND, MI:  
2,883,142, CANC. INT. CL. 41.

HEALTH FUSION BRANDS, INC., MARIETTA, GA:  
3,961,173, PUB. 3-1-2011. INT. CL. 32.

HEALTHCARE INSIGHTS, LLC, LAKE FOREST, IL,  
HEALTHCARE INSIGHTS, LLC, LAKE FOREST, IL:  
2,530,704, REN. 4-11-11. INT. CL. 36.

HEALTHTECH, INC., GOLDEN, CO:  
2,882,071, CANC. MULTIPLE CLASS, INT. CLS. 9, 10  
AND 42.

HEALTHGATE DATA CORP., BURLINGTON, MA:  
2,880,938, CANC. MULTIPLE CLASS, INT. CLS. 41 AND  
44.

HEALTHICUE, LLC, AVENTURA, FL:  
3,961,399, PUB. 3-1-2011. INT. CL. 44.

HEALTHY OPTIONS INC., PORTLAND, OR:  
2,555,161, REN. 4-8-11. INT. CL. 35.

HEARST COMMUNICATIONS, INC, NEW YORK, NY:  
3,961,961, INT. CL. 9.

HEART & VASCULAR INSTITUTE PLLC, DETROIT, MI:  
3,963,655, INT. CL. 44.

HEARTLAND BREWERY, INC., NEW YORK, NY:  
2,881,375, CANC. INT. CL. 32.

HEARTLAND FOUNDATION, ST. JOSEPH, MO:  
2,882,255, CANC. MULTIPLE CLASS, INT. CLS. 16 AND  
41.

HEATH & SHERWOOD (1964) LIMITED, KIRKLAND LAKE,  
ONTARIO, CANADA:  
2,382,124, CANC. INT. CL. 9.

HEATH, DAVID MICHAEL, ALPHARETTA, GA:  
2,881,601, CANC. INT. CL. 9.

HEATHER WILLENS, PACIFIC PALISADES, CA:  
3,963,590, INT. CL. 33.

HEBERT, TIM, AVON, CO:  
2,883,358, CANC. INT. CL. 16.  
2,883,365, CANC. INT. CL. 16.

HECHO LATINO INC., DALLAS, TX:  
3,962,087, MULTIPLE CLASS, INT. CLS. 14, 25 AND 35.

HEFLIN, KEITH D., SHELBYVILLE, TN:  
2,427,455, REN. 4-11-11. INT. CL. 35.  
2,443,273, REN. 4-11-11. INT. CL. 9.

HEIDELBERGER DRUCKMASCHINEN AG, HEIDELBERG,  
FED REP GERMANY:  
3,960,296, PUB. 3-1-2011. MULTIPLE CLASS, INT. CLS. 2  
AND 7.

HEINEN'S, INC., WARRENSVILLE HEIGHTS, OH:  
3,960,995, PUB. 3-1-2011. INT. CL. 33.

HEINRICH HAHNE GMBH & CO. KG, DATTELN, FED REP  
GERMANY:  
3,960,693, PUB. 3-1-2011. MULTIPLE CLASS, INT. CLS. 1,  
2, 17 AND 19.

HEIRLOOM HOSPITALITY GROUP, LLC, ASHEVILLE, NC:  
3,962,934, INT. CL. 43.

HEIRS OF ALEX AND ENGRACIA REYES SR., INC.,  
MALATE, MANILA, PHILIPPINES:  
3,960,345, PUB. 3-1-2011. MULTIPLE CLASS, INT. CLS. 30  
AND 43.

HELEN OF TROY LIMITED, ST. MICHAEL, BARBADOS:  
1,643,467, REN. 4-8-11. MULTIPLE CLASS, INT. CLS. 9  
AND 11.  
2,882,599, CANC. MULTIPLE CLASS, INT. CLS. 9, 11, 21  
AND 26.  
2,883,359, CANC. INT. CL. 11.

HELENA HOLDING COMPANY, WILMINGTON, DE:  
2,444,790, REN. 4-8-11. INT. CL. 1.

HELENA RUBINSTEIN, 75008 PARIS, FRANCE:  
2,880,617, CANC. INT. CL. 3.

HELLA GOOD, LLC, MILPITAS, CA:  
3,962,172, INT. CL. 25.

HELP ME SELL ME, LLC, ROSWELL, GA:  
3,963,752, INT. CL. 35.

HELPFUL HORSEMANSHIP, INC, AIKEN, SC:  
3,961,389, PUB. 3-1-2011. INT. CL. 35.

HEMANT VIRKAR, GAITHERSBURG, MD:  
3,960,510, PUB. 3-1-2011. MULTIPLE CLASS, INT. CLS. 9,  
35, 42 AND 44.

HEMISPHERE TRADING OF NY, LLC, HOLLIS, NY:  
3,961,686, PUB. 3-1-2011. INT. CL. 21.

HENKEL AG & CO. KGAA, DUESSELDORF, FED REP  
GERMANY:  
3,962,591, INT. CL. 3.

HENKEL CORPORATION, ROCKY HILL, CT:  
2,882,136, CANC. MULTIPLE CLASS, INT. CLS. 35, 40  
AND 42.

HENRY DUARTE LICENSING, INC., LOS ANGELES, CA:  
2,882,223, CANC. INT. CL. 35.

HEPA CORPORATION, ANAHEIM, CA:  
3,963,277, INT. CL. 11.

HERAEUS KULZER GMBH, D-63450 HANAU, FED REP  
GERMANY:  
3,960,229, PUB. 9-28-2010. MULTIPLE CLASS, INT. CLS.  
8, 9 AND 17.

HERB PHARM, INC., WILLIAMS, OR:  
2,462,384, REN. 4-11-11. INT. CL. 5.

HERBST ANDY, COPPEROPOLIS, CA, DBA RACE NUTS:  
3,962,771, INT. CL. 29.

HERISSUE LLC, PORTLAND, OR:  
3,961,387, PUB. 3-1-2011. INT. CL. 9.

HERITAGE COFFEE CO., LTD., LONDON, ONTARIO,  
CANADA:  
2,882,628, CANC. INT. CL. 30.

HERMES FUND MANAGERS LIMITED, LONDON, UNI-  
TED KINGDOM:  
3,960,869, PUB. 3-1-2011. INT. CL. 36.

HERMES INTERNATIONAL, PARIS, FRANCE:  
2,881,477, CANC. INT. CL. 18.

HERMES INTERNATIONAL, 75008 PARIS, FRANCE:  
3,961,022, PUB. 3-1-2011. INT. CL. 3.

HERO USA, INC., FONTANA, CA:  
3,963,478, INT. CL. 35.  
3,963,479, INT. CL. 35.

HERRICK, STEVEN MICHAEL, ST. LOUIS PK, MN:  
3,960,243, PUB. 3-1-2011. INT. CL. 25.

HERRINGTON & COMPANY, INC., IRVINE, CA:  
2,382,867, CANC. INT. CL. 25.

HERSCH AND COMPANY, LOS ANGELES, CA:  
2,882,797, CANC. INT. CL. 28.

HERSHEY CHOCOLATE & CONFECTIONERY CORPORA-  
TION, WHEAT RIDGE, CO:  
1,273,766, CANC. INT. CL. 30.  
3,961,872, PUB. 3-1-2011. INT. CL. 30.

HERSHEY CHOCOLATE & CONFECTIONERY CORPORA-  
TION, WHEAT RIDGE, PA:  
3,961,915, PUB. 3-1-2011. INT. CL. 30.

HERSHEY CHOCOLATE & CONFECTIONERY CORPORA-  
TION, WHEAT RIDGE, CO:  
3,961,916, PUB. 3-1-2011. INT. CL. 30.  
3,961,917, PUB. 3-1-2011. INT. CL. 29.  
3,961,918, PUB. 3-1-2011. INT. CL. 30.  
3,963,460, INT. CL. 30.

HERTZ & SELCK GMBH & CO., FED REP GERMANY:  
3,960,653, PUB. 3-1-2011. MULTIPLE CLASS, INT. CLS. 1,  
3, 30, 32 AND 33.

HERTZ EQUIPMENT RENTAL CORPORATION, PARK  
RIDGE, NJ:  
3,960,620, PUB. 3-1-2011. MULTIPLE CLASS, INT. CLS. 37  
AND 40.

HERVOCHON, DEAN P., CHICAGO, IL, DBA THE GO TO  
GAY GUY:  
3,963,860, INT. CL. 35.

HESCO, WARREN, MI:  
3,960,374, PUB. 3-1-2011. MULTIPLE CLASS, INT. CLS. 37  
AND 42.

HESSING, FRANK, HOUSTON, TX:  
3,963,777, INT. CL. 35.

HEWITT, RICHARD, SANTA BARBARA, CA, DBA ENDEA-  
VOUR IV, INC.:  
1,918,856, CANC. INT. CL. 20.

HICO, INC., ENCINO, CA:  
3,962,045, MULTIPLE CLASS, INT. CLS. 3 AND 10.

HID GLOBAL CORPORATION, IRVINE, CA:  
3,962,069, INT. CL. 9.

HIGATV PRODUCTIONS LLC, LAS VEGAS, NV:  
3,961,132, PUB. 3-1-2011. INT. CL. 41.

- HIGH Q LASER PRODUCTION GMBH, A-6845 HOHENEMS, AUSTRIA:  
2,687,955, CANC. MULTIPLE CLASS, INT. CLS. 9 AND 42.
- HIGHWATER DESIGNS LIMITED, CHELTENHAM, UNITED KINGDOM:  
2,383,759, CANC. MULTIPLE CLASS, INT. CLS. 9 AND 42.
- HILARY J. CHOLHAN, MD, ROCHESTER, NY:  
3,963,373, INT. CL. 44.
- HILDEGARD BRAUKMANN KOSMETIK GMBH & CO. KG, FED REP GERMANY:  
3,055,709.
- HILL, CHRIS, G., LOUISVILLE, CO:  
2,883,120, CANC. INT. CL. 42.
- HILL'S PET NUTRITION, INC., TOPEKA, KS:  
3,963,358, MULTIPLE CLASS, INT. CLS. 5 AND 31.
- HINDES, GARY, WILMINGTON, DE:  
3,961,390, PUB. 3-1-2011. INT. CL. 16.
- HINSON, CHRIS, CLEARWATER, FL:  
2,880,834, CANC. INT. CL. 41.
- HIRAMEKI INTERNATIONAL GROUP, INC., CITY OF INDUSTRY, CA:  
2,881,794, CANC. INT. CL. 35.
- HIREKO TRADING COMPANY, INC., CITY OF INDUSTRY, CA:  
2,883,355, CANC. INT. CL. 28.
- HIREPOTENTIAL INC., DENVER, CO:  
2,460,495, REN. 4-13-11. INT. CL. 35.
- HISTORICAL ASSOCIATION OF SOUTHERN FLORIDA, INC., THE, MIAMI, FL:  
2,382,188, CANC. MULTIPLE CLASS, INT. CLS. 16 AND 41.
- HITACHI TELECOM (USA), INC., NORCROSS, GA:  
2,882,733, CANC. INT. CL. 9.
- HL USA, INC., SANTA FE SPRINGS, CA:  
2,882,184, CANC. INT. CL. 28.
- HLT DOMESTIC IP LLC, MCLEAN, VA:  
3,963,015, INT. CL. 43.
- HNI TECHNOLOGIES INC., MUSCATINE, IA:  
2,882,651, CANC. INT. CL. 11.
- HOB ENTERTAINMENT, INC., BEVERLY HILLS, CA:  
2,881,917, CANC. INT. CL. 41.
- HOBBY LOBBY STORES, INC., OKLAHOMA CITY, OK:  
3,963,212, INT. CL. 17.
- HOFFEY, JAMES J., AUBURN, MA:  
2,382,739, CANC. INT. CL. 37.
- HOLDING SOPREMA, STRASBOURG CEDEX, FRANCE:  
3,962,482, MULTIPLE CLASS, INT. CLS. 2, 3 AND 19.
- HOLDING SOPREMA, 67100 STRASBOURG CEDEX, FRANCE:  
3,962,483, MULTIPLE CLASS, INT. CLS. 2, 3 AND 19.
- HOLISTIC MANAGEMENT INTERNATIONAL, ALBUQUERQUE, NM:  
3,960,845, PUB. 3-1-2011. MULTIPLE CLASS, INT. CLS. 9, 35 AND 41.
- HOLLEY PERFORMANCE PRODUCTS, INC., BOWLING GREEN, KY:  
3,960,251, PUB. 3-1-2011. INT. CL. 41.  
3,961,992, INT. CL. 12.
- HOLMBERG COMPANY, INC., MINNEAPOLIS, MN:  
3,962,476, INT. CL. 16.
- HOLMES, QUENTIN M., TORRANCE, CA:  
2,882,605, CANC. INT. CL. 25.
- HOLOPACK VERPACKUNGSTECHNIK GMBH, FED REP GERMANY:  
3,922,137, COR. MULTIPLE CLASS, INT. CLS. 37, 39 AND 42.
- HOLT'S COMPANY, WILMINGTON, DE:  
2,880,987, CANC. INT. CL. 34.
- HOLTZBRINCK PUBLISHERS HOLDINGS, LLC, NEW YORK, NY:  
2,881,485, CANC. INT. CL. 16.
- HOLZ-HOERZ GMBH, 72525 MUNSINGEN, FED REP GERMANY:  
2,439,776, REN. 4-12-11. INT. CL. 10.
- HOME AND GARDEN PARTY, LTD., MARSHALL, TX:  
2,881,488, CANC. INT. CL. 35.  
2,883,285, CANC. INT. CL. 21.
- HOME HEALTHCARE SOLUTIONS, INC., ATLANTA, GA:  
3,961,304, PUB. 3-1-2011. INT. CL. 35.
- HOME INSTEAD, INC., OMAHA, NE:  
3,960,988, PUB. 3-1-2011. INT. CL. 41.  
3,963,348, INT. CL. 45.
- HOME LEGEND, LLC., CHINO, CA:  
3,961,269, PUB. 3-1-2011. INT. CL. 27.
- HOMEAVENUE, INC., ST. LOUIS PARK, MN:  
2,865,076, CANC. INT. CL. 36.
- HOMEDICS, INC., COMMERCE TOWNSHIP, MI:  
2,882,646, CANC. INT. CL. 11.
- HOMEGOODS, INC., FRAMINGHAM, MA:  
3,962,690, INT. CL. 35.
- HOMER TLC, INC., CLAYMONT, DE:  
2,883,161, CANC. INT. CL. 11.
- HONDA GIKEN KOGYO KABUSHIKI KAISHA (HONDA MOTOR CO., LTD.), MINATO-KU, TOKYO 107, JAPAN:  
2,881,943, CANC. INT. CL. 28.  
2,882,041, CANC. INT. CL. 28.
- HONEY FARMS, INC., WORCESTER, MA:  
3,963,569, INT. CL. 9.
- HONEYWELL INTERNATIONAL INC., MORRISTOWN, NJ:  
2,383,491, CANC. INT. CL. 9.  
3,963,032, INT. CL. 9.  
3,963,530, INT. CL. 17.
- HONG KONG CITY TOYS FACTORY LIMITED, KOWLOON, HONG KONG:  
2,462,825, REN. 4-13-11. INT. CL. 28.
- HOOD RIVER DISTILLERS, INC., HOOD RIVER, OR, DBA BROKER'S IMPORTS:  
925,621, REN. 4-11-11. U.S. CL. 49 (INT. CL. 33).
- HORIBA JOBIN YVON INC., EDISON, NJ, SPEX INDUSTRIES, INC., EDISON, NJ:  
1,641,143, REN. 4-11-11. INT. CL. 9.
- HORIBA, LTD., MINAMI-KU, KYOTO, JAPAN:  
2,314,104, REN. 4-8-11. INT. CL. 9.
- HORMEL FOODS, LLC, AUSTIN, MN:  
2,428,383, REN. 4-8-11. INT. CL. 29.  
3,961,904, PUB. 3-1-2011. INT. CL. 29.
- HORST, MARY GARVEY, SANTA FE, NM, DBA MIND-BODY VISIONS:  
3,962,930, INT. CL. 41.
- HORWATH INTERNATIONAL REGISTRATION, LTD., NEW YORK, NY:  
3,960,937, PUB. 3-1-2011. MULTIPLE CLASS, INT. CLS. 37, 39, 41 AND 43.
- HOSPITAL AND HEALTHSYSTEM ASSOCIATION OF PENNSYLVANIA, PHILADELPHIA, PA:  
2,880,681, CANC. MULTIPLE CLASS, INT. CLS. 16, 35 AND 41.
- HOT TOPIC, INC., CITY OF INDUSTRY, CA:  
3,962,502, INT. CL. 35.
- HOT TUNA INTERNATIONAL PLC, LONDON, ENGLAND, UNITED KINGDOM:  
2,363,494, REN. 4-11-11. INT. CL. 25.  
2,363,494, CANC. MULTIPLE CLASS, INT. CLS. 9, 14 AND 18.
- HOT WATER PRODUCTS, INC., MILWAUKEE, WI:  
3,961,730, PUB. 3-1-2011. INT. CL. 11.
- HOTELS.COM, L.P., DALLAS, TX:  
3,962,112, INT. CL. 39.  
3,962,126, INT. CL. 39.
- HOTPRINTS LIMITED, LONDON, UNITED KINGDOM:  
3,961,093, PUB. 3-1-2011. INT. CL. 40.
- HOUGHTON MIFFLIN COMPANY, BOSTON, MA:  
2,882,491, CANC. INT. CL. 41.
- HOUPower WATCHES, LLC, SHAKER HEIGHTS, OH:  
2,883,019, CANC. INT. CL. 35.
- HOUSTONIAN GOLF, LTD., HOUSTON, TX:  
2,439,085, REN. 4-11-11. INT. CL. 35.
- HOWARD, JAMES, PHOENIX, AZ:  
3,961,025, PUB. 3-1-2011. INT. CL. 41.
- HOWARD, VEDA N., LITHONIA, GA:  
3,961,048, PUB. 3-1-2011. INT. CL. 41.



HOWICK APPAREL LTD., LAURENT, QUEBEC H4N 1W9, CANADA:  
2,880,636, CANC. INT. CL. 25.

HOY SHOE COMPANY, INC., ST. LOUIS, MO:  
1,148,982, REN. 4-14-11. INT. CL. 25.

HOYA CORPORATION, TOKYO, JAPAN:  
715,035, REN. 4-14-11. U.S. CL. 26 (INT. CL. 9).

HP-CHEMIE PELZER GMBH, WITTEN, FED REP GERMANY:  
2,818,847, COR. MULTIPLE CLASS, INT. CLS. 12 AND 17.

HPL, L.L.C., GILBERT, AZ:  
3,963,635, INT. CL. 11.

HROBOWSKI, DAVID, LOS ANGELES, CA:  
2,440,933, REN. 4-11-11. INT. CL. 35.

HS TM, LLC, NEWARK, DE:  
2,449,777, REN. 4-8-11. INT. CL. 36.

HSI IP, INC., GRAND CAYMAN, CAYMAN ISLANDS:  
2,882,591, CANC. INT. CL. 6.

HT ENTERPRISES, CAMPBELLSPORT, WI:  
2,469,352, REN. 4-13-11. INT. CL. 28.

HUANG'S INC., OWINGS MILLS, MD:  
3,960,402, PUB. 3-1-2011. INT. CL. 41.

HUAWEI TECHNOLOGIES CO., LTD., SHENZHEN, CHINA:  
3,960,388, PUB. 3-1-2011. MULTIPLE CLASS, INT. CLS. 37 AND 42.

HUBBARD FEEDS INC., MANKATO, MN:  
2,882,734, CANC. INT. CL. 9.

HUBBS MACHINE & MANUFACTURING, INC., CEDAR HILL, MO:  
3,960,226, PUB. 3-1-2011. MULTIPLE CLASS, INT. CLS. 9 AND 42.

HUDSON CONSULTING & MANAGEMENT, LLC, MIAMI, FL:  
3,962,579, INT. CL. 29.

HUFCOR, INC., JANESVILLE, WI:  
3,962,659, INT. CL. 20.

HUFNAGEL, ZORKA, PULTNEYVILLE, NY, AKA HUFNAGEL, Z.:  
3,918,427, AM. INT. CL. 41.

HUGHES, MARK E., SWARTHMORE, PA:  
2,882,319, CANC. INT. CL. 35.

HUGOTON ROYALTY TRUST, DALLAS, TX:  
2,443,184, REN. 4-11-11. INT. CL. 36.

HUMAN GENOME SCIENCES, INC., ROCKVILLE, MD:  
2,881,980, CANC. INT. CL. 5.

HUMANA INC., LOUISVILLE, KY:  
3,962,344, INT. CL. 44.

HUMBLE ENDEAVORS, LLC, SCOTTSDALE, AZ:  
3,962,762, MULTIPLE CLASS, INT. CLS. 31 AND 35.  
3,962,763, MULTIPLE CLASS, INT. CLS. 31 AND 35.

HUMICON LLC, HAUPPAUGE, NY:  
3,962,300, MULTIPLE CLASS, INT. CLS. 16 AND 34.

HUN B.V., THE, WERVERSHOOF, NETHERLANDS:  
2,783,516, AM. INT. CL. 35.

HUNT, STEPHEN, ANGOLA, IN:  
3,963,784, INT. CL. 44.

HUNTER DOUGLAS, INC., UPPER SADDLE RIVER, NJ:  
2,882,044, CANC. INT. CL. 7.  
2,882,431, CANC. INT. CL. 20.

HUNTER, KATHERIN, BROOKSVILLE, FL:  
3,962,465, INT. CL. 35.

HUNTER, SHELLEY A., DANVILLE, CA:  
3,962,735, INT. CL. 35.

HUNTER, THEODORE R., FAIRFIELD, CA, DBA STAR-FIRE:  
2,881,174, CANC. INT. CL. 9.

HUSQVARNA U.S. HOLDING, INC., CHARLOTTE, NC, WHITE CONSOLIDATED INDUSTRIES, INC., CLEVELAND, OH:  
2,451,997, REN. 4-14-11. INT. CL. 7.

HUTCHISON, MARY MORRIS, COLUMBUS, OH:  
2,881,804, CANC. INT. CL. 41.

HUTTON & KLOHE ENTERPRISES, LLC, PHOENIX, AZ:  
2,882,209, CANC. INT. CL. 16.

HYATT CORPORATION, CHICAGO, IL:  
3,963,137, INT. CL. 36.  
3,963,138, INT. CL. 43.

HYDE PARK ART CENTER, CHICAGO, IL:  
3,960,493, PUB. 3-1-2011. INT. CL. 35.

HYDRA PURE, INC., KILLINGWORTH, CT:  
2,882,080, CANC. INT. CL. 11.

HYDRANAUTICS, INC., OCEANSIDE, CA:  
3,962,479, INT. CL. 11.

HYDRO-AIR COMPONENTS, INC., HAMBURG, NY:  
2,881,100, CANC. INT. CL. 11.

HYDROPOOL INC., MISSISSAUGA, CANADA:  
3,962,013, MULTIPLE CLASS, INT. CLS. 1, 11 AND 19.

HYPE-IP LIMITED, GIBRALTAR, GIBRALTAR:  
3,962,214, MULTIPLE CLASS, INT. CLS. 5 AND 32.

HYPERVOCAL, LLC, WASHINGTON, DC:  
3,963,678, INT. CL. 41.

HYPHEN SOLUTIONS, LTD., ADDISON, TX:  
2,882,718, CANC. INT. CL. 35.

HÖGANÄS AB, SWEDEN:  
3,960,705, PUB. 3-1-2011. MULTIPLE CLASS, INT. CLS. 1, 6 AND 42.

I AM MAD AT YOU CARDS, INC., OCEAN RIDGE, FL:  
3,961,404, PUB. 3-1-2011. INT. CL. 16.  
3,961,405, PUB. 3-1-2011. INT. CL. 16.  
3,961,475, PUB. 3-1-2011. INT. CL. 16.

I.C.E.D. MANAGEMENT, INC., CYPRESS, TX:  
3,960,403, PUB. 2-8-2011. MULTIPLE CLASS, INT. CLS. 35 AND 40.

IAN LAUDER, REDMOND, WA, DBA CYBER-SEA, INC:  
2,880,737, CANC. INT. CL. 9.

IBALANCE MEDICAL LLC, BOULDER, CO:  
3,608,010, COR. INT. CL. 10.

IBASIS, INC., BURLINGTON, MA:  
3,962,837, INT. CL. 16.

IBEY, JERRY A., WHITTIER, CA, DBA CREATIVE TECHNICAL SERVICES:  
2,443,849, REN. 4-11-11. INT. CL. 9.

IBRIK COFFEES, INC., MAULDIN, SC:  
2,882,562, CANC. INT. CL. 35.

IBT HOLDINGS, LLC, DEERFIELD BEACH, FL:  
3,960,242, PUB. 3-1-2011. INT. CL. 11.

IBW HOLDINGS, LLC, HOLLYWOOD, FL:  
3,960,283, PUB. 3-1-2011. INT. CL. 35.

ICARUS ENERGY, LLC., FAIRFIELD, CT:  
3,961,989, INT. CL. 11.

ICB MANUFACTURING, SOUTH PASADENA, CA, DBA TIME LABORATORIES:  
2,882,933, CANC. MULTIPLE CLASS, INT. CLS. 3, 5 AND 11.

ICBC BROADCAST HOLDINGS, INC., NEW YORK, NY:  
2,440,681, REN. 4-8-11. INT. CL. 41.  
2,440,682, REN. 4-8-11. INT. CL. 38.

ICC INNOVATIVE CONCEPTS CORPORATION, TORRINGTON, CT:  
2,383,512, CANC. MULTIPLE CLASS, INT. CLS. 8 AND 9.

ICC USA, INC., LOUISVILLE, KY:  
3,963,527, INT. CL. 31.

ICD AMERICA LLC, NEW ROCHELLE, NY:  
2,475,270, REN. 4-14-11. INT. CL. 17.

ICELAND, INC., PITTSBURGH, PA:  
2,613,946, CANC. MULTIPLE CLASS, INT. CLS. 35 AND 39.

ICI SUPPLY, INC., PARAMOUNT, CA, DBA ICI NATURAL:  
3,829,580, CANC. INT. CL. 3.

ICIM CORPORATION, NEW ALBANY, IN, DBA PLANET TELECOM:  
3,962,908, INT. CL. 35.  
3,962,909, MULTIPLE CLASS, INT. CLS. 35, 37, 38 AND 42.  
3,962,910, MULTIPLE CLASS, INT. CLS. 35, 37, 38 AND 42.  
3,962,943, INT. CL. 35.  
3,962,944, MULTIPLE CLASS, INT. CLS. 35, 37, 38 AND 42.  
3,962,945, MULTIPLE CLASS, INT. CLS. 35, 37, 38 AND 42.

ICLOOLY CO., LTD., GYEONGGI-DO, REPUBLIC OF KOREA:  
3,962,853, INT. CL. 9.

- ICNW, INC., LIBERTY LAKE, WA:  
2,881,836, CANC. INT. CL. 11.
- ICONIC TSUNAMI, LLC, SMYRNA, DE:  
3,963,440, INT. CL. 9.
- ICR, INC., BALTIMORE, MD:  
3,961,096, PUB. 3-1-2011. INT. CL. 42.
- IDEA NUOVA, INC., NEW YORK, NY:  
3,962,010, INT. CL. 24.
- IDEAL BINARY, LTD., DUBLIN, IRELAND:  
3,961,495, PUB. 3-1-2011. INT. CL. 9.
- IDEMITSU KOSAN CO., LTD., TOKYO 100-8321, JAPAN:  
3,960,818, PUB. 3-1-2011. INT. CL. 31.
- IDESK GROUP LIMITED, WEMBLEY, MIDDLESEX, UNITED KINGDOM:  
2,880,569, CANC. MULTIPLE CLASS, INT. CLS. 9, 16, 35, 38, 41 AND 42.
- IDITAROD TRAIL COMMITTEE, WASILLA, AK:  
1,642,734, REN. 4-14-11. MULTIPLE CLASS, INT. CLS. 14, 21, 25 AND 26.
- IDR MARKETING PARTNERS, LLC, BERWYN, PA:  
2,441,842, REN. 4-9-11. INT. CL. 35.
- IDT DENTAL GROUP, LLC, TEANECK, NJ:  
3,962,873, INT. CL. 5.
- IDT NETHERLANDS, B.V. (PUERTO RICO BRANCH), SAN JUAN, PUERTO RICO:  
2,383,625, CANC. INT. CL. 16.  
2,383,635, CANC. INT. CL. 16.
- IFC PRODUCTS, INC., LINDEN, NJ:  
3,960,255, PUB. 3-1-2011. INT. CL. 30.
- IGG INC, GRAND CAYMAN, KY1-1107, CAYMAN ISLANDS:  
3,960,343, PUB. 3-1-2011. MULTIPLE CLASS, INT. CLS. 9 AND 41.
- IGT, RENO, NV:  
3,962,242, INT. CL. 9.  
3,962,277, INT. CL. 9.  
3,962,396, INT. CL. 9.  
3,962,467, INT. CL. 9.  
3,962,473, INT. CL. 9.
- IKARUS USA LLC, CAPE CORAL, FL:  
3,961,468, PUB. 3-1-2011. INT. CL. 9.
- IL LUGANO, LLC, FORT LAUDERDALE, FL:  
3,962,193, INT. CL. 43.
- ILA ST. CLAIRE, LLC, RESTON, VA:  
2,882,563, CANC. INT. CL. 42.
- ILLINOIS TOOL WORKS INC., GLENVIEW, IL:  
3,963,387, INT. CL. 17.
- ILSCO CORPORATION, CINCINNATI, OH, DBA FTZ INDUSTRIES:  
3,962,592, INT. CL. 9.
- IMAGECARE, INC., BARRINGTON, IL:  
2,880,953, CANC. INT. CL. 9.
- IMAGENETIX, SAN DIEGO, CA:  
3,963,497, INT. CL. 5.
- IMAGES.COM, INC., NEW YORK, NY:  
2,382,667, CANC. INT. CL. 42.  
2,383,085, CANC. INT. CL. 42.
- IMAGEWEAR APPAREL CORP., WILMINGTON, DE:  
2,447,978, REN. 4-12-11. INT. CL. 9.  
3,962,221, INT. CL. 25.
- IMAGINAIL CORPORATION, LARGO, FL:  
2,882,849, CANC. MULTIPLE CLASS, INT. CLS. 3, 7 AND 42.
- IMAGINATION FACTORY, INC., THE, GRAND RAPIDS, MI, AKA IFI:  
3,961,273, PUB. 3-1-2011. INT. CL. 42.
- IMAGINATION TECHNOLOGIES LTD, HERTFORDSHIRE WD4 8LZ, UNITED KINGDOM:  
2,881,327, CANC. MULTIPLE CLASS, INT. CLS. 9 AND 42.
- IMAGING HEALTHCARE SPECIALISTS, LLC, SAN DIEGO, CA:  
2,382,678, CANC. INT. CL. 41.
- IMERGENT, INC., OREM, UT:  
3,963,203, MULTIPLE CLASS, INT. CLS. 35, 41 AND 42.
- IMERYS MINERALS LIMITED, CORNWALL PL24 2SQ, UNITED KINGDOM:  
2,881,054, CANC. MULTIPLE CLASS, INT. CLS. 1 AND 2.
- IMERYS MINERALS LTD., CORNWALL, UNITED KINGDOM, ECC INTERNATIONAL LIMITED, ST. AUSTELL, CORNWALL PL25 4DJ, ENGLAND:  
1,648,607, REN. 4-9-11. INT. CL. 1.
- IMMUDYNE, INC., MOUNT KISCO, NY:  
2,383,983, CANC. INT. CL. 3.
- IMMVAC, INCORPORATED, COLUMBIA, MO:  
1,681,754, REN. 4-14-11. INT. CL. 5.
- IMPACTRX, INC., MT. LAUREL, NJ:  
3,963,332, INT. CL. 35.
- IMPERIAL PUBLISHING, INC., COMMACK, NY:  
3,961,143, PUB. 3-1-2011. INT. CL. 42.
- IMPERIAL TOY, LLC, NORTH HILLS, CA:  
3,962,661, INT. CL. 28.
- IMPLEX.NET, INC., MINNEAPOLIS, MN:  
2,876,812, CANC. INT. CL. 9.
- IMPLUS FOOTCARE, LLC, DURHAM, NC:  
2,882,373, CANC. INT. CL. 9.
- IMPORT EXPORT INTERNATIONAL, WATERFORD, MI:  
3,962,261, MULTIPLE CLASS, INT. CLS. 29 AND 30.
- IMPROPER PUBLICATIONS, INC., BOSTON, MA:  
3,961,764, PUB. 3-1-2011. INT. CL. 16.  
3,961,766, PUB. 3-1-2011. INT. CL. 16.
- IMST GMBH, FED REP GERMANY:  
3,960,730, PUB. 3-1-2011. MULTIPLE CLASS, INT. CLS. 9 AND 42.
- IN TOUCH MINISTRIES, INC., ATLANTA, GA:  
2,542,037, REN. 4-12-11. INT. CL. 42.  
2,543,672, REN. 4-12-11. INT. CL. 41.  
2,543,673, REN. 4-12-11. INT. CL. 42.  
2,545,554, REN. 4-12-11. INT. CL. 41.  
3,960,401, PUB. 3-1-2011. INT. CL. 38.
- INA CORPORATION, PHILADELPHIA, PA:  
713,296, REN. 4-11-11. U.S. CL. 102 (INT. CL. 36).
- INC RESEARCH, INC., RALEIGH, NC:  
3,961,733, PUB. 3-1-2011. MULTIPLE CLASS, INT. CLS. 9, 41 AND 42.
- INCENERGY, LLC, AUSTIN, TX:  
3,963,202, INT. CL. 35.
- INCEPTURE, INC., JACKSONVILLE, FL:  
2,882,687, CANC. INT. CL. 9.
- INCOGEN, INC., WILLIAMSBURG, VA:  
3,961,028, PUB. 3-1-2011. INT. CL. 9.
- INCREDIBLE TECHNOLOGIES, INC., ARLINGTON HEIGHTS, IL:  
3,961,020, PUB. 3-1-2011. INT. CL. 28.
- INDEPENDENT OWNERS COOPERATIVE, LLC, FREEPORT, ME:  
2,382,726, CANC. INT. CL. 42.
- INDEPENDENT PURCHASING COMPANY (AUSTRALASIA) LTD., NORTH SYDNEY, AUSTRALIA:  
3,963,144, INT. CL. 35.
- INDEXATOR AB, 922 00 VINDELN, SWEDEN:  
2,382,830, CANC. INT. CL. 7.
- INDIANA PAGING NETWORK, INC., LAPORTE, IN:  
3,961,581, PUB. 3-1-2011. INT. CL. 9.
- INDIANAPOLIS COLLEGE, INC., PLAINFIELD, IN:  
2,883,368, CANC. INT. CL. 41.
- INDIGO ROOT, LLC, KIRKLAND, WA:  
3,963,839, INT. CL. 20.
- INDOOR SCIENCES, INC., CHICAGO, IL:  
3,963,868, MULTIPLE CLASS, INT. CLS. 35 AND 41.
- INDUPOLLO USA LLC, LAUDERHILL, FL:  
2,881,107, CANC. INT. CL. 39.
- INDUSTRIA DE PELES MINUANO, LTDA., LINDOLFO COLLOR, R.S., BRAZIL:  
2,881,005, CANC. INT. CL. 18.
- INDUSTRIAL MAGNETICS, INC., BOYNE CITY, MI:  
2,880,972, CANC. INT. CL. 9.
- INDUSTRIAL REVOLUTION, INC., REDMOND, WA:  
3,961,241, PUB. 3-1-2011. INT. CL. 11.
- INDUSTRIE HOLDING GMBH, AUSTRIA:  
3,960,658, PUB. 3-1-2011. MULTIPLE CLASS, INT. CLS. 7, 9, 12, 35, 36, 37 AND 42.
- INEOS EUROPE LIMITED, MIDDLESEX, UNITED KINGDOM:  
2,383,495, CANC. MULTIPLE CLASS, INT. CLS. 1 AND 42.

INFERTILITY CENTER OF HOUSTON, HOUSTON, TX:  
2,883,410, CANC. INT. CL. 44.

INFIMED, INC., LIVERPOOL, NY:  
2,882,683, CANC. INT. CL. 42.

INFINEON TECHNOLOGIES AG, 81669 MUNICH, FED REP GERMANY:  
2,881,478, CANC. INT. CL. 9.

INFINITELABS LLC, ORLANDO, FL:  
3,961,407, PUB. 3-1-2011. INT. CL. 5.  
3,961,415, PUB. 3-1-2011. INT. CL. 5.  
3,961,424, PUB. 3-1-2011. INT. CL. 5.

INFINITY CONSULTANT GROUP LLC, KANSAS CITY, MO:  
3,963,626, INT. CL. 35.

INFO GROUP, INC., THE, FRAMINGHAM, MA:  
2,880,564, CANC. INT. CL. 9.

INFOCUS CORPORATION, PORTLAND, OR, INFOCUS CORPORATION, PORTLAND, OR:  
2,442,116, REN. 4-12-11. INT. CL. 9.

INFORMATICA 64, S.L.U., 28932 MOSTOLES MADRID, SPAIN:  
3,963,050, INT. CL. 42.

INFORMATION MANAGEMENT SOLUTIONS, LLC, SAN ANTONIO, TX:  
3,963,728, INT. CL. 39.

INFOTERIA CORPORATION, TOKYO, JAPAN:  
3,961,768, PUB. 3-1-2011. INT. CL. 9.

INFOVISTA SA, LES ULIS, FRANCE:  
2,442,528, REN. 4-9-11. INT. CL. 9.

INFRASTRUCTURED: FITNESS INSIDE & OUT, LLC, GERMANTOWN, MD:  
2,830,128, COR. INT. CL. 41.

INFUSINO, SUSAN, SCHAUMBERG, IL:  
3,963,049, INT. CL. 9.

INGENIATRICS TECNOLOGIAS, S.L., SEVILLA, SPAIN:  
3,960,354, PUB. 11-2-2010. INT. CL. 42.

INGRID S. TIGHE, BIRMINGHAM, MI:  
3,962,712, INT. CL. 35.

INHALE, INC., SANTEE, CA:  
3,961,544, PUB. 3-1-2011. INT. CL. 34.  
3,961,547, PUB. 3-1-2011. INT. CL. 34.

INI-ABASI, ANIEKAN, WINDSOR, ONTARIO, CANADA, AKA ELISHA GOODMAN:  
3,962,702, MULTIPLE CLASS, INT. CLS. 9 AND 16.

INKAN GROUP, LLC., TORRANCE, CA:  
3,963,313, INT. CL. 43.

INLIFE, LLC, IRVINE, CA:  
3,962,648, INT. CL. 34.  
3,962,655, INT. CL. 35.

INNOVA BRASS, INC., OMAHA, NY:  
2,881,066, CANC. INT. CL. 35.

INNOVATION RANDERS A/S, DENMARK:  
3,960,819, PUB. 3-1-2011. INT. CL. 20.

INNOVATION SPECIALTIES, CULVER CITY, CA:  
3,962,244, INT. CL. 40.

INNOVATIVE MED INC., IRVINE, CA:  
3,960,873, PUB. 3-1-2011. INT. CL. 21.

INNOVATIVE STORAGE DESIGNS, INC., MEQUON, WI:  
2,883,298, CANC. INT. CL. 20.  
2,883,299, CANC. INT. CL. 20.

INNOVATIVE SURGICAL TECHNOLOGY, INC., LOS ALAMOS, NM:  
2,880,874, CANC. INT. CL. 10.

INOVA DIAGNOSTICS, INC., SAN DIEGO, CA:  
2,115,253, AM. MULTIPLE CLASS, INT. CLS. 1, 5 AND 10.  
2,115,254, AM. MULTIPLE CLASS, INT. CLS. 1, 5 AND 10.  
3,936,651, AM. MULTIPLE CLASS, INT. CLS. 1, 5 AND 10.

INPOTRON SCHALTNETZTEILE GMBH, HILZINGEN, FED REP GERMANY:  
3,960,723, PUB. 3-1-2011. MULTIPLE CLASS, INT. CLS. 9 AND 42.

INQUBIT, INC., TORRANCE, CA:  
3,960,886, PUB. 3-1-2011. INT. CL. 36.

INSPECTION CONSULTING INC., VANCOUVER, WA:  
2,881,077, CANC. INT. CL. 42.

INSPIRATION BEVERAGE COMPANY, LLC, LAKEWOOD, CO:  
3,962,390, MULTIPLE CLASS, INT. CLS. 25 AND 32.  
3,962,391, MULTIPLE CLASS, INT. CLS. 25 AND 32.  
3,962,393, MULTIPLE CLASS, INT. CLS. 25 AND 32.

INSPIRATIONAL NETWORK, INC., THE, CHARLOTTE, NC:  
2,884,139, COR. INT. CL. 41.

INSPIRON, INC., BROOKLYN, NY:  
3,962,998, INT. CL. 37.

INSTITUTIONAL INVESTOR, INC., NEW YORK, NY:  
2,883,371, CANC. MULTIPLE CLASS, INT. CLS. 16 AND 36.

INSURANCE AUTO AUCTIONS, INC., WESTCHESTER, IL TO INSURANCE AUTO AUCTIONS, INC., WESTCHESTER, IL:  
2,382,030, CANC. INT. CL. 36.

INTEGRATED PAIN MANAGEMENT, S.C., CHICAGO, IL:  
3,962,798, INT. CL. 10.

INTEGRITY MUTUAL INSURANCE COMPANY, APPLETON, WI:  
3,962,976, INT. CL. 36.

INTELAGARD, INCORPORATED, LAFAYETTE, CO:  
2,395,768, REN. 4-11-11. INT. CL. 9.

INTELISTAF HEALTHCARE, INC., BOCA RATON, FL:  
2,881,748, CANC. INT. CL. 35.

INTELLECTUAL ARCHITECTS LTD., EAGAN, MN:  
2,881,845, CANC. INT. CL. 41.

INTELLECTUAL RESERVE, INC., SALT LAKE CITY, UT:  
3,961,803, PUB. 3-1-2011. MULTIPLE CLASS, INT. CLS. 16 AND 41.

INTELLIGIRL, INC., NEW YORK, NY:  
2,882,001, CANC. MULTIPLE CLASS, INT. CLS. 9, 35 AND 41.

INTELLIKEY CORPORATION, WEST MELBOURNE, FL:  
1,639,581, REN. 4-8-11. MULTIPLE CLASS, INT. CLS. 9 AND 42.

INTELLISPHERE, LLC, PLAINSBORO, NJ:  
3,961,798, PUB. 3-1-2011. INT. CL. 41.

INTELLIWARE, INC., BETHANY, OK:  
2,883,148, CANC. INT. CL. 9.

INTERDESIGN, INC., SOLON, OH:  
2,778,441, COR. INT. CL. 1.

INTERFACEFABRIC, INC., ATLANTA, GA:  
2,881,048, CANC. INT. CL. 24.

INTERFASHION LTD., LYNDHURST TERRACE, HONG KONG:  
2,880,717, CANC. MULTIPLE CLASS, INT. CLS. 3, 18 AND 25.

INTERMEX WIRE TRANSFER, LLC, MIAMI, FL:  
2,446,107, REN. 4-14-11. INT. CL. 36.

INTERNAP NETWORK SERVICES CORPORATION, ATLANTA, GA:  
2,383,370, CANC. INT. CL. 38.

INTERNATIONAL AUTO PARTS, INC., CHARLETTESVILLE, VA:  
2,883,370, CANC. INT. CL. 3.

INTERNATIONAL BREAST CANCER RESEARCH FOUNDATION, INC., MADISON, WI:  
2,881,133, CANC. INT. CL. 36.

INTERNATIONAL BUSINESS MACHINES CORPORATION, ARMONK, NY:  
2,383,758, CANC. INT. CL. 9.

INTERNATIONAL BUSINESS MACHINES CORPORATION, ARMONK, NY, AKA IBM CORPORATION:  
2,880,615, CANC. MULTIPLE CLASS, INT. CLS. 9 AND 42.  
2,880,628, CANC. MULTIPLE CLASS, INT. CLS. 9 AND 42.  
2,880,798, CANC. INT. CL. 42.

INTERNATIONAL BUSINESS MACHINES CORPORATION, ARMONK, NY:  
2,881,923, CANC. INT. CL. 37.

INTERNATIONAL CHURCHILL SOCIETY, CHICAGO, IL:  
1,640,451, REN. 4-11-11. INT. CL. 16.

INTERNATIONAL CHURCHILL SOCIETY, HOPKINTON, NH:  
1,640,451, COR. INT. CL. 16.

- INTERNATIONAL COLLEGE OF DENTISTS, ROCKVILLE, MD:  
3,961,566, PUB. 3-1-2011. MULTIPLE CLASS, INT. CLS. 14 AND 16.
- INTERNATIONAL DATA GROUP, INC., FRAMINGHAM, MA:  
2,404,448. REN. 4-13-11. INT. CL. 42.
- INTERNATIONAL EXPOSITION CO., INC., WESTPORT, CT:  
2,465,630. REN. 4-8-11. INT. CL. 35.
- INTERNATIONAL FINANCIAL REPORTING STANDARDS FOUNDATION, WILMINGTON, DE:  
3,963,741, MULTIPLE CLASS, INT. CLS. 9 AND 16.
- INTERNATIONAL FLYFISHING NETWORK, LLC, GREENVILLE, NC, DBA INTERNATIONAL BONEFISHING SOCIETY:  
2,883,408, CANC. MULTIPLE CLASS, INT. CLS. 25 AND 41.
- INTERNATIONAL FOODSTUFFS CO., SHARJAH, UNITED ARAB EMIR.:  
2,444,218. REN. 4-9-11. INT. CL. 30.
- INTERNATIONAL GEM & JEWELRY SHOW, INC., ROCKVILLE, MD:  
2,883,389, CANC. INT. CL. 35.
- INTERNATIONAL GROOVING & GRINDING ASSOC., INC., WEST COXSACKIE, NY, DBA IGGA:  
3,963,880, INT. CL. 35.
- INTERNATIONAL KICKBALL FEDERATION, LLC, PARKLAND, FL:  
3,963,838, INT. CL. 41.
- INTERNATIONAL MERCHANDISING INC. SDN BHD (CO#645198-T), SELANGOR DARUL EHSAN, MALAYSIA:  
3,962,135, INT. CL. 25.
- INTERNATIONAL NEWS, INC., KENT, WA:  
2,881,274, CANC. INT. CL. 25.
- INTERNATIONAL PAPER COMPANY, MEMPHIS, TN:  
3,963,409, MULTIPLE CLASS, INT. CLS. 35 AND 39.
- INTERNATIONAL PAPER PRODUCTS CORPORATION, WESTFIELD, MA:  
3,963,451, INT. CL. 40.
- INTERNATIONAL PIPE MACHINERY CORPORATION, SIOUX CITY, IA, CONCRETE PIPE MACHINERY COMPANY, SIOUX CITY, IA:  
911,683. REN. 4-13-11. U.S. CL. 23 (INT. CL. 7).
- INTERNATIONAL SOCIETY OF BEVERAGE TECHNOLOGISTS, DALLAS, TX:  
3,961,079, PUB. 3-1-2011. INT. CL. 35.  
3,961,080, PUB. 3-1-2011. INT. CL. 35.
- INTERNATIONAL SOIL TECHNOLOGIES, INC., GILBERT, AZ:  
2,883,189, CANC. INT. CL. 40.
- INTERNATIONAL TECHNICAL SOLUTIONS, LLC, KENNESAW, GA:  
2,881,839, CANC. INT. CL. 35.
- INTERNATIONAL VIRTUAL ASSISTANTS ASSOCIATION, HENDERSON, NV:  
3,961,165, PUB. 3-1-2011. U.S. CL. B.
- INTERNATIONAL WINDOW TREATMENTS, INC., CERRITOS, CA, DBA CUSTOM CRAFT COMPANY:  
2,882,548, CANC. INT. CL. 20.
- INTERNET BRANDS, INC., EL SEGUNDO, CA:  
2,443,626. REN. 4-8-11. INT. CL. 42.
- INTERNET MATRIX, INC., SAN DIEGO, CA, DBA VETMATRIX:  
3,961,232, PUB. 3-1-2011. INT. CL. 44.
- INTERNET PHYSICIAN INC, NORTH PLATTE, NE:  
3,961,218, PUB. 3-1-2011. INT. CL. 41.
- INTERNET TESTING SYSTEMS, LLC, BALTIMORE, MD:  
3,962,864, INT. CL. 41.
- INTERPHASE CORPORATION, PLANO, TX:  
2,882,666, CANC. INT. CL. 9.
- INTERPLAY PRODUCTIONS, IRVINE, CA TO INTERPLAY ENTERTAINMENT CORP., BEVERLY HILLS, CA:  
2,103,798, CANC. INT. CL. 28.
- INTERSTATE ELECTRONICS CORPORATION, ANAHEIM, CA:  
2,882,993, CANC. INT. CL. 9.
- INTERTAPE POLYMER CORP., BRADENTON, FL:  
2,882,345, CANC. INT. CL. 17.
- INTERUSH HOLDINGS LTD., IRVINE, CA:  
3,962,004, MULTIPLE CLASS, INT. CLS. 35, 38, 39, 41, 42 AND 45.  
3,962,006, MULTIPLE CLASS, INT. CLS. 35, 38, 39, 41, 42 AND 45.
- INTERVOICE, INC., DALLAS, TX:  
2,882,260, CANC. INT. CL. 9.
- INTREPID TRAVEL PTY LTD, FITZROY, VICTORIA 3065, AUSTRALIA:  
3,960,410, PUB. 3-1-2011. MULTIPLE CLASS, INT. CLS. 39, 41 AND 43.
- INTREXON CORPORATION, BLACKSBURG, VA:  
3,963,262, MULTIPLE CLASS, INT. CLS. 1 AND 5.
- INTRICON CORPORATION, ARDEN HILLS, MN:  
3,960,395, PUB. 3-1-2011. MULTIPLE CLASS, INT. CLS. 9 AND 10.
- INTRINSIC BIOPROBES, INC., TEMPE, AZ:  
3,961,443, PUB. 3-1-2011. INT. CL. 9.
- INTRINSIC BIOPROBES, INC., PHOENIX, AZ:  
3,961,445, PUB. 3-1-2011. INT. CL. 42.
- INTUIT INC., MOUNTAIN VIEW, CA:  
2,382,841, CANC. MULTIPLE CLASS, INT. CLS. 36 AND 42.
- INVENT FOR LIFE, INC., GRANADA HILLS, CA:  
3,963,707, INT. CL. 16.
- INVENTIV HEALTH, INC., SOMERSET, NJ:  
2,882,585, CANC. INT. CL. 9.
- INVENTIVE PRODUCTS, LLC, PLANO, TX:  
3,960,340, PUB. 3-1-2011. INT. CL. 32.
- INXPO, INC., CHICAGO, IL:  
3,961,056, PUB. 3-1-2011. INT. CL. 42.
- IO DATA CENTERS, LLC, PHOENIX, AZ:  
3,963,695, INT. CL. 42.
- IONZ BLUEWATER SOLUTIONS, INC., FT. LAUDERDALE, FL:  
2,880,887, CANC. MULTIPLE CLASS, INT. CLS. 11, 37 AND 42.  
2,880,888, CANC. MULTIPLE CLASS, INT. CLS. 11, 37 AND 42.
- IOTO CORP., CHICAGO, IL:  
3,963,681, INT. CL. 9.
- IOWA BANKERS ASSOCIATION, DES MOINES, IA:  
2,391,195. REN. 4-12-11. INT. CL. 42.
- IOWA MACHINE SHED CO., MOLINE, IA:  
1,158,504. REN. 4-9-11. INT. CL. 42.
- IP CLEANING S.P.A., ITALY:  
3,960,817, PUB. 3-1-2011. INT. CL. 7.
- IP HOLDINGS UNLTD LLC, NEW YORK, NY:  
3,963,361, INT. CL. 14.
- IPICO INNOVATION INC., BURLINGTON, ONTARIO, CANADA:  
3,960,431, PUB. 3-1-2011. INT. CL. 9.
- IPR - INTELLIGENTE PERIPHERIEN; FÜR ROBOTER GMBH, FED REP GERMANY:  
3,960,717, PUB. 3-1-2011. MULTIPLE CLASS, INT. CLS. 7 AND 9.
- IPSOS-ASI, LLC, CINCINNATI, OH:  
2,423,356. REN. 4-9-11. INT. CL. 35.
- IRWIN INDUSTRIAL TOOL COMPANY, FREEPORT, IL:  
2,882,587, CANC. INT. CL. 7.
- ISLAND WORLD APPAREL, LOS ALAMITOS, CA:  
3,963,158, INT. CL. 25.
- ISLE OF CAPRI CASINOS, INC., ST. LOUIS, MO:  
2,533,966. REN. 4-13-11. INT. CL. 42.
- ISP INVESTMENTS INC., WILMINGTON, DE:  
3,963,672, INT. CL. 1.
- ISPICE LLC, LONGWOOD, FL:  
3,961,947, PUB. 3-1-2011. INT. CL. 43.
- ISRAEL DISCOUNT BANK OF NEW YORK, NEW YORK, NY:  
2,394,481. REN. 4-12-11. INT. CL. 36.
- ISTOBAL, S.A., L'ALCUDIA, VALENCIA, SPAIN:  
3,962,985, INT. CL. 7.
- IT'S A FRIEND THING., SPRINGFIELD, MO:  
2,881,486, CANC. INT. CL. 25.
- IT'S JUST LUNCH INTERNATIONAL LLC, PALM DESERT, CA:  
3,962,270, INT. CL. 45.

ITRENEW INC., NEWARK, CA:  
3,963,164, INT. CL. 9.

IVAN MANUEL ANTON SORIANO, 03296 ELCHE (ALICANTE), SPAIN:  
2,882,796, CANC. INT. CL. 25.

IVANKO BARBELL COMPANY, SAN PEDRO, CA:  
2,389,609, REN. 4-14-11, INT. CL. 28.

IVR TECHNOLOGIES, INC., TORRANCE, CA:  
3,961,546, PUB. 3-1-2011, INT. CL. 42.

IZ+ REAL ENTERTAINMENT, LLC, UPPER MARLBORO, MD, DBA IZ+ REAL ENT:  
3,961,059, PUB. 3-1-2011, INT. CL. 9.

IZI MEDICAL PRODUCTS, LLC, BALTIMORE, MD:  
3,963,670, INT. CL. 10.

J & C CRAWFORD, INC., ROUGEMONT, NC, DBA CRUISERWORKS:  
3,961,826, PUB. 3-1-2011, INT. CL. 35.

J AND L MARKETING, INC., LOUISVILLE, KY:  
2,882,981, CANC. INT. CL. 16.

J WORLD SPORTS, INC., HACKENSACK, NJ, FORMERLY J WORLD PRODUCTS, INC.:  
3,961,231, PUB. 3-1-2011, INT. CL. 18.

J. CANNON, INC., FORT WORTH, TX:  
3,960,257, PUB. 3-1-2011, INT. CL. 3.

J. FLETCHER CREAMER & SON, INC., HACKENSACK, NJ:  
2,441,901, REN. 4-9-11, INT. CL. 37.

J. LLOYD INTERNATIONAL, INC., CEDAR RAPIDS, IA:  
2,881,108, CANC. INT. CL. 11.

J. MORITA USA, INC., IRVINE, CA:  
2,383,278, CANC. INT. CL. 5.

J.A. WOOLLAM CO., INC., LINCOLN, NE:  
3,961,999, INT. CL. 9.

J.B. CHEMICALS AND PHARMACEUTICALS LIMITED, MUMBAI, INDIA:  
2,881,590, CANC. INT. CL. 5.

J.B.S. LTD., NEW YORK, NY:  
3,962,586, INT. CL. 25.

J.C. TOYS GROUP, INC., MIAMI, FL, BARVAL TOYS, INC., MIAMI, FL:  
1,639,853, REN. 4-12-11, INT. CL. 28.

J.L. ANDERSON AGENCY, INC., REELSVILLE, IN:  
2,175,314, CANC. INT. CL. 36.

J.P. ENTERPRISES, INC., CHESTERFIELD, MO:  
2,382,855, CANC. INT. CL. 35.

J.W. HARRIS CO., INC., MASON, OH:  
2,882,607, CANC. INT. CL. 6.

J&L MARKETING, INC., LOUISVILLE, KY:  
3,962,681, INT. CL. 35.

J&N AUTO ELECTRIC, INC., CINCINNATI, OH:  
3,961,439, PUB. 3-1-2011, MULTIPLE CLASS, INT. CLS. 7, 9 AND 12.

J-ZOO, INC., VISTA, CA:  
2,882,704, CANC. INT. CL. 28.

JABBAWOCKEEZ, LLC, LOS ANGELES, CA:  
3,963,275, MULTIPLE CLASS, INT. CLS. 18 AND 25.

JACK CREEK CELLARS, INC., TEMPLETON, CA:  
3,963,183, INT. CL. 33.

JACK HSU, ALEXANDRIA, VA:  
3,962,858, INT. CL. 9.

JACKSON PARTNERS, LTD., PARK CITY, UT:  
2,382,495, CANC. MULTIPLE CLASS, INT. CLS. 36 AND 37.

JACKSON SPALDING, INC., ATLANTA, GA:  
3,962,645, INT. CL. 35.

JACMEL JEWELRY, INC., LONG ISLAND CITY, NY:  
2,883,356, CANC. INT. CL. 14.

JACQUIE AICHE, INC, LOS ANGELES, CA:  
3,962,723, INT. CL. 14.

JADWIN, ANDY W., SPARTA, MO:  
2,882,925, CANC. INT. CL. 8.

JAE DESIGN CONCEPTS, INC., NORTHBROOK, IL, DBA ALBUM DESIGNER NETWORK:  
2,883,411, CANC. INT. CL. 9.

JAGRO CUSTOMS BROKERS AND INTERNATIONAL FREIGHT FORWARDERS, INC., CRANFORD, NJ:  
2,431,734, REN. 4-13-11, INT. CL. 39.

JAKKS PACIFIC, INC., MALIBU, CA:  
2,881,871, CANC. INT. CL. 28.  
2,882,330, CANC. INT. CL. 28.

JAMBA JUICE COMPANY, EMERYVILLE, CA:  
3,962,705, INT. CL. 29.  
3,962,706, INT. CL. 29.

JAMES AUSTIN COMPANY, MARS, PA:  
3,851,498, CANC. INT. CL. 3.

JAMES CARIDI, GAINESVILLE, FL AND MICHAEL J. MAIMONE, ISLAND PARK, NY:  
3,962,978, INT. CL. 9.

JAMES RUEDI AND ASSOCIATES, INC., ISSAQUAH, WA:  
2,383,195, CANC. INT. CL. 42.

JAMIE LYNN LIVINGSTON, LAS VEGAS, NV:  
3,961,323, PUB. 3-1-2011, INT. CL. 3.

JAMIE WALLACE, ROUND ROCK, TX:  
3,963,085, INT. CL. 20.  
3,963,088, INT. CL. 20.

JANG SOO FURNISHING, INC., RIDGEFIELD, NJ:  
3,960,870, PUB. 3-1-2011, INT. CL. 20.

JANIG GMBH, D-90451 NURNBERG, FED REP GERMANY:  
2,882,226, CANC. MULTIPLE CLASS, INT. CLS. 14, 15 AND 20.

JANN BLACKSTONE-FORD, DISCOVERY BAY, CA, DBA JANN BLACKSTONE-FORD:  
3,963,843, MULTIPLE CLASS, INT. CLS. 16 AND 41.

JAPAN TOBACCO INC., TOKYO, JAPAN:  
2,880,644, CANC. INT. CL. 34.

JASON & JEAN PRODUCTS INC., CORONA, NY:  
3,960,241, PUB. 2-8-2011, INT. CL. 3.

JASON INDUSTRIES, INC., ELKHART, IN:  
2,880,818, CANC. INT. CL. 12.

JASON INTERNATIONAL, INC., NORTH LITTLE ROCK, AR:  
2,444,923, REN. 4-14-11, INT. CL. 11.

JASON WINDEBANK AND JOHN DOUGLAS MOSHY PARTNER, THE, BURBANK, CA:  
2,880,917, CANC. INT. CL. 35.

JAV-JR LLC, LONG ISLAND CITY, NY:  
3,962,962, INT. CL. 25.

JAX, INC., MENOMONEE FALLS, WI, FORMERLY BEHNKE LUBRICANTS, INC.:  
3,961,882, PUB. 3-1-2011, INT. CL. 4.

JAY A. HUMINSKY, PLANO, TX:  
3,963,324, INT. CL. 25.

JAY, COBB & MARLEY, ONTARIO, CA:  
3,960,915, PUB. 3-1-2011, INT. CL. 36.

JAYFOUREM, LLC, DARIEN, CT:  
2,880,743, CANC. INT. CL. 43.

JAYSIX USA, FREDERICKSBURG, VA:  
2,883,334, CANC. INT. CL. 25.

JB CUSTOM LINENS, LLC, STAMFORD, CT:  
3,961,189, PUB. 3-1-2011, INT. CL. 24.

JB SANDLIN REAL ESTATE, FT. WORTH, TX, DBA SANDLIN REMODELING:  
3,961,778, PUB. 3-1-2011, INT. CL. 37.

JBR ENVIRONMENTAL CONSULTANTS, INC., SANDY, UT:  
3,960,537, PUB. 3-1-2011, MULTIPLE CLASS, INT. CLS. 35, 37, 42 AND 45.

JBS FISHING LINE, LLC, DORA, AL:  
3,961,515, PUB. 3-1-2011, MULTIPLE CLASS, INT. CLS. 6, 9, 16, 21 AND 25.  
3,961,559, PUB. 3-1-2011, INT. CL. 21.

JDI, INC., MISSOULA, MT:  
2,881,788, CANC. INT. CL. 10.

JEAN ELLEN SEDLMAYR MACMILLAN, HONOLULU, HI:  
3,962,496, INT. CL. 25.

JEAN-MARC MENAT, FRANCE:  
3,960,646, PUB. 11-23-2010, MULTIPLE CLASS, INT. CLS. 35, 41 AND 42.

JEDRZEJEWSKI, RICHARD, RIVERSIDE, IL:  
2,881,024, CANC. INT. CL. 19.

JEF INTERNATIONAL, INC., MESA, AZ, DBA LOBINA LURES:  
2,881,117, CANC. INT. CL. 28.  
2,881,121, CANC. INT. CL. 28.



- JEFF CHRISTIAN & COMPANY LLC, BEACHWOOD, OH:  
3,961,428, PUB. 3-1-2011. INT. CL. 35.
- JEFFERSON, RACHEL, BOWIE, MD, DBA TRUTH BE  
TOLD POLYGRAPH SERVICES:  
3,960,951, PUB. 11-23-2010. INT. CL. 45.
- JELIAS ENTERPRISE LTD, TORONTO, CANADA:  
3,960,277, PUB. 3-1-2011. INT. CL. 25.
- JELIGHT COMPANY, INC., IRVINE, CA:  
2,717,619, CANC. INT. CL. 11.
- JELLY KIDS, INC., SHERMAN OAKS, CA:  
2,881,532, CANC. INT. CL. 5.  
2,881,533, CANC. INT. CL. 5.
- JELLY KIDS, INC., LOS ANGELES, CA:  
2,881,534, CANC. INT. CL. 5.
- JELLYVISION, INC., CHICAGO, IL:  
2,383,568, CANC. INT. CL. 9.
- JEMINI INTERNATIONAL INC., BONITA SPRINGS, FL:  
2,893,431, CANC. MULTIPLE CLASS, INT. CLS. 21 AND  
35.
- JENAMAR, GRANITE BAY, CA:  
2,992,530, COR. INT. CL. 37.
- JENERIC/PENTRON, INC., WALLINGFORD, CT:  
2,883,312, CANC. INT. CL. 5.
- JENNER SALES CORP., HARRISTOWN, IL:  
3,961,594, PUB. 3-1-2011. MULTIPLE CLASS, INT. CLS. 35  
AND 37.
- JENNIFER YOAKUM, LONGVIEW, TX AND HAL WITT,  
LONGVIEW, TX:  
3,962,394, INT. CL. 5.
- JENNINGS, MARTIN, ATLANTA, GA AND JENNINGS,  
KATHY T., ATLANTA, GA:  
2,881,713, CANC. INT. CL. 27.
- JERRY BOY, INC., BEDFORD HEIGHTS, OH:  
2,883,183, CANC. INT. CL. 29.
- JERRY L. FALWELL, LYNCHBURG, VA:  
2,382,656, CANC. INT. CL. 41.
- JESSE WHITE FOUNDATION, LTD., CHICAGO, IL:  
3,960,962, PUB. 3-1-2011. INT. CL. 41.
- JESUS HEART FOUNDATION, INC., SAN JOSE, CA:  
3,961,554, PUB. 3-1-2011. INT. CL. 6.  
3,961,555, PUB. 3-1-2011. INT. CL. 9.  
3,961,685, PUB. 3-1-2011. INT. CL. 21.
- JETBOARDER PTY LTD, SYDNEY, AUSTRALIA:  
3,963,789, INT. CL. 39.
- JETSET STUDIOS, INC., LOS ANGELES, CA:  
3,960,290, PUB. 3-1-2011. INT. CL. 41.
- JEWELRY HOSPITAL, INC., AMARILLO, TX:  
2,881,704, CANC. INT. CL. 37.
- JEZOWSKI & MARKEL CONTRACTORS, INC., ORANGE,  
CA:  
3,962,288, INT. CL. 37.
- JHONY USA INC., NEW YORK, NY:  
3,963,067, INT. CL. 3.  
3,963,068, INT. CL. 3.
- JIANG, RODERICK, MR., VICTORIA, BC, CANADA:  
3,962,124, INT. CL. 29.
- JIDOSHA DENKI KOGYO CO., LTD., TOTSUKA-KU, YO-  
KOHAMA, JAPAN:  
2,382,710, CANC. MULTIPLE CLASS, INT. CLS. 9 AND  
12.
- JIMENEZURIBE, GLORIA, DOUGLSTON, NY:  
3,962,766, MULTIPLE CLASS, INT. CLS. 16 AND 25.
- JKRLHB, LLC, BEVERLY HILLS, CA:  
3,962,269, INT. CL. 44.
- JL AUDIO, INC., MIRAMAR, FL:  
2,383,156, CANC. INT. CL. 9.  
2,383,157, CANC. INT. CL. 9.
- JLO HOLDING COMPANY, LLC, SANTA MONICA, CA:  
2,881,298, CANC. MULTIPLE CLASS, INT. CLS. 14 AND  
25.
- JMD CORPORATION, JACKSON HEIGHTS, NY:  
2,881,115, CANC. INT. CL. 16.
- JNS DATA SYSTEMS, LLC., LA, CA:  
3,962,618, INT. CL. 9.
- JO MALONE LIMITED, WARRINER GARDENS, ENG-  
LAND:  
2,882,105, CANC. INT. CL. 35.
- JOAN BOYCE, LLC, NEW YORK, NY:  
3,962,197, MULTIPLE CLASS, INT. CLS. 18 AND 25.
- JOAN ELAINE CASELLA, NEW YORK, NY:  
3,963,594, INT. CL. 25.
- JOHN A. BROWN, FAIRBURN, GA:  
3,962,854, INT. CL. 25.
- JOHN JOSEPH AUGUST, VOLCANO, HI:  
3,962,097, INT. CL. 19.
- JOHN PLAYER & SONS LIMITED, DUBLIN 12, IRELAND:  
2,383,007, CANC. MULTIPLE CLASS, INT. CLS. 25 AND  
34.
- JOHN RICH & SONS INVESTMENT HOLDING COMPANY,  
WILMINGTON, DE:  
2,883,238, CANC. INT. CL. 20.
- JOHN W. HAGGARD JR., MADISON, WI, DBA ALL  
COFFEE CONCEPTS LLC:  
3,961,690, PUB. 3-1-2011. INT. CL. 11.
- JOHNNY LINDY COMPANY, LOS ANGELES, CA:  
2,880,565, CANC. INT. CL. 9.
- JOHNSON & JOHNSON, NEW BRUNSWICK, NJ:  
2,383,619, CANC. INT. CL. 5.  
2,383,620, CANC. INT. CL. 5.  
2,428,757, REN. 4-12-11. MULTIPLE CLASS, INT. CLS. 3  
AND 5.  
2,882,030, CANC. INT. CL. 5.  
3,961,560, PUB. 3-1-2011. INT. CL. 5.  
3,962,484, INT. CL. 3.
- JOHNSON CREATIVE PUBLISHING, INC., MADISON, AL:  
2,882,399, CANC. MULTIPLE CLASS, INT. CLS. 16 AND  
35.
- JOHNSON FINANCIAL GROUP, INC., RACINE, WI:  
2,441,558, REN. 4-11-11. INT. CL. 36.  
2,880,811, CANC. INT. CL. 36.
- JOHNSON PREMIUM HARDWOOD FLOORING, INC.,  
CITY OF INDUSTRY, CA:  
3,960,284, PUB. 4-21-2009. INT. CL. 19.
- JOHNSON PRODUCTS COMPANY, INC., DALLAS, TX:  
3,962,526, INT. CL. 35.
- JOHNSON, JAMIE A, FOSTORIA, OH:  
2,881,459, CANC. INT. CL. 25.
- JOHNSON, JILL L., SANTA BARBARA, CA:  
3,960,271, PUB. 3-1-2011. INT. CL. 25.
- JOHNSON, KATHLEEN B., BOCA RATON, FL:  
3,960,234, PUB. 3-1-2011. INT. CL. 16.
- JOHNSON, THOMAS N.P. III, RICHMOND, VA:  
2,882,886, CANC. INT. CL. 36.
- JONMOR INVESTMENTS, INC., WILMINGTON, DE:  
3,963,041, MULTIPLE CLASS, INT. CLS. 29 AND 43.
- JORDALI, HOWLA, TURLOCK, CA:  
2,883,397, CANC. INT. CL. 3.
- JOSEPH & EDNA JOSEPHSON INSTITUTE OF ETHICS, LOS  
ANGELES, CA:  
3,963,441, MULTIPLE CLASS, INT. CLS. 16 AND 20.  
3,963,442, MULTIPLE CLASS, INT. CLS. 16, 20 AND 25.
- JOSEPH M. ANDERSON, SANBORN, NY:  
3,960,911, PUB. 3-1-2011. INT. CL. 34.
- JOSTENS, INC., MINNEAPOLIS, MN:  
3,963,779, INT. CL. 42.
- JPJ INVESTMENT HOLDING CORP., CARSON CITY, NV:  
3,961,878, PUB. 3-1-2011. INT. CL. 8.
- JPMORGAN CHASE & CO., NEW YORK, NY:  
718,714, REN. 4-11-11. U.S. CL. 102 (INT. CL. 36).  
2,883,366, CANC. INT. CL. 36.
- JPS ELASTOMERICS CORPORATION, HOLYOKE, MA:  
2,382,614, CANC. MULTIPLE CLASS, INT. CLS. 17 AND  
19.
- JQL ELECTRONICS INC, DEARFIELD, IL:  
3,962,301, INT. CL. 9.
- JR. ZECH, DAVID W., HAMILTON, VA:  
2,393,145, REN. 4-11-11. INT. CL. 37.
- JSJ FURNITURE CORPORATION, GRAND HAVEN, MI:  
3,962,622, INT. CL. 20.
- JT MONEY, LLC, ATLANTA, GA:  
2,383,122, CANC. INT. CL. 41.
- JTEKT CORPORATION, OSAKA, JAPAN:  
1,645,032, REN. 4-8-11. INT. CL. 9.
- JTM PROVISIONS COMPANY, INC., HARRISON, OH:  
3,961,187, PUB. 3-1-2011. INT. CL. 43.

JUAN MARTINEZ, ATWATER, CA:  
3,963,310, INT. CL. 25.

JUBILEE DIAMOND INSTRUMENT LTD., SAN PO KONG, KOWLOON, HONG KONG:  
3,963,567, INT. CL. 9.

JUDITH RIPKA CREATIONS INC., NEW YORK, NY:  
2,382,581, CANC. INT. CL. 14.

JUDY L. REDPATH, RESTON, VA, DBA VISTA WEALTH STRATEGIES:  
3,960,220, PUB. 3-1-2011. INT. CL. 36.  
3,960,221, PUB. 3-1-2011. INT. CL. 36.

JUEDISCHES MUSEUM BERLIN, 10969 BERLIN, FED REP GERMANY:  
2,880,651, CANC. INT. CL. 42.  
2,880,652, CANC. INT. CL. 41.  
2,880,653, CANC. INT. CL. 18.

JUKEN NEW ZEALAND LIMITED, AUCKLAND, NEW ZEALAND:  
2,881,496, CANC. INT. CL. 19.

JULIA SVOBODA, WEST HOLLYWOOD, CA:  
3,960,356, PUB. 8-10-2010. INT. CL. 9.

JUPITER BONSAI, INC., JUPITER, FL:  
3,962,663, INT. CL. 31.

JUST LAWYERS INC., SAULT STE MARIE ONTARIO, CANADA:  
2,714,061, CANC. INT. CL. 42.

JUST ONE MORE RESTAURANT CORPORATION, NEW YORK, NY:  
3,962,129, MULTIPLE CLASS, INT. CLS. 8, 11, 21 AND 24.

JUVENON, INC., ORINDA, CA:  
2,882,916, CANC. INT. CL. 5.

JWIN ELECTRONICS CORP., PORT WASHINGTON, NY:  
3,962,757, INT. CL. 9.

K & G ASSOCIATES, INC., TROY, MI, DBA TRADEMASTER, INC.:  
2,883,269, CANC. INT. CL. 9.

K B SOCKS, INC., INGLEWOOD, CA:  
3,961,419, PUB. 3-1-2011. INT. CL. 25.

K WEBER COMMUNICATIONS LLC, CUERO, TX:  
3,963,495, INT. CL. 14.

K. HANSOTIA & CO., INC., MIAMI, FL:  
3,963,305, INT. CL. 34.

K.E. PETERS BILLIARD SUPPLY, INC., MINNEAPOLIS, MN:  
2,384,037, CANC. MULTIPLE CLASS, INT. CLS. 35 AND 37.

K-2 CORPORATION, SEATTLE, WA:  
3,963,301, INT. CL. 12.

KABA ILCO CORP., ROCKY MOUNT, NC:  
3,961,573, PUB. 3-1-2011. INT. CL. 7.

KABBALAH CENTRE INTERNATIONAL, INCORPORATED, LOS ANGELES, CA:  
2,383,239, CANC. INT. CL. 25.  
2,383,240, CANC. INT. CL. 14.

KABUSHIKI KAISHA ATOM JAPAN, TSU-SHI, MIE-KEN, JAPAN, TA ATOM JAPAN INC.:  
2,536,992, REN. 4-13-11. INT. CL. 32.

KABUSHIKI KAISHA BANDAI, TOKYO, JAPAN:  
3,962,590, MULTIPLE CLASS, INT. CLS. 16, 28 AND 41.

KABUSHIKI KAISHA KOMATSU SEISAKUSHO; (KOMATSU LTD.), TOKYO 107-8414, JAPAN:  
3,960,759, PUB. 3-1-2011. MULTIPLE CLASS, INT. CLS. 7, 9, 12, 37 AND 42.

KABUSHIKI KAISHA MEIDENSHA; (MEIDENSHA CORPORATION), JAPAN:  
3,916,300, COR. INT. CL. 9.

KABUSHIKI KAISHA SHUEISHA, CHIYODA-KU, TOKYO 101-8050, JAPAN, TA SHUEISHA INC.:  
2,882,060, CANC. INT. CL. 28.

KABUSHIKI KAISHA SONY COMPUTER ENTERTAINMENT, TOKYO, JAPAN, TA SONY COMPUTER ENTERTAINMENT INC.:  
3,960,415, PUB. 3-1-2011. MULTIPLE CLASS, INT. CLS. 21, 24 AND 25.

KABUSHIKI KAISHA SUN FIELD, FUKUOKA, JAPAN, DBA SUN FIELD INC.:  
2,882,381, CANC. INT. CL. 30.

KABUSHIKI KAISHA TOSHIBA, TOKYO, JAPAN, TA TOSHIBA CORPORATION:  
2,880,711, CANC. INT. CL. 9.

KABUSHIKI KAISHA TOSHIBA, TOKYO, JAPAN:  
3,960,223, PUB. 3-1-2011. INT. CL. 37.

KABUSHIKI KAISHA TOSHIBA, JAPAN:  
3,960,822, PUB. 3-1-2011. INT. CL. 9.

KADENA INDUSTRIES COMPANY, LTD., HANGZHOU, CHINA:  
3,963,228, INT. CL. 24.

KAKITA, JENNIFER, LAS VEGAS, NV:  
3,961,219, PUB. 3-1-2011. INT. CL. 41.

KALEIDOSCOPE MARKETING GROUP LLC, MT. PLEASANT, SC:  
3,963,627, INT. CL. 36.

KALEIDOSCOPE 3D LIMITED, AUCKLAND, NEW ZEALAND:  
3,962,519, MULTIPLE CLASS, INT. CLS. 35, 38, 41 AND 45.

KALIN, DAVID P., PALM HARBOR, FL, DBA INTERNATIONAL BOARD OF MEDICINE AND SURGERY:  
3,960,346, PUB. 3-1-2011. U.S. CL. B.

KALLE GMBH, 65203 WIESBADEN, FED REP GERMANY:  
3,963,612, INT. CL. 1.

KALMBACH FEEDS, INC., UPPER SANDUSKY, OH:  
3,963,098, INT. CL. 31.

KALTENBACH & VOIGT GMBH, BIBERACH, FED REP GERMANY:  
2,881,600, CANC. INT. CL. 10.

KAMHI WORLD, INC., CLEARWATER, FL:  
2,883,229, CANC. INT. CL. 28.

KAMLAR CORPORATION, ROCKY MOUNT, NC:  
3,962,967, INT. CL. 31.

KANEKA CORPORATION, OSAKA, JAPAN:  
3,961,228, PUB. 3-1-2011. INT. CL. 1.

KARAGOZ, ARMEN, BOULDER, CO:  
2,881,958, CANC. MULTIPLE CLASS, INT. CLS. 9, 35 AND 42.

KARO BIO AB, HUDDINGE, SWEDEN:  
2,392,768, REN. 4-9-11. INT. CL. 42.

KAROUN DAIRIES, INC., SUN VALLEY, CA:  
3,960,582, PUB. 3-1-2011. INT. CL. 29.

KASHI COMPANY, LA JOLLA, CA:  
2,883,143, CANC. INT. CL. 30.

KASHUK, SONIA, NEW YORK, NY:  
2,881,297, CANC. MULTIPLE CLASS, INT. CLS. 3, 8, 18, 21 AND 24.

KATAHDIN PAPER COMPANY LLC, MILLINOCKET, ME:  
3,961,512, PUB. 3-1-2011. INT. CL. 16.  
3,961,513, PUB. 3-1-2011. INT. CL. 16.

KATE & CO., BOULDER, CO:  
2,882,936, CANC. INT. CL. 9.

KATE SPADE LLC, NEW YORK, NY:  
2,384,267, CANC. INT. CL. 16.

KATE SPADE, LLC, NEW YORK, NY:  
2,455,406, REN. 4-12-11. INT. CL. 18.  
2,882,141, CANC. INT. CL. 16.

KATHARINE JAMES, INC., LOS ANGELES, CA:  
3,961,759, PUB. 3-1-2011. INT. CL. 14.

KATHLEEN M. MURPHY, MINNEAPOLIS, MN:  
3,961,592, PUB. 3-1-2011. INT. CL. 45.

KATHLEEN TAYLOR, SAN DIEGO, CA:  
3,962,451, INT. CL. 45.  
3,962,452, INT. CL. 42.  
3,962,453, INT. CL. 35.

KATHRYN S. BARRETT, MILWAUKEE, WI:  
2,881,536, CANC. INT. CL. 42.

KATHY CASEY, INC., SEATTLE, WA:  
2,474,089, REN. 4-9-11. INT. CL. 42.

KATYAMUSIC, LLC, LOS ANGELES, CA:  
3,961,477, PUB. 3-1-2011. INT. CL. 18.

KATZ, REBECCA, SAN RAFAEL, CA:  
3,961,130, PUB. 3-1-2011. INT. CL. 41.

KAUKA, ROLF, THOMASVILLE, GA:  
2,800,652, CANC. INT. CL. 25.

KAYON CORPORATION, CHARLESTON, SC:  
2,880,638, CANC. MULTIPLE CLASS, INT. CLS. 18 AND 25.

- KAYSER-ROTH CORPORATION, GREENSBORO, NC:  
3,962,058, MULTIPLE CLASS, INT. CLS. 20 AND 24.
- KAYTEE PRODUCTS INCORPORATED, CHILTON, WI:  
3,963,002, INT. CL. 21.
- KAZAN, INC., BRADENTON, FL:  
2,383,064, CANC. INT. CL. 35.
- KCD IP, LLC, HOFFMAN ESTATES, IL:  
2,881,736, CANC. INT. CL. 9.
- KCI LICENSING, INC., SAN ANTONIO, TX:  
3,963,054, INT. CL. 10.
- KCP TECHNOLOGIES, INC., EMERYVILLE, CA:  
3,962,096, INT. CL. 41.
- KDP FOOD LTD. LIABILITY CO., MCCOY, CO:  
2,883,089, CANC. INT. CL. 29.
- KEEN ASSOCIATES, LLC, DURHAM, NC:  
3,961,549, PUB. 3-1-2011. INT. CL. 35.
- KEISER CORPORATION, FRESNO, CA:  
3,960,319, PUB. 3-1-2011. INT. CL. 28.
- KEITH A. KENNEALLY, SOUTH SAN FRANCISCO, CA:  
3,962,811, MULTIPLE CLASS, INT. CLS. 11, 20 AND 39.
- KEITH M. CUMMING, WELLAND, ON, CANADA:  
3,961,467, PUB. 3-1-2011. INT. CL. 21.  
3,961,470, PUB. 3-1-2011. INT. CL. 21.
- KEITH, DIANE, MILLBRAE, CA. DBA HOMEFIRES - THE JOURNAL OF HOMESCHOOLING:  
2,441,001, REN. 4-9-11. INT. CL. 41.
- KEL-GAR, INC., DALLAS, TX:  
2,382,951, CANC. INT. CL. 12.
- KELLOGG COMPANY, BATTLE CREEK, MI:  
2,882,851, CANC. INT. CL. 30.
- KEMPER DEVELOPMENT COMPANY, BELLEVUE, WA:  
3,961,206, PUB. 3-1-2011. INT. CL. 41.
- KEN BYERS AND HAKAN JOHANSON, CLEARWATER, FL:  
3,963,754, INT. CL. 5.
- KENNEDY, THOMAS E., POMPANO BEACH, FL:  
2,881,660, CANC. INT. CL. 22.
- KENNETH COLE PRODUCTIONS (LIC), INC., NEW YORK, NY:  
3,962,367, INT. CL. 25.
- KENNETH COLE PRODUCTIONS (LIC), LLC, NEW YORK, NY:  
3,962,383, INT. CL. 25.
- KENNEY, KRISTIN N., MONTCLAIR, NJ:  
3,961,825, PUB. 3-1-2011. INT. CL. 41.
- KENOSHA BEEF INTERNATIONAL LTD., KENOSHA, WI:  
2,882,707, CANC. INT. CL. 29.
- KERALAGE LLC, MONROE, NY:  
3,963,325, INT. CL. 3.
- KERR CORPORATION, ORANGE, CA:  
2,382,598, CANC. INT. CL. 10.
- KERSHENSTINE, TIMOTHY A., KENNER, LA:  
3,960,592, PUB. 3-1-2011. INT. CL. 32.
- KETTLE FOODS, INC., SALEM, OR:  
2,881,773, CANC. MULTIPLE CLASS, INT. CLS. 29 AND 30.
- KEYMARK ENTERPRISES, LLC, BOULDER, CO:  
2,882,637, CANC. INT. CL. 9.
- KEYNOTE SYSTEMS, INC., SAN MATEO, CA:  
2,881,364, CANC. INT. CL. 42.
- KF TEA USA INC, FLUSHING, NY:  
3,961,011, PUB. 3-1-2011. INT. CL. 43.
- KFORCE INC., TAMPA, FL:  
3,961,771, PUB. 3-1-2011. INT. CL. 42.
- KH TECHNOLOGY CORPORATION, GEORGE TOWN, CAYMAN ISLANDS:  
3,963,281, INT. CL. 9.
- KHOURY, JOSEPH FRANCIS, HASMIEH, LEBANON:  
2,882,935, CANC. INT. CL. 35.
- KHT JOINT VENTURE, LLC, CHARLESTON, SC:  
3,962,201, INT. CL. 18.
- KIBLER, ANDREA J., LANCASTER, CA. DBA THE ROCK STAR NAILS AND KIBLER, DAVID W., LANCASTER, CA:  
3,961,046, PUB. 3-1-2011. INT. CL. 3.
- KICAP MANAGEMENT LP, IRVINE, CA:  
2,882,094, CANC. INT. CL. 36.
- KID MOVES LLC, SAN FRANCISCO, CA:  
3,961,275, PUB. 3-1-2011. INT. CL. 16.  
3,961,318, PUB. 3-1-2011. INT. CL. 16.
- KIDCHING, BLAUVELT, NY:  
3,960,576, PUB. 3-1-2011. INT. CL. 36.
- KIDDE FIRE FIGHTING INC., EXTON, PA:  
2,882,242, CANC. INT. CL. 1.
- KIDS FARM, INC., COEUR D'ALENE, ID:  
2,881,321, CANC. INT. CL. 9.
- KIDS FOUNDATION, BEL AIR, CA:  
2,882,202, CANC. INT. CL. 16.
- KIDS INCLUDED TOGETHER - SAN DIEGO, INC., SAN DIEGO, CA:  
3,960,923, PUB. 3-1-2011. INT. CL. 41.
- KIKINI LIMITED, SAN DIEGO, CA:  
3,962,360, INT. CL. 45.
- KILOWATTS ELECTRIC SUPPLY, CORP., MIAMI, FL:  
3,960,938, PUB. 3-1-2011. INT. CL. 35.
- KIM, DAIGON, GLENDALE, CA:  
2,883,032, CANC. INT. CL. 41.
- KIM, GUN WOO, ANAHEIM, CA, AKA KIM, GREG W.:  
3,960,430, PUB. 3-1-2011. INT. CL. 12.
- KIM, WON JIN, TUSTIN, CA:  
3,961,545, PUB. 3-1-2011. INT. CL. 9.
- KIMAYA USA, INC. SECAUCUS, NJ:  
3,963,674, INT. CL. 14.
- KIMAYA USA, INC., SECAUCUS, NJ:  
3,963,673, INT. CL. 14.
- KIMBERLY ELLNER, WESTFIELD, NJ, DBA YOGA WEST:  
3,961,352, PUB. 3-1-2011. INT. CL. 41.
- KIMBERLY-CLARK WORLDWIDE, INC. NEENAH, WI, TECNOL, INC., NORTH RICHLAND HILLS, TX:  
1,640,357, REN. 4-12-11. INT. CL. 10.
- KIMBERLY-CLARK WORLDWIDE, INC., NEENAH, WI:  
2,883,165, CANC. INT. CL. 16.
- KIND, LLC, NEW YORK, NY:  
3,963,173, INT. CL. 29.
- KINDA LIKE MUSIC, INC., JERICHO, NY:  
2,880,930, CANC. INT. CL. 9.
- KING ELECTRICAL MANUFACTURING COMPANY, SEATTLE, WA:  
3,960,570, PUB. 3-1-2011. INT. CL. 11.  
3,960,586, PUB. 3-1-2011. INT. CL. 11.
- KING, JANELLE, CHARLES TOWN, WV AND WILLIAMS, DENA, CHARLES TOWN, WV AND CEASER, SANYEA, CHICAGO, IL AND EDWARDS, WHITNEY, CHARLES TOWN, WV:  
3,962,442, INT. CL. 41.
- KING, LINDA LUE, LOVELAND, CO:  
3,961,577, PUB. 3-1-2011. INT. CL. 16.
- KINGSHIP MARINE LIMITED, CENTRAL, HONG KONG:  
2,882,061, CANC. INT. CL. 37.
- KIRSCHNER, DIANA, NEW YORK, NY:  
3,961,217, PUB. 3-1-2011. INT. CL. 41.
- KIRSCHNER, JACALYN, TAMPA, FL:  
2,882,434, CANC. INT. CL. 41.
- KISCHE USA LLC, WOODINVILLE, WA:  
3,961,455, PUB. 3-1-2011. INT. CL. 25.
- KISZKA, THOMAS G., HATBORO, PA, DBA PRECISION IMAGES DESIGN:  
2,881,643, CANC. INT. CL. 16.
- KIWI SPORT PRE SCHOOL LIMITED, MANUKAU, AUCKLAND, NEW ZEALAND:  
3,962,224, MULTIPLE CLASS, INT. CLS. 35, 41 AND 43.
- KIYOHARA KABUSHIKI KAISHA, JAPAN:  
3,960,744, PUB. 3-1-2011. MULTIPLE CLASS, INT. CLS. 9, 14, 18, 25 AND 26.
- KLARQUIST SPARKMAN, LLP, PORTLAND, OR:  
2,457,391, REN. 4-8-11. INT. CL. 42.
- KLEENZ-IT, L.P., HOUSTON, TX:  
2,883,024, CANC. INT. CL. 3.
- KLEIN, DEBORA A., LOS ANGELES, CA:  
3,960,440, PUB. 3-1-2011. INT. CL. 44.
- KLUDGE INC., ORILLIA, ONTARIO, CANADA:  
3,961,675, PUB. 3-1-2011. INT. CL. 37.
- KMS TEAM GMBH, FED REP GERMANY:  
3,960,704, PUB. 3-1-2011. MULTIPLE CLASS, INT. CLS. 35, 41 AND 42.

KNIGHT CORPORATION, KAILUA, HI, KNIGHT DEVELOPMENT CORPORATION, HONOLULU, HI:  
1,617,683. REN. 4-11-11. INT. CL. 25.

KNIGHTSBRIDGE ADVISERS LLC, BARTLESVILLE, OK:  
3,963,814. INT. CL. 36.

KNOWLEDGE ADVENTURE, INC., TORRANCE, CA:  
3,963,066. INT. CL. 41.

KNOWLEDGE INFUSION, LLC, MINNEAPOLIS, MN:  
3,962,746. MULTIPLE CLASS, INT. CLS. 9, 35 AND 41.

KNOWLEDGE LEARNING ENTERPRISES, INC., GOLDEN, CO:  
2,882,063. CANC. MULTIPLE CLASS, INT. CLS. 41 AND 42.

KNOWLEDGEPOINT360 GROUP, LLC, NEW JERSEY, NY:  
2,882,455. CANC. INT. CL. 41.  
2,882,456. CANC. INT. CL. 41.

KNOWLES ELECTRONICS, LLC, ITASCA, IL:  
2,881,986. CANC. INT. CL. 9.

KOA SPEER ELECTRONICS, INC., BRADFORD, PA:  
3,939,362. COR. INT. CL. 9.

KOCH-GLITSCH, LP, WICHITA, KS:  
2,881,796. CANC. INT. CL. 6.

KOENIG & BAUER AKTIENGESELLSCHAFT, D-97080 WURZBURG, FED REP GERMANY:  
2,454,851. REN. 4-8-11. INT. CL. 7.

KOHLER CO., KOHLER, WI:  
3,962,014. INT. CL. 20.  
3,963,312. INT. CL. 11.

KOLLER ENTERPRISES, INC., FENTON, MO, DBA SCIENTIFIC LIGHTING PRODUCTS:  
1,169,147. REN. 4-9-11. INT. CL. 11.

KOLLMAN, MICHAEL S, MADISON, WI:  
2,883,187. CANC. INT. CL. 20.

KOLO LLC, HARTFORD, CT:  
3,962,206. INT. CL. 42.

KOMATSU FOREST AB, 907 04 UMEA, SWEDEN:  
2,382,344. CANC. INT. CL. 7.

KOMAX INDUSTRIAL CO., LTD., SEOUL, REPUBLIC OF KOREA:  
2,882,691. CANC. INT. CL. 21.

KOMORI CORPORATION, TOKYO 130-8666, JAPAN:  
2,882,114. CANC. MULTIPLE CLASS, INT. CLS. 7, 9, 11, 37, 41 AND 42.  
2,882,115. CANC. MULTIPLE CLASS, INT. CLS. 7, 9, 11, 37, 41 AND 42.

KONAMI DIGITAL ENTERTAINMENT CO., LTD., MINATO-KU, TOKYO, JAPAN:  
2,882,175. CANC. INT. CL. 28.  
2,882,177. CANC. INT. CL. 28.  
2,882,195. CANC. INT. CL. 28.  
2,883,353. CANC. INT. CL. 28.

KONICA MINOLTA BUSINESS SOLUTIONS U.S.A., INC., RAMSEY, NJ:  
3,962,041. INT. CL. 9.

KONINKLIJKE PHILIPS ELECTRONICS N.V., EINDHOVEN, NETHERLANDS:  
2,382,273. CANC. INT. CL. 9.  
2,382,441. CANC. INT. CL. 9.

KONINKLIJKE PHILIPS ELECTRONICS N.V., NETHERLANDS:  
3,960,708. PUB. 3-1-2011. MULTIPLE CLASS, INT. CLS. 9, 11 AND 42.

KORB, ALAN D, BELMONT, NH, DBA TUFF FURNITURE:  
3,963,450. INT. CL. 20.

KOREGON ENTERPRISES, INC., BEAVERTON, OR:  
2,457,197. REN. 4-14-11. INT. CL. 10.

KORSON, THOMAS E., DENVER, CO:  
3,961,842. PUB. 3-1-2011. INT. CL. 41.

KOSE CORPORATION, CHUO-KU, TOKYO 103, JAPAN:  
2,383,570. CANC. INT. CL. 3.

KOSE CORPORATION, CHUO-KU, TOKYO, JAPAN:  
2,880,631. CANC. MULTIPLE CLASS, INT. CLS. 8 AND 21.

KOSHFAM, SAMUEL, SAN DIEGO, CA:  
3,961,484. PUB. 3-1-2011. INT. CL. 25.

KOSTAL INDUSTRIE ELEKTRIK GMBH, LÜDENSCHIED, FED REP GERMANY:  
3,960,860. PUB. 3-1-2011. INT. CL. 9.

KOTABISH, CHING, STATEN ISLAND, NY, DBA PINK AUBERGINE:  
3,962,626. INT. CL. 25.

KRAFFT, JACK S., AUSTIN, PA, DBA FRAMING ON STONE AND KRAFFT, LINDA S., AUSTIN, PA, DBA FRAMING ON STONE:  
3,960,338. PUB. 3-1-2011. INT. CL. 19.

KRAFT FOODS GLOBAL BRANDS LLC, NORTHFIELD, IL:  
2,440,798. REN. 4-8-11. INT. CL. 30.  
2,444,737. REN. 4-14-11. INT. CL. 29.  
3,962,346. INT. CL. 9.

KREUTLE, SYLVIA C., FT., COLLINS, CO AND TOOHEY, LYNN, FT., COLLINS, CO:  
2,382,345. CANC. INT. CL. 9.

KRISTALLGLASFABRIK SPIEGELAU GMBH, FED REP GERMANY:  
3,960,679. PUB. 3-1-2011. INT. CL. 21.

KRISTOPHER GOODRICH, LONG VALLEY, NJ:  
3,961,263. PUB. 3-1-2011. INT. CL. 37.

KROHN & MOSS, LTD., CHICAGO, IL:  
2,883,376. CANC. INT. CL. 42.

KRON, HERMAN R, PETALUMA, CA:  
3,961,783. PUB. 3-1-2011. INT. CL. 1.

KRONOSPAN SCHWEIZ AG, 6122 MENZNAU, SWITZERLAND:  
2,880,611. CANC. INT. CL. 19.

KT GRANT, INC., BROADVIEW HEIGHTS, OH:  
2,553,791. REN. 4-12-11. INT. CL. 7.

KT GRANT, INC., BROADVIEW HEIGHTS, OH:  
2,553,792. REN. 4-12-11. INT. CL. 7.

KUBSCH, JULIE, NORMAL, IL:  
2,383,190. CANC. INT. CL. 42.

KUCUHEAD INC, SHERMAN OAKS, CA:  
3,963,189. INT. CL. 25.

KUHN S.A., FRANCE:  
3,919,055. COR. MULTIPLE CLASS, INT. CLS. 35, 38 AND 41.

KUMAR, REKHA ANAND, CLIFTON, NJ:  
2,882,593. CANC. INT. CL. 10.

KURT MANUFACTURING COMPANY, INC., FRIDLEY, MN:  
2,383,741. CANC. INT. CL. 7.

KURTZ BROS., CLEARFIELD, PA:  
1,662,434. REN. 4-13-11. INT. CL. 16.

KUTRUBES, DORIA L., WALTHAM, MI, DBA RADAR SOLUTIONS INTERNATIONAL:  
2,443,974. REN. 4-12-11. INT. CL. 42.

KX TECHNOLOGIES LLC, WEST HAVEN, CT:  
3,960,392. PUB. 3-1-2011. MULTIPLE CLASS, INT. CLS. 1 AND 11.

KXH, INC., MIXXION, TX:  
3,933,287. COR. INT. CL. 10.

KYSER-FAIRLEY, KIMBERLY, LEWISVILLE, TX:  
2,882,870. CANC. INT. CL. 16.

K2 CONCEPTS INCORPORATED, LANCASTER, PA:  
3,960,884. PUB. 3-1-2011. INT. CL. 16.

L. PERRIGO COMPANY, ALLEGAN, MI:  
3,962,760. MULTIPLE CLASS, INT. CLS. 3 AND 8.

L.C. INDUSTRIES, INC., CHICAGO, IL:  
2,883,351. CANC. INT. CL. 25.

L.I.D. LTD., NEW YORK, NY:  
2,882,191. CANC. INT. CL. 14.

L.I.S. DEPOT CO., TAIPEI, TAIWAN:  
2,881,016. CANC. INT. CL. 25.

L&P PROPERTY MANAGEMENT COMPANY, SOUTH GATE, CA:  
2,880,852. CANC. INT. CL. 20.  
3,963,177. INT. CL. 7.

L-1 IDENTITY SOLUTIONS OPERATING COMPANY, INC., STAMFORD, CT:  
2,882,046. CANC. INT. CL. 9.

L'ALPINA MAGLIERIE SPORTIVE S.P.A., 20137 MILAN, ITALY, L'ALPINA DI LEARDO ED ENEA GABRIELLI, MILAN, ITALY:  
918,964. REN. 4-11-11. U.S. CL. 39 (INT. CL. 25).

L'OREAL, PARIS, FRANCE:  
2,882,614. CANC. INT. CL. 3.  
3,961,924. PUB. 3-1-2011. INT. CL. 3.



- L'OREAL USA CREATIVE, INC., NEW YORK, NY:  
2,496,231, REN. 4-11-11, INT. CL. 3.  
2,882,932, CANC. INT. CL. 3.  
2,883,213, CANC. INT. CL. 3.  
3,962,714, INT. CL. 3.  
3,962,730, INT. CL. 3.  
3,962,764, INT. CL. 3.  
3,962,812, INT. CL. 3.  
3,963,593, INT. CL. 3.
- LA IDOL FASHION, INC., LOS ANGELES, CA:  
3,961,556, PUB. 3-1-2011, INT. CL. 25.
- LA REYNERA, LLC, HOUSTON, TX:  
3,962,252, INT. CL. 29.
- LA VERDOSA, S.L., MADRID, SPAIN:  
3,962,417, INT. CL. 33.
- LA.MET. S.P.A., 35030 VEGGIANO (PD), ITALY:  
2,882,297, CANC. INT. CL. 14.
- LAB ARMOR, INC., SAN ANTONIO, TX:  
3,962,582, MULTIPLE CLASS, INT. CLS. 6 AND 9.  
3,962,583, INT. CL. 6.
- LABRADA BODYBUILDING NUTRITION, INC., HOUSTON, TX:  
3,963,157, INT. CL. 5.
- LABYRINTH, INC., NEW YORK, NY, DBA LABYRINTH THEATER COMPANY:  
2,880,839, CANC. MULTIPLE CLASS, INT. CLS. 25 AND 41.
- LACOMBE, AMY, LOS ANGELES, CA:  
2,866,472, CANC. INT. CL. 21.
- LADY BURD EXCLUSIVE COSMETICS, INC., FARMINGDALE, NY:  
2,882,397, CANC. INT. CL. 3.
- LAFRAMBOISE, DONNA, TORONTO ONTARIO, CANADA:  
2,883,041, CANC. INT. CL. 9.
- LAGARDERE SCA, FRANCE:  
3,960,666, PUB. 3-1-2011, MULTIPLE CLASS, INT. CLS. 9, 16, 28, 35, 38, 41 AND 42.
- LAING BAN INTERNATIONAL INC., HSIN CHUANG CITY, TAIPEI HSIEN, TAIWAN:  
2,880,865, CANC. INT. CL. 25.
- LAIRD NORTON TYEE TRUST COMPANY, SEATTLE, WA:  
3,911,346, AM. INT. CL. 41.
- LAKESHORE CENTRE HOLDINGS LLC, CHICAGO, IL:  
2,880,965, CANC. INT. CL. 41.
- LAKIM INDUSTRIES, INC., RANCHO DOMINGUEZ, CA, DBA QUALI-TECH MFG. CO.:  
3,961,584, PUB. 3-1-2011, INT. CL. 16.
- LAL, CRYSTAL, CHEVERLY, MD:  
2,883,427, CANC. INT. CL. 14.
- LALUEZA, NICHOLAS, HIGHLAND LAKES, NJ:  
3,961,571, PUB. 3-1-2011, INT. CL. 25.
- LAMBI FUND OF HAITI, WASHINGTON, DC:  
3,961,205, PUB. 3-1-2011, INT. CL. 36.
- LAMPLIGHT FARMS INCORPORATED, MENOMONEE FALLS, WI:  
3,960,910, PUB. 3-1-2011, MULTIPLE CLASS, INT. CLS. 4, 5 AND 11.
- LANCASTER COUNTY BIBLE CHURCH, MANHEIM, PA:  
3,960,456, PUB. 3-1-2011, MULTIPLE CLASS, INT. CLS. 9, 41 AND 45.  
3,960,457, PUB. 3-1-2011, MULTIPLE CLASS, INT. CLS. 9, 41 AND 45.  
3,960,458, PUB. 3-1-2011, MULTIPLE CLASS, INT. CLS. 9, 41 AND 45.
- LANCOME PARFUMS ET BEAUTE & CIE, PARIS, FRANCE:  
2,882,647, CANC. INT. CL. 3.  
2,882,660, CANC. INT. CL. 3.  
2,882,662, CANC. INT. CL. 3.  
3,960,548, PUB. 3-1-2011, INT. CL. 18.
- LAND O'LAKES, INC., ARDEN HILLS, MN:  
3,960,919, PUB. 3-1-2011, INT. CL. 35.
- LANDACORP, INC., LOUISVILLE, KY:  
3,962,088, INT. CL. 9.
- LANDO & ANASTASI, LLP, CAMBRIDGE, MA:  
3,963,107, INT. CL. 41.
- LANDOLL CORPORATION, MARYSVILLE, KS:  
3,963,804, INT. CL. 7.
- LANDRY'S TRADEMARK, INC., HOUSTON, TX, BAYPORT RESTAURANT GROUP, INC., MIAMI, FL:  
1,666,211, REN. 4-11-11, INT. CL. 42.
- LANDSCAPE STRUCTURES, INC., DELANO, MN:  
3,962,258, INT. CL. 28.
- LANG, DANIEL JOSHUA, NORTH BEND, WA:  
2,882,855, CANC. INT. CL. 42.
- LANGFORD, MICHAEL, LOUISVILLE, KY:  
3,963,394, INT. CL. 45.
- LANKAO LUIS WINEMADE CO., LTD., CHINA:  
3,960,684, PUB. 3-1-2011, INT. CL. 33.
- LANTOR B.V., NETHERLANDS:  
3,960,738, PUB. 3-1-2011, MULTIPLE CLASS, INT. CLS. 17, 19 AND 24.
- LAPPOTS, FELIX, STAMFORD, CT:  
2,882,371, CANC. INT. CL. 41.
- LASERLIFE AMERICAS, INC., GRAYS MILLS, WI:  
2,383,222, CANC. INT. CL. 7.
- LASKO HOLDINGS, INC., WILMINGTON, DE:  
3,961,442, PUB. 3-1-2011, INT. CL. 11.
- LATCHMAN, ROBERT, RAHWAY, NJ:  
3,960,334, PUB. 3-9-2010, INT. CL. 30.
- LATEX FOAM INTERNATIONAL HOLDINGS, INC., SHELTON, CT:  
2,883,067, CANC. INT. CL. 20.
- LATIBAER EHF, GARDABAER 210, ICELAND:  
3,962,171, INT. CL. 32.
- LATINO GEAR, INC., SAN FRANCISCO, CA:  
2,880,932, CANC. INT. CL. 25.
- LAUNCH, LLC, SPARTANBURG, SC, DBA LAUNCH SOMETHING:  
3,961,564, PUB. 3-1-2011, INT. CL. 42.
- LAURA GELLER MAKE-UP STUDIOS, LTD, NEW YORK, NY:  
3,961,699, PUB. 3-1-2011, INT. CL. 3.  
3,961,747, PUB. 3-1-2011, INT. CL. 3.
- LAUREN JONES, HIGHLANDS RANCH, CO, DBA L2S:  
3,961,694, PUB. 3-1-2011, INT. CL. 41.
- LAVENDER I.P., INC., SAN MARINO, CA:  
2,881,554, CANC. INT. CL. 3.  
2,881,555, CANC. INT. CL. 3.
- LAVENDER, JAY, LOS ANGELES, CA:  
3,962,094, INT. CL. 41.
- LAVERANA GMBH & CO. KG, WENNIGSEN, FED REP GERMANY:  
2,880,902, CANC. INT. CL. 3.
- LAW BULLETIN PUBLISHING COMPANY, CHICAGO, IL, DBA LAW BULLETIN INFORMATION NETWORK:  
1,641,652, REN. 4-8-11, INT. CL. 42.
- LAWLISS, KAREN E., PLATTSBURGH, NY:  
2,883,152, CANC. INT. CL. 16.
- LAYERZERO POWER SYSTEMS, INC., SHAKER HEIGHTS, OH:  
3,963,770, INT. CL. 9.
- LAZEL, INC., DALLAS, TX:  
3,961,960, PUB. 1-18-2011, INT. CL. 42.
- LBA HEALTHPLANS, INC., TIMONIUM, MD:  
2,443,891, REN. 4-11-11, INT. CL. 36.
- LBB ENTERPRISES, LLC, HENDERSON, NV, DBA IDIGYA:  
3,963,517, INT. CL. 45.
- LBC LIPS BY CARLA, SUGAR LAND, TX:  
3,961,264, PUB. 3-1-2011, INT. CL. 35.
- LBI.LLC, BUFFALO, WY, AKA LITTLE BITS INC:  
3,961,677, PUB. 3-1-2011, INT. CL. 31.
- LE CREUSET OF AMERICA, INC., EARLY BRANCH, SC:  
2,883,122, CANC. INT. CL. 21.
- LE, HUNG, LAKEWOOD, CO, DBA THE YABBY HUT AND THE YABBY HUT, LLC, LAKEWOOD, CO, DBA THE YABBY HUT:  
3,960,903, PUB. 3-1-2011, INT. CL. 43.
- LEACHCO, INC., ADA, OK:  
3,962,327, MULTIPLE CLASS, INT. CLS. 10 AND 20.
- LEAK IT OUT, INC., LAS VEGAS, NV:  
3,963,194, MULTIPLE CLASS, INT. CLS. 35, 42 AND 45.  
3,963,195, MULTIPLE CLASS, INT. CLS. 35, 42 AND 45.
- LEARNING DIVIDENDS INC., CALGARY, ALBERTA, CANADA:  
2,882,072, CANC. MULTIPLE CLASS, INT. CLS. 9, 16



- AND 41.  
LEARNINGHERBS.COM, LLC, CARNATION, WA:  
3,961,529, PUB. 3-1-2011. INT. CL. 28.
- LEBAZ, INC., MOONACHIE, NJ:  
2,881,507, CANC. INT. CL. 18.
- LEDDY, DIANA, THETFORD CENTER, VT:  
3,961,492, PUB. 3-1-2011. INT. CL. 16.
- LEE KANG HUN, REPUBLIC OF KOREA:  
3,960,807, PUB. 3-1-2011. INT. CL. 43.
- LEE PROCUREMENT SOLUTIONS CO., DAVENPORT, IA:  
2,382,304, CANC. INT. CL. 42.
- LEE, CHRISTOPHER MARK, CREAMRIDGE, NJ:  
3,960,429, PUB. 3-1-2011. INT. CL. 9.
- LEE, JESSICA LYNN, SANTA MONICA, CA:  
2,882,955, CANC. MULTIPLE CLASS, INT. CLS. 3 AND 4.
- LEE, ROBERT H, III, BIRMINGHAM, AL:  
3,963,411, INT. CL. 7.
- LEE, SANG, MONUMENT, CO AND LEE, JAY, MONUMENT, CO:  
3,960,565, PUB. 3-1-2011. MULTIPLE CLASS, INT. CLS. 9, 18, 25, 41 AND 42.
- LEEDOM MANAGEMENT GROUP, INC., SARASOTA, FL:  
3,961,194, PUB. 3-1-2011. INT. CL. 36.
- LEGACY BAKING COMPANY, LLC, LUFKIN, TX:  
3,960,987, PUB. 3-1-2011. INT. CL. 30.
- LEGACY PROMOTIONS INC., VANCOUVER, CANADA,  
LEGACY PROMOTIONS INC., VANCOUVER, CANADA:  
2,453,349. REN. 4-9-11. INT. CL. 36.
- LEGACY STORE L.L.C., THE, ROANOKE, VA:  
2,882,310, CANC. INT. CL. 9.
- LEGACY TECHNOLOGIES, SAINT FRANCISVILLE, LA:  
3,962,051, INT. CL. 3.
- LEHLE GMBH, 71116 GÄRTRINGEN, FED REP GERMANY:  
3,960,721, PUB. 3-1-2011. MULTIPLE CLASS, INT. CLS. 11  
AND 42.
- LEICA CAMERA AG, D-35606 SOLMS, FED REP GERMANY:  
2,458,939. REN. 4-14-11. INT. CL. 9.
- LEIDELMEYER, HEATHER, MAGNOLIA, TX:  
3,963,640, INT. CL. 25.
- LEITH, KATHERINE HENRIETTA, COLUMBIA, SC:  
3,962,472, MULTIPLE CLASS, INT. CLS. 18 AND 25.
- LEKOV, A.S., BLOVICE, CZECH REPUBLIC:  
2,880,720, CANC. MULTIPLE CLASS, INT. CLS. 6, 7 AND  
9.
- LEMMON, TIMOTHY J., NEW YORK, NY:  
3,962,046, MULTIPLE CLASS, INT. CLS. 16, 35 AND 36.
- LEMORD, IAN C.A., BROOKLYN, NY, DBA LEMORD, IAN  
C.A.:  
3,962,174, MULTIPLE CLASS, INT. CLS. 18 AND 25.
- LENMAR ENTERPRISES, INC., CAMARILLO, CA:  
3,961,810, PUB. 3-1-2011. INT. CL. 9.
- LENS JACKETS, ATLANTA, GA:  
3,961,040, PUB. 3-1-2011. INT. CL. 21.
- LES VINS SKALLI, FRANCE:  
3,960,791, PUB. 3-1-2011. INT. CL. 33.
- LESSLER, EVAN MARCUS, SUISUN CITY, CA:  
2,883,420, CANC. INT. CL. 25.
- LEUNG, YING SUK, TSUEN WAN, HONG KONG:  
2,881,775, CANC. INT. CL. 14.
- LEVAN MANUFACTURING INC, ALBANY, OR:  
2,382,717, CANC. INT. CL. 20.
- LEVEL 3 COMMUNICATIONS, LLC, BROOMFIELD, CO:  
2,882,178, CANC. MULTIPLE CLASS, INT. CLS. 35 AND  
38.
- LEVESQUE, SUZETTE M., COLLEGEVILLE, PA:  
3,960,552, PUB. 3-1-2011. INT. CL. 45.
- LEVITON MANUFACTURING CO., INC., LITTLE NECK,  
NY:  
2,882,541, CANC. INT. CL. 9.
- LEVITON MANUFACTURING CO., INC., MELVILLE, NY:  
3,963,314, INT. CL. 9.
- LEVY, NATALIE, CANOGA PARK, CA:  
3,961,805, PUB. 3-1-2011. INT. CL. 5.
- LEWIS BROTHERS BAKERIES, INC., EVANSVILLE, IN,  
HART'S BAKERY, INC., SIKESTON, MO:  
556,609. REN. 4-13-11. U.S. CL. 46 (INT. CL. 30).
- LEXANI HOLDINGS, INC., CORONA, CA:  
3,963,403, INT. CL. 12.
- LEXXUS INTERNATIONAL, INC., DALLAS, TX:  
2,882,285, CANC. INT. CL. 3.
- LF, LLC, MOUNT MOURNE, NC:  
2,880,610, CANC. INT. CL. 19.
- LF, LLC, WILMINGTON, DE:  
2,931,853, COR. MULTIPLE CLASS, INT. CLS. 11, 21  
AND 31.  
2,931,854, COR. MULTIPLE CLASS, INT. CLS. 11, 21  
AND 31.
- LG ELECTRONICS INC., SEOUL, REPUBLIC OF KOREA:  
2,880,802, CANC. INT. CL. 7.  
3,960,373, PUB. 3-1-2011. INT. CL. 9.  
3,962,676, INT. CL. 35.  
3,962,948, INT. CL. 9.
- LIBERTY BLOOMS, INC., MIAMI, FL:  
3,961,169, PUB. 3-1-2011. INT. CL. 31.
- LIDA KULUMCULUK SANAYI VE TICARET LTD., NUR-  
UOSMANIYE - ISTANBUL, TURKEY:  
3,962,030, INT. CL. 14.
- LIFE RESET BUTTON, LLC, MERRITT ISLAND, FL:  
3,963,371, INT. CL. 41.  
3,963,427, INT. CL. 45.  
3,963,502, MULTIPLE CLASS, INT. CLS. 41 AND 45.
- LIFEGUARD STORE, INC., THE, NORMAL, IL:  
3,961,063, PUB. 3-1-2011. INT. CL. 35.
- LIFEPORTR INC, WOODLAND, WA:  
3,960,855, PUB. 3-1-2011. INT. CL. 11.
- LIFESOUTH COMMUNITY BLOOD CENTERS, INC., GAI-  
NESVILLE, FL:  
3,961,117, PUB. 3-1-2011. INT. CL. 44.
- LIFESTYLE UHREN GMBH, ECHING, FED REP GER-  
MANY:  
3,963,286, MULTIPLE CLASS, INT. CLS. 14 AND 34.
- LIFETIME BRANDS, INC., GARDEN CITY, NY:  
2,448,150. REN. 4-12-11. INT. CL. 21.
- LIGHTHOUSE COMMUNICATIONS, INC., DES MOINES,  
IA:  
2,880,728, CANC. MULTIPLE CLASS, INT. CLS. 38 AND  
42.
- LIGHTNING STRIKES TWICE, LLC, LEXINGTON, KY,  
DBA LEXINGTON HORSEMEN:  
2,882,534, CANC. INT. CL. 41.
- LIGHTYEAR TECHNOLOGY, INC., ROSWELL, GA:  
2,881,619, CANC. MULTIPLE CLASS, INT. CLS. 9 AND  
10.
- LILLEHOFF, TROY, CENTENNIAL, CO AND MOOK,  
MATT, CENTENNIAL, CO:  
3,963,790, INT. CL. 25.
- LILLYPAD PRODUCTIONS, LLC, FLORENCE, SC:  
3,963,321, INT. CL. 41.
- LIMING NETWORK SYSTEMS CO., LTD., SHENZHEN,  
CHINA:  
2,882,116, CANC. MULTIPLE CLASS, INT. CLS. 9, 38  
AND 42.
- LIN, QI DONG, HOUSTON, TX:  
3,960,908, PUB. 3-1-2011. INT. CL. 43.
- LINCOLN GLOBAL, INC., CITY OF INDUSTRY, CA:  
3,961,713, PUB. 3-1-2011. INT. CL. 6.
- LINDA JOHNSON, MOLINE, IL:  
3,963,328, INT. CL. 14.
- LINDSEY CREATIONS, INC., DALLAS, TX:  
3,960,613, PUB. 3-1-2011. INT. CL. 25.
- LINK SNACKS, INC., MINONG, WI:  
3,963,166, INT. CL. 29.
- LINKEDIN CORPORATION, MOUNTAIN VIEW, CA:  
3,963,244, INT. CL. 35.
- LINNELL SKIN CARE, INC, FORT LAUDERDALE, FL:  
3,962,195, INT. CL. 3.
- LIONBRIDGE TECHNOLOGIES, INC., WALTHAM, MA:  
3,961,587, PUB. 3-1-2011. INT. CL. 35.
- LIONS GATE ENTERTAINMENT, INC., SANTA MONICA,  
CA:  
3,960,619, PUB. 3-1-2011. MULTIPLE CLASS, INT. CLS. 9,  
21, 34 AND 41.
- LIP IVO, INC., CENTENNIAL, CO:  
2,469,278. REN. 4-12-11. MULTIPLE CLASS, INT. CLS. 3

- AND 5.  
 LIPING, WANG, HANGZHOU 31005, CHINA:  
 3,961,402, PUB. 3-1-2011. INT. CL. 25.  
 LIQUID LIFESTYLE PROMOTIONS, TAIPEI, TAIWAN:  
 3,960,929, PUB. 3-1-2011. INT. CL. 41.  
 LISA ASHLEY, INC., THOUSAND OAKS, CA:  
 3,962,581, INT. CL. 3.  
 LISA KLINE, INC., LOS ANGELES, CA:  
 2,442,393, REN. 4-12-11. INT. CL. 25.  
 LISA PROTTER, MALDEN, NY:  
 3,961,727, PUB. 3-1-2011. INT. CL. 30.  
 LITERA CORP., MCLEANSVILLE, NC:  
 3,960,443, PUB. 3-1-2011. INT. CL. 9.  
 LITIGATION SYSTEMS, INC., WASHINGTON, DC:  
 2,880,586, CANC. INT. CL. 9.  
 LITTLE DONKEY'S, INC., CORALVILLE, IA, DBA PAN-  
 CHERO'S MEXICAN GRILL:  
 2,525,220, REN. 4-9-11. INT. CL. 42.  
 LITTLE LUXURIES HANDMADE BATH AND BODY CARE  
 ESSENTIALS, CHARLOTTE, NC, AKA LITTLE LUXU-  
 RIES:  
 2,880,736, CANC. INT. CL. 3.  
 LIU, SU-JUN, IRVINE, CA:  
 3,963,315, INT. CL. 15.  
 LIVE IN WONDER LLC, HENDERSON, NV:  
 3,963,588, MULTIPLE CLASS, INT. CLS. 25 AND 41.  
 LIVING ASSISTANCE SERVICES, INC., HAVERTOWN, PA:  
 2,442,068, REN. 4-12-11. INT. CL. 42.  
 LIVING FOR LIFE MD, LLC, SALT LAKE CITY, UT:  
 3,963,193, INT. CL. 44.  
 LIZ CLAIBORNE, INC., NEW YORK, NY:  
 1,660,255, REN. 4-8-11. INT. CL. 3.  
 2,882,059, CANC. MULTIPLE CLASS, INT. CLS. 20 AND  
 24.  
 LIZHAN ENVIRONMENTAL CORPORATION, GRAND  
 CAYMAN KY1-1112, CAYMAN ISLANDS:  
 3,960,517, PUB. 3-1-2011. INT. CL. 18.  
 LNO S.A., GENEVA, SWITZERLAND:  
 3,963,489, INT. CL. 38.  
 3,963,490, INT. CL. 41.  
 3,963,491, INT. CL. 42.  
 LOADING MEDIA SARL, SWITZERLAND:  
 3,960,830, PUB. 3-1-2011. MULTIPLE CLASS, INT. CLS. 9,  
 16, 28 AND 41.  
 LOBO SYSTEMS LIMITED, DERBY, UNITED KINGDOM:  
 2,382,515, CANC. MULTIPLE CLASS, INT. CLS. 6 AND  
 20.  
 LOBODA, ARVID THORWALD, FED REP GERMANY:  
 3,960,719, PUB. 3-1-2011. MULTIPLE CLASS, INT. CLS. 6  
 AND 9.  
 LOCAL MOTION, INC., HONOLULU, HI, LOCAL MOTION,  
 INC., HONOLULU, HI:  
 1,160,101, REN. 4-11-11. MULTIPLE CLASS, INT. CLS. 25  
 AND 28.  
 LOCATEL FRANCE, FRANCE:  
 3,960,771, PUB. 3-1-2011. MULTIPLE CLASS, INT. CLS. 9,  
 37, 38 AND 42.  
 LOCKHEED MARTIN CORPORATION, BETHESDA, MD:  
 2,441,628, REN. 4-8-11. INT. CL. 28.  
 LOCUS TECHNOLOGIES, MOUNTAIN VIEW, CA:  
 2,382,390, CANC. INT. CL. 42.  
 LODESTAR TECHNOLOGY LABS LLC, ATLANTA, GA:  
 3,961,816, PUB. 3-1-2011. INT. CL. 35.  
 LOFTIN, JEFF, S. SHREVEPORT, LA:  
 2,489,473, REN. 4-14-11. INT. CL. 9.  
 LOGAN, CHARLES W., MORIARTY, NM:  
 3,963,773, INT. CL. 12.  
 LOGISTICS MANAGEMENT INSTITUTE, MCLEAN, VA:  
 3,962,555, INT. CL. 42.  
 LOMA LINDA UNIVERSITY ADVENTIST HEALTH  
 SCIENCES CENTER, INC., LOMA LINDA, CA:  
 3,960,326, PUB. 8-11-2009. INT. CL. 41.  
 LONE STAR KEMAH VENTURES, CLEAR LAKE SHORES,  
 TX:  
 3,961,567, PUB. 3-1-2011. INT. CL. 33.  
 LONE STAR WELLNESS HOLDINGS, LLC, EULESS, TX:  
 3,961,811, PUB. 3-1-2011. INT. CL. 44.  
 LONG, CHRISTOPHER, DANA POINT, CA:  
 2,383,471, CANC. INT. CL. 25.  
 LONG, MICHAEL V, FREDERICK, MD:  
 3,961,280, PUB. 3-1-2011. INT. CL. 9.  
 LONGUST DISTRIBUTING, INC., MESA, AZ:  
 3,961,310, PUB. 3-1-2011. INT. CL. 19.  
 3,961,314, PUB. 3-1-2011. INT. CL. 19.  
 LONSDALE SPORTS LIMITED, SHIREBROOK, NG208RY,  
 UNITED KINGDOM:  
 1,353,454 NEW CERT. 5-17-2011. INT. CL. 25.  
 LONZA SALES AG, BASEL, SWITZERLAND:  
 2,443,434, REN. 4-11-11. INT. CL. 1.  
 LOOPBACK, LLC, DALLAS, TX, DBA LOOPBACK COM-  
 MUNICATIONS:  
 3,961,769, PUB. 3-1-2011. INT. CL. 35.  
 LORD & TAYLOR LLC, NEW YORK, NY:  
 3,963,700, INT. CL. 35.  
 LORD GRIFFON LLC, LOS ANGELES, CA:  
 3,963,602, INT. CL. 14.  
 LORICK, LEON, ENGLEWOOD, NJ:  
 3,464,452, COR. INT. CL. 41.  
 LORIT LLC, LAS VEGAS, NV:  
 3,962,310, INT. CL. 3.  
 LOS ANGELES PROVISION COMPANY, INC., HUNTING-  
 TON PARK, CA:  
 2,881,001, CANC. INT. CL. 29.  
 LOS ANGELES TIMES COMMUNICATIONS, LLC, LOS  
 ANGELES, CA:  
 3,961,490, PUB. 3-1-2011. INT. CL. 41.  
 LOSI, MARY ANN, TRENTON, NJ:  
 1,677,804, REN. 4-14-11. INT. CL. 31.  
 LOTTE SHOPPING CO., LTD., SEOUL, REPUBLIC OF  
 KOREA:  
 3,960,601, PUB. 3-1-2011. INT. CL. 20.  
 LOUDEYE TECHNOLOGIES, INC., SEATTLE, WA:  
 2,639,504, CANC. INT. CL. 40.  
 LOUIS BERKMAN COMPANY, THE, STUEBENVILLE, OH:  
 2,883,194, CANC. INT. CL. 3.  
 LOUIS DREYFUS HOLDING COMPANY INC., WILTON,  
 CT:  
 2,882,949, CANC. INT. CL. 35.  
 LOUIS SIMPSON AND SAMUEL'S LLC, NEW YORK, NY:  
 3,960,989, PUB. 3-1-2011. INT. CL. 18.  
 3,960,993, PUB. 3-1-2011. INT. CL. 25.  
 LOUISE DE BELLEMONT, F-56000 VANNES, FRANCE:  
 3,960,678, PUB. 3-1-2011. MULTIPLE CLASS, INT. CLS. 5,  
 6, 9, 10, 11, 12, 18, 20, 21, 25 AND 27.  
 LOVABLE PRODUCTS INTERNATIONAL, INC., NEW  
 YORK, NY:  
 2,882,804, CANC. INT. CL. 20.  
 LOVATO, JR., MD, ALFRED A, ALBUQUERQUE, NM:  
 3,963,486, INT. CL. 9.  
 LOVELACE RESPIRATORY RESEARCH INSTITUTE, AL-  
 BUQUERQUE, NM:  
 3,962,385, MULTIPLE CLASS, INT. CLS. 1, 35 AND 42.  
 LOVIN' SCOOPFUL, LLC, SEATTLE, WA:  
 3,962,684, INT. CL. 35.  
 LOYALIST COLLEGE, BELLEVILLE, ONTARIO, CANADA:  
 3,961,562, PUB. 3-1-2011. INT. CL. 41.  
 LPS IP HOLDING COMPANY, LLC, JACKSONVILLE, FL:  
 2,880,937, CANC. INT. CL. 42.  
 2,881,455, CANC. MULTIPLE CLASS, INT. CLS. 36 AND  
 42.  
 LSI LOGIC CORPORATION, MILPITAS, CA:  
 2,384,060, CANC. INT. CL. 9.  
 2,384,131, CANC. INT. CL. 9.  
 LSP PRODUCTS GROUP, INC., IRVING, TX:  
 1,656,746, REN. 4-11-11. INT. CL. 11.  
 LUBRI-PUMP, INC., VAN, TX:  
 2,435,250, REN. 4-8-11. INT. CL. 7.  
 2,437,028, REN. 4-8-11. INT. CL. 7.  
 LUBY'S FUDDRUCKERS RESTAURANTS, LLC, HOUS-  
 TON, TX:  
 3,960,901, PUB. 3-1-2011. INT. CL. 43.  
 LUCKY BRAND DUNGAREES, INC., VERNON, CA:  
 2,383,437, CANC. INT. CL. 25.  
 LUCKY GOLD, LLC, ARLINGTON, TX:  
 2,882,951, CANC. INT. CL. 43.

LUCKY STRIKE ENTERTAINMENT, LLC, SHERMAN OAKS, CA:  
3,961,919, PUB. 3-1-2011. INT. CL. 35.

LUCTOR INTERNATIONAL, L.L.C., ORLANDO, FL:  
3,963,131, INT. CL. 33.

LUFTHANSA CARGO AG, 65451 KELSTERBACH, FED REP GERMANY:  
2,880,619, CANC. INT. CL. 39.

LUGO, TEODOLO, LONG BEACH, CA:  
3,961,041, PUB. 3-1-2011. INT. CL. 25.

LUMINESS LP, STAFFORD, TX:  
3,962,890, MULTIPLE CLASS, INT. CLS. 3 AND 7.

LUMISOURCE, INC., ELK GROVE VILLAGE, IL:  
2,882,604, CANC. INT. CL. 11.  
3,962,957, INT. CL. 18.

LUMLUX LIGHTING (SUZHOU) INC., SUZHOU, CHINA:  
3,963,106, INT. CL. 9.

LUNADA BIOMEDICAL, LOS ANGELES, CA:  
3,962,963, INT. CL. 5.

LUPE FUENTES, LLC, SHERMAN OAKS, CA:  
3,961,604, PUB. 3-1-2011. INT. CL. 41.  
3,961,657, PUB. 3-1-2011. INT. CL. 41.

LUSTBERG, A. MICHAEL, SANTA ROSA, CA:  
3,962,044, INT. CL. 5.

LUTRON ELECTRONICS CO., INC., COOPERSBURG, PA:  
1,154,629, REN. 4-9-11. INT. CL. 9.

LUVMAT, WESTMINSTER, CO:  
3,963,025, INT. CL. 28.

LUXE INNOVATIONS, LLC, SPRINGFIELD, VA:  
3,960,920, PUB. 3-1-2011. INT. CL. 18.

LUXE LINK LLC, SANTA MONICA, CA:  
3,962,950, INT. CL. 6.

LUXURIOUSITY, INC., SANTA MONICA, CA:  
2,881,684, CANC. INT. CL. 9.

LYCO MANUFACTURING, INC., COLUMBUS, WI:  
2,882,699, CANC. INT. CL. 7.

LYDELL JEWELRY DESIGN STUDIO, INC., NEW YORK, NY:  
3,960,588, PUB. 3-1-2011. INT. CL. 14.  
3,960,590, PUB. 3-1-2011. INT. CL. 14.

LYFEPUBLICATIONS, BALTIMORE, MD:  
3,962,933, MULTIPLE CLASS, INT. CLS. 35 AND 41.

LYNN, JACKSON, SHULTZ & LEBRUN, P.C., SIOUX FALLS, SD:  
3,963,079, INT. CL. 41.

L18 HOLDINGS, INC., NEW YORK, NY:  
3,963,693, MULTIPLE CLASS, INT. CLS. 35 AND 43.  
3,963,694, MULTIPLE CLASS, INT. CLS. 35 AND 43.

M & E INNOVATIVE SOLUTIONS LLC, LEE'S SUMMIT, MO:  
3,962,991, INT. CL. 26.

M. E. REDMOND GROUP, INC., SOMERS, CT, DBA ON THE FLY COMPUTER GUY:  
3,961,558, PUB. 3-1-2011. INT. CL. 42.

M. MEERAPFEL SOHNE BELGIUM S.A., BRUSSELS, BELGIUM:  
2,881,392, CANC. MULTIPLE CLASS, INT. CLS. 25, 34, 35 AND 40.

M.G.M. MOTORI ELETTRICI S.P.A., ITALY:  
3,960,747, PUB. 3-1-2011. INT. CL. 7.

M.T.R.E. ADVANCED TECHNOLOGIES LTD., YAVNE, ISRAEL:  
2,749,181, CANC. INT. CL. 10.

M&A EVENTS INC., COUNCIL BLUFFS, IA:  
2,883,391, CANC. INT. CL. 41.

M&E INNOVATIVE SOLUTIONS LLC, LEE'S SUMMIT, MO:  
3,962,989, INT. CL. 14.

M&G DURAVENT, INC., VACAVILLE, CA:  
3,962,005, MULTIPLE CLASS, INT. CLS. 6 AND 11.

M&M INCORPORATED, SAIPAN, N. MARIANA ISLAND:  
3,961,123, PUB. 3-1-2011. INT. CL. 35.

MABEL'S LABELS INC., HAMILTON, ONTARIO, CANADA:  
3,960,404, PUB. 3-1-2011. MULTIPLE CLASS, INT. CLS. 20 AND 24.

MACHADO CONSULTING, INC., SUTTON, MA:  
3,960,559, PUB. 3-1-2011. INT. CL. 42.

MACHAIRA ENERGY, LLC, BELLAIRE, TX:  
3,961,296, PUB. 3-1-2011. INT. CL. 40.

MACK, CHRISTOPHER R., NEW YORK, NY, DBA 8B MARKETING & MEDIA:  
3,962,056, INT. CL. 41.

MACKKEY, JR., JAMES F., TEWKSBURY, MA:  
3,963,316, INT. CL. 28.

MACLEAN POWER, L.L.C., FRANKLIN PARK, IL:  
3,963,190, INT. CL. 6.

MACRO RETAILING, INC., GREENWICH, CT:  
2,883,097, CANC. INT. CL. 25.

MAD DOGG ATHLETICS, INC., VENICE, CA:  
3,962,020, INT. CL. 9.

MADARAS GALLERY, INC., TUCSON, AZ, DBA MADARAS GALLERY:  
3,962,460, INT. CL. 16.  
3,962,461, INT. CL. 25.

MADISON FILTER GROUP LIMITED, HASLINGDEN, LANCASHIRE BB4 4EJ, UNITED KINGDOM:  
2,882,084, CANC. MULTIPLE CLASS, INT. CLS. 11 AND 24.

MADISON SQUARE GARDEN, L.P., NEW YORK, NY:  
3,961,669, PUB. 3-1-2011. INT. CL. 41.  
3,961,670, PUB. 3-1-2011. INT. CL. 41.

MADLER PTY LIMITED, ST. IVES NSW 2075, AUSTRALIA:  
2,882,435, CANC. INT. CL. 30.

MADVIN, JEREMY, WESTLAKE VILLAGE, CA, AKA JEREMY MADVIN:  
3,961,431, PUB. 3-1-2011. INT. CL. 1.

MAGBACKER, LLC, BRUNSWICK, GA:  
3,962,318, INT. CL. 19.

MAGELLAN CORPORATION, SANTA CLARA, CA:  
2,615,849, CANC. INT. CL. 9.

MAGIC CIRCLE CORPORATION, COATESVILLE, IN, DBA DIXIE CHOPPER:  
3,961,940, PUB. 3-1-2011. INT. CL. 7.

MAGNAFUEL PRODUCTS, INC., COLORADO SPRINGS, CO:  
3,961,376, PUB. 3-1-2011. MULTIPLE CLASS, INT. CLS. 7 AND 9.

MAGNESIUM ELEKTRON NORTH AMERICA, INC., MADISON, IL:  
1,889,107, REN. 4-12-11. INT. CL. 1.

MAHAR MANUFACTURING CORP., VERNON, CA, DBA FIESTA CONCESSION CORP.:  
3,963,645, INT. CL. 28.  
3,963,708, INT. CL. 28.

MAHLE CLEVITE INC., ANN ARBOR, MI:  
2,880,808, CANC. INT. CL. 41.

MAHSSA, EFTEKHAR CLARK, HOUSTON, TX:  
2,882,725, CANC. INT. CL. 44.

MAID OF THE MIST CORPORATION, NIAGARA FALLS, NY:  
2,916,631, CANC. MULTIPLE CLASS, INT. CLS. 26 AND 34.

MAIDENFORM, INC., ISELIN, NJ:  
3,962,255, INT. CL. 25.

MAIORANA, JAMES, R., FARMINGDALE, NY:  
2,881,826, CANC. INT. CL. 41.

MAJEED, MUHAMMED, PISCATAWAY, NJ:  
2,883,147, CANC. INT. CL. 3.

MAJESTIC DRUG CO., INC., SOUTH FALLSBURG, NY:  
1,183,438, REN. 4-14-11. INT. CL. 5.

MAJOR LEAGUE LACROSSE LLC, BOSTON, MA:  
3,963,179, INT. CL. 41.  
3,963,180, INT. CL. 41.

MAKE IDEAS, INC., LA JOLLA, CA:  
3,963,787, INT. CL. 28.

MALLINCKRODT INC., ST. LOUIS, MO:  
2,883,335, CANC. INT. CL. 5.

MAMMA CHIA, LLC, BONSALL, CA:  
3,963,538, INT. CL. 32.  
3,963,539, INT. CL. 32.

MAN CAVE SPORTS LLC, INDIANAPOLIS, IN:  
3,960,922, PUB. 3-1-2011. INT. CL. 41.

MANATRON, INC., PORTAGE, MI:  
2,882,253, CANC. INT. CL. 42.

MANCILLAS, ELIJAH, WEST COVINA, CA AND MANCILLAS, JOSHUA, WEST COVINA, CA:  
3,961,499, PUB. 3-1-2011. INT. CL. 41.

- MANHATTAN CHOCOLATES & NUTS, INC., BROOKLYN, NY:  
2,881,916, CANC. INT. CL. 30.
- MANHATTAN MINI STORAGE, LLC, NEWARK, NJ:  
1,647,052, REN. 4-9-11. INT. CL. 39.  
1,647,684, REN. 4-9-11. INT. CL. 39.
- MANHEIM NRT, LLC, ATLANTA, GA:  
2,882,296, CANC. INT. CL. 35.
- MANIFATTURA R. VALENTI S.R.L., ITALY:  
3,960,703, PUB. 3-1-2011. INT. CL. 25.
- MANNINGTON MILLS, INC., SALEM, NJ:  
2,880,976, CANC. INT. CL. 35.
- MANOR CAPITAL, LLC, GRANITE BAY, CA:  
3,960,376, PUB. 3-1-2011. MULTIPLE CLASS, INT. CLS. 35 AND 36.
- MANUEL G. GOMEZ, SHIRLEY, NY:  
3,963,559, INT. CL. 32.
- MANZIONE, JOHN JOSEPH, BAY SHORE, NY:  
3,962,186, INT. CL. 3.
- MAPLE LEAF BAKERY, INC., DES PLAINES, IL:  
3,962,546, INT. CL. 30.
- MARIAH MEDIA INC., SANTA FE, NM:  
3,961,161, PUB. 3-1-2011. MULTIPLE CLASS, INT. CLS. 16 AND 41.
- MARIE FRANCINE LINDA GAYET, VENTURA, CA:  
3,961,723, PUB. 3-1-2011. MULTIPLE CLASS, INT. CLS. 9 AND 41.
- MARIN WAVES TRACK & FIELD CLUB, LLC, SAN RAFAEL, CA:  
3,961,016, PUB. 3-1-2011. INT. CL. 41.
- MARINE FLOATS CORPORATION, TACOMA, WA:  
3,962,158, INT. CL. 19.
- MARINE TECHNOLOGY SOCIETY, INC., COLUMBIA, MD, AKA MTS:  
3,960,451, PUB. 3-1-2011. MULTIPLE CLASS, INT. CLS. 9, 16, 35, 36 AND 41.
- MARINO, STEVEN, HOBOKEN, NJ:  
2,882,329, CANC. MULTIPLE CLASS, INT. CLS. 35, 40, 41 AND 42.
- MARIO CAMACHO FOODS, LLC, PLANT CITY, FL:  
919,496, REN. 4-11-11. U.S. CL. 46 (INT. CL. 30).
- MARK NICKERSON, BOISE, ID:  
3,962,959, INT. CL. 25.
- MARKESBERY MUZZLE LOADERS, INC., FLORENCE, KY:  
2,552,976, REN. 4-8-11. INT. CL. 13.
- MARKESTIL S.L., ALICANTE, SPAIN:  
2,881,521, CANC. INT. CL. 20.
- MARKETING PARTNERS, INC., BETHLEHEM, PA:  
3,960,248, PUB. 3-1-2011. INT. CL. 35.
- MARKEToonIST, LLC, LOS ANGELES, CA:  
3,961,458, PUB. 3-1-2011. INT. CL. 35.
- MARKMONITOR INC., BOISE, ID:  
2,882,814, CANC. MULTIPLE CLASS, INT. CLS. 9 AND 42.
- MARKS, JONATHAN, SAN RAFAEL, CA:  
2,881,891, CANC. INT. CL. 25.
- MARKS, NORMAN H., GENEVA, NE AND MARKS, KENNETH R., GENEVA, NE:  
3,960,252, PUB. 3-1-2011. INT. CL. 6.
- MARMITE FOOD EXTRACT CO., LIMITED, THE, LONDON, ENGLAND TO UNILEVER PLC, WIRRAL, MERSEYSIDE, ENGLAND:  
146,810 NEW CERT. 5-17-2011. U.S. CL. 46.
- MARQUIP, LLC, PHILLIPS, WI:  
3,963,650, INT. CL. 7.
- MARRERO PUBLISHING, INC., TUCSON, AZ, DBA ARIZONA COLLECTOR'S GUIDE:  
3,963,751, INT. CL. 35.
- MARRIOTT INTERNATIONAL, INC., BETHESDA, MD:  
2,446,992, REN. 4-9-11. INT. CL. 18.  
2,446,993, REN. 4-9-11. INT. CL. 28.  
2,446,994, REN. 4-9-11. INT. CL. 25.  
3,963,222, INT. CL. 43.
- MARS, INCORPORATED, MCLEAN, VA:  
2,383,301, CANC. INT. CL. 16.  
2,549,334, REN. 4-9-11. INT. CL. 30.
- MARSHALL BISCUIT COMPANY, INC., SARALAND, AL:  
2,881,825, CANC. INT. CL. 30.
- MARSHALL OUTDOOR PRODUCTS, LLC, BATON ROUGE, LA:  
2,882,417, CANC. INT. CL. 11.
- MARTIN MARIETTA MATERIALS, INC., RALEIGH, NC:  
3,963,283, INT. CL. 19.
- MARTIN, RICARDOS.B, MARIETTA, GA, DBA INFUSION ESSENTIALS:  
3,963,367, INT. CL. 3.
- MARTINEAU, JEAN-PAUL, REDDING, CA:  
2,382,884, CANC. INT. CL. 11.
- MARUMAN GOLF KABUSHIKI KAISHIKI (MARUMAN GOLF CORPORATION), TOKYO, 110-0005, JAPAN:  
2,882,419, CANC. INT. CL. 28.
- MARVEL CHARACTERS, INC., MANHATTAN BEACH, CA:  
3,961,100, PUB. 3-1-2011. INT. CL. 20.
- MARY JANE PARRISH, MIRAMAR BEACH, FL:  
3,963,704, INT. CL. 25.
- MARY QUANT COSMETICS JAPAN LTD., SHIBUYA-KU, TOKYO, JAPAN:  
2,384,021, CANC. INT. CL. 3.
- MARY WINKLER, STERLING HEIGHTS, MI:  
3,961,158, PUB. 3-1-2011. INT. CL. 14.
- MASCHINENBAU KITZ GMBH, 53844 TROISDORF, FED REP GERMANY:  
3,962,238, MULTIPLE CLASS, INT. CLS. 6, 7, 17, 19, 20, 37, 40 AND 42.
- MASISA USA, INC., ATLANTA, GA:  
2,883,117, CANC. INT. CL. 19.
- MASSAGE ENVY FRANCHISING, LLC, SCOTTSDALE, AZ:  
3,960,464, PUB. 3-1-2011. INT. CL. 44.
- MASTER POWER TRANSMISSION, INC., GREENVILLE, SC, REEVES PULLEY COMPANY, COLUMBUS, IN:  
540,777, REN. 4-8-11. U.S. CL. 23 (INT. CL. 7).
- MASTER SUPPLEMENTS, INC., VICTORIA, MN:  
3,961,914, PUB. 3-1-2011. INT. CL. 5.
- MASTER'S VOICE, INC., BRISTOW, OK:  
3,961,817, PUB. 3-1-2011. INT. CL. 41.
- MASTERGRIP, INC., IRVING, TX:  
3,962,142, INT. CL. 28.
- MATERIALS SCIENCE TECHNOLOGY INC., CONROE, TX:  
3,962,795, INT. CL. 5.
- MATERIALS SYSTEMS INC., LITTLETON, MA:  
2,440,289, REN. 4-9-11. MULTIPLE CLASS, INT. CLS. 9, 40 AND 42.
- MATHIS, BEVERLY C., PHILADELPHIA, PA:  
2,880,683, CANC. INT. CL. 44.
- MATHIS, TORRANCE, BROOKLYN, NY:  
2,881,333, CANC. INT. CL. 14.
- MATSUSHITA ELECTRIC INDUSTRIAL CO., LTD., OSAKA, JAPAN:  
2,882,762, CANC. MULTIPLE CLASS, INT. CLS. 35 AND 42.
- MATTEL, INC., EL SEGUNDO, CA:  
2,880,748, CANC. INT. CL. 28.  
2,882,883, CANC. INT. CL. 28.  
2,882,917, CANC. INT. CL. 28.  
3,960,907, PUB. 3-1-2011. INT. CL. 28.  
3,960,918, PUB. 3-1-2011. INT. CL. 28.  
3,962,083, INT. CL. 28.  
3,962,713, INT. CL. 28.  
3,962,738, INT. CL. 28.  
3,962,739, INT. CL. 28.  
3,962,863, INT. CL. 28.  
3,963,438, INT. CL. 28.  
3,963,439, INT. CL. 28.  
3,963,498, INT. CL. 28.  
3,963,561, INT. CL. 28.
- MATTOCKS, NORMAN, CHESTERFIELD, MI:  
3,962,064, INT. CL. 41.
- MAVERICK DISTILLERY LIMITED, OAKVILLE, ONTARIO, CANADA:  
3,960,382, PUB. 3-1-2011. INT. CL. 33.
- MAXCYTE, INC., GAITHERSBURG, MD:  
3,960,557, PUB. 3-1-2011. INT. CL. 9.
- MAXI DRUG, INC., WARWICK, RI:  
2,383,008, CANC. INT. CL. 35.



MAYA OVERSEAS FOODS, INC., MASPETH, NY:  
3,963,679, INT. CL. 29.

MAZDA MOTOR OF AMERICA, INC., IRVINE, CA:  
3,963,199, INT. CL. 36.  
3,963,544, INT. CL. 36.

MBC IP CO., JASPAR, IN:  
3,960,579, PUB. 3-1-2011. INT. CL. 20.

MBF STAINLESS VALVES LTD., TERREBONE, CANADA:  
3,960,322, PUB. 3-1-2011. INT. CL. 7.

MBM COMPANY, INC., CHICAGO, IL:  
3,963,148, INT. CL. 14.

MBTI TRUST, INC., FORT WASHINGTON, PA:  
2,528,222, REN. 4-8-11. INT. CL. 42.  
2,528,223, REN. 4-11-11. INT. CL. 42.

MC CONNELL, GLORIA J., BOCA RATON, FL:  
3,962,765, INT. CL. 3.

MCAFFEE, INC., SANTA CLARA, CA:  
2,710,120, CANC. MULTIPLE CLASS, INT. CLS. 9 AND 42.  
3,960,405, PUB. 3-1-2011. MULTIPLE CLASS, INT. CLS. 9, 37 AND 42.  
3,960,406, PUB. 3-1-2011. MULTIPLE CLASS, INT. CLS. 9, 37 AND 42.

MCCAIN, MARILYN MICHELLE, BURBANK, CA:  
3,963,509, INT. CL. 43.

MCCALLUM, VENTRESS, LOS ANGELES, CA:  
2,383,022, CANC. INT. CL. 42.

MCCRANE, INC., NAPA, CA, DBA HARBINGER:  
2,882,378, CANC. INT. CL. 28.

MCD ENTERPRISES, INC., BOSTON, MA:  
3,960,532, PUB. 3-1-2011. INT. CL. 36.

MCDANIEL, JONATHAN, HOLLYWOOD, CA, AKA LIL JAY:  
2,882,194, CANC. INT. CL. 41.

MCELROY, JAMES RANDALL, SHOBONIER, IL:  
3,962,685, INT. CL. 9.

MCFADDEN, JOHN, EDEN PRAIRIE, MN:  
3,963,775, INT. CL. 18.

MCFARLAND, ANTHONY, HYATTSVILLE, MD:  
2,883,386, CANC. INT. CL. 25.

MCGANN, ROBERT C., WALTHAM, MA AND MCGANN, CANDICE K., WALTHAM, MA:  
2,882,229, CANC. MULTIPLE CLASS, INT. CLS. 3, 16, 20 AND 30.

MCGINTY, LUCINDA M., WATERTOWN, NY:  
2,881,877, CANC. INT. CL. 9.

MCGOUGH CONSTRUCTION CO., INC., ST. PAUL, MN:  
2,433,040, REN. 4-9-11. INT. CL. 37.

MCGUIRE, DAYMIAN LEE, OAKWOOD, OH:  
3,962,951, INT. CL. 25.

MCGUIRE, MICHELE, WESTMINSTER, MD:  
2,881,887, CANC. INT. CL. 43.

MCKAY, HARRY J., HARWICK, PA:  
3,960,970, PUB. 3-1-2011. INT. CL. 16.

MCKENZIE RIVER CORPORATION, SAN FRANCISCO, CA:  
3,963,155, INT. CL. 36.

MCKENZIE, GUY, CLEVELAND QLD, AUSTRALIA:  
2,393,542, REN. 4-13-11. INT. CL. 25.

MCMICHAEL, EUGENE, NEW YORK, NY:  
2,881,418, CANC. INT. CL. 39.

MCMURRAY, ANTHONY, BRANDON, FL, DBA ISH WEAR INT'L AND MCMURRAY, BEVERLY, BRANDON, FL, DBA ISH WEAR INT'L:  
2,881,972, CANC. INT. CL. 25.

MCPHEE ELECTRIC, LTD., FARMINGTON, CT:  
3,960,476, PUB. 3-1-2011. INT. CL. 37.

MDL INNOVATIONS, HAMPTON COVE, AL, DBA CALLED.COM:  
3,961,180, PUB. 3-1-2011. INT. CL. 45.

MDR FITNESS CORP., SUNRISE, FL:  
2,383,354, CANC. INT. CL. 5.

MEADOWS, ROB, LAS VEGAS, NV:  
2,881,892, CANC. INT. CL. 9.

MEADWESTVACO CORPORATION, STAMFORD, CT:  
2,881,884, CANC. INT. CL. 1.

MEADWESTVACO CORPORATION, RICHMOND, VA:  
3,963,124, INT. CL. 42.

MEARS ACQUISITION COMPANY, ORLANDO, FL:  
3,961,907, PUB. 3-1-2011. INT. CL. 35.  
3,961,908, PUB. 3-1-2011. INT. CL. 35.  
3,961,909, PUB. 3-1-2011. INT. CL. 35.  
3,961,910, PUB. 3-1-2011. INT. CL. 35.  
3,961,911, PUB. 3-1-2011. INT. CL. 35.  
3,961,912, PUB. 3-1-2011. INT. CL. 35.

MEAT BUN, LLC, SANTA MONICA, CA:  
3,961,621, PUB. 3-1-2011. INT. CL. 25.

MEATHEAD MOVERS, INC., SAN LUIS OBISPO, CA:  
3,962,520, MULTIPLE CLASS, INT. CLS. 35 AND 39.  
3,962,521, MULTIPLE CLASS, INT. CLS. 35 AND 39.  
3,962,531, MULTIPLE CLASS, INT. CLS. 35 AND 39.

MECHANICAL ELECTRICAL SHEET METAL ALLIANCE (MESA), ALBUQUERQUE, NM, DBA MESA:  
3,961,526, PUB. 3-1-2011. INT. CL. 35.

MECHTRIX CORPORATION, MENOMONEE FALLS, WI:  
1,661,445, REN. 4-13-11. INT. CL. 7.

MEDCATH INCORPORATED, CHARLOTTE, NC:  
3,960,487, PUB. 3-1-2011. MULTIPLE CLASS, INT. CLS. 41 AND 44.

MEDCO HEALTH SOLUTIONS, INC., FRANKLIN LAKES, NJ:  
3,962,822, MULTIPLE CLASS, INT. CLS. 35, 36 AND 44.

MEDECO SECURITY LOCKS, INC., SALEM, VA:  
3,963,016, INT. CL. 9.

MEDERER GMBH, D-90763 FURTH, FED REP GERMANY:  
2,881,091, CANC. INT. CL. 30.

MEDIA BOOST LTD., ROSH HA'AYIN, ISRAEL:  
3,961,121, PUB. 3-1-2011. INT. CL. 35.

MEDIA RECOVERY, INC., DALLAS, TX:  
3,379,401, COR. INT. CL. 9.  
3,420,472, COR. INT. CL. 9.  
3,420,473, COR. INT. CL. 9.  
3,427,703, COR. INT. CL. 9.

MEDICAL BRIDGES, INC., HOUSTON, TX:  
3,960,953, PUB. 3-1-2011. INT. CL. 35.  
3,960,955, PUB. 3-1-2011. INT. CL. 35.

MEDICAL DIGEST, INC., NORTHFIELD, IL:  
2,880,941, CANC. INT. CL. 16.

MEDICAL FLIGHT SERVICES LLC, MESA, AZ:  
3,963,881, INT. CL. 39.

MEDICIGROUP INC., KING OF PRUSSIA, PA:  
2,515,932, REN. 4-8-11. INT. CL. 41.

MEDICITY, INC., SALT LAKE CITY, UT:  
2,882,006, CANC. INT. CL. 35.

MEDINA, EDUARDO, DALLAS, TX:  
2,881,268, CANC. INT. CL. 25.

MEDISIM LTD., NEVE ILAN, ISRAEL:  
3,963,404, INT. CL. 10.

MEDTRONIC MINIMED, INC., NORTHRIDGE, CA:  
3,962,859, INT. CL. 44.

MEDTRONIC XOMED, INC., JACKSONVILLE, FL:  
2,881,890, CANC. INT. CL. 10.

MEDTRONIC, INC., MINNEAPOLIS, MN:  
2,478,454, REN. 4-12-11. INT. CL. 10.

MEGA BRANDS INTERNATIONAL, LUXEMBOURG, ZUG BRANCH, ZUG, SWITZERLAND:  
3,962,662, INT. CL. 28.

MEGA MART CO., LTD., SEOUL, REPUBLIC OF KOREA:  
3,962,117, INT. CL. 43.

MEGAMEDIA LTD., WANCHAI, HONG KONG:  
3,960,316, PUB. 3-1-2011. MULTIPLE CLASS, INT. CLS. 38, 39, 42 AND 45.

MEL BAY PUBLICATIONS, INC., PACIFIC, MO:  
2,881,501, CANC. INT. CL. 9.

MELALEUCA, INC., IDAHO FALLS, ID:  
2,535,089, REN. 4-8-11. MULTIPLE CLASS, INT. CLS. 3 AND 4.  
2,880,639, CANC. INT. CL. 21.

MELANIE M. KATES, M.D., P.C., PENFIELD, NY:  
3,963,649, INT. CL. 44.

MELLER EQUIPAMENTOS E TECNOLOGIA INDUSTRIA E COMERCIO LTDA., ESPIRITO SANTO, BRAZIL:  
3,963,273, INT. CL. 7.

MELLON FORENSIC GROUP, INC., KEY LARGO, FL:  
2,881,240, CANC. MULTIPLE CLASS, INT. CLS. 41 AND 42.



- MELROSE TELEPHONE COMPANY, MELROSE, MN:  
3,961,136, PUB. 3-1-2011. MULTIPLE CLASS, INT. CLS. 35 AND 37.
- MEMA MATES LLC, NEWTOWN, PA:  
3,961,676, PUB. 3-1-2011. INT. CL. 37.
- MEMBERS FIRST FEDERAL CREDIT UNION, LOUISVILLE, KY:  
2,880,560, CANC. INT. CL. 36.
- MEMBERS MARKET, LLC., BYRON CENTER, MI:  
3,963,870, INT. CL. 35.
- MEMORIAL TOUCH, INC., PORTLAND, OR:  
2,882,586, CANC. MULTIPLE CLASS, INT. CLS. 31 AND 37.
- MEMORIES PRESERVED PHOTOGRAPHY LLC, RICHMOND HEIGHTS, OH:  
2,883,134, CANC. INT. CL. 41.
- MENPER DISTRIBUTORS INC., MIMI, FL:  
3,961,333, PUB. 3-1-2011. INT. CL. 5.
- MENTAL HEALH RESOURCE FOUNDATION, OGDEN, UT, DBA UPWARD REACH:  
3,961,698, PUB. 3-1-2011. INT. CL. 44.
- MERA TIERNANHRUNG GMBH, FED REP GERMANY:  
3,960,700, PUB. 3-1-2011. INT. CL. 31.
- MERASTAR INSURANCE COMPANY, CHATTANOOGA, TN:  
2,382,779, CANC. INT. CL. 36.
- MERCEDES MEDICAL, INC., SARASOTA, FL:  
3,963,096, INT. CL. 1.
- MERCHSOURCE, LLC, FOOTHILL RANCH, CA:  
3,962,777, INT. CL. 11.  
3,962,778, INT. CL. 11.  
3,962,887, INT. CL. 10.  
3,963,019, INT. CL. 9.
- MERCK KGAA, DARMSTADT, FED REP GERMANY:  
1,640,095, REN. 4-8-11. INT. CL. 1.
- MERIDIAN TELECOM, INC., NEWPORT BEACH, CA:  
3,962,371, MULTIPLE CLASS, INT. CLS. 37, 42 AND 45.
- MERIDIAS CAPITAL, INC., SALT LAKE CITY, UT:  
2,880,821, CANC. INT. CL. 36.
- MERRICK ENGINEERING, INC., CORONA, CA:  
2,882,903, CANC. INT. CL. 20.
- MESA INSURANCE ADMINISTRATORS, INC., SANTA ROSA, CA:  
2,880,641, CANC. INT. CL. 36.
- MESTEK, INC., WESTFIELD, MA:  
2,881,881, CANC. INT. CL. 11.
- METABOLAB, LLC, BEVERLY HILLS, CA:  
3,963,151, INT. CL. 5.
- METALS SUPPLY ALLIANCES, LLC, PITTSBURGH, PA:  
2,880,671, CANC. INT. CL. 35.
- METAMAG INC., STRATHROY, ONTARIO, CANADA:  
2,882,640, CANC. INT. CL. 42.
- METRO INDUSTRIES, INC., WILKES-BARRE, PA:  
3,962,537, MULTIPLE CLASS, INT. CLS. 6, 20 AND 21.
- METRO INFECTIOUS DISEASE CONSULTANTS, L.L.C., HINSDALE, IL:  
3,963,493, INT. CL. 44.
- METROPOLITAN LIFE INSURANCE COMPANY, NEW YORK, NY:  
2,384,371, CANC. INT. CL. 16.
- METROPOLITAN PIER AND EXPOSITION AUTHORITY, CHICAGO, IL:  
2,461,372, REN. 4-13-11. INT. CL. 42.  
2,461,373, REN. 4-13-11. INT. CL. 41.
- METROPOLITAN TRANSPORTATION AUTHORITY, NEW YORK, NY:  
2,881,223, CANC. INT. CL. 28.
- METROSONICS CONCEPTS LIMITED, NEW YORK, NY:  
3,960,258, PUB. 12-18-2007. MULTIPLE CLASS, INT. CLS. 9 AND 41.
- METZ, JOHN RICHARD, SONOMA, CA:  
3,962,109, INT. CL. 28.
- METZGER, CASSANDRA, WASHINGTON, DC:  
2,881,885, CANC. INT. CL. 41.
- MEYER INTELLECTUAL PROPERTIES LIMITED, KOWLOON, HONGKONG, CHINA:  
3,963,562, INT. CL. 8.
- MEYER, CONNIE, TAKOMA PARK, MD:  
2,881,964, CANC. MULTIPLE CLASS, INT. CLS. 35 AND 41.
- MEYNARD DESIGNS, INC., WALTHAM, MA:  
2,882,010, CANC. INT. CL. 25.
- MGA ENTERTAINMENT, INC., NORTH HILLS, CA:  
2,881,893, CANC. INT. CL. 28.
- MGM WINE & SPIRITS, INC., WEST ST. PAUL, MN:  
2,938,419, CANC. INT. CL. 33.
- MHM SERVICES, INC., VIENNA, VA:  
3,961,498, PUB. 3-1-2011. INT. CL. 44.
- MHT SECURITIES, L.P., DALLAS, TX:  
3,960,450, PUB. 3-1-2011. INT. CL. 36.
- MICELL TECHNOLOGIES, INC., DURHAM, NC:  
3,963,243, INT. CL. 10.
- MICHAEL BRUCE BELLUOMINI, MILL VALLEY, CA:  
3,963,525, INT. CL. 36.
- MICHAEL FRANTI, ENCINO, CA:  
3,960,380, PUB. 3-1-2011. MULTIPLE CLASS, INT. CLS. 9 AND 41.
- MICHAEL J. FREEMAN, GLEN COVE, NY:  
3,962,086, MULTIPLE CLASS, INT. CLS. 9 AND 28.
- MICHAEL J. KIRKORIAN, FRESNO, CA:  
3,960,982, PUB. 3-1-2011. INT. CL. 1.
- MICHAEL JOHN LEVAUL, BONITA SPRINGS, FL:  
3,724,523, CANC. INT. CL. 41.
- MICHAEL SHANNON PHILLIPS, BROOKLYN, NY:  
3,961,479, PUB. 3-1-2011. INT. CL. 41.
- MICHAEL-DAVID, LLC, LODI, CA:  
2,883,054, CANC. INT. CL. 33.
- MICHELLE DEBORAH, HAT COUTURE, NEW YORK, NY:  
2,880,844, CANC. INT. CL. 25.
- MICHELLE'S OUTRAGEOUS, INC., LOS ANGELES, CA:  
2,882,749, CANC. INT. CL. 30.
- MICHIGAN EDUCATION ASSOCIATION, THE, EAST LANSING, MI:  
2,882,458, CANC. INT. CL. 35.
- MICROSOFT CORPORATION, REDMOND, WA:  
2,882,801, CANC. INT. CL. 35.  
3,962,611, INT. CL. 42.  
3,962,693, INT. CL. 9.  
3,962,716, MULTIPLE CLASS, INT. CLS. 9 AND 41.
- MIDSTATE BANCORP, INC., OKLAHOMA CITY, OK:  
2,528,803, REN. 4-12-11. INT. CL. 36.
- MIDWESTERN PET FOODS, INC., EVANSVILLE, IN:  
3,962,894, INT. CL. 31.
- MIGHTY LION VENTURES LP, CYPRESS, TX:  
3,960,350, PUB. 3-1-2011. INT. CL. 16.
- MIGUEL TORRES, S.A., 08720-VILAFRANCA DEL PE-NEDES BARCELONA, SPAIN:  
2,882,187, CANC. INT. CL. 33.
- MIKAYELYAN, GRIGORI, GLENDALE, CA:  
3,962,729, INT. CL. 45.
- MIKULSKIS, DAVID, DARIEN, IL:  
3,961,361, PUB. 3-1-2011. INT. CL. 41.
- MIL-SPEC MONKEY, INC., SAN JOSE, CA:  
3,962,658, INT. CL. 35.
- MILE HIGH NEW YORK CORP., NEW YORK, NY:  
2,382,537, CANC. INT. CL. 25.
- MILESTONE COMMUNICATIONS, INC., SEASIDE, CA:  
2,545,013, REN. 4-9-11. INT. CL. 35.
- MILK PRODUCTS, LLC, CHILTON, WI, TRI ASSOCIATES, INC., SOUTH MINNEAPOLIS, MN:  
912,427, REN. 4-13-11. U.S. CL. 18 (INT. CL. 5).
- MILLARWORLD LIMITED, WEST HOLLYWOOD, CA AND ROMITA, JOHN S., WEST HOLLYWOOD, CA:  
3,961,734, PUB. 3-1-2011. INT. CL. 16.
- MILLENNIUM CAPITAL AND RECOVERY CORPORATION, HUDSON, OH:  
3,961,252, PUB. 3-1-2011. INT. CL. 39.  
3,961,254, PUB. 3-1-2011. INT. CL. 39.
- MILLENNIUM LAWNS, INC., BEDFORD PARK, IL:  
3,960,591, PUB. 3-1-2011. INT. CL. 5.
- MILLENNIUM MILLS, INC., LAFAYETTE, GA:  
2,442,349, REN. 4-12-11. INT. CL. 27.
- MILLER, CAROLE HANNA, PUNTA GORDA, FL:  
3,963,028, INT. CL. 28.

MILLER, CHARLA, GRAND ISLAND, NE:  
3,963,382, INT. CL. 21.

MILLER, CYNTHIA K., SILVER CREEK, NY:  
1,617,723, REN. 4-14-11. INT. CL. 25.

MILLER, JACK B., SHERMAN OAKS, CA:  
2,873,885, CANC. INT. CL. 40.

MILLER, RACHEL JEAN, PLACITAS, NM AND MASSEN-  
GILL, JIM, PLACITAS, NM:  
3,961,973, MULTIPLE CLASS, INT. CLS. 16, 25, 41 AND  
45.  
3,961,974, MULTIPLE CLASS, INT. CLS. 16, 41 AND 45.  
3,961,975, MULTIPLE CLASS, INT. CLS. 16, 25, 41 AND  
45.  
3,961,976, MULTIPLE CLASS, INT. CLS. 16, 41 AND 45.

MILLIGAN, JOSEPH JAMES, OAKDALE, MN:  
3,962,717, MULTIPLE CLASS, INT. CLS. 9 AND 41.

MILOU COUTURE INC., ALLENTOWN, PA:  
3,960,390, PUB. 3-1-2011. INT. CL. 35.

MILWAUKEE ELECTRIC TOOL CORPORATION, BROOK-  
FIELD, WI:  
2,462,767, REN. 4-13-11. INT. CL. 7.

MINASSIAN, PATRICIA, LAGUNA NIGUEL, CA:  
3,962,670, INT. CL. 35.  
3,962,671, INT. CL. 35.

MIND & BODY RESEARCH LTD., GIBRALTAR, GIBRAL-  
TAR:  
3,961,207, PUB. 3-1-2011. INT. CL. 41.  
3,961,208, PUB. 3-1-2011. INT. CL. 41.

MINDWORKS, INC., SANTA CLARA, CA:  
2,881,395, CANC. INT. CL. 42.

MINE O' MINE, INC., WOODLAND HILLS, CA:  
2,383,494, CANC. MULTIPLE CLASS, INT. CLS. 9 AND  
25.

MINERVINO, ANTHONY, WEST ORANGE, NJ, DBA JUG-  
GLA:  
3,961,861, PUB. 3-1-2011. INT. CL. 9.

MINNESOTA LIVING ASSISTANCE, INC., MINNEAPOLIS,  
MN, DBA BAYWOOD HOME CARE:  
3,960,902, PUB. 3-1-2011. INT. CL. 45.

MINNESOTA PUBLIC RADIO, ST. PAUL, MN:  
2,881,889, CANC. INT. CL. 16.

MINNESOTA STATE LOTTERY AGENCY, ROSEVILLE,  
MN:  
1,679,634, REN. 4-13-11. INT. CL. 36.

MINNTECH CORPORATION, MINNEAPOLIS, MN:  
2,882,809, CANC. INT. CL. 10.

MINORITY PASSPORT INTERNATIONAL LLC, CLARK,  
NJ:  
3,961,784, PUB. 3-1-2011. INT. CL. 38.  
3,961,953, PUB. 3-1-2011. INT. CL. 35.

MINOT STATE UNIVERSITY, MINOT, ND:  
3,961,800, PUB. 3-1-2011. MULTIPLE CLASS, INT. CLS.  
14, 16, 25 AND 41.

MIRACLE STRETCH, LLC, SAN FRANCISCO, CA:  
3,963,542, INT. CL. 10.

MIRAMAR BRANDS GROUP, INC., PASADENA, CA, SIDE-  
OUT SPORT, INC., MONROVIA, CA:  
1,627,248, REN. 4-14-11. INT. CL. 25.

MISERICORDIA UNIVERSITY, DALLAS, PA:  
3,961,154, PUB. 3-1-2011. INT. CL. 9.

MISHRA, ALLAN, MENLO PARK, CA:  
3,962,619, INT. CL. 5.

MISSOURI AUCTION SCHOOL, INC., OVERLAND PARK,  
KS, AKA MISSOURI AUCTION SCHOOL:  
1,150,274, REN. 4-12-11. INT. CL. 9.

MISTY MOUNTAIN TEAS, NEW DURHAM, NH:  
3,961,343, PUB. 3-1-2011. INT. CL. 35.

MISUMARU USA CORPORATION, FAIRFIELD, CA:  
3,962,302, MULTIPLE CLASS, INT. CLS. 18 AND 22.

MITCHELL, RONALD, CALUMET CITY, IL:  
3,961,097, PUB. 3-1-2011. INT. CL. 41.

MITCHELL, TRACY E., BETHESDA, MD, DBA THE AR-  
BEIT GROUP, INC.:  
2,499,915, REN. 4-12-11. INT. CL. 38.

MITIG8 LTD., LONDON, UNITED KINGDOM:  
3,961,821, PUB. 3-1-2011. MULTIPLE CLASS, INT. CLS.  
35, 36, 42 AND 45.

mitsubishi tanabe pharma corporation, osaka,  
japan:  
3,961,874, PUB. 3-1-2011. INT. CL. 5.  
3,961,875, PUB. 3-1-2011. INT. CL. 5.  
3,961,876, PUB. 3-1-2011. INT. CL. 5.  
3,961,877, PUB. 3-1-2011. INT. CL. 5.

MIX-MASTERS, INC., LEBANON, OH:  
2,881,161, CANC. INT. CL. 3.

MIX-MIZER, INC., KINGSPORT, TN:  
1,150,843, REN. 4-9-11. INT. CL. 9.

MIYAKOSHI PRINTING MACHINERY CO., LTD., NARA-  
SHINO-SHI, CHIBA, JAPAN:  
3,960,595, PUB. 3-1-2011. INT. CL. 7.  
3,960,596, PUB. 3-1-2011. INT. CL. 9.

MLT INC., EDINA, MN:  
2,383,116, CANC. INT. CL. 42.  
2,383,117, CANC. INT. CL. 39.

MMA SPORT FEDERATION, LAS VEGAS, NV:  
3,963,875, INT. CL. 41.

MMH PTY LTD, AUSTRALIA:  
3,960,834, PUB. 11-23-2010. MULTIPLE CLASS, INT. CLS.  
18 AND 20.

MMI-IPCO, LLC, LAWRENCE, MA:  
3,963,140, INT. CL. 25.

MMI-IPCO, LLC, LAWRENCE, MA:  
3,963,139, INT. CL. 24.

MOBILE LOAVES & FISHES, INC., AUSTIN, TX:  
3,961,633, PUB. 3-1-2011. INT. CL. 35.  
3,961,635, PUB. 3-1-2011. INT. CL. 43.  
3,961,705, PUB. 3-1-2011. INT. CL. 43.

MOBILE SCRIPTS, LLC, CORAL GABLES, FL:  
3,963,803, MULTIPLE CLASS, INT. CLS. 35, 39 AND 44.

MOBILE TECHNOLOGY, INC., SALT LAKE CITY, UT:  
2,881,002, CANC. INT. CL. 9.

MOBILITY DEPOT, THE, BATON ROUGE, LA:  
2,880,643, CANC. INT. CL. 12.

MODELL ASSOCIATES, INC., BASALT, CO:  
2,383,359, CANC. INT. CL. 35.

MODERCO INC., PROVINCE OF QUEBEC, CANADA:  
2,880,920, CANC. INT. CL. 19.

MODERN MASTERS, INC., SUN VALLEY, CA:  
3,962,616, INT. CL. 2.

MODERN SPIRITS LLC, MONROVIA, CA:  
3,961,213, PUB. 3-1-2011. INT. CL. 33.  
3,963,564, INT. CL. 33.

MODERN WOODMEN OF AMERICA, ROCK ISLAND, IL:  
3,963,749, INT. CL. 36.

MODERNE GLASS COMPANY, INC., ALIQUIPPA, PA:  
3,962,650, INT. CL. 40.

MOHAMED, MEDHAT, BRONX, NY:  
2,383,960, CANC. INT. CL. 30.

MOHAMED, MEDHAT, DIX HILLS, NY:  
3,963,609, INT. CL. 30.

MOHAWK CARPET DISTRIBUTION, INC, CALHOUN, GA:  
2,455,954, REN. 4-9-11. INT. CL. 27.  
2,881,312, CANC. INT. CL. 23.

MOHAWK CARPET DISTRIBUTION, INC., CALHOUN, GA:  
3,963,000, INT. CL. 2.  
3,963,001, INT. CL. 27.  
3,963,005, INT. CL. 27.

MOLE-RICHARDSON COMPANY, HOLLYWOOD, CA:  
2,449,211, REN. 4-12-11. INT. CL. 25.  
2,473,413, REN. 4-12-11. INT. CL. 25.

MOLON LAVE, LLC, CHICAGO, IL:  
3,962,268, MULTIPLE CLASS, INT. CLS. 30 AND 39.

MOLOR PRODUCTS COMPANY, OSWEGO, IL:  
3,962,870, INT. CL. 28.

MOLSON CANADA 2005, TORONTO, ONTARIO:  
2,880,591, CANC. MULTIPLE CLASS, INT. CLS. 32 AND  
35.

MOMENTIVE CHEMICAL INVESTMENTS INC., COLUM-  
BUS, OH, BORDEN COMPANY, THE, NEW YORK, NY:  
384,795, REN. 4-9-11. U.S. CL. 5 (INT. CL. 1).

MONATT, MICHELLE M., MADISON, CT:  
2,881,290, CANC. INT. CL. 44.

MONGELL, JAN, VILLA PARK, CA:  
2,382,740, CANC. MULTIPLE CLASS, INT. CLS. 25 AND  
42.

- MONKEY MEDIA SOFTWARE INC., VANCOUVER, BC, CANADA:  
3,961,102, PUB. 3-1-2011. INT. CL. 42.
- MONSANTO TECHNOLOGY LLC, ST. LOUIS, MO:  
3,963,334, INT. CL. 5.  
3,963,499, INT. CL. 5.
- MONTANA RIVER RANCH, BAINVILLE, MT:  
2,382,688, CANC. INT. CL. 42.
- MONTFORD HALL, ASHEVILLE, NC:  
3,963,152, INT. CL. 44.
- MONTGOMERY JR., STEVEN L., CHARLOTTE, NC:  
3,963,090, MULTIPLE CLASS, INT. CLS. 9, 14, 16 AND 25.
- MOONSHADOW S.P.A., RIMINI, ITALY, MOSCHINO, FRANCESCO, MILAN, ITALY:  
1,646,022, REN. 4-14-11. INT. CL. 18.
- MOORE III, WILLIAM E., VALDOSTA, GA:  
3,963,095, INT. CL. 28.
- MOORE NORTH AMERICA, INC., GRAND ISLAND, NY:  
2,882,789, CANC. INT. CL. 35.
- MOORE, FRED J., NEW YORK, NY:  
2,383,765, CANC. INT. CL. 25.
- MOORE, JOHN A., BRANSON, MO:  
3,960,575, PUB. 3-1-2011. INT. CL. 9.
- MOORE, RALPH L., ATLANTA, GA:  
2,883,295, CANC. MULTIPLE CLASS, INT. CLS. 16 AND 25.
- MOORE, SAMUEL, OLD HICKORY, TX:  
3,962,200, INT. CL. 25.
- MORALES, REBECCA, GREELEY, CO, DBA ALBERTO'S RESTAURANT:  
2,781,235, CANC. INT. CL. 42.
- MORAN REGENERATIVE MEDICINE (MRM), LLC, SAN DIEGO, CA:  
3,963,667, INT. CL. 42.
- MORANA ACCESSORIOS LTDA EPP, SAO PAULO, BRAZIL:  
3,960,264, PUB. 3-1-2011. INT. CL. 14.
- MORE THAN MANAGEMENT, INC., NANUET, NY:  
2,882,600, CANC. INT. CL. 41.
- MORELES, SELOMITH RAMIREZ, IRAPUATO, MEXICO:  
3,962,647, INT. CL. 5.
- MORELLI, GERARD A., BEAVERTON, OR:  
3,962,810, INT. CL. 12.
- MORGAN, TROY, SAN MARCOS, CA:  
2,390,066, REN. 4-9-11. INT. CL. 28.
- MORGAN, TROY, CARLSBAD, CA:  
2,391,774, REN. 4-9-11. INT. CL. 25.
- MORGENSTERN, FELICIA L., SAN DIEGO, CA:  
2,383,696, CANC. INT. CL. 41.
- MORTGAGES LTD., PHOENIX, AZ:  
2,383,218, CANC. INT. CL. 36.  
2,383,220, CANC. INT. CL. 36.
- MOTHER-EASE INC., VIRGIL, ONTARIO, CANADA:  
2,881,520, CANC. INT. CL. 25.
- MOTOROLA TRADEMARK HOLDINGS, LLC, LIBERTYVILLE, IL:  
3,962,131, INT. CL. 9.
- MOTRICITY, INC., BELLEVUE, WA:  
2,883,214, CANC. INT. CL. 9.
- MOULDWORKS LLC, PORTLAND, OR:  
2,882,999, CANC. INT. CL. 9.
- MOUNT GAY DISTILLERIES LIMITED, BRANDONS SAINT MICHAEL, BARBADOS:  
3,961,572, PUB. 3-1-2011. INT. CL. 33.
- MOUNT LUCAS MANAGEMENT CORPORATION, PRINCETON, NJ:  
2,383,036, CANC. INT. CL. 36.
- MOUNTAIN PACIFIC INSTITUTE, LLC, BELLEVUE, WA:  
3,962,294, INT. CL. 36.
- MOVADO LLC, WILMINGTON, DE:  
3,963,357, INT. CL. 14.
- MPHASIS CORPORATION, NEW YORK, NY:  
2,642,305, CANC. INT. CL. 42.
- MPM MEDICAL, INC., IRVING, TX:  
2,550,056, REN. 4-8-11. INT. CL. 5.
- MPVM, LLC, BURBANK, CA:  
3,963,443, INT. CL. 41.
- MR. GASKET, INC., CLEVELAND, OH:  
2,882,545, CANC. MULTIPLE CLASS, INT. CLS. 7 AND 12.  
2,882,546, CANC. MULTIPLE CLASS, INT. CLS. 12 AND 16.
- MR. IDEA, INC., ATTLEBORO, MA:  
3,962,923, MULTIPLE CLASS, INT. CLS. 18 AND 25.
- MR. WILLS, INC., TORONTO, CANADA:  
3,962,091, INT. CL. 41.
- MRI MOBILE LIMITED PARTNERSHIP, BOISE, ID:  
2,886,263, CANC. INT. CL. 44.
- MRK FINE ARTS, LLC, NEW CANAAN, CT:  
3,962,570, INT. CL. 9.
- MTI WHIRLPOOLS, INC., SUGAR HILL, GA:  
3,963,077, INT. CL. 11.
- MTP MEDICAL TECHNICAL PROMOTION GMBH, 78579 NEUHAUSEN OB ECK, FED REP GERMANY:  
2,476,951, REN. 4-11-11. INT. CL. 10.
- MU KAE CO., LTD., TAICHUNG, TAIWAN:  
2,881,062, CANC. INT. CL. 12.
- MUDDERS AND POTTERS HOUSE, GREENVILLE, SC:  
2,881,874, CANC. INT. CL. 41.
- MUELHENS GMBH & CO. KG, 50828 KOELN, FED REP GERMANY:  
2,881,025, CANC. INT. CL. 3.
- MUELLER SPORTS MEDICINE, INC., PRAIRIE DU SAC, WI:  
3,961,366, PUB. 3-1-2011. MULTIPLE CLASS, INT. CLS. 10 AND 28.
- MULCAHY, DAVID NATHANIEL SEBASTIAN, TORTONA, ITALY, DBA WORLDSTOVE:  
3,962,204, INT. CL. 7.
- MULE DESIGN STUDIO, INC., SAN FRANCISCO, CA:  
3,961,864, PUB. 3-1-2011. INT. CL. 41.
- MULLEN, JEFFREY M., LAKELAND, TN:  
3,963,710, INT. CL. 24.
- MULLINEUX, CHRIS, RIEBEEK KASTEEL, SOUTH AFRICA, DBA THE ROLLING STONE WINERY:  
3,963,795, INT. CL. 33.
- MULTIMEDIA GAMES, INC., AUSTIN, TX:  
2,882,626, CANC. INT. CL. 9.  
3,962,874, INT. CL. 9.  
3,962,875, INT. CL. 9.  
3,962,876, INT. CL. 9.
- MUM KNOWS BEST LIMITED, UNITED KINGDOM:  
3,960,655, PUB. 3-1-2011. MULTIPLE CLASS, INT. CLS. 9, 16, 35 AND 41.
- MUNCHKIN, INC., NORTH HILLS, CA:  
3,963,149, MULTIPLE CLASS, INT. CLS. 6 AND 20.
- MUNICH REINSURANCE AMERICA, INC., PRINCETON, NJ:  
3,962,823, INT. CL. 36.
- MURATA MACHINERY, LTD., KYOTO-SHI, KYOTO, JAPAN:  
3,960,276, PUB. 3-1-2011. INT. CL. 9.
- MURPHY'S WAVES LIMITED, GLASGOW, UNITED KINGDOM:  
3,960,947, PUB. 3-1-2011. INT. CL. 7.
- MURRAY, KIMBERLY M., MARINA DEL REY, CA:  
2,882,866, CANC. INT. CL. 43.
- MUSEA EN ERFGOED ANTWERPEN, 2000 ANTWERP, BELGIUM:  
3,960,530, PUB. 3-1-2011. INT. CL. 41.
- MUSHIN NYC LLC, NEW YORK, NY:  
3,963,760, INT. CL. 41.
- MUSIC BY MAIL INC., BROOKLYN, NY:  
2,881,879, CANC. INT. CL. 14.
- MUSIC CHOICE, HORSHAM, PA:  
3,962,761, MULTIPLE CLASS, INT. CLS. 35 AND 38.
- MUSIC INTELLIGENCE PROJECT, LLC, OLD LYME, CT:  
3,962,413, MULTIPLE CLASS, INT. CLS. 9 AND 41.
- MUSICARES FOUNDATION, INC., SANTA MONICA, CA:  
2,882,159, CANC. INT. CL. 42.
- MUSICOREY, PORTLAND, OR:  
3,961,782, PUB. 3-1-2011. INT. CL. 9.

MUTASIAN MEDIA, LLC, PALM BEACH GARDENS, FL:  
 3,962,153, INT. CL. 16.  
 3,962,154, INT. CL. 16.  
 3,962,155, INT. CL. 16.

MVP (H.K.) INDUSTRIES LTD., NORTH POINT, HONG KONG:  
 2,459,360. REN. 4-11-11. MULTIPLE CLASS, INT. CLS. 7 AND 11.

MWASE, ERNEST, WEST DENE, SOUTH AFRICA:  
 3,963,526, INT. CL. 7.

MX USA, INC., JENKINTOWN, PA:  
 3,962,379, INT. CL. 44.

MY BIG IDEAS, LLC, FAIRFIELD, NJ:  
 3,962,741, INT. CL. 24.

MY FAVORITE BUG, LLC, LOS ALAMOS, NM:  
 3,961,489, PUB. 3-1-2011. INT. CL. 20.

MY FAVORITE GROOMER, WATAUGA, TX:  
 3,961,112, PUB. 3-1-2011. INT. CL. 44.

MYCAREERNETWORK.COM, LLC, LOUISVILLE, KY:  
 3,963,296, INT. CL. 35.

MYERS, CHARLES DAVID NEFF, PORTLAND, OR:  
 3,961,331, PUB. 3-1-2011. INT. CL. 41.

MYLIKES, INC., SAN FRANCISCO, CA:  
 3,962,815, INT. CL. 35.

MYRIN INSTITUTE, INC., THE, GREAT BARRINGTON, MA:  
 3,961,279, PUB. 3-1-2011. INT. CL. 41.

MYTRAVEL GROUP PLC, MANCHESTER, UNITED KINGDOM:  
 2,880,685, CANC. MULTIPLE CLASS, INT. CLS. 9, 16, 35, 36, 38, 39 AND 43.  
 2,880,686, CANC. MULTIPLE CLASS, INT. CLS. 9, 16, 35, 36, 38, 39 AND 43.

MYVESTA FOUNDATION, INC., WASHINGTON, DC:  
 3,963,876, INT. CL. 35.

M2 COMPANIES, LA VERNE, CA:  
 3,961,838, PUB. 3-1-2011. INT. CL. 9.

M3 NORDIC AB, YSTAD, SWEDEN:  
 3,961,433, PUB. 3-1-2011. INT. CL. 25.

M4 GROUP, LLC, CRESTED BUTTE, CO:  
 3,963,718, INT. CL. 9.

N HOLDING AB, SOLLENTUNA, SWEDEN:  
 3,963,805, INT. CL. 9.  
 3,963,806, INT. CL. 9.

NACCARI, DAVID "THE NAC", NEW ORLEANS, LA:  
 2,881,430, CANC. INT. CL. 41.

NACIONAL DE ALIMENTOS Y HELADOS, S.A. DE C.V., SANTA CATARINA, N.L., MEXICO:  
 3,963,833, INT. CL. 30.

NACIONALES, ELIJAH. D., SAN PEDRO, CA:  
 2,883,247, CANC. MULTIPLE CLASS, INT. CLS. 9, 16 AND 41.

NADIA RODEN, NEW YORK, NY:  
 3,963,822, INT. CL. 30.

NAMCO BANDAI GAMES AMERICA INC., SANTA CLARA, CA:  
 3,962,574, INT. CL. 9.

NAME RITE, L.L.C., TEMECULA, CA:  
 3,928,882, COR. MULTIPLE CLASS, INT. CLS. 9 AND 18.

NANA PATRICIA MCPEAK, EL DORADO HILLS, CA:  
 3,733,998, COR. INT. CL. 5.

NANJING COMPTech MATERIALS CO., LTD., NANJING, CHINA:  
 3,961,697, PUB. 3-1-2011. INT. CL. 17.

NANTEEKA GLOVES, SAN FRANCISCO, CA:  
 3,963,505, INT. CL. 25.

NANTONG JIANGHAI CAPACITOR FACTORY, PINGCHAO, NANTONG, JIANGSU PROVINCE, CHINA:  
 2,551,609. REN. 4-13-11. INT. CL. 9.

NAP INCORPORATED, OKAYAMA-KEN, JAPAN:  
 3,960,606, PUB. 3-1-2011. MULTIPLE CLASS, INT. CLS. 14 AND 18.

NAPA WINE COMPANY, LLC, OAKVILLE, CA:  
 2,882,706, CANC. INT. CL. 33.

NAPOLEX CORPORATION, TOKYO, JAPAN, TANAKA MANUFACTURING CO., LTD., ARAKAWA-KU, TOKYO, JAPAN:  
 1,649,415. REN. 4-14-11. INT. CL. 12.

NAS VENTURES LLC, WHITE PLAINS, NY:  
 3,962,718, INT. CL. 20.

NAT SHERMAN, INC., FORT LEE, NJ:  
 2,882,331, CANC. INT. CL. 34.

NATHANIEL JEWELRY INC., NEW YORK, NY, DBA DESIGNS BY DAVIDOFF:  
 2,383,990, CANC. INT. CL. 14.

NATION-E AG, PFAFFIKON, SWITZERLAND:  
 3,960,868, PUB. 3-1-2011. MULTIPLE CLASS, INT. CLS. 1, 4, 9, 39 AND 40.

NATIONAL ACADEMY OF ENGINEERING FUND, WASHINGTON, DC:  
 3,961,284, PUB. 3-1-2011. INT. CL. 42.

NATIONAL ALLERGY SUPPLY, INC., DULUTH, GA:  
 3,962,683, INT. CL. 24.

NATIONAL ASSOCIATION FOR PRINTING LEADERSHIP, INC, PARAMUS, NJ:  
 2,480,076. REN. 4-14-11. INT. CL. 42.

NATIONAL ASSOCIATION FOR STOCK CAR AUTO RACING, INC., DAYTONA BEACH, FL:  
 2,881,007, CANC. INT. CL. 35.  
 3,960,526, PUB. 3-1-2011. INT. CL. 41.  
 3,963,416, INT. CL. 41.  
 3,963,422, INT. CL. 43.

NATIONAL ASSOCIATION OF COLLEGIATE DIRECTORS OF ATHLETICS, CLEVELAND, OH:  
 2,880,742, CANC. INT. CL. 41.

NATIONAL ASSOCIATION OF STATE BOARDS OF ACCOUNTANCY, INC., NASHVILLE, TN:  
 3,963,573, INT. CL. 41.  
 3,963,574, INT. CL. 41.

NATIONAL BUSINESS TRAVEL ASSOCIATION, ALEXANDRIA, VA:  
 3,962,078, INT. CL. 35.

NATIONAL CATHOLIC EDUCATIONAL ASSOCIATION, WASHINGTON, DC:  
 2,880,901, CANC. INT. CL. 35.

NATIONAL FOUNDATION FOR CREDIT COUNSELING, INC., WASHINGTON, DC:  
 3,962,196, INT. CL. 36.

NATIONAL GARDENING ASSOCIATION, INC., SOUTH BURLINGTON, VT:  
 3,960,254, PUB. 3-1-2011. INT. CL. 16.

NATIONAL HISPANIC COUNCIL ON AGING, WASHINGTON, DC, AKA NHCOA:  
 3,962,457, INT. CL. 41.

NATIONAL HOCKEY LEAGUE, NEW YORK, NY:  
 3,961,015, PUB. 3-1-2011. INT. CL. 25.

NATIONAL HOT ROD ASSOCIATION, GLENDORA, CA:  
 2,883,050, CANC. INT. CL. 41.

NATIONAL INVESTOR RELATIONS INSTITUTE, VIENNA, VA:  
 3,961,765, PUB. 3-1-2011. U.S. CL. 200.

NATIONAL LIFE INSURANCE COMPANY, MONTPELIER, VT:  
 2,883,196, CANC. INT. CL. 36.

NATIONAL ORTHODONTIX MGMT, PLLC, SAN ANTONIO, TX, DBA SUN ORTHODONTIX:  
 3,961,386, PUB. 3-1-2011. INT. CL. 44.

NATIONAL PACKAGING SERVICES CORPORATION, GREEN BAY, WI:  
 2,521,254. REN. 4-12-11. MULTIPLE CLASS, INT. CLS. 16 AND 21.

NATIONAL PASTEURIZED EGGS, LLC, LANSING, IL:  
 2,446,452. REN. 4-14-11. INT. CL. 29.

NATIONAL PAYMENT SYSTEMS CORP., DUBLIN, OH:  
 2,880,995, CANC. INT. CL. 36.

NATIONAL PRESORT., INC., DALLAS, TX:  
 2,383,936, CANC. INT. CL. 9.

NATIONAL PUBLISHING AND TECHNOLOGY, INC., BONITA SPRINGS, FL:  
 3,962,609, MULTIPLE CLASS, INT. CLS. 9 AND 41.

NATIONAL RAILROAD PASSENGER CORPORATION, WASHINGTON, DC:  
 2,383,355, CANC. INT. CL. 39.  
 2,719,069, AM. INT. CL. 28.

- NATIONAL SCHOOL BOARDS ASSOCIATION, ALEXANDRIA, VA:  
2,882,045, CANC. INT. CL. 16.
- NATIONAL SOCCER COACHES ASSOCIATION OF AMERICA, THE, KANSAS CITY, KS:  
1,651,865. REN. 4-8-11. U.S. CL. 200.
- NATIONAL WOMEN'S HEALTH RESOURCE CENTER, WASHINGTON, DC:  
2,882,011, CANC. INT. CL. 16.
- NATIONAL YELLOW PAGES MEDIA, LLC, INDEPENDENCE, OH:  
3,961,400, PUB. 3-1-2011. INT. CL. 35.
- NATIVE AMERICAN NATURAL FOODS, KYLE, SD:  
3,962,053, MULTIPLE CLASS, INT. CLS. 14, 25 AND 29.
- NATREON, INC., NEW BRUNSWICK, NJ:  
3,961,785, PUB. 3-1-2011. INT. CL. 5.
- NATURAL PRODUCTIONS, LLC, ORLANDO, FL:  
2,881,475, CANC. INT. CL. 25.
- NATURAL SWEET VENTURES, LLC, SUGAR LAND, TX:  
3,884,373, COR. INT. CL. 30.
- NATURALAWN OF AMERICA, INC., FREDERICK, MD:  
2,543,921. REN. 4-12-11. MULTIPLE CLASS, INT. CLS. 37 AND 42.  
3,960,848, PUB. 3-1-2011. INT. CL. 44.
- NATURALLY COOL, FAIRFIELD, CT AND WOLF, PAMELA M., FAIRFIELD, CT:  
3,962,988, INT. CL. 25.
- NATURALLY SLIM, INC., GARLAND, TX:  
3,962,892, INT. CL. 41.
- NATURE'S PATH FOODS INC., RICHMOND, CANADA:  
2,541,433. REN. 4-12-11. INT. CL. 30.  
2,541,434. REN. 4-12-11. INT. CL. 30.
- NATURE'S PILLOWS INC., TREVOSE, PA:  
3,962,480, INT. CL. 20.
- NATURE'S SUNSHINE PRODUCTS, INC., PROVO, UT:  
2,384,363, CANC. INT. CL. 5.  
2,483,417. REN. 4-12-11. INT. CL. 5.
- NATURE'S WINDOW, INC., GLADSTONE, MO:  
2,442,635. REN. 4-12-11. INT. CL. 42.
- NATURMED INC., CAMP VERDE, AZ:  
3,963,676, INT. CL. 5.
- NAVAJO ARTS & CRAFTS ENTERPRISE, WINDOW ROCK, AZ:  
3,960,632, PUB. 3-1-2011. INT. CL. 34.  
3,960,633, PUB. 3-1-2011. INT. CL. 34.
- NAVAJO MANUFACTURING COMPANY, DENVER, CO:  
3,963,734, INT. CL. 9.  
3,963,735, INT. CL. 9.
- NAVICO, INC., TULSA, OK:  
3,963,582, INT. CL. 9.
- NAVNEET PUBLICATIONS (INDIA) LTD., DADAR (W) MUMBAI, INDIA:  
2,882,919, CANC. INT. CL. 16.
- NBO GROUP, INC., SANTA FE SPRINGS, CA:  
3,960,878, PUB. 3-1-2011. INT. CL. 9.
- NCL FOODS, INC., EDEN PRAIRIE, MN:  
2,882,169, CANC. INT. CL. 30.
- NEARVERSE INC., HUNTINGDON VALLEY, PA:  
3,962,924, INT. CL. 42.
- NEFF, CARY E., ORO VALLEY, AZ AND NEFF, PATRICIA, ORO VALLEY, AZ:  
2,777,602, CANC. MULTIPLE CLASS, INT. CLS. 41 AND 43.
- NEHMEH ENTREPRISES & INDUSTRIES LLC, DOHA, QATAR:  
3,961,813, PUB. 3-1-2011. INT. CL. 35.
- NEIGHBORHOOD DIABETES SHOPPE, WAKEFIELD, MA:  
2,881,084, CANC. MULTIPLE CLASS, INT. CLS. 35 AND 41.
- NEILL TECHNOLOGIES, INC., HAMMOND, LA:  
2,425,651. REN. 4-9-11. INT. CL. 9.  
2,483,955. REN. 4-8-11. INT. CL. 9.
- NELL, DOMINIKA, NOVE MISTO, CZECH REPUBLIC:  
3,963,746, INT. CL. 9.
- NEMCO MOTORSPORTS, INC., MOORESVILLE, NC:  
2,480,816. REN. 4-8-11. MULTIPLE CLASS, INT. CLS. 16, 25 AND 41.
- NEMEC, GALE B., ALEXANDRIA, VA:  
3,961,044, PUB. 3-1-2011. INT. CL. 41.
- NEO FOODS PVT. LTD., BANGALORE, INDIA:  
3,926,410, COR. INT. CL. 29.
- NEOGENIS LABORATORIES, INC, AUSTIN, TX:  
3,961,381, PUB. 3-1-2011. INT. CL. 5.  
3,961,717, PUB. 3-1-2011. INT. CL. 5.
- NEOMICRO, WEST MONROE, LA:  
2,881,690, CANC. INT. CL. 42.
- NETBIZ, INC., TUALATIN, OR:  
3,960,490, PUB. 3-1-2011. MULTIPLE CLASS, INT. CLS. 35 AND 42.
- NETCOM INFORMATION TECHNOLOGY, INC., NEW YORK, NY:  
3,961,257, PUB. 3-1-2011. INT. CL. 41.
- NETCONNECT HEALTHCARE SYSTEMS, LLC, ST. PETERSBURG, FL:  
3,962,089, MULTIPLE CLASS, INT. CLS. 9 AND 42.
- NETHERFIELD VISUAL LTD., EDINBURGH EH 22 3NX, SCOTLAND:  
2,883,257, CANC. INT. CL. 20.
- NETSCH, STEVEN P., EDEN PRAIRIE, MN:  
2,644,621, CANC. INT. CL. 35.
- NETVMG, INC., ATLANTA, GA:  
2,880,688, CANC. INT. CL. 41.
- NETWORKS ASSOCIATES TECHNOLOGY, INC., SANTA CLARA, CA:  
2,882,578, CANC. INT. CL. 9.
- NEUBERGER BERMAN GROUP LLC, NEW YORK, NY:  
3,962,421, INT. CL. 36.
- NEUBERGER BERMAN MANAGEMENT INC., NEW YORK, NY:  
2,883,250, CANC. INT. CL. 36.  
2,883,251, CANC. INT. CL. 36.
- NEUMAN, MIRANDA, ALPHARETTA, GA:  
3,963,623, INT. CL. 42.
- NEUMANN, DONALD J., PLYMOUTH, MN:  
3,962,919, INT. CL. 6.
- NEURALTUS PHARMACEUTICALS, INC., PALO ALTO, CA:  
3,962,281, MULTIPLE CLASS, INT. CLS. 5 AND 42.
- NEUROTRON, INC, DENVER, CO:  
3,961,421, PUB. 3-1-2011. INT. CL. 9.
- NEW AGEING INTERNATIONAL PTY LTD, PORT MELBOURNE, AUSTRALIA:  
3,960,631, PUB. 1-8-2008. INT. CL. 5.
- NEW ECONOMY FUND, LOS ANGELES, CA:  
1,439,497, COR. INT. CL. 36.
- NEW HOLLAND PUBLISHING (SOUTH AFRICA) (PROPRIETARY) LIMITED, CAPE TOWN, SOUTH AFRICA:  
3,963,294, INT. CL. 39.
- NEW HOPE MILLS INC., AUBURN, NY:  
3,961,831, PUB. 3-1-2011. MULTIPLE CLASS, INT. CLS. 29, 30 AND 31.
- NEW ISCAR LTD, TEFEN, ISRAEL:  
2,882,220, CANC. INT. CL. 7.
- NEW JERSEY MONTHLY, LLC, MORRISTOWN, NJ:  
3,961,418, PUB. 3-1-2011. INT. CL. 16.
- NEW LIFE INTERNATIONAL, GOODLETTSVILLE, TN, DBA NATIONAL COMMUNITY FOUNDATION:  
2,445,487. REN. 4-14-11. INT. CL. 36.
- NEW LIFE MINISTRIES, PIANO, TX:  
2,880,621, CANC. MULTIPLE CLASS, INT. CLS. 35 AND 41.
- NEW METHOD TECHNOLOGIES, INC., LARGO, FL:  
2,881,041, CANC. INT. CL. 9.
- NEW MEXICO ENTERTAINMENT & DIGITAL INDUSTRY ASSOCIATION, ALBUQUERQUE, NM:  
3,961,220, PUB. 3-1-2011. INT. CL. 35.
- NEW PENDULUM CORP., WILMINGTON, DE:  
2,881,149, CANC. INT. CL. 27.  
3,962,601, INT. CL. 21.
- NEW WAYS OF WORKING LLC, LOS GATOS, CA:  
3,960,836, PUB. 3-1-2011. INT. CL. 35.
- NEW YORK COMMUNITY BANCORP, INC., WESTBURY, NY:  
3,963,639, INT. CL. 36.



NEW YORK INSTITUTE OF TECHNOLOGY, OLD WEST-BURY, NY:  
1,640,475. REN. 4-11-11. INT. CL. 16.  
1,641,369. REN. 4-11-11. INT. CL. 25.

NEW YORK LIFE INSURANCE COMPANY, NEW YORK, NY:  
2,446,678. REN. 4-14-11. INT. CL. 36.

NEW YORK MILKSHAKE COMPANY, INC., NEW YORK, NY:  
2,882,510. CANC. INT. CL. 43.

NEW YORK RESTORATION PROJECT, NEW YORK, NY:  
3,963,080. INT. CL. 41.

NEW YORK TIMES COMPANY, THE, NEW YORK, NY:  
2,475,639. REN. 4-14-11. INT. CL. 41.

NEW YORK YANKEES PARTNERSHIP, BRONX, NY:  
2,383,508. CANC. MULTIPLE CLASS, INT. CLS. 16 AND 25.

NEWBERRY, KYMBERLY S., LOS ANGELES, CA, DBA "SIGGI DIMANCHE":  
3,960,893. PUB. 3-1-2011. INT. CL. 41.

NEWBY TEAS (U.K.) LIMITED, UNITED KINGDOM:  
3,960,746. PUB. 3-1-2011. INT. CL. 30.

NEWER TECHNOLOGY, INC., WOODSTOCK, IL:  
3,963,628. INT. CL. 9.

NEWGISTICS, INC., AUSTIN, TX:  
3,961,946. PUB. 3-1-2011. INT. CL. 41.

NEWMARKET IMPRESSIONS, LLC, BEVERLY HILLS, CA:  
3,961,661. PUB. 3-1-2011. INT. CL. 40.

NEWPARK DRILLING FLUIDS LLC, THE WOODLANDS, TX:  
2,421,755. REN. 4-9-11. INT. CL. 40.

NEWPORT CORPORATION, IRVINE, CA:  
1,640,907. REN. 4-8-11. INT. CL. 9.

NEWTIN A.S., CZ-140 00 PRAHA 4, CZECH REPUBLIC:  
3,960,648. PUB. 3-1-2011. MULTIPLE CLASS, INT. CLS. 9, 35, 36, 38, 41 AND 42.

NEXPOINT TECHNOLOGIES INC., HARRISONBURG, VA:  
2,881,602. CANC. INT. CL. 42.

NEXT STEP PUBLISHING, INC., VICTOR, NY:  
3,963,134. INT. CL. 41.

NEXT VEGETALES S.A. DE C.V., DEL MIGUEL HIDALGO, MEXICO:  
3,962,881. INT. CL. 31.

NEXTBOOK, INC., NEW YORK, NY:  
2,883,140. CANC. INT. CL. 41.

NEXUS BIOSYSTEMS, INC., POWAY, CA:  
2,882,609. CANC. INT. CL. 9.

NEXXUS LIGHTING, INC., ORLANDO, FL:  
2,882,828. CANC. INT. CL. 9.

NFSP MARKETING, LLC, MONTGOMERY, AL:  
3,963,659. INT. CL. 35.

NGC WORLDWIDE, INC., YALESVILLE, CT:  
2,443,509. REN. 4-9-11. INT. CL. 28.

NHC COMMUNICATIONS INC., MOUNT-ROYAL, QUEBEC H4P 1A9, CANADA TO MUX LAB INC., QUEBEC, CANADA:  
2,016,006. CANC. INT. CL. 9.

NICHOLSON'S WHOLESALE FIREWORKS, KAUFMAN, TX:  
2,883,190. CANC. INT. CL. 13.

NICI AG, 96264 ALTENKUNSTSTADT, FED REP GERMANY:  
2,882,367. CANC. INT. CL. 28.

NICOLE'S INC., CHICAGO, IL:  
2,881,036. CANC. INT. CL. 30.

NICOLLE, DOUGLAS, DALLAS, TX:  
2,881,322. CANC. INT. CL. 9.

NIEDWESKE, LINDA, MORRISTOWN, NJ:  
3,961,149. PUB. 3-1-2011. INT. CL. 36.

NIFFENEGGER, BEVERLY, CLOUDCROFT, NM:  
2,883,207. CANC. INT. CL. 16.

NIFL/TEAM EVANSVILLE, EVANSVILLE, IN:  
2,882,511. CANC. INT. CL. 41.

NIHON VIDEO SYSTEM CO., LTD., TSUSHIMA-SHI, AICHI, JAPAN:  
3,960,906. PUB. 3-1-2011. INT. CL. 9.

NIKE, INC., BEAVERTON, OR:  
3,962,725. MULTIPLE CLASS, INT. CLS. 17 AND 25.

NIKKEN, INC., IRVINE, CA:  
2,882,246. CANC. INT. CL. 25.

NIKKO ASSET MANAGEMENT CO., LTD., TOKYO 107-6242, JAPAN:  
3,962,275. INT. CL. 36.

NIKON CORPORATION, TOKYO, JAPAN:  
3,963,706. INT. CL. 9.

NILODOR, INC., BOLIVAR, OH:  
2,383,506. CANC. INT. CL. 5.

NIRVANIX, INC., SAN DIEGO, CA:  
3,963,750. INT. CL. 9.

NISIMOV WATCH CO., INC., LOS ANGELES, CA:  
2,881,676. CANC. INT. CL. 14.

NISSAN JIDOSHA KABUSHIKI KAISHA, YOKOHAMA-SHI, KANAGAWA-KEN, JAPAN, TA NISSAN MOTOR CO., LTD.:  
2,880,647. CANC. MULTIPLE CLASS, INT. CLS. 9, 12, 16 AND 37.

NISSAN JIDOSHA KABUSHIKI KAISHA, YOKOHAMA-SHI, JAPAN, DBA NISSAN MOTOR CO., LTD.:  
3,960,293. PUB. 3-1-2011. MULTIPLE CLASS, INT. CLS. 12, 35 AND 37.

NISSIN FOODS (U.S.A.) COMPANY, INC., GARDENA, CA:  
2,883,393. CANC. INT. CL. 30.

NITE BEAM PRODUCTS, LLC, CHARLOTTE, NC:  
3,961,629. PUB. 3-1-2011. MULTIPLE CLASS, INT. CLS. 18, 25 AND 26.

NL&C, LLC, EL PASO, TX:  
3,961,500. PUB. 3-1-2011. INT. CL. 35.

NO REST AT THE TOP, INC, SEATTLE, WA:  
3,960,899. PUB. 3-1-2011. INT. CL. 25.

NOBLE WAR PRIZE, INC., SOUTHAMPTON, NY:  
3,962,935. MULTIPLE CLASS, INT. CLS. 25 AND 28.

NOBLE, RICHARD A., GARLAND, TX:  
2,882,910. CANC. INT. CL. 20.

NOKIA CORPORATION, FINLAND:  
3,960,668. PUB. 6-22-2010. INT. CL. 9.

NOOR UL MUSHTAQ, JAMMU & KASHMIR, INDIA:  
3,962,790. INT. CL. 7.

NORBORD INDUSTRIES INC., TORONTO, ONTARIO M5C 2W4, CANADA:  
2,441,854. REN. 4-12-11. INT. CL. 19.

NORDIC SEMICONDUCTOR ASA, N-0213 OSLO, NORWAY:  
3,960,643. PUB. 3-1-2011. INT. CL. 9.

NORDSTROM, INC., SEATTLE, WA:  
3,962,979. INT. CL. 35.

NORIT N.V., AMERSFOORT, NETHERLANDS:  
140,896. REN. 4-8-11. U.S. CL. 6 (INT. CL. 1).

NORTH AMERICAN AUDIO GROUP, INC., EMERSON, NJ:  
2,403,354. REN. 4-14-11. INT. CL. 9.

NORTH AMERICAN BUS INDUSTRIES, INC., ANNISTON, AL:  
3,961,841. PUB. 3-1-2011. INT. CL. 12.

NORTH AMERICAN GREEN, INC., POSEYVILLE, IN:  
3,962,202. INT. CL. 31.

NORTH AMERICAN RESCUE, LLC, GREER, SC:  
3,960,363. PUB. 3-1-2011. INT. CL. 5.

NORTH AMERICAN SALT COMPANY, OVERLAND PARK, KS, KOOS, INC., KENOSHA, WI:  
1,651,248. REN. 4-13-11. INT. CL. 1.

NORTH AMERICAN SALT COMPANY, KANSAS CITY, MO:  
3,963,355. INT. CL. 1.

NORTHERN FEATHER CANADA LTD., DELTA, CANADA:  
3,960,259. PUB. 3-1-2011. MULTIPLE CLASS, INT. CLS. 20 AND 24.

NORTHERN LATITUDE CEA, LLC, ANCHORAGE, AK:  
3,961,704. PUB. 3-1-2011. INT. CL. 31.

NORTHERN SALES COMPANY INC., KENT, WA:  
3,962,983. INT. CL. 30.

NORTHERN TOOL & EQUIPMENT COMPANY, INC., BURNSVILLE, MN:  
3,963,521. MULTIPLE CLASS, INT. CLS. 7 AND 8.

NORTHLAND ALUMINUM PRODUCTS, INC., MINNEAPOLIS, MN, ANCHOR HOCKING CORPORATION, LANCASTER, OH:  
1,148,955. REN. 4-14-11. INT. CL. 21.

NORTHWEST AIRLINES, INC., EAGAN, MN:  
2,383,824. CANC. INT. CL. 42.

- NORTHWESTERN UNIVERSITY, EVANSTON, IL, WILD-CAT WRESTLING CLUB, INC., CHICAGO, IL:  
1,155,912. REN. 4-8-11. INT. CL. 41.
- NORWALK WASTEWATER EQUIPMENT COMPANY, NORWALK, OH:  
2,437,897. REN. 4-14-11. MULTIPLE CLASS, INT. CLS. 8, 16, 20 AND 37.
- NORWEGIAN AMERICAN HOSPITAL, CHICAGO, IL:  
2,449,010. REN. 4-11-11. INT. CL. 42.
- NOSVA LP, LAS VEGAS, NV, DBA EXIT MOBILE:  
3,962,011. INT. CL. 38.
- NOTESHACK.COM, LLC, LITTLE ROCK, AR:  
2,881,272. CANC. INT. CL. 16.
- NOVARTIS AG, BASEL CH-4056, SWITZERLAND:  
2,882,850. CANC. INT. CL. 5.
- NOVARTIS AG, BASEL, SWITZERLAND:  
3,962,855. INT. CL. 5.
- NOVATECH PROCESS SOLUTIONS, LLC, PORTLAND, OR:  
2,436,421. REN. 4-11-11. INT. CL. 9.
- NOVAURORA, INC., PITTSBURGH, PA:  
2,881,184. CANC. INT. CL. 42.
- NOVO ALTUM LIMITED, BUCKINGHAMSHIRE, UNITED KINGDOM:  
3,960,492. PUB. 3-1-2011. MULTIPLE CLASS, INT. CLS. 9, 16, 35, 36, 41 AND 45.
- NOVOZYMES A/S, BAGSVAERD, DENMARK:  
2,881,466. CANC. MULTIPLE CLASS, INT. CLS. 1, 24, 25 AND 41.  
2,881,568. CANC. INT. CL. 1.
- NSF INTERNATIONAL, ANN ARBOR, MI:  
2,383,422. CANC. INT. CL. 42.
- NS412, LLC, GARLAND, TX:  
3,962,893. MULTIPLE CLASS, INT. CLS. 29, 30, 32, 38 AND 41.
- NU ORBIT MEDIA INCORPORATED, SEYMOUR, IN:  
2,968,159. AM. MULTIPLE CLASS, INT. CLS. 35 AND 42.
- NU-WORLD CORP., CARTERET, NJ:  
2,406,032. REN. 4-11-11. INT. CL. 3.  
2,460,033. REN. 4-12-11. INT. CL. 3.
- NUCOR CORPORATION, CHARLOTTE, NC:  
3,963,302. INT. CL. 6.  
3,963,303. INT. CL. 6.
- NUERA GROUP INC., EL MONTE, CA:  
3,962,116. INT. CL. 25.
- NUESTRO VINO, LLC, HOPLAND, CA:  
3,961,995. INT. CL. 33.
- NULINE PHARMACEUTICALS INC., GLENDALE, CA:  
3,963,407. INT. CL. 44.
- NUMERATOR, LLC, NEW YORK, NY:  
2,883,212. CANC. INT. CL. 36.
- NUMIS NETWORK, LLC, TAMPA, FL, DBA NUMIS NETWORK:  
3,960,494. PUB. 3-1-2011. INT. CL. 14.
- NUTRAMARKS, INC., PARK CITY, UT, MAKERS OF KAL, INC., WOODLAND HILLS, CA:  
1,639,500. REN. 4-9-11. INT. CL. 5.
- NUTRAMARKS, INC., PARK CITY, UT:  
2,882,953. CANC. INT. CL. 5.
- NUTRIQUINE, NAAMLOZE VENNOOTSCHAP, BELGIUM:  
3,943,086. COR. INT. CL. 5.
- NUTRITION CENTER, INC., DOUGLAS, WY:  
2,473,691. REN. 4-10-11. INT. CL. 5.  
2,531,656. REN. 4-14-11. INT. CL. 5.
- NUTTO, LLC, CHICAGO, IL:  
3,962,987. INT. CL. 21.  
3,962,992. INT. CL. 21.  
3,962,993. INT. CL. 21.
- NUTTY MUNKEY, INC., SPRINGFIELD, MO:  
2,881,703. CANC. INT. CL. 35.
- NUVO BODY, LP, BEAUMONT, TX:  
2,881,567. CANC. INT. CL. 5.
- NUVONYX INC, CARLSBAD, CA:  
3,961,309. PUB. 3-1-2011. INT. CL. 5.
- NW ALPENGLOW, INC., KIRKLAND, WA:  
3,961,378. PUB. 3-1-2011. INT. CL. 44.
- NZ HEALTH NATURALLY PTY LIMITED, AUSTRALIA:  
3,960,674. PUB. 3-1-2011. INT. CL. 5.
- O'DONNELL, STEVEN B., SANTA FE SPRINGS, CA:  
2,882,069. CANC. INT. CL. 4.
- O'KEEFE, MELINDA, MAHOPAC, NY:  
3,961,550. PUB. 3-1-2011. INT. CL. 40.
- O'NEAL INSURANCE SERVICES, UPPER MARLBORO, MD:  
3,962,946. INT. CL. 35.
- OAK CLIFF SHIRT COMPANY, INC., DALLAS, TX:  
2,880,673. CANC. INT. CL. 25.
- OAK HALL INDUSTRIES, LP, SALEM, VA, DBA OAK HALL CAP & GOWN/CE WARD/BENTLEY & SIMON:  
3,962,345. INT. CL. 25.
- OAK PATCH GIFTS LLC, EUGENE, OR:  
2,881,786. CANC. INT. CL. 14.
- OAKWOOD, INC., THE, DALTON, GA:  
3,963,866. INT. CL. 43.
- OASIS INTERNATIONAL DEVELOPMENT CORP., COCONUT CREEK, FL:  
3,963,808. INT. CL. 35.
- OBCHTCHESTVO S OGRANITCHENNOY OTVETSTVENNOSTYOU "GRICHKO", RU-113095 MOSCOU, RUSSIAN FED.:  
3,960,796. PUB. 3-1-2011. MULTIPLE CLASS, INT. CLS. 25 AND 35.
- OBJECTIVE INVESTMENTS, L.L.C., NEW YORK, NY:  
2,882,983. CANC. INT. CL. 36.
- OBP CORPORATION, LAWRENCE, MA:  
3,963,837. INT. CL. 10.
- OBSCHESTVO S OGRANICHENNOI; OTVETSTVENNOSTYU; "NAUCHNO-PROIZVODSTVENNAYA FIRMA; "MATERIA MEDICA HOLDING", RUSSIAN FED.:  
3,960,772. PUB. 3-1-2011. INT. CL. 5.  
3,960,773. PUB. 3-1-2011. INT. CL. 5.
- OBSCHESTVO S OGRANICHENNOY OTVETSTVENNOSTYU "SPLAT-COSMETICA", RUSSIAN FED.:  
3,960,811. PUB. 3-1-2011. INT. CL. 3.
- OCEAN DIRECT, LLC, HAWTHORNE, CA:  
3,963,723. INT. CL. 29.
- OCEAN GEAR USA INC., FLUSHING, NY:  
2,882,690. CANC. INT. CL. 28.
- OCEAN PACIFIC APPAREL CORPORATION, IRVINE, CA:  
2,882,299. CANC. INT. CL. 28.
- OCEAN PACIFIC SUNWEAR, LTD., TUSTIN, CA TO OP HOLDINGS LLC, WILMINGTON, DE:  
1,639,594. CANC. MULTIPLE CLASS, INT. CLS. 9, 16 AND 42.
- OCEAN TECHNOLOGY, INC., ARNOLD, MD:  
2,880,900. CANC. INT. CL. 29.
- OCEANUS OPERATING COMPANY LIMITED, UNITED KINGDOM:  
3,960,732. PUB. 3-1-2011. MULTIPLE CLASS, INT. CLS. 9 AND 42.
- OCIMUM BIOSOLUTIONS, INC., GAITHERSBURG, MD:  
2,882,142. CANC. INT. CL. 9.
- OCTAPharma AG, LACHEN, SWITZERLAND:  
3,960,294. PUB. 3-1-2011. INT. CL. 5.
- OCTAVE VINEYARD, LLC, WALLA WALLA, WA:  
3,962,036. INT. CL. 31.
- OCULIS LABS, INC., OWINGS MILLS, MD:  
3,962,085. INT. CL. 9.
- OCULUS INFO INC., TORONTO, CANADA:  
3,960,289. PUB. 3-1-2011. MULTIPLE CLASS, INT. CLS. 9 AND 42.
- ODESSA CHAMBER OF COMMERCE CORPORATION, ODESSA, TX:  
1,617,869. REN. 4-8-11. INT. CL. 35.
- ODNT 2, INC., NEW ORLEANS, LA:  
2,881,667. CANC. INT. CL. 43.
- OFF WALL STREET CONSULTING GROUP, INC., CAMBRIDGE, MA:  
1,679,351. REN. 4-8-11. INT. CL. 16.
- OHARARP LLC, DAYTON, OH:  
3,961,996. INT. CL. 9.
- OHASHI TECHNICA USA INC., SUNBURY, OH:  
2,507,167. REN. 4-8-11. INT. CL. 6.  
2,510,456. REN. 4-8-11. INT. CL. 6.

OHIO ASSOCIATED ENTERPRISES, LLC, PAINESVILLE, OH:  
3,962,936, INT. CL. 9.  
3,962,939, INT. CL. 9.

OHIO STATE BAR ASSOCIATION, COLUMBUS, OH:  
3,962,549, INT. CL. 45.

OIKOS S.R.L., GATTEO MARE (FC), ITALY:  
3,043,076, CANC. INT. CL. 27.

OKAMOTO INDUSTRIES, INC., BUNKYO-KU, TOKYO, JAPAN:  
3,963,740, INT. CL. 10.

OKLAHOMA TOURISM & RECREATION DEPARTMENT, OKLAHOMA CITY, OK:  
2,880,954, CANC. INT. CL. 35.

OLAES ENTERPRISES, INC., POWAY, CA, DBA ODM:  
2,881,116, CANC. INT. CL. 25.

OLD NATIONAL BANCORP, EVANSVILLE, IN:  
2,882,979, CANC. INT. CL. 36.

OLD SCHOOL LLC, MILFORD, DE:  
3,961,259, PUB. 3-1-2011. INT. CL. 25.  
3,961,277, PUB. 3-1-2011. INT. CL. 25.  
3,961,525, PUB. 3-1-2011. INT. CL. 25.

OLD WORLD BREWING COMPANY, INC., STATEN ISLAND, NY:  
2,739,500, CANC. INT. CL. 32.

OLIN CORPORATION, ST. LOUIS, MO:  
142,353, REN. 4-9-11. U.S. CL. 9 (INT. CLS. 13 AND 34).  
1,168,283, REN. 4-8-11. INT. CL. 13.

OLIVER-TOLAS HEALTHCARE PACKAGING, LLC, GRAND RAPIDS, MI:  
3,960,236, PUB. 3-1-2011. INT. CL. 17.

OLSEN, ROY WARREN, SEABROOK, TX:  
2,880,650, CANC. INT. CL. 36.

OLYMPUS CORPORATION, TOKYO, JAPAN:  
3,962,786, INT. CL. 9.

OMNI HOTELS MANAGEMENT CORPORATION, IRVING, TX:  
2,883,083, CANC. INT. CL. 43.

OMNI-PLANT CORPORATION, PEARLAND, TX:  
3,961,426, PUB. 3-1-2011. INT. CL. 42.

OMS INVESTMENTS, INC., LOS ANGELES, CA:  
2,882,649, CANC. INT. CL. 1.

OMX AB, STOCKHOLM, SWEDEN:  
3,960,496, PUB. 3-1-2011. MULTIPLE CLASS, INT. CLS. 35, 36, 41 AND 42.

ONE BIG MAN & ONE BIG TRUCK MOVING CO., INC., SAN FRANCISCO, CA:  
2,888,774, CANC. INT. CL. 39.

ONE ON ONE BASKETBALL, INC., WASHINGTON, DC:  
3,961,950, PUB. 3-1-2011. INT. CL. 41.

ONE SCRIBE MEDIA LLC, BROOKLYN, NY:  
3,961,176, PUB. 3-1-2011. INT. CL. 35.

ONE WELLNESS, LTD., TORTOLA, BR. VIRGIN ISLANDS:  
3,961,456, PUB. 3-1-2011. INT. CL. 28.

ONE WORLD FOODS, INC., AUSTIN, TX, DBA STUBB'S LEGENDARY KITCHEN, INC.:  
3,960,287, PUB. 3-1-2011. INT. CL. 43.

ONE-TOUCH AUDIO & VIDEO INTEGRATION, LLC, SAN DIEGO, CA:  
2,883,038, CANC. INT. CL. 9.

ONLINE OPTICAL OUTLET LLC, KENT, OH:  
2,881,519, CANC. INT. CL. 35.

ONTARIO LOTTERY AND GAMING CORPORATION, TORONTO, ONTARIO, CANADA:  
2,382,389, REN. 4-14-11. INT. CL. 41.

ONTECNIA MEDIA NETWORKS, S.L., VALENCIA, SPAIN:  
3,960,999, PUB. 1-4-2011. MULTIPLE CLASS, INT. CLS. 9 AND 38.

ONWARD MULTI-CORP INC., WATERLOO, CANADA:  
3,962,218, INT. CL. 21.

OON-RECYCLING SOLUTIONS, S.A., PORTUGAL:  
3,960,760, PUB. 3-1-2011. MULTIPLE CLASS, INT. CLS. 4, 7 AND 40.

OP HOLDINGS LLC, WILMINGTON, DE, OCEAN PACIFIC SUNWEAR, LTD., TUSTIN, CA:  
1,639,594, REN. 4-8-11. MULTIPLE CLASS, INT. CLS. 14, 18, 24, 25 AND 28.

OPEN COMPLIANCE & ETHICS GROUP, PHOENIX, AZ:  
3,962,179, MULTIPLE CLASS, INT. CLS. 35 AND 42.

OPEN INTERFACE NORTH AMERICA, INC., SEATTLE, WA:  
2,880,629, CANC. INT. CL. 9.

OPPENHEIMERFUNDS, INC., NEW YORK, NY:  
3,961,452, PUB. 3-1-2011. INT. CL. 36.

OPPORTUNITY HOLDING, LLC, SAN ANTONIO, TX:  
3,961,619, PUB. 3-1-2011. INT. CL. 41.  
3,961,620, PUB. 3-1-2011. INT. CL. 35.  
3,961,622, PUB. 3-1-2011. INT. CL. 25.  
3,961,628, PUB. 3-1-2011. INT. CL. 5.

OPTELEC U.S., INC, CHELMSFORD, MA:  
3,962,877, INT. CL. 35.

OPTICSVALLEY, ARCUEIL CEDEX, FRANCE:  
3,960,640, PUB. 3-1-2011. MULTIPLE CLASS, INT. CLS. 9, 38 AND 42.

OPTIMAL HEALTH SYSTEMS LLC, CYPRESS, TX:  
3,961,820, PUB. 3-1-2011. INT. CL. 35.

OPTOVISION TECHNOLOGIES, INC., DALLAS, TX:  
2,881,910, CANC. MULTIPLE CLASS, INT. CLS. 9 AND 37.

OPTRONIC TECHNOLOGIES, INC., WATSONVILLE, CA:  
3,962,767, INT. CL. 9.

ORANGE BANG, INC., SYLMAR, CA:  
3,960,381, PUB. 3-1-2011. INT. CL. 32.

ORCHARD ENTERPRISES NY, INC., NEW YORK, NY:  
3,961,118, PUB. 3-1-2011. INT. CL. 41.

ORE ORIGINALS, INC., LONG BEACH, CA:  
3,962,449, MULTIPLE CLASS, INT. CLS. 18 AND 21.

ORFEVRERIE CHRISTOFLE, 75008 PARIS, FRANCE:  
542,990, AM. U.S. CL. 28.

ORGANIZATION UNITED FOR RESPECT AT WALMART, WASHINGTON, DC:  
3,961,881, PUB. 3-1-2011. INT. CL. 35.

ORGANO GOLD ENTERPRISES INC., RICHMOND, B.C., CANADA:  
3,962,509, INT. CL. 30.

ORIAKU, NKECHINYERE, BUFFALO, NY AND EGWU, CHETACHI, FT. LAUDERDALE, NY AND EGWU, ADELE, RIVERDALE, NY:  
3,963,534, INT. CL. 3.

ORIGIN POINT BRANDS, LLC, CHARLESTON, SC:  
3,962,125, INT. CL. 6.

ORIGINAL IDEAS, INC., LA QUINTA, CA:  
3,962,816, INT. CL. 20.

ORIGLIERI, MARCUS, TUCSON, AZ:  
2,403,542, REN. 4-14-11. INT. CL. 14.

ORION ELECTRONICS, INC., LOS ANGELES, CA:  
3,961,457, PUB. 3-1-2011. INT. CL. 11.

ORION GENOMICS, LLC, ST. LOUIS, MO:  
2,384,178, CANC. INT. CL. 42.

ORKIN EXPANSION, INC., WILMINGTON, DE:  
3,962,303, INT. CL. 37.  
3,962,362, INT. CL. 37.  
3,962,363, INT. CL. 37.

ORLANDO INFORMATION NETWORK INC, ORLANDO, FL:  
3,960,519, PUB. 3-1-2011. INT. CL. 35.

ORLANDO/ORANGE COUNTY CONVENTION & VISITORS BUREAU, INC., ORLANDO, FL:  
2,461,611, REN. 4-12-11. INT. CL. 35.

ORLY INTERNATIONAL, INC., VAN NUYS, CA:  
3,963,550, INT. CL. 3.  
3,963,551, INT. CL. 3.  
3,963,552, INT. CL. 3.  
3,963,553, INT. CL. 3.  
3,963,554, INT. CL. 3.  
3,963,610, INT. CL. 3.

ORTHO DEVELOPMENT, CORP., DRAPER, UT:  
2,882,036, CANC. INT. CL. 10.

ORTHO TECHNOLOGY, INC., TAMPA, FL:  
3,963,029, INT. CL. 10.

ORTIZ, MATTHEW, HASTINGS-HDSN, NY:  
3,961,548, PUB. 3-1-2011. INT. CL. 9.

OSNAT GAD, INC., STATESBORO, GA:  
2,449,442, REN. 4-12-11. INT. CL. 14.

- OSRAM SYLVANIA INC., DANVERS, MA, GTE SYLVANIA INCORPORATED, STAMFORD, CT:  
1,157,947. REN. 4-13-11. INT. CL. 11.
- OSRAM; GESELLSCHAFT MIT BESCHRÄNKTER HAF-  
TUNG, MÜNCHEN, FED REP GERMANY, DBA OSRAM  
GMBH:  
3,960,754, PUB. 3-1-2011. MULTIPLE CLASS, INT. CLS. 9  
AND 11.
- OSY INC., BROOKLYN, NY:  
1,190,793. REN. 4-9-11. INT. CL. 26.
- OTARIAN LONDON LIMITED, LONDON, UNITED KING-  
DOM:  
3,960,584, PUB. 3-1-2011. INT. CL. 43.
- OTICON A/S, DENMARK:  
3,960,823, PUB. 3-1-2011. INT. CL. 10.
- OTKRYTOE AKTSIONERNOE OBSHCHESTVO "NIZHE-  
GORODSKY MASLO-ZHIROVOY KOMBINAT", RUS-  
SIAN FED.:  
3,960,788, PUB. 3-1-2011. INT. CL. 30.
- OTOPIO PTY LIMITED, FERN TREE, AUSTRALIA:  
3,960,372, PUB. 6-15-2010. INT. CL. 16.
- OTTER PRODUCTS, LLC, FORT COLLINS, CO:  
3,963,182, INT. CL. 9.
- OURPET'S COMPANY, FAIRPORT HARBOR, OH:  
3,961,731, PUB. 3-1-2011. INT. CL. 19.
- OUTHCUNIS, BRETT, ONSET, MA, DBA NINE POINTS  
ENTERTAINMENT:  
3,962,752, INT. CL. 28.
- OUTOKUMPU OYJ, FINLAND:  
3,960,824, PUB. 3-1-2011. INT. CL. 6.
- OUTSPARK, INC., SAN FRANCISCO, CA:  
3,963,042, INT. CL. 9.  
3,963,043, INT. CL. 41.
- OVERLAKE SERVICE LEAGUE, BELLEVUE, WA:  
3,962,845, MULTIPLE CLASS, INT. CLS. 35 AND 36.
- OVERTIME INC., HOUSTON, TX, DBA FEDERAL WAGE  
AND LABOR LAW INSTITUTE:  
2,880,982, CANC. INT. CL. 16.
- OXEMIN PTY LIMITED, NORTH SYDNEY, AUSTRALIA:  
3,960,784, PUB. 3-1-2011. MULTIPLE CLASS, INT. CLS. 9  
AND 42.
- OXFORD EXPERIENCE LIMITED, OXFORD OX1 3AJ,  
UNITED KINGDOM:  
2,448,035. REN. 4-11-11. INT. CL. 25.
- OXFORD UNIVERSITY PRESS, INC., NEW YORK, NY:  
1,640,281. REN. 4-8-11. INT. CL. 9.
- OZBURN-HESSEY LOGISTICS, LLC, BRENTWOOD, TN:  
3,963,364, INT. CL. 42.
- P & L SAFETY, LLC, BRECKSVILLE, OH:  
3,963,537, INT. CL. 45.
- P. GAVRIELIDES LTD., LARNACA, CYPRUS:  
2,467,013. REN. 4-14-11. INT. CL. 13.
- P. H. GLATFELTER COMPANY, YORK, PA:  
3,962,571, INT. CL. 16.  
3,962,572, INT. CL. 16.  
3,962,573, INT. CL. 16.
- P. MICHAEL FENNESSY, FORT LAUDERDALE, FL:  
2,384,228, CANC. INT. CL. 40.
- P.T. ON CALL, P.S., VANCOUVER, WA:  
2,552,420. REN. 4-8-11. INT. CL. 42.
- P&F WINERIES S.A., L-8009 STRASSEN, LUXEMBOURG:  
3,960,751, PUB. 3-1-2011. MULTIPLE CLASS, INT. CLS.  
32, 33 AND 35.  
3,960,752, PUB. 3-1-2011. MULTIPLE CLASS, INT. CLS.  
32, 33 AND 35.  
3,960,753, PUB. 3-1-2011. MULTIPLE CLASS, INT. CLS.  
32, 33 AND 35.  
3,960,763, PUB. 3-1-2011. MULTIPLE CLASS, INT. CLS.  
32, 33 AND 35.
- P'NENA GROUP, THE, NEW YORK, NY:  
2,383,367, CANC. INT. CL. 25.
- PABST BREWING COMPANY, MILL VALLEY, CA:  
1,883,843, CANC. INT. CL. 32.
- PACER INTERNATIONAL, INC, CONCORD, CA:  
3,961,823, PUB. 3-1-2011. MULTIPLE CLASS, INT. CLS. 35  
AND 39.
- PACIFIC COAST BUILDING PRODUCTS, INC., RANCHO  
CORDOVA, CA:  
2,881,649, CANC. INT. CL. 19.  
2,881,650, CANC. INT. CL. 19.
- PACIFIC COAST FEATHER COMPANY, SEATTLE, WA:  
2,383,659, CANC. INT. CL. 24.
- PACIFIC ENTERMARK VERTRIEBSGESELLSCHAFT  
MBH, HOCHDORF, FED REP GERMANY:  
3,961,000, PUB. 3-1-2011. MULTIPLE CLASS, INT. CLS.  
18, 25 AND 28.
- PACIFIC MARKET INTERNATIONAL, LLC, SEATTLE, WA:  
3,961,436, PUB. 3-1-2011. INT. CL. 21.
- PACIFIC PEBBLES CORPORATION, SAN DIEGO, CA:  
3,960,538, PUB. 3-1-2011. INT. CL. 37.
- PACIFIC POULTRY COMPANY, LIMITED, HONOLULU,  
HI:  
1,639,223. REN. 4-12-11. INT. CL. 30.
- PACIFIC UTILITY INSTALLATION, INC., ANAHEIM, CA:  
2,881,172, CANC. INT. CL. 37.
- PACIFIC WORLD CORPORATION, LAKE FOREST, CA:  
2,883,331, CANC. INT. CL. 3.  
3,963,721, INT. CL. 3.
- PACKAGING MACHINERY MANUFACTURERS INSTI-  
TUTE, INC., ARLINGTON, VA:  
2,882,745, CANC. INT. CL. 16.
- PACKAGING PRODUCTS CORPORATION, NEW BED-  
FORD, MA:  
2,448,308. REN. 4-14-11. INT. CL. 1.
- PACKER, LYNN, NORTH SALT LAKE, UT:  
3,962,727, INT. CL. 9.
- PACON CORPORATION, APPLETON, WI:  
2,883,195, CANC. INT. CL. 16.
- PACTIV CORPORATION, LAKE FOREST, IL:  
3,963,246, INT. CL. 21.
- PAD, LLC, CHICAGO, IL:  
3,962,584, INT. CL. 34.
- PAGE, RODNEY K., WILLOWS, CA:  
3,962,836, INT. CL. 5.
- PAGLIERANI, STEVEN, NANUET, NY:  
3,961,190, PUB. 3-1-2011. INT. CL. 44.  
3,961,191, PUB. 3-1-2011. INT. CL. 44.
- PAIDPOST INC, SHORT HILLS, NJ, AKA VERAXON  
ENTERTAINMENT:  
3,961,245, PUB. 3-1-2011. MULTIPLE CLASS, INT. CLS. 9  
AND 41.  
3,961,913, PUB. 3-1-2011. INT. CL. 9.
- PAINFREE-PERIOD, SANDPOINT, ID:  
3,963,308, INT. CL. 5.
- PAKRA LLC, COLUMBUS, OH:  
3,961,087, PUB. 3-1-2011. INT. CL. 42.  
3,961,088, PUB. 3-1-2011. INT. CL. 41.
- PALACE HOLDING, S.A. DE C.V., CANCUN, QUINTANA  
ROO, MEXICO:  
3,960,411, PUB. 3-1-2011. MULTIPLE CLASS, INT. CLS. 43  
AND 44.
- PALOMAR MEDICAL TECHNOLOGIES, INC., BURLING-  
TON, MA:  
3,963,630, INT. CL. 10.
- PAMPLONA FOODS, INC., MIAMI, FL:  
3,961,134, PUB. 3-1-2011. MULTIPLE CLASS, INT. CLS.  
29, 30 AND 32.
- PANAGO PIZZA INC., ABBOTSFORD, BRITISH COLUM-  
BIA V2S 2A4, CANADA:  
2,510,418. REN. 4-14-11. INT. CL. 30.  
2,517,280. REN. 4-14-11. INT. CL. 30.
- PANGANIBAN, NATHAN Y, SALINAS, CA:  
3,962,185, INT. CL. 35.
- PANGBORN CORPORATION, FAIRBURN, GA, PANG-  
BORN CORPORATION, HAGERSTOWN, MD:  
541,814. REN. 4-11-11. U.S. CL. 23 (INT. CL. 7).
- PANINI AMERICA, INC., ARLINGTON, TX:  
2,882,583, CANC. INT. CL. 16.
- PANTONE, INC., CARLSTADT, NJ:  
2,384,199, CANC. INT. CL. 9.
- PAPA MURPHY'S INTERNATIONAL LLC, VANCOUVER,  
WA:  
3,961,116, PUB. 3-1-2011. INT. CL. 35.



PAQ INSURANCE SERVICES, INC., NEWPORT BEACH, CA:  
2,883,406, CANC. INT. CL. 35.

PAQUETTE, REBECCA, LUDLOW, MA:  
3,963,796, MULTIPLE CLASS, INT. CLS. 35, 44 AND 45.

PARAGON CAPITAL MANAGEMENT, INC., PROVO, UT:  
3,960,279, PUB. 3-1-2011. INT. CL. 36.

PARAGON INDUSTRIES, INC., FRESNO, CA:  
2,483,170, REN. 4-14-11. INT. CL. 35.

PARAMOUNT EQUITY, ROSEVILLE, CA:  
3,961,065, PUB. 3-1-2011. INT. CL. 35.

PARELEC, LLC, ROCKY HILL, NJ:  
2,382,777, CANC. INT. CL. 2.

PARENTING GROUP INC., THE, NEW YORK, NY:  
2,383,179, CANC. INT. CL. 16.

PARENTING TIP OF THE WEEK, LLC, HUNTERSVILLE,  
NC:  
3,963,461, INT. CL. 10.

PARK & SUN, INC., DENVER, CO:  
2,384,100, CANC. INT. CL. 28.

PARK, KWANG SU, GYEONGGI-DO, REPUBLIC OF KOR-  
EA:  
3,962,634, INT. CL. 7.

PARKER WAICHMAN ALONSO LLP, PORT WASHING-  
TON, NY:  
3,961,948, PUB. 3-1-2011. INT. CL. 45.

PARKMOBILE USA, INC., ATLANTA, GA:  
3,963,345, MULTIPLE CLASS, INT. CLS. 36 AND 42.

PARLANTI & PARLANTI LLP, MALVERNE, NY:  
3,961,122, PUB. 3-1-2011. INT. CL. 45.

PARMALAT CANADA INC., ETOBICOKE, CANADA:  
2,882,340, CANC. INT. CL. 30.

PARTNERSHIP OF RAYMOND GOMEZ AND REYNA  
GOMEZ, OREGON HOUSE, CA:  
2,882,376, CANC. INT. CL. 30.

PARTYDRAGON LIMITED, CENTRAL, HONG KONG:  
3,963,231, INT. CL. 20.

PASCAL COMPANY, INC., THE, BELLEVUE, WA:  
1,184,609, REN. 4-14-11. INT. CL. 10.

PASCO SCIENTIFIC, INC., ROSEVILLE, CA:  
2,510,341, REN. 4-12-11. INT. CL. 9.

PATCH PRODUCTS, INC., BELOIT, WI:  
3,963,145, INT. CL. 28.

PATCUD INVESTMENTS, INC, WILMINGTON, DE:  
1,640,648, REN. 4-12-11. INT. CL. 29.

PATEL, RAKESH, BONITA SPRINGS, FL:  
3,963,335, INT. CL. 34.

PATH STUDIOS, LLC, DANBURY, CT:  
3,961,574, PUB. 3-1-2011. INT. CL. 41.

PATRIOT INSURANCE COMPANY, YARMOUTH, ME:  
2,462,765, REN. 4-9-11. INT. CL. 36.

PATTI, ANTHONY G., ALTA LOMA, CA:  
3,962,029, INT. CL. 35.

PATTON, BRANDY, ALBUQUERQUE, NM:  
3,963,213, INT. CL. 35.

PATTY KING INC, HIALEAH, FL, DBA MAJESTY FOODS:  
3,963,445, INT. CL. 30.

PAUL BALDIN ITALY, INC., LAS VEGAS, NV:  
2,881,123, CANC. INT. CL. 14.

PAUL C. LANDIG, OMRO, WI:  
3,962,857, INT. CL. 36.

PAUL DAVIS RESTORATION, INC., JACKSONVILLE, FL:  
3,962,949, INT. CL. 37.

PAUL MAGGARD, WESTON, FL:  
3,963,389, INT. CL. 25.

PAUL MCKENNA, LONDON W84LY, UNITED KINGDOM:  
3,963,232, MULTIPLE CLASS, INT. CLS. 9 AND 16.

PAWN AMERICA MINNESOTA, L.L.C., BURNSVILLE, MN:  
3,962,022, INT. CL. 35.

PAYNE, BARBARA J., CLEVELAND, OH, DBA REALLY-  
GOODFREELANCEWRITER.COM:  
2,881,144, CANC. INT. CL. 41.

PAYSYSTEMS CORPORATION, MONTREAL, CANADA:  
2,882,709, CANC. INT. CL. 36.

PBR INDUSTRIES, INC., FENTON, MO:  
3,961,537, PUB. 3-1-2011. INT. CL. 21.

PC CARD PACKAGING, INC., PITTSFIELD, MA:  
2,883,255, CANC. INT. CL. 9.

PCMS HOLDINGS PLC, COVENTRY, UNITED KINGDOM:  
2,445,406, REN. 4-14-11. MULTIPLE CLASS, INT. CLS. 9,  
16 AND 42.

PCN TECHNOLOGY, INC., SAN DIEGO, CA:  
3,960,514, PUB. 3-1-2011. INT. CL. 38.

PD SIXTY DISTRIBUTOR INC, NORCROSS, GA:  
3,960,871, PUB. 3-1-2011. INT. CL. 35.

3,960,872, PUB. 3-1-2011. INT. CL. 35.

PEACOCK NINE, LLC, CHICAGO, IL:  
2,450,004, REN. 4-11-11. INT. CL. 35.

PEANOTZ, INC., CARPENTER, SD:  
2,882,934, CANC. MULTIPLE CLASS, INT. CLS. 3 AND 4.

PEARCE, JAMES T., SAN ANTONIO, TX:  
2,533,702, REN. 4-8-11. INT. CL. 35.

PEARL JAM, L.L.C., SEATTLE, WA:  
3,960,529, PUB. 3-1-2011. MULTIPLE CLASS, INT. CLS. 9,  
16 AND 25.

3,960,535, PUB. 3-1-2011. MULTIPLE CLASS, INT. CLS. 9,  
16 AND 25.

PEARL, SANDRA SELLERS, NEW YORK, NY:  
3,963,356, INT. CL. 14.

PEARSE, KAREN, HAUPPAUGE, NY:  
2,882,109, CANC. INT. CL. 42.

PEARSON EDUCATION, INC., UPPER SADDLE RIVER, NJ:  
2,400,130, REN. 4-13-11. INT. CL. 16.

2,881,604, CANC. INT. CL. 41.

PEARSON, DURK, TONOPAH, NV AND SHAW, SANDY,  
TONOPAH, NV:  
2,882,351, CANC. INT. CL. 5.

PEDERSEN, CHERYL, SIMSBURY, CT:  
3,962,387, INT. CL. 18.

PEDIATRIC HEART CENTER, BAKERSFIELD, CA:  
3,960,925, PUB. 3-1-2011. INT. CL. 44.

PEDROLLO S.P.A., ITALY:  
3,960,794, PUB. 3-1-2011. INT. CL. 7.

PEI LICENSING, INC., MIAMI, FL:  
2,883,021, CANC. INT. CL. 25.

3,960,946, PUB. 3-1-2011. INT. CL. 25.

3,961,660, PUB. 3-1-2011. INT. CL. 18.

3,961,700, PUB. 3-1-2011. INT. CL. 18.

3,961,901, PUB. 3-1-2011. INT. CL. 9.

3,961,902, PUB. 3-1-2011. INT. CL. 9.

3,961,944, PUB. 3-1-2011. INT. CL. 25.

PELLE PELLE, INC., ROCHESTER HILLS, MI:  
2,442,915, REN. 4-9-11. MULTIPLE CLASS, INT. CLS. 6,  
18, 20 AND 25.

PENDERGAFT, ROBERT L., PORTER RANCH, CA, DBA  
AUNT DOLLY'S GARAGE:  
3,961,153, PUB. 3-1-2011. INT. CL. 41.

PENDLETON, DIANE, JUPITER, FL:  
3,961,788, PUB. 3-1-2011. INT. CL. 20.

PENGO CORPORATION, LAURENS, IA:  
3,963,255, INT. CL. 9.

PENINOU FRENCH LAUNDRY & CLEANERS, INC., SAN  
FRANCISCO, CA:  
2,449,264, REN. 4-8-11. INT. CL. 37.

PENN MUTUAL LIFE INSURANCE COMPANY, THE,  
HORSHAM, PA:  
2,384,185, CANC. INT. CL. 36.

PENNAG INDUSTRIES ASSOCIATION POULTRY COUN-  
CIL, EPHRATA, PA:  
2,382,237, CANC. U.S. CL. A.

PENNFIELD OIL COMPANY, OMAHA, NE:  
3,961,250, PUB. 3-1-2011. INT. CL. 5.

PENNSYLVANIA BUSINESS BANK, PHILADELPHIA, PA:  
2,382,536, CANC. INT. CL. 36.

PENNYWISE POWER LLC, HOUSTON, TX:  
3,961,921, PUB. 3-1-2011. INT. CL. 35.

PENROD BROTHERS, INC., MIAMI BEACH, FL:  
3,960,625, PUB. 10-25-2005. INT. CL. 43.

PENTEL OF AMERICA, LTD., TORRANCE, CA:  
2,382,647, CANC. INT. CL. 16.

PEOPLE GOTTA EAT, INC., SANTA FE, NM:  
2,882,682, CANC. INT. CL. 29.

PER-OLOF EJENDAL AKTIEBOLAG, SWEDEN:  
3,960,825, PUB. 3-1-2011. INT. CL. 9.

3,960,827, PUB. 3-1-2011. MULTIPLE CLASS, INT. CLS. 9  
AND 25.



- PERALTA, MADAY, MIAMI, FL:  
3,963,483, INT. CL. 35.  
3,963,484, INT. CL. 35.
- PERDUE HOLDINGS, INC., WILMINGTON, DE:  
3,962,779, INT. CL. 9.  
3,962,780, MULTIPLE CLASS, INT. CLS. 41 AND 44.
- PERFECT ORDER SOFTWARE SOLUTIONS, MECHANICS-  
BURG, PA:  
2,717,541, CANC. INT. CL. 9.
- PERFECT PUSHUP, LLC, MILL VALLEY, CA:  
3,962,071, INT. CL. 28.
- PERFECT TACT LIMITED, SHATIN, HONG KONG, DBA/  
TRAXON TECHNOLOGIES LTD:  
3,963,254, INT. CL. 9.
- PERFECT 10, INC., BEVERLY HILLS, CA:  
3,962,325, INT. CL. 45.
- PERFECTION PLANT LIQUIDATIONS, LLC, NORTH-  
BROOK, IL:  
3,961,146, PUB. 3-1-2011. INT. CL. 35.
- PERFORMANCE DESIGNED PRODUCTS LLC, SHERMAN  
OAKS, CA:  
2,881,553, CANC. INT. CL. 16.
- PERFORMANCE LEARNING SYSTEMS, INC., CADIZ, KY:  
2,881,015, CANC. INT. CL. 41.
- PERFORMANCE PET NUTRITION, LLC., DURANGO, CO,  
DBA ZUKE'S / A GUY & HIS DOG COMPANY:  
2,883,246, CANC. INT. CL. 31.
- PERFORMANCE TRUST CAPITAL PARTNERS, LLC, CHI-  
CAGO, IL:  
3,960,250, PUB. 3-1-2011. INT. CL. 36.
- PERIO HEALTH PROFESSIONALS, PLLC, HOUSTON, TX:  
3,963,318, INT. CL. 41.  
3,963,447, INT. CL. 41.
- PERKY MOOSE LLC, ATLANTA, GA, DBA PERKY MOOSE  
LLC:  
3,960,853, PUB. 3-1-2011. INT. CL. 30.
- PERNIX THERAPEUTICS, LLC, GONZALES, LA:  
3,962,007, INT. CL. 5.
- PERRIGO FLORIDA, INC., LAKE WORTH, FL:  
2,881,863, CANC. INT. CL. 5.
- PERSHING INVESTMENTS LLC, NEWARK, DE:  
2,880,935, CANC. INT. CL. 36.
- PERSONAL TRAINING INSTITUTE, LLC, JERICHO, NY:  
2,654,808, CANC. MULTIPLE CLASS, INT. CLS. 41 AND  
42.
- PERVASIVE SOFTWARE INC., AUSTIN, TX:  
2,545,778, REN. 4-8-11. INT. CL. 35.
- PET VALU CANADA INC., MARKHAM, ONTARIO, CANA-  
DA:  
3,963,108, INT. CL. 16.
- PETER SCHAEUBLIN, THAYNGEN, SWITZERLAND:  
2,881,393, CANC. MULTIPLE CLASS, INT. CLS. 36, 41  
AND 42.
- PETER VIVIAN, VISTA, CA AND AMY FREDERICK,  
VISTA, CA:  
3,961,258, PUB. 3-1-2011. INT. CL. 20.
- PETERS, LISA R., CHICAGO, IL:  
2,776,345, CANC. INT. CL. 41.
- PETERSON, FRED, JEFFERSON, OH:  
2,882,463, CANC. INT. CL. 7.
- PETERSON, WALTER L., M.D., DALLAS, TX AND LAINE,  
LOREN A., M.D., SHERMAN OAKS, CA:  
2,882,624, CANC. INT. CL. 41.
- PETRO SERVICES, INC., SOUTH AMBOY, NJ:  
3,961,090, PUB. 3-1-2011. INT. CL. 35.
- PETROGLYPH GAMES, INC., LAS VEGAS, NV:  
3,963,192, INT. CL. 9.
- PFE ROLLS, INC., NEENAH, WI:  
906,647, REN. 4-9-11. U.S. CL. 23 (INT. CL. 7).
- PFEIFFER, LAURENCE, COBLESKILL, NY:  
3,962,971, INT. CL. 16.
- PFIZER INC., NEW YORK, NY:  
2,883,069, CANC. INT. CL. 16.
- PHARES TIMOTHY J. ENCINO, CA:  
3,960,635, PUB. 3-1-2011. INT. CL. 28.
- PHARMMD SOLUTIONS, LLC, BRENTWOOD, TN:  
2,882,871, CANC. INT. CL. 9.
- PHI KAPPA PSI, INDIANAPOLIS, IN:  
3,960,603, PUB. 3-1-2011. MULTIPLE CLASS, INT. CLS. 25  
AND 35.
- PHIFER INCORPORATED, TUSCALOOSA, AL, PHIFER  
WIRE PRODUCTS, INC., TUSCALOOSA, AL:  
921,403, REN. 4-11-11. U.S. CL. 13 (INT. CL. 6).
- PHILANTHROPIC RESEARCH, INC., WILLIAMSBURG,  
VA:  
2,882,425, CANC. INT. CL. 39.
- PHILIP R. BERGER & ASSOCIATES, INC, WARRENDALE,  
PA:  
3,961,993, INT. CL. 42.
- PHILIPPINE CULTURAL FOUNDATION, INC., TAMPA,  
FL:  
3,963,821, INT. CL. 41.
- PHOENIX PRODUCTIONS, LLC, FREDERICK, MD:  
2,882,247, CANC. INT. CL. 41.
- PHOENIX SOFTWARE INTERNATIONAL, INC., EL SE-  
GUNDO, CA, DBA VIKING SOFTWARE SOLUTIONS,  
PHOENIX SOFTWARE INTERNATIONAL, INC., EL SE-  
GUNDO, CA, DBA VIKING SOFTWARE SOLUTIONS:  
2,552,738, REN. 4-14-11. INT. CL. 9.
- PHYSICIANS CARE ALLIANCE, LLC, SCOTTSDALE, AZ:  
3,963,836, INT. CL. 3.
- PHYSICIANS FORMULA COSMETICS, INC., AZUSA, CA:  
2,384,341, CANC. INT. CL. 3.  
2,384,357, CANC. INT. CL. 3.
- PHYSICIANS FORMULA, INC., AZUSA, CA:  
3,962,805, INT. CL. 3.  
3,962,806, INT. CL. 3.
- PHYSIK INSTRUMENTE (PI) GMBH & CO. KG, KARLS-  
RUHE, FED REP GERMANY:  
3,962,165, MULTIPLE CLASS, INT. CLS. 7 AND 9.  
3,962,166, INT. CL. 9.  
3,962,167, MULTIPLE CLASS, INT. CLS. 7 AND 9.
- PHYTEL, INC., DALLAS, TX:  
3,963,744, INT. CL. 44.
- PH4 CORPORATION, BLOOMFIELD HILLS, MI:  
2,383,549, CANC. INT. CL. 41.
- PIAB, AB, SE - 18304 TABY, SWEDEN:  
2,383,037, CANC. INT. CL. 7.
- PIDILITE INDUSTRIES LIMITED, MUMBAI, INDIA:  
3,962,101, INT. CL. 16.
- PIERO GUIDI S.R.L., 61029 SCHIETI DI URBINO (PU),  
ITALY:  
1,641,000, REN. 4-14-11. INT. CL. 24.
- PIERRE GOURMET INC., MIAMI, FL:  
2,882,631, CANC. INT. CL. 35.
- PIERSON/GRACE CORPORATION, BOULDER, CO:  
2,418,624, REN. 4-14-11. INT. CL. 35.
- PILKINGTON NORTH AMERICA, INC., TOLEDO, OH:  
2,493,188, REN. 4-8-11. INT. CL. 19.
- PILLSBURY COMPANY, LLC, THE, MINNEAPOLIS, MN:  
389,177, REN. 4-12-11. U.S. CL. 46 (INT. CL. 30).
- PILOT PLASTICS, LLC, FORT WORTH, TX:  
3,960,545, PUB. 3-1-2011. INT. CL. 6.
- PILOTS POINT, LLC, BELLEAIR BLUFFS, FL:  
3,962,000, INT. CL. 1.
- PINKBUDDHA CO., LTD., JAPAN:  
3,960,774, PUB. 3-1-2011. INT. CL. 14.
- PINNACLE ENTERTAINMENT, INC., LAS VEGAS, NV:  
3,961,534, PUB. 3-1-2011. INT. CL. 41.
- PINNACLE MARKETING INCORPORATED, WESTMIN-  
STER, CO:  
2,882,103, CANC. MULTIPLE CLASS, INT. CLS. 16, 20  
AND 25.
- PINNER, PATRICIA, ASHEVILLE, NC, DBA THE BELIEVE  
TEAM:  
3,963,414, U.S. CL. 200.
- PINOOK USA, LLC, ORLANDO, FL:  
3,963,118, INT. CL. 10.
- PINOVA, INC., BRUNSWICK, GA, HERCULES POWDER  
COMPANY, WILMINGTON, DE:  
547,942, REN. 4-8-11. U.S. CL. 6 (INT. CL. 1).
- PINTO, GEORGE, SCHILLER PARK, IL:  
3,963,515, INT. CL. 41.
- PIRAT FREDERIC, VILLEPREUX, FRANCE:  
3,961,339, PUB. 3-1-2011. INT. CL. 35.

PIRELLI TYRE S.P.A., MILAN, ITALY:  
2,382,018, CANC. INT. CL. 12.

PIZZA DONINI INC., MONTREAL, QUEBEC, CANADA:  
2,390,750, CANC. INT. CL. 42.

PIZZA HUT, INC., DALLAS, TX:  
2,883,163, CANC. INT. CL. 30.

PJ PACK, LLC, ELKHORN, WI:  
2,880,634, CANC. INT. CL. 21.

PLACE OF HOPE FOUNDATION, INC., PALM BEACH GARDENS, FL:  
3,963,855, INT. CL. 43.

PLANET SMOOTHIE FRANCHISES, L.L.C., ATLANTA, GA:  
2,473,487, REN. 4-14-11. MULTIPLE CLASS, INT. CLS. 32 AND 35.

PLANET SMOOTHIE, LLC, ATLANTA, GA, PLANET SMOOTHIE HOLDINGS, INCORPORATED, ATLANTA, GA:  
2,454,648, REN. 4-13-11. INT. CL. 35.

PLANET SMOOTHIE, LLC, ATLANTA, GA:  
2,456,712, REN. 4-13-11. INT. CL. 5.

PLANET 9 STUDIOS, SAN FRANCISCO, CA:  
2,384,390, CANC. INT. CL. 42.

PLANITACTION, GALENA, MD:  
2,883,126, CANC. INT. CL. 35.

PLANTATION INVESTORS, LLC, SOUTHERN PINES, NC:  
2,882,400, CANC. INT. CL. 35.

PLANTOPIA, INC., TAMPA, FL:  
2,881,776, CANC. INT. CL. 16.

PLASMA AUTOMATION INC., BOHEMIA, NY:  
3,961,463, PUB. 3-1-2011. INT. CL. 7.  
3,961,464, PUB. 3-1-2011. INT. CL. 7.

PLASTECH ENGINEERED PRODUCTS, INC., DEARBORN, MI:  
2,881,919, CANC. MULTIPLE CLASS, INT. CLS. 7 AND 9.

PLASTICHE CASSANO SRL, 21012 CASSANO MAGNAGO (VA), ITALY:  
2,382,435, CANC. INT. CL. 25.

PLASTPRO, INC. 2000, LIVINGSTON, NJ:  
2,382,318, CANC. INT. CL. 19.

PLAXO, INC., MOUNTAIN VIEW, CA:  
3,961,757, PUB. 3-1-2011. MULTIPLE CLASS, INT. CLS. 42 AND 45.

PLAYBOY ENTERPRISES INTERNATIONAL, INC., CHICAGO, IL:  
3,963,276, INT. CL. 41.  
3,963,330, INT. CL. 10.

PLAYDOM, INC., MOUNTAIN VIEW, CA:  
3,960,892, PUB. 3-1-2011. MULTIPLE CLASS, INT. CLS. 9, 41, 42 AND 45.

PLAYFUL PALATE, L.L.C., OVERLAND PARK, KS:  
2,881,444, CANC. INT. CL. 29.

PLUM CREEK TIMBER COMPANY, INC., SEATTLE, WA:  
2,444,304, REN. 4-12-11. MULTIPLE CLASS, INT. CLS. 19 AND 31.

PLUMFUL FOODS, INC., HOUSTON, TX:  
3,963,853, INT. CL. 29.  
3,963,854, INT. CL. 29.

PLUS GROUP, INC., THE, LOMBARD, IL:  
2,647,930, CANC. INT. CL. 35.

PLYO SYSTEMS, LLC, COLORADO SPRINGS, CO:  
3,962,299, INT. CL. 28.

PNY TECHNOLOGIES, INC., PARSIPPANY, NJ:  
3,962,644, INT. CL. 9.

PO SUN HON, RANCHO CUCAMONGA, CA:  
3,961,605, PUB. 3-1-2011. INT. CL. 14.

POCKET SOFT, INC., HOUSTON, TX:  
3,963,463, INT. CL. 9.

POINT INC., IBARAKI, JAPAN:  
2,880,919, CANC. MULTIPLE CLASS, INT. CLS. 18 AND 25.

POINT 3 BASKETBALL, LLC, ATLANTA, GA:  
3,963,133, INT. CL. 25.

POLAR WARE COMPANY, SHEBOYGAN, WI:  
2,882,396, CANC. INT. CL. 21.

POLDING PARTNERS INC., THE, GUELPH, ON, CANADA:  
2,882,019, CANC. INT. CL. 18.

POLISH MINISTRIES INCORPORATED, DALLAS, TX:  
3,961,822, PUB. 3-1-2011. INT. CL. 45.

POLLINA TOURS AND TRAVEL, INC., HICKSVILLE, NY:  
3,961,522, PUB. 3-1-2011. INT. CL. 39.

POLYZOS, ATHANASIOS, ONTARIO M4N3H8, CANADA:  
3,960,330, PUB. 3-1-2011. INT. CL. 13.

POMDEVICES, LLC, DURHAM, NC, DBA POMDEVICES, LLC:  
3,963,547, INT. CL. 9.

POMMERY S.A., 51100 REIMS, FRANCE:  
2,882,062, CANC. INT. CL. 33.

PONDERING ARMORED VEHICLE, LLC, TAYLORS, SC:  
2,883,256, CANC. INT. CL. 28.

PONZIO, FRANK, MANTOLOKING, NJ:  
2,383,501, CANC. INT. CL. 41.

POOF-SLINKY, INC., PLYMOUTH, MI:  
2,881,932, CANC. INT. CL. 28.

POPPACK LLC, SAN FRANCISCO, CA:  
3,963,009, INT. CL. 20.

POPULAR, INC., SAN JUAN, PUERTO RICO:  
2,442,402, REN. 4-12-11. INT. CL. 36.  
2,883,237, CANC. INT. CL. 36.

PORCELANOSA GRUPO A.I.E., VILA-REAL (CASTELLÓN), SPAIN:  
3,962,488, INT. CL. 19.

PORRARO, RICHARD A., CLEARWATER, FL:  
3,961,856, PUB. 3-1-2011. INT. CL. 3.

PORTAL GOURMET L.L.C., ATLANTA, GA:  
3,962,879, INT. CL. 30.

PORTICO ACQUISITION, LLC, NEW YORK, NY:  
3,963,241, MULTIPLE CLASS, INT. CLS. 3, 20, 21, 24, 25 AND 27.  
3,963,242, MULTIPLE CLASS, INT. CLS. 3, 20, 21, 24, 25 AND 27.

PORTUCEL - EMPRESA PRODUTORA DE PASTA E PAPEL, S.A., 2901-861 SETUBAL, PORTUGAL:  
3,920,196, COR. INT. CL. 16.

PORZILLI, LOUIS B, ROCKAWAY, NJ:  
3,960,433, PUB. 3-1-2011. MULTIPLE CLASS, INT. CLS. 37 AND 42.

POSEY, DANIEL L, KINGSLAND, TX:  
3,963,092, INT. CL. 28.

POSI-TS LLC, TELFORD, PA:  
3,963,420, INT. CL. 25.

POSTITOS INC., LOS ANGELES, CA:  
3,962,459, MULTIPLE CLASS, INT. CLS. 35 AND 38.

POTENTIAL AT WORK, INC., BLACK MOUNTAIN, NC:  
2,457,295, CANC. INT. CL. 42.

POTTER ENTERPRISES LLC., WILTON, CT:  
3,960,930, PUB. 3-1-2011. INT. CL. 37.

POUND, PATRICIA WESCOAT, NEW YORK, NY:  
3,963,097, INT. CL. 25.

POWELL, AZIZI, PITTSBURGH, PA:  
2,881,119, CANC. INT. CL. 41.

POWER BY HAND, NASHVILLE, TN:  
2,880,648, CANC. MULTIPLE CLASS, INT. CLS. 38 AND 41.

POWER SOLUTIONS, INC., TITUSVILLE, FL:  
3,961,497, PUB. 3-1-2011. INT. CL. 9.

POWERARC, INC., SHREWSBURY, MO:  
3,963,086, INT. CL. 9.  
3,963,087, INT. CL. 9.

POWERPICK, INC., PHOENIX, AZ:  
2,883,422, CANC. INT. CL. 36.

POWERPLAY STRATEGIES INCORPORATED, SURREY, BC, CANADA:  
3,963,503, INT. CL. 16.

POWERS, NATHAN, COSTA MESA, CA:  
3,962,929, INT. CL. 25.

POWERTECH INDUSTRIAL CO., LTD., TAIPEI HSIEN, TAIWAN:  
3,962,694, INT. CL. 9.

POWERWALL, INCORPORATED, SAN FRANCISCO, CA:  
3,961,237, PUB. 3-1-2011. MULTIPLE CLASS, INT. CLS. 11 AND 20.

POZEN INC., CHAPEL HILL, NC:  
3,963,238, INT. CL. 42.

PPG ARCHITECTURAL FINISHES, INC., PITTSBURGH, PA:  
3,963,575, INT. CL. 2.

- PPM 2000 INC., EDMONTON, ALBERTA, CANADA:  
2,448,480. REN. 4-12-11. INT. CL. 9.
- PR TRADING CO., HOUSTON, TX, DBA POLAR RAY  
SUNGLASSES:  
2,883,322, CANC. INT. CL. 9.
- PRACTICE FUSION, INC., SAN FRANCISCO, CA:  
3,961,383, PUB. 3-1-2011. MULTIPLE CLASS, INT. CLS. 42  
AND 44.
- PRAIRIE GARDENS, INC., CHAMPAIGN, IL:  
2,880,850, CANC. INT. CL. 35.
- PRAIRIECOMM, INC., ARLINGTON HEIGHTS, IL:  
2,881,952, CANC. INT. CL. 9.
- PRAUS, LLC, WICHITA, KS:  
3,961,393, PUB. 3-1-2011. INT. CL. 41.
- PRE HOLDING, INC., MIDLOTHIAN, VA:  
3,962,724, INT. CL. 10.
- PRECISE BIOMETRICS AB, LUND, SWEDEN:  
3,960,904, PUB. 3-1-2011. MULTIPLE CLASS, INT. CLS. 9  
AND 42.
- PRECISION, INC., PELLA, IA:  
3,963,767, INT. CL. 7.
- PREGIS INNOVATIVE PACKAGING INC., DEERFIELD, IL:  
3,962,223, INT. CL. 17.
- PREMIER GOODS LLC, MIAMI LAKES, FL:  
3,963,874, INT. CL. 35.
- PREMIUM KNOWLEDGE GROUP, DALLAS, TX:  
3,960,564, PUB. 3-1-2011. MULTIPLE CLASS, INT. CLS. 9  
AND 35.
- PREP-MASTERS, INC., LOS ANGELES, CA:  
2,881,126, CANC. INT. CL. 35.
- PRESBIBIO, LLC, LOS ANGELES, CA:  
3,962,643, INT. CL. 10.
- PRESERVATION ASSESSMENT SERVICES, LLC, DALLAS,  
TX, AQUATERRA ENVIRONMENTAL SERVICES CORP.,  
NEW YORK, NY:  
1,667,043. REN. 4-8-11. INT. CL. 42.
- PRESS 8, LP, AUSTIN, TX:  
3,961,223, PUB. 3-1-2011. INT. CL. 38.
- PRESSIMONE, JENNIFER H., CLERMONT, FL:  
3,963,811, INT. CL. 44.
- PRESSMAN, STUART, PEMBROKE PINES, FL:  
3,961,804, PUB. 3-1-2011. INT. CL. 10.
- PRESTIGE & CREATION, INC., HOUSTON, TX:  
2,881,989, CANC. MULTIPLE CLASS, INT. CLS. 35 AND  
42.
- PRESTIGE GAMING LLC, ANADARKO, OK:  
3,962,968, INT. CL. 9.
- PRETE JR., PETER ALLEN, GLENDORA, NJ:  
3,961,850, PUB. 3-1-2011. INT. CL. 35.  
3,961,851, PUB. 3-1-2011. INT. CL. 35.  
3,961,852, PUB. 3-1-2011. MULTIPLE CLASS, INT. CLS. 24  
AND 25.  
3,961,853, PUB. 3-1-2011. MULTIPLE CLASS, INT. CLS. 24  
AND 25.
- PRETTY UGLY LLC, EDISON, NJ AND DAVID HORVATH,  
EDISON, NJ AND SUN-MIN KIM, EDISON, NJ:  
3,963,847, INT. CL. 28.  
3,963,848, INT. CL. 28.
- PRETZELMAKER, INC., SALT LAKE CITY, UT:  
2,883,057, CANC. INT. CL. 30.
- PREVAIL HEALTH SOLUTIONS, CHICAGO, IL, AKA PRE-  
VAIL:  
3,962,209, INT. CL. 44.
- PREVENTIVE BEVERAGES, LLC, HAVERFORD, PA:  
3,963,685, INT. CL. 5.  
3,963,686, INT. CL. 5.
- PRICE-RITE AUTO CARE INC., RIO RANCHO, NM, DBA  
PRICE-RITE AUTO CARE INC.:  
3,960,841, PUB. 7-13-2010. INT. CL. 37.
- PRICE, MANDIE L, CYPRESS, TX, DBA GOLD N' DELI-  
CIOUS TANS:  
3,960,546, PUB. 3-1-2011. MULTIPLE CLASS, INT. CLS. 3  
AND 44.
- PRICewaterHOUSECOOPERS LLP, NEW YORK, NY:  
2,883,360, CANC. INT. CL. 42.
- PRIDEROCK CAPITAL PARTNERS, LLC, WEST PALM  
BEACH, FL, AKA PRCP:  
3,962,339, INT. CL. 36.
- PRIMARY INVESTMENTS GROUP LIMITED, ROAD  
TOWN, TORTOLA, BR.VIRGIN ISLANDS:  
3,963,827, INT. CL. 5.
- PRIMESOURCE BUILDING PRODUCTS, INC., IRVING, TX:  
2,448,100. REN. 4-8-11. INT. CL. 6.
- PRINCE MARKETING & COMMUNICATIONS, INC.,  
NASHVILLE, TN, DBA PRINCE MARKET RESEARCH,  
INC.:  
3,960,323, PUB. 10-27-2009. INT. CL. 35.
- PRINCIPAL FINANCIAL SERVICES, INC., DES MOINES,  
IA:  
3,961,137, PUB. 3-1-2011. INT. CL. 44.
- PRINT N' WEAR PTY LTD., CURRUMBIN QUEENSLAND,  
AUSTRALIA:  
2,383,578, CANC. INT. CL. 25.
- PRIOR, KRISTINA L., JUPITER, FL:  
3,960,525, PUB. 3-1-2011. INT. CL. 21.
- PRISTINA CAPITAL PARTNERS, LLC, MIDLAND PARK,  
NJ:  
3,962,324, INT. CL. 11.
- PRL USA HOLDINGS, INC., WILMINGTON, DE:  
3,963,229, INT. CL. 18.  
3,963,230, INT. CL. 18.
- PRO IDEE VERSAND GMBH & CO. KG, AACHEN, D-52070,  
FED REP GERMANY:  
2,880,633, CANC. MULTIPLE CLASS, INT. CLS. 7, 8, 9, 11,  
14, 18, 20, 21, 24, 25, 28, 35 AND 39.
- PROBST, LAURENT, MAISONS ALFORT, FRANCE:  
3,960,389, PUB. 3-1-2011. INT. CL. 33.
- PROCON INC., KNOXVILLE, TN:  
3,962,049, INT. CL. 9.
- PROCOPIO, CORY, HARGREAVES & SAVITCH LLP, SAN  
DIEGO, CA:  
3,961,024, PUB. 3-1-2011. INT. CL. 45.
- PROCTER & GAMBLE BUSINESS SERVICES CANADA  
COMPANY, HALIFAX, NOVA SCOTIA, CANADA, ORAL  
B. COMPANY, SANTA CLARA, CA:  
547,130. REN. 4-13-11. U.S. CL. 29 (INT. CL. 21).
- PROCTER & GAMBLE COMPANY, THE, CINCINNATI, OH:  
2,476,637. REN. 4-12-11. INT. CL. 3.
- PROCTOR HOMER WARREN, INC., TROY, MI, DBA  
PROCTOR FINANCIAL INSURANCE CORP.:  
2,801,929, CANC. INT. CL. 36.
- PROCYTE CORPORATION, REDMOND, WA:  
2,384,086, CANC. MULTIPLE CLASS, INT. CLS. 3 AND 5.
- PROCYTE CORPORATION, MONTGOMERYVILLE, PA:  
2,393,915. REN. 4-9-11. INT. CL. 5.
- PRODOTTI STELLA S.P.A., ITALY:  
3,960,790, PUB. 3-1-2011. MULTIPLE CLASS, INT. CLS. 29  
AND 30.
- PRODUCTORA Y COMERCIALIZADORA DE PASTAS,  
INC., ALAJUELA, COSTA RICA:  
3,960,561, PUB. 3-1-2011. INT. CL. 30.
- PRODUCTOS DAMEL S.A., CREVILLENTE (ALICANTE),  
SPAIN, DAMEL, S.A., ELCHE (ALICANTE), SPAIN:  
1,149,092. REN. 4-14-11. INT. CL. 30.
- PRODUCTOS FINOS DE AGAVE, S.A. DE C.V., GUADALA-  
JARA, JALISCO, MEXICO:  
2,443,813. REN. 4-14-11. INT. CL. 33.
- PROENZA SCHOUER, LLC, NEW YORK, NY:  
3,961,073, PUB. 3-1-2011. INT. CL. 14.
- PROFESSIONAL DISPOSABLES INTERNATIONAL, INC.,  
ORANGEBURG, NY:  
3,962,952, INT. CL. 16.
- PROFESSIONAL FEDERAL CREDIT UNION, FORT  
WAYNE, IN:  
3,961,542, PUB. 3-1-2011. INT. CL. 36.
- PROFESSIONAL FINANCE ACCOUNTING CORPORA-  
TION, STONE MOUNTAIN, GA:  
2,882,874, CANC. INT. CL. 16.
- PROFIL INSTITUTE FOR CLINICAL RESEARCH, INC.,  
CHULA VISTA, CA:  
3,960,329, PUB. 11-23-2010. MULTIPLE CLASS, INT. CLS.  
35, 41, 42 AND 44.
- PROFILE ACCESSORIES, INC., EMBRO, ONTARIO, CANA-  
DA:  
3,961,505, PUB. 3-1-2011. INT. CL. 3.

PROFOUND EFFECTS, INC, FOX POINT, WI:  
2,881,307, CANC. INT. CL. 9.

PROFUSE HEALTH, LLC, ALTAMONTE SPRINGS, FL:  
3,961,030, PUB. 3-1-2011. INT. CL. 5.

PROGENYHEALTH, INC., CONSHOHOCKEN, PA:  
3,961,894, PUB. 3-1-2011. INT. CL. 42.

PROGRESSIVE OUTDOORS, LLC, ADDISON, TX:  
3,962,841, INT. CL. 13.

PROGRESSIVE TECHNOLOGIES, LLC, MITCHELL, SD:  
3,061,615, COR. INT. CL. 6.

PROJECT FASTAGS, INC., ORANGE, CA:  
2,384,377, CANC. INT. CL. 20.

PROJECT ORBIS INTERNATIONAL, INC., NEW YORK, NY:  
2,444,397, REN. 4-9-11. INT. CL. 42.

PROJECT PERICLES, INC., NEW YORK, NY:  
2,880,823, CANC. INT. CL. 41.

PROKARATE & BOXING SUPPLIES, INC., LAKE WORTH, FL:  
3,960,238, PUB. 3-1-2011. MULTIPLE CLASS, INT. CLS. 25 AND 28.

PROMARK BRANDS INC., MERIDIAN, ID:  
3,963,428, MULTIPLE CLASS, INT. CLS. 14, 20, 21, 24, 25, 26 AND 28.

PROMARK BRANDS, INC., MERIDIAN, ID, DBA PROMARK BRANDS, INC.:  
2,883,306, CANC. INT. CL. 30.

PROMETIC LIFE SCIENCES INC., MONT-ROYAL (QC), CANADA:  
2,383,274, CANC. INT. CL. 42.

PROMOTION IN MOTION, INC., CLOSTER, NJ:  
3,960,857, PUB. 3-1-2011. INT. CL. 30.

PROMOTIONAL PRODUCTS ASSOCIATION INTERNATIONAL, IRVING, TX:  
3,961,743, PUB. 3-1-2011. INT. CL. 35.  
3,961,749, PUB. 3-1-2011. INT. CL. 35.  
3,961,750, PUB. 3-1-2011. INT. CL. 35.  
3,961,751, PUB. 3-1-2011. INT. CL. 35.  
3,961,752, PUB. 3-1-2011. INT. CL. 41.

PROQUEST LLC, ANN ARBOR, MI:  
2,382,248, CANC. INT. CL. 16.

PROSEED NEW ZEALAND LIMITED, AMBERLEY, NEW ZEALAND, NEW ZEALAND FORESTRY CORPORATION LIMITED, WELLINGTON, NEW ZEALAND:  
1,644,563, REN. 4-11-11. INT. CL. 31.

PROSPECTION, LLC, INDEPENDENCE, OH:  
2,881,204, CANC. MULTIPLE CLASS, INT. CLS. 35 AND 42.

PROTEA BIOSCIENCES, INC., MORGANTOWN, WV:  
3,962,332, MULTIPLE CLASS, INT. CLS. 9 AND 42.

PROTEAM, INC., BOISE, ID:  
3,963,366, INT. CL. 7.

PROTEAN POWER PTY LTD, AUSTRALIA:  
3,960,650, PUB. 3-1-2011. MULTIPLE CLASS, INT. CLS. 7, 37, 39, 40 AND 42.

PROTEUS BIOMEDICAL, INC., REDWOOD CITY, CA:  
3,963,272, MULTIPLE CLASS, INT. CLS. 5, 9, 10, 41, 42 AND 44.

PROTHERA, INC., RENO, NV:  
3,960,571, PUB. 3-1-2011. INT. CL. 5.

PROVEN WINNERS NORTH AMERICA LLC, CAMPBELL, CA:  
3,962,803, INT. CL. 31.

PROVENTUS GLOBAL HOLDINGS, LLC, PARKTON, MD:  
3,962,487, INT. CL. 9.

PROVO CRAFT & NOVELTY, INC., SPANISH FORK, UT:  
2,881,770, CANC. INT. CL. 16.

PRUDEN, DAVID M, WATSONVILLE, CA:  
2,644,625, CANC. INT. CL. 41.

PRUDENTIAL INSURANCE COMPANY OF AMERICA-THE, NEWARK, NJ:  
1,150,626, REN. 4-8-11. INT. CL. 36.

PRYOR, PAULA, TORRANCE, CA, DBA PERMA YOUTH HEALTH:  
3,960,418, PUB. 3-1-2011. INT. CL. 3.

PRZYBILLA, KURT, A, BROOKLYN, NY:  
2,609,889, CANC. INT. CL. 28.

PS CORP LTD., QUEBEC, CANADA:  
3,961,233, PUB. 3-1-2011. INT. CL. 25.

PUBLIC WORKS DEPARTMENT, LLC, NAPLES, FL:  
3,961,260, PUB. 3-1-2011. INT. CL. 25.

PUBLICACIONES SEMANA S.A., BOGOTA, COLOMBIA:  
3,960,449, PUB. 3-1-2011. INT. CL. 16.

PUCKETT, MICHAEL, RED BLUFF, CA AND PUCKETT, SHERRY, RED BLUFF, CA:  
3,961,427, PUB. 3-1-2011. INT. CL. 25.

PULSAFEDER, INC., ROCHESTER, NY:  
3,963,337, INT. CL. 9.

PULSE NETWORK LLC, HOUSTON, TX:  
2,440,346, REN. 4-13-11. INT. CL. 18.  
2,452,635, REN. 4-13-11. INT. CL. 36.  
2,452,638, REN. 4-12-11. INT. CL. 36.  
2,882,480, CANC. INT. CL. 36.

PUNITA LEATHERS, INC., CHANTILLY, VA:  
2,881,334, CANC. INT. CL. 18.

PURA VIDA COFFEE, INC., SEATTLE, WA:  
3,937,935, COR. INT. CL. 30.

PURDUE PHARMA L.P., STAMFORD, CT:  
3,961,896, PUB. 3-1-2011. INT. CL. 44.  
3,961,897, PUB. 3-1-2011. INT. CL. 44.

PURE BIOLOGICAL SYSTEMS, INC., LAS VEGAS, NV:  
3,961,709, PUB. 3-1-2011. INT. CL. 1.

PURE FISHING, INC., COLUMBIA, SC:  
3,962,565, INT. CL. 28.  
3,962,566, INT. CL. 28.

PURE ROMANCE, INC., LOVELAND, OH:  
3,960,949, PUB. 3-1-2011. MULTIPLE CLASS, INT. CLS. 10, 25, 28, 35 AND 41.  
3,960,950, PUB. 3-1-2011. MULTIPLE CLASS, INT. CLS. 5, 10, 16, 25, 28, 35 AND 41.

PURINA MILLS, LLC, ARDEN HILLS, MN:  
2,883,300, CANC. INT. CL. 31.

PURINA MILLS, LLC, ST. LOUIS, MO:  
2,883,337, CANC. INT. CL. 31.

PUSTERLA, SERGIO, ESTEBAN, BENAVIDEZ, ARGENTINA:  
3,960,379, PUB. 3-1-2011. INT. CL. 7.

PUTNAM LUMBER & EXPORT COMPANY, JACKSONVILLE, FL:  
2,881,583, CANC. INT. CL. 35.

PUTNAM RETAIL MANAGEMENT, INC., BOSTON, MA:  
2,881,946, CANC. INT. CL. 36.

PYXIX MOBILE, INC., WALTHAM, MA:  
2,881,313, CANC. INT. CL. 9.

Q. B. ENTERPRISES, INC., CULPEPER, VA:  
2,880,829, CANC. INT. CL. 24.

QED BIOSCIENCE INC., SAN DIEGO, CA:  
2,438,608, REN. 4-11-11. INT. CL. 42.

QIAGEN GMBH, 40724 HILDEN, FED REP GERMANY:  
3,960,628, PUB. 3-1-2011. MULTIPLE CLASS, INT. CLS. 1, 5 AND 9.

QN LABS, LLC, ROUND ROCK, TX:  
3,962,994, INT. CL. 5.

QSPAC INDUSTRIES, INC., CERRITOS, CA:  
3,963,664, INT. CL. 17.

QUADION CORPORATION, MINNEAPOLIS, MN, MINNESOTA RUBBER COMPANY, MINNEAPOLIS, MN:  
916,632, REN. 4-8-11. U.S. CL. 21 (INT. CL. 9).

QUALCOMM INCORPORATED, SAN DIEGO, CA:  
2,882,806, CANC. MULTIPLE CLASS, INT. CLS. 38 AND 42.

QUALITY NEON SIGN COMPANY, JACKSONVILLE, FL, DBA HARBINGER:  
3,963,492, MULTIPLE CLASS, INT. CLS. 9, 37 AND 40.

QUALITY SHREDDING CORP., WANTAGH, NY:  
3,961,397, PUB. 3-1-2011. INT. CL. 40.

QUALITY SOLUTIONS, INC., WICHITA, KS:  
3,961,120, PUB. 3-1-2011. INT. CL. 35.

QUALMAN, ERIK, CAMBRIDGE, MA:  
3,962,231, MULTIPLE CLASS, INT. CLS. 9 AND 16.

QUANTA ASSOCIATES, L.P., HOUSTON, TX:  
3,961,033, PUB. 3-1-2011. INT. CL. 37.

QUANTUM SOFT, LLC, LAS VEGAS, NV:  
3,962,113, INT. CL. 44.

QUEEN BEE GARDENS, LTD., LOVELL, WY:  
3,960,454, PUB. 3-1-2011. INT. CL. 30.



- QUEENSBURY HOSPITALITY LLC, FORT LAUDERDALE, FL:  
3,961,696, PUB. 3-1-2011. INT. CL. 43.
- QUETICO PARTNERS LLC, MINNEAPOLIS, MN:  
3,960,936, PUB. 3-1-2011. INT. CL. 36.
- QUIKSCRIBE PTY LTD, TOORMINA NSW, AUSTRALIA:  
2,881,387, CANC. INT. CL. 9.
- QUIRKY, INC., NEW YORK, NY:  
3,960,507, PUB. 3-1-2011. INT. CL. 42.
- QUOTEWIZARD.COM, LLC, SEATTLE, WA:  
3,961,075, PUB. 3-1-2011. INT. CL. 35.  
3,961,076, PUB. 3-1-2011. INT. CL. 35.
- QURB, INC., SAN MATEO, CA:  
2,883,211, CANC. INT. CL. 9.
- QWEST COMMUNICATIONS INTERNATIONAL INC., DENVER, CO:  
3,960,511, PUB. 3-1-2011. INT. CL. 16.
- Q4X, INC., PASO ROBLES, CA:  
3,961,531, PUB. 3-1-2011. INT. CL. 33.  
3,961,533, PUB. 3-1-2011. INT. CL. 33.  
3,961,536, PUB. 3-1-2011. INT. CL. 33.  
3,961,538, PUB. 3-1-2011. INT. CL. 33.
- R. & M MARKETING SERVICES, INC., BRIDGEWATER, NJ:  
2,881,687, CANC. INT. CL. 35.
- R.G. BARRY CORPORATION, PICKERINGTON, OH:  
2,881,494, CANC. INT. CL. 25.
- R.O.W., INC., COEUR D'ALENE, ID, GRUBB, PETER H., COEUR D'ALENE, ID, DBA ROW:  
1,644,642, REN. 4-13-11. MULTIPLE CLASS, INT. CLS. 39 AND 41.
- RA, MAXWEALTH, LANCASTER, CA, AKA RA, MAX:  
3,963,181, INT. CL. 16.  
3,963,368, INT. CL. 16.
- RACE CITY ROLLER DERBY, INC., CHARLOTTE, NC:  
3,961,308, PUB. 3-1-2011. INT. CL. 41.
- RACKTIVITY, NAAMLOZE VENNOOTSCHAP, BELGIUM:  
3,960,831, PUB. 3-1-2011. INT. CL. 42.
- RADIO FLYER INC., CHICAGO, IL:  
2,881,725, CANC. INT. CL. 12.
- RADIOLOGICAL HEALTH SERVICES, P.C., PORT JEFFERSON, NY:  
2,881,148, CANC. INT. CL. 44.
- RADIOLOGY BUSINESS MANAGEMENT ASSOCIATION, FAIRFAX, VA:  
3,960,333, PUB. 3-1-2011. MULTIPLE CLASS, INT. CLS. 16, 35 AND 41.
- RADLOVIC, MICHAEL, LOS ANGELES, CA:  
2,882,500, CANC. INT. CL. 36.
- RAGING KNOWLEDGE EDUCATIONAL SERVICES, INC., WESTPORT, CT:  
2,883,061, CANC. INT. CL. 41.
- RAIDLIGHT, SAINT-GENEST-MALIFAU, FRANCE:  
3,961,729, PUB. 3-1-2011. MULTIPLE CLASS, INT. CLS. 14, 18 AND 25.
- RAIN DESIGN INC, SAN FRANCISCO, CA:  
3,961,799, PUB. 3-1-2011. INT. CL. 9.
- RAINBOW LIGHT NUTRITIONAL SYSTEMS, INC., SANTA CRUZ, CA:  
3,962,672, INT. CL. 5.
- RAINMAKER THINKING, INC., NEW HAVEN, CT:  
2,446,062, REN. 4-14-11. MULTIPLE CLASS, INT. CLS. 35 AND 41.
- RAKKU INC., LOS ANGELES, CA:  
3,960,467, PUB. 3-1-2011. INT. CL. 21.
- RALPH AND PAUL ADAMS, INC., BRIDGEVILLE, DE:  
1,191,789, REN. 4-9-11. INT. CL. 29.
- RALPH C. TYLER, P.E., P.S., INC., CLEVELAND, OH:  
2,882,595, CANC. MULTIPLE CLASS, INT. CLS. 37 AND 42.
- RAMIREZ, HERNANDO JR, MIAMI, FL AND METIN, SARA, MIAMI, FL:  
3,962,904, INT. CL. 33.
- RAMIREZ, JANICE, ATLANTA, GA AND RAMIREZ, ALDO, ATLANTA, GA:  
3,961,094, PUB. 3-1-2011. INT. CL. 43.
- RAMP SPORTS, LLC, PARK CITY, UT:  
3,963,556, INT. CL. 28.  
3,963,557, INT. CL. 28.  
3,963,558, INT. CL. 28.
- RAMPAGE, LLC, BRIDGEPORT, CT:  
2,882,893, CANC. INT. CL. 28.
- RAMSELL HOLDING CORPORATION, OAKLAND, CA:  
3,962,793, INT. CL. 35.
- RANKAM GROUP LIMITED, KOWLOON, HONG KONG:  
2,881,817, CANC. INT. CL. 28.
- RARE BREED DISTILLING LLC, SAN FRANCISCO, CA:  
2,882,234, CANC. INT. CL. 33.
- RATH AG, A-1010 WIEN, AUSTRIA:  
2,447,831, REN. 4-8-11. MULTIPLE CLASS, INT. CLS. 1 AND 17.
- RATH, MATTHIAS, NL-7609 KL ALMELO, NETHERLANDS:  
2,880,677, CANC. MULTIPLE CLASS, INT. CLS. 5, 30 AND 32.
- RATIONAL INTELLECTUAL HOLDINGS LIMITED, DOUGLAS, ISLE OF MAN:  
3,962,882, MULTIPLE CLASS, INT. CLS. 9 AND 41.  
3,962,883, MULTIPLE CLASS, INT. CLS. 9 AND 41.
- RAUCKMAN UTILITY PRODUCTS, L.L.C., SWANSEA, IL:  
3,960,965, PUB. 3-1-2011. INT. CL. 9.
- RAVINTORAISIO OY, FINLAND:  
3,960,727, PUB. 3-1-2011. MULTIPLE CLASS, INT. CLS. 5, 29, 30 AND 32.
- RAYMOND JAMES FINANCIAL, INC., ST. PETERSBURG, FL:  
3,962,156, INT. CL. 36.  
3,962,220, MULTIPLE CLASS, INT. CLS. 35 AND 36.  
3,963,692, INT. CL. 36.
- RAYPAX CO., LTD., SEOUL, 135-090, REPUBLIC OF KOREA:  
2,882,098, CANC. INT. CL. 42.
- RAYTHEON COMPANY, WALTHAM, MA:  
3,963,291, INT. CL. 7.
- RAYTHEON TCS COMMERCIAL, INC., HERNDON, VA:  
3,160,519 NEW CERT. 5-17-2011. INT. CL. 9.
- RAYTHEON TRUSTED COMPUTER SOLUTIONS, INC., HERNDON, VA:  
3,390,371 NEW CERT. 5-17-2011. INT. CL. 9.  
3,737,417 NEW CERT. 5-17-2011. INT. CL. 9.
- RB PROMOTIONS, INC., PITTSBURGH, PA:  
2,882,675, CANC. INT. CL. 41.
- RCI HOLDINGS, L.L.C., BELTSVILLE, MD:  
3,962,834, INT. CL. 40.
- RDA STERLING HOLDINGS CORPORATION, JACKSONVILLE, FL:  
3,962,262, INT. CL. 35.  
3,962,263, INT. CL. 35.
- RDI CONSTRUCTION, INC., SOUTH POINT, OH:  
2,881,744, CANC. INT. CL. 1.
- READ TECHNOLOGIES, INC., IRVINE, CA:  
2,883,049, CANC. INT. CL. 41.
- READY TO RUMBLE, LLC, LOS ANGELES, CA:  
2,384,054, CANC. INT. CL. 25.
- REAGAN HAYES, INC., LOS ANGELES, CA:  
3,962,560, INT. CL. 20.
- REALCOMM PROPERTIES, INC., DESTIN, FL:  
2,882,673, CANC. INT. CL. 43.
- REALESPLACE LLC, PLANO, TX:  
3,960,320, PUB. 3-1-2011. INT. CL. 42.
- REALPRO TRAINING AND CONSULTING, WOODBURY, NY:  
3,961,767, PUB. 3-1-2011. INT. CL. 42.
- REALTYU, INC., ALISO VIEJO, CA:  
2,881,978, CANC. INT. CL. 41.
- REASONABLE ZONE COMPANY LIMITED, HANOI, VIETNAM:  
2,881,499, CANC. INT. CL. 35.
- RECKITT BENCKISER LLC, PARSIPPANY, NJ:  
2,881,502, CANC. MULTIPLE CLASS, INT. CLS. 3 AND 21.
- RECOVERY+SOLUTIONS, INC., RICHMOND, TX:  
3,961,039, PUB. 3-1-2011. INT. CL. 35.



RED BLUFF BULL SALE COMMITTEE, RED BLUFF, CA:  
2,884,900, CANC. INT. CL. 31.

RED DEVELOPMENT, LLC, KANSAS CITY, MO:  
3,963,293, INT. CL. 37.

RED DOE STUDIOS, LLC, SHOHOLA, PA:  
2,883,181, CANC. INT. CL. 3.

RED JAVELIN COMMUNICATIONS, INC., SUDBURY, MA:  
2,881,625, CANC. INT. CL. 35.

RED.COM, INC., LAKE FOREST, CA:  
3,962,593, INT. CL. 9.

RED'S GARDEN CENTER, INC., NORTHBROOK, IL, DBA RED'S:  
3,962,357, MULTIPLE CLASS, INT. CLS. 1 AND 31.

REDBALL, LLC, BENSON, MN:  
2,881,612, CANC. MULTIPLE CLASS, INT. CLS. 7 AND 9.

REDI-NATIONAL PEST ELIMINATORS, INC., SEATTLE, WA:  
1,680,601, REN. 4-12-11, INT. CL. 37.

REDI2 TECHNOLOGIES, INC., OAKLAND, CA:  
3,961,535, PUB. 3-1-2011, MULTIPLE CLASS, INT. CLS. 9 AND 42.

REDMAN, MALIK Y., VALLEY VILLAGE, CA:  
3,961,684, PUB. 3-1-2011, INT. CL. 35.

REED CONSTRUCTION DATA LLC, NORCROSS, GA,  
WADE PUBLISHING CO., SAN FRANCISCO, CA:  
932,277, REN. 4-14-11, U.S. CL. 38 (INT. CL. 16).

REED ELSEVIER PROPERTIES INC., WILMINGTON, DE:  
2,881,166, CANC. INT. CL. 35.  
2,881,190, CANC. INT. CL. 16.

REED, DAN, CORTE MADERA, CA:  
2,672,528, CANC. INT. CL. 35.

REED, DOUGLAS, MARIANNA, FL:  
2,881,618, CANC. INT. CL. 35.

REEF INDUSTRIES, INC., HOUSTON, TX:  
1,183,010, REN. 4-8-11, INT. CL. 22.

REES ASSOCIATES, INC., OKLAHOMA CITY, OK:  
3,962,969, INT. CL. 42.  
3,962,970, INT. CL. 42.

REEVES INTERNATIONAL, INC., PEQUANNOCK, NJ:  
2,469,094, REN. 4-11-11, INT. CL. 28.

REFLANGE, INC., HOUSTON, TX:  
1,674,767, REN. 4-11-11, INT. CL. 6.  
1,676,541, REN. 4-11-11, INT. CL. 6.

REGATTA RESEARCH & MONEY MANAGEMENT, LLC.,  
METARIE, LA:  
3,963,783, MULTIPLE CLASS, INT. CLS. 16 AND 41.

REISFELD, SORIA, GUTTERSON & SHERIDAN DENTAL  
SERVICES, PLLC, HAUPPAUGE, NY:  
2,444,796, REN. 4-13-11, INT. CL. 42.

RELATIONSHIP TOOLBOX LLC, STAMFORD, CT:  
3,962,353, MULTIPLE CLASS, INT. CLS. 9, 41 AND 45.

RELIABLE TIRE CO., BLACKWOOD, NJ:  
2,383,131, CANC. INT. CL. 12.

RELIANT ENERGY RETAIL HOLDINGS, LLC, HOUSTON,  
TX:  
3,963,249, MULTIPLE CLASS, INT. CLS. 35 AND 36.

REMIS GESELLSCHAFT FÜR ENTWICKLUNG; UND VER-  
TRIEB VON TECHNISCHEN; ELEMENTEN MBH, FED  
REP GERMANY:  
3,960,710, PUB. 3-1-2011, MULTIPLE CLASS, INT. CLS. 11  
AND 12.

REMSPEC CORPORATION, STURBRIDGE, MA:  
2,881,824, CANC. INT. CL. 9.

RENEGAR, ROBERT M., MURFREESBORO, TN AND  
CRAW, JOHN J., MURFREESBORO, TN:  
2,383,248, CANC. INT. CL. 25.

RENO BASTIAN ENTERPRISES, INC., NORTH MANKATO,  
MN:  
3,960,563, PUB. 3-1-2011, INT. CL. 30.

RENPURE, L.L.C., EDINA, MN:  
3,963,417, INT. CL. 3.  
3,963,418, INT. CL. 3.  
3,963,419, INT. CL. 3.

RENTALMAX L.L.C., WHEATON, IL:  
2,457,570, REN. 4-14-11, MULTIPLE CLASS, INT. CLS. 41  
AND 42.

RENTMEN LTD, SOFIA, BULGARIA:  
3,961,042, PUB. 3-1-2011, INT. CL. 45.

RENZ, AMY, MARBLEHEAD, MA:  
3,962,164, MULTIPLE CLASS, INT. CLS. 31 AND 36.

REPLENISH BOTTLING, LLC, WEST HOLLYWOOD, CA:  
3,961,681, PUB. 3-1-2011, INT. CL. 3.

REPORTSNOW, INC., CENTENNIAL, CO, FORMERLY  
DOMINION SOFTWARE, LLC:  
3,960,393, PUB. 8-31-2010, INT. CL. 9.

REPUBLIC INC., OTTAWA, CANADA, DBA WEDDING  
REPUBLIC:  
3,961,221, PUB. 3-1-2011, INT. CL. 41.

REPUBLIC SERVICES, INC., PHOENIX, AZ:  
3,963,714, INT. CL. 40.

RESOLUTION INTERACTIVE AB, UMEA, SWEDEN, DBA  
RESOLUTION INTERACTIVE AB:  
2,648,075, CANC. INT. CL. 9.

RESOLVE SPECIALTY PRODUCTS LLC, MENASHA, WI:  
3,962,843, INT. CL. 6.

RESPONSE MARKETING, INC., MONTGOMERY, AL:  
2,882,708, CANC. INT. CL. 44.

RESTIVO, MARY ANN, NEW YORK, NY:  
2,882,439, CANC. INT. CL. 25.

RESTORATION HARDWARE, INC., CORTE MADERA, CA:  
3,960,568, PUB. 3-1-2011, MULTIPLE CLASS, INT. CLS. 20  
AND 21.

RESTREPO GUTIERREZ, SANTIAGO, BOGOTÁ, COLOM-  
BIA:  
3,962,320, INT. CL. 30.

RETAIL CONCEPTS OF MINNESOTA, INC., WINDER-  
MERE, FL:  
3,963,862, INT. CL. 3.

RETAIL MERCHANTS ASSOCIATION OF TIDEWATER  
VIRGINIA, INC., NORFOLK, VA:  
2,383,845, CANC. INT. CL. 42.

RETAIL ROYALTY COMPANY, LAS VEGAS, NV:  
3,961,928, PUB. 3-1-2011, INT. CL. 36.  
3,962,015, INT. CL. 25.

RETRO TELEVISION, INC., CHATTANOOGA, TN:  
3,962,330, INT. CL. 41.

REVAH HOLDINGS, INC., LOS ANGELES, CA:  
2,883,099, CANC. INT. CL. 25.

REVLON CONSUMER PRODUCTS CORPORATION, NEW  
YORK, NY:  
2,881,647, CANC. INT. CL. 3.  
3,962,408, INT. CL. 9.  
3,962,637, INT. CL. 3.

REVPAR GURU, INC., MIAMI, FL:  
3,961,482, PUB. 3-1-2011, INT. CL. 42.

REXAIR LLC, TROY, MI:  
3,963,161, INT. CL. 21.  
3,963,162, INT. CL. 21.  
3,963,163, INT. CL. 21.

REYCO INDUSTRIES, INC., MOUNT VERNON, MO:  
2,435,711, REN. 4-11-11, INT. CL. 12.

RHODE ISLAND NOVELTY, INC., CUMBERLAND, RI:  
3,963,018, INT. CL. 28.

RHODEN, MATTHEW B., FREEPORT, NY:  
3,963,014, INT. CL. 33.

RHODES, ARTHUR B., SELLERSBURG, IN:  
2,882,403, CANC. MULTIPLE CLASS, INT. CLS. 7 AND  
11.

RIC INVESTMENTS, LLC, WILMINGTON, DE, RESPIRO-  
NICS, INC., MURRYSVILLE, PA:  
1,640,359, REN. 4-8-11, INT. CL. 10.

RICELAND FOODS, INC., STUTTGART, AR:  
2,881,818, CANC. INT. CL. 5.

RICH BLOSSOM WATCH MANUFACTORY LIMITED,  
TSUEN WAN, NEW TERRITORIES, HONG KONG:  
2,882,526, CANC. INT. CL. 14.

RICH PRODUCTS CORPORATION, BUFFALO, NY, JON  
DONAIRE PASTRIES, INC., LOS ANGELES, CA:  
1,150,576, REN. 4-11-11, INT. CL. 30.

RICH PRODUCTS CORPORATION, BUFFALO, NY:  
3,960,924, PUB. 3-1-2011, INT. CL. 30.

RICH, JOHN, NASHVILLE, TN:  
3,962,132, INT. CL. 25.

RICHARD E. COLGIN I LTD., DALLAS, TX, DBA THE  
COLGIN COMPANIES:  
2,881,799, CANC. INT. CL. 30.

- RICHARD J. CELLINI, CAMBRIDGE, MA:  
3,960,578, PUB. 3-1-2011. INT. CL. 35.
- RICHARD M. FOXX, M.D., P.C., INDAIN WELLS, CA:  
2,881,793, CANC. INT. CL. 44.
- RICHARD RUE, MCKINNEY, TX:  
3,961,829, PUB. 3-1-2011. INT. CL. 11.
- RICHARD SEAN GARBER, CORONA, CA:  
3,962,424, INT. CL. 25.
- RICHARD WELSH, YUCCA VALLEY, CA:  
3,962,420, INT. CL. 37.
- RICHARD WOLF GMBH, KNITTLINGEN, FED REP GER-  
MANY:  
3,963,856, INT. CL. 10.
- RICHTREE MARKETS INC., TORONTO, ONTARIO M5H  
2G4, CANADA:  
2,881,975, CANC. MULTIPLE CLASS, INT. CLS. 35 AND  
42.
- RICK FRIEDMAN ENTERPRISES, LTD, NEW YORK, NY:  
2,624,617, CANC. INT. CL. 25.
- RICON CORPORATION, PANORAMA CITY, CA:  
2,882,669, CANC. INT. CL. 12.
- RICOS INTELLECTUAL PROPERTY LTD., SAN ANTONIO,  
TX:  
2,882,291, CANC. MULTIPLE CLASS, INT. CLS. 29 AND  
30.
- RIDLEY BLOCK OPERATIONS, INC., MANKATO, MN:  
2,383,998, CANC. INT. CL. 5.
- RIGHT BRAIN HOLDINGS, LLC, LYNDHURST, OH:  
3,829,023, CANC. INT. CL. 25.
- RIGHT EDUCATION, INC., THE, BETHESDA, MD:  
2,882,002, CANC. INT. CL. 41.
- RIGHTNOW TECHNOLOGIES, INC., BOZEMAN, MT:  
2,941,356, COR. INT. CL. 9.
- RIIP, INC., WILMINGTON, DE:  
2,446,817, REN. 4-11-11. INT. CL. 9.
- RINCON JIMENEZ ENTERPRISES LLC, FALLS CHURCH,  
VA:  
3,866,894, COR. INT. CL. 35.
- RIOCAN REAL ESTATE INVESTMENT TRUST, TORONTO,  
ONTARIO, CANADA:  
3,961,184, PUB. 3-1-2011. INT. CL. 36.
- RIOU, COLIN B. CASTEL, GUERNSEY:  
3,961,243, PUB. 3-1-2011. INT. CL. 28.
- RIPARIUS CORPORATION, TIMONIUM, MD:  
1,641,533, REN. 4-13-11. INT. CL. 37.  
1,641,533, CANC. MULTIPLE CLASS, INT. CLS. 36, 40  
AND 42.
- RISE AND SHINE, LLC, DELAFIELD, WI:  
3,961,597, PUB. 3-1-2011. INT. CL. 14.
- RITZ CAMERA & IMAGE, L.L.C., BELTSVILLE, MD:  
3,963,011, INT. CL. 16.
- RIVER VALLEY VINEYARD, INC., UTICA, IL, DBA AU-  
GUST HILL WINERY:  
3,963,285, INT. CL. 33.
- RIVERSIDE MILITARY ACADEMY, INC., GAINESVILLE,  
GA:  
2,382,798, CANC. INT. CL. 41.
- RLI INSURANCE COMPANY, PEORIA, IL:  
2,883,374, CANC. INT. CL. 36.
- RLPS, LLP, LANCASTER, PA:  
2,547,030, REN. 4-8-11. INT. CL. 42.
- RMO, INC., DENVER, CO:  
3,961,719, PUB. 3-1-2011. INT. CL. 44.
- RMS PACKAGING, INC., PEEKSKILL, NY:  
2,446,792, REN. 4-11-11. INT. CL. 17.
- RMSG, LLC, HAMILTON, NJ:  
3,961,835, PUB. 3-1-2011. INT. CL. 35.
- ROBERT BOSCH TOOL CORPORATION, MOUNT PRO-  
SPECT, IL:  
3,963,398, INT. CL. 7.
- ROBERT JASON NICEWARNER, HOUSTON, TX:  
3,961,430, PUB. 3-1-2011. INT. CL. 43.
- ROBERT L. O'BLOCK REVOCABLE TRUST, SPRINGFIELD,  
MO:  
3,960,306, PUB. 3-1-2011. U.S. CL. B.
- ROBERT P. NICKELL, TORRANCE, CA:  
3,962,445, INT. CL. 25.  
3,962,478, INT. CL. 25.
- ROBIN BRITT, ANNAPOLIS, MD, DBA BRITT'S INDUS-  
TRIES:  
3,960,470, PUB. 3-1-2011. INT. CL. 16.  
3,960,471, PUB. 3-1-2011. INT. CL. 16.
- ROBIN INDUSTRIES, INC., CLEVELAND, OH:  
2,882,909, CANC. INT. CL. 12.
- ROBISON'S, INC., IDAHO FALLS, ID:  
1,639,810, REN. 4-8-11. INT. CL. 25.
- ROCHA MARES, MIGUEL, MEXICO, MEXICO:  
2,881,358, CANC. INT. CL. 14.
- ROCK & ROLL MUSIC CORPORATION, BRANSON, MO:  
2,881,469, CANC. INT. CL. 41.
- ROCK BACK PIZZA, INC., CHATTAHOOCHEE HILLS, GA:  
3,962,627, INT. CL. 43.
- ROCKBESTOS-SURPRENANT CABLE CORP., CLINTON,  
MA:  
2,880,864, CANC. INT. CL. 11.
- ROCKIN' BAJA LOBSTER PROPRIETARY RIGHTS HOLD-  
ING COMPANY, LLC, NEWPORT BEACH, CA:  
2,881,644, CANC. INT. CL. 29.
- ROCKWELL BROWN WINES LLC, NORTH BEND, WA,  
DBA ROCKWELL BROWN WINES:  
3,961,608, PUB. 3-1-2011. INT. CL. 33.
- ROCKY FORK FORMULAS, INC, WESTERVILLE, OH:  
3,961,642, PUB. 3-1-2011. INT. CL. 5.
- ROCLAND WINE IMPORTS, SAN FRANCISCO, CA:  
3,962,914, MULTIPLE CLASS, INT. CLS. 32 AND 33.  
3,963,046, INT. CL. 33.
- ROCZEY, KEVIN, SANTEE, CA, DBA TRAILSPRO:  
3,961,602, PUB. 3-1-2011. INT. CL. 9.
- RODALE INC., EMMANUS, PA:  
2,384,393, CANC. INT. CL. 16.  
3,962,105, INT. CL. 16.  
3,962,106, INT. CL. 16.
- RODRIGUEZ, ALEJANDRO, LOS ANGELES, CA:  
2,881,847, CANC. INT. CL. 25.
- ROGER D. POPA, TRAVERSE CITY, MI, DBA PETOSKEY  
PETE'S:  
3,962,466, INT. CL. 25.
- ROGERS, PAMELA M, CAPE CORAL, FL, DBA RECKLESS  
WOMEN:  
3,962,784, INT. CL. 35.
- ROLF C. HAGEN (USA) CORP., MANSFIELD, MA:  
2,454,111, REN. 4-11-11. INT. CL. 31.
- ROLLINS BULLDOG TOOLS LIMITED, UNITED KING-  
DOM:  
3,960,797, PUB. 3-1-2011. INT. CL. 8.
- ROOFTOP GROUP USA, INC., MISSION VIEJO, CA:  
3,963,616, INT. CL. 28.  
3,963,663, INT. CL. 28.
- ROPE WORKS, INC., DRIPPING SPRINGS, TX:  
2,518,542, REN. 4-14-11. INT. CL. 28.
- ROSARIO, PAUL, BAYVILLE, NJ AND ROSARIO, JEANNE,  
BAYVILLE, NJ AND KAPS, THOMAS, JACKSON, NJ AND  
KAPS, THERESA, JACKSON, NJ:  
3,961,954, PUB. 3-1-2011. INT. CL. 37.  
3,961,955, PUB. 3-1-2011. INT. CL. 37.
- ROSENAY, CHARLES F., ORANGE, CT:  
2,882,021, CANC. INT. CL. 35.
- ROSENBAUM & ASSOCIATES, P.C., CHICAGO, IL:  
2,883,155, CANC. INT. CL. 42.
- ROSENBAUM & ASSOCIATES, P.C., NORTHBROOK, IL:  
2,883,404, CANC. INT. CL. 42.
- ROSENBERG, MICHAEL, NEW MILFORD, NJ:  
3,963,688, INT. CL. 35.
- ROSS, DAVID JONATHAN, RANCHO PALOS VERDES, CA:  
3,960,959, PUB. 3-1-2011. INT. CL. 9.
- ROSSY YVES, SWITZERLAND:  
3,960,657, PUB. 3-1-2011. MULTIPLE CLASS, INT. CLS.  
12, 16, 25 AND 28.
- ROSTRA PRECISION CONTROLS, INC., LAURINBURG,  
NC:  
3,960,842, PUB. 8-31-2010. INT. CL. 9.
- ROTEM INC., SKOKIE, IL:  
3,962,905, INT. CL. 29.  
3,963,091, INT. CL. 29.

ROTH & RAU MUEGGE GMBH, REICHELSCHEIM, FED REP GERMANY:  
3,960,649, PUB. 3-1-2011. MULTIPLE CLASS, INT. CLS. 9, 37, 41 AND 42.

ROWDY ORBIT IPTV, LLC, MARTINSBURG, WV:  
3,962,274, INT. CL. 38.

ROXBURY MILLS, INC., ROCKAWAY, NY:  
2,020,921, CANC. INT. CL. 25.

ROY LOMAS CARPET CONTRACTOR, INC., KULPSVILLE, PA:  
3,960,926, PUB. 3-1-2011. INT. CL. 35.

ROYAL BANK OF CANADA, MONTREAL, CANADA:  
3,962,664, INT. CL. 36.

ROYAL CREDIT UNION, EAU CLAIRE, WI:  
2,881,645, CANC. INT. CL. 36.

ROYAL OAK ENTERPRISES, LLC, ROSWELL, GA:  
3,963,622, INT. CL. 4.

ROYAL TECHNOLOGIES CORPORATION, HUDSONVILLE, MI:  
3,960,315, PUB. 12-1-2009. MULTIPLE CLASS, INT. CLS. 40 AND 42.

ROYAL VENDORS, INC., KEARNEYSVILLE, WI:  
2,882,321, CANC. INT. CL. 9.  
2,882,322, CANC. INT. CL. 9.

RSM MCGLADREY, INC., BLOOMINGTON, MN AND MCGLADREY & PULLEN, LLP, BLOOMINGTON, MN:  
3,962,216, MULTIPLE CLASS, INT. CLS. 9, 35, 36, 42 AND 45.

RSUPPORT CO. LTD., SEOUL, REPUBLIC OF KOREA:  
3,962,734, INT. CL. 42.

RTR FUNDING LLC, NORTH MIAMI, FL:  
2,882,053, CANC. MULTIPLE CLASS, INT. CLS. 35, 36 AND 42.

RTST, INC., NEW YORK, NY:  
3,960,598, PUB. 3-1-2011. INT. CL. 41.

RUB IN LOVE, INC., WARRENTON, MO:  
2,881,191, CANC. INT. CL. 11.

RUBBER VULK-PNEUS E ACESSORIOS, LDA, 3750-599 AGUEDA, PORTUGAL:  
3,962,032, MULTIPLE CLASS, INT. CLS. 1, 6, 7, 8 AND 12.

RUBY JR, RALPH, STATE UNIVERSITY, AR:  
3,961,023, PUB. 3-1-2011. MULTIPLE CLASS, INT. CLS. 9 AND 25.

RUDOLPH TECHNOLOGIES, INC., FLANDERS, NJ:  
2,382,625, CANC. INT. CL. 9.

RUFFLEBUTTS, INC., BELMONT, NC:  
3,961,375, PUB. 3-1-2011. INT. CL. 25.

RUSS' OF HOLLAND, INC., HOLLAND, MI:  
1,178,642, REN. 4-13-11. INT. CL. 42.  
1,179,621, REN. 4-13-11. INT. CL. 42.

RUSSELL-NEWMAN, LTD., DENTON, TX:  
2,881,124, CANC. INT. CL. 25.

RUSSELL, ERICH, SAN FRANCISCO, CA:  
2,882,882, CANC. INT. CL. 33.

RUTH'S HOSPITALITY GROUP, INC., HEATHROW, FL:  
3,961,753, PUB. 3-1-2011. INT. CL. 43.

RUUD LIGHTING, INC., RACINE, WI:  
3,963,370, INT. CL. 11.

RX SAFES, INC., HENDERSON, NV:  
3,961,761, PUB. 3-1-2011. INT. CL. 6.

RYAN, OWEN, CHARLOTTE, NC:  
3,963,240, INT. CL. 30.

RYBOVICH BOAT COMPANY, LLLP, FORT LAUDERDALE, FL:  
3,962,063, MULTIPLE CLASS, INT. CLS. 35, 37, 39, 40, 41 AND 43.

RYLAND ORGANIZATION COMPANY, CALABASAS, CA:  
3,961,986, MULTIPLE CLASS, INT. CLS. 37 AND 42.

RYU, SEUNG KYUN, NEW YORK, NY:  
3,960,945, PUB. 3-1-2011. INT. CL. 35.

R2K, INC., NEW YORK, NY:  
2,455,208, REN. 4-11-11. INT. CL. 42.

R3 SYSTEMS GROUP, BUFFALO GROVE, IL:  
2,880,778, CANC. INT. CL. 36.

S & S PRODUCT DESIGN, INC., BLOOMINGTON, MN:  
2,883,111, CANC. INT. CL. 21.

S B INDUSTRIES, LLC, MYSTIC, CT:  
3,963,429, INT. CL. 1.

S. AUDIT GMBH WIRTSCHAFTSPRÜFUNGSGESELLSCHAFT, KÖLN, FED REP GERMANY:  
3,962,351, INT. CL. 35.

S. C. JOHNSON & SON, INC., RACINE, WI:  
3,963,304, INT. CL. 5.  
3,963,722, MULTIPLE CLASS, INT. CLS. 4 AND 5.

S.P.C.M. SA, FRANCE:  
3,960,792, PUB. 3-1-2011. INT. CL. 1.

S.T.A.T. TEAM NURSING, INC., ARNOLDS PARK, IA:  
2,881,306, CANC. INT. CL. 35.

S&L MARKETING GROUP, CLERMONT, FL:  
3,961,325, PUB. 3-1-2011. INT. CL. 9.  
3,961,329, PUB. 3-1-2011. INT. CL. 9.

SA.DU.SA. S.P.A., I-52040 AREZZO, ITALY:  
2,881,182, CANC. INT. CL. 14.

SABAN ENTERTAINMENT, INC., LOS ANGELES, CA:  
2,383,569, CANC. INT. CL. 28.

SABIA JR., VINCENT F., VERO BEACH, FL:  
3,961,493, PUB. 3-1-2011. INT. CL. 12.

SABOGAL, ELKIN CAMILO, METHUEN, MA, DBA MUSELKO:  
3,962,529, MULTIPLE CLASS, INT. CLS. 41 AND 42.

SABONA RHEUMATIC RELIEF COMPANY, LTD., SAXMUNDHAM SUFFOLK, UNITED KINGDOM:  
2,382,675, CANC. INT. CL. 14.

SAEGIS PHARMACEUTICALS, INC., HALF MOON BAY, CA:  
2,882,416, CANC. MULTIPLE CLASS, INT. CLS. 5 AND 42.

SAFE-PLAY MANUFACTURING COMPANY, INC., NORTH PLATTE, NE:  
901,753, REN. 4-8-11. U.S. CL. 22 (INT. CL. 28).

SAFEHARBOR EMPLOYER SERVICES, CLEARWATER, FL:  
2,880,729, CANC. INT. CL. 35.

SAFEHARBOR EMPLOYER SERVICES, PALM HARBOR, FL:  
2,880,730, CANC. INT. CL. 35.

SAFELITE GROUP, INC., COLUMBUS, OH:  
2,382,919, CANC. INT. CL. 37.

SAFETY INNOVATIONS, LLC, NEW BERLIN, WI:  
3,962,321, MULTIPLE CLASS, INT. CLS. 6 AND 9.

SAFETY OPTICAL SERVICE CO., LEWISVILLE, TX:  
2,881,180, CANC. INT. CL. 9.

SAFETY TURF INC., OAKS, PA:  
2,874,478, CANC. INT. CL. 40.

SAFETY-KLEEN SYSTEMS, INC., PLANO, TX:  
2,445,678, REN. 4-8-11. INT. CL. 42.

SAFEWAY INC., PLEASANTON, CA:  
2,459,186, REN. 4-8-11. INT. CL. 31.  
2,881,213, CANC. INT. CL. 30.

SAGEL, GAIL, WESTPORT, CT:  
3,962,715, MULTIPLE CLASS, INT. CLS. 3, 35 AND 44.

SAHA, PAMELA, BROOKLYN, NY:  
3,960,360, PUB. 3-1-2011. INT. CL. 28.

SAINT LOUIS UNIVERSITY, ST. LOUIS, MO:  
3,961,133, PUB. 3-1-2011. MULTIPLE CLASS, INT. CLS. 25 AND 41.  
3,961,806, PUB. 3-1-2011. INT. CL. 16.  
3,961,933, PUB. 3-1-2011. INT. CL. 14.  
3,961,934, PUB. 3-1-2011. INT. CL. 9.  
3,961,935, PUB. 3-1-2011. INT. CL. 10.  
3,961,936, PUB. 3-1-2011. INT. CL. 28.  
3,961,937, PUB. 3-1-2011. INT. CL. 18.  
3,961,938, PUB. 3-1-2011. INT. CL. 21.

SAINT-GOBAIN CERAMICS & PLASTICS, INC., WORCESTER, MA:  
2,440,217, REN. 4-11-11. INT. CL. 7.

SAINT-GOBAIN PERFORMANCE PLASTICS CORPORATION, WAYNE, NJ:  
2,883,268, CANC. INT. CL. 21.

SAISEIKO CO., LTD, SAITMA-KEN, JAPAN:  
2,881,339, CANC. MULTIPLE CLASS, INT. CLS. 1 AND 11.

SAKRETE OF NORTH AMERICA, LLC, CHARLOTTE, NC:  
716,707, REN. 4-12-11. U.S. CL. 12 (INT. CL. 19).

SALESFORCE.COM, INC., SAN FRANCISCO, CA:  
3,960,332, PUB. 3-1-2011. INT. CL. 38.

- SALGADO, RENOIR A., OAKLAND, CA, DBA TRUE SKOOL:  
3,960,341, PUB. 3-1-2011. INT. CL. 35.
- SALON DEVELOPMENT, INC., ST. PAUL, MN, DBA SALON DEVELOPMENT CORPORATION:  
3,962,291, INT. CL. 41.
- SALT RIVER PIMA-MARICOPA INDIAN COMMUNITY, THE, SCOTTSDALE, AZ:  
2,444,574. REN. 4-11-11. INT. CL. 25.  
2,444,576. REN. 4-11-11. INT. CL. 25.
- SALTER, NICOLA, SHERMAN OAKS, CA:  
2,883,309, CANC. INT. CL. 3.
- SALTMARSH, III, THOMAS W., LONGWOOD, FL:  
3,963,501, INT. CL. 32.
- SALVATION ARMY, THE, WEST NYACK, NY:  
2,882,357, CANC. INT. CL. 41.
- SAM MEINER, ORLANDO, FL:  
3,962,331, INT. CL. 43.
- SAM MOON TRADING ENTERPRISE, LTD., FRISCO, TX:  
3,961,166, PUB. 3-1-2011. MULTIPLE CLASS, INT. CLS. 9, 14 AND 18.
- SAM'S PRODUCTS, INC., SOPHIA, NC:  
3,963,058, INT. CL. 30.
- SAME SEEDS DIFFERENT WINDS FOUNDATION, STAMFORD, CT:  
3,960,498, PUB. 3-1-2011. MULTIPLE CLASS, INT. CLS. 9 AND 41.
- SAMMONS III, JOHN F., FORT WORTH, TX:  
3,963,543, INT. CL. 16.
- SAMSON DISTRIBUTING INC., WELLINGTON, FL:  
2,469,886. REN. 4-12-11. INT. CL. 5.
- SAMSUNG ELECTRONICS CO., LTD., KYUNGKI-DO, REPUBLIC OF KOREA:  
2,880,693, CANC. INT. CL. 9.
- SAMSUNG ELECTRONICS CO., LTD., SUWON-SI, GYEONGGI-DO, REPUBLIC OF KOREA:  
3,963,207, INT. CL. 9.  
3,963,381, INT. CL. 9.  
3,963,433, INT. CL. 9.
- SAMUEL, GAW, CARRICKFERGUS, UNITED KINGDOM, TA DATAGRID STORAGE:  
3,961,162, PUB. 3-1-2011. INT. CL. 42.
- SAN-TEC, INC., LINDEN, NJ:  
3,961,142, PUB. 3-1-2011. INT. CL. 3.
- SANCHEZ, MATTHEW F., SANTA BARBARA, CA:  
3,963,869, INT. CL. 41.
- SANDEL MEDICAL INDUSTRIES L.L.C., CHATSWORTH, CA:  
3,840,435, COR. INT. CL. 10.  
3,893,720, COR. INT. CL. 10.
- SANDERS CANDY FACTORY, INC., BALDWIN PARK, CA:  
3,013,789, AM. INT. CL. 30.
- SANDERSON, FRED, RENTON, WA:  
2,881,232, CANC. INT. CL. 37.
- SANDLER SYSTEMS, INC., OWINGS MILLS, MD, TA SANDLER TRAINING:  
2,498,251. REN. 4-8-11. INT. CL. 41.
- SANDLOT, LLC, FORT WORTH, TX:  
3,960,971, PUB. 3-1-2011. MULTIPLE CLASS, INT. CLS. 35, 41 AND 42.
- SANDRA L. BLANKFIELD INC, HOUSTON, TX, DBA BRANCHWATER TAVERN:  
3,962,597, INT. CL. 43.
- SANDRA RICH GMBH, D-56242 EBERNHAWN, FED REP GERMANY:  
2,382,348, CANC. INT. CL. 21.
- SANDVIK MINING AND CONSTRUCTION OY, FI-33330 TAMPERE, FINLAND:  
3,960,683, PUB. 3-1-2011. MULTIPLE CLASS, INT. CLS. 9 AND 42.
- SANESE SERVICES, INC., COLUMBUS, OH:  
2,442,613. REN. 4-8-11. INT. CL. 42.
- SANFILIPPO, ANDREW P., JACKSONVILLE, FL:  
2,883,084, CANC. INT. CL. 16.
- SANOLITE CORPORATION, ELIZABETH, NJ:  
2,487,023. REN. 4-11-11. MULTIPLE CLASS, INT. CLS. 3, 5 AND 21.  
2,492,110. REN. 4-11-11. MULTIPLE CLASS, INT. CLS. 3, 5 AND 21.
- SANTARIS PHARMA A/S, DENMARK:  
3,960,665, PUB. 3-1-2011. MULTIPLE CLASS, INT. CLS. 1, 5 AND 42.
- SANTOON PRODUCTIONS INC., TARZANA, CA:  
2,881,988, CANC. INT. CL. 16.
- SANTORELLI, DOMENICO, VALLEY STREAM, NY:  
2,880,886, CANC. INT. CL. 21.
- SANTOS LAGUNA, S.A. DE C.V., C.P. 27000, MEXICO:  
2,880,762, CANC. INT. CL. 28.
- SANYO ELECTRIC CO., LTD., JAPAN:  
3,960,647, PUB. 3-1-2011. INT. CL. 12.
- SAORA KABUSHIKI KAISHA, YOKOHAMA-SHI, KANAGAWA, JAPAN, DBA SAORA INC.:  
2,882,795, CANC. MULTIPLE CLASS, INT. CLS. 9 AND 42.
- SARA LEE BAKERY GROUP, INC., DOWNERS GROVE, IL:  
3,960,948, PUB. 3-1-2011. INT. CL. 30.
- SARAMAX APPAREL GROUP, INC., NEW YORK, NY:  
3,960,935, PUB. 3-1-2011. INT. CL. 25.
- SARASOHO ENTERPRISE CONTENT MGMT & DESIGN, LUTZ, FL:  
3,961,292, PUB. 3-1-2011. INT. CL. 42.
- SARGENT MANUFACTURING COMPANY, NEW HAVEN, CT:  
2,882,418, CANC. INT. CL. 6.
- SARGENTO FOODS INC., PLYMOUTH, WI:  
2,441,758. REN. 4-14-11. INT. CL. 40.
- SARGENTO FOODS, INC., PLYMOUTH, WI:  
3,962,257, INT. CL. 42.
- SARIN TECHNOLOGIES, LTD., KFAR SABA, ISRAEL:  
3,960,478, PUB. 3-1-2011. INT. CL. 9.
- SARPES BEVERAGES, LLC, GOLDEN BEACH, FL:  
3,962,431, INT. CL. 32.  
3,962,432, INT. CL. 32.
- SARRIS HOLDINGS, LLP, CANONSBURG, PA:  
3,963,849, INT. CL. 30.
- SARTORIUS AG, 37075 GOETTINGEN, GERMAN DEM REP:  
3,960,231, PUB. 3-1-2011. INT. CL. 9.
- SATCO PRODUCTS, INC., BRENTWOOD, NY:  
2,383,726, CANC. INT. CL. 11.
- SATI-BABI, INC., TERRE HAUTE, IN:  
2,393,263. REN. 4-12-11. INT. CL. 29.
- SATIN BUTTERFLY BABY BOUTIQUE, L.L.C., ATLANTA, GA, DBA SATIN BUTTERFLY BABY BOUTIQUE:  
3,961,487, PUB. 3-1-2011. INT. CL. 25.
- SAUCIER, DIANE E., CHICAGO, IL AND TITLEBAUM, JESSICA, CHICAGO, IL:  
3,961,703, PUB. 3-1-2011. INT. CL. 35.
- SAUTER FEINMECHANIK GMBH, D-72555 METZINGEN, FED REP GERMANY, WILLY SAUTER KG, 7418 METZINGEN, WURTTENBERG, FED REP GERMANY:  
900,711. REN. 4-13-11. U.S. CL. 23 (INT. CL. 7).
- SAVANH, BOBBY B, PORTLAND, OR:  
3,962,847, INT. CL. 11.  
3,962,848, INT. CL. 11.  
3,962,849, INT. CL. 9.
- SAVE-A-LOT FOOD STORES, LTD., EARTH CITY, MO:  
2,883,209, CANC. INT. CL. 32.  
2,883,210, CANC. INT. CL. 32.  
3,962,615, INT. CL. 32.
- SAVORY SAUCES, INC., ATLANTA, GA:  
2,883,402, CANC. INT. CL. 30.
- SAVOYA, DALLAS, TX:  
3,961,072, PUB. 3-1-2011. INT. CL. 35.
- SAWGRASS TECHNOLOGIES, INC., MOUNT PLEASANT, SC:  
2,383,305, CANC. INT. CL. 2.
- SAWYER JOHN & CO., INC., COAL VALLEY, IL, DBA CREEKSIDE VINEYARDS:  
3,962,423, INT. CL. 33.
- SAZERAC COMPANY, INC., NEW ORLEANS, LA:  
3,960,839, PUB. 3-1-2011. INT. CL. 33.
- SB WORLDWIDE, LLC, BATTLE CREEK, MI:  
3,962,033, MULTIPLE CLASS, INT. CLS. 25 AND 45.
- SCANBUY, INC., NEW YORK, NY:  
2,882,070, CANC. MULTIPLE CLASS, INT. CLS. 9, 35



- AND 42.  
 SCANLON LEADERSHIP NETWORK, EAST LANSING, MI, FORMERLY SCANLON PLAN ASSOCIATES:  
 2,881,072, CANC. INT. CL. 35.  
 SCATE TECHNOLOGIES, INC., ORION, MI:  
 2,881,146, CANC. INT. CL. 41.  
 SCHAFFNER MANUFACTURING COMPANY, INC., PITTSBURGH, PA:  
 2,382,881, CANC. MULTIPLE CLASS, INT. CLS. 6 AND 20.  
 SCHAPER APARTMENT KG, 20149 HAMBURG, FED REP GERMANY:  
 2,880,713, CANC. MULTIPLE CLASS, INT. CLS. 3, 16, 36 AND 43.  
 SCHATZMAN, JAMES C., AURORA, CO:  
 2,883,395, CANC. INT. CL. 9.  
 SCHEIDER, WALTER, ANN ARBOR, MI:  
 2,384,149, CANC. INT. CL. 41.  
 SCHELLING, CHRISTIANNE E, THREE RIVERS, CA:  
 3,961,828, PUB. 3-1-2011. INT. CL. 5.  
 SCHEMMER ASSOCIATES INC., THE, OMAHA, NE:  
 2,384,139, CANC. INT. CL. 42.  
 SCHERING-PLOUGH HEALTHCARE PRODUCTS, INC., MEMPHIS, TN:  
 3,962,212, INT. CL. 5.  
 SCHILL + SEILACHER GMBH, D-71032 BOEBLINGEN, GERMAN DEM REP, SCHILL & SEILACHER GMBH & CO., BOBLINGEN, FED REP GERMANY:  
 1,186,270, REN. 4-13-11. INT. CL. 1.  
 SCHLOSSER, JAMES B., SAN RAFAEL, CA:  
 2,882,008, CANC. INT. CL. 42.  
 SCHLUTER-SYSTEMS KG, DE-58640 ISERLOHN, FED REP GERMANY, SCHLUTER-SCHIENE GMBH, ISERLOHN, FED REP GERMANY:  
 1,645,259, REN. 4-11-11. INT. CL. 19.  
 SCHMIDT, RUSSEL A., NORTH OAKS, MN:  
 2,382,517, CANC. INT. CL. 9.  
 SCHNABEL RESTAURANTS, LLC, NAVARRE, OH:  
 3,963,178, INT. CL. 43.  
 3,963,452, INT. CL. 43.  
 SCHNEER, BARRY A, MIAMI, FL:  
 3,960,479, PUB. 3-1-2011. INT. CL. 7.  
 SCHNEIDER ELECTRIC USA, INC., PALATINE, IL:  
 2,517,370, REN. 4-13-11. INT. CL. 9.  
 SCHNEIDER INTERNATIONAL, INC., GREENBAY, WI:  
 3,963,732, MULTIPLE CLASS, INT. CLS. 35 AND 39.  
 SCHNEIDER NATIONAL, INC., GREENBAY, WI:  
 3,963,731, MULTIPLE CLASS, INT. CLS. 35 AND 39.  
 SCHOLASTIC INC., NEW YORK, NY:  
 2,555,327, REN. 4-11-11. INT. CL. 16.  
 3,963,568, INT. CL. 28.  
 SCHOLFIELD AUTO PLAZA, L.L.C., WICHITA, KS:  
 2,382,025, CANC. INT. CL. 42.  
 SCHOLZ, ALEXANDER, 53507 DERNAU, FED REP GERMANY:  
 3,960,706, PUB. 3-1-2011. MULTIPLE CLASS, INT. CLS. 10 AND 41.  
 SCHOR, EDWARD, TORRINGTON, CT:  
 3,962,348, INT. CL. 25.  
 3,962,349, INT. CL. 25.  
 SCHROEDER, SANDI, LOS ANGELES, CA:  
 3,960,488, PUB. 3-1-2011. INT. CL. 44.  
 SCHUBERTH GMBH, FED REP GERMANY:  
 3,960,828, PUB. 3-1-2011. INT. CL. 9.  
 SCHWAN'S IP, LLC, MARSHALL, MN:  
 3,962,636, INT. CL. 30.  
 SCHWARTZ, BERNARD, BROOKLINE, MA:  
 2,384,319, CANC. INT. CL. 16.  
 SCHWEGMAN, KATIE R., BLOOMINGTON, MN:  
 3,961,138, PUB. 3-1-2011. INT. CL. 8.  
 SCHWORAK ENTERPRISES LLC, SALEM, OR, DBA BEST LITTLE HAIR HOUSE:  
 3,961,553, PUB. 3-1-2011. INT. CL. 44.  
 SCHYDLOWSKY, ANDREW, SANTA BARBARA, CA:  
 2,443,047, REN. 4-12-11. INT. CL. 5.  
 SCHYLLING, DAVID, SOUTH HAMILTON, MA:  
 2,883,267, CANC. INT. CL. 28.  
 SCIACQUA, MICHEAL, NORTH BEND, WA:  
 3,961,425, PUB. 3-1-2011. INT. CL. 35.  
 SCIENCE & TECH CMO, INC., DENVER, CO:  
 3,962,745, INT. CL. 41.  
 SCIENCE APPLICATIONS INTERNATIONAL CORPORATION, MCLEAN, VA:  
 2,442,328, REN. 4-12-11. INT. CL. 42.  
 SCIENTIFIC INSTRUMENT SERVICES, INC., RINGOES, NJ:  
 2,384,376, CANC. INT. CL. 16.  
 SCISIVE CONSULTING LP, NEW YORK, NY:  
 3,961,031, PUB. 3-1-2011. INT. CL. 35.  
 SCM SOLUTIONS, LLC, NEW BERLIN, WI:  
 3,961,779, PUB. 3-1-2011. INT. CL. 35.  
 SCONYERS, INC., AUGUSTA, GA, AKA SCONYERS BAR-BQUE:  
 1,167,804, REN. 4-13-11. INT. CL. 42.  
 SCONYERS, INC., AUGUSTA, GA, AKA SCONYERS BAR-BQUE:  
 1,184,010, REN. 4-12-11. INT. CL. 29.  
 1,186,184, REN. 4-13-11. INT. CL. 42.  
 SCOOP MANAGEMENT LLC, NEW YORK, NY:  
 2,444,013, REN. 4-9-11. INT. CL. 35.  
 SCOREBUGS, FARMINGTON HILLS, MI:  
 2,881,752, CANC. INT. CL. 9.  
 SCOTT FREDMAN, VENICE, CA:  
 3,962,802, INT. CL. 41.  
 SCOTT, DAVID, DENVER, NC:  
 3,961,815, PUB. 3-1-2011. INT. CL. 9.  
 SCRATCH MUSIC GROUP, INC., NEW YORK, NY:  
 3,963,150, INT. CL. 41.  
 SDI TECHNOLOGIES INC., RAHWAY, NJ:  
 3,962,012, INT. CL. 9.  
 SDM LTD., MINERAL WELLS, TX:  
 3,962,503, INT. CL. 32.  
 SEÑORIO DE VILLARRICA, S.L., E-26340 SAN ASENSIO (LA RIOJA), SPAIN:  
 3,960,686, PUB. 3-1-2011. INT. CL. 33.  
 SEÑORIO DE VILLARRICA, S.L., SPAIN:  
 3,960,691, PUB. 3-1-2011. INT. CL. 33.  
 SEA FEAR, LARGO, FL:  
 3,963,206, INT. CL. 25.  
 SEA WORLD LLC, ORLANDO, FL:  
 2,443,976, REN. 4-12-11. INT. CL. 41.  
 SEAGATE TECHNOLOGY LLC, SCOTTS VALLEY, CA:  
 3,963,454, INT. CL. 9.  
 SEALY TECHNOLOGY LLC, TRINITY, NC:  
 2,883,177, CANC. INT. CL. 20.  
 SEAMAN SCHEPPS & CO., INC., NEW YORK, NY:  
 2,512,684, REN. 4-11-11. INT. CL. 14.  
 SEAN DACEY, LLC, ATLANTA, GA:  
 2,881,580, CANC. MULTIPLE CLASS, INT. CLS. 25, 32 AND 43.  
 SEARCH AMERICA, INC., MINNEAPOLIS, MN:  
 3,962,187, INT. CL. 35.  
 SEARS BRANDS, LLC, HOFFMAN ESTATES, IL:  
 3,962,415, INT. CL. 7.  
 3,962,416, INT. CL. 7.  
 3,963,546, MULTIPLE CLASS, INT. CLS. 41 AND 44.  
 SEATTLE UNIVERSITY, SEATTLE, WA:  
 3,960,419, PUB. 9-28-2010. MULTIPLE CLASS, INT. CLS. 21, 25 AND 41.  
 SEAWEED BATH CO., LLC, THE, AUSTIN, TX:  
 3,963,614, INT. CL. 3.  
 SEAWORLD PARKS & ENTERTAINMENT LLC, ORLANDO, FL:  
 2,445,267, REN. 4-13-11. INT. CL. 41.  
 SECRET SOLUTIONS, LLC., PEARLAND, TX:  
 2,881,134, CANC. INT. CL. 5.  
 SECURA INC., NAPERVILLE, IL:  
 3,962,960, INT. CL. 28.  
 SECURITIES AMERICA ADVISORS, INC., LAVISTA, NE:  
 3,961,967, INT. CL. 36.  
 3,961,968, INT. CL. 36.  
 SECURITY COMPANY, DULUTH, MN, DBA SECURITY JEWELERS:  
 1,676,439, REN. 4-11-11. INT. CL. 42.  
 SEEIDEAS INC., MASON, OH:  
 2,882,287, CANC. INT. CL. 16.



- SEHGAL AMAN, SANTA CLARA, CA, DBA CHANNELVISION INC.:  
3,960,895, PUB. 3-1-2011. INT. CL. 42.  
3,960,896, PUB. 3-1-2011. INT. CL. 42.  
3,960,958, PUB. 3-1-2011. INT. CL. 42.
- SEL-FEX, C.A., CARACAS, VENEZUELA:  
2,881,156, CANC. INT. CL. 25.
- SELECT COMFORT CORPORATION, MINNEAPOLIS, MN:  
2,881,772, CANC. INT. CL. 20.
- SELECT COMFORT CORPORATION, PLYMOUTH, MN:  
2,883,076, CANC. MULTIPLE CLASS, INT. CLS. 20 AND 24.
- SELECTED CHEMICAL PRODUCTS COMPANY, WAUKESGAN, IL, DBA SELECTED BEAUTY PRODUCTS COMPANY:  
3,961,082, PUB. 3-1-2011. INT. CL. 3.
- SELKIRK CORPORATION, RICHARDSON, TX:  
3,962,312, INT. CL. 11.
- SELL, JILL, SAGAMORE HILLS, OH:  
3,963,879, INT. CL. 35.
- SELLARS ABSORBENT MATERIALS, INC., MILWAUKEE, WI:  
3,963,274, INT. CL. 16.
- SEMIKRON INTERNATIONAL GMBH, 90431 NÜRNBERG, FED REP GERMANY:  
3,960,821, PUB. 3-1-2011. INT. CL. 9.
- SEMINARCONCERTS INTERNATIONAL INC., LAS VEGAS, NV, DBA MUSIC 4 LIFE:  
3,961,631, PUB. 3-1-2011. INT. CL. 44.
- SEMPA POWER SYSTEMS LTD., NORTH VANCOUVER, BC, CANADA:  
3,884,824, COR. MULTIPLE CLASS, INT. CLS. 37 AND 42.
- SENECHAL, AMY, CHASKA, MN:  
3,961,568, PUB. 3-1-2011. INT. CL. 35.
- SENGSTAKEN ENTERPRISES, INC., OXNARD, CA:  
3,962,127, INT. CL. 25.
- SENIOR LIFE INSURANCE COMPANY, THOMASVILLE, GA:  
2,883,407, CANC. INT. CL. 36.
- SENORX, INC., IRVINE, CA:  
3,961,812, PUB. 3-1-2011. INT. CL. 10.
- SEPANTA DESIGN, LLC, VIENNA, VA:  
3,961,873, PUB. 3-1-2011. INT. CL. 43.
- SEPTEMBER PRODUCTIONS, INC., BRENTWOOD, TN:  
2,836,574, CANC. INT. CL. 41.
- SER SOLUTIONS, INC., DULLES, VA:  
2,882,113, CANC. INT. CL. 42.
- SERVICEBENCH, INC., STERLING, VA:  
3,962,900, INT. CL. 42.
- SERVICECENTRAL TECHNOLOGIES, INC., ATLANTA, GA:  
2,514,454, REN. 4-8-11. INT. CL. 9.
- SERVICEMAGIC, INC., DENVER, CO:  
2,881,371, CANC. INT. CL. 35.
- SETON HALL UNIVERSITY, SOUTH ORANGE, NJ:  
3,961,579, PUB. 3-1-2011. INT. CL. 35.
- SETTLES KRICK, INC., BOISE, ID:  
2,447,041, REN. 4-9-11. INT. CL. 33.
- SHAKY'S USA, INC., ALHAMBRA, CA:  
2,880,997, CANC. INT. CL. 43.
- SHALEE PRODUCTIONS LLC, AGOURA HILLS, CA:  
3,963,577, MULTIPLE CLASS, INT. CLS. 9 AND 41.
- SHALOM INTERNATIONAL CORP., PERTH AMBOY, NJ:  
3,961,991, INT. CL. 16.
- SHANGHAI CREATOR APPAREL & ACCESSORIES CO., LTD., SHANGHAI, CHINA:  
3,962,807, INT. CL. 25.
- SHANGHAI YANG LIPENG FRIED DUMPLING RESTAURANT MANAGEMENT CO., LTD., SHANGHAI, CHINA:  
3,960,779, PUB. 3-1-2011. INT. CL. 43.
- SHANNON BELL, MARY, MIDDLETOWN, MD, DBA LOVING GIFTS FROM HEAVEN:  
3,962,665, INT. CL. 16.
- SHAPELLES ENTERPRISE INC., HARRISBURG, NC:  
3,963,883, INT. CL. 32.
- SHAPIRO, NANCY B., OLNEY, MD:  
3,962,660, INT. CL. 16.
- SHAREBUILDER CORPORATION, SEATTLE, WA:  
3,962,095, INT. CL. 36.
- SHAREHOLDERS BRANDS, LLC, TWO RIVERS, WI:  
2,881,735, CANC. INT. CL. 29.
- SHARP HEALTHCARE, SAN DIEGO, CA:  
3,963,142, INT. CL. 44.
- SHEILA FRIEDMAN, BENSLEM, PA, FORMERLY STOLTZ/FRIEDMAN ASSOCIATES AND DR. DONALD R. STOLTZ, BENSLEM, PA, FORMERLY STOLTZ/FRIEDMAN ASSOCIATES:  
3,961,049, PUB. 3-1-2011. INT. CL. 41.
- SHELHIGH, INC, UNION, NJ:  
2,881,105, CANC. INT. CL. 10.
- SHELTON, COLETTE M., LOS ANGELES, CA, DBA COCO-COZY:  
3,961,483, PUB. 3-1-2011. INT. CL. 35.
- SHEN YUN PERFORMING ARTS, INC., CUDDEBACKVILLE, NY:  
3,960,232, PUB. 3-1-2011. INT. CL. 41.  
3,960,233, PUB. 3-1-2011. INT. CL. 41.
- SHEPARD, SANDRA HOUGH, CHICO, CA:  
3,963,061, INT. CL. 25.
- SHERRILL, DAN, LEWISVILLE, TX:  
3,961,791, PUB. 3-1-2011. INT. CL. 17.
- SHERWIN-WILLIAMS COMPANY, THE, CLEVELAND, OH:  
3,962,191, INT. CL. 2.
- SHERWOOD AMERICA, INC., FULLERTON, CA:  
2,881,565, CANC. INT. CL. 9.
- SHERWOOD BRANDS, LLC, ROCKVILLE, MD:  
3,961,742, PUB. 3-1-2011. INT. CL. 29.
- SHIELDS & LESKO, P.C., WEST MIFFLIN, PA:  
2,383,432, CANC. INT. CL. 42.
- SHIFT4 CORPORATION, LAS VEGAS, NV:  
3,962,703, INT. CL. 42.
- SHIM, SUN, PARAMOUNT, CA:  
3,960,539, PUB. 3-1-2011. MULTIPLE CLASS, INT. CLS. 25 AND 28.
- SHIMANO INC., SAKAI CITY, OSAKA, JAPAN:  
3,963,122, INT. CL. 25.
- SHINGLES, DAVID JAY, ALLENTOWN, PA, DBA HEALTH DETECT AND SHINGLES, JONATHAN LEE, ALLENTOWN, PA, DBA HEALTH DETECT:  
2,679,936, CANC. INT. CL. 42.
- SHIPWORKS BRISBANE PTY. LTD., HEMMANT QUEENSLAND, AUSTRALIA:  
2,883,419, CANC. INT. CL. 37.
- SHISEIDO COMPANY, LTD., TOKYO, 104-10, JAPAN:  
2,451,752, REN. 4-11-11. INT. CL. 3.
- SHOE BRANDING EUROPE BVBA, B-9700 OUDENAARDE, BELGIUM:  
3,963,842, INT. CL. 25.
- SHOE LORD, INC., TORRANCE, CA:  
2,384,293, CANC. INT. CL. 35.
- SHOGAKUKAN PRODUCTION CO., LTD., TOYKO, JAPAN:  
2,883,086, CANC. INT. CL. 24.
- SHORETOURS.COM, LLC, IDAHO FALLS, ID:  
2,881,215, CANC. INT. CL. 35.
- SHORTCAST INC, SAN MATEO, CA:  
3,961,614, PUB. 3-1-2011. INT. CL. 9.
- SHOWVAKER, JESSE A, SIMPSONVILLE, SC:  
3,961,802, PUB. 3-1-2011. INT. CL. 25.
- SHUEISHA INC., TOKYO, JAPAN:  
2,384,002, CANC. INT. CL. 9.
- SIALIX, INC., VISTA, CA, FORMERLY GC-FREE, INC.:  
3,963,778, MULTIPLE CLASS, INT. CLS. 1 AND 5.
- SIDNEY, WILLIAM, GREENWOOD, CA AND ALKIRE, JEFF, GREENWOOD, CA:  
3,963,116, INT. CL. 37.
- SIEBAY INC., PARK RIDGE, IL:  
3,960,253, PUB. 3-1-2011. INT. CL. 45.
- SIEG, CHARLES R., INVERNESS, IL:  
3,961,286, PUB. 3-1-2011. INT. CL. 42.
- SIEGEL, STEVEN J., LA JOLLA, CA:  
2,443,122, REN. 4-11-11. INT. CL. 41.
- SIEMENS AKTIENGESSELLSCHAFT, MUNICH, FED REP GERMANY:  
2,382,428, CANC. INT. CL. 10.  
2,720,302, CANC. MULTIPLE CLASS, INT. CLS. 35 AND

42.  
SIEMENS AKTIENGESELLSCHAFT, MUNCHEN, FED REP GERMANY:  
2,880,620, CANC. MULTIPLE CLASS, INT. CLS. 9, 35, 38, 39 AND 42.
- SIEMENS AKTIENGESELLSCHAFT, MUNICH, FED REP GERMANY:  
2,881,338, CANC. INT. CL. 9.
- SIERRA DESIGN MANUFACTURING, INC., LIVERMORE, CT, DBA MOORE ROOM:  
3,961,504, PUB. 3-1-2011. INT. CL. 6.
- SIGE SEMICONDUCTOR INC., OTTAWA, ONTARIO, CANADA:  
2,882,988, CANC. INT. CL. 9.
- SIGMA GAME INC., LAS VEGAS, NV:  
2,882,457, CANC. INT. CL. 9.
- SIGNAL INVESTMENT & MANAGEMENT CO., WILMINGTON, DE:  
3,962,610, INT. CL. 3.
- SIHL GMBH, DÜREN, FED REP GERMANY:  
3,962,024, INT. CL. 16.
- SIKICH LLP, AURORA, IL:  
2,659,249, CANC. INT. CL. 42.
- SILT-SAVER, INC., CONYERS, GA:  
2,541,770, REN. 4-8-11. INT. CL. 11.
- SILVER LINE BUILDING PRODUCTS LLC, NORTH BRUNSWICK, NJ:  
2,883,139, CANC. INT. CL. 40.
- SILVER OAKS PUBLISHING, INC., MOLINE, IL:  
2,383,197, CANC. INT. CL. 9.
- SILVERMAN, SARAH, EAST HAMPTON, NY:  
3,963,037, INT. CL. 25.
- SIMAS, CAROLINE H., CHARLOTTE, NC:  
3,962,271, INT. CL. 16.
- SIMON, STACY, PHILADELPHIA, PA:  
3,961,437, PUB. 3-1-2011. INT. CL. 30.
- SIMONA AMERICA, INC., HAZELTON, PA:  
2,880,914, CANC. INT. CL. 17.
- SIMONIZ USA, INC., BOLTON, CT:  
3,962,336, INT. CL. 9.
- SIMPLE INVENTIONS INC., SHARON, MA:  
2,883,007, CANC. INT. CL. 42.
- SIMPLE LOGIC INC., TORONTO, CANADA:  
2,400,166, REN. 4-11-11. INT. CL. 42.
- SIMPLEXITY, LLC, RESTON, VA, SIMPLEXITY, INC., HERNDON, VA:  
2,518,245, REN. 4-14-11. MULTIPLE CLASS, INT. CLS. 35 AND 42.
- SIMPLISSE, INC., ST. LOUIS, MO:  
3,963,215, INT. CL. 20.
- SIMPLY CANVAS, INC., AKRON, OH:  
3,961,833, PUB. 3-1-2011. INT. CL. 40.  
3,961,836, PUB. 3-1-2011. INT. CL. 40.
- SIMPLYFUN, LLC, BELLEVUE, WA:  
3,963,677, INT. CL. 28.  
3,963,716, INT. CL. 28.
- SINCLAIR FINANCE COMPANY, SALT LAKE CITY, UT:  
3,961,680, PUB. 3-1-2011. MULTIPLE CLASS, INT. CLS. 35 AND 37.
- SINGH, TEJINDER, HALF MOON BAY, CA:  
3,961,787, PUB. 3-1-2011. INT. CL. 36.
- SINGLETON EQUIPMENT, LLC, LIVINGSTON, LA:  
3,962,726, INT. CL. 7.
- SIRIUS XM RADIO INC., NEW YORK, NY, XM SATELLITE RADIO INC., WASHINGTON, DC:  
2,547,677, REN. 4-14-11. INT. CL. 38.
- SIRIUS XM RADIO INC., NEW YORK, NY:  
2,556,817, REN. 4-13-11. INT. CL. 38.
- SISCO TEXTILES N.V., WILLEMSTAD, CURACAO, NETHERLANDS ANTILLES:  
3,962,141, INT. CL. 25.
- SISQUOC HEALTHCARE, INC., NEWPORT BEACH, CA:  
3,963,691, INT. CL. 3.
- SIXNET, LLC, BALLSTON LAKE, NY:  
3,963,073, INT. CL. 9.  
3,963,074, INT. CL. 9.  
3,963,075, INT. CL. 9.  
3,963,076, INT. CL. 9.
- SJHI (XIAMEN) CO., LTD., XIAMEN, FUJIAN, CHINA:  
3,961,453, PUB. 3-1-2011. INT. CL. 11.  
3,961,523, PUB. 3-1-2011. INT. CL. 11.  
3,961,528, PUB. 3-1-2011. INT. CL. 11.
- SKAN IÇ VE DIS TICARET INSAAT ELEKTRONIK TEKSTİL GIDA VE MADEN SANAYİ ANONİM ŞİRKETİ, TURKEY:  
3,960,814, PUB. 3-1-2011. INT. CL. 22.
- SKANDINAVISKA ENSKILDA BANKEN AB (PUBL), NEW YORK, NY:  
2,882,029, CANC. INT. CL. 36.
- SKF USA INC., KULPSVILLE, PA, MICRODOT MANUFACTURING, INC., SALT LAKE CITY, UT:  
1,154,873, REN. 4-11-11. INT. CL. 17.
- SKIN OF STEEL, NFP, GLENVIEW, IL:  
3,961,155, PUB. 3-1-2011. MULTIPLE CLASS, INT. CLS. 35 AND 36.
- SKIN SPECIALIST, LLC, CONSHOHOCKEN, PA:  
3,961,527, PUB. 3-1-2011. INT. CL. 3.
- SKY FINANCIAL GROUP, INC., BOWLING GREEN, OH:  
2,382,535, CANC. INT. CL. 36.
- SKYBOX SECURITY, INC., PALO ALTO, CA:  
2,882,974, CANC. INT. CL. 9.
- SKYDIVE UNIVERSITY, INC., DELAND, FL:  
3,960,996, PUB. 3-1-2011. INT. CL. 41.
- SKYFIBER, INC., BRYAN, TX:  
3,961,809, PUB. 3-1-2011. INT. CL. 9.
- SKYLINE CORPORATION, ELKHART, IN:  
1,179,027, REN. 4-11-11. INT. CL. 12.
- SKYWAY LUGGAGE COMPANY, SEATTLE, WA:  
2,492,169, REN. 4-11-11. INT. CL. 18.  
2,492,169, AM. INT. CL. 18.
- SLEEP INNOVATIONS INC., WEST LONG BRANCH, NJ:  
2,383,898, CANC. INT. CL. 20.
- SLEEPING GIANT, INC., HASTINGS, NE:  
2,882,290, CANC. INT. CL. 20.
- SLIDEME LLC, SEATTLE, WA, DBA SLIDEME:  
3,960,312, PUB. 3-1-2011. INT. CL. 9.
- SLIM & FIT FRANCHISE, LLC, CONCORD, OH:  
3,962,975, INT. CL. 41.
- SLIPNOT EYEWEAR, INC., BOULDER CREEK, CA:  
2,881,571, CANC. INT. CL. 9.
- SLOAN VALVE COMPANY, FRANKIN PARK, IL:  
2,883,326, CANC. INT. CL. 11.
- SLSB, LLC, MADISON, IL:  
3,963,759, INT. CL. 6.
- SMART CITY HOLDINGS, LLC, LAKE BUENA VISTA, FL:  
2,483,275, REN. 4-11-11. INT. CL. 38.
- SMART SALES SOLUTIONS LLC, BEND, OR:  
3,963,287, INT. CL. 41.
- SMARTDISK CORPORATION, FORT MYERS, FL:  
2,881,483, CANC. INT. CL. 9.
- SMARTPLUG SYSTEMS LLC, SEATTLE, WA:  
3,963,764, INT. CL. 9.
- SMARTPOOL, INC., LAKEWOOD, NJ:  
3,961,998, INT. CL. 7.
- SMARTSET AUTOMATION LLC, PLYMOUTH, MN:  
2,383,976, CANC. INT. CL. 9.
- SMEDLEY FINANCIAL SERVICES, INC., SALT LAKE CITY, UT:  
2,883,131, CANC. INT. CL. 36.
- SMI HOME PRODUCTS, INC., GLEN GARDNER, NJ:  
2,881,362, CANC. INT. CL. 35.
- SMILE SANGYO CO., LTD., OSAKA, JAPAN:  
3,962,997, INT. CL. 20.
- SMITH INTELLECTUAL PROPERTY, LLC, GREENCASTLE, IN:  
2,444,764, REN. 4-9-11. INT. CL. 10.
- SMITH, GREGG, BEND, OR AND SMITH, SHARON, BEND, OR AND SMITH BRYNNE, SCOTTSDALE, AZ:  
3,963,720, INT. CL. 14.
- SMITH, RONNIE G., CYPRESS, TX:  
3,962,829, MULTIPLE CLASS, INT. CLS. 35, 37 AND 42.
- SMITH, SUSAN K., LAKELAND, FL:  
2,487,770, REN. 4-14-11. INT. CL. 16.
- SMITHKLINE BEECHAM (CORK) LIMITED, COUNTY CORK, IRELAND:  
2,881,663, CANC. INT. CL. 5.

- SMITTY'S SUPPLY, INC., ROSELAND, LA:  
3,963,211, MULTIPLE CLASS, INT. CLS. 1 AND 4.
- SMOKE ON AEROBATICS, L.L.C., HOUSTON, TX:  
3,963,800, INT. CL. 25.
- SMP INDUSTRIES, INC., CHATTANOOGA, TN, STAINLESS METAL PRODUCTS, INC., CHATTANOOGA, TN:  
910,883. REN. 4-9-11. U.S. CL. 32 (INT. CL. 20).
- SMS MEER GMBH, 41069 MOENCHENGLADBACH, FED REP GERMANY, SMS HASENCLEVER GMBH, DUSSELDORF, FED REP GERMANY:  
1,622,148. REN. 4-14-11. INT. CL. 42.
- SMSC EUROPE GMBH, KARLSRUHE, FED REP GERMANY:  
3,962,311, INT. CL. 9.
- SMYTH & HELWYS PUBLISHING, INC., MACON, GA:  
2,490,886. REN. 4-13-11. INT. CL. 42.
- SNAP SURVEYS, LTD., PORTSMOUTH, NH:  
1,997,287. REN. 4-12-11. INT. CL. 9.
- SNITCH, LLC, LOUISVILLE, KY:  
2,881,258, CANC. MULTIPLE CLASS, INT. CLS. 16 AND 45.
- SNYDER-MARK DRUGS ROSELLE, INC., ROSELLE, IL AND WOUND CARE ON WHEELS, NAPERVILLE, IL:  
2,883,017, CANC. INT. CL. 5.
- SOARINGWORDS, INC., NEW YORK, NY:  
3,963,154, INT. CL. 41.
- SOCIETE AIR FRANCE, 95747 ROISSY-CHARLES-DE-GAULLE, FRANCE:  
2,444,124. REN. 4-8-11. INT. CL. 39.
- SOCIETE DES PRODUITS NESTLE S.A., 1800 VEVEY, SWITZERLAND:  
2,882,167, CANC. INT. CL. 42.  
3,963,323, INT. CL. 11.
- SOCIETE EN NOM COLLECTIF LA CLOSERIE DES LILAS, 75006 PARIS, FRANCE:  
2,382,128, CANC. INT. CL. 42.
- SOCIETE GENERALE, 75009 PARIS, FRANCE:  
2,450,412. REN. 4-11-11. MULTIPLE CLASS, INT. CLS. 16, 36 AND 38.  
2,450,412, CANC. INT. CL. 35.
- SOCIETE GUY LAROCHE, 75008 PARIS, FRANCE:  
2,382,443, CANC. INT. CL. 25.
- SOCIETY CLOTHING COMPANY LLC, BOSTON, MA:  
3,963,412, INT. CL. 25.
- SOCIÉTÉ NATIONALE DES CHEMINS DE FER FRANÇAIS (SNCF), FRANCE:  
3,960,652, PUB. 3-1-2011. MULTIPLE CLASS, INT. CLS. 12, 16, 35, 38, 39 AND 43.
- SOCKWA CORPORATION, OXNARD, CA:  
3,960,934, PUB. 3-1-2011. INT. CL. 25.
- SODASHI PTY LTD., NORTH FREMANTLE, AUSTRALIA:  
3,962,061, INT. CL. 3.
- SOFTLIFE CORPORATION, THE, NORTHBROOK, IL:  
2,882,369, CANC. MULTIPLE CLASS, INT. CLS. 9 AND 42.
- SOFTWARE SOLUTIONS INTEGRATED, LLC, SHELBYVILLE, IL:  
3,961,353, PUB. 3-1-2011. INT. CL. 9.
- SOHO PUBLISHING COMPANY, NEW YORK, NY:  
3,963,832, INT. CL. 16.
- SOL BRANDS, INC., WILDEY, ST. MICHAEL, BARBADOS:  
3,962,159, INT. CL. 4.
- SOLARWORLD AG, BONN, FED REP GERMANY:  
3,963,125, INT. CL. 9.
- SOLFRANE, 75003 PARIS, FRANCE:  
2,881,967, CANC. MULTIPLE CLASS, INT. CLS. 3 AND 18.
- SOLIDA WERK WERKZEUGTECHNIK GMBH & CO. KG, D-5630 REMSCHEID 1, FED REP GERMANY:  
2,444,090. REN. 4-13-11. INT. CL. 7.
- SOLLEN TECHNOLOGIES, LLC, DALLAS, TX:  
2,882,033, CANC. INT. CL. 42.
- SOLO CUP OPERATING CORPORATION, LAKE FOREST, IL:  
1,640,527. REN. 4-8-11. INT. CL. 21.
- SOLSTICE LIVING SOLUTIONS, INC., SCOTTSDALE, AZ:  
3,963,094, MULTIPLE CLASS, INT. CLS. 44 AND 45.
- SOLVAY ENGINEERED POLYMERS, INC., AUBURN HILLS, MI:  
2,882,502, CANC. INT. CL. 17.
- SOLVAY SA, BELGIUM:  
3,960,809, PUB. 3-1-2011. MULTIPLE CLASS, INT. CLS. 1 AND 40.
- SOMERS, CANDACE L., HENDERSON, NV, DBA CRAZY-MARE:  
3,962,800, INT. CL. 35.
- SOMETRICS, INC., EL SEGUNDO, CA:  
3,963,522, INT. CL. 16.
- SOMMER METALLBAU-STAHLBAU; GMBH & CO. KG, FED REP GERMANY:  
3,960,745, PUB. 3-1-2011. MULTIPLE CLASS, INT. CLS. 6 AND 19.
- SONIC SOLUTIONS LLC, NOVATO, CA:  
2,471,889. REN. 4-9-11. INT. CL. 9.
- SONNENBERG & PARTNERS, LLC, RIDGEWOOD, NJ:  
3,961,599, PUB. 3-1-2011. INT. CL. 35.
- SONOMA COUNTY TOURISM BUREAU, INC., SANTA ROSA, CA:  
3,961,462, PUB. 3-1-2011. INT. CL. 35.
- SONY ELECTRONICS INC., PARK RIDGE, NJ:  
2,882,644, CANC. INT. CL. 16.
- SONY PICTURES DIGITAL PRODUCTION INC., CULVER CITY, CA:  
2,881,109, CANC. INT. CL. 9.
- SOON, LIM OK, GANGDONG-GU, SEOUL, REPUBLIC OF KOREA:  
3,961,978, INT. CL. 25.
- SORHAGEN, ROGER, FLANDERS, NJ:  
2,881,835, CANC. INT. CL. 41.
- SOS NOVELTIES, INC., PASADENA, CA:  
3,963,646, INT. CL. 4.
- SOSIK LLC, LOUISVILLE, KY:  
2,882,929, CANC. INT. CL. 20.
- SOTO, MARK, GRANITE BAY, CA:  
3,961,476, PUB. 3-1-2011. INT. CL. 41.
- SOUND DESIGN TECHNOLOGIES LTD., BURLINGTON, ONTARIO, CANADA:  
2,881,940, CANC. INT. CL. 9.
- SOUND VITALITY, LLC, LAGUNA NIGUEL, CA:  
2,882,839, CANC. INT. CL. 10.
- SOUNDFIELD LIMITED, WAKEFIELD, UNITED KINGDOM:  
3,960,256, PUB. 3-1-2011. INT. CL. 9.
- SOURCE INDUSTRIES, INC., SAN FERNANDO, CA:  
3,960,549, PUB. 3-1-2011. MULTIPLE CLASS, INT. CLS. 3, 9, 14, 18, 25 AND 35.
- SOUTH BEACH BEVERAGE COMPANY, INC., NORWALK, CT:  
2,881,733, CANC. INT. CL. 32.
- SOUTH JERSEY PARALEGAL ASSOCIATION, HADDONFIELD, NJ:  
3,962,395, U.S. CL. B.
- SOUTHERN CALIFORNIA BEVERAGE CORPORATION, SANTA ANA, CA:  
2,883,133, CANC. INT. CL. 32.
- SOUTHERN DIVERSIFIED PRODUCTS, LLC, HATTIESBURG, MS:  
3,961,672, PUB. 3-1-2011. INT. CL. 2.
- SOUTHERN DREAM FOODS, INC., LOUISVILLE, KY:  
2,882,057, CANC. INT. CL. 30.
- SOUTHERN POVERTY LAW CENTER, INC., THE, MONTGOMERY, AL:  
2,444,532. REN. 4-12-11. MULTIPLE CLASS, INT. CLS. 16 AND 42.
- SOUTHERN REFRIGERATED TRANSPORT, INC., TEXARKANA, AR:  
3,961,369, PUB. 3-1-2011. INT. CL. 39.  
3,961,372, PUB. 3-1-2011. INT. CL. 39.
- SOUTHLAND PRINTING COMPANY, INC., SHREVEPORT, LA:  
2,384,286, CANC. INT. CL. 7.
- SOUTHWIRE COMPANY, CARROLLTON, GA:  
3,962,047, INT. CL. 9.

SOVEREIGN RUBBER LIMITED, STOCKPORT, CHESHIRE, ENGLAND:  
2,881,545, CANC. MULTIPLE CLASS, INT. CLS. 1, 17 AND 27.

SPA LOGIC, INC., THORSBY, ALBERTA T0C 2P0, CANADA, SPA LOGIC, INC., THORSBY, ALBERTA T0C 2P0, CANADA:  
2,426,046, REN. 4-13-11, INT. CL. 11.

SPACE AGE SERVICES, INC., TAMPA, FL:  
2,881,257, CANC. MULTIPLE CLASS, INT. CLS. 38 AND 45.

SPARKMAN INTERPRISES, LLC, WINCHESTER, VA:  
3,961,401, PUB. 3-1-2011, INT. CL. 9.

SPARTAN MOTORS, INC., CHARLOTTE, MI:  
3,963,379, INT. CL. 9.

SPEAK THE WORD CHURCH INTERNATIONAL, GOLDEN VALLEY, MN:  
2,646,056, CANC. MULTIPLE CLASS, INT. CLS. 9 AND 16.

SPECIALIZED BICYCLE COMPONENTS, INC., MORGAN HILL, CA:  
3,963,415, INT. CL. 12.

SPECIALTY CONCRETE PRODUCTS, INC., WEST COLUMBIA, SC:  
2,382,113, CANC. INT. CL. 16.

SPECIALTY PHARMA ASSOCIATION, BIRMINGHAM, AL:  
3,961,017, PUB. 3-1-2011, INT. CL. 35.  
3,961,021, PUB. 3-1-2011, INT. CL. 35.  
3,961,144, PUB. 3-1-2011, U.S. CL. 200.

SPECTRASENSORS, INC., SAN DIMAS, CA:  
2,882,813, CANC. INT. CL. 9.

SPEDIA, INC., WILMINGTON, DE:  
3,961,160, PUB. 3-1-2011, INT. CL. 45.

SPEECHWORKS INTERNATIONAL, INC., BOSTON, MA:  
2,882,269, CANC. INT. CL. 9.

SPEEDWARE LTEE./LTD., ST. LAURENT, QUEBEC, CANADA:  
2,881,559, CANC. INT. CL. 9.

SPEEDWAY LLC, ENON, OH:  
2,882,897, CANC. INT. CL. 9.  
2,882,898, CANC. INT. CL. 38.

SPENCER GIFTS LLC, EGG HARBOR TOWNSHIP, NJ:  
2,547,947, REN. 4-13-11, INT. CL. 35.

SPENCER, DOUGLAS, NAPLES, FL:  
2,443,757, REN. 4-12-11, INT. CL. 35.

SPIELO MANUFACTURING ULC, MONCTON, NEW BRUNSWICK, CANADA:  
2,883,176, CANC. INT. CL. 9.  
3,962,057, INT. CL. 9.

SPINELLI, JAMES, DEVON, PA:  
3,962,378, INT. CL. 25.

SPIR COMMUNICATION (S.A.), 13100 AIX EN PROVENCE, FRANCE:  
2,880,707, CANC. MULTIPLE CLASS, INT. CLS. 16, 35, 36, 38 AND 41.

SPIRENT COMMUNICATIONS OF ROCKVILLE, INC., GERMANTOWN, MD:  
2,881,994, CANC. INT. CL. 9.

SPIRITSINGLES.COM, MIAMI BEACH, FL:  
2,670,280, CANC. INT. CL. 42.

SPORNETTE INTERNATIONAL, INC., HOMEWOOD, IL:  
2,882,386, CANC. INT. CL. 21.

SPORT & SPINE S.A.S. REHABILITATION SERVICES LTD., ABBOTSFORD, BRITISH COLUMBIA, CANADA:  
2,880,574, CANC. INT. CL. 10.

SPORTCRAFT, LTD., MT. OLIVE, NJ:  
2,882,834, CANC. INT. CL. 28.

SPORTS BINGO, INC., CHARLESTON, SC:  
3,961,598, PUB. 3-1-2011, INT. CL. 28.

SPORTS ET LOISIRS, FRANCE:  
3,960,735, PUB. 3-1-2011, MULTIPLE CLASS, INT. CLS. 18, 25, 28 AND 35.

SPOTWAVE WIRELESS INC., OTTAWA ONTARIO K2K 3C7, CANADA:  
2,880,637, CANC. INT. CL. 9.

SPRATT CYCLE SUPPORT, INC., PONTE VEDRA BEACH, FL:  
2,545,145, REN. 4-11-11, INT. CL. 12.  
2,550,182, REN. 4-12-11, INT. CL. 12.

SPRECK, RYAN T., DANA POINT, CA:  
2,883,200, CANC. INT. CL. 9.

SPRINGS GLOBAL US, INC., FORT MILL, SC:  
2,383,991, CANC. INT. CL. 24.

SPRINT COMMUNICATIONS COMPANY L.P., OVERLAND PARK, KS:  
2,883,380, CANC. INT. CL. 38.

SPRIZZARE SOAP CAFE LLC, HENDERSON, NV, DBA SWEET BUBBLE SOAP CAFE:  
3,961,796, PUB. 3-1-2011, INT. CL. 3.

SPRUCE NATURALS, LLC, RENO, NV:  
3,962,210, MULTIPLE CLASS, INT. CLS. 29 AND 30.

SPX CORPORATION, CHARLOTTE, NC, SOLA ELECTRIC COMPANY, CHICAGO, IL:  
547,029, REN. 4-11-11, U.S. CL. 21 (INT. CL. 9).

SPYGLASS INTEGRATION, INC., SAN FRANCISCO, CA:  
2,880,766, CANC. MULTIPLE CLASS, INT. CLS. 35, 38 AND 42.

SQUARE, INC., SAN FRANCISCO, CA:  
3,962,489, MULTIPLE CLASS, INT. CLS. 35, 36 AND 38.

SQUATTING LIZARD INDUSTRIES, LLC, CHANDLER, AZ:  
2,881,168, CANC. INT. CL. 30.

SQUAWKSPOT, INC., DALLAS, TX:  
3,962,450, INT. CL. 36.

SR HOLDINGS, LLC, LEXINGTON, MA:  
1,139,234, CANC. MULTIPLE CLASS, INT. CLS. 18, 25 AND 26.

SRAM CORPORATION, CHICAGO, IL:  
2,382,371, CANC. INT. CL. 12.

SRI SPORTS LIMITED, KOBE-SHI, HYOGO, JAPAN:  
3,963,506, INT. CL. 28.

SSCUS ACQUISITION CO., CHICAGO, IL TO SSCUS ACQUISITION CO., CHICAGO, IL:  
2,814,415, CANC. INT. CL. 41.

SSM HEALTH CARE OF OKLAHOMA, INC., OKLAHOMA CITY, OK:  
3,963,792, INT. CL. 38.

ST. DOMINIC JACKSON MEMORIAL HOSPITAL, JACKSON, MS:  
3,963,333, INT. CL. 44.

ST. LOUIS CARDINALS, LLC, ST. LOUIS, MO, ST. LOUIS NATIONAL BASEBALL CLUB, INC., ST. LOUIS, MO:  
1,152,691, REN. 4-13-11, INT. CL. 41.

STADA ARZNEIMITTEL AG, 61118 BAD VILBEL, FED REP GERMANY:  
2,881,354, CANC. MULTIPLE CLASS, INT. CLS. 5, 42 AND 44.

STAFF AND LINE, FRANCE:  
3,960,669, PUB. 3-1-2011, MULTIPLE CLASS, INT. CLS. 9, 35, 38 AND 42.

STAGED DIABETES MANAGEMENT LLC, FRANKLIN LAKES, NJ, DBA MATREX LIMITED LIABILITY COMPANY:  
2,882,102, CANC. INT. CL. 9.

STAGEIT CORP., LOS ANGELES, CA:  
3,963,512, INT. CL. 38.

STAHL, THOMAS A., SAN FRANCISCO, CA:  
3,960,583, PUB. 3-1-2011, INT. CL. 42.

STAN WINSTON CREATURES, INC., VAN NUYS, CA:  
2,882,775, CANC. MULTIPLE CLASS, INT. CLS. 16 AND 28.

STANDARD & POOR'S FINANCIAL SERVICES LLC, NEW YORK, NY:  
2,382,446, CANC. INT. CL. 36.  
3,963,388, MULTIPLE CLASS, INT. CLS. 36 AND 42.

STANDARD COMMERCIAL CORPORATION, WILSON, NC:  
2,881,464, CANC. MULTIPLE CLASS, INT. CLS. 35 AND 40.

STANDARD TEXTILE CO., INC., CINCINNATI, OH:  
2,383,853, CANC. INT. CL. 5.  
3,962,175, INT. CL. 24.

- STANDBY HOLDINGS PTY LTD, BRISBANE, QUEENSLAND, AUSTRALIA:  
2,504,580. REN. 4-8-11. INT. CL. 42.  
2,504,580. CANC. INT. CL. 39.
- STANDISH, JODI, OMAHA, NE:  
3,961,077. PUB. 3-1-2011. INT. CL. 41.
- STANLEY STEEMER INTERNATIONAL, INC., DUBLIN, OH:  
2,442,125. REN. 4-11-11. MULTIPLE CLASS, INT. CLS. 35 AND 37.
- STAPLES THE OFFICE SUPERSTORE, LLC, FRAMINGHAM, MA:  
2,880,756. CANC. INT. CL. 25.
- STAPLES, THELMA, HILLSIDE, NJ:  
2,882,780. CANC. INT. CL. 25.
- STAPLEX COMPANY, INC., THE, BROOKLYN, NY, OUSANI, JAMES J., BROOKLYN, NY, DBA THE STAPLEX COMPANY:  
540,853. REN. 4-13-11. U.S. CL. 23 (INT. CL. 7).
- STAR LABS/FORAGE RESEARCH, INC., CLARKSDALE, MO:  
1,151,350. REN. 4-8-11. MULTIPLE CLASS, INT. CLS. 1 AND 5.
- STAR TOUR OPERATOR, INC., MIAMI, FL:  
2,881,622. CANC. MULTIPLE CLASS, INT. CLS. 39 AND 43.
- STARAQUA WATER TREATMENT SYSTEMS, S.L., MADRID, SPAIN:  
3,960,712. PUB. 3-1-2011. MULTIPLE CLASS, INT. CLS. 1 AND 11.
- STARCARE ASSOCIATES, INC., NEWPORT BEACH, CA:  
2,881,652. CANC. INT. CL. 36.  
2,881,653. CANC. INT. CL. 36.  
2,881,654. CANC. INT. CL. 36.
- STARFISH, LLC, NEW YORK, NY:  
3,960,352. PUB. 3-1-2011. INT. CL. 35.
- STARK, CLARA C, ROBINS, IA:  
3,960,553. PUB. 3-1-2011. INT. CL. 16.
- STARTEK, INC., DENVER, CO:  
3,960,366. PUB. 3-1-2011. INT. CL. 35.  
3,960,367. PUB. 3-1-2011. INT. CL. 35.
- STARWOOD CAPITAL GROUP L.L.C., GREENWICH, CT:  
2,891,495. CANC. MULTIPLE CLASS, INT. CLS. 35 AND 39.
- STASYS LIMITED, FARNHAM, SURREY, UNITED KINGDOM:  
2,881,493. CANC. MULTIPLE CLASS, INT. CLS. 9, 35, 38, 39, 41 AND 42.
- STATE FARM MUTUAL AUTOMOBILE INSURANCE COMPANY, BLOOMINGTON, IL:  
3,962,494. INT. CL. 36.
- STATE OF FLORIDA, DEPARTMENT OF TRANSPORTATION, TALLAHASSEE, FL:  
3,962,137. MULTIPLE CLASS, INT. CLS. 36, 39 AND 42.
- STATE OF UTAH - CIO'S OFFICE, AMERICAN FORK, UT:  
2,881,673. CANC. INT. CL. 35.
- STAWITZ, NANCY L., NEW CUMBERLAND, PA:  
3,962,072. MULTIPLE CLASS, INT. CLS. 3 AND 16.
- STEGGERT, PETER F., BUFORD, GA:  
3,963,747. INT. CL. 20.
- STEINEN HOLDINGS, INC., PARSIPPANY, NJ:  
3,961,440. PUB. 3-1-2011. MULTIPLE CLASS, INT. CLS. 6 AND 7.
- STEP FORWARD GROUP, LLC, LOS ANGELES, CA:  
3,962,544. INT. CL. 42.
- STEP UP SPORTS, INC., RIALTO, CA:  
2,881,128. CANC. INT. CL. 41.
- STEPHANIE GIORDANO, BROOKFIELD, WI:  
3,962,856. INT. CL. 3.
- STEPHEN MINISTRIES, ST. LOUIS, MO:  
2,445,795. REN. 4-9-11. INT. CL. 41.
- STEPHENS, JASON T., BAKERSFIELD, CA:  
3,962,972. INT. CL. 25.
- STEPSTONE, INC., GARDENA, CA:  
2,464,095. REN. 4-8-11. INT. CL. 19.
- STEP5 VENTURE PARTNERS GP, LLC, EAST PALO ALTO, CA:  
3,962,366. INT. CL. 36.
- STEREOFAME, INC., PONTE VEDRA BEACH, FL:  
3,961,952. PUB. 3-1-2011. INT. CL. 41.
- STERN, ROBERT A, MONROE TOWNSHIP, NJ:  
3,962,510. INT. CL. 42.
- STEUP, MIKE, ISERLOHN, FED REP GERMANY:  
3,961,606. PUB. 3-1-2011. INT. CL. 9.
- STEVEN M. SHRIVER, CEDAR RAPIDS, IA:  
3,962,284. INT. CL. 25.
- STEVENS, DENNIS L., FLUSHING, NY:  
3,961,586. PUB. 3-1-2011. INT. CL. 41.
- STEWART-HAAS RACING, LLC, KANNAPOLIS, NC:  
3,962,199. MULTIPLE CLASS, INT. CLS. 5, 6, 9, 12, 14, 16, 18, 20, 21, 24, 25, 26, 27, 28, 35 AND 41.  
3,962,205. MULTIPLE CLASS, INT. CLS. 5, 6, 9, 12, 14, 16, 18, 20, 21, 24, 25, 26, 27, 28, 35 AND 41.
- STEWART, THOMAS R., PHILADELPHIA, PA:  
3,963,036. INT. CL. 21.
- STEWART, TONY, KANNAPOLIS, NC:  
2,454,637. REN. 4-13-11. MULTIPLE CLASS, INT. CLS. 6, 9, 14, 16, 18, 19, 20, 21, 24, 25, 27, 28 AND 41.
- STICHTING GMP + INTERNATIONAL, NL-2517 JL DEN HAAG, NETHERLANDS:  
3,960,729. PUB. 3-1-2011. MULTIPLE CLASS, INT. CLS. 31, 42 AND 44.
- STICK, ALEX, MCKINLEYVILLE, CA:  
2,579,742. CANC. INT. CL. 41.
- STICKY RIBHOUSE, LLC, ATLANTA, GA:  
3,961,593. PUB. 3-1-2011. INT. CL. 30.
- STIEFEL LABORATORIES, INC., WILMINGTON, DE:  
2,881,359. CANC. INT. CL. 3.
- STIFEL, NICOLAUS & COMPANY, INC., ST. LOUIS, MO:  
3,962,405. INT. CL. 9.
- STILLHOUSE, LLC, NEW YORK, NY:  
3,961,609. PUB. 3-1-2011. INT. CL. 16.  
3,961,895. PUB. 3-1-2011. INT. CL. 33.
- STILLMAN, ALLISON, OJAI, CA, DBA ROMANCING THE DIVINE:  
3,962,791. INT. CL. 3.
- STINGR SOLUTIONS LLC, ORLANDO, FL:  
3,962,245. INT. CL. 18.
- STÉPHANE KAY, SWITZERLAND:  
3,960,677. PUB. 3-1-2011. MULTIPLE CLASS, INT. CLS. 25, 35, 41 AND 42.
- STOELTING, LLC, KIEL, WI:  
2,441,290. REN. 4-12-11. INT. CL. 7.
- STONEFLY NETWORKS, INC., SAN DIEGO, CA:  
2,882,895. CANC. INT. CL. 9.
- STONZ WEAR INCORPORATED, KAMLOOPS, CANADA:  
3,960,291. PUB. 3-1-2011. INT. CL. 25.
- STOREFLIX, LLC, MASON, OH:  
3,962,704. INT. CL. 42.
- STORMAN PRODUCTIONS INC., CLEARWATER, FL:  
2,383,254. CANC. INT. CL. 42.
- STORMWATER FILTERS CORP, WESTMINSTER, CA:  
3,960,858. PUB. 3-1-2011. INT. CL. 11.
- STORYMANAGER, INC., OAKLAND, CA:  
2,883,220. CANC. INT. CL. 9.  
2,883,221. CANC. INT. CL. 9.
- STRATEGIC MARKETING AND PLANNING, INC., CHAMPAIGN, IL, AKA STRATEGIC MARKETING AND MAILING:  
3,963,654. INT. CL. 35.
- STRATHMORE PARTNERS LP, CONCORD, NH:  
2,881,065. CANC. INT. CL. 35.
- STREET LAW, INC., SILVER SPRING, MD:  
3,962,673. INT. CL. 9.
- STRENFLEX, WALLISELLEN, SWITZERLAND:  
2,883,059. CANC. INT. CL. 16.
- STRENGTH OF NATURE, LLC, SAVANNAH, GA:  
3,962,911. INT. CL. 3.
- STRIMPLE, RANDALL L., WESTMINSTER, CO:  
3,963,840. INT. CL. 43.
- STRUNK AND ASSOCIATES, L.P., HOUSTON, TX:  
2,882,012. CANC. INT. CL. 36.
- STRYKER IMAGING CORPORATION, HARTLAND, WI:  
2,882,107. CANC. INT. CL. 42.
- STUART J WARD, CAMAS, WA:  
3,961,396. PUB. 3-1-2011. INT. CL. 11.



STUDENT LOAN XPRESS, INC., SAN DIEGO, CA:  
2,883,361, CANC. MULTIPLE CLASS, INT. CLS. 16 AND 36.

STUDIO IP HOLDINGS LLC, WILMINGTON, DE:  
2,445,276. REN. 4-8-11. MULTIPLE CLASS, INT. CLS. 20 AND 24.

STUDIOCANAL IMAGE, BOULOGNE-BILLAN COURT, FRANCE:  
2,881,983, CANC. INT. CL. 25.  
2,881,984, CANC. INT. CL. 28.

STYLEMARK, INC., ORMOND BEACH, FL, RIVIERA TRADING INC., NEW YORK, NY:  
2,504,806. REN. 4-8-11. INT. CL. 14.

SU, JE GEM, PENANG, MALAYSIA:  
2,746,600, CANC. INT. CL. 35.

SUBAIR SYSTEMS, L.L.C., GRANITEVILLE, SC:  
2,444,270. REN. 4-13-11. MULTIPLE CLASS, INT. CLS. 7 AND 11.

SUBCON PRODUCTS, INC., TOTOWA, NJ:  
2,383,213, CANC. INT. CL. 11.

SUBLIMINAL PRODUCTIONS, AURORA, CO:  
3,962,364, MULTIPLE CLASS, INT. CLS. 9 AND 41.

SUCCESS OCEAN INDUSTRIAL LTD., ROAD TOWN, TORTOLA, BR. VIRGIN ISLANDS:  
2,882,200, CANC. INT. CL. 25.

SUCCESSION CAPITAL FINANCIAL SYSTEMS, L.L.C., TUCSON, AZ:  
3,962,314, INT. CL. 42.

SUDAFRICA IMPORT-EXPORT, S.L., SPAIN:  
3,960,725, PUB. 3-1-2011. INT. CL. 14.

SUDIMPLANT, F-31500 TOULOUSE, FRANCE:  
3,960,750, PUB. 3-1-2011. MULTIPLE CLASS, INT. CLS. 5, 9 AND 10.

SUGATSUNE KOGYO CO., LTD., CHIOYDA-KU, TOKYO, JAPAN:  
3,888,601, COR. INT. CL. 6.

SUGHRUE MION, PLLC, WASHINGTON, DC:  
2,515,252. REN. 4-12-11. INT. CL. 42.

SULLIVAN, SHARLENE G., POUGHKEEPSIE, NY:  
2,880,697, CANC. INT. CL. 41.

SULPHUR MILLS LTD., MUMBAI, INDIA:  
3,960,446, PUB. 11-23-2010. INT. CL. 5.

SULTEX AG, RUETI, SWITZERLAND:  
2,880,689, CANC. INT. CL. 7.

SULZER METCO MANAGEMENT AG, SWITZERLAND:  
3,960,761, PUB. 3-1-2011. MULTIPLE CLASS, INT. CLS. 1, 6 AND 7.

SUM-HOLD CO. LTD., TAIPEI, TAIWAN:  
2,882,295, CANC. INT. CL. 18.

SUMINISTROS A. LORENZO BARROSO, S.A., SPAIN:  
3,960,739, PUB. 3-1-2011. MULTIPLE CLASS, INT. CLS. 6, 7 AND 35.

SUMITOMO FORESTRY CO., LTD., TOKYO, JAPAN:  
3,960,543, PUB. 3-1-2011. MULTIPLE CLASS, INT. CLS. 35, 36, 37 AND 42.  
3,960,544, PUB. 3-1-2011. MULTIPLE CLASS, INT. CLS. 35, 36, 37 AND 42.

SUMMER LONDON DZIGNS LLC, VALENCIA, CA:  
3,961,276, PUB. 3-1-2011. INT. CL. 11.

SUMMER STREET CAPITAL PARTNERS, LLC, BUFFALO, NY:  
3,961,521, PUB. 3-1-2011. INT. CL. 36.

SUMMERBELL, CEDRIC, RIO RANCHO, NM:  
3,963,347, INT. CL. 25.

SUMMIT CATALOG CO, CENTENNIAL, CO:  
3,963,877, INT. CL. 42.

SUMMIT ENTERTAINMENT, LLC, SANTA MONICA, CA:  
3,783,356, COR. INT. CL. 20.

SUMMIT EXECUTIVE REALTY JEFFREY & ASSOCIATES, LLC, BOSSIER CITY, LA:  
3,960,222, PUB. 3-1-2011. INT. CL. 36.

SUMMIT LAW GROUP, P.L.L.C., SEATTLE, WA:  
2,536,518. REN. 4-8-11. INT. CL. 42.

SUN ABRASIVES CO., LTD., ANSAN-CITY, KYONGGI-DO, REPUBLIC OF KOREA:  
2,382,462, CANC. INT. CL. 3.

SUN CHEMICAL CORPORATION, PARSIPPANY, NJ:  
3,962,485, INT. CL. 2.  
3,962,486, INT. CL. 2.  
3,962,550, INT. CL. 2.

SUN RESEARCH LLC, SANTA CRUZ, CA:  
3,961,163, PUB. 3-1-2011. INT. CL. 3.

SUN STREET CENTERS, SALINAS, CA:  
3,960,435, PUB. 3-1-2011. INT. CL. 35.

SUN, DONALD J.C., SAN GABRIEL, CA:  
2,881,755, CANC. INT. CL. 28.

SUNBEAM PRODUCTS, INC., BOCA RATON, FL:  
3,962,773, MULTIPLE CLASS, INT. CLS. 7 AND 9.

SUNCOR ENERGY INC., CALGARY, ALBERTA, CANADA:  
2,880,898, CANC. INT. CL. 4.

SUNEX INTERNATIONAL, INC., GREENVILLE, SC:  
2,383,835, CANC. INT. CL. 35.

SUNFBR ENTERPRISES CO., LTD., TAIPEI, TAIWAN:  
2,881,017, CANC. INT. CL. 28.

SUNGLASS DESIGNS, INC., SCOTTSDALE, AZ:  
2,881,086, CANC. INT. CL. 9.

SUNKIST GROWERS, INC., SHERMAN OAKS, CA:  
931,895. REN. 4-9-11. U.S. CL. 46 (INT. CLS. 1, 5, 29, 30, 31 AND 32).

SUNNYLAND BULGUR WHEAT, INC., FRESNO, CA, DBA SUNNYLAND MILLS:  
2,883,153, CANC. INT. CL. 30.

SUNPAN TRADING & IMPORT INC., TORONTO, CANADA:  
3,960,432, PUB. 3-1-2011. MULTIPLE CLASS, INT. CLS. 11 AND 20.

SUNPOWER, INC., ATHENS, OH:  
2,446,619. REN. 4-8-11. INT. CL. 7.

SUNRISE ASTON GARDENS VENTURE, LLC, MCLEAN, VA:  
2,383,468, CANC. INT. CL. 42.

SUNRISE COFFEE COMPANY, INC., LAGUNA NIGUEL, CA:  
2,883,381, CANC. INT. CL. 30.

SUNRISE PUBLICATIONS, INC., BLOOMINGTON, IN, DBA SUNRISE GREETINGS:  
3,961,840, PUB. 3-1-2011. INT. CL. 16.

SUNRISE REALTY, L.L.C., IRVING, TX:  
2,881,925, CANC. INT. CL. 36.

SUNS LEGACY PARTNERS, LLC, PHOENIX, AZ:  
2,556,935. REN. 4-13-11. INT. CL. 25.

SUNSHINE MAKERS, INC., HUNTINGTON BEACH, CA:  
2,482,327. REN. 4-11-11. MULTIPLE CLASS, INT. CLS. 36 AND 42.

SUNSHINE MILLS, INC., RED BAY, AL:  
3,963,733, INT. CL. 31.

SUNTRUST BANKS, INC., ATLANTA, GA:  
2,383,352, CANC. INT. CL. 36.

SUPERBOATS, INC., LINDENHURST, NY:  
2,554,951. REN. 4-11-11. INT. CL. 12.

SUPERBOLT, INC., CARNEGIE, PA:  
2,392,392. REN. 4-9-11. INT. CL. 6.

SUPERIOR MEDICAL LLC, HUGO, MN:  
3,960,914, PUB. 3-1-2011. INT. CL. 10.

SUPERMEDIA LLC, DFW AIRPORT, TX:  
3,962,538, MULTIPLE CLASS, INT. CLS. 9, 16, 35, 36, 38, 39, 41 AND 42.  
3,962,539, MULTIPLE CLASS, INT. CLS. 9, 16, 35, 36, 38, 39, 41, 42 AND 45.

SUPPLYLOGIX, INC., GRAPEVINE, TX:  
3,961,412, PUB. 3-1-2011. INT. CL. 35.

SUPPORT OUR TROOPS FOUNDATION, INC., DAYTONA BEACH, FL:  
3,961,135, PUB. 3-1-2011. INT. CL. 36.

SUPRA TELECOMMUNICATIONS AND INFORMATION SYSTEMS ACQUISITION CORP., ARLINGTON, VA:  
2,881,152, CANC. INT. CL. 38.

SUPRE, INC., DALLAS, TX:  
3,962,536, INT. CL. 3.

SURFACE STRIKE MANAGEMENT, FISHERS, IN:  
3,961,005, PUB. 3-1-2011. INT. CL. 41.

SURFACES USA, NORTH HOLLYWOOD, CA:  
3,961,131, PUB. 3-1-2011. INT. CL. 35.

- SURFATECH CORPORATION, DACULA, GA:  
3,961,478, PUB. 3-1-2011. INT. CL. 1.
- SURFDOG, INC., ENCINITAS, CA:  
3,961,473, PUB. 3-1-2011. INT. CL. 9.
- SURKLE VENTURES, LLC, BROOKLYN, NY:  
3,963,683, INT. CL. 30.  
3,963,684, INT. CL. 30.
- SURRY COUNTY ECONOMIC DEVELOPMENT AND  
TOURISM, DOBSON, NC:  
3,963,362, INT. CL. 35.
- SUSAN LANDAU DESIGNS, LOS ANGELES, CA:  
2,881,785, CANC. INT. CL. 14.
- SUSHI POP, LLC, HOUSTON, TX:  
3,961,172, PUB. 3-1-2011. INT. CL. 43.
- SUSSKIND & ALMALLAH EYE ASSOCIATES, PA, TOMS  
RIVER, NJ:  
2,384,342, CANC. INT. CL. 42.
- SWAN ENTERPRISES, INC., RENO, NV:  
2,882,156, CANC. INT. CL. 25.  
2,882,579, CANC. INT. CL. 25.
- SWANSON VINEYARDS AND WINERY, OAKVILLE, CA:  
3,963,159, INT. CL. 33.
- SWANSON, BRYON, HIGHLANDS RANCH, CO:  
3,962,090, INT. CL. 9.
- SWEET STREET DESSERTS, INC., READING, PA:  
2,499,012, REN. 4-8-11. INT. CL. 30.
- SWENCO PRODUCTS, INC., POPLAR BLUFF, MO:  
2,382,732, CANC. INT. CL. 25.
- SWETS & ZEITLINGER B.V., LISSE, NETHERLANDS:  
2,882,363, CANC. MULTIPLE CLASS, INT. CLS. 35, 41, 42  
AND 45.
- SWIATEK, JOYCE, CLIFTON, TN:  
2,382,792, CANC. INT. CL. 29.
- SWIMC, INC., NEWARK, DE:  
2,384,042, CANC. INT. CL. 8.
- SWIMC, INC., NEWARK, DE, SWIMC, INC., NEWARK, DE:  
2,536,813, REN. 4-13-11. INT. CL. 2.
- SWIMC, INC., NEWARK, DE:  
2,882,967, CANC. INT. CL. 2.
- SWING IT INC., NEW YORK, NY:  
3,961,089, PUB. 3-1-2011. INT. CL. 3.
- SWINGLE, CHARLES, MURRIETA, CA AND BEHRENS,  
WILHELM, MURRIETA, CA:  
3,961,289, PUB. 3-1-2011. INT. CL. 28.
- SWITCH STICKS LTD., EVERSLED WALK, LONDON,  
UNITED KINGDOM:  
3,961,002, PUB. 3-1-2011. INT. CL. 18.
- SWIVLER, LLC, WOODLAND, WA:  
2,882,907, CANC. MULTIPLE CLASS, INT. CLS. 25 AND  
28.
- SYLVAN R. SHEMITZ DESIGNS, INC., WEST HAVEN, CT,  
SHEMITZ, SYLVAN R., WEST HAVEN, CT:  
912,720, REN. 4-13-11. U.S. CL. 21 (INT. CL. 11).
- SYMMETRY CORPORATION, MILPITAS, CA:  
3,960,386, PUB. 3-1-2011. INT. CL. 32.
- SYNCOPOLIS, INC., ST. LOUIS, MO:  
3,963,624, INT. CL. 35.
- SYNEXXUS, INC., ARLINGTON, VA:  
3,960,394, PUB. 1-25-2011. MULTIPLE CLASS, INT. CLS.  
9, 35 AND 42.
- SYNGENTA PARTICIPATIONS AG, BASEL, SWITZER-  
LAND:  
3,963,319, INT. CL. 30.
- SYNOPSIS, INC., MOUNTAIN VIEW, CA:  
2,383,451, CANC. INT. CL. 9.  
2,880,704, CANC. INT. CL. 9.
- SYRACUSE CHINA COMPANY, TOLEDO, OH:  
3,962,821, INT. CL. 21.
- SYSCO CORPORATION, HOUSTON, TX:  
1,640,626, REN. 4-14-11. INT. CL. 29.
- SYSTEM-POOL, S.A., SPAIN:  
3,960,781, PUB. 3-1-2011. INT. CL. 11.
- SYSTEMS ENGINEERING ASSOCIATES INTERNATIONAL  
INC., MELBOURNE BEACH, FL:  
3,960,963, PUB. 3-1-2011. INT. CL. 9.
- SYSTEMS, INC., GERMANTOWN, WI:  
2,881,505, CANC. MULTIPLE CLASS, INT. CLS. 6, 7 AND  
19.
- SZABO, JANET, KALISPELL, MT:  
2,881,135, CANC. INT. CL. 16.
- S2 SYNERGY LLC, DALLAS, TX, DBA POO-POURRI:  
3,962,564, INT. CL. 5.
- T & J BIOMEDICAL, OSPREY, FL:  
3,963,632, INT. CL. 5.  
3,963,634, INT. CL. 5.
- T P CYCLE AND ENGINEERING INC., BETHEL, CT, DBA  
TP ENGINEERING:  
2,382,135, CANC. MULTIPLE CLASS, INT. CLS. 7 AND  
12.
- T. D. SOFT COMMUNICATIONS, LTD., HERZLIYA 46410,  
ISRAEL:  
2,882,337, CANC. INT. CL. 9.
- T. EDWARD WINES LTD., NEW YORK, NY:  
3,961,288, PUB. 3-1-2011. INT. CL. 33.  
3,961,300, PUB. 3-1-2011. INT. CL. 33.  
3,961,715, PUB. 3-1-2011. INT. CL. 33.  
3,961,716, PUB. 3-1-2011. INT. CL. 33.  
3,961,718, PUB. 3-1-2011. INT. CL. 33.
- T. ROWE PRICE GROUP, INC., BALTIMORE, MD:  
3,961,714, PUB. 3-1-2011. INT. CL. 41.
- T. EDWARD WINES LTD., NEW YORK, NY:  
3,961,287, PUB. 3-1-2011. INT. CL. 33.
- T.G.I.C. IMPORTERS, INC., WOODLAND HILLS, CA:  
3,963,487, INT. CL. 35.
- T-MOBILE USA, INC., BELLEVUE, WA:  
3,962,146, INT. CL. 38.  
3,963,524, INT. CL. 38.
- TABLETOPS UNLIMITED, INC., CARSON, CA:  
3,671,206, COR. INT. CL. 21.
- TACKMOBLIE LLC, LAGRANGE, GA:  
1,640,379, REN. 4-8-11. INT. CL. 12.
- TACO JOHN'S SEASONINGS LIMITED PARTNERSHIP,  
CHEYENNE, WY:  
2,479,699, REN. 4-12-11. INT. CL. 30.
- TACTYON, FAIRMONT, WV:  
3,963,432, INT. CL. 42.
- TAFT, RAY, REDWOOD CITY, CA:  
3,961,038, PUB. 11-23-2010. MULTIPLE CLASS, INT. CLS.  
35 AND 41.
- TAGLIAMONTE, NINO, VICENZA, ITALY:  
3,962,617, INT. CL. 14.
- TAHOE BOARD WORKS, LLC, RENO, NV:  
3,960,967, PUB. 11-23-2010. INT. CL. 28.  
3,960,968, PUB. 11-23-2010. INT. CL. 28.  
3,960,975, PUB. 11-23-2010. INT. CL. 25.  
3,960,976, PUB. 11-23-2010. INT. CL. 25.  
3,963,799, INT. CL. 25.
- TAIWAN FU HSING INDUSTRIAL CO., LTD., KAOHSIUNG  
COUNTY, TAIWAN:  
3,962,594, MULTIPLE CLASS, INT. CLS. 6 AND 9.
- TAIWAN NAN SHAN BAMBOO WARE CO., LTD., TAIPEI,  
TAIWAN:  
2,383,905, CANC. INT. CL. 13.
- TAJMAHAL SPORTS COMPANY, U.S.A. CORP., CHICAGO,  
IL:  
3,960,597, PUB. 3-1-2011. INT. CL. 28.
- TAKARA SHUZO CO., LTD., SHIMOGYO-KU, KYOTO,  
JAPAN:  
2,881,908, CANC. INT. CL. 32.
- TAKSHA UNIVERSITY, HAMPTON, VA, AKA TAKSHA  
UNIVERSITY:  
3,961,085, PUB. 3-1-2011. INT. CL. 41.
- TALARI NETWORKS, INC., CUPERTINO, CA:  
3,961,446, PUB. 3-1-2011. INT. CL. 9.
- TALBOT, JEFFREY, SAN MARINO, CA:  
3,962,691, INT. CL. 35.
- TALENTLAB INC., KANATA, ONTARIO, CANADA:  
2,880,588, CANC. INT. CL. 35.
- TAMAR GELLER MEDIA, LLC, LOS ANGELES, CA:  
3,961,848, PUB. 3-1-2011. INT. CL. 36.
- TANDEM WINES LLC, HEALDSBURG, CA:  
3,963,662, INT. CL. 33.
- TANTEC GMBH, WIMSHEIM, FED REP GERMANY:  
3,961,570, PUB. 3-1-2011. INT. CL. 7.
- TAR PRODUCTIONS, INC., SOLANA BEACH, CA:  
3,962,409, INT. CL. 41.

TARGET BRANDS, INC., MINNEAPOLIS, MN:  
2,881,549, CANC. MULTIPLE CLASS, INT. CLS. 42 AND 43.  
3,961,922, PUB. 3-1-2011. INT. CL. 36.  
3,961,927, PUB. 3-1-2011. INT. CL. 35.

TARGET MEDIA PARTNERS OPERATING COMPANY, LLC, LOS ANGELES, CA:  
3,961,683, PUB. 3-1-2011. INT. CL. 16.

TASHUA HILL, LLC, CHICAGO, IL:  
3,962,273, INT. CL. 35.

TATA SONS LIMITED, MUMBAI, INDIA:  
3,963,247, MULTIPLE CLASS, INT. CLS. 36 AND 38.

TATE, INCORPORATED, ALEXANDRIA, VA:  
3,963,235, INT. CL. 9.

TATJANA FRISCH, FED REP GERMANY:  
3,960,768, PUB. 1-25-2011. MULTIPLE CLASS, INT. CLS. 18, 20, 24 AND 35.

TATONKA TRADING COMPANY, PORT SAINT LUCIE, FL:  
3,961,773, PUB. 3-1-2011. INT. CL. 13.

TAVERAS, CARMEN, R, WESTBURY, NY, DBA GOLD NATURALS:  
3,961,110, PUB. 3-1-2011. INT. CL. 5.

TAVERN PRODUCTS, INC., NEW PORT RICHEY, FL:  
2,881,253, CANC. MULTIPLE CLASS, INT. CLS. 30 AND 32.

TAYLOR CAPITAL GROUP, INC., ROSEMONT, IL:  
2,383,592, CANC. INT. CL. 36.

TAYLOR-LISTUG, INC., EL CAJON, CA:  
3,962,788, INT. CL. 15.  
3,962,789, INT. CL. 15.

TAYLOR, PAUL C., JR., NOVELTY, OH:  
3,961,977, INT. CL. 25.

TAYMARK, INC., NORTH MANKATO, MN:  
1,657,712, REN. 4-12-11. INT. CL. 42.

TBC TRADEMARKS, LLC, LAS VEGAS, NV:  
2,462,822, REN. 4-14-11. INT. CL. 12.

TBL PARTNERS, LLC, NEW YORK, NY:  
3,960,917, PUB. 3-1-2011. INT. CL. 37.

TCF FINANCIAL CORPORATION, WAYZATA, MN:  
3,962,792, INT. CL. 36.  
3,962,842, INT. CL. 36.

TEAM SCARAB, INC., SANTA BARBARA, CA:  
2,405,428, REN. 4-13-11. INT. CL. 12.

TEATRO ZINZANNI, SEATTLE, WA:  
2,881,586, CANC. MULTIPLE CLASS, INT. CLS. 41 AND 43.

TECH DATA CORPORATION, CLEARWATER, FL:  
2,383,081, CANC. INT. CL. 35.

TECH PAC LLC, LEXINGTON, KY:  
2,556,619, REN. 4-8-11. INT. CL. 5.

TECHFLEX, INC., SPARTA, NJ:  
3,960,358, PUB. 3-1-2011. INT. CL. 9.

TECHMETALS, INC., DAYTON, OH:  
2,485,941, REN. 4-14-11. INT. CL. 40.

TECHNOIMAGING, L.L.C., SALT LAKE CITY, UT:  
3,962,079, INT. CL. 42.

TECHNOS CO., LTD., HIRAKATA-SHI, OSAKA 573-0164, JAPAN:  
2,881,060, CANC. INT. CL. 9.

TECHNOVINEYARD, INC., NEWCASTLE, CA:  
3,962,438, INT. CL. 44.

TECHTRONIC FLOOR CARE TECHNOLOGY LIMITED, ROAD TOWN, TORTOLA, BR. VIRGIN ISLANDS:  
2,383,636, CANC. INT. CL. 7.

TECKCHEK INC., MORRISVILLE, NC:  
2,881,962, CANC. MULTIPLE CLASS, INT. CLS. 41 AND 42.

TECNOLOGIC 3 SRL, ITALY:  
3,960,740, PUB. 3-1-2011. MULTIPLE CLASS, INT. CLS. 1 AND 6.

TECUMSEH PRODUCTS COMPANY, TECUMSEH, MI:  
2,382,516, CANC. INT. CL. 7.

TEDD CYCLE, INC., NEWBURGH, NY:  
3,940,093, COR. MULTIPLE CLASS, INT. CLS. 7 AND 11.  
3,940,104, COR. MULTIPLE CLASS, INT. CLS. 7 AND 11.

TEKNOVUS, INC., PETALUMA, CA:  
3,962,208, INT. CL. 9.

TELARUS, INC., FOUNTAIN VALLEY, CA:  
2,883,308, CANC. INT. CL. 42.

TELEBRANDS CORP., FAIRFIELD, NJ:  
3,963,351, INT. CL. 26.

TELECA AB, MALMÖ, SWEDEN:  
3,960,731, PUB. 3-1-2011. MULTIPLE CLASS, INT. CLS. 9, 38 AND 42.

TELUS CORPORATION, EDMONTON, ALBERTA, CANADA:  
3,963,126, INT. CL. 36.

TEMPERATURE SERVICE COMPANY, INC., ELK GROVE VILLAGE, IL:  
2,471,544, REN. 4-11-11. INT. CL. 37.

TEMPLE UNIVERSITY - OF THE COMMONWEALTH SYSTEM OF HIGHER EDUCATION, PHILADELPHIA, PA:  
2,512,267, COR. INT. CL. 41.

TEMPUS FUGIT, LLC, PETALUMA, CA:  
3,963,748, INT. CL. 33.

TENCAP TENNIS, LLC, FAIRWAY, KS:  
3,960,862, PUB. 3-1-2011. INT. CL. 42.

TERM OF ART PRODUCTIONS LLC, MINNEAPOLIS, MN:  
3,963,064, INT. CL. 41.

TERRA THERAPY, INC., JACKSON HEIGHTS, NY:  
2,882,401, CANC. INT. CL. 3.

TERRADIME, LLC, PITTSBURGH, PA:  
3,962,568, INT. CL. 36.

TERREMARK NORTH AMERICA, INC., MIAMI, FL:  
2,880,665, CANC. MULTIPLE CLASS, INT. CLS. 9, 35, 41 AND 42.

TESSITURA CARLO LAMPERTI E FIGLIO S.P.A., MILANO, ITALY:  
3,960,302, PUB. 3-1-2011. INT. CL. 25.

TETRAVITAE BIOSCIENCE, INC., CHICAGO, IL:  
3,962,081, INT. CL. 1.

TETROSYL LIMITED, BURY, UNITED KINGDOM:  
2,881,320, CANC. MULTIPLE CLASS, INT. CLS. 1 AND 19.

TEVA PHARMACEUTICALS USA, INC., NORTH WALES, PA:  
3,960,604, PUB. 3-1-2011. INT. CL. 5.

TEXAS CABLE NEWS, INC., DALLAS, TX:  
2,441,913, REN. 4-9-11. INT. CL. 38.

TEXAS EDUCATION AGENCY, AUSTIN, TX:  
2,881,403, CANC. INT. CL. 9.  
2,881,404, CANC. INT. CL. 16.  
2,881,405, CANC. INT. CL. 41.

TEXAS PNEUMATIC TOOLS, INC., REAGAN, TX:  
2,384,355, CANC. INT. CL. 35.

TEXAS STAR NUT AND FOOD COMPANY, INC., BOERNE, TX:  
2,963,788, COR. INT. CL. 29.

TEXAS TALENT MUSICIANS ASSOCIATION, SAN ANTONIO, TX:  
3,960,424, PUB. 3-1-2011. INT. CL. 41.

TEXTILE DECOR UK LTD, UXBRIDGE, UNITED KINGDOM:  
3,962,103, MULTIPLE CLASS, INT. CLS. 24 AND 27.

TEXTRON INNOVATIONS INC., PROVIDENCE, RI:  
3,962,470, MULTIPLE CLASS, INT. CLS. 7 AND 9.

TF CORNERSTONE INC., NEW YORK, NY:  
3,962,355, INT. CL. 36.

THAI BAMBOO RESTAURANT, L.L.C., SPOKANE, WA:  
3,961,432, PUB. 3-1-2011. INT. CL. 43.

THAI CERAMIC CO., LTD., THE, BANGKOK 10800, THAILAND:  
2,450,417, REN. 4-9-11. INT. CL. 19.

THANE INTERNATIONAL, INC., LA QUINTA, CA:  
3,962,819, INT. CL. 28.

THAUT, DENNIS R., EUGENE, OR:  
2,443,366, REN. 4-8-11. INT. CL. 25.

THE ACTIVE NETWORK, INC., SAN DIEGO, CA:  
3,963,520, MULTIPLE CLASS, INT. CLS. 25, 41 AND 44.

THE AFTERMARKET COMPANY, PHOENIX, AZ:  
2,881,422, CANC. INT. CL. 35.

THE AMERICAN ACADEMY OF DERMATOLOGY NURSE PRACTITIONERS, TAMPA, FL:  
3,963,861, INT. CL. 41.

- THE AMERICAN ARCHITECTURAL FOUNDATION, INC., WASHINGTON, DC:  
3,960,518, PUB. 3-1-2011. MULTIPLE CLASS, INT. CLS. 16, 36 AND 41.
- THE AMERICAN COLLEGE OF PSYCHIATRISTS, BERKELEY, CA:  
2,881,674, CANC. MULTIPLE CLASS, INT. CLS. 35 AND 41.
- THE AMERICAN SOCIETY FOR AESTHETIC PLASTIC SURGERY, GARDEN GROVE, CA, AKA THE AESTHETIC SOCIETY:  
3,961,006, PUB. 3-1-2011. INT. CL. 35.
- THE APPLESMITH, HOLDREGE, NE:  
2,881,753, CANC. MULTIPLE CLASS, INT. CLS. 4, 21 AND 35.
- THE AUSTEN GROUP, L.L.C., EAGLE, CO:  
3,961,303, PUB. 3-1-2011. INT. CL. 35.  
3,961,313, PUB. 3-1-2011. INT. CL. 35.
- THE B'LASTER CORPORATION, VALLEY VIEW, OH:  
3,961,004, PUB. 11-23-2010. INT. CL. 4.
- THE BALTIMORE TAILQATORS SOCIETY, INC., HENDERSON, MD:  
3,960,230, PUB. 3-1-2011. INT. CL. 36.
- THE BELL GROUP, ALBUQUERQUE, NM, AKA RIO GRANDE:  
3,961,650, PUB. 3-1-2011. INT. CL. 21.
- THE BERMINATOR, LLC, LOS ANGELES, CA, DBA DEAR BAD DAD, LLC:  
3,961,298, PUB. 3-1-2011. INT. CL. 41.
- THE BLACK & DECKER CORPORATION, TOWSON, MD:  
2,882,912, CANC. INT. CL. 7.  
3,963,820, INT. CL. 7.
- THE BOARD OF REGENTS OF THE UNIVERSITY OF TEXAS SYSTEM, AUSTIN, TX:  
3,963,234, INT. CL. 32.
- THE BONE MARROW FOUNDATION, NEW YORK, NY:  
3,960,421, PUB. 6-15-2010. INT. CL. 36.
- THE BOOSALIS GROUP, INC., MINNEAPOLIS, MN:  
3,960,844, PUB. 3-1-2011. INT. CL. 35.
- THE BOPPY COMPANY, LLC, GOLDEN, CO:  
3,963,261, MULTIPLE CLASS, INT. CLS. 24 AND 28.
- THE BOW WOW BUDDIES FOUNDATION, INC., BOULDER, CO:  
3,961,265, PUB. 3-1-2011. INT. CL. 41.  
3,961,266, PUB. 3-1-2011. INT. CL. 36.
- THE BRADFORD EXCHANGE, LTD., NILES, IL:  
3,963,237, INT. CL. 20.
- THE BRAMTON COMPANY, IRVING, TX:  
3,963,360, INT. CL. 16.
- THE BUCKLE, INC., KEARNEY, NE:  
3,963,391, MULTIPLE CLASS, INT. CLS. 14 AND 25.
- THE BURIED LIFE, INC., SAN RAFAEL, CA:  
3,960,453, PUB. 3-1-2011. INT. CL. 25.
- THE BUSINESS ROUNDTABLE, WASHINGTON,, DC:  
3,961,807, PUB. 3-1-2011. INT. CL. 16.
- THE CARTOON NETWORK LP, LLLP, ATLANTA, GA:  
2,881,756, CANC. INT. CL. 41.
- THE CARTOON NETWORK, INC., ATLANTA, GA:  
3,963,566, INT. CL. 41.
- THE CENTER FOR OPTIMAL ADULT DEVELOPMENT, WESTMINSTER, CO:  
3,961,461, PUB. 3-1-2011. INT. CL. 45.
- THE CHARITY STRIPE, NORTHBROOK, IL:  
3,963,099, INT. CL. 36.
- THE CHICAGO HIGH SCHOOL FOR THE ARTS, CHICAGO, IL:  
3,962,501, INT. CL. 41.
- THE CHRISTIAN TODAY, LOS ANGELES, CA:  
2,881,715, CANC. INT. CL. 16.
- THE CLIP COMPANY, LLC, KAYSVILLE, UT:  
2,880,890, CANC. INT. CL. 9.
- THE COLUMBIA TRIATHLON ASSOCIATION, INC., CO-LUMBIA, MD:  
3,960,900, PUB. 3-1-2011. MULTIPLE CLASS, INT. CLS. 25 AND 41.
- THE CONVEX GROUP, LLC, ATLANTA, GA:  
2,883,275, CANC. INT. CL. 9.  
2,883,276, CANC. INT. CL. 21.
- THE DEPOSITORY TRUST AND CLEARING CORPORATION, NEW YORK, NY:  
3,963,071, INT. CL. 36.
- THE DETROIT INSTITUTE OF ARTS, DETROIT, MI:  
2,881,033, CANC. INT. CL. 36.
- THE DEWITT COMPANY, INC., SIKESTON, MO:  
3,960,522, PUB. 3-1-2011. INT. CL. 22.
- THE DONOR TREE, LLC, JACKSON, MS:  
3,961,367, PUB. 3-1-2011. INT. CL. 36.
- THE DREAM WORKS, INC., KANSAS CITY, KS:  
3,960,994, PUB. 11-23-2010. INT. CL. 44.
- THE EUPHORIA ENTERTAINMENT LLC, MONROE, NJ:  
3,961,338, PUB. 3-1-2011. INT. CL. 41.
- THE FARBER CONSULTING GROUP, INC., LEVITTOWN, NY:  
2,882,914, CANC. INT. CL. 9.
- THE FORTEC GROUP INC., MISSISSAUGA, ONTARIO:  
2,881,311, CANC. INT. CL. 9.
- THE GABRIEL FOUNDATION, DENVER, CO:  
3,961,496, PUB. 3-1-2011. INT. CL. 16.
- THE GARLIC GURU, WILBRAHAM, MA:  
3,961,186, PUB. 3-1-2011. INT. CL. 43.
- THE GILLETTE COMPANY, BOSTON, MA:  
3,962,440, INT. CL. 8.  
3,962,922, INT. CL. 8.
- THE GOOD MUSIC RECORD CO., INC., BEDFORD HILLS, NY:  
2,383,791, CANC. MULTIPLE CLASS, INT. CLS. 9 AND 35.
- THE GREAT ATLANTIC & PACIFIC TEA COMPANY, INC., MONTVALE, NJ:  
2,881,606, CANC. MULTIPLE CLASS, INT. CLS. 35 AND 43.
- THE GREEN MICROGYM, INC., PORTLAND, OR:  
3,961,061, PUB. 3-1-2011. INT. CL. 41.
- THE GUZZLE CORPORATION, LONDON, ONTARIO, CANADA:  
2,882,830, CANC. INT. CL. 30.
- THE H. D. LEE COMPANY, INC., WILMINGTON, DE:  
2,881,672, CANC. INT. CL. 25.
- THE HARTZ MOUNTAIN CORPORATION, SECAUCUS, NJ:  
1,639,499, REN. 4-11-11. INT. CL. 5.  
2,384,160, CANC. INT. CL. 21.
- THE HEALTH COMPANY, LONDON LTD, TOTNES, UNITED KINGDOM, TA BEAMING BABY:  
3,962,458, MULTIPLE CLASS, INT. CLS. 3, 5, 16 AND 25.
- THE HEREAFTER INC., SISTER BAY, WI:  
3,963,205, MULTIPLE CLASS, INT. CLS. 9 AND 39.
- THE HERITAGE ARCHIVES, YUCAIPA, CA:  
3,961,854, PUB. 3-1-2011. INT. CL. 39.
- THE HOUSE ON F STREET, LLC, CLEVELAND, OH:  
3,961,959, PUB. 9-28-2010. MULTIPLE CLASS, INT. CLS. 35 AND 41.
- THE HUMANE SOCIETY OF THE UNITED STATES, WASHINGTON, DC:  
3,961,069, PUB. 3-1-2011. MULTIPLE CLASS, INT. CLS. 16 AND 35.
- THE INK WELL FOUNDATION, INC., NEW YORK, NY:  
3,962,545, INT. CL. 41.
- THE INSTITUTE FOR URBAN RESEARCH AND DEVELOPMENT, LOS ANGELES, CA:  
2,881,613, CANC. INT. CL. 30.
- THE INSTITUTE OF ELECTRICAL AND ELECTRONICS ENGINEERS, INC., PISCATAWAY, NJ, AKA IEEE:  
3,962,266, MULTIPLE CLASS, INT. CLS. 16 AND 41.
- THE INTERNATIONAL GROUP, INC., WAYNE, PA:  
2,880,718, CANC. INT. CL. 4.
- THE J. M. SMUCKER COMPANY, ORRVILLE, OH:  
1,150,549, REN. 4-11-11. INT. CL. 29.
- THE JIM HENSON COMPANY, INC., LOS ANGELES, CA:  
3,962,098, MULTIPLE CLASS, INT. CLS. 9, 16, 25, 28, 38 AND 41.
- THE JUDY RIDE FOUNDATION, ST. LOUIS, MO:  
2,881,714, CANC. INT. CL. 36.
- THE KESSLER ENTERPRISE, INC., ORLANDO, FL:  
3,962,429, INT. CL. 43.  
3,962,938, INT. CL. 43.



- THE KLEIN GROUP, INC., ATLANTA, GA:  
3,961,447, PUB. 3-1-2011. INT. CL. 41.
- THE KNOT, INC., NEW YORK, NY:  
2,881,718, CANC. INT. CL. 25.
- THE KROGER CO. OF MICHIGAN, NOVI, MI:  
3,963,289, INT. CL. 30.
- THE LIBMAN COMPANY, ARCOLA, IL:  
3,962,719, INT. CL. 21.
- THE LIEN TRUST, DAVID A. AND MURIEL M. LIEN, TRUSTEES, BATTLE GROUND, WA:  
1,150,375, REN. 4-11-11. INT. CL. 16.
- THE MARIN INSTITUTE, SAN RAFAEL, CA, AKA MARIN INSTITUTE:  
3,962,230, INT. CL. 41.
- THE MEGA LIFE AND INSURANCE COMPANY, NORTH RICHLAND HILLS, TX:  
2,880,674, CANC. INT. CL. 36.
- THE METRAFLEX COMPANY, CHICAGO, IL:  
3,962,680, INT. CL. 6.
- THE MISS, LLC, DURHAM, NC:  
3,961,868, PUB. 3-1-2011. INT. CL. 35.
- THE NASDAQ STOCK MARKET, INC., NEW YORK, NY:  
2,882,426, CANC. MULTIPLE CLASS, INT. CLS. 36 AND 38.
- THE NATIONAL COLLEGIATE ATHLETIC ASSOCIATION, INDIANAPOLIS, IN:  
3,960,301, PUB. 3-1-2011. INT. CL. 41.
- THE NEGRO LEAGUES BASEBALL MUSEUM, INC., KANSAS CITY, MO:  
2,413,318, REN. 4-8-11. INT. CL. 35.
- THE NELSON PAINT COMPANY, KINGSFORD, MI:  
2,881,860, CANC. INT. CL. 28.
- THE NEUROMATRIX GROUP, LLC, ALPHARETTA, GA:  
3,962,507, INT. CL. 35.
- THE NEW YORK TIMES COMPANY, NEW YORK, NY:  
3,960,969, PUB. 11-9-2010. MULTIPLE CLASS, INT. CLS. 9 AND 41.
- THE NIELSEN COMPANY (US), LLC, SCHAUMBURG, IL:  
3,962,147, MULTIPLE CLASS, INT. CLS. 35 AND 38.
- THE ORIGINAL E-Z GRADER CORP., CHAGRIN FALLS, OH:  
2,881,898, CANC. INT. CL. 9.
- THE PEER GROUP INC., KITCHENER, ONTARIO, CANADA:  
2,882,677, CANC. MULTIPLE CLASS, INT. CLS. 9 AND 42.
- THE PENN STATE RESEARCH FOUNDATION, UNIVERSITY PARK, PA:  
3,963,030, INT. CL. 40.
- THE PILLSBURY COMPANY, LLC, MINNEAPOLIS, MN, MCGLYNN BAKERIES, INC., EDEN PRAIRIE, MN:  
1,656,383, REN. 4-8-11. INT. CL. 30.
- THE POWER OF PEACE LLC, CRARYVILLE, NY:  
3,963,736, INT. CL. 35.
- THE PRICE COMPANY:  
*See— COSTCO WHOLESALE MEMBERSHIP, INC..*
- THE PROCTER & GAMBLE COMPANY, CINCINNATI, OH:  
2,883,175, CANC. INT. CL. 3.  
2,883,184, CANC. INT. CL. 3.  
2,883,270, CANC. MULTIPLE CLASS, INT. CLS. 3, 11 AND 21.  
2,883,271, CANC. MULTIPLE CLASS, INT. CLS. 3, 11 AND 21.  
2,883,272, CANC. MULTIPLE CLASS, INT. CLS. 3, 11 AND 21.  
3,963,317, INT. CL. 3.
- THE PROFESSIONAL BASKETBALL CLUB, LLC, SEATTLE, WA:  
2,882,835, CANC. INT. CL. 35.
- THE PRUDENTIAL INSURANCE COMPANY OF AMERICA, NEWARK, NJ:  
3,961,655, PUB. 3-1-2011. INT. CL. 36.
- THE QUADRANT CORPORATION, BELLEVUE, WA:  
2,881,546, CANC. MULTIPLE CLASS, INT. CLS. 36 AND 37.  
2,881,547, CANC. MULTIPLE CLASS, INT. CLS. 36 AND 37.  
2,881,548, CANC. MULTIPLE CLASS, INT. CLS. 36 AND 37.
- THE RACHEL LAMB PROJECT, LLC, BEDFORD, TX:  
3,962,016, INT. CL. 25.
- THE RAGE GROUP INC., CALABASAS, CA, DBA RAGE MODELS, RAGE TALENT AGENCY, RTA-RAGE TALENT AGENCY, RTA, RAGEWEAR, RAGE MODELS & TALENT, LA FIT MODELS:  
3,961,429, PUB. 3-1-2011. INT. CL. 35.  
3,961,434, PUB. 3-1-2011. INT. CL. 35.
- THE RARING CORPORATION, VANCOUVER, WA:  
3,962,656, INT. CL. 11.
- THE REINA TRUST BUILDING INSTITUTE, INC., STOWE, VT:  
2,950,983, AM. INT. CL. 45.  
2,959,081, AM. INT. CL. 45.
- THE RESIDUAL WEALTH SYSTEM INC., PLANTATION, FL:  
3,962,540, INT. CL. 36.
- THE ROB NELSON COMPANY, VANCOUVER, WA:  
3,962,342, INT. CL. 25.
- THE RUGGED BEAR COMPANY, NORWOOD, MA:  
3,963,431, INT. CL. 35.
- THE RUNNERS ON A MISSION FOUNDATION, LOUISVILLE, KY, AKA THE ROAM FOUNDATION:  
3,960,837, PUB. 3-1-2011. INT. CL. 35.
- THE SAFE CIG, LLC, LOS ANGELES, CA:  
3,961,222, PUB. 3-1-2011. INT. CL. 34.
- THE SAMUEL ROBERTS NOBLE FOUNDATION, INC., ARDMORE, OK:  
3,960,897, PUB. 3-1-2011. MULTIPLE CLASS, INT. CLS. 36, 41, 42 AND 44.  
3,960,898, PUB. 3-1-2011. INT. CL. 41.
- THE SANDY BOTTOM ENTERPRISES, LLC, ANNAPOLIS, MD:  
3,963,665, INT. CL. 33.
- THE SENATORS (RET.) FIRM, LLP, SANTA ANA, CA:  
3,963,809, MULTIPLE CLASS, INT. CLS. 35 AND 45.
- THE SIEGEL GROUP NEVADA, INC., LAS VEGAS, NV:  
3,961,268, PUB. 3-1-2011. INT. CL. 43.
- THE SMART INSTITUTE, LLC, SHERMAN OAKS, CA:  
2,882,354, CANC. INT. CL. 41.
- THE SMILEY GROUP, INC., LOS ANGELES, CA:  
3,962,180, MULTIPLE CLASS, INT. CLS. 16 AND 25.
- THE SQUEEZE INN LLC, GALT, CA:  
3,960,594, PUB. 3-1-2011. INT. CL. 43.
- THE STAYWELL COMPANY, LLC, YARDLEY, PA:  
3,961,045, PUB. 3-1-2011. INT. CL. 42.  
3,961,053, PUB. 3-1-2011. MULTIPLE CLASS, INT. CLS. 16, 42 AND 44.
- THE TEACHERS' LOUNGE, INC., ST. LOUIS, MO:  
3,961,646, PUB. 3-1-2011. INT. CL. 35.
- THE TEACHING COMPANY, LLC, CHANTILLY, VA:  
3,963,174, MULTIPLE CLASS, INT. CLS. 9, 16 AND 35.
- THE TENNIS CHANNEL, INC., SANTA MONICA, CA:  
3,962,736, INT. CL. 41.
- THE TOASTED NUT, LLC, ROSWELL, GA:  
3,963,873, INT. CL. 30.
- THE TORO COMPANY, BLOOMINGTON, MN:  
1,150,168, REN. 4-8-11. INT. CL. 4.
- THE TORONTO-DOMINION BANK, TORONTO, CANADA:  
3,960,300, PUB. 3-1-2011. INT. CL. 36.
- THE TOWN OF MOUNT PLEASANT, MOUNT PLEASANT, SC:  
3,961,519, PUB. 3-1-2011. INT. CL. 35.  
3,961,561, PUB. 3-1-2011. INT. CL. 35.
- THE TRIBUNE COMPANY, CHICAGO, IL:  
2,384,053, CANC. INT. CL. 25.
- THE UNITED STATES JUNIOR CHAMBER OF COMMERCE, TULSA, OK:  
813,205, CANC. U.S. CL. 200.
- THE VELVET CHOCOLATIER LLC, OWINGS MILLS, MD:  
3,961,282, PUB. 3-1-2011. INT. CL. 30.
- THE VOLATILITY EXCHANGE CORPORATION, GILLETTE, NJ:  
3,962,947, INT. CL. 36.
- THE WEATHER CHANNEL, LLC, ATLANTA, GA:  
2,443,945, REN. 4-14-11. INT. CL. 18.



- THE WELLA CORPORATION, WOODLAND HILLS, CA:  
2,883,182, CANC. INT. CL. 3.
- THE WOODLANDS TOWNSHIP, THE WOODLANDS, TX:  
2,880,771, CANC. MULTIPLE CLASS, INT. CLS. 35, 39, 40,  
41, 44 AND 45.
- THE ZAPPA FAMILY TRUST, COMPRISING ADELAIDE  
GAIL ZAPPA, A U.S. CITIZEN, STUDIO CITY, CA:  
2,880,907, CANC. INT. CL. 41.
- THECITYOF.COM, LLC, CORPUS CHRISTI, TX:  
3,960,846, PUB. 3-1-2011. INT. CL. 35.
- THERAPEASE CUISINE, INC., GREENFIELD, WI:  
3,960,249, PUB. 3-1-2011. MULTIPLE CLASS, INT. CLS. 43  
AND 44.
- THERATECHNOLOGIES, INC., ST-LAURENT, CANADA:  
3,962,100, INT. CL. 5.
- THERAVANCE, INC., SOUTH SAN FRANCISCO, CA:  
2,882,778, CANC. INT. CL. 5.
- THERM-IC PRODUCTS GMBH, 8200 GLEISDORF, AUS-  
TRIA:  
3,960,273, PUB. 3-1-2011. MULTIPLE CLASS, INT. CLS. 5,  
9, 11 AND 25.
- THERMA-TRU CORP., MAUMEE, OH:  
2,382,539, CANC. INT. CL. 19.
- THERMAL COMFORT, INC., KELLER, TX:  
2,651,970, CANC. INT. CL. 11.  
2,674,787, CANC. INT. CL. 11.
- THERMAL FLUIDS, INCORPORATED, SOUTH EASTON,  
MA:  
2,883,031, CANC. INT. CL. 1.
- THERMOHAUSER GMBH, FED REP GERMANY:  
3,960,687, PUB. 3-1-2011. INT. CL. 21.
- THIAM, ALIAUNE, ATLANTA, GA:  
3,962,267, INT. CL. 18.
- THIGHMASTER WORLD CORPORATION, CALABASAS,  
CA:  
2,882,995, CANC. INT. CL. 3.  
2,882,997, CANC. INT. CL. 3.  
2,882,998, CANC. INT. CL. 3.
- THINGS REMEMBERED, INC., HIGHLAND HEIGHTS, OH:  
2,444,538, REN. 4-9-11. INT. CL. 35.
- THINKPETS, INC., SANTA MONICA, CA:  
3,963,413, INT. CL. 35.
- THIRD REPUBLIC MEDIA, LLC, NEW YORK, NY:  
2,883,343, CANC. INT. CL. 16.
- THIRD WAVE, INC., ORIENTAL, NC:  
3,962,755, INT. CL. 16.
- THIRTEEN, NEW YORK, NY:  
2,393,421, REN. 4-11-11. INT. CL. 16.  
2,393,422, REN. 4-11-11. INT. CL. 41.
- THOIP, LONDON, UNITED KINGDOM:  
3,960,272, PUB. 8-18-2009. MULTIPLE CLASS, INT. CLS.  
9, 16, 25, 28 AND 41.
- THOMAS JEFFERSON UNIVERSITY, PHILADELPHIA, PA:  
2,446,348, REN. 4-12-11. INT. CL. 42.  
3,963,031, MULTIPLE CLASS, INT. CLS. 16, 41 AND 44.
- THOMAS JUDD CO., INC., SIMPSONVILLE, SC:  
2,881,420, CANC. INT. CL. 37.
- THOMAS WEISEL PARTNERS GROUP, INC., SAN FRAN-  
CISCO, CA:  
2,446,549, REN. 4-11-11. INT. CL. 36.
- THOMAS, DWAYNE, PENNSAUKEN, NJ:  
3,963,069, INT. CL. 41.
- THOMPSON & CO. OF TAMPA, INC., TAMPA, FL:  
3,963,224, INT. CL. 34.  
3,963,225, INT. CL. 34.
- THOMPSON MAHOGANY COMPANY, PHILADELPHIA,  
PA:  
2,473,172, REN. 4-11-11. INT. CL. 35.
- THOMPSON, HELVIUS, DALLAS, TX, DBA H3 ART-  
WORKS, INC.:  
2,881,658, CANC. INT. CL. 16.
- THOMSON INC., INDIANAPOLIS, IN:  
2,382,694, CANC. INT. CL. 16.
- THOMSON REUTERS (HEALTHCARE) INC., ANN ARBOR,  
MI:  
2,880,899, CANC. INT. CL. 41.
- THOMSON REUTERS (MARKETS) LLC, NEW YORK, NY:  
2,384,069, CANC. MULTIPLE CLASS, INT. CLS. 9 AND  
36.
- THOR TECH, INC., OHIO, MI, AIRSTREAM, INC., JACK-  
SON CENTER, OH:  
1,189,944, REN. 4-9-11. INT. CL. 12.
- THOR TECH, INC., SAGINAW, MI:  
2,383,092, CANC. INT. CL. 12.
- THOR TECH, INC., JACKSON CENTER, OH:  
3,962,037, INT. CL. 19.
- THORATEC CORPORATION, PLEASANTON, GA:  
2,446,716, REN. 4-8-11. INT. CL. 9.
- THORLABS, INC., NEWTON, NJ:  
3,961,929, PUB. 3-1-2011. INT. CL. 9.
- THORP DIRECT SALES, INC., DORAVILLE, GA:  
3,962,389, INT. CL. 25.
- THQ WIRELESS INC., CALABASAS HILLS, CA:  
2,881,162, CANC. INT. CL. 35.
- THREE DOGS & A CAT, INC., PRESCOTT, AZ:  
2,439,143, REN. 4-9-11. INT. CL. 28.
- THREE LITTLE MONKEYS, LLC, FRUIT HEIGHTS, UT:  
3,961,247, PUB. 3-1-2011. INT. CL. 35.
- THRIVING CHURCHES INTERNATIONAL, INC., MIND-  
EN, NV:  
3,962,225, INT. CL. 41.
- TIANJIN PUYOU MECH. & ELEC.; EQUIPMENT MFG. CO.,  
LTD., CHINA:  
3,960,733, PUB. 3-1-2011. MULTIPLE CLASS, INT. CLS. 7  
AND 9.
- TICKETS.COM, INC., COSTA MESA, CA:  
2,880,740, CANC. INT. CL. 35.
- TIDES CENTER, THE, SAN FRANCISCO, CA:  
2,382,572, CANC. INT. CL. 41.
- TIDY TANKS LTD, LANGLEY, B.C., V2Z 2T8, CANADA, D.  
TIDY WELDERS LTD., LANGLEY, BRITISH COLUMBIA,  
CANADA:  
1,153,627, REN. 4-13-11. INT. CL. 6.
- TIETO OYJ, FINLAND:  
3,856,884, COR. MULTIPLE CLASS, INT. CLS. 9, 16, 35,  
37, 38, 41, 42 AND 45.
- TIHANYI, ISABELLE C., LA JOLLA, CA:  
2,882,566, CANC. INT. CL. 25.
- TIMBERLEADS, INC., PORT ROYAL, PA:  
2,453,154, REN. 4-8-11. INT. CL. 36.  
2,453,155, REN. 4-8-11. INT. CL. 36.
- TIME INC., NEW YORK, NY:  
2,384,349, CANC. INT. CL. 35.
- TIMEWIRE TECHNOLOGIES, LLC, PURCELLVILLE, VA:  
3,963,065, INT. CL. 9.
- TIMOTHY J. MCGUINNESS, MIAMI, FL, AKA TIM  
MCGUINNESS:  
3,960,867, PUB. 3-1-2011. INT. CL. 42.
- TIMOTHY R. ROBERTO, LA MIRADA, CA:  
3,961,834, PUB. 3-1-2011. INT. CL. 28.
- TIN LIZZY'S HOLDINGS, LLC, ATLANTA, GA:  
3,961,516, PUB. 3-1-2011. INT. CL. 43.
- TIP-TOP SCREW MANUFACTURING, INC., OSCODA, MI:  
2,441,555, REN. 4-8-11. INT. CL. 6.  
2,441,595, REN. 4-8-11. INT. CL. 6.
- TIRZETTO GROUP, INC., THE, NEWPORT BEACH, CA:  
2,382,037, CANC. MULTIPLE CLASS, INT. CLS. 35, 36  
AND 42.
- TISHA TRINETTE CASIDA, PUEBLO, CO:  
3,960,516, PUB. 3-1-2011. INT. CL. 35.
- TITAN INTERNATIONAL, INC., QUINCY, IL:  
2,442,677, REN. 4-13-11. INT. CL. 12.
- TITAN PET PRODUCTS, INC., RALEIGH, NC:  
3,962,981, INT. CL. 9.
- TITAN TIRE CORPORATION, QUINCY, IL:  
3,960,362, PUB. 3-1-2011. INT. CL. 12.
- TITANIC RESORTS, INC., LAS VEGAS, NV:  
2,383,828, CANC. INT. CL. 42.  
2,396,264, REN. 4-12-11. INT. CL. 41.
- TIWAK, MONTPELLIER, FRANCE:  
2,881,324, CANC. MULTIPLE CLASS, INT. CLS. 9, 28, 41  
AND 42.
- TKT, INC., NASHVILLE, IL:  
2,451,018, REN. 4-14-11. INT. CL. 39.

TLD NETWORKS LIMITED, LONDON SW3 4TX, ENGLAND:  
2,880,635, CANC. INT. CL. 42.

TNT LOGISTICS NORTH AMERICA INC., JACKSONVILLE, FL:  
2,882,560, CANC. INT. CL. 9.

TOBI B. GREENE, NEW YORK, NY:  
3,962,654, INT. CL. 3.

TOBIAS, CHRISTINE M, DOWNERS GROVE, IL, DBA ENVIROMONSTER AND PARKINSON, DAVID R, DOWNERS GROVE, IL, DBA ENVIROMONSTER AND MACARUS, JORDAN D, WESTMONT, IL, DBA ENVIROMONSTER:  
3,962,358, INT. CL. 9.

TOCARA INC., ST. LAURENT, QUEBEC, CANADA:  
3,960,266, PUB. 3-1-2011. MULTIPLE CLASS, INT. CLS. 14, 16 AND 35.

TODAY'S DENTAL NO. 1, LTD., PHOENIX, AZ, FARRAN, HOWARD E., II, PHOENIX, AZ:  
1,640,873. REN. 4-13-11. INT. CL. 42.

TODD WINSLOW PIERCE LLC, VAIL, CO:  
3,961,354, PUB. 3-1-2011. INT. CL. 41.

TOGNANA PORCELLANE S.P.A., CASIER (TREVISO), ITALY:  
2,881,442, CANC. INT. CL. 21.

TOKIND A/S, DK-8362 HORNING, DENMARK:  
2,383,600, CANC. INT. CL. 12.

TOM FELTENSTEIN ENTERPRISES INC., WEST PALM BEACH, FL:  
2,881,542, CANC. MULTIPLE CLASS, INT. CLS. 35 AND 41.

TOM'S OF MAINE, INC., KENNEBUNK, ME:  
3,961,451, PUB. 3-1-2011. MULTIPLE CLASS, INT. CLS. 41 AND 42.

TOMALES BAY FOODS CORP., POINT REYES STATION, CA:  
3,963,661, INT. CL. 29.

TOMLINSON, SHELLIE R., LAKE PROVIDENCE, LA:  
3,962,928, INT. CL. 25.

TOMTOM INTERNATIONAL B.V., AMSTERDAM, NETHERLANDS:  
3,962,804, INT. CL. 9.

TOMY CORPORATION, NEWPORT BEACH, CA:  
2,881,018, CANC. INT. CL. 28.

TONER PLUS, INC., MCHENRY, IL:  
2,881,401, CANC. MULTIPLE CLASS, INT. CLS. 2, 7, 9 AND 20.

TONI HOLDING COMPANY, L.L.C., EDINA, MN:  
2,882,352, CANC. INT. CL. 14.

TONOKA HEALTH ENTERPRISES, THOUSAND OAKS, CA:  
3,962,162, INT. CL. 41.

TOOB LLC, SYLMAR, CA:  
3,960,377, PUB. 3-1-2011. INT. CL. 9.

TOP CODERS, LLC, GILBERT, AZ:  
3,963,781, INT. CL. 35.  
3,963,782, INT. CL. 35.  
3,963,785, INT. CL. 35.

TOP DOWN SIDING, LLC, VERO BEACH, FL:  
3,962,065, MULTIPLE CLASS, INT. CLS. 6, 19 AND 37.

TOP FLOOR CREATIONS, INC., NEW CANAAN, CT:  
2,883,045, CANC. INT. CL. 28.  
2,883,046, CANC. INT. CL. 28.

TOP GLORY BUSINESS LIMITED, ROAD TOWN, TORTOLA, BR.VIRGIN ISLANDS:  
2,446,628. REN. 4-11-11. INT. CL. 18.

TOP'S HANDBAGS, VERNON, CA, DBA ALYSSA, EMPELIA:  
3,963,377, INT. CL. 18.

TOPEKA INVESTMENTS MANAGEMENT LIMITED, ROAD TOWN, TORTOLA, BR.VIRGIN ISLANDS:  
3,961,272, PUB. 3-1-2011. INT. CL. 41.

TOPIA, LTD., PORTLAND, OR:  
2,880,999, CANC. INT. CL. 40.

TORAY KABUSHIKI KAISHA (TORAY INDUSTRIES, INC.), TOKYO, JAPAN:  
3,960,933, PUB. 11-23-2010. INT. CL. 1.

TORDELLA DEMOGRAPHICS INC., ARLINGTON, VA:  
2,382,972, CANC. INT. CL. 35.

TOTAL DYNAMICS SOLUTIONS, LLC, EDINA, MN:  
3,960,921, PUB. 3-1-2011. MULTIPLE CLASS, INT. CLS. 9 AND 42.

TOTAL GRAIN MARKETING, LLC, BLOOMINGTON, IL:  
3,962,021, MULTIPLE CLASS, INT. CLS. 35 AND 39.

TOTAL IMAGE PROTECTION, INC., ORANGE, CA:  
3,961,319, PUB. 3-1-2011. INT. CL. 37.

TOTAL PETROCHEMICALS USA, INC., HOUSTON, TX, FINA OIL AND CHEMICAL COMPANY, DALLAS, TX:  
1,649,241. REN. 4-13-11. MULTIPLE CLASS, INT. CLS. 4 AND 34.

TOTAL RESOURCES INTERNATIONAL, WALNUT, CA:  
3,961,737, PUB. 3-1-2011. INT. CL. 5.

TOUGH JEANS LIMITED, KWAI CHUNG, NEW TERRITORIES, HONG KONG:  
2,880,889, CANC. INT. CL. 35.

TOURNAMENT ONE CORP, STAMFORD, CT:  
3,961,892, PUB. 3-1-2011. INT. CL. 9.  
3,961,893, PUB. 3-1-2011. INT. CL. 9.

TOURNAMENT ONE CORP, STAMFORD, CT, AKA T1 GAMING, T1, TOC:  
3,963,354, INT. CL. 9.

TOWER PRODUCTS INCORPORATED, SAUGERTIES, NY:  
2,541,160, REN. 4-12-11. INT. CL. 9.  
2,547,948, REN. 4-12-11. INT. CL. 9.  
2,880,654, CANC. INT. CL. 9.

TOY STATE INDUSTRIAL LTD., TSIMSHATSUI, KOWLOON, HONG KONG:  
3,962,554, INT. CL. 28.  
3,962,606, INT. CL. 28.  
3,962,607, INT. CL. 28.  
3,962,608, INT. CL. 28.  
3,962,740, INT. CL. 28.

TOYAMA, THOMAS NORMAN, HOLLYWOOD, FL:  
2,882,082, CANC. MULTIPLE CLASS, INT. CLS. 15 AND 25.

TOYOTOMI CO. LTD, MIZUHO-KU, NAGOYA, JAPAN:  
1,186,405. REN. 4-11-11. INT. CL. 6.

TOYOTOMI CO., LTD, NAGOYA 467-0885, JAPAN, KERO-SUN, INC., KENT, CT:  
1,185,427. REN. 4-8-11. INT. CL. 6.

TRACTO-TECHNIK GMBH, 57368 LENNESTADT, FED REP GERMANY:  
2,882,075, CANC. MULTIPLE CLASS, INT. CLS. 7, 9, 37 AND 42.

TRACTOR SUPPLY CO. OF TEXAS, LP, BRENTWOOD, TN, TSC INDUSTRIES INC., NASHVILLE, TN:  
1,183,496. REN. 4-9-11. MULTIPLE CLASS, INT. CLS. 7 AND 12.

TRADEBANK INTERNATIONAL, INC., LAWRENCEVILLE, GA:  
3,961,103, PUB. 3-1-2011. INT. CL. 36.

TRANSBARRIER PHNC.ARMACEUTICALS, I, TUSCALOOSA, AL:  
3,961,239, PUB. 3-1-2011. INT. CL. 5.

TRANSCO INC., CHICAGO, IL:  
3,962,276, INT. CL. 17.

TRANSCONTINENTAL EVENTS, LLC, SEATTLE, WA:  
2,881,550, CANC. INT. CL. 35.  
2,881,551, CANC. INT. CL. 35.

TRANSFAR INTERNATIONAL CORP., TAIPEI, TAIWAN:  
3,963,844, INT. CL. 21.

TRANSPARENT FINANCIAL SERVICES, INC., CHICAGO, IL:  
3,961,417, PUB. 3-1-2011. INT. CL. 42.

TRANSPARENT HEALTH GROUP LLC, MEDIA, PA:  
3,960,541, PUB. 3-1-2011. INT. CL. 35.

TRANZYME, INC., BIRMINGHAM, AL:  
2,881,665, CANC. INT. CL. 42.

TRAUST SOLLUS WEALTH MANAGEMENT, LLC, PRINCETON, NJ:  
2,384,321, CANC. MULTIPLE CLASS, INT. CLS. 35 AND 36.

TRAVEL ANGELS NETWORK, INC., MURRIETA, CA:  
3,960,874, PUB. 3-1-2011. INT. CL. 41.

TRAVELER OVERSEAS MAGAZINE, L.L.C., DALLAS, TX:  
3,961,514, PUB. 3-1-2011. INT. CL. 16.

- TRAVELERS INDEMNITY COMPANY, THE, HARTFORD, CT:  
3,963,449, INT. CL. 36.
- TRAVELERS INDEMNITY COMPANY, THE, HARTFORD, CT:  
3,962,235, INT. CL. 36.
- TRAVELPORT, LP, PARSIPPANY, NJ:  
2,880,955, CANC. INT. CL. 42.
- TRAYLOR BROS., INC., EVANSVILLE, IN:  
3,960,882, PUB. 3-1-2011. INT. CL. 4.
- TREEPAK SA DE CV, NAUCLAPAN, EDO MEXICO, MEXICO:  
3,960,462, PUB. 3-1-2011. INT. CL. 16.  
3,960,463, PUB. 3-1-2011. INT. CL. 16.
- TREewise THE ORGANIC EXPERTS LTD., EAST HAMP-  
TON, NY:  
2,880,656, CANC. INT. CL. 44.
- TRENDMAKER HOMES, INC., HOUSTON, TX:  
2,882,876, CANC. MULTIPLE CLASS, INT. CLS. 36 AND  
37.
- TREPSI, S.A. DE C.V., HUIXQUILUCAN, MEXICO:  
3,963,110, INT. CL. 9.  
3,963,111, INT. CL. 16.  
3,963,112, INT. CL. 41.
- TRES MONKEY, INC., LOS ANGELES, CA:  
2,881,624, CANC. INT. CL. 25.
- TRESPAPHAN GMBH, D-66539 NEUNKIRCHEN, FED REP  
GERMANY:  
2,880,567, CANC. INT. CL. 16.
- TRI-MER CORPORATION, OWOSSO, MI:  
2,453,933, REN. 4-13-11. INT. CL. 11.
- TRI-STATE DISTRIBUTORS, INC., MOSCOW, ID:  
3,960,246, PUB. 3-1-2011. INT. CL. 35.
- TRI-STATE PUMP, INC., FARMINGDALE, NJ:  
3,963,204, INT. CL. 7.
- TRICEN TECHNOLOGIES, INC., PORT SAINT LUCIE, FL,  
DBA TRICEN TECHNOLOGIES:  
3,960,939, PUB. 3-1-2011. INT. CL. 42.
- TRICO PRODUCTS CORPORATION, ROCHESTER HILLS,  
MI:  
3,963,165, INT. CL. 12.  
3,963,168, INT. CL. 12.
- TRIGO CORPORATION, TOA BAJA, PUERTO RICO, DBA  
RUM ALAMBIQUE CO.:  
1,639,915, REN. 4-8-11. INT. CL. 33.
- TRILIX MARKETING GROUP, INC., JOHNSTON, IA:  
3,961,204, PUB. 3-1-2011. INT. CL. 35.
- TRILLIUM ASSET MANAGEMENT CORPORATION, BOS-  
TON, MA:  
3,962,884, INT. CL. 36.  
3,963,023, INT. CL. 36.
- TRIMBLE NAVIGATION LIMITED, SUNNYVALE, CA:  
1,671,646, REN. 4-11-11. INT. CL. 9.
- TRINA SOLAR LIMITED, GRAND CAYMAN KY11111,  
CAYMAN ISLANDS:  
3,962,410, INT. CL. 1.
- TRINA SOLAR LIMITED, GRAND CAYMAN KY1-1111,  
CAYMAN ISLANDS:  
3,962,411, INT. CL. 11.
- TRINET HR CORPORATION, SAN LEANDRO, CA:  
3,961,119, PUB. 3-1-2011. MULTIPLE CLASS, INT. CLS.  
35, 36 AND 42.
- TRIPLETT, JOSEPH DAVID, LAS VEGAS, NV:  
3,962,638, INT. CL. 25.
- TRIQUINT SEMICONDUCTOR, INC., HILLSBORO, OR:  
3,962,066, INT. CL. 9.
- TRIRIGA INC., LAS VEGAS, NV:  
3,960,280, PUB. 3-1-2011. MULTIPLE CLASS, INT. CLS. 9,  
35 AND 42.
- TRISA HOLDING AG, 6234 TRIENGEN, SWITZERLAND:  
2,881,409, CANC. INT. CL. 3.
- TRIUMPH DESIGNS LIMITED, DERBYSHIRE, DE12 7JP,  
ENGLAND:  
2,382,654, CANC. INT. CL. 25.
- TROY CORPORATION, FLORHAM PARK, NJ:  
3,962,082, INT. CL. 1.
- TROY GROUP, INC., SANTA ANA, CA:  
2,610,645, CANC. INT. CL. 9.
- TROY UNIVERSITY, COLUMBUS, GA, DBA TROY UNI-  
VERSITY:  
2,880,830, CANC. INT. CL. 41.
- TRS HOLDING, INC., HARTFORD, CT:  
2,383,325, CANC. MULTIPLE CLASS, INT. CLS. 9 AND  
16.
- TRU VUE, INC., MCCOOK, IL:  
2,382,242, CANC. INT. CL. 21.
- TRUBEND SYSTEMS, INC., CLAREMORE, OK:  
3,960,481, PUB. 3-1-2011. INT. CL. 9.
- TRUCK PRIDE PARTNERS, LLC, BRANFORD, CT:  
2,880,853, CANC. INT. CL. 37.
- TRUEVIEW ENHANCED VISION SYSTEMS, LLC, SACKETS  
HARBOR, NY:  
3,961,107, PUB. 3-1-2011. INT. CL. 9.
- TRUEWAVE, L.L.C., SALINE, MI:  
1,681,040, REN. 4-9-11. INT. CL. 9.
- TRUMARK FINANCIAL CREDIT UNION, TREVOSE, PA:  
3,962,092, INT. CL. 36.
- TRUST RISK MANAGEMENT SERVICES, INC., ROCK-  
VILLE, MD:  
3,963,435, MULTIPLE CLASS, INT. CLS. 35 AND 36.
- TRUSTCORE FINANCIAL, INC., BRENTWOOD, TN:  
2,882,645, CANC. INT. CL. 36.
- TRUSTEES OF PRINCETON UNIVERSITY, THE, PRINCE-  
TON, NJ:  
1,640,205, REN. 4-8-11. MULTIPLE CLASS, INT. CLS. 6,  
14, 16, 18, 20, 21, 24, 25, 26, 28 AND 41.  
1,640,205, CANC. INT. CL. 8.
- TRUSTEES OF THE PWC BUSINESS TRUST, THE, NEW  
YORK, NY:  
3,963,629, INT. CL. 45.  
3,963,631, INT. CL. 45.
- TSA STORES, INC., ENGLEWOOD, CO:  
2,882,777, CANC. MULTIPLE CLASS, INT. CLS. 9, 25  
AND 28.
- TSIT WING INTERNATIONAL COMPANY LIMITED,  
ROAD TOWN, TORTOLA, BR. VIRGIN ISLANDS:  
3,960,523, PUB. 1-11-2011. INT. CL. 30.
- TSX INC., TORONTO, ONTARIO, CANADA:  
2,881,900, CANC. INT. CL. 36.
- TTI TESTRON, INC., WOONSOCKET, RI TO DELAWARE  
CAPITAL FORMATION, INC., WILMINGTON, DE:  
2,384,275, CANC. INT. CL. 42.
- TUCKER MILLING, LLC, GUNTERSVILLE, AL:  
3,963,586, INT. CL. 31.  
3,963,587, INT. CL. 31.
- TUFF TURF, INC., GLENDALE, AZ:  
2,880,855, CANC. INT. CL. 27.
- TUPLER, JULIE, NEW YORK, NY:  
3,963,867, INT. CL. 10.
- TURTLE WAX, INC., WILLOWBROOK, IL:  
1,641,355, REN. 4-11-11. INT. CL. 25.  
3,962,192, INT. CL. 21.
- TUTOGEN MEDICAL GMBH, NEUNKIRCHEN AM  
BRAND, FED REP GERMANY:  
2,881,435, CANC. INT. CL. 5.
- TUTTLE, ALTON B. JR., WESTMINSTER, MA:  
2,883,318, CANC. INT. CL. 41.
- TV2MORO, INC., PASADENA, CA:  
3,962,290, INT. CL. 41.
- TWANG PARTNERS, LTD. SAN ANTONIO, TX:  
3,962,559, INT. CL. 30.
- TWELVE SOUTH, LLC, MT. PLEASANT, SC:  
3,961,373, PUB. 3-1-2011. INT. CL. 9.
- TWIN CITY CO-OPS FEDERAL CREDIT UNION, FALCON  
HEIGHTS, MN:  
2,382,349, CANC. INT. CL. 36.  
2,382,350, CANC. INT. CL. 36.
- TWIN CITY KNITTING COMPANY, INC., CONOVER, NC:  
3,963,297, INT. CL. 25.
- TWIN HEART CLOTHING INC., MOUNT-ROYAL, QUE-  
BEC, CANADA:  
3,960,417, PUB. 3-1-2011. INT. CL. 25.
- TWIN HENS, INC., PRINCETON, NJ:  
2,882,394, CANC. INT. CL. 30.

TWIN RIVERS PAPER COMPANY LLC, MADAWASKA, ME:  
 3,961,509, PUB. 3-1-2011. INT. CL. 16.  
 3,961,510, PUB. 3-1-2011. INT. CL. 16.  
 3,961,511, PUB. 3-1-2011. INT. CL. 16.

TWO-TWENTY RECORDS MANAGEMENT, LLC, PISCATAWAY, NJ:  
 3,961,626, PUB. 3-1-2011. INT. CL. 35.

TWO'S COMPANY RELATIONSHIPS BY DESIGN, LLC, ALPHARETTA, GA:  
 3,962,986, INT. CL. 45.

TWOMEY CELLARS, LLC, CALISTOGA, CA:  
 3,961,274, PUB. 3-1-2011. INT. CL. 33.

TWOTHIRDS CLOTHING GMBH, FED REP GERMANY:  
 3,960,654, PUB. 3-1-2011. INT. CL. 25.

TY GALLANDER, ROCKWALL, TX, DBA THINKING OUT OF A BOX:  
 3,962,425, INT. CL. 16.

TYMAX MARKETING GROUP, LLC, FRISCO, CO, DBA MIND REDESIGN:  
 3,960,957, PUB. 3-1-2011. INT. CL. 44.

TYNDALE HOUSE PUBLISHERS, CAROL STREAM, IL:  
 913,668, REN. 4-11-11. U.S. CL. 38 (INT. CL. 16).

TYPE 20 S.R.L., VARALLO POMBIA (NO), ITALY:  
 2,382,139, CANC. MULTIPLE CLASS, INT. CLS. 9 AND 28.

TYSON FARMS, INC., SPRINGDALE, AR:  
 3,961,261, PUB. 3-1-2011. INT. CL. 29.

TYTOM, INC., TALBOTT, TN:  
 3,961,301, PUB. 3-1-2011. INT. CL. 43.

U BETTER SING!, INC., AUSTIN, TX:  
 3,963,197, INT. CL. 41.

U. S. TSUBAKI, INC., WHEELING, IL, UNION CHAIN AND MANUFACTURING COMPANY, THE, SANDUSKY, OH:  
 386,520, REN. 4-11-11. U.S. CL. 23 (INT. CL. 7).

U.S. DIGEST MAGAZINE, HOLLIS HILLS, NY:  
 2,881,356, CANC. INT. CL. 16.

U.S. EDUCATION CORPORATION, MISSION VIEJO, CA:  
 3,963,739, MULTIPLE CLASS, INT. CLS. 9, 35, 36 AND 41.

U.S. FOODSERVICE, INC., ROSEMONT, IL:  
 3,961,923, PUB. 3-1-2011. INT. CL. 30.

U.S. KIDS GOLF, LLC, NORCROSS, GA:  
 2,383,145, CANC. INT. CL. 28.

U.S. SMOKELESS TOBACCO BRANDS, INC., GREENWICH, CT:  
 2,882,117, CANC. INT. CL. 16.

U.S. VISION, INC., GLENDORA, NJ:  
 3,963,196, INT. CL. 9.

UBM AVIATION WORLDWIDE LIMITED, BEDFORDSHIRE, UNITED KINGDOM:  
 2,883,088, CANC. MULTIPLE CLASS, INT. CLS. 9 AND 39.

UGO ENTERTAINMENT, INC., NEW YORK, NY:  
 3,963,523, INT. CL. 35.

UGUR SAHIN, MAINZ, FED REP GERMANY:  
 3,960,587, PUB. 3-1-2011. MULTIPLE CLASS, INT. CLS. 5, 42 AND 44.

UHS OF DELAWARE, INC., KING OF PRUSSIA, PA:  
 3,960,465, PUB. 11-23-2010. MULTIPLE CLASS, INT. CLS. 41 AND 44.  
 3,962,441, INT. CL. 44.

UKRAM INDUSTRIES LIMITED, INDIANAPOLIS, IN:  
 3,960,361, PUB. 3-1-2011. INT. CL. 11.

ULBRANDT, BARBARA E., ALPHARETTA, GA:  
 2,883,396, CANC. INT. CL. 35.

ULTIMATE JOURNEYS, LLC, SEATTLE, WA:  
 2,883,127, CANC. INT. CL. 39.  
 2,883,128, CANC. INT. CL. 43.

ULTRA LEARNING SYSTEMS, LLC, PHOENIX, AZ:  
 3,962,282, MULTIPLE CLASS, INT. CLS. 44 AND 45.

ULTRA PET COMPANY, INC., ANDERSON, SC:  
 3,961,738, PUB. 3-1-2011. INT. CL. 31.

ULTRADNS CORPORATION, STERLING, VA:  
 2,459,099, REN. 4-13-11. MULTIPLE CLASS, INT. CLS. 38 AND 42.

ULTRATERA CORPORATION, HSIN CHU, TAIWAN:  
 2,881,315, CANC. MULTIPLE CLASS, INT. CLS. 9, 40 AND 42.

UMA DISTRIBUTORS, LLC, ALTAMONTE SPRINGS, FL:  
 3,961,488, PUB. 3-1-2011. INT. CL. 11.

UMICORE, BELGIUM:  
 2,882,182, CANC. INT. CL. 6.

UMICORE, SOCIÉTÉ ANONYME, BELGIUM:  
 3,960,661, PUB. 3-1-2011. MULTIPLE CLASS, INT. CLS. 6 AND 37.

UNCLE RAYS, LLC, DETROIT, MI:  
 2,500,545, REN. 4-13-11. MULTIPLE CLASS, INT. CLS. 29 AND 30.  
 2,883,320, CANC. INT. CL. 29.

UNDER ARMOUR, INC., BALTIMORE, MD:  
 3,963,256, INT. CL. 28.

UNDERGROUND SYSTEMS, INC., ARMONK, NY:  
 3,962,157, INT. CL. 9.

UNEX CORPORATION, MAHWAH, NJ:  
 2,384,121, CANC. INT. CL. 7.

UNGA B.V., NL-1012 RW AMSTERDAM, NETHERLANDS:  
 3,960,789, PUB. 3-1-2011. INT. CL. 28.

UNICELL LIMITED, TORONTO, ONTARIO, CANADA:  
 2,444,422, REN. 4-14-11. INT. CL. 12.

UNICO INTERNATIONAL TRADING CORP., BOCA RATON, FL:  
 3,963,548, INT. CL. 3.  
 3,963,549, INT. CL. 3.  
 3,963,702, INT. CL. 3.

UNIFI MUTUAL HOLDING COMPANY, LINCOLN, NE:  
 3,961,242, PUB. 3-1-2011. INT. CL. 36.  
 3,961,867, PUB. 3-1-2011. INT. CL. 36.

UNILEVER PLC, MERSEYSIDE, ENGLAND, UNITED KINGDOM:  
 2,447,467, REN. 4-8-11. INT. CL. 3.

UNILEVER PLC, MERSEYSIDE, UNITED KINGDOM:  
 2,456,838, REN. 4-8-11. INT. CL. 3.

UNILEVER SUPPLY CHAIN, INC., CLINTON, CT:  
 3,962,392, INT. CL. 30.

UNILIN FLOORING NC, LLC, CALHOUN, GA:  
 3,963,884, INT. CL. 27.

UNION LABOR WORKS, INC., NEW FAIRFIELD, CT:  
 3,962,868, MULTIPLE CLASS, INT. CLS. 35 AND 42.

UNIQUE SOLUTIONS, INC., WILKESBORO, NC:  
 2,882,465, CANC. INT. CL. 9.

UNITED AMERICAN INSURANCE COMPANY, MCKINNEY, TX:  
 3,963,765, INT. CL. 16.

UNITED ASPHALT COMPANY, CEDARBROOK, NJ:  
 3,962,674, INT. CL. 2.

UNITED AUBURN INDIAN COMMUNITY, LINCOLN, CA:  
 3,963,474, INT. CL. 35.  
 3,963,475, INT. CL. 35.  
 3,963,518, INT. CL. 44.

UNITED BUSINESS MEDIA LLC, MANHASSET, NY:  
 2,882,623, CANC. INT. CL. 16.

UNITED ENERGY TRADING, LLC, LAKEWOOD, CO:  
 3,961,201, PUB. 3-1-2011. INT. CL. 35.

UNITED FOOTBALL LEAGUE, LLC, NEW YORK, NY:  
 3,963,353, INT. CL. 41.  
 3,963,423, INT. CL. 41.  
 3,963,424, INT. CL. 25.  
 3,963,425, INT. CL. 25.  
 3,963,426, INT. CL. 41.

UNITED FOOTBALL LEAGUE, LLC, NEW YORK, NY:  
 3,963,093, INT. CL. 41.

UNITED INDUSTRIES CORP., ST. LOUIS, MO:  
 2,882,091, CANC. INT. CL. 1.

UNITED OF OMAHA LIFE INSURANCE COMPANY, OMAHA, NE:  
 1,666,962, REN. 4-11-11. INT. CL. 36.

UNITED PLASTICS CORPORATION, MOUNT AIRY, NC:  
 3,962,422, INT. CL. 17.

UNITED SITE SERVICES, INC., WESTBOROUGH, MA:  
 2,489,123, REN. 4-8-11. INT. CL. 42.

UNITED STATES AIR FORCE, WRIGHT-PATTERSON AFB, OH:  
 3,961,641, PUB. 3-1-2011. INT. CL. 9.



- UNITED STATES DEPARTMENT OF HOMELAND SECURITY, WASHINGTON, DC:  
3,962,492, MULTIPLE CLASS, INT. CLS. 35 AND 41.  
3,963,191, INT. CL. 42.
- UNITED STATES DISTILLED PRODUCTS COMPANY, PRINCETON, MN:  
3,963,006, INT. CL. 33.
- UNITED STATES METAL POWDERS INC., FLEMINGTON, NJ:  
3,962,621, INT. CL. 6.
- UNITED STATES MINERAL PRODUCTS COMPANY, STANHOPE, NJ, DBA ISOLATEK INTERNATIONAL, SMITH & KANZLER CORP., LINDEN, NJ:  
715,627. REN. 4-12-11. U.S. CL. 12 (INT. CL. 17).
- UNITED STATES OLYMPIC COMMITTEE, COLORADO SPRINGS, CO:  
2,382,044, CANC. INT. CL. 30.  
2,882,207, CANC. INT. CL. 14.
- UNITED STATES POSTAL SERVICE, WASHINGTON, DC:  
2,444,770. REN. 4-9-11. MULTIPLE CLASS, INT. CLS. 35 AND 39.
- UNITEDHEALTHCARE CHILDREN'S FOUNDATION, INC., MINNETONKA, MN:  
2,880,912, CANC. INT. CL. 36.
- UNITIKA LTD., HYOGO-KEN, JAPAN:  
2,882,093, CANC. INT. CL. 31.
- UNITY INTERNATIONAL FOUNDATION, MIAMI, FL:  
3,961,688, PUB. 3-1-2011. INT. CL. 41.
- UNIVERSAL DE DESARROLLOS ELECTRONICOS, S.A. (UNIDESA), 08226 TERRASSA (BARCELONA), SPAIN:  
2,384,001, CANC. INT. CL. 9.
- UNIVERSAL FURNITURE INTERNATIONAL, INC., HIGH POINT, NC:  
2,883,369, CANC. INT. CL. 20.
- UNIVERSAL INTIMATES, LLC, NEW YORK, NY:  
3,960,849, PUB. 3-1-2011. INT. CL. 25.
- UNIVERSAL SERIAL BUS IMPLEMENTERS FORUM, INC., BEAVERTON, OR:  
3,962,217, INT. CL. 42.
- UNIVERSAL TRAILER CORPORATION HORSE/LIVE-STOCK GROUP, CINCINNATI, OH:  
2,444,011. REN. 4-8-11. INT. CL. 12.
- UNIVERSIDAD DE ALICANTE, 03690 ALICANTE, SPAIN:  
2,882,274, CANC. MULTIPLE CLASS, INT. CLS. 38 AND 41.  
2,882,323, CANC. MULTIPLE CLASS, INT. CLS. 38 AND 41.
- UNIVERSITIES ALLIED FOR ESSENTIAL MEDICINES, CORP., BERKELEY, CA, AKA UAEM:  
3,960,973, PUB. 3-1-2011. INT. CL. 35.
- UNIVERSITY FEDERAL CREDIT UNION, AUSTIN, TX:  
2,881,620, CANC. INT. CL. 36.
- UNIVERSITY OF MARYLAND UNIVERSITY COLLEGE, ADELPHI, MD:  
3,962,825, INT. CL. 16.
- UNIVERSITY OF NEW HAMPSHIRE, DURHAM, NH:  
3,962,039, INT. CL. 9.
- UNIVERSITY OF RHODE ISLAND, KINGSTON, RI, DBA UNIVERSITY OF RHODE ISLAND:  
3,963,791, INT. CL. 5.
- UNIVERSITY OF WEST FLORIDA, PENSACOLA, FL:  
3,962,352, INT. CL. 9.
- UNIVERSITY OF WYOMING, LARAMIE, WY:  
3,960,515, PUB. 9-28-2010. MULTIPLE CLASS, INT. CLS. 21 AND 28.
- UNIVISION COMMUNICATIONS INC., LOS ANGELES, CA:  
3,963,384, INT. CL. 41.  
3,963,471, INT. CL. 41.
- UNSPOKEN, LLC, WEST HOLLYWOOD, CA:  
3,963,657, INT. CL. 25.
- UP INTERNATIONAL GMBH, GARMISCH-PARTEN-KIRCHEN, FED REP GERMANY:  
3,960,682, PUB. 11-23-2010. MULTIPLE CLASS, INT. CLS. 12 AND 28.
- UPLIFT EDUCATION, IRVING, TX:  
3,960,239, PUB. 3-1-2011. INT. CL. 41.
- UPSTART TECHNOLOGIES, INC., SAN FRANCISCO, CA, DBA PAPERLESS POBOX:  
2,882,792, CANC. INT. CL. 40.
- US DATANET CORPORATION, SYRACUSE, NY, DBA USA DATANET:  
2,881,543, CANC. MULTIPLE CLASS, INT. CLS. 35 AND 41.
- US FLOORS, INC., DALTON, GA:  
3,960,889, PUB. 3-1-2011. INT. CL. 2.
- US INVESTIGATIONS SERVICES, LLC, FALLS CHURCH, VA:  
2,881,611, CANC. INT. CL. 45.
- USA DETERGENTS, INC., NORTH BRUNSWICK, NJ:  
2,883,171, CANC. INT. CL. 3.
- USHG, LLC, NEW YORK, NY:  
3,960,472, PUB. 3-1-2011. MULTIPLE CLASS, INT. CLS. 35 AND 41.  
3,960,473, PUB. 3-1-2011. MULTIPLE CLASS, INT. CLS. 35 AND 41.  
3,960,474, PUB. 3-1-2011. MULTIPLE CLASS, INT. CLS. 35 AND 41.
- USPL AUTO ACCESSORIES, INC., HARTLAND, WI:  
2,881,865, CANC. INT. CL. 12.
- USTMAN TECHNOLOGIES, INC., LAKEWOOD, CO:  
2,382,479, CANC. INT. CL. 35.
- UTILIPOINT INTERNATIONAL, INC., ALBUQUERQUE, NM:  
2,882,276, CANC. INT. CL. 38.
- UTOPIA FINANCIAL FITNESS, SAN DIEGO, CA:  
2,882,362, CANC. INT. CL. 36.
- UTTER VENTURES, INC., SEATTLE, WA:  
2,881,503, CANC. MULTIPLE CLASS, INT. CLS. 8 AND 30.
- UY, REGINALD, TINLEY PARK, IL AND KUBACZYK, KRISTOPHER, TINLEY PARK, IL AND SNEE III, JOHN, TINLEY PARK, IL:  
3,963,617, INT. CL. 41.
- UZZARDI, CHRISTINA MARIE, LOS ANGELES, CA, DBA STYLE BITE:  
3,961,013, PUB. 3-1-2011. INT. CL. 45.
- VACO MICROTECHNOLOGIES, 38760 VACRES ALLIERES ET RISSET, FRANCE:  
2,882,433, CANC. INT. CL. 11.
- VACUUM ENGINEERING & MATERIALS CO., INC., LOS GATOS, CA:  
3,960,351, PUB. 3-1-2011. MULTIPLE CLASS, INT. CLS. 1 AND 6.
- VADIUM TECHNOLOGY, INC., TACOMA, WA:  
2,881,628, CANC. INT. CL. 9.
- VALENCE TECHNOLOGY, INC, LAS VEGAS, NV:  
2,881,757, CANC. INT. CL. 9.
- VALENCIA, ROSARIO, VICTORVILLE, CA:  
3,962,628, INT. CL. 25.
- VALLABHANENI, S. RAO, SCHAUMBURG, IL:  
2,880,731, CANC. INT. CL. 41.
- VALLEY BREWING COMPANY, STOCKTON, CA:  
2,882,348, CANC. INT. CL. 32.
- VALTREND, LLC, EAGLE, ID:  
3,963,175, INT. CL. 35.
- VALUE SMART PRODUCTS, INC., SUWANEE, GA:  
2,534,700. REN. 4-13-11. INT. CL. 3.
- VALUEVISION MEDIA, INC., EDEN PRAIRIE, MN:  
3,963,436, INT. CL. 5.
- VAMBERI, GABOR, LEESBURG, VA:  
3,962,120, INT. CL. 30.
- VAN TUYL, THOMAS R, CONCORD, CA, DBA HORNEY TOADS:  
3,961,271, PUB. 3-1-2011. INT. CL. 30.
- VANDA BEAUTY COUNSELOR COMPANY, ORLANDO, FL, BEAUTY COUNSELORS, INC., DETROIT, MI:  
386,217. REN. 4-11-11. U.S. CL. 51 (INT. CL. 3).
- VANEGAS, FRANCESCA, BONITA SPRINGS, FL:  
2,881,027, CANC. INT. CL. 35.
- VANGUARD HEALTHCARE PRODUCTS, INC., KINGSTON, NY:  
3,961,384, PUB. 3-1-2011. INT. CL. 5.
- VANISH CAMO, LLC, MONTROSE, CO:  
3,960,876, PUB. 3-1-2011. INT. CL. 12.



VANITY FAIR, INC., BOWLING GREEN, KY:  
2,882,880, CANC. INT. CL. 25.

VANTAGE SPECIALTIES, INC., GURNEE, IL, E. I. DU  
PONT DE NEMOURS AND COMPANY, WILMINGTON,  
DE, DBA DU PONT:  
1,678,957, REN. 4-8-11. INT. CL. 3.

VANTIUM CAPITAL, INC., IRVING, TX:  
3,962,639, INT. CL. 42.

VARTA MICROBATTERY, INC., WHITE PLAINS, NY:  
1,154,641, REN. 4-11-11. INT. CL. 9.

VB ENTERPRISES, LLC, FORT WORTH, TX, DBA VELVET  
BOX:  
3,961,360, PUB. 3-1-2011. INT. CL. 35.

VCAP HOLDINGS, AUSTIN, TX:  
3,962,042, INT. CL. 36.

VECTOR AEROSPACE HELICOPTER SERVICES INC.,  
RICHMOND, CANADA:  
2,881,127, CANC. INT. CL. 37.  
2,881,129, CANC. INT. CL. 37.

VECTOR MANAGEMENT LTD., WINNEPEG R3Y 1G4,  
MANITOBA:  
2,882,047, CANC. MULTIPLE CLASS, INT. CLS. 9, 35  
AND 42.

VECTOR TOBACCO INC., RESEARCH TRIANGLE PARK,  
NC:  
2,883,026, CANC. INT. CL. 34.

VEECE, COSTA MESA, CA:  
2,881,185, CANC. INT. CL. 25.

VEVMA NUTRITION COMPANY, SCOTTSDALE, AZ:  
3,961,151, PUB. 3-1-2011. MULTIPLE CLASS, INT. CLS. 5  
AND 32.

VENTIS CORPORATION, CARSON CITY, NV:  
3,962,443, INT. CL. 9.

VENTURA FOODS, LLC, BREA, CA:  
3,962,631, INT. CL. 40.

VERCURY INC., PLEASANTON, CA:  
3,961,632, PUB. 3-1-2011. INT. CL. 42.

VERDUZCO EDUARDO, EL PASO, TX, DBA KARMEN:  
3,961,624, PUB. 3-1-2011. INT. CL. 44.

VERTEX STANDARD USA, INC., CYPRESS, CA:  
2,382,981, CANC. INT. CL. 35.

VERTI-CRETE, SANDY, UT:  
3,962,769, INT. CL. 19.

VERY PERSONAL INCORPORATED, ST. PAUL, MN:  
2,882,836, CANC. INT. CL. 41.

VESPER HOSPITALITY INVESTMENTS, LLC, PHILADEL-  
PHIA, PA:  
3,961,156, PUB. 3-1-2011. INT. CL. 43.

VESTAS WIND SYSTEMS A/S, DENMARK:  
3,960,701, PUB. 3-1-2011. INT. CL. 7.  
3,960,798, PUB. 3-1-2011. INT. CL. 7.  
3,960,799, PUB. 3-1-2011. INT. CL. 7.  
3,960,800, PUB. 3-1-2011. INT. CL. 7.  
3,960,801, PUB. 3-1-2011. INT. CL. 7.  
3,960,802, PUB. 3-1-2011. INT. CL. 7.  
3,960,803, PUB. 3-1-2011. INT. CL. 7.  
3,960,804, PUB. 3-1-2011. INT. CL. 7.  
3,960,805, PUB. 3-1-2011. INT. CL. 7.  
3,960,812, PUB. 3-1-2011. INT. CL. 7.

VETERANS OF VALOR, INC., INDIANAPOLIS, IN:  
3,960,528, PUB. 3-1-2011. MULTIPLE CLASS, INT. CLS. 36  
AND 45.

VETS CHOICE, INC, DEER PARK, NY:  
3,961,344, PUB. 3-1-2011. INT. CL. 31.

VEZINA, MARGUERITE A., MARCO ISLAND, FL:  
3,962,931, INT. CL. 21.

VIACOM INTERNATIONAL INC., NEW YORK, NY:  
2,881,576, CANC. INT. CL. 41.  
2,881,961, CANC. INT. CL. 25.  
2,881,966, CANC. INT. CL. 16.  
2,882,784, CANC. INT. CL. 41.  
2,883,141, CANC. INT. CL. 41.  
3,960,843, PUB. 3-1-2011. INT. CL. 41.

VIAL GMBH, 50672 KÖLN, FED REP GERMANY:  
3,960,688, PUB. 3-1-2011. MULTIPLE CLASS, INT. CLS. 20  
AND 21.

VIALTA, INC., FREMONT, CA:  
2,882,409, CANC. INT. CL. 9.

VIBRATION MOUNTINGS & CONTROLS, INC., BLOO-  
MINGDALE, NJ:  
706,598, REN. 4-8-11. U.S. CL. 23 (INT. CL. 7).

VICAR OPERATING, INC., LOS ANGELES, CA:  
3,962,462, MULTIPLE CLASS, INT. CLS. 9, 10, 39, 41 AND  
42.  
3,962,463, MULTIPLE CLASS, INT. CLS. 9, 10, 39, 41 AND  
42.  
3,962,464, MULTIPLE CLASS, INT. CLS. 9, 10, 39, 41 AND  
42.

VICEROY HOTELS, L.L.C., LOS ANGELES, CA:  
3,961,591, PUB. 3-1-2011. INT. CL. 43.

VICTOR INDUSTRIES, INC., MISSOULA, MT:  
2,882,232, CANC. INT. CL. 1.

VICTORIA LOVELAND-COEN, CHAPEL HILL, NC:  
3,961,345, PUB. 3-1-2011. INT. CL. 45.

VICTORIA'S SECRET STORES BRAND MANAGEMENT,  
INC., REYNOLDSBURG, OH:  
2,883,341, CANC. INT. CL. 3.  
3,961,774, PUB. 3-1-2011. INT. CL. 25.  
3,963,363, INT. CL. 25.

VICTORIANO MARTÍNEZ VICARIO, BARCELONA, SPAIN:  
3,960,838, PUB. 3-1-2011. INT. CL. 3.

VISSMANN WERKE GMBH & CO. KG, ALLENDORF, FED  
REP GERMANY:  
3,961,563, PUB. 3-1-2011. INT. CL. 11.

VIEWSONIC CORPORATION, WALNUT, CA:  
2,404,250, REN. 4-11-11. INT. CL. 28.  
2,408,609, REN. 4-11-11. INT. CL. 11.  
2,410,609, REN. 4-9-11. MULTIPLE CLASS, INT. CLS. 9,  
14, 16, 18, 20 AND 25.

VIKTORIA ENTERPRISES, INC., DAYTONA BEACH, FL:  
2,882,176, CANC. MULTIPLE CLASS, INT. CLS. 14, 25, 28,  
35 AND 41.

VILLAGE OF COOPERSTOWN, COOPERSTOWN, NY:  
3,960,310, PUB. 3-1-2011. INT. CL. 41.

VINCENT SHOE STORE SWEDEN AB, SWEDEN:  
3,960,639, PUB. 1-9-2007. INT. CL. 25.

VINEYARD KINDA, INC., VINEYARD HAVEN, MA:  
3,961,125, PUB. 3-1-2011. INT. CL. 35.

VINICOLA VALE DO BARRO, SA, PORTUGAL:  
3,961,055, PUB. 3-1-2011. INT. CL. 33.

VINOS LOCOS CON ALMA (VILCA) SA, PANAMA CITY,  
PANAMA:  
3,960,485, PUB. 3-1-2011. MULTIPLE CLASS, INT. CLS. 32  
AND 33.

VINTAGE SPORTSWEAR, INC., CORAL GABLES, FL:  
3,961,255, PUB. 3-1-2011. INT. CL. 25.

VIRBAC S.A., F-06516 CARROS, FRANCE:  
3,961,891, PUB. 3-1-2011. INT. CL. 5.

VIRGIN HEALTHMILES, INC., FRAMINGHAM, MA:  
3,962,308, INT. CL. 35.

VIRGIN MOBILE USA, L.P., OVERLAND PARK, KS:  
3,962,866, MULTIPLE CLASS, INT. CLS. 9, 35 AND 38.  
3,962,955, MULTIPLE CLASS, INT. CLS. 9, 35 AND 38.

VIRGINIA MASON RESEARCH CENTER, SEATTLE, WA:  
2,883,090, CANC. INT. CL. 42.

VIRTUA HEALTH, INC., MARLTON, NJ:  
3,963,671, INT. CL. 44.

VIRTUAL SECURITY CORPORATION, WEST PALM  
BEACH, FL:  
2,883,167, CANC. INT. CL. 45.  
2,883,168, CANC. INT. CL. 45.

VITABIOTICS LTD., LONDON, ENGLAND:  
2,487,383, REN. 4-13-11. INT. CL. 5.

VITACAP LABS, LLC, FARMINGDALE, NY:  
3,963,309, INT. CL. 40.

VITAMINS USA.COM, INC., DALLAS, TX:  
3,961,966, INT. CL. 5.

VITIENE, ERIKA SARAH, BRADENTON, FL:  
3,961,382, PUB. 3-1-2011. INT. CL. 43.

VITRA PATENTE AG, SWITZERLAND:  
3,960,692, PUB. 3-1-2011. MULTIPLE CLASS, INT. CLS.  
20, 26 AND 28.

VITRUVIAN EXPLORATION, LLC, THE WOODLANDS, TX:  
3,962,426, INT. CL. 40.  
3,962,427, INT. CL. 42.

- VIVEBIO, LLC, NORCROSS, GA:  
3,962,589, INT. CL. 10.
- VIVENDI, FRANCE:  
3,960,675, PUB. 3-1-2011. MULTIPLE CLASS, INT. CLS. 9,  
16, 35, 38, 41 AND 42.  
3,960,676, PUB. 3-1-2011. MULTIPLE CLASS, INT. CLS. 9,  
16, 28, 38, 41 AND 42.
- VIVOTECH, INC., SANTA CLARA, CA:  
3,962,613, INT. CL. 42.
- VLIEGER FARMS SUPPLY, INC., MAURICE, IA:  
2,881,746, CANC. MULTIPLE CLASS, INT. CLS. 1 AND  
35.
- VM PRODUCTS, BEDFORD, TX:  
3,962,375, INT. CL. 37.
- VOCOLLECT, INC., PITTSBURGH, PA:  
3,963,757, MULTIPLE CLASS, INT. CLS. 9 AND 42.
- VOICEWISE TECHNOLOGIES, LLC, FAIRFAX, VA:  
2,881,510, CANC. INT. CL. 9.
- VOITH PAPER PATENT GMBH, HEIDENHEIM, FED REP  
GERMANY:  
2,881,377, CANC. INT. CL. 7.
- VOIVOD, SAN FRANCISCO, CA:  
2,881,068, CANC. INT. CL. 9.
- VOLUNTARY PURCHASING GROUPS, INC., BONHAM,  
TX:  
3,962,984, INT. CL. 5.
- VOLVO TRADEMARK HOLDING AB, GSE-405 08 GÖTE-  
BORG, SWEDEN, AKTIEBOLAGET VOLVO, GÖTEBORG,  
SWEDEN:  
1,159,752, REN. 4-11-11. INT. CL. 8.
- VORTECH ENGINEERING, INC., CHANNEL ISLANDS, CA:  
3,962,143, INT. CL. 7.
- VORTEX VENTURES, INC., HOUSTON, TX:  
3,962,354, INT. CL. 7.
- VORTEX, INC., KETCHUM, ID:  
3,963,545, INT. CL. 5.
- VOXLAND, FRANCE:  
3,960,714, PUB. 3-1-2011. MULTIPLE CLASS, INT. CLS. 9,  
35 AND 38.
- VOY ENTERPRISES, LLC, NEW YORK, NY:  
2,883,151, CANC. INT. CL. 36.
- VOYCIT, INC., SPANISH FORK, UT:  
3,961,147, PUB. 3-1-2011. MULTIPLE CLASS, INT. CLS. 35  
AND 45.
- VTB, INC., MOUNTAINTOP, PA:  
3,961,283, PUB. 3-1-2011. INT. CL. 11.  
3,961,285, PUB. 3-1-2011. INT. CL. 11.
- VTLS, INC., BLACKSBURG, VA:  
3,961,007, PUB. 3-1-2011. INT. CL. 9.
- VYMED CORPORATION, GERMANTOWN, MD:  
3,962,248, INT. CL. 42.
- VYZO, LLC, OVERLAND PARK, KS:  
2,881,633, CANC. INT. CL. 42.  
2,881,634, CANC. INT. CL. 42.
- W & F APPARELL, INC., NEW YORK, NY:  
2,882,956, CANC. INT. CL. 25.
- W. R. GRACE & CO.-CONN., COLUMBIA, MD:  
1,640,119, REN. 4-12-11. INT. CL. 1.
- W.E. BASSETT COMPANY, THE, SHELTON, CT:  
3,033,485, COR. INT. CL. 8.
- W.I.N.O.S., INC., BOONE, NC:  
3,962,055, INT. CL. 21.
- W.R. GRACE & CO.-CONN., COLUMBIA, MD:  
917,482, REN. 4-11-11. U.S. CL. 12 (INT. CL. 19).
- WACHOVIA CAPITAL FINANCE CORPORATION ( NEW  
ENGLAND) AS. AGENT, BOSTON, MA:  
2,881,049, CANC. MULTIPLE CLASS, INT. CLS. 7, 9, 40  
AND 42.
- WADA, HIROSHI, SACRAMENTO, CA, DBA TEMPORARY  
ROMANCE:  
3,961,689, PUB. 3-1-2011. INT. CL. 25.
- WADE, CANDACE, GOODYEAR, AZ:  
2,938,756, CANC. INT. CL. 35.
- WAG-N-TRAIN LLC, NEW BRIGHTON, PA:  
3,961,249, PUB. 3-1-2011. INT. CL. 35.
- WAGGIN' TRAIN, LLC, ANDERSON, SC:  
3,963,143, INT. CL. 31.
- WAGON PLC, WARWICK, UNITED KINGDOM:  
2,881,515, CANC. MULTIPLE CLASS, INT. CLS. 12 AND  
42.
- WAKEFERN FOOD CORP., KEASBEY, NJ:  
2,465,289, REN. 4-14-11. INT. CL. 35.  
2,465,289, AM. INT. CL. 35.
- WAL-MART STORES, INC., BENTONVILLE, AR:  
3,963,383, INT. CL. 33.
- WALK THE PLANK, LLC, JACKSONVILLE BEACH, FL:  
2,882,145, CANC. INT. CL. 42.
- WALKER OF MELBOURNE, MELBOURNE, FL:  
3,961,414, PUB. 3-1-2011. INT. CL. 43.
- WALKER, ALQADIR, WEST ORANGE, NJ AND THOMAS,  
DABO, WEST ORANGE, NJ:  
2,881,456, CANC. INT. CL. 41.
- WALLDINGER RACING, INC., INDIANAPOLIS, IN:  
3,962,002, MULTIPLE CLASS, INT. CLS. 16, 25 AND 41.
- WALTHER SCHOENENBERGER PFLANZENSAFTWERK  
GMBH & CO., D-71106 MAGSTADT, FED REP GER-  
MANY, HENSELWERK, GMBH, MAGSTADT, FED REP  
GERMANY:  
1,641,012, REN. 4-14-11. INT. CL. 5.
- WAM ESSENTIALS, INC, MINERAL WELLS, TX:  
3,961,939, PUB. 3-1-2011. INT. CL. 3.
- WANTED LTD., LONDON SW18 1UU, UNITED KINGDOM:  
2,882,067, CANC. INT. CL. 28.
- WAPNICK, EMILIE, MONTREAL, CANADA:  
3,961,469, PUB. 3-1-2011. INT. CL. 45.
- WARD, STUART J, CAMAS, WA:  
3,961,394, PUB. 3-1-2011. INT. CL. 11.  
3,961,395, PUB. 3-1-2011. INT. CL. 11.
- WARGAMING.NET LLP, UNITED KINGDOM:  
3,960,707, PUB. 3-1-2011. MULTIPLE CLASS, INT. CLS. 9,  
16 AND 41.
- WARNACO U.S., INC., MILFORD, CT:  
2,882,286, CANC. INT. CL. 25.
- WARNER BROS. ENTERTAINMENT INC., BURBANK, CA:  
2,383,446, CANC. INT. CL. 41.  
2,502,729, REN. 4-11-11. INT. CL. 41.  
2,883,321, CANC. INT. CL. 9.
- WARNER-LAMBERT COMPANY LLC, MORRIS PLAINS,  
NJ:  
2,882,845, CANC. INT. CL. 5.
- WARNOCK FOODS PRODUCTS, INC., MADERA, CA:  
3,961,316, PUB. 3-1-2011. MULTIPLE CLASS, INT. CLS. 29  
AND 30.
- WARREN, RICHARD A., ARLINGTON, TX:  
2,882,982, CANC. INT. CL. 18.
- WARRICK, MERCEDES, LAS VEGAS, NV:  
3,963,405, INT. CL. 41.
- WARRIOR SPORTS, INC., WARREN, MI:  
2,883,053, CANC. INT. CL. 28.
- WARSON GROUP, INC., ST. LOUIS, MO:  
2,883,219, CANC. INT. CL. 25.
- WASH & GO CAR WASH CORP., CORONA, CA:  
2,881,834, CANC. INT. CL. 37.
- WASHINGTON MUTUAL, INC., SEATTLE, WA:  
2,881,909, CANC. INT. CL. 36.
- WASHINGTON TENNIS & EDUCATION FOUNDATION,  
WASHINGTON, DC:  
3,962,813, MULTIPLE CLASS, INT. CLS. 9, 16, 36 AND 41.
- WASTE MANAGEMENT, INC., HOUSTON, TX:  
2,882,610, CANC. INT. CL. 40.  
3,932,028, COR. INT. CL. 40.  
3,962,838, INT. CL. 41.
- WATCH COMPANY ROMANOFF, RUSSIAN FED.:  
3,960,758, PUB. 3-1-2011. INT. CL. 14.
- WATCHFUL NETWORK, INC., GREENSBORO, NC:  
2,883,216, CANC. INT. CL. 35.
- WATER CADDY GOLF, LLC, BELLEVUE, NE:  
3,963,003, INT. CL. 21.
- WATERSAVER FAUCET CO., CHICAGO, IL:  
3,960,370, PUB. 3-1-2011. MULTIPLE CLASS, INT. CLS. 6  
AND 11.
- WATKINS MANUFACTURING CORPORATION, VISTA,  
CA:  
2,442,784, REN. 4-12-11. INT. CL. 11.

WATSON, JAMES B., ENCINITAS, CA:  
 2,449,589, REN. 4-11-11. INT. CL. 7.  
 WAYPOINT FINANCIAL CORP., HARRISBURG, PA:  
 2,880,909, CANC. INT. CL. 36.  
 WCM INDUSTRIES, INC., COLORADO SPRINGS, CO:  
 3,961,663, PUB. 3-1-2011. INT. CL. 11.  
 3,961,664, PUB. 3-1-2011. INT. CL. 11.  
 3,961,665, PUB. 3-1-2011. INT. CL. 11.  
 3,961,666, PUB. 3-1-2011. INT. CL. 11.  
 3,961,667, PUB. 3-1-2011. INT. CL. 11.  
 WE PAY DOUBLE, LLC, CEDAR RAPIDS, IA:  
 3,962,973, INT. CL. 36.  
 3,962,974, INT. CL. 36.  
 WEATHERDATA SERVICES, INC., WICHITA, KS:  
 2,431,829, REN. 4-12-11. INT. CL. 42.  
 WEATHERHOLT & ASSOCIATES, LLC, ANCHORAGE, AK:  
 3,963,258, INT. CL. 9.  
 WEAVER, MATTHEW, SAN ANTONIO, TX:  
 3,961,659, PUB. 3-1-2011. INT. CL. 8.  
 WEB.DE AG, KARLSRUHE, FED REP GERMANY:  
 2,881,341, CANC. MULTIPLE CLASS, INT. CLS. 9 AND  
 38.  
 WEBCE LP LLLP, RICHARDSON, TX:  
 3,961,182, PUB. 3-1-2011. INT. CL. 41.  
 3,961,188, PUB. 3-1-2011. INT. CL. 41.  
 3,961,576, PUB. 3-1-2011. INT. CL. 41.  
 WEBCOR L.P., SAN MATEO, CA:  
 2,643,523, CANC. INT. CL. 37.  
 WEBER ENTERPRISES, LLC, WHITEWATER, CO, DBA  
 WEBER BUILT PRODUCT DESIGN AND DEVELOP-  
 MENT:  
 3,963,034, INT. CL. 12.  
 WEBROOT SOFTWARE, INC., BROOMFIELD, CO:  
 2,538,432, REN. 4-11-11. INT. CL. 9.  
 WEBSTER VETERINARY SUPPLY, INC., ST. PAUL, MN:  
 3,961,524, PUB. 3-1-2011. INT. CL. 9.  
 WEBSTER, MORRIS, MILWAUKEE, WI:  
 2,880,735, CANC. INT. CL. 30.  
 WEBTOOLS, L.L.C., JACKSON, MO:  
 2,382,956, CANC. INT. CL. 36.  
 WEBZEN INC, GANGAM-GU, SEOUL, REPUBLIC OF  
 KOREA:  
 3,960,339, PUB. 3-1-2011. MULTIPLE CLASS, INT. CLS. 9,  
 16, 28, 41 AND 42.  
 WEC HOLDINGS, LLC, LAS VEGAS, NV:  
 3,962,062, INT. CL. 38.  
 WEIGHT WATCHERS INTERNATIONAL, INC., NEW  
 YORK, NY:  
 3,963,579, INT. CL. 5.  
 3,963,580, INT. CL. 29.  
 3,963,581, INT. CL. 30.  
 3,963,584, INT. CL. 29.  
 WEIHAI JINHONG CHEMICAL CO., LTD., WEIHAI, CHI-  
 NA:  
 3,960,461, PUB. 3-1-2011. INT. CL. 1.  
 WEIL NOMINEES PTY LTD, PRAHRAN VIC, AUSTRALIA:  
 3,962,534, INT. CL. 22.  
 3,962,535, INT. CL. 24.  
 WEIL'S MATTRESS COMPANY, INC., NORTH CHARLES-  
 TON, SC:  
 2,883,282, CANC. INT. CL. 20.  
 WEINER, KRISTEN, WALNUT CREEK, CA, DBA DEAF-  
 HOOD YOGA:  
 3,962,742, INT. CL. 41.  
 WEINTRAUB SOFTWARE DESIGN ASSOCIATES, INC.,  
 PEORIA, AZ:  
 2,881,347, CANC. INT. CL. 42.  
 WELCH FOODS INC., A COOPERATIVE, CONCORD, MA:  
 2,383,800, CANC. INT. CL. 32.  
 WELCHEL ENTERPRISES, L.L.C., OKLAHOMA CITY, OK:  
 2,881,671, CANC. INT. CL. 12.  
 WELCOME CO., LTD., HSI CHIH, TAIPEI HSIEN, TAIWAN:  
 3,963,226, INT. CL. 9.  
 3,963,227, INT. CL. 9.  
 WELLNESS CENTERS OF AMERICA, INC., DULUTH, GA:  
 3,963,083, INT. CL. 44.  
 3,963,084, INT. CL. 44.  
 WELLPET LLC, TEWKSBURY, MA:  
 2,664,033, AM. INT. CL. 31.  
 WELLPOINT, INC., INDIANAPOLIS, IN:  
 2,382,213, CANC. INT. CL. 36.  
 WELLS ENTERPRISES, INC., LE MARS, IA:  
 1,167,538, REN. 4-8-11. INT. CL. 30.  
 WELLS FARGO & COMPANY, MINNEAPOLIS, MN:  
 2,883,347, CANC. INT. CL. 16.  
 3,960,308, PUB. 3-1-2011. INT. CL. 36.  
 WELLS FARGO HOME MORTGAGE, A DIVISION OF  
 WELLS FARGO BANK, N.A., DES MOINES, IA:  
 2,384,088, CANC. INT. CL. 36.  
 WELLS' DAIRY, INC, LE MARS, IA:  
 3,960,629, PUB. 2-10-2009. INT. CL. 30.  
 WELLSHIRE FARMS, INC., SWEDESBORO, NJ:  
 2,826,485, CANC. INT. CL. 29.  
 WENDY BELL, COQUITLAM, BC, CANADA:  
 3,960,408, PUB. 3-1-2011. MULTIPLE CLASS, INT. CLS. 10  
 AND 25.  
 WENTE BROS., LIVERMORE, CA:  
 3,961,945, PUB. 3-1-2011. INT. CL. 33.  
 WERLIN, JERALD D., LONG ISLAND CITY, NY:  
 2,881,012, CANC. INT. CL. 42.  
 WERNER CHRIST GMBH, FED REP GERMANY:  
 3,960,806, PUB. 3-1-2011. MULTIPLE CLASS, INT. CLS.  
 12, 18, 20, 24 AND 25.  
 WERX, LLC, PARK CITY, UT, DBA SEASONFIVE:  
 3,962,518, MULTIPLE CLASS, INT. CLS. 18 AND 25.  
 WEST COAST NOVELTY CORPORATION, ALAMEDA, CA:  
 3,962,846, INT. CL. 25.  
 WEST LAKE FOOD CORPORATION, SANTA ANA, CA,  
 DBA BANH CUON TAY HO RESTAURANT CORPORA-  
 TION:  
 3,961,320, PUB. 3-1-2011. INT. CL. 29.  
 WEST PUBLISHING CORPORATION, EAGAN, MN:  
 2,382,973, CANC. INT. CL. 42.  
 WESTAR ENERGY, INC., TOPEKA, KS:  
 3,963,135, INT. CL. 36.  
 WESTBAN HOTEL INVESTORS, LLC, BETHESDA, MD:  
 2,883,241, CANC. INT. CL. 43.  
 WESTERFIELD, JAMES, FREEBURG, IL:  
 2,883,357, CANC. INT. CL. 31.  
 WESTERN BAGEL BAKING CORP., VAN NUYS, CA:  
 2,384,176, CANC. INT. CL. 30.  
 WESTERN CORPORATE FEDERAL CREDIT UNION, SAN  
 DIMAS, CA:  
 2,384,010, CANC. INT. CL. 36.  
 WESTERN NEW YORK PUBLIC BROADCASTING ASSO-  
 CIATION, BUFFALO, NY:  
 3,962,516, MULTIPLE CLASS, INT. CLS. 16, 38, 41 AND  
 42.  
 WESTERN NEWS&INFO, INC., YUMA, AZ:  
 3,960,499, PUB. 3-1-2011. INT. CL. 41.  
 WESTERN RESERVE LIFE ASSURANCE COMPANY, ST.  
 PETERSBURG, FL:  
 2,882,703, CANC. INT. CL. 36.  
 WESTINGHOUSE LIGHTING CORPORATION, PHILADEL-  
 PHIA, PA:  
 2,883,249, CANC. INT. CL. 11.  
 WESTLAKE MEDICAL OF AUSTIN, LTD., AUSTIN, TX:  
 2,442,724, REN. 4-13-11. INT. CL. 36.  
 2,442,724, COR. INT. CL. 36.  
 WESTLAKE MILLER LLC, WINTER HAVEN, FL:  
 3,961,209, PUB. 3-1-2011. INT. CL. 31.  
 WESTRIM, INC., VAN NUYS, CA:  
 2,882,737, CANC. INT. CL. 28.  
 WEXLER PACKAGING PRODUCTS, INC., NORTH WALES,  
 PA:  
 2,880,957, CANC. INT. CL. 7.  
 WGBH EDUCATIONAL FOUNDATION, BOSTON, MA:  
 3,963,346, INT. CL. 9.  
 WGI INNOVATIONS, LTD., GRAND PRAIRIE, TX:  
 3,962,995, INT. CL. 11.  
 WHEN THEY COME BACK, LLC, TYLER, TX:  
 3,963,887, INT. CL. 36.  
 WHI SOLUTIONS, INC., WHITE PLAINS, NY:  
 2,881,131, CANC. INT. CL. 42.

- WHITE, JAMES E. JR., BEVERLY HILLS, CA, DBA JIM WHITE ENTERPRISES:  
3,960,304, PUB. 3-1-2011. INT. CL. 41.
- WHITE, SUSAN A., WASHINGTON, DC:  
3,963,729, INT. CL. 25.
- WHITEHEAD, JOHN W., CHARLOTTESVILLE, VA:  
2,341,677, REN. 4-8-11. INT. CL. 41.
- WHITEWAVE SERVICES, INC., DALLAS, TX:  
3,963,375, INT. CL. 32.  
3,963,376, INT. CL. 29.
- WHITTINGTON, COZY, WHEATON, IL, DBA KNOWLEDGE-EDGEPATH:  
3,961,695, PUB. 3-1-2011. MULTIPLE CLASS, INT. CLS. 42 AND 45.
- WHOLE FOODS MARKET IP, L.P., AUSTIN, TX:  
2,882,450, CANC. INT. CL. 30.
- WHOLELIFE PUBLISHING, INC., GILBERT, AZ:  
2,883,005, CANC. MULTIPLE CLASS, INT. CLS. 16 AND 44.
- WICK BUILDING SYSTEMS, INC., MAZOMANIE, WI:  
2,384,174, CANC. INT. CL. 19.
- WIEDEN, BOB, EGAN, MN:  
2,883,223, CANC. INT. CL. 14.
- WIENER, ANDREW ROBERT, OAKLAND, CA:  
2,881,683, CANC. INT. CL. 42.
- WILBUR-ELLIS COMPANY, SAN FRANCISCO, CA:  
911,126, REN. 4-13-11. U.S. CL. 6 (INT. CL. 5).  
3,961,777, PUB. 3-1-2011. INT. CL. 1.  
3,961,890, PUB. 3-1-2011. INT. CL. 5.
- WILD BIRD CENTERS OF AMERICA, INC., GLEN ECHO, MD:  
2,556,054, REN. 4-13-11. INT. CL. 35.
- WILD BIRDS UNLIMITED, INC, CARMEL, IN:  
3,963,055, INT. CL. 21.
- WILD PLANET ENTERTAINMENT, INC., SAN FRANCISCO, CA:  
2,882,984, CANC. MULTIPLE CLASS, INT. CLS. 9 AND 28.
- WILDIZE FOUNDATION, ASPEN, CO:  
2,549,849, REN. 4-8-11. MULTIPLE CLASS, INT. CLS. 16 AND 36.  
2,549,850, REN. 4-8-11. MULTIPLE CLASS, INT. CLS. 16 AND 36.
- WILDLIFE SOLUTIONS, INC., SANFORD, FL:  
2,383,072, CANC. INT. CL. 42.
- WILDLIFEDIRECT, INC., WASHINGTON, DC:  
3,960,364, PUB. 3-1-2011. MULTIPLE CLASS, INT. CLS. 35 AND 36.  
3,960,365, PUB. 3-1-2011. MULTIPLE CLASS, INT. CLS. 35 AND 36.
- WILDWOOD INDUSTRIES, INC., BLOOMINGTON, IL:  
2,384,344, CANC. INT. CL. 16.
- WILLCO INC., LAFAYETTE, IN:  
2,880,908, CANC. MULTIPLE CLASS, INT. CLS. 16 AND 35.
- WILLIAM BRICE, GILBERT, AZ:  
3,963,834, INT. CL. 13.
- WILLIAMS FRIED CHICKEN, INC., DALLAS, TX:  
2,881,610, CANC. INT. CL. 35.
- WILLIAMS SCOTSMAN, INC., BALTIMORE, MD:  
3,962,140, INT. CL. 6.
- WILLIAMS, EARL NUNNALLY, NEW YORK, NY:  
2,393,504, REN. 4-8-11. INT. CL. 25.
- WILLIAMS, LEBARRON, NORFOLK, VA:  
3,963,120, INT. CL. 41.
- WILLIAMS, MICHAEL, WOODSTOCK, NY:  
2,890,385, CANC. MULTIPLE CLASS, INT. CLS. 16 AND 41.
- WILLIAMS, MICHAEL DEWAYNE, HOLLAND, MO:  
3,962,541, INT. CL. 25.
- WILLIAMS, MICHAEL O. D.D.S., GULFPORT, MS:  
3,961,979, INT. CL. 10.
- WILLIAMS, MIDGE, EAST SANDWICH, MA:  
3,962,138, INT. CL. 16.
- WILLIAMS, SHARON, CULLOWHEE, NC:  
2,881,802, CANC. INT. CL. 25.
- WILLIAMSON-DICKIE MANUFACTURING COMPANY; THE, FT. WORTH, TX:  
723,146, CANC. U.S. CL. 39.
- WILLIAMSON, CHARLES E., SEATTLE, WA:  
2,881,394, CANC. INT. CL. 41.
- WILLIE GEORGE MINISTRIES, INC., TULSA, OK:  
2,881,248, CANC. INT. CL. 41.
- WILLWORK, INC., SOUTH EASTON, MA:  
2,382,709, CANC. MULTIPLE CLASS, INT. CLS. 37 AND 42.
- WILMINGTON TRUST COMPANY, WILMINGTON, DE:  
3,962,530, INT. CL. 36.
- WILSON-PASTOR, BRITTA, ENCINITAS, CA:  
3,962,377, INT. CL. 25.
- WILSON, CHRISTOPHER, NEW YORK, NY:  
2,881,111, CANC. INT. CL. 41.
- WILSON, TIMOTHY P., NORTH WILKESBORO, NC:  
2,881,929, CANC. INT. CL. 16.
- WILTZ, NICHOLAS MARK, HOOD RIVER, OR:  
3,961,502, PUB. 3-1-2011. INT. CL. 22.
- WIMAX FORUM, SAN DIEGO, CA:  
3,960,274, PUB. 9-1-2009. INT. CL. 41.  
3,960,275, PUB. 9-8-2009. INT. CL. 41.
- WIN SCHULER FOODS, INC, SOUTHFIELD, MI:  
3,961,990, INT. CL. 29.
- WIND RIVER TOBACCO COMPANY, LLC, JACKSON, WY:  
3,929,006, COR. INT. CL. 34.
- WINDGAN TRADING S.A., SWITZERLAND:  
3,960,766, PUB. 3-1-2011. INT. CL. 5.
- WINDROSE GROUP, LLC, GREENWOOD VILLAGE, CO:  
3,962,603, INT. CL. 16.
- WINDWARD PROJECT MANAGEMENT LLC, ANNAPOLIS, MD:  
3,962,632, INT. CL. 35.
- WINEGARD ENERGY, INC., DUARTE, CA:  
2,882,385, CANC. MULTIPLE CLASS, INT. CLS. 6, 7, 11 AND 19.
- WINEISIT.COM CORP., AMHERST, NY:  
2,882,026, CANC. INT. CL. 35.  
2,882,027, CANC. INT. CL. 35.
- WINFIELD CONSUMER PRODUCTS, INC., WINFIELD, KS:  
1,666,635, REN. 4-8-11. INT. CL. 12.
- WINSTON FURNITURE COMPANY OF ALABAMA, INC., POMPANO BEACH, FL:  
2,883,066, CANC. INT. CL. 28.
- WINTTECH AMERICA, INC., NORWALK, CA:  
3,961,026, PUB. 3-1-2011. INT. CL. 17.
- WINTER BEE, INC., LOS ANGELES, CA:  
3,963,482, INT. CL. 25.
- WINTER HEAT, L.C, PARK CITY, UT:  
1,612,858, REN. 4-8-11. INT. CL. 11.
- WINTER PARK RECREATIONAL ASSOCIATION, WINTER PARK, CO:  
3,963,726, INT. CL. 41.
- WINTON, WENDY C., MILPITAS, CA:  
3,960,359, PUB. 3-1-2011. INT. CL. 5.
- WIRE JOURNAL, INC., THE, GUILFORD, CT:  
918,534, REN. 4-9-11. U.S. CL. 38 (INT. CL. 16).
- WISCONSIN CHAMBER ORCHESTRA, INC., MADISON, WI:  
3,963,756, INT. CL. 41.
- WISCONSIN REO REALTY INC., MILWAUKEE, WI:  
3,963,841, INT. CL. 36.
- WISE BUYS INC., ATLANTA, GA:  
3,961,108, PUB. 3-1-2011. INT. CL. 25.
- WISECHOICE BRANDS, LLC, ALEXANDRIA, VA, DBA WISECHOICE:  
3,960,489, PUB. 3-1-2011. INT. CL. 42.
- WISECRACKER LLC, PETALUMA, CA:  
3,963,236, MULTIPLE CLASS, INT. CLS. 9 AND 18.
- WISEHEALTH, INC., SEVERNA PARK, MD:  
3,961,726, PUB. 3-1-2011. INT. CL. 42.
- WISEMAN INSURANCE AGENCY, LLC, PROVO, UT:  
3,960,585, PUB. 3-1-2011. INT. CL. 36.
- WITS END HOLDINGS, BROOKFIELD, CT:  
3,963,886, INT. CL. 35.
- WIZETRADE GROUP, LLP, THE, DALLAS, TX:  
2,883,130, CANC. INT. CL. 9.



WM. B. COLEMAN CO., INC., HARAHAN, LA:  
3,962,388, INT. CL. 25.

WM. WRIGHT CO., WEST WARREN, MA:  
1,640,598, REN. 4-8-11. INT. CL. 26.

WM. WRIGLEY JR. COMPANY, CHICAGO, IL:  
2,882,410, CANC. INT. CL. 30.  
3,962,675, INT. CL. 30.  
3,963,528, INT. CL. 30.

WMF WUERTTEMBERGISCHE METALLWARENFABRIK  
AG, 73309 GEISLINGEN/STEIGE, FED REP GERMANY:  
2,882,751, CANC. MULTIPLE CLASS, INT. CLS. 8 AND  
21.

WMS GAMING INC., WAUKEGAN, IL:  
3,962,198, INT. CL. 41.  
3,962,471, INT. CL. 9.  
3,962,511, INT. CL. 9.  
3,962,512, INT. CL. 9.  
3,962,556, INT. CL. 9.  
3,962,557, INT. CL. 9.  
3,962,558, INT. CL. 9.

WMWC, LLC, LAS VEGAS, NV:  
3,963,513, INT. CL. 44.

WNBA ENTERPRISES, LLC, SECAUCUS, NJ:  
2,547,890, REN. 4-8-11. INT. CL. 41.  
2,881,596, CANC. INT. CL. 41.

WOLCHKO, JOHN F., MARTINSVILLE, VA:  
2,442,446, REN. 4-12-11. INT. CL. 38.

WOLFE'S BOROUGH COFFEE, INC., CENTER TUFTON-  
BORO, NH, DBA THE BLACK BEAR MICRO ROASTERY:  
3,960,298, PUB. 3-1-2011. INT. CL. 30.

WOLLOVER, DAVID R., FALLS CHURCH, VA:  
3,961,485, PUB. 3-1-2011. INT. CL. 25.

WOLSTENHOLME, MICHAEL, GRANADA HILLS, CA:  
3,962,176, INT. CL. 41.

WOMAN OWNED BUSINESS, INC., GLENDALE, AZ:  
2,882,444, CANC. INT. CL. 35.

WOMEN'S SPORTS FOUNDATION, EAST MEADOW, NY:  
2,883,145, CANC. INT. CL. 36.  
2,883,146, CANC. INT. CL. 41.

WONDER GROUP, INC., CINCINNATI, OH:  
2,880,679, CANC. INT. CL. 41.

WOO, SANG K., LOS ANGELES, CA:  
3,963,010, INT. CL. 25.

WOODBURY, BENJAMIN C., HOLDEN, MA:  
2,882,565, CANC. INT. CL. 42.

WOODRIDGE LABS, INC., VAN NUYS, CA:  
2,882,613, CANC. INT. CL. 3.

WOOTON, LUCILA, LAKE FOREST, CA:  
2,882,832, CANC. MULTIPLE CLASS, INT. CLS. 3 AND  
42.

WORKFLEX SOLUTIONS LLC, CARROLLTON, TX:  
3,961,034, PUB. 3-1-2011. MULTIPLE CLASS, INT. CLS. 35  
AND 42.  
3,961,035, PUB. 3-1-2011. MULTIPLE CLASS, INT. CLS. 35  
AND 42.

WORLD ACCESS, INC., RICHMOND, VA, AKA MONDIAL  
ASSISTANCE:  
3,960,484, PUB. 3-1-2011. INT. CL. 36.

WORLD BLACK BELT, INC., TARZANA, CA:  
2,883,202, CANC. INT. CL. 25.

WORLD DRYER CORPORATION, BERKELEY, IL:  
3,962,913, INT. CL. 11.

WORLD HEART CORPORATION, SALT LAKE CITY, UT:  
3,963,284, INT. CL. 10.

WORLD HUNTING GROUP ENTERPRISES, INC., CAN-  
TON, IL:  
3,962,315, INT. CL. 9.

WORLD MARTIAL ARTS INTERNATIONAL LTD., VIC-  
TOR, NY:  
3,961,603, PUB. 3-1-2011. INT. CL. 25.

WORLD TRIATHLON CORPORATION, TAMPA, FL:  
2,384,055, CANC. INT. CL. 3.

WORLD WRESTLING ENTERTAINMENT, INC., STAM-  
FORD, CT:  
3,960,447, PUB. 3-1-2011. INT. CL. 41.

WORLDMEMBER, INC., ST. LOUIS, MO:  
2,881,850, CANC. INT. CL. 35.  
2,881,852, CANC. INT. CL. 9.

WORLDPANTRY.COM, INC., SAN FRANCISCO, CA,  
WORLDPANTRY.COM, INC., SAN FRANCISCO, CA:  
2,462,295, REN. 4-12-11. INT. CL. 35.

WORLDPANTRY.COM, INC., SAN FRANCISCO, CA,  
WORLDPANTRY.COM, INC., SAN FRANCISCO, CA:  
2,444,875, REN. 4-13-11. INT. CL. 35.

WORLDWIDE DISTRIBUTORS, KENT, WA:  
3,963,476, INT. CL. 25.

WORLDWIDE VAPOR, INC., HUNTINGTON BEACH, CA:  
3,963,798, INT. CL. 9.

WORSHIP TOOLBOX, INC., LAS VEGAS, NV:  
3,962,902, MULTIPLE CLASS, INT. CLS. 9 AND 16.

WORTHINGTON CHRISTIAN SCHOOLS, INC.,  
WORTHINGTON, OH:  
2,436,912, REN. 4-13-11. MULTIPLE CLASS, INT. CLS. 25  
AND 41.  
2,455,043, REN. 4-13-11. MULTIPLE CLASS, INT. CLS. 25  
AND 41.

WOUND, OSTOMY AND CONTINENCE NURSES CERTI-  
FICATION BOARD, INC., MILWAUKEE, WI:  
2,439,903, REN. 4-12-11. U.S. CL. B.

WOW! TECHNOLOGIES, INC., LAS VEGAS, NV:  
2,881,345, CANC. INT. CL. 9.  
2,881,346, CANC. INT. CL. 9.

WPA INTERNATIONAL LTD, DORSET, UNITED KING-  
DOM:  
2,881,897, CANC. INT. CL. 10.

WRANGLER APPAREL CORP., WILMINGTON, DE:  
3,961,062, PUB. 3-1-2011. INT. CL. 9.

WRIGHT, ANN, GARRISON, NY:  
3,960,859, PUB. 3-1-2011. INT. CL. 20.

WRIGHTSON URQUHART LIMITED, ABERDEEN AB51  
5BJ, UNITED KINGDOM:  
2,880,587, CANC. MULTIPLE CLASS, INT. CLS. 35 AND  
36.

WSOL, INC., PIANO, TX:  
3,960,228, PUB. 3-1-2011. INT. CL. 35.

WTC-TRADE MART, L.P., DALLAS, TX:  
2,880,978, CANC. INT. CL. 35.

WWW VIAJEZ COM, S.A. DE C.V., ESTADO DE MEXICO,  
MEXICO:  
3,960,599, PUB. 3-1-2011. INT. CL. 9.  
3,960,600, PUB. 3-1-2011. INT. CL. 9.

WYCKOFF, PETER J., SUNLAND, CA:  
2,525,202, REN. 4-8-11. INT. CL. 4.

WYNNWOOD ARMY, L.L.C., LEWISVILLE, TX:  
2,448,179, REN. 4-14-11. INT. CL. 41.  
2,448,180, REN. 4-14-11. INT. CL. 41.

W3 INNOVATIONS, LLC, CUPERTINO, CA, DBA BROKEN  
THUMBS APPS:  
3,961,551, PUB. 3-1-2011. INT. CL. 9.

X-L PLASTICS INC., CLIFTON, NJ:  
2,441,666, REN. 4-8-11. INT. CL. 40.

X-LARGE LICENSING, LLC, LOS ANGELES, CA:  
2,882,227, CANC. INT. CL. 35.

XAKTSOFT, INC., POWELL, OH:  
2,882,493, CANC. INT. CL. 42.

XCEL ENERGY INC., MINNEAPOLIS, MN:  
3,963,253, MULTIPLE CLASS, INT. CLS. 35, 36, 39, 41  
AND 42.

XENEREX BIOSCIENCES, SAN DIEGO, CA:  
2,882,755, CANC. MULTIPLE CLASS, INT. CLS. 1 AND  
42.

XERXES CORPORATION, MINNEAPOLIS, MN:  
2,882,315, CANC. INT. CL. 11.

XIPWIRE, INC., PHILADELPHIA, PA:  
3,963,176, INT. CL. 36.

XIRION, LLC, MCALLEN, TX:  
2,881,685, CANC. INT. CL. 38.

XO COMMUNICATIONS, LLC, HERNDON, VA:  
2,882,653, CANC. INT. CL. 35.

XPRESSFIX, LLC, OVIEDO, FL:  
3,961,775, PUB. 3-1-2011. INT. CL. 37.

XPROTEAN, INC., HAYWARD, CA:  
2,881,721, CANC. INT. CL. 9.

X6D LIMITED, NEOCLEOUS HOUSE, CYPRUS:  
3,960,883, PUB. 3-1-2011. INT. CL. 9.



- Y'S PUBLISHING CO., INC., NEW YORK, NY:  
3,961,001, PUB. 3-1-2011. INT. CL. 16.
- YÜKSEL SERAMİK SANAYİ VE TİCARET ANONİM ŞİRKETİ, TURKEY:  
3,960,783, PUB. 3-1-2011. INT. CL. 19.
- YAKIMA BAIT CO., GRANGER, WA, JOHN J. HILDEBRANDT CORPORATION, LOGANSPOUT, IN:  
1,167,481. REN. 4-12-11. INT. CL. 28.
- YAMAHA CORPORATION, SHIZUOKA, JAPAN:  
3,961,980, INT. CL. 9.
- YAMAHA CORPORATION OF AMERICA, BUENA PARK, CA:  
3,962,070, INT. CL. 15.
- YANECKO, MICHAEL J., NOVATO, CA, DBA NO NASTY NEST AND YANECKO, JANE, NOVATO, CA, DBA NO NASTY NEST:  
3,960,521, PUB. 3-1-2011. INT. CL. 20.
- YANGZHOU GELIBAO POWER MACHINE COMPANY LIMITED, YANGZHOU CITY, JIANGSU, CHINA:  
3,963,188, INT. CL. 7.
- YANTAI VALIANT FINE CHEMICALS CO., LTD., YANTAI, SHANDONG, CHINA:  
3,963,500, INT. CL. 1.
- YARDIGREEN, INC., MIAMI, FL:  
3,961,610, PUB. 3-1-2011. INT. CL. 35.
- YEAGER, SANDRA, BENTON, AR:  
3,961,413, PUB. 3-1-2011. INT. CL. 3.
- YEDOR, ROBERT, SCOTTSDALE, AZ:  
2,883,185, CANC. INT. CL. 30.
- YELLOW MATTER ENTERTAINMENT, LLC, STUDIO CITY, CA:  
3,961,925, PUB. 3-1-2011. INT. CL. 9.
- YELLOWPAGES.COM, LLC, GLENDALE, CA:  
3,963,299, MULTIPLE CLASS, INT. CLS. 35 AND 41.
- YES YES, INC., STAFFORD, VA:  
3,960,219, PUB. 6-6-2006. INT. CL. 37.
- YES! MEDIAWORKS LLC, WESTBOROUGH, MA:  
3,962,953, INT. CL. 41.
- YESKE BUİE INC., SAN FRANCISCO, CA:  
3,963,057, INT. CL. 36.
- YILDIZ HOLDING A.S., USKUDAR, ISTANBUL, TURKEY:  
3,963,516, INT. CL. 30.  
3,963,653, INT. CL. 30.
- YIP, CHUNGHO, MA ON SHAN, NT, HONG KONG:  
3,962,701, INT. CL. 35.
- YOCOM, GARY, STANFORD, KY:  
3,963,048, INT. CL. 8.
- YOGURT PIZAZZ, LLC, BRENTWOOD, CA, DBA YOGURT PIZAZZ:  
3,960,840, PUB. 3-1-2011. INT. CL. 30.
- YOO, SOO HYUN, BLUE BELL, PA:  
3,961,253, PUB. 3-1-2011. INT. CL. 44.
- YORK COLLEGE OF PENNSYLVANIA, YORK, PA:  
3,962,513, MULTIPLE CLASS, INT. CLS. 25 AND 41.
- YOU'VE GOT IT MAID! LLC, FREMONT, CA:  
2,498,472, CANC. INT. CL. 37.
- YOUBET.COM, INC., WOODLAND HILLS, CA:  
2,882,222, CANC. INT. CL. 36.
- YOUNG AMERICA CORPORATION, EDINA, MN:  
2,881,883, CANC. INT. CL. 35.
- YOUNG AUDIENCES OF OREGON, INC., PORTLAND, OR:  
1,642,994. REN. 4-12-11. INT. CL. 36.
- YOUNG COLORADO, L.L.C., LOUISVILLE, CO:  
1,608,667, CANC. MULTIPLE CLASS, INT. CLS. 1, 3, 4, 5 AND 10.
- YOUNG, RONALD ALEXANDER (SCOT), WEST MIDLANDS, UNITED KINGDOM:  
3,832,687, COR. MULTIPLE CLASS, INT. CLS. 3, 12 AND 21.
- YOUNGDO IND. CO., LTD., BUSAN, REPUBLIC OF KOREA:  
3,962,920, INT. CL. 6.
- YOUNGER BIOTECHNOLOGY CO., LTD., TAIPEI CITY, TAIWAN:  
3,963,101, INT. CL. 30.
- YOUNGS RUBBER CORPORATION, NEW YORK, NY TO CHURCH & DWIGHT CO., INC., PRINCETON, NJ:  
544,931, AM. U.S. CL. 10.
- YTC SUMMIT INTERNATIONAL, INC., ARCADIA, CA:  
2,880,942, CANC. INT. CL. 20.
- YU JIANG NING, STOCKTON, CA:  
3,962,903, INT. CL. 25.
- YUZZIT, LLC, PHOENIX, AZ:  
3,961,086, PUB. 3-1-2011. INT. CL. 35.
- YZY INC, MIAMI, FL:  
3,962,640, INT. CL. 3.
- Z GAMING, LLC, WHITE PLAINS, NY:  
2,882,271, CANC. MULTIPLE CLASS, INT. CLS. 28 AND 41.
- Z.YNG COMMUNICATIONS, INC., HAMPSTEAD, QUEBEC:  
2,881,931, CANC. INT. CL. 42.
- Z'BAG, LLC., NEW YORK, NY:  
3,962,203, INT. CL. 28.
- ZACCHINO, CATHERINE, PORTLAND, OR AND ZACCHINO, DOMINICK, PORTLAND, OR:  
3,960,371, PUB. 3-1-2011. INT. CL. 28.
- ZAKRYTE AKTSIONERNE TOVARYSTVO "ROSAVA", UKRAINE:  
3,960,832, PUB. 3-1-2011. INT. CL. 12.
- ZANGHI, MICHAEL J., WILLIAMSVILLE, NY:  
2,883,135, CANC. INT. CL. 3.
- ZARRO EMIDIO, ROYAL OAK, MI:  
3,962,481, INT. CL. 8.
- ZCEPT, THOUSAND OAKS, CA:  
3,963,198, INT. CL. 28.
- ZEENYX SOFTWARE, INC., HOPKINTON, MA:  
3,963,434, INT. CL. 9.
- ZENECA LIMITED, LONDON, ENGLAND:  
2,798,195, CANC. INT. CL. 5.
- ZENIMAX MEDIA INC., ROCKVILLE, MD:  
3,961,398, PUB. 3-1-2011. INT. CL. 9.
- ZEPHYR CORPORATION, MINATO-KU; TOKYO 107-0052, JAPAN:  
3,960,722, PUB. 3-1-2011. INT. CL. 7.
- ZEROX CORPORATION, NORWALK, CT:  
2,384,288, CANC. INT. CL. 2.
- ZESTCASH, INC., LOS ANGELES, CA:  
3,963,514, INT. CL. 36.
- ZESTIVITIES!, INC., CROZET, VA:  
3,960,623, PUB. 8-17-2010. INT. CL. 35.
- ZHEJIANG ANTONG ELECTRIC CO., LTD., CHINA:  
3,960,726, PUB. 3-1-2011. INT. CL. 9.
- ZHEJIANG GANGLONG; NEW MATERIAL CO.,LTD, CHINA:  
3,960,765, PUB. 3-1-2011. INT. CL. 24.
- ZHEJIANG HUAHONG ARTS & CRAFTS CO., LTD., YIWU, ZHEJIANG PROVINCE, CHINA:  
2,881,541, CANC. INT. CL. 14.
- ZHEJIANG KEDU ELECTRIC MANUFACTURING CO., LTD., ZHEJIANG, CHINA:  
3,960,702, PUB. 3-1-2011. INT. CL. 9.
- ZHEJIANG SANOU MACHINERY LIMITED COMPANY, CHINA:  
3,960,813, PUB. 3-1-2011. INT. CL. 7.
- ZIBA IP HOLDINGS, LLC, ARTESIA, CA:  
3,962,731, INT. CL. 35.  
3,962,732, INT. CL. 44.  
3,962,733, INT. CL. 3.
- ZIFRU MARKETING AG, CH-6302 ZUG, SWITZERLAND:  
2,882,411, CANC. INT. CL. 29.
- ZIGMO, LLC, GLEN ALLEN, VA:  
3,962,801, INT. CL. 37.
- ZODIAC MARINE & POOL, FRANCE:  
3,960,711, PUB. 3-1-2011. INT. CL. 11.
- ZOELLER PUMP COMPANY, LOUISVILLE, KY:  
3,962,334, MULTIPLE CLASS, INT. CLS. 7, 9, 11 AND 19.
- ZOTOS INTERNATIONAL, INC., DARIEN, CT:  
2,883,108, CANC. INT. CL. 3.
- ZOTTER HOLDING GMBH, A-8333 KORNBERG BEI RIEGERSBURG, AUSTRIA:  
3,960,782, PUB. 3-1-2011. INT. CL. 30.
- ZOUK HOLDINGS PTE LTD., SINGAPORE, SINGAPORE:  
2,883,390, CANC. INT. CL. 41.
- ZOYOK LTD., NEWPORT BEACH, CA:  
2,434,938. REN. 4-8-11. INT. CL. 42.

ZUMTOBEL LIGHTING GMBH, LEMGO, FED REP GERMANY:  
 3,960,573, PUB. 3-1-2011. MULTIPLE CLASS, INT. CLS. 9 AND 11.  
 3,960,574, PUB. 3-1-2011. MULTIPLE CLASS, INT. CLS. 9 AND 11.

ZURICH INSURANCE COMPANY LTD, ZURICH, SWITZERLAND:  
 2,880,684, CANC. INT. CL. 36.

ZVON ENTERTAINMENT, L.L.C., ALAMO, CA:  
 3,962,048, INT. CL. 41.  
 3,962,050, INT. CL. 9.

ZWIENER, WOLFGANG, NEW YORK, NY:  
 3,962,038, INT. CL. 30.

ZWIMPFER, HANS, CH-4058 BASEL, SWITZERLAND:  
 2,881,095, CANC. MULTIPLE CLASS, INT. CLS. 37 AND 42.

ZYLOO RESEARCH LABORATORIES LLC, TEMECULA, CA:  
 3,961,334, PUB. 3-1-2011. INT. CL. 3.  
 3,961,335, PUB. 3-1-2011. INT. CL. 3.  
 3,961,903, PUB. 3-1-2011. INT. CL. 3.

0837947 BC LTD., NORTH VANCOUVER, BC, CANADA:  
 2,881,147, CANC. INT. CL. 32.

1057697 ONTARIO INC., NIAGARA FALLS, ONTARIO:  
 2,896,437, CANC. MULTIPLE CLASS, INT. CLS. 9, 16 AND 44.

1345302 ONTARIO INC., TORONTO, ONTARIO, CANADA:  
 2,880,585, CANC. INT. CL. 35.

143 DESIGNS, LLC, LOS ALTOS HILLS, CA:  
 3,962,561, INT. CL. 14.

1821 COMICS, LLC, LOS ANGELES, CA:  
 3,961,843, PUB. 3-1-2011. INT. CL. 16.

2 GRRRLS, INC., BIRCHWOOD, MN:  
 2,882,131, CANC. MULTIPLE CLASS, INT. CLS. 9, 21 AND 28.

2TOMS, LLC, DUBLIN, NH:  
 3,962,595, INT. CL. 5.

2TOR, INC., NEW YORK, NY:  
 3,961,091, PUB. 3-1-2011. MULTIPLE CLASS, INT. CLS. 35 AND 41.

20/20 MARKETING LLC, SOUTH ST. PAUL, MN:  
 3,963,021, INT. CL. 41.

21ST CENTURY INSURANCE AND FINANCIAL SERVICES, INC., WILMINGTON, DE:  
 3,962,338, INT. CL. 36.

211 MAMARONECK AVE. RESTAURANT, LLC, MAMARONECK, NY:  
 3,961,863, PUB. 3-1-2011. INT. CL. 43.

212, LLC, EDEN PRAIRIE, MN:  
 3,963,171, INT. CL. 14.

2124708 ONTARIO LTD, THUNDER BAY, ONTARIO, CANADA:  
 3,961,043, PUB. 3-1-2011. MULTIPLE CLASS, INT. CLS. 16 AND 41.

3BACK LLC, RACINE, WI:  
 3,960,977, PUB. 3-1-2011. MULTIPLE CLASS, INT. CLS. 35 AND 41.  
 3,960,997, PUB. 3-1-2011. MULTIPLE CLASS, INT. CLS. 35 AND 41.

3KIB, LLC, WESLEY CHAPEL, FL:  
 3,961,507, PUB. 3-1-2011. INT. CL. 35.

3M COMPANY, ST. PAUL, MN:  
 3,963,288, INT. CL. 28.

3PD, INC., MARIETTA, GA:  
 3,831,155, AM. MULTIPLE CLASS, INT. CLS. 37 AND 39.

328 SUPPORT SERVICES GMBH, 82234 WEßLING, FED REP GERMANY:  
 3,960,743, PUB. 3-1-2011. INT. CL. 12.

360 INNOVATIVE MARKETING AND COMMUNICATIONS, LLC, WILMETTE, IL, DBA 360 INNOVATIVE MARKETING AND COMMUNICATIONS, LLC.:  
 3,961,008, PUB. 3-1-2011. INT. CL. 35.

365 SCHEDULE, LTD., NORTH RICHLAND HILLS, TX:  
 3,960,894, PUB. 3-1-2011. MULTIPLE CLASS, INT. CLS. 9 AND 42.

37.37, INC., LOS ANGELES, CA:  
 3,960,506, PUB. 3-1-2011. INT. CL. 25.

4086864 CANADA INC., QUEBEC, CANADA:  
 3,960,348, PUB. 3-1-2011. INT. CL. 25.

411 WEB DIRECTORY INC., CULVER CITY, CA:  
 3,960,321, PUB. 3-1-2011. INT. CL. 35.

5STONES HOLDINGS, LLC, VIENNA, VA:  
 3,962,251, INT. CL. 43.  
 3,962,283, INT. CL. 43.

500 GROUP INCORPORATED, STAMFORD, CT:  
 2,881,905, CANC. MULTIPLE CLASS, INT. CLS. 6 AND 7.

510 SOFTWARE GROUP, LAKE ARROWHEAD, CA:  
 2,383,896, CANC. INT. CL. 42.

589 JEWELRY DESIGN, INC., NEW YORK, NY:  
 1,644,359, REN. 4-9-11. INT. CL. 14.

6 CURRY'S, INC, BUFORD, GA:  
 3,961,235, PUB. 3-1-2011. INT. CL. 41.

6 FIGURES PDR, LLC, JACKSON, MS:  
 2,881,675, CANC. INT. CL. 41.

600 UK LIMITED, HECKMONDWIKE, UNITED KINGDOM:  
 1,161,629, REN. 4-9-11. INT. CL. 7.

638 BREWING COMPANY, INC, WINSTON SALEM, NC, DBA FOOTHILLS BREWING:  
 3,961,199, PUB. 3-1-2011. INT. CL. 32.

76 WEST LLC, PHILADELPHIA, PA:  
 3,962,504, INT. CL. 43.

8X8, INC., SUNNYVALE, CA:  
 3,962,776, MULTIPLE CLASS, INT. CLS. 9, 38 AND 42.

800 JR CIGAR, INC., WHIPPANY, NJ:  
 2,555,912, REN. 4-8-11. INT. CL. 34.

835 AVENUE OF THE AMERICAS, L.P., NEW YORK, NY:  
 3,962,043, INT. CL. 43.

9093-9349 QUEBEC, INC., BAIE-COMEAU, CANADA:  
 2,882,872, CANC. INT. CL. 29.

\* \* \* \* \*